





IV 1526



Digitized by the Internet Archive  
in 2016

[https://archive.org/details/jewelerscircular00unse\\_0](https://archive.org/details/jewelerscircular00unse_0)



42 NASSAU STREET, NEW YORK

Established 1813.

# SETH THOMAS CLOCK CO.

THOMASTON, CONN.

No. 20 MURRAY STREET, New York.

16 Worship Street,  
LONDON, E. C.

172 State Street,  
CHICAGO.

7 Montgomery Street,  
SAN FRANCISCO.

# F. KROEBER,

Manufacturer of CLOCKS,

No. 8 Cortlandt Street, New York.

FACTORIES:—NEW HAVEN, CONN., and NEW YORK CITY.

SUPERIOR GRADE OF

## WALNUT CLOCKS A SPECIALTY!



"BIRDIE."  
Thirty Hour, Lever, Nickel; 1/2 Size.

NEW HAVEN CLOCKS,

E. N. WELCH CLOCKS,

SETH THOMAS CLOCKS,

AT LOWEST MARKET PRICES!



"AURORA."  
Thirty Hour, Lever, Alarm, Nickel; 1/2 Size



THE

# Jewelers' Circular and Horological Review.

VOLUME X.

NEW YORK, FEBRUARY, 1879.

No. 1.

THE

## JEWELERS' CIRCULAR AND HOROLOGICAL REVIEW,

*The recognized organ of the Trade, and the official representative of the Jewelers' League.*

A Monthly Journal devoted to the interests of Watchmakers, Jewelers, Silversmiths, Electro-plate Manufacturers, and those engaged in the kindred branches of art industry.

### SUBSCRIPTION:

To all parts of the United States, Canada, Great Britain and the West Indies,  
**\$2.00 Per Annum; Postage paid.**

To France, Switzerland, Germany, Mexico, the Republics of South America, and Australia, \$2.50 per annum. Postage paid.

*All communications should be addressed to D. H. HOPKINSON, 42 Nassau Street, New York. Advertising rates made known on application.*

AGENCIES: { J. H. PURDY & CO., No. 170 State Street, Chicago.  
PRATT & CO., Ninth and Arch Streets, Philadelphia.  
HERMAN BUSH, No. 14 Mytongate, Hull, England.  
FREARSON BROS., Adelaide, Australia.

MESSRS. LEE & WIGFULL, the well known Electro-plate manufacturers, (John Street Works), Sheffield, England, have kindly consented to receive subscriptions.

### NOTICE TO SUBSCRIBERS.

THE TENTH VOLUME OF THIS JOURNAL BEGINS WITH THE PRESENT NUMBER. THOSE OF OUR READERS WHOSE TERM OF SUBSCRIPTION EXPIRED WITH THE LAST ISSUE, AND WHO HAVE BEEN NOTIFIED BY OUR USUAL CIRCULAR, WILL CONFER A FAVOR BY RESPONDING AS PROMPTLY AS POSSIBLE, AS ALL SUBSCRIPTIONS TERMINATING WITH THE LAST NUMBER WILL BE DISCONTINUED IF NOT RENEWED.

### The Condition of Trade.

WHILE the signs of the times are favorable to business enterprises in general, promising an improvement in all branches, the members of the jewelry trade should not be too sanguine regarding any marked improvement in their line of business immediately. There are numerous reasons why the jewelry trade should be among the last to feel the impetus of better times. It was the first to be seriously affected by the demoralization which fell upon the country in 1873, and it will naturally feel coming prosperity only after it has been assured in other avenues. It is an exceedingly sensitive business, more dependent upon the whims and fancies of the public than any other. During the past few years country dealers accumulated extensive stocks of goods which have not been entirely disposed of, and what remains is now *passé* and of little comparative value. Styles have changed, and those goods which were fashionable and in demand a few years ago are now unsalable. As a consequence the assets of many retailers will not hold up to the value that has been placed upon them. All the skill of designers and the fine work of skilled artisans, exceeding the cost of the metal upon which they have been expended, are lost upon jewelry that has gone out of style. The workmanship is lost, and that which remains is the simple metal, fit for nothing else but the melting pot. Many dealers in taking account of their stock, have figured their *passé* jewelry at cost price, thinking in so doing they have made a liberal allowance. In this way they have deceived themselves, and given a fictitious value to their assets, deceptive alike to themselves

and their creditors. It will take some time for the trade to work itself free of this incubus of unsalable stock, and to get down to a hard pan basis.

That there is so large an amount of out-of-style jewelry in the hands of retailers is largely attributable to the anxiety of certain manufacturers to sell their goods at all hazards. During the dull times, in order to make a show of doing business and to keep their factories going, they have forced their goods upon the market, many times upon unwilling buyers. We have frequently had occasion to condemn this practice, and urge upon manufacturers the policy of keeping the supply within the limits of legitimate demand. But, in spite of our cautions, and the experience of many years, overproduction has been the rule in nearly all lines of the trade. As a consequence, the retailers will seek to work off their old goods under the impetus of improved business before buying new stocks. Not till they fail to do this will they consign the old stock to the melting-pot, mark down their assets, and commence ordering to replenish. While, therefore, other branches of business are already feeling the indications of better times at hand, the jewelry trade will have to wait yet a little longer before it experiences much of an improvement; there is much deadwood and *débris* yet to be cleared away.

But the outlook is promising. Specie payments have been resumed without producing the slightest ripple of consternation or confusion in the commercial world. This fact alone, which was by so many declared to be impossible, has done more to restore confidence among business men than anything else that could have occurred. The general tenor of conversation among business men is of the most hopeful character. There seems to be a determination upon all sides that there *shall* be an improvement in business. To reach such a determination is half the battle. The croakers have retired from the field, and instead of their dismal prognostications of "hard times and worse coming," we hear the more welcome exclamations of "business improving; lots to do; all the orders we want," etc. We rejoice at this improved condition in the affairs of our neighbors; we could wish that the jewelry trade was already included among those who are experiencing the good effects of better times; but we can wait patiently, satisfied that it is among the things that are to be. We do not know of any branch of trade that can stand improvement better than the jewelry industry. There are any number of men engaged in it who are perfectly willing to be made rich by means of it, and we do not know of any more deserving of good fortune. They have borne their share of the burdens of general stagnation meekly if not cheerfully, and have been always ready to respond liberally to the many calls of charity which the hard times have made necessary. They have borne themselves like worthy and sympathetic citizens during the years of the country's distress, and now that the country is feeling better they are entitled to and will receive their share of the rewards.

### Promptness a Business Requisite.

THERE is great complaint of the lack of business courtesy and promptness that prevails among interior dealers. They neglect to acknowledge the receipt of goods forwarded them, are oblivious to statements of accounts, and totally ignore letters addressed to

them on matters pertaining to their business. This is a great oversight on the part of the delinquent dealers, and, if they but knew it, operates to their injury. Promptness in all things is a business requisite, without which success cannot be achieved. It ranks second only to capital in establishing credit, and the lack of it tends to depreciate the credit of even him whose capital is known to be abundant. "He is good, but he is slow," is "damning a man with faint praise," yet is a common response to inquiries regarding a man's credit. It is highly unsatisfactory to deal with these "slow coaches," to whose offence of not paying promptly is added that of positive discourtesy in not replying to ordinary business letters.

We are aware that country dealers generally do not keep private secretaries, but the correspondence required of them is ordinarily quite limited. It is such a simple thing to acknowledge the receipt of goods, or of letters—a postal card will often suffice—that the burden is not a hard one to bear. But beside the satisfaction one enjoys in receiving prompt replies to business communications, the men who give credit so largely as our manufacturers do have rights in the matter which cannot be overlooked with impunity. They have a right to demand free and frank communication with their debtors, and when this is refused they grow suspicious of them, begin to make inquiries regarding them, and their credit suffers in consequence. Many a man who was "solid" as to his assets has been brought under the ban of suspicion, and the value of his trade discredited because he lacked the courtesy to promptly answer business communications. Creditors are men not to be avoided by debtors, nor are their letters to be looked upon always as pressing invitations to a settlement. As a rule they are frank, hearty men, ready to meet their fellow-men half way in all matters relating to business. But they have their own engagements, and, in order to meet them, must know upon what to depend at the hands of those who are indebted to them. A prompt answer to their inquiries readily satisfies them. It is not, however, solely in the matter of indebtedness that the country dealers show their discourtesy—it crops out quite as seriously in many little items that go to make up the grand aggregate which is denominated business. Lack of promptness is the rule, and is an evil from which all suffer. The average country dealer can answer all his business correspondence in half an hour a day, yet because he neglects to attend to it, he causes his correspondents to become annoyed, his creditors to get uneasy, and brings himself into bad repute. The old proverb says "Procrastination is the thief of time," and we add that "it is a wise man who answers business letters promptly."

### What Constitutes False Representation.

IN order to establish fraud and deceit based upon false representations, the representations must be of existing circumstances, must be false in fact, and the party making them must believe or have reason to believe them false, and such false representations must influence the other party to contract. It will be seen that several requirements must all be fulfilled to constitute fraud, and these should be examined one at a time.

1st. False representations must be of actually existing circumstances. Thus, if a purchaser were to allege that he would receive \$10,000 to-morrow and pay for the bill of goods he was buying, this would not be a false representation because it might be possible that he would get the money. But if he stated that \$10,000 was owing to him which sum he would collect, this would be a false representation because no such sum was actually owing to him at the time of speaking. Fraud is misrepresentation or concealment as to the existence or non-existence of some fact or circumstance, but the subject matter of misrepresentation or concealment must be in the past or present and not in the future. The distinction is somewhat subtle, but will be intelligible with a little thought, which will show that a lie which cannot come true is different from a statement which possibly may be fulfilled.

2d. The representations must be false in fact. The falsity may be conveyed in any way; by actual words, by innuendo, by gesture, by silence. All acts, omissions and concealments of the truth, whether wilful or made in ignorance, are false representations. Thus a man may represent that his house is solvent while in reality it is on the brink of bankruptcy. If he believes what he says, then he merely utters a falsehood or makes a misstatement of fact and is not liable for fraud, but if he knows the real condition of affairs, he lies and is guilty. This brings us to the next head.

3d. The party making false representations must believe or have reason to believe them false. In other words the misstatement must be wilful and against his information. Thus if a purchaser stated that he believed his bank balance was about \$10,000, while he knew that a note for \$3,000 was payable that day, or if he did not know how much really was to his credit, he would be liable; but when a dormant partner in good faith referred to the balance sheet of his firm without warranting or alleging knowledge of its correctness, he was adjudged innocent of fraud upon mere proof that the balance sheet was incorrect and represented the firm in a more prosperous condition than it really was.

In general there is little difficulty in determining whether representations are false to the knowledge of the maker. This question of fact is easily settled by the evidence in each particular case. The party alleging fraud must first prove the falsity of the representations, and in nine cases out of ten an inference of the knowledge on the part of the maker follows as a matter of course and the burden of proving his innocence then falls upon him. The condition of the mind of the maker of false representations at the time of the utterance thereof is ascertained by reference to all the concurrent facts, and if not always a matter of absolute proof is easily arrived at by the aid of circumstantial evidence; but nice questions have arisen in cases where it is sought to charge principals for false representations willfully made by their agents. The law, however, is finally settled, that if the false representation be made in the performance of the agent's duty, and in pursuance of his authority, that the principal will be held liable on the reason that every person employing an agent is under obligation to pay some regard to the diligence, skill and integrity of the agent he selects, and to his fitness to perform duties with which he is charged. This is no more than right, for where one of two innocent parties must suffer from the fraud or misconduct of another, he who has reposed a trust and confidence in the fraudulent agent ought to bear the loss. For example if a traveler for a silver-ware house wilfully made false representations concerning his goods, the firm would be liable; but if he had in his possession gold bracelets belonging to his employers, but which he was not authorized to sell, and wilfully made false representations thereto relating in order to secure a sale, then the firm would not be held liable, unless they ratified his acts by reaping the benefit thereof.

The courts have often been called upon to decide as to the liability for fraud of a man in insolvent circumstances, who, knowing he is so, makes purchases on credit without disclosing the actual facts. The mere omission of a purchaser to disclose his insolvency, if unaccompanied by any intent to defraud, does not constitute fraud. Thus a dealer who knows he is insolvent may make large purchases on speculation, and, if his action be in good faith and made in a reasonable hope of profit, he is not guilty of fraud. Further, the mere intention of a vendee not to pay for the goods he purchases, if unaccompanied by any misrepresentation or concealment, is not fraud, such as to vitiate the sale. Thus if a purchaser who is in insolvent circumstances order an invoice of goods—nothing more being in view save the bare order—and the goods are sent without inquiry, no fraud has been committed so as to vitiate the sale, but if he were on the eve of an assignment, or knew that an execution was out against his stock, then he would be liable. The main question in such cases is the good or bad faith of the party sought to be charged, and this is ascertained from the facts of each particular case as presented in evidence.



4th. The false representations must influence the making of the contract; that is to say, the person who is damaged must show that he relied upon the truth of the false statement, and was induced thereby to enter into the bargain. Thus a party might tell any amount of lies about the condition of his business, and if these statements were not believed but the sale made with the knowledge and belief on the part of the vendor that such statements were untrue, allegations of fraud would not be supported.

We have next to consider the effect of fraud upon the contract. The party wronged can either forthwith disaffirm the transaction and on tender of whatever consideration may which have been received by him reclaim his property, or he can sue for the damages sustained by him. It often happens that property obtained by fraud is found in the possession of a third party, and in this case it often devolves upon him to prove that he is a *bona fide* purchaser, for good consideration, and that his bargain cannot be reinstated without loss to him. Thus if diamonds obtained by fraud were sold in ordinary course of trade, the purchaser might prove that he purchased them in good faith, and his title would prevail against the claim of the original owner; but if any notice or even suspicion of knowledge were brought home to him, or if the diamonds had been taken to secure a prior debt, then the original owner would be entitled. In any case action must be taken upon the discovery of the fraud, as neglect to proceed, subsequent affirmance, or to compromise on good answers to allegations of fraud. In cases when fraud is discovered after a contract has been made but before the performance, the party deceived may stop short or enforce the contract at his pleasure, but he has in any case a right to recover whatever damages may be due him.

Finally, a recovery in a civil action for fraud can be enforced by process against the person. If an execution against the goods is returned unsatisfied, the party guilty of fraud can be arrested and put in jail.

Criminal proceedings can also be instituted against every person who with intent to deceive or defraud, designedly by color of any false token or writing, or by any false pretense obtains from any person any money, goods, etc. These proceedings should only be taken in very clear cases. 1st. Because the requirements as to evidence of guilt are very strict and technical. 2d. Because indictment and conviction on a criminal charge destroys the social and commercial life of the party condemned, and such terrible punishment should only be invoked in extreme cases.

Finally, if you are a vendor, be cautious in your credits; if you are a purchaser, be careful as to your statements. On the one side ask proper questions, and on the other give truthful answers. If this were done as it should be there would be no need or manner of use for an article such as the foregoing.

### Compounding Felonies.

THE failures in the jewelry trade in this country during the first month of this year aggregate nearly or quite half a million of dollars. Some of them has been as outrageously fraudulent in their nature as any transactions that ever disgraced any of our commercial industries. The perpetrators of these failures have apparently taken advantage of the fact that the bankruptcy laws have been repealed, and that their creditors have virtually no redress against any rascality they choose to indulge in. One comes to New York and coolly says to his creditors, "I have failed; liabilities heavy, assets few; I want a clean bill of health, and credit for more goods; I will pay you twenty-five cents on the dollar for the sake of getting a new start; take that or nothing." If a creditor becomes inquisitive or suspicious, they ask, as did Tweed, of infamous memory, "what are you going to do about it?" Creditors have heretofore been willing to compromise for almost anything rather than take the trouble of looking into the matter. As a consequence, these fraudulent failures are becoming monotonously frequent. Every new compromise made with a debtor of this class paves the way for many others to follow

his example. The aggregate of their swindles not only consume the profits of the creditor class, but bids fair to make sad inroads upon invested capital if an end is not put to it.

It can be stopped if the creditor classes will but make up their minds to do it. Instead of compounding the felonies of their fraudulent debtors, they should institute a rigid investigation into every case, and, where there is any evidence of fraud, institute summary proceedings against the offenders. Let it be once understood that every failure is to be thoroughly investigated by a committee of creditors and those speculative dealers who thrive by repeated failures, will be speedily driven from the business. This can be readily done, and should be insisted upon before any proposition for a compromise is listened to. In fact, this uninquiring compromising is, from a moral standpoint, compounding felony, an offence for which our statutes provide severe penalties. Yet many men who pride themselves upon being good citizens, who are members of churches, and leaders in good moral works, enter into negotiations with men whom they know to be rascals, deserving of State prison, in the hope of recovering a portion of the money due rather than prosecute them for their offences. If a bank that has been robbed compromises with the thieves, and, on recovery of a portion of the money stolen, permits them to go unpunished, there is a hue and cry raised at once against compounding a felony. Wherein does this differ from compounding for twenty or twenty-five cents on the dollar with a debtor who, you are morally certain, has robbed you as positively and with as deliberate purpose as the thieves robbed the bank? From a moral standpoint there is no difference whatever.

It is high time this business was stopped, and these fraudulent debtors not only driven out of the business, but into State prison. A few cases heroically treated would cure the disease from which the trade is suffering. When failures to the tune of half a million dollars a month are reported, the brunt of which is borne by eastern manufacturers and jobbers, it is time to call a halt. Creditors are unanimously of the opinion that something should be done, but are divided as to the best means to be employed. Investigation and criminal prosecution in case fraud is discovered, seem to be their only safety. Unity of action is all that is necessary to secure this result, and we hope to see some definite plan of proceeding in cases of proposed compromises agreed upon. The trade cannot stand a continuance of the raids that has recently been made upon it; good nature and forbearance have ceased to be virtues, and the time for summary action has arrived.

There are cases where a failure is the most honest and upright policy a man can adopt towards his creditors. When a dealer finds that his business has become unprofitable, and that to go on is but to get deeper into the slough of debt, honesty demands that he shall frankly tell his creditors and place his affairs in their hands for settlement. Such men always find their New York creditors liberal and generous, full of sympathy, and ready to give them a helping hand. Of course, they do not come within our classification of fraudulent debtors, nor are our remarks intended to apply to them. But for the rascals and scalawags we have no consideration, and hope the day is near when they will receive their deserts at the hands of the trade.

### The Jewelers' Protective Union.

AT the first annual meeting of this organization held recently, the officers of the previous year were re-elected, Mr. W. R. Alling, of Alling, Bros. & Co., being the President. This society was organized about six months ago in consequence of the numerous robberies being committed upon jewelers and their travelers. Mr. Alling, who had sustained a severe loss by theft of a sample trunk, was prominent in organizing the Union, and has the satisfaction of knowing that the half year's business fully demonstrates its success and usefulness. As a result of its efforts, aided by the untiring energy of Mr. Alling, upwards of \$12,000 worth of stolen jewelry have been recovered, two thieves have been sent to State Prison, and

a third one would follow his companions but for the fact that he is nearly dead with consumption and not likely to participate in any more robberies. There are eighty-one members of the Union, to whom one hundred and twenty-four certificates have been issued, each certificate entitling the holder to the protection of the Union. The Pinkerton Detective Agency is retained to conduct the detective branch of the business. The Secretary and Treasurer is Mr. Ira Goddard, of George W. Pratt & Co. and the executive committee consists of Messrs. L. A. Parsons, of Wheeler, Parsons & Hayes, Thomas Slater, of Enos, Richardson & Co., S. Oppenheimer, of Oppenheimer, Bros. & Veith, W. Smith, of William Smith, & Co., and J. M. Miller, of Miller Bros. There are no paid officers in the organization, which represents sufficient capital to secure the conviction and punishment of all who attempt to live by depredating on the trade. Its main object is to punish the thieves and not to compound felonies. It is largely to the personal efforts and determined persistency of Mr. Alling that the Union has succeeded so well.

THE second annual election of officers of the Jewelers' League took place on the 21st of January, 1879, at the rooms of the Board of Insurance Brokers, No. 164 Broadway. Some sixty-five or seventy of the members were present. The meeting was unusually interesting, and resulted in the re-election of the old officers, with one exception only, as Mr. Yerrington, the able and efficient Secretary and Treasurer, had declined the honor of re-election, and Mr. J. D. Lyon, of the firm of Lyon & Hardy, was chosen in his place. Our readers will find elsewhere the second annual report of the League, which will convey ample information to those contemplating membership. This admirable institution deserves the cordial co-operation of every member of the trade; it is one of the cheapest modes of life insurance, for the reason that these trade organizations utilize every cent of the premiums paid, while the companies are obliged to pay heavy expenses and large salaries to their officials. Associations such as the Jewelers' League are fast rivaling established Life Insurance Companies. Every person under 45 years of age, who is in any way connected with the watch, clock, jewelry, and the kindred branches of industry, is eligible for membership, and we think it the duty of every responsible dealer to join the League. An advisory board of members, residing throughout the country, has been appointed for the purpose of informing members of the trade, who may contemplate membership, as to the aims and objects of this Association, and reference to the report will show the names and residences of these gentlemen.

MESSRS. D. APPLETON & CO. has just published a small hand book for collection of curiosities and bric-a-brac, which will prove a very useful book to the trade. The title "Bibelots and Curios," is in itself a curiosity, but the name of the author, Mr. Frederic Vors, is well known as that of a conscientious expert. The readers of this paper must be familiar with his concise and terse style of writing to which he has contributed some interesting articles on art and manufacture. Mr. Vors was for several years in the workshop of Barbedienne, in Paris, as a voluntary clerk to learn the bronze and enamel manufacture, and since then has been connected both with the manufacturing and selling departments of Tiffany & Co. He has also had no small success as a lecturer, and has been the expert employed by the convention of the two "Loan Exhibitions" which have been so successful in this city. The public ought to be grateful to this gentleman for not inflicting on them an expensive work: his book is small and very precise, and in less than 120 pages treats of pottery, porcelain, glass, enamels, metal work, arms, clocks, watches, musical instruments, fans, lacquer-work and furniture, besides having a glossary of French and English words and names used in the trade relating to these articles. We have no doubt that every salesman in that line will bless Mr. Vors for this book and learn it by heart and remember it better than he did his catechism.

THE American Watch Company have superceded the compact which heretofore existed between manufacturers and jobbers, and substituted in place thereof a business arrangement which will commend itself to the approval of the trade. They propose to adopt a new system for the sale of Waltham watches based upon the actual volume of transactions done by their customers within a given time. All dealers, regularly engaged in the watch trade, including retailers, will be treated upon equal terms, the only distinction being made in favor of customers taking large orders, who will be allowed special discounts, the rate depending upon the amount of goods handled by them. This new departure will tend to conform dealings in watches to the same principles which govern other branches of trade, and which have always been recognized as just and equitable. The old arrangement between manufacturers and jobbers was one-sided and entirely in favor of the companies without corresponding benefit to the jobber. By adhering to it the latter was deprived of the privilege of regulating his own profits, and frequently lost customers by his inability to compete with his less scrupulous competitors, who evade the letter of the agreement by selling watches strictly at stipulated rates but throw in other goods at nominal prices.

THE trade has been greatly annoyed and put to great expense by losses or miscarriage of goods in the hands of express companies. A plan has lately been devised by means of which the safe transportation of express goods to the trade is insured. A first class insurance company has undertaken to insure goods in transit at a certain rate, and to indemnify the owner if they are lost. Manufacturers and dealers can send packages of goods or samples in this way at very small cost. Heretofore express companies have required the value of each package to be marked on its outside, regulating their charges according to valuation, and, unless this was done, were not responsible for any amount exceeding \$50. By this system of insuring goods so sent, this valuation is done away with, the rate charged being at so much per \$1000. Much anxiety, annoyance and expense will be saved by this new feature in the shipment of goods, which also includes goods sent by Registered Mail.

#### American Jewelry.

THE time is within the recollection of almost every person who reads the JEWELERS' CIRCULAR when the heading of this article would have suggested anything but what it suggests to us today; for so rapid and remarkable has been the advance of American manufacturers in this tasteful and elegant industry that it is an acknowledged fact that American goldsmiths' work is unrivalled in the world. This assertion is not contradicted by the fact that some processes of enamelling, or mosaic work or certain forms of glyptic art are carried to a higher degree of perfection in France or Italy than here; for although those arts lend themselves gracefully to the goldsmith craft, they are not essentially a part of it.

Without quoting statistics we may safely say that the importation of French, English, Roman or other continental jewelry has decreased year by year until it is now insignificant in amount, while the average excellence of the goods sold by first-class dealers throughout the United States has advanced almost in a corresponding degree. Looking over some of the recent productions of Messrs. Durand & Co., (whose elegant offices are at No. 44 East Fourteenth Street, in this city, and whose admirably organized manufactory is at Newark, N. J.,) we were particularly impressed with the superiority of the massive gold work in the English style, as we were wont to call it when the best goods of that class came from England. Nor do we refer to any special or elaborate pieces made to illustrate the capabilities of American workmen, but to the staple goods, the rings, sleeve buttons, chains, bracelets and such every-day articles that are continually made and sold to the trade throughout the country. The characteristic enterprise of our people has entered into this trade and is governed by a determination to excel that will keep the standard from ever becoming lower. In the manufacture of jewelry,

as in every other industry, art or profession, there is always room at the top, and no one who produces the best can fail to command a ready market at all times.

In 18 karat colored gold work we were shown a quantity of serpent bracelets and finger rings that we venture to assert would surprise the London shopkeepers who, a few years ago, found plenty of American customers for similar wares, but who are gradually opening their eyes to the fact that Americans are fast becoming the most exacting buyers of Jewelry in the world, for the reason that their taste has been rapidly educated up to a high standard. The delicate and beautiful, but extremely fragile Roman etruscan work is now made here far better than in Italy, and while the native goods have equal beauty with the foreign, they have besides a substance and strength that the Roman jewelry notoriously want.

By recently discovered methods this style of work, *i. e.*, jewelry adorned with delicately raised tracery is made of various shades of color instead of all "yellow" like the Roman, and green, red and other colors are made with equal facility. Combinations of gold and platinum of the most intricate designs are blended with beautiful harmony, and the Oriental, particularly the Japanese devices we have lately seen, follow no school that has been developed in Europe, but are types of a system of decoration that has been assimilated by our own designers and given us, and the world, "something new in jewelry."

The best American goods are not meretricious either, there is no false pretense about them, and without boastfulness we may say that they combine the grace and elegance which has been long regarded as the quality of French jewelry with the strength and durability specially claimed for the English. There are not wanting witnesses to assert that the French taste is expressed in goods of feeble strength, nor would it be a revelation to declare English jewelry clumsy. We believe that the period of charlatanism in American manufacturers has passed away and that that most powerful of all causes among manufacturers as well as in every sphere of life—self interest—will keep American jewelry in the van for all coming time.

A Failure of the Period.

MARCUS KRONBERG, of Chicago, has failed, and has been to New York to see what his creditors are going to do about it. His liabilities are estimated at \$180,000, and the actual value of his assets is uncertain. They consist of real estate, which is mortgaged, old goods, and the usual amount of cats and dogs. Certain goods, cash, and securities, which Mr. Kronberg had disposed of among members of his family, and a favored creditor, may also be recovered for the general benefit. At the first meeting with the New York creditors Mr. Kronberg offered forty cents, then fifty cents on the dollar, and a very pretty showing his affairs make.

Immediately after it became known in Chicago that Mr. Kronberg was in New York trying to negotiate a settlement, a circular, signed by several firms, was sent on, in which the Chicago jobbers, therein specified, expressed their belief that Mr. Kronberg could pay one hundred cents on the dollar, and asked that no settlement should be granted until a thorough examination had been made. Accordingly a joint committee, New York being represented by Messrs. W. Smith, H. P. Richmond, and H. G. Slack, and Chicago by Messrs. T. W. Baxter and Paul Jurgens, proceeded to the scene of action, and after a thorough examination of books and witnesses, which extended over some ten days, completed a careful, able, and thorough report, which was presented to a meeting of creditors at New York on the 7th inst.

By this report it appears that in August, 1877, Mr. Kronberg gave his wife two houses, worth from \$10,000 to \$15,000. They were to repay her for diamonds and money given to him some years previous. Nevertheless, on the day of his failure, Kronberg gave his wife \$10,358.22, as he now says, for the same purpose, and a further sum of \$4,911.91, wherewith to pay some foreign customers and provide sustenance for his family. The committee are advised by counsel that the real estate may be recovered. On the same day when he made his assignment he paid his niece, Mrs. Stift, \$3,742.99 as a balance for three years' service, alleged to have been due her, although during such alleged service she had been at liberty to draw

what she might deem requisite for her personal expenses. Mr. Kronberg had never fixed her salary, nor could he state the particular period of time which the three years covered. It is to be borne in mind that Mrs. Stift had not been in the regular employ of Kronberg since her marriage, some two years ago, except as she may have assisted her husband in the store at St. Louis, nor were any books produced to show any amount standing to her credit prior to 31st December, 1878.

On the same day, the 11th January, 1879, Mr. Stift, who had been in charge of the St. Louis store, was paid \$2,505.67 on account of alleged services rendered during the preceding eighteen months, although during that period numerous entries on Kronberg's books show that his salary was \$15 per week. The account of this St. Louis venture is very interesting:

Total goods sent to St. Louis, - - - -	\$32,086 40
" " returned at sundry times, \$3,676 45	
" " " at close by Stift, 5,522 01	
" depreciation on last named lot from invoice price as per Stift's statement, - - 2,500 00	11,698 46
" goods unaccounted for. - - - -	20,387 94
" (Sales \$16,207 61).	
" Cash received from St. Louis, \$10,331 87	
" Expenses as recorded, - - 5,875 74	16,207 61
" Not accounted for in either goods, money or expenses, - - - - -	4,180 33

Mr. Kronberg also claims that, at his request, some three years ago, Mr. Wallach of this city, visited Chicago, and brought with him \$15,000 in money, which he lent to Kronberg. This transaction, however, was never entered upon the books, nor can Mr. Kronberg give the date, although he alleges the interest has been paid, he cannot say where, when or how, nor can he state what was done with the money. However, when Mr. Wallach came on to Chicago, on the 9th January, 1879, it was quietly arranged without dispute that all interest had been paid, and Mr. Kronberg executed a deed of trust to his attorney, securing the \$15,000 by a transfer of three houses on Franklin street, Chicago, and a fruit farm in Illinois. It also appears, that at the same interview, Mr. Kronberg informed Mr. Wallach of his insolvent condition before the making of the deed of trust before mentioned, and to secure a further debt of \$15,000 alleged to have been due for merchandise, certain goods valued by the committee, after personal inspection, at not less than \$30,000, were taken from Kronberg's stock and deposited in the vault of the First National Bank of Chicago, in the name of Kronberg's attorney, to pay legal costs, &c., and Wallach & Co.'s claim in full, should no satisfactory arrangement be made with the general creditors.

It was learned that Mrs. Kronberg had two boxes in the safety vaults before referred to. These boxes were opened; in one were found policies on Kronberg's life, and in the other nothing. Mr. Kronberg subsequently explained that on the morning of such examination a package of notes and securities had been taken out of the second box, and given to his legal adviser, who subsequently turned over about \$10,000 of notes to the assignee, representing that they were those taken from the vaults. These notes have been mixed with the other papers, but as Mr. Kronberg reported good notes, amounting to less than \$5,000, it seems strange that this property, which should have gone to the assignee, was deposited by Mrs. Kronberg in her own special box. The committee further report, that \$27,000 of bad debts, estimated as worthless by Mr. Kronberg in his statement, will probably realize some \$14,000, and that \$37,000, stated as "doubtful" and available for not more than \$10,000, will probably realize \$30,000.

The report, an abstract of which we have published, was read to the creditors by Mr. Baxter, and Mr. Kronberg was invited to explain. He admitted the facts alleged, and offered to throw the property which he had given to his family into the assets, if his proposition was accepted.

At a subsequent meeting, held on the 11th inst., the committee recommended that Mr. Kronberg should be released on the following conditions:

The property conveyed to Wallach and the goods deposited in the First National Bank of Chicago, to be relinquished; but Kronberg's wife to retain the property now in her name, and Kronberg the money appropriated by him previous to his failure to liquidate overdrafts, and legal expenses. The committee regret that they can accomplish nothing better. A dividend of 60 to 70 cents on the dollar may be expected.

Some thirty-nine creditors have signed his release on the terms proposed by the committee, and more are expected to follow.

The facts in this case are so plain that comment is superfluous.

## Practical Hints on Watch Repairing.

BY EXCELSIOR.—No. 47.

### EXAMINING THE ENGLISH OR "PATENT" LEVER.

739. The English lever watch, although having the detached lever escapement, is in nearly every part different from the "anker," both in construction and arrangement. The principal point of difference is that the motive force is equalized throughout the 26 or 28 hours of running, by means of the fuzee and chain. In winding, the fuzee must be turned backward. This would of course affect the rate very seriously. Maintaining works are therefore added, to maintain the forward movement of the train, even during the winding. This equality of the motive force is unquestionably useful in arriving at the highest attainable perfection of timekeeping, as it greatly lessens the labor of the adjuster in securing isochronal vibrations of the hair-spring, by lessening the amount of the different variations for which the isochronal adjustment is expected to compensate. It is not indispensable, however, for equally good results can be attained with the toothed or "going barrel," by proper attention and skill, as is shown by the performance of the finest American and Swiss levers. But, for common or cheap watches, the complexity and insecurity of the fuzee and chain arrangement more than balance all the benefit derived from it, and for such uses it is not to be commended. Judging from the small number of workmen in this country who have "good luck" in repairing the English lever, it would seem to be very little understood. As there are a great many of this style of watch in use, it will be pretty fully treated of, particularly as the explanations of several points will apply equally to the American lever, which will come next in order, as well as to the duplex and chronometer. The workman will do well to note the latter part of section 636.

740. Examine the case; correct the cannon pinion or end of center pinion arbor when touching the glass, the hands rubbing together, or in the dial holes, etc., as directed for the detached lever. See if the cannon pinion is properly tight, (198). See that the bolt which fastens the movement in the case holds it tightly; that the bolt is not loose, but held as snugly on the plate as possible and remain free; that when pushed back it does not touch the fourth wheel; that the point of the screw that holds it to the plate does not stick up far enough to touch the fourth wheel; that its spring works well and smoothly. Open; see that the joint is tight and works well. If there is any reason to suspect that the balance cock, or its end stone or screws touch the dome of the case, try as in section (640). In  $\frac{3}{4}$  plate movement, see that no part, (as the chain on the barrel, the main wheel teeth, the balance rim or screws, the end of lever fork, etc.,) can touch the case band or middle, either in opening, or when shut down. Also see that the lifting or locking spring or the bolt, when pushed back, do not touch any part of the movement. If it has a band around the edge, see that any of the above mentioned parts do not touch it, either inside or outside. Any such defect found must be corrected, and should be noted on the bench slip, (618). Then remove the joint pin, and take movement from the case.

741. In a full plate watch, the cap over the movement should be thoroughly examined. See that it fits nicely down to the plate, all around the edge, and around the bolt; that it is held tightly; that the two screw studs are tight in the watch plate, and their slots of the right height to work well on the slide; that the winding arbor cup does not rub on the cap, either in the hole, or inside the cap,—although it should come as close as possible and not touch; that the balance cock is free in the opening, but well fitted; if the cock touches, make a minute of it, and, after the watch is repaired and put together, if the cock still touches, it should be freed, to remove any liability of being sprung to one side by the cap; that the case lifting or locking springs do not rub on the cap; if they do, dress

them off to clear, or, if that cannot be done, dress out the cap where the rubbing has marked it. Now take off the cap, and see that the main wheel teeth or the chain does not rub on the inside,—shown by marks on the gilding; that the fourth wheel or the end of lever fork don't come to the edge of plate, and touch the cap; ditto, of the stop bar, (775); ditto, of the balance and the end of lever, in  $\frac{3}{4}$  plate movement. If the balance is oversprung, see that the cap does not press on the hair-spring bar or stud, and either cause it to rub on the balance rim, when held dial up, or to throw the further side of the hair-spring down against the balance arms. Also, that the cap does not press the regulator down, and cause the same trouble. If doubtful, test as in section (640); it will also generally be shown by a rubbing sound, when held with the dial upward, and is best listened to when in the case. Sometimes the balance cock sets so far through the opening, that the balance rubs in the top of the cap, when held dial up—also shown by the sound. If it is heard to scrape, and the balance end-shake is none too great, the cap must be bumped up to clear.

742. See that the slide moves easily, but not loosely; that its holding edges naturally set over the edges of the stud holes, as the slide moves; that, when at the unlocked end of its motion, the holes of the slide exactly coincide with those in the cap. If the slide then sets over the cap holes, so as to interfere with the studs coming through freely, either in removing or replacing the cap, alter the middle slot in the cap, as required. Either file the slot longer, or close up one end a little, so that, when the middle pin of the slide rests against the end of the slot, the cap and slide holes will exactly meet, as above stated. To take off the slide, unscrew and remove the middle pin, by its head on the top of the slide. If this is worn off so that you cannot turn out the screw by it, pry up the middle of the slide very carefully till the bottom of the middle pin is level with the surface of the cap, then push the slide along till the end pins come to holes at the ends of their slots, when the slide will come off. If necessary to replace the slide, in the same condition, hold the middle up as before described, while you press the end pins down through their holes and push the slide along till the middle pin drops into its slot. The end pins should be smooth, and well undercut, fitting their slots well, and with heads large enough to hold the slide closely down on the cap. The middle pin need not be undercut, but should be well smoothed or polished off.

743. See that the dial or dial-frame lies flat on the pillar plate; that the edges of the plate and the dial (or its frame) are even (644), that the notch in the frame is right for the bolt; that the pins hold it tight, and allow no side play on the pillar plate; that the dial is not held up by the end of the fuzee or barrel arbor, or the ratchet wheel, click, or screw, or the minute wheel pinion, or its pin, or the head of a bridge screw, etc. (645). Especially, see that the minute circle has the centre pinion arbor for its center. Test by watching the point of the minute hand while turning it once around. No matter how perfect the marking of the dial may be, if it has not the same center as the hands it will not show correct time, but may perhaps be a minute or more out of the way in fifteen minutes after setting, and be right again in fifteen minutes more, (202). If the dial is found to be out of center, move it on the frame to bring it correct. For directions for regulating with such a dial, etc., see Practical Treatise on the Balance Spring, pages 101 to 103. A poor dial will add to the above the irregularity of its marking, and no dependence can be placed on a watch with such defects. Sometimes the pillar plate is warped in gilding, or otherwise. If so, when the movement is apart, test it on a flat plate, and level it, then make the dial frame fit to it, and the dial fit to the frame. If the dial rocks on the frame, dress off the enamel at the places that touch, with an emery lap or file. If the dial-frame posts are loose in the holes in the pillar plate, bend the two lower posts outwards, or from each other. If the pin holes in the posts are not right for the plate, but too high, or below the surface, plug them up and drill new holes, as it is important that the pins be well placed, else they will fail to hold

the dial properly, or will work out. If you have any occasion to bend the post of a gold dial, be very careful, or you will bend the dial and spoil it. The safe way is to file the post at its base, to make it bend easier.

(744) If the dial-frame posts are loose in the frame, always make them tight. Rivet them in, resting the upper ends on a lead block, to prevent damaging them, or closing the pin holes by flattening them. If necessary, to make them secure, also solder them in, flowing the solder well all around, but do not leave enough on to prevent the dial coming down flat on the frame, or the frame flat on the plate. If a dial-frame post is gone, a new one is easily made and attached. To fit a new post to the dial itself, see section (290). See that the joint is fast on the frame; if not, rivet, and if necessary solder it also. But in most cases it can be made solid without recourse to soldering. Lastly, pin the dial fast to its frame, and make sure that the pins cannot work out, either by bending the smaller ends, or by getting the larger ends into a hollow in the frame, or by doing both. It will not do to depend upon their being merely tight in their holes.

(745) Examine the cannon pinion, minute and hour wheels, etc. Sometimes the pipe or socket of the hour wheel is so thin that, when the hour hand is pressed down hard, it compresses the pipe and makes it tight on the cannon pinion. File out the socket of the hand, till it will go down to its place without making the hour wheel bind on the pinion. See previous directions for hour wheel, (195, (645), minute wheel, (648) and cannon pinion, (197, 198,) (646). If the minute wheel pin is loose, tighten by heading it down on inner side of pillar plate, or fit a new one. The cannon pinion is often liable to work up on its arbor, and especially in watches which set by the stem or by an extra setting arbor, so that there is no chance to keep the pinion pressed down with the key in setting the hands. In such cases, even a pretty well fitted pinion may gradually work up, till it binds the hour wheel against the dial, or causes trouble in the action of the wheels, and deranges the rate or stops the watch. Workmen sometimes drill through the center pinion arbor, and put in a pin, over the cannon pinion. But this cannot always be done and, besides, the pin wears fast, and the job does not look well. A good way to prevent this is by forming a slight tit within the cannon pinion, to work in a groove on the center pinion arbor, which keeps the cannon pinion always at the same height.

(746) To make the tit, file into one side of the pinion, with a small round file, not coming too near through to the bore, but only getting it thin enough to raise a slight tit inside with the prick punch. Then push the cannon pinion straight down to its shoulder on the arbor, turn it around, and pull it straight off. This will make a mark around the arbor, where the tit comes. The center pinion should be put in the lathe, and a very shallow groove cut in the arbor, exactly on the mark. Having given a slight tap with the prick punch, to renew the tit, which has been partly obliterated, slip the pinion on the arbor again to see if the groove is in the right place. If so, when the pinion reaches its seat against the shoulder, you will feel and hear the tit snap into the groove. If the groove is cut too high it will keep the pinion from going down to its proper place, and, make it run too high on the arbor; if too low, the tit will not reach it. But it is better too low than too high, as it can be made higher by cutting the groove a little broader, to reach up to the tit. But if too high, there is no help but to make another tit higher up, to meet it properly. The old tit should be first pressed out with a round broach, well oiled. Having got a good fit, give the new tit another tap with the punch, and put a little oil in the groove when putting the watch together.

(747) Another serious and quite common trouble with the cannon pinion, is found when the pinion is turned out hollow in the bottom, to go over and around the projecting end of the bush or "stopping" of the center pinion pivot hole. In order to get a good length of hole for the bearing, the bush is left higher than the surface of the pillar plate, and this shoulder causes the trouble. On examining the watch, the center pinion seems to have no end-shake, or is actu-

ally bound and tight. On taking the movement partly to pieces, we find that the center pinion is perfectly free, with plenty of end-shake; but when we put it together again, the pinion is bound, as before—sometimes tight enough to hold and stop the watch, sometimes only causing irregularity in the going. The balance will have a good motion a part of the time, and in a little while it will hardly vibrate far enough to escape, or perhaps hold up altogether. Whenever the bush projects, and the cannon pinion goes over it, make sure that the hollow cannot possibly rub on the bush, by turning it out wider or larger, if necessary, but no deeper. But if a bush is needlessly spread, or broad, it can be turned off to make it a little smaller; but the top should not be taken off, as a long hole is desirable, (757).

(748) If the center pinion hole in the bush is worn, the pinion of course will be pressed to the worn side of the hole, and the opposite side of the bush will rub in the cannon pinion hollow. The proper remedy for this, is to close up the hole, or fit a new bush. Sometimes the cannon arbor, or that part of the center pinion on which the cannon pinion turns, is not true or concentric with its pivot or bearing. This will carry the cannon pinion eccentrically or out of center, and make its hollow rub on the bush. In a fine movement and perfect job, the center pinion should be put in the lathe, and the cannon arbor turned off true and smoothed up, then a new cannon pinion fitted if necessary. But if the cannon arbor is true with the pinion leaves, and the pivot or bearing is not concentric with the pinion leaves the proper remedy would be to turn the bearing off, true, and fit the bush hole to its new size. In a common job, if the cannon arbor is not too much out of true, the hollow may simply be turned out larger to clear the bush. But, whenever this fault is found, try the depthings of the motion wheels very thoroughly, turning them through all positions and testing their freedom and depthing frequently. When the watch is apart, try the cannon pinion alone over the bush, and see that the hollow is large enough to have plenty of side shake upon it. Then put the center pinion through the bush, press the cannon pinion down to its shoulder, and see if the pillar plate has plenty of shake between the shoulder and the cannon pinion. If so, this fault may be considered cured. In the same way, in a  $\frac{3}{4}$  plate movement, see that the center staff, cup, washer, etc., are free, by trying the upper plate alone, with the center pinion, staff, etc., in their places on it.

(749) *For examining the escapement*, see directions under Detached Lever Escapement, (313) to (463). In addition, see that the end of the lever fork does not rub on the potance; that the escape wheel teeth do not rub either the potance or the lower cap jewel slip; that the ends of the potance screw or steady pins do not stick above the surface of the plate and touch the balance arms, rim or screws; that none of the jewel setting screws can touch the balance, nor the projecting pivots of the center or other pinions. In  $\frac{3}{4}$  plate movement, see that the balance and its screws are free from the chain, and its hook, and from the steel wheel, main wheel or fuzee, when at their highest end-shake. Be particular to test the "draw," (325) to (328), by pushing the outer end of lever fork from the banking pins and bringing the guard pin against the edge of roller table. If the fork does not return of itself to its rest against the banking pins, the cause should always be sought out and remedied as it is very important to have this correct. Also, see that the guard pin does not touch the inside of the regulator ring, when the lower fork rests against the banking pins; and that the guard pin is not so long that, at its highest end-shake, it can come too near the hair-spring collet, or the collet of the balance staff. In any of the above cases the remedy is obvious.

(750) *The end-shakes* should be carefully examined, and, if faulty, there is a certain order for correcting them when the watch is apart. First, try the center pinion, then the escape wheel pinion and the pallet arbor. The plates of English levers are generally quite soft, and can be bent or "bumped" to change the shakes. Having got the center pinion and pallet arbor correct, we next adjust

the escape wheel pinion. If its end-shake is too great, bump the upper plate down, or the pillar plate up, according as the escape wheel should be made higher or lower in order to work properly on the pallet jewels; and the reverse if there is too little end shake; or the shoulder of the proper pivot can be turned back instead, (297). Having pinned the plates together and found these three end-shakes correct, the play of the fourth and third pinions can generally be adjusted by bumping the third bridge, (the false plate or bar under the dial, up or down, as required. If these pinions must be lowered, to cause parts to clear, the upper plate will have to be bumped down to hold them down. But if they need to be raised, thus lessening the end-shake, it is better to free them by taking off the shoulders of the upper pivots, than by bumping the plate up.

751 The end-shakes of the fuzee and detent come last. First notice how the main wheel should stand to clear the pillar plate, then bump the bridge or bar to suit. If the upper hole is jeweled, and the fuzee requires the jewel to be lowered, instead of bumping the plate to do this, the jewel setting can be lowered in the plate by turning the shoulder lower. If the fuzee ought to go higher, the plate can be bumped, or the upper shoulder of the fuzee arbor can be turned off a little and repolished. But if the shoulder is already quite narrow, and turning it back would make it still narrower, (from having a fancy undercut below the shoulder, that should not be done. If the upper plate must be turned out to free the fuzee cap and beak, the hollow should be regilt. If the main wheel rubs the pillar plate only on one side, uprighting the fuzee arbor will cure that and give end-shake. The shake of the detent is then adjusted to secure its proper action in the steel or maintaining wheel. In "bumping" the plate, rest it on the end of a hollow stake, with paper between the stake and the gilding. Use a round-end punch fitting into the hollow around the pivot hole, and large enough to rest on the whole surface of the countersink; if it merely rests on the bottom of the countersink, it will probably drive out the bush or "stopping," instead of springing or "bumping" the plate. Although comparatively unobjectionable for the pillar plate, "bumping" cannot be recommended for the upper one, but it is often unavoidable. If well done, it will hardly be detected on the outside, but at any rate the end-shakes must be made correct.

752 The *uprights* of the different parts are often very much "out," but if the pivot holes are all jeweled, it is difficult to remedy them, and should not be undertaken without special reasons or orders. A jewel can be taken out, and a new setting or bezel turned eccentrically to the old one, but the jewel to fit this will be so much larger than the others as to at once proclaim the alteration to all beholders. If the jewel is in a setting which can be taken out, its seat in the plate can be cut out larger and eccentric, and a new jewel and setting fitted, but little larger than the old one. If the holes are not jeweled, they can be more easily altered, by plugging up the old hole, uprighting from the bottom hole to find the place for the upper one, drilling it, and cutting a countersink for it. Before uprighting any part, examine all the depthings that will be affected, and alter the holes in such a way as to improve the depthings or do them the least injury. If the depthings are correct, while the pinions or arbors tip over so badly that they must be uprighted, altering the top holes will affect the depthings the least, as the bearings are generally near the bottoms. But if the depthings are defective, and moving the bottom holes so as to correct the uprights will also correct the depthings, do that way; if it will not, then upright by altering the top holes, and correct the depthings separately, as required, either by altering the bottom holes, or by enlarging or diminishing the size of the faulty wheel.

### The English Jewelry Trade in 1878.

It must at first sight appear to be a sorry task to have to regard the at least unprogressive fortunes of this industry during the year which has now closed. That it has shared the evil times through which many staple trades in this country have passed, or are still passing, it is hardly necessary to remark. That an article of luxury can be first dispensed with, when means are narrowed, and the pinch of misfortune is felt, is a truism which does not require to be proved.

It would seem, therefore, that a few words might suffice to complete a profitless annual record, and that there was nothing to do except to wait for better days.

Yet this is hardly so. There are a few notable features in the jewelry trade in Birmingham which are worth considering, even by members of other trade communities, while it is important that they should be kept in view by the jewelers themselves, both employers and employed. The manufacture of jewelry is not a trade which is "protected" by trade unionism either of masters or men. The manufacturers are usually sufficiently divided both in opinion and interest to prevent any adequate combination to regulate wages or hours of work. Moreover, the branches into which the trade is divided renders such an undertaking impossible or desirable than in almost any other local industry. On the other hand, the workmen themselves are so numerous that even in times of good trade they are fully equal to the demands made upon them; while in times of bad trade a large amount of unskilled labor is forced to seek refuge in other occupations. Beyond this, the facilities which the skilled workman has for commencing business, and thus of emerging from the ranks of the employed, constantly remove those more energetic spirits who might be disposed to lead the van of trade agitation. All these causes combined have effectually removed from this industry any fear of that so-called "protection" which is said to have proved so disastrous to some British manufactures. It is worth while, therefore, to inquire into the results of this state of things, almost unique as it is, among the special trades of Birmingham.

To begin with the skilful working jeweler, who keeps his eyes open, saves a few pounds, and starts in business—the moment this man is able to descend from his garret, take a small shop, and employ additional hands, he looks at the economies of trade in a manner much more closely than his former employer would, or perhaps could, have done. He begins with boys, and the first man he employs will be certainly obtained on the cheapest terms. Often the very hand-to-mouth nature of his trade at first demands this; but the result, nevertheless, is that an amount of jewelry, good, bad, and indifferent, generally the latter, is produced at prices which will ensure an entrance into any market that is in any way open to English trade. As a singular instance of the way in which this complete freedom of the jewelry trade operates, we may mention that even during the late Paris Exhibition certain bracelets, said to be infringements of a French patent (though the infringement has been denied), were made and sold by Birmingham jewelers, exported into France, and exposed for sale in Paris shops at lower prices than the French makers could offer them at.

It may be urged that all this is a mistake, and that the low wages produced by this state of things are evils which ought to be remedied. But it is an error to suppose that low wages are necessarily produced by this freedom of the trade. The workman turned employer may at his commencement of business employ cheap labor, but it is also a noticeable fact that he employs labor which would otherwise be unemployed in that special manufacture. Many thousands of articles of jewelry made in Birmingham have been sold during the year now closing which would never have been sold had they not been produced so cheaply. To carry out the analysis of results—the workman employer before referred to, as he enlarges the sphere of his operations and follows a true course of progress, also improves the style of his work, finding that he can improve the selling prices of his jewelry as he employs more skilled labor, and thus pays better wages. The whole of the workmen, therefore, the skilled and the unskilled, find in their respective places a larger sphere of operations in consequence of the complete freedom of the trade. The fact is, that a large amount of business has been done in Birmingham in this special department of which the public are unaware. Of course, it has been done at a small profit, like much business in other trades during the year 1878; but the fact that it has been done means that very many persons have been employed here who would otherwise have been unemployed, and that the town has maintained

its hold upon a manufacture which is intimately connected with its present and future well-being.

While the course of trade during the year has been chequered with privation for the great majority of the employed, the employers themselves have also found, superadded to the difficulties of steering against the wind, the financial troubles arising from a past exaggerated prosperity. The gigantic bank failures and commercial collapses which have marked the business history of the past few months have been but the culmination and bursting of great sores which have affected the whole commercial body. The "leaps and bounds" of trade, and the jewelry trade especially, which marked the period of five or six years since led on to a development of production and speculation, almost in excess of the *then* demand. This demand was curtailed by foreign wars and domestic disasters, especially by the American collapse of 1873-4. Since that time all connected with the Jewelry trade—shippers, factors, manufacturers—have been vainly trying to stimulate trade at home and abroad in every conceivable fashion. A healthy stimulus is one thing, but too often an unhealthy stimulus has been applied. A speculative business, instead of leading to fortune, had led to the bankruptcy court, and the losses of many manufacturers during the past year have been frequent and serious. But while many shippers and factors, as well as shopkeepers, have fallen before the adverse winds, it is one of the most satisfactory features of the Birmingham jewelry trade that so few of the manufacturers themselves have succumbed. It speaks well for their thrift and forethought, as well as for the general prudence with which they have conducted their affairs, that in spite of their many losses, due often to the exertions of over sanguine travelers, they have so successfully weathered the storm.

Something must be said upon the art progress or otherwise of the jewelry trade in 1878; and here, leaving for a moment the stocks that alarm the business world, we look at a brighter picture. During the present year we have witnessed, perhaps, the finest collection of modern jewelry which has yet been gathered together in one place. The Paris display, if it did not include all the best art work of the most advanced nations in this department, at least included in all that the taste and skill of the politest nation in the world could offer for the purchase, the envy, or the imitation of her rivals. Germany was absent; and England, although well represented to a small extent by a few good cases, was practically absent. But France put forth her strength, and nothing could surpass the splendor and beauty of her display. All who were present were charmed by its range and magnificence, while careful observers waited to see what the effect would be upon popular taste. So many English people attended that it might well have been expected that among at least the more wealthy classes a new style would have developed itself. Such has frequently been the case after an exhibition of so special a character, and we might reasonably have looked forward to a renewal of the phenomenon. This was the more likely, because the main features of the Paris jewelry were so essentially different from those which prevail in England. The slight, fanciful, and varied forms, the open continuous scrolls, the polished red color of the gold—all these were distinct characteristics which might easily have led to a change of fickle fashion in Great Britain. There may, and probably will be in course of time, some tendency in one of these directions, but at present it may fairly be said that the effect of the Paris Exhibition upon English taste has been absolutely nothing. Nor, in making this statement, need it be presumed that this is either a misfortune or a fault. Granting a certain solid insular taste in personal ornaments, which is supposed—erroneously supposed—to be peculiar to Britishers, yet there is a soundness and good sense in a large proportion of the jewelry manufactured for the middle and upper classes here which would not be improved by the addition of the more trivial graces of Parisian style. The forms we adopt are usually geometrical, the ornaments are generally adapted with apparent regard to the use it is required to perform, and the decoration, though not elaborate or obtrusive, is more frequently well placed. It is impos-

sible to look at many of the typical specimens of jewelry of the purely French school without the conviction that they are mere constructed ornament, and that the maker has gone to details for his design. There is often a want of unity in what would be otherwise exquisite specimens of the jeweler's art. The workmanship has been delightful where yet the workman required a central leading idea. It may, therefore, have been no discredit to the judgment of the British jeweler that he has not been to any large degree influenced to depart from his original principles of the design by the examples lately displayed at Paris.

Though the great expectations of trade revival which were formed at the conclusion of European peace have not yet been fulfilled, and though the displays of commercial soundness have disastrously affected the jewelry trade for the time being, yet there are not wanting signs that better days are at hand. Clear-headed business men now recognize the fact that the disasters and ruin of the past three years were far too real and widespread to be healed at once by a treaty of peace, whatever its character; and all can perceive to-day that the very foundations of trade had been sapped by unscrupulous enterprise. These matters must take time before the equilibrium can be restored, and a healthy trade can return. It cannot be otherwise than satisfactory to know that, through so trying an ordeal, this great Birmingham industry has been upheld, and has fairly maintained its ground in the two differing requirements of cheapness and style. While no market has been closed on the question of prices, some at least of the best houses have been able to employ regularly, at full working hours, the quota of skilled workmen, and to compete in the highest walks of the goldsmith's art. The greater number of Mayors' chains made during the year have been designed and carried out in Birmingham, and one of these has been considered worthy to hold its own in the pages of the *British Art Journal*.

Altogether, if the Birmingham jewelers—not only the employers, but the rank and file of this individual army of some 10,000 persons who take the name—are true to their cause, that cause has a bright future. The great need is Art education, as, in a trade of taste and fancy such as this, the mere mechanic is foredoomed to the merest drudgery. If the masters, no less than the men, will cultivate this taste and fancy, then the whole, or at least the greater portion of the trade, will enjoy the advantages of higher remuneration, and more constant employment. The public taste will be improved, and the sure advancement and increase of the demand for beautiful personal ornaments will be the result.

### The Microphone in Surgery.

THE value of the microphone in operations for stone and other delicate surgical manipulations, has just been shown at the London University College. The apparatus consisted of the usual feeble battery with wires, connected with two telephones running to different parts of the room. The ordinary Sound used in operations for crushing the stone was attached by a wire to the circuit of the battery. Near the handle a piece of carbon such as is used by Professor Hughes, was carefully balanced and attached by a delicate string to the battery circuit. When the end of the Sound strikes against the smallest piece of calculus, the acoustic wave is transmitted along the steel of the instrument to the carbon, where it is transformed into electric vibrations, which are multiplied through the telephone, so that the noise becomes loud and unmistakable. The carbon arrangement on the Sound must not be too delicate, nor the battery too strong; but with the microphone properly adjusted, it was easy by trial to detect the presence of even a minute fragment of unremoved calculus. The carbon needed only to be fitted to the probe, also, to detect bullets or fragments of bone. But while it is quite possible for a skillful surgeon to make himself absolutely certain by means of the microphone of what he was previously only morally convinced of, no very remarkable results, at least in ordinary practice, are anticipated from the use of the instrument.

## Legal Regulations for the Standard of Gold and Silver Ware in the Different Countries of the World.

BY EDWIN W. STREETER.

Has the statesman to deal with the gold trade and with the silver trade in the same manner, or in a different manner?

The above mentioned petition was signed by *silver* manufacturers alone. Why do not the manufacturers of gold demand the same measures? The petitioners themselves give the reason for their abstinence. Although they would most willingly (says the petition) have laid before the Confederation a scheme for legislation upon gold ware also, they were not able to obtain proposals for the same from the principal manufacturers of gold ware in Pforzheim, Stuttgart and Hanover, because the legal treatment of this branch of trade presents much greater difficulties. The small size of the objects seem to render it impossible that they should bear a distinct stamp; in the case of the greater number of gold ware, the value of the pure metal is of much less significance in proportion to the price of the article, than in the case of silver ware; and the value of the metal is by many jewelers made quite subordinate to the setting (the best setting) for stones or pearls. Lastly, a very important export trade in cheap gold articles has risen in Germany, which would be if in Germany itself interruptions were placed in the way of sale by legal enactments as to standards.

These grounds of opposition only prove that the disadvantages bound up with legal restrictions upon the commerce in precious metals are more apparent with regard to gold than to silver ware. No sound reason, however, exists to require that the trade in silver ware should be dealt with differently from the trade in gold manufactures. It is true that, generally speaking, it is easier to place a stamp upon silver ware than upon gold ware; yet there are many silver articles, such as rings, chains and filagree work, which either cannot be stamped at all, or only with great difficulty. Further, the small value of the metal in many gold articles can be no reason for passing over the great number in which the value of the metal is very considerable; and thirdly, as to the injury which the export trade in gold ware would suffer through a government regulation of the standard; this applies equally to the case of silver ware.

"The trade of Pforzheim," writes the Chamber of Commerce in that town, "owes its existence and its present extent to its deliverance from every impediment in the form of decrees as to the standard of the manufactured gold. It is by this means that it is in a position to manufacture for all parts of the world, and to adapt itself to the requirements of trade." If it be true, then, that the salability of all ware depends principally upon the skill with which the manufacturer suits the tastes of the purchasers, can any reason be found why the freedom so advantageous to the German gold manufacture should be considered injurious to the so closely connected trade in silver ware.

We have heard of yet another ground for supporting a separate legislative treatment of the trades in gold and in silver ware. The Swabian Chamber of Trade and Commerce affirms, according to this year's "Alte Allgemeine Zeitung," of the 9th of March, in the judgment sent in to the Bavarian Government upon the legal regulation of the standard of gold and silver ware, that important authorities had pointed out that in many of the uses to which silver is applied, particularly in utensils for food, a lower standard than that of  $\frac{800}{1000}$  acts in a manner injurious to health. So long, however, as these "important authorities" remain unknown, we may be allowed to doubt their assertion, as regards the utensils for food. And what other silver utensils could by any possibility act in a manner injurious to health? The only injurious substance which might be formed in the use of spoons containing copper, is the so-called "verdigris."

The formation of a verdigris from an acid and fine copper is, however, a very slow process; so that food must have been immersed for

days in an acid fermentation, and a spoon for a still longer time, before the formation of verdigris could take place. Verdigris might be formed rather more quickly from the contact of silver articles with very acid food; but even in this case an injurious effect would result only from very great want of cleanliness, and from the utensil in question being allowed to remain unwashed for a considerable time. Even when we have taken these exceptionable conditions into account, still it does not appear why the exact standard of  $\frac{800}{1000}$  should form the boundary at which all danger of poisoning disappears; and even were this the boundary, it would by no means follow that it would be beneficial to prescribe for all silver goods (for instance, watch cases) such a minimum standard.

In this case, which we by no means consider as proved, it would be necessary that police directions should be published on the subject; but no reason exists why legislation should deal with the whole silver trade otherwise than it does with the gold trade.

Besides, it is but seldom that one of the trades in precious metals has been exempted, while the burdensome attentions of the statesman and the tax-gatherer have been at the same time bestowed upon the other.

Has experience been favorable to legal regulations as to exact standards of precious metal ware, or the contrary?

"By their fruits ye shall know them." If we glance over an epitome of the laws which in the states of Europe treat of the precious metal trade, and if we consider that in almost every small country one law has been superseded by another because each has been insufficient to attain its object, and how this again has been supplemented by a second, third, fourth, and so on continually, we shall feel inclined at once to pronounce in favor of freedom in this department of national economy.

We know that in the Aanton of Neufchatel, during a period of 119 years (from 1754 to 1873), *thirteen laws* were framed; in France, during a period of 332 years (1506 to 1838), *forty-three laws* were framed; and in England, during a period of 616 years (from 1238 to 1854), *fifty-six laws* were framed, which altered more or less the standard of precious metals. We see, therefore, that it was found necessary to alter the laws relating to the standard of precious metal ware during the periods just mentioned, in Neufchatel every nine years, in France every seven years, and in England every eleven years. This is only the number of which information has come down to us. Were the whole number known to us the failure of legislation upon this subject would be far more plainly manifested.

Experience, therefore, has pronounced in this matter against interference by the State. But we are far from holding by the false principle that "to experiment is better than to study." Let us rather endeavor by deductive reasoning to obtain the *truth*.

Can the legal regulations of the standard of precious metal ware be justified by deductive reasoning?

Two motives have existed to induce legislators to subject the precious metal trade to legal restrictions. Either the Exchequer felt that no more fitting object of taxation could be found than the ornaments of the rich, or economist have demanded that the State should here exercise its power; oftener, indeed, both motives have ruled at the same time, as in France, for example, until now. Thanks to the financial position of the German Empire, however, we have to deal only with the second motive.

The first question is: Are there any valid grounds for demanding different legal regulations for the trade in precious metal ware from those applied to all other trades, which—with slight exceptions—have the right of manufacturing goods of any quality? Among the exceptions here adverted to, the government control of chemists' shops stands foremost. Next comes the legal testing of firearms, which has been introduced in Belgium and in other countries also. It should be further mentioned that in Great Britain the anchors and anchor-chains of every British ship must be tested at a legally authorized place. Attention should be turned to the fact that in these exceptions, it is the *life* or *health* of the purchaser which comes un-



der consideration, whereas in the precious metal trade it is his *interest* only that is concerned. Though there certainly are other instances of State interference in behalf of the well being or the interest of the purchaser, it must not be overlooked that to every such exercise of State control objections may be raised, and indeed have been raised, which are entitled to consideration. Thus the necessity for the control of weights and measures might seem to one (without pronouncing judgment upon the measure) to be reduced by the fact of the gradual adoption of a more scientific system of cookery, which obliges heads of households to provide themselves with scales and measures for the purpose of maintaining a check upon tradesmen.

The control of weights and measures, of firearms, anchor-chains, apothecaries' shops, and other productions of trade, is a remnant of times gone by, in which the manufacture of a far greater number of goods than at present was subjected to the supervision of the State. Thus, in the thread and linen patents to Bohemia, Moravia, and Silesia, in the years 1724, 1750, and 1755, minute directions were given as to the quality of these products, even their length and breadth being specified; and the paper regulation of 1754 determined the weight of each description of paper, and particularized its length and breadth.

The decrees relating to weaving were of a similar character; and those as to the quality of silk goods, light cloth and velvet manufactures, issued in the last century, were conceived in the same spirit. If, however, the removal of legal restrictions may be rightly called the chief characteristic of national progress, if the most important laws of modern times in the civilized states of Europe have originated nothing, but have rather renewed old decrees, how cogent must be the reasons which could induce the legislators of to-day to impose new restrictions. In any case, few will be willing to adopt the principle that the *rule* shall be formed upon the failure of legal restrictions upon trade, and the justification mainly indicated by exceptional cases. The question of the legal regulation of the trade in precious metals will therefore have to be judged by the *rule*; and those who approve of government restrictions will have to sift to the bottom their reasons for the exceptional ground on which they rely.

*What are these reasons?*

Let us take the bull by the horns. The chief consideration alleged in behalf of the regulation of the standard of gold and silver wares, and which underlies most of the attempts made to justify this usurpation of power by the State on the ground of prudence, is the circumstance that gold and silver are also applied to the coinage of money.

The horns of the bull with which we have here to contend, vanish like an empty phantom when one reflects that this circumstance is a purely accidental one, and this accident does not furnish the smallest justification for the legal regulation of the standard of precious metal ware. It is true that it might have appeared convenient to the legislators of centuries gone by, in which the alloy of precious metals was not so well understood as to-day, to provide by law that the precious metal utensils of the country should have the same standard as the coins, so that the trouble might be avoided of altering the standard of the utensils when melted down before the test could be applied to the coinage of money. But to-day, when the art of refining and alloy has made such great progress, if we adopt this argument of our forefathers as our *own*, a representation is advanced as to the part played by precious metals in our national economy which we do not hesitate to designate as doubtful and misleading to an astonishing degree. And yet this justification of the legal regulation of the standard of precious metal ware recurs in almost every case in which such a regulation is recommended. Indeed, to speak quite plainly, the chief reason (in our opinion) why so little energy has been manifested on behalf of freeing the precious metal ware from legal restrictions, and upholding its freedom, is because

the State stamps the sign of its authority upon gold and silver coins; a circumstance which seems to confuse the judgment. Because it happens that neither precious stones nor any other materials are made use of as money, the multitude cries, Let gold and silver be considered holy! Let them bear, in whatever form they appear, the mark of the State! Very well; now we shall see that the stamp of the State upon precious metal ware may prove to be a mark of Cain; nay, that it often is such.

With no more leniency than we show to the supporters of this much valued argument for the legal regulation of the standard of precious metal ware, shall we judge those who base their defence of its regulation by the State upon the necessity of maintaining its character as a measure of value.

It is very easy to see that one could not possess in gold rings or plate an absolute measure of value if the manufacture of such articles, in all standards, were permitted. It would be necessary, therefore, to fall back on the position which few States have ventured to take up, viz., that only one standard should be authorized.

It is very evident, and the experience of other States has also proved, that legal restriction leads to the most serious disadvantages. It lays the greatest possible difficulties in the way of the requirements of trade and the gratification of the public. It hinders the export of the produce of native industry, and any attempt to enforce its regulations must lead to measures for watching over the customs; for the transgression of a legal restriction attended by so many evil consequences may be regarded as matter of course.

Apart from all these evil consequences however, it is to be observed that the necessity of insisting upon relief from the legal restriction of the standard of precious metal ware to *one* degree still exists.

In earlier times gold and silver ware often supplied the place of the means of exchange, which were then scarce. In this way the English country nobleman, who had no money for his parliamentary journey to London, gave his plate to the nearest goldsmith, who, in return, provided him with a letter of credit to a London goldsmith, at that time a London banker. Now, however, in no civilized country is there any lack of means of exchange. Where, then, lies the necessity of multiplying the materials of exchange?

But the public will be protected! Gold and silver, it is argued, are amongst the most costly of wares, and here and nowhere should the State protect us from fraud. Let the State, then, do its duty. The costliness of gold and silver is an argument for the proposed demand which will not hold good. For why should the public be found to require protection in the purchase of ware precisely of the value of gold and silver? Why not in the purchase of wares which, at the same weight, are of *higher* value? For instance, in the purchase of diamonds. Why not, also, in the purchase of ware, the value of which, at like weight, lies *between* the value of gold and silver? As, for instance, in the purchase of lace. Or, again, why not in the purchase of ware, the value of which, at the same weight lies *below* the value of silver?

It has been further stated that the public should especially receive protection from the State in the purchase of precious metal ware, because the public is not sufficiently competent in the matter to be guarded against the salesman. If this principle holds good, to what mass of wares would it apply? For example, how great is the difference between real and imitation champagne; between genuine and imitation lace; between good and bad cloth; between good and bad clocks; between real stones and paste; between real pearls and glass imitations; between good spectacles and bad, etc. How difficult it is for the layman at times to exercise a correct judgment upon these wares, and yet it never occurs to us to call in the aid of the State in making a purchase of any one of them? Do we depend, then upon the honor of the seller? By no means; but upon the recognition the latter has of his own advantage, which will prevent him from placing in jeopardy the custom of not only one person, but of all. There is, therefore, not the smallest ground for calling in State aid, in making our purchases of gold and silver.

## Proceedings of the Horological Club.

### A DISTINGUISHED BODY OF WATCH AND CLOCK MAKERS.

#### *Fifty-ninth Discussion.—Communicated by the Secretary.*

[NOTICE.—Correspondents should write all letters intended for the Club separate from any other business matters, and headed "Secretary of the Horological Club." Direct the envelope to D. H. Hopkinson, Esq. Write only on one side of the paper, state the points briefly, mail as early as possible, as it must be received here not later than two days before the end of the month in order to be discussed and reported in the CIRCULAR for the next month.]

#### REGULATOR PENDULUM WANTED.

*Secretary of the Horological Club:*

I have a Swiss regulator, with an old gridiron pendulum, and have a great deal of trouble with it, as to regulating it, and would like to know where and at what price I can procure a better and more satisfactory one. It is of ordinary size, beats seconds, and is a very accurately finished movement, with a pin escapement, jeweled throughout. If some one of the worthy members of the Club can tell me where I can procure one they will greatly oblige me. I read the CIRCULAR regularly, and have for the last three years, and find it the most interesting journal of all, and I have read a great many, both English and German.

F. GOOSMAN, Somerville, Tenn.

Mr. Goosman did not state whether he wanted a better gridiron pendulum irrespective of the kind. A lively debate ensued between the advocates of the gridiron, the mercurial, and the zinc-and-steel pendulums, each one claiming his favorite to be the best. But as Mr. G. stated that he had the CIRCULAR for the past three years, the Chairman ruled out the debate, and recommended Mr. G. to look over our Proceedings from August to December, 1877, where the advantages of the different kinds of pendulums were fully discussed. After concluding which kind he would prefer, he could obtain one from any of the manufacturers of regulators and fine clocks who advertise in the CIRCULAR.

#### PRACTICAL HINTS ON WATCH REPAIRING.

*Secretary of the Horological Club:*

Please inform us if "Practical Treatise on the Balance Spring and the Compensation Balance," and "Practical Hints on Watch Repairing," advertised in the CIRCULAR, are the same book. We have the first-named book, and want the other if it is a different book. S. & P.

Mr. Isochronal said the above was only one out of the many constantly received asking for similar information. The "Practical Treatise" is the first series of "Practical Hints on Watch Repairing," as published in book form, under that title. Only one series of these articles has yet been finished and republished. It was to be regretted that only a limited number of copies had been printed, and the supply might soon be exhausted. In a few years they would be worth three times the price now asked for them, unless a new edition was got out. That was not likely to be the case, as the majority of those in the trade who were sufficiently enlightened and enterprising to appreciate such works would have been supplied from the present edition, which had been carefully revised by Excelsior himself, and might be depended upon as a thoroughly reliable guide for the practical workman, in all the fine adjustments of watches and chronometers. Those who have not already secured a copy of this valuable treatise should do so at once, and not run the risk of being compelled to borrow it from some more wide-awake neighbor, or buy it second-handed, at a greatly increased price. A synopsis of its contents was given in the CIRCULAR for September, 1877, and the work has been commended and endorsed by the Club as one that every workman should own.

#### MEASURING DISTANCES WITH THE MILLIMETER GAUGE.

*Secretary of the Horological Club:*

Please submit the following question to our esteemed Horological Club: What is the best method to measure correctly, on a lever, the distance from the center of motion to the points of the arms where the lifting-planes commence at the ends? I am in possession of the best gauges used by our trade, viz., gauges reading 1-100 *m.*, manufactured by M. Grossmann, but I encounter great difficulties because I have to take the distance with a depthing tool as well as I can, and then measure the points of the depthing tool with the *m.* gauge. This never gives it as accurate and quick as desirable, if, for instance, I want to replace faulty pallets, in case the watch had a poor motion for this reason. The same trouble I also have if I want to measure the inside corners of a Swiss escape-wheel.

L. H.

Mr. Horologer thought the method pursued by Mr. H. was probably as accurate as any, unless he had tools specially for such measurements. First, the lever, including the fork, pallets and arbor, fastened together in their proper position, should be fitted in one side or jaw of the depthing tool. It is best to measure it while together, because, if the pallets were tried alone, the depthing tool slide would find the center of the hole, whereas the center of the hole in the pallets was seldom the actual center of motion when in use, as the pallets are shifted forward or back on the arbor to suit the depthing, etc. The hole is therefore made large enough to allow for this shifting, and the center of motion of the pallets, when adjusted in position, may be in front, or back, or to one side of the center of the hole.

Having got the lever in the depthing tool as above, the very fine point of a slide in the other jaw is brought to exactly touch the corner of the pallets, the distance of which from the center you wish to know. You then measure with your gauge from the outside of that slide to the outside of the opposite one, carrying the lever, and set it down. Next measure the diameter of one of the slides, and take that amount from the former, and you have the distance from the center of motion of the pallets to the chosen point on the pallet face. Because, if you deduct the diameter of one of the slides, it is equal to deducting half the diameter on both slides, which would give the measurement from the center of one to the center of the other: provided, that the slides are of the same diameter. If not, measure each separately, and deduct one half of both. The line of measurement must be at exactly right angles across the two centers, as holding the gauge slantingly or diagonally across will increase the apparent distance.

To make this method quite correct, the depthing tool must be perfect, the two slides on each side exactly in a straight line with each other, the line of one pair exactly parallel with that of the other pair, the tapers of the slide points true, both on the male and female centers, and the points exactly in the centers of the slides, which must be perfectly round, smooth, and of equal size from end to end. If the points are not in the middle of the slides, by measuring the diameters and halving them, you halve the error. But if you try to measure directly, from one slide point to the other, it is impossible to get it exact, but it will at best be a mere approximation or estimation.

The same process is followed with the escape wheel to get the distance from the center of motion to the inner corners of the teeth. It should be said, however, that it may not be necessary, in replacing either pallets or wheel, to know the exact measurement spoken of. Pallets may be selected which have the same distance from the center of the hole to the corners of the faces, or a greater or less distance, as desired, without actually measuring the distance. Then, if the hole in the new pallets is large enough, they can be shifted on the arbor the same as the old one had been, to get them in the best position, after which steady pins can be inserted to hold them there. But pallets may be found which are correct as to the distance from center of motion to the corners, but the distance between the two corners may be too great or small. If the old ones were correct in that respect, a brass slip should be filed up to fit the corners exactly, to gauge the new ones by.

If Mr. H. has ever made for himself one of the Angle Meters described by Excelsior in his Practical Hints a year or so ago, he can very easily test both these distances by first getting the pallets in proper position on the bed plate, by the upper arbor, then putting into the sliding clamp a steel claw with very fine point. This point is brought over one corner, then carried over to the other, and the scale shows the angle between the two corners. By putting the new pallets in position, and bringing the claw point over the two corners it would at once be seen whether they were the same distance from the center, and had the same angle between the corners as the old ones. In making these and other measurements and trials of the escapement, Mr. H. will find Excelsior's articles on the detached lever

escapement of the greatest value to him. Every watchmaker who wishes to understand this subject and work intelligently should study them. They were published in the CIRCULAR, he believed, in the first half of Vol. VIII, for 1877.

#### REMOVING JEWEL SETTINGS.

*Secretary of the Horological Club :*

I see a great many ways advocated to take out jewel settings in plates and balance cocks. A simple and sure way, without marring or defacing either plate or setting, is to take a small piece of ivory, say two or three inches long, put it in your lathe, turn it round at the end, a trifle smaller than will just pass through the hole in the cock or plate, and square the end. With that you can push the jewel setting out with ease, and no danger of marring either setting or plate. W. W. C.

Mr. McFuzee said the idea was a good one, and the workman could easily make several sizes, to push out all kinds of set jewels. He would suggest that the end of it should be turned out a little hollowing, so that the pressure would be given by the outer edge resting on the brass, and no pressure would rest on the jewel or its bezel.

#### EXPERIENCE WITH LATHES—EYE-GLASS STAND.

*Secretary of the Horological Club :*

Being a steady reader of the CIRCULAR, I feel indebted to some of our brethren for the interesting items that have appeared from time to time on the different ways of doing work, and I believe that many of us have received much benefit therefrom. I have taken quite an interest in the articles about putting in balance staffs, without cement, and it makes me feel like telling my experience with lathes, as it may be a benefit to some young watchmaker starting out in life for himself. When I first started in business I did not have any more money than I knew what to do with, so of course I thought it would be best to economize all I could, and did so in buying my tools. I first bought me a Swiss pivot lathe, and used cement. Then I had use for a universal lathe, so I bought another Swiss lathe. I then found that other workmen could do their work as well as I could, and much quicker, by using the American lathe with the split chucks. So I accordingly bought me a No. 2 Stark lathe, because they were the cheapest. To my disappointment I found that I was worse off than ever, as none of the chucks were true. And now comes the part we want to call economy, but how are we going to make it look so? I had the three lathes on hand, and they had cost money enough to have bought a first-class one, but what was I to do with them? That was a question that proved a hard one to answer. But I had now come to the conclusion to have a perfect tool in the way of a lathe, and at once set myself to work to find one, and not to let economy enter with the contract this time. After looking and studying over all the different makers' lathes, I bought a No. 1½ Whitcomb lathe (hard), made by the American Watch Tool Co., of Waltham, Mass., and now I have the pleasure of knowing that I have got a perfect tool, and one that will remain so. I use it for everything, pivoting, jewel setting, turning out wheel sinks, and in fact it more than covers all the ground that my other three lathes did, and is much more convenient.

I have made an eye-glass holder, for use in pivoting, and as it works so nicely I will give you a little description of it here. The eye-glass is attached to a piece of Stubbs' steel wire, about No. 20, bent off at right angles, and the rod slides vertically in a brass tube, mounted on a heavy base, which can be set in any position on the work bench at pleasure. All the eye-glass stands I have ever seen had to be adjusted to the work every time they were moved away from the lathe, but this has only to be adjusted once to the height and fastened there with the set screw. When you wish to have it out of the way, it is only necessary to set it aside, and move it up to the lathe when wanted, and it remains in focus until the job is finished.

W. S. H.

#### INCOMPETENT SALESMEN OF WATCHES.

*Secretary of the Horological Club :*

While you are discussing the troubles of watchmakers, I wish to call your attention to a very serious difficulty which causes great loss and annoyance to manufacturers of fine and complicated watches, as well as loss of customers and profit to dealers themselves.

This trouble arises from the fact that a very large majority of salesmen seem to know nothing whatever about fine watchwork, or the construction of anything out of the common order. In these dull times, when it requires a skillful person to explain the attractive features, fine workmanship and superior finish of a valuable timepiece, in order to induce the customer to buy something above the ordinary cheap watch, a great many sales are lost, simply because they do not know, and therefore cannot tell, why the former is better and worth the additional price. So in showing off a complicated watch they do not understand its principles or construction, nor how to manipulate it properly to show its operation, but go stumbling and bungling along at imminent risk of breaking something or getting it out of order, when they will curse the maker or that style of watch, make a job for the

watchmaker to repair up, lose the customer and the profits of the sale, and muddle things generally.

In every community, however small, but more especially in all cities, there is a class of persons who are able, and would willingly buy good watches, if they could be made to understand why they were superior, and what they would receive for the extra price charged. Another class are to high-toned to wear any cheap trash, but would like rare and costly goods because they are above the reach of the common herd. They want something that they can safely swell on. But none of these will buy an article which the salesman cannot explain to them, so that they will know how to use it without danger of having it "go off" like some infernal machine and make them ridiculous, besides incurring a heavy bill by the repairs for getting it into a shape to go off again.

What is needed is sufficient knowledge among salesmen to explain to the satisfaction of the intending purchaser in what the superiority consists, what advantages they will receive from it, how to take proper care of it, how to manipulate the fly-back, or whatever it is, to make it operate perfectly, and so on. Many of them are mere counter-jumpers, who know nothing about mechanism of any kind, whether common or complicated, and who sell a watch in the same way as they would a clock key or a load of brick. They have not sense enough to call up the watchmaker to show off something they don't understand themselves, or are afraid he may expose their ignorance or controvert some of their yarns. So they do the best they can by blowing, praise the article extravagantly, contradict themselves, fail to make it work successfully, or perhaps break it, and the customer concludes that jewelers are an unprincipled lot, trying their best to swindle him out of his money. This is no fancy sketch, but an actual and serious state of things, and I hope you will ventilate it in your honorable body.

NEMO.

Mr. Clerkenwell thought it really was too much as Nemo had said. There was a growing demand for fine watches of a complicated character, which might be greatly increased if properly fostered and cultivated, and greatly to the advantage of all the parties. Watchmakers were too often content to "sell a watch," instead of trying to sell as good a one as they could. They try to show how cheap a watch they can furnish, and the consequence is that they lose the profits they might just as well have made, the customer gets a poor thing which never can give satisfaction, and the country is flooded with trash which repairers are expected to make keep good time or lose the patronage of their wearers. The result is that the whole trade is playing out and going to the bad as fast as it can. People conclude they might as well do without any watches at all as to carry and support such things, repairers and dealers have no business, and manufacturers can find no buyers.

Instead of all this the dealer should impress upon the customer, the fact that he must pay according to quality, that if he chooses to take a low grade watch, because it is cheap, he can only expect a low grade of service from it. Advise him to buy just as good a watch as he can afford. Show him the different kinds, explain why this is better and costs more, about what kind of service he can expect of each, and be sure you do not promise more than the watch can fulfill. Tell him just what each grade is capable of doing, and then put the responsibility of choice upon himself. If he chooses a cheap watch he will then understand what he takes. If he wants a good one, and trusts in your honesty and knowledge of the business, he will take the higher priced one, because he will see that he cannot get what he is looking for unless he pays the price of that quality. Warn him especially against dealers who will promise anything to make a sale, and will foist an inferior article upon him in his ignorance of real values. Even at a lower price than you ask him, they will make a greater profit on their inferior goods than you do on the good. A reputation for strict integrity is the most valuable thing in our trade. Next, is a thorough knowledge of the business. When once the community feel that his word can be implicitly depended upon, every time, they will give him their patronage—for only with such a man can they feel safe in buying goods they know nothing about. And it is only by following the course just outlined that such a reputation can be established. A man who tries to be smart, is apt to be too smart for his own good. A reputation for honesty is better than one for smartness. If a man does not understand some part of his trade he should take measures to learn it thoroughly, otherwise he is no better than the botches in those respects. Let every one improve himself, and respect himself, and the entire trade will

rise in the public estimation, business will grow better, and every branch of it will be more prosperous and profitable.

#### BESCHERER'S ROUNDING UP MACHINE.

*Secretary of the Horological Club:*

Will a member of your body please inform me as to the quality and execution of work of the rounding up machine of C. Bescherer, described in No. 15, Vol. II, *Deutsche Uhrmacher Zeitung*. Can the machine be bought in America, and at what price? M. H.

As none of the members present had had any experience with this machine, we would be pleased to hear from any of our readers who have.

#### THE GREAT AMERICAN \$1.00 WATCH.

Mr. Jewelcracker said he was requested to announce that a new invention, called the Great American \$1 watch, would shortly be brought out. It could be warranted to keep better time than the sun itself. Everybody knew that the sun didn't keep any time at all. It was always fast or slow, or something was the matter with it. Any dealer having the agency of this article would be able to undersell all his competitors, and take the whole trade. It would also be just the thing for apprentices to practice on and learn the trade at small expense. Watch tinkers would not be bothered repairing this new style of timepiece, as it would be cheaper to throw it away and buy a new one.

Of course it would make trade brisk, for the demand would be huge, and all a man would have to do would be to rake in the dollars and warrant the watches. Being so cheap, the public generally would invest, and no doubt most everybody would carry several of them to be ready for horse trades and such. The religious papers could afford to give both a watch and a chromo to every subscriber, and the increased spread of evangelical literature thereby would be something enormous, besides providing all good christians with reliable time-pieces, and so making them reliable men. This great invention would also do away with the botches, for other kinds of watches would go out of use and this kind would not need repairing, so the botches would be just as anybody, and would become respectable citizens, join the church, and die happy. In view of this immense revolution in trade and commerce, and the stupendous effect on morals, manners, and civilization generally, that would result from the introduction of this novelty, he thought there should be a universal upheaval of welcome and gratitude when it made its appearance, which he was confidentially informed would be before soon.

#### A New Back for Sleeve-Buttons.

WE call the attention of the trade to a new back for Sleeve Buttons, for which a patent was recently granted.

It combines several important improvements over the present style of solid backs, and consists, as shown in the accompanying cuts, of a narrow flat band of metal which forms the post and is turned around in the form of an ordinary flat back, with the end slightly overlapping

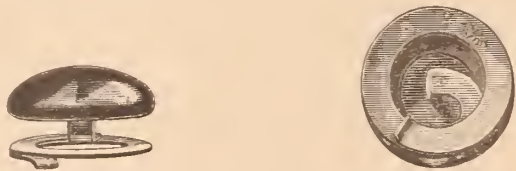

its circle and turned up sufficiently to enable one to easily slip it into the button hole, and by a simple turn to adjust it the same as an ordinary button, the action requiring no effort whatever.

It has the following advantages:

It is put on and taken off more easily than any other button.

There is no crushing of the wristband and consequently tearing of the button-holes is altogether avoided.

There is less pressure required to adjust it than the ordinary button, and as there is no strain whatever, the backs are never broken off. It is safer than the common flat back, because the button-holes may be made much smaller and are not enlarged by putting in the button. Its cost will be only a trifle if anything over the old style button.

Being flat and not pointed, it does not puncture the under-shirt to the skin when the wearer leans against anything, which is a serious annoyance with spiral studs.

It is perfectly simple and cannot get out of order.

License for manufacturing can be obtained from the inventor, by addressing MR. LEON BARRE, care MESSRS. TIFFANY & CO., New

York, on the payment of a royalty, which will be very small, with a view of bringing them into universal use.

Every one has experienced the annoyance of forcing the new style button into a new or stiffly starched wristband or taking it off when in a hurry, and the few persons who have worn this new button pronounce it the most convenient and easily adjusted that has been made.

The button-hole may be so small as to be entirely covered by the button, or the new backs may be worn in full sized button-holes with perfect security.

Studs made with the new back can be worn in ordinary button-holes without danger of their coming out, as the bosom is not crushed in adjusting the stud, but left perfectly smooth and flat.

It is also an improvement on the spiral back, for it works easier and cannot get out of order by flattening, stretching, or otherwise as is the case with the spiral studs, rendering them very difficult to take off.

#### Gold Mining in Russia.

COLLECTED FROM AUTHENTIC SOURCES, BY HERMAN BUSH, EUROPEAN PUBLISHERS' AGENT, HULL, ENGLAND.

OF all the gold-producing countries in Europe the Russian Empire stands foremost as regards the quality of gold found there, which has been rapidly increasing within the last few years. Twenty years ago the quantity realized amounted to about 50,000 pounds per annum to 60,000, 80,000, and then to nearly 100,000 pounds. There are two groups of gold deposits in Russia, one on the eastern flanks of the Urals, and the other in Siberia in the districts of Perm, Tomsk and Yeniseisk, where considerable quantities of gold are found mingled with the sand and gravel, as well as auriferous quartz hewed out of the immense rocks. The processes adopted by the gold collectors vary according to the varied kinds of deposit. The quartz-mining occasionally bring forth nuggets of some note, one nugget having been unearthed weighing no less than seventy-eight pounds, being of the value of about \$20,000.

The mining system of Russia is curiously managed. Every native or naturalized subject, except a government employe, is allowed to search for gold; if an explorer finds that his search has been successful he announces the fact to the government and applies for permission to avail himself of the discovery. A mining officer is sent to examine the spot and to mark out the district of about two English square miles, of which the explorer is put in possession, so far as regards gold extracting. The speculator, who must be a man of capital to enter on such a project, builds huts for workmen, fixes machines and offices and lays in stores of provisions, for the location is often many miles distant from any town. The laborers are mostly persons exiled from Russia to Siberia, and they receive fair wages from the speculators. The sands are collected and washed, or the quartz broken and crushed, the nuggets separated and the fine particles of gold amalgamated with mercury, and the gold is brought to as clear a state as possible.

At the fall of the year, when the increasing cold brings the operations to a close, the gold is carried to a government establishment for the purpose in the nearest town. It is there weighed, registered, melted, moulded into ingots, assayed and accurately valued. The ingots are transmitted to St. Petersburg and coined into money, which is paid to the speculator minus a certain percentage retained by the government.

It appears that the government, being desirous to encourage these operations, does not press very hardly on the speculators. The adventure, however, is a precarious one, for often the returns do not pay the expenses or fall greatly short of the outlay, while at other times a capitalist is ruined before gold appears in any quantity; occasionally, however, it turns out a lucky hit. An instance is related of a speculator who spent thirty-five thousand out of forty thousand roubles borrowed money, before any fruits resulted, but luck then showered upon him so abundantly that in a few years he became a millionaire.

The quantity of gold found in Russia is, on the whole, poor in comparison with the deposits found in Australia and California, for although considerable masses have occasionally been met with, much of the auriferous ground now profitably worked in Russia, where labor is cheap and water abundant, would, if situated in California or Australia, be totally valueless. The result of the gold washing and mining for the last ten years, ending with 1877, realized about 950,000 pounds of the precious metal.

### The Electric Watch.

IT is a well known fact to scientists that the effects of electric currents have a disastrous effect upon watch movements. Baron Bosca, the celebrated prestidigiturer, was the first to turn it to account in his conjuring tricks, and astonished Louis Phillippe, of France, very much one day by causing his royal watch to stop or start at will.

One of America's greatest scientists who is soon to revolutionize civilization with his electric light, found this out to the cost of his chronometer, and in the moments in which his powerful intellect seeks recreation from the ardent strain to which it is daily subjected, conceived and has nearly perfected an electric watch, which will in the future revolutionize the trade to such an extent that we think that the fact ought to be mentioned in this paper.

The new timepiece is composed of two separate pieces, each of the size and shape of an ordinary pocket chronometer. To insure perfect isolation, the cases are made in vulcanized rubber, and are carried in the two vest pockets. An ornamental chain, also in rubber, connects them and serves to conceal the wire which runs from one, the generator, to the other, the timepiece proper. The generator contains a mechanism similar to that of the pedometer. The oscillating pieces are of flint glass and amber for fine movements, and of rosin for cheaper ones. The motion of the body causes them to rub against a piece of rat skin so arranged as to produce electricity by friction in the same way as in an electrophone, where a cake of rosin is charged by being rubbed by the skin of a cat. At the top of the generator is a condenser which accumulates enough of the fluid to allow the watch to run for a sufficient time should the motion of the body of the wearer remain in repose for some time.

The timepiece contains no spring or escapement, for our savant thinks that these delicate pieces of machinery are expensive, liable to be easily put out of order, and altogether too complicated for the advanced state of perfection towards which we are rapidly advancing. He has even to a great extent done away with wheels, the only ones in the new apparatus being those which transmit the motion of the hour hand to the one which records the flight of the seconds.

The movement of mechanism may be briefly explained as follows: the central pinion which carries the hand carries also a wheel nearly as large as the watch though very light. This wheel is armed on its circumference with attachment like those on a chronometer balance. They are made of soft iron and become magnets, and are consequently alternatively drawn and repulsed as the courant passes through them. The courant that magnetizes them comes from twelve diminutive electro-magnetic coils placed on the inner rim of the case, and corresponding to the twelve divisions on the dial. As each passes in front of the magnet a very simple commutator sends the courant to the next magnet and keeps the large wheel in constant rotation. The great difficulty, and that which our great electrician has successfully overcome, though he is still reticent on the details of this part of his instrument, is the distributor which ensures the regularity of the flow of the courant which naturally governs the regularity of the motion of the hands. He has nevertheless told us that he uses the same principle as that employed in the electro-meters which are to register the incoming courant in houses where the electro light will be used. Another interesting improvement is that the glass which covers the dial contains a small bulb filled with rarified gas, and that by pressing on a small button the passage of a small electric courant make the bulb sufficiently luminous to light up the dial in the dark and plainly reveal the position of the hands. This effect is produced in a similar manner to that which scientists are familiar with in the "Geisler tubes." For a small additional expense a repeating attachment is added to the watch, which gives to the wearer as many slight electric shocks as there are units in the number of the hour and double shocks for the quarter hours.

### Antiquities.

A RECEPTION which was numerously attended was recently held at the rooms of M. Gaston L. Feuardent, No. 30 Lafayette Place. M. Feuardent, who is a numismatist of great distinction, comes to the United States recommended by so high an authority as Mr. R. S. Poole, keeper of the medal room of the British Museum. The coins were exhibited in convenient cases ranging along the length of the room, and comprised a period commencing 800 B. C., up to the choicest specimens of American times. Conspicuous was the exceedingly rare coin of Mithridates III., King of Pontus. A single glance suffices to show when art was at its height, until by rapid stages it declined through Rome to the bizarre of the Byzantine period. Here is a piece of Heraclius. It is a Hercules strangling the lion. That hero is brought out in relief on the face of a small silver coin. So grand is the conception that the god seems imbued with the power of strangling a hundred beasts. It shows a reserve of physical force. A century or so later, thews and muscles would have been in too great prominence; in the decline of art these would have been the biceps of a gladiator. Here are some coins of Cleopatra, by no means indicative of the beauty of Egypt's Queen. Here is the old money of Ægina. Look at the Athenian money. People ignorant of numismatics must learn that even in the time of Pericles, when art was at its zenith, Athens kept to old Archaic forms and types, and did not care for the beautiful on her money. We think the much-abused nickel was due to American invention. Error again. It was a Bactrian king who made white bronze and nickel money. Here is a square piece some century or more before the time of Christ. It bears on it an elephant and the sacred bull still adored by the Hindoo. For the first time in New York, lovers of antique art saw those charming figurines in terra cotta, coming from the tomb of Tanagra. Here is a charming little lady, some ten inches high, the perfection of elegance and grace. How daintily her robes are draped. She holds in her hand a lotus leaf. It is the perfection of art condensed in small form. Visitors at the Trocadéro saw a superb collection of these Tanagra figures. At M. Feuardent's there were some twenty-five of them. Such figures are almost priceless. For form, for study of ancient costume, for truthfulness, they are, indeed, finds of the greatest value. A wonderful addition to this collection was the display of prehistoric implements, notably arms, tools, bronzes and jade instruments, coming from lacustrine dwellings, principally from the Lake of Bienna. How is it possible that these Swiss, who lived untold ages ago, could have had jade? This rare substance is only found in Siberia and China. Was there interchange of commodities at these prehistoric periods? The bronze instruments are curious. Here are knives which Tiffany intends copying, and razors somewhat Chinese in form. Stranger still are the copper buttons. It is puzzling to think that the lacustrine dandy wore a coat with metal buttons. It was Boucher de Perthes, at St. Archaël and Abbeville, who first proved geologically by finding stone tools at lower strata, when delving way down in the Tertiary beds at Thenay, that man was many tens of thousands years older than we thought he was. M. Feuardent exhibited this most wonderful collection.

Thoroughly familiar with the vast range of objects exhibited, M. Feuardent's explanations were of the greatest interest. The rooms were crowded throughout the whole evening, the visitors comprising the leading numismatics and archæologists of New York.

Imitation diamonds made of Rhine pebbles are now used in Paris for many purposes. There are not only diamond buttons, mounted like solitaire, or in clusters, but buckles for the shoes and belts in all conceivable designs. There are also fastenings for necklaces and bracelets of velvet, and very small buckles to fasten the ribbon loops which are placed down the front of dresses and on the lower part of sleeves. Earrings, crosses, and ornamental pins are also made of these stones.

## The Thermometer.

BY W. MATTIEU WILLIAMS.

JUST as our primary ideas of gravitating force are derived from our sensations of muscular effort, so are our primary ideas of heat dependent upon our sensations of temperature.

That these sensations are of but small value for measurement of temperature is easily tested by taking three basins, and, in the first, placing water as hot as the hand can bear; in the second, cold water; and, in the third, a mixture of equal quantities of the hot and cold water. Then immerse one hand in the first, the other in the second, and after holding them there a few minutes plunge both into the third. The same water will appear hot to one hand and cold to the other.

We must, therefore, find for mathematical purposes some other general effect of temperature which is more measurable, and more consistent than our direct sensations. Such is afforded by the increase of the bulk of bodies which accompanies elevation of temperature. I shall call this materials according to the applications or range of temperature to be measured, would demand an exposition of the laws of heat. I can, therefore, only briefly explain some leading features in the construction of the most important and largely used class of thermometers, and define the standard of temperature.

As we well know, the ordinary expansion of water in a tumbler or other common vessel is too small to be easily visible. It amounts to  $\frac{2}{3}$  between its freezing and boiling points; that of mercury is  $\frac{1}{5}$  in the same range. By causing a wide vessel to overflow into a narrow one connected with it, we can so elongate this small proportion as to render it easily measurable. An ordinary thermometer tube is such a narrow vessel so connected; its bore is of thread-like slenderness, and its bulb is comparatively of great capacity. If the bulb is filled with liquid, and then by a rise of temperature the liquid is made to overflow, this overflow is caught in the tube, it is there outstretched, and its expansion is visually (though of course not actually) magnified for the purposes of inspection and measurement. Strictly speaking, the actual expansion is not thus indicated, because the glass vessel itself also expands, though in a much smaller degree. The visible expansion is the difference between that of the mercury and the glass.

As temperature is progressive, and has neither beginning or ending, so far as our knowledge goes (absolute zeros of temperature have been imagined but never physically demonstrated), we must select a starting point of natural and invariable temperature. Two such were suggested by Sir Isaac Newton, viz., the temperature of melting snow or ice, and that of pure water boiling under a given atmospheric pressure.

These supply us not only with fixed starting points, but also with a definite distance, or range of temperature between them. This interval between the thawing of ice and boiling water is the universally adopted unit of temperature. It is a natural, fixed, and easily definable and verifiable quantity. The "degrees" of our thermometer scales are artificial and arbitrary sub-divisions of this natural interval.

In the Centigrade scale it is divided into 100 parts; in Reaumur's scale into 80 parts; in Fahrenheit's scale into 180 parts, with an imaginary and false zero at 32° below thawing point.

I need scarcely say that the first essential to the accuracy of a thermometer is that the tube shall be of equal capacity throughout, or, if variable, that the graduation shall vary accordingly. This is tested by the process called "calibration," *i. e.*, by passing into the a little mercury, say sufficient to measure half an inch when in the tube, then by running this along the tube, and measuring it at different parts, any irregularity of bore will be at once seen by variations of the length of this little mercurial stick. It must become shorter where the tube is wider, and lengthen where it is narrower. The best thermometers are graduated accordingly. The length of the degree in any particular instrument is, of course, determined by the relation of the bore of the tube to the contents of the bulb, and this (after calibration) is tested by immersing it when filled, first in a mixture of ice and water, marking the height of the thermometer there, and then in the vapor of boiling water under the given atmospheric pressure, and marking the height thereby attained. The interval between these is then divided to the scale required. Only standard thermometers are thus directly marked; ordinary thermometers are graduated by comparison with the standard instruments when both are exposed to the same temperature. In Mr. Casella's workshop is a tank with glass sides, heated from below, the water in which may be violently or thoroughly agitated by means of dashers

worked by a treadle. The best instruments, next to the "natural standard" thermometers, are compared with the standard by immersing both both in this. Ordinary instruments are graduated by comparison in the air of a suitable apartment.

We commonly call these fixed points the freezing and boiling points of water, but I think it would be more correct to call them the thawing and condensing points of water, seeing that if water is kept at rest in a smooth vessel it may fall many degrees below thawing point before it freezes. A rapidly flowing river may do the same. Water may also be raised many degrees above its condensing temperature before it boils. The thawing and the condensing temperatures are not thus variable.

My proposed innovation is further justified by the manner in which these fixed points are actually and practically determined in the fundamental standardizing of thermometers.

The first point is fixed, not by immersing the thermometer in freezing water cooled down by the thawing of ice. Small fragments of ice are agitated in the midst of distilled water, and the thermometer receives its temperature from the water that is doing the work of thawing, and which is cooled thereby. Formerly, the "boiling point" was determined by immersing the bulb of the standard thermometer in boiling distilled water, but Mr. Casella informs me that, more recently, when the demands of science required subdivision to small fractions of the conventional degrees, the best makers found, in spare of every precaution, serious discrepancies upon making severe comparisons between the boiling points thus determined on such delicate thermometers—that is, on thermometers in which the steam tube is so fine in proportion to the bulb that there shall be half an inch or more between each degree, and this divided into small fractions.

This discrepancy has been overcome by immersing the thermometer in the vapor of water instead of the water itself, by using an apparatus in which the thermometer is above the water, and is heated by the condensation of the vapor upon its surface. To prevent any loss of heat by its own radiation, the tube surrounding the bulb is double, and the steam occupies the jacket space between the two tubes, as well as the inside of the inner tube.

The filling of the thermometer bulb through so small an aperture as its capillary tube appears at first sight a difficult task, but it is easy enough. The bulb is heated and some air expelled by its expansion. Then the end of the tube is immersed in mercury, and as the bulb cools, some of the mercury is forced by atmospheric pressure to occupy the space vacated by the air previously expelled. This is repeated, and the mercury is heated to boiling if necessary, and the tube entirely filled upon the condensation of its vapor. Finally, the filled tube is raised to just the highest temperature it is intended to indicate, and a blow-pipe jet or flame is thrown upon the part which corresponds to the graduation for this maximum temperature. As the glass fuses it is drawn out and asunder there, and is sealed while quite full of mercury. On the cooling down and contraction of the mercury, the space left above it in the tube is thus a vacuum, so far as air is concerned.

The existence of such a vacuum may be tested by simply inverting a mercurial thermometer. In a vacuum the mercury runs freely down to the end of the tube, if the bore is of moderate size; if large, it even falls with a "click." If the bore is very small, a jerk is necessary to overcome the adhesion of the mercury to the sides of the glass.

The bulbs are blown by sealing (*i. e.*, melting together) one end of the tube, then heating that end, and blowing it out while red hot. The accuracy with which this is done by the glass-blower is marvellous. He can regulate the size of the bulb to that of the diameter of the tube so nearly, that grosses of common thermometer tubes are blown to suit grosses of ready engraved scales, and the same man can blow for a scale one-eighth of an inch to a degree, one-tenth, one-twentieth, and so on as required and do it within a very small range of error.

Another curious fact is, that these men, with very few exceptions, are Italians, or of Italian parentage, and not only do all they come from Italy, but from one part of Italy. They are Milanese, and they make barometers and other glass philosophical instruments demanding quantitative accuracy.

The founders of the trade were Tagliabue and Pastorelli, whose names may still be seen on old barometers. Among their pupils and worthy successors are Messrs. Negretti and Zambra, and Mr. Casella, to whom we are indebted for the loan of the instruments before you. These and others are naturalized and patriotic Englishmen, though bearing Italian names and worthily proud of their Italian parentage.

The neighborhood of Hatton-garden was the original place of settlement of these scientific Italian artisans, and thereabouts they are

still to be found. They and their humbler artistic compatriots have established a curious little Italy here, and across the Holborn, around Leather-lane.

There is a multitude of other thermometric devices, self-registering and otherwise, in which air or other liquids take the place of the mercury. Many such are on the table, but time does not permit me to describe them. There are good reasons why mercury is preferred for all ordinary purposes.

1st. It is a better conductor of heat than any other available liquid. The importance of ready conduction may be shown by the simple experiment of passing the bulb of any thermometer rapidly through the flame of a spirit-lamp. The indicating liquid will at first fall in the tube and afterwards rise, as though the contact of the flame lowered the temperature, and emergencies from the flame raised it. This apparent paradox is due to the expansion of the glass before sufficient time has elapsed for the heat to be communicated to the mercury. A water, spirit, acid, or glycerine thermometer receives the heat much more slowly than the mercury. 2nd. The quantity of heat required to raise a given bulk of mercury one degree is less than half of that demanded for raising temperature of the same bulk of water to the same extent.

A third and very important advantage of mercury is the great range between its freezing and boiling points. It is obvious that a water thermometer would be useless for any temperature below its freezing point or above its boiling point, but this is not all. It would not do even to approach these, for all liquids, and more especially water, are subject to serious irregularities in their co-efficients of expansion (*i. e.*, the amount of expansion produced by a given increase of temperature) as they approach the temperature at which they solidify or vaporise. They are only available for a certain middle range between these, and they vary a little even then, expanding rather more for each degree as the temperature rises. In the case of mercury, its expansion from 0° to 1° Centigrade is 179 millionths; between 35° and 151° it amounts to 197 millionths, progressively advancing between these.

Those large public thermometers displayed on the door-posts of opticians and other shops are usually filled with sulphuric acid, which has a much greater range than water, between freezing and boiling.

Alcohol is used for temperatures approaching or falling below the freezing point of mercury.

As gases expand so much more than mercury for a given increase of temperature (above 18 times as much, and all gases alike), and as they expand more uniformly than liquids, it might be supposed that air thermometers should be commonly used.

The principal reason why air is so little used as a thermometric indicator is, that in common with other gases it is almost, if not quite, a non-conductor of heat, and that radiant heat may pass through it so largely as scarcely to affect it.

This form of air thermometer, with two bulbs connected by a U-shaped tube, in which is a bar of colored liquid midway between the bulbs that are driven down the stem of the warmer bulb and up that of the cooler, is Leslie's differential thermometer, which did good service in the hands of its inventor, but is now almost superseded by the *Thermopile*, a small thermo-electric battery, which develops an electric flow when one face is made warmer than the other the electric disturbance being rendered evident and measurable by the deflection of a magnetic needle. For the measurement of temperatures too high for the mercurial thermometer solids are used. These are called pyrometers, or "fire measures." That on the table contains an iron rod, which is plunged in the furnace wherever the heat is to be measured, and its expansion pushes a rack, or a toothed quadrant, which acts upon a toothed wheel which turns the index of this dial. Wedgwood's pyrometer is based upon the drying and consequent contraction of small sticks of moistened china clay.

### Precious Stones and Gems.

BY EDWIN W. STREETER.

THOMAS NICHOLS says, "The Turquoise is a hard gem, of no transparency, yet full of beauty: its color is sky-blue, out of a green, in which may be imagined a little milkish infusion. A clear sky, free from all clouds, will most excellently discover the beauty of a true Turquoise." This gem is throughout of the same beauty, as well internally as externally; it requires no help of tincture or foil to set it off in grace, the constancy of its own beauty being its support.

"It hath its name Turcicus," (or Turquoise) says Baccius, "either because of its excellent beauty, or because it is brought from the Turks."

Its exquisite color, which loses nothing by candle-light, is thought

to be owing to a certain quantity of protoxide of copper. Those of the Oriental Turquoise, which retain their color perpetually, are said to belong to the "Old Rock;" while those that lose their color, or grow green, are ascribed to the "New Rock."

According to old writers, the Turquoise was found, in their day, in the remote parts of India, and was conveyed to Turkey to be cut; whence, probably, it derived its name.

Most of the Oriental mineral Turquoise is obtained now from a mountainous district in the northeast of Persia, lying between Mushead and Neshapore, 35° n. lat. and 58° e. long.; or from the valley of the Galesteo River, southeast of Santa Fe.

The ore forms thin veins on flinty slate rock, and the people of Bucharest strike it off the matrix, with bullets covered with moss which are thrown from slings, the rocks being generally inaccessible. They then take the ore to the market of Moscow, where it is cut and polished. Boetius says he never saw a Turquoise larger than a filbert.

We only know of Turquoise as compact and uncrystallized, having no cleavage, and possessing a conchoidal fracture and a hardness which is represented by 6, together with a specific gravity of 2.6 to 2.8. Opinions vary as to its chemical nature. Looking at the results of the many analyses, they agree only in proving the presence of phosphate of alumina, oxide of copper, iron and water. It is infusible before the blow-pipe, and cannot be affected by acids. It is doubtful whether the Turquoise was known to the Ancients; but in the middle ages it was well-known and most highly valued, and few stones had such wonderful gifts and virtues attributed to them as this had. But to realize these advantages, it was a necessary condition that the stone should have been received as a gift. Even to this day, in the northeast, there is a proverb, "That a Turquoise given by a loving hand carries with it happiness and good fortune;" and another, "That the color of a Turquoise pales when the well-being of the giver is in danger." The Orientals cut or bored texts from the Koran on Turquoise, and filled up the interstices with gold. There are some very good specimens of engraved mineral Turquoise, but they are neither very ancient nor many in number. Thomas Nichols speaks of one possessed by the Duke of Hetruria, which was the size of a hazel-nut, and had the image of Julius Cæsar engraved on it. There are two in the collection of the Duke of Orleans: on one of which is engraved an image of Diana with her quiver, and on the other that of the Empress Faustina. A jeweler in Moscow has one two inches long, cut in the shape of a heart, and said to have belonged previously to Shah Nadir, who wore it as an amulet. It contains a verse from the Koran, in gold, and 5,000 roubles is the price asked for it.

In the year 1808, a magnificent necklace of Turquoise was sold for 9,000 francs. It consisted of twelve stones, of a beautiful pale blue, none of which were of any great size; but each of them was engraved in relief with a figure of one of the twelve Cæsars.

Major MacDonald lent a very fine Turquoise to the Exhibition of 1851, which had been found in a soft yellow sandstone quarry in the Desert of Arabia; but the so-called MacDonald or Egyptian Turquoises are of hardly any value, as their color fades when exposed to the light. And so it happened with that exhibited in 1851: it was bought for a large sum of money, but within a year it had so faded as to be almost worthless.

The Fossil Turquoise must not be confounded with the Mineral; as the former is really nothing more than the teeth of fossil mammalia, colored probably by contact with phosphate of iron and copper; it differs entirely from the mineral in composition and original structure, and rarely if ever loses its color. Abroad it is more valued than in England, in consequence of this freedom from outward change, but it is not so valuable as the pure rock Turquoise.

The Orientals had, and still have, a deep veneration for Star Sapphires.

The localities of star-stones are the same as those of other Sapphire crystals.

When light shines upon these stones, stars of six rays are seen, an appearance which attracts much attention, and gives proportionate pleasure. This may be termed its specialty, and is more observable when the stone is convex. The color is a greyish-blue; occasionally blue and red specimens are met with.

These star-stones, according to their color, are designated star ruby, star sapphire, or star topaz.

Only of late years have they been of any value in England. In Ceylon, but a few years back, they could have been purchased for a few shillings, as the natives had but little regard for them. The finest star ruby I have seen was valued at £200, and is in the possession of a private gentleman, who obtained it from a noted collection. If a pair of these stones could be obtained their value would undoubtedly be largely augmented. The price of these gems is

mainly determined by their size and quality; small star sapphires range from £2 to £10; large sapphires, £10 to £100. Star rubies obtain higher prices; but star-stones, of a secondary rank, are of little or no value.

The River Sangaris (according to Plutarch) produces a gem called aster, which is luminous in the dark, and called by the Phrygians "Ballen," "The King." A gem called "Asterites," found inside a huge fish called "Pan," from its resemblance to that god, is also described by Ptolemy Hephæstion. The stone was a potent love-charm, and when exposed to the sun shot forth flames. It was used by Helen of Troy for her own signet, and to it she owed all her conquests. Helen, however, was not of human origin simply, and her beauty was as great at seventy as at seventeen. The term asteria has been used by different authors in various senses at various times; but Pliny understood by it the same gem that we do at present. The star sapphire, is also known under the title of Astrapia lightning stone, from its supposed action in a colorless or an azure ground, sending out, as it were, rays of lightning diverging from the centre.

Amber is a fossil, and its exterior conditions, as well as the chemical composition, point to its resinous vegetable origin. This view is further strengthened by its occurring in connexion with brown coal and bituminous wood.

If further proof were wanting of the vegetable origin of Amber, it exists in the inclusion of insects, plants, pieces of wood, moss, seed, and little stones, all of which may be seen in that which is found on the coast of the Northern Seas. The condition of this inclusion shows the liquid nature of the resinous matter as it took up and involved the insects; and it shows, also, the subsequent slow process of their petrefaction.

When insects are caught and retained in their tenacious resin of our northern pines, we find as a rule that their bodies are bent, their feet broken off, or their wings rolled together. It is not so, however, with the insects of the ancient world found buried in amber, where the most delicate parts of the creature are preserved in the most natural position.

The innumerable organic remains, which this resin has preserved uninjured for thousands of years, give us a marvellous peep into the vegetable kingdom of the Tertiary period, to which amber belongs. We here see plants quite unknown among the flora of the North sea-coast woods, but which have a relationship to the flora of the coasts of the Mediterranean. The insects embedded in amber, on the contrary, are like those with which we are quite familiar.

Amber is somewhat brittle, and has a specific gravity of 1, as nearly as possible the same as that of sea-water. Its hardness is 2.4 to 2.5. Its fundamental or ground-color is yellow in all shades, running on one side into white and hyacinth red, and on the other into brown and black. The green and blue specimens are never pure.

From the following names given to amber by various nations, we derive their idea and knowledge of it, viz.: "Yellow," "Gallatinous," "Sap of ligneous matter," "Extract of Straw."

Wherever amber is found, whether in France, Holland, Greenland, Sweden, Italy, Sicily, Spain, Siberia, China, or India, it is in combination with the brown-coal formation of the Tertiary period. This combination is very instructive. The most prolific fields of amber are the great plains of North Germany, and the North sea-coasts, between Lymfjord and the Elbe.

Commerce and Amber dates back to very early times, and as was the case thousands of years ago, large quantities are still sent to Breslau, Odessa, and Constantinople. Amber forms a very important industry not only in the Dantzic, Königsberg, Stolpe, and Lubeck, but in Vienna, Constantinople, Calamia, and Sicily; indeed, in almost every town where "Galanterie" is acceptable. In Stolpe alone the amber industry amounts yearly to about £10,000. In Paris the most exquisite wares are made of amber, and command extraordinary high prices. Innumerable are the articles made of it, amongst others, microscopic lenses, aerometers, and busts. Necklaces, and bracelets of Amber are sent to Egypt and India, and the meanest Turk seeks a piece of it for his pipe, not only because it is pleasant to the lip, but because he has a belief that it will preserve him from inhaling pestilence.

Amber is much valued by the Ancients, particularly by the Romans. The Greeks very early received from the Phœnicians chains made of amber, both for the neck and arms, and it is mentioned in connexion with the heathen mythology from very ancient times. The sisters of Phœton, mourning and weeping at his unhappy end, attracted the pity of the gods, who mercifully changed them into trees, so says the legend, and their tears still flowing on, became amber. A still stranger origin is given to this fossil, in the well-known couplet of the fire-worshippers,—

"Around thee shall glisten the loveliest amber,  
That ever the sorrowing sea bird had wept."

## Novelties in Jewelry, Etc.

Cameos are in fashion again.

Bell-shaped pendants are much worn.

Cable necklaces are as popular as ever.

Bangle rings still retain their popularity.

Gold bead or gold ball necklaces have not yet gone out of fashion.

Conch shell ornaments still retain their popularity for young girls.

Oriental and Japanese designs are seen in much of the new jewelry.

Bangles with the lover's knot on the back of the arm are popular novelties.

Boating Brooches are of metal crossed oars, boats, and the cap of the oarsman across the oars.

Solitaire diamonds in a crown setting of gold or platinum are the unrivalled fashionable ear-rings.

Fancy necklaces are in daisy, aster pansy, forget-me-not, flat basket rosette and oblong links.

Domestic ideas are represented in lace pin brooches in the form shovels, tongs, pokers, dust-pans and brooms.

Carnelian sets including the necklace, pendant brooch and ear-rings, are carved in antique intaglio patterns.

All sorts of yachting, coasting, lawn tennis croquet, and other sporting devices appear in lace pin brooches.

Pendants are the popular ornaments in jewelry, either in the form of lockets, or crosses of various forms.

Hunting brooches take the shape of whips with the cap, saddle, stirrups, bridle or spurs laid across the lash.

Sets of jewelry consisting of brooch, earrings, necklace, and bracelets are not as arbitrarily the fashion as formerly.

Alternate links of etruscan and polished faceted gold form many of the handsomest novelties in necklaces and bracelets.

Fashion now allows of the wearing of but one glove, to display finger jewelry.

Nine ladies are studying wood carving and modeling at the Boston museum of fine arts.

Amber shell necklaces and bracelets are much sought for, and are costly ornaments.

Snake bracelets, winding several times around the arm and having jeweled eyes, are among late novelties in jewelry and ornaments.

Among the most elegant novelties in tortoise shell are port monnaies and card cases, with a perfectly made tiny watch in the side.

Combs of real tortoise shell are massive in design, and shows balls and bars instead of the foliage patterns which were once in vogue.

The style of jewelry most in vogue in Paris is the Etruscan. A series of medallions linked together with gold chains form the necklace.

Tortoise-shell ornaments for the hair or neck, and brooches, bracelets and watch cases of carved Neapolitan shell are very fashionable.

Jewelry for the hair and imitation jeweled ornaments for this purpose are seen in great quantities and variety in the jewelry and fancy stores.

The favorite style for wearing the pendant suspended by an inch wide satin ribbon around the neck, though the necklace and chain are still worn.

Musical lace pins are small bugles, cornets, flutes, clarionets, flageolets, guitars, horns of all kinds, and sometimes an open music book, with an enamelled bird singing on the lines of the bars of music.

All sorts of stones are cut in cameo—chalcedony, sardonyx, topaz, amethyst, onyx, agate—and all sorts of translucent, opaque and striated stones and shells of various kinds are used for these artistic gems.

Very wide bracelets are worn half way between the elbow and wrist with the elbow sleeve universally adopted for *toiletts de ceremonie* season; another narrow gold or jeweled bracelet is sometimes worn at the wrist.

Handsome sets of ornaments, comprising comb, ear-rings, bracelets and a locket, are of dark red shell, ornamented with bees and beetles of amber shell. Amber shell alone is also used in ornaments, and whole sets are made of it. They are particularly becoming to brunettes.



## Foreign Notes.

Silver was first coined by Phidon, King of Argos, about 860 B. C., the epoch of the building of Carthage, and about 140 years after the construction of Solomon's Temple.

A *blue sapphire* of Marvelous size has been recently found in the gem district of the island of Ceylon. It weighs two pounds in the rough, and was discovered by two boys, who sold it for a trifle, not aware of its nature. It is said to be worth \$50,000.

Mr. William Gibson, the well-known jeweler of Belfast, Ireland, presented General Grant with a beautiful cigar holder, of black oak, artistically engraved, with shamrocks surrounding a harp, and ornamented with ivy leaves. The mounting is of engraved gold, with the General's monogram, and the mouthpiece is of pure amber. It was enclosed in a morocco case.

A clock made entirely of bread has lately been received in Milan, Italy. It was constructed by an Indian, who, having no means of purchasing material, saved a portion of the soft part of his daily bread for the purpose. He solidified it with a certain salt which rendered it very hard and insoluble in water. The clock keeps good time, and the case, also of hardened bread, displays artistic talent.

During the past year a new and valuable coral bed was discovered on the southwest of Sicily, between Sciacca and Porto Empedocle. The coral is not only abundant but of excellent quality. One coral merchant of Terra del Greco, having fifty barks employed on the bed, secured in a few days ten tons of coral of the very finest quality. The Algerian coral grounds have been nearly deserted on account of the new finds.

A German periodical is responsible for the following method of making malleable brass: Thirty-three parts of copper and five of zinc are alloyed, the copper being first put into the crucible, which is loosely covered. As soon as the copper is melted, zinc, purified by copper, is added. The alloy is then cast into moulding sand in the shape of bars, which, when still hot, will be found to be malleable, and capable of being brought into any shape without showing cracks.

A Russian lady, Mme. Hélène Gajewska, who was charged with obtaining advances on paste diamonds and other other bogus jewelry, and disposing of similar articles to unsuspecting dealers, was recently acquitted at Berne, Switzerland, but in the meantime she had been imprisoned for four months in Austria awaiting proceedings for extradition, and nine months in Switzerland, pending preparations for her trial. There was no case against her, but she had no redress for the wrong done by her arrest and imprisonment.

Large consignments of German cutlery and hardware, manufactured by G. D. Schaeff, of Solingen, have reached England, and some of them have arrived at Sheffield, where they have produced no little excitement. The goods for the most part are exceptionally fine, prices remarkably low. Tailors' scissors, for example, cutting true from heel to toe, were offered at half the local price, and the Sheffield men themselves conceded that the get-up and finish equalled any of their own make. The cheapness of spring cutlery and "Lancashire goods," so-called, was startling. Four-blade knives with pearl handles, were offered at 6 shillings 6 pence per dozen; braces and bits at half the usual price; small hand vises at 8 shillings a dozen; hinges at 5½ pence a dozen, and pliers and compasses at equally low rates. This is the first invasion of the kind from the Continent of Europe, and it is a bearding of the lion in his den with a vengeance. The English attempt to explain the disparity in price by saying it is owing to the long hours and low pay of German workmen and to the more general use there of machinery.

A large number of the guilds of London took their rise in the times of the plantagenet Kings, and some of them even back to Norman times. The charters of the older ones were mostly granted by Edward III. and Richard II. in the fourteenth century. Many of them, however, had been in existence from one hundred to two hundred years previous to that time, but were then mostly without charters, and had none of the rights of corporate societies. The guild of the goldsmiths can certainly be traced back as far as 1180, and the mercers back to 1172. Probably both came into existence before these known dates. The fishmongers are still older, and were chartered by Edward I., in the latter part of the thirteenth century. The twelve great companies are the mercers, grocers, drapers, fishmongers, goldsmiths, skinners, merchant tailors (sic), haberdashers, salters, ironmongers, vinters and clothesworkers. Many of them have great wealth, and all the prominent ones have great halls where they occasionally give expensive feasts. About forty of the minor companies have no halls, and some of these have so diminished in numbers as scarcely to be able to keep up their organizations.

It has been supposed that the so-called magic mirrors of the Japanese have their strange properties imparted to them either by stamping or cooling so as to produce an inequality of density of the surface of the metal of which they are made. Profs. Ayrton and Petty have just given a new explanation. They say that there are extremely slight irregularities in the curvature of the polished surface of such a nature that the thicker parts, corresponding with the raised patterns on the back, are flatter than the remaining convex surface, and that thus there is less dispersion of light from the thick portion than from the thinner. This theory of the structure of the mirrors was thoroughly tested and it was found to account for all the phenomena. After some trouble Professor Ayrton discovered the method for producing the convexity of the face of the mirror. The surface, while cold, was scratched by a *megebo*, or distorting rod, and during this operation the mirrors become visibly concave, but receiving a "Buckle," they sprang back again so as to become convex when the pressure of the rod was removed. The thicker parts yielded less under the pressure, and their assumed convexity was therefore less.

There is a singular brooch in the shop window of a Paris jeweler to which a curious tale is attached. This breastpin is mounted with great art and set with gems. It is divided in four parts and shows four twisted, bent and blunt ordinary pins under a transparent enamel. A foreign count was years ago arrested for a political offence and dragged to prison. His cell happened to be rather a dark one. The day after his arrest he began to think how terrible it would be to live long in such a dungeon with nothing to do, and as he thought he fumbled about his coat pockets. While doing so he discovered four pins. He held the four for some moments, then flung them right and left about his narrow cell. He went down on all fours and carefully felt in every direction until he had recovered them. Then he got up and commenced rescattering them for the sake of another exciting hunt. This he did six or seven times a day for seven long years, when the prisoner was set at liberty. The four pins were kept, and a Comtesse is to wear the brooch they are enshrined in. The Comte has related that had he lost one of his four pins he could not have endured captivity. Each time he flung them about he fancied they were quite lost, and the ardor with which he crawled over his nude floor was the equal to that of the chase.

In the French horological section at the Paris Exposition were two clocks remarkable for their mechanism. On the top of one of them is seated a handsome Greek lady, a figure hardly a span high, with a small barrel organ, held by a boy, resting on her knees. With the clock's last stroke the miniature organ is set in motion, and plays a tune, the boy keeping time with his head. On the left arm of the figure is a bright starling, which, as soon as the piece is played out, repeats the melody, accompanied by the movements of the lady's head. The mechanism of the second clock is even more wonderful. The clock is surmounted by a figure representing a juggler in Oriental costume, seated behind a golden table. To his right stands three large silver bells on a plate. The juggler raises himself as the clock strikes, and gesticulates with his hands as if in preparation for his feats, takes up one of the bells, shows it to the spectators to convince them that it is empty, then seizes another bell and puts both on the table. He lifts them up again, and under each now lies a golden egg, which appears and disappears repeatedly. Sometimes they both disappear; sometimes they increase in number, and instead of two, three or four eggs are seen. The little magician's performance reaches the climax when he lifts up the third bell and displays a bronze ball to the astonished audience. This bronze ball bursts immediately after, and a Lilliputian bird about the length of a finger nail, makes it exit and pipes a tune. The next moment all vanishes again, and the clever performer, after a graceful bow, resumes his seat.

It is said that there is a clock in the Guildhall Museum, London, of which the motive power is hydrogen gas, generated by the action of diluted sulphuric acid on a ball of zinc. The clock itself resembles a large colored glass cylinder without any cover, and about half full of sulphuric acid. Floating on the top of this acid is a glass bell, and the gas generated forces forward this concave receiver until it nearly reaches the top of the cylinder, when, by the action of a delicate lever two valves become simultaneously opened. One of these allows the gas to escape, thereby causing the receiver to descend, and the other permits a fresh ball of zinc to fall into the acid. The same operation is repeated as long as the materials for making the gas are supplied, and this is effected without winding or manipulation of any kind. The dial plate is fixed to the front of the cylinder, and communicates by wheels, etc., with a small glass perpendicular shaft, which rises with the receiver and sets the wheels in motion.

## Trade Gossip.

"There is a tide in the affairs of men," and Kronberg's has turned.

The Jewelers' Circular commences its tenth volume with this issue. Reed & Barton will occupy their magnificent store, Nos. 9 and 11 Union Square, about March 15.

The venerable Ezra Kelly, whose watch oils are known the world over, lies dangerously ill at his home in New Bedford, Mass.

Savage & Lyman, the Montreal jewelers, had a very satisfactory holiday business.

Newell Whitford, formerly in the jewelry business at Lawrence, Mass., died at St. Michael's Island, Azores, where he had gone for his health.

Our good friend H. J. King, for many years with Messrs. Enos Richardson & Co., has entered into an engagement with Messrs. Baldwin, Sexton & Peterson.

A. Seligman, of this city, claims to have been robbed of \$5,000 worth of diamonds while in a sleeping car on the Louisville and Nashville Railroad.

Alfred B. Miller has left the employ of Messrs. Randall, Baremore & Co., to take charge of the New York establishment of the Wilcox Silverplate Co.

The jewelry store of Messrs. Myers & Finch, St. Paul, Minn., was burned out on the evening of the 4th inst. Their loss is fully covered by the insurance.

Mr. F. E. Morse, formerly with the American Clock company, has become the Western representative of the E. N. Welch Manufacturing Co., at 170 State Street, Chicago.

Messrs. Saxton, Smith & Co. have removed to No. 15 Maiden Lane, where they will be happy to see all their old friends and as many new ones as may favor them with a call.

Samuel W. Fellows, formerly of Methuen, Mass., has succeeded to the business of the late Newell Whitford at Lawrence, Mass., and will open with a new stock of attractive goods.

Charleston, South Carolina, has abolished the tax of \$5 a day to drummers, having found that the indirect loss to the community was greater than the profit accruing from the impost to the city treasury.

The watch worn by Major Andre when he was arrested as a spy is said to be in the possession of an Oshkosh (Wis.) woman. It is a curious oval-shaped watch, inscribed inside "John Andre, 1774."

Mr. Geo. N. Fenn has severed his connection with Messrs. Rogers & Bro., with whom he has been for the last three years, and has entered into an engagement with Messrs. Saxton, Smith & Co., the well known gold chain manufacturers.

Howard & Scherrieble have adopted the emblem of the four-leaved clover or shamrock for their trade mark, but the goods themselves can not be bought with any of your sham "rocks," and don't you forget it.

The Committee sent to Chicago to investigate the failure of M. Kronberg have returned, and submitted their report to the creditors. It is a remarkably clear, exhaustive and impartial document, and reflects great credit on the gentlemen composing the committee.

It is discouraging, but it is true, that the year is already more than a month old, and neither Benjamin Franklin's nor Lafayette's original gold watch has been discovered in a pawnbroker's shop in a Western city. Something strange about this.

Mr. Daniel T. Tenney, an old and successful jeweler, many years since retired from business, has presented a magnificent bronze statue of the Father of his Country to the old town of Newburyport, his native place. The statute was cast in this city by Fisher Bro.

Cross & Beguelin have leased the store now occupied by the Wilcox Silver Plate Company, and expect to move in their new business house about May 1st. We are sure that every one in the trade will be glad to hear of the continued prosperity of this honorable firm.

Charles Woodford and George Lee, alias "Snatchem," the thieves who stole \$12,000 worth of jewelry from Max Freund & Co.'s traveler, in the Palmer House, Chicago, pleaded guilty in the Criminal Court of that city, and will probably be sent to the State prison for five years. Woodward turned State's evidence.

The Watch Importers' Association held a meeting January 23d, 1879, and elected the following named gentlemen officers for the ensuing year: President, Mr. J. J. Hyde; Vice-President, Mr. Louis Strasburger; Treasurer, Mr. F. Quinche; Corresponding Secretary, Mr. Arnold Nicoud; Recording Secretary, Mr. J. Eugene Robert.

Mr. James P. Rich, for several years with Messrs. Saxton, Smith & Co., has severed his connection with that house, and has entered the employ of Messrs. A. H. Smith & Co., importers of diamonds. We congratulate Messrs. S. & Co. on having secured the services of so able a gentleman, and Mr. Rich on the good fortune that has befallen him.

Simpson, Hall, Miller & Co. will occupy their new establishment, No. 36 E. 14th Street, Union Square, about February 15th. The store has been fitted up under the personal supervision of Messrs. B. & W. B. Smith, the well known show case and cabinet makers, whose admirable and ingenious workmanship has won them a high reputation in the trade.

We are glad to learn that the retailers of Illinois are taking steps to form a society, with the object of restraining certain so-called jobbing houses, from flooding the country with "Wholesale price-lists," and invading the legitimate sphere of the retailer by canvassing his customers direct through the medium of circulars.

The *Frankfurter Zeitung* gives the gloomiest report of trade in Berlin. Fancy custom is at a perfect standstill. Good customers have been lost through inferior articles being palmed off on them. Foreigners passing through make very few purchases. The Russians especially, who formerly bought largely in Berlin, have transferred their custom to Paris, where they say they are better served.

Nathan Lederman, a youth in the employ of Messrs. Kossuth, Marx & Co., has for some time past been stealing his employers goods, and pawning them. On the 8th instant, he was detected in the act of pledging a handful of gold rings. The young rascal was arrested and now languishing in the toms awaiting indictment. Lederman has confessed to the robbery, the amount of which he cannot state.

The fine enameled ware known as Cincinnati Faience originated with Miss Louise McLaughlin, of that city, whose experiments were first successful in 1877. It is fired in a kiln at a temperature of 9,000°, the famed Limoges faience of France being fired to no more than 5,400°. The enamel of Cincinnati faience is exceedingly brilliant in color, and so hard that the point of any steel instrument is said to make no impression upon it. This invention is indirectly a result of the excellent schools of design for which Cincinnati is justly honored.

In the last number of the CIRCULAR we reported the robbery of Rauth & Sons, jewelers, doing business in the Bowery. It was reported that this place had been entered by burglars and robbed of from \$6,000 to \$9,000 worth of goods. Since then the value of the goods lost has been raised to \$15,000. Mr. Rauth asked a compromise with his creditors, offering 20 cents on the dollar, which he subsequently raised to 30 cents. While there is little doubt but Mr. Rauth's store was entered by burglars, there are circumstances connected with the robbery which render his creditors loath to accept the terms offered.

Deitrich & Kipp, of Indianapolis, Ind., have been robbed of a quantity of watches and movements, and \$200 is offered by the authorities of that city for their recovery. The following is a description of the property stolen: One 18 kt. Hunting Case, Stem-Winder, with Springfield, Ill., Carrier movement; No. of Case 11893. One 14 kt. Hunting Mansard Case, Stem-Winder, engine turned, with landscape engraved on one side, with P. S. Bartlett new model Movement, Exp. Balance. One 14 kt. 20 line Hunting Case Lorigines' Stem-Winder, Nickel Movement, No. 63459. One Ladd Hunting Case, with S. W. Co. Movement, Key-Winder. One Boss Hunting Stem-Winding Case, for new model 18 size movement. One 18 kt. Lady Fancy Enameled Hunting Case, Stem-Winder, No. 60998, with Elgin Movement, No. 515747. One 18 kt. Lady Hunting Case, Stem-Winder, No. 64208, with Riverside Movement, No. 821586. One 14 kt. Lady 15 line Hunting Case, Swiss Stem-Winder, Nickel Movement and Breguet Hairspring. One 12 kt. Lady Elgin Flat Hunting Case, No. 61661. One 14 kt. Lady Elgin Hunting Case, with Dexter St. Movement. One 14 kt. Lady Flat Hunting Case No. 11811, with Ellery Movement No. 1075591. One 14 kt. Lady Flat Hunting Case Swiss Lever Watch No. 28226, red gold, enameled. One 14 kt. Lady Flat Hunting Case Swiss Lever Watch No. 42462, enameled. One 14 kt. Lady Hunting Case Swiss Lever Watch No. 35297. One 14 kt. Lady Hunting Case Swiss Lever Watch No. 33521, frosted and enameled. One 14 kt. Lady Hunting Case Swiss Lever Watch No. 35002, frosted and enameled. One 14 kt. Lady Hunting Case Swiss Lever Watch, fancy enameled and set with three diamonds. One 14 kt. Lady Hunting Case Swiss Lever Watch No. 92684. One 14 kt. Lady Hunting Case Swiss Lever watch, plated cap. One 10 kt. Lady Hunting Case Swiss Lever Watch, plated cap, Nickel Movement. One 10 kt. Lady Hunting Case Swiss Lever Watch, plated cap Nickel Movement.

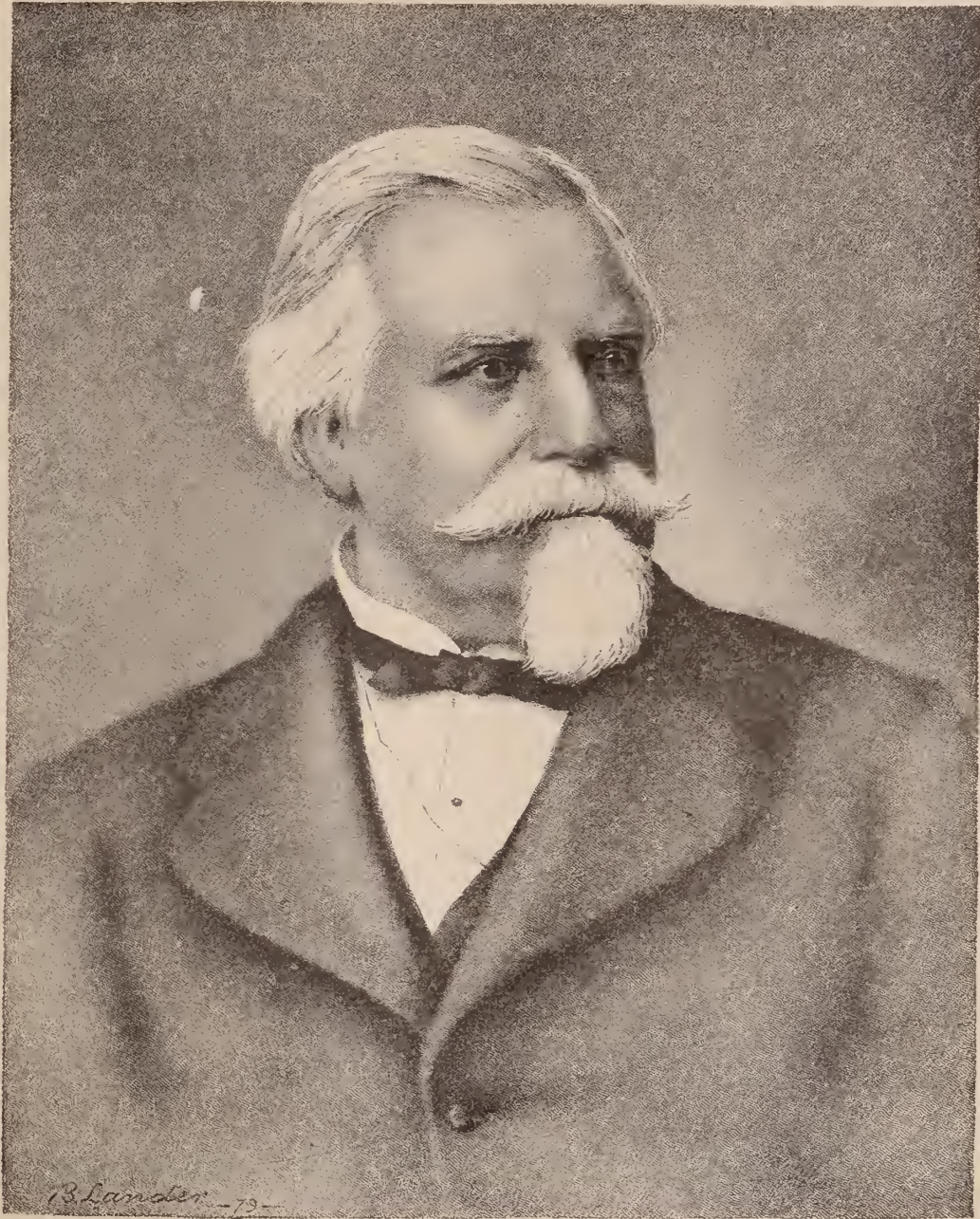

*Yours truly*  
*J. Guerin*

*Drawn expressly for the Jewelers' Circular by B. Lander, from his Original Crayon Portrait in possession of the New York Jewelers' Association.*



# Jewelers' Circular and Horological Review.

VOLUME X.

NEW YORK, MARCH, 1879.

No. 2.

THE

## JEWELERS' CIRCULAR AND HOROLOGICAL REVIEW,

*The recognized organ of the Trade, and the official representative of the Jewelers' League.*

A Monthly Journal devoted to the interests of Watchmakers, Jewelers, Silver-smiths, Electro-plate Manufacturers, and those engaged in the kindred branches of art industry.

### SUBSCRIPTION:

To all parts of the United States, Canada, Great Britain and the West Indies,  
**\$2.00 Per Annum; Postage paid.**

To France, Switzerland, Germany, Mexico, the Republics of South America, and Australia, \$2.50 per annum. Postage paid.

*All communications should be addressed to D. H. HOPKINSON, 42 Nassau Street, New York. Advertising rates made known on application.*

AGENCIES: { J. H. PURDY & CO., No. 170 State Street, Chicago.  
PRATT & CO., Ninth and Arch Streets, Philadelphia.  
HERMAN BUSH, No. 14 Mytongate, Hull, England.  
FREARSON BROS., Adelaide, Australia.

ME-SRS. LEE & WIGFILL, the well known Electro-plate manufacturers, (John street Works), Sheffield, England, have kindly consented to receive subscriptions.

### A Standard for Gold

THE principal reason for the demoralization that has characterized the jewelry interest for the past six or eight years, had its origin within the jewelry trade, and consists of the degradation of the gold standard that has been continually going on. Time was, within the memory of quite young men in the business, when a jeweler was regarded as a person of standing and respectability in his community, as a responsible business man, whose goods were all they were represented to be, and whose dealings with his fellow-citizens were in the highest degree honorable. Now, as one of them remarked to us recently, the average jeweler has to slink to and from his place of business by back alleys and by-ways lest he meet some customer who has been swindled in the goods he has sold him. He, of course, lays the blame upon the manufacturer, not seeming to comprehend that the only goods manufacturers turn out are those for which there is a demand. What is needed is a standard for gold; or, rather a law imposing severe penalties upon those who sell goods whose intrinsic value is below what is it represented to be. Such a law will make no war upon the cheaper grades of goods, but will simply prevent degraded goods being sold under false pretenses as fine goods. There is a legitimate demand for cheap jewelry, and those who cater to it comply with the legitimate laws of supply and demand; but when they palm off upon the public base imitations for fine goods they commit a fraud which should subject them to such penalties as are provided for other criminal offences of like magnitude.

A decision recently given by one of our courts held that where a person had bought "gold" goods, and the goods furnished assayed below twelve karats fine, there were misrepresentation and fraud, and he was not bound to pay for them. In other words, it was decided that gold degraded below twelve karats was no longer gold, but a

base composition, for which payment could not be exacted when sold as gold. In accordance with this decision some of our manufacturers have specified in their bills the quality of the metal of which the goods were composed, marking them 18 karat or 10 karat as the facts might warrant. By this means the purchaser was deprived of any excuse for refusing payment. This is an excellent plan for both buyer and seller to adopt, and, if it were general, there would be less fraud practiced in the jewelry business. The fact is, however, that many of the retail dealers do not want to know the character of the goods they sell. They buy them without inquiry, and sell them without explanation. It would disturb the consciences of some of our good methodistical dealers if they were *informed* that the so-called gold goods were base metal with a veneering of gold; so long as they are not so *informed* they can sell them for gold without a twinge of conscience, although they are morally certain regarding their character. Every jeweler knows the intrinsic value of 18 karat gold, and he also knows that when manufactured goods are offered to him for less than this price, without any allowance for cost of manufacture, there is a swindle somewhere. Yet hundreds of dealers sell these goods for genuine gold, placating their consciences by informing their customers that they bought of such and such manufacturers, whose reputation in the trade is excellent. They consent to *act* the lie, well knowing it to be a lie, but seek to shift the responsibility to the shoulders of the manufacturers. The fact is, this class of dealers and manufacturers are in a conspiracy to rob the public, and it is to prevent such robberies that we would be glad to see laws enacted to punish the perpetrators. It is this substitution of the false for the real that has brought the jewelry trade into disrepute and to its present demoralized condition. An instance in point: recently a well known manufacturer got out a fine gold pin, of a new and attractive design. For a time it sold well, but soon his travelers notified him that the same pattern was being sold at a less price by another house. Obtaining a sample of the cheaper article it was found to be base metal simply washed with gold. Yet this base metal was put on the market for gold, and dealers who were warned against it replied that they preferred not to *know* the truth, for if they did they could not *conscientiously* sell the goods. If this is not "whipping the devil across lots" we do not know what it is. It is this class of dealers who create a demand for bogus jewelry, and so keep alive its manufacture. A well known London jeweler recently advertised extensively that as he sold nothing but 18 karat goods, manufacturers were warned that all goods offered him for sale would be subjected to the usual test, and all that fell below 18 karats would be rejected. As a consequence, he was overrun with customers, the public having confidence in his goods, and he very speedily amassed a fortune. This is an experiment that might be tried to advantage in this country.

This matter of degrading gold goods is of national importance, and one that Congress is justified in taking notice of. A national law should be enacted fixing the standard of the various grades of manufacturers' gold, and providing severe penalties for misrepresentation and deceit; also that manufacturers shall specify in their bills of sale the quality of the goods in karats under penalties for violation. Such a law, rigidly enforced, would relieve the trade of much of

the odium that now attaches to it, and give the public a measure of protection that is now entirely lacking. We ask an expression of the trade upon this subject, and beg that those who are willing to petition Congress for the enactment of such a law to forward us their names. If the proposition meets with favor we will prepare such a petition and send around for signatures, and strive to secure such legislation at the next session of Congress as will prevent the sale of cheap, degraded goods for genuine gold. Honest dealers most certainly will approve of such a law, and we hope they will aid us in our efforts to drive out of the trade those who connive at and aid in the perpetration of frauds that are little better than highway robbery.

### Is Overproduction at Fault?

THE reason most generally given for dull trade is, overproduction. While it may be true that there are too many goods in the market, it is doubtful if overproduction is responsible for the stagnation that has been a prominent feature of the jewelry trade for several years. We are more inclined to attribute it to a lack of confidence on the part of the public in the integrity of the goods offered them, and of the members of the trade in each other. The fact is that the jewelry trade offers a wider field for the practice of deception and fraud than almost any other, and during the past few years large numbers of unprincipled men have obtained a foothold in it. They have degraded the quality of all classes of goods, and have unblushingly palmed off upon a credulous public the base material for the genuine. That there has been most intolerable overproduction of this class of goods we are willing to admit, and the fact that the country has been flooded with it has tended to make all classes suspicious of everything offered under the head of jewelry. For this condition of things dealers are largely to blame. They have not given that support to the legitimate manufacturers that they were entitled to, but have allowed themselves to be entrapped into placing the bogus imitations and the genuine goods side by side in their show cases, and, for the sake of a few dollars, have urged the purchase of the fraudulent article. No sooner is a new design in fine jewelry put upon the market than it is followed by its base counterpart, and dealers are prone to push the sale of the latter because the percentage of profit to them on such goods is greater than on the genuine. Manufacturers naturally become discouraged when they see base imitations driving from the market goods of intrinsic value that have cost them much money, labor and anxiety. It is scarcely to be wondered at that some firms which lay claim to respectability have been demoralized and themselves become manufacturers of debased goods. Instead of combining to keep up the manufacture of fine goods, to educate the public to a just appreciation of the frauds that are being perpetrated, and to drive out the illegitimate that thrives at the expense of the legitimate, they sit supinely by and see their business fall away from them, or meekly follow the example of those whom they despise, crying all the time that "overproduction is the ruin of the business." Overproduction has sins enough of its own to answer for without being saddled with those which are the offspring of inordinate greed, deception and fraud.

Dealers and manufacturers are alike to blame for this substitution of the false for the true, the former for educating public taste to demand the spurious and the latter for supplying the demand. There is a legitimate field for cheap jewelry, and neither THE CIRCULAR nor dealers in fine goods object to its being cultivated. As chromo lithography is to high art, so is cheap jewelry to fine gold goods. But when the chromo is sold for an oil painting the transaction becomes a fraud, of which our criminal courts would take cognizance. Not so in the jewelry business. Goods are sold as being made of gold, when the seller knows they are plated or filled, and that the outside is but a thin covering of precious metal. The manufacturer may or may not be a party to the fraud, but the dealer knows by the price he pays for his goods whether

they are genuine or not. No better indication of their true character is required than the invoice of the manufacturer. It is beneath the dignity of any dealer of respectability to place debased goods by the side of the genuine, of which the former is a fraudulent imitation. In France jewelers are prevented by law from keeping the false and the genuine in the same place of business, a wise precaution, but one impossible to put in practice in this country. If, however, dealers themselves saw fit to draw this line of demarkation, they could do so with profit to themselves, and there would be but little cause to complain of overproduction. The public has been so deceived with spurious jewelry that now when a person wishes ornaments of any kind he makes up his mind at first that he is going to be swindled any way, and that consequently, he might as well pay for cheap goods at the start as to pay for the genuine and afterward find he has been swindled. Could the traffic in fine and cheap goods be disassociated, each branch having its recognized dealers, reputable and trustworthy, it would be far better for the public and for the trade. Let all honorable dealers discourage the substitution of the false for the real, encourage the manufacturers of fine goods and give the cold shoulder to their fraudulent imitators, and we shall soon have a decidedly improved condition of trade. Overproduction is not so much at fault for stagnation in the jewelry business as the demoralization that has fallen upon the morals of those who engage in it.

### Trade We Should Have.

OUR consul at Amoy, Mr. Henderson, writes to the State Department that a good market for American clocks and watches may be found in China. Mr. Henderson does not appear to know that a great obstacle to the building up of this trade is the unlawful extortions imposed by the local governors of the various provinces. While American goods should be permitted to pass free of duty from one province to another, these petty governors exact a tax upon them that operates almost as effectually to prevent their general introduction as would a law prohibiting their sale. This practice may not be known to the parent government, and our agents in China cannot do a better service to their countrymen than to have these restrictions removed. China offers a good field for the sale of certain classes of goods. Cheap clocks and watches could readily be so popularized as to create a ready market. Chinese timepieces are clumsy, awkward affairs, constantly getting out of order, and wholly untrustworthy. But to attempt to build up an American trade means branch establishments, offshoots from parent houses. The attempt to send goods there on consignment has not been crowned with any better success than it has in South American countries—the debtors are too far from the creditors to be looked after properly. The Chinese masses take little note of time, but, as they are of a punctitious disposition, they could be readily educated up to an honest appreciation of American timekeepers. But it would also be necessary to teach their workmen to do the repairing, for they are a jealous people, and prefer to patronize "home industry." Mr. Henderson, is strongly of the opinion that an American agency of some large American clock and watch company would do a large and profitable business. It probably would for a number of years, but the imitative faculty, which the Chinese possess in such a high degree, would probably soon lead them to making Chinese goods on the American plan. Lacking, however, the originality and exquisite taste of American workmen, they would necessarily fall short in their designs, however they might succeed in imitating the mechanism of clocks and watches. What they require are the cheaper grades of goods, and all clocks would require a striking apparatus. The Germans have something of a trade in China, but would not be able to compete with American made goods. The experiment is worth trying, and might prove a great relief to our overstocked market.

### Taking their Grievances in Hand.

WE have received a copy of a circular dated at Manchester, Iowa, addressed to the jewelers of that State, calling for a State Convention of Jewelers, to be held March 19th. The object of the meeting, as stated, is "to devise, perfect and carry out some plan by which we may protect ourselves from the ravages of those interlopers, the so-called jewelry jobbers, in the practice, so destructive to the interests of the retail jewelers, of sending their wholesale catalogues and discount sheets to persons not in the watch and jewelry business." We are glad to see that the advice given in THE CIRCULAR has so soon taken root. Heretofore, the retailers have contented themselves with grumbling at this cut-throat practice, instead of adopting retaliatory measures. The so-called jobbers of whom they complain, have no right in the trade which any one is bound to respect. They are simply pirates, sailing under false colors. By making false representations to manufacturers, they succeed in getting the trade discount on their purchases, but instead of selling to the trade, they swarm over the country, selling their stock at retail at wholesale prices. The West is flooded with their circulars, and their traveling "bummers" invade every precinct, canvassing for orders from anybody who will buy, offering individual buyers the same discount which the retailer can get. Of course, this is destructive to the trade of the retailers, and they are justified in combining against it. They cannot compete with such traffic, especially if they expect to pay for their goods, a formality which these self-styled jobbers often forget to comply with. We commend the Iowa jewelers for the stand they have taken, and hope their example will be followed by dealers in other States. This illegitimate dealing is one of the principal causes of the depression prevailing in the trade. When this Convention assembles, we suggest that it would be a good idea for it to prepare a circular, stating their grievances, for the use of all the members, to be freely distributed among their customers. There is a predominant sense of justice pervading the human breast that, if appealed to, would secure for the retailers the sympathy and support of the public. The tricks and devices of these fraudulent jobbers could be thus fully exposed as well as the characters of the goods they deal in.

It seems to us that the proper course for the retailers to pursue is to come to a definite and distinct understanding with manufacturers as to who shall be considered jobbers and entitled to jobbers' discounts. These men who hawk their goods about the country, selling at retail to everybody, certainly are not jobbers. The time is approaching when the manufacturers must decide which they will support and sell to, the honest retailers, who expect to pay for their goods and have a standing in the community in which they live, or these poachers on the retailers' preserves, who rob them of the trade which of right belongs to them. As the retailers are the medium through which the manufacturers expect to reach the consumers, anything tending to injure the retail business, or to impair the credit and standing of the dealers, must react upon the manufacturer. Their interests are identical, and the temptation to sell a few more goods should not induce the manufacturers to encourage illegitimate trade that is little better than piracy. Such trade is built up on a basis of fraud and misrepresentation, and cannot be successful without the employment of deceit and false pretences. Manufacturers may find it profitable to encourage it for a time, but in the end they are sure to be the losers. Wisdom would dictate that they should take their stand beside the retailers and unite with them in their efforts to crush out all illegitimate traffic.

#### Jaques Guédin.

WITH this number of THE CIRCULAR we present an excellent and life-like portrait of the late Jaques Guédin, formerly of the well known firm of Ve. J. Magnin, Guédin & Co. Mr. Guédin died Nov. 9, 1878, and a sketch of his life was printed in THE CIRCULAR of that month. Mr. Guédin was one of the best known

members of the jewelry trade in this city. A genial, pleasant gentleman of the old school, always polite and affable, a man of the strictest integrity, and of excellent business capacity. After his death, Mr. Benjamin Lander, the well known artist, made for the Jewelers' Association a most admirable crayon portrait of the deceased, which now adorns the rooms of the Association, an artistic reminder of the many excellent qualities of the original. From this portrait Mr. Lander has copied for THE CIRCULAR the picture which we herewith present to our many readers. Mr. Lander was formerly a member of the trade, and is personally well known to many in it. Having a talent for drawing, and especially for the production of life-like crayon portraits, and having succeeded in producing several very fine "counterfeit presentments" of prominent jewelers' he finally gave up the business and devoted himself exclusively to art. Success has crowned his efforts, we are happy to say, and his orders for portraits come in faster than he can execute them. In a very brief space of time he has stepped into the foremost rank of artists in his specialty, and finds few if any equals. All who remember the pleasant and ever-welcome face of Mr. Guédin, will recognize the fidelity to nature of the artist. The jewelry trade should feel honored at having graduated an artist of Mr. Lander's excellence.

#### An Old Landmark Gone.

THE dissolution and retirement from business of the well known firm of Chatterton & Dodd, the last of the many successors of the house of Arthur, Peckham & Co. (Mr. J. B. Rumrill being the Co.), carries some of the older members of the trade back to the time when the old house was founded, full forty years ago. Arthur Peckham & Co. were for many years the leading jewelry house in this city. They did a large and successful business, and the different members of the firm retired with ample fortunes. They were succeeded by Peckham, Dennis & Co., Merrill, Fitch & Allin, Fitch & Chatterton, Chatterton & Dodd, and with the retirement of the last named firm the long line runs out. Mr. Peckham died a few years since. Mr. Arthur and Mr. J. B. Rumrill, the surviving members of the old firm are enjoying themselves in their retirement, and would seem from their appearance to have many years of happiness as well as usefulness before them. The reason given for the retirement of Chatterton & Dodd is that the business is so overdone that there is no longer a profit in it, and that to jeopardize their capital by continuing would be folly. Mr. Chatterton therefore takes charge of the stock for the purpose of closing up the affairs of the firm, while Mr. Dodd will probably keep out of business till times improve. Meantime he will devote his energies to the regeneration of the city of Orange, N. J., of which municipality he is an incorruptible Alderman—a position for which his rotundity of corporosity eminently fits him. The trade in general will regret the retirement of these gentlemen from a business in which they have been so long and pleasantly known.

IN a recent number of THE CIRCULAR we called attention to the fact that certain jewelers in the country, who sustained reputations for honesty, had fallen under suspicion of receiving stolen goods, from the fact that they bought goods from unknown and irresponsible persons at prices far below market rates. They may have suspected that they were stolen, but, in the absence of positive knowledge, their greed tempted them to buy because the prospective profits promised to be large. Since the publication of that article several country dealers have notified New York firms who had lost goods that they had some which were bought under suspicious circumstances, and that they were ready to surrender them on identification. These "respectable" firms whose "quickenened consciences" were so suddenly stirred to a realization of the results to which their irregular practices might lead, show by their course that they were not so much ashamed of the act as they were of being found out. A little publicity often acts quicker than the best detective.

**A** MOVEMENT has been started by the leading business men of New York to have a World's Fair in this city in 1889—ten years hence. Judge Hilton, Chairman of the Committee of Arrangements, has appointed the following gentleman members of the Executive Committee: Charles L. Tiffany, John A. Stewart, Abram S. Hewitt, Daniel F. Appleton, David Dowes, Orestes Cleveland, Horace Porter, Henry M. Alexander, Fletcher Harper, Thomas C. Acton, Richard M. Hoe, Jackson S. Schultz, Edward Clark, Norvin Green, William B. Dinsmore, Dennis C. Wilcox, Benjamin B. Sherman, Samuel B. H. Vance, and Samuel D. Babcock. The jewelry trade is ably represented, it will be seen, by Charles L. Tiffany, of Tiffany & Co., Daniel F. Appleton, of Robbins and Appleton, and Dennis C. Wilcox, of the Meriden Britannia Company. Ten years is a good while to wait, but, fortunately, there is little danger of any of these gentlemen dying of old age meantime, and the jewelry interest will be sure of being well cared for under their supervision.

### An Ingenious Clock.

**A** CLOCK having "three times more dial indications and more moving embellishments than any clock on earth," has just been finished in Columbus, Ohio—the result of eight years of toil. In a few days it will be on exhibition in Columbus and then will begin the grand tour of the States. From the *Columbus Journal* the particulars of this remarkable structure are learned. The maker's design was that it should be "an embodiment of the great events of our national history." To begin with, he has supported it by a "ponderous pair of eagle claws, draped and banded by the thirteen stars of the thirteen original States." It is five feet wide and ten high, and the two sides have representations of the two greatest events in American history—the War of Independence and the War for the Union. Independence Hall is there, with the old cracked bell within the belfry, and an old man ready to ring it. The Goddess of Liberty strikes the hour, and the Goddess of Justice balances the scales in favor of industry. In the center of an æolian harp is a model of the famous Strasbourg clock only four inches by twelve in size. For the grand Apostolic pageant the figures have been made after Leonardo's painting. All the allegorical figures are made of ivory, except the one of Satan, which is very properly made of ebony and has garnet eyes. Historic scenes are enacted on a stage. At the first quarter hour a locomotive appears, as the emblem of our first progress in industry. At the second the bell is tolled in Independence Hall and Washington walks majestically across the scene. At the third the Apostles bow to the figure of Christ, Peter denies his Lord and the cock crows. A skeleton hastens along bearing a green scarf on his shoulders, with the words "time flies," and an infant emerges from an opening door with a rattling-box in its hand. Just before the full hour arrives a phonograph makes music to herald its coming. At midday Emancipation is acted. Lincoln, proclamation in hand, moves towards a slave bound to an auction-block, while the slave turns to look upon his deliverer his shackles fall and his hands are raised as in a prayer of thanksgiving.

### The City Clock Winders.

**F**OR a good many years, running back into the '50s, old James Rogers wound the clocks belonging to the city. His successor is John McCarten, whose place of business as a watch and clock maker is at No. 304 West Forty-eighth Street. His official title is "Regulator of Public Clocks," and he is employed by the Department of Public Works, at the magnificent salary of \$300 a year. Considering that he not only winds but regulates, oils and repairs the clocks, his office is hardly a sinecure. Each of the clock companies employ a winder to look after the clocks of its customers, and they also wind certain church and other great clocks which may have been put up by other makers. Mr. H. Reynolds is winder for the Seth Thomas Clock Company, of No. 20 Murray Street. He has charge of the clocks of the Jefferson Market Court House, the Cus-

tom House, the Equitable building, the Dutch Reformed Church on Fifth Avenue and Twenty-ninth Street, the Brick Church on Fifth Avenue and Thirty-seventh Street, and many more well known public clocks, from St. George's in Stuyvesant Square to Harry Hill's in Houston Street. This wide range includes many sidewalk clocks, some of which are now beneath the sidewalk, others on the first floor of the store or building opposite, and not infrequently the same movement controls the hands on other dials in front of and inside the building. Then there are numerous eight-day clocks in banks, insurance offices, schools and private houses, to be attended to promptly at nearly the same hour on the same day of every week. The winder has each day's route on his book, attends to fifteen or twenty clocks a day, and gets from \$15 to \$20 a week. He works from 9 o'clock to 4 o'clock, for not many places are open to receive him early in the morning. The purchasers of clocks pay the makers so much a year for taking care of their clocks, and are thus assured of the correct time and no running down from neglect in winding. The annual rate for their service is from \$10 to \$100, according to the size of the clock. Where there are several clocks in one suit of offices, a store or private house, the usual charge is \$10 for the first and \$5 each for the rest, or the maker puts up the clock and agrees to wind and regulate it for so long, as the Seth Thomas Clock Company did with the one at the Bloomingdale Asylum for six months, subject to a new bargain for further service. It is literally "steady work," and in the case of big clocks in some of the towers where a huge crank is employed, it is very hard work.

Mr. D. W. Bradley, now employed in a different department in the Seth Thomas Clock Company, for many years was a clock winder on his "own hook." He had charge of the Trinity, St. Paul's, St. John's, St. Mark's and many more great clocks. The old clock in St. Paul's, since it was made in London in 1798, has been wound by many hands which are now still forever, but its own hands still keep moving. It requires 850 turns of the crank to wind up the clock in Trinity tower. The St. John's clock has been running since 1812. The clock on the City Hall is one of the best in New York—Mr. Bradley says he ran it for eight months, from June 1, 1866, to February 1, 1867, without once moving the hands, and as a general thing there are not more than fifteen seconds variation in three months' running. Other fine clocks in the city, especially esteemed by horologists are the clock on the *Tribune* tower, St. George's, at the Dutch Reformed Church, the Gilsey House, and the Charlier Institute. Mr. Bradley, in days past, had in charge, besides many public clocks, more than two hundred others all keeping the same time. The winder should be competent to regulate and to repair any difficulty, and this he does on his rounds unless it is something serious which requires a special workman. Howard & Co. take care of the *Tribune*, Dime Savings Bank and many more large clocks. A Mr. Sperry now winds Trinity's, St. John's and St. Paul's. All the leading dealer; and manufacturers generally attend to the clocks of their own customers. The winder really holds an office of much responsibility, for the clock owners hold him directly responsible if there is the slightest deviation from the correct time. The down-town bankers and insurance people are the most particular. They go by "ball time," and if their dials do not indicate 12 sharp when the ball drops, they are sure to drop down on the winder when he makes his next week's round.

### Japanese Bronzes.

**I**N a report to Sir Harry Parkes on the commerce of Hiogo, and Osaka, for the year 1878, which has just been issued by the Foreign Office, Consul Flowers says that the bronze, porcelain and embroidery manufacturers continue to maintain their high reputation abroad, and they have executed large orders for the recent exhibition. The bronze ware, he says, is made with the rudest possible appliances. From the beautiful and richly chased articles which are turned out, one would expect to see large manufactories provided with modern appliances of every description, but in reality the work-



shops are no better than ordinary blacksmiths' shops. The process is roughly as follows: "The moulds which, of course, vary according to the shape of the vase or bowl it is desired to make, are made of wood, sometimes covered with straw. On this a coating of clay is placed; over this comes a layer of wax, which is moulded into the design required. Another thick coating of clay is then added, and the inner wooden mould being taken out, the orifice at each end is closed. Two holes are then made at one end connecting with the layer of wax, so as to enable the wax when melted to run out, and through these the molten bronze enters, filling the interstices occupied by the wax. The subsequent process of casting is of the rudest kind. The earthen mould is placed in a small clay oven, hollowed out in the floor of the workshop, the size of which depends upon that of the casting. The oven is then filled with charcoal and closed, with the exception of a circular opening at the top, on which a chimney, a foot or so high, is built of wet clay. The oven is connected underground with a wooden bellows, protected from the sparks and heat from the furnace by a small earthen or stone wall a foot high, and which is worked by hands and feet. The first operation is to melt the wax, which runs out, leaving the impression of the design stamped firmly in the surrounding layer of clay. This done the mould is taken out and allowed to cool. It is then put a second time into the furnace, as before, and the molten bronze is then poured into the mould through the holes by which the wax escaped. After the bronze has filled the mould, the chimney is knocked off, the oven is supplied with fresh charcoal laid evenly around the mould, and a lid being put on the oven, furnished with small perforated holes, the bellows are set to work again for an hour or more, according to the size of the casting taken. This operation generally occupies a day. When the casting is taken out of the oven the earth outside and inside is scraped off and reveals the vase or bowl in a rough state. It is then put into the hands of rough workmen, boys being mostly employed in this part of the work, by whom it is polished and scraped with a knife until it presents a smooth surface. It then passes on the hands of the carver, who fills in the details of the designs. When his work is done the vase or bowl is dipped into a boiling solution of vinegar, sedge and sulphate of copper, in order to give it the proper color. A few finishing touches in the way of polish is added, and the article is finished and ready for sale.

### Proceedings of the Horological Club.

A DISTINGUISHED BODY OF WATCH AND CLOCK MAKERS.

*Sixtieth Discussion.—Communicated by the Secretary pro tem.*

[NOTICE.—Correspondents should write all letters intended for the Club separate from any other business matters, and headed "Secretary of the Horological Club." Direct the envelope to D. H. Hopkinson, Esq. Write only on one side of the paper, state the points briefly, mail as early as possible, as it must be received here not later than two days before the end of the month in order to be discussed and reported in the CIRCULAR for the next month.]

There was an unusually large gathering of members of the Club on the occasion of the last meeting, an especially interesting session being anticipated. The hall never looked more bright and cheerful; the elegant center table around which the members are wont to array themselves was laden with scientific books of reference, together with numerous instruments brought for special illustrations of topics to be brought forward. In the corner, opposite the door, the grand piano stood so enticingly open that Gorge Hollis could not refrain from thumping it loudly (in the base) every time he passed. The cosy arm-chairs and luxurious sofas were all occupied by the members of the Club, who chatted in familiar intercourse, or discussed knotty technical points in the vigorous manner that characterizes them. A bright, ruddy coal fire in the open grate threw its light and shadow upon the surroundings as the flames flickered and twisted their winding and tortuous way up the chimney. From the walls there beamed down upon the assembly the portraits of those grand old masters in the art of horology, who, having enriched the science with the works of their lives, have passed quietly and calmly to the great Beyond, where time is not and that which we call science is made plain as the sun at noon-day. The cheerful aspect of the room and the benignant expression upon the countenances of the members, betokened a session of extraordinary interest.

Alas! how is frail humanity doomed to disappointment! *L'homme propose, et Dieu dispose.* When the President entered the room his countenance was shaded in gloom, while the bulbous excrescence upon the apex of his nasal protuberance was observed to be several shades darker than usual. He proceeded at once to his place at the head of the table, rapping with his diamond-tipped gavel to secure attention, proceeded in lugubrious strains to remark:

"*Gentlemen of the Club:*—It becomes my painful duty to discharge an obligation that weighs upon my heart with crushing effect. I cannot find words in which to make the announcement which I am convinced will blanch your cheeks and fill your souls with woe and lamentations. I had intended to deliver a brief essay this evening, occupying six or eight hours of your valueless time, but the sad information I am about to impart deprives me of that privilege and robs you of an opportunity of being intensely edified. I can say no word to comfort you in the affliction that is about to fall upon you, and therefore will abruptly announce the calamity that has befallen our organization. Our Secretary is sick—he is suffering from an acute attack of colly-wobbles, and will not be able to be with us this evening."

Consternation seized upon the members and it was some time before any one could find voice with which to speak. Then Mr. Tenyob moved that Lan Bender be appointed a committee of three to prepare suitable resolutions. Without putting it to vote the President declared the motion carried, and during the next fifteen minutes, amid profound silence, the Committee was engaged upon the painful task assigned to him. At the end of that time Lan Bender arose, with tears trickling from his eyes, and moisture streaming from the tip of his nose, and said:

MR. PRESIDENT—As Chairman of the Committee assigned to the solemn task designated by you, I have to report that your Committee unanimously recommend the adoption of the following whereas and resolution, as follows, to wit, viz., namely:

*Whereas*, An inscrutable and all-wise Providence has seen fit to invade our peaceful and highly scientific Club, and smite to the death our late lamented brother"—

Here the president interposed the remark that he thought the Committee was altogether too unanimous—that it insisted upon killing the absent Secretary when the fact was that he was only sick—had colly-wobbles, in fact, and would probably be restored to health by the diluted doses of paregoric that were now being administered to him at regular intervals by two devoted attendants, armed with back-action pedometers to secure accuracy. The sickness of the Secretary, he said, was a calamity in itself, and he did not propose to sit quietly by and see the poor man slaughtered entirely if he knew it. [Cries of "hear, hear," from several members].

Lan Bender, who is a new member, and exceedingly retiring in his disposition, was utterly crushed, and sank under the table, an indistinguishable mass of collapse.

The President then decided that the Club would dispense with the resolutions until the Secretary's return, when his familiarity with the subject would enable him to write such as would be satisfactory to himself.

On motion, Tom Cliffson, a journalist from the rural districts, was appointed Secretary *pro tem*, and instructed to furnish the regular report of the proceedings of the Club to THE JEWELERS' CIRCULAR. [This being his first attempt at reporting, the Secretary *pro tem* begs the editor to correct all grammatical errors, bad spelling and writing, and put the thing in proper shape].

The President then said that it was moved and seconded that the Club take a recess of ten minutes while a dirge was sung for the speedy delivery of the Secretary from the deadly grip of the irresistible collywobbles.

All then surrounded the grand piano, where, amid silence so profound that you could have dropped a pin anywhere, the President sang that beautiful *Te Deum in excelsis*, commencing with those impressive lines

"Mother may I go out to swim,  
Yes you may my daughter,  
Hang your clothes upon a limb,  
But don't go nigh the water."

He played as an accompaniment "John Brown's Body," while Tenyob assisted him upon the combhairicum, breathing thereupon the gentle notes of "Rock me to sleep, mother." A more impressive scene is seldom witnessed. When the dirge was ended the members blew their respective noses in one united sonorous blow, and then returned to the business of the evening.

The President said that it would be impossible to do much, as the Secretary had all the papers, but if some one would pass him another glass of beer he would read a document which he had just received. He proceeded to read a paper which was wholly unintelligible, while the members gazed fondly at him over the tops of the beer-laden crystal cylinders (with handles to them) which were placed before them at short intervals.

At the conclusion of the reading Mr. Davius Podd remarked that, as the beer was all gone, he presumed it was imperative for the meeting to adjourn.

The President replied that it was, and casting "one longing, lingering look behind" at the empty keg, he departed with an abruptness that indicated the intensity of his thirst.

[To the Editor:—This report may not be quite in keeping with previous ones, but it is correct. I didn't know many of the members by name, nor by sight, for their faces were hidden by their glasses (beer) most of the time.—TOM CLIFFSON, *Secretary pro tem.*]

P. S.—The Secretary has come out ahead in his fight with collywobles, and will be on deck next month.—T. C., *S. p. t.*

N. B.—What are collywobles, anyhow?—T. C., *S. p. t.*

P. S. No. 2.—I can't attach the seal of the Club to this report because the President put it in his pocket thinking it was his watch. He didn't discover his mistake till "his uncle" refused to lend him \$10 on it, and then he threw it in a passing sewer.—T. C., *S. p. t.*

[NOTE BY THE EDITOR.—Having been informed that the Secretary of the Horological Club was sick, and that there was to be an important discussion at the last meeting, we sent a youthful stenographer to report the proceedings. The above is the result. It is apparent that the young man strayed into the rooms of some bacchianian organization, became confused with beer, and wrote out the above jumble. This shows the folly of a person undertaking to do what he knows nothing about, and illustrates the many temptations that surround unwary youths in this great city, especially those who attempt to obtain a foothold in horological pursuits. Of course this report does not have the slightest application to the staid and scientific Horological Club.]

### Jade Stone.

The loan exhibition at the Academy of Design is rich in a material by which the Chinese and Japanese set great store. The stone called nephrite or jade has always possessed extraordinary qualities in their estimation, and it is probable that Western nations once held similar views. It is not absolutely known to have been used in the classical days of Greece and Rome, although the *nilion* of Pliny agrees well enough with its more usual appearance. It occurs in many different shades of green and gray, sometimes mottled or "mossy," sometimes with a rosy hue. The pale-green and dark-green, milky white or clouded varieties seem to please the fastidious taste of Oriental artists and Princes. But something more than its beauty has lent it the high reputation it enjoys. Various popular beliefs which are founded upon its supposed powers, both in practical medicine and the art of magic, have given it a position among minerals which rarer stones have not attained. It is very difficult stone to work, owing to the presence of the exceedingly hard material called silica which enters into the composition of all its true varieties. The presence of silica has won for jade a by-name, expressing the use to which it has been put by nations not well supplied with iron. By them it has sometimes been called axe-stone. In general, the Chinese and Japanese, when working it into cups, tablets, and small figures, engrave it with very low reliefs. They seldom cut it into the high relief that bone, ivory, and wood receive under their skillful fingers, and seem to get æsthetic pleasure in connecting the subdued coloring of the material itself with conventional figures of plant or animal life that do not approach closely to the actual thing represented. They like to use jade for guards to night-lamps, enjoying thoroughly the

effect of light shining through the opaque greenish walls. They thus secure at once a subdued and agreeable light, and reveal the cutting of the artist on the walls of the lamp-guard. Some of the jadeite jars used for this purpose, which have come either by purchase or through the spoils of war from China, are as much as two feet in diameter and height. Standing on the floor at the head of the sleeping-mats of high officials or wealthy merchants, they doubtless added much to the physical and spiritual comfort of their owners.

In China and Japan superstition clings to a thousand articles which Europeans, save in exceptional cases, no longer regard with veneration or dread. Jade-stone exerts a strong impression on the imagination of Orientals. On one side, the feeling has a root in actual belief in the curative properties of the stone when administered to a patient in the form of powder. Diseases of the kidney are so treated, and hence the term nephrite arose, from the Greek word *nephros*, kidney. On the other side, a magic virtue was attributed to the stone; it was believed to keep off evil or unlucky spirits. The mandarin kept it near him at night in an ornamental as well as useful form. The commoner who could not afford such luxuries bore it about his person in the shape of an amulet called *feit-sui*, and, as usually happens, consumed far more of the material in commerce than did his rich superior with his expensive taste for the elaborated article. A curious connection between Asia and Europe in pre-historic times, has turned up in the discovery of just such amulets of jade or nephrite among the ancient lake dwellings of Switzerland. There is no place in Europe where the hard varieties used in the arts are found. The jade amulets in the lake dwellings must, therefore, have come from Siberia or Turkestan. That their meaning was identical can hardly be doubted. Just like the engraved plates found in the burial-places of American mound builders, the round jade carvings of the lake dwellers of Switzerland may be explained by the customs of to-day in stagnant China; they were used as fetiches.

The largest collection of jade-stone ornaments in the city is probably that of Mr. Robert Hoe, now on exhibition in the North Room at the loan collection. There are eighteen pieces, comprising inscribed tablets mounted on stands, bottles, bowls, little cups, and circular ornaments. A cup with lizards, of remarkable excellence, has been placed, with good reason, in the same case. The catalogue says that it is of uncertain materials, looking like bone or ivory. There can be no doubt that it is one form of jade, or, rather, a member of the same family as jade, nephrite and prehnite. Asbestos belongs to the same kindred, and yet nothing could be further in outward appearance from the close, tough texture of jade-stone than the open threads of asbestos, a mineral that can be woven into fire-proof garments just as it comes from the earth. Another material of similar chemical elements is called mountain leather, and another mountain cork. The little cup with lizards is doubtless what is called ligniform asbestos, owing to its close resemblance to the texture of a very hard wood.

Mr. Hoe's case of jadeites is not the only example of the stone in the North Room. There are solitary tablets and jars of the same rare material scattered through the other cases, and one cup in particular, unnumbered, is of singular beauty. It represents an open flower surrounded by buds and leaves, the latter being very far detached from the cup. There is also an incense vase, very deeply pierced by the engraver, and a jade cup, said to be of the Ming dynasty, which are marvels of skill. The dignity of the jade-stone among minerals is such that Prof. Heinrich Fischer, of Freiberg, published a large volume on its merits alone. The book is hard to get in this country; it is said to treat exhaustively of jade both as a mineral, an ornament, and an object of superstition.

**A**LUMINUM AND PLATINUM IN MANUFACTURE OF WATCHES.—In ordinary watches their correctness depends greatly upon their position, whether this be a vertical or horizontal one. The reason is that the more rapidly rotating wheels principally, but more or less all of them, are made of too heavy material. Brass, or a similar composition, is, as a rule, too heavy, and, as an immediate consequence, it

will not be immaterial whether a wheel presses with its full weight vertically upon their axis (that is, rests on the point of it), or whether the pressure of its weight is exerted on the circumference of the axis. The latter is naturally the more correct position, insuring a correct, even, and unchanged movement of the watch. Hence the steady desire to keep the watch in an upright position. Much less felt will be the influence of changed position, especially of that of the more rapidly rotating wheels, if these are made of the thrice lighter aluminum instead of brass. Used for that purpose aluminum constitutes an important improvement, since the position then becomes a matter of no influence on the movements of the watch. The friction, and therefore the wear of the wheels, are reduced, and oiling may often be dispensed with. Platinum, however, by its heaviness, is indicated for the manufacture of balances, as they become thereby more independent of exterior shocks.—*G. F. Reisenbichler, in Schweizer Gewerke-Blatt.*

THE chromo business was so greatly overdone in premiums for subscribing to religious newspapers that it fell into ridicule. Any journal that would now offer these polychromatic or horological premiums would be laughed at. Acting on the knowledge of this fact, the *Church Union* offers a novelty in religious premiums. The new premium is a seven-shooter pistol, with enough cartridges to kill half the cats in a subscriber's neighborhood. The proprietor of the newspaper recommends these weapons to be used as means of defence against burglars and tramps, and says that in view of the great number of these objectionable members of society a pistol is a "household necessity." As one of the pistols and enough ammunition to set it going, and the newspaper for one year are all included in what the subscriber gets for three dollars, it will be seen that the pistols are not of the most costly kind. Still, they will be good enough for home practice. It is believed that a majority of church people and other subscribers to religious sheets are not experts with firearms. Some churches have shooting galleries, but the introduction of these have been severely criticised by people of churches which have no such encouragement to accurate marksmanship. Though these pistols may be pretty things to look at, and may for a while swell the subscription list of the paper, it is thought in some quarters that the eventual result of distributing pistols with piety will be to thin out the subscribers to a frightful extent, and to make the obituary department a feature of the paper.

### Watch and Chronometer Jeweling.

NUMBER TWO.

*Continued from page 188, Vol IX.*

IN considering the making of the jewels from the various materials enumerated in the first article, the reader must bear in mind that much detail, and perhaps repetition, are unavoidable, if the description is to be of use in the practical sense to the artisan, the whole process being made up almost entirely of *littles*; and any essay on it would be incomplete were we to neglect the little things and motions of the processes. With the close of the last article we had arrived to the manipulation, which we now propose to consider. In order to give some system to the descriptive part, we will take up the subject of the tools used by the jeweler, which are comprised in the following list: First, and most important of all his tools is his lathe; no very complex affair, comprising simply a head, stock and a mandrel (*well fitted*, with no tremble, and no end shake in its bearings), a common T rest, a driving wheel with stand and its band, and a treadle hung on the outer end and connected with the crank by a leather strap. It is not a very formidable tool, nor is it easily deranged; but in very fine and delicate manipulations it is essential that considerable care should be exerted to keep the mandrel in such a condition that while it is immovable in a vertical or longitudinal line it is left perfectly free to revolve with the greatest of ease; for one of the greatest requisites is speed.

There are three varieties of the jeweling lathe, but no difference in the principle. The English use a small brass tool not more than five or six inches in length, and with a very small swing—the

mandrel being fitted to a steel bushing on its front end, and a pointed center at the back bearing, is a very strong and substantial arbor, but for good work and durability it lacks length. The small swing of the lathe necessitates a very low rest; but in drilling this perhaps is an advantage, as the operator is enabled to rest his hand on the bed of the lathe, which is quite broad. The band generally used is common catgut, and is unobjectionable in all but that of joining the ends. Now, joining the ends may seem of but little importance, but it is; for a knot in the band is very apt to cause the arbor to "jump," and in drilling a very fine hole the cherished drill (and a good one *is* cherished) is broken. No one but a sluggard or a saint could have such an accident happen without an exhibition of impatience. The jeweler in England drowns his sorrow, on such an occurrence, with a quart of ale. The best material for a band is good well tanned calf-skin; it is easily made, most any shoemaker being able to cut from a small piece of leather a band from fifteen to twenty feet long, and the shred thus obtained may be drawn through any wire plate whose holes are of sufficient diameter; or in case of the absence of any such a plate, a common pinion stake can be profitably used, as the sharp edges of the finished face will cut the superfluous corners from the square leather thread and leave it uniform in diameter and nearly round. It is now rolled between two surfaces and is ready for use. The most prominent virtues of this band may be summed up as, *first*, elasticity; so that if the driving wheel is not true, the strain arising from the inequality will not be transmitted to the arbor; *secondly*, it can be easily joined without the formation of a knot; and, *thirdly*, the mice will not eat it; the last may seem trivial, but it has occurred in a large establishment that the depredations of the mice were a cause of serious inconvenience, as well as a loss of money and time. The English lathe, as thus described, is a very handy tool in the hands of an operator who has learned the use of it, and got his hand accustomed to the dimensions, but for the general watchmaker, it is of very limited value.

The Swiss jeweling lathe is too well known to need any description. Like all other human productions it has its advantages and imperfections; its valuable points are, that the arbor is longer, projects farther from the front bearing than in the English lathe, and has a much greater swing—thus enabling the operator to use skives and laps of all kinds of larger diameter, and of course more rapid in action; and the lathe itself can be used on the bench for all kinds of watch repairing either the old verge or the Jacot lathe—no inconsiderable advantages; but it has the arbor turned down too thin in the neck of the front bearing, causing a tendency to tremble. In the Swiss style of drilling this is hardly an objection, but it is not good when the English diamond drill is used. The American lathe is a better tool for general work, and can be used for jeweling with all the advantages of the English and Swiss, with none of their defects. As a matter of course, the prime necessity in each is rapid motion. To accomplish this the driving wheel is usually of large diameter, but light in weight, as it is necessary to control its motions with ease and speed; the wheel should be well and truly turned up on its face by the hole in the center, and hung on well made bearings—not conical centers—as the pressure of the screws that hold the centers has a tendency to spring the shaft in the crank, causing the wheel to "wobble." The advantage of a leather strap is that it is more elastic, and gives less shock to the wheel and lathe mandrel than if made of iron.

The alcohol lamp is a most important adjunct to the lathe, it being what the screw wrench is to other lathes. It should be small, with the wick tube placed on the side at a strong angle, something like the spout of an ordinary coffee-pot, only it should enter the side at the bottom of the lamp—a small wick, and consequently flame, only being needed. A very pretty lamp which any watchmaker can fabricate for himself, and which is superior to any lamp he can buy, may be got up in this manner: Select a common house britannia lamp, such as are used in hotels for bed-room purposes, drill a hole in the side just above the bottom plate, and solder in

the hole one of the drawn brass tubes used in the manufacture of the pendolder; a common hollow penholder will answer admirably by cutting off its closed end, and this lamp is neat in appearance, and the size of the tube is just about the desideratum.

The tools that belong to the lathe proper may be summed up as the skive, lap and chucks; the lap has been described in a former part of this article, and it only remains to treat of the skives and chucks. The skive is nothing more or less than a circular saw, or really a lap, only the thin edge is used in place of the face. It is made from soft sheet iron, planished up true but slightly dishing, and is clamped on an arbor between two flanges which are held together by means of a screw and nut on the arbor; the object of the dishing being to render the part left exposed outside the flanges rigid, so as not to "buckle" when the charging process is being done, or by the pressure of the stone in being cut. Except in the factories, the skive is not much used by the jewelers, their lathes being too small to permit an economical use of the instrument. The lapidary uses it extensively, as he has sometimes large stones to slit, which would be ruined were he to attempt cleavage by a blow. The charging of a skive is a simple operation, yet requires no little skill to effect a good result.

After having trued up the plate, both as to center and plane of revolution, the arbor is set in motion at full speed, a small quantity of coarse diamond powder in oil is taken up in the hollow of a quill cut something like a toothpick. Having a piece of cornelian in one hand, the operator presses it with a gentle degree of force against the edge and with the other hand he applies the powder as near the stone as convenient, which becomes attached to the edge of the skive, through the viscosity of the oil, and is carried along on the edge until it comes under the piece of carnelian; the pressure of the stone imbeds the particles of the powder in the soft iron. The use of the quill is suggestive from the fact that its shape is all that could be desired, while its elasticity could not be equalled in any other way.

After two or three revolutions, the skive begins to cut the carnelian used as the burnisher; that is of no importance, for a new spot on the face of the cornelian with a fresh charge of the powder, will generally charge the edge with diamond sufficient to do a large amount of work. The object to be slit is held to the edge of the skive by the lapidaries in their fingers; but the small stones used by the jeweler are cemented on the end of a stick, and thus can be applied to the cutting edge with facility, the skive being kept well oiled during the operation of slitting.

For jewelers' purposes the chucks are nothing more or less than short pieces of brass with a screw on one end to join it to the mandrel; it is placed in the lathe as true as possible and then turned off with a common steel graver to any form and dimension.

So much for the lathe and its adjuncts; it would be useless, however, without the two important bench tools—the diamond cutter and the drill; these are made the same way, the only differences being the size and form adapted to their different uses. To make a cutter, the artisan selects a fragment or "Bort" of the size desirable—the form, as a matter of course, being that which presents the best cutting edges and adaptability for being firmly set in the stock, which he proceeds to make in this manner: Taking one of his chucks, he anneals it by heating it red hot and plunging it in cold water, then places it in the nose of the mandrel, turns it off true and drills a hole in the end large enough to receive the "Bort," and deep enough to enable him to have stock enough to hold the diamond. The outside of the chuck is now turned down with a neck just back of the bottom of the recess, tapering the end of the chuck from the bottom of the neck outward to the end; the piece is now ready to receive the cutter, which is placed in the recess in such a manner that it will be larger in the hole than outside; the operator, then, with a pair of plyers, pinches the two sides of the end together on the diamond, the soft brass yielding and taking the form of the "Bort;" in the pinching the whole form of the end of the chuck is

changed; it is elongated on each side of the diamond; by pinching with a pair of plyers these elongations, it will be obvious that the stone is bound on the edge of the setting almost as if it were a piece of soft wire twisted around the cutter; the rough parts are trimmed off with a file, the balance of the chuck turned up to suit the convenience of the operator. For additional strength, it is sometimes soldered in with silver solder, which fills up all the crevices, and thus forms a solid bed for the diamond. The drill is made in precisely the same way, the only difference being in size and delicacy of manipulation.

The miscellaneous articles are such as are generally used on the watch bench, such as tweezers, plyers, files, gravers, etc. He uses also pieces of iron and copper wire and of lead in the form of short cylinders, also glass plates for facing, and boxwood for various uses.

### Practical Hints on Watch Repairing.

BY EXCELSIOR.—No. 48.

EXAMINING THE ENGLISH OR "PATENT" LEVER.—*Continued.*

(753) *Fourth Wheel.* See that it runs well free from the pillar plate, and the point of the third bridge screw. Its proper position is midway between the plate and escape wheel. See that it does not rub on the potance, when raised to its highest end-shake; nor on the cap jewel slide, screws, etc.; nor on the center wheel; nor touch the third pinion, the nearest pillar, the dial post, or the pin that goes through it. This last is a very common fault. Workmen will put a long pin through the dial post, the end of it runs under the fourth wheel or into its teeth, and he wonders what ails the watch that it keeps stopping or won't go at all. Sometimes the wheel runs so near the post that it is not safe to have the pin project through it at all. This point should always be thoroughly looked after, and the pin cut off so short that it cannot reach to the points of the teeth, unless the wheel is so high above the pin that there is no possibility of their touching. Even then, if the pin is carelessly put in its point may curl up and touch the teeth. If the fourth wheel runs over the inner end of the bolt, see that it cannot touch that, nor the point of the screw that holds the bolt, and that the bolt cannot be pushed in so far as to reach the wheel. See that the fourth pinion does not touch the sides of its sink through the pillar plate; that the lower corners of its leaves do not rub on the third bridge.

(754) If there is a stop to catch into the fourth wheel and hold it when desired, see that the wire cannot touch the teeth when not intended to. The base of the wire should be fast in the stop so that it cannot turn, and the end should be vertical where it engages with the teeth. See that the notches, and the point that works in them, are sharp and sound, and the steel hard; that the stop does not move too easily, else it may get changed by accident and stop the watch. To make it move harder, cut the notches deeper, leaving the ridge between the notches unchanged,—or make the spring press harder. It would be better to bend the wire so that it cannot touch the wheel at all, than to leave it liable to catch all the while. The same directions apply when the wire is made to catch into the escape wheel, or the balance rim.

(755) *Third Wheel.*—See that its teeth do not rub on the third bridge at either end; nor on the lower fourth pinion jewel, or its setting; nor around the sides of its sink in the pillar plate; nor on the spring that throws the bolt out; nor on the minute wheel, which sometimes stands over the sink; nor up under the center wheel, when at its highest end-shake; nor on the collet under the fuzee,—neither on the washer, nor on the pipe or socket around the lower end of the fuzee arbor; nor on the pin that holds the collet on the arbor, the ends of which frequently stick out considerably outside of the pipe. When the third wheel sink runs into the side of the fuzee arbor sink, the last named point should be very carefully looked to

See that the third pinion does not touch the teeth of the main or steel wheel, nor the chain on the fuzee; that the chain hook cannot touch it in passing. The hook is often fitted so imperfectly that it sticks out much further than the rest of the chain and causes trouble with the third and center pinions. When this is the case, it must be made to set as closely as possible to the groove in the fuzee, and if it still sticks out too much, dress off the back.

(756) *Center Wheel*.—See that it is level, and true both in the round and the flat; that it does not rub on the bottom of its sink or hollow; nor on the end of the minute wheel pin, which often sticks through the plate into the sink; nor around on the sides of its sink; nor on the third wheel,—being careful to also see if the metal is not thicker between the third pinion leaves, which is often the case, from thinning the wheel after it is staked on the pinion, leaving a sort of hub in the pinion, on which the center wheel teeth are very likely to rub; nor on the fuzee collet, or its pin, (792); nor on the lower fuzee jewel, or its setting; nor up under the potance, or its cap jewel slip, or screws, when at its highest end-shake; nor up under the main wheel, or the barrel, or the fourth wheel. Sometimes it is difficult to make the center wheel clear all around, but it should be done. The center pinion pivots must of course be straight and sound, well fitted in their pivot holes, and the wheel perfectly true and level. If the wheel then interferes with anything, the rubbing parts must be dressed off, or the wheel raised or lowered as found necessary, by bumping its pivot holes up or down (751.) If they are jeweled, great care will be required to avoid cracking the jewels. No pressure should be put on them or their setting, but outside of both. In emergencies the pinion shoulders may be turned back a little and repolished (297). If the wheel rubs on the bottom of its sink and also has excessive end-shake, the lower pivot hole can be bumped up, and remedy both the rubbing and the end-shake. If the wheel must be raised, the sink must be turned out deeper. Sometimes when the wheel rubs badly, and is pretty thick, it can be thinned some in the lathe, but this is seldom advisable.

(757) *Center Pinion*.—This should be upright, sound and well polished, its pivots or bearings not rusty, cut or worn, but straight and smooth, well fitted to the pivot holes, (whether the latter are in brass or jeweled,) and should have good broad shoulders to rest against the plates, to retain the oil. When the shoulders are too narrow the oil will run from the pivots. The pivot holes on both the center pinion and the fuzee arbor should be good and long, as the pressure is so great that it will force the oil out of a short hole, from the bearing surface being so small. It consequently wears fast, the pivot runs dry, rusts and cuts, and the rust wears on both pivot and hole—being a sort of polishing powder, something like sharpe, only made in a different way. Many workmen think, when they find the pivots of these parts rusty and badly cut, that somebody has put them up without oil; but the trouble is generally in holes too thin for the pressure coming upon them. Oil will not cure it, nor will dressing off the pivots and bushing the holes prevent the same thing occurring again, unless the bushings are made longer, giving surface enough to retain the oil between the rubbing parts. This also shows why center holes closed up with the punch almost always result in cut and rusty bearings. If a hole is closed up, it should be so done as to move up the entire side of the hole, then enlarge and smooth it out to the proper size with the round broach, (687), so that the whole length of the hole, when done, shall bear on the pivot.

(758) When the lower center pinion pivot is cut, it should be put up in the lathe, and the rough part turned off, till you get a straight and cylindrical bearing, then grind and polish up perfectly. Sometimes, in turning out the grooves as above, you will take off all the shoulder, and the pivot will be no larger than the cannon arbor, (748). This of course would not do, as it would leave nothing to keep the cannon pinion from being pressed entirely down against the plate, where it would rub and bind, and probably stop the watch. In such a case you should fit on a piece of steel, from which to make

a new and larger bearing. Take a piece of steel wire, drill a hole of the size you have turned the arbor down to, and cut it off a little longer than the bearing surface is to be,—one end being finished off to fit up against the pinion shoulder. Then harden, temper to a blue, and drive it on down to the shoulder. If thought necessary, it can be soft soldered on, using but little solder, being careful not to overheat the pinion or wheel, and to clean off every trace of the soldering fluid, by washing thoroughly, first in clean water (without soap,) then soaking in alcohol. Turn this collar down to the proper size and length, for the pivot bearing, finish up nicely, and you have a job that will wear about as well as a new pinion.

(759) If the hole was jeweled, when the pivot is fitted to the jewel the job is done. But if the hole is in brass, if not too much worn, it can be brouched out a trifle, to a perfectly smooth, sound surface, and the pivot fitted to that. If too much worn to allow of doing this, we must fit a new bush in our pivot hole. To put in the bush or stopping to fit, broach out the hole until the bush will have some thickness when drilled, and chamfer the ends of the hole slightly. Then file up a piece of hard brass wire to a perfect fit, cut off and rivet it in. Do not rivet too hard or you will warp or stretch the plate. If well fitted it will need but little riveting to make it fast. Now we must drill the pivot hole so that the pinion shall stand perfectly upright in the plates. To do this, pin the plates firmly together, put up in the universal lathe, centering them from the upper pivot hole, which we will suppose is perfect, or not seriously worn. We can then strike a center in the bush which, when cut out, will hold the pinion upright. Drill the hole a little smaller than required, and finish it with one of the lathe cutters, which will make it more true and perfect than drilling alone. At the same time we can turn off the surface of the bush smooth, and level with the remainder of the old stopping, if desired. If the bush is too long for the cutter to reach through, after cutting the hole as deeply as you can, you can either reverse the plate, center from the completed end of the hole, and turn out the other side, or you can simply broach out what is left, and finish with the round broach, which will both polish and harden the metal. The hole should, of course, have been left a little small in this case, else the round broach would make it too loose.

(760) If you have no universal lathe (which is almost inexcusable nowadays, when a lathe, or a universal head fitting into your bench lathe, can be had so cheaply,) after pinning the plates together, find the center by the old-fashioned upright tool. Rest the upper plate level on a ring of suitable size, get the point of the lower arbor in the upper pivot hole, then with the point of the upper arbor mark a center on the bush. Drill with the upright drilling tool, and finish with the round broach, as above described. If the upper pivot of the center pinion is badly cut, a new pivot should be inserted (653), and well fitted to its pivot hole.

(761) Supposing the center pinion to be sound and correct, and the pivots to be well fitted in their holes, if the leaves hit the teeth of the steel mainspring wheel on the fuzee, they should be shortened a little to clear the teeth, and the ends repolished. If the mainspring wheel is too large, that can be changed, or cut smaller. The bottoms of the teeth should only come out even with the circle of the fuzee bottom, and if they fall a hair short of that size, it will do no harm if the detent is well filled. If the chain hook touches the pinion leaves, that should be remedied as directed for the third pinion. If the leaves rub on the potance, or the pinion arbor rubs in the hole through the potance foot, dress off the potance. If the leaves rub on the lower corner of the spring barrel, either shorten them a little, or turn off the barrel at the corner, but no deeper nor higher up than is necessary to obtain clearance. If well done, it will do no harm, and not look badly. But it must not be turned off so high as to take any off where the chain runs on it, nor too near that, as it would tip over the chain at the edge. In such a case, and when the pinion leaves cannot safely be shortened down, it would be better to move the barrel out a little by altering both its arbor holes in the plates, or fit in a

smaller barrel. The lower center pinion pivot should not stick too far through its bush in the pillar plate. If it does, turn the shoulder back a little, to shorten the bearing, then repolish. The shoulder should hold the cannon pinion, so that its leaves will just clear the plate, and the top of the cannon pinion leaves should be just above the surface of the minute wheel, which will then be free from the hour wheel.

(762) *The Barrel* should stand "level" with the pillar plate, and free from the plate; from the bridge over it; from the center wheel, and its pinion; from the corner of the balance sock that sets over it; from the screws that hold the click and its spring, whether they are on the bridge or on the pillar-plate, underneath the dial; from the potance; and from the sides of its sink or hollow in the upper plate. If the barrel interferes with the main wheel teeth, it must either be turned off (761), or moved from the fuzee (761). If its top stands higher than the surface of the upper plate, and interferes with the balance, or comes too near it, (especially with a cut expansion balance,) it should be lowered, either by springing both ends, (675), or by lowering the arbor, by turning off the lower shoulder which rests against the pillar plate, and bumping down the upper hole, in the bridge. (665.) See that the barrel does not rub against the socket of the regulator. If so, the latter must be dressed off to clear, else the barrel may move it out of place and derange the timing; or work it up against the hair-spring; or make its pins touch the balance arms, and perhaps stop the watch.

(763) See that the barrel not only is level, but runs truly when it turns on the arbor. This can be tested, while in the watch, by winding, stopping at each quarter-turn of the barrel, or oftener, to see if it is still level with the plate; or so observed during the test of the chain, (772); or it can be tested when out of the watch, by winding up the arbor with the sliding tongs and letting the barrel turn slowly in the fingers, (677) taking care to press the barrel only on its sides, as, if the fingers extended over the corners, they would compel the barrel to run truly, and transfer any irregular motion to the tongs, where it would be unobserved. The better way is to test in the watch, with the chain on it. If not true, it must be made so by altering the head, (677). Sometimes the barrel will run truly on the arbor, but does not stand level with the plate. This may be caused by the arbor not being upright in the plates, or by the arbor bearings which pass through the plate holes not being concentric with those on which the barrel turns. Test by turning the barrel arbor half around in the plates. If the barrel tips the same as before, the arbor is not upright; but if it tips in the opposite direction, the arbor bearings are defective at one or both ends. Put up the arbor in the lathe, centering from the barrel pivots or bearings, and turn off the plate bearings till concentric with the former, then close the plate holes to fit them.

(764) The barrel may run "level," that is, true in the flat, but be eccentric, or not true in the round. If you can so place the head of the barrel that that end will be concentric, the other end can be trued up by filing the hole towards the full side and closing it up from the scant side; otherwise, both ends must be corrected so. Be careful to make a thorough setting up of the metal, and preserve a good bearing surface through the whole length of the hole, (678, 757). Or the holes can be plugged up, the barrel centered from the sides, and the holes cut centrally in the bushes, as described for the tooth barrel, (679). The barrel head should of course be tight in its groove, and if not it should be made so, (677). If it is warped or wrinkled, it should be made level, and if the edge is bruised or untrue, mount it on an arbor and turn off the projections and roughness; or fit a new head.

(765) If the barrel has been spread by the breaking of the mainspring, close it up by the barrel-contracting tool, sold by all dealers. The old way was to stretch the head till it would go in tightly,—leaving the barrel deformed, and deforming the head to suit it. By contracting the barrel, it can be made about as good as ever. Be careful to use a plunger large enough to cover the bottom of the barrel, when driving it down, or you may bulge in the bottom, out of shape. Or-

dinarily, the barrel should be kept horizontal while being driven down, in order to compress all the sides alike, so that the head, when sprung in, will be in the true center. But if one side of the barrel is sprung out more than the other, the former can be compressed more by inclining the barrel while closing it. Even if only one side was spread, while the other was still perfect and vertical to the bottom, by placing the sound side in contact with the side of the cavity in the tool, and driving it down in that position, the compression would evidently be confined to the other side; as the sound side would be parallel with the side of the cavity, and supported by the barrel bottom, leaving the opposite and unsupported side to relieve all the effect of the pressure. But if the side of the barrel is broken or cracked at the hook hole, it will be of no use to labor with it, as it would not be strong enough for safety, even if it could be made perfectly true again,—and a new barrel should be fitted.

(766) The barrel must be free on the arbor, having just perceptible end-shake, but no more. This should be tested with the spring out. If the end-shake is not the same when the spring is put in again, there must be some rubbing of the spring. The coils may not be true, or level, (683); or the arbor hook may not be in the center, and so hold the inner end of the spring against one end of the barrel; or the hole in the spring may not be in the middle, and produce the same effect. If so, there will probably be a mark within the barrel, showing which way the fault is. If the hook is of the right size and thickness, widen the hole in the mainspring, to let the end stand free in the barrel when the hook pulls on it. The barrel arbor pivots should be closely fitted, and if cut, should be turned down and repolished, and the holes closed or bushed, (679.)

(767) The nut or arbor center should be one-third the diameter of the barrel head; the hook should be only long enough to reach through the spring,—not project beyond it. It need not be very much undercut in front, as it will hold the spring well if the central end fits it closely, (684). A good improvement is to cut the edge of the nut in a spiral instead of circular form, placing the hook at the part nearest to the center of the nut. As the second coil of the spring passes over the end and its hook, it will have a circular support, instead of being strained over the lump or corner formed by the end of the spring, (and the hook, when that is long,) as with the ordinary round nut. This is quite important with the English lever springs, which are comparatively thick and unyielding, and would considerably lessen the danger of their breaking, if they are of high temper.

### Jottings.

We learn from a dispatch to one of our daily papers that the stock of Messrs. Koehler & Ritter, of San Francisco, Cal., has been attached for \$70,000.

Mr. John R. Greason, of the firm of Greason, Bogart & Pearce, recently purchased for a trifling sum an old dingy looking picture, which upon being restored turns out to be a genuine Rembrandt.

The retirement of Mr. C. C. Adams from the Adams & Shaw Co. is deeply regretted by his old friends in the trade. The business will continue under the management of Mr. George R. Collis.

A small package of diamond jewelry belonging to Messrs. Oppenheimer Bros. & Veith, of this city, is missing from the office of the express company. The goods in question were sent on approval, and not suiting were returned to the firm, who fortunately have a policy of insurance covering such risks, the amount of which will be promptly paid on proof of claim.

Robert Crawford of Guelph, Canada, is reported to have absconded, taking with him his stock of jewelry and leaving debts to a considerable amount. Crawford is described as a Scotchman with a broad accent, is below medium size, and has an agreeable cast in his eyes, and is said to be a good workman. He is thought to be somewhere in this city.

Marcus Kronberg, of Chicago, is in town trying to adjust his affairs with his creditors. A settlement will possibly be affected on the terms proposed by the committee. There are circumstances, however, connected with his failure which render many of his creditors loath to accept such terms.

## Legal Regulations for the Standard of Gold and Silver Ware in the Different Countries of the World.

BY EDWIN W. STREETER.

WITH regard to the defence of legal regulation of precious metal ware in the form of compulsion to alloy the upper and middle standards, that it will lead at last to impossibility of manufacturing precious metal wares of very low standard, whose worth is lost with the destruction of the form of the article; even this ground for the proposal under consideration does not hold good, in our opinion. It implies that the small quantities of gold and silver which escape by friction in the mechanical working of these metals are lost; but this is not true, except as to infinitesimally small particles. For buyers of old gold and silver at the highest price are always to be met with, and any one having a remnant of a chain or other trinket, of however low a standard, can always sell it. This is owing to the fact that the art of refining has advanced at a great rate, insomuch that one nowadays is able to extract minute specks of gold and silver even out of the most heterogenous matter. The goldsmiths are accustomed to sweep their workshops out once a year or thereabout and to send the sweepings to so-called refiners, that the gold and silver dust may be extracted by them.

In the next place, the wildest possible extension of the use of precious metal ware, which is paralyzed by legal restrictions but encouraged by freedom, is to be regarded as advantageous to the wealth of the people; because we must remember that the trade in gold and silver ware represents one of the most suitable investments of superfluous capital. In the purchase of precious metal ware a satisfactory result is ensured to both those aims which it is usual to keep in view in the investment of capital—viz., security and proportionate interest. The best security at all events of the investment of a limited capital is, as in this instance, the possession of one's own property; while the interest is fully represented in the beautifying of existence which we owe to gold and silver ornaments and gold and silver plate. Since the public takes so much pleasure in precious metal ware, such an outlay of capital obtains the importance of a very alluring investment for spare cash. The use of precious metal ware, so loudly decried, positively serve to augment the savings of a nation.

Oriental, therefore, and all other nations who are not able to invest their capital with security, have done well to decide upon investing it in precious stones and gold and silver ornaments, "And yet," as Count von Moltke, with much insight into national economy, remarks, "Such nations indicate by the very abundance of their ornaments how poor is their wealth as a nation."

However, they have made a virtue of necessity. As a further argument in support of the fact that the use of precious metal ware is conducive to the wealth of a nation, we may add that in proportion to the hold obtained by precious metal ware will the sale of ornamental goods made of the inferior metals and low qualities of gold diminish. The working power is therefore preserved to the nation, which would otherwise be wasted in the manufacture of trifles.

It is to be further noted that ornaments made of precious metals are generally preserved with greater care than the perishable, worthless goods known under the name of "Quincaille," and also that fashion is far less capricious in jewelry than in these less important articles. Whoever possesses a golden ornament, if of 18-carat gold, knows himself to be worth its value, £3, 3s. 8½d. per ounce. He is independent of the mutations of fashion.

Few persons are in a position, or even have the wish, to be guided by the fashions of the gold and silver manufacturers. On the contrary, in many families old-fashioned silver is used in preference. If government regulations of the standard of gold and silver is defensible neither on the ground that gold and silver are also made use of as money, nor because silver plate formerly answered as a measure of value, nor because the public either claim protection on account

of the high value of precious metal goods, or have a difficulty in deciding the standards, nor, finally, because advantage might accrue to the wealth of the nation, then, on the whole, it is not required at all. For no other arguments have been produced in favor of legal regulation in this department, and we claim to have proved that no reason exists for deviating from the rule in this particular of gold and silver ware, which rule is the non-interference of the State with trade.

If we ask the reader to follow us still further, it is because we are convinced that the public, in the formation of its views, is not decisively influenced by the evidence of non-justification. Let us, therefore, return to experiment, and assume that neither the inductive proof which we sought to establish in Section 4, nor yet the deductive method argued in this section, has overthrown the principle of legal regulation of the standard of gold and silver ware; and let us ask:—

What methods have been applied or proposed in order to render possible the legal regulation of the standard of gold and silver wares; and what actual or conjectural results does the application of these methods yield?

Those government rules which lay upon the manufacturers of gold and silver ware a compulsory degree of one or more standards are called, in the Austrian reports, *Imperative-preventive Control*, and for the practical working of this control, government offices are erected for the purpose of testing the manufactured gold and silver wares and of providing them with the government stamp. This is the system employed in Austria. The authorities at the Imperial Stamping Office in Vienna have had the goodness to supply us with a statistical report of the precious metal ware which had passed through the office in Austria from 1867 to 1873. This report shows that the entire weight of stamped precious metal ware increased from '67 to '72, but decreased in '73. The entire weight stamped of gold and silver in lbs. troy, for these several years is as follows:—

	Gold Ware.	Silver Ware.
1867.....	3143'6715.....	33904'412
1868.....	5718'0020.....	56516'526
1869.....	6915'4038.....	60480'822
1870.....	6868'5030.....	58709'914
1871.....	8566'5005.....	70992'130
1872.....	10353'8170.....	91783'805
1873.....	10223'9881.....	87067'221

The director, in sending these figures, remarks:—"It is to be concluded from the dates contained in this statement that the present stamp law of the Imperative-preventive Control, and the principle on which it is grounded, have had a very serviceable influence upon the development of the gold and silver trade, and upon the credit of the Austrian gold and silver ware."

Upon this we must observe that to all appearance the figures embrace the foreign as well as the home stamped precious metal ware, and that therefore no conclusion can be drawn from them as to the influence of the system upon the precious metal trade of Austria. Supposing even that in these figures the precious metal ware coming from abroad was not included, still the increase of the entire weight of precious metal ware stamped in Austria under the control system has to be considered side by side with the rise or increase of the same trade in other lands where the control system is different. And that the import of foreign ware must and does play a considerable part in Austria is proved by the following notice of a member of the Chamber of Commerce in the year 1871. The Secretary of the Chamber of Commerce who has sent it to us, tells us that the views contained in it may still be relied upon.

The stamp law, which came into operation on the 1st of January, 1867, from which the tradesmen of Vienna fully anticipated a permanent rise of business, has not fulfilled their expectations, but rather produced all the disadvantages which were predicted by us at the time in repeatedly delivered opinions.

Foreign competition, the suppression of which was the real motive

of the Viennese petitioners in demanding an official stamping, while the protection of the public from fraud was the ostensible pretext, is more active than before; and the import increases visibly, because the trade of Pforzheim, Gmunden and Hanau very soon accommodated itself to the Austrian stamping directions.

Besides it was easy to foresee the importer of manufactured goods has a considerable advantage over the home producer, when one remembers the vexatious determinations of the law, which can be, or rather must be, carried out in the case of the home productions, but which cannot be closely observed in the finished goods. The importer, again, risks nothing in the attempt to introduce goods contrary to prescription, except the return of the same, while the home producer has all goods of insufficient standard destroyed, by which operation he becomes a loser to the extent of the cost of their manufacture.

Home trade is further confined to the large towns principally; generally to Vienna and Prague, where the law is carried out in well-organized offices by officials trained to the business. But in the smaller towns, where gold and silver workers are installed as chief testers (of whom, to say the least, we may assert that they are not trained to the work), much ware is passed for the importer which does not comply with the law, and with which the home manufacturer cannot compete. This, however, is not the place to consider this point more closely, nor would the removal of the disadvantages be practicable even if we could, for the government cannot establish well-arranged stamping offices in all such places without keeping upon their paid staff a large number of insufficiently occupied officials, and so largely increasing the burdens.

In the Hungarian countries, also, the law appears not to be of advantage to the native industry, for it is impossible to compete in Hungary with the wares of Pforzheim, where it is difficult to meet with ware answering to the legal prescriptions, even among that legally imported. These are expressive facts the causes of which are not difficult to discover.

The first of the numerous difficulties which can be raised against the compulsory control of the State consists in the question whether the charges inseparable from the enactment of such regulations bear any proportion to the advantages, if any such were possible, that the public receive against fraud. These charges are in many countries very large. None are so small as in Lucerne, where *each* of the two testers receives yearly the sum of four francs.

In Austria, in 1867, the testing fees were 76,049 florins; and in 1871 they were 198,758 florins. But far more than the figures of cost do the prohibitive regulations weigh, which are inseparably connected with the imperative preventive control of the standard. These regulations find expression in two different ways. First, there is the fact that compulsory preventive control can only promise a good result if at the same time precautions are taken that no precious metal wares be imported which have a lower standard than that fixed for home manufacture. Otherwise home industry would be prejudiced in the highest degree. Consequently, compulsory preventive control by the State must inevitably be followed by protective regulations directed against foreign competition in the interest of home industry; and thence arises the disadvantage that the public will be able, neither at home nor abroad, to provide itself with precious metal ware to its liking.

Secondly, compulsory preventive control has had the disadvantage in many countries—France, for example—of compelling the framers of the law to define certain degrees of standard for precious metal ware destined for exportation. How can this be done? If of the same standards for home, the good repute of the precious metal ware abroad is lost; and, if this be their sole object, the unfairness to those at home is evident. But however this may be, it is clearly perceptible that legal regulations which confine an industry so closely in the chains lead to the most obnoxious results. If the framers of the law prescribe certain standards for precious metal ware destined

for abroad, then the precious metal industry is forced into deceptive courses which must lead them, in the natural order of things, to deviate from these regulations. As, however, the interests of one industry cannot be disconnected from those of the whole community, it follows that, if the precious metal industry descend to deceptive and crooked ways, the whole collective industries of the country suffer with it, and are equally degraded.

As a further disadvantage connected with compulsory preventive control, we must cite the fact that manufacturers of precious metal ware could not escape burdensome oppression from the application of control of this kind. Least of all will those manufacturers escape who do not live in the great centres of this industry. As it is impossible to have control establishments in all places, they must either send their ware to the nearest control office, often with serious loss of time and money, not to mention the great risk, or else seek a dwelling in the neighborhood of a control office. Quite apart from the sacrifices which must result to individual manufacturers, the framers of the law give rise to a grouping of industries of this nature—a grouping which cannot be for the interests of the country. This aspect of the question, however, is of much less importance in the case of the precious metal industry than in that of other crafts, since the headquarters of the goldsmiths' art have always been confined to the seats of riches and luxury, and therefore to a very few places.

It would be a disadvantage of the most serious kind to compel the goldsmiths of small towns to shift their quarters to the departmental capitals or to give up their occupation, since for many of them there would be no alternative. Again, the buyer of a gold or silver article, if he live in a small town without a control station, will have to give a larger sum for it than if he bought it in one of the larger towns, because the expense of the transit of the article backward and forward to the office has to be made good to the manufacturer, and therefore the buyer will prefer to make his selection in the capital, where he will have a greater choice and less expense.

In spite of the fact that those gold and silversmiths who live in the center of their craft enjoy the possible advantage of having a control office on the spot, they are beset by manifold burdens in consequence of compulsory preventive control. For it is quite clear that extraordinary laws have no prospect of being obeyed unless they are accompanied by extraordinary means of enforcement. Hence we find—in France, for example—institutions for the inspection of shops and workshops, of the burdensome nature of which we need offer no proof, the character of the system being sufficiently indicated by its name.

The petition of the German Silver manufacturers, which has been often referred to, ignores the rules which would be necessary to secure the execution of the proposed law. It is evident, however, that although it would be scarcely possible to introduce an inspector of shops and workshops in the German Empire, still the control offices in the three great neighboring States of the empire could not well be dispensed with if legislation were to decide upon making a definite degree of standard compulsory. Were it desirable to renounce the control offices, it must be observed that the State cannot avoid heavy punishments for the transgressions of its laws upon standard, if the law is not to remain a dead letter. But then what a government rod would the person who signed the petition in question have laid up for themselves! The wish was to gather roses, but their thorns were forgotten. A workman whose time is precious, and who has not at hand the can containing gold of the standard demanded by law, makes use (perhaps *merely* through error) of gold of a lower standard. Where is here the boundary between oversight and fraud? Might not a similar case happen to every manufacturer of precious metal ware? Does not each one, then, stand daily in danger, not only of being sentenced to severe punishment, but of injury to the highly-prized reputation of his firm?



Alloys of Gold.

**G**OLD, the base of all artistic adornment used by our craft; the elegant drapery in which the public demand our minute horological machines shall be clothed; its beautiful rich color, so capable of fine artistic effects; its density and compact grain, susceptible of the most exquisite polish; its wonderful malleability and ductility, eminently qualifying it for the skillful manipulations of the engraver, enameller and chaser; its almost total exemption from corrosion, defying the strongest simple acids,—give it a just claim to the title “regal;” and right majestically does it tower above its fellow-metals in gravity, ductility, malleability and permanency.

Want of space, as well as a rigid adherence to alloys used in the trade, forbid our going into the intensely interesting details of its history; the operations of mining and refining; the sources and annual amount of production from every quarter of the Globe—iron being the only metal exceeding it in general distribution.

Alloys of gold form the basis of nearly all metallic ornamentation, leaf gold and gold foil being the only forms in which the pure metal is used; all alloys debase it; on the contrary, it confers upon the baser metals intrinsic value, as well as useful properties. Coin, the basis of all mercantile transactions, and the unit of measure for all values, is an alloy, the composition of which is determined by governmental enactment, based upon their several necessities.

The quality of gold alloys is measured by the term karat, or carat; frequently the simple abbreviation K is used. It is said to be derived from the name of a bean, the produce of a species *erythina*, a native of the district of Shangallas, in Africa, a famous mart of gold dust. The tree is called *kuara*, a word in the language of the country signifying sun, because it bears flowers and fruit of a flame color. As the dry seeds of this pod are always of nearly uniform weight, the natives have used them from time immemorial to weigh gold. The beans were transported into India at an ancient period, and have long been employed there for weighing diamonds. The carat of the civilized world consists of 4 nominal grains, a little lighter than 4 grains troy—it requiring  $74\frac{1}{6}$  carat grains to equipoise 72 troy grains. In estimating or expressing the fineness of gold, the whole mass spoken of is supposed to be divided into 24 equal parts, and the number of those parts that are fine gold determines the quality. If 16 of the 24 parts are fine gold, and 8 are of baser metal, the quality is 16 k. If 22 parts of a mass are of fine gold and 2 parts base, the mass is 22 k. fine. Fine gold, that is chemically pure gold, is divided into the same 24 parts, and as each part is pure gold, the mass is 24 k. fine. Half fine gold and half base metal is 12 k. fine. The money value of the base metal added to reduce the quality of the gold, does not at all enter into the determination of the quality of the alloyed mass. Whether we add silver, or brass or copper, or a mixture of all these, the number of parts of pure gold is the quality of the mass. Intrinsically the value of 12 k. gold, alloyed with silver only, is greater than 12 k. gold alloyed with copper, by the difference in price between silver and copper, but both alloys are 12 k. fine.

A new and more intelligible nomenclature has been recently adopted by the governmental assayers. Gold or silver which is chemically pure, is called 1,000ths fine; it being understood as consisting of 1,000 parts of pure metal. If 500 parts be gold, and 500 parts some other metal, the alloy thus formed is said to be  $\frac{500}{1000}$  fine, which is equivalent to 12 k. of the old nomenclature. To reduce the quality of gold, as expressed in carats, to 1000ths, it is only necessary to know that there is 41 2-3 thousandths of fine gold in one carat; and the number of carats multiplied by 41 2-3 gives at once the thousandths fine; conversely, to convert carats into thousandths, it is only necessary to divide the 1000ths by 41 2-3.

The present standard in the United States for gold coin is  $\frac{900}{1000}$  fine. The 100 parts alloy is copper and silver, and at least 50 of the 100 parts must be silver. Before July, 1834, the gold coin was  $\frac{916\frac{2}{3}}{1000}$  fine, the “Eagle” weighing 270 grains. From that date to January, 1837, U. S. coin was  $\frac{899\frac{1}{4}}{1000}$  fine, the “Eagle” weighing 258 grains. Since then it remains at  $\frac{900}{1000}$ , the “Eagle” weighing 258 grains. The following table shows the quality of such foreign coins as are usually met with:

Australia Sovereign, 1855-60.....	916 fine.
Austria, { Ducat.....	989 “
{ Souverain.....	900 “
Brazil, 20 Milreas.....	917.5 “
Central America, 2 Escudos.....	853.5 “
Chili, old Doubloon.....	870 “
Englanv, Av. Sovereign.....	916 “
France, Av. 20 Francs.....	899 “

North Germany, 10 Thaler.....	895 fine.
South “ Ducat.....	986 “
Italy, 20 Lire.....	898 “
Mexico, new Doubloon.....	870.5 “
Netherlands, 10 Guilders.....	899 “
Peru, Doubloon.....	868 “
Prussia, 10 Thaler.....	903 “
“ New Union Crown.....	900 “
Russia, 5 Roubles.....	916 “
Spain, 100 reals.....	896 “
Sweden, Ducat.....	975 “
Turkey, 10 Piasters.....	915 “

It is a matter of considerable importance to the jeweler to know the quality of the various gold alloys in which he deals. Assaying is the only process for obtaining such knowledge, and to arrive at truthful and economical results requires the best chemical knowledge and the most careful manipulations. Two ways are practised by assayers, one called “parting,” by dissolving the alloy by acids and recovering the separate metals by precipitation, the other by cupellation. This is founded upon the feeble affinity which gold and silver have for oxygen, in comparison with copper, tin, and the other cheap metals, and on the tendency which the latter metals have to oxidize rapidly when in contact with lead at a high temperature, and sink with it into any porous earthy vessel, in a thin viriform state. The porous vessel is made of wood ashes, free from soluble matter, or from burned bones reduced to fine powder.

It has been found by experiment that 16 parts of lead are sufficient to pass one part of copper down into the cupel, and  $\frac{3}{10}$  of lead will pass one of silver. The cupels allow the fused oxides to flow through them as through a fine sieve, but are impermeable to the particles of metals; and thus the former pass readily down into their substance, while the latter remain upon their surface; hence the liquid metal preserves a hemispherical shape in the cupel, as quicksilver does in a glass cup, while the fused oxide penetrates their substance like water. Long practice and delicate trials can alone guide to the proper quantity of lead to be employed for every various state of the alloy. The most expert and experienced assayer by the cupel, produces a series of approximate conjectural results which fall short of chemical demonstration and certainty in every instance. This mode of assaying depends so much on the variable temperature, the unknown proportion of copper, and the mere judgment of the senses, that it has been mostly superseded by the humid process, which has all the precision that can be desired.

Assaying is not refining of gold; it is simply taking a very small fragment of a homogeneous mass of alloy, and operating upon it to determine its intrinsic value—that is, the quantity and value of whatever metals may be contained in it. Refining, on the contrary, is operating upon the whole quantity, and separating and recovering the whole of the metals in a pure state. It might be interesting to some to detail these processes, but would be of no practical value, as no one, without proper facilities and the greatest experience, could operate successfully. The custom now is to send to the United States Mint, or any branch office, or to some reliable assayer. For a small fee, an assay, truthful in result, can be had; or, if gold is to be refined, send at once to a professional refiner, and the pure metals are returned to you at an expense far less than it is possible to do it yourself, even were you capable.

As very many of our readers are obliged, by the necessities of their location, to do a little of everything, combining the occupation of jeweler with that of watchmaker, a few rules, with illustrations will be given, which will enable them to produce any quality of alloy desired from such material as they have at hand, without being obliged to resort to either assayers or refiners. Gold coin—whose quality is known—and a set of “test needles,” are the basis of all the operations of compounding. Test needles can be had of any assayer, and are usually for sale by material dealers. They consist simply of eight or ten little slips of metal, on the end of each of which is soldered a piece of gold of known quality, from 6 k., 8 k., 10 k., up to 22 k. Such a set of test needles are exceedingly useful in a shop where there is constant inquiry as to the quality of gold articles; and, in the present advanced state of alloying, it is not safe to pronounce an opinion as to the quality of gold, by simple inspection—color being, in such cases, the principal guide to judgment. With these, and a piece of black basalt, or a piece of black slate-stone, which is a very good substitute, and a bottle of good nitric acid, very correct judgment can be formed of the quality of a gold alloy.

Rub the article to be tested upon the stone till you have a bright metallic spot or stripe; by the side of it rub off some of the test needle which you supposed to be the same quality, then apply to both

spots at the same moment a drop of the acid. The inferior quality will first change color under the action of the acid, or if the quality be very low, both metallic streaks will disappear almost as soon as the acid is applied. In that case, the spot to first disappear is the poorest quality. Try your needles higher and lower, till one is found whose action under the acid is the same as the alloy under inspection; 18 carat and upward will require "aqua regia" as the test acid, because nitric acid does not act upon gold of that quality, and would give no indications by change of color. With a very little practice very correct results can be arrived at by these tests, and the error in all ordinary transactions will be trifling. This method has the additional advantage that the test can be made in the presence of the customer, who can see for himself that it is truthful, and that he is not the victim of deception, and there is no class of tradesmen who are so dependent for success upon their reputation for honest dealing as jewelers. The opportunities for cheating are so great that the public are quite too willing to suspect, and even accuse the trade of "ways that are dark and tricks that are vain."

In connection with inquiries as to quality of gold, there is always the additional question, "What's it worth?" Pure gold, at the United States Mint, is valued per oz. troy at 20,67.184368; and to find the value of gold per oz. of any degree of fineness expressed in 1000ths, multiply the above amount by the number of 1000ths. Example, 1 oz. gold  $\frac{900}{1000}$  fine is worth  $20,67.184368 \times 900 = 18,604.651212$ . Pure silver, 1000ths fine, is valued at the United States Mint per oz. troy at 1,34.444 + or 1,34 $\frac{1}{2}$ ; and the value for any other fineness is found by the same rule as for gold.

The subject of alloying gold in the proper proportions, to obtain some desired result, either of quality or value, has probably puzzled practical jewelers more than any other one thing; and the dozen of different qualities of goods, all warranted the same fineness, places the compounders of those alloys among that class of tradesmen who wish to "deceive," or who "don't know." It is no uncommon thing to see a practical melter go nearly distracted over the query of how much of this, that or the other thing is required to produce this, that, or the other quality. His dilemma results from the want of a little mathematical knowledge, and which he might acquire in the time he is scratching his puzzled head for solutions of his problems. This may be one reason why jewelry, guaranteed by houses that are called "first class," shows such a diversity of quality as to lead inevitably to the presumption that they are really ignorant (assuming their honesty) of the real fineness and value of their wares. Such discrepancies in the statement of qualities is probably the basis of the wide-spread and almost universal suspicion with which all such statements are received; and a customer's countenance often says, "perhaps that's so," when his politeness refuses to put the suspicion into words.

### Courtesy a Business Requisite.

*Editor Jewelers' Circular:—*

Your article in the January number of the CIRCULAR entitled "promptness a business requisite," suggests a heading to this letter of "courtesy a business requisite," and beneath it I would plead that ordinary courtesies be shown to that much misused class, the Jewelry Commercial Travelers.

The jewelry trade of the country is, as a class, esteemed by other classes of merchants and people—a refined and courteous body of men, and the salesmen are among the most considerate and obliging to their customers; in all the larger cities the members of the trade and their employes have the *entree* to the best society of their respective localities. The intimation that one is a jeweler, accompanying an introduction to a stranger, has generally the effect of impressing the stranger that he is meeting a gentleman of standing in the community, and such impression is generally proven correct and in accord with his urbanity and affability. A well-bred considerate gentleman is the same gentleman under all circumstances, and the only purpose of this communication is to show that in some cases the said gentlemen are not *the gentlemen* they would be under other circumstances.

Now I do not propose to charge the trade or jewelry buyers at large with inconsistencies or discourtesies; for, upon reading this, many of the travelers will call to mind several gentlemen with whom they come in business contact, whom it is a genuine pleasure to call upon, whether the call results in an increase of sales or not; but it is the constant experience of the gentlemen who represent our manufacturing and jobbing houses on the road, that the courtesy and affability which characterize the department of storekeepers whilst acting as salesmen, is sadly lacking when their attention is diverted to the

traveling salesman, who patiently awaits their leisure in order to introduce himself or his goods. When a traveler enters the place of business of a jeweler, the natural inference should be that he enters for a business purpose; such being the case, he should be entertained, and his purpose of calling (if he does not immediately make it known) learned with business promptness.

Has it ever occurred to the jewelers throughout the country, that the expenses of a traveling salesman, exclusive of his own salary, will average one dollar for each hour during which he can transact his business? Each hour which he is kept waiting, causes a loss to the salesman's employers of at least one dollar, which could as well be saved by granting an interview at once, and deciding whether the buyer will look through his samples or not. The question of buying is a secondary one; the traveler does not feel that he has done his duty to himself nor his house at home, until he has at least placed his goods or samples before the buyer. In many cases the buyer will dawdle away sufficient time to have looked through the goods of the traveler, and thus have satisfied him, saved the time of both, and have seen perhaps some new styles of goods, or learned prices of which he did not know before.

It will be said, doubtless, that travelers are urgent, persistent in their efforts to secure attention and consequent sales, and if the buyers bought of each one of the number of travelers who present themselves, that they would buy themselves into bankruptcy; but *per contra*, if the same decision be shown in refraining from buying when urged, which is shown in being ready to meet the traveler half-way in his advances, the traveling men are possessed of sufficient acumen generally to stop short of offensive persistence in crowding their goods upon the buyer.

There are buyers who, through the very firmness of their adherence to courteous treatment of travelers, save themselves many of the annoying features of the system of commercial traveling. I might mention several whose names are almost synonymous with courtesy, who when complimented for their politeness to the traveling fraternity state, that their stores are their reception rooms for business men, as truly as their parlors or drawing rooms serve the same purpose for their society friends. Who can ever forget the pleasure experienced after a call upon Mr. Franklin Butler, years ago, in Philadelphia? One could walk smilingly out of his store without having transacted a dime's worth of business; would that he were still living as an example to some of our younger upstarts. Can it be that the jewelry trade of the country lacks the refinement and consideration of the feelings of other men which prevailed in the trade when the present heads and members of firms were "on the road," years ago? We did not then so often hear the expressions which are now so current among travelers: "A— is no gentleman;" "I have been in B—'s store for the last time;" "If I had been a match pedler C— couldn't have used me worse;" "Did not my duty to the house I represent oblige me, I would never call on D— again;" "when E— appoints certain hours during which he will look at goods, he should at least be on hand during those hours and not keep us waiting."

There are no harder working, more enduring, less complaining men in the country than these commercial travelers. They are required to transact a counting-room or salesroom business without any of the conveniences usual to such places, while at the same time experiencing all the annoyances and deprivations of travelers. When the storekeeper closes his business and goes home to his family, the traveler packs up his trunk and takes the night train for the next city, where, as if he had been luxuriating all night upon a bed of eider down, he appears bright, cheerful and urbane, and ready to furnish the goods with which you trade and make your living, together with the news and gossip of the city he has just left. He must ever be bright, hopeful, never depressed or low spirited, even if his sales are but half the footing of his previous trips. It certainly requires no small effort to be affable under all the strain, mental and physical, which he is required to endure, and the wonder is that he is not oftener discourteous to the storekeeper than the latter is to him.

I hope these few expressions may show to those for whom they are intended, that it will be to their interest as men, and their credit as gentlemen, to facilitate rather than to hinder the traveling salesman in the pursuit of his calling. If the usages of civilized society do not sufficiently demand from the host, courteous treatment of him who comes under his roof, if but for a few moments, the buyers will be at least interested to learn that the less the time of the traveler wasted, the less the expenses of traveling, and the less the cost of placing the goods in his store.

SENEX.

MARCH, 1878.

## Historical Sketches of Jewish Trade.

THE connection of the Jews with the pottery and glass industries dates back almost to the earliest periods of which we have any credible record. Both pottery and glass are referred to many hundreds of times in the Bible, and not only are the industries and its results particularly mentioned, but they very often serve symbolical purposes in the poetic imagery of the prophets, which in itself is conclusive proof of the general familiarity of the people with them. In the early days of which we speak, the periods which preceded and succeeded the life of Moses, the independent commercial importance of the children of Israel was not great, although before their slavery in Egypt they must have taken a very prominent part in the commerce of that land. But even considering the subordinate nature of their general trade, they seem to have been prominently connected with the pottery and glass industries. Nor is this surprising. The matrix of the pottery industry was Egypt, with the commerce of which in every branch we have already shown that the Jews must have been intimately associated, and glass was made not only by the early Egyptians too, but also by the Phœnicians, who for so many years worked peaceably with the Jews in all commercial affairs. We are distinctly told in Holy writ that during the Egyptian captivity the children of Israel were employed in "brick making," and Sir Gardener Wilkinson has shown in his work on the "Ancient Egyptians" that this name was employed not only to indicate the manufacture of bricks, but also that of pottery. It is, therefore, very probable that at least in the manufacture of the humbler species of pottery the captive Israelites were largely employed, and this will explain the contemptuous manner in which potters are spoken of in several passages in the Bible. It is easily credible that the manufacture of pottery was associated with some idea of social degradation, when we find the phrase "being amongst the pot herds," so often used to indicate a low social status; and this interpretation too may probably explain a passage in the Psalms which says that "though ye have lien among the pots, yet shall ye be as the wings of a dove covered with silver, and her feathers with yellow gold" (Ps. lxxviii. 13). There are many passages, on the other hand to be found amongst the writings of the latter prophets, which seem to convey a higher idea of pottery, and which are written with a facility and glibness only possible to a people amongst whom the manufacture of pottery had become almost a national occupation. Especially in symbolical phraseology is this the case. The processes and work of the potter are constantly instanced as apparently the nearest and popular similes. Thus Isaiah (lxiv. 8) exclaims, "But now, O Lord, Thou art our Father, we are the clay, and Thou our potter, we all are the work of Thy hand." The same species of imagery is also used by the same prophet to inculcate great moral lessons. It is said (Isaiah xlv. 9), "Woe unto him that striveth with his maker! Let the pot herds strive with the pot herds of the earth. Shall the clay say to him that fashioneth it, what makest thou? or thy work, he hath no hands?" Jeremiah makes a still more striking reference to pottery in the promulgation of the doctrine of the omnipotence of God than which probably no religious lesson is more important, and which of necessity must have been taught with the assistance only of the most comprehensible phraseology and symbolism that a simple people could appreciate. It occurs in the eighteenth chapter of Jeremiah, and it says: "The word which came to Jeremiah from the Lord, saying, Arise and go down to the potter's house and there I will cause thee to hear my words. Then I went down to the potter's house, and behold he wrought a work on the wheels. And the vessel that he made of clay was marred in the hand of the potter; so he made it again another vessel, as seemed good to the potter to make it. Then the word of the Lord came to me, saying, O house of Israel, cannot I do with you as this potter? Saith the Lord, Behold as the clay is in the potter's hand, so are ye in mine hand, O house of Israel." It is, indeed, difficult to show what par-

ticular part the early Israelites took in pottery industries of remote antiquity, but these quotations tend to prove that the manufacture to which we allude was something more than merely known amongst our forefathers. It is demonstrable that during their Egyptian captivity they must have taken part in their Egyptian pottery, and on this head we believe the circumstantial evidence is complete. It is equally proved by the familiarity of the Hebrew prophets with the processes of manufacturing pottery, and the numerous occasions on which they have instanced these processes for metaphorical purposes in appealing to the popular mind, that the pottery industry must have largely employed our ancestors; and, therefore, when we are asked what was the position of the Israelites in the pottery industry, we should say that being possessed of the technical knowledge of both the Egyptians and the Phœnicians, they made all the clay and earthenware utensils that they required themselves. This will sufficiently explain the passage we have quoted; had the children of Israel done more than we have indicated, they would assuredly have left some lasting evidence of the extent of their industry.

If there are Scriptural texts which would seem to convey that the manufacture of pottery amongst the early Hebrews was associated with some idea of degradation, and which, consequently, are evidence that our forefathers were employed in making only the common pottery, it seems to us that the other biblical verses we have quoted, in which the deity is not seldom compared with the potter, show some appreciation of a higher state in the pottery manufacture. However that may be, whether the Israelites were employed in Egypt in making fine pottery or not, it is indubitable that in the shape of their knowledge of the glass industry they carried off from Egypt a very complete acquaintance with the manufacture of the finer species of Egyptian pottery. The fusion of glass was well known to the Egyptians during and before the period of the bondage of the children of Israel, and this process must have been closely connected with the pottery industry, for many of the vases and fictile ornaments made by the ancient Egyptians were glazed over with a vitrified substance containing the proper proportion of the ingredients for making glass. But it was not only in this embryonic form that the followers of Moses made the acquaintance of the glass industry in Egypt. The specimens of Egyptian beads preserved in the different museums of Europe show that in the days of Moses a very high state of perfection had been reached by the Egyptian glass industry. In some of them colors are blended with more exquisite skill than in any specimens of modern art with which we are acquainted. There is biblical evidence that these beads, both round and oblong, were used by women in the time of Moses for ornamental work, in the same way as they are now used in embroidery. The Israelites seem also to have learnt from the Egyptians the art of making imitation gems of glass, for there can be no doubt that the onyx, so often mentioned by Moses as necessary in the equipment of a priest, was nothing more than cut glass. The same may be said of crystal, which was put forward in the Authorized Version as the translation of *sekukith*, because at that time the antiquity of glass had not been so conclusively proved as in our times. Moses orders that the onyx stones which were placed on the shoulders of the Ephod should be engraven with "the names of the children of Israel," and he says distinctly that these engravings shall be "like the engravings of a signet." Now it is a fact that Egyptian seal rings are made of glass, because the impressions could be carved more easily upon this substance than upon stone; and it is therefore probable that not only was the Mosaic onyx of glass, but that the children of Israel in their exodus carried off with them a valuable knowledge of the glass industry which must have been of inestimable value to them in their subsequent dealings with the Phœnicians. The best evidence, however, that the practice of making objects in earthenware and glass existed amongst the early Israelites is contained in the commandment which refers to graven images. The practice of making such images is distinctly Egyptian, for in the land of the Pharaohs, armlets, fetishes, and other instruments of idolatry were almost invariably made of glass or porcelain.

That the Jews were, during the period of their national existence, closely connected with the manufacture of glass, is proved by the numerous references which are made to it in the Talmud. These references prove indubitably that the Jews were amongst the first to carry the manufacture of glass abroad, for we are told distinctly that they were the first glass-blowers in Rome (Shabbat, Jer. 7. 2). In Kelim, 8, 9, there is every detailed mention of the construction of ovens necessary in the manufacture of glass. In Tas. Midda c. 9, colored and white glass are referred to. One very astonishing incident in the Talmudical references to glass manufacturers is the colossal size and multifarious character of some of the objects which it is stated were made of glass. In Kelim 30, 1-4, we are told of a table, large, medium, and small size dishes, looking-glasses, spoons, large goblets, capacious tuns and small flasks—all of glass; In Kelim 11, 8, a species of lace work made with glass beads is mentioned; and in the same work we find a mythical obelisk sixty feet high described as being composed of glass. In other portions of the Talmud candelabra, beds, chairs, forms, pedestals, scales and weights are also mentioned as having been made of the same ubiquitous material. It is stated, too, that glass was sold by weight, and merchants and manufacturers are constantly referred to in the great work to which we refer.

It is a very curious coincidence—deserving of some record—that notwithstanding the high state of perfection which the Phœnician glass industry reached, no such connection can be traced between it and the Jews, as between the latter and the Egyptian glass manufacturer, and yet the materials prescribed by Moses for the composition of the Ephod were all distinctly Phœnician. “And thou shalt make the ephod of gold, of blue and of purple, of scarlet and fine twisted linen, and thou shalt take two onyx stones,” etc., etc. All these materials were in ancient industry more identified with Phœnicia than Egypt, for we have it upon authority of both Ezekiel and Homer that Sidon was famed for all these materials. This coincidence might be made the subject of an interesting archæological investigation.

### The Thermometer.

*Continued from February Number.*

THE Rumford medal of the Royal Society was awarded to Professor Daniell for the invention of his pyrometer. It is, perhaps, the best we have, but it is very little used. A simple, reliable and practically convenient pyrometer is still wanted.

The cause of our sensations of heat was formerly described as a subtle imponderable fluid, to which the name of “caloric” was given. It is now regarded as an activity of matter itself, or by some highly imaginative mathematicians, as the activity of a supposed ethereal and very vivacious something surrounding the supposititious atoms, or molecules of matter.

I cannot discuss these theories here, and only name them to indicate that the temperature measured by pyrometers and thermometers is not the heat itself, but one of its most obvious effects. If the rise or fall of temperature were always proportional to the quantity of heat transmitted, temperature would serve as a measure of heat, but such is not the case. The amount of heat force demanded to raise 1 lb. of water 1 deg. will raise 1 lb. of mercury or platinum 30 degs., or 1 lb. of iron 10 degs. If 1 lb. of mercury at 70 degs. be agitated with 1 lb. of water at 39 degs., the temperature of the mixture will be 40 degs., the mercury having lost 30 degs., in raising the water 1 deg. With equal bulks the mercury will lose more than twice as much as the water gains.

If two thermometers, with blackened bulbs, and of the same size, be filled, one with mercury and one with water, both raised to the same temperature, and equally exposed to radiate and thus cool down, the mercurial bulb will cool down twice as fast as the water

bulb, though both gave out equal heat in equal times. In like manner, if both were exposed equally to some steady source of heat, such as the flame of a small lamp, the mercury, while absorbing the same amount of heat as the water, would gain more than twice as much temperature. The temperature of one body is therefore not a heat measure as compared with the temperature of another.

Some kind of work demanding a constant expenditure or exertion of heat force, is required for measuring quantities of heat, or “calorimetry,” as it is termed.

The thawing of ice, the boiling of water, under stated conditions, or simply the raising of the temperature of a given quantity of water, are conveniently used for this.

I have here a calorimeter, invented by Mr. Lewis Thompson, and constructed with its appliances by Mr. Jonathan Wilkinson, of Grimsthorpe, Sheffield, which is of considerable practical value and deserves to be better known than it is. Gas engineers understand and use it, as it is described by Mr. Samuel Clegg in his classical treatise on gas-making. I have used it myself in Sheffield and found it practically satisfactory. I had to send to Sheffield for this, not being able to get one in London.

Its purpose is to determine the calorific value of any given sample of fuel, coal, wood, coke, charcoal, gas tar, petroleum, refuse, etc., by simply burning a fixed quantity of the fuel under a fixed quantity of water, and measuring the heat resulting from its combustion by the rise of temperature of the water.

### The Ceylon Sapphire.

IT is reported from Ceylon that two little boys of that place have found a sapphire weighing two pounds, at worth at least \$50,000. If we may believe the ancient notion that supernatural influences are imprisoned in precious stones, then the gem that these two Cingalese lads have picked up might, if properly engraved, be used as a panacea for all the ills that ever effected modern mortals. It is not surprising that the largest sapphire yet known should have been found at Ceylon. The island has for ages been a vast treasure-store of gems, and even the rapacity of the old Roman adventurers failed to exhaust its riches. Of all these brilliant gems, none was more esteemed by the ancients than the sapphire. Solinus describes it as a stone of great price, but liable to exhibit defects, and as “the gem that feels the influence of the air, and sympathizes with the heavens and does not shine equally if the sky be cloudy and bright. Pliny’s description, distinguishing it from the amethyst, is remarkably fine. He says the difference between them consists in this, “That the violet splendor of the amethyst is diluted in the sapphire, and so far from filling the eye, does not even touch it, fading away more speedily than the flower (hyacinthus) of the same name.” Then the stone was not only valued for its extreme beauty, but also for its hardness, it being only second to the diamond in that respect. On this account, in olden times it was used uncut and only rudely polished. In fact, before the days of Cæsar, engraved sapphires were hardly known. Mr. King, of Trinity College, Cambridge, England, a great authority on gems, however, states that a small etruscan scarab on an inferior variety of the stone has come under his notice, and he has also seen a splendid head of Jupiter cut in sapphire in the purest style of ancient Greek art. This gem was discovered ornamenting the pommel of a Turkish dagger, “the intaglio turned downward, and the back of the stone rudely faceted by the Oriental lapidary into whose hands it had fallen, an additional proof of its genuine antiquity.” One of the most celebrated of all engraved sapphires is the great signet of the august Emperor Constantine, which weighs fifty-three carats. Time was when the sapphire was supposed to possess extraordinary moral influences and spiritual potencies; but nowadays it is only a luxury amid luxuries, and this newly discovered stone will no doubt be merely prized as a jewel or a work of art,

## Precious Stones and Gems.

BY EDWIN W. STREETER.

AMETHYST is a term now applied to all the violet, purple, blue, and other crystals of quartz which, when fractured, present the peculiar undulated structure described by Sir David Brewster. This is, however, an entirely distinct species from the true Oriental amethyst, which is a variety of Sapphire, of a deep shade of violet, mentioned already under corundum.

They are found in the galleries of old mountains, sometimes in iron and sometimes in agate beds. Those of the finest violet are found in Siberia, India, Ceylon, Persia, Carthage, and Brazil. In cutting them as many facets as possible are given, in order to intensify the color and lustre. This stone takes a beautiful polish, and as none harmonizes better with gold, it forms a gem of great beauty, but since the discovery of it in America, it seems to have lost caste. Brazil, of all the places just mentioned, furnishes us with the best specimens of the dark colored stones. In America it occurs of extraordinary size. A block sent thence to India is said to have weighed 98 pounds. A variety known as Spanish amethyst is sometimes met with in very old-fashioned jewelry; it exhibits the true purple color at one time so much prized; whence they came is unknown. The common amethyst is found in all parts of the world. A block measuring a foot square, but with scarcely any color, was recently in my possession.

To show the fall in the value of this stone, we quote one instance, viz., the amethyst necklace of Queen Charlotte. It consisted of well-matched and very perfect stones, although only of the common variety, and was valued at £2,000; it would now hardly realize £100. Intagli of very ancient date and in every style are met with in amethyst. As a rule stones of a pale color are used for engraving rather than the dark; as an exception to this rule, King says, he himself has seen, perhaps the grandest Greek portrait in existence, a head of Mithridates, cut in a large amethyst, of the deepest violet color, which was found a century ago in India. There is another very ancient intaglio of the head of Pan in the Uzielli collection. In early times the amethyst seems to have been a favorite stone for engraving. One of the largest of the kind was the gem representing a bust of Trajan, of which the Prussian treasury was robbed during Napoleonic wars.

Agate, strictly speaking, does not belong to mineralogy, which deals only with the characteristics of simple minerals, that is to say, those which, by their mechanical division, in all their fragments are essentially of the same quality and condition.

By the term agate we understand a collective substance; it implies a conglomeration of certain silicates, or quartz minerals, which in texture, color, and transparency are diverse one from the other. These minerals are Chalcedony, Carnelian, Quartz, Jasper and some others. Two or more of these in a conglomerate, forming a mixed cohesive mass and presenting spots and stripes, is denominated agate. According to certain fancied similitudes, which this stone displays to things in common use, it receives a distinguishing name.

Riband agate exhibits strata or layers of different colors which play one into the other. Where the colors are beautiful and sharply defined, and the strata run parallel to the surface of the stone it is called onyx or agate onyx; and, in a narrower sense, that is called band agate wherein there appears stripes of varied hues. If these stripes converge towards a center, it receives the name of the circular agate; and if in this center there are other colored points, it is called the eye agate. In rainbow agate the stripes form a bow, presenting the colors of the iris when the stone is held towards the sun or a strong light; the thinner the stone the more this peculiarity is noticeable.

In speaking of Oriental and Western agate, we understand that all

the most beautiful and translucent sorts belong to the Oriental, and the less valuable to the Western variety.

The agate, onyx and chalcedony are produced almost exclusively in a peculiar kind of stone originating in melaphyre, black porphyry and trapp.

In a district of  $8\frac{3}{4}$  square miles, stand the two little towns of Oberstein and Idar, the chief centers of the agate industry. Not only is a great proportion of the inhabitants of these towns in some way occupied in cutting, polishing and coloring these stones, but for miles round every tributary of the Rhine is dotted by the homes of those who follow this business.

In 1770 there were only twenty-six cutting and polishing mills in Birkenfeld, whereas in 1870 they were 180, half of which were built in the twenty years preceding. In each mill there are four or five whetstones. These stones are firm quartz sandstone which is obtained from Zweibrücken; two men ordinarily work together at the same stone. Much of the agate is cleaved to the requisite form by means of the hammer, a work which exacts much skill from the artisan. He must be well acquainted with the natural planes and cleavage direction of the stone, and have dexterity enough to take advantage of them. The purchase of the stone in the rough is generally undertaken by professional dealers in agate wares, who commit them to the cutters and polishers to form them into articles in demand. The artificers are paid by the piece or by the dozen.

Alexandrite is found in Takowaja, and as it contains the two chief colors of the Russian Empire, red and green, it is called Alexandrite. A small amount of chromo-oxide gives it its green color, which is much admired in daylight; and it contains just a trace of copper and oxide of lead, which makes it look dark red by artificial light. By daylight these two colors intermingle, the green predominating. If the stone be turned towards the setting sun, or towards a flame, the red predominates. It is an extraordinarily good specimen of Trichroism.

Aquamarine partakes of the nature of the emerald and the beryl, both of which are varieties of the same species, but the aquamarine contains oxide of iron in place of the oxide of chromium. Its hardness being less than that of first-class stones—7.5 to 8, detracts from its value in the jeweler's estimation.

Most of the aquamarine comes to us from Brazil already cut; but the stones are found elsewhere, viz., in the granite regions in Siberia, in the Ural Mountains and in the Altai Mountains. Formerly they were obtained from the frontiers of China.

This gem is a great favorite with the English, chiefly because it possesses the advantage of retaining its lustre in artificial light. Jewelers distinguish the varieties of this stone in a manner peculiar to themselves, viz., the green and blue varieties they call aquamarine, while the yellow variety receives the name of beryl. But the former is again subdivided: into (1) *aquamarine*, pure, light sky blue; (2) *Siberian aquamarine*, light greenish blue, bright lustre and faintly colored; (3) *aquamarine Chrysolite*, greenish-yellow, sometimes yellowish-green, with bright lustre.

Aquamarine is made into a variety of ornaments. It is said that the Emperor Commodus possessed an Hercules engraved on aquamarine by Hyllus; and that in the treasures of Odescalchi there was a stone engraved by Quintitius, representing Neptune drawn by sea horses. In the National Library in Paris, there is a beautiful engraving of the head of Julia, the daughter of Titius, by Evodus, on aquamarine. An aquamarine  $2\frac{1}{8}$  inches long, and  $2\frac{3}{8}$  in thickness adorned the tiara of Pope Julius II.

*Bloodstone*.—The variety of hematite used for ornament is found generally in fibrous masses, having a curved, round, kidney-shaped or clustered upper surface. It is opaque, and the cleavage is imperfect, fracture sub-conchoidal and uneven; its hardness 4.5. The color varies from dark steel-grey to blood-red and brownish-red, and possesses a slight and imperfect metallic lustre. It consists of hematite in a pure condition, viz., oxide of iron; the chemical com-

position of which is 69.34 of iron and 30.66 of oxygen ( $\text{Fe}^2 \text{O}^3$ ). It is infusible by itself but with borax and subjected to a fierce heat, the part on which the outer circle of the flame impinges becomes a dark red, but turning to yellow when cool, whereas the center remains a bottle-green.

Hematite is found in various formations in Andreasburg in the Hartz; Saalfeld in Thuringia; Waldenburg in Silesia; Rothenfels and Hohenburg in the Pfalz, and in Bohemia, France and Spain.

The hematite or bloodstone is not much used for ornament, except for signet rings, but is most useful as a polish for other stones and for metals. We have noticed it here because of its value in ancient times. The art of engraving seems to have first been experimented on the bloodstone. The largest number of the old Babylonish and Egyptian intaglios consists of the hematite or bloodstone.

Some believe the carnelian or red chalcedony to have derived its name from "Carion," the place where it was earliest found. Others that it comes from "Caro" *flesh*. The ancients called it Sarda, either from the town of Sardis in Asia Minor, or from the Arabian word "Sard," (*yellow*). Luther translates the word "Odem" or "Adam," (*red*) (Exodus, chap xxvii, v. 17), by Sarda, so well known was the stone at that early period.

Carnelian is chiefly found in dense, imperfect balls; often, however, in obtuse-angled pieces. Its color varies from blood red to wax yellow, and reddish brown; it is cloudy, seldom striated, semi-transparent and of waxy lustre. Its hardness is somewhat less than chalcedony. By heat the color of carnelian becomes intensified, probably because of its coloring matter, oxy-hydrate of iron being changed into oxide of iron. By an over application of heat it sometimes loses its color and becomes white, pale and friable. Carnelian is found mostly as rubble and filling-up material in the air bladder of Almandine. It is found with amethyst and chalcedony at Oberstein in the province of Birkenfeld, in sandstone at Waldshut in Baden, and of extraordinary beauty as rubble at Barotsch in the province of Guzural in the East Indies. In the same manner it is found in the rivers of Uruguay. The jewelers and lapidaries distinguish the different kinds of carnelian by the following names:—1st, masc. or carnelian of old stone, dark red. 2d, fem. pale red passing into yellow. 3d, sarder, brown, passing into pomeranian and yellow. 4th, sardonyx, where layers of the sarder alternate with layers of white. 5th, carnelian onyx, blood-red stripes playing into white. 6th, carnelian beyrl, a whitish yellow.

Carnelian is cut on a leaden plate with emery and polished on a wooden one with pumice stone. It receives its last touch of polish, on a plate consisting of lead and tin, with water. It is generally cut into squares, hexagons or octagons; sometimes round or by giving to the upper part the *treppen* or graduated cut. To increase the lustre it often receives a silver or golden foil, or the under part is touched with color corresponding to that of the stone. The color is improved and intensified by means of heat, as has been before mentioned, which alters its yellowish hue into a pleasing red.

Carnelian is used for rings, seals, watch-keys and other articles of adornment. It is very much employed for cameos and for engraving. In cutting a cameo from a carnelian the snow white layer would be made use of for the figure; the red for a base or ground work; and should it have a third layer of milk-white, it would serve for the hair in the figure of the cameo. The cameos which we receive from India, are most *bizarre* in their appearance. The natives cover the whole stone with carbonate of soda, and subject it for a moment to intense heat, so that a hard molten mass is produced in which they cut the figure.

Carnelian of a beautiful color is of more value than the other varieties of chalcedony. The blood red stands first and the pale red next. Since the Oberstein industry of the artificial coloring of precious stones, the value has diminished, and probably the market has not been improved by the very large importation of Brazilian stones. Of course the price paid for this stone depends greatly upon

the degree of transparency, purity and beauty of color, and upon its freedom from flaws.

This stone was probably chosen by the Greeks and Romans for cameos in consequence of its possessing a beautiful color and a certain hardness, a facility for manipulation. We shall mention only a few of the many famous specimens.

The oldest Greek gems known are in the collection of the Emperor of Germany. One of them is a carnelian, on which is represented a winged Jupiter appearing to Semele, and the other an opaque sardonyx, on which is engraved a draped figure of Venus. They are more modern however, than the butterfly of the first epoch of the Etruscan art of engraving.

There is a carnelian of the earliest period in the St. Petersburg collection, on which a man's head is engraved, with most artistically arranged beard.

The British Museum possesses an example of the second period, viz., a carnelian butterfly carrying a representation of Venus, of very fine workmanship. The dress of the goddess hangs in rich and graceful folds, and has a border round it, and she is furnished with large wings.

A carnelian of the third period is in the Royal Collection of Vienna, and represents Helena with wings on her shoulders. On a small carnelian in the collection at Florence, there is a head of Apollo, adorned with laurels and fillets.

In the Berlin Museum there is an unique Indian carnelian, almost as transparent as the Hyacinth, engraved with the head of Sextus Pompeius. One of the most famous of the ancient deep-cut stones represents the birthday festival of Dionysius, and was once in the possession of Michael Angelo.

The crystalline form of the chrysoberyl belongs to the rhombic system. It is usually found in the same sands as those which furnish crystals of topaz and corundum. Twins of two kinds and great beauty are found in the emerald mines of Takowaja, east of the Catharine Mountains in the Ural. The cleavage is imperfect—parallel to the faces of the right-angled prisms; fracture conchoidal and uneven; hardness 8.5; specific gravity 3.6 to 3.8. It is brittle, transparent, translucent, and possesses in a high degree the power of double refraction, and a vitreous and oily lustre. The color varies from asparagus-green to grass green, greenish-white, and yellowish. A peculiar bluish opalescence, in the inner part of the stone, is to be seen at times. The streak is white. Under friction it becomes electric, and remains in that condition for hours. Perhaps no mineral has had so many analyses with such a variety of results as the chrysoberyl. Klaproth and Aredson considered it to be silicic and alumina. To Seybert we are indebted for the discovery of glucini in chrysoberyl. He conceived it to be composed of silicic acid, alumina, and an aluminate of glucinum or beryl earth. Thomson declared he could find no silicic acid in it, and was confirmed in this view by Mr. Rose. Chrysoberyl is therefore composed of a combination of alumina and glucina, a small portion of the latter being replaced by oxide of iron. It undergoes no change before the blow-pipe, but fuses with great difficulty into a clear glass by means of borax. Acids have no effect upon it, but with a solution of cobalt it becomes blue.

Asparagus or yellow-green chrysolite was known in very early times to the people of Ceylon and Brazil. In Ceylon it was found in the sand of the river in company with tourmaline, spinel and sapphire. On the east side of Borneo also, it is found in the river sand, and in flooded lands with crystals, gold dust, diamond, topaz and emerald. In Pegu it is found amongst pebbles and river sand. In Brazil, pieces of this chrysoberyl of the size of a hazel nut, and of yellowish-green color, are sometimes met with while washing for diamonds. Of late years it has also been found in Connecticut, North America, in well formed tables and prisms, with tourmaline, garnet and beryl, in the granite strata; and at Saratoga and Greenfield in New York State, in regular twin crystals with tourmaline, garnet and apatite.

## Workshop Notes.

Messrs. Alvan Clark & Sons, of Cambridgeport, Mass., whose fame as telescope makers is world wide, have just furnished Carleton College, Northfield, Minn., with a new equatoreal. The mounting of the of the telescope is of the latest and most approved style. It rests on a trapezoid of brick work extending six feet above the capstone of the main pier, which is even with the floor of the dome of the observatory. The brick work supports a base of cast iron, made to receive the polar and equatoreal axes, which carry the right ascension and declination circles. The former circle is eleven inches in diameter and reads to two seconds of time; the latter is fifteen inches in diameter and reads to thirty seconds of arc. Both are divided on silver, provided with two verniers, and reading microscopes. These circles are of excellent workmanship. The object glass has a clear aperture of eight and one-fourth inches, and a focal length of ten and one-half feet. It is mounted in a tube made of steel, and painted black, except the finely burnished brass finish that carries the cell for the objective and the eye-piece. The telescope is provided with a position micrometer, an illuminating apparatus and everything that can be desired for fine measurements and double-star work in general. There is a full battery of eye-pieces, giving the widest range of power that can be used with a telescope of the size. The driving-clock is known as the Bond spring governor driving-clock. The new equatorial is an admirable piece of work, has been mounted and adjusted by the makers with the greatest care, and will be certain to give an excellent account of itself, although it cannot nope to rival such large instruments as the 26-inch refractor at the Naval Observatory, Washington, or the 18½-inch refractor at the Dearborn Observatory, Chicago, both of which, in the hands of Professors Hall and Burnham, have done so much to extend the reputation of Messrs. Clark & Sons.

M. Senlecq, of Ardres, France, has recently submitted the plan of an apparatus intended to reproduce telegraphically at a distance the images obtained in the camera obscura. The apparatus is based on the property possessed by selenium of offering a variable and very sensitive electrical resistance according to the different gradations of light. It consists of an ordinary camera obscura, containing at the focus an unpolished glass and any system of autographic telegraphic transmission; the tracing point of the transmitter, intended to traverse the surface of the unpolished glass, if formed of a small piece of selenium held by two springs acting as pincers, insulated and connected, one with a pile, the other with the line. The point of selenium forms the circuit. In gliding over the surface, more or less lightened up, of the unpolished glass, this point communicates, in different degrees and with great sensitiveness, the vibrations of the light. The receiver is a tracing point of black lead or pencil for drawing very finely, connected with a very thin plate of soft iron, held almost as in the Bell telephone, and vibrating before an electromagnet, governed by the irregular current emitted in the line. This pencil, supporting a sheet of paper arranged so as to receive the impression of the image produced in the camera obscura, translates the vibrations of the metallic plate by a more or less pressure on that sheet of paper. The working of the new machine will be watched with some interest; but at present it is theoretical rather than practical.

Pearls will never tarnish nor lose their brilliancy if kept in dry, common magnesia, instead of the cotton wool used by jewelers.—*British Horological Journal*.

Enamel chasing and engraving may be protected from the effects of heat in hard soldering if covered with McLane's anti-oxidize, a solution now universally adapted in all the leading factories for protecting the color of gold enamel while passing through the fire.

When arbors and other pieces of steel get bent in hardening, they can be easily and effectively straightened by placing them on a piece of soft iron, and striking them a number of gentle blows on the hollow side with the pin of a hammer. Arbors should be tempered in oil, and not by blueing, as is the practice with some watchmakers; a more regular and uniform temper is obtained by smearing them with oil and burning it off by holding the hardened arbor in a flame till the ore just catches alight.

The color known as "ormolu" may be given to gilt articles by applying a mixture of alum, hematite, salt, and strong vinegar. Dip the article in this mixture, then subject to heat till the composition becomes blackened, then place in cold water; finally brush with vinegar until quite free from coloring medium.

A beautiful gold-beetle colored bronze may be prepared in the following manner: Mix equal parts of table salt and chromate of potash; tel the powder be finely mixed and passed through a sieve; this pow-

der is then put in a crucible and covered with a layer of salt. The crucible is covered and the contents allowed to boil for half an hour. After cooling the contents are carefully washed out with water, and the mass on being rubbed will show a beautiful bronze.—*Metallarbeiter*.

**FROSTED SILVER.**—The dead fretted appearance on silver is produced in the following manner: The article has to be carefully annealed either in a charcoal fire, or with a blowpipe before a gas flame, which will oxidize the alloy on the surface, and also destroy all dirt and greasy substances adhering to it, and then boiled in a copper pan containing a solution of diluted sulphuric acid—of 1 part of acid to about 30 parts of water. The article is then placed in a vessel of clean water and scratch-brushed or scoured with fine sand, after which the annealing and boiling out is repeated, which will in almost all cases be sufficient to produce the desired result. If a very delicate dead surface, such as watch dials, etc., is required, the article is, before the second annealing, covered with a pasty solution of potash and water, and immediately after the annealing plunged in clean water, and then boiled out in either sulphuric acid solution, or a solution of 1 part cream of tartar and 2 parts of common salt to about 30 parts of water. If the article is of a low quality silver it is well to add some silver solution, such as used for silvering, to the *second* boiling out solution. If the article is of a very inferior silver, the finishing will have to be given by immersing it in contact with a strip of zinc in a silver solution.—*H. Bush*.

The shining changes of colors on a polished surface of mother-of-pearl may be transferred to silver by the aid of a Smee's battery in the following manner: First of all the shell of the pearl must be prepared by grinding and polishing. Next a metallic impression must be taken of the surface. For this purpose a metal fusible at a low temperature is best adapted, which is accomplished by pouring the metal into a cavity lined with paper saturated with oil, and as soon as air bubbles have ceased to come to the surface of the poured metal, a paper card is gently drawn over it to remove the oxide until it assumes a bright lustre, when the shell is suddenly pressed into the molten metal. It is then allowed to cool down, and the shell taken off; and if the impression is found to be correct, the same must be *immediately* immersed into the silver bath for plating, and the connection of the battery formed. In a few minutes a film of silver will be deposited on the impression of the casting, and be a true copy of the shell surface. In about five or six hours the film will become a sheet thick enough to be peeled off with a penknife. Smee's battery consists of a platinized silver plate between two amalgamated zinc plates fastened on a wood frame; the existing liquid is water acidulated with sulphuric acid. The depositing solution must be a cyanide silver solution, with a strong excess of cyanide. By means of this the beautiful array of colors peculiar to mother-of-pearl can be transferred to small silver plates, which may be advantageously applied for ornamentations of art metal work.—*Herman Bush*.

## Foreign Notes.

The Shah of Persia is disposing of his superfluous diamonds. A large quantity of an inferior quality have been consigned to a Parisian dealer with instructions to sell.

A grand national exhibition is to be held in Moscow in 1880, which will probably be accompanied by great festivities, as it will coincide in point of time with the celebration of the 25th anniversary of the Emperor Alexander's accession to the throne.

A national exhibition will take place at Brussels in connection with next year's great independence fetes. The cost of erecting the necessary buildings in iron and glass, and surrounding them by plantations on twelve hectares of ground on the ancient Champs des Manœuvres, is estimated at 18,000,000 francs,

A French jeweler in 1870 sold a lady a 5,000 set of jewelry, giving a written promise to take the articles back if they were not approved. She wore them six years and then asked to have them exchanged for something of a newer fashion. The courts have finally decided that he must do so, and a London tribunal has rendered a similar decision where a customer wore a diamond ring before returning it.

M. Rabinet of the French Academy of Sciences, gives the following test for distinguishing colorless gems from diamonds. If a person looks through a transparent stone at any small object, such as the point of a needle or a little hole in a card, and sees two small points, or two small holes, the stone is not a diamond. All white colorless gems, with the exception of the diamond, make the object examined appear double; in other words double refraction whenever exhibited by a stone, is conclusive proof that it is not a diamond.

## Trade Gossip.

Square mosaic pins are among the newest styles of jewelry.

Mr. M. S. Smith, of Detroit, has gone to Florida on account of ill health.

John Law, of Winterset Iowa, has established himself in business at the Dalles, Oregon.

Nelson & Cook, Lanesboro, Minn., have sold out to Louis Miller. Mr. Cook will locate at Leke Kampeska, D. T.

Mr. Harrison B. Smith, of the firm of Messrs. Alfred H. Smith & Co., sailed for Europe in the Algeria on the 26th ult.

Mr. Louis Strasberger sails for Europe in the Germania on the 26th inst. *Bon voyage.*

Mr. H. Beguelin of Messrs. Cross & Beguelin sailed for Europe in the Scynthia on the 8th inst.

J. A. Abray one of the oldest importers of watches lies dangerously ill at his residence in Cranford, N. J.

Mr. Frank D. Taylor and family are at one of the Bahama Islands, having gone there by the advice of his family physician.

A Providence machinist has made \$300,000 worth of gold and silver models of locomotives, ships, palace cars, &c. The number is 56.

Mr. Louis Runkel has withdrawn from the firm of L. Hammel & Co. The house will continue under the firm name of L. Hammel & Co.

Nathan Lederman, the youth who robbed Messrs Kossuth Marx & Co. of several thousand dollars worth of jewelry, has been sent to the State reformatory.

A fire occurred in the factory of Ketcham & McDougal on the evening of the 5th ult.; fortunately the stock and machinery escaped with slight damage.

"The late Jim Fisk's \$10,000 opera glass, set with five hundred diamonds," is the first prize in a lottery at the Orthodox Hebrew Fair in Boston.

A watchmaker named Marcus Wright, of Illinois, has fallen heir to \$1,000,000. We'd "rather be Wright than be President"—provided he gets the money.

The newest design in conch-shell earrings is a shell, from which bends a tiny nereid trailing her fingers over the brim, as if trying to wet them in the sea.

Messrs. Baldwin, Sexton & Peterson have opened an office at 120 Sutter Street, San Francisco, Cal., where a full line of their artistic productions may be seen.

Mr. Thomas J. Crothers has withdrawn from the old established firm of Carrow, Crothers & Co. The house will continue under the firm name of Carrow, Bishop & Co.

Mr. L. A. Cuppia has secured the services of the well known expert worker in coral, Mr. De Fillippo, who will have charge of the repair department of his establishment.

A fire recently occurred in the upper part of the building occupied by W. J. Suttie, optician, destroying a large proportion of his stock; his machinery, however, escaped.

Mr. E. A. Lauten, has removed from 68 Prince Street to No. 4 Great Jones Street, one door from Broadway, where he displays a large variety of jewelry boxes, cases and trays.

Messrs. Mabie Todd & Bard, have just introduced a very useful and attractive novelty in the shape of a pencil and watch key combined. The key is self adjusting (Birch's patent), and will wind any watch.

A mechanical curiosity is a wooden watch, carried as a time piece by Mr. N. Devoit, of Bristol, Tenn. All the works, except some of the finer parts, are made of boxwood, the case of brown olive wood and the dial of buffalo horn. It weighs only half an ounce.

C. H. Hastings, of Messrs. Carter, Howkins & Sloan, has gone to Hot Springs, Arkansas, by advice of his physician. Our genial friend has been out of health for some time, and greatly needs a respite.

Mr. Joseph N. Tingley, who recently retired from the firm of Tingley, Sinnock & Sherrill, has again began business at No. 9 Maiden Lane, and will confine his efforts to the production of Stone Rings.

Fancy combs and other decorations for the hair are abundant and particularly handsome now; the former show many openwork designs in silver, which are first choice for ladies with dark hair, and there are pins, ball and trefoil, in silver, jet and enamel.

Mr. Phelps, for several years in the employ of Messrs. Eugene Jaccard & Co., St. Louis, has been admitted in the firm of Merrick & Walsh. The house will conduct business under the firm name of Merrick, Walsh & Phelps; we wish them a prosperous career.

Superintendent Walling has received information that on the night of November 24, 1878, the jewelry store of D. Felipe Hecht, of Porto Rico, was broken into by burglars and robbed of diamond jewelry and watches valued at \$4,320. It is supposed that the stolen goods have been brought to this city to be disposed of, and the police were directed to look out for them.

Mr. G. W. Childs, A. M., is the owner of a collection of rare clocks, forty in all, one of which is valued at six thousand dollars. Some do duty in the *Ledger* office, and the remainder in his marble residence on Walnut Street. In addition to their artistic value, the music of their tickings serves to remind the bard that at every tick a mortal is departing and ought to be embalmed in mortuary verse.

At a late loan collection in Norwich, Conn., Colonel C. M. Ferris exhibited an old watch with the following inscription:—"This watch was purchased by Sylvanus Ferris, of Greenwich, Conn., about 1754. It was then an old watch, having on its case that patch it now bears. It was carried by him through many hard battles of the French and Indian wars of Ticonderoga and Crown Point in 1739. Also through the war of the Revolution; and when the Tories came to ransack and plunder his house, he would bury it in the ashes of the fire-place. It has never been out of the family, always having been preserved with great care.

Jefferson, writing to Madison from Paris, February 8, 1786, speaking of a watch which the latter had purchased in Philadelphia, says: "I can get for you here one made as perfect as human art can make it for about twenty-four louis. For twelve louis more you can have, in the same cover, but on the back and absolutely unconnected with the movements of the watch, a pedometer, which shall render you an exact account of the distances you walk." Who knows anything of these ancient pedometers? The modern ones are about the size of an ordinary watch, and need a special pocket; but if the whole machinery can be placed in one cover, why, it will be quite convenient, and make more desirable this curious and useful little instrument. Who can tell us about the Paris pedometer of old?

We have received a copy of the "X. Y. Z. Railway guide," an admirable publication just issued by Mr. Waring. It is designed to simplify travel to and from New York City. As everybody at some time visits New York it is desirable that they should be informed as to the readiest means of getting in and out of the city. This guide gives this information in the simplest manner possible. It is arranged alphabetically. If one wants to go to any given point he has but to turn to the name of the place, and, under the name, he will find the routes by which he can travel, the time of leaving and arrival of trains or boats, the distance, fare, etc. For simplicity of arrangement the X. Y. Z. has never been equalled. We commend it to all travellers as an invaluable book of reference.

At the regular meeting of the executive committee of the JEWELERS' LEAGUE, held February 7th, 1879, the following gentleman were elected members:—William Billing, with Dennison Manufacturing Co., N. Y.; W. W. Child, Jackson, Michigan; Wm. W. Covell, Providence, R. I.; Wm. S. Dolbey, New York; John R. Greason, of Greason, Bogart & Pierce, N. Y.; Max L. Gutmann, Rochester, N. Y.; Geo. W. Hutchison, of Hutchison & Huestis, Providence, R. I.; Christopher D. Marsh, of C. D. Marsh & Co., Rahway, N. J.; David Marx, of Marx & Weiss, New York; Frank S. Ogilvie, with Brinard & Steele, New York; Geo. W. Parks, Brooklyn, N. Y.; Morris Prager, New York; Geo. W. Simons, of Simons, Bro. & Co., Phila., Pa.; Henry E. Somerville, with Samuel Krik & Sons, Baltimore, Md.; Jos. F. Tingley, Newark, N. J., Chas. L. White, with Randel, Baremore & Co., City; Anton Koenen, of A. Koenen & Bro., City.

A remarkable old miser has just died in Dublin, and curiosity is rife regarding his property, which is said to be worth \$500,000. The old man, whose name is Law, was a jeweler for many years, but for the last fifteen or twenty years he has lived an absolutely solitary life in a large house in Lower Dominick street. Since his death a large number of persons have come forward as relatives, and doubtless there are many in America who are related to this remarkable man, and might like to send in their claims at once. His house when searched was found to contain some old and curious books, a few jars of whisky, many wine bottles, some empty; a great quantity of tea leaves, which he appears to have carefully preserved in basins after he had extracted all the essence from them. In the room where he slept, and where he probably contracted the bronchitis that caused his death, it was wonderful how a human being could exist. What served for a bed stood in one corner, and with the exception of a very narrow passage round about it, the floor was covered with a mass of indescribable rubbish.



No. 24 Doelen Straat,  
AMSTERDAM, HOLLAND.

No. 1 Gaertner Platz,  
MUNICH, GERMANY.









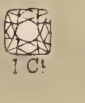

# E. AUG. NERESHEIMER,

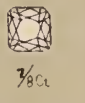
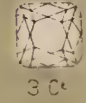
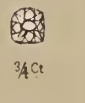
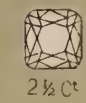
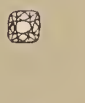
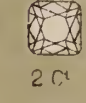
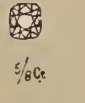
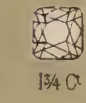
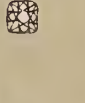
IMPORTER OF DIAMONDS,

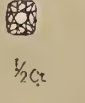
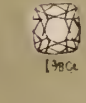
21 Maiden Lane,

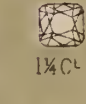
NEW YORK.

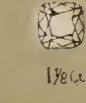
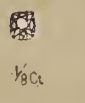
TABLE FOR CALCULATING THE PRICE OF DIAMONDS PER CARAT AND FRACTIONAL PARTS THEREOF.

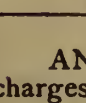
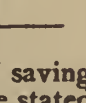
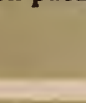
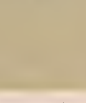
SIZE OF DIAMONDS.	LOOSE DIAMONDS OF ALL SIZES AND GRADES							THE SAME, MOUNTED IN EAR-RINGS, RINGS, STUDS, PINS, &c. SENT ON APPROVAL AT THE VERY LOWEST MARKET RATES.	LOOSE DIAMONDS OF ALL SIZES AND GRADES							SIZE OF DIAMONDS.
	1 Kt.	1-2	1-4	1-8	1-16	1-32	1-64		1 Kt.	1-2	1-4	1-8	1-16	1-32	1-64	
 10 Ct	\$300.00	\$150.00	\$75.00	\$37.50	\$18.75	\$9.37	\$4.68	\$90.00	\$45.00	\$22.50	\$11.25	\$5.62	\$2.81	\$1.40		
 5 Ct	\$250.00	\$125.00	\$62.50	\$31.25	\$15.62	\$7.81	\$3.90	\$85.00	\$42.50	\$21.25	\$10.62	\$5.31	\$2.65	\$1.32		
 3 Ct	\$200.00	\$100.00	\$50.00	\$25.00	\$12.50	\$6.25	\$3.12	\$80.00	\$40.00	\$20.00	\$10.00	\$5.00	\$2.50	\$1.25		
 2 1/2 Ct	\$155.00	\$77.50	\$38.75	\$19.37	\$9.68	\$4.84	\$2.42	\$75.00	\$37.50	\$18.75	\$9.37	\$4.68	\$2.34	\$1.17		
 2 Ct	\$132.00	\$66.00	\$33.00	\$16.50	\$8.25	\$4.12	\$2.06	\$70.00	\$35.00	\$17.50	\$8.75	\$4.37	\$2.18	\$1.09		
 1 3/4 Ct	\$122.00	\$61.00	\$30.50	\$15.25	\$7.62	\$3.81	\$1.90	\$65.00	\$32.50	\$16.25	\$8.12	\$4.06	\$2.03	\$1.01		
 1 1/2 Ct	\$115.00	\$57.50	\$28.75	\$14.37	\$7.18	\$3.59	\$1.79	\$60.00	\$30.00	\$15.00	\$7.50	\$3.75	\$1.88	\$0.98		
 1 Ct	\$110.00	\$55.00	\$27.50	\$13.88	\$6.94	\$3.47	\$1.73	\$55.00	\$27.50	\$13.75	\$6.87	\$3.43	\$1.71	\$0.85		
 3/4 Ct	\$106.00	\$53.00	\$26.50	\$13.25	\$6.62	\$3.31	\$1.65	\$51.00	\$25.50	\$12.75	\$6.37	\$3.19	\$1.59	\$0.79		
 1/2 Ct	\$105.00	\$52.50	\$26.25	\$13.12	\$6.56	\$3.28	\$1.64	\$50.00	\$25.00	\$12.50	\$6.25	\$3.12	\$1.56	\$0.78		
 1/4 Ct	\$104.00	\$52.00	\$26.00	\$13.00	\$6.50	\$3.25	\$1.62	\$49.00	\$24.50	\$12.25	\$6.12	\$3.06	\$1.53	\$0.76		
 1/8 Ct	\$103.00	\$51.50	\$25.75	\$12.88	\$6.44	\$3.22	\$1.61	\$48.00	\$24.00	\$12.00	\$6.00	\$3.00	\$1.50	\$0.75		
 1/16 Ct	\$102.00	\$51.00	\$25.50	\$12.75	\$6.37	\$3.18	\$1.59	\$47.00	\$23.50	\$11.75	\$5.87	\$2.94	\$1.47	\$0.73		
	\$101.00	\$50.50	\$25.25	\$12.62	\$6.31	\$3.15	\$1.58	\$46.00	\$23.00	\$11.50	\$5.75	\$2.87	\$1.43	\$0.71		
	\$100.00	\$50.00	\$25.00	\$12.50	\$6.25	\$3.12	\$1.56	\$45.00	\$22.50	\$11.25	\$5.62	\$2.81	\$1.40	\$0.70		
	\$99.00	\$49.50	\$24.75	\$12.37	\$6.19	\$3.09	\$1.54	\$44.00	\$22.00	\$11.00	\$5.50	\$2.75	\$1.38	\$0.69		
	\$98.00	\$49.00	\$24.50	\$12.25	\$6.12	\$3.06	\$1.53	\$43.00	\$21.50	\$10.75	\$5.37	\$2.69	\$1.34	\$0.67		
	\$97.00	\$48.50	\$24.25	\$12.12	\$6.06	\$3.03	\$1.51	\$42.00	\$21.00	\$10.50	\$5.25	\$2.62	\$1.31	\$0.65		
	\$96.00	\$48.00	\$24.00	\$12.00	\$6.00	\$3.00	\$1.50	\$41.00	\$20.50	\$10.25	\$5.12	\$2.56	\$1.28	\$0.64		
	\$95.00	\$47.50	\$23.75	\$11.87	\$5.94	\$2.97	\$1.48	\$40.00	\$20.00	\$10.00	\$5.00	\$2.50	\$1.25	\$0.62		
	\$94.00	\$47.00	\$23.50	\$11.75	\$5.87	\$2.93	\$1.46	\$39.00	\$19.50	\$9.75	\$4.87	\$2.43	\$1.21	\$0.60		
	\$93.00	\$46.50	\$23.25	\$11.62	\$5.81	\$2.90	\$1.45	\$38.00	\$19.00	\$9.50	\$4.75	\$2.37	\$1.18	\$0.59		
	\$92.00	\$46.00	\$23.00	\$11.50	\$5.75	\$2.87	\$1.43	\$37.00	\$18.50	\$9.25	\$4.62	\$2.31	\$1.15	\$0.57		
	\$91.00	\$45.50	\$22.75	\$11.37	\$5.68	\$2.84	\$1.42	\$36.00	\$18.00	\$9.00	\$4.50	\$2.25	\$1.12	\$0.56		

AN ADVANTAGE TO DEALERS.—Customers ordering Goods of me will have the advantage of saving charges by Express on values. All Goods in transit being fully insured both ways, and no value need be stated on packages.

Orders Solicited.



# Jewelers' Circular and Horological Review.

VOLUME X.

NEW YORK, APRIL, 1879.

No. 3.

THE

## JEWELERS' CIRCULAR AND HOROLOGICAL REVIEW,

*The recognized organ of the Trade, and the official representative of the Jewelers' League.*

A Monthly Journal devoted to the interests of Watchmakers, Jewelers, Silver-smiths, Electro-plate Manufacturers, and those engaged in the kindred branches of art industry.

### SUBSCRIPTION:

To all parts of the United States, Canada, Great Britain and the West Indies,  
**\$2.00 Per Annum; Postage paid.**

To France, Switzerland, Germany, Mexico, the Republics of South America, and Australia, \$2.50 per annum. Postage paid.

*All communications should be addressed to D. H. HOPKINSON, 42 Nassau Street, New York. Advertising rates made known on application.*

AGENCIES: { J. H. PURDY & CO., No. 170 State St. et, Chicago.  
PRATT & CO., Ninth and Arch Streets, Philadelphia.  
HERMAN BUSH, No. 14 Mytongate, Hull, England.  
FREARSON BROS., Adelaide, Australia.

MESSRS. LEE & WIGFULL, the well known Electro-plate manufacturers, (John street Works), Sheffield, England, have kindly consented to receive subscriptions.

### A Standard for Wrought Gold.

WE have received during the past month numerous letters from prominent jewelers endorsing the editorial in the last CIRCULAR in favor of the establishment of a legal standard for manufactured gold. Some of the most prominent firms in the trade have sent us their names, urging that means be taken to direct the attention of Congress to this matter. One of these writes: "You have expressed our sentiments exactly, and we will cheerfully co-operate with you and others in the trade, to bring about the enactment of any law whereby the manufacturer may be held liable, criminally or otherwise, for any adulteration below representation, of his goods." This is precisely the point that the CIRCULAR seeks to attain—punishment for fraud. We wage no war upon cheap goods, as such, but upon that class of fraudulent goods that is palmed off upon the public for the genuine article. There is a legitimate demand for cheap goods, and the manufacture of such is an honest, legitimate enterprise. But when goods are made that scarcely know the sight of gold, and are represented to be 14 to 18 karats fine, the transaction becomes a swindle that deserves to be ranked with "bogus lotteries" or the "sawdust swindle." This degradation of the standard of wrought gold has tended to bring the jewelry trade into disrepute, and to lead the public to look with suspicion upon all classes of jewelry. In the manufacture of gold chain this is particularly noticeable, especially in colored spring chains. In this, a copper wire is inserted within the chain to give it form. Ordinarily, this wire is removed by acids, the hollow remaining, serving to give the chain the required springiness. But swindling manufacturers not only degrade the standard of the gold used, but leave the copper wire inside, whereby greater weight is secured; the base combination being sold for pure gold. Watch cases are also found in the market stamped as 18 k. gold which are made of any quality from 10 to 14 karats. There would

be no objection to the trade in this class of goods provided they were truthfully represented, but when the public is deluded into the belief that they are composed of 14 or 18 karat gold, the swindler should be summarily punished.

But manufacturers are by no means entirely responsible for the upbuilding of this traffic in spurious goods. Retail dealers find a large profit in the sale of them, and encourage their manufacture. An amusing illustration of this occurred recently. A retail dealer from the rural districts, was complaining how he had been cheated by a New York manufacturer. He had been in the habit of buying a special line of 18 k. goods, but concluded that a 14 k. article would do as well. So he ordered a lot of plain rings made of 14 k. gold, with special instructions that they be stamped 18 k. These went off so well that our rural dealer thought he could still further reduce the quality; there was too much richness in 14 karats for his constituency. So he ordered the next lot to be made of 12 karat gold, but stamped with the 18 karat brand. These also sold well, and the swindle was not detected. Growing greedy, and thinking there was still too much richness in the goods for his profit, he ordered the next lot made of 10 k. gold, still maintaining the 18 karat stamp. And here was where the joke of his complaint came in: after working off most of his 10 karat goods, he thought he would see how they were made, and sawed a sample in two. His conscience received a frightful shock when he found that the manufacturer had palmed off upon him, the virtuous dealer, a lot of filled goods! His denunciations of that wicked manufacturer were vigorous and emphatic, and like the captain of the "Pinafore," most of them began with a "big, big D." But this is but a sample of the course pursued by a large number of dealers. If they can get degraded goods fraudulently stamped at a low price, they have no hesitation in selling them for fine goods, although they know they are swindling their customers. If dealers did not create the demand for them, spurious goods would not be manufactured. They cannot plead that they are imposed upon, for, the prices they pay are sure indications of the quality of the goods.

There is scarcely anything offered to the public in which the opportunities for perpetrating fraud are so great as gold goods, and, consequently, nothing that calls more loudly for legislation to protect purchasers, who are absolutely without the means of protecting themselves. There is nothing in the exterior of gold goods by which a fraudulent stamp can be detected, and manufacturers themselves are frequently obliged to assay their goods to ascertain whether or not their workmen are robbing them. The public has nothing to rely upon but the word of the dealer, and, unfortunately, truthfulness is not a marked characteristic of the trade in these degenerate days. It is a duty which Congress owes to the public to enact laws which shall prevent the possibility of such swindles being perpetrated in the future as are now enacted daily. Congress has established standard weights and measures for the protection of the public, and provided penalties for violations of these standards. A standard for wrought gold is quite as much a necessity. Every article manufactured, should bear its own certificate of quality. A standard can be readily attained. In England, it is done, and alloys of gold with silver or copper are recognized and distinctly marked. It is assumed that there are 24 karats in unity, and  $\frac{3}{32}$ nds in the karat. Standard gold contains 22 karats of pure gold and 2 karats of alloy. In a simil r

way, articles of jewelry are denominated 14 karat, 16 karat, 18 karat, etc., according to the proportion of fine gold with the alloy. These distinctions should be legally recognized in this country, and severe penalties provided for manufacturers who make any article for sale below the standard it is represented by them to be. Wherever practicable, the stamp of quality should be impressed upon the goods themselves, but whether the goods are so marked or not, it should be required by law that a bill of sale should accompany all goods, and such bill to express in karats their quality; this to be accepted as evidence of a guarantee by the seller that the goods are what they purport to be. Such a law, rigidly enforced, would soon rid the markets of spurious jewelry, and goods of all classes would stand upon their merits. But, above all, the public would be protected from the swindling tricks and devices of unscrupulous men, who have fastened themselves upon the trade because it offers extraordinary facilities for swindling the public.

We have already received the names of many prominent men in the trade, approving of our proposition to appeal to Congress for the enactment of suitable laws to cover the points indicated. We hope others will follow their example, and express their opinions freely upon the subject. The jewelry trade has sunk to a very low point in the estimation of the public because of the many dishonorable practices resorted to by men in the business who ought to be in State Prison. We know of no better way of driving them out of the trade than by securing the passage of laws compelling them to be honest. We urge the trade generally to write us upon the subject and let us know whether or not we shall be upheld by them in seeking to enforce honesty and integrity in the manufacture and sale of gold goods.

#### Entitled to Consideration.

**M**ESSRS. Canfield Bros. & Co., of Baltimore, whose failure was announced several months ago, have issued a statement of their affairs, in which they offer to pay their creditors fifty cents on the dollar, cash, in settlement of their claims, which will no doubt be accepted. The firm of Canfield Bros. & Co. have for many years been one of the best known Jewelers in the South. Recently, after years of devotion to the best interests of the trade, the firm was forced to make an assignment under the bankrupt laws of the State, for the benefit of their creditors. A committee was appointed to investigate the affairs of the firm, and they have been unable to find any evidence of fraud, extravagance or misrepresentation on the part of the unfortunate gentlemen. The failure was a legitimate one, due to the depressed condition of trade, and causes entirely beyond the control of the insolvent firm; accordingly, the committee recommends the acceptance of the offer by the firm, and that they be permitted to continue the business.

We are pleased to observe that the creditors of this firm are inclined to deal leniently with them, and to extend to them every encouragement possible. This failure was not due to any fault of theirs; they were simply overwhelmed in the maelstrom of financial distress that has swept over the country and wrecked so many enterprises, that were seemingly prosperous. One mistake made by the firm which aided in their downfall, is so very common to the trade that we cannot forbear directing attention to it. This mistake lay in the over-valuation of their stock on hand, naturally in the transaction of so extensive a business, they accumulated a large collection of unsalable goods, rendered so by changes in public taste through introduction of more taking designs, etc. The firm failed to make proper allowance for the depreciation in values of goods of this character, but continued to carry them in their accounts of stock at nearly or quite their cost price. No one, probably, was more surprised than they at the depreciation which an appraisal of their stock showed. Their self-deception in this respect contributed largely to their disaster, and finally overtook them. Had they recognized the depreciation earlier, they might have sought, and possibly found a remedy. It is highly to the credit of the firm that they find such lively sym-

pathy in their misfortune and also the trade that readily recognizes business integrity and honesty of purpose. Messrs. Canfield Bros. & Co., spent a life time in giving tone and character to the Jewelry business, and they are entitled to every consideration that can be shown them now that misfortune has fallen upon them at a time of life that is typified by the "sere and yellow leaf."

#### Organized for Protection.

**A** large representation of the jewelers of Illinois met in convention at Springfield on Wednesday, April 3, 1879, in pursuance of a call originating in Jacksonville, for the purpose of organizing an association for the protection of the trade from unjust competition. E. R. P. Shurly, of Chicago, was chosen temporary Chairman, and he briefly stated the object of the meeting, after which it was decided to permanently organize a State Association. The following officers were chosen for the ensuing year: President.—E. R. P. Shurly, of Chicago. Vice President.—J. S. R. Scoville, of Morris. Secretary and Treasurer.—Otto E. Curtis, of Decatur. Executive Committee.—W. C. Sommer, of Springfield; W. L. Mason, of Jacksonville, and J. E. Boynton, of Jerseyville.

A constitution was then adopted. The regular meetings of the association will be held on the first Tuesday of April and October of each year, at such places as the association may from time to time decide.

The following resolution reported by the Committee were unanimously adopted by the convention.

The committee you appointed to draft and present resolutions for your approval would most respectfully report the following for adoption.

*Resolved.* That it is to the interests of the retail Watchmaker and Jewelers to buy their Clocks, Watches, Jewelry and Plated-ware only of houses that feel it to be to their interest to sell to us, and protect our interests by not sending Illustrated price lists broadcast over the country to parties outside of the trade.

*Resolved.* That we do not countenance or buy of Houses that solicit outside trade.

*Resolved.* That it be the duty of every member of the association to notify the Secretary of every instance whereby any travelling Jeweller solicits outside trade or of every instance where any jobbing House send their illustrated price lists to parties not in the trade.

*Resolved.* That the Secretary notify each member of any transgressor of the above.

*Resolved.* That as we are the distributors of a majority of the watches made in this country, that it is to our interests to handle only watches that are made by parties who are willing to protect us and that we consider that Manufacturers who allow the wholesale prices of their watches to be sent to parties outside of the trade do not wish us to handle the same that we will therefore in self defense look elsewhere.

Following are delegates of the association to the Jewelers' Convention of the Northwest, to be held in Chicago, on Thursday, May 15, 1879: A. H. Fisher, Springfield, and J. S. R. Scoville, Morris. These gentlemen were given power to appoint eight more delegates to act with them. After which the convention adjourned to meet in Decatur, in October next. The association has already a membership of between four and five hundred jewelers, representing all sections of the State. New applications are rapidly coming in, and the association bids fair to become a power for good in the trade of the West. This is a gratifying beginning, indicating a degree of earnestness that promises to eradicate many of the evils from which the trade has so long suffered. Illinois has, in this matter, set an example which the jewelers of other States will do well to follow.

The Jewelers of Iowa, held a Convention March 19th, which was numerously attended and harmonious in its action. Up to going to press we have not received a detailed report of the proceedings. We are informed that at both the above conventions there were present numerous agents of certain jobbing houses, with a view to influencing action in the interests of such jobbers and creating internal dissensions in the associations. They were not, however, permitted to take part in the proceedings. This movement for self protection is not approved of by the class of jobbers legislated against by the convention, and we warn the retailers against allowing them a voice in their deliberations.

### "How's Business?"

THIS is the salutation one meets with at every step, but which is seldom truthfully answered. One will respond in an absent-minded manner, another will explain that trade is dull, but better than last year, another is sanguine and extravagant as to the amount of trade he is doing, while still another will assume an expression as though he had a bad toothache, and announce dogmatically that the country is going to the dogs, and trade is not worth a continental "bow-wow." Such is the diversity of expression, it is almost impossible to ascertain the actual condition of trade, but, judging from reports from those houses whose business is the most extended, we are of the opinion that trade thus far this year has been better than for the corresponding period last year. It should be borne in mind, however, that the Fall trade began late, and that the Spring trade will consequently be delayed also. Add to this the fact that the season is very backward, some sections of the country being still snowed under, and still others suffering from inundations, and it is not surprising that trade thus far has been dull. There are indications, however, that it will improve with the advent of pleasant weather, and even those who are not usually over-sanguine predict a decided improvement in the volume of Spring trade over that of last year. But dealers should not contribute to their own discomfiture. If they assume a lugubrious expression and croak of evil to come, they thereby contribute largely to bring about the result they deprecate. Let them look on the bright side, keep a stiff upper lip, and resolve that there shall be an improvement in trade, and their confidence will beget confidence in others. There is no use of mourning extravagantly till the corpse is ready. The jewelry trade has many years of lively activity in it yet, and if the members of it will only put their best feet foremost, drop their sniveling and weeping, put on smiles, and resolve that business must improve, they will adopt the surest method to improve it. We predict a fair and increasing amount of trade this season, and trust the croakers will cease their predictions of further disaster to the jewelry business.

MARCUS KRONBERG, of Chicago, whose singular failure sometime since was noticed in our columns, has spent sometime in New York with a view to settling with his creditors. His efforts are meeting with a greater degree of success than was to have been anticipated from circumstances surrounding the case, and it is probable a settlement will be made, on the terms recommended by the committee appointed to investigate his affairs. The proposition requires that Mr. Kronberg shall surrender all property that was sequestered, and the security, on Wallack's claim for \$15,000 shall be relinquished, the property so surrendered to be turned over to the assignee for the benefit of the creditors, many of whom have signed a release on the terms proposed. From a dollar-and-cent standpoint, this is, probably, the most satisfactory way of disposing of a case that has already created a great scandal in the trade, but, from a moral standpoint, it is not a case to compromise.

The report of the committee of creditors, implies criminality on his part, and if such implications are founded in fact, it is unfortunate that such facts are not used to secure the proper punishment of Mr. Kronberg. If he is guilty of criminal practices, he should be brought to trial; if he is not guilty, the committee have done him an injustice.

If the trade would, on one or two occasions lay aside their high regard for the mighty dollar, and consent to the sacrifice of a little something for the sake of principle, common honesty and fair dealing, an improved tone would soon be imparted to the business. But so long as the half dollar in hand for the dollars' worth of credit obscures the vision of our best men in the business, dishonest bankrupts will abound and honest men will be driven out of business.

Mr. Kronberg, was sometime since arrested in this city, at the instance of John Foley, a creditor, and held to bail. Judge Donohue has since denied a motion to vacate the arrest, and Mr. Kronberg will consequently, have to face the music in this case at least or forfeit his bail.

THE Ansonia Clock Company is building a large and elegant factory in Brooklyn, which, when completed, will be the largest and most convenient factory of its kind in this or any other country. It will be furnished with every convenience and modern improvement that skill and taste can devise. The machinery designed for the new factory is to be of the most approved kind, embracing many labor-saving novelties. This Company is noted for the many inventions in machinery which they have devised for improving the mechanism and reducing the cost of their products. The new factory will be the model clock factory of the world.

The company is also making extensive alterations in their warehouse on Cliff street, formerly occupied by Phelps, Dodge & Co. It is entirely rebuilt by the Ansonia Clock Company, for their sales and exhibition rooms, where every novelty manufactured by them can be seen at all times. This building, which is now approaching completion, will also be a model of convenience and elegance.

H. F. CHANDLER, late in the employ of Rogers & Brother, as a traveller in the North West, left the employ of that Company recently, in their debt—the day after, he induced a jeweler in Mason City, Iowa, to endorse a draft on the house for \$150, which he got cashed. Since then he has not been heard from, and the Iowa jeweler is mourning over a returned draft, it has since transpired that this man Chandler has unsettled balances to his debt with one or two other firms for whom he travelled.

The trade should be on their guard against this man, if he ever turns up again, and also refuse to endorse or cash drafts for travellers, unless they know the parties have the authority to draw on their employers; in case of any doubt a telegram at the expense of the house would settle the matter.

There is a good deal of this kind of "unpleasantness" (that does not often get into the papers,) that might easily be avoided by the exercise of a little caution.

THE Jewelers' Protective Union, was organized something over a year ago, for the purpose of protecting Jewelers sample trunks while in the hands of travelers, who met with unprecedented success in the trade. As will be seen from the list of its membership, published elsewhere.

Not only has the Union been successful in the trade, but has been the means of recovering thousands of dollars worth of goods stolen from the travelers by enterprising "road agents." It is receiving the hearty endorsement of the best houses in the trade, and has become a terror to evil doers, as is testified to by the four or five thieves who have been sent to State prison through its agency. Pinkerton's well-known detective bureau is employed to co-operate with the Union in the detection of thieves who seek to prey on the innocent and guileless young men who travel for jewelry houses.

THERE has been considerable moving this Spring by firms in the jewelry and kindred branches of trade. In Maiden Lane and its immediate vicinity rents have not materially changed from the prevailing rates of last year. There seems to be a desire to secure good locations about Union Square, and, were there more available quarters surrounding that locality a decided impetus would be given to the movement in that direction.

The upper side of Union Square would make a splendid place for the concentration of the jewelry business, and if three or four of our large manufacturers were to locate in that block, they would soon find themselves surrounded by others in the same line of trade.

AT a meeting of the Illinois Retail Jewelers' Association, recently held at Springfield, Ill., the Jewelers Circular was duly appointed and designated as the official organ of that association. We are glad to learn that the retail jewelers of Illinois and Iowa are going to work in right good earnest. We hope to meet them at the Convention to be held in Chicago in May next.

### The Iowa Retail Jewelers' Protective Association.

JUST as we go to press, and subsequent to printing the report of the Illinois association, we are in receipt of a full report of the proceedings of the Iowa Retail Dealers Protective Association, which we renumberize as follows :

The convention assembled at Marshalltown, March 19th, and adopted the following Preamble, Constitution and By-Laws:

We, the undersigned, retail jewelers of the State of Iowa, believing that it is for our mutual interest to meet together for the interchange of horological knowledge ; and that it is necessary for us to take some measures that will restrict the injudicious distribution of catalogues, price lists, discount sheets, etc., by jobbers who neither recognize our rights as retailers nor the principles that govern all honorable business relations ; and realizing, as we do, that the depression in our trade is in a great measure due to this cause, earnestly invite the retail jewelers of the United States to co-operate with us in our efforts to protect ourselves from what has become a dangerous monopoly of the retail jewelry trade of this country by the so-called jewelry jobbing houses. We also invite the attention of the manufacturers to the justice of our demands, believing that it is their duty, as far as lies in their power, to protect us in the sale of their wares, as it is through the retail dealers that their goods reach the masses. In view of these facts, and to the furthering of these ends, we do establish this

#### CONSTITUTION.

ARTICLE 1. This Society shall be known as The Iowa Retail Jewelers' Protective Association.

ART. 2. The officers of this society shall consist of a President, two Vice-Presidents, a Secretary, a Treasurer and an Executive Committee of three. They shall be elected by a majority of the members present at the annual meeting, and shall hold their office one year or until their successors are elected.

ART. 3. Any vacancies occurring in any of these offices before the expiration of their term shall be filled by the Executive Committee.

ART. 4. The duties of these officers shall be the same as those of similar organizations.

ART. 5. A copy of the Constitution and By-Laws shall be sent to all retail jewelers in the State not in attendance at the Convention that they may sign the same and return to the Secretary together with the initiation fee, which shall entitle them to membership.

ART. 6. No member shall be expelled from this society until specific charges are presented in writing and the same are sustained by a two-thirds vote of the society or its representative authority.

ART. 7. Fifteen members shall constitute a quorum.

ART. 8. The Secretary and Treasurer shall report at the expiration of their terms of office.

ART. 9. This society may from time to time enact such By-Laws as it deems necessary for the government and regulation of the society.

ART. 10. The Constitution and By-Laws may be amended by a two-thirds majority present at any regular meeting.

#### BY-LAWS.

SECTION 1. This society shall meet on the third Wednesday in March of each year ; but a special meeting may be called by the officers of the Association.

SEC. 2. We recognize the practical or professional jeweler, who makes that calling his leading business, as the only legitimate customer of the jewelry jobber. In view of this fact, which has been utterly disregarded in the past, we do solemnly bind ourselves not to buy goods of any jobber or manufacturer who, after this date, willfully send out catalogues, price-lists or discount sheets, soliciting the trade of private parties or firms, not as we deem, legitimately in the watch, jewelry and silverware business ; or who sells direct to, or fills orders from, private parties or firms who may be in possession of, or have access to, catalogues heretofore issued.

SEC. 3. It shall be the duty of each member of this Association to report any violation of the above that may occur in his vicinity to the Secretary, whose business it shall be to notify every member belonging to the Association, as well as the Secretaries of the different States which may organize similar societies.

SEC. 4. The initiation fee shall be one dollar.

SEC. 5. The yearly dues shall be two dollars, paid half-yearly in advance.

The following were chosen as officers of the Association for the ensuing year.

William N. Boynton, of Manchester, President ; Henry Robinson, of Council Bluffs, First Vice-President ; Charles Bachman, of Ottumwa, Second Vice-President ; W. F. Bingham, of Monticello, Secretary ; W. W. Wormood, of Dubuque, Treasurer.

Executive Committee :—H. Plumb, of Des Moines ; W. H. Beck, of Sioux City ; C. H. Taylor, of Cedar Rapids.

The President, Mr. Boynton, was elected a delegate to attend the Chicago convention in April. The Watchmakers' and Jewelers' League of the United States, send as a representative to the Association, Mr. A. P. Boynton, of Chicago. The convention recognized the Jewelers' League and its representative in the following manner :

We, The Retail Jewelers' Protective Association, of the State of Iowa, were pleased to meet your representative, Mr. A. P. Boynton. We were also pleased to recognize his credentials and extend to him, as the representative of The Watchmakers' and Jewelers' League of the United States, the right hand of fellowship, and assure your organization that you will receive our hearty co-operation as a State Association. We will be pleased to be represented in a similar manner at your convention next April by our President, Mr. William Boynton, of Manchester Iowa.

A vote of thanks was extended to Mr. Osborn for his services as Chairman ; also, to the jewelers of Marshalltown for free use of hall, etc. A report of the Convention was ordered published in THE JEWELERS' CIRCULAR.

The report of Mr. Lewis, Treasurer *pro tem.* was accepted and the Executive Committee ordered reimbursed for the expense of issuing calls for Convention ; amount, seventeen dollars and ninety-seven cents.

The Secretary's salary for the ensuing year was placed at one-hundred and fifty dollars.

Adjourned to meet the second Wednesday in September at Des Moines.

W. F. BINGHAM, *Secretary.*

The following is a list of the charter members of the Association :

Ezra Nichalls, Eldora ; Alph Koonts, Albia ; Park Finley, Bloomfield ; Chas. Bachman, Ottumwa ; Wm. P. Hansen, Belle Plaine ; J. P. Alden, Oscaloosa ; J. C. Adson, Albia ; L. Fish, Mt. Vernon ; Freeman Townley, Fairfield ; Geo. A. Warden, Ottumwa ; A. H. Belle, Belle Plaine ; J. H. Stanley, Cedar Falls ; H. P. Bristol, Jefferson ; E. M. Howes, Clinton ; Belk & Dickinson, Clinton ; O. Startzman, Iowa City ; W. W. Wormood, Dubuque ; C. S. Raymond, Clinton ; H. P. Proctor, Grinnel ; D. R. Lewis, Manchester ; W. F. Bingham, Monticello ; Geo. Phillips, Brooklyn ; A. D. Hill, Atlantic ; G. M. Godfrey, Ottumwa ; Henry Plumb, Des Moines ; Edd Hornstein, Boone ; F. A. Bristol, Tama City ; A. C. Taylor, Cedar Rapids ; J. W. Morgan, Marshalltown ; Balliet & Weld, Waterloo ; F. H. Peck, Waverly ; Withers & Bates, Traer ; N. Stenenger, Dennison ; Will H. Beck, Sioux City ; W. N. Boynton, Manchester ; S. H. Clauson, Dennison ; John Broadhead, Marshalltown ; Henry Robinson, Council Bluffs ; J. C. Miller, Nevada ; Israel Moore & Co., Marshalltown ; E. E. Halsted, Waterloo ; C. E. Mann, Mason City ; A. W. Hurst, Centerville ; F. S. Widl, Marshalltown ; J. B. Stenenger, Tipton.

Mr. Boynton, President of the association, has issued a circular to the retail dealers of the State, inviting them to join the Association. We quote the following, which has the right ring and evidently means business :

"Do not forget that it is the leaguering together of the smaller dealers that will quickly bring these pillaging jobbers to time. Too long have we delayed this matter. Too long have we meekly submitted to the wrongs heaped upon us ; so long, indeed, that it is a serious question to-day whether the watch and jewelry business, as a distinctive branch of trade, must not cease to exist. Look about you, on either hand, and see the ruin wrought, the havoc made, with our trade, by these marauders who, not being content with selling us their goods, must build up competition on every corner, till the grocer, the druggist, and every peanut-stand in the land dabble in jewelry. Even this we might endure, for these parties must have a profit to live, and we could share the trade with them, though our children went hungry and our wives in rags ; but when these so-called jobbers send forth, broadcast over our land, their illustrated catalogues with discount sheets equalling the discount given us, offering to sell a single article to a private party—a *non-dealer*—at

the same rates they sell us in quantities, thereby taking advantage of the extra discounts they receive as jobbers, to rob the retailer of his trade, our business is wrested from us, and the day of the retail jeweler is doomed. Is it not high time that we all unite, and in the name of those dependent upon us for support demand from the manufacturer that he confine the jobber to his proper calling, or grant us the same rates of discount given the so-called jobber, that we may compete with him?—for the legitimate jobber no longer exists in the West, but in isolated cases at the best. It is for us for you to say whether we longer submit to this wrong or not. Will you join with us in demanding the rights that are ours? Not in a "bulldozing" way, but with that earnest firmness, manliness, honored among men. Let us be moderate, if moderation will do, but if forced to 'throw stones,' by the gods we will teach them the weight and solidity of the Iowa 'hard-heads.'

"If two-thirds of the Iowa jewelers so determine, success will be ours. Already our sister States, Minnesota, Wisconsin, Illinois, Missouri, Nebraska, Kentucky, Ohio, Michigan, Indiana and Tennessee are taking action in this matter. Shall Iowa, who was foremost in the field, prove least in numbers when marshaling her clan? This, sir, is for you to say; for your action to answer.'

### A Voice from California.

*Editor Jewelers' Circular :*

In knocking around from place to place, as my business calls me, many peculiar notions are presented to me, but no where that I have ever been have I found such ignorant narrow ideas as possess the business men of this Coast. Details of an association just being formed here for the protection of the jobbing jewelers being brought to my notice, and believing it would be of interest to your readers, I give you the details. To more fully understand the intention of this association, you must know, that all operations on this Coast seem not to be able to survive except when worked on a monopoly basis, *i. e.*, the railroads are all in the hands of one corporation. The mining stock board another, and the different branches of business if possible are conducted in the same way; in the jewelry trade one man claims to own or control the whole trade and says he can rule or ruin who he likes.

The original plan of doing business is for a jobbing house to supply a retail house with all the goods they want, and carry the accounts; if the retail house gets a little slow, interest at the rate of ten per cent, a month, compounded every month, has been charged; when profits were large this rate of interest did not bother, but now with small profits this interest has become such a load as to make it almost impossible for a dealer so situated to live; some recent failures, and a flaw in the insolvency law which gives the first party attaching a firm of *more than one person* a preferred claim, has caused a feeling of distrust which would have closed very many retail stores, and bothered if not closed many of the jobbers. To stay this panic, a combination of the trade has been formed for mutual protection, specially in making the attachment of any member include all claims held by the association. Any movement that tends to bring the members of a trade together in consultation, and to acquaintance with each other is of course a good thing; now comes the rub and giving you the first article of the By-Laws shows the narrow mindedness.

ARTICLE 1. All manufacturing and wholesale jewelers and dealers in articles connected with that trade, whose *principal place of business* is in San Francisco, and the *resident representative* of the *Seth Thomas Clock Company*, shall be eligible for membership.

This article purposely bar out all New York houses having representatives here, with the one exception, and as the jobbers do not carry clocks, the Clock Company is no competitor, while the other New York houses represented here are competitors. You can readily see the point. At the first meeting to organize this association the New York houses were invited; at that meeting a Committee was appointed to make By-Laws; at the following meeting the New York representatives were not invited, and I am creditably informed that at the meeting when the By-Laws were presented not a *native born* American citizen was present; the trade is mostly in the hands of Germans, many of them Jews; so you can see that in this glorious country

of California, not only the "Chinese," but the American born if representing New York houses in the jewelry line "must go."

The jobbing jewelers at the present rate of profit on their old plan of doing business, can make no money and do not seem to know how to get their business in a profitable shape, and think if they can only drive out the Eastern houses they can get their former large profits. To accomplish this they are ready for any scheme, but if they can not find some better plan than the one just adopted, I fear they will not accomplish much as it virtually gives the Eastern houses the whip handle, as they can guard themselves without protecting the rest of the trade. The blustering way these people go to work, one would think they would rule or ruin, but in case they find they cannot rule, they stop far short of the latter, as this would involve ruin to themselves.

The dealers trade are doing all they can to get out of the way of trading with the jobbers, as you can readily judge from the foregoing, and also because all the jobbers sell at retail and often sell the retailers own customers. In talking to representatives of New York houses, I should judge they are well satisfied that the trade has made this association and better satisfied that they have been left out in the cold. This is a great country and a glorious climate, and the most liberal people in the world, if one does not enter into competition with them.

In the recent failure of a large jeweler, the *fair dealing* of the principal creditor, the wholesaler who claims to own the jewelry business here, and who claims also to have everything his own way in this one failure, is to be *commended*. The creditor's lawyers had a letter drawn up, addressed to the sheriff, purporting to come from the debtor, requesting the sheriff to sell the whole business, stock, fixtures and all, in one lot to the highest bidder, the creditor calculating in this way he would have no competition, and not only satisfy his own claim, but make a good thing beside in obtaining the stock, store and fixtures, at less than half its value; especially as he had had his men take the stock and no one else had had the opportunity. The debtor refused to do it, of course incurring the enmity of the creditor, who ordered the store closed till he could obtain judgement.

March 22d, 1879.

MORE ANON.

### A Change of Base.

F. G. Meyer has removed to 53 Nassau Street.

J. M. Goddard has removed from No. 25 to No. 3 Maiden Lane.

J. F. Fradley removes from 21 to 20 John Street,

George A. Eaton & Co., have removed to No. 15 Maiden Lane.

Julian Galliet has removed to No. 1 Maiden Lane.

Champanois & Co. have removed to No. 1 Maiden Lane.

J. S. Franklin has removed to No. 41 Maiden Lane.

Lincoln, Tiff & Co., have removed to No. 15 Maiden Lane.

The Wilcox Silver Plate Co. will remove from No. 21 to No. 6 Maiden Lane.

H. Muhr's Sons will remove about May 1st, to 633 & 635 Chestnut St., Philadelphia.

D. Prince, of Newark, has removed from 63 R. R. Avenue to No. 13 and 15 N. J. R. R. Av. of that City.

Carter, Howkins & Sloan have moved into the front office formerly occupied by E. Howard & Co. of the Whiting Building.

Frankel & Folkart will remove on or about May 1st, from 192 Broadway to 21 John Street.

E. Howard & Co. have removed from the Whiting Building to No. 2 Maiden Lane.

Cross & Beguelin will occupy the ground floor of their old building No. 21 Maiden Lane, about May 1.

Tiffany & Co.'s wholesale Watch department has removed from No. 14 John Street to their new offices in the Whiting building, Broadway, corner Fourth Street.

The Whiting Manufacturing Co. will occupy the ground floor of their building, cor. Broadway and Fourth Street about May 1.

Richard Oliver will remove about May 1st from No. 11 to No. 23, John Street.

Simpson, Hall, Miller & Co., have removed to their new store, No. 36 East Fourteenth Street, corner University Place, Union Square.

A Bernhard & Co. will occupy the three upper floors of No. 2 Maiden Lane about May 1.

Charles F. Terhune & Co. have removed from No. 17 to No. 16 Maiden Lane, ground floor.

Chatellier & Spence will remove from 652 Broadway to the room formerly occupied by the Whiting Manufacturing Co., in the Whiting Building.

## Proceedings of the Horological Club.

## A DISTINGUISHED BODY OF WATCH AND CLOCK MAKERS.

*Sixty-first Discussion.—Communicated by the Secretary.*

[NOTICE.—Correspondents should write all letters intended for the Club separate from any other business matters, and headed "Secretary of the Horological Club." Direct the envelope to D. H. Hopkinson, Esq. Write only on one side of the paper, state the points briefly, mail as early as possible, as it must be received here not later than two days before the end of the month in order to be discussed and reported in the CIRCULAR for the next month.]

[*Personal.*—The Secretary is in receipt of numerous letters referring to his absence from the last meeting of the Club, and wishes to express his regret that the readers of our Proceedings should have been deprived of their monthly budget of information through his means. It was unavoidable, however, and totally unexpected, until almost the hour of meeting. As the members present were informed of his illness and inability to report their remarks, and furthermore, as he had with him all the letters, etc., sent in for consideration, the honorable gentlemen could hardly have done otherwise than they did, viz.: make the evening pass off as pleasantly as they could. So far as they were concerned, their heads certainly were level. The blame, if any, for the absence of the usual character of matter, the Secretary takes entirely upon himself. He has this consolation, however, that it has afforded an opportunity to learn how widely and closely our Proceedings are read, and this knowledge will spur us all to new endeavors to meet the expectations of our vast army of friends.

We would request them not only to read and be profited, but to each add his mite to the monthly store of ideas. Do not be content with merely asking for information, but send in your own "wrinkles" and "kinks," improved ways of working and new tools. And when a question is answered here, if you have some other way which you think better than that described, or just as good, write it out and send it along. Almost every one has found out something that others would be glad to know, and if each would communicate his little trade secrets, a vast stock of valuable hints would be gathered up,—now useful only to one or to a few, but would then be of great advantage to all,—and even those who had contributed their share would receive back many fold more than they gave. Nor need they fear giving the benefit to those who would give nothing in return, for this latter class, as a rule, have no information worth giving. They can neither learn by their own experience, nor profit by that of others.]

## CLEANING SILVER THIMBLES.—DATING TIMEPIECES.

*Secretary of the Horological Club :*

Will some one of your Honorable body please inform us how to clean such an article as *Silver Thimbles*, perfectly clean and white? When we get a new lot of thimbles, they are white and nice, but after a while they become brown and look bad, and we know of no means whereby to restore them to their original whiteness, especially the countersinks, or needle holes.

Also, please inform us the reasons why *Time pieces*, are not dated, so as to show at what time they were made. D. P. & S.

Mr. Clerkenwell advised to dip in a solution of 3 oz Cyaide of Potassium to 1 quart of water. This will take the tarnish or oxide off. Wipe the plain part with a clean chamoise skin. If this will not restore them, they will have to be annealed and refinished.

If makers of Clocks and Watches were to put the date on their goods, and did not sell them very soon after, no one would buy them, because they would say they were not new.

## GLOSSING ESCAPE WHEELS.

*Secretary Horological Club.*

Please inform me the best way to *finish* and *gloss* an escape wheel, as those seen in fine English watches? There is no trouble in finishing the sides, but I fail to get satisfactory results with the teeth and web.

W. P. H.

Mr. McFuzee said it was done in English shops with a hard leather lap, of the same shape as the second cutter, (which gives the shape to the tooth, after the first cutter has roughed it out,) and used dry, with very fine glossing stuff. Common rouge is not suitable, as it is liable to stick to the leather and clog. Four or six wheels are usually glossed at once, and the inner ones will be found to be more finely finished than the outside ones, which are generally a little streaky. The leather lap should bear very lightly, and be well supplied with the glossing stuff. It would be difficult to gloss one wheel separately, as Mr. H., probably desires to do, by this method,—unless he should cut a false plate to support the teeth underneath, while glossing, to prevent them being bent; even then it would be a slow

and risky undertaking. If he is able to cut the wheel itself, in the first place, he could at the same time cut the supporting plate, the two being cemented together with as little cement as possible, or else use a second plate over the wheel, when the cement would be needless. Then gloss the teeth and web of the whole, before taking them apart or disturbing them.

## MAKING WATCH HANDS.

*Secretary of Horological Club :*

I should like to know if watch hands are made in this country, and where? If I could find out the different processes they go through from the ruff stock to finished hands, I would be willing to pay for the desired information. If you can inform me I shall be much obliged.

W. H. B.

Mr. Waltham replied that hands are made from flat steel wire, obtained from Washburn & Moen, of Worcester, Mass. This is run through a self-feeding power press to punch out the blanks, which are annealed, and then swedged under drops, to the form of the hand to be made,—either "Spade Moen, Morning Glory, or Flour de Lis." The swedging of hour hands draws up the socket, after swedging, the "Flash" or "Fin," spread out between the dies, is punched or "Trimmed" off. Holes for hour wheel and setting arbor are drilled or punched, and then reamed to size. They are then hardened, "tumbled," to clean and break off burrs and roughness, then tempered, straightened, polished, blued and carded for market.

The highest skill is required in making the swedging and trimming dies, as they must be alike in profile, so that the trimming shall exactly correspond with the swedging. The "Flour de Lis" require great care and skill in the making of dies. The dies are made in halves, *i. e.*, there is a joint in the die through the axis of the hand.

## ANOTHER UPRIGHT HOLDER.

*Secretary of Horological Club :*

I have for 18 months been using a tool of my own invention and make, something similar to that described by Excelsior on page 41 of his "Treatise on the Balance Spring," the principal difference being that the base of mine is a common movement holder, made so as to take in the whole plate of a watch, or the watch dial, plate, hands, and all. The rim of the holder has a hole drilled through it, through which the main upright rod is placed, and its thumb nut screwed on underneath, until perfectly tight, solid and upright, and at a true right angle from the movement holder all around. The other parts are the same in principles of working, but not exactly in shape, save that I use no bristle.

I had been intending to get a patent on it, as I was not aware of the fact that any such an instrument was ever used by another.

I like mine better than that in the book, as it dispenses with his *base*, as he has to use a holder too, and with mine I can get a hold on any kind of a watch—and with that it appears to me to be difficult on some kinds that I have seen. I can hold one with dial on, hands and all, as well as with them off. Mine is used for very many purposes beside hair-spring fitting.

L. W. B.

*Secretary of Horological Club :*

Enclosed please find a photograph of an upright holder like which Excelsior describes in his "Treatise on the Balance Spring," except that it is fastened to a movement holder, which I think is a little improvement on his, as it leaves both hands free to work with the spring. I made it all of rough material but was something over "a day" doing it though.

R. J. S.

Mr. Isochronal said that the attaching of the Upright holder to the Movement holder was not new, as a correspondent in Illinois had sent us a tintype of one a couple of years ago, and several had since described the same combination. The great trouble in that construction was that, if the notches in the jaws of the movement holder were not formed exactly as they should be, they would hold the watch movement in a plane which would not be at a right angle with the upright slide or the arbor. In other words, the arbor would not be vertical to the watch plate, and would hold the balance staff out of upright. Movement holders are not generally considered "tools of precision," nor need they be so for the uses they are made for. The jaws, even if true in one position, may not be true when moved to a different one. Even screwing them down more or less tightly may change them.

But the base shown by Excelsior will infallibly secure truth, (unless the watch plate has been bent or "butchered,") as it is made true itself, and then clamped directly upon the plate. Excelsior's tool is also used for many other purposes, which he specified. He says that merely for hair-spring fitting perfect truth and accuracy are not necessary,—but it is always better in making a tool to make it as it should be, while you are about it.

Mr. Satterthwait's upright holder was very neatly made, but there



was more labor expended on it than necessary, especially in the upright slide, which would be quite as servicable if made of the same size all the way up, and would be more handy so, in some cases. The bristle-holder should have the milled head on a long wire, which will reach out over the movement far enough to enable the bristle to be brought up against the rim of the balance, to hold it till the instant for starting, when the seconds-hands of the watch and the regulator coincide, and so that the slightest notion of the milled head will instantly let the balance free, starting off with a full vibration,—and will as instantaneously stop the balance again when desired, for comparison of time.

Several correspondents had mentioned the attaching of the upright to the movement holder, for the great advantage of leaving both hands free while working, but there was nothing to prevent the watch being held in the movement holder, or in any other way most convenient, after the upright holder was attached to it. Excelsior's tool was more handy in one respect, that the watch could be taken out of the movement holder, and turned over for inspecting the hands or comparing time while the watch was running, without disturbing the upright holder. This could not be done with the upright attached to the movement holder, especially when the latter has a close plate for its base. In such a case, the movement must be taken out for inspection, and then carefully readjusted to its former position when replaced. So on the whole he was inclined to think Excelsior's plan would be preferable.

Mr. S., speaks of it taking him over "a day" to make his tool. No doubt it did, for it was nicely gotten up. Nevertheless, after getting the materials together, by using straight polished steel rods, (which could be bought of material houses,) of the right sizes, for the arbors or slides, drilling the holes as described on page 41 of the "Practical Treatise," and not spending too much time on the thumb screws, he thought, one could be well made in a day. But it would be worth while spending several days on it, for the sake of the ease and perfection of the work that could be done by its aid.

#### MAKING WATCH JEWELS.

##### Secretary of Horological Club :

You could do myself, and may be a good many of your readers, a favor by stating in one of your next numbers, how to make the different grades of diamond dust, and what disks or laps the American Watch Factories use for grinding and polishing jewels? Or if it is described in any of the past numbers, point out where it can be found. An old one always willing to learn.

Our correspondent will find that two or three articles on making watch jewels have been published in the *Circular* within a few months, and others will follow at intervals.

#### HOW TO ALLOY COIN GOLD.

##### Secretary of Horological Club :

Can any book be purchased, that tells, how to alloy gold to any karat? Please answer in *Jewelers Circular*. If not, how is 18 karat gold alloyed out of coin. F. H.

Mr. Rolliver replied, coin is about 22 karat fine. To find out how much alloy you need to a dwt. of coin, multiply the 24 grains in a dwt. by the quality, 22, and divide the amount by the quality you wish to make your gold. You will then get the number of grains of alloy you need to each dwt., by deducting the 24 grains from the product of dividing.

#### INFORMATION WANTED ABOUT A LONDON CLOCKMAKER.

##### Secretary of Horological Club :

Will you have the goodness to tell us what you can respecting a clock maker named T. Lowndes, of London, when he lived, about date of death, etc., or refer us to some work from which the information can be derived, and much oblige. Yours truly, T. & Co.

As none of the Club present could give the desired information, we should be pleased to hear from any reader who may know.

#### PRACTICAL HINTS ON WATCH REPAIRING.—EXCELSIOR'S BOOK.

##### Secretary of Horological Club :

I have received the first number of the *Circular*, and notice in the "Proceedings of the Horological Club," a letter signed S. & P., asking for information as regards, "Practical Treatise on the Balance Spring and the Compensation Balance," also "Practical Hints on Watch Repairing," and you say they are not the same. Now I write to ask whether the first named book can be bought, and at what price, the lowest? Also, if the second named book is the same, in book form, as the series of articles now being published in your *Circular*? Please answer, as I have been contemplating the purchase of some work pertaining to watch repairing, and judging from the articles by Excelsior, think that it would be just the thing I have been looking for. J. M. W.

Mr. Isochronal said that these questions had been answered over and over. But every month new subscribers ask them again, and of course we repeat the answers, feeling it our duty to assist all we can in the dissemination of works of such value as these unquestionably are.

"The Practical Treatise on the Balance Spring, and the Compensation Balance," contains the first series of Excelsior's Practical Hints on Watch Repairing, revised, enlarged, and republished in book form by D. H. Hopkinson, Esq., the publisher of the *Circular*, who sends it postpaid to any address for \$3 50.

The Practical Hints now running, in the *Circular*, are the second series of those articles, which is not yet finished, and of course has not been republished, and cannot be till finished. The back numbers of the *Circular* containing these articles have been so extensively called for, that the large number of extra copies printed have been entirely exhausted, except those of quite recent date. There is therefore no way to obtain the earlier articles except to borrow some neighbor's *Circulars*, or wait till they are brought out in book form. He hoped that, when that was done, a liberal edition would be published, as there was no other work for which such a demand had arisen in the trade as there had been for this and its predecessor, and he would add, that there was none which deserved it more. He was prompted to these remarks by the fact that the supply of the book already published was getting short, and might soon be exhausted. Those who had not already secured a copy should do so at once. A synopsis of its contents is given in the *Circular* for September, 1877, and the Club has given it the highest praise and endorsement at several meetings.

Another reason for explaining this matter so fully is that, very often subscribers would send for "Excelsior's book on Watch Repairing," and on receiving the Practical Treatise would think they had not got what they sent for, and write to the Club asking if they were the same thing, etc., etc. We generally pay no attention to such inquiries, having more important questions to answer. In a few days they would generally write again, saying that it was all right, just what they wanted, the best work on the subject they ever read, sorry they had troubled us about it, etc., etc. It was of course very proper for them to apologize for their mistaken complaints, but it would be still better if they would look a little further than the title page, before sending them. The introduction gives in full the information which we were asked to send "at once," or "in the next *Circular*." If purchasers would wait till they had read a little in the book and knew something about it, they would not need to write at all, and would save themselves, us, and the publisher much time, trouble and annoyance. So many such letters, and subsequent apologies, had been received, that he had felt called upon to refer to the subject this once, to show why they had never been answered. As for the occasional customer who thinks the whole art of watch repairing, in all its details, ought to be taught in one book, it would be a waste of powder to answer him at all. He is only fit to be held up before the Club as a horrible example of the effects of ignorance.

#### REPAIRING GERMAN JEWELRY.—TEXT BOOK FOR ENGRAVERS.

##### Secretary of Horological Club :

Please state the best way for repairing German jewelry, that is filled with wax, as I find it very difficult on account of the wax boiling out.

Also please state where I can get the best Text Book for Engravers, and oblige. M. K.

Mr. Rolliver thought that the best text book on engraving was "McLeish's Alphabets for Jewelers and Engravers use," price \$2 00.

In repairing jewelry filled with wax, if you want to hard solder it, you must warm it and let all the wax run out. You can refill it by putting it in a pan of melted wax. Cover the outside of the article with plaster of paris; the wax will not then adhere to the gold.

If you want only to soft solder the article, you must blow the flame and melt your solder very quick. Some wax will run out but not enough to hurt.

#### ROUNDING-UP CONES, C. J. B. Z.

##### Secretary of Horological Club :

In the old "Horological Journal," formerly published by G. B. Miller, there is on page 129, vol. 4, for 1873, a Rounding-up cone described under the head of "The Rounding-up Cone, C. J. B. Z." Are they to be had in this country? And if so where, and what is the cost complete, and what for the Cones alone? E. B. W.

The Chairman called upon Mr. Uhrmacher, to inform our correspondent as to the cost and operation of the set he had.

Mr. Uhrmacher said he would have preferred to say nothing about them, as they had not met his expectations. He had described their construction and operation before the Club at the meeting for December, 1876, as given in a circular he had received about them, at the

same time expressing his opinion that, if well made, they would be very useful, and also very much cheaper than the well-known Rounding Up Tool. Besides, he thought that in many cases the Cones would be preferable for truing up wheels already staked on their pinions, evening the spaces between the bearing surfaces of the teeth, and changing the curve of the points to suit their particular pinions, and secure ease and smoothness of motion.

He had afterward written to Mr. Grossmann, the agent in Germany, and who had written a letter to the Club calling attention to these Cones, at the same time remitting the regular retail price for a set of five, which was 32 francs in gold, and requesting him to have the kindness to see that a perfect set was sent, as he (the speaker) would perhaps be again called upon to report to the Club concerning them, and would like to be able to report favorably, for the credit of fatherland, if for nothing else.

After a delay of several months they came, but he was sorry to say that they were unfit for use. One Cone, out of the five, was true at one end, the other four were not true anywhere. Of course he could have gone to work at them, and perhaps get them in a fit state to use, but he had never bothered with them, as he had a good Rounding Up Tool, and, besides, did not care to waste his time in making over the abortions of others. If anybody wanted to try it, he could have the whole set in the original package, for one-half the cost. [To this offer, there was no response.]

He still thought, however, that the principle was a good one, and capable of giving a useful and valuable tool. Whether foreign tool-makers could not make them correctly, except by chance, or whether they thought anything was good enough to send over to this country, he did not know. But he certainly could not advise Mr. W., to waste money, time and patience on these things. The Hopkins Tool Company make a series of straight pinion-shaped cutters, but they were not so desirable as the Cone shape, and they were also designed to be used by rolling them in the fingers,—a way of using which he could not recommend at all. But if that Company, or some other, would make the regular Cone Rounders, for use in a suitable tool or frame, and make them as they should be, and as the foreign article is designed to be made, he thought there would be a paying demand for them. Otherwise he could only advise workmen to buy a good Rounding Up Tool, which could now be had for from \$30.00 to \$50.00 according to quality and number of pieces.

Mr. Rubypin said that he had obtained a set of them, before the gentleman who had just spoken, and his experience had been precisely the same, so far as regards their being unfit for use. He mentioned this to prevent our friends on the other side of the water from thinking that Mr. Uhrmacher was the only one who had received poor ones,—or that his unfavorable comments were occasioned by his personal loss,—which we all knew would be impossible in his case, and that he was a gentleman who would not say what he thought was right, regardless of the money view of it.

Mr. Uhrmacher only hoped that some of them would insinuate such a motive, and he would bring forward an array of names and facts that would make some old country personages squirm in their boots, if they could feel any shame at having their rascally practices brought home to them. These Cone Rounders were not the only frauds sent over here from abroad. It was so in other tools, and watch materials of all kinds,—cheap watches, clocks, and small wares of every description. What was too poor to sell at home, the refuse of the factories and shops, was gathered up, and the miserable rubbish sent to America, as if they thought the Yankees were a nation of idiots, who could not tell whether anything was good or not. Ask any old-country workman what he thinks of the largest share of the materials brought over here. Mr. U., said he would like to enlarge upon this subject, and thought he could make it interesting—for some. But he had already spoken so long, he would desist. [Cries of "Go on! Go on!"] He thanked the members for their support and approbation, but there were other meetings to come, after this one. There was a time for all things.

#### BALDWIN'S BARREL-CATCH INSERTER.

is a very handy little tool sent in for inspection by Arkell & Company, of Canajoharie, N. Y. It consists of a drill for drilling the hole through the barrel, a screw tap directly behind it, for tapping the hole, and a little further back is a die for cutting the thread on a wire, to fit in the hole and form the hook. All is in one piece, saving the trouble of looking up drills, taps and screw plate holes of the same sizes, and it would seem quite possible, as the inventor claims, to fit in a new catch or hook, all complete, in one minute. There are three different sizes or sets, enclosed in a nice handle or case, and sold for \$1.25.

#### HERZOG'S RIVET EXTRACTOR.

is another handy and excellent tool, used for removing the rivets from the joints of breast pins, lockets, bracelets, etc., which it accomplishes

to perfection without hammering, marring the joint, or spreading the end of the rivet. It can be used even in the worst cases, where ordinarily another workman would have to be called to strike the punch. It will be indispensable to every workman who cares for his time or temper, or the looks of his work. It is sold for \$1.00 by A. S. & J. Herzog, 51 Nassau Street, New York.

#### WATCHMAKERS TROUBLES, NO. 6.

##### Secretary of Horological Club:

At the request of Mr. Clerkenwell, I will explain in what way, and the terms I used to take apprentices and improvers at watch making and repairing, always using the old fashioned Swiss lathe, as I never used any other for pivoting or fitting pinions or staffs. After taking a boy about 15 or 16 years old on trial, I could see in a few months if he had any mechanical ideas about him. If I found that he had not, I would not have him at any price, or undertake to teach him. But if I found that he seemed to like the business, and would take to it readily, I would engage him for from 4 to 5 years, paying him three dollars a week for the first year, and increasing his pay each year at the rate of one dollar more per week, for the remainder of his time, but giving him a chance to make overwork as soon as he was competent; which if he was at all smart and intelligent, he could easily do at the end of the first or second year. By this, if industrious, he could earn as much by overwork as by his wages. This I never found any to object to, and by the time their apprenticeship was over, if there was any work on new pieces to make, etc., that they had not the time or inclination to make, they at least knew how they should be made to be correct, and were then enabled to find out defects in watches, and could either correct them, or tell how it should be done—for there is one thing that I wish to mention, and of which I am certain; that if a watchmaker or repairer is keeping a store, and has to get up from his bench every few minutes to attend to customers, regulate watches, etc., there are certain parts of watch-making that it will be next to impossible for him to do properly himself, such as pivoting fine work, escapement making, setting depths, fitting hair-springs, particularly Toropronal ones, adjusting, etc.

Its for myself, after having worked for years at making the repeating parts of watches, and I considered that I was a good turner and filer, as well as a fair mechanic, I had to pay in London a premium of 50£ sterling, or \$250 for one year's work at escapement making, pivoting, and finishing on fine Lever and Duplex movements. In Europe it is usual to pay a premium varying according to the term of the apprenticeship, and the skill of the master. Its to my terms of taking improvers, or young men who had worked or picked up the business, and could file or turn, and thought that they were watchmakers, because they could take a watch to pieces, brush it out, put it together, and it would tick right or wrong; but knew very little of the principle of horology. I would take them for 2 or 3 years, paying them about five dollars a week for the first year, and raising their wages as they showed improvement. I never objected to paying them the full value for their services, or ever had any that have worked either with or for me that would object to do so again. They might say that I was *too particular* with my work, but I maintain that it is the only way that good workmen are made, in never leaving anything to pass by saying: "*Oh, that is good enough, it will pass.*" If you pretend to do anything good, do it over and over again till it is right, do not leave any fault or defect to be found, if your work is examined by good and practical workmen after it leaves your hands. In taking improvers, there is often great trouble; in getting them out of many bad habits that they sometimes have got into, particularly if they have worked with *botches*, or have picked up the business, and they are often too proud to be advised. It is more difficult to get them out of their way of working, than it is to teach one who never had a pair of tweezers, a graver, or a file in his hand, and they require more watching, as they will often when hurried, scamp their work.

For a young man who has the means and opportunity of keeping a store, it certainly is desirable that he should understand something about watch making and repairing, but otherwise, if possible, learn some other trade, as it is not a healthy trade, unless one has plenty of exercise, for the mind, eyes and brains are taxed to much by following it too closely. I had myself to leave the bench for some years and work at farming, before I could resume working at watch making. But without wishing to discourage any young man, who wishes to be a watchmaker, if he has a taste for it, I will say, learn to file and turn well, go under instruction with some good practical workman, and get a copy of "Excelsior's Treatise on Watch Making, etc." By it he can learn the whole theory of the watch, but to make him more perfect, he will have to study it practically, on watches. Such is the advice of

EXPERIENCE.

The members as usual, agreed with Mr. E., and several wished to add suggestions, but it being late a motion to adjourn was carried.

## Practical Hints on Watch Repairing.

BY EXCELSIOR.—No. 49.

EXAMINING THE ENGLISH OR "PATENT" LEVER.—Continued.

(768) *The Mainspring* should be long enough to give the arbor at least  $3\frac{3}{4}$  turns, and not more than  $4\frac{1}{2}$  turns. For directions for fitting, see sections (680, 711). Also, see (785) to (788). The strength should be such as will give the balance a good motion, when the movement is in good condition, but no stronger than necessary to do that. One and one quarter turns constitute the most desirable arc of vibration, from one extreme to the other. But in cheap movements it might take a spring strong enough to tear the works to pieces to get that vibration, and, for such, three-fourths of a turn will be as large a motion as can ordinarily be expected. In putting the movement together, key up the mainspring one-half to three-fourths of a turn of the arbor; and more if the spring is quite long, and will allow it. Much depends upon the spring being well keyed up, in the English lever. That amount will insure a good vibration of the balance till the chain is all off the fuzee in running. Of course, the spring must not be keyed up so much that it will not allow the fuzee to wind the chain clear up, as the winding will then be stopped by the chain, instead of by the stop works; with imminent risk of pulling the chain apart every time you wind. This can be avoided by allowing three turns of the arbor for the winding, and the rest for keying up.

(769) The mainspring hook, to hold well, should not be large, and should fit its hole in the barrel nicely, but not too tightly. The sides of the hole should be sound and square; the front or holding end should exactly fit the front of the hook, but the back end may slope more, from the outside of the barrel to the inside, than the back of the hook does, so that the latter will enter easily, and fit perfectly on the outside. The pivot of the hook should be made near its front or hooking end, as it holds the spring more firmly and safely. If a new hook is wanted, drill the spring at the right height for the hole, by marking it through the hole in the barrel. Then file up the hook steel to fit the barrel hole, put it through from the outside far enough to form the pivot, and mark the curve of the barrel on its side. This mark will show the shape of the base or shoulder to fit the spring, and also to make the pivot vertical. Rough out the pivot with the file, and finish cutting it with a hollow drill. File up the shoulder of the hook, slightly countersink the hole on the inside of the spring, rivet the hook in, cut off to the right length, and finish just level with the exterior of the barrel. Be careful not to file the barrel or mar the gilding.

(770) *The Chain.* The length of the chain depends on the movement; when there is plenty of room between the plates, and the fuzee sits low, chain may be longer than if the facts are not as above described. But there should not be over one-half (or three-quarters at the utmost) of a turn of chain on the barrel when wound entirely up. But if the fuzee sets well up to the upper plate, the chain must be very short, to prevent "riding." Not over one-quarter inch of chain should rest on the barrel, when wound up to the stop, in such a case, and it is also well to file the top of the hook sloping, to guide the chain off, if it should be inclined to ride. If this will not cure the riding, another hook hole must be drilled a little higher up in the barrel. Always drill obliquely, to avoid broaching out the hole too large; and always plug up the old hole, and finish off nicely, both for the looks, and to save future trouble and loss of time by mistaking the correct hole. If the chain then rubs the plate, a groove should be turned around the edge of the barrel opening through the plate, to free it.

(771) If the chain-hook hole is improperly placed in the barrel, it will cause trouble. If it is too high, the chain will rub around on the potance plate, and if the chain is also too short, the stop bar must be filed very thin or let into the upper plate. If the chain hook is too low, the second coil of chain will ride on the first, in running

back on the barrel. In the majority of watches, the hook hole should be drilled just low enough for the chain to well clear the upper plate. The length of the chain should then be regulated as in section (770). The point or lip of the hook should all enter its hole, so that the body of the hook may lie close to the barrel. The metal of the hole should fit the bearing surface of the lip, so that the point will be well supported up to the body of the hook, and not merely held by the tip end of the lip. If so, it will be very likely to snap off the hook, and the hole should be broached out till it will fit the whole holding edge of the lip.

(772) The mainspring and chain should not be wound entirely up, to test the length of the chain, etc., as above described, while the movement is together, lest you should have trouble to let it down safely. It is better to remove the third wheel, then you can safely and quickly wind the chain up and let it back at pleasure. To do this, fasten your pin vise or sliding tongs firmly and *straightly* on the fuzee-arbor square, seeing that there will be room for the vise or tongs to turn without hitting anything. Hold the movement between the thumb and the first and second fingers of your left hand, while you hold the vise or tongs pressed between the palm of the hand and the third and fourth fingers. When fully prepared, so that neither the vise nor the movement can turn, unscrew and remove the third bridge, first lifting up the end which will free the third wheel, before you free the fuzee arbor. Having got it off safely, take out the third wheel, and replace and screw on the bridge, when you can take the vise or tongs in your right hand, and let the fuzee slowly down. If the fuzee pivots are jeweled, some care must be used to avoid twisting the arbor, or allowing it to pull itself out of vertical while the bridge is off, or you may split the upper fuzee jewel. The balance should also be removed for safety during these tests. It may be necessary to say to the apprentice that he must never take out the lever or escape wheel, nor let the plates apart, while the spring is wholly or partly wound up, but must invariably first let down the mainspring as above, or else wait till the watch has run entirely down in the natural way.

(773) When wound entirely up and then let back, the chain should not ride; nor rub on the upper plate; nor on the potance; and should pull evenly from the first turn of the fuzee to the last one. If, on again winding, the chain shows any inclination to leave the groove of the fuzee, or "run over," the fault can be remedied by inclining the upper fuzee pivot a little away from the barrel, either moving the upper pivot from, or the lower one towards, the barrel. Sometimes the chain is inclined to lie down, flat on the barrel. This may sometimes be cured by putting on the chain "the other end to," but a new chain is better if the old one is an inveterate subject. The chain, when down, can generally be raised up by pushing the barrel backwards a little, to free the chain from strain, when it will spring up on its edge again. The best way is to take a rather blunt graver, rest it upon the pillar behind the barrel, and, using it upon the pillar as a fulcrum, with the point pressed firmly against the barrel, it can easily be set back a little. It must not be pressed back too far, or the chain may unhook, or drop over the end of the barrel. Nor must the point of the graver slip or break off, or the chain, and possibly the mainspring, will probably be broken. The chain can be moved up or down on the barrel, by running a thin screw-driver, or other similar tool, along the chain; but the pressure should be only against the *bottom*. If you press against the *upper* edge, you will tip it over, and perhaps break it.

(774) *The Stop Works* consist of a *stud* in the upper plate, carrying a *stop bar*, which plays freely on a pivot in the stud, and is normally held down by a *stop spring*. The chain runs under this bar, and as it coils on the finger it raises the bar till the winding is completed, when the bar is designed to be level with a projecting *beak*, fastened to or a part of the steel *cap* on the top of the fuzee, which beak then meets the end of the bar, and the fuzee is prevented from turning any further. When they meet, a line through the length of the bar should form a right angle with a line from the point of the beak to fuzee center. The length of the bar should therefore be such as to reach inward a distance equal to that of the fuzee center, and the length of the beak should be such that the bar will lap on the beak the breadth of its end, *i. e.*, the beak will just cover the end of the bar, not reach beyond it. The length of the beak will depend on how far the bar is set from the fuzee, which should be far enough to prevent it interfering with the fuzee grooves, when at its lowest position. The edge of the beak should be tolerably fine, but not sharp, and the notch in the end of the bar should be clear, and in the same line (horizontal) as the edge of the beak, so that they may take a firm and safe hold when they meet. If the parts are not as described, they will be liable to slip off, and fail to stop the winding, when a broken chain will be the result, and perhaps a broken mainspring also.

(775) The bar should be free to play up and down, but have little or no side play in the stud. If it does not play freely, remove the stop spring, and see what the trouble is. If the slot in the stud is bruised or rough, smooth it out; if too open, close it; if the pin or pivot binds in the bar, free it. The pin should be tight in the stud, but free in the bar, and if the bar hole is not large enough for freedom open it a little, and then take off any feather edge around the hole. If the end of the bar drops so low as to touch on the fuzee, it may catch in the groove and damage that or itself as the fuzee turns. The shoulder, back of the pin hole, is designed to rest against the plate and prevent this. If the bar drops too low, this corner of the shoulder can be stretched to hold the bar higher. The joint or flat of the bar, and especially its lower corner should not project outside of the stud, as it is liable to rest against the inner surface of the cap, when that is on the movement, which would prevent the spring from pressing the bar down, but hold the point up so that it would meet the beak the first time it came around in winding. Although the watch would not be wound up, it would seem to the owner to be so, because he could not wind any further, and the next thing would be the stopping of the watch by running down. When the flat projects out, it must be taken off enough to clear the cap.

(776) After winding up the chain and letting it back, so that it has found its proper place on the barrel, again wind clear up (with the sliding tongs on the fuzee arbor), and examine how the bar and beak meet. If the end of the bar is then too high or low, bend it so that, from the point of contact with the chain to the end, it will point lower or higher, respectively, and try again, till correct. The bar can be thus bent, when the chain is let entirely down, by a pair of plyers with long and thin jaws. Be very careful, or you may bend it too much and crack it. It can also be bent to make the point higher, without letting the chain down, by getting the end of the bar squarely on the end of the beak, and using a thin screw-driver between the beak and the stud to spring the middle down. Very often the bar gets as high as it can go before the chain is entirely wound up; and, when it is fully wound, the chain is considerably crooked by the bar. In this case, if the end of the bar is correct, the place where the chain rubs, called the "passing hollow," should be filed away to keep the chain from pressing up so hard against it. But the trouble may be that the end of the bar is needlessly thick. If so, file away the upper surface till it will not only rise high enough to let the chain remain straight when quite wound up, but can also rise a little higher yet when pushed up. Of course, it must not be filed enough to weaken it, but, when the end is as thin as it should be, complete the freeing of the chain, etc., by filing the passing hollow.

(777) After winding the chain entirely up, let it back slowly, and notice when the beak first reaches the bar, going down, whether the point passes freely over it or partly catches on the side. If the latter the upper surface of the bar should be filed down till the beak will not catch on the edge, nor rub on the top. This is supposing that the bar met the beak properly when entirely wound, and the chain was straight, etc., as described in section (776), and in such case, the above fault will seldom be found. After letting the beak back past the bar, as above stated, wind it up again till it comes just to the end of the bar, and notice whether they partly catch, or the beak passes freely above the end. In the former case, file away the upper surface of the bar, till the parts clear perfectly at the turn before the last, but meet properly at the last turn. After such alterations, see that the notch in the end of the bar is correct. The passing hollow should be well rounded and smooth, to favor the easy passage of the chain. No rule can be given for its depth, as that depends on how high the fuzee sets up to or into the upper plate. In fitting a new bar, an approximate rule is that, when pressed up against the plate the surface of the hollow should be on a level with the upper side of the top of the fuzee groove. But it must be tried with the chain, as before described, and altered till the chain can raise it to the highest point with as little rubbing and pressure as possible, as already explained.

(778) The stop spring should be arranged to act as nearly through its whole length as may be. We generally see them resting flat on the plate, almost to the point, which only is raised to press on the bar. The spring should be so curved as to keep out of reach of the beak, and should act on the bar very near to the stud, instead of at a point from one-third to one-half its length from the stud, as many ignorant workmen leave it, which is liable to prevent it from rising high enough (the spring being between it and the plate), and also causes it to press too hard on the chain. The first named fault has the same effect. If the bar is properly fitted and free, a very little pressure will suffice to keep it in its place, *i. e.*, to press it away from the plate except when raised by the chain. This requires only strength enough to overcome the friction of the joint in the stud to raise the weight of the bar when the watch is held with the dial

upward. This should be looked to, to make sure that it will do so, but no more.

(779) See that both the bar and the beak and cap are free from the point of the balance cock screw, or its steady pins, projecting through the upper plate, and from the screws that hold the upper fuzee jewel setting or bush. If any of these stick out, take off the ends level with the plate. The stop bar should not be too broad, but, especially in a small watch, be as narrow as consistent with proper stiffness. The stud must be tight in the plate, or it may turn, and carry the end of the bar out of the reach of the beak. If loose, take out the bar, rest the stud on a lead block, to prevent bruising, and rivet it securely. When the solid stop is used, instead of that before described, see that it rises horizontally or parallel with the plate, to the proper height, and no more, and that the spring is not too stiff.

(780) *The Maintaining Works.* A steel wheel called the *maintaining wheel*, between the fuzee and the main wheel, connects the two in such a manner that, as the chain pulls on the fuzee, the ratchet and clicks carry the steel wheel around with it till stopped by a thin but broad spring, called the *going spring*; one end of the going spring is attached to the steel wheel, the other to the main wheel, and as soon as the chain has pulled the fuzee (and maintaining wheel) around so far that the tension of the going spring equals the pull of the chain, the steel wheel is prevented from moving any faster than the main wheel. If the fuzee is properly formed, the main-spring and the going spring remain balanced, and the two wheels maintain the same relative positions till the watch is almost run down. The main wheel is of course urged on by the same force as if the fuzee was connected directly to it, as in the verge watch, by a click resting against a tooth of the ratchet, instead of by an elastic spring-connection. In practice, however, this balancing of the springs is seldom found, but the compression of the going spring is limited by a pin in its free end, playing in a slot in the main wheel. When the pin rests against the end of the slot, there ensues a rigid connection between the fuzee and the main wheel, irrespective of the tension of the going spring.

(781) The chain having pulled the fuzee (and the steel wheel) forward to the limit allowed by the stiffness of the going spring, or till the pin reaches the end of the slot, an exterior click called the *maintaining click* or *detent* drops into the teeth of the steel wheel, and prevents it from backing, even when the fuzee is relieved from the pull of the chain, or is turned backward in winding. Accordingly, the compression of the going spring between the steel and main wheels urges on the latter, while the fuzee is reversed and the watch wound, with practically the same force as if the chain was still pulling it forward, thus maintaining the propelling force undisturbed. Otherwise, while the watch was being wound backward, the escape wheel would run backward, just as the ordinary weight clock ticks backward while being wound, which would render the rate irregular and unreliable, and frequently stop the watch. The workman will, therefore, see the importance of having the maintaining works in proper condition, if he expects good time-keeping.

(782) The detent point should be sharp and free from bruises or bends, and fit nicely into the teeth of the steel wheel, the same as a click should fit in any ratchet. The point should be but a trifle broader than the thickness of the wheel, and must not interfere with the brass of the fuzee, nor catch on the chain hook or chain. It must also be so shaped underneath that it will not rub or grind on the main wheel teeth as they pass under it. The height of the fuzee being properly adjusted (783), with its end-shake as small as possible, the parts should have the following relative positions: When both the fuzee and the detent are at their lowest end-shake, the detent should be just free from the main wheel teeth; and the same when both are at their highest end-shake; when the fuzee is at its lowest, and the detent at its highest, the detent point should be about three-fourths the thickness of the steel wheel above the main wheel teeth, which amount is the utmost that should be allowed for the end-shake of either the fuzee or the detent, and one-half its thickness would be preferable. The detent spring should act upon the wing of the detent about midway between its end and the detent arbor. The point of the spring should never touch up under the shoulder above the wing, as it is likely to keep the detent point from dropping into the teeth. So, also, if it rested against the arbor on its way to the wing, the dropping of the point would be uncertain. When the wing is on the opposite side of the arbor from the point, the spring should not reach to the arbor. With either kind of detent, always be sure that the spring presses hard enough to guaranty its dropping. Of course, the detent arbor should be well pivoted, both pivots and holes in good condition and well fitted, with good shoulders to the pivots, so that the end-shake can be properly regulated, as above described. The wing should be dressed off at the bottom, if it comes too near the plate. For the going spring and its slot, see the Fuzee (794).

## Legal Regulations for the Standard of Gold and Silver Ware in the Different Countries of the World.

BY EDWIN W. STREETER.

FINALLY, it is to be considered that a close inspection of the standard of precious metal ware is surrounded with very great technical difficulties. It is indeed often impossible, and that not only in the case of very small articles which would have to be wholly destroyed in order to establish their standard accurately, but also in the case of larger ornaments.

At the sitting of the Committee of the Austrian House of Delegates, on the 16th of October, 1863, a person conversant with the subject spoke as follows: "I ask how shall this brooch be brought under control? It consists of three parts; the lower rim is hollow, the middle is enameled, and the upper part is of delicate flowers. Where shall it be inspected if every part must separately bear a stamp? Perhaps the pin only is to be subject to control. That will content neither the public nor the authorities, for every person is at liberty to detach the pin and to fix on it a bad article, in which case I must bear the responsibility." Analogous cases occur very frequently.

It has often happened that chains, necklaces and bracelets consisting of several parts, having received the stamp on one part only, have in all the other unstamped parts had gold of a lower standard substituted for the proper one.

Mr. Nessman, Director of the government offices in Hamburg, who has a thorough practical knowledge of the art of gold manufacture in the provinces also says: "A teapot of Copenhagen silver being stamped in several places, it was imprudently purchased by me at the worth of Copenhagen silver. When melted down it turned out that the actual body of the teapot—the most considerable part—was of insufficient standard. In the case of chains, the outside parts (terminating links) of which are stamped, even a pretty well practised eye cannot always detect the lower standard of the parts which are soldered on to them, because the electro-plating gives a similar color even to the inside parts which cannot be polished."

The public would fare worse, however, if an exact government control were impossible, and certain categories of precious metal ware were forbidden. The laws collected above contain numerous examples of this; and it is easy to see what great and exceptional hindrances are here laid on a manufacturer, and to what an extent the satisfaction of the requirements of luxury is narrowed in this way, and consequently how much more costly the articles become. So in several states precious metal ware filled with cement, which combined cheapness with the object of the law is totally forbidden. The stripe test is insufficient in many cases to establish an accurate investigation, and even the test in the crucible can only prove the standard of the single portion of an article. To establish accurately the standard of the whole mass of an article of gold or silver it would be required to melt it down. It must be granted that by the increased number of tests adopted the standard may be settled at pleasure. In countries having a preventive state control, the average probability of the standard being decided correctly is not great. Everyone who is interested in this side of the question can easily obtain convincing proof.

Nothing is more significant than the fact imparted by Mr. Singer, a competent authority, in the Committee of the Austrian Deputies, viz., that the principal testers in Munich at the time the control was undertaken by the corporation, did not pay respect to the Austrian official control. These gentlemen received knife handles provided with the official control stamp, in which inferior metal was to be found at the rate of 34 florins' worth in 24 handles. Another good authority stated that, in spite of official control, fraud was to be met with "really very frequently, and in much accredited houses or firms."

The *Pforzheim Observer* has over and over again reported cases bearing incontrovertible testimony to the inadequacy of Austrian control. In the issue of that journal for the 7th of January, 1874, we read that gold rings manufactured in Pforzheim were repeatedly rejected by the Viennese control offices, in spite of their having the legal standard, which shows that business should only be done with Austria with the greatest precaution and care. One cannot shut one's eyes to the fact that the preventive system of control is calculated to injure its business intercourse, even with those foreign nations which are inclined to submit themselves to the restrictions of standard. We hear on all sides, and from many countries, that the imperative preventive control has not attained its principal object, viz., the protection of the public, and it has therefore been aban-

doned as unsatisfactory in Belgium, Italy, the Swiss Cantons, and elsewhere. Other nations, in the course of their experiments, are arriving at the conclusion that the struggle of competition forms at once the best and the sole security for the protection of the public. Even in France, where the public submit more willingly to state control than in any other country, the system is being shaken, and it may be calculated that the legal limitations to the precious metal, trade will at last be remoulded.

If the system of state control for all precious metal ware be abolished it is not of importance that the control should be maintained for a portion of these goods, viz., for wares the manufacturers or sellers of which deem it advisable to add to the reputation of their name the guarantee of the state, or, as not unfrequently happens, to re-establish the former by the help of the latter.

We feel the less inclined to address ourselves to this so-called *facultative* system which leaves the standard prescribed by imperative preventive control optional to the seller or manufacturer. For if the state which undertook to watch over the standard of precious metal ware did not succeed in protecting the public from fraud, how shall that state succeed which assumes the control only to oblige? If the state be not in a condition to protect the public from fraud, and yet shelters with its credit the credit of a certain class of its citizens it becomes the accomplice of those who endeavor to defraud the public.

Since, however, the system of facultative control has been adopted in several states in which the imperative preventive control has proved itself untenable, we see on the one hand that the step was too radical in passing at once from preventive control to complete freedom. On the other hand, the influence of the manufacturers to whom this system promises advantage, certainly at the public cost, remains paramount; so it is easy to be understood that in Geneva, for instance, where the precious metal trade has a great reputation, and finds a large outlet abroad, a decision was made in favor of this system.

There is not the smallest reason why the same thing should take place in the German empire, for, although the German gold ware is extensively purchased abroad, it really is not on account of its pre-eminent beauty or special purity of standard, but on account of its cheapness. Cheapness, however, cannot be certified by a government stamp.

The last proposition which we have to examine runs thus:—To prescribe by law to the manufacturer the marking of the standard and of his own firm, or of a sign for the same.

This is a proposal which reappears in many of the judgments of the Chambers of Commerce kindly imparted to us.

It is certainly true that this has already taken place in the Grand Duchy of Hesse, through a decree of the 2d of June, 1829, by which the manufacturers of precious metal ware are rendered legally answerable, under penalties, for the correctness of the standard declared. But the question is whether the public will in this way obtain a better protection than the option of a civil lawsuit at present secures to it.

It is next to be considered that responsibility under penalties in a province where an error may so easily occur, is a vexatious demand upon the manufacturers of precious metal ware; a demand which, in increasing the responsibility in the pursuit of the trade, cannot fail to diminish the number of those who are inclined to devote themselves to it. A rise in the price of precious metal ware must therefore follow upon a law of this nature. The fraudulent dealer, however, will not be deterred by the threat of penal consequences from practising fraud, even to the widest extent. He will consider with psychological accuracy that the public, regarding the great risk incurred by every seller of fraudulently announced standards, will never think it worth while, just on that account, to have the ware tested according to its standard. This legislation, therefore, has simply had the effect of throwing the public off its guard. The undoubted increase of fraud is to be foreseen in consequence. These cases of fraud would, however, be less frequently punishable, because, as a rule, they would come to light only on the sale of the object in question at the worth of the metal. But, as articles of precious metal are long preserved, many years would probably have passed by during which fraudulent persons may have died or disappeared. Even supposing a case of fraud to be for once discovered immediately, how few would there be who would give themselves all the trouble and loss of time involved in going to law. For fraud generally will be practised only upon a buyer who is not likely to have the standard tested, and he, moreover, will be the buyer of ware of small value. The seller will be cautious in the case of a buyer in whose eyes the worth of the metal is of importance.

The remarks we have made are further supported by the fact that the guarantee given to the buyer by a law of this kind is very insuffi-

ficient. For how small is the worth of a stamp! In the next place, a large group of precious metal ware must of necessity be excluded from stamping: such, as for instance, as gold and silver beads, very fine chains, filigree work, and ware covered with enamel. How can a stamp be placed upon these? Thus the legal compulsion of the employers to stamp the manufactured precious metal ware is necessarily subject to a considerable exception.

Again, since it must be left to the judgment of the individual to decide as to ware that will take a stamp and ware that will not, the dishonest dealer will aim at overpassing the limit, and seek to profit by the legally allowed exceptions, on the pretext of the widest possible sale of wares of a very low standard.

A much larger question is bound up in this of stamping ware manufactured of metal of different standards.

Even the most enthusiastic supporter of the government regulation of the standard of gold and silver ware, if he have only a suspicion of the exigencies of the trade, will not desire this. What then is to be done? In the Committee of the Austrian House of Delegates, to which reference has been made already, a manufacturer showed an ornamental article which would have to receive forty-eight stamps if all the parts of different standards and all those parts which could be separated and replaced by others were to be stamped. How often do such cases occur? How great would be the labor of the manufacturer for which naturally he would be obliged to reimburse himself, and who would care to buy articles thus covered over with stamps? It has been proposed to prescribe the declaration of the average standard. But this can only be found out by melting the article in question. The purchased ware would have to be destroyed that the seller may be under control.

And what is to be done with those articles which consist of precious and of inferior metal, the compound parts of which cannot be separated without destroying the articles? What is the use of the declaration of standard to me if I cannot gauge the quantity of gold or silver in the article? It is therefore evident that in a very large number of cases the proposed law could not be carried out and that in an equally large number it would be useless.

Even for the remaining cases the stamp does not appear to be advisable. In order that the sign of the manufacture might assure a proper security, each manufacturer must make use of a separate one, and throughout the German empire every manufacturer would have to deposit his trade-mark in the Imperial Chancellery, whose care it would be to see that every manufacturer had a different one. How easily an exchange might be made is particularly evident from the fact that a maximum size of stamp would require to be prescribed in order to reduce as much as possible the number of wares which, from their small size, would not bear a stamp. And if a manufacturer was bent on employing a false stamp, consider how easy it is to imitate a stamp, and how difficult in such a case would be the proof. How often have the genuine official stamps been cut out and soldered into wares of lower standard. Can the same thing not be done with a private stamp? How widely, therefore, through the land would a door and gate be opened for fraud! "As a good father will not disown his children, so the custom of impressing the trade mark of the manufacturer upon machines, lamps, dresses, and so forth, is the sign of a manufacturer confident in the goodness of his wares, and it will be only the false gold manufacturer who will raise objections to this demand (that of stamping his firm and place of abode upon the wares)." So writes Karl Roscher.

We doubt this, most decidedly. It may easily happen that a gold manufacturer of high repute is compelled for a time, at a certain crisis of his affairs, to use a very low standard instead of a high one. It would be of great importance to him to send them out without his stamp, in order that his credit may not suffer; and if this were not possible it would be better he should renounce altogether the manufacture of cheap articles.

An author has the liberty of writing anonymously, or with a *nom de plume*, when he is not quite content with his writings; why may not a goldsmith have the same liberty?

Very often it happens that the purchaser himself does not desire the stamps of standard and firm on the article, and the retail dealer not seldom has a very great objection to them.

The public, as a rule, are not all desirous of the firm or the standard being marked on the goods. The bad name of a firm or a low degree of a firm would make a gift almost worthless. Many who have very little money to spare, and are yet anxious to give pleasure, would be debarred from making any present at all if this were to be insisted upon.

And this is a consideration of no small moment in the times in which we live; for it is in just those precious metal wares that are so universally used for presents, and whose principal object is to gratify vanity, that appearance plays the most conspicuous part. Make this

impossible, and the German precious metal industry would suffer from the severest blow it could possibly receive.

To demand the stamp of standard on our ware would be simply to brand them in foreign lands. In the Austrian Chamber of Deputies it was stated "that the Orientals get the most of their large supplies from the German manufactories, exactly because they have no stamps upon the wares."

1. The Imperative Preventive Control;
2. The Facultative Control System; and
3. The Manufacturer's Sign or Stamp on the wares are the three principle systems of legal regulation of the standard of gold and silver ware.

What interest have the workers in precious metals and their employers in the question of the legal regulation of exact standards of gold and silver ware?

In Geneva and the centers of industry—Neufchatel, Jura, in Chaux-de-Fonds and Locll—where the question of the standard was at one time the great question of the day, and swallowed up almost all other interests, many of the working classes took a very prominent position in battling for the legal regulation of a high standard. In Jura, for instance, the watch-case makers so bestirred themselves. There, as in all centers of precious metal trade, it has been found, that the manufacture of gold and silver of high standard leads to a higher average rate of wages than the manufacture of precious metals of a lower standard.

We hear from a Geneva goldsmith—"Generally, handiwork is less remunerated on works of 14 carats than on works of 18 carats."

Naturally! With the increase in value of the raw material the wages of the workmen increase, as they must be of a high class, and able to give security for their trustworthiness and honesty. The manufacturer, therefore, is required to pay a very high price for reliable labor, of which the supply is limited.

Another fact of great importance is, that gold and silver of a high standard are, as a rule, only manufactured into articles whose workmanship is of a high class. Any one inclined to possess an ornament of greater solid value than usual, will also, to make the outside correspond to the inside, pay a high price for a new and tasteful pattern, beautifully executed. And that these designs may be skilfully executed, workmen of high class ability are necessary.

The manufacture of precious metal ware of a very high standard generally goes hand-in-hand with special care in carrying out the design. But if any design has been multiplied hundreds of times, of course the manufacturer reckons upon purchasers who attach no importance to the possession of new designs, and who are not inclined to spend much money upon gold or silver plate. This class of purchasers, representing the great majority, are therefore satisfied with articles made in numbers by machinery, which, as the manufacturer very rightly judges must, in order to attain their object, be very cheap, and consequently of a low standard.

If, however, it be true that in working high standards the relatively greater trustworthiness and skill of the workman demand a higher rate of wages, still we must not forget that in places where only the manufacture of precious metal of a high standard is allowed by law, the sum total of goods ordered will be correspondingly small, and consequently will only slightly influence the demand for workmen.

Nevertheless it is also an undoubted fact, that the demand for workmen in the manufacture of precious metals of a low standard, having skill and reliability only of a medium order, will be greater than in the other case; and that the collective amount of wages paid will exceed what would have been paid under such a legal restriction. It is not to be doubted that *freedom in the application of the standard tends to the advantage of the workmen.*

If freedom in the choice of the standard tends to the advantage of the working class, how fares it with the manufacturer?

In relation to this inquiry it must be admitted that in workshops in which ware of a low standard is made, and where customers are proportionately large, the cost of carrying on the business is smaller than in workshops which serve but few customers and employ but few workmen. The rent, the furnishing, and the technical and mercantile superintendence are not, in proportion, as dear in the first as in the last.

Again, the larger manufacturer, who is permitted by law to work all standards, can afford to sell much cheaper ware than one not so favorably situated.

Of course those who exclusively work at the highest standard will, as a rule, suffer no disadvantage in the event of that alone being legalized.

We must not omit to take into account those periods of stagnation which occur so often and so suddenly in trades specially devoted to luxury. A war, or a crisis in the Funds, operates adversely to them at once. Thus, a Viennese silversmith told us at the Exhibition that

he had twenty-three silver dinner-services on hand, with the name and arms of those who had ordered them, owing to some sudden inability on their part to pay for them.

In these times, when trade is so dull, it would be a benefit to many a manufacturer if he could work at what standard he pleased, and so suit the tastes and means of the many. And apart from material gain, he would have the great advantage of being able to retain his staff of skilled workmen, who know the secrets and working of his establishment, instead of dismissing them for lack of employment.

*Of course, freedom in the choice of the standard would be an undoubted advantage to the manufacturer.*

The Geneva goldsmith above quoted confirms this statement. "Liberty of standard," he says, "is in my opinion a very good thing. If we had it not in Geneva, we should absolutely have nothing to do at this moment."

Let us record here that the goldsmith who writes this generally works only metal of very high standard. His letter is dated April, 1873, a time of serious commercial depression in Geneva.

### Watch Oils.

AN oil fit to be used as a lubricator for fine mechanism should possess the following essential qualities: It should neither thicken nor dry up, nor get hard at a low temperature nor should it be subject to oxidation. In spite of the vast progress natural science has made of late years, it has not succeeded in discovering an animal or vegetable oil possessing these combined properties without previous artificial manipulation. Let us mention a few instances:

Almond oil has the valuable property not to become firm till below 17 deg. R., but it oxidates sooner than any other oil. Poppy seed oil will withstand cold to 15 deg. R., and preserves itself well from oxidation; but it is one of the "drying oils," and therefore useless as a watch oil. Olive oil, up to the present the most useful among watch oils, does not dry or thicken, nor does it oxidate for a comparatively long time, but it hardens already at 2 deg. R. The properties of neat's foot oil are similar to those of olive oil, but it exceeds the latter in resistance against oxidation. These few articles will sufficiently show why technical chemistry always considered the production of an oil, fulfilling in every respects the requirements of fine mechanics, as one of the most difficult tasks. Most of the oils supplied to the trade answer this purpose but imperfectly. It is, therefore, not to be wondered at when conscientious men act with caution in introducing any novelty in that department; the more so, because the hitherto employed methods for testing oils required considerable time, and were often attended with loss. We think it will be useful to our readers if we point out the means by which such tests can be made with the least trouble and cost, and in the shortest time. We will first divide the oils into two classes:

*Drying Oils.*—The best known among which are: Linseed, hempseed, poppy-seed and castor oil.

*Non-drying Oils.*—To which belong olive and colza oils, and those from the larger kernels, as almonds, hazel and beech nuts, etc.

That drying oils are useless and objectionable for fine mechanism is evident, because they dry on exposure to the air by absorbing oxygen and generate carbonic acid. The quicker or slower drying depends simply upon the thickness with which the oil has been applied. A higher temperature will considerably accelerate the effects of oxygen, an advantage of which painters and cabinet makers—the principal consumers of this kind of oils—avail themselves when despatch in their work is required. Oils, as regards this point, are, therefore, very easily proved. The article to be examined is laid as thin as possible on a piece of glass or china, and the latter is then put on a stove, care being taken not to expose it to too high a temperature, to prevent the oil from boiling, which would take place at 240 deg. R., is quite sufficient to dry a thin layer of such an oil into a glassy substance in a few days. This simple process supersedes all others. There are oils which do not belong to this class, but gradually thicken because they contain considerable quantities of mucilage, pectic acid, etc. Such is the case with oils from the larger kernels, as almonds, beech and hazel nuts. An exposure of these oils to a higher temperature will, in a few hours, manifest this defect also. The next evil lies in the little resistance which oils offer to lower degrees of temperature. Every fat is, again, a conglomeration of other solid and liquid substances. The former are called stearine, margarin, palmitin; and the latter, olein, elain. According to the proportions of solid and liquid substances, the fat requires a higher or lower temperature to become liquid or solid. Tallow, for instance, melts only at 32 deg. R., while linseed oil remains still liquid at 22 deg. R. An oil which can resist 10 deg. R. will do very well for general purposes. The temperature in a room, even without a fire, will, at 25 deg. R., in the open air, not sink below 8 deg. to 10 deg. R., and besides, in the watch pocket, next to the body, the watch is

safely guarded from extreme cold. The watch manufacturer has not to consider extraordinary cases, and if the inhabitants of the frigid zone and Arctic navigators expose their chronometers to extreme degrees of cold in the open air, he is not answerable for the rash treatment of his work. If oils have to be tried as to their capability of withstanding a low temperature in summer time, the necessary degrees of cold may be produced as follows: 15 parts of Glauber's salt (the small crystallized sort) are put in a vessel of glass or china, and the flask of oil to be tested is immersed in it. This done, a mixture of 5 parts of muriatic acid and 5 parts of cold water is poured over the salt. By means of a thermometer, such as is used for liquids, the temperature can be controlled, and when it shows 8 deg. to 10 deg. R., the flask may be taken out and the oil examined. If it has remained perfectly liquid, it has satisfactorily undergone the required test. Chemists can without difficulty separate the firm ingredients from oil, and produce an article which will stand 25 deg. R., but this cannot be done without injuring it in other respects.

We come now to the most serious of all defects in watch oils, viz., oxidation, and therefore give our special attention thereto. Fats in general (liquid as well as solid) belong to the saline bodies, although they have in appearance nothing in common with salt. Salt is the name chemists give to a combination of an acid with a base, and under these bases they understand the oxides of iron, copper, etc., the alkalis, the alkaline earths, as lime, baryta, etc. The well-known Glauber's salt is also a combination of sulphuric acid with sodium for its base. The same base with carbonic makes our soda; and kitchen salt consists of chlorine with sodium for its base; or, more exactly, with the elementary substance of sodium, the natrium. If, in this combination, the acid is predominant, it is called acetic salt; if the base, basic salt; and if they are both alike, neutral salt. Such neutral salts are all our natural healthy fats. The acids they contain are called pyroleic acids (stearic acid, elaic acid, etc.), and the base, not yet known in its elementary state, is termed lilyoxyd, which, by further development, produces the better known glycerine. Although these pyroleic acids are naturally neutral, and when bound to their bases cannot act as acids, yet they have an inclination to absorb oxygen from the surrounding atmosphere, especially at higher degrees of heat. This is what, in chemistry, is called oxidation. If this process continues, the acid in the oil becomes predominant, and then acts on metals precisely in the same way as any other acid, only its damage is slower and less apparent to the eye. The result is evident. Fine works, lubricated with such an oil, lose in volume, and the injury, which is often attributed to friction, is in reality the effects of this change in the oil. But this condition of the oil does not manifest itself till it has attained a highly injurious degree, and the work of destruction has already begun. The organs of taste and smell are therefore insufficient to ascertain what degree of inclination an oil has to become rancid, or even to indicate at once when it has actually become so. The following method will answer this purpose: Pour the oil in a bottle, together with an equal quantity of water, in which soda (carbonic natrium) has been dissolved; then shake it violently and let the mixture stand for some hours. If the two liquids separate perfectly, particularly under a higher temperature, it is a proof that the oil is free from acid. On the contrary, if a whitey substance shows itself between the two, it is certain the acid is present. Another method is based on the great sensibility of litmus paper in regard to acids. Litmus paper can be bought at the chemist's, but may be easily prepared as follows: Bring powdered litmus in contact with pure water (distilled is best) until the latter has absorbed enough coloring matter to dye dark blue immersed slips of paper. The slips are then thoroughly dried, and any acid applied to them will change their color to a violet, or even red, according to the strength of it. Acids which have become free in an oil will have the same effect. It must be remarked that litmus blue, held to the light, is of a reddish tint in itself; and that litmus tincture, well shaken, will present rays of glaring red in the sunlight, and, as the papers immersed in the oil become transparent, they will show a light reddish hue even in the purest oil. But a little practice and comparison will soon enable one to distinguish the effects of an acid on litmus blue.

In conclusion, we may correct a few traditional errors. Many think the clearer an oil the better it is. A bad color certainly indicates impurities, but if colorless or yellow it is in this respect immaterial. In fact, those very clear oils are generally most apt to become rancid, because the methods employed for the clearing process tend mostly to forward oxidation. To test the fluidity of oils by letting different sorts run off an inclined plane is also a doubtful experiment. Not only are there oils so poor in body that they flow too freely, and do not give the required protection against friction, like the sesame oil, but many other obstacles—scarcely observable with the naked eye—such as a slight unevenness in the surface of the plane, may influence the trial.—*German Watchmakers' Journal.*

Alloys of Gold.

IN the preceding article it was suggested that the discrepancies existing in the absolute qualities of gold goods—all asserted to be the same quality—might occur from the loose method of compounding them; very few melters being absolutely *sure* of the relative quantities and fineness of the metals from which they are compounded. When pure metals only are used, there is no possible excuse for error; and if there be one, it should be christened with a more harsh name, cheat, swindle, or deception being a better word to use.

If ten pounds, ounces, pennyweights or grains of chemically pure gold be melted with fourteen pounds, ounces, dwt. or grains of some other metal, it will produce 10 k. for a certainty. But if 10 dwt. of gold coin be melted with 14 dwt. of some other metal it will not make 10 k. alloy, because the gold coin is not 24 k. fine. Many manufacturers have taken the unwarranted liberty of calling an alloy 18 k. which is made up of 18 parts coin and 6 parts base metal.

When alloys of various qualities are compounded with each other, the resulting mixture is a little more complex. For instance, melt together—

11 oz. gold	23 k. fine.
8 " "	21 1/4 "
6 " "	24 "
2 " "	base metal

The resulting quality is easily found by multiplying

11 oz. × 23	=	253
8 " × 21 1/4	=	170
6 " × 24	=	144
2 " × 0	=	00
<hr/>		
27 oz.		567 k.
567		
27		
<hr/>		
		= 21 k. for the quality of the mass.

The complication increases somewhat when it is desired to produce an alloy of 18 k. from alloys of several different qualities, say 12 k., 22 k., 15 k., 20 k.; then it becomes necessary to know exactly the quantity of each to be taken to produce the required quality. The rules simply will be given without going into explanations of the "reasons for the rules." Write down the statement of the problem in this form:

18 k.	12.....	4
	15.....	2
	20.....	3
	22.....	6

Link, by a line, any quantity of alloy *greater* than the desired quality to one that is *less*, and set the difference between the given quality and the quality sought opposite the number to which it is linked, and it will show you at once the quantity to be taken of each kind to produce the 18 k. desired. In proof that the result is correct we have

4 dwt × 12 k.	=	48
2 " × 15 k.	=	30
3 " × 20 k.	=	60
6 " × 22 k.	=	132
<hr/>		
15 dwt.		270
<hr/>		
	270 ÷ 15 = 18 k.,	the quality sought.

The formula may be varied without affecting the truth of the result, as

18 k.	12.....	2 × 12 = ... 24	} = 270
	15.....	4 × 15 = ... 60	
	20.....	6 × 20 = ... 120	
	22.....	3 × 22 = ... 66	
<hr/>			15

Suppose you have gold 17 k., 18 k., 22 k., and wish to produce an alloy of 21 k. fine.

21 k.	17.....	× 1 = ... 17	} = 189
	18.....	× 1 = ... 18	
	22.....	4 × 3, × 7 = ... 154	
	<hr/>		
<hr/>		9	189

Again with some pure gold and some 12 k., 16 k., 17 k. and 22 k., you wish to produce 18 k.

18	12....	4 × 12 = 48	} 450
	16..	6 × 16 = 96	
	17..	6 × 17 = 102	
	22..	6 × 22 = 132	
	24.....	3 + 1 = 3 × 24 = 72	
<hr/>		25	450

With a little practice there is no difficulty in reaching correct results. The problem becomes more complicated when any one of the ingredients is limited. For example, you have 10 dwt. 18 k. gold, some 16 k., 20 k., and 22 k.; you wish to know how much fine gold you must add to bring the alloy up to 22 k. fine.

22	16.....	2 × 16 = 32	} 440
	18....	10 dwt. × 18 = 36	
	20.....	2 × 20 = 40	
	22..	2 × 22 = 44	
	24..	6 + 4 + 2 + 0 = 12 × 24 = 288	
<hr/>		20	288

This gives you the quantity of each of the various kinds to produce 22 k. Now there is 10 dwt. of the 18 k., and the same proportion must be taken of each of the other qualities. Then as the difference against that quality whose quantity is limited, is to each of the other differences, so is the quantity of that to the quantity required of each of the others, thus:

2	:	2	:	10	:	10
2	:	2	:	10	:	10
3	:	12	:	10	:	60

Consequently the ingredients will be,

10 dwt. 16 k. (proof)	10 × 16 = 160
10 " 18 k.	10 × 18 = 180
10 " 20 k.	10 × 20 = 200
60 " 24 k.	60 × 24 = 1440

90 dwt. 1980 k.

Often two or more of the ingredients will be limited in quantity— as how much gold of 14 and 16 k. must be melted of 6 dwt. of 19 k. and 12 dwt. of 22 k., to produce an alloy of 20 k. fine.

First find what will be the quality of a mixture made of the given quantities of the given ingredients. In the case given these are,

6 dwt. 19 k. = 114 k.	} = 378	= 21 k. fine.
12 dwt. 22 k. = 264 k.		
<hr/>		18

From which the quantity of 14 and 16 k. can be found as previously shown.

20	14.....	1
	16.....	1
	21.....	6 × 4 = 10

The proportions are there found as in 10 : 1 : : 18 (sum of the given quantities) : 18, the quantity required of the 14 and 16 k.

Proof 1.8 dwt. 14 k. = 25.2	} 432	= 20 k.
1.8 " 16 k. = 28.8		
6 " 19 k. = 114.0		
12 " 22 k. = 264.0		
<hr/>		21.6

Another case will often occur when it is desired to produce a certain quantity of a given quality from various ingredients. Having gold 15 k., 17 k., 20 k., 22 k., you wish to melt 40 dwt. of 18 k.

First find out how much of each of these qualities are required to produce 18 k.

18	15.....	4	} = 10
	17.....	2	
	20.....	1	
	22.....	3	

Then as the sum of *all* the ingredients is to the required quantity, so is the quantity of *each* of the ingredients found to the quantity required, thus

10	:	40	:	4	:	16	of 15 k.
10	:	40	:	2	:	8	" 17 k.
10	:	40	:	1	:	4	" 20 k.
10	:	40	:	3	:	12	" 22 k.

Or the proportions can be varied and the result will be the same, thus,

18	15.....	2	which will give	8 dwt. 15 k.
	17.....	4	"	16 " 17 k.
	20.....	3	"	12 " 20 k.
	22.....	1	"	4 " 22 k.

From these illustrative examples no one need be at a loss to readily



figure out any combination of qualities and quantities with mathematical certainty.

Gold will unite with nearly if not quite all the metals, making alloys of more or less usefulness. Gold has a strong affinity for iron, and unites readily with it and with steel; 8 per cent. iron is a pale yellow gray color, very ductile and tenacious and harder than gold; 15 to 20 per cent. iron has a grey color and takes a beautiful polish. 75 to 80 per cent. is so hard as to be very well adapted for cutting instruments, and is nearly the color of silver.

Copper also sustains most friendly relations with gold, freely uniting in any proportion. A very little sensibly alters the color of gold, and almost any desired color may be obtained by skillfully admixing copper and silver. The maximum hardness of gold and copper alloy is obtained by the use of  $\frac{1}{8}$  copper. All gold alloys are more fusible than pure gold.

Silver and gold also unite in all proportions, the maximum hardness being attained with  $\frac{1}{3}$  silver.

The green gold of jewelers is 70.8 gold and 29.2 silver. To deepen the color of gold and silver alloy the following composition is sometimes used: 1 oz. yellow wax; 2 oz. calcined alum; 12 cx red chalk; 2 oz. verdigris; 2 oz. peroxide of copper.

All the ingredients except the wax must be ground to an impalpable powder and mixed with the melted wax, moulded while plastic into sticks like ceiling wax. The surface of the gold to be darkened is rubbed over with the mixture and heated till the wax be all burned off—then wash the article in a liquor—1 pint water, 2 oz. ashes of calcined crude tartar, 2 oz. common salt, and 4 oz. sulphur. If designed to be bright it must be burnished—not polished.

Manganese 1 part and gold 88 parts form a pale yellow-gray alloy of considerable lustre and hardness but little ductility.

Nickle and gold produce an alloy of brass-yellow color, quite brittle. Cobalt and gold unite forming a dull yellow brittle alloy. Antimony unites with gold, but the most minute quantity entirely destroys its ductility. Tin and gold form a compound more fusible than gold, and is somewhat ductile when cold, but easily crumbles at a red heat.

Zinc in a very small quantities renders gold brittle. Melted gold will absorb sufficient of the vapor of zinc to make it brittle.

Lead in any quantity as minute as  $\frac{1}{10000}$  will impair the ductility of gold. The vapor of arsenic in contact with heated gold renders it brittle, and the minute quantity so absorbed cannot be separated, even at a very high temperature.

Such facts go to show most conclusively that the slovenly, careless manner of handling and melting gold in many shops is the cause of the great difficulty experienced in getting gold to work. The smallest particle of zinc, lead, tin, antimony or bismuth creeping in accidentally with a lot of old gold and going into the crucible, will make long hours of painful labor, and perhaps never be eliminated except by refining. Inquiries come in public and private from all quarters for instruction how to make brittle gold "work." In nine-tenths of the cases more or less of these base metals are in the bar and refuse to vacate; they won't be entirely burnt out nor will they leave by rolling and remelting and fluxing; sometimes by persistent means of this sort (depending on what the obnoxious metal is), they are diminished to such an infinitesimal quantity that the artist is able to get it to work. All such stuff had better be sent at once to the refiner; get pure metals, alloy them properly and carefully, and such troubles will seldom vex you.

### Majolica.

BY JAMES JACKSON JARVIS.

THE taste for pottery having become so general in America, and collectors of its multifarious forms, according to Dr. Prime, already numbering more than 10,000, some account of the recent revival of this art industry in Florence cannot fail to interest many of your readers. Happily, it has ceased to be necessary to apologize for a passion for an article coeval with the first rudiments of civilization, at once the most practically useful and the most capable of being wrought into forms of beauty, on account of its easy manipulation, its plastic ductility, its capacities of design and coloring, and, not least, the cheapness and variety of its artistic toilets. Although composed of the most common and homeliest material, shapeless in itself, it offers measureless scope to the inventive and poetical faculties of man, from the crudest efforts of the child at modeling some natural object, to the most elaborate and beautiful forms and decorative designs that

originate in the imaginations of the greatest artists. Moreover, time itself has no perceptible effect on its delicate structure, if but shielded from brutal violence; so that when the subtle qualities of sculpture and painting are combined in it, unlike their other material mediums, they are lodged in a habitation virtually imperishable and unchangeable. No other baser substance is capable of so many varied and novel surprises of form, ornamentation, and artistic device; of acquiring such æsthetic value and high price, and yet in substantial use, benefit and joy, be more within the reach of all men. Pottery, indeed, is both a fine and industrial art, worthy of being cherished by every one, in its higher developments, as a national industry, particularly adapted to the expansion of the æsthetic faculties, and preparing to comprehend and enjoy the noblest works of art. Hence the present fashion of seriously collecting all those specimens of every nation, savage or civilized, which illustrate its diversity and progress, is one to be permanently cherished. For the objects thus gathered largely epitomize the history of all mankind, and are subtly significant of human aims and aspirations, be they high or low, wise or foolish.

One of the most interesting factories for making majolica, established in May, 1878, is just outside of Porta Romana, Florence, not far from the studio of Launt Thompson. It is owned by Giuseppe Cantagalli, brother of Ulyse Cantagalli, so agreeably known in the diplomatic circles of Washington and Brazil a few years since. The original plant is more than a century old, having long been used in manufacturing the cheapest kind of crockery for the use of the neighboring peasantry. This is continued, but in keeping with the spirit of the time in the revival of the artistic processes of the fifteenth and sixteenth centuries, Cantagalli's chief enterprise is now directed toward the reproduction of the various kinds of decorative majolica wares which formerly gave renown and prosperity to the Umbrian towns, principally Urbino, Gubbio, Castel Durango, Faenza, Pesaro, Chaffagiolo and Deruta. These wares consisted of medicine jars, bottles, dishes, cups, plates, jars, flower vases, an infinite variety of ornamental objects, from the cheaper sort of artistic work to the finest and most expensive—after the designs of Raphael, the greatest artist of the period—which last were reserved mainly for princely gifts and aristocratic distinctions. Twenty-five years ago they were all plentiful in the bric-a-brac market, and could be bought for trifling sums. Now, as all collectors know, good pieces by Maestro Giorgio of his brilliant reflecting ware, and by Xanto, Fontana, and other skilled artists, are competed for at hundreds of dollars each, and not uncommonly bring thousands. Indeed, no money will now buy the fines, specimens to be found only in the collections of the wealthiest connoisseurs; while fair characteristic examples of these several manufacturers are bought up at large prices as fast as discovered.

The impossibility of supplying the demand for the old ware induced Cantagalli last year to attempt the revival of the commoner varieties of all these old qualities, accurately repeating their forms, designs and colors in the same kind of terra cotta and of similar workmanship. He gets his clay from Mintespertoli, 14 miles from Florence. So successful has he been in his reproductions, that only an expert's eye can detect the slightest differences in the glazes and average tones from the patterns used, the general designs and coloring being quite as good. Were it not for the invariable factory-mark of a cock, which all of his pieces bear, they might be readily sold, and possibly are where it is unknown, to amateurs as genuine Italian majolica of the before-named towns, three and four centuries old. But in going to the factory the visitor may see an old pattern-plate, or other article which has cost from one hundred to five or more hundred francs, beside the imitations that Signor Cantagalli sells for one-twentieth, and sometimes a thirtieth or fortieth, of the market value of the originals. Thus far, his reproductions—and many are quite elegant and effective every way—vary from 6 cents to \$5 each, there being nothing dearer than the last figure. His commercial aim is so to cheapen the lower grade of artistic productions as to place them within reach of the lightest purses. This he is able to do because

the old pottery plant, which has cost very little, suffices for all immediate purposes. He employs between 40 and 50 men and boys, all taken as green hands, to be practically instructed by successive stages in every department. His best designers and painters a few months ago had no skill in art whatever; but such is the aptitude of the Tuscan laborer for this work, that they have become in this brief time very competent artists, and are themselves now originating novel forms and new designs, besides accurately reproducing old ones with much freedom, breadth, rapidity and lightness of stroke. The only instruction received is in the factory itself. It is Cantagalli's plan not to confine his wares to reproductions, but in time to introduce as many original articles as his facile workmen can invent, at the same time gradually perfecting his clays and improving the material branches of his wares. The finer and more costly ancient majolicas, he thinks, could be rivaled by his working staff if the public would pay for their extra cost, but at present the sole demand is for the genuine old ones from a few rich collectors, willing to pay their weight in gold, or even more for exceptional specimens.

The clay is manipulated in its first stages by small boys, who get only 2 francs per week wages. They are fine, healthy, handsome little fellows, with well-developed chests and arms, acquired from the kneading processes, and seem contented with the position. The adult workmen receive from 18 to 20 francs per week. There are several good singers among them, and they enliven the labors by their fine voices. Those who have risen to the rank of artists, and are exclusively employed in the decorative and inventive departments, get from 1½ to 4½ francs per day. Thus, 80 cents is the highest daily wages earned in this establishment, and some efficient art hands only receive 30 cents for a long day's work. Certainly no other country, and perhaps no other province of Italy, can begin to compete with Tuscany in the cheapness and abundance of the skilled labor requisite for the production of artistic majolica. The only drawback is the higher cost of fuel as compared with coal-bearing countries. But this is likely to be partially remedied before long, so that Florence may finally, on this small beginning, re-establish an important industry which shall help revive her former commercial prosperity. There are many elements here that need only a little co-operative action and judicious enterprise to become fountains of wealth in all that relates to the minor æsthetic industries, such as wood-carving, metal-work, mosaics and even glass.

### A Deserved Charity.

THE Fair of the Swiss Benevolent Society was held at Irving Hall for four days, commencing March 26th, and was a pronounced success. This Society has been in existence nearly forty years, and has the support of the best and most influential Swiss residents. Its object is to take care of the needy Swiss who come to this country in search of employment. It often occurs with Swiss emigrants as with those of other nationalities, that their resources are exhausted in making our shores, and, unless otherwise cared for they would become a charge upon our charitable institutions. The Swiss Benevolent Society's mission is to look after the poor and destitute Swiss, to provide for their necessities, and to furnish them with employment. In this manner, the Society has expended upwards of \$100,000 in cash, and contributed large quantities of food and clothing to the support of deserving Swiss residents, and has procured employment for hundreds of them. This Society enlists the earnest sympathy and has the confidence of gentlemen of that nationality, who enjoy a prominence in the importing of Watches, etc. During the past five years of business stagnation, the funds of the Society were exhausted by reason of the numerous applications for assistance and it was for the purpose of securing additional funds that the fair at Irving Hall was held. We are pleased to say, that the plan was successful, the articles contributed for sale were numerous, and many of them rare and valuable, and the Hall was crowded all the time during the continuance of the fair. The sales footed up to nearly \$12,000.

### Correspondence.

*Editor of Jewelers' Circular:*

Through the columns of your very welcome and widely circulating journal allow me to call the attention of the watchmakers and jewelers of the United States to the great importance of the present uprising among the retail jewelers throughout the whole country. I have just returned from the Iowa State Convention, where I met some sixty-five or seventy delegates from all over the State. The meeting was very enthusiastic and at the same time very harmonious. They all seemed to think exactly alike on all main questions, prominent among which was that of a remedy for the evils from which we have suffered so long and patiently. In effect we unanimously came to the conclusion that we have certain rights and privileges which the manufacturers and the so-called jobbers would do well to respect. The only remedy which seems to be of the least possible utility in the case is for every retailer to drop at once all further dealings with any concern that has been in the habit of scattering their ruinous circulars. If we owe them anything pay them up as fast as possible and deal so far as practical thereafter direct with the manufacturers and importers. In this way we shall be able to get an extra discount, especially for cash, even in small bills. There are other important advantages that may grow out of the small bill and cash system, viz., parties in limited circumstances will not buy so heavily as to load themselves with too much stock and too much indebtedness as is often the case when they order through traveling agents. They will learn to buy light for cash with increased discounts.

There is to be another convention early in September at Des Moines, Iowa, which will also be largely attended. In the meantime another is called for the 2d of April at Springfield, Ill., and yet another at Chicago on the 15th of April. As yet we have not heard much from Wisconsin except by private letters, all of which speak in the most encouraging terms. The very shallow and gauzy letter published by a pretended leading house in this city was read at the Iowa meeting with ludicrous effect. That jobber, among other gratuitous advice to the insulted retailer, suggested that the dealer who should keep himself untrammelled by secret orders, leagues, etc., was the one who would prosper. This reminds us of the fable of the man who concluded to raise a superior stock of chickens. He procured a lot of eggs of a celebrated kind and got an old hen to hatch them out. They looked very fine. He put them into a coop, but the next morning he missed two of them, and the following morning he missed two or three more. This would never do. He went to work making a large strong box to put his hen and choice brood into for safety. While at work Mr. Reynard, the fox, came along and asked him what he was making. "I am making a safe place for my chickens," he replied. "O, you evidently don't understand this chicken business as well as I do, Mr. Farmer; I have made the chicken trade my main business; in fact have devoted my whole life to it. You let me mind the chickens while you attend to your cattle and sheep." "Well, now, Mr. Reynard," said the farmer, "I rather think you know a little too much about this chicken matter; in fact I guess you know something about my missing chickens, and I propose hereafter to take good care of them myself."

Now it occurs to me that we too have left the management of our chickens to the tender mercies of the jobbers, scalpers and middlemen. Let us hereafter look to our own interests by dealing direct with the manufacturer and the importer. The latter would be glad to encourage that plan by giving us the extra discount heretofore allowed the middlemen, especially when the trade learn the great advantage of buying smaller bills and paying cash—less money lost in bad debts. These so-called jobbers usually live in fine houses, often keeping fast teams, and always dressing better than we can afford to. Whose money do they grow fat on?—when they produce nothing, not to say anything of the heavy traveling expenses of the "Bummer." Surely they have lived upon our chickens too long. Let us bury our little hatchets that we have been hacking each other with and take up the battle-ax in our combined self-defense against these foxes, and the desired remedy will speedily follow.

CHICAGO, March 25th, 1879.

A. P., Watchmaker.

*Editor of Jewelers' Circular:*

The frequent peculiar failures which have recently taken place in California prompt us to communicate to you some information which may be of benefit to your many subscribers. Since the repeal of the late obnoxious "Bankrupt Act" we have had opportunity to realize the beauty of "State Rights" in the operation of the State Laws as affecting the collection of debts, past, due and doubtful, but nowhere so much so as in the so-called "Golden State."

In California, we are informed, the State Laws are peculiar, and discriminate between people effecting contracts in the State or out of it. It appears by a section of the Amended Code of Civil procedure that attachments cannot issue where contracts are made out of the State. Is it therefore suggested that contracts be legally made. Such a course would materially aid creditors during these times of financial imbecility, Respectfully,

NEW YORK.

SAFFORD & FORNACHON.

## Precious Stones and Gems.

BY EDWIN W. STREETER.

PLINY speaks of the chrysoprase as a gem well known to the ancients, and tells us that they made vessels of it, and that the stone was obtained from India in great quantities. It has been said, however, that chrysoprase was first discovered by a Prussian officer near a mill on the Kosemitz Mountains in 1740. It is quite certain that chrysoprase has been used for centuries, although its true home has not been accurately ascertained until lately. The costly mosaic walls of St. Wenzel's Chapel in the Cathedral of St. Beit, at Prague, built in the 14th century, contain splendid specimens of chrysoprase. Frederick the Great used this stone very largely in adorning Sans Souci. In the palace of Potsdam there are two tables formed of chrysoprase, three feet long, two feet broad, and two inches thick.

Chrysoprase is found in Silesia, near Kosemitz, Glasendorf, and Baumgarten, not far from Frankenstein. It occurs in veins of serpentine, in company with other minerals, such as quartz, hornstone, chalcedony, opal and pimeite, the two last receiving their color in the same manner as the chrysoprase, viz., from oxide of nickel. The chrysoprase as a rule is laid bare by the heavy rains washing away the soil on the hills, and is occasionally also turned up by the plowshare.

The green opal, which is found in company with the chrysoprase, is called the chrysopal. Among the less precious stones the chrysoprase is perhaps the greatest favorite, possessing a beautiful apple-green color of many shades and a transparency and capability of a high polish, together with the advantage of being found in large pieces. One of its peculiarities is that by constant use (such as sealing), it partly loses its color and gradually becomes paler. Heat and sunshine even affect the color. This is caused by the fact of one of its constituents parts being nickel. It was the great chemist Klaproth discovered this fact, and also that it contained a small quantity of water. The nickel oxide is therefore probably united with water as a hydrate in the chrysoprase, making the metallic oxide appear more varied and beautiful in color. If, by the influence of heat, a particle of water in the stone is lost, the beauty of the color vanishes more or less. The chrysoprase is chiefly used for signet rings, buckles and pins. The working of the stone must be done with great care, as if too great a heat be applied it splinters and loses color. As a rule it receives the table-cut or "Cabochon" form. The lapidaries of Warmbrun are the principal cutters and polishers of chrysoprase.

The value of the chrysoprase depends upon its color and freedom from flaws. It is not so much valued now as in former times, but it still obtains a higher price than any other variety of chalcedony, good specimens realizing from £5 to £20.

The garnet or carbuncle was a great favorite with the ancients. Several antique garnets have been found in Roman ruins, some being round, and some cut; the latter receiving the name of "Garnet Plates," the underside of which is ground convex to give them a more perfect transparency. In former days it was more frequently engraved, and several beautiful specimens are now to be seen in Paris, Turin, Rome and St. Petersburg, among which is the grand masterpiece of art, the representation of "Sirius," engraved on the celebrated Marlborough garnet. The small degree of hardness possessed by this stone renders engraving on it comparatively easy.

The word garnet, or, as the Germans call it, granat, owes its origin to the similarity in color to the blossom and kernel of the pomegranate, a fruit of Southern Europe; it is not a name of ancient date; Pliny calls it "carbuncle," from "Carbo," a live coal; both names are derived from its bright red color. According to some authorities, however, it is thought that the origin of garnet is "granium," a grain, because it is so often found in that condition. The precious garnet is often called "almandine," from the city of Ala-

banda in Carien. Its color is blood-red, cherry, or brownish-red, which, unlike the Oriental amethyst, gains nothing by candle-light. On the contrary, it assumes an orange tint, which detracts from its beauty. The crystals are almost always imbedded in the rock singly. Its specific gravity is from 4 to 4.2, and its hardness is 7.5. It possesses a bright lustre and is transparent. It occurs very frequently mixed with a variety of other stones, and the places where it is found are so numerous that only a few of the most important can be mentioned.

In the mountains below the river Enns in Austria large transparent crystals of almandine are found in serpentine. In the Zillertal and Tyrol crystals of an inch in size are found imbedded in the stratum of chlorite slate in granite. These are taken to Bohemia and worked into ornaments. The crystals found in Bohemia are generally reduced to powder for polishing purposes.

In Norway it is found in granular masses associated with augit, epidot and hornblende. Some specimens have been obtained of rare beauty. In Sweden fine large crystals are found imbedded in schist.

Switzerland is rich in garnet. On the St. Gothard large and small crystals of blood-red color are found in mica-schist. In the Rheinwalde extraordinary large crystals of bright red color are found in rich quartz gneiss, and in the Simplon Pass they are found in the glacier streams of small size but very beautiful.

They occur in great abundance near to Almeria, in Spain, with cordierite, diorite, and also in gneiss.

In Hindostan garnet is abundant in the debris of mountains, and in Ceylon it occurs everywhere in gneiss, particularly at Tricomalee and at Adam's Peak.

The crystals which come from Siria in Pegu, and which are called Sirian almandine, are more than ordinarily fine.

In Greenland they not unfrequently fall out of the matrix, which is a chlorite slate, and leave a regular colored impression behind. In the United States they occur in granite, hornblende, and gneiss. In Mexico beautiful crystals occur in the fissures of granite rock, in chalcedony, and in lime; and in Brazil in a variety of places, sometimes in chalk, or in talc and slate, and not unfrequently in river beds in company with diamonds.

In Australia very fine crystals are found near Oven and the Peel River.

There are several kinds of garnet used for ornaments, but the red varieties only have been used to any extent as jewels. They used formerly to command high prices, and retained their popularity to quite a recent date, and even lately a carbuncle of the size of half-a-crown has been known to bring as much as £50, but they may be said to have quite gone out of fashion. The several varieties employed by the jeweler are distinguished by their peculiarities of color or cutting, and are known by special names. The almandine, a beautiful stone of a rich claret color, is the most highly esteemed. The finest stones of this class come from Ceylon and Pegu.

The pyrope, sometimes known as the Bohemian garnet, is of a blood-red color, never purple. When cut like a brilliant it is very bright, but owing to its occurring in small pieces, it is more usually rose-cut, and mounted as a *pavé*. Its chemical composition differs from the almandine in having only 10 per cent. of protoxide of iron, 15 per cent. of magnesia, and 5 per cent. of lime. It is found principally in Saxony and Bohemia. Its specific gravity is slightly lower than that of the almandine.

The carbuncle is simply an almandine cut *en cabochon*, that is, with a convex surface, the back frequently being hollowed out so as to display the deep color of the stone and enable the jeweler to "foil" it.

The jacinth, sometimes called the hyacinth, is an orange-red variety, and differs in some respects in character from the deep red garnets, and is considered by lapidaries as a distinct stone. This is a mistake, as its crystalline form and typical composition are identical with that of the other garnets. Its chief difference, besides its

peculiar color, is a lower specific gravity and the presence of 30 per cent. of lime in lieu of protoxide of iron. The specific gravity is 3.65. It is known to mineralogists as the *essonite* or *cinnamon stone*.

Jacinth or cinnamon stone comes almost entirely from Ceylon, where it is found in large pieces in the strata of rocky mountains. These stones are generally finely colored and transparent. They are cut thin on account of the depth of color, with a pavilion-cut below and a broad table above, bordered with small facets.

At Dissentis, in Switzerland, beautiful crystals are found of a reddish-yellow color, in a sort of quartz formerly called by the name of hyacinth of Dissentis; and equally fine with diopside in Piedmont and St. Gothard. From the dolomite region of Mexico we obtain cinnamon stone of a beautiful red color, almost identical with spinel. A new variety of garnet has recently come into the market from Siberia; in color it is a beautiful green, very brilliant, and unlike any other stone that we have.

The different species of jasper, and the variety of opinions concerning it, render a description difficult. The Greek name "jaspis," according to Isidore, "signifieth green, and such a green as doth illustriously shine forth with a very supreme viridity or greenness of glory." Pliny considers the jaspis a gem of a dull green color, like an emerald, but not so transparent. In his 37th book he reckons up no less than ten kinds of this gem. "The third of these," he says, "is like to air, and is called *Erizusa*, because it resembles the morning of an autumnal heaven; "and the tenth kind," he writes, "is like to crystal," which occurs with the description of it in Holy Writ; but he himself prefers the purple jasper to all other kinds, and next to this that which resembles the rose. Baccius declares "that the pleasure which may be seen in a jasper, the beauty of which ariseth from the mixture of many excellent greens and whites, cannot be expressed." The name itself is very ancient. This gem is the "*Jaseph*," or eleventh stone, in the breastplate of the high priest. The glory of the jasper is often made use of in the Holy Scriptures to represent the New Jerusalem.

Pliny assures us that Eastern nations wore pieces of it as amulets, and Nicols, who wrote in the middle of the 17th century, says in his quaint way: "Divers do very superstitiously attribute much power and virtue to the cross-white jaspers, if figures and characters be engraved upon them."

The red jasper was much valued in early times for engraving. In Florence the yellow jasper is largely employed for mosaics, and the riband jasper for cameos. "We have seen," says Pliny, "a large jasper of 15 ounces in weight, upon which was worked a likeness of Nero." For finer work the piece of jasper is divided by a copper edged saw, used with fine sand, or pieces of a more carefully selected size are cut and polished with emery.

In the Vatican there is a beautiful vase of red jasper, with white veins, and another of black jasper with yellow veins. In China the emperor's seal is of jasper, and in that country the stone is valued highly.

It is found in compact masses of kidney shape, or in pebbles, very seldom in clusters. Its colors are green, yellow and red of various shades, rarely blue. That known as the Egyptian jasper is found in round masses, and is of intense red or ochre yellow, deepening into chestnut-brown, according to the preponderance of one or other coloring matter. Very frequently the colors form stripes or zones in the stone, which are probably the result of decomposition of the upper surface. Genuine jasper has a perfect conchoidal fracture, and a peculiarly dull lustre. The brown jasper, with its concentrated light or dark stripes, is found in abundance in the ridges and sands of the deserts. Near Cario it occurs in masses, which probably belonged to the chalk formation.

Its great capability of polish and the abundance in which it is found in the birthplace of Moses, must have first drawn attention to it, and may account for the Jews examining into its character and properties and making much use of it.

The red jasper is found in great plenty near Muhlheim in Bresgau, in the granular iron of that district, which suggests a similar origin with that of flint.

Common jasper, generally red and brown, but sometimes yellow and black, is found in iron and iron-stone, in a variety of places. Riband or striped jasper occurs in compact masses with thin conchoidal fracture. It has stripes or zones of grey, green, yellow, red, and brown, and is mostly found in Siberia, but is also obtained in smaller quantities in Sicily, Corsica, the Hartz and Tyrol.

The so-called porcelain jasper is only burnt clay. The many-colored jasper has frequent rents, wheteby the appearance and lustre suffer. In Sicily they practice the art of filling up the fissures or rents with a cement made of nut oil and tragacanth, but when this cement becomes quite dry the rents reopen.

Thomas Nichols writes: "This gem or stone of price, for its fullness of glory and excellence of beauty, cannot admit of any foyle or tincture to commend its beauty withall," and further, "It is ascribed, by way of glory, to the King of Egypt, that the first adulteration of the jasper by tincture was from him, but the glory of this praise, if I be not mistaken, doth even become his shame."

The Spaniards found amongst the ornaments of the Indians dwelling upon the shores of the Amazon grotesque figures formed of labrador, supposed to have been exhumed from the tombs of the old Mexicans. It is now found principally on the coast of Labrador, and is sent home by the missionaries.

The crystals belong to the triclinic system. The cleavage is perfect; the fracture uneven; and it possesses a pearly or vitreous lustre. The color is grey, brown or greenish. Usually a play of various colors may be observed, in which blue and green are predominant. It is translucent. The stones which have the most beautiful colors come from the coast of Labrador and St. Paul's Island, where they are found in masses, and from Finland, where they are found in loose blocks.

Great care has to be taken in the manipulation of this stone to preserve the play of color, for if many facets are given to it, this wholly disappears. Large and beautiful specimens of this stone are highly valued. The first block of labrador was brought to Europe in 1775, and it was discovered in Russia in 1781. Still later two blocks were found on the shores of the Paulkovia, which exceeded all hitherto known specimens in size. One of these was a Russian ell in length, and the second weighed one thousand pounds. It is valued for jewelry and ornamental purposes on account of its beautiful colors. Value from £1 to £10, according to its lustre.

The lapis-lazuli is remarkable for its beautiful color. The Arabians call it "Azul" (blue). It is without doubt the sapphire of Pliny, who speaks of it as being "like to the serene blue heavens fretted with golden fire." The lapis-lazuli crystallizes in the tesseral system. Its specific gravity is from 2.3 to 2.4, and its hardness 5.5. The color varies from pale azure to deep blue, with a tint of green, but it is seldom quite pure, being subject to white and yellow spots, caused by the presence of iron pyrites, which considerably lessen its value. It is brittle, has but little lustre, and is transparent only at the corners. The chemical composition of this stone, according to Varrentrapp, is, silica 45.5, alumina 31.17, sulphuric acid, 5.8, soda 9, and lime 5.5, added to which is a little iron, sulphur and chlorine. The beautiful color is no doubt owing to the combination of a silicate with a sulphate mixed with a little sulphuret of iron. It fuses with great difficulty, and expands before the blow-pipe, after which it becomes a porous, colorless glass, but if heated with saltpetre it turns to a beautiful green. According to Field, the variety of this stone which comes from Cordilleras, loses its blue color by heat, but regains it on cooling.

In the Cordilleras, near the sources of the Cazadero and Vias—little tributaries of the Rio Grande, not far from the high road leading to the Argentine Republic, and a short distance from the great water sheds of the Chili dominions, the lapis-lazuli is found in a thick stratum of carbonate of lime, accompanied by small quantities of iron pyrites.

## The Jewelers' League.

We devote this column to the interests of the League and its membership. Letters or inquiries pertinent to its business or purposes, and which might interest the trade or inquirers, will be herein answered. Address *Jewelers' League*, Box 4001, P. O. New York, or the office of THE CIRCULAR

Candidates who propose becoming members will do well not to procrastinate after the applications are filled out and ready for action by the Executive Committee. Mr. A. J. Norman, late in the employ of Messrs. Stillman Adams & Co., jewelers, of this city, had his application ready several weeks prior to the March meeting, and finally promised the gentleman who sought his application that he would present it at the April meeting, but in the interim he was stricken down with pleuro-pneumonia, and death resulted from the severity of the attack. We know of several who have had their application blanks filled out for many months, but they neglect to send them in. Which one of these can assure us he will not be in his grave before the next monthly meeting?

The zeal which has been shown recently among the members, and the friendly competition in securing candidates for membership augurs well for large accessions of members during the year. One comparatively new member presented twelve members at the last meeting, and if he repeats the performance we shall feel under the necessity of publishing him. We wish we had a pole long enough to stir ALL the members up to their duty.

We have received very cordial letters from Mr. Fred. I. Marcy, and Mr. L. F. Giering, members of the Advisory Board from respectively Providence, R. I., and Bethlehem, Pa., both of whom, judging from the tenor of their letters, are about to institute a raid among the eligible gentlemen in their respective neighborhoods. Send them along, fellow members, we will take all the good ones you may recommend, and then will call for more.

We have a letter from a gentleman in Springfield, Ill., who wants a \$2,000 policy in the League in exchange for one of like amount which he holds in the Equitable, because the latter is too expensive. Sorry we can't accommodate him; in the first place we do not speculate in life insurance policies, and in the second place our benefits are *table d'hote* rather than *a la carte*. We pay what the number of members multiplied by two dollars would amount to. We have no benefits of fixed amounts; the amount paid a beneficiary varies as the number of members until the League is filled up. If a gentleman wants a payment of \$2,000 to go to his widow or heirs, if he is a good risk, we would be pleased to acquire him as a member, wind him up and then set him going after other members, and thus soon secure the number requisite to make a payment of two or more thousands of dollars.

Our Secretary complains that in members changing their addresses do not advise him thereof. Please remember that "a notice sent to the last address given shall be considered a legal notification," (Constitution, Art. 5, Sec. 2), consequently a member might be dropped from the roll for not responding to a notification sent to his last recorded address, and it would cause him trouble and expense to be reinstated.

Dr. Joshua G. Wilbur, No. 153 Broadway, has been appointed examining surgeon, *vice* Dr. Decker resigned.

The following named members were admitted at the regular meeting of the Executive Committee, held on Friday, March 7th.

James A. Smith, with Bryant & Bentley; Charles H. Arms, with Tiffany & Company; Milton P. Bagg, with Tiffany & Company; Léon Barre, with Tiffany & Company; Nathaniel F. Baldwin, of Baldwin & Company, St. Joseph, Mo; Francis T. Bemis, of Bigelow, Kennard & Company; Henry C. Bucklin, with J. T. Scott & Company; W. Francis Cory, with Chatterton & Dodd; Hibbard G. Gill, Philadelphia; William T. Gough, with Carter, Howkins & Sloan;

Andrew W. Hart, of Hart Brothers, Brooklyn; William M. Harker with Joseph B. Bowden & Company; William S. Hedges, of W. S. Hedges & Company; Charles P. Herold, Philadelphia; James L. Hovey, with Bigelow, Kennard & Company; Leon P. Jeanne, of Jeanne Brothers; DeLancy Kennedy, Jr., with D. M. Fitch & Company; William Leding, with Carter, Howkins & Sloan; Joseph Lindauer, with Tiffany & Company; Howard D. Lowd, with Tiffany & Company; Samuel Mc C. Miller, of Phelps & Miller, San Francisco; James E. Moore, Chicago; Charles E. Offerman, with L. A. Kotzow & Company, Providence; Henry C. Plumb, Des Moines; William H. Salt, with Tiffany & Company; Le Grand Strang, Amsterdam, N. Y.; James T. Scott, Jr., of J. T. Scott & Company; Charles N. Scott, Worcester, Mass; Edward P. Tiffany, with F. G. Whitney & Company; Henry C. Weir, with H. Rowlands, Albany; Harris C. Wilkinson, of Royal Manufacturing Company.

At this meeting one candidate was rejected.

At a special meeting held on March 12th, the following members were elected. Charles C. Camerden, with A. M. Hays & Company; Asa W. Armington, with Shreve, Crump & Low; Oluf C. Hanson, with N. Matson, Chicago; William G. Pratt, with Elgin National Watch Company; Erik L. Vognild, with N. Matson & Company. At this meeting one candidate was rejected.

At the last regular meeting held on April 5th, the following were elected members: John R. Andrews, of Tiffany & Company; Josiah B. Baxter, with Frederick I. Marcy & Company, Providence; Albert N. Bliss, with Bliss & Dean, Attleboro; Amasa B. Britton, with Black, Starr & Frost; William Crane, with C. W. Kennard & Company; Harry M. Carle, with Dueber Watch Case Company; Edward N. Cook, with John A. Riley & Company; Timothy Conklin, Morrisania, N. Y.; David J. Dannahy, with Robbins & Appleton, Boston; J. H. A. Davisson, with J. E. Caldwell & Company; Frank A. Dawes, with Tiffany & Company; Arthur T. Evans, with T. D. Bowen, Chicago; George N. Fenn, with Saxton, Smith & Company; Robert F. Forrester, with Colby & Johnson; William S. Foster, with Bigelow, Kennard & Company; Henry Dreyfus, of Sussfeld, Lorsch & Company; Damon Greenleaf, Jacksonville, Fla.; William R. Gardner, with Tiffany & Company; Charles E. Glor, with Tiffany & Company; Frank W. Harmon, with J. B. Mathewson & Company; Charles L. Heiser, with Taylor & Brother; George H. Houghton, with Gorham Manufacturing Company; John T. Howard, Jr., with Cox & Sedgwick; David S. Jones, with Bigelow, Kennard & Company; Henry M. Kimball, with Bigelow, Kennard & Company; Edward L. Libby, with D. C. Percival & Company; Charles F. Livermore, with Robbins & Appleton, Boston; Edward Livingston, with Saxton, Smith & Company; John G. Koenen, of Koenen & Brother; Charles A. Marsh, with Stephen Richardson & Company, N. Attleboro; John F. Minaldi, with Sexton & Cole; William E. Montoux, N. Y.; Frederick H. Miller, with Shoemaker & Company; John C. Mount, with Randel, Baremore & Company; Joseph Newick, with Frank Horton, N. Y.; John P. Owen, with Robbins & Appleton, Chicago; F. H. Mc C. Proudfoot, N. Y.; David S. Plumb, with Tiffany & Company; Wallace Rand, with C. W. Kennard & Company; George W. Reynolds, Jr., with Bigelow, Kennard & Company; Clarence H. Richardson, of Stephen Richardson & Company, N. Attleboro; Charles Q. Sampson, with Tiffany & Company; Theron J. Smith, of T. J. Smith & Company, N. Attleboro; Charles H. Taisey, with Robbins & Appleton, Boston; G. Carrington Taylor, of Taylor & Brother; William B. Tilton, with S. W. Bailey, Boston; John W. Tooker, with J. H. Johnston, N. Y.; William H. Weld, of Weld & Brother, Lockport; Moses Weis, of Marx & Weis, N. Y.

Three applications were rejected and three were referred for correction or future consideration. Over one hundred members have been added since the annual meeting, making a present total of 399.

The introduction of Celluloid in the manufacture of eyeglass frames is the latest adaptation of this wonderful substance. There seems to be no limit to its adaptation. It constitutes an excellent substitute for ivory, and is equal in color to the real material. Tortoiseshell is another scarce and dear product, of which a close imitation is produced in Celluloid and the Spencer Optical Manufacturing Company have succeeded in successfully introducing it in the manufacture of eyeglass frames which seems particularly adapted to this purpose, for it not only resists atmospheric changes, but is exceedingly tough and difficult to break, while its lightness and beauty of color will commend it at a glance. The springs are made of a composition of metal that will not corrode or rust. The increasing demand for these goods is a convincing proof of their growing popularity.

## Trade Gossip.

H. Muhr's Son's factory at Philadelphia has been burnt out.

E. J. Allen, of Charlotte, N. C., has lately made an assignment, and is endeavoring to affect a compromise with his creditors on a basis of forty per cent.

Messrs. Tiffany & Company have recently ordered two of Henry Troemner's fine scales of large capacity for weighing gold.

Mr. J. Eugene Robert, and family sail for Europe in the steamer Herder, on the 24th inst.

Mr. J. Abry is, we are glad to say rapidly recovering from his late severe attack of pleuro-pneumonia.

The grand fair for the benefit of the Swiss Benevolent Society, is a great financial success.

We have no desire to alarm timid persons unnecessarily, and far be it from us to hint that life is short, and insurance companies uncertain, only the Spring crop of failures begin to come in.

Mr. M. P. Kennard, late of the firm of Biglow, Kennard & Company, of Boston, has qualified for the office of U. S. Sub-Treasurer, of Boston, to which position he has lately been appointed.

The principal centres for the manufacture of coral ornaments are Naples, Leghorn and Marseilles. In the former more than 1,000 women are employed in making coral beads for necklaces, etc.

It will be no fault of Ex-Judge Hilton, and the gentlemen of the Executive Committee, if the promised World's Fair in 1885, will not surpass anything of the kind in the past.

A high art porcelain factory is to be started in Philadelphia. Trenton will have to bestir itself if it wants to retain its pre-eminence as the pottery centre of this country.

Messrs. Jeanne Brothers, have recently patented a very ingenious device for showing diamonds of any size from  $\frac{1}{2}$  to a 5 or 6 karat stone in the same setting. This will be exceedingly useful to retail dealers.

Elisha M. Smith, of Providence, has been missing for some time, and his friends fear that he has committed suicide, he was last seen on the steamer Stonington, while on her way to this city, on the 8th ult.

The genial John H. French, the well-known jewelry auctioneer is closing out the stock of A. H. Miller, of Chicago, at public auction. Mr. Miller, it is reported will retire permanently from the jewelry business.

Carrier, Marshall & Company, of Toronto, wholesale dealers in Watches, Jewelry, etc., have made an assignment to A. W. Murdock, official assignee, who is making a thorough investigation of the causes of their failure.

We learn that Mr. J. P. Stevens, of Atlanta, Ga., is about to leave the ranks of "the loved ones," and join the noble army of martyrs, our gallant friend will shortly lead to the Hymenial altar, one of Atlanta's fairest daughters.

The firm of Sunderlin & McAllaster, of Rochester, N. Y., has dissolved by mutual consent. Mr. Sunderlin having purchased the interest of Mr. McAllaster, and will continue the business under the firm name of L. Sunderlin & Company.

Buying bric-a-brac at high rates is a good way to encourage home industry. One purchaser has a revolver, recently purchased here, which he avers, and he is quite ready to swear to the fact, was taken out of the tumulus on the field of Marathon.

"David" for the past 15 years, well-known to the city trade as porter for Rogers & Brother, died on Wednesday, March 26th, of Bright disease; his familiar face and dry humor, will be missed by those whom he has faithfully served for so long a period.

The members of the Hardware Board of Trade recently held a meeting, to consider the expediency of recommending the passage of a National Bankrupt Law. There seemed to be a general desire for a National law to protect creditors and lessen the expenses of bankruptcy proceedings.

Finding a man behind his shop counter in the small hours, a Kentucky jeweler did not stop to ask any questions, but proceeded forthwith to lodge fifteen buckshot where he thought they would do the most good; result, one dead burglar, and several living burglars warned of the risks of their profession.

Charles Rowell, the English pedestrian and winner of the Ashley belt at the recent tournament at Gilmore's Garden this city, uses an American Pedometer, and writes Messrs. Tiffany & Company, the following note: "I carry one of your American Pedometers, and find it marks the distance exactly either in walking or running."

Yours, etc.

CHARLES ROWELL.

R. Humphreys Elias, who has been in the habit of advertising himself as Richard Humphreys, has made an assignment for the benefit of his creditors, his wife appearing as a preferred creditor for \$15,000. Humphrey has been doing a brilliant business in bogus diamonds, advertised as gems from Golconda, etc., and has succeeded in palming off a considerable quantity of these goods under various delusive names.

It was that "most gentlemanly of all the saints" Saint Francis de Sales, who says in his introduction to the Devout Life.—"All kinds of precious stones cast into honey become more brilliant thereby, each one according to its color, and all persons become more acceptable in their vocation when they join devotion with it." The practice of "cooking" certain stones, as for example agates, in honey is as old as Pliny.

A youth in the employ of Messrs. Tiffany & Company, has been detected in stealing a large quantity of silverspoons, which he offered for sale at various retail stores in this city. A few days ago he offered to sell Mr. J. H. Johnston, the well-known jeweler in the Bowery, a dozen silverspoons. But suspecting something crooked in the youth and recognizing the goods as Tiffany & Company's patterns he immediately communicated his suspicions to the firm, who succeeded in fastening the guilt upon the young thief.

Signor Alessandro Castellani, who, together with his father and brother Augusto, has been, during the last forty years, the restorer of antique Roman jewelry to the markets of the world, has just made his official report to the Italian Government upon the jewelry exhibited last year, at Paris, particularly that from England, France and Italy, which took first rank, in his opinion. He advocates the formation, in all countries of artistic industrial museums for educating the public taste and encouraging young workers in gold.

The Importers' Association is composed of the leading importers of watches, who do business in New York. These gentlemen have organized this association with a view of concentrating their efforts for the purpose of protecting the trade in Swiss watches, and disseminating correct and useful information regarding their manufacture. It has been in existence about eighteen months, and during that time has performed much work, and attained excellent results in the direction indicated.

Mr. R. R. Haskell, formerly with the Gorham Manufacturing Company, and last year with the Adams & Shaw Company, has left the road and located in San Francisco. He has arranged to represent on the Pacific Coast the well-known firms of Enos Richardson & Company, manufacturers of fine gold jewelry, gold chains, etc. Reed & Barton, manufacturers of plated ware, of Taunton, Mass., Taylor & Brother, dealers in diamonds and pearls, and Wood & Hughes, silversmiths. Mr. Haskell will carry full lines of the goods manufactured by these firms, and is their accredited representative on the Pacific Coast. Mr. Haskell is well-known in the trade, and his many friends will wish him success in his new departure.

Vatalio Himmer, a Third Avenue jeweler, was arrested on an order of arrest issued by Judge Lawrence of the Supreme Court, in a suit for \$5,000 damages for slander, false imprisonment and injury to the person of Mrs. Annie McGarrett, the wife of an employe of the Metropolitan Elevated Road, whose complaint alleges that on the morning of March 10th, she entered the defendant's store to buy a ring, and not being able to suit her taste, declined to make a purchase. Himmer accused her of having stolen a ring, and had her arrested on his complaint. At the station house she was searched and sent to the Seventh District Police Court and discharged upon a preliminary examination. Himmer is held in \$3,000 bail by the Sheriff.

A sensational story is going the rounds of the press of an alleged discovery of the artificial manufacture of silver by Dr. T. Farriss, Jr., of the Iowa Wesleyan University, which carries one back to the days of the old alchemists. Dr. Farriss, it seems, when taking his class through a course of instruction in the primary chemical compounds, was in the habit of setting aside the refuse waters, and one day was startled by the unusual silvery reaction which had taken place in these solutions. This led him to investigate. Result—the artificial manufacture of silver, a business on which the Doctor is said to have entered now on a large scale. Of course, details of the new process are kept rigidly secret from the scientific world, though credulous capitalists may be attracted by the glittering prospect just as they have been in the past by Keeley motors and other impossibilities.

# Jewelers' Circular and Horological Review.

VOLUME X.

NEW YORK, MAY, 1879.

No. 4.

## THE JEWELERS' CIRCULAR AND HOROLOGICAL REVIEW,

*The recognized organ of the Trade, and the official representative of the Jewelers' League.*

A Monthly Journal devoted to the interests of Watchmakers, Jewelers, Silver-smiths, Electro-plate Manufacturers, and those engaged in the kindred branches of art industry.

### SUBSCRIPTION:

To all parts of the United States, Canada, Great Britain and the West Indies,

**\$2.00 Per Annum; Postage paid.**

To France, Switzerland, Germany, Mexico, the Republics of South America, and Australia, \$2.50 per annum. Postage paid.

*All communications should be addressed to D. H. HOPKINSON, 42 Nassau Street, New York. Advertising rates made known on application.*

AGENCIES: { J. H. PURDY & CO., No. 170 State Street, Chicago.  
PRATT & CO., Ninth and Arch Streets, Philadelphia.  
HERMAN BUSH, No. 14 Mytongate, Hull, England.  
FREARSON BROS., Adelaide, Australia.

MESSRS. LEE & WIGFULL, the well known Electro-plate manufacturers, (John Street Works), Sheffield, England, have kindly consented to receive subscriptions.

*This journal is published on the 15th of every month, and will, on receipt of the yearly subscription of \$2.00, be forwarded regularly to any address in the United States or Canada for twelve months. The present volume commenced with the February issue, and intending subscribers can be supplied with back numbers so as to have the volume complete.*

### The Capital of Credit.

THE assertion has often been made, and facts, so far as they can be ascertained, would seem to justify it, that at least nineteen out of twenty business men in this country fail soon or late. The Republic is certainly a land of failures as well as of successes, and a peculiarity of both is that they are seldom permanent. Indeed, failure is frequently the consequence of many successes, and success is at last the crown of repeated failures. Americans are rarely so satisfied with any kind of success as not to crave another kind, and they utterly refuse, when they fail, to stay failed, however discouraging their circumstances or their outlook. They have such faith in the resources of the country and in their own that they are not apt to be cast down by financial misfortune, which they regard as temporary. It is this faith, possessed generally in excess, which makes them imprudent, not to say reckless, in the management of their own affairs. They take small pains to avoid disaster, from which they feel that they can soon rally. A modicum of distrust, even of despondency, might be beneficial to them and—their creditors.

Business has been regarded in many lights and from many points of view. It has been defined as the application of intelligence and industry to the laws of trade, as a uniform system of buying cheap and selling dear, and as an organized attempt of the few to defraud the many. In this country particularly, it would seem to be in the main a scheme for obtaining and perpetuating credit, without which, in most cases, it could not be carried on. So long as a man has credit, it is very little trouble to get on. When he is obliged to pay here, he can borrow there; meeting a note in one bank, he can be sure of discount in another; when a firm takes up its paper, it can put out new paper; thus exchanging money, as it were, from the right hand to the left, and sustaining credit by extending it. A house

that has once been fairly established can continue indefinitely without any considerable capital, provided it has preserved its credit. Old firms fail every few weeks, in times like these, and, though they have given support and importance to their members for several generations, are found to have had no financial foundation for many years. Such failures invariably excite surprise and a great deal of comment, as if they were unprecedented instead of common, and the surprise and comment are repeated when the next failure, with like conditions and under like circumstances, shall have occurred. It is common to say of many merchants that they live on what they owe, and paradoxical as it sounds, the saying is, in a commercial sense, true. They incur what is called legitimate obligations; but these are so much increased, and often created under circumstances so peculiar, that they become illegitimate without receiving the name. Indeed, the boundary between the legitimate and the illegitimate is so slightly marked in certain circles that the two get inextricably confused, and the moral ideas of the merchants along with them. When the obligations fall due, and new ones cannot be incurred in their stead, suspension or stoppage comes, followed by compromise or bankruptcy, and another commercial experiment, attended, after a given time, with the former results. A number of firms fail regularly and periodically, sometimes through sheer dishonesty, but generally from lack of method, economy and foresight. One might suppose that, after two or three failures, they would so destroy confidence in their capacity to manage that they could get no further credit, and be compelled therefore to retire. But such is not the case. Competition is so active that, unless a man be thought positively dishonest—even then he is not denied opportunities—he can usually command credit, and continue a long, uninterrupted and brilliant series of insolvencies.

How large a proportion of merchants is there who fail whenever they are called upon to settle the greater part of their debts! They can always pay if they are not called to pay very much, and so long as they have the privilege of borrowing. Deprive them of this privilege, force them to depend on themselves, put them to their financial purgation, and they go to pieces. They are strong only while they are not taxed; they are responsible only while their responsibility remains untested. This is well shown by the periodical panics, financial reactions, commercial torpors, from which we so often suffer as to demonstrate our national extravagance, imprudence and want of forethought. When these occur, any number of houses topple down, and among them many that have enjoyed public confidence, and been regarded as very sound. Their discomfiture is ascribed to external causes; but investigation generally shows that their condition was bad; that their affairs had been ill managed; that they had expended far more than they were justified in expending; and that their failure is owing to their further inability to fly kites, procure accommodations, and defer by various shifts the day of reckoning.

The great cause of failures in this country is the unwillingness of merchants to do business in accordance with their capital and to live within their means. They provide very liberally for their pleasures and caprices; they extend themselves indefinitely, and make their creditors take most of the risk. They seem determined to get on at somebody else's cost. However their business may shrink or their profits be reduced, they do not diminish their expenses, and when the crash comes they are among the least hurt. There are merchants and merchants; but, certainly, many of them depend on credit they do not deserve, and live on what they owe and do not pay.

### Mortgaging their Stocks.

OUR attention has recently been called to certain commercial agency reports of a character calculated to startle the creditor class in the jewelry trade. By these reports we see that in several instances retail dealers in different sections of the country have been mortgaging their stock, or portions of it, or their store fixtures and appliances for doing business, in consideration of small loans, thus placing their property beyond the reach of their creditors—the men who are the actual owners of the goods. While it is questionable how far the law will sustain mortgages of this character, the uncertainty attending the enforcement of the many diverse laws in the different States, precludes creditors from seeking legal protection. This practice is fraught with great danger to the manufacturers and jobbers, whose business is nearly all transacted on a basis of credit, but, if persisted in, cannot fail to be more disastrous in the future to the retailers themselves than to any other class. If creditors once get the idea that goods they sell on credit are to be immediately mortgaged to secure other debts than their own, there will speedily be a revolution in the methods of doing business. Manufacturers and jobbers will be compelled, for their own preservation, to refuse credit entirely, and to sell only for cash or approved and substantially endorsed paper. They must have some sort of security, and, if honor and principle are to depart from the trade, they will, of course, be forced to exact payment on delivery. Under this practice of mortgaging goods not paid for, the retailer can deprive his creditors of all possible chance of obtaining payment for the goods so mortgaged, while the mortgage itself may be a pure fiction. Several instances of this kind have been noted of late, and the trade naturally feels considerably exercised in consequence.

Another practice, subversive of all security to the creditor class, has also been developed recently. In one or two cases of failure it has come to light that the retailer has been carried along in business for years by some bank, which advanced him such sums as he required on pledges of watches, jewelry, or other portions of his stock in trade. When the final crash came, and the retailer was obliged to put up his shutters, the bank appeared as a preferred creditor, or with some lien upon the goods to which the law gives preference. Practices of this kind are rapidly undermining the credit system of the country, and destroying that confidence among business men which is necessary for the maintenance of commercial intercourse. As inter-state commerce is now so general and so extended, it is becoming a necessity that it should be regulated by national rather than State laws, which are so frequently at variance with each other. The creditor class of the country is entitled to a reasonable amount of protection, that is now being denied them, while their interests are being imperiled more and more every year.

### Assaying Jewelry.

THE CIRCULAR has recently printed several articles relating to debased goods, insisting that the best interests of the trade demanded that there should be fixed standards of quality established. Our position has been endorsed by the leading members of the trade in all sections, and we are glad to learn that our efforts are bearing good fruit. We are informed that the practice of assaying goods as received from the manufacturers is becoming general among retailers, and there are more goods sent to the assayers this year than ever before. The courts have held that payment cannot be exacted for goods that are inferior in quality to what they are represented to be. That is to say, if goods are sold as being made of fourteen karat gold, and it can be shown that they are largely composed of base metal, the purchaser is lawfully justified in refusing payment. Therefore the assay test is being resorted to for the purpose of ascertaining to what extent manufacturers are imposing upon their customers. We are glad to note this fact. Nothing has tended to bring the jewelry trade into disrepute so much as degrading the standard of goods. It is nothing more nor less than downright swindling

to receive money for goods represented to be of one quality, when, as a matter of fact, they are far inferior to the representation. Let the retailers exact with every bill of goods a certificate specifying in karats their quality, and then repudiate payment for all that fall short of the standard specified. It is unfortunate that the law does not fix the standards for manufactured gold, and provide penalties for infractions; it does, however, propose to protect the business public from confidence operators, and from being imposed upon by unscrupulous men. We hope the retailers will continue to assay the goods received by them, and to insist that they shall be equal in quality to the representations made by the seller. When they fall short of these representations, the criminal Code will furnish them redress. By this means the men who are making a business of degrading their goods, and selling base metal for gold, may be driven out of the business, and room made for those whose transactions are governed by honesty, integrity and fair dealing.

### The Howard Watch Company.

THE financial embarrassment of the Howard Watch Company, of Boston, has awakened much sympathy in the trade, because of the standing of the Company, and the many years it has been successfully engaged in business. Their present embarrassment, which, it is believed, will be only temporary, it is claimed, was caused by endorsing the paper of Sackett, Davis & Co. for \$30,000. Fearing some of the Providence banks might step in, other creditors, to whom the Company owed \$25,000, obtained an attachment. J. W. J. Pier-son, agent for the Company, states that the total liabilities were only \$140,000, and that the assets were largely in excess of this amount, consisting of two large factories, machinery, tools, and stock on hand at Boston and New York. He claims that the Company did not owe \$500 for materials, and if allowed to control the matter would soon settle its affairs. Several of the creditors have signed an agreement to accept their present indebtedness in the stock of a re-organized company, the present proposition being to increase the capital stock of the Company from \$120,000 to \$250,000, pay off all indebtedness, and start afresh with nearly \$100,000 paid in. It is believed that this arrangement will be acceptable to all in interest, and that the Company will go on as usual with renewed vigor, "a consummation devoutly to be wished."

THE following is a copy of a communication recently received by a number of the undersigned's creditors in this city. Further comment is unnecessary.

INDIANAPOLIS, April 8th, 1879.

GENTLEMEN: I am compelled to inform you of the painful fact that I have failed. I have contended with all my ability, but had finally to give up. Fletcher's Bank, of this city, has been carrying me for several years, with the expectation that I would be able to get through, but it became evident to the bank and myself that I must go down, and something had to be done at once.

If I made an assignment for the benefit of my creditors, which I had commenced to do, then my assets would have been sacrificed and creditors realized but little.

My indebtedness to the bank had increased to over \$35,000. By virtue of my condition and the certainty of great loss in the event of an assignment, Francis M. Churchman agreed to purchase my stock in full payment of all my indebtedness to the bank, which my legal advisers thought the best possible thing to do in the interest of all concerned. I made the sale and took up all my said liability to the bank.

This leaves me with some little property, out of which I hope to be able eventually to pay my creditors more than they would have realized under any other arrangements I could have made.

I intend to do everything in my power to pay what I owe. I shall prepare statement of my assets and liabilities and transmit to you in a few days, or as soon as they can be prepared, and shall then await the expressed wish of my creditors if they can agree upon any general course.

Respectfully,  
W. H. CRAFT.



## Misplaced Confidence.

A SUIT was recently brought before Judge Briggs, of Philadelphia, to compel John M. Arundel, a lawyer of that city, to refund a large sum of money obtained from certain former clients on alleged false and fraudulent representations. The following is a brief statement of the facts in the case, as shown by the petition filed, and not denied in the answer: In October, 1876, Chatellier & Spence, Durand & Co., J. Eugene Robert, Carter, Howkins & Sloan, Sexton & Cole, Mulford, Hale & Cottle, Dominick & Haff, Thomas G. Brown, Eiseman Brothers, and the Whiting Manufacturing Company, all of New York, and the Middletown Plate Company, of Middletown, Conn., intrusted to John M. Arundel, for collection, claims against the late firm of Mansfield & Baird, amounting to \$9,548.50, Chatellier & Spence being the agents and attorneys, in fact, for all the creditors. Arundel agreed to take the claims and not charge more than 5 per cent., and that in the event of collecting the whole amount, 60 per cent. having been offered in the settlement. Arundel obtained from his clients, from time to time, various sums of money, amounting to \$1,467.20, pretending that the money was required to be paid out by him in various legal proceedings. Of the whole amount of \$1,467.20 advanced by the clients for costs, Arundel actually expended for costs only \$26, so far as appeared, the rest going into his pocket. During the reading by Rufus E. Shapley, attorney for the petitioners (Arundel's former clients), of the letters and telegrams on which Arundel obtained the advances, Judge Briggs remarked: "His clients must have been wonderfully credulous men," to which Mr. Shapley replied that they had confidence in Arundel and the charges in New York, to which they were accustomed, were much higher than in the courts here. "They were accustomed to being fleeced at home," said Judge Briggs. William H. Johnson, who appeared for Arundel, objected to the word "fleeced" being applied to an attorney.

"Fleeced," said Mr. Shapley, "this was robbery. It is worse than going out into the street and putting your hand into a man's pocket and taking his money. It is worse than the acts of the worst professional swindler." The last proceeding in court which Arundel had looking to the collection of these claims was February 17, 1877, and yet a large part of the money was applied for and received afterwards, when not a thing was being done. On the 22d of February Arundel telegraphed, "To go on necessitates further expenses. Mail to-day check for \$100." A month later telegraphed, "Require Monday \$12, in each of the eleven suits. State Court. Mail to-day \$132. Something decisive soon." And so on from month to month, under one pretext or other, he kept drawing on his clients for pretended costs and referring to action which never took place. After the death of Matthew Baird, the father of Walter Baird, of the firm of Mansfield & Baird, Arundel was paid \$9,832.44, the full amount of the claims, with \$300 in the way of interest and costs. Of this amount he paid over to the creditors only \$7,625.11, and to cover up the conversion to his own use of a part of the balance, as well as of the \$1,467.20 previously advanced to him by his clients for costs, he returned to Chatellier & Spence \$1,204 out of the principal sum collected for all the creditors, and to account for the balance, he falsely claimed that he had paid out \$150 for costs in Common Pleas suits and \$256 for costs in bankruptcy and had retained \$1,500 for his fee, leaving, however, a balance of \$564.53 for which he never in any way attempted to account. The total amount received by Arundel in settlement of the claims and for costs from his clients was \$11,299.64. Of this sum he returned \$3,829.11 and retained \$2,470.53. For two-thirds of the 40 per cent. in dispute at the time the claims were placed in his hands, the petitioners gave him credit for \$26 actually expended in costs, \$491.63 being 5 per cent. on the \$9,832.44 collected, and for \$250 returned to Mr. Shapley, the present counsel for the petitioning creditors, about a year after the settlement was made, leaving a balance of \$1,702.90, which Judge Briggs' order yesterday was made to cover. Mr. Shapley stated

to the Court that every opportunity had been given to Mr. Arundel to return the money, and intimated that the present proceedings were not with the hope of recovering, but rather to rid the bar of a member who brought reproach upon an honorable profession. And he gave notice that unless the money was paid by Saturday next, he should ask the Court to enforce its order by an attachment for contempt, which will put Mr. Arundel in jail.

Mr. Chatellier is deserving of the greatest praise in following this disgraceful matter up.

## Cleaning Fine Watches.

WATCHMAKERS complain that there is no profit nowadays in repairing fine watches. The manufacture of cheap grades has developed, also, a swarm of "blacksmiths," who call themselves watchmakers, and who attempt to do repairing at very low rates. As a consequence, the general public, rejoicing in cheap watches, has got an idea that a watch should be repaired at a trifling cost, and that the cost should not vary whether the watch be a valuable one or a cheap one. Among the thousands of watchmakers in the country, there are comparatively few who are competent to repair a fine movement, or who should be permitted to handle one. A fine watch is a most delicate instrument, whose machinery is often complicated and very sensitive. It is a science, as well as an art, to make one, and science and art are required to repair it when accident disorganizes it. Such labor cannot be found in every blacksmith shop, and, when found, is deserving of liberal compensation. Owners of fine watches should know something regarding the skill of the workman to whom they entrust them for repairs. Many watches have been ruined by falling into the hands of incompetent workmen for repairs, and, too frequently, the maker of the watch is condemned for that which is the fault of a bungler who has attempted to put it in order. There is as much difference between cheap and fine watches as there is between a cart horse and a thoroughbred. Anyone can take care of the former, but, if the value of the latter is to be maintained, he must have careful and judicious treatment.

THE San Francisco *Morning Call* of April 17th publishes the following: The wholesale jewelers and manufacturers of silverware of this city, who met a few weeks ago for the purpose of forming a mutual protective association, assembled again yesterday afternoon, at 120 Sutter Street, where nearly twenty firms were represented; among the number was the American Clock Company. A. C. Titcomb, the President, was in the chair. The organization was perfected by the adoption of a Constitution and By-Laws and the completion of the election of officers, who now are A. C. Titcomb, President; M. Wunsch, Vice-President; E. Lorsch, Secretary; and Charles Ackerman, Attorney. The institution is similar in its objects to that of the Merchants' Protective Association, which are to protect the interests of its members, prevent settlements without full investigation, resist inequitable and fraudulent settlements, and bring about joint action in the collection of debts which are not in the ordinary course of business. The intention of the members is to promote honest industry by encouraging those in whom they have confidence, while, at the same time, they guard against imposition by others, expecting by united effort to lend a healthy action to the trade and contribute to its growth.

A FEW days since a well-known firm advertised for a salesman. Here is one of the replies received:

GENTLEMEN: I have just closed management of large manufacturing Fashion House, and am open for any position where ability and its results are recognized.

Am one of the best salesmen in America.

Have no particular knowledge of jewelry bus; but will master it in a week and sell more goods than any man you have. Highest testimonials and ample security.

The only thing that prevents the writer of that note from becoming President of the United States is his extreme modesty. Self-depreciation is, evidently, a weakness of his, and it would not be surprising if it hurried him to an early grave.

## Scenes in a Jewelry Store.

THE trials of a hotel clerk are often cited as something beside which the afflictions of Job were but a side-show. But the hotel clerk's position is a paradise compared to that of the jewelers, who combines with the selling of jewelry the repairing of watches, and whose place of business happens to be on a crowded thoroughfare. He is overrun with inquiries as to the correct time by hundreds of persons to whom he is under no obligation whatever, and asked to diagnose the complaints of hundreds of watches whose owners, after extracting a professional opinion gratuitously, and having their watches set to the correct time, take their departure with the remark that they "will get the darned thing fixed when they get home."

Our friend Hastings, an expert watchmaker, is situated in one of these unpleasant locations, and he declares that the amount of gratuitous work he does, if paid for at fair prices, would make his fortune in a year. Having a little leisure the other day, we drop in for a little chat with Hastings, well knowing that we should not interfere with his business, for he can chat to a friend without interrupting his work. Here is an outline of what occurred in the course of half an hour:

*Time, 11 A. M.; scene, jewelry store; Hastings at work at his bench, glass screwed in his eye, examining the intricate viscera of a fine chronometer. Enter fussy stranger.*

F. S.—"Can you fit me with a watch key? watch run down, lost key, want a new one."

HASTINGS.—"Certainly, Sir," replies Hastings, unscrewing the glass from his eye, and laying down his work regretfully. Hunts among the keys, fits one to fussy stranger's watch, winds it and sets it to the correct time.

F. S.—"What's the price of this key?"

H.—"Ten cents."

F. S.—"Ten cents! Holy mother of Moses! I can buy 'em off boys in the street for three cents. This is a swindle!"

H.—"You needn't take it if you don't want it."

F. S.—"Take it! Of course I won't take it! Do you think I'll pay ten cents for a key when I can buy one for three? Not much!"

*Exit F. S. with indignation. Hastings resumes his seat, adjusts his glass, and goes to work on his chronometer.*

H.—"Now that's what I call a profitable customer. He comes in, interrupts my work, takes my time, gets me to set his watch going, and then mentally damns me for my good nature. But the world is full of his kind. He didn't want to buy a key; he knew he left his at home, but he wanted his watch wound and set; he had it done, and it wasn't in his nature to be grateful for the favor, so he makes up a lie for the purpose of getting a chance to abuse me. He'd rather lie than say thank you. I have lots of such customers; they're profitable, they are; piles of money in them."

*[Enter German, evidently a market gardener.]*

GERMAN.—"Did you got some leetle vatches for a lady?"

H.—*[Unscrewing his glass and putting away his work. He exhibits watches in great variety.]* "Yes, Sir; I've watches of all kinds. About what priced one do you want?"

G.—"Vell, I vant a nice leetle von for my girl. I'm going to be marrit next veek, und I vant to give de gal a nice leetle vatch. She is a nice gal, und makes pies for de bakery, und I wants to give her a pooty leetle vatch."

H.—"Well, here's a nice one, gold case, back action patent lever escapement, fourteen holes for jewels, compensation balance wheel, independent movement, warranted to run a life-time. I'll sell you that for \$65."

G.—"Dat's a pooty vatch, und dat pie gal vould look bully mit it on, but I don't vant to pay more as \$50 for a vatch. Dese is har dimes, und I haf to vork too hart for dat money to pay so much. I gif you \$50 vor it."

H.—"I can't afford to sell it for less than \$65. What difference does it make to you whether you pay \$50 or \$65—ain't you going to

marry the girl, and won't the watch be yours again in a week?"

G.—"Dot's so, by gracious! I didn't dink of dat. If I gif dat pie gal de vatch und den marry her, den I own de gal und der vatch too, und if I haf to pay taxes on dot vatch, den I sell again. All right. I dake it for \$65. Put it in a piece of paper und write de pie gal's name on top of it. Perhaps you'll vant to buy it back pretty quick, don't it?" *Exit German with a grin on his face that makes his mouth look like the opening of navigation.*

*Hastings resumes his work, but hardly gets seated when an elderly portly gentleman, who, producing a \$10 silver watch, says:*

"Good morning, Hastings. Is that chronometer of yours right?"

H.—"Yes, Sir; exactly with the time-ball yesterday."

E. P. G.—"I don't take much stock in that there time-ball. It varies. 'Spose there's a strong wind a blowin' when the ball ought ter drop, and the wind gits under the ball and holds it up, don't it lose time, I want to know? Then it's a nuisance anyhow; a crowd of folks git around on the corners, a twistin' their blessed necks out of joint a watchin' for the ball to drop, and a lot of thievin' pick-pockets goin' through 'em all the time. I lost a spectacle case that way last week, and got a crick in my neck a twistin' of it for to get a look at that blasted ball a droppin'. I believe that there's been more'n \$50,000 stolen out of the crowds watchin' for that ball by dodratted pickpockets. It's a nuisance, and the Board of Health ought ter abolish it afore people twist their heads off."

H.—"Well, my chronometer has the right time." *[Takes E. P. G.'s watch and pretends to regulate it.]*

E. P. G.—"Wall, if that's so, that watch of mine has lost ten seconds in two weeks. You guaranteed it to keep good time, and if you don't regulate it I'll throw it back on your hands." *[Exit E. P. G.]*

H.—*[Resumes work.]* "That old buffer's worth a million dollars, but he's penurious as — Mephistopheles. His wife and daughters, however, buy a good deal of me, so I try to keep on the right side of him. He came in two months ago and bought that \$10 watch, and expects it to keep as exact time as a Bliss Chronometer. He bothers me to death regulating it for him."

*[Enter fast young buck with \$300 watch to compare time.]*

F. Y. B.—"Mornin', Hastings. How's your time? All right. Watch only gained seven minutes this week; she's comin' down to biz; don't care so long as she's fast, but don't let her get slow; shall die if she goes slow. She's a bully good watch, and I'm glad I got her. Give her a little turn backward, and I'll try her another week. Bye bye."

H.—*[Having attended to young man, takes his seat and resumes work.]*

*[Enter little girl.]*

L. G.—"Mister Hastings, will yez plaze tell me mother what time it is?"

H.—"Half-past eleven." *[Exit L. G. Returns again in two minutes.]*

L. G.—"Mister Hastings, will yez plaze tell vhat time it is?"

H.—"I just told you, don't bother me any more."

L. G.—"Well, that wuz for me mother, and this is for Missus Finnigan, sure, who tould me to ax yez, and yez needn't git huffy about a little thing like that. Yez kin kape yer ould time if yez don't want ter tell it, an' I'll tell Missus Finnigan that yez tould her to go to the divil, an' won't she be mad." *[Exit L. G.]*

*[Enter an Irish sailor in an advanced stage of intoxication, accompanied by a wretched-looking woman, also intoxicated.]*

I. S.—"Say, mister, I want to see a ring; a wedding ring, do ye moind; me and the old gal here's goin' ter get spliced, and she sez she must have a ring. Give us a goold one, not too big, and a chape one, too."

W. L. W.—"I'll not have a chape one, sure. I want one as good as Moll McFadden's, or you'll be no husband uv moine, do yez hear that. Sure, I'm not so hard pushed fur a man that I'm goin to be put off wid a brass ring. Not much I ain't."

I. S.—“Hould yer whist, old gal. Sure, hain't I bought lots ov weddin' rings afore, and don't I know vhat I'm doin'. Sure, I'll fix you all right.” [*A ring is finally selected, and a compromise made on a dollar and a half.*]

W. L. W.—“That's very good av yez, Jack. It bates Moll McFadden's ring to smidereens. Shure, now, I'll have me name put on it. Not my name, but vhat it will be after we're married. Vhat that is, sure I don't know. Vhat the divil is yer name any way, Jack? Faith, I niver saw yez till to-day, un' only heard yez called Jack.”

I. S.—“Well, Miss Maginnis, yer name will be Mrs. Jack O'Donnell as soon as the priest has said the words, an' that's as good a name as any in the Booklyn Presbytery.”

W. L. W.—“True for yez, Jack; but I'm thinkin' I'm not the only woman that wears it. But divil a moind do I moind. I'd marry yez if yez was Brigham Young. I'll be as honest a woman as Moll Maginnis ony way.” [*Exit happy couple on their way to the priest.*]

Lunch time having arrived, Hastings put on his coat and steered us for a lunch counter, having lost nearly half a day attending to the wants of a lot of people who gave him “more kicks than hapence,” and whose aggregate purchases were summed up in the \$1.50 wedding ring bought by the drunken Irish couple and the \$65 watch sold to the German gardener.

### Venetian Glass.

THE mystery of “Venetian glass” has been solved. Within the last two years the secrets so vainly sought for of the glassblowers of antiquity have been found out by the modern representatives of perhaps the oldest industry in Europe, and the celebrated “murrhine” of Pliny and other objects of veneration to connoisseurs are now reproduced (not imitated) by the deft and learned workmen of the Venetian Isles. So great is the gain to science, that the heads of the most famous glass manufactories in Europe (as well as most of the different *musées*) have bought at very high prices samples of these revived arts of the ancients, and the Cross of the Legion of Honor awarded to M. Giovanni Castellani, the Director of the Society, by M. Waddington, is an act of justice and a further proof of the Minister's own fine discernment in matters archæological and artistic.

It is but fair to state that the great expenses entailed for many years by the ceaseless efforts of Murano to attain excellence have been borne by a group of Englishmen. So that England has her share in the merits of the Society, whose first and constant patroness has been the energetic and enlightened Queen of Italy.

ALREADY there are indications of a desire for the restoration of the Bankrupt Law. The hardware merchants of this city have given emphatic expression to their sentiments on this subject at a recent meeting of the Board of Trade, setting forth the delay and difficulty in proceeding under the separate State laws now in force, and arguing in favor of a uniform enactment freed from the objectionable features of the measure which has been repealed. The old agitation promises to come up again.

MESSRS. KEARNEY & SWARTCHILD, of Chicago have just issued a very useful and attractive catalogue containing an almost endless variety of illustrations of goods in which they deal. This is one of the most complete works of its kind we have ever seen and reflects great credit on the compilers. We are assured that this catalogue will be confined exclusively to dealers inside the trade who will find it of great convenience in selecting goods.

THE jewelers of Nebraska are following in the footsteps of those of Illinois, Iowa, and Indiana, and met in convention at Omaha, May 6, to consider the grievances to which they are subjected by piratical jobbers. The call for the convention was signed by the prominent retailers of the State, and the movement promises to be fully as successful as those State organizations which have preceded it.

THE case of Marcus Kronberg (that guileless and much injured individual of Chicago) has assumed a new phase. It will be remembered that Kronberg some time since made an assignment to Mr. Bradford Hancock for the benefit of creditors, Charles S. Stift, who had been in the employ of Kronberg for several years, received permission from the assignee to fill orders for goods from certain of Kronberg's former customers. It is now charged that Stift took advantage of this permission and by collusion with the assignee's clerks, who were also formerly in Kronberg's employ, abstracted a large quantity of goods from the stock.

When Stift wanted goods, he would go to one of the clerks and buy a small bill, but would, it is alleged, wrap up goods of three or four times the value of those paid for. Detectives got wind of the “little game,” and arrested Stift, Harkness, Frank Murphy, Bernard Murphy, and two women of the town. One or two of the clerk's confessed and told the whole *modus operandi*, and their alleged confession is said to have implicated Kronsberg, who was also subsequently arrested and held in \$5,000 bail.

The case was recently brought into court, and to the surprise of everybody, the prosecution was mysteriously abandoned. It appeared afterwards that Kronberg had raised the sum of \$12,000 and paid it over to the assignee, which was about the value of the property the accused were charged with having diverted. It is understood that Mrs. Kronberg has assigned her dower interest in certain real estate, thus making that property available for the payment of her husband's debts. We learn that the balance of the goods in the hands of the assignee have been disposed of to B. F. Norris & Co. for \$35,500, which does not include the outstanding notes and accounts. For these it is reported an offer of \$25,000 has been made. When the end of this disgraceful affair is to be reached it is impossible to predict.

MESSRS. COX & SEDGWICK, the well known makers of onyx jewelry, &c., introduce in this number an illustrated sheet of designs representing a number of new and attractive examples of onyx work of artistic merit. Messrs. Cox & Sedgwick is one of the oldest houses in this branch of the business, and their goods have achieved a high reputation among the leading houses in the trade. The sheet of new designs here presented will be found of great convenience to dealers, and may be shown to intending purchasers without exposing prices. A price list, corresponding with the number under each object on the sheet, will be forwarded to dealers *only* on application. The trade is, therefore, fully protected against the exposing of prices to outsiders.

### Removals.

Shoemaker & Co. and McIntire, BeDell & Co. have removed to the office formerly occupied by Cross & Begnelin, No. 21 Maiden Lane.

Mulford & Bonet have removed to the office formerly occupied by Brown & Hobby No. 21 Maiden Lane.

The Illinois Watch Company have removed from No. 11 to No. 21 Maiden Lane, above Enos Richardson & Co.

The Wilcox Silver Plate Co. have removed from No. 21 to No. 6 Maiden Lane.

J. B. Bowden & Co. have removed to No. 1 Maiden Lane.

J. B. & S. M. Knowles have removed to No. 8 Liberty Place, near Maiden Lane.

Dorrance, Edge & Co. have removed to No. 12 John street (ground floor).

Edward Todd & Co. have removed to 44 East 14th street, Union Square.

Nordt and Schlag have removed from 366 Broom street, to 17 Maiden Lane.

S. M. Lewis & Co. have removed to the office formerly occupied by the Illinois Watch Co. No. 11 Maiden Lane.

R. J. Herbert has removed to No. 16 Maiden Lane.

Charles Gagnebin has removed from 64 Nassau to 4 Maiden Lane

## Proceedings of the Horological Club.

A DISTINGUISHED BODY OF WATCH AND CLOCK MAKERS.

*Sixty-second Discussion.—Communicated by the Secretary.*

[NOTICE.—Correspondents should write all letters intended for the Club separate from any other business matters, and headed "Secretary of the Horological Club." Direct the envelope to D. H. Hopkinson, Esq. Write only on one side of the paper, state the points briefly, mail as early as possible, as it must be received here not later than two days before the end of the month in order to be discussed and reported in the CIRCULAR for the next month.]

REPOLISHING ADJUSTED BALANCES, AND SEVERAL OTHER INQUIRIES.

*Secretary Horological Club:*

I wish to ask you, through your Club, the *best manner* of restoring the polish to an adjusted balance. I often find the brass part of the rim and the screws badly tarnished, which occasionally, too, seems to have been caused by careless handling with the fingers. Also the best manner of cutting the small countersinks for the screw heads in the sides of American cap jewel settings. I have always worked on the steel lathe, but having recently purchased an American lathe, I am a little at a loss how to do all kinds of work. In drilling a staff, I put it in the lathe, and hold the drill in a small slide vise, but do not drill but a short distance before a tit forms in the bottom of the hole. I wish, also, to know how to centre a staff or cylinder in wax, after the hole has been drilled and the plug driven in and is ready to be turned?  
A. A. M.

Mr. Uhrmacher said that the best way to clean a tarnished expansion balance was by dipping it in a weak solution of cyanide of potassium in water, for a moment, then rinse off thoroughly in clean water free from soap, finally drop into absolute alcohol, and dry in boxwood sawdust. If the balance staff has on it any parts with jewels cemented in with shellac, etc., they must be taken off, as the alcohol would dissolve the cement and loosen the jewels. Some watchmakers do not seem to know that alcohol will dissolve the cement, and are greatly surprised, after cleaning a watch with alcohol, to find pallet jewels, ruby pin, etc., coming loose, and causing no end of trouble. Workmen would save themselves and customers a great deal of annoyance and loss of time if they would try to understand the nature and action of the substances they use. It should be remembered that cyanide of potassium is poisonous, either to swallow or to get into cuts or wounds. It must be thoroughly cleaned off any parts of the movement, as it will rust steel if the least trace of it remains.

The countersinks in the jewel settings are cut at the same time as the rest of the countersinks, in the plate, while the setting is in its place, and held from revolving under the action of the cutter.

The trouble with Mr. M.'s drill was that it was not sharp, or not properly shaped, with the two cutting edges alike and the point in the centre. It is better to support the back end of the drill in the tail-stock arbor, as it will then be sure to be in line, and drill to the centre.

In centering the staff, the sound pivot must fit down to the bottom of the countersink in the lathe chuck, and the countersink itself must of course be true, sound, and central. The outer end of the staff is to be centred by pressing against some shoulder or part that is true and sound, while the lathe is running and the wax just soft enough to yield easily. The end of a pin tongue, peg-wood point, or any other such small part, may be used to press against the shoulder. Some even use the finger nail, but that is rather primitive. The position of the piece should be such that it will just hit the shoulder, as it wobbles around and comes near the point, advancing the latter till the staff ceases to wobble at all, but no further. If pushed further, it will of course push the staff out of centre again. The point should not merely be moved forward, but must at the same time press the staff endwise towards the chuck, else the pivot in the wax will get out of centre. By thus pressing "corner-wise," the sound pivot is kept to the bottom of the countersink, as well as the broken end centred. The corner or shoulder used for truing the

staff must of course be free from wax. After the staff is centred, the truing point may be removed, even if the wax is not yet quite hard, provided the lathe is kept running till it gets hard enough to keep its shape and support the staff.

NEW OILING WIRE.—LINES FOR ENGRAVING.

*Gentlemen of the Horological Club:*

Appreciating the efforts of your honorable body for the good of our craft, I submit for your inspection and approval a watch oiler which possesses at least two good points, as you will readily see by examining. How to make it: Take smallest size cambric needle, insert the point in a suitable handle, grind off half the eye, and the thing is done. Anyone that tries this plan will like it; the needle is tempered and strong; the polished steel will not rust or corrode the oil. The two projecting points of the eye hold the oil between them; the right quantity is insured and very easily applied to the right spot.

To draw parallel lines for engraving letters on spoons or other curved surfaces, pieces of watch mainsprings, of suitable lengths and various widths, are probably the best thing in use. Lines can be drawn equidistant from the centre, and perfectly parallel, by holding a piece of spring on the spoon with the outspread fingers of the left hand, and drawing a tracing point along each edge without moving the spring. If a wide space between lines is wanted, two pieces of spring can be used as one—that is, laying them together, side by side. "B. No. 6."

The oiling wire was passed around for inspection, and the members were highly pleased both with its neatness and the ease with which it could be made. They also thought the method of tracing parallel lines for engraving a good one. Let us hear from all of our readers who have new "wrinkles," and handy ideas of all kinds. It will be no loss to them, and may be very useful to scores of other workmen.

IMPROVED CHRONOMETER BALANCE.

*To the Secretary of the Horological Club:*

I have recently invented an improved chronometer balance for watches which I have named a *protected balance*, and perhaps I can give you a description of it, sufficiently accurate for you to judge of its merits, and I would be happy to submit its claims to the judgment of so experienced a body of practical men as the members of the Horological Club.

Starting with the proposition that the balances of the higher grade of American watches (and perhaps others) have gradually come to be made needlessly heavy by the loading of the sixteen to twenty heavy-headed screws all around its circumference, it has come to pass that should the watch have a fall, the pivots of the balance staff or the jewels are sure to be broken, or if the pivots are not hard enough to break, they are bent or headed into the jewel holes so as to be withdrawn with great difficulty.

Realizing this necessity for a lighter balance, I have constructed one with an outer solid steel rim, with its arms as usually made, and just within this, with just space enough between for expansion, and fastened to the arms are two segments of a laminated brass and steel expansion rim, thinner and lighter than is required where there is no protection, and dispensing with all the screws except what is necessary for adjustment, and those working freely through the outer rim in holes agreeing with the holes in the expansion rim. I have constructed a balance for which I claim the following, among other, advantages, viz.:

1st. Protection to the expansion rim from injury from jolts, falls and rough usage of every kind.

2d. A lighter balance, admitting of a weaker mainspring, one less liable to break, and resulting in no damage when it does break; also a greater number of revolutions of the great wheel, admitting higher number of leaves in the pinions of the train.

3d. The expansion rim being thinner and lighter, is more sensitive to changes of temperature, whereby adjustment is simplified and more easily accomplished.

I am well aware that we watchmakers do not regard these frequent mishaps resulting from heavy balances as so great an evil as we should do under other circumstances, seeing that by these we get our *bread and butter*; but I am very sure that the great body of *watch wearers* who have to pay for these frequent mishaps will welcome any reform which promises to render the use of a good watch *less costly and more safe* than heretofore.  
D. B. F.

Mr. Isochronal was afraid that our correspondent had not studied very deeply into the philosophy of the compensation balance. The rim of the ordinary expansion balance is made of that thickness

which is believed to operate most advantageously for the production of compensational effects. The number and weight of the screws are also regulated to suit the same end. The size of the pivots, in a fine watch, is intended to bear such a proportion to the size and weight of the balance as will favor the adjustments to positions and isochronism. When all this is arranged, and an accurate time piece is the result, it is no fault of the watch, or of the maker, that the pivots are liable to break in case of accident. To make them too large to break, or to make the balance lighter, would be to render good performance impossible, for the sake of guarding against the effect of careless usage. The lightening of the balance would also necessitate the reformation of the entire train of the movement. So that the proposed remedy would be a hundred times worse than the evil it was designed to cure.

Our correspondent should procure a copy of *Excelsior's* book, where he will find explained the whole theory of the compensation balance, the hair-spring, the proportions of pivots, frictions, etc. with all other directions for securing the closest adjustment for heat and cold, different positions, isochronism, and rate, besides a great number of other valuable points, important for every watchmaker to know. The book is published by D. H. Hopkinson, Esq., the publisher of the *Jewelers' Circular*, and sent postpaid to any address for \$3.50. The expenditure of this small sum would have saved our correspondent much time and labor, experimenting on a fallacy, the expense of applying for a patent, and last, but not least, the mortification and disappointment of certain failure. Even in the ordinary routine of the workshop, this book will save every workmen an amount of perplexity, experimenting, study and vexation, that he would hardly believe possible without actual experience of its usefulness.

#### FITTING IN BALANCE STAFF.

*Secretary of the Horological Club :*

I am a reader of the *Circular*, and have carefully studied the different modes for doing the many things of which your correspondents write. Have noticed especially the subject of putting in balance staffs. How, I will gladly submit my way for doing this, having seen in all the articles upon the subject very closely allied to what I have made my practice, and to those who are situated like myself—have no split chuck lathe, it may be of profit. I take an unfinished staff, such as can be had of any material dealer, the best that I can get, and in them the temper will be found generally good. Otherwise I temper it to suit myself. File each end to fit in the centers of a verge or hand lathe, and in the ordinary way of turning with collet and bow, fit the rollers, using, for polishing, a strip of bell-metal, first with pulverized oil stone and a little oil, then crocus. For a *fine* polish, finish up with a piece of peg-wood flattened, and made perfectly smooth, and a little Vienna lime moistened with alcohol. The balance and hair-spring collet are fitted correspondingly. To make the pivots, I use my bench lathe with cement chuck of a proper size, countersunk to a perfect center. True the staff up with a piece of peg-wood, and this, as all workmen know, can be quite perfectly done. After getting the correct height for the balance or length for the roller end of the staff, finish the lower pivot—viz., turn down with the graves to nearly the size required, finish up with bell metal polisher shaped for conical pivot, using oil stone and crocus the same as on the larger portion of the staff. I seldom use a pivot burnisher, only upon the extreme end of the pivot. It is really, in my estimation, almost a useless tool in making a balance staff. I then remove the staff from the chuck and make it the right length, measuring from the end of the lower pivot. Again cement it in the chuck, true up and proceed to make the upper pivot. That finished, and wax removed from staff, I return again to my hand lathe, and gently run the graves over the face or shoulder against which the balance rests, to insure its trueness. I have practised this method and prefer it to many others, using my bow lathe to finish the larger portions of the staff for the convenience in fitting roller, balance and hair-spring collet, the bench lathe for the satisfactory results in making conical pivots, the kind I most invariably use for staffs. Both are indispensable, and to the apprentice who has access to a live spindle, I say, neglect not the bow lathe, as many are apt to do, for you will regret it later in life. E. T. J.

Mr. McFuzee had no doubt this method would give good results, but he thought it would be apt to take more time than some others.

Still, after getting used to that way, it might perhaps be as rapid as others, in the hands of the workman who followed it, and for that reason Mr. J. could probably do as quick a job by it as others could in their ways. His observation and experience with workmen had taught him that the same way of working was not always the best for all persons. Some could work more easily, readily and perfectly in one way, others in another. He would, of course, require his apprentices to follow a method which would yield good work, but beyond that would leave them to their own preferences. He considered that the most important point of all was to get thoroughly used to some particular method, whatever it might be, and stick to it. A man who had no definite way of working, would seldom prove much of a workman.

#### ANOTHER WAY OF FITTING BALANCE STAFFS.

*Secretary of Horological Club :*

I have had good success in turning balance staffs, as follows : Place your piece of steel firmly in any good strong chuck, even if it is a little out of true. Turn the upper end, fit on the balance, turn collet bearing and pivot. Now turn down the lower end and fit roller by guage. Now turn lower pivot, and when it is turned down so small as to be in danger of being broken, plug the tail spindle with a piece of soft wood and bring it up carefully against upper pivot which is already finished. This will steady your work, so you can finish up the lower pivot nicely without danger of breaking it. I think this way is preferable, although somewhat similar to the plan called hubbing in a previous number of the *Circular*.

Mr. McFuzee said the principal difference between the method of Mr. A. and "hubbing," was in using peg wood to support the pivot, instead of soft solder. The former would answer, of course, and saved the trouble of fitting up an arbor or center for the tail stock, but he thought that it would hardly prove so firm and reliable a support as the soft solder. However, there are more ways than one to do a thing, and with proper care each one can succeed in his own way.

#### "ASSOCIATION OF PRACTICAL WATCHMAKERS."

*Secretary of Horological Club :*

You are beset with complaints in every imaginable form, from subscribers to the *Circular*, and there seems to be a general dissatisfaction among the jewelers of the country. If it isn't one thing it is another, and from the sending of circulars by the Chicago jobbers, so-called, to every country merchant, minister or hotel keeper, to the plan of compromising with every rascal that has succeeded in laying aside enough to offer twenty-five cents cash—through the kindness of some friend, of course,—the poor retailer is in constant hot water. I have always thought that there was a remedy for all the abuses complained of by the formation of an Association of practical watchmakers. Had your call for a meeting, during the centennial, been more largely observed, the retail dealers would to-day have been able to stop all these abuses of the jobber. Another idea has forced itself upon me, and that is, that there are too many watchmakers—so-called—in the business ; and the only way that I can see to check this growing evil is for the "Association of Practical Watchmakers" to resolve that hereafter they will take no more apprentices, as long as we have no laws governing apprentices as to the length of time they shall be compelled to serve before hanging out their signs as practical watchmakers. If this plan were universally observed, in five years time we would see a marked change for the better in the standing of the retail jewelers of the country. They could get better prices for their skilled labor, and better prices for their goods, because there would be fewer boys in business on a limited capital, to compete with men who have spent years to perfect themselves in the trade they have chosen. Cannot you begin the good work by using your influence with the retail dealers in New York and vicinity ? A small beginning will soon grow to a large organization. Let a few men in the city, who are known to the skilled workmen, get together and form an organization, and send out a call for members through your valuable paper, with the understanding that in order to become a member every applicant must pass a certain examination, before he is entitled to receive his diploma, and let the membership fee be sufficient to pay for something handsome, that they can frame and hang up over their work bench, to show to their customers that they have finished their trade and are entitled to their confidence. Hoping this may meet with your approval and that some good may result from it, I remain, very truly yours, A. SUBSCRIBER.

Mr. Horologer said that in this city a large share of the watchmakers have determined to take no more apprentices, as they can

hire jobbing watchmakers too cheaply to pay for being bothered with apprentices. He also believed that was very extensively the feeling throughout the country. The trouble came mostly from dealers who were so stingy to hire a boy to sweep out, tend fires, and do errands, but tried to sponge his services by giving him the idea that he would learn the trade as part of his pay. If a boy was really taken with that view, he should be properly instructed; if he was not, then that should be plainly understood, and the boy not allowed to think that he would be a workman at the end of a year or two. To do so, was to swindle the boy, assist him to impose upon the public, and make both the boy and his master nuisances to the rest of the trade. If the damage and vexation could be confined to those who were guilty of the practice, it would not matter. But, unfortunately, it is only the decent part of the trade who suffer all the consequences, as no one but a botch or a slink would follow such a course,—and such men generally had no reputation or standing to be injured.

As to the Association of Practical Watchmakers, it was a difficult point to settle on just what a man should be required to know in order to get a certificate that he was a good workman. But the union of dealers to act against the jobbers who sent circulars broadcast, and the other enemies of the legitimate trade, is already a fixed fact. A number of enterprising spirits in the west have organized under the name of the Watchmakers and Jewelers League of the U. S., with headquarters at Chicago. A general meeting would be held about the time this month's CIRCULAR is issued, and the next number will probably contain full information. We all hope that this undertaking may meet with the amplest success, and that our trade may at last enjoy the benefits of the organization, of which nearly all other branches have already availed themselves, and which they have found so conducive to their interests in every way.

#### THE JEWELERS' PIN VISE

is a well-known tool, advertised in the *Circular*, by the Lowell Wrench Company, of Worcester, Mass., and is a credit to them. The sample was inspected with high commendation by the members, many of whom had used it and pronounced it far superior to the imported article. It is of hardened steel, nickle plated, the handle is nicely milled, giving a firm grip for rolling in the fingers, and the whole is turned true to centre. It holds firmly anything placed in it, and altogether is a most excellent tool for the bench.

PATENT reflectors to throw daylight into darkened workshops are used in London and other large towns in England, and are found eminently advantageous for buildings where the daylight is obstructed, owing either to the small size of windows or the too close proximity of opposite walls. They can be easily adapted to all kinds of windows, and will greatly conduce to general health and comfort. The reflecting surfaces are fitted in strongly made wooden frames, so constructed as to resist the action of the weather, all that is required to ensure the durability of the reflector being that the cementing is properly done, and the frame repainted once a year. They are made of corrugated, patent silvered glass of various kinds, varying in price from \$1 to \$1.50 per square foot, and are also made of copper, silver plated, from \$2 per square foot. They would especially command the attention for jewelers, watchmakers, etc., stores and workshops having an insufficiency of daylight. The patentee and manufacturer of the same is also making the most intensifying and approved reflectors of all kinds and shapes for gaslight.—(*Communicated by H. Bush, Hull, England.*)

SPOTS of verdigris on gilt book-cases are best removed by touching the same with a piece of cotton wool on which there is poured a small quantum of spirits of ammonia, and then clearing off the ammonia with cotton wool and clean water; the remaining brown spots are then covered with bronze powder by means of a camel's hair brush damped in diluted gum arabic solution. It is very difficult to prevent the formation of these green spots, as they are caused from remains of the copper solution which are held in the pores of the zinc castings.

## The Jewelers' League.

We devote this column to the interests of the League and its membership. Letters or inquiries pertinent to its business or purposes, and which might interest the trade or inquirers, will be herein answered. Address *Jewelers' League*, Box 4001, P. O. New York, or the office of THE CIRCULAR.

It should be understood by each person intending to become a member of the League, that the application submitted by him in writing becomes, if accepted, the foundation of a contract. By means of this document the League seeks to obtain accurate information respecting the past and present health of the applicant and the details which tend to make him eligible. As the basis of a contract, therefore it is clearly to the interest of the applicant to furnish the required information without reservation, concealment or evasion, no matter how numerous or unimportant the questions may, to him, appear. The membership and privileges will extend over a long period, and future complications may be prevented by taking proper care that the application shall contain the whole truth and nothing but the truth.

Again, applicants should be particular to specify "the full name and address of the person or persons to whom he desires, in case of his decease, to have his death-loss" paid (Constitution and By-laws, Art. 1, Sec. 1), "My executors," "my heirs," "my estate," will not do. The benefits of the League are intended for the widow, orphans, or near relatives or friends of the member, and not for his estate, or its creditors, in case he dies insolvent. Its benefits, if made payable to a certain person or persons by name, will reach them regardless of the claims of creditors. Where there are more than one beneficiary, each name and address should be given, as well as the share each is intended to receive. We cannot be too particular when directing how money should be paid after death. We cannot be recalled and consulted as to our wishes (there is little doubt about that), and therefore it would be wise to direct intelligently before death, and whilst there is no doubt of our ability to do direct; *vide* the case of Vanderbilt's will.

Our League is destined to live a long and useful life if properly conducted. The principles of similar organizations are correct in themselves, and if that were all that is necessary to their continuity, they would all stand strongly; but their management is a principal as necessary to their stability as the principles themselves. The gentlemen who have been selected to conduct its business have been chosen on account of the evidences of success which have accompanied them in the conducting of their own respective callings, and the business reputations of these gentlemen are at stake in the management of the League. These who are so well known in the trade will never permit any looseness in the administration of its affairs. The business pride of these officers will be an important incentive to them to safely and judiciously carry on the business of the League. We regret that so many of the trade have made it inconvenient for them to join, by having become members of associations which are springing up all over the land, and which are managed by men who have no such incentive to preserve their own and the association's reputation before their friends and acquaintances in their respective trades by continuous labor in their behalf. After the novelty of management and position dies out, they will become careless and inattentive to the duties of their offices, and their ropes of sand fall to pieces. We hope our own trades will see the wisdom of joining the League, which is strictly within the trade, where they can more closely follow, and more readily hold the officers to strict account for, the management of its affairs.

The League has been fortunate in securing the services, as examining and consulting surgeon, of Dr. Joshua G. Wilbur, a graduate of the medical department of Harvard University, and a gentleman of so great experience in the particular department to which he is appointed—he having examined over twelve thousand (12,000) applicants for life insurance in the best companies, including the Mutual Benefit, Massachusetts Mutual, State Mutual of Worcester, Mass., Travelers of Hartford, Phoenix of Hartford, Connecticut Mutual, and occasionally for the New York Mutual.

At recent meetings of the Executive Board, in conformity with the resolution passed at the annual meeting, the following-named gentlemen have been appointed members of the Advisory Board:

H. Plumb, Des Moines, Ia.; H. A. Desraimes, Elizabeth, N. J.; M. H. Mason, Attleton Falls, Mass.; P. R. Tonder, Troy, N. Y.; J. E. Bell, Ozdensburgh, N. Y.; E. W. Haven, Syracuse, N. Y.; F. Goosmann, Somerville, Tenn.; Wm. H. Bradshaw, Marshall, Ill.; Wm. W. Child, Jackson, Mich.; Max L. Gutman, Rochester, N. Y.; Nath. F. Baldwin, St. Joseph, Mo.; Le Grand S. Strang, Amsterdam, N. Y.; Charles N. Scott, Worcester, Mass.

We have received several communications from Mr. Sted. H. Hale and Mr. Henry Plumb, members of the Advisory Board, in respectively Chicago and Des Moines, Iowa. Through the instrumentality of the former, the merits of the League will be properly presented to the Convention of Jewelers of the Northwestern States, to be held in Chicago on May 15th, and it is hoped his efforts may result in a large accession of members. Dr. Wilbur, the examining surgeon, will doubtless be present at the Convention to examine such as may wish to join the League, and lest there should be more than he can examine within the limited time of the Convention, Mr. Hale has secured the additional services of Dr. Delamater, of Chicago.

Mr. Plumb is actively at work forwarding the interests of the League in his State.

We have also a pleasant letter from Mr. S. Orlando Trippe, accompanying two applications for membership, from Selma, Ala. Mr. Trippe, who is the Advisory Board member for Selma, states that although there are but few eligible members thereabout, he is going to work in earnest among them.

The following were elected members at the meeting held on 2d inst.:

Henry S. Crump, with Wm. Moir, New York; Wm. Blumers, with Tenner & Baum, New York; James A. Clancy, of Selma, Ala.; S. Cottle, 9 Bond street, New York; A. M. Edwards, Buffalo, N. Y.; Robt. S. Ferguson, of A. C. Benedict & Co., New York; Francis A. Goeltz, 363 Third Avenue, New York; Calvin P. Harris, with Reed & Barton, New York; Ferd. F. Ide, Springfield, Ill.; Francis L. Kennedy, with Aiken, Lambert & Co., New York; Solomon Pepperman, of Uniontown, Ala.; Geo. W. F. Raven, with M. Fox & Co., New York; Daniel P. Rosman, with Cook, Groeschel & Co., New York; Geo. D. Stevens, of Broadway, New York; James E. Spencer, of J. E. Spencer & Co., New York; John R. Scofield, with Wood & Hughes, New York; Charles R. Thoma, with Ernest Thoma, New York; Willis J. Follett, with H. F. Barrows & Co., North Attleboro', Mass.; Robert W. White, Jr., with Simpson, Hall, Miller & Co., New York; Edwin M. Wheeler, with Reed & Barton, New York.

One candidate was rejected and one referred back for correction. Mr. George H. Richards, Jr., was appointed additional member of the Advisory Board for Boston, the number of members in that city having reached twenty-four.

### A Study from Nature.

MR. M. MATTIEW WILLIAMS, in a recent lecture before the London Society of Arts, thus described the method of procuring the webs or fine hair-lines used in telescopes: In the Autumn the mathematical instrument maker goes on his spider-hunting expedition, generally on Sundays. He carries some pill boxes in his pocket, selects well-fed, full-grown specimens, and puts each in a separate box, knowing the savage habits of his six-legged friends; for if two or more were put together in the same box, only a collection of amputated limbs and mangled bodies would be found on returning home. The webs are secured for use and storage by making a fork of iron wire, four or five inches long, and one and a half to two inches between the bifurcations. The spider is held in the left hand, and allowed to drop, which he readily does when dissatisfied with his quarters, but before falling he glues an end of cord to the finger, and then lets himself down easily by gradually spinning it out and hanging by it as it lengthens. The instrument maker catches this cord across his fork, and by turning attaches it to one side; then he goes on turning the fork and advancing it, so that as the spider continues paying out his cable, a series of obliquely-crossing threads are wound upon the fork, which when charged, is carefully laid in a box or drawer for use. The elasticity of the iron wire keeps the webs sufficiently stretched, and they are applied to the "stop" by simply laying the fork over it in such wise that one of the stretched webs shall fall upon the mark made on its face. When thus in position, a drop of varnish or glue, made by dissolving shellac in alcohol, is let fall upon each side; the spirit rapidly evaporates and the web is fixed.

### Welding Platinum.

SOME months ago, I (Thos. Garcide, in the *Chemical News*) had a platinum dish, which had a small hole on the side near the bottom, and the dish was consequently useless for most purposes. I was about to consign it to the old platinum, when it struck me, this metal being "weldable," I might manage to repair it. Having already a mould for this dish, made of plaster of Paris, and not of wood, this served admirably as an anvil. I then cut a piece of moderately thin platinum foil, about 3 mm. diameter, and rubbed this and the part of the dish where the hole was with sea-sand until perfectly bright and clean. Having fixed the dish and its mould in an upright position, I laid the platinum foil over the hole and directed the flame from a table blowpipe upon the spot. A pair of scissors served as a hammer, and by gently tapping with these the two pieces of platinum united perfectly, and made so neat a joint that one would scarcely observe it unless one's attention was called to it. I have used the dish for all kinds of purposes since, but the union is as good as ever. In the above operation the plaster of Paris mould, although very dry, was split and cracked by the heat in all directions, nevertheless it had sufficient cohesion to last until the operation was concluded. I find that platinum wires are very easily joined in this way.

### Reproduction of Ancient Glass.

WITHIN the last two years the secrets so vainly sought for of the glass-blowers of antiquity have been found out by the modern representatives of perhaps the oldest industry in Europe, and the celebrated "murrhine" of Pliny and other objects of veneration to connoisseurs are now reproduced (not imitated) by the deft and learned workmen of the Venetian Isles. So great is the gain to science, that the heads of the famous glass manufactories in Europe (as well as most of the different *musées*) have bought at very high prices, samples of these revived arts of the ancients, and the cross of the Legion of Honor has been awarded to M. Giovanni Castellani, the Director of the Royal Society of Murano, by the French Government, for the discoveries of the society in this department of art, and for its services in connection with the recent exhibitions at Paris.

### Imitation Pearls.

THERE is no precious stone that is imitated so well as the pearl—in fact, the artificial pearl is superior to the genuine in regard to the durability of its lustre and capacity to resist deleterious influences. Thus, for instance, the genuine pearl, being nothing but a carbonate of lime, becomes ruined when put into boiling water, and will entirely dissolve in strong vinegar, while the imitation is not affected. The only point of inferiority is that the imitation pearl, being made of hollow glass beads, is more fragile than the real pearl, and is easily broken.

Various substances are used to coat the inside of the glass, but the best material is derived from the scales of a little fish called the bleak—*Leuciscus Arburnus*. The scales are dried, reduced to powder, thoroughly washed, and rubbed successively several times. The different portions of water used in these washings are allowed to settle. The water being carefully drawn off by a siphon, a lustrous matter of the consistency of oil remains at the bottom. This substance is called by the French "Essence d'Orient," or essence of pearl. To preserve it and prevent it from becoming putrid, it is mixed with ammonia.

The further process of pearl making consists in blowing this essence of pearl, combined with melted gelatin, into hollow beads made of a peculiar kind of fine glass of a bluish tint. These having received an even and perfect incrustation on their inner surfaces, are then filled with a mucilage of fine gum arabic. For one ounce of the lustrous material no less than a thousand fish are required. Fortunately this kind of fish is very abundant. This process was invented 220 years ago, by Moise Jaquin, a bead manufacturer in Paris.—*Manufacturer and Builder*.

### Estimating Metals in Ores.

AT the late meeting of the Philadelphia Academy of Sciences, Professor G. A. Koenig exhibited his recently invented "chronometer," an instrument designed for the purpose of making delicate determinations of the presence of certain metals in ores. It is based upon the optical fact that complementary colors extinguish each other if mingled in proper proportions; for instance, if to a green solution a red solution be added, the liquid, if the proper conditions be complied with, will become colorless. Professor Koenig has applied this principle to the colors which certain metals, as iron, manganese, copper, etc., produce when fused with borax, which is the only chemical used in this method of analysis. He prepares glasses or beads containing known quantities of a metal in one hundred parts, and observes how thick a glass of the complementary color must be to produce extinction. To accomplish this the instrument is furnished with a glass wedge of a green or red color, cut at an angle of about one degree. By moving this wedge before the glass bead, with the help of a suitable rack movement, a scale moves at the same time, and when the point of extinction of color is arrived at, the reading of the scale refers to a table showing the percentage of metal contained in the examined substance. By this method of analysis a correct determination of manganese in an iron ore can be made in fifteen minutes, or a copper estimation in thirty minutes.

MESSRS. COLBY & JOHNSON, of this city have recently introduced an attractive watch case made from Celluloid, that bids fair to become universally popular.

These Celluloid cases will strike any person of culture as unique, stylish and substantial. They are susceptible of a high polish, and are not effected by extremes of temperature, nor will wear diminish their beauty of polish and color.

They are also, dust and waterproof; can be engraved or inlaid to suit the fancy of the wearer, and are much cheaper than silver cases.

Celluloid is one of the most remarkable and valuable inventions of modern times. In appearance it closely resembles the finest ivory, but differs from it in possessing a greater degree of elasticity, and being entirely impervious to the effects of heat, cold, or dampness.

The application of Celluloid in the manufacture of watch cases, is the invention of Messrs. Colby & Johnson, who are also owners of the patent. During the holidays a very large number were sold without much effort, and they are certainly destined to become exceedingly popular.—*The Dry Goods Bulletin*.

## Views of Correspondents.

*Editor of the Jewelers' Circular:*

The retail Jewelers of this State met in Convention at Springfield, Ill., on March 2d, for the purpose of organizing themselves into a "Protective League," in view, if possible, to remedy or abolish certain real or supposed evils existing and inflicted upon them by various Jobbers and Manufacturers, in the promiscuous scattering of Price Lists, supplying "outsiders," or those not considered "legitimate" in the trade, with goods at special figures, etc., etc. The attendance was small, but an organization was perfected, resulting in a call for a second meeting, to be held in Chicago during May.

Having been duly invited, but unable to attend, I prepared a letter to my colleagues, which, however, delayed in transit, failed to reach the Secretary until after their adjournment. Disappointed in not having been heard, I submit the same to you for your perusal, with request to publish it.

Self-preservation seems to be the fundamental principle, inate within, and controlling alike, all nations, sects, communities and individuals. The right to act in defense of this vital law will readily be conceded by all and to all. Any means employed and enforced by courts, governments, churches, or individuals encroaching upon the rights of others in their pursuit of self-preservation, or the legitimate accumulation of property, would be promptly resented by all, as an usurpation of unjust authority, if not absolute tyranny.

Thus originates our spontaneous antipathy and abhorrence against certain "communistic" theories, which would take from the rich their surplus wealth, and divide alike among all, regardless of character and merit, the earnings and compensations of years of struggle, and the just reward of energy and genius.

Thus alone roll on the wheels of civilization; thus alone is evolved from crude and barbarous races a glorious and noble manhood; and thus alone are swept out of existence those parasites and drones of the human family who live but to consume, to make room for the grand onward march of those who work, think, invent and build up industry, science and art, to make wiser, purer and happier their fellow-man.

Throughout nature we may find, if we study into her deep mysteries, the guide and rule for our actions during life, and ample demonstration of the law of compensation which will reward true merit and cause happiness, and punish vice or incapacity with pain and deprivations. In "the struggle for life" in the animal kingdom "the survival of the fittest" illustrates but the inevitable fate in store for all mankind incompetent to battle life successfully in all its phases and vicissitudes, and not even exempting the members of the subtle and beautiful art, of which I have the pleasure and honor of being an enthusiastic devotee.

Upon this law of nature then depends the intellectual development and moral elevation of the human race. It places the means of happiness into those hands who know best how to promulgate and invest these means for the benefit of the greatest number, and who best secure the perpetuity and harmony of the State. If idleness and vice were instrumental in procuring riches, all society would soon be disorganized, profligacy would replace virtue, ignorance supersede wisdom, and tyranny usurp the throne of liberty. With such condition of things vice and riot would soon so undermine the health, wealth, the material and mental condition of society, that it would inevitably result in a general decline, fall and absolute disintegration and final annihilation of every vestige of humanity from the face of the earth.

Intelligence, mental superiority, are *alone* inducive to social purity, and productive of the greatest degree of happiness to the greatest number.

To be successful, then, in this "struggle," socially, morally and financially; to conquer all foes, to overthrow all obstacles, to meet boldly and master unfavorable conditions and circumstances, to defy all competition, to succeed in spite of every thing, this is the problem each must solve for himself, and its accomplishment the highest duty and noblest mission of man.

As a "struggle for life" develops the physical attributes, the senses and the instincts of the animal world, so a struggle for success in business develops the latent forces of the intellect, and builds up the business man. As a continuous use of the arm develops muscle, so a struggle, and a necessity of continued thought and study, and an exercise of all our energy and ingenuity is productive of the greatest mental power, and the development of a superior race of men.

What is the cause of so many of the children of rich parents being worthless, helpless and dissipated characters? Because in their childhood they were not engaged in, or subjected to, this invigorating, healthy struggle for life, not dependent in their youth upon the exer-

cise of their own muscle and brain, and thus when brought in possession of wealth, when intelligence and good judgment are necessary for its successful manipulation and its safe and profitable investment, they are helpless, utterly incapacitated to manage their estate, and in "the struggle for life" they succumb, and their wealth vanishes like dew before the morning sun.

Unfit to battle life successfully, they are a victim of that inexorable law, "the survival of the fittest." All is well! The whirlpool which has drawn them into its vortex will remain, a solemn warning to all those who venture upon the sea of life without work, without effort and without energy.

"Competition is the life of trade." It makes a man strong, unfolds his intellect, and is inducive of his own happiness and that of his fellow-man.

Now it is quite natural for human nature and selfish mortals to imagine those wicked and evil who are the cause of detracting trade from them, and who, as competitors, threaten to rob them of their bread and butter; and the greatest philosopher can hardly look without a grudge, to say the least, upon the superior prosperity of his competitors.

But is this right? Are we, who are directly interested, and whose welfare is jeopardized, competent to judge in the matter? I think not. Let the public decide between us. If they—his and my patrons—decide he is doing wrong, if he sells goods under false pretenses, or at too *high* a price, and ignores others beside myself, then it must be true. But if his only crime is publishing of prices; if he is selling goods "fearful low"—far too low in my opinion, but the great public are benefitted thereby—and I alone suffer the inevitable consequences, then, I say, let the principle of "the greatest happiness to the greatest number" alone decide the equity of the case.

The public, the *many* have rights far above those of the individual. To this principle all else must be sacrificed. And if my competitor can sell cheaper, and thus give the people the benefit, and more for their money than I can, let the inevitable take its course, let *him* survive, and if I go under, let me seek and follow a pursuit in which I can prosper and survive in spite of all competition.

Now these are hard times, which force one and all of us to exert all the resources of our intellect to succeed. The means to bring about such an end, each one must individually decide upon. It will, in my opinion, be highly impracticable, and even injudicious, to establish in this or any other convention a code for the future government of all. Mankind—I am speaking now of intelligent and moral men—prosper best when entirely without restraint and in the fullest enjoyment of personal liberty. The intellect is then free to contrive, invent, plan and execute something new all the time. Freedom is progressive. Restraint is slavery. Slavery in any form is degrading.

No two of us are alike situated. All conditions, and necessities, and circumstances are essentially different. You may pledge yourself to certain rules and they might benefit one, but they would bring perplexity and ruin to another. It might liberate one and lift him out of trouble, but it would shackle and demoralize a dozen.

But it is the promiscuous scattering of price lists especially, and its pernicious results which prompted you, my friends, to call this convention. Well, I know all about price lists. I have quite lately published my prices of staple goods in half a dozen papers, as also through the medium of 3,000 circulars, and I assure you I have enough of it! I am satisfied now that any price list ever published has been a lever in the hands of the publisher's competitors, to the former's greatest injury. *Give me my competitors prices and I am safe.* I can beat him and take his trade away from him every time. Let all those who doubt this statement try it. Publish prices and see how your competitor (by offering the few goods you advertise five per cent. less) will sell the goods! The profit lost on a few will readily be made up on the many articles which cannot be advertised or properly specified.

Concerning the jobbers' price lists in the hands of those outside of the trade: While this may cause slight mischief occasionally in bringing down prices, yet it is for the public, if not for our good. Yet granting that it does a great deal of mischief, what right have we to dictate to Morris, Giles, Clapp, and many other enterprising business houses, how to do business, or to withdraw from them our patronage for doing that which they, possessed of an equal acute sense of justice as ourselves, consider eminently fair and proper? And the *right* to do it all must concede to them.

But supposing the members of the Convention, as a matter of revenge or supposed self-protection, pledge the withdrawal of their patronage from these firms, may it not, if they are true to their pledges, be suicidal and result disastrous to them?

I have received within a week, from one of these houses, a list giving me on a certain watch a price, \$6 00 less than I could buy same watch in any other store in the world. Supposing now that I were



pledged not to buy of such a house, and my competitors were free, how could I compete with them and survive?

This same spirit that seeks to deprive a jobber of certain personal liberties which are self-evidently just and lawful in themselves, would deprive you of branching out in a certain line of goods, upon which some other individual already claims priority or the exclusive right. It says to you: "What right have you to put in a stock of fancy goods, or cutlery, or pictures, or toys, or notions," etc.? "It is not legitimately in your line. I make a speciality of these things, and you are interfering with my trade," etc. Shame on such a spirit of mercantile discourtesy! Why, I have a right by law, by equity, by common sense and justice, to add a stock of boots and shoes, of clothing, or cooking stoves, to my stock if I think proper, and it is naught but a disgraceful spirit of egotism which would object to it.

My friends, in closing permit me to submit to you again, for your especial consideration, the equity and justice of the following propositions:

The absolute right of each individual to seek and employ such means for his self-preservation and the accumulation of wealth, as his energy and genius may dictate, providing these means are consistent with honesty and justice.

That competition in trade, like "the struggle for life" in nature, while often a thorny path to success, and which may necessitate the sacrifice of the individual not able or willing to battle life successfully, is yet productive of the greatest good, in evolving all the latent power and energy in man, in building up a glorious race of thinkers and workers, which alone can make man truly noble and happy.

That development of energy and power in one will, by the law of heredity, result in transmitting these grand characteristics to future generations.

That thus only can the dreams of Utopia, or a Paradise on earth, be ever realized, and mankind be made better, purer and happier.

That the public, upon whom we are alike dependent, will not endorse the action of the Convention, when in its protective policy it seeks to establish a form of monopoly that favors the prosperity of the few, at the expense of the many.

That in this glorious age of liberty and advanced thought it is inconsistent with the spirit of this country to dictate to anyone how and what to do, as long as the rights of others are respected and not encroached upon.

That "might is right," when resulting in the public good.

ROCHELLE, Ill. Fraternally yours, OTTO WETTSTEIN.

*Editor of Jewelers' Circular :*

In the February meeting of the Franklin Institute (Philadelphia), Mr. P. H. Dudley exhibited a series of Clocks which were so arranged as to show simultaneously the same time at different places, and another series showing the local mean time of different cities at XII. noon in Washington, and all of them supplied with a simple but ingenious contrivance to correct any error that might accrue from one day to the other.

In explaining his invention, Mr. Dudley spoke as follows:

"It is hardly necessary to point out how desirable it is, or how compulsory for the safe working of a railroad, that all clocks along a line should point to exactly the same time. Not only that it affords greater safety, but the road-bed and rolling stock also may be worked to greater advantage, for the trains can be run in shorter intervals, and consequently a greater number of trains may be run over the same road in one day. The idea of synchronizing clocks is not exactly a new one, and different methods have been devised to set clocks correct by means of the electrical current. The most complete system of that kind is the one applied by Dr. Hipp, of Neuchatel (Switzerland), which was on exhibition here during the Centennial, and which was a series of clocks or secondary dials from one standard clock. But the cost of installation of clocks of that kind is very great, the main clock with its appurtenances, commutator, etc., etc., costing alone \$1,000, each secondary dial from \$30 to \$60, and besides they require a separate line of wires which cannot be used for any other purpose, and which would increase the first cost some \$50 to \$100 per mile, according to location. In a period of general depression of railroad interest as the present one, it was not to be expected that the railroad companies would take hold of so costly a thing, and the efforts of the inventor had to be turned to such appliances as would be cheapest and reliable at the same time. After repeated trials I have so much simplified the construction of the correcting attachment that the clock can be furnished at a very slight advance over their original cost; the correcting capacity of each one is about six minutes (three minutes fast or slow), and since it is only necessary to correct them once a day, the telegraph line may be used all the time for ordinary business, with

the exception of a few minutes at noon, when the Washington Time Signal is transmitted over the wires. At that time the operator switches from the telegraph instrument off to the clock wire, the current passes through the electro magnet of the clock, its armature is attracted, and thereby the hands of the clock moved backward or forward, as the case may be. The signal once passed, the switch is turned again, and the line is ready to be used for telegraphing as before. As standard for correction has the signal been used which is sent from the Naval Observatory at Washington every noon precisely; for at present it is not uncommon to find from one-quarter to one-half minute difference between the chronometers of the large establishments, and yet all pretend to have the exact time. But this difference—small as it may seem—causes much confusion and loss of time to business men, and great inconvenience to the traveling public. The clocks which you see fitted up here are very good time-keepers of themselves; each one is guaranteed to run within a minute in a week, and even if by some interruption on the wires the signal could not be sent for some days, they would be only fractions of a minute out of the way, and with this additional attachment—correcting even the smallest error—they may be relied upon as being absolutely correct at any time. In many of the railway disasters the cause is traceable to a difference in time between the different stations, and it is my firm belief that this invention will go a good way towards removing the cause of such fatalities. Another advantage of these clocks is that by a simple device they can be made to show either exactly alike, as I have them arranged here (pointing to his left side), where I have set up a series of them which indicate Philadelphia time, and which I have marked Philadelphia, Wilmington & Baltimore Railroad, as they can be made to show the mean local time of different cities, as shown to the right, where the clock marked Washington points exactly to XII., whilst

	Hour.	Min.
Boston,	XII.	23
New York,	XII.	12
Philadelphia,	XII.	7
Pittsburgh,	XI.	48
Chicago,	XI.	17
New Orleans,	XI.	7
Omaha,	X.	44
Salt Lake City,	IX.	40
San Francisco,	VIII.	58

point to their respective local time."

Mr. Dudley retiring, a great deal of interest was manifested in this novel invention, and several of the gentlemen present, having already telegraphic connection with the Philadelphia Local Telegraph Company, ordered clocks of this description put up in their private houses or offices, availing themselves of an additional convenience which science has added to our comfort and welfare.

PHILADELPHIA, March, 1879.

L. BREITINGER.

*Editor Jewelers' Circular :*

I saw a letter to-day from quite a prominent house in your city reflecting severely upon the movement lately inaugurated in the Northwestern States to protect the jewelry trade, wherein he does very many, in fact a large majority, of the jewelers a gross injustice, and departs very much from the Christian precept of "Judge not." The names of many honorable men are enrolled in this movement—men who have been before the trade for years unsullied and untainted, and whose integrity is undoubted. Rest assured the "Jewelers' League" of the United States is not formed to aid fraud or to be used for any such purpose, or a "ring to procure credit;" nor does its Constitution admit of any such construction. It allows no accumulation of funds, no revenue other than that actually required to pay for printing and postage, and a small salary to its Secretary. Neither does it propose to "ruin the jobber and honest importer." But let us see what is does propose to do.

It proposes to regulate the dishonest jobber, the man who uses the favors given him by manufacturers and importers to entirely ruin the retail trade, who gets these extra discounts under the pretence that his business is confined entirely to the trade. How is it in this city? It is impossible for a retail jeweler to make more than a bare living. The Eastern manufacturers and importers have built up large jobbing houses, who call themselves such, yet two-thirds of their business is devoted to selling at retail, often when one "runs the other," at less rates than the retailer can buy of them for cash. The Western jobbers have been selfishly covetous in soliciting and inviting retail trade at wholesale prices. I will admit a few exceptions, houses who have adhered to the system of selling to the trade exclusively, or if they do retail, they sell at a retail price.

The object of the "Jewelers' League" is more especially to cultivate a friendly feeling between those engaged in the trade in different places, stop if possible the "cutting of prices," and endeavor to make the trade profitable. Manufacturers may argue that the more "cutting" and the lower goods are sold the better for them. This is a fallacy. Goods sold at a small margin eventually forces the seller to compromise, or else the sheriff sells him out at a ruinous loss to the manufacturer and importer.

But I am occupying too much space. I merely wished to caution those in the retail trade to beware how they listen to the dulcet sound of "ye traveling man's" voice while he is denouncing the "League." All that is required is equal and exact justice, and the watch company or manufacturer who says, "Ask your jobber about our goods," will find the noise of their machinery gradually ceasing, and the rust will gather on their tools and the dew upon their wheel belt, and their books will be closed forever. All that is required is a fair show. We do not intend to dictate to any importer or manufacturer, but if they sell their goods to "jobbers" who flood the country with circulars and price lists, why the retail dealers will not sell their watches or repair them—that is all. If in every large city a plated ware company think there is money in having a retail store to sell goods at 40 per cent. off to every "fair customer," we say we will have none of that ware, we will not sell it. If clock companies want to do a retail business, let them do it, but they will not be aided by the League. We hope to see the entire discount business discarded, and those who can purchase the most have the best rates. It is ridiculous when we have to get a person outside of the trade to go to a jobber to buy our goods CHEAP, or to get that watch at the *agency* for less than the *retailer*. I hope to see the jewelry business a distinctive business still, and trust the clouds that have so long hung over it may disappear, and each "jeweler" stand as esteemed and honored as of old, when a member of "Ye Honorable Guild."

Before I close allow me to say that the jewelers throughout the Northwest honor the course you have taken in this matter, and I believe firmly that this movement will be of great benefit to the trade at large, especially to those engaged in the wholesale trade, and it will result in an increased income to those engaged in the retail business, and, in consequence, more sure and prompt payment all round.

E. R. P. S.

CHICAGO, Ill.

*Editor of the Jewelers' Circular:*

At a meeting of the Silver Plated Ware Manufacturers' Association, held on the 17th inst., a circular of the Iowa Jewelers' Association—stating that a member of our Association had offered to allow an extra discount of 10 per cent. to dealers in Iowa who would club together and make their purchases amount to \$1,000—was laid before the members. The treasurer of the company referred to emphatically repudiated and ignored any such arrangement, and said the circular was published entirely without their company's knowledge or consent, in direct violation of their obligations to the Association. As this circular was probably sent to all the jewelers in Iowa, it is desirable that publicity should be given to this repudiation, and I shall feel obliged if you will print it in your next number.

Yours respectfully,  
NEW YORK, April 19, 1879.

FRANK H. HOYT,  
*Assistant Secretary.*

### A New Invention.

A good invention once made known is sought after by everybody who can apply it to personal use—if such may be done at an economy either in the first outlay or arising from the construction of the newly-invented object, during the period in which it is used—and the knowledge of this, to a great measure, spurs the inventive genius of this country.

The watchmaker's science suggests to the working mind many deficiencies where improvements may be successfully applied, and, indeed, from the number of patents taken out yearly, for the improvement of watch movements, we can see how much has been done of late toward making the movements perfect. With but few exceptions, however, the cases to hold these movements have undergone no material change; nor have they kept pace with the improvements in movements.

A new and ingenious case has recently been patented by Mr. E. C. Fitch, of Robbins & Appleton, which is manufactured by the American Watch Company of Waltham. It is offered to the trade as an open-face stem-winding case, tightly closed, which renders the movement completely inaccessible to dust or moisture. A description of this device is published elsewhere in this number, and will be read with interest by the entire trade.

### Self-Luminous Clock Dials.

BY HENRY MORTON, PH.D., PRESIDENT OF THE STEVENS  
INSTITUTE OF TECHNOLOGY.

MY attention having been drawn to the luminous clocks which have recently been offered for sale in several places, I made an analysis of the substance with which their dials are coated, and found it to consist of nothing but the well known phosphorescent compound, sulphide of calcium, attached by means of some resinous medium, like varnish. But while the material in its composition is far from novel, something or other in its method of manufacture and consequent condition gives it such intensity of properties as has never been approached before. The light given out by these clocks is a violet blue, like that which Becquerel produced with aragonite, but Becquerel makes no mention of anything whose duration of luminosity approaches that of these clock dials. In making up some of these preparations I have noticed that out of the same batch some portions will glow by phosphorescence much more brightly than others, so that evidently this difference depends upon some very small structural or molecular variation, and there can be little doubt that it is by some method of securing a desirable condition of this sort that the remarkable efficiency in these clock dials is attained. If still further advances should be made in this direction it is easy to imagine some very wonderful results, before which even Mr. Edison's new electric burner will fade into insignificance. Thus, if our walls were painted with such a substance, they would absorb light enough during the day to continue luminous all night, and thus render all sources of artificial light useless, superceding even the new electric burners, no matter how little they might cost, for it would then only be necessary to provide curtains, which could be drawn over the walls, like shades over the windows, when darkness was desired. The coloring of houses on the outside with a like material would also evidently obviate the need of street lamps. I do not, like some of Mr. Edison's friends, in reference to his new electric burner, expect that this still more remarkable and economical source of light is certain very shortly to displace gas and all other sources of artificial illumination, but if conjectures are to be the order of the day, I do not see why this conjecture is not as good as many others which have been made. Seriously, this new form of the phosphorescent sulphide of calcium, made of the cheap materials, sulphur and lime, is a truly wonderful substance, which may well suggest strange possibilities for the future.

In the cabinet of the Stevens Institute are numerous specimens of phosphorescent powders—sulphides of calcium, barium and strontium—which represent the best products heretofore obtained. These, if exposed to strong sunlight or to an electric discharge, or the like, will glow for many minutes in the dark. One of these clocks, however, I found would continue to glow with sufficient brightness to be visible across a room all night, and could be read at any time if approached closely. After being shut up in a box for five days, this clock was still visible in total darkness, when the eyes had been rendered sensitive by remaining in the dark for a few minutes. This clock dial is also readily "excited" by lamplight or gaslight, or indeed by any source of light containing rays above the yellow of the spectrum. The light from a Bunsen burner with soda in the flame, if filtered through yellow glass, will not excite it, however; but if the yellow glass is omitted, the blue rays of the Bunsen burner flame will serve to excite the phosphorescence of this remarkable material. The cause of this action is believed to be somewhat as follows: When light falls on certain bodies its vibrations cause molecular changes which are not permanent, but are only maintained by the action of the "exciting" vibrations, somewhat as a mass of plastic substance can be kept in a soft condition by constant stirring. When the exciting cause is removed, the molecules return to their normal positions, and, in so doing, set up vibrations which are the cause of light, very much as the solidifying of water evolves heat. Thus these bodies, when exposed to daylight, absorb, as it were, the light energy, and re-emit the same afterwards. The phosphorescent property of sulphide of calcium has been known since 1768, when Canton prepared it by heating together intensely for an hour three parts of calcined oyster shells with one part of sulphur. Its properties in this relation have been elaborately studied by Becquerel, who published his researches in the "Annales de Chimie et de Physique," and has also devoted a large part of the first volume of his book, "La Lumiere," to this subject. He found that by employing lime in different forms, such as Iceland spar, marble, oyster shells, aragonite, etc., products emitting different colors by phosphorescence, such as orange, yellow, green, blue and violet, were obtained.

## Watch Oil and Oiling.

BY H. BUSH, HULL, ENGLAND.

AS is well known, all parts in machinery exposed to friction, require oiling in order to preserve them by thereby materially reducing the friction. As the oiling is limited to these parts, it is advisable to make in their immediate surroundings reservoirs of comparative size to hold the oil for the purpose in order to prevent it flowing on space not required oiling. This is best effected by taking out a portion of the metal and thereby producing a kind of cavity, generally called chamfer, in which the friction takes place. An oil for fine machinery such as watches, to answer its purpose as lubricator must possess the combined properties of not drawing acid like vegetable oil, nor evaporate like fish oil, not thicken in cold, nor become too thin in high temperature, which will cause its running away from the spot it is intended. Amongst the various watch oils in the market the one manufactured of refined neats foot oil is the only kind to combine all these qualities. The quantity of oil to be applied requires great consideration; too little will be insufficient to decrease friction, too much will act to great disadvantage by firstly producing an unsightly appearance, and secondly, retarding the free action of the fine parts of the movement in continual motion during its going and accelerate the adhesion of dust-fazes and thereby occasion a slowness of motion, and consequently an irregularity in time-keeping; the escapement especially ought to be oiled very sparingly and no oil applied too near the balance spring, as this would not only allow the free collection of dust on this delicate part but may also stick some of the coils together, whereby the watch would naturally go a deal too fast.

The cleaning of articles, on which too much oil has been applied, is best effected by immersing them in benzine for a few minutes, which dissolves all oil and grease. Shellac which is used for fastening the ruby pin, jewel-pallets, etc., is not the least affected by the benzine, which, besides this important advantage evaporates very quickly, so that articles dried in clean cotton cloth after removing from the benzine, will be completely clear and free of it. In order to use the benzine for this purpose with the best possible results and to avoid any disappointments from using impure benzine, it is requisite to procure a benzine free of acid, and a test to this effect is easily made by dipping a piece of litmus paper (to be obtained of any druggist) into the same; if the blue color of the paper remains unchanged, the benzine is free of acid, if it assumes a reddish color the presence of acid is thereby indicated. The injurious affects of the detected acid in the benzine may be neutralized by the addition and solution in the same of such a quantity of potash until litmus paper remains unchanged in color in it. Litmus is such a reliable test for this purpose by possessing the property of detecting sulphuric acid, even though diluted with 100,000 times its weight in other fluids. The satisfactory results of these proceedings are substantiated by thorough testing, and may be fully relied upon without making any preliminary experiments.

A SOLDERING fluid free of acid is prepared in the following manner: Small pieces of zinc or spelter are thrown into muriatic acid and left there until the acid becomes saturated with the solution of the zinc, which is indicated by the ceasing of the effervescence of the acid and the remaining of pieces of zinc undissolved. Then clear the solution by decanting the liquid from the sediment at the bottom of the vessel, and add to it spirits of ammonia about the third part of the bulk of the solution, which will neutralize all the free acid, and dilute with an equal quantity of rain water. This fluid will not rust iron or steel, and will answer all purposes of soldering, as well as tinning. If a gentle heat be applied to the muriatic acid for the dissolving of the zinc, the preparation is effected in less time and more reliable.—*From the Deutsche Metall-Industrie Zeitung, by H. Bush, Hull, England.*

LUMINOUS dials for watches, clocks and barometers are produced by the application of a composition of sulphur with calcium. Although the article appears to be a novelty at the present time, and an alleged invention of late, it is nevertheless well known, that the luminous properties of sulphur united with calcium and other ingredients were discovered more than 200 years ago, during the manipulations of alchemists, but were not applied to the present purpose. Nicolet et Cie, Watch dial manufacturers in La Chaux-du-fonds, Switzerland, have brought these dials to a great degree of perfection, and succeeded in giving them the same appearance as enamelled dials, and as their dials are not thicker than the ordinary enamelled ones, they may easily be substituted on watches and clocks, etc., as a matter of change.

The only difficulty is, that the watches and clocks with these dials are necessarily to be exposed to daylight, in order to shine in the dark, and does the shining at night extend for the same length of time as the exposure of the same to daylight, and will therefore be requisite to hang or lay the watch during the day against the window, instead of carrying it in the pocket, if the luminous properties are required to make themselves manifest. These dials are made of thin glass, covered at the back with the sulphate-calcium mixed with copal-varnish. If in time the shining of the dials have become weakened, the coating of the mixture may be dissolved in spirits of turpentine and a new coating applied. For this purpose the sulphate-calcium can be had in powder. The dials are also made with black ground and white (luminous) figures, which have a very pleasing appearance.—(*Communication by Herman Bush, Hull, England.*)

THE best connection of broken pieces of alabaster is effected by dipping each part in molten alum and pressing the pieces quickly together; the alum will harden at once, and any projection of superfluous alum may be removed by filing and polishing; or mix a solution of gum arabic with finely powdered alabaster, which makes a good and durable cement if the broken pieces are closely tied and the cement allowed to set.

TO recover the gold out of gilding solutions, which by accident have been spoiled, or for which there is no more use, add saturated oxalic acid solution, or sulphate of iron solution, either of which will precipitate the gold as powder. The solution is then to be filtered through fine muslin, the powder remaining on the muslin carefully washed with lukewarm water, and after allowing it to dry, mixed with a small quantity of equal parts of powdered borax and saltpetre and fused in a crucible or on charcoal.—*H. Bush, Hull.*

THE best method to preserve the gilding on watch movements is to place the parts to be cleaned in benzine, which will dissolve all oily and greasy substances, and after removal and drying in clean cotton cloth will require but the least brushing to restore the original lustre of the gilded articles.—*H. Bush, Hull.*

THE United Watchmakers' Association in Germany have offered, and after careful perusal of the competing manuscripts, awarded a prize for the best treatise of a practical and theoretical guide for watchmakers apprentices, which will be published shortly.

TO protect stones, enamel, chasing, and engraving from the effects of heat in hard soldering, cover the exposed part with a thick paste of whiting and water. This simple process, which may be new to some, is much cleaner and safer than any other method in use.

PEARLS will never tarnish and lose their brilliancy if kept in dry, common magnesia, in lieu of the cotton wool used in jewel cases.

## Workshop Notes.

Small articles may easily be coated with silver by dipping them first into a solution of common salt, and rubbing with a mixture of one part of precipitated chloride of silver, two parts of potassa alum, eight parts of common salt, and the same quantity of cream of tartar. The article is then washed and dried with a soft rag.

**TO PURIFY OIL.**—To make the oil pure, take a good sized bullet or other piece of lead which has a thick coating of lead rust, cut it up fine, put into the oil, and let it stand for two weeks. This causes the acid to settle, and it then resembles milk at the bottom. Now pour off the top, and your oil is pure. Common clock oil can be treated in this manner and made better than some watch oil.

**TO RESTORE LUSTRE.**—If not too much darkened it may be restored by dipping the wheel in pure muriatic acid. Test your acid by dipping a piece of polished steel in it; if it destroys the polish, reduce the acid with rain water until it will not. Rinse the wheels well in water. This will also restore the polish to steel that has been blued by heat.

Metal-workers may turn to useful account the fact that M. S. Mesnier has made mixtures of iron and nickel chlorides, reduced by hydrogen at a red heat, yield well defined alloys, sometimes admirably crystalline, and closely analogous to the meteoritic alloys of iron and nickel.

Dr. Holz has found that the specific magnetism of magnetic iron-stone is the greatest of all magnetic substances hitherto examined. Its maximum permanent magnetism is nearly as great as and partly greater than steel, as hard as glass, and its permanent magnetization is sooner removed in demagnetization, with the same external agencies, than that of steel.

The old alloy of silver and brass cannot be relied upon for soldering. It is liable to burn if overheated, an alloy of equal parts of copper and coin silver. This alloy requires a slightly higher temperature to fuse than the brass alloy, is much softer to use and will not burn, and is as fluid as water, while there is no comparison as regards the soundness of the joints obtained.

A good method for turning up watch bezels is to chuck a piece of thin brass on the lathe, sufficiently large to contain the defective bezel, turn it down till the bezel will snap on, as it does on the watch-case, then you have it both round and flat, and you can turn or burnish out the groove for the glass at your pleasure. If it should be a little loose and turn down on the chuck, shellac will remedy the difficulty. It is only the very thin bezels that suffer from being bent out of round, thick, strong ones never give trouble.

To remove blue from steel. Take one drop of muriatic acid to six drops of water, and instead of immersing the article, use a piece of pith and moisten the end with the acid water; use it the same as in cleaning, and you will find that the color will disappear; follow up with clean pith moistened with clean water, and finally with alcohol. This will be found a very safe way and the fumes of the acid will not destroy or injure the finest steel work.

A good compound for polishing and cleaning metals is composed of 1 oz. of carbonate ammonia dissolved in 4 oz. water; with this is mixed 16 oz. Paris white. A moistened sponge is dipped in the powder, and rubbed lightly over the surface of the metal, after which the powder is dusted off, leaving a fine brilliant lustre.

A correspondent sends to workshop notes the following item in regard to the polishing of levers and pallets:—Having duly prepared the lever or pallets for fine polish or red stuff, finish off with a brass polisher, rubbed smooth on a dry bluestone, using very little well ground red stuff, and polish off dry. This will not get so good a color, particularly on the pallets, as red stuff on a polisher made of of grain tin. A tin polisher should be filed with a rough file for tempered steel, and with a smoother one, as a bastered pillar file, for soft steel, as the pallets. Do not polish off dry in either case, or the work will look porous. Cleanliness is indispensable, and the polisher should be prepared afresh every time polish is put on.

The following is a receipt for making a good cement for uniting metal to glass:—Take 1 lb. shellac dissolved in a pint of strong methylated spirit, to which is to be added 0.05 part of solution of India rubber in carbon bisulphide; or take 2 ounces of a thick solution of glue, and mix with 1 ounce of linseed oil varnish, or 3/4ths of an ounce of Venice turpentine; boil together, and agitate. The pieces cemented should be fastened for 50 or 60 hours to get fixed.

The Japanese make a very curious and handsome kind of copper, by casting it under water, the metal being highly heated and the water also being hot. The result is a beautiful rose-colored tint, which is not affected by exposure to the atmosphere.

## Jeweler's Rouge.

(BY HERMAN BUSH, WORKING JEWELER.)

**T**HE rouge which is used by gold and silver-smiths, watch-case makers, watchmakers, and art metal workers, to give the finishing polish or gloss on their manufactures, is a red oxide of iron, and produced in various ways and qualities.

The ordinary rouge in commerce is obtained on a large scale as a secondary or by-product in the manufacture of concentrated sulphuric acid, where it forms the residue of the distilled sulphate of iron which is, however, generally contaminated with nitric acid, and must, therefore, be boiled in a solution of potash to neutralize the injurious effects resulting from its presence. This rouge does not always possess the property required for its use, as it often contains small hard lumps liable to produce scratches on the polished surface; and in order to avoid this, it ought to be carefully washed and levigated, in a glazed earthen vessel, with clear water, sufficient to allow the grosser particles to sink to the bottom; the liquid is poured off into another vessel, and the deposit thrown away. The vessel containing the liquid is then covered with a cloth, and set for twenty-four hours to allow the water to deposit all the rouge it contains; the water is then poured away, and the rouge dried in the air; but to render it more perfect it is again washed and cleared of any coarse substances, and after again being dried, diluted with spirits of wine, placed on the fire and allowed to burn, which will remove and destroy any grease which may have been present.

A good rouge is made by breaking up into small pieces sulphate of iron, generally called *green copperas*, placed in a crucible, and subjected to a degree of heat in a furnace sufficient to melt gold or silver; the crucible is then removed from the fire and left to cool, and the copperas will then be found to have changed its color to deep yellow. The mass is then powdered, sieved, and again placed in a crucible, covered and left in the fire until no more vapor is observed to come from the crucible; it is then removed and left to cool, when it will be found as a loose powder of a light red color, which should be boiled in water, washed and levigated.

Another good rouge is made by taking sixteen parts of calcined sulphate of iron, sixteen parts of well-dried potash, and one part of saltpetre, and placed in a crucible, covered and exposed for about an hour to a good heat in the furnace, taken out and left to cool, and finely powdered, washed and levigated. This rouge will have a brown color, similar to coffee, and may be used in this state; yet if again exposed for a short time, in a well-covered crucible, in a good furnace heat, it will assume the much liked violet color, and will be of a superior quality.

Another excellent rouge is made by dissolving one part of oxalic acid in six parts, and two parts of clear protosulphate of iron in eight parts of boiling rain or distilled water; each solution filtered through fine linen, again separately boiled and mixed with each other whilst boiling, which will produce a yellow precipitate, which should be dried and placed in a metal pan over the fire or a spirit lamp, and stirred about for some minutes, when it will assume a cinnamon color.

Rouge is made in a variety of colors, from light red to dark violet; this is owing to the various degrees of heat applied, the greater the heat the darker the color; for gold and silver the light colored one, generally called "gold rouge," is best adapted, whilst for steel the dark-colored "steel rouge" answers best for the purpose.

Rouge must always be used in a moist state, and in order to obtain a good gloss the articles should first be polished with a less fine quality, and finished with the best sort. The various qualities of the different kinds are produced in the following manner:—Place three glass or china basins in a dust-free place, fill one of these with clean water, and put a quantity of powdered rouge into the same, and keep stirring with a piece of wood until properly dissolved; then allow to settle for about half a minute and pour the liquid into the second basin, leaving the deposit behind; then allow the liquid to settle for about a minute, and pour into the third basin, also leaving the deposit behind; the liquid in the third basin is then allowed to settle thoroughly and carefully separated from the deposit; this deposit will naturally be of a finer kind than the one in the second basin, whilst the deposit in the first basin, containing all the impurities, may be thrown away.

The deposits are then dried and kept in well-closed boxes, and when used moistened with spirits of wine; the polishing begun with the second and finished with the third deposit.

By these means the best possible rouge and polish, and far superior than in any other way, will be obtained.—*British Horological Journal.*

## Practical Hints on Watch Repairing.

BY EXCELSIOR.—No. 50.

### EXAMINING THE ENGLISH OR "PATENT" LEVER.—*Continued.*

(783) *The Fuzee.*—The fuzee proper is the grooved, cone-shaped piece, between the main and maintaining wheels, and the fuzee cap with its stop beak. But, as generally spoken of, it includes all the parts connected together on the fuzee arbor, and for convenience they are all brought under that head. Commencing at the top, see that the dirt cup on the winding square does not rub on the upper plate. If it does, either make it fit higher on the arbor, or turn it off underneath till it clears the plate. Always replace the cup with its dot corresponding with the nick on the square, which is the way it was fitted on. If the square is worn, file it up (686, 688), and then fit a new key for the owner to use. If the fuzee pivots are worn or cut, turn down and repolish, and close the holes to them, or, what is better, fit new bushes (679) or jewels. Or, if too much cut, and not convenient to fit a new jewel, turn it down and fit on a collar (758) to suit the jewel. The bushes of the fuzee, like those of the center wheel, should be good and long, to prevent the pressure forcing the oil out, and cutting (757), and the shoulders of the pivots or bearings should also be broad, to help retain the oil on the pivots. In these large pivots, the slight additional friction, caused by the broad shoulders, is of less importance than the advantage secured by them. But in the other wheels, where the pressure is less, and there is no danger of forcing the oil out of the holes, the shoulders should be narrower, till, in the escape wheel and lever, the shoulders may be advantageously cut away entirely and prevented from touching by the use of end stones. In the escapement, the lessening of the friction is the great object; but with the center pinion and the fuzee arbor, the retention of the oil is of equal or greater importance. The fuzee cap should be free of the potance plate, or the fuzee jewel setting, or bush, or screws, and firm in its place on the fuzee. The beak should be as described in section (774).

(784) As the object of the fuzee proper is to equalize the motive force, or the pull of the mainspring on the train, the groove should approach its center in the same proportion as the tension or strength of the mainspring increases in winding. As the power increases it will act upon a shorter lever, and the effect upon the train will then be equalized. If the groove is not properly cut, or if the spring is not adapted to the fuzee, the object of the latter is unattained, and the benefit of the whole arrangement is to that extent lost. The motive force will be more nearly equal or uniform than it would be without the fuzee, but the advantage gained may or may not be sufficient to make up for the disadvantages incident to the equalizing mechanism. But even if the fuzee and spring are precisely adapted to obtain the best possible effect, by the maker, it may all be rendered fruitless by a careless repairer. In putting the watch together after cleaning, etc., if the mainspring is not keyed up the same amount as was done by the maker, its strength or tension will not increase in the same proportion when wound, as it did as keyed up by the maker, and will no longer correspond to the shape of the fuzee. The difference may be slight, or it may be enough to destroy the useful effect of the fuzee. Again, the original mainspring may break, the workman who puts in a new one may either not know or not care about the mutual adaptation of the fuzee and the spring, and a perfect watch will be reduced to the common level, by the insertion of a mainspring unsuitable for the fuzee, although perhaps otherwise good and well fitted.

(785) To be sure, the hair-spring could be isochronized to compensate for the inequality of the motive force, the same as in the toothed-barrel movements,—but that would be more trouble than to fit in a suitable mainspring. The isochronal adjustment was not carried to that extent, originally, in most cases, because the fuzee obviated the necessity for so doing. But when the fuzee fails to

fulfill its intended office, there is no provision for the need thus caused, and the watch becomes in that respect defective and incompletely adjusted, or, in other words, it is no longer a fine timepiece, but only a good or common one, according to the amount of the defect spoken of. The fitting of a mainspring in a fine English lever is therefore a particular job. A spring that will be just right for one fuzee, might not answer at all for another. There are many different shapes of fuzee found in use, but they may be roughly divided into three classes, as far as the practical workman is concerned.

(786) Some fuzees have straight conical sides, tapering more or less rapidly; others have a hollow rounded outline; still others diminish in diameter very rapidly for the first two turns or so, and the rest of the turns taper but little, and are rather small. As a general indication, it may be said that the first-named shape will operate best with their mainsprings keyed up as high as they safely can be; the second shape will take the middle turns of the spring (709); the last will operate well only with the lowest turns, or with a spring so short that there is no margin for keying up. This, however, makes no allowance for the difference in springs, etc., but, with a good English lever spring of suitable strength for the movement, it will approximate to correctness. Close adaptation of the spring and the fuzee, or a positive determination of the fitness of the spring for the fuzee, is got by the use of the adjusting-rod. Supposing the watch to be run down, the chain is wound till it forms a tangent to the fuzee groove, or, in other words, till the line of the chain, from the barrel to the hook, will form a right angle with a line from the hook to the fuzee center. This is the lowest point of the winding at which the motive force exerts its normal influence on the train. The laws of the adjusting rod are clamped on the fuzee square, and held horizontally, while the weight is moved along the rod till it just balances the pull of the spring, and fastened there. If it will so balance when tried at every position of the fuzee till fully wound up, the mainspring and the fuzee are suitable for each other.

(787) If the weight will not quite balance the spring at any point of the fuzee, the groove is not cut deeply enough at that place (for that spring); if the weight is too heavy and more than balances the spring, the fuzee groove is there cut too deeply, or too near the center, for that spring and that amount of keying up. In the former case (the weight not balancing), keying it up higher would probably make the progression of its strength more suitable to the fuzee as it is; in the latter case (weight too heavy), it should not be keyed up so much. But, as already intimated (711, 768), the English lever requires the spring to be pretty well keyed up, and if it does not then suit the fuzee, another should be tried. But a close adaptation of spring and fuzee may require the altering of the groove on the fuzee, as indicated by the rod. Instead of fastening the weight as described, which refers to testing with the third wheel removed, or with the barrel and fuzee alone, the actual strength of the pull of the mainspring at different points, while the movement is together, can be ascertained by sliding the weight along the rod till it just balances, thus, as it were, weighing the net motive force at each point. From these several weights, its equality or variation could be clearly seen, and different springs thus be compared.

(788) A rough approximation can also be got by observing the extent of the balance vibrations (while the movement is together and running), at different points of the winding. Whenever the vibrations increase, it corresponds to the weight not quite balancing; smaller vibrations, to the weight overbalancing, etc., as before described. But in these observations, it will be necessary to watch the vibrations for several minutes at each trial, to allow for the difference in the arcs caused by any defects in the train. For instance, if the depthing of the main wheel in the center pinion is not correct, the vibrations will vary considerably in extent as each tooth passes through the different stages of its action upon the pinion leaf (724). These variations in the balance arcs must be noted, and the *greatest* extent of the vibrations at each trial taken. But the adjusting rod will afford a more correct and more convenient means of testing the

uniformity of the motive force. This subject will be more fully treated in the article on Springing, should the writer be able to find time to furnish it.

(789) The fuzee grooves may require to be cut deeper, not only to secure uniformity in the motive force, but from being too shallow, with the sides worn or broken off, so that they will not hold the chain properly. Make a flat cutter, as thick as the groove is wide, and sharpen up the end square across, then fasten in a suitable handle. Mount your fuzee in the lathe, with the arbor truly centered, and turn it slowly with the hand while you press the cutter against the bottom of the groove, resting it freely on the lathe rest. As the cutter acts on the smaller portions of the fuzee it slides over the rest and follows up the groove, which with a little care can be deepened as desired, either through its whole length, or only in any particular portion of it. Of course, when accuracy is desired, the depth of the cut must be regulated by testing with the adjusting rod, showing where it should be deepened, and whether much or little, to enable its mainspring to give an equal pull from the top to the bottom of the fuzee. The chain should fit the groove nicely, but not be tight. To test, wind the chain tightly on the fuzee, then hold the fuzee suspended from the hook in the fingers, and see if the weight of the fuzee will unwind the chain from the groove to the bottom. If the groove is rough, rub off the burs, etc., with a peg-wood point and oil stone dust.

(790) *The Main Wheel* should stand "level" with the plate, and run truly as it turns. See that it is free from the pillar plate; the center wheel; third pinion; the point of the screw that holds the third bridge, under the dial; the barrel, and the chain on it; the pillar; dial post or its pin; the bolt, or its spring, etc. In  $\frac{3}{4}$  plate movements, see that it cannot touch the balance rim or screws. If it is not level with the plate, upright the arbor. If it rubs on the plate, and the end-shake is considerable, it can be raised, and the lower pivot hole, in the bar or third bridge, also raised; to keep it up. If the end shake must not be lessened, nor the arbor shoulders turned back to let it stand higher (751), the main wheel can be raised in several ways. If it is quite thick and can be turned thinner without detriment to the strength of the teeth, etc., do that. If the steel wheel is very thick, that can be thinned. Sometimes there is considerable thickness of brass at the top of the fuzee, between the top groove and the fuzee cap. If so, the cap can be taken off, the metal at the top of the fuzee turned off a little, and the winding arbor driven into the fuzee that much further, which will raise the fuzee and main wheel. On replacing the cap, it will be necessary to bead the end of the stop bar down a little to make it meet the beak as before. If absolutely necessary, which will not often be the case, the pillar plate can be turned out to clear the main wheel, after which the hollow thus made should be polished and gilt. Of course, if the main wheel rubs the plate only on one side, uprighting the arbor will cure that.

(791) If the main wheel rubs on the center wheel, and the latter cannot be lowered without rubbing on the third wheel, or, for any other reason,—the former must of course be raised, as above directed. If it does not run truly in the flat, it probably does not fit up closely against the steel wheel and fuzee. But if any of the parts are not true with the arbor, find in which one the fault originates, and remove the cause. If the main wheel gapes apart from the steel wheel on one side, it must be trued or tightened, and the opening thus closed up. If the main wheel interferes with the chain on the barrel, the latter should be moved (761), unless the chain is unnecessarily broad, when that can be changed for a narrower one. If it interferes with the balance rim or screws, in a  $\frac{3}{4}$  plate, and they cannot be replaced by shorter ones, or otherwise made to clear, of course the fuzee must be moved away from the balance, by altering the bushes, or jewels. In doing this, the depthing of the main wheel in the center pinion must not be changed, if correct. Get the distance with the depthing tool, and, with one point resting in the center pinion hole, mark a curve with the other on the bridge or plate, and

the center of the fuzee hole must be kept on this curve, but may be moved along it to one side, enough to clear the balance. A curve can be marked as above on both plates, or the lower hole can be moved as required, then the upper one plugged up, and a new hole uprighted from the lower one (704, 705).

(792) The collet at the bottom of the fuzee arbor must hold the main and steel wheels and the fuzee closely together, so that there is no opening or gaping at the edges, yet allow the wheels to turn on the arbor easily and smoothly. If too tight, the maintaining works cannot operate properly, or not at all. Some fasten the collet on the arbor with a soft pin, and then free the fuzee sufficiently by tapping on the bottom end of the arbor, while holding the wheel in the fingers. This bends the pin, and so secures the desired ease of motion, but care must be taken not to bruise or spread the end of the arbor. A better way is to fit in a hardened steel pin, tight in the arbor, and alter the collet to get the proper freedom for the fuzee. When so fitted, it will always go together the same, without trouble. The ends of the pin should not stick out beyond the pipe of the collet, and, of course, the pipe must not reach down below the shoulder of the arbor pivot, nor quite to it. Finally, see that the pin from the slot of the going spring does not stick out below the main wheel, and rub on the pillar plate, the center wheel, etc. If it does, it must be shortened up.

(793) Now take the fuzee apart. See that the ratchet is fast in its place; the teeth and the clicks clean, sound, and work well; and that the springs hold the clicks to their work, but do not bear on them too near their points, as that would only cause them to wear faster, without doing any good. If a new ratchet is needed, don't bother with the old rivets or holes, but pin the wheel on as most convenient, drilling and pegging firmly, then turn it out properly. If a new click is wanted, see that the click pivot hole is straight and cylindrical, with a very slight chamfer at the further end. Then select your click wire to fit properly, cut a pivot on the end, with a hollow drill of suitable size, making the pivot to just about reach through the hole, as only very slight riveting is needed. See that the click works nicely in the wheel, and that, when the point is at the bottom of a tooth, the strain comes *not* on the pivot, but on the back of the click resting against the ring. When correct, saw it off just level with the ring, and polish off the end, which will give all necessary freedom. Support it on a small stake which will set inside the ring, and rivet down the pivot, tight enough to prevent the click coming out, yet perfectly free.

(794) *The "going spring"* (780) should be smooth and free from bruises or burs, whether on the top, bottom, sides or edges. It should be well fastened at its rear end, and hold the moving or free end firmly to its place against the ring. Its pin should be free in the slot in the main wheel, and rest against the back end of the slot, when not compressed. On turning the fuzee arbor to force the pin to the further end of the slot (the fuzee being together), the spring should carry it promptly and easily back to its rest against the back end of the slot, and this motion of the spring and pin should be free and smooth. If the strength of the going spring needs to be tested, it is done by the adjusting rod,—placing the weight in the same place as it was when testing the fuzee for the strength of the mainspring (786). When so arranged, the weight should not carry the pin through more than about three-fourths the length of the slot, from the point of rest. The remainder of the possible motion of the pin (one-fourth the length of the slot) furnishes a yielding connection between the fuzee and main wheel, in case of the key slipping, the owner trying to wind the wrong way, etc., as well as a provision for a different strength of mainspring.

(795) Sometimes, on applying considerable force, the pin of the going spring will not only go to the end of the slot, but slip under it and press the main wheel off. To cure this, undercut the front side of the pin a little, and file the end of the slot vertical. If the pin has cut a groove on the inside of the main wheel, by frequent slipping under the end of the slot, punch the metal down from the outside till the inner surface of the wheel is level,—i. e., fill up the groove from the outside of the wheel. All being correct, and clean, oil the clicks, the going spring, the centers of the steel and main wheels, and the washer of the collet, pin together, and see that the parts are neither too tight nor so loose that they can gape apart, but can move easily on each other as already described.

## Watch and Chronometer Jeweling.

NUMBER THREE—Continued from page 28.

THE watchmaker is well aware that there are two forms of a jewel: one commonly called a plate hole, where the end shake is made by the shoulders of the pivot, another where the shake is effected on the ends; the latter being accompanied by an end stone. As the process is about the same for both, we will take a common plate hole for an illustration of the making, promising that the description will be interrupted frequently by the necessity of explaining some process to which we may allude. A piece of stone, say Aqua Marine, is selected; if large, the jeweler may slit it up by means of the skive, but generally it is broken into fragments; these are sorted for the different sized jewels it is desired to make. The workman now fits his lap on the lathe, and taking a fragment he holds it against the face of the lap, the end of the finger being protected by a piece of cloth, which is also useful in wetting the lap, as it must not be let to get dry during the operation. In a very short time a flat face is produced on the stone. So far but little tact or skill is exercised, but is not necessary to make a flat parallel to the first: for the object of the whole proceeding is to reduce the broken fragment to a plate of stone, just the thickness of the intended jewel; but this is a nice point in the sense of feel, as the stone is completely hid by the finger and cloth, while being operated on by the lap. Practice alone can enable one to do it with truth and rapidity; a few hints may enlighten the task. The finger may be pressed on any side of the stone, being cut; the lap then will cut faster on the side of pressure, and thus a wedging piece may be brought parallel. The experimenter must work very cautiously, not hastening, but examining very often the condition of his work and correcting as he goes along. The piece having been thus reduced to a small slab of stone, irregular in form on the edges, it must be rounded as near a circle as the eye can judge and the means allow, which is done by means of a pair of plyers, nicking off the prominent projections until a small circular disc is formed. This is now in a condition to go on the lathe to be turned into the shape as seen in Fig. 1 in the plate.

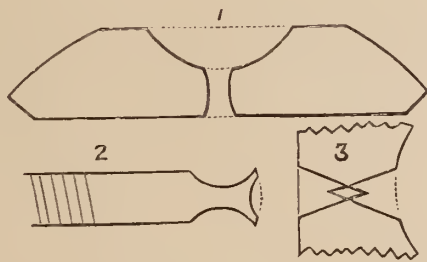

Now commences the first operation on the lathe. A chuck is first turned up in the manner illustrated by Fig. 2; the neck there shown is of essential service as it allows the end to be heated by a small flame as the conduction backwards towards the lathe is prevented in a great measure; the hollow in the end of the chuck is made in order to insure and get a bearing surface for the object. The chuck having been thus formed, the operator sits at the lathe in such a position that he can reach his left arm around to the back of the lathe; he now with a lamp gently waving the end of the chuck, touching it frequently with gum-shellac, and when warm enough the gum will flow over the face of the chuck; the stone is now held over the flame long enough to warm it, and placed against the face, and the flame delicately applied until with the points of the tweezers the stone moves with facility over the face; the lamp is now withdrawn, and revolving the lathe very slowly, the stone is pushed either way until the piece is centered to general truth. It must be observed that the less shellac applied the stronger will be the cement, therefore a pressure must be exerted against the flat of the stone while adjusting it to the centre.

The work is now left to cool, which is done very quickly, and is then ready for turning off. This is done with a diamond cutter—both the stone and cutter being kept wet. The outside edge is turned round, and a slight chamber made with the cutter on the face corner. The stone is now ready to drill half way through from the face side. This drilling requires a few words, and is a very important part of the performance; the size of the drill and the truth of the centre being the most particular points in any jewel. While the lathe is running, the operator presses his drill against the centre of the stone exactly; it is easy to say he does it, but it has required of him much practice and many broken drills to acquire the tact to discern the accurate centre and plant his drill so that no eccentric motion of the drill can be observed when the lathe is in motion. Again, much judgment must be exercised to drill the hole just deep enough to meet the one to be drilled from the other side in the centre of the stone after the oil cup is turned out. The hole being drilled from the face of the piece must be turned on the chuck; this is done by warming the shellac, taking off the stone, and putting the face side against the chuck, observing the same precautions as before.

A new process of centring now obtains. Before we merely observed the general truth; now absolute truth is required. The chuck is warmed until, as before, the stone glides easily over its face; when the rest is fixed near the work and while the lathe is revolving slowly, a piece of stick or the points of the tweezers is gently brought up to the outside edge of the stone; if it projects from the centre on any side, the high side will be rubbed in towards the centre, and a few turns (if the operation be conducted gently) will bring the circumference of the work again in the same centre as it was before being reversed on the lathe; if it is true, it follows that the hole now out of sight is also in the centre, for the hole and the outside were concentric.

There are what we call the convex and the concave; these are now to be made; the convex is generally turned up first, and it is important for success that the figure should be nearly true, as it may bother a great deal in forming up for polishing. The oil cup is now to be turned in, which operation is generally done with a smaller diamond cutter; the same precautions given for the large surface must be observed, but there is a greater difficulty in the operation. This difficulty is caused by the tendency of the cutter every once in a while to run over the centre when the bottom of the oil cup is being made, thus creating a tit which is fatal to drilling, as it throws the drill out of the centre. The drill is now put until it reaches the corresponding hole from the other side; the form of the hole which is now pierced through is in section of the form represented in cut No. 3. The jewel, now in a rough state, is in condition to be brought to a uniform surface on both the convex and concave, for the diamond tool has left rings, and in a turning by eye a perfectly true form has not been obtained. This process is effected, first, by a sort of a former, which consists of a piece of brass wire of a diameter considerably greater than that of a jewel; in the end of this wire a concavity is cut somewhat larger than the convexity of the jewel; some coarse powder being placed in the concavity, it is applied to the stone on the chuck. It is apparent that if held directly against the stone in the centre it would affect only the top of the convex; a wobbly motion is given to the former, so that in the course of a few revolutions of the lathe it has acted on every part of the stone, and in a very short time the surface of the convex will become uniform and of a true shape. The oil cup is treated in a similar manner, save that the former is convex on the end.

Having arrived at the formation of a jewel in the rough, we will leave the subject for a future number. As the object of the article has been to give a practical exhibit of the *modus operandi*, nothing was left but to give such minute descriptions as would enable any watchmaker, by a little practice, to make a jewel for himself, should he be in a position where it would be difficult to obtain the desired article.

## Metals and Alloys.

BY GEORGE E. GEE.

UNDER the above heading we sometime since published a series of articles by Mr. Gee, taken from his interesting work, "*The Practical Gold Worker*" we take pleasure in again introducing him to our readers, through the present series of continued papers copied from the *Jeweler and Metal Worker, British*.

The first question that calls for information is one of some moment: How to work up gold filings, scraps of gold and gold-plated jewelry, &c. This question has been asked and answered in several of the leading trading and scientific journals. Invariably, the information imparted is not practical, or, in other words, such as could not be successfully applied in practice by the ordinary workman or jobbing jeweler to his own pecuniary advantage, because it is imperfect in all the practical details of mechanical art. The *régime* of metal-working can only be adequately described by those who have actually played some practical part in it, and gained working knowledge by a display of experimental workshop manipulations. For a full and complete description of treatment with reference to the above question, we cannot do better than refer the reader to Mr. G. E. Gee's work on "Gold-working," where every detail in connection with the subject is described. However, a few extra remarks will not be misplaced here, or unwelcome to a portion of our readers. Lead and soft solder are, amongst the metals, the most objectionable, and the most likely to get mixed with jewelers' filings; especially will this be the case in a *jobber's* trade, from the repairing of articles containing portions of soft solder. Now, in the re-melting of gold, this solder is found most troublesome and difficult to deal with; and if this be the case with gold, how much more so must it be with filings or dust which contain impurities of all kinds. Contemporary journals have recommended the picking out of all impurities of a nature likely to prove injurious in the subsequent working of the prepared metal. This idea is at once preposterous to the practical working metallurgist, for all such like feculent matter is too infinitesimal to be detected by the human eye; and as science has not yet discovered any mechanical contrivance in her deep researches to assist in and make the process an available one, we must adopt some other *modus operandi* if we desire to be successful in the task of removing or destroying all extraneous matter with which dust or filings become impregnated. The best, most exact and cheapest way to deal with substances of that kind is, to well burn the filings in an iron ladle, or some other equal substitute. This operation burns and destroys all organic matter, such as dirt, grease, and all other ingredients of a kindred nature, and thus brings the bulk down into a smaller compass. When this has cooled off a little, the contents should be thoroughly magnetized to remove therefrom every trace, if possible, of iron or steel filings, which are sure to get into the dust in the course of working up the mother material. These extracted filings should be again preserved, and when a sufficient quantity has been accumulated, they may be sold to the *gold refiner*. The gold dust should, after this operation, be put into a clay crucible—not plumbago—with a little carbonate of potash, sufficient to well cover the top and so protect the contents from the air and draught of the flues of the furnace. A good heat should be given of half an hour or so to enable the dust to become properly melted, to assist which a few small crystals of saltpetre may be added towards the end of the operation to perfect the process. When the dust has become properly fused, it will work its way to the bottom of the crucible. At this stage it should be withdrawn from the furnace, and placed aside to cool in a secure place, and then the crucible may be broken at its base with a hammer, and the lump of gold will present itself in a form corresponding to the shape of the crucible. As we have said before in these pages, the best and cheapest plan to deal with this kind of refuse is to sell it to the gold refiner, who has large appliances, and does his work on a large scale, and consequently at the lowest possible cost, and he will either pay for the precious metals extracted in current coin, or exchange the amount in new gold. We may observe that no refiner

will take an assay from the lump in its present form, therefore, before submitting it for his test, it will be absolutely necessary to again melt the compound. This time it may be done in a plumbago pot with a little charcoal to protect it from the air, and when properly fused, it becomes a liquid, and may at once be removed from the fire, and poured into an ingot mould in the same manner as an ordinary melting. The previous lump of metal will now be in the form of an ordinary bar, and in a perfect state for the operations of the refiner. In a subsequent article we shall describe how the several metals may be separated from the bulk on a small scale suitable for the workshop.

In our previous remarks we described the common and more general method of treating jewelers' lemel; we now go a step further by entering into the details of a plan whereby all such waste may be made to do duty again by its previous operator, although we distinctly say that it is not a profitable undertaking to the small or large manufacturer, unless special advantages exist upon the premises for conducting the process on a most economical scale; and as such advantages seldom do exist, we are justified in penning these remarks in opposition to the introduction of the process by those persons less experienced in jewelers' work, and whose labors would be certain to result in ignominious failure.

The plan, then, which we intend to speak of is called the "Refining of Lemel," whereas the one already described was simply the "collecting" of it. The former branch of the art is more chemical than the latter, and is always performed with an acid or acids which destroys the baser alloys from the more precious metal.

Whenever this process is about to be performed, it will be necessary to first collect the lemel in the way already laid down, and then to ascertain its quality by means of the testing acid. If the alloy is too good in quality, it will not be so easily parted or separated from its baser ingredients by the acid which is to be subsequently introduced for its purification, therefore in the remelting it will be imperative that some extra alloy should be added to bring down the gold to the proper quality for parting; and as silver is the best metal to employ, enough of that material should be added so as to make the gold occupy the position of one-fourth part in the whole composition. This is to be added to the pot in the second melting process; and instead of pouring the contents of the crucible into an ingot mold, it should be poured into a deep vessel of water from some height, in order to the more finely granulate the mixture; stirring the water briskly in a circular direction greatly assists the operation.

The mixture will be found at the bottom of the vessel in small grains, or nuggets, if the process has been well performed. These grains must be carefully collected and dried, and subsequently placed in a glass flask free from lead—or any other suitable vessel—and treated with acid.

The acid employed is that most corrosive one known as *nitric acid*; it may be used as follows, and should always be in proportion to a given weight of the material to be parted or purified. If the nitric acid is of the best quality, it will be the safest to prepare the solution in these proportions: Alloy for parting, 1 oz.; best nitric acid, 1 oz.; water, 2 ozs.

This mixture emits dangerous fumes, and great care is required in the manipulation thereof to prevent danger to health. In the absence of proper mechanical appliances, the process may be conducted upon a hearth, taking care that the fumes escape effectually. Towards the end of the operation the fumes will begin to cease, partly because the acid has done its work, and partly because its action has been retarded by the amount of work done; therefore, before drawing off the acid, it will be advisable to increase the temperature a little, in order to keep up the requisite chemical action and vigor. In this way all the ingredients except the gold gradually become dissolved, and in order to perfectly complete the process, it will be absolutely necessary for a fresh supply of nitric acid to be added to the semi-dissolved mass, always removing the first one before an addition is made. By a repetition of these means the gold becomes perfectly pure, and is in the form of a dark powder at the bottom of the operating vessel, and only requires to be melted with a little flux to show its true form and nature. The undissolved gold at the bottom of the vessel should be well washed with hot water to remove all traces of acid previous to melting. If the gold has not been properly purified from its base ingredients it will not work properly, but be possessed of a brittle nature, which is most difficult to get rid of. To perform the process properly is more difficult than it appears to be. The nitric acid destroys the copper, silver, lead, tin, or pewter with which the lemel may be contaminated, and in fact every thing except the gold, always providing the mixture has been properly prepared.

(To be continued.)



## Precious Stones and Gems.

BY EDWIN W. STREETER.

THE Malachite was known and valued by the Ancients. Pliny, who calls it "Molochitis," describes it as an opaque stone, of a rich Emerald-green, and says that its name was derived from the color of the "Malve," and that it was much used for seals, and was worn by children as a certain protection against evil.

Malachite is not rare. It is found in Siberia, at Moldavia in the Bannal, at Saalfeld in Thuringia, in Prussia, at Chessy near Lyons, in Poland, Cornwall, and extensively in Queensland. It is generally the product of the decomposition of minerals containing copper. There is a beautiful variety composed of oxide of iron, which is found in great quantity in the Ural.

Malachite is found in crystals, but perfect specimens are very rare; its color is light-green, with a paler streak, and its lustre adamantine inclining to vitreous, but the fibrous incrustations are silky. It is translucent, nearly opaque, and brittle. Its hardness is 3.5 to 4, and its specific gravity 4. Its composition is, generally, carbonic acid, oxide of copper and water. When heated in a glass tube, it gives out the water and becomes black; and it fuses with borax to a deep-green globule, and ultimately affords a bead of copper. Owing to its magnificent color and capability of polish, malachite is highly valued for ornamental purposes, and is frequently inlaid with, and often used to cover, inferior stones, for vases, tables, caskets and the like. It is polished by means of Tripoli, on a tin plate. In the collection at St. Petersburg there is a mass, 3½ feet square, of the most beautiful Emerald-green; it weighs 90 lbs., and is valued at 525,000 roubles.

From the mines at Nischne-Tagilsk, belonging to Mons. Demidoff, a block of beautiful green malachite was taken out, 16 feet long, 7½ feet wide and 8½ feet thick.

One of the most perfect specimens of malachite work is the vase which stood for a long time in the great rotunda of the old Museum in Berlin. It is covered with tiny pieces, cut in little "tables," and so joined that it could not be perceived. It was made by order of the Emperor Nicholas in honor of King William III. of Prussia.

Of the antique engraving on malachite, Kohler speaks, in the highest praise, of a cameo with the head of Isis. He says: "The head of the goddess is drawn with a definiteness, tenderness and refinement that could not be surpassed."

Although the Ancients only knew of its existence in Arabia, the results of modern discovery show a far more extended range of its habitat.

"The Selenite," says Andreas Baccius, "is a kind of gem which doth contain in it the image of the moon, and it doth represent it increasing and decreasing according to the increase and decrease of the moon in its monthly changes." The Greeks, who call it "Aphroselene," which signifies the splendor of the moon, or a beam of the moon, with their lively imagination, often discovered in natural objects resemblances to other organic forms, and ascribed to them virtues and properties according to their interpretation. The moonstone is a good example of this. The Romans called it "Lunaris." Pliny mentions four varieties of it. The first, or the female, was egg-shaped, white, and filled with a soft sweet clay. The second, or male, was externally reddish, and had within a stony substance. The third contained a sweetish sand. The fourth, or the Laonian variety, had a crystalline core. The best kind, he says, "were to be found in the eagle's nest only, whence the name Aetites, Eagle's Stone." The substance itself, according to De Boot, is one of those calcareous hollow concretions, white, or sometimes tinged with iron, familiar to geologists. This gem is found in Macedonia, and in appearance is like frozen water. The stone now known as moonstone is found on the higher mountainous regions of India. Dioscorides says "it is found in Arabia, and is endued with virtues, as of making trees fruitful and of curing epilepsy;" he adds "that in the night it

will illuminate the place that is next to it, yet not by any transmission of light, but by the collection of light into itself." This stone is remarkable rather for the fables which cling to it than for its substantial value or qualities.

Onyx is a very celebrated variety of tinted agate, and is found almost exclusively in melaphyre and black porphyry. The Oriental onyx is obtained from India, Egypt, Arabia, Armenia and Babylon. The inferior variety mostly comes from Bohemia.

Some stone, called by translators onyx, ranked among the highest class of gems in the ante-Christian world. It is often mentioned in the writings of Greek and old Hebrew authors. Pliny likens it in color to the human finger nail; and it is upon this similarity that its Greek name onyx is based. According to this author the stone is marked with white, horn-colored, brown and black bands or zones, which are arranged in flat, horizontal planes.

The Greeks attached the following mythological origin to this stone: "Cupid, with the sharp point of his arrow, cut the nails of the sleeping Venus, which fell into the Indus; but as they were of heavenly origin they sank, and became metamorphosed into onyx."

The onyx has been chiefly used for cameos, and very costly vessels. In making the cameo, the figure is carved out of the light color, and stands in relief on the dark ground. One of the most famous of the antique cameos is the Mantuan vase; the base is brown, and on it, in relief, are groups of white and yellow figures, representing Ceres and Triptolemus in search of Proserpine. The vase is formed from a single stone, and is seven inches high and two and a half broad. There is an onyx cameo in the Vatican library representing Octavius Augustus; and, in the Emperor's cabinet at Vienna, there are some specimens of exquisitely cut antique onyx. In the Museo Nazionale at Naples there are many specimens; among others, an onyx cameo (eleven inches by nine), representing the apotheosis of Augustus; and another with the head of Medusa carved on one side, and the apotheosis of Ptolemy on the other. Among the remarkable cameos in the National Library of Paris is one of Tiberius with an ox; a second, of Marcus Aurelius and Faustina; a third, of Agrippina and her two children; and a fourth, of Jupiter armed with lightning. An antique sard-onyx cameo, in the Mineralogical Museum of the Marquis Dree, representing the bust of Faustina, cut on a five-colored basis, was sold for 7,171 francs.

Onyx has been found in such large masses that small pillars have been made of it—there are six such in the Basilica of St. Peter at Rome. At Cologne, in the Temple of the Three Magi, there is one broader than the palm of the hand. Appianus says that "Mithridates, King of Pontus, had 2,000 cups of this gem;" it is scarcely possible, however, to believe that they could have been the true Oriental onyx.

Boetius mentions the Arabian onyx as "black, with white zones or circles, by reason of which many colors are caused in it. It is called an onyx only when the black appeareth as it were under a white. It is a gem that hath many viens, compassed about with milky zones or girdles, and meeting in a pleasing concord and consent."

It is not at all probable that the onyx which Professor Aaron Pick shows to be the *Shouham* of Holy Writ was the same composite stone with that which modern writers designate by that name, for it is classed with the ruby, topaz, diamond, chrysolite, jasper, sapphire, and chrysoptase. This great Hebrew scholar believes it to have been the carbuncle.

The Peridot is a very ancient stone, at one time considered of more value than the diamond, and worn by ladies for many centuries as an ornament. It has a very pleasing yellowish-green color, and is susceptible of a fine polish, but is so soft as to be easily scratched. The Oriental peridot is a beautiful gem. Its crystallization is rhomboidal; its lustre vitreous, and it is translucent and transparent. As it is composed of silicate of magnesia, colored by peroxide of iron, it is less dense than stones of the first class. It is turned to jelly if macerated in sulphuric acid. Its specific gravity is 3.4; its hardness 5.6; it possesses double refraction and acquires electricity by friction. Formerly it was doubtful what its form of crystallization really was, as it was found in fragments much worn by the action of water, but well-defined crystals have been found in Vesuvius, which prove that they are rhomboidal prisms.

## Trade Gossip.

The latest novelties in fans are of fine wire, painted by hand.

h. s. A. Bessac has succeeded Loyd & Fritz, of Memphis, Tenn. Kronberg begins to realize that the "way of the transgressor is hard."

Mr. H. C. Haskell is confined to his home with a severe attack of rheumatism.

Mr. C. Pequignot, of Philadelphia, sails for Europe on the 7th inst. in the steamer Canada.

Mr. C. W. Schumann and Mr. W. B. Durand left on the 26th ult., in the steamer Germania, for Europe.

An Egyptian design for a lace pin is a snake curled around a bar from which swings a scarboeus in burnt topaz.

Mr. W. S. Hedges, of Messrs. W. S. Hedges & Co., diamond importers, sailed in the steamer Algeria April 30th.

Cameos are again fashionable, and are especially affected by young ladies. They are to be the favorite jewelry this Summer.

Mr. A. E. Juillerat has retired from the firm of M. J. Paillard & Co., and will establish himself permanently in business in San Francisco.

Daniel Veit, dealer in jewelry at No. 26 Maiden Lane, made an assignment to Samuel Weil, giving a preference for \$3,171.48 to Sophie Veit.

Coral and diamonds are now all the fashion in Vienna since the Empress appeared at the Industriellen ball with this combination for the first time.

Mr. R. H. Galbreath, of Messrs. Duhme & Co., Cincinnati, Ohio, and Mr. E. Bissinger, of New York, will sail for Europe in the Galia on May 28th.

There is \$9,000,000 worth of royal plate in Windsor Castle. Just think of all the comfort and happiness this wealth might bring to starving thousands.

The Sheriff has taken possession of the store of Edward W. Prescott, jeweler, of No. 605 Broadway, who has confessed judgment to Thomas W. Check for \$1,347.

C. A. Gallagher, formerly with Messrs. Tingly, Sinnock & Sherrill before the dissolution of that firm, is now in the employ of Messrs. Sinnock & Sherrill, successors.

Maiden Lane is radiant with new and attractive signs, and many of the stores in the old street are in a general state of upsidedownativeness consequent to moving.

Nickel-plated, gilded and silvered horse shoes, with fanciful hand-painted decorations, and the motto "Good Luck" at the top, are pretty things for philopœna presents.

Mr. F. D. Taylor (firm of Taylor & Bro.) and family sail in the Bothnia on the 21st inst. Mr. Taylor expects to reside in Paris as resident-buyer for his house in this city.

Diamond ribbon collar necklaces are the fashion of the passing moment, set in *pavé* style, and with clasps that make them available either for a pair of bracelets or for a necklace.

Messrs. H. Muhr's Sons, of Philadelphia, whose factory was recently destroyed by fire, are again running their full force of workmen, and are filling all orders with their accustomed promptness.

Among novelties in jewelry are lace pins of Limoge enamel or porcelain, with classic mythologic figures and Greek treatment of the subjects, the bar being surrounded with diamonds in fancy skeleton gold enamel setting.

A typographical error in Mr. L. A. Cuppia's advertisement made us say formerly with Ennis Bros. The types should have said formerly with Errico Bros. The compositor who set up the card has expiated his offence.

A Swiss exhibition of machines and tools used in the manufacture of watches, jewelry and musical boxes, is in contemplation. At the suggestion of the Society of Arts in that country, the Government have appointed a Commission to report on the prospect.

A school for the training of watchmakers has been opened in St. Petersburg, Russia. The managers and teachers are all Swiss, and selected from the best masters in Geneva. The pupils are exclusively Russians. The institute will be assisted by Government.

George Larue's jewelry store at Ypsilanti, Mich., was entered by burglars on the evening of the 19th ult., and robbed of several thousand dollars worth of watches and jewelry. Larue had recently sold his safe, and was keeping his goods in a case until he should purchase another.

Fans will be greatly adopted the coming season. They are made to correspond with particular toilets, and are decorated in the richest manner. Rare fans, uniform in size and exquisitely colored, are mounted on costly sticks, and even the tips of feathers are in some cases decorated with paintings.

The latest novelty in diamond earrings are made of two narrow ribbons of diamonds in flexible *pavé* setting, each ribbon finished with a pear-shaped pearl, with calix of small diamonds. The longest ribbon is in front of the lobe of the ear, the shortest at the back. A spring catch fastens the wire or bar that passes through the hole in the lobe of the ear.

At a recent meeting of the British Archæological Association to statements made that thimbles were of recent date, evidence was adduced to show that they were well known to the Romans. The earliest examples, however, in England and North Europe appear to have been of leather, one of that material being shown. It was in use in County Cork so late as 1820. A large number of examples of brass, dating from 1500, were exhibited. They were mostly found in London, and some of the seventeenth century have inscriptions.

Thomas F. McDonald, a young clerk who was discharged from E. C. Dunning's recently, on account of dull times, was arrested by Detective Haley, a few minutes after he had handed two gold chains, valued at \$90, to Joseph Stern, alias Johnson, the keeper of a stand near the Chatham Bank. Stern was also arrested. McDonald confessed that he had stolen the chains from Dunning's store, and Mr. Dunning identified them. Stern also admitted his guilt, and offered the officer \$30 to release him. Stern was committed for trial, and McDonald released on nominal bail.

Professor James Thompson has recently constructed a machine which, it is said, by means of the mere friction of a disk, a cylinder and a ball, is capable of going through a variety of complicated calculations which occur in the highest application of mathematics to physical problems, so that, by its aid, an unskilled laborer may perform the work of ten skilled mathematicians. This machine is represented as applicable alike to the calculation of tidal, of magnetic, of meteorological, and perhaps all other periodic phenomena; it will solve the different equations of the second and possibly even of higher orders; and, through the same invention, the problem of finding the free motions of any number of mutually attractive particles, unrestricted by any of the approximate suppositions required in the lunar and planetary theories, is reduced to the simple process of turning a handle.

A Baltimore man recently wrote to Herbert Spencer for an explanation of the paradoxical customs of the Japanese, citing examples as follows: "A piece of cord in Japan is twisted from left to right in the process of manufacture. A plane is drawn toward the person using it. The teeth of a saw are so 'set' that it is the upward pull which cuts. Their books commence at what we would call the end, turning the leaves from left to right, while the lines run up and down the page, instead of across, and the pages are numbered at the foot. The face of their clock moves and the hands are stationary. They say 'It is 4 o'clock,' meaning that it lacks four hours of being noon, while with us it is always so much past the starting point." Mr. Spencer replied that the question involves "a wider range than at first sight appears," but declined to express his views, on the plea of lack of time.

On the evening of April 11th Mr. H. E. Spadone, of Messrs. Spadone & Abal, left Providence for New York, via Stonington boat. Upon arriving at the boat he secured stateroom No. 111, to which he carried his valise, containing samples of jewelry to the value of \$2,000. Before the boat left the wharf he had occasion to leave the room for a few minutes, but carefully locked the door. Immediately after his departure a sneak thief requested one of the porters to take a pitcher of ice water to room No. 111, and told him not to mind about locking the door as he was coming back in a minute. He followed the porter into the room, took the valise and left the boat. Mr. Spadone did not discover his loss until some time after the boat had left. On Monday morning he made known his loss to the officers of the Jewelers' Protective Union, of which Messrs. Spadone & Abal are members, and inside of forty-eight hours his valise had been recovered, with all the goods in perfect order. The Union has proved worthy of the confidence reposed in it on every occasion that its services have been called into requisition. It has demonstrated its usefulness, and should receive the support of the entire trade.

# Jewelers' Circular and Horological Review.

VOLUME X.

NEW YORK, JUNE, 1879.

No. 5.

## THE JEWELERS' CIRCULAR AND HOROLOGICAL REVIEW,

*The recognized organ of the Trade, and the official representative of the Jewelers' League and the Watchmakers' and Jewelers' Guild of the U. S.*



A Monthly Journal devoted to the interests of Watchmakers, Jewelers, Silversmiths, Electro-plate Manufacturers, and those engaged in the kindred branches of art industry.

### SUBSCRIPTION :

To all parts of the United States, Canada, Great Britain and the West Indies,

**\$2.00 Per Annum ; Postage paid.**

To France, Switzerland, Germany, Mexico, the Republics of South America, and Australia, \$2.50 per annum. Postage paid.

 All communications should be addressed to D. H. HOPKINSON, 42 Nassau Street, New York.  Advertising rates made known on application.

AGENCIES: { J. H. PURDY & CO., No. 170 State Street, Chicago.  
PRATT & CO., Ninth and Arch Streets, Philadelphia.  
HERMAN BUSH, No. 14 Mytongate, Hull, England.  
F. H. BRAKE & CO., 11 Clifford St., Detroit, Mich.

*This journal is published on the 15th of every month, and will, on receipt of the yearly subscription of \$2.00, be forwarded regularly to any address in the United States or Canada for twelve months. The present volume commenced with the February issue, and intending subscribers can be supplied with back numbers so as to have the volume complete.*

### The Watchmakers' and Retail Jewelers' Guild.

We devote a good portion of our space this month to the publication of a full report of the proceedings of the first meeting of the above named Association. It convened in Chicago on the 15th of May under the name of the Watchmakers' and Retail Jewelers' League of Illinois, but, the necessity for a national organization of this character being recognized, the change from a State Association to a National Guild was consummated. The aims and objects of the Guild are fully set forth in the resolutions adopted, and in the Constitution and By-Laws agreed upon. They are substantially the same as those adopted by the various State Associations, which will in the future co-operate with the Guild. These organizations are yet in their incipiency, having been recently called into existence to redress certain grievances of which the retail dealers complain at the hands of the jobbers.

It is to be regretted that the session of the Guild was confined to a single day. Much of this time was necessarily taken up in organizing, and this work was crowded through so rapidly that it is still crude and imperfect. Many delegates, supposing the session would last two or three days, arrived after the meeting adjourned, and were considerably disappointed at not having a voice in the proceedings. Another year, however, the Guild will not be likely to be so precipitate, and those matters which were but briefly alluded to, can be discussed at length. These protective associations are meeting with very general approval in the trade, and we are informed that upwards

of two thousand retail dealers are enrolled as members of the several State Associations, and enter heartily into the spirit of them. This forms a constituency that is not to be lightly regarded by the manufacturing and jobbing interest. These dealers have thus combined to resist certain encroachments made upon their business by members of the jobbing fraternity. Retail dealers do not propose to use these organizations for aggressive purposes; they do not make war upon the legitimate jobbers; but they do protest against jobbers selling goods at retail at wholesale prices. This is the principal grievance; incidental to it are the other ones—of jobbers deluging the country with circulars and price-lists, offering to sell goods to any one at wholesale prices, and that travelers for jobbing houses, after selling all the goods they can to dealers, display their wares in hotels and sell to the landlord, the cook, the chambermaid, and whoever else will buy, thus supplying the customers of the retail dealers with goods at lower prices than he can afford. Taking advantage of the special rates given to jobbers, they thus rob the retail dealers of their legitimate trade, and at the same time bring them into disrepute. The resolutions adopted by the Guild not only protest in vigorous terms against these abuses of the special privileges accorded to the jobbers, but the members pledge themselves not to buy of jobbers guilty of these practices, nor of the manufacturers who sell to them. These may seem idle threats, savoring of proscription, and curtailing the rights of individuals; but these dealers are forced to be in earnest, for they have beheld their legitimate trade diverted from them year after year by men who represent themselves to be jobbers for the purpose of obtaining jobbers' discounts, but who sell at retail at jobbers' prices. The retail dealers are thus placed at a disadvantage, and cannot hope to make a living and pay their creditors in the face of such opposition. They, therefore, demand that these practices shall be discontinued, and that the manufacturers shall come to their assistance, by refusing to give the jobbers' discounts to jobbing retailers. Half a dozen or more States have perfected organizations having substantially the same objects as the Guild, and the movement is still young; it has, in fact, but just begun. Already the dealers speak in language that cannot be misunderstood, nor should it pass unheeded; for the individual members comprising these associations exert a power that will certainly make itself felt. Some of the jobbers affect to treat these organizations with contempt, and claim that they can break them up; they do not seem to comprehend that there is a life-and-death struggle on the part of the retail dealers, and that they *must* carry their point, and restrict the business of the jobbers to its legitimate field, or themselves be driven from business. Unless checked, the abuses of which they complain will spread until the retail business will be absorbed by jobbers and traveling salesmen, retailing goods through the country at wholesale prices. It was made very clear during the debates in the Convention, that it is not against jobbers that the retailers make war, but against the abuses referred to. So far from being antagonistic to the jobbing interest, the retailers regard legitimate jobbers with a friendly eye, and desire to cultivate intimate business relations with them.

One important feature requiring the united action of the trade was but lightly touched upon, and that is the desirability of having a uniform and universal price-list for watch repairing. There is now a great diversity in this matter, and that fact leads to much bickering

and ill-feeling in the trade. The Guild and the State Associations should use their influence to establish fair and equitable rates for all kinds of watch repairing, and to induce the trade, both in and out of the Associations, to adopt them. At present, there is very little profit derived from this branch of the business, while it should be a source upon which the watchmaker should be able to rely for a goodly portion of his expenses.

It should also be the aim of these associations, and their tendency is in that direction, to promote better feeling among local dealers. The fact that men are competitors in business does not necessitate that they become mortal enemies, or that they should villify and abuse each other. But, we are sorry to say, personal ill feeling is too apt to accompany spirited competition. Mr. Jones, for instance, buys a watch of Brown, who is a jeweler, and pays him a price from which Brown makes a fair living profit. Soon after, Jones' watch wants cleaning and he drops in to Thompson's to have it done. Thompson is Brown's rival, and loses no opportunity to abuse him, a compliment which Mr. Brown returns in kind whenever opportunity presents. Thompson incidentally asks Jones where he got the watch, and how much he paid for it. Jones informs him, and Thompson innocently remarks: "It beats nature how Brown can get such prices for goods; I can't do it; I haven't the conscience to ask them; I would have been glad to have sold you that watch for five dollars less." No man likes to be swindled; so Jones "pitches into" Brown for having charged him too much, and Brown retaliates by calling Thompson a thief, a robber, and other pet names. Here is a pretty quarrel at once, and it is kept up, perhaps, for years. The men become personal enemies, and if what each said of the other was true, both ought to be in State Prison. The Associations can do much to put down this sort of thing, by bringing these deadly rivals together, and proving to both that each has good qualities, and is a pretty clever sort of a fellow. The trade must respect itself if it would be respected. Members of it must be respectable, dignified and trustworthy if they would command the respect and confidence of the public. When Thompson abuses Brown, he brings reproach upon the trade in general. The jeweler's art has been held in high repute for ages, and the handiwork of its craftsmen has been ranked as high art. It should be so considered to-day, and would be, did those who practice it maintain the dignity that should characterize them. State Associations can do good missionary work in this direction.

The discussion of the subject relative to the desirability of having standards for all grades of wrought gold was discussed by the Guild, and the position heretofore taken by THE CIRCULAR fully endorsed. We trust the agitation of this subject will eventually develop some plan whereby manufacturers will be compelled to guarantee, by stamp or otherwise, the quality of the goods they place upon the market. At present, the dealers need protection fully as much as the public does. The dealer who orders 18-carat goods has no means of knowing whether they are 14 or 18 carats fine, unless he assays them at his own expense. This he cannot do, and therefore sells them as best he can, with or without a guarantee. The market is full of blind goods, made to sell for what they seem, not what they are, having no reputable godfather or godmother to guarantee them. They are put forth by manufacturers to catch whoever will bite. Had we laws requiring that the products of every manufacturer should be guaranteed for just what they are, and severe penalties provided for deception, the quality of gold goods would be much improved. Dealers should refuse to receive any goods the quality of which is not certified to by the seller. Let them require that the quality of goods shall be stated in carats in the accompanying bill, and refuse to pay for goods that are below the quality thus certified to, and manufacturers will then be held accountable. As it is, there is no certificate or guarantee of quality; the dealer accepts what is sent him, and the manufacturer thus shifts the responsibility from his shoulders to those of the dealer. In the absence of laws fixing standards for wrought gold, dealers have no other way to protect themselves than the one suggested. As an

illustration of the effect of stamping goods, we may cite the watches sold by Robbins & Appleton. Some time since they adopted the practice of putting a certificate in the back of the 18-carat watch-cases made by them, setting forth the quality of the case, and pledging the honor of the firm that they were all they were represented to be. As a consequence, there has been a great demand for these cases, and the firm is kept busy in filling orders for them. Let other responsible manufacturers imitate their example with other classes of goods, and it will prove a great stimulant to the sale of the better grades of jewelry.

At the Convention, the jobbers whose practices are complained of were granted an opportunity to reply to the charges made against them. Their side of the question is substantially this: they sell to dry-goods dealers, druggists, and others, because this class of customers are better pay than the jewelers. Their transactions in jewelry are secondary to some other business; jewelry is used by them as a bait to catch customers; their revenue being derived from another source, they pay their bills more promptly than jewelers do. There is a great amount of truth in this statement, and it is unfortunate for the jewelers that they are slow pay. If they met their bills more promptly, their credit would be better. But the jobbers omitted a portion of the argument: the very fact that dry-goods men druggists, etc., use jewelry simply as a bait to catch customers; that they do not deal in it for the sake of a profit, nor to make a living by handling it, constitutes one prominent reason why jewelers are slow pay. The trade which should, by right, come to them is captured by these outsiders, who sell without a profit in the hope of making it up from goods in their legitimate line. The dry-goods man sells jewelry at cost to attract customers to buy dry-goods, on which his profit is made. He floods the country with cheap jewelry, and destroys the trade of the retail dealer. No wonder the latter is slow pay; the wonder rather is that he pays at all. The jobber puts into the hands of outsiders a club with which to beat his brains out, and then complains because he does not pay his bills promptly. Give the retailers full command of the trade that fairly belongs to them, and they will pay their bills promptly enough. They used to do it, and the jewelry business was esteemed one of the safest and best going, until the jobbers introduced the pernicious practice of selling to outsiders, whose transactions in jewelry constitute only a side-show to their regular business. If the jobbers want a reform in the matter of payments, let them first reform their methods of doing business, and give the dealers a chance. We do not pretend in our report to give the language, verbatim, used in the discussions of the various topics presented to the Guild for consideration, but simply to outline the general tenor of the debates, preserving the spirit of the sentiments expressed which were in full sympathy with the resolutions adopted. From this it will be gathered that the members present were in earnest, and mean all that the resolutions say.

### The Boys on the Road.

THERE is no harder worked or more deserving class of men in the community than the commercial travelers. Separated from their homes and families, deprived of all social enjoyments, denied the companionship of friends, enjoying but few of the comforts of life, their work never ended, their life-lines are not cast in pleasant places by any means. To persons of sedentary habits a life "on the road" appears to be exceedingly pleasant; it certainly does offer the attractions of change and novelty to young men. But after one has made a business of traveling for a few months, instead of enjoying the trips, they become monotonous, tiresome and disagreeable. The traveler of a few years' experience envies those more favored salesmen who remain at home, have regular hours of business, home comforts, and the many attractions to be found in society, and in the round of pleasures offered in the cities. But the commercial traveler must yield to his destiny; for him there is no regularity of habits; he must eat and sleep as circumstances permit, and not be overchoice as to what he eats or where he sleeps. If fate brings him to a first-class, well kept hotel for a day, he is thankful; but if, on the contrary, he finds

himself in a second or third-class hotel, where the food is wretched and abominably cooked, where the beds are dirty and pre-empted by insectivorous tramps who pay no bills, he accepts what is offered, if not with cheerfulness, at least with no more *cursor* remarks than are warranted by the surroundings. But, however lodged or fed, lodging and food must always be secondary considerations with the boys on the road. They are more given to consulting time-tables, and studying the arrival and departure of trains, than to looking after their creature comforts. They have their routes laid out, and to make connections is of far greater importance to them than anything except selling goods. Night and day they are on the road, sleeping and eating as they can, stopping off at intervals to call on customers, selling what goods they may, but always anxious to keep down expenses, lest their employers find fault.

A great source of anxiety to the travelers in the jewelry trade is the valuable stock of samples they are compelled to carry. Railroad and express companies assume no responsibility for baggage beyond that of an ordinary traveler, such responsibility being limited in value to \$100. But the travelers for jewelry houses must carry in their trunks samples aggregating hundreds of thousands of dollars. Here is a pecuniary responsibility that is a constant source of anxiety to the commercial traveler. Sleeping or waking, that trunk-full of valuables is constantly present in his mind. To no one else can he transfer this responsibility. Even in the best hotels he is exposed to robbery, and there is no more security in them than in the baggage-car. His own vigilance and watchfulness are the only safeguards for his employers' valuables. That the utmost integrity characterizes this class of salesmen is evidenced by the fact that an instance of one making way with the thousands of dollars' worth of goods entrusted to him is scarcely remembered in the trade. They go and come, traveling from one end of the country to another, exposed to innumerable perils, and all the temptations that surround young men; yet, when they return to their employers, they invariably present a "clean bill of health," accounting to the last cent for the goods which were entrusted to them.

As a rule, commercial travelers are genial, whole-souled fellows, full of life and activity, overflowing with anecdotes and good stories, pleasant companions to fall in with, yet possessing excellent business qualifications, and keenly alive to everything relating to the interests of their employers. An important part of their duty is to ascertain the financial standing and business surroundings of the dealers whom they visit, and upon their reports depends, to a great extent, the credit of the dealer reported upon. Being familiar with the jewelry business in all its phases, they are fully qualified to give valuable advice to the country retailers, and many times do so to the great advantage of the latter. They bring to the retailers, in sections remote from the manufacturing centers the latest novelties and designs, and sell them at the lowest prices. Through the agency of the boys on the road, the dealers in Omaha or Denver can obtain new goods almost as quickly as the dealers in New York, and at the same rates. It has been stated that the expenses of the travelers are added to the cost of the goods sold to the retailer, but this is a mistake. The active competition maintained on the road as well as in the salesrooms, insures the lowest rates to purchasers in remote places equally with those in the cities. The expenses of the traveler are borne by his employer, except, occasionally, when the bill is a little too high, the traveler goes down into his own pocket rather than ask his employer to pay it.

There are occasions when the equanimity of the traveler is seriously disturbed. For instance, after having laid out his route and arranged his dates, he enters a town that he has looked forward to with confidence in his ability to sell a good bill, and encounters a rival just taking his departure, after having canvassed the town and sold everybody everything they want or can be induced to buy. His chagrin, however great, finds expression outwardly only in an invitation to his fortunate competitor to "take something," trusting to luck to get ahead next time. To avoid such encounters, and to time his visits oppor-

tunely, when his customers' stock needs replenishing, requires much study and tact. If his arrival is opportune, he is hailed with delight; but, if otherwise, he is slightly spoken of as "one of those bummers" who are hunting trade. The profession of commercial travelers is an honorable one, and those who follow it honestly and in an honorable manner are entitled to every consideration. They should be made welcome, treated with courtesy, and made to feel that they are benefactors to the trade, and not an encumbrance or a nuisance. Commercial travelers have done more to extend the trade of this country than any other one thing. They carry the products of our factories and workshops to the remotest regions, and place them directly before those who need them, and are willing to pay for them. Fortunate is the manufacturer or dealer who secures a good traveler, and many of these owe their success in business to the fact that they were lucky enough to secure the services of a competent salesman to travel for them. But, valuable as commercial travelers are, their worth is not fully appreciated, or their services adequately recompensed. This latter is a mistake, for the traveler who is curtailed in salary and scrimped in his allowance for expenses, forced to put up at cheap hotels, and wear an air of impunctuality all the time, loses heart in his business, is robbed of his self-respect, and taught to think unkindly of his employers. Under such circumstances, he is easily discouraged, and not likely to do as well as he would if satisfied with his own condition, and looked with respect upon the employers who treated him liberally. While commercial travelers are, as a rule, gentlemen by instinct and education, there are a few who are the reverse of this; men who make a business of misrepresentation, and trust to sharp tricks for their profit; sycophantic rogues, purely selfish, uncleanly in speech and in person, whose impudence and cheek are only exceeded in brazenness by the wares they offer. These men are avoided by the respectable travelers, and they bring into discredit the men who employ them. As a whole, however, commercial travelers are jovial, whole-souled fellows, keen business men, and of great advantage to both buyers and sellers. We do not, of course, refer to those infants fresh from primary schools, who have recently been put on the road on the score of economy, but to that responsible and respectable class of travelers who have the reputations of themselves and their employers at stake. To them the country looks for extended business, and in them will be vested eventually our largest business interests. Many of our most successful merchants received their early training on the road, and their places will be filled by others who are undergoing this preliminary apprenticeship. England has obtained her commercial supremacy mainly through the efforts of her commercial travelers. Although the territory covered by them is much smaller than ours, England has eleven commercial travelers where we have one. The profession is yet in its infancy in this country; with its growth our national prosperity will increase. We wish every success to the boys on the road, and trust their numbers may rapidly increase.

---

### Obituary.

FRANK D. TAYLOR.

It again becomes our painful duty to chronicle the death of another well-known and prominent member of the jewelry trade. Mr. FRANK DAVIS TAYLOR, of the firm of Taylor & Brother, died at New Haven, May 20, of heart-disease, aged 37 years. Mr. Taylor was one of the most promising young men in the business, finely educated, of refined and cultivated tastes, possessing indomitable energy and industry, he was beloved and respected by all who knew him. At the commencement of his career he began the study of law, but, in 1863, entered the old importing house of Read, Taylor & Co. In a short time his industry and business accomplishments gave him a thorough knowledge of the business, and, after one or two changes, the firm became Taylor & Brother.

The deceased had long been a sufferer from the disease that ultimately caused his death; but his strong will combated it so deter-

inedly that his life was prolonged considerably in spite of adverse conditions and opinions. In January last he went to Nassau on account of his health; but, receiving little benefit, it was deemed best for him to sojourn in Europe for a time. He had, accordingly, made arrangements to locate, with his family, in Paris, as resident buyer for the firm. His family were sojourning temporarily at the residence of his wife's father, Mr. R. S. Fellows, at New Haven, where he was taken ill soon after his arrival with the final sickness which resulted in his death. He preserved his consciousness to the last, and, while knowing that the end was near, he maintained a perfect serenity of mind. His death was truly majestic in its calmness, and impressive beyond description.

The deceased was frank, open and generous by nature and by cultivation, happy, pleasant and social in his disposition, and manly and upright in his business. Above any meanness himself, he despised it in others. He was possessed of the highest ideas of business rectitude and commercial morals, and overflowed with those higher attributes of true manhood which made one feel better and happier on coming in contact with him. While condemning many of the equivocal practices in business most vigorously, he was gentle and forbearing to individuals, and a fault manfully acknowledged was freely forgiven, and thenceforth constituted a claim upon his friendship. Possessing a mind quickened by study and cultivated by travel and observation, he was a most pleasing companion, an instructive conversationalist, and a genial element in social life. His early demise is a loss to the trade of which he was a most useful member, and his afflicted friends have the profound sympathy of all who knew him.

Mr. Taylor was one of the earliest members of the Jewelers' Association, having been its treasurer from 1875 to 1877. The funeral services were conducted at the residence of Mr. Fellows, in New Haven, by Rev. Dr. Stephen H. Tyng, Jr., (of whose congregation Mr. Taylor was a member,) assisted by the Rev. Mr. Clark, of Brooklyn. It was attended by several members of the trade and large numbers of the friends of the family. The body was interred in the old cemetery at New Haven.

### Wooden Pendulums.

AN interesting discussion recently took place at a meeting of London clock-makers on compensation pendulums. The general judgment seemed to be in favor of plain wooden pendulums for all sorts of time-pieces. One speaker said that wooden pendulum rods were generally in use for turret and church clocks, and also in regulators. Another concurred in that statement, and he thought that if wooden pendulums were good for church clock, they might usefully be adopted for bracket clocks. He had accordingly altered a very old family clock of that description, and of the best London make, by substituting a wooden for a brass pendulum, with very decided advantage. It might possibly be worth while to make a similar alteration generally; brass, being a cheaper and a prettier material, having probably been used by the makers of bracket clocks without consideration. A third maker never used anything but wood, when he could help it, for railway, church, or turret clocks. Another speaker considered that one of the advantages in the use of wood for pendulums might be that, in a fall of temperature, when the rod would be shortened, the hygroscopic property of the wood would come into play, which would tend to lengthen it, and so cause a natural compensation by the thermometric and hygroscopic properties of the wood acting in opposite directions. In some climates that certainly might be the case, though in others they would work together, when the effect would be to increase the error. It was stated that a wooden pendulum with a leaden bob had been affixed to a regulator clock in one of the leading shops, and was keeping excellent time. It was a very simple form of pendulum, and might be made very economically. Further testimony was borne to that form of pendulum. Dr. Mann had used one in Natal, which was simply a rod of varnished wood supporting a cylindrical bob of lead. It was, of course, subjected

there to great and rapid changes in the atmospheric pressure and to diversities of heat, but it worked excellently for many years. Subsequently it was replaced by one of Frodsham's best steel pendulums, and though there was some improvement, it was much slighter than might have been expected. In short, it was about as good a pendulum as could be conceived.

### The Navisphere.

A NEW instrument, which promises to be of great service in navigation has been recently described to the French Academy by M. de Magnac. It is called a navisphere, and its use is to indicate in a few seconds, without calculation being required, the names of the stars that are above the horizon at a given moment, to show their altitudes and azimuths, to determine approximately the proper angle of course for going from one point to another by an arc of a great circle, and the distance between these points. The instrument has two parts—the first consisting of a celestial sphere, having stars of the first and second magnitude marked on it. This sphere rests on a spherical zone, wherewith it can be placed in all possible positions. The second part (receiving the special name of metrosphere) comprises the system of the horizon, the meridian, and the vertical, represented by a circle, a semicircle, and a quarter of a circle of metal. The arc representing the meridian is fixed at right angles to the (horizontal) circle of the horizon, joining the latter at zero and 180 deg. Its own zero is in the middle, and represents the zenith, thence it is graduated to 90 deg. on either side. One end of the quarter circle, representing the vertical, turns about a fixed axis in the middle of the meridian; its other end is adjusted to pass along the circle of the horizon. With this system, then, it is possible (1) to trace arcs of a great circle on the sphere and measure their lengths (2) to measure the angles formed by two great circles. Obviously, too, all spherical triangles may be solved with the apparatus. Experiments have already been made with it on board the steamship Washington, of the Transatlantic Company, and with very favorable results.

### Silver Thimbles.

THE manufacture of silver thimbles is very simple, but singularly interesting. Coin silver is mostly used, and is obtained by purchasing coin dollars. The first operation strikes a novice as almost wicked, for it is nothing else than putting a lot of bright silver dollars fresh from the mint into dirty crucibles, and melting them up into solid ingots. These are rolled into the required thickness, and cut by a stamp into circular pieces of the required size.

A solid metal bar of the size of the inside of the intended thimble, moved by powerful machinery up and down in a bottomless mold of the outside of the people, bends the circular disks into the thimble shape as fast as they can be placed under the descending bar. Once in shape, the work of brightening, polishing and decorating is done upon a lathe. First, the blank form is fitted with a rapidly revolving rod. A slight touch of a sharp chisel takes a thin shaving from the end, another does the same on the side and the third rounds off the rim.

A round steel rod, dipped in oil and pressed upon the surface gives it a lustrous polish. Then a little revolving steel wheel, whose edge is a raised ornament, held against the revolving blank, prints that ornament, just outside the rim. A second wheel prints a different ornament around the center, while a third wheel with sharp points makes the indentation on the lower half and end of the thimble. The inside is brightened and polished in a similar way, the thimble being held on a revolving mold. All that remains to be done is to boil the completed thimbles in soapsuds, to remove the oil, brush them up, and pack them for the trade.

A petition is being circulated among the business houses in the trade, asking them to close their stores on Friday and Saturday, July 4th and 5th, in order to give their employes two days holiday.

## Proceedings of the Horological Club.

### A DISTINGUISHED BODY OF WATCH AND CLOCK MAKERS.

*Sixty-third Discussion.—Communicated by the Secretary.*

#### REPAIR AND SALES BOOK FOR WATCHES.

*Secretary of Horological Club :*

Is there such a thing for sale as a Repair and Sales Book of Watches, for dealers use? If there is where can I get it?

W. H. W.

Mr. Clerkenwell replied that, during a recent trip to the West, he had seen such a book, with printed headings, etc., but had not noticed where or by whom it was published. He thought that if the publisher would advertise it, he would find a considerable sale for it.

*Secretary of Horological Club :*

Will you please tell how Morrison's gold and silver solution, for electro-plating without a battery, can be made more durable? I have used it according to directions, and the process does as recommended, but seems easy to wear off. It don't seem as hard as it ought to be. There is probably some one of your members who can give me some light in regard to it. It is highly recommended for small jobs, but don't seem to last long.

W. W. J.

Mr. Electrode suggested that perhaps Mr. J. did not get on a coating thick enough to be durable. If the directions were well followed, there should be no trouble but that, and that could be remedied by longer exposure in the solution.

#### LUMINOUS DIALS.

*Secretary Horological Club :*

I wish to ask for information in regard to illuminated watch and clock dials. I have tried the sulphide of barium, as given in the *Circular*, but have not been successful. Please place this before the Club, as information on the subject will be interesting to many.

DIALS.

Mr. O'Lever said that all that was known to the public had been published in the *Circular*. The superior luminosity of the imported dials is due to some process of preparing them, known only to the manufacturers. We should be pleased to hear from any one who can throw light upon the subject.

#### DOUBLE-ACTION PUSH-PIECE.

*Secretary Horological Club :*

I have a watch with double-action pusher, opening the case. The pusher is not split, but solid, and acts by turning the pendant ring. The pusher refuses to perform. What is the trouble?

E. W. C.

Mr. McFuzee replied that there were several constructions of double-acting push-pieces, but he thought it likely the one Mr. C. had was closely fitted in the end of the stem, but had considerable play where it passed through the case center or ring, to reach the springs, and this loose end was thrown to one side by an eccentric screw or pin through the pendant ring. This screw was fitted near the outer part of the ring, so that, instead of being in the center of the hole through the stem, it was considerably to one side of the center. On turning the ring down, the screw would be above the center of the hole, and would of course throw up the inner end of the push-piece, causing it to act on that holding spring which was uppermost, and open that part of the case.

If the push-piece did not operate at all, *i. e.*, it would not open the case, it might arise from some faults as in the common single-acting variety. The end might be worn off and not reach the spring, or not push it far enough to unlock; the pusher top or cap might strike the end of the stem before the case was opened; the screw might be bent, and hold the pusher back, by hitting in the slot through it; or it might be clogged with dirt. If it operated, but did not properly act upon the upper spring every time, the screw might be bent; the slot worn too wide, so that the screw did not throw the pusher up high enough;

or the pusher might be bent, or loose at the top of the stem. If the pusher is long enough, straight the slot in it just wide enough for the screw to pass freely through it but no more, the screw straight, the ends of the ring well fitted to the holes in the stem, and the pusher well fitted in the top of the stem, it should and will operate properly.

#### COMPARING TIME TO A TENTH OF A SECOND.

Mr. Regulator wished to modify his reply to a correspondent who had asked, several months ago, if the time could be compared to one-tenth of a second by a common regulator. The reply was correct, as far as it went, *viz.*: That it could not be done without some additional device for dividing the seconds. But it had since occurred to him that he ought to have explained more fully the usual method of comparing time closely, which was to run the watch for a number of days before comparing, and then divide up the error found, according to the number of days. Should the watch lose  $\frac{1}{2}$  second in five days, that would of course be  $\frac{1}{10}$  second per day. Or if it gained 12 seconds in five days, that would be  $1\frac{2}{10}$  seconds per day, provided both the regulator and watch run uniformly, day by day.

For full particulars on the different ways of regulating and comparing fine timepieces, causes of variations in the rate, and proper courses to follow in each case, he would refer the gentleman to Excelsior's book, "Practical Treatise on the Balance Spring, and the Compensation Balance," published at the *Circular* office. He considered it altogether the best practical book on fine watch-work to be found in the English language. No workman who was not actually a pauper, so that it was absolutely impossible for him to buy it, should think of doing without it. He would find its teachings useful every day of his life, helping him to raise the standard of his skill in everything he did, to understand what he was doing, how to do it in the best way, and why it was the best. It would teach him not only to work, but to think, and to improve both in manual skill and in real knowledge of his profession—for the good workman works with his head as well as hands.

#### HONEST ASSAYERS WANTED.

We are frequently asked by our readers to give them the name of some good honest assayer, to whom they could send their sweeps, etc., with safety, and the assurance that they would not be swindled out of half of the proceeds. We know of no more honorable, straightforward business house, anywhere than Mr. L. Lelong & Bro., assayers, of Newark, N. J. They enjoy the confidence of a large clientage of manufacturers in this city, and no one need fear to send them all his sweeps and fragments of any kind, and rely upon receiving full value in return.

#### ADJUSTING WATCHES.—CLOSE TIME.

*To the Secretary Horological Club :*

Is a Regulator or Box Chronometer considered a tool, or stock and fixtures?

What is the closest time on record for one year? What make and what escapement?

How, and what length of time does it take to adjust and regulate a first-class watch of any make?

[The above letter was referred to our leading manufacturer of marine chronometers, who sent in the following reply.]

*Secretary of Horological Club.*

1. We have always taken our Regulator in our account of stock as stock,—neither fixture nor tool. See Webster's definition of "tool."

2. We have often known of our Chronometers returning from voyages of over a year without any perceptible error. It might be, however, there had been some small error which the navigator, with his means, could not detect. The same could be said of some regulators. The only fair way to judge this matter is to know what the extreme variation had been within the year. It is safe to say that no time-piece has gone an entire year absolutely without error. But what is the best running ever produced, we do not know.

3. This depends on the acquired skill of the operator, and a certain amount of good fortune in any particular case. Sometimes they are found right at first,—at others, the cases are obstinate.

J. B. & Co.

#### RESTORING TEMPER OF SOFT WIRE.

*To Secretary Horological Club :*

The advertisement of "Jenkins" Patent Pin Point, in the March number of the *Circular*, suggests the use of the following method of restoring the temper of any kind of wire after having been hard soldered. For pin tongues, fasten the point securely in the pin vice. Hold the point end with a pair of flat pliers. Turn the vice, thus twisting the wire, which will give it a spring temper without injury to the form of the wire.

EBERSOLE.

Mr. McFuzee said that when the wire was not too soft, this would give considerable elasticity, although not equal to draw or roll temper. If the tongue showed roughness after twisting, it could be removed by burnishing.

#### DEFECTIVE DETACHED LEVER ESCAPEMENT.

*Secretary of the Horological Club :*

I shall be thankful for any detailed information you may give me, through your Club, pertaining to grinding off locking faces of club escape-wheel teeth; the best manner of moving pallet jewels forward and adjusting them accurately in their slots; and how to turn down an eccentric pallet arbor. This information is desired to learn best practical mode of remedying too shallow pitched escapements, and rounded front corners of club-wheel teeth. I have a small American lathe.

O. M. K.

Mr. Uhrmacher said that the teeth should not be ground off at all. By grinding them back far enough to square up the rounded front corners, the length of the incline on the ends of the teeth would be shortened, and the impulse angle of the escapement lessened by that amount. The proper remedy for a defective wheel is to replace it with one which is properly formed and perfect.

It will also be easier to fit a new wheel than to turn an eccentric pallet arbor, to remedy a shallow escapement. In most cases, however, the pallets can be moved forward on the arbor enough to correct a shallow pitching. Directions for doing this, and also for moving and adjusting the pallet jewels, are given in Excelsior's articles on the detached lever escapement, published in the *Circular* about two years ago. It is seldom advisable to move the pallet jewels, as it produces a radical change of the entire wheel-and-pallet action. But if they have become loose, they must of course be adjusted in position, and Excelsior's articles tell how it should be done. Every workman should study them carefully, both for the practical information and processes given, and also for the knowledge of the principles on which the escapement is based, and which should govern our operations, that is conveyed.

#### REMOVING TARNISH AND BLUEING.

*Secretary of Horological Club :*

Will some one of your honorable body state the best receipt for removing tarnish from the bright parts of a watch *quickly*, without injuring the surface of same? Also, for removing blueing from a pinion that has been heated?

S. E. G.

Mr. O'Lever said there was no way of brightening the gilded parts without affecting the surface at least a little. But with proper care, the injury would be very slight. The most common way is to dip the tarnished pieces in a weak solution of cyanide of potassium. If dirty or greasy, they should first be washed with soap and water, and a brush more or less stiff, according to the surface, and the thickness and nature of the gilding. Some scour the pieces in soap and water containing enough of ammonia to give it a strong smell. Spots could be removed by applying a little of either cyanide or ammonia solution to them, with gentle rubbing. Care must be used, as, if the plating is thin, either solution will take it all off, if used too strong or too long. The ammonia process is preferable when there are steel parts on the pieces, which are inconvenient to take off, as the cyanide is liable to rust them.

Blueing is generally removed by weak muriatic acid,—say one drop of acid to five of water. The piece is either dipped in this, or rubbed with a bit of peg-wood wet with it. As for himself, he did not favor the use of acids for that and other purposes, so much as many workmen seemed to. He thought it better to polish off the pinion with fine oil-stone dust, and finish up with sharpe or hard rouge, used on a slip of boxwood with oil,—being careful, of course, not to grind the pinion leaves any more than enough to take the color off, as too much scouring would alter their shape.

#### WHAT TO DO WITH A MAGNETIZED WATCH.

*Secretary of the Horological Club :*

Please inform me, through the columns of the *Circular*, what course to take with a watch that has become magnetized? I know of a fine English lever watch, that was magnetized by the owner holding a magnet near the balance-wheel. Is it ruined for correct time?

A. E.

Mr. Horologer replied that a magnetized watch was worthless for keeping time. No dependence could be placed on its correctness, nor could it be told in what direction its error would show itself. His own opinion, as was well known to the Club, was that there was no way to thoroughly demagnetize steel parts, which had unfortunately become charged with magnetism, except to heat them red hot. That view was also taken by so excellent an authority as "Excelsior," in his book. Others, however, were confident that it could be done without heating. This subject had been discussed at different meetings of the Club, some three years ago, and reports would be found in our Proceedings, published in the *Circular* at that time. Mr. E. could try the methods there given, if he choose, and satisfy himself as to their value.

#### CHANGING THE MAIN WHEEL DEPTHING.

*Secretary Horological Club :*

I have a quicker way of changing the depthing between the barrel and center wheel than "Excelsior" describes, *i. e.*, when everything is tight or new about the ratchet and bridge.

Remove *only* the *click* and *click spring*, (if it has both) place the ends of the bridge on some hard surface—I place them on the jaws of my vice, covered with copper or thick paper, to prevent marring the bridge. Then, with a smooth-faced punch placed opposite the ratchet, I drive the bridge which ever way it is required to go.

If the depthing is too shallow, place the sides of the bridge (the sides next the center wheel) on the jaws of vice (as above), and with the punch placed at the opposite side, in the center of the bridge, drive it what is required. If the depthing is too deep—*vice versa*. This process relates to Swiss watches with the barrel hung to the bridge. If the watch is worn, etc., bush up, etc., as described by "Excelsior," and change depthing as above; for the angle made in the bridge is so very slight, it does not affect the steady pins or screw-holes in replacing on the plate.

If it is a Swiss watch, with loose ratchet and breaming at bottom,—the process will be the same for the bridge with the ratchet in it, but the bottom hole will have to be changed to correspond,—which can be done by "Excelsior's" directions, which I offer no improvement upon.

P. M. W.

N. B.—I do not remove the cap of the ratchet, nor the ratchet, or the barrel,—*all are left attached to the bridge save the click and click-spring*.

On hearing this letter read, the Chairman remarked that one of his apprentices had discovered this quick way of changing the depthing, a few days before, and tried it while he happened to be looking that way. It was a fine lever movement with solid ratchet arbor, the polished steel ratchet-cover held by three screws. The young man laid the bridge across his vice, and proceeded about as Mr. W. directs, gave a smart tap with the hammer, when off went the heads of the screws, and away flew the cover into the show-window full of goods. As it *ricocheted* around, from one side to the other, it was impossible to tell in what part of the window it landed. The consequence was, the youth had to get over into it, and move pretty much everything



out before he found the lost piece. Then all had to be rearranged anew, which took a good half hour, in the hottest part of the afternoon of a hot day. What with the heat, the jeers of the workmen, and the wondering stares of the passers-by, he judged that the youngster sweat about a quart. Then it used up the rest of the afternoon to dig out the remnants of the screws and fit new ones. Altogether, that apprentice was firmly convinced of the truth of the old adage, that "the longest way around is the shortest way home."

The Chairman then added that he had noticed this good thing about "Excelsior's" directions, that he gave the best and safest ways of doing work; if not always the quickest. But in watch-work the safe way was generally the quickest also. At all events work should be well done, whatever the time it might require. He thought this writer showed care and judgment in his selection of methods, and was to be commended for insisting that work should be executed in ways that were sound in principle and safe in practice. The Practical Hints were always reliable and useful, and when published in book form he intended to present a copy to each of his apprentices, as their guide and authority on the points that were treated in it.

### A Combination Chain, Slide, etc.

WE herewith present a novelty just introduced by Messrs. Oppenheimer Brothers & Veith, of this city. It is a combined guard chain slide, locket and breast-pin, and pendant. It is so constructed as to serve the above-named purposes. As a slide for a watch-chain,

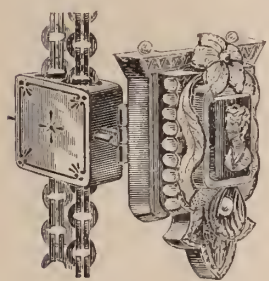

it forms a very attractive ornament; by detaching it from the chain, it may be worn as a pendant to a neck-lace; that portion of the ornament through which the chain passes may be detached, forming of itself a neat and tasteful chain slide, while the locket becomes a breast-pin or pendant. It is handsome in design and workmanship, and cannot fail of being appreciated by the trade and the public. The novelty of the design does not increase the price. Messrs. Oppenheimer Brothers & Veith have received a patent for this ornament, which is well deserving such recognition.

THE Derby Silver Plate Company have removed from No. 18 John Street to No. 27 Maiden Lane.

THE Chicago office of the Waterbury Clock Company has removed from 197 State to 63 Washington Street.

MR. D. PRINCE, Assayer of Gold, 15 R. R. Avenue, Newark, N. J., makes returns on the day of its receipt. This will doubtless be interesting to country dealers.

MESSRS. HIRSH BROS. of No. 23 Maiden Lane, have enlarged their salesrooms, and fitted it up with every requisite for the better display of goods and convenience of buyers.

MESSRS. KELLER & UNTERMEYER are the only authorized Agents for the International Watch Company's Watches, a full line of which they have always in stock. They are also the manufacturers of the celebrated Portrait Locket so popular in the trade, and other novelties of similar importance.

### Jewelers' League Column.

SINCE our last issue the Executive Board has held two meetings and the following named gentlemen were elected to membership: Benjamin Allen, Chicago; Chas. Bartens, of Bartens & Rice, New York; Charles E. Bulkley, President Whiting Manufacturing Company, New York; Edward T. Carrington with E. N. Welch Manufacturing Company, Chicago; Samuel Cohen, New Orleans; Chas. D. Crosby, with Chas. N. Scott, Worcester; Eugene J. Cuendet, of E. Jaccard & Co., St. Louis; Chas. H. Crump, of Shreve, Crump & Low, Boston; Ianthus G. Dillon, of Turner & Dillon, Wheeling, W. Va.; Abm. H. Fisher, Springfield, Ill.; Wm. R. Gregg, with E. Jaccard & Co.; Edward L. Groff, with J. B. Mayo & Co., Chicago; Arnold A. Ingraham, New York; Sylvester T. Johnston, with Mermod, Jaccard & Co., St. Louis, Mo.; Edmund Kinsel, with Mermod, Jaccard & Co.; Joseph C. Klaholt, Springfield, Ill.; Ralph B. King, with Tiffany & Co.; John R. Lilja, with Benjamin Allen & Co., Chicago; Chas. E. Mason, Illinois Watch Co., Chicago; William T. Miller, with H. D. Merritt & Co., New York; Francis E. Morse, with E. N. Welch Manufacturing Co., Chicago; Henry Oppenheimer, Chicago; Archibald Picken, Bristol, Tenn.; John H. Purdy, of J. H. Purdy & Co., Chicago; Adolph C. T. Raefle, of Paulus & Raefle, Philadelphia; James Rice, Jr., New York; Henry W. Strang, with H. E. Drake, Elmira, N. Y.; Samuel Strauss, New York; Wm. C. Sommers, Springfield, Ill.; Ephraim D. Switzer, San Diego, Cal.; Wm. Walsh, of Merrick, Walsh & Phelps, St. Louis; Prentiss M. Whitman, Beaufort, S. C.; Christian O. Young, of B. W. Clapp, Young & Co., Chicago; August Schrader, with Bergstein & Son, New York; Solomon Bauman and August Kurtzborn, of L. Bauman & Co., St. Louis; John Brison, with Enos Richardson & Co.; Cyrus N. Gibbs, Framingham Centre, Mass.; John S. Spencer, of J. E. Spencer & Co., New York.

Two candidates were rejected.

The following were appointed members of the Advisory Board for their respective localities: Jacksonville, Fla.—Damon Greenleaf; Springfield, Ill.—Charles E. Mason; Wheeling, West Va.; I. G. Dillon; Bristol, Tenn.—Archibald Picken; Elmira, N. Y.—H. W. Strang; San Diego, Cal.—E. D. Switzer; Beaufort, S. C.—D. M. Whitman. Chicago having now over twenty members, Caleb Clapp was appointed additional member, his colleague being S. H. Hale.

Our League and its purposes were fully presented to the convention of the jewelry trade (whose proceedings are fully recorded in another column) by Mr. Stedman H. Hale, our advisory member for Chicago, ably assisted by Mr. Dan. H. Hopkinson our fellow member, and Dr. Joshua G. Wilbur, our surgeon. Although not as successful as we would wish in the accession of members directly from the convention, they were successful in securing a goodly number, both in Chicago and St. Louis, who will be valuable acquisitions to our roll. Cincinnati must bestir herself in this matter, for her two competitors are leading her by "several laps."

We have received a very pleasant and encouraging letter from Mr. Fred. Goosman, advisory member in Somerville, Tenn., and we thank him heartily for his good wishes and efforts in behalf of "Our League" as he affectionately terms it.

The Executive Board have deemed it best to hereafter limit the efficiency of medical examinations to sixty days. Applicants whose medical certificates are older in date than sixty days when received by the Secretary, will be required to furnish more recent certificates of health.

Applications for membership should be sent directly to the Secretary of the League, who will immediately acknowledge the receipt of the application and admission fees, and in fulfilment of his duty will present it to the Executive Committee. Applications should not be sent nor handed to a friend, officer or member, trusting it will reach its destination in time. One gentleman was rejected at the January meeting because he had completed his forty-fifth year, while his application was traveling over the country in his friends trunk, neglected until too late to be acceptable.

It is unfortunate that the association of jewelers in the Northwestern States should have adopted the appellation "Watch-makers and Jewelers' League," as we have already had communications sent to us in regard to that association, indicating a confusion of identity on account of the similarity of name, although wide of each other in their purposes. The editor of this journal has however been assured that the association changed its name to the "Watch-makers and Jewelers' Guild" as soon as the coincidence of name and probable consequent embarrassment was called to their attention.

Our League now numbers 458. Average age, 36 years.

### Repairing Swiss Watches.

ANY one doing largely in repairs to foreign watches, must have been struck at times by the inconsistent and ignorant manner in which they have been repaired, especially in the country. This arises in many instances, I believe, more from ignorance of the proper method to pursue than from lack of will on the part of the workman; it is also in many instances due to a want of the necessary tools to execute the work properly.

The object of this article is to show, if possible, how to avoid these inconsistencies, by substituting a proper and consistent method of repair; and, although I do not for a moment wish to insinuate that this is the only method that will produce good results, at least I am assured that any one exchanging their method for mine will not lose by the exchange.

By far the greater portion of foreign watches that one gets to repair in the country are of common quality, and in these cases it is very difficult to do all that is necessary to put the watch in thorough order, pay one's self, and give satisfaction to the customer. As however, there is no conjuring in the matter, the man whose work gives the best results, will, in the long run, get the most patronage, and this will be the one who spares neither time or trouble to make his work as perfect as possible.

I will suppose that you have a Swiss horizontal watch to examine and repair, and proceed in the following order:

Preliminary examination before removing movement from case.—Wind the watch a little, if down, and try it by the ear in each of the following positions, viz., with the 6 up, 12 up, dial and cock up. By this method you can usually detect the following faults: Not in beat, wheel rubbing in cylinder passage, cylinder pivots acting on shoulders instead of their ends, incorrect fourth depth with scape pinion, pendulum spring rubbing or balance cock or centre wheel, &c. Next ascertain that centre pinion or set square is free of glass, also bottom of case; see that teeth of barrel are *well* free of band of case *when shut*; it is often free (in thin gold cases) when open, but shutting the case pinches the band in and fouls barrel: to try it put a piece of paper between teeth and barrel and shut the case; if foul it will mark or cut the paper.

See that dirt cups on winding and set squares are free of dome; frequently the dome presses on the centre bar and binds the centre pinion, causing, if not instant stoppage, the oil to disappear, and the pivots to cut. See that balance is free of case; if it is much out of flat it will probably be foul of the case or center wheel. See the fly spring, when the cover is shut, is not foul of the balance.

Put a key on set square, and turn the hands to see that they are free of themselves, the dial and glass; if they do not turn truly it will proceed from either the centre holes being out of upright, a bent set square, or a badly fitted pinion.

Here let me impress on those who take the trouble to read this the necessity of making a note on your board paper of all the corrections as you come to them; it is very little trouble, and saves the annoyance of finding, when your watch perhaps is cleaned and together, that some important item has been forgotten.

Take the movement from the case *in paper*—nothing is so slovenly as working without—and lock the train, by putting a bristle through either fourth or scape wheel; remove cock and balance, being particularly careful not to strain the pendulum spring; put the balance and cock in tray, and remove the hands by means of two pieces of steel; take one piece in each hand, the movement lying on the board; place one under each side of hour hand boss, depress the ends, and both hands are off at once, without danger of marking or slipping; the seconds hand can be removed in the same manner without danger of bending the pivot. Remove dial and motion work, using brass plyers to take hold of the canon pinion to avoid marking it.

At this stage, if I have reason to suspect that the escapement is faulty, I generally remove the pendulum spring from the balance,

putting cylinder and cock in their places, and try the escapement. First, see that the web of scape wheel is free of cylinder passage, also that the top of tooth is free of upper plug; then, with a little power on, and either a piece of paper or a cork wedge under the balance to check its motion, try if all the teeth have sufficient drop, both out and inside. If only one or two teeth are tight, the vibration of the balance is checked each time they are in action; if the balance is watched when going (with the pendulum spring on) it will be seen at once how the vibrations fall off when these teeth are in action. If the drop is sufficient inside, but none out, it would show a wheel too small; if the reverse, a wheel too large, *if the depth is correct*.

The method of correcting the wheel, where only some of the teeth are without the necessary freedom, is to mark with red stuff a tooth which has the proper amount of shake, remove the wheel, and open a hole in a piece of thin sheet brass until this tooth will just enter; this serves as a gauge to shorten the other teeth by, being careful to operate on the *points* of the teeth, either with the ruby file, or steel and oil-stone dust, finishing with bell metal and red stuff lengthways, and followed by a burnisher. The tooth should be rounded both ways, so that a mere point is in contact with the cylinder.

The question of depth is a vexed one, some workmen setting it deep and some shallow, each having some supposed advantage to urge for their practice. Saunier, in his work says,—

“To insure that the drop is no more than sufficient to secure proper action of the mechanism, it is of the first importance that the middle of a straight incline correspond to the centre of the cylinder.” Or, suppose a line drawn from top to point of tooth and bisected, that point should pass the centre of cylinder jewel hole.

Further, he shows why this rule should not be departed from: “The older watchmakers adjusted the escapement so that the middle of a straight incline came rather beyond the centre of cylinder, *in order that the point of rest might be tangential*. Among modern makers, it is universally recognized that more is lost by making the outside drop excessive, than is gained by a slight diminution of the friction during rest.”

“Some watchmakers of the present day, who, from insufficient knowledge are not in a position to judge correctly as to the cause of the circumstances which they observe, have asserted that they obtained a greater regularity by making the middle of the plane fall a little short of the centre of the cylinder.” Before making any alterations to the escapement, it is necessary to be certain that the scape wheel is perfectly upright, as a simple alteration to this may correct one or all these faults.

After examining the escapement it will be necessary to look over all jewel holes, noting cracked ones, and in brass, those that are too wide; trying end shakes, &c.; also, to see that the passage in the scape cock, for the wheel teeth, is not too close, so as to draw off the oil, as when this is the case it is impossible to get the piece to go for any length of time.

You will now take the movement completely down—foreign workmen use a brass block, with a series of holes drilled in it, to place the screws in; it is a good plan, as if left in their respective bars or cocks they are apt to get lost. Having the piece down you will examine all pivots to see that none are cut or bent. The barrel and its arbor and stop work should also receive attention; it should turn with freedom, and perfectly true, any want of truth in these particulars being fatal to good going.

I have now, I think, touched on most of those points that should receive attention in examining a watch previous to repair; probably not all, to do that would require more space than I have at my disposal. I now propose to return to the escapement, and in the same order that I have examined, speak of the various repairs and alterations, commencing with the cylinder.

(To be continued.)

## Practical Hints on Watch Repairing.

BY EXCELSIOR.—No. 51.

EXAMINING THE ENGLISH OR "PATENT" LEVER.—*Concluded.*

(796) In taking apart the full-plate English lever, turn the movement with the pillar plate up, holding the upper plate in the fingers. Then, on separating the plates, the lever and escape wheel will remain safely on the upper plate. But, if held the other side up, the lower pivot of the pallet arbor sticks in its hole, while the potance pulls up the end of the fork, at great risk of bending or breaking off the pivot. In many watches the escape wheel reaches over the potance in the same way, and is also liable to be injured or have its pivot broken off. When apart, see that all the false plates or bridges are fast in their places; the potance, especially, must be secure, and if taken off, should be replaced exactly as before, or the balance staff will be out of upright. See that all the plate jewels are tight in their settings (655); also the balance hole jewel. If the latter is a set jewel, and merely fitted in its sink in the potance or cock, see that it is fitted *tightly*, so that it can neither move sideways, nor tip up edgewise and bind on the pivot. See that the potance slide is so placed as to bring the centre of the end stone under the pivot hole in the hole jewel, and if the jewel is not tight in the slide, cement it fast. See if all the pillars are tight in the plate; if not, rest their ends on a lead block and rivet securely.

(797) In making the different tests described in these articles, the plates require to be pinned together and unpinned so often, that it will be found quite convenient to have a lot of long pins for that special use; and it will also avoid bruising the permanent pins, etc. These large ones can be made by filing up common brass dressing pins, and if the heads are left on they can be inserted and removed with the fingers. The permanent pins should always be taken out in a certain order, and laid down in the same order, so that the same pins will be put back in their different holes. A good way is to begin at the pillar at the right of the barrel, and remove them in succession around the plate to the other side of the barrel, laying the pins down from left to right, as taken out, and, say an inch apart on the bench, to prevent mixing. In this way, we can always know which pin goes in any particular hole. Screws should be treated in the same manner. If the pins are rough, too tapering, clumsy looking, or do not fit properly, make new ones; as it is important that they should hold the plates securely, and stay in their places, as well as look decently. Pins which go under the balance cock or barrel bridge, should stick outside of the pillars on both sides of them, enough to reach well on the plate and hold it down securely, but not far enough to touch in the edges of the holes in the bridge that goes over them, as this would prevent the bridge coming down properly upon the plate, besides causing it to incline at the other end, and alter the end-shake of the part beneath it.

(798) When ready to put the movement together, first oil all the holes that have end stones, (except the balance holes,) or which will be inconvenient to oil after the plates are together. Then take the upper plate in hand, with the under side up, put the lever, escape and other wheels, etc., in their places, and put on the pillar plate. After getting the lever and escape wheel pivots entered in the pillar plate holes, and a long pin through the nearest pillar to hold the plates together, you can turn the movement the other side up, and finish, if more convenient. It will sometimes be necessary to do this, in order to get the maintaining detent in. Use a piece of clean soft paper, to prevent the skin touching the clean plates. When all are entered, the plates permanently pinned, and the barrel in, test the end shakes (651), freedom of the parts from each other, and in their holes (650). Also try the freedom of the pivots by wiggling the main wheel, as in section (633). The pivots should be free enough to see them move very slightly sideways in their holes, by using the glass. The train should be able to run backward freely, with very slight pressure, (the balance not being inserted yet) but the

lever should lock the escape wheel instantly when the main wheel is pressed forward. Oil the lower center pinion hole, put on the cannon pinion, and try its freedom over the stopping.

(799) Insert the long chain-hook in the barrel, and wind the chain entirely up on the barrel, holding the coils in place with the thumb, to prevent them getting loose, slipping off the lower end of the barrel, etc.; then put the end of the chain under the pillars and hook it to the fuzee pin, which should have been previously turned up just far enough to reach it with the tweezers (786). Having hooked it, put on the ratchet wheel and turn the barrel arbor enough to tighten the chain, and two teeth more. Next key up the mainspring, by turning the barrel arbor one-half or three-fourths of a turn (786), as may be suitable in that particular case. Oil the balance holes, top and bottom, and the top center pinion hole, put on the balance and its cock, test their freedom every way, and adjust the hair-spring carefully, see that it is in beat, etc., and put the regulator where it was before. If any further adjustment of the keying up of the mainspring is necessary, make the tests and alterations now. Then wind the watch entirely up, moving the chain on the barrel, as may be necessary to make it come properly in the fuzee groove, and see that the stop bar meets the beak squarely. If there is considerable chain left on the barrel, it should run parallel with the upper plate, from the fuzee to the barrel, and the surplus chain should none of it be left lower on the barrel than that level, but rise gradually from that to the hook. Then oil all the other pivot holes in the pillar plate, and pin on the dial. Put on the hour hand and try the freedom of the hour wheel (745), and examine if all the pinions, etc., are still free and have proper end shake. The banking pins are often bent during cleaning, and they should be tested again (315, 387). If there is any reason to think the guard pin has been bent, test that also. It is a good idea, if the guard pin is not exactly vertical, to make a note of its position or inclination when taking the watch apart, and see that it is still the same before putting it in again. Finally, see that the pins in the dial posts cannot touch the fourth wheel (753); the main wheel or barrel; nor interfere with the working of the detent or its spring; then oil the other pivot holes in the upper plate, and the lever pallets (726); put on the fuzee arbor cup (783), and the cap over the movement; fit on the seconds (194, 288) and minute hands (196, 637); put it in the case, and you are ready for the timing, etc. as directed in sections (729 to 733.)

## EXAMINING THE AMERICAN LEVER WATCH.

(800) The American watch is a combination of the English and Anker levers, but omitting the fuzee and chain, and otherwise modified in various respects. A large share of the directions already given will therefore apply to this. In addition to them, the following will be specially applicable to the American construction. See that the dial is held close to the plate. The holes through the dial posts are often drilled so far above the plate, that it is hard to make the pins hold it securely. In such cases, the better way is to plug up the old holes, and drill new ones just above the surface of the plate. See if the pins are liable to touch any of the wheels, etc.; in the  $\frac{3}{4}$  plate movements, they are very apt to interfere with the lever pallets, if quite long, and should be safely shortened. When the dial is held by screws set in the edge of the plate, they should be taken out when the dial is removed, as they are apt to be brushed out and lost in the cleaning. See that the hands do not touch in the dial holes, etc., (193 to 199, 288 to 293, 637); that the sunk-seconds dial is tight and correct (638); examine the cannon pinion (646, 745); the motion wheels (648); and see if the lower bridges or false plates under the dial are tight in their places.

(801) *The Balance.*—See that the balance is true, both in the flat and the round; that it or its screw heads do not run too near the plate, as a trifle of dirt will stop it, or the jar of carrying may spring the free ends of the segments (of a cut expansion balance) down enough to rub on the plate, and either stop it or seriously interfere with its value as a timepiece. If the watch has been carried some

time with this fault, it will be shown by a circular mark on the plate. If so, the balance should be raised. If there is considerable space between the lower hole and cap jewels, (not the *settings*) the end stone may be raised, either by taking off the face of its setting level with the jewel, or, if it is already level, take off the under face of the setting of the hole jewel, to enable the jewels to come closer. *The jewels should not come so near together as to touch*, as that would prevent the proper retention of the oil at the pivot hole. It should be remembered that this depends on capillary attraction between the contiguous surfaces. As this always draws a fluid *to the smallest spaces*, in order that the oil may be drawn into the pivot hole as needed, the space between the pivot and the side of its hole must be smaller than that between the surfaces of the hole and cap jewels. It will be seen, therefore, that if the jewels are in contact, or too close together, they will draw the oil from the hole, and leave the pivot to run dry. On the contrary, if they are too far apart, the oil may spread over the surface of either or both, and so be carried away from the pivot hole. If the two jewels are at the correct distance apart, more oil will be required when the outer surface of the hole jewel is rather flat, than when it is quite convex in outline. In the former case, the oil will be spread further from the hole; in the latter, it will remain in a drop gathered at the top of the jewel around the hole, whence the pivot will draw it into the hole as required, so long as the supply lasts.

(802) In the case supposed in section (801), if the jewels are as near together as they should be, *both* should be raised in their sink. Turn off the upper side of the hole jewel setting, to let it stand deeper in the sink, being careful not to remove any of the jewel bezel, which of course, will set up in the hole. Do not turn *the sink deeper*, nor turn off the *edge* of the setting, as the accuracy of the position of the pivot hole depends upon the close fit of the setting in the sink. The jewel bezel, however, should pass freely into the hole made for it. The hole jewel being raised, the end stone will follow it up, and the screws must be let in deeper, to hold both up to their new places. This is done by deepening the recess in the potance for the screw head, till the bottom of the recess is as low in the potance as in the edge of the end stone setting, with the freeing tool, or with a hollow drill. Some workmen run a little soft solder in the notches in the end stone setting, then put the setting in its place and trim the solder down level with the bottom of the recess in the potance. But this way cannot be recommended as either substantial or workmanlike.

(803) See that the balance or its arms cannot touch the regulator or regulator pins, or hair-spring bar, or hair-spring stud, either above or below. Also see that it cannot touch a projecting pivot of the center or other wheels, or of the pallet arbor, nor the heads of any screws that hold the set-jewels in the plate. Turn it slowly past the suspected obstruction, examining closely with the glass as it passes. To detect contacts above it, raise the balance to its highest end shake, with the oiling wire or a stiff bristle, and move slowly under the part; or, if convenient, invert the movement and examine in that position. See that the balance cannot touch on the barrel head, or the projecting lip of the mainspring brace, or the pivot of its T cross. If the balance screws are not turned entirely in, do not alter them, as they may have been so placed during the adjustment for temperatures, or for rate (215). Turn the balance slowly around and see if the ends of the screw heads can touch or come very close to the foot of its bridge, or the main wheel bridge, etc. If so, something must be done. In a common watch, it will probably be safe to turn the screws in to the heads, afterwards re-poising the balance. But in an adjusted movement, first test the poise of the balance (71 to 76). If it is out of poise, the screws have probably been moved accidentally, or by some workman who did not know what he was doing. But if it is properly poised, and the screw heads run quite closely to the bridge, put the movement together again, and test it in the cold-box (269). If it stops at freezing temperature, take it out quickly and see if the screw heads are in contact with

the adjacent metal. If so, it is evident that the sides of the bridge must be turned out to clear, or else the screws must be turned in or replaced by shorter ones of the same weight.

(804) But before making any alteration, apply another test to see if the adjustment for heat is correct. If it is, the quickest way to remedy the interference is to turn off all interfering metal to clear the balance. We can change the screws for heavier and shorter ones, but that is quite a particular and tedious job to do, and is likely to alter the poise, the rate, and the adjustment for temperatures, and will require numerous tests and trials to determine its correctness. On the other hand, if we had found the adjustment for heat not correct, when tested as above, the probability would be very strong, (supposing the balance to be correct in shape, that the screws had got out of their proper positions, and we could at once turn them in—excepting the two (or four) “quarter screws.” If they also stuck out so far as to interfere, they could likewise be turned in, and then the balance poised by turning them out a little as required. We might have turned the screws all in at first, instead of making the several precautionary trials spoken of. But if, by so doing, we should ruin the adjustment for heat and cold, it would take much longer to restore it than to have made the tests. As it is our chief duty to see that we do no harm, even if we can do no good, to work brought for repairs, it becomes our duty to first find whether it will be proper and safe to alter the screws before doing so, and the finer the movement, the greater the necessity for this. It might seem to the inexperienced workman that, if the screws interfered as described, they would not have been placed where they were, by any competent adjuster. But that does not necessarily follow. There might be several reasons for the balance being in that condition. The reader is referred to the “Practical Treatise on the Balance Spring, and the Compensation Balance,” for explanations, as the subject is too extensive to be properly treated here, and repetition of the matter is unnecessary. He will also find there the full directions for making all the tests spoken of above, and correcting the error when found. Those who have not the conveniences or experience for making them, should in all cases adopt the safe course, to leave the balance as it is, and free it by turning off the interfering bridge.

(805) Notice if the balance is upright, and stands at an equal distance above the plate, all around. If not, find whether the steady pins of the balance-cock or the potance are too small, and loose in their holes, allowing one or the other to be moved. If so, it should be put back in its proper place, and the balance examined again. Sometimes the steady pins have been tinkered at, or accidentally bent. In straightening them up, first notice what the effect will be, (628,) or you may make the matter worse. If the trouble is not there, the hole-jewel setting may be too small to fill the sink; or it has been filed off on one edge, and got out of centre; or the jewel itself may be loose in the setting. In the first case, the proper remedy is to replace the setting with one that cannot move about; but the old setting may, in a common watch, be stretched slightly to make it fill the sink, by means of a sharp, hollow punch, large enough to rest on the inner surface of the setting, very near its edge, so that but little force will be required. If the punch was applied to the outer surface of the setting, (which bears upon the shoulder of the sink,) the punching would infallibly get the jewel out of level. The punch must, of course, be held upright, to act equally on every side of the setting, and the jewel and its bezel protected from any pressure during the operation. The same kind of a punch is used for driving the jewel settings out or in—only it is not sharp, but flat, as large as the sink will receive, and made of iron, hard brass, or ivory, to avoid marring the engraving when driving the end stone in.

(806) Many workmen make little nicks in the edge of the setting, to enlarge it; but, when done in this way, the eye is the only dependence for keeping the jewel-hole in the centre. In the second case noted above, either replace the setting or enlarge it on the scant side, till the jewel-hole is brought to the centre of the sink, and the setting fills it. In the third case, firmly bend the setting down upon the

jewel, first around the edge, then on the top. Whenever this fault (loose jewel) is detected, never put up the movement till you have made it absolutely impossible for the jewel to move in its setting, or the setting in its sink. The effect of a loose jewel is, when jarred out of its proper position, to cause the pivot to bind in the hole, more or less, according as the jewel fits the pivot more closely, or to the amount of its motion. The watch, when put up, goes all right, with a fine vibration, etc.; but, when looked at again, the motion of the balance is smaller and feeble, or the balance will even catch and be held tight, generally at or near the position of rest. On examining, no fault is found in the escapement, the balance seems correct, having sufficient end-shake, and falls freely (650); and it moves off briskly again when started, only to slack up or stop as before, sooner or later, either in the shop or in the owner's pocket. Some workmen take a short-cut to remedy this fault by filing the balance pivots down so small that they will be sure to be free in their holes, even if the jewel is jarred out of place. But this should not be allowed, as it is only creating another bad fault to cover up the former, instead of correcting it, as they ought to.

(807) If the balance plays nicely, with one side up, (horizontal,) but the motion dies down considerably when held the reverse side up, and there is no rubbing of the lever fork and roller table in the latter position, nor any of the faults mentioned in section (803), the trouble may be a short pivot, cracked or worn end-stone, or its setting not held to its place—the effect in each case being to let the pivot so far through the jewel that its shoulder rubs, instead of being held up clear of the jewel. See that the end-stone is tight in its place, or make it so. If broken, or it has a small dent worn in it by the end of the pivot, replace with a sound and harder one. If the end stone is sound, and fast in its place, with the setting resting against the hole-jewel setting, yet the pivot shoulder rubs on the hole-jewel, see if the jewels are level with the faces of their settings, or very nearly so, so that they should not be brought any closer together (801). If they are not quite level, the end stone can be raised by turning off the setting of either jewel which is much below the face, and altering the screws to hold the settings together (802). But if this could not be done without making the jewels too close together, the pivot shoulder must be taken off a little, either by the shoulder scraper, (297,) or, for a conical pivot, by grinding back (297).

(808) Instead of a short pivot, the hair-spring collet may have worked up on the balance staff, so as to touch the jewel, when held dial up; or it, or the spring itself, may rub on the regulator or its ring. The ruby pin may stick out far enough to touch the point of a screw holding the jewel setting, or on the surface of the potance, or some roughness on it. If the balance motion is weak or uncertain in all positions, the ruby pin may be loose, and should be cemented fast. This is often the case, being generally caused by some workman having cleaned it with alcohol, (279,) and so dissolved off the cement. If the motion of the balance is queer, after a watch has been newly cleaned or repaired, look for a piece of a bristle sticking from under some screw-head, or caught and broken off in some crevice, or in the rim of the balance itself. When examining the balance motion, always be sure, first, that the seconds hand does not touch at any part of its revolution, or its socket or the pivot rub in the dial-hole.

Metals and Alloys.

THEIR USES, COMPOSITION AND TREATMENT.

By the Author of "The Practical Goldworker" and "Silversmiths' Handbook."—Continued.

HAVING been requested to give some general information with reference to the processes of frosting and finishing silver and metal work, we cannot refrain from entering upon a subject that must prove highly interesting to at least a large portion of our readers, now that silver and gilt work is so much in fashion. A few particulars,

then, in this direction, will be a useful auxiliary to the previous information which has been imparted through the pages of this journal. But it must not be understood for one moment, although every process and every detail may be here laid down for the perfect and most complete accomplishment of the art, that the uninitiated or even the less experienced operator can do the same work, and achieve such good results as the skilful workman. This is the case, we believe, with our correspondent who asks the question, and to whom every necessary information has been imparted pursuant, to this subject, in the lately published *Silversmiths' Handbook*, which work we know our correspondent has carefully read. The frosting of silver goods is not done with an acid or combination of acids, but is simply due, as we have already stated, to scratching with the scratch-brush. These scratch-brushes take different forms, according to the kind of work to be submitted to them for frosting, and are made of various strengths; that is, the wires of them are specially prepared of several thicknesses, and when a very fine satin finish is required, a brush of very fine wire is taken, and so on. A brush with wires thicker and thicker in proportion is taken as a more extended roughness is desired. These wire scratch brushes are fixed upon a horizontal spindle in the lathe; the latter is made to revolve by means of the foot of the operator, and a treadle attached to the crank of the lathe, but where a gas engine can be employed it is far preferable, as the speed is much greater and far more regular. Frosting requires great speed to do the work nicely. The wires of the scratch-brush must lie even on the surface, all of the same length, and always kept straight at the points, otherwise the frosting will not be regular. Sometimes the little hand scratch-brushes are employed for coarser work; four of them are taken and firmly secured in four corresponding grooves in a circular chuck, which screws into the lathe. The ends of the four little brushes are repeatedly cut off as occasion requires, in order to present a straight surface for continual contact with the work.

Metal-work is first prepared for gilding by dipping, and when gilt, submitted in the same manner as silver to the processes just described.

Metalwork can be frosted by acids with advantage, whereas no good results can be arrived at with silver, or by its treatment in any analogous manner, as the color, in the first place—and this is highly important—would be very inferior, and the frost produced would in no manner compare with that produced by the scratch-brush.

A few good recipes consist as follows for dipping metal goods. Each one effects a bright frosted surface upon work submitted to their various actions, and this, of course, is always providing the alloy is right of which such work is composed:—

No. 1.

Nitric acid.....	4	ozs.
Sulphuric acid.....	1	"
Common salt.....	1/2	"
	<hr/>	
	5 1/2	ozs.

In preparing this solution add the sulphuric acid to the nitric, and lastly put in common salt in a state of fine dry powder. Keep your work free from water, and dip it in the mixture for a few seconds only. The work must be scrupulously clean and free from grease of every kind.

No. 2.

Nitric acid.....	4	ozs.
Muriatic acid.....	4	"
Hydrochloric acid.....	1/2	drachm.

Prepare the mixture, and treat it exactly the same manner as the previous one; be careful and not leave the work in the solution too long.

No. 3.

Nitric acid.....	1	ozs.
Muriatic acid.....	1	"
Common salt.....	1	"
	<hr/>	
	3	ozs.

Well mix these ingredients together by stirring, and then dip the work in for a very short time only, when the object of your desire will be readily attained.

To be continued.

## The Geneva International Exhibition of Tools and Machinery.

THIS exhibition of tools and machinery for horological purposes, jewelry, and kindred branches of trade, will take place in May and June, 1880, in the New Municipal School of Horology. The managing committee will nominate a permanent receiving officer, at the place of exhibition, from the 15th of March, 1880, the date on which articles may be sent. The Exhibition will comprise six groups and twelve classes, as follows:

GROUP I.—1st class. *Raw Materials*: Metals rough and prepared; enamel; wood for inlaying; materials for cases; chemical products for gilding, silvering, electrotyping, polishing, etc., oils, grease, etc.

GROUP II.—2nd class. *Fittings for workshops*: Models and plans; various systems of lighting, warming and ventilation; benches, chairs, drawers, strong boxes, rubbing boards, etc.

GROUP III.—*Instruments, tools and processes to determine the dimensions, the weight, and the proportions of matter, gague-work, and to reproduce articles, etc.* 3rd. class. *Measuring instruments*: Rules and graduated compasses, micrometers, balances, etc. 4th class. Compasses of proportion for pitchings, magnifying glasses, microscopes, etc. 5th class. Photographic proofs, and impressions on plaster, wax, gutta-percha, etc.

GROUP IV.—*Motive powers, transmitters, etc.* 6th class. Small engines, hydraulic, steam, gas, compressed air, heated air, transmitters. Pulleys, straps, ropes, lubricators, treadles—plans and schemes.

GROUP V.—*Machines, tools, and methods for working metals, wood, ivory, shells, etc.* Chemical and physical. Stoves for melting, annealing, enameling, tempering, etc. Bellows, blowpipes, soldering lamps, crucibles, muffles, ingot moulds, apparatus used in gilding, silvering, nickeling, electroplating, coloring, etc. Mechanical. 8th class. Machines and tools working by pressure or tension. Forging tools, anvils, hammers, stamping machines, balances, rolling machines, wire-drawing machines. 9th class. Machines and tools for dividing materials. Shears, balance-cutters, planes, cutting machines, engine turners, plating, screw boring, tap-borers. Systems of screws, pins, matrixes, blocks, etc. 10th class. Grinding tools, lapidaries, polishing lathes, brush scratchers, mills, etc. 11th class. Gripping tools, vices, pincers, tweezers, etc.

GROUP VI.—*Theoretical and practical information connected with the objects exhibited.* 12th class. Special methods, models and designs. Mathematical instruments; apparatus for the study of geometry, mechanics, relating to the subjects of the exhibition.

The Exhibition will open on May 1, 1880. Articles may be sent from March 15, 1880. The closing is fixed for June 30, 1880. If the Committee think proper the Exhibition may remain open a month longer.

*Conditions of Admission.*—One copy of the same object only may be exhibited by the same person. The Committee, however, may grant exceptions to this rule. Exhibitors engage not to withdraw their goods until the termination. The Committee furnishes the space gratis, also the tables for small objects, and undertakes the cost of fire insurance. An engine, for showing the smaller mechanical articles, is free of charge, to exhibitors.

All costs of carriage to be defrayed by exhibitors. Demands for space to be addressed, *Comité de l'Exposition d'outillage a l'Athénée a Genève*, when the necessary forms to be filled up, and all information will be forwarded.

A jury of exhibitors will examine the exhibits, selected from the different nationalities exhibiting.

At the close of the Exhibition there will be a distribution of recompenses, consisting of diplomas.

## Views of Correspondents.

*To the Editor of the Jewelers' Circular:*

I am usually much pleased in reading the "Views of Correspondents" in your paper; but last month I found a communication that has kept my brain perplexed ever since to find the meaning of. It is signed Otto Wettstein, of Rochelle, Ill. I wish it had been accompanied with a dose of Rochelle salts that could have worked out its meaning. The writer starts out with the statement that he has prepared this elaborate essay, this philosophical treatise, to present to the Jewelers' Protective League of his State, but that it failed to reach its destination. It may have been its own weight that delayed it, but probably it got entangled in the labyrinthian turnings and twistifications of its own hyperbole. I congratulate the League upon being spared an infliction.

Mr. Wettstein philosophizes through a page and a half upon the political and social economies of nations and governments, the inalienable rights of individuals, and ventilates platitudes and truisms that were worn threadbare before the Flood. As near as I can find out, he objects to the retail trade entering any protest against the illegitimate practices of so-called jobbers, and claims that they have the right to deluge the country with circulars offering to sell goods at retail at wholesale prices; in fact, he claims that, having bought the goods cheaply, they have the right to sell cheaply, the public being benefitted thereby. The public ought to be thankful that Mr. Wettstein has undertaken to become its champion, and, like Don Quixote, has gone forth to battle with its enemies, the retailers. But the public would be better pleased with his literary efforts if he would send an interpreter with each article.

As to jobbers selling goods at retail, the point is simply this: the manufacturers sell them goods at low rates with the stipulation, either positively made or implied, that they are not to sell them again at retail, but are to deal with the trade, leaving the retailer to supply the public, the actual consumers. The term "jobber" is one well understood in all lines of business, and defines one who acts a middle-man between the producer and the person who sells his products by small quantities, to individuals. It is impossible, in our trade, for manufacturers to deal directly with the thousands of retailers—the system would be too cumbersome. There is a necessity, therefore, for jobbers in the trade centers to take the place of the manufacturers and serve the retailers in the vicinity of such centers. They become, virtually, the agents of the manufacturers, and, as such, receive special discounts from him. Custom, that makes laws as well understood as those emanating from our Legislatures, says this jobber must not sell his goods at retail, but must serve the small dealers at such rates as will leave them a reasonable margin of profit. To enable him to do so, he has received special discounts, and, in accepting such discounts, he became morally and in honor bound to observe the usages and the laws of trade in disposing of those goods. When he sells them at retail, he violates a pledge, given either positively or impliedly. The fact that he gives himself out to be a jobber, and not a retailer, is understood in the trade to be a promise that he will not sell goods at retail. No jobber can do so without believing his claim to being a jobber, and violating the trust reposed in him in consequence of the claim so made. When, in addition to selling in his immediate vicinity at retail at wholesale prices, he invades the territory of those retailers who are his customers, and scatters his circulars and price-lists broadcast, offering to undersell his own customers, he adds deliberate robbery to his other dishonorable practices.

The trade in general has universally condemned this practice, and denounced those who indulge in it. Only those who make a profit by dishonoring themselves attempt to defend it, unless I except that Quixotic philosopher of the Teutonic cognomen, Mr. Otis Wettstein, of Rochelle, Ill. His motto, "Might is right," may do very well for Italian brigands or frontier "road agents;" but if a party of these latter were to invade Mr. Wettstein's premises, rob his store, and hang him to a lamp-post, he would probably raise serious objections, even though their act should "result in the public good." Of course, I do not mean to imply that Mr. Wettstein ought to be robbed and hanged, but to convey, by parallel illustration, the disasters these retailing jobbers are inflicting upon the legitimate retail trade.

Yours truly,

CHARLES A. PAINE.

Springfield, June 1st, 1879.

The house of Gaston L. Fenardent & Co., the opening of which we mentioned in this paper last February, has met with a growing success. Some of our manufactures have found the way to 30 Lafayette Place, and secured some remarkably fine coins for jewels, at remarkably low prices. It is through the successful efforts of Mr. Fenardent who was the fortunate possessor of the King Antique gems that this unique collection is probably secured for the Metropolitan Museum—for he sold it to the President of the Trustees, M. J. Taylor Johnson, who holds it at the disposition of the Museum for a sum much inferior to that offered by a collector outside of the city. Any of our subscribers who want information on coins, intaglios or any archæological or mythological subjects cannot do better than apply to Mr. Fenardent who will disinterestedly furnish them the accurate information which a lifelong study and his position of expert at the British Museum for eleven years fully warrant.

### Watch and Chronometer Jeweling.

THE convex and concave surfaces of the stone having been brought up to an even, regular surface, we proceed to polish. It must be remarked that in using the "former" we must not trust entirely to its agency to get a regular surface, for if the jewel is left very rough from the diamond cutter, or the form is very much out of a true circle, the "former" is very apt to make the convex come out of true with the face, and thus render it almost impossible to set with truth in its position in the watch; therefore, the workman is careful to turn off the convex as near the segment of a circle as he can. The same cautions, in a less degree, are to be adopted in forming the oil-cup—not so much for the sake of truth as to avoid the diminished brilliancy incident to irregular form; the light not being reflected in the most favorable directions for effect.

The polishers for all stones as soft as aqua marine are made of lead, used with tripoli and water. The tripoli is a mass of shells, and is exceedingly sharp until it becomes rubbed fine by the friction of the stone on the polisher; then it is capable of producing a very superior polish. The polisher is made of a small piece of lead wire, say an inch and a half long, and of about the same diameter as the jewel, or generally somewhat larger; the end is filed off flat and a concavity formed in it; but, as lead is soft, the workman merely takes the point of a knife or graver and cuts out a conical cavity, as on application to the hard stone the lead will be forced to assume a circular form. The tripoli, having been mixed up in water, the polisher is dipped in the mixture and then applied to the surface to be polished. The friction between the stone and polisher (for the speed must be great) soon heats the stone, and if persisted in would melt the shellac, and thus take the work off the lathe. To avoid this the polisher is held on but a few seconds at a time, the surface of the stone wiped off and examined as to progress. After a few applications the stone will begin to obtain a semi-polished condition, and at this stage the operation will be accompanied by a very peculiar squeal (it can be called nothing else), the indication that a polished surface is being attained. At this point the water dries very rapidly, from the tripoli, and increased care is needed to avoid overheating the work. The object being to obtain a finely polished surface and truth combined, the process must be discontinued as soon as the polish is uniform, for then the stone has a true convex, parallel in all its diameters to the face. The oil-cup or concave is treated precisely like the convex, a reverse polishing tool being used, and the convex end of this is generally filed with a coarse file, being held and rotated in the fingers of the left hand. The file marks are of service, as they receive the tripoli, and thus enable the polisher to more firmly hold it. The hand is kept moving in a backward and forward elliptical direction during the whole time; for if the polisher were to remain quiescent, creases would be formed, and thus render a good polish unattainable. When a very superior job is to be done, a piece of boxwood is used, the grain end having been formed to match the stone, either on the convex or in the oil-cup. The slight chamfer on the face of the jewel is now polished with a slip of lead and tripoli, and the stone is ready to be removed from the lathe, to be topped and faced. The oil-cup meets the convex in a sharp edge, and is generally ragged after the polishing of those two surfaces. This roughness is remedied by facing a process applied as well to the flat surface. The means employed are various, some jewelers preferring one, and others different methods; but the general principles are alike in all cases. There may be used a flat piece of boxwood, planed off on the end of the grain, with the finest variety of diamond powder. This is very effective, and is open only to the objection that the powder is wasted, as it is absorbed into the wood. A plate of a mixture of lead and tin—say half and half—is scratched with a coarse file, and tripoli used as a polishing material. The jewel is laid flat on the metal and tripoli, and rubbed about with gentle pressure by means of a pointed piece of peg-wood placed in the hole, care being had to keep the jewel revolving and

changing its position as much as possible. When the tripoli is about dry on the plate the stone will be found polished, but it must be examined at short intervals during the process. This way of facing seems very simple and easy to accomplish, but it will be found to present some few difficulties, the greatest one of which is the liability of the surface to *drag*—that is, small fractures of the face will be torn out, and then the stone has to be faced on the lap again before it can be polished. This is to be deprecated, as the refacing almost invariably throws the jewel out of true with the convex, besides making the finished jewel too thin. The best method for both the ring on the top and the face of the jewel is that in which a glass or stone face, with diamond powder is used. As the glass or stone faces are of great importance in subsequent metal operations, a very minute description of the mode of preparation will not be out of place, especially when it may be asserted that there is no process so rapid or satisfactory in its results for polishing the flats of steel work. The workmen selects three plates of glass—plate is preferred, as it affords a truer surface; but a better choice is to select two pieces of, say the glass plates used for Daguerreotype purposes, and another piece of hard lime glass; the reason for which preference will be seen. Two of the plates are rubbed together with emery, of a grade of from 60 at first, finishing with a grade of 80. The surfaces must be ground until a uniform appearance is obtained. In all cases the grinding plate should be frequently turned around in every direction and changed from its course of every stroke, as thus only uniformity of surface can be produced with truth. One of the plates is now taken for a grinder of the hard plate; this last must have been ground previously to as near a true plane as possible, which may be effected on a plate of cast iron, with sharp sand or No. 20 grade emery, with water. Between the hard and soft plate, emery of 90 grade is used, and the grinding process is continued until the hard glass has a perfectly uniform surface, but it will be found that the grain of the lime glass is much finer than the other plate, which, in its turn, is coarser than the plate that has been laid aside. Could we obtain glass of three unequal degrees of hardness, a better polishing plate would be obtained. However, we have now three plates of different degrees of fineness. It may be of advantage to reduce the finest plate still more by the use of another piece of glass with the finest washed emery. The coarsest plate is of no advantage to the jeweler, but may be used by the watch repairer for reducing his flat steel work to a fine gray, with a perfectly true surface, by the use of Arkansas oil-stone dust and oil. After washing the oil-stone dust from the piece of work it may be transferred to the second class, using sharp or crocus, with oil; this will give the steel a fine face, with a peculiar—apparently pellucid—polish, but of very fine uniformity. Again (cleanliness is all important in polishing), it is taken to Plate No. 3, which will, provided the surface be perfectly clean, give a polish without any polishing substance; but should an exquisite black polish be desired, well levigated rouge, mixed with alcohol, should be used. The ease with which steel can be polished by this process, and the cheapness of the apparatus, recommends the method to any watch repairer. He must, however, be sure that, before using, the plates are free from dust of any kind; and in order to render the finest plate perfectly clean, it should be well washed with alcohol, and wiped dry with a very soft, clean cotton cloth. The stone surfaces are prepared in somewhat the same manner as the glasses. There should be selected two stones—say the cornelian red, such as were sometime ago favorite stones for breast pins—and any other agate of another color, no matter what; the only care being had that both are uniform, with no striæ or lines of cleavage. These stones are very low priced and easily obtained, and are generally so true that but little labor is to be expended in facing up. The difference in the color is important only from the fact that the two will almost invariably differ in hardness. These two stones are first to be faced down to a true surface on a piece of cast iron, with No. 20 grade emery, with water, and then the two may be ground together with a very fine grade of emery until they touch in every part of the two surfaces; they are then finished with No. 2 diamond powder and oil. One of these stones may be used for facing and topping jewels; the other, for polishing brass settings, as will be described when we come to the metal department of jewelery.

(To be continued.)

## Precious Stones and Gems.

BY EDWIN W. STREETER.

ROCK Crystals are found in a variety of forms, sometimes of extraordinary size. Their color varies from pure white to greyish-white, yellow-white, yellowish-brown, clove-brown, and black. They possess double refraction and transparency. The electricity obtained by friction lasts about half an hour, rarely longer except under favorable conditions. Before the blowing-pipe many colored crystals lose their tints. The frequent admixture of chlorite, asbestos, rutile, iron pyrites, gold, and radiolite in the crystals is very remarkable. The green color of the last is like a blade of glass inclosed in ice. The liquid or gaseous contents, which move as you turn the Crystal, are very interesting. There are pieces received from Madagascar, which have a thousand such bladders on a square inch, and when subjected to friction, give out a perfume like burnt oil.

The places from whence Rock Crystal is derived are so numerous, that we give but a few, chiefly those which yield it in large quantities for commerce.

In Europe, near St. Gothard it is found in company with Mica, Hornblende, Granite, and Felspar. A little distance from the "Grimsel" it is found as quartz-ore in the mines of Jochle Berg and Zinkenstock. In 1735, the yield from the mine of Zinkenstock alone was valued at £2,250. The most famous mine, perhaps, is that of Fischbach, in Visperthal, which supplied the Crystal for the great Pyramid of Marsfeld, 1797. This block measured three feet in diameter, and weighed over 800 lbs. It is now in the Natural History Museum at Paris. The neighborhood of Mont Blanc yields beautifully clear crystal, which affords employment and wealth to the inhabitants of Chamounix. It is also found in Friedeberg, Salzberg and Gillerthal in Tyrol, and in Hungary, France and Scotland. In the clear cells of the snow-white marble of Carrara it is found in great purity.

Ceylon affords it abundantly, and the natives use it for ornamenting their temples.

Madagascar supplies large blocks, and the common sand in this island is full of little crystals.

Rock Crystal was known to the Ancients. The Greeks valued it for its purity and its regular form. Theophrastus mentions that it was selected for seals. Pliny mentions several times in his Nat. Hist. 37. 9, that the Romans were well acquainted with its habitat in the Alps, and that they employed it largely for household luxury and adornment. They worked it into wine jugs, glasses, vases, and other vessels, such as moderns now obtain much cheaper from the glass factories. The Ancients believed it to be ice, and feared to expose it to great heat lest it should melt. Nero possessed two very beautiful drinking glasses and a ladle of Rock Crystal, for which he paid a large sum of money. When he heard of the loss of his kingdom, he is said to have broken the two glasses in anger, to punish the age in which he lived, and jealous lest any one should thenceforward drink out of them.

The Empress Livia gave to the Capitol a piece of Crystal weighing 50 lbs.; and the Roman physicians used Crystal balls as lenses, in order to burn out sores. In the kingdom of Greece, the pure-water Crystal was rarer than the tinted; and, probably, was first made use of under the Roman Emperors. The Crystal was set for rings uncut much more frequently than cut.

We find an engraving on Rock Crystal mentioned, of the contest between Hercules and Antæus; and a representation of Arisinoë on a second.

As a rule, Rock Crystal receives the form of the Brilliant, Rosette, or Table; the exception being the Rainbow Quartz, the Hair and Needle Stone, which are cut *en cabochon*. To cut or engrave on Rock Crystal a Diamond point is used.

Rock Crystal is used for rings, pins, ear-rings, seals, caskets, gems, and other *Bijouterie*. It is also used for Cameos, Intaglios, lenses and spectacles. For personal ornament, the clear, perfect, small Crystals are used, or the angles of the larger ones.

It is said that one of the finest works in Rock Crystal in existence, is an urn, 9½ inches in diameter, 9 inches high, and this, together with the foot or pedestal on which it stands, is formed of one piece. On the upper part is a representation of Noah asleep, his children holding a covering, and a woman with a basket of fruit in her hand. This urn belongs to the French Crown, and cost 100,000 francs.

The cups of Rock Crystal in the Vatican, and similar articles of domestic luxury in private hands, still retain a high value, although the large supply from Madagascar of the material itself, has greatly reduced its rarity, and therefore its price.

The Topaz. This interesting classic gem, called in Hebrew "Pitdoh," by Professor Aaron Pick, and "Pitdah" by Gesenius, (according as each reads the Massoreth), the latter of whom imagines that it is derived from Sanscrit "pita" (pale), and that the "Topasion" is a transposition from "Pitdoh" to "Tipdoh," was certainly found in Ethiopia. Old mineralogists described it as a pale yellowish gem found in an island of the Red Sea. Boetius says it is of "diluted green color with yellowness added to it," and this is confirmed by the virtues then attributed to it "the Topaz calms anacreontic temperaments." The Topaz, although divided into Oriental and Occidental, should, strictly speaking, be divided into the variety composed of nearly pure alumina, now designated Oriental), and the specimens which contain little more than 57 parts of alumina, the other parts, consisting of silica and fluorine, (called the Occidental). Its hardness is from 8 to 9; its specific gravity about 3.6; it possesses double refraction, and develops electricity by friction.

In Hindoostan, in 1665, Tavernier saw a Topaz weighing 157¾ carats in the treasury of Aurengzebe, which that monarch had purchased for a sum corresponding to £18,000 of our money.

The Topazes found in the beds at Capao, in Brazil, secured a net profit of £3,000 lbs. in twelve years. In the Ural, north of Katharinburg, it is found in Graphic, Granite, and Albite. In St. Petersburg is a heavy Crystal, 4¾ inches long and 4½ wide, weighing 31 lbs. In the east of Siberia it is found in blue crystals, in company with Beryl, Rock Crystal, and Felspar.

In Australia, the green and yellow Crystals of Topaz are found in Saxony, the pale violet, and in Bohemia, the sea-green variety. In Brazil, the red specimen graduating from a pale to a deep carmine tint, has been discovered; here the prism is ordinarily rhomboidal, having at each end a four-faced pyramid, and its color is precisely that described as the Ethiopian Topaz. The varieties are described as the colorless, the Siberian, pale blue, with a slight green cast, the red, the citron, and the Saxon straw yellow.

Although the the Topaz has a hardness little less than the Diamond, several have been found engraved; that in the Bibliotheque Royal, in Paris, is set in a signet-ring, having the portraits of Philip II, and Don Carlos deeply cut in it. There is also a Citron yellow Topaz, representing an Indian Bacchus.

The antique Topaz in St. Petersburg, engraved with the constellation of Sirius, is of excellent workmanship. There was a celebrated Arabian Amulet composed of Topaz, having in Arabic, bored through it, "From God alone is success;" this now belongs to a Parisian jeweler.

The *Goutte d'Eau*, which is capable of exquisite polish, is a colorless Topaz. If cut as a Brilliant, with a small table, the pure gem forms a beautiful ornament; and some specimens found, both in New South Wales and also in Brazil, are worthy of careful cutting, polishing, and setting. It has been already stated that the so-called Diamond in the Portugese Treasury is certainly a Topaz.

(To be continued.)



## The Watchmakers' and Jewelers' Guild.

THIS association met in annual convention on May 15, at the Sherman House, Chicago. There were present during the session between 85 and 100 jewelers and watchmakers, representing State and local organizations. Great interest was manifested in the proceedings throughout.

### MORNING SESSION.

The Convention was called to order by Mr. E. R. P. Shurly, the Chairman, who stated the aims and objects of the organization. We give the substance of his address, as follows:

*Gentlemen:* I am gratified at such a large assemblage of the trade. It betokens that the interest awakened is on the increase, and the objects we wish to accomplish are within our grasp. All successful trades, callings and professions have their organizations for social intercourse, self-interest, and for the general good. They meet and interchange ideas. These Trade Guilds are old institutions, and at one time exerted a powerful influence for good in the European cities. They were auxiliary to civilization; at the same time they protected the trade and its manufacturers, fostered inventions, and distributed rewards to those who excelled in producing works of art and usefulness.

For some years past there had been a desire on the part of many engaged in the trade to form an association. And here let me say that for the successful inception of this idea we are under obligations to Mr. Hopkinson, editor of the *Jewelers' Circular*, of New York, and Mr. Mather, editor of the *Watchmaker and Metal-worker*, of this city. You will become acquainted with these gentlemen, as we hope to hear from them during the session. Those gentlemen and a few others are entitled to the credit; perhaps something may be due to the *Watchmakers' Magazine* for its efforts years ago.

One stormy day in February last, a few persons, members of the trade, gathered in a store in this city and formed the first society for the object of aiding the retail trade. M. Wiard, now of Byron, Ill., was chosen Secretary. A few days subsequent, some gentlemen, who had long brooded over the ills the trade was suffering under, circulated a paper, and obtained many signatures, unaware that a "Richmond was already in the field." Suffice to say, that about two months ago the two organizations, who had just drawn the breath of a new creation, united and formed the present society, known as the "WATCHMAKERS' AND JEWELERS' LEAGUE" of the United States. Other spirited gentlemen, who had long become disgusted at the unfair system some of the jobbers and manufacturers were pursuing in their business, issued a call for a meeting at Springfield, and the Illinois Retail Jewelers' Association sprang into life, powerful enough to take the aggressive; an association numbering amongst its members some of the leading business men of the State.

It will remain with you, gentlemen, to determine the future of this organization. There can be no question about the necessity of a National Society, that will know no South, North, East or West. But how shall it be formed? I am free to confess that State organizations are what are required for actual work, and that the National Society should exist as a body composed of delegates from the State societies, and its sessions should be held at least once each year in different cities. Notwithstanding, if this suggestion should be adopted, it would legislate me out of the exalted position of President; unlike many politicians, I am willing to be shorn of that honor for the good of the whole. I am led to this conclusion from the fact that other States are moving in this important matter to the trade. And soon, from Maine to Oregon, will be in successful operation Jewelers Associations—cultivating friendship, forbearance, mutual improvement, and the good of the trade.

I believe our Constitution could be altered so as to continue this society upon the system named—or, what would be better, dissolve, and, in the twinkling of an eye, reorganize upon the plan of State delegates, with a president and one vice-president from each State; and let each State absorb the members in its organization from this, without further charge for initiation fees. I would suggest the appointment of a committee to consider this matter.

Iowa, that young and powerful State, has organized a Jewelers' Association that is doing effectual work. It is to the front with a President of energy and talent, I expect much from Iowa and its organization. That State has young blood; it told in the late war. The Iowa men, like our own, brought back their colors to show to the fair friends who had placed them in their hands. They were *tonn, soiled and bespattered*; but they had been carried to the *front*. Now, then, gentlemen, we must unfurl our banners and carry them to the front, and engrave upon them "Exact and Equal Justice. No Discriminating Discounts. No Price Lists to the Million."

Nebraska, Indiana, Michigan, Missouri, are forming organizations, and so the work goes on. Many of these States are represented here, and I need not say their delegates are welcome. I also see before me our own State Society, so young in existence, yet already cemented by a bond of friendship. I am carried back to the pleasant hours at Springfield, when our Retail Jewelers' Association was born. Let me tell you there will be a merry time at Decatur next October—a time for work, and a time for enjoyment. But we have grave duties before us here. We must unite for the common good. When we take a step, it must be a firm one, and,

like the imprint on the rock, for all time;—no irresolution, no faltering. We do not say to the middle-man, to the jobber, "Depart from me, ye accursed, into everlasting fire;" but we do say, "We are willing to 'live and let live.' We will not touch your goods unless you reform. You cannot be 'good Lord and good devil.' If we trade with you, you must do a legitimate wholesale business; you must stop retailing at wholesale prices; you must direct your traveling men to cease peddling their goods to every person in the hotels they stop at." Gentlemen, it is for you to apply the remedy; and I tell you, you have it in your own hands, no matter what may be said. You are the distributors of the goods manufactured and imported; and if a class of jobbers continue to prostitute the trade, then swear "by the Eternal" you will not use any of the goods of any manufacturer that supplies them. We do not wish to restrict the energy of the jobber. As a class, they are gentlemen, fair and square in business. There are a few "snide" jobbing houses in the United States, and they can be reached. The retailer is the man that keeps the wheels of the Eastern factories in motion; and if these manufacturers will continue to furnish goods to these houses, aiding them to ruin the jewelry trade as a separate branch, we will let their wheels stop. We have the skill, intelligence, capacity and capital to set the wheels of factories spinning upon the Western prairies, and by the setting sun we will do it. But I do not advocate sectionalism, even in trade. The whole Union is my country and yours. We know only the words, "American industry." I would sincerely regret the necessity for such a course, as there is room enough for all.

It may be necessary for you to glance at the operations of the plated-ware companies; and the clock companies may engage your attention. They are in the habit of supplying every trade and business with clocks at wholesale. Some of these companies have stores in this city who retail: in fact, they monopolize the trade, even to the repairing of clocks; and, upon every occasion, retail a single clock at less than the retailer can sell it. It is so with the plated-ware companies, although they claim it is only the inferior goods they sell at retail—shop-worn, and often dipped. I am also assured by some of the gentlemanly clock agents that they charge "big prices at retail;" or, as one said to me, "tuck it on." Perhaps some gentlemen may know what that means, as it seems to be a wholesale phrase.

We must admit that there are jobbing houses that are fair and liberal. I see some of their members before me—not looking outside the trade. For the coming year others may repent;—there is much "joy over one sinner that repenteth;" yet it is a good thing for his soul to let him alone for a time in his sackcloth and ashes.

But there are other causes at work which have helped to depress the jewelry trade—the hard times! Familiar sound! I remember those words when a boy, leaping the fences in Herkimer county, N. Y., when "Tippecanoe, and Tyler too," was heard at every corner. Every political speech-maker sounded it. *Hard times!* The first words I remember. And being in the jewelry business so many years has intensified them. No matter where you are, you hear it. Where the Atlantic Ocean plays upon the sandy beach of Long Island, as the waves approach and recede, you hear it. Basking in the shade of the Green Mountains, and upon their sunny peaks, as the wind rustles the green leaves, you hear the sound *Hard times*. In the green valleys, the Church, the Senate, the House, the same sound—*Hard times*. Even in the war-whoop of the Indian the sound can be heard. Each particular watch-movement ticks it off, especially the cheap grades. Every notice from your banker makes it more real. Yes! the times are hard, even with the banks full of money, and the elevators full of bursting with the golden grain, the wealth of the West. We know the times are hard, and that is one of the causes of the present unfortunate state of the jewelry trade. This state of trade begets a "lively competition," cutting of prices, the sale of inferior goods, and all manner of devilry to get money to pay debts. It lowers the standard of professional honor, so sacred to the watchmaker and jeweler; in fact, it is part of his capital. I hope but few of us know the wretched feeling of being unable to meet our business obligations. To meet them we often sacrifice our stock, and in the end ourselves. Yes! the hard times have had much to do with the present state of affairs; so have the few unprincipled jobbers almost an equally pernicious effect, and are chargeable, beyond any question, with knocking the trade into "sixes and sevens." Thus we are to blame for the cutting among ourselves. It has had a bad effect upon our trade. Goods have to be made lighter and poorer. What a wonderful faculty is developed in the manufacturer to save gold! A few days ago I was examining some nice looking lockets. The genial traveling gentleman said, "I see you are lost in admiration of these designs." "No," I said, "I am 'lost in admiration' at the wonderful ingenuity shown in soldering those lockets together! Why, they are like cobwebs!" "Well," he said, "they keep improving at the factories!" See the cheat in gold chain. Of course, the public at large are to blame in this age of wanting something for nothing. The demand for cheap goods has forced the manufacturer to produce adulterated wares. It is better to sell goods that are up to the standard, and have that reputation. Bargain-hunters after jewelry always pay the "dearest for the whistle." This lively competition has brought to the surface inferior goods. You may ask, "How does that concern us?" We do not buy nor sell them. But every country dry-goods store is loaded with jewelry that will not remain bright. The druggists' clocks would require a dose of castor oil to make them go. It is for you, gentlemen, to think of a remedy. I think a law could be passed by the State Legislature, or Congress would be the proper authority to enact a law similar to the Hall mark law of England, making it a penal offence to sell any article composed of gold or silver unless it had a government stamp. We know

it requires the utmost caution, even on the part of the most expert, to detect the quality of the goods, especially gold watch-cases; so that the only safeguard for any one is to purchase of his jeweler. I claim that, as a class, watchmakers and jewelers are honest men, and their word over their counter is good. The retail jeweler stands the brunt of the manufacturer's dishonesty. If his 14-carat gold falls short, the retailer does not make the profit.

I trust, gentlemen, that when you report resolutions, they will be such as we can "all stand to and abide by"—conservative, yet as strong as those that sounded in the ears of George the Third. I think I hear a voice, "What about the watch companies?" That recalls me. Well, gentlemen, there is no one feels prouder of the American watch than myself. It is emphatically the "poor man's watch," the best made for the money. Great has been the improvement since some of you were rapt in admiration at the performance of that "bull's-eye." I admire the ingenuity of those who live upon this Continent. Perhaps it may be in the air. It is said the American Indian can beat all creation scalping—so can we in making the watch for the million. So do some of the watch companies in scalping the retailer. If the laws of trade provide that there be jobbers or middle-men in the trade, that point I will not argue. Is it not right that these managers of the watch companies say to these jobbers, "If you retail at wholesale rates, we will cut you off"? Let all the companies do this, and half of the evil is banished. We do not say to the wholesale dealer, "You shall not sell a single watch to any one;" but we do say, "If you do sell outside the trade, it must be at a fair price." Unless the watch companies do this, it will be necessary for us to adopt a trade watch, and push it—a movement perfectly made, that will give satisfaction, and afford a fair profit. Of course, money tells; and the true policy of every one in the retail trade is to be his own *jobber for cash*. You must insist on a reformation in the American watch business; and that company that says, "We only sell to jobbers," let them alone to enjoy themselves for ever in winding the watches they will ever have on hand. Is it just to build up one class at the expense of the retail jeweler? No.

Who is there here who has not invented an escapement, or cannot improve the best watch made? Let him rise. We have vied with the Swiss, and have beaten them on a fair medium-priced watch—the best watch for the money. We tried them on a very cheap watch, and we beat them again—we made the poorest. I am of the opinion the American companies have stood in their own light, so far as grades and discounts are concerned. One thing has become a fixed fact—superior articles are required. So much has been worked off through dry-goods dealers, druggists and auctioneers, that people are coming to the point where they require a good article, and are willing to pay for it. That in itself will ruin the price-list gentry. I think the very low-priced American watch will injure the trade, and eventually be detrimental to the good American production—just as the cheap American clock, lately sold, has increased the trade of imported clocks.

I trust you will all go to work for the good of the whole, and solve, if possible, a mystery as great as that which perplexed the alchemist of old—what makes the jewelry trade so depressed, and what is the remedy? To-day you have many eyes turned upon you. The manufacturers of the East, the jobbers of the West, the thousands whose interests, directly and indirectly, rest in the watch and jewelry trade. Our association has done a world of good—caused the craft to become acquainted, the jobbers to be *particular* about price-lists, one of the largest of the watch companies to do away with their discount system. And it will grind on. Hundreds are enrolled under our banner. It may take time, and will, to accomplish all the reforms we desire. There should be nothing antagonistic between the retailer, importer and jobber: our interests are identical, our pursuits the same, and in building up this association we do that which common sense dictates. The jewelry trade is one of the most important in the country; it runs into many millions of dollars. All classes of society require it; and, as people become refined, the artistic designs and solid goods are sought after. The jeweler's business will never cease to be a distinctive business. Here let me put in a plea for the practical watchmaker, he who sits at the bench, using brain, delicacy of touch, knowledge that it takes years to acquire. There is no business, requiring the same amount of skill, that is so illy requited. The real artist in the profession enjoys the work. Is he paid for it? No! Whose fault? His own. There is no mechanical business in God's world so illy paid. Do your work well, and charge a fair price. In every city and town agree on a price, fair to your patrons and yourselves, and stick to it. In every State there should be a price for work. Each State Society should issue a diploma to competent workman, and to each jeweler who proposes to employ none but the best. All these are matters for your consideration, and part of your duties. You are founding a society for all time; it will stand and be handed down to your children, its constitution a monument of the common sense of the retail jewelers and watchmakers of the year 1879. I tell you, we must protect ourselves. So long as none introduce that little hatchet and a grindstone, we will flourish. We cannot exist under any combinations that are not perfectly honorable. The laws of trade, like those of the Medes and Persians, are *unalterable*; and when honesty is the established fact between the consumer and manufacturer, trade will flourish. It is reviving. The iron interest has awakened, and the furnaces, as gold, belch forth their flames. Capital is moving from its sluggish channel into new enterprises, and soon the hammer and the axe will be heard from the Atlantic to the Pacific, and there is money in every stroke.

In conclusion, cultivate a friendly feeling among yourselves in your cities, towns and villages, with a firm resolution to be honest to yourselves, and a determination

not to trade with those wholesale houses that look for business outside. I trust any member of the trade who may find wholesale price-lists that have been sent to parties outside, will report each case to the Secretary of the State organization, and that he will notify each member. Your sacred honor must be pledged not to trade with the house that sends out circulars in this manner. If the Jewelers' Associations in New York City, Chicago, and other places wished to do the fair thing, they would expel any house that sought to ruin the trade in that way. You are welcome to Chicago, and I hope your visit may be profitable and pleasant.

The address of the chairman was greeted with frequent applause. The remainder of the morning session was devoted to perfecting the details of the organization, after which an adjournment was taken till 2 P. M.

#### AFTERNOON SESSION.

The convention assembled at the appointed hour, and was called to order by the President.

*Mr. King*, of Jacksonville, Illinois, then addressed the convention. He proposed that the organization start a co-operative store. He spoke of considerable length in support of his plan, which is, that the members of the association advance one per cent. on their last year's sales; that with the money so advanced, a co-operative store be established, its managers buying directly from the manufacturers and selling to the members of the Association at cost, less 10 per cent.; that profit being deemed sufficient to pay the expense of management of the store, *Mr. King* argued, that as the jobbers charged a profit of 33½ per cent, this would be saved to those retailers who enjoyed the privileges of the co-operative store, and they could, consequently, undersell their neighbors who did not enjoy such advantage, and still make larger profits than they now do. The idea is substantially that adopted by the Grangers a few years ago, whose co-operative stores both bought and sold for the farmers. In almost every instance this plan proved a failure. *Mr. King's* remarks were listened to attentively, and his proposition was referred to the Committee on Resolutions.

*Mr. Stedman Hale* next addressed the Convention, as the representative of the Jewelers League of New York, a protective and benevolent organization within the trade. *Mr. Hale* concisely and intelligently explained the objects of the League, and so telling was his persuasive eloquence, several of his hearers at once enrolled themselves as members of the League—not that they cared particularly for the benefits that might accrue to themselves, but that they might have the pleasure of contributing to the funeral expenses of some of those other fellows. *Mr. Hale* has, apparently, mistaken his calling—a man with such powers of persuasion should be a life insurance canvasser, or a book agent. If he had kept the floor five minutes longer, he would have captured the entire convention, and when he finally took his seat, the members drew a long sigh of relief, like men who had escaped some fearful peril.

#### A CHANGE OF TITLE.

*Mr. Harris*, from the committee appointed to consider the then present organization of the League, presented the following report:

*To the Watchmakers' and Retail Jewelers' Guild of the United States:*

For the purpose of bringing about a more complete co-operation of the several State organizations, we, your Committee, deem it wise to organize an association to be known as the Watchmakers' and Retail Jewelers' Guild of the United States.

The Guild shall consist of delegates from the several State associations, and of individuals duly qualified, who reside in States where no State organization has been formed.

Each State shall be entitled to one vote for every ten members or fraction thereof of their respective State organization.

The qualifications for membership when no State organization exists shall be the same as specified in the State constitution of States forming this Guild.

The officers shall consist of President, one Vice-President for each State represented in this Convention, Secretary and Treasurer, who shall form an Executive Committee for transacting the business of the Guild when the Guild is not in session.

For the purpose of securing uniformity in organizations, the Constitution and By-Laws of the State of Illinois and Watchmakers' and Jewelers' League of the United States are suggested for State organizations to be hereafter founded.

In those States where no organization now exists, the individual members of the National organization shall be deemed such *ad-interim*, until a State organization shall be formed in the State or territory in which they reside, when they shall be duly transferred.

JOHN W. KING,  
W. N. BOYNTON,  
LEWIS BECKMAN,  
C. H. CHURCH,  
J. HARRIS.

*President Shurly* supported the report in a brief, but effective speech, stating that the design was to organize a United States Guild, formed of delegates from the State Associations. It was not proposed to blot out the local organization, and he wished every member to thoroughly understand the action proposed to be

taken. The Chicago League, which was the first one started, had done a great deal of good, and would be continued as a local organization.

*Mr. M. O. P. Boynton* was in favor of the report, but wished to have the meetings of the new association held in New York, Boston, Philadelphia, and other cities.

*Secretary Harris* said that probably a majority of the committee thought the Watchmakers and Jewelers' League of the United States should be dissolved, because it came in conflict with the State organizations outside of Chicago. The great object to be attained was unity of purpose. The main idea was to have in every recognized trade centre, an association which would discuss questions affecting the trade, and that a correspondence be maintained with the individual members advising them as to what is their interest. The State organizations had this object in view, but there were very few places outside of the trade centres where a body sufficiently large could be brought together to act effectively.

If the League was dissolved, it would be necessary to have an executive committee who should be constantly in consultation. There should be some one individual who would make it his duty to attend to the interests of the League. There should be a central body which would receive information from the secretaries of the State Associations, and notify them of what had been done in the various State Associations. Through this central body a bureau of intercommunication would be organized, which would be found of great value to the interests of the trade.

The report was then unanimously adopted.

#### OFFICERS.

*Mr. Scoville* moved that a committee be appointed to nominate officers of the Guild for the ensuing year. After some debate, the motion prevailed, and the chair appointed Messrs. Scoville, Boynton, O'Hara, Edgar, and Church as such committee.

The committee, after consultation, presented a report.

The following were elected officers for the Guild for the ensuing year: President, E. R. P. Shurly, Illinois; Vice-Presidents—W. R. Weld, Iowa; Lewis Backman, Indiana; John Baumer, Nebraska; A. F. Robertson, Minnesota; G. W. O'Hara, Michigan; A. J. Lawrence, Kansas; Secretary, J. Harris, Illinois; Treasurer, A. Kaempfer, Illinois.

#### A STANDARD OF PRICES.

*President Shurly* introduced the subject of making a standard of prices for watch work. One of the greatest evils to the trade was found in the matter of price lists. He thought there should be grades established. Every watchmaker knew that it was to his interest to do the best work, and to get a fair price for it, but the question was how to get it. He gave a humorous illustration of the effect upon even good men of a desire to cheat watchmakers by claiming that their watches had been cleaned or repaired but a short time before, when, in fact, they had not been touched for several years. He suggested the appointment of a committee to suggest some action in the matter.

*Mr. Anderson* thought the organization was not yet strong enough to effect anything in the direction of specific prices.

*Mr. Bechmann* thought the Guild was strong enough to regulate the prices of good work, but, he thought they were not strong enough to run the entire United States. The Guild was formed for the express purpose of combination in the interest of the trade, and it was only a matter of time when that object would be accomplished.

*Mr. Curtis* thought that each State Association should be instructed to adopt a price-list on all work. This would not bind watchmakers who were not members of the organization, but the members could talk to such parties, and get them to give up to the scale of prices. In conclusion, Mr. Curtis moved that each State Organization be instructed to devise some means of regulating the prices of watch-work. Carried.

#### CONSTITUTION AND BY-LAWS.

*Mr. Scoville* moved that a committee of five be appointed to draft a constitution and by-laws for the Guild.

The motion prevailed, and the chair appointed as such committee, Messrs. J. S. R. Scoville, J. Harris, Shourds, W. H. Edgar, and W. C. Sommers. The committee subsequently presented a report, recommending a constitution and by-laws, which was adopted.

#### STAMPED GOODS.

Vice-President Edgar was called to the chair, and *President Shurly* addressed the Guild, saying: There is a matter that appears to me to be very important, and that is, that there should be some system to compel the manufacturers to stamp the quality of their goods. If you buy of a manufacturer a locket or a chain, or any other article, it should be stamped—"this is ten carats fine, or fourteen carats fine," or whatever it may be. I do not care how competent a jeweler or watchmaker may be, he cannot tell the quality of the gold in an article unless it is thoroughly tested, and sometimes, it has to be assayed to find out what

it is. The manufacturers are getting pretty smart in getting up the color of the gold.

Now, if we determine among ourselves that we will not trade with any manufacturer unless he stamps the quality of his goods and gets it up to the standard, we have got the manufacturer, and can hold him to it. I move that a committee be appointed to draft a resolution, and authorize the Secretary to send that resolution to the manufacturers that this association deem it for the interest of all concerned, that hereafter, all their gold goods should be stamped, and the effect of it will be, that goods will be brought up to the standard, and the jewelry trade will be thrown into the hands of the jewelers.

*Mr. Edgar* was in favor of legislation upon the subject, and thought the government should require gold goods to be stamped. Mr. Shurly replied that the reason why he had not spoken of legislation was, because from some valuable articles which he had read in *The Jewelers' Circular*, he had learned that such a measure was unconstitutional. The way to reach the manufacturers was by moral suasion.

*Mr. Hopkinson, of The Jewelers' Circular*.—I do not know that I have any voice in this meeting, but I feel very much like an Irish Alderman of ours in New York, who, when a certain measure came up affecting his interest, said, "Now I can't remain silent without saying something on this subject." I feel very much as he did, because, this subject is one of great importance. But I find it is in conflict with the constitution of the United States for Congress to pass an Act of the kind suggested. With a State law we should not be benefited, because, if such a law was passed in New York, the manufacturer would simply move over into Jersey, thus avoiding the New York law. I did think at one time that we might be able to get Government to recognize a register's stamp, fixing a standard carat-mark. This would hold every manufacturer using it responsible for the quality of his goods: but even that we find to be impracticable. I do not see any help for the present condition of affairs, unless the manufacturers will bill their goods at fourteen or eighteen carat, or otherwise, as the case may be. Such bill to be held *prima facie* as a guarantee of the goods. I think where fraud is apparent, the purchaser could not be held for the quality of the amount of the bill; I believe that point has been so decided in the Courts of New York.

*President Shurly*—If that was the case you would not have to pay for any goods, for there is nothing that comes up to the standard. (Laughter.)

*Mr. Hopkinson*—I do not see how you can stamp some articles of jewelry without mutilating them. You cannot stamp a chain without mutilating it; if you stamp a swivel, it only certifies to the quality of the swivel. If you could get the manufacturers to give you a personal guarantee with their bills that the goods you purchase are fourteen or eighteen carats, similar to that which Robbins & Appleton introduce in their 18-carat cases, I think that would be sufficient. This is a question in which every manufacturer and retailer is deeply interested, and the public need such protection.

*Mr. Lindstrom* thought it was a very easy thing to mark such jewelry as lockets, and various other articles, and any manufacturer who marked his goods wrong ought to be prosecuted criminally.

The motion to appoint a committee to draw a circular for presentation to the manufacturers was carried, and the following gentlemen were appointed as such committee: Messrs. Hopkinson, J. E. Boynton, of Jerseyville, Illinois, and John King, of Jacksonville, Illinois.

*President Shurly* said there was one watch company who claimed that they had done away with the discount system. This matter of regulating the watch business was going to take time. The retail watch makers and jewelers had the power to regulate the watch trade, so far as buying and selling were concerned. If the manufacturers and jobbers adhered to their practice, he saw no other plan than to adopt a trade watch. The watchmakers and jewelers could take four or five grades of watches, and make an arrangement with any two or three companies, that they should not sell one of those watches to a jobber, and that they should give the retailer the best possible figure on them. In that case, what were the balance going to do about it. The retail dealers would recommend that watch, and if the watch was a good one, the jobbers business would be done. He, however, would not recommend that course unless the watch companies insisted upon giving the jobbers such an unfair advantage over the retailer.

*Mr. Harris* said that the tendency of the times with its railroads, telegraphs, and telephones was to bring the consumer and the producer closer together, and reduce the number of middle men. The handwriting was on the wall, and the middle men must be reduced. The question was whether the manufacturer should dispense directly to the consumer, or whether there should be three steps intervening. On one side was found a concentration of capital, which forms large firms like that of Field, Leiter & Co., and Stewart & Co. A man could go to Field & Leiter's to-day and find an assortment of jewelry and clocks. Those articles were to be sold, not to jewelers, but to dry goods men. The times once was, when each line of trade was confined to its own legitimate articles, but now it was all mixed up, and each line of trade dealt in articles that belonged to the others. The only way this could be counteracted so far as the jewelers was concerned, was by driving outsiders out of the jewelry field by carrying the war into Africa and underselling the invaders in their own lines of business.

The Guild then took a recess until 7.30 o'clock P. M.

## EVENING SESSION,

The Guild reassembled at 7.30 o'clock P. M. President Shurly in the chair.

## RESOLUTIONS.

*Mr. Harris*, from the committee on resolutions, presented the following report, which was adopted.

*To the Watchmakers' and Retail Jewelers' Guild of the United States:*

We, your Committee on Resolutions, beg leave to offer the following:

*Resolved*, That we recognize the practical or professional jeweler, who makes that calling his leading business, as the only legitimate customer of the jewelry jobber.

In view of that fact, which has been utterly disregarded in the past, we do solemnly bind ourselves not to buy goods of any jobber or manufacturer who, after this date, wilfully sends out catalogues, price-lists or discount sheets soliciting the trade of private parties or firms, not as we deem legitimately in the watch, jewelry, or silver-ware business, or who sell direct to, or fill orders from private parties or firms who may be in possession of, or have access to, catalogues heretofore issued.

*Resolved*, That as we are the distributors of a majority of the watches made in the country, it is to our interest to handle only watches that are made by parties who are willing to protect us; and that we consider that manufacturers who allow the wholesale prices of their watches to be sent to parties outside the trade, do not wish us to handle the same; that we will, therefore, in self-defence, urge our customers to buy only such watches as we know to be good, and not placed in the hands of jobbers and others who send their price-lists to parties not in the legitimate jewelry trade.

*Resolved*, That it be the duty of every member of the Association to notify the Secretary of the Association of the State in which he lives, or the Grand Secretary of the Guild, if there be no organization in the State, of every instance whereby any traveling jeweler solicits trade from outside parties, and of every instance coming to his knowledge of any jobbing house sending their illustrated catalogues, price-lists, etc., to parties not in the trade.

JOHN W. KING,  
W. H. EDGAR,  
A. H. FISHER,  
W. C. SOMMERS,  
W. N. BOYNTON,  
J. S. R. SCOVILLE.

*Mr. Church* presented the following resolution, which was adopted:

*Resolved*, That *The Jewelers' Circular* be the official organ of the Watchmakers' and Jewelers' Guild of the United States, and that the proceedings of this meeting be also published in the *Watchmaker and Metal Worker*.

## PLACE OF NEXT MEETING.

The question of the next meeting of the Guild was then taken up, and the following places were nominated—Chicago, Cleveland, Rochester, New York, and St. Louis. A ballot was had which resulted as follows: Chicago, 19, New York, 5, Cleveland, 5, Rochester, 2, St. Louis, 2. Chicago was accordingly declared to be the place of the next meeting of the Guild.

## RESOLUTION OF THANKS

*Mr. Mather*.—There is present a gentleman who is the editor of the finest trade journal in the world. He is known not only throughout this country, but in England, Switzerland, and Germany. I refer to Mr. Hopkinson (Applause). It seems to me Mr. Hopkinson could give us some ideas of his own on different topics.

*Mr. Hopkinson* blushing arose and said: As I remarked before, I came from New York, which will account for my excessive modesty. I am exceedingly obliged to you for giving me an opportunity to distinguish myself, but I come here simply to listen. I wished to see the workings of this institution, and I would greatly prefer to air my eloquence in the columns of my paper. I have paid particular attention to the remarks that have been made here, and I really cannot offer anything that would be of any particular service to you now. I think the ground has been sufficiently covered. I do not know that there is anything which I can say, that has not been better said by those who have preceded me.

*Mr. A. P. Boynton*—Will you state what the Eastern people will think of us, and how they will accept our movements here? We would like to know whether they have already recognized this movement.

*Mr. Hopkinson*—No; they are waiting for developments.

*Mr. Boynton*—You think perhaps another year might bring them around?

*Mr. Hopkinson*—It all depends upon the magnitude of this organization. There is one thing very certain: I do not think the manufacturers of New York will throw away the jobbing trade by any means.

*President Shurly*—Well, we don't ask them to do that.

*Mr. Scoville*—I move you that a vote of thanks be extended to Mr. Hopkinson for his assistance in bringing about this organization. He has ventilated it pretty thoroughly through his journal for some time, and I move that it is a duty which devolves upon us to extend to him our thanks. (Applause.)

*Mr. Hopkinson*—Before the motion is put, I would like to amend by including Mr. Mather.

*Mr. Scoville*—I accept the amendment with a great deal of pleasure. The resolution was unanimously adopted.

## JOBBER ON THE RACK.

On motion of Mr. Scoville, the jobbers and manufacturers present were requested to address the Guild.

*Mr. Webber*, of the firm of Coggsell, Webber & Company, said that he thought the Guild was on the right track, and although you have undertaken a task of great magnitude, you will eventually accomplish a great deal of good to yourselves. I presume those who have been most actively engaged in this matter so far, can already realize the magnitude of the thing you have undertaken. It cannot be accomplished in one meeting, or two, or a dozen. I think it will take a long while to simmer the diverse ideas down, and get something that is practicable and tangible; but I do believe that with the persistence, and with the energy that you display in other things, you will succeed in time, in accomplishing the end sought for. I can only say that for myself and the house I represent, we have always believed it to be our interest to work for the interests of the trade; that their interest was our interest, and that in this matter we are heartily with you.

Mr. Otto Young of Mr. W. D. Clapp, Young & Co., was then called for, and in response spoke substantially as follows:

*Mr. Young*.—Well, gentlemen, I presume I am probably the blackest sheep in the lot here (laughter)—at least, I am so considered by you, I presume; but I am of good size and health, and I can stand it. (Laughter.) I hardly know what to say after reading those resolutions. I understand them to be, that you bind yourselves not to buy from anybody who sells to any one out of the (strictly speaking) jewelry trade; that is, a man must be a watchmaker in order to get the goods.

*The Chair*.—No, that is not the resolution. The resolutions are, simply: If you, in your establishment, sell a watch at retail, that you get a retail price for it. What we are fighting against is, selling watches at retail at wholesale prices.

*Mr. Young*.—This association has no objection to the jobber selling a watch at retail, provided he gets a retail price for it. Have you any objections to selling watches in a dry-goods store, provided the seller has a supply of jewelry?

*The Chair*.—I should object to that. That might be put to a vote. I don't know what the opinion of the others is.

*Mr. Young*.—I must give you my opinion on that subject. There is a great deal of jewelry sold to the general store trade and the dry-goods trade, and I think it is almost an impossibility for the retail jewelers in this country to stop that. I think, if you will present something to the jobbing jewelry trade of Chicago, or the whole country, that shall be in reason, it will be acted upon. If we can sell jewelry to anybody who will retail it out at a profit, that would be all right; but you cannot force anything on this country which you are not willing to do yourself. I do not believe you are willing to throw out your fiddle-strings and musical instruments. You know that interferes with the musical instrument interest of this country. So what you do not wish to give, I do not think you ought to take. I do not come here this evening to flatter you, or anything of that kind. Anybody can do that. I want to tell you my plain opinion about this matter. For instance, I will give you a little sketch of the career of Clapp, Young & Co. They started here as W. B. Clapp & Brother eleven years ago. The highest-price piece of jewelry they sold was probably \$3.00 a dozen. They certainly did not sell to a jeweler, but they sold to other trades a large amount of goods that jewelers would not handle. They moved on Lake street, and still carried that class of goods, and jewelers, hearing about Clapp's cheap jewelry, came there and bought jewelry, to make a profit on it. They finally went into better jewelry, and their general store trade is the best. The general store trade is cheap jewelry, mostly watch-chains. Is it fair for you to ask a jobbing house to throw that most profitable part of their trade overboard—which, if they do not sell to them, somebody else will? I do not think it is. You must try and draw a happy medium there, and, if you do, you will be successful in your undertaking, and I will pledge you that we will help you all we can. If you do not, you simply force us to go so much stronger for that other trade. We have our goods in our store, and we must sell them, and we are going to sell them. I would suggest that this Convention appoint a conference committee to confer with the jobbers and see whether they cannot find this middle way.

Now, without wishing to accuse the other jobbers of Chicago of anything, I will ask Mr. Webber and Mr. Giles, who are present, if a dry-goods man went into either of their stores, and wanted to buy a bill of three or four hundred dollars' worth of jewelry, would they give him wholesale rates?

Messrs. Giles and Webber failing to respond to the inquiry, Mr. Young said: I must take it for granted that it is so.

*Mr. E. P. Boynton* said: The constitution of the organization recognized the right of houses to sell jewelry and watches to parties who make the watch trade a leading business.

*President Shurly*.—There is a remedy for that, and a fair and square one. It is this. I do not blame Mr. Young for selling his goods. We do not attempt to force anything. We are gradually going to work up the opinion of the trade to the point we think is right. There is a way for taking away the market for Mr.

Young's goods in the direction of the dry-goods and druggist trade. If every country member that can possibly command a capital of \$100 or \$150 would take one little corner of his store, and, if a druggist in his place sells jewelry, let him get some of the leading soaps, and put in his store some of the perfumes that ladies buy, or some of those articles on which there is a big profit, and that the druggist counts on to pay his rent, and put them down five per cent. below the druggist's rate;—the little the druggist makes on the jewelry trade would soon vanish. The druggist would soon be in condition to say to the jeweler, "I'll trade you my jewelry, Mr. Jeweler, for your soaps and perfumes." The same course pursued with the dry-goods trade in the matter of dress trimmings, buttons and silk, would soon bring that branch of trade to its knees. We do not say to the jobber, "You shall sell so and so, but we do say, "It is right and just, if you do retail a single article, you should get a retail price for it." Otherwise, we say to the watch manufacturers and the manufacturers of plated ware: "Gentlemen, if you are going to put into the hands of these men this power that is going to sacrifice the jewelry trade, and sacrifice us as jewelers, and bring the watchmaking process down to the process of making a brass key, and drive the watchmaker into a basement to continue his trade, and blot out of existence the jewelry trade as it has existed for years, we won't handle your goods." But I say, equal and exact justice to all men. I respect the jobber of Chicago just as much as any man that lives here. They are nearly all of them honest men, and good business men. I respect the energy they display in business. Once in a while I take up a paper from Michigan or Wisconsin, from a district where there is probably not more than one jeweler to every twenty miles, and I find an advertisement: "Send for a price-list, and we will sell to your house." I regret it because it kills the jewelry business. I want it understood by the jobbers that we do not purpose to be aggressive, and dictate to any man how to do his business; but we propose to try and build up the trade of the jeweler and watchmaker. (Applause.)

Mr. Anderson said he did not advocate preventing anybody from selling what goods he had on hand; but the jewelers would deal with those who would, in turn, protect them. It would be as well for the dealers to sell to the jewelers as to anybody that comes along.

Mr. Young—As to freezing out the dry goods men, so far as jewelry is concerned nothing would please me better. We shall issue a catalogue this Fall. Now, I want to say, that every time we agree to do a certain thing, we will do it. I will do this, as an experiment: So far as our house is concerned, we will only send catalogues to actual watchmakers, or to a jeweler who employs a watchmaker as a workman. We shall not throw our dry goods trade overboard in a minute—we will first wait and see how your experiment with the soap and silk will work—but we will not try in the meantime to get more; we shall keep what we have got, but we would be willing to throw that overboard to-morrow if we could immediately increase our trade on the other side, which I do not think we can do in a few months. But, if your suggestion can be put into effect, we had rather sell to one thousand customers, than to two thousand. We would a great deal rather sell only to the jewelry trade, not only because we think they could use the same amount of goods, but they could pay a great deal better. If the result of the action of this Association would be to abolish the selling of jewelry to anybody else except the jewelry retailers I would be willing to put down \$5,000 to-night for that purpose. I think it would be a good investment. Try that, and we will do all we can, but you cannot expect us to give up our trade.

Mr. Giles, of the firm of Giles Bros., of Chicago, was called for, and in response said: I would very much prefer to listen to some one else. The jobbers of Chicago might have something to say in explanation of a great many charges made against them, but I am not here to defend them. There are many things in which I think they can improve their mode of doing business, but there are two sides to this question. The jobbers in Chicago employ a capital of about \$2,000,000, and this facilitates business between the manufacturers and the consumers. The annual sales in Chicago amount to about \$5,000,000 which is about equal to the whole State of Missouri, including St. Louis, and Wisconsin and Iowa. It enables the manufacturers the more readily to get the wherewithal to conduct the manufactures, and enables them to reach the small dealers. There are many little questions that are constantly coming up, which show to us that we all, manufacturers, jobbers and retailers, ought to pull together. It is only seldom that our interests conflict, and I believe the jobbers, as a general rule would be willing to comply with any reasonable regulations that might be established. I believe the retailers are justified in saying to the jobbers "If you are going to sell to us, you must stop selling to our customers, or attempt to interfere with our trade in our own towns and districts." I am told by some that there are men traveling who drum the jewelers, and afterwards go out and drum the dry goods men, the butcher, the baker, and the chambermaid, and peddle their goods from door to door. Now, could we not do away with this unnecessary expense of travelers, and, perhaps, in lieu thereof, get an extra discount of, say, four to seven per cent.?

Mr. Aulth said it was a fact that the jobbers would not throw away their business, and if the jobbers would come in and protect the retailers, the retailers would purchase of such houses. And so far as those who would not protect the retailers, they would be passed by.

Mr. Fixler said that he had dealt with Mr. Young for several years, but he found the catalogue used by Clapp, Young & Company in the hands of a good many men in his town. Those men came to him, and told him if he did not sell them goods at the prices stated in the catalogue, they would do their trading in Chicago.

Mr. Edgar called attention to the fact, that about holiday time the jobbers were very anxious to sell to the retail jewelers, and after having disposed of all they could to them, they reduced their prices fifteen or twenty per cent., and took away the trade which legitimately belonged to the retailers. Said Mr. Edgar "If they do it now, we will carry the goods back, or not pay the bill, or won't do anything." (Laughter and applause.)

Mr. Young—I want to say that I am not scared at all, but I am willing to do anything that is for the interest of the jobbers, and the retailers as well. If they work together they can do a great deal better than if they work against each other. If the retailers will have a conference with the jobbers, I have no doubt, we will come to some conclusion that will benefit both of us in the end.

Mr. Haskell moved that the chair appoint a conference committee of five, and that the Wholesale Dealers Association be requested to appoint a similar committee for the purpose of coming to an understanding in the matter.

Mr. Shurly moved to lay the motion on the table.

The motion prevailed.

A motion by Mr. French to reconsider the resolutions was declared out of order by the chair.

Some discussion followed upon the question of the exact interpretation of the resolutions, during which Mr. Young took the floor, and said that there was only a small percentage of the jewelry trade present. Many of his customers had told him that they would not join any jewelry association as long as he did not tread on their corns. Their language was, "Sell us goods cheap, that is all we want; we don't care anything about the Association." As he understood the resolutions, they operated like a bomb-shell that would come in to burst up Clapp, Young & Co. If that firm was only engaged in a jewelry trade, the resolutions would burst up their business. I want to ask you said Mr. Young, Is that right? Is that fair? Is it just? I do not think it is. You pass resolutions to force the business of selling jewelry all into one channel; whereas, so long as business has been carried on in this country, jewelry has been handled with other goods. You cannot do what you propose to do in a minute, and you cannot do it without the assistance of the jobber and the manufacturer.

The jobbers having fully ventilated their views of the matter, and the business of the Guild having been transacted, an adjournment was had until the second Thursday of May, 1880.

## Coral.

THE popular idea that coral is formed by an insect busily working to build up reefs in the ocean, is erroneous. A piece of coral is composed of the skeletons of tiny animals that in life are covered with a gelatinous substance. More than a thousand species of the coral animal have been described by Dana in his work entitled "Corals and the Coral Islands."

Of the sub-kingdoms into which the animal kingdom is divided, namely, vertebrates, articulates, mollusks, radiates, and protozoans, coral animals belong to the radiate division. These creatures have no sense except a low degree of sensitiveness, and live in salt, clear water, having a temperature of from 68° to 85° Fah. They do not live singly, but grow together in clusters, which start from a single, little animal, that is soft, oval, white, and jelly-like, and has the power of rapid motion. It attaches itself either to a rock or the sea-bottom by one end, while the other spreads. Then a mouth, stomach, tentacles, and corporeal partitions are soon formed, and the last become quite hard from accumulations of particles of lime.

Coral animals belong to the class familiarly called polyps, and they multiply themselves by eggs and also by budding, until there are countless numbers living together in one community. Different kinds of coral bud in different ways; as some grow in bunches, others in round masses, and so forth. A piece of dead coral shows the spot where every animal has lived. As a mass of coral grows, the lower creatures gradually die, but their hard skeletons, consisting mainly of carbonate of lime, remain and furnish a firm foundation for those that work above them. By the striking of the waves against this foundation, its interstices gradually become filled with mud, bits of shells, and other substances which sea water contains, so that it grows firmer and firmer. If such a foundation is laid upon an elevation of the ocean floor, it is likely to continue to increase in size; but by the time it has reached the sea level, the whole community of coral animals has become lifeless, for the polyps cannot live out of water. The beating billows break off portions of the skeleton formation, which are soon worn into sand by the water, and afterwards, perhaps, thrown with other debris upon the surface of the mass, which is thus supplied with soil. Then, perhaps, seeds are scattered upon this soil, which give rise to vegetation, and so a pleasant home is prepared for man.

These coral structures, called reefs, are often circular in form, and many of them inclose a lake or lagoon, whose waters furnish an excellent harbor for ships.

These reef-builders have not only built up large islands, but also considerable portions of the continents of Europe and America; and some of their structures must be of great age, as remains of a pre-historic civilization have been found upon them.—From a lecture delivered by Prof. B. F. Mudge in Science Observer.

## Trade Gossip.

Antique coins are being copied to form the backs and fronts of lockets.

Coiffeurettes is the name applied to a novelty in ornamental hair-pins that promises to become quite popular.

The Chicago Agency of the Waterbury Clock Company has removed from No. 197 State street to No. 63 Washington street.

W. C. Ball, formerly with the Dueber Watch Case Co. of Cincinnati, has associated himself with Mr. D. R. Whitcomb, of Cleveland.

Mess. H. Muhr's Sons, of Philadelphia, are now comfortably situated in their new and attractive offices at Nos. 633 and 635 Chestnut street.

W. Rapple, formerly a commercial traveler, has purchased the stock of H. P. Hancock, (assigned,) at Lansing, Mich., and will continue business there.

Rubies are again coming into public favor in England and France, and will be extensively worn this winter. Prices of these gems are advancing accordingly.

Greason, Bogert & Pierce were recently victimized out of some \$2,500 worth of diamond jewelry by a swindler who had gained the confidence of one of the firm.

The Jewelers' Protective Union, an organization established for the protection of jewelers' stocks while in the hands of travelers on the road, has issued 160 certificates of membership.

Sneak thieves broke into the office occupied by Champenois & Co. and W. B. Bowden & Co., No. 1 Maiden Lane, but were frightened off before they had a chance to steal anything of value.

Geo. Fox, *alias* Burt, formerly in the jewelry business at Au Sable, and latterly at Grand Rapids, Mich., has been sentenced to fifteen years' imprisonment for a murder committed eleven years ago.

Our elegant friend, J. H. French, the successful jewelry auctioneer, is exercising his gigantic intellect and expending considerable eloquence over the bankrupt stock of M. Kronberg at Chicago.

Mr. J. A. Abry's co-partnership with Mr. Aug. Mayor has been dissolved by mutual consent. Mr. Chas. Leo Abry liquidates the affairs of the firm, and will continue the business under his own name.

J. A. Montgomery, a jeweler at Port Hope, Canada, is reported to have absconded with the most valuable portion of his stock. His liabilities are said to reach \$10,000. Several Toronto and Montreal jewelers are among his victims.

Messrs. Jaccard & Co.'s jewelry store at St. Louis was recently entered by burglars and robbed of some three thousand dollars' worth of jewelry, consisting of thirty-two fine cameo sets and a large lot of rolled platē goods of different kinds.

Mr. Henry Troemner, the well-known scale manufacturer of Philadelphia, has recently furnished the United States Mint at New Orleans with several pairs of scales, the beauty, finish and accuracy of which are highly spoken of by the Mint officials.

A work of art, in solid silver, designed for presentation to Henry H. Rueter, of Boston, President of the Brewers' Association of the United States, has for several days been on exhibition at the salesroom of the Whiting Manufacturing Company, silversmiths, and has been greatly admired by the art critics.

Under the new German tariff, the following articles will be subject to the duties mentioned: (a) Watches, wholly or in part made with precious metals, pearls, etc., per 100 kilos., 600m.; (b) articles of jet, amber, meerschaum, ivory, etc., opera-glasses, clocks, etc., 120m. The German mark is equal to about 25c. of our money.

In the case of Rauth & Son, recently tried before Judge McAdam, in Chambers, on motion to vacate the order of arrest, the Judge rendered a decision granting the motion discharging the orders of arrest without costs, but requires the defendants, as a condition of their release, to stipulate that they will not bring actions for false imprisonment.

Mr. Otto Stoelker, of Montgomery, Ala., a jeweler and highly respected citizen, was recently sued by Miss Meins, who charged him

with having made false accusations regarding her. She asked for \$20,000. After a trial lasting several days, the jury gave her a verdict for one dollar, which carried an equal amount of costs. The lady's estimate of the damage done her was too high by four cyphers.

J. Hammershlag, traveler for Mr. Noah Mitchell, of this city, was in Lexington, Kentucky, recently, when the Phenix Hotel was burned. Returning from a walk through the town, he found the hotel in flames, and offered fifty dollars to any one who would bring out his sample trunk. Finding no takers, he rushed into the burning building himself, fought his way to his room, and returned to the street in safety with his trunk containing several thousand dollars' worth of jewelry.

Look out for your watches when the electric light comes in vogue. Not that thieves will be more prevalent, but an unseen thief will be let loose on a scientific community that will steal the watches, yet leave them in the pockets of the victims. If a man approaches the generator of electricity with a watch in his pocket, the steel therein will be magnetized and the watch ruined. Be warned in time. One of Edison's men has lost two fine watches in this way by forgetting to leave them at home.

An order has recently been issued by the Grand Chancellor of the Legion of Honor, at Paris, forbidding merchants, members of that order, from exhibiting the emblematic cross for advertising purposes, or to reproduce the same on their bill-heads, show cards, signs or vehicles. Members, however, are at liberty to adjoin their title as knights of the legion to their signatures. The new Perfect of the Paris Police has notified these industrial knights that they must at once obey the edict of the grand Chancellor.

In an English county court last month a lady brought an action against a country jeweler to recover money for a ring containing a stone which she had bought as a diamond, but which proved to be what several experts designated as a "Cape stone, falsely called a diamond." These persons added that "Cape diamonds" were comparatively valueless, and lacked lustre, hardness and color, the essential qualities of the Brazilian stone. Judgment was for the plaintiff, but the case is to be appealed, and the matter is likely to cause much excitement in the diamond-dealing world.

Mr. Stephen Preston, Jr., of No. 50 Fourth Avenue, is, we believe, the first watchmaker to utilize the time-ball on the Western Union Building to regulate the time in his store. Mr. Preston has a time-ball in his show-window that is connected by telegraph with the Western Union time-ball, and drops simultaneously with that. His standard clock is compared every day with the Washington, Cambridge and Alleghany Observatories, and its error determined within one-hundredth of a second. It seems to us that the time-ball might be rendered of great service to watchmakers, and Mr. Preston has demonstrated that our idea was correct.

The laborers engaged in excavating for the Davidson block, at the corner of Sixth and Jackson streets in St. Paul, unearthed what is undoubtedly an interesting and extremely valuable curiosity. It consisted of two pieces of Roman Catholic communion service, of solid silver—a chalice and a salver. They are of good workmanship, the chalice being finely chased near the base, and the salver around the rim, both being well preserved and bright. Upon each are prominently engraved the letters I. H. S., a cross resting upon the central letter. There is at present no record of any loss of such a communion service from any of the Catholic churches in St. Paul, and if it should prove to be at least two hundred years old, the theory is that these relics were a portion of the effects which were taken from Father Hennepin by the Indians in 1680 or thereabouts.

The Vienna *Extrablatt* tells the following curious story: "A poor Hungarian Jew lately brought a black pearl to a Pesh jeweler and begged him to value it and give him what he could for it. He was told that the pearl was of great value, and that he had better take it to Biedermann, of Vienna, which he did, and was naturally asked where he had obtained possession of such a rarity. He answered that he had got it from the valet of the late Count Lovis Batthyani. Upon inquiry, it turns out (according to the *Extrablatt*) that this is one of the three black pearls which, more than 150 years ago, were stolen from the English crown, and which were for a long time vainly sought for, it being at that period supposed that these were the only three black pearls in existence. How Count Batthyani came by this one is not explained. The British Government has bought the black pearl for 20,000 florins (\$8,000)."

THE

# Jewelers' Circular and Horological Review.

VOLUME X.

NEW YORK, JULY, 1879.

No. 6.

THE

## JEWELERS' CIRCULAR AND HOROLOGICAL REVIEW,

*The recognized organ of the Trade, and the official representative of the Jewelers' League and the Watchmakers' and Jewelers' Guild of the U. S.*

A Monthly Journal devoted to the interests of Watchmakers, Jewelers, Silver-smiths, Electro-plate Manufacturers, and those engaged in the kindred branches of art industry.

### SUBSCRIPTION.

To all parts of the United States, Canada, Great Britain and the West Indies,  
**\$2.00 Per Annum; Postage paid.**

To France, Switzerland, Germany, Mexico, the Republics of South America, and Australia, \$2.50 per annum. Postage paid.

*All communications should be addressed to D. H. HOPKINSON, 42 Nassau Street, New York. Advertising rates made known on application.*

### A National Standard for Wrought Gold.

THE CIRCULAR has maintained that a National standard for wrought gold is a necessity of the times, to protect the retail dealers as well as the public from the debased goods that are now palmed off upon them by unscrupulous manufacturers. At the recent session of the National Jewelers' Guild, this subject was discussed, when the editor of THE CIRCULAR stated, that he had been informed that Congress could not legislate upon the subject without violating the Constitution. Since then, we have made further inquiries, and learn that while there is a doubt regarding the authority of Congress to interfere in trade matters of this kind, there are, nevertheless, two sides to the question, and very good reasons to believe Congress has the power, if it chooses to exercise it, to regulate many things in reference to inter-state commerce that are now sadly out of joint.

The third clause of section eight of the Constitution, confers upon Congress power "to regulate commerce with foreign nations, and among the several States, and with Indian tribes." From this section, and no other, Congress has based its authority "to regulate commerce" between the States in various ways, notably in authorizing the construction of the several Pacific Railroads, in the establishment of National Banks, the Freedman's Bureau, etc. Last winter, a proposition passed both houses, giving to railroads, which owe their existence to charters granted by State authority, to add a general telegraphic business to the other privileges which they enjoy. The bill in which this was incorporated did not become a law, but this particular clause was approved by both houses in spite of the active hostility of the Western Union Telegraph Company. Congress thus jealously asserted its right "to regulate commerce" between the States. In its dealings with the Indians, the Government, deriving its authority from the clause above quoted, has tenaciously adhered to its right therein conferred, and has refused to abrogate that right to any State, notwithstanding the fact that certain ones of the Indians have become civilized and absorbed in the population of individual States; so long as they maintain their tribal relations, the Government has jealously insisted upon its right to deal with them exclusively.

Some question has been raised as to what constitutes "commerce." When the Constitution was framed, the era of railroads, telegraphs, and many great enterprises had not dawned upon the country. These need regulating quite as much as the commercial methods then in vogue, and the terms of the Constitution must be construed to cover the modern methods as fully as it does the old. Commerce is no longer restricted to the traffic carried on between a few important seaports, as it was a hundred years ago, but every manufacturer regards the entire country as his field of operations for the sale of his products. Inter-state commerce is the backbone of the nation's prosperity, and consequently, should be controlled by the Federal Government instead of separate State legislation. Laws universal in their application should regulate the relations maintained between buyer and seller, the collection of debts, provide for bankruptcy, and specify what is legitimate commerce and what is fraudulent. Where it is possible to provide standards for staple goods, the public is entitled to the protection afforded by such standards. Congress has provided a standard of weights and measures, regulates gauging of whisky, and does a thousand and one other things pertaining to the regulation of commerce that are of no greater importance than providing a standard for wrought gold, stipulating what shall constitute degrees of fineness, and providing penalties for misrepresentation of quality.

The necessity for a national standard for wrought gold is so apparent that no argument is necessary to convince any one at all familiar with the trade. Gold goods are no longer considered matters of luxury, but certain things are looked upon as necessary for every person to own. Watches, for instance, have become indispensable, as have certain articles of personal adornment. The imposition practiced upon the people in these respects by unscrupulous dealers aggregate thousands upon thousands of dollars annually. So-called gold goods, stamped eighteen carats fine, frequently consist of a thin plating of gold on a base metal foundation, the pure gold forming but an infinitesimal portion of the product of an assay of the goods. Debased gold goods have become the rule rather than the exception, and comparatively few articles possess the intrinsic value in gold that they are represented to contain. The public that buys these goods has no possible means of detecting their fraudulent character. Externally, they have every appearance of being genuine, and dealers who sell them are as ignorant of their true character as those who buy them. There is no way, short of assaying them, that their true value can be ascertained, and this, of course, can seldom be done. There are few other manufactures that are so well calculated to deceive that even experts fail to discover their true quality. The quality of the products of our looms can be determined to a nicety by unfailling tests; the products of the soil are familiar to all; but the workshops of the goldsmith turn out products that no man save him who makes them, can estimate the value of. The public certainly needs protection from fraudulent practices in articles that have become so much a matter of necessity as have certain classes of gold goods. State legislation can never accomplish the object, for what might be the law in New York State would not apply to Illinois, and Louisiana might not legislate upon the subject at all. What is wanted is Congressional legislation that shall be uniform in all the States. As the jewelry interest is an extensive one, contributing

largely to the foreign and inter-state commerce of the country, recognized by Government as a commercial industry whenever taxation is in question, it seems to us that there can be no doubt as to the power of Congress to provide such regulations as are necessary to protect the public from imposition by means of it. A remedy for many of the existing irregularities of the trade, not to say barefaced frauds, would be found in the establishment of a standard for wrought gold and the providing of adequate penalties for misrepresentation.

### Fraudulent Debtors.

**B**ENJAMIN MAYER, of the late firm of Hirsch & Mayer, was recently convicted in the Court of Oyer and Terminer, of obtaining goods by false representations. It appears that Mayer represented to a number of commission merchants that his firm was perfectly solvent, and so obtained goods to a large amount. Soon after the firm failed, and the assets were *nil*. What became of the goods does not appear. Some of the swindled creditors resolved to make an example of this fraudulent bankrupt, and had him indicted by the Grand Jury, the charge resting upon his transactions with Converse, Stanton & Davis. The guilt of the accused was clearly shown, and he was convicted by a jury. In sentencing Mayer to imprisonment for two years and six months, to pay a fine of \$6,000 and remain committed until the fine was paid, Judge Barrett complimented the prosecuting firm upon having sacrificed their private interest to the public good, in putting an end to the career of a man who was preying upon the public. The Judge said:

"It is satisfactory to see our New York merchants taking high public grounds and seeking to stamp out fraud and fraudulent bankruptcy without regard to their own personal interests. There is that atmosphere about this prosecution. We are entreated to be merciful, but on no substantial grounds, and we cannot fail to see that the exercise of undue clemency would only serve to neutralize what has been done to punish an undoubtedly fraudulent bankruptcy.

"Some time since in this court some persons were tried for arson, and the effect of the conviction in those cases was wholesome. Indeed, since then we have heard of no fires at all in the localities where they had previously been so frequent. We now come to another class of crimes nearly as detrimental to the public interest, and at last some one has been brought to the bar of justice. The effect of this conviction will also undoubtedly be wholesome, and will tend to check fraudulent bankruptcies. It is very important now, with reviving trade and improving industries, that the spirit of our mercantile community should not be dampened by the prevalence of fraud, which is as calamitous in its way as even the shrinkage of values."

A petition has been circulated among the representative houses of the various industries, including the jewelry trade, endorsing the sentiments expressed by Judge Barrett. It has been unfortunate for trade in general and the jewelry trade in particular, that vigorous legal measures were not instituted against fraudulent bankrupts some years ago. Hundreds of thousands of dollars have been offered up by the jewelry trade as a sacrifice to that spirit of compromise that has characterized its dealings with the fraudulent class that prey upon it, and will continue to prey upon it as long as that spirit is permitted to predominate. It may afford some in the business consolation to know that scoundrelism is not entirely confined to the jewelry trade. We thought they had a monopoly of it, but the Mayer case proves we were mistaken. We were led into this error from the fact that the jewelry trade, more than any other, has been in the habit of compounding felonies with confessed thieves, aiding them in covering up their criminal transactions, and after getting them out of the clutches of the law, starting them in business again. We could name any number of cases, where the jewelry trade has compromised frauds quite as flagrant as that of Mayer, and where the fraudulent debtors were fully as deserving of State prison as Mayer. Now, that the commission merchants and Judge Barrett

have shown that the prison doors can be opened to this class of scoundrels, we hope to hear of fewer instances of compromising with fraudulent debtors. A little moral courage and backbone displayed by the trade in this direction, will have a tendency to destroy the brood of vampires that have been sucking its life blood for years.

We are not advocates of harsh measures to men who are unfortunate in business, but there is a wide difference between misfortune and crime. A man may be unfortunate, and failure may be the only honest course for him to pursue. For such men we have every charity, and would heartily second any effort made to start them anew. But for the sneaking frauds in the business, who obtain credit with the deliberate purpose of defrauding their creditors, we have the utmost contempt, and would be glad to be instrumental in securing their incarceration in State prison. Frauds of the Mayer description perpetrated upon the jewelry trade, have contributed almost as much to the depression that characterizes that interest as the hard times. Many a firm can show by their books that the sums they have been swindled out of just marks the difference between profit and loss in the year's business. The conviction of Mayer should be given the greatest amount of publicity, that those men who are contemplating fraudulent failures may understand that the courts have found the means for punishing scoundrels of their class as they deserve. The gentlemen who secured the conviction of Mayer, thereby abandoning any chance that might have existed for a compromise, are deserving the thanks of the entire mercantile community. The fact that the accused subsequently appealed from Judge Barrett's decision and was admitted to bail, does not alter the facts in the case, but exemplifies the ingenious construction of our laws for enabling men to avoid the penalties attached to their misdeeds.

### Artful Dodgers.

**I**T has been a source of wonder and surprise to all the trade how certain out-of-town firms can afford to publish such elaborate and costly catalogues and price lists as they do, and with which they deluge the country. It seems that some of these enterprising firms have been in the habit of assessing the manufacturers from whom they buy largely, from \$100 to \$500, as their share of the expense of this costly publishing. They represent that these catalogues are to be extensively circulated, and that the benefit the manufacturers will receive from the elaborate puffs of their goods will be something immense. The Providence and Attleboro manufacturers have thus far furnished the greater number of victims to this blackmailing scheme, although other fields have been worked to some extent. Of course, these blackmailers are very persuasive, profuse in promises, and even threaten to withdraw their trade in case of a refusal to patronize their catalogue. Some of them have thus secured enough money to pay for all their printing for the year; and one specially enterprising chap, not far from Cincinnati, is said to have built a fine house out of the proceeds of his catalogue scheme.

This is an illegitimate transaction, and those manufacturers who lend themselves to it are doing a great injury to the regular jobbers who seek to do an honest and fair business. It amounts to paying a portion of the expenses of the catalogue publisher, which is equivalent to a special discount on the goods he buys. It enables him to obtain advertising gratuitously, while his competitor has to pay full price. In lending themselves to this paltry swindle, manufacturers are aiding in the injury, of other customers, a proceeding which cannot fail to react upon their own heads when found out. Of course, such advertising does the manufacturer no good whatever, for these catalogues are not circulated among those who are likely to buy of him, but are intended to work up a trade for the jobber alone, and his interests are carefully looked after at the expense of the manufacturer. Some of these victims have discovered the swindle and have grown profane over it. But we have no sympathy to waste on them. They attempted to do a smart thing, to overreach their neighbors, and find instead that they have simply been blackmailed. Those



jobbers who do business enough to warrant the publication of expensive catalogues are not the kind of men to go begging around for money to pay for the printing, or blackmailing their creditors for the same purpose. Those who are idiotic enough to be captured by such a transparent swindle deserve their fate, and should pocket their losses without whining.

THE jewelry trade is regarded as a regular bonanza for canvassers for advertising. Any man who gets up any sort of a scheme for advertising looks upon the jewelry trade as a remarkably good field to cultivate. As a consequence dealers are overrun with solicitors for advertising for books, maps, directories, newspapers, periodicals, religious and profane journals, and a lot of the wildest and most impracticable schemes imaginable. Some of them are weak enough to squander their money on such adventurers, and of course, never get any returns for it. Such advertising does not reach the class of persons who are likely to become patrons of the trade; on the contrary, publications of the adventurous kind are only intended to entrap the unwary, and seldom achieve a circulation beyond the counter of the dealer in waste paper. Ann street paper dealers are overrun with papers of this kind, which they buy, fresh from the press, for waste paper. The science of advertising lies in a judicious use of those mediums that reach and are likely to influence customers. It is for this reason that so many specialty newspapers have become successful. They seek out a special field to labor in and cultivate it thoroughly. They are devoted to the interest they represent; and spare neither trouble nor expense to reach every person in the country who is identified with that interest, either as a manufacturer, a buyer or a seller. No other medium can so well meet the wants of the advertisers in that special line. The wise man places his money where it is likely to bring him returns, and does not scatter it promiscuously about, nor invest in every wild venture that is brought to his notice. Advertising judiciously is money well invested, but much can be wasted on printer's ink without bringing any returns.

THE New York Jewelers' Base Ball Association, with a membership strictly within the trade, was recently challenged by an alleged similar organization at Providence to play a friendly game on the 3d July. The New York Club accepted the invitation, and on arriving at Providence were greeted in a most hospitable manner. The boys were conducted to the Narragansett Hotel, where a sumptuous breakfast awaited them, after which the competing teams started for the field, and the playing commenced. The New York team was composed entirely of amateurs, but the Providence association had, in an unfair and secret manner, enlisted the services of two professionals, and the natural consequence was that victory was awarded to the Providence team. They, however, have won no honor, but, on the contrary, have lowered themselves in the estimation of all honorable men by the unfair advantage taken of their visitors. The New York association is composed of gentlemen, who enter into their sports in a spirit becoming gentlemen, and it was simply disgraceful to ring in professional aid against them.

The Providence association may look at this in a humorous light, but it should not be so considered. It is too great a descent from honor to be humorous. If any of our readers have made bets on the match, we advise them not to pay without an appeal to a competent authority in such matters.

It is but fair to say that the boys speak in the highest terms of praise of the hospitality of the Providence club—they were treated well and often—and we cannot but regret that anything unpleasant should transpire to mar the pleasure of the visit.

THE numerous robberies perpetrated upon jewelers throughout the country, has suggested the idea that an organization might be formed within the trade to secure the conviction of the thieves and the recovery of the goods. In many instances, the persons rob-

bed cannot afford to employ special detectives to aid them, and the local police in small places are not equal to the task of circumventing expert thieves. It is proposed, therefore, to form an Association, to which the dealers of the country shall contribute a small sum annually; then, in case any member is robbed, the Association would employ Pinkerton's Detective Agency to "work up the case." By this means, the person robbed would be relieved of the expense of pursuing the thieves and of prosecuting them. The knowledge that such an association existed in the trade would deter professional thieves from making raids on jewelers, and those persons who are suspected of robbing themselves occasionally, would scarcely take the risk of so doing if they were sure that a searching investigation would be made by skilled detectives. The proposition seems to us a commendable and feasible one, and we should be pleased to have an expression of opinion from members of the trade on the subject.

THE New York Watchmaker's Society, established in 1866, is an organization of practical watchmakers, having head-quarters at Turner Hall, Fourth street. Its membership, at present, is mainly composed of Germans, but its doors are open to all competent watchmakers, none others being admitted to membership. The initiation fee is \$5.00, and the dues fifty cents a month. The Society is benevolent in its aims, providing for needy members, in case of sickness, paying funeral expenses when required, and obtaining situations for those who need them. The weekly allowance for sickness is \$5.00 per week. All members are subjected to a thorough examination as to their knowledge of the business and their capacity as workmen before being admitted to membership, the determination being to admit none but competent workmen. At present, the membership numbers forty. These hold monthly meetings for business and debate, when subjects relating to the horological art are discussed in their practical bearings. The organization is a worthy one, and deserving the support of all practical workmen. Employees desiring workmen may obtain them by addressing the Society, at this office.

THE Assignee of Marcus Kronberg, of Chicago, has paid to the creditors of that worthy individual, a dividend of 33 1-3 per cent. Many of the creditors have been exceedingly annoyed by having their probated accounts returned by the assignee on account of their not agreeing with the books kept by Kronberg. In many instances they have been obliged to prove the delivery of the goods before the assignee would recognize the account. Kronberg's peculiar style of book-keeping is as annoying to the assignee as to the creditors, and it is causing delay in the settlement of the estate. Kronberg was in New York recently, but left abruptly the following day. It is unfortunate for him that the trade in general does not feel as kindly towards him as a few manufacturers do. Notwithstanding the peculiar, not to say suspicious features of Kronberg's recent failure, a few manufacturers are quite as anxious to sell him his goods as ever, urge him to extend his account, and allow him to name his own time for settlement. When such recklessness prevails, it is no wonder that the per centage of the losses in the jewelry trade exceeds that of almost any other.

CONGRESS has passed a bill authorizing the President to appoint Commissioners to represent this country at the International Exhibitions to be held in Sydney, and Melbourne. The sum of \$20,000 is appropriated to defray the expenses of these Commissioners. The Sydney Exhibition opens next month, so that little time is left for our manufacturers to get their exhibits ready. Of firms interested in the jewelry business, the following will be represented at Sydney: Reed & Barton, Simpson, Hall, Miller & Co., Meriden Britannia Co. Silver-Plated Ware; Gorham Manufacturing Company; L. W. Fairchild, gold pens, etc.; Ansonia Clock Company, Seth Thomas Clock Company; American Watch Company; Waterbury Clock Company.

The Melbourne Exhibition will not take place till later, sometime between October, 1880 and May, 1881. In view of the fact that Australia was largely represented at our Centennial Exhibition, and that there is a large and profitable field there for Yankee enterprise to cultivate, it is to be hoped that Congress will make a more liberal appropriation in aid of our exhibitors, to enable all who desire to be fully represented.

The Jewelers' League.

We devote this column to the interests of the League and its membership. Letters or inquiries pertinent to its business or purposes, and which might interest the trade or inquirers, will be herein answered. Address *Jewelers' League*, Box 4001, P. O. New York, or the office of THE CIRCULAR.

A gentleman who will, doubtless, soon become a member, and an active one, asks if we pay any per centage for securing members. No, sir! but your beneficiary will get the benefit of two dollars more for each member you or any other member may secure. Art. V, Sec. 1, of our by-laws distinctly states that "This League is formed for *mutual benefit*, and NOT for profit of any individual member."

We wish the members of the League who are traveling men would display a little more zeal in behalf of the League when "on the road." A few words spoken to a salesman or watchmaker whilst the traveler, perhaps, awaits the attention of the buyer, would awaken an interest on the part of such employee which columns of printed matter might not effect. If interest is awakened, a postal sent to our worthy Secretary, with the address of such party given thereon, and a request that documents be sent, would always meet with a ready response. Please remember this, Commercial Men!

The average age of our total membership at the close of the June meeting was 35 67-100 years, being a very slight advance on the average age of 35 50-100, as mentioned in the annual report of the Executive Committee. Although each member is growing older, and the average, therefore, should be greater, still the constant accession of younger members keeps the average down. Men ought to join right away, at as early age as possible. When in the course of several years we reach the average death rate of the membership—that is, the average member who will die in each year—then the League will just pay the total value of the death losses which have been paid from time to time by each member—no more, no less—but until that average, which is many years away in the future, is reached, each member gets infinitely more than his money's worth; for instance, one who has been a member, and thus fully entitled to all the benefits of the League since our organization, has paid his entrance fee, first assessment therewith, and one death assessment since, amounting in all 10 seven dollars. Should that man die to-day, his beneficiary would be paid, \$902.50, which in any first-class insurance company would cost about \$24.

The League takes none but healthy men, and is managed with strict economy in the expenses of the organization, and that is why its benefits are now, and will continue to be, so cheaply obtained.

At the meeting held on July 2d, the following gentlemen were elected members.—Joseph F. Bartlett, Clinton, Mass.; Louis A. Becker, with Tiffany & Co., N. Y.; Arthur K. Camp, of Stanley & Co., Milwaukee; David B. Churchill, of Churchill & Chace, N. Y.; George F. Churchill, with Shreve, Crump & Low, Boston; William T. Gale, with Tiffany & Co., New York; Frederick W. Gesswein, New York; Robert C. Holden, with Hutchinson & Huestis, Providence; Horace J. Hooton, of Hooton & Savary, Boston; Frank S. Mead, Perth Amboy, N. J.; Winthrop A. Moore, Newport, Ky., with Dueber Watch Case Company; Philip Nast, of Nast & Greenzweig, N. Y.; David D. C. Percival, of D. C. Percival & Co., Boston; Edwin A. Thrall, New York; Russell F. Truslow, Huntingdon Tenn.; George W. Van Nortwick, with Hutchinson & Huestis, Providence.

Three applications, on account of irregularities, were referred back to the applicants for correction.

A paper, signed by twenty-eight members, was received, requesting the Executive Committee to take the necessary steps toward the adoption of a distinctive membership badge, to be worn or not at the option of the members. A matter of so much moment as this, requiring more time than the press of business at that meeting would admit of, it was considered advisable to lay over until the next

regular meeting. At that meeting a plan will be developed which will doubtless meet the approval of each member, as each member's assistance and advice will be invited.

Our League now numbers 475.

The cities containing the greatest number of our members are as follows: Albany, 3; Milwaukee, 3; Pittsburgh, 4; Springfield, Ill., 5; Newark, N. J., 6; Brooklyn, N. Y., 8; Baltimore, Md., 9; St. Louis, 10; Providence, R. I., 11; Philadelphia, Pa., 16; N. Attleboro, Mass., 17; Chicago, 25; Boston, 29; N. Y. City, 262.

A MAN who had no luck at mining in Colorado found himself in Denver with only a little of his capital left. He had a large brick made of worthless metal, except a heavy coating of gold, and a solid gold corner. Then he went to a fortune seeker, and said: "Several years ago a friend of mine was indiscreet enough to attach himself to a gang of road agents. A big haul was made, and he received a solid gold brick as his share. All of the robbers had been captured and sent to the penitentiary, with the exception of the young man. He kept quiet, and is now leading a respectable life. He still is in possession of the gold brick, but he dares not offer it for sale at the Denver Mint or at any of the jewelry stores, for fear of raising suspicion. The price is \$3,500, about half what it was really worth." The fortune hunter was told to break off a corner as a sample. Of course the piece was taken from the small part that was gold. Eventually he bought the brick, and sent it to St. Louis, where it is now on exhibition.

AN elderly Christian woman in a Turkish city earned a livelihood for her infirm husband and numerous family by acting as a broker for the sale of jewels in the harems of the wealthier class of Mussulmans. One day she was told to take all the jewels she had for sale to a house where she had occasionally been employed in her calling. Her husband accompanied her to the door of the harem, and said he would wait there for her, as he had been in the habit of doing. After he had stood at the door for several hours, he knocked, and three negresses appeared; and he asked them to tell his wife to come to him. They denied that the wife had come to the house that day, and treated him as a madman. He went home, hoping that she had, unseen by the black slaves, left the harem by some other door, and gone to their own house; but nothing had been heard of her there. For several days he went about the town inquiring for her without success. At last he happened to meet in the street the youngest of the three negresses whom he had seen at the Turkish house, a girl of 15; she stopped him, saying she was so sorry for him, that she would tell him the whole truth; and then she related how her mistress had taken his wife into a room where there was a trap-door opening above a deep vault, and there asked her to show the jewels she had brought. They were carefully examined and placed on a divan. Her mistress then, with the help of the two other female slaves, pushed the poor woman into the vault, and closed the trap over her. All this the girl said she had seen; and she added that they had heard his wife's cries until late at night, and supposed that she must then have died from the effects of her fall. In the morning, she continued, the body was taken out by a small staircase leading down to the vault from the court-yard, and buried in the garden by the same black slaves. Armed with this statement, the husband laid an accusation against both the Turkish lady and her two negresses. The tribunal ordered a domiciliary visit to the house, but nothing was found that could inculpate any one. He then applied for the summoning of the young negress to give evidence, but she was not summoned, and no trial took place, the husband of the lady being high in office, rich, and influential, which were three good reasons from screening his wife from justice. The jewels obtained by this abominable crime, were worth £800, and their different owners who had merely intrusted them to the murdered woman for sale, never heard more of them, though it is believed that the President and members of the tribunal had been requested, not without compliance, to select a few of them for the use of their harems.

## Proceedings of the Horological Club.

A DISTINGUISHED BODY OF WATCH AND CLOCK MAKERS.

*Sixty-fourth Discussion.—Communicated by the Secretary.*

[NOTICE.—Correspondents should write all letters intended for the Club separate from any other business matters, and headed "Secretary of the Horological Club." Direct the envelope to D. H. Hopkinson, Esq. Write only on one side of the paper, state the points briefly, mail as early as possible, as it must be received here not later than two days before the end of the month in order to be discussed and reported in the CIRCULAR for the next month.]

### PROPORTIONS FOR THE DETACHED LEVER ESCAPEMENT.

*Secretary of Horological Club :*

In making a Watch, let me know the length of the lever to the size of the escape wheel; and the height of the balance or size of the balance to the size of a certain escape wheel. Supposing a great wheel measures 20 on the wheel plate, how am I to find the size of the rest of the wheels by it?  
C. A.

Mr. Uhrmacher replied, that there are no arbitrary or fixed proportions for the different parts, as this escapement admits of greater variations in the proportional sizes than any other. Consequently different makers have very different ideas and systems for constructing the escapements of their respective manufactures. The length of the lever relatively to the diameter of the escape wheel shows the greatest variations of any part of the escapement—some levers being made very short, while the acting length of others would be as much as three times the diameter of the wheel.

In this escapement there are many considerations to be taken into account, in determining the proportional sizes to be adopted in any particular case, among which might be mentioned the different proportions of the moving force to the weight and diameter of the balance, and to the required speed of its vibrations, as well as to the amount of care which can be bestowed on the execution of the escapement, the particular form in which it is to be constructed and arranged, etc. A finely made and closely fitted escapement would admit of proportions which would be utterly unsafe in a cheaply made and loosely fitted one. The same may be said of the sizes of wheels for the train. It is first necessary to decide on the exact construction of the movement, and what it is to do, before the sizes of the wheels, pinions, etc., can be settled.

The effects of different proportions in the escapement are discussed in M. Grossmann's Essay on the Detached Lever, published at Glashutte, Germany; in Saunier's French work on Modern Horology; and in Excelsior's English articles on the Anker and English Lever Escapements published in the *Circular*. It would be impossible to definitely advise Mr. A, without knowing all the details of his proposed watch. The better way would be for him to study the above named writers, and decide for himself upon the proportions which would best meet the objects he had in view.

*Secretary of Horological Club :*

I have a single cell, two-quart Smee battery, but have found the following difficulty in silver-plating old watch cases: The battery appears to work all right, and the silver is laid on evenly and nicely, but after taking out, the coating can sometimes be peeled off with the finger. Often, if put in for a few minutes for the first time, that coat will stick, then, after cleaning, and leaving in an hour or so till thoroughly coated, it will then peel off as described. Can any one of your esteemed members tell the difficulty, and would it be asking too much if some one would give full directions for running such a battery? My experience before has been with a Bunsen.

I will offer a "wrinkle" or two of my own, which may be new to some one.

In taking the temper out of hard staffs in order to drill, without injury to adjacent parts, I have found the following method to work very nicely: Take a small piece of charcoal, as large as a pea, or larger, according to size of staff: make a hole in it into which the end of the staff may be inserted; then holding the staff with the pliers, direct the flame of the lamp upon the coal until it is ignited, when it can be kept in a red glow by the blowpipe alone, until all consumed. This will not even blue the rest of the stuff, and will usually take out the temper sufficiently to drill. If once will not do, it may be repeated several times till the end is accomplished.

To take broken plate screws out of American watches, I have two methods: *First*, when it can be done, I turn them out with the sharp point of a graver. When this cannot be done, with a thin screw file I file into the end of the post until the broken screw is reached and a slot made in it by which it can be easily raised. Some may call that "botchwork," but I cannot see that it injures the post, and when the upper plate is on, and the screw in, cannot be seen.

W. H. K.

Mr. Electrode thought, from the description, that the fault was probably in the defective cleaning of the case in the first place, or handling it with the fingers afterwards. The fault was not in the battery, if properly fitted up, for the Smee battery was well adapted for electro-plating.

The case, if very much tarnished and covered with oxide, should be either thoroughly scoured, or dipped in an acid solution, or both, depending on the material, etc. It should, if greasy, be washed with soap and water, or dipped in a strong solution of potash in water. It should be finally rinsed in clean water, connected with the battery, and put into the plating solution while still wet from the rinsing. The connecting of the case with the battery before immersion, is to prevent the solution from corroding or producing any effect upon the clean surface before the battery current passes through it, and secure the immediate proper deposition of the foundation of the coating. That done, the coating should adhere.

Plating is more apt to peel off from a case which is dry when put in the solution, and especially if it has been exposed to the air some little time before immersion. Aside from any tarnishing of the case which might result from this exposure, the air seems to adhere to the surface and prevent the solution from acting well upon it. With very troublesome cases, some platers make a practice of dipping them in a solution of chloride of zinc in water, (common soft-soldering solution,) just before immersion. But that is injurious to the plating solution, and should only be tried in case of necessity, and then only with a small quantity of solution, which should be kept separated from the rest. It will generally be sufficient to thoroughly clean the article as before described, connect with the battery, and immerse while yet wet from the cleaning and rinsing.

BOOK FOR "W. H. W."

*Secretary of Horological Club :*

If W. H. W. will address O. H. Woodworth, Columbia City, Indiana, he can get the book he inquired for. T. F. W.

Mr. L. F. G. also gives the same address.

INFORMATION WANTED.

*Secretary of Horological Club :*

DEAR SIR:—I have just bought and put in order an old hand made 8 day clock, brass face and movements, with calendar. Will you help me to find out about when it was made, or where the maker lived? I suppose it to be 100 to 200 years old. Azariah Priar, Lebanon, is the name on the face of the movement. What Lebanon is it?  
S. W. B.

If Mr. B. will correspond with the watchmakers of Lebanon, Pa., he will probably obtain the desired information.

REMARKABLY FINE SCREW CUTTING ON A LATHE.

WALTHAM, Mass. June 23d, 1879.

*Secretary of Horological Club.*

Enclosed is a screw  $\frac{1}{100}$ th of an inch in diameter, with 150 threads to the centimeter, equal to 375 to the inch. We can cut 500 to the inch, but consider the 375 as a severer test of workmanship, as the coarser the thread, the *smaller the screw at the bottom of the thread*, which in this case is  $\frac{5}{10000}$  of an inch, with this lathe, made expressly for such work, we can cut any taps, from  $\frac{1}{100}$ th of an inch upwards, and from 500 threads to the inch downwards. Is this fact of general interest? If so, you may put it where it will do the most good.  
Respectfully,

AMERICAN WATCH TOOL CO.

This specimen was examined by the members with a powerful glass, and found to be a perfect, clearly cut screw, over  $\frac{1}{8}$  inch long (exclusive of the head), well finished and straight, notwithstanding its minute diameter. All agreed that it was the finest specimen of machine cut screw they had ever seen, and that it reflected credit on

the lathe on which such work could be done, and on the skill of the workman who cut it. We are glad to call attention to the fact, and without doubt there are many uses for which such fine screws will be invaluable, being as perfect and true as they are small.

#### HEGHT'S TOOL FOR CUTTING JEWEL SETTINGS.

Attention was also called to Mr. Phil Hegt's ingenious tool for cutting the settings for jewels. The jewel to be set is first tried in a guage having a series of punched settings, graduated in twelve sizes. Then the setting in which it fits properly is used for getting the jaws of the cutter in position, when they will cut a setting of identically the same size. The whole thing is so quickly, neatly and surely done, that it is actually a pleasure to set jewels with this tool. The cutter and guage are mailed complete for the low sum of \$2.25, as advertised in the *Circular*.

#### "THE PRACTICAL TREATISE" AND "EXCELSIOR'S BOOK."

Mr. Clerkenwell stated that a number of letters had been sent in, asking where to get the "Practical Treatise" mentioned by Excelsior in his Practical Hints; also, about "Excelsior's Book;" if it was the same as the former, who publishes it, etc? He would inform our correspondents that the "Practical Treatise" and "Excelsior's Book" are the same work. It is published by the publisher of the *Jewelers' Circular*, who will send it, postpaid, to any address for \$3.50, at which price it will prove the best investment a workman could make. This book was also sometimes called "Practical Hints on Watch Repairing," and correctly so, as it comprises the first series of those articles, revised and enlarged. The Practical Hints now being published in the *Circular* are the second series, which is not completed, and of course has not been republished.

The only way the gentlemen can now obtain the first series is in the book form, as before stated—and already the stock of books is very small, owing to the great call for them from every part of the country. It would be superfluous to repeat the many commendations the Club has given Excelsior's Book, and we would refer the inquirers to the reports of our proceedings in the back numbers of the *Circular* for full details. But every reading workman must know that Excelsior's Practical Hints are the most valuable and serviceable to the working watchmaker of anything within his reach. They contain full instructions, from details elementary enough for the beginner to others sufficiently advanced for the most skillful—something suited for the needs of every grade of workman, and all thoroughly practical and trustworthy. As the publisher had stated, the more experienced the workman, and therefore qualified to judge, the more hearty and enthusiastic his praises of Excelsior's Book, as a practical guide and reference book. It has become a standard work for the watchmaker's bench; so much so, that for one not to have it is considered evidence that he is rather "slow" or something worse.

Our correspondents are advised not to put off sending for it too long, or they may not be able to get it at all; in which case only a man who has thoroughly studied it, and worked by it, could appreciate the loss they will sustain by the deprivation.

#### NICKEL-PLATING PROCESS WANTED—RENEWING OLD FILES—GOLD-PLATING POWDER.

##### *Secretary of Horological Club:*

Will some of your honorable members tell me how to prepare a nickel solution for plating; also, how to construct a battery that will do the most efficient work; and will there be any danger of small tools becoming magnetized while going through the process? I would also ask what ruby files are principally used for, and how used the most advantageously?

Some time ago I gathered together a lot of old worn-out files, both large and small, coarse and fine, and boiled them for half an hour in saleratus water (4 oz. saleratus to 1 qt. of water.) I then washed them in clean water, and stood them in a solution of sulphuric acid and water, (4 oz. of sulphuric acid to 1 qt. of water.) I removed the small and fine files at the end of forty-five minutes, but the larger and coarser ones I let remain for two or three hours, looking at them occasionally to see that they didn't cut too much. I then washed them thoroughly with a stiff brush and plenty of clean

water; then dried and oiled them a little to prevent their rusting. I have used them for several months, and I think they cut as well and last nearly as long as new files.

I also use a gold friction powder that I find very handy in removing or covering over-spots on gold or plated articles. Where the plate is worn off, and where I do not care to dip the articles in a solution, I dissolve twenty-four (24) grains of fine gold (coin) in one half ( $\frac{1}{2}$ ) oz. nitro muriatic acid, and then abstract the acid with clean blotting paper. When the paper is thoroughly dry I burn it and pulverize the ashes.

#### LONE STAR.

Mr. Electrode said that the process of nickel-plating, as usually followed, was covered by patent, and, as our correspondent would have to pay a royalty for using it, he had better get instructions from headquarters and follow the entire process as adopted by the patentee. He can probably get all the desired information, as well as suitable chemicals and apparatus, from Condit, Hansom & Van Winkle, of Newark, N. J. There have been published processes for giving a thin coating of nickel by boiling the articles in certain solutions, without any battery. But he had no knowledge of their value, and could not in general recommend experimenting with cheap or untried methods, as they were likely to result in disappointment and loss. Old practitioners might succeed with them, but beginners would do better to follow some standard methods, and use all the means and appliances which experience had shown to be desirable. Tools will not be magnetized by the battery, only by coils of wire, or by electro magnets. But they will be magnetized by a machine which produces electricity.

Ruby files are employed for working on materials too hard for steel files, as in opening the slats in finished cylinders, etc. Being very fragile, they must be used with the utmost care, to avoid breaking them.

The process of cleaning and renewing old files would be found useful wherever there was a lot of worthless files lying around the shop. Very often, when the files did not need recutting, they were so clogged up with dirt and grease that they were of little service. A good boiling in the saleratus water, with a thorough scouring afterwards, would make a great difference in their working, even without the acid bath.

The method of using the gold powder was not stated, but it was doubtless rubbed on the bare spots with chamois skin moistened with water. The spots should first be well cleaned, the same as for plating with a battery, to resist the deposition of the gold upon them.

#### POLISHING PIVOTS.

##### *Secretary of Horological Club:*

Will some member of your most honored body please inform me, through your Proceedings, the best way to polish pivots, and the best polish to use for that purpose? G. A.

Mr. McFuzee answered that there were a number of ways to polish pivots. After turning the pivot down about to size, it is ground with oil stone dust and oil, till the marks of the graver are removed, and a smooth "gray" or dead white surface is obtained—the pivot now being of a size to barely enter its hole, and perfectly shaped. It is then polished with sharp or hard rouge. Both the grinding and polishing are best done with slips of bell metal filed to shape, and used like the old-fashioned pivot burnishers. Many workmen finish off with Vienna lime or diamantine to give a fine gloss, but this is hardly necessary if the polishing with sharpe is well done, as that gives a splendid black lustre that is the ideal of perfect polish for steel. The polishing should not be continued too long, or the surface will become a sort of brown color and of inferior appearance. If the "gray" has been well done, a very little further manipulation will suffice to produce the polish, and as soon as it is reached the process should stop. But if the brown shows itself, the surface should again be stoned off, and the polishing repeated. Some workmen take the trouble to finish off the pivot in the Jacot lathe, with the pivot burnisher, in order to harden the surface and make it wear better, and less easily scratched and marred. The foregoing refers to working with the live spindle lathe. If Mr. A. uses the old-fashioned steel verge lathe, or "turns," he is, of course, confined to the pivot file and burnisher for finishing the pivots.

## Views of Correspondents.

To the Editor of the *Jewelers' Circular* :

Herewith we hand you a letter recently received by us. It is unique, as showing the possible future of the plated-ware business.

GENTLEMEN:—Believing gold and silver, as precious metals, were designed by God to be for ornament and use, and not a means of robbing the people of their hard earnings through a plea that gold and silver is necessary as a basis for the money of a country, I write to ask you if you ever make cooking vessels either of the solid or plated metals referred to. God directed the Israelites in making altars not to use iron upon them,—“*Deut.* 27 : 5.” I believe iron as cooking utensils are injurious to health, and were therefore prohibited.

We have a prophecy in “*Zechariah*, 14 : 20,” that the pots in the Lord’s house shall be like the bowls before the altar. I believe after the settlement of this great financial question, when it is clearly shown that it is not necessary to use our gold and silver to make exchange of produce, our silversmiths will have plenty of work making useful articles which the people will be able to buy because of their prosperity, when they shall see that the laws given for cleanliness were given for health as well.

If you do not make cooking utensils, if I were to forward the money, could you make me two stew pans, to hold about a gallon and a half apiece, lined with gold? If you could, please let me know what amount it would be necessary to send, and oblige,

Yours respectfully,

A. B. C.

To the Editor of the *Jewelers Circular* :

I have read with pleasure your articles in the interest of the retail dealers, but I think you have been too severe on the jobbers. That is, I do not think sufficient discrimination is made at all times between those jobbers who do a fair, honest, legitimate trade, and those “skins” who call themselves jobbers, but go about the country doing a retail trade. Legitimate jobbers are true friends of the retailers, and should be supported. They bring to the very doors of the retailers the goods they need, and save them long and expensive journeys to reach the manufacturers. So long as they can confine their operations to jobbing they are a convenience and a benefit to trade, but when they first come to us and sell all they can, and then go out and sell at retail under our noses, to our own customers, they are destroying the foundation of legitimate trade.

But the jobbers are not alone in this petty business. Some of the eastern manufacturers do identically the same thing. These send out their travelers to sell to jobbers, and after they have filled them up, they call on us retailers, and from us go to outsiders and sell at retail to whoever will buy. I have known them to sell to druggists, stationers, and even to pay their bills at the hotel from the goods in their sample trunks. They even undersell the jobbers, and of course, can discount the retailers all to pieces. A certain class of Providence and Attleboro manufacturers have been quite as guilty in this respect as any of the “snide” jobbers elsewhere. I hold, that the true interests of the trade lies in the cultivation of close business relations between the legitimate jobbers and the retailers. To this end, they should organize societies for mutual protection against the machinations of unscrupulous manufacturers. They are natural allies, and should work together to crush out the retail manufacturers, who are quite as unscrupulous regarding the quality of their goods, as they are to their purchasers. I hope to see THE CIRCULAR go into this matter as vigorously as it has into the “skin” jobbers.

RETAILER.

To the Editor of the *Jewelers' Circular* :

I admire argument, logic, force, and powerful analysis in an oponent; I honor a strong and energetic competitor; but my whole nature revolts to meet a blackguard. What is more noble, more exhilarating than free discussion and an honest difference of thought between intellectual men? In a world made up of a variety of human organism, with no two possessed of same cranial development, it were strange indeed if we could all think alike and reason from like causes, in the same channel to identical conclusions. It is impossible. We might as well hope to bring affinity between the fire and water, fraternity and feeling between the hyena and the lamb, or harmony of thought between Popery and modern progress.

It is well that it should be so. It is through agitation and originality of thought and reasoning that civilization alone progresses. Power of thought is the noblest attribute of man. To reason—a pre-

rogative which alone places the crown of superiority upon his brow.

It is in bad taste now-a-days, for any person or for a majority of persons, to usurp a robe of autocracy and infallibility and say to any one, “we are right and you are wrong,” or to meet with ridicule and slander the honest thought of others. It is inconsistent with fairness, liberty, and noble manhood. When manifested in any one individual, this spirit becomes contemptible and disgraceful.

In the absence of an authoritative omniscient judge or censor, it becomes each individual to grant to another the most absolute freedom of thought, freedom of speech, freedom of reason, be the conclusion right, or be they wrong.

But an honest, earnest, severe, or even a scathing criticism is always in order and ever welcome, if personalities are avoided, by the honest seeker after truth.

If the argument of Mr. Charles H. Paine, in his reply to my letter had not been sandwiched in between such cowardly abuse and vulgar arrogance, I should have been happy to continue in a friendly manner the discussion with him, as it is, I consider him unworthy of the notice of a gentleman.

ROCHELLE, Illinois, June 20, 1879.

OTTO WETTSTEIN.

P. S.—*En passant*: Please permit me to state, in consideration of his remark that “the communication has kept my brain perplexed ever since. \* \* \* I wish it had been accompanied by a dose of Rochelle salts, that could have worked out its meaning;” that if the gentleman (?) has not yet obtained the desired relief, I will cheerfully send him a liberal dose of the salts, seeing the “seat of his learning” is within the seat of his — breeches.

J. W.

NEW YORK, June 25th, 1879.

To the Editor of the *Jeweler's Circular* :

DEAR SIR:—There is an article in your June number, entitled “The Boys on the Road,” which is written in a spirit of such exaggerated and fulsome eulogy, that it seems to the writer that the *men* in the workshop, should make some criticism of it lest the “boys” should gain a further supply of a quality which, as evidenced by the article in question, they already have in abundance; namely, conceit.

From the tone of the article, one would suppose that the “boys” in question “separated” as alleged “from their homes and their families, deprived of all social enjoyments, denied the companionship of friends, enjoying but few of the comforts of life” &c., &c., were in rather a worse position in life than a soldier in the midst of an Indian campaign, or a miner who never sees the light of day; and that in comparison to these poor “boys,” the *men* who hammer and polish into shape the wares without which the drummers occupation would be gone, have an easy, smooth, and unclouded existence.

The writer has no wish to detract from the services which the drummers perform, or to deny to any man the credit due him when he does the work assigned to him as well as he knows how; but the author of the article in question, one should bear in his mind, if it be not too full of his woes and hardships to stand a further load, that the men engaged in the manufacturing branch of the trade have their peculiar troubles to bear, and usually bear them like men without drivelling into print about them.

If comparisons were not odious, a picture might be drawn of a workman of our trade, day in and day out hurrying to the dingy shop two or three hours before the poor half starved drummer has partaken of the inferior food provided at “Willard’s” or the “Continental” and, the day long alternately stand over a burning forge and stoop over his workbench, working with head and hands to overcome the numerous difficulties which lie in the way of turning the metal and stone into salable stock; and after his day’s work is done, take himself to his home, there to expend a good part of his meagre wages in providing for himself and family the necessary food, which the traveling salesman has provided for *him* at the expense of his employers.

The “boy” on the road complains too, that after his exhausting labors of the day are over, he has to rack his poor brain with the study of time-tables, instead of seeking his couch, or taking some innocent recreation to which his zealous and continued work has entitled him. As the time-table is usually displayed in the precincts of the bar or billiard room, it might be said that this fact had something to do with the avidity with which the drummer consults the time-table; it is a well-known fact that drummers never drink nor play billiards, because “they desire to keep down expenses.”

The writer of the article referred to, after a general eulogy of the immaculate virtue of the “boys,” says that the drummers “more than any other one thing,” have increased the trade of this country to its present proportions, &c.

This statement is so extravagantly conceited that a severe answer does not seem out of place.

The drummer should remember that the jewelry and other businesses existed before the name "drummer" had any other significance than a military musician—that the business never has and could not exist without the artisan; and if the trades should agree to the total abolition of "drumming" they would still survive. The noble army of drummers has become a necessity only in the same way that the army of Germany has become a necessity, namely, because they maintain a similar one in France.

If both were reduced both countries would be better off.

This answer may seem to be too bitter, but as Mark Twain says in a criticism of his—"Murphy, its for your own good."

AN OLD JEWELER.

## Repairing Swiss Watches

*Continued from page 88, Vol. X.*

Working in a new cylinder has been several times described in the *Journal*; I do not, therefore, purpose describing that at present. In the event of the cylinder pivots being bent—and such an event is of frequent occurrence—some workmen have recourse to a pair of smooth plyers, made just hot enough to turn the color of the pivot to be straightened to a blue; but in this class of work it is rare to meet with a pivot so hard as to require this treatment. It will generally be sufficient, after filling the body of the cylinder with shellac, and at the same time fixing either a bone or brass ferrule, to use a bell-metal polisher on the "Jacot Tool;" taking care to select a notch slightly larger than the pivot, which you have previously measured with the guage that accompanies the tool for that purpose. You will then use a smaller notch, finishing with a burnisher expressly made for this tool, and sharpened No. 1 emery-stone, or emery of similar coarseness on a zinc or lead block; the latter being the better material, the most convenient size being a square block about seven inches long and one and a quarter inches wide, got up true on each of its four sides. The burnisher should be put in a Swiss handle, similar to a pen-holder, and nearly as long, fastened in with shellac or sealing-wax; it can thus be set perfectly straight with the handle. In sharpening, the block should rest against the front of the work-board, pointing from you, and plentifully supplied with emery and oil; mixed not too thickly, the handle held lightly in the right hand, and the first finger of the left applied on the top of burnisher; the stroke should be from point to heel, lifting it from the block for the return stroke. For reducing a pivot the burnisher should be cut on a No. 2 stone or emery of a similar grade.

Should a pivot be broken in this process a new plug will be necessary; the removal of the old plug should be done by means of a punch, of a knee shape, resting the shell of cylinder on a brass stake for that purpose; this stake should have a slight recess turned in it, just large enough to admit the cylinder, and the hole sufficiently large to admit the plug when driven out; a slight tap with a light hammer will remove the plug, and a new one should be turned from a piece of staff steel, which has been previously hardened and tempered, let down to a full blue color. The part which enters the cylinder should be perfectly parallel, not tapered, or the shell would probably be burst in putting it in; if you have a micrometer to measure it with it is a simple matter. Having fitted the plug to the shell (it should enter about a third of the distance it has to go), the centre has to be cut off, and the head made flat and polished; this can be done in the screw head, or balance tool; the portion which is to form the new pivot and arbor you will roughly shape before cutting off.

## PIVOTING C. LINDEP.

The plug has now to be fixed in position in the cylinder; some workmen use a punch similar to the one used to remove the plug, only flat on its face, resting shell of cylinder on the punch, and tapping plug in with the hammer; others press the plug in with the extreme end of a thin, flat burnisher, holding plug in vice, or a stake for that purpose, the latter in my opinion being the preferable plan. The plug has now to be centred; you will use for this purpose a steel runner similar to the one used for rounding up the end of a pivot, but with larger holes; these should be loosely chamfered out, hardened and polished; the extreme end of the cylinder will work in one of these holes, which should be plentifully supplied with oil. The top pivot being protected by running in a brass runner, having a hole sufficiently large to admit the pivot freely, the shoulder taking the thrust, you can thus turn the extreme end of the plug true with the body of the cylinder. Having centered the plug, it only remains to turn the hollow and pivot, leaving the latter three degrees larger than it will be ultimately required, burnishing it down this amount with first the rough and then the fine burnisher.

If the upper pivot is the one broken, it will sometimes be possible with a high cylinder to do without a new plug, by knocking out the old one sufficiently to allow you to turn another pivot on it; at the same time, this is not so good as replacing the plug with a new one, as the plug has a tendency to draw oil away from the wheel teeth. It will not be necessary to describe the method of replacing the upper plug, as it is nearly similar to the lower.

There is yet one other way of replacing a pivot that is broken, viz.: by drilling through the old plug and inserting a piece of steel, somewhat larger than the shoulder of the old one. The centring runner which I described when speaking of the new plug, must be used, and a recess turned in the plug sufficiently deep to start the drill truly. Of course before doing this, the cylinder will be filled with shellac or sealing-wax, to enable it to withstand the pressure. Having the hollow turned sufficiently deep to bury the angle of the drill, you will remove the centring runner and replace it with one having a hole in it to take a drill, which for this purpose, should be short and strong, and not relieved much behind the cutting part. If ground to cut only one way, and tapered in thickness to the point, it will work quickly and well. Although the plugs of Swiss cylinders are not very hard, it is not best to use oil to the drill; spirits of turpentine is the best lubricator for this purpose. The pressure on the drill, which, when cutting, will be considerable, should be relieved at the return stroke of the bow; if your drill is sufficiently hard and not driven too rapidly, the drilling will proceed pleasantly. Having drilled the plug through, you will insert a piece of steel, previously hardened, tempered, and polished down to size, and not too taper, or a piece of a cutting pivot broach may be blued and inserted. Previous to inserting you will round up and burnish the end nicely, and any burr thrown up on the plug by the drill must be removed by a steel polisher and red stuff, resting it on cork, while doing so to keep it flat.

The new piece can be tapped in with a light hammer, while resting the shell on a punch replace the shellac in cylinder, and with the centring runner turn the extreme end of plug to a centre. You can now proceed as described in making a new plug.

Hitherto, I have said nothing about the size of the pivot with relation to its hole; now, this is apparently a very easy thing to do correctly, but to an inexperienced workman it is not so. The side shake in cylinder pivot holes should be greater than to ordinary train holes; one-sixth is the amount prescribed by "Saunier;" the size of pivot relatively to the cylinder about one-eighth the diameter of the body of the cylinder. It is very necessary that this amount of side shake should be correctly recognized; if less than the amount stated, the watch, though performing well when the oil is fresh, fails to do so when it commences to thicken. The only accurate way of getting at the correct amount of shake, is to make a pivot or two to a jewel hole by means of a micrometer; the eye will soon become capable of correctly estimating the amount necessary. If any doubt exists, a round broach can be used to size the pivot hole, and the micrometer will then decide the question.

*(To be continued)*

## Practical Hints on Watch Repairing.

BY EXCELSIOR.—No. 52.

EXAMINING THE "AMERICAN" LEVER.—*Continued.*

(809) *The Escapement.*—The wheel and pallet action in American movements can generally be watched through two holes made in the plate for that purpose. In the coarser grades, the lockings are quite deep, but in the finer ones, the caution in section (718) should be observed in testing. See that the banking screws are tight in the plate. If not, close the hole a little on the under surface of the plate. A loose banking screw is sure to be moved out of place by the continual knocks of the lever, and derange the action of the escapement. Before turning the banking screws to adjust the lockings, see which way each should be turned to carry the pin in or out, as may be required, for any given motion of the screw head may carry the pin in either direction, depending on which side of the center it is on. Many workmen content themselves with turning each one slowly inward till the balance cannot escape, then outward just enough for the guard pin to clear the roller table well, and the balance to play freely. That might answer if that was all which required adjustment, or everything else was known to be correct. But there are many other points equally important to be examined, and the only safe method is to follow the directions already given in full, under "Detached Lever Escapement." (313 to 473, also (749). The hair-spring and its requirements for all conditions, and all grades of movements, will be found fully considered in the "Practical Treatise," etc., before mentioned. If the escape wheel does not act on the pallets at the right height, it can be changed by driving its collet up or down on the pinion arbor. Always examine if the escape wheel is tight on the pinion. If not, take it off, and tighten the collet with the hole-closing punch. This must be carefully done, to avoid getting the wheel out of centre when replaced. See if the belly or the tail of the lever, can touch on the escape wheel, when the latter is raised; if the pallet jewels are loose, they must be adjusted in position and cemented in.

(810) In the  $\frac{3}{4}$  plate movements, or any similar constructions having the balance sunk, be very particular to see that the lever is perfectly free under its bridge, and both pivots free in their holes, either side up, with the proper amount of end shake. Examine the escapement very carefully, especially the fork-and-roller and safety actions, in the different positions of the movement. See if any of the wheels come too near the bottoms of their sinks, or around their edges; if the outer end of the lever fork, or the balance rim or screws, or the main wheel teeth can touch the case or its springs, or the ring around the movement, when one is used; if the main and center wheels can get so near together as to touch, or the main wheel rub on the center of the center wheel, in the pinion; if the center wheel can work partly or entirely over the tops of the third pinion leaves. Be sure that the upper plate is firmly screwed to its place when you try the end shakes; and that the movement holding screw will not pull the plates apart, or spring the upper one, and so change the shakes, when the movement is fastened in the case.

(811) *The Train.*—Examine all depthings, pivots, pivot holes or jewels, pinion leaves, etc. Look over every wheel for bent teeth; also the wheels and their sinks and the plates for any mark of rubbing or scratching, and if found, search out and remove the cause of it. Move the contiguous wheels as near together and far apart as their end shakes will allow, and see if they can touch, or rub on the hubs on the pinions, or can get over or under the ends of the pinion leaves. The end-shakes in American levers can safely be less than was directed for the Anker (651). Up to the third pinion, the end-shake should never exceed the diameter of the balance pivots; for the third and centre pinions it may be a trifle more, but must never exceed twice that diameter, even for the center pinions. The balance pivots are selected as the standard, merely as a conve-

nient part for comparison. In fine movements with fine pivots, the end-shakes may correspond. Care must be taken that the pivots are free in their holes in all positions. A pivot will seem to bind in its hole or jewel at times, while perfectly free at other times. Take out the lever, then screw the plates together again, and move the train with very slight pressure on the main wheel, in all positions of the movement, to see if there is any sticking. If so, it will be easy to see where it is. See if the jewel is tight in its setting, and the edge of the hole not rough or chipped; the pivot not too small for the holes, (658); if the pivot is in the least bent; if it is perfectly round, and cylindrical or of equal diameter from end to end, or is a little larger just at the shoulder or at the end; or if it is has a "lump" at the shoulder, (297, 650); or is rusty, marred or bruised, etc. In any such case, the remedy is obvious. When an extra center staff or setting arbor is used for setting the hands, it should be perfectly free to turn, so that the motion works can carry it with them without perceptible friction or effort, but not have so much play in its holes as to shake about.

(812) If the fourth wheel runs too near the plate, raise it on the pinion arbor (809). If the teeth come very near the pillar, dress that off. If too near the center wheel, raise it. Be sure that the pins in the dial posts cannot touch this or any other wheel. Sometimes the points of the screws which hold the third bridge, or false plate under the dial, stick up too far and interfere with the fourth wheel. In a  $\frac{3}{4}$  plate movement, see that the fourth wheel teeth cannot touch the balance rim, or its screws, or the screws on the lever pallets. In the latter case, raise the wheel; in the former see the same fault in English levers, (791, 803). See if the third wheel runs too near the plate; or can touch the potance, or the heads of the screws which hold the set jewels; or if the third pinion leaves touch the side or bottom of its sink.

(813) See if the centre wheel is true in the round, and in the flat; if any teeth are bent, or corners worn, (659). Raise it to its highest end-shake, and see if it can touch under the main wheel. If it does, and the pinion is upright, pivot holes not worn, and the end-shake correct, (811), spring the arms down to clear the main-wheel, if it can be done without rubbing the bottom of its sink. If not, raise the barrel, either on its arbor or by raising arbor and all. But if this would bring the barrel too near the balance, then the center wheel should be lowered, and the sink turned deeper, if necessary, to clear. If the centre pinion has too much end-shake, confining its play will probably prevent it from rubbing on the main-wheel, and should be done by bumping the upper center-pinion pivot hole down a little. Take off the potance, place the pivot hole on the stake, over a hole say  $\frac{1}{8}$  inch in diameter, and drive down the metal center with a round headed punch. The object is not to drive down the pivot bush, (when the hole is bushed,) but the metal around it also, in a sort of conical elevation having the hole in the center. A very little will generally be sufficient. If the pivot hole is slightly closed by the operation, shown by the pivot being too tight in it, open it with a round broach. Before driving up a pivot hole, or closing it, always clean it out perfectly bright, dry and clean, otherwise you may never be able to get the dirt out entirely, after working at it. After bumping the hole as described, it may be necessary to countersink the hole for the pinion, or hollow, in the foot of the potance, to allow the potance to come close and flat on the plate, as before. If only the outer edge of the center wheel rubs on the main-wheel, that can generally be cured by springing the arms down.

(814) When the watch is apart, see if the center wheel rubs on the bottom of its sink, and whether all around or only on one side. In the former case, the wheel should generally be raised by bumping up the lower pivot hole, when there is considerable end-shake; but if the shake is no more than enough, bend up the arms. If this would make the center and main-wheels touch, turn out the sink, instead of raising the wheel. In the latter case, above named, (the wheel rubbing only on one side,) the pinion is not upright; one pivot or pivot hole badly worn; or the bottom of the centre-wheel sink is

not level, and should be turned out deeper. Also see if the rache wheel can project into the bottom of the sink, high enough to rub on the center wheel. When this occurs, it makes a cause of stoppage which is often very puzzling to discover. It is generally shown by marks of scraping on the under side of the center wheel teeth, or some of them. The remedy is to bump the plate towards the dial, at the edge of the center wheel sink, and just over the ratchet wheel, enough to hold the ratchet teeth below the reach of the center wheel. A very little will do this, but the ratchet should be screwed in place and tried, to be sure that it cannot get higher than the bottom of the center wheel sink. In a  $\frac{3}{4}$  plate movement, examine if the center wheel teeth can rub on the edge of the balance cock, or the balance, or touch the hair-spring.

(815) If the centre pinion leaves or arbor can touch in the hole or hollow through the potance foot, dress out the latter to give plenty of clearance. See if the pinion is upright; if the pivots or pivot holes are sound and well fitted, or worn, rusty or cut. If so, see center pinion in English Lever, (758.) If the lower pivot hole is worn, and the bearing is thin, put in a new bush long enough to retain the oil and be durable, (757). If a reversible or "safety" center pinion, of whatever shape, is used, try it to see that it works properly, and is not stuck so tightly that it could not loosen itself in case the main-spring should break, as then it would be no better than a solid pinion. After cleaning, oil the screw slightly, to prevent any possibility of rusting,—but too much oil will be as bad as none at all.

(816) If the main wheel teeth can touch the sides of its sink, or the pillar, or the dust band, the latter surfaces must be dressed off to clear. If the main wheel rubs on the pillar plate, first see if the barrel turns truly on the winding arbor. If it appears at all untrue, it is better to take out the mainspring, and try the barrel alone on the arbor, as it is then much easier to see whether it is perfectly true. If not, true it, either by shifting the head around, (677), or altering its center bearing, (678, 679). If true, but it rubs the plate on one side only, the arbor probably needs uprighting, either by shifting the top or bottom bridge, if they are movable, or by altering the bearings or pivot holes, (670, 703). If the arbor inclines toward or from the center pinion, alter that hole which will improve the depthing of the main wheel in the centre pinion; if the depthing is too deep, move the lowest or nearest pivot away from the pinion; if too shallow, move the further pivot nearer to the pinion. Where the inclination of the arbor is sideways, either the top or bottom hole may be moved, as found desirable. If the main wheel rubs on the plate all around, the barrel should be raised, either on the arbor, (675), or arbor and barrel together, (665). But if raising the barrel would bring it too near the balance, that should not be done, but the pillar plate turned out to clear it properly.

(817) The main wheel depthing is often faulty, when the hight and end shake of the barrel are correct, (766) the arbor upright, etc. It may be corrected in the same way as in the Anker, by moving both top and bottom holes equally, in the required direction (678, 703). Sometimes, when it is difficult to do this, a shallow depthing may be improved by cutting back the fronts of the teeth, so that the straight portion will reach nearer to the point before it meets the curved portion, thus practically enlarging the pitch circle of the wheel. It may be done on a cutting engine or a rounding-up tool, using a flat cutter with only one cutting side, (the other being smooth or "safe,") as it is both needless to cut the backs of the teeth, and weakens them to do so. The front sides should be in line with the center of the wheel, as before. With care and skill, the teeth can be filed by hand, but each tooth must of course be filed exactly the same as the others, else the irregularity would cause them to butt and catch on the pinion leaves. The operation can of course be applied in shallow depthings on other wheels, when they cannot be enlarged or moved up closer. Even when when well done, this dressing off of the fronts of the teeth is not recommended as equivalent

to correcting the depthing without changing the shape of the teeth, but it is greatly preferable to the shallow depthing. Although the wheel is practically enlarged by the operation, and in so far improved, a portion of the curve is removed from the tooth, and what remains is no longer such a curve as is required to enable the tooth, after passing the line of centers, to drive the pinion leaf uniformly, with a rolling motion, and consequently with the least possible amount of rubbing, slipping or friction. This subject will be more fully treated hereafter, in the article on wheel and pinion depthings, etc. If the curves on the back sides of the teeth show marks of rubbing, they may be dressed off a little with the cutter or file, to prevent the interference.

(818) Push the barrel to its highest end-shake, and see if it can touch the balance rim or its screws, or rub in the upper-plate, or on the under side of its bridge, or on the points of the screws holding the arbor dirt cup, or under the corner of the balance cock, or against the side of the potance, or in the dust ring. In the first case, if the end-shake of the barrel is more than necessary for freedom, lessen it and keep the barrel down by bumping up the lower pivot-hole, (675). If the shake is correct, the barrel should be lowered to well clear the balance, unless that would cause it to rub on the plate or on the center wheel. If so, it may sometimes be easier to raise the balance, (801, 802), than to turn out the plate or lower the center wheel to clear. In any other of the above cases of rubbing, the interfering parts must be dressed off enough to clear the barrel or main wheel. The barrel being out, take the winding-arbor square in the sliding tongs, holding the barrel in the fingers, wind up the spring and let it back, and see if it rubs, squeaks or jumps, (683), or moves smoothly and easily and is perfectly free. Also see that the barrel runs truly on the arbor (677, 816, 817). The arbor should take about six turns, or a little more, without the stop works. Try the stop works as in section (708). They should generally be adjusted to take the highest turns of the mainspring, to secure as nearly uniform strength as possible, (711). But this is subject to the demands of isochronism, danger of overrunning, etc.

(819) If the mainspring hooks on a catch inserted in the barrel see that it catches well and cannot slip off; also, that the hook has not been pressed out, through the barrel, so that it projects outside and touches the potance or dust ring. If a hook merely projects, it should be dressed off; but if has been pressed through, even a little it will be safer to fit a new one, as the other probably is or soon will be loose. If the main spring has a brace at the end, see that its lip cannot stick through the barrel cover so far as to interfere with the balance rim or its screws, when the barrel is at its highest end-shake. This is a common fault, caused by fitting a new mainspring and leaving the lip of the brace too long. The movement seems to be all right, but the owner will say that it stops once in a while. The trouble probably is that the brace is too narrow and the lip too long, and if it happens to stick out the furthest when it is under the balance rim, the barrel at its highest end-shake, and the balance at its lowest, the lip will stop the balance, (especially a cut expansion balance,) although it may never touch except when all the parts are in the positions just stated. The brace should very nearly fit the barrel, so that it will have little if any play up or down. The lip will then always have the same hight in its slot in the cover, and should just come through level with the surface, but no more. On the other hand, the lip should not be too short, as it is liable to be drawn under the cover, (which would be worse than none at all,) especially if the brace and mainspring are a little narrow for the barrel, or if the lip is weak or soft, and is bent back by the winding. In any such case, fit a new brace of proper width, spring temper, with the lip of the proper length, stiff and upright.

(820) The same mysterious stoppage is caused, although not so often, by the projecting pivot of the T-cross or pivoted brace. This is a small plate riveted on the end of the mainspring, with pivots fitting in holes in the barrel,—instead of the ordinary hook. This



like the brace, should fit well in the barrel, so that the pivots will have only one position in their holes, (even when the mainspring is too narrow) and the outer ends of both pivots should be made just level with the surface of the barrel. If the body of the plate is too narrow, it may be pushed up or down in the barrel, causing one pivot to stick out too far, while the other may hardly enter its hole. The front or holding sides of the pivots should be smooth and polished, as, if sharp or rough, they would cut and wear the holes. The front should also be vertical, else the pull of the mainspring would tend to force the plate and spring against one end of the barrel, instead of their being free. If the inclination of the front of both pivots was backward, there would be danger of forcing the barrel cover out, or at least springing up that side of it so that it would interfere with the balance when the two were nearest together. With a cut expansion balance the danger is greater, as the free ends of the segments of the rim would be swung against the barrel head by the jars of carrying, although they could not touch if held still. Even if this did not result in actual stoppage of the watch, it would render it impossible to get a uniform rate, or to depend upon it for time.

(821) See that the ratchet, the click, and its spring are sound and in good condition, well fitted, and operate perfectly, (693, 697). In some varieties, this spring makes some trouble in putting the movement together. This may be obviated by first screwing the wheel and click in their places on the bridge, which should then be turned over and the spring properly arranged, when the bridge can be put on over the barrel. When the self-acting or circular click is used, the acting faces of the point should coincide in shape with the spaces between the ratchet-teeth, and when so, at a free rest in the teeth, the acting end of the click should rest squarely against the other end of the circle. This supports the point and spring against the pull of the mainspring when wound. If left unsupported, except by the elasticity of its spring, the click would probably soon snap off. This defective fitting is doubtless the principal cause of the prejudice against the circular clicks. But when properly tempered and shaped, thick enough to fill the space between plate and bridge, not too stiff, neither crowding against their steady pins, nor loose enough to shift back and forth during the winding, there should not, and seldom will, be any fault to find with their operation or durability. The faults named in this article are not more the faults of American levers than of any other watches having the same constructions, *i. e.*, set jewels, screw balances, etc. And in like manner, many other points noted under other constructions should be attended to in examining this one.

(822) The dust ring, around the movement should be examined, both inside and outside, for marks of rubbing; or, in a new movement, to see whether it approaches any acting part too closely. Those most liable to touch are the balance (when sunk), the outer-end of the fork, the fourth wheel, and especially the barrel and main wheel. Be sure that it cannot rub either the points or the *upper sides* of the main wheel teeth. When it comes very near, but you cannot see whether it actually touches, put a slip of writing paper between and press the ring down to its place. If too close, the paper will show the marks. When the simple elastic band is used, and there is no screw in the pillar plate to fix its position, either fit in a screw or put a thin screw driver in the slot in its edge, and slide the ring each way till it hits the barrel, noticing the position of the slot at each extreme, then place it midway between the two, and the ring will of course clear the barrel, unless it touches on the upper edges of the teeth. Sometimes the dust ring hits on a poorly fitted case lifting spring, and is pressed against the barrel or teeth when in the case, although free when out of it. In such instances, the movement generally goes into the case quite hard, and has to be well squeezed to get it down to its right place. The neatest way to free the ring from any interfering part is to hold it against a rapidly revolving lap, fed with oil stone powder and oil, till the place of rubbing is freed. If the workman has no other means, he can scrape it away with a sharp

graver, always in the same direction, so that it will look neatly when done.

(823) There are other constructions of American watches, but the explanations already given will be sufficient. The Howard watches differ from other half and three-quarter plates, mainly in the arrangement of the mainspring and winding works, and in having maintaining works. There will be no difficulty in understanding the latter, after the directions given under the same heading in the English Lever. There is seldom any fault in these watches except in the escapement, unless as the result of accident or of being handled by botches. Many devices which have not been described are found in the better grades of American and other levers, but it would extend these articles too long to treat them fully here. The object has been to confine them to the faults most often found, and make them useful to the largest number of workmen. Perhaps, at some other time the writer may give an article on stem-winding and setting devices, improved regulators and other attachments found in the finer class of watches of both American and foreign makes. He would be glad, however, if some other writer would take up the subject without waiting for him, and treat it fully.

(824) Owing to the use of ready-made cases, instead of those fitted to their respective movements, as in foreign made watches, great care should be taken in examining the fitting of the movement in the case. The movement should never be forced to its place, but the case altered till it will go in with very gentle pressure. Sometimes the shoulder in the upper ring is not turned deep enough to let the movement down as it should, and the glass bezel rests on the dial, or even presses it to one side, causing rubbing in the hour or seconds-hand hole. If this is suspected, shut the bezel down without the glass in it, and examine. If pressing on the dial will stop the watch, the enamel may be uneven or lumpy underneath, or some pivot too long, or sticks up too far, and touches the dial. Ascertain where the fault is, and grind off the enamel to clear, unless the blame is in the pivot. See that the shoulder of the case lets the movement down far enough for the upper or potance plate to come fairly through the back ring. Then the steady-pin should be tight in its place, fit the hole in the case nicely, so as to hold that side of the movement secure. If the pin is loose, screw in a new one; if too small for its hole, fit in a larger one; if it does not hold the movement in the proper position, drill a new hole for it in the case.

(825) Sometimes the back ring is too small for the potance plate, and either does not let it come through properly, or binds on it when it is through. In the latter case it is liable to spring the plate to one side, and cause trouble. The ring should be trimmed out with the scraper, just enough to take in the plate easily, but no more. If the movement holding screw is threaded in the pillar-plate and the potance plate sticks in its ring as described, tightening the screw may spring the plate down on the shoulder of some pinion, especially if the end-shakes are slight. Or, if the screw is seated in the potance plate, tightening too much may pull the plates apart; or spring the upper one, and derange the end shakes; or strain on the pillar screws, and cause them to snap off at the first fall or hard knock the watch gets. The case being trimmed till the movement will go properly to its place with slight pressure, the holding screw should be turned down enough to just bear firmly on the edge of the case, but not bear hard. Its office is not to hold the movement in its place, but to prevent it getting out of place. If the movement is in the least loose, the case should be altered to fit it. The screw alone could not hold it, but would be continually working around and letting it loose again.

To obtain a beautiful deep black polish on iron or steel which is so much sought after, it is required to boil one part of sulphur in ten parts of oil of turpentine, the product of which is a brown sulphuric oil of disagreeable smell. This should be put on the outside as slightly as possible, and heated over a spirit lamp till the required black polish is obtained.

## Watch and Chronometer Jeweling.

*Continued from page 93, Vol. X.*

IN topping, the stone is laid on the finest glass, with a small quantity of the finest diamond powder, and held by a pointed piece of peg-wood in the hole. The wood must not touch the plate, and must not enter the hole so, but that it can have perfect freedom of motion. A few circular strokes, combined with straight lines, will develop a finely defined circular flat on the top of a stone, having a polish superior to the rest of the surface. The jewel is now turned over on the same plate, and the face polished in the same manner. It need not be stated in lengthy terms that the higher the polish the face of the jewel gets, the more brilliant its appearance when set in the watch plate.

The jewel has now received all the work necessary to its external form and polish; the hole, however, is as it was left by the diamond drill, with a sharp corner in the centre that must be taken out, and the sides of the hole finished, and the corners chamfered off and polished. This operation is called opening, and on it depends the real working value of the finished jewel. The jewel may be first set or opened before; in either way the process is the same. In opening by hand, the only tools used are some pieces of wire, say an inch and a quarter long; these are filed to a long taper point—the longer the taper the less risk there will be of breaking the stone in opening. The jewel, whether set or unset, is put up on a chuck which has been drilled to a good depth from the end, to allow the opener to pass through the hole, and yet be perfectly free at its point. This opener, generally of copper wire, is dipped in No. 2 diamond powder; then, the lathe being set in motion at its highest speed, the end is introduced into the hole, and the powder begins to cut—the stone being held by the copper wire, which is held lightly in the fingers, and pressed against the side of the hole; for if it were introduced in a straight line with the mandrel, the powder would grind the opener in very much like a screw, and it being taper, the jewel would be split. It will readily be seen that the form of the hole may be made to suit the requirements of the maker, either perfectly straight taper, or rounded in the vertical sides. The opener is moved backwards and forwards through the hole while the operation is going on, and occasionally rotated in the fingers, the reverse of the motion of lathe spindle, and again must be held in an angular position to the line of the mandrel. This operation is continued with No. 2 powder until the sides of the hole are of the desired form in vertical section, and of a uniform surface. The jewel is now cleaned of the accumulated diamond stone dust and oil, the peg-wood being used for the hole. To clean the surface, the best article is soft new bread, which not only takes off the powder, but effectually takes up the oil, so that the effect of any process may be observed. It is used also by the pinion makers, and all other steel polishing, on account of its detersive quality and the ease with which it may be used. No. 3 powder is now to be used to obtain a polish. In the soft stones tripoli may take its place, used on a copper opener; but the powder is most economical in time. A piece of tortoise-shell, such as a comb-tooth, filed up to a long taper, may be used; or, as is the practice of Mr. James Queen, the best jeweler in the United States, or, indeed, one of the best in the world—a piece of peg-wood answers every purpose, provided the speed is increased. This last process generally leaves the hole of the requisite polish and form. The only thing remaining is, to take off the corners of the hole. This is done by a rounded conical point, charged with fine powder. The corner on the oil-cup side requires but little consideration, but the face side must be chamfered the slightest possible amount, or the bevel may admit the shoulder of the pivot, thus causing a defective end shake and an increased friction, which might be very detrimental if it occurred in the fourth or scape holes. The jewel is now supposed to be ready to be put in its place in the watch, provided it has been opened to a proper size for the side shake.

The opening of jewel holes is done by the jewel-makers in the American watch factories in an entirely different way, as the opener is not held in the hand, and the speed is increased twofold. The advantages gained are speed and a round hole. It is almost impossible to get a round hole by the hand process, especially in an English drilled jewel. The elasticity of the opener allowing it to follow the shape of the opening made by the meeting of the diamond drill, in some cases the hole will be angular, but with the corners rounded off, at others, of an oval form; this last being highly objectionable, as if the proper side shake is taken from one diameter, the pivot will be too large or else too small. To remedy these defects and still lessen the cost, the jewel was chucked as usual; only the spring chuck was used, and the jewel placed in a setting which was thus in a condition to be held truly both in centre and in plane. On the bed of the lathe is placed another head stock facing the other, but set at a slight angle, which is but little more than that of one-half the taper of the wire; this head stock has a hollow mandrel with a spindle inside that rotates with it, but capable of motion longitudinally.

The wire opener is held by the inside spindle, and the power is applied in such a manner that the spindle, together with the wire, revolves with the same rapidity in a contrary way to the mandrel holding the jewel. One consequence of this arrangement is, that double speed is achieved; another, that, owing to that duplicated speed, the opener cuts away the inside of the hole before it has time to leave its own place, and therefore the hole is round. A common round Swiss pivot broach may be made a good test of the circular truth, for the broach is not round, and were it to be introduced into an angular or oval hole, the high sides of the broach would fill the low sides of the hole, so that rotation of the broach would be impossible; but in a round hole it would make no difference, were the broach five sided, oval, or of any irregular section; another advantage is, that No. 2 powder is used for opening and polishing at one operation, but the saving of time is the greatest element of value where large quantities of work are to be dispatched. By the old process the jeweler could open about thirty pairs per day; by the new, a girl could open from 125 to 159 pairs in the same time, the work done being of as good quality as that performed by the skilled workman.

## A Sea Captain's Strategy.

A CHINESE Silversmith, residing at Ceylon, brought home some *silver spoons*, as he called them, to a captain of a ship who had ordered them. The captain, suspecting that the Chinese had played him a trick, common in China, of adding no small quantity of *tutenague* (*Chinese copper*, and alloy of copper, zinc, and nickel; a name given in *India* to zinc or spelter) to the usual proportion of alloy, taxed him with the cheat, which he denied with the strongest assertion of his innocence. The captain then told him that he had brought with him from England a famous water, called *lie-water* which, being placed on the tongue of a person suspected of telling an untruth, if the case were so, burned a hole in it; if otherwise, the party escaped with honor, and unhurt.

The Chinaman thinking it a trick, readily consented; upon which, with much form, a single drop of *aquafortis* was put upon his tongue; he instantly jumped about the room in violent pain crying out, "very true, half *tutenague*" in hopes that confessing the fact, might stop the progress of the *lie-water*, which from the pain he felt, he had some reason to think possessed the property ascribed to it. Several Europeans who were present, and who had bought different pieces of plate from him, now put similar questions to him; and he confessed that it had been his uniform and constant practice to add a very large quantity of *tutenague* to every article made at his shop, for which, during the continuance of the pain, he promised ample separation.

## Precious Stones and Gems.

BY EDWIN W. STREETER.

THE Tourmaline, known in Saxony as "Schorl," from the name of a village where it bounds, is mainly composed of alumina, silica, and boracic acid, although there are specimens which contain a small quantity of iron and manganese. The crystallization is rhomboidal; its cleavage is imperfect, and its fracture conchoidal. It is very brittle. Its hardness is 7 to 7.5, and its specific gravity 2.9 to 3.2. Tourmaline is rarely found of pure water. Its colors are very varied, consisting of shades of greys, yellows, greens, blues, and browns; they all have a tendency towards the darker hues, even to black. A black or red kernel is not infrequently found in the midst of the stone.

Tourmaline possesses double refraction. Some specimens polarize slight perfectly, and by the aid of the polariscope it is easy to detect the pure gem from the yellow and green specimens.

Tourmaline, in common with other Precious Stones, develops electricity under friction, and is a mineral of the greatest interest from a thermo-electric point of view. Its dust is attracted by the magnet.

The Dutch introduced Tourmaline somewhat more than a century ago, into Europe from Ceylon. The first written history of it we find in a book published in Leipsig, 1707, called "*Curious Speculations of Sleepless Nights*." It is mentioned also in the catalogue of a collection of stones sent over from Ceylon to Leyden in 1711. This stone was not sent in large quantities to Europe, and the German Jews were almost the only purchasers of it.

*Varieties of Tourmaline*:—Siberian Tourmaline is of carmine hyacinth, purple, or rose-red, running into violet-blue. When polished, its lustre resembles that of the Oriental Ruby. We obtain it from Siberia, Ceylon, the Urals, Saxony, the Isle of Elba, and the United States, where it has been discovered in great perfection and abundance, which has caused a reduction in its value. That found in Peru is of a beautiful red, strongly resembling the Ruby. Indicolite, or Brazilian Sapphire, is of a pleasing blue color. When very carefully polished it looks like the Sapphire. The Green Tourmaline, or Brazilian Emerald, is of an olive or darker green. It takes a perfect polish. Crystals of great beauty are found in Minas-Geraes, the Isle of Elba, the Urals, and St. Gothard. The Yellowish Green Tourmaline (Ceylon Chrysolite) is very like Aquamarine, and is found in the river-beds of Ceylon and Brazil. Colorless Tourmaline occurs very seldom in pieces worth the cutting and polishing. The most beautiful specimens are found in Elba, and in Dolomite mountains. Brown Tourmaline is a variety not used for ornament. Ceylon and Switzerland yield a fair supply.

The value of the Tourmaline depends upon the color, quality and size of the specimens; one of exceptional color and purity, of five carats weight, would be worth £20.

*The Zircon, Jargoon, or Hyacinth*. The Zircon, Jargoon of Lapidaries, and Hyacinth, are all varieties of the same stone. Its name in Greek is "Uakinthis," in Latin "Hyacinthus," in German "Hyacinth," and "ein breuneder Jacinth," and in French "Jacinthe la belle." We apply the term Hyacinth to transparent and bright colored varieties; Jargoon to crystals devoid of color, and of a smoky tinge, which are occasionally sold as inferior Diamonds. Anselmus Boetius gives the following description of this gem. (1st) "There are some that flame like fire, or are similar in color to crimson or to natural vermilion, these the French jewelers call 'Jacinthe la belle,' and these they esteem the best. (2d), Those with a yellow-red color. (3d), Others which are like unto Amber, so that they can hardly be distinguished from it, but by their hardness. These are of no great value, by reason of the atoms they contain, and the multiplicity of small bodies which are in them, which do hinder their transparency and translucency."

"One of these," Cardanus says, "he was wont to wear about him, for the purpose of procuring sleep, to which purpose it did seem somewhat to confer, but not much." (4th), "There is a fourth kind which have no redness at all in them, which are like to white pellucid Amber, and these are of least value."

We distinguish the Zircon by its quadrilateral crystals, terminating at both ends in a pyramid. It is of adamantine lustre, transparent and sub-translucent. The fracture is conchoidal. This stone is most probably the Lincurium of Theophrastus. When looked at through a microscope, in front of a strong light, a watery texture is to be seen which the French call "*Ratine*," (nappy), and which has the appearance of water when spirit is poured into it. This "nappy" look is its special characteristic, and enables one to identify it among all other stones of a similar nature. When submitted to great heat, its lustre becomes stronger, but at the same it loses color. In former times this gem was more highly valued than at present. In order to prepare the stone for ornaments, such as rings, pins, earrings, etc., it is ground on a leaden plate with emery powder, and polished on a copper plate with powdered rotten-stone. The forms given to the Zircon are generally the rose, the table and the brilliant.

Inferior Zircons require peculiar setting to show them to advantage; but a perfect one requires no aid, it is beautiful in itself, as well as valuable. There is a splendid specimen of ancient engraving on a Zircon in the Paris Museum, the workmanship of which is exquisite; it is 5.4 millimetres in length, and 3.4 in width, and represents Moses with the two tables of law. Lord Duncannon has in his collection a Zircon with an engraving on it representing an athlete.

Nicols, writing 225 years ago of the Zircon, says, "They are found in Ethiopia, India and Arabia. The Arabs distinguish three kinds: 1. Rubri Coloris; 2. Citrini Coloris; 3. Antimonii Coloris. Of these the worst is found in the River Isera, which is upon the confines of Silesia and Bohemia. The best and most excellent ones are brought from Cananor, Calicut, and Cambia." The number of places in which Zircon is now found has greatly increased, and it would not be too much to put them down at 120.

In the original beds nine tenths belong to the volcanic or Plutonic stones. It is found in the refuse both of active and exhausted volcanos, in porous and dense basalt, as well as in pitchstone and granite. It is very remarkable that the Zircon has not hitherto been found in certain classes of volcanic stones, such as Melaphyre, and Trachyte.

*Coral* is the product of gelatinous creatures which come under the class of polypi: there are many varieties, but we have only to do with precious coral—"isis nobillis." This polypus production is like a tree with leafless branches, the stem of which, in rare cases, is as thick as a man's body, but generally about a foot high, and an inch thick.

The calcareous axis of the "isis nobillis," is distinguished by its size, hardness; and capability of polish, as well as by its beautiful red color. It has a sort of leathery covering in the cells, to which the polypi adhere. In the soft rind which surrounds the axis there are small lime-needles, and outside the nets of the common canals which the little creatures lives.

The polypi consist of a soft gelatinous substance. When they sit undisturbed in their cells, one can see distinctly, by means of a microscope, that each possesses eight soft, three-cornered, leafy feelers, which are notched on each side, and situated in a simple circle round the mouth, by means of which they catch their food, and convey it to this aperture. If one of these feelers is touched ever so slightly, this act is sympathetically conveyed to each creature in the coral hive. There seems to be among naturalists, a conviction that the coral insects, or polypi, possess a common feeling, which by some wonderful organization vibrates through the whole root as it were, one organized body. Although the polypi show such a remarkable sensitiveness, it has never been discovered that they possess nerves, or any of the five senses. Their digestive organs are developed only in the smallest degree. In the common living polypi, as in the case

of the precious coral, the food goes into a hole in the stomach, and is there well mixed with water, and circulated hither and thither in little vessels, and so conveyed to the whole mass of Polypi, which are in direct communication with each other. The nourishment of the Polypi is derived from tiny creatures, and particles of plants, found in the water. They have a great dislike to the light, and to a disturbance of the water, either one or the other of which will drive them suddenly back to their cells.

The home of the precious coral is the Mediterranean, more especially on the African coast. It is formed in clefts of the rocks by the creatures themselves—a very tedious operation, indeed, when we consider that it is found at a depth of 700 feet.

Obtaining the coral is quite as fruitful a source of traditions and fairy tales among the fishermen of the Mediterranean, as the buried treasures in the hearts of the mountains to the Germans.

The Coral fishery is carried on with much zeal and energy in many places, but especially on the coasts of Tunis, Algiers, Corsica, the Red Sea, Persian Gulf, and Sicily. On the African coast, which for centuries has been most celebrated for its coral, is the sea-port of Calle, or Kalak, where the trade is most successfully carried on. Although the fishery has for years been worked by Corsicans, yet this particular industry has been taken up by French energy. In the year 1450, France had an establishment there whose occupation was, above all things, the coral fishery. It was conducted by a company who received the privilege of working it provided they employed Provincials only.

In the year 1791 the fishery became free for all Frenchmen who traded with the Levant and States of Africa. Three years after a change in the arrangements took place. In 1802, England took possession of Calle, and restored it back in 1816. During this time the fishery was carried on vigorously, not less than 400 boats being devoted to this industry. In 1830, new arrangements were made by which the Italians had to pay a duty for it, the French being exempted. Still, the Italian vessels predominated. Each coral boat has twelve or thirteen sailors on board. The fishery begins in March and the fishers return home in October. Coral is obtained in the following manner: two iron rods about seven feet long, and having four prongs, are bound crosswise together, and wrapped up in hemp about half an inch thick, and bound to this is a net-work bag. In the middle of the rods a weight of lead is fastened. This machine is let down by means of cable, and when drawn up again, it catches the projecting Coral in the hemp, which is gently brought to the surface. Very clever and experienced divers will themselves bring up a strong branch of it. The coral is next cut in specified lengths, and separated according to thickness, size, and beauty, and then with or without polishing, sold. Coral is bored by steel needles, and in Italy this is done by hand, but in Leipzig, Karl Hoffman has invented a machine for boring, and has thereby rendered it much cheaper. The larger the coral and the paler its color, the more valuable it is in our day. The most beautiful production is called "Flower of Blood." The working of coral is principally carried on in Marseilles, Genoa, and Leghorn. In the last named city, as many as 300 work-people are employed, and most of the coral goes to India, China, and Japan. In India the dark-red variety has always been valued. Every Oriental strives to get a string of corals for his turban, or at least sufficient to decorate the handle of his sword. They think that to leave their dead without ornaments of coral, is to give them over to the hands of mighty enemies. There is scarcely an Indian to be found without at least one or two rows on one of his arms; those who can afford it have them on both arms, and the rich wear red coral on head, throat, and legs.

The Brahmins and Fakirs use coral beads for rosaries to count their prayers. The Chinese mix the red coral with Jade beads, and wear them as ornaments for the neck and head.

The use of coral in Europe, if we except England and Russia, is not large. At the commencement of this century, however, coral of

a beautiful blood-red, set in gold or silver, was fashionable for earrings, bracelets, necklaces, and baby rattles, in the nursery of the middle and upper classes.

The pale coral has been for the last twenty years rising in value: the rose tinted variety, when cut into a resemblance of the fanciful shapes assumed by Pink Pearls, obtains an enhanced value.

The price of the pale and sound coral, is at present from £10 to £100 per ounce. The beautiful rose-colored variety ranges from £100 to £200 per ounce; and the red varies, according to color, from £2 to £20 per ounce.

It is often used for cameos, being soft. At the sale of the Empress Eugenie's jewels, by Messrs. Christie and Manson, in 1872, a fine suite of carved coral and gold ornaments realized a high price: this probably may be explained by its having belonged to so distinguished a person. Fine specimens of carved coral are not at all uncommon.

Coral was formerly in great repute as a talisman against enchantments, witchcraft, thunder, tempests, and other perils. It was consecrated to Jupiter and Phœbus.

It would not be wise to say that Coral either has lost, or will permanently lose, its share of popularity. It was only as the competitor of wisdom that it was said, "No mention shall be made of coral or pearls, for the price of wisdom is above rubies."

*Pearls.* There is a large variety of molusca which exhibit certain deformities, known by the name of pearls, and which by their beauty and rarity, rank with the most costly of precious gems. The most highly valued by the name "margarita," (the sea pearl oyster), and "unio margarita," (or river pearl oyster). The first of these live on the coast of Ceylon, in the Persian seas, on the Japanese coast, the coast of Mexico, and California, and West Australia. The second is somewhat large, and drags itself along the sand and slime of the brooks and rivers of Europe and North America.

The pearls in the inside of the oyster-shell, are generally bluish-white or yellow bodies of round or pear shape. They lie partly on the inner side of the shell, near the edge, and partly on or in the living creature. Pearls of the greatest value have a pure orient, white, black, or pink tint, that is to say, a fine color, with a lively lustre that sparkles in the light, or with the whiteness that reflects lustre.

Tavernier says "that all pearls are white, and that the yellow and other tints are induced by putrid products, resulting from the treatment of the shells in the place of their production; the shells being left in the air that they may open themselves after the creature is dead. The work is thus accomplished without any expense, and without breaking the pearls, an accident that occurs very frequently, if the shells are opened artificially;" and he further states "that yellow pearls are never found in shells that remain in the water."

The specific gravity of the pearl is 2.684. According to their size they receive certain names; those of extraordinary size, are called paragon pearls; when the size of a cherry, cherry pearls; small, piece pearls; smaller, seed pearls; smallest, dust pearls. Then according to their form they receive their names: oval and long, pear pearls; while the badly formed specimens are known as "baroques" pearls.

Pearls frequently take grotesque shapes, and are used in works of art and for caricatures. There is a very large collection of such in the green vaults at Dresden: one a Spanish court dwarf of the time of Charles II., made out of a pearl the size of a hen's egg.

There appear sometimes in the market, pieces of pearl substances, which are taken out of the shells, consisting partly of mother-of-pearl, and partly of a pearly substance. They are called phantasy pearls, and they are only valuable according to the purpose to which they are applied. Barbot mentions a strange circumstance about these phantasy pieces: "A French pearl merchant, in Mexico, bought one of these pieces of a fisherman, for a small sum of money, in order to learn something of them. He was not a little surprised, on cutting it in half, to find a perfect, round pearl inside, of purest water and brilliant lustre, weighing 14¾ carats, and which he sold some time after in Paris for 5,000 francs—about half its value."

## On the Compensation of Clocks, Watches and Chronometers.<sup>1</sup>

(By EDWARD RIGG, M. A., Assayer in the Royal Mint.)

With very few exceptions, the mechanical arrangements used for the measurement of time are regulated by a more or less heavy body, oscillating in a circular path round a centre of motion. In stationary clocks, this control is obtained by means of a pendulum, under the influence of gravity; and, in portable time-keepers, by a balance independent of the directive action of gravity, but subject to the influence of a delicate spring.

The motion of the train of wheels being solely determined by the release of a tooth of the escape wheel through the motion of this regulator, it will be evident that each of its oscillations must be performed in the same period of time, in order that the hands may continue to travel with constant velocities. Various circumstances, however, tend to prevent our attaining this absolute uniformity, and any device introduced into a time-keeper, supplementing the mere mechanism required to maintain the motion of the regulator; or the application of any principle in such a manner as to make the uniformity more perfect, must be included under the term "compensation." The subject, then, has a very wide significance, and it would be impossible, in a single paper, to profitably discuss the several phenomena that interfere with the going of a time-keeper; but it may be well to draw attention to the following table, which gives the influences that are of primary and secondary importance in two separate classes:—

### CLASS I.

1. Motive force.
2. Isochronism.
3. Heat.

### CLASS II.

1. Atmospheric pressure.
2. Electricity and magnetism.
3. Hygrometry.
4. Gradual acceleration (in chronometers).
5. Gravity.

It is only intended to consider the third in Class I. (heat), and the first in Class II. (atmospheric pressure), with any degree of completeness, but a few words on the other point may not be out of place.

The well known fuzee and chain of the English watch and the chronometer, and the very great variety of constant force or *remontoire* escapements, were introduced to neutralize the want of uniformity in the force exerted by a coiled spring; but the opinion is now held by many, that in watches intended for ordinary use, where very great accuracy is not needed, the force, although far from uniform, will give satisfactory results, if the spring be so proportioned to its barrel that it requires about four turns of the key for complete winding up, only three of which are ever called into action for the purpose of impelling the train. In frictional rest escapements, such as the horizontal, the resistance to the motion of the balance, owing to the pressure of the tooth, increases as the motive force increases, and in this way the mechanism itself compensates, approximately, for any variation in the force.

Strictly speaking, of course, isochronism should include the entire subject of compensation; for all that we require is to cause each oscillation to occupy the same period of time; but the term is exclusively used to refer to that fundamental condition, in virtue of which the duration of an oscillation of the regulator is entirely independent of the amplitude of the arc described. A pendulum requires to move on a cycloidal curve for its oscillations to be isochronal, and, if its path is circular, the long arcs occupy a longer period. The experiments of Winnerl and Laugier<sup>2</sup> prove that the

length and thickness of the suspension spring and the weight of the bob may be so correlated as to give isochronal motion; and Dr. Hipp<sup>3</sup> points out that the escapement may have a like action. A method of isochronizing the motion of a pendulum was exhibited by Loseby at the Exhibition of 1851, but it was not found to be successful when tried. The length of the balance-spring of a chronometer or watch may be so adjusted that the force of its elasticity is exactly proportional to the angle through which the balance is turned; when this is the case, the vibrations of the balance will be isochronal. This point is generally found at about the eighth coil in a cylindrical spring, and the twelfth coil when the spring is a flat spiral; with a greater length the balance will lose in the long arcs as compared with the short arcs, and with a less length the reverse is the case.

Very little is positively known as to the precise nature of the action exerted by electricity and magnetism on chronometers. Experiments were made by Fisher and Barlow in 1820, by Harvey,<sup>4</sup> in 1824, by Arnold and Dent in 1833,<sup>5</sup> and others. A remarkable change in the rate is at times observed on transferring a chronometer from the observatory on board ship, and this has generally been regarded as due to the magnetism of the vessel; Delamarche and Ploix,<sup>6</sup> however, satisfied themselves experimentally that this cause was not sufficient to account for so great a change. When the atmosphere is charged with electricity, the chronometer is known to vary in sympathy with the magnetic needle, generally causing an acceleration in the rate. The same is the case in magnetic storms.<sup>7</sup>

When a deal pendulum rod is employed that has not been properly prepared, it will expand, in a damp atmosphere, through the absorption of moisture; the clock will, therefore, lose on its rate. In chronometers, damp air is detrimental, in that it gives rise to oxidation of the highly polished surfaces. Dent believed that the oxide thus formed on the surface of the balance-spring increases its elastic force, and thus occasions the remarkable acceleration that is observed to occur in the rate of a chronometer after it has gone for some time, an acceleration that at times amounts to as much as four or five seconds a day after two years. M. Robert,<sup>8</sup> however, considers the thickening of oil a more probable cause. C. Frodsham<sup>9</sup> considered it to be caused by a change in the molecular state of the spring, but Villarceau<sup>1</sup> has shown that under certain conditions, it may be occasioned by resistance at the balance pivots, thus confirming M. Robert's view.

Finally, the difference in the value of terrestrial gravity at various points on the earth's surface causes a corresponding change in the rate of pendulum clocks, but is without influence on time-keepers that are controlled by a balance. For the formula for the period of an oscillation of a pendulum shows that it depends, other things being equal, inversely on the square root of the value of gravity as usually measured; so that an increase of this force, in geometrical progression, causes the rate of the clock to increase arithmetically. Under this heading may also be included the variation in the centrifugal force due to the earth's rotation, which is zero at the poles, gradually increasing to a maximum at the equator; but it is very rarely that such influences as these need be regarded.

### COMPENSATION FOR THERMOMETRIC VARIATION.

It must not be assumed that what is known as a compensation pendulum or balance can be applied with advantage to any form of clock or watch. In either case, rapid manufacture and low price may render unavoidable faults of construction, that give rise to greater variations in the rate than are caused by temperature; and any form of compensation that is not accurately adjusted and well

1. A paper read before the members of the Society of Arts, on Wednesday, March 12th 1873; Mr. W. Ellis, F. R. A. S., presiding. Revised by the author.

2. "Comptes Rendus," 1845.

3. "Journal Suisse d'Horlogerie," li. 85.

4. "Brande's Quarterly Journal of Science," (1824), xvii. 364.

5. "Nautical Magazine," li. (1833), 262.

6. "Comptes Rendus," xviii. 462.

7. "Revue Chronometrique," iv. 471.

8. "Revue Chronometrique," vi. 329, and "Horological Journal," xi. 37. See also a letter from Mr. Knudsen at p. 79.

9. Reports of Juris, 1862.

1. "Annales de l'Observatoire de Paris," t. vii.

sued to the train, may occasion greater irregularity than would be experienced on replacing it by a pendulum or balance of ordinary construction. A change of temperature will influence the rate of a clock in two ways, only one of which sources of irregularity can be corrected efficiently by means of a compensation pendulum. It will produce a change in the acting surfaces through variation in the consistency of oil, &c., and it will alter the length of the pendulum. A reduction of the temperature below zero, as well as an excessive heat, has a very detrimental effect on the oil, and, with a plain steel pendulum, the mere change in its length will only cause a variation of 0.53 second in twenty-four hours for each degree Centigrade rise or fall of temperature (or 0.3 second, using Fahrenheit's scale). It follows that an uncompensated steel pendulum, that is correct in spring temperature, will only lose through expansion 1' in the hottest fortnight of summer, and gain a similar amount in winter.

Escapements may be divided into two classes, frictional rest and detached escapements. In the first, such as the verge and horizontal escapements in watches, or the Graham escapements in clocks, the pendulum or balance is never free from the mechanism by which it is driven; but in the second class, of which the lever escapement in watches may be taken as an example, the pendulum or balance only engages with the train long enough for the impulse to be applied. Now, all the acting surfaces must be supplied with oil, and, as the consistency of this is modified by temperature, a varying resistance is opposed to the motion of the balance when a frictional rest escapement is employed. The irregularity which this variation gives rise to in the rate is commensurate with that caused by expansion due to the change of temperature, and it evidently cannot be permanently counteracted by any system of compensation, since it depends on the age of the oil, &c. This disturbing influence has the greatest weight in watches; it is of sufficient importance to render compensation balances useless, and they are, therefore, never employed with this class of escapement. Moreover, such watches possess a kind of natural compensation of their own, for, as will be presently seen, the tendency of a watch is to gain in cold weather, and at the same time the oil will become thicker, and offer an increased resistance to the motion of the balance. The converse will be the case in warm weather. Clocks with undetached escapements are also subject to this influence, but in a less degree.

The conditions of the problem of compensation in clocks regulated by a pendulum, are so entirely different from those met with in time-keepers that are regulated by a balance and balance-spring, that it will be necessary to consider the two cases separately. We will begin with the more simple case of the pendulum.

The well known formula for the time of oscillation of a simple pendulum<sup>2</sup> shows that this period varies with the square root of the length, and calculation shows that an increase of  $\frac{1}{100}$ th, the initial length causes a loss of one minute in 24 hours. From this data it is easy to determine the effect of a given rise or fall of temperature, if the material of which the pendulum rod is composed be known. It is only necessary to multiply together the co-efficient of linear expansion per degree, the number of degrees change of temperature, and 720 to obtain the alteration per 24 hours in minutes. Thus, for a rise of 20° Centigrade (36° Fahr.) with a steel pendulum rod, for which the co-efficient of expansion per 1° Centigrade is 0.0000124, the clock will lose 10.7 seconds on its daily rate.

The most obvious mode of diminishing the sensibility of the pendulum to variations of temperature is to employ a material for the rod that is but little influenced by such changes. Glass and wood have been suggested, but the former is objectionable on account of its fragility. Very good results may be obtained with a carefully made wooden pendulum, and well-seasoned deal is usually employed;

<sup>2</sup>  $= 2\pi \sqrt{\frac{l}{g}}$ —where  $l$  is the length of the pendulum  $g$  the value of gravity (32.2), and  $\pi$  the ratio of the circumference to the diameter of a circle. If two pendulums of lengths  $l$  and  $l'$  differ to the extent of one minute in 24 hours, it may be shown that  $\frac{l-l'}{l} = \frac{60}{86400} = \frac{1}{1440}$ , and hence we obtain  $\frac{l-l'}{l} = \frac{1}{1440}$  very approximately.

but M. Winnerl, of Paris, recommends the wood used for the sounding boards of pianos as the best. In any case, it must be straight-grained and without faults, and it is advisable to make the bob cylindrical instead of lenticular, since the rod is liable to twist through torsion. The principal objection to the wooden pendulum, lies in its sensitiveness to variations in the hygrometric state of the atmosphere. In 1834, Baron de Prony made experiments on varnished and unvarnished deal rods, to determine the effect of moisture, and he found with the hygrometer at 70° (saturation being 100°) that the varnished rod showed a loss of only 1.07 seconds in 24 hours, as compared with its rate in dry air; whereas the elongation of the unvarnished wood occasioned a loss of 2.98 seconds. M. H. Robert a celebrated French clock maker, soaked the wood in a drying oil after having thoroughly seasoned it; the wood was then left to dry and was varnished; he also avoided the effects of moisture by enclosing the rod in a brass box. Kater mentions that a gilded teak rod is unaffected by moisture; and, finally, Sir E. Beckett proposed that the rods should be subjected to a creosoting process.

(To be continued.)

### Zorzi's Compensating Pendulum.

THE compensating pendulum\* of M. Zorzi is composed of two rigid rods of steel of equal dimensions, placed one behind the other in such a way that, while the dilatation of the one by the effect of heat takes place downwards, the other operates upwards. The first has the pendulum bob at its lower extremity, and constitutes the pendulum proper; the other, which serves for compensation, carries soldered to its lower part a small moving arm, corresponding to another arm which sustains the rod carrying the pendulum-bob.

When the temperature varies it produces in the two rods a lengthening or shortening in an inverse manner in the one or the other; and the lowering or rising of the pendulum bob is corrected by the play of the two arms, so that the position of the centre of oscillation remains invariable.

It is the same with the centre of suspension, which remains constant in the plane of two parallel rods, and so closely placed that they leave a very small gap, by which the spring carrying the stem of the pendulum-bob—that is to say, the rod of the pendulum—passes freely. In this manner the positions of the centre of oscillation and the centre of suspension, remain invariable—the length of the pendulum does not vary, whatever may be the changes in the temperature.

In case the rods, although made of the same steel, have not the same co-efficient of dilatation, M. Zorzi has essayed to correct this fault by the following plan: A micrometric screw is placed at the bottom of the fixed rod; this screw subdivides the height of a millimetre in ninety parts, and serves to lengthen or shorten the fixed rod by this small amount in such a fashion that the variations of the rod of the pendulum can be perfectly compensated.

In addition this excellent workman has placed above a graduated arc, on which a hand marks the smallest dilatation or shortening; and besides, a graduated circle of an arc below, on which a hand indicates the smallest displacement of the axis of the pendulum-bob, either ascending or descending. It remains to be seen if, in practical application, the pendulum here described gives exactly and constantly the compensation desired. It is probable that the arrangement of the arms might prove a source of imperfection; but this is only conjectural; and certainly M. Zorzi, able workman and practician that he is, will be able to judge how far these doubts are well founded. But of this we are assured that there is no system which surpasses for simplicity that of the wooden rod, and for exactitude those of mercury compensation. Those having a wooden rod have a dilatation so small that it need not be taken into account; at the same time they could only serve for regulators of the second-class. Regulators of the first-class are at present constructed with steel pendulum-rods, with a vase, likewise in steel, to contain the mercury, and the compensation is so perfect that they leave nothing to be desired.

The editor of the *Revue Chronometrique* says: "Let us add to the remarks of the editor of *Des Mondes* that the Zorzi pendulum is described in the old work of Thiout, and in our own day Jarossay has re-edited it, but without any great success.

## Workshop Notes.

Berthelot has determined the specific heat of liquid gallium to be 0.0802, and of solid gallium 0.079. The specific atomic heat is 5.59 in the liquid, and 5.52 in the solid state.

The following is a liquid which will dissolve silver—without attacking copper, brass or German silver—from silvered objects, plated ware, etc. It is a mixture of one part of nitric acid with six parts sulphuric, heated in a water-bath to 160° Fahr., at which temperature it operates best.

Mosaic silver is an amalgam of equal parts of tin, bismuth and mercury; 50 grammes of good tin is fused in a crucible, and as soon as melted 50 grammes of bismuth are stirred in with an iron wire until it is all liquid; the crucible is then removed from the fire, stirred as long as liquid, and then 25 grammes mercury added, and all mixed uniformly until stiff enough to be ground upon a stone.

TO CLEAN PEARLS.—Soak them in hot water in which bran has been boiled with a little salts of tartar and alum, rubbing gently between the hands when the water will admit of it. When the water is cold, renew the operation until the discoloration is removed; rinse in luke warm water, and lay the pearls in white paper in a dark place to cool and dry.

To impart a beautiful black color to bronze use—a strong concentrated thin solution of nitrate of silver is required for this purpose. It should be mixed with an equal solution of nitrate of copper, and well shaken together. The pieces which require coloring are dipped into this solution and left for a short time. When taken out, they should be equally heated till the required black color makes its appearance.

Helm says that amber exhibiting no fracture is permeable to water, and that it contains as much as 4 per cent. of sulphur in a state of organic combination. This sulphide had probably been absorbed by the amber in the condition of hydrogen sulphur after its formation. Gedanite, another fossil resin, differs from amber by containing a smaller proportion of oxygen, and it is also softer, more fusible, more soluble in ether, and free from succinic acid.

Deshayes states the following relations between the chemical composition and the mechanical properties of steels: Carbon renders steel rigid and elastic, increasing its elastic tension, but diminishing its power to resist rupture if more than 0.500 be added. Manganese renders steel rigid and elastic and increases its elastic tension, but the elongation and contraction remain considerable, giving thus a good resistance to shock. Silicon acts like carbon, inducing hardness and slightly diminishing elongation. Sulphur decreases the breaking strain and resistance to shock. Phosphorous renders steel deficient in body, and, if its proportion exceeds 0.250 per cent., fragile to shock. Chrome imparts properties of the same nature as manganese.

Fleitmann has succeeded, by a very simple device, in obtaining cast nickel in a malleable and ductile form, even when cold, while cobalt prepared in the same manner possessed such hardness when cold that he expects it can be used for cutting instruments, while hot it is both malleable and ductile. His process consists in adding to the fused metal, through a hole in the lid of the crucibles,  $\frac{1}{8}$  per cent. of metallic magnesium, which possesses a remarkable power of destroying carbonic oxide. The author is of the opinion that the porous and crystalline character of cast nickel is due to its absorption of carbonic oxide gas in a molten state. It is not impossible, however, that owing to the great affinity of magnesium for nitrogen, its action may be due to the destruction of cyanogen in the metal. Cobalt prepared in this manner possessed none of the reddish color attributed to it in the text books, but actually excelled nickel in whiteness and brilliancy. He also welded these metals on to iron and steel at a white heat, and strips thus welded were rolled out to the finest number without separating from each other.

Removing the roller from the main-wheel arbor, in cases where it is screwed on, is sometimes troublesome, unless some convenient tool is at hand to do it with. Such a tool may be made in a few moments by taking a pair of old (or new) round nose plyers, and grinding or filing the points to a size and shape that will enter into the holes usually, made in the roller for the convenience of unscrewing it; the plyers can be opened to any distance required, and consequently will fit all sizes. Place the winding square firmly in a bench key held in the left hand; then apply the points of the round plyers in the holes of the roller, and by a firm, steady pressure it will be easily unscrewed, with no danger of damage to any part.

FUSIBLE BRONZE.—A very fusible bronze is obtained by the addition of tin; but by adding too much tin the bronze becomes dry, and especially in using it with large articles, where an unfavorable straining or tension takes place, it cracks quickly. To avoid this, the bronze should be composed of 82.45 parts of copper, 10.30 parts of zinc, 4.10 parts of tin, and 3.15 parts of lead.

A very good poising tool can be made by adapting to one end of an ordinary depthing tool two new centres of steel wire—about a half inch of the inner end of each of which is filed away somewhat beyond the diametrical line. Harden and polish these ends, and they will present, when properly fastened in the tool by the set screws, a very nice sharp angle on which to poise the balance. The adjustment for the length of staff is, of course, made by the screw which opens the tool.

Watchmakers, according to observations by Dr. Macario, of Nice, are liable to headaches, giddiness, general spasms, benumbing of the lower limbs. These phenomena are doubtless caused by intensity of mental application, examination of the minute component parts of watches, and the position they are obliged to take during work. For examining small wheel work they have often to arm their right eye with a lens, weakening vision on that side. The seated and forward-bending position at work hinders the movements of respiration, contracts the chest, and, if there be predisposition, produces pulmonary tuberculosis. All these morbid effects are increased in working immediately after a meal. The doctor recommends interrupting work at intervals, walking or taking some corporeal exercise, bathing the fatigued eyes with a solution of chloride of sodium acidified with a little brandy, accustoming oneself to use the two eyes alternately, and allowing time for digestion.

## Business Notes.

The Ansonia Clock Company is to be congratulated on having secured the services of Mr. Herman Reinecke, one of the ablest horologists in this country. Mr. Reinecke spent many years in mastering the profession of watch and clock-making, and has, by industry and application, placed himself in the front ranks of workmen in his line, who not only bring experience and skill to their practical work, but brains and intelligence as well. He will be a valuable acquisition to the Ansonia Clock Company, an establishment noted for enterprise and skill in all branches of their business.

In the advertisement of Mr. Phil Hecht, in which he advertises a new and useful Jewel Setting Cutter for cutting the bezel or rim that holds the jewel to the plate, the types incorrectly states that "there being twelve sizes of punched bezels on each"—it should read—"there being twelve sizes of bezels made by this tool. We would state that this is one of the most ingenious and useful tools ever introduced for the purpose for which it is designed, and is highly spoken of by those who have used it.

Messrs. Colby & Johnson have discovered a new use for celluloid. They have recently been granted letters patent for its adaptation to Show Cases, and there is every likelihood of its becoming exceedingly popular in this class of goods.

The Weston Dynamo Electric Machine is a valuable apparatus for electro-plating, electro-typing, telegraphing, etc., now extensively in use among the largest electro-plate establishments not only in this country, but in the leading cities of Europe. It is claimed for it that it will generate more electricity with a less amount of power than any other machine in use. It is commended by all who use it and is introduced in all the industries when it is available. Parties desiring to know more of the merits of this machine would do well to consult the advertisement of Messrs. Condit, Hanson & Van Winkle, elsewhere in the Journal.

Messrs. Helfenstein & Bourke have recently introduced a very unique and attractive novelty in adjustable sleeve buttons that promises to become exceedingly popular. A glance at the advertisement elsewhere, will convey a clear idea of its special feature and advantages, which are said to be substantial, and of real merit.

Mr. A. Lounsbury whose advertisement appears on the second page of this Journal, offers a large and attractive variety of Solid Gold Rings, embracing 180 patterns of the best and nearest designs, and finished in workmanship like manner.

These goods are offered to the jobbing trade at prices that will induce purchasers.

### Phosphorescent Powders.

A RECENT English patent is to obtain and to utilize at night time the light taken, or absorbed during the day time from direct or indirect sunlight, or from an artificial light, either by employing phosphorescent powders simply after exposure, or by augmenting their brilliancy by means of electricity. The composition and manufacture of the luminous products and their applications without the use of electricity, is thus described: 100 parts by weight of a carbonate of lime and phosphate of lime, produced by the calcination of sea-shells, and especially those of the genus *Tridacna* and the cuttle fish bone, are to be intimately mixed with 100 parts by weight of lime rendered chemically pure by calcination, and add 25 parts by weight of calcined sea salt; from 25 to 50 per cent of the whole mass of sulphur, which incorporate therewith by the process of sublimation; and from 3 to 7 per cent. of coloring matter in the form of powder composed of mono-sulphure of calcium, barium, strontium, uranium, magnesium, aluminum, or other minerals or substance producing the same physical appearances, *i. e.*, which, after having been impregnated with light, becomes luminous in the dark. After having mixed these five ingredients intimately, the composition obtained is ready for use according to different methods of application. In certain cases, and more specially for augmenting the intensity and the duration of the luminous effect of the composition, the patentees add a sixth ingredient in the form of phosphorus reduced into powder, which is obtained from seaweed by the well-known process of calcination. As to proportion, it is found that the phosphorous contained in a quantity of seaweed, representing 25 per cent of the weight of the composition formed by the five above named ingredients, gives very good results.

The phosphorescent powder thus obtained and reduced into paste by the addition of a sufficient quantity of varnish, such as copal, may serve with advantage for illuminating a great number of objects, *c. g.*, buoys, sea compasses, barometers, street plates, sign boards, and other similar objects, by arranging it in more or less thick coatings upon a plate of metal, wood, glass, or other material, covered by a transparent glass; this powder may also be employed for theatrical scenery or pictures, artificial flowers, and other similar articles, by the application of one or more coatings of the powder incorporated in the varnish, or else by varnishing previously these objects and by sprinkling the dry powder upon the varnish still damp, and in this case the covering piece made of glass or other transparent material may be suppressed.

These powders are also employed for manufacturing solid objects generally made of cellulose, paper paste, papier-mache, artificial ivory, sometimes called coralline, and other materials of a similar nature, by sprinkling the surface of these objects, or only certain parts of the surface (still damp or moist) which are usually exposed to light, and by compression in moulds or otherwise in order to incorporate definitely the phosphorescent powders into the surfaces. The amount of powder applied should not exceed the thickness of a thin sheet of cardboard; it may be employed either for coating the whole surface or certain fraction thereof, so as to produce various designs, inscriptions, or effects. For this application various powders are also applied, which contain different coloring matters, so as to produce effects of various colors.

The dry phosphorescent powders are also converted into translucent flexible sheets of unlimited length, thickness, and width, by mixing them with about 80 per cent of their weight of ether and collodion in equal parts in a close vessel, and rolling the product into sheets, with which any object may be covered which is intended to be luminous in the dark.

The phosphorescent powders may also be intimately mixed with stearine, paraffine, rectified glue, isinglass, liquid silex, or other transparent solid matter, in the proportion of from 20 to 30 per cent. of the former with from 50 to 80 per cent. of either of these substances,

and this mass is then reduced into sheets of variable length, width, and thickness, according to their intended applications. A luminous glass is also manufactured by means of the above mentioned phosphorescent powders by mixing the same in glass in a fused state in the proportions of from 5 to 20 per cent. of the mass of glass. After the composition has been puddled or mixed it is converted into different articles, according to the ordinary processes; or after the manufacture of an object still warm and plastic made of ordinary glass it is sprinkled with the powders, which latter are then incorporated into the surface of the article by pressure exerted in the mould, or in any other suitable way.

It has been observed after various trials that the passage of an electric current through the different compositions augments their luminous properties or brilliancy to a great extent; this peculiarity is intended to be utilized in various applications too numerous to describe, but of which buoys form a good example. The current of electricity is furnished by plates of zinc and copper mounted on the buoy itself, when the latter is used at sea, but in rivers and fresh water inlets the battery will be carried in the interior of the buoy. To secure the full effect, from 10 to 20 per cent of fine zinc, copper, or antimony dust is added to the phosphorescent powder above described. The patentees, Peiffer, MacCarty and De Sagan, have devised a special form of buoy, which they claim is their invention, in company with the various applications above described.—*Scientific American*.

IN all ages jewels of price have been a ready incentive to crime, but now a few cases are on record in which they have been the agent of the crime, instead of its cause. *Cesar Borgia* possessed a ring with a sharp-edged setting, which would occasionally scratch the hand of some guest whom he was greeting with special cordiality; and no one who received this compliment was ever known to survive it more than a day or two. A similar fatality attended a celebrated decoration much used by two or three of the Russian Czars. When clasped around the recipient's neck, its point was apt to puncture the skin if awkwardly handled, and death speedily followed. One of the native Princes of India, when about to fall into the hands of his enemies, swallowed a sharp pointed diamond, which caused instant death by cutting a vein in his throat. A diamond in the possession of a noble French family, which was said to have caused the death of all its owners in turn, put the climax to its malign influence by ultimately forming part of the famous necklace which played so fatal a part in the history of *Marie Antoinette*.

### Trade Recipes.

Zinc is made easier soluble by the addition of 10 per cent. of bismuth or cadmium, or 5 per cent. of each. With this addition, zinc melts twice as easily as otherwise.—*Inventors' Record*.

ALLOY FOR SOLDERING TIN OR ZINC PLATES.—An excellent alloy for soldering tin or zinc plates is obtained by mixing two parts of lead with one part of English bar tin. The lead is melted first, and after removing the lead dross formed by melting, the tin is added.

BLACK LACQUER FOR METAL OR WOOD.—Nine parts of shellac are dissolved in fifty parts of methylic alcohol and set aside for a few days. Then ten parts of pulverized asphaltum are dissolved in fifty parts of coal tar benzine. Both liquids being mixed, a sufficient quantity of lamp black is added to give it the required density. When necessary, it may be diluted with a mixture of alcohol and benzine.—*Chemiker Zeitung*.

CEMENT FOR CAST IRON.—Five parts of sulphur, two parts of graphite, and two parts of fine iron filings are melted together, taking care that the sulphur does not catch fire. The parts previously warmed are covered with the cement reduced to a pasty consistence on a fire, and firmly pressed together. This cement, it is said, is well adapted to fill out leaks in cast iron vessels.



## Trade Gossip.

Mr. George C. Taylor, of Messrs. Taylor & Bro., sailed for Europe June 7th, on the steamer City of Richmond.

Mohn & Walker, makers of Morocco Cases, have been succeeded by the George W. Walker Morocco Case Manufacturing Co.

The superstition as to precious stones warding off ill is still rife in Russia, as was evident during the recent plague.

R. H. Chapman, a clerk in an Elmira jewelry store, has confessed the robbery of a large amount of jewelry from his employer.

C. E. Russeil, formerly of Carrolton, Ill., has removed to Kansas City, Mo.

A. E. Paillard, of Messrs. M. J. Paillard & Co., sailed for Europe in the steamer St. Laurent, which left this port on the 25th ult.

The latest design for a scarf ornament consists of a pin, a big A and a figure 4.

Mr. Charles L. Tiffany, of the firm of Tiffany & Co., Union Square, has been elected President of the Metropolitan Savings Bank.

A new style of spoon very small and slender, is called "old Newport," and is after Queen Anne designs.

Earnest Gundlach, of Rochester, announces an electric light of his own, the result of fifteen years of study.

Mr. John H. French, the popular jewelry auctioneer, has gone to Green Lake, Wis., with his family for a few weeks' vacation.

Mr. D. W. Granbery, of the firm of Hall, Nicoll & Granbery, sailed for Europe in the Circassian on the 7th ult., and will remain abroad about three months.

B. F. Norris & Co., of Chicago, who purchased Kronberg's stock to sell at public auction, is said to have cleared \$12,000 by the investment.

A. B. VanCott, of Chicago, Horace Clark, of Sterling, Ill., and C. Hubbard, of M. Gregor, Iowa, have formed a co-partnership, with a view of opening a Jewelry store, at Yankton, Dakota Territory.

Mr. George H. Taylor, of G. H. Taylor & Co., Providence, was recently joined in holy wedlock to Miss Jennie Neil, of Harlem. The result, no doubt, of her abiding faith in Providence.

Andrew Sahaffer's Jewelry Store, No. 455 Broad street, Newark, was entered by sneak thieves on the evening of the 20th ult., and robbed of six gold chains and a small quantity of plated goods.

Bracelets with lead pencils attached are among the latest fancies. These pencils are run through a ring attached to the bracelet when not in use.

Frederick A. Giles, of the late firm of Giles, Wales & Co., agents for the United States Watch Co., died at Montague, Mass., on the 18th ultimo, of Consumption.

Mr. T. Le Boutillier, of the firm of Le Boutillier & Co., makes his semi-annual visit to Europe in search of novelties for the Fall trade.

French, the jewelry auctioneer, is selling the stock of J. P. Tryner, of Bloomington, Ill. Mr. Tryner will establish himself in business at Denver, Col.

The New York Academy of Sciences, on June 2, adjourned until Autumn, after discussing a paper read by Mr. J. S. Lamson, on prehistoric pottery and other antiquities recently procured from some graves at Chiriqui. Several archæological specimens were exhibited.

New and elegant hair pins are of pure gold. The horse shoe shape is the favorite shape, though there are very small open fans, arrows, daisies and stars. Silver ones are also seen, but the gold is the most fashionable.

Mr. George R. Howe, of the firm of Carter, Howkins & Sloan, has led to the Hymenial altar Miss Louise A. Barber, of Homer, N. Y. The result of this union will doubtless lead to an interesting family of little shavers.

Handsome sconces at the Meriden Company's are in the black glass with relief of white female figures. The candlesticks on each side are ornamented with the pictures of cards. The sconces are so arranged that they may be hung or used as a mantel or table ornament.

It is said that an oysterman at the Hotel Brighton has found a fine pearl. Everybody will now rush to Coney Island and eat oysters in spite of the absence of the "r" from the names of the summer months.

Another brilliant Kearneyism:—"The credit of the United States is better than silver or gold, because it does not wear away by friction, nor is it absorbed by the requirements of the arts, like precious metals"

E. B. Carter, late of Kearney Neb., but now a resident of Omaha, has been compelled to make an assignment in consequence of the Kearney Nat. Bank failure, of which he was a director. It is reported that he has made a satisfactory settlement with his creditors.

The National Hotel, at Nos. 3 and 5 Cortlandt Street, one of the oldest inns of the city, is to be torn down at once to make way for a seven story office building. The property belongs to the N. J. Smith estate.

Mr. J. W. Miles, the able, courteous cashier of the Meriden Britannia Company, has embarked for the second time upon the sea of matrimony. Miss Kane, one of New York's fairest daughters, is the happy bride.

Eugene E. Post, of the late firm of Post & Speir, has been arrested on an indictment found by the Grand Jury, charging him with obtaining goods under false representations, and held to answer in \$3,000 bail, which was promptly furnished by his friends.

Charles F. Burroughs has been arrested on charge of swindling Greason, Bogart & Pierce out of \$2,500 worth of Diamonds. The prisoner was placed at the bar of General Sessions, on an indictment for grand larceny, and pleaded not guilty. He was remanded for trial.

Mr. Musgrove, of the firm of Brown & Musgrove, Nassau, N. P., was recently in town with a fine collection of Conch pearls. These goods are but little known in this country, but are highly appreciated by French jewelers. Fine specimens are said to be worth from \$20 to \$25 a carat.

A gentleman left his watch at Tiffany's early in 1876, to be repaired—went to Europe and forgot all about it until a few days ago, when he called at the jewelers, and to his surprise found his time-piece ready for delivery. In most stores it would have been "sold to pay storage."

A. H. Miller, of Chicago, who with a view of retiring from active business, disposed of his entire jewelry establishment at public auction, has purchased the stock and fixtures of Chas. Falch (formerly Rosenberry & Falch) and intends replenishing with a new and attractive stock for the Fall trade.

A young lady living on Murray Hill has a singular pet and ornament. It is a live Brazilian beetle with spots like brilliant diamonds. A gold chain harness has been made for it. One end of the gold tether is fastened to the shoulder of the lady's dress and the beetle disports himself on the fair parade ground so far as the chain will permit.

Three hundred and sixty-six failures were reported in the city in the six months ending on June 30, in which the aggregate liabilities amounted to \$11,582,656, and the assets were valued at \$5,990,346. Compared with the corresponding six months of the year, 1878, the above figures present a very hopeful exhibit, as were then reported 514 failures, with gross liabilities footing up \$39,030,195; assets, \$41,012,662.

That was a jolly fishing party that devastated the waters of Maine recently. It consisted of A. K. Sloan, of Carter, Howkins & Sloan, E. C. Fitch, of Robbins & Appleton, Charles H. Sloan, of Hart & Sloan, and D. H. Buell, of Hartford. They had a good time, and their skill as fishermen was abundantly demonstrated. Indeed, it is rumored, that they emptied all the lakes in the State of trout, not leaving so much as a solitary bite behind for the boys that expected to take their vacations out in trouting in that region. Since they left, the prices of trout has advanced in Maine, in keeping with the thermometer.

Superintendent Walling, of New York, has received a list of the jewelry stolen recently from the store of Robert C. Linke, No. 77 Westminister street, Providence, R. I. A reward of \$500 is offered for the recovery of the property, which is valued at about \$15,000. The list embraces about fifty gold and silver watches, a large assortment of gold chains, three costly diamond rings, and a miscellaneous collection of cameo, amethyst, seal and garnet rings, bracelets, pins, etc. The police are of the opinion that Irving & Porter, who escaped recently from Raymond street Jail, in Brooklyn, are the robbers.

### Foreign Notes.

Japanese designs are extensively introduced in the decoration of silver locket, now so popular in England and France.

Corals and diamonds are all the fashion in Vienna since the Empress appeared at the Industriellen ball with this combination for the first time.

The forty-ninth annual meeting of the British Association for the advancement of Science, will commence at Sheffield on August 20. Prof. G. J. Allman will preside.

The International Watch Manufactory of Schaffhausen, Switzerland has decided to send some of its productions to the Sidney Exposition. They will consist of one hundred pieces of their best designs.

The select Committee on Hall working, appointed by the House of Commons, to enquire into this important question, have decided upon their report. It is understood that they will recommend the continuance of the Hall work in its present form, without any material alteration.

A dealer in antiquities of Dresden has recently bought a clock, once the property of the Bourbon family. It was stolen from the Tuileries in 1792, on the occasion of the attack on that palace, and afterwards purchased by a German nobleman, then resident in Paris. The price paid for it was \$600.

Geneva will hold, in 1881, an international exhibition confined to watches, jewelry, snuff boxes and musical boxes. The Grand Council is said to have voted the credits necessary for the preparatory works. The exhibition will be the first of an international character which has taken place in Switzerland.

The French are admittedly quick in recognizing the merits of a substance for decorative purposes. They are now making jewelry from nickel ore. The gray-green ore from the New Caledonian nickel mines, has recently been sold under the name of *noumeite* named after Noumea, the capital of the colony.

Under the new German Tariff, the following articles will be subject to the duties mentioned, viz.: watches, wholly or in part made with precious metals, pearls, etc., 100 kilos, 600 m; articles of jet, amber, meerschaum, ivory opera glasses, clocks, etc., 120 m. The German mark is equal to about 25c. of our money.

A French provincial watchmaker exhibits the following announcement to the public:—"New Patent System.—Watches repaired in 24 hours by a mechanical process." Some of his less clever fellow craftsmen insinuate that the "mechanical process" is simply an application of the shoe blacking machine shown at the Paris Exposition.

The second sale of the diamonds and jewels of Queen Christiana has produced over \$52,000. The chief articles were a magnificent necklace, containing 529 pearls, which was sold for \$14,860; the clasp, which was disposed of separately, bringing \$4,280; a necklace of 2,500 pearls, which was sold for \$6,700; a broad girdle of sapphires and brilliants, which was sold for \$8,420; and a corresponding necklace, which was sold for \$2,900.

Queen Victoria leaves to the care of servants when she goes away from home, \$9,000,000 worth of royal plate in her castle of Windsor, which includes a gold service for 140 persons, ordered by George IV.; a shield formed of snuff boxes, worth \$45,000; thirty dozen plates, worth \$50,000; an Indian peacock of precious stones, valued at \$150,000, and Tippoo's footstool, a tiger's head, with a solid ingot of gold for his tongue.

*Little pigs in gold and silver* are now extensively worn in Vienna as jewelry. Pins, charms, bracelets, stick-handles—everything is for the moment porcine. The Court introduced, and the rest of the world naturally followed them. The fashion has come from Germany, and was introduced to commemorate the happy escape of the Emperor William from all the risks and dangers he has lately run, and his "Schweins' gluck," or pigs' luck—meaning splendid luck—as the German phrase goes, in coming out of it all so well.

A curious instance of the recovery of a lost ring inside of a root of celery occurred in Sweden. Mrs. B—, in planting celery in the garden in spring, and while digging holes for the small plants with her finger, unconsciously dropped her ring in one of the holes. A plant was duly inserted into the hole and doubtless through the lost ring, and as the root grew the ring must have become imbedded in the substance. The ring had been given up for lost until the following winter, when the mystery was cleared by its turning up among the soup at dinner in a portion of the celery root.

An Australian lady having lost an eye, wore, instead of a glass counterfeit, a diamond in the socket of the obliterated organ. The truly brilliant orb sparkled so brightly and was so suggestive of riches that a Parisian adventurer married the lady on sight, took her to the gay city with him, and there having squandered all her property, he one night decamped, carrying off her diamond eye, which she used to keep in a glass of water by her bedside. The deserted wife is now suing the pawnbroker who advanced money on it to her husband for the recovery of the jewel.

The *Archives Israelites* says, that in the eighteenth century the laws of Prussia required that every wealthy Jew that married should buy his porcelain at the royal manufactory at Berlin. The Director often took the money, and made his own selection of pieces to be given in exchange. Moses Mendelssohn, although celebrated as a philosophical thinker and writer, was obliged to submit to this law, and he received 40 porcelain apes, of life size, some of which are still preserved in the Mendelssohn family. This method of oppressing conscience for the encouragement of ceramic art, was established during the reign of Frederick the Great.

A statistical genius has been estimating the cubic contents of the great pyramid and the work done in its construction. He finds that the labor expended on the great pyramid was equivalent to lifting 15,733,000,000 cubic feet of stone one foot high. If accounts can be relied upon, it took 100,000 men twenty years to complete it. There are innumerable railroads in the United States where a greater quantity of cubic feet have been raised to the same height with one-tenth the number of men in one-half to one-third the same time. The London and Birmingham Railway, in its building, lifted 25,000,000,000 cubic feet of material one foot high. The road was built by 20,000 men in less than five years.

The *Commission des Horloges* appointed by the City of Paris to examine means of obtaining unification of the hour in that city, have adopted a project, which has been presented to the Municipal Council, with an estimate of 80,000 francs. This will allow of organizing twelve horary centres, which will act under the direct influence of the clock of the Observatory, and will be arranged in two different circuits, and from these centres will radiate other circuits actuating (in the first instance) regulating apparatus of twenty-eight of the principal municipal clocks in different quarters of Paris. Another improvement just introduced into Paris is that of the establishment by the Prefecture of the Seine, of offices for weighing and measuring in different quarters of the capital. Three kiosques, like those connected with omnibuses, have been opened for the purpose. Particulars as to arrangements are posted up in all the streets.

The late Bishop of L— was entertaining a party of guests at his house, when he was called away to see a sick friend residing in some neighboring hamlet. The interview being over, the Bishop looked at his watch and found that he must take a short cut through the fields instead of the usual road, to enable him to get home in time for dinner. On his arrival he found that his watch was missing. Although much annoyed, he said nothing about the matter. On the following day he was again sent for to see his friend, and again had to return through the fields. While getting through a gap in the hedge, to his surprise he found his watch suspended by a twig. At dinner he told the story to his guests. And one of them asked: "And was the watch going, my Lord?" To which he wittily replied: "Yes, but my only surprise, Sir, was to find that it wasn't *gone*." *Chambers' Journal*.

The Chinese Ambassador at the Berlin Court, Li-fang-pao, is famed among his countrymen as one of the most eminent among their learned men. He has not neglected the opportunities which his travels in Europe have afforded him of making himself acquainted with the details of Western civilization. Li-Fang-pao has been examining the remains of Grecian pottery of the Trojan and pre-Trojan period, and has made a valuable discovery. He proves that the vases found in Trojan territory and buried in excavations, dating from pre-Trojan ages, such as those referred to by Schliemann, are really of Chinese origin. On one of these vessels Li-Fang-pao finds an inscription to the effect that, about 1,200 years before the Christian era, some enterprising individual had enclosed in the vase three pieces of muslin and despatched them for inspection. It seems, therefore, that this piece of pottery, at all events, significantly records the fact of the commercial intercourse which existed so far back as the pre-Trojan era between the industrious natives of Cathay and the enterprising merchants of Asia Minor and Greece.

# Jewelers' Circular and Horological Review.

VOLUME X.

NEW YORK, AUGUST, 1879.

No. 7.

THE

## JEWELERS' CIRCULAR AND HOROLOGICAL REVIEW,

*The recognized organ of the Trade, and the official representative of the Jewelers' League and the Watchmakers' and Jewelers' Guild of the U. S.*



A Monthly Journal devoted to the interests of Watchmakers, Jewelers, Silversmiths, Electro-plate Manufacturers, and those engaged in the kindred branches of art industry.

### SUBSCRIPTION:

To all parts of the United States, Canada, Great Britain and the West Indies,

**\$2.00 Per Annum; Postage paid.**

To France, Switzerland, Germany, Mexico, the Republics of South America, and Australia, \$2.50 per annum. Postage paid.

 All communications should be addressed to D. H. HOPKINSON, 42 Nassau Street, New York.  Advertising rates made known on application.

### Protection from Fraud Required.

WHILE THE CIRCULAR is the friend of every legitimate branch of the Jewelry trade, it has no sympathy with fraud of any description, whether practiced within or without the trade. Unfortunately, there is much of it to be found within the trade; indeed, there is scarcely a manufacturer of legitimate goods in any branch of the business that has not been the victim of fraud of some kind. The phase of swindling from which they suffer most, is in the imitation of their goods in debased metal. Scarcely is a new style of goods placed upon the market than some unscrupulous manufacturer produces a spurious imitation of it, made of debased metal, which is palmed off upon a credulous public as the genuine article. By these means, the public and the dealers are swindled, and an honorable business brought into disrepute. So closely are genuine goods imitated in base metal that experts are often deceived, and the ordinary dealer finds it impossible to distinguish between the false and the true. Thus the trade is often made an agent in its own despoiling. We are not complaining now of cheap jewelry, that is made and sold as such, for this is legitimate business, and there is a special field for it; so long as cheap jewelry is represented to be just what it is there is no room for complaint; but it is when misrepresentation is resorted to, and degraded goods sold for genuine gold goods that the fraud and swindle come in, working irreparable injury to the trade, and deceiving the public.

We have contended that the remedy for this evil lies in the establishment of a national standard for wrought gold, and the enactment of laws providing severe penalties for the manufacture and sale of any goods represented to be of one standard that did not come fully up to that standard. It is claimed that Congress has no right, under the Constitution, to legislate upon this subject; that the regulation of such matters belongs to individual States; but we have held heretofore, and still maintain, that Congress *has* the power delegated to it by the Constitution, to regulate all matters pertaining to the commerce of the country. It is expressly provided in the Constitution, that Congress shall have the power to regulate commerce

between this and other countries, and also between the several States. The question has been before the Supreme Court of the United States several times, and in every instance, the right of the general Government to regulate commerce has been sustained. In rendering their decisions upon these questions, the Justices have defined the meaning of the word commerce. The celebrated case of *Gibbons vs. Ogden*, tried in 1824, was one of the first instances where the question of the right of an individual State to control commerce was brought in question. The State of New York had granted to Fulton and Livingston the exclusive right to navigate the waters of the State, in vessels propelled by steam, and this right had been assigned to Gibbons. Ogden had received a permit, under the laws of Congress, to do a coasting trade in steamboats, and Gibbons brought suit against him for infringement of his special privilege. The State courts sustained Gibbons, and Ogden appealed to the United States Supreme Court. Daniel Webster and Attorney General Wirt defended the rights of the Federal Government; while Emmett and Oakley represented the State. Seldom has a case attracted so much attention as did this one, and rare indeed have been the occasions when such eloquence and legal ability have been displayed. In delivering the judgment of the court, chief Justice Marshall said:—

“The subject to be regulated is *commerce*, and our Constitution being, as was aptly said at the bar, one of enumeration and not of definition, to ascertain the extent of the power it becomes necessary to settle the meaning of the word. The counsel of the appellee would limit it to traffic, buying and selling, or the interchange of commodities, and do not admit that it comprehends navigation. This would restrict a general term to one of its significations. Commerce undoubtedly is traffic, but it is something more,—it is *intercourse*. It describes commercial *intercourse* between nations and parts of nations. \* \* \* Commerce as it is used in the Constitution is a *unit every part* of which is indicated by the term. If this be the admitted meaning of the word, in its application to foreign nations, it must carry the same meaning throughout the sentence and remain a *unit*, unless there be some plain intelligible cause which alters it.”

And Mr. Justice Johnson, concurring with the Chief Justice, said:—

“Commerce in its simplest signification means an exchange of goods, but in the advancement of society, *labor, transportation, intelligence, care*, and the *various mediums of exchange* become commodities, and enter into commerce; the subject, the vehicle, the agent, and *their various operations*, become objects of commercial regulations. Shipbuilding, the carrying trade, the propagation of seamen, are such *vital agents* of commercial prosperity that the nation which could not legislate over these subjects would not possess the power to regulate commerce.”

The same idea, viz.: that all the constituent elements of commerce are included in that term and are subject to congressional regulation, has been maintained repeatedly by the Supreme Court in other cases. If, therefore, “the *subject, the vehicle,*” etc., become objects of commercial regulation, most certainly the *integrity* of the “subject,” the object itself, comes within the purview of Congress. Watches, clocks, jewelry, plate, etc., constitute “subjects” of commerce, and, under the decisions of the Supreme Court, Congress has a right to establish standards by which the value of these articles shall be regulated. We have a standard of weights and

measures, declaring how many pounds of wheat shall make a bushel, and how many inches shall make a foot; these standards regulate commercial transactions in all articles subject to such measurements; it is just as lawful, and fully as necessary, that we should have a standard regulating the degrees of fineness of wrought gold, establishing a standard value for such goods that shall be universally understood and recognized. Under such a standard, 18 karat gold would be worth a certain sum per pennyweight; 14 karat gold another certain sum; this value would not be fixed, any more than the price of wheat can be fixed, but would be subject to the conditions of the market for gold; but a person buying 14 karat gold would be as certain of getting what he paid for, as one who buys a bushel of wheat according to the established standard. The right of Congress to establish such a standard for wrought gold is clearly conferred by that clause of the Constitution empowering it to regulate commerce. Commerce is composed of many diverse constituent elements, and the right to regulate the greater, necessarily includes the right to regulate the lesser, or the numerous factors going to make up our commerce. In regulating our exports and imports of jewelry, the Government not only recognizes jewelry as part of our commerce, but taxes it according to the standard established by the usages of the trade. In matters of taxation, jewelry plays an important part; but its value as a taxable commodity would be greatly enhanced if it was assessed in accordance with a national standard.

The legitimate trade would be glad to see Congress legislate upon this subject, and a suffering people certainly are entitled to this protection. Under the existing laws, a manufacturer is only governed by his conscience in his representations to the public, and honest men are made to suffer for the acts of those to whom conscience is a stranger. A manufacturer's name is no longer his own property for, after he has devoted a lifetime to building up a reputation for honesty, and fair dealing, some unscrupulous scoundrel puts forth so close an imitation of his name, attaching to it debased and fraudulent goods, as to rob the original of all value. Imitation and spurious goods are the most demoralizing features the jewelry trade has to contend with, and it is high time Congress interfered to protect honest dealers and a swindled public from the tricks of designing rascals.

### The "Boys on the Road."

THE June number of THE CIRCULAR contained an editorial article, having the above caption, intended as a recognition of the valuable services conferred upon the trade by its traveling men. In the July number "An Old Jeweler" replies to this article, characterizing it as an "exaggerated and fulsome eulogy" of the travelers, made at the expense of the workmen in the shops. Our correspondent is unaccountably mistaken in classing an editorial article as a contribution emanating from some of the travelers, no one of whom suggested it or knew aught about it. Our correspondent evidently is not so conscientious a reader of THE CIRCULAR as he should be, or he would not have failed to have discovered that it has been persistently and consistently a eulogist of the skill, intelligence, originality and superiority of the workmen in the factories connected with the jewelry trade. Not only have we complimented them upon their achievements, but their industry, loyalty and fidelity to the best interests of the trade have been repeatedly commended in our columns, and THE CIRCULAR has also been an earnest champion for their rights, and an advocate for liberal compensation as the reward for special skill and intelligence. We cannot, therefore, be accused of lauding one element of the trade at the expense of another.

The fact is, there are many factors required in the successful management of the jewelry trade of to-day. The methods of conducting the business have changed materially in many respects within the past few years. As the workman requires a greater variety of tools with which to complete his work artistically, and acceptably,

so does the trade require additional agencies to what it once knew in conducting its business successfully. Jewelry is no longer merely an article of luxury, to be indulged in by the wealthy, who have leisure and inclination to seek among the dealers for it, but modern skill and labor-saving machinery have tended to popularize it, and to make it more or less a matter of necessity with the masses. As the demand for jewelry increased, the methods for supplying that demand had to be added. The trade is now divided into distinct and separate branches, including the manufacturer, with his scores of skilled workmen and an abundance of improved machinery; the jobber, who takes the goods in bulk from the manufacturer and distributes them throughout the country; and the many thousands of retailers who deal directly with the people. As a medium of communication between the jobbers and the retailers, comes the commercial traveler, whose appearance upon the scene as a factor to the success of the trade, was made necessary by the extent of country covered, by the constant demand for new styles, and the active competition that has grown up in all branches. It is he who, by his visits to the retailers, creates a demand for goods, keeps informed as to what are the requirements of the trade, knows what goods are salable and rejected by the public, who suggests new styles, who keeps watch of the financial condition of his customers for the benefit of his employer; and, finally, it is the traveler, who sells the greater portion of the goods turned out by the manufacturers. Remove the travelers from the road and the primary effect would be to reduce the amount of goods manufactured; consequently, the number of men employed also; to cut down the wages of the workmen, and to deprive the employers of the means of paying such as were retained. The "Boys on the Road" have become as important and necessary an element to the success of the jewelry trade as are skilled workmen and capitalists to manufacture goods; they are the medium through which the majority of the sales are made, and, without liberal sales, where would be the use of either workmen or capitalists in the workshop? THE CIRCULAR has no intention to exalt one of the elements of the trade at the expense of another, but to give credit to each as it deserves. It is no detriment to the thousands of skilled workmen engaged in the manufacture of jewelry to say, that the "Boys on the Road" are important agents to the successful conduct of the business, or that they are an industrious, honorable, self-sacrificing class of men, discharging their duties faithfully, and contributing greatly to its prosperity. We are glad to have "An Old Jeweler" maintain the rights of the workmen; but he should not disparage the other important elements of the trade, or seek to detract from their importance or services.

### Signs of Improvement in Trade.

THE weather for the last few weeks has been very favorable to the farmers, who have been gathering their hay crop, which in the Middle and Eastern States especially is one of the heaviest ever cut, so that hay is now low in price and excellent in quality. The promise of the other crops is generally flattering throughout the country, though in some States agriculture has suffered to a degree from too abundant rains. The outlook, however, is that the harvest of cereals will be exceptionably large, both because of the greater acreage planted, and because of the average healthy condition of the crop.

Short grain harvests in France and in England assure us a foreign demand for our surplus of the cereals which will enable us to dispose of these crops at remunerative prices; and the consequence must be the further advance of all the business interests of the country.

When we hear that the manufacturing interest is generally in a satisfactory condition, the mills and machine shops, as a rule, working up to full time, with a full force of labor, we get a sign of the renewed prosperity of trade which is unmistakable. Another indication is afforded in the large decrease of the number of business failures for the first half of the year as compared with the corresponding period of 1878, and the four previous years.

During the past six months the total of failures in the United States was 4,058, against 5,825 for the same time in 1878; and the liabilities were only sixty-five millions, against one hundred and thirty millions. The circumstance that last year there was a rush to take advantage of the Bankrupt act before the date of its repeal must be remembered as one of the exciting causes of the large total of failures for 1878; but during the last six months not only was the number less than in any year since 1876, but both the aggregate of liabilities and the average of liabilities were also far less.

Another gratifying proof of improvement, which argues an increased demand for labor, is afforded by the report of Supt. DUDLEY of the operations of the Building Department of this city during the first half of the year. It shows that building is gaining in New York at a rapid rate, "the number of buildings proposed to be erected and the cost of the same being much greater than for some years past." On the first of July the total of new buildings in progress was 961, against 715 at the same time last year. The estimated cost of the structures for which plans were submitted during the six months, was \$11,754,552, against \$8,327,375 in 1878—a gain of \$3,427,177.

The indications of the swelling of the tide of business prosperity and an enlargement of the demand for labor, of which these are a few of the more important, are as indisputable as they are encouraging.

**M**ANUFACTURERS and jobbers are frequently greatly annoyed by the lack of explicitness in the orders they receive from dealers. These latter, knowing the kind of goods they want, seem to take it for granted that everyone else does also, and they send their orders blindly. Comparatively few men in the trade, so far as we know, are sufficiently inspired as to enable them to read the thoughts of a dealer a thousand miles away. Dealers should be as explicit as possible in their orders, designating the goods they want by the private marks which the manufacturer puts upon them; or, if duplicating orders, refer to bills of previous dates for description of goods. Occasionally a dealer sends a rough sketch of the goods he wants, but these efforts are generally so crude that it is difficult to determine whether it is a gold watch or a mud turtle that is wanted. Sometime since a traveler for a jewelry house exhibited to a western dealer samples of different kinds of pencils; the dealer didn't want any at the time, but said he would order direct from the house later. When the traveler got home he received a postal from the dealer saying, "send me a dozen of those pencils you showed me." The traveler was at a loss which kind was meant, and so wrote to ask whether he wanted gold or rubber pencils. A few days later the traveler being absent, the head of the firm was astonished and somewhat confounded on receiving a postal on which was written the cabalistic words: "rubber, rubber, rubber!" Recovering from his astonishment after a time, and being a man of prompt business habits, he immediately replied by postal: "I have rubbed her; what shall I do next?" Had the dealer been a little more explicit in his first order, he would have spared the modest head of that house much confusion and embarrassment. He would also have received his pencil cases in much less time than he ultimately did.

**I**N the next issue of THE CIRCULAR we shall commence the publication of a series of interesting and important articles on the subject of "Art Work in Silver." These articles are from the pen of Mr. Pierpont, one of the best known, skilful, and artistic designers of the present day, formerly designer and modeler for the Gorham Manufacturing Company, and latterly with the Meriden Britannia Company. Mr. Pierpont is recognized as one of the best classical designers of the age, whose work has contributed much to the elevation of style and taste in silverware in this country. The series of articles he has prepared on the subject are replete with research, study, and experience, and cannot fail to be of great value to the trade. The articles are thoroughly practical, and will be invaluable not only to the workmen in the shops, but to all who are engaged in any way in the silver and plated ware trade.

**T**HE Metropolitan Museum of Art, now located in the Central Park, under the direction of Gen. Cesnola, have decided to make an Industrial Art Collection. Efforts are being made to interest all who represent our best American manufacturers in contributing to this collection, and a number have already done so. There is no doubt of the necessity of such a museum in this country, and once established on a proper basis it will doubtless have a decidedly beneficial effect on the progress of art in this country. It is hoped to open the museum in November next, with metal work only, and afterwards, as soon as possible, increase the collection with other departments. The committee are desirous of securing the assistance of the manufacturers of the best styles of American art, and request contributions from them and others interested in the progress of art in the United States. Any further information will be gladly given by Dr. T. Egleston, Prof. of Metallurgy, of Columbia College, who has been appointed by the Trustees to make this collection.

**I**N the case of John Foley vs. Marcus Kronberg, of Chicago, the defendant has settled the suit brought against him by paying Mr. Foley's claim in full together with costs and counsel fees. Mr. Foley refused to compromise with Kronberg when that gentleman failed, but sued for the full amount due and secured his arrest. The Assignee of Kronberg's estate paid Mr. Foley *pro rata* with the other creditors, and Mr. Kronberg paid the difference to secure his release from the entanglements Mr. Foley had thrown around him.

**A** SALE lately took place in Paris of the magnificent collection of jewels owned by the late Mme. Musard. The total of the first three sittings reached the large sum of 1,078,910 francs. We take the following account from the *Moniteur des Arts*, of the 27th ult.:—"The first sitting of the sale of the pearls, diamonds and other jewels of the late Mme. Musard, drew on Monday to the Hotel Drouot, the principal jewelers of Paris, who disputed in quite a lively manner for the first series of ornaments and diamonds. In the elegant crowd at the back of the hall we noted several ladies of the best society. The sale of Monday comprised the numbers 19 to 23 of the sets of diamonds. Among the most important pieces of jewelry must be noted a very beautiful necklace, consisting of five large diamonds, surrounded by a row of brilliants connected by a double row of bezels with clasp and hooks, ornamented with a brilliant surrounded by a row of bezels, sold for 124,500 francs; a pendant, 30,550f.; another, 38,000f.; a pair of earrings, 51,500 francs; two eardrops, 43,600 francs; a necklace (barrette and pendants), 48,000f.; an aigrette (a bunch of flowers in diamonds), arranged for the hair, 23,800f.; a diadem composed of thirty-four bezels and of a crescent in diamonds, 24,000f.; a necklace of fifty-one brilliants, 26,600f.; a necklace of sixteen pieces, formed of double laurel wreaths in brilliants, and fixed on black velvet, 21,900f.; a necklace of quadrangular *rosaces* in brilliants, 19,000f. The first day's sale produced the total sum of 534,255f.

The second day's sale amounted to 333,295. The necklace of 475 pearls was sold to M. Mannheim, expert, at the price of 170,000f., and the clasp of this magnificent necklace, which had been detached from it, was acquired by a foreign amateur for the sum of 12,350f.; which brings the total price of the ornament up to 182,350. The other jewels which ran up to the highest prices were: A necklace of 298 pearls, 25,100f.; a brooch, ornamented with a sapphire, 20,050f.; a necklace of nine sapphires, 19,000f. The results of the third day's sale reached 211,360f. A diadem formed of a square emerald, surrounded by thirty-seven brilliants, was sold for 24,550f.; a brooch (opal surrounded by fourteen brilliants), 17,500f.; a necklace of twelve bezels, each bearing an opal, surrounded with diamonds, 18,600f.; a badge formed of an uncut emerald, surrounded by knots of roses and a row of brilliants, and terminated by an uncut emerald drop, 20,000f.; a diadem with a ground of diamonds, set with three emeralds, 17,400f. The total of the first three day's sale is 1,078,910f.

Proceedings of the Horological Club.

A DISTINGUISHED BODY OF WATCH AND CLOCK MAKERS.

*Sixty-fifth Discussion.—Communicated by the Secretary.*

[NOTICE—Correspondents should write all letters intended for the Club separate from any other business matters, and headed "Secretary of the Horological Club." Direct the envelope to D. H. Hopkinson, Esq. Write only on one side of the paper, state the points briefly, mail as early as possible, as it must be received here not later than two days before the end of the month in order to be discussed and reported in the CIRCULAR for the next month.]

WHY DOES A LEVER CLOCK STOP?

*Secretary of Horological Club:*

What causes a lever clock to stop, when it is thoroughly repaired? The balance pivots are sharpened, the steel sockets drilled to a point, the pivots of the balance have plenty of play, and the anchor is set at the right distance from the escape wheel. Some generally stop when lying on the back, but that is caused on account of balance pivots having too much play. Mine goes for about two days, and then it will stop. I have heard some watchmakers complain about them. Please answer at your next meeting. SUBSCRIBER.

Mr. O'Lever replied that the cause of stopping might be in the angle, or amount of taper, given to the balance pivots, and to the holes in the sockets or bushes. Neither the pivot nor the pivot hole should come to a perfectly sharp point. If they do, when the pivot runs on end, if both the pivot and the hole have the same angle or taper, they will fit together so closely that the clock cannot run. If the pivot is more obtuse than the hole, it will wedge in the socket, and not touch on the point at all. If the pivot is sharper or more acute than the hole, it will play very nicely, but the fine point will not last long, and then the pivot will wedge in the hole as just stated.

The pivot and hole should be quite small at the point or bottom, (but not sharp,) well rounded, smooth and polished. Both pivot and hole should be quite acute, *i. e.*, slightly tapering, so that, even when there is plenty of end-shake for freedom, there will be but little side play to the pivot in the socket. The pivot should be more acute than the hole. When running on end, it will run freely on its point; when running on the side, the friction will always be at the point, and consequently near the center or axial line of the balance staff, the position most favorable to free vibration. Further, when the pivot rests on end, it should not fit the socket, but be a little smaller at that point, so that it will be perfectly free. And if there is any danger of the point of the pivot wearing off, it should be a little more free, to allow for this wear, otherwise it will soon be tight in the socket, and refuse to go when running on end.

In "Subscriber's" case, supposing all the depthings, etc., to be correct,—especially the main-wheel depthing, which makes a great deal of trouble in spring lever clocks, unless well fitted,—and the action of the escape wheel on the lever, and of the lever notch on the pin, to be all right, the trouble is probably in the improper fitting of the balance pivots in the sockets, as already explained. The strength of the mainspring overcomes the excessive friction, when first wound up, but as soon as the clock is partly run down, and the spring weakened, it stops.

A FRIEND OF THE CLUB.

*Secretary of Horological Club:*

I am a regular reader of your Proceedings, and wish to say to you that I highly appreciate the information you give us, and hope you will keep on in the good work. I have been a reader of the CIRCULAR for several years, and have also one of Excelsior's books on the Balance Spring. I would not be without either of them for *ten times* their cost. I would like to be able to add something to the *many good things each month*. I almost feel guilty for not trying to do so, but will not attempt an infliction at present.

Respectfully yours,

C. F. H.

Mr. O'Lever said this was only a sample of the letters constantly coming in, commending our course. We are glad to know that our friends appreciate our efforts, and hope that each one will do a little to help us along, by writing out a description of some new tool he has gotten up, or some way of doing something, which is quicker, easier or better than the usual way. Every workman of experience has something of this kind which would be new and valuable to others. It will take but a short time to write it out and send to us. Let every man do his share, and we shall all be gratified and bettered, and nobody the loser by it.

BLACK ENAMEL.—SETTING JEWELS.

*Secretary of Horological Club:*

Will some one of your members inform me what is a good, easily made and easily applied black enamel?

I wish something that I can use to give a black appearance to letters engraved on silver, gold, or ivory, something that could be applied without much trouble.

Also how are the small bridges of swiss and other watches held when cutting the jewel seats, and what kind of tool used, to burnish down the bezel, as nicely as generally seen in them? And how is tool held?

J. D. H.

Mr. Ruby Pin thought that perhaps the soft black enamel sold by all material houses, for repairing watch dials, would answer Mr. H's purpose for the gold and silver goods. It would hardly do for the ivory, however, as the heat required to make it flow would be liable to either scorch the ivory or cause the enamel to penetrate the fine veins and cracks, over the whole surface, and make it look dirty and streaked.

For this purpose it would be necessary to mix up some kind of black cement that did not require heat, but was adhesive enough to stick in the grooves. Even black putty would make a hard and durable filling, if one could wait for it to dry.

Mr. H. will probably find it the easiest way to cement his bridges on a flat faced chuck, of a live spindle lathe, centering them truly while the cement is soft. The bezel is burnished down by a small tool shaped to suit the work, highly polished and tempered, held over the lathe rest, with the hand, like other tools.

A DRILL TO CUT HARD STEEL.

*Secretary of Horological Club:*

For years past there has been great inquiries in regard to drilling staffs, pinions, &c. I will offer my method which I have found to be perfect and sure every time. I found it impossible to make a drill, and then to temper it so it would drill without drawing the temper of the staff. But by first tempering my steel to make my drill, I overcome all difficulties; after tempering my steel, I have a small corundum wheel attached to my lathe, which I grind and shape my drill—and when finished, it is all ready for use, and I will guarantee to drill any pinion or staff in any watch without drawing the temper. I find the Howard staff very hard to drill, but this method is sure every time; also, this drill can be made large enough to drill out screws when broken off. In the studs of the American Watch Plate, drill a hole in the screw, and then drive in a plug, and you can very easy turn out the broken screw.

J. P. W.

Mr. McFuzee thought this way was an excellent idea, and recommended our readers to try it. He hoped Mr. W. would give us more particulars as to how he shaped his steel before hardening, if he left it the full hardness, or let it down, and how much, how his wheel was arranged, how he ground the drill, what shape, cutting edges, how he held the drill while drilling, and many other points our readers would like to know, from one who had made a practical success of it. We are always glad to receive these valuable practical items, and trust our friends will furnish full particulars when they write. Any watchmaker interested enough to drop me a card with his address, I will make and send him a drill, and also full instruction for making the same.

Yours very respectfully,

J. P. WILCOX.

## WILL PRACTICAL HINTS BE REPUBLISHED?

*Secretary of Horological Club :*

Will Practical Hints on Watch Repairing by Excelsior, now being published in the JEWELERS' CIRCULAR, be published in book form? I have the Treatise on the Balance Spring, and would like to get Practical Hints also.

Please answer, and oblige

A. E. A.

*Secretary of Horological Club :*

Owing to your recommends, I sent for the book containing Excelsior's Practical Treatise on the Balance Spring, and will say that I greatly appreciate it. I have several works on watch and clock repairing, also have been a subscriber for several trade journals, but the best is the JEWELERS' CIRCULAR AND HOROLOGICAL REVIEW. I read them all closely, and have received much valuable information as regards the proper ways of repairing all kinds of watches. But the Treatise by Excelsior is an Excelsior in the true sense. I say it is A No. 1, exceedingly scientific. I thought I was about as good at fitting all kinds of hair-springs as was necessary, but I have to give up to Excelsior's Treatise. I tell you there is plenty of scientific information concerning hair-spring fitting for the best workman to think over. Please mention when the next volume of Excelsior's Practical Hints is ready to send out, as you can count one sold to me.

S. N.

Mr. Isochronal said it was understood that the Practical Hints were to be republished in book form, on the completion of the series of articles, and, in fact, that a large number of copies had already been spoken for. Anything written by Excelsior was sure of general attention and ready sale. His articles were so practical, full, thorough, and trustworthy, that they met the wants of workmen of every class, and in a way that no other writers had attempted. As the back volumes of the CIRCULAR were long since out of print, there were hundreds of readers of the later Practical Hints to whom the earlier articles were inaccessible, to their great disappointment and loss. And even those who had been favored enough to have them from the beginning, would like them collected into compact and handy book form) with the corrections and additions to be made by the author. It was also understood that the present series of articles was drawing to a close, but when they would be completed, it would be impossible to say. We all hope he will not stop till he has thoroughly treated and finished his subject, and given us another standard work like the Practical Treatise on the Balance Spring, so warmly commended by Mr. S. N. His letter is like those of all purchasers, and we can only repeat what we have so often said before, that every watchmaker should have a copy.

## RATING SHEET FOR WATCHES AND CHRONOMETERS.

Messrs. J. H. Purdy & Co., 170 State St., Chicago, Ills., sent in a very convenient and well arranged rating sheet, published and sold by them. First, is a place for description and number of watch, and name of owner. Down the left side are the twelve months, and over the top the days of the month, so that there is a small space for each day of every month, for a year. In each space is a place to put down the gain or the loss, in minutes or seconds; a place to make a simple mark to indicate that the watch was set, or regulated, or both, on that day. At the end it is arranged to give a summary of the year's performance, for each month by itself, showing total mean, total variation, mean slow, greatest variation slow, mean fast, greatest variation fast. In short, it affords a complete record of the performance of the watch, is well printed, on strong and durable paper, and is something that every dealer, repairer, and owner of a fine watch should have. The price was not stated.

## BOOK ON WATCH ESCAPEMENTS.

*Secretary of Horological Club.*

I have had the pleasure of reading your JEWELERS' CIRCULAR, and take the liberty of asking you to give some information. I wish to know if there is any book of any kind that will explain how

to put in a cylinder in a watch, to get the right size of scape wheel, the measure of pallets, in short, the whole escapement of a watch? I write this, for I am anxious to know more of that part of the business.

I have been reading the Practical Hints on Watch Repairing by Excelsior, and like them very much from which I gained much very valuable information. I hope you will not let this pass unnoticed, but will let me here from you at an early day.

H. H. T.

Mr. Isochronal said Mr. T. would find full information in Excelsior's Practical Hints some two years ago, if he could get those numbers now. It was doubtful, however, whether they could be obtained. The call for back numbers containing Excelsior's articles had been very large, and the supply was probably exhausted of the numbers containing his articles on the different kinds of escapements. If so, he would have to wait till they were republished in book form. One other work could be got by Mr. T., and that was Saunier's Modern Horology, now being translated into English. Price, \$13.

## ROLLED PLATE JEWELRY.

*Secretary of Horological Club :*

Is rolled plate jewelry plated after it is made, or is it stamped with dies from rolled plate stock?

G. W. S.

Mr. O'Lever replied that plates of gold and of composition are first joined and the composite plate is then rolled to the desired thickness, and formed into any shape, having the gold side out of course. Sometimes the whole is thinly plated afterwards, to cover the back, where that is left exposed.

## GLASS COVER FOR LATHE.

*Secretary of Horological Club :*

I shall be very thankful for any information you may give as to where I can find a *glass cover for a lathe*. I think it very necessary that lathes should be covered up when not in use, as they are subject to the changes of atmosphere, as well as dust, etc.

O. O. G.

Mr. Clerkenwell said that a glass cover could be obtained of any New York jobber of fine and fancy clocks, by sending the inside space and height wanted. However, the freight would be considerable from this city. Probably they could be had from the Chicago jobbers also, but he could not specify the name of any house there.

## NEW WATCH ESCAPEMENT—EQUALIZING THE POWER OF THE MAINSPRING.

*Secretary of Horological Club :*

I send you to-day, by registered mail, a rough model of a watch escapement, which I think is new. I would like the *Horological Club* to pass judgment on the principle. It being so imperfectly made, and out of proper proportions, and not adjusted in any part, I cannot expect this model to hardly show the object in view, but will try to explain. The object in view was to get an escapement similar to the *Chronometer*, with the advantage of it receiving the *impulse* or *power* in both directions of the play of the balance. Without any further explanation, any one versed in these matters will understand from the model sent.

I also send a mainspring barrel of the American watch, with an attachment on the end of the spring, with friction rollers running in slots made in the barrel, which when wound up, draws to the center, and as the watch runs down, it passes gradually to the circumference, which I think will equalize the power to some extent.

J. H. P.

Mr. Isochronal explained the construction of the escapement, which had on the balance staff the usual roller table and ruby pin of the detached lever, working with a lever fork of the usual American form, except that it had underneath, and between the arbor and the notch, a block which served to lock the escape wheels. The sweep of the lever was governed by bankings as usual, and its sole use is to lock the escapement, as before stated. There are two escape wheels, each about the size of the ordinary fourth wheel, the first one having a pinion, as usual, and its teeth meshing into and driving

the second. The block on the lever is about over the intersection, of the two wheels, the lever arbor being planted on one side of the intersection and the balance staff on the other. The impulse is given by a number of vertical pins set into the web of each wheel, acting alternately on a sort of anchor or pallets on the balance staff, below the roller table.

The model shows much study and ingenuity on the part of Mr. P. and reflects credit on his constructive skill, but unfortunately it is not new. A similar escapement is shown in Saunier's French work on Horology, but a little different in details—instead of vertical pins, that had a sharp toothed escape wheel placed over each of the gear wheels, and on the same arbors. These escape wheel teeth acted on the ends of the anchor, each wheel driving its end from the outside towards the inside, or towards the other wheel, while Mr. P.'s pins drive their pallets from the inside, outward, alternately in each direction. The locking mechanism of that is some different from his, and there are some advantages gained by having the further or outside gear and escape wheels smaller than their mates and drivers.

But it was useless to further explain the differences, or advantages of one over the other; because, in either of them, the friction, the complexity and difficulty of making and adjusting them, etc., throw them practically out of the race. As has been repeatedly stated by many horological authorities, no escapement has the slighted chance of being adopted which is not at least as simple in design, as easy of construction and adjustment, as free from friction and liability of derangement or injury by accident, and giving as perfect results, as the four principal escapements now in use. It may be added that, since the latter improvements in the chronometer escapement, it can be constructed and adjusted so easily and cheaply, that no new escapement can be adopted unless it is equal in every way to the present detached lever or chronometer escapements. The chronometer, to be sure, takes the impulse only in one direction, but that, although theoretically at fault, is practically of very little moment,—too little to warrant the addition of an additional escape wheel, or even of a second locking spring acting on the same escape wheel.

Mr. P.'s going barrel is not new, having been the subject of many experiments, both in this country and in Europe. It is also described in Saunier's work, and the speaker recollected seeing it at the Paris Exposition, in 1867. The slots in the barrel ends have been made radial, tangential, and of other shapes. The use of friction rollers on the pivots of the mainspring brace has been suggested, but considered impracticable, practically. Those made by Mr. P. operate well, but both the rollers and the ends of the pivots project outside of the barrel, which cannot be allowed. It would very difficult to head down the pivots enough to hold the rollers on securely, yet leave them free to turn, and at the same time have the body of the brace free inside the barrel, yet so closely fitted that neither pivot with its roller could project outside of the barrel. While this might, with sufficient care, be accomplished in any special case, it would not be commercially practicable. Even when accomplished, the regularity with which the pivots roll to and from the center depends largely on the natural curve of the outer end of the mainspring, and also on the shape of the inner coils, and not entirely on the tension of the spring as it should.

In the opinion of practical men, the importance of equalizing the motive force of watches is very much lessened since the discovery of how to isochronize the hairspring, and still more by also using long mainsprings. It is a cardinal rule with modern watch designers, to use the greatest convenient length of mainspring, giving several turns to its arbor, and then to utilize, for the purposes of the 24 hours running, only a part of them, and those either the middle or upper turns. By so doing, they secure a comparatively uniform strength, and whatever inequality of motive force remains can be compensated for by a proper fitting of the hairspring to secure isochronal vibrations. The excellence of the performance of both American and foreign watches based on this system proves its correctness.

But for watches having extra-large barrels or arranged to run more than one day, or in clocks, this arrangement of the mainspring brace with friction rollers on its pivots would doubtless be very useful.

In conclusion, Mr. I. said he was sorry to seem to disparage the ideas of our correspondent, but presumed that the gentleman wanted to know the actual truth, whether agreeable or otherwise. It was certainly better to be dissuaded from undertakings which could not be practically successful than to be flattered into continuing to give them time, study and expense, only to find, at last, that all was wasted and useless. Furthermore, as there were at all times a large number of workmen studying on new escapements, and the equalization of motive force, he had answered the questions quite freely in the hope that it might be of service to many others besides Mr. P.

## Patents.

Containing notes of all Patents, Designs, Trade Marks, Labels, &c., relating to the trades represented by the CIRCULAR, granted by, or registered in, the Patent Office, since the last issue; and also notes of decisions in the Circuit Courts and the Supreme Court of the United States, which involve new or interesting points of law or practice on the subject of Patents.

PREPARED BY CROSS AND ADAMS.

- July 1.* PATENTS.  
217,061. Bracelet. Robert T. Chapman, Louisville, Ky.  
216,930. Button and Stud. Benjamin J. Angel, Attleboro, Mass.  
216,955. Diamond-Cutting Machine. Anthony Hessels, New York.  
217,092. Earring. William E. Green, Providence, R. I.  
206,954. Earring. Louis Heckmann, assignor of  $\frac{3}{8}$  interest to W. H. Wade and E. P. Davis.

- July 8.*  
217,264. Napkin Holder. Willard L. Bundy, Auburn, N. Y.  
217,318. Buttons and Studs. Frank P. Barney, Norton, Mass.  
217,437. Collar and Cuff Fastener. Julius Wehl, New York.  
217,413. Ornamental Hair Pin. William Schultz, Birmingham, Conn.  
217,279. Ornamental Panels for Jewelry. Nathaniel Grant, Providence, R. I.  
217,398. Manufacture of Stock-plate for Jewelry. Jno. S. Palmer, Providence, R. I.  
217,420. Spectacle Bow-Hinge. John S. Spencer, New York.  
217,291. Watch and Clock Pinions. Francis Lambert, Ansonia, Ct.  
217,419. Safety Centre Pinion for Watches. Jacob A. Smith, Salem, Ohio, assignor of  $\frac{1}{2}$  interest to C. F. Kesselmiere.  
217,326. Watch Escapement. Victorien Bousset, Morez-du-Jura, France.

- July 15.*  
217,453. Stock for Bracelets, &c. Charles Downs, Providence, R. I.  
217,522. Jewelers' Frosting Tool. G. B. Fitty, J. Baxter and M. E. Rowe, Attleboro, Mass.  
217,662. Covered Articles of Plated Ware. H. E. Wilcox and J. Jepson, assignors to Meriden Britannia Company, West Meriden, Conn.  
217,461. Covered Dish for Butter, &c. W. E. Hawkins, Boston, Mass.

- July 22.*  
217,778. Eye Glasses. Garrett C. Daboll, Buffalo, N. Y.  
217,835. Nose-Clamp for Eye Glasses. Nicholas Watry, San Francisco, Cal.  
217,738. Water Cooler. Fredrique R. Lewis, Troy, N. Y.

- July 29.*  
217,861. Manufacture of Wire Fastening for Jewelry. Wm. W. Covell, assignor to F. I. Marcy, Providence, R. I.  
217,966. Button and Stud Fastening. Clarence L. Watson, assignor to Gould, Watson & Co., Attleboro, Mass.  
218,009. Watch. Rufus Folsom, assignor of  $\frac{1}{2}$  interest to S. Meyers, of Boston, Mass.  
218,077. Bronzing Machine. Albert Steiner, Chicago, Ill.  
217,945. Glass Polishing Apparatus. James W. Jacobs, assignor to himself and W. S. Jacobs, of Jeffersonville, Ind.

- July 1.* DESIGNS.  
11,269. Vases. Melville D. Jones, Boston, Mass. Term 7 years.  
11,271. Pencil Case Charm. Jacob Z. Marinus, Jr., assignor to Charles H. Downs, Boston, Mass. Term 7 years.  
11,276. Clock Case Front. Charles L. Brown, New York, assignor to E. N. Wells Manufacturing Co., Forestville, Ct. Term 7 years.

- July 8.*  
11,289. Spoon and Fork Handles. George W. Shiebler, Newark, N. J. Term 7 years.

- July 15.*  
11,295. Ornamental Chain. Daniel A. Beam, Newark, N. J. Term 3 $\frac{1}{2}$  years.  
11,296. Card Basket. Thomas J. Linnekin, N. Y. assignor to Dreyfuss & Sachs, same place. Term 3 $\frac{1}{2}$  years.

- July 22.*  
11,303. Funeral Ornaments. Charles H. Leonard, Meriden, Ct. Term 7 years.

- July 1.* TRADE MARKS.  
7,451. Spectacles and Eye Glasses to H. Hirschberg, St. Louis Mo. The word-symbol "Diamond," the letters "H. H.," and the name or title "H. Hirschberg."

- July 8.*  
7,497. Electro-Plated Table Ware to William Rogers, Hartford, Conn. "The title 'Wm. Rogers' and 'the arbitrarily-selected symbols representing an Eagle and a Star.'"

- July 29.*  
7,547. Gold Pens, Pencils, Pen and Pencil Cases, &c. to Leroy W. Fairchild, New York, N. Y. "The word 'Fairchild.'"

- July 8.* LABELS.  
2,004. Title "Extra Heavily Plated Medium Knives," William Rogers, Hartford, Conn.

An English decision of very great interest, as affecting the rights of a certain class of operators, has been recently promulgated, to the effect that when a partnership at will is formed for the purpose of working an invention, for which Letters Patent have been issued to one member of said partnership, the Patent becomes an asset of the partnership, and each partner acquires a right to practice the invention.

The federal law upon the subject of Trade Marks has been declared void by Judge Dyer, of the U. S. District Court for Wisconsin, upon the ground that there is no constitutional right in Congress to legislate upon the subject.



## Repairing Swiss Watches.

Continued from page 108, Vol. X.

## HALF-SHELL FOUL OF WHEEL.

IN this case it will sometimes be possible to raise the cylinder sufficiently by stoning down the brass setting of the lower cylinder end piece, where there is much space between it and the jewel hole; at the same time it should not touch it, as in that case the oil would be prevented from entering the reservoir, and the pivot would speedily run dry.

If this method is not available, the cylinder notch can be lowered by either a ruby file or steel polisher and oilstone dust, resting the balance on either a piece of pith, or cork, while doing so.

## BOTTOM PLUG FOUL OF WHEEL.

The cylinder can be lowered by shortening the lower pivot, bending the cock down a little to correct the end-shake; should the pivot not be long enough to admit this, the shoulder must be turned back and repolished. In the event of its being a square-shouldered pivot, the triangular burnisher used on the Jacot tool will be the safest, as by this means, not only is it impossible to break off the pivot, but it will not be smaller at the shoulder, a thing very likely to happen with the turns and polisher.

Should the balance, by being lowered, have become foul of the scape cock, it must be raised by its bars until free, trying it in the calipers until true.

## SCAPE WHEEL.

I have already spoken somewhat largely of faults in connection with examining, but in the case of a very bad wheel it would be much easier to change, than to attempt to correct it; there is such facility now for doing this, wheels of very good quality can be got for such a low price, and in such a variety of sizes and heights, that it is rarely a difficult matter to get one a correct size. In sending for a new wheel, it is always best to turn a sink in a piece of brass in the mandrel, as a gauge for size; and if the wheel is not sent, a notch cut for the height also. The removal of the wheel from the pinion should be done on a pinion-riveting stake, in a hole that just fits loosely the pinion; a pointed hollow punch, preferably of brass, fitting freely over the pivot, or in the hollow of rivets, should be used, and a light hammer. The size of the hole in wheel is the next consideration; it will most probably be considerably smaller than the old one. The common way of opening this hole is to broach it, and as the wheel is generally too hard to broach as you get it from the material dealers, it is usually put on a wire, and the wire in the flame of a lamp until sufficiently softened.

This is rather a risky way of doing it, the wheel is liable to be got out of flat, or broken in the operation; a far safer and better plan is to grind out the hole without softening the boss. A long and soft arbor is filed lengthways: it should not be too taper, and used with either fine emery or oil-stone dust, the wheel having previously been shellaced by its back to either an old fourth wheel, or some light circular piece of brass to protect the teeth, and handle it by. Particular care should be taken not to run the arbor dry while grinding, but to keep it liberally supplied with oil, so that it does not stick. Should the boss be too thick, leaving insufficient rivet, it can be turned down with a hard graver. To turn down the seat, if the watch is flat, would be rather a difficult matter; but if it is at all high it can be done, supposing that the slot in cylinder will admit of it. The hole having been ground out until it fits firmly on to pinion, it should be riveted lightly with a hollow steel punch, revolving the wheel a little between each blow of the hammer, which should be very light. Its truth in flat should be examined from time to time by means of the brass calipers and straight-edge; if the riveting is carefully done the wheel will be true. It will rarely be necessary to bump the arms of a wheel if carefully riveted. The size of punch should be such that it just goes easily over the shoulder of pinion, and its face should be perfectly polished.

## SCAPE PINION.

This pinion, for reasons that I shall presently mention, is more often met with in a bad condition than in any other, except the centre. You will frequently find this pinion so much cut as to cause wonder that the watch goes at all; of course, accurate timing with a pinion in this state is impossible. Owing to its small size most country jobbers fight shy of it, letting it go as long as the watch continues to tick. The reason that these pinions cut so quickly is that, first, as a rule, to common qualities of work they are very *small*. Secondly, from an absence of shoulder to the pivots, the oil runs into the leaves, and mixes with the dust, &c., forming a cutting mixture, which, becoming imbedded in the soft brass of the fourth wheel teeth, speedily destroys the shape of the leaves. In addition to all this, the pinions themselves, are, as a rule, soft, and not remarkable for their good shape or polish. In order to avoid as far as possible these evils, it is necessary to get the best pinions, rejecting all such as are at all unequal or of bad shape, being at the same time sure that the pinion is correctly sized. In order to insure this I should suggest sending fourth wheel, and having pinion secured to it, instead of trusting to the size of old pinion. In addition, the shoulders to pivots should be of sufficient extent, the extreme carner sloped off cleanly, and hollows of sufficient depth carefully cut; and lastly, that only sufficient oil should be applied to these pivots; generally they get more than is necessary.

To work in a new pinion when the old one is present will give no trouble as to height. The pinion being removed from the wheel, all the measurements can be taken from it, and transferred to the new one by means of the millimetre gauge. This gauge is much lighter in its action than the *douzieme* gauge, and altogether more suitable, the divisions, too, are finer and clearer, two-tenths of a millimetre, roughly speaking, being equal to one *douzieme*. The jaws of this tool as bought are not always closely fitted, and as they are hard they can only be corrected by grinding. A piece of flat brass, similar to a barrel cover, is fixed on an arbor, and adjusted to run true in flat; a little emery and oil or stone dust is applied on each side of it. The turns having been put in the vice sideways, so that the gauge can hang freely, the jaws should be allowed to close on the lap, and a few revolutions will grind both jaws true and perfectly parallel. After this alteration it is very likely that the pointer will pass beyond zero on the index: the end of the pointer must be gripped in the vice with a piece of card to prevent marking, and pulled gently until it again indicates correctly.

When the old pinion is absent it will be best to proceed in the following manner: Having put in the cylinder, a brass collet similar to a pivoting ferrule should be roughed out, its thickness being a little in excess of the height you imagine the scape pinion head to be. This is placed in the scape wheel sink, and the wheel on top of it; you can now offer the wheel to the cylinder passage, and see whether it is a correct height. You will continue to reduce the thickness of collet until the wheel is at a correct height. Having removed the wheel and cylinder, you will measure over the collet and lower jewel hole with the millimetre gauge (previously removing the end piece). Next measure the thickness of the jewel hole; this being deducted from the previous measurement, will give the distance from the lower pivot shoulder to the seat of wheel. The height of pinion head will be less than this, of course; how much will depend on the position of the fourth wheel. The leaves should come just through the wheel teeth; any excess is bad, for the reason I have already mentioned, viz., attracting the oil from the holes. After screwing on the scape cock, the distance over both jewel holes should be measured, care being taken not to bend down the cock in doing so; deduct the thickness of both jewel holes, and you have the distance from shoulder to shoulder, or the height. These measurements should be set down on paper as you take them, to avoid a mistake.

The actual work of running in the pinion may be done in the following order: The pinion, as got from the material dealers, will generally be much longer than is necessary, the leaves only being twice as long as pinion will be when completed. The first thing is to see that the leaves run true; next, as one end of pinion is always polished, that end should be kept for the face; a very little touching up with a bell-metal polisher and diamantine, will be all that is necessary to do to it. Then turn down the leaves until the wheel will just pass on a short distance, and gradually let it down into its proper position, finishing with oil-stone dust and steel polisher. The distance from the lower pivot shoulder you will have previously got by the means described just now. The wheel should fit firmly on to the pinion, and the seat be but slightly undercut, almost square. If properly fitted, very little riveting will suffice; on the other hand, if loosely fitted, no amount of riveting will make it sound, and probably the pinion face will be bulged and spoilt, in your endeavors to get the wheel tight. Having marked just above the boss of wheel with a safe-edged file, remove wheel, and proceed to turn down the leaves to this mark, taking care not to remove any of the diameter of the arbor in doing so.

You will now reduce the length of the arbors, leaving each about half a pivot longer than they will ultimately be required, cutting them off with the graver, and at the same time turning rather long centres. Having turned off one end it should be passed through a hole in a runner, and the extreme point turned true and conical; the opposite end should then be treated in the same manner. If all this is done, with the graver in the turns, the pinion will be kept centred; if you use a file for making the centres you will probably get it out of truth. You will now proceed to mark the place for the shoulder of upper pivot, leaving it a shade high, and turn it down a little square: knowing where this shoulder will be you can see how deep the hollow will have to be cut. If there is much distance above the seat of wheel, a slight hollow will suffice; but if, as is usually the case, there is but little distance, the hollow will have to be deep and rather large, the object being to prevent the oil being drawn away from the pivot. Cutting a hollow in a foreign pinion is not such a difficult matter as in an English one, as the steel is softer; nevertheless, some little attention to the graver you use for this purpose will be necessary. Some workmen use square and others lozenge gravers, but for the purpose in question I always prefer a square "Vautier" graver; in fact, the smallest size made for turning. These foreign gravers are superior to the English in temper and finish, and are altogether pleasanter to work with. Then again, the handle for this purpose should be very light, cane or common Hondurs mahogany for instance; in fact for this purpose I prefer no handle at all, simply putting a small knob of sealing-wax on the end and around the angles some distance up. Should it be handled, the wood should have the hole bored through, the graver can thus pass right up the handle and be fixed with shellac; it will thus avoid breaking off a piece, or having it an unwieldy length. Having stoned up the graver to a long point, the sides, instead of being placed quite flat on the stone to remove the burr, should be slightly raised in sharpening, so that a small facet is ground on each side of the belly, thus reducing the otherwise too acute angles, and strengthening the point. This should be done on a smooth Arkansas stone; Turkey is too rough; then, with a bell-metal polisher and diamantine, polish both sides and top angle; when finished, the point should be allowed to rest on the nail, and if properly done it will hang in, and not slip. With a tool in this condition and a weak bow, the hollows can be cut both quickly and well; if a still better finish is desired, nearly dry red stuff on a peg will give it a nice bright appearance. But to return to the pinion: having completed the upper hollow, and turned down the arbor to meet the root (it should be considerably smaller at the root of hollow than at the shoulder), the pinion can be reversed in the turns and the lower hollow cut, and the pivot roughed out, the height being measured from the shoulder of top pivot. If the pinion requires facing, I generally do it at this stage. Finally, turn down the pivots until they are about three degrees larger than they will ultimately be required, to allow for burnishing, being particularly careful to turn the shoulder perfectly square. The last cut should be down the shoulder of pivot, so as to leave a *very slight notch*; when burnished this will disappear, and no lump be perceptible in the corner. The burnishing will, of course, be done on the Jacot tool and with a flat burnisher, the preparation of which I propose to describe further on. Having completed the pivots, and rounded the ends off and burnished them, so that they will not scratch the nail if tried on it, it only remains to turn off the corners off pivot shoulders with a polished graver, and to rivet on the wheel in the manner described in speaking of replacing scape wheel.

(To be continued.)

## A Study in Stalactites.

SOME rare carbonate of lime formations from the recently-discovered cave, near Luray, in Page County, Va., have been placed on exhibition at Tiffany's. The specimens are some of them mounted on plaster of Paris bases, as they are too frangible to withstand jar or concussion without extraneous support. Others, being sections of stalactites and stalagmites of the most familiar pattern, can be easily duplicated when broken, and are less valuable and curious as formations from nature's laboratory. The rarest of the forms are perhaps two fine specimens of calcite, shining white and very beautiful, showing a distinct crystalline surface. Both are egg-shaped masses, and, according to Prof. Egleston, of Columbia College, very rare in this country. Two specimens of calcareous tufa, similar in shape, but of a dull brown color and a spongy texture, are also worth careful examination. A large group of water crystals lies near the latter. The peculiarity of the collection lies in the extraordinary variety of color, and in the fantastic shapes of the stalactite and stalagmite formations. In a corner of the case lie seven slender, straw-like forms, some of them perforated like pipe-stems, and other perfectly solid, though not strictly homogeneous in their structure. The coral stalactites, less delicate and attenuated, but of a beautiful pink tint, are, also, comparatively rare forms, although, indebted for their coloring-matter to an admixture of earthy salts, held in solution along with the carbonate of lime, and leaving the latter, upon the water being evaporated, of a pale coral tint, very evenly diffused, and penetrating to the core of the formation. Of the nodular and travertine stalagmites the reader may form a clear conception by imagining a group of puff balls, of various sizes, united to a general centre by thickened and irregular stems. The tuberoso and dendritic stalactites are more elaborate examples of the same primitive type that appears in the nodular stalagmites, and both may probably be accounted for by the interposition of some organic matter mixed with the solution of lime carbonate in such a manner as to render the mixture more or less viscid in its consistency. The most striking and beautiful specimens in the collection are a group of candescent white alabaster stalactites, perfectly conical in their shape and perfectly homogeneous in their structure. These are not so rare as the woody fibre or dendritic, and raise no interesting questions of geology, but they are more beautiful and more likely to attract attention.

The specimens on exhibition have been examined by a number of professional men, among them Prof. Egleston and Prof. Eaton, and have given a new impulse to speculation respecting the processes of nature. The cave at Luray, after a descent of about 40 feet, dips beneath an elevation in the valley, with a gentle inclination, for the distance of a mile and a half. The floor is formed by the surface of the clay formation that underlies the whole valley; the roof, by the vast limestone stratum superimposed upon the former. The open space is consequently neither more nor less than probably the bed of some extinct subterranean lake which has gradually subsided. Near the mouth of the cavern, for half a mile or more, the stalactites and stalagmites are dead, and have commenced to scale, showing that the subsidence began here, and that the earlier formation is slowly giving way. In so far as there is any present increase in the more recent forms, it appears to be due to the percolation through the soil and the limestone roof of the surface rain-fall. The floor of the cave is very muddy, after a severe storm, thus furnishing abundant evidence of the agency of surface water in the formations now going on. While considerably smaller than Mammoth Cave, the grotto of Luray possesses a wealth and variety of carbonate of lime formation not shared by any previously discovered in this country. The Indians were aware of its existence, and the tracks of animals in the clay bottom, together with the discovery of the bones of an Indian boy in a remote gallery, furnish indubitable evidence that the opening has not been closed for more than two centuries.

## Precious Stones and Gems.

BY EDWIN W. STREETER.

FROM time immemorial the real Pearl—that which is formed in the seas and rivers—has attracted the attention of mankind, by its pleasing and bright exterior, its regular form and peculiarly soft union of prismatic colors. It has been for ages past the emblem of purity, beauty, and nobility; and for an equally long period the mind of man has been occupied as to its origin. Most fantastic are many of the representations, viz.: that the Pearls are tears of fallen angels, or dew-drops from Heaven, which had fallen on a summer's night into the lap of the sea, and which had been taken prisoners by the oysters, who had opened their shells to receive them; or again (not so beautiful, but nearer the truth), that the Pearls were a diseased formation generated by the animal in the same manner as like diseases in man. A clearer insight into the being and reality of the Pearl, was obtained by Europeans after the perfection of the microscope. The first clear information which we owe to it, is that the Pearl is of the same formation as the oyster-shell. The shells of all the oysters which give Pearls have three layers; the outside is of a friable character, generally blackish-green in color, and of a horny nature; this is the outer skin, and consists of thin scales or leaves, which exhibit no regular form. Then follows a second, composed of innumerable diminutive, horny cells, filled with a calcareous mass: it is in these principally that the various pigments are deposited which give to so many shells their exquisite colors. The third and inner layer has a more foliated form, and an uniform foundation, which appears on the outside like fine folds, and when the light shines upon it produces a peculiar Mother-of-Pearl sheen which is so beautiful in many of the shells. The Mother-of-Pearl owes its incomparable lustre, not to its material, which is nothing but lime, but solely to the soft and tender unevenness of its surface.

We owe a great deal of our knowledge of the Pearl oyster to Dr Von Heszling, who devoted much time and talent to the study of it. Almost every person who has written upon the origin of the Pearl has an opinion of his own upon it, and we are not much wiser than the Ancients in this particular. One thing, however, is quite clear, viz., that the Pearl, whether it be free or attached, is not the healthful production of regular life, but, on the contrary, a disease, or produced by disease.

Here and there attempts have been made to form artificial Pearls, but it has not been very successful. The Chinese have done more in this trade than any other nation, but they can never produce them so perfectly as to deceive. They, however, have been able to produce grotesque figures, covered with a pearly substance, some curious specimens of which are now in the possession of W. J. Ingram, Esq., M. P. It is not an uncommon belief that the Pearl is the egg of the oyster.

With regard to River Pearl oysters it is well-known that some rivers are much richer in them than others; and the reason for this inequality has been sought, but not with satisfactory results.

The Pearl fisheries of the Ancients were in the Persian Gulf (which to this day produces the most beautiful Pearls in great abundance), in the Indian Ocean, the Red Sea, and the Coromandel coast. Those in the Red Sea are now partly exhausted. Ceylon was well known to the Phœnicians, who went there for Pearls, and up to this time it has held its own as one of the most prolific of our Pearl fisheries; it is now closed for a year or two, in consequence of the diminution in its produce. The home of the Pearl-oyster is in sand-banks, lying off the west coast of the island, in the Bay of Manaar. The first Europeans who obtained firm footing in Ceylon were the Portugese in 1506. They made a contract with the then ruler of the island, that he should pay them a yearly tribute of

spices and Pearls, by which they made a great profit. At that time during the Pearl fishery, they were collected on the island from fifty to sixty thousand people of all kinds—divers, tailors, merchants, and tradesmen. The Pearls belonged generally to the people who sought them; but the Portugese bought most of them at a very low price. In 1640, the Dutch obtained power, and seized upon the Pearl fishery in Ceylon. Under them the native Indians, who congregated there to the number of 200,000, were allowed for twenty alternate days to fish for themselves, and every other day for the Government; after which the produce was sold to the highest bidder. Such fishing took place every three years. In consequence of a dispute between the Dutch and the Rajah, fishing at the oyster bank at Manaar was forbidden, whereby for years it was left unworked, viz., from 1760 to 1796, until the English had rule there, who therefore had the benefit of the accumulation during those years. The gain in the one year of 1793, after deducting the cost, was £140,000. It is estimated that the same sum would be realized every seventh year, if the fishing of twenty days were restricted to the once in seven years. The fishing takes place in March and April, when the sea is calmest, and before the fishing commences the bank is tested by experienced divers.

Gathering or obtaining the Pearls is an occupation of great difficulty and danger. It is performed by divers who are trained to their work from earliest childhood. Sometime before the fishing commences, they take a particular diet, and all their limbs are daily rubbed with oil. At the appointed time they go to the Pearl bank, offer up their devotions, strip themselves of their dress, stop their ears with cotton-wool, compress their nostrils by means of an instrument made of horn, and bind over their mouths a sponge soaked in oil, which resists the water for a certain time. They then sling a rope round their body, and generally hang a heavy stone on their feet, and so throw themselves down to the Pearl bank. This stone they slip off as soon as they are on the right spot, and it is drawn up again. When the diver touches the bank, he takes a sharp knife and loosens the oysters from it, and collects as many as he can into a sort of net which he has upon his body. The time he is under the water is about a minute, his gain in that time from eight to ten oysters. With occasional breathing times, he descends forty or fifty times. If anything occurs while he is under the water, either that he is faint, or that sharks approach, he gives a sign with his rope, and is raised at once. Many at the end of the day bleed at the mouth and nose, and the strongest of them can only work at the fishery for a few years.

In modern times the diving is much less dangerous to life, owing to the diving-bell. It is only a pity that it is too dear to allow of its universal use. With this a single diver can gain from one to four thousand oysters in the fishing season. The divers either have a share in the gains, or are paid daily wages in money.

The oysters are deposited in a shut-up or enclosed space and left to get foul, whereby most of them open of themselves; but after three or four days the stench is intolerable. These foul creatures are then washed and rinsed in troughs with sea-water, until the Pearls are deposited on the earth. It is not every oyster that possesses Pearls. When the Pearls are dry, they are arranged according to size, and sold at once to agents for the market.

The first news of the presence of Pearls in the Persian Seas, which we of the West received, was from the Macedonian Greeks. Metasthenes, an officer of Seleucus, King of Syria, gives an account of them. In later times, from 1515 to the beginning of the 17th century, the Portugese became masters of these fisheries; and during the subsequent period the native princes again became possessed of them. At the most favorable time for fishing, viz., from June to September, 30,000 men live there on the divers' boats. Except a small duty paid to the Sheikh of the harbor, the fishing is free. The method of diving and of obtaining the Pearl from the oyster is much the same as at Ceylon. The sword-fish is the great

enemy here that the divers have to guard against; and every one has a dagger in his girdle to ward it off. The enormous sum realized here yearly is from £300,000 to £350,000, the purchasers being the Indian, Arabian, and Persian merchants. Most of the Pearls found here are sent by way of Mascate to Bombay, and on to China. The Chinese also receive many Pearls from the Sooloo Archipelago, lying between Borneo and Mindanao.

The Pearl fishery in the Red Sea was in early times very important. Under the Ptolemies, and later under the Egyptian Caliphs, merchants settled on the coasts, and by means of a successful trade in Pearls became extraordinarily rich. There are still Pearls to be found in the Red Sea, by the Island of Dhalak, opposite Massowa, on the Abyssinian coast. The negroes are generally the fishers here, and the fishing takes place in the winter months, from December to April, after the heavy rains; the average gain being one Pearl from five oysters. The other principal fisheries in the Eastern hemisphere, are Japan, Java, Sumatra, and the Bosphorus.

There are Pearl banks on all parts of the coasts of America, and since the beginning of the 17th century the Pearls of California have been rivals of the treasures of Panama. Hundreds of poor Indians are now employed in California as divers. On the coast of Columbia the Pearls are of a peculiar and beautiful lustre, and on the south coast of the island of Cuba the product is similar to that of the Persian Sea. On the coast of New Jersey, Pearls were discovered by a farmer, who, when fishing for oysters, found in one of them a large Pearl: since then the product has been large, and of good quality.

Of late years Pearls have been discovered in Australia, from whence some of large size and of good quality have been imported into England. The Fiji Islands also supply us with very fine specimens; the necklace presented to the Empress Eugenie being composed of Pearls found in those islands, and valued at several thousand pounds. It is computed that out of 20,000,000 oysters, 4,000,000 or one-fifth, only contain Pearls. The river Pearl-oyster is found largely in America, Asia, and Europe, particularly in the north. We obtain many also from France and Scotland, from the Ilz in Bavaria, the Vattava in Bohemia, and the Elster in Saxony, the last of which is famous for its Pearls. There are said to be 44 little rivers in the north of Russia and Finland in which Pearl-oysters are found. The most beautiful of the Elster Pearls are in the Green vaults at Dresden; they may not surpass the Oriental Pearl but can without depreciation take their place beside it.

The rivers in Scotland produce a great many Pearls, which are mostly defective in form and size, but those of a pinkish hue however, are considered of great value, and necklaces made of them sometimes realize from £300 to £500, and are much prized by English ladies. A few Pearls are found in the Irish rivers, but they are of inferior value.

The price of Pearls depends upon their size, beauty, and rarity. In Europe perfectly white specimens and those slightly tinged with blue are most valued. The Indians, Arabians, and Chinese prefer those with a yellow tinge, which have this advantage over the former that they do not lose their lustre and tint from wear. All the sums mentioned by different authors as to the price of Pearls only mislead the buyer, for the value depends greatly upon their shape, and varies as much as that of a Diamond. For instance, a 1-carat Pearl may be worth from 24s. to 40s.; 2-carat Pearls, if fine, from £6 to £8; and large and fine Pearls range from £2 per grain, upwards. The variation being so great, I have gone from the beaten track, and have given no table of their value, which is only to be ascertained by a competent knowledge of the market.

Pearls were very highly valued in ancient times, especially in Asia and Egypt, for the inhabitants of those lands regarded them as the most beautiful gift of the elements in which they had their origin and worthy of the honor of decorating their deities. They ranked next the most precious gems, and took their place with ivory and precious metals, and the sweet-smelling spices of Arabia, Sidon, and

Tyrus. Pearls were an article of commerce among the earliest commercial people, viz., the Phœnicians. Theophrastus places them amongst the most loved and valued stones, and, speaking of their size, says, "They are like to the large eyes of fish." In the Old Testament history they are mentioned with favor; and Job regarded them as a great and costly article. The Babylonians, Medes, Persians, and indeed all the then nations of the world, held the Pearl in the highest esteem. The Persian nobles used to wear in the right ear a golden earring containing Pearls; and in Athens the same kind of earring was worn in the right ear by youths of noble birth. These golden earrings generally contained two or three Bell Pearls, which made a sound every time the head moved. In Pompeii, on a skeleton of a lady, were found two golden earrings, each containing two beautiful Pearls. The Ethiopian, and Egyptian princes and nobles, used this gem more than any other in the adornment of their persons. The Pearl is intimately bound up with the history and traditions of India, one of which says that their god *Vishnu* discovered Pearls and employed them for the adornment of his daughter. Indian women from the earliest times have worn gold and ivory richly set with them. There was a remarkable law in India that anyone who bored Pearls and Precious Stones unskilfully, should not only make good the mischief, but pay a fine of 250 Panas. Among the ancient Chinese, the Pearl was highly valued as an amulet, the possession of which was supposed to increase the beauty of the body. Pearls are said to have been paid as "tribute" 2,300 years B. C., and it is stated that 100 years B. C., the exorbitant and wilful luxury in Pearls was written against by the authors of that day.

The Romans called the large ball-shaped Pearls "Uniones;" the pear-shaped Pearls, "Elenchi;" and the half-ball shape, "Tympania;" and those which possessed the most beautiful white color received the name, "Exaluminatæ Margaritæ." Pompey, the victorious Roman general, the conqueror of Pontus and Syria, found in the palace of Mithridates a wonderful collection of Precious Pearls, which laid the foundation, in later years, of a most valuable museum in Rome. In his third great triumph against the Asiatic Princes, 61 years B. C., he took thirty-three crowns of Pearls. After this period the Pearl luxury became quite a disease in Rome. The philosopher Seneca spoke very sharply against the Roman women or wearing so many Pearls. He declares that they would not bend nor give obedience to their husbands, until double or treble the value of their own settlements was dangling from their ears. Roman ladies wore necklaces of Pearls which cost 200,000 francs, also ornaments for the breast, consisting of thirty-four half-ball Pearls, and thirty-four cylinder-form cut Precious Stones, dresses, shoes, and bracelets, richly covered with costly Pearls. Julius Cæsar presented to Servilia, mother of Marcus Brutus, a magnificent Pearl which he obtained as booty in Egypt, the value of which was estimated at 990,000 francs. Another famous Pearl, in possession of the Egyptian Queen Cleopatra, was, after her death, presented by a Roman Ambassador to the then Emperor, Septimus Severus, for his wife; but he, to set an example against the ever-increasing tendency to this luxury, ordered it to be sold for the good of the State. No purchaser, however, could be found to pay for it according to its value, whereupon the Emperor had it cut into two pieces, and made into two earrings for the image of the goddess Venus, which was in the Pantheon, saying, that the Empress would be setting a very bad example to his subjects if she wore in her ears things too valuable to be paid for. The Romans used also to decorate their temples and dwelling-houses with Pearls, and ladies used to hire them for their own personal adornment at great festivals; the Pearl merchants called "Margaritarii," thus drove a flourishing trade by letting them for the occasion. The wife of Caligula wore in her parure Pearls to the value of 7,000,000 francs: Nero distributed them lavishly on his favorites; and it is stated that Claudius dissolved Pearls of great value in a strong acid and gave it to his guests. In ancient times, pulverized Pearls were used as medicines, but they acted simply in the same manner as chalk.

### Antique Coin Jewelry.

THE present reigning fashion of setting antique coins of gold and silver as jewels, is by no means a modern invention. Jewelry among the ancients, as soon as civilization had made some slight advance, ceased to be purely ornamental, and became symbolical—that is to say, conveyed some meaning either for the person who wore it, or the person who had given it.

In many of the tombs of Greece, we find coins set as jewels' often with very elaborate settings, though in general the only pieces found are what was termed "funerary jewels," and made in the least expensive way possible to produce the necessary show; for the Ancients were too practical to bury with their dead, things of great value. Thus the jewels in the Castellani and di Cesnola collections are of very light material, and decorated in a manner which can give but a faint idea of the talent of the goldsmiths of Athens or Rome. The funerary jewels consisted of rings, earrings, sometimes a clasp, and often a diadem wider in front than at the ends; the extremities and front are pierced with three holes, through which passed the strings which attached the jewel to the head, but no vestiges of their cords have ever been found.

This jewelry has reached us in a good state of preservation, for it was not always easy to find; and also because of certain superstitious reasons which prevented the barbarians, when they swept down and to a great extent destroyed the civilization of Rome, from removing them; but they melted or broke up everything valuable they could lay their hands on, and by the few specimens which accidentally escaped destruction, we can surmise what a wealth of beautiful things were annihilated by these barbarian invaders.

In the Celtic and Frank tombs, jewelry of quite a different character is found; it is heavier, though not so well wrought, but it contains precious stones, and even diamonds, though uncut or only rudely shaped into "cabochons."

The first jewel was the ring, which we find in all historical documents from the earliest time. For many centuries rings were a current coin, and were used as such by the Egyptians until after the dynasty of the Ptolemies, that is, until Greek princes reigned over Egypt, and introduced the Grecian coinage. Rings were also used as signets, and served to attest public documents and private contracts. The Egyptian Scarabee had a name or inscription cut into the lower surface which made it available to make an imprint in wax or any other plastic substance. Soon the art of cutting intaglios made great advance and reached its highest degree of perfection about two hundred and fifty years before Christ.

The New York Museum of Art is likely soon to possess an important collection of antique intaglio rings, which was made by the Rev. C. W. King, of Cambridge, in England, who is one of the most learned writers on the Egyptian art. Mr. J. T. Johnston, to secure it for the Museum, purchased it for himself—holding it for six months at the disposal of the Museum, thereby allowing the trustees ample time to raise the necessary funds.

The principal feature of antique stone cutting, and that to which a great deal of its merit is no doubt due, is the fact that the cutter and the designer were generally the same man. The amount of action and life thrown into the figures is wonderful, and no mechanic could have cut a stone so artistically, had he not himself conceived the subject. Sub-division of labor is the great cause of the artistic inferiority of modern productions compared with those of the Ancient and even the Renaissance periods.

The inscriptions on antique jewels are in most cases the name of the possessors. On intaglios the name of the owner cut on the stone has often been taken for the signature of the artist. On Roman rings, mottoes are often seen. For instance, the following, "*Accipe multis annis dulcis*," has been found in open work. In the middle ages the implanted superstitions, led people to seek means of protection of an equally mysterious character. Thus precious stones were set as rings or amulets, and endowed with some mystic

virtue. The Beryl, for instance, was a charm against enemies; Moon stones made the bearer proof against steel; others warn the wearer against danger or poison.

Pre-historic bangles and bracelets have been found in the lake dwellings of Switzerland, and some of them show an advanced stage of workmanship. They are in bronze, cast in moulds and ornamented with chasing.

In modern times, imitation of the jewelry of the ancients has been much in vogue at different times. The Empress Eugenie, once appeared at one of the balls at the Tuileries wearing an exquisite Egyptian necklace of antique make. A well informed archæologist, in passing, complimented her on wearing that magnificent gem, which for centuries had rested on the breast of a Royal Mummy. Her majesty, disgusted at the thought, at once tore the jewel from her neck, and sent it back to the dealers who had sold it to her. It is now in the collection of the British Museum.

The Duchess of St. Albans has a neckpiece very elaborately set in gold, the twelve medallions of which are each a gold coin (aurei) of each one of the twelve Cæsars, in a perfect state of preservation.

The coins used with the best effect for jewelry, are the silver coins of Greece, with gold settings.

### Hall-Marking in England.

THE Select Committee over which Sir Henry Jackson presided, decided, by a majority of one, against a voluntary system of hall-marking, and say: "To the principle of compulsory assaying and marking articles of gold and silver manufacture there are no doubt some objections. It is possible that if the matter were new, and it were for the first time in contemplation to establish an assay under the control of Government, these objections might prevail. But in this country the system has existed substantially in its present form since the reign of Edward I. Without speculating on its origin, and while making due allowances for its defects, it is established that it has resulted in the creation and maintenance of a high standard of excellence for all British assayed wares, which has not only raised the reputation of British workmanship at home and abroad, but has also created a large amount of private wealth readily convertible by reason of the guarantees of value which the hall-marks afford. As far as can be ascertained, most British manufacturers, and by far the largest number of the dealers, cling to the maintenance of the system with marked tenacity. The public do not complain of it. It also appears that foreign watch-cases are sent to this country to be hall-marked in yearly increasing numbers. Nor should the antiquarian aspect of the question be altogether disregarded. At any rate this should prevail to the extent of throwing the burden of proof on those who propose the abolition of a system which has existed for 500 years.

An alteration of the law is suggested by foreign-made watch-cases having a distinctive mark put upon them to show the source of maintenance, but the letter "F" is considered too like present marks to be easily distinguishable from them. The following amendments are also suggested:—

"(a.) The assaying authorities should be allowed to return imported articles which are found below standard instead of breaking them up, as at present. (b.) A dome made of base metal should not exclude watch-cases from being hall-marked. (c.) The assay authorities should have power to mark articles which, though standard, have enamel or other metals or substances added for the purpose of ornament only. (d.) The lower standard of gold, viz., 15, 12, and 9 carats (equal respectively to  $\frac{1}{4}$ ,  $\frac{2}{4}$ , and  $\frac{3}{4}$  of pure metal) should be discontinued. A composition containing less than two-thirds of pure metal ought not to be called by the name of that metal. (e.) The whole of the assay offices should be placed under the direct supervision of the Mint, so that a uniform standard of quality shall be guaranteed. (f.) So long as a license duty is maintained it should be levied at a uniform rate." And the abolition of the duties on gold and silver is advocated by the Committee, as soon as the Chancellor of the Exchequer can see his way to do without the amount received through them.

It is worth while remembering that while a considerable portion of the press in this country is not in favor of hall-marking, there is a part of the trade in the United States desirous of acclimatizing it in that country, because the manufacturers there who make the quality of their cases up to the figures they put on them (18 k., or whatever else they may be) would like to be protected against those who put similar figures but not the same amount of precious metal beneath them, by which unfair competition they are put at a great disadvantage and the American public unfairly treated.

## Jewelry.

*Continued from page 68, vol. IX.*

WHEN stones are to be set as details, or when they constitute the real basis of the design, the gold is gradually wrought to receive the stones in their proper position. The setting is never effected, as may be supposed, by being cemented into position, for the metal itself is so wrought that, after the stone is placed in its proper receptacle, the gold is closed firmly over the edges of the cut gem, holding it securely in its place. At a comparatively recent date, ready-made mountings for stones, made by machinery, have been in use, not only in imitation but in real work. These are so contrived that the various portions of an article are cut separately and afterwards soldered together in such a manner as to receive the stones for fixing in the usual way. A still cheaper process is also in use, consisting of a strip of metal having a serrated edge. The proper portions of the strips of metal being fixed to receive the stones, the serrations are bent over to retain them.

To set gems properly, so as to bring out all the beauty and special features of a stone according to the cutting, requires great experience and sound judgment. The angle at which one stone is fixed in relation to another, the importance of the light being not simply refracted, but seen in transition so as to bring out the beauty of the color, are points which require no ordinary consideration; for stones which by one mode of setting would look very brilliant, may be made to look very commonplace by another mode.

Enameling is largely employed in the embellishment of jewelry, to give variety of color and contrast to surfaces. This may be described as essentially of two kinds, *champlevé* and *cloisonné*. The former is a method or system by which the enamel is applied to the surface of the metal, thus giving the details by means of a vitreous paste, which when fixed by heat becomes attached to the metal, either as an opaque or transparent body. Here again, as in the case of the manufacture of paste or artificial stones, the metallic oxides come in as coloring substances. One species of *champlevé* enamel approaches the *cloisonné* in character, from the fact, that the enamel is fired into channels cut in the surface of the metal by the graver, these channels form a bed in which the vitreous paste is secured by the side walls of the fissures incised for the purpose, and so far serve the same purpose as the metal partitions used in the *cloisonné* method. This latter is of Oriental origin, and is similar to that employed with such remarkable success in the elaborate enameled decorations of the Japanese and Chinese.

The surface to be decorated à la *cloisonné* (from *cloison*, a partition wall), is divided into sections according to the nature of the designs to be produced by the raised tints of enamel to be employed. The outline of each section is given by a wall composed of a thin piece of metal, cut and bent to the proper shape, and soldered at right angles to the surface. Thus, prior to the insertion of the vitreous substance which, when fused, becomes the colored enamel, filling up each division with its proper tint, the design is represented in outline by the thin walls of metal soldered upon the surface. After the fusion is completed, the whole is ground down to a uniform surface of metal and enamel, the metal giving a bright outline running between the various tints of color employed. The fusion is produced by submitting the object to be enameled, or such portion of it as may be easily handled, to the action of a charcoal or coke fire, raised to a sufficiently intense heat inside a muffle or furnace, practically under the eye of the enameler, who watches the progress of the fusion, and regulates the application of the fire accordingly. It is needless to say that the vitreous paste which constitutes the enamel, is fusible at a much lower temperature than the metal which forms the structure of the object. Some vitreous paste for enameling purposes are so easily fusible, or technically so *soft* that they can be fused by a blow-pipe in an ordinary candle; but these are essentially for surface decorations in color, mostly on surfaces already covered with a coating of white enamel paste.

Enameled details of this class are extensively used by some jewelers as a specialty; able painters in enamel, such as Essex, Bell, and others, being employed to paint the subjects, which, however, have been principally heads of animals, the favorite subjects being after Landseer. The enameling is done in gold, the name of the artist and date of the year being painted on the back of each subject. These are principally used for gentlemen's scarf pins or scarf rings. Other subjects, such as classical heads painted in cameo effects, are also used.

Another method of decorating the surface of jewelry is by engraving. This is largely and almost universally employed for the delicate details of modern jewelry, and is, for the most part, the result of the dexterous use of the graver. These details are the subject of careful consideration on the part of the designer and manufacturer, especially in the best class of work. The skill and dexterity with which some objects are embellished by rich diaper work and scrolls, sometimes intermingled or varied with engine turnings, carried over surfaces which would otherwise present a monotonous and unsatisfactory appearance, is very remarkable. The brilliant variation of the metal, and the play of light and shadow thus introduced, without interfering with the generic form, give great art value to what might otherwise look heavy and uninteresting.

As a matter of course, machinery and mechanical contrivances of an elaborate or permanent character can only be economically employed where a number of articles of the same design are required to be produced, or where the details of the article admit of repetition to a very large extent. A chain is an extreme example of the economic value of machinery when employed in its production. A brooch or bracelet is the very reverse, except where a very large number are required to be manufactured, as in the instance of imitation jewelry of a cheap class.

The first step towards a mechanical means of repetition is made, when a number of articles of the same size and design are required for the market. In that case, a die or dies are cut in steel for the exact and ready repetition of the various details which go to the making up of the design as a whole. Say, for example, the decorative gold drops to a pair of earrings. In this case the two sides of each drop will be produced from the same die, making four repetitions in a single pair. The die being cut to the design, the workman takes a thin plate of gold of the proper size, and proceeds gradually by the use of hammer and punch to drive the metal into the hollow of the die; as he does this, he has from time to time to anneal the metal, as already mentioned in the illustration of the *repoussé* process used in high-class hand work. Of necessity he gets a number of these plates into the same condition, anneals them, and then goes on again. Ultimately each piece of gold takes the shape of all the details, and also the surface of the *intaglio* of the die; being, in fact, a *relievo* representation of it. When completed the two sides of the ear drop are soldered together by the use of the blowpipe, gold solder of a suitable alloy to be readily fused, and a little borax, as a flux, being employed in uniting the edges. Filed and smoothed, the proper fitting to the hooks which suspend the earring and drop to the ears has also to be accomplished by hand, the hook itself and the rosette, or other decorative detail, from which the drop is suspended, being also produced either from another die, or by some other mechanical contrivance.

*(To be continued.)*

THE watch found by the body of the late Prince Imperial had doubtless been left by the Zulus under the supposition that it was a charm, which, if taken, would render the holder liable to the ill luck of the previous wearer. It was an ordinary time-piece, and was purchased by Napoleon I. when he was a lieutenant of artillery. He wore it as First Consul, as Emperor, and until his last sickness at St. Helena. Napoleon III. became its owner, and wore it during his attempts at revolution at Strasburg and Boulogne. From the time that he became President to the hour of his death at Chislehurst, he never separated himself from it. The ex-Empress subsequently gave it to her son, who wore it constantly. It often required repairs, even during the time of its first wearer. He looked at it one day while talking with Marshal Berthier, and found that it had stopped. Berthier asked why he did not procure better one. "What can you expect of a watch?" said Napoleon. "We shall have to stop one day, ourselves." The locket worn by the Prince had been brought from Egypt by the first Napoleon, who also wore the sword taken by the Zulus. The gold chain had belonged to Napoleon III.

## Practical Hints on Watch Repairing,

By EXCELSIOR. No. 53.

### EXAMINING THE DUPLEX WATCH.

(826) *The Hands.*—See if the long seconds hand clears both the glass and the dial; that the other hands clear it and each other, at any part of their end shake; that the center of the minute hand, or the top of the socket of its wheel, don't rub on the center of the seconds-hand. If they do, either the seconds hand should not be shoved down so far on its pivot, or if it would be made insecure by standing higher, put a foil washer over the hour wheel to hold the two wheels down, without pressing much on them when they are down. Also use a washer whenever these wheels have too much end-play, or if the hour wheel tips when the hands are turned. Take off the seconds hand, and see if any black or bright marks on its center or its socket indicate that that rubs or touches inside the steel cylinder. If so, put it on a broach, or file a stiff wire to fit it, holding the broach or wire in the pin vise, and file away the rubbing parts of the socket, then roll it and file the whole socket round and smaller. Put the finger on the point of the minute hand, then rub the tweezers against the socket of the hour hand, and see if it is perfectly free. Hold the hour hand, and try the freedom of the minute hand or wheel, in the same way. Try these tests in several positions of the hands, when putting the watch together, and do not leave them till they are free in all positions, whether together, opposite, etc., as the binding of the hands is a common cause of stoppage. See that both hands have a little end shake after the dial is screwed to its place. If the hour hand or wheel rubs in the dial hole, free it.

(827) *The Dial.*—See if the dial screw head can touch the balance, or the wings on its rim, or the point of any of the wing screws. If the points of the last stick out too far, shorten them; if not, dress off the dial-screw head to clear. Remove the dial and examine the motion works carefully (193 to 199, 648). Test the tightness of the center staff in the center pinion, and of the wheel on its end, by holding the wheel with the finger nail while you turn the staff with the key. If the wheel is not quite tight on the staff, it should be made so, by closing the hole. But great care must be used in doing this, not to get the hole out of the center of the wheel at one end or the other, in which case the wheel would not run truly in the round, or in the flat, or both, and might rub the plate or dial, and fail to gear properly into the middle or connecting wheel. In replacing the dial, do not screw it up too tight, or it may bind the dial wheels and stop the watch. It is a good idea to wait till you get it into the case, then make dial just tight enough to prevent shaking, as frequently the dial rests on the case, or on the band around it, or both, and the position they hold it in is not the same as would make it tight when out of the case.

(828) *The Escapement* was fully treated under the head of Duplex Escapement, sections (464 to 553). Examine particularly if the roller jewel is perfectly tight on the balance staff, (468, 495,) and runs truly (497); if the repose teeth can get up or down beyond the end of the notch in the roller; if the notch is free from cement to its very ends, and its edges smooth and sound; that the repose wheel is large enough, or near enough to the roller, and the repose teeth are free in the notch, (469 to 471); that the notch is on the line of centers or the watch in beat (503, 504); that the impulse finger is at a proper angle with the notch to give a safe impulse drop, (522); that the size of the roller jewel is such as to carry out the function of "control," (476 to 486, 833); that the repose teeth of the escape wheel cannot touch the fourth pinion, nor the impulse teeth touch its bridge or the third wheel, (466); that the wings are tight on the balance rim, (464); the condition of the hair-spring, balance, pivots, jewels, etc., correct. Some special directions for timing and adjusting the duplex are given in sections (125 to 127) in the "Practical Treatise on the Balance Spring, and the Compensation Balance."

If the watch has a stop lever, see section (754). To test the different actions of the escapement with the angle meter, see sections (527, 528).

(829) *The Train.*—See if the fourth wheel rubs in its sink, or on the heads of the screws that hold the steel center piece. If so, dress them off, or turn out the sink deeper, unless the wheel can safely be raised enough to clear, by bending the arms. If the wheel is too low, and has too much end shake, both faults can be cured by driving up the plug in the center-piece a little. Afterwards, try the pivot in, to see that the hole has not been battered up; if so, open it with the round broach to free the pivot again. If the hole is much worn, fit a new plug. If the fourth pinion has no end shake, and the wheel should go lower, drive the plug further down in the center-piece. If the wheel should be raised, and the main bridge gives too little end shakes for the third and center pinions, raise the bridge by inclining it upward; if those end-shakes are correct, the end of the bridge, with the upper fourth jewel can be bumped or sprung up a little; or turn back the upper fourth pinion shoulder with the shoulder-scraper (297). If the third wheel runs so high as to interfere with the balance or its wings, or low enough to touch the impulse teeth of the escape wheel, bind its arms down or up respectively. If it is not true in the flat, it should always be made so, or it may interfere with both. If it has too much end-shake, that must be confined. If it interferes with the balance, and lowering it would make it touch the impulse teeth of the escape wheel, (its end-shake being as small as is safe) either they must be shortened a little, or the balance raised.

(830) If the center wheel rubs up under the main wheel, either confine its end-shake, spring its arms down, lower it in the plate, or raise the barrel. If it is not level, upright the center pinion. If the main wheel rubs on the plate, all around, and has too much end-shake on the barrel arbor, spring the upper hub down (674) and so remove both faults; if the end-shake is correct, it can be raised, by springing both hubs (675); or by turning the ratchet sink deeper in the plate, and making the ratchet cover follow and hold it up (831). If the main wheel only rubs the plate on one side, true the barrel (677); or upright the arbor. If the barrel runs truly on the arbor, but tips, and on turning the arbor half around, without changing the position of the barrel, it tips in the same direction as before, the arbor is out of upright; but if it tips in the opposite direction, the arbor is warped or sprung out of true. To upright the arbor, see ratchet wheel (831). If the arbor is out of true, take off the barrel, screw the ratchet in its place, turn the arbor with the key, and find where the fault is. Then soften the arbor, straighten it up if possible, reharden, and temper to a purple. Or fit in a new arbor. If the upper corner of the barrel rubs on the center washer, it will be quickest to put on a smaller washer. If it rubs on the edge of the large bridge, or on the case, those parts should be dressed off to clear. All depthings, wheels, teeth, pivots, pivot holes or jewels, freedoms, end-shakes, etc., should be examined as already directed in the Detached Lever Train.

(831) *The Winding Works*—The click should be well formed, and held closely to the wheel by its spring; it should be free on its screw, but not too loose. The screw should always be screwed down till its shoulder rests firmly on the plate. If that causes its head to bind the click, put a washer under the screw, of the same size as the shoulder, and thick enough to have the click free when screwed down tightly. If the click was too free, cut out a slight sink around the screw-hole, to let the shoulder of the screw in, and so lower the head, closer to the click. The teeth of the ratchet should be sound and perfect, and the wheel must be snugly held by its cover, so that it can support the barrel and main wheel perfectly, firm and level, under any pressure. If the ratchet is loose from wear file the under surface of its cover level. If the ratchet sink or bed in the plate is worn, turn off the *outer* portion of the cover in the lathe, instead of filing up the whole under surface,—leaving the central part intact, to project into the sink a little and hold the ratchet securely. (692, 693). If the arbor is not held upright, alter the bot-

tom of the ratchet sink to make it upright,—bumping up the low side of the sink, if the barrel may stand a little higher, or turning out the high side, if it should not. Then screw the cover down so as to hold the ratchet in contact with the entire bottom. If the socket or pipe of the ratchet wheel is poorly fitted to the arbor, and holds it out of true (830), either correct the faulty fitting, or replace the piece which is damaged or imperfect. The pin which holds the pipe on the arbor should be of hard steel, so that it can be easily driven out when necessary without bruising it, and go together as before. The ends should not project outside of the pipe, but come just level with the surface. The notch is first made to correspond on the pipe and the arbor, by turning the arbor while the ratchet is held still by the click.

(832) *The Stop Works* should be carefully examined, as they are often the cause of stoppage. The female stop or large ring should move freely, but not be loose. This should be tried with the male stop taken off. The ring should then be turned around, and must not catch, bind or move hard at any place. If it does, either smooth it off, or smooth out the groove it runs in, as may be required. If too loose, burnish down the top edge of the groove, till the ring will move easily and smoothly, but be sure to stay wherever it is left. Then put on the male stop, and try. When approaching the arms of the female stop, the end of the finger must not strike the corners of the arms, as it would be liable to butt and catch, stopping the watch; but it should reach beyond the corners, safely on the sides of the arms. Of course, when passing the arms in winding, the finger should move the ring far enough to leave it in the above position, so that when the finger returns, in running down, it will find the arms in proper position to receive it in the manner just described. If it does not leave the arms far enough along to receive it properly, a longer finger should be fitted. When the spring is wound up, the finger rests against one end of the ring; and, when fully run down, against the other end. In the latter position, the spring should be keyed up at least far enough to give the balance a good motion, on winding up one or two teeth of the ratchet (712, 725). How much higher it shall be keyed up, will depend on the circumstances of the case. See "mainspring." In keying up, the spring is wound up as far as it is desired to be, at the lowest point, and the male stop is then put on with the finger resting against the "down" end of the ring. It must never be keyed up so high that the finger cannot rest firmly against the top end of the ring, without straining on the spring.

(833) *The Mainspring*.—Try the freedom of the barrel on the arbor; the width, truth and freedom of the spring in the barrel, etc. as directed under the same heads in "Examining the Detached Lever Train." In the duplex, it is important that the strength of the mainspring should be suitable for the size and weight of the balance, and the proportions of the escapement—especially of the wheel and roller action, (476). If these elements are properly harmonized or adapted to each other, the fuzee may safely be dispensed with, without loss. Nevertheless, the duplex is often made with a fuzee, etc., and it should be capable of very fine time-keeping. When the fuzee, etc., are used, see under those heads in English Lever Train, for directions for examining. Supposing the escapement to have been originally well designed and executed, the diameter of the roller jewel would be such as to secure the function of "control," (476 to 486). As the mainspring was wound up and became stronger, it would tend to cause larger vibrations of the balance; but this would be counteracted by the correspondingly greater frictional resistance to the motion of the balance, arising from the greater pressure of the repose teeth against the roller jewel, tending to diminish the balance vibrations.

(834) If the size of the roller jewel was in the correct proportion to the size and weight of the balance, the "control" would be complete, and would secure practically equal vibrations during the running time allowed by the stop works, even without the employment of the

fuzee. We can test the harmony or adaptation of the different parts by noticing the effect of winding. If the extent of the vibrations increases materially as the spring is wound up, the roller is too small; and if it diminishes, too large. First let the balance acquire its natural or permanent vibration, with the barrel arbor wound up only a few teeth above the bottom or lowest point of the stop works. Then wind one turn higher, and again note the size of the vibration, so comparing the arcs for each turn of the arbor till the top. If the vibrations are practically equal, the size of the roller, etc., is correct, and we may proceed to examine as to the proper strength of the mainspring. The above test should be made before putting on the dial, for convenience of letting the mainspring down again if necessary. Hold the movement in the same (preferably horizontal) position in each trial.

(835) During the preceding test we should have a nearly constant vibration of say one turn, or  $360^\circ$ , with the watch clean and in good condition. If it was larger than that, the spring should not be keyed up so much, or, if it already takes only the lowest turns, (709, 711,) a weaker spring would be an improvement; if smaller, key the spring up more, or, if it already takes the highest turns, fit in a stronger one. As a general rule, the main-spring should be well keyed up in the duplex, both to get all its available impelling force, and because the same will then be more nearly uniform in the different turns, (712). For, although the function of "control" can neutralize the effect of variations in the motive force, yet it is advisable not to require too much from it, but to avoid as many disturbing causes as possible. But as the control may not be complete, and generally is not, it becomes specially important to key up the spring, so as to use the highest turns. In conclusion, a few words may be said regarding the manipulation of the mainspring to correct or neutralize the effect of an improper size of roller jewel, (834), (supposing this to be the only fault,) when a suitable size cannot be obtained. If the roller is too small, the balance vibrations will become larger as the watch is wound, and if the largest vibrations exceed  $1\frac{1}{4}$  turns, a weaker spring should be fitted, as they may be made still larger by riding, jumping, etc., and cause danger of tripping, (526). If the roller is too large, and the vibrations are reduced below three-quarters of a turn, or  $270^\circ$ , by winding, the watch will be liable to "set" and stop, and a weaker spring will be better. In either of the above cases, the spring employed should be keyed up to the highest point, for the reasons already given. These expedients are not given as being the equivalents of replacing the rollers by others of proper sizes, but merely as in some degree lessening the evil effects of those used.

#### EXAMINING THE CHRONOMETER WATCH.

(836) Full directions for testing and adjusting the chronometer escapement were given in sections (534 to 616). The inexperienced workman should especially heed the caution in section (616), about either letting down the main-spring or locking the escape wheel, before loosening or taking out the balance for any purpose. The escape wheel teeth are easily bent by any accident, as the wheels are made as light as possible; and the quicker the balance vibration, the lighter the wheel must be, as the inertia of a heavy wheel would make it slow to get under motion at each impulse, and this lagging or sluggishness would cause tripping in a poorly made escapement, (543). But the wheel must always be heavy enough to be perfectly stiff and firm, when the teeth drop on the locking jewel. All the adjustments of the escapement must be carefully completed; also those of the hair-spring and the balance, for isochronism, temperatures and rate. For directions, see "Practical Treatise," etc., which includes the first series of the Practical Hints, relating to those subjects. No "scamping" or half-way work must be allowed; although the perfect chronometer escapement is capable of the finest time-keeping possible, yet, if not fully adjusted, etc., it will give less satisfaction to the wearer than a lever escapement.



(837) *The Train*.—If the workman has attentively read the directions for examining the trains of the lever and duplex watches, he will only need to be reminded that, as the finest performance is expected from the chronometer watch, the examination of the train should be very thorough, and any defects found, should be remedied only in the best manner. See that every depth is perfect; the pinions adapted to the wheels engaging in them; the curves of the teeth and pinion leaves correct; the pivots straight, well made, highly polished, and well fitted in their jewel holes; the jewels faultless; the end-shakes and freedoms well adjusted, etc., etc. If a toothed barrel is used, adjust the stop works precisely as they were before cleaning, if known to be correct. If that point is doubtful, adjust them according to sections (709 to 712). This, however, is subject to the remarks on overrunning, tripping, etc., in the article on the chronometer escapement; and, if the main-spring when properly keyed up, gives a balance vibration too large or too small, it should be changed for one of more suitable strength.

(838) If a fusee and chain are used, see directions for the corresponding parts in the article on the English Lever, and be sure that the main-spring and fusee are suited to each other. It may be thought that, in the chronometer, the hair-spring is isochronized as fully as possible for all variations in the motive force reasonably to be expected, and therefore, even if the main spring and fusee were not perfectly adapted, it would do no great harm. But such reasoning is entirely wrong. That adaptation, as well as of all the other parts, should be made as perfect as can be. While the chief merit of the chronometer is that it will allow the finest possible adjustments to be made, and the performance will be correspondingly excellent, yet, if they are not properly made, the chronometer can claim no superiority over other watches of the same quality, and may even be inferior to them for actual service in the pocket. All mechanical faults should be removed, whether of the motor, the train, or the escapement; then, and only then shall we reap the full benefit of the adjuster's skill and patience,—then, and only then, will it be worth while to carry the adjustments to the extremes of nicety which are practicable, although not always profitable.

(839) Always examine every steel piece in the movement, and the springs, etc., in the case, for any trace of magnetism, as a magnetized part will render impossible that fine performance which is expected of this variety of watch, and may prevent it keeping any time at all. It takes but a moment to test the parts, by touching one end of them, (when clean and dry,) to a minute bit of perfectly soft iron,—say 1-16 inch of well annealed binding wire, also clean and dry. If it adheres, the part is magnetized, and should either be discarded and replaced by one free from magnetism, or demagnetized by exposing to a red heat, then rehardening, tempering and polishing. Previous to this operation, the piece must be removed from the wheel or other part connected with it. It should be kept from exposure to the air while heating and hardening, to prevent scaling of the surface, which would ruin a pinion or other similar closely-fitted piece, whose value depends on the retention of the exact original form and size. All such should be replaced with new pieces. Be sure that there are no magnets anywhere around, nor any magnetized tools on the bench, so that no watch can be injured while in your hands.

(840) In setting up, be sure that the motion works, hands, etc., are in the best possible condition. The dial, too, should be exactly concentric with the hands, the divisions evenly spaced off, especially those of the seconds dial. First get the seconds hand exactly with that of the regulator, at the 60 mark, then set the other hands. The latter should not turn so hard that moving them backward will stop the watch, but they must be tight enough to go, without fail. In comparing time, for regulating your watch, stand squarely in front of the regulator. If that is not convenient, or if the dial is pretty high, it is a good idea to set some fine watch exactly with the regulator, and place that squarely in front of you, to insure getting the others exact. For full directions for regulating or rating, for any kind of hair-spring, whether with or without regulators, and under all circumstances, see the "Practical Treatise on the Balance Spring, and the Compensation Balance."

## On the Compensation of Clocks, Watches and Chronometers.

(By EDWARD RIGG, M. A., Assayer in the Royal Mint.)

*Continued from page 115, Vol. X.*

It is unquestionable that a carefully made wooden pendulum is to be preferred in all clocks, other than the very best astronomical clocks; in conjunction with a well made train, it can be relied on to give a more uniform rate than any unadjusted compensation pendulum. Indeed, such a pendulum may give rise to very great irregularity, if, as is perfectly possible, the arrangements for compensation tend to produce an opposite effect to that which is required.

An immense variety of devices have been proposed for correcting this error of temperature, but they may be classified under four heads:—

1. Two or more solid and rigid substances employed in conjunction, and so arranged that the vertical downward expansion of one is neutralized by the vertical upward expansion of another.
2. Two metals of different expansibilities actuating levers, and thus maintaining the length of the pendulum invariable.
3. Two metals of different expansibility, rigidly joined together by soldering or otherwise, employed to vary the distance of a weight from the centre of suspension whenever the temperature varies.
4. Pendulums in which mercury is employed.

Before referring to examples of these classes, it will be well to explain the exact nature of the problem under consideration. The ideal or "simple" pendulum of the mathematician consists of a heavy particle of no dimensions, connected with the centre of suspension by an inflexible string without weight; and, in order that its vibrations may be described in equal times, the arcs traversed must be very small, and the length of the pendulum must be invariable. Such a pendulum cannot of course exist in practice, but it is possible to calculate, for any actual pendulum, what would be the length of the simple pendulum, satisfying the above conditions, to which it corresponds. Thus, if  $a b$  be the total length of a pendulum the period of whose oscillation is  $t$ , and  $a c$  be the length of a simple pendulum that oscillates in the same time,  $a c$  is the simple pendulum corresponding to  $a b$ . The point  $a$  is termed the centre of suspension, and  $c$  is the centre of oscillation. The one necessary and sufficient condition to be satisfied by the compensated pendulum is that this length  $a c$  remain invariable.

The earliest design of pendulum of the first-class is the well known "gridiron" of Harrison. It was invented in 1722, by Graham, but he soon abandoned this form in favor of mercury compensation, and the system was perfected by Harrison. From the diagram, which exhibits all the essential features, it is seen to consist of a heavy bob suspended by nine vertical rods, five of these being of steel and four of brass. The principle of its action may be easily demonstrated by means of two simple experiments.

Above this trough containing spirits of wine, two rods, one of steel and the other of zinc (used instead of brass in order to increase the effect) are supported horizontally; their left hand extremities are fixed, and the right hand ends actuate two fingers, at present pointing in the same direction. On igniting the spirit, the two rods will expand, but to different degrees, and this fact is shown by the pointers gradually separating from each other.

Now vary the experiment. Take rods of the same two materials, but let their lengths be inversely proportional to their expansibilities, that is, if the length of steel is 1, the length of zinc will be 0.4. Connect their extremities at  $A$ , and support them over a trough, the end  $B$  of the steel being rigidly fixed, while a light pointer is attached to  $C$ , the free end of the zinc. Since  $A C$  is to  $A B$  as the expansion of  $A B$  is to the expansion of  $A C$ , it follows that the expansion of  $A C$  towards the right will move the point  $C$  just as much in that direc-

tion as the entire rod A C is moved towards A through the expansion of A B. Hence the point C will remain fixed, a fact which is made evident by the steadiness of the pointer.

A pendulum required to vibrate seconds must be of such a length as to make the distance between the centres of suspension and oscillation 39.14 inches; and it must further satisfy the condition here indicated, namely, the expansion of steel downwards must equal that of brass upwards. The coefficients of expansion of steel and brass are respectively 0.0000124 and 0.0000188 per 1° Centigrade, and it can easily be shown that the smallest number of rods that can satisfy this condition, keeping the pendulum symmetrical, is nine.<sup>3</sup> The arrangement of the rods and the mode in which they effect the required object needs but little explanation. The outer steel rods are firmly pinned at right angles to the upper brass cross-piece, but they are only held loosely by the pins in the lowest cross-bar. This carries two brass rods expanding upwards, and each pair is loosely held by pins in the same way. The innermost steel rod hangs from a pin at its upper end, passes freely through the lower cross-pieces and supports the pendulum bob by a nut at its extremity.

The necessity for so many rods has always been regarded as a serious objection to this form of pendulum, and many attempts have been made to avoid the difficulty. Troughton suggested a very elegant arrangement, in which the four brass rods are replaced by two brass tubes, the five steel rods being joined in a manner corresponding to that above indicated. The bulk of the pendulum rod is thus diminished to a tube 0.6 in. in diameter, an important point, since the centre of oscillation is thereby lowered, and a shorter pendulum can be employed. As already noticed, zinc has a much higher expansibility than brass, and attention was, therefore, directed towards the employment of this metal. By increasing the length of the pendulum, and placing the bob some distance above the lower end of the pendulum, supported by a short cylinder of zinc, Berthoud<sup>4</sup> succeeded in obtaining sufficient compensation with only two brass rods and three of steel; and, even with a brass cylinder in place of the zinc, the compensation was at times found to be complete. This is a compact form of gridiron pendulum, but long, and the excessive friction between the rods is a serious objection. Berthoud constructed them about 13 in. long, beating half-seconds, and the centre of oscillation comes very near the centre of the bob.

Reid, Tiede, Jacob, Ward, Dent, and others invented pendulums in which zinc and steel are employed in conjunction, and in an interesting arrangement suggested long ago by Robert, zinc is associated with platinum as being at the opposite end of the scale of expansibility. The form adopted by Jacob<sup>5</sup> is worthy of notice on account of its extreme facility of adjustment. The central rod is of steel, and terminates in a screw bearing a locking nut, which supports a rectangular zinc frame. A screw thread is cut on the upper portion of this, and a nut on it supports the frame that carries the bob. Assuming the pendulum to be under or over-compensated, it will only be necessary to elevate the upper screw and depress the lower one, or *vice versa*, and the effective length of the zinc will thus be altered as required. The expansion of zinc being more than double that of steel, a single zinc rod less than the length of the pendulum will suffice for the compensation.

The only other combination of these two metals that need be specially referred to is the pendulum employed by Dent & Co., for astronomical clocks, in which the bob is of lead, and the steel and zinc are two concentric tubes, the rod also being of steel. A zinc tube resting on the rating nut support, at its upper end, a steel tube

by which it is enclosed; to the lower end of the steel is fixed, by its centre, the lead bob covered with a brass jacket. Holes are drilled through the steel and zinc tubes in such a manner that each portion of the pendulum is equally influenced by thermometric variation.

The pendulum by M. Robert, above referred to, is described in the "Bulletin de la Société d'Encouragement" (xxviii. 56) for 1829. A light platinum tube passes through a zinc bob, and terminates in a steel screw, which carries the rating nut. The bob extends to half the height of the rod, and its upward expansion is sufficient to neutralize the downward expansion of this latter.

Numerous other combinations of two or more substances have been suggested from time to time, but detailed reference to them is unnecessary, since the principle of all is identical. J. L. Smith<sup>6</sup> employed a vulcanite tube surrounding the lower extremity of a steel rod, in a manner somewhat analogous to Berthoud's pendulum, only that the tube passed up within the (copper) bob; Ley<sup>7</sup> used zinc and glass similarly arranged; and Callaud<sup>8</sup> proposed a combination in which steel, brass, and platinum (wire) are used. The brass tube resting on the timing nut supports a plate at its upper end, through which pass two screws attached to the extremities of a platinum wire. This, passing round a groove in the pendulum bob, raises it as the brass tube expands, and the adjustment for compensation somewhat resembles that of Jacob's pendulum. Benzenberg's pendulum, as modified by Kater,<sup>9</sup> consists of a lead tube traversed by an iron wire, the bob being suspended by two iron wires from the upper end of this tube. By employing deal and zinc, Kater succeeded in reducing the length of compensation metal so as to conceal it within the bob; and Baily proposed a cheap construction that has been much used, in which the upward expansion of a cylindrical lead bob neutralized the downward expansion of a deal rod.

(To be continued.)

THE Virginia (Nev.) *Chronicle* announces that Edison recently exchanged several letters with Professor Stewart, of Virginia City, on the subject of platinum, where it is likely to be found, &c. In his last reply Professor Stewart stated that in Santa Clara County, Cal., platinum exists in a seam of talc, incased in hard schistose rock. About two years ago men worked the mine, selling the platinum in San Francisco for \$12 or \$15 an ounce. They mashed up the talc and separated the crystals of platinum by some simple process. The schistose rock was so hard, however, and the seam of talc so narrow—being only from twelve to fifteen inches wide—that the men were compelled to give up the work as unprofitable. But the Professor has an idea that by the application of the proper instruments the mine might be made to pay. The seam, although narrow where explored, might widen as depth was gained. At any rate, that probability would be in favor of the miners.

The Professor is sorry now that he did not go quietly to Santa Clara County himself when Edison first wrote to him, get possession of the platinum mine and receive the \$20,000 prize. He says he wrote to a friend of his in California about the circumstance, telling him where the mine was located, and he supposes he has got possession of it by this time. The Professor wrote to Edison that in Trinity and Humboldt Counties, Cal., in the early days, the gold was so heavily alloyed with drift platinum that the purchasers of gold dust, not knowing the value of platinum, frequently refused to buy the alloy at all. Sometimes the gold would be alloyed to such an extent that it would not fetch more than \$3 or \$4 an ounce. The presence of platinum joined with the gold of those localities leads the Professor to think that a body of the mineral might be found there if looked for. No platinum has yet been found in Nevada, but there is no telling what luck might follow industrious prospecting.

3. For, let  $n$  be the number of downward expanding steel rods, and  $n'$  the number of upward expanding brass rods, and assume them to be approximately of equal lengths; we have  $n$  coefficient of expansion of brass 0.0000188 3 very nearly. There are

$n'$  " " " " Steel 0.0000124 2  
then five rods required theoretically, and four additional ones are needed in practice to give rigidity and symmetry to the pendulum.

4. Moinel, "Traité Général d'Horlogerie," II. 412.

5. Exposition Universelle. Saunier, p. 92.

6. "Comptes Rendus," lxxxiii. 202.

7. "Horological Journal," xix. (1877), 74.

8. "Revue Chronométrique," IV. 626.

9. Kater and Lardner's "Mechanics," p. 265.

## Watch and Chronometer Jeweling.

## NUMBER FOUR.

IN the description of jewel-making, we have taken a soft stone, aqua marine, as the material, and a common plate hole as the form; but there are some slight modifications when ruby or chrysolite is used, and the polishing is invariably done by the use of fine powder. The form of a jewel to which an end stone is to be fitted differs very materially from a plate hole—one side is convex, the other has a plain face and two concaves, the end stone fitting to the convex side. On the whole, however, the process is alike for all kinds of stones, and therefore we need not particularize, but may mention that the jewels for end stones are generally much better made than plate holes, as in chronometers the quality of the work cannot be too good. We might add some few paragraphs on the making of roller jewels, pallets, duplex rollers, etc.; but it is hardly of much importance, for the processes differ only in the shape to be formed—the milling, grinding, and polishing being identical. The English roller pin has generally a flat side, produced very simply, by placing a number of the round pins on a fine-surfaced plate of glass, with a little facing powder; a common cork is now placed on the hole of the pins, and a few strokes of the hand will make the flat surface. End stones are merely turned up on the convex and polished in the same style as the jewel.

We have now followed the stone from the rough up to the finished state, and it is ready to be placed in its seat in the watch or chronometer. This department of jewelery is of more importance to the general watch repairer than the maker, for he frequently has jobs in which a jewel is to be replaced by reason of fracture, or, as it sometimes happens, from its being rough and so cutting the pivot. In such a case if the pivot is repolished it will have too much side-shake. Among some, whose pride of workmanship is of very low grade, it is the custom when a jewel is broken to replace it with a brass bushing. A knowledge of jewelery would break up such a pernicious habit from motives of economy, for in nine cases out of ten a jewel can be replaced in one half the time, and the result will be a good job. Two styles of jewelery are used in the trade: in one the jewels are set directly in the metal of the plate or cock, the Swiss watch being nearly always jeweled in this manner, even in first-class work, and in the majority of English watches the lower holes are thus set in the bar and plate. In the other and best style, the jewels are set in settings, which, having been trued on the outside with the hole, are let in the plate and retained by jewel screws.

In repairing, the Swiss style gives much less trouble than the English screwed jewel-setting, for if the watchmaker has a fair stock of holes he can hardly fail to find one of the number of very nearly the size of the original; such an one having been selected with reference to the size of the hole as well as to the seat, the workman, having removed all the fragments from the jewel seat, carefully rubs back the burnished edge of the seat; he now places the stone in the seat, being very careful to have it have an even bearing; then he burnishes the edge back again over on the face of the jewel. This operation can be performed in one-half the time it would take to fit in a bushing, lay off the depth, drill the hole, and free off the face to get a proper end-shake. The same thing, it is needless to say, can be done in English work, but there is a difficulty, as the setting is generally stripped very close to the stone; this renders the size deceitful, for if the jewel is very thick in the convex it will apparently fit, when in fact it may be too small. In cases where a jewel is to be replaced in a screwed seat, it is best to make a new setting; as in that way the workman may true up the hole perfectly—a matter of no small consideration, for many of the holes purchased of the material dealers are very considerably out of truth.

The first step in jewel-setting is to select the jewels in reference to the size of the holes and pivots; this is generally done by trial, or the workman may open a hole to the right size should he have none

that are right. Opinions as to the proper degree of side-shake are somewhat diversified; and again, the same degree would not be advantageous, as applied to the hole train; and again, in English watches wheels and pinions are very much seen out of upright, which condition would render a large degree necessary, or the pivot would bind on opposite corners of the hole. As a matter of course, no wheel should be out of upright; but this fact is discovered in a large proportional number of English levers. This want of truth is sometimes a great annoyance to the workman, especially in repairing; for he must cut out the holes in the plate to receive the jewel-settings from the centre of the pivot-hole in each plate; were they true he could upright the frame, and cut the holes by taking but one centre, and without removing the pillar-plate until the job is finished. In sizing the holes for the pivots, unless the workman has had some considerable experience, mistakes will very often occur, even with brass holes. A gauge can be made that will give the sizes with great accuracy, provided a good split-gauge is at hand; it will require some little trouble to make it perfectly true, but a sufficient degree of truth may be attained by any one accustomed to the use of the file and split-gauge. In the first place a piece of good wire (steel) about  $3\frac{1}{2}$  inches long is filed as nearly as possible to a regular taper, ending in a fine point. This may be rendered a true taper if the workman will get a machinist to plane a groove with a diamond-shaped tool in a block or bar of steel; he can get the requisite taper by elevating one end of the bar when in the plane; this steel should be hardened to the highest point. The needle now may be filed up in the taper groove thus planed; the sides of the taper will be straight lines, and the truer the face of the block the truer the lines.

The large end of the needle is now inserted in a small block that is fitted to a bar of brass, and the small end projected through a small nozzle at the end of the bar; it will be understood that the block and needle are free to move on the bar. If, now, we make the nozzle a stand-point we may, with the split-gauge, place the needle, and consequently the block, at any degree marked on the gauge which rests against the nozzle; the degree may be marked off on the longitudinal bar, and thus a mark corresponding to every degree on the gauge may be made on the needle bar. The longer the taper the more delicate the instrument will be.

This mode of mensuration for the side-shake has an additional value, inasmuch that it habituates the workman to use known quantities, rather than trust to the rule of thumb. The split-gauge that is the basis of measurement is easily obtained in a form that combines the whole range of watch sizes, from the finest pivot to the largest watch-glass: We now refer to Dennison's combined gauge an article indispensable to every watchmaker, who may, by it, size wire or plate to all the sizes indicated by any Stubb's gauge, also the diameter of wheels and pinions most perfectly. The price is very moderate, when the wide range of sizes is considered.

WESTERN sovereigns are not the possessors of the finest diamonds in the world, for the Rajahs of Matan, Borneo, and the Shah of Persia have the largest hitherto known. The one belonging the Emperor of the Monguls weighed 279 carats, (about four grains each,) and was valued at 12,000,000 francs. The famous Orloff, the property of the Russian crown, is one of the most remarkable diamonds, on account of the well-known circumstances under which it was brought to Europe. The large stone belonging to the Emperor of Brazil, which weighs 1,730 carats, would be worth many millions were not its brilliancy diminished by certain defects. The Sultan of Nizam's diamond weighs 400 carats; that of the Emperor of Austria, 29 grains; and that of the King of Portugal,  $25\frac{1}{2}$  grains. The famous Koh-i-Noor, or Mountain of Light, is the property of the Queen of England. The one which adorned the tiara of Pius IX., and was bequeathed by him to his successor, Leo XIII., is one of the finest stones known. It came from the treasury of the Duke of Burgundy, seized at Granson. It was sold after the battle to a Jew of Berne for 3 crowns, then successively for 5,000 and 6,000 ducats, and afterwards purchased for 14,000 by Luigi Sforza, from whom it passed into the hands of Pope Julius II, for 20,000 ducats. Every one knows that the "Regent," of the weight of 136 carats, is the finest of the diamonds belonging to the French regalia. Connoisseurs consider it to be worth 12,000,000 francs.

## Trade Gossip.

Mr. W. H. Hedges, of Messrs. W. N. Hedges & Co., has returned from Europe.

J. Lawrence, an old and well known city traveler, recently died in an insane retreat.

Wm. Brady, an old and well-known Jeweler, of Harrisburg, Pa., died suddenly on the 29th ulto.

Mr. E. Aug. Neresheimer, diamond importer, arrived from Europe on the 25th ult., in the steamer Oder.

A. E. Shader, of Messrs. Kearney & Swartschild of Chicago, is sojourning with his family in Minneapolis, Minn.

Fires are occurring in Jewelry stores with such alarming frequency that it is feared the retail Jewelry trade is literally going to blazes.

Mr. Thos. J. Pierpont, the well known designer and modeller of the Meriden Britannia Co., has resigned his position in that company.

Harry Osborn has left the employ of the Whitney Manufacturing Co., and has entered into an engagement with the Derby Silver Plate Company.

The Jewelry stores of J. A. Rawson and J. H. Starbuck, Amherst, Mass., were recently damaged by fire. Their loss is fully covered by insurance.

A recent fire in Orilla, Canada, destroyed the jewelry stores of J. B. Thompson and M. C. Drew. Their stocks were partly covered by insurance.

The New Haven Clock Co. announce that they will hereafter sell goods in quantities to suit purchasers, instead of by the full package, as heretofore.

Mr. Max Gutman, of Rochester, N. Y., is making an adjustable watch key, the jaws of which open parallel and can be adjusted to fit at pleasure.

At a recent fire in New Orleans, Mr. A. M. Hill's stock of jewelry was badly damaged by water, his loss however, is said to be fully covered by insurance.

H. C. Ostrander has severed his connection with the firm of Thos. W. Adams & Co., and has entered into a business engagement with Randel, Baremore & Co.

Messrs. Aiken, Lambert & Co. will exhibit examples of their gold pens, pencil cases, &c., at the International Exhibitions, to be held in Sydney and Melbourne, Australia.

Mr. Ethel C. Hine, formerly of the American Clock Co., has recently returned from Japan, to take charge of the E. N. Welch Clock Co's establishment in this City.

The Duke of Argyll and his daughter visited Tiffany's recently, in company with Gen. Di Cesnola, and purchased some examples of the reproductions of the Cypriote jewelry.

A rich ornamented garter is one of the regulation presents to a German royal bride, and an illustrated German paper depicts such an article given to the Empress fifty years ago.

Owing to circumstances over which he had no control Chas. F. Burroughs, the diamond thief who swindled Greason, Bogart & Pierce, will pass a prolonged vacation in prison.

The great clock of the Parliamentary Palace of Westminster has, by the Astronomer-Royal's report, been within one second of true time on 80 per cent. of the days of observation.

A. K. Shiebler has retired from the firm of Durfey & Shiebler. David J. Reynolds takes Mr. Shiebler's interest, and the house continues under the firm name of Durfey & Reynolds.

Mr. H. C. Haskill, the enterprising manufacturer, has recently introduced another novelty in seal rings called the "Marquis," an illustration of which appears in his advertisement elsewhere.

The London guilds have been waking up amazingly of late, in view of a threatened inquiry as to what they do with their revenues, and whether nearly all goes for turtle and sillery, as some aver.

Harry J. Frochen, at one time an employee in the Elgin Watch factory, committed suicide by poisoning himself at Madison, Wis. The deceased was known as Baron Frochen and is said to have been of noble birth.

One of the newest fancies in jewelry is the "old oaken bucket" set in solid gold; the earrings are tiny golden buckets, and the pin is a perfect little windlass, with rope coiled around it from the end of which the bucket is suspended.

A fly is the fancy ornament of the day, a pretty little fly, so skillfully and perfectly imitated that it looks like life. When it is mounted on a pin, and fastened in a corner of the necktie it deceives every one. Flies are also worn as earrings.

Mr. Lynch, diamond merchant, of 925 Broadway and late of the New York Hotel, wishes it understood that he has no connection with the John T. Lynch, of No. 918 Broadway, who is at present in litigation in a civil and criminal suit about the Fulton Market diamonds.

The jewelry thieves who recently victimized Henry Harrison have been identified, by one of the firm of R. S. Peters & Co., as the parties who stole some \$60 worth of jewelry from their store in Philadelphia. Their addresses for the next five years to come will probably be Sing Sing.

E. A. Tyler, an old and respected Jeweler, at New Orleans, died in that city on the 19th ult. The deceased was a native of Boston, and had been a resident of New Orleans for over forty years. He retired from active business some three years ago, on account of failing health, and his death will be universally regretted by a host of friends.

A Chicago man declares that he has a shekel that came from the mint of King David, but a Jerseyman states that he has the identical five cent nickel which Cain wanted Abel to give him just before he belted him with a club. If the world in general does not believe this story we can't help it. It is the privilege of greatness to be misunderstood.

I. S. Lawrence, for many years well and favorably known on the road, has established himself in the watch and jewelry business at No. 5 Maiden Lane, where he keeps a choice selection of desirable Jewelry and Watches. Particular and careful attention is given to orders for special goods, monogram work, cases for movements, etc., and in fact all kinds of special work.

On the evening of July 2d, some sneak thief entered the store of A. P. Boynton, of Chicago, and succeeded in making off with thirty-five gold watches, which were exposed in a glass show case. It is supposed the thief had accomplices outside to whom he passed the goods. One or two arrests have been made, but no clue to the missing property has been discovered.

Randall, Barmore & Co. have been enlarging the windows of their offices, whereby they obtain "more light" which enable them to do justice to the goods they deal in. It is the belief of these gentlemen that this improvement will enable them to see that "coming prosperity," regarding which so much has been said, at the very first moment it becomes visible to the naked eye.

The General Term of the City Court has handed down an opinion in the case of Alice Pierson, respondent, vs. Jacob Morch, affirming the judgment of the Court below—Mrs. Pierson to recover the amount of a reward claimed to have been offered by Morch for the recovery of a quantity of valuable diamonds, which he left in a Long Island Railroad car. He had the package with him, laid it on the seat, and got out at Hunter's Point, forgetting the package. Mrs. Pierson found the Jewelry, and sued Morch for the amount of the promised reward, about \$500, and the jury gave her a verdict for the amount claimed. Judge Neilson writes the opinion and Judge McCue concurs.

A burglar was caught in the act of breaking into the jewelry store of Messrs. Becker & Lathrop, of Syracuse, N. Y., recently. He had in his possession (besides the tools of his trade) two watches, which the police suspect were stolen. The description of the gold gent watch is as follows: 10 or 12 carat case, stamped 18 carat, Miller movement, No. 676.485, case scratched with a point in the inside near the joint, "L. A. T. 2 / 79 spring H"—

The watch was attached to a 14 carat vest chain, with a plated intaglio charm. Any information in regard to the above watch transmitted to Becker & Lathrop, Syracuse, N. Y., will doubtless help to convict the thief, and probably restore the watch to its owner.

## The Jewelers' League.

We devote this column to the interests of the League and its membership. Letters or inquiries pertinent to its business or purposes, and which might interest the trade or inquirers, will be herein answered. Address *Jewelers' League*, Box 4001, P. O. New York, or the office of THE CIRCULAR.

At a regular meeting of the Executive Committee, held on Friday, 1st inst., the following gentlemen were elected to membership: Nicholas J. Tommins, with H. Rowlands; Henry Rowlands, Albany, N. Y.; David F. Conover, of D. F. Conover & Co., Philadelphia, Pa.; Philip M. Carpenter, of Hodges & Carpenter, Attleboro, Mass.; Clement B. Bishop, of Carrow, Bishop & Co., New York; Henry L. Graves, with Reed & Barton, New York; Fredrick W. Hoffman, with H. Rowlands, Albany, N. Y.; Milton W. Jackson, Macon, Miss.; James Kinchan, with Illinois Watch Co., Springfield, Ill.; Charles Edgar Righter, of D. F. Conover & Co., Philadelphia; William L. Slack, New York; Chester Shepard, Jr., with Middletown Plate Co., Middletown, Conn.

Three applications were referred for further medical examination, and two applications were rejected.

The communication from twenty-seven members requesting the committee to institute proceedings toward the adoption of a distinctive membership badge, which may be worn or not, at the option of the members, and which was tabled at the previous meeting, was taken up and acted upon, developing a resolution as follows: That we request each member who may feel so disposed, to send gratuitously to the Secretary, a design or designs suitable for such badge, with nothing else upon the face or back of the design, which might identify the designer, except a private mark known only to the designer; such design or designs shall be accompanied by a perfectly plain envelope, sealed securely, and containing the designers name and address, together with his private mark, a duplicate of which shall be upon the design. On the first day of October next, the designs so received shall be referred by the Secretary to a committee of five members to be at that time selected by the President of the League from the membership, exclusive of the officers, which committee shall be instructed to select the one in their judgment, best adapted to such purpose; upon their reporting to the Executive Committee, the envelopes which have in the interim been in the keeping of the Executive Committee, shall be opened at a meeting of said committee, and the designer's name thus being learned, shall be published in the proceedings of the committee, which shall also recommend to the League in annual meeting that the said selected design be the authorized badge of the League.

This scheme, at which we hinted in our last issue, is well digested and gives each member an opportunity to share in a friendly rivalry among the tasteful and artistically inclined members of our trades, and will doubtless result in something unique and neat. The most modest man in the land may send his design and not be overshadowed by the prestige of one more famous, as by the process outlined in the resolution, each design will stand and be judged solely on its merits.

The Secretary was instructed to send a circular embodying the resolution, to each member and to others who, although not members, might be pleased to compete; at the same time a circular was ordered to be sent to the membership urging them to continued efforts to enlarge our membership and consequent mutual benefits.

Our membership now numbers 487.

We have received a communication which we give in full, and which speaks for itself:

*To the Editor of the Jewelers' Circular:*

SIR,—Permit me through the columns of the CIRCULAR, to ask the members of the Jewelers' League the propriety of creating a "Reserve Fund." As a member, I take great interest in its welfare, and desire to see it placed on a solid foundation.

What assurance have the members, that they shall exist, as an organization fifteen years hence?

At present there are 475 members, and each may have as many different ideas on the subject, and, in expressing my views, I do it with a hope that something tangible, may grow out of a discussion of the matter. and that the necessity of creating such a fund, will appear to the minds of every member.

It should be the purpose of our League to give to all its members, as efficient, and certain insurance as offered by the regular insurance companies, but without their expense. If "insurance companies require large yearly payments (because under large expenses) for the purpose of accumulating a Reserve Fund," it is no reason that we must do the same. If we are capable of giving insurance—cheaply—why cannot we accumulate a Reserve Fund by the same method? If "insurance companies handle, trade, &c. with their Reserve Funds for profit!" it is not necessary that we shall follow in their footsteps, in that regard, any more than we should adopt their rules and regulations, for the management of our association. Our worthy Executive Committee in their annual report, state that "in our scheme the funds are retained, and used in their own business, by the members individually, each of whom can doubtless invest, or utilize his own funds as sagaciously as could be done by another."

One would suppose from the above, that an extra outlay from each member must be made, and that a Reserve Fund could not be created in any other way. To that I differ, contending that such a method is not necessary, inasmuch that it can be accomplished by indirectly taxing the members. But to carry out their supposition, of directly taxing each member, and as they do not state any amount, I will, viz.: ten cents. What! the small sum of ten cents! Now will our worthy Executive Committee "rise and explain" how much benefit the "retention" of ten cents "in their business" will accomplish? Also, how "each member can invest or utilize his own fund (of ten cents) more sagaciously" or to a better advantage, or purpose than can be done a Reserve Fund of 475—ten cents.

But gentlemen, you are not to be asked to expend, for the creation of a Reserve Fund, the extra sum of one cent, much less ten cents. A Reserve Fund, can be raised by deducting from all receipts, the sum of ten (10) per cent., instead of five (5) per cent. as now, which amount shall be equally divided between the Secretary and Treasurer and a "Reserve Fund."

Upon the payment by the Executive Committee of each and every assessment, all amounts belonging to the "Reserve Funds," shall be deposited in a responsible Trust Company, and when the amount reaches eleven hundred dollars (\$1,100) or larger, it shall be converted into Government Bonds, and these shall be deposited in a Trust Company, subject to such rules as the members may approve.

Our worthy Executive Committee state that "if properly managed an association like ours should live year after year." To that I agree, but why don't they say "will live year after year," simply because associations like individuals are fallible, and if so, I would ask, what guarantee have the members, that live to a good age, and possibly outlive the association? I answer, none whatever unless we create a Reserve Fund.

But our committee put it thus, "the longer lives paying for the shorter lives, as they should do for the privilege of living long lives." What justice! A penalty attached for taking care of one's health! Surely, "wonders never cease."

BROOKLYN, July 21st, 1879.

"134."

"134" invites correspondence upon the points he presents; lest therefore some errors might follow his communication, we kindly place beside it a few matters of record:—The annual report contains no "supposition of directly taxing each member," the "supposition" or inference is drawn by "134" himself, after which he states it erroneously as a fact. "134" apparently quoting from the says "our worthy Executive Committee state that 'if properly managed an association like ours should live year after year,'" and asks "why don't they say 'will live year after year.'" The report in discussing co-operative organizations says "if as properly and judiciously managed as any mercantile business, there is no reason why such associations should not live year after year &c." In his quotation "insurance companies require large yearly payments (because under large expenses) for the purpose of accumulating a Reserve Fund," the words within the parenthesis do not appear in the report, nor is the expression "Reserve Fund" used anywhere in the report, which latter fact will also indicate the inaccuracy of "134"'s quotation "insurance companies' officers handle, trade, &c. with their Reserve Funds for profit." We make these statements and corrections lest the misquotations become the foundations of entangling discussions, and whilst Davy Crockett arises before us with his chunk of wisdom "be sure you're right, then go ahead." If an interest is aroused in this matter of a Reserve Fund we shall fully discuss it at some future time, and meanwhile this column is open to the members for brief, concise expressions of opinion, reasoning or argument.

## Business Notes.

D. D. Greenleaf, of St. Paul, Minn., has published a neat and useful catalogue and price-list for the exclusive use of retailers. The work is copiously illustrated with new and attractive designs of Clocks, Watches, Jewelry, Tools and Materials of all kinds for Watchmakers and Jewelers' use. The catalogue is a very creditable affair and reflects great credit on the enterprise of Mr. P. F. Eagan, the manager of the establishment.

Messrs. Simpson, Hall, Miller & Co., the distinguished manufacturers of Electro Plated Ware, are constantly offering the most attractive designs in Silver-Plated Ware. Their establishment, No. 36 East 14th Street—one of the handsomest in this city, is replete with novelties in both flat and hollow ware. Other new and original designs are being added in rapid succession, so that the stock is always full and rich in artistic designs.

Messrs. L. H. Keller & Co., the well known importers of Watch Materials, Tools, etc., have in consequence of increasing business been compelled to enlarge their premises for the better display of their stock. Their establishment is now one of the best appointed stores in this city, where everything in Watchmakers' Tools and Materials, etc. can be found. Messrs. Keller & Co. are the agents for several important specialties, a description of which appears in their card elsewhere.

We learn that the New Haven Clock Co., 62 Reade Street, have discontinued their rule to sell in "full packages" only. They will hereafter fill orders in quantities to suit purchasers. This enterprising company have added to their stock a full line of E. Ingraham & Co.'s Clocks, E. Howard & Co.'s Regulators, and an attractive display of imported Marbles and Bronzes, suitable for the requirements of their trade. Their establishment in Reade Street, is a model of neatness with every requisite for the display of goods and the convenience of buyers.

Mr. Albert Lorch invites the attention of the trade to his large and comprehensive line of patent accommodating Spectacles and Eye Glasses in gold, silver and steel frames. The advantages of these Spectacles and Eye Glasses are that the frames are so constructed that the lenses are interchangeable; any glasses being readily adjusted to any frame, the construction of which constitutes a spring which tightly holds the lense in place. A limited supply of frames consequently gives a customer opportunity to select from a large and varied assortment of lenses. While these glasses are patented, the manufacturer takes no advantage of this fact, but offers them at prices which cannot fail to satisfy. He also offers a full line of American and Foreign Watches, as well as an attractive stock of Jewelry of the latest designs and patterns.

Messrs. C. G. Alford & Co. presents in this issue of the journal a very neat and artistic page of illustrations, representing the latest novelties in articles of personal adornment. The Ganteline is the latest attraction in ladies' Jewelry, and has met with such unprecedented popularity in gold goods that Messrs. Alford & Co. have been induced to secure from the patentee the exclusive right to reproduce them in fine rolled plate. The designs are all new and original, embracing a large variety of subjects that cannot fail to compel attention. Messrs. Alford & Co. confine their efforts strictly to the legitimate Jewelry trade and in no case do they sell to outsiders. We therefore take great pleasure in stating this fact to our readers, who will doubtless appreciate their method of doing business. Price-lists of these and other new goods will be forwarded to dealers only, upon application.

## Views of Correspondents.

This department of THE CIRCULAR is open for communications relating to the jewelry trade, but the editor does not hold himself responsible for the sentiments expressed by contributors. We invite correspondence, but require that it shall be free from all personalities, and the writer's integrity guaranteed by the disclosure of his true name to the editor. Anonymous communications will not be noticed.

## WATCHMAKERS' AND JEWELERS' CONVENTION.

To the Editor of the *Jewelers' Circular*:

CHICAGO, July 30, '79.

As a reader of your Journal for the past few years, and in behalf of all fair-minded craftsmen, let me thank you for the full report of the late Watchmakers' and Jewelers' Convention, and especially for the very able editorial in reference thereto. The work is progressing slowly but surely in the right direction, and the line will soon be drawn between those houses who wish to do a legitimate wholesale business and those who do not. The Retail Jewelers are terribly in earnest, and it rests with all to say how speedy the remedy can be applied to make the movement successful. I can say to our friends in the country do not cease in the good work; if the devil has hid his horns it is only for a time, and about the time you think all is serene "price-lists" will spring from every mail. It is necessary that we should have your corial co-operation; therefore, if there is no State Society yet organized, send your name to the President or Secretary of the Watchmakers and Jewelers Guild of the U. S., at Chicago, Ill. But my advice is to organize in every State. Those gatherings are very pleasant and much pleasure and profit will ensue from your attendance, and in a year or so we can dismiss trade problems, listen to scientific Horological dissertations, and look forward to our State meetings with pleasurable anticipations always hoping Mr. Editor that you may be present to contribute your share to the success of the cause.

I am very truly yours, E. R. SHURLY.

## THE BOYS ON THE ROAD.

To the Editor of the *Jewelers' Circular*:

SIR:—In the last number of your valuable paper I notice a communication from "Old Jeweler," taking you to task for having said a pleasant word for the hard-worked "Boys on the Road." This is but the cropping out of the old jealousy that has always existed, and probably always will exist, being fostered by the trades unions, between the work-shop and the offices of those capitalists whose enterprise and means make the work-shops possible. "Old Jeweler" seems to be, judging from the style of his communication, either sailing under false colors, claiming to be an employer instead of a workman, or is one of those old hands who has acquired a slight proprietary interest because of services rendered in the past. He has not the frankness of a man at the bench, and if he were what he claims to be he would not undervalue the services of commercial travelers. But I would like to ask him, of what value is the possession of skill, taste, industry, and all the virtues and qualities that are required to make jewelry, unless there is a sale for such jewelry? Where would the demand for such goods come from but for "the Boys on the Road?" Let the "Shoemaker stick to his last," the workman to his bench and the traveler to the road; both are necessary to the success of the business, and I venture to say that if the travelers were taken from the road, the work-shops would be instantly closed for lack of funds to pay the workman.

TRAVELER.

## PROTECTION FROM ROBBERIES.

To the Editor of the *Jewelers' Circular*:

We regard the idea you suggest in the present number of your paper, of forming an association for protection from robberies with great favor. Taxing the Jeweler of the country a small yearly sum of \$3 or \$5 would realize an ample fund to employ the best detective talent of the country when required by one of the members.

One year ago we were robbed by a party of three professional thieves, supposed to be from St. Louis, of eleven gold watches and some money. Had we had such a protective association, it would have been almost impossible for the thieves to have got away with the plunder, and without detection.

We offered a reward, and went to considerable expense in trying to recover our property. We had an offer from St. Louis detectives stating, that if we would pay expenses they would find the party. As the party was supposed to be in Buffalo, we did not feel that we could afford the risk of two or three hundred dollars expense upon our loss, and thus the thieves got away to do the same thing over again, whenever or wherever the opportunity presents itself, in proof of which we will say that an Indianapolis Jeweler was robbed exactly in the same way, and we think by the same party two or three months ago.

We will read any communication in your journal from brother craftsmen on the subject with great interest, and trust that with your assistance, an association will be formed that will protect us from these Road Agents. Yours, etc., F. J. L.

## AN OLD INDIAN RELIC.

To the Editor of the *Jewelers' Circular*:

PETOSKEY, Mich., June 7, 1879.

I send you herewith a description of an Indian breast-plate, made of silver, which I now own. Please inform me at what time A. & J. Scrymgeour, of New York, were in business, and if they have any successors. I wish to obtain the origin and history of this relic, and will be obliged for any assistance you may render.

A. ROBERTSON.

It consists of a silver breast-plate of circular form, eight inches in diameter, and was recently purchased of an Indian. On the concave surface of the plate are engraved the figures of an officer, and an Indian chief. The officer is dressed in the uniform of a regular officer of the War of 1812, while the chief is dressed in full Indian costume, his head dress being decorated with feathers and plumes. Upon his breast is suspended a large medallion, on which is the likeness of some white man, possibly a President of the United States. The officer is presenting the chief with a string of wampum, while the Indian is extending the feathered calumet, or pipe of peace. Between the two is a bear, which possibly has some reference to the name of the chief, or is commemorative of some exploit in his career. Above the heads of the twain is an outspread eagle, grasping a shield in his talons, and surrounded by fifteen stars, which probably has reference to the number of States at some particular period. Below is the inscription, "Chief—Cataw—Chief," the second being undoubtedly the name of the chief. Around the rim of the plate, suns, moons and stars of large size, are engraved at regular intervals. The maker's brand upon the plate is "A. & J. Scrymgeour, New York." It is of pure silver, and its weight is 7½ ounces, making its value as

impression is that it was gotten up expressly as a present to some Indian chief high in authority, and that the engraving represents a treaty, either of peace or for the cession of land between the United States and some tribe or tribes of Indians. The Indian who sold it seemed to part with it without the slightest reluctance or emotion, which would hardly be the case had it been an heirloom, or obtained in a strictly legitimate manner, as the Indians are much inclined to the preservation of any article which indicates a descent from some great chief or warlike brave. We should like to see the history of the relic investigated by some Indian antiquarian, and are of the impression that it was manufactured about the period of the War of 1812. It was sent to Chicago not long since, partially for the purpose of investigation, but no light was thrown upon its history. By what combination of circumstances it found its way into the hands of Indians at this point, is a matter for the curious to speculate upon.

## JOBBER'S RETAILING.

To the Editor of the *Jewelers' Circular*:

In the May number of your valuable paper, Otto Wettstein contributed a paper ostensibly in defence of those jobbers who do a retail business, but which was in fact, a conglomeration of German transcendentalism and maudlin platitudes on the "inalienable rights of man." So far as his communication came within the limits of human comprehension, it assumed the position that each individual has a moral right to "employ such means for his self preservation and the accumulation of wealth" as he sees fit. In your June number I ventured to controvert this assumption, and to show that every individual was morally amenable to the laws and customs of the country, as well as to the recognized distinctions and usages pervading the commercial and industrial branches of trade. I attempted no argument with Mr. Wettstein upon his peculiar philosophy, so badly confused and muddled in his attempted elucidation of it, but contented myself with affirming the proposition that a jobber who asks and receives special favors from manufacturers because of his being a jobber and not a retailer, is morally bound to confine himself to a jobbing business, and that when he invades the retail field, availing himself of his jobber's privileges to undersell and undermine the legitimate retailer, he is guilty of breach of commercial honor, acts a lie, and is unworthy of the respect or confidence of the trade. In your last number, Mr. Wettstein replies in a communication as remarkable for its scurrility and billings-gate blackguardism, as his first was for his ignorance and befogged "philosophy." The question at issue was entirely ignored, and instead of an argument in support of retail jobbers, there is nothing but personal abuse of myself, both vile and indecent. I regret that I had not met a more reputable foe, for I should have been glad to have continued the discussion in the interest of my fellow retailers throughout the country, but to personal abuse, there is but one answer, and that lies in the toe of one's boot. As Mr. Wettstein is out of range, I am denied the privilege of according him an appropriate reply. While I regret having been the metal about \$8, but its value as a historic relic far exceeds its intrinsic value. Our means of drawing to your dignified columns the last effusion of Mr. Wettstein, the fact that he there appeared before your readers in his true character, will, doubtless, be regarded by them as some compensation for his indecency. With this, ends my notice of the individual, and I trust, all correspondence for THE CIRCULAR of an abusive personal character.

CHARLES H. PAINE.

## SPIDER LINES.

To the Editor of the *Jewelers' Circular*:

In the article in May number, 1879, entitled "A Study from Nature," a method of collecting "spider lines" for the use of instrument makers is described, which is also the way usually adopted by persons when using instruments in the field such as transits or theodolites, if, by chance, their lines become broken or damaged.

Possibly a description of another way of doing the same thing will not be amiss. The objection to using the freshly spun web of a spider, is, that the strands are apt to be of unequal size, being thin in some parts, and thick in others, while they often have knots or lumps attached to them.

The way that I was instructed to get webs, and which I have since practiced, was to get the cocoon of the wood spider, which the female spins around the eggs, and which are found fastened to the under side of boards upon old buildings or fences. The strands from these are much finer and smoother than those from ordinary cob-webs, and from the cocoon, very evenly and cleanly spun strands may be selected.

My mode of stretching them on a brass ring or other mounting, for astronomical transit use is to select a smooth clean looking strand about three inches long, attach each end of this to the two legs of a small pair of callipers, opened about two inches, and stiff enough in the joint to keep in any position. A small bit of beeswax serves to fasten each end of the strand; then open the callipers about an inch more, or enough to stretch the strand smooth and straight.

The ring upon which the webs are to be mounted should be previously ruled by a micrometer dividing machine, which serves to indicate where the webs are to be placed if they ever break, and also fixes the distances between them equal. Lay the ring down rule side uppermost, then bring the strand already stretched upon the callipers down over the first ruled line, touch each end with a very small bit of melted beeswax, which cooling instantly fastens the web. The strand can then be broken off beyond the ring, and another one placed upon the callipers as before.

When all the vertical lines or webs are in position, they can be examined with a powerful eye piece, or strong watchmaker's glass, and if not exactly right, can be adjusted by touching the wax with a blunt needle warmed in the flame of a spirit lamp, which melts the wax, and enables you to move the web a little either way, the wax cooling the instant you remove the warm needle. For fastening the webs, I like this mode better than with glue or varnish, both of which take some time to harden, and after they have once set, you cannot move the web.

When the vertical webs are all in position, then place the horizontal one in the same manner, the place for which should also be ruled exactly at right angles to the vertical lines.

I think it is better to take a cocoon from the outside of a building, as I have had two sets of "spider lines" ruined by contracting and breaking during a wet time, succeeding a very dry spell, which were made from a cocoon taken from the inside of a building, while the one made from the outside cocoon has stood through cold and heat, and weather dry and wet, it having been exposed to a temperature of 15° below zero in winter, and go above in summer.

Delicate as these spider webs are, they may, nevertheless, be readily handled, and will endure more rough usage without breaking, than people generally imagine. Yours respectfully, CHAS. S. BLACKMAN, Montreal, C. E.

# THE Jewelers' Circular and Horological Review.

VOLUME X.

NEW YORK, SEPTEMBER, 1879.

No. 8.

## THE JEWELERS' CIRCULAR AND HOROLOGICAL REVIEW,

*The recognized organ of the Trade, and the official representative of the Jewelers' League and the Watchmakers' and Jewelers' Guild of the U. S.*

A Monthly Journal devoted to the interests of Watchmakers, Jewelers, Silver-smiths, Electro-plate Manufacturers, and those engaged in the kindred branches of art industry.

### SUBSCRIPTION:

To all parts of the United States, Canada, Great Britain and the West Indies,  
**\$2.00 Per Annum; Postage paid.**

To France, Switzerland, Germany, Mexico, the Republics of South America, and Australia, \$2.50 per annum. Postage paid.

*All communications should be addressed to D. H. HOPKINSON, 42 Nassau Street, New York. Advertising rates made known on application.*

### Improvement in Trade.

THERE is noticeable now a decidedly better feeling in the jewelry trade, and the prospects are that the Fall trade will be much more extensive than for several years past. Manufacturers and dealers feel much more hopeful, and are preparing to meet the demands made upon them. It is noticeable, also, that the improved demand is mainly for the better grades of goods, which is one of the most hopeful signs of the times. The prosperity of the country seems to have inspired the people with a desire to return to the real in all that pertains to art, and to abandon the cheap imitations. The class of goods most generally sought for are those of a rich and substantial character. Cheap, showy, and flimsy jewelry that has so long had the run of the market, is being put aside, and there seems to be a prospect that goods of intrinsic value and artistic workmanship, are once more to become popular. The demand for precious stones is also improving, while dealers in the imitation paste articles see their trade falling away from them. During the past few years, manufacturers of fine goods could scarcely tell what the public wanted, the times were so hard, and the demand so light. Purchasers were no longer inclined to buy jewelry in sets, as previously, but were content with buying a single piece of new jewelry, which would be worn with odd pieces from old sets. Thus pins were not of the same pattern as earrings, and bracelets were of a different style from either. While the demand for uniform sets is improving, the taste for odd pieces seems also to be on the increase. Fashion is a fickle jade, and he who strives to meet her demands has a hard task before him. Our manufacturers of jewelry seem to be equal to the emergency, and are stocking up with fine goods of new and unique designs which cannot fail to catch the popular fancy.

It should be the aim of manufacturers and dealers to embrace this opportunity for bringing the popular taste back to a proper appreciation of artistic goods. Do not be content to meet purchasers half way, but urge upon them the desirability of investing their money only in that which is not only beautiful to the eye, but possesses an intrinsic value of its own that no change of fashion can take from it. A ten dollar watch may keep good time for awhile,

but one feels a great deal better satisfied if he knows that the watch in his pocket is not only an infallible time keeper, that will last, as such, for a life time, but is also worth in actual money the two or three hundred dollars it cost him. It is the same with jewelry. A fine, genuine diamond is not only a source of satisfaction to the wearer, but can be converted into good solid cash at any time. Wearers of cheap jewelry sacrifice a portion of their self respect everytime they put it on. They feel that their personal decorations are a sham, and apprehend that every one they meet knows the fact. If it is true, as stated, that mankind is apt to place an estimate upon a man according to the clothes he wears, it is also true that he is judged to a considerable extent by his personal decorations. The man who decks himself out with paste diamonds and flashy jewelry of the cheap description, is apt to be set down as a sham or a sharper, while a good opinion will be formed of him whose ornaments are few, but chaste, real and substantial. The trade can do much for its own improvement by striving to impress upon their customers a few of these well-known facts. With an increased demand for fine goods there will come, also, a greater demand for skilled workmen, and a higher appreciation of artistic workmanship. Retail dealers throughout the country can do much, if they are so inclined, to encourage this growing desire for the better qualities of goods, and by so doing, improve their own condition. There is little profit and less satisfaction to a dealer who is really a good judge of good work, and whose tastes are elevated, in handling poor imitations of fine goods, made of debased metal and thrown together in a cheap and flimsy manner. He is dissatisfied with a patronage that is limited in its appreciation of the capabilities of his profession to that which is merely cheap and tawdry. It is always pleasanter to deal in the real and substantial, and at the same time the profits are larger. This latter consideration should have weight if no other does. The trade has suffered greatly of late by the degradation of its standards; if it is possible, as the signs of the times indicate, to get back into the old and time-honored ways of supplying the demand for jewelry, the public, as well as the trade, will be greatly benefitted thereby.

### A Standard for Wrought Gold Necessary.

THE CIRCULAR, as our readers well know, has been a strenuous advocate for the adoption, by our Government of a standard for wrought gold. The abundance of goods that are manufactured from debased metal and put on the market as fine goods, renders such a standard not only absolutely necessary, but also requires that severe penalties be provided for those who sell debased goods for the genuine article. Our position on this question has been earnestly endorsed by the leading houses of the country, and there is hope that such a sentiment in favor of the proposition will eventually manifest itself as will compel Congress to enact such laws as will protect the public and the trade from the impositions of unprincipled manufacturers and dealers. A Select Committee of Parliament has recently been investigating what is known in England as the system of Hall marking. Gold and silver goods of certain kinds are required to be sent to the Jewelers' Guild, there to be assayed and receive the Hall mark, which is a certificate of its quality.

There are so many exceptions, however, of goods that do not require marking, or that cannot be marked, that the system found many opponents, and a movement was made to have it abolished, and a voluntary system adopted by dealers. This committee investigated the subject very thoroughly—the trade papers assisting them with many suggestions. After mature deliberation, the committee has reported against the system of voluntary marking, but recommends that compulsory marking in future be done under the supervision of the Mint. Referring to the compulsory system of marking, the committee says:

“In this country the system has existed substantially in its present form since the reign of Edward I. Without speculating on its origin, and while making due allowances for its defects, it is established that it has resulted in the creation and maintenance of a high standard of excellence for all British assayed wares which has not only raised the reputation of British workmanship at home and abroad, but has also created a large amount of private wealth readily convertible by reason of the guarantees of value which the hall-marks afford. As far as can be ascertained, most British manufacturers, and by far the largest number of the dealers, cling to the maintenance of the system with mark tenacity. The public do not complain of it.”

As England has established legal standards for gold, for the violation of which penalties are provided, the abrogation of the hall mark would not, probably, be so disastrous as it would were not legal standards maintained. Pure gold, by the English standard is 24 carats fine, and the law recognizes as gold metal degraded as low as 9 carats. The Select Committee recommends that the standards below 16 carats be abolished. On this point they say that “a composition containing less than two-thirds of pure metal, ought not to be called by the name of that metal.” If such a rule were enforced in this country, a very large proportion of our manufacturers in so-called “wrought gold” would be forced to put up their shutters. In France it is unlawful to alloy gold below 18 carats fine, so that purchasers of gold goods in France, of French manufacture, are pretty sure to obtain their money's worth.

We do not require in this country any elaborate system of marking, like that which prevails in England, but we do need a Federal law requiring that all goods shall be of the intrinsic value that they are represented to be. This can be obtained by establishing a legal standard for wrought gold. Manufacturers would improve the opportunity thus offered to establish their reputations for honest dealing, by affixing to their goods a mark of their own as a certificate of quality. By so doing, they would show to the public that they took pride in the quality of their work, and challenged an assay of its fineness. The quality of such goods as it is impracticable to stamp, should be certified to in the bill rendered, and any misrepresentation of quality, either by stamp or bill, should work a forfeiture of the goods, and render the manufacture liable to fine and imprisonment. Such a law would work no hardship to honest dealers—on the contrary, it would protect their goods from being imitated in base metal—but it would compel manufacturers of cheap goods, having but a symptomatic show of gold in their composition, to sell them for their true value, and without misrepresentation. The adoption of the recommendation of the Parliamentary Committee, that no alloy containing less than two-thirds pure metal should be called by the name of that metal, would prevent the sale of anything as gold that did not assay 16 carats fine. This is a standard that would commend itself to all dealers in fine goods, while those who handle the cheaper goods should not complain at being required to sell their goods for their true value. The English writers upon this subject generally condemn the recommendation of the Committee to retain the compulsory system of Hall marking, but approve of their suggestions relative to preserving and elevating the gold standard. When the trade becomes so demoralized, as it has in this country, that dealers in jewelry, who are supposed to be experts, are deceived by the manufacturers, and used as instruments for deceiving the

public, it is time for Congress to interfere. In previous articles we have endeavored to show that Congress has the constitutional right to establish such a standard. This right is conferred by this clause of the Constitution that empowers Congress to “regulate commerce with foreign countries and between the States.” The Supreme Court has repeatedly held that commerce is composed of many constituent elements, and that Congress has the right to legislate for the regulation of all factors necessary for the success of our commerce. Jewelry is certainly one of these factors, and the public has a right to Federal protection from the frauds that are perpetrated in its manufacture.

### Prohibitive Licenses.

TEXAS has passed a law imposing a license tax of \$200 upon all non-residents selling goods within the limits of that State. This tax is equal almost to a prohibition upon commercial travelers, few of them finding sufficient trade in that State to warrant them in paying so dearly for the privilege of drumming it up. The new constitution which California proposes to adopt, authorizes the legislature to provide for the levying of a similar tax upon commercial travelers. It is singular that in this enlightened age, legislators can be found who are willing to revive laws that have been abandoned by older States as impracticable and burdensome upon their own people.

License laws were formerly in force in several States of the Union, but as they were found to operate as a restriction upon trade, and to impose additional cost upon consumers, they have either been repealed or their enforcement abandoned. All laws of this character, imposing unequal taxation, are opposed to the spirit of the age, and fall like a wet blanket on the live and enterprising men who seek to build up and extend our commerce. If they submit to be thus imposed upon, they simply pay the tax into the State treasury and add it to the price of the goods they sell to residents of the State. The result is, therefore, simply additional taxation levied indirectly upon the people. But there are many dealers who will refuse to send their agents into the States where such an onerous tax is laid upon them. As a consequence, as the mountain will not come to Mahomet, Mahomet must come to the mountain. Commercial travelers being prohibited from visiting their customers in Texas, the Texas dealers must take a long and expensive journey to reach the jobbers and manufacturers whose goods they desire to purchase.

Commercial travelers are recognized as necessary factors to the successful prosecution of nearly every mercantile business. They visit the retail dealers in every section of the country, carrying full lines of samples of the latest and most approved styles of goods, and the retailer has but to order what he wants from the samples exhibited at the prices named. It saves him a world of annoyance and expense, and he is quite as well served as though he visited the manufacturers in person. A few years ago, before commercial travelers became “an institution” of the country, dealers in the west and south were compelled to visit the eastern cities once or twice every year for the purpose of making their purchases—journeys which cost them large sums of money in those days. Now, however, the commercial traveler visits them at stated intervals, and the necessity for the eastern trip is obviated. To impose an excessive and burdensome tax upon them is a hardship upon the local merchants, rather than upon the houses whose agents the travelers are. Texas and California may insist upon this discriminating tax for a time, but eventually they will see the folly of it, and we have no doubt but the obnoxious law will be speedily repealed. It is difficult, however, in these days of professional demagogism, to predict what absurdity the average legislator may not be guilty of, and it is possible these prohibitive laws may be retained for sometime.



### Our Defective Patent Laws.

THE Patent laws of this country need thorough revision. At present they are so imperfect as to be of little value to inventors. Indeed, they are so little respected, that the obtaining of a patent for a really good thing has come to be but the preliminary step in a protracted law suit. It gives to the patentee no rights that any one is bound to respect. In the jewelry trade many patents are obtained for new and original designs, or for ingenious devices in manufacturing, but no sooner is the design or device found to be of value than, it is forthwith copied by unprincipled imitators. A manufacturer of fine jewelry, for instance, at great labor and expense, gets up a new design that promises to become popular; he obtains a patent, and proceeds to incorporate the design in fine goods. No sooner are these placed on the market than he finds them duplicated in degraded metal and the goods displayed side by side with his own. The manufacturer of the debased goods may have changed the design in some unimportant particular, but the imitation is so close as to injure, if not entirely destroy the sale of the better class of goods. This would not be possible if our patent laws gave that protection in reality that they pretend to. If the patentee seeks redress from him who has imitated his goods, he must bring suit against him, assume the burden of proof, and enter upon an interminable litigation. Should he be so fortunate as to obtain a decision in his favor at the end of four or five years, he awakens to the fact that the fashions have changed, the market has been flooded with the imitation goods, and that his patent is no longer of value to him.

A patent should be *prima facie* evidence that the patentee has a property right in the article patented. It should be competent for him to go into any United States court, and on presentation of his patent, and making an affidavit that it is being infringed upon, be granted an injunction restraining the infringer from stealing his invention. The burden of proof would then rest with the infringer to show that he was not trespassing upon the rights of the patentee; otherwise the injunction should be made permanent. Summary treatment of those who steal the brains of others is the only way to check this growing evil. As to the evasion of a patent by some immaterial modifications of the patented article, the courts have held that this is no answer to a charge of infringement. If the general character of the patented article is imitated, it does not matter that some of its details have been changed. But there are few patentees in the jewelry trade who care to go to the trouble and expense of a prosecution for infringement, while the state of our patent laws is such that the guilty ones are almost sure to escape, leaving the one who has been injured to pay the costs. We are glad to note, however, that one member of the trade, whose advertisement will be found on another page, has determined not to be despoiled of his inventions. He gives due notice that infringers upon his patent will be vigorously prosecuted to the full extent of the law. If a few of the persons who make a business of stealing designs and devices could be mulcted in heavy damages, the pernicious practice would be put an end to. But the true remedy for the trouble is a thorough revision of our patent code, and the injection into it of such provisions as would give full and unquestioned protection to inventors.

### Goods on Consignment.

WITH the advent of an increased demand for goods in the jewelry line that has already set in for the fall trade, there is a disposition on the part of manufacturers and jobbers to send out less on consignment than heretofore. This plan of placing goods has not been found profitable from a pecuniary standpoint, but highly injurious to both parties to the transaction. The owner of goods sent out on consignment, having an exalted idea of their value, counts upon the sale of large quantities, and is disappointed and embarrassed in his calculations when the greater part of them are returned. Instead of having prosecuted a thriving business, he finds his goods thrown back on his

hands, shop worn and unsalable, the season in which he might have disposed of them having passed, and is obliged to refinish them or melt them over. The retail dealer who receives them on consignment is embarrassed by having on hand a large stock of goods that he does not own, and which is likely to overshadow his old stock, and prevent its sale. The men in the retail trade who are doing the best and most profitable business are those who carry a light stock of fresh goods, ordering only such as they are confident of disposing of readily, and such as embody the latest and most fashionable designs. The consignment plan of placing goods is an outgrowth of the old system of sending them on memorandum, and is equally in violation of the legitimate laws of trade. It cannot, for the best interests of the trade, be too speedily abandoned. Let buyer and seller make up their minds to indulge only in legitimate transactions, and to perform these upon true business principles, and it will be the better for both. The seller should abstain from attempting to overstock his customers, and the buyer should consent to take only such goods as he is confident he can find purchasers for. An excessive stock of goods is an incubus to a retailer that cannot fail to embarrass him seriously, and there is no excuse for his taking on storage a quantity of unsalable goods that do not belong to him, and that he has no prospect of disposing of. We hope to see the consignment plan entirely abandoned at an early day.

### Retaliation.

THERE is a little war raging in this city between the retail crockery dealers and the tea dealers from which the Jewelry trade may draw a lesson. The tea dealers, as an inducement to customers to purchase, are in the habit of giving them some article of glass or crockery ware. Quite a run has thus been secured by the tea dealers to the detriment of the retail crockery men. At a recent meeting of the Crockery Dealers' Protective Association, a committee that had been appointed to remonstrate with the tea dealers, reported that the latter refused to discontinue the practice of giving away crockery, as they found a profit in so doing. The crockery dealers therefore, resolved, that on and after September 1st, they would retail tea at their crockery stores at strictly wholesale prices. A committee was appointed to buy tea at wholesale, and distribute at cost to the crockery dealers.

This is carrying the war into Africa precisely as we have advised retail dealers to do in the Jewelry business. They complain of dealers in other lines of goods dabbling in jewelry. Carry the war into Africa. If a hardware man keeps jewelry, get a line of fine cutlery and undersell him; if a dry goods man goes into jewelry, undersell him with some specialty in his line; if the druggist poaches on your preserves, get a line of perfumery and undersell him, or open a soda water fountain in your show window. We are not in favor of guerrilla warfare on general principles, but the laws of self preservation teach us that when a man treads on our corns, a blow on his proboscis is the quickest method of instructing him to respect our vested rights in said corns. "Every man to his trade" is a good motto, but no game chicken will be crowded from his own roost without adopting retaliatory measures.

### The Trade in Time-Pieces.

GALIGNANI'S *Messenger* furnishes the following statistics with regard to the manufacture of clocks and watches. Whether the figures are trustworthy or not, we are not prepared to say. France is placed at the head of the list, and is credited with the production of chronometers, watches, time-pieces, clocks, annually to the value of 65,000,000 francs; then comes Switzerland, with watches, 60,000,000 francs; America, in watches and Dutch clocks, 32,000,000 francs; England, chronometers and watches, 16,000,000 francs; Austria, time-pieces, 10,000,000 francs; Germany, in time-pieces and a few thousands of watches, 25,000,000 francs. These figures give a total con-

siderable over 200,000,000 francs for the whole watch and clock making trade of the world. The amount assumes the greater importance when the fact is remarked that, differing from nearly all other business, the raw material enters so slightly into the prime cost, the principal expenditure being almost exclusively in labor. The approximate number of articles produced is as follows: France, about 1,000,000 pieces annually; Germany turns out more, some 2,000,000, but they are of a much inferior average price. The same may be said of the American manufacture, which provides commerce every year with 700,000 or 800,000 objects. As far as watches are concerned, Switzerland heads the list with an annual production of 1,500,000. France follows with 500,000; the United States produces from 300,000 to 350,000, and England some 200,000, but these are of very superior quality. The enormous total is that 2,500,000 watches and 4,000,000 time-pieces are annually dispersed to the four quarters of the globe.

**Embarrassed.**

**COGSWELL, WEBER & CO.**, of Chicago, who, in 1878, asked of their creditors an extension of credit, are again in trouble. Dissensions have arisen between the partners, induced by tale-bearers and mischief makers, and harmony in the management of the business has ceased to exist. W. Smith & Co., one of the creditors, have levied upon the stock, which is now in the hands of the sheriff. Mr. Cogswell has issued a circular to the creditors of the firm, giving his version of existing difficulties, which seems candid on its face, and puts his partners in an unfavorable light. A committee has been appointed to look after the interests of the creditors, consisting of Messrs. Bailey, of the Waterbury Clock Co., Thorpe, of Philadelphia, Potter, of Providence, and Morse, of Chicago.

Messrs. Morse & Thorpe, members of the committee, have investigated the affairs of the above firm, and report as follows:

CHICAGO, Sept. 6, 1879.

*To the Creditors of Cogswell, Weber & Co.:*

In pursuance of your direction, your Committee came to Chicago, and not only found the affairs of Cogswell, Weber & Co. in the Sheriff's and Receiver's hands, under a judgment in favor of Wm. Smith & Co., of New York, and a large number of suits and attachments pending, in behalf of other creditors, but they found that the Receiver was not temporary, but permanent. For some days your Committee labored in getting a correct idea of the value of the assets, and ascertaining about the amount that could be realized for them, in the meantime using their best endeavors to procure an agreement between the partners to settle and go on with the business, believing that the better course; but without avail.

Your Committee procured offers, which were to be cash or its equivalent, that, in their judgment, would net in the neighborhood of fifty per cent. to the creditors, after paying the expenses of Receiver, Sheriff, etc. At this point, Mr. Cogswell came forward and offered to untake a cash settlement of fifty per cent. if the Committee and Receiver would give him time to make the attempt.

The Receiver and Committee have agreed to give him ten days in which he is to have an opportunity of doing to, if possible.

In the judgment of the Receiver and Committee, this will be the extent that can be realized if the assets are sold under the most favorable circumstances, at Sheriff's or Receiver's sale, which latter course will, of necessity, destroy the value, if any there be, of the good will and continuance of the concern. It should be borne in mind that all sales are suspended. The estate is subject to heavy expenses of Sheriff, Custodians, Receiver, etc., and the fall trade is rapidly passing. The Committee, therefore, recommend immediate action, and respectfully ask your concurrence in their report. For the better judgment of creditors, we hereby append an exhibit of the Assets and Liabilities, as shown by the books and inventory,

Committee, { CHARLES N. THORPE,  
F. E. MORSE.

**RESOURCES AND LIABILITIES AS SHOWN BY MR. COGSWELL.**

RESOURCES.		LIABILITIES.	
Cash.....	\$ 2,210 28	Bills Payable.....	\$31,662 28
Merchandise.....	36,768 91	Accounts Payable.....	25,391 14
Furniture and Fixtures.....	2,644 48		
Bills Receivable.....	5,496 10	Total.....	\$57,053 42
Accounts Receivable.....	35,459 48		
Total.....	\$82,609 25		

**RECAPITULATION.**

Resources.....	\$82,609 25
Liabilities.....	57,053 42
Surplus.....	\$25,555 83

**ABSTRACT OF BOOKS, AUG. 18, 1879—REDUCING ASSETS TO MARKET VALUE.**

RESOURCES.		LIABILITIES.	
Merchandise, 33 1/2 per cent. off ..	\$24,512 61	Accounts and Bills Payable.....	\$60,198 10
Accts. and Bills Receivable, 33 1/2 per cent. off ..	27,324 32	Total .....	\$60,198 10
Total .....	\$51,836 93		

**THE FOLLOWING IS AN ABSTRACT OF FIGURES FROM THE BOOKS:**

Liabilities Feb. 1, 1879 .....	\$46,141 54	Liabilities Aug 1, 1879.....	\$57,053 42
Assets Feb. 1, 1879 .....	71,398 87	Assets August 1, 1879.....	77,754 49
Accts. Receivable, Feb. 1, 1879 ..	37,216 71	Amount of Accounts Received	
Accts. Closed into Profit and Loss, Aug 1, 1879.....	2,455 77	August 1, 1879 .....	40,955 58
Amount purchased in six months ending Aug. 1, 1879.....	64,474 77	Amount paid on accounts, old and new, same period.....	51,081 96
Expense in conducting business 6 months ending Aug. 1, 1879.....	10,545 50	Gross gain on sales same period..	10,030 42

**Palladium Balance Springs.**

THE British Horological Journal for July, publishes a remarkable article by a correspondent, calling attention to a new material for the manufacture of balance springs. It will be noted that it is claimed that balance springs made from palladium are unaffected by heat, will not oxidize, and possess the requirements of a fine spring in a higher degree than those made from any other metal. From the description given it will be seen that palladium balance springs are affected reversely by atmospheric changes from steel springs. The article is of so much importance that we give it entire below.

There are few businesses which afford greater scope for the introduction of novelties than that of watchmaking. Changes with more or less the right to be regarded as improvements, either in process or style, material or mechanism, are constantly being heard of; but among them all, it may be doubted if any introduction of late years, is of so great importance as that to which I now wish to draw the attention of your readers. It is simply a hair-spring that *will not rust*, though it be placed in sea-water or sulphuric acid, that possesses the elasticity of the finest, hardened, and tempered steel spring, and at the same time considerable tenacity, and what is still more remarkable, is practically *unaffected by heat*. Of certain samples submitted to me I have subjected one to a severe trial. I screwed it on a brass plate, and held it in the gas until the plate was nearly red hot, and on close examination I could not discover that it had expanded in the slightest degree. The same spring after being thus treated, could be drawn up from the plate by the outer coil, a distance of four or five inches, returning to its position as flat as before, the great heat having had no detrimental effect upon its elasticity.

I also submitted one of these springs to the judgment of Mr. Walsh. His experience fully agrees with mine, as will be seen from the following, which he has written to me in reference to the matter:

"My opinion is that balance-springs made of the same material as the one you gave me, would be very valuable in resisting the effect of damp, thereby causing rust, for I put it in water, and placed it on a wet piece of blotting paper for several hours, without the least injurious effect. I then made it nearly red hot on a bluing pan, without producing any apparent change, and afterward tested it for elasticity, and found it quite equal to a hardened and tempered steel balance-spring. Not having tried one on a watch, of course I cannot speak as to results in performance, but should think it would be quite equal to steel."

Of course, the fact of the production of such articles suggests a variety of speculation in regard to application and practical utility I have not at present had time to ascertain to what extent they have been used, or under what conditions. I have, however, been assured that watches sprung with these springs have been placed in competition with others sprung in the usual ways at Geneva, and results have demonstrated their superiority. It is also found that the best results from these springs are obtainable when applied to balances of special and ascertained proportions. There is no doubt that in common watches, with ordinary steel or gold balances, the errors arising from the variations of temperature will be greatly lessened by the employment of these springs. The advantages of their being inoxidable are obvious, especially in marine chronometers and timepieces, and for watches destined for use in hot climates; and it seems to me that unless there be some objection as yet undiscovered in them, they will be found so much more advantageous to ordinary springs, as to cause them to be generally adopted. Connected with this production is a remark by Mr. Rigg, in that portion of his lecture reported in your last issue. He quotes the experience of M. Paillard, that springs made from alloyed palladium (such as I have described), give a gain of 40 seconds with an increase of temperature of 30° Centigrade, whereas all other metals, except platinum, give a greater or less loss. This is a point that may well be borne in mind in testing this article.

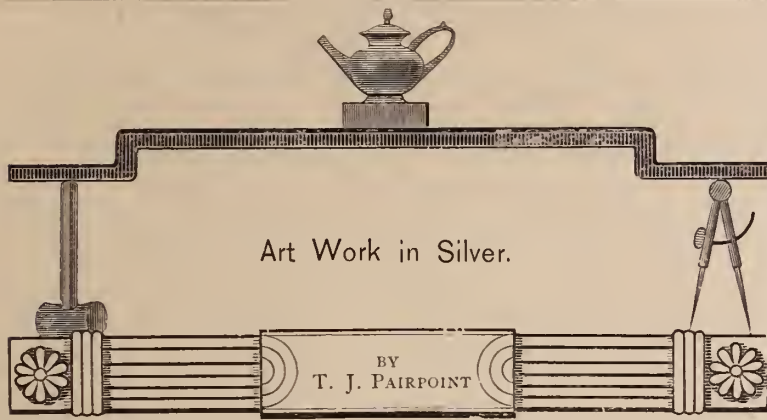

IN art manufactures of all kinds, taste should exercise a controlling influence in every department, visibly asserting itself in ornamental designs, and imparting a character to our industrial productions, which cannot fail to be recognized and appreciated; it enables us to beautify and elevate our works, and is always scrupulously careful to exclude even a suggestion of vulgarity. The natural desire of the human mind is to decorate and adorn, and when this desire is governed and controlled by taste, the result is an unqualified source of pleasure. By the term taste, we mean a carefully cultivated judgment resulting from earnest study and research, in which the several forms and methods of decoration are duly considered; by this study we are enabled to bring together and compare the various styles that have been produced at different periods, and by nations under whose fostering care the fine arts have flourished. We find each age having its distinctive characteristics, some severe and pure, and others faulty, and in order to exercise the necessary judgment to determine the false from the true, not from any impulse of fancy, but based on the operations of reason, we need an educated taste, one that is uncultivated and simply founded upon instinct or fancy, is uncertain and valueless, having no fixed first principles or foundation upon which to base their judgment, and to make it become reliable, it must be subjected to a course of careful training. In the earlier times of manufacturing, it was simply mechanical suitability that was required, but as society and educational advances, it is necessary to combine beauty with fitness, and those who show the evidence of superior taste and elegance in their productions cannot fail to have the merit of their works recognized.

There is now everywhere shown a desire for the beautiful in all articles, whether for use or ornament; this feeling being only the natural result of the mind, craving for that which will give enjoyment. Addison remarks in one of his essays, on the pleasures of the imagination "Our sight is the most perfect and delightful of all the senses," and in another he says—"There is nothing which makes its way more directly to the soul than beauty;" fine forms and good ornamentation therefore are necessary to give pleasure through the medium of the eye, even as good music delights us through the ear, and it becomes in this way an important commercial element. The new movement that recently has shown itself all through New England, and the endeavor to establish art schools in the principal cities, show a general desire to become better acquainted with art matters, and to cultivate that taste which shall enable them to appreciate and enjoy beauty of form, and harmony of graceful lines, and the more refined the taste becomes, the more pressing will be the need for chaste and pure designs in all our productions.

The very vague efforts in this direction so frequently displayed, is the result of striving to produce something new, without having sufficiently studied that which has been done in times past; it is not only necessary for us to know what our contemporaries have done, but also what has been achieved in past ages; if we strive after novelty to the exclusion of the accepted styles and forms, the probability is that we exclude all that is beautiful and harmonious. The valuable knowledge to be gathered from the study of the arts of different nations through the various epochs of their history, is very

important and of immense advantage to the student; by the aid of this knowledge his mental capacity becomes enlarged and matured, and his thoughts are diffused over a more extended area; the great men of all ages have thus drawn lessons of experience from those who have preceded them, and every age and generation leaves a wealth of practical thought to those who come after them; we look to the past for guidance in working out independent and original ideas such as would be adapted to our own circumstances and requirements, and it enables the student to impart refinement and expression to his work, and beautiful form that has ever been used admits of infinite variation, without detracting in the smallest degree from its original grace, if in our treatment we always bear in mind the necessary elements of harmony, order, symmetry, proportion, and repose.



An artistic production is a visible expression of the mental or spiritual conception of the human intellect, an embodiment of the ideal. The activity of the mind necessitates an external representation to complete its development, and therefore the creative faculty of an artistic thought, is accompanied by an active realization which causes the otherwise inexpressible and intangible idea to become a palpable fact. Language can but very imperfectly explain what is an artistic idea, as it is almost impossible to express suitably in words the subtle working of the mind, and the peculiar individuality of feeling from which proceeds the conception of a work of art. The best and most comprehensive exponent of it, is the work itself. Schlegel says "Deep feeling is the only true source of lofty art; it is feeling which reveals to us true ideas and correct intentions, and gives that indefinable charm never to be conveyed in words, but which the hand of the painter, guided by the poet soul alone can diffuse throughout all his works. From religious feeling, love and devotion, arose the silent inborn inspiration of the old masters; few indeed now seek their hallowed inspiration or tread the paths by which alone they could attain it, or emulate that earnest endeavor to work out the principle of serious and noble philosophy which is discoverable in the works of Durer and Leonardo de Vinci." The aim of the true artist is ever upward and onward, striving in each successive work to surpass the previous one; it is this essentially progressive and elevating spirit which we wish to apply to our manufactures, pressing forward with unrelaxed energies until industrial art shall become developed into high art. Some writers affirm that the two are so thoroughly distinct that they cannot be blended, but this view of the subject is narrow and conservative, and is not justified by the examples of past ages, especially as applied to plate and metal work. When studying the history of industrial art, we must direct our attention in the first place to the cradle of civilization, ancient Egypt, whose monuments and tombs abound with sculptures and paintings, presenting to our view the greatest possible variety of records, sacred and profane, historical and domestic, from the time when the Egyptian nation recorded in primitive sculptured characters the first attempt of that soul stirring inspiration which finds expression in art, through the succeeding ages, until the high state of their civilization, and the rapid rise and growth of their various handicrafts, built up the prosperity and magnificence of the empire, and caused it to be looked upon by other nations, as the center of art, science, and industry.

In the very earliest period art was a sacred profession, and devoted exclusively to religious purposes; its practice was regulated by laws established for that purpose which were rigidly enforced—the artists being selected from families of rank, and educated like the priesthood. At a later date, historical subjects were permitted to occupy their attention, and the wars and conquests of the kings

were sculptured on their palace walls and tombs; afterwards incidents of ordinary public and domestic life were recorded, not even omitting the smallest detail. A review of ancient metal work is highly interesting. Historians, travelers, geologists, and the antiquarian lead us from one subject to another, bringing almost the whole known world within the range of its history, and giving us everywhere retrospective views of the earliest beginnings of states and empires. It exhibits before our eyes a sort of panoramic view of history, in which past and present, civilized empires and barbarous states, each in turn claim our attention, and blended with this profusion of historic matter are glimpses of religion, which in all ages have exerted a powerful influence upon art, the gaudy extreme of savage life contrasting with the civilization of the Greeks, and the magnificence of the Romans; we find legends, anecdotes, and criticism inextricably mixed with it, and the various forms and style of the vases, bowl cups and other articles of utility and beauty, that engage our attention, as we are led from one age to another; each nation moulding and forming their productions in accordance with the prevailing feeling and taste of the period.



The spirit or inspiration of the present day which is progressive, should pervade in all its bearings the general effect of silver or plated ware; this feeling is largely exhibited in the excessive profusion of trifles intended for the adornment of our homes, and which for ingenuity have never been surpassed; the same frivolity of purpose, would be altogether out of place in our plate, but the progressive spirit should be plainly demonstrated. A knowledge of the antique will always prove beneficial to the silversmith, but forms borrowed from them must at all times be thoroughly diffused with a utilitarian principle, and the conscientious artisan should strive to produce fine execution, rising with and never transcending the modesty of simplicity, and never descending to the vulgar; and if the design is of architectural proportions, the construction should be of the least complicated kind; it should be simple without degenerating into baldness, or florid without becoming coarse, but be characterized by a style that is at once full, free and flowing.

Every article ought plainly to show the purpose for which it is intended, exhibiting at a glance the usefulness as well as the beauty of the design; this combination of the essentially useful, with beauty and grace of form, and fine detail of decoration, must be acceptable to all. How many of the necessary surroundings of our daily life are unlovely, and in some instances, positively unsightly, and the only feeling with which they are regarded is simply toleration because they are useful; but if the element of beauty is introduced, the eye when resting upon them is gratified with a sense of pleasure and repose, and we feel that it is very desirable to possess an object in which utility and beauty are admirably blended. In no province of industry does this more directly apply, than in the production of silver and plated goods, and the mechanical perfection to which our manufactures have attained must either remain stationary and in time decline, or must be pursued into this higher branch.

It is seldom that sufficient attention is bestowed even in expensive silver ware on the combination of the artistic with the mechanical construction, one usually predominates over the other to the detriment of the whole; this injudicious treatment generally arises from one of two causes, first, that the silversmith or mounter is frequently ignorant of the principles of construction, or artistic considerations of any kind, consequently his work unaided by an artist will be purely mechanical and usually without taste or style, or secondly, the artist although a good draughtsman and designer, may be altogether unacquainted with the mechanical part of the manufacturing, the possibilities and impossibilities of silversmithing, and therefore, his designs, although expressing pure sentiment and style, may be quite impracticable and unsuited to the material in which it is to be made; in order to effect

a perfect combination of these two essential elements, the artist and the artisan must each understand theoretically at least the principles of the other; to combine the highest possible excellence with the most complete utility should be the chief aim, and the observant designer will always be able to draw from the teachings of nature which demonstrate that in her works, the useful and the beautiful are so intimately connected that we cannot detract or interfere with the one part without very materially impairing the other. In domestic plate of all kinds, simplicity is very desirable, and is quite compatible with fine sentiment, as all will observe who refer to the antique, and notice their useful and at the same time simple and graceful forms. The poetic sentiments which they express and the love of the beautiful, which the contemplation of true works of art inspire, should be familiar in every home, exerting a beneficial and refining influence upon the formation of the character and tastes of the rising generation. The minds of the youthful are so susceptible to impressions, that if the taste is early directed to contemplate and appreciate true beauty, its refining influence grows with them and becomes a part of themselves; if rightly directed, pure and chaste beauty becomes a power, it ennobles and elevates the mind and causes the soul to aspire to a more perfect condition of harmony, peace and repose than the materialism of the present age affords.

The direct influence of the floral and vegetable world upon artistic manufactures must be duly considered, the origin of so much that is beautiful and graceful can be directly traced back to it, and it forms such a very important element of design that students will find a little serious study in this direction to be very profitable. There is an inexhaustible variety of forms, combinations and color suggested by flowers and fruits, leaves and stems, trees, shrubs and herbs, if the artist knows just where, when, and why to seek for them; and to this end a knowledge of botany would prove a valuable auxiliary, and at the same time teach the ornamental draughtsman to have a scientific comprehension of the plants he selects for his models, giving him an insight into the possible variations and developments of the species, each variation being sources of fresh beauty and grace, from which may be derived much that is new yet perfectly consistent, Every stem is peculiarly adapted for its own kind of foliage, and the eye will derive far greater pleasure from the contemplation of truthful elements naturally combined, than from incongruous and unnatural admixture of floral and vegetable forms

The mercantile value of artistic talents, when applied to industrial productions, will become more fully demonstrated as the aesthetic education advances, and it would be a great stride in the right direction,

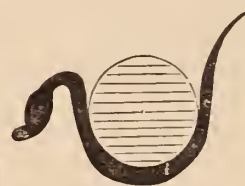

if some means could be adopted to secure to the skilled artisan some education in industrial art matters, the advantages accruing to the manufacturer, from such a movement, are obvious. The designer may now prepare his drawings and models most carefully and satisfactorily, but in passing through

the hands of the uneducated and inartistic workman, in the several stages of production, it loses all of that fine feeling and pure sentiment which the models expressed and which constitute their chief beauty; but without some slight knowledge on the part of the workman it is quite impossible for him to retain and carry out in the work the sentiment that was expressed in the design; a little more cultivated mind power guiding the mechanical forces is needed, to build up and strengthen parts that without this union are frequently weak and meaningless.

Mr. Ruskin says in reference to the education necessary to the advancement of art applied to manufacture: "It seems to me that we are all too much in the habit of confusing art as applied to manufacture with manufacture itself. For instance, the skill by which an inventive workman designs and moulds a beautiful cup, is skill of true art; but the skill by which that cup is copied and afterwards multiplied a thousandfold is skill of manufacture; and the faculties which enable one workman to design and elaborate his original piece are

not to be developed by the same system of instruction as those which enable another to produce a maximum number of approximate copies of it in a given time. Farther: it is surely inexpedient that any reference to purposes of manufacture should interfere with the education of the artist himself. Try first to manufacture a Raphaël; then let Raphaël direct your manufacture. He will design you a plate or cup, or a house, or a palace when ever you want it, and design them in the most convenient and rational way; but do not let your anxiety to reach the platter and the cup interfere with your education of the Raphaël. Obtain first the best work you can, and the ablest hands, irrespective of any consideration of economy or facility of production. Then leave your trained artist to determine how far art can be popularized or manufacture ennobled."

In this age we are especially privileged in our studies of classical art matters; the extensive research and many valuable discoveries resulting therefrom, made during the last half century, have opened up a new and more comprehensive field of inquiry and instruction, and we are enabled to follow the career of the different styles through the various stages of progression and triumph, decline and fall, each as they passed away, becoming known only as sculptured histories, unmistakably stamped with the peculiarities of the races who had produced them; thus, the Egyptians themselves, are depicted with life-like faithfulness in their paintings and sculptures. Greek art records the biographical history of the Greeks, and when Greece became a Roman province, although the arts were still practiced by the Grecians themselves, their work became essentially Roman in character under Roman rule. The same relationship also existed between Byzantine art and the people of the Eastern empire, each style belongs to its own people, and when the races among whom they flourished declined and passed away, their art ceased to have an active existence, and they became like the people, a thing of the past.

A brief review of some of the leading features of the various ornamental styles, may be found useful, as every one in anyway connected with ornamental manufactures, should know and be able to recognize some of the most prominent characteristics of the several orders; of course, to obtain a thorough comprehension of this branch of art, it is necessary to understand the motives which governed and prompted each race or nation to produce their distinctive style, but this would be beyond the province of these pages; we can therefore give but a brief glimpse at each.

Every age or nation has been distinguished in its method of ornamentation by certain peculiarities, some original, others reproductions of former styles, with perhaps a few modifications. The most ancient of these, the Egyptian, is claimed to be the most perfect in all that is necessary to form a true style of art; its teachings are the soundest, because inspired direct from nature. It is asserted by some authorities that the Egyptian is the only style in which the most perfect specimens are the most ancient, their earliest known works were their finest productions, and the dynasties which followed were content with copying what their predecessors had done, without in anyway improving upon or developing what had already been accomplished. In all the later styles, they improved, elaborated and enriched the first principles upon which the style was founded, but the contrary appears to have been the case with the Egyptians. This style is of a hieroglyphical character, each of the elements having some significance or meaning. It was very rarely they used any form of decoration, for the beauty of effect alone. In that primitive age they endeavored to make each design tell some story, or commemorate an event in history; this necessarily makes the ornamentation of a limited capacity in comparison with later styles, although the variety produced from so few types, and those of such a simple character is remarkable; their manner of arrangement was always extremely simple and symmetrical, but profuse in rich and costly material and gorgeous colors, employing gold, silver, precious stones, ivory, etc. The skill they exhibited in architecture is really surprising; the solid masonry of their movements would have withstood the ravages of

time to the present day, had they not been used as convenient quarries to supply stones for the erection of new edifices, but though the greater part of their finest buildings have been thus destroyed, the remains that are left fully attest the grandeur of their proportions, and the mechanical skill of their construction. They were not deficient in taste which in their case was purely original, and afterwards served as models for much of that wonderfully successfully art that was brought to such perfection by the Greeks. In everything pertaining to religious matters the artists were obliged to conform to rules which long usage and prejudice had firmly established; it was unlawful to introduce any innovations in sacred subjects, but in articles for domestic use, furniture and objects for decorating their households there was no law restricting them, and the elegant form of some of the vases, their furniture, and the designs of their architecture often exhibited very considerable taste; but the stern regulations of the priest-hood forbade any departure from the conventional mode of representing the human figure; no attempt was made to copy nature or give the natural action of the limbs, but the same formal outline and stereotyped attitudes were constantly repeated; thus fettered it was impossible for them to make that progressive development which other nations under more favorable conditions attained.

Among the emblems frequently used is the reed which signifies royalty; the crook, emblematical of majesty and power; the symbolic eye which was placed in all kinds of conspicuous positions over doors, on tombs and boats, etc., its symbolism expressing the all seeing presence of the deity, it was also an emblem of the land of Egypt; they constantly used the lotus or water lily, as a type of the Nile, from whose inundations Egypt derives its fruitfulness, and the zig zag as expressive of flowing water; but the winged globe or beetle were the most extensively used symbols; these are found in every kind of ornament, from the adornment of their buildings to the engraving of their richest gems; they were considered a kind of talisman or symbol in honor of the good spirit, hence the reason of their prominent use; the Ibis also was considered a sacred symbol, and the Asp and Cartouche was quite often used; the cartouche is a sculptured ornament in the form of a scroll unrolled, on which were inscriptions, or sometimes they were of an oval form and inscribed with royal names, and feathers were used as an emblem of sovereignty. Mingled with these we find many of the natural products of the country treated in a conventional manner and selected with a view to some typical expression. These symbols are the essential elements of Egyptian decorative art; it is from these that the designer has to draw when he wishes to introduce the Egyptian character into his work, as they are always recognized as appertaining to that style. The Assyrians, Babylonians, and the people of Ninevah carried it to a higher position; a careful inspection of the Assyrian and Ninevah marbles in the British Museum will show at once the advanced state of their sculptures; their grouping is bolder, and the human figure is treated with more attention to natural details. In conception, freedom, and correctness of outline they do not compare with the Greeks, but they have a boldness, a strength, and an appearance of life that excites admiration, and make them valuable as works of art. They represent in their sculptures all the various phases of warfare: the battle, the pursuit, besieging cities, etc., and the chase is represented in which the lion, the stag, the antelope and other animals are introduced; and in all these the strict conventionalism of the Egyptians was discarded, and in its place we find a more spirited and varied manner of treatment.

The Greeks took another step in art; they introduced various elements for their own sake purely, as ornament, combining artistic with religious considerations. The Egyptians had produced many fine and useful forms, but the Greeks improved and ornamented them with beautiful and suitable decoration; they were particularly partial to symmetrical proportion in all their works; even in their oratory it is expressed by the careful measure of their periods, and it was also a governing principle in their lyrical poetry; the same care is noticeable in the decoration of their houses and temples; the Greek

artist always endeavored to carry out a perfect symmetry and parallelism of grouping. Some of the chief characteristics of Greek ornament are the fret, an angular interlaced ornament, the vitruvian, scroll, named after Vitruvius, consisting of a series of undulating flowing lines; the anthemion, or Greek honeysuckle; the echinus, or horse chestnut; the astragal; the guilloche, which is an ornament consisting of three lines loosely interwoven, similar to an ordinary braid or plait; and the volute, this is a spiral decoration, said by Vitruvius to have been suggested by the curls worn on each side of a lady's face, but it has been considered more probable that it originated in the spirals of shells; it is sometimes known as the ram's horn.

Greek art is divided into three orders, the doric, ionic and corinthian; the latter being by far the richest of the three; in it the Acanthus is the distinguishing feature; these three orders are not distinct styles, but simply the progression of one, each as it succeeded, accepting the previous order, but adding something to it. The Doric derives its name from the Greek tribe of the Dorians, by whom it was invented, and most frequently used, and whose serious and dignified character is well expressed in it; we find the echinus as the prevailing element. The Ionic tribe who originated the order of that name, being of a lighter and more versatile character, expressed themselves in a more ornamental style, and we have the Volute, or ram's horn added the echinus of the Doric.



The Corinthian is characterized by a row of acanthus leaves below the volutes, which in this order are somewhat modified. The Corinthian was not fully developed until the end of the fourth century, B. C. There is always great simplicity in the arrangement of the details of Greek ornament, being usually placed horizontally one row of ornament above another. The earliest Greek drawings are of a stiff, antiquated type, similar to those discovered on vessels and in sculptures at Ninevah and Babylon, and this style was retained in combination with a greater freedom of treatment, at a more advanced period. Among the first steps of development is noticeable the strange admixture of animal forms, with arabesque or half human and half animal figures. The human figure was drawn with an appearance of rigidity, when represented in repose, and when in positions of activity the action was unnaturally violent. At a later date their drawings became more individual and freer from traditional conventionalism; the composition began to show that symmetry in grouping for which they became renowned, and the human figure exhibited more dignity, with greater freedom of treatment. Kramer calls this period the severe style; and later, when further developments had taken place, and severe dignity had been succeeded by grace and beauty, he terms it the beautiful style. The perfection of art to which the Greeks attained, may be attributed to their spirit of enthusiasm; they gloried in it, and their highest aspirations were directed to the adornment and service of their temples. Their artists who were renowned for their genius and skill, were honored as beings of a superior order; they looked upon artistic genius as a divine gift, and therefore worthy of honor, but the artist to be so honored, must love his art for its own sake, and devote his skill to the enrichment of their gods

or temples, or to the benefit of the nation without egotism or personal vanity. The devoted attachment of the Greeks to the fine arts, has been commented upon by many writers, and Cicero tells us that they enthusiastically admired all works of art, and there was no calamity, they were so little able to bear, as the pillage of their temples and cities. It was this national enthusiastic love of art which enabled them to elevate it to a degree of perfection which has never since been equalled.

The period when Greek art attained its highest perfection lasted from about 460 B. C. until about 366 B. C., during which time the Parthenon was rebuilt, and Phidias, the greatest sculptor the world has ever produced, executed his celebrated works known as the Elgin marbles now preserved in the British Museum. These marvellous productions are worthy specimens of Grecian art, and are acknowledged to be the very highest standard of excellence in sculpture.

**H**OLES in hard steel may be made with nitric acid. To apply it cover the steel plate, at the place where you wish the hole, with a thick layer of melted wax: when cold make a hole in the of the size you want the hole in the plate, then put on one or more drops of strong nitric acid, leave it on for some time, wash off with water, and if not eaten through, apply other drops of the same liquid and continue this until the plate is perforated.—*Ironmonger.*

**T**HE Watchmakers' and Jewelers' Mutual Aid Association, is the title of an organization formed in Chicago March last. Its name indicates its character. A constitution and by-laws have been adopted, numerous members of the trade have enrolled their names, and the association is now in full working order. The following named gentlemen constitute the board of officers for the current year: President, J. S. R. Scoville, of Morris, Ill.; Vice-President, A. M. Church, of Chicago, Ill.; Secretary and Treasurer, Capt. E. R. P. Shurly, of Chicago, Ill.; Executive Committee, W. E. Higley, late of N. Matson & Co., A. French, of Chicago, and J. Harris, of Green Bay, Wis.; Examining Surgeon, H. D. Garvin.

**S**ELLING THE JEWELS.—The Plantagenets were very rough-and-ready financiers. When Richard I. took it into his head to try conclusions with Saladin, he raised the needful by turning the crown manors and the fortresses of Roxburg and Berwick into hard cash, selling offices of trust to the best bidders, and did not hesitate to avow that he would dispose of London itself if a purchaser were forthcoming. Strangely enough, Cœur de Lion never seems to have thought of doing the same by his crown jewels. Henry III. was the first English monarch who had recourse to that undignified expedient. The idea, indeed, did not originate with him; for it is recorded that when some person or persons unknown suggested the replenishing of the royal coffers by selling the crown plate and jewelry the King hinted a doubt as to the likelihood of finding purchasers, and being assured that the citizens of London would gladly accommodate him. Henry exclaimed: "On my word, if the treasury of Augustus were brought to sale, the citizens are able to be the purchasers. These clowns, who assume to themselves the name of Barons, abound in everything, while we are reduced to necessities!" Notwithstanding his indignation, Henry, like other men in his predicament, was willing enough to deal with the full-pursed ones he abused, and so, in 1248, he sold the citizens of London all the plate and jewelry he had not already mortgaged to the merchants of France. The relief afforded was, however, only a temporary one for seven years later we find him demanding 8,000 marks of the Jews, and answering their remonstrance against the exaction by pleading that he was a beggar, spoiled and stripped of all his revenues, without a farthing wherewith to keep himself, and therefore must have money from any hand and by any means.—*All the Year Round.*

## Watch and Chronometer Jeweling.

The side-shake having been determined, the first step is the setting. There are a few small tools used in this operation that are worthy of an illustration. The Figs 1 and 2 are respectively a cutter and burnisher. As a matter of course, the sizes are arbitrary,

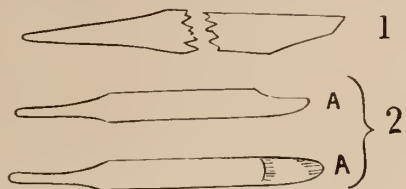

in order to suit all kinds of work. Fig. 1 is the general form of the cutter for centring, made of flat steel, and ground in the form represented. To make a proper concave seat for the jewel, the corner should be slightly rounded. The Figs. 2 are the burnishers, not only for jewelry setting, but extremely useful in a variety of the ordinary watch repairs—made of common Stubbs round wire, the end being first turned up round, and a flat filed on one side; the corners are rounded off, and a tang forged on the other end. The acting end is now hardened, and then drawn soft from the tang to about an eighth of an inch from the point. The rubbing surface is now to be made uniform with oil stone powder, and then finished with rouge, until a high polish is effected. While using, a piece of sole leather is found valuable to preserve the necessary surface. It, like the cutter, is put in a good handle, and forms, as said before, a handy tool on very many occasions, such as setting stones in jewelry, etc. These tools having been provided, if the operator has no spring chuck, he screws a piece of brass wire in the lathe mandrel, and drills a hole in it, first centring it with the sharp cornered tool No 1 in the cut. The hole, of course, is smaller than the external diameter of the jewel to be set, and the shoulder turned in is to be of the exact size, leaving it with a bevel for the convex of the jewel to rest on. It will be obvious that, if the jewel is not true on the convex, the plane of the face will not come true when rubbed in; if it does run out the burnisher is liable to slip off and break the stone. The shoulder having been cut, the jewel is now introduced, and, in order to make it stay, is slightly wetted. The setting is turned off at a slight bevel with the true face, and by means of the burnisher the edge of this bevel is rubbed down on the slight chamfer and face of the stone; the burnished edge is polished by means of a piece of cork, dipped in rouge, and applied during a few revolutions of the lathe.

In this operation nothing but a hand tool has been supposed to have been used. If, however, a large number of jewels have to be set, it would become tedious as well as unprofitable to set them by hand. This was more especially the case in the inception of the watch manufacture of the United States. A large number to be set and but few to do the work, it became a very perplexing problem to do the required quantity in the old style. Mr. E. Howard, one of the proprietors of the Boston Watch Company, comprehended the difficulty, and set his active mechanical brain at work to devise some way by which the jewel might be set true without skilled labor. And here it will not be out of place to pay a tribute to Mr. Howard for the services he has rendered to Horological pursuits in the United States. We will not point to the Howard & Davis clock—is it not seen wherever time is of any importance?—but the firmness, sagacity, and almost intuitive knowledge of mechanics that he possesses will not be fully understood for years; and yet to no one man are the United States so much indebted in so far as the manufacture of watches is concerned. We remember the dark days of its history, when the infant was unable to walk—when everything was to be almost, as it were, created; even those who were to do the work had to be educated. Perhaps as good a pun, or play on words, was never made than by Mr. H., when in explaining before a committee

the hard lines the Company had passed through, one of the gentlemen remarked: "Why, Mr. Howard, you ought to be knighted!" "Why," said Howard, "I have been 'be-knighted' for the last three years." But it was not so easy a task to navigate the watch factory through the stormy financial seas. In the mechanical parts, however, Mr. Howard was triumphant; not that he invented even a tithe of the processes and tools, but he had the sagacity to appreciate the value of any plan which might be submitted, and he had the firmness to carry out the idea, in the face of all the opposition of those who should have aided—indeed of the absolute treachery of those in his employ. We do not assert that he was the entirety of the watch-making, but we will assert that he has done more than any other one man to bring the watch manufacture to its present high standing in this country. With this passing tribute we will rest at present, but shall, in a future article, give the reasons, *in extenso*, for our assertion.

We take the more pleasure in thus recognizing the worth of one of the earliest pioneers in watch work in the United States, from the fact of having been in his employ for sometime, and having had the opportunity to notice, not only his general kindness and true-heartedness but that strong mechanical will that, while it criticised unmercifully any plan offered, was always open to conviction on a reasonable demonstration.

Mr. Howard *did* invent the SWING REST, and as the principle is founded on true geometrical premises we will try to give an outline of its general construction—premising that the point of departure is in every case the absolute geometrical centre of revolution of the mandril of the lathe, and also that in this case the spring-chuck is used in connection. As handy as the shellac may be, it is expensive, when the operations are repeated an infinite number of times. The setting is a piece of punched brass, a little larger than the size required when finished, and is held in the jaws of the spring-chuck as any other piece of work, by the external circumference. A hole is drilled in the blank first, and then a cutter represented at F and G, in Fig. 3, is used for getting the true size of the jewel. Let C represent the centre of the lathe-mandrel, and the circle a hole we wish cut in the metal held in the chuck. Now, if we make a rest to carry the cutter, hanging on a centre at a point below C, say B, with the cutter at E, it is evident that the point or cutting edge of the cutter will preserve its relation to the circle, however

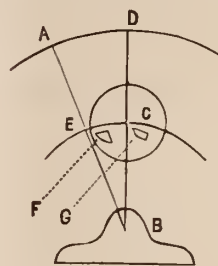

far we may swing it from the centre, C; but in all cases C and E are equally distant from the point B; if, now, we continue the lines B C to D, and B E to A, the arc between the points A and D is twice the arc E and C; but when one side of the circle, of which C is the centre, is cut away, the diameter of the hole will be increased by twice the amount of the cut; therefore, if B A should be moved towards D, until it coincides with B D, and the edge of the cutter point F coincides with C, the whole axis of rotation would be in the same straight line with the cutter. Now, D being stationary, and A movable, if an object, say a jewel, is laid on the arc A D, it will measure its own diameter in the cut at the arc E C. As a matter of course, it will strike the reader that the distance B C, or B E, must be exactly equal to C D, or E A. The line D B represents a solid part of the rest, while A B is a frame pivoted to the rest at B, and is movable forward, that is, toward the workman; the tool is held by means of a spindle moving through the frame at E. This rest is not confined alone to jeweling, for it can be adapted to every variety of watch repairing, pivoting, polishing, or facing, and might be applied to any existing lathe with the most gratifying results.

It must be remembered that the jewel thus set is in the piece of brass wire that forms the chuck; it will therefore be necessary to cut the wire off, in order to obtain the required depth of setting for the thickness of the plate. This is accordingly done, and the jewel with its setting, is reversed on another chuck, whose face is smaller

than the face of the stone; therefore, when the stone is trued up by its own centre, the outside of the setting may be turned off to the size of the largest diameter of the hole in the plate, and the face of the setting may be made parallel to the face of the jewel. The jewel and setting, thus far finished, are now ready to be put in the plate. The lower holes have already been set in the bar and pillar plate, so we must sink the upper hole in just far enough to allow the pinion a sensible motion endwise, which motion is called the end-shake. To get the proper end-shake, the jeweler now reverses the setting and jewel on a chuck face, a trifle larger than the setting; thus he has the jewel with the face out, as when he set it. He now turns a shoulder on the setting that just fits the smallest diameter of the hole in the plate, and tries the setting in. If he has set the lower holes with reference to the level of the face of the upper holes to the lower side of the potance plate, he may leave the face of the jewel just level, take it from the chuck by a sudden jerk of the plate while the setting is in its place, and try his pinion in by putting it in its place and placing the two plates in their true positions. If, now, he has in his judgment too much shake, he chucks up the jewel again and takes a slight chip off the shoulder, and continues this tedious operation until he has succeeded. But, suppose he gets, by accident, no shake at all, he will burnish the edge or corner of the shoulder down, and thus raise the face of the jewel in the plate. This pernicious and very unworkmanlike way is not to be commended; the setting should be made anew, for the hole requires a good square face to rest on—not the sharp edge of a burnished rim of brass. The getting of the proper degree of end-shake is a very delicate matter. When we add to the difficulties already described the fact that the plates hardly ever go together alike in the separate trials, for it would be too much to screw together the plates every time he tries the shake, therefore he will judge by the pressure of his finger and thumb, and still find himself mistaken when the watch is finally put together. In nine cases out of ten in such a condition of affairs, the workman will “bump” the plate, in order to remedy the defect. Even in some high grades of English levers, the watch maker may detect that the finisher has “bumped” the plate to get the proper degree of end-shake, rather than take a small amount off the pinion shoulder in case the shake was too large, or reset the jewel were the shake too close. While this style of jeweling may not affect the owner of a watch, it is perplexing to the repairer, who, on taking down and putting up the movement, finds that he has again to adjust, by *bumping*, the mistakes of the watchmaker.

The ordinary course of jeweling in England renders it almost impossible to make correct shakes without subsequent adjustments, for the watches are jeweled in the grey, or before gilding, and in the process of gilding the plates are annealed, thus warping them out of the truth, or position in reference to which the jewels were set. Now, the only true plan on which any screwed jeweling should be done is, to jewel after gilding. The watch may be all set up and put in running order before a jewel (except the cock and foot holes) is put in; then it may be taken down and gilded; then the jeweling may be done with a certainty of the parts coming together with the same regularity as a well made steam-engine. Again, in brushing the plates for gilding, the sides, or at least one edge of the hole in the plate, will necessarily become burred up, and the jewel when replaced, will be found not to go to its place truly, in consequence. True, it is much more trouble to jewel after gilding, as the plates are liable to be scratched or even tarnished by frequent handling; but it should be understood that watchwork in all cases requires care, and no excuse can be had for any scratching by any one who professes to jewel a watch.

In the English mode of watch finishing and jeweling, the end-shakes are invariably attempted to be made in relation to the level of the plates. The whole process, as there carried on, is one of unmixed stupidity; not in so much as to the quality of the work when done as in the mode of doing. The general operation is for the frame maker to send the frame to the finisher in the following

described condition: The plates are put together and pinned or screwed; the train, with barrel and fuzee and motion work, together with the potance and cock, are in readiness for the finisher. The pinions and arbors are left long, and, in order to put the frame together, holes are drilled in the plates for them to pass through. These holes are not planted with any reference to accuracy in the matter of depth, and are as large as the largest parts of the respective pinion staffs and arbors. The first thing for the finishers consideration is to get the lengths between shoulders in relation to position. These having been marked, his next step is to bush up all the holes, stone off the plate, and then proceed to lay off his depths. After having turned up and finished all the shoulders and pivots, according to the marks made on the train, the new holes having been drilled in the bushings and the escapement put in, the watch is inspected; and if the depths are correct, the plates and train to be jeweled are sent to the jeweler. He turns out *the plugs* that had been put in by the finisher and replaces them by jewels; but it sometimes happens that the frame maker has made the hole so far off from depth that the true hole for the pivot will fall outside the bushing; in this case the jeweler has no other choice than to cut out the plate to the full diameter of this eccentric bushing. It will be seen at once that all this work on the bushing is not only utterly lost, but a positive injury.

The jeweler having set the faces of his jewels level with the surface of the plate, the end-shakes are supposed to come right; the frame is now sent to be gilded, and, as said before, this process is almost fatal to the preservation of the correct shake.

In the American companies the shoulders are all finished to gauge, and at one time the jewels were set in the pillar plate in the Swiss style, with their faces level, the shake being got by the greater or less sinking of the potance plate jewels in the plate. As the distance between shoulders was intended and supposed to be equal, there would have been but little difficulty, provided the conditions were fulfilled; such, however, was not the case. The height of the pillars, the warping of the plates in gilding, and the difference that is inseparable in the dimensions of a number of pinions, conspired to prevent, by the accumulation of the errors, the result that otherwise might reasonably have been anticipated.

Where so many watches were to be jeweled per day, it became a very important matter to diminish the repetitions of manipulations that so seriously retarded the work. The only method that could be devised was, to make the work self-measuring; that is cut the shoulders on the jewel settings by the lengths of the pinions, when they absolutely gauge the depth of the shoulder. The principle of self-measurement in work was never better shown than in the end-shake tool now in use in all the factories. A brief description, in words alone, will answer to enable the reader to comprehend the tool, and the principle on which it is founded.

If a cutter were made to cut the shoulder, and at the same time a stop that rested on the face of the jewel, it is certain that the shoulder would always be of the same depth. Now, if the stop were made variable in relation to the cutter, it is equally evident that the shoulders could be varied at will. The next step in the process of reasoning was, to devise some means by which that stop was varied in exact proportion to the length of the pinions. But here was another difficulty—the pillars cannot be exactly equal in gauge, and the shoulders cut in the plates were widely astray from equality. Whatever care might be exercised in the use, even of the best appliances, an error will always creep in. Here, then, were four measurements to be effected by one tool, which, at the same time was intended to cut the work exactly to those measurements. The difficulties will be the more readily understood when the fact is considered, that the measurement is so small—being in most of the train not over one and a half degree, where the degree is only the one-twenty-five-hundredth of an inch; and that the mere fact of a few degrees of difference in temperature applied to the instrument would invariably either take up the allowed amount or double the shake.



## Repairing Swiss Watches.

*Continued from page 127, Vol. X.*

I have said nothing of the ferrule to be used in working in this pinion. The ordinary screw ferrule is not at all adapted for this purpose, being too heavy and thick. A small brass or bone pivoting ferrule about five or six millimetres diameter, and dished in form, is the most convenient; first, broached to fit on the arbors of pinion and after it is shortened, a similar one, with a hole sufficiently large to fit on the leaves. There will be no necessity to remove it until the piece is completed. The groove in these ferrules should be deep, to avoid the hair slipping off, and square to prevent the hair jamming. I use a moderately weak bow and horse-hair to turn the leaves down, and afterwards complete the turning, with a very weak bow and human hair; horse-hair is altogether too coarse and clumsy.

### MAKING A NEW SCAPE COCK.

Those readers of the JOURNAL who took the trouble to read the article from the correspondent at the Paris Exhibition on the prices paid for manufacture, must have been struck by the amount mentioned for gilding, less being paid for a dozen blanks or movements than here is paid for one. The brass of which these blanks are made is in the first instance not very hard, and after it has been gilt the thin pieces have become very soft, in fact, in some cases rotten. In no case is this more apparent than in the case of the scape cock; if thin, and the passage at all deep, it is impossible even to brush it without altering the form of the piece, and consequently the scape wheel end shake. Frequently, I have seen them broken at the passage and put together with soft solder, making a very sound and workmanlike job, of course. Now there is nothing very difficult about the making of a new cock (the jewel I have supposed sound, and if so it can be reset without much trouble). A piece of good brass, known in the trade as "best hard sheet watch brass," a special quality to be procured of only one firm at present, is the proper material for this, and indeed for any purpose in connection with watch repairs. It works well under the file, and is tougher in rubbing down than the common sort; it also takes a good color when polished, is filed up nearly to the width of the old bar, and draw-filed until it just enters the recess (if there is one) for it; next it should be filed flat, and left slightly thicker than it will ultimately be required. Having placed the piece in its position, mark the spot for the screw-hole through the frame, and drill it to fit the screw with only just freedom. Screw the cock down firmly, and drill the steady pin holes through the holes in frame, afterwards broaching them true and upright, from the cock side, of course. Next the pins must be fitted; these should be made of hard wire, filed with a very smooth old pin file, and burnished; the ends also rounded off and burnished; their size should be such that they will not go quite through the cock, when twisting them in fixed in the pin-vice. The under side of holes in cock should be slightly chamfered; then having put in the pins and cut them off, file the tops flat, and placing the the lower side of cock on a pinion riveting stake, drive the pins through until they project about one and a half times their diameter; if they are longer they will be liable to get bent in taking on and off. Some workmen use a little oilstone dust to make the pins hold, but if properly fitted it is unnecessary. Now open the pin holes in the frame a little, and if the work has been done carefully the cock will come on and off smoothly and without sticking, the pins will each fit independently, and not depend on one another as is often the case. You will now put in the balance, and note if the cock is too high, and if so, how much? the best and quickest way to reduce it is to put the frame in the mandrel, centreing it by the lower scape hole, and turn down the bar, previously placing a small piece of peg cut taper under the nose of cock to prevent it from springing from the cutter. Having turned it down sufficiently, allowing a little for stoning up, you will test the correctness of the centering of the lower cylinder hole by pegging it true. Now, I have seen this ex-

pression used several times in the JOURNAL, and I have a strong suspicion that many workmen have not the remotest idea what it means. I have asked several, and have found some who knew nothing at all about it. The object of pegging is to test the accuracy of a hole already centred by the pump centre, and if, as is often the case, it is not perfectly true, to correct it. Cut a good sound peg to a long and taper point, that will enter freely the hole to be tested. Having brought up the hand rest to within say half an inch from the hole, a flat is cut on one side of the peg to prevent its turning round, it is then put into the hole, the flat resting on the tee, which should be adjusted at such a height that the peg is supported horizontally, or if anything the unsupported end highest; now on the mandrel being revolved, if the hole is not correctly centred the end of peg will exhibit this error in a magnified degree; if the distance from the end of peg to the rest is six times greater than the distance from the hole to the rest, the error will of course be magnified six times. Having slightly slacked the dog screws of the mandrel, the work can be minutely shifted either with the fingers or by tapping it with a tool handle or some similar object to prevent bruising the frame. Having corrected the centring and tightened the dog-screws, the cock can be screwed on and centred with a graver similar to the one for cutting a hollow. The cock is now ready to receive the jewel hole; if it is to be sent to the jeweler you will of course send the frame and cock together with the pinion, and he will give you the correct end-shake. Having the hole set, you proceed to round off the end of cock, striking a circle ro file to, with the dividers set to mark a circle whose diameter is that of the bar or rather more. Having stoned down the top of cock, and seen that it is free of balance, take off the edges square with a very smooth file; you will now cut the wheel passage. Shellac the cock by its top to a flat piece of brass, about one and a half inches diameter, having a hole in the centre so that you can feel the jewel hole with the pump-centre (the pieces of stamped brass known as brass-edge blanks are convenient for this purpose, they should be turned true and flat on each side); having coated a tooth of the scape wheel with rouge, place the pivot in its hole, and mark on the cock the position the passage must occupy, select a cutter about as broad as the wheel tooth and polished on its faces, and place it in the slide-rest, proceeding to cut the passage in the following manner: The palm of the left hand being applied to the platform of mandrel, it can be rocked to and fro about a quarter of a turn, the right hand meanwhile advancing the cutter by means of the slide screws. The passage should be well free of the wheel teeth, both sides and top, to avoid the oil being drawn from the teeth; you can test this, as I have already stated, by putting a thick layer of rouge on the teeth, and turning the wheel.

### RESETTING A JEWEL HOLE.

To a workman accustomed to cutting hollows, &c., in wheels and pinions, the trouble of setting or resetting a jewel hole will not be very great; and to those, more especially, who living at a distance from the jeweler renders the sending work to and fro by post a matter of some delay and risk, it should be a great convenience. In such a case as I have just supposed, viz., a new scape cock, and where the old stone is uninjured and of the correct size, very little difficulty, will I think, be experienced in making a satisfactory job of it. The tools required are few and simple; and when their use and form are known, can be easily made by the workman himself. For the purpose in hand you will require a narrow cutter or drill, similar to No. 1; this can be made from a piece of "hooking in" steel, hardened and tempered to a straw color. Another somewhat similar cutter, but broader in the mouth for turning the recess for the stone, Nos. 2 and 3 (the shape of the mouth of this cutter will depend on the shape of stone to be set; if, as is usually the case with escape holes, the top of stone is quite flat, the cutter will have a square mouth; on the other hand, where the top of stone is round, the cutter will be rounded to a similar curve, so that the stone

touches its seat all over). A thin lozenge graver, similar to that described for cutting hollows, will also be required; and finally, a burnisher, to rub down the setting, its shape being that which the workman finds most convenient. The form I prefer is that of No. 4; there are no edges to it; it is rounded everywhere, and polished with red stuff on a leather buff. This latter tool, when in use, should be frequently cleaned on a leather buff, and afterwards passed over the moist palm of the hands; if this were not frequently seen to, the small particles of brass, which continually adhere to the burnisher, would tear up the setting instead of burnishing it; the natural moisture of the hand acts as an efficient lubricator, and for a time prevents this adhesion taking place.

I have supposed the cock to be already centered, and drilled through with a small hole perfectly true; this latter condition is most essential, as if it is not true the whole would be out of upright.

The next thing will be to fix the cock by its upper side to a chuck, similar to that marked *c* in the drawing. The tool which is shown in the drawing, although not the one used by professional watch jewelers, is a very good substitute in a case like this. The regular watch-jeweler's lathe is so seldom to be found in the workshop of the country watchmaker, that I have not thought it worth while to describe it. The tool of which I give a drawing is so universal in its uses, that it or some similar tool should be in the hands of every workman. The tool in question is called a balance tube, costing, according to its size, from fifteen to thirty shillings; a small size is preferable for this purpose, as it runs lighter, requiring less power to drive it. Although this tool is usually worked by means of a bow, it can be used with far greater ease and comfort if worked by means of either a hand or foot wheel. I have for some time past used one of the German hand wheels, sold now at most tool shops, and made

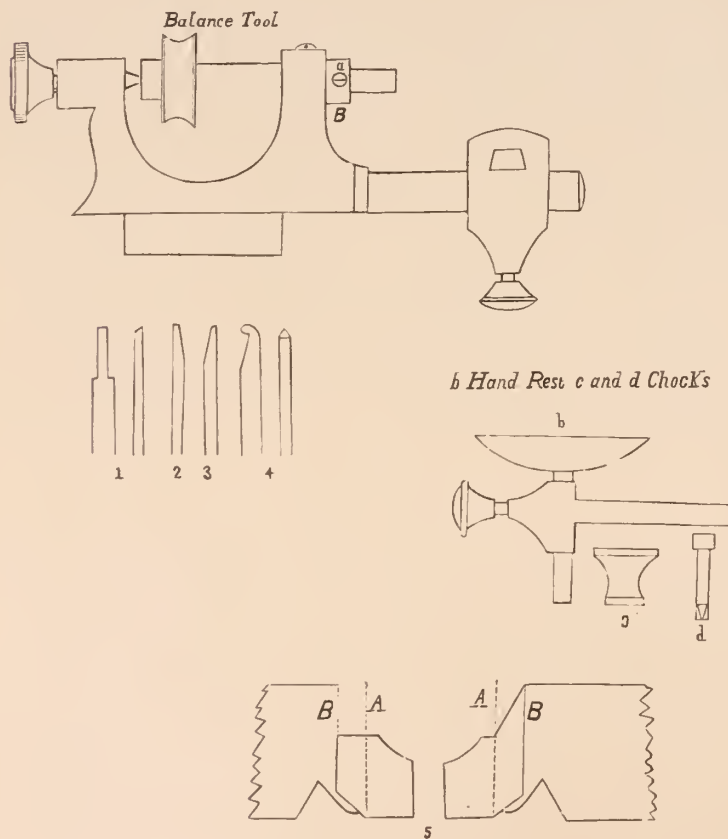

to screw under the workboard. The casting, carrying the wheel has two slots in it at right angles to one another; one at right angles to the work-board, enabling you to push it completely under, out of the way; and the other vertical, for the purpose of raising or lowering wheel to tighten the band; it can thus be used to work either the mandrel, screw-head tool or turns. It is far pleasanter to use than the bow, and quicker, the tools in either case being fixed in the vice

as usual. In the tool drawn, the mandrel is hollow, the smaller chucks being fitted inside, and fixed by the screw *a*. The larger chucks, such as would be used in jewelers a chariot, or balance cock, are fitted outside the mandrel, going right up to the collar at *b*; a pin in that collar goes into a corresponding hole in the boss of chucks, rendering them secure from turning. Having, then, the cock fixed by cement to a chuck, similar to *c* in sketch, apply the flame of a spirit-lamp under the chuck, at some distance from the end, until the wax is thoroughly soft, and with a peg cut to the shape of a screw-driver at the end, except that the end should be cut off in a slanting direction; apply the corner of this peg to the center hole in the cock, at the same time revolving the mandrel by means of the wheel or bow. As soon as the piece is centred truly, gradually bring the flat of peg in contact with the face of cock, thus bringing it true in flat; remove the lamp, keeping the peg in contact with the cock until the wax is set. The spirit lamp for this purpose should be a metal one, having a spout of such a length, that, standing on the board, the flame comes at the right height under the chuck. If any doubt exists as to the piece being correctly centred, it can be tested by means of a peg, as already described. The next thing will be to open the hole to *A A*, see sketch No. 5. The diameter of this hole will be regulated by the size of the stone to be set; it need only be sufficiently smaller than the stone to insure a sound seat for it. It must be opened to its full size at this stage; any attempt to enlarge it after setting the stone would endanger its soundness. You will, therefore, with the cutter No. 1, turn through the cock until you come to the cement, taking care not to cut into the chuck. You will now turn out the recess *B B* for the stone to its proper size and depth; the depth of this sink will, of course, determine the end shake. Usually these scape holes are set, with the face of stone just beneath the level of the cock; if it is set much lower a sink of the necessary depth must be turned in the cock first, to the depth you require the surface of stone sunk. Having opened the recess top, fit the stone just firmly, but with no shake; see that it goes to the bottom of the sink (the stone is held while fitting it on the end of a piece of pin-wire, slightly smaller than the stone in diameter, and fixed by sealing-wax or shellac); the opening for the stone should be made, if possible, at one cut; if you have to retouch it frequently the fitting will most probably be lost. The stone being fitted, the hollow as its back should be cut; this hollow should be of such a shape, that, while it removes sufficient metal to enable you to rub down the setting, it by no means weakens the cock. The stone being removed from the pin, and the wax dissolved by boiling it in spirits of wine, pick it up on the point of a finely cut peg, and press it into its seat firmly with the flat end. It only remains to turn down the thin edge of setting in this matter, viz.: beginning at the bottom of the hollow, and sweeping the burnisher over towards the center of stone, being careful not to press too hard on it. The brass can be made to flow nearly over the stone: all that is necessary in this case is to turn the edge down *soundly*. The thickness of the piece to be rubbed down will be best found by experiment; it can hardly be too thin *if sound*—on the other hand, if left too thick, it is possible to break the stone in the attempt to set it. If the hollow has been cut with a polished graver, the application of a peg and a little fine red stuff nearly dry will produce a good appearance on it. Finally, reverse the cock on the chuck, fixing and centering it by its under side, and strip the hole, *i. e.*, turn with a polished cutter from the bottom of the sink a straight chamfer, being particularly careful not to remove any of the metal that the stone rests on; the application of the peg and red stuff will finish it. The only object of this chamfer is to improve the appearance of the top of cock.

Pieces larger than can be swung in this tool can be done in the mandrel, the English mandrel being preferable for this purpose, as it can be driven at a higher speed being worked by a band and wheel the multiplying power of the Swiss gearing not being so great.

(To be continued.)

Knowing our watch to be a 4th wheel seconds, by its giving the above ratio, or by any other means, we have the following *Rule*: *Divide the teeth in the 4th wheel by the leaves in the escape pinion, and multiply by double the number of teeth in the escape wheel.* The quotient will be the beats per minute. Example: 4th wheel 70, escape wheel 15, escape pinion 7. As 7, the number of escape pinion leaves, is contained 10 times in 70, the number of 4th wheel teeth, the escape wheel revolves 10 times as often as the 4th wheel. And there being 2 beats to each tooth, there are 30 beats for each revolution of the escape wheel, or 10 times  $30 = 300$  beats per minute.

$$70 \div 7 = 10 \times 30 = 300.$$

Multiplying this by 60, of course gives the beats per hour. Example: 4th wheel 80, escape wheel 15, escape pinion 8.

$$80 \div 8 = 10 \times 30 \times 60 = 18,000 \text{ beats per hour.}$$

(847) *To find the number of Seconds the 4th Wheel or Pinion takes to make a revolution.* This rule is applicable to all watches, but is specially useful with non-seconds watches. *Rule*—*Multiply the numbers of the center and 3d wheels; divide this by the product of the 3d and 4th pinions, and divide 3,600 by the quotient.* Example: Center wheel 72, 3d wheel 64, 3d and 4th pinions 8 leaves each. As the 3d pinion makes 9 turns to the center wheel 1, and the 4th pinion 8 turns to 3d wheel 1, the 4th pinion must make  $8 \times 9 = 72$  turns to the center wheel 1, i. e., in one hour or 3,600 seconds, which is 1 turn in 50 seconds.

$$72 \times 64 = 4,608 \div 8 \times 8 = 72, \text{ and } 3,600 \div 72 = 50.$$

If the watch has a seconds hand, and is together, and running, the same can be ascertained very closely by comparison with the seconds-hand of a good regulator, by proper quickness and skill.

(848) It is sometimes the case that the workman, in fitting a new hair-spring, will cut it off to length and try to time it by the seconds-hand, supposing, of course, that it makes one turn in a minute,—only to find, on completing the regulation by the minute hand, that the spring is too short and must be thrown away. Trains are made in which the 4th pinion revolves in all the way from 27 to 62 seconds. The worst of these have no seconds-hands, but it is not very rare to find seconds-hands which revolve as far out as 46 or 43 seconds. Seconds-hands revolving in the fifties are common, not only in watches, but even in so-called watchmaker's regulators.

The same rule will, of course, apply to clocks, and the watchmaker can test his regulator, if he has any doubt of the correctness of its seconds-hand. Multiply the wheels together, from the center wheel to the one revolving with the seconds-hand; divide this by the product of the pinions into each other, from the one gearing into the center wheel to the one carrying the seconds-hand; and with this quotient divide 3,600, the number of seconds in which the center wheel and minute hand make one revolution.

(849) *To find the number of Revolutions of the Escape Wheel or Pinion per Minute or Hour.* This can be done in three ways: 1st. *Rule*—*Multiply the center, 3d and 4th wheels together; divide this by the product of the 3d, 4th and escape pinions.* Example: The wheels 80, 75, 80; the pinions, 10, 10, and 8.

$$80 \times 75 \times 80 = 480,000 \div 10 \times 10 \times 8 = 800, \text{ gives } 600 \text{ turns per hour.}$$

2d *Rule*—*Find the number of times each pinion turns to one revolution of the wheel it gears into, and multiply the three numbers together.* Taking the above example, the 3d pinion turns eight times as often as the center wheel; 4th pinion,  $7\frac{1}{2}$  times as often as the 3d wheel; and the escape pinion, 10 times as often as the 4th wheel. As each pinion carries forward its gain, and multiplies it by the gain of its own wheel into the next pinion, and that by the next, the number of revolutions of the last pinion or wheel in any train, for one of the first wheel, can be found by multiplying together the successive gains made by each intersecting wheel and pinion, as

$$8 \times 7\frac{1}{2} \times 10 = 600 \text{ turns per hour as before.}$$

Lastly, if we know the number of beats per minute, or hour, we can work from the other end of the train, by the 3d *Rule*—*Divide the number of beats per minute or hour by double the number of escape*

*wheel teeth.* Take the same example, the beats being 300 per minute or 18,000 per hour:

$$300 \div 30 = 10 \text{ per minute, } 18,000 \div 30 = 600 \text{ per hour.}$$

(850) *To find the Numbers for the Pinions, in a 4th wheel seconds train, the numbers of the wheels and the beats per hour being known.* Suppose we have a watch whose 3d, 4th and escape wheel pinions are entirely rusted out or gone, the wheels being 80, 75, 80, 15, and the number of beats per hour should be 18,000—what must be the numbers for the missing pinions in a 4th wheel seconds watch? In this case, the 4th pinion must turn 60 times to the center wheel once. Consequently we look for pinion numbers which will give the ratios 8 and  $7\frac{1}{2}$ , with their wheels, (846), which are a 3d pinion of 10 for the center wheel of 80, and a 4th pinion of 10 for the 3d wheel of 75. To find the escape wheel pinion, we follow Rule 3d in section (849), and get the number of times the escape wheel turns in one minute, or one revolution of the 4th wheel. Dividing 300, the beats per minute, by 30, double the escape wheel teeth, gives 10 turns of the escape wheel pinion to one of the 4th wheel. Consequently, the escape pinion has one-tenth as many leaves as the 4th wheel has teeth:  $80 \div 10 = 8$  leaves. In non-seconds watches this method cannot be followed, and we have the following rule:

(851) *To find the Numbers for the Pinions in any Train, whether 4th wheel seconds or non-seconds, we have this Rule*—*Multiply the wheels together, double the product, and divide this by the number of beats per hour.* The quotient is that number which is produced by multiplying together the required numbers for the missing pinions; and the number for each pinion is obtained by resolving this composite number, or product obtained by the rule, into its component parts. Example: The wheels are 80, 75, 80, and 16, with 18,000 beats per hour. According to the rule in section (845), the number of beats per hour is the quotient obtained by doubling the product of the wheels, and dividing this by the product of the pinions. It follows, therefore, that if we double the product of the wheels, and divide this by the beats per hour, we shall have the product of the pinions. Doing so, we have

$$80 \times 75 \times 80 \times 15 \times 2 = 14,400,000 \div 18,000 = 800.$$

We can, in many cases, tell by inspection and slight mental calculation, what the numbers of the pinions should be. In the above example, we evidently have a 4th wheel seconds train, and easily fix the 3d and 4th pinions as 10 and 10, which leaves 8 for the escape pinion, as  $10 \times 10 \times 8 = 800$ . But in other cases we might waste considerable time in guessing numbers and multiplying them together, to see if the final product was correct. We must therefore have some rule applicable in every case.

(852) *To "Break Down" a Composite Number, and Resolve it into the Correct Numbers for the Different Pinions, the product of which will of course be the same as the composite number we started with.* *Rule*—*Divide the given composite number by prime numbers, commencing with the smallest, until no remainder is left, and the last quotient is 1. Then arrange the different divisors into as many sets as there are pinions, in such a manner that the divisors of each set, multiplied together will produce a suitable number for the pinion.* Premising that prime numbers are those which cannot be divided by other numbers without leaving a remainder, (as distinguished from composite numbers which are the product of two or more numbers,) let us break down the number 800, instead of guessing its component parts. According to the rule, we divide it by 2, as often as it will, then by 3 as often as that will, then by 5, 7, 11, 13, and so on, until the quotient is 1, putting each successive quotient under the original numbers, and the divisors in a vertical line by themselves. The following exhibits the process. We will also break down the numbers 1,440, 480, and 504, in order to have examples enough to make the matter perfectly clear.

2	800	2	1440	2	480	2	504
2	400	2	720	2	240	2	252
2	200	2	360	2	120	2	126
2	100	2	180	2	60	3	63
2	50	2	90	2	30	3	21
5	25	3	45	3	15	7	7
5	5	3	15	5	5		1
		5	5		1		
			1				

## Practical Hints on Watch Repairing,

BY EXCELSIOR. No. 54.

WHEELS AND PINIONS, PITCHING, DEPTHING, PROPER CURVES, &amp;C.

(841) We now come to a subject of prime importance: the gearing of wheels and pinions, their proportionate sizes, their depthing or intersection, and the shapes of the teeth and the pinion leaves, in order to secure a smooth and easy action, uniform transmission of the motive power through the train, and the reduction of friction, wear and loss of force to the least possible amount.

Strange to say, notwithstanding its importance, writers have generally contented themselves with merely touching upon the subject here and there, or uttering a few vague generalities and stock phrases, which sound very nicely, but convey no real practical information to the workman. For example, everybody has read that the teeth should have the epicycloid curve, and that an epicycloid is the curve described by a point in a circle which is rolled around the periphery of another circle. That seems to tell the whole story, and sounds very satisfactory,—or, as Mr. Weller would say, it is “werry filling.” But, after all, what does it teach? How much wiser is the workman? What has he learned about the matter? Let us draw a circle and an epicycloid curve, and see.

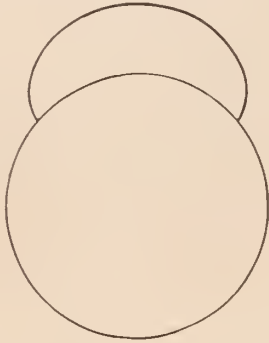

(842) Fig. 42 shows our curve, on the circle. Now, what will he do with it? Most assuredly, the end of the tooth should not be made of that shape, even if it was proportionately shortened up small enough to apply to one tooth. What part or parts of the curve will he use? How much of it will he use? Why those parts and not others? Will the whole length of the tooth be made of that shape, or only a part, and how much? All this may be very plain to experienced watchmakers, but, for their consideration before we come to treat of these curves, I will give question or two which they may ask themselves, to test the thoroughness of their knowledge of the subject, viz:—Suppose a wheel and pinion are correctly proportioned for each other, with the depthing correct, and the teeth of the wheel and leaves of the pinion perfectly formed, with theoretically correct epicycloid curves on each, will or will not the sliding of the teeth on the leaves be prevented, and the teeth simply roll upon the leaves without rubbing or friction? Can the effect of an incorrect proportion between the sizes of the wheel and the pinion be neutralized by changing their depthing?

Without going specially into the theory of these topics, but looking at them as one practical workman writing for others, I shall treat them with considerable fullness, as becomes their importance; following the rules and conclusions of Camus, Berthoud, Reid, Saunier, Willis, and others acknowledged as the best authorities on these subjects,—modifying them to accord with the results of the most recent and trustworthy researches and experiments.

(843) *The Train.* First in order is the consideration of the proper number of teeth in the wheels, and leaves in the pinions, for a well proportioned train which, on the one hand, shall enable the motive power to keep the mechanism in motion for say 30 hours,—the motion of the train being moderated and made uniform by the balance and its spring; and, on the other hand, is so arranged that the center pinion, carrying the minute hand, shall revolve once in 60 minutes, and the fourth pinion, carrying the seconds-hand, once in

60 seconds. In some movements the fourth pinion does not revolve in 60 seconds. Such are called *non-seconds* movements, and generally carry no seconds-hand. But nearly all modern watches above the lowest grades have the fourth pinion revolving once a minute, whether with or without seconds-hands, and are termed *fourth wheel seconds* watches. To bring about the movement of these parts in the stated periods, no special arrangement is obligatory, as many different series of numbers may be used for the wheels and pinions, only observing that their diameters should diminish gradually, from the main to the escape wheel, and of course the numbers of the teeth and leaves should become smaller in the same proportion.

(844) As these articles are not for watchmakers, but for watch repairers, it will not be necessary to study the different numbers and proportions, and plan out the train. The repairer has nothing to do with them, as they are already fixed upon and carried into execution before the watch reaches him. We will therefore confine ourselves to cases where wheels or pinions are lost, and to ascertaining the numbers of the teeth of the wheels or pinions which must be selected to supply the places of the missing ones,—which is often a puzzling task, even to the experienced workman, especially when dealing with unusual arrangements of train, as there are no tables having all the possible combinations, which he can consult. But, by knowing the rules, he can easily calculate for any train, even if new and different from anything before made. To make the statements complete, it will sometimes be necessary to bring in facts which are rather elementary and well known, from which to deduce our rules and explanations.

(845) *To find the number of Beats per Hour.* This depends on the number of the wheels and of their teeth, and of the pinions and their leaves, in the train,—excluding the center pinion and the main wheel. There are two beats or vibrations of the balance for each tooth of the escape wheel. Therefore, if we know the number of teeth in the center, 3d, 4th, and escape wheels, and the 3d, 4th, and escape wheel pinions, we find the number of beats per hour by the following *Rule*: *Multiply the numbers of the teeth in the several wheels together, and double the product; also multiply the numbers of the leaves in the several pinions together; divide the former product by the latter.*

Example:—Center wheel has 80 teeth, 3d wheel 75, 4th wheel 80, escape wheel 15, 3d pinion has 10 leaves, 4th pinion 10, escape pinion 8. Multiplying the wheels together, we have 7,200,000; doubled, is 14,400,000. Multiplying the pinions together gives 800. Dividing the former product by the latter, the quotient is 18,000, as the number of beats per hour. The process is expressed more concisely as follows:

$$80 \times 75 \times 80 \times 15 \times 2 = 14,400,000 \div 10 \times 10 \times 8 = 800, \text{ gives } 18,000.$$

To save one multiplication, multiply by *double* the number of escape wheel teeth. Example:—The wheels are 72, 64, 64, and 16, pinions 8, 8 and 8.

$$72 \times 64 \times 64 \times 32 = 9,437,184 \div 8 \times 8 \times 8 = 512, \text{ gives } 18,432.$$

The number of beats per hour could also be ascertained by counting the vibrations during one minute, by a good regulator, and then multiplying by 60. But very few workmen can get the exact number in that way, or come nearer than from 2 to 5 beats per minute to the exact number. But by calculation we can ascertain even to a fraction of a beat in a minute, the number the watch makes when regulated.

(846) *To find the number of Beats per Minute,* in a 4th wheel seconds watch. As the 4th wheel, in this case, revolves 60 times to the center wheel once, the numbers of the center and 3d wheels and of the 3d and 4th pinions must be such as to give this ratio of 60 to 1. Whatever the numbers may be, the teeth of the center wheel should be 8 times as many as the leaves of the 3d pinion, and the 3d wheel should be  $7\frac{1}{2}$  times the 4th pinion. The proportion may be 80 to 10, and 60 to 8; or 64 to 8, and 60 to 8; or any other numbers which will secure this proportion. The order may be reversed, as, 75 to 10, and 64 to 8, which still gives the ratio of 60 to 1.

(853) Assorting these divisors into sets, so as to obtain numbers which may reasonably be supposed to be suitable for the pinions, in each case, and observing that the numbers should decrease from the 3d to the escape pinion,—or, at least, not increase, we separate the divisors of the number

800 into :	480 into :	504 into :
$2 \times 5 = 10$	$2 \times 5 = 10$	$3 \times 3 = 9$
$2 \times 5 = 10$	$2 \times 2 \times 2 = 8$	$2 \times 2 \times 2 = 8$
$2 \times 2 \times 2 = 8$	$2 \times 3 = 6$	$7 = 7$

The divisors of 1,440 can be divided into two different series of numbers, as

$2 \times 2 \times 3 = 12$	$3 \times 5 = 15$
$2 \times 2 \times 3 = 12$	$2 \times 2 \times 3 = 12$
$2 \times 5 = 10$	$2 \times 2 \times 2 = 8$

But the last series is evidently unsuitable for use. By a little judgment, in cases when two or more different series can be arranged, the workman will be able to select the one adapted to the movement.

(854) To find the Numbers for the Wheels, in any train, knowing the numbers of the pinions, of the escape wheel teeth, and of the beats per hour. This is the reverse of the process in section (851). Rule—Multiply the product of the pinions into each other, by the beats, per hour, and divide by double the number of escape wheel teeth. The quotient will be a composite number made up by multiplying together the required numbers for the wheels, which must be broken down by the same process as directed for pinions, (852,853). Example: Escape wheel has 15 teeth, the pinions are 10, 10 and 8 leaves, 18,000 beats per hour.

$$10 \times 10 \times 8 = 800 \times 18,000 = 14,400,000 \div 30 = 480,000.$$

In order to save room, the process of dividing is omitted here, as the workman can readily do that for himself. Suffice it to say, that the divisors are 8 twos, 1 three and 4 fives. Arranging them in sets, as already explained, we get

$$2 \times 2 = 4 \times 2 = 8 \times 2 = 16 \times 5 = 80 \text{ teeth for center wheel.}$$

$$2 \times 2 = 4 \times 2 = 8 \times 2 = 16 \times 5 = 80 \text{ teeth for 3d wheel.}$$

$$3 \times 5 = 15 \times 5 = 75 \text{ teeth for the 4th wheel.}$$

Or in a 4th wheel seconds watch, the sets may be arranged in the order to make the numbers 80, 75 and 80, in order to get the ratio of 60 to 1 between the 4th and center wheels. Another example: Escape wheel, 15 teeth, pinions 6, 6 and 6, 18,000 beats per hour.

$$6 \times 6 \times 6 = 216 \times 18,000 = 3,888,000 \div 30 = 129,600.$$

Breaking down this number, the divisors are 6 twos, 4 threes and 2 fives. These can be arranged in two ways, to give two sets of numbers for the teeth of the wheels, as

$$2 \times 3 = 6 \times 3 = 18 \times 3 = 54. \quad 2 \times 2 = 4 \times 3 = 12 \times 5 = 60.$$

$$2 \times 5 = 10 \times 5 = 50. \quad 2 \times 2 = 4 \times 2 = 8 \times 2 = 16 \times 3 = 48.$$

$$2 \times 2 = 4 \times 2 = 8 \times 2 = 16 \times 3 = 48. \quad 3 \times 3 = 9 \times 5 = 45.$$

Example: Escape wheel 16, pinions 12, 12 and 10 with 14,400 beats per hour.

$$12 \times 12 \times 10 \times 14,400 = 20,736,000 \div 32 = 648,000.$$

The divisors are 6 twos, 4 threes, and 3 fives, arranged as follows:

$$2 \times 2 = 4 \times 2 = 8 \times 2 = 16 \times 2 = 32 \times 3 = 96, \text{ center wheel.}$$

$$2 \times 3 = 6 \times 3 = 18 \times 5 = 90, \text{ 3d wheel.}$$

$$3 \times 5 = 15 \times 5 = 75, \text{ 4th wheel.}$$

(855) When the escape wheel, also, is gone, the task becomes more difficult. If there is no indication in the escapement by which we judge of the probable number of teeth the missing escape wheel had, we take the number we think most likely to be suitable, double it, and use this product to divide by, as in the foregoing examples, then resolve the quotient into sets, as already described, and see if the numbers thus found for the wheels would answer in the watch. If not, take another number for the escape wheel teeth, double it and use that as the trial number, doing this till a reasonable train is obtained. In a 4th wheel seconds watch, the numbers for the center and 3d wheels can be easily tested, by their giving the ratio of 60 to

1, between the 4th and center wheels, (846). The number allotted for the teeth of the 4th wheel can be tested, by being of proper size for the escape wheel pinion. For instance, if that pinion has six leaves, and the 4th wheel is allotted 48 teeth, then the wheel must be 8 times the diameter of the pinion, or it will not work; showing that the series of numbers is not the right one, and another must be arranged. If the wheel has 45 teeth, then it must be  $7\frac{1}{2}$  times as large as the pinion, and so on. These measurements refer to the primitive diameters of the parts, as will be explained hereafter. Of course, in the absence of any easier way, this method can be used for testing the correctness of the numbers allotted to the other wheels, also, or even for ascertaining the numbers. But the method by counting, etc., as before described, is easier, and does not require the elaborate means for accurate measurement which are indispensable in the method by measurement.

### Rowell's Improved Lens for Spectacles.

WE illustrate herewith an improvement in lenses for spectacles, recently perfected and patented by Mr. J. R. Rowal, of Hill N. H. Although the improvement is very simple in its character, it is said that it makes a wonderful difference in vision. The lens has two foci, and is therefore capable of forming two distinct images. This peculiar feature will be more readily understood by reference to the engraving, in which Fig. 1 shows the lenses complete, mounted in a spectacle frame in the usual way.

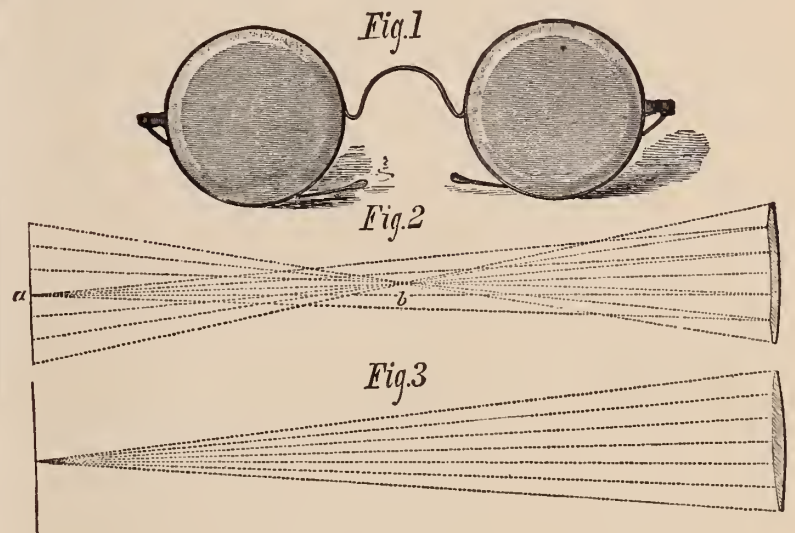

In Fig. 2 is shown a diametrical section of the lens, and the direction of the light rays is shown by dotted lines. Fig. 3 is a diametrical section of an ordinary lens.

It will be noticed that in the improved lens the central portion is the long focus, converging the rays at *a*, while the annular portion is of comparatively short focus, converging the rays at *b*.

Mr. Rowell tells us that this lens is adapted to any eye that would be suited by an ordinary lens focusing at any point between *a* and *b*, and that it requires only twelve sizes, or five different lenses, to fit all eyes met with in the ordinary practice of the optician.

Another feature claimed by the inventor as important is that the field of vision appears to be amply illuminated, and that vision is far more distinct than with ordinary lenses.

The Spencer Optical Manufacturing Company of this city, have secured the exclusive right to manufacture these goods under the above patent.

**EXPANSION OF WROUGHT IRON AND CAST STEEL.**—It is important in workshop manipulation to remember that if a piece of cast steel be made red hot and quenched in cold water it will become longer, but if the same operation be performed upon a piece of wrought iron it will become shorter.

## Proceedings of the Horological Club.

### A DISTINGUISHED BODY OF WATCH AND CLOCK MAKERS.

#### *Sixty-sixth Discussion.—Communicated by the Secretary.*

[NOTICE.—Correspondents should write all letters intended for the Club separate from any other business matters, and headed "Secretary of the Horological Club." Direct the envelope to D. H. Hopkinson, Esq. Write only on one side of the paper, state the points briefly, mail as early as possible, as it must be received here not later than two days before the end of the month in order to be discussed and reported in the CIRCULAR for the next month.]

#### HOW TO ALTER A MERCURIAL PENDULUM.

*Secretary of Horological Club:*

My regulator has a mercurial pendulum, and when regulated, and runs right in cold weather—it runs considerable fast in warm weather. Please inform me how to obviate the difficulty.

M. L. G.

Mr. Regulator replied that the clock should first be regulated to run correctly in a moderate or medium temperature. This being effected, if it gains in both heat and cold, the compensation is too strong, and the quantity of mercury should be diminished. But if it loses in extreme temperatures, add more mercury. If the trouble is in the amount of the mercury, the clock should gain in both heat and cold, if it gains in either one,—and lose in both, if it loses in either,—when regulated properly for medium temperature. If the action of the compensation is known to be correct, and the clock still gains in hot weather while running correctly in winter, and the mechanism is all in order and not gummed up with dirt or poor oil, perhaps the pendulum suspension spring is too stiff. But before altering that, be sure that the compensation, etc., are correct, and do not cause the trouble.

#### MAKING COUNTER-SINKS FOR SCREWS IN JEWEL SETTINGS.

*Secretary of Horological Club:*

Please explain a practical way of making the countersink for the head of the screws in American cap jewels, and oblige

#### OSCILLATION.

Mr. Uhrmacher said he took a flat brass plate, and turns out a cavity just large enough and deep enough to take in the jewel setting, (the jewel being in). In the center of the cavity, a smaller hole was drilled entirely through the plate. Put the setting in and cement it fast. This plate now represents the balance cock, before the counter sinks or screw holes are cut. Now make a dot or mark with a fine point of any kind, in the plate, on each side of the setting, just where the center of the screws will come, to correspond in position with the screw holes in the balance cock. Center the plate by one of these holes or marks, on a cement chuck of a live spindle lathe, and turn out a counter-sink in both the plate and setting, of the size and depth you want. Then center by the other dot, and cut that. Use a very sharp, square faced graver to finish the sides of the countersinks. The same plate and hole can of course be used for other settings, if of the right size.

#### INFORMATION WANTED ON CLOCK ESCAPEMENT.

*Secretary of Horological Club:*

Please explain what is called Fay's Patent Anti-Friction Noiseless Knee-Joint Clock Escapement. Patented May 11th, 1858.

L. X. F.

No one present knew anything of it. Perhaps some of our readers can explain it.

#### COMPARING WATCHES WITHIN HALF A SECOND.

*Secretary of Horological Club:*

Is it possible for a person to compare two American watches together, and tell within  $\frac{1}{2}$  second, how close they are together? I claim that you cannot get  $\frac{1}{2}$  seconds on an ordinary watch when the second hand does not stop even on the seconds. We have had an argument in the shop. Please inform me whether I am correct or not.

J. W. T.

Mr. McFuzee said that an American watch with a good seconds-dial could be compared by a good regulator within one-half or even one-fifth of a second, or a single beat, either by listening to the tick of the clock, or by the method described in the Appendix of Ex-celsior's book.

But as for comparing two watches together to within one-half second, he had his doubts. It was possible that it might be done, by a person of exceptionally quick motions and perceptions, but he thought that before he would quite believe it, he should want to see it done, and then test the correctness of the performance by comparing each watch, singly, with a regulator, which would show precisely how near they were together.

#### NICKEL PLATING WITHOUT A BATTERY.

*Secretary of Horological Club.*

Last July, Mr. Lone Star asked for a nickel plating solution to use without a battery. The following process is said to work well. To a dilute solution of chloride of zinc, 5 to 10 per cent of nickel sulphate is to be added, to impart a decidedly green color to it, and the solution is then heated to boiling in a porcelain vessel. The clouding of the liquid from the separation of the basic zinc salt need not be heeded, as it will not interfere with the effectiveness of the bath. Carefully clean the articles from oxide or grease, and suspend them in the solution from thirty to sixty minutes. No battery is required, but the bath must be kept at a boiling temperature. When the articles are uniformly coated, they are removed, washed in water, in which a little chalk is suspended, dried and polished with chalk or other suitable material." J. M. M.

Mr. Electrode said that aside from the question of whether the above process was covered by the United Nickel Co's patents, the description was very defective. What is a "dilute solution?" How much chloride of zinc to a quart of water? Then "5 to 10 per cent." of nickel sulphate is added. Does it mean in that proportion to the chloride solution, by weight,  $\frac{1}{4}$  to  $\frac{1}{8}$  lb. of nickel sulphate to a quart of solution? Or does it mean that a solution, containing 5 to 10 per cent. of the nickel salt, is to be added to the other solution till a decidedly green color is produced? When done, "wash in water in which a little chalk is suspended," Is a piece of chalk suspended in the water? If so, its effect on the water would require a powerful imagination to discover. If it means that chalk powder is mixed in the water, it should say that—Mr. Electrode added that the above was a sample of the majority of the "receipts" published on all subjects. They look all right to the inexperienced workman, but when he comes to try them, he finds them so vague that he can only find out what they mean by a series of experiments, which make more bother and loss of time than they come to. And even if he finds out how to work the process, it may prove to be a poor one, and worthless for his purposes or perhaps, for any purpose. Correspondents should either send us receipts that they have used themselves, and know to be all "right," or which they know enough about to give clearly, and with such particulars that experimenters will be able to try them if they wish. As for himself, he would repeat his advice, given last month, on this subject, and thought it would be better for those wishing to nickel plate to follow it, and not waste time and money on cheap and uncertain processes.

Mr. Electrode wished to correct an error in the report of his remarks last month; where it reads that the article should be well cleaned to "resist" the deposition of the gold, he said to "assist" it.

#### THE "PAINLESS" EAR PIERCER.

*Secretary of Horological Club:*

We send you herewith one of our "Painless" Ear Piercers patented by us June 25th, 1878. We would like you to present it to the members of the club at your next meeting for their inspection.

Recognizing the need for some improved method of piercing Ears whereby perfect accuracy could be attained and suffering from pain

abolished, we have at considerable expense patented an instrument which we trust will commend itself to you and meet with the approval of the trade throughout the country.

MULFORD & BONNET.

Mr. McFuzee explained the tool to the club. All present were very highly pleased with it, and convinced that it would be a success. It can be adjusted on the ear to the place preferred for the hole, compression applied to prevent any pain, a piece of cork supports the ear lap while being pierced, and the needle pierces the ear exactly at the place selected for the hole. The needle is long, and is fitted in a neat handle. Its point is detachable, the shank of it being turned off, and fits in a hole drilled into the end of the needle. As the needle passes through the ear, this point is forced into the cork. A slight pressure on a spring throws the cork and its holder, and the compression piece, back entirely out of the way, leaving the front of the ear lap exposed, with the needle projecting through it. As the point is still sticking in the cork, there is, of course, a small hole in the end of the needle. Into this hole the end of the ear wire is placed, and the needle pushed back through the ear, carrying the ear wire through the new made hole without tearing or irritating it, or allowing it to close up on the withdrawal of the needle. The whole can be done by any one, in a few seconds, easily, safely and accurately, and removes all objections from what has always before been considered one of the most disagreeable operations in the whole business. The tool is neatly made, nickel plated, and put in a handsome box, and should be in the hands of every dealer in jewelry.

#### A DRILL TO CUT HARD STEEL.

*Secretary of Horological Club :*

Last month I sent a little article on drilling to your honorable body, and I gave my way and method of making, and furthermore, I stated in my article, if any one was interested enough to send me his address, I would send him a drill and full instructions how to make the same. But Mr. McFuzee thought that I did not explain the method very satisfactorily, and I did not intend to. If he noticed the article a little closer, his remarks would not be necessary, as the points he referred to, you could find out by addressing me. But I omitted my address, and as I have received several letters on the subject, I will now explain how I make them, and where to purchase the corundum wheel. The wheel can be found at A. Friedenthal, 42 Maiden Lane, and also the steel wire. To prepare the wheel, take a brass or cement chuck, and with shellac fasten the wheel on the chuck, and place it in the lathe; taking an old burnishing file, and warm it, set the lathe in motion, and lay the warm file on the wheel, and you can bring the wheel to run perfectly true, making one edge round and leave the other square, and your wheel is in working order. Place a piece of wire in the rest of your lathe, and attach to that a piece of spring, to keep the wheel moist when in use, letting the spring touch the wheel while in motion, so as not to draw the temper of your wire when grinding your drill. To prepare the wire for making the drill, take a piece about three inches long, and make it to a cherry red, and drop it into a cup of sperm oil, and I never let down the temper of the wire. Then, to make the wire the right size, I set the lathe in motion, and roll the wire between the thumb and fore finger, until it is the desired size. Then lay the wire on the wheel and grind away one-third of the wire, turn it over and grind the other side the same, and the remainder will be flat. Then make the point oval by passing backward and forward across the wheel while in motion. To make the freeing for the drill, hold it to the round side of the wheel, and it will cut away for to make the freeing for the drill, and then the drill is ready for use. Place your pinion or staff in the lathe center, and hold the drill at an angle of 45 degrees, set the lathe in motion, carrying the drill directly over the bed of the lathe, and you will have no difficulty drilling the hole; always use oil. Great care must be taken

with the drill, as it is very easily broken. I hope this explanation will be satisfactory to Mr. McFuzee, and to all who try the same.

J. P. W.

Mr. McFuzee said that he had not intended to express any dissatisfaction with the former letter, but as Mr. W. had offered to send "full instructions" for making the drills, it followed that he had not given them in that letter, or there would, of course, be no occasion for anybody to send for them. He therefore had suggested that Mr. W. should furnish them to the club, for the benefit of *all* our readers.

He thought that Mr. W. did not suspect what an avalanche of letters such an offer would draw upon him, and did not suppose that he really wanted to give all his time to making drills and writing out "full instructions" for the next three or four months, and more or less for a year to come, or as long as new readers should happen to see the offer. He had therefore mercifully crossed out that offer. But by some mistake of the compositor, a part of it was printed, after all, giving the name, but no address. With even that slight clue to the identity of the writer, Mr. W. seems to have had several inquiries, so, he can imagine what a flood of them there would have been, if his letter had been given in full. Inquiries have also been sent to the publisher of the *circular*, and to the club, for the full address, but as the whole letter was used as "copy" for the printer, and has long since been destroyed, we have no means of knowing it.

#### WHY A PLATED CHAIN TARNISHES.

*Secretary of Horological Club :*

I have a good roll plate gent's chain, curb pattern, that seems to be plated good, but lay it by a few days, and it will get brassy on some of the links, but will rub right off with the brush, and looks all right again. Under the magnifying glass, it seems to be *good* plate, but acts very queerly. Can any of your honorable body tell why it does so? It's not worn any that one can see.

J. W. W.

There are many causes that will tarnish a plated chain. If it is wrapped in tissue paper bleached by chlorine gas, or laid with rubber goods of any kind, that will turn it black. Dyed velvet, cotton or flannel, or silk watch guards,—in fact, anything wherein acid is used, will discolor even gold goods, so will anything which contains sulphur, or which has been in contact with matches, vulcanized rubber, or similar materials, so that it smells of sulphur even a little. Ladies' neck chains and jewelry often tarnish because they use some popular hair or toilet preparations containing sulphur, or from handling the jewelry after touching their hair with the fingers. Common illuminating gas, the fumes from a coal fire, and many other sulphurous acid vapors, will turn jewelry, silver or plated ware.

#### THE BEST CHRONOMETER DETENT.

*Secretary of Horological Club :*

Which detent (in the chronometer escapement) is considered the best, the English or the pivoted one?

Which is the easiest to build?

WATCH MAKER.

Mr. Uhrmacher said good makers could produce equally good results with either kind, by adapting it according to its peculiarities—its advantages and faults. One might be preferable in one case, the other in another. The English detent is generally preferred for box chronometers, having slow vibrations, and always kept in one position, while the pivoted detent is preferred for pocket chronometers, with quicker trains. If perfectly poised, it is not affected by different positions, as the English detent is.

As to its construction, the pivoted detent is rather easier to make, but more difficult to plant in the watch properly. It is also somewhat troublesome to get the banking screw in the best position to prevent recoil or quivering. Which would be preferable, on the whole, could only be decided after a careful consideration of all the conditions and circumstances of the particular case.

## BLACK FILLING FOR ENGRAVING.

*Secretary of Horological Club:*

In reading over the proceedings of the *Horological Club* of August, which I must say is always the first article read by me, I noticed that J. D. H. asked for a black substance to be used after engraving.

Perhaps what I use may be of service. Buy a piece of "black ball" of a shoemaker, and, on any parts wished to be filled in, rule it in hard over the engraving, then wipe it off briskly with a woolen rag. I have used the above a number of years on metal and ivory. In the latter, I think it cannot be excelled. C. N. G.

Mr. Ruby Pin was obliged to Mr. G. for his communication. He knew of "black ball" or "heel ball" being used for that purpose, but it did not occur to him while he was replying to J. D. H., last month. He trusted that all of our readers who might know of ways better than, or even as good as those mentioned in our discussions on various subjects, would send them in to us. The information would be useful not only to the correspondent making the inquiry, but to a great many others who read these Proceedings. The trouble will be trifling, but the amount of information we should all receive if this course was generally followed, would be simply immense.

## WATCH RATING SHEET.—POISING EXPANSION BALANCES.

*Secretary of Horological Club:*

I see in last number of the *CIRCULAR*, that J. H. Purdy & Co., of Chicago, have sent to you for inspection one of their rating sheets. You will find enclosed one that I used and had for sale in 1872, and it was an original idea with me. I have used them ever since, and find them very useful, and a very good advertisement, and worth the time it takes to use them.

As I have found a great number of balancewheels, especially chronometer balances, very badly cut up by some one poisoning them, I will take the liberty of giving my plan for poisoning them. In the first place, I find almost every American wheel with the slots in screws filled up with gummed oil and polishing powder. I take my peg wood, sharpen the end flat, clean the slots out, and then put the balance in my poisoning tool and try it. If not correct, then take the slotting file and take a little out of the slots where it needs it, and not off of the end of the screws. It makes a better job, and does not show.

J. W. T.

Mr. Horologer said the principal difference between the rating sheet of Purdy & Co., and that of Mr. T., was that the latter had simply a space for each day in the year, in which one could put down anything that was desired; while the former had each of these spaces, subdivided and printed, with separate places for writing the loss, the gain, if set, and if regulated. Both are convenient and useful, but the former is the more complete.

As regards the poisoning of screw balances, the course stated by Mr. T. is a good one when the balance rim is not cut. But great caution must be used in making any alteration in a cut expansion balance especially one which is really adjusted, and compensates for heat and cold. It is safe to say that all such balances made by any American Watch Co., were properly poised when sent out from the factory, and will, of course, continue so, unless something happens to them. Balances are more often got out of poise by careless handling while cleaning, than in any or all other ways,—resulting in bending one of the arms, more or less. They are also often overheated while in the lathe for some purpose, by workmen who use cement chucks. They do not return to their former shape, although workmen generally suppose they do. If one part of the rim is heated more than the other, and even when there is no perceptible difference in that respect, the result is not only a change of shape, but an *unequal* change, and the balance is out of round, and differently shaped on the different sides. Balances are also sprung out of shape by various kinds of accident.

After thoroughly cleaning a balance, so that there can be no dirt around the screws, in the slots, in the vacant screw holes of the rim,

or elsewhere, if the balance is found to be out of poise, the first thing to do is to try it in the calipers, to see if it is true. The rim should be perfectly round or circular, at the medium temperature. But the temperature of the shop will sometimes be such that the ends of the rim will curve inward or outward from perfect roundness, or from a perfect circle. When this is the case, both ends should curve in or out exactly the same amount, in the same place, and the same direction. If they do, the balance is true, and the want of poise is probably owing to the screws. First, notice whether the screws are either all turned in up to the heads, or, if any are partly turned out, then whether those which are exactly opposite to them, in the other side of the rim, are turned out exactly the same. This observation does not concern the screw at each end of the balance center bar or arms, nor in a fine watch, the two screws midway between these two, called "quarter screws," as these two (or four) screws are used for poising and rating purposes. As a general rule, the screws should all (except the "quarter screws") be turned in up to the heads, but not tightly. But if the watch is a fine one, whose balance has been carefully adjusted, the screws must not be filed, nor turned in or out, or disturbed in any way, unless the workman has a full understanding of the philosophy of adjusting balances for temperatures, positions and rate. Otherwise, he may completely ruin the carefully perfected adjustments. There are much worse evils than a balance a little out of poise. It may even be the case that the balance has been purposely put a little out of poise in perfecting the adjustment to positions. And although one may think it should not be so, he ought not to change it unless he is a better workman than the adjuster who put it so.

Even if he finds the balance out of true, and the two sides unequally shaped, when tried in the calipers, he must not bind the segments of the rim to true it, without carefully thinking over the whole ground. That is an operation that requires not only knowledge and judgment, to decide whether one should be bent out, or the other bent in, to make them alike, or both bent, where they should be bent, or whether they should be bent at all,—but also skill, to avoid bending them too much, or in some screw hole, and straining or cracking the rim. If it is bent in and out too often the texture of the metal is changed, it will no longer expand and contract like the other side, and the balance is ruined. A balance may be one sided from having one part of the rim temporarily expanded more than the other, by holding in the warm fingers; and it may be unequally contracted by something cold. In these cases it will come true of itself after a little, when the temperature of the different sides is the same, and more quickly by laying it flat on a cool metal plate. In a word, the balance of a fine watch should not be altered in any way, except by workmen who thoroughly understand the object and construction of a compensation balance, and its various adjustments. Those who are not thoroughly well informed and experienced in these matters, should study Excelsior's book, which is the best practical guide on these and similar points published in the English language. In closing, Mr. Horologer said, he had been rather lengthy in his observations, but it was Mr. T.'s fault. If that gentleman had only said that his method of poisoning was to be limited to uncut balances, there would have been no need of so long a speech by him. If any of our readers felt aggrieved, he hoped they would lay it all to Mr. T.

A FRENCH jewelers store in Barcelona was recently robbed of diamonds and other stones worth about \$300,000. A fortnight ago the Marseilles police noticed several rather seedy-looking individuals going from one jeweler's shop to another offering diamond-studded trinkets for sale. No time was lost about their arrest, and the wealth of Golconda seemed to be on their persons. On one was found precious stones to the value of 17,500 francs, and a waist belt holding nearly 6,000 francs in coin, while an examination of the others vestments, revealed jewels and money to the value of 11,000 francs. A woman who had also come from Barcelona, but had not disembarked at Marseilles, was taken into custody, and found also to have in her possession an unusual number of watches.



## Views of Correspondents.

This department of THE CIRCULAR is open for communications relating to the jewelry trade, but the editor does not hold himself responsible for the sentiments expressed by contributors. We invite correspondence, but require that it shall be free from all personalities, and the writer's integrity guaranteed by the disclosure of his true name to the editor. Anonymous communications will not be noticed.

NEW YORK, August 25th, 1879.

To the Editor of the *Jewelers' Circular*:

DEAR SIR—When I wrote the communication published in your July number, I had no intention, either to disparage the services of the commercial travelers or to provoke any personal controversy. I desired simply to oppose the idea expressed in your June article that the path of the "Boy on the Road" was a particularly unmitigated thorny one, and I ventured, in sustaining my views, to cite some well known facts which tend to render the lot of the "boy" more easy to bear, and even make it compare favorably with that of the men in the other branches of the trade.

In your paper of this month one of the drummers flies to the rescue of his slandered corps, and instead of taking any notice of the facts contained in my letter, he valiantly, under the shield of his fictitious signature, makes a *personal* assault upon the "Old Jeweler." After an humble obeisance to "those capitalists whose enterprise make the workshops possible, &c.,"—the traveler proceeds to charge "Old Jeweler" with having sailed under "false colors"—and more to the same effect.

The writer is not aware that in his July communication he made any personal claims or pretensions whatever, and he has as yet failed to discover the relevancy to the questions under discussion of traveler's rambling statements.

Were the "Old Jeweler" disposed to enter into a wordy encounter, he might inquire of "Traveler" why he does not display *his* colors more clearly. It is difficult to discover from his letter whether he is a new and adolescent recruit to the drum corps, or a fierce and hirsute drum major, who by many years of abstinence from "time tables" has accumulated enough of his beloved capital to start a little drum corps of his own.

"Traveler" boldly inquires. "Where would the demand come from but for the "Boys on the Road?" which is a "lazy one" and might be thus answered: The demand would come from those of our fellow-citizens who delight in the adornment of their persons with jewelry, and who, if they had the money and wanted the goods would pretty certainly find some way to exchange one for the other, even if they had to hire an expressman. However, if the conjuring up before his brain of the dreadful results that would follow the disbanding of the drum-corps, is a source of happiness and contentment to "Traveler," the last one to interfere with his harmless amusement is

"THE OLD JEWELER."

To the Editor of the *Jewelers' Circular*:

ROCHELLE, Ills., Aug. 17th, 1879.

The subject now agitating the jewelers world is so broad and complicated in its nature, as also interlinked with so many different phases of society and commercial life, that a full elucidation of all its relations requires more thought than can be expressed upon a dozen pages of commercial note. You favored my first letter with a place in your valuable JOURNAL, but as many of the more practical ideas were necessarily crowded out, I submit to you now a continuation of the argument. I am in favor of Jewelers' Leagues or Associations established for the purpose of mutual benefit, the cultivation of fraternal feeling among the trade, the discussion of existing evils, and to provide remedies for their abolishment; to suggest, propose, contrive, invent ways and means for the general reformation and elevation of our subtle and beautiful trade. I am in favor of the establishment of any and all measures of reform that are just, fair and practicable; but I am now, after hearing many new arguments in favor of them—as I was at the date of my first letter—emphatically opposed to "Protective Leagues," or that branch of them, which propose to circumscribe the rights and privileges of one or all to sell goods to anyone, or anywhere, or at any time, at any price. I will never be one of the many who cry out and demand individual protection, and thereby inflict the same wrongs upon others, which they indignantly denounce and repudiate when imposed upon them.

This "great wrong" inflicted upon us, by a few jobbers selling goods at retail, is all imaginary. This is no wrong at all! It is all right, and an evil no more to be regretted or deplored than the existence of any other competition. It is not only right, it is eminently fair, just and legitimate in law or equity. No man is "morally amenable to the laws and customs of the country" as applied to the mode of doing business, providing he does not rob or defraud the public, simply because there are no such laws to be amenable to. Every boot-black, every traveling vagabond with a pack upon his back, every tinker, every cobbler, every country jeweler or merchant prince, all are alike "monarch of all they survey" and a law unto themselves; and if Stewart will sell goods at cost, and Tiffany retail below cost, they have an emphatic and absolute right to do so, even to the general consternation of the retail dry goods and jewelers trade who may tumble by the way-

side; and I say: "Lay on Macduff! and damned be he who first cries hold, enough!" Are not the many benefited? the great public to whom all else must give away? Then what matters it, if a few unfortunates become engulfed in the wild whirlpool of trade? Is it not so throughout the grand struggle for life? But let not the weak kneed loose courage; no one has an unlimited supply of goods to sell without a profit; prices will again regulate themselves by the laws of trade, and make it possible for the "small fry" to live, even if the big fish make a tremendous splurge with their mammoth tails occasionally.

I have a brother in northern Illinois, also a jeweler (and, strange to say, a great champion of this protective movement against the retailing jobber; so much so, that he had about fifteen pages of foolscap prepared for the CIRCULAR in reply to my first letter, but not having it ready in time for the issue following, he omitted to send it,) who for some cause best known to himself, has lately reduced the prices of cleaning watches to 50 cents, joints, pins, catches, crystals (!) to 5 cents, etc., etc., and does good work too. Now while I regard his course, in thus degrading the compensation for the highest mechanical art to the level of a boot-black's pay, as very unwise and pernicious, yet I cheerfully grant him the right to do so, and were he to set up shop next door to me and work for nothing, though he might ruin my trade, I would still continue to entertain the same brotherly love for him I have now, when he is fortunately out of reach of my territory; although in such a case, I would place a detective over him to guard him, should his symptoms of lunacy become violent. At present he is making lots of money.

I have been accused of writing in the interest of the retailing-jobber. This charge is as shallow as it is false! I have worked at the bench since my twelfth year, am now forty-one, and have been a retailer in this place for twenty years. I expect to live and die here; the town being small I can hardly hope to "evolve" out of my present humble condition. Yet "the boys on the road" tell me I have the finest store and best stock of goods of any jeweler in so small a city in the west. This I "evolved" out of my "kit," \$4.00, a chest of books and a determination to succeed by study and application in the retail trade. I love my trade as well as any jeweler, and will do all I can to make it prosperous, creditable and honorable. But as I have survived so far in spite of all competition, in spite of the jewelry kept in almost every dry goods, grocery and clothing store, so I believe I shall survive in the future. And I often trade with the jobber who sells outside of the trade, and "who sends price-lists to any one." I have only the best of feeling towards them, and, if they sold to every man, woman or child within twenty miles of here, this feeling of fraternity should not, and, I think, would not be broken. If I couldn't sell jewelry and successfully compete with them, I could fix watches and make a good living; and if I could not do that I could sell goods for some other jeweler; and if I could not do that, I could black boots or do something else to support myself and family.

But of late I have found it is precious little jewelry these jobbers sell outside of the two "legitimate" jewelers here. Not because they would not if they could, but because they could not if they would. I find also Mr. Dry Goods very considerate, and assuming a very friendly attitude towards me and my business affairs, and to prove the interest he takes in my welfare, he has offered his entire stock of jewelry at fifty cents on the dollar! But,—thank you! no takers. Mr. Grocery—Toy—Notion and Jewelry Dealer also sends "the boys on the road" off sadly, "hardly ever" with an order; and his sales are pitiful, in spite of the beautiful appearance of his stock, resembling in colors all the magnificent hues of the rainbow. Mr. Clothings stock has also assumed these gorgeous tints, and yet, in spite of the rarity, and the low prices of all these goods, the public do not see their own interest and buy of—Wettstein.

Need the sun envy the flickering light of the *tallow dip*? So the honest jeweler and watch repairer, who is capacitated to meet the wants of an intelligent and cultured public, need not fear price-lists, the botch, the peddling gorilla, the auction fiend or grocery store jewelry stocks. They will only add lustre to his fame and skill, and he is bound to survive in spite of all! Then, why should I grieve at the jobber? As long as I prosper and get a good living, denying myself none of the comforts of life and abundance to share with my wife and five babies? If I can sell a watch away from him or my competitor, I'll do it every time; then why not concede the same privileges to them?

It is a lack of energy, capacity, enterprise; and a proof of incompetency to battle life successfully in the struggle for commercial success, which prompts the hundred notions advanced, clamoring for protection. It is a mode of begging, soliciting outside help, to enable one to improve his business, to make more money. It is also an indirect form of tyranny, imposing restraint and slavery upon and violating the rights of those who are supposed to interfere with our business and detract customers from us. It says, "Get out of here! I monopolize this town. I insist on priority right to sell to its citizens the goods they want at prices which I consider just and fair. I know what is right. Jewelry should be sold at a hundred per cent. profit, and watches and chains at fifty; and a man of my stamp and genius should not be degraded by competing with everybody; but, come, fellow jewelers, let us unite and establish prices; withdraw our patronage from any jobber who will sell to any one outside of our society; this will ruin them, and we will have it all our own way, and soon become rich and happy."

These are the true motives which prompt a call for "protection." But the thoughtful and true man will stand aside and say, "Let me be free, as I cheerfully

concede freedom to others. Let me fight the great battle of life bravely, nobly, and, if possible, to ultimate success; but should I fail and lie prostrate at the feet of one more qualified to reach the goal of my ambition, and being equally honest, let me put nothing in his way, but reach out the hand of fellowship and say: "Let the fittest survive!" It is all for the best."

To thinking minds, the many letters of grievances, all clamoring for protection, which have found their way into the several trade journals of late, are extremely pitiful, though many of them verge terribly on the ludicrous. One jeweler in Iowa insists that if the Elgin company does not stop selling to "outsiders," they, the Protective League Jewelers should decide never to repair them, (!) and this would soon bring the company "to time." Another brother went still further in solving this great problem, by suggesting that the League or its members should stamp each piece of jewelry they sell, and that when a customer brought in a piece of jewelry not so stamped, they should refuse to repair it, and thus the public would soon learn its interests and duties towards regular dealers." This logic is on a par with most all other letters which I have seen expressive of this "grievance."

But the fact is, there is but one remedy for the existing evil of excessive competition, and that must be sought, as it was my endeavor to make clear in my first letter—in *individual effort, excellence and superiority*. The struggle for life in nature, and the survival of the fittest, is the inexorable law which pervades the commercial and social world as it does the animal kingdom. Any jeweler, if he is a good watch repairer, can "survive" in any town where the supply of equally good or superior services to those which he can render is not already greater than the demand. Supposing a jeweler who for years has prospered in a place should suddenly discover a great falling off in his trade, and find the cause to be not a lesser demand for goods or work but a new supply in shape of a competitor, a first-class mechanic and large stock. Now, it is evident that a new effort is necessary on his part or he will go under. The struggle commences, renewed efforts are put forth; the dormant intellect is aroused; everything is put in prime order for the great battle. The store is renovated; the goods fixed up and newly arranged; the jewelry polished and re-carded; new stock selected with great care, to create a sensation, and all made as attractive as possible. The customers are received with lots of smiles and best attention; watchwork is done with greatest of care; jewelry repaired and cleaned as new; concessions are made in prices; goods marked down in general, and advertisements sent out to entice the public to "return their patronage to one who by long years of experience has learned that to succeed in business, honesty is ever the best policy, and low prices next." Thus the battle rages! What is the result? If both cannot live and prosper financially, the fittest—he who does best by the public—will survive. The best man will win!

There is no effort without a cause. A rush to any store is an infallible indicator showing where it is the peoples interest to trade. No individual is "morally amenable" to trade anywhere and when it comes to dollars and cents, I find no one holds himself amenable to trade with friend or brother, heathen or christian, jew or infidel, but all go where they can do the best on the dollar. So if my trade is dull and in "hard times," I exert all my ingenuity to discover by what new methods I can stimulate trade and how to *make it an object* for people to trade with me. And so far I have discovered, when I *have made it an object* and have done just a little better by my customers than anyone else—not necessarily in prices, but in quality of work, accommodations, assortment, styles, attraction of store and goods, fair dealing in the past, etc., etc.—I have invariably obtained the largest share of the trade. Some get mad at a customer for trading elsewhere! just think of it! when they alone are in fault!

The proposition of a correspondent that a "jobber who asks and receives special favors from manufacturers, because of his being a jobber and not a retailer, is morally bound to confine himself to a jobbing business, and that when he undersells the legitimate retailer he is guilty of a breach of commercial honor, and acts a lie;" is preposterous and absurd. Alas! that the largest share of the trade of our country should be in the hands of scoundrels and thieves! Why do the people not arise in their might and extinguish these vile dens of traffic from our fair land by withdrawing their patronage from such unprincipled rascals and villains (*all of which* the above monstrous proposition implies,) as Stewart & Co., Tiffany & Co., Rogers & Brother, Matson & Co., Field, Leiter & Co., Jansen, McClurg & Co., and thousands of others of our leading firms, in every branch of trade who sell both at wholesale and retail? And pray, what "favors" do these firms receive from the manufacturers? I wonder what "favors" the author of this profound proposition would receive from them, if he was without a dollar? and whether the jobbers, *per se*, receive those "favors" or the dollars which they possess, and which must be paid over as so much cash, or vouchers it they be paid over in the short future, or these "favors" would not be forthcoming. The "favors" thus being exploded, the "moral obligation" of jobber to producer, in a transaction entirely dependent upon the cash paid for it, and transferring the absolute right and ownership of the wares from one party to another, is exploded also! There is no law, no obligation, or stipulation, either direct or implied about it. Of course, it is policy to sell goods in large quantities at a less per cent. of profit than small lots, and pays just as well or better; so that when Mr. Jobber comes with his cash, or its equivalent, to buy \$1,000 or \$10,000 worth of goods of the manufacturer, the latter, if any one, is the recipient of "favors," but not the buyer.

OTTO WETTSTEIN.

## Precious Stones and Gems.

BY EDWIN W. STREETER.

THE story of the extravagant and luxury loving Cleopatra, Queen of Egypt, is well known. She is said to have once made a bet with Marc Antony, that in a single meal she would swallow the value of two millions of francs. Antony, of course, deemed this impossible, but he was so on convinced to the contrary, when Cleopatra took the Pearl from one of her earrings, dissolved it in vinegar, and drank it. She was about to take the Pearl from the other ear, when Lucius Plautus staid her hand, declaring she had won the wager without further loss. This Pearl which was saved, afterwards came as we have said into the hands of the Romans.

Later on, Pearls still retained their great value. Pliny places them next in value to the diamond; Isidore ranks them as first among the pale-colored Precious Gems. Not only among the Eastern nations, but also among the aborigines of America, the Pearl held a high place; this was seen by the Spaniards, who disturbed them in their possessions. In old Peru, none but those of princely blood were allowed to wear them; and the temple of Montezuma, in Mexico, was lined with gold and silver, adorned with Pearls of the highest value. In Florida, also, the Spaniards found a perfect treasure of Pearls.

One of the largest known in Europe, was called La Perigrina, the Incomparable. It weighed 126 carats, and was pear-shaped. Gongibus of Calais, brought it from India, in 1620. When laid before Philip IV., King of Spain, he said, "How could you concentrate your whole fortune upon so small a thing?" to which the merchant replied, "Because I knew that the world held a King of Spain who would buy it of me." This gem is now in the possession of Princess Youssof. (Value, 80,000 ducats.)

Another large Pearl, of the form and size of a pigeon's egg, weighing 134 grains, came from Panama; it belonged to Philip II. of Spain, and was valued at 50,000 ducats. The Emperor Rudolph II. possessed one of 180 grains; and Napoleon I. had one nearly as large. The Pearl which the King of France gave to Madame de Maintenon, and which was offered for sale in 1819, weighed 27½ carats. The Pearl belonging to the Shah of Persia, is above an inch in diameter, and in 1633 was valued at 1,600,000 francs; and that in the possession of the Arabian Mascate at 800,000 francs. The Crown Prince of Prussia gave a necklace of thirty-two Pearls, valued at 500,000 francs, to his bride, the Princess Royal of England.

*Colored Pearls.* It is very difficult to determine whether colored Pearls where known to the Old World, our own Saxon word *perl* signifying "a gem or white speck:" the name, by which the black, azure, bronze, green, or pink Pearl was designated, has not been satisfactorily ascertained. The value set therefore by the Ancients on this beautiful animal product, which is found of every tint and shade is not to be easily assigned. In modern times the value of tinted Pearls is better gauged.

Pink Pearls are found in the rivers of South America and in the Bahama Islands, and vary in value according to their quality, shape and size, the price ranging from 5s. to £6 per grain. Black Pearls are found in the Gulf of Panama, in the Pacific, and in Western Australia, and rise in value from £1 to £10 a grain. Pearls of rare color, or of any fanciful tint or shade, obtain prices commensurate with their demand and scarcity.

The specimen known as *La Perle rosee* ranks with the clear white Pearl, but it has this drawback, that its irregularity of form sometimes presents so inelegant a shape, as to prevent its being used for a personal adornment.

It is not unusual to find specimens of pale pink Coral cut and shaped like a *pearl rosee* offered for sale as such; but an experienced eye will not fail to detect the special sheen of the concentric layers of which the Pearl is composed, and distinguish it from the glistening of the cellular structure of the Coral.

Inferior colored Pearls are sometimes dyed black or russet brown, and sent into the market; but the absence of the true Oriental tint and lustre is so marked, that only a very inexperienced eye can be deceived by them.

The famous necklace of the Empress Eugenie, consisting of a row of matchless black Pearls, realized the large sum of £4,000, after the removal of the Pearl forming the snap, which was subsequently sold for 1,000 guineas, to form the centre of a bracelet.

Hemetite, an important iron-ore, is frequently used in the manufacture of imitation Black Pearls.

Concluded.

## Jottings.

THE correspondent of a Swiss paper warns collectors of antiquities to beware of fabricated specimens of articles purporting to belong to the age of bronze, and to have been found among the remains of lake dwellings and in the beds of rivers. He says there is a regular manufactory of these things near the Lake of Blenne, and that bronze swords are being offered at roof. each, which are not worth as many centimes.

IN a series of articles on mining on metallurgy at the Paris Exhibition is promulgated the following interesting data on the method of making Damascus steel sword blades at Zlatoust, in the Ural:—The pig iron used in making the latter is a spiegel, with 8 per cent of manganese, which is partly converted into puddled steel and partly refined. The cast-steel ingots of about five pounds weight are made from selected qualities of puddled steel, 61 per cent. of the crucible charge being hard, 23 per cent. medium steel, 10.37 per cent. refined pig iron, and 3.71 pure magnetic ore. The tilted bars are twice piled for shear steel, a layer of sulphide of antimony being placed between the different bars. The final pile is made of four square bars, about one-eighth of an inch in the side.

WITH this issue of the CIRCULAR we print the series of articles on "Art Work in Silver." Their author, Mr. Thomas J. Pairpoint, is one of the most skilful and artistic designers of the present day, having a reputation that is world wide. His articles cannot fail to interest the trade and all lovers of the fine arts, or to aid in elevating the standard of this class of goods, and bring them into better appreciation. It is the aim of the CIRCULAR to instruct as well as to entertain, and, to this end, we seek the co-operation of the best talent. The numerous valuable articles on the technique of the art of watch making have been highly appreciated, and we bespeak for Mr. Pairpoint's articles on art in silverware—intelligent, and thoughtful perusal.

THERE have been a great number of alloys resembling gold and silver patented. The last which has come to our knowledge is a patent recently granted in England to one Thomas Meiffre, of Marseilles, France, for the following ingredients:

GOLD ALLOY.—800 parts of copper, 28 of platinum, and 20 of tungstic acid are melted in a crucible under a flux, and the melted mass poured out into alkaline water, so as to granulate it. It is then melted together with 170 parts of gold.

SILVER ALLOY.—65 parts of gold and 4 parts of tungsten are melted together and granulated; also, 23 parts of nickel, 5 of aluminum, and 5 of copper, in a separate crucible, to which is added a piece of sodium, in order to prevent oxidation. The two granulated alloys are then melted together. Both alloys resist the action of sulphureted hydrogen.

MR. HAWTHORNE, of New York, who went to Cincinnati a few days ago on a visit, had an experience in that city, which is simply unparalleled. Setting off his very handsome dress was a \$600 diamond pin, the diameter of which was about 1/2 inch. While sauntering up Broadway, he stopped in front of Haggerty's produce establishment, and bent over a pile of coops to watch the antics of some of the chickens which were feeding. The diamond caught the eye of a silly fowl—a hen, of course—and darting its head between the laths it seized the gem. Unfortunately the setting was not what it should have been, and a sharp jerk tore it loose. The hen swallowed the diamond, and Mr. Hawthorne's attempt to catch it gave it such a fright it rushed in among the other chickens and lost its identity so far as he was concerned. He went into the store to complain and was delayed somewhat. When he came out again the coops had all been moved, and Hawthorne could not even recognize the \$600 one. A conference was held with Mr. Haggerty, and it was agreed that the only way to make sure of the jewel was to kill all the chickens in the coops. This was not a great undertaking, for the house supplies hotels with dressed chickens, and would not have much trouble in disposing of the lot. So Haggerty agreed that if he was allowed 25 cents a dozen for killing immediately he would find the diamond. The coops were carried to the dressing-room, and the 72 dozen chickens were killed. The 858th chicken had the diamond carefully stowed away inside, and Mr. Hawthorne gladly paid \$18 for the killing, and \$10 to the woman who found the diamond. This is a tough story we know, but it is vouched for by Deacon Richard Smith of the Cincinnati Commercial, therefore, we are bound to believe it.

A NEW and very beautiful style of jewelry has just been brought out by A. J. Hedges & Co. Each piece presents two surfaces, the sunken surface being of gold, differing in color from the upper surface. On the lower surface is engraved imitations of leaves and other beautiful designs, which are protected from wear by the raised surface that surrounds them. The effect produced much resembles intaglio, which is the result of the harmonious blending of different shades of gold and artistic engraving with the bright metal of the wearing surface. These goods, which are of the finest quality, promise to become very popular.

ONE of the richest and rarest treasure chambers in the world is that belonging to the Sultans of Morocco, in the city of Fez. It was established there in 815 by the Sultan Edris ben Edris, the founder of the city, and it has been enriched by some addition to its valuables or rarities by almost every one of his successors. There are preserved in it many precious relics belonging to the time of the Moorish rule in Spain, and there is a sword of Ferdinand the Catholic, the handle of which is a mass of precious stones. It is needless to say that this treasury is most carefully guarded, and some travelers say that there are in it and about it nearly 2,000 locks. Some months ago the sultan Sidi Muley Hassen, who has been long suffering from gout, confided the charge of the Fez treasury to his brother, Prince Muley Abbas, who, in his turn, intrusted it to the Governor of Fez. A few weeks ago the Sultan was presented by one of his vassals with a splendid revolver, which was adorned with gold and precious stones. His majesty ordered it to be lodged in the treasury, but, upon entering the chamber, some boxes were found broken open and completely emptied of their contents. The Sultan had several persons arrested, but the inquiry led to no result; and he has now offered a reward of \$38,000 for the discovery of the thieves.

## The Jewelers' League.

We devote this column to the interests of the League and its membership. Letters or inquiries pertinent to its business or purposes, and which might interest the trade or inquirers, will be herein answered. Address *Jewelers' League, Box 4001, P. O. New York*, or the office of THE CIRCULAR.

The regular meeting of the Executive Committee, was held on Friday, September 5th, when the following named gentlemen were elected to membership: Messrs. John C. McClymont, with Carrow, Bishop & Co., New York; William H. Beck, Sioux City, Iowa; William H. Ferris, with Reed Ferris, New York; Charles A. Fowler, of Fowler Bros., New York; George Greenzweig, of Nast & Greenzweig, San Francisco, Cal.; Edward Hirsch, of Hirsch Bros., New York; Edward Kraft, Philadelphia, Pa.; Jens F. Pendersen, with E. A. Thrall, New York; Charles McKenzie, with Robbins & Appleton, Boston, Mass.; Kossuth Marx of Kossuth Marx & Co., New York; Monroe Marx, with K. Marx & Co., New York; Robert Schaefer, with Randel, Baremore & Co., New York; Harry A. Scofield, with G. & S. Owen & Co., New York; Charles A. Steurer, with Randel, Baremore, & Co., New York, and Charles H. Witherspoon, Hillsboro, Ill.

One application was rejected, one was returned to the applicant after ineffectual attempts to get it in proper shape for action, and two were referred for correction. The Secretary was instructed to make the necessary alterations on the books, changing the beneficiaries of two of the members in response to their requests made in the regular form.

The Secretary again calls the attention of the members to the necessity of advising him promptly, of any change of address. The last circulars sent out developed the fact that many members had changed their addresses without so advising him. We again remind the members as we did in our April issue "that a notice sent to the last address given shall be considered a legal notification." (Constitution, Art 5, Sec. 2). Non-compliance with this request may cause important notices to go astray and consequent serious embarrassment to the members.

It is advisable that the members or others who intend submitting designs for the badge of the League, in conformity with the circular recently sent out, should send them to the Secretary as promptly as possible, as the Special Committee to whom they are to be submitted, will be appointed by the President on October 1st.

We have been asked when the design is selected by the Special Committee, whether the design will "have the job" of making the badges. In reply we would state that when the design is chosen, the selection will be of the *design only*; that design will be recommended to the League in annual session as the authorized badge, and if adopted at that time, then the members will either make their own respectively, or employ any manufacturer they please to make them from the approved design. It has been suggested that it be either engraved on wood or lithographed, and a copy sent to such members as desire one, or perhaps one to each member when the notices of the annual meeting are sent out: thus the members will be able to vote more intelligently in regard to its adoption when the matter is brought before the meeting.

One fellow member Mr. J. H. Johnston of this City, in reply to the recent circular of the Executive Committee urging the members to activity in recommending new members, humorously suggests the presentation of a chrono to the member presenting the largest number of candidates, and offers one of his well known "taking advantages of the situation" if the idea be approved by the officers; we have a vague idea that a silver tea service, or a pair of three karat diamond knobs would, as a premium, most effectually infuse the "spirit of aggregation" into the members. Don't all speak at once.

The total membership now numbers 502.

## Workshop Notes.

To recover the gold from old silver-gilt lace. First of all, extract all silk or cotton not directly interwoven with the metallic threads, and burn the lace in order to destroy all remaining silk and organic matter, wash and clean well of all ashes, press the silver threads into as small a compass as possible, dry and dissolve in pure nitric acid (free from muriatic, which is tested by dropping a small piece of nitrate of silver into and no clouding will be produced), diluted with an equal quantity of distilled water, after dissolving, dilute again with about eight times the quantity of distilled or boiled rain-water, let stand undisturbed for several hours, in order to allow the gold, which will remain undissolved in minute particles, to settle, decant the liquid carefully from the sediment and wash the same for three or four times with warm distilled water, adding the washings to the decanted solution; dry and melt the sediment with a small addition of equal parts of finely powdered borax and saltpeter, which will produce a button of fine gold.

The silver, which is held in a dissolved state in the decanted liquid is dissolved by adding by degrees small quantities of muriatic acid, which will precipitate the silver as chloride; allow to settle after each adding, and continue to repeat until no more clouding be observed. Decant the fluid carefully from the precipitated chloride of silver, wash three or four times with warm water, dry and melt with carbonate of soda, which will realize chemically pure silver.

To strip the gold from old fire-gilt watch-plates. Remove all steel parts and cover the plates with a paste of two parts of sulphur to one of salammoniac in vinegar, anneal in charcoal-fire and plunge into water acidulated with sulphuric acid, and leave therein for several hours, and, before removing, brush with a fine and soft scratch-brush, when the gold will become loosened to the shape of fine scales, the water is then filtered, and the gold which will remain on the filter, washed, dried, and melted with finely powdered borax and saltpeter.

Advantageous method to strip the silver from old silver-plated articles. Take a cast iron vessel and pour into strong sulphuric acid, add about one-eighth part of powdered saltpeter and bring to a boiling heat, dip into this acid a bucket made of sheet iron perforated at the side and bottom, and therein place the articles to be stripped and keep moving about up and down until the coating of the silver has dissolved, lift the bucket out and let drip into the acid and rinse in cold water, remove the stripped articles and treat another lot in the same way. The dissolving of the silver will take but a few minutes in the beginning, will work slower after the acid has taken up a quantity of silver, and will cease to act when saturated with it. The solution has the property of dissolving silver only, and barely affecting the inferior metals of which the articles to be stripped are constructed. The silver is reduced by pouring the solution whilst hot into a leaden vessel and immersing therein clean copperplates, when the silver will flock in a metallic state on to the plates, which are removed and washed in clean water, and the immersion repeated until no more silver becomes deposited on the copperplates; the solution is finally tried for silver by dropping into it a small quantity of saturated saltwater, which will produce clouding or precipitation if silver be retained in the acid solution; or the whole of the silver may be reduced by precipitation of salt solution, which should be added by degrees until no more precipitate is formed. The acid is then carefully decanted, the precipitate washed with clean water to remove all the acid, dried and melted with carbonate of soda.—H. BUSH.

To effect the best possible results in timing an ordinary watch to the various positions, it is absolutely necessary to strictly observe the condition of the pivots of the cylinder or staff in lever, etc., escapements, and the jewel-holes in which the pivots run. The pivots ought in all cases not be unnecessary long, be made conical at the shoulder and elongating, perfectly cylindrical for about one and a half the length of the jewel-hole, in order to rest freely on the cap jewel. When the watch is in a horizontal position, the point of the pivot should be quite flat, with merely the sharp edge removed and well polished; a pivot so constructed will work easy in all positions, and be least exposed to bending or breaking. The hole in the jewel should always be of the same length as the width of it, which is the proper size to equalize the friction of the pivot, whether the watch be in vertical, horizontal, or slanted position. If the hole is found to be larger than the diameter, the length can easily be reduced with the aid of a diamond drill, the end of which to be of a round instead of a sharp pointed shape, or too large a hole may be reduced in a few seconds, the bars of the polished steel effected in the hollow of the jewel is quite immaterial to the action of the pivot, as long as it is kept clean. Last of all, the balance should be carefully poised, and the balance spring be kept quite flat and free.—From *Albert Johann's Lehrbuch der Uhrmacherkunst*.

## A Couple of Curious Clocks

DR. J. L. BLAIR, of Abingdon, Illinois, has recently completed a clock which is locally regarded as one of the most wonderful pieces of mechanism ever made. This clock is 8 feet 2 inches high, 3 feet 4 inches wide, and 10 inches deep—lower half. The upper half is 6 inches deep and has a circle top. The largest wheel is 13 inches in diameter. The longest shafting is 3 feet. Weight of clock, 118 pounds; of weights—two in number—8 and 22 pounds. The case and works are mostly made of black walnut wood. In addition to its time-keeping capacity, this clock minutely illustrates (it is claimed) the composition and movements of the solar system. Time is indicated at the center of the sun, a ball 15 inches in diameter. Around the sun the planets circle in their respective orbits. The earth is 3 inches in diameter, turns on its axis once a day, and goes round the sun in an orbit 9 feet in circumference once a year. In its daily revolution the earth indicates the time of day everywhere, shows day and night, longitude, and so on.

The moon  $1\frac{1}{4}$  inches in diameter, accompanies the earth with the proper motion, illustrating its phases, eclipses, and the rest. The motion and phases of Venus are illustrated in like manner, and similarly the orbits and motions of other planets. Halley's comet, 7 inches long, traverses an orbit 14 feet in circumference, with a period of 76 years.

At the right of the clock a skeleton, 10 inches high, strikes the hours. At the left another skeleton plays a tune as often as required. A skeleton "Father Time" swings his scythe at the centre of the lower half of the clock. Above are places for showing pictures of historical events. Other details are described, at great length and with much enthusiasm, in the local newspaper, the most remarkable feature being the circumstance that the entire contrivance was whittled out with a jack-knife in the space of one year.

This Abingdon clock, however, appears to be a very rude affair in comparison with one now on exhibition in Detroit, Mich. The latter is the work of Mr. Felix Meier, a mechanic, and is said to eclipse the famous clock at Strasbourg in complexity and interest. It stands 18 feet in height, and is enclosed in a black walnut frame elaborately carved and ornamented. The crowning figure is that of Liberty, upon a canopy over the head of Washington, who is seated upon a marble dome. The canopy is supported by columns on either side. On niches, below, at the four corners of the clock, are four human figures representing infancy, youth, manhood and age. Each of these figures has a bell in one hand and a hammer in the other. The niches are supported by angels with flaring torches, and over the centre is the figure of Father Time. At the quarter hour the figure of the infant strikes his tiny bell; at the half hour, the figure of the youth strikes his bell of louder tone; at the third quarter the man strikes his bell, and at the full hour the gray beard. Then the figure of Time steps out and tolls the hour, as two small figures throw open doors in the columns on either side of Washington, and a procession of the Presidents of the United States follows. As the procession moves, Washington rises and salutes each figure as it passes, and it in turn salutes him. They move through the door on the other side, and it is then closed behind them. This procession moves to the accompaniment of music played by the clock itself. The music machinery is capable of playing several airs.

The mechanism also gives the correct movement of the planets around the sun, comprising Mercury, which makes the revolution once in 88 days; Venus once in 224 days; Mars once in 686 days; Vesta once in 1,327 days; Juno once in 1,593 days; Cerus once in 1,681 days; Jupiter once in 4,332 days; Saturn once in 29 years; Uranus once in 84 years. As these movements are altogether too slow to be popularly enjoyed, the inventor has added a device by which he can hasten the machinery to show its workings to the public.

There are dials which show the hour, minute and second in Detroit, Washington, New York, San Francisco, London, Paris, Berlin, Vienna, St. Petersburg, Constantinople, Cairo, Peking and Melbourne. The clock also shows the day of the week and Month in Detroit, the month and season of the year, the changes of the moon, etc. It is said that Mr. Meier has worked upon this clock nearly 10 years, and for the last four years has devoted his whole time to it.

No doubt this ingenious contrivance may make a curious and possibly a remunerative show; still it would seem that the maker's time, skill, patience, and ingenuity might have been put to better use.

Patents.

Containing notes of all Patents, Designs, Trade Marks, Labels, &c., relating to the trades represented by the CIRCULAR, granted by, or registered in, the Patent Office, since the last issue; and also notes of decisions in the Circuit Courts and the Supreme Court of the United States, which involve new or interesting points of law or practice on the subject of Patents,:

PREPARED BY CROSS & ADAMS.

Aug. 5.

PATENTS.

- 218,155. Watchmakers' Lathe Chuck. Ralph P. Bell, Fort Dodge, Iowa.
- 218,157. Buttons and Studs. William H. Blaney, Attleborough, Mass.
- 218,206. Retaining-Spring for Watch-Barrels. Warren N. Wilcox, Shellsburg, Iowa.
- 218,215. Watch Case Springs. Geo. H. Bannister, Newark, N. J.
- 218,224. Chronograph. Edward G. Boynett, New York.
- 218,267. Combined Crayon Holder and Watch Key. Jos. Hoffman, New York, assignor to Jos. Reckendorfer, same place.
- 218,268. Chronometer Movement. Peter Holler, Brooklyn, N. Y.
- 218,344. Pendulums. Oron W. Wade, and David G. White, Oskaloosa, Iowa.

Aug. 12.

- 218,368. Clock. John Ditmeier, Rochester, N. Y.—A device for communicating motion from the works of a clock to a distant dial, by means of connecting rods and pulleys.
- 218,416. Hinged Tops for Molasses Pitchers. Homer Wright, Pittsburg, Pa.
- 218,485. Ornamental Chain. Iotham P. Carpenter, Attleborough, Mass.
- 218,502. Fasteners for Watch Stems. Geo. F. Dobiecki, Brooklyn, N. Y.
- 218,556. Safety Pinion for Watches and Clocks. Chas. S. Mosely and Abraham Bitner, Lancaster, Pa.
- 218,613. Watch Winding Device. Wm. H. Zinn and Major D. Porter, Boston, Mass.

Aug. 19.

- 218,638. Buttons and Studs. Peter Nenney, Attleborough, Mass.
- 218,688. Buttons and Studs. Willard E. Robinson, Providence, R. I. A stud, the head of which can readily be removed and redjusted.

Aug. 26

- 218,864. Buttons and Studs. Chas. Downs, Providence, R. I.
- 218,916. Ice Pitcher. Joseph B. Beach, West Meriden, Conn. This pitcher has an inner vessel made of glass, porcelain, or similar material, is so constructed, that it can easily be removed.
- 218,945. Clock. John Ditmeier, Rochester, N. Y.
- 218,963. Ornamental Chain-Links. James L. Healy, Attleborough Falls, Mass., assignor to Davidson Bros., New York.
- 218,980. Clock. Joshua M. Josias, New York.
- 219,008. Manufacture of Jewelry. John Obrig, Newark, N. J. This important improvement in the art of illuminating, or producing an ornamental face for jewelry consists in cutting apertures corresponding in shape with the outline of the required design in a plate of gold or other suitable metal, and fastening to its under side a metal plate whose surface, as seen through the apertures is of a color or style differing from that of the upper plate.
- 219,040. Clock. John Treat, New York, assignor of 1/2 his right to John Karst, same place.
- 8,873. (Reissue.) Sheet Metal Spoons. Horace Whitney, and Elijah D. Goodrich, Cambridge, Mass., assignees by mesue assignments of James Fallows.

Aug. 12.

TRADE MARKS.

- 7,587. Watches. Charles Perret, Brooklyn, N. Y., assignor to Leon L. Gallet, Chaux-de-Fonds, Switzerland. "The word-symbol 'Lady Racine.'"
- 7,588. Watches. Same to same. "The word-symbol 'Railroad.'"
- 7,589. Watches. Same to same. "The word-symbol 'Continental.'"

Aug. 19.

- 7,596. Watches and Watch Movements. Auguste Saltzman, Plainfield, N. J. "The Monogram composed of the letters and character "S & V."

Aug. 26.

- 7,617. Main-spring for Watches. Cross and Beguelin, New York. "The arbitrarily-selected designation "Eugene Mathey."

Aug. 5.

DESIGNS.

- 11,314. Forks, Spoons, &c. Hiram W. Hayden, Waterbury, Conn., assignor to Holmes, Booth & Haydens, same place. Term of Patent 14 years.
- 11,323. Watch-chain and Charm. William K. Atwood, Providence, R. I. Term 7 years.
- 11,324. Table Forks. Richard N. Oakman, Jr., Turner's Falls, Mass. Term 7 years.

Aug. 12.

- 11,325. Ice Pitcher. Henry Berry, Huntington, Conn., assignor to the Derby Silver Company, same place. Term 3 1/2 years.
- 11,331. Caster Bottles. Joseph B. Beach, West Meriden, Conn., assignor to the Derby Silver Company, Huntington, Conn. Term 14 years.
- 11,333. Fork and Spoon Handles. Edward C. Moore Yonkers, assignor to Tiffany & Co., New York. Term 14 years.

Aug. 19.

- 11,359. Scarf Pin. John L. Remlinger, Providence, R. I., assignors to Wm. A. Beatty, Pawtucket, R. I. Term 3 1/2 years.

Aug. 26.

- 11,387. Pencil Cases. Ephraim S. Johnson, New York. Term 7 years.

Aug. 12.

LABELS.

- 2,033. Title: "New Patterns, Marquis Egyptian Tipped." Wm. Rogers, Hartford, Conn.
- 2,034. Title: "New Patterns, Linden Countess, Venetian." Wm. Rogers, Hartford, Conn.

An important decision affecting design patents, as to what may be included in the claim, has been made by Acting Commissioner Doolittle reversing the decision of the examiner that no sub combination of features shown could be allowed. The Commissioner holds that more than one separate and independent design cannot be claimed in the same application; but where the design is an entirety, a claim for the entire design, as well as claims for sub-combination of the parts, is allowable.

The learned Commissioner says:

"Care should be taken that an application for a design patent does not embrace claims for more than one separate and independent design. In such cases, the application should be divided, as in other classes of inventions. But where one claim is made, which covers the entire device, there is no reason why the practice in other classes, of also making claims for combinations of the separate features, should not be permitted. (Shepard, *ex parte*, C. D. 1870, 22.) Otherwise, an infringer might use with impunity almost the entire design." \* \* \* \*

"If the applicant is the inventor of a new design as an entirety, as well as of each of its parts, or several of its parts in combination, his claims should be commensurate to his rights."

Business Notes.

Kordman & Michel, lapidaries and dealers in precious stones, have removed from 32 Maiden Lane to 59 Nassau Street.

C. B. Wilkinson and J. D. Lennon, have formed a co-partnership under the firm name of Wilkinson & Lennon, and will direct their especial energies to the manufacture of Masonic pins, rings, charms, etc.

Welch & Miller announce that they will shortly issue a new catalogue of designs embracing many new and elegant patterns never before published to the trade. Copies will be forwarded to dealers on application.

Messrs. Koch & Dreyfus, of New Orleans, have opened a branch office at 20 Maiden Lane. Mr. Dreyfus will remain in town during the enforcement of the quarantine laws. The firm will then be represented by Mr. L. Hirsch.

J. A. Brown & Co. have issued an elegant illuminated show case, representative of the Ladd Patent Stiffened Gold Watch Cases. The card is unique in design, combining emblematic devices with ornamental lettering in a highly artistic manner, the whole intended to convey an idea of the progress of the age. The harmonious blending of bright colors with gold and silver tints aptly illustrates the progress made of late in the lithographic and typographic arts. This card will be sent to any dealer on application, and is well worthy of a conspicuous place on their walls.

Burbank Manufacturing Co., dealers in spectacles and eye-glasses, and makers of gold and silver thimbles, offer a large and comprehensive assortment of goods in this line that cannot fail to please purchasers. Their gold and silver thimbles have a standard reputation in the trade, and are designed to suit the requirements of all classes of dealers, while their spectacles and eye-glasses embracing a wide variety of styles are mounted in gold, silver, shell, rubber, steel, &c., and are among the most attractive goods in the market. This celebrated self-adjusting eye-glass is an illustration of which appears in their advertisement is deservedly popular, and has achieved the greatest success. Buyers visiting the city would do well to look over their stock.

With this issue of the CIRCULAR Leroy W. Fairchild presents an elegant illustrated sheet of designs in pencil cases. These are samples of a few of the latest and most desirable styles of pencils made by this well-known manufacturer, whose enterprise in this line has never been excelled. Wherever writing is practiced, there will the Fairchild pens and pencils be found. As a work of art, this illustrated sheet will bear the closest criticism; the designs are artistic, the engraving is done in the highest style of the art, while the coloring is superb. This sheet will be found of great value to dealers, enabling them to readily show to customers the latest styles in pencils. Dealers who carry but a limited stock of goods, will find it especially valuable, as they can sell by this as readily as though they had the goods to exhibit. Mr. Fairchild is entitled to great credit for the enterprise shown in thus bringing his goods to the attention of the trade, in so artistic and pleasing a manner.

Mr. Henry C. Haskell, the enterprising manufacturer of artistic jewelry is constantly introducing new and taking novelties. His last effort is "The Marquis Ring," a new design that seems to have caught the popular fancy; this has been followed by an equally attractive style called the Knickerbocker, both of which are illustrated in his advertisement. The sale of "Mispah" and "Bangle" rings has been almost unprecedented and their increasing popularity render them desirable goods for dealers. Many new and attractive novelties is being introduced in rapid succession in time for the holiday trade. Catalogue of design and price list sent to dealers on application.

Our old friend James Daggett Yerrington, of the Morse Diamond Cutting Co., of this city, has sent us some beautiful specimens of American gems, from Arizona. They consist of hyacinths, amandines and jacinthes. They are rich and exquisite in color, and, it is needless to say, are coming from the Morse Company artistically cut. Arizona is known to be rich in minerals, and continued research bids fair to develop a wealth of precious stones, suitable for personal decoration.

## Trade Gossip.

Business is booming.

Fancy buckles are worn with belts.

Mr. Henry Fera recently arrived from Europe.

Mr. Charles Glatz arrived from Europe in the *Canada* on the 28th ultimo.

Mr. Louis Strasburger returned from Europe on the 11th inst., in the *Baltic*.

Mr. Harrison B. Smith, of A. H. Smith & Co., sailed for Europe in the *Cythia*.

Mr. M. S. Smith, of Detroit, sailed for Europe in the *Britanic* on the 30th ult.

Ear-rings in Roman and Grecian designs of dead gold are quite fashionable.

E. W. Trask, of Aurora, Ill., sailed for Europe in the *Britanic* August 30.

Juergens & Anderson, of Chicago, have lately gone into the manufacture of jewelry.

S. Glickauf & Co., of San Francisco, Cal., have opened a branch establishment in Chicago.

The factories and workshops in Newark and Providence are working a full force of workmen.

J. F. Andrews has disposed of his tools and fixtures to Mr. Maass, formerly of the firm of Maass, Cook & Groschell.

A design of a badge suggested for the Jewelers' League represents one man working, and three standing looking at him.

Small gold and silver ornaments made in the form of umbrellas, guns, mandolins, etc., are taking designs for lace pins.

There are immense masses of gold hoarded in France, England, and Germany. Oh, for a mass! 'Twould give our soul repose.

A stean table in the Celluloid Fancy Goods Company's establishment, Newark, recently exploded, seriously injuring several workmen.

E. Harris and C. Shaefer, formerly with Messrs. M. W. Galt Bros., & Co., of Washington, have formed a co-partnership, under the firm name of E. Harris & Co.

One hundred cutlers and their families recently arrived in this city from Sheffield, England, they were brought out by the Freary Cutlery Co. of Bridgeport, Conn.

Ladies belts made of figured satin and woven in gold and silver is one of the latest novelties introduced by the Gorham Manufacturing Co., they are exceedingly beautiful and deservedly popular.

Francis F. Heyse, jeweler, of Brooklyn, has made a general assignment for the benefit of creditors to Robert Graham. There are two preferred creditors, John Van Der Vegt and Max Freund & Co.

The Iowa Watchmakers and Jewelers Association will meet in Convention at Des Moines the latter part of the month; a full report of the proceedings will appear in the October issue of the JOURNAL.

The way to convert modern pottery into the antique is to boil the former in oil and bury it in wood ashes. One will be astonished to find how quickly the new article will become in appearance a veritable antique.

Teardrop rings consisting of bangles with small pear-shaped pendants, are now worn in Paris. One forces as many of these rings as possible on a single finger, and it is understood that each tear is the gift of a friend.

The Boston *Post* funny man has seen a gold watch intended for a present from a lover to his sweetheart. It runs all right during the day, but takes from 7 P. M. till 3 A. M. for the hand to get around to registering 10;30.

It is rumored that the Co-operative Watch Case Manufactory, (A. A. Jeannot & Co.,) contemplate dissolving, January 1st, and will organize a new firm with Mr. A. K. Shiebler, formerly of Durfey & Shiebler as financial manager.

People who are fond of punching holes in United States coin are perhaps not aware of the fact that such amusement is against the law of the land. The penalty for so doing is two years' imprisonment and \$2,000 fine for every offence.

Silver jewelry has been introduced at the English court for half mourning. Necklaces and ear-rings to match are of beads of sterling silver, unpolished, and resembling dark pearls at a distance. The necklaces are made of graduated beads.

Newport fashion leaders are reviving bangles with a vengeance, the more dingy and tarnished they are the more antique they look. Massive gold coins attached to narrow bands are mixed with the motly collection, which cannot be too varied or too large.

The police of this city are in possession of a valuable diamond ring, that is thought to have been among the goods stolen from C. R. Link's jewelry store, at Providence, R. I. Detectives are working up the case, and a very interesting denouncement may shortly be expected.

A Paris paper is responsible for the statement that French workmen have fallen so far behind in skill and artistic design in the manufacture of numerous articles, including watches and jewelry, that the attention of the government has been called to the loss of trade this will occasion.

A sneak thief entered the jewelry store of D. & N. Weil, No. 40 Maiden Lane, and while pretending to look at some jewelry, succeeded in secreting some ear-rings, etc. on his person, finding that he was discovered, he made a dash for the door, followed by the clerk, who succeeded in capturing him.

Great change has come over the manner and style of wearing jewelry. The pink and white pearls forming a single button at the tip of the ear, which were affected a couple of years since, gave the idea of wearing diamonds during the day, and diamond button ear-rings have been the fashion during the season that has just terminated.

J. A. Montgomery, who, some since, absconded from Port Hope, Canada, with some \$10,000 worth of goods belonging to his creditors, has been arrested in St. Louis with \$7,000 of the stolen property in his possession. Montgomery is lodged in Coburg Co. Jail, awaiting trial. The Canadian authorities have admitted the goods recovered, duty free.

A Jacksonville, Florida man, is reported to have purchased a lover's alarm clock that works like a charm. At 10 o'clock it strikes loudly, two little doors open, and a man with a dressing gown and cap on glides out, holding in his hand a card inscribed "good night." As he bows and smilingly retires back into the clock, the young man takes the hint, says "Good night" to the fair daughter and departs.

Mulford & Bonnet have just introduced a new and very beautiful instrument for piercing ears. It is instantaneous in its action, and so enticing in appearance, that whoever sees it instantly desires to have his or her ears pierced. Retail dealers who desire to attract to their places of business all the beauty and wealth of their respective localities, should immediately provide themselves with this delicate instrument, whose operation gives pleasure where pain was anticipated.

Charles Bahret, a traveling agent in the employ of Sussfeld, Lorch & Co., committed suicide on the 18th ultimo, by shooting himself, in a room at the Burnet House, Cincinnati. No cause is assigned for the rash act, except that the man might have taken his life while in a fit of melancholia. Bahret had been engaged in the retail jewelry business in Poughkeepsie, where he had a wife and family, until a short time ago, when he failed. Sussfeld, Lorch & Co. were among the creditors, and after he had settled with them by paying fifty cents on the dollar, he asked the firm for a position as traveling salesman, and last March they took him into their employ. At the time of his death there was a balance due to his credit in the hands of the firm.

The crown jewels of France are to be sold for the benefit of the State. In a report presented by a legislative committee it is briefly declared that all the jewels, with the exception of a few which possess special historic claims to a place in the Museum, "will be disposed of as having become henceforth of no use." The report continues: "These jewels cannot henceforth serve the uses for which they were collected by the monarchy at great expense. They involve the cost of taking care of them, and are exposed to risks of different kinds. It is desirable, moreover, that they should not appear to any one as stepping stones to a restoration." The Chamber may accordingly be expected to parody Cromwell's phrase, and to issue an edict to "take away those baubles." It is rumored that many of the collection have mysteriously disappeared.

# THE Jewelers' Circular and Horological Review.

VOLUME X.

NEW YORK, OCTOBER, 1879.

No. 9

## THE JEWELERS' CIRCULAR AND HOROLOGICAL REVIEW,

*The recognized organ of the Trade, and the official representative of the Jewelers' League and the Watchmakers' and Jewelers' Guild of the U. S.*

A Monthly Journal devoted to the interests of Watchmakers, Jewelers, Silversmiths, Electro-plate Manufacturers, and those engaged in the kindred branches of art industry.

### SUBSCRIPTION:

To all parts of the United States, Canada, Great Britain and the West Indies,

**\$2.00 Per Annum; Postage paid.**

To France, Switzerland, Germany, Mexico, the Republics of South America, and Australia, \$2.50 per annum. Postage paid.

*All communications should be addressed to D. H. HOPKINSON, 42 Nassau Street, New York. Advertising rates made known on application.*

### Anticipated Scarcity of Goods.

THE CIRCULAR, which is a careful observer of the signs of the times, gave notice several months ago that the Fall trade in jewelry would be greater than had been known for several years. The splendid harvests which the country produced, the fact that business generally had reached a basis of hard-pan, and the fact that stocks throughout the country had been very much depleted during the years that dealers sold little and bought less, pointed clearly to a revival of trade this Fall in all branches. Other industries felt the improved demand somewhat in the Spring, but the jewelry trade, always the last to catch the effects of better times, did not feel the new impetus until the time arrived for dealers to make their Fall purchases. During the past two months the demand for goods has been so active that the indications are that many of the manufacturers will be caught with a short supply. Fearing such may be the case, some of the principal manufactories of Attleboro, Providence, Newark and other places, are running to their full capacity, even working nights to keep up with their orders. This is a condition of things that has not existed for so many years that it is almost impossible to believe it, but not only is this true, but the jobbers are doing a larger amount of business than has fallen to their lot in several years. The revival of trade so confidently predicted by us has indeed set in, and the prospects for the future are most flattering.

A noticeable feature of the new demands that the better classes of goods are required, and it is in these that the market is especially deficient. Manufacturers had almost abandoned hope of the public taste returning again to an appreciation of fine goods, and so had but light stocks of them on hand. As the country begins to feel easier in its finances, the old preference for the real and genuine articles of adornment in place of the cheap and unsubstantial, is returning. In attempting to meet the increasing demand for better goods, we hope the manufacturers will not go to the other extreme, and overstock the market. The stringency in the trade the past few years has been due almost as much to overproduction, resulting in forced and unprofitable sales, as to the hard times. It is more con-

ducive to a healthy state of trade that the supply should be within than above the demand.

As one result of improved trade, skilled labor is becoming scarce, and wages are advancing. Diamond setters can scarcely be found out of employment, while competent artisans in other branches are scarce. This is due partly to the fact, that, during the hard times the workmen in the jewelry trade have been forced to seek other employment. They readily become proficient in other industries, and naturally drift into the trades for which their peculiar localities are noted. Thus the large hat manufacturing establishments of this city and Newark have given employment to large numbers of jewelers, and they naturally stick to a trade that promises greater permanency than does their legitimate one. Scarcity of labor, however, is not likely to be of long duration, for, if the present revival of trade shows signs of permanency, and the scale of compensation is increased, the men will soon return to the bench.

Another noticeable feature of the increased demand for gold goods, is found in the number of salesmen who are setting up in business for themselves. These men, on the road or behind the counter, are keen observers, and having noted the fact that business is improving, have taken advantage of the situation to launch their own barks upon the sea of commerce. We wish them, and all others in the trade, abundant success. But we also warn them to go slow. There is a possibility that this business revival may be but a sudden spurt, and that the time is not yet ripe for the return of permanent prosperity. Do not be carried away with a hurrah, but judiciously cut your coat according to your cloth. Above all, now is a good time to obliterate that great abuse in the trade—deceptive alike to buyer and seller—placing goods on memorandum. Cater to the honest, legitimate demands of the public, but do not try to force the market by overstocking dealers and having the goods turned back on your hands, thus converting what was apparently a good season, into one of disaster. A permanent and successful business is a creature of slow growth, requiring careful and judicious nursing. Prosperity that comes to stay must be courted as delicately as a coy maiden. Don't be precipitate and frighten the fair damsel.

### American Workmen.

NOWHERE is there so great a versatility of talent among workmen as in this country, and nowhere is it more conspicuously displayed than in the jewelry trade. It is a common saying among us, alluding to a workman whose talents are numerous, that he is a "jack of all trades," and it is not uncommon to find men who are skilled in half a dozen trades. The jewelry business combines half a dozen or more different branches, each of which, in European countries is practiced as a distinct and separate industry. Here, however, the practical jeweler is supposed to be a watchmaker, an engraver, a mender of trinkets, a good salesman, and, not unfrequently a designer, and very often an inventor and patentee. Indeed, if he is also the proprietor of a retail store, he is expected to know and do all these things, buy and sell all kinds of goods, and to have an intimate knowledge regarding each and all of them. As a rule he is found equal to the emergency, and not only satisfies his customers but

makes a good living by prosecuting his multifarious callings. There is something in the atmosphere of America, that breeds enterprise, and tends to develop all the latent talent of which a man is possessed. The encouragement given to genius puts every man on his mettle, and he becomes ambitious to rise above the sphere of life into which he was born and educated. Our national maxim, "one man is as good as another, if not better," teaches him that he is liable to be struck with sudden wealth, and, consequently, with social position and recognition as another, and this acts as a spur to his ambition, developing the best there is in him. In European countries, the law of caste prevails to such an extent, that there is little hope of a man's rising by his own energies. He is born a blacksmith or a watchmaker, is trained up in the paths his father tread in, and such are the laws of caste, he has little prospect of departing therefrom. He becomes a machine, does what his father did before him, in the same manner that it was done by his progenitors generations before. He is trained to a specialty, and has no ambition to go beyond that specialty. If he is a watchmaker, the idea of engraving or selling goods, of designing or inventing anything seldom enters his head. He is content to plod along in the rut assigned him by the laws of caste, never hoping to rise above the social level into which he was born, and expecting to see his children follow in his footsteps. The reverse of all this characterizes the American workman. He has the world before him, and is taught that he is and will be what he makes himself; that there is plenty of room at the top of the ladder, and that the topmost rung is as free for him to occupy, if he can reach it, as to the greatest favorite of fortune. Hence the versatility of our artisans, and hence also, the number of men who have risen from the workman's bench to positions of trust and honor. The jewelry trade offers special facilities for the advancement of those who devote themselves in early life to mastering its practical requirements. New York points with pride to its many wealthy and honored citizens who commenced life as apprentices in the jewelry trade. That trade developed their latent talents and offered them a fitting field for its exercise. Versatility made them useful, the facilities offered them to master the trade in all its branches, developed in them an ambition to rise above the bench, and their industry and application achieved the result. In no country in the world does the workman have so many advantages as in this, and no country can show so vast an army of intelligent, skilled and ambitious workmen.

### The Clock Trade.

THE present condition of the clock trade is very far from satisfactory to manufacturers. While there is little complaint as to the demand for clocks, the prices realized from their sale are not calculated to inundate manufacturers with sudden wealth. The introduction of an inferior grade of goods, of the very cheapest class, has tended more than anything else to bring about this unfortunate condition. By catering to an irregular demand for an unusually cheap grade of goods, manufacturers have over-reached themselves, for dry goods men and other outside buyers, have entered into competition with each other in the sale of clocks, and, as a consequence, the manufacturers have had their prices cut down till the profits are so small that they are not perceptible without a magnifying glass. It has got so now that fancy goods and notions dealers, dry goods merchants and many others, keep lines of clocks, of a cheap grade, that are especially manufactured for this outside trade. These are forced off upon the public, without any guarantee, and, consequently, to the great injury of the general trade. When a watchmaker or a jeweler sells a clock, he is required to guarantee it for a certain length of time, and to repair it if it gets out of order. But with outsiders, no guarantee is given, nor can they be expected to do any repairing. These cheap goods have been sold of late regardless of cost. The outside dealers usually order largely and pay cash, and the manufacturers' necessities make the cash a desirable commodity for them to

handle. As a consequence of this degradation of the standard of American clocks, the country has been flooded with cheap and inferior clocks, each one of which has taken the place of a better one, and has also served to bring discredit upon this branch of American industry. By thus degrading the quality of their goods, and selling them with little profit, the manufacturers have interfered largely with the sale of their better grades of goods, at the same time that they have inflicted serious injury upon the retail dealers, who have been forced to compete with these outsiders.

This degradation of the clock manufacture to the level of the chromo business is in every way to be regretted. There are regular channels through which the manufacturers can reach their customers without catering to irregular outside influences. The regular jobbers and retail dealers can handle all the clocks for which there is a demand, and when that trade is diverted into other channels it can only result in injury to all those who are or should be directly interested in disposing of this class of goods. The public is also injured from the fact that cheap and inferior clocks are imposed upon them without any sort of guaranty, and from which there is no appeal. It is to be hoped that manufacturers will speedily discover the error of their ways, return to the legitimate avenues of trade, and no longer seek the adulterous arms of outsiders. Above all they should limit their productions to those classes of goods that will reflect credit upon them, and be worthy of the high reputation hitherto achieved by the manufacturers of American clocks.

### Obituary.

DAVID R. GROW.

WE regret to announce the death of Mr. D. R. GROW, at Maywood, Ill., on the 16th of September. He had been connected with the Waterbury Clock Company for more than twenty years, and for the past ten years was their representative at Chicago. By his ability, and devotion to the best interests of the trade, he had won the respect of all with whom he came in contact, and the personal regard of dealers in this line of goods.

At a meeting of the wholesale jewelers and clock manufacturers of Chicago, held at the rooms of the Chicago Jewelers' Association, the following resolutions were adopted:

*Whereas*, It has pleased divine Providence to remove from our midst Mr. DAVID R. GROW, who for many years has been intimately associated with us in our business and social relations;

*Resolved*, That while we bow in submission to the divine will, we feel keenly in his death the loss of a genial friend, an esteemed competitor, and an honorable, an upright business man; and that we extend to his family our sympathy and condolence in this great bereavement.

*Resolved*, That this action be communicated to his family, in behalf of the wholesale and retail jewelers and clock trade, and other business associations of Chicago.

Touching tributes to the memory and character of the deceased as a business man were paid in appropriate remarks by M. F. TOMPKINS, Mr. C. H. MORSE and Mr. M. BAILEY.

Copies of the resolutions were ordered to be engrossed upon parchment and framed, to be presented to the family of the deceased and for the rooms of the Chicago Jewelers' Association, of which the deceased was a member.

ISAAC SPEER.

MR. ISAAC SPEER, senior member of the firm of I. & C. W. SPEER, Jewelers, died in Chicago, September 20, in the 70th year of his age. Mr. SPEER was born in 1809, at Fairfield, N. J., but removed to Chicago in 1840, where he has since been identified with the jewelry trade. He lost heavily by the great fires with which Chicago was visited, but recovered sufficiently to leave a moderate competence to his family. He was accustomed to say that his real public work was limited to voting honestly, and to having once had the honor of presenting a liberty-pole to the city of Chicago; this latter act having been done in 1846, when he brought a liberty-pole from the region of St. Joe, which was said to be the first one ever conveyed to or planted in this country. In a word, ISAAC SPEER was a good example, during his long life in Chicago, of a quiet, upright business man, and of the truest sort of a citizen.



### The Iowa Retail Dealers Association.

WE print elsewhere a report of the recent meeting of the Iowa Association, held at Des Moines. The meeting was spirited and full of interest, and the address, which we print, show the spirit that animates the members of the Association. We regret that want of space precludes the publication of a more extended report of the proceedings.

It will be seen from the address made by Mr. Shurly, President of the National Guild, that the retail trade is moving in the matter of a stamp as a guarantee of the quality of the goods which retail dealers are required to sell. At present they are as ignorant of the quality of the goods sent them by the manufacturers, as the public that buys them. Goods represented to be 14 or 16 carats fine, may be debased to any extent and the retailers be wholly unable to detect the fraud. They need protection quite as much as the public does. In the absence of a national standard for wrought gold, the National Guild proposes to adopt a stamp, and have it placed upon goods specially manufactured for the members of the Guild, by manufacturers who give a satisfactory guarantee that the goods are precisely what they are represented to be. Some manufacturers have already entered into this arrangement, and the negotiations are pending with others, so that it is hoped before long the members of the Guild will be supplied with full lines of goods that they can conscientiously recommend to their customers, and guarantee to be of the quality represented.

Manufacturers generally would find it greatly to their advantage if they would voluntarily adopt a stamp for their goods which should be a guarantee to purchasers that they were getting the value of their money. Robbins & Appleton have long affixed a certificate of this character to watches manufactured by them, whereby purchasers are assured that the case is manufactured of gold of a certain degree of fineness. The well established reputation of the firm is all the guarantee required, and the certificate is evidence that the goods are of their own manufacture, and consequently not subject to imposition. By this means an extensive foreign as well as domestic demand for their goods has been created and they are reaping the reward of the policy adopted by them. If other manufacturers would do the same the public as well as themselves would be great gainers thereby.

THE Directors of the Mint at Washington has sent out a circular to manufacturing jewelers, asking them to furnish him a statement showing their annual or monthly consumption of gold and silver in the manufacture of their goods. He desires to know how much of the metal consumed is from United States coin, how much from bullion, and how much from old manufactured articles. His object is to get correct statistics relative to the production and consumption of gold and silver. It seems to us that this is a very round-about way of getting at the desired information, and would suggest that instead he apply to the various assay offices, public and private, and get their returns of precious metals assayed during any given period; he knows how much is consumed in the manufacture of coin, and can ascertain how much is exported; the difference between the amount assayed and that coined and exported goes into manufactures. There is, also a certain amount of coin used in manufactures, but the amount of this cannot be even approximately ascertained owing to the large number of persons engaged in the business, many of them small capitalists working for other parties, who are never known to the public, and cannot be reached by circulars from the mint. The nearest approximation that can be made to the quantity of precious metals used in manufactures is to be obtained in the manner we have suggested.

RECENTLY, a young man, representing himself to be an agent of M. M. Rouvenaut & Cie, of Paris, rented the premises, No. 21 John Street, and branched out in the jewelry business. He first employed, carpenters, painter, etc., to put the premises in excellent and attractive condition, and engaged a gentleman favorably known

in the trade to assist him. By virtue of his assistant's acquaintances, he obtained credit for a small amount of jewelry, and commenced operations. His first month's rent he paid by a draft on Rovenaut & Cie, which the landlord accepted, supposing it to be all right. In a few days, however, he ascertained that the Paris firm knew nothing about the young man who claimed to represent them in New York, and the draft was returned dishonored. Meantime the carpenters and painters clamored for their pay, but the young man's remittances have not yet arrived. He is supposed to be the person known as Gerrnd Fuller, who has been identified with similar swindling transactions before. His business at No. 21 John Street has been discontinued.

THE fall trade has commenced much earlier this year than usual, and large amounts of goods have already been sold. Of course the early buyers get the pick of the market, new styles of goods being snapped up greedily, while those that are a little *passé* are taken to fill in with. Manufacturers have been so long catering to a dull demand that they were not prepared for the rush, and are now busy making up an extra supply of choice goods. We advise dealers to forward their orders as soon as possible. If the demand is active now, what may be expected when the holiday trade sets in? Those who covet a choice of the new goods presented this season cannot send in their orders to soon.

AT the recent Convention of the Illinois Jewelers' Association, at Decatur, it leaked out that the traveling agent for a certain Chicago jobbing house, while at Red Oak, Iowa, sold \$185 worth of jewelry to the guests and chambermaids of the hotel at which he was stopping. The purchasers took the goods to the local jewelers to find out their intrinsic value, and in this way the tricks of this "road agent" were made known. The local jewelers immediately wrote to the principal of the jobbing house referred to, and he replied that his traveler had exceeded his authority. If this be true the offending traveler should be dismissed at once before he has further opportunities for pirating on the retail trade.

A CONTEMPTIBLE trick has lately been observed in Maiden Lane, and vicinity. No sooner does an express wagon drive up to the door of a respectable dealer to receive packages than it is instantly surrounded by half a dozen boys trying to spy out the names of the parties to whom these packages are sent. This information is used by the employers of these boys, who send circulars and price-lists to the addresses thus surreptitiously obtained, and in other ways seek to injure the trade of respectable dealers. This may be a *smart* way to train up a boy to commercial pursuits, but it seems to us to border closely upon petty larceny.

WE present with this issue the first of a series of articles by Professor ALFRED M. MAYER, upon the "Demagnetization of Watches." Professor MAYER is widely known as a scientist of deep research and great ability; the present series of articles will add greatly to the information of those who are studying one of the most interesting subjects connected with the horological art.

### A Wonderful Invention.

THE deaf can hear by means of their teeth! The audiphone, an instrument invented by a Western Yankee for alleviating the misery of deafness, is simply a sheet of vulcanized rubber, about 1-22 of an inch in thickness, set firmly in a handle of the same material. In the upper rim of this sheet are pierced some holes, through which passes a silken cord. This goes down on the inner side of the sheet, to the handle, through a slot in which it passes. By pulling this cord the sheet is bent over at any angle the user may desire. Each person has to ascertain for himself what kind of a curve of the rubber sheet will enable him to hear best. Generally it is very slight—only about 10 or 12 degrees—though apparently the deafer the person the

greater the curve must be. When used, the person holding it simply touches the upper edge of the fan or audiphone against his teeth of the upper jaw. The voice of the speaker strikes upon this tense sheet of rubber, and communicates to its vibrations, which in turn are imparted to the teeth, and then pass to the auditory nerve. With this operation the outer ear has nothing whatever to do; the delicate machinery through which sound passing from without makes an impression upon the auditory nerve is not used at all. The outer ear may be stopped up entirely, so far as it is possible to do it, and yet one hears distinctly the moment the audiphone is applied to the teeth. It is necessary to use the teeth of the upper jaw for the reason that they are more nearly in contact with the auditory nerve; nor does it make much difference whether the teeth be one's own or artificial, so long as those artificial teeth are tightly fitted; for when that is the case, the vibration is imparted about as well as when they are natural teeth. The inventor is deaf himself. He happened one day to hold a watch between his teeth, and noticed that he could distinctly hear its ticking, though when he held it to his ear no sound was audible. This set him to thinking that possible he might be able to invent some device by which the sound of human voice could be transmitted to the auditory nerve through the medium of a tube, just as the ticking of a watch had been.

### The Story of a Ring.

A DAY or two ago a jeweler of the Rue Rambuteau was much surprised by a visit from a working man, who offered to sell him a splendid diamond ring, worth at least 10,000 francs, for the small sum of 400 francs. His suspicion being aroused by the divergence between the value of the trinket and the sum asked for it by the would-be vender, he said he would call at the abode of the latter, Aubervilliers, on the morrow and pay the amount. The workman, apparently well satisfied, went off, and the jeweler immediately communicated the matter to the Commissary of Police, who proceeded to Aubervilliers, and found the possessor of the ring at supper, surrounded by his half a dozen children. On being told that the ring was worth 10,000f. he evinced much unaffected astonishment, and said he could not understand how his sister could have sunk such a sum in a ring. Upon inquiry, in fact, it turned out that his sister had undoubtedly left him the ring upon her death two years previously, and that she had acted as lady's maid to the wife of a nobleman attached to a foreign embassy. This news gave the official a clue which he was not tardy in following up. Having presented himself at the diplomatist's residence, the wife of the latter at once recognized the ring as one that had mysteriously disappeared six years before. The upshot of the affair is that the workman, who had acted throughout in good faith, and had stated that, had he known the ring was not honestly and justly his, he would have taken steps to return it, is rewarded by the rearing and education of his six children, being taken in hand by the rightful owner of the jewel. Thus the matter ends happily for all parties. The lady very unexpectedly recovers her lost diamond, and the workman's honesty is adequately rewarded.

### Patents.

Containing notes of all Patents, Designs, Trade Marks, Labels, &c., relating to the trades represented by the CIRCULAR, granted by, or registered in, the Patent Office, since the last issue; and also notes of decisions in the Circuit Courts and the Supreme Court of the United States, which involve new or interesting points of law or practice on the subject of Patents.

PREPARED BY CROSS & ADAMS.

Sept. 2.

#### PATENTS.

219,081. Combined Watch-Chain Bar and Pencil. Leroy W. Fairchild, New York. A hollow chain bar, in combination with a detachable pencil-case, constructed in telescopic tubular sections, which are extended to their full capacity by the withdrawal of the pencil from the case, and retracted by returning it thereto without further manipulation.

- 219,091 & 219,092. Ornamental Chains. Chas. F. Heckmann, Plainville, Mass.
- 219,097. Alloy for Jewelry. William Wheeler Hubbell, Washington, D. C. The alloy metal of gold, silver and copper, for jewelry, watch-cases or gold-ware, consisting of 24 parts, of which 16 parts or thereabout are gold, the remainder, 8 parts being an alloy, 2 4-10 parts or thereabout silver, and the rest copper, forming a solid ternary alloy.
- 219,202. Dies, for Manufacturing Jewelers' Settings. Christian Blanchard, Jersey City, N. J.
- 219,204. Sleeve Button. William Bourke, New York.
- 219,218. Process of Reducing Celuloid Tubes to Paper or Other Forms. Wm. B. Carpenter, Newark, N. J., assignor to himself and the Celuloid Novelty Co., same place.
- 210,265. Alloy Metals for Metric Silver Coin and Silverware. Wm. W. Hubbell, Washington, D. C. Gold, silver and copper; 895.8 parts of silver, 42 parts of gold, and 100 parts of copper.
- 219,279. Celuloid Linings for Ice Pitchers and Vessels of a Similar Nature. Marshall C. Leferts, New York.
- 219,325. Sleeve and Collar Buttons. Rickerson M. Tripp, New York.
- Sept. 9.
- 219,350. Buttons and Studs. Wm. R. Dutemple, Providence, R. I., assignor of half his right to Israel M. Hopkins, same place.
- 219,371. Shirt Studs or Buttons. Doliver S. Spaulding, Mansfield Mass.
- 219,445. Jewelry Charms. Solomon Coleman, Taxing District of Memphis, Tenn.
- 219,468. Cases for Spectacles and other articles. Edward J. Hauck, Brooklyn, N. Y.
- Sept. 16.
- 219,564. Pocketbook. Wm. E. Beames, New York. The combination of a portemonnaie or pocket-book, a bracelet or band for the wrist, and a locking device which detachably fastens the same together, said parts being adapted to permit the portemonnaie to be removed from the arm without removing the bracelet.
- 219,642. Jewel Caskets. Wm. L. Martin, Middletown, Conn., assignor of half his right to Geo. J. Russell, same place.
- 219,646. Method of Manufacturing Plated Stock for Jewelry. Andrew M. Murray and Edward Bent, North Attleborough, Mass. This method consists in soldering together, edge to edge, pieces of rolled plated stock of different colors, cut into regular shapes, so as to produce on one side of the composite plate a multi colored surface of plated metal, and on the other a similarly formed surface of base metal.
- 219,675. Pendants for Watch-Cases. Casimir H. Bisson, Henderson, Minn.
- 219,760. Gem Settings. Chas. F. Quimbey, Attleborough, Mass.
- 219,772. Method of Fastening Gems. Joseph Schuehr, Paris, France.
- Sept. 23.
- 219,807. Casting Metals with Platinum. Jean B. A. Dodé, Rheims, France. (Patented in England, Jan. 19, 1877.) A process of platenizing metal enameled or otherwise, by the employment of a mixture in which platinum is held in suspension by an essential oil.
- 219,889. Combined Napkin Ring and Support. Annie C. Winn, Boston, Mass., assignor to E. A. G. Roulston, same place.
- 219,908. Coffee Urn. Julian A. Chase and Preserved W. Arnold, Pawtucket, R. I.
- 220,002. Manufacture of Spoons and Forks, and 220,003, Spoons and Forks, Robert Wallace, Wellingford, Conn. Spoons and Forks manufactured from cold-rolled, homogeneous steel, and coated with silver.
- Sept. 30.
- 220,036. Astronomical Clocks or Cosmochronotropes. James F. Sarralt, Steubenville, Ohio.
- 220,050. Ice Pitchers. S. Wm. Babbitt, West Meriden, Conn.
- 220,080. Manufacture of Spoons, &c. Alfred E. Lyman, (Arthur W. Lyman, Administrator,) Brooklyn, N. Y., and Arthur W. Lyman, Geneva, Ohio. In the manufacture of spoons, ladels, &c., the handle, formed with lips, one having a projection or projections, and the other a correspondingly shaped depression or depressions, and the bowl inserted and clasped between the lips.
- 220,195. Split-Second Time Register. Wm. A. Wales, Newton, Mass., assignor Wm. B. Fowle, same place.
- Sept. 2. DESIGNS.
- 11,388. Pens. Geo. Bradford, Mt. Vernon, N. V. Term 14 years.
- Sept. 9.
- 11,405. Clock-Case. Geo. Muller, New York, assignor to the Seth Thomas Clock Co., Thomaston, Conn. Term 3½ years.
- 11,409. Jewelry Settings. Chas. F. Wood, Summitt, N. J. Term 3½ years.
- Sept. 16.
- 11,413. Bracelet. Thomas G. Brown, New York. Term 7 years.
- 11,414 to 11,419, inclusive. Pencil Cases. LeRoy W. Fairchild, New York. Term 7 years.
- 11,420. Badge. Geo. Wolf, Louisville, Ky. Term 3½ years.
- 11,422. Pencil Cases. LeRoy W. Fairchild, New York. Term 7 years.
- Sept. 23.
- 11,431. Spoon and Fork Handles. F. Willson Rogers, Hartford, Conn. Term 7 years.
- 11,432 to 11,435, inclusive. Pencil-Cases. LeRoy W. Fairchild, New York. Term 7 years.
- Sept. 30.
- 11,441. Pencil-Case. LeRoy W. Fairchild, New York. Term 7 years.

### Meeting of the Iowa Retail Jewelers' Protective Association.

THE second annual meeting of the above named Association was held at Des Moines, Iowa, Sept. 10, 1879. The Convention was not so numerously attended as it was anticipated, owing to the fact that the date for the meeting was unfortunately fixed at a time when twenty-nine Counties in the State were holding their regular Agricultural Fairs. As these are occasions when country retailers pick up a goodly amount of trade, they were forced to send their regrets to the Convention for their enforced absence. What was lacking in members, however, was made up in spirit, and the proceedings were highly interesting.

The Convention was called to order by W. N. Boynton, the President, who, after roll-call, delivered the following address :

#### THE PRESIDENT'S ADDRESS.

*Gentlemen of the Association :*

We have met in this, our second, convention, for the consideration of questions of importance to our future, as merchants, as mechanics, as good citizens, and I hope you have come, freighted with words of wise suggestion, for our mutual good. I need no better evidence than your presence here, to convince me of the interest you take in the movement we have set afoot—a movement, the wrong doings, the greed of those who should have been our friends, forced us to make.

For years we have borne with mean meekness, the thrusts of the jobbers' steal—(mark I spell this steal with an *a*) bending our energies to the war amongst ourselves, till the heavy oppression from without crushed the dissension within, and melted our jealous hate into love for common good.

Scarce six months have passed since we cast aside the gauntlet of local rivalry to meet in convention, at Marshalltown. A mass of honest hearts, heavy with the doleful outlook before us, unschooled in politics, unskilled in diplomacy, unversed in matters of state, but made brave by oppression, determined to devise by some means, a remedy for the wrongs we suffered. Smarting under the wounds we bore, we pledged our faith, henceforth, to work in unison. That day, when we clasped hands, as brothers tried, all green-eyed dissension died, and the new-born spirit of friendship, cried "shoulder to shoulder, we will force the usurping jobber to respect our rights, or hurl him from his throne"—Words he may well heed, for they are being repeated by Illinois, Nebraska, Missouri, Minnesota, Wisconsin, Ohio, Michigan, Indiana, Kansas, Kentucky, and Tennessee, and will continue to spread, passing from State to State, till they sound throughout our land. Gentlemen, this uprising, this banding together of the jewelers of our great North-west, is no boy's play—a thing of to-day, to-morrow dead; but the earnest work of determined men, whose rights have been ignored, trampled under foot, by parties they have done much to enrich, who will never give up till they force history to repeat itself. "When the oppressed rise they carry the day." In my mind, my friends, that day is not far off. Before this Convention adjourns, I think we will hear the cock crow that ushers in the morn, the dawn of that day when the rights of the honest retailer will be respected, and the indiscriminate, catalogue issuing jobber left in silence and alone to watch the busy spider weave his web from clock to clock, that has long since ceased to tick, to catch the lonesome fly, as he spots the undusted wares, with the trade marks of time.

At the Chicago Convention, where I had the honor of representing this Association, it was thought best, for the purpose of bringing about a more complete co-operation of the several State Associations, to form an organization, made up of delegates from the several State Associations, whose duty it should be, to legislate for the general guidance of the several State organizations, as a sort of Congress or Grand Lodge, which we called the Watchmakers' and Retail Jewelers' Guild of the United States. For officers of this Guild we elected Capt. E. R. P. Shurly of Chicago, President, who to-day is honoring our Convention with his presence, and will follow me with an address. I am sure you will be pleased to hear, 1st Vice-President, W. R. Weld of Iowa, 2d Vice-President, L. Beckman of Indiana, 3d Vice-President, John Baumer of Nebraska, 4th Vice-President, A. P. Robinson of Minnesota, 5th Vice-President, G. W. O'Harra of Michigan, 6th Vice-President, A. J. Lawrence of Kansas, Secretary J. Harris, of Illinois, Treasurer A. Kempfer of Illinois. All of the above named gentlemen are well known to be able and energetic workers in the cause for which we are struggling. Gentlemen, the formation of this Guild, I hope you

will heartily endorse, as our State organization binds its members to work in unison, so this Guild binds the State Associations into union of action, and will prove the mighty lever that shall sweep these illegitimate catalogues from the face of our land into that abyss of the damned, where their publishers can revise them at their leisure. But gentlemen you will hear more of the proposed workings of this Guild from its able President, also as to what is being done by the retail jewelers in other States.

Gentlemen, you will pardon me I trust, if I repeat in part what I caused to be published to you with my report of the Chicago Convention. The part I refer to is in relation to the Guild stamp—for this dawn, this day-break, this new light I have spoken of is to come through our Guild stamp, *an honest stamp to stamp honest goods for honest men to sell*. A stamp that would meet the approval of that honest Irish member of parliament, who moved for the benefit of his constituents, that there be a law passed to take effect throughout the United Kingdom of Great Britain "that a quart bottle should be made to hold a quart." What we want is better goods and a better guarantee as to quality, than the mere say-so of any manufacturer or jobber, or their traveling agents. Our honor as professional jewelers demands that we know the quality of the goods we handle. Our customers think we do, but we know we do not, nor can we school ourselves to tell with certainty the wearing qualities of goods known as "rolled plate."

Only a few days ago, I took back from a customer a ladies breast-pin, which I had bought for and sold as being good rolled plate only a few months before. The pin, when new, looked well, and was of good finish, but the gold on it was as thin and gauzy as the conscience of its maker. I care but little for the dollar and a half I lost, but, my friends, it was mortifying to be forced to indirectly confess ignorance or knavery. But I drew comfort from the thought that if God would spare me to meet with you to-day, I would beg of you to take such action as should prevent any member of this Association from experiencing the chagrin I then felt. It is to J. H. Purdy of Chicago, I am indebted for the first idea of stamping our goods with a trade-mark that should be our own. An idea that is destined to make him as popular with the people as he is to-day with the majority of the Iowa jewelers. This Mr. Purdy is now in New York to see what arrangements can be made with the manufacturers there. He will also visit Providence, R. I., to see if Providence will smile on our Guild stamp, in making plated goods. There is no fear but we can find plenty of manufacturers who will give the bonds and be glad to make the goods. The date of our Convention places the Iowa jewelers in position to take the initiatory step, which you will find other States will follow. When our Guild Stamp is patented and arrangements made with our chosen manufacturers, we will have some handsome placards struck, displaying our Stamp and the private stamp of each manufacturer with a copy of the contract made, and bond given as a guarantee against fraud. This placard we can have framed to sit upon our show cases, to show our customers the reason why we know the goods we handle are of the quality we claim for them. Gentlemen, with such a guarantee we can drive all other goods out of the market in point of competition. Gentlemen, I hope you will give this matter of stamping goods due consideration, and if you approve of the idea, will appoint a committee to consult with Mr. Purdy and the executive committee of the Guild, who can have our stamp patented and arrange with the manufacturers.

Now, my friends, I have a word to say in regard to the jobbing houses, to-day borne on our black list as having forfeited all claims to our future patronage. We have given these houses due warning of our grievances, and of our determination; we have done more; I myself have patronized some of these houses since last March, after receiving a promise that no more catalogues would be issued to parties outside the legitimate trade. You may ask me if I believed what they said when this promise was made; I answer I did not, but deemed it best to try them as a matter of policy as well as a matter of justice. In my mind it was policy to prevent an open rupture, if we could be assured of good conduct in future, as few of us were prepared for war. I deem it unjust to punish a man for an act committed before any law existed declaring the act a crime. Some of you may think me too conservative in this matter. To such I would say, I did what I thought politic as your President, and what I thought right as a man. These houses must now go by the board, so far as our patronage is concerned. The fault has been their own and they must abide by the issue.

My friends, I have already taxed your patience long enough, but I cannot pass this opportunity without saying a word concerning our bench-work and the poor prices paid for our labor. When we consider the amount of time expended in schooling to master the work at the bench, the trials and tribulations we have to pass through,

from the green apprentice, to the cub, from the cub to the jour, from the jour to the master-mechanic, we have to confess no class of men are so poorly paid. I would that the jewelers of this Association might rise above the grease of the mechanic, and, like lawyers, struggle to make their reputation place the price of their fees. It is always the poorer mechanic that cuts down the price of work. He says so himself, for the very act confesses to the world that he lacks skill and ability to compete fairly and squarely with his competitor. But this class of watchmakers do not belong to our organization. "Do good work and charge good prices," should be the motto of the watchmakers of this Association. We have lived through several years of "hard times" and have been forced to charge for our work in keeping with the purses of the people—I say we have lived through, and so we have. Business of every kind is picking up, and all hearts are joyously welcoming the dawn of better days. Is this not the time we should resolve on fairer prices for our work? We know that with most of us, our bench-work is the mainstay of our business, it is from this our principle revenue comes. It is from this we support our homes and school our children; it is from this we must provide for old age. If we trifle it away, the fault is our own, we have the remedy in our hands. It is for us to say whether we work with profit to ourselves or give our hard earnings to a thankless people.

The address was received with applause, and several gentlemen briefly coincided with the sentiments expressed.

Capt. E. R. P. Shurly, President of the Watchmakers' and Jewelers' Guild of the U. S., being called upon, spoke as follows:

Mr. President and fellow-workers: In a cause as noble as that which animated our fathers in the warfare for the benefit of the human race—your fair State is one of the monuments of their success, and your Association from its appearance is destined to be a monument of our success. When I see the earnest faces and the interest evinced, I can say it matters not with other States, but in this, success is assured, even as our fathers achieved success although at the expense of a political war, so will we, but with the pen, and what is yet more potent, the purse. They desired the equality of man before the law, we desire the equality of trade. We have embarked in this with a fixed determination to accomplish our object just as the earlier settlers in your beautiful State said, "we will remain here and our arms shall defend our homes." We have entered upon a work that is noble because it is just. It may not benefit us as much as it will those who are studying the rudiments and will be our successors in the jewelry trade.

The sun will rise and set many times before we surrender our trade as a distinctive business. Already our organizations have done a vast amount of good; I need point you only to the trade paper of the day (*The Jewelers' Circular*), for an illustration; a perusal of the advertisements in that, will convince you that the heaven is working. And here let me say that we are deeply indebted to *The Jewelers' Circular* for aid and comfort in this movement. But I presume all of you take it as it is essential to us for the trade news of the day. I sincerely believe that nearly all of the jobbing houses in Chicago are doing a legitimate business. The few houses that still persist in following the old path will ere long cease to be jobbing houses and you must, from principle, cease to patronize them. I am aware that many of the manufacturers and jobbers think we are merely at play; that the movement is of no consequence and will gradually cease to exist. Some of the eastern travelers scout the idea of a successful Association, yet I noticed that when a traveler for a prominent eastern firm was accused of peddling to persons outside of the trade, their response was emphatic "we will discharge any man in our employ that does so." I believe the western jobbing houses are behaving themselves; they say that any of their employes selling outside of the trade while on the road will meet with prompt dismissal. I can say that all cases reported to the officers of the Guild will meet with prompt attention, and the resolutions adopted in May at the National meeting is binding on the States and I trust will be lived up to. I know that we will succeed. The ringing words of your President will sound in your ears long after you have left this city. In another way their organization will be of incalculable benefit and the means of rational enjoyment. They will cause the members of the trade to become acquainted, to know each other to bring to the surface those genial feelings so antagonistic to selfishness and jealousy, and warm up the best instincts of our nature. We do not know it but I can tell you that the watchmakers are as a class most intelligent gentlemen? their neighbors know it; the barber knows it, the gunsmith, and especially his own family know it, all the village know it, people like to lounge in his store; he is witty, full of anecdote; who can tell so good a story, or raise

a laugh so quickly, or is more ready to aid the needy and distressed? Yes, the universal decree is, he is a clever fellow, but the other watchmaker across the way don't know it, he swears he is quite the reverse. Both are of the opinion that about the meanest man in town is that other watchmaker; these associations will introduce these men, and prove that the verdict of the people was right, and bring these watchmakers and jewelers together; make them acquainted. "Why hang it," says Brown, "I never thought that Smith across the way was such a clever fellow." That is not all, but pleasant associates spring up and friendships that are lasting. Some of the most pleasant acquaintances and friendships have been formed by me since these organizations were inaugurated, and if nothing more is accomplished, I shall bless the movement for that; but much has been done, although to many it may seem nothing; it is a matter to accomplish such lasting results that the good can be seen at once, but I tell you gentlemen that these organizations are a necessity, every trade and calling in the last few years have found it so. Competition on the one hand and the avarice of the human race on the other, have ruined trade, driven it out of its legitimate channel, and is building up monopolies to our sorrow; but we will achieve success; we must succeed in this contest. But the retailer of every State and Territory must stretch forth his hand to aid; we must have his personal influence as well as his dollar: the whole human race has been fighting the devil for these thousands of years, and yet have not succeeded in driving him out of the employ of some of the jobbers; we have only been in this contest a few months, but in addition to your state, Indiana, Michigan, Kansas, and other States are moving, to say nothing of the Watchmakers' and Jewelers' Guild of the United States, which Association I have the honor to represent. I assure you that society is a working organization. As States form Associations so will its labor be lighter. Yes, sir, we mean business; we mean it squarely and honestly, and will continue the fight until those who have advantages from the manufacturers to sell to the trade shall do a legitimate business. We propose to raise the standard of the goods sold so that the Guild stamp shall be a guarantee of the quality of the stock, and I predict that within three years time the goods most sought after in our trade will be those bearing that stamp. I heartily agree with your President in this matter, and see no reason why a state organization should not have a stamp, although it might be better in after years when all the States are organized to have a U. S. Stamp. I have had quite a voluminous correspondence with many of the manufacturers upon this point. Some are afraid of offending the jobbers by making such an agreement. The executive committee of the United States Guild have authorized the Hampden Watch Co. to make sample movements (eight grades) that can be procured by members of the States and U. S. Societies and none other. The Company have pledged themselves not to sell those to jobbers. The trade mark has been secured, which is "Watchmakers' and Jewelers' Guild." These movements are to be made in a very superior manner; I consider this will, in a measure, settle the watch question. At all events, it is an experiment worth trying, if they prove as good and profitable as we hope.

Another matter I consider vital that has been touched upon, is the gradual decrease in the price of watchwork; also, in the wages of journeymen, a decrease greater in proportion than the fall in gold or other commodities warrant; a fall to that degree that we may well say "what are we coming to." We all know that the majority of the people who wear watches are entirely ignorant of the mechanical parts of the instrument; they look upon it as being something as simple as a door lock, and cannot see exactly when a bill comes in for repairing that watch; neither can they imagine that one or two days can be passed away upon the intricate parts of that machine, and then the work is not done. But for some reason, many of those carrying watches, men too, who are fair and liberal in other matters, will beat the watchmaker if possible, and he seems to be willing they should. Of course, the custom of guaranteeing the work is an old one that must be continued; but it should not be done unless the customer is willing to pay a fair price for putting the watch in order to start with. There is no class of work that is so poorly paid. If Tom Hood lived in our day, instead of singing the "Song of the Shirt" he might substitute the watch. But this depression in the price of watch work does not come from excess of labor, but from a miserable, jealous competition, actuated by a devilish "day in the marger" spirit. Did you ever stop to figure on the profits of watchwork, the cost of tools and materials, rent of store, and other attendant expenses? Just figure the profit on cleaning a watch for one dollar. For that price it must be done in an unworkmanlike manner, and then it is done at a pecuniary loss. My voice is for the State associates to regulate this matter; establish a fair honest price between yourself and customer, and cause the work to be done well

Yes, there must be an understanding in every city, town and village. Do the best work, and be paid for it. Remember, there is only an average of fifteen years for those at the bench; a fair price is all that is desired. I am of the opinion that it would be beneficial to the community to pay a fair price. We feel, in addition to the pride the good workman takes, the satisfied feeling that we are paid for it, and we take no chances of "I guess it will go," but do all things well.

The "Price List" system for selling goods has been an incubus upon our trade, a help to the dishonest jobber, and a vast injury to the people at large who purchase watches and jewelry. Through that system thousands of dollars worth of inferior grades of goods are put upon the market and upon the unsuspecting retailer, and through him upon the people. It has engendered unfair competition, lowered the standard of commercial honor, been the means of some of our factories producing goods that they knew were a fraud. To it mainly can be attributed the inferior grade of American watches, produced by some of the factories, and the poor grade of jewelry and goods in general. In fact, this system has compelled factories to turn out cheap goods. There is more satisfaction all round in selling a good watch—more pleasure to the customer and ourselves. I am glad you utterly disclaim the Price List system. The jobber loves it; to him it is more pleasing than the music of dollars, because he knows in his own heart of hearts, that Price Lists, like tares that fall by the way side and do not fall upon stony ground, multiply. The time has come when they who do a jobbing business must define their position. Yes, we must, if necessary, strike back of them, even to the manufacturer who sells to them. God knows I bid you success. I am glad to see you thus assembled, and hope every watchmaker and jeweler in this young and noble State will join. The cost is the best investment he ever made in his life. I am not here to speak for trade unions; I doubt their utility. There is no conflict between capital and labor with us; but we want associations for friendship, mutual counsel, the interchange of ideas, and for the detection of those rascally sneaks who deceive the Eastern manufacturers into the idea that they are jobbers, take advantage of the favors granted them by Eastern manufacturers as jobbers, and then peddle their trashy goods from door to door throughout the West. When I think of these men, I believe that a soul could pass through the eye of a needle, and that a cambric one. It is for these and others who violate the lawful rules of trade, that we require the discipline of associations. We cannot expect to regulate these evils at once; yet the time is at hand for action, and I ask you as men to set your foot upon those firms that are the instruments of ruining your trade. Capital cannot, much as it may vaunt itself, dictate. A house that claims to own one-third of the jewelers of the west and "will not be dictated to," notwithstanding their capital, may find their foundation laid in sand. I will admit, trade has changed. We see great business houses absorbing the trade. Especially is that so of some large dry goods firms. You and I can remember fifteen years ago the tidy little notion stores in most of the streets of our large cities, kept by women. But these great houses have ruined this trade of the widow, and notwithstanding the proprietors pay taxes on millions, they retail all the little toys and articles of petty note that graced the widow's store, even to dollar clocks, and silver thimbles at 40 cents apiece. These large dry goods firms have diverted trade, driven the widow to the wash tub, and the sewing girl to the grave. The question of bringing it back to its proper channel is the one to be considered. I am not sure but that question will resolve itself into the fact that we must dabble in fancy goods too, for self protection. Yes, gentlemen, there is no other way. You must fight the devil with his own weapons. Place all manner of things in your stores to sell; but always purchase of those who do a wholesale business. I must stop. I think you will be glad of it. I know that the watchmakers and jewelers of Iowa will stand by the flag; never stop until every man that uses an eye glass shall have enrolled his name. I can pledge you that the next meeting of the Watchmakers' and Jewelers' Guild of the United States will be an influential one, and by that time, (next May,) we will have accomplished something substantial for the trade, in addition to what has been done. I thank you, gentlemen, for your kind reception, and, in after years I shall ever remember the kindness shown me at this session. And allow me to add, that in Major Boynton you have a President who is bound to make the Iowa Jewelers' Association the best.

The speaker was heartily applauded at the close of his address.

Miscellaneous business being called for, some irregularities practiced by certain so-called jobbers of Chicago were exposed. These jobbers have been supposed to be carrying on a fair and legitimate business, but were handsomely caught in a trap set for them by retailers who suspected them. Their "tricks and their manners"

were condemned in no unmeasured terms by the members of the Convention.

Resolutions cordially endorsing the course of *The Jewelers' Circular and Horological Review*, and thanking it for its able and persistent advocacy of the rights of retail dealers were passed with applause.

Resolutions were also passed expressing appreciation of the services of the "watchmaker and metal worker," and to Mr. Shurly and the growing guild he so ably represents. The Convention proved beyond doubt that the determination to have fair play has increased to almost the point of a crusade, and the membership of the Association which has doubled since last March may safely be counted on to embrace nearly every Iowa dealer at the next annual meeting which will be held at Cedar Rapids.

### Ohio Pearl Fisheries.

ABOUT twenty years ago pearls were discovered in the Little Miami River, Warren County, Ohio, and since then the search for them has been one of the recognized industries of the region. The mussels which furnish the pearls are found in beds anywhere from the banks to the middle of the river, and are generally discovered by the feet of the pearl fisher. About fifty men and boys are engaged in this work. They wade into the river from the knees to the neck.

With their feet they feel the shells, and raise them by their toes to a height where the hands can reach them without stooping so as to bring the head under water. Miniature canoes tied to the shore and floating out are used to deposit the shells. When a bushel or more have been collected the fisher goes to the shore, and sitting down on the grass in some cool shade, he opens the shells with a large knife.

The pearls are found between a slight membrane that lines the shell and the shell itself, a translucent web of texture between a cob-web and a film of mica. Occasionally the pearl is embedded in the shell so firmly that only an expert lapidary can safely detach it. This is rare. The number of pearls found in a single shell at the Miami fisheries rarely exceed three, and on an average only one shell out of one hundred and fifty has any pearls at all. It is common experience to bring to shore bushels of shells with never a pearl. One may work for days with no reward; again, he may take from \$5 to \$100 in a single day. The uncertainty is likely half the fascination of the work to the peculiar class of men and boys who prosecute it.

About a year ago a wealthy banker of Waynesville, H. Harris, began to purchase the pearls, which had previously been bought by New York and European dealers chiefly, and has since made a large and fine collection. Mention is made of one fine specimen, the Everhart pearl, found in the Miami and sold to Messrs. Tiffany & Co., in New York for \$900. The Tiffany's sold it to a party in France for \$1,000 and bought it back for \$1,500, and made a final sale of it for \$2,800.

The season of the pearl fisheries of the Little Miami lasts only from June till October, as it is necessarily dependent upon the warmth of the water. The fisher works about six or seven hours per day, seldom remaining longer than two hours consecutively, in the water. It would seem as if the work would be very unhealthy, leading to malaria and attendant train of low fevers and vital exhaustion, but it was not spoken of particularly in that way.

Recently a pearl of the most extraordinary beauty and brilliancy was accidentally found on the Waynesville side of the river by Morton L. Roberts, a little lad of 11 years, the son of J. A. G. Roberts of the Adams Express Company of Cincinnati. Morton was visiting some relatives there, and went down to get mussel shells to border a flower bed for his aunt. There were a quantity of these that had been looked over by fishers and thrown aside, and it was in one of those that the observing eye of the little boy detected the gem that promises to be a very valuable one. It is said to be the largest pearl ever taken from this region, and perfect in its symmetry. It has the brilliancy of the purest and most intense tints of the opal. It seems to rest in an auccole of color, so delicate, yet so glowing, as to suggest to one a dream of color. It will undoubtedly prove a pearl of rare value. Its weight is six carats.

## Practical Hints on Watch Repairing,

BY EXCELSIOR. No. 55.

(856) *To Find the Numbers for the Escape Wheel Pinion and the Fourth Wheel*, in a fourth wheel seconds watch, the number of teeth in the escape wheel and the beats per minute being known. *Rule: Divide the beats per minute by double the number of escape wheel teeth. The quotient is the ratio between the numbers of the 4th wheel and the escape wheel pinion.* Example:—Escape wheel has 15 teeth; 300 beats per minute. As there are two beats or vibrations for each tooth, there will be thirty beats to each revolution. It will therefore require  $300 \div 30 = 10$  revolutions of the escape wheel for 300 beats, which will be made in one minute. Hence the escape wheel turns ten times while the 4th wheel does once, and the 4th wheel must have ten times as many teeth as the escape pinion has leaves. If we take 6 leaves, the wheel must have 60 teeth; if 7 leaves, 70 teeth; 8 leaves, 80 teeth. We choose that number which will harmonize with the rest of the train. If the other pinions were 12 and 10, or 10 and 10, probably 8 would be a suitable number for this one, with 80 teeth for the 4th wheel. But if that would be out of proportion with the other wheels, take 70 teeth, with 7 leaves for the escape wheel pinion. In other cases, 60 and 6 would be more suitable. Of this, the workman can judge for himself in each case.

(857) But if there is a fraction in the quotient obtained by the above rule, then make an improper fraction, having the number of beats per minute for the numerator, and double the escape wheel teeth for the denominator. Then reduce the fraction till the denominator becomes a number suitable for the escape pinion, and the numerator one suitable for the 4th wheel. Example:—Escape wheel 15 teeth, 288 beats per minute.

$$288 \div 30 = \frac{288}{30}; \text{ divided by 3, gives } \frac{96}{10}; \text{ by 2, gives } \frac{48}{5}.$$

Of these, 5 would be small for a pinion, we therefore select the other fraction, which gives 10 leaves for the escape pinion, and 96 teeth for the 4th wheel. We might have divided the original fraction by 2, but the resulting numbers for both the wheel and pinion would be too high for watches, although they might do for other machinery. Example:—Escape wheel 15 teeth, 290 beats per minute.

$$290 \div 30 = \frac{290}{30}; \text{ divided by 5, gives } \frac{58}{6}.$$

(858) *To Find the Numbers for the Escape Wheel Pinion and the Fourth Wheel* in a non-seconds watch, the numbers of the center, 3d, and escape wheels, the 3d and 4th pinions, and the beats per minute, being known. *Rule: Find the number of seconds the 4th wheel pinion takes to make a revolution; from this number of seconds calculate the number of beats the escape wheel gives during that time; divide this number of beats by double the number of the escape wheel teeth.* The quotient is the ratio between the numbers of the 4th wheel and the escape pinion, as in section (856). Example:—Center wheel 72, 3d wheel 64, escape wheel 15, 3d and 4th pinions each 8, 288 beats per minute. According to section (847), we find the number of seconds to a revolution of the 4th pinion as follows:

$$72 \times 64 \div 8 \times 8 = 72, \text{ and } 3,600 \div 72 = 50 \text{ seconds.}$$

Then by simple rule-of-three we say, as the number of seconds in a minute is to the number of beats in a minute, so is the number of seconds to one turn of the 4th wheel, to the number of beats in that time, thus:

$$60 : 288 :: 50 : 240 \text{ beats.}$$

This divided by 30, double the escape wheel teeth, gives 8 as the ratio between the 4th wheel teeth and escape pinion leaves. If we take a pinion of 6, the wheel must have 48 teeth; if 7, 56 teeth; if 8, 64 teeth,—selecting the most suitable number as in section (856). If the number of escape wheel teeth had been 16, we would have divided 240 by 32, thus:

$$240 \div 32 = \frac{240}{32} = \frac{120}{16} = \frac{60}{8}.$$

Or, wheel 60 and pinion 8, as explained in section (857). With a wheel of 14 teeth we would have

$$240 \div 28 = \frac{240}{28} = \frac{120}{14} = \frac{60}{7}.$$

In a similar way we can get the numbers for any other wheel and the pinion it gears into.

(859) *To Find the Number of Leaves for a missing Escape Wheel Pinion*, in a 4th wheel seconds watch, the numbers of the escape and 4th wheels, and the beats per minute, being known. According to section (856), if we divide the number of beats per minute, by double the escape wheel teeth, we have the number of turns the escape wheel pinion should make per minute, or to one turn of the 4th wheel, *i. e.*, the ratio between the number of their revolutions, and, consequently, between the numbers of their teeth and leaves. We can then divide the number of 4th wheel teeth by this ratio, and we get the number for the pinion leaves. Example:—Escape wheel 15, 4th wheel 80, 240 beats per minute.

$$240 \div 30 = 8, \text{ and } 80 \div 8 = 10 \text{ leaves.}$$

But as this method sometimes gives fractions, and increases the difficulty of computation, another is given which cannot yield fractions, and requires but one division or operation. *Rule: Multiply the 4th wheel teeth by double the escape wheel teeth, and divide the product by the beats per minute.* The above example would be worked out thus:

$$80 \times 30 = 2400 \div 240 = 10 \text{ leaves, as before.}$$

Example: 4th wheel 60, escape wheel 14, 240 beats per minute.

$$60 \times 28 = 1680 \div 240 = 7 \text{ leaves for the pinion.}$$

(860) *To Find the Number of Leaves for the Escape Wheel Pinions* in a non-seconds watch. In a 4th wheel seconds watch, we have known data on each side of the missing part, *viz.*:—The number of beats, and the number of turns of the 4th wheel, which are made in the same space of time, one minute. But in a non-seconds watch we have no determined starting point nearer than the center wheel. We might first find the number of seconds taken for one turn of the 4th wheel, then the number of beats in that time, and from that get the result we seek, but that would require three different operations. A simpler way is by a modification of the rule in section (845). By examining the example there given, it will be seen that if we multiply all the wheels together, and double that, this product will be the same as that obtained by multiplying all the pinions together, and that by the beats per hour. In the present case, one of the pinions is gone, but we multiply what we have, and the inequality of the two products will show where the omitted number is and its value.

*Rule:—Multiply the numbers of the teeth in the several wheels, and double the product; then multiply the pinions together, and that by the beats per hour; divide the former product by the latter.* Example:—Wheels, 80, 75, 80, and 15, pinions 10 and 10, beats per hour 18,000.

$80 \times 75 \times 80 \times 15 \times 2 = 14,400,000 \div 10 \times 10 \times 18,000 = 8$  leaves for the escape pinion. This train makes a 4th wheel seconds watch, but the rule holds goods for that as well as non-seconds watches, of which we give this example:—Wheels 72, 72, 64, 16, 3d pinion 8, 4th pinion 8, 18,432 beats per hour.

$$72 \times 64 \times 64 \times 32 = 9,337,184 \div 8 \times 8 \times 18,432 = 8 \text{ leaves.}$$

(861) *To Find the Number of Teeth for a Missing Escape Wheel.*—In a 4th wheel seconds watch, we can modify the process outlined in section (859). As the 4th wheel revolves in 60 seconds, we divide the number of teeth by the escape pinion leaves, the quotient being the number of turns the escape pinions make per minute. Dividing the number of beats per minute by that, gives the number of beats for each turn, and as there are two beats for each tooth, one-half of that number of beats gives the number of teeth. This process can be considerably shortened by the following *Rule:—Multiply the beats per minute by the number of escape wheel pinion leaves, and divide the product by the number of the 4th wheel teeth.* The quotient is double the number for the teeth in the escape wheel. Example:—4th wheel 70, escape pinion 7, 300 beats per minute.

$$300 \times 7 = 2100 \div 70 = 30, \text{ or } 15 \text{ teeth.}$$

(862) In a non-seconds watch we must go back to the center wheel as a starting point. Get, by the 1st rule in section (849), the number of revolutions the escape wheel or pinion makes per hour. Divide the number of beats per hour by that, and we have the number of

beats to each revolution of the escape wheel, which is twice the number of teeth in the wheel. To get this all in one operation we have the following *Rule*:—*Multiply the 3d, 4th and escape pinions together, and that by the beats per hour; multiply the center, 3d and 4th wheels together; divide the former product by the latter.* The quotient is double the number for the teeth of the escape wheel. Example:—Wheels 80, 80, 75, pinions 10, 10 and 8, 18,000 beats per hour.

$10 \times 10 \times 8 \times 18,000 = 14,400,000 \div 80 \times 80 \times 75 (480,000) = 30$ , or 15 teeth.

(863) Clock escape wheels can be found by the same rule,—multiplying the center and 3d wheels together, and dividing by the product of the 3d and 4th (or escape) pinions, gives the number of revolutions of the escape wheel per hour. Divide the number of beats per hour by this, and we have double the number of teeth required in the escape wheel. This process is shortened by following the rule. Take a clock beating seconds for an example:—Center wheel 64, 3d wheel 60, 3d and 4th or escape pinions 8 and 8, 3,600 beats per hour.

$8 \times 8 \times 3,600 = 230,400 \div 64 \times 60 (3,840) = 60$ , corresponding to 30 teeth in the escape wheel, and 60 beats per minute or revolution of the wheel. When there are more wheels and pinions than this, the process is the same,—multiplying the wheels together, and the pinions together, as before.

(864) *To Find the Number of Teeth for a Missing 4th Wheel*, in a 4th wheel seconds watch. According to the rule in section (856) if we divide the beats per minute by double the escape wheel teeth, we have the ratio between the escape wheel pinion and the 4th wheel, or the number of turns the former makes to one of the latter. If the pinion turns 10 times to the wheel once, the wheel evidently must have 10 times as many teeth, and so with any other ratio. Hence this *Rule*:—*Multiply the beats per minute by the number of escape pinion leaves, and divide by double the number of the escape wheel teeth.* The quotient is the number for the 4th wheel teeth. Example:—Escape wheel 15, pinion 7, 240 beats per minute.

$240 \times 7 = 1680 \div 30 = 56$  teeth.

(865) *To Find the Number for the Teeth of Either the Center or 3d Wheel, or for the Leaves of the 3d or 4th Pinion*, in a 4th wheel seconds watch. In either of the above cases, we can avail ourselves of the fact that the product of the center and 3d wheels must be 60 times as much as that of the 3d and 4th pinions; or the ratios of the two wheels to their intersecting pinions must be 8 and  $7\frac{1}{2}$ , (846). Hence if we have one wheel of 64, and two pinions of 8 and 8, we know that, as 64 and 8 give the ratio of 8 to 1, the other wheel must give the ratio of  $7\frac{1}{2}$  to 1 with the pinion of 8, which will be  $7\frac{1}{2} \times 8 = 56$ . Or if we have wheels of 80 and 60, and one pinion of 8, which gives the ratio of  $7\frac{1}{2}$  to 1 with the wheel of 60, we know that the other pinion must be as 8 to 1 with the wheel of 80, which will give 10 for the number of pinion leaves. Or we can get our result at once (by this *Rule*):—*Multiply the wheels together (if we have both); then multiply the pinions together and that by 60; divide the larger number by the smaller.* The quotient is the number for the missing part. Example:—Center wheel 75, 3d pinion 10, 4th pinion 8.

$10 \times 8 \times 60 = 4,800 \div 75 = 64$  teeth for 3d wheel.

(866) *To Find the Number for any Missing Wheel, or Missing Pinion.*—This is designed especially for non-seconds watches, but it will apply to any,—although the preceding rules will not apply to non-seconds watches. It is based on the fact that the product of all the wheels, (from the center to the escape wheels, both included,) being doubled, bears a certain proportion to the product of all the pinions, (3d, 4th, and escape,)—and that proportion is expressed by the number of beats per hour. If that number is 18,000, then the product of the wheels, when doubled, is 18,000 times as much as the product of the pinions. Or, if we multiply the product of the pinions by 18,000, this product will be equal to that of the wheels into each other. But if the number for one of the parts is left out of the calculation, the products will no longer be equal, and by dividing the larger one by the smaller, we shall get the exact number for the mis-

sing part, no matter which it may be. Hence the following *Rule*:—*Multiply all the wheels you have, and double the product; multiply all the pinions you have, and that by the beats per hour; then divide the greater number by the lesser one.* The quotient is the number for the missing part. Example:—3d wheel 64, 4th wheel 64, escape wheel 14, pinions 8, 8 and 7, beats per hour 17,920,—wanted the number for the center wheel.

$8 \times 8 \times 7 \times 17,920 = 8,028,160 \div 64 \times 64 \times 28 (114,688) = 70$  teeth.

Further examples are unnecessary.

(867) *To Find the Numbers for both a Missing Wheel and its Pinion*, is a difficult task in a non-seconds watch, unless we know the beats per hour. If we know that, we can calculate from each end of the train, until we arrive at the missing part. If that is the escape wheel and pinion, for instance, we can find, by section (847), the number of seconds for a revolution of the 4th wheel; then, by simple proportion, calculate the number of the 4th wheel teeth which would pass a given point, or act on the escape pinion, in one minute; next work from the other end of the train, trying first the most likely number for the escape wheel teeth, say 15, doubling it, and dividing the beats per minute by 30, we have the number of turns the escape wheel or pinion makes per minute—say 10 turns, during which it will act upon say 60 teeth of the 4th wheel, or six teeth to each turn; the pinion therefore has six leaves. Should the result not prove to be suitable, we must take another number for the escape wheel teeth, and try again.

(868) We cannot follow the summary process in the preceding section (867), because in this case we have not merely *one* ratio to deal with, as in sections (856) and (858), for the escape pinion and 4th wheel, but any result we could obtain by the calculation would be the product of two ratios, or the aggregate of the action of four different parts. For instance, if the 4th wheel and pinion were gone, the result would be the ratios of the 3d wheel to the 4th pinion, and the 4th wheel to the escape pinion, multiplied together. The first ratio might be 8, the second  $7\frac{1}{2}$ . But the omission of parts would be in favor of the wheel side of the equation as regards the first ratio, and the second would be in favor of the pinion side,—the net result on one side would be one-eighth of what all the parts would have given, and the other side would be divided by  $7\frac{1}{2}$ . If both ratios happened to be the same, as 8 to 1, then the net results would be equal on both sides of the equation, and the calculation would give absolutely no indication as to the numbers of the missing parts. Instead of the foregoing methods by counting, we may follow the method by measurement, as directed hereafter, and from the 3d wheel find the 4th pinion suitable for it, and from the escape pinion find the 4th wheel.

(869) *To Find the Number of Beats per Hour*, when a part of the train is gone. The preceding rules for finding the numbers of missing parts require us to know the number of beats per hour or minute. As this gives the ratio between the product of the wheels and that of the pinions, we know the final result of our train, either in revolutions or time. But when this is not known, we are all at sea in repairing a broken train, for we have no means of telling what the train should do, or should be. Not knowing what relation the wheels should bear to the pinions, as a whole or a train, we cannot tell what relation any missing part should bear to those next to it. We have one fixed fact, at one end of the train; that the center wheel should revolve once per hour, but nothing at the other end, from which to deduce the intermediate parts. In such a case we must either find the number of vibrations of the balance per minute, by observation, or we may adopt the method of finding the number and size for the missing part by measurement, in which case we shall not need to know the beats per hour. But we will now follow the method by simple counting, which we have thus far relied upon.

(870) We can count the beats per minute with comparative ease, if the 3d, 4th and escape wheels and pinions are all left, as by gently pressing on the 3d wheel we can cause the balance to take its normal vibration, while we count their number by the eye during one

revolution of the seconds-hand on a good regulator. If the 3d wheel and pinion are gone, it becomes harder to apply a uniform and continuous pressure or motive force for the balance. If the escape wheel and pinion are the last ones left, we may loop a fine silk thread to one arm of the wheel, then wind it a dozen or more times around the pinion arbor, keeping it away from the pivot, and by gently pulling on the end we can give the balance just a full, natural vibration, but no more, during the minute we are counting,—and by this means get the number about as accurately as if the watch was running. It will be easier to count the vibrations in one direction only, then double the number. Make a number of trials, and average the different numbers,—especially when the escape wheel and pinion also are gone, and the balance is made to vibrate alone. For various precautions for securing a correct count, see the Practical Treatise on the Balance Spring, and the Compensation Balance.

(871) *To Find the Number for the Center Pinion, or the Main Wheel, in a going-barrel watch.* As the numbers of the center pinion and main wheel were of no consequence in the preceding calculations, the "train" has thus far been considered as complete without them, and they have been reserved for separate treatment. As the stop-works are contrived to allow four turns of the barrel, and the watch should run 30 or 32 hours, each turn corresponds to either  $7\frac{1}{2}$  or 8 turns of the center pinion, generally 8. Therefore, if the center pinion has 12 leaves, the main wheel should have either 90 or 96 teeth; if 10 leaves, 75 or 80 teeth, and so on,—according as the ratio is  $7\frac{1}{2}$  or 8. This can be determined by measurement, to find whether the main wheel is  $7\frac{1}{2}$  or 8 times the diameter of the pinion, and the numbers of the teeth and leaves must have the same ratio as the diameters, whether we deduce the number of the teeth from that of the leaves, or the reverse.

(872) In making the measurement of the center distance, get the exact distance between the pivot holes of the center pinion and the barrel arbor, either in their bridges or in the plate, depending on which are the least worn or liable to become changed or wrong. If the former, the barrel arbor and center pinion must be removed, and the bridges finely secured in their proper places. The centers of the depthing tool must be kept exactly vertical to the plate while measuring, pushing the centers out as required for filling the pivot holes. But after measurement is obtained, the centers must be made to project the same amount, when ascertaining the distance by applying the points to a graduated scale or otherwise. Having thus obtained the center distance, measure whichever part you have, say the pinion, and get the geometrical radius. This being deducted from the center distance, leaves the radius of the main wheel, from which you find the ratio between the radii of the wheel and the pinion. If it is 8 to 1, then you multiply the number of the pinion leaves by 8, and you have the proper number for the teeth of the wheel. The radius being doubled, you have its exact primitive diameter. To find the size and number for a lost pinion, reverse the operation. The subject of calculating by measurement will be more fully treated, further on.

(873) *To Find the Number for the Main Wheel Teeth, in a fuzee watch.* In this case, there are three factors concerned,—the number of teeth in the main wheel, the number of leaves in the center pinion, and the number of turns to the groove on the fuzee. The watch should go 30 hours, although in many cases 27 or 28 hours is the limit of actual performance. The number of revolutions of the main wheel in the allotted time of running is, of course, the same as the number of turns given to the groove on the fuzee. Supposing the groove to have four turns, the main wheel revolving with it also has four turns, and, in order to turn the center pinion 30 times around, the ratio between the wheel and the pinion must be 30 to 4, or  $7\frac{1}{2}$  to 1. If the pinion has 12 leaves, the wheel must have  $12 \times 7\frac{1}{2} = 90$  teeth. Hence we have this Rule:—*Multiply the number of hours the watch will run with once winding, by the number of the pinion leaves, and divide by the number of turns on the fuzee.* The quotient will be the number for the main wheel teeth. Example:—Center pinion 12 leaves, fuzee  $7\frac{1}{2}$  turns, to run 30 hours.

$$12 \times 30 = 360 \div 7\frac{1}{2}, \text{ or, } 720 \div 15, \text{ or } 360 \div 7.5 = 48 \text{ teeth.}$$

(874) *To Find the Number for the Center Pinion Leaves, it is only necessary to transpose the terms, and we have this Rule:—Multiply the main wheel teeth by the turns on the fuzee, and divide by the hours of the running.* Example:—Main wheel 50 teeth, 6 turns on the fuzee, to run 30 hours.

$$50 \times 6 = 300 \div 30 = 10 \text{ leaves for center pinion.}$$

(875) *To Find the Number of Turns the Groove on the Fuzee Should have.* Rule:—*Multiply the leaves of the center pinion by the hours of the running, and divide by the main wheel teeth.* Example:—Center pinion 10, main wheel 80, to run 28 hours.

$$10 \times 28 = 280 \div 80 = 3\frac{1}{2} \text{ turns for the groove.}$$

In fine watches the length of the fuzee groove should bear a certain relation to the number of turns the barrel arbor makes, from the lowest to the highest point of the main spring, when wound with the sliding tongs, holding the barrel in the fingers. For instance, if the length of chain which fills the fuzee groove makes four turns on the barrel, the length of the mainspring should be such that the barrel arbor can make six turns in winding it up. If that length of chain makes  $3\frac{1}{2}$  turns around the barrel, the arbor should make about  $4\frac{3}{4}$  to 5 turns in the barrel. But in common watches, the mainspring does not generally give the arbor over 4 turns, or even as low as  $3\frac{3}{4}$  or  $3\frac{1}{2}$ .

(876) *To Find the Number of Hours a Fuzee Watch will Run with Once Winding.* Rule:—*Multiply the main wheel teeth by the turns of the fuzee groove, and divide by the center pinion leaves.* Example:—Main wheel 72 teeth, center pinion 16, 6 turns to the fuzee groove.

$$72 \times 6 = 432 \div 16 = 27 \text{ hours, nearly.}$$

In a box chronometer, there is plenty of room, and the fuzee groove may have more turns. Example:—Main wheel 80, center pinion 20, fuzee grove 10 turns.

$$80 \times 10 = 800 \div 20 = 40 \text{ hours running.}$$

(877) *To Find the Numbers for the Motion Works or Dial Wheels.*—These include the canon pinion, the minute wheel, the minute pinion or "nut," and the hour wheel. These are so arranged that the canon pinion shall turn just 12 times as often as the hour wheel. This is secured by making the two ratios 3 and 4, which being multiplied together give 12. If the canon pinion has 10 leaves, the minute wheel should have 40 teeth; and if its nut has 12 leaves, the hour wheel should have 36 teeth. Or the proportion may be reversed, and the minute wheel have 3 times the number for the canon pinion, and its nut  $\frac{1}{4}$  number for the hour wheel. In any case the numbers for a missing part may be found by the following Rule:—*Multiply the pinions together, and that by 12, then multiply the wheels together, and divide the greater number by the less.* The quotient will be the number for the missing part. Example:—Canon pinion 12, minute wheel 48, minute nut 14. Wanted, the hour wheel.

$$12 \times 14 \times 12 = 2,016 \div 48 = 42 \text{ teeth for hour wheel.}$$

(878) *To Find the Numbers for the Minute and Hour Wheels.* Here we have but one of the products which the rule requires,—that of the pinions, multiplied by 12. But that number, according to the rule, would be equal to the product of the two wheels. Hence we break down the number 2,016, and resolve it into two numbers, one of which must be 4 times the canon pinion, the other 3 times the minute pinion,—or the reverse. Breaking down 2,016, as in section (852), we get 5 twos, 2 threes, and 1 seven, which may be arranged

$$2 \times 2 = 4 \times 2 = 8 \times 2 = 16 \times 3 = 48, \text{ for the minute wheel.}$$

$$2 \times 3 = 6 \times 7 = 42, \text{ for the hour wheel.}$$

(879) *To Find the Numbers for the Minute Wheel and Pinion,* we use the two ratios, 4 and 3. Example:—Canon pinion 14, hour wheel 48. To divide 48 by 4 would give 12 for the minute nut, and  $14 \times 3 = 42$  for the minute wheel. Or we can compute the ratios in the reverse order, and get  $14 \times 4 = 56$  for the minute wheel, and  $48 \div 3 = 16$  for the minute pinion.

If the hour wheel, also, is gone, we multiply the canon pinion by 4, which gives  $14 \times 4 = 56$  teeth for the minute wheel, then construct the other ratio according to the nut which the minute wheel has on it. If that is 16, then  $16 \times 3 = 48$  teeth for the hour wheel. If it is 18, then  $18 \times 3 = 54$  for the hour wheel.

If all the motion works are gone, we select the numbers to suit ourselves, with the ratios of 4 and 3, only limited by the space we have for fitting them in the watch. The following are approved numbers.

CANON PINION.	WHEEL.	MINUTE NUT.	HOUR WHEEL.
14	56	18	54
14	56	16	48
12	48	14	42
12	36	10	40



## Frankish and Celtic Jewelry.

A VERY interesting collection of treasures, found in Frank Tombs, by M. HENRI DE MORGAN, has been put on exhibition, but not for sale by Mr. G. L. FENARDENT at his establishment in Lafayette, Place. The jewelry of these ancient warriors is particularly interesting, and nothing like it has ever been seen in this country before.

Mr. DE MORGAN, during the summers of 1871, 1872 and 1873, opened no less than eight hundred sepulchres, which were in a burial ground he was lucky enough to strike quite accidentally. He was rusticated in Normandy, when some peasants, knowing his taste for archeology, brought him some pieces of iron, which had been dug up in a field near by, and which they said were unquestionably weapons of an English army, which had once been defeated in the neighborhood. The young archeologist knew better, and at once began operations in the field where the specimens had been found.

It was a well known fact to him that the Frankish and Celtic tribes always buried their dead with their heads toward the rising sun; so, with a compass in hand, he started a trench, running north and south, thus striking the tombs at the side.

Weapons of iron, such as axes, swords, spears, arrow heads and the central bosses of wooden shields came to light, also some rude earthenware vases and jewels in the shape of buckles, clasps, earrings, necklaces, brooches, pins and rings. They were of gold, silver, glass, bronze, damasceened iron and a white metal resembling German silver.

In one show-case are arranged, on the chalk outline of a skeleton, the different accoutrements found in the tomb of a chief, placed in the same positions as that in which they were found, for as each grave was opened a careful diagram of it was made, showing where the different pieces stood. The jewels of this Frankish warrior, who was buried about six hundred years after the Christian era, consist of a gold clasp, which is admirably preserved; it is of a triangular form about two inches long, and one inch and a half at the base. The angles are ornamented with raised circular bosses or knobs connected with mounted filigree ornaments. The lines consist of a series of small circles containing each in the center a small granule of gold, such as we find on Etruscan gold work; the central motive is a raised triangle with slightly bevelled sides.

Several silver buckles smaller than the gold one, held to the belt, the purse and other articles which hung from it, and were used in the same manner as the more modern chatelaine. These buckles are made in exactly the same principle as those now in use, only they are heavier, and the tongue is much stronger. The corners are well rounded off, giving them the outline of a very massive but slightly compressed horse shoe. On the side by which they were secured to the leather straps we find a hinged plate on which the heads of the rivets form rudimentary ornaments. Some of these buckles, of larger dimensions are decorated with incised lines, intersecting each other and very carefully drawn. The clasp of the purse resembles those now used on the leather bags the ladies hang from their girdles, and in this case some fragments of the stuff of which it was made were still clinging to it. The relatives of the warrior must have thought that he would not need much pocket money, for all he possessed were three coins, two of which are ancient counterfeits of Roman pieces, and the other a Byzantine of little value. At that period of history the Romans were very unscrupulous in the way in which they treated their less civilized neighbors, and often palmed off on them, in the payment of tributes or ransoms, large sums of counterfeit coin, struck by the government for that special purpose. A bronze clasp of singular workmanship held the cloak on the right shoulder. It is about two inches long, and shaped like an S.

The design is a double headed serpent, rather stout in the center, with a head at each end of the body. These heads, which form the extremities of the S, are armed with wide open beaks, which seem to bite the body, thus closing the ends of the line. A large bronze

buckle fastened the baldric. The hinge in the center is very artistically employed as an ornamental element from which the curves and tongue start, forming secondary lines.

At the feet were the fastenings of the sandals; they are of iron damasceened in silver. The lines of precious metals are interwoven and symmetrically twisted in a manner suggestive of the later Runic ornament, and the early Gothic. The page of illustrations in OWEN JONES' Grammar of Ornament, gives many of these gaunt designs, though none of them are colored so as to give the idea of Damasceen work.

From the belt of the Chief hung several pieces of metal, the use of which it is difficult to explain, perhaps were the keys or stylets. One of them is a pair of tweezers, very well made, an improvement over the modern ones, is a center tongue over which the jaws close; this gives a better chance of biting the object to be extracted, most likely a thorn or a splinter, or to pull out the beard, as they always did. On the left side we see the iron dagger, and at the end the silver tip of the sheath.

Another show case is exclusively devoted to jewelry. There are brooches and earrings; the former in gold or silver, some of circular shape, decorated with Etruscan work, into which are mounted pieces of colored glass accurately cut into the required shape; the center is a knob or cabochon, sometimes of real stone, sometimes of earthenware, representing a turquoise. One brooch in this case is designed like a wheel, spaces between the slender spokes, radiating from the centers, are filled with red glass, mounted on stencil suggesting cloisonne enamel.

Other brooches represent birds and animals conventionalized in a curious manner. For instance, a bird resembling a parrot has a large glass eye nearly as big as his head, and another similar piece in his tail. A horse is made into an ornament by bending the front leg back and the hind one forward so as to bring them together.

The ear-rings are large circles of bronze, closing on a bead or head. Some of these beads are of gold curiously wrought, while others are in bronze like the ring, but decorated with glass or precious stones. Silver and bronze rings are also found, but with little or no decoration. Large damasceened clasps and buckles form an important item of the collection. A curious study could be made of the great variety of glass beads they used for necklaces. Stringing the larger ones in the center and the smaller ones at the ends. These were used both by the men and the women in great profusion, as personal ornaments.

In some of these beads, pieces of glass have been inserted in the paste, and produce a singular effect. Amber was also much used for beads, and many pieces are found on the necklaces. Pins and needles are also found. Grecian antiquities, Tanagra figurines, coins, etc., etc., form the balance, which is now on free exhibition.

IN 1838 a beautiful locket, forming a small padlock, was found in digging a grave in the churchyard at Devizes, in Wiltshire. It was composed of two bufonites united by a silver band, and having the wards of the lock in the cavity between them, and the keyhole in the centre of one of the stones. The workmanship appeared to be evidently of sixteenth-century date. It was probably worn not only as an ornament, but as a charm, and as such, being most valuable, was buried with its possessor. This "find" is well described by Mr. Cunnington in an interesting paper read before the Wilts Archæological and Natural History Society. Such being the potency and value of the toadstone, Lupton, in his "Notable Things," tells how to make quite sure that you have got a real stone, and not a mere counterfeit. His test is a very quaint one! "Hold," says he, "your stone before a toad, so that he may see it well, and if it be a right and true stone, your toad will leap toward it, and make as though he would snatch it from you, for he envieth so much that man should have that stone."

## The Jewelers' League.

We devote this column to the interests of the League and its membership. Letters or inquiries pertinent to its business or purposes, and which might interest the trade or inquirers, will be herein answered. Address *Jewelers' League*, Box 4001, P. O. New York, or the office of THE CIRCULAR.

At the regular monthly meeting of the Executive Committee, held on Friday evening the 3d inst., the following gentlemen were elected to membership:—Charles W. Ackerman, with Palmer, Bachelder & Co., Boston; Ulric Z. Maltby, Oswego, N. Y.; Adolph H. D. Wedeking, with Kearney & Swartzchild, Chicago; Henry G. Bailey, with Ripley, Howland & Co., New York; Moritz Faulkenau, Jr., and David E. Oppenheimer, of Faulkenau & Oppenheimer, New York; Charles Gardner, with Bergstein & Son, New York; Henry K. Heller, of Heller & Bardel, New York; Paul H. Jeannot and Victor J. Klebaur, with A. A. Jeannot & Co., Brooklyn, N. Y.; Adolph H. Otto, with F. Otto, Rochester, N. Y.; James W. Sanders, Schenectady, N. Y.; Charles Y. A. Thompson, with Heller & Bardel, New York; Charles C. Vallette, with A. Saltzman, New York; Elbert E. Wadsworth, New York; and Joseph C. Whitehouse, with Tiffany & Co., New York.

Since the circular was sent out to all the members of the League, urging a general concerted effort to enlarge the membership, 43 have responded by recommending 30 members. In several cases the candidates were, possibly, so refractory that it required the combined efforts of two members each to recommend them, both of the two recommending members thereupon conceiving that they have secured an additional member each—it reminds us of the schoolboys' *sottovoce* "two into one you can't," while pondering over his sum in division. The "twice one is two" principle (*i. e.*, each member getting another) would enlarge the membership, more satisfactorily, and it is hoped that the 444 members who have not yet responded to the circular letter of August 1st, may have been in the meantime putting the multiplication table into practice in anticipation of the *next* monthly meeting.

Sixteen new members were admitted at the last meeting, making the membership now number 518. It is doubtful if any organization similar in purpose to ours can equal the extraordinary statement that since the organization of the League, May 26th, 1877, it has met with but one death-loss.

As Christmas time approaches, we suggest to employers, whether members of the League or not, that no better nor more acceptable present could be made to an employé than the gift of a membership. This could be done by the employer paying the entrance fee of \$3, the first assessment of \$2, and the expense of medical certificate, after which the employé can himself sustain his membership. Employers would consult their own as well as their employés' interests by giving this matter some thought. By leading an employé into the League, he will in many instances be relieved from the oft repeated subscription toward the assistance of the families of deceased employés; the employé will hardly miss the few luxuries he might perhaps deny himself in order to pay his assessments as they are made from time to time.

The Secretary has received 16 designs for the League membership badge, in compliance with the request sent out in August. These each have the designer's private mark (known only to the designer) upon them, and will be placed in the hands of the Special Committee, appointed by the President, to select the one in their judgment best adapted for such purpose. The Special Committee consists of Messrs. Dyer Brainerd, of Brainerd & Steele; Lysander T. Best, with Hayward & Briggs; Andrew K. Shiebler, of Durfey & Shiebler; Dan. H. Hopkinson of the JEWELERS' CIRCULAR; George W. Washburn, with Randel, Baremore & Co. When the decision of the Special Committee is arrived at, it will be published in this column.

An impression existing among some members that the League is amenable to the authorities of the State of New York for a periodical

accounting in the same manner as insurance organizations, a very full and explicit opinion has been obtained from the Counsel of the League to the effect that such is not the case. "The Jewelers' League was incorporated under the Act of 1848, as amended by the Act of 1872, relating to the Incorporation of Benevolent, Charitable and Scientific Societies, &c. It is in no sense a business corporation, and should be carefully guarded from assuming any such appearance." An inspection of its constitution and by-laws will show that the word insurance is not mentioned anywhere therein. "It is a purely benevolent institution, designed principally to benefit the families of deceased members. There is no accumulation or investment of capital, and under the charter, could be none."

This opinion effectually replies to the letter of member No. 134, in the August number, wherein he advocates the accumulation of a reserve fund. In order to do so, the League would be required to become re-chartered under another Act, which might not permit the accomplishment of the present benevolent purposes of the League.

## Business Notes.

Mr. W. N. Walker, 18 John Street, has introduced a very fine article of jewelry cotton. It comes in rolled sheets of various colors, and can be cut into any required length. Its great convenience renders it desirable for jewelers.

F. Willson Rogers, of W. Rogers & Son, of Hartford, Conn., has just patented a new and elegant design for a spoon and fork handle, an illustration of which is given in their advertisement in our columns, and can be secured only of the above firm. Dealers interested in plated ware will find it to their advantage to consult their advertisement.

Messrs. H. Muhr's Sons, of Philadelphia, manufacturers of the standard filled rings, bearing the popular trade mark—crown 18 lion—have secured a large trade for this class of goods. These rings were exhibited at the Paris Exposition and received the highest award for goods of this description, and their workmanship and finish were spoken of in the highest term of praise. The firm also make solid gold rings, the workmanship upon which is not excelled.

Mr. Louis Strasburger has recently returned from Europe, where he has visited the principal diamond marts of the old world in search of gems suited for the requirements of this market. His house is now receiving invoices of carefully selected goods, which cannot fail to satisfy the taste of the most critical judges. This firm's stock of watches embraces a wide range of goods, from the most complicated and extensive of the cheapest grades imported.

Birch's Self Adjusting Watch Keys, now so well and favorably known throughout the world, seems to be growing in popularity, not only with the workmen in the trade who have adopted it as their bench key, but by the general public, who have learned to appreciate its great convenience. New and beautiful designs in celluloid of various colors, ivory, pearl, gold plate and gold, suitable for charms, etc., have recently been introduced, which seems to have hit public fancy.

Messrs. May & Stern, Importers of Foreign Watches, materials tools, &c., agents for the sale of domestic movements and cases, and makers of jewelry, present an attractive display of novelties in their line. They direct especial attention to their large and comprehensive assortment of solid gold seal rings, in cameo, amethyst, topaz and onyx, embracing all the newest styles and patterns. Messrs. May & Stern have been in business a good many years, and enjoy the confidence and esteem of a large clientele of friends.

Cross & Beguelin, importers of Swiss watches, watch tools, materials, etc., and jobbers in American watches, since they have occupied the first floor of No. 21 Maiden Lane, have had their store elegantly and conveniently fitted up, with all the modern improvements for the transaction of business. They have added other lines to their business, including traveling clocks, opera and field glasses, and the Rogers & Bro. flat and hollow ware, and have recently taken the agency of the Charles E. Jacot Watch. Dealers visiting New York can find in their establishment every thing required in the watch business, their stock of tools being full and complete, embracing every novelty of a practical nature.

The Howard Watch & Clock Co., of Boston, recently suffered from temporary financial embarrassment, which, was however, speedily arranged to the satisfaction of all concerned. Several evil minded busy bodies, nevertheless, took advantage of their difficulties to circulate the report that the Howard Watches were no longer manufactured, and, by innuendos and insinuations, to discredit the Company. This underhand business is cowardly, and forms no legitimate feature of honest competition. The Howard Watch Company is still manufacturing their well known movements, and are maintaining their standard of excellence. The Howard movement has done much to make the reputation of American Watches, and, amid all the vicissitudes of the trade, their quality has never been degraded.

## Watch and Chronometer Jeweling.

No one can fail to appreciate the difficulties that must be encountered to avoid so many causes of error. The simplest form will be conceived if we should take a hollow arbor, terminating at one end in an adjustable cutter with a square corner, the other end being furnished with a small hollow nipple, just the size of the largest shoulder cut in the plate. Running in this arbor are two small spindles, meeting just in the centre where the ends of the inside spindles correspond to the exact length of the outside arbor. Now, if any size was placed between the two centre ends, the inside spindle would be increased in length by just the size added. The upper plate is first jeweled with the faces of the stones just level with its under surface; as a matter of course, the depth of the shoulder in the plate is of no importance. The lower plate is now cut out from the dial side for the jewel setting, with a shoulder for the reception of the jewel. The plates are not screwed together, and the two arbors are applied to it—one on the outside, with its tit or nipple resting on the shoulder in the hole of the pillar plate, the other passing through and resting on the face of jewel in the upper plate. A pinion, the one designed for the place, is now put in between the centre ends of the inside spindles, and the stop pushed back in relation to the corner of the cutter. It is evident that the inside spindle lengthened as it is by the distance between the shoulders of the pinion, must now be a measure of the difference between the stop and the corner of the cutter; and therefore, if the cutter, with its stop fastened to it securely, be brought up to a jewel in its setting while it is revolving in the lathe, a shoulder will be cut on the setting just deep enough to allow it to enter the lower plate sufficiently to make the distance between the faces of the two jewels exactly equal to the gauge between the shoulders of the pinion. The end shake can now be definitely made by increasing the length of the stop portion of the inside spindle, as it would lessen the depth of the shoulder on the setting. The object of the above description has been to give a general idea of the principle. A minute description of the tool would imply the necessity of drawings, and as the information would be of little use, except in a factory, we deemed it useless to give it, our object being only to show the principle of direct automatic measurement. In practice, the tool was found capable, with care, of doing the work of a dozen men, with a degree of accuracy never attained by hand. Great care is, however, required in its use, as the slightest pressure or change of temperature will alter the result.

In the last number it was stated that the end-shake tool would be of little use anywhere save in a factory. The statement was true. On reflection, we have concluded that the principle on which the tool is founded is capable of too extensive application to the ordinary repair shop, to be passed over with a merely verbal description. We have, therefore, considered the subject worthy of a more extended description, and illustrated by a diagram, and we do this the more willingly as the idea may be very much enlarged in its application to small tools. The following facts warrant us in our assertion:

The principle of self measurement was carried out in topping off the settings level with the plate, and also in countersinking the jewel-screws. The use of the principle enabled the movement to be jeweled after gilding with as much ease as it had been done in the old style. We have, for the sake of further illustrations, given the two diagrams that show the whole philosophy of the tool. It must be remembered, however, that the diagrams are not intended as working drawings, and many parts are left out that are important in the real instrument. Enough is shown, though, to enable any one to comprehend the reasoning on which the tool was founded.

On reference to the last number the reader will find that two spindles are mentioned—in fact, three; for the inside spindle is made of two pieces meeting in the centre of the hollow space cut out

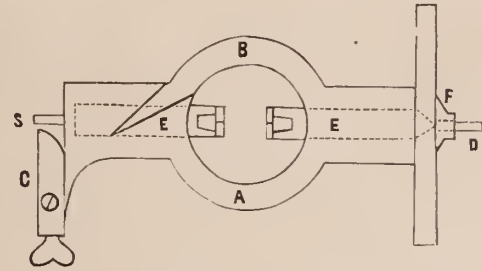

from the centre of the outside spindle. Let A represent the hollow arbor at the centre B; it is expanded so as to leave room for the largest wheel intended to be used. The two inside spindles are indicated by E; the ends S and D being reduced to gain room; the end S is let into E by means of a fine screw that enables the operator to lengthen or shorten the absolute lengths of the two. C is the cutter, adjustable for diameter. On the centre ends of the spindle E, a plate is fastened, with a V cut in the upper edge, and the spindle ends are slotted, 1 and 2, in order to furnish room for the pivots. It will be obvious that the shoulder must rest solidly against the end of E. By looking at the drawings the reader will see that if the two Es are closed together in the centre at B, the ends S and D would be exactly equal to the whole distance C and D + the amount of end-shake to be left. The screw, G, serves to adjust the cutter to the right diameter of the shoulder on the jewel setting. There can be no mode of mensuration more accurate, for it is evident that the distance between the two ends of the Es will be the exact length of any pinion put between the Vs, and thus the full distance between the shoulders is self-measured. In letting in the screws the heads were self-measured, and let in flush with the plate, without a burr, and with sufficient bite on the setting to prevent any looseness. While the countersinking was being done, the settings were prevented from turning by an ingenious system of clamps that enabled the stops to reach the plate and yet hold the jewel firmly.

The following diagram will give an idea of how the automatic system may be applied to tools on the bench, to enable the repairer to perform his work without trial.

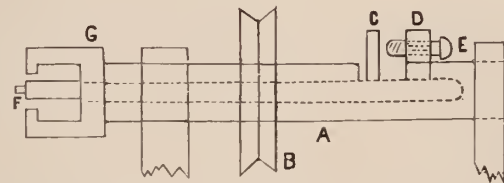

If we suppose A to be the outside spindle, running in two standards, 1, 1, and to be driven by the pulley, B. We have a good external view on the end of A; at G is a frame let on to the end of the mandrel, free to rotate, but perfectly solid so far as an end motion is concerned, and thus it happens that the mandrel, A, will revolve inside the collar, G. While the whole frame connected with G will remain motionless, as the mandrel, A, has an end long motion at will, and G is permanently fixed, G will move with the mandrel, A, endwise. The mandrel, A, is hollow, and on one side has a slot cut, through which a piece, C, projects, that is firmly fastened to the inside, I. Screwed into the outside spindle is the leg, D, through which an adjusting screw is tapped, in order to make the contact perfect when the cutting lip, F, is exactly level with the stop face of C; if, then, anything to be measured were placed in the space between the point of the adjusting screw, E, and the inside face of C, the cutting lip of F would project from the stop face of G by just the thickness of the article to be measured, or rather that is intended to measure itself. In some of the common polishing and facing tools that are on the watch bench, this principle might be introduced to advantage; the more so, as any repairer could make a tool for use either with the ordinary lathe or the bow. There is one thing that renders the principle of advantage, and that is its certainty. We have supposed the jewel set in the plate with the proper

end-shake; the next step is to counterbore for the jewel screw-heads. As the screw holes are drilled a slight distance from the hole in plate and the countersink cuts with but one lip at a time on the jewel setting, it will be seen that the countersink has a tendency to turn the setting around in the plate, as if it were a toothed wheel and the cutter a pinion of one leaf; to avoid this in the grey work, the settings are cemented in by means of shellac—some using it in solution of alcohol, and others by heat, the same as in cementing up the work on the chuck. We would condemn this last, as the heat has too much tendency to warp the plates, and thus destroy the very work the jeweler has been so long engaged in perfecting. It is absolutely necessary, however, that the settings should be firmly set in the plate, and held while the countersinking is going on, as the leverage between the tip of the tool and the outside corner of the cutting edge is so great, that the setting is almost sure to be rotated unless very firmly fixed. Where the movements are jeweled in the grey, the whole plate, with the settings, screws, and all, are first filed down to a level and then stoned, the screws and settings taken out, and while the plates are sent to the gilder, the jeweler proceeds to give that exquisite polish generally observed on the jewel setting, both on the top and in the chamfer cut down to the convex of the stone. It would be a mistake, however, to apply the word polish to the chamfer, for there is not the first process of polishing applied to effect the result. The whole point consists in the condition of the cutting edges of the tools used in cutting away the superfluous metal from the setting. There have been many devices for the shapes and many more to render polishing possible, but it will be found to be the only really practicable process, where the graver point or cutting edge is brought up to a grade of polish equal, if not superior to the polish sought to be obtained in the setting.

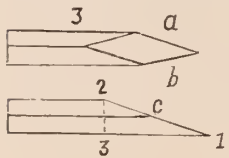

We will suppose that we take a common steel graver, "Stubbs," and on grinding off the point at the angle 1, 2, 3, say  $30^\circ$ , being careful to leave the plane represented between A and B perfectly level, we may proceed to finish the two edges, A and B, up to a point that shall be equal to the finish we desire to produce in the cut of the setting. At this point we must diverge from jewelery to a somewhat different branch of watch-work, but which, in its turn, demands the very same conditions. We refer to the engine-turned work on the ordinary case, as well as the best class of work offered to the public.

We would premise that in this case we are speaking of how the polish on the barleycorn is effected. It is done entirely by the cutting edge of the cutting-tool, held in the slide rest. The value of the tool depends on equal angles and perfectly polished cutting edges. Another point is to be considered, and that is that the brilliancy of the polish would be much affected by difference in the angle at which the light is reflected, and thus, on the best class of watch-cases the cutting edges of the tools are made at an angle of  $30^\circ$  on each side of what the machinist might call a diamond point; but the angle made from the bottom should be  $60^\circ$ . Hollzapffel constructed a tool called the Goniometer, that was intended to furnish the workman with a positive mode of getting the proper angles with certainty. This instrument is founded on the same principle that is employed in determining the angles of crystals. The whole science of cutting a gem depends entirely on the angle in proportion to the refractive power of the material, and just the same with the brilliancy of the barleycorn on the watch case. Other things being equal, the angle of the cutter that gives the best reflection of light will be best for brilliant effect. Now, in what is technically called "stripping," the angle at which the bevel is cut has much to do with not only its own brilliancy, but adds largely, when well done, to the lustre of the stone. The graver, as generally used by the jeweler, is of the more importance, as he has to judge of the effect from personal experience.

We wish, then, to make an edge on the graver that shall be able, with careful manipulation, to make a clean, polished cut. If any of

our readers have been in a machine shop, and observed the operator in the act of turning off a shaving from a piece of wrought iron, with the aid of water, he will comprehend our meaning of a polish cut. The jeweler, after having ground the point of the graver to the angle we have indicated,  $30^\circ$ , proceeds to put on this face between A and B, as fine a polish as can be effected on any piece of steel. No pains are spared to make it perfect; and as it is important, not only to the jeweler, but the general artisan, we will give a minute description of the process.

Depending somewhat on the habitat of the workman, he may use emery, oil-stone powder, or what is much better, sapphire, pulverized and floated off, to get the various degrees of fineness, as is done with diamond powder. As the oil-stone dust is within the reach of every watch repairer, we shall take that as the modulus of operation. We will then suppose that the workman has the glass plates, of which we have in a former article given so minute a description; if he has not these, he may use with advantage a piece of the ordinary bell metal that has been brought up to a surface by grinding on a cast-iron face, with sand and water. After a fair surface has been obtained, the face is roughed up with a sharp file, in order to hold the finishing powder in the grooves made by the teeth of the file. It will be seen what importance may be attached to this form of surface, when we come to treat of setting the diamond end stone, so much used in the best classes of watches and chronometers. At all events, the bell metal surface must be so prepared that the polishing material may in every case be retained by the vacant spaces. Great care must be exercised in grinding the face of the graver, if the true level is attained. Assuming that the grinding plate has been well prepared, the first material used after the grindstone, will be the oil-stone powder, in oil. It requires a steady stroke and hand to keep the graver at exactly the same angle, and if it is not so done the subsequent polishing necessary will be impossible. After the face of the graver on the angle has been effected, it remains to finish the two other sides that constitute the cutting edges. In this consists the real difficulty, for if the smallest deflection takes place in regard to a *perfect plane* meeting the angle of the plane side, the edge will not be perfect for cutting purposes. In such cases, the graver is laid flat on the face of one of the sides and ground down until the edges meet; but the surface of the two sides where they meet the edges of the angle should be a *perfect dead level*. In fact, the finishing the graver will require some considerable practice. After the edge has been rendered perfectly uniform, it is polished up with first sharp, and then by means of a boxwood slip, used with the Vienna lime. If after the boxwood and lime you find the edges of the graver gives a sensation of roughness to the finger-nail, it will be necessary to again grind the graver, and again go through the same process of finishing. There can never be a certainty of a good edge on any new graver only after the temper has been ascertained.

MR. CHANDLER ROBERTS, at a recent meeting of the Physical Society, gave some results which he had obtained from an examination of certain alloys by means of the induction balance. He had been able to detect a difference of one part in 1,000 in the amount of silver in two shillings of equal weight. He also pointed out that Mathiessen divided alloys into three classes—(1) solidified solutions of one metal in another; (2) solidified solutions of one metal in an allotropic modification of another metal; (3) solidified solutions of allotropic modifications of both metals. For the first class the curve of electric conductivity is a straight line; for the second, a parabolic curve; for the third, a bent line. Mr. Roberts found that the balance gave the characteristic curve for the first class with an alloy of lead and tin, and for the second with an alloy of gold and silver. With a copper-tin alloy, which is a good example of the third class, he found the curve given by the balance to be intermediate between Alfred Risch's curve of density and Mathiessen's curve of conductivity, and considers that the balance is influenced by the density as well as the conductivity of the metal interposed.

## Practical Experiments in Magnetism, with Special Reference to the Demagnetization of Watches.—No. 1.

BY ALFRED M. MAYER.

THROUGH the courtesy of MESSRS. MUNN & Co., Editors of the SCIENTIFIC AMERICAN, we present to our readers the following interesting Essay, as it originally appeared in that Journal :

The extensive uses now made of electro-magnets in telegraphy, in dynamo electric machines, and in the many practical applications of electro-magnetism, have greatly increased the risks of damage to watches by their magnetization. I have no doubt that in any one of our larger cities there are scores of watches safely packed away in drawers regarded as past recovery from overdoses of magnetism. They are looked upon by their owners as bullion, kept in reserve for "a rainy day."

To be aware of the danger is not a sufficient guard against accidents. My own experience is a case in point: I had already silenced one watch, saturating it with magnetism by approaching an electro-magnet in my laboratory which had been allowed to remain in action by the person who had that day used it in his experiments. After purchasing another watch, I always took the precaution to place it on my office table before I approached the large electro-magnet of the Stevens Institute of Technology. I always did this, no matter whether the magnet was or was not in action. But one day I was suddenly called out of the room and detained by a visitor or a half hour or more. I took my watch from the table as I passed out of the room. I returned to my laboratory with my mind entirely engrossed with the experiments I had in hand, walked up to the magnet, rearranged the apparatus and charged the magnet. My watch at the time was not 3 inches from the pole of this huge magnet! I was only aware of my "accident"—call it, if you will, thoughtlessness about the watch or thoughtfulness about the experiments—when that afternoon I leisurely walked to the station to take a train, and was informed that "it had gone over half an hour." My watch had lost half an hour in about three hours! Persons more cautious than I, have had the same experience, for it is impossible, without idiocy supervening, to be constantly thinking of a watch. I have also remarked that out of the two or three dozen owners who have had watches apparently ruined by this same large magnet, each one considered "the other feller" a careless and thoughtless person until his turn come to do the same thing, when he was in a really thoughtful mood—about something, which was not his watch.

My last magnetic accident turned my thoughts to ways of taking the magnetism out of watches. I have succeeded perfectly, and the process which I have finally adopted as the best is so simple that any one can practice it, and that, if you wish, without even detaching your watch from its chain.

Though the process is simple, yet, of course a knowledge of the elementary facts and laws of magnetism is required to understand how it is done; and I know that every intelligent American mechanic, really wishes to understand the reasons for performing the operations that he may be called on in practicing any new process.

To render clear to all the operations used in demagnetizing (that is in taking the magnetism out of) a watch, I will assume that I am addressing those who have little or no practical experience as experimenters in magnetism, and also those who wish to be at the least expense in practicing watch demagnetization. I will, therefore, explain the facts and principles of magnetism on which the operations depend, by describing actual experiments made with apparatus which is so cheap and homely that it can be made by any one with a very little trouble and at a trifling expense.

I will at once proceed to show how to make the simple instruments required in our preliminary experiments and in the demagnetization of a watch.

The Magnet may be made out of a piece of a large rat-tail file. The one I have used is 7 inches long and averages  $\frac{3}{8}$  of an inch in

diameter. There is something either in the quality of the steel or the temper of these files which makes them capable of receiving powerful charges of magnetism. The most powerful magnet I have ever examined is the rat-tail file just spoken of. It lifts several times its own weight. If a large rat-tail file cannot be had, then a piece of Stubs steel, 10 inches long, and  $\frac{1}{2}$  inch in diameter, must be obtained. This steel rod must be first heated to cherry red, and then lowered gradually, while in an upright position into a bucket of water. This will render it hard and capable of receiving and retaining a magnetic charge. The file or steel rod is magnetized either by drawing it over the pole of powerful electro-magnet) or by wrapping around it insulated copper wire, and passing through the wire a current of electricity from a galvanic battery.

The Magnetometer.—We call thus the small magnetic needle suspended in a glass shade by a fiber of silk, Fig. 1. It is made thus: Take a number 4 or 5 needle, and draw it several times, from point to eye, over the N. end of your magnet. This operation will magnetize the needle, and when suspended from its middle, its pointed end will point toward the north. Now, on to a piece of wood, B, which is 3 inches square, glue and screw the slips, A and A, across its grain, so that it cannot warp. Then on its upper side paste a piece of damp white drawing paper. When this has dried it will be tightly stretched on the piece of wood. Draw on the paper a circle slightly larger in diameter than the length of the No. 4 needle. Divide one-half of this circle off into 180 parts of one degree each; or, if that be too tedious, divide the semi-circumference into ninety equal parts of two degrees each. To suspend the needle, you get a skein of floss silk, such as is used in embroidery. This silk is untwisted, and from it you can readily draw a thread formed of a few fibers, which is very delicate and without the slightest twist or torsion in it. To suspend the needle, stick to its middle a small dot of wax. Then press the end of the silk thread into the wax and work the wax over it with the fingers. The other end of the thread is

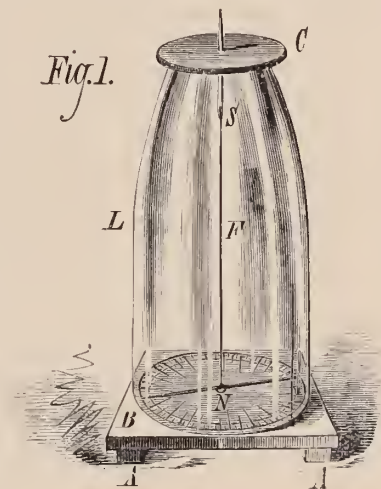

passed through the eye of a large No. 1 or 2 needle. This needle is then passed through a hole in a piece of cardboard, C, placed on top of the lamp chimney, L. The silk thread must be of such a length that when the needle is pushed downward through the hole in C, the magnetic needle, N, may be brought to rest on the paper covering the block, B. Now, on slightly drawing up the needle, S, the magnetic needle, N, will hang just above the board B, and will swing round with its pointed, or N. end toward the north of the horizon. After many oscillations the needle will come to rest and will point in a direction which is called the magnet meridian. This direction is different for different places. Here, in New York, it makes an angle of  $7^\circ$  with the true north and south line, and the N. end of the needle points  $7^\circ$  to the west of the true north. This pointing of a suspended needle away from the true N. is called its magnetic declination, or magnetic variation. In New York and its vicinity the magnetic declination is  $7^\circ$  west.

In addition to the magnet and magnetometer the experimenter will need the following materials:

Three pieces of soft iron. One piece 12 inches long and  $\frac{3}{8}$  inch in diameter; another piece three inches long and  $\frac{1}{4}$  inch in diameter; a third piece,  $1\frac{1}{4}$  inch long and  $\frac{3}{8}$  inch in diameter. These pieces of iron should be made very soft by heating them to bright redness and then allowing them slowly to cool in hot ashes.

A piece of steel wire, 6 inches long and  $\frac{1}{16}$  inch in diameter.

Iron filings, made from soft iron and passed through a fine sieve.

*Pieces of window glass.* Two 12 inches by 6, and two pieces 6 inches square.

*A small bottle of spirit varnish,* such as photographers put over their negatives.

Needles, nails, and tacks of various sizes.

With the above simple and cheap things a great many interesting and beautiful experiments can be made; and we will now show how to obtain from these homely instruments much information that is really sound and useful.

*Experiments showing in what a Magnetic Substance differs from a Magnet.*—Place the magnetometer on the table and allow the magnetic needle to come to rest. Now take the piece of soft iron 3 inches long and bring it slowly up to the magnetic needle, always keeping the piece of iron pointing toward the point of the needle, as shown in Fig. 2. You will observe that the point of the needle moves toward the iron, turning around its center, C, in the direction shown by the arrow.

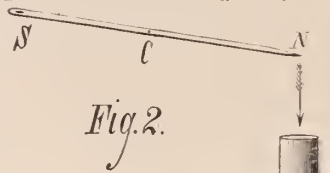

Fig. 2.

Slowly and steadily draw away the piece of iron. As you do so, the needle slowly turns on its center, C, and comes again into the magnetic meridian.



Fig. 3.

Now bring the piece of iron up to the eye end of the needle, and you will see that this end turns toward the iron in the same manner as did the point of the needle in the previous experiment. Thus we find that a piece of soft iron attracts either end of the magnetic needle. Each end moves toward the iron. If this be so, it necessarily follows that if you point the piece of iron directly toward the center of the needle and bring it up to the needle in this position, keeping care always to have the length of the piece of iron at right angles to the length of the needle, the needle will not move, but remains steadily pointing in the magnetic meridian. Each end of the needle is equally attracted toward the iron, and as each end tends to turn in the direction shown by the arrows in Fig. 4, it remains at rest under the action of two equal forces tending to rotate the needle in opposite directions.

Now we will make some experiments similar to those just described, but differing in this: we use a magnetized No. 1 sewing needle instead of the piece of soft iron. Take a No. 1 sewing needle and draw it from point to eye over the N. end or pole of your rat-tail file magnet. You will, by this operation, have converted the needle into a magnet, and if you suspend it, as I wish you now to do, like

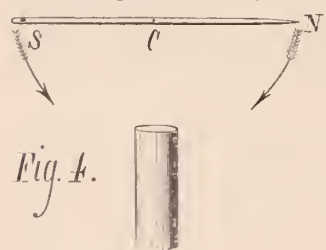

Fig. 4.

the needle of your magnetometer, you will find that it points in the magnetic meridian with its point toward the north. The ends of magnets, or, more accurately speaking, certain points in the center of magnets and near their ends are called the poles of the magnet. To distinguish these two poles, they are respectively called north pole or south pole, corresponding to the end of the needle which points toward the north or south geographic pole. The points of our magnetized needles are, therefore, north poles, while their eye ends are south poles.

Bring the No. 1 needle up to the needle of the magnetometer, with its point toward the point of the magnetometer needle, and with its length always at right angles to the magnetic meridian, as shown in Fig. 5. The

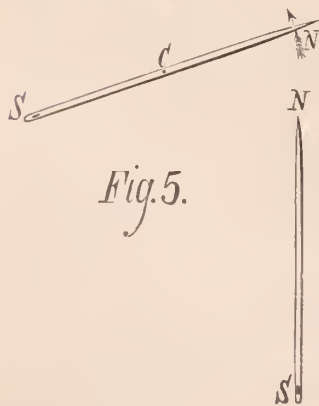

Fig. 5.

N. pole of the needle moves away from the north pole of the No. 1 needle, and we here have *repulsion* instead of attraction, as we had when the piece of iron was placed in the same position. Now point the north pole or point of the No. 1 needle toward the eye end, or south pole of the magnetometer needle, as shown in Fig. 6. In this position of No. 1 needle, the S. pole of the suspended needle moves toward the N. pole of the No. 1 needle. So in this experiment we have attraction of the S. pole toward the N. pole. Thus we have found out that the north poles of magnets repel each other, while the north pole of one magnet attracts the south pole of another magnet. This being the case, it follows that the No. 1 needle, attracting the S. pole of the suspended magnet and repelling its N. pole, must, when pointed at right angles to the suspended needle and directed toward its center, C, cause the suspended needle to rotate, its S. pole moving toward the point of the No. 1 needle, as shown in Fig. 7.

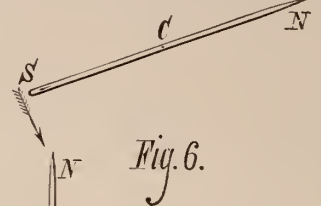

Fig. 6.

The experimenter must now compare this experiment with the similar one with the piece of iron. The iron when pointed toward the center of the magnetic needle did not rotate it, but when the magnetized needle is placed in the same position the suspended needle rotates and its N. pole moves away from the N. pole of the No. 1 needle.

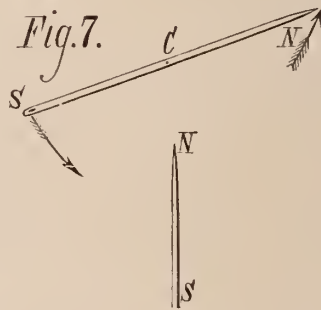

Fig. 7.

Let us vary these experiments by pointing the eye end, or south pole, of the needle first toward the N. end and then toward the south



Fig. 8.

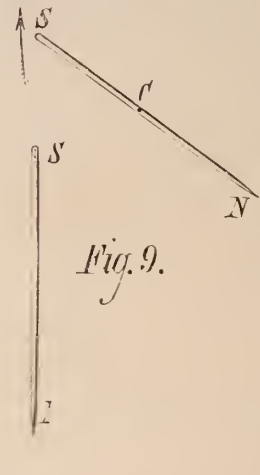

Fig. 9.

end of the magnetometer needle, and then toward the center of this needle. Figs. 8, 9, and 10 show the results of these experiments. They differ from those of Figs. 6, 7, and 8 in this: the south pole of the magnetized No. 1 needle acts on the suspended needle in place of the north pole. The results are as follows: The S. pole of the No. 1 needle repels the S. pole of the suspended needle and attracts its N. pole; and consequently when its eye end is pointed toward the center, C, of the suspended needle the latter has its N. end pulled toward the No. 1 needle and its S. end repelled. It necessarily turns around its center, C, its N. pole moving toward the eye end or S. pole of the No. 1 needle.

These are very simple experiments, yet they have already given us the knowledge of an important law, which may be summed up thus:

*Like poles repel each other, while unlike poles mutually attract each other.*

These experiments also give us a practical and easy method of determining whether a body is merely a magnetic substance like or

piece of soft iron, or a piece of nickel or cobalt; or is a magnet like our No. 1 magnetized needle.

Each end of a bar of a magnetic substance attracts either the N. or S. pole of a suspended magnet; but a magnet has poles, and one of its ends acts to attract one end of a suspended magnet, while the other end of the magnetic bar will repel the same end of the suspended magnet. Hence, to tell whether a certain bar is a magnetic substance or a magnet, we place it with its length at right angles to a suspended magnet, and pointing toward its center. If in these circumstances the suspended magnet remains at rest, then the bar is formed of a magnetic substance, or one which has no action whatever on a magnet. To determine whether the latter is the nature of the bar, we bring one of its ends near an end of the suspended magnet; if the latter remains at rest, then the bar is formed of a substance which has no sensible magnetic action on the suspended needle. If, however, the suspended magnet turns when the bar is placed at right angles to its length, then the bar is a magnet, and the end of it which is toward the needle is the pole which is of the same name as the pole of the suspended magnet which moves away from the bar.

With the magnetometer we may, therefore, determine the name of the pole of a magnet by the direction in which the magnetometer needle moves, and we can compare its intensity with another magnet by observing the number of degrees of the circle over which the needle rotates.

These experiments on the mutual attractions and repulsions of magnets may be modified in a very pleasing manner by allowing a

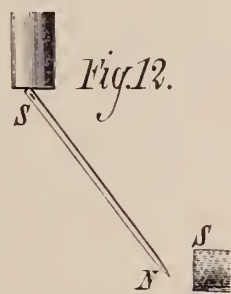
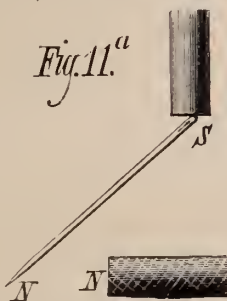
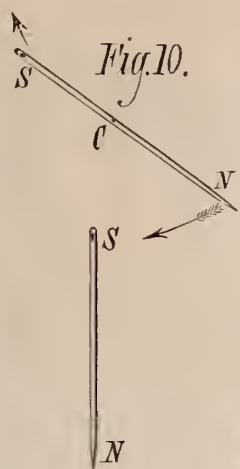

No. 1 magnetized needle to adhere from the end of a piece of soft iron, and approaching to the free end of the needle first one pole and then the other of the magnet. Figs. 11a, 12, 13, and 14 may serve to clearly show the different phases of these experiments without further explanation.

*Experiments in Magnetic Induction.*—Pour some iron filings on a sheet of paper and roll your rat-tail file in them. Lift the magnet from the paper and you will see that the filings stick in the form of bristles or brushes to the two ends, and at some distance from the two ends of the magnet, but to the middle portion of the magnet no filings adhere, as is shown in Fig. 11.

Stick the end of the piece of soft iron in the filings; you will see that they do not adhere. Now stand the piece of iron upright in the filings and bring the rat-tail file down on the upper end of the

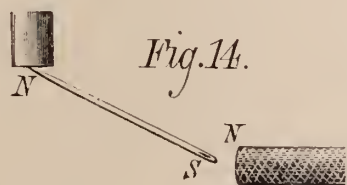
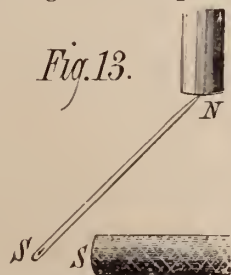

iron. Lift the magnet, and the iron, you will find adheres to the magnet; also, you will observe that the iron itself is now magnetic, for the filings adhere to it, as shown in Fig. 15.

If you take hold of the piece of iron with one hand and then detach the magnet, lifting it above the iron, you will see that the iron loses its magnetism, for the filings fall when the magnet is removed to a distance from the iron. Yet it is not necessary that the magnet should actually touch the iron to render it magnetic, for you will find that the iron will attract the filings and cause them to adhere to it even when the magnet is held at a short distance above the end of the iron, as shown in Fig. 16, though the quantity of iron filings which it is capable of holding, and consequently the strength of its magnetism, is less than when the iron adhered directly to the magnet.

The above experiment is modified in an interesting manner by using different sized nails, brads, and tacks in place of the filings.

In this experiment represented in Fig. 17, the magnet has directly adhering to it a large nail. This nail is thus made a magnet, and it



in turn holds up a smaller nail, and this a yet smaller one, which in turn supports a brad, and this brad a smaller one, and to this sticks a tack, and to the tack adheres some iron filings. Each nail in turn acts on the nail or tack which adheres to it, just as the magnets acts on the large nail directly adhering to it.

Thus it is seen that the magnet induces the iron to become a magnet like itself when it touches the iron or is held near it; hence this action of a magnet on soft iron is called *induction*.

We will now repeat these experiments in induction, but we will use a piece of steel in place of the soft iron. Select a short thick

sewing needle that contains no magnetism. Of this you may be sure if, when the needle is pointed toward the center of the magnetometer needle, and at right angles to its length, it does not cause the latter to rotate. If the needle, when dipped in iron filings, does not cause them to adhere to its ends it will be free enough of magnetism for our experiments.

Having tested the needle and found it free of magnetism, you now hang it to the end of the rat-tail file magnet and bring its free end into the filings. They now adhere to the needle, as shown in Fig. 18.

Hold the needle between the fingers of one hand and remove the magnet to a distance with the other hand. You now see that the needle behaves differently from the piece of soft iron, for when the magnet was removed from the latter the iron filings dropped from its end, but in the case of the needle the filings remain suspended. In other words, the iron is only temporarily

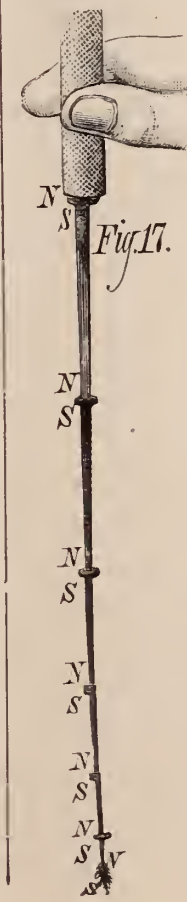

magnetized by induction; that is to say, it remains magnetized only while in contact with the magnet. On the other hand, the needle is permanently magnetized by induction; that is, it remains magnetized after the magnet has been removed from it. This difference in the after effects of induction on soft iron and steel is best observed in the following experiment.

Take a piece of the softest iron, and having ascertained that it is entirely free of magnetism, draw it repeatedly over the end of the magnet; if the iron is really soft you will find that even repeated stroking on the magnet cannot give it the power of attracting the filings. However, generally the iron will retain a slight, though often very slight, amount of magnetism, and will cause a few particles of filings to adhere to it. Now perform the same experiment with a large sewing needle, and observe how powerful a magnetic charge has been given to it. When rolled in the filings large tufts adhere to its ends, surprising those who have never seen before how strong a magnet may be thus made of a large sewing needle.

This retention of a magnetic charge by steel enables us to readily fashion magnets of any form and size. If steel or some other easily worked body had not this property we would be obliged to construct our mariner's compass needles out of the hard and brittle calamite or loadstone. Indeed, it would be difficult to select from the whole range of the special properties of matter one more valuable to man, or more necessary to his present high and widely spread civilization, than this one of the capability of steel to receive and retain the properties of the loadstone.

*Further Experiments in Magnetic Induction.*—Let us, by means of other simple experiments, examine more minutely into the nature of this magnetic induction.

Take two pieces of very soft iron wire and suspend them by silk fibers, as shown in Fig. 19. Hold the ends of the fibers separated, between the thumb and forefinger, so that the wires may hang a quarter of an inch or so apart. Now bring them slowly down toward the N. end of the magnet, as shown in Fig. 19. They now no longer hang parallel to each other, but are inclined, the upper ends of the wires repelling each other, so that the two suspending threads are forced outward and no longer hang vertically. This repulsion between the upper ends of the soft iron wires is caused by their having the same magnetic polarity. We have already seen that like poles mutually repel.

(See experiments described in Figs. 5 to 14.) If the N. pole of the magnet is pointing upward, as shown in Fig. 19, then the lower ends of the suspended iron wires are of S polarity and their upper ends are of north polarity.

The experiment just described may be modified by simply holding the two wires parallel to each other between the thumb and forefinger and bringing their ends to touch the end of the magnet. They will adhere to the magnet, and on relieving the wires between the thumb and finger they will at once fly apart, from their mutual repulsion, as shown in Fig. 20.

Take seven pieces of iron wire, each about one inch long, and run them through small corks, about  $\frac{1}{4}$  of an inch long, and  $\frac{3}{16}$  inch in diameter. Throw these pieces of wire into a bowl of water and they will float vertically. They will come to rest at various haphazard positions on the water. Evidently there is no order in their arrangement. Now take your rat-tail file magnet, and, holding it in a vertical position, bring it over the water in the bowl. At once the

pieces of wire sail toward the magnet, and after many motions among themselves they at last take up the definite figure of a hexagon with a floating wire in its center, as shown in Fig. 21.

This is a beautiful illustration of magnetic induction, and this experiment tells the whole story when viewed in the light which another gives, and which will be at once described before speaking further of the one just made.

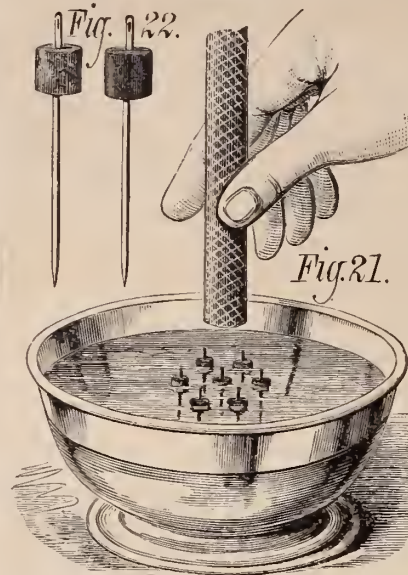

made by halving one of the corks just described. In other words, the corks which will float these needles are  $\frac{1}{4}$  inch long and  $\frac{3}{16}$  inch in diameter. Now throw these needles in the bowl of water. They repel one another, and if time enough be given them they will at last reach the edge of the bowl and will arrange themselves at equal distances apart around the border of the water. They do so because when floating upright their like poles are opposed to each other, as shown in Fig. 22, and these like poles mutually repel.

While the needles remain on the border of the water in the bowl, bring down vertically the rat-tail file over the center of the water, with its N. pole pointing downward. The magnetic needles at once rush towards the middle of the bowl, and after moving about each other for a while they end by forming the same regular geometric figure of the hexagon, with a needle in its center, as happened in the experiment with the floating iron wires, shown in Fig. 21. In the experiment with the magnetic needles we know the exact magnetic conditions of the experiment. We know that the needles are magnets, and that their south poles are pointing upward and their north poles are down in the water. The like poles of these needles being opposed, they mutually repel, and keep apart till the N. end of the magnet has been brought over them; then this strong north pole attracts the upper or south poles of the needles, and they draw toward the N. pole of the magnet. In other words, the attraction existing between the N. pole of the magnet and the south poles of the needles is stronger than the repulsive force existing between the needles. The needles therefore move toward the magnet and approach one another till their mutual repulsive actions keeping them apart just balance the attraction of the magnet which tends to bring them together.

If the magnet be held at rest, the figure of the hexagon remains at rest; but if the magnet be slowly raised, the hexagon enlarges as the magnet goes further off from the hexagon, for in this case the attractive action of the magnet diminishes. If, however, the magnet approaches the hexagon, the latter shrinks in size, for the attractive force of the magnet on the hexagon increases, and the needles approach till their increased mutual repulsion exactly equals the increased attraction exerted by the magnet on them when the magnet is nearer the hexagon.

If the reader's interest should be excited by the description of these new experiments in magnetism, he will find in the SCIENTIFIC AMERICAN SUPPLEMENT, No. 129, an extended description of them and of the phenomena which they may serve to explain and illustrate, with a full set of the various figures found by different numbers of floating magnets. (To be continued.)



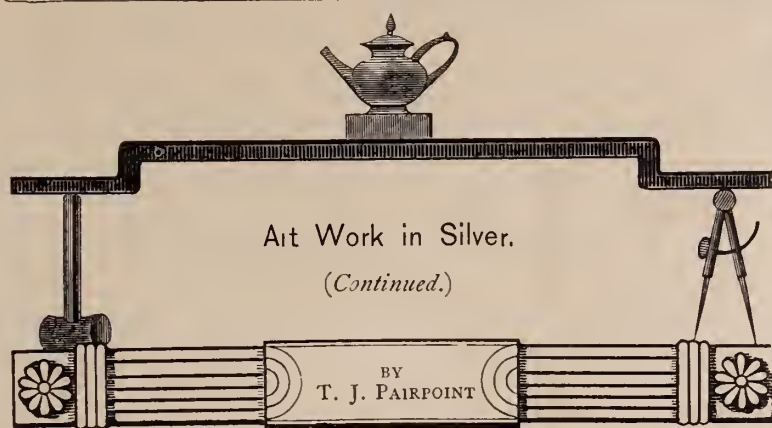

ROMAN art was greatly influenced in all its branches by Greek traditions, and its influence is recognizable at the earliest period. After the conquest of Campania, the knowledge of Greek art and institutions, became more widely diffused throughout the Roman empire. The adoption by the Romans of their architectural forms was owing to the similarity or connection of religious belief and ceremonial. This similarity leading them to suppose they must have had a common origin. The Roman, which is the last of the ancient styles, lacked the refinement and purity of the Greeks in the treatment of their decorations, but they attained a greater magnificence by an enriched and profuse use of details, scroll growing out of scroll, and leaf over leaf, they overloaded with ornament, and in the excess of decorative elaboration, lost much of that purity and fine sentiment, which always characterized the Greeks. The acanthus scroll very elaborately developed is characteristic of Roman art, and they used a combination of the three Greek orders subject to various modifications. They also introduced human, animal and vegetable forms, grotesquely treated, much more frequently than the Greeks. The Trojan scroll is a fine specimen of the rich and gorgeous development of the Roman style, but the acanthus leaf entered most prominently into all kinds of Roman decoration; it is found in every variety of development and elaboration, adorning alike the grand proportions of their architectural structures, and the smallest objects of ornamentation. The Corinthian column and capital was by them richly developed and perfected, the capital being formed of two or three rows of acanthus leaves, from between which appear human, or animal forms, flowers and volutes. The Romans added very few new elements in their decoration, the principal one being the shell. The Tuscan style was often used by them, and it exhibited a strong resemblance to the Doric order.

The Etruscans used Greek forms introducing modifications of their own, and the Romans borrowed it again from the Etruscans, and was by them again modified, and developed into a distinct system.

The Romans had not that absorbing love of art possessed by the Greeks, they cared for it only as an article of luxury and ostentation, and although their best works were executed by Greek artists, Roman influence caused them to have a Roman character, and as their wealth and power increased, art began to decay, their works became gorgeous and elaborately ornamental, but they sacrificed that grandeur of simplicity, which is inseparable with fine taste. In passing from the best period of Roman art, their architecture which had been simply an elaboration of the Grecian style gradually lost that purity of character which had been so highly prized by the Greeks, and in its place a degraded style of ornament was adopted, which is known by the term Romanesque. In this, the natural and the artificial are combined, floral ornament and foliage with animal forms both real and imaginary.

The use of the arch is a distinctive characteristic of Roman architecture, the arching or vaulting principal being one of its essential elements. The horizontal architrave on columns is identified with the Greeks, but the Romans preferred the arch in their buildings, but at the same time retained the Grecian forms of construction, overloading and exaggerating the decorative details; thus,

when the arch or vaulted covering was used, the column which was no longer needed as a support was still retained as an ornament.

The Greeks frequently erected columns to perpetrate the memory of a great man or hero; this usually bore his statue, or some object referring to, or symbol expressive of, his peculiar attributes or deeds. The Romans borrowed this custom from them, increasing the height of the monument, and sometimes encircling it with bass-reliefs, arranged in spiral curves around the shaft, representing the actions or circumstances to be commemorated.

The Romans introduced the triumphal arch, sometimes using them for the same purpose as the columns, but more frequently they were erected for the triumphal entry of a victorious emperor or commander, returning from a successful war. One of the most important and interesting of these is the triumphal arch of the Emperor Constantine, erected in celebration of his victory over Maxentius, and the establishment of Christianity in the Roman State. These triumphal arches are characteristic of the warlike national spirit of the Romans, in the same manner that the public games and gymnasia were of the Greeks.

The Byzantine style originated through the introduction of Christianity, and completely altered the previously used character and style of ornament. The symbolism of Egypt appears to have exerted considerable influence upon the Christians of the Byzantine empire, in fact, all Christian decoration is founded upon it.

The representation of subjects connected with the new faith, combined with the influence of the ancient symbolic mysticism, was demanded by the Greek and Roman people, in the decoration of their churches. At this period, ornamental art was rarely used merely as decoration, but always in connection with and forming a part of the worship. Some of the principal symbols are the monogram of Christ, inscribed in various ways, the cross, the aureola, and the nimbus. The aureola is a halo of light and glory, surrounding the whole body, and supposed to emanate from a divine person. The nimbus is the same halo but surrounding only the head, the latter is of Pagan origin, and the early Christians were much opposed to using it as a sacred decoration, but it was finally admitted as an element in Christian art. The nimbus of Christ is in the form of a cross more or less defined, while that distinctive of the Virgin Mary, is a circlet of small stars. A nimbus composed of rays diverging in a triangular direction, represents the Eternal Father, and when it is square in form, it signifies that the person was alive when represented, and it is intended as a mark of honor and respect. We find as an outgrowth of the nimbus or circle, the trefoil, quatrefoil, and other forms, the trefoil being typical of the Trinity, and the quatrefoil, of the four Evangelists, as bearing witness of Christ. The angel, the lion, the ox, and the eagle also are symbols of the Evangelists. The lily and the serpent were also used, but the cross, the circle, and the dome, are the prevailing elements. In the earliest centuries of the Byzantine, the style was very simple and primitive, as they zealously excluded every form, however beautiful, which had been identified with paganism. But as time passed on, and paganism itself gradually disappeared, and Christianity became more widely spread, the scroll, the anthemium, and other ancient forms, conventionally treated, were admitted, and as there were no restrictions in the use of color, a very gorgeous style was gradually developed. At this time, the Christian churches were decorated with a magnificence that was intended to eclipse the grandeur of their former pagan temples. The interior of the edifices were entirely covered with mosaic work, paintings and draperies, so that in which ever way the worshippers turned, their eyes met with some representations that were designed to inspire devotional feelings, and at the same time by a profuse use of gilding and symmetrical arrangement of ornament would excite the admiration of these beauty loving nations. So much care was bestowed upon these decorative arrangements, that St. Chrysostome remarked that in his day, all admiration was reserved for the goldsmiths and weavers.

Both the Saracenic and Gothic styles originated from the Byzantine. In the Saracenic no representation of any living thing was allowed, neither animal or vegetable. The Mohammedan law was, very strict in this particular, hence, arose the necessity for considerable artistic ingenuity, resulting in perhaps a more beautifully simple style of ornamentation than any that had preceded it, although the rigid care with which they excluded any natural living forms, gives it a slightly artificial character. Geometrical figures and the ordinary forms used in the classic period, together with the peculiarly Saracenic method of introducing inscriptions into their designs, are the chief features.



This style is mainly composed of a series of curves and angles, and interlacings, and by the eighth century, when they commenced to elaborate and enrich, their curves became floral forms, and the lines and angles developed into beautiful tracery and strap work, enriched by the characteristic ornamental inscriptions, the general effect of which strikes one, as made up of continual contrasts of light and shade and color, and like the Byzantine's they exhibited more skill in the general effectiveness of their work, than in careful details or combinations.

The Gothic is peculiarly a geometric and pointed style, with all the symbolism of the Byzantine contained in it. The chief characteristic is an elaboration of geometrical tracery, circles, trefoils, quatrefoils, etc., with the pointed arch, which was also an element of the Saracenic style. Vertical and diagonal lines are preferred to all others in the tracery, and sometimes we find natural flowers mingled with it, usually copied from any plant or flower found growing in the immediate vicinity. The Gothic scroll usually consists of a foliated serpentine instead of the succession of spiral forms, as in former styles, but the distinctive characteristics are more pronounced when some historic emblem or ornament is introduced, such as the Fleur de lis, trefoil leaf, Tudor flower, etc. Tracery, which plays such a very important part in Gothic ornamentation, passed through several stages of transition and development, known successively by the terms, plate, bar, geometrical, flowing, flamboyant and perpendicular. Plate tracery is characterized by a flat surface, pierced with open spaces; these spaces or openings being in the earlier periods in the forms of a plain circle, which become developed into trefoil, quatrefoil, and more elaborate forms, as it approached the

bar period. In this period we find that the arch heads are divided by a bar of equal thickness, instead of the ornamental piercings which before separated them and all the following variations of tracery from this style to the perpendicular are based on these principles. Geometrical tracery became one of the greatest successes of Gothic architecture. By its aid, the window which formerly had been considered an undesirable necessity, became in connection with the pointed arch form, one of the most striking and attractive objects in a building.

The circle is always an important element, and in this period there are frequently three or more circles grouped together under one arch. The spaces formed by the intersection of the bars, offered an opportunity for the introduction of ornamental details, and they were accordingly filled with quatrefoil, cinquefoil, and various other decorations.

Another important feature was soon added, which to a great extent usurped the place of the circle. This object consisted of a pointed oval figure formed by two intersecting segments of circles, called the Vesica, from its supposed resemblance to a fish, which in the Greek contains the initial letters of our Saviour's name. The various forms of geometrical tracery, are distinguished by their separate designs, so that in many cases it would be possible to take out the centre piece of a fine geometrical composition, and use it by itself as an independent and complete piece of ornamentation. When we arrive at the transition period, we find this system of separate composition discarded, and some graceful and elegant designs are substituted, the chief characteristics of which, is to flow into each other, thus giving the title of flowing. One of the first forms assumed by the flowing tracery, is the reticulated, that is formed somewhat like the meshes of a net, and when it is used in combination with the circle and other forms, and also with convergent and divergent lines, it is extremely graceful and pleasing; but when the reticulated form is used alone, unvaried by other details, it becomes monotonous and tiring. The next form of flowing tracery is the flamboyant in which the convergent and divergent lines or figures predominate. The designs of this type are very intricate and show an absence of geometrical construction. The most prominent feature by which it is distinguished, is the supposed resemblance to a flame hence, the origin of the name Flamboyant. That period of flowing tracery is the best which combines leaf-like and natural forms, strengthened and supported by the blending of geometrical patterns, as the flamboyant style by the exclusion of this element, lost that vigor and strength which their use always imparts and degenerated into simple prettiness.

In the perpendicular period the leading features are a straight line prominently placed, with increased height and breadth of proportions; also a return to the earlier form of arch slightly flattened on the side. This style grew rapidly into favor, and we find it used by the artists on every occasion that presented itself. The parts that had been previously left plain, were now covered by every variation of tracery. From this profuse use of ornament arose another variation known as the fan tracery. One of the most beautiful monuments of this period is Henry the Seventh, Chapel Westminster Abbey. When admiring this stupendous work, one cannot help feeling a sense of wonder at the vast conception of the design, as well as the patient skill required to work out such an elaboration of detail. In fan tracery, the straight line is the prominent feature, terminating in a fan shape form, richly decorated on every available space. There are innumerable examples of this style of ornament to be found in stone and metal screens, fonts, pulpits, and tombs, scattered throughout England and the Continent of Europe.

Nothing can be conceived more magnificent than the full development of this style, with its tracereid vaulting and its elaboration of details; yet as the magnificence increased, luxury of form began to take the place of the purity and severity of classical and geometrical construction, which is the true foundation and motive power of art.

About the beginning of the thirteenth century classical art was revived in Italy, and is best known by its French name of Renaissance. There are four Italian styles of this revival, the trecento, the quattrocento, the pure cinquecento, and the mixed cinquecento or renaissance. This revival was for a long time simply a return to the classical orders of architecture. The revival of strictly classical ornamentation, was not fully developed until the sixteenth century. In the fifteenth century, we find a frequent recurrence to ancient examples, mixed with some original arbitrary forms: the pierced and scrolled shields or cartouches, together with strap work or tracery, were used, and the introduction of exact natural imitations, is a prominent feature of this style of the early renaissance.

The pure cinquecento was an endeavor on the part of the great artists of that day, to establish a purity of style surpassing all former revivals of classical art, and therefore they excluded every element that was not sanctioned by ancient examples. Their object was to revive the purity of form practiced by the Greeks combined with the gorgeous decoration of the Romans, and even to develop it if possible, to a still greater degree of variety. To this end they rejected the scrolled shields, tracery, and other arbitrary forms, which had been used in the early renaissance, and elaborated all the most prominent characteristics of Greek and Roman art. The acanthus scroll was again a predominant feature with combinations of human, animal and vegetable forms, and the grotesques arabesques; also a beautiful variation of the ancient athenian. All natural objects were admitted; and the extreme beauty of the lines is very marked in all their work. This style is considered to be the highest standard of ornamental art that has yet been attained in it we find the most perfect forms, and pleasing effects with perpetual variety. Some works of this period, and among others, those of Benvenuto Cellini, contain a combination of all the various styles in one, classical forms and decorations, foliated scrolls of the Byzantine, Saracenic strap work and interlacings, the cartouch and natural reproductions of animal and floral forms with arabesque. This mixture of styles is also known as renaissance, although the word is more appropriate when applied to the revival of classical art, as renaissance signifies new birth.

The Louis Quatorze is the last of the historic styles, as the Louis Quinze and the Rococo are merely varieties of the Louis Quatorze. The principal features are the shell and the scroll, the anthemium was also used, treated as a shell by being made convex. All classic ornamentation as well as the elements of the cinquecento and a small acanthus scroll, were admitted, but only as accessory details of the more prominent scroll and shell. This style was very extensively used on gilt stucco work, which, for a time, seems to have been preferred to decorative painting, and the absence of color, gave rise to the necessity of having a great play of light and shade, and in order to effect this, true symmetrical arrangement was not always considered. Indeed in some varieties it appears to have been purposely avoided. The play of light and shade holds such a prominent position in this style that every other consideration is subordinate to it, and for this reason, they very rarely admit a flat surface in their details, but preferred one that was convex or concave, and for the same reason the wave line was frequently introduced.

The Louis Quatorze is extensively used for the decoration of English silver work, for which it is peculiarly adapted. It does not depend upon any assistance of color to make the designs effective, and therefore, in this particular branch of industry, it has been preferred to other styles. The Queen Anne plate, so much prized by English connoisseurs is simply an application of Louis Quatorze under English sentiment; the forms are good and suitable for silver, the decoration has a fine metallic effect, and in England it has gradually grown into favor, and been generally accepted as an appropriate style for silver ware; but this is not the only reason why Queen Anne plate is sought after; there is, in addition to it, a his-

torical interest attached to the period when these works were produced, which makes it very valuable in the estimation of collectors or connoisseurs.

The absence of symmetry became more marked until that most degraded of all styles—the rococo—was developed in which it appears to have been entirely excluded. This style exaggerated the main characteristics and peculiarities of the Louis Quatorze, scroll and shell ornaments are abundant, combined with birds, fish pavilions, rock work, and enormous flowers, thrown together without any constructive property or connection. The profuse abundance of details is the predominant feature, sacrificing all meaning and taste, for a lavish and overloaded effect. In the earlier period before the rococo was fully developed, when some attention was paid to the grouping of the various parts and masses, some good effects were produced, but when symmetry was entirely discarded, the scrolls degenerated into merely a kind of crimped shell work, and the designs became only a mass of details without meaning or individuality.

### Goldbeaters' Wages.

THE Goldbeaters' Protective Union of New York and Philadelphia are seeking an advance of wages. They have been in receipt of late years, for men's work, of from \$3.60 to \$4 a "beating," varying in different cities, and demand a uniform rate of \$6, which those of this city received after the war. During the war the price was \$8, and for some years before it, \$5. The sixteen establishments of New York, employing about 125 men and 100 women, have all conceded the rise demanded, and will begin to pay it to-morrow. Philadelphia has four firms, employing about two hundred men and girls, in addition to a number of boys. They are using machinery, which enables them to dispense with much men's work and employ the cheaper labor of women and boys. The union desire the abolition of the machinery. Boston, Hartford and Chicago, each possess three firms, employing in each city about 30 men and 25 girls; San Francisco has four firms, employing 25 men and 20 girls; Cincinnati and Buffalo, each two, employing 10 men and 8 girls; and New Haven, St. Louis, Baltimore and Albany, each one firm, employing 4 or 5 men and 3 girls.

One beating and a half a week will enable a man, at \$6, to earn \$9. He can sometimes earn a dollar or two over that amount. Women can with great quickness and practice make \$8, but their average is not over \$5.50. The gold is distributed to the men in ribbons the thickness of ordinary writing paper seven yards long and one inch wide, and weighing fifty penny-weights. The value of each is \$50. A "beating" consists of one of these ribbons. It is cut with scissors into pieces of one inch square, and put into a "cutch" of leaves of prepared paper, and pounded with a broad hammer by hand until each inch is broadened into a sheet over three inches square. It is now gold leaf in the first stage. The ragged edges are cut off with a very sharp knife, and each square is divided into four parts. Each quarter is placed in a "shoder," or series of leaves of goldbeaters' skin, and again pounded by hand until it extends to four inches square. These are again cut into squares of one inch, and pounded in "moulds" until they spread to about five inches square. They are then ready for the women, who cut them with a "wagon," or sliding knife with two blades, into squares of  $3\frac{3}{8}$  inches, and place each leaf between two leaves of little paper books, which are sold to gilders, bookbinders and painters, at fifty cents a book. A beating makes eighty books, which sell for \$40. This is an apparent loss of \$10, but sufficient is cut from the edges to make this up as well as to pay for labor and expenses. It leaves, however, a reported profit of only about \$1 a beating. A man employing ten men would thus realize little more than \$15 a week, besides the value of his own labor, and would be required to keep about \$1,000 worth of gold on hand.

Goldbeaters' skin is made from the entrails of oxen. The leaf sold to dentists is of thicker quality than that used by gilders, and passes only through the cutch or first pounding. It is sold in books at from \$25 to \$29 an ounce.

## Views of Correspondents.

## DISCOUNTS ON FLAT AND HOLLOW WARE.

*To the Editor of the Jewelers' Circular.*

We desire a short space in your valuable paper to call attention to a matter, which in justice, we think, should be righted. It interests a large number of country jewelers, of whom your correspondent is one. While we have no fault to find with the combination of Flat ware and Hollow ware manufacturers, but approve of the same as a preventative of cutting and the purchase by one jeweler cheaper than by another, we think the rule of allowing discount only to those dealers who buy at least \$500 of each kind of goods each six months, is hard, and works an injustice to country dealers, and its results only benefits city dealers.

What reference is made to, is illustrated, for instance, in my own case. The business capacity of the town where I trade, does not warrant the carrying of a stock of over \$400 worth of each kind of ware every six months. For the last two years my purchases have averaged about \$400 each six months in both hollow and flat ware. If \$500 worth of each kind was bought in that time, my stock would be too large. The result is that while I buy \$1,600 worth of each kind in the year, more than three times \$500, I do not get one cent of discount. I am not allowed any more than a country dealer, in the most out of the way place, who buys \$50 worth in a year. There are hundreds of jewelers in towns of 4,000 and 5,000 inhabitants, whom the rule affects in the same way.

Now justice demands a change. Either discount should be allowed upon the aggregate amount bought in the whole year if it exceed \$500, or else the amount to be bought within the six months should be reduced. We think the latter the better plan. Why not allow a discount upon every \$100 worth bought? Such a change would be a great advantage to the trade, is the opinion of your correspondent.

A COUNTRY JEWELER.

*To the Editor of the Jewelers' Circular.*

I read with much interest the article on "Watch and Chronometer Jeweling," in the September number of the CIRCULAR. I heartily endorse the well merited tribute therein paid to Mr. E. HOWARD, who, besides being a whole souled man, is endowed with more energy and perseverance than any man I ever knew; but for him the factory in Roxbury would be among the things of the past. He would scorn to claim the authorship of anything not emanating from his own brain, but the writer of the article above referred to, would lead your readers to suppose that Mr. HOWARD had invented the End Shake Tools (though I don't suppose such was his intention). Mr. N. B. SHERWOOD was the inventor of the "End Shake Tools," also of the "Jewel Opener," the Jewel Screw Head Counter Sink Tool, &c. The last named tool was so made that by putting a jewel screw in a slot provided for the purpose, you could countersink a hole in the gilded plate that would let the screw head in flush with the plate, and not throw up any burr. Had Mr. SHERWOOD patented these tools as I advised him to do, he could have had something to fall back upon in his last days. As he did not see fit to do this, Mr. HOWARD kindly paid him a sum of money after he left the factory. Mr. HOWARD will please pardon me for telling this on him, for I presume that I am the only one who knew of his doing so besides the interested parties.

After Mr. HOWARD, I believe that Mr. SHERWOOD did more to make watchmaking a success in America than any other man living or dead. These two men virtually improved the machinery and introduced such features as made it possible for the American system to succeed. They overcame the great obstacles. Could Mr. SHERWOOD have lived, and been endowed with the stability and perseverance of Mr. HOWARD, and have remained with him, there is no telling what they could not have done. Both being men of active inventive minds, and having a love for their work.

My object, Mr. Editor, in this communication, is not to detract from my friend Mr. HOWARD, but to give the credit of the invention of the End Shake Tools, &c., to the one, though dead, to whom it belongs. Speaking of Mr. HOWARD, who but him, could ever have found out how to give that matted appearance to watch plates that all American and English movements have. The Factory had sent a man to Europe purposely to find out this secret, but he failed to obtain it. So Mr. HOWARD determined that he *would* find out this secret himself, and by perseverance he did so. Some of those who may know of how he did discover this secret may say it was accidental, but that makes no difference, it was the *result* of that perseverance that characterizes the man.

JAS. FRICKER.

AMERICUS, GA., Sept. 29, 1879.

*To the Editor of the Jewelers' Circular.*

COLUMBUS, O., Sept. 25, 1879.

In the September number of your valuable journal I notice a long communication from OTTO WETTSTEIN, of Rochelle, Ill., intended to be a defense of those so-called jobbers, who do a retail business, and who flood the country with their price lists, inviting everybody to buy goods of them at *retail* at *wholesale* prices. The most of his article is devoted to a recital of his personal history and peculiar views on social and political economy, abounds in capital "I's," but begs the real question at issue. That question simply is whether the honest men in the jewelry trade will support and encourage imposters, who do business under false pretenses. This is the issue raised by the retail dealers, whose trade is injured by these imposters, and no sophistry put forth by Mr. WETTSTEIN can divert them from their declared purpose of rooting out this acknowledged evil. These retailing jobbers are imposters and an evil, because by misrepresenting to the manufacturers that they are jobbers, they secure lower prices than the retailers can obtain, and then invade the retailers' field and undersell him, which they are enabled to do by reason of the special discount they have obtained from the manufacturers. Retail dealers appreciate the value of jobbers in the business, and recognize the justice of their obtaining lower prices than are accorded to the retailers. They buy in larger quantities, and save the manufacturers the trouble and annoyance of keeping numerous accounts with the small dealers. For doing the work they are entitled to a profit fully as much as the retailers is entitled to his profit. So long as the jobbers confine themselves to their legitimate sphere, selling only within the trade, we wish them every success; but when they seek the individual patronage, of Tom, Dick and Harry, they trespass upon our preserves, lose their character as jobbers, and forfeit all right to the special rates accorded them by the manufacturers. They become simply pirates, sailing under false colors, deceiving the manufacturers and plundering the retail dealers.

I am rejoiced to see the firm stand taken against this class of jobbers by the various state organizations of retail dealers, and hope the good work will be pressed forward till manufacturers will not dare to sell to imposters who represent themselves to be jobbers, yet use every means, fair and foul, to wreck the retail trade.

W. H. JOHNSON.

HOWARD BROS., of the so-called "Independent Watch Co.," of Fredonia, N. Y., have adopted a new method of disposing of their wares. They address circulars, show cards, etc., to express and railroad agents, requesting them to act as agents for the sale of their watches, and offering to throw in a plated chain with the sixth watch sold. The agent who accepts these terms is furnished with plenty of printed matter, circulars, etc., to give him facilities for spreading the news that cheap watches can be had of him. The Agent of the United States Express Company, at Dunkirk, seems to have bitten at the bait, for we find he is using the Express Company's stationery to advertise the "Independent Watch Co." Envelopes with the Express Company's name printed on one side, are covered all over the back with the printed advertisement of the Watch Company, and other stationery is used in a similar manner. We call the attention of the United States Express Company to the manner in which this agent is using the material furnished him to the prejudice of other patrons of the Company. The public ought to understand that the legitimate avenues of trade are the only ones that can be safely patronized or with an assurance that the goods purchased are what they purport to be.

On the Compensation of Clocks, Watches and Chronometers<sup>1</sup>(By EDW. RIGG, M. A., *Assayer in the Royal Mint.*)

ACCORDING to Short,<sup>2</sup> compensation by means of levers was suggested by Graham, but abandoned in favor of mercury. In the hands of Ellicott, it gave some very good results, and an excellent specimen of this form of pendulum may be seen in the hall of the London Institution. Its mode of action will be understood from two diagrams taken from Reid.<sup>3</sup> The rod consists of a brass bar enclosed between two flat steel bars, but all three are free to expand independently downwards, being rigidly fixed at their upper ends. The bob is free to move on the rod, and is hollowed out in its centre, to receive the mechanism shown in the second figure. The brass bar presses on a loose steel pin, which, by means of an intermediate brass piece, actuates two horizontal levers centred on the steel of the pendulum rod. The bob is supported at the extremities of these levers, and, since the expansion of brass is greater than that of steel, it will be evident that any change of temperature will thus cause the bob to rise or fall; by varying the points at which the bob is supported, the extent of this motion may be altered, and thus the compensation adjusted.

In pendulums of more modern construction, the three rods are separate, having the appearance of a gridiron, with steel in the middle and brass or copper on either side. A horizontal right and left-handed screw is held in a stud on the middle rod, and engages in studs in the external rods, and thus, by a slight rotation in either direction, the length of the acting arms of the levers, and therefore the degree of compensation, can be varied. A pendulum working on the lever principle was patented by the celebrated engineer, Richard Roberts, of Manchester,<sup>4</sup> but it does not seem to have been employed.

Lastly, an ingenious contrivance by Tremeschini<sup>5</sup> should be mentioned, as it acts on an entirely novel principle, although levers are used. The rod consists of two detached bars of copper and steel, fixed at their upper ends, and bent at an angle backwards, so that the centre of gravity of the bob, which is supported on a horizontal arm, may be directly below the centre of suspension. This arm is pivoted at the extremity of the copper rod, the steel being bent a second time, and pivoted at a point a few inches in advance, while the bob can be moved horizontally by means of a nut. Assume the arm to be horizontal at a certain temperature. If the pendulum become hotter the copper and steel rods will expand, but in different proportions, the expansions being nearly in the ratio of three to two. The horizontal arm *AB*, will, therefore, take the inclined position *A'B'* and on still further heating it will move to *A''B''*. The inventor points out that on the horizontal line *ABC* there is one point through which all these lines pass, and that, on making the centre of gravity of the bob coincide with this point, the pendulum will be unaffected by heat and cold. The problem is, however, not so simple as here stated, for the pivot of the steel rod will move almost in a vertical direction, whereas that of the copper will expand outwards, and, assuming these pivots to be accurately fitted, the co-efficient of expansion of the arm itself must be proportioned to that of the rods, if the rods are to continue in the same relative positions. Calculation or a geometrical construction shows that (employing the proportions given in a description by the inventor,) the short horizontal piece would be required to have a co-efficient of expansion about 2.2 times that of copper, in order that the pins might always be equally free from strain, and the position of the bob in a vertical direction remain unaltered. It is hardly necessary to observe that a metal with so high a co-efficient of dilatation does

not exist; but the geometrical principle is interesting, and advantage may some day be taken of it.

The forms of pendulum that are included in Class III. are almost as numerous as those which have the gridiron for a type. They are all based on the following fact: If, at a certain mean temperature, strips of two metals of different expansibilities—such as steel and brass—are rigidly united in the form of a straight rule, then an increase of temperature will cause the pair to bend with the more expansive (brass) outwards, and on a fall of temperature the converse will be the case. The reason for this fact is so obvious as hardly to require explanation. Although both metals expand, the steel, relatively to the brass, will contract in heat, and this can be illustrated by a simple experiment analogous to the last. A compound strip of steel and zinc is here fixed rigidly at one end over the trough, and a tongue, projecting from the free end, actuates a bent lever. This lever terminates in a long vertical pointer, and any motion of the strip in a vertical plane will thus be indicated by a movement of the pointer to the right or left. Steel is above, and, on applying heat, the pointer moves to the left, indicating a motion upwards, and the converse is the case on cooling the strip. Of course, a similar effect would be observed if the metal were curved; indeed, straight strips are rarely employed in practice.

Brass and steel are nearly always employed in conjunction, and the combination may be made available for compensation in three ways: (1) raising and lowering the entire pendulum, by being attached to the suspension spring or thread, which passes between two edges near together, a plan adopted by Destigny<sup>6</sup> for small clocks; (2) moving one or more auxiliary weights to or from the center of suspension; (3) by moving the entire bob in a vertical direction, as is done in Cole's pendulum. It is strange that, while nearly every compensation balance involves the use of bimetallic strips, the device is very rarely applied to pendulums, although the second mode of employing it seems, at any rate, to afford good means of effecting the final adjustment of the compensation. The great merit of the system is that the motion is continuous, and not step by step, as in the two classes previously considered.

A curious arrangement, involving the use of bimetallic strips, was patented in 1840, by Dent,<sup>7</sup> and deserves mention. He proposed to communicate the impulse to the pendulum at its center of percussion, and two arms projected from the escapement, placed below the pendulum, on either side of the bob for this purpose. Two U-shaped compensation strips were attached to the bob, and received the impulse from these arms; on heating, the pendulum lengthened, the strips moved outwards, and were therefore struck with greater rapidity, since the arc of vibration was diminished; thus the loss occasioned by the expansion of the rod was counteracted.

In 1855, Merceron showed, at the Paris Exhibition, a pendulum in which the effect of temperature was avoided by forming the rod of a series of bimetallic strips arranged alternately, and Ingold<sup>8</sup> proposed methods for carrying out this principle; modifications were also suggested by Saunier.<sup>9</sup> It is only necessary to point out that the brass is on an equal number of concave and convex sides, and thus the position of the bob, which is supported at its center, remains unchanged, since one bend will tend to close to the same distance as the next tends to open.

The only other application that remains to be noticed was proposed by the Astronomer-Royal, for effecting the final adjustment of the compensation, and adopted in the Greenwich sidereal clock.<sup>1</sup> Two small straight bimetallic arms, carrying weights, are held friction-tight on the crutch axis, and, by varying their inclination, it is possible to alter the vertical distance through which their common center is moved on a change of temperature. This motion is anticipated to

6 Roret's "Manuel d'Horlogerie" (1850), p. 95.

7 Specification No. 8625 (1840).

8 "Revue Chronométrique," iii. 83 and 131.

9 "Revue Chronométrique," iii. 142.

1 "Nature," xi. 433; and "Horological Journal," xvii. 26.

1 A paper read before the members of the Society of Arts, on Wednesday, 12th February, 1879; Mr. W. Ellis, F. R. A. S., presiding. Revised by the Author.

2 "Phil Trans," 1752.

3 "Treatise on Clock and Watchmaking" (1826), 367.

4 Specification 12,207 (1848).

5 "Revue Chronométrique," viii. 95; and Patent No. 2671 (1873).

produce the requisite change in the rate of the clock, but it has not yet been found necessary to bring it into action.

We now come to the fourth and last class of pendulums, those in which mercury is employed. Graham first advocated its use in 1722, and the pendulum has only undergone slight modifications since his day. The form ordinarily met with in regulator clocks consists of a steel rod, terminating in a stirrup of the same metal, which carries a glass cup of mercury. When the temperature rises, the steel becomes longer, but the volume of the mercury increases, and, since its expansion is greater than that of glass, its level rises, and there is thus a tendency to maintain the position of the center of oscillation constant. Obviously, a certain volume will exactly suffice to maintain it stationary, and the pendulum will then be independent of temperature. There is some difficulty in introducing the mercury without carrying down bubbles of air, and M. Fenon recommends the use of a long glass funnel, reaching to the bottom of the vessel, for this purpose. Two principal objections have been urged against the mercury pendulum; the glass vessel, being a very poor conductor, makes the metal it contains change temperature much less rapidly than does the steel rod, and the compensating metal, mercury, is not necessarily at the same temperature as this rod. Several makers have attempted to avoid the first-mentioned difficulty by distributing the mercury through two or more vessels, but this practice increases the difficulties of adjustment. A more convenient method is to replace the glass by an iron vessel, and prolong the rod into the mercury; in this case, it is also possible to expel air from the metal by boiling *in situ*. Laugier<sup>2</sup> made experiments with a view to ascertain the most convenient diameter of the vessel as compared with that of the rod (of iron), a proportion which of course is dependent on the specific heat and conductivity of the metals. He finds that the iron jar should be four times the diameter of the rod, and he further states that in pendulums of the first two classes the diameters of iron, copper, and zinc rods should be to each other in the proportion 100, 135, 109.

In comparing the several kinds of pendulums, it is to be observed that most of the forms included in the first two classes are equally satisfactory for a change in the temperature of the entire length of the rod, or for only a portion of its length, but this is not the case with the third and fourth classes. Now, the temperature of a clock-case, with seconds pendulum, may vary as much as 3° or 4° Centigrade, and in such a case the mercury or bimetallic compensation would not be brought into action, although the rod would certainly be lengthened. This is the principal reason urged against Graham's pendulum by the French makers. They prefer the gridiron, which is objected to in England, on account of the great number of contacts, and the consequent non-continuous action of the compensation (a criticism which also applies to lever pendulums), the expense of its construction, the weight of the upper portion of the pendulum, and the pressure on the upper ends of the compensating rods. Mercury, is however, being now gradually discarded in favor of pendulums of the first class, such as that of Dent, which has often been found to give more uniform results than the mercury pendulum. But Sir W. Thomson,<sup>3</sup> who has studied the question of compensation in connexion with his new design of astronomical clock, concludes that the use of steel rods is a mistake, as the pendulum rod should be formed of a substance having the least possible expansibility, such as glass or platinum. Mercury, having a high specific gravity and expansibility, should be the other in preference to lead, unless the capillary uncertainty of its surface is found to occasion irregularities in the rate. He is, therefore, applying to his tide-gauges pendulums formed entirely of glass and mercury, with rounded agate knife edges, and anticipates that the error will be found to be not more than one-tenth that usually observed; and he points out that, if these precautions are not sufficient, it will be necessary to enclose them in an air-tight case at constant temperature. It is interesting to compare this latest form of compensation with that

invented just fifty years ago by Robert, which in great measure satisfied the conditions laid down by Sir W. Thomson.

#### BAROMETRIC VARIATIONS.

Let us now pass to the means adopted for counteracting the effects produced by variations in the atmospheric pressure. Baily, in his celebrated paper read before the Royal Astronomical Society in 1823, seems to have been the first who drew the attention of astronomers to this source of irregularity, and the researches of Bessel and Sabine threw much light on it. Dr. Robinson,<sup>4</sup> in 1833 proposed to attach two light barometer tubes, filled with mercury, on either side of the pendulum rod; the effect of which would be that whereas, on the barometer rising, the increased resistance due to the friction, &c., would tend to occasion a loss, the fact of a small quantity of mercury raising towards the center of suspension, in consequence of the rise in the barometer, would neutralize this effect. The amount of the error that has to be corrected has been variously estimated by different observers at from 0.42" to 0.23" per 24 hours for each inch rise or fall of the barometer; but, as Baily pointed out, it depends on the arc of oscillation of the pendulum. For in a circular pendulum the period of the long arcs is slightly greater than that of the short arcs; if, therefore, at the normal pressure, the pendulum describe a given arc, any increase of pressure will oppose a greater resistance, and, the arc being slightly diminished, its period will be increased. A point must exist at which these two influences neutralize each other, and Baily calculated it to be 2°.45', a result which has been confirmed by the experience of the Westminster clock, as this is found to show no variation to correspond to changes in the barometer. Experiments by Dr. Hipp,<sup>5</sup> at the Neuchatel Observatory, lead him to the conclusion that this effect of the air, however, is not a simple modification of the amplitude, and that the irregularities observed are caused by the escapement, suspension spring, &c., a view which is also held by Redier.<sup>6</sup> Several attempts have been made to avoid this source of error by enclosing the clock in an exhausted space, and Redier<sup>7</sup> and Hutton<sup>8</sup> attempted to enlarge or contract the air space of the pendulum. Only two systems are in practical use, namely, that proposed by the Astronomer-Royal,<sup>9</sup> and applied to the sidereal clock at Greenwich, and the very elegant arrangement adopted by Redier.<sup>1</sup>

In the former the acting force of gravity is supplemented by that of a small permanent magnet, so arranged that its distance from the pendulum bob varies with every rise and fall of the barometer. The magnet is suspended from one extremity of a short balance beam, while the other end carries a pendant, terminating in a steel disc which floats on the surface of the mercury in a syphon barometer. Two bar magnets are fixed to the pendulum bob, at a mean distance of 3¾ inches from the magnet, and the short arm of the barometer has twice the diameter of the long arm, so that a fall of one inch moves the magnet half an inch further from the magnets.

Redier adopted an extremely simple device, which he states to be perfectly efficacious. It can be applied to any pendulum. To a transverse bar fixed above the pendulum bob, the exhausted box of an aneroid is fixed, and a weight is attached to the under side. If, now, the atmospheric pressure increase, the weight will be raised in consequence of the contraction of the box; and it is obvious that when this weight is properly adjusted, its motion will so alter the position of the center of oscillation as to counteract the loss or gain caused by barometric variations.

4 "Memoirs of the Royal Astronomical Society," vol. v, p. 125.

5 "Journal Suisse d'Horlogerie" ii. (1877), p. 85.

6 "Revue Chronometrique," ix. 281.

7 "Revue Chronometrique," ix. 177.

8 Patent No. 11,427, 1846.

9 "Nature," vol. xi. p. 433.

1 "Comptes Rendus," lxxxiii. 1174.

(To be continued.)

2 "Comptes Rendus," xxv. 415.

3 "Nature," xi. 229.

## Trade Gossip.

Pearls are found in the Llano River, Texas.

The opal, for a season in disfavor here, is again largely worn.

The jewelry business is beginning to see the light of other days.

Diamonds and pearls associated, are popular for engagement rings.

Fine pearls are in great demand, the oriental being most sought after.

Making watch chains of horse hair is a new Jacksonville, Florida, industry.

E. J. Cady & Co., formerly of Beloit, Wis., have removed to Cincinnati, O.

Numerous large buyers are in town and the hearts of our dealers rejoice thereat.

Black onyx is very fashionable, and fine goods in this material are in great demand.

Rich enamel, wrought in mixtures of bright colors, is a leading novelty in jewelry.

Horseshoes of silver, studded with diamond nails, are among the shoe buckles of the season.

The clock at the City Hall appears to have no self respect. Its always running itself down.

Wilcox's jewelry store, at Markdale, Canada, was destroyed by fire on the evening of the 19th Sept.

Constant Merrett, of Wabasha, Minn., died suddenly a few weeks ago, while working at his bench.

There is just now an unusually large number of fine rubies and emeralds in the hands of the importers.

The Morse Diamond Cutting Company have just received some very fine specimens of African garnets.

Alexander Newburger, Jeweler, 531 Sixth Ave., has been robbed of some \$700 worth of jewelry by sneak thieves.

It is rumored that M. Kronberg has rented a store on State St., Chicago, with a view of again going into business.

There's no special style of engraving engagement rings. A spider's web with a fly in it is a pretty device. Either party may be the spider.

Whenever Bartholdi, the sculptor, feels particularly mad he just goes and puts a head on his gigantic statue of Liberty, defying everybody.

The jewelry store of C. M. Allen, Plainview, Minn., is reported to have been robbed of a large number of watches and a quantity of jewelry.

There is a growing demand for sapphires and pearls, the former is being so closely imitated that experts themselves are often deceived in them.

At the last annual meeting of the New York Jewelers' Association, Mr. Daniel F. Appleton, President, and the rest of the officers were re-elected.

The Illinois Jewelers Association held its Annual Convention at Decatur, October 1st. A report of its proceedings will appear in our next issue.

The fashionable comb is three pronged, with a wide tortoise rim which forms half a loop in front of the high chignon or frizettes. False hair is going out of fashion.

Mr. Thos. W. Baxter, who acquired some notoriety in the trade, from having occupied the position of manager of the Elgin Watch Co. has been dismissed from their employment.

There is a marked increase this season in the demand for pianos all over the country. This is another sign of good times. Music, like love, flies out o' window when poverty pinches.

There is a great scarcity of old mine stones in consequence of the Golconda mines having completely given out. Fine old gems are bringing fabulous prices in the markets of the world.

When paste diamonds are mounted in six karat gold, the combination is not satisfactory. The paste may for a while deceive, but when the allged gold turns black the deception is rendered abortive.

If the street Arab who threw a stone through one of the plate glass windows of our sanctum and destroyed our diamond pointed inkstand will call around he will hear of something to his advantage.

Happy are the people who have odd furniture with elephant's trunks or lion's heads, for Hindoo models are now coveted. Old families are mounting their lumbering side-boards with brass and old china.

No new developments have been made during the past month in the affairs of COGSWELL, WEBER & Co., of Chicago, except that the firm has offered fifty cents on the dollar in settlement of their accounts.

F. A. Lindstrand, a retail jeweler, on Twenty-second Street, Chicago, was recently robbed of twelve gold watches, by a gang of sneak thieves, who entered his store under the pretext of purchasing a pair of spectacles.

Silver jewelry, which had its origin in England when Queen Victoria assumed her second mourning, and which had one season here, is coming back, though our shops do not yet show it in the abundance of those of Paris and London.

One of the newest fancies in jewelry is the "old oaken bucket" set in solid gold; the earrings are tiny golden buckets, and the pin is a perfect little windlass, with rope coiled around it from the end of which the bucket is suspended.

A young man named William A. Johnston, of Salem, O., recently entered the jewelry store of Otto Wettstein, Rochelle, Ill., bought a pistol, had it loaded by the clerk, and placing the muzzle against his breast, shot himself through the heart. No cause for the suicide has been ascertained.

The Koran interdicts the wearing of gold ornaments during prayer, and in order to avoid the trouble of taking off and putting on their rings, the Persians used silver ones on these occasions. Tavernier, the French traveling jeweler, relates that Abbas II. bought a gold ring of him, and then had the stone reset in a silver ring.

Wm. Bruce of Milwaukee, while out driving on Oct. 1st, was run into by a runaway horse, receiving such injuries that he died three hours later. Mr. Bruce had been in the jewelry business in Milwaukee for twenty-five years, and was highly respected. He is reported to have accumulated a modest competence from his business.

Maiden Lane wears a busy air of late, business "booming" in a most satisfactory manner. A procession of express wagons is kept employed daily carrying away goods for shipment, and country buyers fill the stores and streets to overflowing. It looks like the good old days when manufacturers and dealers were making money, and everything was lively.

Our esteemed correspondent, Mr. Herman Bush, of Hull, writes us that delegates from the various Watchmakers Societies from all parts of Germany have held, in the beginning of September, a grand three days meeting, at Dresden, under the guidance of Herr R. Stackel, editor of the *Deutsche Uhrmacher Zeitung*, to consider and promote the mutual interests and progress of the trade.

There is a legend common in Scandinavia that a dishonest hand-maid of the Blessed Virgin purloined her mistress's silver scissors, and that she was transformed into a lapwing for punishment, the forked tail of the bird being a brand of the theft, and that the bird was doomed to a continual confession of the crime by the plaintive cry, "Tyvit, tyvit!" that is in Scandinavian, "I stole them! I stole them!"

Mr. Frederic Voss, with whose name the readers of this paper are familiar, has been requested by the Committee of Management of the Free Saturday Lectures, which are given in the large hall of the Cooper Institute, to give the opening lecture next month. The subject selected is "The Craft of the Silversmith." The lecture will be furly illustrated with experiments, manipulations and stereopticon photographs.

An old lady from the country, quite hard of hearing, recently visited Tiffany's, and became much interested in the statuary and bronzes. She finally came across one that puzzled her, and she called out to one of the clerks "I say you, here! can you tell me what this here image is?" "That is Keescher's Venus" bawled the clerk in the old lady's ear. "Kiss yer what?" indignantly exclaimed the venerable damsel, thinking she had been insulted. The clerk blushed and hastily decamped, while the ancient maiden continued her investigations without further inquiry.

## Proceedings of the Horological Club.

A DISTINGUISHED BODY OF WATCH AND CLOCK MAKERS.

Sixty-seventh Discussion.—Communicated by the Secretary.

[NOTICE.—Correspondents should write all letters intended for the Club separate from any other business, and address them to the Secretary of the Horological Club. Direct the envelope to D. H. Hoskin, Esq. Write only on one side of the paper, state the points briefly, mail as early as possible, as it must be received here not later than two days before the end of the month in order to be discussed and reported in the CIRCULAR for the next month.]

## REPAIRING MUSIC BOXES.

Secretary of Horological Club:

I do not quite understand what causes a peculiar fife-like, whistling sound in a music box I have for repairing. Will some of the experts in your Club be kind enough to tell me how it is caused and how repaired? Also, what firm in New York is best prepared to do such work?  
H. P.

Mr. Clerkenwell said that the trouble was probably either in the spirals on the under side of the keys, or some part about the box was loose. Either of these faults would cause a sort of buzzing noise, which might sometimes sound like whistling. The binding of the spirals should not be undertaken by inexperienced hands, but a loose piece could be detected by making the keys sound by running some smooth, round pointed piece over them, till the ones where the noise was made were found. These make them sound, at the same time pressing the finger on the different parts which might make the buzzing. When the right one is touched the sound will stop, then tighten the loose piece, or do such other alteration or repairing as it may need. M. J. Paillard & Co., 680 Broadway, New York, are prepared to do all kinds of repairing on musical boxes.

## MAKING WATCH WHEELS.

WALTHAM, Sept 19th, 1879.

Secretary of Horological Club:

I take the first opportunity to write up watch wheel making for your correspondent, and the samples and drawing enclosed will aid you in understanding the subject.

The brass used for wheels is called Lancashire Brass, and for many years the American factories imported from Lancashire all they used. But the Scoville Manufacturing Co., of Waterbury, now make a fine grade of brass, and supply most, if not all American factories. The English and Swiss practice is to punch out a round blank, then remove the sectors between the arms, one at a time, then finish the arms and rim with file and scraper, then drill the hole in the center, then screw it to the pinion, then cut the teeth. By this process, only one wheel can have teeth cut at once.

The American practice is to punch out, at one motion of the press, the wheel as shown in figure 2, then shave it, *i. e.*, repunch it, removing the roughness of the first punching by passing the wheel through a second die which smooths the arms, rim and hub.

The perfect accuracy of the die work can be seen by putting any section, *a, a, a*, into any space in the shaved wheel, and looking towards the light. I may add that the shaving process removes  $\frac{2}{1000}$  from each side of the arm, *i. e.*, the first punch leaves the arm at the rim  $\frac{1}{1000}$  of an inch broad, the second leaves it  $\frac{17}{1000}$  of an inch. After shaving, the wheels are cut in stacks of 25 to 40 at one time, by arboring them by the inside of the rim. Then the center hole is drilled by holding the wheel by the tops of the teeth.

The American Watch Tool Co., of Waltham, Mass., are prepared to make any and all machines required by this system of wheel making.

If the above is not complete enough, advise us, and we will try to make it full and clear.  
Respectfully,

A. WEBSTER, per A. W. T. Co.

Mr. Horologer exhibited the samples and sketches. Fig. 1 shows the strip of metal from which the round blanks are first punched. Fig. 2 shows the wheel with the sectors punched out, ready to be arborized and cut in the cutting engine. The accuracy of the work was indeed wonderful. While the sectors would easily go in or come out, they would not fall out, and when

held to the light there was only a faint line to be seen at the edges. Any section would fit into any opening. A power press which will punch to  $\frac{1}{1000}$  of an inch, and with the parts and fitting so exact, may be called the perfection of machinery, and bears witness to the matchless skill of the makers. No wonder our American made watches, turned out by such perfect made machinery, prove to be durable and accurate.

## EXCELSIOR'S PLAN FOR CHANGING DEPTH OF LEVER ESCAPEMENTS

Secretary of Horological Club:

Have just received the *Circular* for September, 1879. And as I have one of Excelsior's books, *Treating on the Proper Ways of Setting Hair Springs, &c.*, will say that I am so well pleased with the directions therein given, that I would exceedingly like to be informed as to Excelsior's proper plan for changing the depth of lever escapements in Swiss and American watches. I have several plans, but I have a notion the Excelsior's is the best, as he is so exact in his treatise on the Hair Spring and Balance Wheel, and also on Repairing, which I see in the *Jewelers' Circular*. I notice it stated that those copies containing this information have all been taken up, therefore I make the request.  
S. N.

Mr. Isochronal stated that he had examined those numbers of the *Circular* which contained Excelsior's remarks on changing the wheel and pallet depth, and found that it would require several pages of the *Journal* to give all relating to the subject. Sometimes only one pallet or arm should be moved, or one more than the other. He gave different ways for ascertaining that point, for examining and adjusting the "escapement angle," or position of the lever fork on the pallets, which was as important as the depth, and likely to be changed by changing the depth. Also, rules for getting the proper center distance for the wheel and the pallets, examining the "drops" of the teeth on the pallet, freedom of the teeth from the backs of the pallets, and in passing off their edges, whether a deflection depth is caused by the wheel and pallets being set too close or too distant, or by improper forms of the pallets or of the teeth, and many other defects, which perhaps, ought to be remedied instead of changing the depth. He treated the whole subject, as he has done all others, fully and completely, and in a way better adapted for the practical workman than any other writer he knew of. He could only advise Mr. N. to wait a little longer, and the *Practical Hints* would be republished in another book, when he could obtain Excelsior's complete treatise on all of the different escapements, and different kinds of watches, and how to repair them, which would be a book worth having.

## STONES CHANGING COLOR WHILE SOLDERING RINGS.

Secretary of Horological Club:

Will you please inform me through the columns of your valuable journal, why an amethyst stone should turn white while hard soldering? for such was the case with me. I consider the stone a paste of whiting and water, and soldered the ring; when I took the whiting off the stone was turned white. Please answer in your next *Circular* and tell me if this occurs often, and whether the stone was a good one or only an imitation. It looked like a good one.

Respectfully, F. W. C.

Mr. Rolliver replied that all amethysts would lose their color if made hot enough. Some change color with less heat than others. There are some real stones, such as topaz, colored artificially to represent amethysts; they would lose color with less heat than real amethysts. I don't think an imitation would lose its color by being made red hot. When soldering a ring with a stone in it, you should protect the stone so that it cannot get hot.

## USE OF BOTTOM'S HAIR SPRING GAUGE.

Secretary of Horological Club:

Will some member of the Club inform me how to use "Bottom's Hair Spring Gauge," both in altering a spring to suit, also in selecting new spring?  
Respectfully,  
X. Y. Z.

Mr. Urmacher said that the use of the gauge was merely a comparison of the stiffness of the tested spring with that of the spring in the gauge. The former being fastened to the spindle, if the stiffness of one was the same as the other, any motion of one



Fig 2.



Fig 1.



would produce an equal motion in the other, as shown by the dial. If their strength were different, the amount of their motions would be different, and in this way the dial would show the comparative strength of different springs so tested. If a spring was too weak for the watch, it could be tried in the gauge, and then another spring could be selected which would be stiffer, as tried by the same gauge. But it was not generally used for altering a spring to regulate it. Mr. Bottom died three or four months ago. What effect this would have on the further manufacture of his gauges, or if any, he did not know.

#### WHO MAKES THE BEST WATCH FOR THE MONEY?

*Secretary of Horological Club:*

I am a young man just starting in business. I expect to stay here; and I want to build up a good reputation for selling honest goods at honest prices; and, of course, I want to sell them and buy them as low as I can. I have the most trouble to decide what watches to make a specialty of. Anybody can get good watches by going to some famous maker and paying a big fancy price for them. But I know that just as good watches can be had for less money. But I don't know who makes the best watches for the money. Every man I talk with recommends a different watch as the very best of all watches. Some don't know any more about it than I do; but they have got used to that kind of watch, and like it the best. Some will sell any kind of watch they can make a big profit on, and don't care whether it plays out in ten years or ten days. And so it goes through the whole list, from A to Z.

What I want to know is, who makes a really good and substantial watch, that will stand use, and last, and give satisfaction, and is sold for an honest price? What I want is a good watch, one that I can recommend as the best of its class or grade, and will prove to be what I recommend it, and not turn out to be a snide, and prove me to be a liar, or a rascal, or a fool, and one I can buy as low as a good watch can be made. There is so much humbug and mockery about this thing that a man never knows what to believe. At least I don't, and I reckon I am not the only one in that boat.

Now, Mr. Secretary, what I want is this: I want you to send this letter to "Excelsior," and have him say what is the best watch or watches for a country watchmaker, that wants to do a square business, and not pay two prices. If anybody knows, he knows, that is a dead sure thing. And if there is anybody I know that I would believe, he is the man. I have read his articles in the *Jewelers' Circular* over three years, and I have got his book, and I am satisfied he is a square man, whoever he is. Now, I don't suppose he will like to have much to say about it, as it might make bad feelings with other makers, but I pledge my word nobody shall know it but myself, and furthermore, I will pay him what he charges, if he will give me his opinion. I mean that. I would give more for his real opinion than any other man I know. It would be worth having, and it would be an honest opinion. I enclose my business card, and refer you to \* \* \* Now, Mr. Secretary, I hope you will see to it, and send this to him as soon as possible, and you will oblige, W. B.

The Secretary observed that this was a sample of the letters with which Excelsior was overrun, only they were generally directed to the Editor of the *Circular*. It should be forwarded as requested, but it would probably be useless, as Excelsior had uniformly declined to express any preference for the goods of one maker over those of another. It was quite natural that, in his role as a writer on horological matters, he should wish to be disinterested, unhampered, and not mixed up with business preferences and personalities. Taking the contrary course would provoke jealousies and perhaps hard feelings. This he naturally wanted to avoid, more especially as it was no object to him either way. He thought that Mr. B's offer of money would make no difference, as Excelsior undoubtedly would give his opinion freely, if he gave it all. And if he did not consider it proper to give it, money would not induce him. Although nobody knew who Excelsior was, it was generally supposed, from various reasons, that he was in independent circumstances, and therefore above any such inducements.

As to Mr. B's idea that "anybody could get good watches by going to some famous maker and paying big fancy prices for them," he would find, by experience, that even that course would not always succeed. What he wants to know is not so easy to find out as he seems to think. And if Excelsior could be induced to give his views,

observations and experience, or some plain rules deduced therefrom, by which an intelligent watchmaker could safely judge for himself, we city dealers would be quite as glad to have his opinions on that subject as any "country watchmaker" could be. That is something that we would all like to know. And we quite agree with Mr. B. that no one would be better qualified to speak knowingly and authoritatively on that point, than Excelsior. His long continued series of Practical Hints on Watch Repairing shows that he both knows what will constitute a good, durable and satisfactory time-piece, and also that he is practically familiar with the many different kinds, and a man who has observed closely, studied thoroughly and thought much on such matters.

He would forward Mr. B's letter, accompanied with the assurance that the Club would feel equally gratified to receive his opinion. But he thought it probable, from past experience, that we all might as well make up our minds to be disappointed of getting it.

#### THE INTERCHANGEABLE CUTTING PLYERS.

Mr. Clerkenwell exhibited a sample of this tool, sent in by Mr. Phil. Hecht, of 13 Maiden Lane, this city. It acts by a sort of double leverage, giving a very powerful cutting action. There is a set screw in the handle, which prevents straining the jaws, and is set so that the cutting edges can just barely meet but cannot be forced any closer or harder on each other. The jaws can either one or both, be taken out for sharpening, and replaced in a moment, by a hardened steel screw pin. Heretofore, if any part of the plyers was broken, the whole was ruined, but with these, either of the handles or jaws can be replaced at slight expense, all the parts being made interchangeable. It is a very strong, neatly made and convenient tool, and, to cap the whole, it has a spring to throw the handles apart, a feature which workmen will appreciate.

#### MAKING A CLOCK GO SLOWER.

*Secretary of Horological Club:*

If a new Yankee Clock runs too fast, say an hour or two in twenty-four, and the case is too short to admit a longer pendulum rod to make it slower, which is the best method to accomplish that purpose? I have had two or three cases of this kind lately, and the suggestion of a weaker pendulum spring or a heavier ball failed to have the desired effect. If some member of your honorable body, or any brother watch-maker, could answer the above, which would certainly interest many in the trade, he would greatly oblige a constant reader of the *Journal*.

X. L. L.

Mr. McFuzee said that if the pendulum ball could not be got low enough, the only remedy would be to alter the escapement. If it gains so much as an hour or two in a day, the number of teeth in the escape wheel would appear to be wrong. First, see if the wheels and pinions are all tight on their arbors, that no wheel can get over or under its pinion or slip by, that the escape wheel teeth cannot get above or below the pallets so as to slip by, in any position of the verge on its pin, and finally see if the verge wire is tight in the verge, that the teeth work deep enough on the pallets for a good motion, the loop neither too tight on the pendulum rod nor gives it too much play, and that it does not rub either the dial or clock plate, or strike the alarm wire, etc. If all these are correct, he can find if the escape wheel has the correct number of teeth by studying Excelsior's Practical Hints in the *Circular* of last month. He thought that some of the rules there given, if modified a little, would help him out of his difficulty.

#### INFORMATION ON OLD CLOCKS.

*Secretary of Horological Club:*

I noticed in the *Circular*, No. 6, page 105, that S. W. B. wants information. There were clocks of that kind made, but I don't know anything about Azariah Prior. J. H. Kelly made clocks of that kind; but he died about three years ago. Mr. B. can find out all about it if he will correspond with J. G. Kelly (son of the deceased), J. K. Landermillich and J. H. Newhart. They all have large establishments. I am acquainted with all of them. Yours truly,

S. P. BAIR, Goldsboro, York Co., Pa.

#### GLASS COVERS FOR CLOCKS.

*Secretary of Horological Club:*

Mr. O. O. G., asks where he can get glass shades. I can procure for him the round shades or the baloon shaped shades of any size or

light, at the glass factory here. The Company do not manufacture these for sale, but as an accommodation I will get the blowers to make one occasionally for any who may want. Address,

R. B. FREEMAN, Jeweler, Blossburg, Pa.

MAGNETIZED SCREW DRIVER.

*Secretary of Horological Club :*

I have a screw driver that is magnetized. It will lift small screws, ratchet screws will hang on it, and I can put them where I want without dropping off. Will some of your members inform me, if it will do any harm to the watch movement by screwing or unscrewing screws in watches? C. F. W. M.

Mr. McFuzee said that no tool should be allowed on the watch bench which was magnetized. It would magnetize the other tools by contact, and that very soon. A screw driver would magnetize the screws, and they would magnetize the tweezers, and they everything else. Any screw or other piece which is magnetized, in a watch, will render it impossible for the watch to keep accurate time, and in some cases prevent it keeping any time at all.

THE JEWELERS' CIRCULAR ABROAD.—LATHE ATTACHMENT.

RIPON, YORKSHIRE, ENGLAND, July 16, 1879.

*Secretary of Horological Club :*

The horological world is much indebted to D. H. HOPKINSON, for producing so useful and elegant a trade journal. If the articles especially those by Excelsior are carefully read and put in practice, the botches complained of must cease to exist. America is not alone in that respect: their name are legion here. Few watches here pass into your hands but have been maltreated by some botch. I always look forward with pleasure for the arrival of your journal. You give us a happy combination of practical matters, not overdosed by theory.

I enclose description of a lathe attachment, which I have found very useful. It does its work quickly and perfectly. No jobber who adopts it will want to be without it. By its aid you can repair a roller damaged by pliers or some careless workman, can quickly reduce the size of a roller, have it round in circle, square on the edge, and the corners of the crescent, or passing hollow, quite perfect, not rounded. By its use the repairer will be able to improve many a lever escapement.

It consists of a brass frame, 2½ or 3 inches long, perhaps an inch wide, and any convenient thickness, with the middle cut back in front, and carrying two centers near its forward edge, fastened by thumb screws from the rear, similarly to the steel verge lathe. The roller to be operated on, is placed upon an arbor, which is fastened between the two centers, the line of the centers being parallel with the axial line of the live spindle. The frame has a shank to screw into the tool holder of the slide rest, by means of which it can be fed forward and back and from side to side. The frame should not be horizontal, but inclined upward enough to bring the centers level with the lathe spindle or nearly so.

For grinding, you want an iron lap, screwed to the lathe spindle, used with oil stone powder or sharp crocus. For polishing, you require a zinc lap, or a combination of zinc, antimony and bismuth, used with diamantine. The laps must be faced off true,—not hollow nor rounded. Charge the lap, set the roller on the arbor in rapid motion with the finger, advance it to the lap with the slide rest handle, and while being ground move it across the face of the lap with the other handle. Mind you don't overdo it, as it cuts away fast. Withdraw the roller from the lap, by the slide rest handle, while the latter is in motion. The zinc lap is used in the same way in polishing. Always oil the arbor points in the centers, before commencing work.

W. THACKER.

Mr. McFuzee said this letter showed that our unrivalled American trade journal, the *Circular*, was appreciated abroad, as well as at home. There is no horological paper published in any language, which begins to compare with it. It ought to, and he hoped it soon would, have every intelligent workman for a subscriber. Those who do without it show that they certainly have no desire to inform themselves, for if they did, they could find no other means for acquiring so much and so valuable information on all points.

Mr. Thacker's remarks about Excelsior and the botches, suggested to him that Excelsior had really hit upon and was carrying out the best practical plan for eradicating the botches,—that of educating them into good workmen. If any way could be found to place his writings before every botch in the land, and induce him to study and practice them faithfully, there would soon be very few botches left.

We should be glad to hear from Mr. T. again, and others of our foreign readers, with descriptions of time and labor saving appliances improved tools, modes of working, etc., etc.

"THE CONTEMPTIBLE DUPLEX ESCAPEMENT."

*Secretary of Horological Club :*

In the *Jewelers' Circular*, page 133, Excelsior says: "If the extent of the vibrations (in the duplex escapement) increases materially as the spring (as per going barrel watch) is wound up, the roller is too small; and if it diminishes, too large." The fact that more motive force has the power to reduce tension (motion in the regulator ought to be considered (by the Club) a phenomena, and the cause explained (where the seat of the resistance may be adapted to the going barrel) and disgust its readers justly with the duplex principle. The diameter of the roller has nothing whatever to do with the above extraordinary result; which is due entirely to altered distance of the repose from the line of centers. Aug., 79. (H. 2, 3.) J. MUMA.

Mr. Isochronal regretted to say that, although Mr. Muma's letter as it appears above, had been somewhat reconstructed, he was still unable to make out the whole of its meaning. He had supplied omissions, corrected punctuation, etc., and partially translated it into English, but the only part clearly intelligible, was the last sentence, referring to "a phenomena" in the action of "the Contemptible Duplex Escapement." The only way the distance of the repose from the line of centers can possibly be changed by winding the spring, is by the increased pressure of the repose tooth upon the roller, forcing the balance pivots to the further side of their holes, something that occurs even when the spring is first wound, and which is of very slight importance if the pivots are properly fitted in their holes. But even allowing the pivots to be very loose in their holes, so that its effect would be considerable, the effect would be exactly opposite to that spoken of,—instead of the vibrations increasing, it would make them less, proving that Mr. Muma's explanation does not show why they increase. The real cause of the increase is that the roller is too small, as Excelsior stated. With a larger roller, the repose tooth would press upon it further from the center of the balance axis, having more influence in retarding the vibrations. If the roller was of the right diameter, the tooth, would press harder on it as the watch was wound, and the spring become stiffer, and, between the two influences, the vibrations would continue to be of the same extent. If the roller was too large, the resistance of the tooth acting too far from the center of the roller, would retard the vibrations more and more as the spring was wound, and they would diminish. Mr. Muma can very easily prove this by changing the rollers in a duplex whose escape wheel bridge could be moved to and from the balance holes.

As to "adapting the seat of the resistance to the going barrel," he could not imagine what Mr. Muma referred to. He would suggest that, in future letters, Mr. Muma use more paper, and express his meaning more fully. He could not expect the Club to answer letters which they could not understand without consulting a fortune teller as to its import, and he certainly had no moral right to exasperate our placid feeling by using such blood-curdling hieroglyphics as those in his last line.

*Secretary Horological Club :*

Mr. GABRIEL FURMAN, of Newburg, showed us a watch recently, which, it is supposed, was formerly the property of Major JOHN ANDRE, of revolutionary fame. It is of the large bulls eye pattern, about three inches in diameter, but is very thin—the movements and case being only about one quarter of an inch in thickness. The marks on the movement show that it was made by THOMAS CAMPBELL, Albany, and bears date 1774. The name of JOHN ANDRE is engraved on the bottom of the cap. On the inside lid are engraved the following marks: "8318—1086—18k—t'k'." The case is eighteen carats fine, and the movements are evidently of foreign manufacture. Will some of our friends inform us what Albany gave birth to this watch, and who the THOMAS CAMPBELL named was? The watch is certainly a valuable relic, and there is little doubt but it was formerly owned by Major ANDRE. Any information regarding it will be of interest.

# Jewelers' Circular and Horological Review.

VOLUME X.

NEW YORK, NOVEMBER, 1879.

No. 10

THE  
**JEWELERS' CIRCULAR AND HOROLOGICAL REVIEW,**

*The recognized organ of the Trade, and the official representative of the Jewelers' League and the Watchmakers' and Jewelers' Guild of the U. S.*

A Monthly Journal devoted to the interests of Watchmakers, Jewelers, Silversmiths, Electro-plate Manufacturers, and those engaged in the kindred branches of art industry.

**SUBSCRIPTION:**

To all parts of the United States, Canada, Great Britain and the West Indies,

**\$2.00 Per Annum; Postage paid.**

To France, Switzerland, Germany, Mexico, the Republics of South America, and Australia, \$2.50 per annum. Postage paid.

*All communications should be addressed to D. H. HOPKINSON, 42 Nassau Street, New York. Advertising rates made known on application.*

## Our Export Trade.

SOMETIME since persistent efforts were made to engage this country actively in trade with South America, Australia and other foreign countries. Rose-colored letters from residents in those countries were given the greatest publicity, setting forth how and wherein our avenues of commerce might be extended. Agents of the government, inflated with official vanity, and anxious to spread the fame of their country, wrote detailed letters to the Secretary of State, who caused the same to be printed, setting forth the character of trade in their several localities, and the requirements of each. Quite a furore was created, and as a result, many adventurers took advantage of the enthusiasm and victimized our merchants to a considerable extent, by representing that they were familiar with these countries, and could sell large quantities of goods. Many succeeded in obtaining consignments of goods and established themselves abroad as agents of American manufacturers and dealers. Sufficient time has elapsed to enable judgment to be formed as to the success of this reaching out for foreign trade. It may be set down that, as a rule, these ventures have not paid, and in most instances have been disastrous. At the time this export furore was at its height, THE CIRCULAR warned the trade against being tempted by it, pointing out that to attempt to do business so far from the home base was in violation of the laws of trade. Resident agents were too far away to pay much heed to instructions from those of whom they received the goods, but sold them as would best insure a profit to themselves. Their returns have been spasmodic and wholly unsatisfactory, and the men who trusted their goods to resident merchants have lost most of their ventures. The merchants at that distance can laugh at all efforts to collect from him, and his paper goes to protest without subjecting him to the slightest annoyance. It is only those manufacturers and dealers who have sent their own agents into those countries that have profited by this export trade. Even these have suffered from excessive competition. Take Australia, for example. There are but few places of importance, and these are supplied with all they require by their resident merchants. When the export fever broke out among

us, Australia was overwhelmed with American goods of all kinds. They accumulated at the ports of entry, transportation facilities being limited, till they became a drug in the market, and certain classes of American goods were sold there for less than the cost of production. Legitimate dealers found themselves in competition with a lot of adventurers, who had goods that they never intended to pay for and were selling at any price. The Australian markets are at present supplied with more goods of every kind than can be sold in five years. The prospect of working off our over production in that direction is exceedingly limited. What is true of Australia is true of South America. A lot of adventurers worked up the export trade among us and have been prosecuting it to their sole profit.

The fact is, an export trade, like a home trade, cannot be successfully conducted without the personal care and watchfulness of those directly interested in the goods to be disposed of. England has built up her immense export trade by establishing branch houses in those countries to which she sent her goods, and placing some interested person in charge of them. Often these agents have identified themselves with resident merchants, deriving much advantage thereby, but the Englishmen did not let their own goods pass beyond their immediate control until they were paid for them. Our people, on the contrary, sent their goods on consignment or open account to whoever chose to order them, and, as a consequence, generally lost their venture. We have no doubt but a large export trade in the South American States, and in other portions of the globe, awaits us whenever we set about developing it in a systematic business-like way, but we shall never profit by the foreign demand for our goods until we follow the goods and receive the pay for them. Foreigners are free enough to order liberally, but the question of settlement is another affair altogether. Our trade with European countries is a different matter, as it can be conducted through houses of known standing, and that are amenable to similar laws and trade customs that prevail here. Our advice to the jewelry trade is to avoid dabbling in the export trade until they can afford to attend to it personally. They may not get rid of so many goods as they otherwise would, but they will make more money in the long run.

## A Trade Stamp of Value.

THE CIRCULAR has been a strenuous advocate for the adoption of a national standard of value for wrought gold, and we still hope to see such a standard adopted. We have also approved the plan adopted by manufacturers of stamping their goods as a guaranty of their quality, or attaching to them a certificate to the same effect. The Iowa Jewelers' Guild, however, has undertaken to enforce this idea of stamping goods in a manner that cannot fail to be disastrous to those who conform to the plan suggested by the Guild. The degradation of the quality of goods which manufacturers have indulged in has placed the retail dealers in an embarrassing position. Goods that will not assay above eight or ten carats are sold to them as fourteen carats fine, and they are unable to distinguish the difference, except by assaying, which it is not convenient to do at all times. The dealers sell these goods for what they are represented to be, and, as they fail to give satisfaction, their credit with their customers is

impaired, when they are in no wise responsible for the fraud practiced by the manufacturers. The Iowa Guild proposes to adopt a stamp for itself, and to contract with certain manufacturers to place this stamp on the goods furnished by them to members of the Guild, this stamping being a pledge of the Guild that the goods are what they are represented to be. It is understood that the members will give their patronage to manufacturers who will employ this stamp. While this plan may give to the members satisfactory goods of certain kinds, it will also antagonize all manufacturers who do not use this stamp, but who may make goods fully as trustworthy. If, for instance, they obtain a certain kind of watch bearing this stamp, all other makers of watches will immediately cease dealing with members of the Guild, and will use their influence against the goods offered by them. The Guild, by this arrangement, binds itself to take special goods from certain manufacturers, and thus shut themselves off from dealing with competitive manufacturers and from the advantage of purchasing in open market. By buying one line of goods exclusively of one house, they promote unhealthy competition, not only to their own injury, but to the detriment of the manufacturer who cater to them. They will also become the prey of designing persons, who will avail themselves of the Guild stamp as a means for working off old styles of goods, loading the shelves of dealers with unsalable articles that cannot compete with the new styles that are constantly being brought out. The Guild must buy the goods thus stamped at a fixed price, and are thereby prevented from availing themselves of the fluctuations of the market. In all movements of the kind proposed there is a recoil that should be guarded against. The above are some of the objections to the Iowa plan, and others will suggest themselves to persons interested in the business.

Instead of adopting an exclusive policy, as is embraced in the adoption of a Guild stamp, the Iowa Association should lend its influence to compel *all* manufacturers to make their goods fully up to the standard they are represented to be. To this end, the adoption of an individual stamp by manufacturers, by which they guarantee the quality of their goods, would be an important step. The recoil of the Iowa plan, however, is likely to outweigh any advantages that the members may enjoy, even temporarily.

### Assaying Gold Goods.

WE were recently shown a chain that was colored to represent fourteen karat gold, and was sold as such that would only assay ten karats fine. The market is full of various kinds of goods of substantially the same character. They are manufactured in fraud, and sold by misrepresentation and deceit. They are exceedingly dangerous goods for dealers to handle, as their fraudulent character cannot be discovered, even by experts, without assaying them. Of course, such goods are unsatisfactory to purchasers, and their righteous indignation is visited upon the heads of the innocent dealers, who, instead of being a party to the fraud, are themselves the victims of the manufacturers. It has become a custom in the trade to represent as gold any article into the composition of which gold enters. As a matter of fact, pure gold is recognized as being twenty-four karats fine, and when this is degraded by base metal to a point below twelve karats, it ceases to be gold, and has degenerated into some other metal alloyed with gold. As the base metal preponderates, it is a misnomer to call it gold; it becomes simply an imitation, and is deserving of consideration only as such. Manufacturers who make such goods and sell them as of a higher standard, are guilty of swindling, and we do not doubt, could be convicted in a court of justice. It should be an accepted rule of the trade that goods that will not assay twelve carats should not be paid for as gold goods, and when ten karat goods are represented to be fourteen karats fine, payment for them should be refused and the seller prosecuted for swindling. The demand for cheap jewelry, and the unscrupulous competition indulged in its sale, has induced manufacturers to degrade the quality, till much wrought gold now on the market contains far more copper

than conscience. The fraudulent character of this alloy, miscalled gold, accounts for the low price at which much jewelry has been sold of late, apparently below the cost of manufacture. Had they possessed the degree of fineness represented, they could not have been sold for the price.

We see no reason why frauds in jewelry should not be exposed and punished equally with frauds in anything else. If a buyer comes to a dealer, and by misrepresenting his financial condition, obtains goods on credit, he is liable to prosecution for obtaining goods under false pretenses. If a manufacturer sells ten karat goods and represents them to be fourteen karats, we do not see why he is not equally amenable to punishment for obtaining money under false pretences. We are glad to learn that dealers are getting more into the habit of assaying goods purchased, and calling the manufacturers to account for discrepancies between actual value and the value represented. We hope to see them go further, and prosecute the guilty ones for misrepresentation and fraud. A few convictions on such charges would do much to purify the atmosphere by which the trade is surrounded. There are quantities of goods in the market on which is impressed the symbol "14 K," that will not assay ten karats. This cabalistic sign, like gray hairs, covers a multitude of sins. Machinery and cheap labor have done much to cheapen jewelry, but no amount of machinery or cheap labor can make fourteen carat goods out of ten carat gold. In such instances, the cheapness of the goods are due to the fraud rather than to the machinery used. We make no protest against cheap jewelry, *per se*. There is a legitimate demand for plated and filled goods, and for other cheap varieties. That this demand should be supplied is but complying with the universal laws of trade. It is the misrepresentations practiced in selling the impure for the pure that we reprehend. It is no more excusable to lie about the quality of jewelry than it is to lie about the quality of dry goods. If the men who swindle in jewelry were the victims of a swindle in anything they buy, no one would set up a more vigorous howl than they. It makes all the difference with them whose ox is gored. They have an advantage, however, over most tradesmen in that their frauds are more easily concealed. A more general assaying of gold goods and the rejection of the base metal qualities, would tend to bring about a reformation in manufacture. Let it be distinctly understood that metal that will not assay twelve karats is not gold, but base metal, and dealers have the remedy against the deception in their own hands.

### Obituary.

MR. Charles Lemkuhl, a well known jeweler of Baltimore, died at his residence in that city on the 4th inst.

Mr. C. Liebenaw, a watchmaker, recently died at Manitowoc, Wis. in the 91st year of his age. He worked at the bench till well advanced in his 89th year, when he retired and died a year later. He was reputed to be a good workman, and was highly respected in the community in which he lived.

Mr. J. E. Grant, of the firm of G. B. Owen & Co., manufacturers of clocks, died at his residence in Brooklyn, N. Y., on Friday the 7th inst., of Bright's disease of the kidneys, in the 30th year of his age. The deceased was a young man of sterling integrity and fine business ability, and his death will be deeply felt by a large circle of friends. His remains were taken to Winsted, Conn. for interment.

Mr. Charles Wendell, of the firm of Charles Wendell & Sons, of Chicago, died in that city Oct. 17th. Mr. Wendell was a Russian by birth, having been born in Riga, the capital city of Livonia, in 1832. He came to America at the age of about 17, and to Chicago in 1860, where he engaged in the jewelry business, which he followed with unvarying success until, at the time of his death, he had established one of the largest and most prosperous wholesale houses in the city in that branch of trade. A man of strict and unswerving integrity, he stood high in the commercial world, while the social connections of himself and family were of the very best. The business will be continued by the sons under the same firm name as heretofore.

John Augustus Abry, for many years identified with the watch trade of this city, died at Cranford, N. J., November 11th. He was born at Besancon, France, and came to this country in 1835. He immediately became engaged in the importation of watches, and for many years was one of our largest importers. He had extensive business relations with the leading makers of Europe, and was well and favorably known to the trade in this country. Mr. Abry retired from active business in favor of his son sometime since, and had been in ill health for a long time, his death succeeding a protracted and painful sickness. The deceased leaves a wife and five grown children. Mr. Abry was a gentleman of excellent business capacity, and had a large number of warm friends, who will sincerely mourn his loss.

Minor E. Norton, a gentleman connected with different jewelry firms, both in the East and the West, committed suicide in San Francisco, October, 22d. Mr. Norton was born in 1848, and at the age of 17, he began to learn the watchmaking trade with D. H. Buell, of Hartford. He subsequently removed to this city, and was the western traveler for Baldwin, Sexton & Peterson. Recently Mr. Norton had been successfully identified with Colorado mining operations. In company with others he owned some valuable mining property, and at the time of his death was visiting San Francisco in relation to it. On arriving there, he found that his partner had disposed of the entire property and decamped with the proceeds. Mr. Norton's loss was about \$65,000, and this so weighed upon his mind, that in a fit of despondency he took his life. He was a genial, courteous gentleman, highly thought of in the trade, and one who had many friends. His parents and two sisters live at North Guilford, Conn., where the remains of the deceased were buried on the 7th inst.

MR. Maurice Wendell, of Chicago, is out with an announcement that he is about to establish a journal to be called *The Watch*, which is to be published in the interest of watchmakers and jewelers. It is pleasing to us to note that Mr. Wendell approves of the CIRCULAR in as much as he has copied a portion of the design of our title page. We always did admire our title page, and commend Mr. W's good taste in copying it. If he will go still further and copy liberally from the CIRCULAR each month, he will make a journal that cannot fail to interest the trade.

THERE have been numerous robberies perpetrated on jewelers during the past month in different parts of the country by burglars. It is unquestionably true that the scoundrels are posted from New York as to who is buying heavily, and that the movements of various gangs of burglars and thieves are directed from this head center of iniquity. The trade needs especially to be on its guard this fall, for it is generally understood that jewelers are buying liberally, and their stocks offer irresistible temptation to thieves and burglars. Travelers on the road need also to be on the alert, for they are carefully watched in every city they visit, by thieves who only need a favorable opportunity to make off with their trunks.

AS the "business boom" continues to be felt in the jewelry business, a horde of drummers, for certain out of town manufacturers, are found infesting Maiden Lane, as they formerly did when business was brisk. They hang around the doors of respectable dealers, and eagerly seize upon purchasers, and insist upon showing their samples. They waylay customers in hallways, on the stairs, on the sidewalk and not unfrequently follow them into the offices of resident dealers. Their pertinacity and boldness is only excelled by that of the highway robber. They have become an intolerable nuisance, and ought to be driven away by the police. We would suggest that this is the best place we know of to utilize Captain Williams and his club.

THE Middletown Plate Company has just published an elaborate and elegant illustrated catalogue. It is beautifully gotten up, being printed on heavy tinted paper, and bound in blue and gold. The illustrations are engraved in the highest style of the art, and gives a most excellent idea of the works produced by the company. Everything in the silver-plated ware is here represented, from a tea-

spoon to a full dinner set. Among the designs, all of them beautiful, are many that are new, and illustrate how nearly perfect this art has become. The genius of the artist, combined with the skill of the workmen, have succeeded in reproducing in silver ware articles of use that are really gems of artistic work. A price list is combined with the catalogue, and is designed solely for the use of the trade and will be issued to none others.

THE semi-annual meeting of the Illinois Retail Jewelers' Association was held at Decatur, Ill., Oct. 1st, J. E. Boynton occupied the chair, and in his address, called attention to improved conditions in the trade that have been brought about by the association. He said that usually at this time of the year the country was deluged with price lists and catalogues of jobbing houses seeking retail trade, but this year there were but few of these in circulation. On the contrary, some of these jobbers had officially announced that they would sell only at wholesale. He congratulated the Association on the progress made. President E. R. P. Shurly, of United States Watchmakers and Jewelers' Guild, stated that great progress was being made by the Guild, its membership was increasing, and its influence being widely extended. He spoke also, of the good work being done by various State associations, and assured the retailers that these organizations were rapidly becoming a power for working reforms in the business methods of the trade. Remarks were made by several of the members upon the condition of trade, a considerable amount of routine business was transacted and the convention adjourned to meet in Springfield, Ill., the first Wednesday in April, 1880.

MR. Kronberg, of Chicago, is out with an announcement that he "has started anew." Whether it is a new system of doing business he has started or a new way to pay old debts he does not state, perhaps he intends to combine both features. He certainly intends to utilize any material for doing business that he finds at hand, for he announces that he will supply goods enumerated in the catalogues of other dealers, provided he is supplied with a reference to the catalogue in which the articles desired are mentioned. This is an economical method of doing business, and saves Mr. Kronberg, agent, the expense and trouble of publishing a catalogue of his own. It makes no difference to him that others have spent thousands of dollars in getting out these catalogues, intended for their benefit. The morality of the transaction is not likely to trouble Mr. Kronberg, in the least. We have not much sympathy for the catalogue makers as a rule, but this does not justify M. Kronberg, agent, in laying violent hands upon them and appropriating them to his own use. Mr. Kronberg, agent, himself hopes that he "is still remembered." There is no doubt of this, he has given abundant occasion for keeping his memory ever green in the hearts and pockets of many who had dealings with him. It may be some consolation to dealers to know, when selling him goods, that they are selling to an agent instead of to Mr. Kronberg personally, as an agent may have responsibilities that Mr. Kronberg has not. We wish Mr. Kronberg, agent, in his resurrected firm, all the success he deserves.

MILLER Brothers, of this city, have commenced proceedings against A. J. Smith & Co., of Providence, for an alleged infringement of a patent for a rustic sleeve button, introduced by Miller Bros. Without attempting to pass an opinion upon the merits of a controversy that the courts are called upon to decide, we are nevertheless rejoiced to see that members of the trade who produce new and original designs, and go to the trouble and expense of having them patented, are determined to defend whatever rights a patent confers upon them. One of the greatest evils in the trade is embraced in the pirating of designs and styles that are introduced in fine goods, and reproducing them in cheaper grades. Miller Bros. are determined to bring this case to a decision, for the purpose of establishing as a precedent if possible, the fact that original designs will be protected by the courts.

## Main Spring Barrels.

ARGUMENT ON THE MERITS AND DEFECTS OF THE DOUBLE-BRIDGED OR BOTTOM-SUPPORTED AND SINGLE-BRIDGED OR HANGING MAIN SPRING BARRELS IN HORIZONTAL AND OTHER KINDS OF SWISS WATCHES WITHOUT A FUZEE.

*Extracted and translated from the Deutsche Uhrmacher Zeitung, and with additions, by HERMAN BUSH, Hull, England.*

A QUERY by H. D., "Which construction of main-spring barrel, the hanging one on the top bridge, or the one between two bridges is the best and most recommendable in Swiss Watches," occasioned the following exchange of opinions:

M. G. It requires no proof or argument that the main-spring barrel between two bridges and supported at the bottom is decidedly the best. In most cases there is the requisite height or space in the movements for it. The arbor in such a barrel is simpler made and the ratchet, if out of order, easier replaced. The watches with the hanging or bottom unsupported mainspring barrel made now-a-days give a striking proof of the unreasonable clinging to old systems, without considering progress and improvements in the manufacture.

T. D. expresses his opinion in the favor of the *hanging* main-spring barrel, and concludes that both kinds of barrels are supported on the ends of their axis, with the only difference that the *axis itself* on the bottom-supported main-spring barrel has its ends in pivot holes with inevitably more or less in and side-shake, whilst the arbor on hanging spring barrel is held *free* from insufficient room or inshake in a manner which leaves nothing more desirable. The strong pivot which runs through the bridge widens the pivot-hole only very imperceptibly, and influences very triflingly on the depth of the barrel teeth in the center-wheel pinion, whilst the arbor remains in a thorough vertical position, until the bridge of the barrel and the covers over the ratchet are worn away, which would not happen before the watch had been in use for many years. With the *bottom supported* mainspring barrel we have fitting and inshake of the pivots to begin with. The pivots being thinner, are more liable to wear their resting places. If the position of the stopworks is not very accurately placed and performed, the corners of the square holding the stopfinger will soon destroy the pivothole, and the repairer will find that the supported barrel is in spite of its nomenclature, very shaky, and occasions more trouble in readjusting its proper depth and free running, as with the *hanging barrel*, where the bridge over the barrel and the covering on the ratchet only require to be properly hollowed out for the tight fitting of the ratchet between them, to hold the arbor in a continuous vertical position. The hanging barrel, would, in consideration thereof far more deserved to be called "supported" as the one with four shoulders and inshake. The only advantage in the bottom-supported barrel is, that the watch so constructed requires less power in winding, and ought to be applied only on a watch which is thoroughly accurate in the fitting of its arbor and receptacles, and allows sufficient space for the bridge below without lessening the required width of the mainspring.

M. G. replies to the foregoing as follows:

1. I cannot see that the *hanging* mainspring barrel is supported at both ends of its axis. The axis is the arbor, and its ends are resting, the one on the top and the other on the bottomside of the barrel, and, in consequence thereof, the lower end of the axis is *not supported*,

2. Both systems must be compared in their respectively either superior or defective finish. I prefer the superior one, as the simplest, and find it inadmissible to compare the performance of a superior finished of one kind with the performance of a faulty one of the other.

3. The arbor of a double-bridged mainspring barrel must have no inshaken or sideshake in its pivot holes, and if the pivots and holes are originally well made, they will not perceptibly wear out through merely winding up the watch once in 24 hours, and it occurs very seldom indeed, that these holes require bushing.

4. After comparing both mainspring barrels, each one executed in good workmanship, it cannot be denied that the strength of the position of the *hanging* barrel is dependent on the four, or very often only three small screws which hold the cover over the ratchet, while the double-bridged barrel is kept between two plates of the movements.

5. If, for instance, everything in connection with the hanging barrel is well done, does it not occasionally happen that one of these screws breaking or giving way, considering the thinness of the bridge for holding the threads of the screws. With the *supported* barrel these screws are not exposed to any weighty strain, and in case they do give way, it will affect the winding only, whilst with the *hanging* barrel it will, besides the winding, bring the depth of the barrel teeth out of order.

6. Another great consideration is the result of a hanging barrel in the hands of a botching repairer. Could anything be more vexing than to repair a bridge which has been refiled, to admit a closer fitting of the clickspring, to such an extent as to hasten an eventually inevitable bursting of the hole in the bridge, and how often is this not met with.

7. For the manufacturer the hanging barrel offers no advantage, as by equally good execution the supported barrel will, notwithstanding the (additional) lower bridge, be easier, and consequently cheaper constructed.

8. For the repairer, the hanging barrel creates a source of disarrangements. Occasionally he finds that a negligent repairer has omitted to oil the ratchet, to diminish friction, and the ratchet has in the *unoiled* state of *increased* friction worn out the place of its enclosure, and the barrel gets shaky; or he finds that the screws are unproportionally thick with bad heads, and deprive the necessary strength; or the pinhole on the lower end of the arbor is half open and not fit to properly hold the pin below the stopfinger; or the teeth of the ratchet wheel are chipped or worn off, when it will be necessary to make an entirely new arbor, etc. How much more simple is the taking in parts and putting together of a double-bridge mainspring barrel. If the ratchet is injured, it can quite easily be replaced. I will finally observe, that the practical Americans unexceptionally employ the double-bridged barrel in the manufacture of their watches.

G. F. The exchange of opinions in the *Trade Periodicals*, will no doubt rouse the manufacturers to earnest considerations of subjects treated with so much interest, and lead them to reply and to adopt such systems in the construction of their watches as best adapted for the purpose. As far as my experience goes, I have always preferred the barrel between two bridges to the hanging one, and for the best answering its purpose we cannot fail to admit the simple way of repairing, or rather, replacing an injured ratchet wheel. It is at any rate absolutely necessary, that any of the systems adopted be mechanically proper in execution. If the barrel between two bridges is on top and bottom sufficiently strong for the holes to withstand the widening by the arbor, and the lower bridge possesses the requisite resistance to withstand the pressure of winding, I think it may invariably be preferred to the hanging barrel.

H. Bush. There is certainly an advantage with the double-bridged mainspring barrel in the comparatively simple way of replacing an injured ratchet wheel, yet a similar plan, with only a slight difference of additional work can be adopted to the arbor of the hanging barrel in the following manner: The old and chipped teeth and a little more of the wheel to bring the same to about half its original diameter, are filed away as centrally as possible, and reduced in thickness by filing equally on all sides of the square to about half its size, then a ratchet wheel is selected of the required size and thickness and fitted well on the square of the arbor. The ratchet wheel is, after this preliminary preparation, soldered on its upper side to a piece of brass with a hole in the centre and fixed in the universal lathe or burin-fix, and a cavity turned out in the centre of its lower side to admit the reduced remainder of the old ratchet wheel on the arbor; it is then removed from the brass plate, carefully cleared of adhering solder, hardened and tempered, the recess well cleansed and the wheel finally placed in proper position on the arbor and the two parts gently soldered together, when after clearing away any superfluous solder, the arbor and ratchet will in every respect answer the purpose of a solid and new arbor.

(To be Continued.)

### The Law More Certain.

IN our number of February, 1878, we referred to the case of Messrs. M. W. Galt, Bro. & Co., of Washington, *vs.* Adams Express Company, then pending in the Supreme Court of the District of Columbia, and touched upon the uncertainties of the law respecting the liability of common carriers.

Turning to our number of January, 1878, we find that the case and our editorial of that date were based upon this condition of facts.

January 7th, 1875, the company's agent called at the plaintiff's store and received three packages, containing plate, coin and jewelry directed to New York, and gave a receipt or domestic bill of lading for each, the company's printed form, with which the reader is familiar, the blanks in this case being filled up by the plaintiff's book-keeper, so that it read :

"Received of M. W. Galt, Bro. & Co., one box, value asked, not given." Freight \$1.50, in one receipt, 25 cents on each of the other two, these rates being inserted by the company's agent, though nothing was really said about the contents or the value of the packages by any one. It had been the custom of the plaintiffs, for the period of twenty-five years, to deal with the company in this way, the latter's agent regulating the charge for freight by weight or measurement.

The company put the goods in its car, and the train leaving Washington collided with another at Benning's Station, near Washington, setting the car in question on fire, which burned up the plaintiff's goods.

The accident was owing to the negligence of a switch-tender in the employ of the Baltimore and Potomac R. R. Co., which railroad company was the agent or servant of the express company.

The plaintiffs subsequently asked for a settlement of their losses on the basis of the valuation of the goods, as set forth in a bill of particulars, amounting in all to \$699.38. The company's agent refused, and offered the plaintiff's \$50, on the largest package, and the full value of the other two, *viz.*: \$12.88, which the plaintiffs declined to accept.

The point made by the counsel for Messrs. Galt was that the company's limit upon its liability was of no avail in the presence of proved gross negligence. Here the limit was \$50, according to valuation made by the company's agent in the absence of any standard set up by the shippers, so recited on the receipt or bill of lading, but the value proved at the trial was about \$700, for which verdict and judgment were given, and upon which appeal taken. The case was argued last month before the Court in General Term, and the decision of the court below unanimously affirmed.

Mr. Justice James delivered the opinion of the court. He recognized the receipts, although only signed by one party as furnishing the terms of a mutual contract, and that they were binding upon both parties up to that point where, after the company acknowledges liability for gross negligence, it provides that even this liability shall be limited to the value of the goods named in the receipt. Here he says :

"This is not in good faith a valuation of property. Its legal effect, and, therefore, its legal intent, is to restrict the measure of damages recoverable in case of negligence, and thus to exempt the wrongdoer from a part of his responsibility; and, as a matter of interpretation, the meaning of a clause which operates only in this way is not to be changed by giving to it an arbitrary name.

\* \* \* \* \*

We hold, then, that the intent and operation of this condition is merely to exempt the express company from a part of its obligations as a common carrier, in case the damage done to the shipper by its fault shall exceed the amount of fifty dollars. If we are right in this conclusion, we have next to consider whether a common carrier can lawfully stipulate for a partial exemption from his full liability in cases of gross negligence.

We are aware that in some of the States, notably in some which possess, or perhaps are possessed by vast railroad corporations, the doctrine of exemption by special contracts has been carried to extremes; but if this court were disposed to follow such a lead, it is prohibited to do so by the rulings of its superior, the Supreme Court of the United States."

After discussing the case of Lockwood, 17 Wallace, and the relations of the common carrier to the public, and the individual as a member thereof, Judge James lays down the following proposition :

"The principle of the rule is, that any agreement which operates to interfere with the public right touching the care and good faith of common carriers, is an agreement against public policy and welfare, and is therefore void; and as an agreement that his negligence shall

be cheap must operate in this way, it necessarily falls within that principle.

We are of opinion, therefore, that the court instructed the jury correctly, in allowing them to find for the full value of plaintiff's property, notwithstanding the conditions of the bill of lading, if they should find that the loss was occasioned by the gross negligence of the defendant.

As to the duty of a shipper to advise the carrier that the actual was greater than the apparent value of the article shipped, we hold that his omission to give such information does not affect his rights, unless it justifies the carrier in adopting the course of conduct by which the loss occurred. A carrier who is allowed to suppose that an article may be handled in a particular manner is not responsible for so handling it, and the shipper has to submit to the natural effect of his own omissions to give proper information. But that case is not before us. It can hardly be imagined that the omission of the plaintiffs to disclose the exceptional value of their shipment tempted the defendant to wreck and burn its train.

### What the Jewelers are Doing.

AMONG the endless quaint and charming conceits revived from antiquity, great numbers are seen in jewelry. The advent of "good times" seem to have inspired our leading makers of rich goods and induced a sort of friendly rivalry as to who shall excel in artistic productions. Baldwin, Sexton & Peterson presents some of the most beautiful effects in lace pins, of delicate and fantastic draped work wrought by chemical processes, into so many shades of color that the shimmers of gems and gold are brought into harmony with the most delicate laces and daintiest fabrics of the loom. An exquisite design for a lace pin or for an ornament for the hair is a branch of field roses, the petals of the flowers being studded with diamonds and the pistils, of gold dust, tipped with diamond specks. The veining of the leaves in pale green and gold is exquisite. Another exquisite pin represents a graceful spray of lily of the valley, which combines pure white pearls with exquisitely engraved leaves of gold. The diamond work of this firm embraces a great variety of new and novel designs, exquisite in taste and of the most delicate workmanship.

Hale & Mulford have introduced a new and desirable bracelet, so designed that the edges are raised to protect the surface of the bracelet, which is highly ornamented. This ornamentation takes on various beautiful and unique designs, ranging from the antique to the modern in style. These goods are protected by letters patent, so that dealers may be assured that they will not be imitated in cheap goods of a degraded standard. They are also manufacturers of rich cameo goods, embracing designs that are exquisite, in the production of which some wonderful effects are obtained.

Thomas G. Brown, whose wonderful reproduction of the classical jewelry found in the Castillani and Cesnola collections have made him famous in the trade throughout the world, has an elegant assortment of jewelry of this class, which is rich in both design and workmanship. He is also constantly adding novelties to his designs, embracing examples of antique jewelry as well as the new styles, of modern times.

Chatellier & Spence have an established reputations for the richness and great variety of work produced by them in colored gold, embracing examples of the Roman, Etruscan and other styles of colored jewelry. Their work in this line is conceded to closely border on the realms of high art in the production of jewelry. Their stock embraces the widest possible range of articles of personal adornment.

Carter, Howkins & Sloan present an endless variety of fine goods of all kinds, from goods calculated to satisfy the most refined and cultivated taste to those of a more merchantable character. The application of chemistry to the production of jewelry appears to have reached its highest point of perfection in the goods manufactured by this firm. Mr. Howkins, who has charge of the mechanical department, has a fertile imagination, which he uses to good advantage in the production of new styles, while the resources at his command seem equal to almost anything. Mr. Carter, a veritable Nestor in the trade, is as active as he was twenty years ago, and is as ambitious as ever to maintain the reputation of the firm.

It would be an endless task to attempt to enumerate the variety of goods to be seen at Tiffany & Co's. Their immense establishment is filled with goods of the highest order, of all designs, and of rare beauty. It is a museum of art in jewelry, and is a resort of buyers visiting the city, who call to observe and note the prevailing styles. Here will be found the productions of the greatest manufacturers of both Europe and America. An admirer of art in jewelry cannot spend a day more profitably than in visiting the establishment of Tiffany & Co.

other. But even there the distinction between the two terms might well be insisted upon. For instance, in the wheel and pallet action of the detached lever escapement, the pitching would refer to the adaptation of the wheel and the pallets to each other, as regards size and proportions, and the depthing to their intersection, determined by the distance between their centers of motion or pivot holes.

In examining watch trains the fault with defective gearings will more often be found in the pitching than in the depthing, as a workman can adjust the depthing passably, who would be utterly unable to tell whether the pitching or proportionate sizes of the wheel and pinion were correct or not. But even about depthings there is a very general lack of knowledge. Most workmen think that a depthing certainly is not too deep if the wheel and pinion run freely together and have plenty of shake and freedom in each other. But that freedom proves nothing as to the depthing, for there will generally be enough shake for freedom even when the depthing is altogether too deep, if the pitching is correct and the teeth are of proper shape, and this is especially the case with high-numbered pinions. In all but a few exceptional cases the wheel and pinion should be so planted that their pitch circles will just meet, but no more, *i. e.*, the thickest part of the teeth will just reach to and bear upon the thickest part of the leaves, at the instant when the point of contact is on the line of centers, or, as generally expressed, the teeth shall take the leaves "swell to swell." After treating on the proper curves for the ends of the teeth, we will consider when a change of depthing may partially neutralize the effect of improperly-shaped teeth or incorrect pitching.

(892) *Terms Relating to Wheel Teeth.* In Fig. 44, *EE* is the

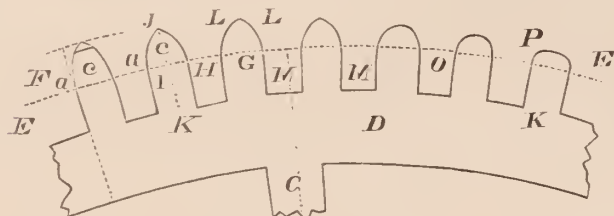

Fig 44

pitch line, or a part of the pitch circle, and passes through the thickest parts of the teeth, where the straight parts of the sides, or *flanks*, *MM*, join the curved parts or *faces*. *LL*. When necessary to distinguish them, the acting side of the tooth is called the front flank, or front face, and the whole is called the *front*, or front side; the other, the *back*. The distance across a tooth marked, *G*, is its *thickness*. The *breadth* of a tooth is the distance across the edge of the wheel, or the thickness of the metal of the web. *J* is the *point* and *K*, the *root* of the tooth. Sometimes the points of the teeth are flat instead of sharp or round, as is seen near *F*. The distance across is then called the thickness of the point. The distance from the root, *K*, to the point, *J*, is variously called the *length*, *height*, or *depth* of the tooth, "length" being the proper term. From *K* to the pitch line, or *I*, is the *length* or *depth to the pitch line*. From *G* to the point of the tooth is the *addendum*, (plural, *addenda*), or *length* or *depth beyond the pitch line*. The length of the addendum varies with the thickness of the tooth, and the degree of curvature; as the thinner the tooth, or the more rapidly it curves, the sooner it comes to a point. The shape of this curve again varies with the proportion between the diameters of the wheel and of the pinion it gears into, as will be explained when we reach the formation of the epicycloid curve.

(893) By giving to the addenda a curve suitable for the ratio between each wheel and its pinion, we secure the minimum amount of friction and wear, and the maximum economy of the motive force. Therefore differently curved addenda are required in different circumstances. Fig. 44 shows several forms of teeth. The first one at the right may be called the botch or shapeless tooth, *P*, unfit for any

use. The next, *O*, has a semi-circular addendum, a form only suitable for a tooth or leaf which is *driven*, but not for the driver. The third is better fitted for a driven than a driving tooth, and the fourth is a little better, as are the two last; and each will be the best for some particular circumstances. The last one, if used with a high-numbered pinion, may require to be shortened at the point, as seen near *F*, which is a part of the circle passing through the extremities of the teeth, like *DD*, in Fig. 43. The distance on the pitch line between the flanks of two adjacent teeth, as *H*, is a *space*. In watch wheels the spaces are generally equal to the thickness of the teeth, but in some cases is greater or less, as will be explained further on. *D* is the *web*, and *C* the *arm* of the wheel.

(894) *Measuring Tools, etc.* We see that, in a good gearing, there are three principal requisites. Not only must the forms of the teeth and leaves be suitable, but the wheel and pinion must be of proper sizes for each other, and, finally, they must be so planted in the watch that they will work into each other to just the proper depth. Perhaps the most important of all is the one we are now considering, the proportionate sizes of the wheel and pinion. This is particularly so with low-numbered pinions. In the case of a 6-leaf pinion great care is necessary to have it of the exact size to suit the wheel it gears into. In making such measurements, very accurate and perfect tools are needed. There are various tools in the market for showing at once the proportionate sizes of wheels and pinions, such as sectors, proportion circles, etc. But as very few have or are likely to obtain them, description will be needless. There are many more common tools, which measure accurately, and can also serve for all other purposes of measuring as well as for merely sizing wheels and pinions.

(895) Among the best of these are the series of tools made especially for watchmakers by M. Grossmann, of Germany, including the teeth-measure, meter-measure, and micrometer. The tenth-measure, or spring guage, is for ordinary measurements of lathe work, wire, plate, the bottom of barrels, sinks, etc. This shows to tenths of a millimeter, equal to about  $\frac{1}{250}$  inch, and will take in objects up to  $\frac{3}{8}$  inch. The meter-measure is a sliding rule having rectangular arms, between which objects are measured. It is divided into millimeters, and by the use of the vernier shows tenths of a millimeter, and will take in several inches. It can be had provided with two points, by which center distances, etc., can be taken, and which can be used for marking the measurements as obtained, drawing circles on metal, etc. The micrometer measures to  $\frac{1}{1000}$  millimeter, equal to about  $\frac{1}{2500}$  inch. It may be had with its dial divided into fractions of an inch, instead of millimeters. The micrometer is made in two forms—the more usual form is round, the other has two long arms or jaws. The latter is better suited for rough handling, is somewhat cheaper, and nearly as accurate as the former. The round micrometer will take in objects up to  $\frac{1}{4}$  or  $\frac{1}{2}$  inch; the other the same, or it can be made as desired.

(896) Many workmen use improved vernier calipers, made by Brown, Sharpe & Co., of Rhode Island. These are similar to the "meter-measure," and are made in various forms, some of them measuring to  $\frac{1}{1000}$  inch, or they can be had graduated to show to  $\frac{1}{40}$  millimeter. They also make a small "micrometer caliper," to measure articles less than one inch diameter, which is claimed to measure to  $\frac{1}{1000}$  in. or  $\frac{1}{80}$  millimeter with accuracy. It is scarcely necessary to say whatever measuring tools are procured, the one indispensable requisite is perfect accuracy. Without that, they will only mislead instead of informing. A pair of very fine-pointed dividers or "compasses," and an ivory graduated scale, divided off to tenths and thousandths of an inch, are also needed. In fact, some of the old masters had nothing better than the two last articles to make their measurements with, but used them with such care and skill that the calculations made by their aid are yet accepted as correct. A pair of well made "pump dividers" will also be very useful. Remarks on the use of them, and of the depthing tools have already been given.



## Practical Hints on Watch Repairing,

BY EXCELSIOR. No. 56.

WHEELS AND PINIONS, PITCHING, DEPTHING, PROPER CURVES, &amp;C.

(880) *To Find the Size of Pinion* suitable for a given wheel, by measuring the teeth of the wheel. Having first determined the number of leaves the pinion is to have, by one of the preceding rules, or otherwise, we have next to find the diameter which will secure a correct pitching, and insure that it will work properly into the given wheel. We will first consider a rough method commonly followed, then the strictly accurate and scientific one. By the former, the diameter of the pinion is obtained by measuring the correct number of teeth and spaces on the wheel it gears with. This measurement is taken with the pinion gauge or calipers, and cannot be considered trustworthy until the pinion selected by it has been tried, with the wheel, in the depthing tool, and the action found correct. Workmen of long experience, taking great care, having good tools, and skill to use them properly, can obtain quite close approximation to correctness by this method; but in the hands of the great majority it is only a means of picking out a pinion suitable to test in the depthing tool. The proportion adopted for the measurement is itself not strictly accurate, and must be varied to suit many cases, the taking of the measurement by the pinion gauge is at best a rough process, and the selection of the pinion by the gauge affords another chance of error. But as there are many workmen who will not use any other more accurate method which requires a little more trouble or thought, it will be better to give this, than to leave them to select pinions entirely by guesswork. In measuring, "full" means a trifle larger. As, for a 10-leaf pinion, "4 teeth, full," means from the outside of the first to the outside of the fourth, at their widest part, on the pitch line, and that the gauge must not be tight, but go easily over them. "Scant" means the reverse, or that the gauge should be a tight fit on the teeth. Below is a table of sizes according to this system of measurement.

(881) *Table of Sizes of Pinions.*

LEAVES IN PINION.	MEASURE ON THE WHEEL.
4	The calipers should go over the flanks of two teeth, very full.
5	Three teeth on the points, a little scant.
6	Three teeth on the points, and a trifle over; or, measuring on the pitch line, the calipers should reach from the outside or flank of the first tooth, $\frac{1}{4}$ across the third tooth.
7	Three teeth, from outside to outside.
8	Three teeth, and $\frac{3}{4}$ of a space over; or, measuring on the pitch line, from the center of the first tooth, $\frac{1}{4}$ across the fourth.
9	Four teeth on the points, full.
10	Four teeth outside to outside.
11	Four teeth, and $\frac{3}{4}$ of a space more; or, from the center of the first tooth $\frac{1}{4}$ across the fifth.
12	Five teeth, on the points, full.
13	Five teeth, outside to outside.
14	Six teeth, from center to center, scant.
15	Five and one-half teeth, or from the outside of the first to the center of the sixth.
16	Six full teeth, outside to outside.
17	Six teeth, and $\frac{3}{4}$ of a space besides; or, from the center of the first, $\frac{1}{4}$ across the seventh.
18	Seven teeth on the points, full.
19	Seven teeth, outside to outside.
20	Eight teeth on the points.

(882) *Short Rule for the Diameter of Pinions.* The following rule is recommended as a good one by Reid and others. *Rule:* Multiply the number of leaves in the pinion by 2, to the product add 1, and then divide by 3. The quotient will be the diameter for the

pinion. Example: How many teeth and spaces on a wheel will give the proper diameter for an 8-leaf pinion to work into it?

$$8 \times 2 = 16 + 1 = 17 \div 3 = 5 \frac{2}{3},$$

being three teeth, two spaces, and  $\frac{2}{3}$  of a space, taken by the calipers or gauge from the teeth of a wheel not rounded up. To understand this rule, the workman should sketch the outline of a number of teeth and the spaces between them, the ends of the teeth being left perfectly square, and of the same width as the notches or spaces between them. Then, beginning at the outside of the first tooth, count each tooth and space till you reach the required number, which will be the end of the measurement. In this case, you lack  $\frac{1}{3}$  the width of a space, of reaching to the fourth tooth. This measurement may be taken off a wheel with rounded teeth, as follows: You will notice that, if you take this distance with the pinion gauge, then shift its points to the pitch line, so that one is at the center of the first tooth, the other will be  $\frac{1}{3}$  across the fourth, the same as in a finished wheel. This is a fraction less than the size given by the preceding table. The difference, although greater in pinions of some other numbers, is but slight, however, and the rule has the advantage of being easily remembered, so that we can pick out a pinion by it without referring to a table of sizes. But it is believed that the sizes given in the table come as near to perfect correctness as can be attained by this method of measurement. And, as already stated, any such rules must be varied in some cases.

(883) *Allowance in Measurement.* In making measurements, both by the table of sizes and by the rule, allowance must be made, 1st, for different thicknesses and shapes of pinion leaves; 2d, for differently shaped wheelteeth, and 3d, for different ratios between the numbers of the teeth and the leaves. Of two pinions having the same primitive diameter or pitch circle, the one having the thinner leaves will be the smaller in full diameter; and the thicker the leaves the greater the extreme outside diameter of the pinion. The table and rule are calculated for leaves whose thickness is  $\frac{1}{3}$  of the pitch in pinions of less than 10 leaves, and  $\frac{2}{3}$  of the pitch in those having 10 leaves and upward. Therefore, whenever your pinion has leaves thicker or thinner than this, their actual sizes should be slightly larger or smaller than the measurements on the wheel teeth would indicate. When the ends of the leaves are not semi-circular, but are more pointed in shape, similarly to wheel teeth, the diameter of the pinion selected must be correspondingly larger than the measurements from the table and rule, otherwise the primitive diameter will be too small, although the outside measurement may be correct.

2d. The table and rule are calculated for measurements taken from teeth whose ends are properly shaped. The measurement, "3 teeth on the points," would be greater with long-pointed teeth, than with short, blunt-pointed teeth, because the central lines of the teeth being radial lines, they diverge as they leave the center; and the greater the number of teeth included in the measurement, the greater the difference caused by the length of the teeth beyond the pitch circle. Accordingly, when the teeth are quite long-pointed, or quite short and stubbed, the pinion should be selected a little smaller and a little larger, respectively, than the measurement made *on the points of the teeth*. When the measurements are taken *on the pitch circle*, however, the shape of the points of the teeth is of no consequence, in selecting the pinion by it.

(884) 3d. Supposing the measurements in the table and rule to be correct when the wheel has 7 or 8 times as many teeth as the pinion has leaves, where it has only 5 or 6 times as many they would make the pinion either too large or too small, according as its size was taken from the points of the teeth or from the pitch circle. In the former case the effect is the same as noted under the 2d head above. The less the number of teeth in the wheel the more rapidly their central lines would diverge beyond the pitch circle. In the latter case the measurement for a 10-leaf pinion, "4 teeth, outside to outside," would be the same, whether the wheel had 5 or 10 times as many teeth as the pinion had leaves, if it was measured along the *pitch circle*. But the calipers or gauge only measure the distance in

a *straight line*, which will be shorter. The former is a measurement of an arc of a circle, the latter of the chord of that arc; and the greater the curvature of the arc, *i. e.*, the smaller the wheel circle relatively to that of the pinion, the greater the difference between the length of the arc and that of its chord. In the two wheels supposed above, the calipers would show quite a difference when measuring "4 teeth, outside to outside," on each. Supposing the table and rule to give the correct measurement when the wheel is 7 or 8 times the size of the pinion, when it is only 5 or 6 times as large, the measurement would get the pinion too small; and if only 3 or 4 times as large, still more too small. When the ratio is above 8 to 1, a slight allowance is made in the other direction, *i. e.*, the pinion should be a trifle smaller than the measurement, but the difference is not nearly so great as with the smaller ratios. In fact, when the ratio is less than 6 to 1, the measurements obtained by these two methods are not much better than pure guesswork. From these considerations we learn that they are of value only when the ratio of teeth to leaves is about 7 or 8 to 1, and that the measurements should be made only on the pitch circle, when the ratio is below 7 or above 8.

(885) *Different Kinds of Wheels.* Before giving the scientific and accurate method of finding the proper size for either a wheel or a pinion, or both, we must first become familiar with some of the technical terms used in speaking of gearing. A few have already been used, but all will be included in the explanations. Wheels are of different kinds. Those most used in watch work are termed *spur wheels*, the breadth of the teeth being parallel with the pinion axis, and their lengths at right angles to it. When the breadth of the teeth is at right angles to the axis, and their length parallel with it, the wheel is called a *crown or face wheel*, or, more generally, in watch work, a *contrate wheel*, as is seen in the 4th wheels of the old verge watches. A *bevel wheel* has the teeth at an angle with the axis; when the angle is  $45^\circ$ , it is called a *miter wheel*; and, as just stated, when the angle is  $90^\circ$ , it is a *contrate wheel*. Of course spur wheels must act upon each other in the same plane, but bevel wheels do so at an angle. When the teeth point towards the center, it is called an *annular or internal wheel*. A wheel either has a *web* or rim on which the teeth are formed, supported by *arms*, or, if the web is not cut out, into arms but is continuous to the center, it is a *plate wheel*. When there is considerable difference between the sizes of two wheels geared together, the smaller one is called a *pinion*, and its teeth *leaves*. The one which *drives* is the *driver or leader*, the other is the *driven wheel or follower*. In watches the wheel generally drives the pinion.

(886) *Geometrical or Primitive Diameter, Pitch Circle, Radius, etc.* When speaking of escapements, the circle passing through the extremities of the teeth has been called the "wheel circle," because in escape wheels the acting parts are the points of the teeth. But in the train wheels we have a different system. In all calculations, rules, tables, and in ordering wheels or pinions, a certain diameter given, unless otherwise specified, means the *geometrical or primitive diameter*, measured only to the *pitch circle*, not the full or outside diameter got by measuring to the points of the teeth or leaves. In Fig 43,

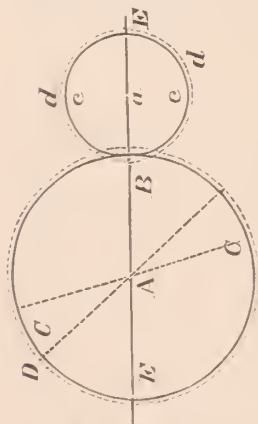

Fig 43.

$CC$  is the *pitch circle* of the wheel, and  $cc$ , that of the pinion, while the circles passing through the extremities of the teeth or leaves are  $DD$ , and  $dd$ , respectively. From  $C$  to  $C$ , would be the geometrical or primitive diameter of the wheel, while from  $D$  to  $D$  would be its *full or working diameter*, and the same with the pinion.

(887) The pitch circle, called by Camus the "primitive circle," is a circle which passes through the teeth (or leaves) at the junction of the straight and the curved portions of their sides. Inside of the pitch circle the sides of the teeth are straight. Outside of it they are curved or rounded off to the points. On the

pitch circle are measured the "pitch" of the wheel, the thickness of the teeth, and the width of the spaces between them, and by it the diameter or velocity of the wheel is calculated or measured. The *radius*, (plural, *radii*), or semi-diameter, is the distance from the center to the pitch circle, as,  $AC$ , or  $AB$ , is the radius of the wheel;  $ac$ , or  $ab$ , that of the pinion. When it is required to distinguish between the radius of the primitive circle and that of the full size, the former is called the *geometrical or primitive radius*, the latter the full or *working radius*. The imaginary line passing through the centers of a wheel and pinion in gear is the *line of centers*, as  $EE$ . The distance between their centers is the *center distance*, as  $A$  to  $a$ .

(888) *Proportional Numbers of Teeth and Leaves.* In ordinary machinery, which does not require any particular proportion between the number of revolutions of the different wheels, it is usual to so arrange the numbers of the teeth and the leaves gearing together, that the former shall not be divisible by the latter without a remainder, but to have an odd tooth, called a "hunting tooth," to prevent the same teeth always coming together on the wheel and pinion. The reason for this is that the duty of the machine is generally more severe at certain intervals than at other times, and if the same teeth which were then engaged always came together they would soon wear out. But in watch work the duty is always uniform, and there is no necessity for any such provision. Besides, the revolutions of the wheels and pinions must bear a certain ratio to each other to produce the correct motions of the different parts. And whatever the ratio between any wheel and pinion may be, that ratio must also be observed in their diameters, and in the number of their teeth and leaves. If the revolutions of the wheel and the pinion it gears into are as 1 to 6, then the number of leaves must be  $\frac{1}{6}$ th that of the teeth, and the geometrical diameter of the pinion  $\frac{1}{6}$ th that of the wheel. Their full diameters will, of course, depend on the shape given to the teeth and leaves outside of the pitch circle.

(889) *Pitch Line, Pitch.* The term "pitch circle," used in relation to wheels, is changed to *pitch line* when applied to single teeth, or to only a few. The *pitch* of a wheel is the distance along the pitch line from the center of a tooth to the center of the next one, as  $c$  to  $c$ , in Fig. 44, or from the front of one to the front of the next, as  $a$  to  $a$ . In other words it is the sum of a tooth and a space. The pitch is found by dividing the circumference of the pitch circle by the number of teeth in the wheel. In the same way the pitch of a pinion is the distance between the centers or fronts of two adjacent leaves, measured along the pitch line, *not* straight across, from  $a$  to  $a$  or from  $c$  to  $c$ . This distinction is especially important in the pinion, as then the difference between the curved arc  $aa$ , and a straight line from  $a$  to  $a$  is considerable, as will be seen by supposing the pinion in Fig. 43 to have six leaves, when the pitch would be  $\frac{1}{6}$  the circle  $cc$ . It has already been stated that the number of wheel teeth must be divisible without a remainder by that of the leaves they gear into. It is also necessary, for a smooth gearing, that the pitch of the wheel and that of its pinion should be the same to avoid the pinion, leaves butting against the teeth or the teeth dropping from each leaf to the next, during their revolution, causing waste of motive force, irregular transmission of both power and velocity, and excessive friction, resulting in rapid wear of the parts or even stoppage of the watch.

(890) *Pitching and Depthing.* As the distance from tooth to tooth or leaf to leaf is called the pitch, the proportioning of wheels and pinions so that they will have the same pitch, and be fitted to gear properly into each other, may be called the *pitching*. The *depthing* or *depth* refers only to the depth to which they gear into each other, irrespective of their correctness in size, form or proportions. With a correct pitching the correct depthing would be such that the pitch circles of the wheel and pinion should just meet; but not pass or intersect each other, as shown in Fig. 43, where the pitch circles just meet at  $B$ . With a faulty pitching we may partially remedy the effect of the error (if slight) by making the depthing more deep or shallow, according to the case, as will be explained hereafter. In treating escapements, "pitching" and "depthing" are generally considered equivalent terms, meaning the depth that the parts work into each

## Practical Experiments in Magnetism, with Special Reference to the Demagnetization of Watches.—No. 2.

BY ALFRED MAYER,

NOW let us return to our experiments with the floating iron wires. These wires were not magnetized, therefore they did not repel one another when thrown into the bowl of water. They differed from the magnetic needles in this, and hence, did not drive one another toward the border of the bowl. But when the magnet was brought over them they acted precisely like the magnetic needles, and formed the same regular hexagon with a floating wire in its center. The force acting on the wires and the needles was the same. It was the N. pole of the magnet. We know that the needles will only move toward the N. pole of the magnet when their south poles are upward and their north poles are down in the water. The wires did the same, and we therefore have a right to assume that when they moved toward the N. pole of the magnet their upper ends were made south poles by the inductive action of the magnet, and their lower ends under the water, were made north poles by the same action.

We can now understand the condition of the polarity in the magnetic chain formed by the suspended nails, brads, etc., in the experiment shown in Fig. 17. To the N. pole of the magnet is attached a nail. The end of the nail touching the magnet is made its south pole by induction, while its other end is made its north pole. This nail now acts just like the magnet which magnetized it, and the nail in turn magnetizes by induction nail No. 2, and this nail No. 3, and so on to the end of the magnetic chain, which is terminated by the magnetized iron filings.

23. *Experiments which show Something about the Nature of a Magnet.*—Take the piece of steel wire, six inches long and one sixteenth of an inch in diameter, mentioned among the articles required in our experiments; score this piece of wire at short distances apart, by filing it around with a sharp file. Now heat the wire to a cherry red, and then plunge it vertically into water. It will now be quite hard, and may be readily made into a magnet by drawing it over the pole of your rat-tail file magnet. Paste a small piece of paper around one of the ends of the steel wire before you magnetize it, and then, if you draw the wire over the N. pole of the magnet, from the papered end to the unpapered end, the papered end of the wire will have north polarity, as may be shown by applying the wire to the magnetometer. The magnetic condition of the wire having been found out, we begin by snapping the wire into small pieces, which is readily done, for the scores on the wire determine where it will break. Place each piece on the table as it is separated from the wire, and with its ends pointing in the same direction which they had when it formed part of the wire. Examine each of these pieces in succession. They will be found to be perfect magnets, with N. poles turned all one way, their south poles turned in the other direction. This examination may be made by means of the magnetometer. The fact that each piece is a magnet may also be readily shown by rolling it in iron filings, when it will be found that the filings adhere to the ends of the piece of wire just as they did to the large magnet. See Fig. 11.

Fig. 23 gives a view of the pieces of wire placed end to end just in the position they had when they formed parts of the steel wire. We see that each piece is a perfect magnet, and that the north poles of these pieces all point to the right, and their south poles all to the left. But each of these little fragments may be broken into two, and so on; and as far as the subdivision may be carried, it has been found that each minute fragment is a perfect magnet with one of its ends a

south, and the other a north magnetic pole. In imagination we may conceive of this subdivision carried so far that one of the particles thus reached may be invisible to the unaided eye. Indeed nothing prevents us from logically assuming that even if a molecule of the steel should be reached it would be found to be a perfect magnet.

*An experiment with a Magnet formed of Steel Filings Packed in a Paper Cylinder,* is interesting when studied in connection with the experiments just made, and will serve to give us further information as to the nature of the magnet.

Take a piece of letter paper, and having wrapped it several times around a lead pencil, paste the free edge of the paper on to that wrapped around the pencil. After the paste has dried you may draw out the lead pencil, and you will then have a tube made of paper. Cork one end of this tube, or you may close it by doubling over the paper at its end and gluing. Fill this tube with steel filings, and then close the other end of the tube. This tube, filled with steel particles, may be formed into a magnet by drawing it over the pole of your rat-tail file magnet. After you have performed this operation several times, present the tube to the magnetometer, and you will find one of its ends is a north, while the other is a south pole. Having thus satisfied yourself that it is really a magnet, shake the tube so that the positions of the particles of steel filings are changed. On testing the tube at the magnetometer it will be found that much, probably all, of its magnetism has gone from it. If it has not all disappeared it can be made to do so by repeated shaking of the tube. This experiment shows that not only must each particle or even molecule of a steel bar be a perfect magnet, but it also shows that these magnetized particles must be arranged in a definite order, that is, with all their N. poles pointing in one direction and their south poles in the opposite direction, so that the body, as a whole, may obtain and retain its magnetic polarity. Before the year 1600, when William Gilbert, the physician to Queen Elizabeth, made the celebrated experiment of breaking a magnet into many parts and testing the polarity of each piece, it had been thought that all of the north polar

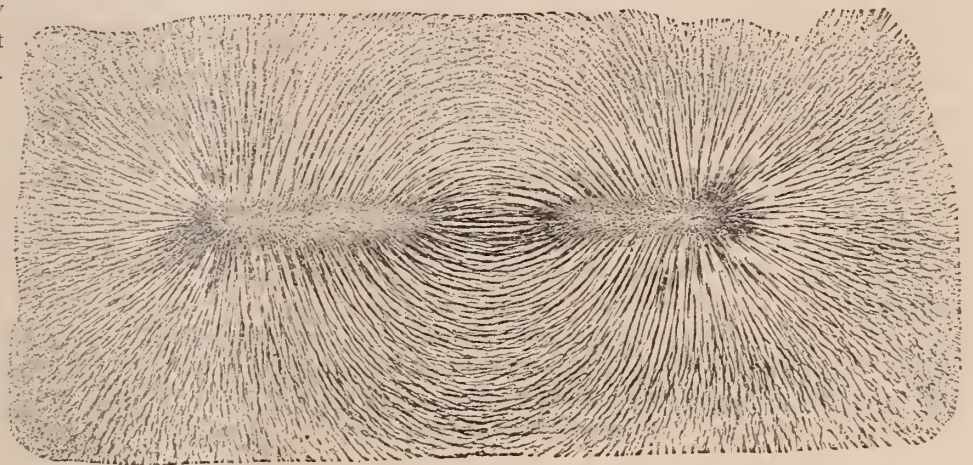

FIG. 24.—MAGNETIC CURVES AS SHOWN BY IRON FILINGS.

magnetism was contained in one end of the magnet, while the other end of the magnet held the south polar magnetism.

*Interesting Experiments* may be made with magnets acting inductively on a great number of iron grains spread on a surface placed over the magnet. We may thus form an idea of how this magnetic influence extends itself into space.

Take a piece of cardboard about one foot long and six inches broad. Support this at its corners on blocks of wood a little thicker than the diameter of your rat-tail file magnet. Place the latter under the cardboard. Now lift the cardboard off its supports and place it to one side on the table. Through a fine sieve sift iron filings evenly and not too thickly over the cardboard. Lift it up carefully and place it over the magnet. A slight bristling of the filings is all that you will observe of the action of the magnet. but on vibrating the cardboard, by letting fall vertically on it a piece of copper wire, or by

tapping it gently with a lead pencil, you will observe curious motions among the grains of filings. They will finally arrange themselves over the magnet in the curves shown in Fig. 24.

Fig. 25 shows the arrangement taken by the iron filings when they are placed on a card and vibrated over the end of a round magnet, the magnet being held in a vertical position under the cardboard.

Fig. 26 are the lines formed over the end of a magnet. Figs. 27 and 28 respectively show the actions of magnets with their unlike and like poles opposite each other.

Fig. 29 is interesting, showing the arrangement of the lines of filings produced on a surface when under it a magnet 216 millimeters long and 12 millimeters in diameter, is acting inductively on a cylinder of soft iron, 32 millimeters long and 10 millimeters in diameter. In April, 1871, I published in the *American Journal of Science* a method I had invented for permanently fixing these lines of iron filings (or *magnetic spectra*, as they are often called) on plates of glass. When thus permanently attached these plates were used as negatives from which a series of photographs were printed, exactly as a photographer prints from an ordinary photographic negative. The admirable engravings of magnetic spectra given in this article were made by a photo-engraving process directly from the glass plates made by me in 1871. These glass plates carrying the magnetic spectra I have also used for several years as slides in the lantern, in order to exhibit them before large audiences and college classes.

The following is the method of permanently attaching these figures to glass. A clean plate of thin glass is coated with a film of hard varnish by flowing over it the spirit varnish used by photographers in coating their negatives. If this is not handy, then a solution of shellac in alcohol will do nearly as well, only the latter requires more heating to cause the iron filings to adhere to it. The varnish is poured on one end of the plate, and then caused to cover the entire plate with an even film, by tilting and draining the plate, just as a photographer does when he coats his plate with collodion. After the varnish has dried to a hard film the plate is placed, varnished side up, over the magnet or magnets, with its ends resting on slips of wood, so that the under surface of the plate just touches the magnet. Fine iron filings obtained from Norway iron, which has been repeatedly annealed, are now sifted uniformly over the plate, and then the magnetic curves are developed by letting fall on the plate vertically at different points a piece of copper wire. The vibrations of the plate momentarily detach the filings from its surface, and at these moments the magnet arranges them in obedience to its inductive action on them. The plate is now lifted from the magnet, being careful to hold it always in a horizon-

tal position, and either placed with its ends resting on bricks over a hot stove, or it is heated over a gas stove. The film of varnish is thus melted, and the filings sinking into it are permanently fixed there after the varnish has cooled. If any filings should remain unattached, they are removed from the plate by letting its edge fall squarely on the table.

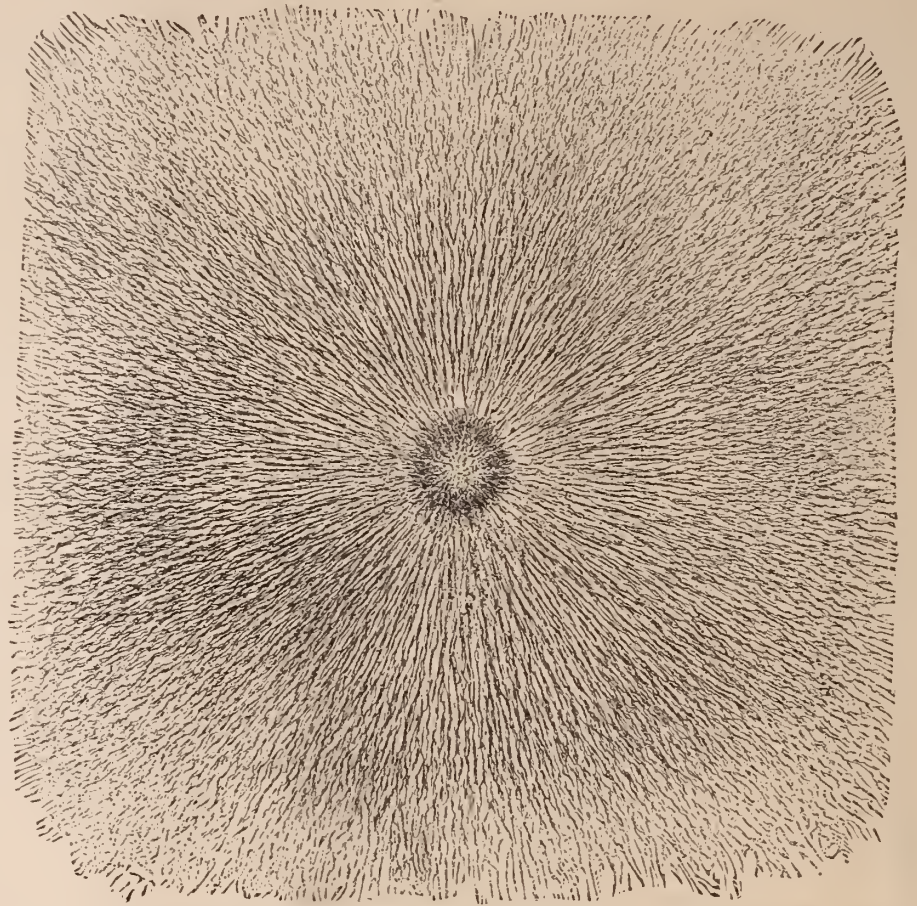

FIG. 25.—ARRANGEMENT OF FILINGS OVER THE END OF A ROUND MAGNET.

The lines forming these magnetic spectra were called "lines of magnetic force" by Faraday. He also devised the term "magnetic field." A *magnetic field* may be defined as any space at every point of which exists a finite magnetic force; while a *line of magnetic force* is a line drawn through a magnetic field in the direction of the force at each point through which it passes. Before the time of Faraday natural philosophers were satisfied with the mere statement that magnets acted at a distance, and followed generally the same law as ruled in the action of gravitation throughout the celestial spaces, that is to say, that the intensity of the magnetic action decreased inversely as the squares of the distances from the pole of the magnet, but Faraday, in the words of Professor Maxwell, "in his mind's eye

saw lines of force traversing all space where the mathematicians saw centres of force attracting at a distance; Faraday saw a medium when they saw nothing but distance; Faraday sought the seat of the phenomena in real actions going on in the medium; they were satisfied that they had found it in a power of action at a distance impressed on the electric fluids." Faraday discovered the general laws which rule the behavior of bodies in the magnetic field. When the magnetic field is uniform—that is, when the lines of magnetic force are parallel—magnetic bodies place themselves in the direction of the lines of force; but when the magnetic field is not uniform, magnetic bodies (like iron, nickel, cobalt, &c.) tend to go from weaker to stronger places of magnetic action, while diamagnetic bodies (like bismuth, borate of lead, &c.) tend to go from

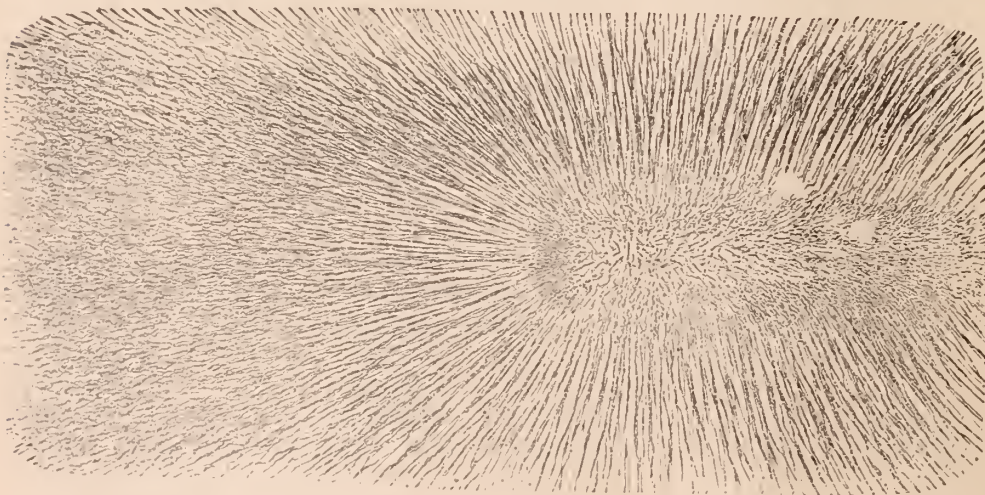

Fig. 26.—LINES FORMED OVER THE END OF BAR MAGNET PLACED PARALLEL WITH ITS PLACE.

stronger to weaker places in the magnetic field.

The conception of the lines of force and the magnetic field, and the statement of the laws ruling the action of bodies in field of a magnet, "formed," says Sir William Thomson, "one of the most brilliant steps made in philosophical exposition of which any instance exists in the history of science. \* \* \* Mathematicians were content to investigate the general expression of the resultant force experienced by a globe of soft iron in all such cases; but Faraday, without mathematics, divined the result of the mathematical investigation, and, what has proved of infinite value to the mathematicians themselves, he has given them an articulate language in which to express their results. Indeed, the whole language of the magnetic field and lines of force is Faraday's. It must be said for the mathematicians that they greedily accepted it, and have ever since been most zealous in using it to the best advantage. Indeed, much of the scientific work of Thomson, and nearly all of Maxwell's celebrated 'Treatise on Electricity and Magnetism,' may be regarded as translations of Faraday's conceptions into the language of mathematical analysis."

Let us now make a few experiments on these lines of magnetic force. We will thus be led to some remarkable results. Form a small magnet of a piece of sewing needle about one-quarter of an inch long. Suspend this with a filament of the floss silk. Having formed a magnetic spectrum, and with the magnet remaining undisturbed under the cardboard or glass, bring the little magnet over one of the lines traced out by the filings. Move the suspended magnet over this line, and you will observe that the length of the needle always lies in the direction of the line, no matter where the needle may be placed over this line. Faraday, from this fact indeed, gave his definition of a line of magnetic force as "that line which is described by a very small magnetic needle, when it so moved in either direction correspondent to its length, that the needle is constantly a tangent to the line of motion."

"The Earth itself is a Great Magnet." These are the words which may be said to form the text on which the illustrious William Gilbert wrote his work "De Magneto," or "On the Magnet," in 1600; and he certainly gave proofs of the truth of his statement, which, when viewed in the light of the knowledge which he himself discovered, forms an era in the history of the experimental sciences.

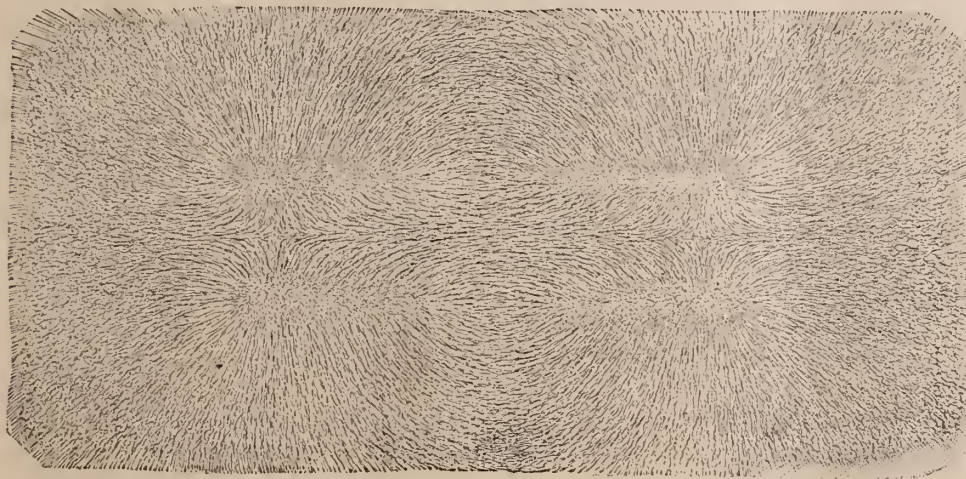

FIG. 28.—MAGNETIC CURVES LIKE POLES OPPOSITE EACH OTHER.

If the earth be a great magnet, then it also must have its lines of force surrounding it and stretching out into space. At first sight it would seem difficult to prove this, for its proof seems to require the existence of some immensely extended, light, movable and luminous matter surrounding the earth, on which its magnetism can act, and

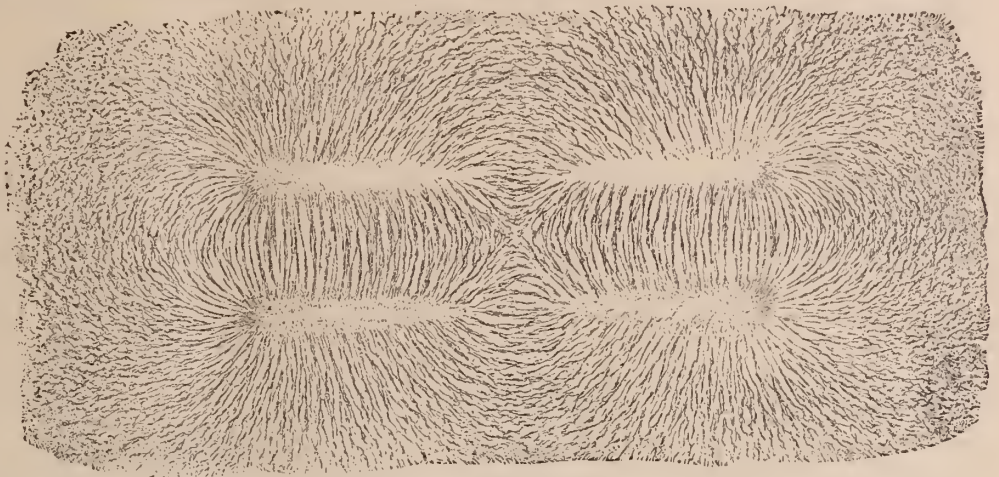

FIG. 27.—MAGNETIC CURVES UNLIKE MAGNETIC POLES OPPOSITE EACH OTHER.

by this action render manifest the direction of its lines of force. Now it so happens that such evidence is not wanting. All of our readers, I imagine, have seen those luminous and movable columns which form the aurora borealis. They appear to start from some level above the northern horizon, and stretching upward appear to converge at some point high up in the heavens. Sometimes this point is higher, sometimes it appears lower, according to the latitude of the observer.

Now we have seen that the magnetic needle always places itself in the direction of, or, more correctly speaking, at a tangent to a line of magnetic force, and it has been often observed that a magnetic needle, when suspended so that it can place itself in any position, either up, down, to the right or to the left, always places itself parallel to those luminous columns. This observation has been repeatedly made in various latitudes, and its general truth is established. The vast luminous rods, which are often 500 miles and over in length, actually trace out in space the earth's lines of magnetic force.

That the earth is a great magnet, you may at any time show to yourself and your friends by a few simple but very charming experiments.

Take the piece of iron, one foot long and three-eighths of an inch in diameter (which I mentioned among the things required in our experiments), and heat it to a dull red heat in the fire, and then allow it slowly to cool in the hot ashes. In cooling the rod it should be placed with its length in an east and west direction. After the rod is cold paste a piece of paper around one of its ends. Take it carefully in the hand and avoid letting it fall or giving it a blow. Bring the papered end of the rod up to the needle of the magnetometer, and point it at right angles to the length of its needle and directly toward its center. You will observe that the needle remains stationary as long as the iron rod points in a horizontal direction toward its center. This is so because the iron is devoid of magnetism, and hence attracts the north end of the needle with a force equal to that with which it attracts the south end of the needle.

Now observe what takes place when we slowly lift up the end of the rod furthest from the magnetometer. The south pole of the needle at once swings around toward the iron rod. This cannot be owing to the inclined position of the iron, because, even in this inclined position, it is symmetrically placed in reference to the needle, and should not on this account cause the latter to turn. Evidently the iron rod has become magnetic from this change of position. The mere tilting up of its end has made it a

magnet. A temporary magnet, it is true, for on slowly lowering the iron into a horizontal position the needle slowly turns into the magnetic meridian, and is then apparently indifferent to the presence of the iron rod.

(To be Continued.)

On the Compensation of Clocks, Watches and Chronometers<sup>1</sup>(By EDW. RIGG, M. A., *Assayer in the Royal Mint.*)

## COMPENSATION OF WATCHES AND CHRONOMETERS.

The problem to be solved in the case of a portable timekeeper differs essentially from that hitherto considered, for the invariable force of gravity is replaced by a balance spring attached to the balance, and affected by any change of temperature. To picture an analogous instance in a clock, it would be necessary to conceive of its being raised from the earth to such a distance as to materially diminish the intensity of gravity. An increase of temperature of  $1^{\circ}$  Centigrade in a chronometer may be taken to correspond to a loss of about 11" per 24 hours,<sup>2</sup> and, to effect a similar change in the rate of a clock in the manner contemplated, it would be necessary to raise it to a distance of no less than 567 yards, or nearly one-third of a mile from the earth's surface. As has been seen above, a similar change of temperature would only alter the rate of a clock with a steel pendulum rod, to the extent of  $0^{\circ}53''$ .

Compensation, then, in the case of chronometers is the more necessary, and it is a matter of greater difficulty as so many circumstances have to be taken into account. These are principally expansion and variation in the tension of the balance spring; thickening of oil; expansion of balance. The resistance opposed by the air is without appreciable effect on the rate. As the main source of variation resides in the spring, it is an object to employ a material for its construction that is but slightly influenced by heat, for by so doing the amount of compensation necessary will be reduced, as well as all irregularities due to its imperfection. Attempts have been made to employ glass for this purpose with some success, as is proved by chronometers made by Dent, of which one is now to be seen in the South Kensington collection of apparatus. Although not justified by experience, the fear of breakage has prevented their general use.<sup>3</sup>

Paillard gives a table showing the effect produced by substituting springs of various metals for the steel springs in an adjusted chronometer, from which it appears that, for a rise in temperature of  $33^{\circ}$  Centigrade, platinum gives a gain of 2 minutes, and palladium of 40 seconds, whereas all other metals gives a greater or less loss; and he concludes by preferring an alloy of palladium. Iridio-platinum has also been recommended, but none of these have ever come into general use.

The compensation may be applied direct to the balance spring, or it may be effected by varying the form of the balance itself.

Many devices for altering the acting length of the springs have been introduced, and they were much in use in the early part of the present and the latter part of the last century, but they have the grave objection of interfering with the isochronism of the spring, and have now been almost universally abandoned. It will, therefore, be unnecessary to do more than indicate their general arrangement.

In one<sup>4</sup> the stud in which the outer extremity of the spring is fixed is displaced, but this method can only be regarded as the very roughest approximation to an efficient compensation. The movement is brought about by fixing the stud to the end of a strip of a highly expansive metal, such as zinc, held by a screw at its other end to the plate of the watch. The exact length is determined by trial. In a second form<sup>5</sup> the arm carrying the curb pin is pivoted on to the index, and moved by a strip of metal, which surrounds the top pivot of the balance; the acting length of the spring is thus modified, as in regulating the watch. A third form was adopted by Breguet<sup>6</sup> for compensating the cheaper class of watches, he fixed one curb pin in the index as usual, and the outer pin, being carried by a curved bimetal-

lic arm attached to the index, was constrained to move towards the fixed pin on a rise of temperature, and from it in the converse case, thus varying the acting length of spring by altering the play allowed to it.

Some very careful experiments made by Dent in 1842,<sup>7</sup> as well as subsequent experiments by Rodanet,<sup>8</sup> seem to show that the change in the tension of a balance spring is exactly in inverse proportion to the change of temperature. Now the inertia of the balance, that is, the resistance it opposes to being set in motion, is proportional to the square of a certain dimension, known as the radius of gyration, which corresponds to the distance between the centres of suspension and oscillation in a pendulum. Hence it follows that, assuming the above law of the tension of the balance spring to be absolutely exact, for the period of vibration to be maintained constant this dimension must so vary that its square is always in inverse proportion to the temperature, for, in that case, its ratio to the tension of the balance spring will be invariable. But we have here assumed that only the tension of the spring varies, whereas the changes in the consistency of oil are of such importance as to materially modify the above conclusion, and the other sources of error already enumerated, have also to be taken into account; the problem thus becomes one of considerable complexity.

The compensation of a chronometer may be divided into two parts. In the first, or primary compensation, the balance is so adjusted that the rate is the same at two extreme temperatures, say  $0^{\circ}$  Centigrade and  $30^{\circ}$  Centigrade; and, in the second, such modifications are required as shall tend to cause the chronometer to maintain this rate at all other temperatures, for it is found that the simple compensation balance, as used in the best watches and in ordinary chronometers, does not suffice to effect that object.

Simple balances are of two kinds, and their forms have remained unchanged since they left the hands of Arnold and Earnshaw at the beginning of the century. Both are shown in this diagram. Their action depends on the principle, already illustrated by an experiment, that if two metallic strips of different expansibility are rigidly connected together, a change of temperature will cause them to change their radii of curvature. The amount of this change is, however, very slight, and the motion for a range of  $100^{\circ}$  Centigrade, when the weight is at a distance of  $90^{\circ}$  from the fixed end of the bimetallic strips, may be shown by calculation to be represented approximately by the interval between two arcs struck with radii of 25 ins and 24.65 ins. The first form of balance consists of a straight steel bar, carrying a curved bimetallic strip at either end, and in these are set a number of small gold screws. The rim is cut through at two points, so that the strips are free to move inward and outward through their entire length, except at the fixed ends. The balance being centered so that the whole is symmetrical, it will be seen that any change of temperature will cause the ends to move to or from the axis of rotation, and thus to modify the radius of gyration of the balance. This construction is usually applied to watches, whereas the use of the second is confined to chronometers. Its mode of action is precisely the same, but the screws are replaced with two weights, whose position on the strips may be varied. The compensation is effected in the first form by changing the position of one or more screws towards or from the free end of the strip to holes provided for this purpose, for by this means the distance through which each mass or metal is moved is varied, and a greater or less change is produced in the radius of gyration. In the chronometer balance the weight is moved along the strip, and fixed by a set screw. But it must be understood that the problem of compensation does not consist solely in determining the exact position to be occupied by the compensating weights; it is necessary also to find the size and moment of inertia of these masses having regard to the distribution of the matter of the other parts of of the balance and the constitution of the bimetallic strips.

1 A paper read before the members of the Society of Arts, on Wednesday, 12th February, 1879; Mr. W. Ellis, F.R.A.S., presiding. Revised by the Author.

2 Delamarche and Ploix, "Comtes Rendus," xlviii.

3 "Journal Suisse d'Horlogerie," i. 207, and ii. 49.

4 Dansart. "Revue Chronometrique," iii. 282.

5 Sandoz. "Revue Chronometrique," vii. 109.

6 See "Rees' Cyclopædia," article "Compensation."

7 See "pamphlet by Dent on "Errors of Chronometers," 1842.

8 "Revue Chronometrique," i. 86.

M. Yvon Villarceau<sup>9</sup> states that the difficulties in the way of compensation are due solely to the imperfections of these strips, and he finds, as the result of an elaborate mathematical discussion of the question, that, for maximum efficiency, the ratio of the thickness of brass to steel should be 17 to 12; that is the inverse proportion of the square roots of their elasticities, and not in the simple inverse proportion of these elasticities as is implied in the ratio 2 to 1, often adopted.

Further, the resarches of Caspari,<sup>1</sup> on the going of chronometers, lead him to conclude, as we should anticipate, that the strips should be made as thick as possible, the weight being no larger than is essential for effecting the compensation.

Attempts have been made to ascertain the exact path taken by a weight of a compensation balance when the temperature varies. M. Rodanet<sup>2</sup> showed experimentally, with a strip of brass and steel in the proportion of 2 to 1, that the center of each weight moves in a straight line, which passes more and more nearly through the balance staff, according as the distance between this weight and the point of attachment of the strip is diminished. It is right to observe, however, that the determination experimentally of the exact path of the weights is a question of considerable difficulty, and these results can only be regarded as approximate. M. Villarceau proposed a more delicate method of experiment than that adopted by Rodanet, but no results have hitherto been published.

It is a fact well known to chronometer makers that if a balance, such as either of those already described, be adjusted so that the same rate is maintained at, say, 0° Centigrade and 30° Centigrade, a gain will be observed in intermediate temperatures; or if adjusted for 15° and 30°, it will lose below 15° and above 30°. This error amounts to about 4 seconds in a range of 30° Centigrade; thus if adjusted for two extreme temperatures (0° and 30°), the maximum gain will occur at the intermediate temperature (15°), and will amount to about 2 seconds. Very many balances have been designed with a view to avoid this source of irregularity; and some of these will be presently described; but it will be well first to consider the error in some detail.

By drawing a series of concentric equi-distant circles cutting the lines which, according to Rodanet's experiments, indicate the path of the compensating weight, it is at once seen that the parts of each line are not equal among themselves; and further, that the ratio of the sections of one line is not identical with that of the sections of any other line. Assuming, then, that the distance traveled by the weight per degree remains constant, the relative rate of motion inwards, at different temperatures, depends on its position along the rim. Now, the ordinary adjustment of the compensation, at, say, 0° Centigrade and 30° Centigrade, only amounts to setting the mass in such a position that its total inward motion for a rise of 30° just neutralizes all the various effects of heat above alluded to, and the relative rate of motion per 1° will depend on the distance between this mass and the fixed end. This distance is, of course, different for each chronometer, and it seems probable that the constants in Lioussou's formula, presently to be referred to, would be found to in part depend upon it.

But at no point along the rim of an ordinary balance is the rate of motion such as to maintain the rate of the chronometer constant for all temperatures. The motion inwards should be more rapid, as compared with that outwards, and it is generally admitted that the weights should approach the center at a gradually increasing rate, receding from it, therefore, with a gradually diminishing velocity; whereas, in the ordinary balance, the converse is the case.

It is not evident, without a little reflection, why the error is a gain at temperatures between those for which the adjustment has been made, and a loss at temperatures both above and below that range; but the figure will at once show that such is the case. Assume the chronometer to be at adjusted for 15° and 35° Centigrade; take two axes of co-ordinates, and let points on the vertical axis indicate tem-

peratures; through these points draw horizontal lines parallel to the other axis of co-ordinates. If distances are measured along the lines corresponding to 15° and 35°, to indicate the tension of the balance spring, and a line be drawn through the points thus determined, the tension at any temperature will be ascertained, on the assumption that it varies uniformly. The motion of the weights, however, and therefore the moment of inertia, does not vary uniformly, and must be expressed by points on a curve of some such form as that shown in the figure.

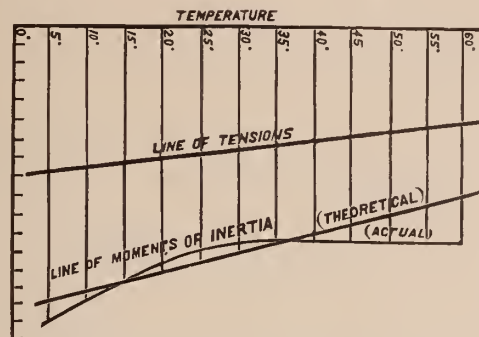

Now, if the ratio of the tension to the moment of inertia were invariable, this latter would be determined for all temperatures by a straight line passing through the points on the curve at which it is made to correspond. The figure shows that, between these points, the tension is relatively in excess, causing a gain, whereas, beyond them on either side the converse is the case, and there is necessarily a loss.

The curve just discussed suggests a means of determining the manner in which the chronometer, as a whole, varies with the temperature. For, assume it to be accurately adjusted at 15° and 35°, and then maintain it, for periods of 24 hours each, successively at a series of different temperatures; the loss or gain due to the change will indicate the distance of the corresponding point on the curve to the right or left of the straight line. Representing now each second by, say, six inches on a large diagram, the observed rates may be plotted, and the curve obtained will at once indicate the gain or loss to be anticipated at any given temperature.

And a further extension of this principle suggests itself. The abscissæ of points on the line of tension represent forces, and the moment of inertia is also measured in the same terms. Hence, the interval between these two lines correspond to a force dependent on temperature, and, so long as it can be kept in a constant proportion to the tension, the rate will be invariable. Now a variation measured in seconds really indicate a change in the proportion subsisting between the two forces, and a number of carefully made observations, through a long range of temperature, might enable the mathematician to formulate the law governing the motion of the weights, and thus to determine their paths.

The method adopted by Mr. Hartnup, of the Liverpool Observatory, for tabulating the errors of chronometers, and that of Lioussou, amount to a simplification of this method, and they have been found of the greatest service in practice.

Lioussou,<sup>3</sup> in an elaborate paper describing observations on a large number of chronometers, concluded that if  $T$  be the mean between the two temperatures at which the chronometer is adjusted, and  $a$  the rate at this mean temperature, the rate,  $m$ , at any other temperature,  $t$ , may be represented by the formula:—

$$m = a \times bx - c(T - t)^4$$

where  $x$  indicates the age of the oil in days, and  $b$  and  $c$  two constants that vary with different chronometers. In a good instrument he finds the several terms to have the values,  $T = 15^\circ$  to  $20^\circ$ ;  $c = 0.02$  as a maximum;  $b =$  not more than  $0.01$  per day;  $a$  will of course, depend on the rating of the chronometer. According to these figures, an instrument that is initially set to lose five seconds a day, at the temperature  $T$ , will, at the end of three years, gain this same amount. Lioussou's formula was modified by Pagel, but Villarceau maintains that both forms are incomplete. He points out that a theorem, known to mathematicians as Taylor's, offers the only complete method of expressing the rate of a chronometer under varying conditions, and this suggestion has been practically examined at sea by Lieut. de Magnac,<sup>4</sup> with very satisfactory results, although the requisite calculations are extremely involved.

Hartnups's<sup>5</sup> method differs materially from that of the French authorities, as his formula only contains one variable term, involving the square of the difference of temperature. Using Lioussou's symbols, the expression becomes  $m = a \times c(T - t)^4$ .

9 "Annales de l'Observatoire de Paris," tom. vii. (Emoires, 1883), p. 1-160.

1 "Comptes Rendus," t. lxxxi. (1875), p. 1122.

2 "Revue Chronometrique," i. 86.

3 See "Comptes Rendus," qxxvi. (1853), p. 894.

4 "Recherches sur l'emploi des Chronometres a la Mer," 1874.

5 "Horological Journal," xx. p. 134.

## Repairing Swiss Watches.

THIS is a fruitful source of error in the lower class of foreign work; it is so often out of truth or round, and its depth with scape pinion incorrect. If you have reason to suspect the correctness of this depth it will be best to try it first in the frame, and then in the depth-tool, for although you can see the action, and judge of the size of the pinion better in this tool, no allowance can be made for side shake, etc. Try then the running of scape pinion while in the frame, by pressing with a fine peg on the end of scape pivot with the left hand, while the right turns the fourth wheel with another peg; if it does not run smoothly, but you can distinctly feel every leaf come into action, you may be sure that something is wrong. Unfortunately, pinions of six make very bad depths, even when correctly sized and pitched. If the workman has a sector, or can get access to one, the best plan will be to try the wheel and pinion by it, and if the wheel is incorrect change it; if the depth is too deep the wheel can be re-cut on the engine; but if it is too small it must be exchanged. It is true some workmen, so called, hammer out this wheel and re-cut it, but the appearance of the wheel after this treatment is not nice. I generally stretch the old wheel with the hammer and re-cut until the depth is right, then exchange the wheel for one of exactly that size, turning a sink in a piece of brass as a gauge to send for the new wheel.

The wheel, as bought, is generally much too thick; as one fact is nearly always polished that is kept for the face; it can be cemented by its face to a true chuck, and turned down to the required thickness, with a sharp cutter in the slide-rest; its thickness can be reduced with less trouble and more certainty thus than by filing. You will now stone out all cutter marks with water of ayr stone and finish it with bluestone. Before opening the hole to size try its truth on a *true* arbor, and if the hole is not in the centre, as is sometimes the case, correct it by one of the following ways. First, you can put a piece of brass in the mandrel and turn a sink to fit the wheel, afterwards with a narrow cutter in the slide-rest turning the hole out true. Or the wheel may be fastened with wax to a chuck on the balance tool and run true by its teeth with either a peg or the thumb nail. If the watch is a good one the bars and crosses of the wheel should be smoothed with an old, fine nicking-file, used lengthways, and finally with boxwood and very fine oilstone dust, or two pieces of water of ayr stone rubbed together with oil, and the resulting thick paste used in the same way on a boxwood slip. Having finished the crosses, the face of the wheel can be touched up with a tin polisher and red-stuff (see note<sup>1</sup>). The thickness of the wheel will, of course, be determined by the depth of seat on the pinion, and as there will most probably be a slight burr thrown up in riveting on the original wheel, that should be removed previous to fitting on the new one. A hollow brass runner, having a hole sufficiently large to clear the second pivot, the shoulder of this pivot working in this runner, should be used while truing up the seat, and at the same time deepening the hollow a little. The wheel can now be let carefully on using a sharp broach and turning it one way, not backwards and forwards; to keep it true, it should fit tightly on to the pinion, and before finally putting it on take a slight chamfer off both sides of the hole to remove any burr thrown up by the broach, and you can proceed to rivet on the wheel, using for this purpose a cylindrical steel punch, having a hole drilled up it sufficiently deep to clear the arbor, and just large enough to fit over the shoulder with freedom.

### SECONDS PIVOT BENT.

This is a very common and annoying fault in foreign work. Fortunately, the very condition which renders them liable to become bent also makes it comparatively easy to get them up straight again, viz., their softness. It is very rare to find one that does not come up again under the treatment I recommended for cylinder pivots. In the event of a broken pivot, or one so cut as to render a new one necessary, it can be done in the balance tool already described, a

hollow chuck, somewhat smaller than the fourth wheel being used, and the wheel fastened to it by cement. It can be run perfectly true by the hollow at the root of the old pivot, or the tips of the pinion leaves, a peg being used of the same shape as described in setting a jewel hole. It will generally be best to entirely remove the shoulder of the old pivot, previously taking the height or distance from shoulder to shoulder with the tenth measure.

Having turned away all the shoulder of the old pivot down to the bottom of the hollow, and at the same time cut a centre sufficiently deep to start the drill true, you will proceed to drill the pinion, using for this purpose a drill of a similar shape to that described for replacing a cylinder pivot. I have found the ordinary Swiss drills sold in sets, and sized by the millimetre gauge from .10 mills. to .11 mills. very convenient for this purpose. They are quite hard enough for drilling *foreign* pinions, and are the correct shape, with this exception—they have a broad chisel point, and if used in that state would require too much pressure to cause them to cut. This should be thinned by resting the flat point of drill on a piece of stone, and with a slip of similar stone reduce the thickness towards the point, so that it is similar to an engineer's drill. All these drills are ground to cut one way only. You will proceed to drill the hole, holding the drill and turning the tool, and using, as a lubricator, spirits of turpentine. The depth of the hole will depend on its size, about twice its diameter will generally be sufficient if properly fitted. The piece of steel to be inserted, you will turn down nearly to size, shaping the shoulder similar to the old one, and finishing with the steel polisher and fine oil-stone dust. It should be almost parallel, and go two-thirds of the way in before driven. Having warmed the chuck and removed the wheel, it can be rested on a pinion riveting stake, and the piece that is to form the new pivot fixed in position by a few light taps of the hammer. You can now pass the end through the centring runner, turn the centre true, and proceed to shape the shoulder and pivot, with the graver in the turns, afterwards removing all roughness with a steel polisher and sharp red stuff; finally finish it with a fine burnisher in the jacot tool. A special centre adapted for seconds pivots accompanies the best of these tools; it has a longer bearing for the pivot than the ordinary centres. Having turned off the extreme corner of the shoulder with a polished graver, it only remains to round up the end of pivot, and it is complete.

In the event of the back pivot being broken, the best method of centring it will be by means of the centring runner described for centring cylinder plugs, turning a recess for the drill with a graver, and using a drill fixed in a runner in the turns, and for the back runner, a hollow one, the *shoulder* of seconds pivot taking the thrust. Care should be taken in making this plug that it is not too taper, as I have seen arbors split from this cause.

### 1 TIN POLISHERS.

Owing to the extreme softness of this metal, the making of polishers at once light and rigid is a task of some difficulty. If it is to be of tin alone, the smallest size that will be of use in polishing wheels will be about  $\frac{1}{4}$ ths of an inch broad, by  $\frac{5}{16}$ ths thick, and even this size will require great care in filing and use to avoid bending. A far better plan is to file up a bell-metal polisher about  $\frac{1}{4}$ th of an inch thick, and of the required width, and to tin the face with a copper bit, muriatic acid and solder, and making a mould for half the length of the polisher in plaster of Paris cast on a layer of grain tin, previously heating the bell-metal to rather more than the melting point of tin. A polisher made in this way is far lighter and more rigid than any solid tin one.

Circular blocks should be cast with a flange on the bottom, and considerably thicker than required. By means of the flange you can grip them in the mandrel and surface them, taking a considerable portion off the top. If there are any impurities or grit in the metal, they have a tendency to rise to the top and are thus removed.

Tin, previous to being cast into blocks, etc., should be carefully melted several times in a *clean* iron ladle, and each time poured from a height while in a molted state into water, thus breaking it up into very small particles, and enabling you to wash it thoroughly to remove all grit, etc.

The file used for finishing the face of tin polishers should be an old smooth-cut one *well worn*. A new file is useless for this purpose, as it clogs and cuts, leaving deep scratches in the metal. The file marks should be stoned out, and finally the face carefully burnished with a flat burnisher.

(To be Continued.)



## Workshop Notes.

Of mixtures of metals which become liquid at temperatures at or below the boiling point of water, there are several known, some of which are placed in convenient order as follows :

1. D'Arcet's : Bismuth, 8; lead, 5; tin, 3 parts. This melts below  $212^{\circ}$  Fah.

2. Walker's : Bismuth, 8; tin, 4; lead, 5 parts; antimony, 1 part. The metals should be repeatedly melted and poured into drops, until they can be well mixed previous to fusing them together.

3. Onion's : Lead, 3; tin, 2; bismuth, 5 parts. Melts at  $97^{\circ}$  Fah.

4. If to the latter, after removing it from the fire, one part of warm quicksilver be added, it will remain liquid at  $170^{\circ}$  Fah., and become a firm solid only at  $140^{\circ}$  Fah.

5. Another : Bismuth, 2; lead, 5; tin, 3 parts. Melts in boiling water.

Nos. 1, 2, 3 and 5 are used to make toy spoons to surprise children by their melting in hot liquors. A little mercury (as in 4) may be added to lower their melting points.

Nos. 1 and 2 are especially adapted for making electrotype moulds. French cliché moulds are made with the alloy No. 2. These alloys are also used to form pencils for writing, also as metal baths in the laboratory, or for soft soldering joints.

In a communication to the Vienna Academy of Science, G. L. Ciamician announces that he has discovered that the spectrum of the metals of the alkaline earths is made up of the spectrum of magnesium and of the less refrangible half of the complete spectrum of oxygen.

Mr. Edison finds that platinum, after it has been rendered homogeneous under the vacuum treatment, is dissolved with great difficulty in boiling aqua regia. He subjected a specimen of the vacuum-treated platinum to the action of boiling aqua regia for five days without dissolving it.

Malleable bronze is made by allowing 38 parts of copper and 25 parts of zinc, the copper being loosely covered with the zinc in the crucible. When the zinc has been fully incorporated with the copper, the alloy is cast in molding sand in the shape of bars, which are said to be capable of being hammered into any shape when hot.

Dr. Cheatham recommends, in the *Louisville Medical News*, the use of sulphate of eserine as a means of delaying the use of spectacles, so that they will not be required for several years, this alkaloid having the power of stimulating the ciliary muscle and thus assisting accommodation. The strength of solution recommended is one grain of the sulphate of eserine to an ounce of water. One drop of this solution is to be put in the eye at night, or when required.

It is recommended to add to fresh plaster of Paris from two to four per cent. of powdered marsh-mallow root, to obtain a plaster that will submit to turning in a lathe. The materials are mixed dry, when the water may be added to form a paste. The plaster sets in about an hour and becomes sufficiently hard to be cut into dominoes, chess-men, and other small articles. A larger percentage, up to eight per cent., of the marsh-mallow root increases the hardness of the plaster. To hasten the setting a little alum may be added to the mixture.

Professor Bottger, who has brought out several new metallurgical and chemical processes of value, offers a new process for bronzing iron and porcelain. The article to be coated with bronze is painted with soluble glass and the solution sprinkled over it from a sieve and then dried, when the surplus powder is rubbed off with a brush. The process is simple and is said to resist heat or washing with alcohol, and takes the burnisher readily. It would seem as if the process might be valuable in decorating stoves and iron-work exposed to the weather.

Guyard discovered uralium about the year 1869, in some commercial platinum obtained from Russian ores. He has lately published an account of it. Next to silver, it is the whitest metal known. It is as malleable as the purest platinum, but much more ductile; and it is nearly as soft as lead. Its melting-point is about the same as that of platinum, and it is not volatile. Its specific gravity is 20.25, and its molecular volume, like that of osmium, platinum, and palladium, is 6.25. Its atomic weight is 187.25. This metal has very nearly the same chemical properties as platinum.

*The Revue Chronometrique* publishes several notes from watch-makers as to the cause of breaking of mainsprings in the process of cleaning, the following extracts from which may be worth noting. One writer says whenever he leaves a barrel in a vessel filled with rectified benzine, no matter how carefully dried the barrel may be afterwards, the spring breaks one or two hours after being replaced in the barrel. He asks if the cause is likely to be from the heat given to the brass by the benzine, and by the effect of the cooling having sufficient power to produce the breakage, and asks any of his fellow-workers who have noticed the same thing to record their experience.

M. Barthe-Baty, of Rheims, says : "A correspondent attributes to the use of benzine in watch cleaning, the cause of the frequent breaking of springs. To that I would observe that I have used for fifteen years the Geneva essence of M. V. Simon, and that by way of experiment I have allowed barrels and springs to remain several days in this essence, and that I have only to record about two instances in a year of the breaking of springs after cleaning. From which fact I cannot attribute the breaking in any way to the use of benzine. If the cause can be proved to arise from the benzine, I can only suppose that it is because the latter was badly rectified."

M. Bailly, of Saint André-de-Cubzac, was accustomed in cleaning his springs to place them in benzine. "As the first writer remarks," he says, "I have noticed that the springs break soon afterwards." He has since given up this procedure, and contents himself with carefully wiping the springs, and the number of breakages has diminished. At the same time he does not think the benzine is altogether the cause because the generality of the ruptures arise from the violent shakings the spring receives in being taken from the barrel, and which disturbs the molecular state slowly acquired by the steel.

Preparation of Metallic Oxide.—Finely divided metallic oxide to serve as coloring in the making of enamel, or to make a plating solution of any required metal, is made by first dissolving the metal in question to saturation in its proper liquid solvent and pouring gradually small quantities into a vessel containing molten rosin, until the rosin will not take up and intermix with any more of the metallic acid solution. The prepared rosin is then spread out on an iron plate and placed over a fire and ignited, when after combustion the remaining sponge like oxide is rubbed to powder and is then fit to be used for its purposes. This method may be advantageously applied in forming oxide of iron, copper, nickel, cobalt, etc. H. Brush, manufacturer, Hull, England.

Test for Silver and Gold.—Dissolve bichromate of potassa in water and add a little sulphuric acid, the solution will have a blood-red appearance, scratch the object with the stone and apply the solution; if silver, a red sediment will remain; but if base metal, the coated parts will disappear or turn yellow. The testing stone must be cleaned after using.

The ordinary method of testing gold by the touchstone, is founded upon the insolubility of this metal in metric acid. If a mark be made in the touchstone with the article under examination, the gold is not dissolved by this acid, whereas golden-colored alloys of inferior value are dissolved and disappear immediately. When articles are very thinly gilded, the detection of the gold in this manner is uncertain, but the following test fluid can be applied with advantage: A little carbonate of copper is put into a test tube, and to this is added, drop by drop, pure hydrochloric acid till the blue powder has dissolved to a clear green fluid, occasionally warming it over a spirit lamp. This concentrated solution of chloride of copper is diluted for use with from ten to eleven times its volume of distilled water. To afford a thorough test the surface of the article should be cleaned by brushing it for a minute or two with a little spirits of wine. A little of the testing fluid is then dropped in and allowed to remain in contact for about a minute. The fluid is then removed by means of a small pipette, and the surface of the metal completely dried with bibulous paper; if no dark spot be then visible, the article is coated with pure gold. If the metallic surface is but lightly gilded, a very slight blackening is sometimes remarked, which may throw a doubt upon the result. In such a case, to make quite certain, a little of the surface may be scraped off, and then the testing fluid again applied. If a dark spot is then perceived, the article may be considered as very thinly gilded.

Varnish for Gilt Articles.—Gumlac, 125 parts; gamboge, 125; dragon's blood, 125; annatto, 125; saffron, 32. Dissolve each resin in 1,000 parts by measure, of absolute alcohol; two separate mixtures must be made with the dragon's blood and annatto, in 1,000 parts of such alcohol; and a proper proportion of each should be added with the gamboge to the varnish, according to the shade of color required.

## Watch and Chronometer Jeweling.

When the temper has been found right, the graver used for a stripping tool should be used solely for that purpose, as by its use for other objects the very fine edge so necessary, is completely destroyed. This tool is not alone used for stripping the jewel setting, but the dirt cups on the barrel arbor and center staff also owe their exquisite polish to the finish of the cutting tool. The jewel screws are, as before stated, counter bored and set, when, on stoning off, the plate, including the top of the settings and the screw, are removed; the jewels, with their settings, taken out of their seats, and the tops, after the stripping, are ready for polishing. Nothing in watch-work can excel in beauty the fine finish that is given to these tops. The method of effecting it is so applicable to wheels and any other small brass work in the watch, that we shall not apologize for the minuteness of the following description. In the articles on the lathe, in preceding numbers, a process was detailed by which a few glass plates might be used, and the mode of preparing the polishing surfaces was fully set forth. It will be very tedious and difficult for the repairer to get just the exact degree of surface; but he need not despair, even if he fails in three or four trials.

What is still better, as stated in the article on the lathe, is a stone surface, the stone being a homogeneous agate or cornelian; it is necessary to have two stones in order to get the required surface, which may be attained by the use of emery, but the result will not be so good as it would if diamond powder were used. The nature of the polish produced by means of the abrading surfaces is somewhat, if not exactly, like that produced by the action of the burnish file on steel; only the polish is much more exquisite, and can be done with a great deal more expedition. The polishing surfaces having been prepared according to the method explained under the head of "The Lathe," they should be wiped very clean with a cotton cloth and alcohol, in order to remove every trace of oil that may by accident have got on the face from contact with the fingers during the manipulations required in the preparation. The jewel setting, or other small brass work, after having been stoned down to a level on a piece of fine Scotch or blue stone, is placed on the polisher, with the stoned surface in contact; it being premised that any traces of the stone dust have been previously washed off. Now, with a piece of clean cotton cloth covering the end of the finger, the work is moved with considerable pressure over the surface of the polisher. The work must be examined after every four or five motions, to ascertain whether it is polished; for if the process is continued too long the brass will be found to clog up the fine grain of the polisher, and a new cleaning will be requisite. We may mention here that where the stone or glass plate has become unserviceable by reason of the brass adhering to it, it may be cleansed very rapidly by means of a drop or two of nitric acid, then washed in water, and afterwards thoroughly dried. As a matter of course, this plan cannot be adopted when the jewel or end stone projects above the top of the setting. When this is found to be the case the workman may be sure either that the stone is too thick or that the end-shake is too great.

In most of the first-class watches, and always in marine chronometers, the cock is jewelled with a diamond end stone, the setting of which requires great skill if a perfect job of work is desired. The first and most important point to be looked after (the face of the stone being all right), is to set the diamond in the steel perfectly level. As the setting is of steel and the diamond generally irregular in its form, the burnisher is of no advantage, and the workman is compelled to use other means.

Fitting a piece of soft steel wire to his lathe mandrel, he drills a hole in it endwise, just large enough to take in the stone, whatever may be the differences in its different diameters. This hole is rather a concave cavity, against the walls of which the convex surface of the stone rests. This end of the steel chuck is cut off at a suitable dis-

tance, to give the correct thickness after finishing. The cavity having been cut a little deeper than the whole thickness of the stone, the face will fall below the steel, which is placed on any block of metal, and the diamond introduced, and with a small steel punch and hammer the workman closes the steel gently over the edges of the diamond's face. In this operation the utmost care has to be taken to keep the face perfectly level with the face of the setting.

After the stone has been fastened in by means of the riveting process, the workman proceeds to flow, by means of fusion, brass around the diamond, in order to fill up the vacant spaces not touched by the stone, by reason of its irregular shape and the fact of its being cut in facets. The soldering being completed, the face of the setting, solder and all, is filled with great care down to a level with the face of the stone. It may be ground on a glass plate with oil-stone powder, but the grinding must be done with the greatest caution or the whole will be out of flat. The stone, with its setting, is now chucked up on the lathe by means of cement (shellac), with the face side on the chuck, and the workman trues it up by means of the outside, as by reason of the brass filling the cavity he is unable to get it true by the centre. The next step is to turn out, in the form of a bevel, all the superfluous brass and steel down to the diamond, and the tyro will find it a very difficult matter to do this apparently easy job.

The difficulties arise from the very irregular shapes in which the diamonds occur, and the hardness of the stone, the corners of the facets taking off the point of the graver almost as fast as they can be sharpened. The brass must be picked out of the irregular faces of the stone, and the great effort is to remove every visible portion of the brass from the cavity, and at the same time bring a true bevel from the edge of the setting down to every part of the diamond, regardless of its great irregularities; this bevel circular surface must be true, and, in order to achieve the subsequent polishing, the angle of the bevel should be a perfect straight line, though in some diamond covers we have seen the surface rounded, polished, and then blued. With a very large diamond this mode produces a fine effect. The usual course of polishing, after a true surface has been attained, is to use a small copper grinder with oil-stone powder; the subsequent surface is got with the usual polishing materials, such as sharp and rough. We have seen a much more exquisite polish obtained by means of fine diamond powder, the tool being nothing more than a common piece of soft iron—say an old horse nail.

The outside of the setting will have its shape determined by the circumstances of the case, and is polished while in the lathe in the same manner as all other steel work; but as the steel setting is soft, there cannot be obtained the fine deep black polish generally found on the steel work of the best class of watches, and particularly of marine chronometers.

The necessity of having the surface so truly level will be seen readily, if the reader will for a moment reflect on the mutual relations that exist between the pivot, jewel hole, and face of the end stone. Thus, if we suppose the face to be inclined at any angle, the tendency of the pressure of the pivot will be to crowd it to one side of the hole constantly; in fact, it would have all the effect on the action that a close hole would, and that, too, without any compensating advantages.

The small steel collet seen around the fusee arbor, is polished in the same manner, though, from the absence of any obstructions in the centre, a rounded polisher can be used that acts exactly the same as the one used for the oil cup of the ordinary jewel, and, as the steel can be hardened and tempered, the degree of finish is limited only by considerations of cost and the requirements of the class of work to which it is to be attached. These collets are generally screwed on with the heads of the screws holding the piece down by means of a small flange that is turned on the outside of the piece; sometimes the steel is set, counter-sunk in the plate. The screws in this case, are rarely counter-sunk, the steel being so very hard in proportion to the brass, the counter-sink tool is almost always broken;

the conditions of an uniformity of metal being absolutely requisite for truth.

This brings us, before we take up the subject of jewel screws, to consider the drilling, counter-sinking and tapping of the jewel screw holes. The American plan, the plates all being alike, is to drill the holes by the aid of a templet, and where the work is jewelled before gilding, of tapping the holes. This practice is not, in the eyes of a good mechanic, the best that could be adopted, for it will readily strike the reasoner that, in counter-sinking, the tit of the counter-sink must necessarily injure the integrity of the thread; and of all the screws in a watch, the jewel screws are the most liable to strip. The English, having no determinate sizes, are compelled to lay off the jewel screw holes according to the circumstances; and, no doubt, some of our readers have been struck with the dissimilar positions laid out in watches of the same manufacture. Thus he will find in one three screws to one setting, while in another he finds three screws holding down two settings. It is, perhaps, of no account so far as the general public are concerned, but the watchmaker suffers when he comes to repair; for, if the three screws have not equal bearings, the watch repairer will be very likely to tilt one or the other of the holes, and thus make a bad side-shake.

There can be no doubt that the best way to lay off the holes would be to make the settings, if possible, of the same size, and then fit in a steel plug having a very wide flange; through the flange a series of holes at regular intervals are to be drilled, and this may be used as a templet. The holes should be drilled small enough to allow the tap to give a full thread, as, when the counter-sink is made, but little stock remains to hold the screw. Again, the slight burr caused by the drill in passing through the plate on the other side, should be taken off as nearly even as possible, with the object of leaving as much stock as possible for the thread.

The jewel screw holes having been drilled, and the settings in their place, the next step is to counter-sink for the jewel screws. If the work is gilded, great caution must be used in order to avoid any burr around the edges of the counter-sink. We have seen workmen who set the whole plate together with the jewel and setting upon the lathe chuck, and with a cutter used on the rest, made the recess—the centre being obtained from the hole to be operated on; but the same object may be attained by using a counter-bore, made in the best style, and run at a very high speed. The most ordinary mechanical mind will comprehend that the counter-boring should be done previous to tapping, and therefore we shall assume that position understood. To make the tool for letting in the screw heads, it is necessary to put up in the lathe a piece of steel wire, and turn down the end with a "tit" of just the size of the hole in which it is intended to be entered. The shoulder, as a matter of course, should be perfectly true and square, and the outside turned off to the accurate size of the head of the screw that is to be put in; the workman, in every case, endeavoring to get the sizes of the heads the same. The really best form of a counter-bore for gilded work, to be used with high speed, is illustrated in the drawing. The spiral form given to the



clearing portion of the tool will enable the chip to roll out of the hole without marring the edges. This tool may be made in the form of a twist drill; that is, the cutting lips may be formed in the same manner, and this gives, provided the groove is sharply undercut, a means by which the chip may come out without touching the edge of the counter-sink; the form compressing the waste material to the centre.

In this the last article on the subject that has been treated on through the preceding numbers of the *American Horological Journal*, we shall not confine ourselves to any defined path, but in a discursive way give some hints that may be of advantage to the watch repairer. In fact, the minutiae embrace a wide range of the ordinary manipulations practised at the bench. The subject of screws used in the work, is of great importance; it is true, that with the imported

article so readily at hand, the repairer has but little call, except occasionally, to make a screw. The price of the jewel screws, of the best quality, ranging from \$1 to \$1.75 per gross, renders the trouble of making too expensive. Now, it must be observed that even a jewel screw, for good service, requires truth; that is, a perfectly equal diameter from the point to the shoulder under the head.

This is a matter of vital importance, for if the screw is taper it will so open the hole when it is forced down, that on removal and replacement the screw will not hold. Again, the head should be turned up parallel, with a perfectly square shoulder, as the bearing on the setting is so small that a slight taper towards the shoulder might leave no hold on the setting, while it may be screwed down solid; if the head be much taper, and slightly large for the counter-sink, the screw will force the setting out of its place, as the bearing in the plate is so much greater than that in the setting. In the nickel plates the holes will not take so good and full a thread as the brass, and consequently, if the watch repairer is obliged to replace a screw, he will be compelled to make the hole slightly larger than if the material was brass.

Accompanying the screws, as they are imported, there are taps left soft purposely; and the repairer will generally, if not always, find the body of the tap turned up to a square shoulder. Now, it may be a very trivial thing to write about, but many a repairer would have been saved hours and hours of vexatious trouble had he taken the precaution to turn or file of that shoulder to a curve before hardening and tempering, as shown in the cut. In fact, a square corner  in any piece of steel is the very weakest part when exposed to the action of fire and water. These taps may be fitted to the lathe, and if there is a tail stock a die may be easily made that may be preserved for future use.

As these dies, thus made, are altogether superior to the ordinary plate, a particular description will not be amiss. Let us suppose the back mandrel to be fitted up with a taper hole; the repairer can then proceed as follows, and he will find that after a short time he can have an assortment of dies from which he can make new taps at any time, and with very little trouble. It is to be assumed that the operator will make the blank taps of the form as shown in the cut. The dies are made, or should be, of good steel wire, turned up with a taper to fit the back mandrel of the lathe; the blank need not have a very large bearing in the taper hole, but should be bored through with a hole much larger than the intended screw. After having been fitted, and the face turned true, a dovetail is made directly across the face, and two thin pieces of steel fitted in the dovetail in such a manner that the ends do not exactly meet in the centre; the broach is now used to make a round hole, excepting the space left by the separation of the ends of the two pieces of steel; the hole is now tapped, the tap being held in the lathe; after hardening and tempering it will be found that a good cutting die has been made, superior to any jam plate.

There can be no doubt of the superiority of this form of tool; and as the dies can be used for making screws, they become doubly valuable. The same process can be applied to the construction of pointing and milling tools for getting accurate uniformity of size; for if we make an attachment to the back spindle precisely like the die as described, and cut away a portion of each of the steel pieces let into the dovetail so that a sharp cutting edge will be formed, and as the steel cutters can be made slightly convex, there can be no mistake in getting a perfect size up to the shoulder. It will hardly pay the repairer to go into a full range of taps and dies, as the imported screws, whether jewel, plate, or cock, are always accompanied by taps, which, if treated as mentioned before in this article, answer all the purposes required by the repairer. Yet there are cases where a screw has to be made for a special job; in such cases the ordinary jam plate, either Swiss or English, subserves the purpose. The dies described, however, do the work much better and with less risk of breakage. There is hardly a repairer that has

not a screw plate with half the holes plugged up by broken screw blanks.

In preparing the tap for use it is always best to *flute* it with a thin equallizing file, the thickness of which must necessarily be in proportion to the size of the tap. This plan, though involving more trouble, is much better than simply filing off three sides, as the last-formed tap merely squeezes out the thread, while the fluted one may be used in a smaller hole as the sharp edges of the flutings *cut* out the metal, leaving the thread in the hole solid metal, not forced into shape; this gives a much stronger thread, and a screw may be removed a greater number of times without the danger of stripping.

We have mentioned the importance of having a perfectly parallel head to the jewel screws; the remark is perfectly applicable to any other screw that is intended to go into a counter-sink, and it will be apparent that it is important that the heads should be concentric with the screw, if a neat fit is to be made in the counter-sink. For the pointing and polishing we will refer the reader to the articles on watch repairing, as the two are so intimately blended with general work that the subject is more germane to watch repairing in general than to any specialty.

There is a very meretricious practice with some members of the trade, of, in case of too close an end shake, burring the bottom of the cock with the point of a graver. The evils arising are, first, that there is no solid foundation for holding the bridge; and next, that the hole end being thrown up, the jewel is brought out of place and the wheel is brought out of upright; but the worst fault is that the successive screwing down will continually tend to flatten down the points of bearing, and thus the watch will never again go together the same. Altogether the practice is beneath any one who aspires to do good work. If the balance staff has too little end shake, the true way is to round off the pivots enough to give the requisite shake; where the shake depends on shoulders of the pinions, the shoulder should be reduced, and the repairer will find in the end that he has profited by doing his work in a correct manner.

Sometimes, in the ordinary Swiss watch, one of the ends to the balance will be found broken; to replace the upper is but a slight job, as the steel disk that holds the regulator as well as the end stone, can be removed; if, however, the repairer cannot find among his stock of material an end stone of just the right size, he may be bothered. He has two modes open to him: he may reduce the stone in the lathe, provided he has a diamond tool, being careful to keep the diameter such that the face of the stone shall not rest on the jewel; if the only stone that he can find near the right size is too thick, the trouble becomes greater; as the steel cover is generally hard, it is difficult to enlarge the hole in depth by any steel tool without first drawing the temper, and this implies repolishing—a troublesome process. The remedy is to use a copper wire, rounded on the end with oil-stone powder, the steel cover being set up in the lathe, and the drill may be run either with the bow or in a lathe. Where the lower stone is broken, the task is much easier, as the brass cap may be easily enlarged.

### The Largest Sapphire in the World.

A CORRESPONDENT writing from Paris says: I have recently been favored with the sight of one of the famous jewels in the world—a stone that has its history and its pedigree, and is celebrated in the annals of the trade and in the annals of the noted gems of Europe; I have held in my hand and admired beneath the rays of the sunlight the finest sapphire that is known to exist. This beautiful and well-nigh priceless stone combines in a singularly perfect degree the leading qualifications in size, shape, color, and water. In form it is a flat oval, being about two inches long by an inch and a half wide. It is cut slightly *en cabochon* on top and into a small facets beneath. Its hue is perfect, being a warm, lustrous, Maarie Louise blue, not so dark as to show black beneath the gaslight but

but having all the velvet softness and purity of tint that is required in a really fine gem of this description. Its weight is 300 carats, and it belongs to a noble and wealthy Russian family, in whose possession it has been for the past two centuries, and it has been placed by the owner in the hands of one of the great diamond merchants of Paris for safe keeping. One of the Rothschild family has offered for it no less a sum than \$300,000, but the offer has been refused. I asked the courteous gentleman in whose care it has been left as to the actual value of the stone. He told me that, being as it was perfectly unique, no precise value could be set upon it, but that he was inclined to estimate it at some \$400,000. He also showed me a string of enormous graduated pearls of extreme purity and fineness (the centre one was as large as a small cherry), and he told me that the necklace belonging to the noble Russian was composed of six similar strings of equal beauty and exceptional size. The great sapphire was mounted to be worn as a brooch, being surmounted with large diamonds of some twenty carats each. Its guardian informed me that the pendant belonging to this brooch was composed of a large pear-shaped sapphire weighing sixty carats, and set in diamonds. The whole collection of jewels belonging to this one family is worth \$2,000,000! "There is no such sapphire as that largest one," continued my informant, "even among the crown jewels of Russia. I furnished myself two very fine ones to the Empress, each weighing sixty carats, but they do not compare with this magnificent gem." The gentleman who spoke was well qualified to give an opinion, as he is one of the few great diamond merchants of world, and is, moreover a noted expert. He it is who was recently sent for by the Russian government to go to St. Petersburg to make a full estimate of the value of the crown jewels, and he furnishes whatever ornaments in precious stones are purchased by the members of the imperial family.

### The Venus of Milo.

THE greatest singularity attaching to the Venus of Milo is its being sculptured from two separate blocks of marble, slightly dissimilar in quality of grain and color. The inferior block comprises nearly all the drapery. The statue has not been sawn into two portions for the purpose of transportation, but was apparently restored in this manner, and is a unique instance of such treatment; that is to say, unique as regards the extent and importance of the restoration. The two blocks (which are of Parian marble) had been fixed in place at some former time by means of metallic bolts, which have left their marks in rust and fracture. The figure was set up either by carpenters or masons in 1821, and wooden wedges were introduced between the two divisions, giving an exaggerated inclination to the body, and destroying its equilibrium. The plinth, which was originally sloped back at a slight inclination, was made horizontal with the pedestal in which it is incorporated. The chisel was very freely used in adjusting the different fractured or divided pieces of marble, and it is not probable that the mischief done can ever be repaired.

It may be interesting to some readers to be informed of what M. Ravaisson suppressed in his published notice on Venus of Milo. A fragment of a plinth, bearing part of an inscription, was discovered with the statue, and in all probability belonged to the Venus, and no other. It is certainly not appropriate to the Hermes, which were invariably set upon the ground, and were never signed at the base. The inscription is to the effect that "Andros, Son of Menides of Antioch, wrought this statue after Maiondro." As Antioch was not founded until after Alexander's death, we may place the probable date of the statue near the third century B. C. It may have been executed by "Andros after Maiondro," but was clearly no vulgar copy, but apparently a repetition of some lost work of wide celebrity; for also at Capua, Brescia, and Falerone were displayed the divine sisterhood of the Venus of Milo.

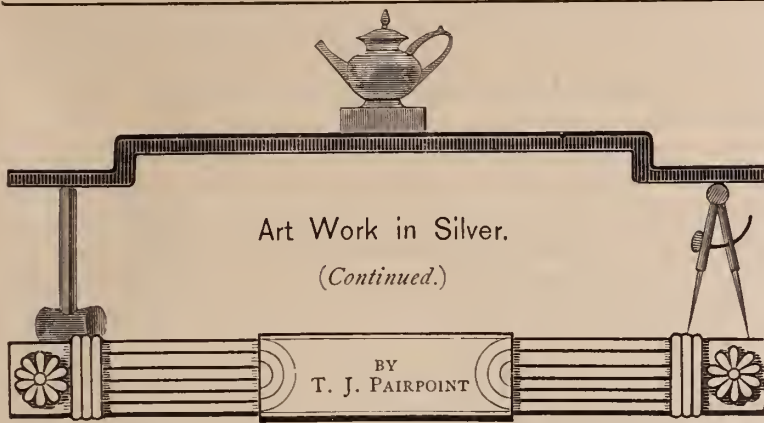

Art Work in Silver.

(Continued.)

BY  
T. J. FAIRPOINT

METAL work is conceded to be one of the earliest arts on record. In one form or another it has been practiced since the time of Tubal Cain, whom the Scriptures designate "an instructor of every artificer in brass and iron." The earliest known specimens are of bronze, but gold and silver have always played an important part in art metal work. All kinds of tools for working metals were made of bronze or copper by the Egyptians and Assyrians, and hardened or tempered by methods unknown to us.

The British Museum, the Armory of the Tower of London, the Louvre, the Museum at Naples, the Cesnola, and other archaeological collections, contain specimens of tools and weapons, some of which are considered to be of pre-historic date. Sir G. Wilkinson refers to Egyptian arms of admirable workmanship that have been found, of the date of two thousand years B. C., and weapons of various description excavated by Dr. Schliemann are supposed to be as old as eleven or twelve centuries B. C. We are also indebted to Sir A. Layard for discovering some very interesting specimens during his researches in Ninevah. The ancient bronzes were quite frequently ornamented with gold and silver, in some instances by the process of gilding or covering with thin sheets of gold, and others damascened or inlaid.

The most primitive method of working metals was with the hammer and tongs, before fire casting became customary every kind of work was produced by these simple means, and as soldering did not come into use until about the same time as casting, these hammered works were fastened together with nails or rivets, which were used at the same time as a decoration, thus serving a double purpose. Considerable skill is often exhibited in the management and distribution of the rivet heads, giving to the work quite a pleasing and very characteristic effect. One of the most important specimens of this kind was discovered in Etruria and is now in the possession of the British Museum. The metal workers of Greece and Rome attained to a great degree of excellence in this art, and their early efforts show strong traces of Egyptian sentiment in their designs. One of the cups found in the necropolis of Vulci is composed entirely of thin sheets of hammered metal, the handle being formed of a single strip bent to the desired curve, and fastened on to the body of the cup with rivets.

To a superficial observer it would appear almost impossible for the ancients to have accomplished so much simply with the help of a hammer and tongs, but these in the hands of a skillful workman undoubtedly are the most useful and important of all tools, no branch of industry is able to do without them, and when we look at the intricate yet delicately adjusted mechanical appliances, brought into use to facilitate our manufactures, we find that most of these wonderful machines consist of an elaborated combination of these simple and primitive yet indispensable tools. Their outward appearance assumes a variety of shapes, but the result to be obtained from the working is the same, and it is through their agency we are enabled to mould and fashion the hardest metals, which would, without their aid, be unapproachable, into forms suitable to our necessities. The history of bronze casting cannot be traced back to its origin, but they are known to have been made by the ancients at a very remote

date. Some specimens have been discovered in Egypt which are supposed to be four thousand years old, and from the description given of some pillars and other articles made for Solomon's Temple by Hiram the Tyrian "who was skillful to work in gold and in silver, in brass, in iron and stone," there is no doubt many of them were cast, for the Scripture says, "He cast two pillars of brass," and again, "He made two chapters of molten brass to set upon the top of the pillars." The Assyrians also produced some remarkable good castings, excelling more particularly in animals. The massive city and palace gates of Babylon were of bronze, and it is assumed that they were cast. There were one hundred of these gates in the outer wall, twenty-five on each side, and they were so large and ponderous that it required machinery to open them. Casting was first introduced into Greece about the sixth century B. C. by Rhæcus and Theodorus. The process of soldering metals, according to Sir G. Wilkinson, was known to the Egyptians several centuries before the time of Glaucus of Chios, whom some historians affirm to have been the inventor. The same authority states that specimens of soldered work were represented at Thebes in sculpture executed one thousand four hundred and ninety years B. C. They are shown to have been composed of plates of metal imbricated or overlapping each other, and sometimes having bands of metal intersecting them at intervals. Pausanias describes a vase made by Glaucus, for Alyattes, King of Lydia, the base of which was composed of imbricated plates of metal, soldered together in the same manner as those represented at Thebes. We may reasonably infer, therefore, that both soldering and casting were previously known, although, perhaps, they were not practiced to any great extent until the time of Glaucus and Theodorus.

The art of inlaying was practiced both by the Egyptians and Greeks. Vases, lamps, candelabra and various other objects were inlaid with gold and silver. The term damascening, so called from the fine inlaid swords and other arms made in Damascus, is principally used when the object to be inlaid is made of iron or steel, but the term equally expresses the style of work when applied to other metals. The Egyptians may have used iron for this purpose as well as silver, copper, and bronze, but owing to its perishable nature no traces of it have been found, but numerous specimens of other metals, decorated in this manner, were discovered at Thebes. Stones were also engraved and the intaglio filled with gold or silver and beaten into it. The same process is used to-day by Eastern nations for the adornment of their hooks, daggers, swords, spears, and a variety of other objects.

It has been assumed that gold was used some time before silver, but the Bible, which is the earliest authentic record we have, mentions the use of both of these metals in Abraham's time. It is said that he was very rich "in cattle, in silver, and in gold," and again he sent by his servant "jewels of silver and jewels of gold," as a present to Rebekah. The Israelites also borrowed jewels of gold and silver of the Egyptians at the time of their exodus, and they must have obtained them in considerable quantities as it was from these they afterwards made the golden calf. It is evident the Egyptians possessed great skill in the working of metals and the management of the various alloys, and Moses had probably learned from them many valuable secrets of the craft, otherwise he would not have been able to take the golden calf which the Israelites had made and burn it, and afterwards grind it to powder.

Gold, silver, and bronze vases and other objects, some of which were inlaid, were quite numerous at the period supposed to be contemporaneous with Moses and Joseph, and silver was so plentiful in Solomon's time that he caused it to be as common as stones in Jerusalem.

Before letters were invented they had no means of placing inscriptions over their dead; it was customary therefore to bury with the deceased some object relating to his craft or mode of life and character. The artisan was interred with the implements of his trade, the warrior with his arms, the mariner with a boat or an oar, the high

priest with his censor, or some emblem of the deity he served. It is in this way so many relics of the pre-historic past have been preserved to us.

The tombs of the Egyptians consisted of one or more chambers, according to the rank of the family. These were decorated with sculptures and paintings representing the various occupations of the people, processions, festivities, method of working the different trades, also agricultural pursuits, fishing, fowling, and boating scenes were depicted. It has been supposed they considered the soul of the occupant took pleasure in the beauty of these sepulchres and in contemplating the representations on the walls of the various scenes of daily occupation or recreations in which they had been actively engaged during life. Objects placed in the tombs varied according to the rank of the deceased, the wishes of friends or other circumstances. Among other things so placed may be mentioned jewels, weapons, tools, papyri, and vases of various sizes, gold, silver, bronze, alabaster, stone, porcelain and glass, being some of the material employed in their manufacture, and many of them were of exquisite workmanship. Rich and costly objects are only found in the tombs of the higher classes, but images of the dead person usually made in wood or stone were common to all.

Many Egyptian vases are of very beautiful form, and are similar to some of the best productions of the Greeks, both in shape and ornamentation. Some of the finest forms date as far back as the fourteenth or fifteenth century before our era, and were made of gold and silver, which they engraved and studded with precious stones, and spoons and ladles made of wood, ivory and bronze, the latter being sometimes gilt. Jewelry of gold and silver was also extensively used. They were a people naturally fond of festivities, ceremonies, and processions, and personal adornment must necessarily have formed an important part with those who participated in them. Rings and necklaces, often engraved with the scarabeus or sacred beetle, also bracelets and anklets or bangles, engraved or inlaid with precious stones, were worn by both sexes. Sir G. Wilkinson speaks of a gold armet in the Lynden Museum bearing the name of the Third Thothmes, which was doubtless once worn by that monarch and he says, without any great extravagance of imagination, we may suppose that perhaps Moses himself may have seen this identical armet, if as it has been assumed, this Thothmes was the Pharaoh who opposed the exodus of the Israelites and into whose presence Moses was so frequently summoned.

Metal mirrors were used by the Egyptians, Greeks and Romans. The earliest ones were made of a mixed metal of which the greater part was copper, and was capable of receiving a very high polish. So well did they understand the composition of this bronze that several specimens in the British Museum which were discovered at Thebes have had their original lustre partially revived, which is remarkable when we consider how many centuries they had been buried in the earth. Their form was usually a slight oval, having handles of wood or metal, frequently of very ornamental device. The Israelites used the same kind of mirror, which, probably, they had brought with them from Egypt, for Moses relates that the brazen laver or wash basin for the use of the priests was made from the mirrors of the women, which he had caused to be delivered up for this purpose, and it is supposed that the whole of the surface of these basins were polished, so that they might serve the double purpose of laver and mirror. The Greeks used bronze mirrors, and they also made some of their drinking vessels with the inside cut and polished into mirrors, so arranged that the reflection of the person drinking was seen multiplied. Silver mirrors was known to them, but were not generally used. The Romans made them of a circular shape, and the greater number were of silver, which had been introduced to their notice by Praxiteles, and was at once preferred to other kinds as that metal was the most suitable for the purpose and the most desirable. Some of their silver mirrors were so large that they reflected the figure at full length, and were, consequently, very costly.

In the laws when silver plate is spoken of in reference to heirship and succession, silver mirrors are generally referred to. Pliny and other writers of that time mentions among the extravagances of the age that every young woman must have a silver mirror.

Numerous goblets of gold and silver were among the votive offerings at the Parthenon, and some of the most celebrated artists in silver and bronze of that period cultivated the art so extensively that their works were eagerly sought after by the Romans up to the latest period. These vases and goblets served as ornaments in the houses of the rich, as prizes for the games, and a votive offering in the temples and groves.

After the conquest of Greece and Asia by the Romans, their great wealth and luxurious habits caused silver to become so common among them that the utensils both for the table and kitchen use were made of this metal. Pliny records that common soldiers had the handles of their swords and their belts studded with silver, and women's baths were covered with the same costly metal. Large manufactories for silver-ware were organized and special artificers employed for each particular branch of the work, the same as are employed in similar establishments of the present day. Among others are mentioned modelers, founders, chasers, polishers, and gilders.

In the late Imperial Library at Paris is a fine collection of more than one hundred silver vessels found in Normandy by Bernay in 1830. These articles, according to their inscription, was the property of one of the temples of Mercury. Another important collection of silver vessels is in the Antiquarian of the Royal Museum Berlin, the style and finish of which stamp them of Roman manufacture, and the form of the inscription on some of them indicate that their date would be the early part of the first century of our era. This collection is of the greatest interest in demonstrating to us the talents possessed by the Romans eighteen centuries ago, and also the excellence of their mechanical skill in the production of silver plate.

The Church has always been very liberal in its patronage of the fine arts; indeed, in the middle ages, they were used almost exclusively for church service and decoration, and as aids to inspire a feeling of veneration. This is the reason that so many European cathedrals and churches possess fine old services of plate, as well as miters, processional crosses, etc., and altars of silver and gold. The Cathedrals of St. Marks, at Venice, has a beautiful gold altar, and also that of St. Ambrose, at Milan.

About the year 726 the artists of the Eastern empire were subjected to a series of persecutions which lasted over one hundred years, and the cruelties and martyrdoms inflicted upon them had the effect of disseminating the arts over France, England and Germany. The Popes of Rome provided large monasteries for the artist monks who were obliged to fly from Greece.

In England the arts had never been entirely neglected since first brought there by the Romans, and the arrival from time to time of the fugitive artists and artificers infused new life into their artistic and manufacturing efforts.

*(To be continued.)*

A new form of mariners' compass has two horizontal hands, resembling the hands of a clock, and free to turn round over the entire surface of the compass card, are made parts of an electrical circuit. The course of the steam-ship having been laid, the hands are brought together on either side of this point, leaving only a space of a few degrees between them. The card is still free to move in any direction, but if it touches the hands on either side, electrical connection is made and a bell rings in the captain's cabin, or in any other part of the circuit, as desired. By this arrangement any deviation by the steersman from the course laid down for him is reported by the bell that rings continuously till the ship's course is correct.

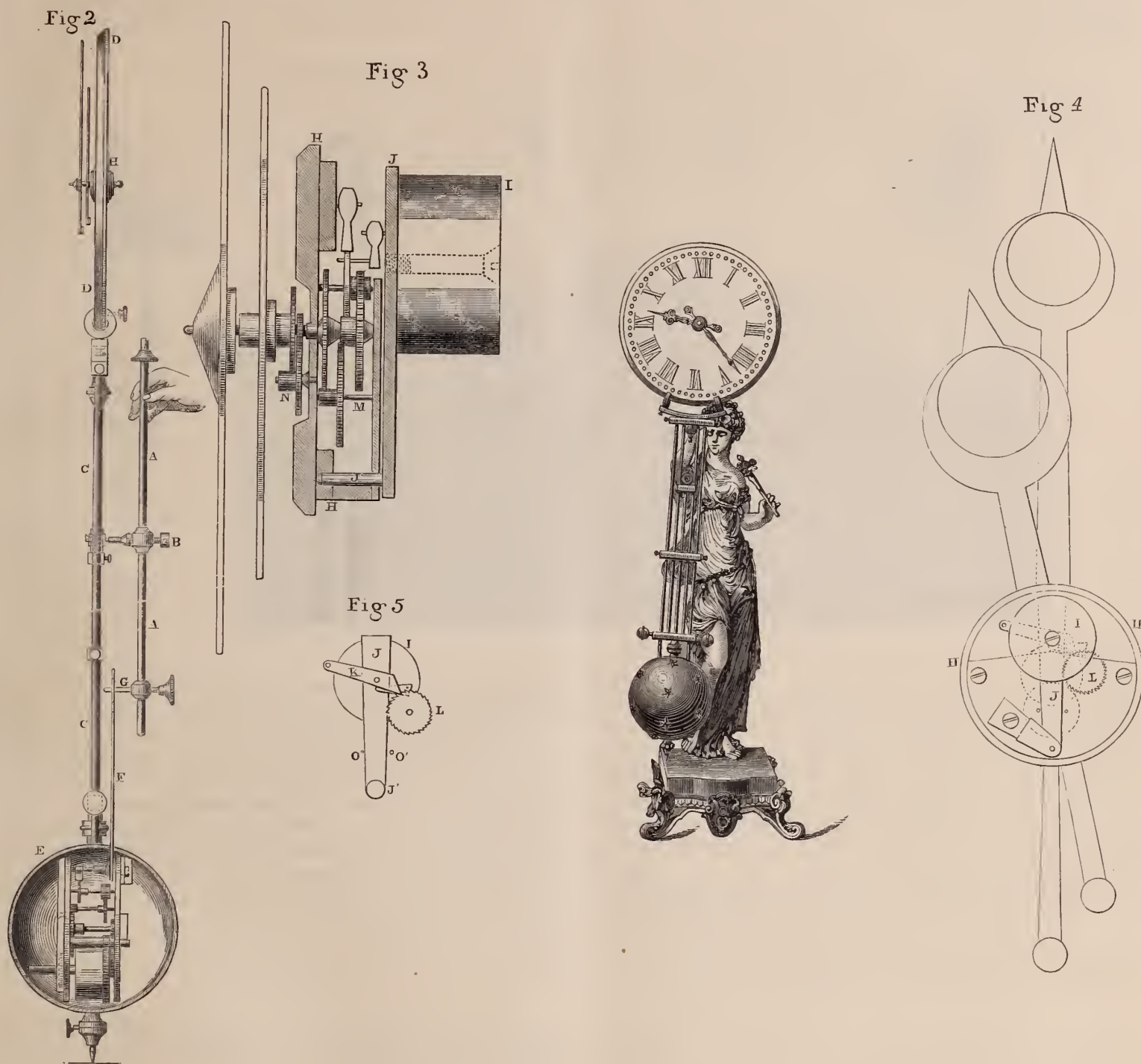

Rosset's Clock.

THIS novel and interesting clock is suspended from the arm of a statuette by a spring on which the pendulum swings. The pendulum is of the gridiron compensating style, and carries at its upper end a glass dial, and the pendulum ball consists of a hollow sphere containing the clock movement. In our engraving, Fig. 1, is a perspective view; Figs. 2, 3, 4, and 5, are detail views showing the construction of the operative parts. The compensated pendulum C, carries at its upper end a transparent glass dial D, and to its lower end is attached the hollow globe E, containing the movement. A forked arm F, extends upward from the movement, and embraces the pin G, attached to the lower end of the rod A, held in the hand of the statuette. In this clock the movement of the arm F, as it is actuated

by the escapement of the clock, gives the pendulum sufficient impetus to keep it in motion.

To the center of the glass dial a small casing H is attached, which contains the mechanism that moves the hands. In this casing is pivoted an arm J, carrying the weight I, and the pawl K. As the pendulum is oscillated, the weight I shifts its position in the casing H, and the pawl K is by this means made to act on the ratchet wheel L, which, being connected by a train of gearing with the arbor carrying the hands, moves the hands forward regularly. The dial mechanism is shown considerably enlarged in Figs. 4 and 5. In a complete clock, like that shown in Fig. 1, the pendulum oscillates without any apparent cause, and without some explanation it would be difficult to imagine how motion is communicated to the hands, as the casing H, which contains the dial mechanism is very small.

## Electric Jewelry.

A NOVEL application of electricity has recently been made in France. Some ingenious person has applied this mysterious power to the production of some novel effects in jewelry. The accompanying illustration shows some of these. The bird in the cen-

ter is an ornament for a lady's head-dress. It is profusely studded with diamonds, and by the application of electricity, which the lady carries concealed about her person, the wings are made to flutter, and the head to turn, producing a novel and surprising effect. One of these was made for the Princess de Metternich. The skull exhibited in the illustration, is made for a scarf pin, and is so constructed that the application of electricity causes the jaws to open and the sight-

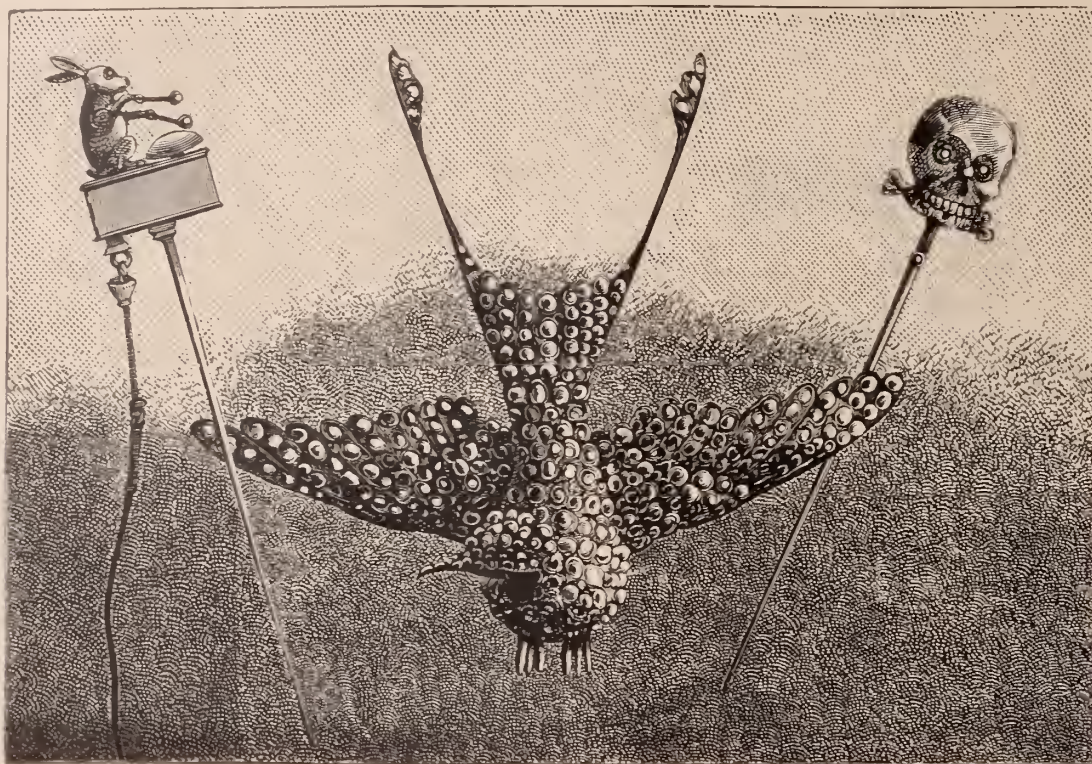

less eyes to move in their sockets. The rabbit is also a scarf pin, and is made to beat upon the drum in front of it at the whim of the wearer. But the curious part of the invention is the battery by which these objects are put in motion. Each of them is attached to an invisible wire, easily concealed in the garments or the hair, the other end of which is connected with a minute battery. This apparatus is not bigger than a pencil-case, and can be easily carried unseen in the waistcoat pocket. It consists of a tube hermetically sealed, containing in the upper half a pile composed of zinc and carbon inclosed in a case of hardened india-rubber (ebonite). The zinc and the carbon only occupy the upper portion of the tube, the lower containing the exciting liquid. So long as the tube is kept in a perpendicular posi-

tion the pile is not reached by the liquid, and consequently no action takes place. But the moment it is placed horizontally, the acid acts on the pile, and a circuit is established which sets the movable parts in action. Thus the wearer has only to vary the position of the tube to produce the motion or stop it at pleasure. The extent to which novelties in this line can be carried can be readily conceived. We do not apprehend, however, that electrical jewelry will ever become the rage in this country. A few curious persons may desire samples as rare curiosities, but ladies of a nervous temperament will scarcely care to go about with a galvanic battery concealed about them, even though it be a miniature affair. Figure 2 in our illustration gives an idea of the mechanism of this kind of jewelry.

## Clocks and Time.

There were never two Pawtucket clocks that agreed. They interrupt each other when striking and give the lie direct in their loud and clanging utterances. For instance, if one clock in a calm, positive and well-calculated way attempts to commence that it is midnight, then another clock will put in its tongue and attempt in a calmer, more positive and better calculated way to contradict its ambitious and noisy neighbor. We despair of ever knowing what time it is, but are quite confident the best time there is, in fact the only time, is the everlasting and ever-present now. The illuminated clock with its glowing and lustrous face points out the inaudible progress of the hours. There is something very solemn about this clock after all the world is still and there is no eye to witness its unswerving fidelity. We learn that our life is like the panting and tired out hare that lies down in the coolness and darkness of the evening and wakes on the morrow to find that Time, the tortoise, has won the race.—*Providence Journal, Pawtucket Letter,*

## A Reliable Watch.

A chap who had an old watch to dispose of "on account of his father's death," was yesterday trying to find a purchaser in front of the City Hall in the person of a young man who was on his way to the Fair grounds.

"I tell you, if you want a reliable watch you won't miss this chance!" argued the owner.

"Looks pretty old," replied the stranger, as he examined the ticker.

"Looks old! Why, that's all the better. It takes years and years to regulate a new watch and know just the hours it's going to stop and the hours you can depend on it to go."

The stranger lacked confidence, and was about to turn away, when the other suddenly asked:

"Say, do you keep a horse?"

"Yes, I do."

"Well, let me tell you something else in favor of this watch. If you got a horse which can trot at all he can make 2:30 by this watch just as well as four minutes. That's honest, sir, and I only ask four dollars for cases, wheels, springs and all."

And yet the stranger wouldn't buy.—*Detroit Free Press.*



## Business Notes.

M. Albert Lorsch has just received an invoice of cheap metal stem-winding watches, ranging in price from \$2.50 upward.

W. J. Suttie, 39 Maiden Lane, is said to be the only optician in the country who splits and grinds Brazillian pebbles from the rough and adjusts them to any desired focus.

Shoemaker & Co., manufacturers of fine jewelry, have introduced a very attractive line of Roman bracelet. They are exceedingly beautiful goods, and deservedly popular.

Messrs. Kossuth Marx & Co., have added to their line of Jewelry a full stock of Diamonds which they import direct, so that dealers may have original parcels to select from.

Messrs. L. & A. Mathey have introduced a very complete and useful instrument for teaching children how to tell the time, a description of which will be found elsewhere, in their advertisement.

The managers of the Cincinnati Exposition have awarded the American Watch Tool Company, of Waltham Mass., two silver medals, one for watchmakers' lathes, and the other for mathematical instruments.

Mr. L. A. Cuppia has introduced a very neat and attractive solid nickel chatelaine with a small stem-winding and setting nickel plated watch attached, these new goods are low in price and are consequently having a good sale.

Mr. O. Schwencke, manufacturer of fine hair goods, has achieved a high reputation as a maker of artistic jewelry in this line. He is constantly producing the newest effects in hair work. Dealers who have special orders for device work, would do well to consult his advertisement on the back inside page of the CIRCULAR.

Messrs. C. G. Alford & Co., manufacturers of the ganteline, now so popular with the trade, will furnish dealers a full size illustration plate of this novel article of jewelry that can be used in the local papers and circulars for advertising purposes. This electrotype will be forwarded prepaid, on receipt of 60 cents, the actual cost of the plate.

Cross & Beguelin have recently assumed the agency of A. Huguenin & Sons fine-complicated watches, comprising pocket chronometers, quarter-split-seconds, fly-backs and repeaters. These goods have a high reputation in the trade and we congratulate the manufacturers on having placed the American agency with so responsible a house.

The ear piercer introduced by Mulford & Bonnet, is becoming quite popular in the trade. Mr. Ernest Peschke, of Macon Ga., writes as follows: "The patent ear piercer you sent me came duly to hand. I am *very much* pleased with it; in fact one feels like having his own ears pierced with so ingenious an instrument. With one word it is elegant, and will supply a want long felt.

Jeanne Bros., makers of diamond mountings and fine jewelry from special designs, are producing many exceedingly beautiful and artistic novelties in their especial line of business, among which we noticed a variety of unique designs in ear rings, representing birds of the richest plumage exquisitely wrought in colored gold, and embellished with small diamonds. These goods are moderate in price and are among the most effective designs in the market.

Mr. C. Glatz, of 12 Maiden Lane, has transferred the manufacture of his gold watch cases from Milford, Pa. to Brooklyn, N. Y., where his facilities are ample to supply the trade with gold watch cases with all new improvements and designs. He has also resumed the importation of Swiss watches, having while in Europe last summer made arrangements to keep a line of Swiss watches adapted to the requirements of the American market.

Messrs. Brown & Brothers, makers of electro-plated ware, have just produced several new and attractive designs in flat ware. The goods of their manufacture are well and popularly known throughout the trade. Their patented heavy spring tempered shank, introduced in their forks and spoons, is considered a great improvement and contributes much to their popularity, whilst the artistic designs that are constantly appearing, render them desirable goods for dealers to handle.

A new style of bracelet has just been brought out by John A. Riley & Co. It has a hinge in the back, which is controlled by a substantial spring concealed within the bracelet. It is made of Roman Gold, and ornamented where the segments meet in various elegant designs, as seen by the cut presented in the firms advertisement, to be found on another page. The advantages of this bracelet are that it can be readily adjusted, is kept in place by the spring within it, and cannot be lost by accident. Riley & Co. control the patent for this bracelet, for which a liberal demand may be anticipated.

We desire to call attention to the National Watch Winder, an illustration of which will be found in the advertisement of the National Watch Winder Company. This is a permanent winding attachment that can be placed upon any key winding watch for fifty cents. It is adjusted to the winding post, and lies flat upon the inner case, so that the outside case closes down upon it. It can be detached when necessary to regulate the hands, but cannot fall off. This attachment serves the purpose of a stem-winder, as it provides a key that cannot be lost, and keeps the

keyhole closed so that no dust can enter. By the adoption of this attachment the owner of a key winding watch does away with much vexation of spirit attendant upon the losing and misplacing of his key.

Messrs. Aikin, Lambert & Co., makers of gold pens, pencil cases, etc., offer an unusual large and attractive stock of novelties in their line, the latest production in pencils consist of fine gold and richly ornamented porcelain enamel work, of the most beautiful and delicate coloring, we noticed over one hundred different designs in these goods, each of them handsomer than the other, and varying in price from \$3 to \$25 each, also a wide range of novel designs in gold and plated pencil charms, embracing a variety of subjects, from the frolicsome monkey to a fac-simile club of the notorious Captain Williams. Messrs. Aikin, Lambert & Co. would also direct the attention of the trade to their assortment of celluloid inlaid work in pencils. Their goods are exceedingly attractive and embrace every variety of effective ornamentation. This house also presents a large line of jewelry of the latest designs suitable for all classes of trade.

## Patents.

Containing notes of all Patents, Designs, Trade Marks, Labels, &c., relating to the trades represented by the CIRCULAR, granted by, or registered in, the Patent Office, since the last issue; and also notes of decisions in the Circuit Courts and the Supreme Court of the United States, which involve new or interesting points of law or practice on the subject of Patents,:

PREPARED BY CROSS & ADAMS.

Oct. 7.

PATENTS.

- 220,233. Stem-Winding Watches. Pauline H. Gontard, Cortibert, Switzerland.  
 220,291. Watchmakers Lathes. Joseph Kesselmeier, Gallion, Ohio.  
 220,390. Egg Tongs. Reinhold, P. H., Koska, East Saginaw, Mich.  
 220,393. Stands for Ice Pitchers. Thomas Leach, Taunton, Mass., assignor to Reed & Barton, same place. A stand for an ice pitcher having an elevated support for the tilting pitcher; an opening beneath with a subjacent draw to catch the drip; a projecting receptacle forming a stand for the goblet and a handle for the drawer, the same having a conduit to the draw for the waste water from the goblet; an elongated friction roller for the draw to travel on; all in combination as described.

Oct. 14.

- 220,483. Fountain Pens. Herman Madeheim, Brooklyn, assignor to George F. Hawkes, New York.  
 220,491. Gardner H. Niles, Attleboro, Mass., assignor to Charles E. Smith, same place. A Stud with helical fastening, combined with a pendant ornament.  
 220,531. Buttons and Studs. Albert C. Greene, Providence, R. I., assignor to Greene & Allen, same place.  
 220,568. Fountain Pens. Charles Baur, New York.  
 8,928. Reissue. Charles Hein, Corona, assignor to Hale & Mulford, New York.

Oct. 21.

- 220,759. Tool for Ornamenting Plated Ware. Henry W. Hirshfield, West Meriden, Conn., assignor to Meriden Britannia Co., same place.  
 220,763. Escapement for Time Keeper. John Jay Johnston, Pittsfield, Ill.  
 220,815. Removable Balances for Watches. Frank A. Earl, Ypsilanti, Mich.  
 220,849. Escapement for Time Pieces. Abner G. Loughlin, Paris, Texas, assignor of one-half his interest to Stephen G. Huddle.  
 220,864. Nose Clamps for Eye-Glasses. Franklin Pierce, Cambridge, Mass.

Oct. 28.

- 220,916. Stem-Winding Watch Keys. Ezra C. Fitch, New York.  
 220,956. Waiters for Pitchers. John W. Boteler, Washington, D. C.

DESIGNS.

Oct. 7.

- 11,455 and 11,456. Pencil Cases. LeRoy W. Fairchild, New York. Term 7 years.  
 11,457. Cases for Watch Charms. James C. Aiken, New York. Term 7 years.

Oct. 14.

- 11,458. Henry J. Davis, Brooklyn, N. Y. Term 7 years.  
 11,461. Scarf Pin or Similar Articles of Jewelry. John L. Remlinger, Providence, R. I., assignor to William A. Beatty, Pawtucket, R. I. Term 7 years.

Oct. 21.

- 11,471. Scarf Pin. William A. Beatty, Pawtucket, R. I. Term 3½ years.

Oct. 28,

- 11,473. Spoon and Fork Handles. Joseph B. Knowles, Providence R. I. Term 7 years.  
 11,474. Clock Dial Rings. George D. Owen, Winsted, Conn. Term 7 years.

## Trade Gossip.

There is a good demand for fine rubies.

Silver watch cases have advanced 5 per cent.

The demand for American gems has largely increased.

There are four Chinese jewelry stores in San Francisco, Cal.

Whitby jet is again fashionable, and very scarce in this market.

There are rumors of another new watch company being started in the west.

Finely painted Limoges Enamels are the latest agony in lace pins and earrings.

The Marquis ring is very fashionable and presents many novel combinations.

James Miller's jewelry store was destroyed in the recent disastrous fire at Parker, Penn.

The Gypsy ring is extensively worn, and is regarded as the correct thing for gentlemen.

An Ohio jeweler auctioned off all his customers' watches left for repair, and skipped the town.

G. H. King, jeweler of Monroe, Wis., was the Democratic candidate for Lieutenant-Governor of that State.

It is reported that the jewelry store of the late D. C. Greenleaf, St. Paul, Minn., is to be sold out.

Many beautiful articles of jewelry are set with tourmalines, peridots, aquamarines, hyacinths and other stones.

Certain parties are doing a lively business in Toronto and Montreal in smuggling diamonds across the border.

Mr. Herman Levison, of Levison Bros., San Francisco, Cal., sailed for Europe in the steamer Herder on the 6th inst.

R. Hudson's jewelry store, at Napoleon, Ohio, was destroyed in the recent conflagration of that town. Insurance not ascertained.

Certain so-called 10 karat chain is made out of anywhere from 6 to 9 karat gold, but they keep calling it gold chain all the same.

Charles Steffany, a watch case maker, residing in Brooklyn, was among the victims in the disaster of the steamer Champion.

Diamond jewelry was never so fashionable, the most fanciful designs are birds, butterflies, flowers and reptiles studded with brilliants.

The moment it was announced that copper had advanced two pence a pound, 10 karat chain bounced up ten cent a pennyweight.

The attention of the finest police force in the world is directed to the box men who obstruct the stairways of Maiden Lane jewelry houses.

Manufacturers of gold watch cases have advanced the price of making, one dollar, in consequence of a material increase in workmen's wages.

The most fashionable earring is now a large cluster, say a pearl, ruby or sapphire center, set around with diamonds, and is about an inch in diameter.

The new French enameled glass pieces seen at Tiffany's look as if made of melted jewels of all kinds, or as if a rainbow had been shattered among them.

Geo. A. Bernard, Wm. Fuchs and J. B. Reissig, of Philadelphia, have formed a co-partnership under the firm name of Bernard & Co., makers of jewelry.

Geo. Becks, jeweler of this city, has brought suit for damages against the Elevated railroad for the loss of an awning burned by sparks from the locomotive.

William Gore, a watchmaker living in Brooklyn, N. Y., is the lucky winner of a \$20,000 lottery prize, consequently all the girls in his neighborhood are going for *Gore*.

A trade journal, speaking of the preparation of the holiday gift season, says "their factory now turns out over 600 doll babies a day." This must be the original Baby Mine.

The New York Jewelers' Association held their fifth annual banquet on the evening of the 13th, at Delmonico's, Fifth Avenue and 26th Street, a full report of which will appear in our next issue.

The favorite stone of the season is the ruby, of which the best jewelers can hardly find enough to satisfy the demand.

H. L. Cortelyou is languishing in Ludlow Street Jail on an alleged charge of procuring goods on memorandum, and failing to make returns for them as promised.

A recent fire in No. 9 Bond Street damaged the building some \$2,500, and the property of J. A. Riley & Co., Dominick & Haff, S. Cottle and Robbins & Appleton was slightly damaged by water.

A watchmaker of the name of O'Flaherty has found the biggest South African diamond on record. The O'Flahertys are a Spanish family of very *hoy* degree. Mr. O'F. will probably be made a Kay Say Bay.

The fashion of wearing flies has reached its loftiest height in Paris. A dragon-fly with a sapphire body and wings of silver lace, veined with diamond dust, is about as gorgeous a creation as one would wish to see.

Burglars entered Charles Babcock's Jewelry store at Troy, N. Y. on the evening of the 19th ult., and blew open his safe, fortunately his goods were protected by an inside burglary proof box, which resisted the efforts of the thieves.

It is reported that the expenses incurred in the settlement of Kronberg's failure amount to \$13,000; if such is a fact, would it not have been to the interest of the creditors to have intrusted Mr. Kronberg with the winding up?

The Prudential Committee of Yale College have instituted a horological bureau in connection with the Winchester observatory, the object being to furnish an accurate time service, and give the local watch industries the advantages afforded by similar observations in Europe.

A new bracelet is made of narrow band gold, clasped with a small golden owl which has emerald eyes. The engraving of the owl's plumage is very fine and the design quite novel. A ring is made of serpent coiled around four times and with a torquoise set in his up-lifted head.

Pearls and other gems are admirably imitated in Paris. Rubies are largely imitated, because the stones are rare. They can hardly be distinguished, the real from the false stones, even by the well informed on the subject.

D. Appleton & Co., publishers, have leased the ground floor and cellar of Robbins & Appleton's new building in Bond Street. Dominick & Haff, silversmith factory and office; Thomas G. Brown, office. Robbins & Appleton will occupy the rest of the building with their offices and gold case factory.

The jewelers are in desperate straits to originate new designs for scarf and shawl pins for the ladies. Nearly every kind of implement is used in miniature for these necessary articles, but we haven't seen a broom reproduced in silver or gold yet. Why should woman's sceptre be thus ignored?

Albert Townsend, jeweler at Mattewan, this State, was robbed on the evening of Oct. 24th, by burglars, who blew open his safe and carried off a hundred watches and much jewelry, almost all of Townsend's stock, and a good deal of property belonging to his customers. The loss amounts to about \$3,000.

The matter of Cogswell, Weber & Co., of Chicago, has been disposed of at last. Mr. Shepard, representing William Smith & Co., of New York, has bought in the stock, fixtures, etc. for \$21,000, subject to the approval of the court. The invoice of assets was: stock, \$24,924; bills receivable, \$24,800; fixtures estimated, \$2,600; total, \$52,325.

A lady in Madrid, Me., who carried a valuable gold watch, was in a house last summer when it was struck by lightning. The watch stopped at the time, and, although jewelers have repeatedly examined it and pronounced it perfect in every particular, it cannot be made to move. It is so magnetized that watchmakers say no part of it could ever be made to do duty if taken out and put into another set of works.

Bracelets have assumed great importance in the fancy of young women with pretty arms to show, since the elbow sleeves came into fashion. And every week there is some new design to tempt the bangle buyer. The latest is a single flower—daisy, buttercup or clover leaf—composed of diamonds set on a slender gold band. All sorts of fanciful and realistic objects, such as locks, serpents swallowing their tails, butterflies, dragons, masks, a bunch of bulrushes, are employed by the skilful designer to ornament this new fangled bracelet.

## Proceedings of the Horological Club.

A DISTINGUISHED BODY OF WATCH AND CLOCK MAKERS.

*Sixty-eighth Discussion.—Communicated by the Secretary.*

[NOTICE.—Correspondents should write all letters intended for the Club separate from any other business matters, and headed "Secretary of the Horological Club." Direct the envelope to D. H. Hopkins, Esq. Write only on one side of the paper, state the points briefly, mail as early as possible, as it must be received here not later than two days before the end of the month in order to be discussed and reported in the CIRCULAR for the next month.

## EQUALIZING THE POWER OF THE MAINSPRING.

*Secretary of the Horological Club :*

In your proceedings for August, I noticed a letter from Mr. J. H. P., speaking of an improved mainspring barrel, with mainspring brace sliding to and from the center, which he cautiously says he "thinks will equalize the power to some extent." This idea of equalizing the power of the mainspring by varying the place of its action on the barrel, is an old fallacy which the club should show up. The fact is, that the power of the spring acting on the barrel is the same, whether it is attached to it at the outer edge or nearer to the center, and I send you a clock model which I fitted up to satisfy myself on this point. To test it, fasten a pin vise or a mainspring scale on the pivot of the pinion. The pin in the main wheel to which the spring is hooked, can be removed and placed in the other hole. Further explanation is superfluous to those interested, I think. B. F.

Mr. McFuzee exhibited the model, with a pair of sliding tongs clamped on the pinion arbor, and wound up the spring till it would turn the pinion and raise the tongs. It seemed to require about the same amount of winding to do this, whether the spring was hooked to the outer hole or half inch nearer the center. In fact, the power appeared to be a trifle less when the spring was hooked to the outer hole. He explained this, however, by the direction in which the spring pulled on the pin. When the pin was in the outer hole, the spring did not pull on it tangentially, or in the direction of the circle (as it did when in the other hole), but considerably toward the center; and the smaller and closer the spring was wound up around the arbor, the nearer towards the center was the direction of the tension on its end. The spring being quite a small one, this oblique pull on the pin neutralizes the increase of strength in the spring. But he thought there could be no question that if the spring could be arranged to pull on the pin tangentially, or in the circle of the pin, instead of towards or from the center, the power it would exert on the main wheel would be directly proportional to the distance of the different holes from the center, the power being greater as the holes were further from the center. As the spring could not well be so arranged, our choice was between the usual rigid attachment of the outer end of the spring, with a diagonal pull towards the center as it was wound up, or a sliding attachment with a more direct pull. For his own part, he thought there was very little gained by any sliding attachment, and there certainly was considerable objection to it, mechanically. As far as concerns watches, the advantage of its use was very questionable. At the same time, he could not admit that the place of attachment of the outer end of the mainspring was a matter of indifference. In exceptional cases it might not affect the amount of power given to the wheel, but such cases were the exception, not the rule. If he had not got Mr. F's idea correctly, we would be pleased to receive his explanation of the matter.

## SILVER OILING WIRE FOR "EXCELSIOR" WORK BENCH.

*Secretary Horological Club :*

Permit me to add a mite on oiling wire for the inspection of your honorable body. After inspection, please present it to "Excelsior" with my compliments. Enclosed is the style of oiling wire I use, only I take less pains with the handle; this is a piece of muscle shell from the Tennessee river, a reminiscence of the war. The object in making it of silver is, that you can see the smallest particle of dust that might stick to it. It will not scratch the bottom of your oil cup, even glass, as a needle would (see May number of the CIRCULAR). Should the joint get broken off, it can be repaired with but little trouble by draw

ing and bending over. I have one I have used for nearly ten years, of course, I have a place to keep it as I do every other tool. I only have on my bench at one time such tools as the kind of work I am at requires; the rest are in three handy draws underneath. I keep my bench covered with white paper; have strips of zinc turned for the front edge ( $\frac{3}{8} \times \frac{3}{4}$  inch), a little more than square, so there will be a little spring to the front edge when it is screwed to the front of the bench that keeps the paper in place, and prevents all small screws, &c., from falling off; I use plain wall paper that has a white back; just where I take my work apart I use (over the other) letter paper without ruling, when I can get it; my bench cover thus will, except where I take the work apart, look neat and clean for nearly two months; should not think anything of it, only that every traveler or agent remarks on the neatness of my work-bench. BERT.

Mr. Isochronal returned thanks in behalf of Excelsior, for the silver oiling wire, which was made as directed by Excelsior in his book, and mounted in a finely finished pearl handle. Excelsior was constantly receiving similar tokens of esteem from his admirers everywhere, and they might all be assured that he fully appreciated their kindly feelings, and was pleased to know that his efforts to inform the trade met with such general favor, and were so generally studied and followed, as indeed, they ought to be, for they were always carefully considered and thoroughly trustworthy. As to covering the whole bench with white paper, he thought it had rather too glaring effect on the eyes. His own bench he had painted a yellow or cream color, and only used white paper where he did his work and under the glass covers. It did not look quite so neat, of course, as if of a spotless white, but he had found that the latter, on a bright sunny day, gave a glaring light that was painful and injurious.

## GLASS LATHE COVER.

*To Secretary of Horological Club :*

O. O. G., in August number, inquired for information regarding a glass lathe cover.

I have one I made about a year ago, which I think is about as good as can be, and at the same time is very cheaply and easily made, and I think more convenient, less liable to be broken, and looks better for the purpose than the glass clock shade referred to in Mr. Clerkenwell's answer to above inquiry. I first took a measurement of the height and length of my lathe and the width I wished to cover on my bench, I then had five square plates of double strength glass, cut of such sizes as would make a box when placed together, of the proportions I wished; I then took strips of linen cloth  $\frac{3}{4}$  inch wide, dipped in glue, and pasted over the corners of the box while I held the several pieces in their proper position. As soon as the glue was hard I had a strong box or cover for the lathe, but to add to its strength I filled the corners all around, inside, opposite to the linen, with putty; I then pasted gilt paper over the cloth, to cover it and give the job a good appearance; I liked the lathe cover so well that shortly afterwards I made another similar cover for my engraving machine, which I still use and would not be without for ten times its cost.

J. W. ERNEST.

Mr. Horologer thought there would be some difficulty about the glue sticking to the glass, unless the ends of the side strips were passed down under the bottom edge and up inside, at the corners. When hard this would form a stiff casing on both sides of the glass. The side strips should also lap on the top strips, to glue them fast together; then the putty inside would make it solid.

## LATHE WORK—TESTING THE THICKNESS OF PLATING, ROUNDING UP CONES.

*Secretary of Horological Club :*

I have been waiting for a clear and practical description of the best way to do thorough work, or work equal to a good class of new work, on the turns and pivoting lathe. Also the best way to test gold or silver-plated goods, to judge of the thickness of plating, etc. Don't be afraid to make the above too plain. Also I would like to know if any American firm have taken up the making of the rounding cones, I feel satisfied that if they should, and make them good, as soon as their merits

were known they would command ready sale, for it is something that I have long felt the need of—a tool that would admit of slight alterations, being made in the pitch of the teeth of wheels of watches.

AN ENQUIRER.

Mr. Clerkenwell said that "Enquirer" was only one out of many who were in hopes that Excelsior would give us a series of articles on Lathe work, on the completion of the present series of Practical Hints. If he could be induced to take up that subject, and treat it in his usual practical and thorough way, we should have another matchless treatise on a subject of general interest. But it was a subject which could not be properly attended to within the limits of our proceedings, as it would require our entire space in the CIRCULAR for many months, to do it any kind of justice.

The only way of testing the thickness of plating that he knew of, was to put on a drop of nitric acid for silver, and of aqua regia for gold, and see how long it took to eat through to the base metal beneath. This was merely a way of comparing the thickness of different plates, and not of telling their real thickness. It was a good deal on the order of scraping it, the thicker the plating the longer it would take to scrape through it. One could tell the difference between a very thin and a very thick plating by cutting through it with the graver, and examining the wall of the cut with a strong eye glass. These ways were a little better than guessing at it, and that was about all. In electro-plating the thickness of the plating can be accurately determined by weighing the articles before and after plating, knowing the amount of silver or gold deposited, and the surface of the articles, the thickness of the coating could be computed.

As for the rounding-up cones, he believed they were not made in this country, although he thought, with our correspondent, that there would be a large demand for them if well made and sold at any reasonable price. In speaking of their changing the "pitch" of the teeth, Enquirer probably meant changing their shapes. The only way to change the pitch of a finished wheel is to make it larger or smaller, *i. e.*, change the diameter of its pitch circle. The rounding-up cones could make the pitch a trifle smaller by extending the curves of the points further down on the teeth, but they could not make the pitch greater. Their object was not to change the pitch of wheels, but to change the shapes of the points, make the points all alike, and correct any unevenness in the roundness of the wheel or the spacing of the teeth. Enquirer could get them imported to order by many of our New York houses, if he wanted a set.

#### ENGRAVING MACHINE.

*Secretary of Horological Club :*

I want to get myself an engraving machine. Please to inform me, through the JEWELERS' CIRCULAR, which is the best, and where they can be obtained, and oblige  
J. W. HUBER.

Mr. Clerkenwell stated that Guerrant's engraving machine, advertised in the CIRCULAR, is a good one, and does a great variety of work. It will probably meet Mr. Huber's wants.

#### SUBSTITUTE FOR KNURLS—CHANGING MAIN WHEEL DEPTHING— RUNNING THE TRAIN DRY.

*Secretary of Horological Club :*

A substitute for knurls is found in Bastard files. The head to be knurled is fixed on a tap or something similar, which is held in the pin vise. The head is drawn *across* the file back and forwards, and turned slowly with moderate pressure, either straight or diagonal, or double diagonal creases may be cut in this way. I made an excellent circular saw and set the teeth in this way.

The method of changing the depthing of main wheel, as described by a correspondent in the June number of the CIRCULAR, is apt to break the bridge at the ratchet sink. My way is to remove the arbor nut and barrel, then lay the bridge on the anvil bottom up and stretch the bridge on the front side, on each side of the ratchet cap (which does not rest on the anvil), with the pene of the hammer, which will make the bridge belly out on the front side, and increase the depthing. To decrease it, stretch it on the back side. At first sight

it may be thought that this will make the steady pin too far apart for the teales, but in two years I have not found a case in which it did. As the edges of these bridges are generally not gilded, any hammer marks may be removed by filing with a fine file; if any remain on the back, under the ratchet catch spring, they must be removed, or they may interfere with the action of the click. Mr. Excelsior advises one thing, which I consider dangerous, having had a couple of cases where it made me trouble before I discovered the cause. It is in running a watch train before oiling, to see if it is all right; for if the train is run ever so little with the pivots dry, they are apt to cut and clog. The preventive is obvious.  
F. W. H.

Mr. H. sent a sample head, which was quite sharply and deeply cut. A sample bridge, altered by his method of changing the main wheel depthing, was also enclosed. While this method would no doubt change the depthing, as Mr. H. claims, it is certain that it could not be done without showing marks on the outside, which a workman should avoid, of all things. The sample bridge showed these marks plainly, by the flattening down of the frosted gilding, making it smooth and polished where it rested on the anvil. Possibly, if the whole of the gilding was smooth and polished, the operation could be performed so as not to be seen, but not with the ordinary gilding.

As to running the train without oil, the speaker said he did not recollect that Excelsior had recommended to do any more than to just test the freedom of the parts, etc., before oiling. But if that would cut and clog the pivots, the jewels were certainly not in a fit condition to leave in the watch. If they were so rough as that, they ought to have their holes smoothed and polished, or else be knocked out entirely, and properly finished holes be put in their places. Excelsior was very particular in insisting that all jewels should be sound and perfectly polished. No jewel which would cut the pivot and clog, even when running without oil, could be called polished, or even decently smooth. Putting on oil would hardly prevent such rough surfaces from cutting. He thought that Mr. H. must either have mistaken the cause of the clogging he mentioned, or else had failed to examine very closely into the finish of the jewels while cleaning the watch. With so good a workman as Mr. H. was, such carelessness was not likely, but the former supposition was the more probable one.

#### TABLE AND MEAN TIME—EXCELSIOR'S BOOK.

*Secretary of Horological Club :*

I wish to obtain a list giving the difference between mean and solar time for each day of the year, in minutes and seconds. Can any one of your honorable body inform me where such a list can be obtained, or a key whereby one may be prepared? Also, where can I obtain a copy of "Excelsior's Book," and what is its cost? Trusting this may have a hearing in your next discussion, I am very respectfully,  
CROWN TOP.

Mr. Regulator said that there were numerous tables published giving the difference between mean and solar time, but contain frequent mistakes in the figures. The only reliable tables he knew of were to be found in the Nautical Almanac, sold by John Bliss & Co., of this city. He did not know the present price of it. Excelsior's book was published by D. H. Hopkinson, Esq., publisher of the JEWELERS' CIRCULAR, and sent postpaid on receipt of \$3.50, and is well worth the money to any workman who wishes to understand the higher branches of his calling and do good work.

#### A LIGHTER COMPENSATION BALANCE AGAIN.

*To the Secretary of the Horological Club :*

I thank you for the notice which you was pleased to take of my communication concerning a protected balance. My reasons for a lighter balance are good and weighty, such as commend themselves to every experienced watchmaker, and I fail to discover anything in what Mr. Isochronal has said to militate against them. I am far from believing that absolute perfection has been obtained in the plan and construction of even the best watch of the best maker on the footstool, or that the introduction of a lighter balance would necessitate the remodelling of the entire train. Let us suppose that by the use of a

lighter balance, we make use of a thinner mainspring, one admitting of six or eight revolutions of the barrel (I have one now operating in a watch admitting of nine revolutions), it is evident, that with such a spring restricted to three or four revolutions in active use, far greater uniformity of draft would be secured, while the thin spring would be less liable to break, and do little or no damage if it should. I think that Mr. L., on reflection, will hardly risk his reputation as a watchmaker on the statement "*that a lighter balance would render good performance impossible, necessitate the reconstruction of the entire train, and be a hundred times worse than the evil it was designed to cure,*" at any rate, I am willing to submit it to the whole body of watchmakers who read the JEWELERS' CIRCULAR, as a jury, and will abide their verdict. I have not had the pleasure of a perusal of Excelsior's remarks on Compensation, Isochronism, &c., and have thus lost much; but I have learned something from my *own* experience of more than fifty years, which, though I have no knowledge to boast of, may partially compensate the loss.

D. B.

Mr. F. proposes a balance with a very thin laminated rim with a second rim of steel, uncut, outside of the former, for its protection in handling. &c. He seems to think there is no reason why the rim of the ordinary compensation balance is made so thick, and so many and so heavy screws used, except the notion of the maker. He would dispense with all the screws, "except those needed for the compensation," and make the rim very thin, in order to make the balance lighter. He must make it very thin, indeed, if his *two* rims are much lighter than the usual *one*.

Mr. Isochronal feared that the gentleman's knowledge of the philosophy of the compensation balance was rather limited, and as the meaning of the former observations on this subject appeared to have been misapprehended, he would explain it again: First, then, there is a certain proportional thickness and breadth of the balance rim, which is found to act most uniformly, and that shape of rim must be used, or we cannot get so perfect a compensation for heat and cold. Therefore a rim which is a good deal thinner and lighter cannot be permitted for *any* reason, except in watches of low grade, in which the compensation is a matter of little importance, or is not even thought of at all. In such a watch, the weight of the balance can be reduced at pleasure, provided it has substance enough left to properly utilize the impulse and make a satisfactory vibration. But in a good watch, that is to be compensated for heat and cold, we must have a balance rim that can expand and contract in the right manner, so as to just correspond to the varying effects of different temperatures upon the balance itself, upon the elasticity of the hair-spring, &c., and no more nor less. It must be such as to give to that precise action, no matter how thick or heavy it may be. Having a rim that expands and contracts in the right *proportions*, it must then be supplied with screws heavy enough to produce the correct *amount* of compensational effect. If that balance is thought too heavy, the right course is to use a *smaller* balance, in which the thickness of the rim, weight of the screws, &c., will be proportionately less; instead of making the compensating rim thinner, using lighter screws, &c. But if the first *size* of balance is used, it should be made substantially as described. Then the hair-spring must be heavy enough for it, the mainspring stiff enough to give it a proper vibration, and the train must be suitable for that motor and moderator. A light balance and light mainspring need a lighter train, finer pivots, &c., than a heavy balance and a stiff mainspring. All this would seem to be perfectly plain.

An unusually light balance, such as Mr. F. advocates, would not be suitable for a movement adapted for the ordinary expansion balance. The hair-spring must be weaker, the escapement more delicate, the train lighter, and pivots finer, and mainspring weaker. It would require a change from one end of the movement to the other. And finally, a laminated rim so thin as his, would then be entirely useless for compensation, and in all probability be greatly inferior to an uncut-rim balance. The rate of the watch would be improved by omit-

ing the interior laminated rim, and using only the solid steel rim of suitable weight. If Mr. F. will inquire of any competent adjuster, or post himself by reading the existing literature on the subject, he will see that my former statements, as well as the present, are fully justified by the facts.

He will also find that Excelsior's "remarks" on compensation and isochronism, occupy a considerable portion of a good sized book, and give information that no one man's experience, for fifty nor five hundred years could gain. It gives the results of the studies, experiments and experiences of hundreds of the best watchmakers who have ever lived, as well as eminent philosophers and mechanists for generations past. And when he shall have mastered its contents, he will see that any amount of "experience" in the ordinary course of watch repairing, would teach a man very little on that subject, although when learned he would find it wonderfully useful in his work.

### Bog Oak Ornaments.

A GENTLEMAN, connected with the manufacture of ornaments from Irish bog oak, gives to *Land and Water* some interesting particulars with regard to the history of that industry. When taken up this bog oak is perfectly black from the action of the peat or bog water. It is very rarely obtained in a sound state, and in most cases the outer portions of the tree or log are rotted, and useless even for fuel. When laid up for use, care must be taken that it is not placed in the open air, lest it may, from the sun's rays, become open and shattered into chips from end to end. To preserve it, it must be put into some cool place, and left to dry gradually, and when properly seasoned it must be cut in lengths from two to four feet, and these lengths be split again, and the sound parts be removed from the unsound.

It takes from four to six years to season some specimens, as in many instances the wood is found at a depth of eight and sometimes ten feet under the surface. When properly seasoned, any portion requiring to be glued becomes hard as stone, and is firmer and less liable to give way than any portion of the manufactured article. The finish is not quite perfect until the article has been for some time in use, and the longer, the finer the article seems to be, no matter whether used as a personal or table ornament. The men employed are all, without exception, self-taught; each one makes his own tools, and will not take any apprentices; and each person has a peculiar taste for a certain class of ornaments, which he follows, and to which he is left to produce the best specimens he can. There are also jewelers who mount and embellish the ornaments with gold and silver, and with rare and most brilliant Irish gems, such as the Kerry Irish diamond, the emerald, the garnet, amethyst, beryl, aquamarine and Donegal pebble. The Celtic ornaments are generally studded with the above native gems; they are beautiful, and most artistically executed. The designs embrace some thousands, and all of them are both classic and historically illustrative of Irish antiquities. Extensive deposits of bog oak and other buried woods have been discovered in Germany.

### Keramic Insanity.

AT a recent sale in London a pair of china jars, enameled with birds and flowers—sweet, pretty things—brought \$2,221. But while the Ceramic craze still continues, though that is moderating, it is gratifying to note that some of the absurd collecting manias are subsiding. At a coin and medal sale in Boston this week, the prices were very low, a Charles II. farthing bringing only 50 cents, a Charles I. farthing 30 cents, a half-penny of 1775, 5 cents, and other and rarer coins and medals were knocked down at insignificant prices. Curious collections of certain kinds in museums, libraries and public galleries are valuable, especially as illustrative of periods and history, but individual collections, even where the collector has a fortune with which to gratify his craving, are always incomplete, imperfect and unsatisfactory. Hence, the desire to collect becomes an insatiable mania, it never is and never can be satisfied. Those who collect on a smaller scale have milder attacks of the same insanity, but no doubt suffer proportionately.—*Boston Transcript*.

## The Jewelers' League.

We devote this column to the interests of the League and its membership. Letters or inquiries pertinent to its business or purposes, and which might interest the trade or inquirers, will be herein answered. Address *Jewelers' League*, Box 4001, P. O. New York, or the office of THE CIRCULAR.

The regular meeting of the Executive Committee was held on the 7th inst., at which the following named gentlemen were admitted to membership: George B. Osborn, with Hodenpyl, Tunison & Co., Moses Bonn, Allegheny, Pa.; Alvin G. Clark, with E. E. Isbell & Co. Cincinnati; and Clarence H. R. Way, of S. Way & Son, Hempstead N. Y.

Six applications were laid over for further inquiry, or referred back to the applicants on account of irregularities or omissions; the committee are continually annoyed by the carelessness of applicants in filling out the blanks, necessitating a delay of at least a month in their admission, and double labor both by the Secretary and the committee, neither of whose duties are any of the lightest. It will be to the interest of all concerned if as much care be taken in the preparation of the application as should be taken in any document which becomes, after death, the basis and conditions of the payment of thousands of dollars to a wife or children. The Committee cannot accept unless the application is beyond cavil.

The Special Committee, consisting of Messrs. Dyer Brainerd, D. H. Hopkinson, Geo. W. Washburn, L. T. Best and A. K. Shiebler appointed by the President for the purpose of judging of, and selecting from, the several designs gratuitously submitted by members and others for a membership badge, rendered their report at this meeting. We quote "Your committee to whom was referred the duty of selecting a design for a badge for our society, beg leave to report: that many designs by various artists were submitted to us, all of which were excellent and reflect great credit upon the artists who presented them. From those presented, your Committee would recommend the adoption of the one hereto attached." This design represents a complete balance wheel (the parts usually made of brass and steel to be represented respectively by gold and platinum). Within the periphery or "rim" and on the front of the "balance wheel arm" is a bared, muscular arm made of gold, the hand grasping a jeweler's or silversmith's hammer, made of platinum; on the outside of the "rim" are "balance wheel screws," made of gold; the *ensemble* very completely representing the combined watch, silverware and jewelry industries; on front of the "rim" of the wheel, around the upper half "Jewelers' League" and at the bottom "N. Y.," the letters in gold, blue enameled. The size to be seven-eighths of an inch in diameter, outside measurement.

This design, so beautifully and simply typifying the kindred trades which the League represents, was, when the blank envelopes accompanying the designs were opened, found to have been furnished by Mr. John Frick, of Mass., John Frick & Co., Nos. 21 & 23 Maiden Lane, N. Y. Mr. Frick, although not a member at present, has very appropriately filed his application for membership, on the principle, probably, that a doctor should take his own medicine. The designer should be able to wear the badge he designs. He has kindly volunteered to make, at his own expense, a model of the badge, which will be placed in the keeping of the Secretary.

The Special Committee return their thanks to the artists who have so kindly aided them by furnishing so many beautiful designs, and the Executive Committee join them in appreciating the kindness which prompted so many responses to their request, as well as the gentle humor with which one of the designs was so completely saturated, that we may take occasion to refer to it further in our next issue.

The report of the Special Committee and their recommendation, jointly, with the report of the Executive Committee, will be presented to the League at the annual meeting in January next, with the recommendation that the design selected be the authorized badge of the League.

The membership now numbers 522.

## Canadian Precious Stones.

NEAR the corner of St. Lambert's Hill, in St. James, Montreal, is a small workshop, not particularly inviting in appearance, with a few blocks of stone in the window, of no apparent value. Nine out of ten persons would pass it unnoticed, and yet it contains a museum of wonderful interest to the naturalist and of much profitable instruction to the general student. The shop is the workshop of a lapidary, Mr. Samuel R. F. Dick, than whom a more competent authority upon the subject of jewels does not exist.

"Are there many precious stones found in Canada, Mr. Dick?" was the first question put by your correspondent.

"There are a great many; but it is surprising to see how little people know concerning them. We have in Canada as beautiful specimens of their kind as you will find anywhere. Now, you perhaps, do not know that there are such stones as Quebec diamonds, which are really rock crystals. I have one specimen here, which I will show you," and the speaker produced a beautiful crystal of intense brilliancy and whiteness. "There are some which an ordinary person could not tell at first from a diamond. The one you now see," he continued, "is just as it was found—it has never been cut; most of them have the same appearance."

"What other stones are there peculiar to Canada?"

"The Ottawa district contains quite a number of them. Here, you observe, is a specimen of Labradorite, so called because it was first found on the coast of Labrador by the Moravian missionaries sixty years ago."

The sample submitted was a common-looking stone of a dull, grayish color, but when held in certain positions, exhibited a beautiful opalescent luster, of a deep rich blue, far superior to any manufactured shade it is possible to find. At certain times all the colors of the rainbow are reflected upon its surface.

"Very little is known of this beautiful stone," observed the lapidary. "I believe the Prince of Wales had a set of jewelry made from it—so I have been told. It is strange so little should be known of this stone. If fashion were to introduce it, society would soon become charmed, for, as you see, it is very lovely."

"Where are they found?"

"They are generally enclosed in boulders, and great care is required in taking them out, as they are liable to crack. Garnets are also found in the Ottawa district of very fair quality, but small in size. Zircon, a stone about which very little is known, except that it has the quality of double refraction in a high degree, is also found in this district. As you will see, it is a four-sided prism, which when polished, gives a beautiful red surface. Next, there are green sapphires found in tolerably large numbers. They are not very valuable, however, although exceedingly hard. Pearls have also been found near the Bay Chaleur, both large in size and very good in quality. Quite a number, I believe, have been found near the Resti gouche."

"Are there many agates found in the Dominion?"

"Those are peculiar to Lake Superior, and consist of two kinds—gray and red; each is similar in its character to the onyx. We have also the chalcedony or red carnelian. Some of the most delicate shades of color are contained in them, as you can see in those samples I have. The chlorastrolite (from *chlor* green, and *astro*, the heaven), very much resembling the malachite, are also found in Lake Superior."

"Do you think there are sufficient precious stones in Canada for exportation?"

"There are plenty, and our native agates are equal to any I have seen anywhere. About twelve months since I made a bracelet of Canadian agates set in gold, and they were equal in appearance and polish to any stone used for the same purpose."

A. B.

# Jewelers' Circular and Horological Review.

VOLUME X.

NEW YORK, DECEMBER, 1879.

No. 11

## THE JEWELERS' CIRCULAR AND HOROLOGICAL REVIEW,



*The recognized organ of the Trade, and the official representative of the Jewelers' League and the Watchmakers' and Jewelers' Guild of the U. S.*

A Monthly Journal devoted to the interests of Watchmakers, Jewelers, Silver-smiths, Electro-plate Manufacturers, and those engaged in the kindred branches of art industry.

### SUBSCRIPTION:

To all parts of the United States, Canada, Great Britain and the West Indies,  
**\$2.00 Per Annum; Postage paid.**

To France, Switzerland, Germany, Mexico, the Republics of South America, and Australia, \$2.50 per annum. Postage paid.

 All communications should be addressed to D. H. HOPKINSON, 42 Nassau Street, New York.  Advertising rates made known on application.

### Responsibility of Retail Dealers.

WE have repeatedly called the attention of the trade to a dangerous class of goods that is being hawked about the country. These goods are usually close imitations of honest made goods, and are fair and good to look upon, but are rotten at the core. They are conceived in fraud and brought forth with intent to deceive. They are made in the flimsiest manner of degraded metal, and their intrinsic value is almost nothing. The chief object of the makers seems to be to cover the greatest possible surface of base metal with the least amount of pure gold. The product thus obtained is sold as 10 or 14 karat gold, according to the credulity of the would-be purchaser. Scarcely a day passes that we do not receive complaints from dealers as to the manner in which they have been victimized by these goods, and their denunciations of the makers pass all bounds. They complain that their credit is injured among their customers, who trust to their integrity when they buy from them. Of course, these degraded goods do not give satisfaction, and the retailer is taken to task by his customer.

It is well enough for the retailers to denounce the manufacturers of this class of goods, but are they themselves guiltless? Manufacturers would not make these goods unless there was a sale for them among the retailers. It is absurd to suppose that they do not, as a rule, know the character of the goods offered them; the price charged is, of itself, proof positive that they are not of the quality they are represented to be, and the retailer buys them because they are cheap, offering a large margin of profit, with a full consciousness that they are not of the value represented. When goods purporting to be 14 karats fine are offered for a less price than the same amount of gold would be worth by weight, the dealer knows full well that they are not 14 karats fine. But they do not care to be too inquisitive; they get the goods at a low price, and can sell them as 14 karat goods, for their customers are not experts, and trust to the integrity of the dealer to protect them from fraud. If no complaint is made subsequently, the dealer congratulates himself on the deceit that has been so profitable to him, but if there is a complaint, the dealer throws the blame on the manufacturer.

Frequently when buying these goods the dealer, to satisfy his conscience, asks the traveler how they compare with the goods of Brown

& Robinson, manufacturers whose goods have a standard value. Of course, the glib salesman assures him that they are just as good as Brown & Robinson's goods and 25 per cent. cheaper. This satisfies the dealer, who keeps that extra 25 per cent. profit in view, and he consents to become a partner in the scheme for robbing the public. It is all very well, gentlemen, for you to complain of the manufacturers, but you are also responsible. You buy these goods with your eyes open, well knowing that they are degraded and fraudulent, and, in selling them to the public you stake *your* reputation, not the manufacturers, upon their integrity. Your customers look upon you as an expert in jewelry, and they trust to *your* judgment and *your* honor to protect them from swindlers. Without your direct aid and connivance these goods would not be made. You furnish the market, and your reputations furnish the makers part of their stock in trade. Of course you do not, in giving your orders, ask for imitation 14 karat goods, made of metal that will not assay more than 6 or 8 karats fine, but you buy these goods of the manufacturers at low rates, knowing that 14 karat goods cannot be furnished at the prices you pay. You thus become *particeps criminis* in the perpetration of a fraud. You are willing to take the chances of occasional detection, having the manufacturers as a scapegoat, for the sake of the profit you can make when not detected. You may escape legal responsibility in this way, but your consciences must be of the most elastic description if they do not accuse you of complicity.

But the injury thus perpetrated in the sale of degraded goods is not confined solely to the public. The manufacturers of the better grades suffer to a very great extent. Brown & Robinson, who are noted for the manufacture of rich and artistic goods, of standard value, spend large sums of money in the production of new and original designs, employing the best artists to make the designs, and paying high wages to skillful workmen to reproduce them in fine gold goods. No sooner are they placed on the market than they are imitated in debased metal by some unprincipled manufacturer, made in close imitation of the genuine, and sold to these complaisant retailers at a low price, and by these they are palmed off upon the public as the genuine article. By this means the trade is not only brought into disrepute, but those manufacturers who are seeking to maintain its honor and integrity, by producing goods of genuine merit, are thwarted in their enterprise, robbed of the just reward of their labors, and deterred from prosecuting their industry. Every manufacturer who spends money and time in producing new designs in fine goods, is menaced with this kind of robbery, which could not be perpetrated without the connivance of the retail dealers, who aid and abet the pillaging manufacturers.

An amusing illustration of the quality of this debased class of goods recently occurred in this city. A manufacturer of cheap neck chains sent to a chemist for some acid to eat away the copper wire used in the manufacture of chains to secure elasticity. The acid was sent, but the manufacturer complained that it was not satisfactory. On investigation, the chemist found that the metal of which the chain was composed was so degraded that the acid had not only eaten away the copper wire but the chain itself! Acting on the base metal, it had entirely disintegrated the chain, and there was nothing left but an infinitesimal portion of crumbling gold. The compound would

not assay above 6 or 8 karats, and was not entitled to be classified as wrought gold.

Retail dealers cannot shake off their responsibility in this matter of palming off degraded goods for genuine. They furnish the medium for their sale; they are experts enough to know their quality, and if they cannot detect the fraud through their experience, they are made aware of it by the prices charged. They deliberately sell as gold articles they have paid for as degraded goods. They may avoid the legal consequences attached to the perpetration of the fraud, but they are none the less morally guilty. The manufacturers say the retail dealers want such goods, so we make them. If there was no demand there would be no supply. Gentlemen, can you afford to assume this responsibility? Can you afford to jeopardize your honor, your integrity and your reputations for the paltry profit these goods afford you? You say that if you don't sell them some one else will. That is the rumseller's excuse, but will it satisfy your consciences? If the retailers will refuse to buy these goods, they will soon be driven from the market, and goods of fine standard quality will take their place. We ask the retail dealers to consider this matter, and to devote henceforth their energies and talents to the creation of an appreciation and a demand for the better grades of goods.

### The Closing Volume.

THE January issue of THE CIRCULAR will bring to a close its tenth volume, and with this, the last number of the closing year, it will not be out of place to say a few words about ourselves. Throughout its entire career, THE CIRCULAR has been devoted to the best interests of the jewelry trade, but never have its efforts in that direction been more conspicuous than during the past year. In glancing over its columns we find them replete, not only with valuable treatises upon the technicalities of the trade, but teeming with articles denouncing the fraud and trickery that has crept into it, and seeking, by earnest and timely words, to elevate the moral standard of manufacturers, jobbers and retailers. In its unrelenting warfare upon dishonorable practices there has been no intermission, while its efforts to maintain the honor and integrity of the jewelry trade have been unremitting. Another course, winking at frauds, and playing a neutral part regarding trickery and chicanery, would have been more profitable in a pecuniary sense, but this could only have been maintained at a sacrifice of THE CIRCULAR'S independence and influence, and the individual honor of its proprietor. We have chosen our course, and are to-day thankful that our pockets are not filled with ill-gotten gains, and have the proud consciousness that the integrity of THE CIRCULAR is unassailable. To this fact is due the influence it exerts in the trade, and the many laudatory commendations we receive from those who, like ourselves, are devoted to the elevation of the trade. The editorial opinions of THE CIRCULAR, it is well known, are not purchasable, and no price that could be named could purchase its commendation of undeserving goods. While we are opposed to fulsome puffery, we do not hesitate to call attention to manufactures that are deserving, and by thus countenancing that which is good, lend our influence to driving out that which is bad. We are happy to say that our efforts in behalf of the trade have not only been appreciated by the trade itself, but have brought us highly complimentary notices from the press of this country and Europe. Even the conservative London *Times* speaks of THE CIRCULAR as "the most intelligently conducted trade journal published in any country."

THE CIRCULAR is a devoted friend of the retail dealers in jewelry, and a bitter opponent of everything calculated to embarrass them. Recognizing that the retailer is the necessary agent through whom the manufacturers and their patrons, the public, are to be brought into business relations, we have earnestly sought to impress upon the manufacturers the necessity of maintaining the rights of the retailers from the encroachments of a class of retailing jobbers, whose whole business career is one of deceit and misrepresentation. Our

efforts in this direction have been fully recognized by the various State Associations of retailers, which have chosen THE CIRCULAR as their official paper. To say that we are proud of our paper and of the influence it exerts both within and without the trade, is not an exhibition of self-complacency, but is a tribute to the sterling qualities of those men who are fighting the good fight for the best interests of the jewelry trade, and who have stood loyally beside us in our efforts for its advancement, encouraging us by word and deed. It is, however, a matter of self-congratulation when we assert that THE CIRCULAR is the handsomest and best printed trade paper in the country. In this respect we claim to have kept pace with the demands of a trade renowned through all time for its artistic skill and aesthetic taste.

The new year comes upon us with a promise of a degree of prosperity that the trade has not known for many years. Already the era of good times is upon us; all branches of industry have felt its welcome effects, and the jewelry trade has not been forgotten. The volume of business transacted during the past three or four months has been double that of the corresponding periods of the previous five or six years. Present indications point to a prosperous business during 1880. We hope THE CIRCULAR may be permitted to share with the trade an improvement in business, and to this end we invite the co-operation of our numerous friends. We promise nothing for the future, except that we will steadily and steadfastly pursue the path we have marked out for ourselves, and, as an indication of what that is, we point to our past record. With best wishes for the success of every legitimate member of the trade, we greet the coming year with confident expectations of better times for us all.

### The Registration of Trade Marks.

VERY much undue excitement has been occasioned in commercial circles by a decision of the Supreme Court of the United States, rendered November 17, relative to trade marks. Three cases for infringement had been carried up to the court, the defence claiming that the law of 1870 and 1876, providing for the registration of trade marks, was unconstitutional. In support of the law counsel argued that the clause of the Constitution that gave Congress the power to legislate in behalf of copyrights and patents conferred, also, the power to provide for the protection of trade marks; it was also contended that trade marks were essential to commerce, and that the Constitution specially gives Congress the power to legislate for the regulation of commerce between the States. In rendering its decision, the court held that a trade mark was not an invention entitling its owner to the protection afforded by a patent or a copyright. In reference to the other point claimed, the court held that while trade marks might be an essential element of commerce, they did not relate specially to commerce between the States, but were also used for commerce within a State. Hence, it was beyond the power of Congress to legislate upon a subject that might bring it in conflict with State legislation. The court, therefore, held the registration law unconstitutional.

When this decision was first made public, there was great consternation in commercial circles, as it was deemed to do away with all protection to trade marks, which, if true, would have been a serious blow to honest trade. But this is not true. The principal advantage conferred by the law in question was the convenience of registration. By such registration it was rendered easy to ascertain whether any given design had been previously claimed. The certificate of registration was also received by the United States courts as *prima facie* evidence of ownership. Under the law, suits for infringements might be commenced in the United States courts instead of State courts. But the law really gave no more protection to trade marks than is conferred by the common law or by statute in some of the States. A trade mark is recognized at common law as property, and one who appropriates the trade mark of another may be prosecuted in the State courts. If the owner and infringer are residents



of different states, then suits may be brought in the United States Courts. Some of the states have special statutes on the subject, rendering the prosecution of infringers easier than it is under the common law. But all laws bearing on the subject recognize property in the trade marks, and accord protection to their owners. The registration law simplified the methods of obtaining recognition of trade marks; it gave no protection to them, however, that was not previously afforded by existing laws. Registration has proved to be a great convenience, and is not to be abandoned because of this adverse decision of the Supreme Court. The Patent Office will continue to register trade marks and issue certificates, and will seek to remedy existing defects by additional legislation.

When the law was passed in 1876, it was not satisfactory to the Senate. It had passed the House, and when brought to the Senate a committee of conference was appointed to adjust points of difference between the House and Senate. In reporting, the Senate Committee stated that the conference had not been satisfactory, but recommended the passage of the bill as being the best they could get, and would be of some advantage to commerce. Senator Conkling took this view of it, and voted for its passage, not because he regarded it as being adequate, but because he deemed it better than nothing. It will be seen that Congress anticipated further legislation upon the subject; the decision of the Supreme Court will simply make such legislation imperatively necessary. There is little doubt but the present Congress will take the matter up, and the decision just rendered will enable the members to perfect a law which will stand the test of judicial investigation.

The time is near at hand when Congress will be called upon to define more clearly what is meant by the term commerce. It is upon that definition that hangs the power of Congress to regulate commercial intercourse between the states. When the Constitution was framed, the commerce of the country was confined mainly to a few large seaport towns, and the framers of that document had no conception of the development that was to occur in this country. Railroads, steamboats and the telegraph have obliterated state lines, and New York to-day communicates as quickly with San Francisco as she could with Philadelphia a hundred years ago. The merchants of that day were content to do a purely local trade, which might well be regulated by the legislatures of the states of which they were residents; but the merchant of to-day over-leaps state boundaries, and traffics with the whole world. His business does not lie within the jurisdiction of any one state legislature, and can only be regulated by that power that is above all states—the Congress of the United States. The Constitution confers upon that body the power to regulate commerce between the states, and what Congress will recognize as coming within its purview is yet to be declared. The Supreme Court has heretofore held that, under the clause of the Constitution, Congress had the right to consider all the factors that go to make up what we call commerce. Upon the principle that the greater includes the less, Congress having the power to regulate commerce, must unquestionably have the power to regulate trade marks, which are essential to the protection of commerce. It is in accordance with this view that THE CIRCULAR has maintained that Congress has the right to prescribe standards of value for wrought gold, designating the degree to which pure gold may be alloyed and still be held to be gold. The point has also been extensively argued of late, that as insurance constitutes an important element of commerce, Congress should legislate for its supervision, thus relieving the companies from the expensive and useless supervision of thirty-eight different states. In fact, commerce in various phases, is appealing to Congress for protection from state authority, and for facilities that state legislatures cannot grant. The question has got to be met at no distant day, and Congress forced to give an interpretation to that clause of the Constitution whence alone it derives its power to regulate commerce between the states.

The recent decision of the Supreme Court in no way interferes

with any rights that the owner of a trade mark may have heretofore acquired. Those rights are protected by the common law, which also provides the means of redress in case they are infringed upon. The decision over-rides no law except that providing for the registration of trade marks. That was more a matter of convenience than of protection. All the trade marks by which our watchmakers and jewelers have heretofore protected their goods are just as valuable to-day as they were before this decision was rendered. No rights have been abrogated and no means of redress set aside. As the registration law, however, was a convenience, and tended to facilitate commercial transactions, it is to be hoped that Congress will re-enact the law with such ironclad amendments as will secure its recognition by the courts.

### The Jewelers' League.

THE Jewelers' League is an organization deserving of the confidence of all persons identified with the jewelry trade. It is designed as a benevolent institution, securing benefits to its members equivalent to life insurance. It has no expensive officers, but is managed by successful business men in the trade, who devote their time and services gratuitously. Its membership is confined exclusively to the trade, and the honor of the trade is consequently pledged to the fulfillment of its promises. The League has been very fortunate thus far, having had but one death claim to pay since its organization. The working men in the business cannot do a better or wiser thing than to become members of the League at this time, thus making their families a Christmas present in the nature of life insurance. Men in the health and vigor of youth are apt to give little heed to the future, or to think of the sufferings and privations that would overtake their loved ones should they become a victim to accident or sudden death. It would be a wise provision for every member of the jewelry trade if he were a member of the League, and thus had the assurance that, in the event of his death, his family would receive the benefits conferred by it. Every man, when he takes a wife, pledges his life for her support and protection, yet many die without leaving either support or protection for those they have sworn to cherish. No provident person can avoid contemplating the condition his family would be left in if he were to die suddenly, and he will wisely take some precaution against leaving them a prey to suffering and want. The League offers such protection to members of the trade, and it is a duty incumbent upon every one to secure membership. This is an excellent time to join, and we hope many will avail themselves of it.

THE annual dinner given by the Jewelers' Association, at Delmonico's, on the evening of November 13, was an event the recollection of which will long linger pleasantly in the memory of all who participated. Not only was the dinner most enjoyable in all its parts, but the speeches were full of good sense, wit and humor, while the social elements of the occasion developed much good-fellowship that will ripen into warm friendships that will be life-long. The arrangements for the entertainment were perfect in all respects; the assembly represented men of standing and well known in the trade, and a number of invited guests of prominence in professional and social circles. This Association exercises an immense power for good in the trade, and, although it does not make much of a parade of its good work, its influence is felt in every branch of the jewelry trade. Its roll of membership embraces the names of many prominent men in the trade, who, through their individual exertions and through the agency of the Association, are constantly seeking to promote the welfare and best interests of the business with which they are identified. In other columns is presented a full report of the proceedings at the annual banquet, but it is impossible to convey on paper an adequate idea of the spirit and hearty good-fellowship that prevailed, or to reproduce the remarks made with the *esprit* that added such zest to their delivery.

## The New York Jewelers' Association.

FIFTH ANNUAL BANQUET AT DELMONICO'S, NOV. 13TH, 1879.

THE Jewelers' Association is one of the best known and most influential organization connected with the manufacturing industries of this country. It embraces among its members the leading manufacturers and jobbers, and represents probably a greater aggregate of wealth than any trade association in the United States. The objects of the Association are the promotion of the best interests of the trade in general, and especially the harmonizing of the interests of the manufacturers and jobbers with those of the retail dealers. The Association is composed mainly of the former classes, but these recognize the fact that their success depends upon the prosperity of the retailer, and they consequently seek to promote that prosperity by all legitimate means. The power for good which the Association exercises is recognized throughout the trade.

The Annual Dinner of the Association is regarded as one of the great events of the social season. It is a reunion of practical, energetic, pushing business men, who come together on these occasions with a few invited friends to throw off the cares of business for the time, and devote their attention to the cultivation of better and pleasanter social relations one with another. Here the rivals in business, between whom there is the sharpest competition throughout the year, engendering, sometimes, considerable business bitterness, stretch their legs under the same mahogany, drink their wine together, and forget the business complications that have previously kept them apart. As the wine goes around, and pleasant anecdotes follow humorous stories, and the witty responses to toasts make them shake their sides with laughter, Jones is surprised to find that Smith, his competitor in business, is, after all, a jolly good fellow instead of the unmitigated scoundrel he has been inclined to think him. As the festivities proceed, the cockles of their hearts get warmed up, and, in the spirit of social good fellowship, Jones raises his glass and says, "Smith, my boy, here's to you," and Smith returns the compliment by responding, "Jones, old fellow, I'm looking at you," and drains off a heel tap to a better acquaintance. It is by such social gatherings as these annual dinners that the cares of business are smoothed away, and the rough angles of individuals rounded off till the round peg is made to fit the round hole instead of expending its energies trying to force its way into a square one. Americans have all too few of social events of this character, and the Jewelers' Association performs an act of real and graceful charity when it thus seeks to soften the antagonisms and rivalries that are the necessary outgrowth of a too selfish confinement to one's own business pursuits and a general ignoring of the cares and ambitions of his neighbors.

Previous dinners of the Association have been uniform successes, but that of the 13th of November surpassed all others in its social and entertaining features. Early in the evening the guests assembled in the spacious parlors of Delmonico's, and at the appointed hour—7 o'clock—the Reception Committee marshalled them into the dining hall. Here four tables were spread, and the seats of each guest having been previously designated by a card bearing his name, the assemblage was soon seated. The tables were elegantly decorated with flowers and emblematical pieces, and garnished with an array of table furniture and ornaments that only Delmonico is equal to. All being in their places, the President of the Association, Daniel F. Appleton, called upon the Rev. Otis H. Tiffany to ask a blessing. After the blessing, an invitation was given to "fall to" and partake of the bounteous feast that had been provided. The character of the tempting array was such that no violent urging was necessary, and soon the click of knives and forks, the popping of corks, and the hum of confidential communication were the only sounds heard. That the banquet was an enticing and appetizing one, will be readily surmised from a perusal of the bill of fare, which included all the delicacies of the season, served up in a

style to please the eye and tempt the most dainty appetite. The following is the menu :

MENU.		
HUITRES.		
Consommé Rachel.		Crème d'Artichauts.
HORS D'OEUVRES.		
Varié.	Brissotins a Suprême.	Varié.
RELEVÉS.		
Saumon á la Venitienne.		Filet de Boeuf á la Comfortable.
ENTREES.		
Paupiettes de Disidonneau au Souvenir.		Ris de Veau á la Bernaise.
		Cailles en Caisse.
SORBET.		
		Au Cardinal.
ROTES.		
	Perdreaux and Bécasses.	Salade.
ENTREMETS.		
Petits Pois.	Haricots Verts.	Tomato Sauté.
SUCRES.		
Pouding á la Humboldt.	Chariotte á la Venitienne.	Brisselets á la Chantilly.
GLACES.		
Napolitaine.	Parfait au Café.	Pièces Montés.
	Fruits and Dessert.	

Ample justice was done to the good things above set forth, to which zest was imparted by a generous distribution of the best of wines. The dinner hour was abundantly improved by the partakers of the feast in cultivating each others' acquaintance, and was pleasantly passed in chatty conversation during the several courses. It was admittedly one of the most brilliant assemblages of the season, embracing many solid business men of the city, as well as distinguished members of the bench, of the legal profession, poets, authors, and gentlemen of culture and refinement.

The following is a list of the gentlemen present :

*Members.*—D. F. Appleton, Henry Robbins, E. C. Fitch, L. J. Mulford, M. G. Baldwin, R. N. Peterson, Aaron Carter, Sr., Aug. K. Sloan, Edward Holbrook, W. C. Spencer, Jos. F. Chatellier, Wm. Spence, C. E. Breckenridge, rep. Wilcox Silver Plate Co.; Isaac M. Miller, Jas. W. Miller, D. C. Wilcox, J. G. Bacon, E. F. W. Eisenmann, H. B. Dominick, L. B. Haff, Thos. G. Brown, Charles Magnus, rep. P. Bissinger; C. B. Yale and G. Selden Yale, from Simpson, Hall, Miller & Co.; Charles G. Cook, Chas. D. Stockwell, of Tiffany & Co.; J. C. Aikin, Thos. E. LeBoutillier, C. P. Harris, from Reed & Barton; A. J. G. Hodenpyl, P. T. Tunison, W. H. Guyer, from Waterbury Clock Co.; L. J. Woolley, from Elgin Nat. Watch Co.; Alfred H. Smith, Wm. S. Hedges, Jas. Hedges, David F. Conover, Seth E. Thomas, E. C. Hine, Frank E. Morgan, from New Haven Clock Co.; H. Olmsted.

*Association's Guests.*—Hon. Noah Davis, Hon. Isaac H. Bailey, Hon. Chauncey M. Depew, Hon. Wm. H. Wickham, Rev. Otis H. Tiffany, J. H. Puleston, M. P., Ben. K. Phelps, Dist. Atty., Whitelaw Reid, Edward T. Bartlett, D. H. Hopkinson.

*Members' Guests.*—J. E. Caldwell, Phila.; Henry Ginnel, City; John Gorham, Providence; Joseph Fahys, City; F. Williams, Phila.; Geo. H. Ford, N. Haven; M. W. Galt, Washington; D. C. Dodd, Newark; A. M. Hayes, City, D. H. Buell, Hartford; E. J. Jaccard, St. Louis; Al. E. Paillard, City; Robt. Black, City; G. W. Banks, Phila.; J. T. Howard, Robt. Leving, A. P. Ward, J. E. Robert, City; W. W. Wattles, Pittsburgh; J. T. Bailey, Phila.; H. Gimsig, Phila.; Chas. Macro, Phila.; H. Mollneaux, San Francisco; Jas. H. Welch, G. T. Woglom, N. Y.; Geo. R. Collis, N. Y.

After the dinner had received proper attention, speeches were in order. President Appleton called the company to order, and addressed them as follows :

## ADDRESS OF PRESIDENT APPLETON.

*Fellow Members of the New York Jewelers' Association :*

We are met, as you are aware, to celebrate the Fifth Anniversary of our Society. I congratulate you, and I am sure our guests—these distinguished gentlemen who honor us to-night by their presence—will join in congratulating you upon the much better auspices under which we meet, never before so favorable since the organization of our Society. Last year, in reviewing the condition of the trade and in giving some statistics, I was forced to take a view of affairs, which, however creditable to you and to the prudence and sound principles with which you had managed your business, was, nevertheless, a very gloomy view as to the results in profits of business. Now all this is

changed, and we are indeed in the midst of an assured prosperity, illustrating the truth of the old adage that "All things come to him who waits." I trust that none of this generation will ever again suffer such a severe and long protracted period of depression in our trade, and it is my expectation as well as my hope that the present good times which have been so long coming, will long continue to gladden our hearts. I ought here to state, perhaps, for the information of those of our friends who may not know the aims and objects of our Society, that we are a company of business men, mostly manufacturers, and altogether wholesale dealers, joined together under most rigid and exclusive rules for mutual benefit and protection in our business pursuits. But we are something besides this. We are citizens of the great City of New York and it is our ambition to maintain such a character for integrity, for enterprise and for skill, as shall entitle us, as a craft, to take no mean position among the agencies that contribute to the grandeur and the glory of the great commercial city of which we are so justly proud. I do not intend to continue my remarks much further. I am surrounded by gentlemen whom you are all very anxious to hear. They have come to speak to us, and I shall, therefore, curtail my remarks.

It remains for me now only to perform the sad duty, to speak the names of our honored dead, and I shall ask you to drink first, in silence, and standing, to the memory of Jacques Guedin, our former President, and Frank Taylor, our former Treasurer.

I have before me letters of regret from many gentlemen. I won't delay you by reading their letters. I will simply announce their names: The Hon. Edward Cooper, Mayor of the City of New York; Hon. Clarkson N. Potter; Chief Judge Daly, of the Court of Common Pleas; Hon. Stewart L. Woodford, Hon. Abram S. Hewitt, General Horace Porter, Rev. F. Courtney, Rev. Robert Colyer, Hon. Joseph H. Choate, who expected, up to the last moment, to be here, and Mr. F. Hahn, President of the Chicago Association.

And now comes my agreeable duty of giving you the first regular toast of the evening. We first honor—"The City of New York; always first and foremost in all that is elevating and ornamental—witness our railroads and our architecture" (and our jewelry). The gentleman who represents the dignity and the majesty of the City of New York, Mayor Cooper, is not able to be with us to-night. In his absence I will call upon ex-Mayor Wickham to respond.

#### REMARKS OF EX-MAYOR WICKHAM.

*Mr. President and Gentlemen:*

I regret, as no doubt you all do, that the present chief magistrate of our city could not be here this evening to respond to this toast. I have used up that subject, "The City of New York," in times gone by, and having, some three years ago, retired to private life, perhaps some other person could have been selected who could more properly and more satisfactorily have responded. However, I cannot say that I was not forewarned, for I received yesterday a notice that I should be called upon to make this response. I have worked all the time since receipt of this notice in trying to frame an intelligent reply to you. The City of New York needs no response. Always first and foremost in all that is elevating and ornamental—witness our railroads and our architecture—and, finally, in brackets, our jewelry. I asked your President for an explanation of this. All he said was, "It is only assigned to you for a text." Elevated and ornamental. He persisted that I should speak of our elevated railroads. Well, they are an accomplished success, and I, for my part, feel justly proud of them. It might be, however, that my friend may have meant the elevated prices that all our railway stocks are reaching down in Wall Street. And here I might speak of what our railways are now doing for New York. They are bringing to this city that which is in turn sent out to feed half of the nations of the earth, and we are getting in return the evidence of a coming prosperity unexampled heretofore. You, no doubt, are feeling the effects of the general revival of business, and the evidence we get of this is the well filled store-houses, the busy factories, those elevators on the river, and the general activity in all our business marts. I congratulate you, gentlemen, upon this state of affairs, and I trust that it is not the beginning of the end. You may look forward to a long bright future, going on prospering and to prosper.

THE PRESIDENT:—

The next toast is—"The Judiciary—the nation's protection; on which her honest citizens rely with implicit confidence." I shall ask to reply to this toast a gentleman whom you will all be very glad to meet, representing, as he does, the highest position in the judiciary of the State, Chief Justice Davis.

#### REMARKS OF CHIEF JUSTICE DAVIS.

*Mr. President and Gentlemen:*

I fully recognize the propriety of calling on the judiciary next after the city. For, taking the city in its corporate sense, as represented by its public functionaries, nothing seems to me to be more proper than that the judiciary should be very near to it. In saying this, however, I make no allusion to our excellent ex-Mayor. Mayors are like blessings, which, Pope says, "Brighten as they take their flight." (Laughter) The judiciary may be able to stand praises from others, and there is nothing I enjoy better than to hear our judiciary eulogized. A friend of mine, who had been to the Arkansas Hot Springs, told me the following story: "The Government owns all the land on which the town stands, and a short time ago they commenced surveying it for the purpose of putting in the market the town site. It was found during the progress of the survey that a church erected by the colored people did not stand in a proper position with the street. I fancy it stood cornerways. The surveyor called upon the pastor of the congregation, and represented that fact to him. The pastor had had this intimated to him very often before and was a little indignant; and finally, after hearing the surveyor, he said: 'Well, I don't care if our church don't stand straight with de street so long as it am square with de Lord.'" Now it is of small importance, I think, whether the judiciary stands square with public opinion, and even, with some exceptions, of course, with the press, provided it stands square with the Lord and its own self: or, in other words, with the law.

It was quite a mistake of your Chairman to speak of all who are here to-night as guests as being prepared to make speeches. Only one of them, to my knowledge, is prepared—my friend, Depew. (Laughter and applause.) His notes I have seen already—notes of the speech he expects to make. I do not mean in print nor even in writing, but he always carries his speech on his countenance. It was never my good fortune before to meet with many of the gentlemen present. I have known some of you personally, and, although I have been extremely anxious to attend your gatherings, I could not very well come before, because I was not invited. I am sorry, therefore, not to have had a previous opportunity, such as I have had to-night, of seeing what sort of a body the Jewelers' Association is. Having seen you, gentlemen, I can only express a sincere regret that my pecuniary means have never before permitted my making the acquaintance of a jeweler. But, looking over this body of gentlemen, seeing the intelligence marked upon your faces, the undoubted industry and ability which your President has so happily commended, I think, may well prompt some, in the language of the Roman matron, to say proudly of the City of New York, "These are my jewel(er)s."

But I do not propose to take up your time longer. I will say, however, a word, as a representative of the judiciary. Organized as our government is, depending entirely for its existence upon the will of the people put expressly in the forms prescribed by law, nothing is so important as to maintain the integrity of the judiciary; because that is ultimately the sole resort for the protection of the institutions under which we live. If the laws were properly enforced through your public officials, in such manner as to secure their full operation by the action of grand jurors, and the administration of the law through the courts, we should be able to secure ultimately for our city a pure and good government. In theory our government is perfect, because in theory the whole body of the people—I mean, of course, the citizens of the State and city—are clothed with the power and are supposed to exercise it, of selecting for themselves the officials who shall represent them. But if it be permitted—by neglect to perform that duty on the part of the people, or by the neglect of public officials to see to it—that the laws are not obeyed, or if the court, which is the ultimate resort to enforce those laws when they are broken, is neglectful of its duty, then we shall soon put an end not only to our government but to the theory of republican representation. And hence I feel quite justified in saying that it is of the greatest importance to maintain in the judiciary men who do not fear or fail to execute and enforce our laws. With this single remark I shall bid you, no doubt greatly to your pleasure, good evening, and thank you for having given me this opportunity to test the cuisine of the establishment, as well as to see the intelligent gentlemen who now sit before me.

THE PRESIDENT:—

The third regular toast I will read, although the gentleman who is assigned to respond to it is not present—"Art in manufactures: the symbol of a nation's progress." The Hon. Joseph H. Choate, who was expected to be present to-night, being absent, I shall go on to the next. The fourth regular toast is—"National and commercial integrity: the test of a people's greatness;" and in response to this,

I shall call upon a gentleman who has never before honored us by his presence, and whom you will greet, I know, enthusiastically—the Hon. Chauncey M. Depew.

REMARKS OF HON. CHAUNCEY M. DEPEW.

*Mr. President and Gentlemen:*

I am very happy to have the opportunity of delivering myself of that prepared speech which I had put in the pocket of my steel-pen coat, to pick out if emergency required. Some of the points I intended to make have been monopolized by the gentlemen who preceded. The compliment I intended to pay has been done, well done, by ex Mayor Wickham, to whom I exhibited my manuscript. But when Judge Davis took me in the corner of the cloak-room and showed me the notes of the little speech he intended to deliver, and then asked me to show him mine, I respectfully declined (laughter), for I know that whatever the judiciary get in their possession the bar never get back again. I have been endeavoring to preserve the harmony of the evening, but cannot longer.

I came here to-night with a great deal of trepidation. Though somewhat accustomed to face public audiences, I never have been accustomed to face audiences that express so much to the ordinary family man as do the manufacturing and wholesale jewelers of this place. To me the saddest occasion in my life has been when somebody, who cannot deny himself, wants something which he cannot procure; and my observation and experience is that he always gets it. When Mr. Appleton handed to me this toast, it seemed to me to be an anomaly that commercial and national credit should be at all a question to be discussed at the dinner of the manufacturing jewelers, because there is one thing that I never attained in its worst plight, and that is, to contemplate successfully the picture of a "busted" jeweler. My idea of a jeweler is a man who makes so much out of everybody else that nobody else is able to meet their maturing obligations, and that accounts largely for the great measure of expiring credit there is in the hard times in this country. A man can get along well with credit and without capital; but if he has credit and capital, he can conquer the world. We have wakened up in a moment to extra prosperity, and we find that though we may have considered ourselves poor for years, everybody is rich. The stores are full of customers, the railroads are crowded with passengers, the streets with happy people, the stock market is buoyant with men whose surplus earnings are going into securities which will never realize a dividend; and these results are brought about by no other cause than that the nation and the world has come to recognize that integrity and honor of this nation is founded on a basis which never again will be questioned or shaken. We have been, for the last five years, in a state of depression which I trust we shall never experience again, and of the many reasons which may be assigned for this, no more probable one exists than this—that there was a large element in the community which doubted the propriety of meeting the national obligations. There were representatives of this element in the national Congress. While it seemed to be a plausible and proper statement that money which had been borrowed by the Government at enormous and usurious interest should not be paid at the face of the obligation, the men who stated it forgot that the money thus secured in a time of peril and lack of credit saved the national life and the government that we have. And the prosperity of to-day is due to the fact that the party which advocated that idea, and the politicians who represented it, sleep in a common grave. The men who persistently and consistently fought this idea from the standpoint of their own experience and their own commercial life, were the merchants of the United States. And upon the repudiationist of the past—of so recent a past—as he lies in his grave, we can pass only that judgment which, in the miner's camp was given by the mourners upon the worst and most vicious rascal in that community, who lay dead. Though urged to say something good for him, his best friends stated, as the most complimentary thing that they could say, "He makes a very quiet corpse."

Mr. President and gentlemen, yours is the oldest, I believe, of the arts that gratify and adorn and, at the same time, create anxiety for the human race. The first ornament, we learn from reliable authority, that was ever worn was a fig leaf. Within a short time after Eve had eaten the apple she set the boys to work to change it into an ornament with which to clasp her comely form, and then for fifty years after the old man had all he could do to raise money to meet her demands. The Queen of Sheba overran all the jewelers of Abyssinia and Arabia to get the jewelry together to give a present to King Solomon, of Judea. Whatever there may have been in olden times of national integrity and national honor, is due to the fact that the jeweler who loaned his money to the nation insisted upon the Government paying its debts and maintaining the credit and national honor. You, gentlemen, are associated with the rest of

the community nearer probably than either the lawyer or doctor, and in more various ways. Recently, in my own family, after a long interval, a lusty boy was born. I was sufficiently gratified and happy, but the first thing that occurred after that was an incursion of spoons and napkin rings, bowls and pitchers, mugs and pap bowls, that exceeded anything that I ever saw in my life, and I came to the conclusion that, after she had clasped her darling boy in her arms, the happiest moment in a mother's life was when the boy looked upon the little ornament for holding his sleeve, upon which "baby" had been inscribed. And then I thought that the next important period was when he stretched himself to the utmost to buy an engagement ring for the girl he loved; and the next period is when the house of the bride is crowded with an exhibition of the various jewelry establishments. Now then, gentlemen, whatever may become of other party crafts, or of other trades, yours is bound to live, because it is founded on and fortified by those elements of human nature which will never die so long as women live to buy and men live to worship them, and thus all is "vanity and pride."

JUDGE DAVIS.—"Didn't I tell you so?"

THE PRESIDENT:

The next toast is—"England and America: Allied by a common lineage, a common language and a common destiny; their united influence will lead through varied paths of industry to a higher civilization, which will stamp its impress upon the world." In response to this toast I would ask a gentleman, who, while he is a member of the Parliament of Great Britain, has been a resident of this country, connected, I think, during the war, with our army. So great an interest has this gentleman manifested in America and American affairs—of course in connection with the affairs of Great Britain—that he has been called at home "the member for America." I shall ask you to fill your glasses and drink to this toast, and receive Mr. J. H. Puleston, M. P.

REMARKS OF MR. PULESTON.

*Mr. President and Gentlemen:*

I thank you, in the first place, for the opportunity that you have afforded me for being here to-night. I thank, you, also, for the kind words and the very cordial greeting I have received. It has been my privilege to receive much hospitality and kindness here in this country, which I shall never forget. I know that a very pleasant incident of this very pleasant visit will be the fact of my having been your guest here to-night. I do not propose to occupy your time, as there are eloquent speakers to follow me. Any words of mine will only detract from, rather than add to, the sentiment which the words of the toast you have just heard read so well express. I arrived here the other day to find that you were on the eve of a great prosperity—a prosperity which I believe to be really permanent, and which will contribute greatly to the development of the resources of a country that has astonished the world by the progress already made. I venture to differ somewhat with the remarks of an honorable friend, Mr. Potter, who was entertained here last night, when he said that this prosperity was due to one exceptional cause. Although I am one of those who think with him that that policy which demands a free interchange of duties between nations is the policy by which the world can be best governed, and especially in an age of progress like this, and I only use the language of one of the most illustrious authorities, Mr. Henry C. Carey, who told me, only a few days before he died, that protection had done so much for this country that the United States would soon be one of the freest nations of free traders in the world. The policy of protection is yours, and it is not our duty on the other side of the Atlantic to refer to it. I venture to contradict the statement which has been recently made in the public press, that England is likely to take any retaliatory or retrogressive action in that particular.

I cannot say to you how much I appreciate the fact of being called upon to respond to a toast couched in such language as this. Nothing can be more grateful to an Englishman, and, I trust, to an American, than to drink cordially to the toast just read. And gentlemen, I can only say that I stand, in a very humble way, as a representative of my countrymen, and I trust that Americans will always feel that in that little island of ours there are English hearts which beat, and beat in response to the good feeling and kinship on this side of the Atlantic.

THE PRESIDENT:

The next toast is—"Morality in business; the symbol of a nation's glory." And in response to this toast, I shall ask the Rev. Dr. Tiffany to speak.

REMARKS OF REV. DR. TIFFANY.

*Mr. President and Gentlemen:*

I desire to thank you very heartily for the privilege of this even-

ings enjoyment; for the opportunity of seeing gathered together the gentlemen who represent so large a proportion, both of the morality of our business and of the elements of our national glory. I am very glad I am called upon to respond to a sentiment which has in it so much of valuable truth. If I were in my pulpit, I think I might make it the basis of a discourse which would be both divine and profitable. I am exceedingly glad that the language of the toast is "morality in business," and not "business morality;" for unfortunately the two terms are by no means synonymous. Very often business morality, as given to the community at large, like the spelling of names to Samuel Weller, depends upon the taste and fancy of the speller. It is not high and elevated principles which make business morality morality in business. In some communities, at least, business morality is at very much below par; reminding one of the remark of a sailor to an old lady of my congregation. Speaking of an island, which the sailor had visited, the old lady, who was very desirous of knowing about the moral condition of the inhabitants, asked if they kept Sunday there. "Keep Sunday," said the sailor, "yes, and every other damn' thing they can lay their hands upon." Morality in business does not merely mean the idea of simple honesty in business, which merely gives honest weights and honest measures, and pays bills at maturity. This might well be, and yet have no real tendency to exalt the glory of the nation in which men transact business upon these honest principles, for it might make simply a collection of hard, close, unaimable, uninteresting men, whose sole idea would be the idea of amassing—whose sole ambition might be in accumulation; and this would not tend really to those elements of strength and glory of which nations are wont to boast. There would be no idea of elevation, no thought of enjoyment, no dignity, embellishment or glory. A whole community of such men would have no real appreciation of the nation which protected them. And this would not be what we desire in national glory and national elevation. But morality in business must be that progressive idea which attaches not only to honesty and integrity, and the faithful performance of obligations, but which develops itself along the lines of progress which the nation, and the community itself, achieve, and has no mean part and is no small factor in the achievement and the accomplishment of these ideas. It is that thought of business, that idea of life in business, which brings with it not simply the utilitarian idea of usefulness, but the added idea of ornament and elegance and beauty. Mere honesty would develop a class of men who might be hewers of wood and drawers of water, and yet, as Ruskin says, "they would think more of the wood they hewed and the water they carried than of the pine forest and the great ocean which rolls like eternity." But there must be, in all that pertains to the morality of business, the bringing in of those purer elements which make the world more like Him who made it. National glory consists, not in the possession of large extents of territory, or in abundant resources of mineral wealth, or of manufacturing skill, or even in the culture which belongs to those who are engaged in these avocations, or in the power which is acquired by its arm, or in any one of the elements of strength which enter into national life; but in the grand union of a national product—of an achieved and perfected harmonious home—the life and the power of national elements, mingled with practical wisdom in the homes of beauty and happiness.

THE PRESIDENT :

I do not like to interfere with the pleasant feelings that have been created by the eloquent and beautiful words of the reverend gentleman who has just taken his seat with a sentiment which is more material, but the order of exercises requires me to give you the next regular toast, which is—"Our customers; they are our best friends, we bid them a hearty welcome." In response to this toast, I shall call upon a gentleman very prominent among our customers, and honored by all who know him for his sterling qualities as a man and as a merchant, Mr. James E. Caldwell, of Philadelphia.

REMARKS OF MR. CALDWELL.

*Mr. President and Gentlemen :*

I am taken by surprise when called upon to make a speech, although it is very well known that I am famous in that line. But speaking for myself and your patrons, we thank you cordially for the opportunity of being present here to-night. I am going to suggest the name of a very intimate friend here who will make a speech for me. He sits upon your platform and not down here. I suggest the name of my friend, Mr. Isaac H. Bailey.

REMARKS OF MR. BAILEY.

*Mr. President and Gentlemen :*

I do not know but this is an interruption of the programme; but, at any rate, I may speak a word upon the practice of the assigning

of a toast to a man which he does not understand. Now if there is any one interest in this community which I only know of by hearsay it is that of the customers of the jewelers. I have not had the good fortune to be one of their customers, though if I were a lawyer, like Mr. Depew, I should have been one before now. I have always had a very great idea of the talents of the jewelers, and especially of the wonderful ingenuity with which they can impart a great deal of value to a very small article. I do not think anybody can ever realize the difference between intrinsic and extrinsic value until he goes to a jeweler to have an ornament passed upon. There is a story told of an ex-member of Congress who is famous, first, for running into debt, and second, for a decided disinclination to pay his debts. One morning this gentleman met a friend whom he said had been having a game of draw poker. Perhaps I ought to explain here to you what draw poker means. It is a game which I would suggest as a good thing for popular clergymen, because they draw well. Well, this man said he had a very bad night of it the night before. He had lost \$600, and that was not the worst of it—\$25 was in cash. Now, gentlemen, I am very sorry to be obliged, as the representative of customers, to be obliged to make any complaint. I do it with a good deal of diffidence, because I am, least of all the sufferers. Mr. Depew has drawn a very painful picture of the disasters which have been drawn upon his fellow men by the frequency of marriages, but he forgot to allude to silver weddings, and I think there is not a man among us who has not, at some time or other, been obliged to seek out a present. You may go through all the jewelry shops in this quarter of the globe, and you will not find anything that has not been found by somebody else. There is no use of hunting; you cannot find anything original. There is one thing that you must introduce in your trade—a thing which will make the fortune of the man who does it—and that is the invention of new articles of silver ware that can do as presents, and not be in danger of being duplicated. You must make something new. Now, in regard to this Jewelers' Association and to its enormous wealth, which Mr. Depew seemed to be taking an inventory of throughout the whole evening, with sinister intent and purpose. I think I did put a damper upon him, however, by telling him that the jewelers are successful because they get all their law done by contract. Gentlemen, Mr. Depew's ingenuity is proof against everything, and I would advise you when you get any legal business done, to get somebody else. I could not at first, understand how, last year, when we met under different circumstances—when we were just emerging from our troubles, and had not yet entered into the present era of prosperity—how it was that two-thirds of all your customers had been obliged to give up. And then, for the first time, I made up my mind that the kind of jewelry business which people ought to engage in was the wholesale. The retailers were not a success, and I have come to the conclusion that it was because, in the first place, they have been so extremely liberal in contributing to your wealth, and so extremely generous in trusting their customers.

THE PRESIDENT :

"Lawyers: We are glad to welcome them as our guests to-night, but hope never to need their professional services." In response to this toast, I shall call upon a gentleman whom we have never before had the pleasure of meeting at our board, the Hon. Benjamin K. Phelps, District Attorney.

REMARKS OF MR. PHELPS.

*Mr. President and Gentlemen :*

I see from the sentiment to which your President has called upon me to respond, that there is a great deal of human nature among jewelers. You, no more than the rest of the world, little know how much you need the services of lawyers, and you apparently little appreciate how much you are, or ought to be, indebted to them. I have been bewildering myself ever since I came here to-night to understand the significance of the decoration on the table which stands in front of the President. (The speaker pointed to an emblematical figure among the table decorations, representing art in the jewelry trade.) I supposed, of course,

THE PRESIDENT (interrupting and taking a bottle from beside Judge Davis' plate)—"The bottle, you mean."

MR. PHELPS (continuing):—No; the bottle is very proper, and it is empty, as I supposed it would be. But there is a decorated ornament which has excited a great deal of curiosity on my part. I suppose that if the Jewelers' Association were to celebrate in that form anybody, it would be either that famous Egyptian Queen, Cleopatra, who contributed to the thrift and profit of the jewelers by dissolving in her wine the precious pearl, or else that they should have erected a shrine in honor of that goddess by whose craft, we are told, the silversmiths all lived, Diana of the Ephesians. But that seems to be neither Diana nor Cleo-

patra—unless in a different dress than any in which we have been accustomed to see them. I think it must be some lawyer who has greatly benefited the trade, I suppose, by rendering his services gratuitously. But I never knew such a lawyer, therefore I cannot imagine whose portrait it can be. I have had some slight connection with your craft in my own peculiar avocation. I was called upon not long since to prosecute a gentleman who had undertaken to ruin the craft to which you belong, by appropriating to himself "without money and without price," articles manufactured by you, and who had availed himself of the opportunity which occurred to him one morning when he was in the ware-rooms of one of your association, to convey, under his cloak, a French clock. The vigilant eye of the jeweler detecting him, however, he was stopped at the door. The clock was found, and the man was called upon to answer at the bar of criminal justice for the wrong which he had committed. The defence was in the strict line of the American policy of protection to home industry. He had stolen a French clock. It was valued—so the proprietor said—at, I think, \$75, and the defence was that he should not be convicted of anything more than petit larceny, because the same clock could be manufactured in this country and sold for \$25. But, unfortunately, the Court did not take precisely that view of the case, and the defendant is now lamenting the heresy of this country, and the shocking manner in which our courts have gone back upon the great American principle of protection to our manufacturing interests.

You, gentlemen, flatter yourselves, I judge, from your toast, that all you have got to do with lawyers is to keep them in good humor by inviting them to dinner, and think that you can dispense in that way with their services. We do not propose to let you off in any such easy fashion. Of course you do not require the services of any lawyers to collect your dues, because, I understand, from my friend Bailey, you have steadily refused to sell goods except for cash on demand. There lawyers are unnecessary. But, gentlemen, let me warn you of one danger. You are engaged, all of you, in the accumulation of vast estates; you propose to leave those estates to your successors, and that is just where we propose to get the best of you. You have got to die sometime, and although individual lawyers may not live, yet the craft will live, and after your death—I know Bailey regrets this. If Bailey had his way, neither lawyers, nor judges, nor juries would exist any longer. But there is a time coming when you, gentlemen, have got to leave your estates, and then there will be lawyers who will be after you, and they will get the best of you, unless you adopt the rule which has been recently advised: "There is only one proper way in which a man can make his will, and that is, that he should leave his estate to the attorneys. It saves litigation, and amounts to the same thing in the long run.

But, gentlemen, I am certainly very happy to congratulate you upon the new era of prosperity upon which you, as I am happy to understand, in common with all the industries of the nation, have now entered—an era, which, judging from its inception, is not to be ephemeral. I can only say with regard to this prosperity, as an excellent clergyman in California is reported to have said. In the early stages of the settlement of the State a miner died, and in order that due honors might be paid to his remains, and there being no clergyman of any other denomination in the neighborhood, recourse was had to the only person available, and that was a Catholic clergyman, who was called upon to officiate at the funeral ceremonies. The most of the persons who attended on that occasion were not members of the Catholic persuasion, and were not familiar with the observances of that church, and after the ceremonies had been completed, so far as the clergyman intended them to go, the audience would not disperse, but remained, and the clergyman seeing that there was no probability of their going away, remarked: "Now, byes, yes can all go, except Smith (the corpse); he'll stay." And I hope with regard to this era of prosperity, whatever else may come and go, that and the Jewelers' Association may stay, and that the lawyers may survive even the Jewelers' Association to partake of that rich distribution when the Jewelers' Association shall have been dissolved by death.

#### THE PRESIDENT:

The next regular toast is—"The press: We recognize its power and usefulness in its commercial as well as in its public sphere." Whatever we may think of the power of the judiciary, of our customers and lawyers, we are united in our opinion as to the influence and the power of the press, and think it decidedly to our interests to keep on the good side of it. One gentleman of the press has consented to be with us to-night, whom, I am sure, you will be glad to meet, Mr. Whitelaw Reid, of the *Tribune*.

#### REMARKS OF WHITELAW REID.

#### Mr. Chairman and Gentlemen:

I have lived to see a new thing under the sun. Solomon, I be-

lieve, said that that could not be done; but Solomon lived before Dr. Newman and myself. I have lived to see a clergyman set aside, and an editor called upon to dismiss the congregation. I have lived to see another thing—to see the President of the Jewelers' Association, in the name and on behalf of that Association, declare his desire for a further, more intimate and more permanent acquaintance with the District Attorney. Now, we editors do not know everything, but there are some things which we do know, and the most important thing is not to cultivate a strong desire for a close acquaintance with the prosecuting attorneys and police officers.

You do not want, Mr. Chairman, to hear from the press. There is only one thing that jewelers want from the press, and that is, cheaper advertising. And, if I may venture to return the compliment, there is only one thing that we want from you, and that is—more advertising at the old rates or at higher ones. But your toast implies that the press has some connection with jewelers. We have enjoyed too many times this privilege which has been referred to so reluctantly—paying cash on delivery.

In spite of the declaration of our friend from the other side, we have shown here some of the advantages of protection. He is himself a good result of what America has attained through a protective system. We have protected ourselves to such an extent that the British Parliament now takes measures in the same direction. Little did I dream that the State of Pennsylvania would bring up a gentleman who should shed honor alike on Pennsylvania and Wales in the British House of Commons. And our friend of Pennsylvania and Wales has lived to see the house of Elkington met on the neutral soil of Paris by the house of Tiffany, and to see the prize come to New York. I believe, gentlemen, that there are other and greater triumphs for your oldest of crafts. And if the press has any duty whatever in reference to the Jewelers' Association, it is to urge you to make New York in jewelry, as in many other things, the Capital of the world.

#### THE PRESIDENT:

Now, gentlemen, I shall ask you to fill your glasses and drink to the last toast—"The Ladies: Though last in our toast, they are first in our thoughts; our jewels, our jewel buyers, and the jewels of their countrymen." And I shall ask to respond to this toast, our old friend, Mr. Bartlett.

#### REMARKS OF EDWARD T. BARTLETT.

#### Mr. President and Gentlemen:

It has been well said that "variety is the spice of life." On looking back over the past year, I find I have only responded to the toast of the ladies three times. Of course, under these circumstances, I naturally have very much that is new and entertaining to say to you on this occasion.

I shall assume that you still hold in memory the very able and elaborate manner in which I treated this subject when addressing you at your last annual dinner.

I experience great regret that my friend, Judge Brady, is not here to endure with you this fourth and most harrowing attempt on my part to present this subject in a new light.

If the Judge were here it would be most fitting—a living illustration of the retributions of history—and for this reason. The Judge was here a year ago, and was therefore chargeable with personal notice that my toast on that occasion was "the Ladies."

You will perceive this is no record or constructive notice—I bring it directly home to him.

Now what think you the Judge did to me after your last dinner? I will tell you. He conspired with the Committee of Arrangements who had in charge the St. Patrick's Dinner, induced them to include me in the list of speakers, and then when asked what subject he thought would be entirely new and agreeable to me, he innocently suggested "The Ladies." I have no positive proof he is implicated with the President in the assignment of toasts for this evening, but I think he rests under strong and well founded suspicions. Realizing the "flow of soul" or something stronger that always develops on an occasion like the present, and knowing that this toast is the last on the list, I did think of repeating my remarks of last year, feeling confident they would go through as a new production, owing to the confusion of ideas peculiar to this stage of the dinner. But it suddenly occurred to me, that the editor of your paper is a sober and steady-going gentleman, and I felt that detection was inevitable, so I have concluded to evolve a few brief remarks at this time. In this extremity I find but one consolation, and that is in my subject. It is agreeable, delightful, many-sided, infinite. It is new every morning, and fresh every evening. It comes to us as each recurring spring—a miracle of beauty—a dream of loveliness—a fresh revelation like that which we are ever discovering in the splendor of the sunset—the silent beauty of a summer night. In

it is my security against the twice told tale, and in it you will find a response to the toast superior to any I could possibly make even though I spoke with the eloquence of a finished orator. You have only to appeal to your own experiences. You have but to summon from the past some vision of womanhood, and it will stand as a token that what I say is true. I pity that man who has not at some period of his life experienced the regeneration born of woman's influence, and woman's love. I pity him who cannot pause in the heat of life's noon-tide and recall, with inexpressible emotion, a mother, sister, wife, or possibly some nameless one whose voice has been silent now these many years, whose beauty faded like the sunset into night. I think that man is safer amid the quicksands and pitfalls of life, who can at times retire into the sanctuary of memory and commune with some gentle spirit who long since joined the angels. There is so much here to drag us down, so much to make us of the earth, earthy, I can well imagine that God could not pronounce good the work of His hands until He had given to man some power to lift him above the level of his own nature, to give life its motive and its guiding spirit. Remove woman from the scene, and what have you left? What would you care for your marts of trade, and your ships that sail the sea? What for your luxurious homes, and your dreams of rest and pleasure before the end shall come? Why life would lose its zest; the wheels of business would cease to move. Even if by some new miracle God should keep filled the ranks of the living—yet what a life it would be to live; what a sunless world—what a weary place of waiting. Literature, music, painting and sculpture are of women born. The poet, the novelist, the composer, the painter and the sculptor derive their best inspirations from her. It has been said that love and death rule the world. With woman love would perish, and death rule supreme! All this is trite enough. Yet there are some things of which the world never grows weary. This toast itself is the best evidence of the fact. Ever since toasts were known among men this one has had the place of honor, the last on the list, even as old wine closes the feast. And verily the last shall be first! The last is first! The ladies are "first in our thoughts, and first in the hearts of their countrymen" in the language of your worthy President.

For some reason, this sentiment of woman always presents to my mind its serious side. The fair sex as a rule receive their share of the world's banter, yet here, at this hour, the name of woman is on our lips in reverent mood, even as the pilgrims sang at parting that grand old Doxology, that carries us back to childhood and the country church by the side of which our dead are sleeping. Therefore, not here the jest at woman's foibles; not here the story of her weakness; but rather do we enthrone her above all, and tender to her the homage of a true knighthood, and while she is first in our thoughts, as has been stated, I would add to the sentiment of the toast the words: "and last in our thoughts," for I doubt not in that supreme hour when the things of time shall fade from the sight of the dying and a breaking glory shall fill the soul with delight, even then the love of woman will assert itself, proving a very benediction to him who is departing from "these crumbling shores of time."

MR. PULESTON proposed that the gentlemen drink to the health of the President of the Association. In doing so, in a few well chosen and complimentary remarks, he paid a glowing tribute to the business character, intelligence and ability of Mr. Appleton, which sentiment was unanimously and heartily responded to.

## REMARKS OF MR. APPLETON.

*Friends and Fellow Members of the Jewelers' Association:*

It is but little I can say to the very complimentary and cordial remarks of my friend Puleston, whom I have known and respected for many years, and the enthusiastic reception which you gave to his remarks. I thank you very heartily for it. I have always considered it a very great honor to have been elected President of your Association, and it was a repeated honor when I was re-elected about eighteen months ago, which I heartily appreciated, and intended never again to allow a repetition of that honor; but when you re-elected me for a third time, I was overwhelmed. Our craft presents many interests, which sometimes conflict with each other, and are often divergent. It has long been my desire and aim to co-operate with those in the Association who are endeavoring to create an *esprit du corps* among ourselves, to join together heartily, not merely in pursuing those present objects for which we are organized as business men, but to elevate the character of our craft, and to secure for it a name and a position of influence which it enjoys in other countries, or sufficient power to establish here and to maintain a standard of quality in the manufacture of the precious metals. These learned gentlemen who have addressed us to-night have recounted the difficulties they have met with whenever they are buying a wedding present.

They are obliged to trust solely to the private stamp which the manufacturer puts upon his wares. Now, in England, it is very different. There, many years ago, the goldsmiths found it convenient, for one reason or another, to put a uniform stamp of quality on their wares, and afterwards, so certainly reliable became that stamp, that the Government assumed it, paid all the expenses of stamping, and clothed it with authority, so that now the stamp which Mr. Puleston referred to a moment ago as a matter for Parliamentary regulation is the very stamp of the goldsmiths of olden times. It is now recognized both by Government and by the purchaser at retail as being entirely reliable. Now we want something of that kind in this country, so that dishonest and unscrupulous manufacturers—for there are such men in our craft, though, happily, there are none such in our Association—may not impose upon the public. It should be the aim of this Association to secure a uniform standard which would be recognized and relied on by all purchasers, and that standard, although it may not be enforced by legal enactment, as in other countries, should have a moral support which would be equally binding and equally effective. Beyond this I have little to say. I know that you will heartily unite in thanking the gentlemen who have come to see us to-night for the eloquent and instructive speeches which they have made, and I believe you all respond to the cordial remarks of our guest from England, who has been distinguished at home as a working member of Parliament, and I trust that he will be returned to the next Parliament. We are honored to-night by representatives of the church, the judiciary, the bar, the press, and by other professions. I know you will join in thanking all of them for their presence, and I thank you, my friends, for the cordial manner in which you have received them.

The entertainment concluded about 11 o'clock, amid the greatest good feeling and expressions of satisfaction. The compliments passed upon those who had the entertainment in charge were many, and all who were present departed with the firm conviction that there is more in this life than mere business transactions, and that the social qualities of human nature present a fertile field for cultivation.

## LETTERS OF REGRET.

The following are the letters of regret received from gentlemen who were invited to be present:

MAYOR'S OFFICE, NEW YORK, NOV. 12, 1879.

D. F. APPLETON, Esq.,

Dear Sir:—Mr. Cooper directs me to say that he has received the kind invitation to be present at the Fifth Annual Dinner of the New York Jewelers' Association on the 13th inst., and fears that illness will prevent his attendance.

Yours respectfully, JOHN TRACEY, Chief Clerk

50 WEST 47TH ST., THURSDAY, 7 P. M.

MY DEAR APPLETON:

I have this moment got home after being in Court from 10 o'clock till 6, and really haven't a leg left to stand upon. I should only mar your hilarity, instead of adding any charm to the occasion. So I hope you will fill my vacant seat, and let me be excused for this once, with the best wishes for the success of your Association.

Yours truly, JOSEPH H. CHOATE.

D. F. APPLETON, Esq.

NEW YORK, NOV. 5TH, 1879.

D. F. APPLETON, Esq.:

I have to thank you for your kindness and thoughtfulness in inviting me to the annual dinner of the Jewelers' Association. I regret very much that my movements next week are so uncertain, and the chances so much against my being in the city at the time, that I shall have to forego the pleasure of being with you on that entertaining occasion. With many regrets, and wishing you a good digestion and stout buttons on your vest,

I remain, yours truly,

HORACE PORTER.

D. F. APPLETON, Esq., *Pres't.*

84 CLINTON PLACE, NEW YORK, NOV. 4TH, 1879.

D. F. APPLETON:

Chief Justice Daly regrets that an engagement for Thursday, 13th inst., deprives him of accepting the polite invitation of the New York Jewelers' Association to dine with them on that evening.

58 EAST 79TH ST., NEW YORK, 1ST NOV., 1879.

Dear Sir:—I very much regret that a prior engagement prevents my accepting the courteous invitation of the New York Jewelers' Association to their annual dinner on 13th inst. Wishing you a most pleasant evening,

I have the honor to remain, yours respectfully, F. COURTNEY.

D. F. APPLETON, Esq.

NEW YORK, 6TH NOV., 1879.

My Dear Mr. APPLETON:

Cordial thanks for your kind note of yesterday. I appreciate your invitation and wish I could be with your Guild; but I have already arranged to visit Chicago next week, and so cannot accept your good cheer. That all good fortune may wait on you and yours, is heartily wished by,

Yours faithfully,

STEWART L. WOODFORD.

Mr. DANIEL F. APPLETON, *President, &c.*, 9 Bond St.

61 WALL ST., NEW YORK, NOV. 8TH, 1879.

D. F. APPLETON, Esq.:

I beg to acknowledge your kind invitation to be present at the Annual Dinner of

the Jewelers' Association on the 13th inst. I have engagements, however, at Court in the Western part of Pennsylvania, during next week, which, I have just learned, may detain me thereover that day, and compel me to forego the pleasure I should otherwise have had of being present with the Association on that occasion.

Truly your obedient servant, CLARKSON N. POTTER.

CHICAGO, NOV. 8TH, 1879.

D. F. APPLETON, Esq. :

Your kind invitation to participate in your Annual Dinner, to be held on the eve of the 13th inst., addressed to W. T. Tompkins, Esq., Pres Chicago Jewelers' Association, was handed to me, as the fortunate successor to that honorable position. In behalf of the Chicago Jewelers' Association, I tender you my sincere thanks for the kind remembrance on this gala occasion; and regret that I cannot share your royal hospitality on account of the thrice welcome "boom" which keeps me here. Please accept a sister's greeting, and believe that the Chicago Jewelers' Association are ever in sympathy with you in any laudable undertaking. With highest regards to you, and the honorable Association you represent,

I am, very respectfully yours, HERMAN F. HAHN.

President Chicago Jewelers' Association.

NEW YORK, NOV. 10TH, 1879.

D. F. APPLETON, Esq. :

It is a matter of real regret to me that I shall not be able to come to your dinner on Thursday evening, owing to an engagement I must needs keep. I should like to eat such a dinner as your Society will be sure to order, and to see you all together and note how the men look who can hide a new worth in fine gold, and create these perpetual surprises of beauty that make it so delightful for our wives and daughters to walk abroad, and so costly for their husbands and fathers when the wedding days and birthdays come round, despite our steady testimony that the wife herself is far above rubies, as the Scripture saith, and that sapphires and diamonds look poor beside the eyes of the girls.

I learned to be very proud of the attention of your Guild when I saw how your work compared with the best they can do in the old lands in the great Exposition in Paris, and took it for a sign that we are to create beauty over here that shall surpass as well as use. You are pioneers in this fine adventure, with other masters in the choicer arts, in the ranks of those who work for the true and beautiful and good. And while the pity is that these things you create minister so often to our poor human beauty, this is not and cannot be your condemnation while you do good and true work. I did not mean to preach a sermon—I think it must be this pen—but to send a regret that I cannot get a share in that dinner and the good time, and express the hope that if indeed there be crowns and other delicate things of that sort in the better life, the New York Jewelers' Association may be there to help make 'em.

Yours, ROBERT COLLYER.

## Practical Hints on Watch Repairing,

BY EXCELSIOR. No. 56.

WHEELS AND PINIONS, PITCHING, DEPTHING, PROPER CURVES, ETC.

(897) *The Use of Symbols.* Supposing the workman to be provided with suitable means for measuring, etc., we are now prepared to consider the accurate method of sizing wheels and pinions, calculating their geometrical radii, and center distance, testing the depthing, etc. In order to facilitate calculations, and the concise expression of our proportions, we use certain letters as the *symbols* of the various parts or terms, as, for example,  $T$ , to represent the number of teeth in the wheel, and  $t$ , the leaves in the pinion, and  $R$  and  $r$ , for the geometrical radii of the wheel and pinion respectively. Then twice the radius,  $2R$ , or  $2r$ , will be the geometrical diameters of the wheel and the pinion, respectively. As the ratio between the revolutions of the wheel and of the pinion it gears into must also be followed (in the inverse order) in the number of their teeth and leaves, and in their respective geometrical radii and primitive diameters, we may express the proportions by symbols, thus:  $T:t::R:r$ , which means that the number of teeth is to the number of leaves, as the radius of the wheel is to that of the pinion; and  $T:t::2R:2r$ , which means that the number of teeth is to that of the leaves as the primitive diameter of the wheel is to that of the pinion. These proportions will, of course, be equally correct when reversed, or otherwise similarly transposed on each side.

(898) As the center distance in any correct gearing is made up by the radius of the wheel, plus that of the pinion, or  $R+r$ , (see fig. 43) we can ascertain, either from the numbers of the teeth and leaves, or from the radii of the wheel and pinion, just what proportion of the center distance is occupied by the radius of the wheel, and what by that of the pinion. Or, knowing the center distance and the numbers of the teeth and leaves, we can calculate the correct radii or diameters of the wheel and pinion for that center distance. For example, if the wheel has 72 teeth, and the pinion 8 leaves, the radius of the wheel must be 9 times that of the pinion. The center distance is therefore made up of 9 parts wheel radius and 1 part pinion radius,

or 10 parts in all; of which the wheel occupies  $\frac{9}{10}$ , and the pinion  $\frac{1}{10}$ . As the ratio between the wheel and the pinion is fractional in some cases, we can follow a method which will give the result without fractional parts, thus: Wheel 60, pinion 8. The ratio is 60 to 8 which we put into the form of a fraction,  $\frac{60}{8}$ , and reduce it to its lowest terms by dividing by 4, which gives  $\frac{15}{2}$ , or  $15 \div 2 = 17$  parts, into which the center distance is divided, of which the wheel occupies 15 parts and the pinion 2, or  $\frac{15}{17}$  and  $\frac{2}{17}$ , respectively.

(899) This gives us the ratio, or the *proportion* between the sizes of the wheel and the pinion, but, to find their *actual sizes*, we have recourse to the following formula:  $T+t:T::R+r:R$ , or, the sum of the teeth and leaves is to the number of wheel teeth, as the sum of the radii of the wheel and pinion, or the center distance is, to the radius of the wheel; or  $T+t:t::R+r:r$ , which gives the radius of the pinion. Taking the former formula, and supposing the wheel to have 72 teeth, the pinion 8 leaves, and the center distance to be .455 inch, we substitute for each letter its value in figures, and our formula becomes

$$72+8=80 : 72 :: .455 : R, \text{ which gives } R=.409 \text{ inch.}$$

Taking the second formula and substituting figures for letters,

$$72+8=80 : 8 :: .455 ; r, \text{ which gives } r=.045 \text{ inch.}$$

It will be noticed that these formulas give us the sizes of the wheel and pinion without first reducing the ratio to its lowest terms as described in the preceding section. The same result will be obtained in the case there given, by dividing the centre distance by 17, and multiplying by 15 for the radius of the wheel, and by 2 for that of the pinion. Either method can be followed that is more convenient in the particular case. By different combinations of a few symbols, a large number of formulas can be developed, by which we can ascertain almost any point we wish to know. If we know the value of three of the terms in a proportion, we can easily calculate the value of the fourth and last term.

(900) *Value of the Addendum.* It is now important for us to know whether there is any regular proportion between the geometrical or primitive diameter, and the full or working diameter. If there is, then, if we know either one, we can from it ascertain the other. If the addenda were always of the same shape and length, there would be such a fixed proportion between them. But, as has already been shown, the length of the addendum depends on the rapidity of the curves of its faces. The greater the curve, the shorter the addendum; while the slower the curve, the longer the addendum. This applies only to wheels which are the drivers, which is the case with watch and clock wheels,—except the motion works, where the canon and minute pinions drive. But the ordinary train pinions are always *driven* by the wheels, and in their case it is usual to dispense with any attempt at epicycloid curves, and to give the addendum of the leaf a semi-circular form, which is the shortest of any. It is therefore evident that the wheel or pinion which drives has considerably longer addenda than that which is driven. A good deal of attention has been given to this point by many of the old writers, but they have reached different conclusions. Reid and the first Arnold gave as a rule that, in the driver, the proportion is

$R : W :: T : T+2.25$ , or  $r : w :: t : t+2.25$ , that is,  $R$ , or  $r$ , the geometrical radius, is to  $W$ , or  $w$ , the working radius, as the number of teeth or leaves is to that number plus  $2\frac{1}{4}$ .

But in case the wheel or pinion is driven, the addition should be  $1\frac{1}{2}$ , and the proportion then is

$$R : W :: T : T+1.5, \text{ or } r : w :: t : t+1.5.$$

Willis, however, recommends to add 3 to the number of teeth in the driver, and 1 to the driven. Charles Frodsham advises  $2\frac{1}{2}$  for the driver, and  $1\frac{1}{4}$  for the driven, and so on—thus showing a wide difference of opinion as to the value of the proportional equivalents of the addenda, or the numbers which will bear the same proportion to the number of teeth or leaves, as the lengths of the addenda do to the lengths of the geometrical radii. We will adopt the letter  $E$  as the proportional equivalent of the driver, and  $e$  for that of the driven, wheel or pinion.



(901) *Proportional Equivalent of the Addendum, for the Driver, (E).* These differences of opinion as to the proper amount do not show that any of them were in error, however, for all of them are right in some cases,—but it probably arose from each deducing his rule from the proportions of the particular form of tooth he considered preferable. A slight calculation shows that when the wheel is the driver, and the thickness of the teeth is equal to the width of the spaces, the value of the addendum is 2 or  $2\frac{1}{4}$  for teeth with very stubbed ends, approaching the semi-circular form. (See Fig. 44.) When the length of the addendum (beyond the pitch line) is  $\frac{3}{4}$  the thickness of the tooth on the pitch line, add  $2\frac{1}{2}$ ; when the addendum is  $\frac{7}{8}$  as long as the thickness of the tooth, add  $2\frac{3}{4}$ ; when the addendum is as long as the tooth is thick, add 3 or  $3\frac{1}{8}$ . Should it be longer, say  $1\frac{1}{8}$  times the thickness of the teeth, add  $3\frac{1}{2}$ ; if  $1\frac{1}{4}$  times as long as the thickness of the teeth, add 4 to the number of the teeth. These last, however, are unusual lengths of the addendum. It will be seen that all of our authorities are right for certain forms of teeth.

(902) As a practical rule for the workman, when he finds on inspection that *the teeth are very stubbed, he should add 2 or  $2\frac{1}{4}$ , according to the flatness of the ends; when quite long and pointed, add 3; for medium length of addendum, such as is found in ordinary well formed teeth, add  $2\frac{1}{2}$ .* This is supposing that the wheel is the driver, and the thickness of the teeth and of the spaces is the same. If the tooth is thicker than the space, the addendum will be slightly longer, and we may add  $2\frac{1}{2}$  instead of  $2\frac{1}{4}$ , etc. If the tooth is narrower than the space, add a little less, as 2 instead of  $2\frac{1}{4}$ , and so on. It should be observed that the size of the wheel, as thus computed, will be only slightly changed by varying the value of the addendum. Thus, in a wheel of 60 teeth, with a geometrical radius of  $\frac{1}{16}$  inch, the working diameter got by adding  $2\frac{1}{4}$  to the number of the teeth, is only  $2\frac{1}{2}$  thousandths of an inch larger than by adding 2, as

$$T : T+2 :: R : W, \text{ or } 60 : 62 :: .6 : W, \therefore W = .620 \text{ inch.}$$

$$T : T+2.25 :: R : W, \text{ or } 60 : 62.25 :: .6 : W \therefore W = .6225 \text{ inch.}$$

But of course we should be as accurate as possible in all calculations, and carefully examine the shape of the teeth before deciding upon the number which will be the nearest to a correct proportional equivalent of the length of the addenda. The operation can be reversed, to get the geometrical from the full diameter.

(903) *Proportional Equivalent of the Addendum, for the Driven, (e).* In watches, the pinions are usually the driven, and, as already stated, their addenda are commonly made semi-circular. It would therefore seem that there should be no difference of opinion as to their proportional equivalent, since there is only one form. Although that is true, there is a variation in another respect,—the thickness of the leaves. In low-numbered pinions, as those with 6 to 10 leaves, the thickness of the leaf is about  $\frac{1}{3}$  the pitch, often less; in higher-numbered pinions, the leaves are about  $\frac{2}{5}$  the pitch; in cannon pinions, etc., about  $\frac{1}{2}$  the pitch, the same as in ordinary wheels. That is to say, that if the distance along the pitch circle, from the front of one leaf to the front of the next, is divided into three equal parts, the thickness of the leaf will occupy one part, in the first case; in the second case, if that distance is divided into five equal parts, the leaf will occupy two of them; in the third case, the leaf takes up one-half of that distance. Calculation shows that, with semi-circular addenda, on leaves whose thickness is  $\frac{1}{3}$  the pitch, we should add 1 to the number of leaves in the pinion, as the value of the addendum; when the leaves are  $\frac{2}{5}$  the pitch, add  $1\frac{1}{4}$ , or 1.25; when they are  $\frac{1}{2}$  the pitch, add  $1\frac{1}{2}$ , or 1.5. It should be remembered, however, that this does not apply to cannon pinions, as they are drivers, nor to any other driving pinion. Therefore, if the workman, on inspection, sees that *the leaves are very thin, he adds 1; if their thickness is more than  $\frac{1}{3}$  the pitch, but not so much as  $\frac{1}{2}$ , he adds 1.25; and if they are about  $\frac{1}{2}$  the pitch, he adds 1.5.*

(904) *Proportional Equivalent of the Addendum, when the Pinion Drives the Wheel.* In this case, the most of the authorities tell us to reverse the order, and add *E*, the equivalent of the driver, (902), to

the number of the pinion leaves, and *e*, the equivalent of the driven, (903), to the number of wheel teeth. And, in practice, this will give very close results. But as we added *different numbers*, to suit different cases, when the wheel was the driver, it will be proper to consider how we shall choose among the different numbers, in the present changed circumstances. When the pinion drives, the leaves are usually made thicker, and the wheel teeth thinner,—the former being very commonly  $\frac{1}{2}$  the pitch, and the latter  $\frac{2}{5}$  of it. The equivalent number for the driver (the pinion) will now be from 2 to 3, and for the driven  $1\frac{1}{4}$  to  $1\frac{1}{2}$ . *When the pinion leaves are quite thick, and the addenda very long and sharp, the value of E may be 3; if the leaves are quite thin and the addenda rather short and blunt, add 2 or 2.25,—the larger number being for pinions of less than 8 leaves. For medium-shaped leaves add  $2\frac{1}{2}$ .* But the value of *e* can never be so small as 1, unless the teeth of the wheel are very thin and flat pointed indeed. *Add  $1\frac{1}{4}$ , or 1.25, for teeth of the common shape for driven teeth, i. e., with semi-circular addenda or ends, and their thickness  $\frac{2}{5}$  the pitch; and  $1\frac{1}{2}$ , or 1.5, when the teeth are  $\frac{1}{2}$  the pitch.*

(905) *To Find the Proportional Equivalent for Any Given Length of Addendum, Whether Driver or Driven.* Although the rules already given are ample for all practical purposes, and will give the correct size of a wheel within two or three one-thousandths of an inch, (902), the inquiring workman who seeks the utmost accuracy, for purposes of calculation, may desire to know how to find exactly the proportional equivalent for any supposable length of the addendum. The process is as follows: Take a wheel of say 60 teeth, with a pitch of 1 inch. Of course it matters not whether the dimensions are inches, or sixteenths, or lines, or millimetres, or anything else, for the *proportions* will be the same whatever the dimensions, and the results will be expressed in those dimensions. For convenience of calculation, we take a pitch of 1 inch. The circumference of the pitch circle will then be 60 inches, and the geometrical diameter  $60 \div 3.1416 = 19.098$ , or  $19\frac{1}{16}$  inches. Suppose the thickness of the teeth to be  $\frac{1}{2}$  the pitch, or the teeth and spaces equal, and each will be  $\frac{1}{2}$  inch. Now, if the end of the tooth is semi-circular, the length of the tooth beyond the pitch line will be  $\frac{1}{2}$  the thickness of the tooth, (disregarding the curvature of the pitch line across the teeth,) as the length of the addendum is equal to the radius of the semi-circle on the end of the tooth, while the thickness of the tooth is equal to the diameter of the semi-circle. This will be so, no matter what the number of the teeth or their thickness. In this case, therefore, the length of the addendum will be  $\frac{1}{4}$  inch, and as there is an addendum at each end of the geometrical diameter we add twice that, or  $\frac{1}{2}$  inch, (equal to the thickness of a tooth,) to the geometrical diameter, and we get the working diameter.

(906) Now our problem is, to find what number will bear the same proportion to the number of teeth in the wheel, as the length of two addenda has to the geometrical diameter, or one addendum to the geometrical radius. This we can now ascertain by a very simple proportion,

$2R : .5 :: 60 : e$ , or  $19.1 : .5 :: 60 : e \therefore e = 1.57$ , or about  $1\frac{5}{16}$  inch. That is to say 60 will be to  $61\frac{5}{16}$ , as the geometrical is to the full diameter of such a wheel as described. But suppose that the length of the addendum is equal to the thickness of the tooth, then the two addenda are equal to the thickness of two teeth, or 1 inch, and our proportion is

$$19.1 : 1 :: 60 : E \therefore E = 3.14, \text{ or about } 3\frac{1}{8}, \text{ and}$$

$60 : 63.14 :: 19.1 : 2W$ , which gives us 20.1 inches for the full diameter of the wheel. Or we can reverse the process and find the geometrical diameter, by knowing the outside diameter, 20.1 inches, 60 teeth, proportional equivalent 3.14, as follows:

$$63.14 : 60 :: 20.1 : 2R \therefore 2R = 19.1 \text{ inches.}$$

In the same way we can find the proportional equivalent of any length of addendum.

(907) But now suppose that the thickness of the tooth or leaf is  $\frac{1}{3}$  the pitch, which will be .333 inch, when the pitch is 1 inch. The length of the addendum will depend on its shape. If semi-circular,

its length will be  $.333 \div 2 = .166$  inch; if its length is equal to the thickness of the tooth, it will of course be  $.333$  inch; if  $\frac{3}{4}$  the thickness of the tooth,  $.333 \div \frac{3}{4}$ , or  $.333 \div .75 = .25$ , or  $\frac{1}{4}$ , inch. Or suppose the thickness of the tooth to be  $\frac{2}{3}$  the pitch, or  $\frac{2}{3}$  inch =  $.4$  inch. Then, if the addendum is semi-circular, its length will now be  $.4 \div 2 = .2$  inch; if the length of the addendum is  $\frac{3}{4}$  the thickness of the tooth, it will be  $.4 \div \frac{3}{4} = .3$  inch long; if as long as the tooth is thick, it will be  $.4$  inch long, and in this case our proportional equivalent found by doubling the length of our addendum, is  $.8$ , and makes the following proportion:

19.1 : .8 : :  $E$ , which gives  $E = 2.513$ , or a little over  $2\frac{1}{2}$ .

In the same way the proportional equivalent can be found for any form of tooth or leaf. Supposing a wheel or pinion of a certain size and pitch, and a certain thickness and shape of teeth or leaves, from these data we can get the length of the addendum, and double that amount for finding the proportional equivalent, by working out the proportions, as shown above. The length of the addendum should not be less than  $\frac{3}{4}$  the thickness of the tooth or leaf, for the driving wheel or pinion, nor less than  $\frac{1}{2}$  the thickness for the driven, in ordinary watch trains. The above method of calculation applies to both wheels and pinions.

908. *Tool for Measuring the Addendum.* It is evident that if we could actually measure the length of the addendum with accuracy, we could get the geometrical and working diameters at once, by simple addition or subtraction. But as there are no tools in market for doing that, so far as I am aware, the practical method commonly used is to estimate, as nearly as possible, without measurements, the length of the addendum, by inspection of the pitch, thickness, and shape of the teeth or leaves, choose the proportional equivalent which seems most suitable, and thus obtain the information we desire by means of one or more of the formulas in sections (915) to (919).

It would not be difficult, however, to make a tool for taking the measurement of the thickness of the tooth and length of the addendum at the same time,—consisting of two thin jaws to clasp the tooth, and, between them, a fine plunger pushed forward by a spring, to rest against the point of the tooth. The two jaws should be connected with an index point, to magnify and show the extent of their opening, and the plunger with another index point, to equally magnify and show the distance it was pushed back by the point of the tooth. A slide, carrying the jaws and other working parts would be moved towards or from the center by a screw attached to the frame or bed piece of the tool and, when the jaws showed the greatest thickness of the tooth, it would be assumed that they embraced it at the pitch line, and their index point would give the thickness of the tooth. At the same time, the index point of the plunger would give the distance from the pitch line to the point of the tooth. Should there be difficulty in deciding upon the exact spot for the pitch line, from the jaws moving some distance without apparent variation in the thickness of the tooth, it would be assumed that the proper place was in the middle of that distance, which could be accurately located by the plunger index. The bed piece should of course be firmly secured to the wheel, so that the central line of the slide, plunger, etc. would be exactly in a line from the centre of the wheel through the point of the tooth. The centre of the wheel could be got on this line by inserting its pinion, as far as it would go, into a tapering notch in the end of the bed piece.

909. *To Find the Number of Hours a Going Barrel Watch will Run with Once Winding.* This and the following sections were, by mistake, omitted from No. 55. Suppose the main wheel to have 80 teeth, center pinion 10 leaves, and the stop work allows 4 turns of the winding arbor. As the center pinion of course turns once in an hour, and the ratio between the number of teeth and leaves is 80 to 10, or 8 to 1, the main wheel will require 8 hours to make one revolution; and as it turns 4 times, it will turn the center pinion  $8 \times 4 = 32$  times around, and the watch will run 32 hours with once winding. Hence this Rule: *Multiply the number of main wheel teeth by the number of turns of the winding arbor, and divide by the number of*

*leaves in the center pinion.* The quotient will be the hours of the running. If there are no stop works, we can count the number of turns of the winding arbor, from the lowest point at which the mainspring will run the watch, to the end of the winding. Example: Main wheel 75 teeth, center pinion 10 leaves, winding arbor turns  $5\frac{1}{3}$  times around.

$$75 \times 5\frac{1}{3} = 400 \div 10 = 40 \text{ hours.}$$

(910) *To Find the Number of Teeth in the Main Wheel, or Leaves in the Center Pinion, for Running any Given Number of Hours.* Suppose the center pinion has 10 leaves, the winding arbor makes 4 turns, and we want the watch to run 30 hours. As it must run 30 hours to 4 turns of the arbor, or the main wheel, which is  $7\frac{1}{2}$  hours for 1 turn, the main wheel must evidently have  $7\frac{1}{2}$  times as many teeth as the center pinion has leaves, in order that the latter may make  $7\frac{1}{2}$  turns to one of the former. This gives us the following Rule: *Multiply the number of hours by the number of pinion leaves, and divide by the number of turns of the arbor.* Our example will then give

$$30 \times 10 = 300 \div 4 = 75 \text{ teeth, for the main wheel.}$$

(911) *To Find the Number for the Leaves of the Center Pinion.* Suppose our main wheel has 75 teeth, the winding arbor makes 4 turns, and the watch must run 30 hours. That will be  $7\frac{1}{2}$  hours to each turn of the arbor, *i. e.*, the center pinion must turn  $7\frac{1}{2}$  times as often as the main wheel, and of course the number of teeth must be  $7\frac{1}{2}$  times the number of leaves. Hence we have this Rule: *Multiply the number of teeth by the number of turns of the arbor, and divide the product by the number of hours the watch must run.* The quotient will be the number for the center pinion leaves.

$$75 \times 4 = 300 \div 30 = 10 \text{ leaves for the center pinion.}$$

### Jottings.

If Professor Proctor ever reads the reports of his lectures on astronomy, he is about as much surprised as the rest of us.

The popularity of the new gold watch cases introduced by Robbins & Appleton is unprecedented, taxing the full capacity of their extensive establishment to keep up with it.

The famous clock tower of Berne has just been restored, and its still more famous tablet in the wall commemorates the building of the tower by Duke Berthold Von Zahringen, who was also the founder of the city.

Sheffield, England, sends large quantities of steel blanks to Connecticut to be struck off into scissors. They are then returned to England, where the fine finishing is done, and they take a final trip to America as Sheffield ware.

H. Terlau, jeweler at Covington, Ky., was recently robbed of forty gold watches and two gold bracelets, by two sharpers who entered his store in the guise of purchasers. Mr. Terlau did not discover his loss until after the thieves had left.

George B. Owen & Co.'s clock factory, at Winsted, Conn., was recently destroyed by fire. The firm, however, with its usual enterprise, has made arrangements for continuing the manufacture of clocks, and there will be no delay in the filling of orders.

A number of chain manufacturers of this city, recently met at the rooms of Safford & Fornachon, for the purpose of arranging uniform prices for gold chains. Nothing definite resulted, however. The matter will probably be further considered at a future meeting.

A Chicago man announces that he has made a machine by means of which in the twinkling of an eye, he can convert Lake Michigan water, or any other water, into light, heat, or steam, as his patrons may desire, besides incidentally knocking the received laws of natural philosophy into a cocked hat. Yet the gas companies are examining meters and collecting bills as usual, and Mr. Edison has not as yet broken off his interesting experiments at Menlo Park.

The Waltham Watch Company gives employment to a large number of girls, and it is a noticeable fact that they are unusually intelligent and possessed of rare refinement. They are noted for being the most intelligent body of working women to be found in this or any other country. They take great interest in their employment, striving to secure perfection in all they undertake. The care and attention which they bestow upon their work may account for the great popularity of the Waltham watches.

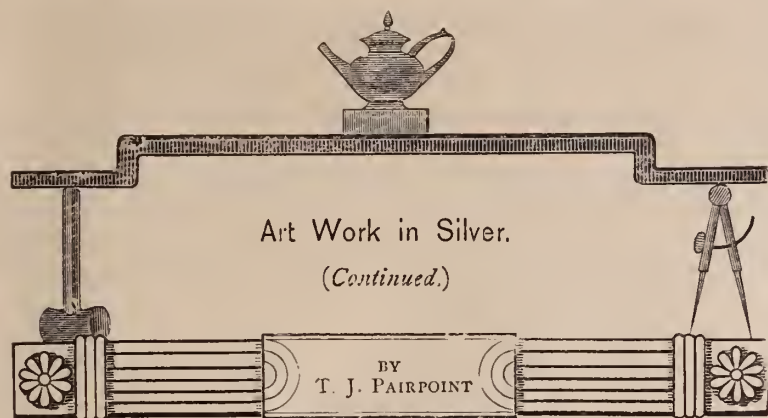

PRACTICAL SILVERSMITHING.

THE character of silver work has considerably changed of late years, owing to the increased demand, the better application of mechanical forces and the improved taste. The fine machinery now employed, whilst being the means of an immense saving both of time and labor, makes the mechanical part of the production perfect. The artistic part has not made the same gigantic strides toward perfection that the mechanical has so fully attained, although considerable progress has taken place since international exhibitions were first instituted, the intercommunication of thought and ideas which resulted from bringing together and comparing the various productions and manufactures of all nations, gave a new impetus to industrial enterprises, and in consequence a better feeling and quality has been introduced. These exhibitions have also in some measure educated the public taste and caused them to demand something more than merely mechanical fitness, the article must not only have this necessary qualification, but must also show some indication of thought in the construction and decoration, and for every apparent eccentricity should be found a reasonable cause. Accordingly the silversmiths of to-day have to study the tea-set or waiter they are about to produce, feeling that to achieve a successful result, each particular part must be carefully considered and adjusted, the ornamentation being in keeping with and suitable to the form selected, not the form being subordinate to the decoration. Every one of the ornamental details should be thoughtfully designed, giving strict attention to its motive and use, and the same care should be observed throughout the various stages of production, while no inharmonious or incongruous element should be admitted, but a direct application of the rules of taste, to the ulterior aim, object, or use of the article. It should also contain the ineffaceable record of its period and origin, records that cannot be changed without losing the individuality that renders it most interesting. When furnishing our tables, the silver or plated ware should be selected with due attention to the general harmony of the design with the other decorations of the dining room. Art in silver is not out of place on the table of a dining room; on the contrary, the talent of an artist, like Benvenuto Cellini, would have been as satisfactorily employed upon a fruit stand, center piece or tea set, as upon shields or other large useless articles, which served for table and side board decoration in the fourteenth and fifteenth centuries; works of this description now belong to a past age, and are valuable to us only as historic references.

The malleability of silver makes it peculiarly adapted for the manufacture of fine plate; the pliant nature of the metal renders it capable of receiving almost any amount of hammering, correcting, expanding or contracting, if the proper attention is given to the annealing; it is the whitest of the metals and is susceptible of a very high polish, and the most fastidious taste can conceive nothing more suitable than silver for spoons, forks, salvers, etc.

It is almost impossible to exaggerate the charm of pure silver work, when used as a medium of artistic expression; and many of the silversmiths' best efforts are those into which architectural proportions are introduced. Experience has taught us that good silver

mounting and soldering will last for centuries. How frequently has silver ware been handed down as heirlooms from generation to generation, without any thought about the artistic merit of the treasured object; but, if the beauty of fine sentiment and skillful execution stamp it as a work of art, how much more worthy of being treasured the object becomes, and who can say what lessons it may teach in the future?

One of the great faults of the present day, even in art, is realism; photographic accuracy in regard to details is one of the follies of the age; it is a mistake for an artist to try to fix on his work the general sensation of beauty conveyed to the mind by a natural scene. The object of ornament is not to present to the mind the representation of natural subjects, but to cause the article upon which the ornament is applied to become as pleasing and agreeable as possible; and therefore the details of a design should not be a reproduction of natural forms, but must be subordinate to the laws of symmetry, and the beauty of effect. A good, bold, conventional manner of treatment, will be far more artistic and satisfactory than a realistic copying of nature.

In England all manufactured gold or silver is subject to a legal regulation of the standard of these metals. This law was first instituted about the year 1230, when it was found necessary to protect the public from fraud, by making it unlawful for silversmiths to manufacture goods of a lower standard than the silver coinage. In the year 1300 this power was invested in the Goldsmith's Company of London, to assay all goods manufactured of precious metals; and in those days, if the ware submitted to be assayed was found to be below the fixed standard, the goods were to be forfeited, and the offender was threatened with fine or punishment if the offence was repeated. The law of forfeiture has long ceased to exist, but the law of assay has now been in force over six centuries, and the Goldsmith's Company assay all gold and silver work made in England, and if the goods are not of the required standard, the articles are broken up and returned to the manufacturer. This law is in many respects a good one, for even the most careful manufacturer cannot always insure the thorough amalgamation of the silver with the alloy when melting, and in that case, one piece of work on being assayed will pass the Hall, while another article made from the same melting may be below the standard. Every one in England, therefore, looks for the Hall mark when purchasing gold or silver, jewelry or plate, as that is a government guarantee of the quality of the metal.

The most beneficial form in which art can be used is when infused into manufactures, decorating and adorning articles of utility, even inexpensive yet necessary objects of domestic plate that are found in every home, can, by this infusion, become tasteful and beautiful. No metal affords a readier means of expression in this respect than britannia; this comparatively valueless metal, if artistically treated, is as capable of expressing a pure and refining influence, as a more costly material, and a vase or tureen fashioned out of britannia can be made to look as beautiful and as graceful as one in silver; and if the ornamentation (be it chasing, engraving or rolled borders) is in good style, it is quite possible to deceive the sense of sight as to its material, particularly as this ware imitates so remarkably well the finish of first-class silver.

The decorative art of silver and britannia ware is the same in principle, and there exists to a great extent a similarity of conditions and purposes, aiming to produce the same results; and these equalizing conditions are still more augmented by the fact that a considerable assortment of articles of the same style and character are made in both metals, and the same models and patterns serve in common for both. The manufacture of britannia metal has made great advances of late years both in style and finish, and the ingenuity that is displayed in the innumerable small things called novelties, is in some cases worthy of more important work, but the greater part of them, owing to their over production, are absurd and inconsistent, wrong in construction, vulgar in decoration, but polished and bright as a

mirror. Some of those which are designed more particularly to catch the eye and attract attention are really amazing in the total incongruity of the elements which are brought together, forms and objects which in themselves and in their appropriate use are excellent, are wrested out of their legitimate province in a vain attempt to make them serve some utilitarian purpose. Works of this character are an insult to good taste, yet the manufacturers find a ready sale for them, and it is quite common to see homes filled with a profusion of such misapplied articles, which are for the most part frivolous in conception, visibly showing a lack of inventive power, and in some cases positively repulsive. The attempts to produce novelties by excluding the fundamental principles of all the accepted styles, must ever be condemned; and it is the more to be deplored, as the present system enables the manufacturer to reproduce good applied art as effectively and rapidly as possible, and if the articles are in the first place carefully designed and decorated, the million can be supplied with good artistic work, as easily and inexpensively as with that of a common and vulgar description.

It may not be uninteresting to some of my readers to lay before them the various processes of the present system of manufacturing silver and plated ware, as few persons out of the business understand how, or by what means, the various effects which are so universally admired are obtained.

Silversmithing, as we understand the word, when looking at a well finished piece of work, really includes several trades, for to produce a silver vase or tea set there will be needed the co-operation of a silversmith or moulder, a die sinker, spinner, stamper, chaser, engraver, plater, gilder, polisher, etc., each doing their part to produce a perfect whole.

After the design has been decided upon, and the several parts modeled, the first step is to take the silver and run it into skillets, after which it is taken into the rolling room and passed between the rollers several times, until the metal is reduced in thickness to the required gauge, the silver is then cut into pieces in sizes to suit the design that is about to be made. There are different methods of forming the body or foundation, the oldest way and the one that can never be entirely superseded, is hammering it by hand into the necessary shape, another way is to stamp or draught the flat piece of metal into blanks and then hammer it into the required form; but the methods most frequently used now is to stamp it and then spin it upon a lathe, instead of hammering, or to spin the body entirely from the flat metal. After this process the mounts, consisting of borders, cast or stamped ornaments, feet or handles are soldered on. It has then to be overlooked by the silversmith, and any roughness or irregularity left by the soldering removed, after which it passes into the hands of the polisher, who obliterates all hammer or file marks and scratches, when it is in a condition to be gilt, burnished or finished according to taste.

If the article is to be chased or embossed, it is done before the mounts are soldered on, and as this process will often stretch the metal it has to be returned to the silversmith, after chasing, to be brought back into its original form. When the article is to be engraved, it passes into that department immediately after the buffing process, except in some cases when the article is gilt or other fancy finishes applied, then the engraving is executed last, and by cutting through the gilding or other surface color, and showing the silver in the incisions, a variety of color is given to the work that is highly effective.

The silversmith commences his work by taking a piece of silver that has been rolled and cut in a circle of suitable size, to fashion a tea or coffee pot. The metal is placed on an indented wooden block and hammered into the indentation, which gives the metal a slight curve, the workman then hammers from the center of the silver to the outer edge in circles, each series of hammering increasing the curve. This process is repeated again and again until it assumes a hemispherical form, it is then placed on an iron stake and again hammered until the sides become sufficiently high and the lower part is elongated

or flattened according to the design. The silversmith then begins to shape or draw in the neck or upper part; this is done by placing the work on a smaller stake and hammering the metal inward and upward. It is very necessary for the silversmith to have a large assortment of these tools to hammer upon, some long, some short, some broad, others narrow, round, oval, half round, and in shapes to suit every conceivable angle that may be required; and as the hammering proceeds, it is necessary to anneal or soften the silver from time to time, as the continual hammering hardens the metal and it would crack if not frequently softened.

The method of forming the body that is most generally used by manufacturers of the present time, is to stamp the round flat piece of metal into a die or mould, and then place the work on a lathe and spin it to the required shape. These two methods represent the past and the present of silversmithing, and each method possesses some advantages that the other does not. Benvenuto Celleni worked his cups and vases from the flat metal with the hammer, and after getting the general outline, would shape and expand or contract any part according to his pleasure.

In Europe there are frequently to be met with some fine old hammered Flemish flagons of the fifteenth and sixteenth centuries, also some pieces of a later date that are called Queen Ann plate. These are certainly not so perfectly round as those the spinning process produces, but there is an indescribable sentiment in the former that is altogether wanting in spun work, and this is one of the reasons why they are so eagerly sought after by collectors in addition to their historic value.

Almost every one is aware of the difference between a sketch and a drawing worked out from a sketch, there is always a charming freedom about the rough lines of the sketch that is very pleasing, and which is frequently lost as soon as the drawing is worked out with mathematical precision and perfectly balanced, the poetry of the composition is obscured, and you feel that the mind has not played so important a part as the rule and compass; it is precisely the same with hammered and spun work, the piece of metal hammered and formed by the smith's hand, expresses the sentiment of the artisan; the spun work, on the contrary, simply bears the stamp of the machine. The hammered article has yet another advantage, the pores of the metal are kneaded in a manner and brought together very closely by the process, and thereby considerably strengthened. The spinning has, on the contrary, the effect of expanding or opening the pores of the metal, and consequently it is weakened. Another common fault in spun work is the frequent uneven thickness of the metal. The hammer is undoubtedly one of the most important tools of the silversmith, and like the iron stakes before mentioned, is very necessary for him to have a number of hammers of various sizes and shapes, and the angle of the faces must vary to suit the work. The hammer has to be held firmly in the hand, and the blow struck fairly on the face, so that the edges do not indent the metals, as such marks are difficult to erase. Hammering is, of course, a much slower process than spinning; by the latter method the manufacturer is enabled to distribute a large order over the factory in a very short time, and can always insure every piece being made a perfect counterpart of its fellow; and as they can make them so rapidly, it enables the producer to furnish the market with a cheap article, which is highly necessary; but to produce a cheap article ought not to be the end and aim of our silversmiths; the cultivated and refined taste needs something more than cheapness to recommend it. There have been some remarkably fine pieces of silver work produced in this country during the last few years, and they have in some measure revived the taste for art plate and caused a demand for hammered work. Spun work can be produced so rapidly and with such perfect uniformity, that the very repetition becomes monotonous, and people of taste begin to inquire for work that shows more skill of hand and less the appearance of being machine made.

*To be Continued.*

## Proceedings of the Horological Club.

A DISTINGUISHED BODY OF WATCH AND CLOCK MAKERS.

*Sixty-ninth Discussion.—Communicated by the Secretary.*

[Notice.—Correspondents should write all letters intended for the Club separate from any other business matters, and headed "Secretary of the Horological Club." Direct the envelope to D. H. Hopkinson, Esq. Write only on one side of the paper, state the points briefly, mail as early as possible, as it must be received here not later than two days before the end of the month in order to be discussed and reported in the CIRCULAR for the next month.]

SOLDERING STONE RINGS.—MAGNETIZED WATCHES.

BLOSSBURG, PA., Oct. 25, 1879.

*Secretary of Horological Club:*

F. W. C. asks a question in regard to stones changing white. In your answer you are correct in your theory that real stones will and imitations will not lose color. The reason is obvious. Pigments used for coloring glass are such as fire will not affect. Should it do so, there would be no dependence as to the result, as the pigment is added to the glass while in a molten state. On the other hand, the colors given to stones are many of a photographic derivation, or in many cases of vegetable origin, both of which heat will destroy. After understanding these things, the way to avoid discoloration is to be sought. Unlike metal, which changes color by oxidation, and may be protected by any substance protecting from the air, the stone must be kept cool. To do this, procure from the iron foundry a handful of moulders' sand, imbed the stone and so much of the ring as is possible, wet the sand around the ring, lay on a few small bits of charcoal and proceed to solder. Do the job quickly, using a strong fire. The sand once procured will answer for future jobs, as it is indestructible. Jewelers who cannot conveniently get the sand where they live, by sending enough to pay the postage to me (a matter of about five cents), will receive enough for use. There are large beds of the sand here.

R. B. FREEMAN, Watchmaker.

In the matter of magnetized watches, I would say, I have cured several completely. If any one has one, and will send it to me, and I do not remedy it, the charge will be nothing. Cheap watches will not be taken.

R. B. F.

Mr. Rolliver said that Mr. Freeman's method of protecting stones from injury was a good one, and was also described at our meeting a number of months ago. As for the "photographic derivation," that probably referred to "moss agates." A great many people think the figures seen in these stones are, as it were, photographed from some real objects in nature. But that idea was unquestionably a mere fancy, having no foundation in fact. The coloring is done by oxides in the veins or cavities of the stone, which take innumerable different shapes, often resembling some object. But it would be strange if they did not sometimes resemble something. But it was impossible that the figures could have a photographic or similar origin, for many reasons. These forms depend on the formation of the veins in the stone and the composition of the matter which infiltrated into them and they would be precisely what they are, no matter to what images they had been exposed. Again, the matter in the veins was not such as could be effected by any exposure to photographic influences. The forms produced in the stones often resemble objects to which it was utterly impossible that they could ever have been exposed, and a photograph without any exposure to the original object, was like an effect without a cause—an impossibility. But he thought it was needless to argue further against this belief, because everything was against it, except the mere accidental resemblance to something—and even they were often purely imaginary.

WATCH REPAIRING RECORD AND RATING SHEET.

Messrs. J. H. Purdy & Co., of Chicago, sent in samples of the above named specialties for watchmakers, which were examined with much pleasure by the Club. The rating sheet was described and commended at our meeting for August. Their watch repairing record appears to be equally complete and convenient. There is a place for the date of repairing, and of delivery, number of the check, of the movement, of the case, and the private mark, the owner's name and address, description of the movement, case, etc., items of repairs with price of each, and the total charge, also for any remarks on the

condition of the watch or other matters to be noted. They are printed in books of 200 to 400 pages, or may be had in loose sheets.

COMPARING WATCHES TO 1-5 SECONDS.

*To the Secretary of the Horological Club:*

In looking over the back numbers of the CIRCULAR, I find in the September number the question asked by J. W. T., as to the possibility of comparison of two separate American movements, one with the other. I had occasion to compare a couple of Swiss movements, years ago, and the method I then adopted has been of much service later, in determining the running time of any movements. The process is simple. Take two movements, cased, or in the tin boxes in which they come, put one between the teeth, the other to the ear—closing the remaining ear. Give the attention to one movement—the one at the ear—as the one in the mouth will be more distinct. Watch the variation of that at the ear, whether it loses or gains in comparison with the one in the mouth. As this only gives the variation of sound, to get the second or fraction thereof, use a fourth or fifth split second, according to the beat of the movement compared, to look at, and I will guarantee you can detect the  $\frac{1}{2}$ ,  $\frac{1}{4}$  or  $\frac{1}{5}$  second variation, easily. This comparing movements can be put to use by a good workman. Having a movement he knows the variation of in 24 hours—and using it with those he repairs, he can detect the slightest variation, and can remedy it without taking so much time as is usually the case and practice,

A. A.

Mr. Clerkenwell said he believed that the question, as originally asked, referred to comparing two watches by the eye, in which case it was necessary to look from one to the other, and it would be exceedingly quick work to compare them within  $\frac{1}{2}$  second. The method proposed by Mr. A. was susceptible of greater speed, as it required mental instead of physical quickness, in comparing the beats of the two watches. Still, it was difficult to see how anything was gained over a comparison of the watch directly with a good regulator, and altering it as required by that. Excelsior, in his book, described a way of comparing a watch with a regulator to  $\frac{1}{5}$  second variation in a minute, which was certainly close enough for most purposes. The same process could be made to detect  $\frac{1}{5}$  second of variation after running 5, 10, or any number of minutes, or even a whole day or a week.

But if the workman has not a reliable regulator, beating seconds, then the comparison of one watch with another might be very useful. But he regretted that Mr. A. had not given more details of his method of comparing. It might be different from the usual way, which was to wait till the two watches ticked exactly together, then count the beats, while varied, and till they coincided again, when one of them had of course gained one tick on the other. If it gained one beat in 20, and the watch made 5 beats a second, it would gain one beat in 4 seconds, and 15 beats or 3 seconds in a minute.

The use of the split seconds watch would be on substantially the same plan, only, instead of listening to two watches, he would listen to one and look at the other, and the latter would show to the eye, at the instant that the two ticks coincided, the number of seconds and parts of seconds which had been required for gaining one beat. This he presumed was the way Mr. A. would use it. But, if not, we should be pleased to receive an explanation of his process. If others have different or better ways, we should also be glad to receive descriptions of them.

BEEMAN'S PATENT HAND DRILL.

Mr. McFuzee exhibited the sample drill sent in by the manufacturers, and explained its many good points. It is really a very handy tool,—simple, durable and effective—much more so than the ordinary tools sold in the shops. It operates by a cord running around a pulley on the drill stock, on the same principle as the ordinary bow drill, but the stock is so held that there is no trouble with the cord getting off the pulley, as it always runs straight, being guided on both sides of the drill pulley. It works with any size of drill above the pivot drill, and will also run reamers, countersinks, etc., and any desired power can be given by straining on the cord while pulling. If desired, the handle can be screwed in the bench vise, and it becomes a stationary drill, to which the work can be held the same as

to a drill run in a lathe. It is a tool which should, and doubtless will, have a large sale. He believed that it was advertised in the CIRCULAR, with prices, and other information.

#### BLACK FILLING FOR ENGRAVING.

*Secretary of the Horological Club:*

I have noticed several articles mentioned for filling the lines of engraving. I use for that purpose good black sealing wax. If the lines are cut in metal, I warm it enough to soften the wax and make it stick, then work it into the lines. With engraving on ivory, wood, or pearl, I use a warm iron, not hot enough to burn the wood or wax, and rub the wax in till entirely filled and covered, and the wax sticks well, then rub off the superfluous wax with pumice stone, and grind off smooth with powdered pumice stone and water, on a smooth flat stick.

G. R. W.

#### FITTING A HAIR-SPRING IN A WATCH.

*Secretary of Horological Club:*

Please inform me how to put a hair-spring in a watch, of the correct strength when the original one is not to be used any more, *i. e.*, so that it is of the same strength as the original one was, so you need not change it after it is fitted.

J. G., JR.

Mr. McFuzee replied that the old spring should be carefully tested in a Bottom's hair-spring guage, after which another spring should be selected having exactly the same strength when tested in the same guage and in the same manner. This new spring will then be so nearly like the old one that if properly fitted in the watch it would not need to be changed, but could readily be timed by slightly moving the regulator as required.

This is a general outline of the method followed with a common watch. But with a fine watch, or even a fairly good one, there are many precautions and requirements to be attended to, beyond merely getting a spring of the right strength. But they could only be explained at considerable length, and would require more space than is allowed in the CIRCULAR for our proceedings. Although the most complete, thorough, trustworthy and practical directions for selecting, fitting and regulating hair-springs, which have ever been published, are to be found in a book published by the Editor of the CIRCULAR, and containing the first series of the Practical Hints on Watch Repairing by Excelsior. This work goes over the whole ground, and gives all information necessary to enable the workman to do a perfect job on any watch, from the common run up to the finest chronometers. Mr. G. can obtain a copy by sending \$3.50 to D. H. Hopkinson, Esq., the publisher of the CIRCULAR, and in it he will find full instructions not only on the point he mentions, but on a great many others which will be equally valuable and useful to the practical workman.

#### MAGNETIC ATTACHMENT FOR LEVER ESCAPEMENTS.

*Secretary of Horological Club:*

August number of JEWELERS' CIRCULAR to hand. I find it very interesting, as I have found former numbers. Also find many valuable advertisements, by which I have found new branches of my business, that possibly I would not otherwise have found. You appear to be headquarters for new and novel things in horological work, and I take the liberty of sending my device to make the lever escapement more perfect, when it has been so badly handled by some jack that it is almost impossible to make it work without new plate, lever, balance staff, etc. It is a circular, permant magnet. A groove is turned out of the plate, just under the balance wheel (Swiss style of watches). The points of the magnet must come very near the lever, but not in contact, as it would stick. The attractive force of the magnet will prevent the slipping by of lever or "over banking." The extra power required by the balance to unlock, on account of the magnetic attracter is compensated by the attracter on the opposite side. I have tried it and it works well. No patent on it; but if it should prove a novelty to you, it is all that I expect.

C. T. M.

Mr. Horologer said that the attachment was a circular steel piece, a little larger than the American circular click. A groove was to be turned out in the plate, around the balance staff, and under the balance. A piece was cut out of the ring, so that it would end at each wall of the lever-sink, the ends near but not touching the lever fork. Its operation and object were plain. Mr. H. expressed his unqualified disapproval of the idea, both on the ground that no magnetized

piece should ever be allowed in a watch, and that even if a magnet was unobjectionable, the benefit derived from it would be neutralized by its mechanical disadvantages. If the magnet exerted any appreciable attraction on the lever, it would be impossible for the balance to unlock it, the motion would at once die down, and the watch would stop. If the attraction was so slight as not to materially interfere with the unlocking, then it certainly would have very little effect in holding the lever against the bankings, against the tendency to slip off and overbank. He thought it would be much easier to remedy the trouble in a workmanlike way, by poisoning the lever, lengthening the fork, etc. If the pallets were so badly off that the teeth could not hold on the locking faces, it would be useless to expect any decent service from the watch till that trouble was removed in some way, and that way certainly should not be by using a magnet.

#### CHRISTMAS PRESENTS FOR THE BOYS IN THE SHOP.

*Secretary of Horological Club:*

I have two apprentices, and thinking to make them Christmas presents of something that would be useful to them, it occurred to me that Excelsior's book would be just the thing. Being now pretty old, and shall probably not work much longer, I have never thought best to buy the book, and do not know whether it would be suitable for the boys. I mean whether it is something they can understand, or whether it is full of theories and doctrines too deep for apprentices to tackle with. Trust you will answer this in the next number of the JEWELERS' CIRCULAR, and much oblige,

R. N.

Mr. Isochronal replied that no better present could have been selected, either for an apprentice or journeyman. There were many things taught in it which an apprentice would not be allowed to attempt practically, and which even the best of workmen were glad to learn. But the most of the book related to matters which would be of use to any workman, either young or old, every day of his life. There were no "theories or doctrines," but it was a plain, clearly written guide for the practical workman, telling fully, and with all the details, how the best workmen do their work.

The Club has so often commended this book that it is needless to say more than that it is one that *every* workman should have. Even Mr. N. himself, although he should never work another day, would be far more than compensated for the cost, if he should get a copy for his own reading. The satisfaction of knowing how many of the most difficult and unusual jobs are done, and of seeing everything so clearly explained, would be a pleasure worth far more than the \$3.50 it cost him. But by all means give the apprentices and young workmen of our land Christmas presents of these books. They will not only be gifts which the boys will like and appreciate, but the knowledge and increased skill they will impart will make their services worth more; and will prove a good investment for the givers, as well as a great and lasting benefit to the recipients.

THE descendants of the Moors in Algeria never lost, under all the oppressions of their rulers, their love for gorgeous jewelry, and many fine specimens of their artificers' famous skill in goldsmith's work have been handed down from generation to generation. The personal ornaments of women are by immemorial custom held to a certain extent, sacred in the East; they cannot be seized for debt, and are easily secreted from the unscrupulous rapacity of the ruling pachas. This accounts for the many heirlooms of jewelry still existing in the houses of the Arabs. But families come down in the world in Africa as well as Europe, and their valuables find their way into the market, represented in Algeria and Morocco by the Jewish dealers in miscellaneous commodities, with the modern addition of the "Mont de Piete" Bureaux in the French possessions. It is at the shops of the former, and at the periodical sales of unredeemed pledges, that the collector has to look for specimens of ancient goldsmith work in the Moresque style. He will find them very different from the paltry imitations which are sold everywhere at the bazaars. The shapes are the same, and have not been altered for centuries; but the ancient specimens are master-pieces of chased pierced, and filigree work in gold or silver, studded in fanciful designs with diamonds, pearls, precious stones, and coral, admirably set and arranged. One must, however, not expect any easy bargain, as even the lower classes of the Arab popularity are fully cognizant of the merits and the value of their ancient Jewelry, and do not shrink from any personal sacrifice to be possessed of a fine specimen.

## Trade Gossip.

Sapphires are being picked up by the handful in Siam.

Texas' tax on commercial travelers amounts to \$220,000.

The Chicago houses are reported to be doing a lively trade.

Fine diamonds are advancing, owing to the increased demand.

The demand for cameos is quite active and prices are advancing.

Horseshoe ornaments now have a bunch of four-leaf clover attached.

It is rumored that another advance in the price of silver watch cases will shortly take place.

Celluloid cigarette cases, made to imitate real shell or malachite, appear among holiday goods.

*Life* says that the English diamond trade is looking up by reason of orders from the United States.

A New Hampshire woman has discovered that a turnip in place of a clock pendulum answers every purpose.

One San Francisco jeweler sold \$26,000 worth of gems for use at Senator Sharon's reception to General Grant.

Pretty shopping bracelets have pencils attached, either of silver or gold, and frequently these are richly jeweled.

Americans wear more watches than any other nation. We have the system of tick to perfection in this country.

Arkell & Co., of Canajoharie, have opened a branch house in Rio Janerio. Their enterprise is deserving of success.

A favorite chatelaine ornament is an oblong silver locket containing a looking glass, which may be put to practical use.

Silver watch case makers are agitating for an increase of wages. They say they are tired of living on the smell of an oil rag.

A big trade in toys is anticipated at Christmas time, and speculative children are urging their parents to go long on the market.

L. Baumann & Co., wholesale jewelers of St. Louis, have opened a branch house in Sparta, Ill., under the management of W. H. Klootz.

Porcelain paintings are exceedingly popular. They are introduced in lace pins, ear-rings, cross-bars for chains, and a variety of other objects.

Europeans from Rangoon and great numbers of Burmese and Shans are said to be flocking to the newly discovered sapphire mines in Siam.

Among novelties in bracelets some of hammered gold show small indentations of the hammer over the surface; others are set with diamonds and other jewels.

Peter Zabrieskowatschiera, a California watchmaker, recently fell dead in San Francisco. It is believed he accidentally swallowed his name while trying to speak it.

A lace pin, simulating a piece of crumpled lace, formed of small diamonds and pinned with a pearl-headed golden pin, makes a tasteful and costly Christmas present.

The trade in Swiss watches is feeling the effects of the business "boom," and the demand for the better grades of these goods is greater than it has been in many years.

Laces for fans are sold separately as Christmas gifts in some cases, and in others are richly mounted with gold loops and a diamond, or sapphire, or a ruby at the rivet.

It is rumored that a youthful Apollo, whose personal charms have graced Maiden Lane for many years, is about to desert the army of loved ones, and cross over to the numerous band of hymeneal martyrs.

A pretty novelty, suitable for a present for a gentleman, is a drinking cup of silver plate, representing a thimble, enclosed in a Russia leather case, on the outside of which are the words, "Just a thimble-ful."

Madame Lina, the daughter of a Genovese watchmaker has settled in London as a repairer and manufacturer of watches. She takes apprentices and proposes to teach women a hitherto untried field of labor.

In the room of a railroad depot in Iowa is the following placard over the clock behind the counter: "This is a clock; it is running; it is Chicago time; it is right; it is set every day at 10 o'clock; now keep your mouth shut."

The Chicago Jewelers' Association will give their annual dinner December 30, at the Palmer House. Our good friend, Stedman Hale, of Chicago, is hereby deputed to eat our share of the good things that will be provided on that occasion.

Hale & Mulford have granted to Carrow, Bishop & Co., the right to manufacture certain bracelets covered by patents issued to the first named gentlemen. Each house will confine itself to certain styles of ornamentation so as not to conflict with the other.

The case of William Fisher, of New York, against the proprietors of the Planters' House, in St. Louis, to recover \$12,000, the value of jewelry stolen from him while a guest of the hotel four years ago, was decided by the United States Court, recently, in favor of the defendants.

The Waltham Watch Company is doing an extensive business these days, the demand for their goods necessitating the running of their factory night and day. Their workmen all wear smiling faces, occasioned by their receiving liberal wages and all the work they can possibly do.

An elegant ornament for a gentleman's smoking table is an old oaken bucket of oxidized silver, old gold and bronze. The well and sweep are of bronze, the bucket of oxidized silver, with old gold bands, and the rope of old gold. It is a cigar holder and ash receiver combined.

A new serpent bracelet clasps the arm in three or four coils, remaining wherever placed, either at the wrist or above the elbow, or it can be uncoiled and used as a necklace. The eyes of the serpents in the richest of the ornaments are formed of jewels—diamonds, emeralds, rubies, or garnets.

By a typographical error in our advertising columns last month the National Watch Winder Company was mentioned as the National Stem-Winding Watch Company. The printer who made the mistake has crossed over to the other shore, and is now expiating his offences in a place specially set apart for stupid type setters.

Mr. Henry Molineux, manager of the Seth Thomas Clock Co.'s business in San Francisco, was married Dec. 4, in Brooklyn, to Kate A. Noyes, daughter of the late Cyrus Flint, Esq. We extend to the happy pair our congratulations, and his numerous friends will join us in wishing them every happiness and prosperity.

In our November issue we announced that the assets of Coggs-well, Weber & Co., of Chicago, had been purchased by Wm. Smith & Co. for the sum of \$21,000. Before the purchase had been ratified by the Court some one else made a higher bid, whereupon Smith & Co. raised their bid to \$24,000, and were declared the purchasers. This sale was ratified by the Court, and became an accomplished fact.

A watchmaker belonging to the town of Ayr, in Scotland, left \$10,000 to build up the "Auld Brig," should it ever fall down. His brothers are trying to break the will, and the case will come up for trial before Lord Young. Lord Young, we may remark, does not belong to the Auld Brigham Young family, although we believe he is a native of the shire of Ayr, where the Auld Brig was born. Persons conversant with Burrrns will remember that this said "Auld Brig" proposed to be a brig when the new "Brig" was nowhere.

In the case of Miller Brothers, of this city, against H. G. Mac-Kinney, for infringement of patented designs for sleeve buttons, the infringing goods being manufactured by Albert J. Smith & Co., of Providence, R. I., the United States Circuit Court has granted an injunction restraining the parties implicated from manufacturing or selling such imitation goods. Miller Brothers are determined to prosecute any person infringing upon their patents, and it is to be hoped that other patentees will adopt similar vigorous measures to maintain their rights.

Ira B. Canfield, senior member of the old and well known house of Canfield Brother & Co., of Baltimore, died suddenly of apoplexy December 6th, while attending to business in his store. The deceased was 71 years of age. The firm of Canfield Brothers & Co. has been established many years, and enjoyed the reputation of being one of the finest houses in Baltimore. The members were well known in this city, where they made extensive purchases. The sudden death of the head of the firm will be a matter of sincere regret to a large circle of friends both within and without the trade.

Some time ago John F. Hopkinson & Co. brought a suit against William M. Elias and Elias H. Elias to recover \$51,000, and in that suit obtained an attachment against some of the defendants' property, on the ground that they were about to fraudulently dispose of their property. The defendants then made an assignment purporting to be for the benefit of their creditors. The plaintiffs then brought a suit to have this assignment set aside. This case was tried before Judge Freedman in the Superior Court. Judge Freedman recently rendered his decision, in which he says:—"The assignment seems to have been conceived and consummated in fraud by men who live by fraud."

## Repairing Swiss Watches.

### WORKING IN A FOURTH PINION.

Hitherto I have spoken only of repairs to this pinion; but as in many cases it will not only be better but quicker to replace it with a new one, I purpose briefly to describe the usual method of working in a new pinion.

Having selected a pinion of the correct size for the third wheel, and fixed to the long arbor an old screw ferrule, cut a thin boxwood slip to a thin edge, and with rather sharp red stuff and oil proceed to polish out the leaves, resting the pinion on a hard cork, or piece of soft wood. The screw ferrule on the arbor enables you to press the first finger of the left hand against it, and thus the pinion is held while polishing; the natural elasticity of the cork or wood allows the pinion to give a little to the motion of the polisher, thus keeping it flat. The leaves having been polished out with wet red stuff, and finished with fine stuff, or diamantine, the truth of the leaves can be tested by running it in the turns. (Should the centres of pinion not be perfect, they must be made so before trying it, by turning through a runner.) Should the leaved portion or pinion on trial prove out of truth, it must be corrected in the following manner, at the same time I may caution those whose experience in the work is not great, that pinions are occasionally met with which it is impossible to get true, owing to one or two leaves being cut deeper than the rest, from some fault in the cutting engine; such should unhesitatingly be rejected as useless. If, while the pinion is in the turns, a piece of soft lead pencil is held on the rest, so that its point just touches the top of leaves, those that are furthest from the center will be marked, thus forming a guide for the correction of the arbor. The *marked side* of the arbor being placed *downwards*, in contact with either a soft steel or brass stake, the upper or hollow side can be stretched by a few light blows from the pane of a small hammer; the blows should be distributed at equal distances over the arbor, and, as these pinions are usually rather soft, some care is required not to overdo it. Having by this means got the leaves to run true, the arbors can be shortened to little more than the ultimate length of the pinion, and the centers turned true. Previous to commencing to work in the pinion, some little attention is necessary to the following points: In some watches the banking, instead of being against a stud in the cock, is against the arbor of the fourth wheel; in this case the diameter of the arbor is of importance, as if too small, and the watch caused to bank by external agitation, the pin would jam against the arbor of fourth wheel and stop the watch. Again, in some callipers of movements, the fourth pinion head comes close to the plane of the balance, and in some positions, if the pinion head is too high, or from excess of end shake the banking-pin touches it, forming a cause of stoppage rather difficult to detect sometimes. The old pinion being removed from the wheel, all the measurements can be taken directly from it. The first thing will be to turn down the leaves to form a seat for the wheel, measuring the height from the pinion face. Care must be taken in fitting a pinion to an old wheel, that the leaves fit into the marks made by the old pinion, otherwise a difficulty will be found in securing the wheel. Having fitted the wheel, try its truth in round in the turns, and if untrue, shift its position on the pinion until it runs quite true, then mark the wheel and a leaf of pinion, so that its position can be found again. You will now shorten the leaves, leaving just sufficient to rivet soundly. If too much is left to be riveted, the pinion face will be bulged and spoilt. If the leaves project the thickness of a sheet of this paper, 10 mm., it will be sufficient if the wheel fits properly), and should be but slightly undercut to insure a sound rivet. You will now rivet on the wheel, using a steel or bell-metal stake to support the pinion, and a polished steel punch of such a size that it fits just freely over the arbor. A piece of tissue paper between the face of pinion and stake will protect it during the riveting, and if care is taken to shift the wheel a little

every few blows, the wheel will be secured true and flat. The face of rivets can be turned flat and glossed, and the hollow cut. The arbor should now be turned to size, leaving a slight shoulder close to the wheel to prevent the polisher coming in contact with it. The arbor can now be polished, burnished, and the position of the upper pivot shoulder marked on it, measuring from the pinion face with the tenth measure. The pivot being turned down to within three degrees of its proper size, the pinion can be reversed in the centers, and the seconds pivot turned down, its position being fixed by measuring from the upper pivot shoulder. The pivots being smoothed with red stuff, are burnished on the Jacot tool to size, leaving only the rounding up, and turning off the extreme corners to complete the work. I may remark that the size of hollow, necessary in the pinion face, is regulated by the length of shoulder there is. Where this is extremely short, a hollow of considerable depth and breadth is required; on the other hand, where the shoulder is of considerable length, a small hollow will suffice.

### THIRD PINION.

In those callipers of movements, in which, from the reversed position of the center wheel the power is received and transmitted from opposite ends of the pinion (as in the case of the third wheel in the ordinary foreign or barred movement), one commonly finds, after the watch has been going for any length of time, the upper pivot considerably worn or cut. This proceeds in many cases from the pivot in the first place being too small to withstand the necessarily great pressure. In addition to this, the leaved portion of the pinion having to be so high to meet the center wheel with safety, renders it difficult to get a sufficient shoulder to the pivot. If, in addition to this, there is an insufficient hollow, and that but roughly cut, it is hardly to be wondered at if the oil rapidly disappears, and the pivot becomes cut.

In repairing these pivots, it will generally not be sufficient to turn out the marks and repolish. If this is done, it often becomes cut again very quickly. It is much better to replace the pivot with one of the original size, and at the same time to see that the extreme corner is cleanly sloped off, and that the hollow is somewhat large, deep and cleanly cut.

Before quitting this part of the subject, I have a few words to say about stoppings. By far the larger number of watch repairers use "bouchons" for this purpose, and, doubtless, they are very convenient. As a rule they are truly drilled, and correctly centered; but the quality of the material is anything but what could be desired; anything softer and more unfit for the purpose it would be difficult to find. If the workman really wishes to have a good and lasting material for his pivot holes, he cannot do better than get a piece of good hard pin-wire about two and a half millimeters diameter, and having fixed a round hole draw plate in the vice, run it through until its diameter is reduced to about half a millimeter *without annealing it*. If the wire is good, it will be impossible to reduce it much smaller without frequent breakages; on the other hand, if it does not become exceedingly hard and springy under this treatment, it is unfit for the purpose required. Supposing that he has a hole to put in, say the third bar hole; having put the frame in the mandrel, and carefully centered it by means of the pump center, test its accuracy by means of a peg, and if right, screw on the bar and broach out the hole (holding the broach, and turning the mandrel to about three times the size of the pivot). Having removed the bar from the frame, drop a broach into the hole until it just fits, and work it round without turning it, until it is full of fine "utters" or cuts, and slightly larger at each end than the middle. A piece of the stopping wire having been carefully filed with a smooth old file until it goes tightly into the hole from the under side of bar, the end is filed perfectly square, and of such a length that it just projects into the oil sink the thickness of a sheet of paper.

(To be continued.)



On the Compensation of Clocks, Watches and Chronometers<sup>1</sup>(By EDW. RIGG, M. A., *Assayer in the Royal Mint.*)

A method very generally adopted for diminishing the error of the ordinary balance consists in adjusting the spring so as not to be absolutely isochronous, but to occasion a slight gain in the short arcs, thus setting one source of error to counteract another. The instrument being adjusted at 15° and 30°, a fall below the lower part will occasion thickening of oil, and therefore short arcs, when the accelerating effect of the spring will come into play. But any departure from true isochronism is by many regarded with suspicion, although Phillips,<sup>4</sup> a high authority on the spiral spring, advocates the above practice.

Bearing in mind that the object of every auxiliary or modification of the ordinary balance is to make the radius of gyration diminish more rapidly with a rise of temperature than is the case with an ordinary balance, and increase more slowly on lowering the temperature, a very few words will suffice to explain the various forms (shown in a diagram); modifications of the circular balance which I have endeavored to select as typical. The first, invented by Le Roy,<sup>5</sup> in 1786, as a means of avoiding the irregularities he observed with the bimetallic strips, is a plain brass balance with uncut rim, and the compensation is entirely effected by the motion of the mercury in two glass thermometer tubes placed radially, the bulbs being filled with alcohol; this was the earliest form in which the motion took place in a straight line directed towards the center. No. 2 is one form of Molyneux's auxiliary, patented in 1840.<sup>6</sup> When the strip in its inward motion reaches a certain position, it comes in contact with a second smaller weight, and the effective movement is thus a product of the motion of both weights; the adjustment being made for low temperatures is thus approximately correct for higher. In Poole's balance, No. 3,<sup>7</sup> a similar result is secured by checking the movement outwards; the adjustment for this case must be made at the higher temperature, and this simple addition to the ordinary balance has often been found remarkably efficient. No. 4 shows Jacob's balance,<sup>8</sup> where a second small balance is fixed within the first, and banked so as only to act in heat; it can be rotated on the balance staff, and thus, while the principle is nearly the same as that of Molyneux, it offers a greater range of adjustment; but the arrangement is complicated, and additions near the center cannot be considered to be satisfactory. In Mercer's balance, which has given very good results, the auxiliary consists of a platinum screw placed at the extremity of a short bimetallic arm.

Hutton and Breguet<sup>9</sup> (J. H.) have patented arrangements for correcting the error in the primary compensation, by modifying the resistance opposed by the air to the movement of the balance, which is enclosed for this purpose in a confined space; but as no such method is ever employed in practice, it will suffice to merely refer to them.

A curious device was devised by a Dutch chronometer maker, Hohwu. Although impracticable in the form he suggested, it is theoretically preferable to those previously described, and I have therefore included it in the selection. A bimetallic helix is adapted near the extremity of the ordinary rim, and carries a collar, in which a weight is screwed, so as to be adjustable. The motion of this weight with a change of temperature, is the resultant of that due to the rim and helix, and its effectiveness depends on the distance between the middle of the helix and the center of gravity of the weight; this, of course, is variable.

Although carried out in a very different manner, the compensation weights, patented in 1843 by Lund,<sup>1</sup> and that more recently proposed

by Vissiere,<sup>2</sup> involve a similar principle. Lund's weights are too complicated for brief description, but it may be mentioned that they appear to be far less sensitive to centrifugal force than do those of Wissiere. Without entering into the details of construction of the latter, it will suffice to say that the weight is carried on a small divided bimetallic ring, attached by an arm to a block, that can be set in any position along the bimetallic rim of the balance. The weight can be moved along the ring for adjustment, and the entire system forming the weight can be rotated about the center of this ring. It is evident that the motion of the weight is the resultant of that due to the two bimetallic strips, and the adjustment consists in so co-ordinating these, that the inward motion is increased, and the outward diminished.

Another balance of this class that remains to be noticed, namely Loseby's,<sup>3</sup> involves the use of mercury. This is contained in two thermometers, curved towards the center of the balance, and some years ago satisfactory results were secured by its inventor; but mercury and glass are very objectionable, and are now never employed.

A balance acting on an entirely different principle to any of the above has been recently invented by Woerd<sup>4</sup> in America. It is characterized by the total absence of the ordinary bimetallic strip, which is replaced by a band of steel, cut near the junctions with the diametral bar; saw-like indentations extend across the entire band, and these spaces are filled in with a highly expansive metal. The uncut portion of the steel, carrying screws, is thus caused to move to or from the center by an amount depending on the number of these teeth; the inventor, moreover, claims that its amount of inward motion gradually increases in accordance with the requirements of theory—in other words, that the tension of the spring and moment of inertia of the balance bear the same ratio to each other in all temperatures—but it is not evident why such should be the case.

Finally, a modification of the ordinary balance has just been suggested by Saunier.<sup>5</sup> The idea seems well worth carrying out, at any rate on an experimental balance, and he expresses a hope that some watchmaker will make such a trial. The two halves of the diametral arm, instead of forming parts of a straight steel bar, are semi-circular bimetallic pieces, with the brass on the inside face. They are so placed that changes of temperature increase the movements of the compensation weights both in heat and cold. It seems certain, from a consideration of the combination of movements, that the effect of such an arrangement will be to produce a motion of the weights more directly towards the center in heat, and less so in cold, thus materially reducing the middle temperature error. With care, the rigidity would be equal to that of the ordinary form, the difficulty of construction need not be great, and all the adjustments would be unaltered.

The impossibility of securing perfect compensation with the ordinary balance induced many attempts to be made to carry out the principle of rectilinear compensation, as illustrated by Le Roy's mercury balance. Hardy proposed to support two weights at the extremities of a flat bimetallic strip, and this system was elaborated by Dent, and is the foundation of some of the more recent forms of balance.

The rectilinear movement is usually brought about by joining the two metals, so that the plane between them is at right angles to the balance staff instead of parallel, as in the ordinary construction; the manner in which this tends to produce the required motion is easily explained. The balance being adjusted for a mean temperature, any application of heat will cause the strip to bend upwards, since brass is below, and the converse will be the case in cold. Now, the amount of the motion to or from the center is determined by drawing a perpendicular from the center of gravity of the weight, which is carried by the upright, to the horizontal; and, by a well-known geometrical

2 "Saunier's Modern Horology," art. 1360.

3 Patent No. 1011, A.D. 1852.

4 "Horological Journal," xxi. pp. 22 and 82.

5 "Revue Chronometrique," x. p. 236; and "Horological Journal," xxi. p.

1 A paper read before the members of the Society of Arts, on Wednesday, 12th February, 1879; Mr. W. Ellis, F.R.A.S., presiding. Revised by the Author.

4 "Revue Chronometrique," v. 290.

5 "Revue Chronometrique," iv. 422.

6 Patent No. 8418 "Horological Journal," xvii. p. 20.

7 "Horological Journal," xvii. p. 23.

8 "Exposition Universelle" (1867), by Saunier, p. 92.

9 Patents, Nos. 11,427 (1846), and 819 (1860).

1 Patents, No. 9969, A.D. 1843.

principle, this is less with a given motion downwards than for the same motion upwards. In Dent's balance on this system,<sup>3</sup> known as the "staple balance," the application of heat causes the two staples to open out, since they are formed of the usual metals, brass and steel, and the weight will thus be raised, the compensation due to the main arm taking place at the same time. The result will be that the movement inwards is still further increased, as compared with that outwards; the ratio subsisting between the two must be varied by a change of the length or thickness of the staples. Some excellent chronometers are fitted with this balance, but it is difficult of construction, not easily poised, and liable to be effected by centrifugal force; Hartnup, therefore,<sup>4</sup> of the Liverpool Observatory, proposed another form which was very successful in the hands of Shepherd, of that town. Its mode of action is not so evident as is that of Dent's; but a few words of explanation must suffice. The entire balance is formed of bimetallic strips. In the central bar, brass is uppermost, but in the other two straight bars, steel. The segments forming the rim are of steel and brass, with their junction inclined at an angle of about 45° to the plane of the balance. The movement of the weight is thus a resultant of three motions. The downward motion of the inner arm increases the space through which the extremity of the other arm travels by one-half, and the sloping segment imparts a skew motion to the weight, the amount of which depends on its position along the rim. The balance, however, is difficult of construction, and has not been successful with other makers.

This skew principle is also taken advantage of in Kullberg's balance, of which there are two or three varieties. *c* represents what he terms the low-rim balance.<sup>5</sup> The center bar is formed of brass and steel, the former uppermost. Two semi-circular bimetallic rims, whose section is shown in a separate sketch, are attached at opposite ends; they are made of considerable thickness, in order to bring the weights near the extremities.

Another balance of Kullberg's design, known as the flat-rim balance has given excellent results, but is, I believe, now rarely used. It is circular in form, and the rim is a flat bimetallic strip of the usual metals.

The last balance I shall refer to is that of Winnerl,<sup>6</sup> which has been recently invented. Three arms are employed, as in Hartnup's, but the central one is entirely of steel, and therefore remains flat in all temperatures. Bimetallic strips of brass and steel, in the proportions recommended by Villarceau (0.43 mm. to 0.32 mm.), are attached to its ends, and these carry at their extremities inclined supports, on which conical platinum weights are screwed. The exact inclination of the arms must be adjusted for each make of chronometer and balance spring. The adjustment is said to be extremely simple, and not to involve the removal of the balance from the instrument. The rates at two extremes are first brought into accordance by raising or lowering the weights, and then, for an increase at a mean temperature, the inclination of the support is diminished, and conversely with a loss. The timing screws are carried on a separate arm. Caspari<sup>7</sup> has discussed the efficiency of this balance, and concludes that it is competent to secure a perfect compensation, and does not interfere with the isochronism of the spring. He has further ascertained that the motion of the weight is the resultant of two motions, one proportional to the temperature and the other to the square of the temperature.

Although this seems to offer some advantages, it cannot be regarded as entirely satisfactory; for there is a great mass of metal at the center, and the poising can never be as easy as in a balance of circular form. Kullberg has, moreover, pointed out that the use of screws for joining the bars is a grave objection.

The consideration of these few specimens, selected from the vast number of balances that have been proposed as means of securing

an exact measure of time, shows that there are still several points far from being satisfactorily solved.

One point that cannot fail to be noticed is, that the adjusting of a chronometer, even when performed by the very best workman, should require almost as many trials, and extend over as long a period, as it did in the days of Arnold and Earnshaw. Surely it is not unreasonable to expect that some of the ingenuity and skill that are devoted to the designing of auxiliaries might be expended in devising some more expeditious means of adjusting the primary compensation, and thus both reduce the cost of production of high-class work and diminish the risk of straining the balance spring or damaging the mechanism, which no amount of care can always avoid. It does certainly appear remarkable, when labor is being diminished as much as possible in all the mechanical arts, that chronometer makers should be so far behindhand in this matter.

Another point that is worthy of notice, illustrated in a marked manner by the annual reports of chronometer trials at Greenwich, is the fact that no form of balance has succeeded in establishing itself as invariably better than others; and even balances that are known to be among the best often figure low in the list. The frequency with which this is to be noticed is hardly explicable, unless we allow that circumstances influence the rate which are beyond the control of any workman, and that, when the performance of a chronometer is exceptionally good, the path of the compensating weights *happens* to accord with the several influences by which the movement of the balance is modified. The composition of the brass, the fineness of steel, degree of hammering, smoothness of acting surfaces, play of pivots, constrained molecular state of metals employed, and, above all, the nature of the oil—all these points may be perfectly satisfactory for compensation up to a certain limit, but beyond that each may have an infinitesimal effect which cannot be isolated or neutralized; and thus a balance whose compensation is perfect in one instrument may not give satisfaction in another, although made by the same workman.

In astronomy—that most exact of all the sciences—it is impossible to avoid even errors of observation, or differences between the actual time of a phenomenon and the period at which it is appreciated by the senses, except by a mathematical device involving probabilities, such as the method of least squares; it is not unreasonable to conclude, therefore, that a point must be reached at which the errors of every machine that is the result of human skill must be neutralized in some similar manner; and the tabulation of chronometer errors is a case in point.

The remark of Sir John Herschel<sup>8</sup> with regard to astronomical instruments is peculiarly applicable to chronometers, where so many actions require to be co-ordinated; and it might be remembered with advantage by many who introduce who introduce novel balances. "Human hands or machines," he says, "never formed a circle, drew a straight line, or erected a perpendicular, nor ever placed an instrument in perfect adjustment, unless accidentally, and then only during an instant of time."

The variation that every auxiliary is designed to correct amounts to only the  $\frac{1}{1000000}$ th part of the period measured for each degree (Centigrade) change of temperature, and this comes very near the limit of sensibility of our best chemical balances, and is even almost comparable with Whitworth's wonderful machines for measuring lengths, &c.—instruments that are characterized by great simplicity, and subject to exceptionally few interfering causes. On the other hand, it must be admitted that the remarkable uniformity observed in the error of all chronometers with balances of the ordinary construction, tends to prove that the above-mentioned influences are of secondary importance; but they certainly do stand in the way of absolute perfection. It becomes a question, then, whether a recognized and comparatively large error, that can be allowed for, is to be preferred, or a so-called perfect compensation, that we feel convinced can never be attained except by accident, and is liable to be destroyed by the rough motion to which a chronometer at sea is always subject. No one would hesitate to select the former.

8 "Outlines of Astronomy," Eleventh Edition, p. 80.

3 Patent No. 9302 (1842). "Horological Journal," xvii. p. 22.

4 "Horological Journal," xvii. p. 24.

5 "Horological Journal," xvii. p. 26.

6 "Horological Journal," xx. p. 32.

7 "Comptes Rendus," lxxxii. 894.

# THE Jewelers' Circular and Horological Review.

VOLUME X.

NEW YORK, JANUARY, 1880.

No. 12

THE

## JEWELERS' CIRCULAR AND HOROLOGICAL REVIEW,

*The recognized organ of the Trade, and the official representative of the Jewelers' League and the Watchmakers' and Jewelers' Guild of the U. S.*

A Monthly Journal devoted to the interests of Watchmakers, Jewelers, Silver-smiths, Electro-plate Manufacturers, and those engaged in the kindred branches of art industry.

### SUBSCRIPTION:

To all parts of the United States, Canada, Great Britain and the West Indies,

**\$2.00 Per Annum; Postage paid.**

To France, Switzerland, Germany, Mexico, the Republics of South America, and Australia, \$2.50 per annum. Postage paid.

*All communications should be addressed to D. H. HOPKINSON, 42 Nassau Street, New York. Advertising rates made known on application.*

THOSE OF OUR READERS WHOSE TERM OF SUBSCRIPTION EXPIRES WITH THIS ISSUE, AND WHO HAVE BEEN NOTIFIED BY OUR USUAL CIRCULAR, WILL CONFER A FAVOR BY RESPONDING AS PROMPTLY AS POSSIBLE, AS ALL SUBSCRIPTIONS TERMINATING WITH THIS VOLUME WILL BE DISCONTINUED IF NOT RENEWED.

### The Holiday Trade

THE holiday trade during the past month, has been more extensive by "a large majority" than during any season for the last five or six years. Everybody seems to have had money to spend, and they have spent it freely. The stores have been thronged day and night, the factories have been taxed to their utmost capacity, while the salesmen have had their hands full of liberal customers. Maiden Lane has presented a busy appearance from morning till night, while dealers in fancy goods and toys have been overwhelmed with buyers. The activity of the holiday trade has reminded us of old times, and has been one of the most convincing indications that prosperous times have come again. Unquestionably the people find themselves with more money in their purses than they have been accustomed to of late, and also that the prospect of replenishing the supply is better. They have been tempted to liberal expenditures by the generous display of novel and attractive goods. Everywhere new designs and artistic novelties greeted the eye, and the inducement to lavish expenditure was almost irresistible. The jewelry trade was especially happy in its provision for the holidays, and was distinguished for the great variety and attractiveness of the goods offered. Good taste pervaded the new goods, and a marked improvement in designs was noticeable even in the cheapest classes of articles of personal adornment. There was a good demand for rich goods that combined artistic skill with intrinsic value. Those manufacturers of fine goods who had risked much in producing rich and valuable goods found their work appreciated, and their labors rewarded. It is safe to say that the holiday trade of 1879 has given an impetus to the manufacture of fine and artistic goods that will be felt for years, and that skill, originality, and superior workmanship will be more in demand in the future. A leading feature of the

trade, and one which will appear to greater advantage hereafter, was the marked preference given to the productions of individual workmanship in contradistinction to cheap machine work. The leading houses in the trade that have produced high grades of goods, giving prominence to the taste and skill of individual workmen, have been uniformly successful, and attracted unusual attention. Seldom, even at the holiday season, has the trade appeared to better advantage, or been more successful than during the month just passed. Those houses that deal in standard solid goods generally found their supply exhausted before the demand was satisfied, and were unable to fill their orders. The leading silver plated ware houses were obliged to recall their travelers, and to decline the orders they had received on account of their inability to supply the goods. Orders thus declined would make a very good showing for a fall trade of the volume we have been accustomed to for the past few years. Another feature of the month was that very few goods were sold on memorandum. All this shows very clearly that the country is in a far more prosperous condition than it has known since the panic; that business is generally good, and prospects flattering, and that confidence in the future is restored.

Hard times have shown our manufacturers how cheaply goods can be made. While prices have been reduced, the margin of profit has been fairly maintained. It used to be said that the waste in an American factory would suffice to run an English factory. This cannot be said now. Our manufacturers have learned to practice all the economies known to their English brethren, and to save in expenses. This, too, without reducing the workmen to starvation wages. Rigid economy practiced during the hard times has taught the lesson that it pays to save at the spigot as well as the bung. It has been a hard lesson for some of them to learn, but will prove their salvation in the future. The trade is now in a better condition than ever before to reap the reward of patience, enterprise and honest dealing. Many of the speculators in the trade, to whom the present dollar was deemed of more worth than reputation, have been driven to the wall; thousands of dollars of indebtedness have been wiped out by compromises, and the business approximates nearer to a cash basis than it has during the past decade. A better feeling prevails in all quarters, and the outlook for the future is most flattering. Now is a good time to enforce better methods of doing business than have prevailed of late years, to effect needed reforms in the credit system, and to insist upon a higher standard of business morality. Let the cold shoulder be given to those who have, during the hard times, shown evidences of trickery or sharp practice. Put them on their good behavior, and when they overstep the limits, send them to Coventry without any compunction. Raise high the standard of honesty and fair dealing, and weed out those who forswear their allegiance to that trite old adage "honesty is the best policy." When trade is "booming" it is the best possible time to extend a helping hand to the deserving, and to lop off those excrescences that have attached themselves to the trade only to bring disgrace upon it. The year 1880 opens most auspiciously, and it needs only the exercise of care and prudence, combined with enterprise and good judgment, to make the harvest as abundant as the promises thereof are prolific.

### Closing the Books for 1879.

IN closing the books for the year 1879, the jewelry trade has the satisfaction of looking back upon the last half year as one of the most prosperous it has known in many years before. The demand for goods sprang up suddenly, catching most of the manufacturers unprepared. Owing to previous dull times, their workmen had scattered, engaging in other avocations from which it was difficult to withdraw them. But the new demand had to be supplied, and the factories were got into operation, but not until the demand for goods had outrun the supply. As a consequence, it has been impossible to catch up, and there are but few of the out-of-town buyers whose orders have been entirely filled. The holiday trade was unexpectedly large, the consequence being that there is nothing left in the market but broken lines of goods. It will take weeks yet for manufacturers to catch up with their orders already received, but all are working to their utmost capacity to accommodate their customers. This condition of things has led some of the distant dealers to believe that they were being neglected, or that some sinister motive prevented the filling of their orders, and much complaining has resulted. The simple explanation is that the goods were not to be had. In the recent demand for the better grades of goods lies much promise for the future. The artistic skill and exquisite taste that have lain dormant in the trade during the years of depression will now have opportunity to display themselves with fair prospect of reaping suitable reward. New designs and attractive wares are required, and their production will tend to develop the best skill there is in the trade.

The condition of the trade was never better than it now is. Country retailers have learned to buy cautiously, and not to overload their stock. In this respect, they should be encouraged by the jobbers. It is very much easier for a dealer to duplicate his orders than it is to work off stock after the market has been supplied, or when new designs have made the goods "old fashioned." A small stock of attractive goods, kept fresh by the addition of all that is new in the way of styles, is far better than an unwieldy stock that is culled over by customers month after month.

It cannot be untimely to sound a word of caution at this time. Because business is lively and goods are selling readily furnishes no warrant for extravagance or recklessness. Jobbers who push business beyond their capital are liable to meet with disaster. If their paper is not provided for and promptly met, their credit suffers. Promptness in meeting obligations is, of itself, an open sesame to credit. Recklessness and personal extravagance breed suspicion. The trade is now on a good footing with excellent prospects ahead. Caution and conservatism, combined with good judgment, will give permanence to the present prosperity.

### Required Legislation in the Interests of Commerce.

IN the December number of THE CIRCULAR, we commented on the recent decision of the Supreme Court declaring unconstitutional the law relating to the registration of trade-marks. While that law was not of so much importance, as it has generally been credited with—the common law affording ample protection to owners of trade-marks—the decision was important as demonstrating the necessity for Federal legislation for the protection of trade and commerce. With the extensive ramifications taken on by commerce during the past few years, the legislation of the several states regarding it is not only inadequate for its protection, but entails endless confusion. This is demonstrated by the interminable litigation forced upon railroad and telegraph lines, whose daily transactions are conducted within the limits of all the States, none of which are competent to control these great corporations in the interests of the public. State legislation has been so hostile to these enterprises that the companies have been forced for years to employ lobbyists in the different State legislatures to look out for their interests. In doing this, legislative bodies have been corrupted, and

valuable franchises sacrificed for bribes. Commercial interests are now so all-pervading that no legislation, short of that enacted by Congress, is adequate to regulate it. This legislation is required, not only for the protection of trade, but for the safety of the public, to prevent imposition.

Congress owes it to the country at this time, when business is reviving and a new-born prosperity is beaming upon us, to take such measures for the protection of trade as shall insure it against abuses that have prevailed in the past. One of the first requisites to the successful transaction of business is a national bankruptcy law, with such provisions as will secure its uniform administration in all the States. The old law was defective, but it was far better than the diverse State bankrupt laws now in force. Another important law required is one providing uniform means in all the States for the collection of debts. State laws relating to the debtor and creditor classes are different in every State, so that New York merchants, for instance, find that it is almost impossible to collect from debtors in other States. They would need to be well versed in the law to understand all the loopholes provided by different State legislatures for the escape of a resident debtor from paying his honest debts to a non-resident creditor. It is no wonder that merchants are glad to accept from other-state debtors anything they choose to offer in the way of compromising their indebtedness. They prefer to take twenty cents on the dollar to going through the annoyance of a prosecution in a distant State, with almost a certainty of being defeated. The business of the country is mainly done upon credit, and debtors and creditors are brought into such close relations that a uniform code of laws should be provided for regulating their transactions, so that debts incurred in one State, may be as readily collected in another as in the one wherein they were contracted. It ought not to be possible for a merchant in Maine or Texas to come to New York, buy goods on credit, take them home and sell them for cash, and then evade payment for them because of the technicalities of the laws of the State of which he is a resident. The authority conferred upon Congress to provide laws for the regulation of commerce between the States, we believe to be adequate to secure the reforms needed for the protection of the creditor class. If this authority is not sufficient, then we should have an amendment to the Constitution conveying such authority. The Constitution as framed by our forefathers has been found to be inadequate in many particulars to the development of the country and its changed conditions, and it will need several more amendments before it can be made to cover all requirements.

The jewelry trade is deeply interested in this matter, and would be greatly benefited by the legislation we have suggested. It would also be greatly benefited if certain restrictions were imposed upon it. For instance, a standard for gold goods is a necessity of the times, owing to the impositions practiced by unscrupulous dealers who degrade gold to a degree that scarcely leaves a symptom of it in their products. These products are sold for 12, 14, or 18 karat gold, when many of them will not assay above 6, 8, or 10 karats fine. If the karat was, by law, declared to be gold of 24 degrees of fineness, and metal consisting of less than 12 karats to be nothing but base metal, and the attempt to sell it as gold to be a fraud, punishable by fine and imprisonment, dealers in fine gold goods would be afforded some protection in the manufacture of the better grades of jewelry, and the public protected from swindlers and thieves. As it is, without a legal standard for wrought gold, debased goods are palmed off as pure gold, the manufacturers of fine goods are driven from the market, and their efforts to maintain the standard of their wares and the integrity of the trade defeated. The designs upon which they spend much time and money, giving employment to skilled artists and workmen, are pirated by the manufacturers of cheap and worthless goods, who reproduce them in degraded metal, and foist them upon an innocent public as genuine gold goods. Congress has prescribed standards for weights and measures, deeming them neces-

sary for the protection of the public, and the laws impose penalties for those who rob by means of short weights or measures. Why has not Congress the right to prevent robbery in the manufacture of gold goods? If it has not that right under the Constitution as it is, then the sooner we have that document amended so as to prevent this and similar frauds, the better it will be for the deluded public. England has adopted such a standard, and the public has learned to have confidence in the goods manufactured in accordance with it. In this country, purchasers have no security but the reputation of the dealer who sells to them, and the dealer is quite as likely as the public to be deceived by the manufacturer. The law should provide, first, a standard for wrought gold and, second, severe penalties to be inflicted upon any one selling gold goods that were of less intrinsic value than they are represented to be. Certainly, Congress having the power "to regulate commerce between the States," has a right to provide laws which shall secure the integrity of the goods which go to make up commerce. If it has the right to say how many pounds of corn shall be required to constitute a bushel, it has the right to fix the limit to which gold may be debased and still be considered gold. An article that is nine-tenths brass and one-tenth gold certainly ought not to be classed among gold goods.

☞ We notice that Congress has already taken up this question as to regulating commerce. One member has proposed an amendment to the Constitution relative to the protection of trade-marks, and the the Committee on Commerce in the House is hearing the various branches of trade upon the general subject of inter-State commerce. Various Boards of Trade throughout the country have appealed to the committee to take cognizance of certain grievances submitted, and the National Board of Trade recommends the creation of a Department of Commerce, to be presided over by a cabinet officer. It would be well for the jewelry trade to take action at this time with a view to securing such legislation as will give it protection from the pirates who are robbing the public through its instrumentality. Commerce of all kinds is appealing for relief from restrictions imposed by State legislation, and for uniform laws governing the transaction of business between the States. The jewelry trade has suffered fully as much as any other because of the inadequacy of the laws governing commercial intercourse, and it should not be behind in exerting its influence to secure needed reforms. Concerted action will accomplish almost anything, and we suggest that the jewelry trade take steps to co-operate with other branches of industry to impress upon Congress the necessity for better laws to govern our inter-State commerce, and to protect individuals in the rights that should accrue to them by reason of their skill, genius, or expenditures of time and money. Let some earnest and vigorous effort be made to protect the honest men in the trade, and drive out the pirates and thieves.

### A Tale for the Marines.

A CABLE dispatch published in this city recently, announced that "Mr. James Maclear of the St. Rollox Chemical Works, has informed the Glasgow Philosophical Society, that after experiments since 1866, he has succeeded in obtaining crystalized forms of carbon which Profs. Tyndall and Smith, and Mr. Maskelyne of the British Museum do not doubt are diamonds." A later dispatch announces that a further examination of Maclear's artificial diamonds proves them to be simply a compound of silica. This story about the production of artificial diamonds, is an old friend of the diamond dealers. It turns up every few years under one guise or another. Heretofore, reports of this nature have originated with the dealers in paste diamonds, who soon followed the announcement with some new device for swindling the public, by palming off worthless paste for genuine diamonds.

The fact is, science long since ascertained the constituent elements of the diamond, but has never yet been able to produce them arti-

ficially. Nature has peculiar processes in their formation that art has not been able to imitate. At various times chemists have been deceived into believing that they had discovered the secret, but further experiments demonstrated their mistake. The diamond has not been and probably never will be produced artificially. One chemist in London who worked twenty years to make artificial diamonds, finally committed suicide. Another chemist who proclaimed that he could take the color out of stones, is now in State prison for swindling, keeping company with the man who proposed to make gold from copper.

In this connection we are reminded of the remarkable discovery made some time since by Dr. W. B. Fletcher, of Indianapolis. The Doctor had a number of pet frogs, one of which at one time escaped. It was afterward found in the register of the Doctor's office, starved to death, and shrunk to half its former dimensions. Dr. Fletcher dissected its body, and when the lungs were reached found those organs clogged with unnumbered little black crystals, which looked like coarse gunpowder. Placed under a microscope these crystals presented regular facets, with smooth surfaces, having the same angle of crystalization as the diamond. The Doctor burned some of them, and they gave off pure carbonic acid gas, and proved to be pure crystals of carbon, as the diamond is. Dr. Fletcher immediately formed a theory based upon this discovery, that in ages remote, the huge reptiles of the antediluvian period, dying under circumstances similar to those under which the frog did, that is, starving to death, or dying of too much heat, may have formed larger crystals of carbon in their gigantic lungs, which in the course of time, became the hard and lustrous diamond which Mr. James Maclear claims he has found the means of making.

### The Commission Business.

WE are informed that in England a practice prevails of selling goods through commission houses that is highly prejudicial to the interests of the trade. If a dealer from Canada goes to London or Birmingham to buy goods, he is taken in hand by one of these commission men, who shows him the samples of various manufacturers. He makes his selection, and the commission merchant buys the goods for him, having them charged to his account. For this accommodation he charges the purchaser ten per cent. He takes the dealer's obligation to pay, with the stipulation that after maturity ten per cent. interest will be charged. The commission man once having got the dealer in his clutches, holds fast to him, and not unfrequently involves him to his utter ruin. When he gets behind on his payments, and reaches that point where he is no longer a profitable customer, the commission man comes down on him without mercy, and closes him out without grace. Several instances of this kind are said to have occurred quite recently in Canada, old and reputable dealers having been closed out in a most summary manner, and left without any resources in their old age. They had become involved with the English commission dealers, and being unable to meet their exorbitant charges, have been proceeded against with the most extreme vigor. It is important for our manufacturers and jobbers in transacting business with Canadian dealers, to ascertain whether or not they are entangled with the English commission dealers, in such manner as to render it possible that American jewelry may be confiscated to satisfy the foreign claimants. It may seem singular that English manufacturers consent to permit middlemen to come between them and their customers, but these middlemen are men of capital and prompt pay, and, as manufacturers are usually in need of money, they prefer ready cash to running accounts. Besides, they do not have to pay any of the middleman's profits, as he makes them out of the purchaser of his goods. The dealers are forced to pay a high price for the use of the commission man's name and credit. It is one of the abuses of the trade that has grown to considerable magnitude in European cities.

Practical Hints on Watch Repairing,

By EXCELSIOR. No. 58.

WHEELS AND PINIONS, PITCHING, DEPTHING, PROPER CURVES, ETC.

(912) *List of Symbols.* Of these we need but six, five of which are put in capitals when referring to a wheel, and in small letters for a pinion. The sixth, (C), refers to both wheel and pinion. They are as follows :

T, and t, represent the number of teeth in the wheel, and leaves in the pinion, respectively.

W, and w, the working radii of the wheel and the pinion, i. e., the full semi-diameters, from the center to the points of the teeth or leaves

2 W, and 2 w, will then be the full or working diameters.

R, and r, the geometrical radii, or distance from the center to the pitch circle.

2 R, and 2 r, will then be the diameters of the primitive circles of the wheel and the pinion, respectively.

C, the center distance, or distance between the centers of a wheel and pinion in gear, or of their pivot holes. Consequently,

$C=R+r$ , or the sum of the geometrical radii of the wheel and pinion.

$C-R=r$ , and  $C-r=R$ , i. e., the center distance, minus either radius, equals the radius of the other part.

A, and a, the two addenda, or the length of a tooth or a leaf outside of the pitch circle. Consequently,

$R+A=W$ , the full or working radius of the wheel, and  $r+a=w$ , the working radius of the pinion.

$2 R+2 A=2 W$ , and  $2 r+2 a=2 w$ .

$A=W-R$ ,  $2 A=2 W-2 R$ ,  $2 a=2 w-2 r$ , etc.

$W-A=R$ , and  $2 W-2 A=2 R$ , i. e., the full diameter, minus the length of two addenda, equals the geometrical diameter.

E, and e, are the proportional equivalents of the addenda of the driver and the driven, respectively.—usually  $2\frac{1}{2}$  for the wheel, and  $1\frac{1}{4}$  for the pinion. But when the pinion is the driver, E and e are usually  $2\frac{1}{2}$  for the pinion, and  $1\frac{1}{2}$  for the wheel, respectively.

(913) *Selecting and Using the Formulas.* It will be neither necessary nor profitable to follow out and explain the development of each of the formulas, nor their meaning, as a very little thought on the part of the workman, and keeping the symbols in memory, will enable him to understand both without explanation. We will therefore merely arrange some of the many possible combinations of terms, under the headings of those terms whose value they may be used for ascertaining. In making up a formula for ascertaining any particular point, always arrange your proportion so that the term you want to find is the last in order. The first three must be terms that you already know, and the ratio between the first and second, must be the same as that between the third and fourth. In using a formula, (having selected one whose first three terms you know,) first substitute for each symbol the number which is its value in that particular case, as shown in sections (899) and (902). You then have a proportion expressed in figures, instead of letters,—excepting the last term, whose value, as yet, you do not know.

(914) In such a proportion, the product of the two middle terms will equal that of the extremes. Consequently, if you have but one of the extremes, divide the product of the means by the extreme you have, and you get the other extreme, i. e., the value of the last term. This is nothing more than the old arithmetical rule-of-three, with which every workman is or should be familiar.

Some of the formulas are substantially the same as others given, only differently expressed. They are all inserted, to aid the workman in understanding the meaning and reasons of the proportions. When we wish to use a certain formula, but do not know the value of one of the first three terms, we first ascertain its value by one of the other sections, then work out our formula. In all cases, the wheel and pinion concerned in the calculation are those which gear

into each other, not those which are riveted together. The formulas in sections (915) to (922) are arranged on the supposition that the wheel drives the pinion. In cases when the pinion drives, we only need to add E to the pinion, and e to the wheel, wherever they are used.

(915.) *To Find (R), the Geometrical Radius, or (2 R), the Geometrical Diameter, of the Wheel,* we have the following formulas from which to select the one whose first three terms we know. If it does not at once give 2 R, the diameter, we can get R, then double it :

$t : T :: r : R$	$t : T :: 2r : 2 R$
$t : r :: T : R$	$t : 2 r :: T : 2 R$
$T+t : T :: R+r : R$	$T+t : T :: C : R$
$T+E : T :: W : R$	$T+E : T :: 2 W : 2 R$
$T+E : W :: T : R$	$T+E : 2 W :: T : 2 R$
$t+e : w :: T : R$	$t+e : 2 w :: T : 2 R$
$t+e : T :: w : R$	$t+e : T :: 2 w : 2 R$

(916.) *To Find (r) the Geometrical Radius, or (2 r) the Geometrical Diameter, of the Pinion.*—When the points of the leaves are of perfect semi-circular shape, we can get the geometrical diameter by carefully measuring its full working diameter, and subtracting therefrom the thickness of one leaf, at the pitch line, (905). Otherwise, we can work out one of the following formulas :

$T : t :: R : r$	$T : t :: 2 R : 2 r$
$T : R :: t : r$	$T : R :: 2 t : 2 r$
$T+t : t :: R+r : r$	$T+t : t :: C : r$
$T+t : R+r :: t : r$	$T+t : C :: t : r$
$t+e : t :: w : r$	$t+e : t :: 2 w : 2 r$
$t+e : w :: t : r$	$t+e : 2 w :: t : 2 r$
$T+E : W :: t : r$	$T+E : 2 W :: t : 2 r$
$T+E : t :: W : r$	$T+E : t :: 2 W : 2 r$

(917.) *To Find (W), the Working Radius, or (2 W), the Working Diameter of the Wheel :*

$T : T+E :: R : W$	$T : T+E :: 2 R : 2 W$
$T : R :: T+E : W$	$T : 2 R :: T+E : 2 W$
$t : r :: T+E : W$	$t : 2 r :: T+E : 2 W$
$t : T+E :: r : W$	$t : T+E :: 2 r : 2 W$
$t+e : T+E :: w : W$	$t+e : T+E :: 2 w : 2 W$
$t+e : w :: T+E : W$	$t+e : 2 w : T+E : 2 W$
$\frac{T+t}{2} : T+E :: R+r : 2 W$	$\frac{T+t}{2} : T+E :: C : 2 W$

(918.) *To Find (w) the Working Radius, or (2 w) the Full or Working Diameter, of the Pinion :*

$T+E : W :: t+e : w$	$T+E : 2 W :: t+e : 2 w$
$T+E : t+e :: W : w$	$T+E : t+e :: 2 W : 2 w$
$T : t+e :: R : w$	$T : t+e :: 2 R : 2 w$
$T : R :: t+e : w$	$T : 2 R :: t+e : 2 w$
$t : r :: t+e : w$	$t : 2 r :: t+e : 2 w$
$t : t+e :: r : w$	$t : t+e :: 2 r : 2 w$
$\frac{T+t}{2} : t+e :: R+r : 2 w$	$\frac{T+t}{2} : t+e :: C : 2 w$

(919.) *To Find (T), the Number of Teeth for the Wheel :*

$r : R :: t : T$	$2 r : 2 R :: t : T$
$r : t :: R : T$	$2 R : T :: 2 r : T$
$R+r : R :: T+t : T$	$C : R :: T+t : T$
$R+r : T+t :: R : T$	$C : T+t :: R : T$
$W : R :: T+E : T$	$2 W : 2 R :: T+E : T$
$W : T+E :: R : T$	$2 W : T+E :: 2 R : T$
$w : t+e :: R : T$	$2 w : t+e :: 2 R : T$
$w : R :: t+e : T$	$2 w : 2 R :: t+e : T$

(920.) *To Find (t), the Number of Leaves for the Pinion :*

$R : r :: T : t$	$2 R : 2 r :: T : t$
$R : T :: r : t$	$2 R : T :: 2 r : t$
$R+r : r :: T+t : t$	$C : r :: T+t : t$
$R+r : T+t :: r : t$	$C : T+t :: r : t$
$w : r :: t+e : t$	$w : t+e :: r : t$
$W : r :: T+E : t$	

(921.) *To Find (C=R+r), the Centre Distance for a Correct Depth-  
ing of a Given Wheel and Pinion :*

$$\begin{array}{l} T : R :: T+t : R+r \\ t : r :: T+t : R+r \\ T+E : 2 W :: \frac{T+t}{2} : R+r \\ t+e : 2 w :: \frac{T+t}{2} : R+r \end{array} \quad \begin{array}{l} T : T+t :: R : R+r, \text{ or } C \\ t : T+t :: r : R+r \\ T+E : \frac{T+t}{2} :: 2 W : R+r \\ t+e : \frac{T+t}{2} :: 2 w : R+r \end{array}$$

(922.) *Example of Formula Worked Out.*—Lest the workmen should think the few last formulas complicated and difficult, we will have one explained and worked out. We want to find the correct centre distance for a wheel of 96 teeth, and a pinion of 12 leaves. If we know the geometrical radius or diameter of the wheel, we select one of the formulas in the upper line. If we know the primitive radius or diameter of the pinion, we select one in the second line. But if we only know the full working diameter of either the wheel or the pinion, we select one in the two last lines. Suppose we only have the working diameter of the wheel, which is  $\frac{3}{4}$ -inch, expressed decimally as .75. We will select the first formula in the third line, which says that the number of teeth in the wheel, plus the proportional equivalent of the addendum, is to the full diameter of the wheel, as half the sum of the teeth and leaves is to the correct centre distance for that wheel and pinion. First substituting the proper figures for each letter, our formula becomes

$$96+2.5 : .75 :: \frac{96+12}{2} : C, \text{ or } 98.5 : .75 :: 54 : C.$$

Multiplying the middle terms, and dividing by the first, gives C=.411 inch, or 411 one-thousandths of an inch. If the teeth of the wheel were quite blunt on the points, the proportional equivalent would be, say 2, and our proportion would then run

$$96+2 : .75 :: \frac{96+12}{2} : C, \text{ which gives } C=.413 \text{ inch.}$$

If we only know the working diameter of the pinion, we select a formula in the last line, and proceed in the same way, putting that diameter in place of 2 w. We might use one of the first formulas, by first working out the geometrical radius or diameter of either the wheel or pinion, as, for instance, by section (916). Thus it will be seen that the whole process is perfectly plain and easy, while getting the desired result with all possible accuracy.

(923.) *Formulas for Use when the Pinion Drives the Wheel.*—Although it should hardly be necessary, after what has been said in sections (912, 914), it may be well to give here those formulas which are different when the pinion drives. For the value of E and e in such cases, see sections (904, 912).

$$\begin{array}{l} T+e : 2 W :: t+E : 2 w \\ \frac{T+t}{2} : t+E :: C : 2 w \\ t : t+E :: 2 r : 2 w \\ t : T+e :: 2 r : 2 W \\ t+E : t :: 2 w : 2 r \\ T+e : t :: 2 W : 2 r \\ T+e : \frac{T+t}{2} :: 2 W : C \end{array} \quad \begin{array}{l} t+E : 2 w :: T+e : 2 W \\ \frac{T+t}{2} : T+e :: C : 2 W \\ T : T+e :: 2 R : 2 W \\ T+e : T :: 2 W : 2 R \\ t+E : T :: 2 w : 2 R \\ T : t+E :: 2 R : 2 w \\ t+E : \frac{T+t}{2} :: 2 w : C \end{array}$$

All formulas in which E and e do not appear, are used without regard to whether the wheel or the pinion drives.

Example worked out : A pinion of 10 leaves drives a wheel of 60 teeth, and the distance between the centers of the pivot holes is  $\frac{1}{2}$  inch. What should be the sizes of the wheel and pinion to gear properly in that center distance? We can, of course, find their geometrical radii and diameters by the directions in previous sections, but for exercise we confine ourselves to the formulas in this section. Suppose we have the pinion, we can measure it and use that measurement for the third term of the last formula on the fifth line, and so get the proper geometrical diameter for the wheel. To find its working diameter, (supposing its teeth to be  $\frac{1}{2}$  the pitch, with well rounded

points), we use the last formula on the second line, which, in figures, will be

$$\frac{60+10}{2} : 60+1.5 :: .5 : 2 W, \text{ or } 35 : 61.5 :: .5 : 2 W=.879 \text{ inch.}$$

If we want to get the working diameter for a suitable pinion for this gear, of ordinary shape for a driver, take the first formula on the second line :

$$\frac{60+10}{2} : 10+2.5 :: .5 : 2 w, \text{ or } 35 : 12.5 :: .5 : 2 w=.179 \text{ inch.}$$

We can now get the geometrical diameter of the wheel by the last on the fourth line, and of the pinion by the first on the sixth line. Selecting the latter to work out, we have

$$60+1.5 : 10 :: .879 : 2 r,=.143, \text{ and } r=.071 \text{ inch.}$$

Then, as C-r=R, we have .5-.071=R=.429 inch, and 2 R=.858 inch for the primitive diameter of the wheel.

(924.) *Selecting a Wheel or Pinion.*—Having, for instance, found the geometrical radius of either one, for a given center distance, the working size of the wheel or pinion can be tested or selected by the aid of that radius and one of the preceding formulas, using a proportional equivalent suitable for the particular shape of the addendum, and whether it is the driver or driven. A short calculation will give us any desired dimension or other information.

When the addenda of the teeth or leaves are semi-circular, we can get the working size without a formula. As already stated, (916), by subtracting the thickness of one such leaf or tooth from the working diameter, we get the primitive diameter. In the same way, by adding the thickness of one tooth or leaf to the geometrical diameter, we will get the full diameter. Therefore, if we have a radius, by simply doubling it and adding the thickness of one tooth or leaf, we find what the working diameter should be for a driven wheel or pinion.

(925.) In speaking of "the right size" for a pinion, we mean that its geometrical diameter is correct, for the shape of its addenda is practically of little importance. Obviously its full diameter will vary with every difference in the shape of the addenda and thickness of the leaves, yet each one of these sizes, if otherwise suited for the wheel, will perform properly in gear with it, and be of "the right size." And, on the other hand, we could select a number of different pinions, all having the same outside diameter, but every one of them having a different primitive diameter, owing to the different shapes of the ends of the leaves, and the different distances from the points at which their curved faces would meet the flanks, *i.e.*, the pitch circle. Only one of them would be of "the right size," all the others being too large or too small, according to the diameter of their pitch circles. These observations are specially applicable with sections (881, 882), which both relate to selecting pinions by their outside measurement, and on the supposition that the leaves have semi-circular ends.

The right size for a wheel, or a pinion which *drives*, means both the geometrical and working diameters, as both must be correct in order to drive uniformly, avoid catching, butting, dropping, etc.

(926.) *Varying from the Theoretically Correct Sizes for the Wheel and Pinion* is recommended by Camus in certain cases, and as his suggestion has been endorsed by successive authorities, it is here inserted in full. It must be remembered, however, that the variation allowable is very slight, because if the defects in the teeth are serious, they should be remedied, or a new and perfect wheel inserted, in which case the correct size should be adhered to. Its practical value to the repairer is chiefly in the intimation that, in case it is impossible to obtain the correct size, the wheel should be slightly too large, relatively to the pinion, rather than the reverse.

"As we can never hope to form the teeth with such accuracy that the pitch circles of the wheel and pinion shall always rotate with equal velocities, and as the inequalities and other faults in the teeth will make the lead measured from the line of centers in some cases

not sufficiently long, so as to occasion buttings, etc., makers will do well to avoid these inconveniences by making the primitive diameter of the piece that drives slightly greater than it should be in comparison with the piece that is driven.

By this increase in the diameter of the wheel, which should be proportioned to the faults that are expected in the form of the teeth, the tooth immediately succeeding that which is leading a leaf after the line of centers will engage with the next leaf somewhat later, and when the first tooth has driven the pinion as far as it can uniformly, the wheel has a somewhat greater velocity than the pinion, and this is a fault; but this intentional fault is less objectionable than the buttings that would probably occur if it were not to exist."

(927.) *Measuring Uneven, Numbered Pinions.*—In taking the outside measurements of either pinions or wheels of uneven numbers, the size obtained is smaller than the actual working diameters, because there is a space opposite a leaf, and we measure from the point of a leaf, (or tooth,) across the center, to the middle of a straight line joining the points of the two adjacent leaves. The pitch circle between the two leaves would, of course, curve outward; and the smaller the number of leaves in the pinion, the greater would be the distance between the curve and the straight line, at the point midway between the two leaves. In wheels, this difference is slight, but in ordinary pinions it becomes a very appreciable amount, and must always be allowed for, when the measurement is taken by a tool whose jaws clasp opposite sides of the pinion.

This difficulty can be avoided by making or finding a truly round hole in a metal plate which will just fit the pinion, without play, then

measuring the diameter of a tapering round broach at the point where it just fills the hole.

(928.) In section (929) is a table, the 2d and 3d columns of which show the ratio between the real working diameter and the caliper measurements of uneven-numbered pinions. Of course, the caliper measurements actually taken from a pinion (of 7 leaves, for example,) will bear the same proportion to the real size of that pinion, that the figures in the 3d column bear to those in the 2d. Therefore, if our pinion calipers .12-inch, we make the following proportion to find  $2w$ :

$$1.092 : .12 :: 1.150 : 2w \therefore 2w = .126 \text{ inch.}$$

In the same way we proceed with any other caliper measurement. This operation will be correct whatever the shape of the pinion addenda may be.

But if the addenda are semi-circular in form, which is usually the case with pinions, then the table will not only give the relation between the true working diameters and the caliper measurements, but also the primitive diameters, and thickness of the leaves. The 2d column shows the working diameter of a pinion whose primitive diameter is 1; the 3d columns show what such a pinion (of an uneven number) will measure in the calipers; the 4th columns give the thickness of the leaves. *When the primitive diameter is not 1, multiply the figures in the table by the size, whatever it may be, to get the real dimensions of that size of pinion, as indicated by the headings of the columns. Or, we can find the primitive diameters of such pinions, from the caliper measurement, by dividing those measurements by the figures in the 4th columns.*

(929.) *Table of Proportions for Pinions with Semi-circular Addenda, the Primitive Diameter being 1.*

Thickness of Leaves, $\frac{1}{3}$ the Pitch.				Thickness of Leaves, $\frac{2}{3}$ the Pitch.			
No. of Leaves.	Full Diameter.	Caliper Size.	Thickness of Leaves.	No. of Leaves.	Full Diameter.	Caliper Size.	Thickness of Leaves.
6	1.175		.175	6	1.209		0.209
7	1.150	1.092	.150	7	1.180	1.121	0.180
8	1.131		.131	8	1.157		0.157
9	1.116	1.082	.116	9	1.140	1.106	0.140
10	1.105		.105	10	1.126		0.126
11	1.095	1.073	.095	11	1.114	1.092	0.114
12	1.087		.087	12	1.105		0.105
13	1.080	1.064	.080	13	1.097	1.081	0.097
14	1.074		.074	14	1.090		0.090
15	1.070	1.057	.070	15	1.084	1.072	0.084
16	1.065		.065	16	1.078		0.078
17	1.061	1.050	.061	17	1.074	1.063	0.074
18	1.058		.058	18	1.070		0.070
19	1.055	1.048	.055	19	1.066	1.059	0.066
20	1.052		.052	20	1.063		0.063

(930.) *Mode of Using the Table.*—The use of the above table for pinions of uneven numbers was explained in section (928). It is also applicable to pinions of even numbers, in getting the primitive diameters from the caliper measurements, or the reverse. The first four columns are for pinions whose leaves are  $\frac{1}{3}$  the pitch; the last four, for those which are  $\frac{2}{3}$  the pitch. The table is computed for pinions having a primitive diameter of 1. The 1st columns give the number of leaves; the 2d, the full working diameters; the 3d, what they will measure in the calipers; the 4th, the thickness of the leaves. As the caliper measurements of uneven numbered pinions will be the same as the full diameters in the 2d columns, they are omitted in the 3d columns. *But when the primitive diameter is different from 1, multiply the figures in the proper column by the real size. If the primitive diameter is 2, 2½, 10, or anything else, all the sizes will be those given in the table, multiplied by 2, 2½, etc. On the other hand, if we want to find the primitive from the full diameter, we divide the full diameter by the figures in the 2d columns of the table. To find the primitive diameter from caliper measurements, we of course divide*

those measurements by the figures of the 3d columns. Example: The primitive diameter of a 7-leaf pinion is .05 inch; what should be its full diameter, and the thickness of the leaves, at  $\frac{1}{3}$  the pitch?

$$1.092 \times .05 = .0546 \text{ inch, full diameter, caliper measurement;}$$

$$1.145 \times .05 = .0572 \text{ inch, true working diameter;}$$

$$.145 \times .05 = .0072 \text{ inch, thickness of leaves at } \frac{1}{3} \text{ the pitch;}$$

$$.180 \times .05 = .009 \text{ inch, thickness of leaves at } \frac{2}{3} \text{ the pitch.}$$

Or, suppose we have a 7-leaf pinion measuring .0546 inch in the calipers, the leaves are  $\frac{1}{3}$  the pitch, with semi-circular ends; what is its geometrical diameter?

$$.0546 \div 1.092 = .05 \text{ inch, primitive diameter.}$$

Having found the primitive diameter, from either the full diameter or the caliper measurements, we can then get the other dimensions by multiplying it by the figures in the proper columns as before:

$$.05 \times 1.145 = .0072 \text{ inch, thickness of leaf; and so on.}$$



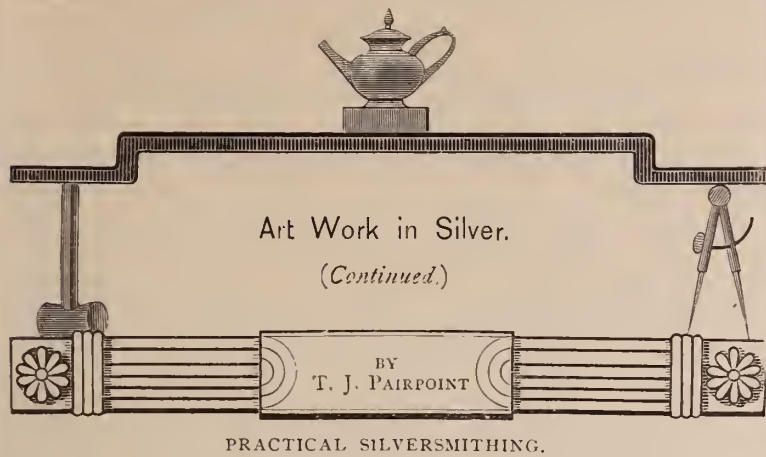

THE trip hammer is quite frequently used in silversmithing. They are of various sizes, the weight of an ordinary one being about twenty pounds; the handle is usually about four feet long, one end of which is firmly secured to a heavy block, having a strong spring which keeps the hammer raised at an angle of about forty-five degrees. The workman when using this hammer, places his hand a short distance from the head and presses it down, causing the blow to descend. It requires very little exertion to strike the blow, as the spring raises it again directly the pressure is removed. This hammer is sometimes worked by steam, and is a nearer approach to the hand hammer in its action than any other, and is therefore peculiarly adapted to certain kinds of work, such as forging out blanks for fork and spoon handles. It has considerable drawing capacity, that is power of spreading out or elongating the metal, and an accuracy of stroke can be depended upon. The operator can adjust the length of the stroke, the rapidity of motion, and the force or weight of the blow, thus bringing it as completely under his control as the ordinary hand hammer.

Swaging is an operation that is extremely useful. A silversmith who is accustomed to the use of this tool is enabled by its means to make a continuous raised line round any article on which such a decoration is desirable. A swage is an iron or steel tool composed of two parts attached together by a hinge, so that it can be opened and the article about to be operated upon passed between the two parts. The face of the swage is made convex, and the lower part concave. This tool is securely held in a vise, the waiter, tureen, or whatever the piece may be, is placed between the convex and concave parts of the swage, and a blow struck with a hammer on the upper part, which forces the metal into the lower or concave part of the tool; the waiter is continually moved as the blows are repeated, until the whole circumference has passed through the swage, leaving an uninterrupted raised line upon the work. These tools are made of various sizes to suit any width of line that may be needed.

Another branch of silversmithing is the mounting, that is soldering on the feet, handles, borders, or any independent pieces of ornament the article requires. The moulder takes the body of the vase and securely ties on with wire the foot (or whichever part it is he is about to solder on) in the proper place, and if it is desirable to confine the heat to that particular spot, loom is placed all round it. The reason of confining the heat as much as possible to the part the moulder is working upon, is to prevent it causing the metal to scale, an operation which takes place in a greater or less degree when the metal is exposed to the action of fire; and it also prevents any delicate parts that have already been soldered from becoming unsoldered. When the part is thus properly adjusted, the moulder applies a flame of gas gradually over the whole, and when that becomes thoroughly heated, he then directs the gas to the part being soldered. The solder is cut into small thin strips, and consequently requires less heat to fuse it than if it were in larger pieces. When it begins to run the moulder regulates the gas, so that the solder is kept moving until the whole of the part is securely soldered on, then the gas is with-

drawn and the work allowed to cool. It is then placed in a solution of vitriol and water, and afterwards scoured and rinsed until perfectly clean.

The borders for tea-sets, vases or bowls are rolled as thick or thicker than the body of the article. The piece of the body is cut out and border inserted and soldered in place; if the border were placed on the vase, and the under part not removed, it would give a thick clumsy appearance, and make it unnecessarily heavy.

Soldering is employed upon larger and more extensive work than putting on feet, handles or ornamental parts, but the method of doing so is the same. Larger work is not so easy to manage as the smaller pieces, and to solder a wide heavy border round a twenty-eight inch waiter, will require an expert workman. In work of this description care has to be taken that the metal becomes properly heated throughout; the heat must not be concentrated until the whole area to be soldered is of a uniform temperature, and the solder must be made to flow steadily and rapidly whilst the metal is at the requisite heat. This process, to be properly executed requires both care and neatness, otherwise a great deal of unnecessary labor in the shape of scraping, filing and riffling is made, which might with care be altogether avoided. Some mounters are exceedingly dexterous in this particular, and the use of gas facilitates the process immensely. It is not more than fifty years ago that silversmiths had to solder with the aid of bellows worked by the foot and the common forge fire, or with a small blow pipe and fluid lamps.

#### DIE-SINKING.

Die Sinking is the process of cutting steel moulds, from which impressions are taken by either stamping or rolling. In silversmithing, spoons, forks, handles, feet, borders, etc., are produced in this way.

The Greeks were very proficient in the Art of die cutting, their coins such for instance as those of Alexander, having been rarely if ever equalled. The Romans were also very expert, and practiced it to a great extent, some of their coins are fine specimens of this work, although they lack the vigor and artistic treatment of the Greek, but the process of stamping was improved by them. The dies that were used to the time of Constantine, were made of hardened brass, after which they were superseded by steel. With the fall of Rome, this art, like others, was degraded and obscured, and it was not until the sixteenth century, that it was again practiced to any extent.

Die sinking is an important branch of silversmithing, being used for decorative purposes, besides the more useful moulds for larger work; when the die is once made, the article can be reproduced *ad infinitum*, and therefore, it is quite easy to realize how necessary a part it becomes when large quantities have to be rapidly made and ornamented. Some work in the form of borders, when carefully designed and executed, are very effective, but when lavishly and indiscriminately used, the effectiveness is frequently spoiled, the same roll border repeated on all kinds of articles and of various sizes, becomes like other machine made work monotonous. When starting upon the practical part of this work, it is most essential to have the steel annealed as soft as possible without deteriorating the quality, if it is very hard the die sinker has to spend as much time in keeping his tools sharpened, as in doing the work, nor can he get such good effects as when the metal is soft, the surface of the die must also be perfectly smooth; too much attention cannot be given to these first principles, the lines that are first made when setting out the work, are more clearly discernable if the surface is thoroughly smooth; for, if these lines are not plainly defined, it causes considerable trouble to determine exactly where to cut, and for this purpose the surface of the die is discolored with copperas.

If the design is a geometrical or repeating pattern, it is necessary to have an accurate scale made of tin or zinc corresponding to the divisions of the design, and of the exact size of the die about to be cut; the scale is placed in the position required, and marked round distinctly with a steel point; if a drawing is used instead of a metal

scale, it is fixed in position with mucilage, and when dry, all the lines are perforated with a fine pointed punch and hammer, following the outline as minutely as possible; after the drawing is transferred in this manner, the paper is moistened with water, and carefully removed, so that it can be used again if necessary. These or similar mechanical methods of outlining, are indispensable in repeating patterns to ensure a uniformity in the repetition of the design.

It is only by long practice that the eye and hand becomes accustomed to reproduce in concave in the die what the convex model expresses, and therefore, in fine work most die sinkers prefer to have a carefully prepared model of the design, from which a plaster mould is taken; this serves as a guide, and enables the workman to realize fully both the relief and general arrangement before he commences to give a direct interpretation in the steel, for after the process of cutting has commenced, the design cannot be altered or interfered with; it may be criticised, but the relief cannot be changed, or any alteration made in the relative importance which the various parts will have when the whole is finished. A depth gage is used in order to obtain accurately the relief required, and the steel is cut to the exact depth before adding any of the details of the design, or elaborating in any way. The workman takes frequent impressions of the die from time to time, with soft wax fine red clay, or a cast of Plaster of Paris, to judge of the effect, and to see if any corrections are necessary, carefully comparing it with the model. The frequent use of these impressions is of great importance, in order to test the progress and correctness of the work; and whenever any doubt arises in reference to either the relief, or the proper flow or curvature of a line, the comparison of an impression of the die with the model, will at once decide the difficulty. When a die is cut, all the edges of the work are beveled from the perpendicular of the face of the die, and the corners are rounded and smoothed so that they will not cut in stamping, or drag in rolling. A practical mechanical knowledge is of greater value to the die sinker than is generally supposed, the conditions under which the metal is stamped into the die, or rolled upon it, have to be duly considered, and the work executed with a view to the harmonious adjustment of the die to the machinery. On roll dies for borders, it is very requisite that the relief should be so distributed, that there will be no strain on the metal; otherwise, if the masses are not divided up sufficiently, the border, when rolled, will present a blurred and indistinct appearance, instead of a sharp and well pronounced impression, and all the lines must flow in accordance with the way in which the roll will turn, thus the metal can be readily pressed into the die, and it must as easily leave it, otherwise it will drag or strain, and in all probability break.

The traverse section of a border must be turned in the roll to the depth required; and if the set edge, or outer moulding on either side is in high relief, a following roll is used, that is—one having the same section in convex, which fits into the figured roll, leaving only space enough for the metal to pass between the two. In hard metal it is advisable to keep the traverse section as shallow as possible, so that the ornament will give a clear and effective relief.

When the design is continuous, a drawing is made of the exact size of the circumference of the roll between the edges of the turned part, so that the design will not show any break when the border is rolled; the drawing is then fastened around the roll, keeping it perfectly true with the turned part, and is perforated with the hammer and point very minutely. If the die sinker is a good draughtsman, he can draw the design direct upon the steel. All the plain parts of the work when finished, are polished with emery powder and oil, and the deeper edges made very smooth, this enhances the beauty of the work, by contrasting with the matted or etched parts.

A largeness and freedom of design is best for this kind of work, the masses being divided and subdivided according to the size of the roll, the ground work should present a flat surface to give effect

of light and shade, and the outline of the whole design when completed, should be plainly visible at least a distance of three feet.

To produce spoons by rolling, two rolls are required, one for the front, and the other for the back of the spoon, fitting together with great nicety, and each cut to the precise depth, so that when the metal is passed between these two, a perfect spoon is produced. The designs are transferred on to the roll, placing them as closely together as possible, so that no useless spaces are left, every revolution will in this way produce as many as can be placed on the surface of the steel, no portion of it being unproductive. An accurate drawing is prepared of each piece which is doubled in the center, and with a needle the design is pricked through, to ensure both sides being exactly alike, after which a V shaped notch is cut at each end where the paper is doubled, a perfectly straight line is drawn round the circumference of the roll for the center of each spoon, and the notches in the drawing are placed directly on the line and secured, after which a fine prick punch and hammer are used, following the perforations made by the needle in the paper: the drawing is then removed, and the die cut to the depth required for one side. When both the outline and relief are perfect before the edge which always rises on the outline is removed, the die is given to the machinist, who places it in the machinery, together with the reverse roll, and screws them closely together, then with one turn of the roll, the designs are transferred on to the reverse roll, which must be cut very accurately to the impression, in order that the two rolls may miter perfectly. When both are nearly finished, the steel is cut away down the edge of the shank of each piece graduating to the thin parts, and nearly to the bottom of the work, at an angle of 45 degrees to allow the silver to get to the bottom; carrying marks are then cut round each piece with a diamond shaped chisel about 3-16 of an inch apart, and about 1-32 of an inch deep, to grip the silver as it passes through; at the tip of each piece, about  $\frac{1}{8}$  of an inch from the outline, must be cut a groove nearly  $\frac{1}{8}$  of an inch deep, and about  $\frac{3}{4}$  of an inch long, at right angles with the center line, to bite the silver when it is just between the rolls. Before the rolls are hardened, it is absolutely necessary that they are very carefully polished on all the plain parts, as the slightest imperfections are more easily discernable in the finished work from rolls, than those that are stamped in dies.

#### ENGRAVING.

Engraving is a method of producing designs by incisions, and it was used by the early Egyptians to decorate vases, drinking cups, etc. Among the Greeks and Romans the engraving of gems was most successfully practiced, sometimes the designs were produced by incision, and at others sculptured into relief. These engraved gems were very highly prized by the ancients, and one of the largest and most important specimens is the Opotheosis of Augustus, which is preserved in the Royal Cabinet of France, it measures eight inches by nine, and on this limited space is engraved more than twenty figures representing dieties and men; it is a marvelous specimen both of patient, labor, and artistic skill. Engraving on plate is closely allied to Niello work; in the latter, the designs are cut upon the metal, and the Niello flowed into the incisions. Some authorities are of opinion that engraving owes its origin to Niello, but from the evidence of its having been practiced by nations of antiquity it would appear more probable that Niello was a supplementary work to it.

About the middle of the fifteenth century, a Florentine goldsmith named Maso Finiguerra was accustomed to take impressions of his engravings, with a viscid water ink on paper, in order to test the progress of his work, and from this arose the practice of taking impressions from an engraved metal plate.

The Chinese engraved on wooden blocks as early as the thirteenth century, using them to stamp paper money.

During the sixteenth century, the gold and silversmiths frequently took impressions of their engraved works by spreading a layer of

melted sulphur, over the face of the work producing a cast in relief of the incised lines; some of these casts are in the British Museum, and are considered among the rarest specimens of the engravers arts.

Etching is frequently combined with engraving, and has very much the same appearance, although the process is altogether dissimilar, etching being produced by corrosion. The invention of etching is generally attributed to Albert Durer, but it is probable that it had been slightly practiced before his time, and he caused it to become more generally known; but it is certain that he brought engraving to a degree of perfection, that has not since been surpassed.

Decorative engraving for silverware consists almost entirely of scroll work and graceful curves, hence, it is highly necessary that the engraver should understand the elements of drawing. The mechanical part is soon imparted, but it needs long practice to be able to produce a clear cut line with its variations of depth and thickness, curves and angles, and also to execute the long flowing lines with uniformity and precision, as well as the necessary accuracy for repeating geometrical patterns, but when that is acquired and the engraver thoroughly understands the various means by which effects are obtained, he can then impart the proper feeling to his work. The sentiment of engraving is purely artistic, and like all efforts in this direction, it depends entirely upon the temperament of the student, if he can concentrate his thoughts sufficiently to impart the desired feeling.

Engraving monograms is a distinct study, it being important in this branch to produce good heraldic effects, in addition to the requisite ornamental character.

The principal tool employed is the graver, which is a rectangular piece of steel about an eighth of an inch wide, and about five inches long. This tool is inserted in a small round handle, the point of the graver having an angle of about sixty degrees; some gravers are lozenge shape, while others again, have points or teeth, by means of which several lines can be cut at once; the common square graver is very frequently used both for heavy or light lines; when heavy ones are to be made, the tool is turned in cutting slightly on one side, which gives a broad flat incision; this graver, in the hands of a skillful workman, will produce several fine effects.

Engraving on silver or plated ware presents a very sparkling appearance, the incisions giving various reflecting surfaces of different depths and angles to the light, which contrast very effectively with the flat or convex surfaces of the piece so decorated.

The manner of holding the graver is quite simple; the round handle of the tool rests upon the palm of the hand, being adjusted in a manner that will give the greatest command of it, while the fingers guide the cutting, point over the curves and scrolls of the design. The engraver usually cuts the heavy or thick lines first, and then the fine ones or *vice versa*, and in many places the lines ought not to join, although they approach each other so nearly, that they appear to do so; this considerably strengthens the work, being on the same principle as that employed when sketching from nature. When decorating large flat surfaces such as silver waiters, the best taste does not cover the entire surface with ornamentation, but one of the most important considerations, is the dispositions of the masses, or grouping of the design in a way that will secure broad open spaces of bright ground, which contrasts admirably with the engraving, especially when shading and teeth tools have been employed, making variety of color, a feature of the work; good effects can thus be produced without interfering with the waiters flat surface, and the massing or grouping of the decoration should be so arranged that when a pitcher is standing in the center the design is not hidden.

In plated goods, where it is necessary to have the design covered with ornamentation without any relieving spaces, (owing to the difficulty of making a large surface of the metal perfectly flat) those

arrangements of design are the best, which are simple and harmonious, having due regard to the effect of properly constructed masses.

In all decoration of silverware, as in sculpture, the artist depends entirely upon light and shadow to produce the various effects required, and to this end every incision of the graver or blow of the chaser's hammer, or the relief of the die cutter's work are each important elements, and it requires an artistic preception to determine their accuracy of relief or intaglio, and their relative merit when in an incomplete state, to the whole.

It need scarcely be said that in all good engraving, the curves or scrolls should be easy and flowing, the sense of the graceful requires it, and practical experience proves it to be correct.

Another very essential point to be studied, is the selection of pleasing, and appropriate designs, if the form of the waiter, or other article, should have a Greek or Roman character, the same style should also be carried out in the engraving; every part of the decoration being in harmony with, and subordinate to the form. If any of the ancient styles, or those of a later period are to be produced, they may be made very attractive by introducing certain modifications, modernizing them as it were, without losing their characteristics; this manner of treating the antique is far preferable to direct copying, it produces a certain degree of originality and individuality in the work that is very desirable, and at the same time, presents an opportunity for some very fine execution. We sometimes see on small articles of plated ware, large flowers and scrolls engraved evidently with the object of covering the metal, but such a total want of proportion is very undesirable on small objects; it should naturally follow, that the flowers and scrolls of the decoration should also be small, and on larger work the ornamentation may very properly, be on a larger scale, but it usually happens that the cheapest articles have the largest scrolls and flowers, presenting very much the same appearance, as a carpet having a very large pattern, placed in a very small room.

The engraver when laying out his work, does not often use a lead pencil to draw the design, as it would in all probability, scratch the polished surface of the silver, but uses instead, a preparation made from scraping the enamel off a card board box, which, mixed with a little water, is applied with a camels hair pencil to the part about to be engraved, this speedily drying, leaves a film like coating on the metal; the workman now takes an ivory point, or a piece of very hard wood sharpened to a point, and with it draws his design on the coating of enamel without in any way scratching or marking the silver, and after the engraving is finished, a soft cloth will at once remove the enamel, leaving the silver perfectly bright and unblemished.

When the designs have to be repeated, as in geometrical patterns or on articles such as waiters or tea-sets, where both sides must necessarily be exactly alike, the engraver uses some mechanical method of transferring the design from the part already engraved; there are several ways of accomplishing this transfer, one of the most commonly used being to fill the incised lines with some viscid substance, upon which a piece of smooth thick paper is firmly pressed and rubbed; when the paper is removed from the work, the greater part of the substance with which the lines were filled, will be found adhering to the paper; this paper is then placed on the silver in the exact spot where the repeated pattern is to be engraved and gently rubbed, when it will be found on removing the paper, that the design is transferred to the silver. The same impression on the paper will frequently transfer the pattern to the metal a great many times. If the design is a geometrical pattern to be repeated round the body of a vase, or the border for a waiter; this object is divided into sections according to the size of the pattern, and when the first section has been drawn on and engraved, the pattern is transferred on to the remaining sections. When spoons and forks are to be engraved, it is very essential to get a complete uniformity throughout

the whole set or number, and, therefore, the system of transferring from the first one is always adopted. Another process of transferring is to prepare a piece of paper by rubbing over it a mixture of wax and tallow, only thinly, coating it; the incised lines of the engraving is then filled with polishing rouge, or lamp black, or printers' ink, wiping off all excess that overflows the lines; the prepared paper is then pressed on and rubbed smoothly and firmly over the work, and if it is a spoon or fork, will also be rubbed all round the edge so as to give an impression of the outline, this is afterwards cut out, giving a pattern precisely the shape of the spoon; when the paper is taken off the engraving, the rouge or black, will adhere to it, and the design can then be transferred to the metal in the same way as by the former process, and the paper pattern being cut out in the shape of a spoon handle, ensures the transfer being adjusted in the exact spot.

Crests or monograms requires a more expert workman than ordinary ornamental engraving, and many engravers devote themselves entirely to this branch of the business. The outline of the monogram is first plainly cut, and the ornamental accessories added either in a plain simple style, or elaborated according as the design requires. The ornamentation of monograms is an important consideration requiring freedom of treatment, and at the same time great care that all the lines should be in perfect harmony with each other, and with the letters themselves; the form of the letters should not be obscured or covered up by the ornamentation, but should be plainly recognizable at the first glance. Monograms are almost universally liked, and some very elegant combinations are often effected; if the style of lettering selected, is that which causes the initials to blend together most gracefully and harmoniously.

When a great number of the same articles are to be similarly engraved, which is frequently the case in soft metal goods, the design is drawn on a piece of leaden foil, thin enough to be quite easily bent; it is then cut through with a needle or pierced after the manner of stencil plates, this pattern is laid on the surface of the article about to be decorated, and the pattern transferred through the piercings, by means of a mixture of lamp black, coach black, varnish and turpentine applied over it with a soft brush; this is a very rapid mode of transferring, and causes a great saving of time and labor, when the work is produced in large quantities.

*To be continued.*

### Views of Correspondents.

[NOTICE.—Correspondents should write all letters intended for the Club separate from any other business matters, and headed "Secretary of the Horological Club." Direct the envelope to D. H. Hopkinson, Esq. Write only on one side of the paper, state the points briefly, mail as early as possible, as it must be received here not later than two days before the end of the month in order to be discussed and reported in the CIRCULAR for the next month.]

#### *Editor Jewelers' Circular:*

I notice in November number of your JOURNAL an article entitled "A Trade Stamp of Value." The writer thereof, while he evidently has the good of the trade at heart, does not, in my mind, fully comprehend the situation. I think I was the first in the field to openly advocate the idea of a Guild Stamp for our goods. Now, when I say *Guild Stamp*, I do not mean a stamp for simply the Iowa State Association, but a stamp for the confederation of the several States Associations, as we are to-day represented in our Guild.

I have given this subject of Guild Stamp much thought, I have tried to strengthen my understanding, by conversing with men of intelligence, that I might grasp all the advantages and guard against all apparent objections.

That my position may be fully understood, let me state that the prime object of our several States Associations, was to *protest en masse* against the pernicious practice indulged in by nearly all western jobbers of sending catalogues, price-lists, with discount sheets broad cast over our territory, thereby, taking the trade from the retailer, or forcing him into ruinous competition.

After we organized, the question came up, "Who are we to let alone?" or, in other words, "How shall we conduct the campaign?" It was apparent to all that we could do nothing to absolutely prevent the jobber from selling outside parties at wholesale, or to our should be customers at retail. All we could do was to force him to chose his class of customers—the *legitimate dealers* or the *promiscuous dabblers*. Neither could we bring any telling pressure to bear upon the manufacturer who sold goods to these non-conforming jobbers—for most of these jobbers have both wit and money to pay for the goods they buy and wit to sell them, and so long as they possess these two

strong points manufacturers will sell them—and who can really blame them from a business point of view?

When Mr. Purdy suggested the idea of stamping our goods with a trade mark that should be our own, I at once saw the advantage we would gain thereby.

1st. By causing our chosen manufacturers to give us a good and sufficient bond as a guarantee against fraud being practiced upon us, we would know the merits of goods so stamped, and could represent them to our customers with honest intelligence. Now, if I can assure my would be customer that in buying of me, he will get, in fact, the article paid for, I have no fears of his ever looking up catalogues, or think of sending abroad for his goods. But, as goods are now made, it is impossible for us to tell, with certainty, their real worth and wearing qualities. This the buyer knows or soon learns, so instead of saying to himself "Where can I go and *get* the quality of goods I pay for?" say, "Where can I send and get *cheated* the same amount for the least money?"

To assay the solid or strip the plated is at best, but to test the article so treated, we can only prove the virtue of the article by sadly marring or destroying it. Like testing heavy ordnance at the War Department, they only know that the gun was perfect in casting, after it is "busted" and they can inspect the inside of it. Yet this does not prove that the next gun cast is free from flaws and faults. I am sick of this class of goods, I am tired of unwittingly robbing my friends and patrons, and placing the fruits of the steal in the pockets of fraudulent manufactures, and consumers are generally getting tired of being commercially pillaged in this way, and will soon demand protection from such rascality, *and they will get it.*

Now the question is, How is it best for the would be honest retailer, that this protection should come?

Surely not by way of a Government Stamp; for then all goods must bear their true quality stamp. To-day, we practical jewelers hold a percentage over the grocers, the druggists and pea-nut stands that dabble in jewelry by our supposed better knowledge of the goods we handle—but with a Government stamp on goods, all these dabblers would be placed on a par with us: as then, the *stamp* would determine the quality of the article rather than the knowledge and experience of the dealer. So we do not want a Government stamp if it could be had, and for the same reason we do not wish all manufacturers to stamp their goods, unless these goods can be kept in their legitimate channel. What we want is a Guild Stamp *honest and truthful*, a stamp that we *Retailers* can control, and see that the goods so stamped, are only handled by regular retail dealers; for we dare not risk them in the hands of the jobber. In fact, I would like to see none but members of our several States Associations allowed to handle our goods. I narrow it down to these men, because these men only are entitled to any advantages that are to be gained thereby. A few jewelers only, when compared to the many in each State where organizations exist, have had the manhood to come out and boldly strike for their rights, they have spent time and money to *squench* the circulation of catalogues, while the inert and pernicious have been equally benefited. There is no objection to these jewelers becoming members of their respective State Associations, but I do not feel like giving them any further benefit of our labor so long as they remain inactive and untaxed outsiders.

We do not propose to *force* any member of our associations to buy these stamped goods, but we can soon create a demand for these goods, that will make it to their interest to do so. Neither do we propose to confine our own stocks to *all* stamped goods. We must keep a line of the present *snides* and *frauds* to meet outside competition, which we can offer at low prices to prove their worthlessness. We retailers are the educators of the people, the goods we recommend they will in most cases buy, providing, we *honestly* think, that what we claim for the goods will prove true. No man can inspire that confidence in another, he does not possess himself. *Let me know that I am right, and I fear no man I know to be wrong.*

So soon as the manufacturers start in on our stamped goods, their interest and ours become mutual. It is to their interest to give us stylish and salable goods at as low a price as they can be *honestly* afforded, that we may be able to catch the eyes and tap the purses of our patrons *as we would not buy goods we could not sell.*

If the manufacturers who do not use our Guild Stamp, wish to combine and make stamped goods to compete with ours, let them do so; we can handle their goods also. No fear of their refusing to sell to us if we have *cash* or *commercial standing*. In all events, the public would be benefited by having honest goods placed in the hands of all dealers, which would improve the reputation for honesty of jewelers generally.

Very truly yours,

W. N. BOYNTON.

On the Compensation of Clocks, Watches and Chronometers<sup>1</sup>(By EDW. RIGG, M. A., *Assayer in the Royal Mint.*)

Recent improvements in the pendulum have tended as much towards reducing the cost of construction as to increasing the efficiency, and it would be well if chronometer makers would follow this example. What is now wanted, as already observed, is a means of materially diminishing the time required for adjustment and poising, and, consequently, reducing the cost; and the inventor of a really efficient and practicable method might rely on benefiting both himself and the trade generally. Too much stress cannot be laid on the necessity of solidity of construction, which is so sadly wanting in a vast number of the improvements that have been proposed; subject to these conditions, any invention that tends to diminish the middle temperature error should be welcomed, but such reduction is not worth having at the sacrifice of solidity.

The Astronomer-Royal, some years ago, pointed out that the chronometers received at Greenwich were very generally found to be unsatisfactory as regards the final adjustment of the compensation, and he, at the same time, suggested a method for facilitating it. Two small weights are carried at the end of an arm held by friction on the balance staff, at the extremities of two light steel springs and these weights are always in contact with the rim. By turning the arm to the right or left, the space through which they move is altered, since each point of the rim moves inwards through a different distance; the effect is thus the same as if the mass of the compensating weights were modified, and the poising of the balance is not disturbed. This appendage must not be regarded as in any sense an auxiliary; it is merely intended to serve the above mentioned purpose, and is stated to be so easy of application, that the final adjustment is now often made at the Observatory.

Very little need be said as to the effect of barometric variations on the rates of chronometers. The question was studied by Jurgensen,<sup>9</sup> and he concludes that their influence is almost unappreciable, absolutely vanishing when the balance spring is so adjusted that a reduction of the arc of vibration by  $150^\circ$  corresponds to a gain of five or six seconds per day. More recently, Villarceau<sup>1</sup> has calculated that, if the resistance opposed by the air to the motion of the balance varies as the square of the velocity, it has no appreciable effect, and this has been confirmed by observation.

In concluding, it may be noticed that no less than five of the physical properties of matter must be taken into account in designing an arrangement for compensation. These are: Dilation, or expansion by heat; conduction, or the power of transmitting heat from a colder to a hotter portion; specific heat, as on it depends the rapidity with which the pendulum or balance assumes the temperature of the surrounding medium; density, or the weight of a unit of mass; and elasticity at varying temperatures, especially in the construction of balances.

While theory is always a valuable guide to the practical observer, a question of such delicacy as the absolute adjustment of a chronometer must be solved by experiment; for, as we have already shown, a motion of the weights towards the center, such that the square of the radius of gyration is inversely proportional to the temperature, will only suffice to maintain the rate uniform on the assumption that the tension of the spring is the sole variable, varying in inverse proportion to the temperature. But we also have changes occurring in the consistency of oil, diameter of balance, motive force, etc., and these cannot be regarded as having precisely the same effects in different cases. It necessarily follows that no balance can exist that is universally applicable, and the only balance capable of such adjustment would be one in which the ratio of the movements per degree could be altered at will throughout the entire range of temperature between any two given points; and even then the effects of oil, etc.,

would, in all probability alter in time. Such a balance has yet to be invented, and, until one exists that satisfies both the demands of theory and practice, it is far preferable to resort to the method already referred to, of tabulating errors, after having carefully adjusted any balance of simple construction, that can be depended upon to behave always in the same manner when under identical conditions.

It only remains for me to express my thanks to Mr. Glasgow, Vice-President of the Horological Institute, for valuable information, and for his kindness in lending me for exhibition this evening, the interesting collection of compensation balances that lies on the table.

## Repairing Swiss Watches.

WORKING IN A FOURTH PINION.

YOU now cut off the wire on the under side of bar and file it down nearly level with the surface, using a piece of thin paper with a hole in it to protect the gilding. Having a polished steel stake fixed in the vice, place the under side of bar on it, and with a round-ended punch of such a size that it will not enlarge the oil sink, secure the stopping in its position by a few blows of the hammer, replace the bar on the frame, screw it down, and centre it with the graver while the mandrel is revolving. Having drilled the stopping through with a drill  $\frac{1}{10}$  mm. smaller than the pivot, open it with a straight broach while in the mandrel, until the pivot just enters the hole, and with a chamfering tool remove the surplus material to the oil-sink, taking off the extreme corner with a sharp drill. Remove the bar from the frame, and if there is any excess of brass on the under side, remove it with a polished cutter, by placing the bar on a chuck in the balance tool, and centreing it by the pivot hole; at the same time you can open the hole to its necessary size for the pivot, with the absolute certainty that it is upright, which, if opened by hand in the ordinary way, it is almost certain not to be. With a hole replaced in this manner, and of the material described, the wear is of many years' duration, and it is almost impossible to see that it has been repaired if it is carefully done. In operating on a hole in the frame, it is best to fix position of hole by the depth tool, and not depend on uprighting from the bar hole, unless you have previously ascertained the correctness of such upright,

In replacing the centre holes great care is required not to get them out of upright or alter the depth on the barrel or third wheel. Where both are to be replaced the following will be the best method of proceeding: Having centered the frame accurately in the mandrel with a narrow cutter and the slide-rest, turn out the hole to receive the stopping (if it is broached it has a tendency to give towards the barrel sink, making the depth deeper), keeping the hole small—not larger than the shoulder of pivot, at all events. A piece of hard wire having been drilled and broached out to just fit the pivot tightly, is put on an arbor, and turned true and taper to fit the hole in frame. Having removed the frame from the mandrel, put a broach in the hole, and work it round to roughen, and slightly enlarge the ends of the hole; drive the stopping in tight from the *inside*, and rivet it with a punch, having a slightly rounded face; a case stake with a piece of paper on it supports the frame while riveting the stopping. Replace the frame in the mandrel, and turn off any excess of stopping with the slide-rest; and, with a narrow cutter, open the hole to fit the pivot. You can now put in the bar (having previously put in either a hollow or solid stopping) and turn out the hole to size. In some cases, where the pivots are taper, it will be necessary to broach the holes slightly at the last; but in most cases they are parallel, and the holes can be opened with the cutter; in this way, there is no fear of getting work out of upright.

CENTRE PINION.

No part of the watch is more subject to wear than this; it is not uncommon to meet with pinions having the pivots cut through, or so

<sup>9</sup> L. U. Jurgensen, "Exacte Mesure du Temps," 1838, p. 200.

<sup>1</sup> "Revue Chronometrique," ix 183; and "Compte Rendus," lxxvii. p. 697.

much as to make it impossible to repair them, rendering a new pinion necessary. This rapid wear proceeds in most cases from the shallowness of the holes, and the total absence of any sink for the oil; in addition to this, there frequently is not a sufficient shoulder to the pivot; and, where this is the case, it is no wonder if the oil disappears and the pivots cut. In selecting a new pinion, some difficulty is sometimes found in getting sufficient size in the body, owing to their being too much reduced by the maker; in addition to this, many are broached from both ends, rendering them untrue when opened out straight. Having a pinion that is true and the right size, the arbor to turn it on requires some attention; to do this on an ordinary arbor is almost an impossibility. The most convenient way is to turn up a piece of staff steel (hardened and tempered so that you can just cut it to fit the pinion, and of only just sufficient length to go through the hole; it must fit the pinion throughout, otherwise it is impossible to work at it with comfort. Having removed the old pinion from the wheel, and measured the height from the face of pinion to the seat for the wheel, you proceed to turn down the leaves and let on the wheel tight. The rivets being shortened to the right length and the hollow cut, the wheel can be riveted on, using a polished steel punch, that just fits easily over the body of pinion—the rivets are turned true and faced—and a brass ferrule opened to fit over the pinion, and secured to the wheel with wax. The position of the lower pivot shoulder is now fixed (measuring from the rivet), and the pivot carefully turned to nearly its correct size. Too much stress cannot be laid on *good turning* for this, and indeed all pivoting. The pinion is now reversed in the centres and the upper pivot turned down; they have now to be polished, and it is here that workmen generally fail, for, unless exceptionally good pivoters, and in constant practice, they round the shoulder and leave a lump in the corner. For this reason I here introduce a drawing of a little tool, by means of which the workman can polish these, and indeed many other pieces, requiring great accuracy, with ease and certainty. It consists, as will be seen from the drawing, of an ordinary depth tool of rather large size, having a piece of brass, A, screwed to either the front or underside, to fix it in the vice while using it.

A piece of brass wire, B, of about two and a half millimetres diameter has its ends bent at right angles for a length of about one and a half inches, and a deep centre made in the extremity of each; its length should be such, that, when an arbor is

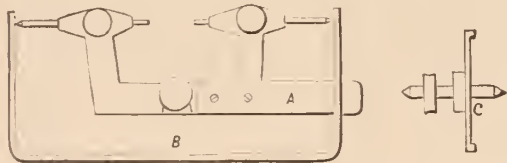

placed between the centres, the ends just spring on the extremities of the centres and couple them firmly together, rendering it possible to traverse the centres and arbor in the direction of their length, by moving the brass coupling. The only other requisites are two circular laps, one of soft steel, and the other bell-metal or zinc; a section of one, C, is given. They can be either screwed or riveted to a brass collet, driven on an arbor (the ferrule of which, to save the hair continually coming off, should have a deep and broad groove in it); the edges of these laps are turned perfectly true, and their faces slightly undercut. The lap in use should be put in the back pair of centres, with its face towards the left; the pinion on its arbor, with the shoulder of pivot towards the lap,—a hair bow is attached to each ferrule, the hair crossing in opposite directions, so that the lap and pinion revolve in opposite directions,—the right hand works the two bows, while the left, by means of the brass coupling, controls the pinion. The depth tool being closed until the lap just touches the pivot lightly, the pivot should be traversed until it arrives at the shoulder, care being taken not to press it hard up, otherwise the shoulder will become round. The steel lap should be used with either very fine oil-stone dust, or sharp red stuff and oil, finishing with the bell metal and fine stuff.

The pivots polished and the shoulders neatly sloped off, it is placed in the frame, and the pivots marked where they are to be cut off; this being done, and the pivots being burnished with a very fine flat burnisher (with the corner polished off), completes the pinion. This tool will be found useful for such an infinite number of purposes in connection with repairing, that it will well repay the workman for the time spent in its construction; plenty of depth tools, sufficiently accurate for this purpose, can be bought second-hand for from three to five shillings.

#### REPAIRS TO BARREL AND BARREL ARBOR.

In foreign watches two varieties of barrel arbor are met with. The first, in which the arbor and ratchet are in one, and secured to the bar by a brass cap covering the ratchet, and forming at the same time the dirt cup. The second, in which the arbor has a large flange or boss bearing against the under side of bar, and is secured to it by the ratchet which is attached to the boss or flange by three screws, passing through the ratchet into the boss. The latter is a very old plan, and not often met with; where it is, and it becomes necessary to repair it, it is very troublesome, involving, making a new nut frequently, to fit the arbor when it has been repolished to make it true; the nut in this case being usually secured by a pin passing right through both nut and arbor. The arbor can be set up in the balance tool, and secured by wax to the cement chuck, the flange or ratchet, as the case may be, bearing against the face of chuck, and run true by some part of the arbor which is not worn. The arbor can now be turned true; slightly tapering and repolished. Where this kind of arbor is met with, the cover is generally in the top of barrel, and in such cases it will be found better and less trouble to put a new cover, instead of stopping the hole. Where, as is usually the case, the cover is very thin after it has been in and out many times, it gets out of flat, and in such a state it is impossible to get the barrel to revolve truly.

Having roughed out the cover from a piece of hard brass, well hammered and filed one side flat, cement it by that side to a chuck (such as a brass-edge turned true), using very little cement, and taking care to press it as close as possible to the chuck while it is cooling; it is now put in the mandrel and centred by the hole in the cover, which at this stage should be small. With a cutter in the slide rest turn the cover to about 10 of a millimetre thicker than it will ultimately be required; the box will be nearly as large as the nut, and should also be left somewhat thicker than the old one. Remove it from the chuck, and cut the notch (by which it is removed from the barrel) with a fine square file; you will now cement it to a chuck on the balance tool slightly *smaller* than the cover, and turn down the edge to fit the barrel. Doing it this way you can apply the barrel directly to it, and fit it with comfort and certainty; the edge should not be too much beveled, or it will soon become loose—an angle of about 80° is right for this—and the extreme corner should be slightly rounded off with a piece of Water of Ayr stone.\*

Having broached out the hole in barrel, and drilled a piece of wire with a hole slightly smaller than the pivot, put it on an arbor and turn it true to fit the hole in barrel tightly, and slightly longer than the hole, securing it by riveting very carefully; if great care is not taken the barrel will become bulged, and the end shake of arbor altered. Having reduced the stopping with a cutter and the slide rest, to its proper thickness, cement the barrel by its face to a chuck on the balance tool, running it true by the tops of the teeth with a peg, taking care that at the same time it runs true in flat, and with a narrow cutter open the whole true to nearly fit the pivot. finishing it with a polished broach (the spindle of tool being hollow allows the broach to pass up it). The cover can now be snapped into its place *without removing the barrel from the chuck*, and its hole opened with the cutter and finished with the broach.

\*In all operations where cement is used for attaching pieces to the chuck or ferrules to the work, when it is required to remove the wax or shellac from the work, it is placed in spirits of wine in a copper boiling-out pan, and held over the flame of the lamp until the boiling spirit dissolves the cement. Great convenience will be found if, instead of this open pan (which is constantly igniting), a few ordinary chemical test tubes of different sizes are procured and used for this purpose. Being transparent, you can see exactly how the work is progressing, and there is also a considerable saving in the amount of spirit used.

Practical Experiments in Magnetism, with Special Reference to the Demagnetization of Watches.—No. 3.

BY ALFRED MAYER.

NOW bring the unpapered end of the rod up to the magnetometer and repeat the above experiments. The needle again turns its south end toward the rod when the latter is tilted upward. This shows that the magnetism of the rod depends alone on its position, and that end which is down is always of north magnetic polarity. It has also been found—and you can prove it for yourself—that when the rod is held inclined in the meridian, with its upper end leaning away from the north, so that it is at an angle of about  $76^\circ$  with the horizon, it has the most powerful magnetism that can be given to it by this means.

All of the above curious facts are explained if we consider the earth itself as a great magnet, with its south magnetic pole situate somewhere near the north geographic pole, and with its north magnetic pole placed somewhere near the south geographic pole. If you carry your small suspended magnetic needle over the length of a magnet, you will observe that the north end of the needle will point downward when it is over the south pole of the magnet, and that the south end of the needle will point downward when it is over the north pole of the magnet; while, when over the center of the magnetic bar, the needle takes up a horizontal position. In the same manner acts a freely suspended magnetic needle when carried over the surface of the earth along a meridian. In a far northerly latitude, on the western coast of Boothia, Sir James Ross, in 1831, found that the magnetic needle pointed directly downward, with its north pole toward the center of the earth. He inferred that he then stood on the termination of a line drawn from the earth's center through its magnetic pole to his feet. Subsequently this bold

the Antarctic seas, it is supposed that the magnetic pole of the southern hemisphere must be somewhere about south latitude  $70^\circ$  and near the meridian of  $125^\circ$  east of Greenwich. This would bring the position of the magnetic pole somewhere on the territory discovered by our countryman Wilkes. The exact position of this point, however, is not known, for no explorer has ever reached it. Also, it has been well ascertained that along an irregular line, situated on the equatorial belt of the earth, the needle has a horizontal position, just as it has when placed midway between the poles of an artificial bar magnet. This irregular equatorial line is called the earth's magnetic equator.

These facts are all explained by conceiving the earth as a huge magnet, and if the earth be a magnet, it also follows that the soft iron rod, when held upright in the southern hemisphere, will have its lower end of south magnetism; while the same end in the northern hemisphere, we have ourselves found, is always

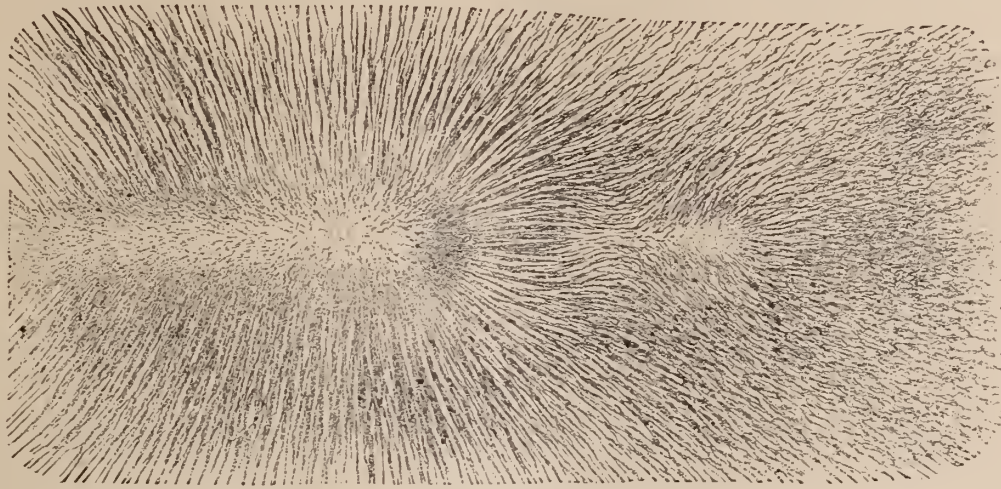
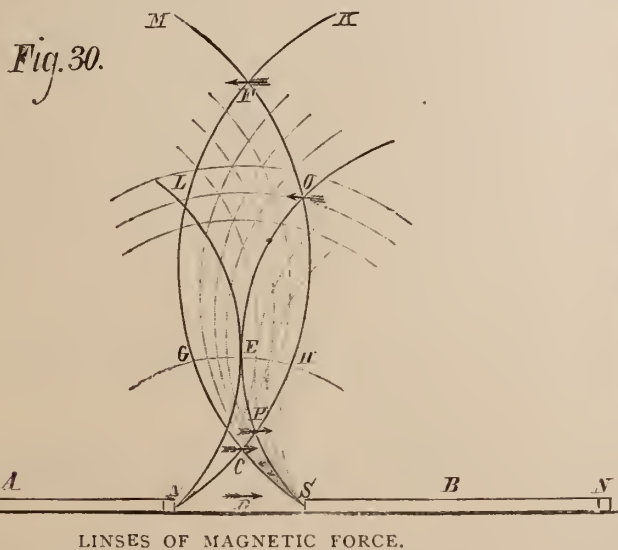

FIG. 29—CURVES SHOWN BY A MAGNET ACTING INDUCTIVELY ON A CYLINDER OF SOFT IRON

of north magnetic polarity. We cannot travel over the earth and test this conclusion for ourselves, but I once found in the Transactions of the Royal Society of London a paper headed "On the tendency of the Needle to a piece of Iron held perpendicular, in several climates. By a master of a ship crossing the Equinoctial Line. Anno 1684." Let the mariner give his own account of his experiments, and we will see that his statements show that when you cross the magnetic equator the lower end of the upright iron rod changes from north to south magnetic polarity: "All the way from England to  $10^\circ$  north latitude, the north end of the needle tended to the upper end of the iron, and the south point to the lower end, very strongly. \* \* \* In latitude  $8^\circ 17'$  south, and meridian distance from the Lizard  $17^\circ 35'$  west, the north point of the needle would not respect the upper end of the iron; but the south point would still somewhat respect the lower end. \* \* \* In latitude  $29^\circ 25'$  south, and  $13^\circ 10'$  west, from the meridian of the Lizard, the south point of the needle respected the upper end of the iron, and the north point the lower end strongly."

On the "Magnetic Neutral Line."—There has recently appeared much discussion about the existence of a position of neutrality near a magnet. That a region of that kind, where there appears a break in the continuity of the magnet's attractive and direct force, exists, I have no doubt; but I cannot agree with those who have declared for the existence of a line, or plane of neutrality in the sense in which Mr. Gary and others have put it. Indeed one hundred and twenty years ago a neutral line was discovered by the celebrated John Robison, Professor of Natural Philosophy in the University of Edinburgh. He is the man of whom James Watt said, "He has the clearest head of any man I know." Having such good endorsement for clearness of head, I cannot do better than let him describe his own experiments:

"Amusing myself in the summer of 1758 with magnetic experiments, two large and strong magnets, A and B (Fig. 30), were placed with their dissimilar poles fronting each other and about three inches apart. A small needle, supported on a point, was placed between them at D, and it arranged itself in the same manner as the great magnets. Happening to set it off to a good distance on the table, as at F, I was surprised to see it immediately turn round on its pivot and arrange itself nearly in the opposite direction. Bringing it back to D restored it to its former position. Carrying it gradually out



mariner undertook another voyage of discovery in search of a similar point on the southern hemisphere, and in 1841 succeeded in reaching south latitude  $76^\circ 12'$ , on Victoria Land, when the south end of the needle pointed downward and made an angle of  $88^\circ 40'$  with the horizon. He concluded from this and other observations that the position where the needle would be vertical was about 160 nautical miles distant. From these and other magnetic observations made in

along D F, perpendicular to N S, I observed it to become sensibly more feeble, vibrating more slowly; and when in a certain point, E, it had no polarity whatever towards A and B, but retained any position that was given it. Carrying it further out, it again acquired polarity to A and B, but in the opposite direction, for it now arranged itself in a position that was parallel to N S, but its north pole was next to N and its south pole to S.

"This singular appearance naturally excited my attention. The line on which the magnets, A and B, were placed had been marked on the table, as also the line, D F, perpendicular to the former. The point, E, was now marked as an important one. The experiments were interrupted by a friend coming in, to whom such things were no entertainment. Next day, wishing to repeat them to some friends, the magnets, A and B, were again laid on the line on which they had been placed the day before, and the needle was placed at E, expecting it to be neutral. But it was found to have a considerable verticity turning its north pole toward the magnet, B, and it required to be taken further out, toward F, before it became neutral. While standing there something chanced to joggle the magnets, A and B, and they instantly rushed together. At the same instant the little magnet or needle, turned itself briskly, and arranged itself, as it had done the day before, at F, quivering very briskly, and thus showing great verticity. This naturally surprised the beholders; and we now found that by gradually withdrawing the magnets, A and B, from each other, the needle became weaker, then became neutral, and then turned round on its pivot and took the contrary position. It was very amusing to observe how simply separating the magnets, A and B, or bringing them together, made the needle assume such a variety of positions and degrees of vivacity in each.

"The needle was now put in various situations, in respect to the two great magnets; namely, off at a side, and not in the perpendicular, D F. In these situations it took an inconceivable variety of positions which could not be reduced to any rule; and in most of them, it required only a motion of one of the great magnets for an inch or two, to make the needle turn briskly round on its pivot, and assume a position nearly opposite to what it had before.

"But all this was very puzzling, and it was not till after several months that the writer of this article, having conceived the notion of the magnetic curves, was in a condition to explain the phenomena. With this assistance, however, they are very clear and very instructive.

"Nothing hinders us from supposing the magnets, A and B, perfectly equal in every respect. Let N H M, N E L, be two magnetic curves belonging to A; that is, such that the needle arranges itself along the tangent of the curve. Then the magnet, B, has two curves, S G K, S E Q, perfectly equal and similar to the other two. Let the curves, N H M and S G K, intersect in C and F. Let the curves, N E L and S E Q, touch each other in E.

"The needle being placed at C would arrange itself in the tangent of the curve, K G S, by the action of B alone, having its north pole turned toward the south pole, S of B. But by the action of A alone it would be a tangent to the curve, N H M, having its north pole turned away from N. Therefore, by the combined actions of both magnets, it will take neither of these positions, but an intermediate one, nearly bisecting the angle formed by the two curves, having its north pole turned toward B.

"But remove the needle to F. Then, by the action of the magnet, A, it would be tangent to the curve, F M, having its north pole toward M. By the action of B, it would be a tangent to the curve, K F G, having its north pole in the angle, M F G, or turned toward A. By this joint action, it takes a position nearly bisecting the angle, G F M, with its north pole toward A.

"Let the needle be placed in E. Then, by the action of the magnet, A, it would be a tangent to the curve, N E L, with its north pole pointing to F. But, by the action of B, it will be a tangent to S. E. Q, with its north pole pointing to D. These actions being

supposed equal and opposite, it will have no verticity, or will be neutral, and will retain any position that is given to it.

"The curve, S E Q, intersects the curve, N H M, in P and Q. The same reasoning shows that when the needle is placed at P, it will arrange itself with its north pole in the angle, S P H; but, when taken to Q it will stand with its north pole in the angle, E Q M.

"From these facts and reasonings we must infer that, for every distance of the magnets, A and B, there will be a series of curves, to which the indefinitely short needle will always be a tangent. They will rise from the adjoining poles on both sides, crossing diagonally the lozenges formed by the *primary or simple* curves, as shown in Fig. 30. These may be called *compound or secondary* magnetic curves. Moreover, these secondary curves will be of two kinds, according as they pass through the first or second intersections of the primary curves, and the needle will have opposite positions when placed on them. These two sets of curves will be separated by a curve, G E H, in the circumference of which the needle will be neutral. This curve passes through the points where the primary curves touch each other. We may call this *the line of neutrality* or inactivity.

"We now see distinctly the effect of bringing the magnets, A and B, nearer together, or separating them farther from each other. By bringing them nearer to each other, the point, E, which is now a point of neutrality, may be found in the *second* intersection (such as F) of two magnetic curves, and the needle will take a subcontrary position. By drawing them farther from each other, E may be in the *first* intersection of two magnetic curves, and the needle will take a position similar to that of C.

"If the magnets, A and B, are not placed so as to form a straight line with their four poles, but have their axes making an angle with each other, the contacts and intersections of their attending curves may be very different from those now represented; and the positions of the needle will differ accordingly. But it is plain, from what has been said, that if we knew the law of action, and consequently the form of the primary curves, we should always be able to say what will be the position of the needle. Indeed, the consideration of the simple curves, although it was the means of suggesting to the writer of this article the explanation of those more complicated phenomena is by no means necessary for this purpose. Having the law of magnetic action, we must know each of the eight forces by which the needle is affected, both in respect of direction and intensity, and therefore able to ascertain the single force arising from their composition.

"When the similar poles of A and B are opposed to each other, it is easy to see that the position of the needle must be extremely different from what we have been describing. When placed anywhere in the line, D F, between two magnets whose north poles front each other in N and S, its north pole will always point away from the middle point, D. There will be no neutral point, E. If the needle be placed at P or Q, its north pole will be within the angle, E P H, or F Q I. This position of the magnets gives another set of secondary curves, which also cross the primary curves, passing diagonally through the lozenges formed by their intersection. But it is the other diagonal of each lozenge which is a chord to those secondary curves. They will, therefore, have a form totally different from the former species.

"The consideration of this compounded magnetism is important in the science, both for explaining complex phenomena, and for advancing our knowledge of the great desideratum, the law of magnetic action.

(To be Continued.)

The bracelet slipper has been introduced in Paris. The shoe is cut very low in front and high up on the instep; it is fastened with a finely chiseled real gold bracelet instead of the usual strap. Another expensive novelty in the same line is the Andalusian boot, made of black satin, with lace ruffles down the front seam, and fastened with real jewel buttons.



## Trade Gossip.

Paper jewelry is the latest agony.

Silver jewelry is again fashionable.

Shed no tears over 1879, which restored prosperity.

Gold dinner cards are the latest among the *bon ton*.

The new finish given to silver plate is called the "snow flake."

The JEWELERS' CIRCULAR completes its X volume with this issue.

Large quantities of South American opals are being sent to this country.

E. J. Baur & Co. have purchased the stock and fixtures of the late F. Waaser.

A peculiarity of the clock is, that as soon as it strikes it goes on with its work.

Cranes wrought in brown, grey, and russet alloys are used to decorate ice pitchers.

Z. B. D. Le Fleurs' jewelry store at St. Catharines, Canada, was recently destroyed by fire.

The *Journal* says of the Chicago holiday trade that there has been nothing like it for seven years.

A watch is a modest little piece of mechanism, or else it wouldn't always keep its hands before its face.

J. W. Brown's jewelry store in Jersey City was recently broken open, and a quantity of valuables stolen.

It would be impossible to estimate the amount and value of jewelry buried all over this world with the dead.

Gotthelf & Co., of Vicksburg, Miss., has purchased the stock and fixtures of Max Kuner, who retires from business.

Dom Pedro while in Europe it is said unloaded four millions dollars worth of diamonds on London and Paris merchants.

L. Egerton, jr., formerly agent for the New Haven Clock Co., has associated himself with the E. N. Welch Manufacturing Co.

Thomas Gunn, an Illinois watchmaker, has eloped with his employer's wife. That is the kind of a concealed weapon he is.

New sleeve-buttons are composed of beaten gold, and have several gems set in each indentation. Double buttons connected by a swivel are newer than studs.

The old fashion of wearing strings of large cut beads in one color, garnet, deep blue or amber, is to be revived. From three to five strands are worn in graduated lengths.

Miss Stevens, a young American lady, has taken the highest diploma for porcelain painting in London, and has orders from the Prince of Wales and the Duke of Connaught.

"Clay was first used in making pottery." We thought it was first used in making Adam. It was very thoughtful in some persons to make pottery before the "first man" was made.

Fruit trays of gold, with apples and grapes in green and amber hues, shaded with black, are shown by the jewelers. Napkins of silver are placed beneath these trays and are used as salvers.

A clever idea in small pieces of silver is a cheese knife with a shallow fork on the back, so that after slicing the cheese it is only necessary to reverse the blade in order to pick up the slice.

Ivory or celluloid toilet sets, consisting of combs, brushes, and hand glasses, make serviceable and beautiful presents. They are sent, of course, in a satin-lined morocco or russia leather box.

Gypsy rings are plain rounded gold bands, set with a ruby, a sapphire, or a cat's eye in the centre, and a diamond on each side. Those stones are buried in the gold, showing only the surface.

An English lady, now in this country, has ordered of Tiffany & Co. a bangle bracelet which is to cost \$40,000. It is made like the bangles of the harem, of beaten gold, and is set with every known jewel.

Diamond merchants, according to the *Philadelphia Chronicle-Herald*, say that their best customers are the wives of rope manufacturers. It is hinted by the *C. H.* that rope manufacturers thrive on hangings.

We take pleasure in wishing our readers a very happy and prosperous New Year, trusting that their digestions during the year may be as easy as their conscience, and their hearts a good deal lighter than their pocket-books.

One-third of the gold that is mined goes to wear and tear, one-third goes into circulation, and one-third into the arts and manufactures. All the gold in the world would make a pile only twenty-five feet wide, forty-five feet long, and twenty-five feet high.

A Londoner worked twenty years to make artificial diamonds, and then drowned himself because he couldn't do it. And yet Maclear, another Englishman, has been following in the footsteps of the other fellow, only he hasn't yet drowned himself.

In digging the foundation for a gasometer at Monaco, nine bracelets, a gold medallion of Gallian, two inches in height, and eight gold medals were discovered. Some of the bracelets are believed to be decorations belonging to a Roman General under Probus.

The jewelers of the country have done the best trade during the past six months that they have done for years. When the books of 1879 are closed, the balance will be found on the right side of the ledger, where the business has been conducted wisely and with good judgment.

Tiffany & Co. have just got up a novelty in playing cards, which is unique, useful, and humorous. The designs for the different suits are excellent, differing entirely from the old pattern of cards, yet presenting the individuality of each card perfectly. They must be seen to be appreciated.

Mr. Feuardent, who has done so much to promote a knowledge of antiquarian art in this city, announces that his very interesting collections of antique bric-à-brac, if they may be so called, will henceforth be on free exhibition at No. 30 Lafayette Place from 9 A.M. until 11 P.M. on week days, and from 1 till 6 on Sundays.

A few days since the plate window of one of the jewelry stores in the Palais Royal, Paris, was broken by a man, who threw a brick against it, seized two diamond necklaces valued at \$6,000 and \$4,000, and ran for dear life. He was arrested, but nothing was found upon him, as his accomplices had departed with the plunder.

The trade is making every effort to recover from the unprecedented rush of the holidays. Accounts of stock now being taken show a smaller quantity of goods on hand than has been known in years before. Manufacturers, however, are hard at work to make up the deficiency, and before the month closes, dealers generally will be stocked up with full lines of goods.

Some time since it was proposed that the Jewelers' Association should have an album containing the pictures of its members. This excellent idea was heartily approved at the time, but, we are sorry to say, the album has not yet assumed gigantic proportions. It is to be hoped members will forward their photographs without further delay, for such a collection will be invaluable.

Myers & Finch, of St. Paul, Minn., have sold the celebrated piece of silverplated ware known as "The Buffalo Hunt." This piece was manufactured by the Meriden Britannia Company for the Centennial Exhibition, and a prize was given the company for the artistic elegance of the work. It is statuette, representing a mounted Indian pursuing a buffalo, and is strikingly realistic in every detail. The purchaser of the stand is not known.

The fact that retail dealers throughout the country were unable to get all their orders filled for new goods has been the best thing that could have happened to them. In the absence of new goods, the dealers made extra efforts to work off their old stock, and the holiday trade enabled them to do this successfully. They can now stock up with fresh goods, embracing the newest designs and latest novelties, thus catering to the increasing demand for better grades of goods. We hope they will make good use of this opportunity, and do their best to educate the public taste to better appreciation of the elegant goods now being manufactured.

An unknown man has been working at the infirmary at Saint Clairs-ville, O., for some time, who could give no account of himself or his past life. Through illness or some mental derangement his remembrance of the past was completely obliterated. Who he was, who his friends were, where he had lived, what even his name was, he did not know. By the publication of his story, however, his friends have identified him as Ralph Cowles, a well-known watchmaker of Cleveland, Ohio, but he is unable to recall his friends. He is actually beginning life anew. The case is not unprecedented, but it presents curious psychological phases well worthy of scientific study.

The trade in precious stones will be one of the first to suffer from the withdrawal of the British Residency from Burmah. Large quantities of sapphires are exported from Burmah to England and the Continent generally; and the supply will now, in a measure, be considerably interfered with. The Burmese sapphires are not so valuable as the Cingalese stones; they lack fire and color, as compared with the latter. They are, however, very good day gems, but at night they have a dull, almost coal-black, appearance. Apropos of precious stones, the diamond trade, which has been in a very queer condition lately, is now looking up. The business done is principally with America; all the fine stones are bought for that market.

# INDEX TO VOL. X.

<i>A</i>		<i>I</i>		<i>R</i>	
American Jewelry.....	4	Is Overproduction at fault.....	22	Removals.....	65
A Failure of the Period.....	5	Iowa Retail Jewelers' Protective Association.....	(4) 167	Reproduction of Ancient Glass.....	69
A New Back for Sleeve Buttons.....	14	Imitation Pearls.....	69	Repairing Swiss Watches.....	88, 108, 126, 151, 206, 238, 252
Antiquities.....	15	Improvement in Trade.....	141	Retaliation.....	143
A Standard for Wrought Gold 21, (1.) 101, 141				Rowell's Improved Lens for Spectacles.....	155
An Old Landmark Gone.....	23	<i>J</i>		Rosset's Clock.....	213
An Ingenious Clock.....	24	Jottings. 4, 30, (3.) 63, 65, 103, 123, 148, 161, 167, 195, 232		Responsibility of Dealers.....	221
Alloys of Gold.....	33, (14)	Jacques Guedin.....	23	Required Legislation.....	242
A Voice from California.....	(5)	Japanese Bronzes.....	24	<i>S</i>	
A Change of Base.....	5	Jade Stone.....	26	Scenes in a Jewelry Store.....	64
A De-erved Charity.....	16	Jewelers' Rouge.....	74	Self-Luminous Clock Dials.....	72
Assaying Jewelry.....	62	Jewelry.....	131	Silver Thimbles.....	84
A Study from Nature.....	69			Signs of Improvement in Trade.....	122
A New Invention.....	72	<i>K</i>		Selling the Jewels.....	148
A Combination Chain, Slide, Etc.....	87	Keramic Insanity.....	219	<i>T</i>	
Artful Dodgers.....	102	<i>L</i>		The Condition of Trade.....	1
A Sea Captain's Strategy.....	112	Legal Regulations for the Standard of Gold and Silverware in the different countries of the World.....	10, 31, (11)	The Jewelers' Protective Union.....	3
A Study in Stalactites.....	127	<i>M</i>		The English Jewelry Trade in 1878.....	8
Antique Coin Jewelry.....	130	Majolica.....	15	The Microphone in Surgery.....	9
Art Work in Silver.....	145, 183, 211, 233, 247	Mortgaging Their Stocks.....	62	The Electric Watch.....	15
A Couple of Curious Clocks.....	162	Misplaced Confidence.....	63	The Thermometer.....	16, 36
Anticipated Scarcity of Goods.....	165	Metals and Alloys.....	78, 91	Trade Gossip.....	20, 40, (20.) 80, 100, 110, 137, 164, 189, 216, 237, 255
American Workmen.....	165	Main Spring Barrels.....	196	Trade We Should Have.....	22
A Wonderful Invention.....	167	Meeting of the Iowa Retail Jewelers' Protective Association.....	169	Taking their Grievances in Hand.....	23
A Trade Stamp of Value.....	193	<i>N</i>		The City Clock Winders.....	24
Assaying Gold Goods.....	194	Novelties in Jewelry, Etc.....	18	The Ceylon Sapphire.....	36
A Reliable Watch.....	214	<i>O</i>		The Jewelers' League.....	19, 68, 87, 104, 138, 161, 176, 220, 223
A Tale for the Marines.....	243	Organized for Protection.....	(2)	The Capital of Credit.....	61
<i>B</i>		Obituary.....	83, 166	The Howard Watch Company.....	62
Business Notes.....	117, 138, 163, 176, 215	On the Compensation of Clocks, Watches, and Chronometers.....	115, 134, 187, 204, 239	The Watchmakers' and Retail Jewelers' Guild.....	81, 95
Bog Oak Ornaments.....	219	Our Defective Patent Laws.....	143	The Boys on the Road.....	82, 122
<i>C</i>		Ohio Pearl Fisheries.....	171	The Navisphere.....	84
Compounding Felonies.....	3	Our Export Trade.....	193	The Geneva International Exhibition of Tools and Machinery.....	92
Courtesy a Business Requisite.....	34	<i>P</i>		Trade Recipes.....	118
Correspondence.....	16	Promptness a Business Requisite.....	1	The Trade in Time-Pieces.....	143
Communication.....	62	Practical Hints on Watch Repairing.....	6, 28, (9.) 75, 89, 109, 132, 154, 172, 199, 230	The Clock Trade.....	166
Cleaning Fine Watches.....	63	Proceedings of the Horological Club.....	12, 25, (6.) 66, 85, 105, 123, 156, 190, 217, 235	The Story of a Ring.....	168
Coral.....	99	Precious Stones and Gems.....	17, 37, (17.) 79, 94, 113, 128, 160, 68	The Law More Certain.....	197
Clocks and Time.....	214	Patent Reflectors.....	68	Tin Polishers.....	206
Canadian Precious Stones.....	220	Phosphorescent Powders.....	118	The Largest Sapphire in the World.....	210
Compensation of Clocks, Watches and Chronometers.....	251	Protection from Fraud Required.....	126	The Venus of Milo.....	210
Closing the Books for 1879.....	241	Patents.....	125, 163, 168, 215	The Closing Volume.....	222
<i>E</i>		Prohibitive Licenses.....	142	The Registration of Trade-Marks.....	222
Entitled to Consideration.....	(2)	Palladium Balance Springs.....	144	The Annual Dinner.....	223
Estimating Metals in Ores.....	69	Practical Experiments in Magnetism, with Special Reference to the Demagnetization of Watches.....	179, 201, 253	The New York Jewelers' Association.....	224
Embarassed.....	144	<i>V</i>		The Holiday Trade.....	242
Electric Jewelry.....	214	Venetian Glass.....	65	The Commission Business.....	243
<i>F</i>		<i>W</i>		<i>IV</i>	
Foreign Notes.....	19, 39, 120	What Constitutes False Representation.....	2	Watch and Chronometer Jeweling.....	27, 77, 93, 112, 136, 149, 177, 208
Fill Ups.....	73, 104	Workshop Notes.....	39, 74, 117, 162, 207	Watch Oils.....	13, 73
Fraudulent Debtors.....	102	Welding Platinum.....	69	Wooden Pendulums.....	84
Frankish and Celtic Jewelry.....	175	What the Jewelers' are Doing.....	197	<i>Z</i>	
<i>G</i>		<i>Z</i>		Zorzi's Compensating Pendulum.....	116
Gold Mining in Russia.....	14	<i>ADDENDA.</i>			
Goods on Consignment.....	143	The Figures in parenthesis denote that the Article will be found on that page of the April number, which by an oversight was folioed the same as that of February			
Goldbeaters' Wages.....	185				
<i>H</i>					
Historical Sketches of Jewish Trade.....	35				
"How's Business?".....	(3)				
Hall-Marking in England.....	130				

## ADDENDA.

The Figures in parenthesis denote that the Article will be found on that page of the April number, which by an oversight was folioed the same as that of February

# Waterbury Clock Comp'y MANUFACTURERS OF AMERICAN CLOCKS,

4 Cortlandt Street, New York.

M. BAILEY, Treasurer.

Illustrated Catalogues and Price Lists furnished  
to the Trade upon application.

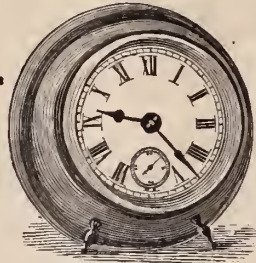

CRICKET.

No. 197 State Street, Chicago.  
Factories, Waterbury, Conn.

**SOLE AGENTS for the ITHACA  
CALENDAR CLOCK CO.**

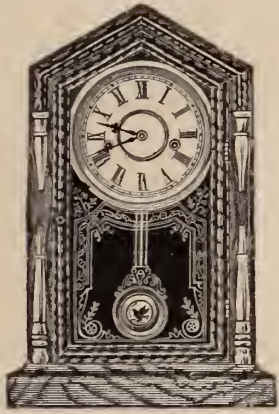

VULCAN.



MONITOR.



SUNRISE.



SULTAN, No. 2.

# New Haven Clock Co.,

FACTORIES AND GENERAL OFFICES,

NEW HAVEN, CONN.

OFFICES AND SALESROOMS:

NEW YORK,

CHICAGO,

No. 62 Reade Street,

117 & 119 State Street.

L. EGERTON, Jr., Agent.

G. A. HARMOUNT, Manager.

MANUFACTURERS OF

## Clocks & Movements

—AND—

Clock Materials of Every Description.

*The Jobbing and Shipping Trade will please  
apply to New York Office for terms.*

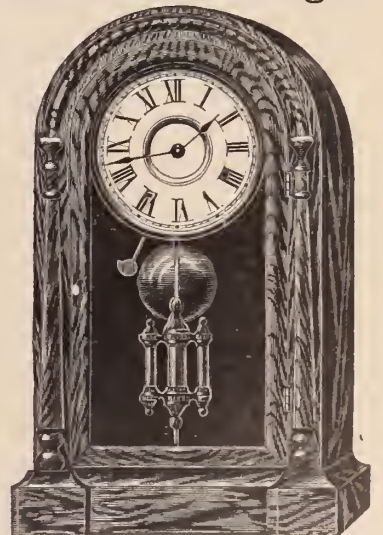

THE TRADE SUPPLIED WITH ILLUSTRATED CATALOGUES AND PRICE LISTS.

# LOUIS STRASBURGER & CO.,

Importers of

## DIAMONDS.

☞ We are direct Importers of Diamonds, dealers will therefore always find ORIGINAL parcels in our stock to select from.

MATCHED PAIRS, IN ALL GRADES AND WEIGHTS, A SPECIALTY!

NEW YORK, 15 MAIDEN LANE.

PARIS, 30 BOULEVARD HAUSSMANN.

Our complete stock of loose and mounted Diamonds enables us to send a full assortment for selection to any first-class house.

## LOUIS STRASBURGER & Co.

### Manufacturers of Watches,

From the finest Stem-Winding and Setting goods to the lowest price Watch in the market.

We manufacture and have continually in stock a complete assortment of the best COMMERCIAL WATCHES ranging from the lowest priced Metal and Silver Watches to the finest Gold Watches, such as REPEATERS, CHRONOGRAPHS (single and split) and all other Timing and Complicated Watches.

Also a full assortment of the INTERNATIONAL and all AMERICAN Movements. *Gold and Silver Cases*, constantly on hand.

We would call particular attention to our complete and varied assortment of NICKEL WATCHES, (black and fancy Dials,) in all grades, styles, and sizes.

THE RAIL-ROAD TIMEKEEPER A SPECIALTY.

SALESROOMS, No. 15 MAIDEN LANE, NEW YORK.

Watch Factory, Rue Leopold, Chaux de Fonds, Switzerland.

JULIUS KING,  
WHOLESALE OPTICIAN,

No. 233 Superior Street, Cleveland.

*On account of the increasing popularity of KING'S PATENT COMBINATION SPECTACLES, certain parties are manufacturing an imitation consisting of a steel framed Spectacle, with a nickel (white metal) or gold nose piece.*

*King's Combination are a finer quality of Spectacle with coin silver nose piece, stamped "King's Pat." The Spectacles and Eye Glasses are interchangeable, and every pair warranted.*

 *The imitations are a plain and direct infringement of my patent, and all persons buying or selling them are liable for damages, and will be prosecuted to the extent of the law.*

**JULIUS KING, Patentee.**

 *An Agent wanted in every place; references can be given to over a thousand dealers who are selling them. For sample and price list, address,*

**JULIUS KING, Cleveland, Ohio.**

# MILLER BROS.,

## MANUFACTURING JEWELERS,

No. 11 MAIDEN LANE, NEW YORK.

Manufactory, 47, 49 & 51 Franklin Street, Newark, N. J.

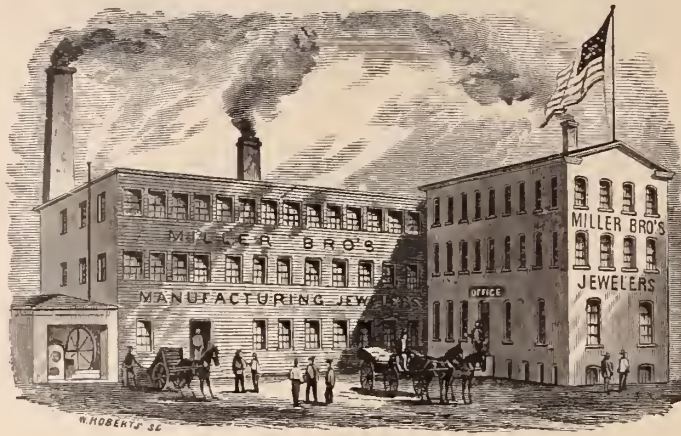

INITIAL GOODS

A SPECIALTY!

Seals, Locketts, Sets, Sleeve Buttons, Studs, Collar and Chemise Buttons.

ATTENTION IS INVITED TO OUR

NEW STYLES OF ETRUSCAN SLEEVE BUTTONS,

MOUNTED WITH

# RUSTIC LETTERS

BIRDS, ANIMAL HEADS AND FANCY ORNAMENTATIONS

## DAVID F. CONOVER & CO.,

(SUCCESSORS TO WM. B. WARNE & Co.)

Importers, Manufacturers and Wholesale Dealers in

# WATCHES AND JEWELRY,

## Silver and Silver-Plated Ware,

AMERICAN WATCH WHOLESALE SALESROOM,

## Southeast Corner Chestnut and 7th Sts.,

(FIRST FLOOR.)

DAVID F. CONOVER, }  
B. FRANK WILLIAMS, }  
C. EDGAR RIGHTER, }

PHILADELPHIA, PA.

# THE MIDDLETOWN PLATE CO.'S

## SUPERIOR SILVER-PLATED WARE.

New Designs in Tea Sets, Water Sets, Pitchers, Tilting Sets, Baskets, Butter Dishes, Syrup Pitchers, Spoon Holders, Cups, Goblets, Waiters, Fruit and Berry Dishes, all in New Designs for 1879.

## MIDDLETOWN PLATE COMPANY,

No. 13 John Street, N. Y.

Middletown, Conn.

The STAR SALT



CASTER COMP'Y

Sole Proprietors and Manufacturers of

CELEBRATED

# STAR SALTS

For convenience, neatness and utility the STAR SALTS have become a household necessity.

The pulverizer in the bottle, as shown by the cuts, keeps the salt pulverized, and obviates the disagreeable habit of spilling the salt by dipping out of an open salt cellar.

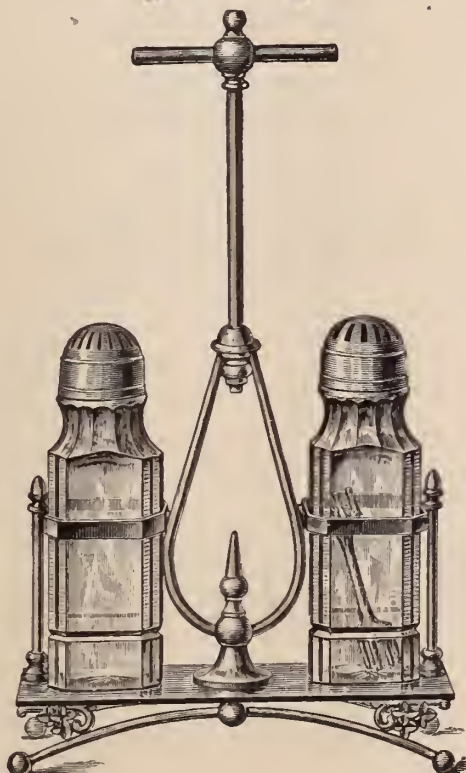

No. 161 Franklin Street,  
BOSTON, MASS.

Place these in the family and Salt Cellars will be discarded.

MANUFACTURED IN ALL VARIETIES OF PLAIN AND FINE CUT GOODS, CASTERS, &c.



Fine Diamond Cut, with Sterling Caps.

Special care given to orders for exportation.

For full descriptions of the above goods see our Illustrated Catalogues, which will be mailed on application.

# SIMPSON, HALL, MILLER & CO.

## Manufacturers of Fine Silver-Plated Ware,

Factories, Wallingford, Conn.

Salesroom, No. 676 Broadway N. Y.



One of the oldest and most reliable manufactories in the country.

Our assortment includes a large and complete line of Hollow Ware, comprising many new and beautiful designs especially produced for the Holiday trade. The attention of the trade is particularly called to these new articles which possess the highest merits, both of construction and ornamentation. Many novelties have recently been added to our line.

Our Solid Table Ware is made of the best Nickel Silver.

**SPOONS, FORKS, LADLES, PIE KNIVES, &C.**

In great variety of Patterns.

**Solid Steel Knives of Superior Quality.**

## REMOVAL.

 We will remove our Salesroom to No. 36 East Fourteenth Street, Union Square, about February 1st, 1879.

NOTE.—We have just issued an illustrated catalogue of our wares, which has been in preparation for several months. This book we will furnish to dealers on application.

# ROGERS CUTLERY COMPANY.



**WM. ROGERS,**

Senior Member and Manager of the Firm of ROGERS BROTHERS. Died Feb. 17, 1873.



**ASA H. ROGERS,**

Of the original ROGERS BROTHERS, and half owner of the Rogers Cutlery Co., when organized. Died Oct. 4, 1876.



**F. WILLSON ROGERS,**

Son of the late Wm. Rogers, and Secretary of the ROGERS CUTLERY Co.

We guarantee our Spoons, Forks, &c., to be plated on 18 per cent. Nickel Silver, as follows:

On TEA SPOONS,	2½ ounces,	or 50 dwts. per gross.
On DESSERT SPOONS,	3¼ " " "	75 " "
On TABLE SPOONS,	5 " " "	100 " "
On DESSERT FORKS,	3¼ " " "	75 " "
On MEDIUM FORKS,	5 " " "	100 " "

Our Spoons, Forks, Ladles, &c., are stamped as follows:

On EXTRA PLATE,	1871 ROGERS	@ 5 oz.
On DOUBLE PLATE,	1871 ROGERS	@ 8 oz.
On TRIPLE PLATE,	1871 ROGERS	@ 12 oz.
On QUADRUPLE PLATE,	'71 ROGERS	@ 16 oz.

 We guarantee our Forks, &c., to be plated 25 per cent. heavier than standard plate.

All Hollow Ware stamped as above are warranted to be plated 50 per cent. heavier than any other brand of goods in the market.

Our Hollow Ware, in addition to our Trade Mark, is stamped SIXTUPLE PLATE, we being the only firm that manufacture this weight of plate.



Our Knives stamped as above, guarantee to strip 12 dwt. of silver per dozen.

Our Knives are guaranteed to be all hand burnished, and are put up in rack boxes, with hinge covers.



 The above is a fac-simile of our guarantee card which accompanies each dozen of our flat ware, and each piece of our hollow ware. Our goods have been in the market since 1871, and are acknowledged by all dealers, who have tried them, to be THE BEST.

 We would call especial attention to the EXTRA STRONG SPRING TEMPERED SHANK, which we have on our Tipped, Fiddle, Saxon and Imperial pattern.



# ILLINOIS WATCH COMPANY,

MANUFACTURERS OF

## KEY AND STEM-WINDING MOVEMENTS.

OFFICES,

SPRINGFIELD, ILLS.

11 MAIDEN LANE, NEW YORK.

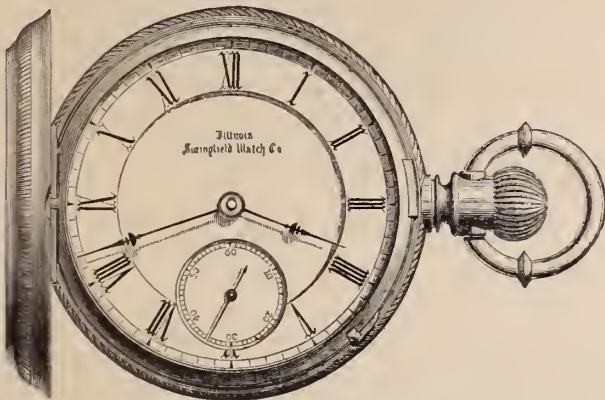

"STUART."

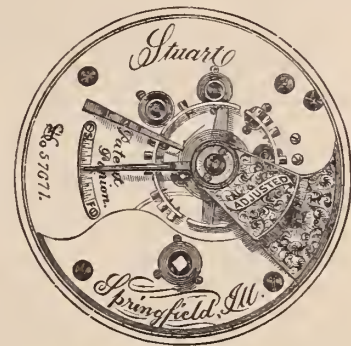

Reverse of Movement.

The above is a fac-simile of the finest grade of 18 size Watch made by us. The first cut shows the Improved **DOUBLE SUNK**, Old English Lettered Dial, and its appearance when cased. The movement is finely adjusted to heat, cold and isochronism, and is guaranteed to be as fine a time-keeper as is made in this country in 18 size, and can now be obtained either for Hunting or Open Face Cases.

### OPEN FACE

"Columbia," "America,"  
"No. 2," "No. 1," and "Interior"  
Stem-winding Movements,  
made especially for Open Face  
Cases, with Fig. XII at the pen-  
dant and Seconds opposite.

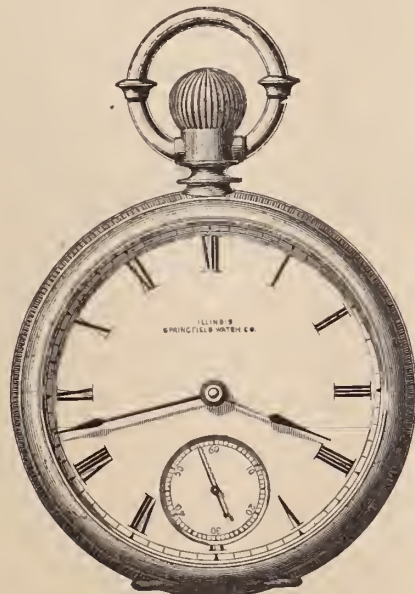

### STEM-WINDERS.

Other Stem-winding grades  
on our list are made to order  
(in 4 to 6 weeks) in the same  
manner, in quantities of five  
or more of a grade.

The extra plate hole is jeweled in all grades, Currier and above.

Jewelers can now obtain our 8 Size Ladies' Key and Stem-winders, fitting Waltham style 8 size cases, from any of the wholesale dealers.

# Swiss Watches!



## OFFICIAL LIST OF AWARDS

### At the **PARIS EXPOSITION, 1878.**

FIRST.—Grand Diploma of Honor, highest award.

TO THE COLLECTIVE EXHIBIT OF SWISS WATCH MANUFACTURERS.

SECOND.—Cross of the Legion of Honor,

TO AN INDIVIDUAL EXHIBITOR OF SWISS WATCHES.

THIRD.—Nine Gold Medals,

TO INDIVIDUAL EXHIBITORS OF SWISS WATCHES.

FOURTH.—Thirty-three Silver Medals,

TO INDIVIDUAL EXHIBITORS OF SWISS WATCHES.

FIFTH.—Forty-two Bronze Medals,

TO INDIVIDUAL EXHIBITORS OF SWISS WATCHES.

SIXTH.—Thirty-three Honorable Mentions,

TO INDIVIDUAL EXHIBITORS OF SWISS WATCHES.

SEVENTH.—One Silver Medal and Eleven Bronze Medals,

TO COLLABORATORS IN THE SWISS WATCH INDUSTRY.



THE  
**MERIDEN BRITANNIA COMPANY,**

**Manufacturers of Fine Electro-Silver Plate.**

Salesrooms, No. 46 E. 14th Street.

Factories, West Meriden, Conn.

UNION SQUARE, NEW YORK.

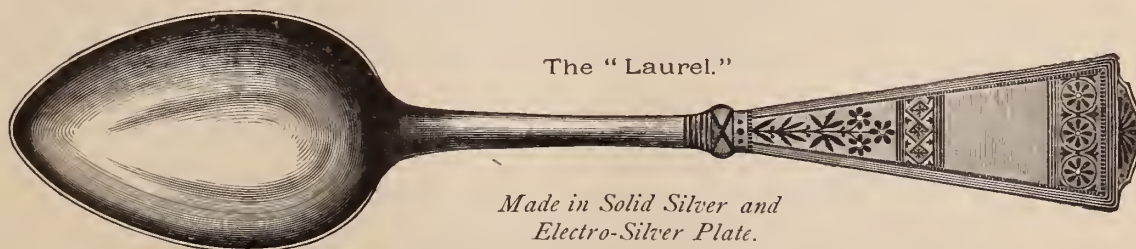

The "Laurel."

*Made in Solid Silver and  
 Electro-Silver Plate.*

We take much pleasure in referring to the reputation we have for many years maintained for manufacturing SPOONS AND FORKS, BEARING THE TRADE MARK, "1847, ROGERS BROS."

Particular attention is invited to our *Patented Process of Electro-Plating Spoons and Forks*, by which the parts most exposed to wear receive an EXTRA COAT OF SILVER. This feature renders these goods more economical and durable than those of any other manufacture, while the increased cost is relatively small. This method of plating we apply to the 4, 8 and 12 oz. plate, as required.

To protect the purchaser against imitations, it should be observed that the Improved Spoons and Forks bear our Trade Mark, "1847, ROGERS BROS., XII."

FIRST PREMIUMS awarded at all Fairs where exhibited, from the World's Fair, 1853, to American Institute Fairs, 1873, 1874 and 1875, inclusive, and at the Philadelphia Exhibition, 1876.

Extract from the American Institute Report:—"Their Porcelain-lined, Double-walled Ice Pitchers are A1, and possess all the qualities the company claim." \* \* \* "We consider the goods made by this company to be by far the best made in this country, and we believe in the world"

# Prize Medal, Paris, 1878.



**Popular!**

**BECAUSE**

**BEAUTIFUL!  
CHEAP!  
DURABLE!**



**The increasing popularity of Boss' Patent Stiffened Gold Watch Cases is the cause of remark by the Trade generally.**

The manufacturers believe the public and times demand a WATCH CASE that shall be *low in price, yet beautiful and serviceable*, and with this established belief they started with two ends in view :

**1st, To greatly Improve the Case.**

**2d, To Reduce the Price.**

To perfect the first it was necessary to add *largely to amount of gold* (nearly 40 per cent.), this has absorbed all saving on improved machinery and economy of production. but it has *been accomplished*, and they now present a Case which they *believe is fully up to the requirements of the most critical trade.*

SECOND.—They reduce the price of the Ladies' Cases nearly to that of the common or low karat Gold Cases, whereas this Case has almost the *same amount of gold and costs more to manufacture.* The *Engraving and workmanship* of all kinds is of a *much more expensive nature.* The gold being of a *much finer quality* presents an *appearance equal to the best solid case and will not discolor or corrode*, being stiffened between the two slates of gold with a lining of nickel composition, it *will not bend or break*, and will *look better and wear longer* than any case of the *same price in the market.*

**Correspondence solicited.**

**Price List furnished upon application to**

## Hagstoz & Thorpe,

SOLE MANUFACTURERS,

Sixth and Chestnut Streets,

PHILADELPHIA.



# C. G. ALFORD & CO.,

## Manufacturing Jewelers,

No. 183 BROADWAY, NEW YORK.

### TO THE TRADE.

*Our efforts to protect the interests of the legitimate Jewelry Trade by refusing to send our Illustrated Catalogue to outside dealers has won the universal approval of the entire retail trade, who have demonstrated their appreciation of our efforts in this direction, by sending us their orders. We are glad to know that our Catalogue occupies an important place in the stores of Retail Jewelers, and that they in many ways find it of great convenience.*

*We have in contemplation certain changes that will add to its interest and usefulness, which will be made known when they assume a definite form.*

*We wish to state that we shall in the future, as in the past, use our best efforts to protect the interest of patrons, the legitimate retail dealers, by publishing a Catalogue exclusively for their use, and one that may be shown to their customers without the risk of exposing their profits.*

**👉** Applicants for copies must enclose business card as a guarantee that they are regularly in the trade.

## L. HAMMEL & CO.,

### Importers of Watch Materials, Tools



We would respectfully call your attention to our new design of an improved Spectacle Case, which will doubtless commend itself to your favorable consideration. The improvement, consisting in the joint being on the top of the case, making it stronger and more durable than the old style of case, and the cut away for the insertion of the Spectacles renders it the most practical case made. These goods are made in all grades of leather and for all styles of spectacles, in price from \$6 to \$13.50 a gross, and stamped to order with name and address of the purchaser, at \$2 per gross extra.

Samples sent by mail on receipt of 10 cents on application to

### Opera Glasses and Optical Goods of Every Description

### SPECTACLES!

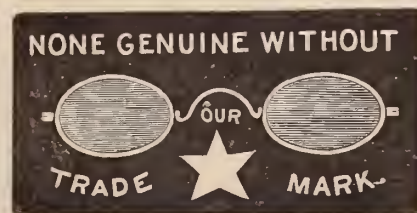

### EYE GLASSES

**👉** We would respectfully call the attention of the Trade to the celebrated **Star Spectacles and Eye Glasses**, of which we are the Sole Importers.

No. 9 Maiden Lane, New York.

**👉** Sole Agents in the United States for **G. B. Wheeler's Star Watch and Clock Oil**, and the Celebrated **Gravier Mainspring**.

**SPECIAL ANNOUNCEMENT!****COLBY & JOHNSON,**

Patentees and Exclusive Manufacturers of



Would state that they will not be able to fill further orders for the above-named goods until after March 1, 1879. Orders already in will be filled as promptly as possible.

**SINNOCK & SHERRILL,****Stone Ring Manufacturers,**

No. 5 MAIDEN LANE,

Factory, Newark, N. J.

**NEW YORK****Dorrance, Edge & Co.**

MANUFACTURERS OF

**THE CELEBRATED WOVEN FABRIC****GOLD CHAIN.***Elegantly Mounted Bracelets, Opera, Leontine,*

VICTORIA WATCH GUARDS &amp; NECKLACES, in all the Newest Designs.

Our stock is unusually complete, and, in addition to the above, a variety of Necklaces, from 1½ to 40 dwt. each, to which we invite the attention of buyers.

**No. 9 John Street, New York.**

Factory, 46 Greene Street, Newark, N.J.

**E. HOWARD & CO.,**

MANUFACTURERS OF

**Fine Watches, Regulators, Office Clocks,**

Electric Watch Clocks &amp; Tower Clocks,

**Office, No. 694 BROADWAY,**

Corner Fourth Street,

**NEW YORK.****No. 114 TREMONT STREET, BOSTON.**

J. W. J. PIERSON, - - AGENT.

LOUIS A. SCHERR.

CHAS. H. O'BRYON.

G. W. SCHERR

**LOUIS A. SCHERR & CO.**

Importers and Wholesale Dealers in

**Watches, Jewelry,**

WATCH MATERIALS, TOOLS, GLASSES, &amp;C.

**Spectacles, Silk Guards, &c.**

Wholesale Agents for American Watches.

**No. 726 CHESTNUT STREET,**

FIRST FLOOR,

**PHILADELPHIA.****BUCKENHAM, COLE & SAUNDERS,**

SUCCESSORS TO

**BUCKENHAM, COLE & HALL,**

IMPORTERS OF

**Diamonds, Pearls****AND OTHER PRECIOUS STONES,****MANUFACTURERS OF FINE JEWELRY,****10 Maiden Lane, New York.**

A large stock of FINE DIAMONDS, Mounted and Unmounted kept constantly on hand. Goods sent on approval to any part of the country on receipt of satisfactory references.

Office of  
**ROBBINS & APPLETON,**  
 AGENTS FOR  
 American Watch Company,  
 No. 9 BOND STREET,

*New York, February 12th, 1879.*

Sir :

*List prices of certain of our movements are to-day fixed as follows, viz.:*

**18 Size, FULL PLATE.**

" BROADWAY," 7 jewels, nickel balance.....	\$ 4 30
"      7    "    cut expansion balance (NEW), .....	4 75
" WM. ELLERY," 2 pairs extra jewels, cut expansion balance.....	8 00
"      2    "    "    "    "    "    "    "    "    "    "    "    Stem Winder.....	10 50
" STERLING," 7 jewels, nickel balance, Stem Winder.. ..	9 00
"      7    "    cut expansion balance, (NEW), Stem Winder....	9 45

**The new list prices of complete Silver Watches are changed to correspond with the above.**

**14 Size, 3/4 Plate.**

" AM. WATCH CO., HILLSIDE " (NEW), 7 jewels, cut expansion balance, Stem Winder, for Hunter or Open Face .....	\$20 00
--	---------

**18 Size, Full Plate, NICKEL Movements.**

" WM. ELLERY," 2 pairs, extra jewels, cut expansion balance .....	\$12 00
"      2    "    "    "    "    "    "    "    "    "    "    "    "    Stem Winder.....	16 50
" P. S. BARTLETT," 2 pairs, extra jewels in settings, cut expansion balance.....	18 50
"      2    "    "    "    "    "    "    "    "    "    "    "    "    Stem Winder	26 50
" WALTHAM WATCH CO." 4 pairs, extra jewels in settings, cut ex. balance .....	26 00
"      "    "    "    4    "    "    "    "    "    "    "    "    "    Stem Winder	34 50
" APPLETON, TRACY & CO." 4 pairs, extra jewels in settings, cut expansion balance, adjusted.....	37 00
"      "    "    "    4    pairs, extra jewels in settings, cut expansion balance, adjusted, Stem Winding....	46 50

All the above are subject to the terms and discounts announced in our circular of the 8th instant.

There will be no change in the quality of any of our grades, except as our constant efforts tend to their improvement. We decline altogether to take any part in the present unwise competition between Swiss and American manufacturers to see which shall make watches of the poorest quality. We intend to sell as low as any American company, but, however low the price, we do not intend to finish a grade of goods upon which it would be a disgrace to us to put our name.

Robbins & Appleton, 9 Bond Street, New York.  
 Robbins, Appleton & Co., 8 Summer St., Boston. } General Agents.  
 Robbins & Appleton, 170 State St., Chicago. }

American Watch Company  
 OF WALTHAM, MASS.

THE  
JEWELERS' CIRCULAR AND HOROLOGICAL REVIEW,

*The recognized organ of the Trade, and the official representative of the  
Jewelers' League.*

A Monthly Journal devoted to the interests of Watchmakers, Jewelers, Silver-  
smiths, Electro-plate Manufacturers, and those engaged in the  
kindred branches of art industry.

SUBSCRIPTION :

To all parts of the United States, Canada, Great Britain and the West Indies,  
**\$2.00 Per Annum ; Postage paid.**

To France, Switzerland, Germany, Mexico, the Republics of South America,  
and Australia, \$2.50 per annum. Postage paid.

*All communications should be addressed to D. H. HOPKINSON, 42 Nassau  
Street, New York. Advertising rates made known on application.*

AGENCIES : { J. H. PURDY & CO., No. 170 State Street, Chicago.  
PRATT & CO., Ninth and Arch Streets, Philadelphia.  
HERMAN BUSH, No. 14 Mytongate, Hull, England.  
FREARSON BROS., Adelaide, Australia.

MESSRS. LEE & WIGFULL, the well known Electro-plate manufacturers, (John  
street Works), Sheffield, England, have kindly consented to receive subscriptions.



ESTABLISHED 1837.

VICTOR BISHOP & CO.

IMPORTERS OF

**DIAMONDS,**

PRECIOUS STONES

—AND—

**CORAL JEWELRY,**

Enamel Paintings, Copper and Platinum.

No. 47 NASSAU STREET, NEW YORK.

House in Paris, 66 Boulevard de Sebastopol.

**SAXTON, SMITH & CO.**

MANUFACTURERS OF

**Fine Gold Chain.**

No. 194 BROADWAY

New York.

Factory, No. 183 Eddy Street, Providence, R. I.

Sole Agents for the new PATENTED CHAIN BAR, containing a Detachable Penail.

ESTABLISHED 1855.

D. LIECHTY & CO.,

MANUFACTURERS OF

**Fine Gold Watch Cases**

No. 140 South Third Street,

Fourth Floor.

PHILADELPHIA

Repairing neatly attended to.

**KOSSUTH MARX & COMP'Y,**

39 MAIDEN LANE, New York.

THE U. S. STANDARD

FINGER SIZE

FOR RINGS.



TIME AND

TROUBLE

SAVED.

Some of the advantages of which, will be found annexed and must be apparent to every Jeweler.

1st. It avoids danger of having rings stolen from tray while trying on to find one the size wanted, and also of being mislaid after taking the size.

2d. It saves time consumed in measuring ring on stick and avoids possibility of making a mistake in doing so, as the size ring is gauged in accordance with the U. S. Standard Stick.

3d. It necessitates trying but one ring on the finger, whereas a dozeu had sometimes to be used before the correct size was obtained.

4th. If the salesman is hurried it is not necessary to make a memorandum of the size, as the ring will remain at the size taken, and can be laid aside until some leisure time.

5th. It can be loaned to customers whereby they will be enabled to take the correct size, instead of using pieces of string and wire, thus making mistakes and often necessitating altering a ring two or three times.

HOW TO USE— Place the thumb of the hand, on which is the finger to be measured, against the joint on the size ring, and draw tight with the other hand.

FOR SALE BY ALL WATCH MATERIAL DEALERS

**WOOD & HUGHES,**

STERLING

**Silverware Manufacturers**

No. 16 JOHN STREET,

NEW YORK.

**KREMENTZ & CO.,**

MANUFACTURERS OF

**FINE JEWELRY,**

No. 13 John Street, New York.

Factory, 361 Mulberry Street, Newark, N. J.

GOODS OF OUR OWN MAKE EXCLUSIVELY.

# GORHAM MANUFACTURING CO.,

## Manufacturers of STERLING SILVERWARE,

Of the highest character and in all branches of the art.

MAKERS AND SOLE PROPRIETORS OF THE GORHAM PLATED WARES,

SO WELL AND FAVORABLY KNOWN TO ALL DEALERS.

Factory, Providence, R. I.

Salesroom, 37 Union Square, New York.

RAPHAEL.

HINDOSTANEE.

KING'S.

SWISS.

COTTAGE.

NEW TIPT.



*Lithographic sheets of our complete list of TWENTY different patterns of Spoons and Forks, showing the most desirable, as well as the most extensive line, will be sent to the Trade upon application.*

WE submit for the convenience of the trade, illustrations of six of our leading Spoon and Fork Patterns, viz., the "RAPHAEL," "HINDOSTANEE," "KING'S," "SWISS," "COTTAGE," & "NEW TIPT."

In the patterns we are prepared to meet orders from stock, while the remaining patterns will be made to order and supplied at reasonable notice.

In addition to the Patterns herein illustrated are

"LADY WASHINGTON," "KNICKERBOCKER," "CORINTHIAN," "ROSETTE," "GORHAM," "ANTIQUE," "PALM," "LOUIS XIV.," "THREADED," "PLAIN TIPT," "QUEEN," and "GRECIAN" in Sterling Silver, and the "ROMAN" and "OLD ENGLISH" in Gorham Plate.

*Branch Office. 120 Sutter Street, San Francisco, in charge of Phelps & Miller.*

"THE RAPHAEL"

Is a rich, soft and highly ornamented pattern, good substantial weights, Teas weighing 9½ and 12 ounces, Dessert, 19 ounces, and Tables 28 ounces per dozen. Possessing the desirable features of elegance in design and outline, and ranging in weight from medium to heavy; it has been most favorably received by the trade and has become one of our leading patterns, especially in flat ware, where design is a feature of prime importance.

"THE HINDOSTANEE"

Is made with a view to meet the want for a spoon equal to the "*Raphael*" in beauty of design, but of a lighter weight, ranging from light to medium. The style of ornament, as shown in the illustration, is as its name indicates, Indian or Hindostanic.

It is graceful in outline, elegant in detail of design, entirely free from the objectionable features of sharp edges, and by the proper distribution of Silver, the very desirable feature of strength in the "*shank*" is obtained, giving to it the appearance of a much heavier spoon. Teaspoons, 7½, 10 and 12 ounces, Dessert, 14 ounces, and Tables, 20 and 24 ounces per dozen.

"THE KINGS"

Is also a substantial pattern, similar in character and feeling to the King's of foreign manufacture, which has for many years been accepted as the standard pattern in the English market. In weight it is similar to the "*Raphael*."

"THE SWISS"

Meets the want for an ornamented pattern of light weight. Teaspoons weighing 7 ounces, Dessert 12 ounces, and Tables 18 ounces. It is tasteful in design, and being light in weight it has been most favorably received by a large portion of the trade.

"THE COTTAGE"

In certain very desirable characteristics has never been surpassed. Its great popularity has stimulated the production of imitations, but as its beauty consists not only in its simplicity but perfection in outline, even the slightest deviation sufficient to avoid infringement of patent is fatal.

"THE NEW TIPT"

In the introduction of this pattern we have succeeded in furnishing an ornamented pattern, which for cheapness closely approximates the old plain tipt.

"THE ANTIQUE"

We invite special attention to this pattern, pronounced by the leading jewelers to be the very best plain pattern in the market. Perfectly plain and symmetrical in outline, the tip smooth, heavy and so perfect in line as to give tone and character to the entire spoon.

THE "ROMAN" AND "OLD ENGLISH"IN GORHAM PLATE.

It is our object in placing these patterns upon the market to offer to the trade the best article in plated spoon work that can possibly be made. Equal in design and finish to those in solid silver, and undistinguishable from them.

ORNAMENTATION.

Our new method of treatment in the ornamentation of Flat Ware wherein we have introduced the most pleasing effects in color engraving and chromatic surface decoration, has greatly enhanced their popularity. While *novelty* is an essential feature in decoration, it should nevertheless be always subordinate to consistency in design. We claim to give to these wares of utility that elegance and consistency in design which meets the views of a cultivated taste and renders to articles of every day use a refining and educating influence.

"CASE COMBINATIONS."

Our extensive variety of desirable patterns and the various styles of finish and decoration enables us to offer to the Trade an almost endless series of combinations for spoon work and accompanying pieces in flat and hollow wares, tastefully encased in Morocco and other leathers, and in plain and ornamented woods.

The Cases are of our own manufacture and possess the desirable features of good taste and durability, and are offered at as favorable prices as is consistent with wares of equal quality.

While we are furnishing a line of low priced cases to meet the demands for inexpensive goods, we take pleasure in offering a line of cases which are receiving universal commendation, and at prices unquestionably cheap for the quality of ware submitted. When competition has for its aim *cheapness* rather than *excellence*, without a due regard to the *taste* and *quality* of the production, it becomes a certain cause of rapid decay to all classes of manufacture.

"COFFEE SPOONS."

The attention given to this class of Spoon Work has resulted in a large and steadily increased demand. "THE MOTHER'S" pattern (antique in design) is perfectly adapted for the purpose, has met with a large sale, and led to an increased demand in all the regular patterns.

As this class of Spoon Work is almost invariably called for in cases, the beauty of the cases has rendered them particularly desirable for presentation purposes, while for general table use the coffee spoon is in growing demand.

The most popular combinations are

6 or 12	Coffee Spoons,	either large or small.
6 "	12 "	and 1 Sugar Spoon.
6 "	12 "	" " 1 pair Sugar Tongs.
6 "	12 "	" " 1 Cream Ladle.
6 "	12 "	1 Cream ladle, 1 pair Sugar Tongs.
6 "	12 "	1 " " 1 Sugar Spoon.

For such combinations, the latest novelty in style, appropriately termed "The Harlequin," has become very popular. The effect of 12 differing from each other in pattern meets with general favor. This has led to the introduction of the latest novelty in this department,

Decorated Coffee Spoons,

wherein each spoon, though of the same outline, but differing in ornament, is rendered particularly attractive by its novel style of decoration, engraved in colors and in endless variety of ornament.

"FLAT WARE."

Our extensive and meritorious assortment of patterns in Spoons and Forks enables us to offer the best assortment of accompanying pieces in Flat Ware, consisting mainly of

KNIVES.—Butter, Cake, Cheese, Crumb, Dessert, Fish, Ice Cream, Melon, Pie, Macaroni, Paper, Pickle, Fruit, Waffle, Pudding, Salad, Bread, Jelly, &c.

FORKS.—Pickle, Oyster, Olive, Salmon Sardine, Toast, Vegetable, Fish, Pie, Macaroni, Beef, Melon, Salad, &c.

SPOONS.—Ice Cream, Berry, Coffee, Egg, Gravy, Ice, Jelly, Salt, Mustard, Nut, Olive, Pap, Preserve, Salad, Individual Salad, Sugar, Vegetable, Pudding, Soup, Toddy, Honey, &c.

LADLES.—Soup, Oyster, Gravy, Olive, Cream and Punch,

TONGS.—Sugar, Ice, Beef, Asparagus, Salad, Pickle, Celery, Toast, &c.

MISCELLANEOUS.—Sugar Lifters, Cheese Scoops, Oyster Servers, Cake Servers, Berry Scoops, Lobster Scoops, Marrow Scoops, Nut Picks, Nut Crackers, &c.

CARTER, HOWKINS & SLOAN,  
**Makers of Fine Jewelry**

*Consisting of Chains, Bracelets, Sets, Pins, Studs, Sleeve Buttons,  
 Rings, &c., in Roman, Etruscan and Enamel.*

Whiting Building, Corner Broadway and Fourth Street,

A. CARTER JR.  
 WM. HOWKINS,  
 A. K. SLOAN.

**NEW YORK.**

C. E. HASTINGS,  
 GEO. R. HOWE,  
 W. T. CARTER.

**HALE & MULFORD,**

MANUFACTURERS OF

**RICH JEWELRY,**

First-class Goods of our own make exclusively.

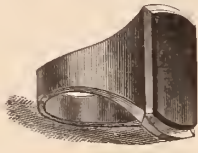
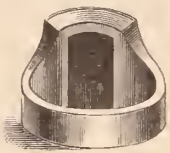

Special attention is called to our Patent Stone Back Seal Rings.

Send for illustrated circular.

No 694 Broadway, cor. 4th Street, New York.  
 (WHITING BUILDING).

Established 1837.

**TAYLOR & BROTHER,**

Late TAYLOR, OLMSTED & TAYLOR,

**Importers of Diamonds and Pearls,**

No. 676 BROADWAY,

**NEW YORK.**

**BALDWIN, SEXTON & PETERSON**

MANUFACTURERS OF

**Fine Jewelry,**

Diamond and Stone Cameo Goods,

**GOLD CHAINS, &c.**

Importers of Diamonds, Pearls, Emeralds, Rubies, &c.

WHITING BUILDING,

**Cor. Broadway and Fourth Street,**

**NEW YORK.**

Established 1817.

**Ve. J. MAGNIN, GUÉDIN & CO.**

Manufacturers and Importers,

FINE SWISS WATCHES.

REPEATERS, CHRONOGRAPHS & CALENDARS.

GENEVA GOLD JEWELRY,

FRENCH CLOCKS AND BRONZES,

RICH FANCY GOODS,

HORSE-TIMERS & PODOMETERS,

GOLD AND SILVER CHATELAINE WATCHES.

No. 29 UNION SQUARE, corner 16th Street, New York.

Gold Medal Awarded, Paris Exposition, 1875.

*Sole Agents for the James Nardin Watch.*

*House in Geneva, 14 Grand Quai.*

**CHATELLIER & SPENCE,**

**Manufacturing Jewelers,**

652 BROADWAY, NEW YORK.

No. 1129 Chestnut Street, PHILADELPHIA, PA.

No. 12 West Street, BOSTON, MASS.

No. 120 Sutter Street, SAN FRANCISCO, CAL.

## ALFRED H. SMITH &amp; CO.,

(Of the late firm of SMITH, HEDGES &amp; CO.)

**Importers of Diamonds,**

14 JOHN STREET, NEW YORK.

**TO THE TRADE.**

In offering to you our RECENT HEAVY IMPORTATIONS of carefully selected Goods, we respectfully call your attention to a few facts bearing upon our ability to fill your orders, to your positive advantage. )

We give to this business our EXCLUSIVE ATTENTION, admitting to our stock no other merchandise whatsoever. )

We are DIRECT IMPORTERS of DIAMONDS, so that, with us, Dealers will find original parcels to select from. )

Our foreign purchases are made by ourselves in person, thus insuring goods best adapted to the requirements of the Trade, and at the lowest possible figures. )

Any goods you may be pleased to order from us, either for your stock, or on Memorandum, will be forwarded by us, without VALUE expressed thereon, and may be returned in like manner, (the same having been insured) thereby saving you the heretofore burdensome charges. )

Exceptionally choice SINGLE STONES, and finely MATCHED PAIRS, will always be found with us, as well as a fine line of MOUNTED GOODS.

Yours, Very Respectfully

ALFRED H. SMITH &amp; CO.

14 John Street, New York.

Established 1834.

**G. & S. OWEN & CO.,**

Makers of Fine GOLD JEWELRY

SPECIALTIES:

Black Onyx Goods,

Hair Chain Mountings,

Hooks and Bars.



The only makers of  
Box and Glass Goods,  
consisting of Pins, Ear-  
Rings, Sleeve Buttons  
and Locketts for pic-  
tures or devices in hair.

☞ All our goods exclusively of our own manufacture.

5 MAIDEN LANE, NEW YORK.

**JOHN A. RILEY & CO.**

MANUFACTURER OF

**Fine Gold Jewelry**

AND ONYX GOODS,

**Nos. 7 & 9 Bond Street, New York.**

No. 126 Kearney Street, San Francisco, Cal.

Established 1813.

**THOMAS G. BROWN,**

MANUFACTURER OF

**FINE JEWELRY,****NEWARK, N. J.**

—AND—

**9 BOND STREET, NEW YORK.****HELLER & BARDEL,**

MANUFACTURERS OF

**Diamond and Pearl Jewelry**

And Dealers in Diamonds, Pearls, &amp;c.

SHAWL AND LACE PINS IN GREAT VARIETY.

*No. 18 John Street, New York.*

☞ A full line of DIAMONDS, mounted and unmounted; also, a large assortment of first-class DIAMOND MOUNTINGS of our own make always on hand. Sketches submitted at any time upon application. We will send goods on selection to responsible houses.

**MOORE & HORTON,****JEWELERS,***No. 11 Maiden Lane, New York.***SPECIALTIES!**

*Stone Cameo, Onyx, Amethyst, Topaz and Pearl Rings,  
Studs, Collar and Sleeve Buttons.*

☞ Also our new fac-simile of Fine African Diamonds, mounted in Rings, Studs, Pins, Ear-rings, Scarf Pins, Medallions.

**W. H. SHEAFER & CO.,****Makers of Fine Jewelry**

CONSISTING OF

BRACELETS, SETTS, LOCKETS, PINS,

STUDS, SLEEVE BUTTONS, RINGS, &amp;c.

**SPECIALTY:—STIFFENED ROMAN BANDS.****No. 908 Chestnut Street, PHILADELPHIA.**

# WM. S. HEDGES & CO.,

*Of the late firm of SMITH, HEDGES & Co.*

IMPORTERS OF

# DIAMONDS,

No. 170 Broadway, cor. Maiden Lane,  
NEW YORK.

*Choice Brilliants in single stones and matched pairs a specialty.*

GOODS SENT ON APPROVAL.

# LYON & HARDY,

30 MAIDEN LANE, NEW YORK,

IMPORTER OF



AND MANUFACTURERS OF

## DIAMOND MOUNTINGS.

All goods ordered for stock or on approval are insured while in the hands of Express Companies.

# CHATTERTON & DODD,

## Makers of Fine Jewelry

*Consisting of Sets, Pins, Ear-Rings, Locketts, Crosses, Sleeve Buttons, Studs, &c.*

No. 19 John Street, New York.

ROMAN, ETRUSCAN AND ENAMEL WORK GENERALLY, SPECIALLY DESIGNED BY US.

*Established 1846.*

WILLIAM RIKER,

*No. 5 Maiden Lane, New York.*

Factory, 42 Court Street, Newark N. J.

 *Would call the attention of the Trade to our Inlaid Bracelets.*

# ENOS RICHARDSON & CO.

MANUFACTURERS OF

## FINE GOLD JEWELRY,

Gold Chains, Locketts, Crosses and Necklaces,

COLORED AND ETRUSCAN WORK.

ENGRAVED AND ENAMELLED GOODS IN GREAT VARIETY.

All Goods sold strictly of our own manufacture.

23 MAIDEN LANE, NEW YORK.

ENOS RICHARDSON,  
THOS. SLATER,

L. P. BROWN,

F. H. RICHARDSON,  
W. P. MELCHER.



Nº 24 DOELEN STRAAT AMSTERDAM, HOLLAND.  
Nº 1 GAERTNER PLATZ MUNICH, GERMANY.

 *Diamonds loose and mounted sent on approval on receipt of satisfactory reference.*

**MANTO OF FINE JEWELRY**  
**ALLING BROS. & CO.**  
**MANTO OF FINE JEWELRY**

Full Line of Roman and Mosaic Goods,  
 Earrings, Buttons, Studs and Rings.

**SPECIALTIES:**

ENGRAVED AND ENAMELED BANDS,  
 CAMEO GOODS.

**170 BROADWAY, NEW YORK.**

DYER BRAINERD.

JOHN W. STEELE.

**BRAINERD & STEELE,**

MANUFACTURERS OF

**Brainerd's Pat. Locketts,**

(Patented June 17, 1874.)



These Locketts combine both beauty and strength. They are made of solid 14kt. gold, and the stones used are the finest obtainable in the market. They cost no more than those of the old style, it indeed as much; and the combination of secrecy and durability renders them much more desirable. We make three sizes in four different shapes—round, oval, cushion and oblong square; and also Sleeve Buttons of the same style, containing a concealed box for miniatures, a novelty new to the Trade.

**FINE GOLD JEWELRY,**  
**No. 9 Maiden Lane,**  
**NEW YORK.**

**L. SAUTER,**  
 MANUFACTURER OF FINE

**Gold & Hair Jewelry & Device Work,**  
**Nos. 65 & 67 Nassau Street, New York.**

**Pattern Books**

containing 300 designs of the most current articles will be sent on receipt of 50 cents, which amount will be returned with the first order.

Orders for Patterns from books of any other manufacturer filled at original prices upon advice of name and number of book.

Patentee and Sole Manufacturer of the Patent Revolving Rings, the design of which will be found in other pattern books. A complete stock of 14kt.

**Solid Jewelry,**

as Stone Rings, Locketts, Studs, Buttons, etc., constantly on hand from which I will send for selection to responsible parties.

JOBBER OF EVERY DESCRIPTION



**CARROW, CROTHERS & CO.,**

MANUFACTURERS OF

**FINE JEWELRY,**

**No. 12 John Street, New York.**

**Specialties!**

FINE LINKED SLEEVE BUTTONS, ROMAN BAND  
 BRACELETS, LOCKETS & CROSSES.

**Platinum Tipped Diamond Settings,**  
 Patented April 16th, 1878, by  
**Ripley, Howland & Co.**

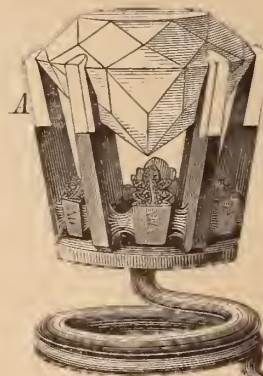

Office, No. 35 Maiden Lane, New York.  
 Factory, 383 Washington Street, Boston, Mass.

Established 1845.

**WILLIAM H. BALL,**  
 SUCCESSOR TO  
**BALL & BARNARD,**

MAKER OF

Roman, Enameled and Engraved

**BANDS.**

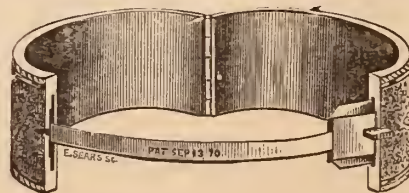

Having given the manufacture of Band Bracelets my entire attention for a number of years, it has been my desire to make a durable article, one that will give satisfaction to the seller as well as the wearer. I desire to call the attention of the trade to the reduction I have just made in prices, still keeping up the standard as to quality, finish, and workmanship. To each pair of BANDS I attach my patent guard without extra charge—thus saving the price of chain—which for seven years past has given entire satisfaction.

**No. 9 JOHN STREET, NEW YORK.**

Factory, 30 & 32 Franklin Street, Newark, N. J.



**EDWARD TODD & CO.**

MANUFACTURERS OF

**GOLD PENS,**



Pencil Cases, Tooth Picks, &c.

**No. 652 BROADWAY,**

Factory, 29 & 31 South 11th St., Brooklyn.

**NEW YORK.**

**C. F. A. HINRICHS,**

29, 31 and 33 PARK PLACE,

Cor. of CHURCH STREET, (Up-stairs) NEW YORK

Successor to M. WERCKMEISTER.

[ESTABLISHED 1801.]

IMPORTER AND DEALER IN

**FANCY GOODS,**

GLASS-WARE,

China, Bronzes, Clocks, Toys, &c.

Sole Agents for the Glass Factories of the Company "ANN," Namuroise, Belgium

Depot for Archery, Cricket & Base Ball Implements.

And C. A. KLEEMANN'S CELEBRATED GERMAN STUDY LAMPS

Agent for ROGER'S GROUPS in Parian, &c.

ESTABLISHED 1855.

**WELCH & MILLER,**

MANUFACTURERS OF MOROCCO, VELVET AND SATIN

**Jewelry Cases, Trays, &c.**

Telescope Sample Cases, with Flexible Trays.

COMPLETE STOCK ON HAND.

**No. 169 BROADWAY, NEW YORK.**

CATALOGUES SENT ON APPLICATION.

**GEO. B. WHEELER,**

**NEW BEDFORD, MASS.**

MANUFACTURER OF FINE

**Watch and Clock Oil.**



THE PORPOISE.

This Oil is made from the best of stock, is free from gum or corrosion, will stand the coldest weather, and is every way reliable.

**L. HAMMEL & CO., Sole Agents,**

**No. 9 Maiden Lane, New York.**

KOCH & CO., Elberfeld, Prussia, Sole Agents in Europe.

**Goldsmith & Schliesser,**

(Formerly of Freund, Goldsmith & Co.)

**Manufacturing Jewelers,**

—AND—

**Importers of Watches & Precious Stones,**

**No. 5 Maiden Lane,**

Factory, 56 West 4th Street,

**NEW YORK.**

Sole Agents for H. L. Mathey, Locle, Switzerland.

**H. Muhr's Sons, Philadelphia.**

**MANUFACTURING JEWELERS,**

**Solid Gold Finger Rings of Every Description.**



**Crown, 18k. Lion.**



On and after January 1st, 1876, our make of Filled Plain Rings will be stamped as above, which stamp is copy righted. Any and every infringement on the above Trade Mark will be dealt with according to law. Every one warranted.

**THESE GOODS ARE SOLD BY ALL THE LEADING JOBBERS!**

Should the house that any retailer deals with not have them we will furnish them with the address of the nearest Jobber. **SELL TO THE JOBBING TRADE ONLY!**

**New York Office, 11 Maiden Lane.**

Address all communications to Philadelphia.

**BERNARD LEVY,**

**Manufacturer of Watch Cases**

—AND—

**JOBBER OF AMERICAN MOVEMENTS.**

**No. 402 Library Street,**

**PHILADELPHIA.**

ALSO, ORNAMENTAL ENGRAVER AND ENGINE TURNER.

**Lubricating Oils, for Watch, Clock and Chronometer Makers.**

The discovery of a Lubricator for FINE MACHINERY, such as Watches, Clocks and Chronometers, that is free from gum and corrosive substances, has taxed the ingenuity of hundreds of men whose efforts have proved a failure. But we are happy to say (being largely interested) that such an article has been supplied by MR. EZRA KELLEY, of New Bedford, Mass., who, after forty years study of the subject, has perfected a Lubricator that recommends itself to all who have used the genuine, (there having been numerous counterfeits in the market,) as witness also the award of a



Diploma and Medal by the judges of the late Centennial Exhibition at Philadelphia. We have no hesitation in saying that his Oils are the BEST manufactured, always uniform in quality and capable of standing all tests applied to lubricating oils. We cheerfully recommend it to all who may in their business require a FIRST-CLASS LUBRICATOR.



**AMERICAN CLOCK CO., (Hine & Thomas.)**

P. S.—The above Oils can be procured at all first-class wholesale Watch and Clock Establishments in the United States, as well as his only Agents, GRIMSHAW & BAXTER, 35 Goswell Street, London England. New Bedford, October 15, 1877.

Dealers in Watches,  
 Importers of Diamonds.

**OPPENHEIMER, BROS. & VEITH,**  
 Manufacturing Jewelers,  
 35 MAIDEN LANE,

S. Oppenheimer, {  
 A. Oppenheimer, {

**New York.**

{ Henry F. Veith.  
 { Gus. F. Veith,

I. PFORZHEIMER.

D. KELLER.

**PFORZHEIMER & KELLER,**  
 IMPORTERS OF  
**Watches and Diamonds**

*Dealers in American Watches,*

AND

**Manufacturers of Jewelry,**

No. 24 JOHN STREET,

**NEW YORK.**

P. O. Box 4144.

**Mathez Watch Company of New York.**

Gents' and Ladies' Stem-Winding Movements

**STRAIGHT LINE, 3-4 PLATE NICKEL.**

These Movements are of six different grades, uniform in size and beautifully finished, and will be SOLD AT LOWER PRICES than any other goods of similar excellence.

A FULL LINE of materials for our movements always kept in stock for the convenience of those using our goods.

**F. H. MATHEZ, Sole Agent,**

**No. 5 Maiden Lane, New York.**

**FOR SALE!**

**A JEWELRY FACTORY!**

DESIRABLY LOCATED IN THIS CITY,  
 BELONGING TO AN OLD ESTABLISHED FIRM.

The factory has a capacity for seventy-five hands, and is complete in all its appointments, the machinery and tools being of the very best.

**WILL BE SOLD AT A GREAT BARGAIN.**

Address, Box 485, New York P. O.

**BREITINGER & KUNZ,**  
 Importers of Watchmakers' Tools,

**MATERIALS, CLASSES, &c.**

**No. 107 North Ninth Street,**  
**PHILADELPHIA.**

Dealers in all kinds of American Watch Materials and American Clock Material. Specialties in Materials for Musical Boxes, Cuckoo Clocks, &c.

Sole Agents in the United States for Bahni Brothers Hardened and Tempered Hairsprings. Agents in the U. S. for J. Becker's (Freiburg, Germany) Gold Medal Regulators, the best in the market. A large assortment of all patterns always on hand; Movements with seconds pendulum for watchmakers' use—all kinds of materials for the same.  
 Wheel Cutting and work done for the trade.

ESTABLISHED 1854. Medal and Diploma Awarded at Centennial Exhibition.  
 JUDGES' REPORT:—Well made and good patterns—Double Hinge as a useful improvement  
 (Patented December 17th, 1867.)

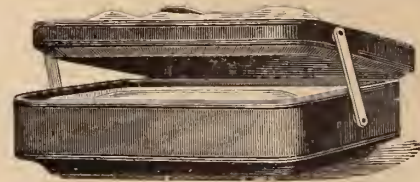

**G. F. KOLB & SON,**  
 MANUFACTURERS OF FINE

**Morocco, Velvet and Cabinet Cases,**  
 FOR JEWELRY, WATCHES & SILVERWARE.

**TRAYS FOR SHOW CASES, TRUNKS, &c.**

**732 Sansom Street, PHILADELPHIA.**

**T. B. BYNNER,**

**Importer & Jobber of Watches**

**DIAMONDS AND FINE JEWELRY,**

And Dealer in the **BEST CLASS OF ROLLED PLATE JEWELRY**

And Key and Stem-Winding American Watches.

**No. 513 Broadway, New York**

**A. N. Clark, Plainville, Ct.**

MANUFACTURER OF

WATCH KEYS,

WATCH CASE SPRINGS,

Watchmakers' & Jewelers'

**BENCH TOOLS.**

Crosby's Jeweling Tools, &c.



Sold by Jobbers in Watch Materials and Notions.

Small articles in metal manufactured to order.

MANUFACTURERS  
OF  
EXCLUSIVELY

**BLACK ONYX GOODS.**

**WOGLOM & MILLER,**  
32 & 34 JOHN STREET,  
NEW YORK.

**ROSKOPF WATCH.**



J. D. HUGUENIN & CO.,  
GENERAL AGENTS,

No. 12 Maiden Lane, New York.

The reputation of this Watch as an accurate timekeeper is fully established, and during the ten years that it has been before the Trade, has won an abiding reputation for fine Time-keeping qualities, and the BEST WATCH for the money in the world.

Send business card for price list.

**BOOZ & THOMAS,**

MANUFACTURERS OF

**Watch Cases & Jewelry,**

108 SOUTH EIGHTH STREET,

Second Story, PHILADELPHIA.

Illustrated Catalogues sent upon application.

Old Gold & Silver Bought or Exchanged.

PARTICULAR ATTENTION PAID TO REPAIRING.

**J. H. PURDY & CO.**

Jobbers of Imported and Domestic

**TOOLS & MATERIALS,**

For the use of Watchmakers, Jewelers, and kindred trades.

WATCH GUARDS, JEWELRY BOXES, SPECTACLES, CARDS,  
SPECTACLE CASES, PEARL GOODS, STEEL CHAINS,  
TAGS, RUBBER TYPE, &c.

No. 170 State Street, Chicago, Ill.

OFFICE WITH CHAS. WENDELL & CO.

**HENRY FERA,**

**Importer of Diamonds,**

No. 9 MAIDEN LANE,

**New York.**

Having my own cutting and polishing establishment at Nos. 23 and 25 Looijersgracht, Amsterdam, Holland, constantly running 36 mills, I am able to offer to the trade a full assortment of Diamonds at very low prices.

Loose and Mounted Goods sent on approval to any part of the country on receipt of satisfactory references.

**HAMILTONS & HUNT,**

MANUFACTURERS OF

**Fine Plated Chains**

AND PATENT BUCKLE BRACELETS,

**Branch Office, 176 Broadway, New York**

FACTORY, 226 EDDY STREET, PROVIDENCE, R. I.



**W. C. GREENE & CO.**  
GOLDSMITHS

MANUFACTURERS OF

RICH SETS IN TAPER WIRE CORAL

Factory 95 PINE ST. PROVIDENCE, R. I.  
Stone-Camco  
Amethyst  
Coral Cameo  
Engraved &  
Brooches  
Sleeve Buttons  
Stud's Buttons  
EAR & C.  
Drops & Crosses

NEW YORK OFFICE, No. 192 BROADWAY.

Wm. C. Greene,

B. W. Greene,

Geo. D. Briggs.

**MILNE & JOURDAIN,**

Manufacturers of Stem-Winding Watch Crowns



13 & 15 Franklin Street, NEWARK, N. J.

Gold Crowns, for Stem-winding Movements, to suit all sizes of Imported or American Watches, in four different styles and seven sizes.

Gold Pushers for Key Movements in every size. Also Gold Crowns for fine Chronograph Watches made to order.

Silver Stem winding Crowns and Key Pushers on hand or made to order. Send for card and samples.

A. MILNE.

A. JOURDAIN.

OFFICE OF  
ROBBINS & APPLETON,  
AGENTS FOR  
American Watch Company,  
No. 9 BOND STREET.

New York, February 8th, 1879.

SIR :

We have decided, after much reflection, to adopt a new system in the sale of Waltham Watches.

The present plan of an arbitrary classification of the dealers, according to their business, as Jobbers and Retailers, and selling to them at different rates on that classification, has been proved to be altogether unsatisfactory.

The basis of the new plan is to treat all dealers, regularly engaged in the watch trade, on equal terms, making the volume of business done with each, within a given time, the only ground of difference in discounts.

We call your particular attention to the fact, that each of our full plate key winding cases is now made to fit both old and new model movements, which, we understand, is also true of the cases made by other manufacturers. These cases are to be distinguished from old model cases by their having two steady-pin holes for the movement.

We again commend our new model full plate movements to your careful examination. You will find great improvements in their general design, in the escapement, in the letting-down arrangement, in the room between wheels, and in the general appearance and finish.

We assert that no watch on the market is at all comparable to these popular watches in real value for the money. Every grade is warranted by certificate. The new terms now offered bring these goods absolutely lower than any others whatsoever.

The General Agents for the  
American Watch Company,  
OF WALTHAM, MASS.

Robbins & Appleton, 9 Bond Street, New York.  
Robbins, Appleton & Co., 8 Summer Street, Boston.  
Robbins & Appleton, 170 State Street, Chicago.

## American Watch Company.

### The New Model BROADWAY.

The best watch for the money ever offered! We have entirely remodeled them with the following special advantages.

The barrel does not project beyond the top plate, thus allowing a plain, tighter-fitting dust band to be used.

The pottance is immovably fixed in the plate, and need never be disturbed. With this pottance so placed it is impossible for the balance to get out of upright, and it is a convenience for repairers. This valuable improvement is secured by patent.

The angles of the pallet jewels, on both sides of the pallet, are the same, and the jewels are interchangeable, which is also convenient for repairers. By this means the whole escapement has been improved.

An improved arrangement for letting down the mainspring without taking off the hands and dial. The barrel can be removed by simply taking off the barrel bridge.

The dials are firmly secured by screws.

The hair-spring stud is in the cock, so that balance and cock can be taken off and replaced without danger of changing the rate of the watch.

All the wheels and pinions run in the solid plate in jewels or otherwise, the third bridge being abandoned, so that no part of the train can get out of upright.

ROBBINS & APPLETON, General Agents,

No. 9 BOND STREET, NEW YORK.

170 State Street, Chicago.

8 Summer Street, Boston.

Waltham Building, London.

# L. & A. MATHEY,

IMPORTERS OF FINE WATCHES AND MOVEMENTS

No. 16 Maiden Lane, New York.



Independent  $\frac{1}{2}$  Seconds, Plain Chronographs, Independent Split Seconds,  
 Minute Repeaters, Double Chronographs, Perpetual Calendars,  
 Minute Chronographs, Pocket Chronometers.  
 MINUTE CHRONOGRAPHS, WITH MINUTE REPEATER.  
 CHRONOGRAPHS, WITH MINUTE REPEATER.  
 AND A FULL LINE OF MEDIUM GRADE WATCHES AND MOVEMENTS.

Sole Agents for the H. L. MATILE WATCHES.

Timing and Complicated Watches a specialty. All our Watches are tried and tested before delivery. Goods sent for examination on satisfactory references.

An attractive line of *Chattelaines* and *Chattelaine* Watches.



Established 1828.

# JACOB BENNETT & SON,

Diamond Setters and Manufacturing Jewelers,

No. 108 SOUTH EIGHTH STREET, PHILADELPHIA.

WE MANUFACTURE AND MAKE A SPECIALTY OF  
 EVERY DESCRIPTION OF

**DIAMOND MOUNTINGS**

SUPERIOR IN DESIGN AND WORKMANSHIP.



MASONIC MARKS,

**Presentation & Lodge Jewels,**

SOCIETY AND POLICE BADGES MADE TO ORDER.  
 FINE WHOLE PEARL JEWELRY.

GOODS SENT ON MEMORANDUM TO ANY PART OF THE UNITED STATES.

# CROSS & BEGUELIN,

Makers and Importers of SWISS WATCHES,

AND DIRECT IMPORTERS OF

Watch Tools, Materials, Glasses, &c.

No. 21 Maiden Lane, New York.

The CENTENNIAL WATCH (Stem-Winding and Stem-Setting) so universally popular, has achieved a standard reputation, and is generally conceded to be the best made watch for the money in this market. Being the sole manufacturers of this celebrated Timekeeper, we are enabled to give it our strongest endorsement. Especial attention is called to the "HENRY BEGUELIN," "DROZ & PERRET," and other well known Swiss Watches, as well as to our full and complete line of all grades of American Watches, on which we give the full trade discount.

The attention of Watchmakers is directed to our new DRILLS, in sets of 21 sizes. The most complete and serviceable drill ever offered.



None Genuine without this TradeMark:

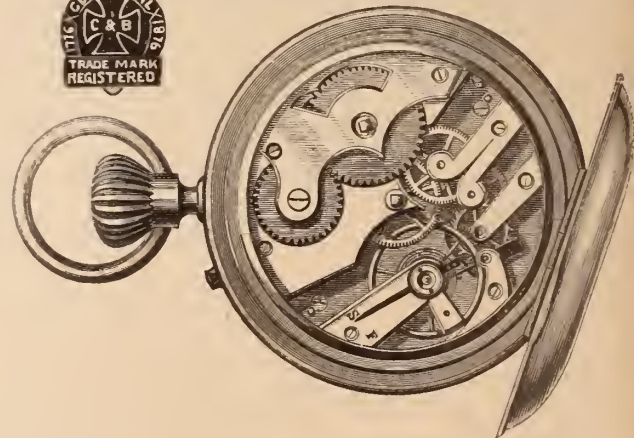

The above is a fac-simile of the Centennial Watch.

# BROWN & BROTHERS

MANUFACTURERS OF

Finest Quality of Electro-Plated Flat Table Ware.

PATENTED HEAVY SPRING TEMPERED SHANK ON FORKS AND SPOONS.

ILLUSTRATED CATALOGUES FURNISHED ON APPLICATION.

WAREROOMS, No. 81 CHAMBERS STREET, NEW YORK CITY.

FACTORIES, WATERBURY, CONN.

P. O. BOX 5731.

# HALL, ELTON & CO., Manufacturers of the Finest Electro-Plated Ware.

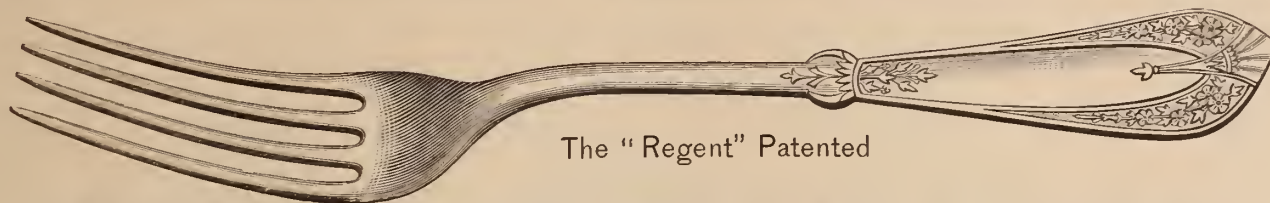

The "Regent" Patented

**UNSURPASSED IN QUALITY, STYLE AND FINISH!**

Factories, Wallingford, Conn. Salesroom, 75 Chambers St., New York.

# HOLMES, BOOTH & HAYDENS, MANUFACTURERS OF ELECTRO-SILVER PLATED Spoons, Forks, Ladles, Fancy Pieces,

**Solid Handle Steel Knives, &c., of the finest quality.**

No. 49 Chambers Street,  
**NEW YORK.**

No. 18 Federal Street,  
**BOSTON.**

Works at Waterbury, Conn.

# AMERICAN PEDOMETER.



Messrs. TIFFANY & CO. invite public attention to the AMERICAN PEDOMETER, a remarkable invention of Mr. Benjamin S. Church, the well known Engineer of the Croton Aqueduct.

This instrument accurately measures the distance a person carrying it walks, showing the amount of daily exercise taken in and out of doors.

Its mechanism is a marvel of simplicity, and can be adjusted to any length of step. It is strong and durable, and the size of a small watch. Ladies, Professional and Business Men, Students, Pedestrians, Sportsmen, Farmers, Surveyors, and others will find it very useful. A table accompanies each Pedometer, giving the number of steps taken in a mile, second, minute, hour and day. Retail Price, \$5.00.

TIFFANY & CO.

UNION SQUARE,

SOLE AGENTS.

NEW YORK

The retail trade supplied only by TIFFANY & CO., 14 John St., who do not sell to Jobbers, but are establishing as "exclusive agents" dealers who order quantities. Early application solicited.

# LONGINES WATCHES.

AWARDED A GOLD MEDAL AT THE  
PARIS EXPOSITION, 1878.

*The only substantial recognition of low-price stem-winders.*



They are acknowledged by competent authority to be SUPERIOR to all other competing LOW-GRADE WATCHES. The cheapness of price, simplicity, durability, superiority of construction and time-keeping qualities, have achieved a high reputation.

SOLD BY ALL LEADING JOBBERS.

# HENRY C. HASKELL,

Manufacturing Jeweler,

No. 12 John Street,

New York.

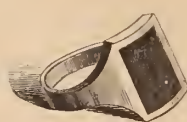

4040

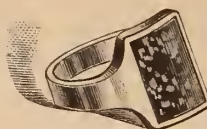

5223

INTAGLIO, CHOICE CAMEOS,  
*Set with Diamonds.*  
PEARL, TURQUOISE, DIAMOND,  
RUBY, SAPPHIRE, &C.  
FULL LINE OF ONYX RINGS,  
*Specially made for MONOGRAMS.*



1549

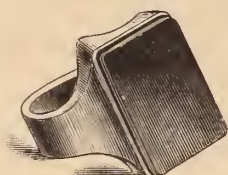

3433

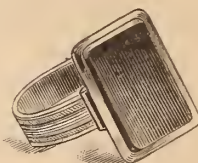

3191

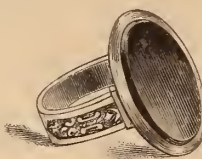

3003



309

*Orders solicited for goods on approval.*

*Stone Seal Engraving and Jobbing of every description promptly and carefully done.*

## REED & BARTON, Manufacturers of Fine Silver-Plated Table Ware OF EVERY DESCRIPTION.

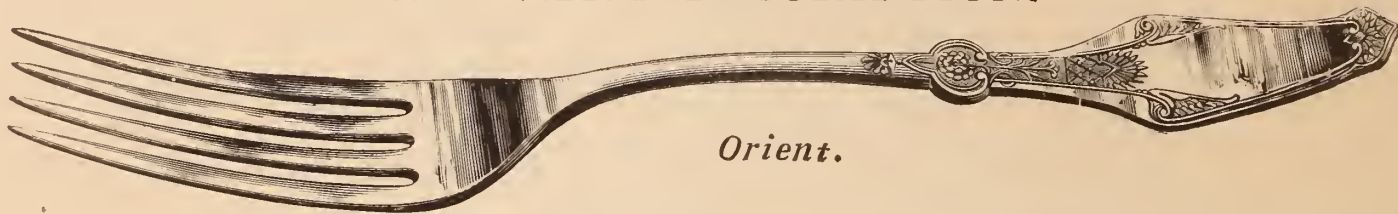

*Orient.*

Would call attention of the trade to their new design of fork (illustrated above) which we believe to be the finest design ever manufactured in plate. We are also manufacturing a great number of new designs in all kinds of hollow-ware, and among other things a great number of Fancy Pieces, such as Jewel Boxes, Card Stands, and Case Cologne Sets, etc., which are specially adapted to the holiday trade.

**Factories, Taunton, Mass.**

**No. 686 BROADWAY, NEW YORK.**

### SPENCER OPTICAL MANUF'G CO.

13 MAIDEN LANE, NEW YORK,

MANUFACTURERS OF

### Spectacles AND Eye Glasses

IN ALL VARIETIES.

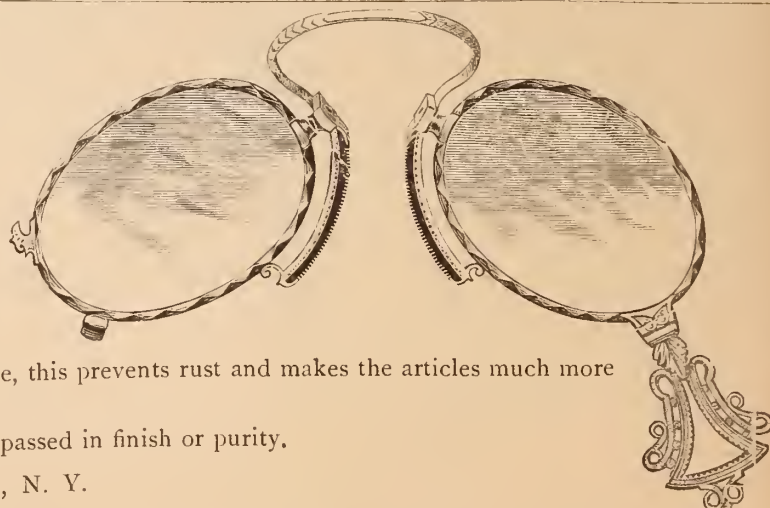

Among the numerous specialties are the Steel Frames plated with Nickle, this prevents rust and makes the articles much more durable.

P. S.—Our lenses are all ground in our own Factory, and cannot be surpassed in finish or purity.

FACTORIES, MT. KISCO, N. Y.

### SPECIAL NOTICE! MANUFACTURING JEWELERS, CHEMISTS, &c.

## BROWN & BROS.,

No. 81 CHAMBERS STREET,

NEW YORK.

Manufacture CHEMICALLY PURE COPPER for ALLOYING, and are prepared to fill orders for same, either in the Wire, Strip or Granulated form. Its PURITY has been attested as follows.

UNITED STATES ASSAY OFFICE, 30 WALL STREET,  
NEW YORK, Dec. 21st, 1877.

BROWN & BROS.

*Dear Sir.*—We have analyzed the two samples of Copper left with us on the 18th instant, one said to be foreign refined Copper as used by jewelers, the other a refined Copper as manufactured by you for the same purpose. We find both samples alike in purity, and no difference can be detected by a careful chemical analysis, both being samples of PURE METALLIC COPPER, having no traces of antimony, tin, arsenic, zinc or lead.

TORREY & EATON.



# TIFFANY WATCHES.

FOR LADIES AND GENTLEMEN.

SIMPLE !

STRONG !

DURABLE !

ACCURATE !

RELIABLE !



ADJUSTED TO

TEMPERATURE and

POSITIONS, and

CASED IN

18 Karat GOLD.

EACH and every movement finished under our own supervision by thoroughly skilled hand labor, and guaranteed to be "as fine time keepers to carry as are made!"

Every genuine TIFFANY WATCH has engraved upon the movement the firm name "TIFFANY & Co." and none others are made by our workmen !

More "value received" than ever before known in the watch business ! Exclusive sale given under special contracts, and circulars for distribution sent gratis !

AGENTS protected and goods sent "on memorandum" for examination or selection upon receipt of satisfactory references ! We do not sell Jobbers!

Refinishing, stoning, raying and engraving nickel movements done on the premises ! Engraving inscriptions, devices and monograms on cases promptly attended to !

The TIFFANY WATCHES are retailed at less than the importation cost of many so-called fine watches!

 Dealers must sell them at our established retail price!

## TIFFANY & Co.

NEW YORK, PARIS, LONDON, GENEVA.

### MAKERS OF FINE AND COMPLICATED WATCHES,

Wholesale Office, 14 John Street, New York.

GEO. R. COLLIS, Manager.

 General Agents for Messrs. Patek, Philippe & Co.'s Watches.

 Sole Agents for the American Pedometer, the most popular and salable article known to the trade.

Retail price, \$5.00.

# ROGERS & BRO.,

Have now in stock a full line of new Low Priced attractive Goods in

## ELECTRO-SILVER PLATE,

No. 690 BROADWAY,

NEW YORK.

*Photographs sent for selection on receipt of business card and references.*

1879.

SPRING TRADE.

1879.

## FRENCH CLOCKS.

We call special attention of the trade to this department of our business. Having received recent large shipments from which we can make unusual inducements.

**TAYLOR & BROTHER,**

No. 676 Broadway,

NEW YORK.

**WHOLESALE ONLY.**

# NOVELTIES

IN DECORATIVE BISQUE, FAIENCE, PORCELAIN, TERRA COTTA AND GLASS.

Our buyer now in Paris will send us about March 1st a full line of the Latest Designs and Decorations in all the celebrated potteries.

Our usual line of

## MARBLE CLOCKS

will also be found with all the latest styles of incrustation.

# Le Boutillier & Co.

No. 3 UNION SQUARE, NEW YORK.

### TO THE TRADE.

We have the honor to call attention to the annexed cut representing our **Superfine Quality three-quarter plate Stem-Winding**  
**FREDERIC NICOUD**

*Movement.* All movements of this grade are adjusted to temperature and positions by Mr. F. Borgsetdt, of Locle, one of the most eminent adjusters in Switzerland, who received a medal at the Paris Exposition of 1878, for the high character of his work.



These movements are provided with a dust-ring and are cased in 18 kt. 60 to 65 dwt. cases with two caps (glass cap and gold cap over it).

We venture to affirm that these watches are equal, if not superior to any watch at the same price in the market.

Prices of the above as well as of the other Nicoud grades of watches sent to the trade upon application, accompanied by business card.

## NICOUD & HOWARD,

Sole Importers of

# NICOUD WATCHES,

No. 14 MAIDEN LANE,

NEW YORK.

ESTABLISHED 1869.

# The Jewelers' Circular and Horological Review.

THE RECOGNIZED ORGAN OF THE TRADE, AND THE OFFICIAL REPRESENTATIVE OF THE JEWELERS' LEAGUE.

## TENTH VOLUME.

THE TENTH VOLUME will begin with the February, 1879, number and will contain a fund of practical information that will render it invaluable to dealers and all persons interested in the Watch, Clock, Jewelry and kindred industries.

To the practical workman the JEWELERS' CIRCULAR is invaluable as a text-book and work of reference. Its pages furnish him with the latest scientific and mechanical ideas, set forth in plain, comprehensible language by specialists of ability and experience. The technical information contained in its columns represents the progress of the age, and every intelligent workman in the country acknowledges the advantages resulting from a study of its pages.

To the country dealer the JEWELERS' CIRCULAR affords thorough, correct and perfect information as to staple and original articles of trade. From it he can learn what to order and where to obtain supplies, he can discover the best source of materials in common use, while the latest novelties are without exception first announced in its columns.

To the leading manufacturers and jobbers the JEWELERS' CIRCULAR has proved to be THE BEST ADVERTISING MEDIUM FOR THE TRADE. Its readers comprise the customers of those houses, and consequently the business announcements are carefully studied, and liberally responded to. Hence an extensive and increasing patronage has been accorded to the JEWELERS' CIRCULAR by the leading manufacturers and jobbers, which speaks for itself and needs no further comment.

The JEWELERS' CIRCULAR has acquired an enviable reputation, by its undeviating advocacy of the highest standard of commercial integrity, and its persistent opposition to those who dishonor and demoralize business by compromise and fraud. It has always been ready to promulgate and further plans and enterprises tending to the public good, and its columns have always been open to the honest expression of private opinion concerning matters which needed to be mended. Its information on commercial matters, much of which is nowhere else to be obtained, is of great importance and benefit, while the completeness of its directory and business columns render it indispensable to those concerned in the trade.

The JEWELERS' CIRCULAR is an art journal worthy of the artistic interest and industries which it represents. The technical articles are illustrated by carefully executed diagrams, and during the past year new designs and trade novelties have been presented, in ten splendid plates, printed in gold, silver and colors. Its elegant and tasteful typography is apparent in its advertising pages, where every announcement is rendered attractive and conspicuous.

The JEWELERS' CIRCULAR is a welcome visitor and powerful influence in the workshop, in the store and in the counting room. The best testimony to its merits is to be found in the indorsement accorded to it by the trade at large. Every one who has goods to sell finds that IT PAYS TO ADVERTISE in the JEWELERS' CIRCULAR, because all who buy goods seek and find their information in its pages, while every dealer and workman finds that IT PAYS TO SUBSCRIBE, because they obtain a return in intelligence and instruction of infinitely greater pecuniary value. In the future, as in the past, no expense or care will be spared to improve the JEWELERS' CIRCULAR, and render it attractive, beneficial, instructive and indispensable; while it is hoped that the continuance of the subscription price at \$2 per annum (a rate far beneath that of any monthly publication of its size and contents), will obtain for it the widest possible circulation both at home and abroad.

All communications to be addressed to D. H. HOPKINSON, 42 Nassau Street, N. Y.

NOW IS THE TIME TO SUBSCRIBE.

SPECIAL SALE

OF THE

“CRESCENT STREET” WATCH,

OFFERED BY THE

AMERICAN WATCH COMPANY,

—OF—

WALTHAM, MASS.



The 18 size movement, named

“American Watch Company, “CRESCENT STREET,” Waltham, Mass.,”

is the only American full-plate movement made to wind and set on the back. It is full jeweled, is provided with compensation balance, accurately adjusted, patent micrometrical regulator, Fogg’s patent pinion, and is popularly known as the

American Railroad Watch.

It is carefully fitted in Sterling Silver Cases ( $\frac{925}{1000}$  fine), and now offered to the trade, in

3 oz. (Hunting or Open Face,) . . . . .	\$22.00 NET.
4 oz. (Hunting or Open Face,) . . . . .	\$23.50 NET.

AMERICAN WATCH CO.,

OF WALTHAM, MASS.

Robbins & Appleton, 9 BOND ST., NEW YORK,  
8 SUMMER ST., BOSTON, General Agents.  
170 STATE ST., CHICAGO,

J. C. AIKIN.

H. A. LAMBERT.

J. B. SHEA.

**AIKIN, LAMBERT & CO.,****MANUFACTURERS OF GOLD PENS,****Pen and Pencil Cases, Pencils, Tooth-picks, and "Novelties"  
in Pencil Goods.****No. 23 Maiden Lane, New York,**

Would call the attention of the Trade to our large and complete line of Pen Goods in all styles and varieties, suitable for the Winter and early Spring demand.

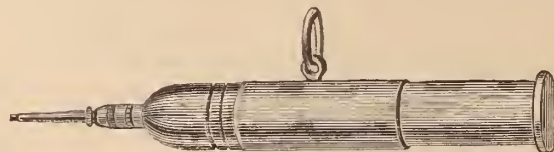

Our introduction last season of Pencils in NEW AND ENTIRELY NOVEL DESIGNS was marked by an unprecedented demand, which establishes the sale of these goods as STAPLES, and as being suited to any season of the year.

The Magic Charms (as per cuts shown below), inlaid with pearl and gold, in form of vines, flowers, birds, etc., on celluloid of assorted colors, in imitation of malachite, tortoise shell, agate variegated marble, etc., are the LATEST and most novel pencils in the market.



Send for circular and new list.

**Branch, No. 113 East Madison Street, Chicago.****IMPORTERS OF ALL GRADES OF****WATCHES,**

SOLE AGENTS FOR

**"PAUL BRETON" and "CHAS. LATOUR," GENEVA.**

LONGINES



EXCELSIOR.

**— SPECIALTIES. —**

AGASSIZ Movements, Gilt and Nickel Stem-Winding, fitting Ladies' Riverside Case.

CHAS. LATOUR Movements, Gilt and Nickel Key-Winding, fitting 10 and 16 size Waltham Case.

PAUL BRETON Movements, Gilt and Nickel Key and Stem-Winding, a full line of these CELEBRATED TIMEPIECES in gold and silver cases of the most approved styles.

METAL OPEN FACE STEM-WINDING "LONGINES" and "EXCELSIOR", 16, 18 and 20 line, the BEST metal Watches in STYLE and QUALITY in the market.

The "LONGINES" received the ONLY GOLD MEDAL at Paris for low-priced Watches against several competitors, and the "EXCELSIOR" is recommended by DR. HIRSCH of the Neuchâtel Observatory having given VERY SATISFACTORY results during a month's trial. NOVELTIES in BLACK and FANCY DIALS for these Watches are selling rapidly. American Watches of all kinds. Gold Cases of any style made to order. Sole Agents for EUREKA HORSE TIMER, the cheapest reliable TIMER ever made, and for PNEUMATIC TIMER which does not require the use of the hand. All Watches sold by us are warranted.

Our assortment of Jewe.r.y is very large and complete, consisting of a general line of RELIABLE goods, both in GOLD and ROLLED PLATE, of new and tasty patterns, and including almost any article a Jeweler would have calls for. Special attention given to ORDERED WORK and REPAIRS. GOODS SENT ON APPROVAL and CORRESPONDENCE invited. Those not acquainted with us will oblige by giving references when ordering.

JANUARY 1st, WE REVALUED OUR ENTIRE STOCK AND HAVE REDUCED PRICES, AND ARE OFFERING GREAT INDUCEMENTS TO PURCHASERS FOR THE SPRING TRADE.

== PRICES REDUCED ==

# FOLDING TRIPLICATE MIRRORS.



*The Folding Mirror has steadily increased in popularity since its introduction, and we can confidently recommend them to the Trade, as the most saleable article in the market.*

*Special arrangements with the manufacturer have just been completed which enable us to make a considerable reduction from former prices.*

*We have a complete stock on hand and are prepared to fill orders for all sizes.*

*Orders for Importation in original cases of fifty mirrors or more, any assortment desired, at special rates.*

## HALL, NICOLL & GRANBERY,

Successors to SCHUYLER, HARTLEY & GRAHAM, in the Fancy Goods Department,

**IMPORTERS**

Clocks, Bronzes, Opera and Field Glasses, Vienna Gilt Goods, Pottery,  
and a full line of Fancy Goods.

SILVER FILAGREE. AMBER AND CORAL JEWELRY.

**Nos. 20 and 22 John Street, New York.**



## Report of the Executive Committee of the Jewelers' League for the term ending January 21st, 1879.

TO THE PRESIDENT AND BROTHER MEMBERS:

*Gentlemen:*—The Executive Committee in presenting this, their second annual report, congratulate you upon the continued and increasing prosperity of the LEAGUE and upon the enviable position it is assuming among the organizations of similar character and purpose.

We refer with especial satisfaction to the fact that since the last report you have been called upon for but one death-loss, that of Mr. Charles W. Menge, who was removed from our midst by an allwise Providence, when but upon the threshold of a vigorous young manhood; and the promptness with which your payments were made to replenish the death-loss fund was doubtless accompanied by the thought that, were it instead the lot of any one of us, who are still in the enjoyment of health, to be taken away from our families and friends he would have as promptly come to the assistance of our loved ones. The promptness with which, considering the stringency of the times, the assessment was paid up is something remarkable and of which we may be justifiably proud, for out of a membership of 240 at the time the assessment was ordered, there was not a single name dropped from the roll for non-payment.

We have during the past term lost one member by death and one by expulsion.

We had at the last annual meeting 132 members, and have admitted 165 members during the year, making at the present meeting a membership of 297, which we consider a very gratifying exhibit, having very much more than doubled during the past year.

One application, on account of the peculiar circumstances accompanying its conveyance to us, was tabled for instructions from the LEAGUE in annual session. This matter will be placed before you at the proper time during this meeting. Now that we have entered upon an era of solid, fixed values, with a most encouraging outlook in the mercantile and financial world, we apprehend a still more rapid accumulation of members; and with the improved prospect in the future, we earnestly hope the members may be encouraged to re-double their efforts to secure eligible and desirable members. Our growth depends entirely upon our own exertions. Your Executive Committee have addressed the membership at various times in as forceful language as they *dare* employ, urging them to renewed and constantly repeated efforts, but, with the energy which we realize is possessed by every member, and which we know each feels should be utilized in behalf of the LEAGUE, having accomplished so much less than we thought both possible and probable, we can only charitably conclude that however good the seed and however conscientiously sown, the fault must of necessity lay in the soil in which they have sown it. Some few of our members have complained most bitterly that, notwithstanding our sturdy, healthy growth, we are not growing in numbers rapidly enough, but upon referring to our records we generally find such complainants to be those, speaking moderately, whose seed sowing has not been fruitful in securing any members whatever.

Of our hundred and eighty-seven of our members have not presented a single candidate; such gentlemen are willing

to share the *benefits* of our LEAGUE without any correlative efforts to *enhance* such benefits.

We have collated the names of those members (exclusive of the Executive Committee) who have recommended more than one member each, beginning with the member recommending the largest number, and present them to you here. These gentlemen are entitled to our hearty thanks for their successful labor in behalf of each and every one of us:

C. Cushing Adams,	Henry E. Ide,
Wm. B. Kerr,	Wm. D. Carrow,
Andrew K. Shiebler,	Wickliffe B. Durand,
David Dodd,	Geo. F. Darden, Baltimore,
George W. Shiebler,	Chas F. Kesmodel, "
Sted. H. Hale, Chicago,	Philo W. Schofield,
Charles J. Fox,	Lewis J. Mulford,
Samuel W. Saxton,	Caleb Clapp, Chicago,
John D. Lyon,	George R. Howe,
Edward S. Smith,	Wm. L. Sexton,
Thomas Slater,	G. W. French, N. Attleboro.
Maurice A. Mead, Chicago,	Charles L. Power,
Dyer Brainerd,	Orville T. Smith,
George N. Wilcox,	James W. Hagan,
E. E. Barrows, N. Attleboro,	Henry A. Polley, Boston,
James C. Rich,	Albert N. Wood, "
Henry C. Ostrander,	Willis E. Carpenter, "
Wm. W. Fisher, N. Attle-	Frederick D. Steck,
boro,	Charles H. Brown,
Joseph P. Bowden,	Webster C. Ball, Cincinnati,
Adolph Luthy,	Jos. Becker, Jr., "
Frederick A. Goodwin,	Frank H. Bliss,
John W. Steele,	Henry K. Dyer,
James B. Godley,	Jno. F. Simons, Philadelphia.
Geo. H. Hodenpyl,	

The members of the Executive Committee have, collectively, recommended one hundred and ninety-one members.

The oldest member on our roll was born August 18th, 1832; the next oldest on August 19th, 1832; the youngest was born October 26th, 1857, and was admitted four days after having attained his majority.

The average age of our whole membership is thirty-five and one-half years.

This average is an important factor in considering the probable cost, to each member, of the amount to be paid his beneficiaries, for upon this depends the average death-rate. Our system of benefitting survivors has not had the years of existence from the statistics of which we might deduce the probable cost of our insurance, but we show from the experience of similar organizations that have been in existence for many years, and benefited widows and orphans to the extent of millions of dollars, that the rate per thousand dollars is about *one-quarter* of that exacted by the insurance companies; it requires the solution of no abstruse mathematical problem for any of us to be convinced that the scheme of insurance which accomplishes its purpose with virtually no expense, is cheaper, whilst it is as fully efficient as that which accomplishes no greater purposes, whilst paying enormous rents, salaries and commissions.

Whereas the insurance companies require large yearly payments for the purpose of accumulating a large sum which is handled, invested and traded with by its officers for its profit, and remotely for the benefit of the insured, in *our* scheme the funds are retained and used in their own business by the members individually, each of whom can doubtless invest or utilize his own funds as sagaciously as could be done by another, until such funds in small payments are required to be paid to the beneficiaries designated by each member of the LEAGUE.

That our and similar spirited organizations are causing the insurance interest deep concern, is evidenced by the plausible arguments being adduced by them against *our* system. One of the most specious is a twelve-page pamphlet, entitled "Co-operative Life Insurance, by Jacob L. Greene," who starts with the premises that "ten thousand men, all aged thirty, agree that when any one of their number dies, each survivor shall pay one dollar to the family of deceased," and then by their well tested tables of mortality, killing off 84 the first year, each survivor pays \$8.43 per \$1,000 of insurance; 85 will die the second year, and the survivors pay \$8.51 per \$1,000 of insurance) 94 die the tenth year, and the survivors pay \$10.36 for each \$1,000

of insurance; during the twentieth year 128 will die, and each survivor will have paid \$15.94 for each \$1,000, and so on until the fiftieth year he kills off 216. All these deductions are made upon the assumption that the original ten thousand men, or the forlorn hope which is permitted to live each successive year, stand quietly, serenely by and see their fellow-members die off without a single effort to replace them by new members of the same age. But he however proceeds to acknowledge that "could as many lives be added each year as are lost, or fail to pay and drop out, the amount of insurance *could* be maintained, but it would not change the cost per thousand," and it is just there that we agree with him, and out of his own mouth convict him of his fallacious reasoning. The Commercial Travelers' Association, which is identical in its scheme with the JEWELERS' LEAGUE, has been in existence over seven years (during which time it has paid over \$200,000 to its beneficiaries), and it proves its average to have been \$4.97 1-2 per \$1,000 of insurance. But *admitting* that it has not yet arrived at the average death rate of its members (which will slightly increase the average cost per \$1,000), it *can not* increase its death rate sufficiently to cost four times its present cost, and even at that exceedingly improbable rate it would cost \$4.00 less than the rate charged by ten first-class insurance companies carefully averaged. There is no probability and hardly a possibility that *our* cost per \$1,000 can ever exceed one-half the insurance companies rates for the average age of our members.

The fundamental principle of life insurance is, that certain sums contributed yearly by the insured are drawn in bulk by the beneficiary. Our principle is that we contribute certain sums to the beneficiaries of fellow-members during our lives, be they longer or shorter, and upon our death the survivors do the same to our beneficiaries, the longer lives paying for the shorter lives, as they *should* do for the privilege of living long lives.

This "Greene" and other pamphlets and papers which have been very lavishly distributed through the mails to the members of our own and sister organizations, contain statements and arguments which are so palpably unjust and incomplete that we feel called upon to utter these few words in self-defense.

The co-operative organizations which have ceased to exist were mostly small local affairs, which, doing good whilst they existed, succumbed for the identical reasons that a much greater number of insurance companies have collapsed, viz., through lack of able, economical business men of integrity to manage their affairs, but with this grave distinction, that, whereas the collapses of the insurance companies entailed losses of millions of dollars which had been entrusted to them by policy holders for future payment, the collapse of assessment associations brings no such hardships, for the reason that each member is daily receiving the value of his money by the fact of his insurance being so cheap, and paying for *nothing* but for insurance. If an association collapse or he drops out, he loses nothing which he has entrusted to it for future contingencies; but if as properly and as judiciously managed as any mercantile business, there is no reason why such associations should not live year after year to bestow their beneficence upon the widowed and fatherless.

We cannot, in justice to the LEAGUE and the positions of honor in which you placed us one year ago, forbear to again remind you of the necessity of providing careful, prudent men for its management. Let not personal favoritism or popularity be so much a requisite for your managers as energy, conservatism, economy, integrity and faithfulness in the performance of the duties which accompany, and are inseparable from the positions of honor in which you may place them.

Your Committee has during the past term held seventeen sessions, regular and special, never having postponed any intended meeting on account of lack of a quorum.

It may not be amiss here to mention, as was done in the last annual report, that while we have acted in a judicial capacity upon the applications brought before us, we have at the same time felt that we should place ourselves in the same confidential relations to the applicant as is held by



his medical adviser who has taken the "Hippocratic" oath that all their professional intercourse shall be confidential. *All and entire*, the confidences which have been placed in us as an Executive Committee, and respectively as gentlemen, have been, and shall continue to be, held by us as most sacred.

Finally, Brother Members, we close our report by returning the charge and responsibilities which you have entrusted to our care during the past year. Whilst realizing a sense of relief after the discharge of our duties of the year, we can not but feel a regret that, after the courtesy and consideration that has characterized our intercourse one with the other, the time for the dissolution of its present membership has arrived; and our earnest hope is that the newly constituted committee may continue to have the best and enduring interests of the LEAGUE as thoroughly at heart as your present old Committee. May our organization live a long life of usefulness.

Most respectfully submitted,

THOMAS SLATER, (ex-officio). ROBERT A. JOHNSON,  
HENRY J. KING, GEORGE R. COLLIS,  
JAMES P. SNOW, W. C. KIMBALL,  
G. T. WOGLOM, *Chairman*.

NEW YORK, January 21, 1879.

## Second Annual Report of the Secretary and Treasurer.

Balance on hand per Annual Report, January 15th, 1878:			
Deposited with the Union Trust Company for Death Loss Fund.....	\$250 50		
In Chatham National Bank for General Fund.....	92 60	\$343 40	
<b>RECEIPTS.</b>			
During the year 1878 from 165 admitted members toward the death loss fund, at \$2.00 each.....	330 00		
From 165 admitted members toward the general fund at \$3.00 each.....	495 00		
Assessment (to replenish the treasury after the death of Charles W. Menge) on total membership, 240, at \$2.00 each.....	480 00		
Interest accrued on deposits.....	6 60	1,311 60	
		\$1,655 00	
<b>DISBURSEMENTS.</b>			
Rent of hall for annual meeting.....	15 00		
Printing blanks, circulars, etc.....	156 67		
Stationery, postage and incidentals.....	67 61		
Rent of Post Office box.....	16 00		
Five per cent. on receipts (Treasurer's fees).....	65 25		
Paid Mrs. Emilie Menge.....	459 50		
Balance on hand this date:			
Deposited with the Union Trust Co., for death loss fund.....	\$567 10		
Deposited in the Chatham National Bank for general fund.....	301 25		
Cash on hand.....	6 32	\$874 67	\$1,655 00

(Signed) J. D. YERRINGTON,  
Secretary and Treasurer.

NEW YORK, January 21st, 1879.

## Minutes of the Annual Meeting, 1879.

NEW YORK, January 21, 1879.

At the second annual meeting of the JEWELERS' LEAGUE, held at No. 164 Broadway, New York, in the Hall of the Board of Fire Insurance Brokers, there were present seventy-five members.

The meeting was, at 2 o'clock P. M., called to order by the President, Mr. Thomas Slater, and the roll of the full membership was called, after which, upon motion, the minutes of the previous annual meeting of January 15th, 1878, were, after the correction of a minor clerical error, adopted as read.

A few introductory remarks, bearing upon the business and growth of the LEAGUE during the past year, were made by the President, after which the report of the Secretary and Treasurer was read and upon motion accepted.

The report of the Executive Committee, after having been read, was accepted and ordered to be placed on file.

The Finance Committee reported having thoroughly examined the Treasurer's books, vouchers and accounts, and found them to be correct, which report was, upon motion, received and ordered on file.

The Chairman of the Executive Committee stated the peculiar case of a candidate for membership whose application was, at a meeting of the Executive Committee, tabled for instructions from the LEAGUE in annual session, when, upon motion of Mr. David Dodd, it was

*Resolved*, That the sense of this body is that it will sustain the Executive Committee if it returns to Mr. William E. Wood his application for membership, he having completed his forty-fifth year before it was either presented to the Executive Committee or placed in the hands of the Secretary.

In pursuance of the thirty days notice regularly given as required by the Constitution, Mr. Andrew K. Shiebler offered a resolution to amend Article II, Section 3, of the Constitution, by striking out the words "not over forty-five nor under twenty-one years of age," and inserting in lieu thereof the words "not over forty-eight nor under twenty-one years of age."

Upon motion of Mr. David Dodd, an indefinite postponement was voted, and a division being called for thereon, resulted in a vote of 42 ayes and 31 naves, whereupon the President announced the motion (to indefinitely postpone) as carried.

Upon motion it was voted that the Secretary be instructed to have printed for circulation (1,000) one thousand copies of a report which shall embrace the reports of the Executive Committee, the Secretary and Treasurer, the minutes of this meeting, a list of members and the officers for the ensuing year.

On motion of Mr. G. T. Woglom, it was

*Resolved*, That for one year from and at the annual meeting of 1879, there shall be appointed or elected as hereinafter provided, a committee which shall be termed

### THE ADVISORY BOARD,

whose duty it shall be to obtain for the Executive Committee such information as may be requested in regard to the eligibility of applicants for membership from the respective localities of the members of such Board, and in other ways to act as resident agents of the JEWELERS' LEAGUE under instructions from the Executive Committee.

Such Advisory Board shall consist of one member in good standing from each city which has one or more resident members, with the exception of New York City; in case the number reaches twenty or more in any one city, each twenty members and fraction of twenty shall be represented in the said Board by one member.

At the present meeting the President shall appoint a nominating committee of three, who shall nominate a complete Advisory Board and report at this meeting.

Upon the receipt of such report the President shall proceed, in the order of their nomination, to appoint such nominated members of the Advisory Board, but in case one or more independent nominations are made of members from the same city, in each such case the candidates shall be voted for by the raised hand and elected by a plurality vote.

In pursuance of the purposes of this resolution, the President appointed as such nominating committee Messrs. John D. Lyon, A. K. Sloan and George W. Shiebler, instructing the said committee to report during this session.

Upon motion of Mr. David Dodd, it was

*Resolved*, That the thanks of the LEAGUE are due and are hereby tendered to the Executive Committee for the faithful manner in which they have performed their duties, for the zeal and fidelity shown by them in caring for all the interests of the LEAGUE, and particularly for the able report made this day by the said Committee of the LEAGUE.

At this point of the proceedings, upon motion of Mr. Chas. Van de Sande, a recess of five minutes was taken.

Upon calling the meeting to order the President announced the election of officers as the next order of business.

Mr. Theo. L. Parker nominated as President for the ensuing year Mr. Thomas Slater. There being no opposing nomination, upon the completion of the balloting the Secretary announced Mr. Thomas Slater as elected President by a unanimous vote.

The President then announced that, in conformity with the Constitution, the Third and Fourth Vice-Presidents during the last year take the positions respectively of First and Second Vice-Presidents, and in consequence thereof the offices of Third and Fourth Vice-Presidents being vacant, it would be in order next to proceed to an election of officers to fill the said positions.

Mr. David Dodd having been nominated by Mr. Theo. L. Parker for Third Vice-President (for two years), and Mr. C. Cushing Adams having been, by Mr. James P. Snow, nominated for Fourth Vice-President (for two years), both gentlemen, upon ballot, were unanimously elected.

Mr. Jas. D. Yerrington having been nominated for Secretary and Treasurer by Mr. Theo. L. Parker, and having declined the nomination, Mr. W. L. Sexton nominated Mr. John D. Lyon for the office of Secretary and Treasurer, and upon ballot he was declared elected unanimously.

The election to fill the vacancies caused by the expiration of the terms of three members of the Executive Committee being now in order, Messrs. Robert A. Johnson, Geo. R. Collis and Wm. C. Kimball having been nominated as members of such committee (for two years) upon ballot they were unanimously elected.

The committee appointed to nominate an Advisory Board rendered its report at this stage of the proceedings, and the following named gentlemen were, in conformity with the resolution, accepted as such Advisory Board:

James Fricker.....	Americus Ga.
Francis H. Piaget.....	Albany, N. Y.
Joseph W. Cary.....	Alton, Ill.
James R. Armiger.....	Baltimore, Md.
Levin F. Giering.....	Bethlehem, Pa.
Samuel M. Tourtellot.....	Boston, Mass.
Charles G. Lewis.....	Brooklyn, N. Y.
William F. Fischer.....	Chattanooga, Tenn.
Stedman H. Hale.....	Chicago, Ill.
Joseph Becker, Jr.....	Cincinnati, O.
William J. Savage.....	Columbus, O.
Henry M. Robinson.....	Danbury, Conn.
William C. Reichneker.....	Denver, Col.
Levi Stevens, Jr.....	Fishkill, N. Y.
Henry W. Hurlburt.....	Hartford, Conn.
John W. King.....	Jacksonville, Ill.
Charles G. Malliet.....	Jersey City, N. J.
Samuel J. Johnston.....	Leesburg, Va.
George W. Meyer.....	Meridian, Miss.
Edward Payne.....	Middletown, Conn.
George S. Greenleaf.....	Milwaukee, Wis.
Wickliffe B. Durand.....	Newark, N. J.
Edward E. Barrows.....	N. Attleboro, Mass.
Charles L. Merry.....	Norwalk, O.
Louis E. Tyler.....	New Orleans, La.
Clinton E. Ford.....	Oneonta, N. Y.
Taylor Chapin.....	Oneida, N. Y.
William Herrick.....	Paris, France.
Joseph T. Bailey.....	Philadelphia, Pa.
Wm. C. Hodge.....	Pittsburgh, Pa.
Fred. I. Marcy.....	Providence, R. I.
Joseph P. Angell.....	Pine Bluff, Ark.
Cornelius H. Miller.....	Rahway, N. J.
Robert L. Winston.....	Richmond, Va.
Albert J. Lewis.....	San Francisco, Cal.
George Olley.....	Schenectady, N. Y.
Silas O. Trippe.....	Selma, Ala.
Alexander Weed.....	Stamford, Conn.
Harrison H. Merrick.....	St. Louis, Mo.
Geo. E. Sherwood.....	Waterloo, N. Y.
Edward Luke.....	Yazoo City, Miss.

Upon motion of Mr. John D. Lyon, it was voted that the Executive Committee be empowered to appoint such additional members to the Advisory Board as they may, from time to time, in conformity with the resolution, deem expedient.

Upon motion of Mr. Robert A. Johnson, it was

*Resolved*, That the thanks of the JEWELERS' LEAGUE assembled in annual meeting are eminently due, and are

hereby tendered, to Mr. D. H. Hopkinson, editor of the JEWELERS' CIRCULAR (the organ of the LEAGUE), for his able and gratuitous services in behalf of the LEAGUE, in the columns of his journal during the past year.

On motion of Mr. David Dodd, it was voted: WHEREAS, The JEWELERS' LEAGUE of the City of New York has more than doubled its membership during the last year, and believing that in a great measure the success of the LEAGUE is due to Mr. Gilbert T. Woglom, Chairman of the Executive Committee, therefore,

Resolved, That the thanks of the JEWELERS' LEAGUE are due and are hereby tendered to Mr. Woglom for his untiring zeal and great attention given to the interests of our association.

Upon motion by Mr. David Dodd, it was voted: WHEREAS, We fully appreciate the services of our late Secretary and Treasurer, it is

Resolved, That this association tender to Mr. Jas. D. Yerrington our most grateful thanks for his efficient services, and the care and attention given to his duties, and that we regret exceedingly his declination to serve the LEAGUE another year.

These complimentary resolutions were briefly responded to by Mr. Yerrington, and by Mr. Woglom on his own behalf and for the Executive Committee.

The President appointed as the Finance Committee for the ensuing year Messrs. William I. Sexton, William H. Ball and William B. Kerr.

At 4.40 o'clock P. M. on motion, the meeting adjourned. (Signed) J. D. YERRINGTON, Secretary.

The following is a List of Members accepted prior to January 21, 1879.

- A
C. Cushing Adams... of The Adams & Shaw Co. New York City
Charles G. Alford... of C. G. Alford & Co.
Julius O. Alike... with James Southwick
James R. Armiger... of Justis & Armiger, Baltimore, Md.
Joseph J. Acheson... with W. H. Shearer & Co., Philadelphia, Pa.
Willard W. Albee... of Holbrook, Whiting & Albee, Attleboro, Mass.
Joseph P. Angell... Pine Bluff, Jefferson Co., Ark.
B
Dyer Brainerd... of Brainerd & Steele, New York City.
Frederick W. Bergstein... of Bergstein & Son.
William Burdel... of Heller & Burdel.
James A. Bogart... of Greason, Bogart & Pierce.
Frederick W. Barthman... of Barthman & Straat.
Julius L. Brown... of Wilson & Brown.
Herman Baum... of Tenner & Baum.
Benjamin O. Booth... of Cohen & Co.
Erhard Bissinger... 192 Broadway.
William H. Ball... 9 John Street.
Louis D. G. Bonet... 599 Broadway.
Edwin H. Brown... 5 Nassau Street.
Frank H. Bliss... with Nathaniel Grant & Co.
Edward G. Boyneit... with Tiffany & Co.
Samuel A. Baldwin... with S. M. Lewis & Co.
Francis D. Brewster... with Henry Ginnel.
Frederick Bohneberger... with Hale & Mulford.
Lyander T. Best... with Hayward & Briggs.
Arthur F. Belcher... with Gorham Mfg Co.
Egerton A. Bliss... with F. G. Whitney & Co.
Joseph B. Bowden... with J. B. Bowden & Co.
Charles H. Brown... with Miller Brothers.
John J. Barker... with Baldwin, Sexton & Peterson.
Joseph T. Bailey... of Bailey, Banks & Bidde, Philadelphia, Pa.
Elwood Bailey... 43 S. 8th Street.
James W. Barry... No. 806 Chestnut Street.
Edward E. Barrows... N. Attleboro, Mass.
Patten S. Bartlett... with American Watch Co. Chicago, Ill.
William J. Bacon... with N. G. Wood & Son, Boston, Mass.
Henry S. Bodge... with Daggett & Coombs, Providence, R. I.
Webster C. Ball... with Duerber Watch Case Co., Cincinnati, O.
Joseph B. Keck, Jr... with Duhme & Co, Cincinnati, O.
John E. Bell... with Bell Bros. Ogdensburg, N. Y.
William H. Bradshaw... with F. Baisley, Marshall, Ill.
Benjamin I. Bachman... Colorado.
C
Charles T. Cook... of Tiffany & Co., New York City
George Courvoisier... of Courvoisier, Wilcox & Co.
Stephen P. Cox... of Cox & Sedgwick.
William D. Currow... of Currow, Crothers & Co.
George W. Cook... of Cook, Groeschel & Co.
Jean G. C. Cottler... of J. Cottler & Son.
Charles C. Cummings... of J. S. Birch & Co.
Charles L. Carrington... of Mayhew, Leonard & Carrington.
Edward M. Carrington... with Field & Co.
George R. Collis... with Tiffany & Co.
Hayward S. Cozens...
Henry J. Conser... with Carter, Howkins & Sloan.
Alexander C. Chase... with Thos. W. Adams & Co.
Nathan P. Carter... 196 Broadway.
Willis E. Carpenter... with Bigelow, Kennard & Co., Boston, Mass.
Taylor Chaplin... with S. Chaplin & Son, Onelda, N. Y.
Caleb Clapp... 161 State Street, Chicago, Ill.
Joseph W. Cary... Alton, Ill.
D
David Dodd... of Chatterton & Dodd, New York City
Wickliffe B. Durand... of Durand & Co.
Emile J. Derzinsnes... of Derzinsnes Bros.
Hippolite A. Derzinsnes...
Edward C. Dunning... of E. C. Dunning & Co.
William Downey... of Downey & Smith.
Simon Dossan... 181 Broadway.
Frank Durand... with Burand & Co.
James Downey... with George W. Shiebler.
Henry K. Dyer... with D. Anson Mfg. Co.
John C. Day... of Day & Clark, Newark, N. J.
Richard J. Donohoe... with Hodge, Goddard & Co., Pittsburg, Pa.
George F. Darden... with W. H. Saxton, Baltimore, Md.
Thomas Davles... with Cateb Clapp, Chicago, Ill.

- E
Richard L. F. Everett... of Bliss Bros. & Everett, New York City.
Emil F. W. Eisenmann... of Eisenmann Bros.
George A. Eaton... of Geo. A. Eaton & Co.
Theodore Evans... with Wheeler, Parsons & Hayes.
Miles W. Evans... with J. Laurent.
Charles A. Easton... with N. G. Wood & Son, Boston, Mass.
Bennett W. Ellison... with Stanley Bros., Attleboro Falls, Mass.
F
E. Charles Fitch... of Robbins & Appleton, New York City.
Charles J. Fox... with M. Fox & Co.
George A. French... with Wm S. Hedges & Co.
Frank C. Fisher... with E. Whitney & Co.
Elton I. Franklin... of E. I. Franklin & Co., N. Attleboro, Mass.
Samuel E. Fisher... of S. E. Fisher & Co.
William W. Fisher...
George W. French...
William F. Fisher... of W. F. Fisher & Bro., Chattanooga, Tenn.
George T. Freeman... with C. Seabury, Boston, Mass.
John H. French... 170 State State Street, Chicago, Ill.
James Fricker... American, Ga.
Clinton E. Ford... Oneonta, Otsego Co., N. Y.
G
Frank S. Gorton... of Baldwin, Sexton and Peterson, New York City.
Avery S. Gardener... with Wheeler, Parsons & Hayes.
James B. Goldy... with John T. Murray.
Chas. D. P. Gibson... 152 Broadway.
Frederick A. Goodwin... with Dennison Mfg. Co.
Fred. B. Gilbert... with Dennison Mfg. Co.
Chas. F. Green... with Tiffany & Co.
Joseph H. Gale... of Joseph H. Gale & Co., Baltimore Md.
Chas. F. Glover... with E. Howard & Co., Boston, Mass.
Walter R. Goodnow... with Bigelow, Kennard & Co.
George S. Greenleaf... with Stanley & Co., Milwaukee, Wis.
Levin F. Giering... 4 South Main Street, Bethlehem, Pa.
Fred Goosman... Somerville, Tenn.
H
Henry Hayes... of Wheeler, Parsons & Hayes, New York City.
Geo. H. Hadenpyl... of Hadenpyl, Thomson & Co.
Horace C. Hardy... of Lyon & Hardy.
George R. Howe... of Carter, Howkins & Sloan.
Courtland E. Hastings.
Dan. H. Hopkinson... of The Jewelers' Circular.
Joseph P. Howard... of Howard & Co.
John B. J. Haack... of Haack & Diolot.
Charles D. Harvie... with Geo. W. Pratt & Co.
Philip K. Hills, Jr... with Robbins & Appleton.
Charles Ilem... with Hale & Mulford.
Charles H. Holder... with Tiffany & Co.
Joseph Hennessy... with Baldwin, Sexton & Peterson.
George W. Harlan... with Baldwin Sexton & Peterson.
James W. Hagan... with Miller Bros.
John R. Harron... with Chas W. Selumann.
James Harkness... with Ketcham & McDougall.
Henry C. Hassell... 12 John Street.
William Herrick... of G. W. May, Firnhaber & Co., Paris, France.
Stedman H. Hale... with Robbins & Appleton, Chicago, Ill.
William C. Hodge... of Hodge, Goddard & Co., Pittsburg, Pa.
E. Washington Hill... with
Charles Holyland...
Eugene C. Holbrook... of Holbrook, Whiting & Albee, Attleboro, Mass.
Henry W. Hubbard... with D. H. Buell, Hartford, Conn.
Edgar W. Haven... with J. Dean Hawley, Syracuse, N. Y.
I
Henry E. Ide... with Lyon & Hardy, New York City.
J
Robert A. Johnson... of Colby & Johnson, New York City.
William H. Jenks... with Tiffany & Co.
John H. Johnston... 150 Bowery.
Paul A. Jeannot... 65 Nassau Street.
August A. Jeannot... of A. A. Jeannot & Co., Brooklyn, N. Y.
Talbot W. Jenkins... Baltimore, Md.
Samuel J. Johnston... Leesburg, Va.
K
Bradford H. Knapp... of Wheeler, Parsons & Hayes, New York City.
Emil F. Kipper... of Kipper, Vogel & Co.
Edward E. Kipling... of Richard Kipling's Sons.
William C. Kimball... with H. F. Barrows & Co.
Henry J. King... with Baldwin, Sexton & Peterson.
Adolphus E. Karselen... with E. Karselen.
Charles Kipper...
William B. Kerr... Alling Bros. & Co.
Stephen B. Kent... with William H. Ball.
Ernst F. Kouzelmann... with Courvoisier, Wilcox & Co.
Charles D. King... with Leroy W. Fairchild.
Theodore Kearney... of Kearney & Swartzchild, Chicago, Ill.
Charles F. Kesmodel... with W. H. Saxton, Baltimore, Md.
Frederick W. Kake... with S. Kirk & Son.
And. J. Kriel... with George Wolf, Louisville, Ky.
John W. King... with George Wolf, Jacksonville, Ill.
L
John D. Lyon... of Lyon & Hardy, New York City.
Frederick H. Larter... of H. Elcox & Co.
Henry C. Lesquereux... of Burbank Mfg. Co.
Philip B. Levy... of B. F. Spink & Co.
Charles G. Lewis... with Randel, Baremore & Co.
Adolph Luthy... with Baldwin, Sexton & Peterson.
Constantin Lucius... 84 Sixth Avenue.
Herman Levy... 105 Fulton Street.
Benjamin Lander... 15 John Street.
John D. Lennon... 142 Fulton Street.
Edward A. Lauten... 65 Prince Street.
John J. Lynch... 340 Fulton Street, Brooklyn, N. Y.
Albert J. Lewis... with Geo. C. Shreve & Co., San Francisco, Cal.
Edward Luke... with H. C. Tyler, Yazoo City, Miss.
M
Lewls J. Mulford... of Hale & Mulford, New York City.
Isaac Mills... of Adams & Shaw Manufacturing Co.
Cornelius H. Miller... of H. D. Merritt & Co.
Jacob Marx... of Kossuth, Marx & Co.
Hugh McDougall... of Ketcham & McDougall.
Alfred B. Miller... with Wilcox Silver Plate Co.
Charles S. Morse... with Bliss & Dean.
Charles G. Malliet... 9 John Street.
Loules Miller... of L. Miller & Bro., Albany, N. Y.

- Harrison H. Merrick... of Merrick & Walsh, St. Louis, Mo.
Frederick I. Marcy... of Fred I. Marcy & Co., Providence, R. I.
Thomas W. Manchester... of Chester, Manches-ter & Co.
George W. Mindil... of G. Mindil & Son, Philadelphia, Pa.
Moses H. Mason... of Mason, Draper & Co., Attleboro, Mass.
George W. Myer... Meridian, Miss.
Charles L. Merry... Norwalk, Ohio.
Maurice A. Meid... with Robbins & Appleton, Chicago, Ill.
N
James D. Nelson... with Woglom & Miller, New York City.
Prosper Nordman... 15 Maiden Lane.
Joseph D. Nutt... 34 John Street.
O
Henry C. Ostrander... of T. W. Adams & Co., New York City.
George Olley... with James Sanders, Schenectady, N. Y.
P
Frank T. Pearce... of Pearce & Hoagland, Providence, R. I.
Theodore L. Parker... with Brainerd & Steele, New York City.
Peter Peterson... with Cox & Sedgwick.
Charles L. Power... with M. Fox & Co.
Herbert W. Phelps... with E. Jaccard & Co., St. Louis, Mo.
Henry A. Polley... with N. G. Wood & Son, Boston, Mass.
Edward Payne... Middletown, Conn.
Francis H. Piaget... Albany, N. Y.
R
Marmaduke Richardson... of Victor Bishop & Co., New York City.
Thomas E. Rice... of Bartenus & Rice.
James J. Richards, Jr... of J. J. & J. M. Richards.
Joseph R. Richards... with
James C. Rich... with Alfred H. Smith & Co.
Henry Rudolph... with Hesselts & Ludeke.
Eugene V. Roddin... of E. V. Roddin & Co., Chicago, Ill.
Julius Rosendale... 730 Chestnut Street, Philadelphia, Pa.
Henry M. Robinson... Danbury, Conn.
George H. Richards, Jr... 388 Washington Street, Boston, Mass.
William C. Reicheneker... Denver, Col.
S
James P. Snow... of G. & S. Owen & Co., New York City.
Samuel W. Saxton... of Saxton, Smith & Co.
Edward S. Smith... of Wheeler, Parsons & Hayes.
John W. Steele... of Brainerd & Steele.
Thomas Slater... of Enos Richardson & Co.
George W. Street... of Geo. O. Street & Son.
Augustus K. Sloan... of Carter, Howkins & Sloan.
William L. Sexton... of Sexton & Cole.
Andrew K. Shiebler... of Durley & Shiebler.
Alfred H. Smith... of Alfred H. Smith & Co.
Harrison B. Smith...
Peter Smith... of Downey & Smith.
Thomas Shaw... of Adams & Shaw Co.
August Saltzman... of Saltzman & Co.
Silas Stuart... of Stuart & Shepard.
Samuel Sondheim... with D. Bruhl.
George F. Stremmel... with Durand & Co.
Alfred Selman... with Robbins & Appleton.
Philo W. S. Shonfeld... with T. W. Adams & Co.
William H. Stodart... with Tiffany & Co.
William W. Stewart... with Aikin, Lambert & Co.
Edmund J. Schofield... with Elgin Watch Co.
Orville T. Smith... with Miller Bros.
William T. Strasser... with M. Fox & Co.
Frederick D. Steck... with J. T. Scott & Co.
A. Barker Snow... with G. & S. Owen & Co.
Levi Stevens, Jr... with Wheeler, Parsons & Hayes.
Charles Stoppelkam... with Freeman & Co.
John R. Susdian... with Dennison Mfg. Co.
Geo. W. Shiebler... 4 Liberty Place.
William H. Saxton... 2 Light Street, Baltimore, Md.
William P. Stutz... 214 W. Baltimore Street, Baltimore, Md.
John F. Simons... of Simons Bro. & Co., Philadelphia Pa.
Charles E. Smith... of C. R. Smith & Son.
Edwin D. Sturtevant... of S. E. Fisher & Co., N. Attleboro, Mass.
William J. Savage... of Columbus Watch Co., Columbus, O.
William S. Stanley Jr... of Stanley & Co., Milwaukee, Wis.
Silas Schonfeld... of Schonfeld, Aston & Co., Plainville, Mass.
Samuel Swartzchild... of Kearney & Swartzchild, Chicago, Ill.
Augustus E. Shader... with
Hiram S. Soimes... with E. I. Franklin & Co., N. Attleboro, Mass.
George E. Sherwood... Waterloo, N. Y.
T
John N. Todd... 9 John Street, New York City.
Reuben A. Thompson... with J. B. Matthewson.
Daniel L. Tirrell... with Ripley, Howland & Co.
Samuel E. Turner... with D. H. Wickham.
James W. Todd... with George W. Platt.
John A. N. Tichenor... with Durand & Co.
Louis Tenner... of Tenner & Baum.
Silas O. Trippe... with S. F. Hobbs, Selma, Ala.
David C. Townsend... with W. H. Shearer & Co., Philadelphia, Pa.
Peter R. Tonder... with E. Marks, Troy, N. Y.
Sam'l M. Tourtellot... with Bigelow, Kennard & Co., Boston, Mass.
Collins B. Taylor... of Freeman & Taylor.
Louis E. Tyler... 115 Canal Street, New Orleans, La.
V
Victor Villaume... Port Orange, Volusia Co., Florida.
Chas. Van de Sande... Hoboken, N. J.
W
Gilbert T. Woglom... of Woglom & Miller, New York City.
Geo. N. Wilcox... of Courvoisier, Wilcox & Co.
George C. White, Jr... of Rogers & Bro.
Robert Welch, Jr... of Welch & Miller.
Newton E. Whiteside... of A. J. Hedges & Co.
Geo W. Washburn... with Randel, Baremore & Co.
Thomas M. Ward... with M. A. Earle.
Wm R. Washburne... with Chatterton & Dodd.
P. Shapter Weir... with E. Stites.
Mendel Weinsteln... with Baldwin, Sexton & Peterson.
Ab'm C. Wortendyke... with Ralph D. Earle.
Stephen G. Watsnsley... with Tenner & Baum.
William T. Weeks... 6 Liberty Place.
Chas. E. Westcott... of G. & S. Owen & Co., Providence, R. I.
F. M. Whiting... of Holbrook, Whiting & Albee, Attleboro, Mass.
Albert N. Wood... of N. G. Wood & Son, Boston, Mass.
Charles H. Wood... with Geo. W. French, N. Attleboro, Mass.
Paul Weber... with Duhme & Co., Cincinnati, O.
Charles Wilfong... with Simons Bro. & Co., Philadelphia, Pa.
Robert J. Walton... with G. T. Sadtler & Sons, Baltimore, Md.
Robert L. Winston... with Nowlan & Co., Richmond, Va.
John H. Willemis... with J. P. Capeite, St. Louis, Mo.
W. Howard Wriggins... 506 Chestnut Street, Philadelphia, Pa.
Alexander Weed... Stamford, Conn.
Y
James D. Yerrington... Morse Diamond Co., New York City.
James Young... with Simons Bro. & Co., Philadelphia, Pa.

# American Open-Face, Stem-Winding WATCHES.

The especial attention of the trade is directed to our full-line of 18 size, Full Plate STEM-WINDING movements, to wind at the figure 12 for Open-Face Cases, of the following companies:

ROCKFORD, ILL., WATCH CO.  
SPRINGFIELD, ILL., WATCH CO.

WALTHAM WATCH COMPANY,  
ELGIN WATCH COMPANY.

**J. T. SCOTT & CO.**

No. 11 MAIDEN LANE,

Sole Eastern Wholesale Agents for the Rockford Watch Company.

## ARHELL & CO.

IMPORTERS OF

### Watchmakers Tools and Materials, also Dealers in Watches and Jewelry.

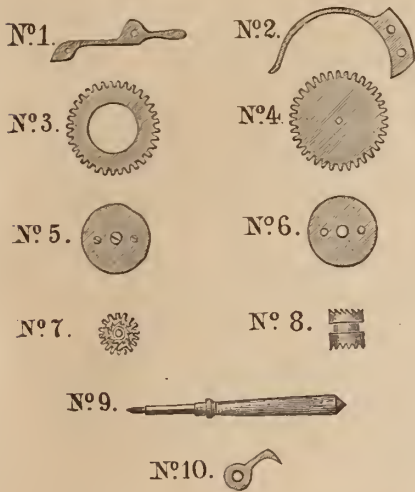

Sole Agents for the "Jequier" Main Spring, the only spring of all exhibits made at the *Paris Exposition* that received a Medal; manufacturers of the "Boss" Engraving Block, the best and most practical in the market. Sole Agents for "Baldwin's" Barrel Catch Inserter, the most useful tool on a watchmaker's bench, saves time and labor. Send to us, or any material dealer for description. We solicit orders from material dealers for these specialties. Sole Agents for "Columbus Watch," for New York and Eastern States, nickel  $\frac{3}{4}$  plate, full jeweled, stem-winding and setting, the most beautiful watch, with best results at least money. Send for descriptive Catalogue. No price list furnished unless requested, and only to the trade. Send for price list of tools and material. Orders intrusted to us filled promptly with experience.



Stem-winding wheels cut and all work for the trade done well at moderate prices.

P. O. Box 8. CANAJOHARIE, N. Y.

## GUERRANT'S ELECTRO-ENGRAVING MACHINE.

It has baffled the skill of the inventive genius of the world for ages to produce a machine that would compete with the skillful hand engraver, and until this machine was invented, all engraving had to be done by hand. And, to-day, it is the only practical engraving machine in existence.

The construction of the machine is not complicated, but simple and durable. It is easily operated. The variety of work it will do is almost incredible, and to be fully appreciated, ought to be seen in operation.

We do not therefore, offer this machine to the public simply as a machine to aid the engraver, but as a perfect, practical engraver in itself, with which any person of ordinary skill can learn in a short time to do any piece of engraving that might be desired and in the very best manner.

It copies from the regular press type of any style of letter or design that is made of type, from the plainest to the finest German text letter or fancy design, at the same time it will reduce the letter or design from the original size to ten different sizes, or so small that it cannot be seen by the naked eye. It will shorten the letters or elongate them, also will lean them forward or backward, will either make a raised or sunken letter, will engrave on any surface, either plain, concave or convex—for instance, such things as Watch Cases, either in or outside; Finger Rings, either in or outside; Bracelets, Napkin Rings, Goblets, Pitchers, Mugs, Waiters, Spoons, Forks, and all kinds of Jewelry; or, in fact, on any article susceptible of being engraved or ornamented with scroll work or fancy designs, &c., either on Gold, Silver, Copper, Brass, Iron, hardened Steel, Glass, Stone, Pearl, Ivory, Bone, Gutta Percha.

No Jeweler or establishment that has engraving to be done should be without it. Machines are sold with limited territory to use them in; or, the exclusive rights to use them in certain town or territory can be purchased with the machine if desired.

For further information, address

WM. HICKSON, Gen. Agt.,  
P. O. Box 1603, PHILADELPHIA, PA.

KAM & HICKSON,  
LYNCHBURG, VA.

Owners of the right of all the Northern and Western States and Territories.

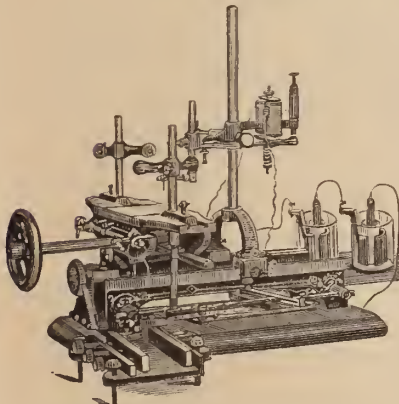

Size of Machine, 12 x 16 inches.

Patented Jan. 18, Oct. 31, 1876, Feb. 25, 1879.

## PRACTICAL HINTS ON WATCH REPAIRING. By "EXCELSIOR."

Including making fitting, testing and adjusting hair-springs, the adjustments for isochronism, position, heat and cold and rate.

Giving full practical directions on every point, with descriptions and illustrations of new tools, methods and principles never before published.

This work is unanimously pronounced the most complete, trustworthy and practical treatise on the balance-spring, and all the adjustments required in even the finest watches and chronometers, ever published. Unlike other writers on these subjects, "Excelsior" has not given mere theoretical propositions, of no real value, nor kept anything back for fear of teaching the trade too much, or raising up competitors to interfere with his profits, but he has honestly and candidly told whatever the practical workman needed to know to make even the most abstruse points clear to all, whether old hands or new beginners. His mode of treating the subjects is unique,—giving enough of the principles which underlie the process to enable the workman to proceed understandingly, but, beyond that, he confines himself entirely to practical details, omitting none, however minute, essential to be known.

Sent to any address in the U. S. on receipt of \$3.50.

D. H. HOPKINSON, Publisher, 42 Nassau st., N. Y.

BERGSTEIN & SON,  
**Manufacturing Jewelers,**  
 No. 20 John Street,  
**NEW YORK.**

**STERN BROS. & CO.**



Manufacturers of  
**Fine Jewelry,**

**30 MAIDEN LANE,**  
 FACTORY, 73 & 75 Fulton St., NEW YORK.

Gold Seal engraved Band-rings and Locketts a specialty.  
 The attention of the trade is directed to our plain Gold filled Rings. Sections of which showing the construction and quality sent upon application.  
 After February 1st, our plain filled rings will bear the above trade mark.

**DAVID PRINCE,**  
**Gold and Silver Refiner,**  
*Assayer and Sweep Smelter,*  
**63 RAILROAD AVENUE,**  
**NEWARK, N. J.**

Sole Agent for Comins' Improved Amalgamator.

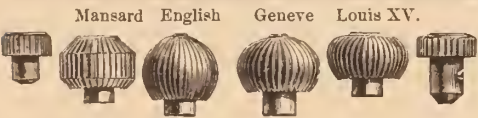

**HENRY LEFORT,**  
**Stem-Winding Watch Crown Manufacturer,**  
 Crowns and Pushers in gold, all sizes, quality and color, made to order. Silver crowns and pushers always on hand.  
 Samples sent on application.  
**80 & 82 Marshall Street,**  
**NEWARK, N. J.**

Designs made and estimates given on all kinds of Engraving for Jewelers.



Illustrations for Books, Mfg Catalogues, &c.  
 Labels and Show Cards Engraved on Metal for Color Printing.

**CORNELL'S**  
**IMPROVED**  
**POLISH PRESERVER,**  
 FOR PROTECTING THE  
 Polish on all Metals, Roman Gold, &c. while soldering.  
**GUSTAVE EPHRAIM,**  
 Sole Agents for the U. S., importer of  
 Watch Material, Tools, &c.  
**8 John St., New York.**

Particular attention paid to Remounting.  
 Price list furnished on application.



Full line of new and original mountings on hand.

**CHAS. F. WOOD,**  
**169 & 171 BROADWAY**  
**NEW YORK**

**Engraver, Incruster of Precious Stones**  
**And DIAMOND SETTER.**

Incrusted Goods a specialty.  
 All kinds of Lapidary Work promptly executed.

Leon Jeanne. Paul Jeanne.  
**JEANNE BROTHERS,**  
 MANUFACTURERS OF  
**DIAMOND MOUNTINGS**  
**And RICH JEWELRY,**  
 Patentees of Jeanne's Ear Wires,  
**No. 1 Maiden Lane, New York.**  
 Designs furnished and estimates given.

**KETCHAM & McDOUGALL,**  
 No. 4 LIBERTY PLACE, NEW YORK.  
 MANUFACTURERS OF  
 Improved Gold and Silver  
**THIMBLES**



AND THE PATENT  
**AUTOMATIC EYE GLASS HOLDER,**  
 Which returns the Eye Glasses to their place on or under the lapel of the vest by simply casting them from the nose, combining all the conveniences of Cord, Hook and Case, without their annoyances.

**J. B. LAURENCOT,**  
 IMPORTER OF  
**WATCH GLASSES,**  
**Optical and Fancy Goods**  
 French Clocks, Musical Boxes, &c.  
**No. 33 MAIDEN LANE.**  
 15 Rue D'Enghien, PARIS. Box 2954, P. O. NEW YORK.

**L. BONET,**  
 Medal at Centennial, 1876.  
**CAMEO**  
**Likenesses,**  
**389 Broadway, New York.**

**REPAIRING FOR THE TRADE.**

**C. G. MALLIET,**  
**Manufacturing Jeweler,**  
**No. 9 JOHN STREET**  
**NEW YORK.**

**A Rare Chance.**

For sale at a bargain, a nice stock of Jewelry, Plated Ware, Clocks, &c., amounting to \$5,000. Time will be given on a part if desired. Situated in one of the most thriving towns of Ohio. Population, 2,500. "Best of reasons for selling." Splendid trade of long standing, and no opposition. For further particulars write to **CHARLES TALCOTT,** GENEVA, Ashtabula Co., O.  
 (Cut this out as it will appear but once.)

**The Morse Diamond Cutting Company,**  
 OF BOSTON.  
**NEW YORK OFFICE:**  
**192 Broadway and 3 John Street.**  
**J. D. YERRINGTON, Agent.**

Rough, Boart, Cabinet Specimens, Roses and Brilliants constantly on hand, and for sale.  
 Fractured Diamonds repaired or recut for the Trade; also Rough Diamonds cut and fashioned to order.

**W. N. WALKER,**  
**DIAMONDS,**  
**Watches and Jewelry,**  
**No. 18 JOHN STREET, NEW YORK.**  
**JOHN J. ARMOUR.**

**HENRY TROEMNER,**  
**710 Market Street.**  
**PHILADELPHIA.**

Manufacturer of Fine Gold Scales,  
**DIAMOND SCALES,**  
 Bullion Balances and Weights, in use at all the U. S. Mints and Assay Offices.

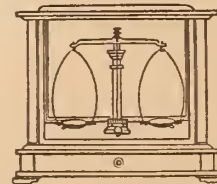

PRICED CATALOGUE ON APPLICATION.

Solid Gold Rings---a Specialty  
**WM. H. ELY,**  
**Solid Gold Rings**  
 MANUFACTURER,  
 Viz., Plain, Chased, Engraved, Enameled, Engine Turned, Shield & Scale. All qualities Warranted Orders Promptly Executed.  
**58 Nassau Street, N. Y.**

# Vulcanite Jewelry Co.

MANUFACTURERS OF

## WHITBY JET,

Combination Whitby Jet and Vulcanite,  
Byron's Patent, May 18, 1869.

Also a full line of Locketts—plain, gold mounted  
and monogram.

No. 191 BROADWAY, N. Y.

Agents for the NEW RUBBER WATCH CASES,  
Fitting all American Movements.

# W. H. LUDEMAN, Chronometer & Watch

## MAKER,

Nos. 75 & 77 Nassau Street,  
NEW YORK.

Repairing of every Description for the Trade.  
FINE WATCHES A SPECIALTY.

To the Trade.—I am now prepared to cut all  
kinds of Stem-Winding Wheels for the Trade.

F. W. C. Nieberg,  
Repairer and Adjuster of  
FINE WATCHES  
and Marine Chronometers,  
No. 8 JOHN STREET  
New York.

# E. WEISKOPF,

MANUFACTURER OF

## Optical Lenses

No. 182 Centre Street, N. Y.

### SPECIALTY!

Cylinder and Prismatic Spectacle Glasses,  
Magic Lantern & Panoramic Lenses.

# FINE HAIR WORK

## Deutsches Geschäft,

The only leading personal Artist in Hair in this country.

### WM. ERNEST MOUTOUX,

Factory and Office, 81 Nassau St., N. Y.

Designs of the most complicated description. Short  
or Baby Hair made in the finest designs in your presence.  
Portraits, or copy of noted paintings, made of family hair.

Received one-half column report on my hair work in the  
New York Trade Journal, of Nov. 9th, 1878. I am the only  
manufacturer who has Medals and Diploma of Honor on  
personal fine work in number for inspection.

Lessons given in all branches. Large pattern books for  
the trade free. Large hair pictures in other books are copy-  
rights from my book and circulated only by my special  
permit. Prices low on orders from known pattern books.

Gold jewelry and engraving by the best workmen done  
on the same plan.

**JNO. F. LUTHER.**  
**79 NASSAU ST. N. Y.**  
MANUFACTURER OF FINE  
PRESENTATION JEWELS  
FOR ALL SECRET SOCIETIES.  
KNIGHT TEMPLAR'S CROSSES  
KEY STONE MARKS  
SOCIETY SCHOOL AND  
College Badges.

# LORiot & OSTROM

Manufacturers of

## Clocks and Fine Movements,

Small Experimental Machinery, Models, Small  
Driving Machinery, &c.

No. 130 FULTON STREET,

Corner Nassau Street,  
NEW YORK.  
Fine Lever Movements for Safe Locks a Specialty.

# O. SCHWENCKE,

(Established over 30 years.)

[Successor to G. GUNZENHAUSER],

MANUFACTURER OF

## Fine Hair Jewelry,

No. 43 MAIDEN LANE,  
New York.

Solid Gold Mountings for Hair Jewelry, kept constantly  
on hand, and made to order at shortest notice.  
Orders from the country trade promptly attended to.

# VOSE & SOUTHWICK, Manufacturers of Gold Jewelry



Sole Makers of  
the Separable  
Sleeve and Col-  
lar Buttons in  
Gold.

No. 183 Eddy Street, PROVIDENCE, R. I.

# ALBERT FRIEDENTHAL,

Importer and Jobber of

WATCHMAKERS' & JEWELERS'

## Materials, Tools and Optical Goods

Real and Imitation Stones,

For Manufacturing and Repairing Purposes  
A SPECIALTY.

Agent for TISDALE'S Watch and Clock Oils.

No. 43 Maiden Lane, New York.

Orders by mail will receive prompt attention.



JEWELLERS' PIN VISE.

PATENTED AUG. 10, 1875

The tool is made of Steel throughout, with the jaws  
and wearing parts hardened. Every part is made to gauge. The  
finish is first-class and nickel-plated. Warranted to outwear  
at least three of the imported pin vises.

Offered in two sizes at \$18 and \$15 per dozen with liberal  
trade discount. Sold by the jobbing trade generally or by the

LOWELL WRENCH CO., WORCESTER, Mass.

# McLane's Anti-Oxidizer.

A Solution for preserving and protecting the  
polish and color of gold and silver while under  
process of hard soldering.

The most delicate engraving and chasing is  
perfectly preserved from tarnishing when treated  
with this solution, and the article on which it is  
placed may be heated to a red heat without fear  
of discoloration. Price, 50 Cents per Bottle.

Sent by Mail, postpaid, on receipt of price.

FOR SALE BY DEALERS IN WATCH MATERIALS.

This Solution is not intended to preserve acid  
color, but will, in a great measure protect it.

RICHARD OLIVER, 11 John Street, N. Y.

Established 1848.

Reliable and prompt.

# COOPER & BRO.

## Wholesale Jewelers,

Importers and dealers in WATCH & CLOCK-  
MAKERS' TOOLS and MATERIALS; also, JEWEL-  
ERS' SUPPLIES, SPECTACLES, OPTICAL GOODS,  
&c. A complete Outfitting Establishment for the  
trade.

Repairs Department established 1865. Every  
description of work done for the trade. Watch  
Repairing, Jewelry and Watch Case Repairing,  
Gold and Silver-Plating, and Fire Gilding.

35 S. Fourth St. (1st floor), PHILADELPHIA



SHUT.



OPEN.

## CHAS. F. TERHUNE & CO.,

Manufacturers & Jobbers in General Jewelry.

No. 17 Maiden Lane, N. Y.

We beg to call the attention of the trade to  
the above cuts, representing MISSIMER'S  
PATENT for the REPLACING OF SLEEVE  
Buttons. It is not separable, but works on a  
simple slide. Recommends itself at sight. Send  
for sample. A liberal discount to jobbers.

# BOURQUIN BROTHERS,

## Manufacturers and Importers of Watches,

All Kinds  
of



WATCHES

MADE

To ORDER.

NO. 20 MAIDEN LANE, N. Y.

FACTORY, BIENNE, SWITZERLAND.

# DIAMONDS

Watches, Jewelry, Clocks, &c.

Low Prices—First-class Stock.

No. 77 Fifth Avenue, entire 2d and 3d Floors

PITTSBURGH, PA.

G. B. BARRETT & CO.

WHOLESALE ONLY.

# W. FICHTENBERG,

## DIE SINKING,

Light Machinery and Tools Made  
to Order.

Also Chasing, Modeling, Designing, and Fine Brass Finish-  
ing. Particular attention given to Making and Repairing  
Electrical Instruments of all kinds.

Hinges, Corners, Locks and all fancy work for Jewelry  
Case makers. In workmanship and charges we defy  
competition. Orders by mail will receive immediate at-  
tention.

104 BEEKMAN STREET,

Corner Pearl Street,

NEW YORK.



Stephen J. Cox

DESIGNER & ENGRAVER

on WOOD

NO. 90 NASSAU STREET,  
NEW YORK.

Jewelers' Work A Specialty.

**HENRY ABBOTT,**  
*Manufacturer of*  
**STEM-WINDING PARTS FOR**  
**WATCHES,**

New Seapments for Watches or Clocks.  
 Models for Patents. Small Tools for Watch-  
 makers and Jewelers.  
 Dies, Cutters, &c., made to order.  
 Fine and Complicated Watches repaired in the  
 best manner, by competent workmen.

Office, 11 Maiden Lane,  
**NEW YORK.**

Factory, 13 & 15 Franklin Sts., Newark, N. J.

*Established 1850.*



**PETER L. KRIDER,**  
 MANUFACTURER OF  
**STERLING**  
**SILVER WARE,**

Medal and Diploma Awarded, &c.

Striking Society Medals in Gold, Silver or Bronze  
 A SPECIALTY!  
 ARTISAN HALL,  
**618 Chestnut Street**  
**PHILADELPHIA.**

**W. F. TREWIN,**  
 Manufacturer of  
**Watch Cases**  
 —AND—  
**Jewelry.**

Prompt and careful attention given to fill-  
 ing orders for all kinds of goods pertaining to the  
 Trade. Goods sent on approval when satisfac-  
 tory references are furnished.  
 Designs and estimates given, and special at-  
 tention paid to orders from jewelers for Watches,  
 Badges, &c., designed for presentation.  
 Every description of Watches and Jewelry  
 carefully repaired for the Trade.  
**730 Chestnut Street, (up stairs),**  
**PHILADELPHIA.**

**GEO. W. DU BOIS,**

(Successor to Albert Landsberg.)



IMPORTER AND MANUFACTURER OF

**Optical Goods,**

**No. 36 MAIDEN LANE,**  
 Near Nassau Street, NEW YORK  
 Sole Agent for  
**BLACK'S PATENT**  
**Interchangeable Spectacles,**  
 AND  
**EYE GLASSES.**

Jewelers and others who keep spectacles for  
 sale will please observe that, with these PATENT  
 SPECTACLES, it is only NECESSARY to have a full  
*Complete Assortment of Lenses and Pebbles*, which  
 being all of a UNIFORM SIZE, will FIT either the  
 Gold, Silver, or Steel Frames, of which but a  
 few of each kind are wanted; an advantage  
 which will give a complete assortment of the  
 finest Spectacles, for one-sixth the capital in-  
 vested in a like assortment of the same quality  
 goods of the old style frames.

For Particulars, price lists, &c., address

**GEO. W. DU BOIS,**  
 New York.

**Journal Suisse d'Horlogerie,**

A MONTHLY TRADE JOURNAL.

*Published in Geneva, under the auspices*  
*of the Industrial and Commercial De-*  
*partments of the Societe des Arts.*

Devoted to the interests and for the advancement  
 of Watchmakers and the art of Horology.

This periodical is under the supervision of a  
 body of watchmakers, who have correspondents  
 in the kindred branches of industry and sciences,  
 who contribute the leading articles of interesting  
 subjects and illustrations, publishes the reports  
 of the different commercial and industrial socie-  
 ties, of which it is the organ, and is, owing to its  
 great circulation all over the world, a valuable  
 advertising organ.

Subscription, 12 francs a year, (or \$2.50).  
 Orders received at the office of THE JEWELERS'  
 CIRCULAR.

**Allgemeines Journal der Uhrmacherkunst.**

Illustrierte Fachzeitschrift für Uhrmacher.

Redacteur, Emil Schneider, Uhrmacher in Naumburg, Germany.

Agents for the United States, WM. MÜHSAM, 316  
 W. Pratt St., Baltimore, and O. W. F. BURGER,  
 cor 5th & Olive streets, St. Louis, Mo., who will  
 give every information with regard to subscrip-  
 tion and advertisements.

The "Allgemeines Journal der Uhrmacherkunst" has  
 taken upon itself the task of elevating the art of watch-  
 making, and to protect and further the interests of the trade.

This Journal appears weekly, and, enjoying a great cir-  
 culation all over the globe, is in a position to offer special ad-  
 vantages for advertisements.



The above engraving gives but a poor idea of the nov-  
 elty and beauty of these signs. The black dots in the  
 letters represents silver discs which vibrate very rapidly.

Where the purpose is to attract attention nothing that  
 has ever been invented so well answers the purpose, for  
 they never fail to excite the greatest curiosity, and passers  
 cannot avoid reading the sign. In the evening gas light is  
 reflected from them with beneficial effect, and the flashes  
 can be seen for a long distance.

For full particulars and prices, address the manufacturer  
 as above.

**HERMAN BUSH'S**  
 EUROPEAN

**Publishers & Advertising Agency**

**HULL, ENGLAND,**

Supplies all English and Foreign Periodicals and Hand-  
 books for Watchmakers, Jewelers and kindred Art In-  
 dustrial trades, and inserts Advertisements in the  
 journals of all countries, at publishers' rates.

No charge made for translating advertisements in  
 foreign languages. Estimates and every information by  
 return of post, on receipt of two cents U. S. Stamp  
 postage for lists; and five cents for letters, if  
 WRITTEN information be required.

Specimen copies procured. Lists free.

**A New Monogram and Alphabet Album**

**J. SABIN & SONS,**

Respectfully announce, that they have now  
 ready a new edition of their well-known book  
 of Monograms and Alphabets.

Engravers, Stationers, Carriage Painters,  
 Jewelers, Gold and Silver Smiths, and De-  
 signers and Decorators generally, will find this  
 book useful, saving time in drawing, and hav-  
 ing available a book of suggestion and refer-  
 ence. A double set of Monograms is included,  
 a number of Alphabets, also a few Heraldic  
 Designs, Crests, Casques, &c.

Printed on fine plate paper, and bound  
 in cloth, \$5.00

We print but a small edition, and early  
 orders are suggested.

"All we have done in this art would be hopelessly  
 eclipsed by the publication of J. Sabin & Sons; as a  
 contribution to a jeweler's stock of designs, it is  
 priceless"—*Jewelers' Circular*.

**J. SABIN & SONS,**

**No. 84 Nassau Street, New York.**

**BIRCH'S  
PATENT  
SCREW KEY.**



The especial attention of the trade is directed to the above, a LIMITED NUMBER of which we have on hand.

THIS IS THE BEST SCREW KEY WE HAVE EVER PUT ON THE MARKET.

Sample by Mail on receipt of 75 Cents.

**J. S. BIRCH & CO.,**

No. 38 Dey Street, New York.

**FRASSE & COMPANY,**

Importers of P. S. STUES',

French, Swiss, German & Sheffield Tools, Files,

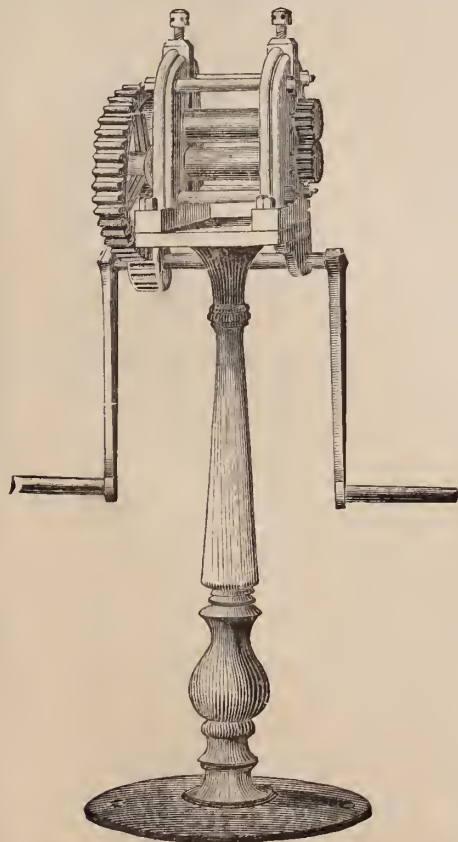

Steel Wire and Materials,

For Watchmakers, Jewelers, Engravers,  
Die-Sinkers, Machinist, &c.

**Tuning Lathes, Drills & Chucks**

Rolling Mills, Draw Plates,

The Celebrated **Rodenbush**

**Piercing Saws,**

Horse Shoe Magnets,

Nurls,

Ingo's,

Chasing Tools,

Engravers' Tools,

Brush Wheels & Buffs,

Hand Brushes and Buffs,

Borax,

Saltpetre,

Beeswax,

Rouge,

Tripoli,

German Silver,

Brass, &c.

**No. 62 Chatham Street,**  
Established 1816

**New York**  
P. O. Box 4627.

**The Burbank Manufacturing Company**

Manufacturers of GOLD & SILVER

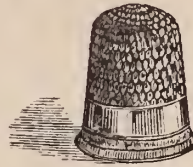

GOLD  
SILVER,  
STEEL,  
RUBBER,  
And SHELL,

**Thimbles,**



BURBANKS  
PATENT.  
EYE GLASS  
Self Adjusting.

**SPECTACLES AND EYE-GLASSES**



OF ALL DESCRIPTIONS.

**SOLID GOLD RINGS**

Office, 14 MAIDEN LANE. NEW YORK.

Manufactory, Springfield, Mass.

NE PLUS ULTRA.

**Williams & Cook's Dust-Proof Watch Keys**

Patented Sept. 1st, 1874.



The Popular Name Key.

A. Nickel Plated Handle and Pipe, Swivel Top, per gross..... \$10.75

English Pattern Key.

C. Nickel Plated Handle and Pipe, Swivel Top, per gross..... \$7.50



**BENCH KEYS.**

Corrugated Gilt Handles, Tempered Steel Pipes, per Set of Six..... \$1.80  
per Set of Three..... .90

**P. Style of Key.**

Gilt Handle. Steel Pipe.

Per Gross..... \$8.50



Our Key Pipes are all warranted to be made of the finest quality of steel. One great advantage his key has over all others, is the mortice through the pipe, making it the most simple and thoroughly dust and moisture-proof, as well as the cheapest key in the market. Our sizes run from 1 to 12: 4 5 and 6 fit Gents' American Watches; No. 8, Ladies' American.

For sale by the Trade generally.

**KENDRICK, DAVIS & CO., LEBANON, N. H.**

SOLE OWNERS AND MANUFACTURERS.

The advantage of our Name Key, as an advertising medium, will at once be seen.

# The Pioneer Watch.

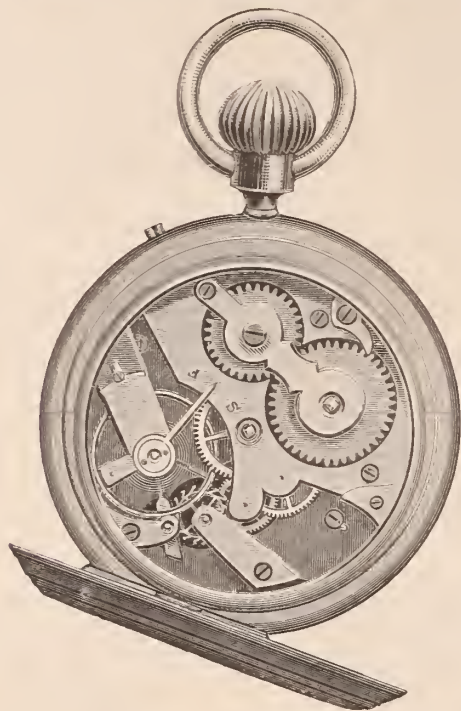

**HENRY GINNEL, Sole Manufacturer,  
No. 31 Maiden Lane, NEW YORK.**

P. O. Box 2967.

The accompanying illustration is a fac-simile of the Pioneer Watch. The Best (stem-winding and stem-setting) Pocket Timekeeper ever offered to the trade. They are cased in silver and German silver—Hunting and Open Face.



Geo. W. Simons,  
John F. Simons,

Peter B. Simons,  
Geo. W. Simons, Jr.

John Specker,  
Fred. M. Simons.

**SIMONS' BROTHERS & CO.**  
MANUFACTURERS OF  
Gold Chain and Jewelry,  
611 & 613 Sansom Street,  
PHILADELPHIA.  
*Awarded Medal and Diploma at the Centennial.*

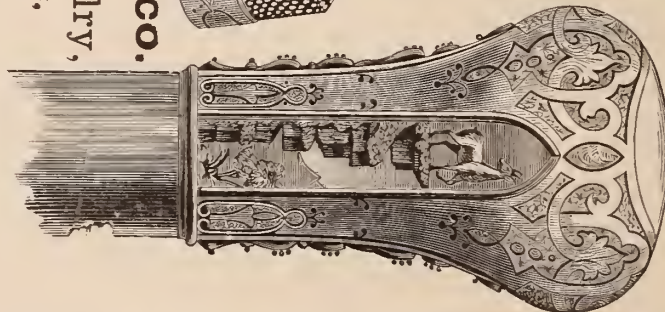
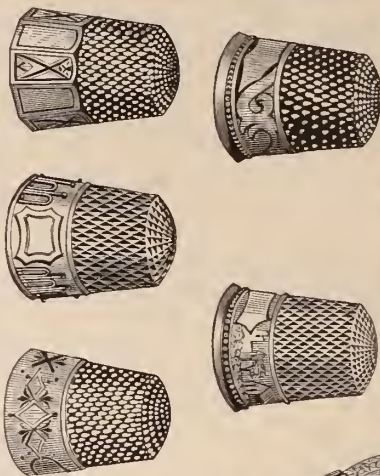

**Simons' Brothers & Co.**  
611 & 613 Sansom Street, Philadelphia

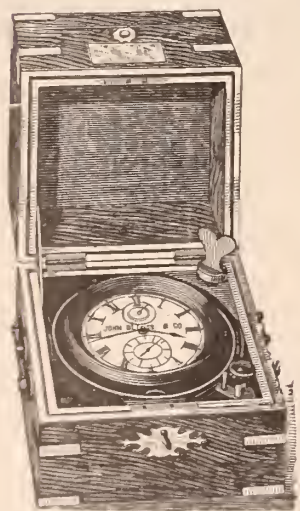

Standard Marine Chronometer  
FOR KEEPING CORRECT TIME.

## JOHN BLISS & CO.

### STANDARD MARINE

## Chronometers and Transits,

### FOR WATCHMAKERS' USE.

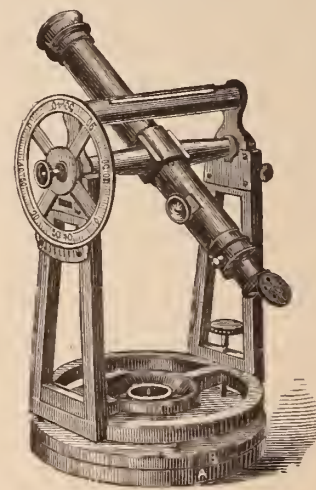

No. 10

## 110 WALL STREET, NEW YORK.

**IMPORTANT NOTICE.**—These Transits are readily set in position without the aid of strictly correct time as a basis for that purpose. Printed instructions, easily understood, accompany each Instrument, and no calculations are required preliminary to setting in position.

As a trial only is required to insure unqualified approval, we are induced to make the following **LIBERAL OFFER**—On receipt by us of satisfactory reference, and 10 per cent. of the price, we will send one of the foregoing Transit Instruments, on hire or trial, for one month, with full printed instructions for setting up and using the same, and if purchased after trial, we will allow the whole hire to apply in part payment, and sell the Instrument on approved note at four months for the balance. Special terms for payment by installments, after trial, on application. We do not make this offer merely to hire these instruments, but to insure a trial with a view to sales, the hire received being only sufficient to cover the cost of repolishing in case they are returned. Send for Illustrated Circular giving full description.

**JOHN BLISS & CO., 110 Wall Street, New York**





Schwencke O.—Manufacturer of Fine Hair Jewelry. Orders from the country promptly attended to. No. 43 Maiden Lane.

**Jewelry Cases, Fancy Boxes, Etc**

Braun, Chr. E.—Manufacturer of Jewelry Boxes, Trays for Show Cases, &c., 62 Chatham st.  
 Loehr & Koerner—Manufacturers of Morocco, Velvet, Satin, Jewelry, Watches and Silverware Cases, Glove, Handkerchief, Ladies' Jewel, Work Boxes, &c., Fancy Trays and Stone Fittings to order, Office and Salesroom 96 John Street, New York.  
 Dahlem, W.—Manufacturer of Cases for Jewelry and Silverware, No. 85 Nassau Street, N. Y. Show Case Trays, &c., at shortest notice.  
 Wiggers & Froelick—No. 60 Nassau street.—Manufacturers of Cases for Jewelry, &c., of every description. Trays for Show-cases, Stands for Show-windows, etc. Jewelers' Traveling Cases, light, convenient and strong.  
 Jackson, Samuel C.—Manufacturer of Box and Trays, for Silverware, Watches, Jewelry &c. 180 Broadway, N. Y.  
 Sturn, L.—Manufacturer and Importer of Cases for Jewelry, Watches, Silverware, &c. No. 15 John street, N. Y.  
 Welch & Miller—Manufacturers of Morocco, Velvet, and Satin Jewelry Cases, Trays, &c. Telescope Simple Cases with flexible Trays. Complete stock on hand. 169 Broadway.

**Jewelry—Fine.**

Aikin, Lambert & Co.—Manufacturers. General stock of Reliable Jewelry, 12 Maiden Lane.  
 Alford, C. G. & Co., Manufacturers. General line fine and reliable goods. Specialties in Onyx goods and chain. 183 Broadway, New York.  
 Andrews, J. F.—Manufacturer of Fine Jewelry, Locketts, Sleeve Buttons and Rings in Stone Cameo, etc., a specialty. 35 Maiden Lane.  
 Baldwin, Sexton & Peterson.—Manufacturers Fine Jewelry. Whiting Building, Broadway and Fourth street.  
 Ball, Wm. H. Manufacturing Jeweler. Fine Gold Bracelets a Specialty. No. 9 John St., N. Y.  
 Barthman & Straat—Manufacturers of Fine Jewelry. Seal and Stone Rings a Specialty Orders promptly attended to. 41 Maiden Lane.  
 Bergstein & Son.—Manufacturing Jewelers, No. 20 John Street.  
 Bernhard, A. & Co.—Manufacturers of Fine Hair Jewelry and Device Work. The latest styles. 169 Broadway, Room 3, New York.  
 Bissinger, E.—Importer of Fine Jewelry, Locketts, Crosses, Neck Chains, &c., No. 192 Broadway.  
 Brown, Thos. G.—Manufacturer of Rich Jewelry Necklaces, Locketts, Bracelets, Sleeve Buttons, etc., 9 Bond street, N. Y.  
 Brainerd & Steele—Successors to Brainerd, Steele & Co., Manufacturers of Fine Jewelry and Brainerd's Patent Locketts. No. 9 Maiden Lane, New York.  
 Burch, Geo. & Co.—(Successors to Burch, De Mott & Coughlin.) Manufacturing Jewelers, 17 Maiden Lane, N. Y. Factory, Newark, N. J.  
 Carrow, Crothers & Co.—Manufacturers of Fine Jewelry, Roman Band Bracelets, Locketts, Crosses, &c. 12 John Street, N. Y.  
 Carter, Howkins & Sloan.—Manufacturing Jewelers, Whiting Building, 4th St. & Broadway  
 Chatellier & Spence.—Manufacturing Jewelers. No. 652 Broadway, N. Y.  
 Cook, Groeschel & Co.—Manufacturers of Fine Jewelry and Locketts, 191 Broadway (over Mercantile Bank), N. Y.  
 Coe, Pincio & Stevens.—Manufacturers of Fine Jewelry. Fine Gold Locketts and Linen Finished White Enameled Goods a Specialty, No. 9 Maiden Lane, N. Y.  
 Chatterton & Dodd—Manufacturers of Fine Gold Jewelry. No. 19 John street, N. Y.  
 Demmert Bros.—Manufacturers and Importers of Fine Jewelry, Cameo and Onyx Locketts, Sleeve Buttons and Sets a specialty. Old No. 9 Maiden Lane, New York.  
 Downey & Smith—Manufacturers of Fine Jewelry. No. 24 John Street.  
 Field & Co.—Manufacturing Jewelers, 8 Maiden Lane, N. Y.  
 Goddard, John M.—Manufacturing Jeweler.—Seal Rings and Fine Locketts a specialty, No. 25 Maiden Lane, N. Y.

Frankel & Folkart.—Manufacturing of Seal, Cameo and Amethyst Rings, a Specialty. Ladies' and Gents' Locketts, Cameo Sets, &c. Also a full line of Diamond Settings, 192 Broadway, cor. John street, N. Y.  
 Goldsmith & Schliesser.—Manufacturing Jewelers and Importers of Diamonds and Watches. No 5 Maiden Lane.  
 Greason, Bogart & Pierce, successors to Arthur, Rumrill & Co., 182 Broadway, manufacturers of fine jewelry and gold chains  
 Hartmann, P.—Manufacturer & Importer of Fine Gold, Diamond, and Filagree Silver Jewelry, No 36 Maiden Lane. P. O. Box 2,454.  
 Haskell, H. C.—Manufacturing Jeweler. Seal Rings a specialty. Special attention to Jobbing of every description. 12 John street.  
 Hunt & Owen.—Manufacturing Jewelers. Office, 5 Maiden Lane.  
 Hale & Mulford.—Manufacturers Rich Jewelry, Whiting Building, Broadway and 4th Street.  
 Jeanne Brothers.—Manufacturers of Diamond Mountings & Rich Jewelry. 1 Maiden Lane.  
 Keller, Chas. & Co.—Manufacturing Jewelers Locketts a Specialty. No. 13 John St., N. Y.  
 Kremenz & Co.—Manufacturing Jewelers, No. 13 John Street, N. Y.  
 Kroll, H.—Manufacturer of Fine Jewelry. Repairing (a specialty) done for the trade at moderate prices, 78 Nassau street.  
 Kuhn & Doerflinger—Manufacturers of Enamel'd and Roman Band Bracelets, also Fine Locketts and Pendants, 18 John street.  
 Lennon, John D.—Manufacturing Jeweler, 142 Fulton street. Flat, and Half-round Gold Bracelets, Roman and Stone Locketts.  
 Moore & Horton.—11 Maiden Lane, Manufacturing Jewelers, Rings, Studs, Collar and Sleeve Buttons, Pins, Ear-rings, &c.  
 Mitchell, Noah.—Manufacturer of Fine Gold Jewelry, 694 and 696 Broadway, N. Y.  
 Miller Bros.—Manufacturers of Fine Jewelry Locketts, Sleeve Buttons, Studs, etc., etc. 11 Maiden Lane, New York.  
 Mulford & Bonnet—Manufacturing Jewelers and Jobbers, 21 & 23 Maiden Lane, N. Y. Particular attention given to Jobbing and Special orders.  
 Marx Kossuth & Co.—Manufacturing Jewelers. 39 Maiden Lane.  
 Owen, G. & S. Co.—Manufacturing Jewelers. Office, No. 5 Maiden Lane.  
 Pendrill, Wm.—Manufacturer of Fine Jewelry, jobbing and repairing for the trade at low rates, 73 Nassau Street.  
 Riker, William—Manufacturer of Jewelry. Inlaid Gold Jewelry a Specialty. No. 5 Maiden Lane, N. Y.  
 Riley, J. A. & Co.—Manufacturing Jewelers, Etruscan Gold and Coral Sets, Roman Bracelets, Necklaces, etc. Onyx Goods a specialty. 7 and 9 Bond street, New York.  
 Richardson, Enos & Co.—Manufacturers of Fine Gold Jewelry, Gold Chains, Locketts, Crosses and Necklaces. Colored and Etruscan Work. No. 23 Maiden Lane, New York.  
 Richardson, J. W. & Co.—Manufacturers of Jewelry, Masonic and other emblems. 196 Broadway, Manufacturing, Providence, R.I.  
 Sexton & Cole—Manufacturing Jewelers, Colored Gold and Onyx Goods a specialty. No. 30 Maiden Lane.  
 Shoemaker & Co.—Manufacturing Jewelers, Cameo Buttons, and Locketts, Roman Gold Goods, etc. No. 21 Maiden Lane, N. Y.  
 Stites, E.—Manufacturer of Fine Jewelry. No. 12 Maiden Lane, N. Y.  
 Sturdy Bros. & Co.—Manufacturers of Jewelry, No. 14 Maiden Lane, New York.  
 Thoma, Ernest—Manufacturer of Fine Jewelry. Sleeve Buttons, Riugs, Ear-rings, &c. No. 173 Broadway, N. Y. Factory, Hackensack, N. J.  
 Tri-r Bros. & Co.—Jewelry. Optical, Rubber, Jet, Shell, Ivory, Amber and Pearl Goods. Silk Guards, Japanese Bamboo Watch Chains a Specialty. No. 15 Maiden Lane.  
 Vulcanite Jewelry Co.—Manufacturers of Whitby Jet and Vulcanite Jewelry, 191 Broadway, N. Y.  
 Wadsworth, E. E.—Manufacturer of Rich Jewelry and fine Rolled Plate. Fine Seal Rings a specialty. 35 Maiden Lane.  
 Wheeler, Parsons & Hays.—Manufacturers of Fine Jewelry, Watch Cases, Gold Chains, &c and Dealer in American and Swiss Watches, No. 2 Maiden Lane, N. Y.  
 Wienhold, Joseph—Manufacturer of Fine Jewelry and Diamond Setter. 24 John St.

Woglom & Miller—Manufacturing Jewelers, Nos. 32 & 34 John street, N. Y. Specialty, Black Onyx goods.

**Jewelers' Boxes.**

Frasse & Co.—Importers of Stubs, French, Swiss, German and Sheffield Tools, Files and Steel Wire for Watchmakers, Jewelers, etc., 62 Chatham street, N. Y.  
 Hammel, L. & Co.—Importers of Materials and Tools for Watchmakers, Jewelers and Engravers—also Optical Goods, &c., 9 Maiden Lane, N. Y.  
 Zimmern, Henry—Importer of Watch Materials, Tools, Glasses, Silk Guards, Silver & Plated Chains, Optical & Fancy Goods, 8 Maiden Lane.

**Lapidaries.**

Kordmann & Michel—Lapidaries, dealers in Precious Stones. Rubies, Sapphires and Peridots cut. No. 32 Maiden Lane.

**Musical Boxes.**

Paillard, M. J. & Co.—Importers & Manufacturers of Musical Boxes, No. 680 Broadway, N. Y.

**Opticians.**

Burbank Man'g Co.—Manufacturers of Spectacles and Eye Glasses of all descriptions, in gold, silver, etc., 14 Maiden Lane, N. Y.  
 Du Bois, Geo. W.—Successor to A. Landsberg, Importer and Manufacturer of Optical Goods 36 Maiden Lane. Box 3993, N. Y.  
 Hammel, L. & Co.—Importers of Spectacles, Opera and Marine Glasses, Telescopes, Microscopes, Optical & Fancy Goods, 9 Maiden Lane.  
 Laurencott, J. B.—Importer of Watch Glasses, Optical and Fancy Goods, Clocks, Brouzes, etc., 33 Maiden Lane, N. Y.  
 Lorsch, Albert—Manufacturer of the Patent Accommodating Spectacles and Eye Glasses in Gold, Silver and Steel, and other Optical Goods, 37 Maiden Lane, N. Y.  
 Serin, A.—Manufacturer of Spectacles and Eye-Glasses, in Steel, Shell and Rubber. Repairing of all kinds. Opera Glasses covered and re-gilt, etc. 169 and 171 Fulton street.  
 Spencer Optical Manufacturing Co.—Gold, Silver, Steel and Nickel Plated Spectacles, Eye Glasses, &c. 13 Maiden Lane, N. Y.  
 Suttie, Wm. J.—Manufacturer of Eye Glasses and Spectacles, in gold, silver, steel and shell, (Price List by mail), 39 Maiden Lane.

**Precious Stones, &c.**

Bissinger, Philip—Importer of Diamonds, Pearls and Precious Stones. Agent for the Bohemian Garnet Goods. No. 22 John St., N. Y.  
 Gruet, Jules.—Importer of Precious and Imitation Stones, Amethysts, Topazes, Cameos, Garnets, Doublets, Imitation Diamonds, Pastes, etc., No. 14 John street. Manufactory at Septmoncel, France.  
 Meyer, Francis Ed.—Successors to John B. Behrmann, Importer of Imitation Precious Stones, all sizes and shapes constantly on hand. No 38 Dey street, P.O. Box, 1981.

**Rings and Shanks.**

Bryant & Bentley.—Manufacturing Jewelers, 35C Patterns Hard Solder Rings, 12 Maiden Lane

**Silverware.**

Gorham Manufacturing Co.—Union Square.  
 Wood & Hughes.—Manufacturers of Fine Silverware. 14 John Street, N. Y.  
 The Adams & Shaw Co.—Manufacturers of Silverware. Cor. Broadway & 4th St., N. Y.

**Silver Plated Ware.**

Hall, Elton & Co.—Manufacturers of the Finest Electro-Plated Ware, salesroom, 75 Chambers street, N. Y.  
 Holmes, Booth & Haydens—Manufacturers of Silver-plated Ware. 47 Chambers street.  
 The Adams & Shaw Co.—Silversmiths, Whiting Building, cor. Broadway & 4th street, N. Y.  
 Meriden Britannia Co.—Manufacturers of Silver plated Ware, Union Square, N. Y.  
 Middletown Plate Co.—Manufacturers of Superior Electro Plate. Factories, Middletown, Conn., Salesroom, 13 John Street  
 Manhattan Silver Plate Company.—Manufacturers of every description and quality of Silver Plated and Bronze Ware, office No. 952 Broadway. Factory 382 to 390 21 Ave.  
 Rogers Cutlery Co.—Hartford, Conn.  
 Reed & Barton—Manufacturers of Fine Plated and Table Ware, of every description, 686 Broadway, N. Y.  
 Rogers & Bro.—Manufacturers of the finest quality of Electro-Plated Ware. 690 B'way.  
 Simpson, Hall, Miller & Co.—Manufacturers of Fine Silver Plated Ware, No. 676 Broadway.



One Organization !      One Management !      One Interest !

---

## VOLUMES ISSUED QUARTERLY.

✎ SHEETS OF CHANGES SEMI-WEEKLY.    CONSTANT REVISIONS AND  
PROMPT NOTIFICATIONS TO SUBSCRIBERS.

# BRADSTREET'S

---

WE shall issue the *Forty-fourth* volume of our *Reports* during the first weeks of January. We submit this edition with confidence, as it has been revised with unusual care and great expense. We are determined to spare no effort to make our work complete, comprehensive and reliable; and to this end we have perfected many improvements which will appear in the January volume, but which have never heretofore appeared in any Commercial Reports. In consequence of the repeal of the Bankrupt Act, we have compiled an abstract of the Collection Laws of the several States, which we print under the proper headings. The compilation of these laws has been made by representative attorneys in each State and may be relied upon. We believe this feature will be appreciated by all who have occasion to grant credits covering different sections of the country. Inasmuch as our books are published quarterly, we shall be able in future to give any amendments to these laws down to the very latest date.

We have also introduced under each town or village head concise information, showing its actual or relative position—whether on a railroad, steamboat or stage route—the population, and whether a telegraph, express, or money order office, and if without a bank or banker, the nearest place where collections may be sent. As a Shipping as well as Collecting Guide, this will be almost invaluable, it being more comprehensive, and we intend it shall be more reliable than any published otherwise. We have also tabulated the Banks and Bankers throughout the United States and Canada, giving their capital, etc., as well as their New York correspondent, which we publish as an appendix to each volume, retaining however, the names as they appear at present under their respective town or city in the regular volume.

These improvements are but an index of what we intend to do for our patrons in the future. Owing and directing our whole business, from London to San Francisco, and from Montreal to New Orleans, we are able to control it in all its branches, so that it is not possible for the interests of our patrons to suffer from conflict with local managers.

Relying solely on the merits of our work, we respectfully solicit an examination of our system, with the assurance of our ability to substantiate all we claim, and with the knowledge that it is worthy of your earnest consideration

## THE BRADSTREET COMPANY.

✎ Offices in all principal cities of the United States and Canada, and London,  
England; also a Continental correspondence.



TO THE TRADE.

My new Illustrated Catalogue, printed in colors, with accompanying Price List, is now ready to be forwarded on application.

New and fashionable

NOVELTIES

of the most elegant designs, in Charms, Magic Pencils, in gold, platinum, silver, rolled gold plate and various rich materials.

Leroy W. Fairchild,  
110 William St., New York.

**JOHN M. GODDARD,**  
3 Maiden Lane, New York.

SPECIALTIES:

BRACELETS, Gold and Rolled Plate, upwards 100 patterns.  
1st Quality Rolled Plate CHAIN and LOCKETS.  
Vest, Neck Guards, Leontines in great variety.

*The Latest Designs in Gold and Fine Rolled Plate Jewelry always in stock.*

SEAL RINGS OF ALL KINDS.

Jewelry repaired, recolored, matched or made to order. Special attention given to the Job Department.

Orders from responsible Jewelers for goods on selection will be filled promptly and intelligently.

**The Burbank Manufacturing Company**

Manufacturers of GOLD & SILVER

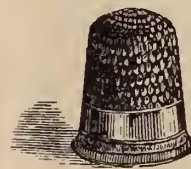

GOLD  
SILVER,  
STEEL,  
RUBBER,  
And SHELL,

**Thimbles,**



EYE GLASS  
Self Adjusting.

SPECTACLES AND EYE-GLASSES



OF ALL DESCRIPTIONS.

**SOLID GOLD RINGS,**

**Office, 14 MAIDEN LANE. NEW YORK.**

Manufactory, Springfield, Mass.

# KEARNEY & SWARTCHILD,

Manufacturers and Jobbers of all kinds of  
*Watchmakers and Jewelers Supplies,*  
Watches, Jewelry, Etc.

113 & 115 STATE STREET,

**CHICAGO.**

300 Page Illustrated Catalogue sent upon application and Receipt of Business Card.



No. 15.



No. 10.



No. 20.



No. 1.



No. 2.



No. 3.



No. 5.



No. 7.



No. 17.



No. 12.

ESTABLISHED 1850.

The only establishment in the United States that is devoted exclusively to the sale of Musical Boxes.

**M. J. PAILLARD & CO.**

MANUFACTURERS, IMPORTERS AND DEALERS IN

**Musical Boxes,**

SUITABLE FOR THE REQUIREMENTS OF ALL CLASSES, OFFER THEIR ENTIRE STOCK AT PRICES THAT WILL COMMAND THE ATTENTION OF BUYERS.

The Musical Boxes made by us, have achieved a world-wide reputation, and it is safe to say that two-thirds of the improvements in Musical Boxes, have originated in our establishment. The patents of which are owned exclusively by us.

Our stock is unusually complete and attractive and embraces many novelties, among which we may mention, the Sublime Harmony, the Harp Piccolo, and several others.

The double mainspring introduced by us is also a decided improvement, as it obviates the necessity of frequent winding. The greatest novelty in Musical Boxes is the interchangeable system of cylinders. These boxes are desirable goods for dealers as the cylinder can be increased to any extent, and a single instrument made to play an infinite variety of music. These cylinders can be ordered at pleasure, and all that is necessary to insure them fitting is to give the number of the box.

Specialties for the Holidays,

Have just received an invoice of Musical novelties consisting of *WORKBOXES, ALBUMS, FOOT STOOLS, CIGAR CASES, DECANTERS, PLATES*, and other fancy articles appropriate for Holiday offerings.

**M. J. PAILLARD & CO.,**

*680 Broadway, New York.*

**A. E. JUILLERAT,**

Agent for the Pacific Coast,

**31 Post St., San Francisco, Cal.**

# B. F. NORRIS & CO.

MANUFACTURING AND

## Wholesale Jewelers

101 & 103 STATE ST.,

CHICAGO.

We are the only Agents for the

### ELGIN LATHE.

Only Western Agents for

Middletown Silver Plate Co.

Only Western Agents for the

### CRESCENT SPECTACLES.



A full Illustrated Catalogue furnished to Dealers.

Send Business Card.

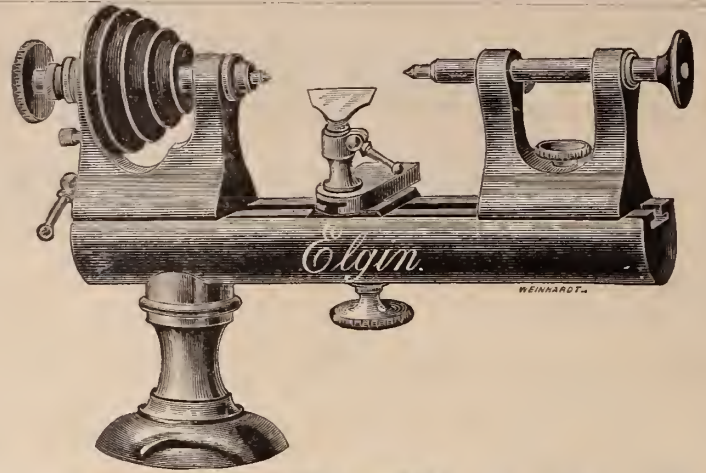

# ERRICO BROTHERS,

19 JOHN STREET, N. Y.

MAKERS AND DIRECT IMPORTERS FROM OUR OWN MANUFACTORY IN NAPLES,

## CORAL, SILVER FILIGREE AND CONCH SHELL JEWELRY,

—OF THE LATEST DESIGNS.—

These goods are made under our own immediate supervision, and designed expressly for this market. Our stock, the largest in the city, is replete with the richest novelties in this line, and is offered to the trade at prices that will tempt buyers.

We would direct the especial attention to our recent importations of CORAL ROSES and CORAL CAMEOS in all the most desirable shades. Also to our new designs in SILVER FILIGREE goods, which we offer at unexceptionably low prices. Buyers, when in town, are invited to an examination of our stock.



Beautifully clear  
and  
Brilliant,  
Standing all tests



Uniform in Quality  
and  
Thoroughly  
Reliable.

A G E N T S .

- CROSS & BEGUELIN, 21 Maiden Lane, N. Y.
- LOUIS A. SCHERR & CO., 726 Chestnut St., Philadelphia, Pa.
- KEARNEY & SWARTCHILD, 147 State Street, Chicago, Ills.
- DINKELSPIEL & NORDMAN, 120 Sutter St., San Francisco.
- P. W. ELLIS & CO., 4 Toronto Street, Toronto, Ont.
- HENNEGEN, BATES & CO., 255 Baltimore Street, Baltimore, Md.
- BOWLER & BURDICK, 208 Superior St., Cleveland, Ohio.

- H. HOFFA, 624 Pennsylvania Avenue, Washington, D. C.
- THOMAS H. CLAPP, 16 South Meridian Street, Indianapolis, Ind.
- WILLIAM SENTER & CO., 54 Exchange Street, Portland, Me.
- GEORGE H. TAYLOR, 136 Westminister Street, Providence, R. I.
- R. HASWELL & SON, 49 Spencer Street, London, England.
- LOUIS MATRIX JOSEPH, St. Croix, Switzerland.
- ARCHILLE PORTAL, 21 Rue des Archives, Paris, France.

We have sold NYE'S Watch and Clock Oils, and they have given universal satisfaction.

A. PAUL & CO., 8 Bromfield Street, Boston, Mass.

Your Oil is gradually taken root here. We have had eighteen months experience with it, and so far have not had a single complaint from any one. We can therefore conscientiously recommend it.

R. HASWELL & SON, London, England.

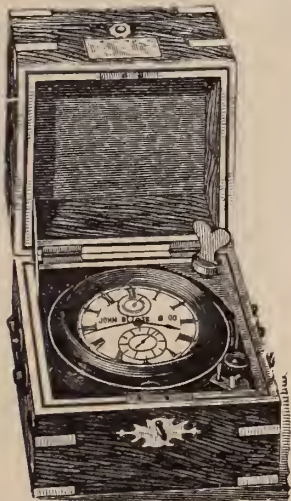

Standard Marine Chronometer  
FOR KEEPING CORRECT TIME.

JOHN BLISS & CO.

STANDARD MARINE

Chronometers and Transits,

FOR WATCHMAKERS' USE.

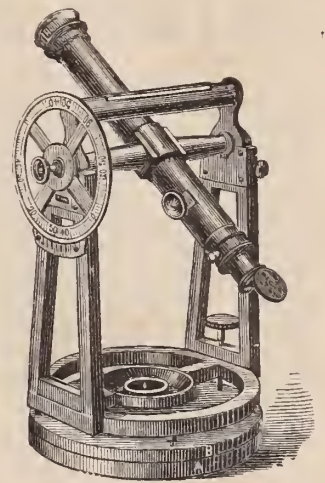

No. 10

110 WALL STREET, NEW YORK.

**IMPORTANT NOTICE.**—These Transits are readily set in position without the aid of strictly correct time as a basis for that purpose. Printed instructions, easily understood, accompany each Instrument, and no calculations are required preliminary to setting in position.

As a trial only is required to insure unqualified approval, we are induced to make the following **LIBERAL OFFER**—On receipt by us of satisfactory reference, and 10 per cent. of the price, we will send one of the foregoing Transit Instruments, on hire or trial, for one month, with full printed instructions for setting up and using the same, and if purchased after trial, we will allow the whole hire to apply in part payment, and sell the Instrument on approved note at four months for the balance. Special terms for payment by installments, after trial, on application. We do not make this offer merely to hire these instruments, but to insure a trial with a view to sales, the hire received being only sufficient to cover the cost of repolishing in case they are returned. Send for Illustrated Circular giving full description.

JOHN BLISS & CO., 110 Wall Street, New York.

**ARKELL & CO.**

IMPORTERS AND DEALERS IN

Watch Materials, Tools,

JEWELRY,

AND ALL GRADES OF AMERICAN WATCHES.

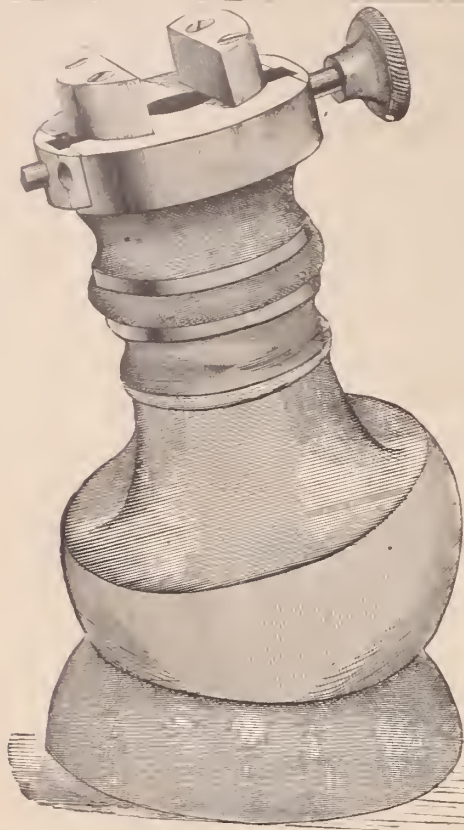

We call the attention of Watchmakers to the "JEQUIER" Main Spring. This spring is the only one of all fabrications exhibited at the "Paris Exposition" that received FIRST and ONLY medal. We claim it is the best in this country, and invite a trial by the trade as a test of its merits. Send for sample and also descriptive catalogue of Columbus Watch, nickel  $\frac{3}{4}$  plate, full jeweled, stem-winding and setting. No price list furnished unless requested and only to the trade.

BALDWIN'S BARREL CATCH INSERTER, indispensable to the Watch Repairer, saves time and labor, sent by mail on approval to the trade free of postage.

We are Sole Agents for the United States of these goods. We also manufacture the BOSS ENGRAVING BLOCK—there are features in its construction different from all others in the market, holds the work to be engraved, of any kind, without attachments. It is practical, simple, and reasonable in price. All these specialties numerated, may be obtained of any regular Dealer in materiale and tools, or direct of us.



P. O. Box 8. Canajoharie, N. Y.



**PATENT IMPROVEMENT IN COUNTER SHOW CASES,**

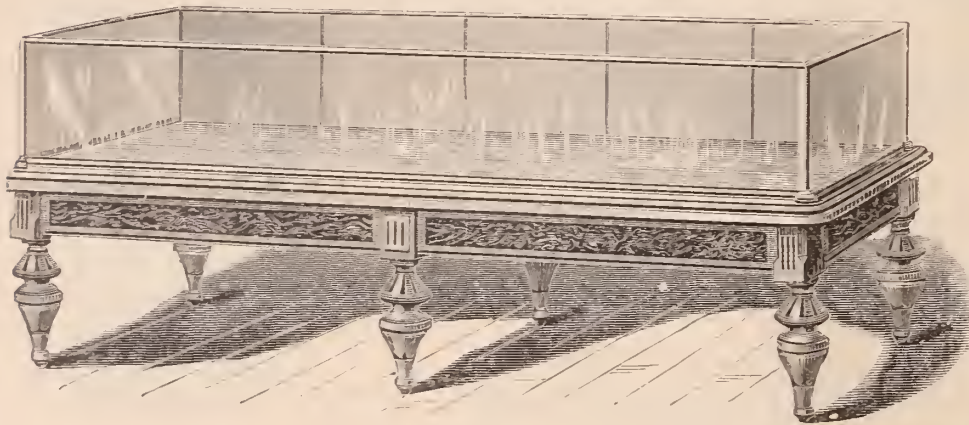

Perpendicular Sliding Door,

(DUST TIGHT.)

REAR VIEW OF CASE SHOWING SLIDING DOOR.

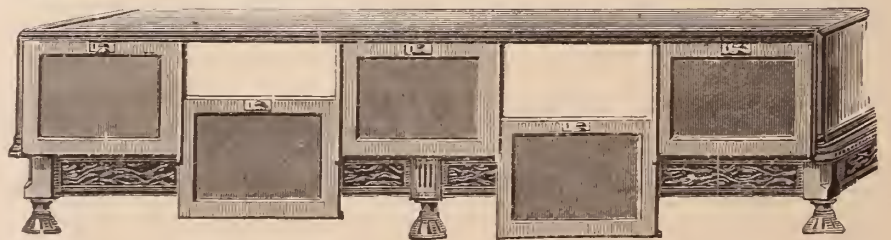

Its advantages are as follows:—The doors are more conveniently opened and closed, less liable to get out of repair or broken, articles are more easily reached in wide cases, mirrors are more safe, it dispenses with hinges, economizes room, excludes dust, and is air tight *when closed*.

Drawings furnished and estimates given for fitting stores in cabinet work complete.

REFERENCES:—Gorham Mfg Co., Rogers & Bro., Mitchell Vance & Co., Meriden Britannia Co., M. S. Smith & Co. Detroit, Mich. D Valentine, Syracuse, N. Y.

**B. & W. B. SMITH,**

**220 West 29th Street, New York.**

**Important to Manufacturers of Jewelry and Silverware.**

**ATCHISON'S**

**Chasing, Matting and Engraving**

**MACHINE,**

Patented March 14th, 1876 and June 12th, 1877.

**HARVEY C. FLAGLER, Sole Agt**

**175 Tremont Street,**

**BOSTON, MASS.**

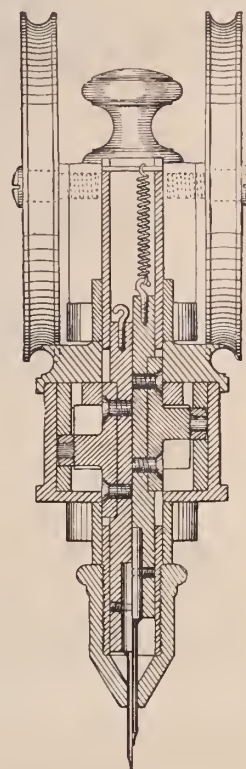
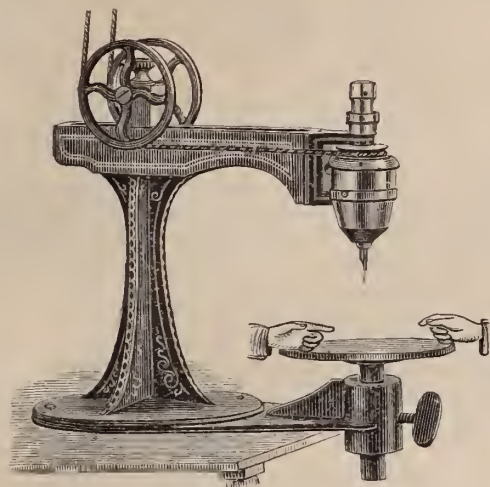

THE undersigned, begs leave to call your attention to the "ATCHISON" CHASING, MATTING AND ENGRAVING MACHINE, and to the merits of this new and useful invention for executing fine and ornamental work on Metals.

By this machine the most beautiful, rich and soft groundwork is produced on GOLD, GOLD-PLATED, SILVER OR SILVER PLATED GOODS.

The thinnest of PLATE is beautifully matted by this machine, and is free from any or all indentations.

Manufacturers of SOLID GOODS will find that goods too thin to be matted by hand can be beautifully FROSTED by this machine WITHOUT the use of CEMENT.

All manufacturers of DIE WORK will find this machine to be of great value, as the thinnest stock that can be struck in a die can be matted without marring.

The groundwork is produced on the metal with great rapidity, the Engraving Tools delivering 7,560 cuts per minute by a new perpendicular and rotary reciprocating motion, and the apparatus is so simple that a boy or girl can attend it and operate it.

Some idea of the capacity of the machine may be formed from the record kept of the work done from May 19th, 1876, to May 19th, 1877. One machine running less than half time, at an expense of One Hundred and Fifty Dollars to the operator, has produced 15,948 pieces of work, and it has taken the place of fifteen hands and effected a saving of 75 per cent. annually on that class of work, during the past three years.

It will afford the subscriber pleasure to lease the above machines at their cost \$100, and a royalty of \$300 per annum, or will negotiate for State rights and respectfully invites an investigation of the merits of the machine, and the class of work it produces.

Yours, respectfully,

**H. K. FLAGLER,**

**175 Tremont Street, Boston, (Evans House.)**

*BOSTON, October 1, 1879.*

**WESTON DYNAMO-ELECTRIC MACHINE CO**

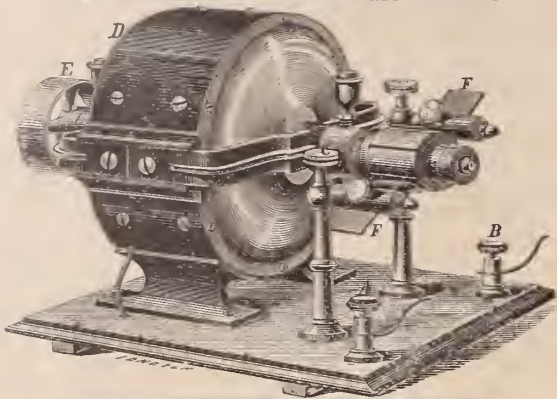

**CONDIT, HANSON & VAN WINKLE**  
Sole Agents NEWARK, N.J. U.S.A.

Machines for Electro-Plating, Electrotyping, Electric Light, Telegraphing, &c.

The Weston Dynamo-Electric Machine is constructed on a new principle giving the greatest amount of electricity with the least consumption of power. Its simplicity and ease of management has already made it the standard machine. The success attending its introduction has already had the effect of inducing parties building machines for similar uses to adopt some of the devices peculiar to our new construction. We beg to call attention to the various patents covering our machines, and to the fact that we guarantee purchasers against any infringement of existing patents, as well as to their adoption and endorsement by the largest manufacturers of the country, in many cases after a previous trial of all other machines.

In addition to the testimonials in our Catalogue of January 1, we beg to refer to the following houses:—Carter, Howkins & Sloan; Enos Richardson & Co.; Bates & Bacon; Short, Nevey & Co.; Stephen Richards & Co.; Meriden Britannia Co.; Russell & Erwin Manufacturing Co.; Reed & Barton; Hall, Elton & Co.; Richardson, Boynton & Co.; Wm. H. Jackson & Co.; Stanley Works; Rogers Cutlery Co.; Chas. Rogers Bros.; Edward Miller Co.; Mitchell, Vance & Co.; Norwalk Lock Co.; Hayden, Gere & Co.; Domestic Sewing Machine Co.; Eberhard Faber; Jos. Dixon Crucible Co.; Mumford & Hanson; Fagan & Son, and over 200 others. OUTFITS FOR NICKEL, SILVER, BRONZE PLATING, etc. The two highest Centennial Awards and three of the Centennial Medals of American Institute.

There are great advantages in the use of these Machines for Manufacturing Jewelers as they are always ready for use, avoiding the use of mercury and the annoyance of fitting up batteries, producing better colored work, and more durable; there are over 30 in use in Attleboro and vicinity alone, and are being rapidly adopted by the trade in Birmingham, Paris, Proszheim, &c.

Machines from \$125 upward.

The Machines may be seen in operation at our New York Office, 92 and 94 Liberty St., 2 doors west of Broadway.

Catalogues of all our goods sent on application.

Established 1854.

**CHAS. THEO. MENCER,**  
Fine Hair Jewelry and Device Work,  
Nos. 32 & 34 John Street, New York.

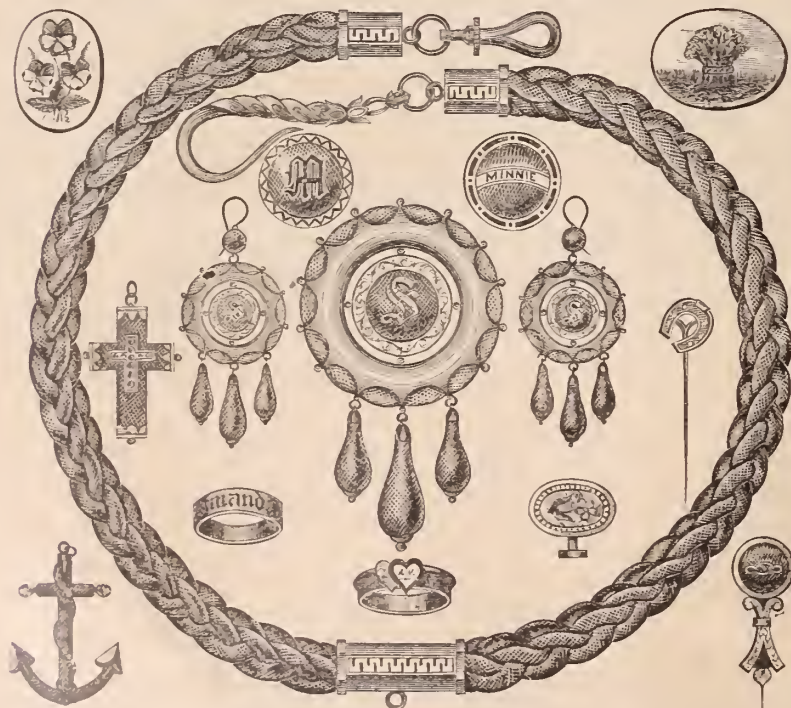

The attention of the trade is invited to the above designs of Hair Jewelry and Device Work, which are a few of the numerous designs contained in my Pattern Book.

I will send a large Pattern Book and Price List, containing all the latest designs on receipt of 50 cts., which will be refunded on first order.

I also fill orders taken from any other book upon advice of name and number of design.

All orders will receive prompt attention, and repairing of Fine Jewelry in all its branches.

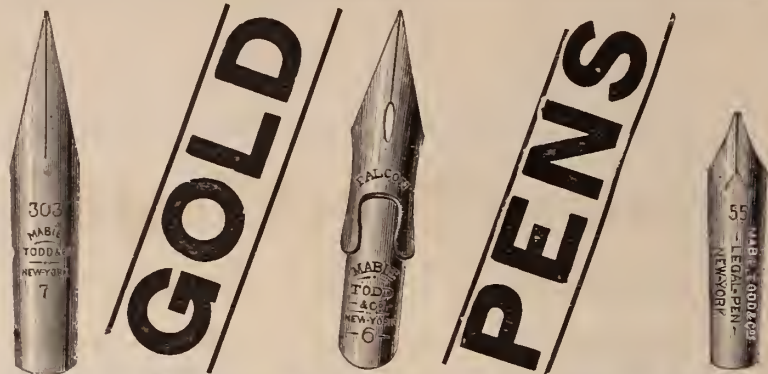

**MABIE, TODD & BARD,**  
MANUFACTURERS OF  
**GOLD PENS, PENCILS, CASES, HOLDERS**

**AND TOOTHPICKS,**  
Of 18kt., 14kt., 10kt., Solid Gold;  
ALSO,  
**Holders and Pencil Cases**

—OF—  
Pearl, Ivory, Gold M'd Rubber, Sterling Silver,  
10kt. and 18kt. Plate.

180 BROADWAY, NEW YORK, U. S. A.



Correspondence Solicited in Reference to our Goods.  
Our new Catalogue will be sent to the trade upon application, when accompanied by a business card.

ESTABLISHED 1869.

**The Jewelers' Circular and Horological Review,**

The recognized organ of the trade, the official representative of the Jewelers' League, the Watchmakers' and Jewelers' Guilds, and the various State Trade Societies.

**SUBSCRIPTION, \$2.00 Per Annum.**

Is published on the 15th of each month.

This Journal is devoted to the interest of Watchmakers and Jewelers, and those engaged in kindred interests.

To the practical workman the JEWELERS' CIRCULAR is invaluable as a text-book and work of reference. Its pages furnish him with the latest scientific and mechanical ideas, set forth in plain, comprehensible language by specialists of ability and experience. The technical information contained in its columns represents the progress of the age, and every intelligent workman in the country acknowledges the advantages resulting from a study of its pages.

To the country dealer the JEWELERS' CIRCULAR affords thorough, correct and perfect information as to staple and original articles of trade. From it he can learn what to order and where to obtain supplies, he can discover the best source of materials in common use, while the latest novelties are without exception first announced in its columns. All communications should be addressed to

**D. H. HOPKINSON,**  
42 Nassau Street, New York.

Or the regular Agents of the Circular.

Sample Copies sent on application.

# American Watch Tool Co.

P. O. Box 999.

WALTHAM MASS.

MANUFACTURERS OF THE WHITCOMB LATHE,

AND

Machinery for Watch, Watch Case and Clock Making

NEW YORK OFFICE, WITH

L. H. KELLER & CO., 64 Nassau Street.

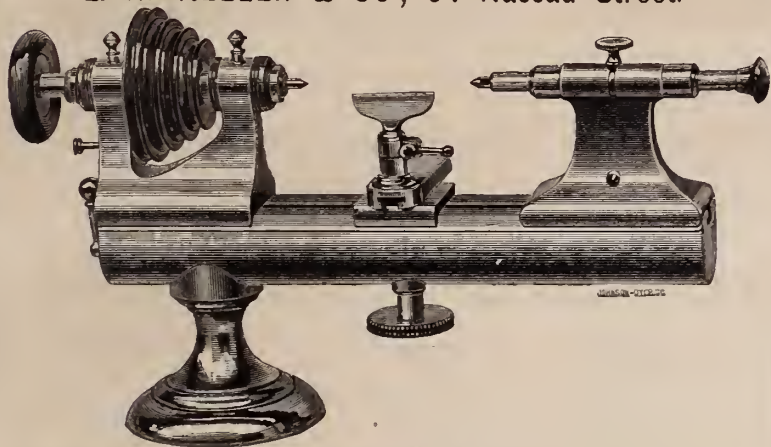

Chicago Office with Chas. Wendell & Co., No. 170 State Street.

# HOPKINS' WATCH TOOL CO., Waltham, Mass.

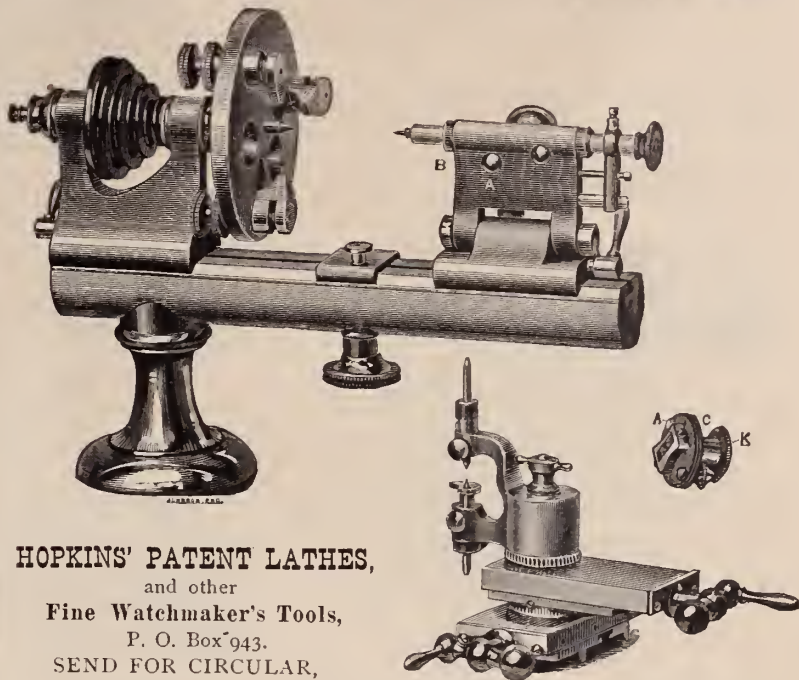

HOPKINS' PATENT LATHES,  
and other  
Fine Watchmaker's Tools,  
P. O. Box 943.  
SEND FOR CIRCULAR,

# S. C. JACKSON,

MANUFACTURER OF

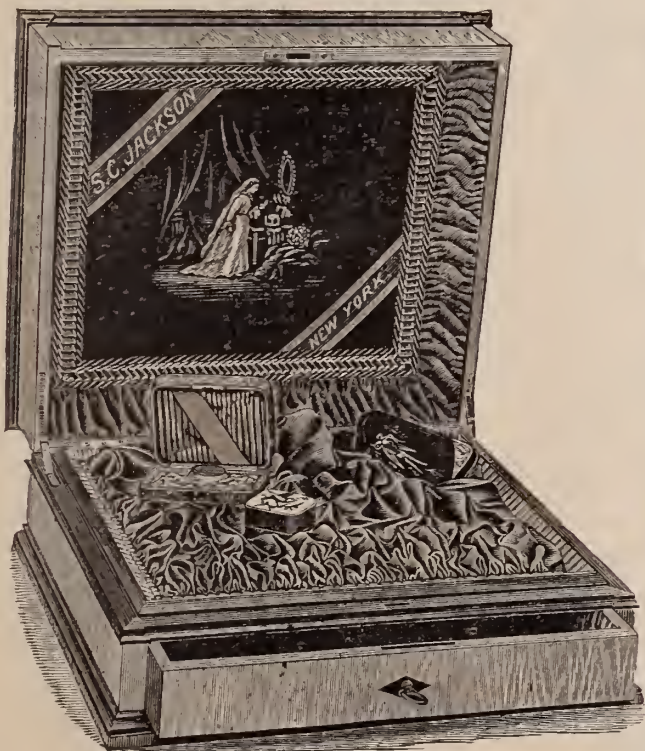

Fine Cases for Jewelry, Watches, Silverware, &c.

180 BROADWAY, N. Y.

Centennial Medal Awarded.

A specialty in Show Case Trays, and Silver Cabinets, made from the finest hard woods, and polished.  
All kinds Sample Cases made to order A full assortment of a cheaper grade of Jewelry and Silverware cases in stock.  
New and elegant Styles now ready, including our paintings on silks, and satins, together with novelties from China and Japan, specially ordered.;

# J. F. FRADLEY.

MANUFACTURER OF

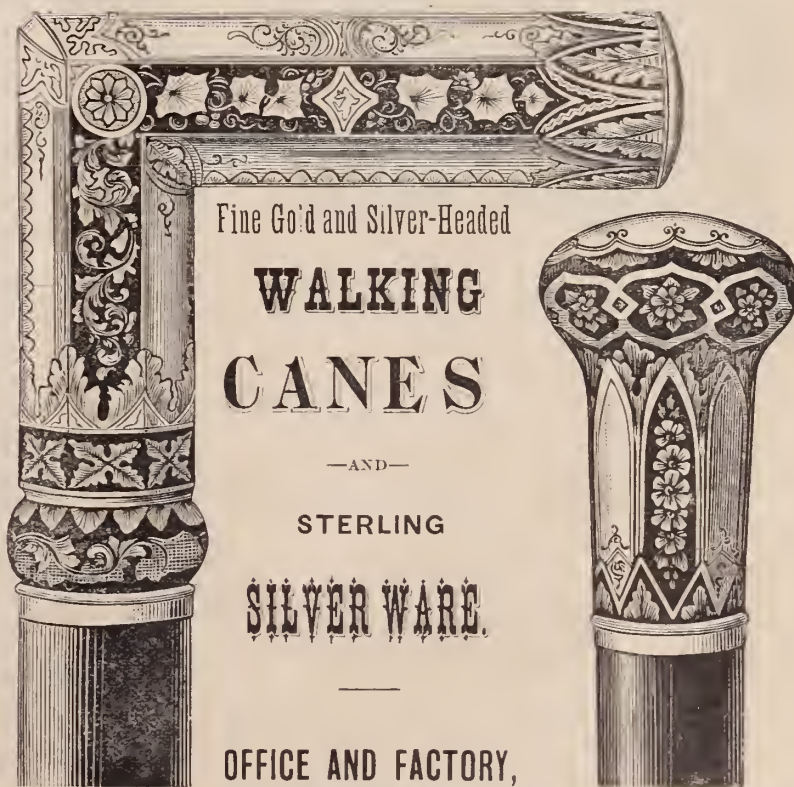

Fine Gold and Silver-Headed

**WALKING  
CANES**

—AND—

STERLING

**SILVER WARE.**

OFFICE AND FACTORY,

**20 JOHN STREET, NEW YORK.**

ESTABLISHED 1856

**WILLIAM PARK,**  
**Stone, Seal & Cameo Engraver**  
 26 John Street, New York.  
**Arms, Crests, Monograms & Devices**  
 Engraved on Lockets, Sleeve Buttons,  
 Rings, Etc.  
*Masonic Engraving a Specialty*  
 ONE TRIAL SOLICITED.

**STERN BROS. & CO.**



Manufacturers of  
**Fine Jewelry,**

**30 MAIDEN LANE**

FACTORY, 73 & 75 Fulton St., NEW YORK.

Gold Seal engraved Band-rings and Lockets a specialty.  
 The attention of the trade is directed to our plain Gold  
 filled Rings. Sections of which showing the construction  
 and quality sent upon application.  
 After February 1st, our plain filled rings will bear the  
 above trade mark.

**LEIMBASH BROS.**

Manufacturers of all kinds of

**DIAMOND JEWELRY.**

A full assortment constantly on hand.

*51 Nassau Street,*

**NEW YORK.**

**H. M. RAYNOR,**

**25 Bond Street, N. Y.**

**PLATINUM**

FOR ALL

**Laboratory & Manufacturing Purposes.**

Native Platinum, Scrap, &c., purchased.

**REPAIRING, COLORING AND GALVANI-  
 ZING FOR THE TRADE.**

**C. G. MALLIET,**

**Manufacturing Jeweler,**

**No. 9 JOHN STREET**

**NEW YORK.**

**P. NEIDHARDT & CO.**

Manufacturers of

**Diamond Mountings**

—AND—

**FINE JEWELRY**

**52 Nassau Street,**

Cor. Maiden Lane,

**NEW YORK.**

P. NEIDHARDT,

B. SCHILLING.

Full line of new and original mount-  
 ings on hand.



Particular attention paid to Re-mounting.  
 Price list furnished on application.

**BLANCARD & OBERLANDER,**

MANUFACTURERS OF

**Settings and Galleries**

Of every Carat of Gold or Silver,  
 Platinum, Platinum-Lined and Fancy  
 Settings a Specialty.

As we melt and refine Platinum ourselves.

**36 & 38 JOHN STREET,  
 NEW YORK.**

Platinum Scraps Exchanged or Purchased.  
 Send for Sample Card.

**VOSE & SOUTHWICK,**

**Manufacturers of Gold Jewelry**



Sole Makers of  
 the Separable  
 Sleeve and Col-  
 lar Buttons in  
 Gold.

No. 183 Eddy Street, PROVIDENCE, R. I.

Mansard English Geneve Louis XV.



**HENRY LEFORT,**

**Stem-Winding Watch Crown Manufacturer,**

Crowns and Pushers in gold, all sizes, quality and color,  
 made to order. Silver crowns and pushers always on hand.  
 Samples sent on application.

**80 & 82 Marshall Street,  
 NEWARK, N. J.**

**ALBERT FRIEDENTHAL,**

Importer and Jobber of  
 WATCHMAKERS' & JEWELERS'

**Materials, Tools and Optical Goods**

**Real and Imitation Stones,**

For Manufacturing and Repairing Purposes  
**A SPECIALTY.**

Agent for TISDALE'S Watch and Clock Oils.

**No. 43 Maiden Lane, New York.**

Orders by mail will receive prompt attention.

**GUSTAV EPHRAIM,**

Successor to Ephraim Bros.

**8 JOHN STREET, NEW YORK,**

Importer and Manufacturer of

Bamboo, Silk Guards and Watch Chains of all  
 Grades. Materials, Watch Glasses,  
 Optical Goods and Jewelry.

Sole Agent for EAGLE SPECTS', CORNELL'S  
 ANTI-OXYDIZER and COURVOSIER  
 MAIN SPRINGS.

**WILKINSON & LENNON.**



212 Broadway,  
 NEW YORK,

**Manufacturing Jewelers**

Masonic Pins, Rings & Charms,  
 School, Athletic, Fine  
 Presentation Medals,

—AND—  
**JEWELS OF EVERY DESCRIPTION.**

Designs furnished free upon ap-  
 plication.

**The Morse Diamond Cutting Company,**

J. D. YERRINGTON, Agent.

**192 Broadway and 3 John Street.**

**NEW YORK.**

Rough Diamonds, Boart, Roses and Brilliants  
 for sale.

Fractured Diamonds repaired, and old stones  
 improved; also Rough Diamonds cut and  
 fashioned to order.

**W. N. WALKER,**

**DIAMONDS,**

**Watches and Jewelry,**

**No. 18 JOHN STREET, NEW YORK.**

**IMPROVED JEWELERS COTTON**

**JOHN J. ARMOUR.**

**HENRY TROEMNER,**

**710 Market Street,**

**PHILADELPHIA.**

**Manufacturer of Fine Gold Scales,**

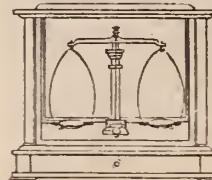

**DIAMOND SCALES,**

Bullion Balances and  
 Weights, in use at all the  
 U. S. Mints and Assay  
 Offices.

PRICED CATALOGUE ON APPLICATION.

**Solid Gold Rings—a Specialty**

**WM. H. ELY,**

**Solid Gold Rings**

MANUFACTURER,

Viz., Plain, Chased, Engraved, Enameled, Engine  
 Turned, Shield & Scale. All qualities Warranted  
 Orders Promptly Executed.

**58 Nassau Street, N. Y.**

**L. BONET,**

Medal at Centennial, 1876.

**CAMEO**

**Likenesses,**

**889 Broadway, New York.**

Established 1848.

Reliable and prompt.

**COOPER & BRO.**

Wholesale Jewelers,  
Importers and dealers in WATCH & CLOCK-  
MAKERS' TOOLS and MATERIALS; also, JEWEL-  
ERS' SUPPLIES, SPECTACLES, OPTICAL GOODS,  
&c. A complete Outfitting Establishment for the  
trade.

Repairs Department established 1865. Every  
description of work done for the trade. Watch  
Repairing, Jewelry and Watch Case Repairing,  
Gold and Silver-Plating, and Fire Gilding.

35 S. Fourth St. (1st floor), PHILADELPHIA

THOMAS M. GUILBERT.

J. CARROW DUBOSQ

**GUILBERT & DUBOSQ,**

Successors to Francis Dubosq & Son,

Manufacturers of

Fine Gold and Strung

**PEARL JEWELRY;**

No. 1031 Chestnut Street,  
PHILADELPHIA.

**DAVID PRINCE,**

**Gold and Silver Refiner,**

Assayer and Sweep Smelter,

13 and 15 New Jersey Railroad Avenue,

**NEWARK, N. J.**

Sole Agent for Comins' Improved Amalgamator.

**A. PICARD,**

Importer and Jobber of

**American and Swiss  
WATCHES,**

Jewelry, Optical Goods, Watchmakers' and  
Jewelers' Tools and Material,

No. 11 North Second Street,

**PHILADELPHIA.**

LOWELL WRENCH CO., WORCESTER, Mass.

JEWELERS' PIN VISE.



PATENTED AUG 10, 1875.

"The Jewelers' Pin Vise is a well-known tool advertised  
in the CIRCULAR, by the Lowell Wrench Company, of Wor-  
cester, Mass., and is a credit to them. The sample was in-  
spected with high commendation by the members, many of  
whom had used it and pronounced it far superior to the  
imported article. It is of hardened steel, nickel-plated, the  
handle is nicely milled, giving a firm grip for rolling in the  
fingers, and the whole is turned true to centre. It holds  
firmly anything placed in it, and altogether is a most excel-  
lent tool for the bench."—*Proceedings Horological Club,*  
*April, 1879.*

**Save your Gold and Silver  
From your waste Wash Water,**

Which can only be done completely by the use of the  
**PATENT CHEMICAL FILTERS,**

Manufactured by us.

This apparatus occupies very little room, does not  
choke up, and is put up at our expense on shares, after  
the water has passed through the usual operations in  
use by Jewelers and others.

For further particulars, address,

**CYRUS O. BAKER, Jr. & CO.**

104 N. J. Rail Road Avenue,

**N. J.**

**NEW YORK**

**Morocco Case Company,**

CASES FOR JEWELRY, WATCHES,  
SILVER-WARE, &c., OF ANY  
QUALITY AND STYLE.

Boxes and Trays for Jewelers' Travelers.  
Show Cases and Window Fittings  
a Specialty.

No. 69 NASSAU ST., cor. John, NEW YORK.

Leon Jeanne.

Paul Jeanne.

**JEANNE BROTHERS,**

MANUFACTURERS OF

**DIAMOND MOUNTINGS  
And RICH JEWELRY,**

Patentees of Jeanne's Ear Wires,  
No. 1 Maiden Lane, New York.

Designs furnished and estimates given.



Ketcham & McDougall

4 Liberty Place, N. Y.

Manufacturers of

**IMPROVED GOLD  
AND SILVER**



**THIMBLES**

— ALSO —



It Winds up the Cord when Not in Use.

**J. B. LAURENCOT,**

IMPORTER OF

**WATCH GLASSES,**

**Optical and Fancy Goods**

French Clocks, Musical Boxes, &c.

**No. 33 MAIDEN LANE.**

15 Rue D'Enghien,

Box 2954, P. O.

PARIS.

NEW YORK.

Established 1850.



**PETER L. KRIDER,**

MANUFACTURER OF

**STERLING**

**SILVER WARE,**

Medal and Diploma Awarded, &c.

Striking Society Medals in Gold, Silver or Bronze

A SPECIALTY!

ARTISAN HALL,

**618 Chestnut Street  
PHILADELPHIA.**

**SWIFT MAN'G CO.,**

12 CORTLANDT STREET,  
NEW YORK,

— MANUFACTURERS OF —

**Jewelers' Wood Nested  
MAILING BOXES.**

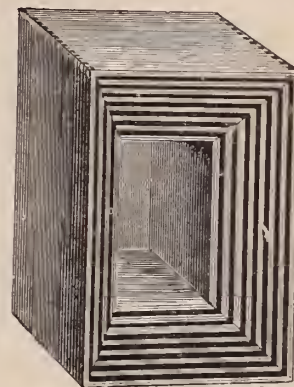

For Mailing and Express Purposes

**J. SPENCER TAYLOR,**  
Agent,

Orders by mail promptly attended to.

**GEO. W. DU BOIS,**

(Successor to Albert Landsberg.)

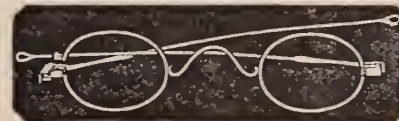

IMPORTER AND MANUFACTURER OF

**Optical Goods,**

**No. 36 MAIDEN LANE,**

Near Nassau Street, NEW YORK

Sole Agent for

**BLACK'S PATENT**

**Interchangeable Spectacles,**

AND

**EYE GLASSES.**

Jewelers and others who keep spectacles for  
sale will please observe that, with these PATENT  
SPECTACLES, it is only NECESSARY to have a full  
Complete Assortment of Lenses and Pebbles, which  
being all of a UNIFORM SIZE, will FIT either the  
Gold, Silver, or Steel Frames, of which but a  
few of each kind are wanted; an advantage  
which will give a complete assortment of the  
finest Spectacles, for one-sixth the capital in-  
vested in a like assortment of the same quality  
goods of the old style frames.

For Particulars, price lists, &c., address

**GEO. W. DU BOIS,**

New York.

# SPENCER

## Optical Manufacturing

### COMPANY,

Manufacturers of Spectacles and Eye Glasses,  
from all materials used for that purpose,  
and of all grades.

**SOMETHING NEW ! !**  
**CELLULOID EYE GLASS FRAMES,**  
Representing the Choicest Selected  
Tortoise Shell and Amber.

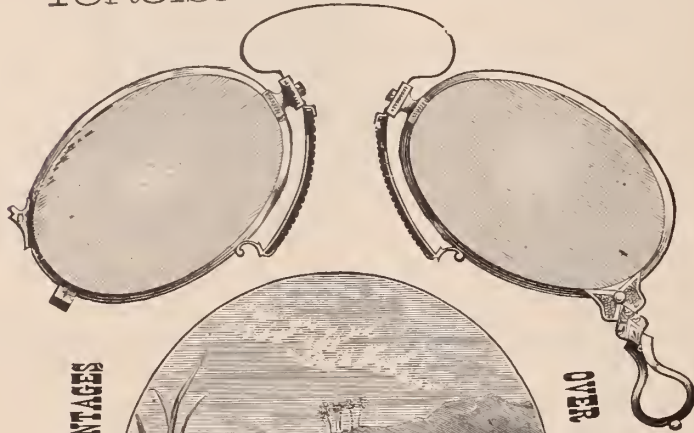

(Turtles rejoicing over the discovery of Celluloid Tortoise Shell,  
Their Occupation Gone.)

They are much **Lighter** than any others. Twenty-five pairs of the frames weigh only one ounce.

They are much **Stronger** and more **Durable** than any others; they can be **Dropped Without Injury** upon the hardest substance.

Their **Beauty Far Surpasses** the ordinary Tortoise Shell Frames commonly in use.

They are **Not Affected** by **Atmospheric Changes**, being equally well adapted to either warm or cold climates.

They are made with **Different Sized Frames** to suit persons whose eyes are either near or far apart.

The Springs are made of a combination of metals which will neither **Rust** nor be effected by heat or frost. These frames are set with **Fine Lenses**, accurately focused to suit all sights, which with the many other advantages, make them **Very Popular**.

**ASK YOUR OPTICIAN OR JEWELER TO SHOW THEM TO YOU.**  
Every Pair Stamped on Handle S. O. M. Co. Pat. Mar. 13, '77.

Parties ordering 3 doz. Celluloid Eye Glasses are furnished with 1,000 copies of circulars similar to this advertisement with name of dealer printed thereon.

**13 Maiden Lane, N. Y.**

Established 1853.

# L. H. KELLER & CO.

Successors to G. A. HUGUENIN,

IMPORTERS OF

## Fine Watch and Clock Materials,

SWISS, ENGLISH, FRENCH & GERMAN

## FILES, TOOLS, & C.

FOR WATCH MAKERS, WATCH CASE MAKERS, JEWELERS  
SILVERSMITHS, ENGRAVERS, CHASERS, DIE  
SINKERS, MACHINISTS, &c.

SOLE AGENTS FOR HALL'S STAKING TOOLS AND  
ROLLER REMOVERS.

AGENTS FOR THE WHITCOMB AND OTHER AMERICAN LATHES.

GENERAL AGENTS FOR THE PHILADELPHIA  
WATCH COMPANY.

American Agents for the Horological Journal, (British).

A Monthly Paper for the advancement of Chronometer, Watch and Clock Making,  
and kindred Sciences. Published under the auspices of the British Horological  
Institute, London. Subscription \$2.50 per year, in advance. Also,

SAUNIER'S TREATISE ON MODERN HOROLOGY, IN  
THEORY AND PRACTICE.

BY M. CLAUDIUS SAUNIER The English Edition will appear in 26 monthly parts,  
Price 50 cents each. Whole Work, \$13 00, postage paid.

Special attention is directed to

**"OUR OWN" Celebrated Mainsprings Graduated**

in thickness to equalize the power, with well rounded edges, and the  
*Highest Crocus Finish throughout*, insuring the least possible friction  
in the barrel, pronounced by expert judges to be the *best made*.

"JURGENSEN" Main Springs recoiling, suitable for the highest grades  
of Swiss Watches.

**"Lutz" Celebrated Hair Springs,**

by numbers, of uniform diameter and strength, the best for  
"BREGUETING."

Fine Hole Jewels of Ruby, Sapphire, Chrysolite, Garnet, Beryl and  
Aqua Marine, with *gauged* (well shaped and polished) holes, numbered  
by the Swiss pivot gauge also, neat black walnut cases, containing  
forty glass vials for assortments of same. The great advantage in hav-  
ing Jewels by numbers will readily be seen as a saving in time and an-  
noyance in selecting and in expense. Dealers once having an assort-  
ment, can replenish or stock up at a comparatively small outlay, as any  
desired quantity of No. and quality can be had of us at all times,  
our stock of jewels being the largest and most complete in the country.

Diamond Charged Broaches for opening and polishing jewel holes.

Diamond Powder and Bort for polishing and grinding 8 different  
grades, in  $\frac{1}{2}$ ,  $\frac{1}{4}$ ,  $\frac{1}{8}$ , and  $\frac{1}{16}$  K vials, bringing it into the reach of all.

Gold Diamond Set and other fine Geneva Hands.

The new Drills in Sets of 54 small, 126 small to medium, and 48  
large; also, sold separately if desired.

A FULL LINE OF MATERIALS FOR THE CELEBRATED WATCHES  
MANUFACTURED BY

## Patek, Philippe & Co.

OF GENEVA, FULLY FINISHED AS FAR AS PRACTICABLE.

## No. 64 Nassau Street,

Near Maiden Lane

## NEW YORK.





**Goldsmiths, &c.**

**Greene Wm. C. & Co.**—Goldsmiths; Manufacturers of Rich Sets in Taper Wire Coral. Office, 192 Broadway.

**Gold Rings.**

**Bowden, J. B. & Co.**—Manufacturing Jeweler.—Solid Gold Rings a specialty, 1 Maiden Lane.  
**Ely, W. H.**—Manufacturer of Solid Gold Rings of every description. No. 58 Nassau Street.  
**Frankel & Folkart.**—Manufacturers of Seal, Camée and Amethyst Rings a specialty. Also a full line of Gold White Stone goods and Diamond Settings. 21 John St., N. Y. etc., No. 4 Liberty Place.  
**Peckham, Wm. H. & Co.**—Manufacturers of Solid Gold Seamless Rings, and Fancy Embossed Rings, Patent Spectacles, Jewelry, etc. No. 4 Liberty Place, N. Y.  
**Sinnock & Sherrill**—Manufacturers of Stone Rings. No. 5 Maiden Lane, N. Y.  
**Tingley, Joseph N.**—Manufacturer of Stone Rings and novelties in Stone Goods. No. 9 Maiden Lane, N. Y.

**Hair Jewelry.**

**Montoux, Wm. E.**—Leading Artist in Hair, and Manufacturing Jeweler, 81 Nassau St., New York. Pattern Books for the trade.  
**Sauter, L.**—Manufacturer of Fine Gold and Hair Jewelry and Device Work. Pattern Book sent on application. Nos. 65 & 67 Nassau St.  
**Schwencke O.**—Manufacturer of Fine Hair Jewelry. Orders from the country promptly attended to. No. 43 Maiden Lane.

**Jewelry Cases, Fancy Boxes, Etc**

**Braun, Chr. E.**—Manufacturer of Jewelry Boxes, Trays for Show Cases, &c., 62 Chatham st.  
**Dahlem, W.**—Manufacturer of Cases for Jewelry and Silverware, No. 85 Nassau Street, N. Y. Show Case Trays, &c., at shortest notice.  
**Loehr & Koerner**—Manufacturers of Morocco, Velvet, Satin, Jewelry, Watches and Silverware Cases, Glove, Handkerchief, Ladies' Jewel, Work Boxes, &c., Fancy Trays and Stone Fittings to order, Office and Salesroom 83 Nassau Street, New York.  
**New York Morocco Case Co**—Makers of Cases for Jewelry, Watches, Silverware, etc. Boxes and Trays for Jewelry. No. 69 Nassau Street, N. Y.  
**Walker, Geo. W., Morocco Case Manufacturing Co.**—Manufacturers of Morocco Cases, 712 Broadway, N. Y.  
**Sturn, L.**—Manufacturer and Importer of Cases for Jewelry, Watches, Silverware, &c. No. 15 John street, N. Y.  
**Welch & Miller**—Manufacturers of Morocco, Velvet, and Satin Jewelry Cases, Trays, &c. Telescope Sample Cases with flexible Trays. Complete stock on hand. 169 Broadway.  
**Wiggers & Froelick**—No. 60 Nassau street.—Manufacturers of Cases for Jewelry, &c., of every description. Trays for Show-cases, Stands for Show-windows, etc. Jewelers' Traveling Cases, light, convenient and strong.

**Jewelry—Fine.**

**Aikin, Lambert & Co.**—Manufacturers. General stock of Reliable Jewelry, 23 Maiden Lane.  
**Alford, C. G. & Co.**, Manufacturers. General line fine and reliable goods. Specialties in Onyx goods and chain. 183 Broadway, New York.  
**Barthman & Straat**—Manufacturers of Fine Jewelry. Seal and Stone Rings a Specialty. Orders promptly attended to. 41 Maiden Lane.  
**Bernhard, A. & Co.**—Manufacturers of Fine Hair Jewelry and Device Work. The latest styles. 2 Maiden Lane, New York.  
**Bissinger, E.**—Importer of Fine Jewelry, Locketts, Crosses, Neck Chains, &c., No. 192 Broadway.  
**Mulford & Bonet.**—Manufacturers of Diamond and Gold Jewelry. Dealers in Rolled Plated Goods, 21 Maiden Lane.  
**Brown, Thos. G.**—Manufacturer of Rich Jewelry Necklaces, Locketts, Bracelets, Sleeve Buttons, etc., 9 Bond street, N. Y.  
**Bryant & Bentley**—Manufacturing Jewelers Rings a specialty. 12 Maiden Lane.  
**Brainerd & Steele**—Successors to Brainerd, Steele & Co., Manufacturers of Fine Jewelry and Brainerd's Patent Locketts. No. 9 Maiden Lane, New York.  
**Burch & Fellows.**—Successors to Geo. Burch & Co., Manufacturing Jewelers, No. 17 Maiden Lane.  
**Carter, Howkins & Sloan.**—Manufacturing Jewelers, Whiting Building, 4th St. & Broadway.

**Chatellier & Spence.**—Manufacturing Jewelers. No. 694 Broadway, N. Y.  
**Champonoi & Co.**—Manufacturing Jewelers, No. 1 Maiden Lane. Specialties—Jet Cluster Goods in Sets and Sleeve Buttons, Engraved and Enameled Goods in Sets, Studs, Sleeve and Collar Buttons, Lace, Shawl and Cuff Pins, Ear Knobs and Crosses.  
**Cook, Groeschel & Co.**—Manufacturers of Fine Jewelry and Locketts, 191 Broadway (over Mercantile Bank,) N. Y.  
**Demmert Bros.**—Manufacturers and Importers of Fine Jewelry, Cameo and Onyx Locketts, Sleeve Buttons and Sets a specialty. Old No. 9 Maiden Lane, New York.  
**Falkenau & Oppenheimer**—Manufacturing Jewelers. Specialty—Knife Edge Work and Rings. 89 Nassau Street.  
**Field & Co.**—Manufacturing Jewelers, 8 Maiden Lane, N. Y.  
**Finkelmeier, Louis**—Manufacturing Jeweler. Jobbing and ordered work for the trade at moderate prices. 73 Nassau Street, N. Y.  
**Goddard, John M.**—Manufacturing Jeweler.—Seal Rings and Fine Locketts a specialty, No. 3 Maiden Lane, N. Y.  
**Greason, Bogart & Pierce,** successors to Arthur, Rumrill & Co., 182 Broadway, manufacturers of fine jewelry and gold chains  
**Hartmann, P.**—Manufacturer & Importer of Fine Gold, Diamond, and Filagree Silver Jewelry, No. 36 Maiden Lane. P. O. Box 2,454.  
**Haskell, H. C.**—Manufacturing Jeweler. Seal Rings a specialty. Special attention to Jobbing of every description. 12 John street.  
**Henderson & Winter**—Jewelers, No. 15 Maiden Lane, New York. Specialties—Stone, Cameo, Onyx, Amethyst, Topaz, Pearl and Turquoise Rings.  
**Hunt & Owen.**—Manufacturing Jewelers. Office 5 Maiden Lane.  
**Hale & Mulford.**—Manufacturers Rich Jewelry, Whiting Building, Broadway and 4th Street.  
**Jeanne Brothers.**—Manufacturers of Diamond Mountings & Rich Jewelry. 1 Maiden Lane.  
**Kellei, Chas. & Co.**—Manufacturing Jewelers Locketts a Specialty. No. 18 John St., N. Y.  
**Krementsz & Co.**—Manufacturing Jewelers, No. 13 John Street, N. Y.  
**Kroll, H.**—Manufacturer of Fine Jewelry. Repairing (a specialty) done for the trade at moderate prices, 78 Nassau street.  
**Kuhn & Doerflinger**—Manufacturers of Enamel'd and Roman Band Bracelets, also Fine Locketts and Pendants, 18 John street.  
**Lennon, John D.**—Manufacturing Jeweler, 142 Fulton street. Flat, and Half-round Gold Bracelets, Roman and Stone Locketts.  
**Moore & Horton.**—11 Maiden Lane, Manufacturing Jewelers, Rings, Studs, Collar and Sleeve Buttons, Pins, Ear-rings, &c.  
**Marx Kossuth & Co.**—Manufacturing Jewelers 39 Maiden Lane.  
**Owen, G. & S. & Co.**—Manufacturing Jewelers. Office, No. 5 Maiden Lane.  
**Riker, William**—Manufacturer of Jewelry. Inlaid Gold Jewelry a Specialty. No. 5 Maiden Lane, N. Y.  
**Riley, J. A. & Co.**—Manufacturing Jewelers, Etruscan Gold and Coral Sets, Roman Bracelets, Necklaces, etc. Onyx Goods a specialty. 7 and 9 Bond street, New York.  
**Richardson, Enos & Co.**—Manufacturers of Fine Gold Jewelry, Gold Chains, Locketts, Crosses and Necklaces. Colored and Etruscan Work. No. 23 Maiden Lane, New York.  
**Richardson, J. W. & Co.**—Manufacturers of Jewelry, Masonic and other emblems. 196 Broadway, Manufacturing, Providence, R.I.  
**Richter, Jacob**—Established 1868. Watch Repairer for the trade. Special attention given to complicated work, 528 State Street.  
**Ripley, Howland & Co.**—Manufacturers of Fine Jewelry and Diamond Mounting. 35 Maiden Lane, N. Y.  
**Sauter, L.**—Manufacturer of Fine Jewelry, Solid Stone Rings and Studs a specialty. Jobbing for the Trade. 65 & 67 Nassau st.  
**Sexton & Cole**—Manufacturing Jewelers, Colored Gold and Onyx Goods a specialty. No. 30 Maiden Lane.  
**Shoemaker & Co.**—Manufacturing Jewelers, Cameo Buttons, and Locketts, Roman Gold Goods, etc. No. 21 Maiden Lane, N. Y.  
**Stites, D. H. & Son**—Manufacturers of Fine Jewelry, Rolled Plated Goods and Chains Parisian Diamond Rings, Studs and Ear-rings a specialty. 41 Maiden Lane, N. Y.

**Stites, E.**—Manufacturer of Fine Jewelry. No. 12 Maiden Lane, N. Y.  
**Sturdy Bros & Co.**—Manufacturers of Jewelry. General line of fine and heavy Rolled Plate Goods. Specialties—enameling on gold plate; graduated wire coral work. 14 Maiden Lane, N. Y.  
**Terhune, Charles F.**—Manufacturing Jeweler, 16 Maiden Lane, N. Y.,  
**Thoma, Ernest**—Manufacturer of Fine Jewelry. Sleeve Buttons, Rings, Ear-rings, &c. No. 173 Broadway, N. Y. Factory, Hackensack, N. J.  
**Trier Bros. & Co.**—Jewelry. Optical, Rubber, Jet, Shell, Ivory, Amber and Pearl Goods. Silk Guards, Japanese Bamboo Watch Chains a Specialty. No. 15 Maiden Lane.  
**Unger, H. & Co.**—Manufacturers of Fine Gold Jewelry, Colored and Etruscan work, Enameled Sets, etc. Office and Factory, 18 Crawford street, Newark, N. J. Box 63.  
**Wadsworth, E. E.**—Manufacturer of Rich Jewelry and fine Rolled Plate. Fine Seal Rings a specialty. 35 Maiden Lane.  
**Wheeler, Parsons & Hays.**—Manufacturers of Fine Jewelry, Watch Cases, Gold Chains, &c and Dealer in American and Swiss Watches, No. 2 Maiden Lane, N. Y.  
**Wienhold, Joseph**—Manufacturer of Fine Jewelry and Diamond Setter. 24 John St.

**Jewelers' Tools, etc.**

**Fraser & Co.**—Importers of Stubs, Freuch, Swiss, German and Sheffield Tools, Files and Steel Wire for Watchmakers, Jewelers, etc., 62 Chatham street, N. Y.  
**Hecht, Phil.**—Importers and dealers in Watch makers' materials, Tools, Optical Goods and Silk Guards, etc. 13 Maiden Lane, N. Y.

**Lapidaries.**

**Fox, M. & Co.**—Practical Lapidaries, No. 1 Maiden Lane, New York.  
**Kordmann & Michel**—Lapidaries, dealers in Precious Stones. Rubies, Sapphires and Peridots cut. No. 59 Nassau Street.

**Masonic Jewelry.**

**Wilkinson, C. B. & Co.**—Manufacturers of Masonic, Odd Fellows, Athletic Clubs and other Jewelry, No. 212 Broadway, New York.

**Opticians.**

**Burbank Man'g Co.**—Manufacturers of Spectacles and Eye Glasses of all descriptions, in gold, silver, etc., 14 Maiden Lane, N. Y.  
**Du Bois, Geo. W.**—Successor to A. Landsberg, Importer and Manufacturer of Optical Goods 36 Maiden Lane, Box 3993, N. Y.  
**Laurencott, J. B.**—Importer of Watch Glasses, Optical and Fancy Goods, Clocks, Bronzes, etc., 33 Maiden Lane, N. Y.  
**Lorsch, Albert**—Manufacturer of the Patent Accommodating Spectacles and Eye Glasses in Gold, Silver and Steel, and other Optical Goods, 37 Maiden Lane, N. Y.  
**Serin, A.**—Manufacturer of Spectacles and Eye-Glasses, in Steel, Shell and Rubber. Repairing of all kinds. Opera Glasses covered and re-gilt, etc. 169 and 171 Fulton street.  
**Spencer Optical Manufacturing Co.**—Gold, Silver, Steel and Nickel Plated Spectacles, Eye Glasses, &c. 13 Maiden Lane, N. Y.

**Precious Stones, &c.**

**Bissinger, Philip**—Importer of Diamonds, Pearls and Precious Stones. Agent for the Bohemian Garnet Goods. No. 22 John St., N. Y.  
**Fox, M. & Co.**—Importers of Diamonds and other Precious Stones, No. 1 Maiden Lane, New York.  
**Gruet, Jules.**—Importer of Precious and Imitation Stones, Amethysts, Topazes, Cameos, Garnets, Doublets, Imitation Diamonds, Pastes, etc., No. 14 John street. Manufactory at Septmoncel, France.  
**Meyer, Francis Ed.**—Successors to John B. Behrmann, Importer of Imitation Precious Stones, all sizes and shapes constantly on hand. No 53 Nassau st., P.O. Box, 1981.

**Silverware.**

**Cuppia, L. A.**—Manufacturer of Solid Silver Novelties, and importer of Silver Filigree, 19 Union Square.  
**Gorham Manufacturing Co.**—Union Square.  
**Wood & Hughes.**—Manufacturers of Fine Silverware. 16 John Street, N. Y.

**Silver Plated Ware.**

- Brown & Bros.**—Manufacturers of first quality of Electro Plated Flat Table Ware. No. 81 Chamber Street, N. Y.
- Hall, Elton & Co.**—Manufacturers of the Finest Electro-Plated Ware, salesroom, 75 Chambers street, N. Y.
- Holmes, Booth & Haydens**—Manufacturers of Silver-plated Ware. 47 Chambers street.
- Meriden Britannia Co.**—Manufacturers of Silver plated Ware, 46 East 14th Street, Union Square, N. Y.
- Middletown Plate Co.**—Manufacturers of Superior Electro-Plate. Factories, Middletown, Conn., Salesroom, 13 John Street
- Rogers Cutlery Co.**—Hartford, Conn.
- Rogers & Bro.**—Manufacturers of the finest quality of Electro-Plated Ware. 690 B'way.
- Simpson, Hall, Miller & Co.**—Manufacturers of Fine Silver Plated Ware, No. 36 E. 14th St.
- Schade, Henry.**—Manufacturer of White Metal and Plated Ware, No. 84 John Street, New York. Price list and catalogue furnished on application.
- Webster, E. G. & Bro.**—Manufacturers of Fine Silver Plated Ware. Office and Warerooms, 14 Maiden Lane, N. Y.

**Show Cases, Etc.**

- Kraft & Hoffmeister**—Manufacturers of Metal Show Cases, Jewelry Trays always on hand, No. 20 North William street, N. Y.
- Smith, B. & W. B.**—Patent Improved Counter Show Cases. Drawings furnished and estimates given for fitting stores in Cabinet Work complete.

**Spectacle Case Manufacturers.**

- Koenen, A. & Bro.**—Manufacturers of Leather Spectacle & Eye Glass Cases, 81 Nassau St., N. Y.

**Thermometers Etc.**

- Tagliabue, Giuseppe**—Thermometer, Barometer and Hydrometer Manufacturer, 302 Pearl street near Beekman, N. Y.

**Thimble Manufacturers.**

- Burbank Manufg Co.**—Manufacturers of Gold & Silver Thimbles, 14 Maiden Lane, N. Y.
- Ketcham & McDougall**—Improved Gold and Silver Thimbles, Nos. 4 and 6 Liberty Place, near Maiden Lane, N. Y.
- Woglom & Miller**—Sole Agents for the "Prime" Thimbles in Gold and Silver, manufactured by Ezra C. Prime. 34 John Street, N. Y.

**Walking Canes.**

- Fradley, J. F.**—Manufacturer of Fine Gold and Silver-headed Walking Canes and Sterling Silverware. Office and Factory, 20 John st.

**Watch Companies.**

- American Watch Co.**—Robbins & Appleton, No. 9 Bond street, N. Y.
- Illinois Watch Co.**—Factory, Springfield, Ill. Office, 21 Maiden Lane.
- Hampden Watch Co.**—of Springfield, Mass. Office, No. 12 Maiden Lane, New York.
- The Howard Watch and Clock Co.**—No. 2 Maiden Lane, N. Y.

**Watch and Chronometer Jeweler.**

- Queen, James**—Watch and Chronometer Jeweler and Pallet Maker, 78 Nassau street, Room 8. Pivots inserted in Pinions, Balance, Staffs, &c.

**Watch Importers, Etc.**

- Aikin, Lambert & Co.**—Importers of Watches, Sole Agents for Paul Breton & Chas. Latour, Geneva. A general line of reliable Swiss Watches. Watch Cases of all styles made to order. 23 Maiden Lane, N. Y.
- Cross & Beguelin**—Importers of Watches, Watch Tools and Materials, dealers in American Watches, No. 21 Maiden Lane, N. Y.
- DuBois, Francis & Co.**—36 Maiden Lane, N. Y., Importers of Watches and Manufacturers of Watch Cases.
- Droz, Henry E.**—Importer of Watches and Watch Case manufacturer. Agent for the "E. Perregaux" Watch, and jobber in American Watches, No. 92 Fulton Street, N. Y.
- Freund Max & Co.**—Importers of Watches Jewelry and Precious Stones, 8 Maiden Lane
- Friedman, S.**—Importer of and dealer in Watches and Jewelry, 40 Maiden Lane.
- Gagnebin, Chas.**—Importer of all kinds of Watches, 4 Maiden Lane. Agent for Ulysse Breting's Fine Chronometers, Chronographs, Anchors, etc.
- Gallet, Julien**—Importer of Watches. No. 1 Maiden Lane.
- Ginnel, Henry**—Importer of Watches, Tools and Materials. No. 31 Maiden Lane, N. Y. P. O. Box, 2967

**Jandorf, P. & Bro.**—Importers of Watches and Jewelry, 182 Broadway, bet. John Street and Maiden Lane, New York.

**Keller, L. H. & Co.**—(Successors to G. A. Huguenin,) Importers of Fine Watch and French Clock Materials, No. 64 Nassau street, N. Y.

**Hirsch Bros.**—Dealers in Watches and Diamonds, and manufacturers of Jewelry. No. 23 Maiden Lane, New York

**Hyde's Sons, John E.**—Wholesale Commission Agents, only, for Jules Jurgensen, of Copenhagen, Ed. Perregaux, of Locc, Jules Monard, of Geneva, and for other makers of all qualities of watches, 22 Maiden Lane.

**Magnin, Ve J. Guedin & Co.**—Importers and Agents of the Nardin Watch, 29 Un. Square.

**Mathey, L. & A.**—Importers of Fine Watches and Sole Agents for the H. L. Matile's Watches, No. 16 Maiden Lane.

**Mathey, F. H.**—Importer of Watches. No. 5 Maiden Lane, N. Y.

**May & Stern**—Importers of Foreign Watches, Materials and Tools, etc. Manufacturing Jewelers. No. 19 John St., N. Y.

**Middleton & Brother.**—Importers of Swiss Watches and dealers in American Watches, Diamonds, Gold Chains, Jewelry, etc., 10 Maiden Lane, N. Y.

**Nicoud & Howard**—Importers and Manufacturers of Watches, No. 14 Maiden Lane.

**Oppenheimer Bros. & Veith**, Dealers in Watches and Diamonds, and Manufacturing Jewelers. No. 35 Maiden Lane, N. Y.

**Robert, J. Eugene**—No. 30 Maiden Lane, New York Agent for Louis Audemar's celebrated watches.

**Schwob, Adolphe**—Manufacturer & Importer of Watches, 11 Maiden Lane, N. Y.

**Stern Brothers & Co.**—Importers of Swiss Watches and wholesale dealers in American Watches, &c., 30 Maiden Lane.

**Scott, J. T. & Co.**—Importers of Watches, and Manufacturers of Jewelry, and Jobbers of all grades American Watches. No. 11 Maiden Lane, N. Y.

**Strasburger, Louis & Co.**—Importers and Makers of Watches of every description. No. 15 Maiden Lane.

**Tiffany & Co.**—Makers of Watches. General Agents for Patek, Philippe & Co. Wholesale office, 694 Broadway, N. Y.

**Watch Cases.**

**Brown, J. A. & Co.**—Manufacturers of The Ladd Patent Stiffened Gold Watch Cases, &c., 11 Maiden Lane, N. Y. Factory, 58 Eddy street, Providence, R. I.

**Watch and Chronometer Repairer.**

**Cerf, B.**—Practical Watchmaker and Repairer, No. 10 John street, N. Y. Repairing and adjusting of Fine Watches done for the trade. All kinds of escape and stem winding wheels cut to order.

**Ludeman, W. H.**—Chronometer and Watchmaker. Repairing of every description for the Trade, 75 & 77 Nassau street.

**Sirois, A.**—Practical Watchmaker, 89 Fulton street. Special attention paid to the repairing of Fine Watches. Pivots inserted.

**Watch Case Repairers.**

**Tarbox, Hiram**—Watch Case Repairing, Springing, Polishing and Engine Turning, 79 Nassau street, (room 22), N. Y.

**Renaud, F.**—Watch-Case Repairer.—Solid and Heavy Rolled Plate Bows and Pendants. Springer and Engine Turner of Cases and Jewelry, 36 Maiden Lane

**Watch Glasses, Shades, Etc.**

**Brown, Edwin**—No. 85 Nassau Street, Imported and own Manufacture Watch Glasses, Flat, Flat Concave, Concave, Convex and fine Geneva's. Fine fitting solicited.

**Hill, Robert S.**—Manufacturer of Watch Glasses, &c., dealer in Imported Glasses, Flat Glasses a specialty; also, Jeweler's Glasses. Nos. 75 & 77 Nassau street, N. Y.

**PHILADELPHIA**

**Booz & Thomas.**—Manufacturers of Gold and Silver Watch Cases and Jewelry, 108 South 8th Street, Philadelphia.

**Bennett, Jacob & Son.**—Diamond Setters and Manufacturing Jewelers. 108 South 8th St.,

**Cooper & Bros.**—Wholesale Jewelers, and Importers of and Dealers in Watch and Clockmakers' Materials, etc. Spectacles and Optical Goods. No. 35 South 4th St., Phila.

**Conover David F. & Co.**—American Watches, Wholesale Salesroom, southeast corner 7th and Chestnut streets, Philadelphia.

**Herold, Chas P.**—Successor to Hildebrandt, Herold & Co., Manufacturing Jeweler and Diamond Setter. Diamonds. 916 Chestnut St

**Krider, Peter L.**—Manufacturer of Sterling Silver Ware, Artisan Hall, No. 618 Chestnut street

**Levy, Bernard**—Manufacturers of gold and silver watch cases, and importers and dealers in Swiss and Amer'n watches, 402 Library st

**Morgan, Charles V.**—Manufacturer of Morocco and Hardwood Cases, 630 Chestnut Street, Philadelphia. Jewelry and Silverware Case, Show Case Trays, Mathematical and Surgical Instrument Cases, etc.

**McCall & Newman**—Manufacturing Jewelers, Filled Plain Gold Rings a specialty, No. 625 Arch street.

**Morgan & Headly.**—Manufacturing Jewelers Cameo sets, Gold sets, Roman Locketts, Rings, Coral sets, and a general line of rich goods. 611 and 613 Sansom street, Philadelphia.

**H. Muhr's Sons.**—Manufacturing Jewelers, Solid Gold an filled Rings a specialty, 633 & 635 Chestnut st. N. Y. Office, 11 Maiden Lane.

**Rosenthal, G. F. C.**—Manufacturing Jeweler and Diamond Setter. Engraving and Designing of Monograms a Specialty. No. 917 Sansom street, Philadelphia.

**Rowe, Geo. A.**—Stone and Metal Seal Engraver, Die Sinker and Medalist. Intaglio cutting. Special rates for large quantities, to manufacturers, 1002 Walnut street.

**Scherr, L. A. & Co.** Wholesale Dealer in Watches Silver Plated Ware, Spectacles, Fancy Goods, Watch Materials, etc., 726 Chestnut street.

**Shearer, W. H. & Co.**—Makers of Fine Jewelry 908 Chestnut Street.

**Simons, Brother & Co.**—Manufacturers of Fine Jewelry, Canes, Thimbles, Chains. 611 & 613 Sansom St., Philadelphia.

**CHICAGO.**

**American Watch Company**, of Waltham, Mass. No. 170 State street, Chicago.

**Charpior & Wathier**—Watchmaker & Jeweler for the Trade, and Wholesale Dealers in Watch Material, Tools, &c., 61 West Kinzie Street, Chicago, Ill. Send for price list.

**Clapp, Bros. & Co.**—Wholesale Jewelers, 63 & 65 Washington st. Catalogue and Price List issued to Watchmakers and Jewelers.

**Frese, B.**—Watchmaking and Repairing for the Trade promptly attended to. Stem-winding and escape wheels cut to order. No. 99 E. Madison St., Chicago, Ill.

**Giles, Bros. & Co.**—Manufacturers and Jobbers in Watches, all classes of Jewelry, Materials, Clocks, Silver Ware, &c., &c. Illustrated Catalogues furnished to dealers upon application. State and Washington sts.

**Glickauf, S. & Co.**—79 and 81 State St., Importers of Watchmakers and Jewelers Supplies Optical Goods, Watches, &c.

**Hahn, H. F. & Co.**—Wholesale Jewelers, 157 and 159 Franklin St. Largest assortment and lowest prices. We do not issue any Catalogue.

**Knights, C. H. & Co.**—Wholesale Jewelers, 125 & 127 State street.

**Kearney & Swartchild.**—113 & 115 State st.—Importers and Jobbers of Watchmakers' and Jewelers Supplies, Watches, Jewelry, &c. Illustrated Catalogue and Price List sent on application and receipt of card.

**Norris, B. F. & Co.**—Wholesale Jewelers and Dealers in Watchmakers' and Jewelers' Supplies. 101 & 103 State street.

**Stein & Ellbogen**—Wholesale Dealers in Watches and Jewelry, 127 State St., Chicago. Specialty, repairing for the Trade.

**Ward, Thos. M.**—Manufacturer of Fine Jewelry, Diamond Mountings a specialty, No. 25 John Street.

**PROVIDENCE**

**Irons, Chas. F.**—Manufacturer of Solid Gold Jewelry. Specialty Emblems, Pins and Charms Masonic, Odd Fellows, &c. 102 Friendship St.

**Perkins, C. H. & Co.**—Manufacturers of fine Gold and Plated Jewelry. 20 Conduit St.,

**NEWARK.**

**Lefort, Henry.**—Stem-winding Watch Crown Manufacturers. 80 & 82 Marshall St.

**Lelong, L. & Bro.**—Gold and Silver Refiners, Assayers and Sweep Smelters, S. W. corner Halsey & Marshall streets, Newark, N. J.

**Milne & Jourdan**—Manufacturers of Stem winding Watch Crowns 13 & 15 Frankli Ave.

MANUFACTURERS OF  
**GOLD AND FINE ROLLED PLATE**  
**JEWELRY,**

Standard Gold Stock Plate Chain,

Bracelets, Necklaces, Locketts, Crosses,

A Specialty!

**SOLID GOLD RINGS**

IN LARGE VARIETY.

Goods sent to all parts of the U. S. on approval, without declaring values, and can be returned to us in the same manner, there by saving our patrons considerable expense by not being obliged to declare values to Express Co.'s.

Diamonds,  
 Pearls,  
 Cameos,  
 Amethysts,  
 Turquoise,  
 Garnets, &c.

In future the **DIAMOND** trade will receive our particular attention. **DIAMONDS** in original packages, singly, or in pairs, mounted or unmounted, will be found constantly on hand.

Manufacturers of the Celebrated

American **SILK GUARDS,**

**39**

**MAIDEN LANE,**

**New York.**

**Kossuth Marx & Co.**



Examples of Rings made by HENRY C. HASKELL, 12 John Street, New York. No. 2.



# Waterbury Clock Comp'y

## MANUFACTURERS OF AMERICAN CLOCKS,

4 Cortlandt Street, New York.

M. BAILEY, Treasurer.

Illustrated Catalogues and Price Lists furnished to the Trade upon application.

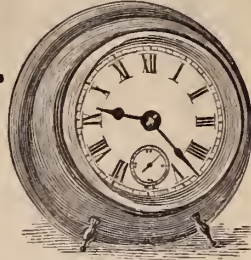

CRICKET.

No. 197 State Street, Chicago.  
Factories, Waterbury, Conn.

**SOLE AGENTS for the ITHACA CALENDAR CLOCK CO.**



VULCAN.



MONITOR.



SUNRISE.



SULTAN, No. 2.

# New Haven Clock Co.,

FACTORIES AND GENERAL OFFICES,

NEW HAVEN, CONN.

OFFICES AND SALESROOMS:

NEW YORK,

CHICAGO,

No. 62 Reade Street,

117 & 119 State Street.

L. ECERTON, Jr., Agent.

G. A. HARMOUNT, Manager.

MANUFACTURERS OF

## Clocks & Movements

—AND—

Clock Materials of Every Description.

*The Jobbing and Shipping Trade will please apply to New York Office for terms.*

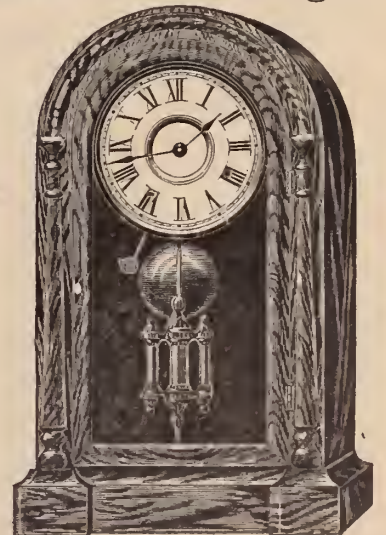

THE TRADE SUPPLIED WITH ILLUSTRATED CATALOGUES AND PRICE LISTS.

# LOUIS STRASBURGER & CO.,

Importers of

# DIAMONDS.

☞ We are direct Importers of Diamonds, dealers will therefore always find ORIGINAL parcels in our stock to select from.

MATCHED PAIRS, IN ALL GRADES AND WEIGHTS, A SPECIALTY!

NEW YORK, 15 MAIDEN LANE.

PARIS, 30 BOULEVARD HAUSSMANN.

Our complete stock of loose and mounted Diamonds enables us to send a full assortment for selection to any first-class house.

## LOUIS STRASBURGER & Co.

### Manufacturers of Watches,

From the finest Stem-Winding and Setting goods to the lowest price Watch in the market.

We manufacture and have continually in stock a complete assortment of the best COMMERCIAL WATCHES ranging from the lowest priced Metal and Silver Watches to the finest Gold Watches, such as REPEATERS, CHRONOGRAPHS (single and split) and all other Timing and Complicated Watches.

Also a full assortment of the INTERNATIONAL and all AMERICAN Movements. *Gold and Silver Cases*, constantly on hand.

We would call particular attention to our complete and varied assortment of NICKEL WATCHES, (black and fancy Dials,) in all grades, styles, and sizes.

THE RAIL-ROAD TIMEKEEPER A SPECIALTY.

SALESROOMS, No. 15 MAIDEN LANE, NEW YORK.

Watch Factory, Rue Leopold, Chaux de Fonds, Switzerland.



# SPECIAL SALE

OF

## ELGIN

### 14 SIZE KEY WINDING MOVEMENTS

At Near Half of Former Prices.

*We have bought the entire line of these movements, viz :*

**No. 35, 7 Jewels, Expansion Balance.**

**No. 39, 13 Jewels, 3 pairs Expansion Balance.**

**No. 37, 15 Jewels, 4 pairs Adjusted Ex: Balance.**

**No. 46, 15 Jewels, 4 pairs Nickel Adjusted Ex. Bal'**

### The Greatest Bargain Ever Offered to the Trade.

*These goods are cased in gold and Silver, hunting or open faced. Movements separately if desired For TERMS and PRICES address the undersigned,*

## HENRY GINNEL,

P. O. Box 2967.

**31 Maiden Lane, New York.**

NASHVILLE, V. P.

# G. S. LOVELL,

Importer and Wholesale Dealer in

## CLOCKS, BRONZES,

AND

## SILVER-PLATED WARE,

CELTIC, V. P.

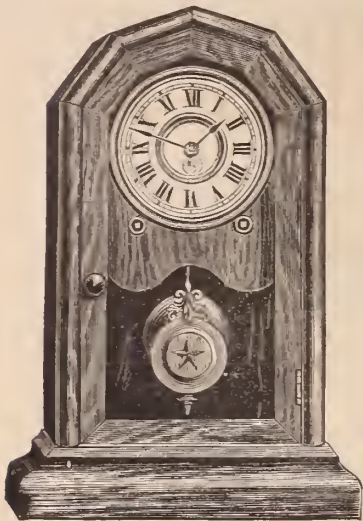

Imports French Marble Clocks, German Cuckoo Clocks,  
Ornamental Bronzes, etc., and wholesales  
**AMERICAN CLOCKS, SILVER-PLATED WARE,**

MADE BY

ANSONIA CLOCK CO. WATERBURY CLOCK CO.  
SETH THOMAS CLOCK CO. E. INGRAHAM & CO.  
AND WM. L. GILBERT CLOCK CO.

MADE BY

WILCOX SILVER PLATE CO.,  
MIDDLETOWN PLATE CO. ROGERS CUTLERY CO.,  
REED & BARTON, AND OTHERS.

AT LOWEST FACTORY PRICES.

**No. 731 Market Street, Philadelphia.**

### BIRCH'S PATENT KEY-RING TRIANGLE.

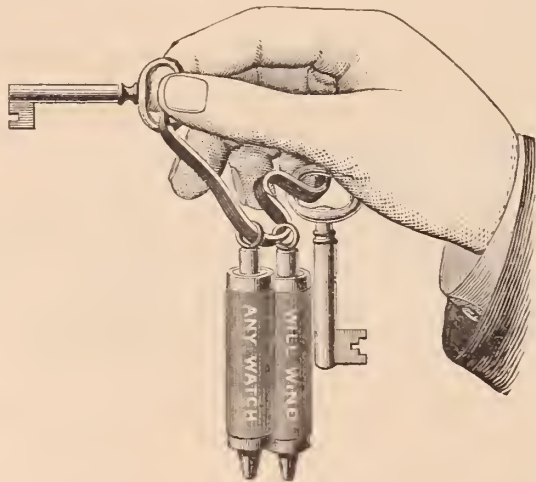

In presenting to the trade an article in such universal demand as a KEY RING, it is necessary to exhibit some marked improvements and advantages in order to induce favorable opinion. This we propose to do in our new KEY RING TRIANGLE, for it embodies simplicity in design, durability in material, and quickness in use. The old-fashioned circular rings are clumsy and inconvenient, especially when carrying a number of Keys, but that is at once avoided in our TRIANGLE, for passing the object Key to the apex, and grasping it between the finger and thumb, the other keys drop down to the base of the triangle, and leave the thumb and forefinger free from all obstructions, so that they can work the Key in the lock with as great ease as if the Key was detached from the triangle.

Nothing can be more simple than the manner of attaching or disengaging the Key from the triangle, as in either case the work is done with one motion. In point of durability, the triangle speaks for itself; for, being manufactured from one piece of steel, it will not break or bend out of shape, a fault so often to be found with the circular key rings now in use.

FOR SALE BY THE TRADE.

J. S. BIRCH & CO.,  
38 DEY STREET, N. Y.

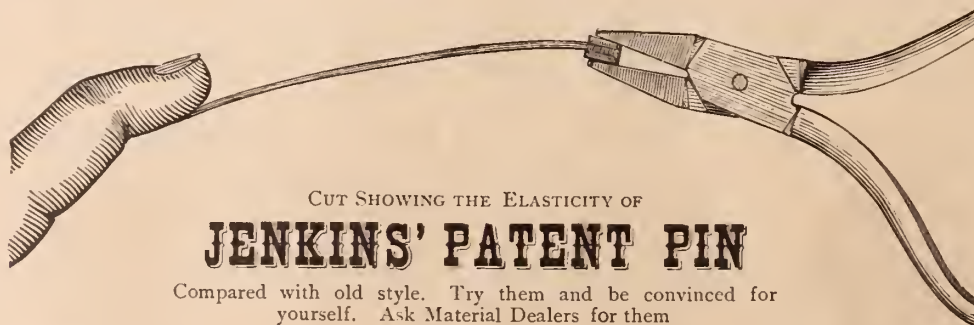

CUT SHOWING THE ELASTICITY OF

### JENKINS' PATENT PIN

Compared with old style. Try them and be convinced for yourself. Ask Material Dealers for them



The original form restored by its own strength.

Infringements on any of these patents will be prosecuted to the fullest extent of the law

Patented March 25th, 1873, August 1, 1876, December 4, 1877, May 21, 1878.



The old style soldered in socket or otherwise, always weak where it should be the strongest.

THE  
**MERIDEN BRITANNIA COMPANY**

MANUFACTURERS OF

**SILVER-PLATED WARE,**

**No. 46 East 14th Street,**

UNION SQUARE,

NEW YORK.

**Porcelain-Lined Ice Pitchers.**

**1847. Rogers Brothers' Spoons, Forks, Table Cutlery, &c.**

☞ We take pleasure in referring to the reputation we have for many years maintained for manufacturing SPOONS AND FORKS, BEARING THE TRADE MARK, "1847, ROGERS BROS."

☞ Particular attention is invited to our *Patented Process of Electro-Plating Spoons and Forks*, by which the parts most exposed to wear receive an EXTRA COAT OF SILVER. This feature renders these goods more economical and durable than those of any other manufacture, while the increased cost is relatively small. This method of plating we apply to the 4, 8 and 12 oz. plate, as required.

☞ To protect the purchaser against imitations, it should be observed that the Improved Spoons and Forks bear our Trade Mark, "1847, ROGERS BROS., XII."

☞ FIRST PREMIUMS awarded at all Fairs where exhibited, from the World's Fair, 1853, to American Institute Fairs, 1873, 1874 and 1875, inclusive, and at the Philadelphia Exhibition, 1876.

☞ Extract from the *American Institute Report*:—"Their Porcelain-lined, Double-walled Ice Pitchers are *Art*, and possess all the qualities the company claim." \* \* \* "We consider the goods made by this company to be by far the best made in this country, and we believe in the world."

The STAR SALT  CASTER COMPANY

Sole Proprietors and Manufacturers of

CELEBRATED

**STAR SALTS**



☞ For convenience, neatness and utility the STAR SALTS have become a household necessity.

The pulverizer in the bottle, as shown by the cuts, keeps the salt pulverized, and obviates the disagreeable habit of spilling the salt by dipping out of an open salt cellar.

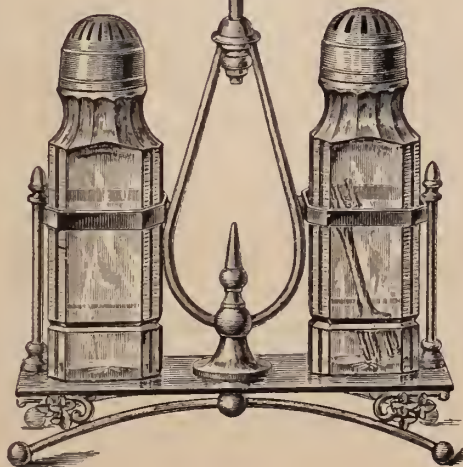

No. 161 Franklin Street,  
**BOSTON, MASS.**

Place these in the family and Salt Cellars  
 will be discarded.

MANUFACTURED IN ALL VARIETIES  
 OF PLAIN AND FINE CUT  
 GOODS, CASTERS, &c.

Special care given to orders for exportation.

Fine Diamond Cut, with  
 Sterling Caps.

☞ For full descriptions of the above goods see our Illustrated Catalogues, which will be mailed on application.

# SIMPSON, HALL, MILLER & CO.

**Manufacturers of Fine Silver-Plated Ware,**

Factories, Wallingford, Conn.

Salesroom, No. 36 E. 14th St., N. Y.



One of the oldest and most reliable manufactories in the country.

Our assortment includes a large and complete line of Hollow Ware, comprising many new and beautiful designs especially produced for the Holiday trade. The attention of the trade is particularly called to these new articles which possess the highest merits, both of construction and ornamentation. Many novelties have recently been added to our line.

**Our Solid Table Ware is made of the best Nickel Silver.**

**SPOONS, FORKS, LADLES, PIE KNIVES, &C.**

In great variety of Patterns.

**Solid Steel Knives of Superior Quality.**

## REMOVAL.

We will remove our Salesroom to No. 36 East Fourteenth Street, Union Square, about February 1st, 1879.

NOTE.—We have just issued an illustrated catalogue of our wares, which has been in preparation for several months. This book we will furnish to dealers on application.

# ROGERS CUTLERY COMPANY.



**WM. ROGERS,**

Senior Member and Manager of the Firm of ROGERS BROTHERS. Died Feb. 17, 1873.



**ASA H. ROGERS,**

Of the original ROGERS BROTHERS, and half owner of the Rogers Cutlery Co., when organized. Died Oct. 4, 1876.



**F. WILLSON ROGERS,**

Son of the late Wm. Rogers, and Secretary of the ROGERS CUTLERY CO.



Our Knives stamped as above we guarantee

To Strip 12 dwts. of Silver per dozen.

Our Knives are guaranteed to be

**ALL HAND BURNISHED,**

and are put up in rack boxes with hinge covers.

**WE GUARANTEE our Spoons, Forks, &c. to be Plated 25 Per Cent. HEAVIER THAN STANDARD PLATE.**

We guarantee Spoons, Forks, &c. to be plated on **18 PER CENT. NICKEL SILVER, AS FOLLOWS:**

On TEA SPOONS,	2½ ounces, or 50 dwts. per gross.
On DESSERT SPOONS,	3¼ " " 75 " "
On TABLE SPOONS,	5 " " 100 " "
On DESSERT FORKS,	3¼ " " 75 " "
On MEDIUM FORKS,	5 " " 100 " "

**OUR SPOONS, FORKS, LADLES, &c. ARE STAMPED**

On EXTRA PLATE,	. . . 1871, ROGERS	Ⓒ 5 oz.
On DOUBLE PLATE,	. . . 1871, ROGERS	Ⓒ 8 oz.
On TRIPLE PLATE,	. . . 1871, ROGERS	Ⓒ 12 oz.
On QUADRUPLE PLATE,	. . . 1871, ROGERS	Ⓒ 16 oz.



All Hollow Ware stamped as above is warranted to be plated

**50 PER CENT. HEAVIER** than any other brand of goods.

Our Hollow Ware in addition to our trade mark is stamped

**SEXTUPLE PLATE,**

we being the only firm who manufacture this weight of plate.

The above is a fac-simile of our guarantee card which accompanies each dozen of our flat ware, and each piece of our hollow ware. Our goods have been in the market since 1871, and are acknowledged by all dealers, who have tried them, to be THE BEST. We would call especial attention to the EXTRA STRONG SPRING TEMPERED SHANK, which we have on our Tipped, Fiddle, Saxon and Imperial pattern

# THE MIDDLETOWN PLATE CO.'S

## SUPERIOR SILVER-PLATED WARE.

New Designs in Tea Sets, Water Sets, Pitchers, Tilting Sets, Baskets, Butter Dishes, Syrup Pitchers, Spoon Holders, Cups, Goblets, Waiters, Fruit and Berry Dishes, all in New Designs for 1879.

---

## MIDDLETOWN PLATE COMPANY,

No. 13 John Street, N. Y.

Middletown, Conn.

---

## C. G. ALFORD & CO.,

Manufacturing Jewelers,

No. 183 BROADWAY,

NEW YORK.

---

### TO THE TRADE.

*Our efforts to protect the interests of the legitimate Jewelry Trade by refusing to send our Illustrated Catalogue to outside dealers has won the universal approval of the entire retail trade, who have demonstrated their appreciation of our efforts in this direction, by sending us their orders. We are glad to know that our Catalogue occupies an important place in the stores of Retail Jewelers, and that they in many ways find it of great convenience.*

*We have in contemplation certain changes that will add to its interest and usefulness, which will be made known when they assume a definite form.*

*We wish to state that we shall in the future, as in the past, use our best efforts to protect the interest of patrons, the legitimate retail dealers, by publishing a Catalogue exclusively for their use, and one that may be shown to their customers without the risk of exposing their profits.*

*Applicants for copies must enclose business card as a guarantee that they are regularly in the trade.*

**MILLER BROS,**  
**MANUFACTURING JEWELERS,**  
 No. 11 MAIDEN LANE, NEW YORK.

Manufactory, 47, 49 & 51 Franklin Street, Newark, N. J.

**INITIAL GOODS**



**A SPECIALTY!**

**Seals, Locketts, Sets, Sleeve Buttons, Studs, Collar and Chemise Buttons.**

ATTENTION IS INVITED TO OUR

NEW STYLES OF ETRUSCAN SLEEVE BUTTONS,

MOUNTED WITH

**RUSTIC LETTERS**

BIRDS, ANIMAL HEADS AND FANCY ORNAMENTATIONS

**DAVID F. CONOVER & CO.**

(SUCCESSORS TO WM. B. WARNE & CO.)

Importers, Manufacturers and Wholesale Dealers in

**WATCHES AND JEWELRY,**

**Silver and Silver-Plated Ware,**

AMERICAN WATCH WHOLESALE SALESROOM,

**Southeast Corner Chestnut and 7th Sts.,**

(FIRST FLOOR.)

DAVID F. CONOVER, }  
 B. FRANK WILLIAMS, }  
 C. EDGAR RIGHTER, }

**PHILADELPHIA, PA.**

# TIFFANY & CO.'S AMERICAN PEDOMETER.

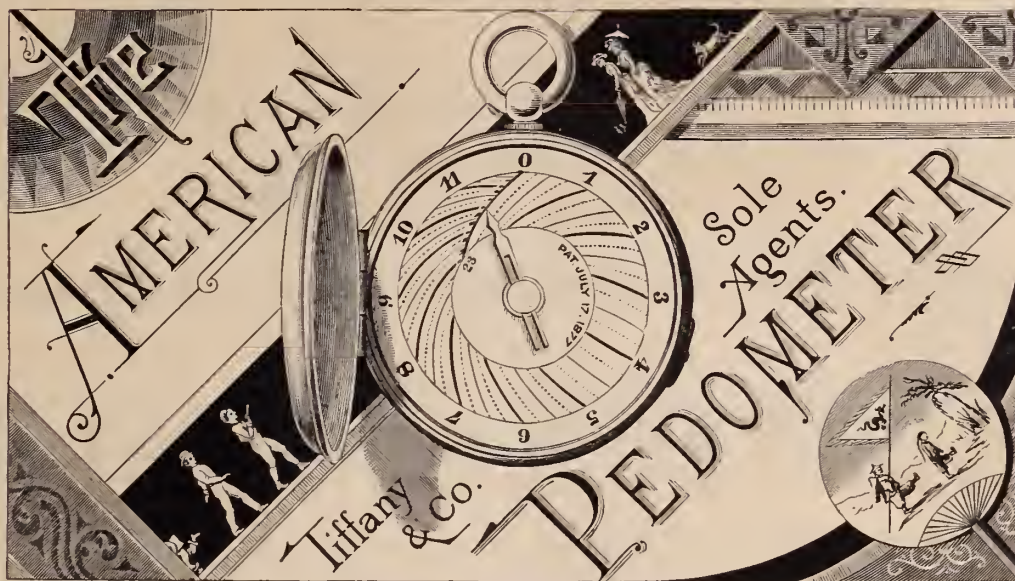

Messrs. TIFFANY & CO. invite public attention to the AMERICAN PEDOMETER, a remarkable invention of Mr. Benjamin S. Church, the well known Engineer of the Croton Aqueduct.

This instrument accurately measures the distance a person carrying it walks, showing the amount of daily exercise taken in and out of doors.

Its mechanism is a marvel of simplicity, and can be adjusted to any length of step. It is strong and durable, and the size of a small watch. Ladies, Professional and Business Men, Students, Pedestrians, Sportsmen, Farmers, Surveyors, and others will find it very useful. A table accompanies each Pedometer, giving the number of steps taken in a mile, second, minute, hour and day.

There are two forms of index, one registering steps from 23 to 35 inches in length, and another, adapted for ladies and children, registering steps from 17 to 26 inches in length. The cases are of nickel-silver, the size of a small watch.

We have just finished an OPEN-FACE with white enameled dial, heavy crystal front, (retail price, \$7.00) but unless otherwise ordered, we send the one registering steps from 23 to 35 inches in length, in hunting case similar to above engraving. Retail Price, \$5.00.

## TIFFANY & CO.

UNION SQUARE,

SOLE AGENTS.

NEW YORK

The trade supplied only by TIFFANY & CO., 14 John St., who do not sell to Jobbers, but are establishing as "exclusive agents" dealers who order quantities. Early application solicited.

# FAHYS'

## No. 1 SILVER CASES.

TRADE MARK.



Guaranteed full weight, made throughout of

### COIN SILVER, AMERICAN STANDARD,

and finished in all the latest and most desirable styles for Hunting and Open-Faced Watches.

These CASES have achieved a high reputation in the trade for their excellence of workmanship and finish.

Dealers will find my stock the largest to select from of any manufacturer in the United States, and an assortment that cannot be found elsewhere.

Price Lists furnished by the Jobbers and by the undersigned.

### JOSEPH FAHYS,

5 Maiden Lane,

**NEW YORK.**



## GORHAM MANUFACTURING COMPANY,



## SILVERSMITHS,

PROVIDENCE

AND

NEW YORK.

---

 California Office, 120 Sutter Street, San Francisco.
 

---

## "TIPT" AND "FIDDLE" PATTERNS.

"TIPT."

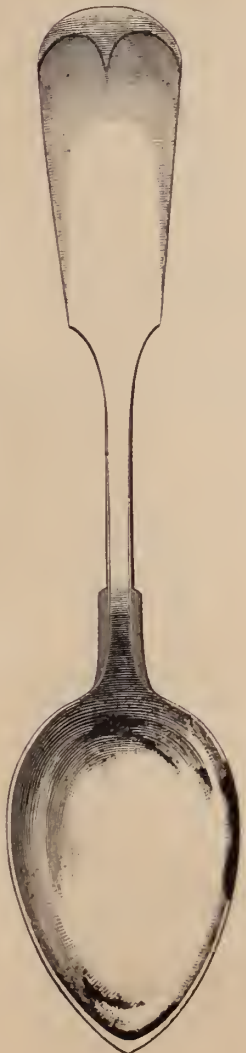

"FIDDLE."

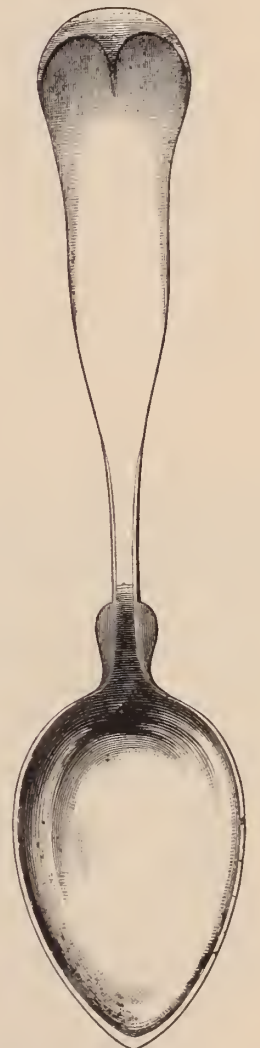

WE have given special attention to these patterns with the specific object of giving additional strength to a spoon which has always, in the light weights, been too weak for actual service. We now offer to the trade a good serviceable spoon in silver of *guaranteed sterling* quality, for a lower price than has hitherto been asked for the common grades.

These patterns which have become "as familiar as household words" throughout the country, have with the exception of those of our own manufacture, generally been made of coin, and often in very inferior quality, though *stamped coin*. While our company adheres strictly to one standard, first quality (sterling  $\frac{925}{1000}$ ), and offer reliable guarantee in that respect, we feel warranted in calling the attention of all dealers to the fact that spoons of these patterns, made from stock of very inferior quality are on the market. Some which we have recently assayed, *stamped coin*, proved to be only  $\frac{730}{1000}$  fine instead of 900.

Tests by United States Mint assay are so readily obtained, we advise all dealers for their own protection to avail themselves of it.

Orders for our "TIPT" and "FIDDLE" and other patterns in dozen work will be stamped with customers' names if preferred to our own.

GORHAM MANUFACTURING COMPANY.

THE  
JEWELERS' CIRCULAR AND HOROLOGICAL REVIEW,



*The recognized organ of the Trade, and the official representative of the  
Jewelers' League.*

A Monthly Journal devoted to the interests of Watchmakers, Jewelers, Silver-  
smiths, Electro-plate Manufacturers, and those engaged in the  
kindred branches of art industry.

SUBSCRIPTION :

To all parts of the United States, Canada, Great Britain and the West Indies,  
**\$2.00 Per Annum; Postage paid.**

To France, Switzerland, Germany, Mexico, the Republics of South America,  
and Australia, \$2.50 per annum. Postage paid.

 All communications should be addressed to D. H. HOPKINSON, 42 Nassau  
Street, New York.  Advertising rates made known on application.

AGENCIES: { J. H. PURDY & CO., No. 170 State Street, Chi ago.  
PRATT & CO., Ninth and Arch Streets, Philad-elphia.  
HERMAN BUSH, No. 14 Mytongate, Hull, England.  
FREARSON BROS., Adelaide, Australia.

 MESSRS. LEE & WIGFULL, the well known Electro-plate manufacturers, (John  
street Works), Sheffield, England, have kindly consented to receive subscriptions.

# Dorrance, Edge & Co.

MANUFACTURERS OF  
THE CELEBRATED WOVEN FABRIC

## GOLD CHAIN.

*Elegantly Mounted Bracelets, Opera, Leontine,*

VICTORIA WATCH GUARDS & NECKLACES, in all the Newest Designs.

Our stock is unusually complete, and, in addition to the above, a variety of Necklaces, from 1½ to 40 dwt. each, to which we invite the attention of buyers.

No. 9 John Street, New York.

Factory, 46 Greene Street, Newark, N. J.

ESTABLISHED 1859

## RINGS A SPECIALTY.

BRYANT & BENTLEY,

No. 12 Maiden Lane, New York,

MANUFACTURE A LARGE VARIETY OF

## FINE SOLID RINGS,

For Ladies and Gentlemen, in CAMEO, AMETHYST, ONYX, TOPAZ, TURQUOISE, GARNET and other stones. FINE CAMEO, CORAL and ROMAN SETS of new and handsome designs. LOCKETS, MEDALLIONS, SHAWL and SCARF PINS, SLEEVE BUTTONS, STUDS, &c. All goods warranted.

We continue to manufacture several hundred patterns of **HARD SOLDER RINGS**, in every style, for men, women and children, stamped and warranted 16 karat fine.



In placing these Oils before the Trade, we do so with entire confidence, from many years' experience in procuring them from the fish, and in their preparation for use, and more than all, the thorough and SEVERE TESTS they have been subjected to in use upon Chronometers in our whale ships, often absent from fifty or sixty months. Liberal samples furnished on application.

AGENTS—Cross & Bequelin, 21 Maiden Lane, New York; Kearney & Swartzchild, 147 State street, Chicago; Glickauf & Newhouse, 120 Sutter street, San Francisco; Bowler & Burdick, 208 Superior street, Cleveland, Ohio; Heeren Bros., 30 Fifth avenue, Pittsburgh, Pa.; Louis A. Scherr & Co., 726 Chestnut street, Philadelphia; Wm. Bond & Son, 97 Water street, Boston; Robert Haswell & Son, 49 Spencer street, London.

LOUIS A. SCHERR.

CHAS. H. O'BRYON.

G. W. SCHERR

# LOUIS A. SCHERR & CO.

Importers and Wholesale Dealers in

## Watches, Jewelry,

WATCH MATERIALS, TOOLS, GLASSES, &c.

Spectacles, Silk Guards, &c.

Wholesale Agents for American Watches.

No. 726 CHESTNUT STREET,

FIRST FLOOR,

PHILADELPHIA.

## WILLIAM BARBER'S Patent Adjustable Eye-Glass.



The above cut represents an Eye-glass possessing the convenience of an Eye-glass and the utility of a Spectacle combined, thereby rendering it practicable for everyone to avail themselves of their convenience, who have heretofore been deprived of their use.

### TRY THEM, WILL RECOMMEND THEMSELVES

We manufacture them from Gold, Nickel, Steel, Shell and Rubber.

WILLIAM BARBER,

Inventor, Patentee and Manufacturer,

No. 243 North 8th Street, Philadelphia, Pa.

Medal and Diploma of Merit  
Awarded by Centennial Com.

## S. C. JACKSON,

MANUFACTURER OF FINE

## CASES

For Jewelry, Silver Ware,  
Trays, &c.

180

BROADWAY  
NEW YORK.



# CARROW, BISHOP & CO.

SUCCESSORS TO

**Carrow, Crothers & Co.**

MANUFACTURERS OF

## GOLD JEWELRY,

**No. 12 JOHN STREET,**

**NEW YORK.**

# SINNOCK & SHERRILL,

Stone Ring Manufacturers,

NO. 5 MAIDEN LANE,

Factory, Newark, N. J.

**NEW YORK**

Established 1845.

# WILLIAM H. BALL,

SUCCESSOR TO

**BALL & BARNARD,**

MAKER OF

Roman, Enameled and Engraved

**BANDS.**

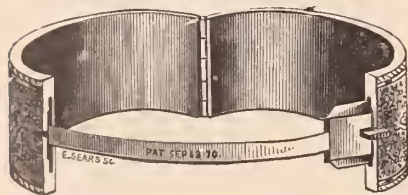

Having given the manufacture of Band Bracelets my entire attention for a number of years, it has been my desire to make a durable article, one that will give satisfaction to the seller as well as the wearer. I desire to call the attention of the trade to the reduction I have just made in prices, still keeping up the standard as to quality, finish and workmanship. To each pair of BANDS I attach my patent guard without extra charge—thus saving the price of chain—which for seven years past has given entire satisfaction.

**No. 9 JOHN STREET, NEW YORK.**

Factory, 30 & 32 Franklin Street, Newark, N. J.

# E. HOWARD & CO.,

MANUFACTURERS OF

**Fine Watches, Regulators, Office Clocks,**

Electric Watch Clocks & Tower Clocks,

**Office, No. 694 BROADWAY,**

Corner Fourth Street,

**NEW YORK.**

**No. 114 TREMONT STREET, BOSTON.**

J. W. J. PIERSON, - - AGENT.

*Established 1818.*

# THOMAS G. BROWN,

MANUFACTURER OF

**FINE JEWELRY,**

**NEWARK, N. J.**

—AND—

**9 BOND STREET, NEW YORK.**

# BUCKENHAM, COLE & SAUNDERS,

SUCCESSORS TO

**BUCKENHAM, COLE & HALL,**

IMPORTERS OF

**Diamonds, Pearls**

**AND OTHER PRECIOUS STONES,**

**MANUFACTURERS OF FINE JEWELRY,**

**10 Maiden Lane, New York.**

A large stock of FINE DIAMONDS, Mounted and Unmounted kept constantly on hand. Goods sent on approval to any part of the country on receipt of satisfactory references.

ESTABLISHED 1837.

VICTOR BISHOP & CO.

IMPORTERS OF

**DIAMONDS,**  
PRECIOUS STONES

—AND—

**CORAL JEWELRY,**

Enamel Paintings, Copper and Platinum.

No. 47 NASSAU STREET, NEW YORK.

House in Paris, 66 Boulevard de Sebastopol.

**SAXTON, SMITH & CO.**  
MANUFACTURERS OF

**Fine Gold Chain.**

No. 14 Maiden Lane.

**New York.**

Factory, No. 183 Eddy Street, Providence, R. I.

Sole Agents for the new PATENTED CHAIN BAR, containing a Detachable Pencil.

**HELLER & BARDEL,**

MANUFACTURERS OF

**Diamond and Pearl Jewelry**

And Dealers in Diamonds, Pearls, &c.

SHAWL AND LACE PINS IN GREAT VARIETY.

*No. 13 John Street, New York.*

A full line of DIAMONDS, mounted and unmounted; also, a large assortment of first-class DIAMOND MOUNTINGS of our own make always on hand. Sketches submitted at any time upon application. We will send goods on selection to responsible houses.

**KOSSUTH MARX & COMP'Y,**

39 MAIDEN LANE, New York.

THE U. S. STANDARD  
FINGER SIZE  
FOR RINGS.

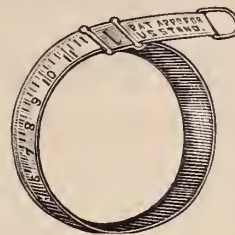

TIME AND  
TROUBLE  
SAVED.

Some of the advantages of which, will be found annexed and must be apparent to every Jeweler.

1st. It avoids danger of having rings stolen from tray while trying on to find one the size wanted, and also of being mislaid after taking the size.

2d. It saves time consumed in measuring ring on stick and avoids possibility of making a mistake in doing so, as the size ring is gauged in accordance with the U. S. Standard Stick.

3d. It necessitates trying but one ring on the finger, whereas a dozeu had sometimes to be used before the correct size was obtained.

4th. If the salesman is hurried it is not necessary to make a memorandum of the size, as the ring will remain at the size taken, and can be laid aside until some leisure time.

5th. It can be loaned to customers whereby they will be enabled to take the correct size, instead of using pieces of string and wire, thus making mistakes and often necessitating altering a ring two or three times.

HOW TO USE— Place the thumb of the hand, on which is the finger to be measured, against the joint on the size ring, and draw tight with the other hand.

FOR SALE BY ALL WATCH MATERIAL DEALERS

**WOOD & HUGHES,**

STERLING

**Silverware Manufacturers**

**No. 16 JOHN STREET,**

**NEW YORK.**

**KREMENTZ & CO.,**  
MANUFACTURERS OF

**FINE JEWELRY,**

No. 13 John Street, New York.

Factory, 361 Mulberry Street, Newark, N. J.

GOODS OF OUR OWN MAKE EXCLUSIVELY.

CARTER, HOWKINS & SLOAN,  
**Makers of Fine Jewelry**

*Consisting of Chains, Bracelets, Sets, Pins, Studs, Sleeve Buttons,  
 Scarf Pins, Rings, &c., in Roman, Etruscan and Enamel,  
 and a full line of Jewelry generally.*

Whiting Building, Corner Broadway and Fourth Street,

A. CARTER JR.  
 WM. HOWKINS,  
 A. K. SLOAN.

**NEW YORK.**

C. E. HASTINGS,  
 GEO. R. HOWE.  
 W. T. CARTER.

**HALE & MULFORD,**  
**Manufacturing Jewelers,**

(WHITING BUILDING).

No 694 Broadway, cor. 4th Street, New York.

Call attention of the Trade to their new style of

**BAND BRACELETS,**

We claim for these Bracelets, the following advantages over the old style, viz. :

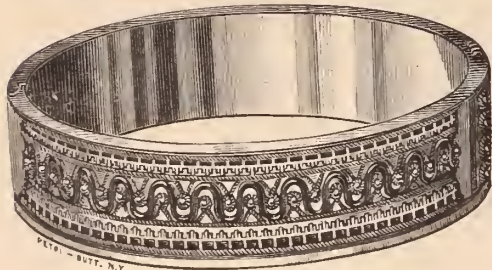

Patented February 25, 1879.

1st. The edge of the Bracelet being raised, forms a protection to the ornamentation.

2d. Less liability of getting damaged, and when damaged, are more easily repaired.

3d. More attractive in appearance.

Prices are as low as any FIRST CLASS 14 KARAT ALL GOLD Bracelet in the market.

Made in all sizes from  $\frac{1}{4}$  inch upwards.

—Established 1837.—

**TAYLOR & BROTHER,**

Late TAYLOR, OLMSTED & TAYLOR,

**Importers of Diamonds and Pearls,**

—AND—

**MANUFACTURERS OF DIAMOND JEWELRY,**

No. 676 BROADWAY,

**NEW YORK.**

**BALDWIN, SEXTON & PETERSON**

MANUFACTURERS OF

**Fine Jewelry,**

**Diamond and Stone Cameo Goods,**

**GOLD CHAINS, &c.**

**Importers of Diamonds, Pearls, Emeralds, Rubies, &c.**

WHITING BUILDING,

**Cor. Broadway and Fourth Street,**

**NEW YORK.**

Office, 120 Sutter Street, San Francisco, Cal.

Established 1817.

**Ve. J. MAGNIN, GUÉDIN & CO.**

*Manufacturers and Importers,*

FINE SWISS WATCHES,

REPEATERS, CHRONOGRAPHS & CALENDARS.

GENEVA GOLD JEWELRY,

FRENCH CLOCKS AND BRONZES,

RICH FANCY GOODS,

HORSE-TIMERS & PODOMETERS,

GOLD AND SILVER CHATELAINE WATCHES.

No. 29 UNION SQUARE, corner 16th Street, New York.

Gold Medal Awarded, Paris Exposition, 1878.

*Sole Agents for the James Nardin Watch.*

*House in Geneva, 14 Grand Quai.*

**CHATELLIER & SPENCE,**

**Manufacturing Jewelers,**

652 BROADWAY, NEW YORK.

No. 1129 Chestnut Street, PHILADELPHIA, PA.

No. 12 West Street, BOSTON, MASS.

No. 120 Sutter Street, SAN FRANCISCO, CAL.

Price Reduced!



Price Reduced!

TO JEWELERS AND DEALERS IN WATCH MAKERS' SUPPLIES.

OUR JEWELLERS' PIN VISE,

—REPRESENTED ABOVE,—

Has for more than two years been on the market, and met with very flattering approval. In offering the tool at the price below, we claim not only the BEST, but the CHEAPEST (considering the quality) pin vise in the market. This tool is made of steel throughout, with the jaws and wearing parts hardened. Every part is made to guage. The finish is first class and nickel plated.

Price - \$1.25 each; or \$15.00 per dozen, square or pointed jaws. Small Size, \$1.00 each; or \$12.00 per dozen, made with pointed jaws only.

Sent post-paid, to any part of the United States on the receipt of price. Order of any first-rate dealer in Watchmakers' Tools, or

THE LOWEL WRENCH COMPANY, WORCESTER, MASS.

Liberal discount to the Trade.

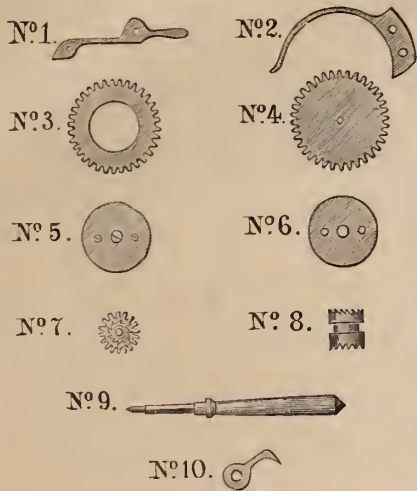

ARHELL & CO.

IMPORTERS OF

Watchmakers Tools and Materials, also Dealers in Watches and Jewelry.

Sole Agents for the "Jequier" Main Spring, the only spring of all exhibits made at the Paris Exposition that received a Medal; manufacturers of the "Boss" Engraving Block, the best and most practical in the market. Sole Agents for "Baldwin's" Barrel Catch Inserter, the most useful tool on a watchmaker's bench, saves time and labor. Send to us, or any material dealer for description. We solicit orders from material dealers for these specialties. Sole Agents for "Columbus Watch," for New York and Eastern States, nickel 3/4 plate, full jeweled, stem-winding and setting, the most beautiful watch, with best results at least money. Send for descriptive Catalogue. No price list furnished unless requested, and only to the trade. Send for price list of tools and material. Orders intrusted to us filled promptly with experience.



Stem-winding wheels cut and all work for the trade done well at moderate prices.

P. O. Box 8. CANAJOHARIE, N. Y.

GUERRANT'S ELECTRO-ENGRAVING MACHINE.

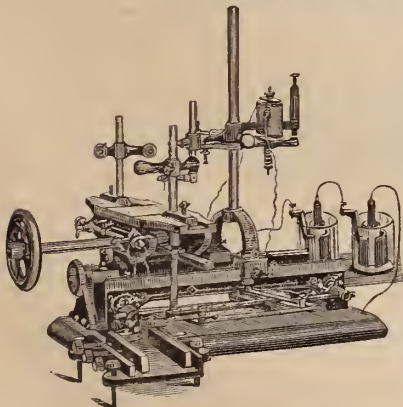

Size of Machine, 12 x 16 inches. Patented Jan. 18, Oct. 31, 1876, & Mar. 4, 1879.

It has baffled the skill of the inventive genius of the world for ages to produce a machine that would compete with the skillful hand engraver, and until this machine was invented, all engraving had to be done by hand. And, to-day, it is the only practical engraving machine in existence.

The construction of the machine is not complicated, but simple and durable. It is easily operated. The variety of work it will do is almost incredible, and to be fully appreciated, ought to be seen in operation.

We do not therefore, offer this machine to the public simply as a machine to aid the engraver, but as a perfect, practical engraver in itself, with which any person of ordinary skill can learn in a short time to do any piece of engraving that might be desired and in the very best manner.

It copies from the regular press type of any style of letter or design that is made of type, from the plainest to the finest german text letter or fancy design, at the same time it will reduce the letter or design from the original size to ten different sizes, or so small that it cannot be seen by the naked eye. It will shorten the letters or elongate them, also will lean them forward or backward, will either make a raised or sunken letter, will engrave on any surface, either plain, concave or convex—for instance, such things as Watch Cases, either in or outside; Finger Rings, either in or outside; Bracelets, Napkin Rings, Goblets, Pitchers, Mugs, Waiters, Spoons, Forks, and all kinds of Jewelry; or, in fact, on any article susceptible of being engraved or ornamented with scroll work or fancy designs, &c., either on Gold, Silver, Copper, Brass, Iron, hardened Steel, Glass, Stone, Pearl, Ivory, Bone, Gutta Percha.

No Jeweler or establishment that has engraving to be done should be without it. Machines are sold with limited territory to use them in; or, the exclusive rights to use them in certain town or territory can be purchased with the machine if desired.

For further information, address

WM. HICKSON, Gen. Agt., P. O. Box 1603, PHILADELPHIA, PA.

KARN & HICKSON, LYNCHBURG, VA.

A. M. GUERRANT, Danville, Va., Agent for the Southern States.

Owners of the right of all the Northern and Western States and Territories.

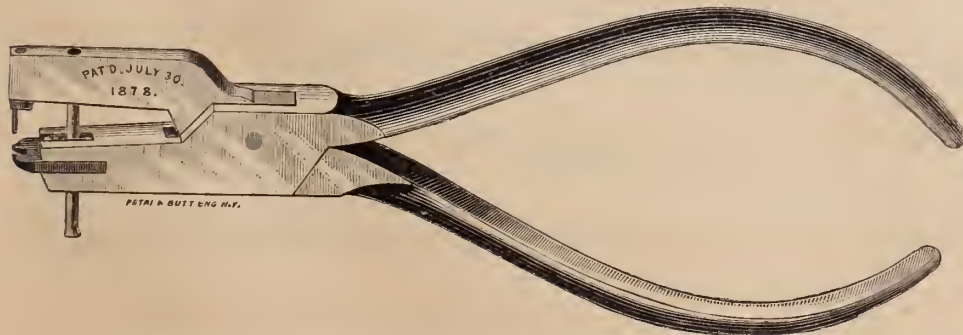

DIRECTIONS FOR USE.—Take the work in the left hand, the tool in the right, place the ejecting finger against the small end of the rivet, the notched jaw being at the other end, and a gentle pressure will remove the rivet.

PRICE \$1.00 EACH.

Every manufacturer of Jewelry is familiar with the trouble of extracting the RIVETS from joints of Jewelry. To obviate this trouble, I place before the trade a RIVET EXTRACTOR, (as represented by the adjoining cut,) which must recommend itself to the trade. This tool will remove any kind of RIVET from the smallest to the largest, from Breastpins, Locketts, Bracelets, &c., and does away with the necessity of one workman. It is manufactured of the best material and is made strong and durable. In case the ejecting finger (or pin) becomes broken (which will never occur, with a little care), remove from the jaw the piece in which the finger is set (this may be done with a flat pleyer) then with a punch drive out the broken fragment remaining, replace it with another pin, and adjust the whole to the jaw as before.

A liberal discount will be made to the Jobbing Trade. Apply to

A. S. & J. HERZOG, Sole Agents, 51 NASSAU ST., N. Y.

# ROGERS & BRO.,

Have now in stock a full line of new Low Priced attractive Goods in

## ELECTRO-SILVER PLATE,

No. 690 BROADWAY,

NEW YORK.

---

*Photographs sent for selection on receipt of business card and references.*

---

1879.

SPRING TRADE.

1879.

## FRENCH CLOCKS.

---

We call special attention of the trade to this department of our business. Having received recent large shipments from which we can make unusual inducements.

**TAYLOR & BROTHER,**

No. 676 Broadway,

NEW YORK.

---

**WHOLESALE ONLY.**



# TIFFANY WATCHES.

FOR LADIES AND GENTLEMEN.

*Independent Minute and Split Second Chronograph.*

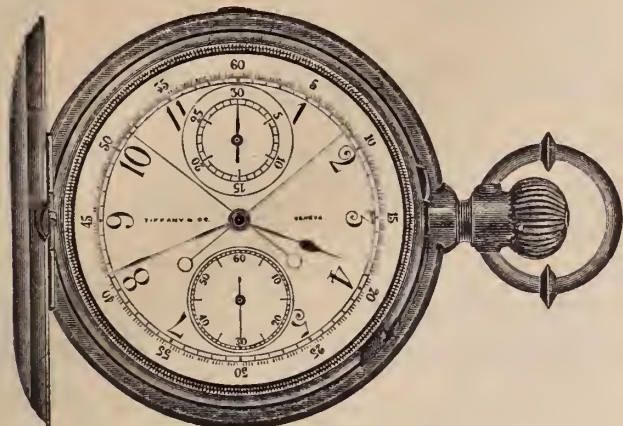

*Fifth-second, Split-second Chronograph.*

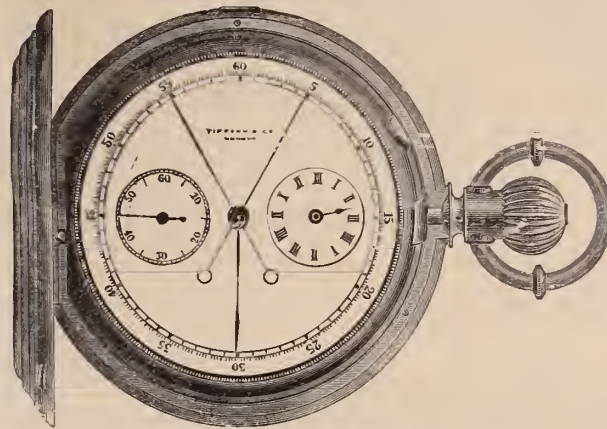

*SIMPLE! STRONG! DURABLE! ACCURATE! RELIABLE!*  
*ADJUSTED TO TEMPERATURE and POSITIONS, and CASED IN 18 Karat GOLD.*

Our new CHRONOGRAPHS (Fly-backs) now ready for Spring Races! Single, split second, minute and second, and the same with Repeaters.

EACH and every movement finished under our own supervision by thoroughly skilled hand-labor, and guaranteed to be "as fine time keepers to carry as are made!"

Every genuine TIFFANY WATCH has engraved upon the movement the firm name "TIFFANY & Co." and none others are made by our workmen!

More "value received" than ever before known in the watch business! Exclusive sale given under special contracts, and circulars for distribution sent gratis!

AGENTS protected and goods sent "on memorandum" for examination or selection upon receipt of satisfactory references! We do not sell Jobbers!

Refinishing, stoning, raying and engraving nickel movements done on the premises! Engraving inscriptions, devices and monograms on cases promptly attended to!

The TIFFANY WATCHES are retailed at less than the importation cost of many so-called fine watches!

 Dealers must sell them at our established retail price!

## TIFFANY & Co.

NEW YORK, PARIS, LONDON, GENEVA.

### MAKERS OF FINE AND COMPLICATED WATCHES,

Wholesale Office, 14 John Street, New York.

GEO. R. COLLIS, Manager.

 General Agents for Messrs. Patek, Philippe & Co.'s Watches.

 Sole Agents for the American Pedometer, the most popular and salable article known to the trade. Retail price, \$5.00. Not sold to Jobbers. Retail Dealers established as "exclusive agents," according to quantity ordered. Circulars and Terms sent upon application, when accompanied by business card.

J. C. AIKIN.

H. A. LAMBERT.

J. B. SHEA.

# AIKIN, LAMBERT & CO.,

**MANUFACTURERS OF GOLD PENS,**

**Pen and Pencil Cases, Pencils, Tooth-picks, and "Novelties" in Pencil Goods.**

**No. 23 Maiden Lane, New York,**



Would call the attention of the Trade to our large and complete line of Pen Goods in all styles and varieties, suitable for the Winter and early Spring demand.

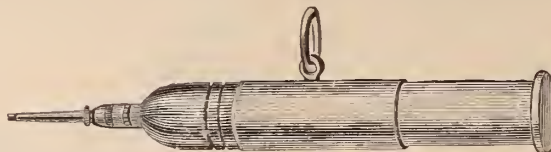

Our introduction last season of Pencils in NEW AND ENTIRELY NOVEL DESIGNS was marked by an unprecedented demand, which establishes the sale of these goods as STAPLES, and as being suited to any season of the year.

The Magic Charms (as per cuts shown below), inlaid with pearl and gold, in form of vines, flowers, birds, etc., on celluloid of assorted colors, in imitation of malachite, tortoise shell, agate variegated marble, etc., are the LATEST and most novel pencils in the market.



Send for circular and new list.

**Branch, No. 113 East Madison Street, Chicago.**

## IMPORTERS OF ALL GRADES OF

# WALTHAM WATCHES,

SOLE AGENTS FOR

"PAUL BRETON" and "CHAS. LATOUR," GENEVA.

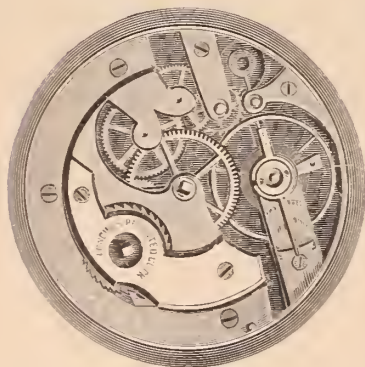

LONGINES



EXCELSIOR.

### — SPECIALTIES. —

AGASSIZ Movements, Gilt and Nickel Stem-Winding, fitting Ladies' Riverside Case.

CHAS. LATOUR Movements, Gilt and Nickel Key-Winding, fitting 10 and 16 size Waltham Case.

PAUL BRETON Movements, Gilt and Nickel Key and Stem-Winding, a full line of these CELEBRATED TIMEPIECES in gold and silver cases of the most approved styles.

METAL OPEN FACE STEM-WINDING "LONGINES" and "EXCELSIOR", 16, 18 and 20 line, the BEST metal Watches in STYLE and QUALITY in the market.

The "LONGINES" received the ONLY GOLD MEDAL at Paris for low-priced Watches against several competitors, and the "EXCELSIOR" is recommended by DR. HIRSCH of the Neuchatel Observatory having given VERY SATISFACTORY results during a month's trial. NOVELTIES in BLACK and FANCY DIALS for these Watches are selling rapidly. American Watches of all kinds. Gold Cases of any style made to order. Sole Agents for EUREKA HORSE TIMER, the cheapest reliable TIMER ever made, and for PNEUMATIC TIMER which does not require the use of the hand. All Watches sold by us are warranted.

Our assortment of Jewelry is very large and complete, consisting of a general line of RELIABLE goods, both in GOLD and ROLLED PLATE, of new and tasty patterns, and including almost any article a Jeweler would have calls for. Special attention given to ORDERED WORK and REPAIRS. GOODS SENT ON APPROVAL and CORRESPONDENCE invited. Those not acquainted with us will oblige by giving references when ordering.

JANUARY 1st, WE REVALUED OUR ENTIRE STOCK AND HAVE REDUCED PRICES, AND ARE OFFERING GREAT INDUCEMENTS TO PURCHASERS FOR THE SPRING TRADE.

# YACHERON & CONSTANTIN,

MAKERS OF

**FINE STEM-WINDING AND STEM-SETTING**

# WATCHES

OF EVERY VARIETY AND SIZE FOR LADIES AND GENTS WEAR.

These celebrated Watches have for many years enjoyed a high reputation for perfection of construction, accuracy of adjustment, and FINE TIME-KEEPING QUALITIES. These movements are now constructed to fit Standard sizes of Cases, and therefore interchange in their respective lines. The machinery employed in the construction of their movements is the most elaborate and perfect, having been devised by the most skillful artisans in Switzerland, and used in the manufacture of these movements long before American Watches were thought of. These movements are artistically cased in 18 karat Gold. Ladies Cases are decorated with tasty and elaborate designs in engraving and enamel work.

**J. A. ABRY,**

*Sole Agent for the United States.*

63 Nassau St., New York.

**J. A. ABRY,**

*Direct Importer from his own manufactory in Neuchatel, Switzerland, of the following grades of Celebrated Watches, viz.:*

Geo. Major, Ch. Hormann & Co., Duval & Gilbert,

# WATCHES,

AND AGENTS FOR THE

A. Hugenin & Son's Complicated Watches and Horse-Timers,

Barbezat Baillot (patented) Calendar Watch,

Estine & Richards' Watch,

And many others. A full line of the above always in stock at greatly reduced prices.

Attention is directed to the Excelsior (patented) Watch, the best and cheapest Stem-Winder in the market. It is cased in Silver and White Metal Cases 16, 18 and 20 lines, with white, black or fancy dials, and is an accurate time-keeper. For sale by the leading jobbers.

# ILLINOIS WATCH COMPANY,

MANUFACTURERS OF

## KEY AND STEM-WINDING MOVEMENTS.

OFFICES,

SPRINGFIELD, ILLS.

11 MAIDEN LANE, NEW YORK.

We would call attention to the reduction in prices and increase of discount, as per our new list, dated February 17th, which may be obtained from wholesale dealers, or from us on receipt of business card.

We will continue to make ALL GRADES of movements, with HARD PLATES, and will leave no means untried which may enable us to furnish STANDARD AND RELIABLE goods, which dealers can FULLY WARRANT.

### OPEN FACE

“Columbia,” “America,”  
“No.2,” “No.1,” and “Interior”  
Stem-winding Movements,  
*made especially for Open Face  
Cases, with Fig. XII at the pen-  
dant and Seconds opposite.*

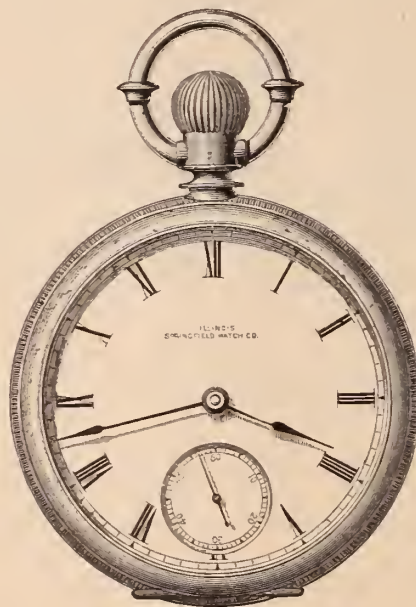

### STEM-WINDERS.

*Other Stem-winding grades  
on our list are made to order  
(in 4 to 6 weeks) in the same  
manner, in quantities of five  
or more of a grade.*

*The extra plate hole is jeweled in all grades, Currier and above.*

 Jewelers can now obtain our 8 Size Ladies' Key and Stem-winders, fitting Waltham style 8 size cases, from any of the wholesale dealers.

We shall open about MARCH 15th, a full line of

## NOVELTIES

IN

# Marble Clocks

Introducing a TINTED DIAL with raised figures. This is the handsomest dial ever shown in this market and can only be seen at our establishment, as we control it for this country.

## Le Boutillier & Co.,

IMPORTERS AND JOBBERS,

No. 3 UNION SQUARE, NEW YORK.



### TO THE TRADE.

We have the honor to call attention to the annexed cut representing our Superfine Quality three-quarter plate Stem-Winding  
**FREDERIC NICOUD**

*Movement.* All movements of this grade are adjusted to temperature and positions by Mr. F. Borgsetdt, of Locle, one of the most eminent adjusters in Switzerland, who received a medal at the Paris Exposition of 1878, for the high character of his work.

These movements are provided with a dust-ring and are cased in 18 kt. 60 to 65 dwt. cases with two caps (glass cap and gold cap over it).

We venture to affirm that these watches are equal, if not superior to any watch at the same price in the market.

Prices of the above as well as of the other grades of Nicoud watches sent to the trade upon application, accompanied by business card.

## NICOUD & HOWARD,

Sole Importers of

# NICOUD WATCHES,

No. 14 MAIDEN LANE,

NEW YORK.

—Established 1842.—

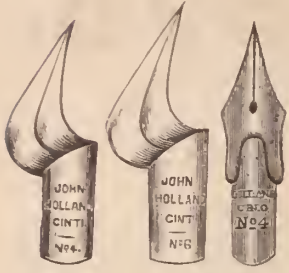

## JOHN HOLLAND,

Manufacturer of Patent "Record," Barrel, Falcon, Stub, and all styles of Long Nib Gold Pens.

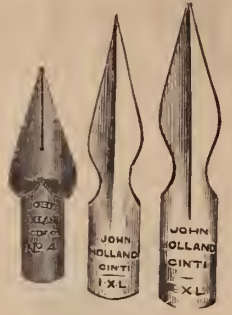

**Fine Solid Gold Pen and Pencil Cases, Pearl, Ivory and Fine Wood Pen Holders, Charm Pencils & Gold Tooth Picks.**

**No. 19 West 4th Street, Cincinnati, Ohio.**



My goods are all made of the quality of gold stated, and finished in first class style. At the CENTENNIAL EXHIBITION the Judges on Awards gave me the HIGHEST AWARD for GOLD PENS, and stated in their report: "For great elasticity and general excellence of Gold Pens." The best quality of IRIDIUM is used on the points, and every pen is warranted.

As I MANUFACTURE all the above articles in my own building, and under my own supervision, I can guarantee quality and offer the trade special inducements in prices.

✍ Handsome show-cases furnished for the display of goods. ✍ Illustrated Catalogues sent free. ✍ Goods sent on approval. ✍ Special attention to repairing Pens and Pencil Cases.

## L. HAMMEL & CO.,

**Importers of Watch Materials, Tools**



We would respectfully call your attention to our new design of an improved Spectacle Case which will doubtless commend itself to your favorable consideration. The improvement, consisting in the joint being on the top of the case, making it stronger and more durable than the old style of case, and the cut away for the insertion of the spectacles renders it the most practical case made. These goods are made in all grades of leather and for all styles of spectacles, in price from \$6 to \$13.50 a gross, and stamped to order with name and address of the purchaser, at \$2 per gross extra.

Samples sent by mail on receipt of 10 cents on application to

**Opera Glasses and Optical Goods of Every Description**

**SPECTACLES!**



**EYE GLASSES**

✍ We would respectfully call the attention of the Trade to the celebrated **Star Spectacles and Eye Glasses**, of which we are the Sole Importers.

**No. 9 Maiden Lane, New York**

✍ Sole Agents in the United States for **G. B. Wheeler's Star Watch and Clock Oil**, and the Celebrated **Gravier Mainspring**.

# Prize Medal, Paris, 1878.



Popular!

BECAUSE

BEAUTIFUL!  
CHEAP!  
DURABLE!



**The increasing popularity of Boss' Patent Stiffened Gold Watch Cases is the cause of remark by the Trade generally.**

The manufacturers believe the public and times demand a WATCH CASE that shall be *low in price, yet beautiful and serviceable*, and with this established belief they started with two ends in view:

**1st, To greatly Improve the Case.**

**2d, To Reduce the Price.**

To perfect the first it was necessary to add *largely to amount of gold* (nearly 40 per cent.), this has absorbed all saving on improved machinery and economy of production, but it has *been accomplished*, and they now present a Case which they *believe is fully up to the requirements* of the *most critical trade*.

SECOND.—They reduce the price of the Ladies' Cases nearly to that of the common or low karat Gold Cases, whereas this Case has almost the *same amount of gold* and *costs more to manufacture*. The *Engraving and workmanship* of all kinds is of a *much more expensive nature*. The gold being of a *much finer quality* presents an *appearance equal to the best solid case* and *will not discolor or corrode*, being stiffened between the two plates of gold with a lining of nickel composition. it *will not bend or break*, and will *look better and wear longer* than any case of the *same price in the market*.

Correspondence solicited.

Price List furnished upon application to

## Hagstoz & Thorpe,

SOLE MANUFACTURERS,

Sixth and Chestnut Streets,

PHILADELPHIA.

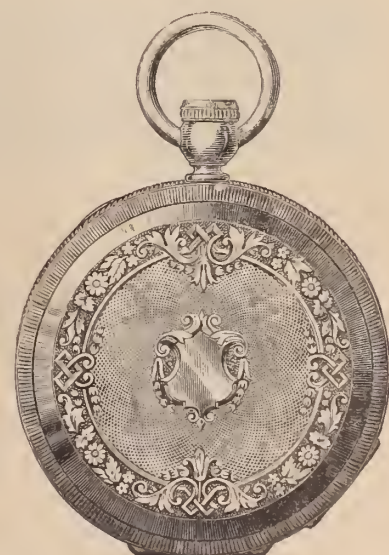

**BERGSTEIN & SON,**  
*Manufacturing Jewelers,*  
 No. 20 John Street,  
**NEW YORK.**

**W. H. LUDEMAN,**  
**Chronometer & Watch**  
**MAKER,**  
 Nos. 75 & 77 Nassau Street,  
**NEW YORK.**

☞ Repairing of every Description for the Trade.  
**FINE WATCHES A SPECIALTY.**  
 To the Trade.—I am now prepared to cut all kinds of Stem-Winding Wheels for the Trade.

**DAVID PRINCE,**  
**Gold and Silver Refiner,**  
*Assayer and Sweep Smelter,*  
**63 RAILROAD AVENUE,**  
**NEWARK, N. J.**  
 Sole Agent for Comins' Improved Amalgamator.

Mansard English Geneve Louis XV.  
  
**HENRY LEFORT,**  
**Stem-Winding Watch Crown Manufacturer,**  
 Crowns and Pushers in gold, all sizes, quality and color, made to order. Silver crowns and pushers always on hand.  
 ☞ Samples sent on application.  
**80 & 82 Marshall Street,**  
**NEWARK, N. J.**

☞ Designs made and estimates given on all kinds of Engraving for Jewelers.



☞ Illustrations for Books, Mfg Catalogues, &c.  
 ☞ Labels and Show Cards Engraved on Metal for Color Printing.

**Vulcanite Jewelry Co.**  
 MANUFACTURERS OF  
**WHITBY JET,**  
 Combination Whitby Jet and Vulcanite,  
 Byron's Patent, May 18, 1869,  
 Also a full line of Locketts—plain, gold mounted and monogram.  
**No. 191 BROADWAY, N. Y.**  
 ☞ Agents for the NEW RUBBER WATCH CASES, Fitting all American Movements.

Particular attention paid to Remounting. Price list furnished on application.



Full line of new and original mountings on hand.

**CHAS. F. WOOD,**  
 169 & 171  
**BROADWAY**  
**NEW YORK**

**Engraver, Incruster of Precious Stones**  
**And DIAMOND SETTER.**  
 Incrusted Goods a specialty.  
 All kinds of Lapidary Work promptly executed.

Leon Jeanne. Paul Jeanne.  
**JEANNE BROTHERS,**  
 MANUFACTURERS OF  
**DIAMOND MOUNTINGS**  
**And RICH JEWELRY,**  
 Patentees of Jeanne's Ear Wires,  
**No. 1 Maiden Lane, New York.**  
 Designs furnished and estimates given.

**KETCHAM & McDOUGALL,**  
 No. 4 LIBERTY PLACE, NEW YORK.  
 MANUFACTURERS OF  
 Improved Gold and Silver  
**THIMBLES**  
  
**AND THE PATENT**  
**AUTOMATIC EYE GLASS HOLDER,**  
 Which returns the Eye Glasses to their place on or under the lapel of the vest by simply casting them from the nose, combining all the conveniences of Cord, Hook and Case, without their annoyances.

**J. B. LAURENCOT,**  
 IMPORTER OF  
**WATCH GLASSES,**  
**Optical and Fancy Goods**  
 French Clocks, Musical Boxes, &c.  
**No. 33 MAIDEN LANE.**  
 15 Rue D'Enghien, Paris. Box 2954, P. O. NEW YORK.

**L. BONNET,**  
 Medal at Centennial, 1876.  
**CAMEO**  
**Likenesses,**  
**889 Broadway, New York.**

**REPAIRING FOR THE TRADE.**  
**C. G. MALLIET,**  
**Manufacturing Jeweler,**  
**No. 9 JOHN STREET**  
**NEW YORK.**

**FINE HAIR WORK**  
*Deutsches Geschäft,*  
 The only leading personal Artist in Hair in this country.  
**WM. ERNEST MOUTOUX,**  
 Factory and Office, 81 Nassau St., N. Y.  
 Designs of the most complicated description. ☞ Short or Baby Hair made in the finest designs in your presence. Portraits, or copy of noted paintings, made of family hair. Received one-half column report on my hair work in the New York Trade Journal, of Nov. 9th, 1878. I am the only manufacturer who has Medals and Diploma of Honor on personal fine work in number for inspection. Lessons given in all branches. Large pattern books for the trade free. Large hair pictures in other books are copyrights from my book and circulated only by my special permit. Prices low on orders from known pattern books. Gold jewelry and engraving by the best workmen done on the same plan.

**The Morse Diamond Cutting Company,**  
**J. D. YERRINGTON, Agent.**  
**192 Broadway and 3 John Street.**  
**NEW YORK.**  
 ☞ Rough, Diamonds, Boart, Roses and Brilliants for sale.  
 ☞ Fractured Diamonds repaired, and old stones improved; also Rough Diamonds cut and fashioned to order.

**W. N. WALKER,**  
**DIAMONDS,**  
**Watches and Jewelry,**  
**No. 18 JOHN STREET, NEW YORK.**  
**JOHN J. ARMOUR.**

**HENRY TROEMNER,**  
**710 Market Street,**  
**PHILADELPHIA.**  
 Manufacturer of Fine Gold Scales,  
  
 DIAMOND SCALES,  
 ☞ Bullion Balances and Weights, in use at all the U. S. Mints and Assay Offices.  
 PRICED CATALOGUE ON APPLICATION.

**Solid Gold Rings—a Specialty**  
**WM. H. ELY,**  
**Solid Gold Rings**  
 MANUFACTURER,  
 Viz., Plain, Chased, Engraved, Enameled, Engine Turned, Shield & Scale. *All qualities Warranted*  
 Orders Promptly Executed.  
**58 Nassau Street, N. Y.**



# ALFRED H. SMITH & CO.

## IMPORTERS OF DIAMONDS

14 JOHN STREET, NEW YORK.

### TO THE TRADE.

*In offering to you our RECENT HEAVY IMPORTATIONS of carefully selected Goods, we respectfully call your attention to a few facts bearing upon our ability to fill your orders, to your positive advantage.*

*We give to this business our EXCLUSIVE ATTENTION, admitting to our stock no other merchandise whatsoever.*

*We are DIRECT IMPORTERS of DIAMONDS, so that, with us, Dealers will find original parcels to select from.*

*Our foreign purchases are made by ourselves in person, thus insuring goods best adapted to the requirements of the Trade, and at the lowest possible figures.*

*Any goods you may be pleased to order from us, either for your stock, or on Memorandum, will be forwarded by us, without VALUE expressed thereon, and may be returned in like manner, (the same having been insured,) thereby saving you the heretofore burdensome charges.*

*Exceptionally choice SINGLE STONES, and finely MATCHED PAIRS, will always be found with us, as well as a fine line of MOUNTED GOODS.*

*Very Respectfully*

ALFRED H. SMITH & CO.

*14 John Street, New York.*

Established 1834.

**G. & S. OWEN & CO.,**  
**Makers of Fine GOLD JEWELRY**

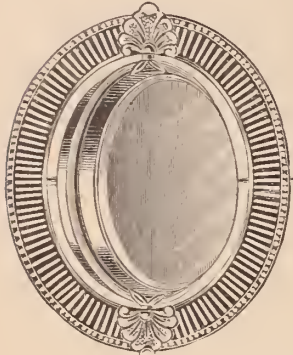

SPECIALTIES :  
 Black Onyx Goods,  
 Roman & Polished Goods,  
 Hair Chain Mountings,  
**Sole Makers**

OF

**BOX AND GLASS GOODS.**

☞ All our goods exclusively of our own manufacture.

**5 MAIDEN LANE, NEW YORK.**

Established 1846.

**WILLIAM RIKER,**

*No. 5 Maiden Lane, New York.*

Factory, 42 Court Street, Newark N. J.

☞ Would call the attention of the Trade to our Inlaid Bracelets.

**JOHN A. RILEY & CO.**  
 MANUFACTURER OF

**Fine Gold Jewelry**

AND ONYX GOODS,

**Nos. 7 & 9 Bond Street, New York.**

No. 126 Kearney Street, San Francisco, Cal.

ESTABLISHED 1855.

**D. LIECHTY & CO.,**

MANUFACTURERS OF

**Fine Gold Watch Cases**

*No. 140 South Third Street,*

Fourth Floor.

PHILADELPHIA

*Repairing neatly attended to.*

**MOORE & HORTON,**

**JEWELERS,**

*No. 11 Maiden Lane, New York.*

**SPECIALTIES!**

*Stone Cameo, Onyx, Amethyst, Topaz and Pearl Rings,  
 Studs, Collar and Sleeve Buttons.*

☞ Also our new fac-simile of Fine African Diamonds, mounted in Rings, Studs, Pins, Ear-rings, Scarf Pins, Medallions.

**W. H. SHEAFER & CO.,**

**Makers of Fine Jewelry**

CONSISTING OF

BRACELETS, SETTS, LOCKETS, PINS,

STUDS, SLEEVE BUTTONS, RINGS, &c.

**SPECIALTY:—STIFFENED ROMAN BANDS.**

**No. 908 Chestnut Street, PHILADELPHIA**

Branch Office 15 John Street, New York.

# WM. S. HEDGES & CO.,

*Of the late firm of SMITH, HEDGES & Co.*

IMPORTERS OF

## DIAMONDS,

No. 170 Broadway, cor. Maiden Lane,

NEW YORK.

*Choice Brilliants in single stones and matched pairs a specialty.*

GOODS SENT ON APPROVAL.

# ENOS RICHARDSON & CO.

MANUFACTURERS OF

## FINE GOLD JEWELRY,

Gold Chains, Locketts, Crosses and Necklaces,

COLORS AND ETRUSCAN WORK.

ENGRAVED AND ENAMELLED GOODS IN GREAT VARIETY.

All Goods sold strictly of our own manufacture.

23 MAIDEN LANE, NEW YORK.

ENOS RICHARDSON,  
THOS. SLATER,

L. P. BROWN,

F. H. RICHARDSON,  
W. P. MELCHER.

## Platinum Tipped Diamond Settings,

Patented April 16th, 1878, by

# Ripley, Howland & Co.



Office, No. 35 Maiden Lane, New York.

Factory, 383 Washington Street, Boston, Mass.

# WHEELER, PARSONS & HAYES,

MANUFACTURERS OF

Watch Cases, Gold Chains & Fine Jewelry,

AND DEALERS IN

AMERICAN AND SWISS WATCHES,

No. 2 MAIDEN LANE, NEW YORK.

# LYON & HARDY,

30 MAIDEN LANE, NEW YORK,

IMPORTER OF

DIAMONDS,

AND MANUFACTURERS OF

DIAMOND MOUNTINGS.

All goods ordered for stock or on approval are insured while in the hands of Express Companies.



Nº 24 DOELEN STRAAT AMSTERDAM, HOLLAND.  
Nº 1 GAERTNER PLATZ, MUNICH, GERMANY.

*Diamonds loose and mounted sent on approval on receipt of satisfactory reference.*

**WANTERS OF FINE JEWELRY**  
**WALLING BROS. & CO.**  
**WANTERS OF FINE JEWELRY**

Full Line of Roman and Mosaic Goods,  
 Earrings, Buttons, Studs and Rings.

**SPECIALTIES:**

ENGRAVED AND ENAMELED BANDS,  
 CAMEO GOODS.

**170 BROADWAY, NEW YORK.**

DYER BRAINERD.

JOHN W. STEELE.

**BRAINERD & STEELE,**

MANUFACTURERS OF

Brainerd's Pat. Locketts,

(Patented June 17, 1874)



These Locketts combine both beauty and strength. They are made of solid 14kt. gold, and the stones used are the finest obtainable in the market. They cost no more than those of the old style, if indeed as much; and the combination of secrecy and durability renders them much more desirable. We make three sizes in four different shapes—round, oval, cushion and oblong square; and also Sleeve Buttons of the same style, containing a concealed box for miniatures, a novelty new to the Trade.

**FINE GOLD JEWELRY,**  
**No. 9 Maiden Lane,**  
**NEW YORK.**

**NOAH MITCHELL,**

MANUFACTURER OF

**Fine Gold Jewelry**

CAMEO SETS, ONYX GOODS,

Medallions, Studs, Sleeve Buttons, Rings and Diamond Settings of all Kinds.

**Diamond Setting a Specialty.**

**694 & 696 Broadway, cor. 4th St., New York**

(Whiting Silver Mfg Co.'s Building.)

ALL ORDERS PROMPTLY ATTENDED TO.

**J. B. BOWDEN & CO.**

*Manufacturer of*

**SOLID GOLD AND STONE**

**RINGS**

All Styles of Children's  
 AND

**FANCY SOLID RINGS,**

A LARGE ASSORTMENT ALWAYS ON HAND.

Old No. 11 Maiden Lane, New York.

**JOSEPH N. TINGLEY,**

Late of the firm of Tingley, Sinnock & Sherrill,

MANUFACTURER OF

**STONE RINGS,**

—AND—

NOVELTIES IN STONE GOODS,

No 9 Maiden Lane, New York.

FACTORY, NEWARK, N. J.

AUBURNDALE, MASS.

**CHRONOGRAPH TIMER,**

**WM. B. FOWLE, Maker.**

Designed for Sporting, Scientific and Mechanical purposes;  $\frac{1}{4}$  and  $\frac{1}{8}$  seconds, fly back.

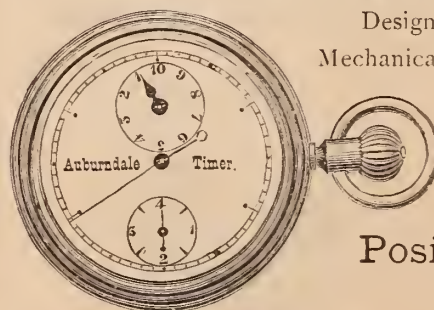

List Price, - - \$15.00

**Positively Accurate.**

Put up in German Silver Cases, Nickel Plated, size of an ordinary watch. Very neat and handsome, supplying a want long felt by those desiring to measure the flight of time with scientific accuracy to the fraction of a second. It indicates positively minutes, seconds, quarters or eighths of seconds, the only instrument registering one eighth of a second made. It is substantially constructed, positive in its action, and will not easily get out of order.

These Chronographs can be obtained from the principal Jobbing Houses in the Trade.

**J. A. BROWN & CO.**

OFFICE AND SALEROOM:  
No. 11 Maiden Lane, N. Y.

FACTORY:  
No. 104 Eddy St., Providence. R. I.

SOLE MANUFACTURERS OF THE

**Ladd Patent Stiffened Gold Watch Cases**

The Best and most durable, and the

CHEAPEST STIFFENED Gold Watch Case

FOR THE MONEY

MADE IN THE WORLD!

All genuine Watch Cases of our manufacture have "G. W. Ladd's Patent, June 11, 1867," stamped upon the side band underneath the glass bezel.

REFUSE ALL OTHERS.

Send for full Descriptive Circular to the

OFFICE AND SALEROOMS

11 Maiden Lane, N. Y.



KEY AND STEM WINDING

Hunting and Open-Face

IN FLAT BEVEL,

Mansard and Oval

SHAPES

Adapted to the various

AMERICAN-MADE MOVEMENTS,

IN

8, 10, 14, 16 & 18

SIZES.

Dealers can obtain them of the Wholesale Watch and Jewelry Houses, or their Travelling Agents throughout the United States and British Provinces,

**BENJ. ALLEN & CO.**

WHOLESALE DEALERS IN

**American and Swiss Watches**

JEWELRY, DIAMONDS,

SILVER & PLATED WARE.

137 and 139 State Street, Chicago.

A full line of Howard Watches in stock. Catalogues sent upon application, to dealers only.

**CHARLES GLATZ,**

MANUFACTURER OF

**Gold and Silver Watch Cases**

No. 12 Maiden Lane,

NEW YORK.

A CARD.—After the recent great Improvements to my Cases, I confidently offer them to the Trade, as being without a superior in the market, and so acknowledged by some of the best houses.

**MAX FREUND & CO.**

**Manufacturing Jewelers.**

IMPORTERS OF

**Watches**

Jewelry and Precious Stones  
8 Maiden Lane

NEW YORK

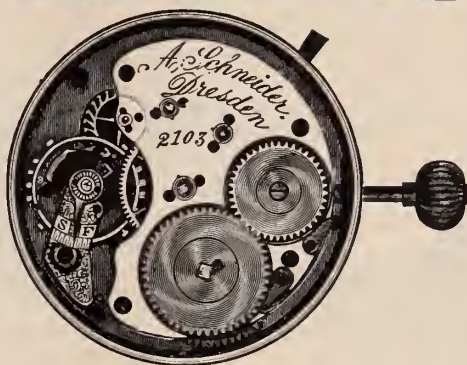

Sole Agents for the Celebrated A. Schneider Watch, Dresden. Also the Standard Watch Co. of New York.

**GUTMANN'S**

**Automatic Hammer and Punches**

Simplified and More Effective.

THIS TOOL takes the place of the third hand, therefore its manifold uses are quickly apparent, and I would only say that it is accompanied by six punches, to wit: 2 hand punches, 1 prick punch, 1 closing hole punch, 1 rivet punch, and 1 pinion punch, all of which fit neatly into the punch holder, and are fastened by the set screw. Its tap is alternately heavy and light and the finger loops are assorted in sizes. The Tool is nickel-plated and boxed, ready to be mailed on receipt of price.

THE OPERATION IS AS FOLLOWS: First, set the hammer; next insert your forefinger through the loop at the top and place the punch with firmness on your work. When you are ready for the blow, push gently on the thumb-piece which produces the concussion on the punch. Your left hand is entirely free to hold the work.

PRICE, \$2-50 EACH.

MAX L. GUTMANN,

Patentee and Manufacturer.

Also, Importer and Wholesale Dealer in

Watch and Jobbing Materials, Tools, Glasses,

Chains, Guards, Jewelry and Watches.

PLEASE SEND YOUR ORDERS.

ROCHESTER, N. Y.

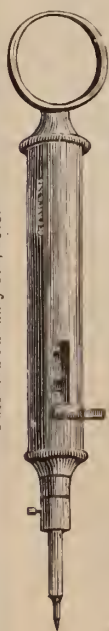

Patented January 8th, 1878.

**CHAS. P. HEROLD,**  
**MANUFACTURING JEWELER,**  
**DIAMOND SETTER**  
AND DEALER IN  
**DIAMONDS.**

916 CHESTNUT ST. PHILA.

N.B. A LARGE STOCK OF 18 Kt. DIAMOND MOUNTINGS, SUCH AS CLUSTER AND SOLITAIRE RINGS, EARRINGS, LACE PINS, SHAWL PINS, CROSSES, STUDS, AND GENTS' PINS, &c, ALL OF WHICH ARE OF MY OWN DESIGNS, AND ARE MADE IN THE FINEST STYLE AND FINISH.

# HART & SLOAN, BUILDERS OF Watch Machinery,

AND MAKERS OF

## INTRICATE MECHANICAL INSTRUMENTS,

363 & 365 MARLET STREET,

NEWARK, N. J.

Having purchased a large lot of Watch Machinery, which we have fitted up and have now at work, are prepared to take orders for all kinds of small work, Gauges, parts of Watches, and fine Instruments of every description.

We have also for sale a lot of small Lathes and special Tools for Watchmakers and amateurs, suitable for repairing Watches and Clocks. We can also furnish all kinds of new Watch Machinery, or special Tools for Clocks, or other fine work; and Small Screws of every description, from 220 to 40 threads to the inch, diameter to correspond.

# Kearney & Swartchild,

Manufacturers of

## "TRIUMPH" LATHE.

Price, Hardened Bearings and Spindles, \$40.00

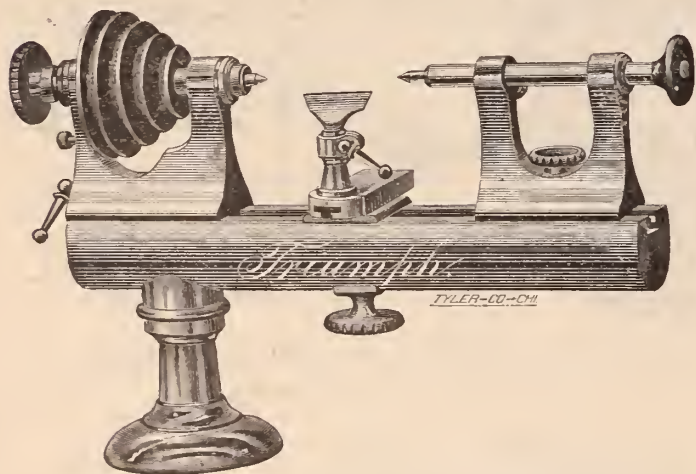

All Split and Wire Chucks are tempered and ground, which makes them perfectly true.

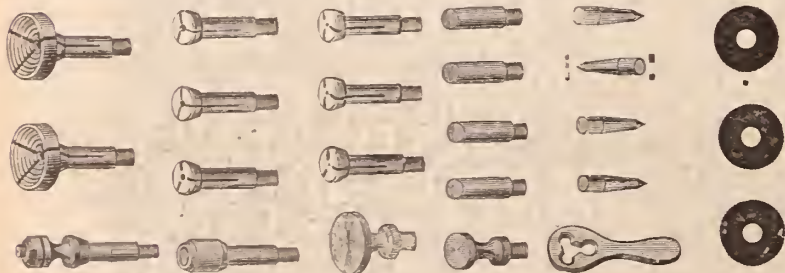

Importers and Jobbers of Tools and Materials, Watches, Jewelry, &c.

Manufacturers of Watchmakers' and Jewelers' Tools.

Illustrated Catalogue sent on application.

Nos. 113 & 115 State Street, Chicago, Ill.

# American Watch Tool Co.

P. O. Box 999

WALTHAM, MASS.

MANUFACTURERS OF THE WHITCOMB LATHE,  
AND  
Machinery for Watch, Watch Case and Clock Making.

NEW YORK OFFICE WITH

L. H. KELLER & CO., 64 Nassau Street.

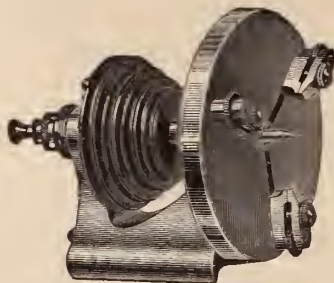

Universal Lathe

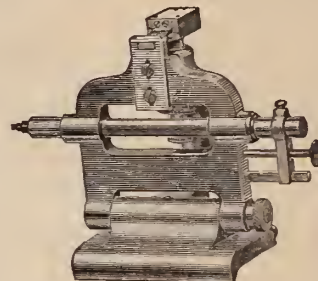

Jewelers Reel

HIGHEST AWARD:  
PHILADELPHIA, 1876.  
BOSTON, - - 1878.

Chicago Office with Chas. Wendell & Co., No. 170 State Street.

NATHAN E. MORGAN.

CHAS. B. HEADLY.

# MORGAN & HEADLY,

MANUFACTURERS OF FINE JEWELRY,  
PLAIN GOLD RINGS, DIAMOND  
MOUNTINGS, SPECTACLES  
AND EYE GLASSES.

## Importers of Diamonds.

A full line of Diamonds, mounted and unmounted, always on hand, which we will send on approval to the Trade, on receipt of reference.



We have added to the manufacture of Gold Spectacles and Eye-Glasses those of Steel, and are able to fill all orders promptly.

Illustrated Catalogues sent on application.

ARTISAN HALL,

Nos. 611 & 613 SANSOM STREET,

PHILADELPHIA.

ESTABLISHED 1853.

CLOCKS



CLOCKS

**B. J. COOKE'S SON,**  
137 N. 3d Street, Philadelphia.  
Catalogues and Price Lists furnished only on application.

**C. F. A. HINRICHS,**  
29, 31 and 33 PARK PLACE,  
Cor. of CHURCH STREET, (Up-stairs) NEW YORK  
Successor to M. WERCKMEISTER.  
[ESTABLISHED 1801.]  
IMPORTER AND DEALER IN

**FANCY GOODS,**  
GLASS-WARE,

China, Bronzes, Clocks, Toys, &c.  
Sole Agents for the Glass Factories of the Company "ANN," Namuroise, Belgium  
Depot for Archery, Cricket & Base Ball Implements.  
And C. A. KLEEMANN'S CELEBRATED GERMAN STUDY LAMPS.  
Agent for ROGER'S GROUPS in Parian, &c.

ESTABLISHED 1855.

**WELCH & MILLER,**  
MANUFACTURERS OF MOROCCO, VELVET AND SATIN  
**Jewelry Cases, Trays, &c.**

Telescope Sample Cases, with Flexible Trays.  
COMPLETE STOCK ON HAND.

**No. 169 BROADWAY, NEW YORK.**

CATALOGUES SENT ON APPLICATION.

**GEO. B. WHEELER,**  
**NEW BEDFORD, MASS.**  
MANUFACTURER OF FINE

**Watch and Clock Oil.**



THE PORPOISE.

This Oil is made from the best of stock, is free from gum or corrosion, will stand the coldest weather, and is every way reliable.

**L. HAMMEL & CO., Sole Agents,**  
No. 9 Maiden Lane, New York.

KOCH & CO., Elberfeld, Prussia, Sole Agents in Europe.

**Goldsmith & Schliesser,**

(Formerly of Freund, Goldsmith & Co.)

**Manufacturing Jewelers,**

—AND—

**Importers of Watches & Precious Stones,**

**No. 5 Maiden Lane,**

Factory, 56 West 4th Street,

**NEW YORK.**

Sole Agents for H. L. Mathey, Locle, Switzerland.

**H. Muhr's Sons, Philadelphia.**

**MANUFACTURING JEWELERS,**

**Solid Gold Finger Rings of Every Description.**



Crown, 18k. Lion.



On and after January 1st, 1876, our make of Filled Plain Rings will be stamped as above, which stamp is copy righted. Any person who attempts to use the above Trade Mark will be dealt with according to law.

**THESE GOODS ARE SOLD BY ALL THE LEADING JOBBERS!**

Should the house that a retailer deals with not have them we will furnish them with the address of the nearest jobber. **SELL TO THE JOBBING TRADE ONLY!**

New York Office, 11 Maiden Lane.

Address all communications to Philadelphia.

**BERNARD LEVY,**

**Manufacturer of Watch Cases**

—AND—

**JOBBER OF AMERICAN MOVEMENTS,**

**No. 402 Library Street,**

**PHILADELPHIA.**

ALSO, ORNAMENTAL ENGRAVER AND ENGINE TURNER.



Diploma and Medal  
We have the honor to inform you that the first-class award has been made to us for our superior quality and reliability of our oils and greases applied to the machinery of the world. We cheerfully recommend it to all who may in their business require a FIRST-CLASS LUBRICATOR.



**SETH THOMAS CLOCK COMPANY, SETH E. THOMAS, Agent.**  
P. S.—The above Oils can be procured at all first-class wholesale Watch and Clock Establishments in the United States, as well as his only Agents, GRIMSHAW & BAXTER, 35 Goswell Street, London England.  
New Bedford, October 15, 1877.

**Lubricating Oils, for Watch, Clock and Chronometer Makers.**

The discovery of a Lubricator for FINE MACHINERY, such as Watches, Clocks and Chronometers, that is free from gum and corrosive substances, has taxed the ingenuity of hundreds of men whose efforts have proved a failure. But we are happy to say (being largely interested) that such an article has been supplied by MR. EZRA KELLEY, of New Bedford, Mass., who, after forty years study of the subject, has perfected a Lubricator that recommends itself to all who have used the genuine, (there having been numerous counterfeits in the market,) as witness also the award of a

Dealers in Watches,

Importers of Diamonds.

**OPPENHEIMER, BROS. & VEITH,**  
Manufacturing Jewelers,

S. Oppenheimer, }  
A. Oppenheimer, }

**New York.**

Henry F. Veith }  
Gus F. Veith }

35 MAIDEN LANE,

I. PFORZHEIMER.

D. KELLER.

**PFORZHEIMER & KELLER,**

IMPORTERS OF

**Watches and Diamonds**

Dealers in American Watches,

AND

Manufacturers of Jewelry,

No. 24 JOHN STREET,

**NEW YORK.**

P. O. Box 4144.

**Mathez Watch Company of New York.**

Gents' and Ladies' Stem-Winding Movements

STRAIGHT LINE, 3-4 PLATE NICKEL.

These Movements are of six different grades, uniform in size and beautifully finished, and will be SOLD AT LOWER PRICES than any other goods of similar excellence.

A FULL LINE of materials for our movements always kept in stock for the convenience of those using our goods.

**F. H. MATHEZ, Sole Agent,**  
**No. 5 Maiden Lane, New York.**

**L. A. CUPPIA,**

Formerly with ENNIS BROS.

IMPORTER OF

**Coral, Silver Filagree**

—AND—

**CONCH SHELL,**

Repairing Coral Jewelry a Specialty.

19 UNION SQUARE,

**NEW YORK.**

Manufactory, No. 39 St. Catarina a Chiaja, Naples, Italy.

**BREITINGER & KUNZ,**  
Importers of Watchmakers' Tools,  
MATERIALS, CLASSES, &c.  
**No. 107 North Ninth Street,**  
**PHILADELPHIA.**

Dealers in all kinds of American Watch Materials and American Clock Material. Specialties in Materials for Musical Boxes, Cuckoo Clocks, &c.

Sole Agents in the United States for Bahni Brothers Hardened and Tempered Hairsprings. Agents in the U. S. for J. Becker's (Freiburg, Germany) Gold Medal Regulators, the best in the market. A large assortment of all patterns always on hand; Movements with seconds pendulum for watchmakers' use—all kinds of materials for the same.

Wheel Cutting and work done for the trade.

ESTABLISHED 1854. Medal and Diploma Awarded at Centennial Exhibition.  
JUDGES' REPORT:—Well made and good patterns—Double Hinge as a useful improvement  
(Patented December 17th, 1867.)

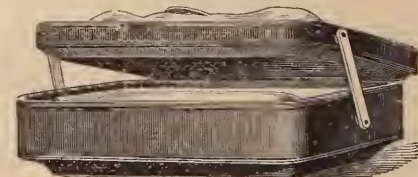

**G. F. KOLB & SON,**  
MANUFACTURERS OF FINE

Morocco, Velvet and Cabinet Cases,  
FOR JEWELRY, WATCHES & SILVERWARE.

TRAYS FOR SHOW CASES, TRUNKS, &c.

732 Sansom Street, PHILADELPHIA.

**Charles F. Terhune & Co.,**  
Manufacturing Jewelers,

17 Maiden Lane,

**New York:**



Sole Manufacturers.



We beg to call the attention of the trade to the above cuts representing  
**PATENT SLIDE BUTTON**

It is not separable, but works on a simple slide. It can be put in and taken out easier than any button made without soiling the cuff. Recommends itself at sight.

A FULL LINE OF ENAMEL AND STONE GOODS IN ABOVE PATENT.

**EDWARD TODD & CO.**

MANUFACTURERS OF

**GOLD PENS,**



Pencil Cases, Tooth Picks, &c.

**No. 652 BROADWAY,**

Factory, 29 & 31 South 11th St., Brooklyn.

**NEW YORK.**



MANUFACTURERS  
OF  
EXCLUSIVELY

**BLACK ONYX GOODS.**

**WOGLOM & MILLER,**  
32 & JOHN STREET,  
NEW YORK.

**ROSKOPF WATCH.**



**J. D. HUGUENIN & CO.,**  
GENERAL AGENTS,

No. 12 Maiden Lane, New York.

The reputation of this Watch as an accurate timekeeper is fully established, and during the ten years that it has been before the Trade, has won an abiding reputation for fine Time-keeping qualities, and the BEST WATCH for the money in the world.

Send business card for price list.

**BOOZ & THOMAS,**

MANUFACTURERS OF

**Watch Cases & Jewelry,**

**108 SOUTH EIGHTH STREET,**

Second Story, **PHILADELPHIA,**

Illustrated Catalogues sent upon application.

**Old Gold & Silver Bought or Exchanged.**

**PARTICULAR ATTENTION PAID TO REPAIRING.**

**J. H. PURDY & CO.**

Jobbers of Imported and Domestic

**TOOLS & MATERIALS,**

For the use of Watchmakers, Jewelers, and kindred trades.

WATCH GUARDS, JEWELRY BOXES, SPECTACLES, CARDS,  
SPECTACLE CASES, PEARL GOODS, STEEL CHAINS,  
TAGS, RUBBER TYPE, &c.

No. 170 State Street, Chicago, Ill.

OFFICE WITH CHAS. WENDELL & CO.

**HENRY FERA,**

**Importer of Diamonds,**

No. 9 MAIDEN LANE,  
**New York.**

Having my own cutting and polishing establishment at Nos. 23 and 2 Looijersgracht, Amsterdam, Holland, constantly running 36 mills, I am able to offer to the trade a full assortment of Diamonds at very low prices.

Loose and Mounted Goods sent on approval to any part of the country on receipt of satisfactory references.

**HAMILTONS & HUNT,**

MANUFACTURERS OF

**Fine Plated Chains**

AND PATENT BUCKLE BRACELETS,

**Branch Office, 176 Broadway, New York**

FACTORY, 226 EDDY STREET, PROVIDENCE, R. I.



**W. C. GREENE & Co**

**GOLDSMITHS**

MANUFACTURERS OF  
RICH SETS IN TAPER WIRE CORAL

Factory 95 FINE ST. Providence, R. I.  
Stone-Cameo Amethyst Coral Cameo Engraved R. Enamel Brooches Sleeve Buttons Studs Crosses EAR DROPS &c.

NEW YORK OFFICE, No. 192 BROADWAY.

Wm. C. Greene,

B. W. Greene,

Geo. D. Briggs.

**MILNE & JOURDAIN,**

Manufacturers of Stem-Winding Watch Crowns



13 & 15 Franklin Street, **NEWARK, N. J.**

Gold Crowns, for Stem-winding Movements, to suit all sizes of Imported or American Watches, in four different styles and seven sizes.

Gold Pushers for Key Movements in every size. Also Gold Crowns for fine Chronograph Watches made to order.

Silver Stem winding Crowns and Key Pushers on hand or made to order. Send for card and samples.

A. MILNE.

A. JOURDAIN.

## American Watch Company.

### The New Model BROADWAY.

The best watch for the money ever offered! We have entirely remodeled them with the following special advantages.

The barrel does not project beyond the top plate, thus allowing a plain, tighter-fitting dust band to be used.

The pottance is immovably fixed in the plate, and need never be disturbed. With this pottance so placed it is impossible for the balance to get out of upright, and it is a convenience for repairers. This valuable improvement is secured by patent.

The angles of the pallet jewels, on both sides of the pallet, are the same, and the jewels are interchangeable, which is also convenient for repairers. By this means the whole escapement has been improved.

An improved arrangement for letting down the mainspring without taking off the hands and dial. The barrel can be removed by simply taking off the barrel bridge.

The dials are firmly secured by screws.

The hair-spring stud is in the cock, so that balance and cock can be taken off and replaced without danger of changing the rate of the watch.

All the wheels and pinions run in the solid plate in jewels or otherwise, the third bridge being abandoned, so that no part of the train can get out of upright.

ROBBINS & APPLETON, General Agents,

No. 9 BOND STREET, NEW YORK.

170 State Street, Chicago.

8 Summer Street, Boston.

Waltham Building, London.

SPECIAL SALE  
 OF THE  
**“CRESCENT STREET” WATCH,**

OFFERED BY THE  
**AMERICAN WATCH COMPANY,**

—OF—  
**WALTHAM, MASS.**



*The 18 size movement, named*

“American Watch Company, **“CRESCENT STREET,”** Waltham, Mass.,”

*is the only American full-plate movement made to **wind and set** on the back, is full jeweled, is provided with compensation balance, accurately adjusted, patent micrometrical regulator, Fogg’s patent pinion, and is popularly known as the*

**American Railroad Watch.**

*It is carefully fitted in Sterling Silver Cases ( $\frac{925}{1000}$  fine), and now offered to the trade, in*

3 oz. (Hunting or Open Face,) . . . . .	\$22.00 NET.
4 oz. (Hunting or Open Face,) . . . . .	\$23.50 NET.

**AMERICAN WATCH CO.,**

OF WALTHAM, MASS.

**Robbins & Appleton,** 9 BOND ST., NEW YORK,  
 8 SUMMER ST., BOSTON, **General Agents.**  
 170 STATE ST., CHICAGO.

# L. & A. MATHEY,

IMPORTERS OF FINE WATCHES AND MOVEMENTS

No. 16 Maiden Lane, New York.



Independent  $\frac{1}{4}$  Seconds, Plain Chronographs, Independent Split Seconds,  
 Minute Repeaters, Double Chronographs, Perpetual Calendars,  
 Minute Chronographs, Pocket Chronometers.  
 MINUTE CHRONOGRAPHS, WITH MINUTE REPEATER.  
 CHRONOGRAPHS, WITH MINUTE REPEATER.  
 AND A FULL LINE OF MEDIUM GRADE WATCHES AND MOVEMENTS.

Sole Agents for the H. L. MATILE WATCHES.

Timing and Complicated Watches a specialty. All our Watches are tried and tested before delivery. Goods sent for examination on satisfactory references.

An attractive line of Chateaines and Chateaine Watches.



Established 1828.

## JACOB BENNETT & SON,

Diamond Setters and Manufacturing Jewelers,

No. 108 SOUTH EIGHTH STREET, PHILADELPHIA.

WE MANUFACTURE AND MAKE A SPECIALTY OF  
 EVERY DESCRIPTION OF

**DIAMOND MOUNTINGS**

SUPERIOR IN DESIGN AND WORKMANSHIP.



MASONIC MARKS,  
**Presentation & Lodge Jewels,**

SOCIETY AND POLICE BADGES MADE TO ORDER.  
 FINE WHOLE PEARL JEWELRY.

GOODS SENT ON MEMORANDUM TO ANY PART OF THE UNITED STATES.

## CROSS & BEGUELIN,

Makers and Importers of SWISS WATCHES,

AND DIRECT IMPORTERS OF

Watch Tools, Materials, Glasses, &c.

No. 21 Maiden Lane, New York.

The CENTENNIAL WATCH (Stem-Winding and Stem-Setting) so universally popular, has achieved a standard reputation, and is generally conceded to be the best made watch for the money in this market. Being the sole manufacturers of this celebrated Timekeeper, we are enabled to give it our strongest endorsement. Especial attention is called to the "HENRY BEGUELIN," "DROZ & PERRET," and other well known Swiss Watches, as well as to our full and complete line of all grades of American Watches, on which we give the full trade discount.

The attention of Watchmakers is directed to our new DRILLS, in sets of 21 sizes. The most complete and serviceable drill ever offered.



None Genuine without this TradeMark.

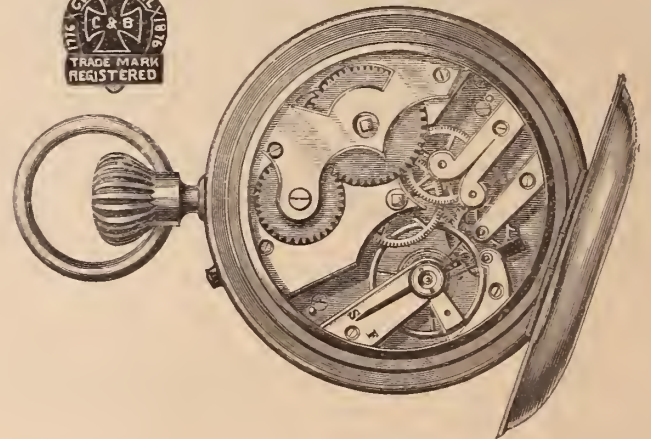

The above is a fac-simile of the Centennial Watch.

## BROWN & BROTHERS

MANUFACTURERS OF

Finest Quality of Electro-Plated Flat Table Ware.

PATENTED HEAVY SPRING TEMPERED SHANK ON FORKS AND SPOONS.

ILLUSTRATED CATALOGUES FURNISHED ON APPLICATION.

WAREROOMS, No. 81 CHAMBERS STREET, NEW YORK CITY.

FACTORIES, WATERBURY, CONN.

P. O. BOX 5731.

# HALL, ELTON & CO.,

## Manufacturers of the Finest Electro-Plated Ware.

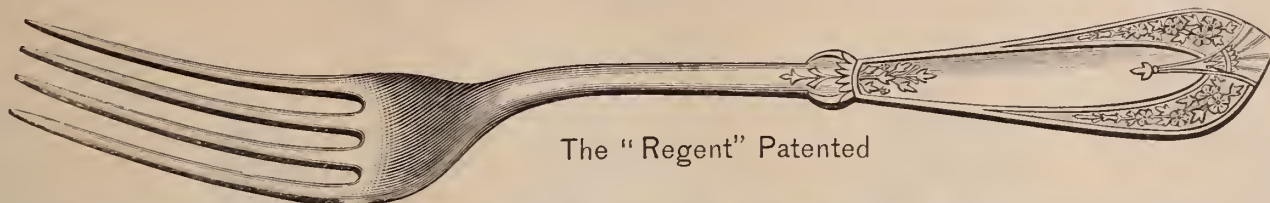

The "Regent" Patented

**UNSURPASSED IN QUALITY, STYLE AND FINISH!**

Factories, Wallingford, Conn.      Salesroom, 75 Chambers St., New York.

# HOLMES, BOOTH & HAYDENS,

MANUFACTURERS OF

**ELECTRO-SILVER PLATED**

## Spoons, Forks, Ladles, Fancy Pieces,

**Solid Handle Steel Knives, &c., of the finest quality.**

No. 49 Chambers Street,  
**NEW YORK.**

No. 18 Federal Street,  
**BOSTON.**

Works at Waterbury, Conn.

SPECIAL NOTICE! MANUFACTURING JEWELERS, CHEMISTS, &c.

## BROWN & BROS.,

No. 81 CHAMBERS STREET,

NEW YORK.

Manufacture CHEMICALLY PURE COPPER for ALLOYING, and are prepared to fill orders for same, either in the Wire, Strip or Granulated form. Its PURITY has been attested as follows.

BROWN & BROS.

*Dear Sir.*—We have analyzed the two samples of Copper left with us on the 18th instant, one said to be foreign refined Copper as used by jewelers, the other a refined Copper as manufactured by you for the same purpose. We find both samples alike in purity, and no difference can be detected by a careful chemical analysis, both being samples of PURE METALLIC COPPER, having no traces of antimony, tin, arsenic, zinc or lead.

UNITED STATES ASSAY OFFICE, 30 WALL STREET,  
NEW YORK, Dec. 21st, 1877.

TORREY & EATON.

# REED & BARTON,

## Manufacturers of Fine Silver-Plated Table Ware

OF EVERY DESCRIPTION.

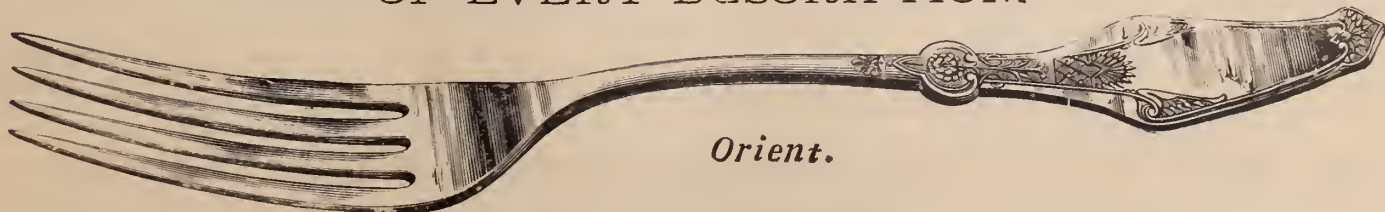

Orient.

Would call attention of the trade to their new design of fork (illustrated above) which we believe to be the finest design ever manufactured in plate. We are also manufacturing a great number of new designs in all kinds of hollow-ware, and among other things a great number of Fancy Pieces, such as Jewel Boxes, Card Stands, and Case Cologne Sets, etc., which are specially adapted to the holiday trade.

**Factories, Taunton, Mass.**

**No. 686 BROADWAY, NEW YORK.**

# HENRY C. HASKELL,

Manufacturing Jeweler,

No. 12 John Street,

New York.

INTAGLIO, CHOICE CAMEOS,  
*Set with Diamonds.*  
PEARL, TURQUOISE, DIAMOND,  
RUBY, SAPPHIRE, &C.  
FULL LINE OF ONYX RINGS,  
*Specially made for MONOGRAMS.*



4040



5223

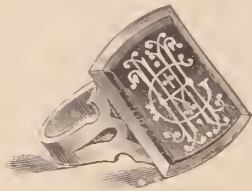

1549

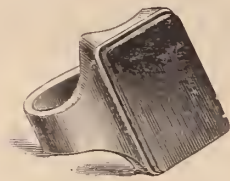

3433



3191

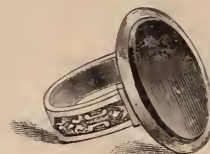

3003



309

*Orders solicited for goods on approval.*

*Stone Seal Engraving and Jobbing of every description promptly and carefully done.*

## American Open-Face, Stem-Winding WATCHES.

*The especial attention of the trade is directed to our full-line of 18 size, Full Plate STEM-WINDING movements, to wind at the figure 12 for Open-Face Cases, of the following companies:*

ROCKFORD, ILL., WATCH CO.  
SPRINGFIELD, ILL., WATCH CO.

WALTHAM WATCH COMPANY,  
ELGIN WATCH COMPANY.

### J. T. SCOTT & CO.

No. 11 MAIDEN LANE,

Sole Eastern Wholesale Agents for the Rockford Watch Company.

## SPENCER OPTICAL MANUF'G CO.

13 MAIDEN LANE, NEW YORK,

MANUFACTURERS OF

## Spectacles AND Eye Glasses

IN ALL VARIETIES.

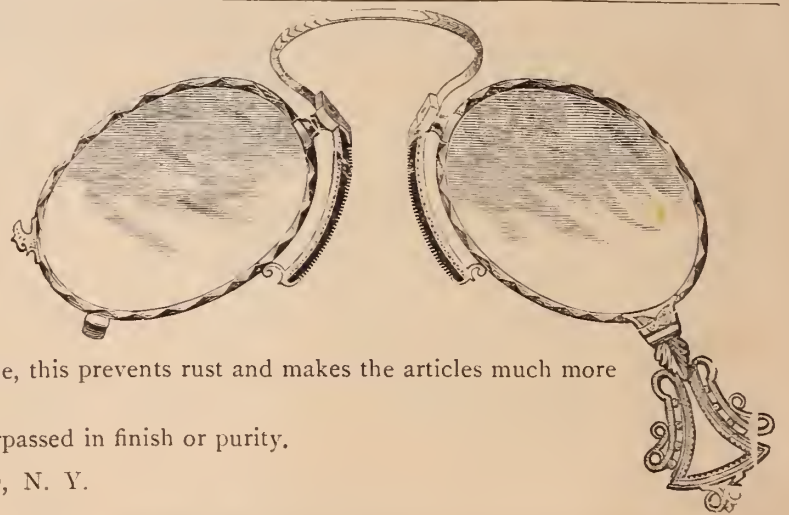

Among the numerous specialties are the Steel Frames plated with Nickle, this prevents rust and makes the articles much more durable.

P. S.—Our lenses are all ground in our own Factory, and cannot be surpassed in finish or purity.

FACTORIES, MT. KISCO, N. Y.

## HAMPDEN WATCH CO.

Manufacturers of KEY AND KEYLESS

General Office and Factory,  
SPRINGFIELD, Mass.

## WATCHES.

New York Office,  
No. 12 MAIDEN LANE.

**COMBINATION**

**Adjustable Watch Key and Magic Pencil.**



By pressing on end A the adjustable jaws B open and will fit any watch. It is a combination of Birch's patent keys with a Magic Pencil, and is secured by letters patent dated July 30, 1878.



The style and size represented is made of Rubber and 18 k. plate

List, \$30 Per Doz.

**MABIE, TODD & BARD,**

Manufacturers of

Gold Pens, Pencils, &c.

180 Broadway,

NEW YORK.

**LORIENT & OSTROM**

Manufacturers of

**Clocks and Fine Movements,**

Small Experimental Machinery, Models, Small Driving Machinery, &c.

No. 130 FULTON STREET,

Corner Nassau Street, NEW YORK.  
Fine Lever Movements for Safe Locks a Specialty.

**STERN BROS. & CO.**

Manufacturers of



Fine Jewelry,

30 MAIDEN LANE,

FACTORY, 73 & 75 Fulton St., NEW YORK.

Gold Seal engraved Band-rings and Locketts a specialty. The attention of the trade is directed to our plain Gold filled Rings. Sections of which showing the construction and quality sent upon application. After February 1st, our plain filled rings will bear the above trade mark.

F. W. C. Nieberg,  
Repairer and Adjuster of  
FINE WATCHES  
and Marine Chronometers,  
No. 8 JOHN STREET  
New York.

Established 1848.

Reliable and prompt.

**COOPER & BRO.**

Wholesale Jewelers,

Importers and dealers in WATCH & CLOCK-MAKERS' TOOLS and MATERIALS; also, JEWELERS' SUPPLIES, SPECTACLES, OPTICAL GOODS, &c. A complete Outfitting Establishment for the trade.

Repairs Department established 1865. Every description of work done for the trade. Watch Repairing, Jewelry and Watch Case Repairing, Gold and Silver-Plating, and Fire Gilding.

35 S. Fourth St. (1st floor), PHILADELPHIA

**JEWELRY PHOTOGRAPHED.**

In order to meet the demands of many of the Manufacturers of Jewelry, Silver Ware, &c., (Tiffany and others) I have erected a SPECIAL SKYLIGHT, for Mechanical Photography, viz:

The Copying of Silver Ware, Statuary, Bric-a-Brac, Paintings, Models, &c.

I propose to keep it busy by adopting the following rates:—8-10. Photographic negative \$1. Proofs 50 cents. Special rates for quantities.

GEO. G. ROCKWOOD, Photographer, 17 Union Squ.  
Established 1859. (Above Tiffany's.)

**VOSE & SOUTHWICK,**  
Manufacturers of Gold Jewelry



Sole Makers of the Separable Sleeve and Collar Buttons in Gold.

No. 183 Eddy Street, PROVIDENCE, R. I.

**ALBERT FRIEDENTHAL,**

Importer and Jobber of

WATCHMAKERS' & JEWELERS'

Materials, Tools and Optical Goods  
Real and Imitation Stones,

For Manufacturing and Repairing Purposes  
A SPECIALTY.

Agent for TISDALE'S Watch and Clock Oils.

No. 43 Maiden Lane, New York.

Orders by mail will receive prompt attention.

**E. A. LAUTEN,**

MANUFACTURERS OF

**MOROCCO, VELVET & SATIN CASES**

FOR

Jewelry and Silver Ware.

New Trays for Lace, Shawl and Scarf Pins,  
Novelties in Brocade Silks,

4 Great Jones Street,

One door from Broadway, NEW YORK.

**Stephen J. Cox**  
DESIGNER & ENGRAVER  
OF  
WOOD  
No. 90 NASSAU STREET, NEW YORK.  
Jewelers' Work a Specialty.



SHUT.

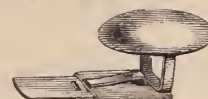

OPEN.

**CHAS. F. TERHUNE & CO.,**  
Manufacturers & Jobbers in General Jewelry.  
No. 17 Maiden Lane, N. Y.

We beg to call the attention of the trade to the above cuts, representing MISSIMER'S PATENT for the REPAIRING of SLEEVE Buttons. It is not separable, but works on a simple slide. Recommends itself at sight. Send for sample. A liberal discount to jobbers.

**JNO. F. LUTHER.**  
79 NASSAU ST. N.Y.  
MANUFACTURER OF FINE  
PRESENTATION JEWELS  
FOR ALL SECRET SOCIETIES.  
KNIGHT TEMPLAR'S CROSSES  
KEY STONE MARKS  
SOCIETY SCHOOL AND  
College Badges.

**E. WEISKOPF,**

MANUFACTURER OF

**Optical Lenses**

No. 182 Centre Street, N. Y.

SPECIALTY!

Cylinder and Prismatic Spectacle Glasses,  
Magic Lantern & Panoramic Lenses.

**BOURQUIN BROTHERS,**

Manufacturers and Importers of Watches,

All Kinds  
of



WATCHES  
MADE  
TO ORDER.

NO. 20 MAIDEN LANE, N. Y.

FACTORY, BIENNE, SWITZERLAND.

**HERMAN BUSH'S**

EUROPEAN

**Publishers & Advertising Agency**

HULL, ENGLAND,

Supplies all English and Foreign Periodicals and Hand-books for Watchmakers, Jewelers and kindred Art Industrial trades, and inserts Advertisements in the journals of all countries, at publishers' rates. No charge made for translating advertisements in foreign languages. Estimates and every information by return of post, on receipt of two cents U. S. Stamp postage for lists; and five cents for letters, if WRITTEN information be required. Specimen copies procured. Lists free.

HENRY ABBOTT,

Manufacturer of

STEM-WINDING PARTS FOR  
**WATCHES,**

New Scapements for Watches or Clocks.

Models for Patents. Small Tools for Watchmakers and Jewelers.

Dies, Cutters, &c., made to order.

Fine and Complicated Watches repaired in the best manner, by competent workmen.

Office, 11 Maiden Lane,  
**NEW YORK.**

Factory, 13 & 15 Franklin Sts., Newark, N. J.

Established 1850.



**PETER L. KRIDER,**

MANUFACTURER OF

**STERLING**

**SILVER WARE,**

Medal and Diploma Awarded, &c.

Striking Society Medals in Gold, Silver or Bronze  
A SPECIALTY!

ARTISAN HALL,

**618 Chestnut Street**  
**PHILADELPHIA.**

**W. F. TREWIN,**

Manufacturer of

**Watch Cases**

—AND—

**Jewelry.**

Prompt and careful attention given to filling orders for all kinds of goods pertaining to the Trade. Goods sent on approval when satisfactory references are furnished.

Designs and estimates given, and special attention paid to orders from jewelers for Watches, Badges, &c., designed for presentation.

Every description of Watches and Jewelry carefully repaired for the Trade.

**730 Chestnut Street, (up stairs),**  
**PHILADELPHIA.**

**GEO. W. DU BOIS,**

(Successor to Albert Landsberg.)

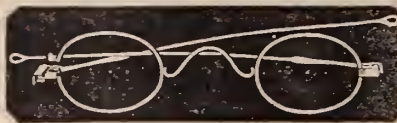

IMPORTER AND MANUFACTURER OF

**Optical Goods,**

**No. 36 MAIDEN LANE,**

Near Nassau Street, **NEW YORK**

Sole Agent for

**BLACK'S PATENT**

**Interchangeable Spectacles,**

AND

**EYE GLASSES.**

Jewelers and others who keep spectacles for sale will please observe that, with these PATENT SPECTACLES, it is only NECESSARY to have a full Complete Assortment of Lenses and Pebbles, which being all of a UNIFORM SIZE, will FIT either the Gold, Silver, or Steel Frames, of which but a few of each kind are wanted; an advantage which will give a complete assortment of the finest Spectacles, for one-sixth the capital invested in a like assortment of the same quality goods of the old style frames.

For Particulars, price lists, &c., address

**GEO. W. DU BOIS,**

**New York.**

**Journal Suisse d'Horlogerie,**

A MONTHLY TRADE JOURNAL.

Published in Geneva, under the auspices of the Industrial and Commercial Departments of the Societe des Arts.

Devoted to the interests and for the advancement of Watchmakers and the art of Horology.

This periodical is under the supervision of a body of watchmakers, who have correspondents in the kindred branches of industry and sciences, who contribute the leading articles of interesting subjects and illustrations, publishes the reports of the different commercial and industrial societies, of which it is the organ, and is, owing to its great circulation all over the world, a valuable advertising organ.

Subscription, 12 francs a year, (or \$2.50). Orders received at the office of The JEWELERS' CIRCULAR.

**A New Monogram and Alphabet Album**

**J. SABIN & SONS,**

Respectfully announce, that they have now ready a new edition of their well-known book of Monograms and Alphabets.

Engravers, Stationers, Carriage Painters, Jewelers, Gold and Silver Smiths, and Designers and Decorators generally, will find this book useful, saving time in drawing, and having available a book of suggestion and reference. A double set of Monograms is included, a number of Alphabets, also a few Heraldic Designs, Crests, Casques, &c.

Printed on fine plate paper, and bound in cloth, \$5.00

We print but a small edition, and early orders are suggested.

"All we have done in this art would be hopeless y eclipsed by the publication of J. Sabin & Sons; as a contribution to a jeweler's stock of designs, it is priceless"—Jewelers' Circular.

**J. SABIN & SONS,**

**No. 84 Nassau Street, New York.**

1860. Nineteenth Annual Statement 1879.

OF THE

**WASHINGTON**

Life Insurance Company,

OF NEW YORK,

OFFICE, COAL AND IRON EXCHANGE,

Corner Cortlandt and Church Streets,

CYRUS CURTISS, PRESIDENT.

Net Assets, December 31, 1877	\$5,072,576 16
Receipts during the year:	
For Premiums	\$955,261 14
For interest	290,060 49
	<b>1,245,321 63</b>

Disbursements:	
Claims by Death	\$201,367 93
Matured Endowments	171,399 90
Surrendered Policies, Cash, Dividends and Return Premiums	483,129 50
Annuities	1,708 32
	<b>\$6,317,897 79</b>

TOTAL PAID POLICY-HOLDERS:	
ERS	\$857,675 65
Taxes	7,253 19
Commuted Commissions	23,915 62
Profit and Loss	6,114 52
Dividends to Stockholders	8,653 75
Expenses—Rent, Coms., Salaries, Postages, Advertising, Medical Examinations, &c.	160,367 85
	<b>1,064,610 58</b>

Net Assets, December 31, 1878. \$5,253,287 21

ASSETS.

U. S. and N. Y. City Stocks	\$2,313,466 30
Bonds and Mortgages	2,27 214 02
Real Estate	414,436 23
Cash on hand and in Banks	224,548 63
Loans on Collaterals	15,187 48
Agents' Balances	15,434 55
	<b>5,253,237 21</b>

Add excess of Market Value of Stocks over cost	93,758 70
Interest accrued and due and unpaid	47,289 76
Deferred and unpaid premiums, less 20 per ct.	108,908 02

Gross Assets December 31, 1878. \$5,503,243 69

LIABILITIES.

Reserve by N. Y. Standard, Company's valuation	\$4,448,480 00
Unsettled Claims	112,182 48
Premiums paid in advance	11,620 26
Unpaid Dividends to Stockholders	175 40
Salaries, Rent, &c.	3,750 00

Total Liabilities as to Policy-holders	\$4,576,207 74
Surplus as regards Policy-holders	927,035 95

Aggregate. \$5,503,243 69

CAPITAL STOCK. \$125,000.00

W. A. BREWER, JR., Vice Pres.

W. HANTUN, Secretary,

CYRUS MUNN, Ass't Secretary.

E. S. FRENCH, Sup't of Agencies.

B. W. McREADY, M. D., Med'l Ex.

**WADSWORTH'S PATENT ELLIPTIC**



**WATCH CASE SPRING**

Each holder is accurately fitted to the Case, and in few minutes the Spring can be adjusted. The Spring works evenly from end to end, and without strain or wear to the most delicate Case.

The Spring is made of the Finest Steel, Drawn and Rolled Hard, which gives it sufficient temper, and so adjusted to the Holder that it retains its elasticity, is not liable to break, and is superior to all others.

\$1.50 per dozen.

C. W. WADSWORTH, PEESKILL, New York.

GROSS & BEQUELIN, 21 Maiden Lane, N. Y.

L. H. KELLER, 64 Nassau Street, N. Y.

**Allgemeines Journal der Uhrmacherkunst.**

Illustrirte Fachzeitschrift für Uhrmacher.

Redacteur, Emil Schneider, Uhrmacher in Naumburg, Germany.

Agents for the United States, Wm. MUSHAM, 316 W. Pratt St., Baltimore, and O. W. F. BURGER, cor 5th & Olive streets, St. Louis, Mo., who will give every information with regard to subscription and advertisements.

The "Allgemeines Journal der Uhrmacherkunst" has taken upon itself the task of elevating the art of watchmaking, and to protect and further the interests of the trade.

This Journal appears weekly, and, enjoying a great circulation all over the globe, is in a position to offer special advantages for advertisements.



**BIRCH'S PATENT SCREW KEY.**



The especial attention of the trade is directed to the above, a LIMITED NUMBER of which we have on hand.

THIS IS THE BEST SCREW KEY WE HAVE EVER PUT ON THE MARKET.

*Sample by Mail on receipt of 75 Cents.*

**J. S. BIRCH & CO.,**

No. 38 Dey Street, New York.

**FRASSE & COMPANY,**

Importers of P. S. STUBS',

*French, Swiss, German & Sheffield Tools, Files,*

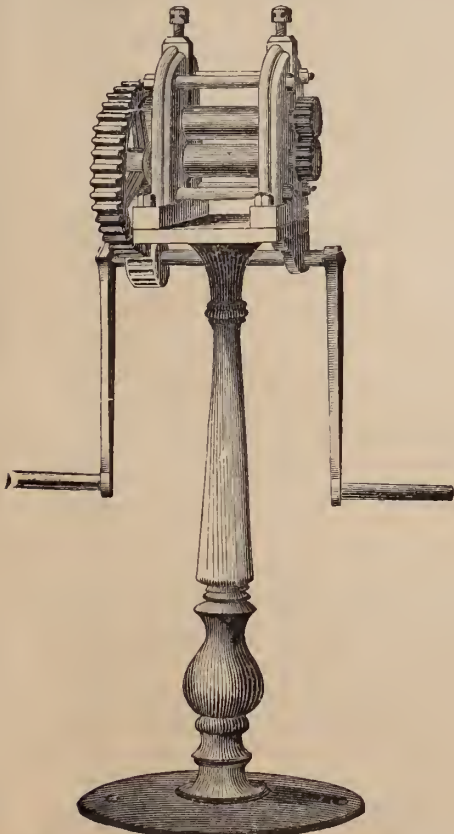

Steel Wire and Materials,

For Watchmakers, Jewelers, Engravers, Die-Sinkers, Machinist, &c.

**Turning Lathes, Drills & Chucks**

Rolling Mills, Draw Plates,

**The Celebrated Rodenbush**

**Piercing Saws,**

- Horse Shoe Magnets,
- Nurls,
- Ingots,
- Chasing Tools,
- Engravers' Tools,
- Brush Wheels & Buffs,
- Hand Brushes and Buffs,
- Borax,
- Saltpetre,
- Beeswax,
- Rouge,
- Tripoli,
- German Silver,
- Brass, &c.

**No. 62 Chatham Street, New York.**  
established 1816 P. O. Box 4627.

**The Burbank Manufacturing Company**

Manufacturers of GOLD & SILVER

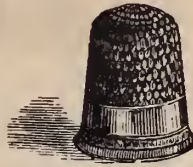

GOLD  
SILVER,  
STEEL,  
RUBBER,  
And SHELL,

**Thimbles,**



EYE GLASS  
Self Adjusting.

**SPECTACLES AND EYE-GLASSES**

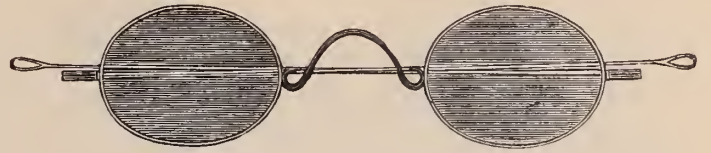

OF ALL DESCRIPTIONS.

**SOLID GOLD RINGS**

**Office, 14 MAIDEN LANE. NEW YORK.**  
Manufactory, Springfield, Mass.

**NE PLUS ULTRA.**

**Williams & Cook's Dust-Proof Watch Keys**

Patented Sept. 1st, 1874.



- The Popular Name Key.**
- A. Nickel Plated Handle and Pipe, Swivel Top, per gross..... \$10.75
- English Pattern Key.**
- C. Nickel Plated Handle and Pipe, Swivel Top, per gross..... \$7.50



**BENCH KEYS.**

- Corrugated Gilt Handles, Tempered Steel Pipes, per Set of Six..... \$1.80
- per Set of Three..... .90

**P. Style of Key.**

- Gilt Handle. Steel Pipe.
- Per Gross..... \$8.50



Our Key Pipes are all warranted to be made of the finest quality of steel. One great advantage his key has over all others, is the mortice through the pipe, making it the most simple and thoroughly dust and moisture-proof, as well as the cheapest key in the market. Our sizes run from 1 to 12: 4, 5 and 6 fit Gents' American Watches; No. 8, Ladies' American.

For sale by the Trade generally.

**KENDRICK, DAVIS & CO., LEBANON, N. H.**

SOLE OWNERS AND MANUFACTURERS.

The advantage of our Name Key, as an advertising medium, will at once be seen.



GEO. W. SIMONS,  
JOHN F. SIMONS,

PETER B. SIMONS,  
GEO. W. SIMONS, JR.

JOHN SPECKER,  
FRED. M. SIMONS.

**SIMONS' BROTHERS & CO.**  
MANUFACTURERS OF

Gold Chain and Jewelry,  
611 & 613 Sansom Street,  
PHILADELPHIA.

Awarded Medal and Diploma at the Centennial.

**Simons' Brothers & Co.**  
611 & 613 Sansom Street, Philadelphia

**The Pioneer Watch.**

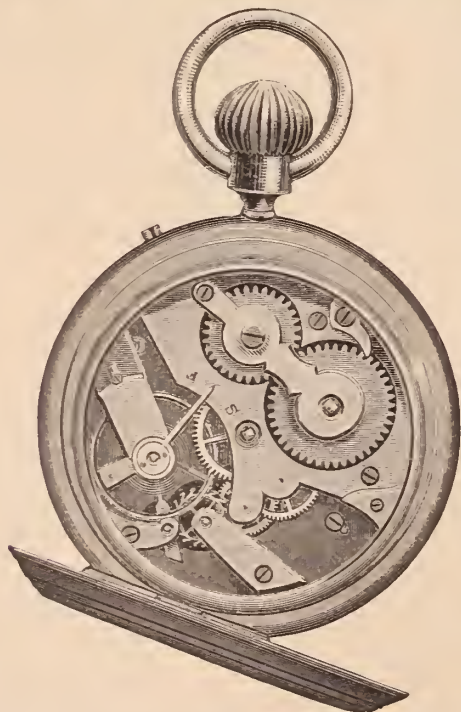

**HENRY GINNEL, Sole Manufacturer,**  
**No. 31 Maiden Lane, NEW YORK.**  
P. O. Box 2967.

The accompanying illustration is a fac-simile of the Pioneer Watch. The Best (stem-winding and stem-setting) Pocket Timekeeper ever offered to the trade. They are cased in silver and German silver—Hunting and Open Face.

**L. H. KELLER & CO.**

Successors to G. A. HUGUENIN,

IMPORTERS OF

**Fine Watch and Clock Materials,**  
SWISS, ENGLISH, FRENCH & GERMAN  
**FILES, TOOLS, & C.**

FOR WATCH MAKERS, WATCH CASE MAKERS, JEWELERS,  
SILVERSMITHS, ENGRAVERS, CHASERS, DIE  
SINKERS, MACHINISTS, &c.

Special attention is directed to "OUR OWN" Celebrated Main Springs graduated in thickness to equalize the power, with well rounded edges, and the Highest Crocus Finish throughout, insuring the least possible friction in the band, pronounced by expert judges to be the best made, "JURGENSEN" Main Springs recoiling, suitable for the highest grades of Swiss Watches.

"LUTZ" Celebrated Hair Springs, by numbers, of uniform diameter and strength, the best for "regulating."

Fine Hole Jewels of Ruby, Sapphire, Chrysolite, Garnet, Beryl and Aqua Marine, with gauged (well shaped and polished) holes, numbered by the Swiss pivot gauge; also, neat black walnut cases, containing forty glass vials for assortments of same. The great advantage in having Jewels by numbers will readily be seen as a saving in time and annoyance in selecting and in expense. Dealers once having an assortment, can replenish or stock up at a comparatively small outlay, as any desired quantity of and No. and quality can be had of us at all times, our stock of jewels being the largest and most complete in the country.

Diamond Charged Broaches for opening and polishing jewel holes.

Diamond Powder and Bort for polishing and grinding 8 different grades, in  $\frac{1}{2}$ ,  $\frac{1}{4}$ ,  $\frac{1}{8}$ , and  $\frac{1}{16}$  K vials, bringing it into the reach of all.

Gold Diamond Set and other fine Geneva Hands.

The new Drills in Sets of 54 small, 126 small to medium, and 48 large; also, sold separately if desired.

NOTE.—We issue no Price Lists and Highly Illustrated Catalogues to attract attention of Dealers to a large assortment of goods in print, but we have the goods in stock and will be pleased to quote prices if desired, or fill orders for any article in our line.

SOLE AGENTS FOR HALL'S STAKING TOOLS AND ROLLER REMOVERS.

Agents for the Whitcomb and other American Lathes.

GENERAL AGENTS FOR THE PHILADELPHIA WATCH COMPANY.

American Agents for the Horological Journal, (British).

A Monthly Paper for the advancement of Chronometer, Watch and Clock Making, and kindred Sciences. Published under the auspices of the British Horological Institute, London. Subscription \$2.50 per year, in advance.

SAUNIER'S TREATISE ON MODERN HOROLOGY, IN THEORY AND PRACTICE.

BY M. CLAUDIUS SAUNIER. The English Edition will appear in 26 monthly parts, Price 50 cents each. Whole Work, \$13 00, postage paid.

**No. 64 Nassau Street,**

Near Maiden Lane,

**NEW YORK.**

## SPECIAL NOTICES.

**TO LET.**—A very desirable Jewellers' Factory, size, 50x50 feet. Excellent light, steam power, heating and elevator. First-class in every respect. Also part of front office on first floor if desired. Will be rented to a good party at a very low rate. John A. Riley & Co., Nos. 7 and 9 Bond Street.

**GEO. E. WILKINS.**—Importer of fine Tools for Watch-makers, cutting and dividing engines, rounding-up tools and cutters, also cutters for stem winding wheels. Fine lathes with the American system of chucks. Dividing engine and rounding-up tool combined. Marine chronometers for sale. Special tools imported to order. 21 South Salina St., Syracuse, N. Y.

**FOR SALE.**—Tools, material and small stock of jewelry in one of the best railroad towns in Western Minnesota. Splendid chance for a beginner with about \$350 cash. Address at once, Harry Saunders, Box 182, Redwood Falls, Minnesota.

**SITUATION WANTED.**—By a young man, three years' experience in the watchmaking and jewelry trade. Can give unexceptional references. Address H. L. Kohler, Pomeroy, Ohio.

**FOR SALE.**—Four Jewellers' Safes—Herring's make. Dimensions—height, 64 inches; width, 51 inches; depth, 18 inches. These safes were made expressly to order and fitted up for the jewelry business. Combination locks and all the late improvements to make them secure against burglary. Will be sold at a sacrifice. Chatterton & Dodd, 19 John Street.

**A COMPETENT WATCHMAKER** and jewelry jobber (German parentage), 18 years experience, wishes to change position. Good recommendations. Willing to go anywhere if steady employment is guaranteed. Address G. S., P. O. Box 121, Auburn, N. Y.

**GOLD PENS.**—Wanted an experienced traveling agent, familiar with the gold pen business. Apply to John Foley, 2 Astor House, New York City.

**WANTED.**—A situation by a young man of steady habits to finish the trade of watch repairing. Has had one year and a half experience. Pay not so much an object as a good opportunity to finish the trade. Address W. S. Penny, Danbury, Conn.

**FOR SALE.**—A first-class jewelry store, in a flourishing town on the Hudson, with about 7,000 inhabitants, one hour's ride from New York. No other jewelry store within a circuit of several miles. Satisfactory reasons for selling. For particulars address M. Schneider, Tarrytown, N. Y.

**AN INGENIOUS INVENTION.**—We witnessed at work to-day at the office of William Hickson, Guerrant's Electro-Engraving Machine, of which he is the General Agent. For ingenuity and completeness it is worthy of Edison. Indeed, we understand that it has passed under the inspection and received the approval of that wonderful genius. We have never seen a more ingenious machine. It so simplifies the difficulties and labors of engraving as to reduce them to almost nothing. We had the pleasure of seeing it in operation on metal, glass and stone, and the work produced was equal to, if not superior, to the best hand work. We were also shown some samples of its work in engraving vignettes, emblems, etc., which we think could not be excelled, and yet withal it is so simple to operate that a boy of 12 or 15, with half an hour's instruction would be able to operate it successfully.

It copies from the regular press type of any style of letter or design that is made of type; from the plainest to the finest German text letter, or fancy design; and at the same time it will reduce the letter or design from the original size to ten different sizes, or so small that it cannot be seen by the natural eye. It will shorten the letters or elongate them; also will lean them forward or backward; will either make a raised or sunken letter; will engrave on any surface, either plain, concave or convex—for instance, such things as watch cases, either in or outside; finger-rings, either in or outside, bracelets, napkin rings, goblets, pitchers, mugs, and all kinds of jewelry; or, in fact, any article susceptible of being engraved or ornamented with scroll work and fancy designs.

We call the attention of our readers to the card of Messrs. Lorient & Ostrom in our advertising columns. This firm make for the trade clocks and fine movements, as well as parts of movements of hand-made clocks. Models and small experimental machinery and lever movements for safe locks are also made to order by them. Mr. Lorient is well known in the trade as a careful and ingenious expert in clock machinery.

Mr. Henry Ginnel, of this city, has bought from the Elgin Company the entire production of their 14 size nameless movements, which he offers to the trade at a great reduction from former prices. Dealers in search of bargains would do well to consult Mr. Ginnel's advertisement to be found elsewhere in the CIRCULAR.

## Buyer's Directory.

A Guide to the prominent Wholesale Houses in the Watch, Clock, Jewelry and kindred branches of Trade in New York, Philadelphia, Chicago, Providence and Newark.

## NEW YORK.

## Bohemian Garnet Jewelry.

**Bissinger, Philip**—Importer of Diamonds, Pearls and Precious Stones. Sole Agent for the Bohemian Garnet Jewelry, 22 John St.

## Clock Companies.

**New Haven Clock Co.**—62 Reade Street, N. Y.  
**Seth Thomas Clock Co.**—20 Murray Street, N. Y.  
**Waterbury Clock Co.**—M. Bailey, Treasurer, Manufs. and Jobbers, No. 4 Cortlandt Street, N. Y., and No. 197 State Street, Chicago.  
**Kroeber, F.**—Manufacturer and Dealer in American and French Clocks, No. 8 Cortlandt St.

## Corals and Coral Jewelry.

**Errico Bros.**—Importers of Coral, Conch-Shell and Silver Filigree Jewelry, etc., 19 John St.  
**Lawson, S.**—Manufacturer of Coral and Black Onyx Jewelry. All kinds of repairing solicited. Goods sent on Mem. 63 Nassau Street.

**Squadri, Ach.**—Manufacturer and Importer of Coral, Conch Shell and Silver Filigree, etc No. 9 Maiden Lane, N. Y.

## Cameo Cutters, Etc.

**Bonet, L.**—(Successor to Bernard & Bonet), Cameo Likenesses, 889 Broadway, N. Y.  
**Wiederer, Peter**—Late Habermeier & Wiederer, Engravers of Cameo Likenesses, Seal Stones. Cameos repaired. 23 John St.

## Charms &amp; Gold Watch Keys.

**Rupp & Held.**—Manufacturing Jewelers, Charms and Gold Watch Keys, with French and English Ratchets, a specialty. 15 John st., N. Y.

## Cutlery.

**Rogers Cutlery Co.**—Hartford, Conn.

**Harrison Bros. & Howson.**—Manufacturers of Fine Ivory and Pearl Table and Pocket Cutlery; Carvers in Cases; Nutpicks, Nutcracks and goods suitable for the jewelry trade. 26 Cliff street. W. C. Burkinshaw, Sole Agt.

## Diamonds.

**Anderson, Otis**—Diamond Merchant and Broker, always ready to pay cash for bargains in Diamonds and Precious Stones, No. 9 Maiden Lane, N. Y.

**Bernhard, A. & Co.**—Manufacturing Jeweler & Importers of Diamonds and Precious Stones, also Diamond Mountings, No. 169 Broadway, Gilsey building.

**Bissinger, E.**—Importer of Diamonds, No. 192 Broadway, New York.

**Bissinger, Philip**—Importer of Diamonds, Pearls and Precious Stones. Agent for the Bohemian Garnet Goods No. 22 John St., N. Y.  
**Buckenham, Cole & Saunders**—Importers of Diamonds and other Precious Stones, No. 10 Maiden Lane, N. Y.

**Fera, Henry**—Importer of Diamonds, and Manufacturer of Fine Diamond Jewelry. No. 9 Maiden Lane, New York. Amsterdam, Holland, 23 Loojersgracht.

**Herbert, R. J.**—Importer and Broker in Diamonds, 24 John Street.

**Hedges, Wm. S. & Co.**—Importers of Diamonds. No. 170 Broadway.

**Lyon & Hardy.**—Importers of Diamonds and Manufacturers of Diamond Jewelry. 30 Maiden Lane, New York.

**Neresheimer, E. Aug.**—Importer of Fine Diamonds. No. 21 Maiden Lane, New York.

**Smith, Alfred H. & Co.**—Importers of Diamonds. No. 14 John Street.

## Diamond Cutters.

**The Morse Diamond Cutting Co. of Boston.**—Henry D. Morse, General Manager. N. Y. Office, 192 Broadway, corner John street. J. D. Yerrington, Agent.

## Diamonds and Diamond Jewelry.

**Bissinger, Philip.**—Importer of Diamonds, 22 John street, N. Y. Agent for the Bohemian Garnet Goods.

**Bornemann, Louis**—Manufacturer of Diamond Jewelry from original designs, 169 and 171 Broadway.

**Taylor & Brother**—Importers of Diamonds and Diamond Jewelry, 676 Broadway.

## Diamond Setters, Etc.

**Asher, J.**—Jeweler and Diamond Setter, Precious Stones Inlaid and Incrusted with Diamonds, Nos. 880 and 882 Broadway.

**Blancard & Oberlander**—Manufacturers of all kinds of Settings and Galleries of any carat of Gold, Silver, Platinum and Platinum Lined. Send for sample cards. 36 and 39 John street, N. Y.

**Wood, Chas. F.**—Engraver and Incruster of Precious Stones and Diamond Setter. No. 169 & 171 Broadway.

**Friend, S.**—Manufacturer of Fine Jewelry, and Diamond Setter. 33 John street, N. Y.

## Dials, &amp;c.

**Caesar Brothers**—Manufacturers of Enameled Clock Meter and Gauge Dials, Patent Door, Coffin and Pew Plates, Druggists' Labels, &c. No. 32 and 34 John Street.

**Gold, John T.**—(Successor to the late T. Gold), Enamel Watch Dial Maker, 81 Nassau St.

## Enamellers, Etc.

**Nutt, J. D.**—Enameler on Gold, Silver and Copper, 32 and 34 John St. Birds, Flowers, etc., Enameled in colors.

**Orr, Jas. C.**—Enameler on Fine Jewelry, Flowers, Birds, &c., Enameled in colors. Band Bracelets (a specialty). 77 Nassau Street.

## Electroplaters, &amp;c.

**Jeandheur, F. & Son.**—Gold and Silver Electro Platers & Fire Gilders, coloring Russian and Gold Jewelry a specialty. 117 Fulton St.

## Engravers and Die Sinkers

**Fackner, Edward**—Carver, Engraver and Chaser on Jewelry and Pencil Cases. Monograms Lettering, &c. 19 John Street.

**Schuller, J. Dan'l**—Stone Seal Engraver Arms Crests, Initials and Monograms engraved on Stone Seals, &c. 71 Nassau street.

## Fancy Goods, Clocks, Bronzes Etc.

**Hall, Nicoll & Granbery**—Importers of Clocks, Bronzes, Folding Mirrors, Fancy Goods, etc. 20 and 22 John Street, New York.

**Hinrichs, C. F. A.**—Importer and Dealer in French, English and German Fancy Goods, etc., etc. 29, 31 & 33 Park Place, N. Y.

**Magnin, Ve J. Guedin & Co.**—Importers of Clocks Bronzes, Musical Boxes & Rich Fancy Goods etc., 29 Union Square.

**Le Boutillier & Co.**—Importers of Fancy Goods, Clocks, Bronzes, &c. 3 Union Square

## Gold Chains, Etc.

**Beck, J. & Son.** Manufacturers of Fine Gold Chains and Chain Bracelets, 10 Liberty place, near Maiden lane, N. Y.

**Dorrance, Edge & Co.**—Manufacturers of the Celebrated Woven Fabric Gold Chain, No. 9 John street.

**Hamiltons & Hunt.**—Manufacturers of Fine Plated Chains and Patent Buckle Bracelets. Branch office, 176 Broadway. Factory, 226 Eddy street, Providence.

**Kaufmann Bros.**—Manufacturers of Gold Chains, and Chain Bracelets, 26 John street; Factory, 331 and 333 Bowery, N. Y.

**Nord & Schlag.**—Manufacturers of Gold Chain. No. 366 Broome St., N. Y.

**Saxton, Smith & Co.**—Manufacturers of Fine Gold Chain. 15 Maiden Lane.

## Gold Pens, Etc.

**Aikin, Lambert & Co.**—Manufacturers of Choice Gold Pens, Cases, Holders, Toothpicks, etc., 12 Maiden Lane, N. Y.

**Mabie, Todd & Bard**—Manufacturers of Gold Pens, 180 Broadway.

**Todd, Edward & Co.**—Manufacturers of Gold Pens, Pencil Cases, Tooth Picks, &c., 652 Broadway, N. Y. Factory, Brooklyn.

## Goldsmiths, &amp;c.

**Greene Wm. C. & Co.**—Goldsmiths; Manufacturers of Rich Sets in Taper Wire Coral. Office, 18 John street.

## Gold Rings.

**Bowden, J. B. & Co.**—Manufacturing Jeweler.—Solid Gold Rings a specialty, 11 Maiden Lane.

**Ely, W. H.**—Manufacturer of Solid Gold Rings of every description. No. 58 Nassau Street.

**Peckham, Wm. H. & Co.**—Manufacturers of Solid Gold seamless Rings and Fancy Embossed Rings, Patent Spectacles, Jewelry, etc., No. 4 Liberty Place.

## Hair Jewelry.

**Sauter, L.**—Manufacturer of Fine Gold and Hair Jewelry and Device Work. Nos. 65 & 67 Nassau Street.

Schwencke O.—Manufacturer of Fine Hair Jewelry. Orders from the country promptly attended to. No. 43 Maiden Lane.

#### Jewelry Cases, Fancy Boxes, Etc

**Braun, Chr. E.**—Manufacturer of Jewelry Boxes, Trays for Show Cases, &c., 62 Chatham st.  
**Loehr & Koerner**—Manufacturers of Morocco, Velvet, Satin, Jewelry, Watches and Silverware Cases, Glove, Handkerchief, Ladies' Jewel, Work Boxes, &c., Fancy Trays and Stone Fittings to order, Office and Salesroom 96 John Street, New York.  
**Dahlem, W.**—Manufacturer of Cases for Jewelry and Silverware, No. 85 Nassau Street, N. Y. Show Case Trays, &c., at shortest notice.  
**Wiggers & Froelich**—No. 60 Nassau street.—Manufacturers of Cases for Jewelry, &c., of every description. Trays for Show-cases, Stands for Show-windows, etc. Jewelers' Traveling Cases, light, convenient and strong.  
**Jackson, Samuel C.**—Manufacturer of Box and Trays, for Silverware, Watches, Jewelry &c. 180 Broadway, N. Y.  
**Sturn, L.**—Manufacturer and Importer of Cases for Jewelry, Watches, Silverware, &c. No. 15 John street, N. Y.  
**Welch & Miller**—Manufacturers of Morocco, Velvet, and Satin Jewelry Cases, Trays, &c. Telescope Sample Cases with flexible Trays. Complete stock on hand. 169 Broadway.

#### Jewelry—Fine.

**Aikin, Lambert & Co.**—Manufacturers. General stock of Reliable Jewelry, 12 Maiden Lane.  
**Alford, C. G. & Co.**, Manufacturers. General line fine and reliable goods. Specialties in Onyx goods and chain. 183 Broadway, New York.  
**Andrews, J. F.**—Manufacturer of Fine Jewelry, Lockets, Sleeve Buttons and Rings in Stone Cameo, etc., a specialty. 35 Maiden Lane.  
**Saldwin, Sexton & Peterson**—Manufacturers Fine Jewelry. Whiting Building, Broadway and Fourth street.  
**Ball, Wm. H.** Manufacturing Jeweler. Fine Gold Bracelets a Specialty. No. 9 John St., N. Y.  
**Barthman & Straat**—Manufacturers of Fine Jewelry. Seal and Stone Rings a Specialty Orders promptly attended to. 41 Maiden Lane.  
**Bergstein & Son**—Manufacturing Jewelers, No. 20 John Street.  
**Bernhard, A. & Co.**—Manufacturers of Fine Hair Jewelry and Device Work. The latest styles 169 Broadway, Room 3, New York.  
**Bissinger, E.**—Importer of Fine Jewelry, Lockets, Crosses, Neck Chains, &c., No. 192 Broadway.  
**Brown, Thos. G.**—Manufacturer of Rich Jewelry Necklaces, Lockets, Bracelets, Sleeve Buttons, etc., 9 Bond street, N. Y.  
**Bryant & Bentley**—Manufacturing Jewelers Rings a specialty. 12 Maiden Lane.  
**Brainerd & Steele**—Successors to Brainerd, Steele & Co., Manufacturers of Fine Jewelry and Brainerd's Patent Lockets. No. 9 Maiden Lane, New York.  
**Burch, Geo. & Co.**—(Successors to Burch, De Mott & Coughlin.) Manufacturing Jewelers, 17 Maiden Lane, N. Y. Factory, Newark, N. J.  
**Carrow, Bishop & Co.**—Manufacturers of Fine Jewelry, Roman Band Bracelets, Lockets, Crosses, &c. 12 John Street, N. Y.  
**Carter, Howkins & Sloan**—Manufacturing Jewelers, Whiting Building, 4th St. & Broadway  
**Chatellier & Spence**—Manufacturing Jewelers. No. 652 Broadway, N. Y.  
**Cook, Groeschel & Co.**—Manufacturers of Fine Jewelry and Lockets, 191 Broadway (over Mercantile Bank,) N. Y.  
**Coe, Pincoe & Stevens**—Manufacturers of Fine Jewelry, Fine Gold Lockets and Linen Finished White Enameled Goods a Specialty, No. 9 Maiden Lane, N. Y.  
**Demmert Bros.**—Manufacturers and Importers of Fine Jewelry, Cameo and Onyx Lockets, Sleeve Buttons and Sets a specialty. Old No. 9 Maiden Lane, New York.  
**Field & Co.**—Manufacturing Jewelers, 8 Maiden Lane, N. Y.  
**Goddard, John M.**—Manufacturing Jeweler.—Seal Rings and Fine Lockets a specialty, No. 25 Maiden Lane, N. Y.  
**Frankel & Folkart**—Manufacturing of Seal, Cameo and Amethyst Rings, a Specialty. Ladies' and Gents' Lockets, Cameo Sets, &c. Also a full line of Diamond Settings, 192 Broadway, cor. John street, N. Y.

**Goldsmith & Schliesser**—Manufacturing Jewelers and Importers of Diamonds and Watches. No 5 Maiden Lane.

**Greason, Bogart & Pierce**, successors to Arthur, Rumrill & Co., 182 Broadway, manufacturers of fine jewelry and gold chains  
**Hartmann, P.**—Manufacturer & Importer of Fine Gold, Diamond, and Filagree Silver Jewelry, No 36 Maiden Lane. P. O. Box 2,454.  
**Haskell, H. C.**—Manufacturing Jeweler. Seal Rings a specialty. Special attention to Jobbing of every description. 12 John street.  
**Hunt & Owen**—Manufacturing Jewelers. Office, 5 Maiden Lane.  
**Hale & Mulford**—Manufacturers Rich Jewelry, Whiting Building, Broadway and 4th Street.  
**Jeanne Brothers**—Manufacturers of Diamond Mountings & Rich Jewelry. 1 Maiden Lane.  
**Keller, Chas. & Co.**—Manufacturing Jewelers Lockets a Specialty. No. 13 John St., N. Y.  
**Krementz & Co.**—Manufacturing Jewelers, No. 13 John Street, N. Y.  
**Kroll, H.**—Manufacturer of Fine Jewelry. Repairing (a specialty) done for the trade at moderate prices, 78 Nassau street.  
**Kuhn & Doerflinger**—Manufacturers of Enamel'd and Roman Band Bracelets, also Fine Lockets and Pendants, 18 John street.  
**Lennon, John D.**—Manufacturing Jeweler, 142 Fulton street. Flat, and Half-round Gold Bracelets, Roman and Stone Lockets.  
**Moore & Horton**—11 Maiden Lane, Manufacturing Jewelers, Rings, Studs, Collar and Sleeve Buttons, Pins, Ear-rings, &c.  
**Mitchell, Noah**—Manufacturer of Fine Gold Jewelry, 694 and 696 Broadway, N. Y.  
**Miller Bros.**—Manufacturers of Fine Jewelry Lockets, Sleeve Buttons, Studs, etc., etc. 11 Maiden Lane, New York.  
**Mulford & Bonnet**—Manufacturing Jewelers and Jobbers, 21 & 23 Maiden Lane, N. Y. Particular attention given to Jobbing and Special orders.  
**Marx Kossuth & Co.**—Manufacturing Jewelers. 39 Maiden Lane.  
**Owen, G. & S. & Co.**—Manufacturing Jewelers. Office, No. 5 Maiden Lane.  
**Pendrill, Wm.**—Manufacturer of Fine Jewelry, jobbing and repairing for the trade at low rates, 73 Nassau Street.  
**Riker, William**—Manufacturer of Jewelry. Inlaid Gold Jewelry a Specialty. No 5 Maiden Lane, N. Y.  
**Riley, J. A. & Co.**—Manufacturing Jewelers, Etruscan Gold and Coral Sets, Roman Bracelets, Necklaces, etc. Onyx Goods a specialty. 7 and 9 Bond street, New York.  
**Richardson, Enos & Co.**—Manufacturers of Fine Gold Jewelry, Gold Chains, Lockets, Crosses and Necklaces. Colored and Etruscan Work. No. 23 Maiden Lane, New York.  
**Richardson, J. W. & Co.**—Manufacturers of Jewelry, Masonic and other emblems. 196 Broadway, Manufactory, Providence, R. I.  
**Sexton & Cole**—Manufacturing Jewelers, Colored Gold and Onyx Goods a specialty. No. 30 Maiden Lane.  
**Shoemaker & Co.**—Manufacturing Jewelers, Cameo Buttons, and Lockets, Roman Gold Goods, etc. No. 21 Maiden Lane, N. Y.  
**Stites, E.**—Manufacturer of Fine Jewelry. No. 12 Maiden Lane, N. Y.  
**Sturdy Bros & Co.**—Manufacturers of Jewelry. General line of fine and heavy Rolled Plate Goods. Specialties—enameling on gold plate; graduated wire coral work. 14 Maiden Lane, N. Y.  
**Thoma, Ernest**—Manufacturer of Fine Jewelry. Sleeve Buttons, Rings, Ear-rings, &c. No. 173 Broadway, N. Y. Factory, Hackensack, N. J.  
**Trier Bros. & Co.**—Jewelry. Optical, Rubber, Jet, Shell, Ivory, Amber and Pearl Goods. Silk Guards, Japanese Bamboo Watch Chains a Specialty. No. 15 Maiden Lane.  
**Vulcanite Jewelry Co.**—Manufacturers of Whitby Jet and Vulcanite Jewelry, 191 Broadway, N. Y.  
**Wadsworth, E. E.**—Manufacturer of Rich Jewelry and fine Rolled Plate. Fine Seal Rings a specialty. 35 Maiden Lane.  
**Wheeler, Parsons & Hays**—Manufacturers of Fine Jewelry, Watch Cases, Gold Chains, &c and Dealer in American and Swiss Watches, No. 2 Maiden Lane, N. Y.  
**Wienhold, Joseph**—Manufacturer of Fine Jewelry and Diamond Setter. 24 John St.

**Woglom & Miller**—Manufacturing Jewelers Nos. 32 & 34 John street, N. Y. Specialty, Black Onyx goods.

#### Jewelers' Boxes.

**Frassé & Co.**—Importers of Stubs, French, Swiss, German and Sheffield Tools, Files and Steel Wire for Watchmakers, Jewelers, etc., 62 Chatham street, N. Y.  
**Hammel, L. & Co.**—Importers of Materials and Tools for Watchmakers, Jewelers and Engravers—also Optical Goods, &c., 9 Maiden Lane, N. Y.

#### Lapidaries.

**Kordmann & Michel**—Lapidaries, dealers in Precious Stones. Rubies, Sapphires and Peridots cut. No. 32 Maiden Lane.

#### Musical Boxes.

**Paillard, M. J. & Co**—Importers & Manufacturers of Musical Boxes, No. 680 Broadway, N. Y.

#### Opticians.

**Burbank Man'g Co.**—Manufacturers of Spectacles and Eye Glasses of all descriptions, in gold, silver, etc., 14 Maiden Lane, N. Y.  
**Du Bois, Geo. W.**—Successor to A. Landsberg, Importer and Manufacturer of Optical Goods 36 Maiden Lane, Box 3993, N. Y.  
**Hammel, L. & Co.**—Importers of Spectacles, Opera and Marine Glasses, Telescopes, Microscopes, Optical & Fancy Goods, 9 Maiden L.  
**Laurencott, J. B.**—Importer of Watch Glasses, Optical and Fancy Goods, Clocks, Bronzes, etc., 33 Maiden Lane, N. Y.  
**Lorsch, Albert**—Manufacturer of the Patent Accommodating Spectacles and Eye Glasses in Gold, Silver and Steel, and other Optical Goods, 37 Maiden Lane, N. Y.  
**Serin, A.**—Manufacturer of Spectacles and Eye-Glasses, in Steel, Shell and Rubber. Repairing of all kinds. Opera Glasses covered and re-gilt, etc. 169 and 171 Fulton street.  
**Spencer Optical Manufacturing Co.**—Gold, Silver, Steel and Nickel Plated Spectacles, Eye Glasses, &c. 13 Maiden Lane, N. Y.

#### Precious Stones, &c.

**Bissinger, Philip**—Importer of Diamonds, Pearls and Precious Stones. Agent for the Bohemian Garnet Goods. No. 22 John St., N. Y.  
**Gruet, Jules**—Importer of Precious and Imitation Stones, Amethysts, Topazes, Cameos, Garnets, Doublets, Imitation Diamonds, Pastes, etc., No. 14 John street. Manufactory at Septmoncel, France.  
**Meyer, Francis Ed.**—Successors to John B. Behrmann, Importer of Imitation Precious Stones, all sizes and shapes constantly on hand. No 38 Dey street, P. O. Box, 1981.

#### Silverware.

**Gorham Manufacturing Co.**—Union Square.  
**Wood & Hughes**—Manufacturers of Fine Silverware. 14 John Street, N. Y.  
**The Adams & Shaw Co.**—Manufacturers of Silverware. Cor. Broadway & 4th St., N. Y.

#### Silver Plated Ware.

**Hall, Elton & Co.**—Manufacturers of the Finest Electro-Plated Ware, salesroom, 75 Chambers street, N. Y.  
**Holmes, Booth & Haydens**—Manufacturers of Silver-plated Ware. 47 Chambers street.  
**Meriden Britannia Co**—Manufacturers of Silver plated Ware, Union Square, N. Y.  
**Middletown Plate Co.**—Manufacturers of Superior Electro-Plate. Factories, Middletown, Conn., Salesroom, 13 John Street  
**Manhattan Silver Plate Company**—Manufacturers of every description and quality of Silver Plated and Bronze Ware, office No. 952 Broadway. Factory 382 to 390 2d Ave.  
**Rogers Cutlery Co.**—Hartford, Conn.  
**Reed & Barton**—Manufacturers of Fine Plated and Table Ware, of every description, 686 Broadway, N. Y.  
**Rogers & Bro.**—Manufacturers of the finest quality of Electro-Plated Ware. 690 B'way.  
**Simpson, Hall, Miller & Co.**—Manufacturers of Fine Silver Plated Ware, No. 676 Broadway.  
**Schade, Henry**—Manufacturer of White Metal and Plated Ware, No. 84 John Street, New York. Price list and catalogue furnished on application.

**Webster, E. G. & Bro.**—Manufacturers of Fine Silver Plated Ware. Office and Warerooms, 14 Maiden Lane, N. Y.

**Show Cases, Etc.**

**Kraft & Hoffmeister**—Manufacturers of Metal Show Cases, Jewelry Trays always on hand, No. 16 North William street, N. Y.

**Smith, B. & W. B.**—Patent Improved Counter Show Cases. Drawings furnished and estimates given for fitting stores in Cabinet Work complete.

**Spectacle Case Manufacturers.**

**Koenen, A. & Bro.**—Manufacturers of Leather Spectacle & Eye Glass Cases, 81 Nassau St., N. Y.

**Thermometers Etc.**

**Tagliabue, Giuseppe**—Thermometer, Barometer and Hydrometer Manufacturer, 302 Pearl street near Beekman, N. Y.

**Thimble Manufacturers.**

**Burbank Manufg Co.**—Manufacturers of Gold & Silver Thimbles, 14 Maiden Lane, N. Y.

**Ketcham & McDougall**—Improved Gold and Silver Thimbles, Nos. 4 and 6 Liberty Place, near Maiden Lane, N. Y.

**Walking Canes.**

**Fradley, J. F.**—Manufacturer of Fine Gold and Silver-headed Walking Canes and Sterling Silverware. Office and Factory, No. 21 John street, N. Y.

**Watch Companies.**

**American Watch Co.**—Robbins & Appleton, No. 9 Bond street, N. Y.

**Hampden Watch Co.**—of Springfield, Mass. Office, No. 12 John St., New York.

**Springfield Watch Co.**—Factory, Springfield, Ill. Office, 11 Maiden Lane.

**Tiffany & Co.**—Makers of Fine and Complicated Watches. Office 14 John street, N. Y.

**Watch and Chronometer Jeweler.**

**Queen, James**—Watch and Chronometer Jeweler and Pallet Maker, 78 Nassau street, Room 8. Pivots inserted in Pinions, Balance, Staffs, &c.

**Watch Importers, Etc.**

**Aikin, Lambert & Co.**—Importers of Watches, Sole Agents for Paul Breton & Chas. Latour, Geneva. A general line of reliable Swiss Watches. Watch Cases of all styles made to order. 12 Maiden Lane, N. Y.

**Bartens & Rice**—Importers of Watches, Watch and Chrometer Makers. No 3 John street.

**Bourquin Brothers**—Importers of Watches from their own manufactory at Biemme, Switzerland, 20 Maiden Lane, N. Y.

**Bynner, T. B.**—Importer and Jobber of Watches, Diamonds and Fancy Goods, and dealer in the best class of Rolled Plate Jewelry. 513 Broadway.

**Cross & Beguelin**—Importers of Watches, Watch Tools and Materials, dealers in American Watches, No. 21 Maiden Lane, N. Y.

**DuBois, Francis & Co.**—36 Maiden Lane, N. Y., Importers of Watches and Manufacturers of Watch Cases.

**Droz, Henry E.**—Importer of Watches and Watch Case manufacturer. Agent for the "E. Perregaux" Watch, and jobber in American Watches, No. 92 Fulton Street, N. Y.

**Freund Max & Co.**—Importers of Watches Jewelry and Precious Stones, 8 Maiden Lane.

**Friedman, S.**—Importer of and dealer in Watches and Jewelry, 40 Maiden Lane.

**Gagnebin, Chas.**—Importer of all kinds of Watches, 64 Nassau Street. Agent for Ulysse Breting's Fine Chronometers, Chronographs, Anchors, etc.

**Gallet, Julien**—Importer of Watches. No. 25 John Street.

**Ginnel, Henry**—Importer of Watches, Tools and Materials. No. 31 Maiden Lane, N. Y. P. O. Box, 2967

**Keller, L. H. & Co.**—(Successors to G. A. Huguenin,) Importers of Fine Watch and French Clock Materials, No. 64 Nassau street, N. Y.

**Hyde's Sons, John E.**—Wholesale Commission Agents, only, for Jules Jurgenseu, of Copen-Lagen, Ed. Perregaux, of Locle, Jules Monard, of Geneva, and for other makers of all qualities of watches, 22 Maiden Lane.

**Kahn, L. & M.**—Importers of Watches, No. 10 Maiden Lane, New York.

**Mathez, F. H.**—Importer of Watches. No. 5 Maiden Lane, N. Y.

**Magnin, Ve J. Guedin & Co.**—Importers and Agents of the Nardin Watch, No. 652 B'way

**Mathey, L. & A.**—Importers of Fine Watches and Sole Agents for the **H. L. Matile's** Watches, No. 119 Fulton Street, N. Y.

**May & Stern**—Importers of Foreign Watches, Materials and Tools, etc. Manufacturing Jewelers. No. 19 John St., N. Y.

**Nicoud & Howard**—Importers and Manufacturers of Watches, No. 14 Maiden Lane.

**Oppenheimer Bros. & Veith**, Dealers in Watches and Diamonds, and Manufacturing Jewelers. No. 35 Maiden Lane, N. Y.

**Quinche & Krugler**—Agents for the Borel & Courvoisier Nickel Movements, 17 Maiden Lane, N. Y.

**Robert, J. Eugene**—No. 30 Maiden Lane, New York Agent for Louis Audemar's celebrated watches.

**Schwob, Adolphe**—Manufacturer & Importer of Watches, 11 Maiden Lane, N. Y.

**Stern Brothers & Co.**—Importers of Swiss Watches and wholesale dealers in American Watches, &c., 30 Maiden Lane.

**Scott, J. T. & Co.**—Importers of Watches, and Manufacturers of Jewelry, and Jobbers of all grades American Watches. No. 11 Maiden Lane, N. Y.

**Strasbourg, Louis & Co.**—Importers and Makers of Watches of every description. No. 15 Maiden Lane.

**Tiffany & Co.**—Makers of Watches. General Agents for Patek, Philippe & Co. Wholesale office, 14 John street, N. Y.

**Watch Cases.**

**Brown, J. A. & Co.**—Manufacturers of The Ladd Patent Stiffened Gold Watch Cases, &c., 11 Maiden Lane, N. Y. Factory, 58 Eddy street, Providence, R. I.

**Watch and Chronometer Repairer.**

**Cerf, B.**—Practical Watchmaker and Repairer, No. 10 John street, N. Y. Repairing and adjusting of Fine Watches done for the trade. All kinds of escape and stem winding wheels cut to order.

**Ludeman, W. H.**—Chronometer and Watchmaker. Repairing of every description for the Trade. 75 and 77 Nassau street, N. Y.

**Sirois, A.**—Practical Watchmaker, 89 Fulton street. Special attention paid to the repairing of Fine Watches. Pivots inserted.

**Watch Case Repairers.**

**Tarbox, Hiram**—Watch Case Repairing, Springing, Polishing and Engine Turning, 79 Nassau street, (room 22), N. Y.

**Renaud, F.**—Watch-Case Repairer.—Solid and Heavy Rolled Plate Bows and Pendants. Springer and Engine Turner of Cases and Jewelry, 36 Maiden Lane

**Watch Guards.**

**American Silk Guard Manufacturing Co.**—Our goods are warranted all silk.—Kossuth Marx & Co. No. 39 Maiden Lane, N. Y.

**Watch Glasses, Shades, Etc.**

**Brown, Edwin**—No. 85 Nassau Street, Imported and own Manufacture Watch Glasses, Flat, Flat Concave, Concave, Convex and fine Geneva's. Fine fitting solicited.

**Hill, Robert S.**—Manufacturer of Watch Glasses, &c., dealer in Imported Glasses, Flat Glasses a specialty; also, Jeweler's Glasses. Nos. 75 & 77 Nassau street, N. Y.

**BOSTON.**

**The Star Salt Caster Co.**—Sole Proprietors and Makers of the Celebrated Star Salts, 161 Franklin Street, Boston, Mass.

**CINCINNATI.**

**Holland, John**—Manufacturer of Gold Pens, Pencils and Pencil-cases, Charms and Gold Tooth-picks, at No. 19 W. 4th street, Cincinnati, Ohio.

**PHILADELPHIA**

**Booz & Thomas**—Manufacturers of Gold and Silver Watch Cases and Jewelry, 108 South 8th Street, Philadelphia.

**Bennett, Jacob & Son**—Diamond Setters and Manufacturing Jewelers. 108 South 8th St., Philadelphia, Pa.

**Cooper & Bros.**—Wholesale Jewelers, and Importers of and Dealers in Watch and Clock-makers' Materials, etc. Spectacles and Optical Goods. No. 35 South 4th St., Phila.

**Conover David F. & Co.**—American Watches, Wholesale Saleroom, southeast corner 7th and Chestnut streets, Philadelphia.

**Hagstoz & Thorpe**—Sole manufacturers of Boss' Stiffened Gold Watch Cases. Sixth and Chestnut Streets, Philadelphia.

**Herold, Chas P.**—Successor to Hildebrandt, Herold & Co., Manufacturing Jeweler and Diamond Setter. Diamonds. 916 Chestnut St

**H. Muhr's Sons**—Manufacturing Jewelers, Solid Gold Rings a specialty, 158 North Second st. New York Office, 11 Maiden Lane.

**Kolb, G. F. & Son**—Manufacturer of fine Morocco, velvet and Cabinet Cases for jewelry watches and Silverware. 722 Sansom street.

**Krider, Peter L.**—Manufacturer of Sterling Silver Ware, Artisan Hall, No. 618 Chestnut street

**Levy, Bernard**—Manufacturers of gold and silver watch cases, and importers and dealers in Swiss and American watches, 402 Library street, Philadelphia.

**McCall & Newman**—Manufacturing Jewelers, Filled Plain Gold Rings a specialty, No. 625 Arch street.

**Morgan & Headly**—Manufacturing Jewelers Cameo sets, Gold sets, Roman Locketts, Rings, Coral sets, and a general line of rich goods. 611 and 613 Sansom street, Philadelphia.

**Pierson, Edwin**—Manufacturer of Fine Imitation Jewelry, Gold and Silver Electro-plater, Fire Gilder, Coloring, Etrusean and Gold Jewelry a specialty. 1320 Chestnut St.

**Rosenthal, G. F. C.**—Manufacturing Jeweler and Diamond Setter. Engraving and Designing of Monograms a Specialty. No. 924 Chestnut street, Philadelphia.

**Scherr, L. A. & Co.** Wholesale Dealer in Watches Silver Plated Ware, Spectacles, Fancy Goods, Watch Materials, etc., 726 Chestnut street.

**Sheafer, W. H. & Co.**—Makers of Fine Jewelry 908 Chestnut Street.

**Simons, Brother & Co.**—Manufacturers of Fine Jewelry, Canes, Thimbles, Chains. 611 & 613 Sansom St., Philadelphia.

**CHICAGO.**

**American Watch Company**, of Waltham, Mass. No. 170 State street, Chicago.

**Charpior & Wathier**—Watchmaker & Jewelers for the Trade, and wholesale Dealers in Watch Material, Tools, &c., 61 West Kinzie Street, Chicago, Ill. Send for price list.

**Frese, B.**—Watchmaking and Repairing for the Trade promptly attended to. Stem-winding and escape wheels cut to order. No. 99 E. Madison St., Chicago, Ill.

**Purdy, J. H. & Co.**—Jobbers of large and small Tools and Materials, for the use of Watchmakers, Jewelers, and kindred Trades. Spectacles—Jewelry Boxes, Plated Chains, &c., &c. No. 170 State street.

**Stein & Ellbogen**—Wholesale Dealers in Watches and Jewelry, 127 State St., Chicago. Specialty, repairing for the Trade.

**PROVIDENCE**

**Irons, Chas. F.**—Manufacturer of Solid Gold Jewelry. Specialty Emblems, Pins and Charms Masonic, Odd Fellows, &c. 102 Friendship St.

**Perkins, C. H. & Co.**—Manufacturers of fine Gold and Plated Jewelry. 20 Conduit St., Providence, R. I.

**NEWARK.**

**Condit, Hanson & Van Winkle**—Manufacturers of Machines for Electro-plating, &c.

**Lefort, Henry**—Stem-winding Watch Crown Manufacturers. 80 & 82 Marshall St.

**Lelong, L. & Bro.**—Gold and Silver Refiners, Assayers and Sweep Smelters, S. W. corner Halsey & Marshall streets, Newark, N. J.

**Milne & Jourdan**—Manufacturers of Stem-winding Watch Crowns Nos. 13 & 15 Franklin Ave., Newark, N. J.

**Prince, David**—Gold and Silver Refiner, Assayer and Sweep Smelter. Sole Agent for Comin's Improved Amalgamator. 63 Railroad Ave.

**Van Houten, Sayre & Co.**—Manufacturing Jewelers, 53 Chestnut street, Newark, N. J.

# PATENT IMPROVEMENT IN COUNTER SHOW CASES,

PERPENDICULAR SLIDING DOOR, DUST-TIGHT.

CENTER COUNTER CASE DOORS RUNNING THROUGH BOTH SIDES.

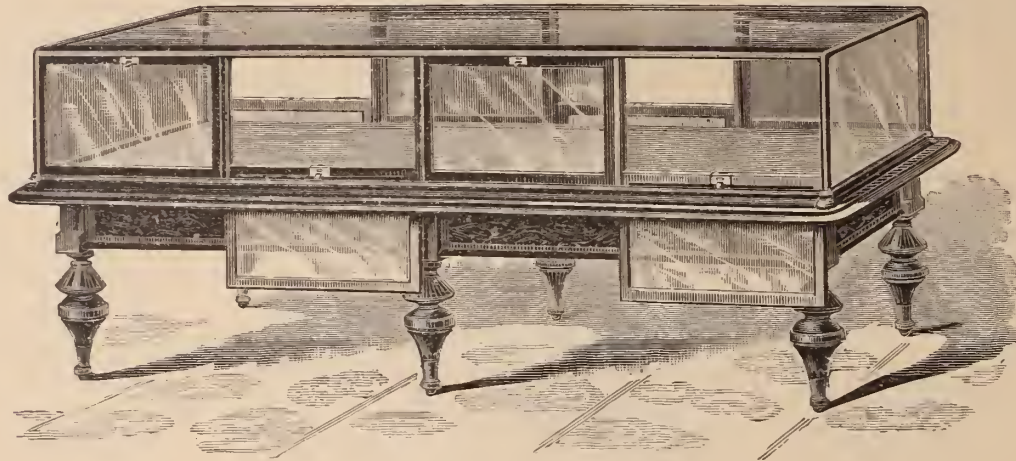

Its advantages are as follows:—The doors are more conveniently opened and closed, less liable to get out of repair or broken, articles are more easily reached in wide cases, mirrors are more safe, it dispenses with hinges, economizes room, excludes dust, and is air tight *when closed*.

Drawings furnished and estimates given for fitting stores in cabinet work complete.

REFERENCES:—Gorham Mfg Co., Rogers & Bro., Mitchell, Vance & Co  
Meriden Britannia Co., M. S. Smith & Co., Detroit, Mich.  
D Valentine, Syracuse, N. Y.

**B. & W. B. SMITH,**  
**220 West 29th Street, New York.**

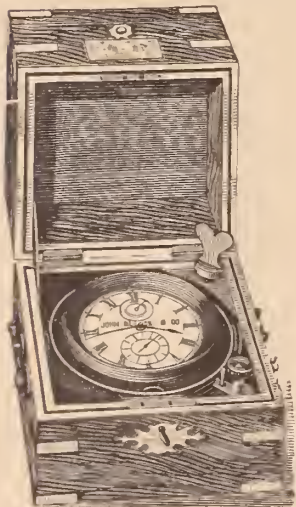

Standard Marine Chronometer  
FOR KEEPING CORRECT TIME.

**JOHN BLISS & CO.**

**STANDARD MARINE**

**Chronometers and Transits,**

**FOR WATCHMAKERS' USE.**

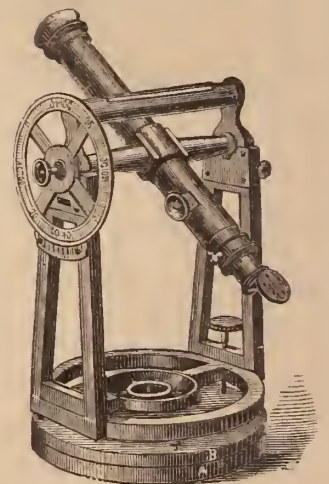

No. 10

**110 WALL STREET, NEW YORK.**

**IMPORTANT NOTICE.**—These Transits are readily set in position without the aid of strictly correct time as a basis for that purpose. Printed instructions, easily understood, accompany each Instrument, and no calculations are required preliminary to setting in position.

As a trial only is required to insure unqualified approval, we are induced to make the following **LIBERAL OFFER**—On receipt by us of satisfactory reference, and 10 per cent. of the price, we will send one of the foregoing Transit Instruments, on hire or trial, for one month, with full printed instructions for setting up and using the same, and if purchased after trial, we will allow the whole hire to apply in part payment, and sell the Instrument on approved note at four months for the balance. Special terms for payment by installments, after trial, on application. We do not make this offer merely to hire these instruments, but to insure a trial with a view to sales, the hire received being only sufficient to cover the cost of repolishing in case they are returned. Send for Illustrated Circular giving full description.

**JOHN BLISS & CO., 110 Wall Street, New York**

# PATENT IMPROVEMENT IN COUNTER SHOW CASES,

PERPENDICULAR SLIDING DOOR, DUST-TIGHT.

CENTER COUNTER CASE DOORS RUNNING THROUGH BOTH SIDES.

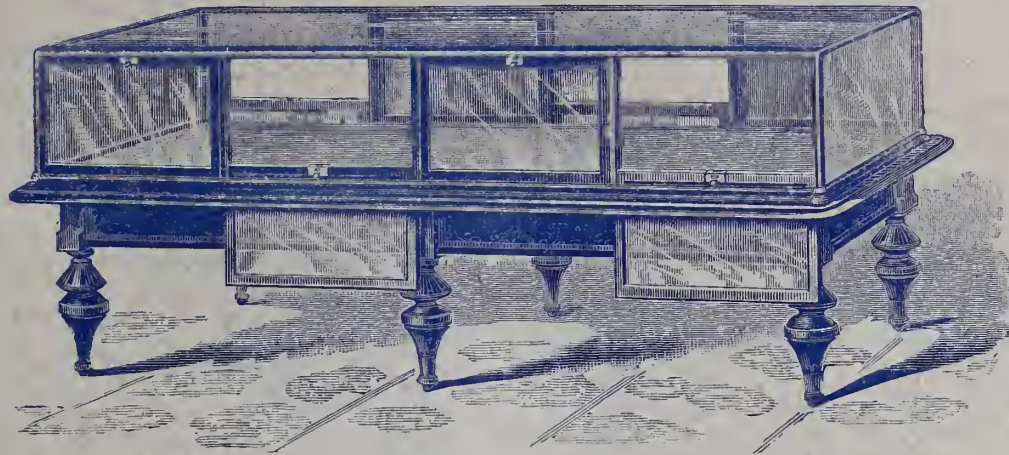

Its advantages are as follows:—The doors are more conveniently opened and closed, less liable to get out of repair or broken, articles are more easily reached in wide cases, mirrors are more safe, it dispenses with hinges, economizes room, excludes dust, and is air tight *when closed*.

Drawings furnished and estimates given for fitting stores in cabinet work complete.

REFERENCES:—Gorham Mfg Co., Rogers & Bro., Mitchell, Vance & Co  
Meriden Britannia Co., M. S. Smith & Co., Detroit, Mich.  
D Valentine, Syracuse, N Y.

**B. & W. B. SMITH,**

**220 West 29th Street, New York.**

## F. P. LOCKKLIN,

MANUFACTURER OF

Gold and Silver-Plated

**Walking  
Canes,**

**JEWELRY**

**&c., &c.**



FACTORY,

**142 Fulton Street, New York**

Between Broadway and Nassau street.



In placing these Oils before the Trade, we do so with entire confidence, from many years' experience in procuring them from the fish, and in their preparation for use, and more than all, the thorough and SEVERE TESTS they have been subjected to in use upon Chronometers in our whale ships, often absent from fifty or sixty months. Liberal samples furnished on application.

AGENTS—Cross & Beguelin, 21 Maiden Lane, New York; Kearney & Swartchild, 147 State street, Chicago; Glickauf & Newhouse, 120 Sutter street, San Francisco; Bowler & Burdick, 208 Superior street, Cleveland, Ohio; Heeren Bros., 30 Fifth avenue, Pittsburgh, Pa.; Louis A. Scherr & Co., 726 Chestnut street, Philadelphia; Wm. Bond & Son, 97 Water street, Boston; Robert Haswell & Son, 49 Spencer street, London.

**HIRSH BROTHERS,**  
Dealers in Watches & Diamonds  
AND MANUFACTURERS OF  
**JEWELRY,**

**No. 23 Maiden Lane, New York.**

☞ Prompt attention given to filling orders for all kinds of goods pertaining to the trade.

HENRY MAY. Established 1854. JOSEPH STERN.

**MAY & STERN,**  
IMPORTERS OF  
Foreign Watches, Materials and Tools  
AGENTS FOR THE SALE OF ALL  
DOMESTIC MOVEMENTS AND CASES.  
**And MANUFACTURING JEWELERS**

**No. 19 John Street, New York.**

☞ **SOLID GOLD SEAL RINGS, in Cameo, Amethyst, Topaz and Onyx, A SPECIALTY.**

**L. LELONG & BRO.**

**GOLD and SILVER REFINERS,**

**Assayers and Sweep Smelters,**

**Southwest Corner Halsey and Marshall Streets,**

**NEWARK, N. J.**

**SWEEPINGS A SPECIALTY.**

**KELLER & UNTERMAYER,**

ONLY AUTHORIZED AGENTS OF

**The International Watch Co.'s  
WATCHES.**

☞ A full and complete assortment of these goods in new and attractive Cases constantly on hand.

**No. 18 John Street, New York.**



**P. HARTMANN,**  
JEWELER AND SILVERSMITH,  
86 MAIDEN LANE,  
NEW YORK.

**ALBERT LORSCH,**

MANUFACTURER OF

PATENT ACCOMMODATING

**Spectacles and Eye Glasses,**

**In Gold, Silver, Steel, &c.**

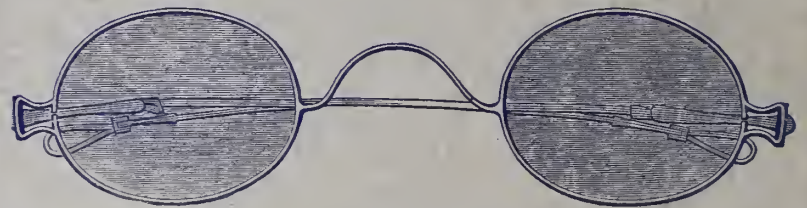

Also Latest Novelties in Fine WATCHES & JEWELRY.

**PRICES REDUCED TO SPECIE BASIS.**

☞ I would call especial attention that with the above Spectacles and Eye Glasses it is only necessary to have one complete assortment of the different kinds of lenses, which being of uniform size, will interchange in all the different kinds of frames, thus giving a complete assortment for a comparatively small outlay

**ALBERT LORSCH, 37 Maiden Lane, New York.**

**LORSCH BROS., 120 Sutter St., San Francisco. Cal.**

**L. & M. KAHN,**

IMPORTERS OF

Sole Agents for  
**James Kahn.**  
**E. Bourquin & Fils**  
AND  
**Alphonse Matile**  
**WATCHES.**

**WATCHES**

112 Kearny St.  
**San Francisco,**  
CALIFORNIA.  
5 Rue des Alpes,  
Geneva,  
SWITZERLAND.

**No. 10 MAIDEN LANE,  
NEW YORK.**

☞ *Manufacturers of the EAGLE TIMER! the Best in the market.*



MARCH, 1879



D. F. HOPKINSON, PUBLISHER.

42 NASSAU STREET, NEW YORK

Established 1813.

# SETH THOMAS CLOCK CO.

THOMASTON, CONN.

No. 20 MURRAY STREET, New York.

16 Worship Street,  
LONDON, E. C.

172 State Street,  
CHICAGO.

7 Montgomery Street,  
SAN FRANCISCO.

## F. KROEBER,

Manufacturer of CLOCKS,

No. 8 Cortlandt St.,

New York.

FACTORIES:—NEW HAVEN, CONN.,  
and NEW YORK CITY.

SUPERIOR GRADE OF

WALNUT CLOCKS A SPECIALTY

NEW HAVEN CLOCKS,

E. N. WELCH CLOCKS,

SETH THOMAS CLOCKS.

AT LOWEST MARKET PRICES!

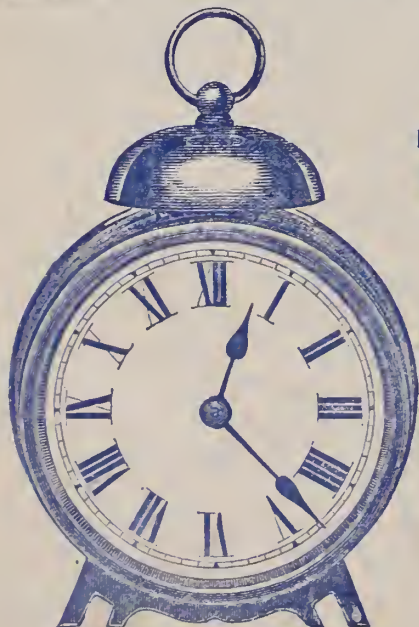

"AURORA."

1 Day Lever, Alarm, Nickel. Height, 5½ inches.



"THISTLE."

1 Day Lever, Alarm, Nickel. Height, 8½ inches.

# New Haven Clock Co.

62 READE ST., NEW YORK.

L. EGERTON, Jr., Agent.

No. 100. WEE-WAG.  
Black or Nickel.

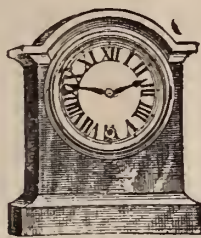

1 Day Time. 1 Day Time Alarm.

DERBY.

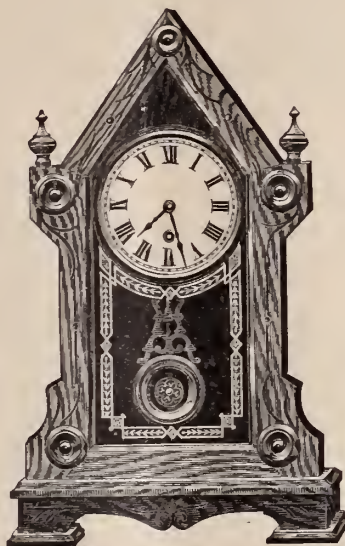

1 Day Time.  
1 Day Time, Alarm.  
1 Day Strike.  
1 Day Strike, Alarm.  
8 Day Strike.  
8 Day Strike, Alarm.

No. 101. WEE-WAG.  
Black or Nickel.



1 Day Time. 1 Day Time, Alarm.

GLOBE CALENDAR.

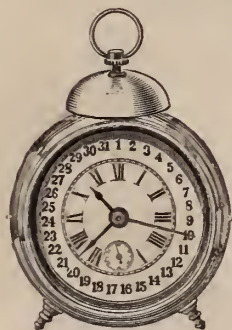

1 Day Time.

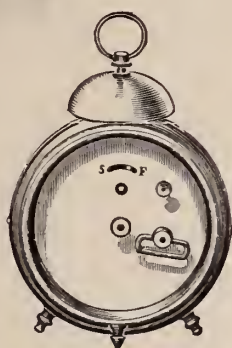

1 Day Time, Alarm.

ACORN.

Brass or Nickel.



1 Day Time.

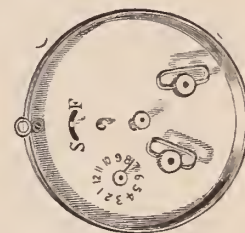

1 Day Time, Alarm.

# WATERBURY CLOCK CO.,

MANUFACTURERS OF AMERICAN CLOCKS,

4 CORTLANDT STREET,

NEW YORK.

M. BAILEY, Treasurer.

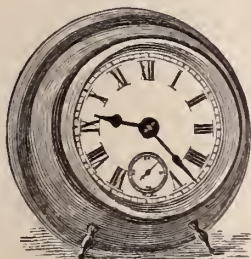

CRICKET.  
30 HOUR LEVER TIME.



CRICKET EXTRA.  
30 HOUR LEVER TIME.

197 STATE STREET,

CHICAGO.

FACTORIES,  
WATERBURY, CONN.



SUNRISE.  
30 HOUR LEVER TIME, ALARM.



TRANSIT.  
30 HOUR LEVER TIME.



INDEX.  
30 HOUR LEVER TIME, CALENDAR.



MONITOR.  
30 HOUR LEVER TIME, ALARM, CALENDAR.

ILLUSTRATED CATALOGUES AND PRICE LISTS FURNISHED ON APPLICATION.

NASHVILLE, V. P.

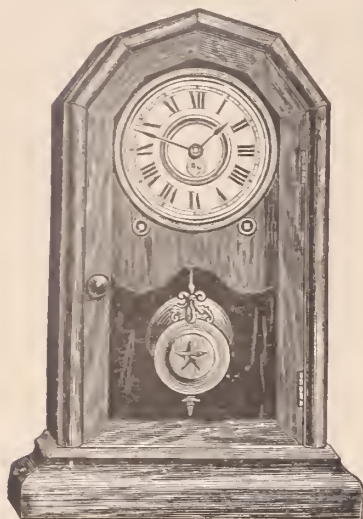

# G. S. LOVELL,

Importer and Wholesale Dealer in

CELTIC, V. P.

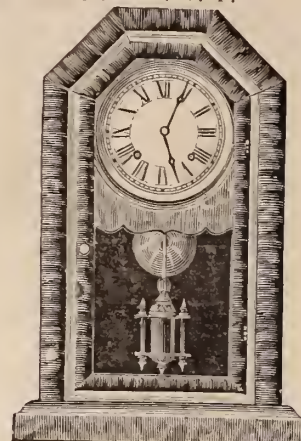

## CLOCKS, BRONZES, AND SILVER-PLATED WARE.

Imports French Marble Clocks, German Cuckoo Clocks,  
Ornamental Bronzes, etc., and wholesales

AMERICAN CLOCKS,

SILVER-PLATED WARE,

MADE BY

MADE BY

ANSONIA CLOCK CO. WATERBURY CLOCK CO.  
SETH THOMAS CLOCK CO. E. INGRAHAM & CO.  
AND WM. L. GILBERT CLOCK CO.

WILCOX SILVER PLATE CO.,  
MIDDLETOWN PLATE CO. MERIDEN BRITANNIA CO.  
REED & BARTON, AND OTHERS.

AT LOWEST FACTORY PRICES.

No. 731 Market Street, Philadelphia.

# The STAR SALT CASTER COMP'Y

Sole Proprietors and Manufacturers of

CELEBRATED

## STAR SALTS

For convenience, neatness and utility the STAR SALTS have become a household necessity.

The pulverizer in the bottle, as shown by the cuts, keeps the salt pulverized, and obviates the disagreeable habit of spilling the salt by dipping out of an open salt cellar.

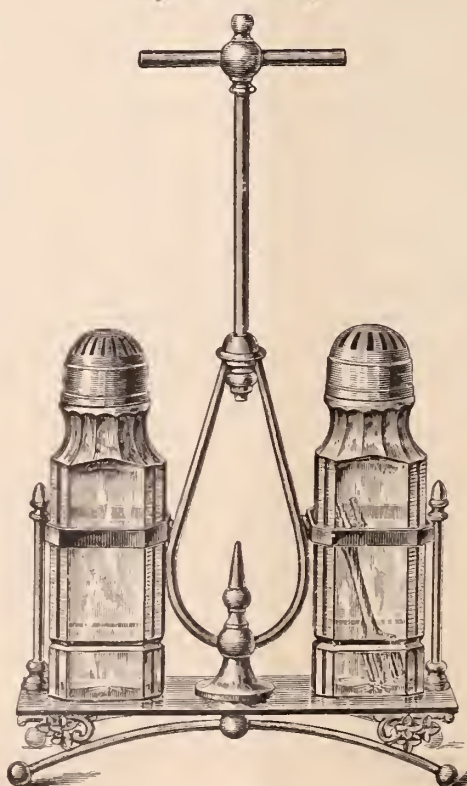

No. 161 Franklin Street  
BOSTON, MASS.

Place these in the family and Salt Cellars  
will be discarded.

MANUFACTURED IN ALL VARIETIES  
OF PLAIN AND FINE CUT  
GOODS, CASTERS, &c.

Special care given to orders for exportation.

Fine Diamond Cut, with  
Sterling Caps.

For full descriptions of the above goods see our Illustrated Catalogues, which will be mailed on application.

# LOUIS STRASBURGER & CO.,

Importers of

# DIAMONDS.

☞ We are direct Importers of Diamonds, dealers will therefore always find ORIGINAL parcels in our stock to select from.

MATCHED PAIRS, IN ALL GRADES AND WEIGHTS, A SPECIALTY!

NEW YORK, 15 MAIDEN LANE.

PARIS, 30 BOULEVARD HAUSSMANN.

Our complete stock of loose and mounted Diamonds enables us to send a full assortment for selection to any first-class house.

## LOUIS STRASBURGER & Co.

### Manufacturers of Watches,

From the finest Stem-Winding and Setting goods to the lowest price Watch in the market.

We manufacture and have continually in stock a complete assortment of the best COMMERCIAL WATCHES ranging from the lowest priced Metal and Silver Watches to the finest Gold Watches, such as REPEATERS, CHRONOGRAPHS (single and split) and all other Timing and Complicated Watches.

Also a full assortment of the INTERNATIONAL and all AMERICAN Movements. *Gold and Silver Cases*, constantly on hand.

We would call particular attention to our complete and varied assortment of NICKEL WATCHES, (black and fancy Dials,) in all grades, styles, and sizes.

THE RAIL-ROAD TIMEKEEPER A SPECIALTY.

SALESROOMS, No. 15 MAIDEN LANE, NEW YORK.

Watch Factory, Rue Leopold, Chaux de Fonds, Switzerland.

THE  
**MERIDEN BRITANNIA COMPANY**

No. 46 East Fourteenth Street,

**UNION SQUARE NEW YORK,**

MANUFACTURERS OF

**SILVER-PLATED WARE,**

Porcelain-Lined Ice Pitchers, Spoons, Forks, Table Cutlery, Etc., Etc.



**The Porcelain-Lined Ice Pitchers**, valued for retaining the Purity and Coolness of Water, as well as for Durability, Cleanliness and Chemical Excellence of their Interior Surface. The Porcelain is Enamelled on Hard Metal and cannot be broken or cracked by rough usage.

We take pleasure in referring to the reputation we have for many years maintained for manufacturing SPOONS AND FORKS, BEARING THE TRADE MARK, "1847, ROGERS BROS."

Particular attention is invited to our *Patented Process of Electro-Plating Spoons and Forks*, by which the parts most exposed to wear receive an EXTRA COAT OF SILVER. This feature renders these goods more economical and durable than those of any other manufacture, while the increased cost is relatively small. This method of plating we apply to the 4, 8 and 12 oz. plate, as required.

To protect the purchaser against imitations, it should be observed that the Improved Spoons and Forks bear our Trade Mark, "1847, ROGERS BROS., XII."

FIRST PREMIUMS awarded at all Fairs where exhibited, from the World's Fair, 1853, to American Institute Fairs, 1873, 1874 and 1875, inclusive, and at the Philadelphia Exhibition, 1876.

*Extract from the American Institute Report*:—"Their Porcelain-lined, Double-walled Ice Pitchers are A1, and possess all the qualities the company claim." \* \* \* "We consider the goods made by this company to be by far the best made in this country, and we believe in the world"

MANUFACTORIES.

West Meriden, Connecticut.

WAREROOMS,

Union Square, New York.



## No. 116. WATER SET.

**CHASED.**

Goblets and Bowl, gilt, \$44.00. Pitcher, \$16.00. Waiter, \$15.00.  
 Bowl, gilt, \$5.50. Goblets, each, \$3.75.

**MANUFACTURED BY**

# THE MIDDLETOWN PLATE COMPANY,

**MIDDLETOWN, CONNECTICUT.**

13 JOHN STREET,  
**New York.**

120 SUTTER STREET,  
**San Francisco, Cal.**

---

The assortment of **NEW GOODS** for Spring of 1879, is unexcelled in Style, Finish and Quality. Buy the **MIDDLETOWN PLATE**, Quality Guaranteed.

# SPECIAL SALE

OF

# ELGIN

## 14 SIZE KEY WINDING MOVEMENTS

At Near Half of Former Prices.

*We have bought the entire line of these movements, viz :*

**No. 35, 7 Jewels, Expansion Balance.**

**No. 39, 13 Jewels, 3 pairs Expansion Balance.**

**No. 37, 15 Jewels, 4 pairs Adjusted Ex. Balance.**

**No. 46, 15 Jewels, 4 pairs Nickel Adjusted Ex. Bal.**

### The Greatest Bargain Ever Offered to the Trade.

*These goods are cased in gold and Silver, hunting or open faced. Movements separately if desired For TERMS and PRICES address the undersigned,*

## HENRY GINNEL,

P. O. Box\_2967.

**31 Maiden Lane, New York.**



# SIMPSON, HALL, MILLER & CO.

MANUFACTURERS OF

## Silver-Plated Ware,

SUPERIOR IN QUALITY, DESIGN AND FINISH.

FACTORIES, WALLINGFORD, CONN.

Salesroom 36 East 14th St., New York.

Our assortment comprises a large line of Hollow Ware and Flat Ware, the product of many years manufacturing, with superior skill and appliances. Dealers in Silver-Plated Wares throughout the country have found our productions desirable in all respects, and perfectly adapted to the requirements of their customers. We have added many new articles to our assortment, and shall continue to produce *DESIGNS OF ORIGINAL AND ARTISTIC* merit in rapid succession.

**OUR SOLID TABLE WARE IS MADE OF THE BEST NICKEL SILVER.**

*SPOONS, FORKS, LADLES, PIE-KNIVES, &c.*

IN GREAT VARIETY OF PATTERNS.

**Solid Steel Knives of Superior Quality.**

Our *ILLUSTRATED CATALOGUE*, recently issued, will be furnished to *REGULAR DEALERS*, on application, inclosing business card.



# ROGERS CUTLERY COMPANY.



**WM. ROGERS,**

Senior Member and Manager of the Firm of ROGERS BROTHERS. Died Feb. 17, 1873.



**ASA H. ROGERS,**

Of the original ROGERS BROTHERS, and half owner of the Rogers Cutlery Co., when organized. Died Oct. 4, 1876.



**F. WILLSON ROGERS,**

Son of the late Wm. Rogers, and Secretary of the ROGERS CUTLERY CO.



Our Knives stamped as above we guarantee

To Strip 12 dwts. of Silver per dozen.

Our Knives are guaranteed to be

**ALL HAND BURNISHED,**

and are put up in rack boxes with hinge covers.

**WE GUARANTEE** our Spoons, Forks, &c. to be Plated 25 Per Cent. **HEAVIER THAN STANDARD PLATE.**

We guarantee Spoons, Forks, &c. to be plated on **18 PER CENT. NICKEL SILVER, AS FOLLOWS:**

On TEA SPOONS,	2½ ounces, or 50 dwts. per gross.
On DESSERT SPOONS,	3¼ " " 75 " "
On TABLE SPOONS,	5 " " 100 " "
On DESSERT FORKS,	3¼ " " 75 " "
On MEDIUM FORKS,	5 " " 100 " "

**OUR SPOONS, FORKS, LADLES, &c. ARE STAMPED**

On EXTRA PLATE,	1871, ROGERS @ 5 oz.
On DOUBLE PLATE,	1871, ROGERS @ 8 oz.
On TRIPLE PLATE,	1871, ROGERS @ 12 oz.
On QUADRUPLE PLATE,	1871, ROGERS @ 16 oz.



All Hollow Ware stamped as above is warranted to be plated

**50 PER CENT. HEAVIER** than any other brand of goods.

Our Hollow Ware in addition to our trade mark is stamped

**SEXTUPLE PLATE,**

we being the only firm who manufacture this weight of plate.

The above is a fac-simile of our guarantee card which accompanies each dozen of our flat ware, and each piece of our hollow ware. Our goods have been in the market since 1871, and are acknowledged by all dealers, who have tried them, to be **THE BEST.**

We would call especial attention to the **EXTRA STRONG SPRING TEMPERED SHANK**, which we have on our Tipped, Fiddle, Saxon and Imperial pattern

## GORHAM MANUFACTURING COMPANY,



## SILVERSMITHS,

PROVIDENCE AND NEW YORK.

California Office, 120 Sutter Street, San Francisco.

*Makers of STERLING SILVER WARES, ( $\frac{925}{1000}$  fine) of the highest character of workmanship and design; also, makers and sole proprietors of the GORHAM PLATED WARES.*

*Illustrated Circulars showing 24 of our leading patterns, in Spoons and Forks, will be sent to the Trade upon application by MAIL.*

**C. G. ALFORD & CO.,**

Manufacturing Jewelers,

No. 183 BROADWAY, NEW YORK.

**TO THE TRADE.**

*Our efforts to protect the interests of the legitimate Jewelry Trade by refusing to send our Illustrated Catalogue to outside dealers has won the universal approval of the entire retail trade, who have demonstrated their appreciation of our efforts in this direction, by sending us their orders. We are glad to know that our Catalogue occupies an important place in the stores of Retail Jewelers, and that they in many ways find it of great convenience.*

*We have in contemplation certain changes that will add to its interest and usefulness, which will be made known when they assume a definite form.*

*We wish to state that we shall in the future, as in the past, use our best efforts to protect the interest of patrons, the legitimate retail dealers, by publishing a Catalogue exclusively for their use, and one that may be shown to their customers without the risk of exposing their profits.*

*Applicants for copies must enclose business card as a guarantee that they are regularly in the trade.*

# MILLER BROS., MANUFACTURING JEWELERS.

No. 11 MAIDEN LANE, NEW YORK.

Manufactory, 47, 49 & 51 Franklin Street, Newark, N. J.

*New this Spring,  
A LARGE LINE OF*

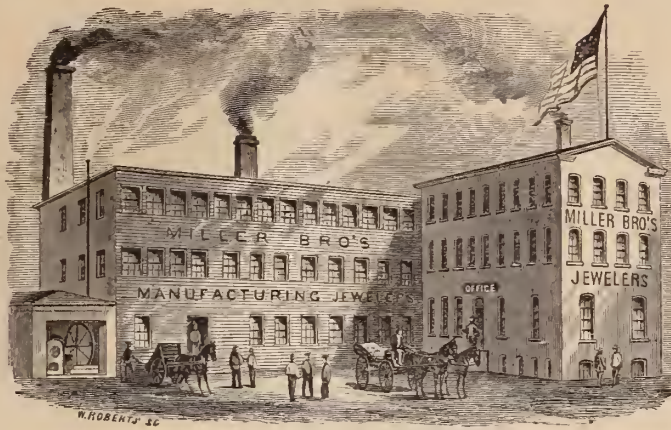

*Novelties for  
Ladies' & Gentlemen's Wear.*

ATTENTION IS INVITED TO OUR  
NEW STYLES OF ETRUSCAN SLEEVE BUTTONS,  
MOUNTED WITH

## RUSTIC LETTERS

BIRDS ANIMAL HEADS AND FANCY ORNAMENTATIONS

Also a full line of Locketts, Sets, Pins, Ear Rings, Sleeve Buttons, Studs, &c. All goods exclusively of our own manufacture.

# DAVID F. CONOVER & CO.

(SUCCESSORS TO WM. B. WARNE & Co.)

Importers, Manufacturers and Wholesale Dealers in

## WATCHES AND JEWELRY.

Silver and Silver-Plated Ware,

AMERICAN WATCH WHOLESALE SALESROOM,

Southeast Corner Chestnut and 7th Sts.,

(FIRST FLOOR.)

JAS. T. SCOTT,  
S. CLEM SCOTT,  
J. T. SCOTT, JR.

# J. T. SCOTT & CO.

Established 1847.

No. 11 MAIDEN LANE, - - - NEW YORK.

SOLE EASTERN

AGENTS FOR

## THE ROCKFORD

## WATCH CO.

AND AGENTS FOR

The Auburndale

## CHRONOGRAPH

TIMERS,

$\frac{1}{2}$  and  $\frac{1}{3}$  seconds, in 18 size  
Nickel-Plated Cases, designed  
for Sporting, Scientific and  
Mechanical purposes.

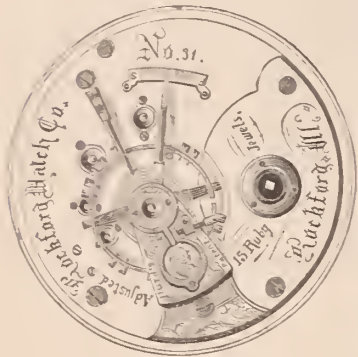

ROCKFORD WATCH.

This Company manufactures eight grades of superior 18 size key and stem wind

**QUICK  
TRAIN,  
Movements.**

ALSO SOLE AGENTS FOR  
**Abbott's Patent  
O pen-Face**

18 size American stem-winders, with XII at pendant and seconds opposite.



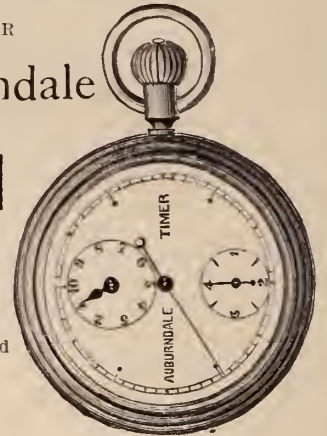

ABBOTT'S PATENT.



AUBURNDALE TIMER.

Manufacturers of Jewelry and Wholesale Dealers in all grades of American Movements.

WATCH CASES, DIAMONDS, CHAINS, SILVER WARE, &c.

 Price Lists furnished upon application to those regularly engaged in the Trade. 

1879.

SPRING TRADE.

1879.

## FRENCH CLOCKS.

We call special attention of the trade to this department of our business. Having received recent large shipments from which we can make unusual inducements.

*We are opening an attractive line of Faience Bronze, the novelty of the Season.*

### TAYLOR & BROTHER,

No. 676 Broadway,

NEW YORK.

**WHOLESALE ONLY.**

# YACHERON & CONSTANTIN,

GENEVA,

## Manufacturers of Fine Watches and Movements

OF EVERY VARIETY AND SIZE FOR LADIES AND GENTS WEAR.

The Vacheron & Constantin Watch enjoys a world wide reputation for its accuracy and perfection of construction. Long before the use of Machinery was thought of in America for the construction of Watches, Messrs Vacheron & Constantin had the most complete Machinery in use, which they have continually improved, so that it is now the most perfect in existence, enabling them to produce an inter-changeable movement in every respect. These movements are artistically cased in 18 karat gold. Ladies sizes in Louis XV style and half Hunters with tasty designs in engraving and enamel. A full line of which is always on hand; also, 19 and 20 line Gilt and Nickel Movements for Open Face and Hunters, with blocks for casing.

J. A. ABRY, 63 Nassau Street, N. Y..

*Sole Agent for the United States.*



### THE Excelsior Watch,

The Most Popular Watch ever Introduced.

*Opinion of Dr. HIRSCH, Director of the Observatory of Neuchatel, (Switzerland,) expressed to the Manufacturers.*

OBSERVATORY OF NEUCHATEL, SWITZERLAND,

March 23d, 1878.



GENTLEMEN :

For some time past I have been desirous of ascertaining what degree of regularity could be attained in the running of a Cheap, Ordinary Anchor, not compensated, but constructed on good principles.

I have therefore examined with interest your stem winding Anchor, "Excelsior," No. 4827, taken at random from a lot, and I have the pleasure to communicate to you the results of my examination, which seems to me very satisfactory.

I have compared it every day for a month, first to know its variation from flat to vertical. I had it running in both positions alternately during two days. The variation in above positions gave a result of 18 seconds, of which it slowed in the vertical position, after which, wishing to verify how much it would loose per degree of temperature, I placed it in the oven and found it lost 12 seconds per degree, which is natural, considering that all Watches not compensated, vary of from 10 to 13 seconds per degree, each day, according to their construction. In short, I carried it about three weeks, during which time it maintained its running very well. During all this time, its average variation was of but **9 seconds per day**, which is certainly very satisfactory for a Watch of this category. You will find herewith a memorandum of its running during the time it was observed by me. Yours, very respectfully,

DR. AD. HIRSCH.

#### DAILY RUNNING.

Feb. 10 to 11—2	12 <sup>s</sup>	} Flat.	Feb. 19 to 20—1	40 <sup>s</sup>	} March 2—3	x	27 <sup>s</sup>		
Feb. 11 to 12—2	9 <sup>s</sup>		Feb. 22 to 23 x 0	30 <sup>s</sup>		March 3—4	x	26 <sup>s</sup>	
Feb. 12 to 13—1	19 <sup>s</sup>	} Vertical.	Feb. 23 to 24 x	20 <sup>s</sup>	March 4—5	x	18 <sup>s</sup>		
Feb. 13 to 14—1	31 <sup>s</sup>		Feb. 24 to 25 x	30 <sup>s</sup>	March 5—6	x	0		
Feb. 14 to 15—2	7 <sup>s</sup>	} Flat.	Feb. 25 to 26 x	31 <sup>s</sup>	March 6—7	x	18 <sup>s</sup>		
Feb. 15 to 16—2	4 <sup>s</sup>		Feb. 26 to 27 x	22 <sup>s</sup>	March 7—8	x	29 <sup>s</sup>		
Feb. 16 to 17—2	45 <sup>s</sup>	} Flat to 29 <sup>s</sup> <sub>3</sub> Oven.	Feb. 27 to 28 x	27 <sup>s</sup>	March 8—11	x	1		
Feb. 17 to 18—1	39 <sup>s</sup>		Feb. 18 to 19—1	43 <sup>s</sup>	Mar. 0—1	x	12 <sup>s</sup>		
				Mar. 1—2	x	28 <sup>s</sup>	March 11—12	x	8 <sup>s</sup>
							March 12—15	x	0 <sup>s</sup>

N. B.—The EXCELSIOR WATCH is imported in Ladies' and Gents' sizes, in Silver, and White Metal Cases, Open Face and Hunters, with White, Black and Fancy dials.

J. C. AIKIN.

H. A. LAMBERT.

J. B. SHEA.

# AIKIN, LAMBERT & CO.,

**MANUFACTURERS OF GOLD PENS,**

**Pen and Pencil Cases, Pencils, Tooth-picks, and "Novelties" in Pencil Goods.**

**No. 23 Maiden Lane, New York,**



Would call the attention of the Trade to our large and complete line of Pen Goods in all styles and varieties, suitable for the Winter and early Spring demand.

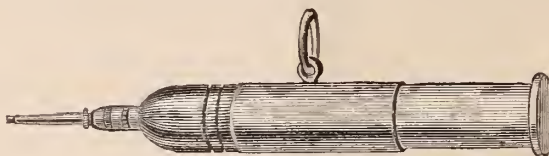

Our introduction last season of Pencils in NEW AND ENTIRELY NOVEL DESIGNS was marked by an unprecedented demand, which establishes the sale of these goods as STAPLES, and as being suited to any season of the year.

The Magic Charms (as per cuts shown below), inlaid with pearl and gold, in form of vines, flowers, birds, etc., on celluloid of assorted colors, in imitation of malachite, tortoise shell, agate variegated marble, etc., are the LATEST and most novel pencils in the market.



Send for circular and new list.

**Branch, No. 113 East Madison Street, Chicago.**

**IMPORTERS OF ALL GRADES OF**

## WATCHES,

SOLE AGENTS FOR

**"PAUL BRETON" and "CHAS. LATOUR," GENEVA.**

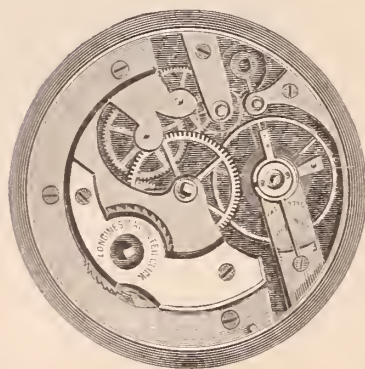

LONGINES



EXCELSIOR.

**— SPECIALTIES. —**

AGASSIZ Movements, Gilt and Nickel Stem-Winding, fitting Ladies' Riverside Case.

CHAS. LATOUR Movements, Gilt and Nickel Key-Winding, fitting 10 and 16 size Waltham Case.

PAUL BRETON Movements, Gilt and Nickel Key and Stem-Winding, a full line of these CELEBRATED TIMEPIECES in gold and silver cases of the most approved styles.

METAL OPEN FACE STEM-WINDING "LONGINES" and "EXCELSIOR", 16, 18 and 20 line, the BEST metal Watches in STYLE and QUALITY in the market.

The "LONGINES" received the ONLY GOLD MEDAL at Paris for low-priced Watches against several competitors, and the "EXCELSIOR" is recommended by DR. HIRSCH of the Neuchatel Observatory having given VERY SATISFACTORY results during a month's trial. NOVELTIES in BLACK and FANCY DIALS for these Watches are selling rapidly. American Watches of all kinds. Gold Cases of any style made to order. Sole Agents for EUREKA HORSE TIMER, the cheapest reliable TIMER ever made, and for PNEUMATIC TIMER which does not require the use of the hand. All Watches sold by us are warranted.

Our assortment of Jewery is very large and complete, consisting of a general line of RELIABLE goods, both in GOLD and ROLLED PLATE, of new and tasty patterns, and including almost any article a Jeweler would have calls for. Special attention given to ORDERED WORK and REPAIRS. GOODS SENT ON APPROVAL and CORRESPONDENCE invited. Those not acquainted with us will oblige by giving references when ordering.

JANUARY 1st, WE REVALUED OUR ENTIRE STOCK AND HAVE REDUCED PRICES, AND ARE OFFERING GREAT INDUCEMENTS TO PURCHASERS FOR THE SPRING TRADE.

**GUTMANN'S**

**Automatic Hammer and Punches**

Simplified and More Effective.

THIS TOOL takes the place of the third hand, therefore its manifold uses are quickly apparent, and I would only say that it is accompanied by six punches, to wit: 2 hand punches, 1 prick punch, 1 closing hole punch, 1 rivet punch, and 1 pinion punch, all of which fit neatly into the punch holder, and are fastened by the set screw. Its tap is alternately heavy and light, and the finger loops are assorted in sizes. The Tool is nickel-plated and boxed, ready to be mailed on receipt of price.

THE OPERATION IS AS FOLLOWS: First, set the hammer; next insert your forefinger through the loop at the top and place the punch with firmness on your work. When you are ready for the blow, push gently on the thumb-piece which produces the concussion on the punch. *Your left hand is entirely free to hold the work.*

Price, \$2.00; Reduced from \$2.50.

**MAX L. GUTMANN,**

Patentee and Manufacturer.

Also, Importer and Wholesale Dealer in

Watch and Jobbing Materials, Tools, Glasses,

Chains, Guards, Jewelry and Watches.

PLEASE SEND YOUR ORDERS.

**ROCHESTER, N. Y.**

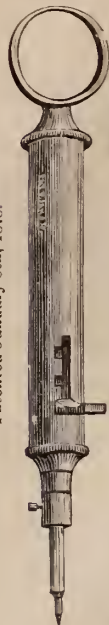

Patented January 8th, 1878.

ESTABLISHED 1855.

**D. LIECHTY & CO.,**

MANUFACTURERS OF

**Fine Gold Watch Cases**

*No. 140 South Third Street,*

Fourth Floor.

**PHILADELPHIA**

*Repairing neatly attended to.*

**BENJ. ALLEN & CO.**

WHOLESALE DEALERS IN

**American and Swiss Watches**

JEWELRY, DIAMONDS,

SILVER & PLATED WARE.

137 and 139 State Street, Chicago.

A full line of Howard Watches in stock. Catalogues sent upon application, to dealers only.

LOUIS A. SCHERR.

CHAS. H. O'BRYON.

G. W. SCHERR

**LOUIS A. SCHERR & CO.**

Importers and Wholesale Dealers in

**Watches, Jewelry,**

WATCH MATERIALS, TOOLS, GLASSES, &C.

**Spectacles, Silk Guards, &c.**

Wholesale Agents for American Watches.

**No. 726 CHESTNUT STREET,**

FIRST FLOOR,

**PHILADELPHIA.**

**Dorrance, Edge & Co.**

MANUFACTURERS OF

**THE CELEBRATED WOVEN FABRIC**



**GOLD CHAIN.**



*Elegantly Mounted Bracelets, Opera, Leontine,*

VICTORIA WATCH GUARDS & NECKLACES, in all the Newest Designs.

Our stock is unusually complete, and, in addition to the above, a variety of Necklaces, from 1½ to 40 dwt. each, to which we invite the attention of buyers.

**No. 9 John Street, New York.**

Factory, 46 Greene Street, Newark, N.J.

**CHAS. P. HEROLD,**  
**MANUFACTURING JEWELER,**  
**DIAMOND SETTER**  
 AND DEALER IN  
**DIAMONDS.**

916 CHESTNUT ST. PHILA.

N.B. A LARGE STOCK OF 18 Kt. DIAMOND MOUNTINGS, SUCH AS CLUSTER AND SOLITAIRE RINGS, EARRINGS, LACE PINS, SHAWL PINS, CROSSES, STUDS, AND GENTS' PINS, &c, ALL OF WHICH ARE OF MY OWN DESIGNS, AND ARE MADE IN THE FINEST STYLE AND FINISH.

# Sussfeld, Lorsch & Co.

IMPORTERS OF

Optical and Mathematical Instruments,

Watchmakers' Tools, Materials, Watch Glasses, &c.

No. 13 Maiden Lane, New York.

Sole Depot in the United States for

BARDON & SON'S

Universal Opera Glasses,

U. S. ARMY & NAVY SIGNAL GLASSES,  
&c., &c.



TRADE MARK

Commission Merchants at 27 Rue de Paradis, Poissoniere, Paris.

Sole Depot in the United States for the

CELEBRATED

Crown Spectacles and Eye Glasses,

OF ALL GRADES.



NORCROSS PATENT DUST-PROOF KEY.



KEY OPEN.

Patented July 14th, 1874.



KEY CLOSED.

This Key is preferred to all others, as there is no possibility of dust accumulating in the pipe. It will not break or wear like other Keys, being made of Stubb's steel, hardened and tempered.

## SINNOCK & SHERRILL,

Stone Ring Manufacturers,

No. 5 MAIDEN LANE,

Factory, Newark, N. J.

NEW YORK

Established 1845.

## WILLIAM H. BALL,

SUCCESSOR TO

BALL & BARNARD,

MAKER OF

Roman, Enameled and Engraved

BANDS.



Having given the manufacture of Band Bracelets my entire attention for a number of years, it has been my desire to make a durable article, one that will give satisfaction to the seller as well as the wearer. I desire to call the attention of the trade to the reduction I have just made in prices, still keeping up the standard as to quality, finish and workmanship. To each pair of BANDS I attach my patent guard without extra charge—thus saving the price of chain—which for seven years past has given entire satisfaction.

No. 9 JOHN STREET, NEW YORK.

Factory, 30 & 32 Franklin Street, Newark, N. J.

## E. HOWARD & CO.,

MANUFACTURERS OF

Fine Watches, Regulators, Office Clocks,

Electric Watch Clocks & Tower Clocks,

Office, No. 2 MAIDEN LANE,

NEW YORK.

No. 114 TREMONT STREET, BOSTON.

J. W. J. PIERSON, - - AGENT.

ESTABLISHED 1859

## RINGS A SPECIALTY.

BRYANT & BENTLEY,

No. 12 Maiden Lane,

New York,

MANUFACTURE A LARGE VARIETY OF

FINE SOLID RINGS,

For Ladies and Gentlemen, in CAMEO, AMETHYST, ONYX, TOPAZ, TURQUOISE, GARNET and other stones. Fine CAMEO, CORAL and ROMAN SETS of new and handsome designs. LOCKETS, MEDALLIONS, SHAWL and SCARF PINS, SLEEVE BUTTONS, STUDS, &c. All goods warranted.

We continue to manufacture several hundred patterns of **HARD SOLDER RINGS**, in every style, for men, women and children, stamped and warranted 16 karat fine.

## BUCKENHAM, COLE & SAUNDERS,

SUCCESSORS TO

BUCKENHAM, COLE & HALL,

IMPORTERS OF

# Diamonds, Pearls

AND OTHER PRECIOUS STONES,

MANUFACTURERS OF FINE JEWELRY,

10 Maiden Lane, New York.

A large stock of FINE DIAMONDS, Mounted and Unmounted kept constantly on hand. Goods sent on approval to any part of the country on receipt of satisfactory references.



ESTABLISHED 1837.

VICTOR BISHOP & CO.

IMPORTERS OF

DIAMONDS,

PRECIOUS STONES

—AND—

CORAL JEWELRY,

Enamel Paintings, Copper and Platinum.

No. 47 NASSAU STREET, NEW YORK.

House in Paris, 66 Boulevard de Sebastopol.

SAXTON, SMITH & CO.

MANUFACTURERS OF

Fine Gold Chain.

No. 15 Maiden Lane.

New York.

Factory, No. 183 Eddy Street, Providence, R. I.

Sole Agents for the new PATENTED CHAIN BAR, containing a Detachable Pencil.

HELLER & BARDEL,

MANUFACTURERS OF

Diamond and Pearl Jewelry,

And Dealers in Diamonds, Pearls, &c.

SHAWL AND LACE PINS IN GREAT VARIETY.

No. 18 John Street, New York.

A full line of DIAMONDS, mounted and unmounted; also, a large assortment of first-class DIAMOND MOUNTINGS of our own make always on hand. Sketches submitted at any time upon application. We will send goods on selection to responsible houses.

KOSSUTH MARX & COMP'Y,

39 MAIDEN LANE, New York.

THE U. S. STANDARD

FINGER SIZE

FOR RINGS.

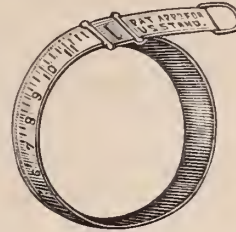

TIME AND

TROUBLE

SAVED.

Some of the advantages of which, will be found annexed and must be apparent to every Jeweler.

1st. It avoids danger of having rings stolen from tray while trying on to find one the size wanted, and also of being misled after taking the size.

2d. It saves time consumed in measuring ring on tick and avoids possibility of making a mistake in doing so, as the size ring is gauged in accordance with the U. S. Standard Stick.

3d. It necessitates trying but one ring on the finger, whereas a dozen had sometimes to be used before the correct size was obtained.

4th. If the salesman is hurried it is not necessary to make a memorandum of the size, as the ring will remain at the size taken, and can be laid aside until some leisure time.

5th. It can be loaned to customers whereby they will be enabled to take the correct size, instead of using pieces of string and wire, thus making mistakes and often necessitating altering a ring two or three times.

HOW TO USE— Place the thumb of the hand, on which is the finger to be measured, against the joint on the size ring, and draw tight with the other hand.

FOR SALE BY ALL WATCH MATERIAL DEALERS

WOOD & HUGHES,

STERLING

Silverware Manufacturers

No. 16 JOHN STREET,

NEW YORK.

KREMENTZ & CO.

MANUFACTURERS OF

FINE JEWELRY,

No. 13 John Street, New York.

Factory, 361 Mulberry Street, Newark, N. J.

GOODS OF OUR OWN MAKE EXCLUSIVELY

CARTER, HOWKINS & SLOAN,  
**Makers of Fine Jewelry**

*Consisting of Chains, Bracelets, Sets, Pins, Studs, Sleeve Buttons,  
 Scarf Pins, Rings, &c., in Roman, Etruscan and Enamel,  
 and a full line of Jewelry generally.*

Whiting Building, Corner Broadway and Fourth Street,

A. CARTER JR.  
 WM. HOWKINS,  
 A. K. SLOAN.

**NEW YORK.**

C. E. HASTINGS,  
 GEO. R. HOWE,  
 W. T. CARTER.

**BALDWIN, SEXTON & PETERSON,**

MANUFACTURERS OF

**Fine Jewelry,**

Diamond and Stone Cameo Goods,

GOLD CHAINS, &c.

Importers of Diamonds, Pearls, Emeralds, Rubies, &c.

WHITING BUILDING,

Cor. Broadway and Fourth Street,

NEW YORK.

**HALE & MULFORD,**  
**Manufacturing Jewelers,**

(WHITING BUILDING).

Ne. 694 Broadway, cor. 4th Street, New York.

Call attention of the Trade to their new style of

**BAND BRACELETS,**

We claim for these Bracelets, the following advantages over the old style, viz. :

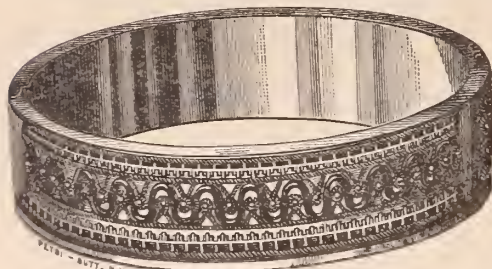

Patented February 25, 1879.

1st. The edge of the Bracelet being raised, forms a protection to the ornamentation.

2d. Less liability of getting damaged, and when damaged, are more easily repaired.

3d. More attractive in appearance.

Prices are as low as any FIRST CLASS 14 KARAT ALL GOLD Bracelet in the market.

Made in all sizes from  $\frac{1}{4}$  inch upwards.

—Established 1837.—

**TAYLOR & BROTHER,**

Late TAYLOR, OLMSTED & TAYLOR,

**Importers of Diamonds and Pearls,**

—AND—

**MANUFACTURERS OF DIAMOND JEWELRY,**

No. 676 BROADWAY,

**NEW YORK.**

Established 1817.

**Ve. J. MAGNIN, GUÉDIN & CO.**

Manufacturers and Importers,

FINE SWISS WATCHES,

REPEATERS, CHRONOGRAPHS & CALENDARS.

GENEVA GOLD JEWELRY,

FRENCH CLOCKS AND BRONZES,

RICH FANCY GOOCS,

HORSE-TIMERS & PEDOMETERS,

GOLD AND SILVER CHATELAINE WATCHES.

Gold Medal Awarded, Paris Exposition, 1878.

*Sole Agents for the James Nardin Watch.*

*House in Geneva, 14 Grand Quai.*

Established 1813.

**THOMAS G. BROWN,**

MANUFACTURER OF

**FINE JEWELRY.**

*Designs furnished for all kinds of Sporting  
 Badges and Medals for Schools & Colleges.*

**NEWARK, N. J.**

—AND—

**9 BOND STREET, NEW YORK.**



ALFRED H. SMITH  
AND CO  
IMPORTERS OF

DIAMONDS

14 JOHN ST.

NEW YORK.

*We are constantly receiving fresh invoices of desirable goods  
in all grades, to which the attention of buyers is invited.*

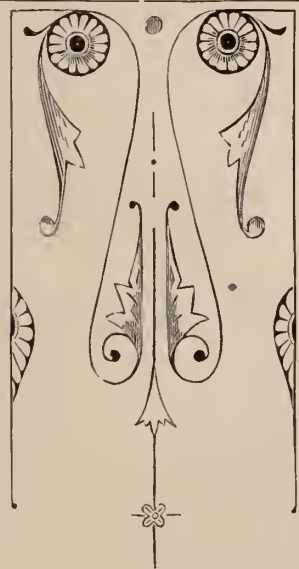
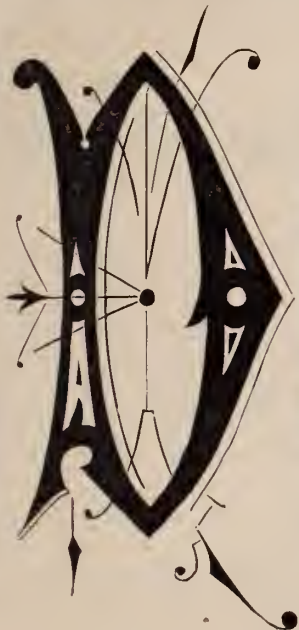
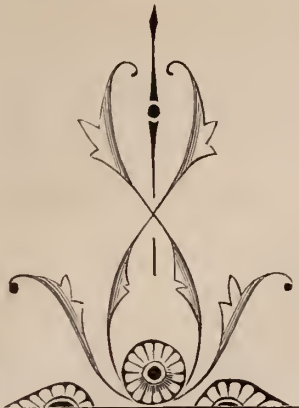

Established 1834.

**G. & S. OWEN & CO.,**  
Makers of Fine GOLD JEWELRY



SPECIALTIES:

Black Onyx Goods,  
Roman & Polished Goods,  
Hair Chain Mountings,  
Sole Makers  
OF  
**BOX AND GLASS GOODS.**

All our goods exclusively of our own manufacture.

5 MAIDEN LANE, NEW YORK.

Established 1846.

WILLIAM RIKER,

*No. 5 Maiden Lane, New York.*

Factory, 42 Court Street, Newark N. J.

☞ *Would call the attention of the Trade to our Inlaid Bracelets.*

**JOHN A. RILEY & CO.**  
MANUFACTURE

**Fine Gold Jewelry**

AND ONYX GOODS,

**Nos. 7 & 9 Bond Street, New York.**

No. 126 Kearney Street, San Francisco, Cal.

**LYON & HARDY,**

30 MAIDEN LANE, NEW YORK,

IMPORTERS OF



AND MANUFACTURERS OF

**DIAMOND MOUNTINGS.**

All goods ordered for stock or on approval are insured while in the hands of Express Companies.

MOORE & HORTON,

**JEWELLERS,**

*No. 11 Maiden Lane, New York.*

**SPECIALTIES!**

*Stone Cameo, Onyx, Amethyst, Topaz and Pearl Rings,  
Studs, Collar and Sleeve Buttons.*

☞ Also our new fac-simile of Fine African Diamonds, mounted in Rings, Studs, Pins, Ear-rings, Scarf Pins, Meç'allions.

W. H. SHEAFER & CO.,

**Makers of Fine Jewelry**

CONSISTING OF

BRACELETS, SETTS, LOCKETS, PINS,

STUDS, SLEEVE BUTTONS, RINGS, &c.

**SPECIALTY:—STIFFENED ROMAN BANDS.**

No. 908 Chestnut Street, PHILADELPHIA

Branch Office 15 John Street, New York

**WM. S. HEDGES & CO.,***Of the late firm of SMITH, HEDGES & Co.*

IMPORTERS OF

**DIAMONDS,**No. 170 Broadway, cor. Maiden Lane,  
NEW YORK.*Choice Brilliants in single stones and matched pairs a specialty.*

GOODS SENT ON APPROVAL.

**ENOS RICHARDSON & CO.**

MANUFACTURERS OF

**FINE GOLD JEWELRY,**Gold Chains, Locketts, Crosses and Necklaces,  
COLORED AND ETRUSCAN WORK.

ENGRAVED AND ENAMELLED GOODS IN GREAT VARIETY.

All Goods sold strictly of our own manufacture.

23 MAIDEN LANE, NEW YORK.

ENOS RICHARDSON,  
THOS. SLATER,

L. P. BROWN,

F. H. RICHARDSON,  
W. P. MELCHER.

DYER BRAINERD.

JOHN W. STEELE.

**BRAINERD & STEELE,**

MANUFACTURERS OF

**Brainerd's Pat. Locketts,**

(Patented June 17, 1874.)

These Locketts combine both beauty and strength. They are made of solid 14kt. gold, and the stones used are the finest obtainable in the market. They cost no more than those of the old style, if indeed as much; and the combination of secrecy and durability renders them much more desirable. We make three sizes in four different shapes—round, oval, cushion and oblong square; and also Sleeve Buttons of the same style, containing a concealed box for miniatures, a novelty new to the Trade.



**FINE GOLD JEWELRY,**  
**No. 9 Maiden Lane,**  
NEW YORK.

**WANTS OF FINE JEWELRY**  
**WALLING BROS. & CO.**  
**WANTS OF FINE JEWELRY**Full Line of Roman and Mosaic Goods,  
Earrings, Buttons, Studs and Rings.**SPECIALTIES:**ENGRAVED AND ENAMELED BANDS,  
CAMEO GOODS.**170 BROADWAY, NEW YORK.****CHATELLIER & SPENCE,****Manufacturing Jewelers,**

652 BROADWAY, NEW YORK.

No. 1129 Chestnut Street, PHILADELPHIA, PA.

No. 12 West Street, BOSTON, MASS.

No. 120 Sutter Street, SAN FRANCISCO, CAL.

LEOPOLD WEIL,

*Manufacturing Jeweler,*

And Dealer in the Latest Novelties in

**Rolled-Plate Jewelry,**

A select assortment of which I have always on hand,

16 MAIDEN LANE, N. Y.

**J. B. BOWDEN & CO.***Manufacturer of***SOLID GOLD AND STONE****RINGS****All Styles of Children's**

AND

**FANCY SOLID RINGS,**

A LARGE ASSORTMENT ALWAYS ON HAND.

No. 1 Maiden Lane, New York.

**NOAH MITCHELL,**

MANUFACTURER OF

**Fine Gold Jewelry**

CAMEO SETS, ONYX GOODS,

Medallions, Studs, Sleeve Buttons. Rings and Diamond Settings of all Kinds.

Diamond Setting a Specialty.

694 &amp; 696 Broadway, cor 4th St., New York

(Whiting Silver Mfg Co.'s Building.)

ALL ORDERS PROMPTLY ATTENDED TO.

AUBURNDALE, MASS.,

**CHRONOGRAPH TIMER,**

WM. B. FOWLE, Maker.

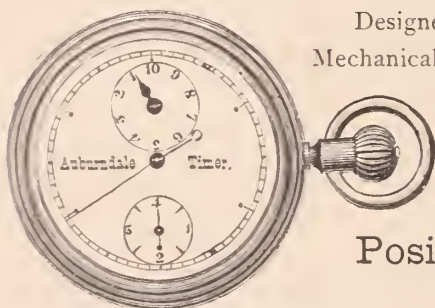
Designed for Sporting, Scientific and Mechanical purposes;  $\frac{1}{4}$  and  $\frac{1}{8}$  seconds, fly back.

List Price, - - \$15.00

Positively Accurate.

Put up in German Silver Cases, Nickel Plated, size of an ordinary watch. Very neat and handsome, supplying a want long felt by those desiring to measure the flight of time with scientific accuracy to the fraction of a second. It indicates positively minutes, seconds, quarters or eighths of seconds, the only instrument registering one eighth of a second made. It is substantially constructed, positive in its action, and will not easily get out of order.

These Chronographs can be obtained from the principal Jobbing Houses in the Trade.

**RANDEL, BAREMORE & CO.****DIAMONDS,**

Corner Maiden Lane and Nassau St.

29 Maiden Lane, **NEW YORK,** 58 Nassau Street.

No. 12 New Burlington Street, LONDON, W.

**CARROW, BISHOP & CO.**

SUCCESSORS TO

**Carrow, Crothers & Co.**

MANUFACTURERS OF

**Fine Gold Jewelry****No. 12 JOHN STREET,****NEW YORK.****Notice Removal.**

CHAMPENOIS &amp; CO., Manufacturing

Jewelers, will remove from

No. 1 1-2 to No. 1 BROADWAY,

Manufacturers of Jet &amp; Enamel Goods

Factory, 44 Hill St., Newark, N. J.

**J. A. BROWN & CO.**

OFFICE AND SALEROOM: No. 11 Maiden Lane, N. Y. FACTORY: No. 104 Eddy St., Providence. R. I.  
SOLE MANUFACTURERS OF THE

**Ladd Patent Stiffened Gold Watch Cases**

The Best and most durable, and the

CHEAPEST STIFFENED Gold Watch Case FOR THE MONEY

MADE IN THE WORLD!

All genuine Watch Cases of our manufacture have "G. W. Ladd's Patent, June 11, 1867," stamped upon the side band underneath the glass bezel.

REFUSE ALL OTHERS.

Send for full Descriptive Circular to the

OFFICE AND SALEEROOMS 11 Maiden Lane, N. Y.



KEY AND STEM WINDING

Hunting and Open-Face

IN FLAT BEVEL,

Mansard and Oval

SHAPES

Adapted to the various

AMERICAN-MADE MOVEMENTS,

IN 8, 10, 14, 16 & 18

SIZES.

Dealers can obtain them of the Wholesale Watch and Jewelry Houses, or their Traveling Agents throughout the United States and British Provinces,

**CHARLES GLATZ,**

MANUFACTURER OF

**Gold and Silver Watch Cases**

No. 12 Maiden Lane,

**NEW YORK.**

A CARD.—After the recent great Improvements to my Cases, I confidently offer them to the Trade, as being without a superior in the market, and so acknowledged by some of the best houses.

**JOSEPH N. TINGLEY,**

Late of the firm of Tingley, Sinnock & Sherrill,

MANUFACTURER OF

**STONE RINGS,**

—AND—

NOVELTIES IN STONE GOODS,

No 9 Maiden Lane,

New York.

FACTORY, NEWARK N. J.

**E. AUG. NERESHEIMER,**

IMPORTER OF DIAMONDS

**21 MAIDEN LANE,**

No. 24 DOELEN STRAAT, Amsterdam, Holland.

No. 1 CAERTNER PLATZ, Munich, Germany.

**NEW YORK.**

Platinum Tipped Diamond Settings,

Patented April 16th, 1878, by

**Ripley, Howland & Co.**

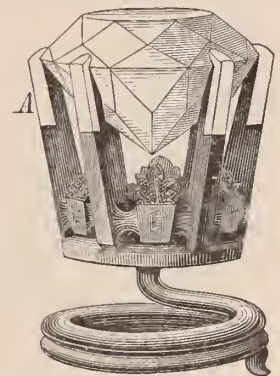

Office, No. 35 Maiden Lane, New York.

Factory, 383 Washington Street, Boston, Mass.

**MAX FREUND & CO.**

**Manufacturing Jewelers.**

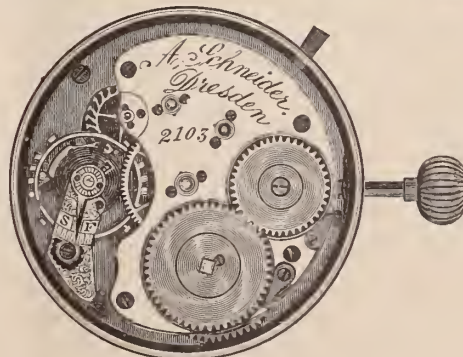

IMPORTERS OF

**Watches**

Jewelry and Precious Stones

8 Maiden Lane

**NEW YORK**

Sole Agents for the Celebrated A. Schneider Watch, Dresden. Also the Standard Watch Co. of New York.

# HART & SLOAN,

BUILDERS OF

## Watch Machinery,

AND MAKERS OF

### INTRICATE MECHANICAL INSTRUMENTS,

363 & 365 MARLET STREET,

NEWARK, N. J.

Having purchased a large lot of Watch Machinery, which we have fitted up and have now at work, are prepared to take orders for all kinds of small work, Gauges, parts of Watches, and fine Instruments of every description.

We have also for sale a lot of small Lathes and special Tools for Watchmakers and amateurs, suitable for repairing Watches and Clocks. We can also furnish all kinds of new Watch Machinery, or special Tools for Clocks, or other fine work; and Small Screws of every description, from 220 to 40 threads to the inch, diameter to correspond.

# Kearney & Swartchild,

Manufacturers of

## "TRIUMPH" LATHE.

Price, Hardened Bearings and Spindles, \$40.00

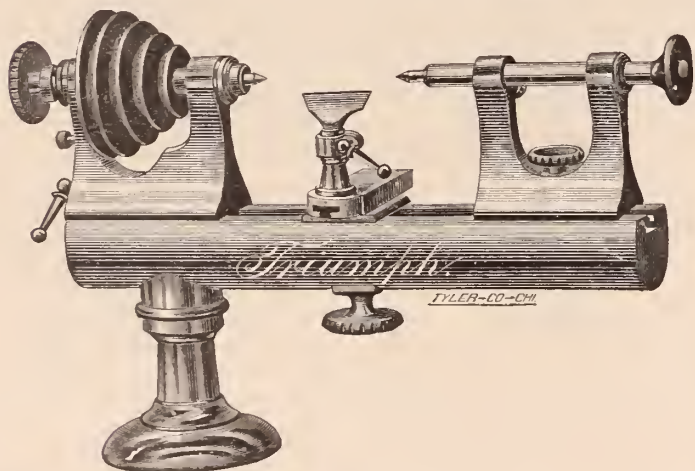

All Split and Wire Chucks are tempered and ground, which makes them perfectly true.

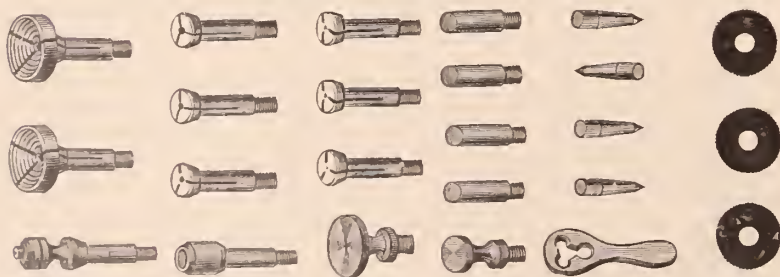

Importers and Jobbers of Tools and Materials, Watches, Jewelry, &c.

Manufacturers of Watchmakers' and Jewelers' Tools.

Illustrated Catalogue sent on application to parties sending business card.

Nos. 113 & 115 State Street, Chicago, Ill.

# American Watch Tool Co.

P. O. Box 999

WALTHAM, MASS.

MANUFACTURERS OF THE WHITCOMB LATHE,

AND

Machinery for Watch, Watch Case and Clock Making.

NEW YORK OFFICE, WITH

L. H. KELLER & CO., 64 Nassau Street.

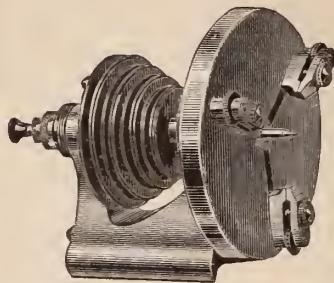

Universal Lathe.

HIGHEST AWARD:  
PHILADELPHIA, 1876.  
BOSTON, - - 1878.

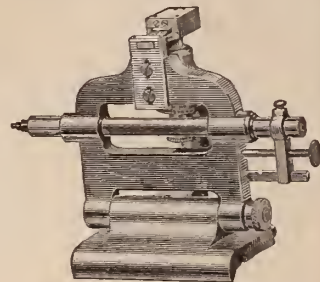

Jewelers Reel.

Chicago Office with Chas. Wendell & Co., No. 170 State Street.

NATHAN E. MORGAN.

CHAS. B. HEADLY.

# MORGAN & HEADLY,

MANUFACTURERS OF FINE JEWELRY,  
PLAIN GOLD RINGS, DIAMOND  
MOUNTINGS, SPECTACLES  
AND EYE GLASSES.

## Importers of Diamonds.

A full line of Diamonds, mounted and unmounted, always on hand, which we will send on approval to the Trade, on receipt of reference.



We have added to the manufacture of Gold Spectacles and Eye-Glasses those of Steel, and are able to fill all orders promptly.

Illustrated Catalogues sent on application.

ARTISAN HALL,

Nos. 611 & 613 SANSOM STREET,

PHILADELPHIA.



ESTABLISHED 1853.

CLOCKS



CLOCKS

**B. J. COOKE'S SON,**  
137 N. 3d Street, Philadelphia.  
Catalogues and Price Lists furnished only on application.

**J. H. PURDY & CO.**

Jobbers of Imported and Domestic

**TOOLS & MATERIALS,**

For the use of Watchmakers, Jewelers, and kindred trades.

WATCH GUARDS, JEWELRY BOXES, SPECTACLES, CARDS,  
SPECTACLE CASES, PEARL GOODS, STEEL CHAINS,  
TAGS, RUBBER TYPE, &c.

No. 170 State Street, Chicago, Ills.

OFFICE WITH CHAS. WENDELL & CO.

ESTABLISHED 1855.

**WELCH & MILLER,**

MANUFACTURERS OF MOROCCO, VELVET AND SATIN

**Jewelry Cases, Trays, &c.**

Telescope Sample Cases, with Flexible Trays.

COMPLETE STOCK ON HAND.

No. 169 BROADWAY, NEW YORK.

CATALOGUES SENT ON APPLICATION.

**GEO. B. WHEELER,**

**NEW BEDFORD, MASS.**

MANUFACTURER OF FINE

**Watch and Clock Oil.**



THE PORPOISE.

This Oil is made from the best of stock, is free from gum or corrosion, will stand the coldest weather, and is every way reliable.

**L. HAMMEL & CO., Sole Agents,**

No. 9 Maiden Lane, New York.

KOCH & CO., Elberfeld, Prussia, Sole Agents in Europe.

**Charles F. Terhune & Co.,**

*Manufacturing Jewelers,*

17 Maiden Lane,

New York:



Sole Manufacturers.



We beg to call the attention of the trade to the above cuts representing

**PATENT SLIDE BUTTON**

It is not separable, but works on a simple slide. It can be put in and taken out easier than any button made without soiling the cuff. Recommends itself at sight.

A FULL LINE OF ENAMEL AND STONE GOODS IN ABOVE PATENT.

**H. Muhr's Sons, Philadelphia.**

**MANUFACTURING JEWELERS,**

Solid Gold Finger Rings of Every Description.



Crown, 18k. Lion.



On and after January 1st, 1876, our make of Filled Plain Rings will be stamped as above, which stamp is copy righted. Any and every infringement on the above Trade Mark will be dealt with according to law. Every one warranted.

**THESE GOODS ARE SOLD BY ALL THE LEADING JOBBERS!**

Should the house that any retailer deals with not have them we will furnish them with the address of the nearest Jobber. **SELL TO THE JOBBING TRADE ONLY!**

**New York Office, 11 Maiden Lane.**

Address all communications to Philadelphia.

**BERNARD LEVY,**

*Manufacturer of Watch Cases*

—AND—

**JOBBER OF AMERICAN MOVEMENTS,**

No. 402 Library Street,

**PHILADELPHIA.**

ALSO, ORNAMENTAL ENGRAVER AND ENGINE TURNER.

**Lubricating Oils, for Watch, Clock and Chronometer Makers.**

The discovery of a Lubricator for FINE MACHINERY, such as Watches, Clocks and Chronometers, that is free from gum and corrosive substances, has taxed the ingenuity of hundreds of men whose efforts have proved a failure. But we are happy to say (being largely interested) that such an article has been supplied by MR. EZRA KELLEY, of New Bedford, Mass., who, after forty years study of the subject, has perfected a Lubricator that recommends itself to all who have used the genuine, (there having been numerous counterfeits in the market,) as witness also the award of a



Diploma and Medal by the judges of the late Centennial Exhibition at Philadelphia. We have no hesitation in saying that his Oils are the BEST manufactured, always uniform in quality and capable of standing all tests applied to lubricating oils. We cheerfully recommend it to all who may in their business require a FIRST-CLASS LUBRICATOR.

SETH THOMAS CLOCK COMPANY, SETH E. THOMAS, Agent.

P. S.—The above Oils can be procured at all first-class wholesale Watch and Clock Establishments in the United States, as well as his only Agents, GRIMSHAW & BAXTER, 35 Go-well Street, London England. New Bedford, October 15, 1877.

Dealers in Watches,  
Importers of Diamonds.

**OPPENHEIMER, BROS. & VEITH,**  
Manufacturing Jewelers,

35 MAIDEN LANE,

S. Oppenheimer, {  
A. Oppenheimer, {

New York.

Henry F. Veith  
Gus F. Veith

I. PFORZHEIMER.

D. KELLER.

**PFORZHEIMER & KELLER,**

IMPORTERS OF

**Watches and Diamonds**

Dealers in American Watches,

AND

Manufacturers of Jewelry,

No. 24 JOHN STREET,

P. O. Box 4144.

NEW YORK.

**Mathez Watch Company of New York.**

Gents' and Ladies' Stem-Winding Movements

STRAIGHT LINE, 3-4 PLATE NICKEL.

These Movements are of six different grades, uniform in size and beautifully finished, and will be SOLD AT LOWER PRICES than any other goods of similar excellence.

A FULL LINE of materials for our movements always kept in stock for the convenience of those using our goods.

**F. H. MATHEZ, Sole Agent,**  
No. 5 Maiden Lane, New York.

**L. A. CUPPIA,**

Manufacturer of Solid Silver Scarf Pins, Sets, etc.

IMPORTER OF

**Coral, Silver Filagree**

—AND—

**CONCH SHELL,**

Repairing Coral Jewelry a Specialty.

19 UNION SQUARE,

NEW YORK.

Manufactory, No. 39 St. Catarina a Chiaja, Naples, Italy.

**BREITINGER & KUNZ,**  
Importers of Watchmakers' Tools,  
MATERIALS, CLASSES, &c.  
No. 107 North Ninth Street,  
PHILADELPHIA.

Dealers in all kinds of American Watch Materials and American Clock Material. Specialties in Materials for Musical Boxes, Cuckoo Clocks, &c.

Sole Agents in the United States for Bahni Brothers Hardened and Tempered Hairsprings. Agents in the U. S. for J. Becker's (Freiburg, Germany) Gold Medal Regulators, the best in the market. A large assortment of all patterns always on hand; Movements with seconds pendulum for watchmakers' use—all kinds of materials for the same.

Wheel Cutting and work done for the trade.

**EDWARD TODD & CO.**

MANUFACTURERS OF

**GOLD PENS,**



Pencil Cases, Tooth Picks, &c.

No. 652 BROADWAY,

Factory, 29 & 31 South 11th St., Brooklyn.

NEW YORK.

JULIEN GALLET,

Importer of Watches,

From his own Factory, Chaux de Fonds, Switzerland.

25 JOHN STREET,

Leon D. Gallet,  
Charles Perret,  
Jule Racine.

NEW YORK.

**A. N. Clark, Plainville, Ct.**

MANUFACTURER OF

WATCH KEYS,

WATCH CASE SPRINGS,

Watchmakers' & Jewelers'

**BENCH TOOLS.**

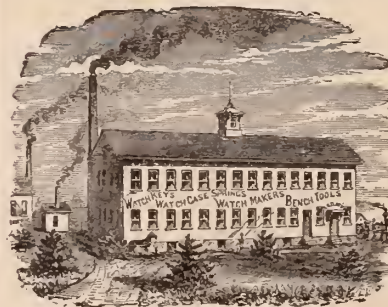

Crosby's Jeweling Tools, &c.

Sold by Jobbers in Watch Materials and Notions.

Small articles in metal manufactured to order.

MANUFACTURERS  
OF  
EXCLUSIVELY  
**BLACK ONYX GOODS.**

The patented **DEEP MOURNING LOCKETS** are original with us, and have stood the test of years of wear. They meet the approval of the trade and the wearers for their superior make and finish, as well as for the correctness of the mechanical principle on which they are constructed.

**WOGLOM & MILLER,**  
32 & 34 JOHN STREET,  
NEW YORK.

**BOOZ & THOMAS,**

MANUFACTURERS OF

**Watch Cases & Jewelry,**

108 SOUTH EIGHTH STREET,

Second Story, PHILADELPHIA.

Illustrated Catalogues sent upon application.

Old Gold & Silver Bought or Exchanged.

PARTICULAR ATTENTION PAID TO REPAIRING.

**T. B. BYNNER,**

**Importer & Jobber of Watches**

DIAMONDS AND FINE JEWELRY,

And Dealer in the BEST CLASS OF ROLLED PLATE JEWELRY

And Key and Stem-Winding American Watches.

No. 513 Broadway, New York

**B. T. PACE'S**  
IMPROVED, CORK-LINED

**WATCH-CHAIN SWIVEL.**

Patented March 19th, 1878.



The object of this invention is to furnish a SWIVEL provided with non-metallic soft elastic lining. Preferably for such packing, I use Cork. Heretofore this class of swivels have been so constructed as to permit a metal bearing upon the Pendant Ring of the Watch or Locket in such manner as to allow an automatic articulation of the Swivel thereon, thus wearing away the pendant ring or bow in a very short time. This Swivel entirely prevents any such wear, and leaving pendant bow perfectly smooth and bright. The packing will last two years or more, and is very easily replaced. This SWIVEL does away with the wrapping of the pendant bow or the use of an old dirty string to prevent its wearing away. Royalty Rights or Entire Right for sale; also, bids for the manufacture of the Swivels in Gold and Gold-rolled Plate solicited. A sample Swivel furnished on application, or, can be seen at the office of the Jewelers' Circular, 42 Nassau street, New York. Address all communications to

**B. T. PACE, Salem, Indiana.**

**HENRY FERA,**  
Importer of Diamonds,

No. 9 MAIDEN LANE,

New York.

Having my own cutting and polishing establishment at Nos. 23 and 25 Looijersgracht, Amsterdam, Holland, constantly running 36 mills, I am able to offer to the trade a full assortment of Diamonds at very low prices.

Loose and Mounted Goods sent on approval to any part of the country on receipt of satisfactory references.

**HAMILTONS & HUNT,**

MANUFACTURERS OF

**Fine Plated Chains**

AND PATENT BUCKLE BRACELETS,

Branch Office, 176 Broadway, New York

FACTORY, 226 EDDY STREET, PROVIDENCE, R. I.

**W. C. GREENE & CO.**  
GOLDSMITHS  
MANUFACTURERS OF  
RICH SETS IN TAPER WIRE CORAL

Factory 95 FINE ST. Providence, R. I.

Stone Cameo  
Amethyst  
Coral Cameo  
Engraved  
Brooches  
Sleeve Sets  
Stud Buttons  
EAR DROPS & C. Studs Crosses

NEW YORK OFFICE, No. 192 BROADWAY.

Wm. C. Greene,

B. W. Greene,

Geo. D. Briggs.

**MILNE & JOURDAIN,**  
Manufacturers of Stem-Winding Watch Crowns



13 & 15 Franklin Street, NEWARK, N. J.

Gold Crowns, for Stem-winding Movements, to suit all sizes of Imported or American Watches, in four different styles and seven sizes.

Gold Pushers for Key Movements in every size. Also Gold Crowns for fine Chronograph Watches made to order.

Silver Stem winding Crowns and Key Pushers on hand or made to order. Send for card and samples.

A. MILNE.

A. JOURDAIN.

Office of  
**ROBBINS & APPLETON,**  
 AGENTS FOR  
 American Watch Company,  
 No. 9 BOND STREET,

*New York, February 12th, 1879.*

Sir:

List prices of certain of our movements are to-day fixed as follows, viz.:

**18 Size, FULL PLATE.**

"BROADWAY," 7 jewels, nickel balance.....	\$ 4 30
" " 7 " cut expansion balance (NEW).....	4 75
"WM. ELLERY," 2 pairs extra jewels, cut expansion balance....	8 00
" " 2 " " " " Stem Winder.....	10 50
"STERLING," 7 jewels, nickel balance, Stem Winder.....	6 25
" " 7 " cut expansion balance, (NEW), Stem Winder.....	6 70

The new list prices of complete Silver Watches are changed to correspond with the above.

**14 Size,  $\frac{3}{4}$  Plate.**

"AM. WATCH CO. HILLSIDE" (NEW), 7 jewel, cut expansion balance, Stem Winder, for Hunter or Open Face.....	\$20 00
---	---------

**18 Size, Full Plate, NICKEL Movements.**

"WM. ELLERY," 2 pairs, extra jewels, cut expansion balance....	\$12 00
" " 2 " " " " " " Stem Winder,.....	16 50
"P. S. BARTLETT," 2 pairs, extra jewels in settings, cut expansion balance....	18 50
" " 2 " " " " " " " Stem Winder	26 00
"WALTHAM WATCH CO." 4 pairs, ex. jewels in settings, cut ex. balance.....	26 50
" " " 4 " " " " " " Stem Winder	34 50
"APPLETON, TRACY & CO.," 4 pairs, extra jewels in settings, cut expansion balance, adjusted.....	37 00
" " " " 4 pairs, extra jewels in settings, cut expansion balance, adjusted, Stem Winding.....	46 50

All the above are subject to the terms and discounts announced in our circular of the 8th inst.

There will be no change in the quality of any of our grades, except as our constant efforts tend to their improvement. We decline altogether to take any part in the present unwise competition between Swiss and American manufacturers to see which shall make watches of the poorest quality. We intend to sell as low as any American company, but, however low the price, we do not intend to finish a grade of goods upon which it would be a disgrace to us to put our name.

Robbins & Appleton, 9 Bond St., New York.  
 Robbins, Appleton & Co., 8 Summer St., Boston.  
 Robbins & Appleton, 170 State St., Chicago.

} General Agents.

American Watch Company,  
 OF WALTHAM, MASS.

PARIS·EXPOSITION·1878.  
 AMERICAN·WALTHAM·WATCHES.



GOLD  
 MEDAL



THE HIGHEST AWARD TO ANY EXHIBITOR IN HOROLOGY

JURORS.

- E. JAPY, Watch Manufacturer . . . . . *France.*
- J. B. GRANDJEAN, Watchmaker . . . . . *Switzerland.*
- C. SAUNIER, Professor of Horology . . . . . *France.*
- CHOPARD, Director of the School of Horology,  
 at Besançon . . . . . *France.*

- T. W. KNOX . . . . . *United States.*
- D. PERRET, Watchmaker . . . . . *Switzerland.*
- C. FRODSHAM, Watchmaker . . . . . *England.*
- REDIER, Watch Manufacturer . . . . . *France.*
- C. SAVOYE, Watch Manufacturer . . . . . *France.*

11-1-1877

11-1-1877

SPECIAL SALE  
OF THE  
**“CRESCENT STREET” WATCH,**  
OFFERED BY THE  
AMERICAN WATCH COMPANY,  
—OF—  
**WALTHAM, MASS.**



*The 18 size movement, named*

“American Watch Company, “CRESCENT STREET,” Waltham, Mass.,”

*is the only American full-plate movement made to wind and set on the back, is full jeweled, is provided with compensation balance, accurately adjusted, patent micrometrical regulator, Fogg’s patent pinion, and is popularly known as the*

**American Railroad Watch.**

*It is carefully fitted in Sterling Silver Cases ( $\frac{925}{1000}$  fine), and now offered to the trade, in*

3 oz. (Hunting or Open Face,) - - - - -	\$22.00 NET.
4 oz. (Hunting or Open Face,) - - - - -	\$23.50 NET.

**AMERICAN WATCH CO.,**

OF WALTHAM, MASS.

**Robbins & Appleton,** 9 BOND ST., NEW YORK,  
8 SUMMER ST., BOSTON,  
170 STATE ST., CHICAGO, **General Agents.**

# L. & A. MATHEY,

IMPORTERS OF FINE WATCHES AND MOVEMENTS

No. 16 Maiden Lane, New York.



Independent  $\frac{1}{4}$  Seconds, Plain Chronographs, Independent Split Seconds,  
 Minute Repeaters, Double Chronographs, Perpetual Calendars,  
 Minute Chronographs, Pocket Chronometers.  
 MINUTE CHRONOGRAPHS, WITH MINUTE REPEATER.  
 CHRONOGRAPHS, WITH MINUTE REPEATER.  
 AND A FULL LINE OF MEDIUM GRADE WATCHES AND MOVEMENTS.

Sole Agents for the H. L. MATILE WATCHES.

Timing and Complicated Watches a specialty. All our Watches are tried and tested before delivery. Goods sent for examination on satisfactory references.

An attractive line of *Chattelaines* and *Chattelaine* Watches.



Established 1828.

# JACOB BENNETT & SON,

Diamond Setters and Manufacturing Jewelers,

No. 108 SOUTH EIGHTH STREET, PHILADELPHIA.

WE MANUFACTURE AND MAKE A SPECIALTY OF  
 EVERY DESCRIPTION OF

**DIAMOND MOUNTINGS**

SUPERIOR IN DESIGN AND WORKMANSHIP.



MASONIC MARKS,  
**Presentation & Lodge Jewels,**

SOCIETY AND POLICE BADGES MADE TO ORDER.  
 FINE WHOLE PEARL JEWELRY.

GOODS SENT ON MEMORANDUM TO ANY PART OF THE UNITED STATES.

# CROSS & BEGUELIN,

Makers and Importers of SWISS WATCHES,

AND DIRECT IMPORTERS OF

Watch Tools, Materials, Glasses, &c.

No. 21 Maiden Lane, New York.

The CENTENNIAL WATCH (Stem-Winding and Stem-Setting) so universally popular, has achieved a standard reputation, and is generally conceded to be the best made watch for the money in this market. Being the sole manufacturers of this celebrated Timekeeper, we are enabled to give it our strongest endorsement. Especial attention is called to the "HENRY BEGUELIN," "DROZ & PERRET," and other well known Swiss Watches, as well as to our full and complete line of all grades of American Watches, on which we give the full trade discount.

The attention of Watchmakers is directed to our new DRILLS, in sets of 21 sizes. The most complete and serviceable drill ever offered.

General Agents for the *Auburndale* Timer,  $\frac{1}{4}$  and  $\frac{1}{2}$  Seconds.



None Genuine without this TradeMark.

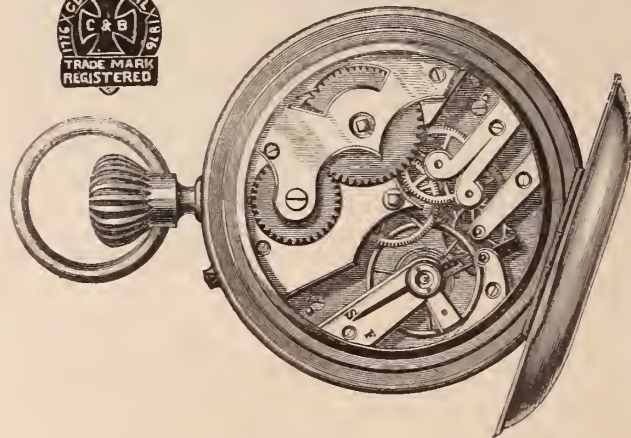

The above is a fac-simile of the Centennial Watch.

# BROWN & BROTHERS

MANUFACTURERS OF

Finest Quality of **Electro-Plated Flat Table Ware.**

PATENTED HEAVY SPRING TEMPERED SHANK ON FORKS AND SPOONS.

ILLUSTRATED CATALOGUES FURNISHED ON APPLICATION.

WAREROOMS, No. 81 CHAMBERS STREET, NEW YORK CITY.

FACTORIES, WATERBURY, CONN.

P. O. BOX 5731.



**REED & BARTON,**  
**Manufacturers of Fine Silver-Plated Table Ware**  
 OF EVERY DESCRIPTION.

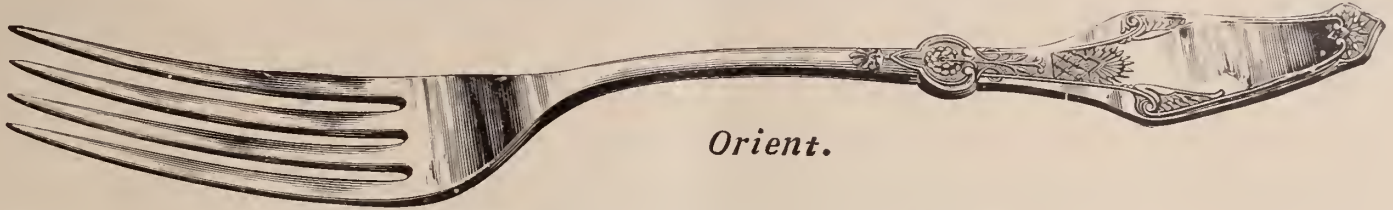

Would call attention of the trade to their new design of fork (illustrated above) which we believe to be the finest design ever manufactured in plate. We are also manufacturing a great number of new designs in all kinds of hollow-ware, and among other things a great number of Fancy Pieces, such as Jewel Boxes, Card Stands, and Case Cologne Sets, etc., which are specially adapted to the holiday trade.

**Factories, Taunton, Mass.**

**No. 686 BROADWAY, NEW YORK.**

**HALL, ELTON & CO.,**  
**Manufacturers of the Finest Electro-Plated Ware.**

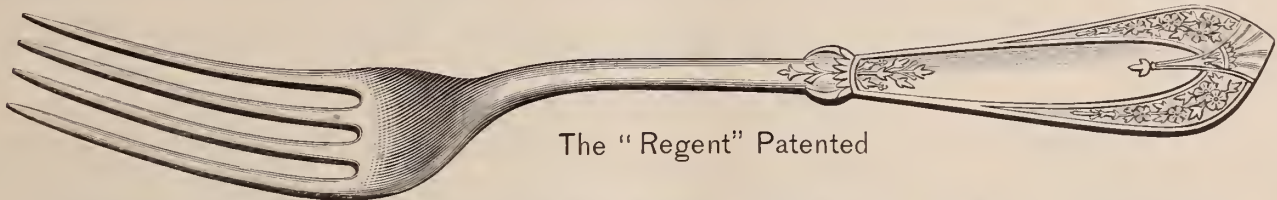

The "Regent" Patented

**UNSURPASSED IN QUALITY, STYLE AND FINISH!**

**Factories, Wallingford, Conn.**

**Salesroom, 75 Chambers St., New York.**

SPECIAL NOTICE! MANUFACTURING JEWELERS, CHEMISTS, &c.

**BROWN & BROS.,**

**No. 81 CHAMBERS STREET,**

**NEW YORK.**

Manufacture CHEMICALLY PURE COPPER for ALLOYING, and are prepared to fill orders for same, either in the Wire, Strip or Granulated form. Its PURITY has been attested as follows.

BROWN & BROS.

*Dear Sir.*—We have analyzed the two samples of Copper left with us on the 18th instant, one said to be foreign refined Copper as used by jewelers, the other a refined Copper as manufactured by you for the same purpose. We find both samples alike in purity, and no difference can be detected by a careful chemical analysis, both being samples of PURE METALLIC COPPER, having no traces of antimony, tin, arsenic, zinc or lead.

UNITED STATES ASSAY OFFICE, 30 WALL STREET,  
 NEW YORK, Dec. 21st, 1877.

TORREY & EATON.

**HOLMES, BOOTH & HAYDENS,**

MANUFACTURERS OF

**ELECTRO-SILVER PLATED**

**Spoons, Forks, Ladles, Fancy Pieces,**

**Solid Handle Steel Knives, &c., of the finest quality.**

**No. 49 Chambers Street,**  
**NEW YORK.**

**No. 18 Federal Street,**  
**BOSTON.**

**Works at Waterbury, Conn.**

“Medal and Diploma awarded at Centennial Exposition for superior mechanical execution and artistic ornamentation.”

Established in 1854.



# C. & A. PEQUIGNOT, Manufacturers of Watch Cases.

DEALERS IN AMERICAN WATCHES AND IMPORTERS OF FINE KEY AND STEM-WINDING MOVEMENTS,  
**Salesroom and Manufactory, 22 South Fifth Street.**  
**PHILADELPHIA.**

A full stock of Key and Stem-Winding Gold Cases always on hand. Goods sent on approval when satisfactory references are furnished.

## HENRY C. HASKELL,

Manufacturing Jeweler,

No. 12 John Street,

New York.



3100



3718

CHOICE INTAGLIO & CAMEO RINGS,  
NOVELTIES IN BANGLE AND GYPSY  
*Set with Diamonds.*

SAPPHIRE, RUBY, TURQUOISE,  
PEARL, &c.



4877



6837



7093



6978



6900



3684

*Orders solicited for goods on approval.*

*The "MARQUIS" Seal Ring, Entirely New, plain, elegant.*



# ERRICO BROTHERS,

19 JOHN STREET, N. Y.

MAKERS AND DIRECT IMPORTERS FROM OUR OWN MANUFACTORY IN NAPLES,

## CORAL, SILVER FILIGREE AND CONCH SHELL JEWELRY

OF THE LATEST DESIGNS.

These goods are made under our own immediate supervision, and designed expressly for this market. Our stock, the largest in the city, is replete with the richest novelties in this line, and is offered to the trade at prices that will tempt buyers.

We would direct the especial attention to our recent importations of CORAL ROSES and CORAL CAMEOS in all the most desirable shades. Also to our new designs in SILVER FILIGREE goods, which we offer at unexceptionably low prices. Buyers, when in town, are invited to an examination of our stock.

## SPENCER OPTICAL MANUF'G CO.

13 MAIDEN LANE, NEW YORK,

MANUFACTURERS OF

## Spectacles AND Eye Glasses

IN ALL VARIETIES.

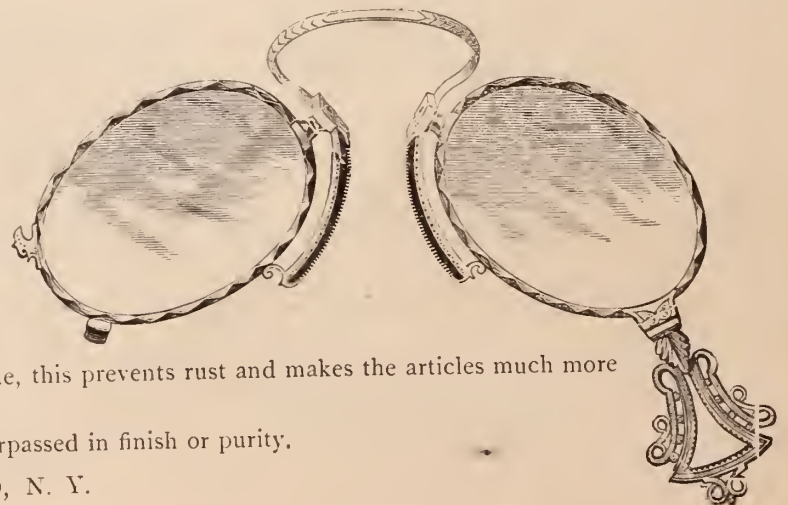

Among the numerous specialties are the Steel Frames plated with Nickle, this prevents rust and makes the articles much more durable.

P. S.—Our lenses are all ground in our own Factory, and cannot be surpassed in finish or purity.

FACTORIES, MT. KISCO, N. Y.

# HAMPDEN WATCH CO.

Manufacturers of KEY AND KEYLESS

General Office and Factory  
SPRINGFIELD Mass.

## WATCHES.

New York Office  
No. 12 MAIDEN LANE.

### THE AMERICAN PEDOMETER.

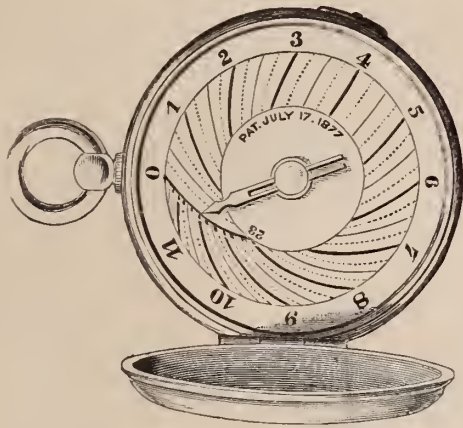

This instrument accurately measures the distance a person carrying it walks, showing the amount of daily exercise taken in and out of doors.

Its mechanism is a marvel of simplicity, and can be adjusted to any length of step. It is strong and durable, and the size of a small watch. Ladies, Professional and Business Men, Students, Pedestrians, Sportsmen, Farmers, Surveyors, and others will find it very useful. A table accompanies each Pedometer, giving the number of steps taken in a mile second, minute, hour and day.

There are two forms of index, one registering steps from 23 to 35 inches in length, and another, adapted for ladies and children, registering steps from 17 to 26 inches in length. The cases are of nickel-silver,

We have just finished an OPEN-FACE with white enameled dial, heavy crystal front, (retail price, \$7.00) but unless otherwise ordered, we send the one registering steps from 23 to 35 inches in length, in hunting case similar to engraving. Retail Price, \$5.00.

SOLE AGENTS, TIFFANY & CO., NEW YORK.

The trade supplied only by TIFFANY & CO., from their new wholesale Watch offices, 694 Broadway, who do not sell to Jobbers, but are establishing as "exclusive agents" dealers who order quantities. Early application solicited.

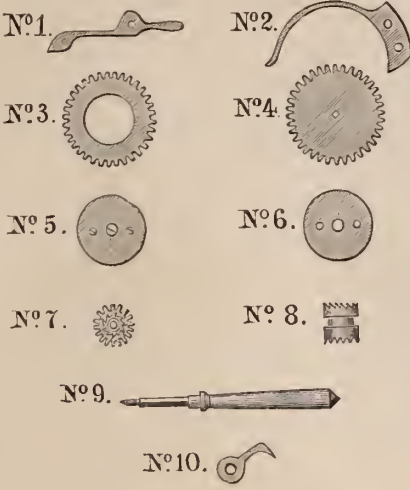

### ARHILL & CO.

IMPORTERS OF

### Watchmakers Tools and Materials, also Dealers in Watches and Jewelry.

Sole Agents for the "Jequier" Main Spring, the only spring of all exhibits made at the Paris Exposition that received a Medal; manufacturers of the "Boss" Engraving Block, the best and most practical in the market. Sole Agents for "Baldwin's" Barrel Catch Insertor, the most useful tool on a watchmaker's bench, saves time and labor. Send to us, or any material dealer for description. We solicit orders from material dealers for these specialties. Sole Agents for "Columbus Watch," for New York and Eastern States, nickel 3/4 plate, full jeweled, stem-winding and setting, the most beautiful watch, with best results at least money. Send for descriptive Catalogue. No price list furnished unless requested, and only to the trade. Send for price list of tools and material. Orders intrusted to us filled promptly with experience.

Stem-winding wheels cut and all work for the trade done well at moderate prices.

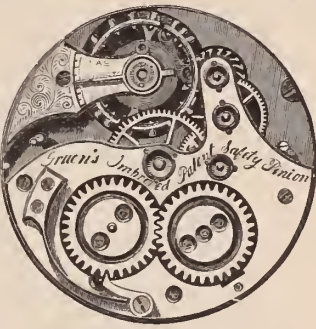

P. O. Box 8. CANAJOHARIE, N. Y.

### GUERRANT'S ELECTRO-ENGRAVING MACHINE.

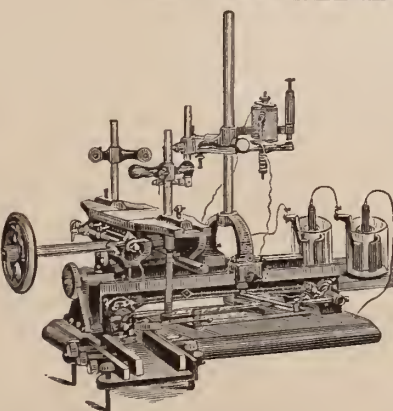

It has baffled the skill of the inventive genius of the world for ages to produce a machine that would compete with the skillful hand engraver, and until this machine was invented, all engraving had to be done by hand. And, to-day, it is the only practical engraving machine in existence.

The construction of the machine is not complicated, but simple and durable. It is easily operated. The variety of work it will do is almost incredible, and to be fully appreciated, ought to be seen in operation.

We do not therefore, offer this machine to the public simply as a machine to aid the engraver, but as a perfect, practical engraver in itself, with which any person of ordinary skill can learn in a short time to do any piece of engraving that might be desired and in the very best manner.

It copies from the regular press type of any style of letter or design that is made of type, from the plainest to the finest german text letter or fancy design, at the same time it will reduce the letter or design from the original size to ten different sizes, or so small that it cannot be seen by the naked eye. It will shorten the letters or elongate them, also will lean them forward or backward, will either make a raised or sunken letter, will engrave on any surface, either plain, concave or convex—for instance, such things as Watch Cases, either in or outside; Finger Rings, either in or outside; Bracelets, Napkin Rings, Goblets, Pitchers, Mugs, Waiters, Spoons, Forks, and all kinds of Jewelry; or, in fact, on any article susceptible of being engraved or ornamented with scroll work or fancy designs, &c., either on Gold, Silver, Copper, Brass, Iron, hardened Steel, Glass, Stone, Pearl, Ivory, Bone, Gutta Percha.

No Jeweler or establishment that has engraving to be done should be without it. Machines are sold with limited territory to use them in; or, the exclusive rights to use them in certain town or territory can be purchased with the machine if desired.

For further information, address

WM. HICKSON, Gen. Agt.,  
P. O. Box 1603, PHILADELPHIA, PA.

KARN & HICKSON,  
LYNCHBURG, VA.

Size of Machine, 12 x 16 inches.  
Patented Jan. 18, Oct. 31, 1876, & Mar. 4, 1879.

A. M. GUERRANT, Danville, Va., Agent for the Southern States.

Owners of the right of all the Northern and Western States and Territories.

# BIRCH'S PATENT SCREW KEY.



The especial attention of the trade is directed to the above, a LIMITED NUMBER of which we have on hand.

THIS IS THE BEST SCREW KEY WE HAVE EVER PUT ON THE MARKET.

Sample by Mail on receipt of 75 Cents.

**J. S. BIRCH & CO.,**

No. 38 Dey Street, New York.

## FRASSE & COMPANY,

Importers of P. S. STUBS',  
French, Swiss, German & Sheffield Tools, Files,

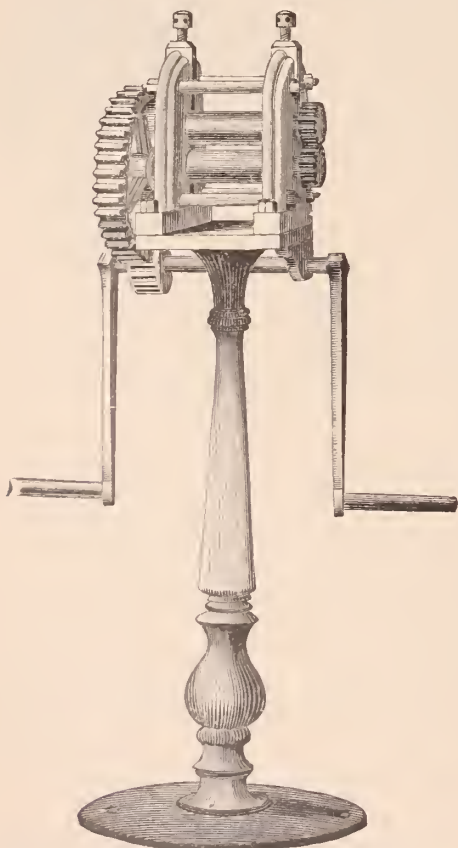

- Steel Wire and Materials,
- For Watchmakers, Jewelers, Engravers, Die-Sinkers, Machinist, &c.
- Turning Lathes, Drills & Chucks
- Rolling Mills, Draw Plates,
- The Celebrated Rodenbush
- Piercing Saws,
- Horse Shoe Magnets,
- Nurls,
- Ingots,
- Chasing Tools,
- Engravers' Tools,
- Brush Wheels & Buffs,
- Hand Brushes and Buffs,
- Borax,
- Saltpetre,
- Beeswax,
- Rouge,
- Tripoli,
- German Silver,
- Brass, &c.

No. 62 Chatham Street, Established 1816.

New York. P. O. Box 4627.

## The Burbank Manufacturing Company

Manufacturers of GOLD & SILVER

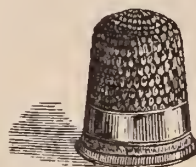

GOLD SILVER, STEEL, RUBBER, And SHELL,

## Thimbles,



EYE GLASS Self Adjusting.

## SPECTACLES AND EYE-GLASSES

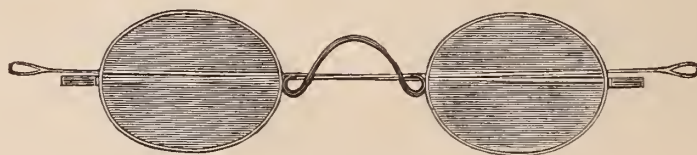

OF ALL DESCRIPTIONS.

## SOLID GOLD RINGS

Office, 14 MAIDEN LANE. NEW YORK.  
Manufactory, Springfield, Mass.

NE PLUS ULTRA.

## Williams & Cook's Dust-Proof Watch Keys

Patented Sept. 1st, 1874.



- The Popular Name Key.
- A. Nickel Plated Handle and Pipe, Swivel Top, per gross..... \$10.75
- English Pattern Key.
- C. Nickel Plated Handle and Pipe, Swivel Top, per gross..... \$7.50



### BENCH KEYS.

- Corrugated Gilt Handles, Tempered Steel Pipes, per Set of Six.....\$1.80
- per Set of Three..... .90

### P. Style of Key.

- Gilt Handle. Steel Pipe.
- Per Gross.....\$8.50



Our Key Pipes are all warranted to be made of the finest quality of steel. One great advantage his key has over all others, is the mortice through the pipe, making it the most simple and thoroughly dust and moisture-proof, as well as the cheapest key in the market. Our sizes run from 1 to 12; 4.5 and 6 fit Gents' American Watches; No. 8, Ladies' American.

For sale by the Trade generally.

**KENDRICK, DAVIS & CO., LEBANON, N. H.**

SOLE OWNERS AND MANUFACTURERS.

The advantage of our Name Key, as an advertising medium, will at once be seen.

# TIFFANY WATCHES.

FOR LADIES AND GENTLEMEN.

*Independent Minute and Split Second Chronograph.*

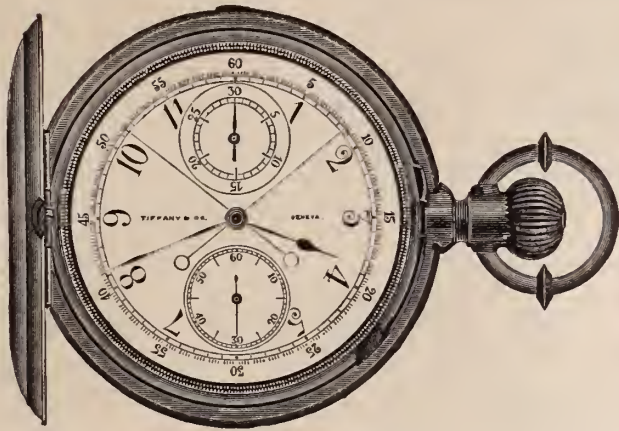

*Fifth-second, Split-second Chronograph.*

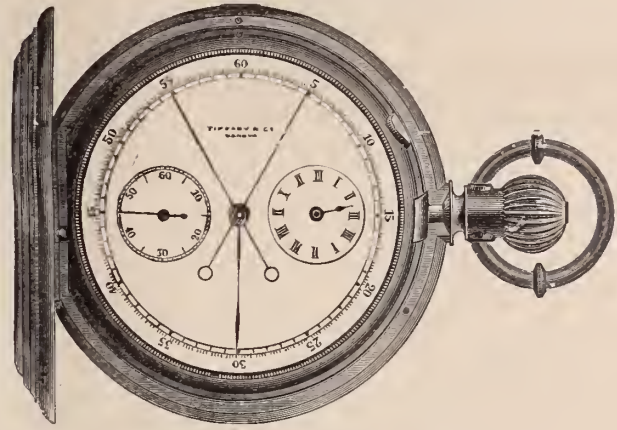

SIMPLE! STRONG! DURABLE! ACCURATE! RELIABLE!  
ADJUSTED TO TEMPERATURE and POSITIONS, and CASED IN 18 Karat GOLD.

Our new CHRONOGRAPHS (Fly-backs) now ready for Spring Races! Single, split second, minute and second and the same with Repeaters.

EACH and every movement finished under our own supervision by thoroughly skilled hand-labor, and guarantee, to be "as fine time keepers to carry as are made!"

Every genuine TIFFANY WATCH has engraved upon the movement the firm name "TIFFANY & Co." and none others are made by our workmen!

More "value received" than ever before known in the watch business! Exclusive sale given under special contracts, and circulars for distribution sent gratis!

AGENTS protected and goods sent "on memorandum" for examination or selection upon receipt of satisfactory references! We do not sell Jobbers!

Refinishing, stoning, raying and engraving nickel movements done on the premises! Engraving inscriptions, devices and monograms on cases promptly attended to!

The TIFFANY WATCHES are retailed at less than the importation cost of many so-called fine watches!

 Dealers must sell them at our established retail price!

## TIFFANY & Co.

NEW YORK, PARIS, LONDON, GENEVA.

### MAKERS OF FINE AND COMPLICATED WATCHES,

Wholesale Office, 694 Broadway, New York.

GEO. R. COLLIS, Manager.

 General Agents for Messrs. Patek, Philippe & Co.'s Watches.

 Sole Agents for the American Pedometer, the most popular and salable article known to the trade. Retail price, \$5.00. Not sold to Jobbers. Retail Dealers established as "exclusive agents," according to quantity ordered. Circulars and Terms sent upon application, when accompanied by business card.

WORKS,  
Newark, N. J.



SALESROOM,  
694 Broadway, N. Y.

THE  
Adams & Shaw Company,  
SILVERSMITHS,

and Makers of Hard Metal Electro-Plate,

694 BROADWAY, . . . . . NEW YORK.

GEO. R. COLLIS, Manager.

We would respectfully call the attention of our old friends, and the trade generally, to the line of goods we are now making, and, while thanking them for past favors, solicit a continuance of the same; trusting that under the **New Management**, with increased facilities for manufacturing, all orders will be attended to with promptness and satisfaction.

Our stock at present is replete with such goods as cannot fail to meet the wants of the trade, and, with new designers at the factory, we are prepared to offer a variety of beautiful articles, novelties in design and finish, in Silver Fancy Goods and Hollow-Ware, with combinations of colors in gold, silver and niello-enamel, Testimonial and Presentation Goods, Spoons and Forks of patterns popular and desirable, and a choice line of Case goods, from single pieces to Cabinets for Wedding Gifts.

Designs and estimates furnished, and particular attention paid to orders for Racing, Field and Nautical Prizes (small and large), Tea Sets, Berry, Fruit, Ice Cream and Jelly Bowls, and General Hollow-Ware, in Sterling Silver or Silver-soldered Electro-Plate.

Respectfully,

The Adams & Shaw Co.

## THE "NEWPORT."

(PATENTED.)

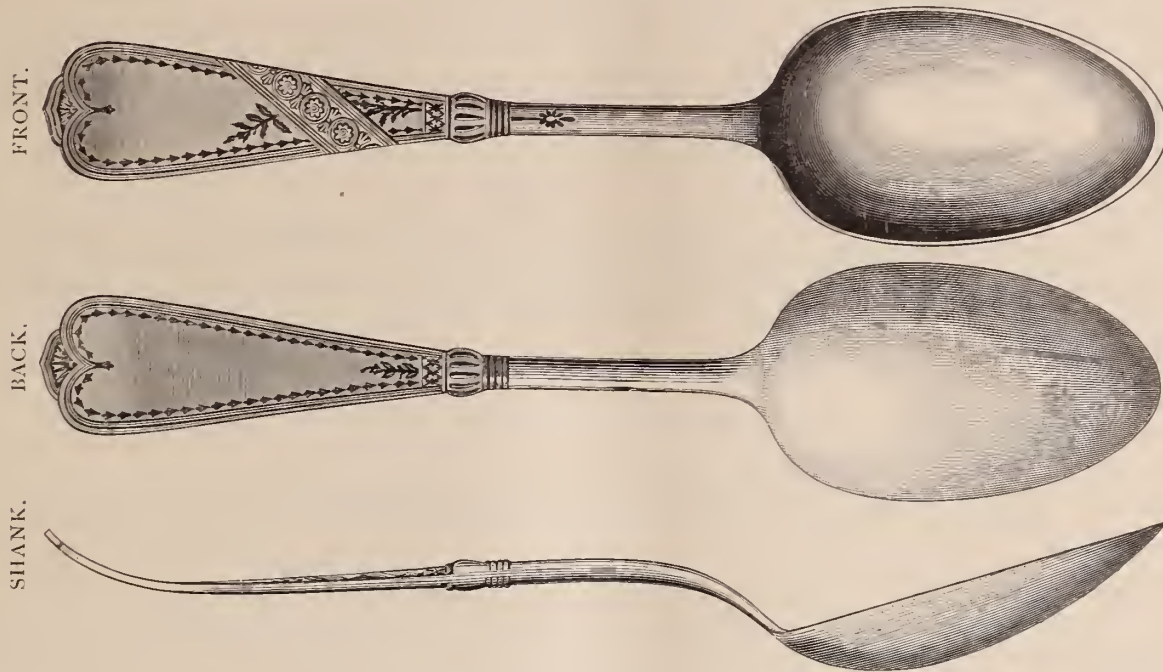

## TO THE TRADE

*We take pleasure in introducing the entirely new and beautiful pattern shown above.*

- THE OUTLINE - - Is graceful and pleasing to the eye, having none of the sharp, angular points so objectionable in many of the recent patterns.
- THE ORNAMENTATION is unique and fine, having the appearance of a Chased or Engraved Solid Silver Spoon.
- THE SHANK - - - Is our well-known heavy, spring-tempered, for which we hold letters patent.

*Every care has been taken to make this pattern as perfect as possible; first proofs of the die were submitted to many of the best experts and largest dealers in this country, and their unanimously expressed opinion is, that "the pattern is the handsomest ever made in plate." and predict for it a large sale.*

*Prices the same as "Crown" and other similar patterns.  
All should add the desirable "Newport" to their stocks.*

*Yours respectfully,*

ROGERS & BROTHER,

690 Broadway, New York.

*April 1, 1879.*

N. B.—To correct erroneous impressions that exist in a few quarters, it is proper to say that the founders of "Rogers & Brother" first introducing electro-plating in this country in 1847. In 1858, this Company was incorporated by them, and at the present time is the only concern in the United States manufacturing Silver-plated ware under the name of "Rogers."

# ILLINOIS WATCH COMPANY,

MANUFACTURERS OF

## KEY AND STEM-WINDING MOVEMENTS.

OFFICES,

11 MAIDEN LANE, NEW YORK. COR. DEARBORN & MONROE STS., CHICAGO.

We would call attention to the reduction in prices and increase of discount, as per our new list, dated February 17th, which may be obtained from wholesale dealers, or from us on receipt of business card.

We will continue to make ALL GRADES of movements, with HARD PLATES, and will leave no means untried which may enable us to furnish STANDARD AND RELIABLE goods, which dealers can FULLY WARRANT.

### OPEN FACE

"Miller Ad." "Currier," "Hoyt"  
"Columbia," "America,"  
"No. 2," "No. 1," and "Interior"  
Stem-winding Movements,  
*made especially for Open Face  
Cases, with Fig. XII at the pen-  
dant and Seconds opposite.*

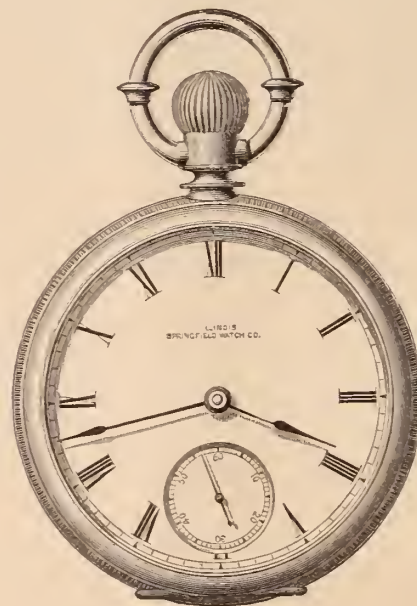

### STEM-WINDERS.

*Other Stem-winding grades  
on our list are made to order  
(in 4 to 6 weeks) in the same  
manner, in quantities of five  
or more of a grade.*

*The extra plate hole is jeweled in all grades, Currier and above.*

Jewelers can now obtain our 8 Size Ladies' Key and Stem-winders, fitting Waltham style 8 size cases, from any of the wholesale dealers.



## SPRING NOVELTIES.

IN

# Marble Clocks

Introducing a TINTED DIAL with raised figures. This is the handsomest dial ever shown in this market and can only be seen at our establishment, as we control it for this country.

## Le Boutillier & Co.,

IMPORTERS AND JOBBERS,

No. 3 UNION SQUARE, NEW YORK.

## J. H. FRENCH,

### AUCTIONEER,

A Specialty Made of Stocks of

**Diamonds, Fine Jewelry, Watches, &c.**

Refer by permission to the following firms for whom sales have been made:

A. H. Miller, Chicago.  
N. Matson & Co., Chicago.  
Giles, Bro. & Co., Chicago.  
Lloyd & Fritz, Memphis.  
F. L. Davies & Bro., Nashville.  
Baldwin & Co., St. Joseph, Mo.  
Kitts & Werne, Louisville.  
E. Jaccard & Co., St. Louis.  
Edward Mead & Co., St. Louis.  
J. S. Conklin, Detroit.  
E. A. Eaton, Grand Rapids, Mich.  
Geo. Meyer, Oshkosh, Wis.

J. H. Johnson, New York City.  
S. S. Delan, New York City.  
F. D. Barnum, Louisville.  
Geo. E. String, (Successor to E. A. Tyler) New Orleans.  
A. Bahn, Austin, Texas.  
L. A. Kinsey, Cincinnati, Ohio.  
O. L. Rosenkrans, Milwaukee, Wis.  
C. A. Belden, Madison, Wis.  
Sylvester Hogan, Cleveland, Ohio.  
Edward Wood, Bay City, Mich.  
C. C. Childs, Pittsfield, Mass.

Office 170 State Street, Chicago, Room 1.

*N. B.—All Correspondence strictly confidential.*

## WILLIAM BARBER'S Patent Adjustable Eye-Glass.



The above cut represents an Eye-glass possessing the convenience of an Eye-glass and the utility of a Spectacle combined, thereby rendering it practicable for everyone to avail themselves of their convenience, who have heretofore been deprived of their use.

**TRY THEM, WILL RECOMMEND THEMSELVES.**

We manufacture them from Gold, Nickel, Steel, Shell and Rubber.

WILLIAM BARBER,  
Inventor, Patentee and Manufacturer,  
No. 248 North 8th Street, Philadelphia, Pa.

Established 1848.

Reliable and prompt.

**COOPER & BRO.**

Wholesale Jewelers,

Importers and dealers in WATCH & CLOCK-MAKERS' TOOLS and MATERIALS; also, JEWELERS' SUPPLIES, SPECTACLES, OPTICAL GOODS, &c. A complete Outfitting Establishment for the trade.

Repairs Department established 1865. Every description of work done for the trade. Watch Repairing, Jewelry and Watch Case Repairing, Gold and Silver-Plating, and Fire Gilding.

35 S. Fourth St. (1st floor). PHILADELPHIA

**W. H. LUDEMAN,**  
**Chronometer & Watch**  
**MAKER,**  
Nos. 75 & 77 Nassau Street,  
NEW YORK.

Repairing of every Description for the Trade.  
FINE WATCHES A SPECIALTY.

To the Trade.—I am now prepared to cut all kinds of Stem-Winding Wheels for the Trade.

**DAVID PRINCE,**  
**Gold and Silver Refiner,**  
*Assayer and Sweep Smelter,*  
13 and 15 New Jersey Railroad Avenue,  
NEWARK, N. J.

Sole Agent for Comins' Improved Amalgamator

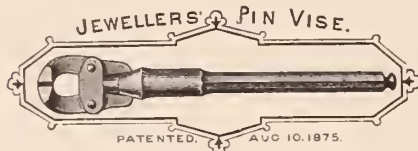

The tool is made of Steel throughout, with the jaws and wearing parts hardened. Every part is made to gauge. The finish is first-class and nickel-plated. Warranted to outwear at least three of the imported pin vises.

Offered in two sizes at \$15 and \$12 per dozen with liberal trade discount. Sold by the jobbing trade generally or by the

LOWELL WRENCH CO., WORCESTER, Mass.

**Vulcanite Jewelry Co.**

MANUFACTURERS OF

**WHITBY JET,**

Combination Whitby Jet and Vulcanite,  
Byron's Patent, May 18, 1869.

Also a full line of Locketts—plain, gold mounted and monogram.

No. 191 BROADWAY, N. Y.

Agents for the NEW RUBBER WATCH CASES,  
Fitting all American Movements.

Designs made and estimates given on all kinds  
of Engraving for Jewelers.

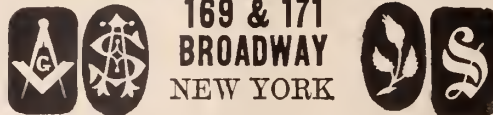

Illustrations for Books, Mfg Catalogues, &c.  
Labels and Show Cards Engraved on Metal for  
Color Printing.

Particular attention paid to Remounting.  
Price list furnished on application.Full line of new and original mount-  
ings on hand.**CHAS. F. WOOD,**

**Engraver, Incruster of Precious Stones**  
**And DIAMOND SETTER.**

Incrusted Goods a specialty.

All kinds of Lapidary Work promptly executed.

Leon Jeanne.

Paul Jeanne.

**JEANNE BROTHERS,**

MANUFACTURERS OF

**DIAMOND MOUNTINGS**  
**And RICH JEWELRY,**

Patentees of Jeanne's Ear Wires,

No. 1 Maiden Lane, New York.

Designs furnished and estimates given.

KETCHAM & McDOUGALL,  
No. 4 LIBERTY PLACE, NEW YORK.  
MANUFACTURERS OF  
Improved Gold and Silver  
**THIMBLES**



AND THE PATENT  
**AUTOMATIC EYE GLASS HOLDER,**  
Which returns the Eye Glasses to their place on  
or under the lapel of the vest by simply casting  
them from the nose, combining all the conven-  
iences of Cord, Hook and Case, without their  
annoyances.

**J. B. LAURENCOT,**

IMPORTER OF

**WATCH GLASSES,**

**Optical and Fancy Goods**

French Clocks, Musical Boxes, &amp;c.

No. 33 MAIDEN LANE.

15 Rue D'Enghien,  
PARIS.Box 2954, P. O.  
NEW YORK.**L. BONNET,**

Medal at Centennial, 1876.

**CAMEO****Likenesses,**

889 Broadway, New York.

**REPAIRING, COLORING AND GALVANI-**  
**ZING FOR THE TRADE.**

C. G. MALLIET,

**Manufacturing Jeweler,**

No. 9 JOHN STREET

NEW YORK.

**FINE HAIR WORK***Deutches Geschäft,*

The only leading personal Artist in Hair in this country.

**WM. ERNEST MOUTOUX,**

Factory and Office, 81 Nassau St., N. Y.

Designs of the most complicated description. Short  
or Baby Hair made in the finest designs in your presence.  
Portraits, or copy of noted paintings, made of family hair.  
I am the only manufacturer who has Medals and Diplo-  
ma of Honor on personal fine work in number for inspec-  
tion.

Lessons given in all branches. Large pattern books for  
the trade. Large hair pictures in other books are copy-  
rights from my book and circulated only by my special  
permit. Prices low.

**The Morse Diamond Cutting Company,**  
J. D. YERRINGTON, Agent.

192 Broadway and 3 John Street.  
NEW YORK.

Rough, Diamonds, Boart, Roses and Brilliants  
for sale.

Fractured Diamonds repaired, and old stones  
improved; also Rough Diamonds cut and  
fashioned to order.

**W. N. WALKER,**  
**DIAMONDS,**

**Watches and Jewelry,**

No. 18 JOHN STREET, NEW YORK.

IMPROVED JEWELERS' COTTON.

JOHN J. ARMOUR.

**HENRY TROEMNER,**  
710 Market Street,  
PHILADELPHIA.

Manufacturer of Fine Gold Scales,

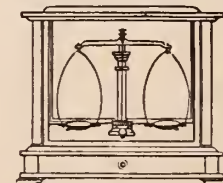

DIAMOND SCALES,

Bullion Balances and  
Weights, in use at all the  
U. S. Mints and Assay  
Offices.

PRICED CATALOGUE ON APPLICATION.

Solid Gold Rings—a Specialty

WM. H. ELY,

**Solid Gold Rings**

MANUFACTURER,

Viz., Plain, Chased, Engraved, Enameled, Engine  
Turned, Shield & Scale. All qualities Warranted  
Orders Promptly Executed.

58 Nassau Street, N. Y.

**EXCELSIOR'S**

Essay on the

**Balance Spring.**

See proceedings of  
Horological Club.

**LORiot & OSTROM**

Manufacturers of

**Clocks and Fine Movements,**

Small Experimental Machinery, Models, Small  
Driving Machinery, &c.

**No. 130 FULTON STREET,**

Corner Nassau Street, **NEW YORK.**  
Fine Lever Movements for Safe Locks a Specialty.

**STERN BROS. & CO.**

Manufacturers of

**Fine Jewelry,**

**30 MAIDEN LANE,**

FACTORY, 73 & 75 Fulton St., **NEW YORK.**

Gold Seal engraved Band-rings and Locketts a specialty.  
The attention of the trade is directed to our plain Gold  
filled Rings Sections of which showing the construction  
and quality sent upon application.  
After February 1st, our plain filled rings will bear the  
above trade mark.

F. W. C. Nieberg,

Repairer and Adjuster of

**FINE WATCHES**

and Marine Chronometers,

**No. 8 JOHN STREET**

New York.

**WADSWORTH'S PATENT ELLIPTIC**



**WATCH CASE SPRING**

Each holder is accurately fitted to the Case, and in  
few minutes the Spring can be adjusted. The Spring  
works evenly from end to end, and without strain or  
wear to the most delicate Case.

The Spring is made of the Finest Steel, Drawn  
and Rolled Hard, which gives it sufficient temper, and  
so adjusted to the Holder that it retains its elasticity. is  
not liable to break, and is superior to all others.

\$1.50 per dozen.

C. W. WADSWORTH, PEESKILL, New York.

GROSS & BEGUELIN, 21 Maiden Lane, N. Y.

L. H. KELLER, 64 Nassau Street, N. Y.

**JNO. F. LUTHER.**

**79 NASSAU ST. N.Y.**

MANUFACTURER OF FINE  
PRESENTATION JEWELS  
FOR ALL SECRET SOCIETIES.  
KNIGHT TEMPLAR'S CROSSES  
KEY STONE MARKS  
SOCIETY SCHOOL AND  
College Badges.

**BOURQUIN BROTHERS,**  
Manufacturers and Importers of Watches,  
WATCHES

All kinds  
of



MADE  
TO ORDER.

**NO. 20 MAIDEN LANE, N. Y.**

FACTORY, BIENNE, SWITZERLAND.

**VOSE & SOUTHWICK,**  
Manufacturers of Gold Jewelry



Sole Makers of  
the Separable  
Sleeve and Col-  
lar Buttons in  
Gold.

**No. 183 Eddy Street, PROVIDENCE, R. I.**

Mansard English Geneve Louis XV.



**HENRY LEFORT,**

Stem-Winding Watch Crown Manufacturer,

Crowns and Pushers in gold, all sizes, quality and color,  
made to order. Silver crowns and pushers always on hand.  
Samples sent on application.

**80 & 82 Marshall Street,  
NEWARK, N. J.**

**ALBERT FRIEDENTHAL,**

Importer and Jobber of

WATCHMAKERS' & JEWELERS'

Materials, Tools and Optical Goods

Real and Imitation Stones,

For Manufacturing and Repairing Purposes  
**A SPECIALTY.**

Agent for TISDALE'S Watch and Clock Oils.

**No. 43 Maiden Lane, New York.**

Orders by mail will receive prompt attention.

**E. A. LAUTEN,**

MANUFACTURERS OF

**MOROCCO, VELVET & SATIN  
CASES**

FOR

Jewelry and Silver Ware.

New Trays for Lace, Shawl and Scarf Pins,  
Novelties in Brocade Silks,

**4 Great Jones Street,**

One door from Broadway, **NEW YORK.**

**Stephen J. Cox**  
DESIGNER & ENGRAVER  
OF  
**WOOD**  
NO. 90 NASSAU STREET  
NEW YORK.  
Jewelers' Work a Specialty.

**COMBINATION**

**Adjustible Watch Key and Magic Pencil**



By pressing on end A  
the adjustable jaws B open  
and will fit any watch. It  
is a combination of Birch's  
patent keys with a Magic  
Pencil, and is secured by  
letters patent dated July  
30, 1878.



The style and size rep-  
resented is made of Rubber  
and 18 k. plate

List, \$30 Per Doz.

**MABIE, TODD & BARD,**

Manufacturers of

Gold Pens, Pencils, &c.

**180 Broadway,**

**NEW YORK.**

**E. HOERNER**  
Manufacturer of Jewelry,  
Diamond and Black ONYX Goods,  
5 Maiden Lane,  
NEW YORK.

**E. WEISKOPF,**

MANUFACTURER OF

**Optical Lenses**

**No. 182 Centre Street, N. Y.**

**SPECIALTY!**

Cylinder and Prismatic Spectacle Glasses,  
Magic Lantern & Panoramic Lenses.

**JEWELRY PHOTOGRAPHED.**

In order to meet the demands of many of the Manu-  
facturers of Jewelry, Silver Ware, &c. (Tiffany and  
others) I have erected a SPECIAL SKYLIGHT, for Mechan-  
ical Photography, viz:

The Copying of Silver Ware, Statuary, Bric-a-Brac,  
Paintings, Models, &c.

I propose to keep it busy by adopting the following  
rates:—8-10. Photographic negative \$1. Proofs 50 cents.  
Special rates for quantities.

**GEO. G. ROCKWOOD, Photographer, 17 Union Squ.**  
Established 1859. (Above Tiffany's.)

**HENRY ABBOTT,**

*Manufacturer of*

**STEM-WINDING PARTS FOR  
WATCHES,**

New Scapements for Watches or Clocks.

Models for Patents. Small Tools for Watch-makers and Jewelers.

Dies, Cutters, &c., made to order.

Fine and Complicated Watches repaired in the best manner, by competent workmen.

**Office, 11 Maiden Lane,  
NEW YORK.**

Factory, 13 & 15 Franklin Sts., Newark, N. J.

*Established 1850.*



**PETER L. KRIDER,**

MANUFACTURER OF

**STERLING  
SILVER WARE,**

Medal and Diploma Awarded, &c.

Striking Society Medals in Gold, Silver or Bronze  
A SPECIALTY!

ARTISAN HALL,

**618 Chestnut Street  
PHILADELPHIA.**

**W. F. TREWIN,**

Manufacturer of

**Watch Cases**

—AND—

**Jewelry.**

Prompt and careful attention given to filling orders for all kinds of goods pertaining to the Trade. Goods sent on approval when satisfactory references are furnished.

Designs and estimates given, and special attention paid to orders from jewelers for Watches, Badges, &c., designed for presentation.

Every description of Watches and Jewelry carefully repaired for the Trade.

**730 Chestnut Street, (up stairs),  
PHILADELPHIA.**

**The Jewelers' Protective Union.**

This organization, which has been in existence over a year, is designed to protect the goods of jewelers while in the possession of travelers. It has been remarkably successful thus far in recovering goods stolen, and securing the punishment of thieves. The Union has adopted the policy of "no mercy to thieves," and intends to follow every thief until the goods he has stolen are returned to the rightful owners and the robber lodged in State Prison. The following is the list of officers and members of the Union, which it will be seen embraces the leading members of the trade.

*President,* Wm. R. Alling. *Sec. and Treas.* Ira Goddard.

*Executive Committee.*

L. A. Parsons, Thos. Slater, S. Oppenheimer,  
Wm. Smith, I. M. Miller.

- Alling Bros. & Co.
- Aiken, Lambert & Co.
- Adams, Thos. W. & Co.
- Brown, Thomas G.
- Baldwin, Sexton & Peterson,
- Bowden, J. B. & Co.
- Barrett, G. B. & Co.
- Bernard, A. & Co.
- Ball, W. H.
- Bass, S.
- Bryant & Bentley,
- Carrow, Bshop & Co.
- Carter, Howkins & Sloan,
- Courvoisier, Wilcox & Co.
- Chamberlain, Samuel W.
- Conover, David F. & Co.
- Coe, Pineo & Stevens,
- Colby & Johnson,
- Dominick & Haff,
- Downing & Keller,
- Eichberg, Samuel,
- Elcox, H. & Co.
- Field & Co.
- Fisher, William M. & Co.
- Freund, Max & Co.
- Fitch, D. M. & Co.
- Goldsmith & Schliesser,
- Goldsohl, M. & Co.
- Gallett, Julien,
- Giles Bros. & Co.
- Herzog, Louis & Co.
- Hcnle Bros.
- Heller & Bardel,
- Hale & Mulford,
- Hopkinson, D. H., Honorary Member.
- Hordenpyl, Tunison & Co.
- Herzog, A. S. & J.
- Hedges, A. J. & Co.
- Haskell, H. C.
- Hodge, Goddard & Co.
- Hirsh Bros.
- Joralemon, A. & Co.
- Kremantz & Co.
- Kronberg, M.
- Kahn' L. & M.
- Koller & Untermeyer,
- Kuhn & Doerflinger,
- Koch & Dreyfus,
- Lorsch, Albert,
- Lyon, Tobias & Son,
- Lyon & Hardy,
- Marx & Weis'
- Miller Brothers,
- Marx, Kossuth & Co.
- Mitchell, Noah,
- Morgan & Headley,
- Moore & Horton,
- Matthewson, J. B. & Co.
- Mulford & Bonnet,

- Matson, N. & Co.
- May & Stern,
- McIntyre, Bedell & Co.
- Neresheimer, E. Aug.
- Oppenheimer Bros. & Veith,
- Owen, G. & S. & Co.
- Pratt, Geo. W. & Co.
- Pollak & Dreyfus,
- Pforzheimer & Keller,
- Richardson, Enos & Co.
- Riley, John A. & Co.
- Randel, Barramore & Co.
- Smith, Wm. & Co.
- Scott, J. T. & Co.
- Shafer, Douglas & Co.
- Saxton, Smith & Co.
- Sterne Bros.
- Strasburger, Louis & Co.
- Spadone & Abel,
- Simons, Bro. & Co.
- Smith, Alfred & Co.
- Speiss & Roswog,
- Sussefeld, Lorsch & Co.
- Spencer, J. E. & Co.
- Sinnock & Sherrill,
- Tiffany & Co.
- Taylor & Bro.
- Wheeler, Parsons & Hayes,
- Wallach, A. & Co.
- Whiting Manufacturing Co.

**GEO. W. DU BOIS,**

(Successor to Albert Landsberg.)



IMPORTER AND MANUFACTURER OF

**Optical Goods,**

**No. 36 MAIDEN LANE,**

Near Nassau Street, NEW YORK

Sole Agent for

**BLACK'S PATENT**

**Interchangeable Spectacles,**

AND  
**EYE GLASSES.**

Jewelers and others who keep spectacles for sale will please observe that, with these PATENT SPECTACLES, it is only NECESSARY to have a full Complete Assortment of Lenses and Pebbles, which being all of a UNIFORM SIZE, will FIT either the Gold, Silver, or Steel Frames, of which but a few of each kind are wanted; an advantage which will give a complete assortment of the finest Spectacles, for one-sixth the capital invested in a like assortment of the same quality goods of the old style frames.

For Particulars, price lists, &c., address

**GEO. W. DU BOIS,**  
New York.

**A New Monogram and Alphabet Album**

**J. SABIN & SONS,**

Respectfully announce, that they have now ready a new edition of their well-known book of Monograms and Alphabets.

Engravers, Stationers, Carriage Painters, Jewelers, Gold and Silver Smiths, and Designers and Decorators generally, will find this book useful, saving time in drawing, and having available a book of suggestion and reference. A double set of Monograms is included, a number of Alphabets, also a few Heraldic Designs, Crests, Casques, &c.

Printed on fine plate paper, and bound in cloth, . . . . . \$5.00

We print but a small edition, and early orders are suggested.

"All we have done in this art would be hopeless y eclipsed by the publication of J. Sabin & Sons; as a contribution to a jeweler's stock of designs, it is priceless"—*Jewelers' Circular.*

**J. SABIN & SONS,**  
No. 84 Nassau Street, New York.

One Organization!      One Management!      One Interest!

---

VOLUMES ISSUED QUARTERLY.

---

☞ SHEETS OF CHANGES SEMI-WEEKLY.      CONSTANT REVISIONS AND PROMPT  
NOTIFICATIONS TO SUBSCRIBERS.

**BRADSTREET'S**  
**Improved Mercantile Agency.**

---

We spare no effort to make our work complete, comprehensive and reliable in all its features, and endeavor to anticipate the wants of our patrons. Many improvements have been recently incorporated which have never heretofore appeared in any Commercial Reports. The compilation of the Collection Laws, which we have printed under the State headings, has been made by representative attorneys, and may be relied upon. We believe this feature will be appreciated by all who have occasion to grant credits covering different sections of the country. Inasmuch as our books are published quarterly, we shall be able in future to give any amendments to these laws down to the very latest date.

We have also introduced under each town or village head concise information, showing its actual or relative position—whether on a railroad, steamboat or stage route—the population, and whether a telegraph, express, or money order office, and if without a bank or banker, the nearest place where collections can be sent. As a Shipping as well as Collecting Guide, this will be almost invaluable, it being more comprehensive, and we intend it shall be more reliable than any published otherwise. We have also tabulated the Banks and Bankers throughout the United States and Canada, giving their capital, etc., as well as their New York correspondent, which we shall publish appendix to each volume, retaining however, the names as they appear at present under their respective town or city as an in the regular volume.

From the commencement of the business down to the present day, this Agency has never failed for an hour to fulfil its contracts with subscribers, and its volumes of Reports, as also Sheets of Corrections, have been issued with a regularity and punctuality as positive as the day of the week or the month of the year. It has survived the severe and *unjust criticisms* of those who had no confidence in the system or in its ability to do what was claimed for it, as also the aspersions of *jealous competitors*, while its pronounced success is the best evidence that it has fulfilled the purposes for which it was established.

It has been from its inception the progressive Agency of the land, but especially since it came under its present management has it made rapid strides, always endeavoring to anticipate the wants of the mercantile community. Having no entangling alliances, owning and controlling its vast business in all its ramifications, it is presented to the commercial world to day as the best exponent of a system which the peculiar characteristics of the country and people have made a necessity.

Relying solely on the merits of our work, we respectfully solicit an examination of our system, with the assurance of our ability to substantiate all we claim, and with the knowledge that it is worthy of the earnest consideration of every grantor or credit.

**CHAS. F. CLARK, President.**



**SIMONS' BROTHERS & CO.**  
 MANUFACTURERS OF  
 Gold Chain and Jewelry.  
 611 & 613 Sansom Street,  
 PHILADELPHIA.  
 Awarded Medal and Diploma at the Centennial.

GEO. W. SIMONS,  
 JOHN F. SIMONS,

PETER B. SIMONS,  
 GEO. W. SIMONS, JR.

JOHN SPECKER,  
 FRED. M. SIMONS.

**Simons' Brothers & Co.**  
 611 & 613 Sansom Street, Philadelphia

Established 1853.

**L. H. KELLER & CO.**

Successors to G. A. HUGUENIN,

IMPORTERS OF

**Fine Watch and Clock Materials,  
 SWISS, ENGLISH, FRENCH & GERMAN  
 FILES, TOOLS, &C.**

FOR WATCH MAKERS, WATCH CASE MAKERS, JEWELERS,  
 SILVERSMITHS, ENGRAVERS, CHASERS, DIE  
 SINKERS, MACHINISTS, &c.

SOLE AGENTS FOR HALL'S STAKING TOOLS AND  
 ROLLER REMOVERS.

**AGENTS FOR THE WHITCOMB AND OTHER AMERICAN LATHES.**

GENERAL AGENTS FOR THE PHILADELPHIA  
 WATCH COMPANY.

American Agents for the Horological Journal, (British).

A Monthly Paper for the advancement of Chronometer, Watch and Clock Making,  
 and kindred Sciences. Published under the auspices of the British Horological  
 Institute, London. Subscription \$2.50 per year, in advance. Also,

SAUNIER'S TREATISE ON MODERN HOROLOGY, IN  
 THEORY AND PRACTICE.

BY M. CLAUDIUS SAUNIER. The English Edition will appear in 26 monthly parts,  
 Price 50 cents each. Whole Work, \$13 00, postage paid.

Special attention is directed to

**"OUR OWN" Celebrated Mainsprings Graduated**

n thickness to equalize the power, with well rounded edges, and the  
*Highest Crocus Finish throughout*, insuring the least possible friction  
 in the barrel, pronounced by expert judges to be the *best made*  
 "JURGENSEN" Main Springs recoiling, suitable for the highest grades  
 of Swiss Watches.

**"Lutz" Celebrated Hair Springs,**  
 by numbers, of uniform diameter and strength, the best for "BRE-  
 GUETING."

Fine Hole Jewels of Ruby, Sapphire, Chrysolite, Garnet, Beryl and  
 Aqua Marine, with *gauged* (well shaped and polished) holes, numbered  
 by the Swiss pivot gauge; also, neat black walnut cases, containing  
 forty glass vials for assortments of same. The great advantage in hav-  
 ing Jewels by numbers will readily be seen as a saving in time and an-  
 noyance in selecting and in expense. Dealers once having an assort-  
 ment, can replenish or stock up at a comparatively small outlay, as any  
 desired quantity of No. and quality can be had of us at all times,  
 our stock of jewels being the largest and most complete in the country.

Diamond Charged Broaches for opening and polishing jewel holes.

Diamond Powder and Bort for polishing and grinding 8 different  
 grades, in  $\frac{1}{2}$ ,  $\frac{1}{4}$ ,  $\frac{1}{8}$ , and  $\frac{1}{16}$  K vials, bringing it into the reach of all.

Gold Diamond Set and other fine Geneva Hands.

The new Drills in Sets of 54 small, 126 small to medium, and 48  
 large; also, sold separately if desired.

NOTE.—We issue no Price Lists and Highly Illustrated Catalogues  
 to attract attention of Dealers to a large assortment of goods in print,  
 but we have the goods in stock and will be pleased to quote prices  
 if desired, or fill orders for any article in our line.

**No. 64 Nassau Street,**

Near Maiden Lane,

**NEW YORK.**

Medal and Diploma of Merit  
 Awarded by Centennial Com.

**S. C. JACKSON,**

MANUFACTURER OF FINE

**CASES**

For Jewelry, Silver Ware,  
 Trays, &c.

180

**BROADWAY  
 NEW YORK.**



**SPECIAL NOTICES.**

**SITUATION WANTED**—By a Watch, Clock and Jewelry Repairer. can also do engraving. Good reference given. Address Adolph Hahn, Sheboygan, Wisconsin.

**FOR SALE**—A new Double Door Fire Proof Safe, two Walnut Side Cases, one imitation Walnut Side Case, one portable Work Bench, Railing and Glass with Gate, one large-sized Silver Plated Watch Rack, Steam Engine and Boiler (½ horse power), one veneered Regulator Case hangs on wall) one Lathe, Wheel and Treadle complete; will sell cheap for cash, or will exchange for Watch Cases and Movements, or other desirable goods. Address Jeweler, N. W. corner Maine and 6th Streets, Quincy, Ill.

**SITUATION WANTED**—By a young man, of nine years experience at the bench, and as salesman; has good tools; can furnish good references. Address, E. B. White, Box, 215, Thomaston, Maine.

**FOR SALE**—A Balance Wheel treddle for jewelers' lathe; entirely new; nothing wrong with it; was not heavy enough for the work I got it for. Cheap for cash. Ed. L. White, Wadsworth, Ohio.

**WANTED**—A first class Watch Maker, who is competent to handle the finest class of work; reference for honesty and ability required; to such a person steady employment and good wages will be paid. Address P. F. Eagan, manager of D. C. Greenleaf's, 77 East Third Street, St. Paul, Minn.

**FOR SALE**—A splendid new cutting machine with complete set of cutters, suitable for cutting watch and clock wheels. Will be sold at a sacrifice. Address L. & A. Mathey, No. 16 Maiden Lane.

**HAVING** given up the jobbing trade, we have about \$2,000 worth of watch tools, materials, glasses, &c., in convenient chests of drawers, which we will exchange for any merchandise suitable for a retail jewelry store, or a bargain for cash. Address Edward Mead Co., cor. 4th street and Washington Avenue, St. Louis, Mo.

An opportunity is offered to an active business man with a cash capital of eight to ten thousand dollars to buy the whole or a half interest in a jewelry store having a well established trade, and one of the best retail stands in St. Louis. For further information address F. K. Shepherd, 2911 Sheridan Avenue, St. Louis, Mo.

**WANTED**—By a competent workman, a position as repairer of fine watches. Understands adjusting. Address G.. care this office.

**FOR SALE**—An old established jewelry store in New Orleans, together with stock and fixtures. Will be sold on easy terms to a responsible party. This is one of the oldest and best known stores in New Orleans, and has a good run of custom. Satisfactory reasons for selling. For particulars address New Orleans, care JEWELERS' CIRCULAR, 42 Nassau Street, N. Y.

**\$175.00** will make you a practical watchmaker, enabling you to make \$25 per week. Those having the cash and mean business need only address T. A. Ninto, Waltham, Mass.

**FOR SALE**—In a flourishing Ohio town, a jewelry store, business, &c., that has paid to its owner \$1,000 per year above all expenses (both store and family) for the last six years. Fixtures new; clean and desirable stock. Good run of work, and sales as good as times will admit of. Good reasons for selling. Address O. B., Box 29, Bellefontaine, Ohio.

**FOR SALE**—A first-class jewelry store, in a flourishing town on the Hudson, with about 7,000 inhabitants one hour's ride from New York. No other jewelry store within a circuit of several miles. Satisfactory reasons for selling. For particulars address M. Schendler, Tarrytown, N. Y.

**TO LET**—A very desirable Jewellers' Factory, size, 50x50 feet. Excellent light, steam power, heating and elevator. First-class in every respect. Also part of front office on first floor if desired. Will be rented to a good party at a very low rate. John A. Riley & Co., Nos. 7 and 9 Bond Street.

**GEO. E. WILKINS**—Importer of fine Tools for Watchmakers, cutting and dividing engines, rounding up tools and cutters, also cutters for stem winding wheels. Fine lathes with the American system of chucks. Dividing engine and rounding up tool combined. Marine chronometers for sale. Special tools imported to order. 21 South Salina St., Syracuse, N. Y.

**FOR SALE**—Tools, material and small stock of jewelry in one of the best railroad towns in Western Minnesota. Splendid chance for a beginner with about \$350 cash. Address at once, Harry Saunders, Box 182, Redwood Falls, Minn. ta.

**SITUATION WANTED**—By a young man, three years' experience in the watchmaking and jewelry trade. Can give unexceptional references. Address H. L. Kohler, Pomeroy, Ohio.

**FOR SALE**—Four Jewelers' Safes—Herring's make. Dimensions—height, 64 inches; width, 51 inches; depth, 13 inches. These safes were made expressly to order and fitted up for the jewelry business. Combination locks and all the late improvements to make them secure against burglary. Will be sold at a sacrifice. Chatterton & Dodd, 19 John Street.

**A COMPETENT WATCHMAKER** and jewelry jobber (German parentage), 18 years experience, wishes to change position. Good recommendations. Willing to go anywhere if steady employment is guaranteed. Address G. S., P. O. Box 121, Auburn, N. Y.

Leopold Weil, for several years a popular salesman on the road, has established himself in business in the Lane, and displays a fine selection of reliable rolled plate novelties.

**Buyer's Directory.**

A Guide to the prominent Wholesale Houses in the Watch, Clock, Jewelry and kindred branches of Trade in New York, Philadelphia, Chicago, Providence and Newark.

**NEW YORK.****Bohemian Garnet Jewelry.**

**Bissinger, Philip**—Importer of Diamonds, Pearls and Precious Stones. Sole Agent for the Bohemian Garnet Jewelry, 22 John St.

**Clock Companies.**

**New Haven Clock Co.**—62 Reade Street, N. Y.

**Seth Thomas Clock Co.**—20 Murray Street, N. Y.

**Waterbury Clock Co.**—M. Bailey, Treasurer, Manufs. and Jobbers, No. 4 Cortlandt Street, N. Y. and No. 197 State Street, Chicago.

**Kroeber, F.**—Manufacturer and Dealer in American and French Clocks, No. 8 Cortlandt St.

**Corals and Coral Jewelry.**

**Errico Bros.**—Importers of Coral, Conch-Shell and Silver Filigree Jewelry, etc., 19 John St.

**Lawson, S.**—Manufacturer of Coral and Black Onyx Jewelry. All kinds of repairing solicited. Goods sent on Mem. 63 Nassau Street.

**Squadrioli, Ach.**—Manufacturer and Importer of Coral, Conch Shell and Silver Filigree, etc No. 9 Maiden Lane, N. Y.

**Cameo Cutters, Etc.**

**Bonet, L.**—(Successor to Bernard & Bonet), Cameo Likenesses, 889 Broadway, N. Y.

**Wiederer, Peter**—Late Habermeier & Wiederer, Engravers of Cameo Likenesses, Seal Stones. Cameos repaired. 23 John St.

**Charms & Gold Watch Keys.**

**Rupp & Held.**—Manufacturing Jewelers, Charms and Gold Watch Keys, with French and English Ratchets, a specialty. 15 John st., N. Y.

**Cutlery.**

**Rogers Cutlery Co.**—Hartford, Conn.

**Harrison Bros. & Howson.**—Manufacturers of Fine Ivory and Pearl Table and Pocket Cutlery; Carvers in Cases; Nutpicks, Nutcracks and goods suitable for the jewelry trade. 26 Cliff street. W. C. Burkinshaw, Sole Agt.

**Diamonds.**

**Anderson, Otis**—Diamond Merchant and Broker, always ready to pay cash for bargains in Diamonds and Precious Stones, No. 9 Maiden Lane, N. Y.

**Bernhard, A. & Co.**—Manufacturing Jeweler & Importers of Diamonds and Precious Stones, also Diamond Mountings, No. 169 Broadway, Gilsey building.

**Bissinger, E.**—Importer of Diamonds, No. 192 Broadway, New York.

**Bissinger, Philip**—Importer of Diamonds, Pearls and Precious Stones. Agent for the Bohemian Garnet Goods No. 22 John St., N. Y.

**Buckenham, Cole & Saunders**—Importers of Diamonds and other Precious Stones, No. 10 Maiden Lane, N. Y.

**Fera, Henry**—Importer of Diamonds, and Manufacturer of Fine Diamond Jewelry. No. 9 Maiden Lane, New York. Amsterdam, Holland, 23 Loojersgracht.

**Herbert, R. J.**—Importer and Broker in Diamonds, 24 John Street.

**Hedges, Wm. S. & Co.**—Importers of Diamonds, No. 170 Broadway.

**Lyon & Hardy.**—Importers of Diamonds and Manufacturers of Diamond Jewelry. 30 Maiden Lane, New York.

**Neresheimer, E. Aug.**—Importer of Fine Diamonds, No. 21 Maiden Lane, New York.

**Smith, Alfred H. & Co.**—Importers of Diamonds, No. 14 John Street.

**Diamond Cutters.**

**The Morse Diamond Cutting Co. of Boston.**—Henry D. Morse, General Manager. N. Y. Office, 192 Broadway, corner John street. J. D. Yerrington, Agent.

**Diamonds and Diamond Jewelry.**

**Bissinger, Philip.**—Importer of Diamonds, 22 John street, N. Y. Agent for the Bohemian Garnet Goods.

**Bornemann, Louis**—Manufacturer of Diamond Jewelry from original designs, 169 and 171 Broadway.

**Heller & Bardel.**—Manufacturers of Diamond and Pearl Jewelry, and dealers in Diamonds Pearls, &c. Also agents for Boss' Patent Stiffened Gold Watch Cases. 13 John Street, N. Y.

**Prager, Morris.**—Importer of Diamonds and Fine Diamond Jewelry 8 Maiden Lane, New York.

**Taylor & Brother**—Importers of Diamonds and Diamond Jewelry, 676 Broadway.

**Diamond Setters, Etc.**

**Asher, J.**—Jeweler and Diamond Setter, Precious Stones Inlaid and Incrusted with Diamonds, Nos. 880 and 882 Broadway.

**Blancard & Oberlander**—Manufacturers of all kinds of Settings and Galleries of any carat of Gold, Silver, Platinum and Platinum Lined. Send for sample cards. 36 and 38 John street, N. Y.

**Wood, Chas. F.**—Engraver and Incruster of Precious Stones and Diamond Setter. No. 169 & 171 Broadway.

**Friend, S.**—Manufacturer of Fine Jewelry, and Diamond Setter, 33 John street, N. Y.

**Dials, &c.**

**Caesar Brothers**—Manufacturers of Enameled Clock Meter and Gauge Dials, Patent Door, Coffin and Pew Plates, Druggists' Labels, &c. No. 32 and 34 John Street.

**Gold, John T.**—(Successor to the late T. Gold), Enamel Watch Dial Maker, 81 Nassau St.

**Enamellers, Etc.**

**Nutt, J. D.**—Enameler on Gold, Silver and Copper, 32 and 34 John St. Birds, Flowers, etc., Enameled in colors.

**Orr, Jas. C.**—Enameler on Fine Jewelry, Flowers, Birds, &c., Enameled in colors. Band Bracelets (a specialty). 77 Nassau Street.

**Electroplaters, &c.**

**Jeandheur, F. & Son.**—Gold and Silver Electro Platers & Fire Gilders, coloring Russian and Gold Jewelry a specialty. 117 Fulton St.

**Engravers and Die Sinkers**

**Fackner, Edward**—Carver, Engraver and Chaser on Jewelry and Pencil Cases. Monograms Lettering, &c. 19 John Street.

**Schuller, J. Dan'l**—Stone Seal Engraver Arms Crests, Initials and Monograms engraved on Stone Seals, &c. 71 Nassau street.

**Fancy Goods, Clocks, Bronzes Etc.**

**Hall, Nicoll & Granbery**—Importers of Clocks, Bronzes, Folding Mirrors, Fancy Goods, etc. 20 and 22 John Street, New York.

**Hinrichs, C. F. A.**—Importer and Dealer in French, English and German Fancy Goods, etc., etc. 29, 31 & 33 Park Place, N. Y.

**Magnin, Ve J. Guedin & Co.**—Importers of Clocks Bronzes, Musical Boxes & Rich Fancy Goods etc., 29 Union Square.

**Le Boutillier & Co.**—Importers of Fancy Goods, Clocks, Bronzes, &c. 3 Union Square

**Gold Chains, Etc.**

**Beck, J. & Son.** Manufacturers of Fine Gold Chains and Chain Bracelets, 10 Liberty place, near Maiden lane, N. Y.

**Dorrance, Edge & Co.**—Manufacturers of the Celebrated Woven Fabric Gold Chain, No. 9 John street.

**Hamiltons & Hunt.**—Manufacturers of Fine Plated Chains and Patent Buckle Bracelets. Branch office, 176 Broadway. Factory, 226 Eddy -tree, Providence.

**Kaufmann Bros.**—Manufacturers of Gold Chains, and Chain Bracelets, 26 John street; Factory, 331 and 333 Bowery, N. Y.

**Nord & Schlag.**—Manufacturers of Gold Chain. No. 366 Broome St., N. Y.

**Saxton, Smith & Co.**—Manufacturers of Fine Gold Chain. 15 Maiden Lane.

**Gold Pens, Etc.**

**Aikin, Lambert & Co.**—Manufacturers of Choice Gold Pens, Cases, Holders, Toothpicks, etc., 12 Maiden Lane, N. Y.

**Mabie, Todd & Bard.**—Manufacturers of Gold Pens, 180 Broadway.

**Todd, Edward & Co.**—Manufacturers of Gold Pens, Pencil Cases, Tooth Picks, &c., 652 Broadway, N. Y. Factory, Brooklyn.

**Goldsmiths, &c.**

**Greene Wm. C. & Co.**—Goldsmiths; Manufacturers of Rich Sets in Taper Wire Coral. Office, 18 John street.

**Gold Rings.**

**Bowden, J. B. & Co.**—Manufacturing Jeweler.—Solid Gold Rings a specialty, 1 Maiden Lane.

**Ely, W. H.**—Manufacturer of Solid Gold Rings of every description. No. 58 Nassau Street.

**Frankel & Torart.**—Manufacturers of Seal, Cameo and Amethyst Rings a specialty. Also a full line of Gold White Stone Goods and Diamond Settings. 192 Broadway, N. Y.

**Peckham, Wm. H. & Co.**—Manufacturers of Solid Gold seamless Rings and Fancy Embossed Rings, Patent Spectacles, Jewelry, etc., No. 4 Liberty Place.

**Sinnock & Sherrill**—Manufacturers of Stone Rings. No. 5 Maiden Lane, N. Y.

**Tingley, Joseph N.**—Manufacturer of Stone Rings and novelties in Stone Goods. No. 9 Maiden Lane, N. Y.

#### Hair Jewelry.

**Montoux, W. E.**—Fine Hair Work a specialty. 81 Nassau Street, N. Y.

**Sauter, L.**—Manufacturer of Fine Gold and Hair Jewelry and Device Work. Nos. 65 & 67 Nassau Street.

**Schwencke O.**—Manufacturer of Fine Hair Jewelry. Orders from the country promptly attended to. No. 43 Maiden Lane.

#### Jewelry Cases, Fancy Boxes, Etc

**Braun, Chr. E.**—Manufacturer of Jewelry Boxes, Trays for Show Cases, &c., 62 Chatham st.

**Clark, J. M.**—Manufacturer of Pen and Pencil Cases for the wholesale trade only. No. 61 Hudson Street, N. Y.

**Loehr & Koerner**—Manufacturers of Morocco, Velvet, Satin, Jewelry, Watches and Silverware Cases, Glove, Handkerchief, Ladies' Jewel, Work Boxes, &c., Fancy Trays and Store Fittings to order, Office and Salesroom 96 John Street, New York.

**Dahlem, W.**—Manufacturer of Cases for Jewelry and Silverware, No. 85 Nassau Street, N. Y. Show Case Trays, &c., at shortest notice.

**Wiggers & Froelick**—No. 60 Nassau street.—Manufacturers of Cases for Jewelry, &c., of every description. Trays for Show-cases, Stands for Show-windows, etc. Jewelers' Traveling Cases, light, convenient and strong.

**Jackson, Samuel C.**—Manufacturer of Box and Trays, for Silverware, Watches, Jewelry &c. 180 Broadway, N. Y.

**Sturm, I.**—Manufacturer and Importer of Cases for Jewelry, Watches, Silverware, &c. No. 15 John street, N. Y.

**Welch & Miller**—Manufacturers of Morocco, Velvet, and Satin Jewelry Cases, Trays, &c. Telescope Simple Cases with flexible Trays. Complete stock on hand. 169 Broadway.

#### Jewelry—Fine.

**Aikin, Lambert & Co.**—Manufacturers. General stock of Reliable Jewelry, 12 Maiden Lane.

**Alford, C. G. & Co.**, Manufacturers. General line fine and reliable goods. Specialties in Onyx goods and chain. 183 Broadway, New York.

**Andrews, J. F.**—Manufacturer of Fine Jewelry, Locket, Sleeve Buttons and Rings in Stone Cameo, etc., a specialty. 35 Maiden Lane.

**Baldwin, Sexton & Peterson**,—Manufacturers Fine Jewelry. Whiting Building, Broadway and Fourth street.

**Ball, Wm. H.** Manufacturing Jeweler. Fine Gold Bracelets a Specialty. No. 9 John St., N. Y.

**Barthman & Straat**—Manufacturers of Fine Jewelry. Seal and Stone Rings a Specialty Orders promptly attended to. 41 Maiden Lane.

**Bernhard, A. & Co.**,—Manufacturers of Fine Hair Jewelry and Device Work. The latest styles. 2 Maiden Lane, New York.

**Bissinger, E.**—Importer of Fine Jewelry, Locket, Crosses, Neck Chains, &c., No. 192 Broadway.

**Brown, Thos. G.**—Manufacturer of Rich Jewelry Necklaces, Locket, Bracelets, Sleeve Buttons, etc., 9 Bond street, N. Y.

**Bryant & Bentley**—Manufacturing Jewelers Rings a specialty. 12 Maiden Lane.

**Brainerd & Steele**—Successors to Brainerd, Steele & Co., Manufacturers of Fine Jewelry and Brainerd's Patent Locket. No. 9 Maiden Lane, New York.

**Burch, Geo. & Co.**—(Successors to Burch, De Mott & Coughlin.) Manufacturing Jewelers, 17 Maiden Lane, N. Y. Factory, Newark, N. J.

**Carrow, Bishop & Co.**—Manufacturers of Fine Jewelry, Roman Band Bracelets, Locket, Crosses, &c. 12 John Street, N. Y.

**Carter, Howkins & Sloan.**—Manufacturing Jewelers, Whiting Building, 4th St. & Broadway

**Chatellier & Spence**,—Manufacturing Jewelers. No. 652 Broadway, N. Y.

**Champenois & Co.**—Manufacturing Jewelers, No. 1 Maiden Lane. Specialties—Jet Cluster Goods in Sets and Sleeve Buttons, Engraved and Enameled Goods in Sets, Studs, Sleeve and Collar Buttons, Lace, Shawl and Cuff Pins, Ear Knobs and Crosses.

**Cook, Groeschel & Co.**—Manufacturers of Fine Jewelry and Locket, 191 Broadway (over Mercantile Bank,) N. Y.

**Coe, Pinneo & Stevens.**—Manufacturers of Fine Jewelry, Fine Gold Locket and Linen Finished White Enameled Goods a Specialty, No. 9 Maiden Lane, N. Y.

**Demmert Bros.**—Manufacturers and Importers of Fine Jewelry, Cameo and Onyx Locket, Sleeve Buttons and Sets a specialty. Old No. 9 Maiden Lane, New York.

**Field & Co.**—Manufacturing Jewelers, 8 Maiden Lane, N. Y.

**Goddard, John M.**—Manufacturing Jeweler,—Seal Rings and Fine Locket a specialty, No. 3 Maiden Lane, N. Y.

**Frankel & Folkart.**—Manufacturing of Seal, Cameo and Amethyst Rings, a Specialty. Ladies' and Gents' Locket, Cameo Sets, &c. Also a full line of Diamond Settings, 21 John street, N. Y.

**Greason, Bogart & Pierce**, successors to Arthur, Rumrill & Co., 182 Broadway, manufacturers of fine jewelry and gold chains

**Hartmann, P.**—Manufacturer & Importer of Fine Gold, Diamond, and Filagree Silver Jewelry, No. 36 Maiden Lane. P. O. Box 2,454.

**Haskell, H. C.**—Manufacturing Jeweler. Seal Rings a specialty. Special attention to Jobbing of every description. 12 John street.

**Hunt & Owen.**—Manufacturing Jewelers. Office 5 Maiden Lane.

**Hale & Mulford.**—Manufacturers Rich Jewelry, Whiting Building, Broadway and 4th Street.

**Jeanne Brothers.**—Manufacturers of Diamond Mountings & Rich Jewelry. 1 Maiden Lane.

**Keller, Chas. & Co.**—Manufacturing Jewelers Locket a Specialty. No. 13 John St., N. Y.

**Kremetz & Co.**—Manufacturing Jewelers, No. 13 John Street, N. Y.

**Kroll, H.**—Manufacturer of Fine Jewelry. Repairing (a specialty) done for the trade at moderate prices, 78 Nassau street.

**Kuhn & Doerflinger**—Manufacturers of Enamel'd and Roman Band Bracelets, also Fine Locket and Pendants, 18 John street.

**Lennon, John D.**—Manufacturing Jeweler, 142 Fulton street. Flat, and Half-round Gold Bracelets, Roman and Stone Locket.

**Moore & Horton.**—11 Maiden Lane, Manufacturing Jewelers, Rings, Studs, Collar and Sleeve Buttons, Pins, Ear-rings, &c.

**Mitchell, Noah.**—Manufacturer of Fine Gold Jewelry, 694 and 696 Broadway, N. Y.

**Miller Bros.**—Manufacturers of Fine Jewelry Locket, Sleeve Buttons, Studs, etc., etc. 11 Maiden Lane, New York.

**Mulford & Bonnet**—Manufacturing Jewelers and Jobbers, 21 & 23 Maiden Lane, N. Y. Particular attention given to Jobbing and Special orders.

**Marx Kossuth & Co.**—Manufacturing Jewelers. 39 Maiden Lane.

**Owen, G. & S. & Co.**—Manufacturing Jewelers. Office, No. 5 Maiden Lane.

**Pendrill, Wm.**—Manufacturer of Fine Jewelry, jobbing and repairing for the trade at low rates, 73 Nassau Street.

**Riker, William**—Manufacturer of Jewelry. Inlaid Gold Jewelry a Specialty. No. 5 Maiden Lane, N. Y.

**Riley, J. A. & Co.**—Manufacturing Jewelers, Etruscan Gold and Coral Sets, Roman Bracelets, Necklaces, etc. Onyx Goods a specialty. 7 and 9 Bond street, New York.

**Richardson, Enos & Co.**—Manufacturers of Fine Gold Jewelry, Gold Chains, Locket, Crosses and Necklaces. Colored and Etruscan Work. No. 23 Maiden Lane, New York.

**Richardson, J. W. & Co.**—Manufacturers of Jewelry, Masonic and other emblems. 196 Broadway, Manufacturing, Providence, R. I.

**Sexton & Cole**—Manufacturing Jewelers, Colored Gold and Onyx Goods a specialty. No. 30 Maiden Lane.

**Shoemaker & Co.**—Manufacturing Jewelers, Cameo Buttons, and Locket, Roman Gold Goods, etc. No. 21 Maiden Lane, N. Y.

**Stites, E.**—Manufacturer of Fine Jewelry. No. 12 Maiden Lane, N. Y.

**Sturdy Bros & Co.**—Manufacturers of Jewelry. General line of fine and heavy Rolled Plate Goods. Specialties—enameling on gold plate; graduated wire coral work. 14 Maiden Lane, N. Y.

**Terhune, Charles F.**—Manufacturing Jeweler, 16 Maiden Lane, N. Y.,

**Thoma, Ernest**—Manufacturer of Fine Jewelry. Sleeve Buttons, Rings, Ear-rings, &c. No. 173 Broadway, N. Y. Factory, Hackensack, N. J.

**Tri-r Bros. & Co.**—Jewelry. Optical, Rubber, Jet, Shell, Ivory, Amber and Pearl Goods. Silk Guards, Japanese Bamboo Watch Chains a Specialty. No. 15 Maiden Lane.

**Vulcanite Jewelry Co.**—Manufacturers of Whitby Jet and Vulcanite Jewelry, 191 Broadway, N. Y.

**Wadsworth, E. E.**,—Manufacturer of Rich Jewelry and fine Rolled Plate. Fine Seal Rings a specialty. 35 Maiden Lane.

**Wheeler, Parsons & Hays.**—Manufacturers of Fine Jewelry, Watch Cases, Gold Chains, &c and Dealer in American and Swiss Watches, No. 2 Maiden Lane, N. Y.

**Wienhold, Joseph**—Manufacturer of Fine Jewelry and Diamond Setter. 24 John St.

**Woglom & Miller**—Manufacturing Jewelers Nos. 32 & 34 John street, N. Y. Specialty, Black Onyx goods.

#### Jewelers' Boxes.

**Frasse & Co.**—Importers of Stubs, French, Swiss, German and Sheffield Tools, Files and Steel Wire for Watchmakers, Jewelers, etc., 62 Chatham street, N. Y.

**Hammel, L. & Co.**—Importers of Materials and Tools for Watchmakers, Jewelers and Engravers—also Optical Goods, &c., 9 Maiden Lane, N. Y.

#### Lapidaries.

**Kordmann & Michel**—Lapidaries, dealers in Precious Stones. Rubies, Sapphires and Peridots cut. No. 32 Maiden Lane.

#### Musical Boxes.

**Paillard, M. J. & Co.**—Importers & Manufacturers of Musical Boxes, No. 680 Broadway, N. Y.

#### Opticians.

**Burbank Man'g Co.**—Manufacturers of Spectacles and Eye Glasses of all descriptions, in gold, silver, etc., 14 Maiden Lane, N. Y.

**Du Bois, Geo. W.**—Successor to A. Landsberg, Importer and Manufacturer of Optical Goods 36 Maiden Lane, Box 3993, N. Y.

**Hammel, L. & Co.**—Importers of Spectacles, Opera and Marine Glasses, Telescopes, Microscopes, Optical & Fancy Goods, 9 Maiden Lane.

**Laurencott, J. B.**—Importer of Watch Glasses, Optical and Fancy Goods, Clocks, Bronzes, etc., 33 Maiden Lane, N. Y.

**Lorsch, Albert**—Manufacturer of the Patent Accommodating Spectacles and Eye Glasses in Gold, Silver and Steel, and other Optical Goods, 37 Maiden Lane, N. Y.

**Serin, A.**—Manufacturer of Spectacles and Eye-Glasses, in Steel, Shell and Rubber. Repairing of all kinds. Opera Glasses covered and re-gilt, etc. 169 and 171 Fulton street.

**Spencer Optical Manufacturing Co.**—Gold, Silver, Steel and Nickel Plated Spectacles, Eye Glasses, &c. 13 Maiden Lane, N. Y.

#### Precious Stones, &c.

**Bissinger, Philip**—Importer of Diamonds, Pearls and Precious Stones. Agent for the Bohemian Garnet Goods. No. 22 John St., N. Y.

**Gruet, Jules.**—Importer of Precious and Imitation Stones, Amethysts, Topazes, Cameos, Garnets, Doublets, Imitation Diamonds, Pastes, etc., No. 14 John street. Manufactory at Septmoncel, France.

**Meyer, Francis Ed.**—Successors to John B. Behrmann, Importer of Imitation Precious Stones, all sizes and shapes constantly on hand. No. 38 Dey street, P. O. Box, 1981.

#### Silverware.

**Gorham Manufacturing Co.**—Union Square.

**Wood & Hughes.**—Manufacturers of Fine Silverware. 14 John Street, N. Y.

**The Adams & Shaw Co.**—Manufacturers of Silverware. Cor. Broadway & 4th St., N. Y.

#### Silver Plated Ware.

**Brown & Bros.**—Manufacturers of first quality of Electro Plated Flat Table Ware. No. 81 Chamber Street, N. Y.

**Hall, Elton & Co.**—Manufacturers of the Finest Electro-Plated Ware, salesroom, 75 Chambers street, N. Y.



**Holmes, Booth & Haydens**—Manufacturers of Silver-plated Ware. 47 Chambers street.  
**Meriden Britannia Co.**—Manufacturers of Silver plated Ware, Union Square, N. Y.  
**Middletown Plate Co.**—Manufacturers of Superior Electro-Plate. Factories, Middletown, Conn., Salesroom, 13 John Street  
**Manhattan Silver Plate Company.**—Manufacturers of every description and quality of Silver Plated and Bronze Ware, office No. 952 Broadway. Factory 382 to 390 21 Ave.  
**Rogers Cutlery Co.**—Hartford, Conn.  
**Reed & Barton**—Manufacturers of Fine Plated and Table Ware, of every description, 686 Broadway, N. Y.  
**Rogers & Bro.**—Manufacturers of the finest quality of Electro-Plated Ware. 690 B'way.  
**Simpson, Hall, Miller & Co.**—Manufacturers of Fine Silver Plated Ware, No. 26 E. 14th St.  
**Schade, Henry.**—Manufacturer of White Metal and Plated Ware, No. 84 John Street, New York. Price list and catalogue furnished on application.  
**Veil, Leopold.**—Manufacturer and dealer in Rolled Plate Jewelry. No. 16 Maiden Lane.  
**Webster, E. G. & Bro.**—Manufacturers of Fine Silver Plated Ware. Office and Warerooms, 14 Maiden Lane, N. Y.

**Show Cases, Etc.**

**Kraft & Hoffmeister**—Manufacturers of Metal Show Cases, Jewelry Trays always on hand, No. 16 North William street, N. Y.  
**Smith, B. & W. B.**—Patent Improved Counter Show Cases. Drawings furnished and estimates given for fitting stores in Cabinet Work complete.

**Spectacle Case Manufacturers.**

**Koenen, A. & Bro.**—Manufacturers of Leather Spectacle & Eye Glass Cases, 81 Nassau St., N. Y.

**Thermometers Etc.**

**Tagliabue, Giuseppe.**—Thermometer, Barometer and Hydrometer Manufacturer, 302 Pearl street near Beekman, N. Y.

**Thimble Manufacturers.**

**Burbank Manufg Co.**—Manufacturers of Gold & Silver Thimbles, 14 Maiden Lane, N. Y.  
**Ketcham & McDougall.**—Improved Gold and Silver Thimbles, Nos. 4 and 6 Liberty Place, near Maiden Lane, N. Y.

**Walking Canes.**

**Fradley, J. F.**—Manufacturer of Fine Gold and Silver-headed Walking Canes and Sterling Silverware. Office and Factory, No. 20 John street, N. Y.

**Watch Companies.**

**American Watch Co.**—Robbins & Appleton, No. 9 Bond street, N. Y.  
**Illinois Watch Co.**—Factory, Springfield, Ill. Office, 11 Maiden Lane.  
**Hampden Watch Co.**—of Springfield, Mass. Office, No. 12 John St., New York.  
**Tiffany & Co.**—Makers of Fine and Complicated Watches. Office 694 Broadway, N. Y.

**Watch and Chronometer Jeweler.**

**Queen, James.**—Watch and Chronometer Jeweler and Pallet Maker, 78 Nassau street, Room 8. Pivots inserted in Pinions, Balance, Staffs, &c.

**Watch Importers, Etc.**

**Abry, J. A.**—Importer of watches and agent for Vacheron and Constantin Watches. 63 Nassau Street, N. Y.  
**Aikin, Lambert & Co.**—Importers of Watches, Sole Agents for Paul Breton & Chas. Latour, Geneva. A general line of reliable Swiss Watches. Watch Cases of all styles made to order. 23 Maiden Lane, N. Y.  
**Bourquin Brothers.**—Importers of Watches from their own manufactory at Bienne, Switzerland, 20 Maiden Lane, N. Y.  
**Bynner, T. B.**—Importer and Jobber of Watches, Diamonds and Fancy Goods, and dealer in the best class of Rolled Plate Jewelry. 513 Broadway.  
**Cross & Beguelin.**—Importers of Watches, Watch Tools and Materials, dealers in American Watches, No. 21 Maiden Lane, N. Y.  
**DuBois, Francis & Co.**—36 Maiden Lane, N. Y., Importers of Watches and Manufacturers of Watch Cases.  
**Droz, Henry E.**—Importer of Watches and Watch Case manufacturer. Agent for the "E. Perregaux" Watch, and jobber in American Watches, No. 92 Fulton Street, N. Y.  
**Freund Max & Co.**—Importers of Watches Jewelry and Precious Stones, 8 Maiden Lane  
**Friedman, S.**—Importer of and dealer in Watches and Jewelry, 40 Maiden Lane.

**Gagnebin, Chas.**—Importer of all kinds of Watches, 64 Nassau Street. Agent for Ulysse Breting's Fine Chronometers, Chronographs, Anchors, etc.  
**Gallet, Julien.**—Importer of Watches. No. 25 Maiden Lane.

**Ginnel, Henry.**—Importer of Watches, Tools and Materials. No. 31 Maiden Lane, N. Y. P. O. Box, 2967

**Howard, E. & Co.**—Watches. No. 2 Maiden Lane, N. Y.

**Keller, L. H. & Co.**—(Successors to G. A. Huguenin,) Importers of Fine Watch and French Clock Materials, No. 64 Nassau street, N. Y.

**Hyde's Sons, John E.**—Wholesale Commission Agents, only, for Jules Juergensen, of Copenhagen, Ed. Perregaux, of Locle, Jules Monard, of Geneva, and for other makers of all qualities of watches, 22 Maiden Lane.

**Kahn, L. & M.**—Importers of Watches, No. 10 Maiden Lane, New York.

**Mathez, F. H.**—Importer of Watches. No. 5 Maiden Lane, N. Y.

**Magnin, Ve J. Guedin & Co.**—Importers and Agents of the Nardin Watch, No. 652 B'way

**Mathey, L. & A.**—Importers of Fine Watches and Sole Agents for the **H. L. Matile's** Watches, No. 119 Fulton Street, N. Y.

**May & Stern.**—Importers of Foreign Watches, Materials and Tools, etc. Manufacturing Jewelers. No. 19 John St., N. Y.

**Nicoud & Howard.**—Importers and Manufacturers of Watches, No. 14 Maiden Lane.

**Oppenheimer Bros. & Veith.**—Dealers in Watches and Diamonds, and Manufacturing Jewelers. No. 35 Maiden Lane, N. Y.

**Robert, J. Eugene.**—No. 30 Maiden Lane, New York Agent for Louis Audemar's celebrated watches.

**Schwob, Adolphe.**—Manufacturer & Importer of Watches, 11 Maiden Lane, N. Y.

**Stern Brothers & Co.**—Importers of Swiss Watches and wholesale dealers in American Watches, &c., 30 Maiden Lane.

**Scott, J. T. & Co.**—Importers of Watches, and Manufacturers of Jewelry, and Jobbers of all grades American Watches. No. 11 Maiden Lane, N. Y.

**Strasburger, Louis & Co.**—Importers and Makers of Watches of every description. No. 15 Maiden Lane.

**Tiffany & Co.**—Makers of Watches. General Agents for Patek, Phillippe & Co. Wholesale office, 694 Broadway, N. Y.

**Watch Cases.**

**Brown, J. A. & Co.**—Manufacturers of The Ladd Patent Stiffened Gold Watch Cases, &c., 11 Maiden Lane, N. Y. Factory, 58 Eddy street, Providence, R. I.

**Watch and Chronometer Repairer.**

**Cerf, B.**—Practical Watchmaker and Repairer, No. 10 John street, N. Y. Repairing and adjusting of Fine Watches done for the trade. All kinds of escape and stem winding wheels cut to order.

**Ludeman, W. H.**—Chronometer and Watchmaker. Repairing of every description for the Trade. 75 and 77 Nassau street, N. Y.

**Sirois, A.**—Practical Watchmaker, 89 Fulton street. Special attention paid to the repairing of Fine Watches. Pivots inserted.

**Watch Case Repairers.**

**Tarbox, Hiram.**—Watch Case Repairing, Springing, Polishing and Engine Turning, 79 Nassau street, (room 22), N. Y.

**Renaud, F.**—Watch-Case Repairer.—Solid and Heavy Rolled Plate Bows and Pendants. Springer and Engine Turner of Cases and Jewelry, 36 Maiden Lane

**Watch Guards.**

**American Silk Guard Manufacturing Co.,**—Our goods are warranted all silk.—Kossuth Marx & Co. No. 39 Maiden Lane, N. Y.

**Watch Glasses, Shades, Etc.**

**Brown, Edwin.**—No. 55 Nassau Street, Imported and own Manufacture Watch Glasses, Flat, Flat Concave, Concave, Convex and fine Geneva's. Fine fitting solicited

**Hill, Robert S.**—Manufacturer of Watch Glasses, &c., dealer in Imported Glasses, Flat Glasses a specialty; also, Jeweler's Glasses. Nos. 75 & 77 Nassau street, N. Y.

**BOSTON.**

**The Star Salt Caster Co.**—Sole Proprietors and Makers of the Celebrated Star Salts, 161 Franklin Street, Boston, Mass.

**CINCINNATI.**

**Holland, John.**—Manufacturer of Gold Pens, Pencils and Pencil-cases, Charms and Gold Tooth-picks, at No. 19 W. 4th street, Cincinnati, Ohio.

**PHILADELPHIA**

**Booz & Thomas.**—Manufacturers of Gold and Silver Watch Cases and Jewelry, 108 South 8th Street, Philadelphia.

**Bennett, Jacob & Son.**—Diamond Setters and Manufacturing Jewelers. 108 South 8th St., Philadelphia, Pa.

**Cooper & Bros.**—Wholesale Jewelers, and Importers of and Dealers in Watch and Clockmakers' Materials, etc. Spectacles and Optical Goods. No. 35 South 4th St., Phila.

**Conover David F. & Co.**—American Watches, Wholesale Salesroom, southeast corner 7th and Chestnut streets, Philadelphia.

**Hagstoz & Thorpe.**—Sole manufacturers of Boss' Stiffened Gold Watch Cases. Sixth and Chestnut Streets, Philadelphia.

**Herold, Chas P.**—Successor to Hildebrandt, Herold & Co., Manufacturing Jeweler and Diamond Setter. Diamonds. 916 Chestnut St

**H. Muhr's Sons.**—Manufacturing Jewelers, Solid Gold Rings a specialty, 158 North Second st. New York Office, 11 Maiden Lane.

**Krider, Peter L.**—Manufacturer of Sterling Silver Ware, Artisan Hall, No. 618 Chestnut street

**Levy, Bernard.**—Manufacturers of gold and silver watch cases, and importers and dealers in Swiss and American watches, 402 Library street, Philadelphia.

**McCall & Newman.**—Manufacturing Jewelers, Filled Plain Gold Rings a specialty, No. 625 Arch street.

**Morgan & Headly.**—Manufacturing Jewelers Cameo sets, Gold sets, Roman Lockets, Rings, Coral sets, and a general line of rich goods. 611 and 613 Sansom street, Philadelphia.

**Pierson, Edwin.**—Manufacturer of Fine Imitation Jewelry, Gold and Silver Electro-plater, Fire Gilder, Coloring, Etruscan and Gold Jewelry a specialty. 1320 Chestnut St.

**Rosenthal, G. F. C.**—Manufacturing Jeweler and Diamond Setter. Engraving and Designing of Monograms a Specialty. No. 924 Chestnut street, Philadelphia.

**Scherr, L. A. & Co.**—Wholesale Dealer in Watches Silver Plated Ware, Spectacles, Fancy Goods, Watch Materials, etc., 726 Chestnut street.

**Sheafer, W. H. & Co.**—Makers of Fine Jewelry 908 Chestnut Street.

**Simons, Brother & Co.**—Manufacturers of Fine Jewelry, Canes, Thimbles, Chains. 611 & 613 Sansom St., Philadelphia.

**CHICAGO.**

**American Watch Company**, of Waltham, Mass. No. 170 State street, Chicago.

**Charpior & Wathier.**—Watchmaker & Jewelers for the Trade, and Wholesale Dealers in Watch Material, Tools, &c., 61 West Kiuzie Street, Chicago, Ill. Send for price list.

**Fresse, B.**—Watchmaking and Repairing for the Trade promptly attended to. Stem-winding and escape wheels cut to order. No. 99 E. Madison St., Chicago, Ill.

**Purdy, J. H. & Co.**—Jobbers of large and small Tools and Materials, for the use of Watchmakers, Jewelers, and kindred Trades. Spectacles—Jewelry Boxes, Plated Chains, &c., &c. No. 170 State street.

**Stein & Ellbogen.**—Wholesale Dealers in Watches and Jewelry, 127 State St., Chicago. Specialty, repairing for the Trade.

**PROVIDENCE**

**Irons, Chas. F.**—Manufacturer of Solid Gold Jewelry. Specialty Emblems, Pins and Charms Masonic, Odd Fellows, &c. 102 Friendship St.  
**Perkins, C. H. & Co.**—Manufacturers of fine Gold and Plated Jewelry. 20 Conduit St., Providence, R. I.

**NEWARK.**

**Lefort, Henry.**—Stem-winding Watch Crown Manufacturers. 80 & 82 Marshall St.

**Lelong, L. & Bro.**—Gold and Silver Refiners, Assayers and Sweep Smelters, S. W. corner Halsey & Marshall streets, Newark, N. J.

**Milne & Jourdan.**—Manufacturers of Stem-winding Watch Crowns Nos. 13 & 15 Franklin Ave., Newark, N. J.

**Prince, David.**—Gold and Silver Refiner, Assayer and Sweep Smelter. Sole Agent for Comin's Improved Amalgamator. 63 Railroad Ave.



Standard Marine Chronometer  
FOR KEEPING CORRECT TIME.

**JOHN BLISS & CO.**  
**STANDARD MARINE**  
**Chronometers and Transits,**  
**FOR WATCHMAKERS' USE.**

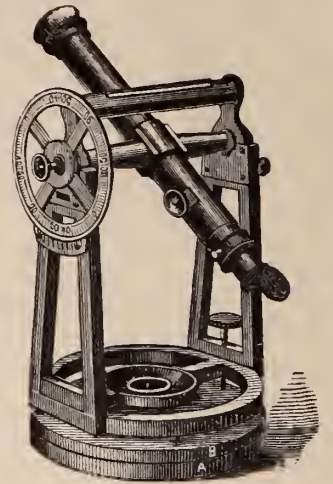

No. 10

**110 WALL STREET, NEW YORK.**

**IMPORTANT NOTICE.**—These Transits are readily set in position without the aid of strictly correct time as a basis for that purpose. Printed instructions, easily understood, accompany each Instrument, and no calculations are required preliminary to setting in position.

As a trial only is required to insure unqualified approval, we are induced to make the following **LIBERAL OFFER**—On receipt by us of satisfactory reference, and 10 per cent. of the price, we will send one of the foregoing Transit Instruments, on hire or trial, for one month, with full printed instructions for setting up and using the same, and if purchased after trial, we will allow the whole hire to apply in part payment, and sell the Instrument on approved note at four months for the balance. Special terms for payment by installments, after trial, on application. We do not make this offer merely to hire these instruments, but to insure a trial with a view to sales, the hire received being only sufficient to cover the cost of repolishing in case they are returned. Send for Illustrated Circular giving full description.

JOHN BLISS & CO., 110 Wall Street, New York

**L. HAMMEL & CO.,**

**Importers of Watch Materials, Tools,**

**Opera Glasses and Optical Goods of Every Description**

We would respectfully call your attention to our new design of an improved Spectacle Case which will doubtless commend itself to your favorable consideration. The improvement, consisting in the joint being on the top of the case, making it stronger and more durable than the old style of case, and the cut away for the insertion of the Spectacles renders it the most practical case made. These goods are made in all grades of leather and for all styles of spectacles, in price from \$6 to \$13.50 a gross, and stamped to order with name and address of the purchaser, at \$2 per gross extra. Samples sent by mail on receipt of 10 cents on application to



**SPECTACLES !**



**EYE GLASSES**

We would respectfully call the attention of the Trade to the celebrated **Star Spectacles and Eye Glasses**, of which we are the Sole Importers.

**No. 9 Maiden Lane, New York**

Sole Agents in the United States for **G. B. Wheeler's Star Watch and Clock Oil**, and the Celebrated **Gravier Mainspring**.

# F. JEANDHEUR, JR.

Old No. 117 Fulton Street,  
New No. 125 Fulton Street, NEW YORK.

For the last eleven years the firm of F. JEANDHEUR & SON have been known to the Wholesale Jewelry Trade of the United States as

## Electro-Platers and Fire Gilders.

Their increased business has now caused them to REMOVE from their old quarters to the large and spacious building, 125 Fulton Street, where they will be happy to see their patrons.

Mr. Jeandheur begs to notify the Trade, that by his NEW PROCESS OF PLATING, Watch Cases, Jewelry, etc., can be finished with a far greater amount of depth of gold than has ever been accomplished, and also at less expense than the old process of fire-gilding. The Trade can rely on this statement, as a trial will abundantly prove, and their well-earned reputation is staked that they will in all cases give satisfaction.

ESTABLISHED 1849.

# O. SCHWENCKE.

Successor to C. Gunzenhausen,  
MANUFACTURER OF

**FINE HAIR JEWELRY,**  
43 Maiden Lane, New York.



Solid Gold Mountings for Hair Jewelry, kept constantly on hand and made to order at short notice.

Orders from the country trade promptly attended to, and Price List and Catalogues furnished at 50 cents each, which will be refunded on first order.

# F. P. LOCKLIN,

MANUFACTURER OF

Gold and Silver-Plated

**Walking  
Canes,**

**JEWELRY**

&c., &c.

FACTORY,

**142 Fulton Street, New York**

Between Broadway and Nassau street.

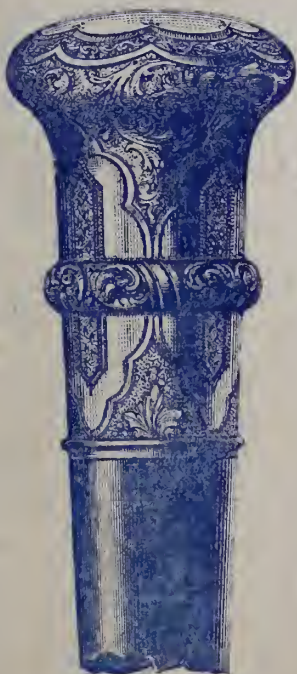

ESTABLISHED, 1863.

# WIGGERS & FROELICK,

60 NASSAU STREET, NEW YORK,

MANUFACTURERS OF

**Cases for Jewelry,**

OF EVERY DESCRIPTION.

Plain and Fancy Trays for Show Cases and Windows.

**Sample Cases & Trunk Trays**

A SPECIALTY!

Trunks fitted with our Trays will carry more goods and carry them safer than by any other method; we having made it a special study to combine CHEAPNESS, LIGHTNESS, CONVENIENCE and DURABILITY.

The attention of the JOBBING TRADE is particularly invited.

**HIRSH BROTHERS,**  
Dealers in Watches & Diamonds

AND MANUFACTURERS OF

**JEWELRY,**

No. 23 Maiden Lane, New York.

Prompt attention given to filling orders for all kinds of goods pertaining to the trade.

HENRY MAY.

Established 1854.

JOSEPH STERN.

**MAY & STERN,**

IMPORTERS OF

Foreign Watches, Materials and Tools

AGENTS FOR THE SALE OF ALL

DOMESTIC MOVEMENTS AND CASES.

**And MANUFACTURING JEWELERS**

No. 19 John Street, New York.

SOLID GOLD SEAL RINGS, in Cameo, Amethyst, Topaz and Onyx, A SPECIALTY.

**L. LELONG & BRO.**

**GOLD and SILVER REFINERS,**

Assayers and Sweep Smelters,

Southwest Corner Halsey and Marshall Streets,

NEWARK, N. J.

SWEEPINGS A SPECIALTY.

**KELLER & UNTERMAYER,**

ONLY AUTHORIZED AGENTS OF

**The International Watch Co.'s**

**WATCHES.**

A full and complete assortment of these goods in new and attractive Cases constantly on hand.

No. 18 John Street,

New York.



P. HARTMANN,  
JEWELER AND SILVERSMITH,  
36 MAIDEN LANE,  
NEW YORK.

**ALBERT LORSCH,**

MANUFACTURER OF

PATENT ACCOMMODATING

**Spectacles and Eye Glasses,**

In Gold, Silver, Steel, &c.

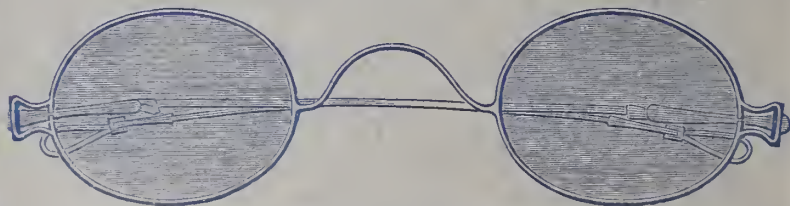

Also Latest Novelties in Fine WATCHES & JEWELRY.

**PRICES REDUCED TO SPECIE BASIS.**

I would call especial attention that with the above Spectacles and Eye Glasses it is only necessary to have one complete assortment of the different kinds of lenses, which being of uniform size, will interchange in all the different kinds of frames, thus giving a complete assortment for a comparatively small outlay

ALBERT LORSCH, 37 Maiden Lane, New York.

LORSCH BROS., 120 Sutter St., San Francisco, Cal.

**L. & M. KAHN,**

IMPORTERS OF

Sole Agents for  
James Kahn.  
E. Bourquin & Fils  
AND  
Alphonse Matile  
WATCHES.

**WATCHES**

112 Kearny St.  
San Francisco,  
CALIFORNIA.  
5 Rue des Alpes,  
Geneva,  
SWITZERLAND.

No. 10 MAIDEN LANE,  
NEW YORK.

Manufacturers of the EAGLE TIMER! the Best in the market.

APRIL, 1879



Qabone

PATTERSON & SON, ENG

D. F. HOPKINSON, PUBLISHER.

42 NASSAU STREET, NEW YORK

Established 1813.

# SETH THOMAS CLOCK CO.

THOMASTON, CONN.

No. 20 MURRAY STREET, New York.

16 Worship Street,  
LONDON, E. C.

172 State Street,  
CHICAGO.

7 Montgomery Street,  
SAN FRANCISCO.

APRIL 10th, 1879.

Competition has forced prices pretty low for goods in our line.  
Our list of prices dated January, 1879, was very carefully made up from present cost and quality. We do not expect to deviate from it, excepting to close out goods not up to standard.  
Our rule is better goods—not lower prices—and we beg your pardon for not having kept it better.  
Very truly,

SETH THOMAS CLOCK COMPANY.

# F. KROEBER,

Manufacturer of CLOCKS,

No. 8 Cortlandt St.,  
New York.

FACTORIES:—NEW HAVEN, CONN., AND  
NEW YORK CITY.

SUPERIOR GRADE OF  
WALNUT CLOCKS A SPECIALTY

SOLE AGENT FOR

E. INGRAHAM & CO.

—AND—

CLOCKS OF ALL MAKERS,

AT LOWEST MARKET PRICES!



"AURORA."

1 Day Lever, Alarm, Nickel. Height, 5½ inches.



"THISTLE,"

1 Day Lever, Alarm, Nickel. Height, 8½ inches.

# New Haven Clock Co.

62 READE ST., NEW YORK.

L. EGERTON, Jr., Agent.

DUCHESS, TIME.  
DUCHESS CALENDAR TIME.  
ROVER ALARM.

Manufacturers of

NICKEL LEVER.

## CLOCKS, MOVEMENTS, AND CLOCK MATERIAL,

AND  
DEALERS WITH THE TRADE.

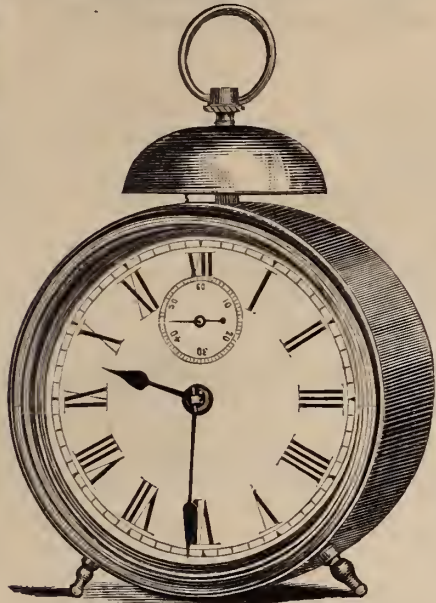

FRONT VIEW—DIAL 4 INCHES.  
1-Day Time, - - \$1.40  
1-Day Calendar Time, 1.75  
1-Day Alarm, - 1.90

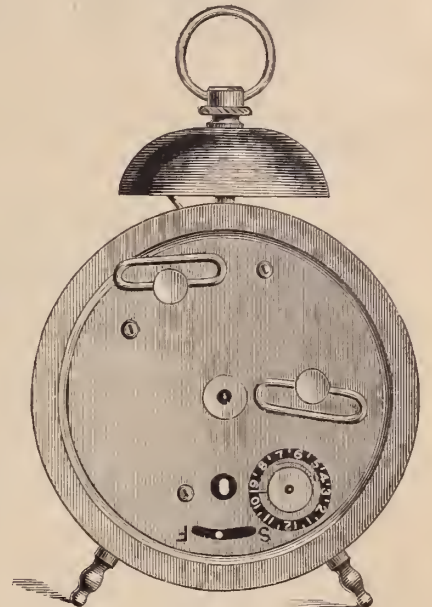

BACK VIEW.

Besides our well-known styles of VENEERED GOODS, we are making several new and beautiful patterns of Black Walnut, visible Pendulum, both Time and Strike, 1-Day and 8-Day, with and without Alarm,

CATALOGUES AND TERMS SENT ON APPLICATION.

# WATERBURY CLOCK CO.,

MANUFACTURERS OF AMERICAN CLOCKS,

4 CORTLANDT STREET,  
NEW YORK.

197 STATE STREET,  
CHICAGO.

M. BAILEY, Treasurer.

FACTORIES,  
WATERBURY, CONN.



CRICKET.  
30 HOUR LEVER TIME.



CRICKET EXTRA.  
30 HOUR LEVER TIME.



SUNRISE.  
30 HOUR LEVER TIME, ALARM.



TRANSIT.  
30 HOUR LEVER TIME.



INDEX.  
30 HOUR LEVER TIME, CALENDAR.



MONITOR.  
30 HOUR LEVER TIME, ALARM, CALENDAR

ILLUSTRATED CATALOGUES AND PRICE LISTS FURNISHED ON APPLICATION.

# LOUIS STRASBURGER & CO.,

Importers of

# DIAMONDS.

—♦—  
We are direct Importers of Diamonds, dealers will therefore always find ORIGINAL parcels in our stock to select from.

MATCHED PAIRS, IN ALL GRADES AND WEIGHTS, A SPECIALTY!

NEW YORK, 15 MAIDEN LANE.

PARIS, 30 BOULEVARD HAUSSMANN.

—♦—  
Our complete stock of loose and mounted Diamonds enables us to send a full assortment for selection to any first-class house.

## LOUIS STRASBURGER & Co.

### Manufacturers of Watches,

From the finest Stem-Winding and Setting goods to the lowest price Watch in the market.

We manufacture and have continually in stock a complete assortment of the best COMMERCIAL WATCHES ranging from the lowest priced Metal and Silver Watches to the finest Gold Watches, such as REPEATERS, CHRONOGRAPHS (single and split) and all other Timing and Complicated Watches.

Also a full assortment of the INTERNATIONAL and all AMERICAN Movements. *Gold and Silver Cases*, constantly on hand.

We would call particular attention to our complete and varied assortment of NICKEL WATCHES, (black and fancy Dials,) in all grades, styles, and sizes.

THE RAIL-ROAD TIMEKEEPER A SPECIALTY.

SALESROOMS, No. 15 MAIDEN LANE, NEW YORK.

Watch Factory, Rue Leopold, Chaux de Fonds, Switzerland.



# SILVER-PLATED WARE.

## THE MERIDEN BRITANNIA COMPANY

No. 46 East Fourteenth Street, Union Square, N. Y.

MANUFACTURERS OF FINE ELECTRO-PLATED TABLE WARE.



The "Laurel."

Made in Solid Silver and Electro-Silver Plate.

Attention is invited to the patented process of electro-plating SPOONS AND FORKS by which the parts most exposed to wear receive an extra coating of silver three times the usual thickness.

The great advantage of this method will be readily seen, as Spoons and Forks always wear through on these exposed points, while the plate is yet good upon other parts of the article.

This sectional plate is recommended for hard service, as it is worth many times the additional cost in durability. All Spoons and Forks stamped "1847—Rogers Bros.—XII," are plated by this process in addition to the regular plate.

To protect the purchaser against imitations, it should be observed that the Improved Spoons and Forks bear our Trade Mark, "1847, ROGERS BROS., XII."

FIRST PREMIUMS awarded at all Fairs where exhibited, from the World's Fair, 1853, to American Institute Fairs, 1873, 1874 and 1875, inclusive, and at the Philadelphia Exhibition, 1876.

Extract from the American Institute Report:—"Their Porcelain-lined, Double-walled Ice Pitchers are Art, and possess all the qualities the company claim." \* \* \* "We consider the goods made by this company to be by far the best made in this country, and we believe in the world."

# The STAR SALT CASTER COMPANY



Sole Proprietors and Manufacturers of

CELEBRATED

## STAR SALTS

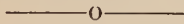

For convenience, neatness and utility the STAR SALTS have become a household necessity.

The pulverizer in the bottle, as shown by the cuts, keeps the salt pulverized, and obviates the disagreeable habit of spilling the salt by dipping out of an open salt cellar.

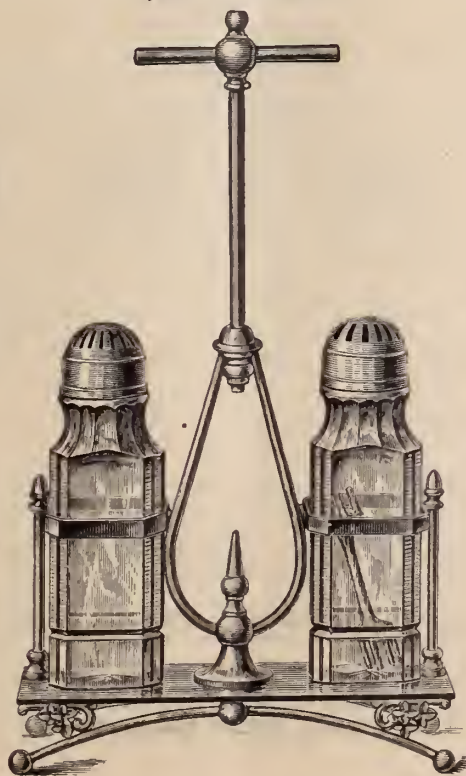

No. 161 Franklin Street, BOSTON, MASS.

Place these in the family and Salt Cellars will be discarded.

MANUFACTURED IN ALL VARIETIES OF PLAIN AND FINE CUT GOODS, CASTERS, &c.

Special care given to orders for exportation.

Fine Diamond Cut, with Sterling Caps.

# SIMPSON, HALL, MILLER & CO.

MANUFACTURERS OF

## Silver-Plated Ware,

SUPERIOR IN QUALITY, DESIGN AND FINISH.

FACTORIES, WALLINGFORD, CONN.

Salesroom 36 East 14th St., New York.



Our assortment comprises a large line of Hollow Ware and Flat Ware, the product of many years manufacturing, with superior skill and appliances. Dealers in Silver-Plated Wares throughout the country have found our productions desirable in all respects, and perfectly adapted to the requirements of their customers. We have added many new articles to our assortment, and shall continue to produce *DESIGNS OF ORIGINAL AND ARTISTIC* merit in rapid succession.

**OUR SOLID TABLE WARE IS MADE OF THE BEST NICKEL SILVER.**

*SPOONS, FORKS, LADLES, PIE-KNIVES, &c.*

IN GREAT VARIETY OF PATTERNS.

**Solid Steel Knives of Superior Quality.**

Our *ILLUSTRATED CATALOGUE*, recently issued, will be furnished to *REGULAR DEALERS*, on application, inclosing business card.

# ROGERS CUTLERY COMPANY



**WM. ROGERS,**  
Senior Member and Manager of the Firm of ROGERS BROTHERS. Died Feb. 17, 1873.



**ASA H. ROGERS,**  
Of the original ROGERS BROTHERS, and half owner of the Rogers Cutlery Co., when organized. Died Oct. 4, 1876.



**F. WILLSON ROGERS,**  
Son of the late Wm. Rogers, and Secretary of the ROGERS CUTLERY CO.



Our Knives stamped as above we guarantee

To Strip 12 dwts. of Silver per dozen.

Our Knives are guaranteed to be

**ALL HAND BURNISHED,**

and are put up in rack boxes with hinge covers.

**WE GUARANTEE** our Spoons, Forks, &c. to be Plated 25 Per Cent. **HEAVIER THAN STANDARD PLATE.**

We guarantee Spoons, Forks, &c. to be plated on **13 PER CENT. NICKEL SILVER, AS FOLLOWS:**

On TEA SPOONS,	2½ ounces, or 50 dwts. per gross.
On DESSERT SPOONS,	3½ " " 75 " "
On TABLE SPOONS,	5 " " 100 " "
On DESSERT FORKS,	3½ " " 75 " "
On MEDIUM FORKS,	5 " " 100 " "

**OUR SPOONS, FORKS, LADLES, &c. ARE STAMPED**

On EXTRA PLATE,	. . . 1871, ROGERS @ 5 oz.
On DOUBLE PLATE,	. . . 1871, ROGERS @ 8 oz.
On TRIPLE PLATE,	. . . 1871, ROGERS @ 12 oz.
On QUADRUPLE PLATE,	. . . 1871, ROGERS @ 16 oz.



All Hollow Ware stamped as above is warranted to be plated

**50 PER CENT. HEAVIER** than any other brand of goods.

Our Hollow Ware in addition to our trade mark is stamped

**SEXTUPLE PLATE,** we being the only firm who manufacture this weight of plate.

The above is a fac-simile of our guarantee card which accompanies each dozen of our flat ware, and each piece of our hollow ware. Our goods have been in the market since 1871, and are acknowledged by all dealers, who have tried them, to be **THE BEST.**

We would call especial attention to the **EXTRA STRONG SPRING TEMPERED SHANK**, which we have on our Tipped, Fiddle, Saxon and Imperial pattern



No. 985,---TEA SET, Six Pieces:---Slop and Cream, gilt, \$54. Butter Dish, \$8. Syrup, \$7. Spoon Cup, gilt, \$6.50. Urn, \$30. Waiter, \$50.

THE ABOVE ALL TO MATCH.

Water Sets, Tilting Sets, Ice Pitchers, seamless lined; also, Baskets, Butter Dishes, Berry and Fruit Dishes, &c., &c. An endless assortment in Roman and Lily borders, original with, and manufactured by

**THE MIDDLETOWN PLATE COMPANY,**  
**MIDDLETOWN, CONNECTICUT.**

13 JOHN STREET,

**New York.**

120 SUTTER STREET,

**San Francisco, Cal.**

The assortment of NEW GOODS for Spring of 1879, is unexcelled in Style, Finish and Quality. Buy the MIDDLETOWN PLATE, Quality Guaranteed.

JAS. T. SCOTT,  
S. CLEM SCOTT,  
J. T. SCOTT, JR.

# J. T. SCOTT & CO.

Established 1847.

No. 11 MAIDEN LANE, - - - NEW YORK.

SOLE EASTERN

AGENTS FOR

## THE ROCKFORD

## WATCH CO.

AND AGENTS FOR

The Auburndale

## CHRONOGRAPH

TIMERS,

$\frac{1}{4}$  and  $\frac{1}{8}$  seconds, in 18 size  
Nickel-Plated Cases, designed  
for Sporting, Scientific and  
Mechanical purposes.

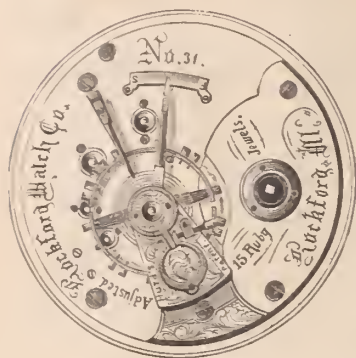

ROCKFORD WATCH.

This Company manufactures eight grades of superior 18 size key and stem wind

**QUICK  
TRAIN,**  
Movements.

ALSO SOLE AGENTS FOR

**Abbott's Patent  
Open-Face**

18 size American stem-winders, with XII at pendant and seconds opposite.



ABBOTT'S PATENT.

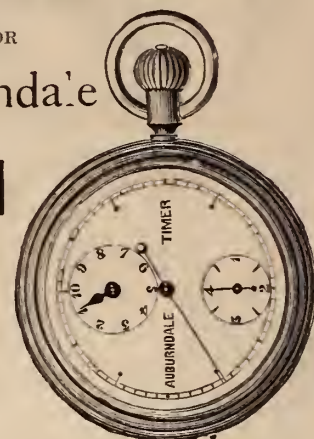

AUBURNDALE TIMER.

Manufacturers of Jewelry and Wholesale Dealers in all grades of American Movements.

WATCH CASES, DIAMONDS, CHAINS, SILVER WARE, &c.

 Price Lists furnished upon application to those regularly engaged in the Trade. 

# C. G. ALFORD & CO.,

## Manufacturing Jewelers,

No. 183 BROADWAY, NEW YORK.

### TO THE TRADE.

*Our efforts to protect the interests of the legitimate Jewelry Trade by refusing to send our Illustrated Catalogue to outside dealers has won the universal approval of the entire retail trade, who have demonstrated their appreciation of our efforts in this direction, by sending us their orders. We are glad to know that our Catalogue occupies an important place in the stores of Retail Jewelers, and that they in many ways find it of great convenience.*

*We have in contemplation certain changes that will add to its interest and usefulness, which will be made known when they assume a definite form.*

*We wish to state that we shall in the future, as in the past, use our best efforts to protect the interest of patrons, the legitimate retail dealers, by publishing a Catalogue exclusively for their use, and one that may be shown to their customers without the risk of exposing their profits.*

 Applicants for copies must enclose business card as a guarantee that they are regularly in the trade.

—Established 1842.—



# JOHN HOLLAND,

Manufacturer of Patent "Record," Barrel, Falcon, Stub, and all styles of Long Nib Gold Pens.

**Fine Solid Gold Pen and Pencil Cases, Pearl, Ivory and Fine Wood Pen Holders, Charm Pencils & Gold Tooth Picks.**

**No. 19 West 4th Street, Cincinnati, Ohio.**



My goods are all made of the quality of gold stated, and finished in first class style. At the CENTENNIAL EXHIBITION the Judges on Awards gave me the HIGHEST AWARD for GOLD PENS, and stated in their report: "For great elasticity and general excellence of Gold Pens." The best quality of IRIDIUM is used on the points, and every pen is warranted.

As I MANUFACTURE all the above articles in my own building, and under my own supervision, I can guarantee quality and offer the trade special inducements in prices.

- ☞ Handsome show-cases furnished for the display of goods.
- ☞ Illustrated Catalogues sent free.
- ☞ Goods sent on approval.
- ☞ Special attention to repairing Pens and Pencil Cases.

## ARKELL & CO.

IMPORTERS AND DEALERS IN

Watch Materials, Tools,  
JEWELRY,

AND ALL GRADES OF AMERICAN WATCHES.

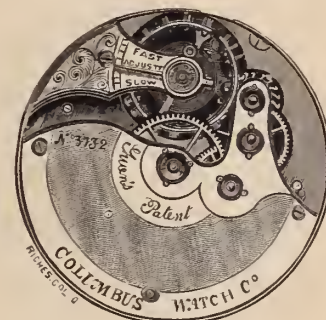

We call the attention of Watchmakers to the "JEQUIER" Main Spring. This spring is the only one of all fabrications exhibited at the "Paris Exposition" that received FIRST and ONLY medal. We claim it is the best in this country, and invite a trial by the trade as a test of its merits. Send for sample and also descriptive catalogue of Columbus Watch, nickel  $\frac{3}{4}$  plate, full jeweled, stem-winding and setting, the most beautiful watch with the best results for least money, quality considered. No price list furnished unless requested and only to the trade.

BALDWIN'S BARREL CATCH INSERTER, indispensable to the Watch Repairer, saves time and labor, sent by mail on approval to the trade free of postage.

We are Sole Agents for the United States of these goods. We also manufacture the BOSS ENGRAVING BLOCK—there are features in its construction different from all others in the market, holds the work to be engraved, of any kind, without attachments. It is practical, simple, and reasonable in price. All these specialties enumerated, may be obtained of any regular Dealer in material and tools, or direct of us.



P. O. Box 8. Canajoharie, N. Y.

# MILLER BROS.

MANUFACTURING JEWELERS,

No. 11 MAIDEN LANE, NEW YORK.

Manufactory, 47, 49 & 51 Franklin Street, Newark, N.

*New this Spring,  
A LARGE LINE OF*

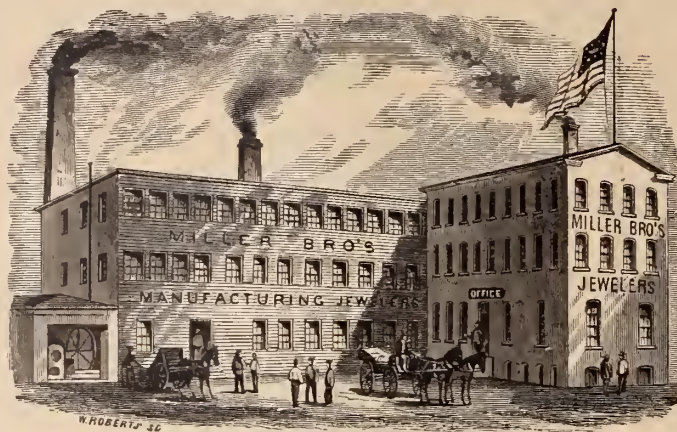

*Novelties for  
Ladies' & Gentlemen's Wear.*

ATTENTION IS INVITED TO OUR  
NEW STYLES OF ETRUSCAN SLEEVE BUTTONS,  
MOUNTED WITH

## RUSTIC LETTERS

BIRDS' ANIMAL HEADS AND FANCY ORNAMENTATIONS

Also a full line of Locketts, Sets, Pins, Ear Rings, Sleeve Buttons, Studs, &c. All goods exclusively of our own manufacture.

## DAVID F. CONOVER & CO.

(SUCCESSORS TO WM. B. WARNE & Co.)

Importers, Manufacturers and Wholesale Dealers in

### WATCHES AND JEWELRY,

Silver and Silver-Plated Ware,

AMERICAN WATCH WHOLESALE SALESROOM,

Southeast Corner Chestnut and 7th Sts.,

(FIRST FLOOR.)

DAVID F. CONOVER, }  
B. FRANK WILLIAMS, }  
C. EDGAR RIGHTER, }

PHILADELPHIA, PA.

J. C. AIKIN.

H. A. LAMBERT.

J. B. SHEA.

# AIKIN, LAMBERT & CO.,

**MANUFACTURERS OF GOLD PENS,**

**Pen and Pencil Cases, Pencils, Tooth-picks, and "Novelties" in Pencil Goods.**

**No. 23 Maiden Lane, New York,**

Would call the attention of the Trade to our large and complete line of Pen and Pencil Goods in all styles and varieties, suitable for demand.

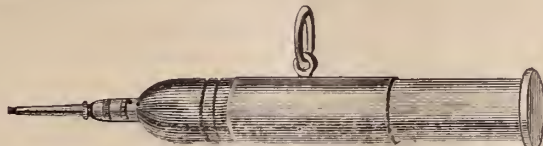

Our introduction last season of Pencils in NEW AND ENTIRELY NOVEL DESIGNS was marked by an unprecedented demand, which establishes the sale of these goods as STAPLES, and as being suited to any season of the year.

The Magic Charms (as per cuts shown below), inlaid with pearl and gold, in form of vines, flowers, birds, etc., on celluloid of assorted colors, in imitation of malachite, tortoise shell, agate vaegriated marble, etc., are the LATEST and most novel pencils in the market.



Send for circular and new list.

**Branch, No. 113 East Madison Street, Chicago.**

**IMPORTERS OF ALL GRADES OF**

## WATCHES,

SOLE AGENTS FOR

**"PAUL BRETON" and "CHAS. LATOUR," GENEVA.**



LONGINES



EXCELSIOR.

**— SPECIALTIES. —**

AGASSIZ Movements, Gilt and Nickel Stem-Winding, fitting Ladies' Riverside Case.

CHAS. LATOUR Movements, Gilt and Nickel Key-Winding, fitting 10 and 16 size Waltham Case.

PAUL BRETON Movements, Gilt and Nickel Key and Stem-Winding, a full line of these CELEBRATED TIMEPIECES in gold and silver cases of the most approved styles.

METAL OPEN FACE STEM-WINDING "LONGINES" and "EXCELSIOR", 16, 18 and 20 line, the BEST metal Watches in STYLE and QUALITY in the market.

The "LONGINES" received the ONLY GOLD MEDAL at Paris for low-priced Watches against several competitors, and the "EXCELSIOR" is recommended by DR. HIRSCH of the Neuchatel Observatory having given VERY SATISFACTORY results during a month's trial. NOVELTIES in BLACK and FANCY DIALS for these Watches are selling rapidly. American Watches of all kinds. Gold Cases of any style made to order. Sole Agents for EUREKA HORSE TIMER, the cheapest reliable TIMER ever made, and for PNEUMATIC TIMER which does not require the use of the hand. All Watches sold by us are warranted.

Our assortment of Jewelry is very large and complete, consisting of a general line of RELIABLE goods, both in GOLD and ROLLED PLATE, of new and tasty patterns, and including almost any article a Jeweler would have calls for. Special attention given to ORDERED WORK and REPAIRS. GOODS SENT ON APPROVAL and CORRESPONDENCE invited. Those not acquainted with us will oblige by giving references when ordering.

JANUARY 1st, WE REVALUED OUR ENTIRE STOCK AND HAVE REDUCED PRICES, AND ARE OFFERING GREAT INDUCEMENTS TO PURCHASERS FOR THE SPRING TRADE.

# Justice to the Swiss Watch Manufacturers.

The *NEW YORK WATCH IMPORTERS' ASSOCIATION* is compelled to state: The American Watch Company, of Waltham, Mass., announces that it received "the highest award to any exhibitor in Horology" at the Paris Exposition of 1878. The whole facts are, that the **Same Medal** which this Company received for American Watches, (*it being the only American Exhibitor,*) was also given to

## Nine Individual Swiss Manufacturers, THE CROSS OF THE LEGION OF HONOR!

IN ADDITION TO ONE OF THEM, AND A

## GRAND DIPLOMA OF HONOR!

FOR THE WHOLE DISPLAY OF SWISS HOROLOGY.

Office of **L. HAMMEL & CO.**

Importers of Watch Materials, Tools and Optical Goods, 9 Maiden Lane, New York.

Every Watch maker knows the necessity of a good and reliable Watch Oil. There are several brands which have hitherto enjoyed excellent reputations, but our experience as well as that of many of our customers has proved them more or less unreliable, in consequence of which we have been for a long time in search of an article that is entirely reliable in every respect, and have found it in the STAR WATCH AND CLOCK OIL, MADE BY GEO. B. WHEELER, OF NEW BEDFORD, MASS., who has given the subject many years of careful study. Our aim now is to bring this oil to the notice of all watch makers, as a thoroughly reliable article, having stood the test of years, a good lubricator, free from gum or corrosive substances and not affected by low temperature. We have sold these oils for the last three years and have always found our customers well pleased with them. We annex hereto some of the testimonials we have received from many reliable business houses and watchmakers throughout the country. The price of Wheeler's Star Oil is as follows:

Watch Oil per bottle, 20 cts., per dozen, \$2.00. Clock Oil, per bottle, 16 cts., per dozen, \$1.75.

ROCHESTER, N. Y., Dec. 25, 1877.

DEAR SIR:—I send you briefly and most cheerfully my opinion of your Watch Oil. We have been using it on our time locks for about a year and a half, and unhesitatingly say that it is uniformly the best oil that I have ever tried. Other oils previously used have failed after first trials, either drying up after a few weeks or changing color and thickening, all of them requiring too frequent cleaning of the movements to be reliable, but yours has so far proved entirely satisfactory.

Respectfully Yours,  
L. F. MÜNGER,  
Manager Sargent & Greenleaf's Time Lock Manufactory.

Office of CLEMENS HELLEBUSH, Esq., Manufacturing Jeweler,  
CINCINNATI, Feb. 1st, 1879.

MESSRS. L. HAMMEL & Co., 9 Maiden Lane, New York.  
DEAR SIR:—Your Wheeler's Star Watch and Clock Oil gives extraordinary satisfaction to my trade.

Please send me 10 gross at your earliest convenience.  
Yours Respectfully,  
CLEMENS HELLEBUSH.

Office of R. JAEGERMANN & CO.,  
Dealers in Materials, Tools, &c., for Watchmakers,  
218 North Fourth Street, St. Louis, Feb. 1st, 1879.

Having tried all manufactures of Watch Oil without finding any superior to Wheeler's Star Watch Oil, I hereby recommend the same to all watch makers as the best in the market and the only one that will stand all tests.

Respectfully,  
MESSRS. L. HAMMEL & Co.,  
9 Maiden Lane, New York. R. JAEGERMANN.

Office of KENNEDY & KOESTER,  
DETROIT, Mich.

DEAR SIR:—Please send us 10 gross each Wheeler's Watch and Clock Oil, by express immediately, and oblige,  
Yours Respectfully,  
KENNEDY & KOESTER.

P. S.—Your oil gets more in demand the longer people try it—they buy Wheeler's sooner than any other.

K. & K.

The following is from Mr. Henry Oehl, Jr., one of the best watchmakers in New York City:

I have used the Watch Oil manufactured by Geo. B. Wheeler, of New Bedford, for some two years, and have so far found it in every way satisfactory. It is uniform in quality and as free from gum and acid as any oil I have ever used.

NEW YORK, June 5, 1878. HENRY OEHL.

Office of M. S. SMITH & CO.,  
Diamond Merchants and Watch Importers,

MESSRS. L. HAMMEL & Co.,  
DETROIT, Mich., March 7, 1879.  
GENTS:—We have great pleasure in recommending the Wheeler Star Watch Oil, which we find equal to the best in the market.

M. S. SMITH & CO.

Office of GEORGE WOLF, Esq.,  
Dealer in Watches, Clocks, Jewelry, &c.,  
LOUISVILLE, Ky., Feb. 4, 1879.

MESSRS. L. HAMMEL & Co.,  
9 Maiden Lane, New York.

After using your Wheeler's Star Watch and Clock Oil for the last eighteen months, I have found it unsurpassed, and congratulate you for having succeeded in placing such an article before the trade.

Yours Respectfully,  
F. W. JARVIS, Watchmaker, with George Wolf.  
[Mr. Jarvis has been forty years in business and is a distinguished Watchmaker.]

NEW YORK, February 15th, 1879.

With the greatest sincerity I recommend the Wheeler's Star Watch Oil to the trade. I have tested it now for a long time and found it always good, and as good an oil as I ever used.

A. DEUHARD,  
Formerly with Ball, Black & Co.



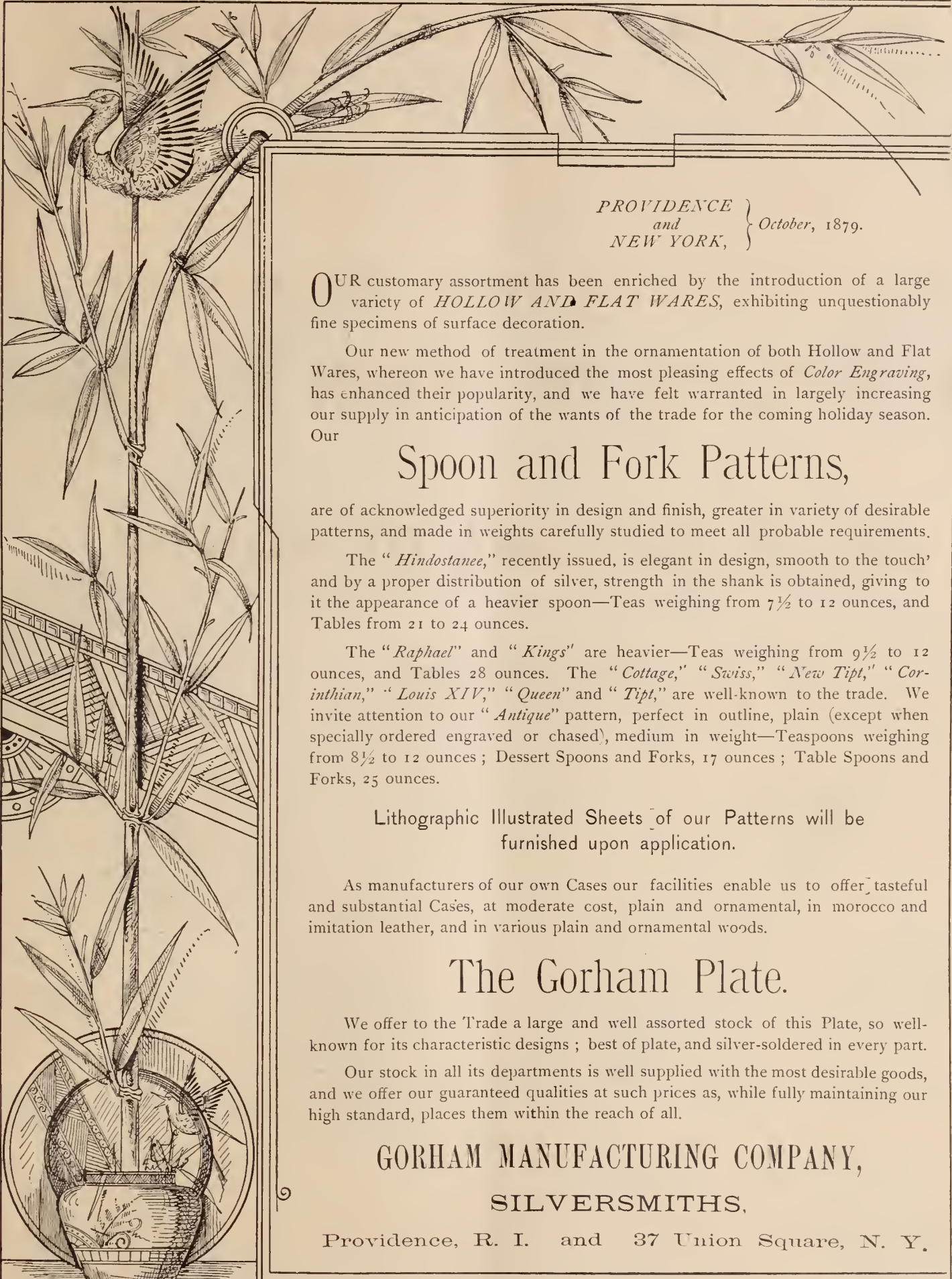

PROVIDENCE  
and  
NEW YORK, } October, 1879.

OUR customary assortment has been enriched by the introduction of a large variety of *HOLLOW AND FLAT WARES*, exhibiting unquestionably fine specimens of surface decoration.

Our new method of treatment in the ornamentation of both Hollow and Flat Wares, whereon we have introduced the most pleasing effects of *Color Engraving*, has enhanced their popularity, and we have felt warranted in largely increasing our supply in anticipation of the wants of the trade for the coming holiday season.

Our

## Spoon and Fork Patterns,

are of acknowledged superiority in design and finish, greater in variety of desirable patterns, and made in weights carefully studied to meet all probable requirements.

The "*Hindustanee*," recently issued, is elegant in design, smooth to the touch and by a proper distribution of silver, strength in the shank is obtained, giving to it the appearance of a heavier spoon—Teas weighing from  $7\frac{1}{2}$  to 12 ounces, and Tables from 21 to 24 ounces.

The "*Raphael*" and "*Kings*" are heavier—Teas weighing from  $9\frac{1}{2}$  to 12 ounces, and Tables 28 ounces. The "*Cottage*," "*Swiss*," "*New Tipt*," "*Corinthian*," "*Louis XIV*," "*Queen*" and "*Tipt*," are well-known to the trade. We invite attention to our "*Antique*" pattern, perfect in outline, plain (except when specially ordered engraved or chased), medium in weight—Teaspoons weighing from  $8\frac{1}{2}$  to 12 ounces; Dessert Spoons and Forks, 17 ounces; Table Spoons and Forks, 25 ounces.

Lithographic Illustrated Sheets of our Patterns will be furnished upon application.

As manufacturers of our own Cases our facilities enable us to offer tasteful and substantial Cases, at moderate cost, plain and ornamental, in morocco and imitation leather, and in various plain and ornamental woods.

## The Gorham Plate.

We offer to the Trade a large and well assorted stock of this Plate, so well-known for its characteristic designs; best of plate, and silver-soldered in every part.

Our stock in all its departments is well supplied with the most desirable goods, and we offer our guaranteed qualities at such prices as, while fully maintaining our high standard, places them within the reach of all.

GORHAM MANUFACTURING COMPANY,  
SILVERSMITHS,

Providence, R. I. and 37 Union Square, N. Y.



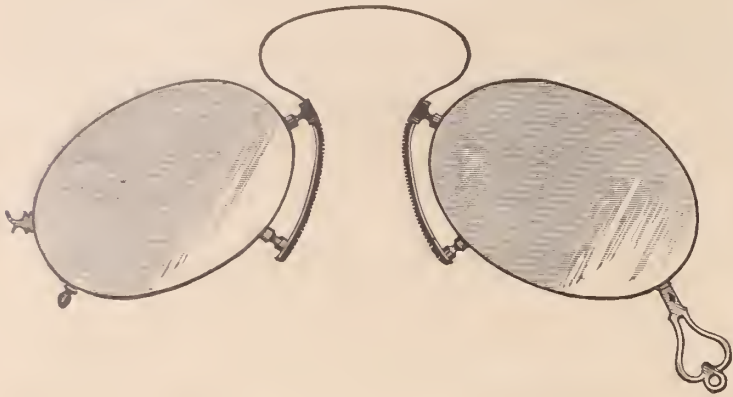

No. 81.

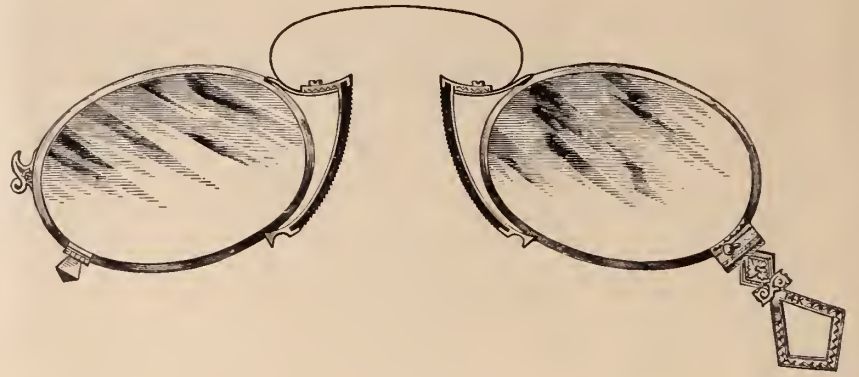

No. 9.



No. 15.

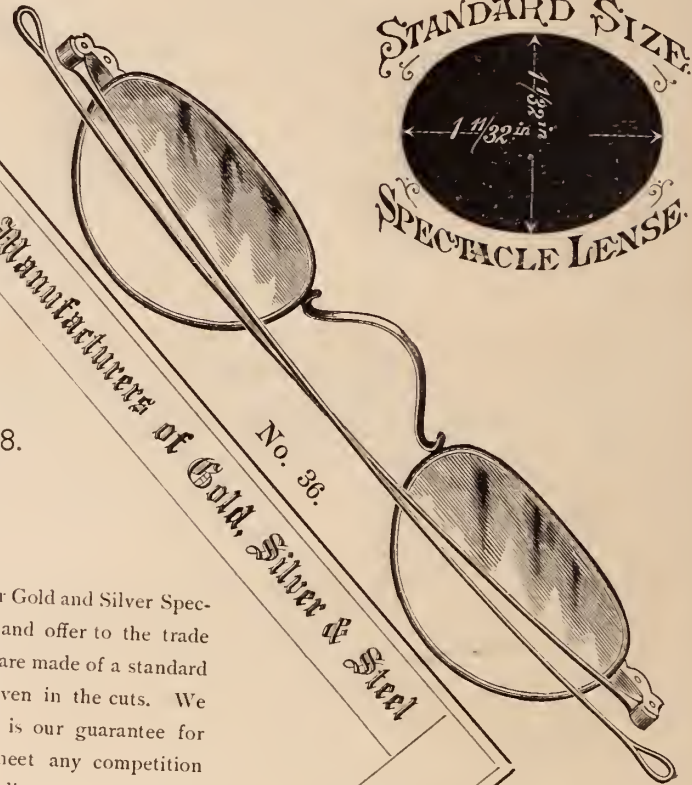

No. 36.

**MORGAN & HEADLY**

Established 1848.

WE are now manufacturing, together with our Gold and Silver Spectacles, a full line of everything in Steel, and offer to the trade the advantage of a *uniform size* of lenses. All are made of a standard size and are interchangeable. The sizes are given in the cuts. We can only add that our reputation in gold work is our guarantee for the steel, and we shall spare no efforts to meet any competition in price as well as maintain our standard of quality.

Illustrated Catalogue mailed on application; from this dealers can order as well as if they had sample case before them.

Respectfully,

MORGAN & HEADLY.

611 & 613 Sanson St., Philadelphia.

Spectacles and Eye Glasses,

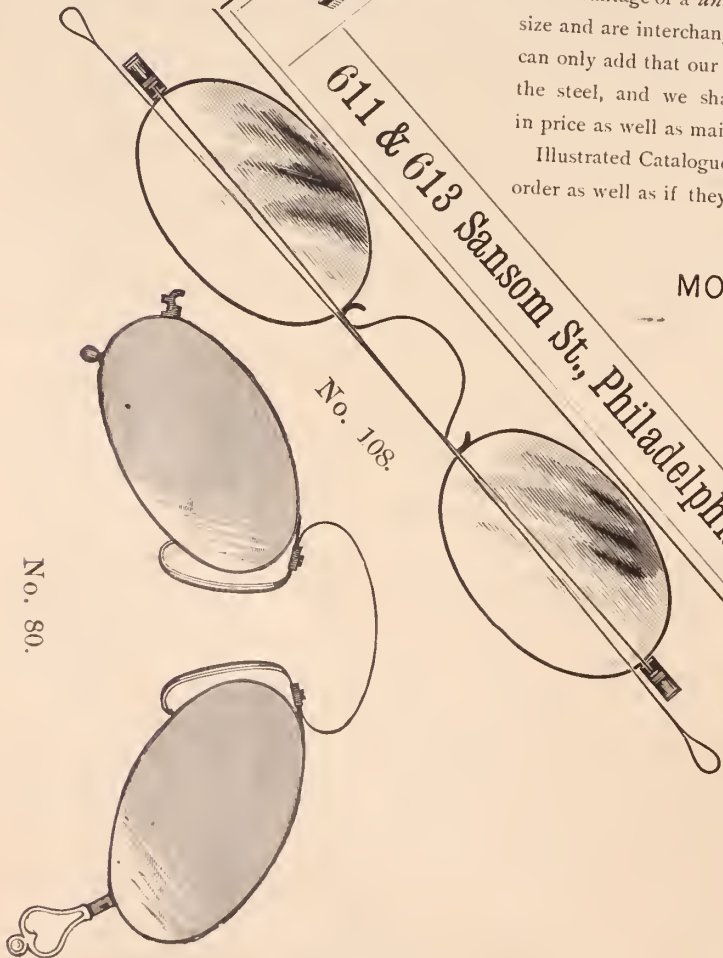

No. 108.

No. 80.

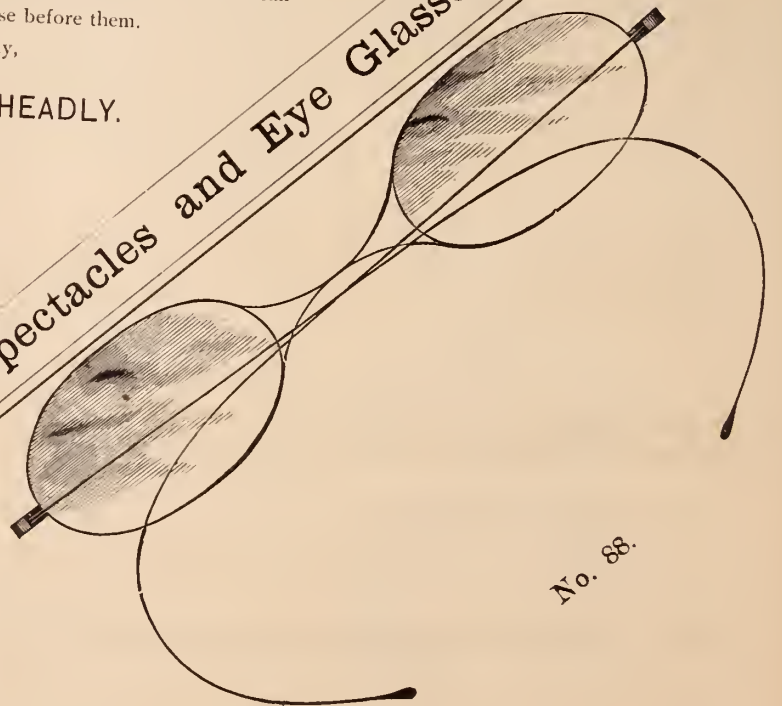

No. 88.

ESTABLISHED 1855.

D. LIECHTY & CO.,

MANUFACTURERS OF

Fine Gold Watch Cases

No. 140 South Third Street,

Fourth Floor.

PHILADELPHIA

Repairing neatly attended to.

AUBURNDALE, MASS.,

**CHRONOGRAPH TIMER,**

WM. B. FOWLE, Maker.

Designed for Sporting, Scientific and Mechanical purposes;  $\frac{1}{4}$  and  $\frac{1}{8}$  seconds, fly back.

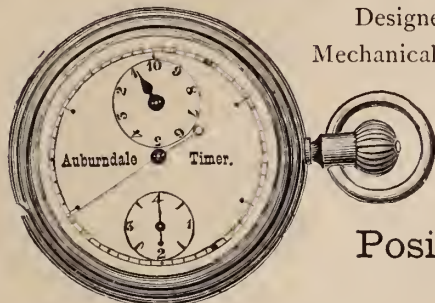

List Price, - - \$15.00

Positively Accurate.

Put up in German Silver Cases, Nickel Plated, size of an ordinary watch. Very neat and handsome, supplying a want long felt by those desiring to measure the flight of time with scientific accuracy to the fraction of a second. It indicates positively minutes, seconds, quarters or eighths of seconds, the only instrument registering one eighth of a second made. It is substantially constructed, positive in its action, and will not easily get out of order.

These Chronographs can be obtained from the principal Jobbing Houses in the Trade.

**BENJ. ALLEN & CO.**

WHOLESALE DEALERS IN

**American and Swiss Watches**

JEWELRY, DIAMONDS,

SILVER & PLATED WARE.

137 and 139 State Street, Chicago.

A full line of Howard Watches in stock. Catalogues sent upon application, to dealers only.

LOUIS A. SCHERR.

CHAS. H. O'BRYON.

G. W. SCHERR.

**LOUIS A. SCHERR & CO.**

Importers and Wholesale Dealers in

**Watches, Jewelry,**

WATCH MATERIALS, TOOLS, GLASSES, &C.

**Spectacles, Silk Guards, &c.**

Wholesale Agents for American Watches.

**No. 726 CHESTNUT STREET,**

FIRST FLOOR,

**PHILADELPHIA.**

WILLIAM BARBER'S

Patent Adjustable Eye-Glass.



PATENTED,  
Jan'y 28, 1879.

The above cut represents an Eye-glass possessing the convenience of an Eye-glass and the utility of a Spectacle combined, thereby rendering it practicable for everyone to avail themselves of their convenience, who have heretofore been deprived of their use.

**TRY THEM, WILL RECOMMEND THEMSELVES.**

We manufacture them from Gold, Nickel, Steel, Shell and Rubber.

WILLIAM BARBER,

Inventor, Patentee and Manufacturer,

No. 248 North 8th Street, Philadelphia, Pa.

**J. H. FRENCH,**  
**AUCTIONEER,**

A Specialty Made of Stocks of

**Diamonds, Fine Jewelry, Watches, &c.**

Refer by permission to the following firms for whom sales have been made:

A. H. Miller, Chicago.

N. Matson & Co., Chicago.

Giles, Bro. & Co., Chicago.

Lloyd & Fritz, Memphis.

F. L. Davies & Bro., Nashville.

Baldwin & Co., St. Joseph, Mo.

Kitts & Werne, Louisville.

E. Jaccard & Co., St. Louis.

Edward Mead & Co., St. Louis.

J. S. Conklin, Detroit.

E. A. Eaton, Grand Rapids, Mich.

Geo. Meyer, Oshkosh, Wis.

J. H. Johnson, New York City.

S. S. Delan, New York City.

F. D. Barnum, Louisville.

Geo. E. Strong, (Successor to E. A. Taylor) New Orleans.

A. Bahn, Austin, Texas.

L. A. Kinsey, Cincinnati, Ohio.

O. L. Rosenkrans, Milwaukee, Wis.

C. A. Belden, Madison, Wis.

Sylvester Hogan, Cleveland, Ohio.

Edward Wood, Bay City, Mich.

C. C. Childs, Pittsfield, Mass.

Office 170 State Street, Chicago, Room 1.

N. B.—All Correspondence strictly confidential.

# COLBY & JOHNSON,

17 Maiden Lane, New York,  
Will be prepared after JUNE 1st, to fill further orders,  
for their Open-Face, Stem-Winding

Nos. 2 & 20,

White Celluloid  
and Gold.

Nos. 1, 10 & 11.

White Celluloid  
and Silver.



Simple,

Durable,

Beautiful,

Economical.

and will introduce, at that time their No. 3 Open-Face Case,  
in White, Black, Malachite or Marbleized Celluloid, Nickel  
center pendant and bow.

The lowest price S. W. Case in the market.

P. S.—No Cases in either Shell or Amber Celluloid.

## SINNOCK & SHERRILL,

### Stone Ring Manufacturers,

NO. 5 MAIDEN LANE,

Factory, Newark, N. J.

**NEW YORK**

Established 1845.

## WILLIAM H. BALL,

SUCCESSOR TO

### BALL & BARNARD,

MAKER OF

Roman, Enameled and Engraved

### BANDS.



Having given the manufacture of Band Bracelets my entire attention  
for a number of years, it has been my desire to make a durable article,  
one that will give satisfaction to the seller as well as the wearer. I de-  
sire to call the attention of the trade to the reduction I have just made  
in prices, still keeping up the standard as to quality, finish and work-  
manship. To each pair of BANDS I attach my patent guard without  
extra charge—thus saving the price of chain—which for seven years  
past has given entire satisfaction.

No. 9 JOHN STREET, NEW YORK.

Factory, 30 & 32 Franklin Street, Newark, N. J.

## E. HOWARD & CO.,

MANUFACTURERS OF

### Fine Watches, Regulators, Office Clocks,

Electric Watch Clocks & Tower Clocks,

**Office, No. 2 MAIDEN LANE,**

**NEW YORK.**

No. 114 TREMONT STREET, BOSTON.

J. W. J. PIERSON, - - AGENT.

ESTABLISHED 1859

## RINGS A SPECIALTY.

BRYANT & BENTLEY,

No. 12 Maiden Lane, New York,

MANUFACTURE A LARGE VARIETY OF

### FINE SOLID RINGS,

For Ladies and Gentlemen, in CAMEO, AMETHYST, ONYX, TOPAZ, TURQUOISE,  
GARNET and other stones. Fine CAMEO, CORAL and ROMAN SETS of new  
and handsome designs. LOCKETS, MEDALLIONS, SHAWL and SCARF  
PINS, SLEEVE BUTTONS, STUDS, &c. All goods warranted.

We continue to manufacture several hundred patterns of **HARD SOLDER**  
**RINGS**, in every style, for men, women and children, stamped and warranted  
16 karat fine.

## BUCKENHAM, COLE & SAUNDERS,

SUCCESSORS TO

BUCKENHAM, COLE & HALL,

IMPORTERS OF

### Diamonds, Pearls

AND OTHER PRECIOUS STONES,

MANUFACTURERS OF FINE JEWELRY,

**10 Maiden Lane, New York.**

A large stock of FINE DIAMONDS, Mounted and Un-  
mounted kept constantly on hand. Goods sent on approval to any  
part of the country on receipt of satisfactory references.

**SAXTON, SMITH & CO.**  
MANUFACTURERS OF

**Fine Gold Chain.**

No. 15 Maiden Lane.

**New York.**

Factory, No. 183 Eddy Street, Providence, R. I.

☞ Sole Agents for the new PATENTED CHAIN BAR, containing a Detachable Pencil.

**MAX FREUND & CO.**

**Manufacturing Jewelers.**

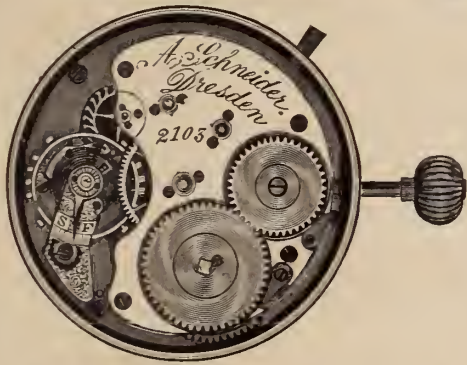

IMPORTERS OF

**Watches**

Jewelry and Precious Stones,  
8 Maiden Lane

**NEW YORK**

☞ Sole Agents for the Celebrated A. Schneider Watch, de n.  
Also the Standard Watch Co. of New York.

**HELLER & BARDEL,**

MANUFACTURERS OF

**Diamond and Pearl Jewelry,**

And Dealers in Diamonds, Pearls, &c.

SHAWL AND LACE PINS IN GREAT VARIETY.

*No. 13 John Street, New York.*

☞ A full line of DIAMONDS, mounted and unmounted; also, a large assortment of first-class DIAMOND MOUNTINGS of our own make always on hand. Sketches submitted at any time upon application. We will send goods on selection to responsible houses.

**KOSSUTH, MARX & CO.,**

No. 39 Maiden Lane, New York,

MANUFACTURERS OF

**Gold and Fine Rolled Plate Jewelry,**

Chains, Necklaces, Locketts, Crosses, &c. &c.

**SOLID GOLD and STONE RINGS**

In large variety,

Diamonds, Pearls, Cameos, Amethysts, Turquoise, &c.

Sole Manufacturers of the Celebrated

**AMERICAN SILK GUARDS.**

**WOOD & HUGHES,**

STERLING

**Silverware Manufacturers**

**No. 16 JOHN STREET,**

**NEW YORK.**

**KREMENTZ & CO.,**

MANUFACTURERS OF

**FINE JEWELRY,**

No. 13 John Street, New York.

Factory, 361 Mulberry Street, Newark, N. J.

GOODS OF OUR OWN MAKE EXCLUSIVELY

CARTER, HOWKINS & SLOAN,  
Makers of Fine Jewelry

*Consisting of Chains, Bracelets, Sets, Pins, Studs, Sleeve Buttons,  
Scarf Pins, Rings, &c., in Roman, Etruscan and Enamel,  
and a full line of Jewelry generally.*

Whiting Building, Corner Broadway and Fourth Street,

A. CARTER JR.  
WM. HOWKINS,  
A. K. SLOAN.

**NEW YORK.**

C. E. HASTINGS,  
GEO. R. HOWE,  
W. T. CARTER.

**HALE & MULFORD,**  
**Manufacturing Jewelers,**

(WHITING BUILDING).

Ne. 694 Broadway, cor. 4th Street, New York.

Call attention of the Trade to their new style of

**BAND BRACELETS,**

We claim for these Bracelets, the following advantages over the old style, viz. :

1st. The edge of the Bracelet being raised, forms a protection to the ornamentation.

2d. Less liability of getting lamed, and when damaged, are more easily repaired.

3d. More attractive in appearance.

Prices are as low as any FIRST CLASS 14 KARAT ALL GOLD Bracelet in the market.

Made in all sizes from  $\frac{1}{4}$  inch upwards.

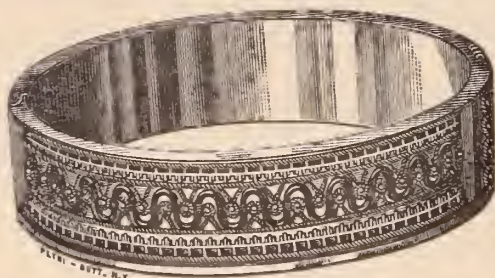

Patented February 25, 1879.

—Established 1837.—

**TAYLOR & BROTHER,**

Late TAYLOR, OLMSTED & TAYLOR,

**Importers of Diamonds and Pearls,**

—AND—

**MANUFACTURERS OF DIAMOND JEWELRY,**

No. 676 BROADWAY,

**NEW YORK.**

**BALDWIN, SEXTON & PETERSON,**

MANUFACTURERS OF

**Fine Jewelry,**

Diamond and Stone Cameo Goods,

**GOLD CHAINS, &c.**

Importers of Diamonds, Pearls, Emeralds, Rubies, &c.

WHITING BUILDING,

**Cor. Broadway and Fourth Street,**

**NEW YORK.**

120 SUTTER STREET, San Francisco, Cal.

Established 1817.

**Ve. J. MAGNIN, GUÉDIN & CO.**

*Manufacturers and Importers,*

FINE SWISS WATCHES.

REPEATERS, CHRONOGRAPHS & CALENDARS

GENEVA GOLD JEWELRY,

FRENCH CLOCKS AND BRONZES,

RICH FANCY GOOCS,

HORSE-TIMERS & PEDOMETERS,

GOLD AND SILVER CHATELAINE WATCHES.

Gold Medal Awarded, Paris Exposition, 1878.

*Sole Agents for the James Nardin Watch*

*House in Geneva, 14 Grand Quai.*

Established 1813.

**THOMAS G. BROWN,**

MANUFACTURER OF

**FINE JEWELRY.**

*Designs furnished for all kinds of Sporting  
Badges and Medals for Schools & Colleges.*

**NEWARK, N. J.**

—AND—

**9 BOND STREET, NEW YORK.**

MAY, 1879



42 NASSAU STREET, NEW YORK

Established 1813.

# SETH THOMAS CLOCK CO.

THOMASTON, CONN.

No. 20 MURRAY STREET, New York.

16 Worship Street,  
LONDON, E. C.

172 State Street,  
CHICAGO.

7 Montgomery Street,  
SAN FRANCISCO.

APRIL 10th, 1879.

Competition has forced prices pretty low for goods in our line.  
Our list of prices dated January, 1879, was very carefully made up from present cost and quality. We do not expect to deviate from it, excepting to close out goods not up to standard.

Our rule is better goods—not lower prices—and we beg your pardon for not having kept it better.

Very truly,

SETH THOMAS CLOCK COMPANY.

# F. KROEBER,

Manufacturer of CLOCKS,

No. 8 Cortlandt St.,

New York.

FACTORIES:—NEW HAVEN, CONN., AND  
NEW YORK CITY.

SUPERIOR GRADE OF

WALNUT CLOCKS A SPECIALTY

SOLE AGENT FOR

E. INGRAHAM & CO.

—AND—

CLOCKS OF ALL MAKERS,

AT LOWEST MARKET PRICES!

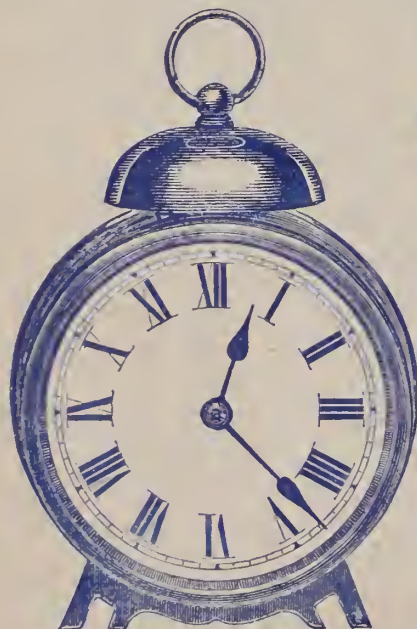

"AURORA."

1 Day Lever, Alarm, Nickel. Height, 5½ inches.



"THISTLE."

1 Day Lever, Alarm, Nickel. Height, 8½ inches.



ALFRED H. SMITH.  
AND  
CO.

IMPORTERS of

# DIAMONDS

114 JOHN ST. N.Y.

THE FINEST GOODS  
IN SINGLE STONES  
AND MATCHED PAIRS  
CONSTANTLY IN STOCK  
ALSO THE MEDIUM AND  
LOWER GRADES OF  
DIAMONDS.

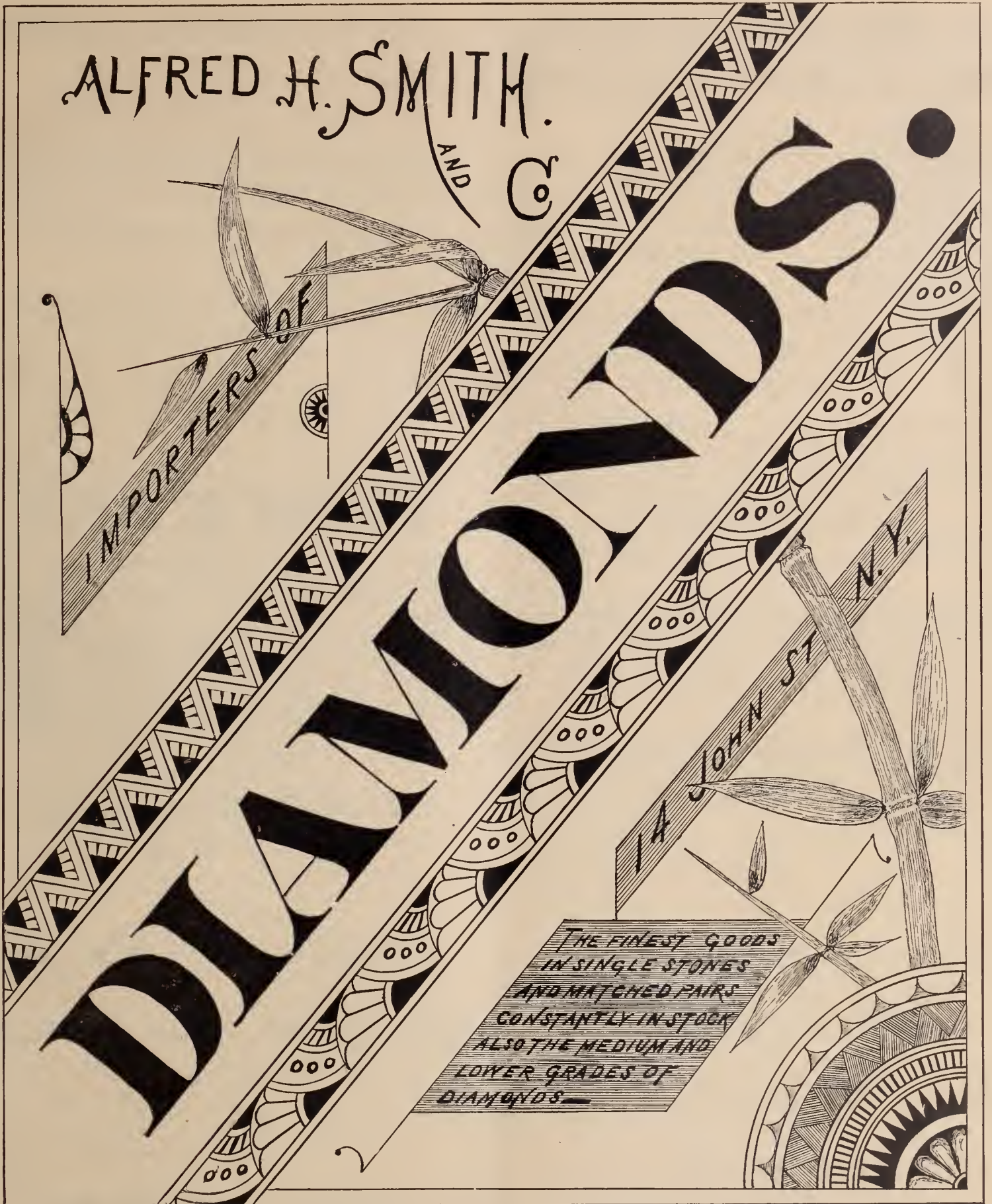

Established 1834.

**G. & S. OWEN & CO.,**  
Makers of Fine GOLD JEWELRY

SPECIALTIES :

Black Onyx Goods,  
Roman & Polished Goods,  
Hair Chain Mountings,  
Sole Makers

OF

**BOX AND GLASS GOODS.**

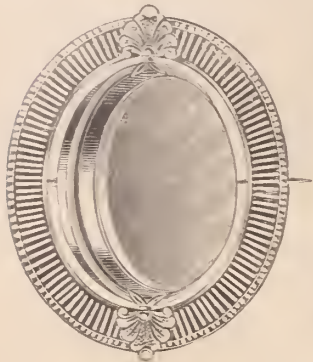

All our goods exclusively of our own manufacture.

5 MAIDEN LANE, NEW YORK.

**JOHN A. RILEY & CO.,**  
MANUFACTURERS OF

**Fine Gold Jewelry**

AND ONYX GOODS,

**Nos. 7 & 9 Bond Street, New York.**

No. 126 Kearney Street, San Francisco, Cal.

**MOORE & HORTON,**

**JEWELLERS,**

*No. 11 Maiden Lane, New York.*

**SPECIALTIES!**

Stone Cameo, Onyx, Amethyst, Topaz and Pearl Rings,  
Studs, Collar and Sleeve Buttons.

Also our new fac-simile of Fine African Diamonds, mounted in  
Rings, Studs, Pins, Ear-rings, Scarf Pins, McCallions.

Established 1846.

**WILLIAM RIKER,**

*No. 5 Maiaen Lane, New York.*

Factory, 42 Court Street, Newark N. J.

Makers of a Fine Line of Society Charms and Pins. Medals  
made to order.

DYER BRAINERD.

JOHN W. STEELE.

**BRAINERD & STEELE,**

MANUFACTURERS OF

**Brainerd's Pat. Locketts,**

(Patented June 17, 1874.)



These Locketts combine both beauty and strength. They are made of solid 14kt. gold, and the stones used are the finest obtainable in the market. They cost no more than those of the old style, if indeed as much; and the combination of secrecy and durability renders them much more desirable. We make three sizes in four different shapes—round, oval, cushion and oblong square; and also Sleeve Buttons of the same style, containing a concealed box for miniatures, a novelty new to the Trade.



**FINE GOLD JEWELRY,**  
**No. 9 Maiden Lane,**  
**NEW YORK.**

**W. H. SHEAFER & CO.,**

**Makers of Fine Jewelry**

CONSISTING OF

BRACELETS, SETTS, LOCKETS, PINS,

STUDS, SLEEVE BUTTONS, RINGS, &c.

**SPECIALTY:—STIFFENED ROMAN BANDS.**

**No. 908 Chestnut Street, PHILADELPHIA**

Branch Office 15 John Street, New York.

# WM. S. HEDGES & CO.,

*Of the late firm of SMITH, HEDGES & Co.*

IMPORTERS OF

# DIAMONDS,

No. 170 Broadway, cor. Maiden Lane,  
NEW YORK.

*Choice Brilliants in single stones and matched pairs a specialty.*

GOODS SENT ON APPROVAL.

# CHATELLIER & SPENCE,

## Manufacturing Jewelers,

694 BROADWAY, NEW YORK.

No. 1129 Chestnut Street, PHILADELPHIA, PA.

No. 12 West Street, BOSTON, MASS.

No. 120 Sutter Street, SAN FRANCISCO, CAL.

# ENOS RICHARDSON & CO.

MANUFACTURERS OF

## FINE GOLD JEWELRY,

Gold Chains, Locketts, Crosses and Necklaces,  
COLORED AND ETRUSCAN WORK.

ENGRAVED AND ENAMELLED GOODS IN GREAT VARIETY.

All Goods sold strictly of our own manufacture.

23 MAIDEN LANE, NEW YORK.

ENOS RICHARDSON,  
THOS. SLATER,

L. P. BROWN,

F. H. RICHARDSON,  
W. P. MELCHER.

# WANTS OF FINE JEWELRY WANTING BROS. & CO. WANTS OF FINE JEWELRY

Full Line of Roman and Mosaic Goods,  
Earrings, Buttons, Studs and Rings.

SPECIALTIES:

ENGRAVED AND ENAMELED BANDS,  
CAMEO GOODS.

170 BROADWAY, NEW YORK.

# LYON & HARDY,

30 MAIDEN LANE, NEW YORK,

IMPORTERS OF



AND MANUFACTURERS OF

## DIAMOND MOUNTINGS.

All goods ordered for stock or on approval are insured while in the hands of Express Companies.

# WHEELER, PARSONS & HAYES,

MANUFACTURERS OF



AND DEALERS IN

AMERICAN AND SWISS WATCHES,

No. 2 MAIDEN LANE, NEW YORK

# J. B. BOWDEN & CO.

Manufacturer of

SOLID GOLD AND STONE

## RINGS

All Styles of Children's

AND

FANCY SOLID RINGS,

A LARGE ASSORTMENT ALWAYS ON HAND.

No. 1 Maiden Lane, New York.

IMPORTER OF DIAMONDS

E. AUG. NERESHEIMER

21 MAIDEN LANE,

N<sup>o</sup> 1 GAERTNER PLATZ
N<sup>o</sup> 24 DOELEN STRATT

NEW YORK

MUNICH-GERMANY.
AMSTERDAM-HOLL.

DIAMONDS LOOSE & MOUNTED SENT ON APPROVAL AND THE VALUE INSURED

Platinum Tipped Diamond Settings,

Patented April 16th, 1878, by

Ripley, Howland & Co.



Office, No. 35 Maiden Lane, New York.

Factory, 383 Washington Street, Boston, Mass.

RANDEL, BAREMORE & CO.

DIAMONDS,

Corner Maiden Lane and Nassau St.

29 Maiden Lane, **NEW YORK**, 58 Nassau Street.

No. 12 New Burlington Street, LONDON, W.

CARROW, BISHOP & CO.

SUCCESSORS TO

Carrow, Crothers & Co.

MANUFACTURERS OF

Fine Gold Jewelry

No. 12 JOHN STREET,

NEW YORK.

JOSEPH N. TINGLEY,

Late of the firm of Tingley, Sinnock & Sherrill,

MANUFACTURER OF

STONE RINGS,

—AND—

NOVELTIES IN STONE GOODS,

No 9 Maiden Lane,

New York.

FACTORY, NEWARK N. J.

**GUTMANN'S**

**Automatic Hammer and Punches**

Simplified and More Effective.

THIS TOOL takes the place of the third hand, therefore its manifold uses are quickly apparent, and I would only say that it is accompanied by six punches, to wit: 2 hand punches, 1 prick punch, 1 closing hole punch, 1 rivet punch, and 1 union punch, all of which fit neatly into the punch holder, and are fastened by the screw. Its tap is alternately heavy and light and the finger loops are assorted in sizes. The Tool is nickel-plated and boxed, ready to be mailed on receipt of price.

THE OPERATION IS AS FOLLOWS: First, set the hammer; next insert your forefinger through the loop at the top and place the punch with firmness on your work. When you are ready for the blow, push gently on the thumb-piece which produces the concussion on the punch. Your left hand is entirely free to hold the work.

Price, \$2.00; Reduced from \$2.50.

**MX L. GUTMANN,**

Patentee and Manufacturer.

Also, Importer and Wholesale Dealer in

Watch and Jobbing Materials, Tools, Glasses,  
Chains, Guards, Jewelry and Watches.

PLEASE SEND YOUR ORDERS.

**ROCHESTER, N. Y.**

**CHAS. P. HEROLD,**  
**MANUFACTURING JEWELER,**  
**DIAMOND SETTER**  
AND DEALER IN  
**DIAMONDS.**

916 CHESTNUT ST. PHILA.

N.B. A LARGE STOCK OF 18 Kt. DIAMOND MOUNTINGS, SUCH AS CLUSTER AND SOLITAIRE RINGS, EARRINGS, LACE PINS, SHAWL PINS, CROSSES, STUDS, AND GENTS' PINS, &c, ALL OF WHICH ARE OF MY OWN DESIGNS AND ARE MADE IN THE FINEST STYLE AND FINISH.

**J. A. BROWN & CO.**

OFFICE AND SALEROOM:  
No. 11 Maiden Lane, N. Y.

FACTORY:  
No. 104 Eddy St., Providence, R. I.

SOLE MANUFACTURERS OF THE

**Ladd Patent Stiffened Gold Watch Cases**

The Best and most durable, and the

CHEAPEST STIFFENED Gold Watch Case

FOR THE MONEY

MADE IN THE WORLD!

All genuine Watch Cases of our manufacture have "G. W. Ladd's Patent, June 11, 1867," stamped upon the side band underneath the glass bezel.

REFUSE ALL OTHERS.

Send for full Descriptive Circular to the

OFFICE AND SALEROOMS

11 Maiden Lane, N. Y.

Dealers can obtain them of the Wholesale Watch and Jewelry Houses, or their Traveling Agents throughout the United States and British Provinces.



KEY AND STEM WINDING

Hunting and Open-Face

IN FLAT BEVEL,

Mansard and Oval

SHAPES

Adapted to the various

AMERICAN-MADE MOVEMENTS,

IN

8, 10, 14, 16 & 18

SIZES.

Medal and Diploma of Merit Awarded by Centennial Com.

**S. C. JACKSON,**

MANUFACTURER OF FINE

**CASES**

For Jewelry, Silver Ware, Trays, &c.

180

**BROADWAY,**

**NEW YORK.**



**SPENCER OPTICAL MANUFACTURING COMPANY,**

**SOLE MANUFACTURERS.**

**No. 13 MAIDEN LANE, NEW YORK.**

(Copyright by Spencer Optical Manufacturing Co., 1873.)

**SOMETHING NEW !!**

**CELLULOID EYE GLASS FRAMES,**

Representing the Choicest Selected

Tortoise Shell and Amber.

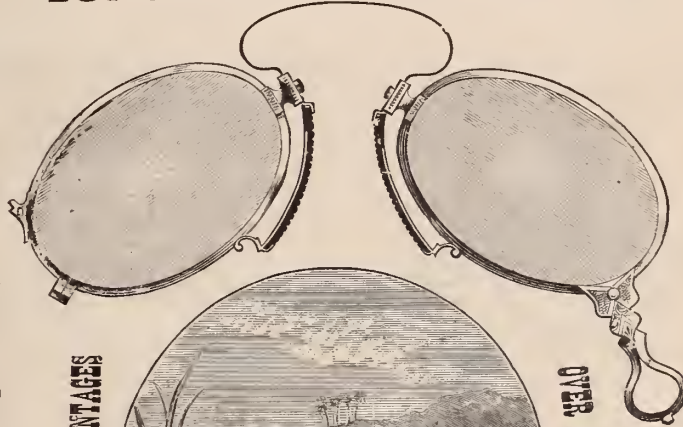

THEY HAVE GREAT ADVANTAGES

OVER ALL OTHER EYE GLASSES

(Turtles rejoicing over the discovery of Celluloid Tortoise Shell, Their Occupation Gone.)

They are much Lighter than any others. Twenty-five pairs of the frames weigh only one ounce.

They are much Stronger and more Durable than any others; they can be Dropped Without Injury upon the hardest substance.

Their Beauty Far Surpasses the ordinary Tortoise Shell Frames commonly in use.

They are Not Affected by Atmospheric Changes, being equally well adapted to either warm or cold climates.

They are made with Different Sized Frames to suit persons whose eyes are either near or far apart.

The Springs are made of a combination of metals which will neither Rust nor be effected by heat or frost.

These frames are set with Fine Lenses, accurately focused to suit all sights, which with the many other advantages, make them Very Popular.

**ASK YOUR OPTICIAN OR JEWELER TO SHOW THEM TO YOU.**  
Every Pair Stamped on Handle S. O. M. Co. Pat. Mar. 13, '77.

# HART & SLOAN,

BUILDERS OF

## Watch Machinery,

AND MAKERS OF

### INTRICATE MECHANICAL INSTRUMENTS,

363 & 365 MARLET STREET,

NEWARK, N. J.

Having purchased a large lot of Watch Machinery, which we have fitted up and have now at work, are prepared to take orders for all kinds of small work, Guages, parts of Watches, and fine Instruments of every description.

We have also for sale a lot of small Lathes and special Tools for Watchmakers and amateurs, suitable for repairing Watches and Clocks. We can also furnish all kinds of new Watch Machinery, or special Tools for Clocks, or other fine work; and Small Screws of every description, from 220 to 40 threads to the inch, diameter to correspond.

MANUFACTURE DE MONTRES DE PRÉCISION  
simples & compliquées  
& DE CHRONOMETRES

Maison fondée en 1811



L. AUDEMARS

BRASSUS

Canton de Vaud (Suisse)



MAISON à Genève

PARIS

Londres New-York

VIENNE

ST.-PETERSBOURG



COURTÈRE PARIS M. L'EMPEREUR D'AUTRICHE



1878

1878

1878

1878

1878

1878

## LOUIS AUDEMARS'

CELEBRATED

# WATCHES

## ANNOUNCEMENT TO THE TRADE!

I have the honor to inform you that the jurors of the Exposition Universal at Paris have awarded me the **FIRST GOLD MEDAL** for the superiority of my **WATCHES**, and that the French Government in recognition of my services in the art of horology has conferred upon me the **CROSS OF THE LEGION OF HONOR**.

LOUIS AUDEMARS.

BRASSUS SUISSE.

The **CROSS OF THE LEGION OF HONOR** is the highest badge of distinction ever conferred on any horologist.

J. Eugene Robert,

SOLE AGENT,

No. 30 Maiden Lane, N. Y.

A Complete Line of these Celebrated Watches always in Stock.

# American Watch Tool Co.

P. O. Box 999

WALTHAM, MASS.

MANUFACTURERS OF THE WHITCOMB LATHE,  
AND  
Machinery for Watch, Watch Case and Clock Making.

NEW YORK OFFICE WITH

L. H. KELLER & CO., 64 Nassau Street.

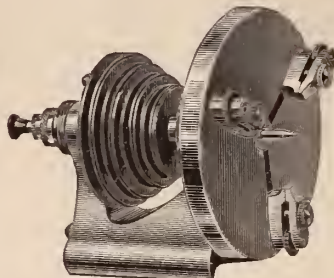

Universal Lathe.

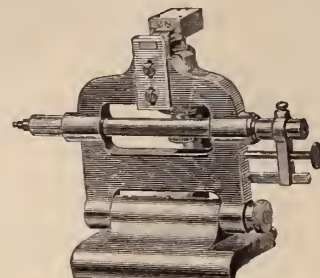

Jewelers Reel.

HIGHEST AWARD:  
PHILADELPHIA, 1876.  
BOSTON, - - 1878.

Chicago Office with Chas. Wendell & Co., No. 170 State Street.

# Kearney & Swartchild,

Manufacturers of

## "TRIUMPH" LATHE.

Price, Hardened Bearings and Spindles, \$40.00

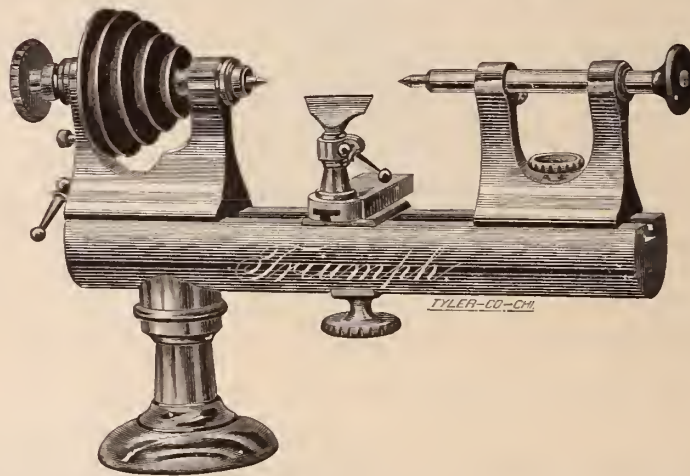

All Split and Wire Chucks are tempered and ground, which makes them perfectly true.

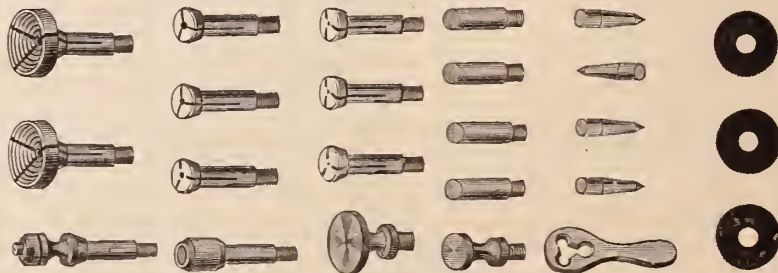

Importers and Jobbers of Tools and Materials, Watches, Jewelry, &c.

Manufacturers of Watchmakers' and Jewelers' Tools.

Illustrated Catalogue sent on application to parties sending business card.

Nos. 113 & 115 State Street, Chicago, Ill.

ESTABLISHED 1853.

C  
C  
L  
O  
C  
K  
S



C  
C  
L  
O  
C  
K  
S

**B. J. COOKE'S SON,**  
137 N. 3d Street, Philadelphia.  
Catalogues and Price Lists furnished only on application.

**J. H. PURDY & CO.**

Jobbers of Imported and Domestic

**TOOLS & MATERIALS,**

For the use of Watchmakers, Jewelers, and kindred trades.

WATCH GUARDS, JEWELRY BOXES, SPECTACLES, CARDS,  
SPECTACLE CASES, PEARL GOODS, STEEL CHAINS, -  
TAGS, RUBBER TYPE, &c.

No. 170 State Street, Chicago, Ills.

OFFICE WITH CHAS. WENDELL & CO.

ESTABLISHED 1855.

**WELCH & MILLER,**

MANUFACTURERS OF MOROCCO, VELVET AND SATIN

**Jewelry Cases, Trays, &c.**

Telescope Sample Cases, with Flexible Trays.

COMPLETE STOCK ON HAND.

No. 169 BROADWAY, NEW YORK.

CATALOGUES SENT ON APPLICATION.

**GEO. B. WHEELER,**

**NEW BEDFORD, MASS.**

MANUFACTURER OF FINE

**Watch and Clock Oil.**



THE PORPOISE.

This Oil is made from the best of stock, is free from gum or corrosion, will stand the coldest weather, and is every way reliable.

**L. HAMMEL & CO., Sole Agents,**

No. 9 Maiden Lane, New York.

KOCH & CO., Elberfeld, Prussia, Sole Agents in Europe.

**Charles F. Terhune & Co.,**

**Manufacturing Jewelers,**

17 Maiden Lane,

New York:



Sole Manufacturers.



We beg to call the attention of the trade to the above cuts representing

**PATENT SLIDE BUTTON**

It is not separable, but works on a simple slide. It can be put in and taken out easier than any button made without soiling the cuff. Recommends itself at sight.

A FULL LINE OF ENAMEL AND STONE GOODS IN ABOVE PATENT.

**H. Muhr's Sons, Philadelphia.**

**MANUFACTURING JEWELERS,**

**Solid Gold Finger Rings of Every Description.**



Crown, 18k. Lion.



On and after January 1st, 1876, our make of Filled Plain Rings will be stamped as above, which stamp is copy righted. Any and every infringement on the above Trade Mark will be dealt with according to law. Every one warranted.

**THESE GOODS ARE SOLD BY ALL THE LEADING JOBBERS!**

Should the house that any retailer deals with not have them we will furnish them with the address of the nearest Jobber. **SELL TO THE JOBBING TRADE ONLY!**

**New York Office, 11 Maiden Lane.**

Address all communications to Philadelphia.

**BERNARD LEVY,**

**Manufacturer of Watch Cases**

—AND—

**JOBBER OF AMERICAN MOVEMENTS,**

No. 402 Library Street,

**PHILADELPHIA.**

ALSO, ORNAMENTAL ENGRAVER AND ENGINE TURNER.

Lubricating Oils, for Watch, Clock and Chronometer Makers.

The discovery of a Lubricator for FINE MACHINERY, such as Watches, Clocks and Chronometers, that is free from gum and corrosive substances, has taxed the ingenuity of hundreds of men whose efforts have proved a failure. But we are happy to say (being largely interested) that such an article has been supplied by MR. EZRA KELLEY, of New Bedford, Mass., who, after forty years study of the subject, has perfected a Lubricator that recommends itself to all who have used the genuine, (there having been numerous counterfeits in the market.) as witness also the award of a

Diploma and Medal

by the judges of the

late Centennial Ex-

hibition at Philadel-

phia. We have no

hesitation in saying

that his Oils are the

BEST manufactured,

always uniform in

quality and capable

of standing all tests

applied to lubricat-  
ing

oils. We cheerfully recommend it to all who may in their

business require a FIRST-CLASS LUBRICATOR

SETH THOMAS CLOCK COMPANY, SETH E. THOMAS, Agent.

P. S.—The above Oils can be procured at all first-class

wholesale Watch and Clock Establishments in the United

States, as well as his only Agents, GRIMSHAW & BAXTER,

35 Goswell Street London England.

New Bedford, October, 15, 1877.



Dealers in Watches,

Importers of Diamonds.

**OPPENHEIMER, BROS. & VETH,**  
Manufacturing Jewelers

35 MAIDEN LANE,

S. Oppenheimer, }  
A. Oppenheimer, }

New York.

{ Henry F. Veith  
{ Gus F. Veith.

PFORZHEIMER.

D. KELLER.

**PFORZHEIMER & KELLER,**

IMPORTERS OF

**Watches and Diamonds**

Dealers in American Watches,

AND

Manufacturers of Jewelry,

No. 24 JOHN STREET,

NEW YORK.

P. O. Box 4144.

**Mathez Watch Company of New York.**

Gents' and Ladies' Stem-Winding Movements

STRAIGHT LINE, 3-4 PLATE NICKEL.

These Movements are of six different grades, uniform in size and beautifully finished, and will be SOLD AT LOWER PRICES than any other goods of similar excellence.

A FULL LINE of materials for our movements always kept in stock for the convenience of those using our goods.

**F. H. MATHEZ, Sole Agent,  
No. 5 Maiden Lane, New York.**

**L. A. CUPPIA,**

19 UNION SQUARE, NEW YORK.

(FORMERLY WITH ERRICO BROS.)

Manufacturer of Novelties in Fine Silver,

Lace Pins, Sets, Scarf Pins and Combs,

IMPORTER OF

**SILVER FILIGREE,**

CORAL AND CONCH SHELL.

Manufactories, 33 John Street, New York and Naples, Italy.

**BREITINGER & KUNZ,**  
Importers of Watchmakers' Tools,  
MATERIALS, CLASSES, &c.  
**No. 107 North Ninth Street,  
PHILADELPHIA.**

Dealers in all kinds of American Watch Materials and American Clock Material. Specialties in Materials for Musical Boxes, Cuckoo Clocks, &c.

Sole Agents in the United States for Bahri Brothers Hued and 1 Tempered Hairsprings. Agents in the U. S. for J. Becker's (Freiburg, Germany) Gold Medal Regulators, the best in the market. A large assortment of all patterns always on hand; Movements with second's pendulum for watchmakers' use—all kinds of materials for the same.  
Wheel Cutting and work done for the trade.

**EDWARD TODD & CO.,**

MANUFACTURERS OF

**GOLD PENS,**



Pencil Cases, Tooth Picks, &amp;c.

**No. 652 BROADWAY,**

Factory, 29 &amp; 31 South 11th St., Brooklyn.

**NEW YORK.**

**Dorrance, Edge & Co.**

MANUFACTURERS OF

THE CELEBRATED WOVEN FABRIC

**GOLD CHAIN.**

*Elegantly Mounted Bracelets, Opera, Leontine,*

VICTORIA WATCH GUARDS &amp; NECKLACES, in all the Newest Desins.

Our stock is unusually complete, and, in addition to the above, a variety of Necklaces, from 1½ to 40 dwt. each, to which we invite the attention of buyers.

**No. 9 John Street, New York.**

Factory, 46 Greene Street, Newark, N.J.

LEOPOLD WEIL,

*Manufacturing Jeweler,*

And Dealer in the Latest Novelties in

**Rolled-Plate Jewelry,**

A select assortment of which I have always on hand.

16 MAIDEN LANE, N. Y.



MANUFACTURERS  
—OF—  
EXCLUSIVELY  
**BLACK ONYX GOODS.**

The patented **DEEP MOURNING LOCKETS** are original with us, and have stood the test of years of wear. They meet the approval of the trade and the wearers for their superior make and finish, as well as for the correctness of the mechanical principle on which they are constructed.

**WOGLOM & MILLER,**  
32 & 34 JOHN STREET,  
NEW YORK.

**HENRY FERA,**  
Importer of **Diamonds,**  
No. 9 MAIDEN LANE,  
**New York.**

Having my own cutting and polishing establishment at Nos. 23 and 25 Looijersgracht, Amsterdam, Holland, constantly running 36 mills, I am able to offer to the trade a full assortment of Diamonds at very low prices.  
Loose and Mounted Goods sent on approval to any part of the country on receipt of satisfactory references.

**BOOZ & THOMAS,**  
MANUFACTURERS OF



**Watch Cases & Jewelry,**  
**108 SOUTH EIGHTH STREET,**  
Second Story, **PHILADELPHIA.**

Illustrated Catalogues sent upon application.  
**Old Gold & Silver Bought or Exchanged.**  
PARTICULAR ATTENTION PAID TO REPAIRING.

**HAMILTONS & HUNT,**  
MANUFACTURERS OF

**Fine Plated Chains**  
AND PATENT BUCKLE BRACELETS.  
**Branch Office, 176 Broadway, New York**  
FACTORY, 226 EDDY STREET, PROVIDENCE, R. I.

**T. B. BYNNER,**  
Importer & Jobber of **Watches**  
DIAMONDS AND FINE JEWELRY,  
And Dealer in the BEST CLASS OF ROLLED PLATE JEWELRY  
And Key and Stem-Winding American Watches.  
**No. 513 Broadway, New York**



**W. C. GREENE & CO.**  
MANUFACTURERS of **GOLDSMITHS.**  
RICH SETS IN TAPER WIRE CORAL

Factory 95 PINE ST. PROVIDENCE, R. I.  
Stone-Cameo Engravers Enamel Sets Brooches Sleeve Buttons Studs Crosses EAR DROPS &c.

NEW YORK OFFICE, NO. 192 BROADWAY.  
Wm. C. Greene, B. W. Greene, Geo. D. Briggs.

**Notice Removal.**

CHAMPENOIS & CO., Manufacturing  
Jewelers, will remove from  
No. 1½ to No. 1 Maiden Lane,  
Cor. Broadway.  
Manufacturers of Jet & Enamel Goods  
Factory, 44 Hill St., Newark, N. J.

**MILNE & JOURDAIN,**  
Manufacturers of Stem-Winding Watch Crowns



**13 & 15 Franklin Street, NEWARK, N. J.**

Gold Crowns, for Stem-winding Movements, to suit all sizes of Imported or American Watches, in four different styles and seven sizes.  
Gold Pushers for Key Movements in every size. Also Gold Crowns for fine Chronograph Watches made to order.  
Silver Stem winding Crowns and Key Pushers on hand or made to order. Send for card and samples.

A. MILNE. A. JOURDAIN.

# DESCRIPTION OF THE NEW PATENT DUST-PROOF STEM WINDING OPEN FACE CASE

Manufactured by  
**THE AMERICAN WATCH COMPANY, WALTHAM, MASS.**  
 SPECIALLY ADAPTED FOR RAILROAD USE.

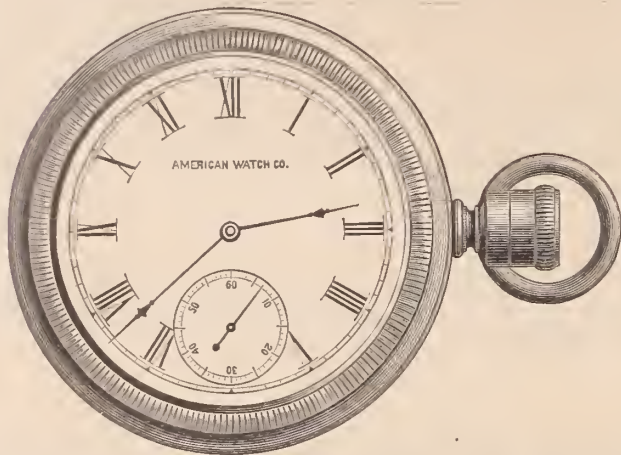

This open-face watch case, which is formed in one seamless piece in any desired shape, opens in the front only to receive the movement. The continuous construction of the body of the case avoids the usual cap and greatly conduces to strength and constitutes one feature of the invention.

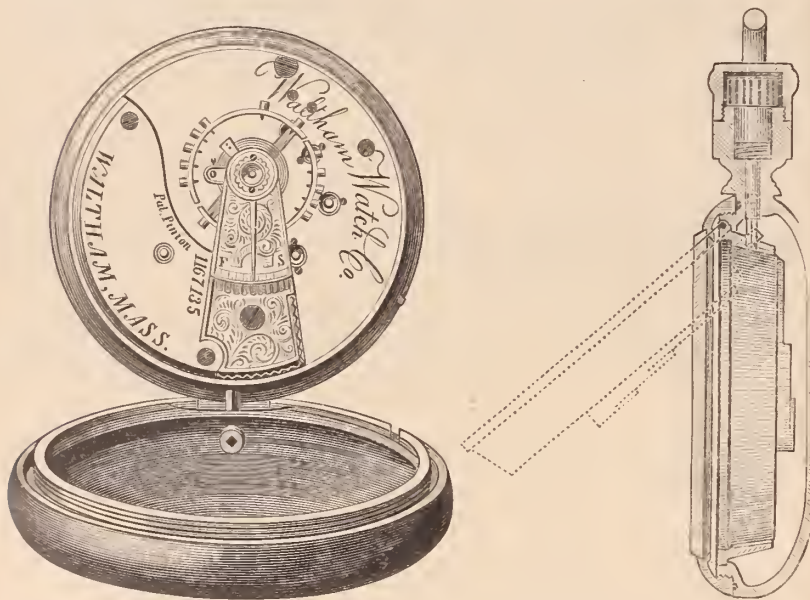

The movement of the Watch is held in a sustaining ring which is hinged to the case on the front edge of the aperture in such a manner that when the bezel is removed the ring with its contained movement may be swung outward, thus rendering the movement readily accessible, and obviating the necessity of a back cap or lid, which thus enables the case to be formed in one seamless piece and constituting another feature of the invention.

The movement is held in the ring in the manner usual in American Watches, and this ring is hinged to the rim of the case just at the base of the stem, the movement being so arranged therein that the winding stud of the movement comes in line with the winding-key of the stem and properly engages therewith. When the movement is to be swung out, however, the stem-winding crown may be pulled partly out, as usual, so as to draw the key out of engagement with the stud, and thus permit the outswing of the movement, as will be understood, the parts becoming readily engaged, when the movement is again swung into the case.

The bezel, into which the crystal is fitted with an especially prepared water-proof, transparent cement, is attached to the case by screwing it thereon, the ring of the bezel being formed with an internal screw thread which meshes with a corresponding thread on the shouldered rim on the face of the case, and as the bezel is thus screwed tightly down the level edge of the rim, forms the air-tight joint with the shouldered rim of the case, which is proof against the entrance of dust or moisture, as will be appreciated.

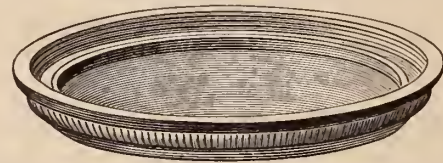

By making the screw-thread on the interior of the bezel, so as to fit a corresponding thread on the interior of the case, we are enabled to construct a watch with only one division in the case, and thus the entrance of dust or moisture to the movement is entirely prevented, which is a very great advantage as compared with those cases in which there is an opening both front and back. The face of the bezel is formed with a marginal circle of milling which affords sufficient frictional grasp to enable the bezel to be readily screwed on or off.

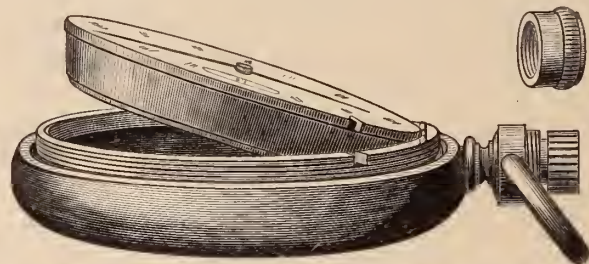

Another feature of the invention consists of the removal of the stem cap, which is designed to tightly fit upon the top of the stem winding-crown, so as to prevent the entrance of any dust or other foreign matter at that part. The stem-cap is attached to the stem by screwing it thereon in the manner of the bezel, and may be readily unscrewed when it is desired to wind the watch, as will be understood.

The cap is of similar diameter with the body of the stem, which latter is formed with a short threaded neck, which screws into the threaded bore of the cap, the bevel edge of the cap being screwed down tightly on the smooth shoulder of the neck so as to form a perfectly tight joint, which effectually prevents the infiltration of any dust or moisture thereat.

These combined features of construction thus form a watch which, while being simple and complete, has the great advantage of being impervious to the entrance of dust or wet. These latter qualities are found to be of great importance to those persons, who most use this class of watches, such as railroad men, travelers, miners, lumbermen and others, who have to make frequent reference to the watch, and who are almost constantly exposed to the influence of dust or moisture.

This new case is made by us both in gold and silver.

It insures great strength and durability with a small amount of metal. Thus a gold case weighing 25 dwts. has a strength of back equal to that of an ordinary case of 30 dwts. to 35 dwts.

It is also made with jointed bezel instead of the threaded screw bezel, if desired.

PRICE LISTS FURNISHED TO THE TRADE ONLY, UPON APPLICATION.

**ROBBINS & APPLETON, General Agents,**

9 Bond Street, New York.

8 Summer Street, Boston.

170 State Street, Chicago.

Holborn Circus, London.

Office of  
**ROBBINS & APPLETON,**  
 AGENTS FOR  
 American Watch Company,  
 No. 9 BOND STREET,

*New York, February 12th, 1879.*

*Sir:*

*List prices of certain of our movements are to-day fixed as follows, viz.:*

**18 Size, FULL PLATE.**

"BROADWAY," 7 jewels, nickel balance...	\$ 4 30
" " 7 " cut expansion balance (NEW).....	4 75
"WM. ELLERY," 2 pairs extra jewels, cut expansion balance ...	8 00
" " 2 " " " " Stem Winder.....	10 50
"STERLING," 7 jewels, nickel balance, Stem Winder.....	6 25
" " 7 " cut expansion balance, (NEW), Stem Winder.....	6 70

**The new list prices of complete Silver Watches are changed to correspond with the above.**

**14 Size,  $\frac{3}{4}$  Plate.**

"AM. WATCH CO. HILLSIDE" (NEW), 7 jewel, cut expansion balance, Stem Winder, for Hunter or Open Face.....	\$20 00
---	---------

**18 Size, Full Plate, NICKEL Movements.**

"WM. ELLERY," 2 pairs, extra jewels, cut expansion balance....	\$12 00
" " 2 " " " " " " Stem Winder,.....	16 50
"P. S. BARTLETT," 2 pairs, extra jewels in settings, cut expansion balance....	18 50
" " 2 " " " " " " " " Stem Winder	26 00
"WALTHAM WATCH CO." 4 pairs, ex. jewels in settings, cut ex. balance.....	26 50
" " " 4 " " " " " " Stem Winder	34 50
"APPLETON, TRACY & CO.," 4 pairs, extra jewels in settings, cut expansion balance, adjusted.....	37 00
" " " " 4 pairs, extra jewels in settings, cut expansion balance, adjusted, Stem Winding.....	46 50

All the above are subject to the terms and discounts announced in our circular of the 8th inst.

There will be no change in the quality of any of our grades, except as our constant efforts tend to their improvement. We decline altogether to take any part in the present unwise competition between Swiss and American manufacturers to see which shall make watches of the poorest quality. We intend to sell as low as any American company, but, however low the price, we do not intend to finish a grade of goods upon which it would be a disgrace to us to put our name.

Robbins & Appleton, 9 Bond St., New York.  
 Robbins, Appleton & Co., 8 Summer St., Boston,  
 Robbins & Appleton, 170 State St., Chicago. } General Agents.

American Watch Company,  
 OF WALTHAM, MASS.

# L. & A. MATHEY,

## IMPORTERS OF FINE WATCHES AND MOVEMENTS

No. 16 Maiden Lane, New York.

Independent  $\frac{1}{4}$  Seconds, Plain Chronographs, Independent Split Seconds,  
Minute Repeaters, Double Chronographs, Perpetual Calendars,  
Minute Chronographs, Pocket Chronometers.

MINUTE CHRONOGRAPHS, WITH MINUTE REPEATER.  
CHRONOGRAPHS, WITH MINUTE REPEATER.  
AND A FULL LINE OF MEDIUM GRADE WATCHES AND MOVEMENTS.

Sole Agents for the H. L. MATILE WATCHES.

Timing and Complicated Watches a specialty. All our Watches are tried and tested before delivery. Goods sent for examination on satisfactory references.

An attractive line of Chateaines and Chateaine Watches.



Established 1828.

# JACOB BENNETT & SON,

## Diamond Setters and Manufacturing Jewelers,

No. 108 SOUTH EIGHTH STREET, PHILADELPHIA.

WE MANUFACTURE AND MAKE A SPECIALTY OF  
EVERY DESCRIPTION OF

### DIAMOND MOUNTINGS

SUPERIOR IN DESIGN AND WORKMANSHIP.



MASONIC MARKS,  
**Presentation & Lodge Jewels,**

SOCIETY AND POLICE BADGES MADE TO ORDER.  
FINE WHOLE PEARL JEWELRY.

GOODS SENT ON MEMORANDUM TO ANY PART OF THE UNITED STATES.

# CROSS & BEGUELIN,

## Makers and Importers of SWISS WATCHES,

AND DIRECT IMPORTERS OF

Watch Tools, Materials, Glasses, &c.

No. 21 Maiden Lane, New York.

The CENTENNIAL WATCH (Stem-Winding and Stem-Setting) so universally popular, has achieved a standard reputation, and is generally conceded to be the best made watch for the money in this market. Being the sole manufacturers of this celebrated Timekeeper, we are enabled to give it our strongest endorsement. Especial attention is called to the "HENRY BEGUELIN," "DROZ & PERRET," and other well known Swiss Watches, as well as to our full and complete line of all grades of American Watches, on which we give the full trade discount.

The attention of Watchmakers is directed to our new DRILLS, in sets of 21 sizes. The most complete and serviceable drill ever offered.

General Agents for the Anburndale Timer,  $\frac{1}{4}$  and  $\frac{1}{2}$  Seconds.



None Genuine without this TradeMark.

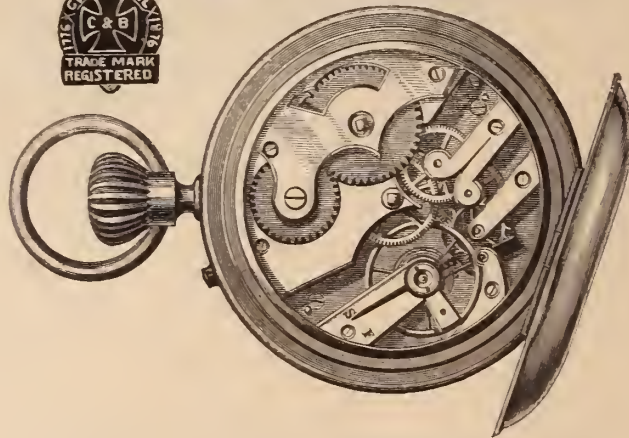

The above is a fac-simile of the Centennial Watch.

# BROWN & BROTHERS

MANUFACTURERS OF

## Finest Quality of Electro-Plated Flat Table Ware.

PATENTED HEAVY SPRING TEMPERED SHANK ON FORKS AND SPOONS.

ILLUSTRATED CATALOGUES FURNISHED ON APPLICATION.

WAREROOMS, No. 81 CHAMBERS STREET, NEW YORK CITY.

FACTORIES, WATERBURY, CONN.

P. O. BOX 5731.

Medal and Diploma awarded at Centennial Exposition, for superior mechanical execution and artistic ornamentation.



Established in 1854.

**C. & A. PEIGNOT,  
MANUFACTURERS OF WATCH CASES,**

DEALERS IN AMERICAN WATCHES AND IMPORTERS OF FINE KEY AND STEM-WINDING MOVEMENTS,  
SALESROOM AND MANUFACTORY, 22 SOUTH FIFTH STREET,  
PHILADELPHIA.

A full stock of Key and Stem-Winding Gold Cases always on hand. Goods sent on approval when satisfactory references are furnished.

**HALL, ELTON & CO.,**

**Manufacturers of the Finest Electro-Plated Ware.**

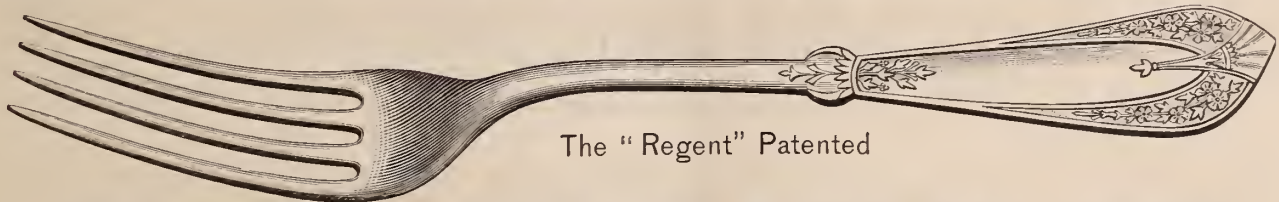

The "Regent" Patented

**UNSURPASSED IN QUALITY, STYLE AND FINISH!**

Factories, Wallingford, Conn. Salesroom, 75 Chambers St., New York.

**HOLMES, BOOTH & HAYDENS,**

MANUFACTURERS OF

**ELECTRO-SILVER PLATED**

**Spoons, Forks, Ladles, Fancy Pieces,**

**Solid Handle Steel Knives, &c., of the finest quality.**

No. 49 Chambers Street,  
**NEW YORK.**

No. 18 Federal Street,  
**BOSTON.**

Works at Waterbury, Conn.

SPECIAL NOTICE! MANUFACTURING JEWELERS, CHEMISTS, &c.

**BROWN & BROS.,**

No. 81 CHAMBERS STREET,

NEW YORK.

Manufacture CHEMICALLY PURE COPPER for ALLOYING, and are prepared to fill orders for same, either in the Wire, Strip or Granulated form. Its PURITY has been attested as follows.

BROWN & BROS.

Dear Sir.—We have analyzed the two samples of Copper left with us on the 18th instant, one said to be foreign refined Copper as used by jewelers, the other a refined Copper as manufactured by you for the same purpose. We find both samples alike in purity, and no difference can be detected by a careful chemical analysis, both being samples of PURE METALLIC COPPER, having no traces of antimony, tin, arsenic, zinc or lead.

UNITED STATES ASSAY OFFICE, 30 WALL STREET,  
NEW YORK, Dec. 21st, 1877.

TORREY & EATON.

# HENRY C. HASKELL,

Manufacturing Jeweler,

No. 12 John Street,

New York.



3100



371∞

CHOICE INTAGLIO & CAMEO RINGS,  
NOVELTIES IN BANGLE AND GYPSY  
*Set with Diamonds.*

SAPPHIRE, RUBY, TURQUOISE,  
PEARL, &C.



4877

Orders solicited for goods on approval.



6837



7093



6978

The "MARQUIS" Seal Ring, Entirely New, plain, elegant.



6900



3684



# ERRICO BROTHERS,

19 JOHN STREET, N. Y.

MAKERS AND DIRECT IMPORTERS FROM OUR OWN MANUFACTORY IN NAPLES,

## CORAL, SILVER FILIGREE AND CONCH SHELL JEWELRY

OF THE LATEST DESIGNS.

These goods are made under our own immediate supervision, and designed expressly for this market. Our stock, the largest in the city, is replete with the richest novelties in this line, and is offered to the trade at prices that will tempt buyers.

We would direct the especial attention to our recent importations of CORAL ROSES and CORAL CAMEOS in all the most desirable shades. Also to our new designs in SILVER FILIGREE goods, which we offer at unexceptionably low prices. Buyers, when in town, are invited to an examination of our stock.

### BIRCH'S PATENT KEY-RING TRIANGLE.

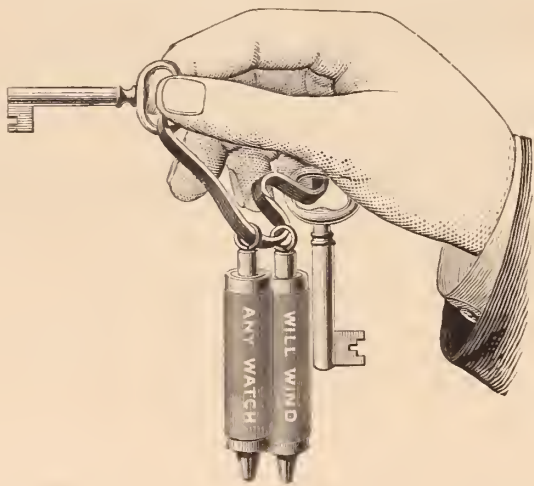

In presenting to the trade an article in such universal demand as a KEY RING, it is necessary to exhibit some marked improvements and advantages in order to induce favorable opinion. This we propose to do in our new KEY RING TRIANGLE, for it embodies simplicity in design, durability in material, and quickness in use. The old-fashioned circular rings are clumsy and inconvenient, especially when carrying a number of Keys, but that is at once avoided in our TRIANGLE, for passing the object Key to the apex, and grasping it between the finger and thumb, the other keys drop down to the base of the triangle, and leave the thumb and forefinger free from all obstructions, so that they can work the Key in the lock with as great ease as if the Key was detached from the triangle.

Nothing can be more simple than the manner of attaching or disengaging the Key from the triangle, as in either case the work is done with one motion. In point of durability, the triangle speaks for itself; for, being manufactured from one piece of steel, it will not break or bend out of shape, a fault so often to be found with the circular key rings now in use.

FOR SALE BY THE TRADE.

J. S. BIRCH & CO.,

38 DEY STREET, N. Y.

## NICOUD & HOWARD,

IMPORTERS OF

# Fine Swiss Watches,

14 MAIDEN LANE,

P. O. Box 2269.

NEW YORK.

SOLE IMPORTERS OF THE CELEBRATED "NICOUD" WATCHES.

Small size Stem Winding Watches a Specialty.

# HAMPDEN WATCH CO.

Manufacturers of KEY AND STEM-WINDING

General Office and Factory  
SPRINGFIELD Mass.

## WATCHES.

New York Office,  
No. 12 MAIDEN LANE.

### GUERRANT'S ELECTRO-ENGRAVING MACHINE.

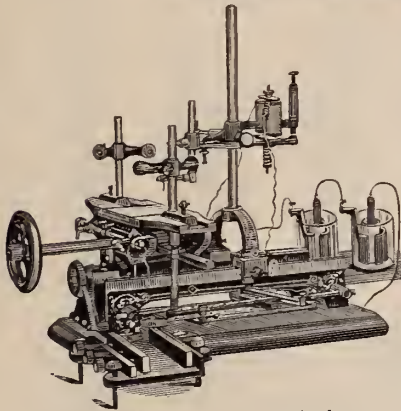

It has baffled the skill of the inventive genius of the world for ages to produce a machine that would compete with the skillful hand engraver, and until this machine was invented, all engraving had to be done by hand. And, to-day, it is the only practical engraving machine in existence.

The construction of the machine is not complicated, but simple and durable. It is easily operated. The variety of work it will do is almost incredible, and to be fully appreciated, ought to be seen in operation.

We do not therefore, offer this machine to the public simply as a machine to aid the engraver, but as a perfect, practical engraver in itself, with which any person of ordinary skill can learn in a short time to do any piece of engraving that might be desired and in the very best manner.

It copies from the regular press type of any style of letter or design that is made of type, from the plainest to the finest german text letter or fancy design, at the same time it will reduce the letter or design from the original size to ten different sizes, or so small that it cannot be seen by the naked eye. It will shorten the letters or elongate them, also will lean them forward or backward, will either make a raised or sunken letter, will engrave on any surface, either plain, concave or convex—for instance, such things as Watch Cases, either in or outside; Finger Rings, either in or outside; Bracelets, Napkin Rings, Goblets, Pitchers, Mugs, Waiters, Spoons, Forks, and all kinds of Jewelry; or, in fact, on any article susceptible of being engraved or ornamented with scroll work or fancy designs, &c., either on Gold, Silver, Copper, Brass, Iron, hardened Steel, Glass, Stone, Pearl, Ivory, Bone, Gutta Percha.

No Jeweler or establishment that has engraving to be done should be without it. Machines are sold with limited territory to use them in; or, the exclusive rights to use them in certain town or territory can be purchased with the machine if desired.

For further information, address

Size of Machine, 12 x 16-inches.  
Patented Jan. 18, Oct. 31, 1876, & Mar. 4, 1879.  
A. M. GUERRANT, Danville, Va., Agent for the Southern States.

WM. HICKSON, Gen. Agt.,  
P. O. Box 1603, PHILADELPHIA, PA.

KARN & HICKSON,  
LYNCHBURG, VA.

Owners of the right of all the Northern and Western States and Territories

## LONGINES WATCHES.



**GOLD MEDAL,  
Paris, 1878**



PARIS, 1867. VIENNA, 1873. PHILADELPHIA, 1876.

The only movement competing with other grades of its class awarded a gold medal at the Paris Exposition. The honors accorded the LONGINES WATCHES by the jurors (many of whom were watchmakers) attest the high esteem in which they are held by watchmakers, who regard them the best watch for the money made.

These goods are made in various styles, cased in nickel, silver and gold materials, and duplicate parts always in stock.

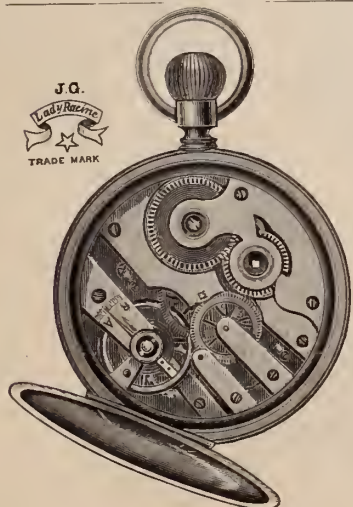

Factory,  
27  
RUE DU PARC,  
Chaux de Fonds,  
Switzerland.

Established 1826.

**JULIEN GALLET,**

CHAS. PERRET, Sole Agent.

Sales Rooms,  
No 1  
MAIDEN LANE,  
NEW YORK.  
P. O. Box, - 4420.

Importer of Watch and Watch Movements,

Would respectfully call the attention of the Trade to the annexed cuts of the Lady's size Watch, Stem-Winder and Stem-Setter, in Nickel, Silver and Gold, White and Black Dials.





Examples of Onyx Jewelry Manufactured by COX & SEDGWICK, 26 John Street, N. Y.



TIFFANY & C<sup>o</sup> .  
 MAKERS OF  
 Fine & Complicated Watches,  
 OFFICE, (Wholesale only)  
 No. 694 BROADWAY, COR. 4TH STREET,  
 GEO. R. COLLIS, *Manager.* NEW YORK.  
 Sole Agents for the American Pedometer:

## THE AMERICAN PEDOMETER.



This instrument accurately measures the distance a person carrying it walks, showing the amount of daily exercise taken in and out of doors.

Its mechanism is a marvel of simplicity, and can be adjusted to any length of step. It is strong and durable, and the size of a small watch. Ladies, Professional and Business Men, Students, Pedestrians, Sportsmen, Farmers, Surveyors, and others will find it very useful. A table accompanies each Pedometer, giving the number of steps taken in a mile second, minute, hour and day.

There are two forms of index, one registering steps from 23 to 35 inches in length, and another adapted for ladies and children, registering steps from 17 to 26 inches in length. The cases are of nickel-silver.

We have just finished an OPEN-FACE with white enameled dial, heavy crystal front, (retail price, \$7.00) but unless otherwise ordered, we send the one registering steps from 23 to 35 inches in length, in hunting case similar to engraving. Retail Price, \$5.00.

SOLE AGENTS,      TIFFANY & CO.,      NEW YORK.

The trade supplied only by TIFFANY & CO., from their new *wholesale* Watch offices, 694 Broadway, who do not sell to Jobbers, but are establishing as "exclusive agents" dealers who order quantities. Early application solicited.

THE  
 Adams & Shaw Company,  
 SILVERSMITHS,  
 and Makers of Hard Metal Electro-Plate,  
 694 BROADWAY, . . . . . NEW YORK.

GEO. R. COLLIS, *Manager.*

# THE "NEWPORT."

(PATENTED.)

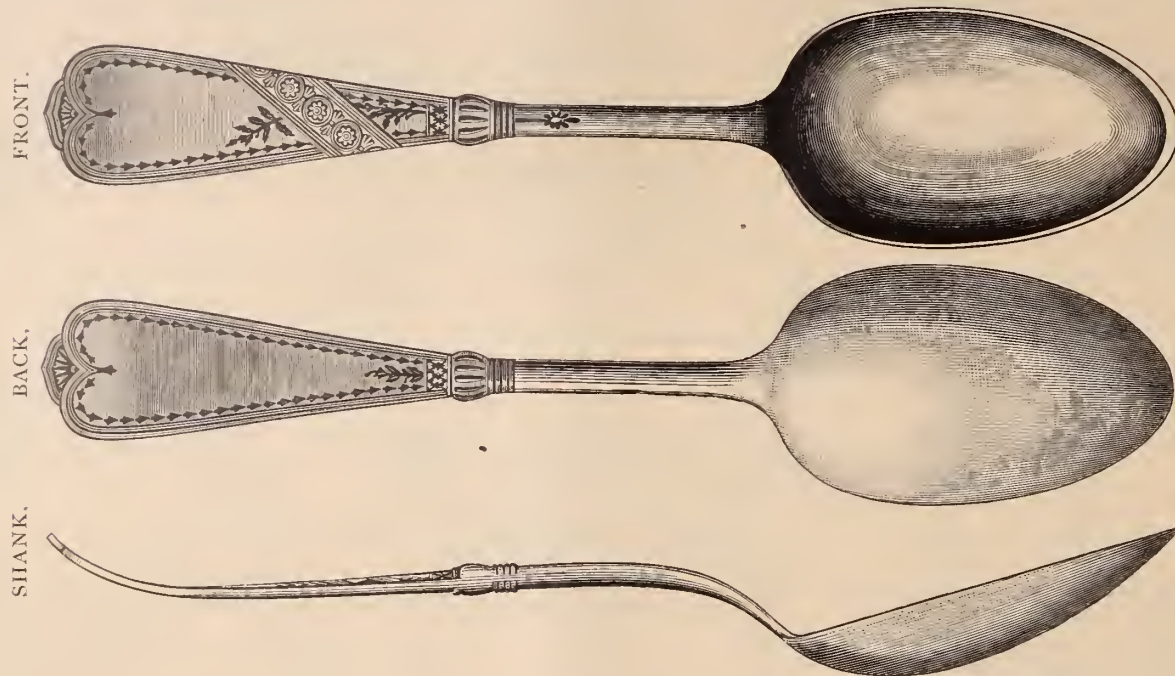

## TO THE TRADE

*We take pleasure in introducing the entirely new and beautiful pattern shown above.*

- THE OUTLINE - - Is graceful and pleasing to the eye, having none of the sharp, angular points so objectionable in many of the recent patterns.
- THE ORNAMENTATION is unique and fine, having the appearance of a Chased or Engraved Solid Silver Spoon.
- THE SHANK - - - Is our well-known heavy, spring-tempered, for which we hold letters patent.

*Every care has been taken to make this pattern as perfect as possible; first proofs of the die were submitted to many of the best experts and largest dealers in this country, and their unani- mously expressed opinion is, that "the pattern is the handsomest ever made in plate," and predic<sup>t</sup> for it a large sale.*

*Prices the same as "Crown" and other similar patterns.  
All should add the desirable "Newport" to their stocks.*

*Yours respectfully,*

ROGERS & BROTHER,

*April 1, 1879.*

690 Broadway, New York.

N. B.—To correct erroneous impressions that exist in a few quarters, it is proper to say that the founders of "Rogers & Brother" first introduced electro-plating in this country in 1847. In 1858, this Company was incorporated by them, and at the present time is the only concern in the United States manufacturing Silver-plated ware under the name of "Rogers."

# ILLINOIS WATCH COMPANY,

MANUFACTURERS OF

## KEY AND STEM-WINDING MOVEMENTS.

Attention is called to the reduction in prices and increase of discount, as per our new list, dated February 17th, which may be obtained from wholesale dealers, or from us on receipt of business card.

We will continue to make *all grades* of movements, with *hard plates*, and will leave no means untried which may enable us to furnish *standard and reliable* goods, which dealers can *fully warrant*.

During this month we will supply jobbers with a new *NICKEL* movement, described as follows:—18 size, full plate, 4 holes jeweled, cut expansion balance, patent pinion, *quick train*, made in Key-Wind, Stem-Wind, and Stem-Wind for Open-Face Cases, at low prices. This movement is fully guaranteed.

### OPEN FACE

"Miller Adj," "Currier," "Hoyt"  
"Columbia," "America," No. 101 Nickel, No. 2, and No. 1, Stem-winding Movements, made especially for Open Face Cases, with Fig. XII at the pendant and Seconds opposite.

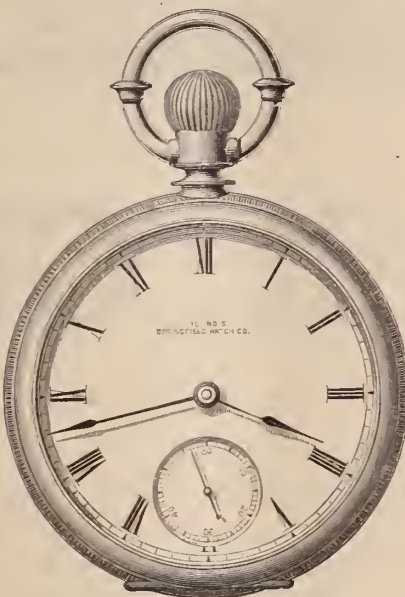

### STEM-WINDERS.

Other Stem-winding grades on our list are made to order (in  $\frac{1}{4}$  to 6 weeks) in the same manner, in quantities of five or more of a grade.

*The extra plate hole is jeweled in all grades, Currier and above.*

Jewelers can now obtain our 8 Size Ladies' Key and Stem-winders, fitting Waltham style 8 size cases, from any of the wholesale dealers.

Removed to

OFFICES,

No. 21 Maiden Lane,  
NEW YORK.

Cor. Dearborn & Monroe Sts.,  
CHICAGO.



## REED & BARTON

MANUFACTURERS OF

SILVER PLATED

# Table Ware,

OF EVERY DESCRIPTION,

Would call special attention to their

## Patent China-Lined Ice Pitchers.

The lining is held in position by the thumb-screws in the cover, and can easily be removed, thus enabling every part to be cleaned, leaving no chance for the collection of rust or other foreign matter between the lining and the outer wall. The lining is made of fine stone china, and has no equal for preserving ice and keeping water pure.

FACTORIES AT

**TAUNTON, MASS.**

SALESROOMS,

**686 Broadway, N. Y.**

# French Clocks.

☞ We make a speciality of this department and are constantly opening new lines which we offer at very low prices.

## TAYLOR & BROTHER,

No. 676 Broadway,

**NEW YORK.**

**WHOLESALE ONLY.**

# Marble Clocks,

In great variety, all the new patterns and colors, at very low prices, to close out our Spring Importations.

LE BOUTILLIER & Co.,

IMPORTERS AND JOBBERS,

Paris,

And 3 Union Square, New York.

# Metallic Faience

Artistically decorated in every form, Vases, Statuettes, Plaques, Candlesticks,  
Etc., Etc., Etc.

Established 1848.

Reliable and prompt.

**COOPER & BRO.**

Wholesale Jewelers,

Importers and dealers in WATCH & CLOCK-MAKERS' TOOLS AND MATERIALS; also, JEWELERS' SUPPLIES, SPECTACLES, OPTICAL GOODS, &c. A complete Outfitting Establishment for the trade.

Repairs Department established 1865. Every description of work done for the trade. Watch Repairing, Jewelry and Watch Case Repairing, Gold and Silver-Plating, and Fire Gilding.

35 S. Fourth St. (1st floor). PHILADELPHIA

**W. H. LUDEMAN,**  
**Chronometer & Watch**  
**MAKER,**  
Nos. 75 & 77 Nassau Street,  
**NEW YORK.**

Repairing of every Description for the Trade.  
FINE WATCHES A SPECIALTY.

To the Trade.—I am now prepared to cut all kinds of Stem-Winding Wheels for the Trade.

**DAVID PRINCE,**  
**Gold and Silver Refiner,**  
*Assayer and Sweep Smelter,*  
13 and 15 New Jersey Railroad Avenue,  
**NEWARK, N. J.**

Sole Agent for Comins' Improved Amalgamator.

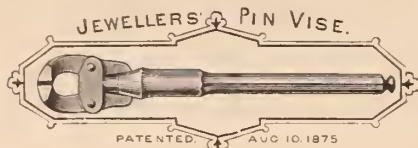

The tool is made of Steel throughout, with the jaws and wearing parts hardened. Every part is made to gauge. The finish is first-class and nickel-plated. Warranted to outwear at least three of the imported pin vises.

Offered in two sizes at \$15 and \$12 per dozen with liberal trade discount. Sold by the jobbing trade generally or by the

LOWELL WRENCH CO., WORCESTER, Mass.

**Vulcanite Jewelry Co.**

MANUFACTURERS OF

**WHITBY JET,**

Combination Whitby Jet and Vulcanite,  
Byron's Patent, May 18, 1869.

Also a full line of Locketts—plain, gold mounted and monogram.

No. 191 BROADWAY, N. Y.

Agents for the NEW RUBBER WATCH CASES,  
Fitting all American Movements.

Designs made and estimates given on all kinds  
of Engraving for Jewelers.



Illustrations for Books, Mfg Catalogues, &c.  
Labels and Show Cards Engraved on Metal for  
Color Printing.

Particular attention paid to Remounting.  
Price list furnished on application.Full line of new and original mount-  
ings on hand.**CHAS. F. WOOD,**169 & 171  
BROADWAY  
NEW YORK

Engraver, Incruster of Precious Stones  
And DIAMOND SETTER.

Incrusted Goods a specialty.

All kinds of Lapidary Work promptly executed.

Leon Jeanne.

Paul Jeanne.

**JEANNE BROTHERS,**

MANUFACTURERS OF

**DIAMOND MOUNTINGS**  
And **RICH JEWELRY,**

Patentees of Jeanne's Ear Wires,

No. 1 Maiden Lane, New York.

Designs furnished and estimates given.

KETCHAM & McDOUGALL,  
No. 4 LIBERTY PLACE, NEW YORK.  
MANUFACTURERS OF  
Improved Gold and Silver  
**THIMBLES**



AND THE PATENT  
**AUTOMATIC EYE GLASS HOLDER,**  
Which returns the Eye Glasses to their place on  
or under the lapel of the vest by simply casting  
them from the nose, combining all the conven-  
iences of Cord, Hook and Case, without their  
annoyances.

**J. B. LAURENCOT,**

IMPORTER OF

WATCH GLASSES,

**Optical and Fancy Goods**

French Clocks, Musical Boxes, &amp;c.

No. 33 MAIDEN LANE.

15 Rue D'Enghien,  
PARIS.Box 2954, P. O.  
NEW YORK.**L. BONNET,**

Medal at Centennial, 1876.

**CAMEO****Likenesses,**

889 Broadway, New York.

REPAIRING, COLORING AND GALVANI-  
ZING FOR THE TRADE.

C. G. MALLIET,

**Manufacturing Jeweler,**

No. 9 JOHN STREET

NEW YORK.

**FINE HAIR WORK***Deutsches Geschäft,*

The only leading personal Artist in Hair in this country.

**WM. ERNEST MOUTOUX,**

Factory and Office, 81 Nassau St., N. Y.

Designs of the most complicated description. Short  
or Baby Hair made in the finest design in your presence.  
Portraits, or copy of noted paintings, made of family hair.  
I am the only manufacturer who has Medals and Diplo-  
ma of Honor on personal fine work in number for inspec-  
tion.

Lessons given in all branches. Large pattern books for  
the trade. Large hair pictures in other books are copy-  
rights from my book and circulated only by my special  
permit. Prices low.

**The Morse Diamond Cutting Company,**

J. D. YERRINGTON, Agent.

192 Broadway and 3 John Street.  
NEW YORK.Rough, Diamonds, Boart, Roses and Brilliants  
for sale.Fractured Diamonds repaired, and old stones  
improved; also Rough Diamonds cut and  
fashioned to order.**W. N. WALKER,**  
**DIAMONDS,**

Watches and Jewelry,

No. 18 JOHN STREET, NEW YORK.

IMPROVED JEWELERS' COTTON.

JOHN J. ARMOUR.

**HENRY TROEMNER,**  
710 Market Street,  
PHILADELPHIA.

Manufacturer of Fine Gold Scales,

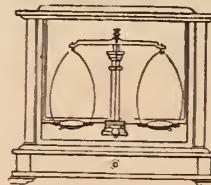

DIAMOND SCALES,

Bullion Balances and  
Weights, in use at all the  
U. S. Mints and Assay  
Offices.

PRICED CATALOGUE ON APPLICATION.

Solid Gold Rings—a Specialty

**WM. H. ELY,****Solid Gold Rings**

MANUFACTURER,

Viz., Plain, Chased, Engraved, Enameled, Engine  
Turned, Shield & Scale. All qualities Warranted  
Orders Promptly Executed.

58 Nassau Street, N. Y.

**REMOVAL.**

WM. PARK, hereby intimates to the trade that he has removed from 181 Broadway to 26 John Street, where he will be happy to receive orders for **STONE, SEAL & CAMEO ENGRAVING** Coats of Arms found and beautifully painted. Arms Crests, Monograms, and Devices engraved on Locketts, Sleeve Buttons, Rings, &c. Masonic Engraving a specialty.

**EXCELSIOR'S**

Essay on the

**Balance Spring.**

Price \$3.50.

**STERN BROS. & CO.**

Manufacturers of



**Fine Jewelry,**

**30 MAIDEN LANE,**

FACTORY, 73 & 75 Fulton St., NEW YORK.

Gold Seal engraved Band-rings and Locketts a specialty.

The attention of the trade is directed to our plain Gold filled Rings. Sections of which showing the construction and quality sent upon application.

After February 1st, our plain filled rings will bear the above trade mark.

F. W. C. Nieberg,

Repairer and Adjuster of

FINE WATCHES

and Marine Chronometers,

No. 8 JOHN STREET

New York.

**WADSWORTH'S PATENT ELLIPTIC**



**WATCH CASE SPRING**

Each holder is accurately fitted to the Case, and in a few minutes the Spring can be adjusted. The Spring works evenly from end to end, and without strain or wear to the most delicate Case.

The Spring is made of the Finest Steel, Drawn and Rolled Hard, which gives it sufficient temper, and so adjusted to the Holder that it retains its elasticity. Is not liable to break, and is superior to all others.

\$1.50 per dozen.

C. W. WADSWORTH, PEESKILL, New York.

CROSS & BEGUELIN, 21 Maiden Lane, N. Y.

L. H. KELLER, 64 Nassau Street, N. Y.

**BOURQUIN BROTHERS,**

Manufacturers and Importers of Watches,

All kinds of



WATCHES

MADE

To ORDER.

**NO. 20 MAIDEN LANE, N. Y.**

FACTORY, BIENNE, SWITZERLAND.

**VOSE & SOUTHWICK,**  
Manufacturers of Gold Jewelry



Sole Makers of the Separable Sleeve and Collar Buttons in Gold.

No. 183 Eddy Street, PROVIDENCE, R. I.



**HENRY LEFORT,**  
Stem-Winding Watch Crown Manufacturer,

Crowns and Pushers in gold, all sizes, quality and color, made to order. Silver crowns and pushers always on hand. Samples sent on application.

80 & 82 Marshall Street, NEWARK, N. J.

**ALBERT FRIEDENTHAL,**

Importer and Jobber of

WATCHMAKERS' & JEWELERS'

Materials, Tools and Optical Goods

Real and Imitation Stones,

For Manufacturing and Repairing Purposes  
**A SPECIALTY.**

Agent for TISDALE'S Watch and Clock Oils.

No. 43 Maiden Lane, New York.

Orders by mail will receive prompt attention.

**E. A. LAUTEN,**

MANUFACTURERS OF

**MOROCCO, VELVET & SATIN CASES**

FOR

Jewelry and Silver Ware.

New Trays for Lace, Shawl and Scarf Pins, Novelties in Brocade Silks,

4 Great Jones Street,

One door from Broadway, NEW YORK.

**JNO. F. LUTHER.**  
79 NASSAU ST. N.Y.  
MANUFACTURER OF FINE PRESENTATION JEWELS FOR ALL SECRET SOCIETIES. KNIGHT TEMPLAR'S CROSSES KEY STONE MARKS SOCIETY SCHOOL AND College Badges.

**COMBINATION**

**Adjustable Watch Key and Magic Pencil**



By pressing on end A the adjustable jaws B open and will fit any watch. It is a combination of Birch's patent keys with a Magic Pencil, and is secured by letters patent dated July 30, 1878.



The style and size represented is made of Rubber and 18 k. plate

List, \$30 Per Doz.

**MABIE, TODD & BARD,**

Manufacturers of

Gold Pens, Pencils, &c.

180 Broadway,

NEW YORK.

**E. HOERNER,**

Manufacturer of Jewelry,

Diamond and Black Onyx Goods,

15 Maiden Lane,

NEW YORK.

**E. WEISKOPF,**

MANUFACTURER OF

**Optical Lenses**

No. 182 Centre Street, N. Y.

**SPECIALTY!**

Cylinder and Prismatic Spectacle Glasses, Magic Lantern & Panoramic Lenses.

**JEWELRY PHOTOGRAPHED.**

In order to meet the demands of many of the Manufacturers of Jewelry, Silver Ware, &c. (Tiffany and others) I have erected a SPECIAL SKYLIGHT, for Mechanical Photography, viz:

The Copying of Silver Ware, Statuary, Bric-a-Brac, Paintings, Models, &c.

I propose to keep it busy by adopting the following rates:—8-10. Photographic negative \$1. Proofs 50 cents. Special rates for quantities.

GEO. G. ROCKWOOD, Photographer, 17 Union Sq. Established 1859. (Above Tiffany's.)

**Stephen J. Cox**  
DESIGNER & ENGRAVER  
of  
WOOD  
NO. 90 NASSAU STREET  
NEW YORK  
Jewelers' Work A Specialty.

**HENRY ABBOTT,**

*Manufacturer of*

**STEM-WINDING PARTS FOR  
WATCHES,**

New Scapements for Watches or Clocks.

Models for Patents. Small Tools for Watch-makers and Jewelers.

Dies, Cutters, &c., made to order.

Fine and Complicated Watches repaired in the best manner, by competent workmen.

**Office, 11 Maiden Lane,  
NEW YORK.**

Factory, 13 & 15 Franklin Sts., Newark, N. J.

*Established 1850.*



**PETER L. KRIDER,**

MANUFACTURER OF

**STERLING  
SILVER WARE,**

Medal and Diploma Awarded, &c.

Striking Society Medals in Gold, Silver or Bronze  
A SPECIALTY!

ARTISAN HALL,

**618 Chestnut Street  
PHILADELPHIA.**

**W. F. TREWIN,**

Manufacturer of

**Watch Cases**

—AND—

**Jewelry.**

Prompt and careful attention given to filling orders for all kinds of goods pertaining to the Trade. Goods sent on approval when satisfactory references are furnished.

Designs and estimates given, and special attention paid to orders from jewelers for Watches, Badges, &c., designed for presentation.

Every description of Watches and Jewelry carefully repaired for the Trade.

**730 Chestnut Street, (up stairs),  
PHILADELPHIA.**

**The Jewelers' Protective Union.**

This organization, which has been in existence over a year, is designed to protect the goods of jewelers while in the possession of travelers. It has been remarkably successful thus far in recovering goods stolen, and securing the punishment of thieves. The Union has adopted the policy of "no mercy to thieves," and intends to follow every thief until the goods he has stolen are returned to the rightful owners and the robber lodged in State Prison. The following is the list of officers and members of the Union, which it will be seen embraces the leading members of the trade.

*President,* Wm. R. Alling.  
*Sec. and Treas.* Ira Goddard.

*Executive Committee.*

L. A. Parsons, Thos. Slater, S. Oppenheimer,  
Wm. Smith, I. M. Miller.

- Alling Bros. & Co.
- Aiken, Lambert & Co.
- Adams, Thos. W. & Co.
- Brown, Thomas G.
- Baldwin, Sexton & Peterson,
- Bowden, J. B. & Co.
- Barrett, G. B. & Co.
- Bernard, A. & Co.
- Ball, W. H.
- Bass, S.
- Bryant & Bentley,
- Carrow, Bishop & Co.
- Carter, Howkins & Sloan,
- Courvoisier, Wilcox & Co.
- Chamberlain, Samuel W.
- Conover, David F. & Co.
- Coe, Pineo & Stevens,
- Colby & Johnson,
- Dominick & Haff,
- Downing & Keller,
- Eichberg, Samuel,
- Elcox, H. & Co.
- Field & Co.
- Fisher, William M. & Co.
- Freund, Max & Co.
- Fitch, D. M. & Co.
- Goldsmith & Schliesser,
- Goldsohl, M. & Co.
- Gallett, Julien,
- Giles Bros. & Co.
- Herzog, Louis & Co.
- Henle Bros.
- Heller & Bardel,
- Hale & Mulford,
- Hopkinson, D. H., Honorary Member.
- Hodenpyl, Tunison & Co.
- Herzog, A. S. & J.
- Hedges, A. J. & Co.
- Haskell, H. C.
- Hodge, Goddard & Co.
- Hirsh Bros.
- Joralemon, A. & Co.
- Kremenz & Co.
- Kronberg, M.
- Kahn L. & M.
- Koller & Untermeyer,
- Kuhn & Doerflinger,
- Koch & Dreyfus,
- Lorsch, Albert,
- Lyon, Tobias & Son,
- Lyon & Hardy,
- Marx & Weis'
- Miller Brothers,
- Marx, Kossuth & Co.
- Mitchell, Noah,
- Morgan & Headley,
- Moore & Horton,
- Matthewson, J. B. & Co.
- Mulford & Bonnet,

- Matson, N. & Co.
- May & Stern,
- McIntyre, Bedell & Co.
- Neresheimer, E. Aug.
- Oppenheimer Bros. & Veith,
- Owen, G. & S. & Co.
- Pratt, Geo. W. & Co.
- Pollak & Dreyfus,
- Pforzheimer & Keller,
- Richardson, Enos & Co.
- Riley, John A. & Co.
- Randel, Barremore & Co.
- Smith, Wm. & Co.
- Scott, J. T. & Co.
- Shafer, Douglas & Co.
- Saxton, Smith & Co.
- Sterne Bros.
- Strasburger, Louis & Co.
- Spadone & Abel,
- Simons, Bro. & Co.
- Smith, Alfred & Co.
- Speiss & Roswog,
- Sussefeld, Lorsch & Co.
- Spencer, J. E. & Co.
- Sinnock & Sherrill,
- Tiffany & Co.
- Taylor & Bro.
- Wheeler, Parsons & Hayes,
- Wallach, A. & Co.
- Whiting Manufacturing Co.

**GEO. W. DU BOIS,**  
(Successor to Albert Landsberg.)



IMPORTER AND MANUFACTURER OF

**Optical Goods,**

**No. 36 MAIDEN LANE,**

Near Nassau Street, NEW YORK

Sole Agent for

**BLACK'S PATENT  
Interchangeable Spectacles,  
AND  
EYE GLASSES.**

Jewelers and others who keep spectacles for sale will please observe that, with these PATENT SPECTACLES, it is only NECESSARY to have a full Complete Assortment of Lenses and Pebbles, which being all of a UNIFORM SIZE, will FIT either the Gold, Silver, or Steel Frames, of which but a few of each kind are wanted; an advantage which will give a complete assortment of the finest Spectacles, for one-sixth the capital invested in a like assortment of the same quality goods of the old style frames.

For Particulars, price lists, &c., address

**GEO. W. DU BOIS,**  
New York.

**A New Monogram and Alphabet Album  
J. SABIN & SONS,**

Respectfully announce, that they have now ready a new edition of their well-known book of Monograms and Alphabets.

Engravers, Stationers, Carriage Painters, Jewelers, Gold and Silver Smiths, and Designers and Decorators generally, will find this book useful, saving time in drawing, and having available a book of suggestion and reference. A double set of Monograms is included, a number of Alphabets, also a few Heraldic Designs, Crests, Casques, &c.

Printed on fine plate paper, and bound in cloth, . . . . . \$5.00

We print but a small edition, and early orders are suggested.

"All we have done in this art would be hopeless, eclipsed by the publication of J. Sabin & Sons; as a contribution to a jeweler's stock of designs, it is priceless"—*Jewelers' Circular.*

**J. SABIN & SONS,**  
No. 64 Nassau Street, New York.



**WESTON DYNAMO-ELECTRIC MACHINE CO**

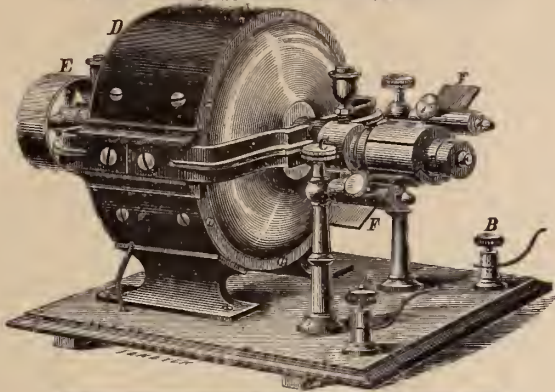

**CONDIT, HANSON & VAN WINKLE**  
Sole Agents NEWARK, N.J. U.S.A.

Machines for Electro-Plating, Electrotyping, Electric Light, Telegraphing, &c.

The Weston Dynamo-Electric Machine is constructed on a new principle, giving the greatest amount of electricity with the least consumption of power. Its simplicity and ease of management has already made it the standard machine. The success attending its introduction has already had the effect of inducing parties building machines for similar uses to adopt some of the devices peculiar to our new construction. We beg to call attention to the various patents covering our machines, and to the fact that we guarantee purchasers against any infringement of existing patents, as well as to their adoption and endorsement by the largest manufacturers of the country, in many cases after a previous trial of all other machines.

THE MERIDEN BRITANNIA CO.,  
WEST MERIDEN, CT., March 20, 1877.

MESSRS. CONDIT, HANSON & VAN WINKLE, Newark, N. J.  
GENTLEMEN:—You may send the two machines as proposed. I will say in regard to them they are splendid machines, and will say to any party you may refer to us that I shall advise them to take no other at any price, as yours is the best in my judgment, as we tried one, kept it, and took out all our old machines and replaced them with two of yours, (making three 12 inch machines in all. Just say to your customers we refer you to the largest plating house in the world. Yours truly,

H. C. WILCOX, President Meriden Britannia Co.

In addition to the testimonials in our Catalogue of January 1, we beg to refer to the following houses:—Carter, Howkins & Sloan; Enos Richardson & Co.; Bates & Bacon; Short, Nevey & Co.; Stephen, Richards & Co.; Meriden Britannia Co.; Russell & Erwin Manufacturing Co.; Reed & Barton; Hall, Elton & Co.; Richardson, Boynton & Co.; Wm. H. Jackson & Co.; Stanley Works; Rogers Cutlery Co.; Chas. Rogers Bros.; Edward Miller Co.; Mitchell, Vance & Co.; Norwalk Lock Co.; Hayden, Gers & Co.; Domestic Sewing Machine Co.; Eberhard Faber; Jos. Dixon Crucible Co.; Mumford & Hanson; Fagan & Son, and over 200 others. Outfits for NICKEL, SILVER, BRONZE PLATING, etc. The two highest Centennial Awards and three of the Centennial Medals of American Institute.

**The Pioneer Watch.**



**HENRY GINNEL, Sole Manufacturer,**

**No. 31 Maiden Lane, NEW YORK.**

P. O. Box 2967.

The accompanying illustration is a fac-simile of the Pioneer Watch. The Best (stem-winding and stem-setting) Pocket Timekeeper ever offered to the trade. They are cased in silver and German silver—Hunting and Open Face.

**J. F. FRADLEY.**  
MANUFACTURER OF



Fine Gold and Silver-Headed

**WALKING  
CANES**

—AND—

STERLING

**SILVER WARE.**

OFFICE AND FACTORY,

**20 JOHN STREET,  
NEW YORK.**



**NE PLUS ULTRA.**

**Williams & Cook's Dust-Proof Watch Keys**

Patented Sept. 1st, 1874.



The Popular Name Key.

A. Nickel Plated Handle and Pipe, Swivel Top, per gross..... \$10.75

English Pattern Key.

C. Nickel Plated Handle and Pipe, Swivel Top, per gross..... \$7.50



**BENCH KEYS.**

Corrugated Gilt Handles, Tempered Steel Pipes, per Set of Six.....\$1.80  
per Set of Three..... .90

P. Style of Key.

Gilt Handle. Steel Pipe.

Per Gross.....\$8.50



Our Key Pipes are all warranted to be made of the finest quality of steel. One great advantage his key has over all others, is the mortice through the pipe, making it the most simple and thoroughly dust and moisture-proof, as well as the cheapest key in the market. Our sizes run from 1 to 12: 4, 5 and 6 ft Gents' American Watches; No. 8, Ladies' American.

For sale by the Trade generally.

**KENDRICK, DAVIS & CO., LEBANON, N. H.**

SOLE OWNERS AND MANUFACTURERS.

The advantage of our Name Key, as an advertising medium, will at once be seen.



Geo. W. SIMONS,  
JOHN F. SIMONS,

Peter B. SIMONS,  
Geo. W. SIMONS, Jr.

JOHN SPECKER,  
FRED. M. SIMONS.

**Simons' Brothers & Co.**  
611 & 613 Sansom Street, Philadelphia

**The Burbank Manufacturing Company**  
Manufacturers of GOLD & SILVER



GOLD  
SILVER,  
STEEL,  
RUBBER,  
And SHELL,

**Thimbles,**



EYE GLASS  
Self Adjusting.

**SPECTACLES AND EYE-GLASSES**



OF ALL DESCRIPTIONS.

**SOLID GOLD RINGS.**  
Office, 14 MAIDEN LANE. NEW YORK.  
Manufactory, Springfield, Mass.

Established 1853.

**L. H. KELLER & CO.**

Successors to G. A. HUGUENIN,

IMPORTERS OF

**Fine Watch and Clock Materials,**

SWISS, ENGLISH, FRENCH & GERMAN

**FILES, TOOLS, & C.**

FOR WATCH MAKERS, WATCH CASE MAKERS, JEWELERS,  
SILVERSMITHS, ENGRAVERS, CHASERS, DIE  
SINKERS, MACHINISTS, &c.

SOLE AGENTS FOR HALL'S STAKING TOOLS AND  
ROLLER REMOVERS.

**AGENTS FOR THE WHITCOMB AND OTHER AMERICAN LATHES.**

GENERAL AGENTS FOR THE PHILADELPHIA  
WATCH COMPANY.

American Agents for the Horological Journal, (British).

A Monthly Paper for the advancement of Chronometer, Watch and Clock Making,  
and kindred Sciences. Published under the auspices of the British Horological  
Institute, London. Subscription \$2.50 per year, in advance. Also,

SAUNIER'S TREATISE ON MODERN HOROLOGY, IN  
THEORY AND PRACTICE.

BY M. CLAUDIUS SAUNIER The English Edition will appear in 26 monthly parts,  
Price 50 cents each. Whole Work, \$13 00, postage paid.

Special attention is directed to

**"OUR OWN" Celebrated Mainsprings Graduated**

n thickness to equalize the power, with well rounded edges, and the  
*Highest Crocus Finish throughout*, insuring the least possible friction  
in the barrel, pronounced by expert judges to be the *best made*

"JURGENSEN" Main Springs recoiling, suitable for the highest grades  
of Swiss Watches.

**"Lutz" Celebrated Hair Springs,**  
by numbers, of uniform diameter and strength, the best for "BRE-  
GUETING."

Fine Hole Jewels of Ruby, Sapphire, Chrysolite, Garnet, Beryl and  
Aqua Marine, with *gauged* (well shaped and polished) holes, numbered  
by the Swiss pivot gauge; also, neat black walnut cases, containing  
forty glass vials for assortments of same. The great advantage in hav-  
ing Jewels by numbers will readily be seen as a saving in time and an-  
noyance in selecting and in expense. Dealers once having an assort-  
ment, can replenish or stock up at a comparatively small outlay, as any  
desired quantity of No. and quality can be had of us at all times,  
our stock of jewels being the largest and most complete in the country.

Diamond Charged Broaches for opening and polishing jewel holes.

Diamond Powder and Bort for polishing and grinding 8 different  
grades, in  $\frac{1}{2}$ ,  $\frac{1}{4}$ ,  $\frac{1}{8}$ , and  $\frac{1}{16}$  K vials, bringing it into the reach of all.

Gold Diamond Set and other fine Geneva Hands.

The new Drills in Sets of 54 small, 126 small to medium, and 48  
large; also, sold separately if desired.

NOTE.—We issue no Price Lists and Highly Illustrated Catalogues  
to attract attention of Dealers to a large assortment of goods in print,  
but we have the goods in stock and will be pleased to quote prices  
if desired, or fill orders for any article in our line.

**No. 64 Nassau Street,**

Near Maiden Lane,

**NEW YORK.**

## SPECIAL NOTICES.

Advertisements under this head, not to exceed six lines, \$1.00 each insertion.

**FOR SALE.**—An old established jewelry store in New Orleans, together with stock and fixtures. Will be sold on easy terms to a responsible party. This is one of the oldest and best known stores in New Orleans, and has a good run of custom. Satisfactory reasons for selling. For particulars address New Orleans, care JEWELERS' CIRCULAR, 42 Nassau street, N. Y.

**FOR SALE.**—A first-class jewelry store, in a flourishing town on the Hudson, with about 7,000 inhabitants, one hour's ride from New York. No other jewelry store within a circuit of several miles. Satisfactory reasons for selling. For particulars address M. Schendler, Tarrytown, N. Y.

**\$175 00** will make you a practical watchmaker, enabling you to make \$25 per week. Those having the cash and mean business need only address T. A. Ninto, Waltham, Mass.

**GEO. E. WILKINS.**—Importer of fine Tools for Watchmakers, cutting and dividing engines, rounding-up tools and cutters, also cutters for stem winding wheels. Fine lathes with the American system of chucks. Dividing engine and rounding up tool combined. Marine chronometers for sale. Special tools imported to order. 21 South Salina St., Syracuse, N. Y.

**FOR SALE.**—A splendid new cutting machine with complete set of cutters, suitable for cutting watch and clock wheels. Will be sold at a sacrifice. Address L. & A. Mathey, No. 16 Maiden Lane.

**TO LET.**—A very desirable Jewelers' Factory, size, 50x50 feet. Excellent light, steam power, heating and elevator. First-class in every respect. Also part of front office on first floor if desired. Will be rented to a good party at a very low rate. John A. Riley & Co., Nos. 7 and 9 Bond Street.

**WANTED** a permanent situation by a first-class Watchmaker, used to fine and complicated Watches, has had charge of a jewelry store for the last four years, best recommendations. Address Watchmaker, Jewelers' Circular.

A. PFAFF, Bangor, Me.

**FOR SALE.** Fine chance for a good man, either Watchmaker or Clerk, to buy a well-established jewelry business, been running 17 years. Keeps a Watchmaker and jeweler at work besides the proprietor. Only about \$400 capital required. Satisfactory reasons for selling. Correspondence solicited. Address

W. L. M., Care Editor Circular.

W. L. MASON, Jacksonville, Ill

**WANTED.**—By a competent workman, a position as repairer of fine watches. Understands adjusting. Address G. care this office.

**FOR SALE.**—In a flourishing Ohio town, a jewelry store, business, &c., that has paid to its owner \$1,000 per year above all expenses (both store and family) for the last six years. Fixtures new; clean and desirable stock. Good run of work, and sales as good as times will admit of. Good reasons for selling. Address O. B., Box 29, Bellefontaine, Ohio.

**FOR SALE.**—Tools, material and small stock of jewelry in one of the best railroad towns in Western Minnesota. Splendid chance for a beginner with about \$350 cash. Address at once, Harry Saunders, Box 182, Redwood Falls, Minnesota.

Messrs. Miller Brothers, the well-known manufacturers of jewelry continue to lead in novelties for which their house is justly celebrated. They present this season an attractive line of goods that must be seen to be properly appreciated. Messrs. Miller Bros. have very wisely patented their most taking designs, and will invoke the aid of the law in all cases of infringements. Their customers are therefore amply protected against the encroachment of rolled plate manufacturers.

Messrs. Oppenheimer, Bros. & Veith, Importers of Diamonds and manufacturers of Jewelry, have for many years enjoyed a high reputation in the trade. Their strict commercial integrity and enterprise have won for them the confidence and esteem of a large clientele of friends, who have also been their oldest and most constant customers. Messrs. Oppenheimer, Bros. & Veith, this season, offer a large and comprehensive line of the most desirable goods to be found anywhere. Their stock embraces the latest novelties and the most attractive styles and patterns, and are offered at prices that will compare favorably with any other responsible house in the trade.

## Buyer's Directory.

A Guide to the prominent Wholesale Houses in the Watch, Clock, Jewelry and kindred branches of Trade in New York, Philadelphia, Chicago, Providence and Newark.

## NEW YORK.

## Bohemian Garnet Jewelry.

**Bissinger, Philip**—Importer of Diamonds, Pearls and Precious Stones. Sole Agent for the Bohemian Garnet Jewelry, 22 John St.

## Clock Companies.

**New Haven Clock Co.**—62 Reade Street, N. Y.

**Seth Thomas Clock Co.**—20 Murray Street, N. Y.

**Waterbury Clock Co.**—M. Bailey, Treasurer, Manuf. and Jobbers, No. 4 Cortlandt Street, N. Y., and No. 197 State Street, Chicago.

**Kroeber, F.**—Manufacturer and Dealer in American and French Clocks, No. 8 Cortlandt St.

## Corals and Coral Jewelry.

**Errico Bros.**—Importers of Coral, Conch-Shell and Silver Filigree Jewelry, etc., 19 John St.

**Lawson, S.**—Manufacturer of Coral and Black Onyx Jewelry. All kinds of repairing solicited. Goods sent on Mem. 63 Nassau Street.

**Squadrilli, Ach.**—Manufacturer and Importer of Coral, Conch Shell and Silver Filigree, etc No. 9 Maiden Lane, N. Y.

## Cameo Cutters, Etc.

**Bonet, L.**—(Successor to Bernard & Bonet), Cameo Likenesses, 889 Broadway, N. Y.

**Wiederer, Peter**—Late Habermeyer & Wiederer, Engravers of Cameo Likenesses, Seal Stones. Cameos repaired. 23 John St.

## Charms &amp; Gold Watch Keys.

**Rupp & Held.**—Manufacturing Jewelers, Charms and Gold Watch Keys, with French and English Ratchets, a specialty. 15 John st., N. Y.

## Cutlery.

**Rogers Cutlery Co.**—Hartford, Conn.

**Harrison Bros. & Pearson.**—Manufacturers of Fine Ivory and Pearl Table and Pocket Cutlery; Carvers in Cases; Nutpicks, Nutcracks and goods suitable for the jewelry trade. 26 Cliff street. W. C. Burkinshaw, Sole Agt.

## Diamonds.

**Anderson, Otis**—Diamond Merchant and Broker, always ready to pay cash for bargains in Diamonds and Precious Stones, No. 9 Maiden Lane, N. Y.

**Bernhard, A. & Co.**—Manufacturing Jeweler & Importers of Diamonds and Precious Stones, also Diamond Mountings, No. 169 Broadway, Gilsey building.

**Bissinger, E.**—Importer of Diamonds, No. 192 Broadway, New York.

**Bissinger, Philip**—Importer of Diamonds, Pearls and Precious Stones. Agent for the Bohemian Garnet Goods No. 22 John St., N. Y.

**Buckenham, Cole & Saunders**—Importers of Diamonds and other Precious Stones, No. 10 Maiden Lane, N. Y.

**Fera, Henry**—Importer of Diamonds, and Manufacturer of Fine Diamond Jewelry. No. 9 Maiden Lane, New York. Amsterdam, Holland, 23 Loojersgracht.

**Herbert, R. J.**—Importer and Broker in Diamonds, 24 John Street.

**Hedges, Wm. S. & Co.**—Importers of Diamonds. No. 170 Broadway.

**Lyon & Hardy.**—Importers of Diamonds and Manufacturers of Diamond Jewelry. 30 Maiden Lane, New York.

**Neresheimer, E. Aug.**—Importer of Fine Diamonds. No. 21 Maiden Lane, New York.

**Prager, Morris.**—Importer of Diamonds and Fine Diamond Jewelry 8 Maiden Lane, New York.

**Smith, Alfred H. & Co.**—Importers of Diamonds No. 14 John Street.

## Diamond Cutters.

**The Morse Diamond Cutting Co. of Boston.**—Henry D. Morse, General Manager. N. Y. Office, 192 Broadway, corner John street. J. D. Yerrington, Agent.

## Diamonds and Diamond Jewelry.

**Bissinger, Philip.**—Importer of Diamonds, 22 John street, N. Y. Agent for the Bohemian Garnet Goods.

**Bornemann, Louis**—Manufacturer of Diamond Jewelry from original designs, 169 and 171 Broadway.

**Heller & Bardel.**—Manufacturers of Diamond and Pearl Jewelry, and dealers in Diamonds Pearls, &c. Also agents for Boss' Patent Stiffened Gold Watch Cases. 13 John Street, N. Y.

**Taylor & Brother**—Importers of Diamonds and Diamond Jewelry, 676 Broadway.

## Diamond Setters, Etc.

**Asher, J.**—Jeweler and Diamond Setter, Precious Stones Inlaid and Incrusted with Diamonds, Nos. 880 and 882 Broadway.

**Barcard & Oberlander**—Manufacturers of all kinds of Settings and Galleries of any carat of Gold, Silver, Platinum and Platinum Lined. Send for sample cards. 36 and 38 John street, N. Y.

**Wood, Chas. F.**—Engraver and Incruster of Precious Stones and Diamond Setter. No. 169 & 171 Broadway.

**Friend, S.**—Manufacturer of Fine Jewelry, and Diamond Setter. 33 John street, N. Y.

## Dials, &amp;c.

**Caesar Brothers**—Manufacturers of Enameled Clock Meter and Gauge Dials, Patent Door, Coffin and Pew Plates, Druggists' Labels, &c. No. 32 and 34 John Street.

**Gold, John T.**—(Successor to the late T. Gold), Enamel Watch Dial Maker, 81 Nassau St.

## Enamelers, Etc.

**Nutt, J. D.**—Enameler on Gold, Silver and Copper, 32 and 34 John St. Birds, Flowers, etc., Enameled in colors.

**Orr, Jas. C.**—Enameler on Fine Jewelry, Flowers, Birds, &c., Enameled in colors. Band Bracelets (a specialty). 77 Nassau Street.

## Electroplaters, &amp;c.

**Jeandheur, F. & Son.**—Gold and Silver Electro Platers & Fire Gilders, coloring Russian and Gold Jewelry a specialty. 117 Fulton St.

## Engravers and Die Sinkers

**Fackner, Edward**—Carver, Engraver and Chaser on Jewelry and Pencil Cases. Monograms Lettering, &c. 19 John Street.

**Schuller, J. Dan'l**—Stone Seal Engraver Arms Crests, Initials and Monograms engraved on Stone Seals, &c. 71 Nassau street.

## Fancy Goods, Clocks, Bronzes Etc.

**Hall, Nicoll & Granbery**—Importers of Clocks, Bronzes, Folding Mirrors, Fancy Goods, etc. 20 and 22 John Street, New York.

**Hinrichs, C. F. A.**—Importer and Dealer in French, English and German Fancy Goods, etc., etc. 29, 31 & 33 Park Place, N. Y.

**Magnin, Ve J. Guedin & Co.**—Importers of Clocks Bronzes, Musical Boxes & Rich Fancy Goods etc., 29 Union Square.

**Le Boutillier & Co.**—Importers of Fancy Goods, Clocks, Bronzes, &c. 3 Union Square

## Cold Chains, Etc.

**Beck, J. & Son.** Manufacturers of Fine Gold Chains and Chain Bracelets, 10 Liberty place, near Maiden lane, N. Y.

**Dorrance, Edge & Co.**—Manufacturers of the Celebrated Woven Fabric Gold Chain, No. 9 John street.

**Hamiltons & Hunt.**—Manufacturers of Fine Plated Chains and Patent Buckle Bracelets. Branch office, 176 Broadway. Factory, 226 Eldy street, Providence.

**Kaufmann Bros.**—Manufacturers of Gold Chains, and Chain Bracelets, 26 John street; Factory, 331 and 333 Bowery, N. Y.

**Nordt & Schlag.**—Manufacturers of Gold Chain No. 17 Maiden Lane, N. Y.

**Saxton, Smith & Co.**—Manufacturers of Fine Gold Chain. 15 Maiden Lane.

## Cold Pens, Etc.

**Aikin, Lambert & Co.**—Manufacturers of Choice Gold Pens, Cases, Holders, Toothpicks, etc., 23 Maiden Lane, N. Y.

**Clark, J. M.**—Manufacturer of Pen and Pencil Cases for the wholesale trade only. No. 61 Hudson Street, N. Y.

**Mabie, Todd & Bard**—Manufacturers of Gold Pens, 180 Broadway.

**Todd, Edward & Co.**—Manufacturers of Gold Pens, Pencil Cases, Tooth Picks, &c., 652 Broadway, N. Y. Factory, Brooklyn.

## Goldsmiths, &amp;c.

**Greene Wm. C. & Co.**—Goldsmiths; Manufacturers of Rich Sets in Taper Wire Coral. Office, 18 John street.

## Cold Rings.

**Bowden, J. B. & Co.**—Manufacturing Jeweler.—Solid Gold Rings a specialty, 1 Maiden Lane.

**Ely, W. H.**—Manufacturer of Solid Gold Rings of every description. No. 53 Nassau Street.

**Frankel & Folkart.**—Manufacturers of Seal, Cameo and Amethyst Rings a specialty. Also a full line of Gold White Stone goods and Diamond Settings. 21 John St., N. Y.

**Peckham, Wm. H. & Co.**—Manufacturers of Solid Gold seamless Rings and Fancy Embossed Rings, Patent Spectacles, Jewelry, etc., No. 4 Liberty Place.

**Sinnock & Sherrill**—Manufacturers of Stone Rings. No. 5 Maiden Lane, N. Y.

**Tingley, Joseph N.**—Manufacturer of Stone Rings and novelties in Stone Goods. No. 9 Maiden Lane, N. Y.

**Hair Jewelry.**

**Montoux, W. E.**—Fine Hair Work a specialty. 81 Nassau Street, N. Y.

**Sauter, L.**—Manufacturer of Fine Gold and Hair Jewelry and Device Work. Nos. 65 & 67 Nassau Street.

**Schwencke O.**—Manufacturer of Fine Hair Jewelry. Orders from the country promptly attended to. No. 43 Maiden Lane.

**Jewelry Cases, Fancy Boxes, Etc**

**Braun, Chr. E.**—Manufacturer of Jewelry Boxes, Trays for Show Cases, &c., 62 Chatham st.

**Loehr & Koerner**—Manufacturers of Morocco, Velvet, Satin, Jewelry, Watches and Silverware Cases, Glove, Handkerchief, Ladies' Jewel, Work Boxes, &c., Fancy Trays and Stone Fittings to order, Office and Salesroom 96 John Street, New York.

**Dahlem, W.**—Manufacturer of Cases for Jewelry and Silverware, No. 85 Nassau Street, N. Y. Show Case Trays, &c., at shortest notice.

**Wiggers & Froelick**—No. 60 Nassau street.—Manufacturers of Cases for Jewelry, &c., of every description. Trays for Show-cases, Stands for Show-windows, etc. Jewelers' Traveling Cases, light, convenient and strong.

**Jackson, Samuel C.**—Manufacturer of Box and Trays, for Silverware, Watches, Jewelry &c. 180 Broadway, N. Y.

**Fahn, L. & M.**—Importers of Watches, Morocco Cases, 712 Broadway, N. Y.

**Sturm, I.**—Manufacturer and Importer of Cases for Jewelry, Watches, Silverware, &c. No. 15 John street, N. Y.

**Welch & Miller**—Manufacturers of Morocco, Velvet, and Satin Jewelry Cases, Trays, &c. Telescope Sample Cases with flexible Trays. Complete stock on hand. 169 Broadway.

**Jewelry—Fine.**

**Aikin, Lambert & Co.**—Manufacturers. General stock of Reliable Jewelry, 23 Maiden Lane.

**Alford, C. G. & Co.**, Manufacturers. General line fine and reliable goods. Specialties in Onyx goods and chain. 183 Broadway, New York.

**Andrews, J. F.**—Manufacturer of Fine Jewelry, Locket, Sleeve Buttons and Rings in Stone Cameo, etc., a specialty. 35 Maiden Lane.

**Baldwin, Sexton & Peterson**—Manufacturers Fine Jewelry. Whiting Building, Broadway and Fourth street.

**Ball, Wm. H.** Manufacturing Jeweler. Fine Gold Bracelets a Specialty. No. 9 John St., N. Y.

**Barthman & Straat**—Manufacturers of Fine Jewelry. Seal and Stone Rings a Specialty Orders promptly attended to. 41 Maiden Lane.

**Bernhard, A. & Co.**—Manufacturers of Fine Hair Jewelry and Device Work. The latest styles. 2 Maiden Lane, New York.

**Bissinger, E.**—Importer of Fine Jewelry, Locket, Crosses, Neck Chains, &c., No. 192 Broadway.

**Brown, Thos. G.**—Manufacturer of Rich Jewelry Necklaces, Locket, Bracelets, Sleeve Buttons, etc., 9 Bond street, N. Y.

**Bryant & Bentley**—Manufacturing Jewelers Rings a specialty. 12 Maiden Lane.

**Brainerd & Steele**—Successors to Brainerd, Steele & Co., Manufacturers of Fine Jewelry and Brainerd's Patent Locket. No. 9 Maiden Lane, New York.

**Burch, Geo. & Co.**—(Successors to Burch, De Mott & Coughlin.) Manufacturing Jewelers, 17 Maiden Lane, N. Y. Factory, Newark, N. J.

**Carrow, Bishop & Co.**—Manufacturers of Fine Jewelry, Roman Band Bracelets, Locket, Crosses, &c. 12 John Street, N. Y.

**Carter, Howkins & Sloan.**—Manufacturing Jewelers, Whiting Building, 4th St. & Broadway

**Chatellier & Spence**—Manufacturing Jewelers. No. 652 Broadway, N. Y.

**Champenois & Co.**—Manufacturing Jewelers, No. 1 Maiden Lane. Specialties—Jet Cluster Goods in Sets and Sleeve Buttons, Engraved and Enameled Goods in Sets, Studs, Sleeve and Collar Buttons, Lace, Shawl and Cuff Pins, Ear Knobs and Crosses.

**Cook, Groeschel & Co.**—Manufacturers of Fine Jewelry and Locket, 191 Broadway (over Mercantile Bank.) N. Y.

**Coe, Pinneo & Stevens.**—Manufacturers of Fine Jewelry, Fine Gold Locket and Linen Finished White Enameled Goods a Specialty, No. 9 Maiden Lane, N. Y.

**Demmert Bros.**—Manufacturers and Importers of Fine Jewelry, Cameo and Onyx Locket, Sleeve Buttons and Sets a specialty. Old No. 9 Maiden Lane, New York.

**Field & Co.**—Manufacturing Jewelers, 8 Maiden Lane, N. Y.

**Goddard, John M.**—Manufacturing Jeweler,—Seal Rings and Fine Locket a specialty, No. 3 Maiden Lane, N. Y.

**Frankel & Folkart.**—Manufacturing of Seal, Cameo and Amethyst Rings, a Specialty. Ladies' and Gents' Locket, Cameo Sets, &c. Also a full line of Diamond Settings, 21 John street, N. Y.

**Greason, Bogart & Pierce**, successors to Arthur, Rumrill & Co., 182 Broadway, manufacturers of fine jewelry and gold chains

**Hartmann, P.**—Manufacturer and Importer of Fine Gold, Diamond, and Filagree Silver Jewelry, No. 36 Maiden Lane. P. O. Box 2,454.

**Haskell, H. C.**—Manufacturing Jeweler. Seal Rings a specialty. Special attention to Jobbing of every description. 12 John street.

**Hunt & Owen.**—Manufacturing Jewelers. Office 5 Maiden Lane.

**Hale & Mulford.**—Manufacturers Rich Jewelry, Whiting Building, Broadway and 4th Street.

**Jeanne Brothers.**—Manufacturers of Diamond Mountings & Rich Jewelry. 1 Maiden Lane.

**Keller, Chas. & Co.**—Manufacturing Jewelers Locket a Specialty. No. 13 John St., N. Y.

**Kremetz & Co.**—Manufacturing Jewelers, No. 13 John Street, N. Y.

**Kroll, H.**—Manufacturer of Fine Jewelry. Repairing (a specialty) done for the trade at moderate prices, 78 Nassau street.

**Kuhn & Doerflinger**—Manufacturers of Enamel'd and Roman Band Bracelets, also Fine Locket and Pendants, 18 John street.

**Lennon, John D.**—Manufacturing Jeweler, 142 Fulton street. Flat, and Half-round Gold Bracelets, Roman and Stone Locket.

**Moore & Horton.**—11 Maiden Lane, Manufacturing Jewelers, Rings, Studs, Collar and Sleeve Buttons, Pins, Ear-rings, &c.

**Mitchell, Noah.**—Manufacturer of Fine Gold Jewelry, 694 and 696 Broadway, N. Y.

**Miller Bros.**—Manufacturers of Fine Jewelry Locket, Sleeve Buttons, Studs, etc., etc. 11 Maiden Lane, New York.

**Mulford & Bonnet**—Manufacturing Jewelers and Jobbers, 21 & 23 Maiden Lane, N. Y. Particular attention given to Jobbing and Special orders.

**Marx Kossuth & Co.**—Manufacturing Jewelers. 39 Maiden Lane.

**Owen, G. & S. & Co.**—Manufacturing Jewelers. Office, No. 5 Maiden Lane.

**Pendrill, Wm.**—Manufacturer of Fine Jewelry, jobbing and repairing for the trade at low rates, 73 Nassau Street.

**Riker, William**—Manufacturer of Jewelry. Inlaid Gold Jewelry a Specialty. No. 5 Maiden Lane, N. Y.

**Riley, J. A. & Co.**—Manufacturing Jewelers, Etruscan Gold and Coral Sets, Roman Bracelets, Necklaces, etc. Onyx Goods a specialty. 7 and 9 Bond street, New York.

**Richardson, Enos & Co.**—Manufacturers of Fine Gold Jewelry, Gold Chains, Locket, Crosses and Necklaces. Colored and Etruscan Work. No. 23 Maiden Lane, New York.

**Richardson, J. W. & Co.**—Manufacturers of Jewelry, Masonic and other emblems. 196 Broadway, Manufacturing, Providence, R.I.

**Sexton & Cole**—Manufacturing Jewelers, Colored Gold and Onyx Goods a specialty. No. 30 Maiden Lane.

**Shoemaker & Co.**—Manufacturing Jewelers, Cameo Buttons, and Locket, Roman Gold Goods, etc. No. 21 Maiden Lane, N. Y.

**Stites, E.**—Manufacturer of Fine Jewelry. No. 12 Maiden Lane, N. Y.

**Sturdy Bros & Co.**—Manufacturers of Jewelry. General line of fine and heavy Rolled Plate Goods. Specialties—enameling on gold plate; graduated wire coral work. 14 Maiden Lane, N. Y.

**Terhune, Charles F.**—Manufacturing Jeweler, 16 Maiden Lane, N. Y.,

**Thoma, Ernest**—Manufacturer of Fine Jewelry. Sleeve Buttons, Rings, Ear-rings, &c. No. 173 Broadway, N. Y. Factory, Hackensack, N. J.

**Trier Bros. & Co.**—Jewelry. Optical, Rubber, Jet, Shell, Ivory, Amber and Pearl Goods. Silk Guards, Japanese Bamboo Watch Chains a Specialty. No. 15 Maiden Lane.

**Vulcanite Jewelry Co.**—Manufacturers of Whitby Jet and Vulcanite Jewelry, 191 Broadway, N. Y.

**Wadsworth, E. E.**—Manufacturer of Rich Jewelry and fine Rolled Plate. Fine Seal Rings a specialty. 35 Maiden Lane.

**Wheeler, Parsons & Hays.**—Manufacturers of Fine Jewelry, Watch Cases, Gold Chains, &c and Dealer in American and Swiss Watches, No. 2 Maiden Lane, N. Y.

**Wienhold, Joseph**—Manufacturer of Fine Jewelry and Diamond Setter. 24 John St.

**Woglom & Miller**—Manufacturing Jewelers Nos. 32 & 34 John street, N. Y. Specialty Black Onyx goods.

**Jewelers' Tools, etc.**

**Frasse & Co.**—Importers of Stubs, French, Swiss, German and Sheffield Tools, Files and Steel Wire for Watchmakers, Jewelers, etc., 62 Chatham street, N. Y.

**Hammel, L. & Co.**—Importers of Materials and Tools for Watchmakers, Jewelers and Engravers—also Optical Goods, &c., 9 Maiden Lane, N. Y.

**Lapidaries.**

**Kordmann & Michel**—Lapidaries, dealers in Precious Stones. Rubies, Sapphires and Peridots cut. No. 32 Maiden Lane.

**Musical Boxes.**

**Paillard, M. J. & Co.**—Importers & Manufacturers of Musical Boxes, No. 680 Broadway, N. Y.

**Opticians.**

**Burbank Man'g Co.**—Manufacturers of Spectacles and Eye Glasses of all descriptions, in gold, silver, etc., 14 Maiden Lane, N. Y.

**Du Bois, Geo. W.**—Successor to A. Landsberg, Importer and Manufacturer of Optical Goods 36 Maiden Lane, Box 3993, N. Y.

**Hammel, L. & Co.**—Importers of Spectacles, Opera and Marine Glasses, Telescopes, Microscopes, Optical & Fancy Goods, 9 Maiden Lane.

**Laurencott, J. B.**—Importer of Watch Glasses, Optical and Fancy Goods, Clocks, Bronzes, etc., 33 Maiden Lane, N. Y.

**Lorsch, Albert**—Manufacturer of the Patent Accommodating Spectacles and Eye Glasses in Gold, Silver and Steel, and other Optical Goods, 37 Maiden Lane, N. Y.

**Serin, A.**—Manufacturer of Spectacles and Eye-Glasses, in Steel, Shell and Rubber. Repairing of all kinds. Opera Glasses covered and re-gilt, etc. 169 and 171 Fulton street.

**Spencer Optical Manufacturing Co.**—Gold, Silver, Steel and Nickel Plated Spectacles, Eye Glasses, &c. 13 Maiden Lane, N. Y.

**Precious Stones, &c.**

**Bissinger, Philip**—Importer of Diamonds, Pearls and Precious Stones. Agent for the Bohemian Garnet Goods. No. 22 John St., N. Y.

**Gruet, Jules.**—Importer of Precious and Imitation Stones, Amethysts, Topazes, Cameos, Garnets, Doublets, Imitation Diamonds, Pastes, etc., No. 14 John street. Manufacturing at Septmoncel, France.

**Meyer, Francis Ed.**—Successors to John B. Behrmann, Importer of Imitation Precious Stones, all sizes and shapes constantly on hand. No. 53 Nassau st., P.O. Box, 1981.

**Silverware.**

**L. A. Cuppia.**—Manufacturers of Solid Silver Novelties, and Importers of Silver Filigree and Cornish Shell. 19 Union Square.

**Gorham Manufacturing Co.**—Union Square.

**Wood & Hughes.**—Manufacturers of Fine Silverware. 14 John Street, N. Y.

**The Adams & Shaw Co.**—Manufacturers of Silverware. Cor. Broadway & 4th St., N. Y.

**Silver Plated Ware.**

**Brown & Bros.**—Manufacturers of first quality of Electro Plated Flat Table Ware. No. 81 Chamber Street, N. Y.

**Hall, Elton & Co.**—Manufacturers of the Finest Electro-Plated Ware, salesroom, 75 Chambers street, N. Y.

**Holmes, Booth & Haydens**—Manufacturers of Silver-plated Ware. 47 Chambers street.  
**Meriden Britannia Co.**—Manufacturers of Silver plated Ware, Union Square, N. Y.  
**Middletown Plate Co.**—Manufacturers of Superior Electro-Plate. Factories, Middletown, Conn., Salesroom, 13 John Street  
**Rogers Cutlery Co.**—Hartford, Conn.  
**Reed & Barton**—Manufacturers of Fine Plated and Table Ware, of every description, 686 Broadway, N. Y.  
**Rogers & Bro.**—Manufacturers of the finest quality of Electro-Plated Ware. 690 B'way.  
**Simpson, Hall, Miller & Co.**—Manufacturers of Fine Silver Plated Ware, No. 26 E. 14th St.  
**Schade, Henry.**—Manufacturer of White Metal and Plated Ware, No. 84 John Street, New York. Price list and catalogue furnished on application.  
**Webster, E. G. & Bro.**—Manufacturers of Fine Silver Plated Ware. Office and Warerooms, 14 Maiden Lane, N. Y.

#### Show Cases, Etc.

**Kraft & Hoffmeister**—Manufacturers of Metal Show Cases, Jewelry Trays always on hand, No. 16 North William street, N. Y.  
**Smith, B. & W. B.**—Patent Improved Counter Show Cases. Drawings furnished and estimates given for fitting stores in Cabinet Work complete.

#### Spectacle Case Manufacturers.

**Koenen, A. & Bro.**—Manufacturers of Leather Spectacle & Eye Glass Cases, 81 Nassau St., N. Y.

#### Thermometers Etc.

**Tagliabue, Giuseppe**—Thermometer, Barometer and Hydrometer Manufacturer, 302 Pearl street near Beekman, N. Y.

#### Thimble Manufacturers.

**Burbank Manufg Co.**—Manufacturers of Gold & Silver Thimbles, 14 Maiden Lane, N. Y.  
**Ketcham & McDougall**—Improved Gold and Silver Thimbles, Nos. 4 and 6 Liberty Place, near Maiden Lane, N. Y.

#### Walking Canes.

**Fradley, J. F.**—Manufacturer of Fine Gold and Silver-headed Walking Canes and Sterling Silverware. Office and Factory, No. 20 John street, N. Y.

#### Watch Companies.

**American Watch Co.**—Robbins & Appleton, No. 9 Bond street, N. Y.  
**Illinois Watch Co.**—Factory, Springfield, Ill. Office, 11 Maiden Lane.  
**Hampden Watch Co.**—of Springfield, Mass. Office, No. 12 John St., New York.  
**Tiffany & Co.**—Makers of Fine and Complicated Watches. Office 694 Broadway, N. Y.  
**The Howard Watch and Clock Co.**—No. 2 Maiden Lane, N. Y.

#### Watch and Chronometer Jeweler.

**Queen, James**—Watch and Chronometer Jeweler and Pallet Maker, 78 Nassau street, Room 8. Pivots inserted in Pinions, Balance, Staffs, &c.

#### Watch Importers, Etc.

**Abry, J. A.**—Importer of watches and agent for Vacheron and Constantin Watches. 63 Nassau Street, N. Y.  
**Aikin, Lambert & Co.**—Importers of Watches, Sole Agents for Paul Breton & Chas. Latour, Geneva. A general line of reliable Swiss Watches. Watch Cases of all styles made to order. 23 Maiden Lane, N. Y.  
**Bynner, T. B.**—Importer and Jobber of Watches, Diamonds and Fancy Goods, and dealer in the best class of Rolled Plate Jewelry. 513 Broadway.  
**Cross & Beguelin**—Importers of Watches, Watch Tools and Materials, dealers in American Watches, No. 21 Maiden Lane, N. Y.  
**DuBois, Francis & Co.**—36 Maiden Lane, N. Y., Importers of Watches and Manufacturers of Watch Cases.  
**Droz, Henry E.**—Importer of Watches and Watch Case manufacturer. Agent for the "E. Perregaux" Watch, and jobber in American Watches, No. 92 Fulton Street, N. Y.  
**Freund Max & Co.**—Importers of Watches Jewelry and Precious Stones, 8 Maiden Lane  
**Friedman, S.**—Importer of and dealer in Watches and Jewelry, 40 Maiden Lane.

**Gagnebin, Chas.**—Importer of all kinds of Watches, 64 Nassau Street. Agent for Ulysse Breting's Fine Chronometers, Chronographs, Anchors, etc.

**Gallet, Julien**—Importer of Watches. No. 1 Maiden Lane.

**Ginnel, Henry**—Importer of Watches, Tools and Materials. No. 31 Maiden Lane, N. Y. P. O. Box, 2967

**Howard, E. & Co.**—Watches. No. 2 Maiden Lane, N. Y.

**Keller, L. H. & Co.**—(Successors to G. A. Huguenin,) Importers of Fine Watch and French Clock Materials, No. 64 Nassau street, N. Y.

**Hyde's Sons, John E.**—Wholesale Commission Agents, only, for Jules Juergensen, of Copenhagen, Ed. Perregaux, of Locle, Jules Monard, of Geneva, and for other makers of all qualities of watches, 22 Maiden Lane.

**Mathez, F. H.**—Importer of Watches. No. 5 Maiden Lane, N. Y.

**Magnin, Ve J. Guedin & Co.**—Importers and Agents of the Nardin Watch, No. 652 B'way

**Mathey, L. & A.**—Importers of Fine Watches and Sole Agents for the H. L. Matile's Watches, No. 119 Fulton Street, N. Y.

**May & Stern**—Importers of Foreign Watches, Materials and Tools, etc. Manufacturing Jewelers. No. 19 John St., N. Y.

**Nicoud & Howard**—Importers and Manufacturers of Watches, No. 14 Maiden Lane.

**Oppenheimer Bros. & Veith**, Dealers in Watches and Diamonds, and Manufacturing Jewelers. No. 35 Maiden Lane, N. Y.

**Robert, J. Eugene**—No. 30 Maiden Lane, New York Agent for Louis Audemar's celebrated watches.

**Schwob, Adolphe**—Manufacturer & Importer of Watches, 11 Maiden Lane, N. Y.

**Stern Brothers & Co.**—Importers of Swiss Watches and wholesale dealers in American Watches, &c., 30 Maiden Lane.

**Scott, J. T. & Co.**—Importers of Watches, and Manufacturers of Jewelry, and Jobbers of all grades American Watches. No. 11 Maiden Lane, N. Y.

**Strasburger, Louis & Co.**—Importers and Makers of Watches of every description. No. 15 Maiden Lane.

**Tiffany & Co.**—Makers of Watches. General Agents for Patek, Philippe & Co. Wholesale office, 694 Broadway, N. Y.

#### Watch Cases.

**Brown, J. A. & Co.**—Manufacturers of The Ladd Patent Stiffened Gold Watch Cases, &c., 11 Maiden Lane, N. Y. Factory, 58 Eddy street, Providence, R. I.

#### Watch and Chronometer Repairer.

**Cerf, B.**—Practical Watchmaker and Repairer, No. 10 John street, N. Y. Repairing and adjusting of Fine Watches done for the trade. All kinds of escape and stem winding wheels cut to order.

**Ludeman, W. H.**—Chronometer and Watchmaker. Repairing of every description for the Trade. 75 and 77 Nassau street, N. Y.

**Sirois, A.**—Practical Watchmaker, 89 Fulton street. Special attention paid to the repairing of Fine Watches. Pivots inserted.

#### Watch Case Repairers.

**Tarbox, Hiram**—Watch Case Repairing, Springing, Polishing and Engine Turning, 79 Nassau street, (room 22), N. Y.

**Renaud, F.**—Watch-Case Repairer.—Solid and Heavy Rolled Plate Bows and Pendants. Springing and Engine Turner of Cases and Jewelry, 36 Maiden Lane

#### Watch Guards.

**American Silk Guard Manufacturing Co.**—Our goods are warranted all silk.—Kossuth Marx & Co. No. 39 Maiden Lane, N. Y.

#### Watch Glasses, Shades, Etc.

**Brown, Edwin**—No. 85 Nassau Street, Imported and own Manufacture Watch Glasses, Flat, Flat Concave, Concave, Convex and fine Geneva's. Fine fitting solicited.

**Hill, Robert S.**—Manufacturer of Watch Glasses, &c., dealer in Imported Glasses, Flat Glasses a specialty; also, Jeweler's Glasses. Nos. 75 & 77 Nassau street, N. Y.

#### BOSTON.

**The Star Salt Caster Co.**—Sole Proprietors and Makers of the Celebrated Star Salts, 161 Franklin Street, Boston, Mass.

#### CINCINNATI.

**Holland, John**—Manufacturer of Gold Pens, Pencils and Pencil-cases, Charms and Gold Tooth-picks, at No. 19 W. 4th street, Cincinnati, Ohio.

#### PHILADELPHIA

**Booz & Thomas**—Manufacturers of Gold and Silver Watch Cases and Jewelry, 108 South 8th Street, Philadelphia.

**Bennett, Jacob & Son**—Diamond Setters and Manufacturing Jewelers. 108 South 8th St., Philadelphia, Pa.

**Cooper & Bros.**—Wholesale Jewelers, and Importers of and Dealers in Watch and Clockmakers' Materials, etc. Spectacles and Optical Goods. No. 35 South 4th St., Phila.

**Conover David F. & Co.**—American Watches, Wholesale Salesroom, southeast corner 7th and Chestnut streets, Philadelphia.

**Hagstoz & Thorpe**—Sole manufacturers of Boss' Stiffened Gold Watch Cases. Sixth and Chestnut Streets, Philadelphia.

**Herold, Chas F.**—Successor to Hildebrandt, Herold & Co., Manufacturing Jeweler and Diamond Setter. Diamonds. 916 Chestnut St

**H. Muhr's Sons**—Manufacturing Jewelers, Solid Gold Rings a specialty, 158 North Second st. New York Office, 11 Maiden Lane.

**Krider, Peter L.**—Manufacturer of Sterling Silver Ware, Artisan Hall, No. 618 Chestnut street

**Levy, Bernard**—Manufacturers of gold and silver watch cases, and importers and dealers in Swiss and American watches, 402 Library street, Philadelphia.

**McCall & Newman**—Manufacturing Jewelers, Filled Plain Gold Rings a specialty, No. 625 Arch street.

**Morgan & Heady**—Manufacturing Jewelers Cameo sets, Gold sets, Roman Locketts, Rings, Coral sets, and a general line of rich goods. 611 and 613 Sansom street, Philadelphia.

**Pierson, Edwin**—Manufacturer of Fine Imitation Jewelry, Gold and Silver Electro-plater, Fire Gilder, Coloring, Etruscan and Gold Jewelry a specialty. 132C Chestnut St.

**Rosenthal, G. F. C.**—Manufacturing Jeweler and Diamond Setter. Engraving and Designing of Monograms a Specialty. No. 924 Chestnut street, Philadelphia.

**Scherr, L. A. & Co.** Wholesale Dealer in Watches Silver Plated Ware, Spectacles, Fancy Goods, Watch Materials, etc., 726 Chestnut street.

**Sheaffer, W. H. & Co.**—Makers of Fine Jewelry 908 Chestnut Street.

**Simons, Brother & Co.**—Manufacturers of Fine Jewelry, Canes, Thimbles, Chains. 611 & 613 Sansom St., Philadelphia.

#### CHICAGO.

**American Watch Company**, of Waltham, Mass. No. 170 State street, Chicago.

**Charpior & Wathier**—Watchmaker & Jewelers for the Trade, and Wholesale Dealers in Watch Material, Tools, &c., 61 West Kinzie Street, Chicago, Ill. Send for price list.

**Frese, B.**—Watchmaking and Repairing for the Trade promptly attended to. Stem-winding and escape wheels cut to order. No. 99 E. Madison St., Chicago, Ill.

**Purdy, J. H. & Co.**—Jobbers of large and small Tools and Materials, for the use of Watchmakers, Jewelers, and kindred Trades. Spectacles—Jewelry Boxes, Plated Chains, &c., &c. No. 170 State street.

**Stein & Ellbogen**—Wholesale Dealers in Watches and Jewelry, 127 State St., Chicago. Specialty, repairing for the Trade.

#### PROVIDENCE

**Irons, Chas. F.**—Manufacturer of Solid Gold Jewelry. Specialty Emblems, Pins and Charms Masonic, Odd Fellows, &c. 102 Friendship St.  
**Perkins, C. H. & Co.**—Manufacturers of fine Gold and Plated Jewelry. 20 Conduit St., Providence, R. I.

#### NEWARK.

**Lefort, Henry**—Stem-winding Watch Crown Manufacturers. 80 & 82 Marshall St.

**Lelong, L. & Bro.**—Gold and Silver Refiners, Assayers and Sweep Smelters, S. W. corner Halsey & Marshall streets, Newark, N. J.

**Milne & Jourdan**—Manufacturers of Stem-winding Watch Crowns Nos. 13 & 15 Franklin Ave., Newark, N. J.

**Prince, David**—Gold and Silver Refiner, Assayer and Sweep Smelter. Sole Agent for Comin's Improved Amalgamator. 63 Railroad Ave.



Standard Marine Chronometer  
FOR KEEPING CORRECT TIME.

**JOHN BLISS & CO.**  
**STANDARD MARINE**  
**Chronometers and Transits,**  
**FOR WATCHMAKERS' USE.**

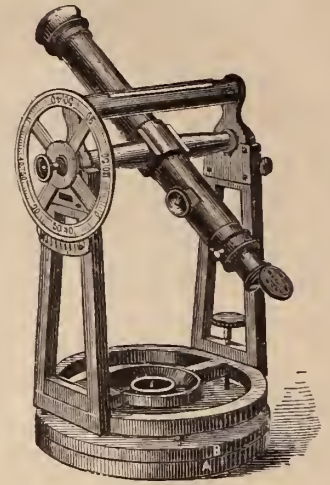

No. 10

**110 WALL STREET, NEW YORK.**

**IMPORTANT NOTICE.**—These Transits are readily set in position without the aid of strictly correct time as a basis for that purpose. Printed instructions, easily understood, accompany each Instrument, and no calculations are required preliminary to setting in position.

As a trial only is required to insure unqualified approval, we are induced to make the following **LIBERAL OFFER**—On receipt by us of satisfactory reference, and 10 per cent. of the price, we will send one of the foregoing Transit Instruments, on hire or trial, for one month, with full printed instructions for setting up and using the same, and if purchased after trial, we will allow the whole hire to apply in part payment, and sell the Instrument on approved note at four months for the balance. Special terms for payment by installments, after trial, on application. We do not make this offer merely to hire these instruments, but to insure a trial with a view to sales, the hire received being only sufficient to cover the cost of repolishing in case they are returned. Send for Illustrated Circular giving full description.

JOHN BLISS & CO., 110 Wall Street, New York

**PATENT IMPROVEMENT IN COUNTER SHOW CASES,**  
**PERPENDICULAR SLIDING DOOR, DUST-TIGHT.**

*CENTER COUNTER CASE DOORS RUNNING THROUGH BOTH SIDES.*

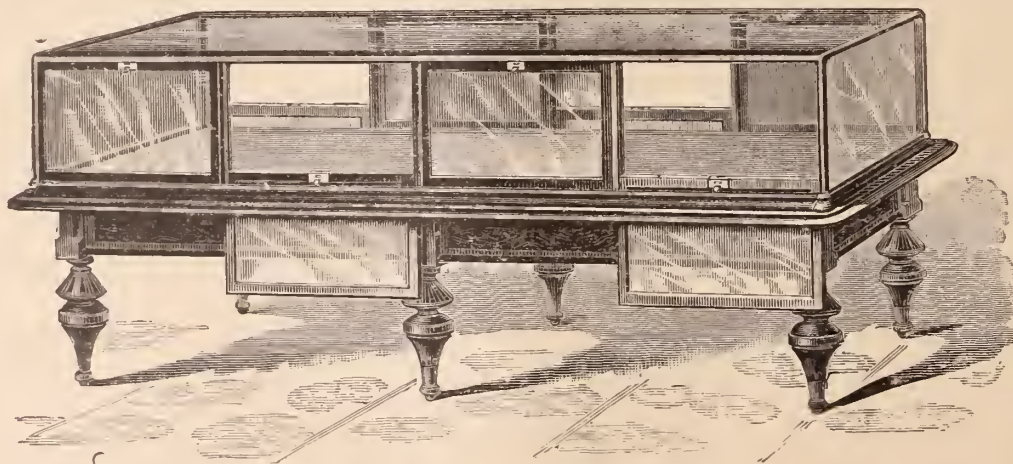

Its advantages are as follows:—The doors are more conveniently opened and closed, less liable to get out of repair or broken, articles are more easily reached in wide cases, mirrors are more safe, it dispenses with hinges, economizes room, excludes dust, and is air tight *when closed*.

Drawings furnished and estimates given for fitting stores in cabinet work complete.

REFERENCES:—Gorham Mfg Co., Rogers & Bro., Mitchell, Vance & Co.  
Meriden Britannia Co., M. S. Smith & Co., Detroit, Mich.  
D Valentine, Syracuse, N. Y.

**B. & W. B. SMITH,**  
**220 West 29th Street, New York.**

# New Haven Clock Co.

62 READE ST., NEW YORK.

L. EGERTON, Jr., Agent.

DUCHESS, TIME.  
DUCHESS CALENDAR TIME.  
ROVER ALARM.

Manufacturers of

NICKEL LEVER.

CLOCKS, MOVEMENTS,  
AND  
CLOCK MATERIAL,

AND

DEALERS WITH THE TRADE.

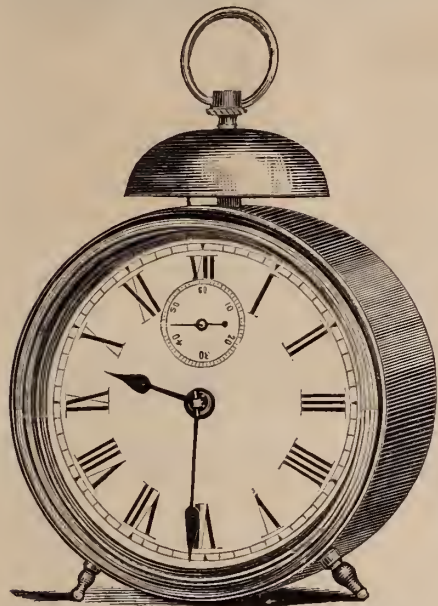

FRONT VIEW—DIAL 4 INCHES.  
1-Day Time, - - \$1.40  
1-Day Calendar Time, 1.75  
1-Day Alarm, - 1.90

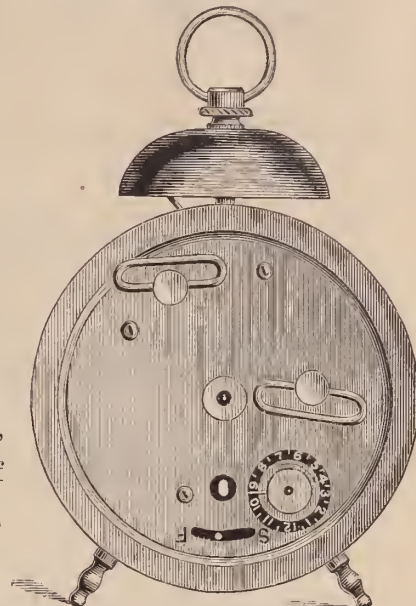

BACK VIEW.

Besides our well-known styles of VENEERED GOODS, we are making several new and beautiful patterns of Black Walnut, visible Pendulum, both Time and Strike, 1-Day and 8-Day, with and without Alarm,

CATALOGUES AND TERMS SENT ON APPLICATION.

# WATERBURY CLOCK CO.,

MANUFACTURERS OF AMERICAN CLOCKS,

4 CORTLANDT STREET,  
NEW YORK.

M. BAILEY, Treasurer.

63 WASHINGTON ST.  
CHICAGO.

FACTORIES,  
WATERBURY, CONN.

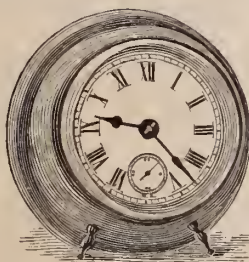

CRICKET.  
30 HOUR LEVER TIME.



CRICKET EXTRA.  
30 HOUR LEVER TIME.



SUNRISE.  
30 HOUR LEVER TIME, ALARM.



TRANSIT.  
30 HOUR LEVER TIME.



INDEX.  
30 HOUR LEVER TIME, CALENDAR.



MONITOR.  
30 HOUR LEVER TIME, ALARM, CALENDAR

ILLUSTRATED CATALOGUES AND PRICE LISTS FURNISHED ON APPLICATION.

# LOUIS STRASBURGER & CO.,

Importers of

## DIAMONDS.

☞ We are direct Importers of Diamonds, dealers will therefore always find ORIGINAL parcels in our stock to select from.

MATCHED PAIRS, IN ALL GRADES AND WEIGHTS, A SPECIALTY!

NEW YORK, 15 MAIDEN LANE.

PARIS, 30 BOULEVARD HAUSSMANN.

Our complete stock of loose and mounted Diamonds enables us to send a full assortment for selection to any first-class house.

## LOUIS STRASBURGER & Co.

### Manufacturers of Watches,

From the finest Stem-Winding and Setting goods to the lowest price Watch in the market.

We manufacture and have continually in stock a complete assortment of the best COMMERCIAL WATCHES ranging from the lowest priced Metal and Silver Watches to the finest Gold Watches, such as REPEATERS, CHRONÔGRAPHS (single and split) and all other Timing and Complicated Watches.

Also a full assortment of the INTERNATIONAL and all AMERICAN Movements. *Gold and Silver Cases*, constantly on hand.

We would call particular attention to our complete and varied assortment of NICKEL WATCHES, (black and fancy Dials,) in all grades, styles, and sizes.

THE RAIL-ROAD TIMEKEEPER A SPECIALTY.

SALESROOMS, No. 15 MAIDEN LANE, NEW YORK.

Watch Factory, Rue Leopold, Chaux de Fonds, Switzerland.



THE  
**MERIDEN BRITANNIA COMPANY**

No. 46 East Fourteenth Street, Union Square, N. Y.

MANUFACTURERS OF

**SILVER-PLATED WARE.**

Porcelain Lined Ice Pitchers, Spoons, Forks,  
 Table Cutlery, etc., etc.

*Extract from the American Institute Report:—*“Their Porcelain-lined, Double-walled Ice Pitchers are Art, and possess all the qualities the company claim.” \* \* \* “We consider the goods made by this company to be by far the best made in this country, and we believe in the world”

**ROGERS CUTLERY COMPANY,**



**WM. ROGERS,**  
 Senior Member and Manager of the Firm of ROGERS BROTHERS. Died Feb. 17, 1873.



**ASA H. ROGERS,**  
 Of the original ROGERS BROTHERS, and half owner of the Rogers Cutlery Co., when organized. Died Oct. 4, 1876.



**F. WILLSON ROGERS,**  
 Son of the late Wm. Rogers, and Secretary of the ROGERS CUTLERY CO.



Our Knives stamped as above we guarantee

To Strip 12 dwts. of Silver per dozen.  
 Our Knives are guaranteed to be  
**ALL HAND BURNISHED,**  
 and are put up in rack boxes with hinge covers.

**WE GUARANTEE our Spoons, Forks, &c. to be Plated 25 Per Cent. HEAVIER THAN STANDARD PLATE.**

We guarantee Spoons, Forks, &c. to be plated on  
**18 PER CENT. NICKEL SILVER, AS FOLLOWS:**

On TEA SPOONS,	2½ ounces,	or 50 dwts. per gross.
On DESSERT SPOONS,	3¼ “	“ 75 “ “
On TABLE SPOONS,	5 “	“ 100 “ “
On DESSERT FORKS,	3¼ “	“ 75 “ “
On MEDIUM FORKS,	5 “	“ 100 “ “

**OUR SPOONS, FORKS, LADLES, &c. ARE STAMPED**

On EXTRA PLATE,	. . . . .	1871, ROGERS	Ⓒ	5 oz.
On DOUBLE PLATE,	. . . . .	1871, ROGERS	Ⓒ	8 oz.
On TRIPLE PLATE,	. . . . .	1871, ROGERS	Ⓒ	12 oz.
On QUADRUPLE PLATE,	. . . . .	1871, ROGERS	Ⓒ	16 oz.



All Hollow Ware stamped as above is warranted to be plated

**50 PER CENT. HEAVIER**  
 than any other brand of goods.  
 Our Hollow Ware in addition to our trade mark is stamped

**SEXTUPLE PLATE,**  
 we being the only firm who manufacture this weight of plate.

*Extract* The above is a fac-simile of our guarantee card which accompanies each dozen of our flat ware, and each piece of our hollow ware. Our goods have been in the market since 1871, and are acknowledged by all dealers, who have tried them, to be THE BEST.  
*Extract* We would call especial attention to the EXTRA STRONG SPRING TEMPERED SHANK, which we have on our Tipped, Fiddle Saxon and Imperial pattern

# SIMPSON, HALL, MILLER & CO.

MANUFACTURERS OF

## Silver-Plated Ware,

SUPERIOR IN QUALITY, DESIGN AND FINISH.

FACTORIES, WALLINGFORD, CONN.

Salesroom 36 East 14th St., New York.



Our assortment comprises a large line of Hollow Ware and Flat Ware, the product of many years manufacturing, with superior skill and appliances. Dealers in Silver-Plated Wares throughout the country have found our productions desirable in all respects, and perfectly adapted to the requirements of their customers. We have added many new articles to our assortment, and shall continue to produce *DESIGNS OF ORIGINAL AND ARTISTIC* merit in rapid succession.

**OUR SOLID TABLE WARE IS MADE OF THE BEST NICKEL SILVER.**

*SPOONS, FORKS, LADLES, PIE-KNIVES, &c.*

IN GREAT VARIETY OF PATTERNS.

**Solid Steel Knives of Superior Quality.**

Our *ILLUSTRATED CATALOGUE*, recently issued, will be furnished to *REGULAR DEALERS*, on application, inclosing business card.

## The STAR SALT



## CASTER COMP'Y

Sole Proprietors and Manufacturers of

CELEBRATED

## STAR SALTS

For convenience, neatness and utility the STAR SALTS have become a household necessity.

The pulverizer in the bottle, as shown by the cuts, keeps the salt pulverized, and obviates the disagreeable habit of spilling the salt by dipping out of an open salt cellar.

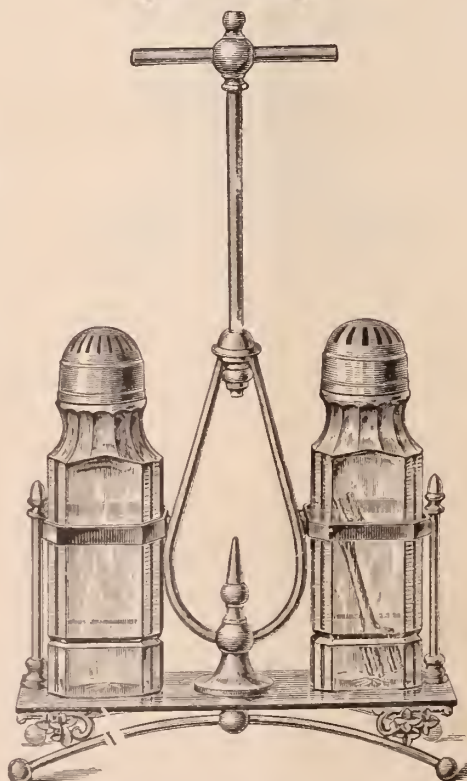

No. 161 Franklin Street

**BOSTON, MASS.**

Place these in the family and Salt Cellars will be discarded.

MANUFACTURED IN ALL VARIETIES OF PLAIN AND FINE CUT GOODS, CASTERS, &c.



Fine Diamond Cut, with Sterling Caps.

Special care given to orders for exportation.

For full descriptions of the above goods see our Illustrated Catalogues, which will be mailed on application.

THE

## MIDDLETOWN PLATE COMPANY,

Superior Silver Plated Ware,

13 JOHN STREET, New York.

MIDDLETOWN, Conn.

120 SUTTER STREET, San Francisco, Cal.

A Superior assortment in new designs of every article of Silver Plated Ware.

KNIVES, FORKS, SPOONS, &amp;c., &amp;c.

ARKELL &amp; CO.

IMPORTERS AND DEALERS IN

Watch Materials, Tools,

JEWELRY,

AND ALL GRADES OF AMERICAN WATCHES.



We call the attention of Watchmakers to the "JEQUIER" Main Spring. This spring is the only one of all fabrications exhibited at the "Paris Exposition" that received FIRST and ONLY medal. We claim it is the best in this country, and invite a trial by the trade as a test of its merits. Send for sample and also descriptive catalogue of Columbus Watch, nickel  $\frac{3}{4}$  plate, full jeweled, stem-winding and setting, the most beautiful watch with the best results for least money, quality considered. No price list furnished unless requested and only to the trade.

BALDWIN'S BARREL CATCH INSERTER, indispensable to the Watch Repairer, saves time and labor, sent by mail on approval to the trade free of postage.

We are Sole Agents for the United States of these goods. We also manufacture the BOSS ENGRAVING BLOCK—there are features in its construction different from all others in the market, holds the work to be engraved, of any kind, without attachments. It is practical, simple, and reasonable in price. All these specialties enumerated, may be obtained of any regular Dealer in material and tools, or direct of us.



P. O. Box 8. Canajoharie, N. Y.

JAS. T. SCOTT,  
CLEM SCOTT,  
J. T. SCOTT JR.

# J. T. SCOTT & CO.

Established 1847.

No. 11 MAIDEN LANE, - - - NEW YORK.

SOLE EASTERN

AGENTS FOR

## THE ROCKFORD

## WATCH CO.

AND AGENTS FOR

The Auburndale

## CHRONOGRAPH

TIMERS,

¼ and ½ seconds, in 18 size  
Nickel-Plated Cases, designed  
for Sporting, Scientific and  
Mechanical purposes.



ROCKFORD WATCH.

This Company manufactures eight grades of superior 18 size key and stem wind

**QUICK TRAIN,**

Movements.

ALSO SOLE AGENTS FOR

**Abbott's Patent Open-Face**

18 size American stem-winders, with XII at pendant and seconds opposite.



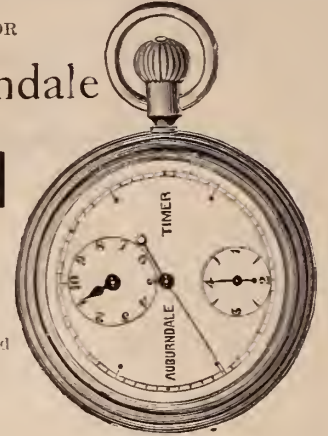

ABBOTT'S PATENT.



AUBURNDALE TIMER.

Manufacturers of Jewelry and Wholesale Dealers in all grades of American Movements.

WATCH CASES, DIAMONDS, CHAINS, SILVER WARE, &c.

 Price Lists furnished upon application to those regularly engaged in the Trade. 

# French Clocks.

 We make a speciality of this department and are constantly opening new lines which we offer at very low prices.

## TAYLOR & BROTHER,

No. 676 Broadway,

## NEW YORK.

### WHOLESALE ONLY.

# MILLER BROS.

MANUFACTURING JEWELERS,

No. 11 MAIDEN LANE, NEW YORK.

Manufactory, 47, 49 & 51 Franklin Street, Newark, N J

*New this Spring,  
A LARGE LINE OF*

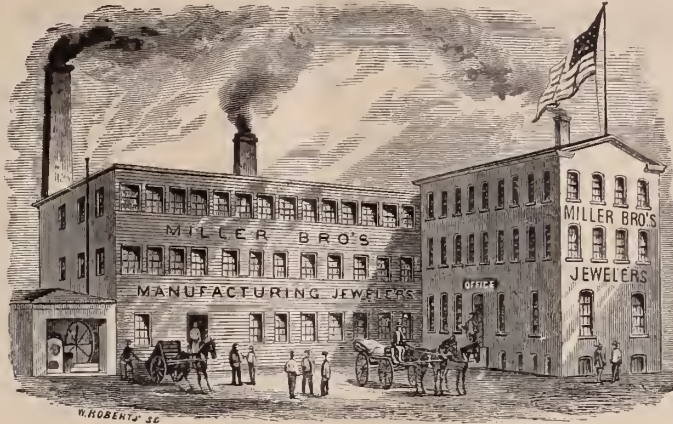

*Novelties for  
Ladies' & Gentlemen's Wear.*

ATTENTION IS INVITED TO OUR  
NEW STYLES OF ETRUSCAN SLEEVE BUTTONS,  
MOUNTED WITH

## RUSTIC LETTERS

BIRDS ANIMAL HEADS AND FANCY ORNAMENTATIONS

Also a full line of Locketts, Sets, Pins, Ear Rings, Sleeve Buttons, Studs, &c. All goods exclusively of our own manufacture.

# DAVID F. CONOVER & CO.

(SUCCESSORS TO WM. B. WARNE & Co.)

Importers, Manufacturers and Wholesale Dealers in

## WATCHES AND JEWELRY,

Silver and Silver-Plated Ware,

AMERICAN WATCH WHOLESALE SALESROOM,

Southeast Corner Chestnut and 7th Streets,

(FIRST FLOOR,)

DAVID F. CONOVER,  
B. FRANK WILLIAMS,  
C. EDGAR RIGHTER.

PHILADELPHIA.

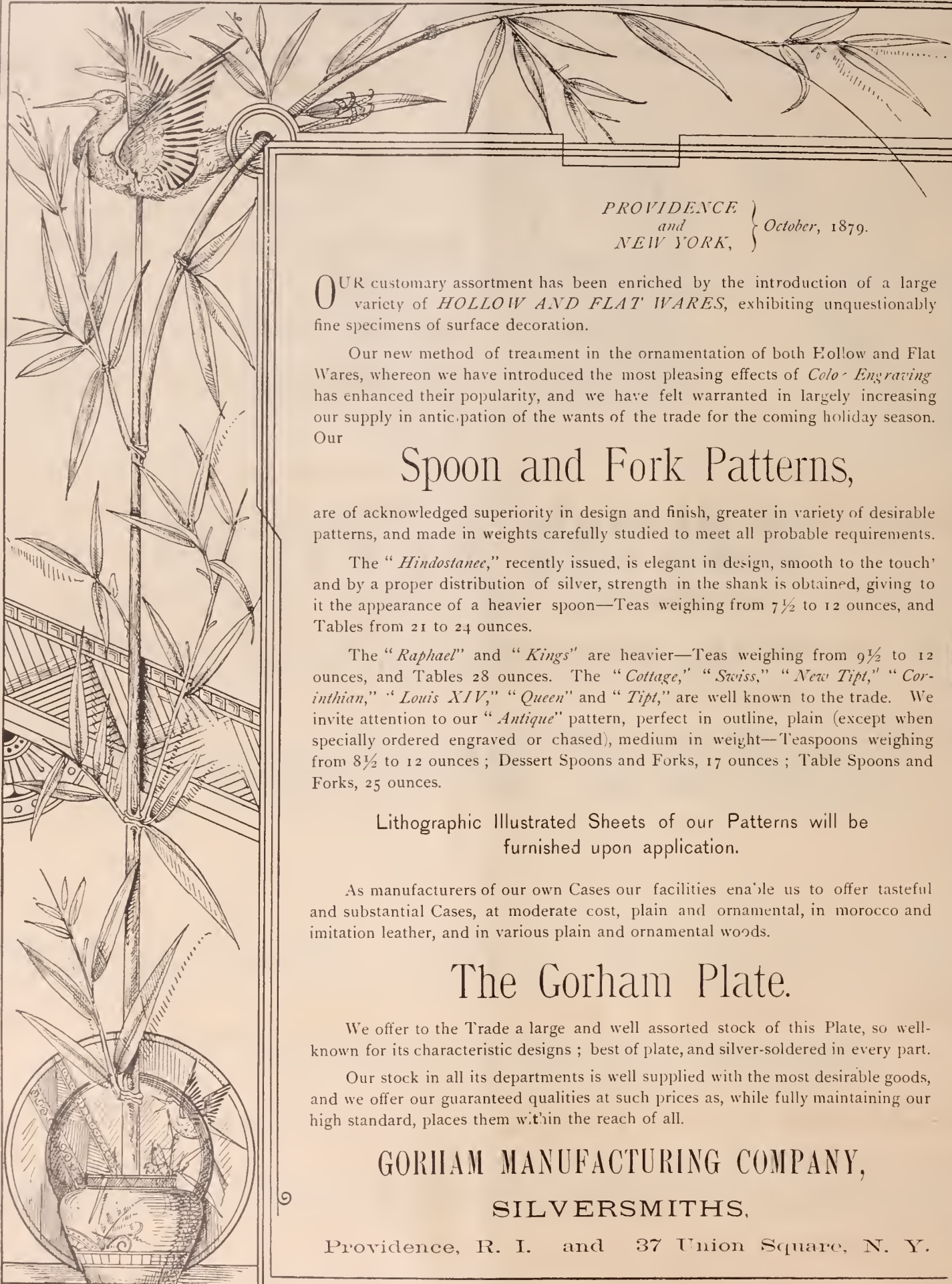

PROVIDENCE }  
and } October, 1879.  
NEW YORK, }

OUR customary assortment has been enriched by the introduction of a large variety of *HOLLOW AND FLAT WARES*, exhibiting unquestionably fine specimens of surface decoration.

Our new method of treatment in the ornamentation of both Hollow and Flat Wares, whereon we have introduced the most pleasing effects of *Color Engraving* has enhanced their popularity, and we have felt warranted in largely increasing our supply in anticipation of the wants of the trade for the coming holiday season. Our

## Spoon and Fork Patterns,

are of acknowledged superiority in design and finish, greater in variety of desirable patterns, and made in weights carefully studied to meet all probable requirements.

The "*Hindustanee*," recently issued, is elegant in design, smooth to the touch and by a proper distribution of silver, strength in the shank is obtained, giving to it the appearance of a heavier spoon—Teas weighing from  $7\frac{1}{2}$  to 12 ounces, and Tables from 21 to 24 ounces.

The "*Raphael*" and "*Kings*" are heavier—Teas weighing from  $9\frac{1}{2}$  to 12 ounces, and Tables 28 ounces. The "*Cottage*," "*Swiss*," "*New Tipt*," "*Corinthian*," "*Louis XIV*," "*Queen*" and "*Tipt*," are well known to the trade. We invite attention to our "*Antique*" pattern, perfect in outline, plain (except when specially ordered engraved or chased), medium in weight—Teaspoons weighing from  $8\frac{1}{2}$  to 12 ounces; Dessert Spoons and Forks, 17 ounces; Table Spoons and Forks, 25 ounces.

Lithographic Illustrated Sheets of our Patterns will be furnished upon application.

As manufacturers of our own Cases our facilities enable us to offer tasteful and substantial Cases, at moderate cost, plain and ornamental, in morocco and imitation leather, and in various plain and ornamental woods.

## The Gorham Plate.

We offer to the Trade a large and well assorted stock of this Plate, so well-known for its characteristic designs; best of plate, and silver-soldered in every part.

Our stock in all its departments is well supplied with the most desirable goods, and we offer our guaranteed qualities at such prices as, while fully maintaining our high standard, places them within the reach of all.

GORHAM MANUFACTURING COMPANY,  
SILVERSMITHS,

Providence, R. I. and 37 Union Square, N. Y.

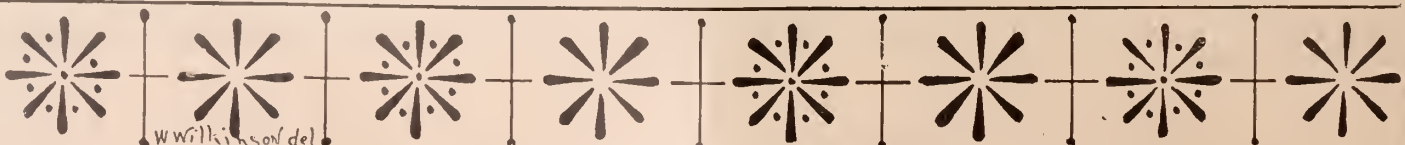

ESTABLISHED 1855.

D. LIECHTY & CO.,

MANUFACTURERS OF

Fine Gold Watch Cases

No. 140 South Third Street,

Fourth Floor.

PHILADELPHIA

Repairing neatly attended to.

LOUIS A. SCHERR.

CHAS. H. O'BRYON.

G. W. SCHERR.

**LOUIS A. SCHERR & CO.**

Importers and Wholesale Dealers in

**Watches, Jewelry,**

WATCH MATERIALS, TOOLS, GLASSES, &C.

**Spectacles, Silk Guards, &c.**

Wholesale Agents for American Watches.

**No. 726 CHESTNUT STREET,**

FIRST FLOOR.

**PHILADELPHIA.**

NATHAN A. MORGAN.

CHAS. B. HEADLY.

**MORGAN & HEADLY,**

MANUFACTURERS OF

**GOLD SPECTACLES,**

**Fine Jewelry, Chains**

AND BRACELETS,

**18 KARAT PLAIN RINGS, &c.**

611 & 613 Sansom Street,

Artisan Hall,

PHILADELPHIA.

A full line of DIAMONDS, mounted and unmounted, always on hand which we will send on approval to the Trade, on receipt of reference.

**BENJ. ALLEN & CO.**

WHOLESALE DEALERS IN

**American and Swiss Watches**

JEWELRY, DIAMONDS,

SILVER & PLATED WARE.

137 and 139 State Street, Chicago.

A full line of Howard Watches in stock. Catalogues sent upon application, to dealers only.

**WILLIAM BARBER'S**  
**Patent Adjustable Eye-Glass.**



The above cut represents an Eye-glass possessing the convenience of an Eye-glass and the utility of a Spectacle combined, thereby rendering it practicable for everyone to avail themselves of their convenience, who have heretofore been deprived of their use.

**TRY THEM, WILL RECOMMEND THEMSELVES.**

We manufacture them from Gold, Nickel, Steel, Shell and Rubber.

**WILLIAM BARBER,**

Inventor, Patentee and Manufacturer,

No. 248 North 8th Street, Philadelphia, Pa.



January 8th, 1878.

**GUTMANN'S**

**Automatic Hammer and Punches**

**Simplified and More Effective.**

THIS TOOL takes the place of the third hand, therefore its manifold uses are quickly apparent, and I would only say, that it is accompanied by six punches, to wit: 2 hand punches, 1 prick punch, 1 closing hole punch, 1 rivet punch, and 1 pinion punch, all of which fit neatly into the punch holder, and are fastened by the screw. Its tap is alternately heavy and light, and the finger loops are assorted in size. The Tool is nickel-plated and boxed, ready to be mailed on receipt of price.

THE OPERATION IS AS FOLLOWS: First, set the hammer; next insert your forefinger through the loop at the top and place the punch with firmness on your work. When you are ready for the blow, push gently on the thumb-piece which produces the concussion on the punch. Your left hand is entirely free to hold the work.

Price, \$2.00; Reduced from \$2.50.

**MAX L. GUTMANN,**

Patentee and Manufacturer.

Also, Importer and Wholesale Dealer in

**Watch and Jobbing Materials, Tools, Glasses,**

*Chains, Guards, Jewelry and Watches.*

PLEASE SEND YOUR ORDERS.

**ROCHESTER, N. Y.**

# COLBY & JOHNSON,

17 Maiden Lane, New York,  
Exclusive Manufacturers of Open-face Stem-winding

White,  
Black,  
Malachite,  
or  
Marbled  
Celluloid.



Gold, Silver,  
or  
Nickel  
Centers,  
Pendants  
and Bows.

SUITABLE FOR ALL 18-SIZE AMERICAN S. W. MOVEMENTS.

We call especial attention to the fact that Celluloid being a NON-CONDUCTOR, the cheaper grades of movements (not adjusted to heat and cold), cased in this material, are not affected by atmospheric changes, and can be relied upon as being much MORE ACCURATE TIME-KEEPERS than the same movements cased in metal of any kind.

# SINNOCK & SHERRILL,

## Stone Ring Manufacturers,

No. 5 MAIDEN LANE,

Factory, Newark, N. J.

**NEW YORK**

C. A. GALLAGHER.

C. E. MOODY.

AUBURNDALE, MASS.

# CHRONOGRAPH TIMER,

WM. B. FOWLE, Maker.

Designed for Sporting, Scientific and Mechanical purposes;  $\frac{1}{4}$  and  $\frac{1}{8}$  seconds, fly back.

List Price, - - \$15.00

Positively Accurate.

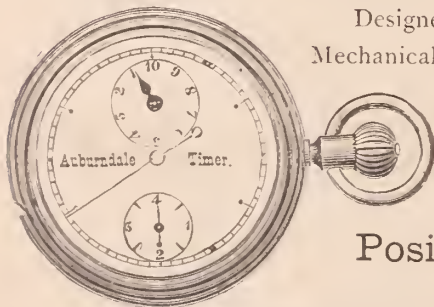

Put up in German Silver Cases, Nickel Plated, size of an ordinary watch. Very neat and handsome, supplying a want long felt by those desiring to measure the flight of time with scientific accuracy to the fraction of a second. It indicates positively minutes, seconds, quarters or eighths of seconds, the only instrument registering one eighth of a second made. It is substantially constructed, positive in its action, and will not easily get out of order.

These Chronographs can be obtained from the principal Jobbing Houses in the Trade.

# E. HOWARD & CO.,

MANUFACTURERS OF

## Fine Watches, Regulators, Office Clocks,

Electric Watch Clocks & Tower Clocks,

Office, No. 2 MAIDEN LANE,

NEW YORK.

No. 114 TREMONT STREET, BOSTON.

J. W. J. PIERSON, - - AGENT.

ESTABLISHED 1859

# RINGS A SPECIALTY.

BRYANT & BENTLEY,

No. 12 Maiden Lane,

New York,

MANUFACTURE A LARGE VARIETY OF

## FINE SOLID RINGS,

For Ladies and Gentlemen, in CAMEO, AMETHYST, ONYX, TOPAZ, TURQUOISE, GARNET and other stones. Fine CAMEO, CORAL and ROMAN SETS of new and handsome designs. LOCKETS, MEDALLIONS, SHAWL and SCARF PINS, SLEEVE BUTTONS, STUDS, &c. All goods warranted.

We continue to manufacture several hundred patterns of **HARD SOLDER RINGS**, in every style, for men, women and children, stamped and warranted 16 karat fine.

# BUCKENHAM, COLE & SAUNDERS,

SUCCESSORS TO

BUCKENHAM, COLE & HALL,

IMPORTERS OF

# Diamonds, Pearls

AND OTHER PRECIOUS STONES,

MANUFACTURERS OF FINE JEWELRY,

10 Maiden Lane, New York.

A large stock of FINE DIAMONDS, Mounted and Unmounted kept constantly on hand. Goods sent on approval to any part of the country on receipt of satisfactory references.



**SAXTON, SMITH & CO.**  
MANUFACTURERS OF

**Fine Gold Chain.**

No. 15 Maiden Lane.

**New York.**

Factory, No. 183 Eddy Street, Providence, R. I.

Sole Agents for the new PATENTED CHAIN BAR, containing a Detachable Pencil.

**IMPORTER OF DIAMONDS**  
**E. AUG. NERESHEIMER**  
21 MAIDEN LANE,  
NEW YORK  
No 1 GAERTNER PLATZ MUNICH-GERMANY.  
No 24 DOELEN STRAIT AMSTERDAM-HOLL.  
DIAMONDS LOOSE & MOUNTED SENT ON APPROVAL AND THE VALUE INSURED

**HELLER & BARDEL,**

MANUFACTURERS OF

**Diamond and Pearl Jewelry,**

And Dealers in Diamonds, Pearls, &c.

SHAWL AND LACE PINS IN GREAT VARIETY.

*No. 18 John Street, New York.*

A full line of DIAMONDS, mounted and unmounted; also, a large assortment of first-class DIAMOND MOUNTINGS of our own make always on hand. Sketches submitted at any time upon application. We will send goods on selection to responsible houses.

**KOSSUTH, MARX & CO.,**

No. 39 Maiden Lane, New York,

MANUFACTURERS OF

**Gold and Fine Rolled Plate Jewelry,**

Chains, Necklaces, Locketts, Crosses, &c. &c.

**SOLID GOLD and STONE RINGS**

In large variety,

Diamonds, Pearls, Cameos, Amethysts, Turquoise, &c.

Sole Manufacturers of the Celebrated

**AMERICAN SILK GUARDS.**

**WOOD & HUGHES,**

STERLING

**Silverware Manufacturers**

**No. 16 JOHN STREET,**

**NEW YORK.**

*206 Kearney Street, San Francisco, Cal.*

**R. H. HASKELL, Agent.**

**KREMENTZ & CO.,**

MANUFACTURERS OF

**FINE JEWELRY,**

No. 13 John Street, New York.

Factory, 361 Mulberry Street, Newark, N. J.

GOODS OF OUR OWN MAKE EXCLUSIVELY

**CARTER, HOWKINS & SLOAN,**  
**Makers of Fine Jewelry**

*Consisting of Chains, Bracelets, Sets, Pins, Studs, Sleeve Buttons,  
 Scarf Pins, Rings, &c., in Roman, Etruscan and Enamel,  
 and a full line of Jewelry generally.*

Whiting Building, Corner Broadway and Fourth Street,

A. CARTER JR.  
 WM. HOWKINS,  
 A. K. SLOAN.

**NEW YORK.**

C. E. HASTINGS,  
 GEO. R. HOWE,  
 W. T. CARTER.

**HALE & MULFORD,**  
**Manufacturing Jewelers,**

(WHITING BUILDING).

No. 694 Broadway, cor. 4th Street, New York.

Call attention of the Trade to their new style of

**BAND BRACELETS,**

We claim for these Bracelets, the following advantages over the old style, viz. :

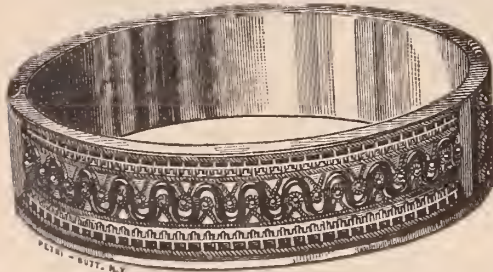

1st. The edge of the Bracelet being raised, forms a protection to the ornamentation.

2d. Less liability of getting damaged, and when damaged, are more easily repaired.

3d. More attractive in appearance.

Prices are as low as any FIRST CLASS 14 KARAT ALL GOLD Bracelet in the market.

Made in all sizes from 1/4 inch upwards.

Patented February 25, 1879.

—Established 1837.—

**TAYLOR & BROTHER,**

Late TAYLOR, OLMSTED & TAYLOR,

**Importers of Diamonds and Pearls,**

—AND—

**MANUFACTURERS OF DIAMOND JEWELRY,**

No. 676 BROADWAY,

**NEW YORK.**

**BALDWIN, SEXTON & PETERSON,**

MANUFACTURERS OF

**Fine Jewelry,**

Diamond and Stone Cameo Goods,

**GOLD CHAINS, &c.**

Importers of Diamonds, Pearls, Emeralds, Rubies, &c.

WHITING BUILDING,

**Cor. Broadway and Fourth Street,**

**NEW YORK.**

120 SUTTER STREET, San Francisco, Cal.

Established 1817.

**Ve. J. MAGNIN, GUÉDIN & CO.**

29 Union Square, New York.

*Manufacturers and Importers,*

FINE SWISS WATCHES,

REPEATERS, CHRONOGRAPHS & CALENDARS

GENEVA GOLD JEWELRY,

FRENCH CLOCKS AND BRONZES,

RICH FANCY GOOCS,

HORSE-TIMERS & PEDOMETERS,

GOLD AND SILVER CHATELAINE WATCHES.

Gold Medal Awarded, Paris Exposition, 1878.

*Sole Agents for the James Nardin Watch.*

*House in Geneva, 14 Grand Quai.*

Established 1813.

**THOMAS G. BROWN,**

MANUFACTURER OF

**FINE JEWELRY.**

*Designs furnished for all kinds of Sporting  
 Badges and Medals for Schools & Colleges.*

**NEWARK, N. J.**

—AND—

**9 BOND STREET, NEW YORK.**

ALFRED H. SMITH & CO.,

No. 14 JOHN STREET, NEW YORK.

OFFER THEIR RECENT IMPORTATIONS OF

DIAMONDS

AT LOW PRICES.

Established 1834.

**G. & S. OWEN & CO.,**

Makers of Fine GOLD JEWELRY

SPECIALTIES :

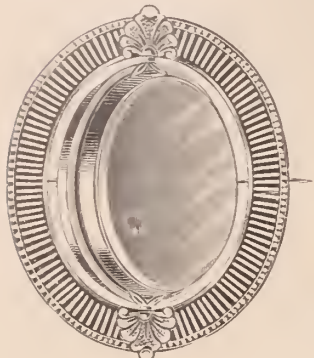

Black Onyx Goods,  
Roman & Polished Goods,  
Hair Chain Mountings,  
The Makers  
OF  
BOX AND GLASS GOODS.

All our goods exclusively of our own manufacture.

5 MAIDEN LANE, NEW YORK.

**JOHN A. RILEY & CO.**

MANUFACTURERS OF

Rich Gold and Onyx Jewelry,

NOVELTIES IN HALF SETS, LACE PINS, SCARF  
PINS AND EAR RINGS,

Engagement Pad Lock Bands, Elastic Snake Bands and  
Chatelaines. Onyx Chatelaines with and  
without Watch Movements.

Nos. 7 & 9 Bond Street, New York.

No. 126 Kearney Street, San Francisco, Cal.

**MOORE & HORTON,**

**JEWELLERS,**

No. 11 Maiden Lane, New York.

**SPECIALTIES!**

Stone Cameo, Onyx, Amethyst, Topaz and Pearl Rings,  
Studs, Collar and Sleeve Buttons.

Also our new fac-simile of Fine African Diamonds, mounted in  
Rings, Studs, Pins, Ear-rings, Scarf Pins, Mc'allions.

**ENOS RICHARDSON & CO.**

MANUFACTURERS OF

**FINE GOLD JEWELRY,**

Gold Chains, Locket, Crosses and Necklaces,  
COLORED AND ETRUSCAN WORK.

ENGRAVED AND ENAMELLED GOODS IN GREAT VARIETY.

All Goods sold strictly of our own manufacture.

23 MAIDEN LANE, NEW YORK.

ENOS RICHARDSON,  
THOS. SLATER,

L. P. BROWN,

F. H. RICHARDSON  
W. P. MELCHER.

DYER BRAINERD.

JOHN W. STEELE.

**BRAINERD & STEELE,**

MANUFACTURERS OF

Brainerd's Pat. Locket,

(Patented June 17, 1874.)



These Locket combine both beauty and strength. They are made of solid 14kt. gold, and the stones used are the finest obtainable in the market. They cost no more than those of the old style, if indeed as much; and the combination of secrecy and durability renders them much more desirable. We make three sizes in four different shapes—round, oval, cushion and oblong square; and also Sleeve Buttons of the same style, containing a concealed box for miniatures, a novelty new to the Trade.



FINE GOLD JEWELRY,  
**No. 9 Maiden Lane,**  
NEW YORK.

**W. H. SHEAFER & CO.,**

**Makers of Fine Jewelry**

CONSISTING OF

BRACELETS, SETTS, LOCKETS, PINS,

STUDS, SLEEVE BUTTONS, RINGS, &c.

**SPECIALTY:—STIFFENED ROMAN BANDS.**

No. 908 Chestnut Street, PHILADELPHIA.

Branch Office 15 John Street, New York.

**WM. S. HEDGES & CO.,**

*Of the late firm of SMITH, HEDGES & Co.*

IMPORTERS OF

**DIAMONDS,**

No. 170 Broadway, cor. Maiden Lane,  
NEW YORK.

*Choice Brilliants in single stones and matched pairs a specialty.*

GOODS SENT ON APPROVAL.



**CHATELLIER & SPENCE,**

**Manufacturing Jewelers,**

694 BROADWAY, NEW YORK.

No. 1129 Chestnut Street, PHILADELPHIA, PA.

No. 12 West Street, BOSTON, MASS.

No. 120 Sutter Street, SAN FRANCISCO, CAL.

**JOSEPH N. TINGLEY,**

*Late of the firm of Tingley, Sinnock & Sherrill,*

MANUFACTURER OF

**STONE RINGS,**

—AND—

NOVELTIES IN STONE GOODS,

No 9 Maiden Lane, New York

FACTORY, NEWARK N. J

**LYON & HARDY,**

30 MAIDEN LANE, NEW YORK,

IMPORTERS OF



AND MANUFACTURERS OF

**DIAMOND MOUNTINGS.**

All goods ordered for stock or on approval are insured while in the hands of Express Companies.

MULFORD & BONNET,

**Manufacturing Jewelers,**

DEALERS IN

**DIAMONDS.**

AND JOBBERS IN

**Fine Rolled Plated Goods,**

No. 21 Maiden Lane,

**NEW YORK.**

# J. B. BOWDEN & CO.

*Manufacturer of*

SOLID GOLD AND STONE

## RINGS

All Styles of Children's

AND

FANCY SOLID RINGS,

A LARGE ASSORTMENT ALWAYS ON HAND.

No. 1 Maiden Lane, New York.

OPPENHEIMER BROS. & VEITH,

MANUFACTURING JEWELERS,

AND

Dealers in Watches and Diamonds,

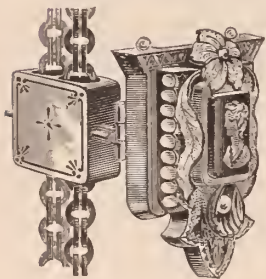

Patented Jan. 3, 1879.

35 Maiden Lane,  
NEW YORK.



Patented June 3, 1879.

Combination Chain, Slide, Pendant and Locket.

See description elsewhere in the JOURNAL.

Platinum Tipped Diamond Settings,

Patented April 16th, 1878, by

Ripley, Howland & Co.



Office, No. 35 Maiden Lane, New York.

Factory, 383 Washington Street, Boston, Mass.

# RANDEL, BAREMORE & CO.

## DIAMONDS,

Corner Maiden Lane and Nassau St.

29 Maiden Lane, **NEW YORK**, 58 Nassau Street.

No. 12 New Burlington Street, LONDON, W.

# CARROW, BISHOP & CO.

SUCCESSORS TO

Carrow, Crothers & Co.

MANUFACTURERS OF

## Fine Gold Jewelry

No. 12 JOHN STREET,

NEW YORK.

# MAX FREUND & CO.

## Manufacturing Jewelers

IMPORTERS OF

# Watches

Jewelry and Precious Stones,  
8 Maiden Lane

NEW YORK

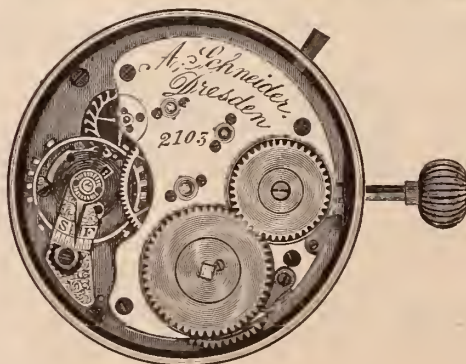

Sole Agents for the Celebrated A. Schneider Watch, Dresden.  
Also the Standard Watch Co. of New York.

**J. A. BROWN & CO.**

OFFICE AND SALEROOM:  
No. 11 Maiden Lane, N. Y.

FACTORY:  
No. 104 Eddy St., Providence, R. I.

SOLE MANUFACTURERS OF THE

**Ladd Patent Stiffened Gold Watch Cases**

The Best and most durable, and the

**CHEAPEST STIFFENED Gold Watch Case**

FOR THE MONEY

**MADE IN THE WORLD!**

All genuine Watch Cases of our manufacture have "G. W. Ladd's Patent, June 11, 1867," stamped upon the side band underneath the glass bezel.

**REFUSE ALL OTHERS.**

Send for full Descriptive Circular to the

OFFICE AND SALEROOMS

11 Maiden Lane, N. Y.



**KEY AND STEM WINDING**

Hunting and Open-Face

IN FLAT BEVEL,

Mansard and Oval

**SHAPES**

Adapted to the various

**AMERICAN-MADE MOVEMENTS,**

IN

8, 10, 14, 16 & 18

**SIZES.**

Dealers can obtain them of the Wholesale Watch and Jewelry Houses, or their Traveling Agents throughout the United States and British Provinces.

**The Pioneer Watch.**



HENRY GINNEL, Sole Manufacturer,

**No. 31 Maiden Lane, NEW YORK.**

P. O. Box 2967.

The accompanying illustration is a fac-simile of the Pioneer Watch. The Best (stem-winding and stem-setting) Pocket Timekeeper ever offered to the trade. They are eased in silver and German silver—Hunting and Open Face.

**COGSWELL, WEBER & CO.,**

**Watches, Jewelry, Silver and Plated**

**WARE;**

*Watchmakers' Tools and Materials,*

**AT WHOLESALE ONLY.**

146 State Street,

(SECOND FLOOR) CHICAGO.

THOS. COGSWELL,  
J. H. WEBER,  
O. W. WALLIS.

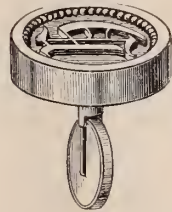

THE

**Adjustable Sleeve-Button.**

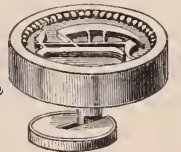

(PATENTED BY WM. BOURKE, JUNE 11, 1878.)

AMONG ITS MANY ADVANTAGES ARE THE FOLLOWING:

- 1st. EASILY ADJUSTED, quick mode of attachment to the cuffs, and obviating any strain on the forefinger and thumb.
- 2nd. DURABILITY AND STRENGTH—Not having springs that will get out of order.
- 3rd. SAFETY.—The parts being strongly connected, there is no possibility of losing either portion.
- 4th. NEATNESS.—Being without knobs or projections, its appearance on the top is not disfigured.
- 5th. ECONOMY.—Wear of the Button-holes and rumpling of the cuffs are avoided.

EVERY PAIR OF BUTTONS WARRANTED AS REPRESENTED.

A large variety of designs ranging from \$4.50 to \$24.00 per dozen pairs. Samples sent upon application.

HELFENSTEIN & BOURKE, Sole Manufacturers,  
202 BROADWAY, N. Y.

**CHAS. P. HEROLD,**  
**MANUFACTURING JEWELER,**  
**DIAMOND SETTER**  
AND DEALER IN  
**DIAMONDS.**

916 CHESTNUT ST. PHILA.

N.B. A LARGE STOCK OF 18 Kt. DIAMOND MOUNTINGS, SUCH AS CLUSTER AND SOLITAIRE RINGS, EARRINGS, LACE PINS, SHAWL PINS, CROSSES, STUDS, AND GENTS' PINS, &c, ALL OF WHICH ARE OF MY OWN DESIGNS, AND ARE MADE IN THE FINEST STYLE AND FINISH.

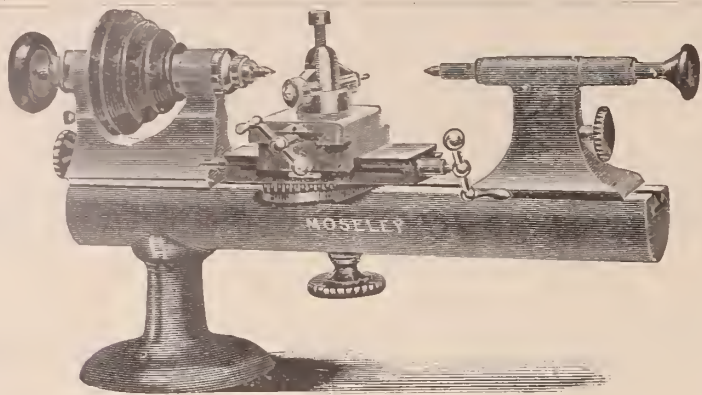

Manufactured by MOSELEY & CO., ELGIN, ILL.

# MOSELEY & CO.

ELGIN, ILLINOIS,

## Designers and Manufacturers of FINE TOOLS.

Send for Catalogue and Price List.

# American Watch Tool Co.

P. O. Box 959

WALTHAM, MASS.

MANUFACTURERS OF THE WHITCOMB LATHE,

AND

Machinery for Watch, Watch Case and Clock Making.

NEW YORK OFFICE WITH

L. H. KELLER & CO., 64 Nassau Street.

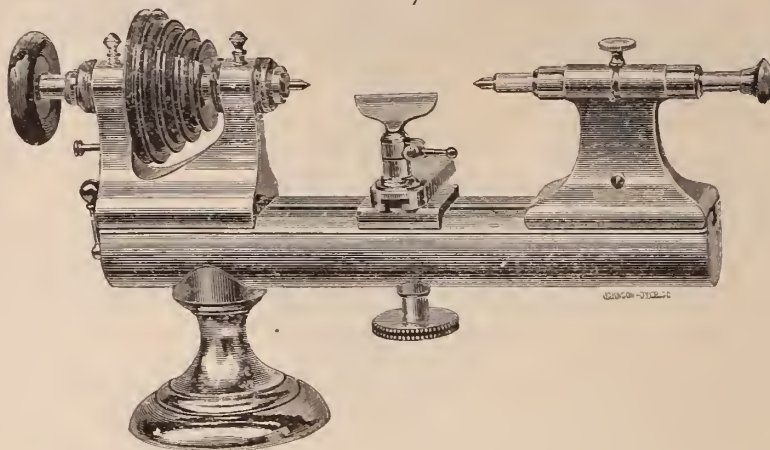

Chicago Office with Chas. Wendell & Co., No. 170 State Street.

SPENCER OPTICAL MANUFACTURING COMPANY,  
SOLE MANUFACTURERS,  
No. 113 MAIDEN LANE, NEW YORK.

(Copyright by Spencer Optical Manufacturing Co., 1879.)

### SOMETHING NEW !!

## CELLULOID EYE GLASS FRAMES,

Representing the Choicest Selected

Tortoise Shell and Amber.

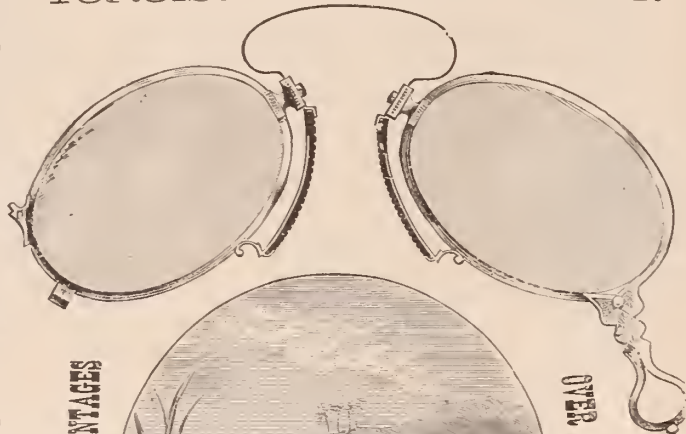

THEY HAVE GREAT ADVANTAGES

OVER ALL OTHER EYE GLASSES.

(Turtles rejoicing over the discovery of Celluloid Tortoise Shell, Their Occupation Gone.)

They are much Lighter than any others. Twenty-five pairs of the frames weigh only one ounce.

They are much Stronger and more Durable than any others; they can be Dropped Without Injury upon the hardest substance.

Their Beauty Far Surpasses the ordinary Tortoise Shell Frames commonly in use.

They are Not Affected by Atmospheric Changes, being equally well adapted to either warm or cold climates.

They are made with Different Sized Frames to suit persons whose eyes are either near or far apart.

The Springs are made of a combination of metals which will neither Rust nor be affected by heat or frost.

These frames are set with Fine Lenses, accurately focused to suit all sights, which with the many other advantages, make them Very Popular.

ASK YOUR OPTICIAN OR JEWELER TO SHOW THEM TO YOU.

Every Pair Stamped on Handle S. O. M. Co. Pat. Mar. 13, '77.

# Kearney & Swartchild,

Manufacturers of

## "TRIUMPH" LATHE.

Price, Hardened Bearings and Spindles, \$40.00

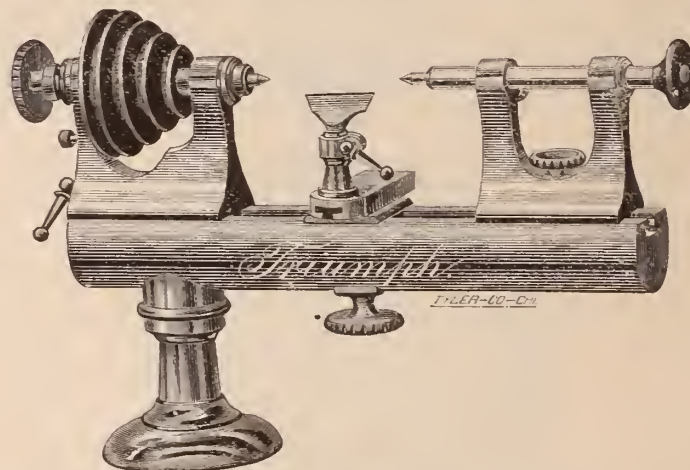

All Split and Wire Chucks are tempered and ground, which makes them perfectly true.

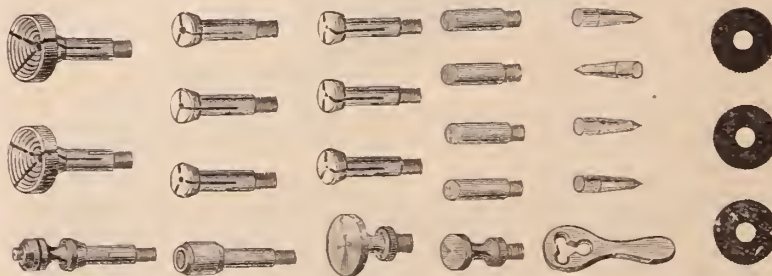

Importers and Jobbers of Tools and Materials, Watches, Jewelry, &c.

Manufacturers of Watchmakers' and Jewelers' Tools.

Illustrated Catalogue sent on application to parties sending business card.

Nos. 113 & 115 State Street, Chicago, Ill.



ESTABLISHED 1853.

CLOCKS



CLOCKS

**B. J. COOKE'S SON,**  
137 N. 3d Street, Philadelphia.  
Catalogues and Price Lists furnished to the Trade only, on application.

GEO. W. PRATT.

IRA GODDARD.

**GEO. W. PRATT & CO.**

MANUFACTURERS AND DEALERS IN

**American and Swiss Watches,**

**SOLID BAND AND SEAL RINGS,**

Gold and Roll-Plated Jewelry,

No. 14 JOHN STREET, NEW YORK.

ESTABLISHED 1855.

**WELCH & MILLER,**

MANUFACTURERS OF MOROCCO, VELVET AND SATIN

**Jewelry Cases, Trays, &c.**

Telescope Sample Cases, with Flexible Trays.

COMPLETE STOCK ON HAND.

**No. 169 BROADWAY, NEW YORK.**

CATALOGUES SENT ON APPLICATION.

**Coral Cream Polishing Fluid**



IS SUPERIOR TO ANY IN USE FOR CLEANING AND POLISHING  
**SILVER, GOLD AND PLATED WARE,**  
AND ALL FINE  
Metallic and Glass Surfaces.

Free from Acid, Mercury, Ammonia,  
Or anything Poisonous or injurious to the Hands or Metal.  
**CHEAPER THAN POWDERS,**  
As there is no waste in using, and produces a more lasting  
brilliantly without injury or wear to the Metal.

Pronounced by Experts to be the finest and  
most brilliant Polish made.

Diploma awarded at American Institute Fair.

Bottle contains 4 fluid ounces.  
IS THE BEST—SELLS THE QUICKEST—AND COSTS THE LEAST.  
Liberal Samples furnished on application.

For Sale by Wholesale Jewelers and Silverware Dealers.  
**BAXTER & HUGHSON,**  
Cor. 8th St. & Broadway,  
CARTER BUILDING, (Room 25,) NEW YORK.

**Charles F. Terhune & Co.,**

Manufacturing Jewelers,

16 Maiden Lane,

New York:



Sole Manufacturers



We beg to call the attention of the trade to the above cuts representing

**PATENTSLIDE BUTTON**

It is not separable, but works on a simple slide. It can be put in and taken out  
easier than any button made without soiling the cuff. Recommends itself at sight.

A full line of Stone, Enamel, Ivory and Pearl goods in above patterns.

**H. Muhr's Sons, Philadelphia.**

MANUFACTURING JEWELERS,

Solid Gold Finger Rings of Every Description.



Crown, 18k. Lion.



On and after January 1st, 1876, our make of Filled Plain Rings will be stamped as above,  
which stamp is copy righted. Any and every infringement on the above Trade Mark will be  
dealt with according to law. Every one warranted.

THESE GOODS ARE SOLD BY ALL THE LEADING JOBBERS!

Should the house that any retailer deals with not have them we will furnish them with the  
address of the nearest Jobber. SELL TO THE JOBBING TRADE ONLY!

New York Office, 11 Maiden Lane.

Address all communications to Philadelphia.

**BERNARD LEVY,**

Manufacturer of Watch Cases

—AND—

JOBBER OF AMERICAN MOVEMENTS,

No. 402 Library Street,

**PHILADELPHIA.**

ALSO, ORNAMENTAL ENGRAVER AND ENGINE TURNER.

Lubricating Oils, for Watch, Clock and Chronometer Makers.

The discovery of a Lubricator for FINE MACHINERY, such as Watches, Clocks and Chronomet-  
tors, that is free from gum and corrosive substances, has taxed the ingenuity of hundreds of men  
whose efforts have proved a failure. But we are happy to say (being largely interested) that such  
an article has been supplied by Mr. EZRA KELLEY, of New Bedford, Mass., who, after forty years  
study of the subject, has perfected a Lubricator that recommends itself to all who have used the  
genuine, (there having been numerous counterfeits in the market,) as witness also the award of a



Diploma and Medal  
by the judges of the  
late Centennial Ex-  
hibition at Philadel-  
phia. We have no  
hesitation in saying  
that his Oils are the  
BEST manufactured,  
always uniform in  
quality and capable  
of standing all tests,  
applied to lubricating  
oils. We cheerfully recommend it to all who may in their  
business require a FIRST-CLASS LUBRICATOR  
SETH THOMAS CLOCK COMPANY, SETH E. THOMAS, Agent.

P. S.—The above Oils can be procured at all first-class  
wholesale Watch and Clock Establishments in the United  
States, as well as his only Agents, GRISHAW & BAXTER,  
35 Go-well Street London England.  
New Bedford, October, 15, 1875.

# DESCRIPTION OF THE New Patent Dust-Proof STEM-WINDING OPEN-FACE CASE,

MANUFACTURED BY THE

AMERICAN WATCH CO.,  
WALTHAM, MASS.

ROBBINS & APPLETON,  
GENERAL AGENTS,

9 BOND STREET, New York. S SUMMER STREET, Boston.  
170 STATE STREET, Chicago.

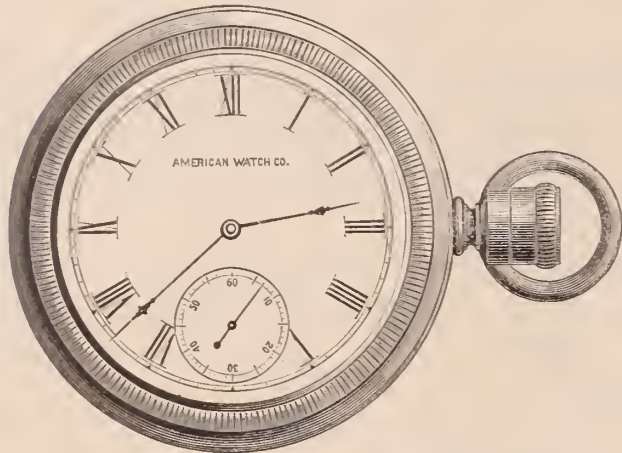

This open-face watch case, which is formed in one seamless piece in any desired shape, opens in the front only to receive the movement. The continuous construction of the body of the case avoids the usual cap and greatly conduces to strength and constitutes one feature of the invention.

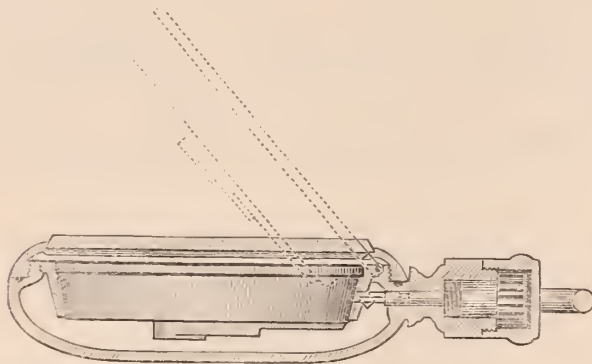

The movement of the Watch is held in a sustaining ring which is hinged to the case on the front edge of the aperture in such a manner that when the bezel is removed the ring with its contained movement may be swung outward, thus rendering the movement readily accessible, and obviating the necessity of a back cap or lid, which thus enables the case to be formed in one seamless piece and constituting another feature of the invention.

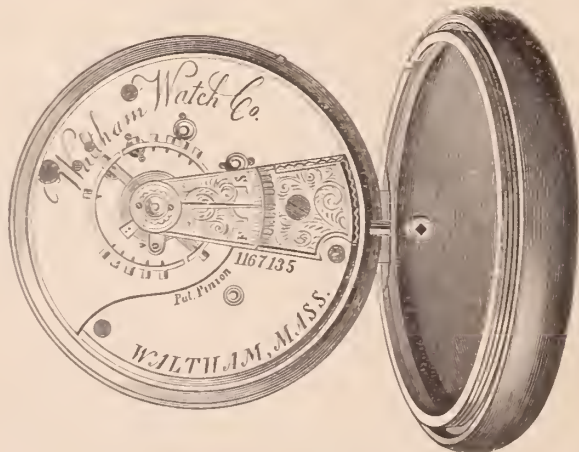

The movement is held in the ring in the manner usual in American Watches, and this ring is hinged to the rim of the case just at the base of the stem, the movement being so arranged therein that the winding stud of the movement comes in line with the winding-key of the stem and properly engages therewith. When the movement is to be swung out, however, the stem-winding crown may be pulled partly out, as usual, so as to draw the key out of engagement with the stud, and thus permit the outswing of the movement, as will be understood, the parts becoming readily engaged, when the movement is again swung into the case.



The bezel, into which the crystal is fitted with an especially prepared water-proof transparent cement, is attached to the case by screwing it thereon, the ring of the bezel being formed with an internal screw thread which meshes with a corresponding thread on the shouldered rim on the face of the case, and as the bezel is thus screwed tightly down the level edge of the rim, forms the air-tight joint with the shouldered rim of the case, which is proof against the entrance of dust or moisture, as will be appreciated.

By making the screw-thread on the interior of the bezel, so as to fit a corresponding thread on the interior of the case, we are enabled to construct a watch with only one division in the case, and thus the entrance of dust or moisture to the movement is entirely prevented, which is a very great advantage as compared with those cases in which there is an opening both front and back. The face of the bezel is formed with a marginal circle of milling which affords sufficient frictional grasp to enable the bezel to be readily screwed on or off.

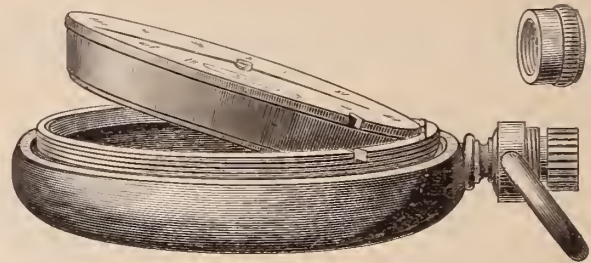

Another feature of the invention consists of the removal of the stem cap, which is designed to tightly fit upon the top of the stem winding-crown, so as to prevent the entrance of any dust or other foreign matter at that part. The stem-cap is attached to the stem by screwing it thereon in the manner of the bezel, and may be readily unscrewed when it is desired to wind the watch, as will be understood.

The cap is of similar diameter with the body of the stem, which latter is formed with a short threaded neck, which screws into the threaded bore of the cap, the bevel edge of the cap being screwed down tightly on the smooth shoulder of the neck so as to form a perfectly tight joint, which effectually prevents the infiltration of any dust or moisture thereat.

These combined features of construction thus form a watch which, while being simple and complete, has the great advantage of being impervious to the entrance of dust or wet. These latter qualities are found to be of great importance to those persons, who most use this class of watches, such as railroad men, travelers, miners, lumbermen and others, who have to make frequent reference to the watch, and who are almost constantly exposed to the influence of dust or moisture.

This new case is made by us both in gold and silver. It insures great strength and durability with a small amount of metal. Thus a gold case weighing 25 dwts. has a strength of back equal to that of an ordinary case of 30 dwts. to 35 dwts.

It is also made with jointed bezel instead of the threaded screw bezel, if desired.

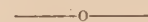

The Water-proof Cement used in cementing the glass in the above cases is an article which we have had especially prepared for this purpose after considerable experimenting. We will furnish it to the trade, on application, at 50 cents per bottle. Forwarded by Mail.

Price Lists furnished to the Trade only upon application.

Office of  
**ROBBINS & APPLETON,**  
 AGENTS FOR  
 American Watch Company,  
 No. 9 BOND STREET,

*New York, February 12th, 1879.*

Sir:

*List prices of certain of our movements are to-day fixed as follows, viz.:*

**18 Size, FULL PLATE.**

"BROADWAY," 7 jewels, nickel balance.....	\$ 4 30
" " 7 " cut expansion balance (NEW).....	4 75
"WM. ELLERY," 2 pairs extra jewels, cut expansion balance ...	8 00
" " 2 " " " " Stem Winder.....	10 50
"STERLING," 7 jewels, nickel balance, Stem Winder.....	6 25
" " 7 " cut expansion balance, (NEW), Stem Winder.....	6 70

**The new list prices of complete Silver Watches are changed to correspond with the above.**

**14 Size,  $\frac{3}{4}$  Plate.**

"AM. WATCH CO. HILLSIDE" (NEW), 7 jewel, cut expansion balance, Stem Winder, for Hunter or Open Face.....	\$20 00
---	---------

**18 Size, Full Plate, NICKEL Movements.**

"WM. ELLERY," 2 pairs, extra jewels, cut expansion balance....	\$12 00
" " 2 " " " " " " Stem Winder,.....	16 50
"P. S. BARTLETT," 2 pairs, extra jewels in settings, cut expansion balance....	18 50
" " 2 " " " " " " Stem Winder	26 00
"WALTHAM WATCH CO." 4 pairs, ex. jewels in settings, cut ex. balance.....	26 50
" " 4 " " " " " " Stem Winder	34 50
"APPLETON, TRACY & CO.," 4 pairs, extra jewels in settings, cut expansion balance, adjusted....	37 00
" " " 4 pairs, extra jewels in settings, cut expansion balance, adjusted, Stem Winding.....	46 50

All the above are subject to the terms and discounts announced in our circular of the 8th inst.

There will be no change in the quality of any of our grades, except as our constant efforts tend to their improvement. We decline altogether to take any part in the present unwise competition between Swiss and American manufacturers to see which shall make watches of the poorest quality. We intend to sell as low as any American company, but, however low the price, we do not intend to finish a grade of goods upon which it would be a disgrace to us to put our name.

Robbins & Appleton, 9 Bond St., New York.  
 Robbins, Appleton & Co., 8 Summer St., Boston.  
 Robbins & Appleton, 170 State St., Chicago.

} General Agents.

American Watch Company,  
 OF WALTHAM, MASS.

**E. STITES,**  
*Manufacturing Jeweler,*  
 No. 12 MAIDEN LANE,  
 New York.  
 COIFFEURETTES.

I. PFORZHEIMER.

D. KELLER.

**PFORZHEIMER & KELLER,**  
 IMPORTERS OF  
**Watches and Diamonds**  
*Dealers in American Watches,*  
 AND  
*Manufacturers of Jewelry,*  
 No. 24 JOHN STREET,  
 NEW YORK.  
 P. O. Box 4144.

**Mathez Watch Company of New York.**

Gents' and Ladies' Stem-Winding Movements  
**STRAIGHT LINE, 3-4 PLATE NICKEL.**

These Movements are of six different grades, uniform in size and beautifully finished, and will be **SOLD AT LOWER PRICES** than any other goods of similar excellence.

☞ **A FULL LINE** of materials for our movements always kept in stock for the convenience of those using our goods.

**F. H. MATHEZ, Sole Agent,**  
**No. 5 Maiden Lane, New York.**

**E. A. CUPPIA,**

19 UNION SQUARE, NEW YORK.

(FORMERLY WITH ERICO BROS.)

*Manufacturer of Novelties in Fine Silver,*

Lace Pins, Sets, Scarf Pins and Combs,

IMPORTER OF

**SILVER FILIGREE,**

CORAL AND CONCH SHELL.

Manufactories, 33 John Street, New York and Naples, Italy.

**BREITINGER & KUNZ,**  
 Importers of Watchmakers' Tools,  
**MATERIALS, CLASSES, &c.**  
**No. 107 North Ninth Street,**  
**PHILADELPHIA.**

Dealers in all kinds of American Watch Materials and American Clock Material. Specialties in Materials for Musical Boxes, Cuckoo Clocks, &c.

☞ Sole Agents in the United States for Buhni Brothers Hued and Tempered Hairsprings. Agents in the U. S. for J. Becker's (Freiburg, Germany) Gold Medal Regulators, the best in the market. A large assortment of all patterns always on hand; Movements with seconds pendulum for watchmakers' use—all kinds of materials for the same.  
 ☞ Wheel Cutting and work done for the trade.

**EDWARD TODD & CO.,**  
 MANUFACTURERS OF  
**GOLD PENS,**



Pencil Cases, Tooth Picks, &c.  
 44 East 14th St., Union Square,  
 Factory, 29 & 31 South 11th St., Brooklyn. **NEW YORK.**

**Dorrance, Edge & Co.**

MANUFACTURERS OF

THE CELEBRATED WOVEN FABRIC

**GOLD CHAIN.**

*Elegantly Mounted Bracelets, Opera, Leontine,*

VICTORIA WATCH GUARDS & NECKLACES, in all the Newest Desins.

☞ Our stock is unusually complete, and, in addition to the above, a variety of Necklaces, from 1½ to 40 dwt. each, to which we invite the attention of buyers.

**No. 12 John Street, New York.**

Factory, 46 Greene Street, Newark, N.J.

**NEW JEWEL SETTING CUTTER**

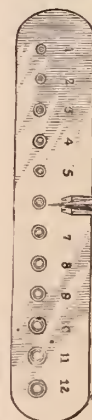

For cutting the bezel, or rim that holds the jewel to the plate of watch movements. In adjusting the jaws to the size of bezel to be cut, the gauge will be found very useful there being twelve sizes of punched bezels on each.

A glance at the sketch will show the practicability and great usefulness of the latest novelty in watchmakers' tools.

Sent with gauge, by mail, postpaid, on receipt of \$2.25.

Orders should be addressed,

**PH. HECHT.**  
**13 MAIDEN LANE.**

*Any article in the Watch Material, Optical, and Silk Guard lines, furnished at lowest rates.*

MANUFACTURERS  
—OF—  
EXCLUSIVELY  
**BLACK ONYX GOODS.**

The patented **DEEP MOURNING LOCKETS** are original with us, and have stood the test of years of wear. They meet the approval of the trade and the wearers for their superior make and finish, as well as for the correctness of the mechanical principle on which they are constructed.

**WOGLOM & MILLER,**  
32 & 34 JOHN STREET,  
NEW YORK.

**HENRY FERA,**  
Importer of **Diamonds,**  
No. 9 MAIDEN LANE,  
**New York.**

Having my own cutting and polishing establishment at Nos. 23 and 25 Looijersgracht, Amsterdam, Holland, constantly running 36 mills, I am able to offer to the trade a full assortment of Diamonds at very low prices.

Loose and Mounted Goods sent on approval to any part of the country on receipt of satisfactory references.

**BOOZ & THOMAS,**  
MANUFACTURERS OF  
**Watch Cases & Jewelry,**



108 South Eighth St., (2d Story) Philadelphia.

Samples of our goods sent on approval, when satisfactory reference is furnished.

**Old Gold & Silver Bought or Exchanged.**  
PARTICULAR ATTENTION PAID TO REPAIRING.

**HAMILTONS & HUNT,**  
MANUFACTURERS OF  
**Fine Plated Chains**  
AND PATENT BUCKLE BRACELETS,

**Branch Office, 176 Broadway, New York**

FACTORY, 226 EDDY STREET, PROVIDENCE, R. I.



This Cut represents the  
**RICKETT'S  
PATENT EYE SHADE.**

It is simply a neat Curved Shade of Hard Rubber  $\frac{3}{4}$  inch wide, that fits under the eyebrows and flares out at the bottom, so as to allow an angle of vision about level with the Horizon. Having met with success in New York, Philadelphia and Boston, and wishing to extend our trade to other cities, we will, for the next thirty days, forward to any one in the TRADE ordering THREE DOZEN SPRING SHADES, an elegant PLASTER BUST, life size, stands twenty-one inches high, and retails in New York for \$3.00; if placed in a prominent window will sell three dozen shades in ten days. Order from any jobber or direct from us. Please state that you want Bust.

PRICES—Spring Shades, \$3.50 per doz., Bow Shades, \$4.50 per doz.  
**RICKETT'S EYE SHADE CO.,**  
85 Nassau Street, New York.

**Wm. C. Greene & Co.**  
GOLDSMITHS  
MANUFACTURERS OF  
RICH SETS IN TAPER WIRE CORAL

Factory 93 PINE ST. PROVIDENCE, R. I.

Stone Cameo  
Amethyst  
Coral Cameo  
Engraved  
Enamel Sets  
Brooches  
Sleeve Buttons  
Stud Buttons  
EAR DROPS  
& C. STUDS & LOSSERS

NEW YORK OFFICE, No. 192 BROADWAY.  
Wm. C. Greene, B. W. Greene, Geo. D. Briggs.



HIGHEST AWARD TO  
**SYLVANUS SAWYER,**  
—FOR—  
**WATCH MACHINERY,**

**Watch & Clock Making Machinery**  
For sale or made to order, either in complete sets, including  
**PUNCHES & DIES AND OTHER SPECIAL TOOLS,**  
Or in parts of sets, to accommodate purchasers.  
ALSO, JEWELER'S LATHES AND TOOLS,  
AND OTHER FINE WORK,  
**MAIN STREET, FITCHBURG, MASS.**

**MILNE & JOURDAIN,**  
Manufacturers of Stem-Winding Watch Crowns

13 & 15 Franklin Street, **NEWARK, N. J.**

Gold Crowns, for Stem-winding Movements, to suit all sizes of Imported or American Watches, in four different styles and seven sizes.  
Gold Pushers for Key Movements in every size. Also Gold Crowns for fine Chronograph Watches made to order.  
Silver Stem winding Crowns and Key Pushers on hand or made to order. Send for card and samples.

A. MILNE.

A. JOURDAIN.

ROGERS & BROTHER,  
**690 BROADWAY, NEW YORK,**  
 MANUFACTURERS OF  
**First Class Silver Plated Ware,**  
 OF EVERY DESCRIPTION.

Established 1828.

**JACOB BENNETT & SON,**  
**Diamond Setters and Manufacturing Jewelers,**  
 No. 108 SOUTH EIGHTH STREET, PHILADELPHIA.

WE MANUFACTURE AND MAKE A SPECIALTY OF  
 EVERY DESCRIPTION OF

**DIAMOND MOUNTINGS**

SUPERIOR IN DESIGN AND WORKMANSHIP.



Dealers in

**DIAMONDS,**

And all kinds of Precious Stones.

PARTICULAR ATTENTION GIVEN TO ALL KINDS OF JOBBING.

**BROWN & BROTHER,**  
 MANUFACTURERS OF  
**Finest Quality of Electro-Plated Flat Table Ware.**  
 PATENTED HEAVY SPRING TEMPERED SHANK ON FORKS AND SPOONS.

ILLUSTRATED CATALOGUES FURNISHED ON APPLICATION.

WAREROOMS, No. 81 CHAMBERS STREET, NEW YORK CITY.

FACTORIES, WATERBURY, CONN.

P. O. BOX 5731.

**J. H. PURDY & CO.**

Jobbers of Imported and Domestic

**TOOLS & MATERIALS,**

For the use of Watchmakers, Jewelers, and kindred trades.

WATCH GUARDS, JEWELRY BOXES, SPECTACLES, CARDS,  
 SPECTACLE CASES, PEARL GOODS, STEEL CHAINS,  
 TAGS, RUBBER TYPE, &c.

No. 170 State Street, Chicago, Ills

OFFICE WITH CHAS. WENDELL & CO.

**To Let---Cheap.**

**Part of Office or Desk Room,**

**WM. H. BALL,**

Manufacturing Jeweler, 9 John st.,

**NEW YORK.**

Medal and Diploma awarded at Centennial Exposition, for superior mechanical execution and artistic ornamentation.



Established in 1854.

## C. & A. PEQUIGNOT, MANUFACTURERS OF WATCH CASES,



DEALERS IN AMERICAN WATCHES AND IMPORTERS OF FINE KEY AND STEM-WINDING MOVEMENTS,

SALESROOM AND MANUFACTORY, 22 SOUTH FIFTH STREET,  
PHILADELPHIA.

A full stock of Key and Stem-Winding Gold Cases always on hand. Goods sent on approval when satisfactory references are furnished.

## HOLMES, BOOTH & HAYDENS,

MANUFACTURERS OF

**ELECTRO-SILVER PLATED**

### Spoons, Forks, Ladles, Fancy Pieces,

**Solid Handle Steel Knives, &c., of the finest quality.**

No. 49 Chambers Street,  
**NEW YORK.**

No. 18 Federal Street,  
**BOSTON.**

Works at Waterbury, Conn.

SPECIAL NOTICE! MANUFACTURING JEWELERS, CHEMISTS, &c.

## BROWN & BROS.,

No. 81 CHAMBERS STREET,

NEW YORK.

Manufacture CHEMICALLY PURE COPPER for ALLOYING, and are prepared to fill orders for same, either in the Wire, Strip or Granulated form. Its PURITY has been attested as follows.

BROWN & BROS.

*Dear Sir.*—We have analyzed the two samples of Copper left with us on the 18th instant, one said to be foreign refined Copper as used by jewelers, the other a refined Copper as manufactured by you for the same purpose. We find both samples alike in purity, and no difference can be detected by a careful chemical analysis, both being samples of PURE METALLIC COPPER, having no traces of antimony, tin, arsenic, zinc or lead.

UNITED STATES ASSAY OFFICE, 30 WALL STREET,  
NEW YORK, Dec. 21st, 1877.

TORREY & EATON.

Established 1845.

## WILLIAM H. BALL,

MAKER OF

Roman, Enameled and Engraved  
**BANDS.**

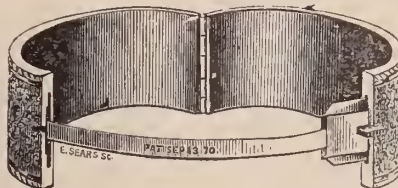

Having given the manufacture of Band Bracelets my entire attention for a number of years, it has been my desire to make a durable article, one that will give satisfaction to the seller as well as the wearer. I desire to call the attention of the trade to the reduction I have just made in prices, still keeping up the standard as to quality, finish and workmanship. To each pair of BANDS I attach my patent guard without extra charge—thus saving the price of chain—which for seven years past has given entire satisfaction.

No. 9 JOHN STREET, NEW YORK.

Factory, 30 & 32 Franklin Street, Newark, N. J.

**T. B. BYINNER,**

### Importer & Jobber of Watches

DIAMONDS AND FINE JEWELRY,

And Dealer in the BEST CLASS OF ROLLED PLATE JEWELRY

And Key and Stem-Winding American Watches.

No. 513 Broadway, New York

# HAMPDEN WATCH CO.

Manufacturers of KEY AND STEM-WINDING

General Office and Factory  
SPRINGFIELD Mass.

## WATCHES.

New York Office,  
No. 12 MAIDEN LANE.

### GUERRANT'S ELECTRO-ENGRAVING MACHINE.

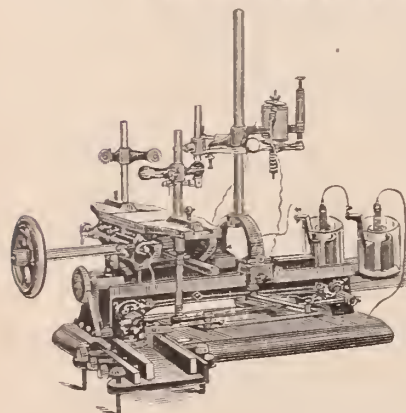

It has baffled the skill of the inventive genius of the world for ages to produce a machine that would compete with the skillful hand engraver, and until this machine was invented, all engraving had to be done by hand. And, to-day, it is the only practical engraving machine in existence.

The construction of the machine is not complicated, but simple and durable. It is easily operated. The variety of work it will do is almost incredible, and to be fully appreciated, ought to be seen in operation.

We do not therefore, offer this machine to the public simply as a machine to aid the engraver, but as a perfect, practical engraver in itself, with which any person of ordinary skill can learn in a short time to do any piece of engraving that might be desired and in the very best manner.

It copies from the regular press type of any style of letter or design that is made of type, from the plainest to the finest german text letter or fancy design, at the same time it will reduce the letter or design from the original size to ten different sizes, or so small that it cannot be seen by the naked eye. It will shorten the letters or elongate them, also will lean them forward or backward, will either make a raised or sunken letter, will engrave on any surface, either plain, concave or convex—for instance, such things as Watch Cases, either in or outside; Finger Rings, either in or outside; Bracelets, Napkin Rings, Goblets, Pitchers, Mugs, Waiters, Spoons, Forks, and all kinds of Jewelry; or, in fact, on any article susceptible of being engraved or ornamented with scroll work or fancy designs, &c., either on Gold, Silver, Copper, Brass, Iron, hardened Steel, Glass, Stone, Pearl, Ivory, Bone, Gutta Percha.

No Jeweler or establishment that has engraving to be done should be without it. Machines are sold with limited territory to use them in; or, the exclusive rights to use them in certain town or territory can be purchased with the machine if desired.

For further information, address

Size of Machine, 12 x 16 inches.  
Patented Jan. 18, Oct. 31, 1876, & Mar. 4, 1879.

WM. HICKSON, Gen. Agt.,  
P. O. Box 1603, PHILADELPHIA, PA.

KARN & HICKSON,  
LYNCHBURG, VA.

A. M. GUERRANT, Danville, Va., Agent for the Southern States.

Owners of the right of all the Northern States and Territories.

## CROSS & BEGUELIN, Makers and Importers of SWISS WATCHES,

AND DIRECT IMPORTERS OF

Watch Tools, Materials, Glasses, &c.

No. 21 Maiden Lane, New York.

The CENTENNIAL WATCH (Stem-Winding and Stem-Setter) so universally popular, has achieved a standard reputation, and is generally conceded to be the best made watch for the money in this market. Being the sole manufacturers of this celebrated Timekeeper, we are enabled to give it our strongest endorsement. Especial attention is called to the "HENRY BEGUELIN," "DROZ & PERRET," and other well known Swiss Watches, as well as to our full and complete line of all grades of American Watches, on which we give the full trade discount.

The attention of Watchmakers is directed to our new DRILLS, in sets of 21 sizes. The most complete and serviceable drill ever offered.

General Agents for the Auburndale Timer,  $\frac{1}{4}$  and  $\frac{1}{2}$  Seconds.



None Genuine without this TradeMark.

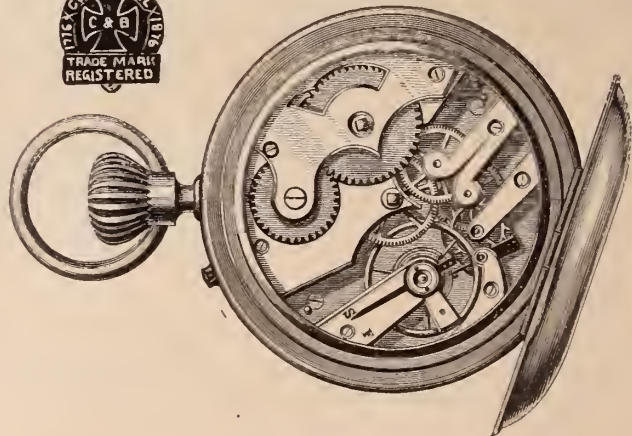

The above is a fac-simile of the Centennial Watch.

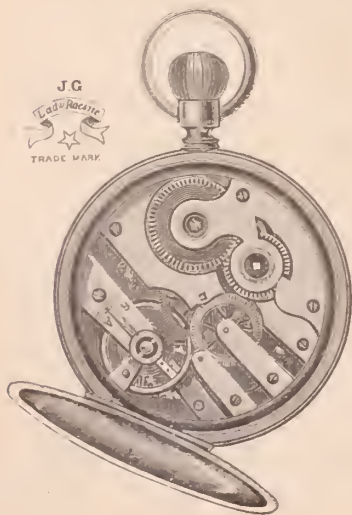

Established 1826.  
Factory,  
27  
RUE DU PARC,  
Chaux de Fonds,  
Switzerland.  
**JULIEN GALLET,**  
CHAS. PERRET, Sole Agent.

Sales Rooms,  
No. 1  
MAIDEN LANE,  
NEW YORK.  
P. O. Box, - 4420.

Importer of Watches & Watch Movements,

Would respectfully call the attention of the Trade to the annexed cuts of the Lady's size Watch, Stem-Winder and Stem-Setter, in Nickel, Silver and Gold, White and Black Dials.





# HENRY C. HASKELL,

Manufacturing Jeweler,

No. 12 John Street,

New York.



3100



37100

CHOICE INTAGLIO & CAMEO RINGS  
NOVELTIES IN BANGLE AND GYPSY  
*Set with Diamonds.*  
SAPPHIRE, RUBY, TURQUOISE,  
PEARL, &C.

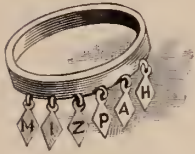

4877



6837



7093



6978



6900



3684

*Orders solicited for goods on approval.*

*The "MARQUIS" Seal Ring, Entirely New, plain, elegant.*

## LONGINES WATCHES.

**GOLD MEDAL,  
Paris, 1878**



PARIS, 1867. VIENNA, 1873. PHILADELPHIA, 1876

The only movement competing with other grades of its class awarded a gold medal at the Paris Exposition  
The honors accorded the LONGINES WATCHES by the jurors (many of whom were watchmakers) attest the high esteem in which they are held by watchmakers, who regard them the best watch for the money made.  
These goods are made in various styles, cased in nickel, silver and gold. Materials and duplicate parts always in stock

## T. A. WILLSON & CO.,

MAKERS OF

Steel Spectacles and Eye Glasses,

Grinders of Spherical, Cylindrical, Prismatic, Plain & Compound  
— LENSES, —

patentees and Sole Manufacturers of the  
"ARUNDEL TINTED"

# SPECTACLES

Nos. 179 180 & 155

With Interchangeable Lens,

THE BEST AND CHEAPEST AMERICAN SPECTACLES MADE

Office and Factory, . . Reading, Pa.

								
10.—SLIDE KEY. (Nickel Plated.)	11.—SLIDE KEY. (Nickel Plated, Hexagon Shell.)	12.—POCKET KEY. (Heavy Rolled Gold Plate Mountings, Plain.)	13.—POCKET KEY. (Sterling Silver Mountings, Plain.)	14.—POCKET KEY. (Sterling Silver Mountings, Engine turned.)	15.—POCKET KEY. (Extra Heavy Rolled Gold Plate Mountings, 18 K., Plain.)	16.—POCKET KEY. (Extra Heavy Rolled Gold Plate Mountings, 16 K., Engraved.)	17.—POCKET KEY. (14 Karat, Gold Mountings, Plain.)	18.—POCKET KEY. (14 Karat, Gold Mountings, Engraved.)

## BIRCH'S

SELF-ADJUSTING

# Watch Keys,

Will Wind any Watch.

For Sale by the Trade Generally.

J. S. BIRCH & CO.

38 Dey Street, New York.

# HEADQUARTERS FOR OPTICAL GOODS.

We have lately imported a full line of

## Opera Glasses, Field Glasses, Telescopes,

### BAROMETERS, COMPASSES, &c.

We have also a complete line of all varieties of

## GOLD & STEEL SPECTACLES AND EYE GLASSES,

ACCURATELY INTERCHANGEABLE, made at the most reliable factories in this country and in Europe. Catalogues of above goods sent on receipt of application accompanied by business card.

### W. B. CLAPP, YOUNG & CO.

IMPORTERS AND JOBBERS,

Nos. 149 & 151 State Street,

CHICAGO, ILL.

Fig. 1

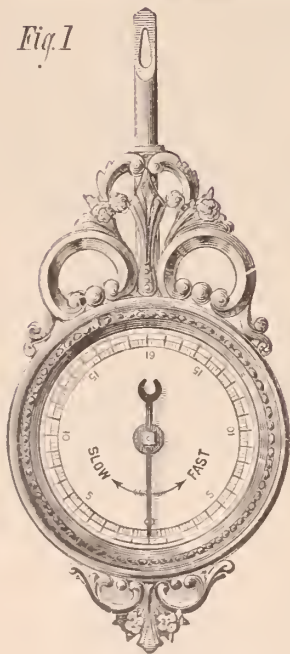

## JACOT'S PENDULUM REGISTER,

I would direct the attention of the trade to the PENDULUM REGISTER here illustrated, confidently believing that it is the simplest, most accurate, and the easiest to regulate of any pendulum now in use. Its advantages over the ordinary pendulum is apparent to every intelligent workman, and it will be appreciated not only by the trade, but by the general public. With the small profit made on common clocks, the dealer cannot afford to spend much time in regulating them.

The simplicity of Jacot's Pendulum enables any purchaser to regulate his clock without experimenting, thereby saving the dealer a great deal of annoyance and profitless interruption.

By the use of this Pendulum, the regulating of clocks is reduced to positive accuracy. The gain or loss of time is corrected by using the key that winds up the clock to turn the hand on the pendulum-dial to the right or left, according to the corresponding gain or loss indicated on the dial. The management of the dial can be readily understood by any purchaser. It can be adapted to the cheapest clock with but a slight additional cost. The undersigned is prepared to furnish these pendulums in any quantity.

Sample No. 1, sent by mail on receipt of 50 cents.

The Round Ball for - - - - - 25 "

Jewelers will find it to their advantage to introduce Jacot's Pendulum in their new clocks, and substitute it for other pendulums in many of the old clocks, and the purchaser would gladly pay the slight difference. Send for Price Lists.

H. C. JACOT, Manufacturer,  
New Haven, Conn.

The above Pendulum is introduced by Mr. F. KROEBER, 8 COURTLAND STREET, N. Y., in all his superior goods of Walnut Clocks at no increase of cost, and in all his second grade of Walnut Clocks at an additional cost of Ten Cents.



Gentlemens Watches,  
 Ladies Watches,  
 Bridge Movement Watches,  
 ¾ Plate Movement Watches,  
 ¾ Plate Patent Reg. Watches,  
 ¼ Plate Movement Watches,  
 Repeaters,  
 Chronographs. (1-5 second)

**TIFFANY & C<sup>o</sup>.**  
 New York. Paris. London. Geneva.  
 MAKERS OF  
**Fine & Complicated Watches,**  
 OFFICE, (Wholesale only)  
 No. 694 BROADWAY, COR. 4TH STREET,  
 GEO. R. COLLIS, Manager. NEW YORK.

Split-Second Chronographs.  
 Minute and Second Chronographs,  
 Chronograph and Repeaters,  
 Minute Repeaters,  
 Five Minute Repeaters,  
 Quarter Hour Repeaters,  
 Repeaters and Chronographs,  
 &c., &c., &c.

## THE AMERICAN PEDOMETER.



This instrument accurately measures the distance a person carrying it walks, showing the amount of daily exercise taken in and out of doors.

Its mechanism is a marvel of simplicity, and can be adjusted to any length of step. It is strong and durable, and the size of a small watch. Ladies, Professional and Business Men, Students, Pedestrians, Sportsmen, Farmers, Surveyors, and others will find it very useful. A table accompanies each Pedometer, giving the number of steps taken in a mile second, minute, hour and day.

There are two forms of index, one registering steps from 23 to 35 inches in length, and another adapted for ladies and children, registering steps from 17 to 26 inches in length. The cases are of nickel-silver,

We have just finished an OPEN-FACE with white enameled dial, heavy crystal front, (retail price, \$6.00) but unless otherwise ordered, we send the one registering steps from 23 to 35 inches in length, in hunting case similar to engraving. Retail Price, \$5.00.

SOLE AGENTS, TIFFANY & CO., NEW YORK.

The trade supplied only by TIFFANY & CO., (from their new *wholesale* Watch offices, 694 Broadway,) who do not sell to Jobbers, but are establishing as "exclusive agents" dealers who order quantities. Early application solicited.

Novelties in design and finish, in Silver Fancy Goods and Hollow Ware, with combinations of colors in gold, silver and nickel-enameled, Testimonial and Presentation Goods, Spoons and Forks of patterns popular and desirable, and a choice line of Case goods, from single pieces to Cabinets for Wedding Gifts.

THE  
**Adams & Shaw Company,**  
 SILVERSMITHS,

and Makers of Hard Metal Electro-Plate,

694 BROADWAY, . . . . . NEW YORK.

GEO. R. COLLIS, Manager.

Designs and estimates furnished, and particular attention paid to orders for racing, Field and Nautical Prizes, (small and large), Tea Sets, Berry Bowls, Fruit and Ice Cream Stands, Jelly Bowls and General Hollow-Ware, in Sterling Silver or Silver-soldered Electro-Plate.

# L. HAMMEL & CO.,

## Importers of Watch Materials, Tools,

### Opera Glasses, and Optical Goods of Every Description,

## SPECTACLES,

## EYE-GLASSES,

### No. 9 Maiden Lane,

### NEW YORK,

Sole Agents in the United States for **G. B. Wheeler's Star Watch and Clock Oil**, and the Celebrated **Gravier Mainspring**.

Every Watch maker knows the necessity of a good and reliable Watch Oil. There are several brands which have hitherto enjoyed excellent reputations, but our experience as well as that of many of our customers has proved them more or less unreliable, in consequence of which we have been for a long time in search of an article that is entirely reliable in every respect, and have found it in the STAR WATCH AND CLOCK OIL, MADE BY GEO. B. WHEELER, OF NEW BEDFORD, MASS., who has given the subject many years of careful study. Our aim now is to bring this oil to the notice of all watch makers, as a thoroughly reliable article, having stood the test of years, a good lubricator, free from gum or corrosive substances and not affected by low temperature. We have sold these oils for the last three years and have always found our customers well pleased with them. We annex hereto some of the testimonials we have received from many reliable business houses and watchmakers throughout the country. The price of Wheeler's Star Oil is as follows:

Watch Oil per bottle, 20 cts., per dozen, \$2.00. Clock Oil, per bottle, 16 cts., per dozen, \$1.75.

ROCHESTER, N. Y., Dec. 25, 1877.

DEAR SIR:—I send you briefly and most cheerfully my opinion of your Watch Oil. We have been using it on our time locks for about a year and a half, and unhesitatingly say that it is uniformly the best oil that I have ever tried. Other oils previously used have failed after first trials, either drying up after a few weeks or changing color and thickening, all of them requiring too frequent cleaning of the movements to be reliable, but yours has so far proved entirely satisfactory.

Respectfully Yours,  
L. F. MÜNGER,  
Manager Sargent & Greenleaf's Time Lock Manufactory.

Office of CLEMENS HELLEBUSH, Esq., Manufacturing Jeweler,  
CINCINNATI, Feb. 1st, 1879.

MESSRS. L. HAMMEL & Co., 9 Maiden Lane, New York.

DEAR SIR:—Your Wheeler's Star Watch and Clock Oil gives extraordinary satisfaction to my trade.

Please send me 10 gross at your earliest convenience.  
Yours Respectfully,  
CLEMENS HELLEBUSCH.

Office of R. JAEGERMANN & CO.,  
Dealers in Materials, Tools, &c., for Watchmakers,  
218 North Fourth Street, St. Louis, Feb. 1st, 1879.

Having tried all manufactures of Watch Oil without finding any superior to Wheeler's Star Watch Oil, I hereby recommend the same to all watch makers as the best in the market and the only one that will stand all tests.

Respectfully,  
MESSRS. L. HAMMEL & Co.,  
9 Maiden Lane, New York.  
R. JAEGERMANN.

Office of KENNEDY & KOESTER,  
DETROIT, Mich.  
DEAR SIR:—Please send us 1 gross each Wheeler's Watch and Clock Oil, by express immediately, and oblige,  
Yours Respectfully,  
KENNEDY & KOESTER.

P. S.—Your oil gets more in demand the longer people try it—they buy Wheeler's sooner than any other.

K. & K.

The following is from Mr. Henry Oehl, Jr., one of the best watchmakers in New York City:

I have used the Watch Oil manufactured by Geo. B. Wheeler, of New Bedford, for some two years, and have so far found it in every way satisfactory. It is uniform in quality and as free from gum and acid as any oil I have ever used.

NEW YORK, June 5, 1878. HENRY OEHL.

Office of M. S. SMITH & CO.,  
Diamond Merchants and Watch Importers,

MESSRS. L. HAMMEL & Co.,  
DETROIT, Mich., March 7, 1879.  
GENTS:—We have great pleasure in recommending the Wheeler Star Watch Oil, which we find equal to the best in the market.

M. S. SMITH & CO.

Office of GEORGE WOLF, Esq.,  
Dealer in Watches, Clocks, Jewelry, &c.,  
LOUISVILLE, Ky., Feb. 4, 1879.

MESSRS. L. HAMMEL & Co.,  
9 Maiden Lane, New York.

After using your Wheeler's Star Watch and Clock Oil for the last eighteen months, I have found it unsurpassed, and congratulate you for having succeeded in placing such an article before the trade.

Yours Respectfully,  
F. W. JARVIS, Watchmaker, with George Wolf.  
[Mr. Jarvis has been forty years in business and is a distinguished Watchmaker.]

NEW YORK, February 15th, 1879.  
With the greatest sincerity I recommend the Wheeler's Star Watch Oil to the trade. I have tested it now for a long time and found it always good, and as good an oil as I ever used.

A. DEUHARD,  
Formerly with Ball, Black & Co.

THE  
**JEWELERS' CIRCULAR AND HOROLOGICAL REVIEW,**

*The recognized organ of the Trade in the United States,*

AND THE REPRESENTATIVE AND OFFICIAL ORGAN OF THE JEWELERS' LEAGUE AND  
THE WATCHMAKERS' AND JEWELERS' GUILD.

THE JEWELERS' CIRCULAR AND HOROLOGICAL REVIEW, established 1869, is appreciated as the most complete and valuable periodical of its class published in any country. It reaches every branch of the jewelry, watch, clock, silverware and kindred trades throughout the United States, and is the only representative of the trade, which has secured, by its intrinsic merits and acknowledged benefits, a legitimate and *bona fide* patronage of paying subscribers, including many of the leading firms in England, France, Germany, Switzerland, Mexico, the West Indies, Brazil, the South American Republics, and other foreign countries.

THE JEWELERS' CIRCULAR is regarded throughout this wide circle of interested and careful readers as a *reliable* authority and independent chronicle with regard to all matters connected with the trade, in its moral, mercantile and mechanical aspects, while its decided straightforward and consistent course of conduct in relation to commercial questions has won widespread approval.

To the practical workman the JEWELERS' CIRCULAR is invaluable as a text-book and work of reference. Its pages furnish him with the latest scientific and mechanical ideas, set forth in plain, comprehensible language by specialists of ability and experience. The technical information contained in its columns represents the progress of the age, and every intelligent workman in the country acknowledges the advantages resulting from a study of its pages.

To the country dealer the JEWELERS' CIRCULAR affords thorough, correct and perfect information as to staple and original articles of trade. From it he can learn what to order and where to obtain supplies, he can discover the best source of materials in common use, while the latest novelties are without exception first announced in its columns.

All communications to be addressed to

**D. H. HOPKINSON,**

*Or the regular Agents of the Circular.*

**42 Nassau Street, New York.**

 The TENTH VOLUME commenced with the February issue. Subscription, \$2.00 per annum.

C. G. ALFORD & CO.  
**Manufacturing Jewelers,**

**183 Broadway, New York.**

WE have noticed with pleasure and satisfaction the action of the Western Jewelers in effecting an organization for the purpose of protecting themselves against the inroads made upon their business by the indiscriminate and wholesale distribution of illustrated catalogues and price lists among other branches of trade and among consumers.

Appreciating the injustice of this practice and realizing fully the great injury to the business of the jeweler, resulting therefrom, we determined two years since, to issue the best catalogue of jewelry ever published, designed for the exclusive use of jewelers only. We made this a prominent feature of our work in our announcement, and from that time we have adhered with unwavering fidelity to our pledge not to provide the dry goods dealers, the confectioners, and the druggists with the means to despoil the jeweler of his legitimate profit, and we feel assured that our efforts in this direction are appreciated by our friends and patrons as shown by the increasing popularity of our book.

We are therefore glad to see that the jewelers are awaking to the importance of defending their interests against the encroachments of this pernicious practice. We again repeat that only jewelers can obtain our Catalogue. Applicants must enclose business card.

C. G. ALFORD & CO.,

183 BROADWAY,

NEW YORK.

JUNE, 1879



Osborne.

PATTERSON SON ENG

D. F. HOPKINSON, PUBLISHER.

42 NASSAU STREET, NEW YORK

Established 1813.

# SETH THOMAS CLOCK CO.

THOMASTON, CONN.

No. 20 MURRAY STREET, New York.

16 Worship Street,  
LONDON, E. C.

172 State Street,  
CHICAGO.

132 Sutter Street,  
SAN FRANCISCO.

## F. KROEBER,

Manufacturer of CLOCKS,

No. 8 Cortlandt St.,

New York.

FACTORIES:—NEW HAVEN, CONN., AND  
NEW YORK CITY.

SUPERIOR GRADE OF  
WALNUT CLOCKS A SPECIALTY

SOLE AGENT FOR

E. INGRAHAM & CO.

—AND—

CLOCKS OF ALL MAKERS,

AT LOWEST MARKET PRICES!



"AURORA."

1 Day Lever Alarm, Nickel. Height, 5½ inches.



"THISTLE."

1 Day Lever, Alarm, Nickel. Height, 28½ inches.



J. C. AIKIN.

H. A. LAMBERT.

J. B. SHEA.

# AIKIN, LAMBERT & CO.,

MANUFACTURERS OF GOLD PENS,

Pen and Pencil Cases, Pencils, Tooth-picks, and "Novelties" in Pencil Goods.

No. 23 Maiden Lane, New York,

Would call the attention of the Trade to our large and complete line of Pen and Pencil Goods in all styles and varieties, suitable for demand.

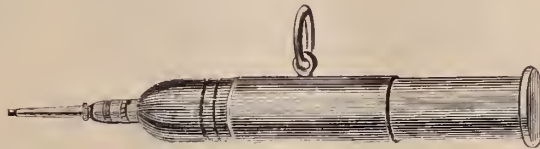

Our introduction last season of Pencils in NEW AND ENTIRELY NOVEL DESIGNS was marked by an unprecedented demand, which establishes the sale of these goods as STAPLES, and as being suited to any season of the year.

The Magic Charms (as per cuts shown below), inlaid with pearl and gold, in form of vines, flowers, birds, etc., on celluloid of assorted colors, in imitation of malachite, tortoise shell, agate veegriated marble, etc., are the LATEST and most novel pencils in the market.



Send for circular and new list.

Branch, No. 113 East Madison Street, Chicago.

IMPORTERS OF ALL GRADES OF

## WATCHES,

SOLE AGENTS FOR

"PAUL BRETON" and "CHAS. LATOUR," GENEVA.

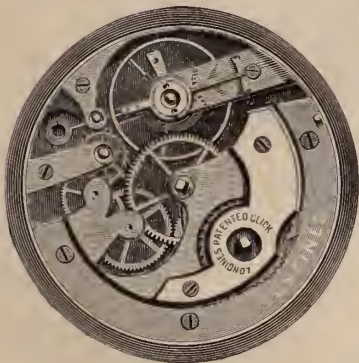

LONGINES



EXCELSIOR.

—SPECIALTIES.—

AGASSIZ Movements, Gilt and Nickel Stem-Winding, fitting Ladies' Riverside Case.

CHAS. LATOUR Movements, Gilt and Nickel Key-Winding, fitting 10 and 16 size Waltham Case.

PAUL BRETON Movements, Gilt and Nickel Key and Stem-Winding, a full line of these CELEBRATED TIMEPIECES in gold and silver cases of the most approved styles.

METAL OPEN FACE STEM-WINDING "LONGINES" and "EXCELSIOR", 16, 18 and 20 line, the BEST metal Watches in STYLE and QUALITY in the market.

The "LONGINES" received the ONLY GOLD MEDAL at Paris for low-priced Watches against several competitors, and the "EXCELSIOR" is recommended by DR. HIRSCH of the Neuchatel Observatory having given VERY SATISFACTORY results during a month's trial. NOVELTIES in BLACK and FANCY DIALS for these Watches are selling rapidly. American Watches of all kinds. Gold Cases of any style made to order. Sole Agents for EUREKA HORSE TIMER, the cheapest reliable TIMER ever made, and for PNEUMATIC TIMER which does not require the use of the hand. All Watches sold by us are warranted.

Our assortment of Jewe'ry is very large and complete, consisting of a general line of RELIABLE goods, both in GOLD and ROLLED PLATE, of new and tasty patterns, and including almost any article a Jeweler would have calls for. Special attention given to ORDERED WORK and REPAIRS. GOODS SENT ON APPROVAL and CORRESPONDENCE invited. Those not acquainted with us will oblige by giving references when ordering

JANUARY 1st, WE REVALUED OUR ENTIRE STOCK AND HAVE REDUCED PRICES, AND ARE OFFERING GREAT INDUCEMENTS TO PURCHASERS FOR THE SPRING TRADE.

**REMOVAL.**

WM. PARK, hereby intimates to the trade that he has removed from 181 Broadway to 26 John Street, where he will be happy to receive orders for **STONE, SEAL & CAMEO ENGRAVING** Coats of Arms found and beautifully painted. Arms Crests, Monograms, and Devices engraved on Locketts, Sleeve Buttons, Rings, &c. Masonic Engraving a specialty.

**H. M. RAYNOR,**  
25 Bond Street, N. Y.

**PLATINUM**  
FOR ALL  
Laboratory & Manufacturing Purposes.

Native Platinum, Scrap, &c., purchased.

**STERN BROS. & CO.**  
Manufacturers of



**Fine Jewelry,**  
30 MAIDEN LANE,  
FACTORY, 73 & 75 Fulton St., NEW YORK.

Gold Seal engraved Band-rings and Locketts a specialty.  
The attention of the trade is directed to our plain Gold filled Rings Sections of which showing the construction and quality sent upon application.  
After February 1st, our plain filled rings will bear the above trade mark.

F. W. C. Nieberg,  
Repairer and Adjuster of  
FINE WATCHES  
and Marine Chronometers,  
No. 8 JOHN STREET  
New York.

**CHAS. F. WOOD,**  
169 & 171  
BROADWAY  
NEW YORK



Engraver, Incruster of Precious Stones  
And **DIAMOND SETTER.**  
Incrusted Goods a specialty.  
All kinds of Lapidary Work promptly executed.

**Stephen J. Cox**  
DESIGNER & ENGRAVER  
on WOOD  
NO. 90 NASSAU STREET  
NEW YORK  
Jewelers' Work a Specialty.

Full line of new and original designs on hand.



Particular attention paid to Remounting. Price list furnished on application.

**VOSE & SOUTHWICK,**  
Manufacturers of Gold Jewelry



Sole Makers of the Separable Sleeve and Collar Buttons in Gold.

No. 183 Eddy Street, PROVIDENCE, R. I.



**HENRY LEFORT,**  
Stem-Winding Watch Crown Manufacturer,

Crowns and Pushers in gold, all sizes, quality and color, made to order. Silver crowns and pushers always on hand. Samples sent on application.

80 & 82 Marshall Street,  
NEWARK, N. J.

**ALBERT FRIEDENTHAL,**  
Importer and Jobber of  
WATCHMAKERS' & JEWELERS'  
Materials, Tools and Optical Goods  
Real and Imitation Stones,  
For Manufacturing and Repairing Purposes  
A SPECIALTY.  
Agent for TISDALE'S Watch and Clock Oils.  
No. 43 Maiden Lane, New York.  
Orders by mail will receive prompt attention.

**E. A. LAUTEN,**  
MANUFACTURERS OF  
MOROCCO, VELVET & SATIN  
CASES  
FOR  
Jewelry and Silver Ware.  
New Trays for Lace, Shawl and Scarf Pins,  
Novelties in Brocade Silks,  
4 Great Jones Street,  
One door from Broadway. NEW YORK.

**JEWELRY PHOTOGRAPHED.**

In order to meet the demands of many of the Manufacturers of Jewelry, Silver Ware, &c. (Tiffany and others) I have erected a SPECIAL SKYLIGHT, for Mechanical Photography, viz:

The Copying of Silver Ware, Statuary, Bric-a-Brac, Paintings, Models, &c.

I propose to keep it busy by adopting the following rates:—S. M. Photographic negative \$1. Proofs 50 cents. Special rates for quantities.

GEO. G. ROCKWOOD, Photographer, 17 Union Sq.  
Established 1859. (Above Tiffany's.)

**REPAIRING, COLORING AND GALVANIZING FOR THE TRADE.**

C. G. MALLIET,  
Manufacturing Jeweler,  
No. 9 JOHN STREET  
NEW YORK.

**O. SCHWENCKE,**  
(Established over 30 years.)  
[Successor to G. GUNZENHAUSER].  
MANUFACTURER OF

**Fine Hair Jewelry,**  
No. 43 MAIDEN LANE,  
New York.

Solid Gold Mountings for Hair Jewelry kept constantly on hand, and made to order at shortest notice. Orders from the country trade promptly attended to.

**The Morse Diamond Cutting Company,**  
J. D. YERRINGTON, Agent.

192 Broadway and 3 John Street.  
NEW YORK.

Rough Diamonds, Boart, Roses and Brilliants for sale.  
Fractured Diamonds repaired, and old stones improved; also Rough Diamonds cut and fashioned to order.

W. N. WALKER,  
**DIAMONDS,**  
Watches and Jewelry,  
No. 18 JOHN STREET, NEW YORK.  
IMPROVED JEWELERS' COTTON.  
JOHN J. ARMOUR.

**HENRY TROEMNER,**  
710 Market Street.  
PHILADELPHIA.  
Manufacturer of Fine Gold Scales,

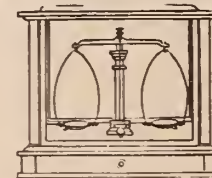

DIAMOND SCALES,  
Bullion Balances and Weights, in use at all the U. S. Mints and Assay Offices.

PRICED CATALOGUE ON APPLICATION.

Solid Gold Rings—a Specialty  
WM. H. ELY,  
**Solid Gold Rings**  
MANUFACTURER,  
Viz., Plain, Chased, Engraved, Enameled, Engine Turned, Shield & Scale. All qualities Warranted  
Orders Promptly Executed.  
58 Nassau Street, N. Y.

Established 1848.

Reliable and prompt.

**COOPER & BRO.**

Wholesale Jewelers,

Importers and dealers in WATCH & CLOCK-MAKERS' TOOLS and MATERIALS; also, JEWELERS' SUPPLIES, SPECTACLES, OPTICAL GOODS, &c. A complete Outfitting Establishment for the trade.

Repairs Department established 1865. Every description of work done for the trade. Watch Repairing, Jewelry and Watch Case Repairing, Gold and Silver-Plating, and Fire Gilding.

35 S. Fourth St. (1st floor). PHILADELPHIA

**E. HOERNER,**

Manufacturer of Jewelry,

Diamond and Black Onyx Goods,

15 Maiden Lane,

NEW YORK.

**DAVID PRINCE,**

Gold and Silver Refiner,

Assayer and Sweep Smelter,

13 and 15 New Jersey Railroad Avenue,

NEWARK, N. J.

Sole Agent for Comins' Improved Amalgamator.

LOWELL WRENCH CO., WORCESTER, Mass.

JEWELLERS' PIN VISE.



PATENTED AUG 10, 1875.

"The Jewelers' Pin Vise is a well-known tool advertised in the CIRCULAR, by the Lowell Wrench Company, of Worcester, Mass. and is a credit to them. The sample was inspected with high commendation by the members, many of whom had used it and pronounced it far superior to the imported article. It is of hardened steel, nickel-plated, the handle is nicely milled, giving a firm grip for rolling in the fingers, and the whole is turned true to centre. It holds firmly anything placed in it, and altogether is a most excellent tool for the bench."—*Proceedings Horological Club, April, 1879.*

**Vulcanite Jewelry Co.**

MANUFACTURERS OF

**WHITBY JET,**

Combination Whitby Jet and Vulcanite,  
Byron's Patent, May 18, 1869,

Also a full line of Lockets—plain, gold mounted and monogram.

No. 191 BROADWAY, N. Y.

Agents for the NEW RUBBER WATCH CASES, Fitting all American Movements.

Designs made and estimates given on all kinds of Engraving for Jewelers.



Illustrations for Books, Mfg Catalogues, &c. Labels and Show Cards Engraved on Metal for Color Printing.

**HENRY ABBOTT,**

Manufacturer of

STEM-WINDING PARTS FOR

**WATCHES,**

New Scapements for Watches or Clocks.

Models for Patents. Small Tools for Watch-makers and Jewelers.

Dies, Cutters, &c., made to order.

Fine and Complicated Watches repaired in the best manner, by competent workmen.

Office, 11 Maiden Lane,

NEW YORK.

Factory, John Street, New York.

Leon Jeanne.

Paul Jeanne.

**JEANNE BROTHERS,**

MANUFACTURERS OF

DIAMOND MOUNTINGS

And RICH JEWELRY,

Patentees of Jeanne's Ear Wires,

No. 1 Maiden Lane, New York.

Designs furnished and estimates given.

KETCHAM & McDOUGALL,  
No. 4 LIBERTY PLACE, NEW YORK.  
MANUFACTURERS OF  
Improved Gold and Silver  
**THIMBLES**



AND THE PATENT  
AUTOMATIC EYE GLASS HOLDER.

Which returns the Eye Glasses to their place on or under the lapel of the vest by simply casting them from the nose, combining all the conveniences of Cord, Hook and Case, without their annoyances.

**J. B. LAURENCOT,**

IMPORTER OF

WATCH GLASSES,

Optical and Fancy Goods

French Clocks, Musical Boxes, &c.

No. 33 MAIDEN LANE.

15 Rue D'Enghien,  
PARIS.

Box 2954, P. O.  
NEW YORK.

**L. BONET,**

Medal at Centennial, 1876.

**CAMEO**

Likenesses,

889 Broadway, New York.

**C. B. WILKINSON & Co.**

212 Broadway,

NEW YORK,

Manufacturing Jeweler,

Masonic Pins, Rings & Charms.

School, Athletic, Fine  
Presentation Medals.

—AND—

JEWELS OF EVERY DESCRIPTION.

Designs furnished free upon application.



**GEO. W. DU BOIS,**

(Successor to Albert Landsberg.)

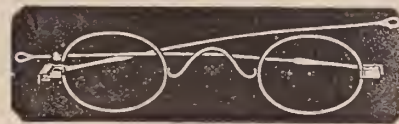

IMPORTER AND MANUFACTURER OF

**Optical Goods,**

No. 36 MAIDEN LANE,

Near Nassau Street, NEW YORK

Sole Agent for

BLACK'S PATENT

Interchangeable Spectacles,

AND

EYE GLASSES.

Jewelers and others who keep spectacles for sale will please observe that, with these PATENT SPECTACLES, it is only NECESSARY to have a full Complete Assortment of Lenses and Pebbles, which being all of a UNIFORM SIZE, will FIT either the Gold, Silver, or Steel Frames, of which but a few of each kind are wanted; an advantage which will give a complete assortment of the finest Spectacles, for one-sixth the capital invested in a like assortment of the same quality goods of the old style frames.

For Particulars, price lists, &c., address

**GEO. W. DU BOIS,**

New York.

Established 1850.



**PETER L. KRIDER,**

MANUFACTURER OF

STERLING

**SILVER WARE,**

Medal and Diploma Awarded, &c.

Striking Society Medals in Gold, Silver or Bronze  
A SPECIALTY!

ARTISAN HALL,

618 Chestnut Street

PHILADELPHIA.



**SIMONS BROTHER & CO.**  
 MANUFACTURERS OF  
 Gold Chain and Jewelry,  
 611 & 613 Sansom Street,  
 PHILADELPHIA.  
*Incorporated Model and Diploma at the Centennial*

Geo. W. SIMONS,  
 JOHN F. SIMONS,

Peter B. SIMONS,  
 Geo. W. SIMONS, Jr.

JOHN SPECKER,  
 Fred. M. SIMONS.

**Simons Brother & Co.**

611 & 613 Sansom Street, Philadelphia

**The Burbank Manufacturing Company**

Manufacturers of GOLD & SILVER

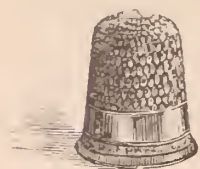

GOLD  
 SILVER,  
 STEEL,  
 RUBBER,  
 And SHELL,

**Thimbles,**



EYE GLASS  
 Self Adjusting.

**SPECTACLES AND EYE-GLASSES**



OF ALL DESCRIPTIONS.

**SOLID GOLD RINGS,**

Office, 14 MAIDEN LANE. NEW YORK.

Manufactory, Springfield, Mass.

Established 1853.

**L. H. KELLER & CO.**

Successors to G. A. HUGUENIN,

IMPORTERS OF

**Fine Watch and Clock Materials,**

SWISS, ENGLISH, FRENCH & GERMAN

**FILES, TOOLS, & C.**

FOR WATCH MAKERS, WATCH CASE MAKERS, JEWELERS,  
 SILVERSMITHS, ENGRAVERS, CHASERS, DIE  
 SINKERS, MACHINISTS, &c.

SOLE AGENTS FOR HALL'S STAKING TOOLS AND  
 ROLLER REMOVERS.

**AGENTS FOR THE WHITCOMB AND OTHER AMERICAN LATHES.**

GENERAL AGENTS FOR THE PHILADELPHIA  
 WATCH COMPANY.

American Agents for the Horological Journal, (British).

A Monthly Paper for the advancement of Chronometer, Watch and Clock Making,  
 and kindred Sciences. Published under the auspices of the British Horological  
 Institute, London. Subscription \$2.50 per year, in advance. Also,

SAUNIER'S TREATISE ON MODERN HOROLOGY, IN  
 THEORY AND PRACTICE,

BY M. CLAUDIUS SAUNIER. The English Edition will appear in 26 monthly parts,  
 Price 50 cents each. Whole Work, \$13 00, postage paid.

Special attention is directed to

**"OUR OWN" Celebrated Mainsprings Graduated**

in thickness to equalize the power, with well rounded edges, and the  
*Highest Crocus Finish throughout*, insuring the least possible friction  
 in the barrel, pronounced by expert judges to be the *best made*.

"JURGENSEN" Main Springs recoiling, suitable for the highest grades  
 of Swiss Watches.

**"Lutz" Celebrated Hair Springs,**  
 by numbers, of uniform diameter and strength, the best for "BRE-  
 GUETING."

Fine Hole Jewels of Ruby, Sapphire, Chrysolite, Garnet, Beryl and  
 Aqua Marine, with *gauged* (well shaped and polished) holes, numbered  
 by the Swiss pivot gauge; also, neat black walnut cases, containing  
 forty glass vials for assortments of same. The great advantage in hav-  
 ing Jewels by numbers will readily be seen as a saving in time and an-  
 noyance in selecting and in expense. Dealers once having an assort-  
 ment, can replenish or stock up at a comparatively small outlay, as any  
 desired quantity of No. and quality can be had of us at all times,  
 our stock of jewels being the largest and most complete in the country.

Diamond Charged Broaches for opening and polishing jewel holes.

Diamond Powder and Bort for polishing and grinding 8 different  
 grades, in  $\frac{1}{2}$ ,  $\frac{1}{4}$ ,  $\frac{1}{8}$ , and  $\frac{1}{16}$  K vials, bringing it into the reach of all.

Gold Diamond Set and other fine Geneva Hands.

The new Drills in Sets of 54 small, 126 small to medium, and 48  
 large; also, sold separately if desired.

NOTE.—We issue no Price Lists and Highly Illustrated Catalogues  
 to attract attention of Dealers to a large assortment of goods in print,  
 but we have the goods in stock and will be pleased to quote prices  
 if desired, or fill orders for any article in our line.

**No. 64 Nassau Street,**

Near Maiden Lane,

**NEW YORK.**

**SPECIAL NOTICES.**

Advertisements under this head, not to exceed six lines, \$1.00 each insertion.

**WANTED** Volume VIII of the Jewelers' Circular complete. Address, C. S. CROSSMAN, Ann Harbor, Mich.

**JEWELERS' Sale** for sale, low, Herring's. Cost \$2,000 Was exposed at the Centennial. Office JEWELERS' CIRCULAR, 42 Nassau St.

**WANTED.**—An experienced worker in Silver Filigree. Must be a good workman, sober and industrious. Wages \$15 a week, and steady employment. Address B. & O. JEWELERS' CIRCULAR.

**WANTED** a situation by a young man 18 years old, to learn the Watchmaking business; has worked at it for six months; satisfactory references. Address, P. O. Box 233, MUNCEY, Pa.

**\$10.00 REWARD!** Ladies' Gold Hunting Case Watch, No. 24,593, "Lalond Freres," makers, engraved "L. H." on outside of case. Return to JOS. P. ANGELL, Jeweler, Pine Bluff, Ark.

**FOR SALE.** A Jewelers' Factory, with ease and goodwill of the business. Tools, mills, dies and machinery in perfect order. Whole or part of front office to let. CHATBERTON & DODD, 19 John Street, New York.

**WATCH** and Jewelry business for sale—Goods, Tools, Fixtures, good-will; doing the best business in that section. Must be sold at once. Good reason for selling. Address, T. A. NINTO, Waltham, Mass.

**SITUATION WANTED.** East or West, by an American Watchmaker (married), has worked 17 years at bench, and as Salesman is good workman, with general knowledge of the business of a good store; best of references, &c. Please address TIME, Care Editor of this Paper.

**TO MANUFACTURING JEWELERS.** The advertiser, a practical and experienced Jeweler, would like to confer with firms in such business, with a view to position as foreman. The best references given as to capability, &c. Address, D. W. C. S., office Jewelers' Circular.

**WANTED** by a man of 10 years' experience in the Jewelry business, a position as Traveling Salesman. Have had some experience on the road. Would not object to working up a new territory. Can give the best of references. Address R. B. T., 113 Madison St., Chicago, Illinois. Care S. F. ESTELL.

**FOR SALE.** Fine chance for a good man, either Watchmaker or Clerk, to buy a well-established jewelry business, been running 17 years. Keeps a Watchmaker and jeweler at work besides the proprietor. Only about \$400 capital required. Satisfactory reasons for selling. Correspondence solicited. Address W. L. M., Care Editor Circular.

**GEO. E. WILKINS.**—Importer of fine Tools for Watchmakers, cutting and dividing engines, rounding up tools and cutters, also cutters for stem winding wheels. Fine lathes with the American system of chucks. Dividing engine and rounding up tool combined. Marine chronometers for sale. Special tools imported to order. 21 South Salina St., Syracuse, N. Y.

**FOR SALE.** A Jewelry Store in Manufacturing Village in New Hampshire. Is center of trade for surrounding towns, having a population of about 12,000. Is a large summer resort, has large trade from summer boarders. This is a rare chance for one with small capital. Will be sold low. Is well-established, and doing a good business. Address, LAMSON BROS., 4 Central St., Lowell, Mass.

**IMPORTANT** to Jewelers.—By sending 25 Cents (in currency), I will forward to your address an INFALLIBLE Recipe for preserving all kinds of plated ware from tarnishing. The ingredients are few, the cost trifling, the work of preparation very simple, and the result all that could be wished for. When prepared it need only be placed in the case where the ware is kept, and needs no further attention. F. H. MADDEX, Care United States Show Case Works, 327 Liberty St., Pittsburgh, Pa.

**TO THE TRADE.**—We offer for sale in bulk our jewelry store with all the stock of watches, jewelry, silver ware and clocks, together with the furniture, fixtures, safes, regulator, watch tools, jewelry shop, and all the requirements of a first-class jewelry store. This, with the lease of the store for unexpired term (it being one of the best stands in St. Louis and at low rent), will be closed out at a bargain. Parties who desire to purchase will please address EDWARD MEAD CO, corner of Fourth Street and Washington Ave., St. Louis, Mo.

**FOR SALE.**—Whole or half interest in an old established Jewelry Store, in a flourishing city of 12,000 inhabitants, in New York State. Party purchasing must command cash necessary for half the amount and be able to give undoubted security for balance, on which easy terms will be given. Must be a live, pushing man, and a practical watchmaker. This is a rare chance for the right man. Satisfactory reasons given for selling, and the highest references given and required. To save unnecessary trouble it is proper to state that this is no advertisement for adventurers without means; nor is it a "great sacrifice." The store has been in the present family for twenty-five years and has survived all competition. It is now desired to obtain a party as described to take the management, either as partner or sole owner. Address, enclosing references, ROGERS & BROTHER, 690 Broadway, New York.

**Buyer's Directory.**

A Guide to the prominent Wholesale Houses in the Watch, Clock, Jewelry and kindred branches of Trade in New York, Philadelphia, Chicago, Providence and Newark.

**NEW YORK.**

**Black Onyx Jewelry.**

**Cox & Sedgwick**—Manufacturers of Black Onyx Jewelry, No. 26 John St., New York.  
**Woglom & Miller**—Manufacturers of (exclusively) Black Onyx Jewelry, 32 & 34 John st., New York.

**Bohemian Garnet Jewelry.**

**Bissinger, Philip**—Importer of Diamonds, Pearls and Precious Stones. Sole Agent for the Bohemian Garnet Jewelry, 22 John St.

**Clock Companies.**

**New Haven Clock Co.**—62 Reade Street, N. Y.  
**Seth Thomas Clock Co.**—20 Murray Street, N. Y.  
**Waterbury Clock Co.**—M. Bailey, Treasurer, Manufs. and Jobbers, No. 4 Cortlandt Street, N. Y., and No. 197 State Street, Chicago.  
**Kroeber, F.**—Manufacturer and Dealer in American and French Clocks, No. 8 Cortlandt St.

**Corals and Coral Jewelry.**

**Cuppia, L. A.**—Importer of Coral and Silver Filigree Jewelry, 19 Union Square, N. Y.  
**Errico Bros.**—Importers of Coral, Conch-Shell and Silver Filigree Jewelry, etc., 19 John St.  
**Lawson, S.**—Manufacturer of Coral and Black Onyx Jewelry. All kinds of repairing solicited. Goods sent on Mem. 63 Nassau Street.

**Squadrioli, Ach.**—Manufacturer and Importer of Coral, Conch Shell and Silver Filigree, etc. No. 9 Maiden Lane, N. Y.

**Cameo Cutters, Etc.**

**Bonet, L.**—Cameo Likenesses, No. 889 Broadway, N. Y.  
**Wiederer, Peter**—Late Habermeier & Wiederer, Engravers of Cameo Likenesses, Seal Stones. Cameos repaired. 23 John St.

**Charms & Gold Watch Keys.**

**Rupp & Held.**—Manufacturing Jewelers, Charms and Gold Watch Keys, with French and English Ratchets, a specialty. 15 John st., N. Y.

**Cutlery.**

**Rogers Cutlery Co.**—Hartford, Conn.  
**Harrison Bros. & Howson.**—Manufacturers of Fine Ivory and Pearl Table and Pocket Cutlery; Carvers in Cases; Nutpicks, Nutcracks and goods suitable for the jewelry trade. 26 Cliff street. W. C. Burkinshaw, Sole Agt.

**Diamonds.**

**Anderson, Otis**—Diamond Merchant and Broker, always ready to pay cash for bargains in Diamonds and Precious Stones, No. 9 Maiden Lane, N. Y.  
**Bernhard, A. & Co.**—Manufacturing Jeweler & Importers of Diamonds and Precious Stones, also Diamond Mountings, 2 Maiden Lane.  
**Bissinger, E.**—Importer of Diamonds, No. 192 Broadway, New York.  
**Bissinger, Philip**—Importer of Diamonds, Pearls and Precious Stones. Agent for the Bohemian Garnet Goods No 22 John St., N. Y.  
**Buckenham, Cole & Saunders**—Importers of Diamonds and other Precious Stones, No. 10 Maiden Lane, N. Y.  
**Fera, Henry**—Importer of Diamonds, and Manufacturer of Fine Diamond Jewelry. No. 9 Maiden Lane, New York. Amsterdam, Holland, 23 Loojersgracht.  
**Herbert, R. J.**—Importer and Broker in Diamonds, 16 Maiden Lane.  
**Hedges, Wm. S. & Co.**—Importers of Diamonds. No. 170 Broadway.  
**Lyon & Hardy.**—Importers of Diamonds and Manufacturers of Diamond Jewelry. 30 Maiden Lane, New York.  
**Neresheimer, E. Aug.**—Importer of Fine Diamonds. No. 21 Maiden Lane, New York.  
**Prager, Morris.**—Importer of Diamonds and Fine Diamond Jewelry. 8 Maiden Lane, New York.  
**Smith, Alfred H. & Co.**—Importers of Diamonds No. 14 John Street.

**Diamond Cutters.**

**The Morse Diamond Cutting Co. of Boston.**—Henry D. Morse, General Manager. N. Y. Office, 192 Broadway, corner John street. J. D. Yerrington, Agent.

**Diamonds and Diamond Jewelry.**

**Bissinger, Philip.**—Importer of Diamonds, 22 John street, N. Y. Agent for the Bohemian Garnet Goods.  
**Bornemann, Louis**—Manufacturer of Diamond Jewelry from original designs, 169 and 171 Broadway.  
**Heller & Bardel.**—Manufacturers of Diamond and Pearl Jewelry, and dealers in Diamonds Pearls, &c. Also agents for Boss' Patent Stiffened Gold Watch Cases. 13 John Street, N. Y.  
**Taylor & Brother**—Importers of Diamonds and Diamond Jewelry, 676 Broadway.

**Diamond Setters, Etc.**

**Asher, J.**—Jeweler and Diamond Setter, Precious Stones Inlaid and Incrusted with Diamonds, Nos. 880 and 882 Broadway.  
**Blancard & Oberlander**—Manufacturers of all kinds of Settings and Galleries of any carat of Gold, Silver, Platinum and Platinum Lined. Send for sample cards. 36 and 38 John street, N. Y.  
**Wood, Chas. F.**—Engraver and Incruster of Precious Stones and Diamond Setter. No. 169 & 171 Broadway.  
**Friend, S.**—Manufacturer of Fine Jewelry, and Diamond Setter. 33 John street, N. Y.

**Dials, &c.**

**Caesar Brothers**—Manufacturers of Enameled Clock Meter and Gauge Dials, Patent Door, Coffin and Pew Plates, Druggists' Labels, &c. No. 32 and 34 John Street.  
**Gold, John T.**—(Successor to the late T. Gold), Enamel Watch Dial Maker, 81 Nassau St.

**Enamelers, Etc.**

**Nutt, J. D.**—Enameler on Gold, Silver and Copper, 32 and 34 John St. Birds, Flowers, etc., Enameled in colors.  
**Orr, Jas. C.**—Enameler on Fine Jewelry, Flowers, Birds, &c., Enameled in colors. Band Bracelets (a specialty). 77 Nassau Street.

**Electroplaters, &c.**

**Jeandheur, F. & Son.**—Gold and Silver Electro Platers & Fire Gilders, coloring European and Gold Jewelry a specialty. 125 Fulton St.

**Engravers and Die Sinkers**

**Fackner, Edward**—Carver, Engraver and Chaser on Jewelry and Pencil Cases. Monograms Lettering, &c. 19 John Street.  
**Park Wm.**—Stone Seal Engraver. Coats of Arms found and engraved. Initials and Monograms engraved. 26 John Street, New York.  
**Schuller, J. Dan'l**—Stone Seal Engraver Arms Crests, Initials and Monograms engraved on Stone Seals, &c. 71 Nassau street.

**Fancy Goods, Clocks, Bronzes Etc.**

**Magnin, Ve J. Guedin & Co.**—Importers of Clocks Bronzes, Musical Boxes & Rich Fancy Goods etc., 29 Union Square.  
**Le Boutillier & Co.**—Importers of Fancy Goods, Clocks, Bronzes, &c. 3 Union Square

**Cold Chains, Etc.**

**Beck, J. & Son.** Manufacturers of Fine Gold Chains and Chain Bracelets, 10 Liberty place, near Maiden lane, N. Y.  
**Dorrance, Edge & Co.**—Manufacturers of the Celebrated Woven Fabric Gold Chain, No. 12 John street.

**Hamiltons & Hunt.**—Manufacturers of Fine Plated Chains and Patent Buckle Bracelets. Branch office, 176 Broadway. Factory, 226 Eddy street, Providence.

**Kaufmann Bros.**—Manufacturers of Gold Chains, and Chain Bracelets, 26 John street; Factory, 331 and 333 Bowery, N. Y.

**Nordt & Schlag.**—Manufacturers of Gold Chain No. 17 Maiden Lane, N. Y.

**Saxton, Smith & Co.**—Manufacturers of Fine Gold Chain. 15 Maiden Lane.

**Cold Pens, Etc.**

**Aikin, Lambert & Co.**—Manufacturers of Choice Gold Pens, Cases, Holders, Toothpicks, etc., 23 Maiden Lane, N. Y.

**Clark, J. M.**—Manufacturer of Pen and Pencil Cases for the wholesale trade only. No. 61 Hudson Street, N. Y.

**Mabie, Todd & Bard**—Manufacturers of Gold Pens, 180 Broadway.

**Todd, Edward & Co.**—Manufacturers of Gold Pens, Pencil Cases, Tooth Picks, &c., 44 East 14th St., Union Square.

**Goldsmiths, &c.**

**Greene Wm. C. & Co.**—Goldsmiths; Manufacturers of Rich Sets in Taper Wire Coral. Office, 192 Broadway.

**Gold Rings.**

- Bowden, J. B. & Co.**—Manufacturing Jeweler.—Solid Gold Rings a specialty, 1 Maiden Lane.
- Ely, W. H.**—Manufacturer of Solid Gold Rings of every description. No. 58 Nassau Street.
- Frankel & Folkart.**—Manufacturers of Seal, Cameo and Amethyst Rings a specialty, Also a full line of Gold White Stone goods and Diamond Settings. 21 John St., N. Y. etc., No. 4 Liberty Place.
- Sinnock & Sherrill**—Manufacturers of Stone Rings. No. 5 Maiden Lane, N. Y.
- Tingley, Joseph N.**—Manufacturer of Stone Rings and novelties in Stone Goods. No. 9 Maiden Lane, N. Y.

**Hair Jewelry.**

- Sauter, L.**—Manufacturer of Fine Gold and Hair Jewelry and Device Work. Nos. 65 & 67 Nassau Street.
- Schwencke O.**—Manufacturer of Fine Hair Jewelry. Orders from the country promptly attended to. No. 43 Maiden Lane.

**Jewelry Cases, Fancy Boxes, Etc**

- Braun, Chr. E.**—Manufacturer of Jewelry Boxes, Trays for Show Cases, &c. 62 Chatham st.
- Dahlem, W.**—Manufacturer of Cases for Jewelry and Silverware, No. 85 Nassau Street, N. Y. Show Case Trays, &c., at shortest notice.
- Jackson, Samuel C.**—Manufacturer of Boxes and Trays, for Silverware, Watches, Jewelry &c. 180 Broadway, N. Y.
- Loehr & Koerner**—Manufacturers of Morocco, Velvet, Satin, Jewelry, Watches and Silverware Cases, Glove, Handkerchief, Ladies' Jewel, Work Boxes, &c, Fancy Trays and Stone Fittings to order, Office and Salesroom 96 John Street, New York.
- Mohn & Walker**—Manufacturers of Morocco Cases, 712 Broadway, N. Y.
- Sturm, L.**—Manufacturer and Importer of Cases for Jewelry, Watches, Silverware, &c. No. 15 John street, N. Y.
- Welch & Miller**—Manufacturers of Morocco, Velvet, and Satin Jewelry Cases, Trays, &c. Telescope Sample Cases with flexible Trays. Complete stock on hand. 169 Broadway.
- Wiggers & Froelick**—No. 60 Nassau street.—Manufacturers of Cases for Jewelry, &c., of every description. Trays for Show-cases, Stands for Show-windows, etc. Jewelers' Traveling Cases, light, convenient and strong.

**Jewelry—Fine.**

- Aikin, Lambert & Co.**—Manufacturers. General stock of Reliable Jewelry, 23 Maiden Lane.
- Alford, C. G. & Co.**, Manufacturers. General line fine and reliable goods. Specialties in Onyx goods and chain. 183 Broadway, New York.
- Andrews, J. F.**—Manufacturer of Fine Jewelry, Lockets, Sleeve Buttons and Rings in Stone Cameo, etc., a specialty. 35 Maiden Lane.
- Baldwin, Sexton & Peterson**—Manufacturers Fine Jewelry. Whiting Building, Broadway and Fourth street.
- Ball, Wm. H.** Manufacturing Jeweler. Fine Gold Bracelets a Specialty. No. 9 John St., N. Y.
- Barthman & Straat**—Manufacturers of Fine Jewelry. Seal and Stone Rings a Specialty Orders promptly attended to. 41 Maiden L
- Bernhard, A. & Co.**—Manufacturers of Fine Hair Jewelry and Device Work. The latest styles 2 Maiden Lane, New York.
- Bissinger, E.**—Importer of Fine Jewelry, Lockets, Crosses, Neck Chains, &c., No. 192 Broadway.
- Brown, Thos. G.**—Manufacturer of Rich Jewelry Necklaces, Lockets, Bracelets, Sleeve Buttons, etc., 9 Bond street, N. Y.
- Bryant & Bentley**—Manufacturing Jewelers Rings a specialty. 12 Maiden Lane.
- Brainerd & Steele**—Successors to Brainerd, Steele & Co., Manufacturers of Fine Jewelry and Brainerd's Patent Lockets. No. 9 Maiden Lane, New York.
- Burch, Geo. & Co.**—(Successors to Burch, De Mott & Coughlin) Manufacturing Jewelers, 17 Maiden Lane, N. Y. Factory, Newark, N. J.
- Carrow, Bishop & Co.**—Manufacturers of Fine Jewelry, Roman Band Bracelets, Lockets, Crosses, &c. 12 John Street, N. Y.
- Carter, Howkins & Sloan.**—Manufacturing Jewelers, Whiting Building, 4th St. & Broadway
- Chatellier & Spence**—Manufacturing Jewelers. No. 694 Broadway, N. Y.
- Coe, Pinneo & Stevens.**—Manufacturers of Fine Jewelry, Fine Gold Lockets and Linen Finished White Enameled Goods a Specialty, No. 9 Maiden Lane, N. Y.

**Champenois & Co.**—Manufacturing Jewelers' No. 1 Maiden Lane. Specialties—Jet Cluster Goods in Sets and Sleeve Buttons, Engraved and Enameled Goods in Sets, Studs, Sleeve and Collar Buttons, Lace, Shawl and Cuff Pins, Ear Knobs and Crosses.

**Cook, Groeschel & Co.**—Manufacturers of Fine Jewelry and Lockets, 191 Broadway (over Mercantile Bank,) N. Y.

**Demmert Bros.**—Manufacturers and Importers of Fine Jewelry, Cameo and Onyx Lockets, Sleeve Buttons and Sets a specialty. Old No. 9 Maiden Lane, New York.

**Field & Co.**—Manufacturing Jewelers, 8 Maiden Lane, N. Y.

**Frankel & Folkart.**—Manufacturing of Seal, Cameo and Amethyst Rings, a Specialty. Ladies' and Gents' Lockets, Cameo Sets, &c. Also a full line of Diamond Settings, 21 John street, N. Y.

**Goddard, John M.**—Manufacturing Jeweler.—Seal Rings and Fine Lockets a specialty, No. 3 Maiden Lane, N. Y.

**Greason, Bogart & Pierce**, successors to Arthur, Rumrill & Co., 182 Broadway, manufacturers of fine jewelry and gold chains

**Hartmann, P.**—Manufacturer & Importer of Fine Gold, Diamond, and Filagree Silver Jewelry, No. 36 Maiden Lane. P. O. Box 2,454.

**Haskell, H. C.**—Manufacturing Jeweler. Seal Rings a specialty. Special attention to Jobbing of every description. 12 John street.

**Henderson & Winter**—Jewelers, No. 15 Maiden Lane, New York. Specialties—Stone, Cameo, Onyx, Amethyst, Topaz, Pearl and Turquoise Rings.

**Hunt & Owen.**—Manufacturing Jewelers. Office 5 Maiden Lane.

**Hale & Mulford.**—Manufacturers Rich Jewelry, Whiting Building, Broadway and 4th Street

**Jeanne Brothers.**—Manufacturers of Diamond Mountings & Rich Jewelry. 1 Maiden Lane.

**Keller, Chas. & Co.**—Manufacturing Jewelers Lockets a Specialty. No. 18 John St., N. Y.

**Kremetz & Co.**—Manufacturing Jewelers, No. 13 John Street, N. Y.

**Kroll, H.**—Manufacturer of Fine Jewelry. Repairing (a specialty) done for the trade at moderate prices, 78 Nassau street.

**Kuhn & Doerfinger**—Manufacturers of Enamel'd and Roman Band Bracelets, also Fine Lockets and Pendants, 18 John street.

**Lennon, John D.**—Manufacturing Jeweler, 142 Fulton street. Flat, and Half-round Gold Bracelets, Roman and Stone Lockets.

**Moore & Horton.**—11 Maiden Lane, Manufacturing Jewelers, Rings, Stnds, Collar and Sleeve Buttons, Pins, Ear-rings, &c.

**Miller Bros.**—Manufacturers of Fine Jewelry Lockets, Sleeve Buttons, Studs, etc., etc. 11 Maiden Lane, New York.

**Marx Kossuth & Co.**—Manufacturing Jewelers 39 Maiden Lane.

**Owen, G. & S. & Co.**—Manufacturing Jewelers. Office, No. 5 Maiden Lane.

**Pendrill, Wm.**—Manufacturer of Fine Jewelry, jobbing and repairing for the trade at low rates, 73 Nassau Street.

**Riker, William**—Manufacturer of Jewelry. Inlaid Gold Jewelry a Specialty. No. 5 Maiden Lane, N. Y.

**Riley, J. A. & Co.**—Manufacturing Jewelers, Etruscan Gold and Coral Sets, Roman Bracelets, Necklaces, etc. Onyx Goods a specialty. 7 and 9 Bond street, New York.

**Richardson, Enos & Co.**—Manufacturers of Fine Gold Jewelry, Gold Chains, Lockets, Crosses and Necklaces. Colored and Etruscan Work. No. 23 Maiden Lane, New York.

**Richardson, J. W. & Co.**—Manufacturers of Jewelry, Masonic and other emblems. 196 Broadway, Manufactory, Providence, R. I.

**Sexton & Cole**—Manufacturing Jewelers, Colored Gold and Onyx Goods a specialty. No. 30 Maiden Lane.

**Shoemaker & Co.**—Manufacturing Jewelers, Cameo Buttons, and Lockets, Roman Gold Goods, etc. No. 21 Maiden Lane, N. Y.

**Stites, E.**—Manufacturer of Fine Jewelry. No. 12 Maiden Lane, N. Y.

**Sturdy Bros & Co.**—Manufacturers of Jewelry. General line of fine and heavy Rolled Plate Goods. Specialties—enameling on gold plate; graduated wire coral work. 14 Maiden Lane, N. Y.

**Terhune, Charles F.**—Manufacturing Jeweler, 16 Maiden Lane, N. Y.,

**Thoma, Ernest**—Manufacturer of Fine Jewelry. Sleeve Buttons, Rings, Ear-rings, &c. No. 173 Broadway, N. Y. Factory, Hackensack, N. J.

**Trier Bros. & Co.**—Jewelry. Optical, Rubber, Jet, Shell, Ivory, Amber and Pearl Goods. Silk Guards, Japanese Bamboo Watch Chains a Specialty. No. 15 Maiden Lane.

**Vulcanite Jewelry Co.**—Manufacturers of Whitby Jet and Vulcanite Jewelry, 191 Broadway, N. Y.

**Wadsworth, E. E.**—Manufacturer of Rich Jewelry and fine Rolled Plate. Fine Seal Rings a specialty. 35 Maiden Lane.

**Wheeler, Parsons & Hays.**—Manufacturers of Fine Jewelry, Watch Cases, Gold Chains, &c and Dealer in American and Swiss Watches, No. 2 Maiden Lane, N. Y.

**Wienhold, Joseph**—Manufacturer of Fine Jewelry and Diamond Setter. 24 John St.

**Woglom & Miller**—Manufacturing Jewelers, Nos. 32 & 34 John street, N. Y. Specialty Black Onyx goods.

**Jewelers' Tools, etc.**

**Fraser & Co.**—Importers of Stubs, French, Swiss, German and Sheffield Tools, Files and Steel Wire for Watchmakers, Jewelers, etc., 62 Chatham street, N. Y.

**Hammel, L. & Co.**—Importers of Materials and Tools for Watchmakers, Jewelers and Engravers—also Optical Goods, &c., 9 Maiden Lane, N. Y.

**Lapidaries.**

**Kordmann & Michel**—Lapidaries, dealers in Precious Stones. Rubies, Sapphires and Peridots cut. No. 32 Maiden Lane.

**Musical Boxes.**

**Paillard, M. J. & Co.**—Importers & Manufacturers of Musical Boxes, No. 680 Broadway, N. Y.

**Masonic Jewelry.**

**Wilkinson, C. B. & Co.**—Manufacturers of Masonic, Odd Fellows, Athletic Clubs and other Jewelry, No. 212 Broadway, New York.

**Opticians.**

**Burbank Man'g Co.**—Manufacturers of Spectacles and Eye Glasses of all descriptions, in gold, silver, etc., 14 Maiden Lane, N. Y.

**Du Bois, Geo. W.**—Successor to A. Landsberg, Importer and Manufacturer of Optical Goods 36 Maiden Lane. Box 3993, N. Y.

**Hammel, L. & Co.**—Importers of Spectacles, Opera and Marine Glasses, Telescopes, Microscopes, Optical & Fancy Goods, 9 Maiden L.

**Laurencott, J. B.**—Importer of Watch Glasses, Optical and Fancy Goods, Clocks, Bronzes, etc., 33 Maiden Lane, N. Y.

**Lorsch, Albert**—Manufacturer of the Patent Accommodating Spectacles and Eye Glasses in Gold, Silver and Steel, and other Optical Goods, 37 Maiden Lane, N. Y.

**Serin, A.**—Manufacturer of Spectacles and Eye-Glasses, in Steel, Shell and Rubber. Repairing of all kinds. Opera Glasses covered and re-gilt, etc. 169 and 171 Fulton street.

**Spencer Optical Manufacturing Co.**—Gold, Silver, Steel and Nickel Plated Spectacles, Eye Glasses, &c. 13 Maiden Lane, N. Y.

**Precious Stones, &c.**

**Bissinger, Philip**—Importer of Diamonds, Pearls and Precious Stones. Agent for the Bohemian Garnet Goods. No. 22 John St., N. Y.

**Gruet, Jules.**—Importer of Precious and Imitation Stones, Amethysts, Topazes, Cameos, Garnets, Doublets, Imitation Diamonds, Pastes, etc., No. 14 John street. Manufactory at Septmoncel, France.

**Meyer, Francis Ed.**—Successors to John B. Behrman, Importer of Imitation Precious Stones, all sizes and shapes constantly on hand. No. 53 Nassau st., P. O. Box, 1981.

**Silverware.**

**L. A. Cuppia.**—Manufacturers of Solid Silver Novelties, and Importers of Silver Filigree and Conch Shell. 19 Union Square.

**Gorham Manufacturing Co.**—Union Square.

**Wood & Hughes.**—Manufacturers of Fine Silver ware. 16 John Street, N. Y.

**The Adams & Shaw Co.**—Manufacturers of Silverware. Cor. Broadway & 4th St., N. Y.

**Silver Plated Ware.**

- Brown & Bros.**—Manufacturers of first quality of Electro Plated Flat Table Ware. No. 81 Chamber Street, N. Y.
- Hall, Elton & Co.**—Manufacturers of the Finest Electro-Plated Ware, salesroom, 75 Chambers street, N. Y.
- Holmes, Booth & Haydens**—Manufacturers of Silver-plated Ware. 47 Chambers street.
- Meriden Britannia Co.**—Manufacturers of Silver plated Ware, 46 East 14th Street, Union Square, N. Y.
- Middletown Plate Co.**—Manufacturers of Superior Electro-Plate. Factories, Middletown, Conn., Salesroom, 13 John Street
- Rogers Cutlery Co.**—Hartford, Conn.
- Reed & Barton**—Manufacturers of Fine Plated and Table Ware, of every description, 686 Broadway, N. Y.
- Rogers & Bro.**—Manufacturers of the finest quality of Electro-Plated Ware. 690 B'way.
- Simpson, Hall, Miller & Co.**—Manufacturers of Fine Silver Plated Ware, No. 36 E. 14th St.
- Schade, Henry.**—Manufacturer of White Metal and Plated Ware, No. 84 John Street, New York. Price list and catalogue furnished on application.
- Webster, E. G. & Bro.**—Manufacturers of Fine Silver Plated Ware. Office and Warerooms, 14 Maiden Lane, N. Y.

**Show Cases, Etc.**

- Kraft & Hoffmeister**—Manufacturers of Metal Show Cases, Jewelry Trays always on hand, No. 16 North William street, N. Y.
- Smith, B. & W. B.**—Patent Improved Counter Show Cases. Drawings furnished and estimates given for fitting stores in Cabinet Work complete.

**Spectacle Case Manufacturers.**

- Koenen, A. & Bro.**—Manufacturers of Leather Spectacle & Eye Glass Cases, 81 Nassau St., N. Y.

**Thermometers Etc.**

- Tagliabue, Giuseppe**—Thermometer, Barometer and Hydrometer Manufacturer, 302 Pearl street near Beekman, N. Y.

**Thimble Manufacturers.**

- Burbank Manufg Co.**—Manufacturers of Gold & Silver Thimbles, 14 Maiden Lane, N. Y.
- Ketcham & McDougall**—Improved Gold and Silver Thimbles, Nos. 4 and 6 Liberty Place, near Maiden Lane, N. Y.
- Woglom & Miller**—Sole Agents for the "Prince" thimble, in gold and silver, 34 John St.,

**Walking Canes.**

- Fradley, J. F.**—Manufacturer of Fine Gold and Silver-headed Walking Canes and Sterling Silverware. Office and Factory, 20 John st.

**Watch Companies.**

- American Watch Co.**—Robbins & Appleton, No. 9 Bond street, N. Y.
- Illinois Watch Co.**—Factory, Springfield, Ill. Office, 21 Maiden Lane.
- Hampton Watch Co.**—of Springfield, Mass. Office, No. 12 Maiden Lane, New York.
- Tiffany & Co.**—Makers of Fine and Complicated Watches. Office 694 Broadway, N. Y.
- The Howard Watch and Clock Co.**—No. 2 Maiden Lane, N. Y.

**Watch and Chronometer Jeweler.**

- Queen, James**—Watch and Chronometer Jeweler and Pallet Maker, 78 Nassau street, Room 8. Pivots inserted in Pinions, Balance, Staffs, &c.

**Watch Importers, Etc.**

- Abry, J. A.**—Importer of watches and agent for Vacheron and Constantin Watches. 63 Nassau Street, N. Y.
- Aikin, Lambert & Co.**—Importers of Watches, Sole Agents for Paul Breton & Chas. Latour, Geneva. A general line of reliable Swiss Watches. Watch Cases of all styles made to order. 23 Maiden Lane, N. Y.
- Bynner, T. B.**—Importer and Jobber of Watches, Diamonds and Fancy Goods, and dealer in the best class of Rolled Plate Jewelry. 513 Broadway.
- Cross & Beguelin**—Importers of Watches, Watch Tools and Materials, dealers in American Watches, No. 21 Maiden Lane, N. Y.
- DuBois, Francis & Co.**—36 Maiden Lane, N. Y., Importers of Watches and Manufacturers of Watch Cases.
- Droz, Henry E.**—Importer of Watches and Watch Case manufacturer. Agent for the "E. Perregaux" Watch, and jobber in American Watches, No. 92 Fulton Street, N. Y.
- Freund Max & Co.**—Importers of Watches Jewelry and Precious Stones, 8 Maiden Lane
- Friedman, S.**—Importer of and dealer in Watches and Jewelry, 40 Maiden Lane.

**Gagnebin, Chas.**—Importer of all kinds of Watches, 4 Maiden Lane. Agent for Ulysse Breting's Fine Chronometers, Chronographs, Anchors, etc.

**Gallet, Julien**—Importer of Watches. No. 1 Maiden Lane.

**Ginnel, Henry**—Importer of Watches, Tools and Materials. No. 31 Maiden Lane, N. Y. P. O. Box, 2967

**Jandorf, P. & Bro**—Importers of Watches and Jewelry, 182 Broadway, bet. John Street and Maiden Lane, New York.

**Keller, L. H. & Co.**—(Successors to G. A. Huguenin,) Importers of Fine Watch and French Clock Materials, No. 64 Nassau street, N. Y.

**Hirsch Bros.**—Dealers in Watches and Diamonds, and manufacturers of Jewelry. No. 23 Maiden Lane, New York

**Hyde's Sons, John E.**—Wholesale Commission Agents, only for Jules Jorgensen, of Copenhagen, Ed. Perregaux, of Locle, Jules Monard, of Geneva, and for other makers of all qualities of watches, 23 Maiden Lane.

**Mathez, F. H.**—Importer of Watches. No. 5 Maiden Lane, N. Y.

**Magnin, Ve J. Guedin & Co.**—Importers and Agents of the Nardin Watch, 29 Un. Square.

**Mathey, L. & A.**—Importers of Fine Watches and Sole Agents for the **H. L. Matile's** Watches, No. 16 Maiden Lane.

**May & Stern**—Importers of Foreign Watches, Materials and Tools, etc. Manufacturing Jewelers. No. 19 John St., N. Y.

**Nicoud & Howard**—Importers and Manufacturers of Watches, No. 14 Maiden Lane.

**Oppenheimer Bros. & Veith**, Dealers in Watches and Diamonds, and Manufacturing Jewelers. No. 35 Maiden Lane, N. Y.

**Robert, J. Eugene**—No. 30 Maiden Lane, New York Agent for Louis Audemar's celebrated watches.

**Schwob, Adolphe**—Manufacturer & Importer of Watches, 11 Maiden Lane, N. Y.

**Stern Brothers & Co.**—Importers of Swiss Watches and wholesale dealers in American Watches, &c., 30 Maiden Lane.

**Scott, J. T. & Co.**—Importers of Watches, and Manufacturers of Jewelry, and Jobbers of all grades American Watches. No. 11 Maiden Lane, N. Y.

**Strasburger, Louis & Co.**—Importers and Makers of Watches of every description. No. 15 Maiden Lane.

**Tiffany & Co.**—Makers of Watches. General Agents for Patek, Phillippe & Co. Wholesale office, 694 Broadway, N. Y.

**Watch Cases.**

**Brown, J. A. & Co.**—Manufacturers of The Ladd Patent Stiffened Gold Watch Cases, &c., 11 Maiden Lane, N. Y. Factory, 58 Eddy street, Providence, R. I.

**Watch and Chronometer Repairer.**

**Cerf, B.**—Practical Watchmaker and Repairer, No. 10 John street, N. Y. Repairing and adjusting of Fine Watches done for the trade. All kinds of escape and stem winding wheels cut to order.

**Ludeman, W. H.**—Chronometer and Watchmaker. Repairing of every description for the Trade. 75 and 77 Nassau street, N. Y.

**Sirois, A.**—Practical Watchmaker, 89 Fulton street. Special attention paid to the repairing of Fine Watches. Pivots inserted.

**Watch Case Repairers.**

**Tarbox, Hiram**—Watch Case Repairing, Springing, Polishing and Engine Turning, 79 Nassau street, (room 22), N. Y.

**Renaud, F.**—Watch-Case Repairer.—Solid and Heavy Rolled Plate Bows and Pendants. Springing and Engine Turner of Cases and Jewelry, 36 Maiden Lane

**Watch Guards.**

**American Silk Guard Manufacturing Co.**—Our goods are warranted all silk.—Kossuth Marx & Co. No. 39 Maiden Lane, N. Y.

**Watch Glasses, Shades, Etc.**

**Brown, Edwin**—No. 85 Nassau Street, Imported and own Manufacture Watch Glasses, Flat, Flat Concave, Concave, Convex and fine Geneva's. Fine fitting solicited

**Hill, Robert S.**—Manufacturer of Watch Glasses, &c, dealer in Imported Glasses, Flat Glasses a specialty; also, Jeweler's Glasses, Nos. 75 & 77 Nassau street, N. Y.

**BOSTON.**

**The Star Salt Caster Co.**—Sole Proprietors and Makers of the Celebrated Star Salts, 161 Franklin Street, Boston, Mass.

**PHILADELPHIA**

- Booz & Thomas.**—Manufacturers of Gold and Silver Watch Cases and Jewelry, 108 South 8th Street, Philadelphia.
- Bennett, Jacob & Son.**—Diamond Setters and Manufacturing Jewelers. 108 South 8th St., Philadelphia, Pa.
- Cooper & Bros.**—Wholesale Jewelers, and Importers of and Dealers in Watch and Clock-makers' Materials, etc. Spectacles and Optical Goods. No. 35 South 4th St., Phila.
- Conover David F. & Co.**—American Watches, Wholesale Salesroom, southeast corner 7th and Chestnut streets, Philadelphia.
- Hagstoz & Thorpe.**—Sole manufacturers of Boss' Stiffened Gold Watch Cases. Sixth and Chestnut Streets, Philadelphia.
- Herold, Chas P.**—Successor to Hildebrandt, Herold & Co., Manufacturing Jeweler and Diamond Setter. Diamonds, 916 Chestnut St
- H. Muhr's Sons.**—Manufacturing Jewelers, Solid Gold Rings a specialty, 633 & 635 Market st. New York Office, 11 Maiden Lane.
- Krider, Peter L.**—Manufacturer of Sterling Silver Ware, Artisan Hall, No. 618 Chestnut street
- Levy, Bernard**—Manufacturers of gold and silver watch cases, and importers and dealers in Swiss and American watches, 402 Library street, Philadelphia.
- McCall & Newman**—Manufacturing Jewelers, Filled Plain Gold Rings a specialty, No. 625 Arch street.
- Morgan & Headly.**—Manufacturing Jewelers Cameo sets, Gold sets, Roman Locketts, Rings, Coral sets, and a general line of rich goods. 611 and 613 Sansom street, Philadelphia.
- Pierson, Edwin.**—Manufacturer of Fine Imitation Jewelry, Gold and Silver Electro-plater, Fire Gilder, Coloring, Etruscan and Gold Jewelry a specialty. 1300 Chestnut St.
- Rosenthal, G. F. C.**—Manufacturing Jeweler and Diamond Setter. Engraving and Designing of Monograms a Specialty. No. 924 Chestnut street, Philadelphia.
- Scherr, L. A. & Co.** Wholesale Dealer in Watches Silver Plated Ware, Spectacles, Fancy Goods, Watch Materials, etc., 726 Chestnut street.
- Shearer, W. H. & Co.**—Makers of Fine Jewelry 908 Chestnut Street.
- Simons, Brother & Co.**—Manufacturers of Fine Jewelry, Cancs, Thimbles, Chains. 611 & 613 Sansom St., Philadelphia.

**CHICAGO.**

- American Watch Company**, of Waltham, Mass. No. 170 State street, Chicago.
- Charpior & Wathier**—Watchmaker & Jewelers for the Trade, and wholesale Dealers in Watch Material, Tools, &c., 61 West Kinzie Street, Chicago, Ill. Send for price list.
- Cogswell, Weber & Co.**—Watches, Jewelry and Silver Plated Ware, Watchmakers' Tools and Materials at whole ale on y, 146 State st., Chicago.
- Frese, B.**—Watchmaking and Repairing for the Trade promptly attended to. Stem-winding and escape wheels cut to order. No. 99 E. Madison St., Chicago, Ill.
- Purdy, J. H. & Co.**—Jobbers of large and small Tools and Materials, for the use of Watchmakers, Jewelers, and kindred Trades. Spectacles—Jewelry Boxes, Plated Chains, &c., &c. No. 170 State street.
- Stein & Ellbogen**—Wholesale Dealers in Watches and Jewelry, 127 State St., Chicago. Specialty, repairing for the Trade.

**PROVIDENCE**

- Irons, Chas. F.**—Manufacturer of Solid Gold Jewelry. Specialty Emblems, Pins and Charms Masonic, Odd Fellows, &c. 102 Friendship St.
- Perkins, C. H. & Co.**—Manufacturers of fine Gold and Plated Jewelry. 20 Conduit St., Providence, R. I.

**NEWARK.**

- Lefort, Henry.**—Stem-winding Watch Crown Manufacturers. 80 & 82 Marshall St.
- Lelong, L. & Bro.**—Gold and Silver Refiners, Assayers and Sweep Smelters, S. W. corner Halsey & Marshall streets, Newark, N. J.
- Milne & Jourdan**—Manufacturers of Stem-winding Watch Crowns Nos. 13 & 15 Franklin Ave., Newark, N. J.
- Prince, David**—Gold and Silver Refiner, Assayer and Sweep Smelter. Sole Agent for Comin's Improved Amalgamator. 63 Railroad Ave.

# FRASSE & COMPANY,

Importers of P. S. STUBS',

*French, Swiss, German & Sheffield Tools, Files,*

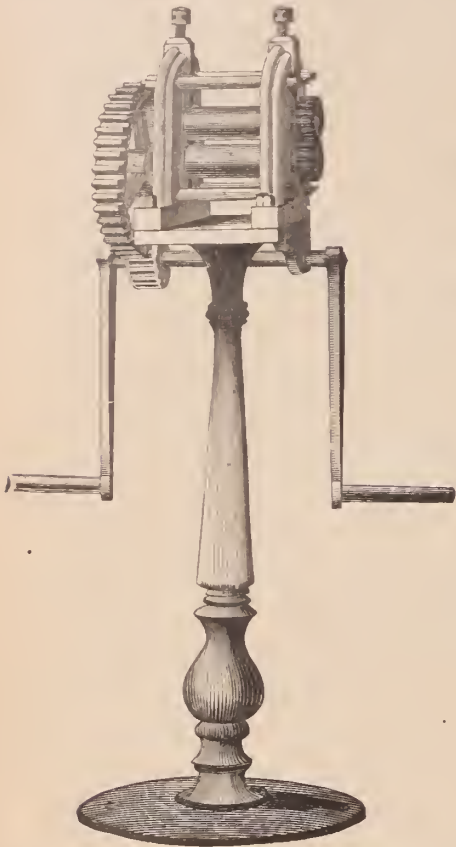

Steel Wire and Materials,  
For Watchmakers, Jewelers, Engravers,  
Die-Sinkers, Machinists, &c.

**Turning Lathes, Drills & Chucks**

Rolling Mills, Draw Plates,

**The Celebrated Rodenbush**

**Piercing Saws,**

Horse Shoe Magnets,  
Nurls,  
Ingots,  
Chasing Tools,  
Engravers' Tools,  
Brush Wheels & Buffs,  
Hand Brushes and Buffs,  
Borax,  
Saltpetre,  
Beeswax,  
Rouge,  
Tripoli,  
German Silver,  
Brass, &c.

**No. 62 Chatham Street,**  
Established 1816.

**New York.**  
P. O. Box 4627.

NE PLUS ULTRA.

## DUST-PROOF WATCH KEYS.

Patented Sept. 1st, 1874.

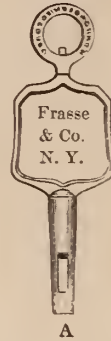

A



C



A

### The Popular Name Key.

A. Nickel Plated Handle and Pipe, Swivel Top, per gross..... \$10.75

### English Pattern Key.

C. Nickel Plated Handle and Pipe, Swivel Top, per gross..... \$7.50



### BENCH KEYS.

Corrugated Gilt Handles, Tempered Steel Pipes, per Set of Six..... \$1.80  
per Set of Three..... .90

### P. Style of Key.

Gilt Handle. Steel Pipe.  
Per Gross..... \$8.50



Our Key Pipes are all warranted to be made of the finest quality of steel. One great advantage this key has over all others, is the mortice through the pipe, making it the most simple and thoroughly dust and moisture-proof, as well as the cheapest key in the market. Our sizes run from 1 to 12: 4. 5 and 6 ft Gents' American Watches; No. 8, Ladies' American.

For sale by the Trade generally.

**KENDRICK, DAVIS & CO., LEBANON, N. H.**

SOLE OWNERS AND MANUFACTURERS.

The advantage of our Name Key, as an advertising medium, will at once be seen.

# PATENT IMPROVEMENT IN COUNTER SHOW CASES,

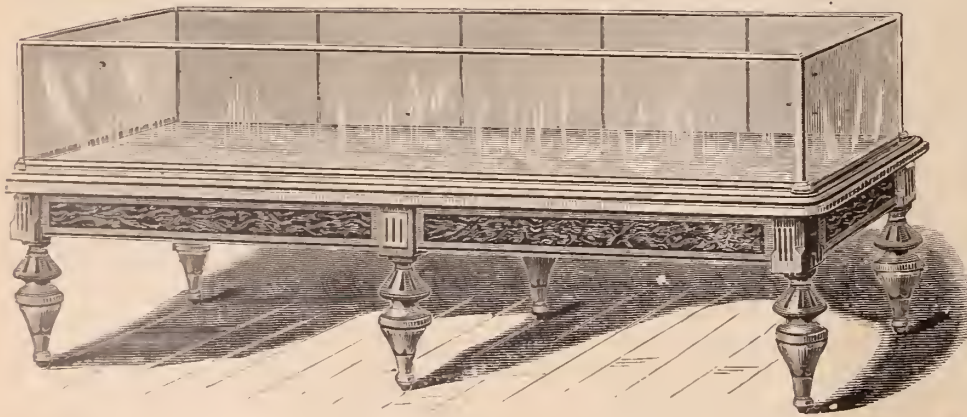

PERPENDICULAR SLIDING DOOR, DUST TIGHT.

CENTER COUNTER CASE DOORS, Running through both sides.

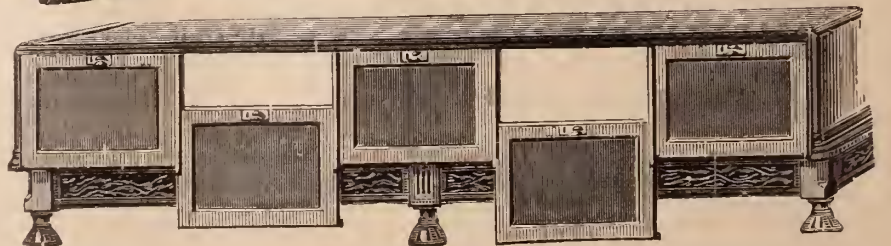

Its advantages are as follows:—The doors are more conveniently opened and closed, less liable to get out of repair or broken, articles are more easily reached in wide cases, mirrors are more safe, it dispenses with hinges, economizes room, excludes dust, and is air tight when closed.

Drawings furnished and estimates given for fitting stores in cabinet work complete.

REFERENCES:—Gorham Mfg Co., Rogers & Bro., Mitchell Vance & Co., Meriden Britannia Co., M. S. Smith & Co., Detroit, Mich. D Valentine, Syracuse, N. Y.

**B. & W. B. SMITH,**

**220 West 29th Street, New York.**



JULY, 1879



D. F. HOPKINSON, PUBLISHER.

42 NASSAU STREET, NEW YORK.

Established 1813.

# SETH THOMAS CLOCK CO.

THOMASTON, CONN.

No. 20 MURRAY STREET, New York.

16 Worship Street,  
LONDON, E. C.

172 State Street,  
CHICAGO.

132 Sutter Street,  
SAN FRANCISCO.

## F. KROEBER,

Manufacturer of CLOCKS.

No. 8 Cortlandt St.,

New York.

FACTORIES:—NEW HAVEN, CONN., AND  
NEW YORK CITY.

SUPERIOR GRADE OF  
WALNUT CLOCKS A SPECIALTY

SOLE AGENT FOR

E. INGRAHAM & CO.

—AND—

CLOCKS OF ALL MAKERS,

AT LOWEST MARKET PRICES!



"AURORA."

1 Day Lever Alarm, Nickel. Height, 5½ inches.



"WHISTLE."

1 Day Lever, Alarm, Nickel. Height, 8½ inches.

# New Haven Clock Co.

117 & 119 State St., Chicago.

62 Reade Street, New York.

G. A. HARMOUNT, Agent.

L. EGERTON, Jr., Agent.

Manufacturers and Jobbers of

## AMERICAN CLOCKS,

### Movements and Clock Material,

Also, Black Walnut, Visible Pendulum Clocks, and Specialties in Brass and Nickel.

Agents for { JEROME & CO., - - - - - Of New Haven, Conn.  
 E. INGRAHAM & CO.. - - - - - Of Bristol, Conn.

Liberal Discounts to the Trade.

# WATERBURY CLOCK CO.

MANUFACTURERS OF AMERICAN CLOCKS,

4 CORTLANDT STREET,

NEW YORK.

M. BAILEY, Treasurer.

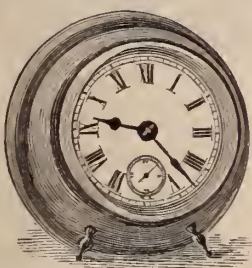

CRICKET.  
30 HOUR LEVER TIME.



CRICKET EXTRA.  
30 HOUR LEVER TIME.

63 WASHINGTON ST.,

CHICAGO.

—  
 FACTORIES,  
 WATERBURY, CONN.



SUNRISE.  
30 HOUR LEVER TIME, ALARM.



TRANSIT.  
30 HOUR LEVER TIME.



INDEX.  
30 HOUR LEVER TIME, CALENDAR.



MONITOR.  
30 HOUR LEVER TIME, ALARM, CALENDAR

ILLUSTRATED CATALOGUES AND PRICE LISTS FURNISHED ON APPLICATION.

**GEO. B. OWEN & CO.**

6 MURRAY STREET,

*Factory, Winsted, Conn.***New York.**

MANUFACTURERS OF

**BLACK WALNUT CLOCKS,**Clocks Manufactured by the following Companies will be  
furnished at lowest Market Rates:

New Haven Clock Co.,  
 Seth Thomas Clock Co.,  
 E. N. Welch Man'f'g Co.,  
 Welch, Spring & Co.,  
 Waterbury Clock Company,  
 Ansonia Clock Company,  
 Wm. L. Gilbert Clock Company,  
 E. Ingraham & Co.

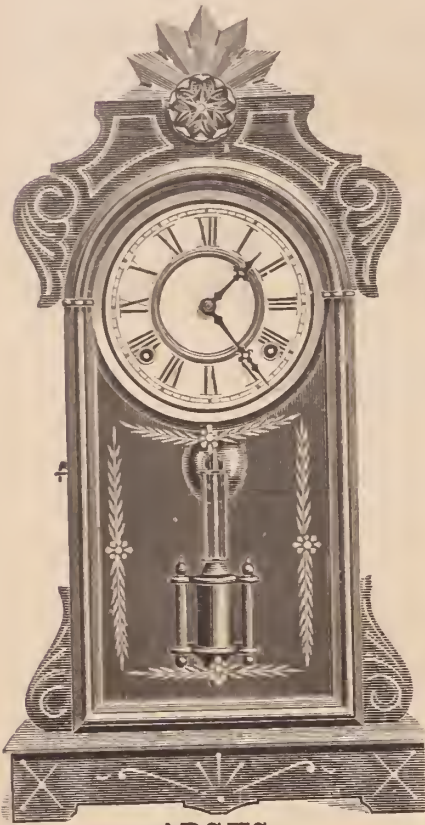
**ARGUS.**

Eight day Strike. Height, 20¼ in.

**AMPHITRITE.**

1 Day Time. Height 17½ in.

Illustrated Catalogues and Price Lists furnished on application,

ESTABLISHED 1868.

**A. LOUNSBURY,**

Manufacturer of every variety of

**SOLID GOLD RINGS,**

PLAIN, OVAL AND BAND.

180 Patterns of Fancy Band Rings, of the most approved Styles  
and Finish, for the Jobbing Trade,

Nos. 101 &amp; 103 Fulton Street,

Corner William Street,

**NEW YORK.**

# LOUIS STRASBURGER & CO.,

Importers of

# DIAMONDS.

☞ We are direct Importers of Diamonds, dealers will therefore always find ORIGINAL parcels in our stock to select from.

MATCHED PAIRS, IN ALL GRADES AND WEIGHTS, A SPECIALTY!

NEW YORK, 15 MAIDEN LANE.

PARIS, 30 BOULEVARD HAUSSMANN.

Our complete stock of loose and mounted Diamonds enables us to send a full assortment for selection to any first-class house.

## LOUIS STRASBURGER & Co.

### Manufacturers of Watches,

From the finest Stem-Winding and Setting goods to the lowest price Watch in the market.

We manufacture and have continually in stock a complete assortment of the best COMMERCIAL WATCHES ranging from the lowest priced Metal and Silver Watches to the finest Gold Watches, such as REPEATERS, CHRONOGRAPHS (single and split) and all other Timing and Complicated Watches.

Also a full assortment of the INTERNATIONAL and all AMERICAN Movements. *Gold and Silver Cases*, constantly on hand.

We would call particular attention to our complete and varied assortment of NICKEL WATCHES, (black and fancy Dials,) in all grades, styles, and sizes.

THE RAIL-ROAD TIMEKEEPER A SPECIALTY.

SALESROOMS, No. 15 MAIDEN LANE, NEW YORK.

Watch Factory, Rue Leopold, Chaux de Fonds, Switzerland.

HONORABLE MENTION, VIENA, 1873.

MEDAL AND DIPLOMA, PHILA., 1876.

HIGHEST AWARD, PARIS, 1878.

# WILLIAM F. NYE'S

## SUPERFINE

# Watch and Clock

# OILS,

New Bedford, Mass., U. S. A.

Beautifully clear

and

Brilliant,

Standing all tests.



Uniform in Quality

and

Thoroughly

Reliable.

### AGENTS.

CROSS & BIGUELIN, 21 Maiden Lane, N. Y.  
 LOUIS A. SCHERR & CO., 726 Chestnut St., Philadelphia, Pa.  
 KEARNEY & SWARTCHILD, 147 State Street, Chicago, Ills.  
 DINKELSPIEL & NORDMAN, 120 Sutter St., San Francisco.  
 P. W. ELLIS & CO., 4 Toronto Street, Toronto, Ont.  
 HENNEGEN, BATES & CO., 255 Baltimore Street, Baltimore, Md.

H. HOFFA, 624 Pennsylvania Avenue, Washington, D. C.  
 THOMAS H. CLAPP, 16 South Meridian Street, Indianapolis, Ind.  
 WILLIAM SENTER & CO., 54 Exchange Street, Portland, Me.  
 R. HASWELL & SON, 49 Spencer Street, London, England.  
 GEORGE H. TAYLOR, 136 Westminster Street, Providence, R. I.  
 LOUIS MATRIX JOSEPH, St. Croix, Switzerland.

ARCHILLE PORTAL, 21 Rue des Archives, Paris, France.

### REFERENCES.

Mr. Wm. F. Nye:

CHICAGO, June 28, 1879.

Dear Sir.—For the past three years that we have been selling your oil, it has given entire satisfaction, and we consider it as good as any oil in the market.

Respectfully Yours,

KEARNEY & SWARTCHILD.

Your watch and clock oil has given universal satisfaction to the trade whom we have supplied, and find it rapidly increasing in favor; it is remarkable for its clear color and brilliancy, and stands the severest tests required of it. We cheerfully commend it to the trade as the best oil in the market.

P. W. ELLIS & CO.,  
 4 Toronto Street, Toronto,

Cleveland, Ohio, June 28, 1879.

Wm. F. Nye, New Bedford, Mass.:

Dear Sir.—We have sold your watch and clock oil for about two years, and as yet, have not heard a single complaint, our customers speak highly of it, and we have reason to believe it is one of the best, if not the best in the market.

Very respectfully,

BOWLER & BURDICK.

East Haddan, Conn. June 27th, 1879.

Dear Sir.—I received in August last, a sample vial of your watch oil, and agreeable to your request for a report would say, that I have used it ever since to the exclusion of all others, and it has given good satisfaction.

Respectfully Yours,

S. D. JOHNSON.

Philadelphia, July 1st, 1879.

Mr. Wm. F. Nye:

Dear Sir.—Our customers who use your watch and clock oil, are well pleased with it.

Yours, &c.,

LOUIS A. SCHERR & CO.

Leslie, Mich., Dec. 11th, 1878.

Wm. E. Nye:

Dear Sir.—I received a bottle of your watch oil and have used it and given it a fair trial, and can cheerfully recommend it as being as good as I ever used.

Very truly yours,

W. W. HENDRICKS,  
 Jeweler.

Wm. F. Nye:

Memphis, Mich., Oct. 24th.

Dear Sir.—I have given your watch oil a severe test, and I find it contains all of the good qualities that you claim for it: it does not gum up readily, and is not affected by the weather, and therefore does not deaden the motion of the watch, as is the case with most oils, and I most heartily recommend it to the trade.

Respectfully Yours,

WM. E. WALTON,

Watchmaker and Jeweler, Memphis, Mich.

Boston, June 26th, 1879.

Wm. F. Nye, Esq., New Bedford.

Dear Sir.—It gives us pleasure to state that we have used your watch and clock oil for the last two years, and have found it very satisfactory.

We have tested it also, by exposing a small quantity for the same length in a hollow in a brass plate, and so far it shows no appearance of thickening, or change of color.

We remain, &c.,

Yours very truly,

WM. BOND & SON.

# THE MERIDEN BRITANNIA COMPANY

No. 46 East Fourteenth Street, UNION SQUARE, N. Y.

MANUFACTURERS OF

## SILVER-PLATED WARE.

Porcelain Lined Ice Pitchers, Spoons, Forks, Table Cutlery, etc., etc.

Particular attention is invited to our *Patented Process of Electro-Plating Spoons and Forks*, by which the parts most exposed to wear receive an extra coat of silver. This feature renders these goods more economical and durable than those of any other manufacture, while the increased cost is relatively small. This method of plating we apply to the 4, 8 and 12 oz. plate, as required.

To protect the purchaser against imitations, it should be observed that the improved Spoons and Forks bears our *Trade Mark, "1847" ROGERS BROS., N.Y.*

FIRST PREMIUM awarded at all Fairs where exhibited, from the World's Fair, 1853, to American Institute Fairs, 1873, 1874, 1875, inclusive, and at the Philadelphia Exhibition, 1876.

Extract from the American Institute Report:—"Their Porcelain-lined, Double-walled Ice Pitchers are All, and possess all the qualities the company claim." \* \* \* "We consider the goods made by this company to be by far the best made in this country, and we believe in the world"

# ROGERS CUTLERY COMPANY,



**WM. ROGERS,**  
Senior Member and Manager of the Firm of ROGERS BROTHERS. Died Feb. 17, 1873.



**ASA H. ROGERS,**  
Of the original ROGERS BROTHERS, and half owner of the Rogers Cutlery Co., when organized. Died Oct. 4, 1876.



**F. WILLSON ROGERS,**  
Son of the late Wm. Rogers, and Secretary of the ROGERS CUTLERY CO.



Our Knives stamped as above we guarantee

To Strip 12 dwts. of Silver per dozen.

Our Knives are guaranteed to be

**ALL HAND BURNISHED,**

and are put up in rack boxes with hinge covers.

**WE GUARANTEE** our Spoons, Forks, &c. to be Plated 25 Per Cent. **HEAVIER THAN STANDARD PLATE.**

We guarantee Spoons, Forks, &c. to be plated on **18 PER CENT. NICKEL SILVER, AS FOLLOWS:**

On TEA SPOONS,	2½ ounces, or 50 dwts. per gross.
On DESSERT SPOONS,	3¾ " " 75 " "
On TABLE SPOONS,	5 " " 100 " "
On DESSERT FORKS,	3¾ " " 75 " "
On MEDIUM FORKS,	5 " " 100 " "

**OUR SPOONS, FORKS, LADLES, &c. ARE STAMPED**

On EXTRA PLATE,	1871, ROGERS	5 oz.
On DOUBLE PLATE,	1871, ROGERS	8 oz.
On TRIPLE PLATE,	1871, ROGERS	12 oz.
On QUADRUPLE PLATE,	1871, ROGERS	16 oz.



All Hollow Ware stamped as above is warranted to be plated

**50 PER CENT. HEAVIER**

than any other brand of goods. Our Hollow Ware in addition to our trade mark is stamped

**SEXTUPLE PLATE,**

we being the only firm who manufacture this weight of plate.

The above is a fac-simile of our guarantee card which accompanies each dozen of our flat ware, and each piece of our hollow ware. Our goods have been in the market since 1871, and are acknowledged by all dealers, who have tried them, to be THE BEST.

We would call especial attention to the EXTRA STRONG SPRING TEMPERED SHANK, which we have on our Tipped, Fiddle Saxon and Imperial pattern

# SIMPSON, HALL, MILLER & CO.

MANUFACTURERS OF

## Silver-Plated Ware,

SUPERIOR IN QUALITY, DESIGN AND FINISH.

FACTORIES, WALLINGFORD, CONN.

Salesroom 36 East 14th St., New York.

Our assortment comprises a large line of Hollow Ware and Flat Ware, the product of many years manufacturing, with superior skill and appliances. Dealers in Silver-Plated Wares throughout the country have found our productions desirable in all respects, and perfectly adapted to the requirements of their customers. We have added many new articles to our assortment, and shall continue to produce *DESIGNS OF ORIGINAL AND ARTISTIC* merit in rapid succession.

**OUR SOLID TABLE WARE IS MADE OF THE BEST NICKEL SILVER.**

*SPOONS, FORKS, LADLES, PIE-KNIVES, &c.*

IN GREAT VARIETY OF PATTERNS.

**Solid Steel Knives of Superior Quality.**

Our *ILLUSTRATED CATALOGUE*, recently issued, will be furnished to *REGULAR DEALERS*, on application, inclosing business card.



## The STAR SALT



## CASTER COMP'Y

Sole Proprietors and Manufacturers of  
CELEBRATED

## STAR SALTS

For convenience, neatness and utility the STAR SALTS have become a household necessity.

The pulverizer in the bottle, as shown by the cuts, keeps the salt pulverized, and obviates the disagreeable habit of spilling the salt by dipping out of an open salt cellar.

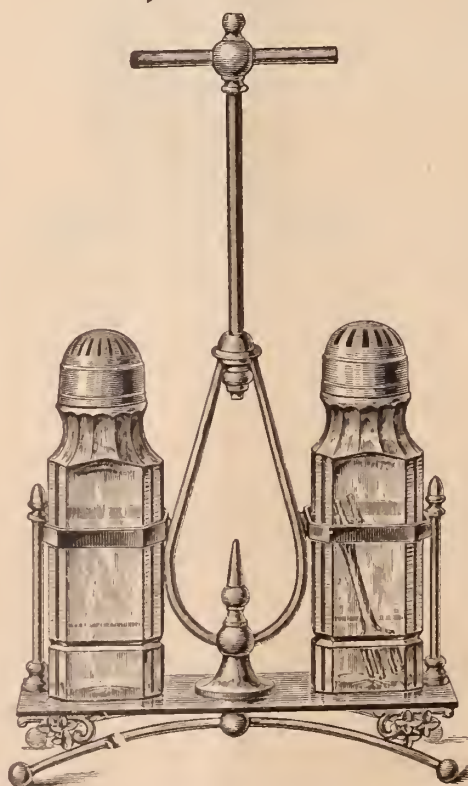

No. 161 Franklin Street  
BOSTON, MASS.

Place these in the family and Salt Cellars  
will be discarded.

MANUFACTURED IN ALL VARIETIES  
OF PLAIN AND FINE CUT  
GOODS, CASTERS, &c.

Special care given to orders for exportation.

Fine Diamond Cut, with  
Sterling Caps.

For full descriptions of the above goods see our Illustrated Catalogues, which will be mailed on application.



THE

## MIDDLETOWN PLATE COMPANY,

Superior Silver Plated Ware,

13 JOHN STREET, New York.

MIDDLETOWN, Conn.

120 SUTTER STREET, San Francisco, Cal.

A Superior assortment in new designs of every article of Silver Plated Ware,

KNIVES, FORKS, SPOONS, &amp;c., &amp;c.

ARKELL &amp; CO.

IMPORTERS AND DEALERS IN

Watch Materials, Tools,

JEWELRY,

AND ALL GRADES OF AMERICAN WATCHES.

We call the attention of Watchmakers to the "JEQUIER" Main Spring. This spring is the only one of all fabrications exhibited at the "Paris Exposition" that received FIRST and ONLY medal. We claim it is the best in this country, and invite a trial by the trade as a test of its merits. Send for sample and also descriptive catalogue of Columbus Watch, nickel  $\frac{3}{4}$  plate, full jeweled, stem-winding and setting, the most beautiful watch with the best results for least money, quality considered. No price list furnished unless requested and only to the trade.

BALDWIN'S BARREL CATCH INSERTER, indispensable to the Watch Repairer, saves time and labor, sent by mail on approval to the trade free of postage.

We are Sole Agents for the United States of these goods. We also manufacture the BOSS ENGRAVING BLOCK—there are features in its construction different from all others in the market, holds the work to be engraved, of any kind, without attachments. It is practical, simple, and reasonable in price. All these specialties enumerated, may be obtained of any regular Dealer in material and tools, or direct of us.



P. O. Box 8.

Canajoharie, N. Y.

JAS. T. SCOTT,  
S. CLEM SCOTT,  
J. T. SCOTT, JR.

# J. T. SCOTT & CO.

Established 1847.

No. 11 MAIDEN LANE, - - - NEW YORK.

SOLE EASTERN

AGENTS FOR

## THE ROCKFORD

## WATCH CO.

AND AGENTS FOR

The Auburndale

## CHRONOGRAPH

TIMERS,

1/4 and 1/2 seconds, in 18 size  
Nickel-Plated Cases, designed  
for Sporting, Scientific and  
Mechanical purposes.



ROCKFORD WATCH.

This Company manufactures eight grades of superior 18 size key and stem wind

**QUICK TRAIN,**

Movements.

ALSO SOLE AGENTS FOR

**Abbott's Patent Open-Face**

18 size American stem-winders, with XII at pendant and seconds opposite



ABBOTT'S PATENT.

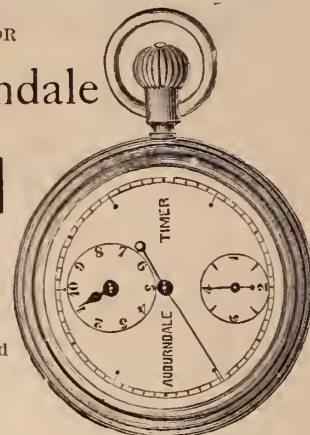

AUBURNDALE TIMER.

Manufacturers of Jewelry and Wholesale Dealers in all grades of American Movements.

WATCH CASES, DIAMONDS, CHAINS, SILVER WARE, &c.

Price Lists furnished upon application to those regularly engaged in the Trade.

J. C. AIKIN.

H. A. LAMBERT.

J. B. SHEA.

# AIKIN, LAMBERT & CO.,

Manufacturers of GOLD PENS,

Pen and Pencil Cases, Pencils, Tooth-picks, and "Novelties" in Pencil Goods.

No. 23 MAIDEN LANE, NEW YORK.



Would call the attention of the Trade to our large and complete line of Pen and Pencil Goods in all styles and varieties, suitable for demand.

Our introduction last season of Pencils in NEW AND ENTIRELY NOVEL DESIGNS was marked by an unprecedented demand, which establishes the sale of these goods as STAPLES, and as being suited to any season of the year.

The Magic Charms (as per cuts shown below), inlaid with pearl and gold, in form of vines, flowers, birds, etc., on



celluloid of assorted colors, in imitation of malachite, tortoise shell, agate variegated marble, etc., are the LATEST and most novel pencils in the market.

Send for circular and new list.

Branch, No. 113 East Madison Street, Chicago.

## Also Importers of all grades of Watches,

Sole Agents for "PAUL BRETON" and "CHAS. LATOUR," GENEVA.

### SPECIALTIES.

AGASSIZ Movements, Gilt and Nickel Stem-Winding, fitting Ladies' Riverside Case.

CHAS. LATOUR Movements, Gilt and Nickel Key-Winding, fitting 10 and 16 size Waltham Case.

PAUL BRETON Movements, Gilt and Nickel Key and Stem-Winding, a full line of these CELEBRATED TIMEPIECES in gold and silver cases of the most approved styles.

METAL OPEN FACE STEM-WINDING "LONGINES" and "EXCELSIOR", 16, 18 and 20 line, the BEST metal Watches in STYLE and QUALITY in the market.

Our assortment of Jewelry is very large and complete, consisting of a general line of RELIABLE goods, both in GOLD and ROLLED PLATE, of new and tasty patterns, and including almost any article a Jeweler would have calls for. Special attention given to ORDERED WORK and REPAIRS.

Goods sent on APPROVAL and CORRESPONDENCE invited. Those not acquainted with us will oblige by giving references when ordering

JANUARY 1st, WE REVALUED OUR ENTIRE STOCK AND HAVE REDUCED PRICES, AND ARE OFFERING GREAT INDUCEMENTS TO PURCHASERS FOR THE SPRING TRADE.

# MILLER BROS.

MANUFACTURING JEWELERS,

No. 11 MAIDEN LANE, NEW YORK.

Manufactory, 47, 49 & 51 Franklin Street, Newark, N. J.

*New this Spring,  
A LARGE LINE OF*

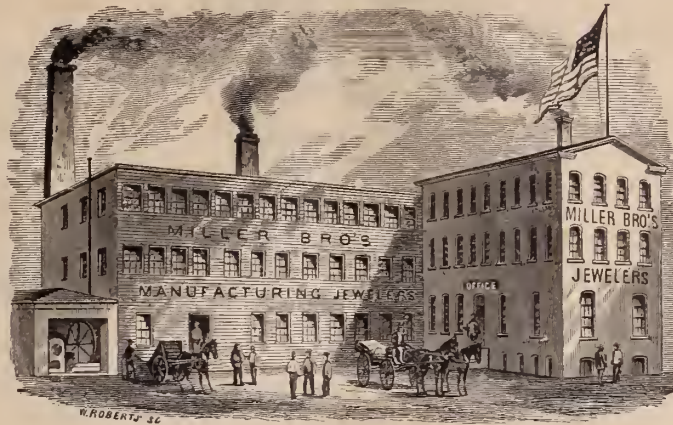

*Novelties for  
Ladies' & Gentlemen's Wear.*

ATTENTION IS INVITED TO OUR  
NEW STYLES OF ETRUSCAN SLEEVE BUTTONS,  
MOUNTED WITH

## RUSTIC LETTERS

BIRDS ANIMAL HEADS AND FANCY ORNAMENTATIONS

Also a full line of Locketts, Sets, Pins, Ear Rings, Sleeve Buttons, Studs, &c. All goods exclusively of our own manufacture.

# DAVID F. CONOVER & CO.

(SUCCESSORS TO WM. B. WARNE & Co.)

Importers, Manufacturers and Wholesale Dealers in

## WATCHES AND JEWELRY.

Silver and Silver-Plated Ware,

AMERICAN WATCH WHOLESALE SALESROOM,

Southeast Corner Chestnut and 7th Streets,

(FIRST FLOOR.)

DAVID F. CONOVER,  
B. FRANK WILLIAMS,  
C. EDGAR RICHTER.

PHILADELPHIA.

## GORHAM MANUFACTURING COMPANY,



## SILVERSMITHS,

PROVIDENCE

AND

NEW YORK

California Office, 120 Sutter Street, San Francisco.

*Makers of STERLING SILVER WARES, ( $\frac{925}{1000}$  fine) of the highest character of workmanship and design; also, makers and sole proprietors of the GORHAM PLATED WARES.*

*Illustrated Circulars showing 24 of our leading patterns, in Spoons and Forks, will be sent to the Trade upon application by MAIL.*

# French Clocks.

 We make a speciality of this department and are constantly opening new lines which we offer at very low prices.

## TAYLOR & BROTHER,

No. 676 Broadway,

### NEW YORK

### WHOLESALE ONLY.

THE  
**JEWELERS' CIRCULAR AND HOROLOGICAL REVIEW,**

*The recognized organ of the Trade in the United States,*

AND THE REPRESENTATIVE AND OFFICIAL ORGAN OF THE JEWELERS' LEAGUE AND  
THE WATCHMAKERS' AND JEWELERS' GUILD.

THE JEWELERS' CIRCULAR AND HOROLOGICAL REVIEW, established 1869, is appreciated as the most complete and valuable periodical of its class published in any country. It reaches every branch of the jewelry, watch, clock, silverware and kindred trades throughout the United States, and is the only representative of the trade, which has secured, by its intrinsic merits and acknowledged benefits, a legitimate and *bona fide* patronage of paying subscribers, including many of the leading firms in England, France, Germany, Switzerland, Mexico, the West Indies, Brazil, the South American Republics, and other foreign countries.

THE JEWELERS' CIRCULAR is regarded throughout this wide circle of interested and careful readers as a *reliable* authority and independent chronicle with regard to all matters connected with the trade, in its moral, mercantile and mechanical aspects, while its decided straightforward and consistent course of conduct in relation to commercial questions has won widespread approval.

To the practical workman the JEWELERS' CIRCULAR is invaluable as a text-book and work of reference. Its pages furnish him with the latest scientific and mechanical ideas, set forth in plain, comprehensible language by specialists of ability and experience. The technical information contained in its columns represents the progress of the age, and every intelligent workman in the country acknowledges the advantages resulting from a study of its pages.

To the country dealer the JEWELERS' CIRCULAR affords thorough, correct and perfect information as to staple and original articles of trade. From it he can learn what to order and where to obtain supplies, he can discover the best source of materials in common use, while the latest novelties are without exception first announced in its columns.

All communications to be addressed to

**D. H. HOPKINSON,**

*Or the regular Agents of the Circular.*

**42 Nassau Street, New York.**

☞ The TENTH VOLUME commenced with the February issue. Subscription, \$2.00 per annum.

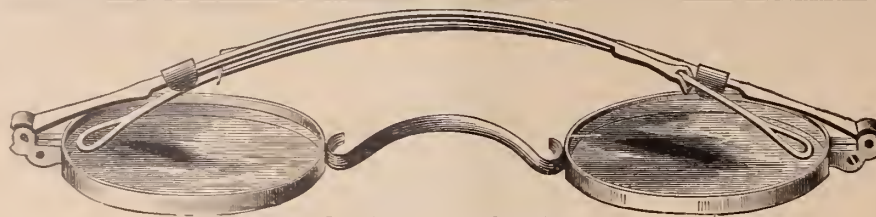

No. 15. Gold Spectacles, Band Slides.



# MORGAN & HEADLY,

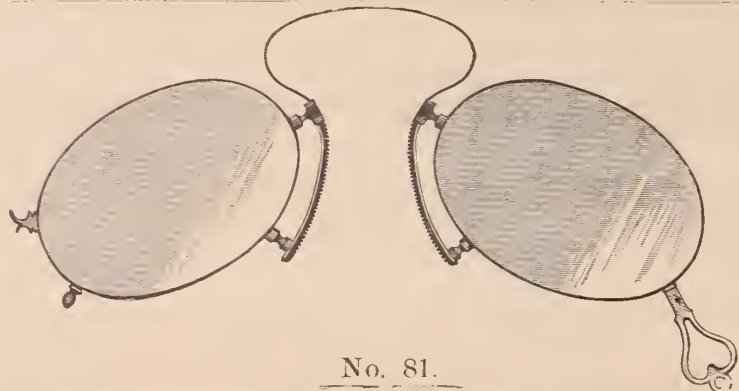

No. 81.

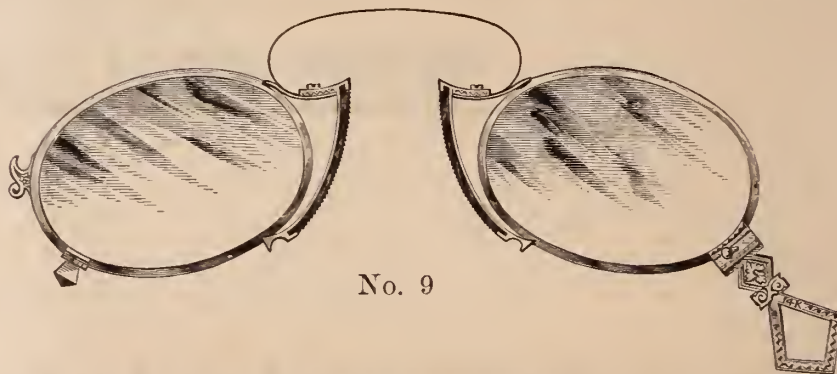

No. 9

## Manufacturers of Gold, Silver and Steel SPECTACLES and EYE GLASSES,

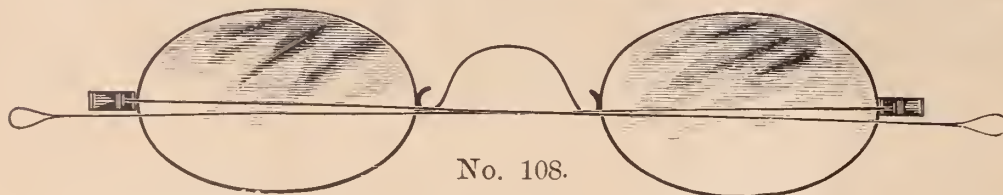

No. 108.

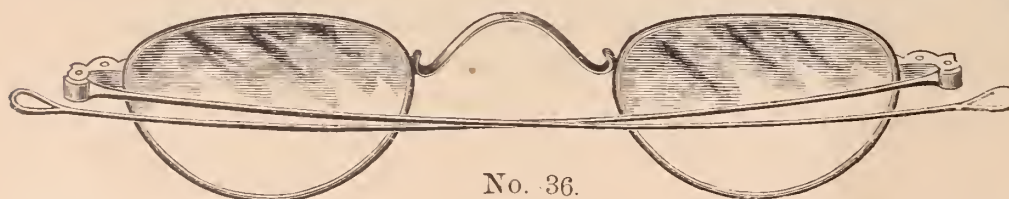

No. 36.



No. 2.

## 611 & 613 SANSOM ST., PHILADELPHIA.

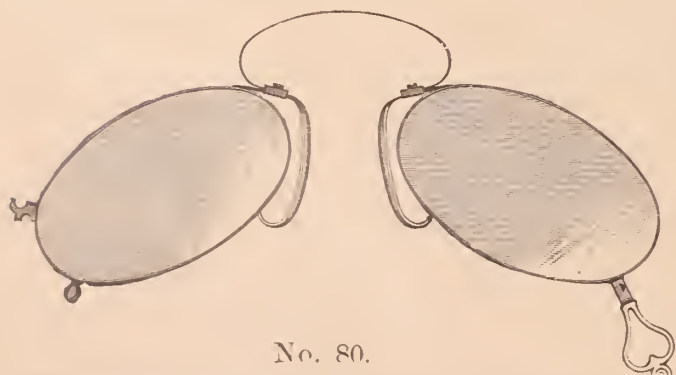

No. 80.

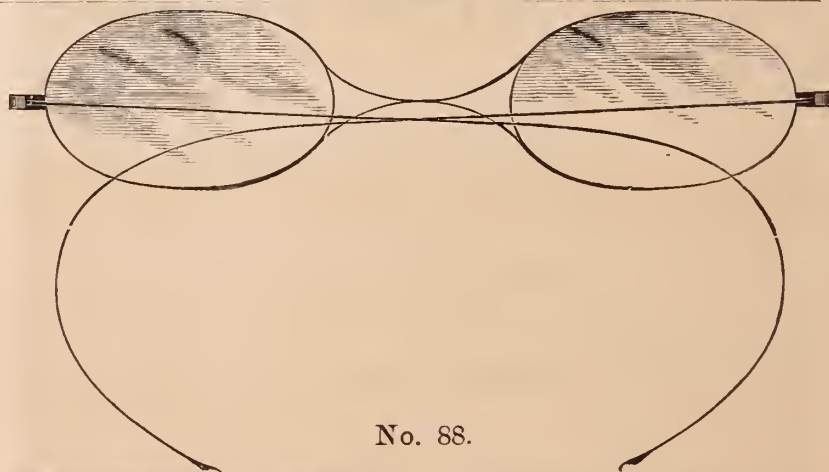

No. 88.

WE are now manufacturing together with our Gold and Silver Spectacles, a full line of everything in Steel, and offer to the trade the advantage of a uniform size of lenses. All are made of a standard size and are interchangeable. The sizes are given in the cuts. We can only add that our reputation in gold work is our guarantee for the steel, and we shall spare no efforts to meet any competition in price as well as maintain our standard of quality. Illustrated Catalogue mailed on application; from this dealers can order as well as if they had sample case before them.

ESTABLISHED 1855.

**D. LIECHTY & CO.,**  
MANUFACTURERS OF

**Fine Gold Watch Cases**  
*No. 140 South Third Street,*  
Fourth Floor. **PHILADELPHIA**  
*Repairing neatly attended to.*

LOUIS A. SCHERR.

CHAS. H. O'BRYON.

G. W. SCHERR.

**LOUIS A. SCHERR & CO.**  
Importers and Wholesale Dealers in

**Watches, Jewelry,**  
WATCH MATERIALS, TOOLS, GLASSES, &C.  
**Spectacles, Silk Guards, &c.**  
Wholesale Agents for American Watches.  
**No. 726 CHESTNUT STREET,**  
FIRST FLOOR,  
**PHILADELPHIA.**

NATHAN A. MORGAN.

CHAS. B. HEADLY.

**MORGAN & HEADLY,**  
MANUFACTURERS OF

**GOLD SPECTACLES,**  
**Fine Jewelry, Chains**  
AND BRACELETS,  
**18 KARAT PLAIN RINGS, &c.**  
*611 & 613 Sansom Street,*  
*Artizan Hall,* **PHILADELPHIA.**

☞ A full line of DIAMONDS, mounted and unmounted, always on hand which we will send on approval to the Trade, on receipt of reference.

**WILLIAM BARBER'S**  
**Patent Adjustable Eye-Glass.**



The above cut represents an Eye-glass possessing the convenience of on Eye-glass and the utility of a Spectacle combined, thereby rendering it practicable for everyone to avail themselves of their convenience, who have heretofore been deprived of their use.

**TRY THEM, WILL RECOMMEND THEMSELVES.**

We manufacture them from Gold, Nickel, Steel, Shell and Rubber.

**WILLIAM BARBER,**  
Inventor, Patentee and Manufacturer,  
No. 248 North 8th Street, Philadelphia, Pa.

**BENJ. ALLEN & CO.**

WHOLESALE DEALERS IN

**American and Swiss Watches**

JEWELRY, DIAMONDS,

SILVER & PLATED WARE.

137 and 139 State Street, Chicago.

☞ A full line of Howard Watches in stock. Catalogues sent upon application, to dealers only.

**GUTMANN'S**

**Automatic Hammer and Punches**

Simplified and More Effective.



January 8th, 1878.

THIS TOOL takes the place of the third hand, therefore its manifold uses are quickly apparent, and I would only say that it is accompanied by six punches, to wit: 2 hand punches, 1 prick punch, 1 closing hole punch, 1 rivet punch, and 1 pinion punch, all of which fit neatly into the punch holder, and are fastened by the set screw. Its tap is alternately heavy and light, and the finger loops are assorted in sizes. The Tool is nickel-plated and boxed, ready to be mailed on receipt of price.

THE OPERATION IS AS FOLLOWS: First, set the hammer; next insert your forefinger through the loop at the top and place the punch with firmness on your work. When you are ready for the blow, push gently on the thumb-piece which produces the concussion on the punch. *Your left hand is entirely free to hold the work.*

Price, \$2.00; Reduced from \$2.50.

**MAX L. GUTMANN,**

Patentee and Manufacturer.

Also, Importer and Wholesale Dealer in

**Watch and Jobbing Materials, Tools, Glasses,**  
*Chains, Guards, Jewelry and Watches.*

☞ PLEASE SEND YOUR ORDERS.

**ROCHESTER, N. Y.**

# COLBY & JOHNSON,

17 Maiden Lane, New York.

Exclusive Manufacturers of Open-face Stem-winding

White,

Gold, Silver,

Black,

or

Malachite,

Nickel

or

Centers,

Marbleized

Pendants

Celluloid.

and Bows.

SUITABLE FOR ALL 18-Size AMERICAN S. W. MOVEMENTS.



We call especial attention to the fact that Celluloid being a NON-CONDUCTOR, the cheaper grades of movements (not adjusted to heat and cold), cased in this material, are not affected by atmospheric changes, and can be relied upon as being much MORE ACCURATE TIME-KEEPERS than the same movements cased in metal of any kind.

# E. HOWARD & CO.,

MANUFACTURERS OF

## Fine Watches, Regulators, Office Clocks,

Electric Watch, Clocks & Tower Clocks,

Office, No. 2 MAIDEN LANE,

NEW YORK.

No. 114 TREMONT STREET, BOSTON.

J. W. J. PIERSON. - - - AGENT.

ESTABLISHED 1859.

## RINGS A SPECIALTY.

BRYANT & BENTLEY,

No. 12 Maiden Lane, New York.

MANUFACTURE A LARGE VARIETY OF

## FINE SOLID RINGS,

For Ladies and Gentlemen, in CAMEO, AMETHYST, ONYX, TOPAZ, TURQUOISE GARNET and other stones. Fine CAMEO, CORAL and ROMAN SETS of new and handsome designs. LOCEETS, MEDALLIONS, SHAWL and SCARF PINS, SLEEVE BUTTONS, STUDS, &c. All goods warranted.

We continue to manufacture several hundred patterns of HARD SOLDER RINGS, in every style, for men, women and children, stamped and warranted 16 karat fine.



AUBURNDALE, MASS.,

# CHRONOGRAPH TIMER

WM. B. FOWLE, Maker.

Designed for Sporting, Scientific and Mechanical purposes;  $\frac{1}{4}$  and  $\frac{1}{8}$  seconds, fly back.

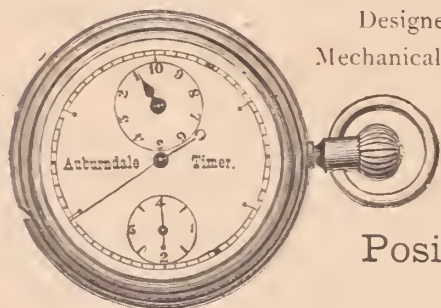

List Price, - - \$15.00

Positively Accurate.

Put up in German Silver Cases, Nickel Plated, size of an ordinary watch. Very neat and handsome, supplying a want long felt by those desiring to measure the flight of time with scientific accuracy to the fraction of a second. It indicates positively minutes, seconds, quarters or eighths of seconds, the only instrument registering one eighth of a second made. It is substantially constructed, positive in its action and will not easily get out of order.

These Chronographs can be obtained from the principal Jobbing Houses in the Trade.

# BUCKENHAM, COLE & SAUNDERS,

SUCCESSORS TO

BUCKENHAM, COLE & HALL,

IMPORTERS OF

## Diamonds, Pearls

AND OTHER PRECIOUS STONES,

MANUFACTURERS OF FINE JEWELRY,

10 Maiden Lane, New York.

A large Stock of FINE DIAMONDS, Mounted and Unmounted, kept constantly on hand. Goods sent on approval to any part of the country on receipt of satisfactory references.



**SAXTON, SMITH & CO.**  
MANUFACTURERS OF

**Fine Gold Chain.**

No. 15 Maiden Lane,

**New York.**

Factory, No. 183 Eddy Street, Providence, R. I.

Sole Agents for the new PATENTED CHAIN BAR, containing a Detachable Pencil.

DYER BRAINERD.

JOHN W. STEELE.

**BRAINERD & STEELE,**

MANUFACTURERS OF

**Brainerd's Pat. Locketts,**

(Patented June 17, 1874.)

These Locketts combine both beauty and strength. They are made of solid 14kt. gold, and the stones used are the finest obtainable in the market. They cost no more than those of the old style, if indeed as much; and the combination of secrecy and durability renders them much more desirable. We make three sizes in four different shapes—round, oval, cushion and oblong square; and also Sleeve Buttons of the same style, containing a concealed box for miniatures, a novelty new to the Trade.



FINE GOLD JEWELRY,

**No. 9 Maiden Lane,**

NEW YORK.

**HELLER & BARDEL,**

Manufacturers of

DIAMOND AND PEARL

**JEWELRY,**

And Dealers in Diamonds, Pearls, &c.



SHAWL AND LACE PINS IN GREAT VARIETY,

*No. 13 John St., New York.*

A full line of DIAMONDS, mounted and unmounted; also, a large assortment of first-class DIAMOND MOUNTINGS of our own make always on hand. Sketches submitted at any time upon application. We will send goods on selection to responsible houses.

**KOSSUTH, MARX & CO.,**

No. 39 Maiden Lane, New York,

MANUFACTURERS OF

**Gold and Fine Rolled Plate Jewelry,**

Chains, Necklaces, Locketts, Crosses, &c., &c.

**SOLID GOLD and STONE RINGS**

In large variety,

Diamonds, Pearls, Cameos, Amethysts, Turquoise, &c.

Sole Manufacturers of the Celebrated

**AMERICAN SILK GUARDS.**

**WOOD & HUGHES,**

STERLING

**Silverware Manufacturers**

**No. 16 JOHN STREET,**

NEW YORK.

*206 Kearney Street, San Francisco, Cal.*

R. R. HASKELL, Agent.

**BREMENTZ & CO.,**  
MANUFACTURERS OF

**FINE JEWELRY,**

No. 13 John Street, New York.

FACTORY, 361 Mulberry Street, - - Newark, N. J.

GOODS OF OUR OWN MAKE EXCLUSIVELY.

**CARTER, HOWKINS & SLOAN,**  
**Makers of Fine Jewelry**

*Consisting of Chains, Bracelets, Sets, Pins, Studs, Sleeve Buttons,  
 Scarf Pins, Rings, &c., in Roman, Etruscan and Enamel,  
 and a full line of Jewelry generally.*

Whiting Building, Corner Broadway and Fourth Street,

A. CARTER JR.  
 WM. HOWKINS,  
 A. K. SLOAN.

**NEW YORK.**

C. E. HASTINGS,  
 GEO. R. HOWE.  
 W. T. CARTER.

**HALE & MULFORD,**  
**Manufacturing Jewelers,**

(WHITING BUILDING).

No. 694 Broadway, cor. 4th Street, New York.

Call attention of the Trade to their new style of

**BAND BRACELETS,**

We claim for these Bracelets, the following advantages over the old style, viz. :

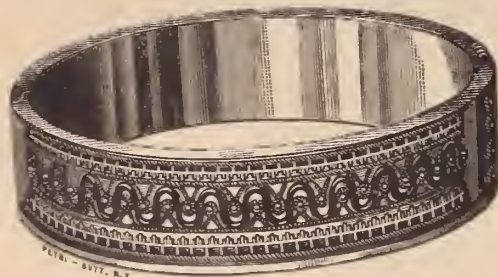

Patented February 25, 1879.

1st. The edge of the Bracelet being raised, forms a protection to the ornamentation.

2d. Less liability of getting damaged, and when damaged, are more easily repaired.

3d. More attractive in appearance.

Prices are as low as any FIRST CLASS 14 KARAT ALL GOLD Bracelet in the market.

Made in all sizes from 1/4 inch upwards.

—Established 1837.—

**TAYLOR & BROTHER,**

Late TAYLOR, OLMSTED & TAYLOR,

**Importers of Diamonds and Pearls,**

—AND—

**MANUFACTURERS OF DIAMOND JEWELRY,**

No. 676 BROADWAY,

**NEW YORK.**

**BALDWIN, SEXTON & PETERSON,**

MANUFACTURERS OF

**Fine Jewelry,**

Diamond and Stone Cameo Goods,

GOLD CHAINS, &c.

Importers of Diamonds, Pearls, Emeralds, Rubies, &c.

WHITING BUILDING,

Cor. Broadway and Fourth Street,

**NEW YORK.**

120 SUTTER STREET, San Francisco, Cal.

Established 1817.

**Ve. J. MAGNIN, GUÉDIN & CO.**

29 Union Square, New York.

Manufacturers and Importers,

FINE SWISS WATCHES.

REPEATERS, CHRONOGRAPHS & CALENDARS

GENEVA GOLD JEWELRY,

FRENCH CLOCKS AND BRONZES,

RICH FANCY GOOCS,

HORSE-TIMERS & PEDOMETERS,

GOLD AND SILVER CHATELAINE WATCHES.

Gold Medal Awarded, Paris Exposition, 1878.

*Sole Agents for the James Narain Watch.*

*House in Geneva, 14 Grand Quai.*

Established 1813.

**THOMAS G. BROWN,**

MANUFACTURER OF

**FINE JEWELRY.**

*Designs furnished for all kinds of Sporting  
 Badges and Medals for Schools & Colleges.*

**NEWARK, N. J.**

—AND—

**9 BOND STREET, NEW YORK.**

AUGUST, 1879.



D. F. FORTNITSON, PUBLISHER.

42 NASSAU STREET, NEW YORK.

Entered at the Post Office in New York as second class matter.

Established 1813.

# SETH THOMAS CLOCK CO.

THOMASTON, CONN.

No. 20 MURRAY STREET, New York.

16 Worship Street,  
LONDON, E. C.

172 State Street,  
CHICAGO.

132 Sutter Street,  
SAN FRANCISCO.

## F. KROEBER,

Manufacturer of CLOCKS,

No. 8 Cortlandt St.,

New York.

FACTORIES:—NEW HAVEN, CONN., AND  
NEW YORK CITY.

SUPERIOR GRADE OF  
WALNUT CLOCKS A SPECIALTY

SOLE AGENT FOR

E. INGRAHAM & CO.

—AND—

CLOCKS OF ALL MAKERS

AT THE LOWEST MARKET PRICES!



"AURORA"  
1 Day Lever Alarm, Nickel. Height, 5½ inches



"THISTLE,"  
1 Day Lever, Alarm, Nickel. Height, 8¼ inches.

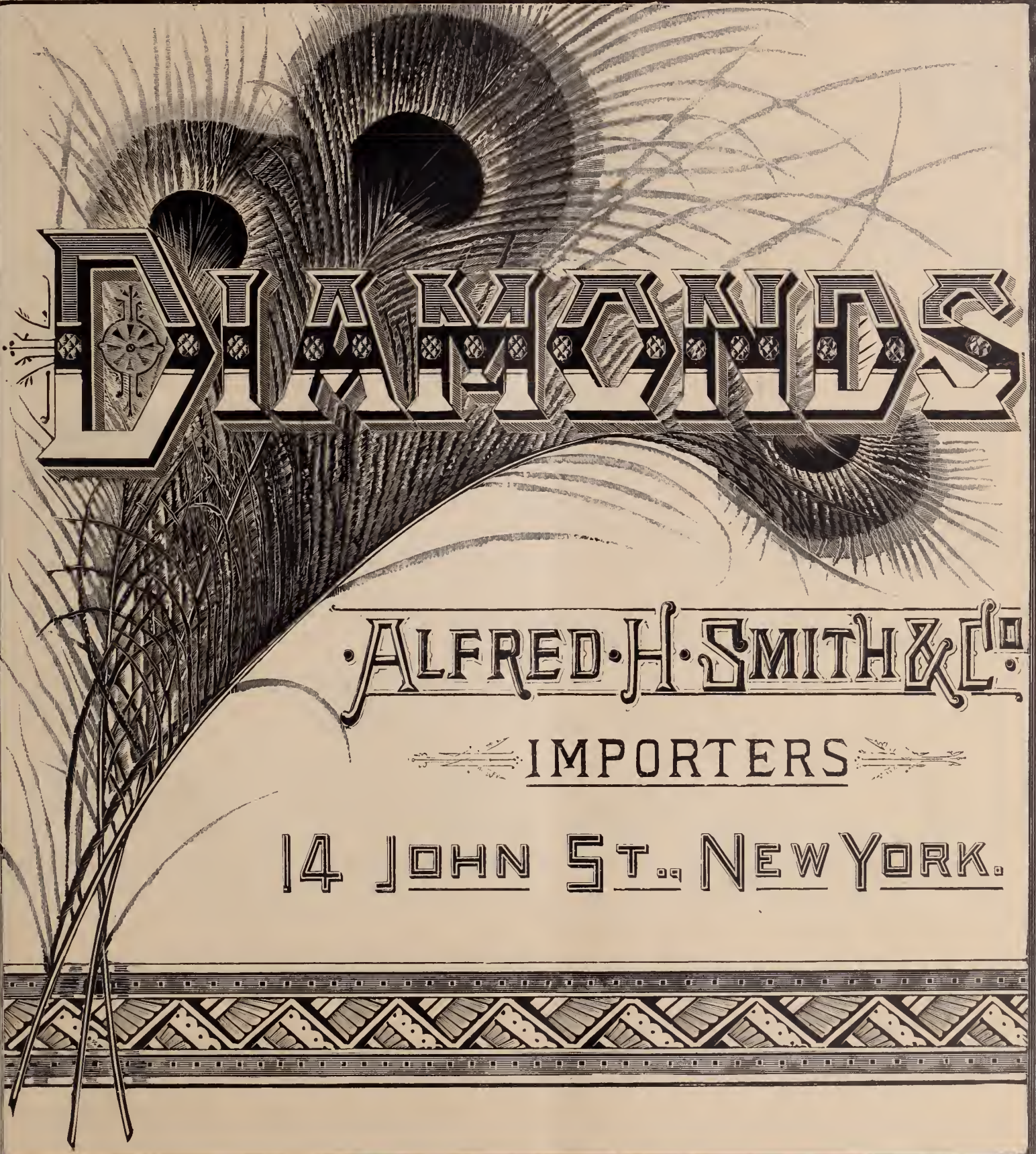

# DIAMONDS

ALFRED H. SMITH & CO.

IMPORTERS

14 JOHN ST., NEW YORK.

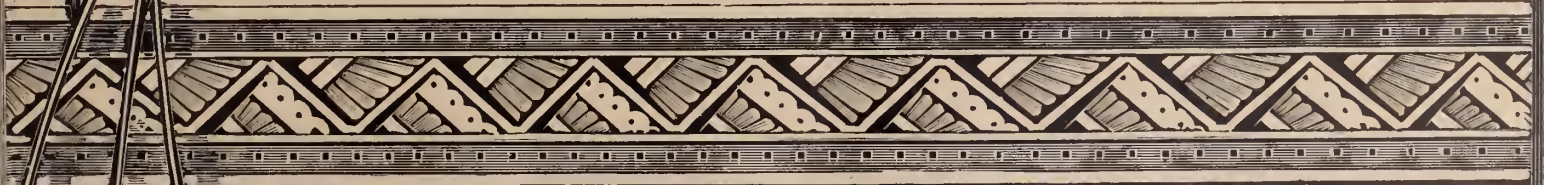

Established 1834.

**G. & S. OWEN & CO.,**  
Makers of Fine GOLD JEWELRY



SPECIALTIES:

Black Onyx Goods,  
Roman & Polished Goods,  
Hair Chain Mountings,  
Sole Makers  
OF  
**BOX AND GLASS GOODS.**

All our goods exclusively of our own manufacture.

5 MAIDEN LANE, NEW YORK.

**JOHN A. RILEY & CO.**

MANUFACTURERS OF

Rich Gold and Onyx Jewelry,

NOVELTIES IN HALF SETS, LACE PINS, SCARF  
PINS AND EAR RINGS,

Engagement Pad Lock Bands, Elastic Snake Bands and  
Chatelaines. Onyx Chatelaines with and  
without Watch Movements.

**Nos. 7 & 9 Bond Street, New York.**

No. 126 Kearney Street, San Francisco, Cal.

MOORE & HORTON,

**JEWELERS,**

*No. 11 Maiden Lane, New York.*

**SPECIALTIES!**

*Stone Cameo, Onyx, Amethyst, Topaz and Pearl Rings,  
Studs, Collar and Sleeve Buttons.*

Also our new fac-simile of Fine African Diamonds, mounted in  
Rings, Studs, Pins, Ear-rings, Scarf Pins, Me'allions.

WHEELER, PARSONS & HAYES,

MANUFACTURERS OF

Watch Cases, Gold Chains & Fine Jewelry.

AND DEALERS IN

AMERICAN AND SWISS WATCHES,

No. 2 MAIDEN LANE, NEW YORK.

**IMPORTER OF DIAMONDS**

**E. AUG. NERESHEIMER**

21 MAIDEN LANE,

NO 1 GAERTNER PLATZ  
MUNICH-GERMANY.

NEW YORK

NO 24 DOELEN STRAIT  
AMSTERDAM-HOLL.

DIAMONDS LOOSE & MOUNTED SENT ON APPROVAL AND THE VALUE INSURED.

W. H. SHEAFER & CO.,

**Makers of Fine Jewelry**

CONSISTING OF

BRACELETS, SETTS, LOCKETS, PINS,

STUDS, SLEEVE BUTTONS, RINGS, &c.

**SPECIALTY:—STIFFENED ROMAN BANDS.**

No. 908 Chestnut Street, PHILADELPHIA.

Branch Office 15 John Street, New York.

# WM. S. HEDGES & CO.,

*Of the late firm of SMITH, HEDGES & Co.*

IMPORTERS OF

## DIAMONDS,

No. 170 Broadway, cor. Maiden Lane,

NEW YORK.

*Choice Brilliants in single stones and matched pairs a specialty.*

GOODS SENT ON APPROVAL.

## CHATELLIER & SPENCE,

### Manufacturing Jewelers,

694 BROADWAY, NEW YORK.

No. 1129 Chestnut Street, PHILADELPHIA, PA.

No. 12 West Street, BOSTON, MASS.

No. 120 Sutter Street, SAN FRANCISCO, CAL.

## HELFENSTEIN & BOURKE,

202 Broadway, New York.

OPEN,

SOLE MANUFACTURER OF THE

PARTLY CLOSED.



**Adjustable Sleeve-Button.**



(PATENTED BY WM. BOURKE, JUNE 11, 1878.)

AMONG ITS MANY ADVANTAGES ARE THE FOLLOWING:

- 1st. EASILY ADJUSTED, quick mode of attachment to the cuffs, and obviating any strain on the forefinger and thumb.
- 2nd. DURABILITY AND STRENGTH—Not having springs that will get out of order.
- 3rd. SAFETY.—The parts being strongly connected, there is no possibility of losing either portion.
- 4th. NEATNESS.—Being without knobs or projections, its appearance on the top is not disfigured.
- 5th. ECONOMY.—Wear of the Button-holes and rumpling of the cuffs are avoided.

EVERY PAIR OF BUTTONS WARRANTED AS REPRESENTED.

*A large variety of designs ranging from \$4.50 to \$24.00 per dozen pairs  
Samples sent upon application.*



## LYON & HARDY,

30 MAIDEN LANE, NEW YORK,

IMPORTERS OF

**DIAMONDS,**

AND MANUFACTURERS OF

## DIAMOND MOUNTINGS.

All goods ordered for stock or on approval are insured while in the hands of Express Companies.

## MULFORD & BONNET,

### Manufacturing Jewelers,

DEALERS IN

DIAMONDS.

AND JOBBERS IN

**Fine Rolled Plated Goods,**

No. 21 Maiden Lane,

NEW YORK.

# ENOS RICHARDSON & CO.

MANUFACTURERS OF

## FINE GOLD JEWELRY,

Gold Chains, Locket, Crosses and Necklaces,  
COLORED AND ETRUSCAN WORK.

ENGRAVED AND ENAMELLED GOODS IN GREAT VARIETY

All Goods sold strictly of our own manufacture.

23 MAIDEN LANE, NEW YORK.

ENOS RICHARDSON,  
THOS. SLATER,

L. P. BROWN,

F. H. RICHARDSON,  
W. P. MELCHER.

# J. B. BOWDEN & CO.

Manufacturer of

SOLID GOLD AND STONE

## RINGS

All Styles of Children's  
AND

FANCY SOLID RINGS,

A LARGE ASSORTMENT ALWAYS ON HAND.

No. 1 Maiden Lane, New York.

OPPENHEIMER BROS. & VEITH,  
MANUFACTURING JEWELERS,

AND

Dealers in Watches and Diamonds,

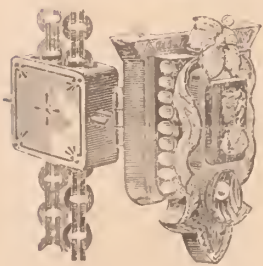

35 Maiden Lane,  
NEW YORK.



Patented June 3, 1879.

Combination Chain, Slide, Pendant and Locket.

# RANDEL, BAREMORE & CO. DIAMONDS,

Corner Maiden Lane and Nassau St.

29 Maiden Lane, **NEW YORK**, 58 Nassau Street.

No. 12 New Burlington Street, LONDON, W.

# CARROW, BISHOP & CO.

SUCCESSORS TO

Carrow, Crothers & Co.

MANUFACTURERS OF

## Fine Gold Jewelry

No. 12 JOHN STREET,

NEW YORK.

Platinum Tipped Diamond Settings,

Patented April 16th, 1878, by

## Ripley, Howland & Co.



Office, No. 35 Maiden Lane, New York.

Factory, 383 Washington Street, Boston, Mass.



**J. A. BROWN & CO.**

OFFICE AND SALEROOM:  
No. 11 Maiden Lane, N. Y.

FACTORY:  
No. 104 Eddy St., Providence. R. I.

SOLE MANUFACTURERS OF THE

**Ladd Patent Stiffened Gold Watch Cases**

The Best and most durable, and the

CHEAPEST STIFFENED  
Gold Watch Case

FOR THE MONEY

MADE IN THE WORLD!

All genuine Watch Cases of our manufacture have "G. W. Ladd's Patent, June 11, 1867," stamped upon the side band underneath the glass bezel.

REFUSE ALL OTHERS.

Send for full Descriptive Circular to the

OFFICE AND SALEROOMS

11 Maiden Lane, N. Y.



KEY AND STEM  
WINDING

Hunting and Open-Face

IN FLAT BEVEL,

Mansard and Oval

SHAPES

Adapted to the various

AMERICAN-MADE  
MOVEMENTS,

IN

8, 10, 14, 16 & 18

SIZES.

Dealers can obtain them of the Wholesale Watch and Jewelry Houses, or their Traveling Agents throughout the United States and British Provinces.

**MAX FREUND & CO.**

**Manufacturing Jeweler**

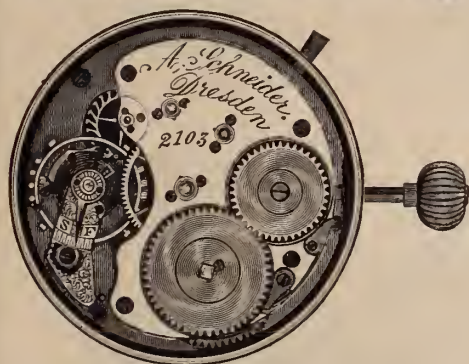

IMPORTERS OF

**Watches**

Jewelry and Precious Stones,  
8 Maiden Lane

NEW YORK

Sole Agents for the Celebrated A. Schneider Watch, Dresden.  
Also the Standard Watch Co. of New York.

**VAN HOUTEN, SAYRE & CO.**

MANUFACTURERS OF

**FINE JEWELRY,**

FACETED GOODS,

Office & Factory, 53 Chestnut St.,

NEWARK, N. J.

**JOSEPH N. TINGLEY,**

Late of the firm of Tingley, Sinnock & Sherrill,

MANUFACTURER OF

**STONE RINGS,**

—AND—

NOVELTIES IN STONE GOODS,

No 9 Maiden Lane,

New York

Factory, Newark, N. J.

**MIDDLETON & BROTHER,**

IMPORTERS OF

**SWISS WATCHES,**

AND DEALERS IN

**American Watches,**

(KEY AND STEM WINDING.)

Diamonds, Gold Chains, Jewelry, Etc.

10 MAIDEN LANE, N. Y.

**CHAS. P. HEROLD,**  
**MANUFACTURING JEWELER,**  
**DIAMOND SETTER**  
 AND DEALER IN  
**DIAMONDS.**

916 CHESTNUT ST. PHILA.

N.B. A LARGE STOCK OF 18 KT. DIAMOND MOUNTINGS, SUCH AS CLUSTER AND SOLITAIRE RINGS, EARRINGS, LACE PINS, SHAWL PINS, CROSSES, STUDS, AND GENTS' PINS, &c. ALL OF WHICH ARE OF MY OWN DESIGNS, AND ARE MADE IN THE FINEST STYLE AND FINISH.

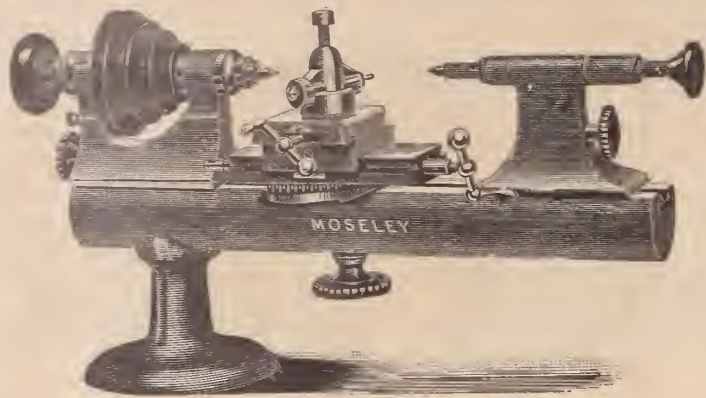

Manufactured by A. O. Moseley, Elgin, Ill.

# MOSELEY & CO.

ELGIN, ILLINOIS,

Designers and Manufacturers of

## FINE TOOLS.

Send for Catalogue and Price List.

# American Watch Tool Co.

P. O. Box 999. WALTHAM, MASS.

MANUFACTURERS OF THE WHITCOMB LATHE,  
AND  
Machinery for Watch, Watch Case and Clock Making.

NEW YORK OFFICE WITH

L. H. KELLER & CO., 64 Nassau Street.

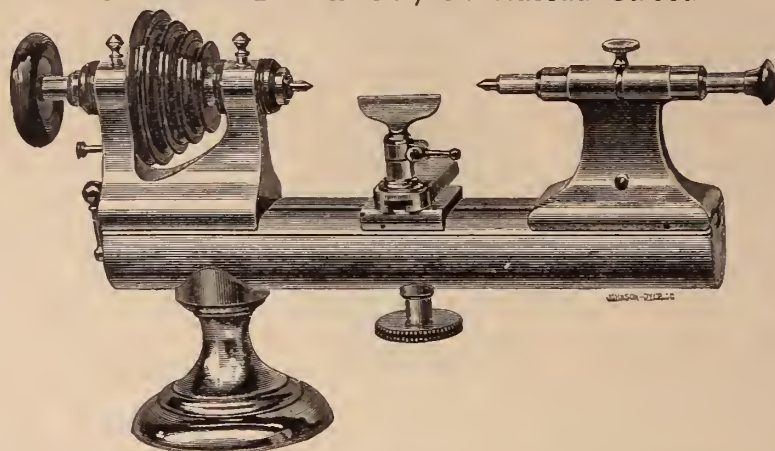

Chicago Office with Chas. Wendell & Co., No. 170 State Street.

**SPENCER OPTICAL MANUFACTURING COMPANY,**  
Manufacturers of Spectacles and Eye Glasses from all materials used for that purpose, and of all grades.  
Parties ordering 3 doz. Celluloid Eye Glasses are furnished with 1,000 copies of circulars similar to  
this advertisement with name of dealer printed thereon.  
13 MAIDEN LANE, N. Y.

**SOMETHING NEW ! !**  
**CELLULOID EYE GLASS FRAMES,**  
Representing the Choicest Selected  
Tortoise Shell and Amber.



THEY HAVE GREAT ADVANTAGES

OVER ALL OTHER EYE GLASSES.

(Turtles rejoicing over the discovery of Celluloid Tortoise Shell,  
Their Occupation Gone.)

They are much **Lighter** than any others. Twenty-five pairs of the frames weigh only one ounce.

They are much **Stronger** and more **Durable** than any others; they can be **Dropped Without Injury** upon the hardest substance.

Their **Beauty Far Surpasses** the ordinary Tortoise Shell Frames commonly in use.

They are **Not Affected** by Atmospheric Changes, being equally well adapted to either warm or cold climates.

They are made with **Different Sized Frames** to suit persons whose eyes are either near or far apart.

The Springs are made of a combination of metals which will neither **Rust** nor be effected by heat or frost.

These frames are set with **Fine Lenses**, accurately focused to suit all sights, which with the many other advantages, make them **Very Popular**.

**ASK YOUR OPTICIAN OR JEWELER TO SHOW THEM TO YOU.**  
Every Pair Stamped on Handle S. O. M. Co. Pat. Mar. 13, '77.

# Kearney & Swartchild,

Manufacturers of

## "TRIUMPH" LATHE.

Price, Hardened Bearings and Spindles, \$40.00

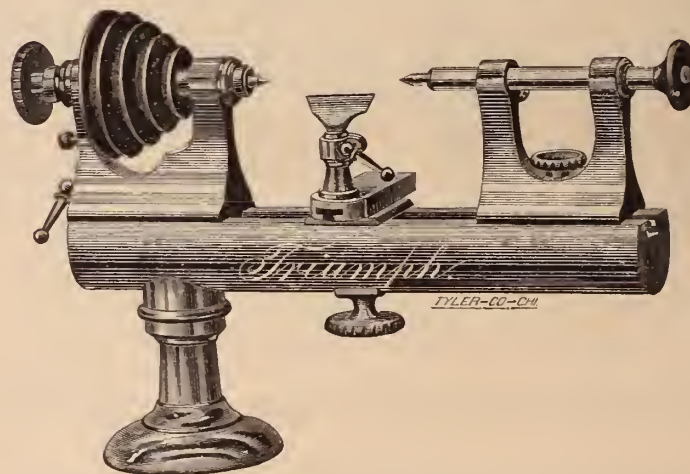

All Split and Wire Chucks are tempered and ground, which makes them perfectly true.

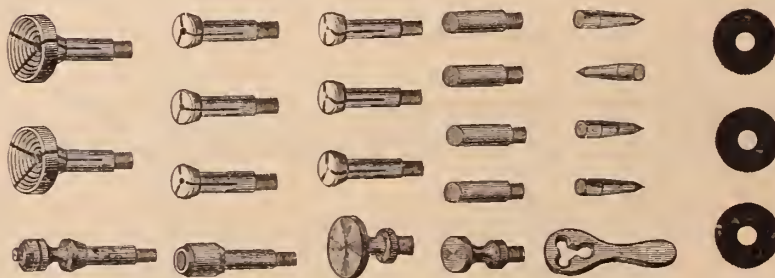

Importers and Jobbers of Tools and Materials, Watches, Jewelry, &c.

Manufacturers of Watchmakers' and Jewelers' Tools.

Illustrated Catalogue sent on application to parties sending business card.

Nos. 113 & 115 State Street, Chicago, Ill.

# Charles F. Terhune & Co.,

Manufacturing Jewelers,

16 Maiden Lane,

New York.



Sole Manufacturers

We beg to call the attention of the trade to the above cuts representing

## PATENT SLIDE BUTTON

It is not separable, but works on a simple slide. It can be put in and taken out easier than any button made without soiling the cuff. Recommends itself at sight.

A full line of Stone, Enamel, Ivory and Pearl goods in above patterns.

GEO. W. PRATT.

IRA GODDARD.

## GEO. W. PRATT & CO.

MANUFACTURERS AND DEALERS IN

# American and Swiss Watches,

SOLID BAND AND SEAL RINGS,

Gold and Roll-Plated Jewelry,

No. 14 JOHN STREET, NEW YORK.

ESTABLISHED 1855.

# WELCH & MILLER,

MANUFACTURERS OF MOROCCO, VELVET AND SATIN

## Jewelry Cases, Trays, &c.

Telescope Sample Cases, with Flexible Trays.

COMPLETE STOCK ON HAND.

No. 169 BROADWAY, NEW YORK.

CATALOGUES SENT ON APPLICATION.

I. PFORZHEIMER.

D. KELLER.

# PFORZHEIMER & KELLER,

IMPORTERS OF

## Watches and Diamonds

Dealers in American Watches,

AND

Manufacturers of Jewelry,

No. 24 JOHN STREET,

NEW YORK.

P. O. Box 4144.

ESTABLISHED 1853.

C  
L  
O  
C  
K  
S



C  
L  
O  
C  
K  
S

**B. J. COOKE'S SON,**  
137 N. 3d Street, Philadelphia.  
Catalogues and Price Lists furnished to the Trade only, on application

## H. Muhr's Sons, Philadelphia.

MANUFACTURING JEWELERS,

Solid Gold Finger Rings of Every Description.



Crown, 18k. Lion.



On and after January 1st, 1876, our make of Filled Plain Rings will be stamped as above, which stamp is copy righted. Any and every infringement on the above Trade Mark will be dealt with according to law. Every one warranted.

THESE GOODS ARE SOLD BY ALL THE LEADING JOBBERS!

Should the house that any retailer deals with not have them we will furnish them with the address of the nearest Jobber. **SELL TO THE JOBBING TRADE ONLY!**

New York Office, 11 Maiden Lane.

Address all communications to Philadelphia.

## BERNARD LEVY,

# Manufacturer of Watch Cases

—AND—

JOBBER OF AMERICAN MOVEMENTS,

No. 402 Library Street,

PHILADELPHIA.

ALSO, ORNAMENTAL ENGRAVER AND ENGINE TURNER.

### Lubricating Oils, for Watch, Clock and Chronometer Makers.

The discovery of a Lubricator for FINE MACHINERY, such as Watches, Clocks and Chronometers, that is free from gum and corrosive substances, has taxed the ingenuity of hundreds of men whose efforts have proved a failure. But we are happy to say, (being largely interested) that such an article has been supplied by MR. EZRA KELLEY, of New Bedford, Mass., who, after forty years study of the subject, has perfected a Lubricator, that recommends itself to all who have used the genuine, (there having been numerous counterfeits in the market,) as witness also the award of a



Diploma and Medal by the judges of the late Centennial Exhibition at Philadelphia. We have no hesitation in saying that his Oils are the BEST manufactured always uniform in quality and capable of standing all tests applied to lubricating oils. We cheerfully recommend it to all who may in their business require a FIRST CLASS LUBRICATOR

SETH THOMAS CLOCK COMPANY, SETH E. THOMAS, Agent.

P. S.—The above Oils can be procured at all first-class wholesale Watch and Clock Establishments in the United States, as well as his only Agents, GRIMSHAW & BAXTER 35 Goswell Street, London, England.

New Bedford, October 15, 1877.



**E. STITES,**  
*Manufacturing Jeweler,*  
 No. 12 MAIDEN LANE,  
 New York.  
 COIFFEURETTES.

**BREITINGER & KUNZ,**  
 Importers of Watchmakers' Tools,  
**MATERIALS, CLASSES, &c.**  
**No. 107 North Ninth Street,**  
**PHILADELPHIA.**

Dealers in all kinds of American Watch Materials and American Clock Material. Specialties in Materials for Musical Boxes, Cuckoo Clocks, &c.  
 Sole Agents in the United States for Bahai Brothers Hardened and Tempered Hairsprings. Agents in the U. S. for J. Becker's (Freiburg, Germany) Gold Medal Regulators, the best in the market. A large assortment of all patterns always on hand; Movements with seconds pendulum for watchmakers' use—all kinds of materials for the same.  
 Wheel Cutting and work done for the trade.

**M. FOX & CO.**  
**Practical Lapidaries,**  
 IMPORTERS OF  
**DIAMONDS**

AND OTHER PRECIOUS STONES,  
 No. 1 Maiden Lane, New York.

**EDWARD TODD & CO.,**  
 MANUFACTURERS OF  
**GOLD PENS,**



Pencil Cases, Tooth Picks, &c.  
 44 East 14th St., Union Square,  
 Factory, 29 & 31 South 11th St., Brooklyn. **NEW YORK.**

**T. B. BYNNER,**  
**Importer & Jobber of Watches**

DIAMONDS AND FINE JEWELRY,  
 And Dealer in the BEST CLASS OF ROLLED PLATE JEWELRY  
 And Key and Stem-Winding American Watches.

No. 513 Broadway, New York

**Dorrance, Edge & Co.**  
 MANUFACTURERS OF  
 THE CELEBRATED WOVEN FABRIC  
**GOLD CHAIN.**

*Elegantly Mounted Bracelets, Opera, Leontine,*  
 VICTORIA WATCH GUARDS & NECKLACES, in all the Newest Desins.  
 Our stock is unusually complete, and, in addition to the above, a variety of Necklaces, from 1½ to 40 dwt. each, to which we invite the attention of buyers.

No. 12 John Street, New York.

Factory, 46 Greene Street, Newark, N.J.

**Clark's Groved Case Springs.**



PAT. 116,777.

Made in four lengths, wide and narrow. The spring sets well away from the movement, the depressions obviate any tendency to move lengthwise. Steel rivets preferably used can be removed more easily than screws. In fitting file away the lower edge until the rivet can be pushed down in front of the spring in the groves. These springs are made from fine steel, carefully tempered and warranted perfectly reliable. To be had of all jobbers in watch materials at manufacturers price—75 cts. per dozen.

**A. N. CLARK,** *Manufacturer of the Celebrated FOUR HOLE CASE SPRINGS, Watch Keys, Bench Tools, Crosby's JEWELING TOOLS, &c.* **Plainville, Ct.**

**NEW JEWEL SETTING CUTTER**



For cutting the bezel, or rim that holds the jewel to the plate of watch movements. In adjusting the jaws to the size of bezel to be cut, the gauge will be found very useful, there being twelve sizes of punched bezels on each.

A glance at the sketch will show the practicability and great usefulness of the latest novelty in watchmakers' tools.

Sent with gauge, by mail, postpaid, on receipt of \$2.25. Orders should be addressed,

**PH. HECHT,**  
**13 MAIDEN LANE.**

*Any article in the Watch Material, Optical, and Silk Guard lines, furnished at lowest rates.*

MANUFACTURERS  
—OF—  
EXCLUSIVELY  
**BLACK ONYX GOODS.**

The patented **DEEP MOURNING LOCKETS** are original with us, and have stood the test of years of wear. They meet the approval of the trade and the wearers for their superior make and finish, as well as for the correctness of the mechanical principle on which they are constructed.

**WOGLOM & MILLER,**  
32 & 34 JOHN STREET,  
NEW YORK.

**BOOZ & THOMAS,**  
MANUFACTURERS OF

Watch Cases  & Jewelry,

108 South Eighth St., (2d Story) Philadelphia.

Samples of our goods sent on approval, when satisfactory reference is furnished.  
**Old Gold & Silver Bought or Exchanged.**  
PARTICULAR ATTENTION PAID TO REPAIRING.

This Cut represents the

 **RICKETT'S  
PATENT EYE SHADE.**

It is simply a neat Curved Shade of Hard Rubber  $\frac{3}{4}$  inch wide, that fits under the eyebrows and flares out at the bottom, so as to allow an angle of vision about level with the Horizon. Having met with success in New York, Philadelphia and Boston, and wishing to extend our trade to other cities, we will, for the next thirty days, forward to any one in the TRADE ordering THREE DOZEN SPRING SHADES, an elegant PLASTER BUST, life size, stands twenty-one inches high, and retails in New York for \$3.00; if placed in a prominent window will sell three dozen shades in ten days. Order from any jobber or direct from us. Please state that you want Bust.

PRICES—Spring Shades, \$3.50 per doz., Bow Shades, \$4.50 per doz.  
**RICKETT'S EYE SHADE CO.,**  
85 Nassau Street, New York.

HIGHEST AWARD TO

 **SYLVANUS SAWYER,**  
—FOR—  
**WATCH MACHINERY,**

Watch & Clock Making Machinery

For sale or made to order, either in complete sets, including  
**PUNCHES & DIES AND OTHER SPECIAL TOOLS,**  
Or in parts of sets, to accommodate purchasers.  
**ALSO, JEWELER'S LATHES AND TOOLS,**  
AND OTHER FINE WORK,  
**MAIN REET, FITCHBURG, MASS.**

**HENRY FERA,**  
Importer of Diamonds,  
No. 9 MAIDEN LANE,  
New York.

Having my own cutting and polishing establishment at Nos. 23 and 25 Looijersgracht, Amsterdam, Holland, constantly running 36 mills, I am able to offer to the trade a full assortment of Diamonds at very low prices.  
Loose and Mounted Goods sent on approval to any part of the country on receipt of satisfactory references.

**HAMILTONS & HUNT,**  
MANUFACTURERS OF

**Fine Plated Chains**  
AND PATENT BUCKLE BRACELETS,  
**Branch Office, 176 Broadway, New York**  
FACTORY, 226 EDDY STREET, PROVIDENCE, R. I.

  
**W. C. GREENE & CO.**  
GOLDSMITHS

MANUFACTURERS OF  
RICH SETS IN TAPER WIRE CORAL

Factory 95 FINE ST. Providence, R. I.

NEW YORK OFFICE, No. 192 BROADWAY.  
Wm. C. Greene, B. W. Greene, Geo. D. Briggs.

Stone Amethyst Coral Engraved & Brooches Sleeve Studs Buttons EAR DROPS & C.

**MILNE & JOURDAIN,**  
Manufacturers of Stem-Winding Watch Crowns



13 & 15 Franklin Street, NEWARK, N. J.

Gold Crowns, for Stem winding Movements, to suit all sizes of Imported or American Watches, in four different styles and seven sizes.  
Gold Pushers for Key Movements in every size. Also Gold Crowns for fine Chronograph Watches made to order.  
Silver Stem winding Crowns and Key Pushers on hand or made to order. Send for card and samples.

A. MILNE. A. JOURDAIN.

# DESCRIPTION OF THE New Patent Dust-Proof STEM-WINDING OPEN-FACE CASE,

MANUFACTURED BY THE

AMERICAN WATCH CO.,  
WALTHAM, MASS.

ROBBINS & APPLETON.

GENERAL AGENTS,

9 BOND STREET, New York. 8 SUMMER STREET, Boston.  
170 STATE STREET, Chicago.

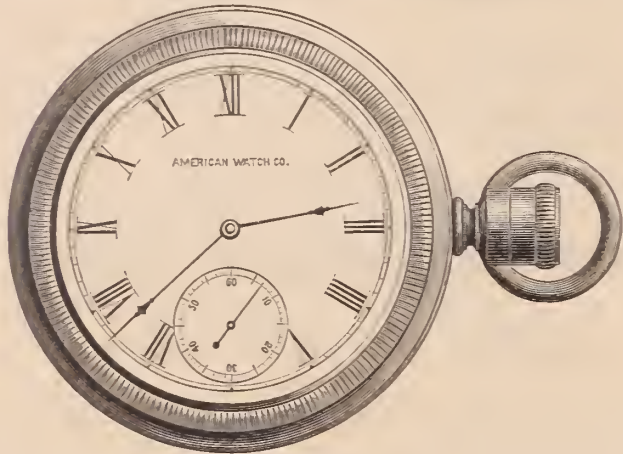

This open-face watch case, which is formed in one seamless piece in any desired shape, opens in the front only to receive the movement. The continuous construction of the body of the case avoids the usual cap and greatly conduces to strength and constitutes one feature of the invention.

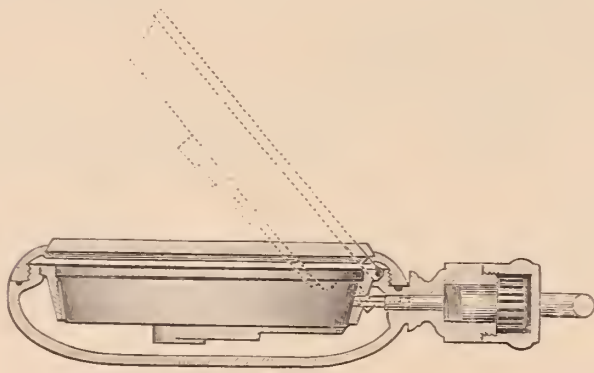

The movement of the Watch is held in a sustaining ring which is hinged to the case on the front edge of the aperture in such a manner that when the bezel is removed the ring with its contained movement may be swung outward, thus rendering the movement readily accessible, and obviating the necessity of a back cap or lid, which thus enables the case to be formed in one seamless piece and constituting another feature of the invention.

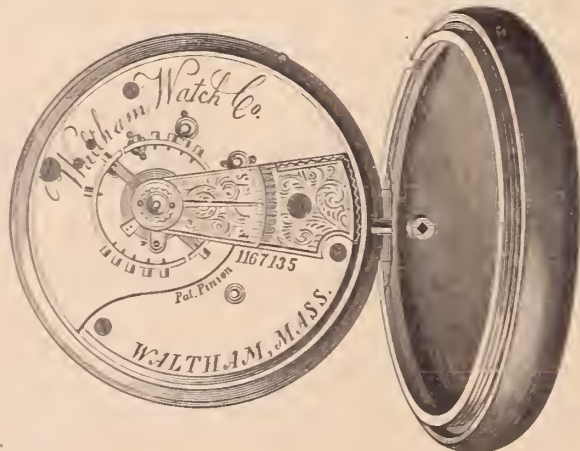

The movement is held in the ring in the manner usual in American Watches, and this ring is hinged to the rim of the case just at the base of the stem, the movement being so arranged therein that the winding stud of the movement comes in line with the winding-key of the stem and properly engages therewith. When the movement is to be swung out, however, the stem-winding crown may be pulled partly out, as usual, so as to draw the key out of engagement with the stud, and thus permit the outswing of the movement, as will be understood, the parts becoming readily engaged, when the movement is again swung into the case.



The bezel, into which the crystal is fitted with an especially prepared water-proof transparent cement, is attached to the case by screwing it thereon, the ring of the bezel being formed with an internal screw thread which meshes with a corresponding thread on the shouldered rim on the face of the case, and as the bezel is thus screwed tightly down the level edge of the rim, forms the air-tight joint with the shouldered rim of the case, which is proof against the entrance of dust or moisture, as will be appreciated.

By making the screw-thread on the interior of the bezel, so as to fit a corresponding thread on the interior of the case, we are enabled to construct a watch with only one division in the case, and thus the entrance of dust or moisture to the movement is entirely prevented, which is a very great advantage as compared with those cases in which there is an opening both front and back. The face of the bezel is formed with a marginal circle of milling which affords sufficient frictional grasp to enable the bezel to be readily screwed on or off.

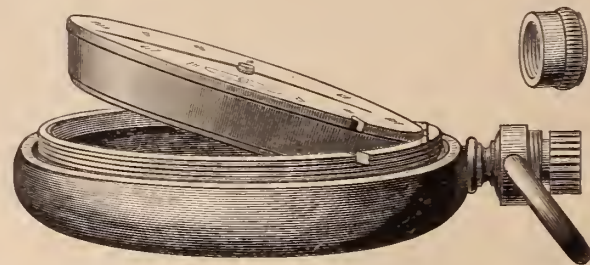

Another feature of the invention consists of the removal of the stem cap, which is designed to tightly fit upon the top of the stem winding-crown, so as to prevent the entrance of any dust or other foreign matter at that part. The stem-cap is attached to the stem by screwing it thereon in the manner of the bezel, and may be readily unscrewed when it is desired to wind the watch, as will be understood.

The cap is of similar diameter with the body of the stem, which latter is formed with a short threaded neck, which screws into the threaded bore of the cap, the bevel edge of the cap being screwed down tightly on the smooth shoulder of the neck so as to form a perfectly tight joint, which effectually prevents the infiltration of any dust or moisture thereat.

These combined features of construction thus form a watch which, while being simple and complete, has the great advantage of being impervious to the entrance of dust or wet. These latter qualities are found to be of great importance to those persons, who most use this class of watches, such as railroad men, travelers, miners, lumbermen and others, who have to make frequent reference to the watch, and who are almost constantly exposed to the influence of dust or moisture.

This new case is made by us both in gold and silver.

It insures great strength and durability with a small amount of metal. Thus a gold case weighing 25 dwts. has a strength of back equal to that of an ordinary case of 30 dwts. to 35 dwts.

It is also made with jointed bezel instead of the threaded screw bezel, if desired.

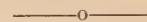

The Water-proof Cement used in cementing the glass in the above cases is an article which we have had especially prepared for this purpose after considerable experimenting. We will furnish it to the trade, on application, at 50 cents per bottle. Forwarded by Mail.

Price Lists furnished to the Trade only upon application.

Office of  
**ROBBINS & APPLETON,**  
 AGENTS FOR  
 American Watch Company,  
 No. 9 BOND STREET,

*New York, February 12th, 1879.*

Sir:

*List prices of certain of our movements are to-day fixed as follows, viz.:*

**18 Size, FULL PLATE.**

"BROADWAY," 7 jewels, nickel balance.....	\$ 4 30
" " 7 " cut expansion balance (NEW).....	4 75
"WM. ELLERY," 2 pairs extra jewels, cut expansion balance.....	8 00
" " 2 " " " " " Stem Winder.....	10 50
"STERLING," 7 jewels, nickel balance, Stem Winder.....	6 25
" " 7 " cut expansion balance, (NEW), Stem Winder.....	6 70

**The new list prices of complete Silver Watches are changed to correspond with the above.**

**14 Size,  $\frac{3}{4}$  Plate.**

"AM. WATCH CO. HILLSIDE" (NEW), 7 jewel, cut expansion balance, Stem Winder, for Hunter or Open Face.....	\$20 00
---	---------

**18 Size, Full Plate, NICKEL Movements.**

"WM. ELLERY," 2 pairs, extra jewels, cut expansion balance.....	\$12 00
" " 2 " " " " " " " Stem Winder,.....	16 50
"P. S. BARTLETT," 2 pairs, extra jewels in settings, cut expansion balance.....	18 50
" " 2 " " " " " " " " Stem Winder.....	26 00
"WALTHAM WATCH CO." 4 pairs, ex. jewels in settings, cut ex. balance.....	26 50
" " " 4 " " " " " " " Stem Winder.....	34 50
"APPLETON, TRACY & CO.," 4 pairs, extra jewels in settings, cut expansion balance, adjusted.....	37 00
" " " " 4 pairs, extra jewels in settings, cut expansion balance, adjusted, Stem Winding.....	46 50

All the above are subject to the terms and discounts announced in our circular of the 8th inst.

There will be no change in the quality of any of our grades, except as our constant efforts tend to their improvement. We decline altogether to take any part in the present unwise competition between Swiss and American manufacturers to see which shall make watches of the poorest quality. We intend to sell as low as any American company, but, however low the price, we do not intend to finish a grade of goods upon which it would be a disgrace to us to put our name.

Robbins & Appleton, 9 Bond St., New York.  
 Robbins, Appleton & Co., 8 Summer St., Boston,  
 Robbins & Appleton, 170 State St., Chicago. } General Agents.

American Watch Company,  
 OF WALTHAM, MASS.

ROGERS & BROTHER,  
**690 BROADWAY, NEW YORK,**  
 MANUFACTURERS OF  
**First Class Silver Plated Ware,**  
 OF EVERY DESCRIPTION.

Established 1828.

**JACOB BENNETT & SON,**  
**Diamond Setters and Manufacturing Jewelers,**  
 No. 108 SOUTH EIGHTH STREET, PHILADELPHIA.

WE MANUFACTURE AND MAKE A SPECIALTY OF  
 EVERY DESCRIPTION OF

**DIAMOND MOUNTINGS**

SUPERIOR IN DESIGN AND WORKMANSHIP.



Dealers in

**DIAMONDS,**

And all kinds of Precious Stones.

PARTICULAR ATTENTION GIVEN TO ALL KINDS OF JOBBING.

**BROWN & BROTHER,**

MANUFACTURERS OF

**Finest Quality of Electro-Plated Flat Table Ware.**

PATENTED HEAVY SPRING TEMPERED SHANK ON FORKS AND SPOONS.

ILLUSTRATED CATALOGUES FURNISHED ON APPLICATION.

WAREROOMS, No. 81 CHAMBERS STREET, NEW YORK CITY.

FACTORIES, WATERBURY, CONN.

P. O. BOX 5731.

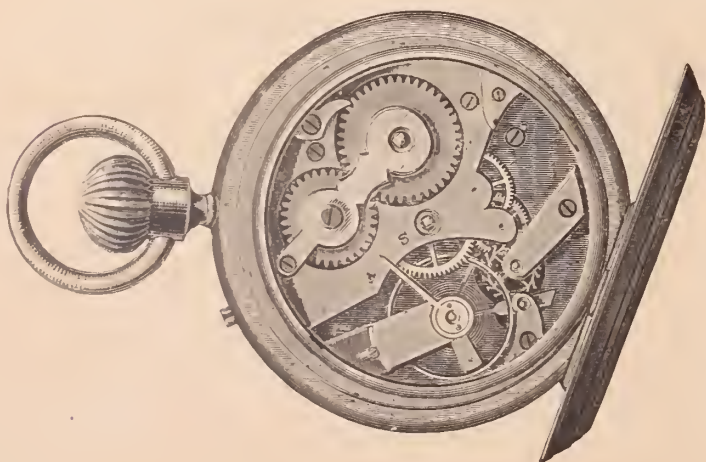

**The Pioneer Watch.**

HENRY GINNEL, Sole Manufacturer,

**No. 31 Maiden Lane, NEW YORK.**

P. O. Box 2967.

The accompanying illustration is a fac-simile of the Pioneer Watch. The Best (stem-winding and stem-setting) Pocket Timekeeper ever offered to the trade. They are cased in silver and German silver—Hunting and Open Face.



Medal and Diploma awarded at Centennial Exposition, for superior mechanical execution and artistic ornamentation.



Established in 1854.

**C. & A. PEQUIGNOT,**  
**MANUFACTURERS OF WATCH CASES,**

DEALERS IN AMERICAN WATCHES AND IMPORTERS OF FINE KEY AND STEM-WINDING MOVEMENTS,  
 SALESROOM AND MANUFACTORY, 22 SOUTH FIFTH STREET,  
 PHILADELPHIA.

A full stock of Key and Stem-Winding Gold Cases always on hand. Goods sent on approval when satisfactory references are furnished.

**HOLMES, BOOTH & HAYDENS,**

MANUFACTURERS OF

**ELECTRO-SILVER PLATED**

**Spoons, Forks, Ladles, Fancy Pieces,**

**Solid Handle Steel Knives, &c., of the finest quality.**

No. 49 Chambers Street,  
**NEW YORK.**

No. 18 Federal Street,  
**BOSTON.**

Works at Waterbury, Conn.

SPECIAL NOTICE! MANUFACTURING JEWELERS, CHEMISTS, &c.

**BROWN & BROS.,**

No. 81 CHAMBERS STREET,

NEW YORK.

Manufacture CHEMICALLY PURE COPPER for ALLOYING, and are prepared to fill orders for same, either in the Wire, Strip or Granulated form. Its PURITY has been attested as follows.

UNITED STATES ASSAY OFFICE, 30 WALL STREET,  
 NEW YORK, Dec. 21st, 1877.

BROWN & BROS.

Dear Sir.—We have analyzed the two samples of Copper left with us on the 18th instant, one said to be foreign refined Copper as used by jewelers, the other a refined Copper as manufactured by you for the same purpose. We find both samples alike in purity, and no difference can be detected by a careful chemical analysis, both being samples of PURE METALLIC COPPER, having no traces of antimony, tin, arsenic, zinc or lead.

TORREY & EATON.

10.—SLIDE KEY. (Nickel Plated.)  
 11.—SLIDE KEY. (Nickel Plated, Hexagon Shell.)  
 12.—POCKET KEY. (Heavy Rolled Gold Plate Mountings, Plain.)  
 13.—POCKET KEY. (Sterling Silver Mountings, Plain.)  
 14.—POCKET KEY. (Sterling Silver Mountings, Engine turned.)  
 15.—POCKET KEY. (Extra Heavy Rolled Gold Plate Mountings, 18 K., Plain.)  
 16.—POCKET KEY. (Extra Heavy Rolled Gold Plate Mountings, 18 K., Engraved.)  
 17.—POCKET KEY. (14 Karat, Gold Mountings, Plain.)  
 18.—POCKET KEY. (14 Karat, Gold Mountings, Engraved.)

**BIRCH'S**

SELF-ADJUSTING

**Watch Keys,**

Will Wind any Watch.

For Sale by the Trade Generally.

**J. S. BIRCH & CO.**

38 Dey Street, New York.

# HAMPDEN WATCH CO.

Manufacturers of KEY AND STEM-WINDING

General Office and Factory  
SPRINGFIELD Mass.

## WATCHES.

New York Office,  
No. 12 MAIDEN LANE.

### GUERRANT'S ELECTRO-ENGRAVING MACHINE.

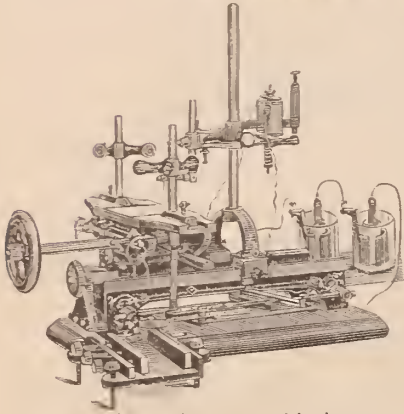

It has baffled the skill of the inventive genius of the world for ages to produce a machine that would compete with the skillful hand engraver, and until this machine was invented, all engraving had to be done by hand. And, to-day, it is the only practical engraving machine in existence.

The construction of the machine is not complicated, but simple and durable. It is easily operated. The variety of work it will do is almost incredible, and to be fully appreciated, ought to be seen in operation.

We do not therefore, offer this machine to the public simply as a machine to aid the engraver, but as a perfect, practical engraver in itself, with which any person of ordinary skill can learn in a short time to do any piece of engraving that might be desired and in the very best manner.

It copies from the regular press type of any style of letter or design that is made of type, from the plainest to the finest german text letter or fancy design, at the same time it will reduce the letter or design from the original size to ten different sizes, or so small that it cannot be seen by the naked eye. It will shorten the letters or elongate them, also will lean them forward or backward, will either make a raised or sunken letter, will engrave on any surface, either plain, concave or convex—for instance, such things as Watch Cases, either in or outside; Finger Rings, either in or outside; Bracelets, Napkin Rings, Goblets, Pitchers, Mugs, Waiters, Spoons, Forks, and all kinds of Jewelry; or, in fact, on any article susceptible of being engraved or ornamented with scroll work or fancy designs, &c., either on Gold, Silver, Copper, Brass, Iron, hardened Steel, Glass, Stone, Pearl, Ivory, Bone, Gutta Percha.

No Jeweler or establishment that has engraving to be done should be without it. Machines are sold with limited territory to use them in; or, the exclusive rights to use them in certain town or territory can be purchased with the machine if desired.

For further information, address

Size of Machine, 12 x 16 inches.  
Patented Jan. 18, Oct. 31, 1876, & Mar. 4, 1879.

WM. HICKSON, Gen. Agt.,  
P. O. Box 1603, PHILADELPHIA, PA.

KARN & HICKSON,  
LYNCHBURG, VA.

A. M. GUERRANT, Danville, Va., Agent for the Southern States.

Owners of the right of all the Northern States and Territories.

## CROSS & BEGUELIN, Makers and Importers of SWISS WATCHES,

AND DIRECT IMPORTERS OF

Watch Tools, Materials, Glasses, &c.

No. 21 Maiden Lane, New York.

The CENTENNIAL WATCH (Stem-Winding and Stem-Setting) so universally popular, has achieved a standard reputation, and is generally conceded to be the best made watch for the money in this market. Being the sole manufacturers of this celebrated Time-keeper, we are enabled to give it our strongest endorsement. Especial attention is called to the "HENRY BEGUELIN," "DROZ & PERRET," and other well known Swiss Watches, as well as to our full and complete line of all grades of American Watches, on which we give the full trade discount.

The attention of Watchmakers is directed to our new DRILLS, in sets of 21 sizes. The most complete and serviceable drill ever offered.

General Agents for the Auburndale Timer,  $\frac{1}{4}$  and  $\frac{1}{2}$  Seconds.



None Genuine without this TradeMark.

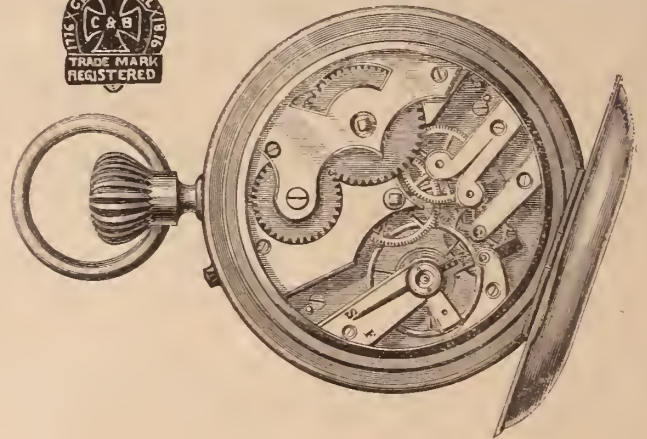

The above is a fac-simile of the Centennial Watch

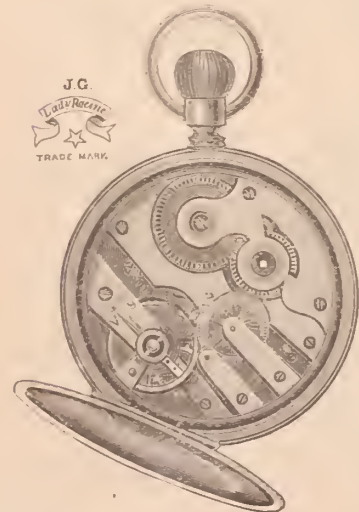

Established 1826.

Factory,  
27  
RUE DU PARC,  
Chaux de Fonds,  
Switzerland.

## JULIEN GALLET,

CHAS. PERRET, Sole Agent.

Sales Rooms,  
No. 1  
MAIDEN LANE,  
NEW YORK.  
P. O. Box, - 4420.

Importer of Watches & Watch Movements,

Would respectfully call the attention of the Trade to the annexed cuts of the Lady's size Watch, Stem-Winder and Stem-Setter, in Nickel, Silver and Gold, White and Black Dials.



**HENRY C. HASKELL,**

Manufacturing Jeweler,

No. 12 John Street,

New York.

**CLASS RINGS,**

NEW STYLES,

AT SPECIAL FIGURES.

CHOICE INTAGLIO & COMEIO RINGS,  
NOVELTIES IN BANGLE AND GYPSY  
*Set with Diamonds.*

SAPPHIRE, RUBY, TURQUOISE,  
PEARL, &C.



1



2



2752



3774



3



4

Orders solicited for goods on approval.

The "MARQUIS" Seal Ring, Entirely New, plain, elegant.

**T. A. WILLSON & CO.,**

MAKERS OF

Steel Spectacles and Eye Glasses,

grinders of Spherical, Cylindrical, Prismatic, Plain & Compound

— LENSES, —

Patentees and Sole Manufacturers of the

"ARUNDEL TINTED"

**SPECTACLES.**

Nos. 179 180 & 155

With Interchangeable Lens,

THE BEST AND CHEAPEST AMERICAN SPECTACLES MADE

Office and Factory, Reading, Pa.

**JAMES IRONS,**

PATENTEE

AND  
Sole Manufacturer



CHEAPEST PLACE TO BUY GOOD

**SHOW CASES,**

Large Assortment.

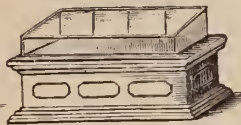

Factory and  
WAREROOMS,

132 & 134

North 4th St.,

PHILADELPHIA.

All kinds always  
on hand.

Cases packed securely to carry to any part of the world,

**G. F. C. Rosenthal,**

Manufacturing Jeweler,

Removed from

924 Chestnut to 917 Sansom St.,

PHILADELPHIA.

The finest Diamond and Pearl Work exclusively.

**Coral Cream Polishing Fluid**

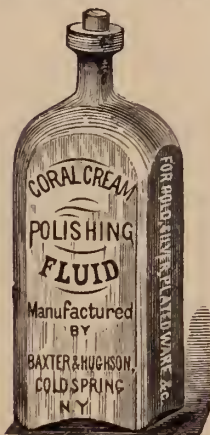

IS SUPERIOR TO ANY IN USE FOR CLEANING AND POLISHING  
SILVER, GOLD AND PLATED WARE,  
AND ALL FINE  
Metallic and Glass Surfaces.

Free from Acid, Mercury, Ammonia,  
Or anything Poisonous or Injurious to the Hands or Metal.

**CHEAPER THAN POWDRES,**

As there is no waste in using, and produces a more lasting  
brilliancy without injury or Wear to the Metal.

Pronounced by Experts to be the finest and  
most brilliant Polish made.

Diploma awarded at American Institute Fair.  
Bottle contains 4 fluid ounces.

IS THE BEST—SELLS THE QUICKEST—AND COSTS THE LEAST.  
Liberal Samples furnished on application.

For Sale by Wholesale Jewelers and Silverware Dealers.

**EDWARD BAXTER,**  
Cor. 8th St. & Broadway,  
BARTER BUILDING, (Room 25.) NEW YORK

**J. H. PURDY & CO.**

Jobbers of Imported and Domestic

**TOOLS & MATERIALS,**

For the use of Watchmakers, Jewelers, and kindred trades.

WATCH GUARDS, JEWELRY BOXES, SPECTACLES, CARDS,  
SPECTACLE CASES, PEARL GOODS, STEEL CHAINS,  
TAGS, RUBBER TYPE, &c.

No. 170 State Street, Chicago, Ills.

OFFICE WITH CHAS. WENDELL & CO.

# W. B. CLAPP, YOUNG & CO.,

## WHOLESALE JEWELERS,

Importers and Jobbers of

Telescopes,  
Field Glasses,  
Barometers,  
Thermometers,  
Spectacles,

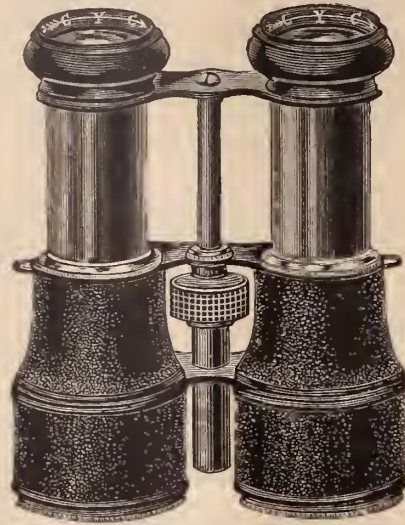

Compasses,  
Opera Glasses,  
Microscopes,  
Eye Glasses,  
Lenses, &c.

ILLUSTRATED PRICE LISTS SENT ON RECEIPT OF APPLICATION ACCOMPANIED BY BUSINESS CARD.

**149 & 151 State Street, Chicago, Ills.**



### JOHN BLISS & CO.

### STANDARD MARINE

### Chronometers and Transits,

### FOR WATCHMAKERS' USE.

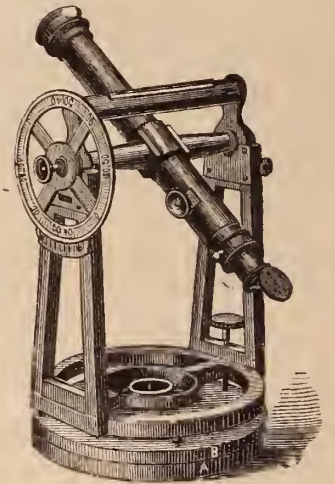

No. 10

Standard Marine Chronometer  
FOR KEEPING CORRECT TIME.

## 110 WALL STREET, NEW YORK.

**IMPORTANT NOTICE.**—These Transits are readily set in position without the aid of strictly correct time as a basis for that purpose. Printed instructions, easily understood, accompany each Instrument, and no calculations are required preliminary to setting in position.

As a trial only is required to insure unqualified approval, we are induced to make the following **LIBERAL OFFER**—On receipt by us of satisfactory reference, and 10 per cent. of the price, we will send one of the foregoing Transit Instruments, on hire or trial, for one month, with full printed instructions for setting up and using the same, and if purchased after trial, we will allow the whole hire to apply in part payment, and sell the Instrument on approved note at four months for the balance. Special terms for payment by installments, after trial, on application. We do not make this offer merely to hire these instruments, but to insure a trial with a view to sales, the hire received being only sufficient to cover the cost of repolishing in case they are returned. Send for Illustrated Circular giving full description.

JOHN BLISS & CO., 110 Wall Street, New York.



# JOHN H. MATHER,

Importer of and Wholesale Dealer in

## WATCH MATERIALS, TOOLS,

—AND—

## JEWELERS' SUPPLIES.

Prompt attention will be paid to Mail Orders. Address.

**JOHN H. MATHER,**

91 East Madison St., Chicago, Ills.

## Watchmaker and Metalworker,

A BI-MONTHLY JOURNAL PUBLISHED IN THE INTEREST OF THE RETAIL WATCH, JEWELRY,  
AND KINDRED ART-INDUSTRIAL TRADES IN THE UNITED STATES,

—BY—

JOHN H. MATHER, Editor,

Publication Office, . . . . No. 91 Madison Street, Chicago.

Subscription Price, 50 Cents, Yearly, in advance.

*Its patrons, who have tried it, pronounce it the best advertising medium extant. Circulates among the retail trade throughout the West and South, the Territories and the Pacific Slope. A guaranteed circulation of nearly 5,000 Copies each issue.*

\* \* Send for Sample Copy and Advertising Rates as above.

# THE STANDARD FILLED RING



## CROWN, 18. LION. FILLED RINGS

### PLAIN & CHASED



EVERY RING GUARANTEED  
BEWARE OF DIFFERENT STAMPS MADE TO IMITATE OUR TRADE MARK.

"There are two points in which it differs from those we have ever before seen. One is in the arrangement of the pendulum, if one may so style that part of the mechanism which responds to the footfall and then acts upon the registering apparatus. This, while arranged so as to quickly respond to the firm tread of one wearer, will also be actuated by the much lighter tread which some other person may have, and in both cases, will respond only *once to one step*. This is an essential point; without it the instrument would be valueless. The French instrument the writer has worn was faulty in this respect, and the fault was one which seemed inseparable from its interior construction, and which was found, though to a less extent, in the English Pedometer. The American instrument has here a decided advantage."

TIFFANY & CO., Sole Agents.

THE  
**AMERICAN PEDOMETER**

IS THE

**Simplest, cheapest and most accurate and convenient walking gauge ever invented.**

There are two forms of index, one registering steps from 23 to 35 inches in length, and another, adapted for Ladies and Children, registering steps from 17 to 23 inches in length. The Cases are of nickel-silver, the size of a small watch.

Price \$5.00 each.

"It did not take long to prove to the wearer of the Pedometer, that she could walk a stated distance each day to the benefit of her health. That beyond that ascertained distance, the exhaustion caused by the exercise taken was not made up by the subsequent night's rest, and the 'dragged-out feeling' which day by day, was present, was in consequence of too much exertion. A fortnight's enforced rest came, and now the Pedometer is worn of choice, from the time of rising until bed-time, more regularly than a watch; and, because the wearer has learned how needful it is not to go beyond what she has found to be the measure of her strength."

TIFFANY & CO., Sole Agents.

Gentlemen's Watches,  
Ladies Watches,  
Bridge Movement Watches,  
¾ Plate Movement Watches,  
¾ Plate Patent Reg. Watches,  
¼ Plate Movement Watches,  
Repeaters,  
Chronographs. (1-5 second)

TIFFANY & CO.

NEW YORK, PARIS, LONDON, GENEVA.

MAKERS OF FINE AND COMPLICATED WATCHES,

Wholesale Office, 694 Broadway, New York.

GEO. R. COLLIS, Manager.

Split-Second Chronographs,  
Minute and Sec'd Chronograph  
Chronograph and Repeaters,  
Minute Repeaters,  
Five Minute Repeaters,  
Quarter Hour Repeaters,  
Repeaters and Chronographs,  
&c., &c., &c.

The medical profession advise the use of a Pedometer by delicate persons in order to regulate the amount of exercise taken.

The price of the American Pedometer is Five Dollars.

NEW YORK, March 25, 1879.  
Messrs. TIFFANY & Co.,

Gentlemen:—I carry one of your American Pedometers, and find it marks the distance exactly, either in walking or running.

Very truly yours,  
CHAS. ROWELL.

TIFFANY & CO., Sole Agents.

THE  
**AMERICAN PEDOMETER.**

PRICE FIVE DOLLARS.

"I have, furthermore, exhibited the Pedometer on the race track, and before the judges, timers and scorers having charge of certain walking matches and pedestrian exhibitions; always to their great interest and curiosity, and the Pedometer's success, as I invariably denoted and stated where the pointer would indicate, and on completion of my walk, showed the gentlemen above-named, that the pointer indicated on the dial, to a hair line, the distance promised and actually walked."

C. TEMPLE FORRESTER, *Pedestrian.*

TIFFANY & CO., Sole Agents.

The instrument has suddenly and from a sanitary standpoint wisely, become the rage.

The American Pedometer,  
Price \$5 00.

"Another point where the inventor of the American instrument has simplified his, and made it superior to Pedometers of foreign make, is the facility of regulating it to the footstep of any wearer."

TIFFANY & CO., Sole Agents.

The Trade supplied only by TIFFANY & CO., (from their new *wholesale* Watch Offices, 694 Broadway,) who do not sell to Jobbers, but are establishing as "exclusive agents" dealers who order quantities. Early application solicited.

C. G. ALFORD & CO.

*Manufacturing Jewelers,*

**183 Broadway, New York.**

WE have not ced with pleasure and satisfaction the action of the Western Jewelers in effecting an organization for the purpose of protecting themselves against the inroads made upon their business by the indiscriminate and wholesale distribution of illustrated catalogues and price lists among other branches of trade and among consumers.

Appreciating the injustice of this practice and realizing fully the great injury to the business of the jeweler, resulting therefrom, we determined two years since, to issue the best catalogue of jewelry ever published, designed for the exclusive use of jewelers only. We made this a prominent feature of our work in our announcement, and from that time we have adhered with unwavering fidelity to our pledge not to provide the dry goods dealers, the confectioners, and the druggists with the means to despoil the jeweler of his legitimate profit, and we feel assured that our efforts in this direction are appreciated by our friends and patrons as shown by the increasing popularity of our book.

We are therefore glad to see that the jewelers are awaking to the importance of defending their interests against the encroachments of this pernicious practice. We again repeat that only jewelers can obtain our Catalogue. Applicants must enclose business card.

C. G. ALFORD & CO.,

183 BROADWAY,

NEW YORK.



Importers of all kinds of



Optical Goods.

French Clocks, strike, visible escapement, from \$20.00 upwards.

## ALBERT BERGER & CO.

MANUFACTURERS AND IMPORTERS OF THE

W. B. & Co. Watch Glasses, Spectacles,  
FRENCH CLOCKS, REGULATORS, MUSICAL BOXES, &c.

Also Lemaire & Bardour & Sons' Opera and Field Glasses.

**No. 47 Maiden Lane, New York**

Factory at Goetzenbruck, Lorraine.

No. 21 Hatton Garden, London. No. 27 Rue-Paradis-Poissonniere, Paris.



9.—LONG WOOD HANDLE BENCH KEY. (Nickel Plated.)

7.—BENCH KEY. (Brass Handle.)

1.—SLIDE KEY.

2.—POCKET KEY.  
(Brass.)

3.—POCKET KEY.  
(Nickel Plated.)

4.—POCKET KEY.  
(Nickel Plated, Hexagon Shell.)

5.—POCKET KEY.  
(Heavy Rolled Gold Plate Mountings.)

6.—CELLULOID MOUNTED KEY,  
With Heavy Rolled Gold Plate Tips.

8.—SHORT WOOD HANDLE KEY.  
(Nickel Plated: for Bench or Pocket use).

**BIRCH'S SELF-ADJUSTING  
W A T C H K E Y S,**

WILL WIND ANY WATCH.

J. S. BIRCH & CO., 38 Dey St., N. Y.

# JOHN F. McINTYRE,

73 Cortlandt Street, New York,

(Late of No. 19 Beekman Street.)

MANUFACTURER OF

## Fine Morocco Cases

### For Jewelry, Silverware and Cutlery.

*Estimates for orders, however large, promptly furnished.*

*Having for years manufactured for the largest houses in the city, I am enabled to refer to a very large number of old patrons.*

*Prices lower than any other manufacturer.*

NE PLUS ULTRA.

## DUST-PROOF WATCH KEYS.

Patent Sept. 1st, 1874.



The Popular Name Key.

A. Nickel Plated Handle and Pipe, Swivel Top, per gross..... \$10.75

English Pattern Key.

C. Nickel Plated Handle and Pipe, Swivel Top, per gross..... \$7.50



BENCH KEYS.

Corrugated Gilt Handles, Tempered Steel Pipes, per Set of Six.....\$1.80  
per Set of Three..... .90

P. Style of Key.

Gilt Handle. Steel Pipe.  
Per Gross.....\$8.50



Our Key Pipes are all warranted to be made of the finest quality of steel. One great advantage this key has over all others, is the mortice through the pipe, making it the most simple and thoroughly dust and moisture-proof, as well as the cheapest key in the market. Our sizes run from 1 to 12; 4, 5 and 6 fit Gents' American Watches; No. 8, Ladies' American.  
For sale by the Trade generally.

**KENDRICK, DAVIS & CO., LEBANON, N. H.**

SOLE OWNERS AND MANUFACTURERS.

The advantage of our Name Key, as an advertising medium, will at once be seen.

HENRY HIRSH,

EDWARD HIRSH.

# HIRSH BROS.

Dealers in Watches & Diamonds

AND MANUFACTURERS OF

## JEWELRY,

No. 23 Maiden Lane, New York.

☛ Prompt attention given to filling orders for all kinds of goods pertaining to the trade.

HENRY MAY.

Established 1854.

JOSEPH STERN.

# MAY & STERN,

IMPORTERS OF

Foreign Watches, Materials and Tools

AGENTS FOR THE SALE OF ALL

DOMESTIC MOVEMENTS AND CASES.

And MANUFACTURING JEWELERS

No. 19 John Street, New York.

☛ SOLID GOLD SEAL RINGS, in Cameo, Amethyst, Topaz and Onyx, A SPECIALTY.

# L. LELONG & BRO.

GOLD and SILVER REFINERS,

Assayers and Sweep Smelters,

Southwest Corner Halsey and Marshall Streets,

NEWARK, N. J.

SWEEPINGS A SPECIALTY.

# KELLER & UNTERMAYER,

ONLY AUTHORIZED AGENTS OF

# The International Watch Co.'s

## WATCHES.

☛ A full and complete assortment of these goods in new and attractive Gold Cases constantly on hand.

No. 18 John Street, New York.

**SILVER FILIGREE JEWELRY.**  
Splendid Silver Bridal Sets,  
Half Sets, Necklaces, Bracelets, &c.

**P. HARTMANN,**  
P. O. BOX, 2454. 36 Maiden Lane, New York.  
Importer and Manufacturer of  
Fine Gold, Diamond & Filigree  
Silver Jewelry.

# ALBERT LORSCH,

IMPORTER AND DEALER IN

# WATCHES,

AND MANUFACTURER OF

## JEWELRY,

ALSO MANUFACTURER OF THE

PATENT ACCOMMODATING

# Spectacles and Eye Glasses,

In Gold, Silver, Steel, &c.

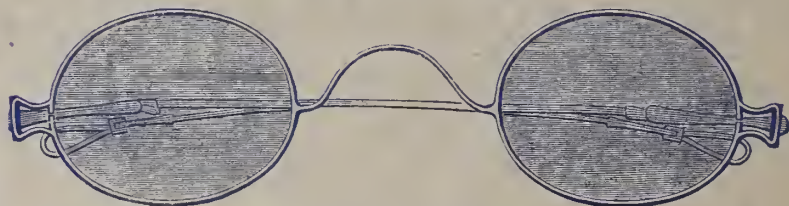

Would call the attention of the trade to the fact, that with the above Spectacles and Eye Glasses, which are constructed to form a Spring by which the lense is held, it is only necessary to have one complete assortment of lenses which being of uniform size, will interchange in all the different kinds of frames, thus giving a complete assortment for a comparatively small outlay. Notwithstanding the numerous advantages of these Spectacles, the prices will compare favorably with those of any other make.

ALBERT LORSCH, 37 Maiden Lane, New York.

LORSCH BROS., 120 Sutter St., San Francisco, Cal.

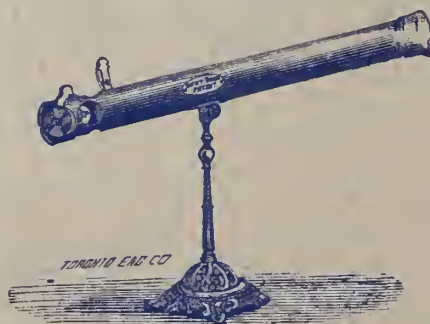

# L. BLACK & CO.'S Spectacle INDICATOR,

Patented in U. S. July 31, 1877.  
Canada, March 19, 1877.

Instruct the customer to place one eye closely against the open end of the tube; put the smallest letter opposite the small hole, and turn until the customer can distinguish a letter or figure. The strength of the spectacles required will be indicated on the index wheel. If the large letters are used, pull up the slide; if not, keep it down.

This instrument is easily adjusted, can not get out of order, is nickel plated, makes a nice appearance, and shows the correct number of lens required.

☛ For particulars, address L. BLACK & CO., Detroit, Mich., or any wholesale Optical Establishment in New York.

# L. HAMMEL & CO.,

## Importers of Watch Materials, Tools,

Opera Glasses, and Optical Goods of Every Description,

SPECTACLES,

EYE-GLASSES,

No. 9 Maiden Lane,

NEW YORK,

Sole Agents in the United States for **G. B. Wheeler's Star Watch and Clock Oil**, and the Celebrated **Gravier Mainspring**.

Every Watch maker knows the necessity of a good and reliable Watch Oil. There are several brands which have hitherto enjoyed excellent reputations, but our experience as well as that of many of our customers has proved them more or less unreliable, in consequence of which we have been for a long time in search of an article that is entirely reliable in every respect, and have found it in the **STAR WATCH AND CLOCK OIL, MADE BY GEO. B. WHEELER, OF NEW BEDFORD, MASS.**, who has given the subject many years of careful study. Our aim now is to bring this oil to the notice of all watch makers, as a thoroughly reliable article, having stood the test of years, a good lubricator, free from gum or corrosive substances and not affected by low temperature. We have sold these oils for the last three years and have always found our customers well pleased with them. We annex hereto some of the testimonials we have received from many reliable business houses and watchmakers throughout the country. The price of Wheeler's Star Oil is as follows:

Watch Oil per bottle, 20 cts., per dozen, \$2.00.

Clock Oil, per bottle, 16 cts., per dozen, \$1.75.

ROCHESTER, N. Y., Dec. 25, 1877.

DEAR SIR:—I send you briefly and most cheerfully my opinion of your Watch Oil. We have been using it on our time locks for about a year and a half, and unhesitatingly say that it is uniformly the best oil that I have ever tried. Other oils previously used have failed after first trials, either drying up after a few weeks or changing color and thickening, all of them requiring too frequent cleaning of the movements to be reliable, but yours has so far proved entirely satisfactory.

Respectfully Yours,  
L. F. MÜNGER,  
Manager Sargent & Greenleaf's Time Lock Manufactory.

Office of CLEMENS HELLEBUSCH, Esq., Manufacturing Jeweler,  
CINCINNATI, Feb. 1st, 1879.

MESSRS. L. HAMMEL & Co., 9 Maiden Lane, New York.

DEAR SIR:—Your Wheeler's Star Watch and Clock Oil gives extraordinary satisfaction to my trade.

Please send me 10 gross at your earliest convenience.  
Yours Respectfully,  
CLEMENS HELLEBUSCH.

Office of R. JAEGERMANN & CO.,  
Dealers in Materials, Tools, &c., for Watchmakers,  
218 North Fourth Street, ST. LOUIS, Feb. 1st, 1879.

Having tried all manufactures of Watch Oil without finding any superior to Wheeler's Star Watch Oil, I hereby recommend the same to all watch makers as the best in the market and the only one that will stand all tests.

Respectfully,  
R. JAEGERMANN.  
MESSRS. L. HAMMEL & Co.,  
9 Maiden Lane, New York.

Office of KENNEDY & KOESTER,  
DETROIT, Mich.  
DEAR SIR:—Please send us 1 gross each Wheeler's Watch and Clock Oil, by express immediately, and oblige,  
Yours Respectfully,  
KENNEDY & KOESTER.

P. S.—Your oil gets more in demand the longer people try it—they buy Wheeler's sooner than any other.

K. & K.

The following is from Mr. Henry Oehl, Jr., one of the best watchmakers in New York City:

I have used the Watch Oil manufactured by Geo. B. Wheeler, of New Bedford, for some two years, and have so far found it in every way satisfactory. It is uniform in quality and as free from gum and acid as any oil I have ever used.

NEW YORK, June 5, 1878.  
HENRY OEHL.

Office of M. S. SMITH & CO.,  
Diamond Merchants and Watch Importers,

MESSRS. L. HAMMEL & Co.,  
DETROIT, Mich., March 7, 1879.  
GENTS:—We have great pleasure in recommending the Wheeler's Star Watch Oil, which we find equal to the best in the market.

M. S. SMITH & CO.

Office of GEORGE WOLF, Esq.,  
Dealer in Watches, Clocks, Jewelry, &c.,  
LOUISVILLE, Ky., Feb. 4, 1879.

MESSRS. L. HAMMEL & Co.,  
9 Maiden Lane, New York.  
After using your Wheeler's Star Watch and Clock Oil for the last eighteen months, I have found it unsurpassed, and congratulate you for having succeeded in placing such an article before the trade.

Yours Respectfully,  
F. W. JARVIS, Watchmaker, with George Wolf.  
[Mr. Jarvis has been forty years in business and is a distinguished Watchmaker.]

NEW YORK, February 15th, 1879.  
With the greatest sincerity I recommend the Wheeler's Star Watch Oil to the trade. I have tested it now for a long time and found it always good, and as good an oil as I ever used.  
A. DEUHARD,  
Formerly with Ball, Black & Co

**REMOVAL.**

WM. PARK, hereby intimates to the trade that he has removed from 181 Broadway to 26 John Street, where he will be happy to receive orders for STONE, SEAL & CAMEO ENGRAVING Coats of Arms found and beautifully painted. Arms Crests, Monograms, and Devices engraved on Locketts, Sleeve Buttons, Rings, &c. Masonic Engraving a specialty.

**H. M. RAYNOR,**

25 Bond Street, N. Y.

**PLATINUM**

FOR ALL

Laboratory &amp; Manufacturing Purposes.

Native Platinum, Scrap, &amp;c., purchased.

**STERN BROS. & CO.**

Manufacturers of

**Fine Jewelry,**

30 MAIDEN LANE,

FACTORY, 73 &amp; 75 Fulton St., NEW YORK.

Gold Seal engraved Band-rings and Locketts a specialty.

The attention of the trade is directed to our plain Gold filled Rings. Sections of which showing the construction and quality sent upon application.

After February 1st, our plain filled rings will bear the above trade mark.

F. W. C. Niecerg,

Repairer and Adjuster of

FINE WATCHES

and Marine Chronometers,

No. 8 JOHN STREET

New York.

Established 1870.

**GUSTAV EPHRAIM,**

Importer and Manufacturer of

**Watchmakers' and Jewelers' Supplies,**Silk, Bamboo Guards and Vest Chains  
of all grades.

JEWELRY AND OPTICAL GOODS.

Sole Agents in the United States

For the Celebrated Eagle Spec's and Eye  
Glasses. Also, Courvoisier Main Springs,  
and Cornell's Anty-Oxidizer,

**Stephen J. Cox**  
**DESIGNER & ENGRAVER**  
on **WOOD**  
NO. 90 NASSAU STREET.  
NEW YORK.  
Jewelers' Work a Specialty.

Full line of new and original mountings on hand.



Particular attention paid to Remounting. Price list furnished on application.

**VOSE & SOUTHWICK,**  
Manufacturers of Gold JewelrySole Makers of  
the Separable  
Sleeve and Col-  
lar Buttons in  
Gold.

No. 183 Eddy Street, PROVIDENCE, R. I.

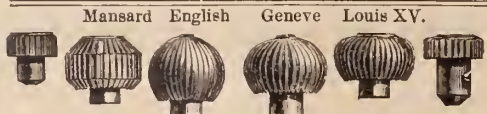
**HENRY LEFORT,**  
Stem-Winding Watch Crown Manufacturer,Crowns and Pushers in gold, all sizes, quality and color,  
made to order. Silver crowns and pushers always on hand.  
Samples sent on application.80 & 82 Marshall Street,  
NEWARK, N. J.**ALBERT FRIEDENTHAL,**

Importer and Jobber of

WATCHMAKERS' &amp; JEWELERS'

Materials, Tools and Optical Goods

Real and Imitation Stones,

For Manufacturing and Repairing Purposes  
**A SPECIALTY.**

Agent for TISDALE'S Watch and Clock Oils.

No. 43 Maiden Lane, New York.

Orders by mail will receive prompt attention.

**E. A. LAUTEN,**

MANUFACTURERS OF

**MOROCCO, VELVET & SATIN  
CASES**

FOR

**Jewelry and Silver Ware.**New Trays for Lace, Shawl and Scarf Pins,  
Novelties in Brocade Silks,

4 Great Jones Street,

One door from Broadway, NEW YORK.

**JEWELRY PHOTOGRAPHED.**In order to meet the demands of many of the Manu-  
facturers of Jewelry, Silver Ware, &c., (Tiffany and  
others) I have erected a SPECIAL SKYLIGHT, for Mechan-  
ical Photography, viz:The Copying of Silver Ware, Statuary, Bric-a-Brac,  
Paintings, Models, &c.I propose to keep it busy by adopting the following  
rates:—8-10. Photographic negative \$1. Proofs 50 cents.  
Special rates for quantities.GEO. G. ROCKWOOD, Photographer, 17 Union Squ.  
Established 1859. (Above Tiffany's.)**REPAIRING, COLORING AND GALVANI-  
ZING FOR THE TRADE.**

C. G. MALLIET,

**Manufacturing Jeweler,**

No. 9 JOHN STREET

NEW YORK.

**EXCELSIOR'S**

ESSAY ON THE

**BALANCE SPRING**

Price \$3 50

42 Nassau Street, N. Y.

**The Morse Diamond Cutting Company,**

J. D. YERRINGTON, Agent.

192 Broadway and 3 John Street.

NEW YORK.

Rough Diamonds, Boart, Roses and Brilliants  
for sale.Fractured Diamonds repaired, and old stones  
improved; also Rough Diamonds cut and  
fashioned to order.

W. N. WALKER,

**DIAMONDS,**

Watches and Jewelry,

No. 18 JOHN STREET, NEW YORK.

IMPROVED JEWELERS' COTTON.

JOHN J. ARMOUR.

**HENRY TROEMNER,**710 Market Street,  
PHILADELPHIA.

Manufacturer of Fine Gold Scales,

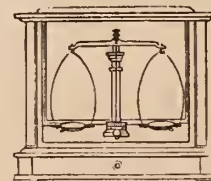

DIAMOND SCALES,

Bullion Balances and  
Weights, in use at all the  
U. S. Mints and Assay  
Offices.

PRICED CATALOGUE ON APPLICATION.

Solid Gold Rings—a Specialty

WM. H. ELY,

**Solid Gold Rings**

MANUFACTURER,

Viz., Plain, Chased, Engraved, Enameled, Engine  
Turned, Shield & Scale. All qualities Warranted  
Orders Promptly Executed.

58 Nassau Street, N. Y.

Established 1848.

Reliable and prompt.

**COOPER & BRO.**  
Wholesale Jewelers,

Importers and dealers in WATCH & CLOCK-MAKERS' TOOLS and MATERIALS; also, JEWELERS' SUPPLIES, SPECTACLES, OPTICAL GOODS, &c. A complete Outfitting Establishment for the trade.

Repairs Department established 1865. Every description of work done for the trade. Watch Repairing, Jewelry and Watch Case Repairing, Gold and Silver-Plating, and Fire Gilding.

35 S. Fourth St. (1st floor), PHILADELPHIA

**E. HOERNER,**

Manufacturer of Jewelry,

Diamond and Black Onyx Goods,

15 Maiden Lane,

NEW YORK.

**DAVID PRINCE,**

Gold and Silver Refiner,

Assayer and Sweep Smelter,

13 and 15 New Jersey Railroad Avenue,

NEWARK, N. J.

Sole Agent for Comins' Improved Amalgamator.

LOWELL WRENCH CO., WORCESTER, Mass.



"The Jewelers' Pin Vise is a well-known tool advertised in the CIRCULAR, by the Lowell Wrench Company, of Worcester, Mass. and is a credit to them. The sample was inspected with high commendation by the members, many of whom had used it and pronounced it far superior to the imported article. It is of hardened steel, nickel-plated, the handle is nicely milled, giving a firm grip for rolling in the fingers, and the whole is turned true to centre. It holds firmly anything placed in it, and altogether is a most excellent tool for the bench."—Proceedings Horological Club, April, 1879.

**Vulcanite Jewelry Co.**

MANUFACTURERS OF

**WHITBY JET,**

Combination Whitby Jet and Vulcanite,  
Byron's Patent, May 18, 1869,

Also a full line of Locketts—plain, gold mounted and monogram.

No. 191 BROADWAY, N. Y.

Agents for the NEW RUBBER WATCH CASES, Fitting all American Movements.

Designs made and estimates given on all kinds of Engraving for Jewelers.



Illustrations for Books, Mfg Catalogues, &c. Labels and Show Cards Engraved on Metal for Color Printing.

**Howard Watches**

ALTERED FROM

**Key to Stem Winders**

HENRY ABBOTT,

Office, 11 Maiden Lane,

NEW YORK.

Factory, John Street, New York.

Leon Jeanne.

Paul Jeanne.

**JEANNE BROTHERS,**

MANUFACTURERS OF

**DIAMOND MOUNTINGS**  
**And RICH JEWELRY,**

Patentees of Jeanne's Ear Wires,

No. 1 Maiden Lane, New York.

Designs furnished and estimates given.

KETCHAM & McDUGALL,  
No. 4 LIBERTY PLACE, NEW YORK.  
MANUFACTURERS OF  
Improved Gold and Silver

**THIMBLES**



AND THE PATENT  
**AUTOMATIC EYE GLASS HOLDER,**  
Which returns the Eye Glasses to their place on or under the lapel of the vest by simply casting them from the nose, combining all the conveniences of Cord, Hook and Case, without their annoyances.

**J. B. LAURENCOT,**

IMPORTER OF

WATCH GLASSES,

**Optical and Fancy Goods**

French Clocks, Musical Boxes, &c.

No. 33 MAIDEN LANE.

15 Rue D'Enghren,  
PARIS.

Box 2954, P. O.  
NEW YORK.

**L. BONET,**

Medal at Centennial, 1876.

**CAMEO**

**Likenesses,**

889 Broadway, New York.

**C. B. WILKINSON & Co.**

212 Broadway,  
NEW YORK,

Manufacturing Jeweler,

Masonic Pins, Rings & Charms,

School, Athletic, Fine

Presentation Medals,

—AND—

JEWELS OF EVERY DESCRIPTION

Designs furnished free upon application.



**GEO. W. DU BOIS,**

(Successor to Albert Landsberg.)

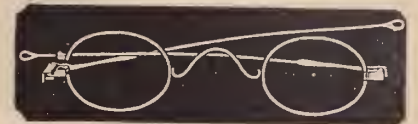

IMPORTER AND MANUFACTURER OF

**Optical Goods,**

No. 36 MAIDEN LANE,

Near Nassau Street, NEW YORK

Sole Agent for

**BLACK'S PATENT**

**Interchangeable Spectacles,**

AND

**EYE GLASSES.**

Jewelers and others who keep spectacles for sale will please observe that, with these PATENT SPECTACLES, it is only NECESSARY to have a full Complete Assortment of Lenses and Pebbles, which being all of a UNIFORM SIZE, will FIT either the Gold, Silver, or Steel Frames, of which but a few of each kind are wanted; an advantage which will give a complete assortment of the finest Spectacles, for one-sixth the capital invested in a like assortment of the same quality goods of the old style frames.

For Particulars, price lists, &c., address

**GEO. W. DU BOIS,**

New York.

Established 1850.



**PETER L. KRIDER,**

MANUFACTURER OF

STERLING

**SILVER WARE,**

Medal and Diploma Awarded, &c.

Striking Society Medals in Gold, Silver or Bronze  
A SPECIALTY!

ARTISAN HALL,

**618 Chestnut Street**

PHILADELPHIA.



**Simons Brother & Co.**  
 611 & 613 Sansom Street, Philadelphia

**The Burbank Manufacturing Company**  
 Manufacturers of GOLD & SILVER



GOLD  
 SILVER,  
 STEEL,  
 RUBBER,  
 And SHELL,

**Thimbles,**



EYE GLASS  
 Self Adjusting.

**SPECTACLES AND EYE-GLASSES**



OF ALL DESCRIPTIONS.

**SOLID GOLD RINGS,**

Office, 14 MAIDEN LANE. NEW YORK.  
 Manufactory, Springfield, Mass.

Established 1853.

**L. H. KELLER & CO.**

Successors to G. A. HUGUENIN,

IMPORTERS OF

**Fine Watch and Clock Materials,**  
 SWISS, ENGLISH, FRENCH & GERMAN  
**FILES, TOOLS, &C.**

FOR WATCH MAKERS, WATCH CASE MAKERS, JEWELERS,  
 SILVERSMITHS, ENGRAVERS, CHASERS, DIE  
 SINKERS, MACHINISTS, &c.

SOLE AGENTS FOR HALL'S STAKING TOOLS AND  
 ROLLER REMOVERS.

**AGENTS FOR THE WHITCOMB AND OTHER AMERICAN LATHES.**

GENERAL AGENTS FOR THE PHILADELPHIA  
 WATCH COMPANY.

American Agents for the Horological Journal, (British).

A Monthly Paper for the advancement of Chronometer, Watch and Clock Making,  
 and kindred Sciences. Published under the auspices of the British Horological  
 Institute, London. Subscription \$2.50 per year, in advance. Also,

SAUNIER'S TREATISE ON MODERN HOROLOGY, IN  
 THEORY AND PRACTICE,

BY M. CLAUDIUS SAUNIER The English Edition will appear in 26 monthly parts.  
 Price 50 cents each. Whole Work, \$13 00, postage paid.

Special attention is directed to

**"OUR OWN" Celebrated Mainsprings Graduated**

in thickness to equalize the power, with well rounded edges, and the  
*Highest Crocus Finish throughout*, insuring the least possible friction  
 in the barrel, pronounced by expert judges to be the *best made*.

"JURGENSEN" Main Springs recoiling, suitable for the highest grades  
 of Swiss Watches.

**"Lutz" Celebrated Hair Springs,**  
 by numbers, of uniform diameter and strength, the best for "BRE-  
 GUETING."

Fine Hole Jewels of Ruby, Sapphire, Chrysolite, Garnet, Beryl and-  
 Aqua Marine, with *gauged* (well shaped and polished) holes, numbered  
 by the Swiss pivot gauge; also, neat black walnut cases, containing  
 forty glass vials for assortments of same. The great advantage in hav-  
 ing Jewels by numbers will readily be seen as a saving in time and an-  
 noyance in selecting and in expense. Dealers once having an assort-  
 ment, can replenish or stock up at a comparatively small outlay, as any  
 desired quantity of No. and quality can be had of us at all times.  
 our stock of jewels being the largest and most complete in the country.

Diamond Charged Broaches for opening and polishing jewel holes.

Diamond Powder and Bort for polishing and grinding 8 different  
 grades, in  $\frac{1}{2}$ ,  $\frac{1}{4}$ ,  $\frac{1}{8}$ , and  $\frac{1}{16}$  K vials, bringing it into the reach of all.

Gold Diamond Set and other fine Geneva Hands.

The new Drills in Sets of 54 small, 126 small to medium, and 48  
 large; also, sold separately if desired.

NOTE.—We issue no Price Lists and Highly Illustrated Catalogues  
 to attract attention of Dealers to a large assortment of goods in print,  
 but we have the goods in stock and will be pleased to quote prices  
 if desired, or fill orders for any article in our line.

**No. 64 Nassau Street,**

**NEW YORK.**

Near Maiden Lane,

## SPECIAL NOTICES.

Advertisements under this head, not to exceed six lines, \$1.00 each insertion.

WANTED Volume VIII of the Jewelers' Circular complete. Address, C. S. CROSSMAN, Ann Harbor, Mich.

JEWELERS' Sale for sale, low, Herring's. Cost \$2,000 Was exposed at the Centennial. Office JEWELERS' CIRCULAR, 42 Nassau St.

WANTED.—A salesman who has been active in the importing business of precious stones. Best of references required. Address A. B. C. Jewelers' Circular.

FOR SALE. A superior Ship's Chronometer, Frodsham make. Apply to C. A. GALLAGHER, Care SINNOCK & SIERHILL, 5 Maiden Lane, New York.

FOUND Gold watch and chain at Manassas, few days after first battle. Address JOS. P. ANGELL, Jeweler, Pine Bluff, Ark.

WANTED.—Nos. 9, 10, 11 and 12 of Vol. VII of this journal. Address, stating price, E. L. THRAL, 2 West Bridge Street, Oswego, N. Y.

WANTED.—A situation as Watchmaker and Jeweler, 7 years experience; and some factory experience. Address D. B. BANCROFT, Richmond, Macomb Co., Michigan.

WANTED a permanent situation by a Watchmaker of ten years experience, and accustomed to all kinds of Jobbing and Watch Repairing. Address, R. W. PETERSON, Oneida, Knox County, Ill.

WANTED.—Situation as Watchmaker or Engraver, either at the bench or as salesman. Twelve years experience in city trade. Best recommendations. Address, "REGULATOR," this office.

FOR SALE.—One pair of 10 inch rollers made by Morgan & Orr, of Philadelphia, in good order, to be sold at a low figure. For particulars apply to PETER L. KRIDER, 618 Chestnut Street, Philadelphia.

WANTED.—By a first-class watchmaker. A steady situation as Repairer and adjuster of fine watches, can furnish the best of references as to ability and integrity. Address G. Care Jewelers' Circular.

FOR SALE. A Jewelers' Factory, with ease and goodwill of the business. Tools, mills, dies and machinery in perfect order. Whole or part of front office to let. CHATTERTON & DODD, 19 John Street, New York.

SITUATION WANTED. East or West, by an American Watchmaker (married), has worked 17 years at bench, and as Salesman is good workman, with general knowledge of the business of a good store; best of references, &c. Please address TIME, Care Editor of this Paper.

WANTED by a man of 10 years' experience in the Jewelry business, a position as Traveling Salesman. He has had some experience on the road. Would not object to working up a new territory. Can give the best of reference. Address R. B. T., 113 Madison St., Chicago, Illinois, Care S. F. ESTELL.

FOR SALE. My entire business for cash. I have the best Jewelry store in the State, (except Chicago.) profits past year, twenty-five per cent, clear on the stock. No trade will be entertained. Must or cash or gilt edge paper. Address, "TRYNER," Jeweler, Bloomington, Ill. City of over 20,000 inhabitants.

FOR SALE. Fine chance for a good man, either Watchmaker or Clerk, to buy a well-established jewelry business, been running 17 years. Keeps a Watchmaker and jeweler at work besides the proprietor. Only about \$4000 capital required. Satisfactory reasons for selling. Correspondence solicited. Address, W. L. M., Care Editor Circular.

GEO. E. WILKINS.—Importer of fine Tools for Watchmakers, cutting and dividing engines, rounding up tools and cutters, also cutters for stem winding wheels. Fine lathes with the American system of chucks. Dividing engine and rounding up tool combined. Marine chronometers for sale. Special tools imported to order. 21 South Salina St., Syracuse, N. Y.

FOR SALE. A Jewelry Store in Manufacturing Village in New Hampshire. Is center of trade for surrounding towns, having a population of about 12,000. Is a large summer resort, has large trade from summer boarders. This is a rare chance for one with small capital. Will be sold low. Is well-established, and doing a good business. Address, LAMSON BROS., 4 Central St., Lowell, Mass.

IMPORTANT to Jewelers.—By sending 25 Cents (in currency), I will forward to your address an INVALUABLE Recipe for preserving all kinds of plated-ware from tarnishing. The ingredients are few, the cost trifling, the work of preparation very simple, and the result all that could be wished for. When prepared it need only be placed in the case where the ware is kept, and needs no further attention. F. H. MADDEN, Care United States Show Case Works, 327 Liberty St., Pittsburgh, Pa.

FOR SALE. A first-class Jewelry Store, established ten years, in a flourishing town on the Hudson of 7,000 inhabitants, beside 800 to 1,000 summer boarders; 1 hour's ride from New York; no other Jewelry Store within a circuit of several miles; store refitted 3 years ago, with seventeen feet of Silver-plated Show Cases, fire and burglar-proof safe, awnings, window shades, signs, reflectors, gas fixtures, etc.; also, large Mirror, and Heater, etc., etc., costing three years ago, \$1,200 will be sold for \$400. Buyer can purchase stock or not. No charge for good will. Lease of store, 2 years to run. Satisfactory reasons for selling. Address, M. SCHINDLER, Tarrytown, N. Y.

## Buyer's Directory.

A Guide to the prominent Wholesale Houses in the Watch, Clock, Jewelry and kindred branches of Trade in New York, Philadelphia, Chicago, Providence and Newark.

## NEW YORK.

## Black Onyx Jewelry.

Cox & Sedgwick—Manufacturers of Black Onyx Jewelry, No. 26 John St., New York.  
Unger, H. & Co.—Manufacturing Jewelers. Fine Onyx and Pearl goods a specialty. Manufacturers of Patent Onyx Bracelet, with Lilly of the Valley mountings. No. 18 Crawford St., Newark, N. J. Box 63.  
Woglom & Miller—Manufacturers of (exclusively) Black Onyx Jewelry, 32 & 34 John st., New York.

## Bohemian Garnet Jewelry.

Bissinger, Philip—Importer of Diamonds, Pearls and Precious Stones. Sole Agent for the Bohemian Garnet Jewelry, 22 John St.

## Clock Companies.

New Haven Clock Co.—62 Reade Street, N. Y.  
Seth Thomas Clock Co.—20 Murray Street, N. Y.  
Waterbury Clock Co.—M. Bailey, Treasurer, Manuf. and Jobbers, No. 4 Cortlandt Street, N. Y., and No. 197 State Street, Chicago.  
Kroeber, F.—Manufacturer and Dealer in American and French Clocks, No. 8 Cortlandt St.

## Corals and Coral Jewelry.

Cuppia, L. A.—Importer of Coral and Silver Filigree Jewelry, 19 Union Square, N. Y.  
Errico Bros.—Importers of Coral, Conch-Shell and Silver Filigree Jewelry, etc., 19 John St.  
Lawson, S.—Manufacturer of Coral and Black Onyx Jewelry. All kinds of repairing solicited. Goods sent on Mem. 63 Nassau Street.

Squ-drilli, Ach.—Manufacturer and Importer of Coral, Conch Shell and Silver Filigree, etc No. 9 Maiden Lane, N. Y.

## Cameo Cutters, Etc.

Bonet, L.—Cameo Likenesses, No. 889 Broadway, N. Y.  
Wiederer, Peter—Late Habermeier & Wiederer, Engravers of Cameo Likenesses, Seal Stones. Cameos repaired. 23 John St.

## Charms &amp; Gold Watch Keys.

Rupp & Held.—Manufacturing Jewelers, Charms and Gold Watch Keys, with French and English Ratchets, a specialty. 15 John st., N. Y.

## Cutlery.

Rogers Cutlery Co.—Hartford, Conn.  
Harrison Bros. & Howson.—Manufacturers of Fine Ivory and Pearl Table and Pocket Cutlery; Carvers in Cases; Nutpicks, Nutcracks and goods suitable for the jewelry trade. 26 Cliff street. W. C. Burkinshaw, Sole Agt.

## Diamonds.

Anderson, Otis—Diamond Merchant and Broker, always ready to pay cash for bargains in Diamonds and Precious Stones, No. 9 Maiden Lane, N. Y.  
Bernhard, A. & Co.—Manufacturing Jeweler & Importers of Diamonds and Precious Stones, also Diamond Mountings, 2 Maiden Lane.  
Bissinger, E.—Importer of Diamonds, No. 192 Broadway, New York.  
Bissinger, Philip—Importer of Diamonds, Pearls and Precious Stones. Agent for the Bohemian Garnet Goods No 22 John St., N. Y.  
Buckenham, Cole & Saunders—Importers of Diamonds and other Precious Stones, No. 10 Maiden Lane, N. Y.  
Fera, Henry—Importer of Diamonds, and Manufacturer of Fine Diamond Jewelry. No. 9 Maiden Lane, New York. Amsterdam, Holland, 23 Loojersgraecht.  
Fox, M. & Co.—Importers of Diamonds and other Precious Stones, No. 1 Maiden Lane, New York.  
Herbert, R. J.—Importer and Broker in Diamonds, 16 Maiden Lane.  
Hedges, Wm. S. & Co.—Importers of Diamonds, No. 170 Broadway.  
Lyon & Hardy.—Importers of Diamonds and Manufacturers of Diamond Jewelry. 30 Maiden Lane, New York.  
Neresheimer, E. Aug.—Importer of Fine Diamonds, No. 21 Maiden Lane, New York.  
Prager, Morris.—Importer of Diamonds and Fine Diamond Jewelry. 8 Maiden Lane, New York.

Randel, Baremore & Co.—Importers of Diamonds, corner Maiden Lane and Nassau St., New York.

Smith, Alfred H & Co.—Importers of Diamonds No. 14 John Street.

## Diamond Cutters.

The Morse Diamond Cutting Co. of Boston.—Henry D. Morse, General Manager. N. Y. Office, 192 Broadway, corner John street. J. D. Yerrington, Agent.

## Diamonds and Diamond Jewelry.

Bissinger, Philip.—Importer of Diamonds, 22 John street, N. Y. Agent for the Bohemian Garnet Goods.  
Bornemann, Louis.—Manufacturer of Diamond Jewelry from original designs, 169 and 171 Broadway.  
Heller & Bardel.—Manufacturers of Diamond and Pearl Jewelry, and dealers in Diamonds Pearls, &c. Also agents for Boss' Patent Stiffened Gold Watch Cases. 13 John Street, N. Y.  
Taylor & Brother—Importers of Diamonds and Diamond Jewelry, 676 Broadway.

## Diamond Setters, Etc.

Asher, J.—Jeweler and Diamond Setter, Precious Stones Inlaid and Incrusted with Diamonds, Nos. 880 and 882 Broadway.  
Wood, Chas. F.—Engraver and Incruster of Precious Stones and Diamond Setter. No. 169 & 171 Broadway.  
Friend, S.—Manufacturer of Fine Jewelry, and Diamond Setter. 33 John street, N. Y.

## Dials, &amp;c.

Caesar Brothers—Manufacturers of Enamel Clock Meter and Gauge Dials, Patent Door, Coffin and Pew Plates, Druggists' Labels, &c. No. 32 and 34 John Street.  
Gold, John T.—(Successor to the late T. Gold), Enamel Watch Dial Maker, 81 Nassau St.

## Enamellers, Etc.

Nutt, J. D.—Enameler on Gold, Silver and Copper, 32 and 34 John St. Birds, Flowers, etc., Enameled in colors.  
Orr, Jas. C.—Enameler on Fine Jewelry, Flowers, Birds, &c., Enameled in colors. Band Bracelets (a specialty). 77 Nassau Street.

## Electroplaters, &amp;c.

Jeandheur, F. & Son.—Gold and Silver Electro Platers & Fire Gilders, coloring Erusean and Gold Jewelry a specialty. 125 Fulton St.

## Engravers and Die Sinkers

Fackner, Edward—Carver, Engraver and Chaser on Jewelry and Pencil Cases. Monograms Lettering, &c. 19 John Street.  
Park Wm.—Stone Seal Engraver. Coats of Arms found and engraved. Initials and Monograms engraved. 26 John Street, New York.  
Schuller, J. Dan'l—Stone Seal Engraver Arms Crests, Initials and Monograms engraved on Stone Seals, &c. 71 Nassau street.

## Fancy Goods, Clocks, Bronzes Etc.

Magnin, Ve J. Guedin & Co.—Importers of Clocks Bronzes, Musical Boxes & Rich Fancy Goods etc., 29 Union Square.  
Le Boutillier & Co.—Importers of Fancy Goods, Clocks, Bronzes, &c. 3 Union Square

## Gold Chains, Etc.

Beck, J. & Son, Manufacturers of Fine Gold Chains and Chain Bracelets, 10 Liberty place, near Maiden lane, N. Y.  
Dorrance, Edge & Co.—Manufacturers of the Celebrated Woven Fabric Gold Chain, No. 12 John street.  
Hamiltons & Hunt.—Manufacturers of Fine Plated Chains and Patent Buckle Bracelets. Branch office, 176 Broadway. Factory, 226 Eddy street, Providence.  
Kaufmann Bros.—Manufacturers of Gold Chains, and Chain Bracelets, 26 John street; Factory, 331 and 333 Bowery, N. Y.  
Nordt & Schlag.—Manufacturers of Gold Chain No. 17 Maiden Lane, N. Y.  
Saxton, Smith & Co.—Manufacturers of Fine Gold Chain. 15 Maiden Lane.

## Gold Pens, Etc.

Aikin, Lambert & Co.—Manufacturers of Choice Gold Pens, Cases, Holders, Toothpicks, etc., 23 Maiden Lane, N. Y.  
Clark, J. M.—Manufacturer of Pen and Pen Cases for the whole-sale trade only. No. 61 Hudson Street, N. Y.  
Mable, Todd & Bard—Manufacturers of Gold Pens, 180 Broadway.  
Todd, Edward & Co.—Manufacturers of Gold Pens, Pencil Cases, Tooth Picks, &c., 44 East 14th St., Union Square.

**Goldsmiths, &c.**

**Greene Wm. C. & Co.**—Goldsmiths; Manufacturers of Rich Sets in Taper Wire Coral. Office, 192 Broadway.

**Gold Rings.**

**Bowden, J. B. & Co.**—Manufacturing Jeweler.—Solid Gold Rings a specialty, 1 Maiden Lane.  
**Ely, W. H.**—Manufacturer of Solid Gold Rings of every description. No. 58 Nassau Street.  
**Frankel & Folkart.**—Manufacturers of Seal, Cameo and Amethyst Rings a specialty. Also a full line of Gold White Stone goods and Diamond Settings. 21 John St., N. Y. etc., No. 4 Liberty Place.  
**Peckham, Wm. H. & Co.**—Manufacturers of Solid Gold Seamless Rings, and Fancy Embossed Rings, Patent Spectacles, Jewelry, etc. No. 4 Liberty Place, N. Y.  
**Sinnock & Sherrill.**—Manufacturers of Stone Rings. No. 5 Maiden Lane, N. Y.  
**Tingley, Joseph N.**—Manufacturer of Stone Rings and novelties in Stone Goods. No. 9 Maiden Lane, N. Y.

**Hair Jewelry.**

**Montoux, Wm. E.**—Leading Artist in Hair, and Manufacturing Jeweler, 81 Nassau St., New York. Pattern Books for the trade.  
**Sauter, L.**—Manufacturer of Fine Gold and Hair Jewelry and Device Work. Nos. 65 & 67 Nassau Street.  
**Schwencke O.**—Manufacturer of Fine Hair Jewelry. Orders from the country promptly attended to. No. 43 Maiden Lane.

**Jewelry Cases, Fancy Boxes, Etc**

**Braun, Chr. E.**—Manufacturer of Jewelry Boxes, Trays for Show Cases, &c., 62 Chatham st.  
**Dahlem, W.**—Manufacturer of Cases for Jewelry and Silverware, No. 85 Nassau Street, N. Y. Show Case Trays, &c., at shortest notice.  
**Loehr & Koerner.**—Manufacturers of Morocco, Velvet, Satin, Jewelry, Watches and Silverware Cases, Glove, Handkerchief, Ladies' Jewel, Work Boxes, &c., Fancy Trays and Stone Fittings to order, Office and Salesroom 83 Nassau Street, New York.  
**Mohn & Walker.**—Manufacturers of Morocco Cases, 712 Broadway, N. Y.  
**Sturm, I.**—Manufacturer and Importer of Cases for Jewelry, Watches, Silverware, &c. No. 15 John street, N. Y.  
**Welch & Miller.**—Manufacturers of Morocco, Velvet, and Satin Jewelry Cases, Trays, &c. Telescope Sample Cases with flexible Trays. Complete stock on hand. 169 Broadway.  
**Wiggers & Froelick.**—No. 60 Nassau street.—Manufacturers of Cases for Jewelry, &c., of every description. Trays for Show-cases, Stands for Show-windows, etc. Jewelers' Traveling Cases, light, convenient and strong.

**Jewelry—Fine.**

**Aikin, Lambert & Co.**—Manufacturers. General stock of Reliable Jewelry, 23 Maiden Lane.  
**Alford, O. G. & Co.**—Manufacturers. General line fine and reliable goods. Specialties in Onyx goods and chain. 183 Broadway, New York.  
**Andrews, J. F.**—Manufacturer of Fine Jewelry, Locketts, Sleeve Buttons and Rings in Stone Cameo, etc., a specialty. 35 Maiden Lane.  
**Baldwin, Sexton & Peterson.**—Manufacturers Fine Jewelry. Whiting Building, Broadway and Fourth street.  
**Barthman & Straat.**—Manufacturers of Fine Jewelry. Seal and Stone Rings a Specialty Orders promptly attended to. 41 Maiden Lane.  
**Bernhard, A. & Co.**—Manufacturers of Fine Hair Jewelry and Device Work. The latest styles 2 Maiden Lane, New York.  
**Bissinger, E.**—Importer of Fine Jewelry, Locketts, Crosses, Neck Chains, &c., No. 192 Broadway.  
**Brown, Thos. G.**—Manufacturer of Rich Jewelry Necklaces, Locketts, Bracelets, Sleeve Buttons, etc., 9 Bond street, N. Y.  
**Bryant & Bentley.**—Manufacturing Jewelers Rings a specialty. 12 Maiden Lane.  
**Brainerd & Steele.**—Successors to Brainerd, Steele & Co., Manufacturers of Fine Jewelry and Brainerd's Patent Locketts. No. 9 Maiden Lane, New York.  
**Burch, Geo. & Co.**—(Successors to Burch, De Mott & Coughlin.) Manufacturing Jewelers, 17 Maiden Lane, N. Y. Factory, Newark, N. J.  
**Carrow, Bishop & Co.**—Manufacturers of Fine Jewelry, Roman Band Bracelets, Locketts, Crosses, &c. 12 John Street, N. Y.

**Carter, Howkins & Sloan.**—Manufacturing Jewelers, Whiting Building, 4th St. & Broadway.  
**Chatellier & Spence.**—Manufacturing Jewelers. No. 694 Broadway, N. Y.  
**Champenois & Co.**—Manufacturing Jewelers, No. 1 Maiden Lane. Specialties—Jet Cluster Goods in Sets and Sleeve Buttons, Engraved and Enameled Goods in Sets, Studs, Sleeve and Collar Buttons, Lace, Shawl and Cuff Pins, Ear Knobs and Crosses.  
**Cook, Groeschel & Co.**—Manufacturers of Fine Jewelry and Locketts, 191 Broadway (over Mercantile Bank.) N. Y.  
**Demmert Bros.**—Manufacturers and Importers of Fine Jewelry, Cameo and Onyx Locketts, Sleeve Buttons and Sets a specialty. Old No. 9 Maiden Lane, New York.  
**Falkenau & Oppenheimer.**—Jewelers, (Specialty, Knife Edge Jewelry & Rings), 89 Nassau st.  
**Field & Co.**—Manufacturing Jewelers, 8 Maiden Lane, N. Y.  
**Goddard, John M.**—Manufacturing Jeweler.—Seal Rings and Fine Locketts a specialty, No. 3 Maiden Lane, N. Y.  
**Greason, Bogart & Pierce,** successors to Arthur, Rumrill & Co., 182 Broadway, manufacturers of fine jewelry and gold chains  
**Hartmann, P.**—Manufacturer & Importer of Fine Gold, Diamond, and Filagree Silver Jewelry, No. 36 Maiden Lane. P. O. Box 2,454.  
**Haskell, H. C.**—Manufacturing Jeweler. Seal Rings a specialty. Special attention to Jobbing of every description. 12 John street.  
**Hellfenstein & Bourke.**—Manufacturers of the Patent Adjustable Sleeve Button, No. 202 Broadway, N. Y.  
**Henderson & Winter.**—Jewelers, No. 15 Maiden Lane, New York. Specialties—Stone, Cameo, Onyx, Amethyst, Topaz, Pearl and Turquoise Rings.  
**Hunt & Owen.**—Manufacturing Jewelers. Office 5 Maiden Lane.  
**Hale & Mulford.**—Manufacturers Rich Jewelry, Whiting Building, Broadway and 4th Street.  
**Jeanne Brothers.**—Manufacturers of Diamond Mountings & Rich Jewelry. 1 Maiden Lane.  
**Kellei, Chas. & Co.**—Manufacturing Jewelers Locketts a Specialty. No. 18 John St., N. Y.  
**Kremetz & Co.**—Manufacturing Jewelers, No. 13 John Street, N. Y.  
**Kroll, H.**—Manufacturer of Fine Jewelry. Repairing (a specialty) done for the trade at moderate prices, 78 Nassau street.  
**Kuhn & Doerflinger.**—Manufacturers of Enamel'd and Roman Band Bracelets, also Fine Locketts and Pendants, 18 John street.  
**Lennon, John D.**—Manufacturing Jeweler, 142 Fulton street. Flat, and Half-round Gold Bracelets, Roman and Stone Locketts.  
**Moore & Horton.**—11 Maiden Lane, Manufacturing Jewelers, Rings, Studs, Collar and Sleeve Buttons, Pins, Ear-rings, &c.  
**Miller Bros.**—Manufacturers of Fine Jewelry Locketts, Sleeve Buttons, Studs, etc., etc. 11 Maiden Lane, New York.  
**Marx Kossuth & Co.**—Manufacturing Jewelers 39 Maiden Lane.  
**Owen, G. & S. & Co.**—Manufacturing Jewelers. Office, No. 5 Maiden Lane.  
**Pendrell, Wm.**—Manufacturer of Fine Jewelry, jobbing and repairing for the trade at low rates, 73 Nassau Street.  
**Riker, William.**—Manufacturer of Jewelry. Inlaid Gold Jewelry a Specialty. No. 5 Maiden Lane, N. Y.  
**Riley, J. A. & Co.**—Manufacturing Jewelers, Etruscan Gold and Coral Sets, Roman Bracelets, Necklaces, etc. Onyx Goods a specialty. 7 and 9 Bond street, New York.  
**Richardson, Enos & Co.**—Manufacturers of Fine Gold Jewelry, Gold Chains, Locketts, Crosses and Necklaces. Colored and Etruscan Work. No. 23 Maiden Lane, New York.  
**Richardson, J. W. & Co.**—Manufacturers of Jewelry, Masonic and other emblems. 196 Broadway, Manufactory, Providence, R. I.  
**Sexton & Cole.**—Manufacturing Jewelers, Colored Gold and Onyx Goods a specialty. No. 30 Maiden Lane.  
**Shoemaker & Co.**—Manufacturing Jewelers, Cameo Buttons, and Locketts, Roman Gold Goods, etc. No. 21 Maiden Lane, N. Y.  
**Stites, E.**—Manufacturer of Fine Jewelry. No. 12 Maiden Lane, N. Y.  
**Sturdy Bros & Co.**—Manufacturers of Jewelry. General line of fine and heavy Rolled Plate Goods. Specialties—enameling on gold plate; graduated wire coral work. 14 Maiden Lane, N. Y.

**Terhune, Charles F.**—Manufacturing Jeweler, 16 Maiden Lane, N. Y.  
**Thoma, Ernest.**—Manufacturer of Fine Jewelry. Sleeve Buttons, Rings, Ear-rings, &c. No. 173 Broadway, N. Y. Factory, Hackensack, N. J.  
**Trier Bros. & Co.**—Jewelry. Optical, Rubber, Jet, Shell, Ivory, Amber and Pearl Goods. Silk Guards, Japanese Bamboo Watch Chains a Specialty. No. 15 Maiden Lane.  
**Unger, H. & Co.**—Manufacturers of Fine Gold Jewelry, Colored and Etruscan work, Enameled Sets, etc. Office and Factory, 18 Crawford street, Newark, N. J. Box 63.  
**Vulcanite Jewelry Co.**—Manufacturers of Whitby Jet and Vulcanite Jewelry, 191 Broadway, N. Y.  
**Wadsworth, E. E.**—Manufacturer of Rich Jewelry and fine Rolled Plate. Fine Seal Rings a specialty. 35 Maiden Lane.  
**Wheeler, Parsons & Hays.**—Manufacturers of Fine Jewelry, Watch Cases, Gold Chains, &c and Dealer in American and Swiss Watches, No. 2 Maiden Lane, N. Y.  
**Wienhold, Joseph.**—Manufacturer of Fine Jewelry and Diamond Setter. 24 John St.  
**Woglom & Miller.**—Manufacturing Jewelers Nos. 32 & 34 John street, N. Y. Specialty Black Onyx goods.

**Jewelers' Tools, etc.**

**Frasse & Co.**—Importers of Stubs, French, Swiss, German and Sheffield Tools, Files and Steel Wire for Watchmakers, Jewelers, etc., 62 Chatham street, N. Y.  
**Hammel, L. & Co.**—Importers of Materials and Tools for Watchmakers, Jewelers and Engravers—also Optical Goods, &c., 9 Maiden Lane, N. Y.  
**Hecht, Phil.**—Importers and dealers in Watch makers' materials, Tools, Optical Goods and Silk Guards, etc. 13 Maiden Lane, N. Y.

**Lapidaries.**

**Fox, M. & Co.**—Practical Lapidaries, No. 1 Maiden Lane, New York.  
**Kordmann & Michel.**—Lapidaries, dealers in Precious Stones. Rubies, Sapphires and Peridots cut. No. 32 Maiden Lane.

**Masonic Jewelry.**

**Wilkinson, C. B. & Co.**—Manufacturers of Masonic, Odd Fellows, Athletic Clubs and other Jewelry, No. 212 Broadway, New York.

**Opticians.**

**Burbank Manf'g Co.**—Manufacturers of Spectacles and Eye Glasses of all descriptions, in gold, silver, etc., 14 Maiden Lane, N. Y.  
**Du Bois, Geo. W.**—Successor to A. Landsberg, Importer and Manufacturer of Optical Goods 36 Maiden Lane, Box 3993, N. Y.  
**Hammel, L. & Co.**—Importers of Spectacles, Opera and Marine Glasses, Telescopes, Microscopes, Optical & Fancy Goods, 9 Maiden Lane.  
**Laurencott, J. B.**—Importer of Watch Glasses, Optical and Fancy Goods, Clocks, Brouzes, etc., 33 Maiden Lane, N. Y.  
**Lorsch, Albert.**—Manufacturer of the Patent Accommodating Spectacles and Eye Glasses in Gold, Silver and Steel, and other Optical Goods, 37 Maiden Lane, N. Y.  
**Serin, A.**—Manufacturer of Spectacles and Eye-Glasses, in Steel, Shell and Rubber. Repairing of all kinds. Opera Glasses covered and re-gilt, etc. 169 and 171 Fulton street.  
**Spencer Optical Manufacturing Co.**—Gold, Silver, Steel and Nickel Plated Spectacles, Eye Glasses, &c. 13 Maiden Lane, N. Y.

**Precious Stones, &c.**

**Bissinger, Philip.**—Importer of Diamonds, Pearls and Precious Stones. Agent for the Bohemian Garnet Goods. No. 22 John St., N. Y.  
**Fox, M. & Co.**—Importers of Diamonds and other Precious Stones, No. 1 Maiden Lane, New York.  
**Gruet, Jules.**—Importer of Precious and Imitation Stones, Amethysts, Topazes, Cameos, Garnets, Doublets, Imitation Diamonds, Pastes, etc., No. 14 John street. Manufactory at Septmoncel, France.  
**Meyer, Francis Ed.**—Successors to John B. Behrmann, Importer of Imitation Precious Stones, all sizes and shapes constantly on hand. No. 53 Nassau st., P. O. Box, 1981.

**Silverware.**

**Gorham Manufacturing Co.**—Union Square.  
**Wood & Hughes.**—Manufacturers of Fine Silverware. 16 John Street, N. Y.  
**The Adams & Shaw Co.**—Manufacturers of Silverware. Cor. Broadway & 4th St., N. Y.



**Silver Plated Ware.**

- Brown & Bros.**—Manufacturers of first quality of Electro Plated Flat Table Ware. No. 81 Chamber Street, N. Y.
- Hall, Elton & Co.**—Manufacturers of the Finest Electro-Plated Ware, salesroom, 75 Chambers street, N. Y.
- Holmes, Booth & Haydens**—Manufacturers of Silver-plated Ware. 47 Chambers street.
- Meriden Britannia Co.**—Manufacturers of Silver plated Ware, 46 East 14th Street, Union Square, N. Y.
- Middletown Plate Co.**—Manufacturers of Superior Electro-Plate. Factories, Middletown, Conn., Salesroom, 13 John Street
- Rogers Cutlery Co.**—Hartford, Conn.
- Reed & Barton**—Manufacturers of Fine Plated and Table Ware, of every description, 686 Broadway, N. Y.
- Rogers & Bro.**—Manufacturers of the finest quality of Electro-Plated Ware. 690 B'way.
- Simpson, Hall, Miller & Co.**—Manufacturers of Fine Silver Plated Ware, No. 36 E. 14th St.
- Schade, Henry.**—Manufacturer of White Metal and Plated Ware, No. 84 John Street, New York. Price list and catalogue furnished on application.
- Webster, E. G. & Bro.**—Manufacturers of Fine Silver Plated Ware. Office and Warerooms, 14 Maiden Lane, N. Y.

**Show Cases, Etc.**

- Kraft & Hoffmeister**—Manufacturers of Metal Show Cases, Jewelry Trays always on hand, No. 16 North William street, N. Y.
- Smith, B. & W. B.**—Patent Improved Counter Show Cases. Drawings furnished and estimates given for fitting stores in Cabinet Work complete.

**Spectacle Case Manufacturers.**

- Koenen, A. & Bro.**—Manufacturers of Leather Spectacle & Eye Glass Cases, 81 Nassau St., N. Y.

**Thermometers Etc.**

- Tagliabue, Giuseppe**—Thermometer, Barometer and Hydrometer Manufacturer, 302 Pearl street near Beekman, N. Y.

**Thimble Manufacturers.**

- Burbank Manufg Co.**—Manufacturers of Gold & Silver Thimbles, 14 Maiden Lane, N. Y.
- Ketcham & McDougall**—Improved Gold and Silver Thimbles, Nos. 4 and 6 Liberty Place, near Maiden Lane, N. Y.
- Woglom & Miller**—Sole Agents for the "Prince" thimble, in gold and silver, 34 John St.,

**Walking Canes.**

- Fradley, J. F.**—Manufacturer of Fine Gold and Silver-headed Walking Canes and Sterling Silverware. Office and Factory, 20 John st.

**Watch Companies.**

- American Watch Co.**—Robbins & Appleton, No. 9 Bond street, N. Y.
- Illinois Watch Co.**—Factory, Springfield, Ill. Office, 21 Maiden Lane.
- Hampden Watch Co.**—of Springfield, Mass. Office, No. 12 Maiden Lane, New York.
- Tiffany & Co.**—Makers of Fine and Complicated Watches. Office 694 Broadway, N. Y.
- The Howard Watch and Clock Co.**—No. 2 Maiden Lane, N. Y.

**Watch and Chronometer Jeweler.**

- Queen, James**—Watch and Chronometer Jeweler and Pallet Maker, 78 Nassau street, Room 8. Pivots inserted in Pinions, Balance, Staffs, &c.

**Watch Importers, Etc.**

- Aikin, Lambert & Co.**—Importers of Watches, Sole Agents for Paul Breton & Chas. Latour, Geneva. A general line of reliable Swiss Watches. Watch Cases of all styles made to order. 23 Maiden Lane, N. Y.
- Bynner, T. B.**—Importer and Jobber of Watches, Diamonds and Fancy Goods, and dealer in the best class of Rolled Plate Jewelry. 513 Broadway.
- Cross & Beguelin**—Importers of Watches, Watch Tools and Materials, dealers in American Watches, No. 21 Maiden Lane, N. Y.
- DuBois, Francis & Co.**—36 Maiden Lane, N. Y., Importers of Watches and Manufacturers of Watch Cases.
- Droz, Henry E.**—Importer of Watches and Watch Case manufacturer. Agent for the "E. Perregaux" Watch, and jobber in American Watches, No. 92 Fulton Street, N. Y.
- Freund Max & Co.**—Importers of Watches, Jewelry and Precious Stones, 8 Maiden Lane
- Friedman, S.**—Importer of and dealer in Watches and Jewelry, 40 Maiden Lane.

**Gagnebin, Chas.**—Importér of all kinds of Watches, 4 Maiden Lane. Agent for Ulysse Breting's Fine Chronometers, Chronographs, Anchors, etc.

**Gallet, Julien**—Importer of Watches. No. 1 Maiden Lane.

**Ginnel, Henry**—Importer of Watches, Tools and Materials. No. 31 Maiden Lane, N. Y. P. O. Box, 2967

**Jandorf, P. & Bro.**—Importers of Watches and Jewelry, 182 Broadway, bet. John Street and Maiden Lane, New York.

**Keller, L. H. & Co.**—(Successors to G. A. Huguenin,) Importers of Fine Watch and French Clock Materials, No. 64 Nassau street, N. Y.

**Hirsch Bros.**—Dealers in Watches and Diamonds, and Manufacturers of Jewelry. No. 23 Maiden Lane, New York.

**Hyde's Sons, John E.**—Wholesale Commission Agents, only, for Jules Jurgensen, of Copenhagen, Ed. Perregaux, of Locle, Jules Monard, of Geneva, and for other makers of all qualities of watches, 23 Maiden Lane.

**Magnin, Ve J. Guedin & Co.**—Importers and Agents of the Nardin Watch, 29 Un. Square.

**Mathey, L. & A.**—Importers of Fine Watches and Sole Agents for the **H. L. Matile's** Watches, No. 16 Maiden Lane.

**May & Stern**—Importers of Foreign Watches, Materials and Tools, etc. Manufacturing Jewelers. No. 19 John St., N. Y.

**Middleton & Brother.**—Importers of Swiss Watches and dealers in American Watches, Diamonds, Gold Chains, Jewelry, etc., 10 Maiden Lane, N. Y.

**Nicoud & Howard**—Importers and Manufacturers of Watches, No. 14 Maiden Lane.

**Oppenheimer Bros. & Veith**, Dealers in Watches and Diamonds, and Manufacturing Jewelers. No. 35 Maiden Lane, N. Y.

**Robert, J. Eugene**—No. 30 Maiden Lane, New York Agent for Louis Audemar's celebrated watches.

**Schwob, Adolphe**—Manufacturer & Importer of Watches, 11 Maiden Lane, N. Y.

**Stern Brothers & Co.**—Importers of Swiss Watches and wholesale dealers in American Watches, &c., 30 Maiden Lane.

**Scott, J. T. & Co.**—Importers of Watches, and Manufacturers of Jewelry, and Jobbers of all grades American Watches. No. 11 Maiden Lane, N. Y.

**Strasburger, Louis & Co.**—Importers and Makers of Watches of every description. No. 15 Maiden Lane.

**Tiffany & Co.**—Makers of Watches. General Agents for Patek, Philippe & Co. Wholesale office, 694 Broadway, N. Y.

**Watch Cases.**

**Brown, J. A. & Co.**—Manufacturers of The Ladd Patent Stiffened Gold Watch Cases, &c., 11 Maiden Lane, N. Y. Factory, 58 Eddy street, Providence, R. I.

**Watch and Chronometer Repairer.**

**Cerf, B.**—Practical Watchmaker and Repairer, No. 10 John street, N. Y. Repairing and adjusting of Fine Watches done for the trade. All kinds of escape and stem winding wheels cut to order.

**Sirois, A.**—Practical Watchmaker, 89 Fulton street. Special attention paid to the repairing of Fine Watches. Pivots inserted.

**Watch Case Repairers.**

**Tarbox, Hiram**—Watch Case Repairing, Springing, Polishing and Engine Turning, 79 Nassau street, (room 22), N. Y.

**Renaud, F.**—Watch-Case Repairer.—Solid and Heavy Rolled Plate Bows and Pendants. Springer and Engine Turner of Cases and Jewelry, 36 Maiden Lane

**Watch Guards.**

**American Silk Guard Manufacturing Co.**—Our goods are warranted all silk.—Kossuth Marx & Co. No. 39 Maiden Lane, N. Y.

**Watch Glasses, Shades, Etc.**

**Brown, Edwin**—No. 85 Nassau Street, Imported and own Manufacture Watch Glasses, Flat, Flat Concave, Concave, Convex and fine Geneva's. Fine fitting solicited.

**Hill, Robert S.**—Manufacturer of Watch Glasses, &c., dealer in Imported Glasses, Flat Glasses a specialty; also, Jeweler's Glasses. Nos. 75 & 77 Nassau street, N. Y.

**BOSTON.**

**The Star Salt Caster Co.**—Sole Proprietors and Makers of the Celebrated Star Salts, 161 Franklin Street, Boston, Mass.

**PHILADELPHIA**

- Booz & Thomas.**—Manufacturers of Gold and Silver Watch Cases and Jewelry, 103 South 8th Street, Philadelphia.
- Bennett, Jacob & Son.**—Diamond Setters and Manufacturing Jewelers. 108 South 8th St., Philadelphia, Pa.
- Cooper & Bros.**—Wholesale Jewelers, and Importers of and Dealers in Watch and Clock-makers' Materials, etc. Spectacles and Optical Goods. No. 35 South 4th St., Phila.
- Conover David F. & Co.**—American Watches, Wholesale Salesroom, southeast corner 7th and Chestnut streets, Philadelphia.
- Hagstoz & Thorpe.**—Sole manufacturers of Boss' Stiffened Gold Watch Cases. Sixth and Chestnut Streets, Philadelphia.
- Herold, Chas P.**—Successor to Hildebrandt, Herold & Co., Manufacturing Jeweler and Diamond Setter. Diamonds. 916 Chestnut St
- H. Muhr's Sons.**—Manufacturing Jewelers, Solid Gold Rings a specialty, 633 & 635 Market st. New York Office, 11 Maiden Lane.
- Krider, Peter L.**—Manufacturer of Sterling Silver Ware, Artisan Hall, No. 618 Chestnut street
- Levy, Bernard**—Manufacturers of gold and silver watch cases, and importers and dealers in Swiss and American watches, 402 Library street, Philadelphia.
- McCall & Newman**—Manufacturing Jewelers, Filled Plain Gold Rings a specialty, No. 625 Arch street.
- Morgan & Headly.**—Manufacturing Jewelers Cameo sets, Gold sets, Roman Locketts, Rings, Coral sets, and a general line of rich goods. 611 and 613 Sansom street, Philadelphia.
- Pierson, Edwin.**—Manufacturer of Fine Imitation Jewelry, Gold and Silver Electro-plater, Fire Gilder, Coloring, Etruscan and Gold Jewelry a specialty. 1300 Chestnut St.
- Rosenthal, G. F. C.**—Manufacturing Jeweler and Diamond Setter. Engraving and Designing of Monograms a Specialty. No. 924 Chestnut street, Philadelphia.
- Scherr, L. A. & Co.**—Wholesale Dealer in Watches Silver Plated Ware, Spectacles, Fancy Goods, Watch Materials, etc., 726 Chestnut street.
- Sheafer, W. H. & Co.**—Makers of Fine Jewelry 908 Chestnut Street.
- Simons, Brother & Co.**—Manufacturers of Fine Jewelry, Canes, Thimbles, Chains. 611 & 613 Sansom St., Philadelphia.

**CHICAGO.**

- American Watch Company**, of Waltham, Mass. No. 170 State street, Chicago.
- Charpior & Wathier**—Watchmaker & Jewelers for the Trade, and Wholesale Dealers in Watch Material, Tools, &c., 61 West Kinzie Street, Chicago, Ill. Send for price list.
- Cogswell, Weber & Co.**—Watches, Jewelry and Silver Plated Ware, Watchmakers' Tools and Materials at whole ale on y, 146 S ate st., Chicago.
- Frese, B.**—Watchmaking and Repairing for the Trade promptly attended to. Stem-winding and escape wheels cut to order. No. 99 E. Madison St., Chicago, Ill.
- Purdy, J. H. & Co.**—Jobbers of large and small Tools and Materials, for the use of Watchmakers, Jewelers, and kindred Trades. Spectacles—Jewelry Boxes, Plated Chains, &c., &c. No. 170 State street.
- Stein & Ellbogen**—Wholesale Dealers in Watches and Jewelry, 127 State St., Chicago. Specialty, repairing for the Trade.

**PROVIDENCE**

- Irons, Chas. F.**—Manufacturer of Solid Gold Jewelry. Specialty Emblems, Pins and Charms Masonic, Odd Fellows, &c. 102 Friendship St.
- Perkins, C. H. & Co.**—Manufacturers of fine Gold and Plated Jewelry. 20 Conduit St., Providence, R. I.

**NEWARK.**

- Lefort, Henry.**—Stem-winding Watch Crown Manufacturers. 80 & 82 Marshall St.
- Lelong, L. & Bro.**—Gold and Silver Refiners, Assayers and Sweep Smelters, S. W. corner Halsey & Marshall streets, Newark, N. J.
- Milne & Jourdan**—Manufacturers of Stem-winding Watch Crowns Nos. 13 & 15 Franklin Ave., Newark, N. J.
- Prince, David**—Gold and Silver Refiner, Assayer and Sweep Smelter. Sole Agent for Comin's Improved Amalgamator. 63 Railroad Ave.

# FRASSE & COMPANY,

Importers of P. S. STUBS,

French, Swiss, German & Sheffield Tools, Files,

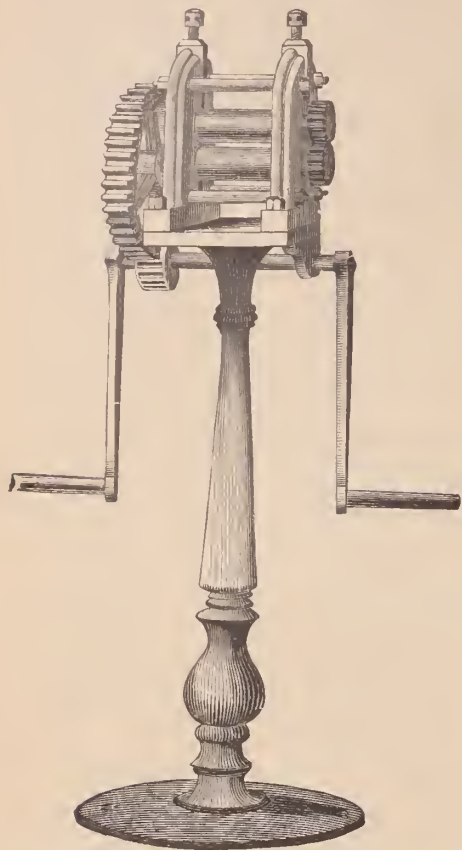

Steel Wire and Materials,

For Watchmakers, Jewelers, Engravers,  
Die Sinkers, Machinists, &c.

Turning Lathes, Drills & Chucks

Rolling Mills, Draw Plates,

The Celebrated Rodenbush

Piercing Saws,

Horse Shcc Magnets,

Nurls,

Ingo's,

Chasing Tools,

Engravers' Tools,

Brush Wheels & Buffs,

Hand Brushes and Buffs,

Borax,

Saltpetre,

Beeswax,

Rouge,

Tripoli,

German Silver,

Bras, &c.

No. 62 Chatham Street,  
Established 1816.

New York.  
P. O. Box 4627.

## WESTON DYNAMO-ELECTRIC MACHINE CO

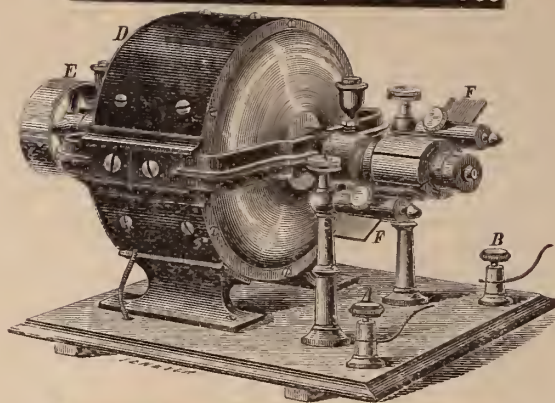

CONDIT, HANSON & VAN WINKLE  
Sole Agents NEWARK, N.J. U.S.A.

Machines for Electro-Plating, Electrotyping, Electric Light, Telegraphing, &c.

The Weston Dynamo-Electric Machine is constructed on a new principle giving the greatest amount of electricity with the least consumption of power. Its simplicity and ease of management has already made it the standard machine. The success attending its introduction has already had the effect of inducing parties building machines for similar uses to adopt some of the devices peculiar to our new construction. We beg to call attention to the various patents covering our machines, and to the fact that we guarantee purchasers against any infringement of existing patents, as well as to their adoption and endorsement by the largest manufacturers of the country, in many cases after a previous trial of all other machines.

In addition to the testimonials in our Catalogue of January 1, we beg to refer to the following houses:—Carter, Hawkins & Sloan; Enos Richardson & Co.; Bates & Bacon; Short, Nevey & Co.; Stephen Richards & Co.; Meriden Britannia Co.; Russell & Erwin Manufacturing Co.; Reed & Barton; Hall, Elton & Co.; Richardson, Boynton & Co.; Wm. H. Jackson & Co.; Stanley Works; Rogers Cutlery Co.; Chas. Rogers Bros.; Edward Miller Co.; Mitchell, Vance & Co.; Norwalk Lock Co.; Hayden, Gere & Co.; Domestic Sewing Machine Co.; Eberhard Faber; Jos. Dixon Crucible Co.; Mumford & Hanson; Fagan & Son, and over 200 others. Outfits for NICKEL, SILVER, BRONZE PLATING, etc. The two highest Centennial Awards and three of the Centennial Medals of American Institute.

There are great advantages in the use of these Machines for Manufacturing Jewelers as they are always ready for use, avoiding the use of mercury and the annoyance of fitting up batteries, producing better colored work, and more durable; there are over 30 in use in Attleboro and vicinity alone, and are being rapidly adopted by the trade in Birmingham, Paris, Pforzheim, &c.

Machines from \$125, upward.

The Machines may be seen in operation at our New York Office, 92 and 94 Liberty St., 2 doors west of Broadway.

Catalogues of all our goods sent on application.

# PATENT IMPROVEMENT IN COUNTER SHOW CASES,

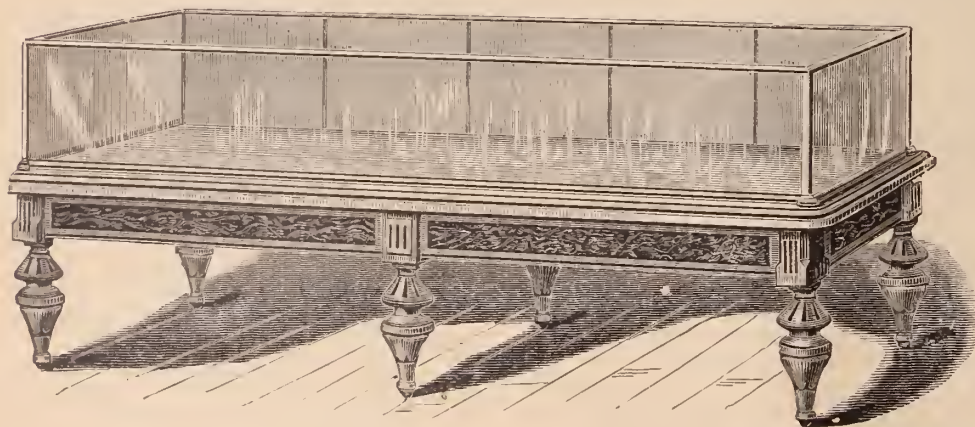

PERPENDICULAR SLIDING DOOR, DUST TIGHT.

CENTER COUNTER CASE DOORS, Running through both sides.

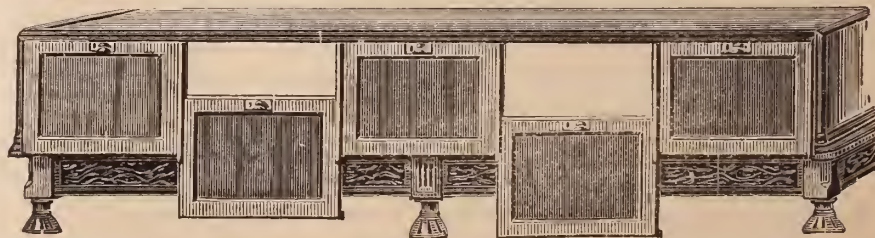

Its advantages are as follows:—The doors are more conveniently opened and closed, less liable to get out of repair or broken, articles are more easily reached in wide cases, mirrors are more safe, it dispenses with hinges, economizes room, excludes dust, and is air tight when closed.

Drawings furnished and estimates given for fitting stores in cabinet work complete.

REFERENCES:—Gorham Mfg Co., Rogers & Bro., Mitchell Vance & Co., Meriden Britannia Co., M. S. Smith & Co., Detroit, Mich. D'Valentine, Syracuse, N. Y.

B. & W. B. SMITH,  
220 West 29th Street, New York.

SEPTEMBER, 1879.



Osborne.

PATTENSON - SON & CO. ENG

D. F. HOPKINSON, PUBLISHER.

Established 1813.

# SETH THOMAS CLOCK CO.

THOMASTON, CONN.

No. 20 MURRAY STREET, New York.

16 Worship Street,  
LONDON, E. C.

172 State Street,  
CHICAGO.

132 Sutter Street,  
SAN FRANCISCO.

## F. KROEBER,

Manufacturer of CLOCKS,

No. 8 Cortlandt St.,

New York.

FACTORIES:—NEW HAVEN, CONN., AND  
NEW YORK CITY.

SUPERIOR GRADE OF  
WALNUT CLOCKS A SPECIALTY

SOLE AGENT FOR

E. INGRAHAM & CO.

—AND—

CLOCKS OF ALL MAKERS

AT LOWEST MARKET PRICES!



"AURORA."  
1 Day Lever, Alarm, Nickel. Height, 5½ inches



"THISTLE,"  
1 Day Lever, Alarm, Nickel. Height, 8¼ inches.

# New Haven Clock Co.

117 & 119 State St., Chicago.

G. A. HARMOUNT, Agent.

62 Reade Street, New York.

L. EGERTON, Jr., Agent.

Manufacturers and Jobbers of

# AMERICAN CLOCKS,

## Movements and Clock Material,

Also, Black Walnut, Visible Pendulum Clocks, and Specialties  
in Brass and Nickel.

Agents for { JEROME & CO., - - - - - Of New Haven, Conn.  
E. INGRAHAM & CO., - - - - - Of Bristol, Conn.

Liberal Discounts to the Trade.

# WATERBURY CLOCK CO.

## MANUFACTURERS OF AMERICAN CLOCKS,

4 CORTLANDT STREET,  
NEW YORK.

M. BAILEY, Treasurer.

63 WASHINGTON ST.  
CHICAGO.

—————  
♦♦♦♦♦  
FACTORIES, WATERBURY, CONN.

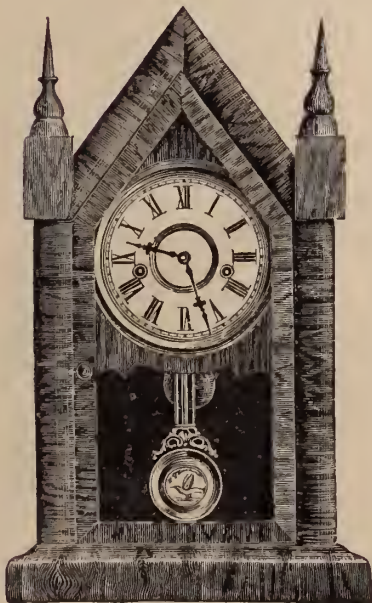

SHARP GOTHIC EXTRA.



CRICKET EXTRA.

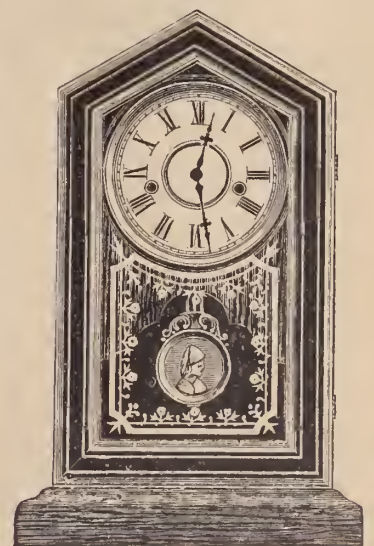

CHESTER.

# GEO. B. OWEN & CO.

6 MURRAY STREET,

Factory, Winsted, Conn.

New York.

MANUFACTURERS OF

## BLACK WALNUT CLOCKS,

Clocks Manufactured by the following Companies will be furnished at lowest Market Rates:

- New Haven Clock Co.,
- Seth Thomas Clock Co.,
- E. N. Welch Man'g Co.,
- Welch, Spring & Co.,
- Waterbury Clock Company,
- Ansonia Clock Company,
- Wm. L. Gilbert Clock Company,
- E. Ingraham & Co.

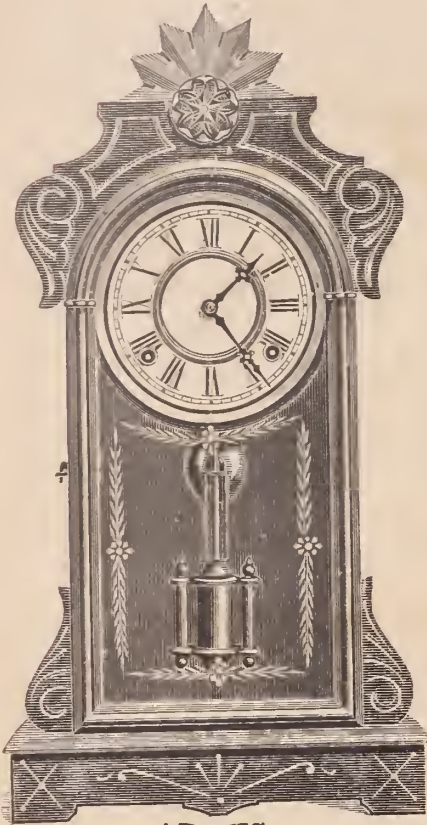

**ARGUS.**

Eight day Strike. Height, 20¼ in.

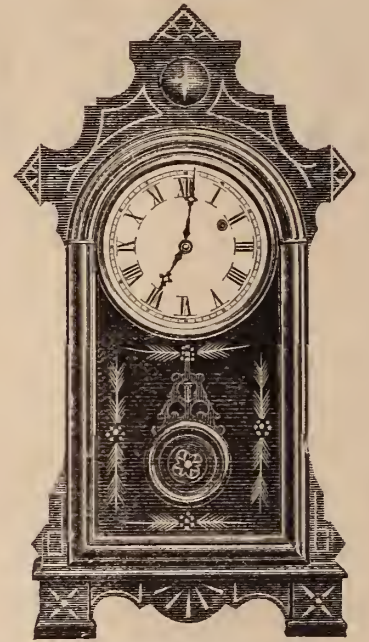

**AMPHITRITE.**

1 Day Time. Height 17½ in

Illustrated Catalogues and Price Lists furnished on application,

## PATENT IMPROVEMENT IN COUNTER SHOW CASES,

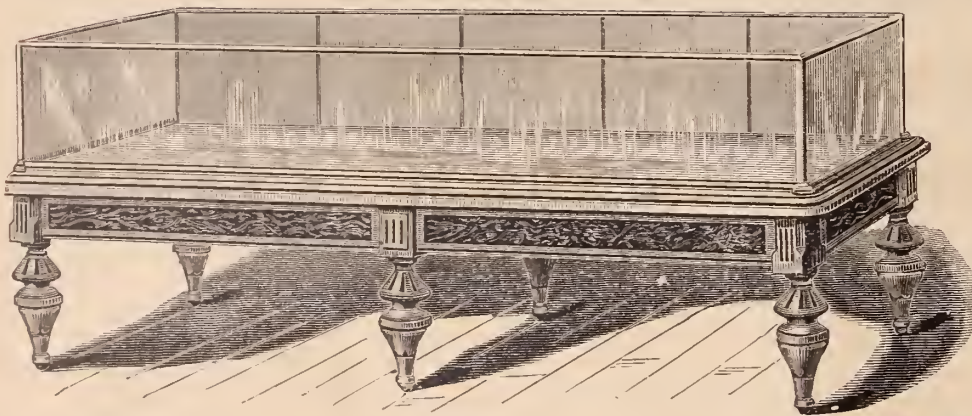

PERPENDICULAR SLIDING DOOR, DUST TIGHT.

REAR VIEW OF CASE SHOWING SLIDING DOOR.

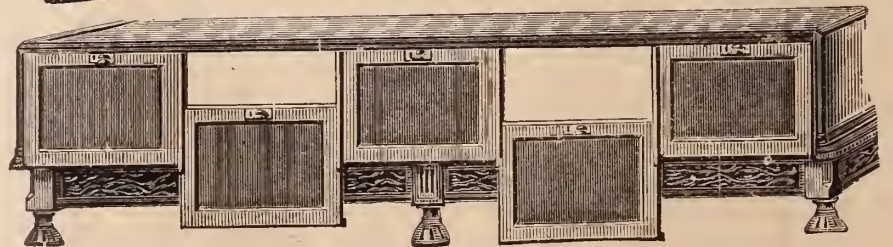

Its advantages are as follows:—The doors are more conveniently opened and closed, less liable to get out of repair or broken, articles are more easily reached in wide cases, mirrors are more safe, it dispenses with hinges, economizes room, excludes dust, and is air tight *when closed*.

Drawings furnished and estimates given for fitting stores in cabinet work complete.

REFERENCES:—Gorham Mfg Co., Rogers & Bro., Mitchell Vance & Co.,  
Meriden Britannia Co., M. S. Smith & Co., Detroit, Mich.  
D Valentine, Syracuse, N. Y.

**B. & W. B. SMITH,**  
220 West 29th Street, New York.

# LOUIS STRASBURGER & CO.,

Importers of

# DIAMONDS.

We are direct Importers of Diamonds, dealers will therefore always find ORIGINAL parcels in our stock to select from.

MATCHED PAIRS, IN ALL GRADES AND WEIGHTS, A SPECIALTY!

NEW YORK, 15 MAIDEN LANE.

PARIS, 30 BOULEVARD HAUSSMANN.

Our complete stock of loose and mounted Diamonds enables us to send a full assortment for selection to any first-class house.

## LOUIS STRASBURGER & Co.

### Manufacturers of Watches,

From the finest Stem-Winding and Setting goods to the lowest price Watch in the market.

We manufacture and have continually in stock a complete assortment of the best COMMERCIAL WATCHES ranging from the lowest priced Metal and Silver Watches to the finest Gold Watches, such as REPEATERS, CHRONOGRAPHS (single and split) and all other Timing and Complicated Watches.

Also a full assortment of the INTERNATIONAL and all AMERICAN Movements. *Gold and Silver Cases,* constantly on hand.

We would call particular attention to our complete and varied assortment of NICKEL WATCHES, (black and fancy Dials,) in all grades, styles, and sizes.

THE RAIL-ROAD TIMEKEEPER A SPECIALTY.

SALESROOMS, No. 15 MAIDEN LANE, NEW YORK.

Watch Factory, Rue Leopold, Chaux de Fonds, Switzerland.

# SUPERIOR ELECTRO-PLATE!

MANUFACTURED BY

# THE MIDDLETOWN PLATE COMPANY,

Factories, MIDDLETOWN, Conn.

Salesrooms,

{ 13 John Street, New York,

{ 120 Sutter Street, San Francisco.

We offer the following **low priced** but **best quality** goods **bearing our Trade Mark**, together with an **unrivalled** assortment of **novel** and **staple** goods in **new** designs for Fall of 1879.



## BUTTER DISHES.

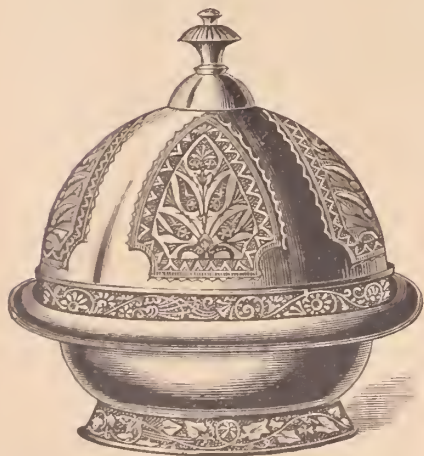

No. 436 Butter, Plain, \$3.50  
No. 436 Butter, Chased, 4.00



No. 435 Butter, Plain, \$3.50  
No. 435 Butter, Chased, 4.00



No. 414 Butter, Plain, \$4.25  
No. 414 Butter, Chased, 4.75

*Continued on next page.*



Middletown Plate Company, Middletown, Conn., continued.



No. 415, Butter, Plain, \$5.00  
No. 415, Butter, Chased, 5.50

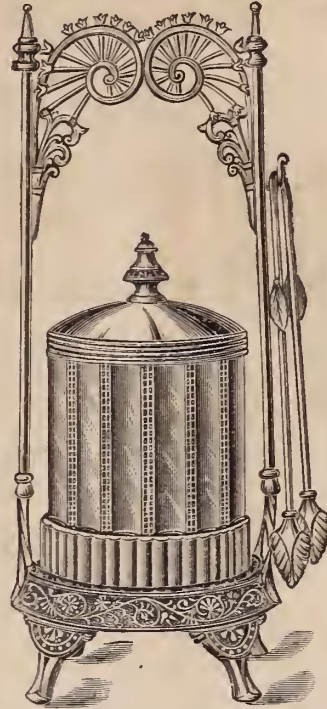

No. 94. Pickle, One Bottle, with Fork, \$3.00

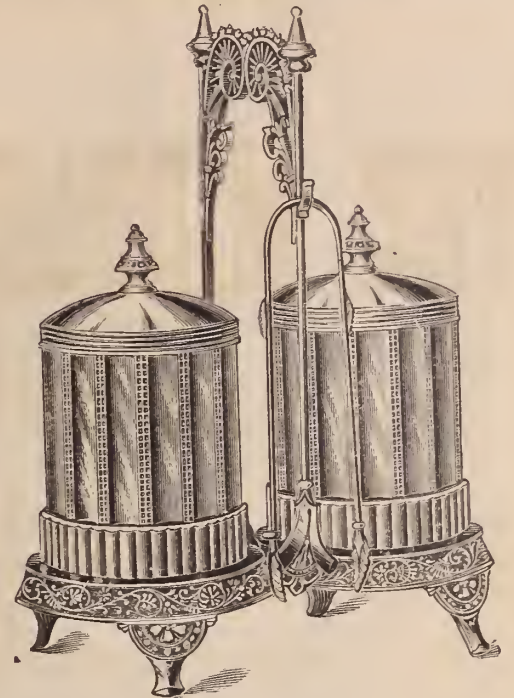

No. 94. Pickle, Two Bottles, with Fork, \$5.00.



No. 1771 { Basket, Plain, . . . . . \$5.00  
Basket Chased . . . . . 5.50

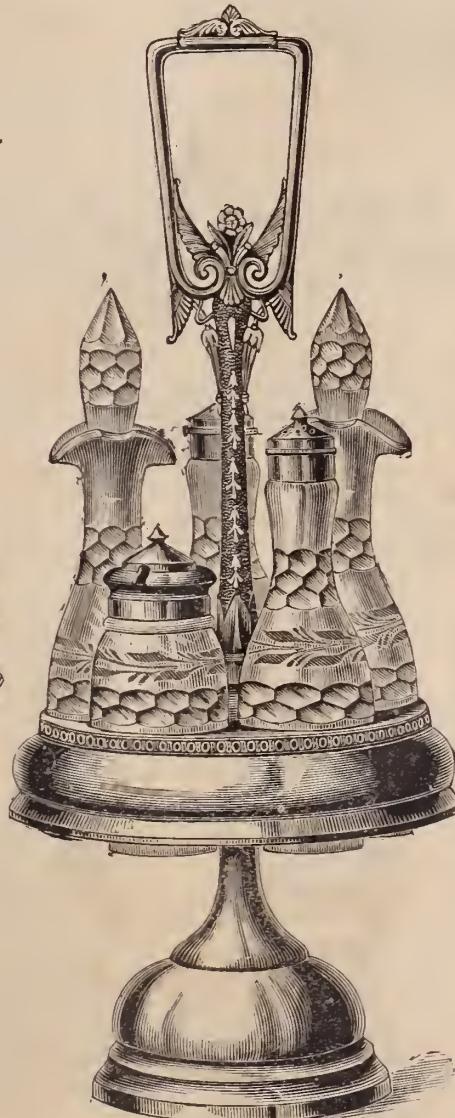

WITH FIVE BOTTLES.  
No. 259, Castor, Plain, \$5.00  
" " " Chased, \$5.50

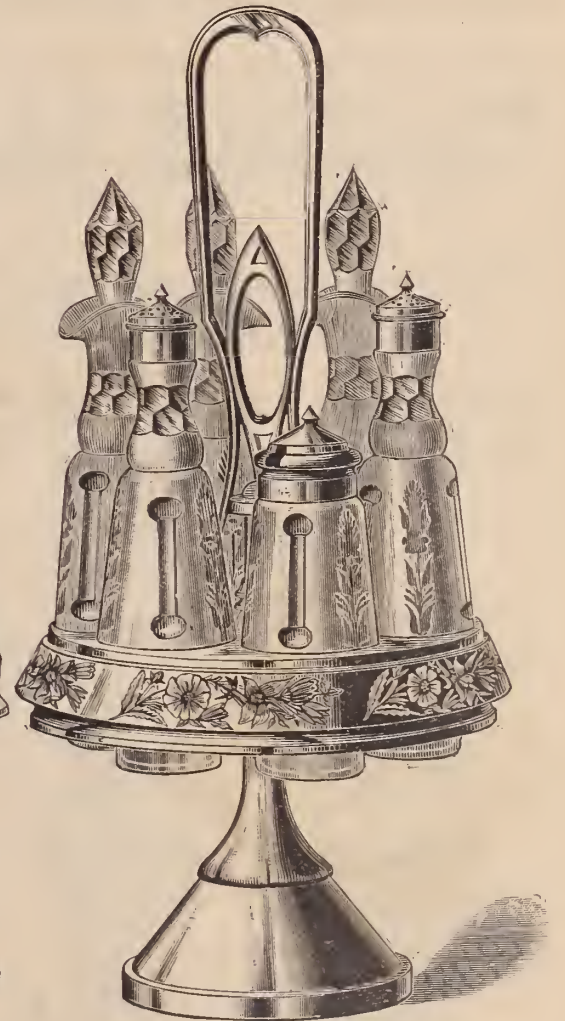

WITH SIX BOTTLES.  
No. 259, Castor, Plain, \$5.50  
No. 259, Castor, Chased, 6.00

ILLUSTRATED CATALOGUES SENT ON APPLICATION, TO THE TRADE ONLY.

# SIMPSON, HALL, MILLER & CO.

36 East 14th St., Union Square,  
NEW YORK.

Factories, Wallingford, Connecticut.

MANUFACTURERS OF THE FINEST QUALITY

## Silver-Plated Ware.

NEW DESIGNS OF SUPERIOR ARTISTIC MERIT NOW  
READY AND IN PREPARATION FOR  
THE FALL TRADE.



# The STAR SALT CASTER COMP'Y

Sole Proprietors and Manufacturers of  
CELEBRATED

## STAR SALTS

For convenience, neatness and utility the STAR SALTS have become a household necessity.

The pulverizer in the bottle, as shown by the cuts, keeps the salt pulverized, and obviates the disagreeable habit of spilling the salt by dipping out of an open salt cellar.

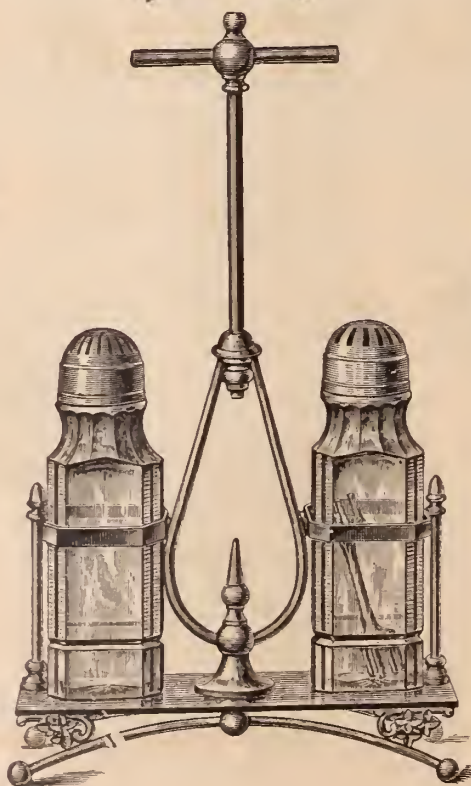

No. 161 Franklin Street  
BOSTON, MASS.

Place these in the family and Salt Cellars  
will be discarded.

MANUFACTURED IN ALL VARIETIES  
OF PLAIN AND FINE CUT  
GOODS, CASTERS, &c.

Special care given to orders for exportation.

Fine Diamond Cut, with  
Sterling Caps.

For full descriptions of the above goods see our Illustrated Catalogues, which will be mailed on application.

**T H E**

# MERIDEN BRITANNIA COMPANY

MANUFACTURERS OF

## Silver-Plated Ware,

46 East Fourteenth St.,

UNION SQUARE,

NEW YORK.

FACTORIES, - - WEST MERIDEN, CONN.

# THE WM. ROGERS MANUFACTURING COMPANY,

—AND—

# THE ROGERS CUTLERY COMPANY,

MANUFACTURERS OF

## Cutlery, and Silver Plated Table Ware.

### Trade Marks:

Established 1871.

On Spoons, &c., 1871 ROGERS © 5 oz.

On Knives, - -



Our Knives are guaranteed

**TO STRIP**

12 dwts. of Silver per Dozen.

All our goods are put up

One Dozen in a Box.

Established 1865.

⚓ WM. ROGERS & Son, A.A.



Our Spoons, Forks, &c., are guaranteed

**TO STRIP**

On Tea Spoons - - 48 dwts. per gross

On Dessert Spoons & Forks, 72 dwts. per gross

On Table Spoons & Med. Forks 96 dwts. per gross

All other Goods in proportion.

All our Spoons, Forks, &c., are guaranteed to be plated upon

**18 per cent. Nickel Silver.**

the best known base for plating upon.

**OUR GOODS ARE PLATED 20 PER CENT. ABOVE STANDARD PLATE.**

**THE WM. ROGERS MANUFACTURING COMPANY,**

WM. H. WATROUS, President.  
F. WILLSON ROGERS, Secretary.

Address all communications to *Drawer 30, Hartford, Conn.*

JAS. T. SCOTT,  
S. CLEM. SCOTT,  
J. T. SCOTT, JR.

# J. T. SCOTT & CO.

Established 1847.

SOLE EASTERN AGENTS FOR

## THE ROCKFORD WATCH COMPANY,

11 MAIDEN LANE,

NEW YORK.

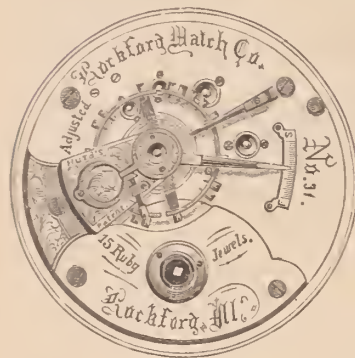

ROCKFORD WATCH.

This Company manufactures eight grades of superior 18 size key and stem wind

**QUICK TRAIN,**  
Movements.

ALSO SOLE AGENTS FOR  
**Abbott's Patent Open-Face**

18 size American stem-winders, with XII at pendant and seconds opposite



ABBOTT'S PATENT.

AND AGENTS FOR  
The Auburndale

### CHRONOGRAPH

TIMERS,

1/2 and 1/3 seconds, in 18 size Nickel-Plated Cases, designed for Sporting, Scientific and Mechanical purposes.

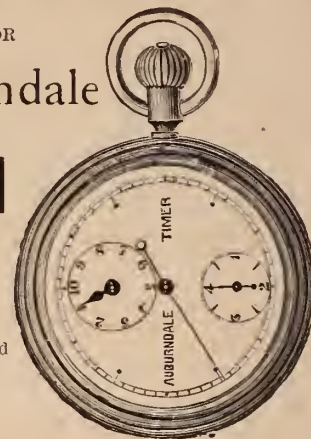

AUBURNDALE TIMER.

Manufacturers of Jewelry and Wholesale Dealers in all grades of American Movements.

WATCH CASES, DIAMONDS, CHAINS, SILVER WARE, &c.

Price Lists furnished upon application to those regularly engaged in the Trade.

J. C. AIKIN.

H. A. LAMBERT.

J. B. SHEA.

## AIKIN, LAMBERT & CO.,

Manufacturers of GOLD PENS,

Pen and Pencil Cases, Pencils, Tooth-picks, and "Novelties" in Pencil Goods.

No. 23 MAIDEN LANE,

NEW YORK.



Would call the attention of the Trade to our large and complete line of Pen and Pencil Goods in all styles and varieties, suitable for demand.

Our introduction last season of Pencils in NEW AND ENTIRELY NOVEL DESIGNS was marked by an unprecedented demand, which establishes the sale of these goods as STAPLES, and as being suited to any season of the year.

The Magic Charms (as per cuts shown below), inlaid with pearl and gold, in form of vines, flowers, birds, etc., on



celluloid of assorted colors, in imitation of malachite, tortoise shell, agate vaegriated marble, etc., are the LATEST and most novel pencils in the market.

Send for circular and new list.

Branch, No. 113 East Madison Street, Chicago.

### Also Importers of all grades of Watches,

Sole Agents for "PAUL BRETON" and "CHAS. LATOUR," GENEVA.

—SPECIALTIES.—

AGASSIZ Movements, Gilt and Nickel Stem-Winding, fitting Ladies' Riverside Case.

CHAS. LATOUR Movements, Gilt and Nickel Key-Winding, fitting 10 and 16 size Waltham Case.

PAUL BRETON Movements, Gilt and Nickel Key and Stem-Winding, a full line of these CELEBRATED TIMEPIECES in gold and silver cases of the most approved styles.

METAL OPEN FACE STEM-WINDING "LONGINES" and "EXCELSIOR", 16, 18 and 20 line, the BEST metal Watches in STYLE and QUALITY in the market.

Our assortment of Jewelry is very large and complete, consisting of a general line of RELIABLE goods, both in GOLD and ROLLED PLATE, of new and tasty patterns, and including almost any article a Jeweler would have calls for. Special attention given to ORDERED WORK and REPAIRS.

GOODS SENT ON APPROVAL and CORRESPONDENCE invited. Those not acquainted with us will oblige by giving references when ordering

JANUARY 1st, WE REVALUED OURENTIRE STOCK AND HAVE REDUCED PRICES, AND ARE OFFERING GREAT INDUCEMENTS TO PURCHASERS FOR THE RETAIL TRADE.

SPECIALTY.

# Marble Clocks,

WITH GONG STRIKE.

On the 15th of August we will be prepared to show the largest stock of French Marble Clocks ever imported into New York.

## Le Boutillier & Co.

No. 3 UNION SQUARE.

### ARKELL & CO.

IMPORTERS AND DEALERS IN

Watch Materials, Tools,  
JEWELRY,

AND ALL GRADES OF AMERICAN WATCHES.

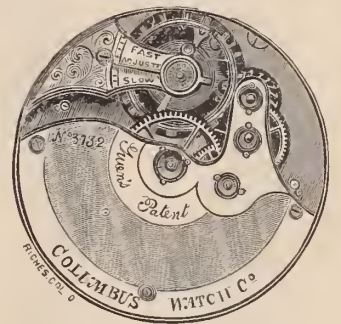

We call the attention of Watchmakers to the "JEQUIER" Main Spring. This spring is the only one of all fabrications exhibited at the "Paris Exposition" that received FIRST and ONLY medal. We claim it is the best in this country, and invite a trial by the trade as a test of its merits. Send for sample and also descriptive catalogue of Columbus Watch, nickel  $\frac{3}{4}$  plate, full jeweled, stem-winding and setting, the most beautiful watch with the best results for least money, quality considered. No price list furnished unless requested and only to the trade.

BALDWIN'S BARREL CATCH INSERTER, indispensable to the Watch Repairer, saves time and labor, sent by mail on approval to the trade free of postage.

We are Sole Agents for the United States of these goods. We also manufacture the BOSS ENGRAVING BLOCK—there are features in its construction different from all others in the market, holds the work to be engraved, of any kind, without attachments. It is practical, simple, and reasonable in price. All these specialties enumerated, may be obtained of any regular Dealer in material and tools, or direct of us.



P. O. Box 8. Canajoharie, N. Y.



# THE STANDARD FILLED RING

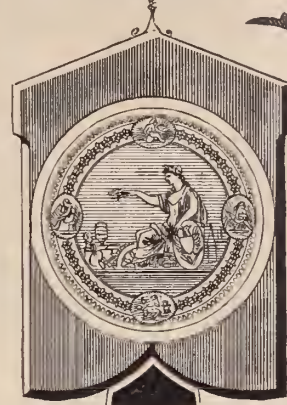

## CROWN 18. LION FILLED RINGS

### PLAIN & CHASED



EVERY RING GUARANTEED  
BEWARE OF DIFFERENT STAMPS MADE TO IMITATE OUR TRADE MARK.



No. 15. Gold Spectacles, Band Slides.



# MORGAN & HEADLY,

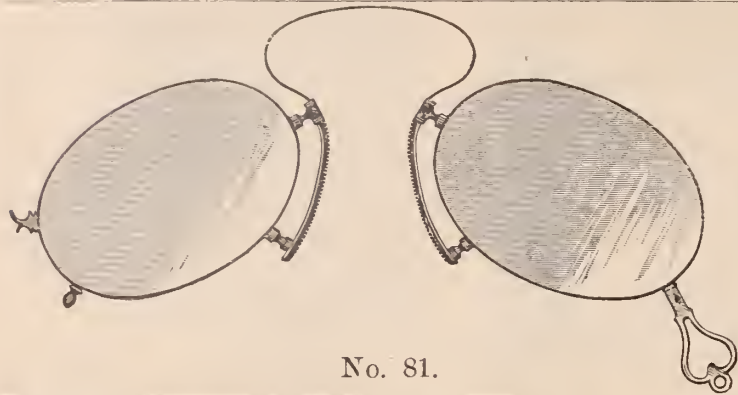

No. 81.

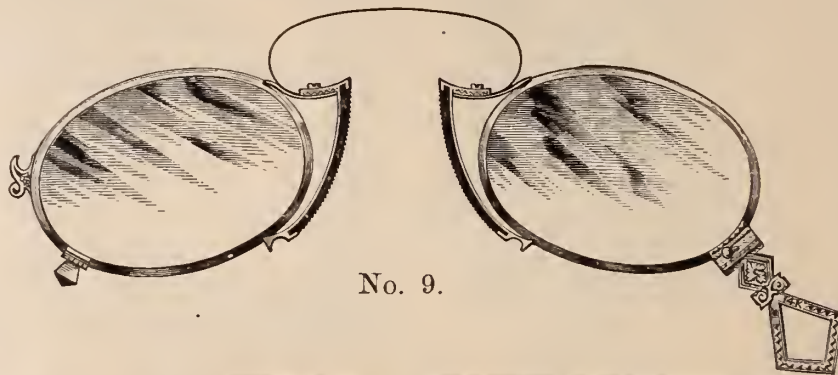

No. 9.

## Manufacturers of Gold, Silver and Steel SPECTACLES and EYE GLASSES,

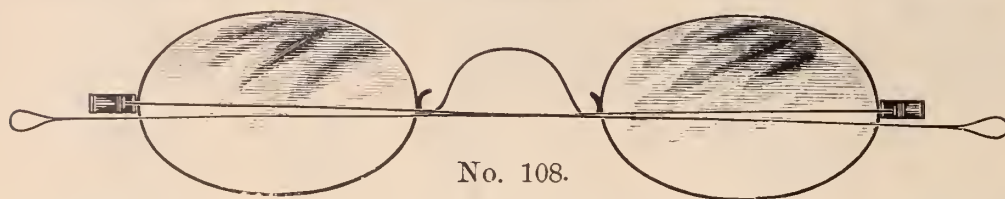

No. 108.

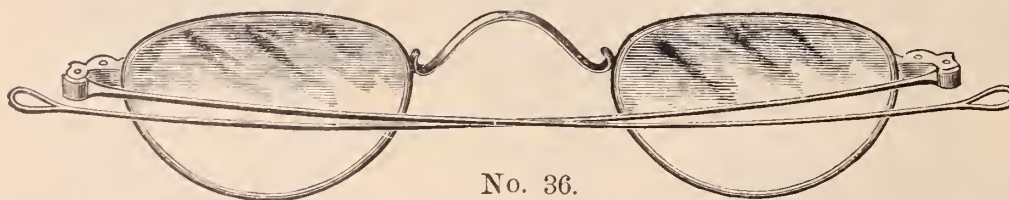

No. 36.



No. 2.

## 611 & 613 SANSOM ST., PHILADELPHIA.

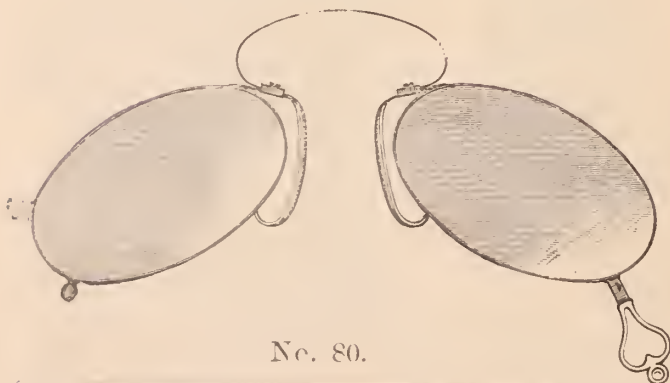

No. 80.

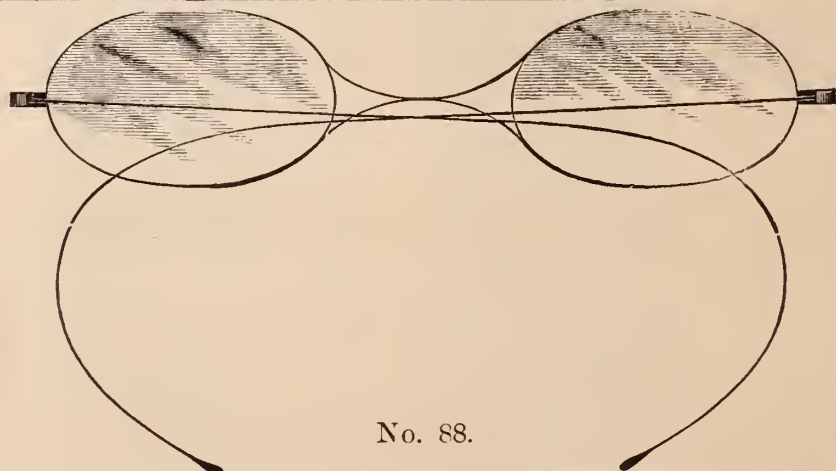

No. 88.

We are now manufacturing together with our Gold and Silver Spectacles, a full line of everything in Steel, and offer to the trade the advantage of a *uniform size* of lenses. All are made of a standard size and are interchangeable. The sizes are given in the cuts. We can only add that our reputation in gold work is our guarantee for the steel, and we shall spare no efforts to meet any competition in price as well as maintain our standard of quality. Illustrated Catalogue mailed on application; from this dealers can order as well as if they had sample case before them.



ESTABLISHED 1855.

D. LIECHTY & CO.,

MANUFACTURERS OF

Fine Gold Watch Cases

No. 140 South Third Street,

Fourth Floor.

PHILADELPHIA

Repairing neatly attended to.

LOUIS A. SCHERR.

CHAS. H. O'BRYON.

G. W. SCHERR.

**LOUIS A. SCHERR & CO.**

Importers and Wholesale Dealers in

**Watches, Jewelry,**

WATCH MATERIALS, TOOLS, GLASSES, &C.

**Spectacles, Silk Guards, &c.**

Wholesale Agents for American Watches.

**No. 726 CHESTNUT STREET,**

FIRST FLOOR,

**PHILADELPHIA.**



January 8th, 1878.

**GUTMANN'S**

**Automatic Hammer and Punches**

Simplified and More Effective.

THIS TOOL takes the place of the third hand, therefore its manifold uses are quickly apparent, and I would only say that it is accompanied by six punches, to wit: 2 hand punches, 1 prick punch, 1 closing hole punch, 1 rivet punch, and 1 pinion punch, all of which fit neatly into the punch holder, and are fastened by the screw. Its tap is alternately heavy and light, and the finger loops are assorted in sizes. The Tool is nickel-plated and boxed, ready to be mailed on receipt of price.

THE OPERATION IS AS FOLLOWS: First, set the hammer; next insert your forefinger through the loop at the top and place the punch with firmness on your work. When you are ready for the blow, push gently on the thumb-piece which produces the concussion on the punch. *Your left hand is entirely free to hold the work.*

Price, \$2.00; Reduced from \$2.50.

**MAX L. GUTMANN,**

Patentee and Manufacturer.

Also, Importer and Wholesale Dealer in

Watch and Jobbing Materials, Tools, Glasses,

Chains, Guards, Jewelry and Watches.

PLEASE SEND YOUR ORDERS.

**ROCHESTER, N. Y.**

**WILLIAM BARBER'S**

**Patent Adjustable Eye-Glass.**



PATENTED,  
Jan'y 28, 1879.

The above cut represents an Eye-glass possessing the convenience of an Eye-glass and the utility of a Spectacle combined, thereby rendering it practicable for everyone to avail themselves of their convenience, who have heretofore been deprived of their use.

**TRY THEM, WILL RECOMMEND THEMSELVES.**

We manufacture them from Gold, Nickel, Steel, Shell and Rubber.

**WILLIAM BARBER,**

Inventor, Patentee and Manufacturer,

No. 243 North 8th Street, Philadelphia, Pa.

**BENJ. ALLEN & CO.**

WHOLESALE DEALERS IN

**American and Swiss Watches**

JEWELRY, DIAMONDS,

SILVER & PLATED WARE.

137 and 139 State Street, Chicago.

A full line of Howard Watches in stock. Catalogues sent upon application, to dealers only.

**CHAS. P. HEROLD,**  
**MANUFACTURING JEWELER,**  
**DIAMOND SETTER**  
AND DEALER IN  
**DIAMONDS.**

916 CHESTNUT ST. PHILA.

N.B. A LARGE STOCK OF 18 Kt. DIAMOND MOUNTINGS, SUCH AS CLUSTER AND SOLITAIRE RINGS, EARRINGS, LACE PINS, SHAWL PINS, CROSSES, STUDS, AND GENTS' PINS, &c. ALL OF WHICH ARE OF MY OWN DESIGNS, AND ARE MADE IN THE FINEST STYLE AND FINISH.

# COLBY & JOHNSON,

17 Maiden Lane, New York.  
Exclusive Manufacturers of Open-face Stem-winding  
White, Gold, Silver,

Black,  
Malachite,  
or  
Marbleized  
Celluloid.



or  
Nickel  
Centers,  
Pendants  
and Bows.

SUITABLE FOR ALL 18-Size AMERICAN S. W. MOVEMENTS.

We call especial attention to the fact that Celluloid being a NON-CONDUCTOR, the cheaper grades of movements (not adjusted to heat and cold), cased in this material, are not affected by atmospheric changes, and can be relied upon as being much MORE ACCURATE TIME-KEEPERS than the same movements cased in metal of any kind.



# SPIESS & ROSSWOG,

MANUFACTURERS OF

## Fine Jewelry and Diamond Goods,

- LOCKETS, CROSSES, SLEEVE BUTTONS AND NECKLACES,  
Rich Sets in Coral Rose, Coral Cameo and Gold.

ENCRUSTED AMETHYST RINGS AND SILVER  
FILIGREE WORK,

Nos. 9 & 11 MAIDEN LANE, NEW YORK.

Also, a complete line in all Coral Goods, as formerly  
imported by A. SQUADRILLI.

# E. HOWARD & CO.,

MANUFACTURERS OF

## Fine Watches, Regulators, Office Clocks,

Electric Watch, Clocks & Tower Clocks,

Office, No. 2 MAIDEN LANE,

NEW YORK.

No. 114 TREMONT STREET, BOSTON.

J. W. J. PIERSON, - - - AGENT.

ESTABLISHED 1859.

## RINGS A SPECIALTY.

BRYANT & BENTLEY,

No. 12 Maiden Lane, New York.

MANUFACTURE A LARGE VARIETY OF

## FINE SOLID RINGS,

For Ladies and Gentlemen, in CAMEO, AMETHYST, ONYX, TOPAZ, TURQUOISE  
GARNET and other stones. Fine CAMEO, CORAL and ROMAN SETS of new  
and handsome designs. LOCFETS, MEDALLIONS, SHAWL and SCARF  
PINS, SLEEVE BUTTONS, STUDS, &c. All goods warranted.

We continue to manufacture several hundred patterns of **HARD SOLDER RINGS**, in every style, for men, women and children, stamped and warranted 16 karat fine.

# BUCKENHAM, COLE & SAUNDERS,

SUCCESSORS TO

BUCKENHAM, COLE & HALL,

IMPORTERS OF

## Diamonds, Pearls

AND OTHER PRECIOUS STONES,

MANUFACTURERS OF FINE JEWELRY,

10 Maiden Lane, New York

A large Stock of FINE DIAMONDS, Mounted and Unmounted,  
kept constantly on hand. Goods sent on approval to any part  
of the country on receipt of satisfactory references.

ESTABLISHED 1837.

VICTOR BISHOP & CO.

IMPORTERS OF

**DIAMONDS,**  
PRECIOUS STONES

—AND—

CORAL JEWELRY,

Enamel Paintings, Copper and Platinum.

No. 47 NASSAU STREET, NEW YORK.

House in Paris, 66 Boulevard de Sebastopol.

**SAXTON, SMITH & CO.**  
MANUFACTURERS OF

**Fine Gold Chain.**

No. 15 Maiden Lane,

**New York.**

Factory, No. 183 Eddy Street, Providence, R. I.

Sole Agents for the new PATENTED CHAIN BAR, containing a Detachable Pencil.

HELLER & BARDEL,

Manufacturers of

DIAMOND AND PEARL

**JEWELRY,**

And Dealers in Diamonds, Pearls, &c.

SHAWL AND LACE PINS IN GREAT VARIETY,

*No. 13 John St., New York.*

A full line of DIAMONDS, mounted and unmounted; also, a large assortment of first-class DIAMOND MOUNTINGS of our own make always on hand. Sketches submitted at any time upon application. We will send goods on selection to responsible houses.

**KOSSUTH, MARX & CO.,**

No. 39 Maiden Lane, New York,

MANUFACTURERS OF

**Gold and Fine Rolled Plate Jewelry,**

Chains, Necklaces, Locketts, Crosses, &c., &c.

**SOLID GOLD and STONE RINGS**

In large variety,

Diamonds, Pearls, Cameos, Amethysts, Turquoise, &c.

Sole Manufacturers of the Celebrated

**AMERICAN SILK GUARDS.**

**WOOD & HUGHES,**

STERLING

**Silverware Manufacturers**

**No. 16 JOHN STREET,**

**NEW YORK.**

*206 Kearney Street, San Francisco, Cal.*

**R. R. HASKELL, Agent.**

**KREMENTZ & CO.,**  
MANUFACTURERS OF

**FINE JEWELRY,**

No. 13 John Street, New York.

FACTORY, 361 Mulberry Street, - - Newark, N. J.

GOODS OF OUR OWN MAKE EXCLUSIVELY.

CARTER, HOWKINS & SLOAN,  
**Makers of Fine Jewelry**

*Consisting of Chains, Bracelets, Sets, Pins, Studs, Sleeve Buttons,  
 Scarf Pins, Rings, &c., in Roman, Etruscan and Enamel,  
 and a full line of Jewelry generally.*

Whiting Building, Corner Broadway and Fourth Street,

A. CARTER JR.  
 WM. HOWKINS,  
 A. K. SLOAN.

**NEW YORK.**

C. E. HASTINGS,  
 GEO. R. HOWE,  
 W. T. CARTER.

**NOTICE.**

Manufacturing Jewelers are hereby notified that the under-  
 signed have obtained Letters Patent, dated February 25th,  
 1879, No. 212,692, for Bracelets constructed of a single band,  
 having ornamentation in relief permanently fixed upon its  
 outer surface, with rigid marginal flanges or projection for the  
 protection of the same, and all infringements, whether in  
 cheap or fine goods, will be promptly and rigorously prose-  
 cuted according to law.

**HALE & MULFORD,**

Broadway & Fourth St.

New York, August 4th, 1879.

—Established 1837.—

**TAYLOR & BROTHER,**

Late TAYLOR, OLMSTED & TAYLOR,

**Importers of Diamonds and Pearls,**

—AND—

**MANUFACTURERS OF DIAMOND JEWELRY,**

No. 676 BROADWAY,

**NEW YORK.**

**BALDWIN, SEXTON & PETERSON,**

MANUFACTURERS OF

**Fine Jewelry,**

Diamond and Stone Cameo Goods,

GOLD CHAINS, &c.

Importers of Diamonds, Pearls, Emeralds, Rubies, &c.

WHITING BUILDING,

**Cor. Broadway and Fourth Street,**

**NEW YORK.**

120 SUTTER STREET, San Francisco, Cal.

Established 1817.

**Ve. J. MAGNIN, GUÉDIN & CO.**

29 Union Square, New York.

Manufacturers and Importers,

FINE SWISS WATCHES,  
 REPEATERS, CHRONOGRAPHS & CALENDARS  
 GENEVA GOLD JEWELRY,  
 FRENCH CLOCKS AND BRONZES,  
 RICH FANCY GOODS,  
 HORSE-TIMERS & PEDOMETERS,  
 GOLD AND SILVER CHATELAINE WATCHES.

Gold Medal Awarded, Paris Exposition, 1878.

*Sole Agents for the James Nardin Watch.*

*House in Geneva, 14 Grand Quai.*

Established 1813.

**THOMAS G. BROWN,**

MANUFACTURER OF

**FINE JEWELRY.**

*Designs furnished for all kinds of Sporting  
 Badges and Medals for Schools & Colleges.*

**NEWARK, N. J.**

—AND—

**9 BOND STREET, NEW YORK.**



ALFRED H. SMITH & CO.

IMPORTERS

14 JOHN ST., NEW YORK.



Established 1834.

**G. & S. OWEN & CO.,**  
**Makers of Fine GOLD JEWELRY**

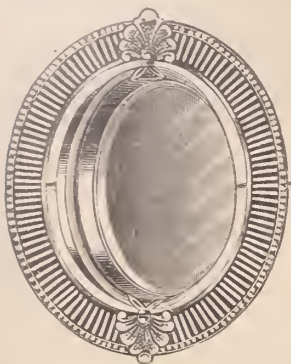

SPECIALTIES :

Black Onyx Goods,  
 Roman & Polished Goods,  
 Hair Chain Mountings,  
**Sole Makers**  
 OF  
**BOX AND GLASS GOODS.**

All our goods exclusively of our own manufacture.

5 MAIDEN LANE, NEW YORK.

**JOHN A. RILEY & CO.**

MANUFACTURERS OF

Rich Gold and Onyx Jewelry,

NOVELTIES IN HALF SETS, LACE PINS, SCARF  
 PINS AND EAR RINGS,

Engagement Pad Lock Bands, Elastic Snake Bands and  
 Chatelaines. Onyx Chatelaines with and  
 without Watch Movements.

**Nos. 7 & 9 Bond Street, New York.**

No. 126 Kearney Street, San Francisco, Cal.

MOORE & HORTON,

**JEWELERS,**

*No. 11 Maiden Lane, New York.*

**SPECIALTIES !**

*Stone Cameo, Onyx, Amethyst, Topaz and Pearl Rings.  
 Studs, Collar and Sleeve Buttons.*

Also our new fac-simile of Fine African Diamonds, mounted in  
 Rings, Studs, Pins, Ear-rings, Scarf Pins, Medallions.

Established 1846.

WILLIAM RIKER,

*No. 5 Maiden Lane, New York.*

Factory, 42 Court Street, Newark, N. J.

Would call the attention of the Trade to our Inlaid Bracelets.

**IMPORTER OF DIAMONDS**  
**E. AUG. NERESHEIMER**  
 21 MAIDEN LANE,  
 NEW YORK  
 N<sup>o</sup> 1 GAERTNER PLATZ MUNICH-GERMANY.  
 N<sup>o</sup> 24 DOELEN STRATT AMSTERDAM-HOLL.  
 DIAMONDS LOOSE & MOUNTED SENT ON APPROVAL AND THE VALUE INSURED

W. H. SHEAFER & CO.,

**Makers of Fine Jewelry**

CONSISTING OF

BRACELETS, SETTS, LOCKETS, PINS,

STUDS, SLEEVE BUTTONS, RINGS, &c.

**SPECIALTY :—STIFFENED ROMAN BANDS.**

**No. 908 Chestnut Street, PHILADELPHIA.**

Branch Office 15 John Street, New York

# WM. S. HEDGES & CO.,

*Of the late firm of SMITH, HEDGES & Co.*

IMPORTERS OF

## DIAMONDS,

No. 170 Broadway, cor. Maiden Lane,

NEW YORK.

*Choice Brilliants in single stones and matched pairs a specialty.*

GOODS SENT ON APPROVAL.



# CHATELLIER & SPENCE,

## Manufacturing Jewelers,

694 BROADWAY, NEW YORK.

No. 1006 Chestnut Street, PHILADELPHIA, PA.

No. 12 West Street, BOSTON, MASS.

No. 120 Sutter Street, SAN FRANCISCO, CAL.

# HELFENSTEIN & BOURKE,

202 Broadway, New York.

OPEN.

EXCLUSIVE MANUFACTURERS OF

PARTLY CLOSED.

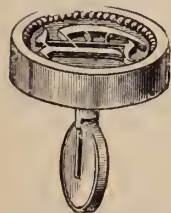

## The Adjustable Sleeve Button

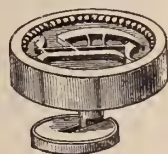

(PATENTED BY WM. BOURKE, JUNE 11, 1878.)

The only Perfect Style of Sleeve Button.

Can be quickly, easily, and securely adjusted without any strain on the forefinger and thumb, rumpling of the cuffs or wear of the button holes. The durability, neatness and safety of its mechanism is unequalled.

EVERY PAIR OF BUTTONS WARRANTED AS REPRESENTED.

*A large variety of handsome designs in Rolled Plate from \$4.50 to \$39.00 per dozen pairs. Plain Pearl and Ivory Top, \$2.50 to \$4.50.*

Samples Sent to Responsible Dealers.

# LYON & HARDY,

30 MAIDEN LANE, NEW YORK,

IMPORTERS OF

## DIAMONDS,

AND MANUFACTURERS OF

## DIAMOND MOUNTINGS.

All goods ordered for stock or on approval are insured while in the hands of Express Companies.

# MULFORD & BONNET,

## Manufacturing Jewelers,

DEALERS IN

## DIAMONDS.

AND JOBBERS IN

## Fine Rolled Plated Goods,

No. 21 Maiden Lane,

NEW YORK.

# ENOS RICHARDSON & CO.

MANUFACTURERS OF

## FINE GOLD JEWELRY,

Gold Chains, Locketts, Crosses and Necklaces,  
COLORED AND ETRUSCAN WORK.

ENGRAVED AND ENAMELLED GOODS IN GREAT VARIETY.

All Goods sold strictly of our own manufacture.

23 MAIDEN LANE, NEW YORK.

ENOS RICHARDSON,  
THOS. SLATER,

L. P. BROWN,

F. H. RICHARDSON,  
W. P. MELCHER.

# J. B. BOWDEN & CO.

*Manufacturer of*

SOLID GOLD AND STONE

## RINGS

All Styles of Children's  
AND

FANCY SOLID RINGS,

A LARGE ASSORTMENT ALWAYS ON HAND.

No. 1 Maiden Lane, New York.

OPPENHEIMER BROS. & VEITH,  
MANUFACTURING JEWELERS,

AND

Dealers in Watches and Diamonds,

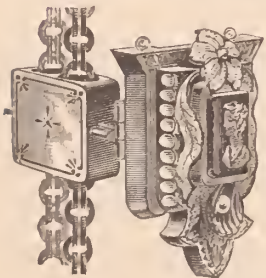

35 Maiden Lane,  
NEW YORK.



Patented June 2, 1879.

Combination Chain, Slide, Pendant and Locket.

# MAINT'G OF FINE JEWELRY ALLING BROS. & CO. MAINT'G OF FINE JEWELRY

Full Line of Roman and Mosaic Goods,  
Earrings, Buttons, Studs and Rings.

SPECIALTIES:

ENGRAVED AND ENAMELED BANDS,  
CAMEO GOODS.

170 BROADWAY, New York.

# RIPLEY, HOWLAND & CO.

383 Washington St., Boston, Mass.

## FINE JEWELRY,

DIAMOND MOUNTINGS, ETC.

OFFICE, 35 MAIDEN LANE.

NEW YORK.

# CARROW, BISHOP & CO.

SUCCESSORS TO

Carrow, Crothers & Co.

MANUFACTURERS OF

## Fine Gold Jewelry

No. 12 JOHN STREET,

NEW YORK.



**J. A. BROWN & CO.**

OFFICE AND SALESROOM: No. 11 Maiden Lane, N. Y. FACTORY: No. 104 Eddy St., Providence, R. I.  
SOLE MANUFACTURERS OF THE

**Ladd Patent Stiffened Gold Watch Cases**

The Best and most durable, and the

CHEAPEST STIFFENED Gold Watch Case FOR THE MONEY

MADE IN THE WORLD!

All genuine Watch Cases of our manufacture have "G. W. Ladd's Patent, June 11, 1867," stamped upon the side hand underneath the glass bezel.

REFUSE ALL OTHERS.

Send for full Descriptive Circular to the

OFFICE AND SALESROOMS

11 Maiden Lane, N. Y.

Dealers can obtain them of the Wholesale Watch and Jewelry Houses, or their Traveling Agents throughout the United States and British Provinces,



KEY AND STEM WINDING

Hunting and Open-Face

IN FLAT BEVEL,

Mansard and Oval

SHAPES

Adapted to the various

AMERICAN-MADE MOVEMENTS,

IN

8, 10, 14, 16 & 18

SIZES.

**JOSEPH N. TINGLEY,**

Late of the firm of Tingley, Sinnock & Sherrill,

MANUFACTURER OF

**STONE RINGS,**

—AND—

NOVELTIES IN STONE GOODS,

No 9 Maiden Lane, New York

Factory, Newark, N. J.

DYER BRAINERD.

JOHN W. STEELE.

**BRAINERD & STEELE,**

MANUFACTURERS OF

Brainerd's Pat. Locketts,

(Patented June 17, 1874.)

These Locketts combine both beauty and strength. They are made of solid 14kt. gold, and the stones used are the finest obtainable in the market. They cost no more than those of the old style, if indeed as much; and the combination of secrecy and durability renders them much more desirable. We make three sizes in four different shapes—round, oval, cushion and oblong square; and also Sleeve Buttons of the same style, containing a concealed box for miniatures, a novelty new to the Trade.



FINE GOLD JEWELRY,

No. 9 Maiden Lane,

NEW YORK.

**MIDDLETON & BROTHER,**

IMPORTERS OF

SWISS WATCHES,

AND DEALERS IN

**American Watches,**

(KEY AND STEM WINDING.)

Diamonds, Gold Chains, Jewelry, Etc.

10 MAIDEN LANE, N. Y.



OFFICE AND FACTORY, 53 CHESNUT STREET NEWARK, N. J.

**MAX FREUND & CO.**  
Manufacturing Jeweler

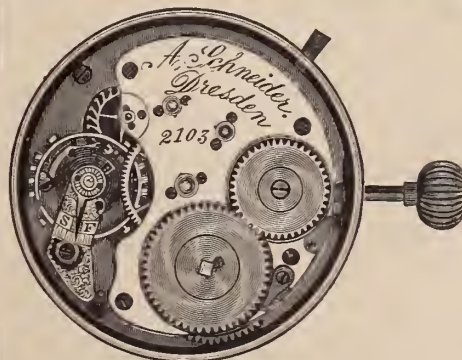

IMPORTERS OF

**Watches**

Jewelry and Precious Stones,  
8 Maiden Lane

NEW YORK

Sole Agents for the Celebrated A. Schneider Watch, Dresden. Also the Standard Watch Co. of New York.

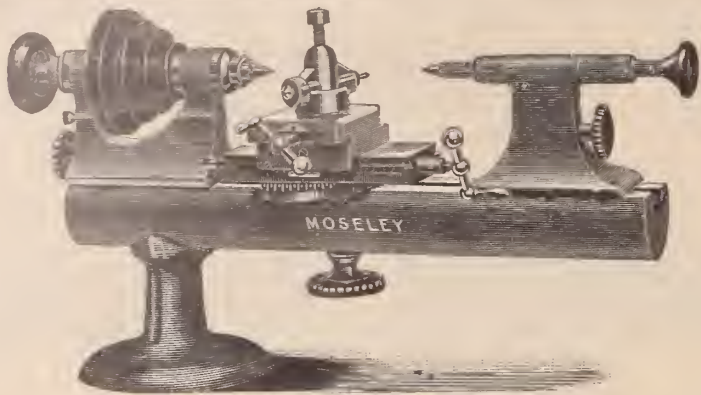

Manufactured by MOSELEY & CO., ELGIN, ILL.

# MOSELEY & CO.

ELGIN, ILLINOIS,

Designers and Manufacturers of

## FINE TOOLS.

Send for Catalogue and Price List.

HOPKINS' WATCH TOOL CO., Waltham, Mass.

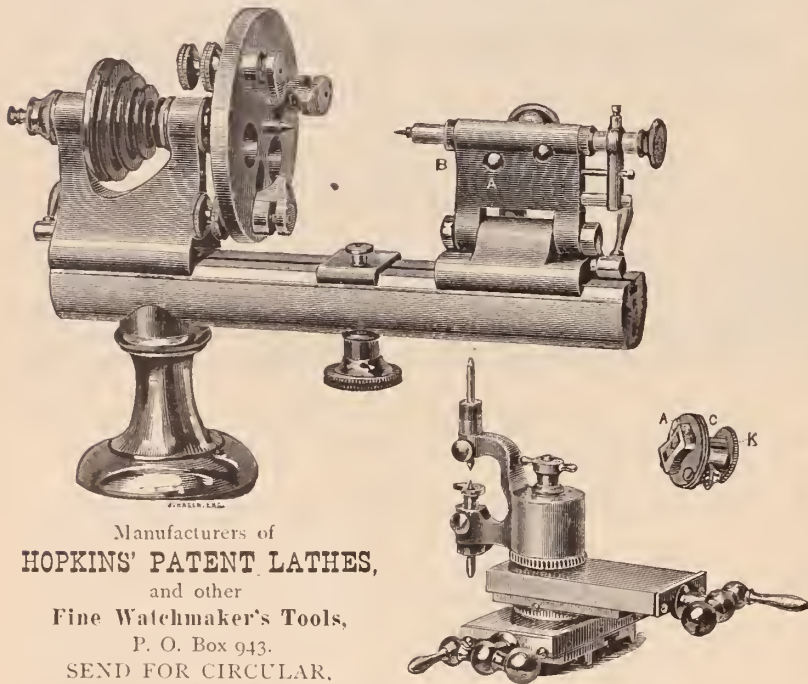

Manufacturers of  
**HOPKINS' PATENT LATHES,**  
and other  
Fine Watchmaker's Tools,  
P. O. Box 943.  
SEND FOR CIRCULAR.

AUBURNDALE, MASS..

# CHRONOGRAPH TIMER

WM. B. FOWLE, Maker.

Designed for Sporting, Scientific and Mechanical purposes;  $\frac{1}{4}$  and  $\frac{1}{8}$  seconds, fly back.

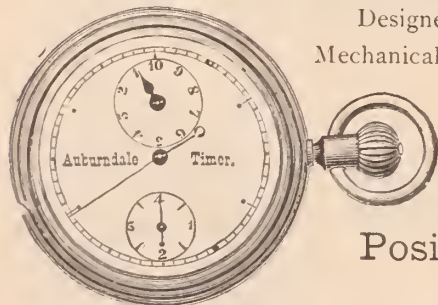

List Price, - - \$15 00

Positively Accurate.

Put up in German Silver Cases, Nickel Plated, size of an ordinary watch. Very neat and handsome, supplying a want long felt by those desiring to measure the flight of time with scientific accuracy to the fraction of a second. It indicates positively minutes, seconds, quarters or eighths of seconds, the only instrument registering one eighth of a second made. It is substantially constructed, positive in its action and will not easily get out of order.

These Chronographs can be obtained from the principal Jobbing Houses in the Trade.

# American Watch Tool Co.

P. O. Box 999

WALTHAM, MASS.

MANUFACTURERS OF THE WHITCOMB LATHE,

AND

Machinery for Watch, Watch Case and Clock Making.

NEW YORK OFFICE, WITH

L. H. KELLER & CO., 64 Nassau Street.

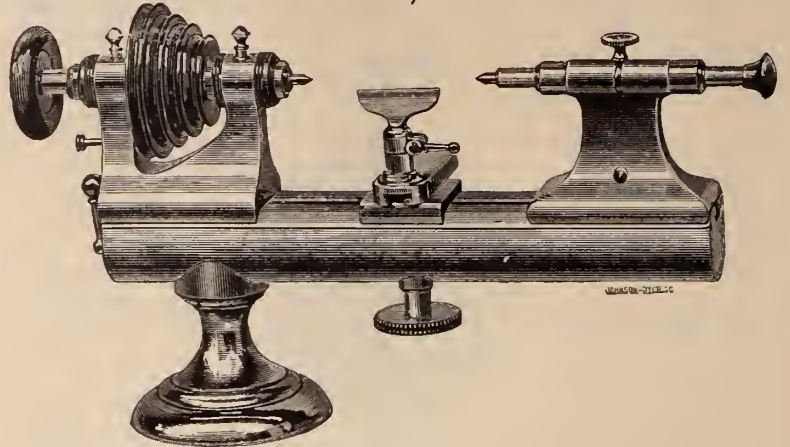

Chicago Office with Chas. Wendell & Co., No. 170 State Street.

# LOUIS HERZOG & CO.

DEALERS IN

## WATCHES,

—AND—

## Manufacturers of Jewelry,



GARNETS A SPECIALTY.

No. 33 MAIDEN LANE,

LOUIS HERZOG,  
LOUIS KAUFMAN.

NEW YORK.

# NOAH MITCHELL,

Manufacturer of all kinds of

# Diamond Jewelry.

DIAMOND MOUNTINGS A SPECIALTY.

A Full Assortment Constantly on Hand.

Nos. 692 & 694 BROADWAY,

Corner Fourth Street,

New York.

ALL ORDERS WILL RECEIVE PROMPT ATTENTION.

ESTABLISHED 1853.

CLOCKS



CLOCKS

**B. J. COOKE'S SON,**  
137 N. 3d Street, Philadelphia.  
Catalogues and Price Lists furnished to the Trade only, on application.

GEO. W. PRATT.

IRA GODDARD.

**GEO. W. PRATT & CO.**

MANUFACTURERS AND DEALERS IN

**American and Swiss Watches,**

**SOLID BAND AND SEAL RINGS,**

Gold and Roll-Plated Jewelry,

No. 14 JOHN STREET, NEW YORK.

ESTABLISHED 1855.

**WELCH & MILLER,**

MANUFACTURERS OF MOROCCO, VELVET AND SATIN

**Jewelry Cases, Trays, &c.**

Telescope Sample Cases, with Flexible Trays.  
COMPLETE STOCK ON HAND.

**No. 169 BROADWAY, NEW YORK.**

CATALOGUES SENT ON APPLICATION.

**JAMES IRONS,**



CHEAPEST PLACE TO BUY GOOD

**SHOW CASES,**

Large Assortment.

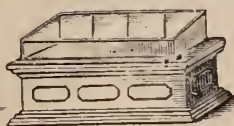

Factory and WAREHOUSES,

132 & 134

North 4th St., PHILADELPHIA.

All kinds always on hand.

Cases packed securely to carry to any part of the world,

**Charles F. Terhune & Co.,**  
Manufacturing Jewelers,

6 Maiden Lane,

New York.



Sole Manufacturers



We beg to call the attention of the trade to the above cuts representing

**PATENT SLIDE BUTTON**

It is not separable, but works on a simple slide. It can be put in and taken out easier than any button made without soiling the cuff. Recommends itself at sight.

A full line of Stone, Enamel, Ivory and Pearl goods in above patterns.

**BERNARD LEVY,**

**Manufacturer of Watch Cases**

—AND—

JOBBER OF AMERICAN MOVEMENTS,

No. 402 Library Street,

**PHILADELPHIA.**

ALSO, ORNAMENTAL ENGRAVER AND ENGINE TURNER.

**G. F. C. ROSENTHAL,**

**Manufacturing Jeweler,**

Removed from

924 Chestnut to 917 Sansom St.,

**PHILADELPHIA.**

The finest Diamond and Pearl Work exclusively.

Lubricating Oils, for Watch, Clock and Chronometer Makers.

The discovery of a Lubricator for FINE MACHINERY, such as Watches, Clocks and Chronometers, that is free from gum and corrosive substance, has taxed the ingenuity of hundreds of men whose efforts have proved a failure. But we are happy to say, (being largely interested) that such an article has been supplied by MR. EZRA KELLEY, of New Bedford Mass., who, after forty years' study of the subject, has perfected a Lubricator, that recommends itself to all who have used the genuine, (there having been numerous counterfeits in the market,) as witness also the award of a

Diploma and Medal by the judges of the late Centennial Exhibition at Philadelphia. We have no hesitation in saying that his Oils are the BEST manufactured always uniform in quality and capable of standing all tests applied to lubricating oils. We cheerfully recommend it to all who may in their business require a FIRST-CLASS LUBRICATOR.

SETH THOMAS CLOCK COMPANY, SETH E. THOMAS, Agent

P. S.—The above Oils can be procured at all first-class wholesale Watch and Clock Establishments in the United States, as well as his only Agents, GRIMSHAW & BAXTER 35 Goswell Street, London, England.

New Bedford, October 15, 1877



**E. STITES,**  
*Manufacturing Jeweler,*  
 No. 12 MAIDEN LANE,  
 New York.  
 COIFFEURETTES.

**M. FOX & CO.**

**Practical Lapidaries,**

IMPORTERS OF

**DIAMONDS**

AND OTHER PRECIOUS STONES,

No. 1 Maiden Lane, New York.

I. PFORZHEIMER.

D. KELLER.

**PFORZHEIMER & KELLER,**

IMPORTERS OF

**Watches and Diamonds**

*Dealers in American Watches,*

AND

*Manufacturers of Jewelry,*

No. 24 JOHN STREET,

**NEW YORK.**

P. O. Box 4144.

**Coral Cream Polishing Fluid**



IS SUPERIOR TO ANY IN USE FOR CLEANING AND POLISHING  
**SILVER, GOLD AND PLATED WARE,**  
 AND ALL FINE  
 Metallic and Glass Surfaces.

Free from Acid, Mercury, Ammonia,  
 Or anything Poisonous or Injurious to the Hands or Metal.

**CHEAPER THAN POWDERS,**

As there is no waste in using, and produces a more lasting  
 brilliancy without injury or wear to the Metal.

Pronounced by Experts to be the finest and  
 most brilliant Polish made.

Diploma awarded at American Institute Fair.

Bottle contains 4 fluid ounces.  
 IS THE BEST—SELLS THE QUICKEST—AND COSTS THE LEAST.  
 Liberal Samples furnished on application.

For Sale by Wholesale Jewelers and Silverware Dealers.

**EDWARD BAXTER,**  
 Cor. 8th St. & Broadway,  
 CARTER BUILDING, (Room 25), NEW YORK.

**BREITINGER & KUNZ,**

IMPORTERS OF

**Watchmakers' Tools and Materials,**

GLASSES, &C., &C.

**No. 107 N. 9th Street, Philadelphia.**

Agency in the U. S. for

**BÄHNI BROTHERS HARDENED & TEMPERED HAIRSPRINGS,**

**G. BECKER'S GOLD MEDAL REGULATORS,**

**DUDLEY'S ELECTRICALLY CORRECTED CLOCK.**

**GEO. W. WALKER MORROCCO CASE M'F'G CO.,**

MANUFACTURERS OF

*Cases for Silverware, Jewelry, &c.,*

**FANCY MOROCCO GOODS OF EVERY DESCRIPTION.**

*Chests in Fancy Woods, &c., &c., &c.*

**712 BROADWAY, - NEW YORK.**

GEO. W. WALKER,  
 President.

JOSEPH MOHN,  
 Vice-President.

SUCCESS AT LAST!



6 inches long for Desk.  
 4 1/2 inches long for Pocket. } Can be sent by Mail.

**F. H. DRAKE & CO.**  
 DETROIT,  
 Mich.

**NEW JEWEL SETTING CUTTER**

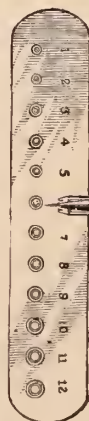

For cutting the bezel, or rim that holds the jewel to the  
 plate of watch movements. In adjusting the jaws to the size  
 of bezel to be cut, the gauge will be found very useful,  
 there being twelve sizes of bezels made by this tool.



A glance at the sketch  
 will show the practicability  
 and great usefulness  
 of the latest novelty in  
 watchmakers' tools.

Sent with gauge, by mail, postpaid, on receipt of \$2.25.  
 Orders should be addressed,

**PHIL. HECHT.**  
**13 MAIDEN LANE.**

*Any article in the Watch Material, Optical, and Silk Guard  
 lines, furnished at lowest rates.*

MANUFACTURERS  
—OF—  
EXCLUSIVELY  
**BLACK ONYX GOODS.**

The patented **DEEP MOURNING LOCKETS** are original with us, and have stood the test of years of wear. They meet the approval of the trade and the wearers for their superior make and finish, as well as for the correctness of the mechanical principle on which they are constructed.

**WOGLOM & MILLER,**  
32 & 34 JOHN STREET,  
NEW YORK.

**BOOZ & THOMAS,**

MANUFACTURERS OF



**Watch Cases & Jewelry,**

108 South Eighth St., (2d Story) Philadelphia.

Samples of our goods sent on approval, when satisfactory reference is furnished.

**Old Gold & Silver Bought or Exchanged.**

PARTICULAR ATTENTION PAID TO REPAIRING.



This Cut represents the  
**RICKETT'S  
PATENT EYE SHADE.**

It is simply a neat Curved Shade of Hard Rubber  $\frac{3}{4}$  inch wide, that fits under the eyebrows and flares out at the bottom, so as to allow an angle of vision about level with the Horizon. Having met with success in New York, Philadelphia and Boston, and wishing to extend our trade to other cities, we will, for the next thirty days, forward to any one in the TRADE ordering THREE DOZEN SPRING SHADES, an elegant PLASTER BUST, life size, stands twenty-one inches high, and retails in New York for \$3.00; if placed in a prominent window will sell three dozen shades in ten days. Order from any jobber or direct from us. Please state that you want Bust.

PRICES—Spring Shades, \$3.50 per doz., Bow Shades, \$4.50 per doz.

**RICKETT'S EYE SHADE CO.,**  
85 Nassau Street, New York.



HIGHEST AWARD TO

**SYLVANUS SAWYER,**

—FOR—

**WATCH MACHINERY.**

**Watch & Clock Making Machinery**

For sale or made to order, either in complete sets, including

**PUNCHES & DIES AND OTHER SPECIAL TOOLS,**

Or in parts of sets, to accommodate purchasers.

**ALSO, JEWELER'S LATHES AND TOOLS,**

AND OTHER FINE WORK,

**MAIN STREET, FITCHBURG, MASS.**

**HENRY FERA,**  
Importer of **Diamonds,**

No. 9 MAIDEN LANE,

**New York.**

Having my own cutting and polishing establishment at Nos. 23 and 25 Looijersgracht, Amsterdam, Holland, constantly running 36 mills, I am able to offer to the trade a full assortment of Diamonds at very low prices.

Loose and Mounted Goods sent on approval to any part of the country on receipt of satisfactory references.

**HAMILTONS & HUNT,**

MANUFACTURERS OF

**Fine Plated Chains**

AND PATENT BUCKLE BRACELETS,

A Full Line of Ladies' and Gentlemen's Roman Stone Lockets,

**Branch Office, 176 Broadway, New York**

FACTORY, 226 EDDY STREET, PROVIDENCE, R. I.

**Wm. C. Greene & Co.**  
GOLDSMITHS

MANUFACTURERS OF  
RICH SETS IN TAPER WIRE CORAL

Factory 95 FINE ST. Providence, R. I.

Stone Cameo Engraved & Enamel Sets Sleeve Buttons Studs Crosses EAR DROPS & C.

NEW YORK OFFICE, No. 192 BROADWAY.  
Wm. C. Greene, B. W. Greene, Geo. D. Briggs.

**MILNE & JOURDAIN,**  
Manufacturers of Stem-Winding Watch Crowns



13 & 15 Franklin Street, **NEWARK, N. J.**

Gold Crowns, for Stem-winding Movements, to suit all sizes of Imported or American Watches, in four different styles and seven sizes.

Gold Pushers for Key Movements in every size. Also Gold Crowns for fine Chronograph Watches made to order.

Silver Stem winding Crowns and Key Pushers on hand or made to order. Send for card and samples.

A. MILNE.

A. JOURDAIN.

## GORHAM MANUFACTURING COMPANY,



## SILVERSMITHS,

PROVIDENCE AND NEW YORK

California Office, 120 Sutter Street, San Francisco.

*Makers of STERLING SILVER WARES, ( $\frac{925}{1000}$  fine) of the highest character of workmanship and design; also, makers and sole proprietors of the GORHAM PLATED WARES.*

*Illustrated Circulars showing 24 of our leading patterns, in Spoons and Forks, will be sent to the Trade upon application by MAIL.*

## DAVID F. CONOVER &amp; CO.

(SUCCESSORS TO WM. B. WARNE &amp; CO.)

Importers, Manufacturers and Wholesale Dealers in

## WATCHES AND JEWELRY.

Silver and Silver-Plated Ware,

AMERICAN WATCH WHOLESALE SALESROOM,

Southeast Corner Chestnut and 7th Streets,

(FIRST FLOOR.)

DAVID F. CONOVER,  
B. FRANK WILLIAMS,  
C. EDGAR LIGHTER.

PHILADELPHIA.

# RANDEL, BAREMORE & CO. DIAMONDS,

Corner Maiden Lane and Nassau Street,

29 MAIDEN LANE,

58 NASSAU STREET,

**NEW YORK.**

No. 12 New Burlington Street, LONDON.

Established 1828.

## JACOB BENNETT & SON, Diamond Setters and Manufacturing Jewelers,

No. 108 SOUTH EIGHTH STREET, PHILADELPHIA.

WE MANUFACTURE AND MAKE A SPECIALTY OF  
EVERY DESCRIPTION OF

**DIAMOND MOUNTINGS,**

SUPERIOR IN DESIGN AND WORKMANSHIP.



Dealers in

**DIAMONDS,**

And all kinds of Precious Stones.

Masonic Marks, Society and School Badges, Made to Order Only. Designs and Estimates Furnished.

PARTICULAR ATTENTION GIVEN TO ALL KINDS OF JOBBING.

## BROWN & BROTHER,

MANUFACTURERS OF

**Finest Quality of Electro-Plated Flat Table Ware.**

PATENTED HEAVY SPRING TEMPERED SHANK ON FORKS AND SPOONS.

ILLUSTRATED CATALOGUES FURNISHED ON APPLICATION.

WAREROOMS, No. 81 CHAMBERS STREET, NEW YORK CITY.

FACTORIES, WATERBURY, CONN.

P. O. BOX 5731.

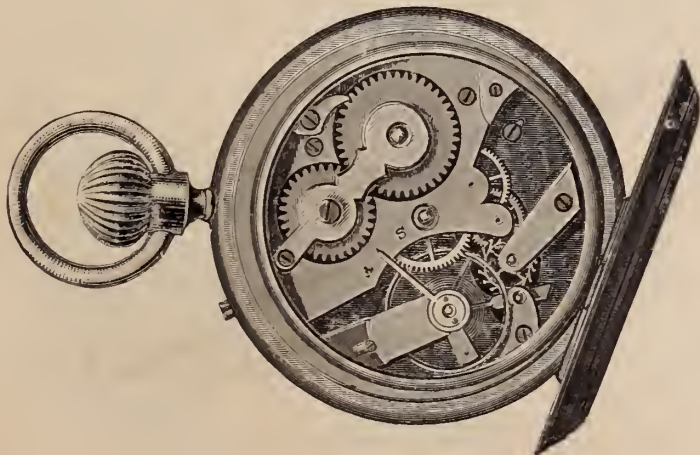

## The Pioneer Watch.

HENRY GINNEL, Sole Manufacturer,

No. 31 Maiden Lane, NEW YORK.

P. O. Box 2967.

The accompanying illustration is a fac-simile of the Pioneer Watch. The Best (stem-winding and stem-setting) Pocket Timekeeper ever offered to the trade. They are cased in silver and German silver—Hunting and Open Face.

# DESCRIPTION OF THE New Patent Dust-Proof STEM-WINDING OPEN-FACE CASE,

MANUFACTURED BY THE

AMERICAN WATCH CO.,  
WALTHAM, MASS.

ROBBINS & APPLETON,  
GENERAL AGENTS,

9 BOND STREET, New York. S SUMMER STREET, Boston.  
170 STATE STREET, Chicago.

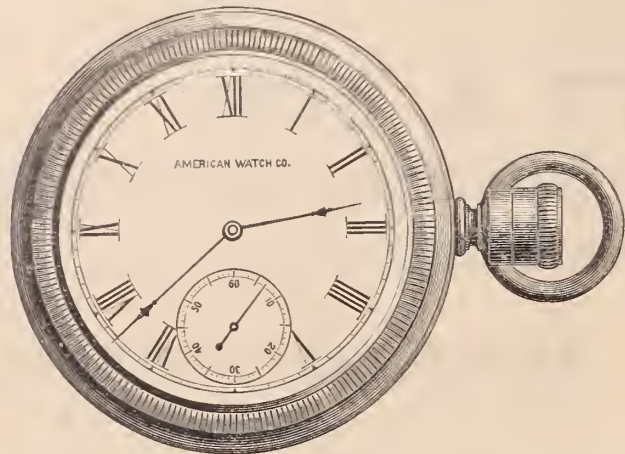

This open-face watch case, which is formed in one seamless piece in any desired shape, opens in the front only to receive the movement. The continuous construction of the body of the case avoids the usual cap and greatly conduces to strength and constitutes one feature of the invention.

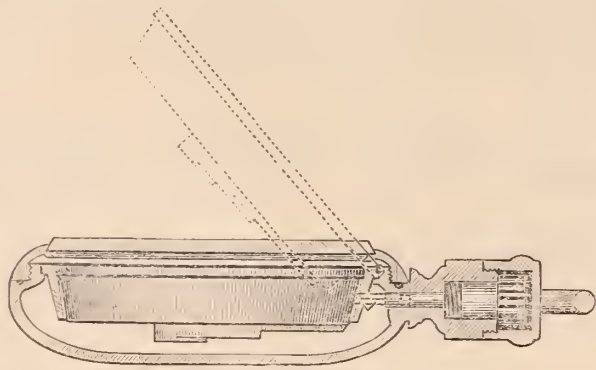

The movement of the Watch is held in a sustaining ring which is hinged to the case on the front edge of the aperture in such a manner that when the bezel is removed the ring with its contained movement may be swung outward, thus rendering the movement readily accessible, and obviating the necessity of a back cap or lid, which thus enables the case to be formed in one seamless piece and constituting another feature of the invention.

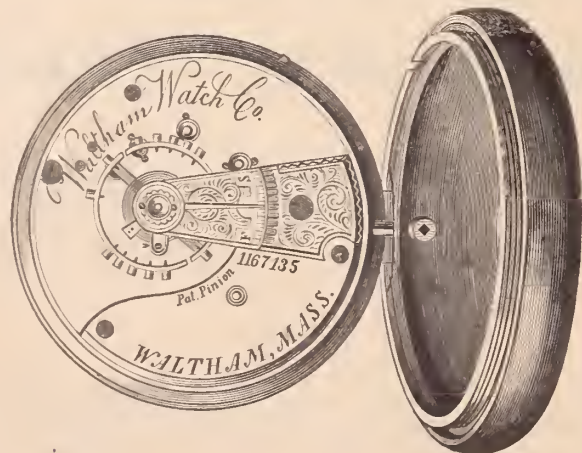

The movement is held in the ring in the manner usual in American Watches, and this ring is hinged to the rim of the case just at the base of the stem, the movement being so arranged therein that the winding stud of the movement comes in line with the winding-key of the stem and properly engages therewith. When the movement is to be swung out, however, the stem-winding crown may be pulled partly out, as usual, so as to draw the key out of engagement with the stud, and thus permit the outswing of the movement, as will be understood, the parts becoming readily engaged, when the movement is again swung into the case.

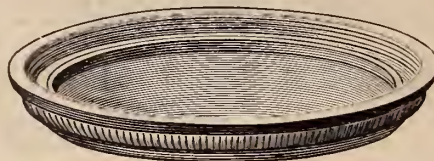

The bezel, into which the crystal is fitted with an especially prepared water-proof transparent cement, is attached to the case by screwing it thereon, the ring of the bezel being formed with an internal screw thread which meshes with a corresponding thread on the shouldered rim on the face of the case, and as the bezel is thus screwed tightly down the level edge of the rim, forms the air-tight joint with the shouldered rim of the case, which is proof against the entrance of dust or moisture, as will be appreciated.

By making the screw-thread on the interior of the bezel, so as to fit a corresponding thread on the interior of the case, we are enabled to construct a watch with only one division in the case, and thus the entrance of dust or moisture to the movement is entirely prevented, which is a very great advantage as compared with those cases in which there is an opening both front and back. The face of the bezel is formed with a marginal circle of milling which affords sufficient frictional grasp to enable the bezel to be readily screwed on or off.

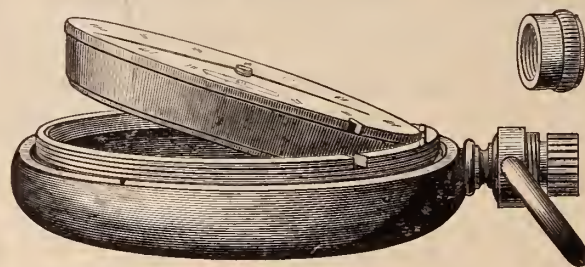

Another feature of the invention consists of the removal of the stem cap, which is designed to tightly fit upon the top of the stem winding-crown, so as to prevent the entrance of any dust or other foreign matter at that part. The stem-cap is attached to the stem by screwing it thereon in the manner of the bezel, and may be readily unscrewed when it is desired to wind the watch, as will be understood.

The cap is of similar diameter with the body of the stem, which latter is formed with a short threaded neck, which screws into the threaded bore of the cap, the bevel edge of the cap being screwed down tightly on the smooth shoulder of the neck so as to form a perfectly tight joint, which effectually prevents the infiltration of any dust or moisture thereat.

These combined features of construction thus form a watch which, while being simple and complete, has the great advantage of being impervious to the entrance of dust or wet. These latter qualities are found to be of great importance to those persons, who most use this class of watches, such as railroad men, travelers, miners, lumbermen and others, who have to make frequent reference to the watch, and who are almost constantly exposed to the influence of dust or moisture.

This new case is made by us both in gold and silver.

It insures great strength and durability with a small amount of metal. Thus a gold case weighing 25 dwts. has a strength of back equal to that of an ordinary case of 30 dwts. to 35 dwts.

It is also made with jointed bezel instead of the threaded screw bezel, if desired.

The Water-proof Cement used in cementing the glass in the above cases is an article which we have had especially prepared for this purpose after considerable experimenting. We will furnish it to the trade, on application, at 50 cents per bottle. Forwarded by Mail.

Price Lists furnished to the Trade only upon application.



# HAMPDEN WATCH CO.

Manufacturers of KEY AND STEM-WINDING

General Office and Factory  
SPRINGFIELD Mass.

## WATCHES.

New York Office,  
No. 12 MAIDEN LANE.

### GUERRANT'S ELECTRO-ENGRAVING MACHINE.

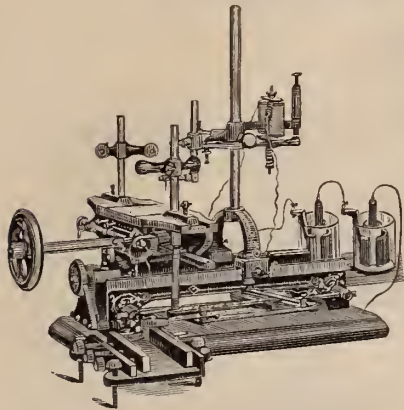

It has baffled the skill of the inventive genius of the world for ages to produce a machine that would compete with the skillful hand engraver, and until this machine was invented, all engraving had to be done by hand. And, to-day, it is the only practical engraving machine in existence.

The construction of the machine is not complicated, but simple and durable. It is easily operated. The variety of work it will do is almost incredible, and to be fully appreciated, ought to be seen in operation.

We do not therefore, offer this machine to the public simply as a machine to aid the engraver, but as a perfect, practical engraver in itself, with which any person of ordinary skill can learn in a short time to do any piece of engraving that might be desired and in the very best manner.

It copies from the regular press type of any style of letter or design that is made of type, from the plainest to the finest german text letter or fancy design, at the same time it will reduce the letter or design from the original size to ten different sizes, or so small that it cannot be seen by the naked eye. It will shorten the letters or elongate them, also will lean them forward or backward, will either make a raised or sunken letter, will engrave on any surface, either plain, concave or convex—for instance, such things as Watch Cases, either in or outside; Finger Rings, either in or outside; Bracelets, Napkin Rings, Goblets, Pitchers, Mugs, Waiters, Spoons, Forks, and all kinds of Jewelry; or, in fact, on any article susceptible of being engraved or ornamented with scroll work or fancy designs, &c., either on Gold, Silver, Copper, Brass, Iron, hardened Steel, Glass, Stone, Pearl, Ivory, Bone, Gutta Percha.

No Jeweler or establishment that has engraving to be done should be without it. Machines are sold with limited territory to use them in; or, the exclusive rights to use them in certain town or territory can be purchased with the machine if desired.

For further information, address

WM. HICKSON, Gen. Agt.,

P. O. Box 1603, PHILADELPHIA, PA.

KARN & HICKSON,

LYNCHBURG, VA.

Owners of the right of all the Northern States and Territories.

Size of Machine, 12 x 16 inches.

Patented Jan. 18, Oct. 31, 1876, & Mar. 4, 1879.

A. M. GUERRANT, Danville, Va., Agent for the Southern States.

## CROSS & BEGUELIN, Makers and Importers of SWISS WATCHES,

AND DIRECT IMPORTERS OF

Watch Tools, Materials, Glasses, &c.

No. 21 Maiden Lane, New York.

The CENTENNIAL WATCH (Stem-Winding and Stem-Setting) so universally popular, has achieved a standard reputation, and is generally conceded to be the best made watch for the money in this market. Being the sole manufacturers of this celebrated Timekeeper, we are enabled to give it our strongest endorsement. Especial attention is called to the "HENRY BEGUELIN," "DROZ & PERRET," and other well known Swiss Watches, as well as to our full and complete line of all grades of American Watches, on which we give the full trade discount.

The attention of Watchmakers is directed to our new DRILLS, in sets of 21 sizes. The most complete and serviceable drill ever offered.

General Agents for the Auburndale Timer,  $\frac{1}{4}$  and  $\frac{1}{2}$  Seconds.

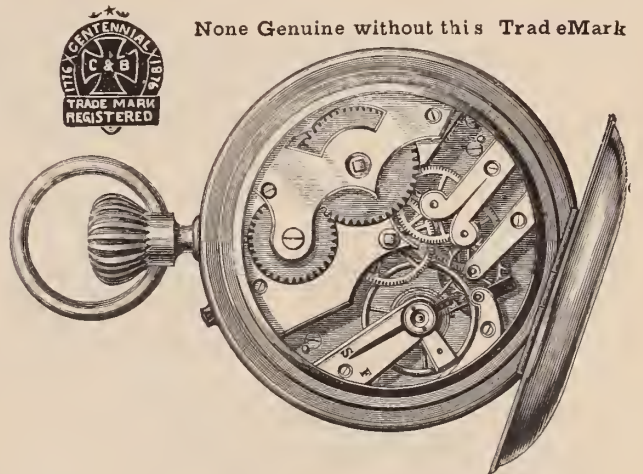

None Genuine without this TradeMark

The above is a fac-simile of the Centennial Watch

Established 1826.

Factory,  
27  
RUE DU PARC,  
Chaux de Fonds,  
Switzerland.

## JULIEN GALLET,

CHAS. PERRET, Sole Agent.

Sales Rooms,  
No. 1  
MAIDEN LANE,  
NEW YORK.  
P. O. Box, - 4420.

Importer of Watches & Watch Movements,

Would respectfully call the attention of the Trade to the annexed cuts of the Lady's size Watch, Stem-Winder and Stem-Setter, in Nickel, Silver and Gold, White and Black Dials.

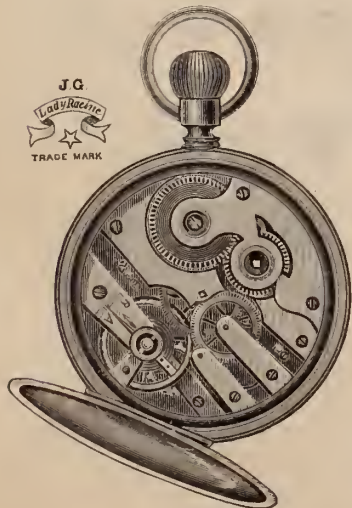

Medal and Diploma awarded at Centennial Exposition, for superior mechanical execution and artistic ornamentation.



Established in 1854.

**C. & A. PEIGNOT,**  
**MANUFACTURERS OF WATCH CASES,**



DEALERS IN AMERICAN WATCHES AND IMPORTERS OF FINE KEY AND STEM-WINDING MOVEMENTS,

SALESROOM AND MANUFACTORY, 22 SOUTH FIFTH STREET,  
 PHILADELPHIA.

A full stock of Key and Stem-Winding Gold Cases always on hand. Goods sent on approval when satisfactory references are furnished.

**HALL, ELTON & CO.,**  
**Manufacturers of the Finest Electro-Plated Ware.**

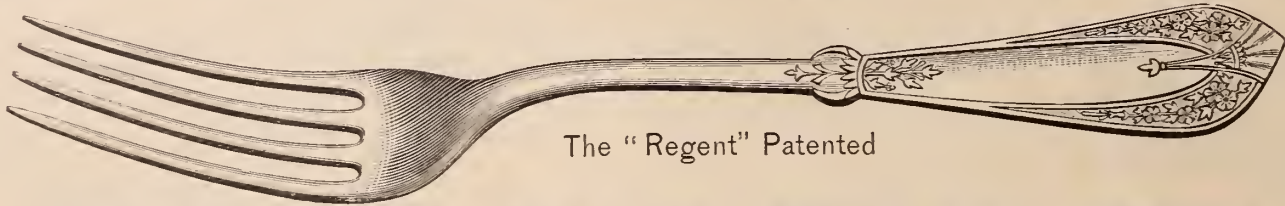

The "Regent" Patented

**UNSURPASSED IN QUALITY, STYLE AND FINISH!**

Factories, Wallingford, Conn. Salesroom, 75 Chambers St., New York.

**HOLMES, BOOTH & HAYDENS,**

MANUFACTURERS OF

**ELECTRO-SILVER PLATED**

**Spoons, Forks, Ladles, Fancy Pieces,**

**Solid Handle Steel Knives, &c., of the finest quality.**

No. 49 Chambers Street,  
**NEW YORK.**

No. 18 Federal Street,  
**BOSTON.**

Works at Waterbury, Conn.

**J. H. PURDY & CO.**

Jobbers of Imported and Domestic

**TOOLS & MATERIALS,**

For the use of Watchmakers, Jewelers, and kindred trades.

WATCH GUARDS, JEWELRY BOXES, SPECTACLES, CARDS  
 SPECTACLE CASES, PEARL GOODS, STEEL CHAINS,  
 TAGS, RUBBER TYPE, &c.

No. 170 State Street, Chicago, Ills.

OFFICE WITH CHAS. WENDELL & CO.

**EDWARD TODD & CO.,**

MANUFACTURERS OF

**GOLD PENS,**



Pencil Cases, Tooth Picks, &c.

44 East 14th St., Union Square,

Factory, 29 & 31 South 11th St., Brooklyn.

**NEW YORK.**

**HENRY C. HASKELL, The 'MARQUIS' RING.**

Four Sizes,  
CAMEO, INTAGLIO, ONYX or BLOOD STONE.

Manufacturing Jeweler,

THE FINEST SEAL RING EVER OFFERED  
THE TRADE.

*Every Stone Warranted  
not to come out.*

No. 12 John Street,

New York.

*Must be seen to be fully appreciated.*

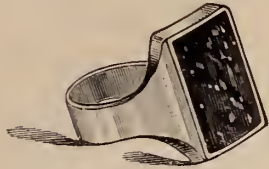

4040



5223



7577



7572

*Samples sent on approval, express paid.*

*Price Lists to Trade only.*

**L. & A. MATHEY,**

**No. 16 MAIDEN LANE,**

IMPORTERS OF ALL GRADES OF

Plain and Complicated Watches and Movements,

SOLE AGENTS FOR THE WELL-KNOWN

**H. L. Matile**

FINE WATCHES OF ASTRONOMICAL PRECISION.

AN ATTRACTIVE LINE OF CHATELAINES AND CHATELAINE WATCHES.



**T. A. WILLSON & CO.,**

MAKERS OF

Steel Spectacles and Eye Glasses,

Grinders of Spherical, Cylindrical, Prismatic, Plain & Compound

— LENSES, —

Patentees and Sole Manufacturers of the

"ARUNDEL TINTED"

**SPECTACLES.**

Nos. 179, 180 & 155

With Interchangeable Lens,

THE BEST AND CHEAPEST AMERICAN SPECTACLES MADE

Office and Factory, . Reading, Pa.

**ERRICO BROTHERS**

**19 JOHN STREET, N. Y.**

MAKERS AND DIRECT IMPORTERS FROM OUR OWN MANUFACTORY IN NAPLES,

**CORAL, SILVER FILIGRÉE AND CONCH SHELL JEWELRY**

OF THE LATEST DESIGNS.



These goods are made under our own immediate supervision, and designed expressly for this market. Our stock, the largest in the city, is replete with the richest novelties in this line, and is offered to the trade at prices that will tempt buyers.

We would direct the especial attention to our recent importations of CORAL ROSES and CORAL CAMEOS in all the most desirable shades. Also to our new designs in SILVER FILIGRÉE goods, which we offer at unexceptionably low prices. Buyers, when in town, are invited to an examination of our stock.

# Optical Goods.



We have recently added to our business a special department of these goods, with a large stock of all varieties of them at lowest prices.

**W. B. CLAPP, YOUNG & CO.,**

**149 & 151 State Street, Chicago, Ills.**

ILLUSTRATED PRICE LISTS SENT ON RECEIPT OF APPLICATION ACCOMPANIED BY BUSINESS CARD.

**FALL OF 1879!**

*A FULL LINE OF NEW AND DESIRABLE GOODS IN*

## ELECTRO-SILVER PLATE

*Attractive in Style, Low in Price, Quality and Finish unsurpassed.*

# ROGERS & BROTHER,

690 BROADWAY, (Near Fourth Street,) NEW YORK.

PRICE LISTS, AND PHOTOGRAPHS OF LATEST STYLES SENT FOR SELECTION, ON RECEIPT OF BUSINESS CARD AND REFERENCE.

*Particular attention is invited to the "NEWPORT" Pattern of Forks and Spoons.*

Novelties in design and finish, in Silver Fancy Goods and Hollow Ware, with combinations of colors in gold, silver and niello-enamel, Testimonial and Presentation Goods, Spoons and Forks of patterns popular and desirable, and a choice line of Case goods, from single pieces to Cabinets for Wedding Gifts.

THE  
**Adams & Shaw Company,**  
**SILVERSMITHS,**  
 and Makers of Hard Metal Electro-Plate,  
**694 BROADWAY, . . . . . NEW YORK.**

GEO. R. COLLIS, Manager.

Designs and estimates furnished, and particular attention paid to orders for racing, Field and Nautical Prizes, (small and large), Tea Sets, Berry Bowls, Fruit and Ice Cream Stands, Jelly Bowls and General Hollow-Ware, in Sterling Silver or Silver-soldered Electro-Plate.

Gentlemen's Watches,  
 Ladies Watches,  
 Bridge Movement Watches,  
 $\frac{3}{4}$  Plate Movement Watches,  
 $\frac{3}{4}$  Plate Patent Reg. Watches,  
 $\frac{3}{4}$  Plate Movement Watches,  
 Repeaters,  
 Chronographs. (1-5 second)

**TIFFANY & Co.**  
 NEW YORK, PARIS, LONDON, GENEVA.  
**MAKERS OF FINE AND COMPLICATED WATCHES,**  
 Wholesale Office, 694 Broadway, New York.

GEO. R. COLLIS, Manager.

Split-Second Chronographs.  
 Minute and Sec'd Chronograph  
 Chronograph and Repeaters,  
 Minute Repeaters,  
 Five Minute Repeaters,  
 Quarter Hour Repeaters,  
 Repeaters and Chronographs,  
 &c., &c., &c.

# French Clocks.

 We make a speciality of this department and are constantly opening new lines which we offer at very low prices.

**TAYLOR & BROTHER,**

No. 676 Broadway,

**NEW YORK**

**WHOLESALE ONLY.**

# ILLINOIS WATCH COMPANY,

MANUFACTURERS OF

## KEY AND STEM-WINDING MOVEMENTS.

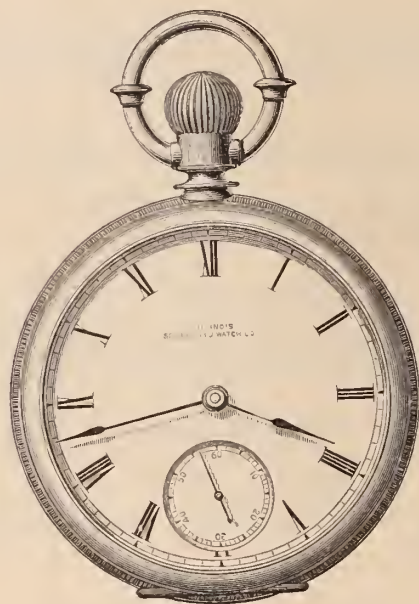

The attention of the trade is called to the following features and advantages in our line :

*First.*—The “**Stuart,**” “**Bunn,**” “**Miller Adj.**” “**Currier,**” “**No. 101,**” (Nickel,) “**Columbia,**” “**No. 2,**” and “**America,**” grades are furnished in Stem-Wind, especially made for Open Face Cases, with figure XII at the pendant and seconds opposite. (NOTE.—Key-wind movements fit either Hunting or Open Face Cases, bringing the figure XII to its proper position.)

*Second.*—All are brass plates are HARD,—not softened in process of gilding.

*Third.*—The position of the train, locating the escapement at the top of the movement, as it hangs in the pocket, causing all dust and dirt to drop out of the escapement, and away from the train, and making the watch more durable.

*Fourth.*—To our **New Movement, No. 101,** nickel top plate, 4-holes jeweled, *Quick Train,* sunk seconds, patent pinion, cut expansion balance, 18 size, being the cheapest and best nickel movement of its description in the market. This movement is made in Key wind and Open Face and Hunting Stem, the lower pivots run in hard brass, and the holes being carefully burnished in the lower plate.

### OFFICES.

No. 21 Maiden Lane,  
NEW YORK.

Cor. Dearborn & Monroe Sts.,  
CHICAGO, ILL.

Factory and Office at Springfield, Illinois,



THE  
★ GANTELINÉ ★

THE GANTELINÉ,

THE ONLY NEW ARTICLE IN LADIES' JEWELRY IN A QUARTER CENTURY.

THE GANTELINÉ FACILITATES THE BUTTONING OF THE GLOVE.

It is formed of a hair-pin shaped link, connected by a chain to a charm of unique design.  
Or any suitable pencil, for memoranda.

It is worn pendant, by slipping the link through the button-hole of the dress;  
which allows the ornament to be displayed with pleasing effect.

We cite the following from the numerous press notices showing its merits.

"Of all the tasteful articles, nothing is so *new or useful* as the GANTELINÉ."—*N. Y. Evening Post*.  
"A *Pretty Ornament*, and a very useful one, and the rage in fashion, is evinced by the number sold."—*N. Y. Mail*.  
"It is really a clever device, *uniting the useful with the beautiful*, and is destined to become popular beyond a doubt."—*Home Journal*.  
"A charming ornament of personal adornment, *remarkable for simplicity, elegance, utility*."—*N. Y. Trade Reporter*.

The above represents one of our elegant silvered Horse Shoe Trays, containing twelve GANTELINÉS, (Tray and Ganteline two-fifths size), and will be found a desirable acquisition to any Jeweler's stock. Nos. 653 and 655 show full size of GANTELINÉ.

These goods are of the *very best gold plate and finish*.

The GANTELINÉS can be ordered on approval in trays, which we have of different shapes, or singly if desired, from any of the above numbers.

We have spared no expense in producing new and beautiful ornaments for the GANTELINÉ.  
A tasteful Show Card will be furnished to every dealer who purchases one dozen or more.

C. G. ALFORD & Co., Manufacturers, 183 BROADWAY, New York.



No. 3.



No. 4

### NICOUD WATCHES,

STEM WINDING, -- HUNTING AND OPEN FACE,  
GENTS' AND LADIES' SIZES.



No. 5 A.

## NICOUD & HOWARD,

SOLE IMPORTERS,

14 MAIDEN LANE,

P. O. BOX 2269.

NEW YORK.



No. 5 B

*SMALL STEM-WINDERS A SPECIALTY.*

Prices sent upon application accompanied by business cards.



No. 7.



No. 8.



# L. HAMMEL & CO.,

## Importers of Watch Materials, Tools,

Opera Glasses, and Optical Goods of Every Description,

### SPECTACLES,

### EYE-GLASSES,

## No. 9 Maiden Lane,

## NEW YORK,

Sole Agents in the United States for **G. B. Wheeler's Star Watch and Clock Oil**, and the Celebrated **Gravier Mainspring**.

Every Watch maker knows the necessity of a good and reliable Watch Oil. There are several brands which have hitherto enjoyed excellent reputations, but our experience as well as that of many of our customers has proved them more or less unreliable, in consequence of which we have been for a long time in search of an article that is entirely reliable in every respect, and have found it in the STAR WATCH AND CLOCK OIL, MADE BY GEO. B. WHEELER, OF NEW BEDFORD, MASS., who has given the subject many years of careful study. Our aim now is to bring this oil to the notice of all watch makers, as a thoroughly reliable article, having stood the test of years, a good lubricator, free from gum or corrosive substances and not affected by low temperature. We have sold these oils for the last three years and have always found our customers well pleased with them. We annex hereto some of the testimonials we have received from many reliable business houses and watchmakers throughout the country. The price of Wheeler's Star Oil is as follows :

Watch Oil per bottle, 20 cts., per dozen, \$2.00.

Clock Oil, per bottle, 16 cts., per dozen, \$1.75.

ROCHESTER, N. Y., Dec. 25, 1877.

DEAR SIR:—I send you briefly and most cheerfully my opinion of your Watch Oil. We have been using it on our time locks for about a year and a half, and unhesitatingly say that it is uniformly the best oil that I have ever tried. Other oils previously used have failed after first trials, either drying up after a few weeks or changing color and thickening, all of them requiring too frequent cleaning of the movements to be reliable, but yours has so far proved entirely satisfactory.

Respectfully Yours,  
L. F. MÜNGER,  
Manager Sargent & Greenleaf's Time Lock Manufactory.

Office of CLEMENS HELLEBUSH, Esq., Manufacturing Jeweler,  
CINCINNATI, Feb. 1st, 1879.

MESSRS. L. HAMMEL & CO., 9 Maiden Lane, New York.

DEAR SIR:—Your Wheeler's Star Watch and Clock Oil gives extraordinary satisfaction to my trade.

Please send me 10 gross at your earliest convenience.  
Yours Respectfully,  
CLEMENS HELLEBUSH.

Office of R. JAEGERMANN & CO.,  
Dealers in Materials, Tools, &c., for Watchmakers,  
218 North Fourth Street, ST. LOUIS, Feb. 1st, 1879.

Having tried all manufactures of Watch Oil without finding any superior to Wheeler's Star Watch Oil, I hereby recommend the same to all watch makers as the best in the market and the only one that will stand all tests.

Respectfully,  
R. JAEGERMANN.  
MESSRS. L. HAMMEL & CO.,  
9 Maiden Lane, New York.

Office of KENNEDY & KOESTER,

DETROIT, Mich.  
DEAR SIR:—Please send us 1 gross each Wheeler's Watch and Clock Oil, by express immediately, and oblige,  
Yours Respectfully,  
KENNEDY & KOESTER.

P. S.—Your oil gets more in demand the longer people try it—they buy Wheeler's sooner than any other.

K. & K.

The following is from Mr. Henry Oehl, Jr., one of the best watchmakers in New York City:

I have used the Watch Oil manufactured by Geo. B. Wheeler, of New Bedford, for some two years, and have so far found it in every way satisfactory. It is uniform in quality and as free from gum and acid as any oil I have ever used.

NEW YORK, June 5, 1878.

HENRY OEHL.

Office of M. S. SMITH & CO.,  
Diamond Merchants and Watch Importers,

MESSRS. L. HAMMEL & CO.,

DETROIT, Mich., March 7, 1879.  
GENTS:—We have great pleasure in recommending the Wheeler Star Watch Oil, which we find equal to the best in the market.

M. S. SMITH & CO.

Office of GEORGE WOLF, Esq.,  
Dealer in Watches, Clocks, Jewelry, &c.,  
LOUISVILLE, Ky., Feb. 4, 1879.

MESSRS. L. HAMMEL & CO.,  
9 Maiden Lane, New York.

After using your Wheeler's Star Watch and Clock Oil for the last eighteen months, I have found it unsurpassed, and congratulate you for having succeeded in placing such an article before the trade.

Yours Respectfully,  
F. W. JARVIS, Watchmaker, with George Wolf.  
[Mr. Jarvis has been forty years in business and is a distinguished Watchmaker.]

NEW YORK, February 15th, 1879.

With the greatest sincerity I recommend the Wheeler's Star Watch Oil to the trade. I have tested it now for a long time and found it always good, and as good an oil as I ever used.

A. DEUHARD,  
Formerly with Ball, Black & Co.



**Factory and Offices, 611 & 613 Sansom Street,**

ARTISAN BUILDING.

THIS old and well-known firm manufacture a greater variety of *SPECIALTIES* than any other one house in the country.—**FINE TINTED AND ROMAN JEWELRY, IN SETS, BRACELTS, EAR RINGS, LOCKETS, &c., &c. GOLD CHAIN, SILVER CHAIN, GOLD THIMBLES, SILVER THIMBLES.**

In both *GOLD* and *SILVER THIMBLES*, in *Styles* and *Finish* we claim to excel all others.

## GOLD HEAD CANES.

These goods we were the *FIRST* to make to any extent, nearly all other makes are *copies of our patterns*, whilst some of our styles *have never yet been imitated*, we being *JEWELERS* as well as *CANE MAKERS*, are able to do more *elaborate* work than those not possessing this advantage.

### ILLUSTRATED CATALOGUE.

Our Illustrated Catalogue of these goods will be ready for gratuitous circulation by *September 15th*, and parties about to order *CAVES* for Fall will do well to reserve orders until they have this *intelligent aid*.

**SIMONS BROTHER & CO.**

**PHILADELPHIA.**

HONORABLE MENTION, VIENA, 1873.

MEDAL AND DIPLOMA, PHILA., 1876.

HIGHEST AWARD, PARIS, 1878.

# WILLIAM F. NYE'S SUPERFINE Watch and Clock OILS,

New Bedford, Mass., U. S. A.

Beautifully clear  
and  
Brilliant,  
Standing all tests.



Uniform in Quality  
and  
Thoroughly  
Reliable.

## AGENTS.

CROSS & BFGUÉLIN, 21 Maiden Lane, N. Y.  
LOUIS A. SCHERR & CO., 726 Chestnut St., Philadelphia, Pa.  
KEARNEY & SWARTCHILD, 147 State Street, Chicago, Ills.  
DINKELSPIEL & NORDMAN, 120 Sutter St., San Francisco.  
P. W. ELLIS & CO., 4 Toronto Street, Toronto, Ont.  
HENNEGEN, BATES & CO., 255 Baltimore Street, Baltimore, Md.

H. HOFFA, 624 Pennsylvania Avenue, Washington, D. C.  
THOMAS H. CLAPP, 16 South Meridian Street, Indianapolis, Ind.  
WILLIAM SENTER & CO., 54 Exchange Street, Portland, Me.  
R. HASWELL & SON, 49 Spencer Street, London, England.  
GEORGE H. TAYLOR, 136 Westminster Street, Providence, R. I.  
LOUIS MATRIX JOSEPH, St. Croix, Switzerland.

ARCHILLE PORTAL, 21 Rue des Archives, Paris, France.

## REFERENCES.

Mr: Wm. F. Nye :

CHICAGO, June 28, 1879.

Dear Sir.—For the past three years that we have been selling your oil, it has given entire satisfaction, and we consider it as good as any oil in the market.

Respectfully Yours,  
KEARNEY & SWARTCHILD.

Your watch and clock oil has given universal satisfaction to the trade whom we have supplied, and find it rapidly increasing in favor; it is remarkable for its clear color and brilliancy, and stands the severest tests required of it. We cheerfully commend it to the trade as the best oil in the market.

P. W. ELLIS & CO.,  
4 Toronto Street, Toronto.

Cleveland, Ohio, June 28, 1879.

Wm. F. Nye, New Bedford, Mass.:

Dear Sir.—We have sold your watch and clock oil for about two years, and as yet, have not heard a single complaint, our customers speak highly of it, and we have reason to believe it is one of the best, if not the best in the market.

Very respectfully,  
BOWLER & BURDICK.

East Haddan, Conn. June 27th, 1879.

Dear Sir.—I received in August last, a sample vial of your watch oil, and agreeable to your request for a report would say, that I have used it ever since to the exclusion of all others, and it has given good satisfaction.

Respectfully Yours,  
S. D. JOHNSON.

Philadelphia, July 1st, 1879.

Mr. Wm. F. Nye :

Dear Sir.—Our customers who use your watch and clock oil, are well pleased with it.

Yours, &c.,  
LOUIS A. SCHERR & CO.

Leslie, Mich., Dec. 11th, 1878.

Wm. E. Nye :

Dear Sir.—I received a bottle of your watch oil and have used it and given it a fair trial, and can cheerfully recommend it as being as good as I ever used.

Very truly yours,  
W. W. HENDRICKS,  
Jeweler.

Wm. F. Nye : Memphis, Mich., Oct. 24th.

Dear Sir.—I have given your watch oil a severe test, and I find it contains all of the good qualities that you claim for it: it does not gum up readily, and is not affected by the weather, and therefore does not deaden the motion of the watch, as is the case with most oils, and I most heartily recommend it to the trade.

Respectfully Yours,  
WM. E. WALTON,  
Watchmaker and Jeweler, Memphis, Mich.

Boston, June 26th, 1879.

Wm. F. Nye, Esq., New Bedford.

Dear Sir.—It gives us pleasure to state that we have used your watch and clock oil for the last two years, and have found it very satisfactory.

We have tested it also, by exposing a small quantity for the same length in a hollow in a brass plate, and so far it shows no appearance of thickening, or change of color.

We remain, &c.,  
Yours very truly,  
WM. BOND & SON.

Established 1849.

Incorporated 1876.

# BRADSTREET'S Improved Mercantile Agency,

Principal Office, 279, 281 &amp; 283 Broadway, N. Y.

THE BRADSTREET COMPANY, PROPRIETORS.

BRANCH OFFICES IN ALL PRINCIPAL CITIES OF THE UNITED STATES AND CANADA,  
AND LONDON, ENGLAND. ALSO, A CONTINENTAL CORRESPONDENCE.

---

One Organization!    One Management!    One Interest!

---

## VOLUMES ISSUED QUARTERLY.

 SHEETS OF CHANGES SEMI-WEEKLY.    CONSTANT REVISIONS AND PROMPT NOTIFICATIONS TO SUBSCRIBERS.

---

TO MERCHANTS, MANUFACTURERS AND BANKERS:—We shall issue the FORTY-SIXTH Volume of our REPORTS during the first weeks of July. We are confident that no previous issue of our work has been so complete, comprehensive, and reliable as this—for we have spared neither expense nor care in perfecting the reports, and have also revised and perfected the many improvements which have been so fully appreciated by our patrons.

We have compiled an Abstract of the Collection Laws of the several States, which we print under the proper headings. This feature will be appreciated by all who have occasion to grant credits covering different sections of the country.

We have also introduced under each town or village head, concise information, showing its actual or relative position—whether on a railroad, steamboat, or stage route—the population, and whether a telegraph, express or money-order office. As a Shipping guide, this will be almost invaluable, it being more comprehensive, and we intend that it shall be more reliable than any published otherwise. We have also tabulated the Banks and Bankers throughout the United States and Canada, giving their capital, etc., as well as their New York correspondent, which we shall publish as an Appendix to each volume, retaining, however, the names as they appear at present under their respective town or city, in the regular volume.

Owning and directing our whole business, from London to San Francisco, as from Montreal to New Orleans, we are able to control it in all its branches, so that it is not possible for the interest of our patrons to suffer from conflict with local managers.

Relying solely on the merits of our work, we respectfully solicit an examination of our system, with the assurance of our ability to substantiate all we claim, and with the knowledge that it is worthy of your earnest consideration.

CHARLES F. CLARK, President.

# The Burbank Manufacturing Company

Manufacturers of GOLD & SILVER



## Thimbles,

GOLD  
SILVER,  
STEEL,  
RUBBER,  
And SHELL,



EYE GLASS  
Self Adjusting.

## SPECTACLES AND EYE-GLASSES

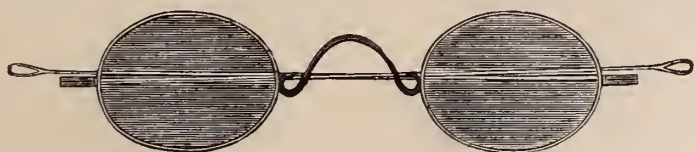

OF ALL DESCRIPTIONS.

## SOLID GOLD RINGS.

Office, 14 MAIDEN LANE. NEW YORK.

Manufactory, Springfield, Mass.

## T. B. BYNNER,

### Importer & Jobber of Watches

DIAMONDS AND FINE JEWELRY,

And Dealer in the BEST CLASS OF ROLLED PLATE JEWELRY

And Key and Stem-Winding American Watches.

No. 513 Broadway, New York

## Clark's Grooved Case Springs.



PAT. 116,777.

Made in four lengths, wide and narrow. The spring sets well away from the movement, the depressions obviate any tendency to move lengthwise. Steel rivets preferably used can be removed more easily than screws. In fitting file away the lower edge until the rivet can be pushed down in front of the spring in the groves. These springs are made from fine steel, carefully tempered and warranted perfectly reliable. To be had of all jobbers in watch materials at manufacturers price—75 cts. per dozen.

**A. N. CARK,** Manufacturer of the Celebrated **Plainville, Ct.**  
FOUR HOLE CASE SPRINGS, Watch Keys, Bench Tools, Crosby's JEWELING TOOLS, &c.



**GOLD**

**PENS**

## MABIE, TODD & BARD,

MANUFACTURERS OF

### GOLD PENS, PENCILS, CASES, HOLDERS

AND TOOTHPICKS,

Of 18kt., 14kt., 10kt., Solid Gold;

ALSO,

### Holders and Pencil Cases

—OF—

Pearl, Ivory, Gold M'd Rubber, Sterling Silver,  
10kt. and 18kt. Plate.

180 BROADWAY, NEW YORK, U. S. A.



Correspondence Solicited in Reference to our Goods.  
Our new Catalogue will be sent to the trade upon application, when accompanied by a business card.

## J. F. FRADLEY.

MANUFACTURER OF



Fine Gold and Silver-Headed

### WALKING CANES

—AND—

STERLING

### SILVER WARE.



OFFICE AND FACTORY,

20 JOHN STREET, NEW YORK.

**REMOVAL.**

WM. PARK, hereby intimates to the trade that he has removed from 181 Broadway to 26 John Street, where he will be happy to receive orders for **STONE, SEAL & CAMEO ENGRAVING** Coats of Arms found and beautifully painted. Arms Crests, Monograms, and Devices engraved on Locketts, Sleeve Buttons, Rings, &c. Masonic Engraving a specialty.

**H. M. RAYNOR,**  
25 Bond Street, N. Y.  
**PLATINUM**  
FOR ALL  
Laboratory & Manufacturing Purposes.  
Native Platinum, Scrap, &c., purchased.

**STERN BROS. & CO.**

Manufacturers of  
**Fine Jewelry,**  
30 MAIDEN LANE  
FACTORY, 73 & 75 Fulton St., NEW YORK.  
Gold Seal engraved Band-rings and Locketts a specialty.  
The attention of the trade is directed to our plain Gold filled Rings. Sections of which showing the construction and quality sent upon application.  
After February 1st, our plain filled rings will bear the above trade mark.

F. W. C. Nieberg,  
Repairer and Adjuster of  
**FINE WATCHES**  
and Marine Chronometers,  
No. 8 JOHN STREET  
New York.

**GUSTAV EPHRAIM,**

Successor to Ephraim Bros.  
8 JOHN STREET, NEW YORK,  
Importer and Manufacturer of  
Bamboo, Silk Gaurds and Watch Chains of all Grades. Materials, Watch Glasses, Optical Goods and Jewelry.  
Sole Agent for EAGLE SPECTS', CORNELL'S ANTI-OXYDIZER and COURVOSIER MAIN SPRINGS.

**Stephen J. Cox**  
DESIGNER & ENGRAVER  
on  
NO. 90 NASSAU STREET  
NEW YORK.  
Jewelers' Work a Specialty.

**BLANCARD & OBERLANDER,**  
MANUFACTURERS OF  
**Settings and Galleries**

Of every Carat of Gold or Silver,  
Platinum, Platinum-Lined and Fancy Settings a Specialty.  
As we melt and refine Platinum ourselves.  
36 & 38 JOHN STREET,  
NEW YORK.  
Platinum Scraps Exchanged or Purchased.  
Send for Sample Card.

**VOSE & SOUTHWICK,**  
Manufacturers of Gold Jewelry

Sole Makers of the Separable Sleeve and Collar Buttons in Gold.  
  
No. 183 Eddy Street, PROVIDENCE, R. I.



**HENRY LEFORT,**  
Stem-Winding Watch Crown Manufacturer,  
Crowns and Pushers in gold, all sizes, quality and color, made to order. Silver crowns and pushers always on hand.  
Samples sent on application.  
80 & 82 Marshall Street,  
NEWARK, N. J.

**ALBERT FRIEDENTHAL,**  
Importer and Jobber of  
WATCHMAKERS' & JEWELERS'  
Materials, Tools and Optical Goods  
Real and Imitation Stones,  
For Manufacturing and Repairing Purposes  
**A SPECIALTY.**  
Agent for TISDALE'S Watch and Clock Oils.  
No. 43 Maiden Lane, New York.  
Orders by mail will receive prompt attention.

**E. A. LAUTEN,**  
MANUFACTURERS OF  
**MOROCCO, VELVET & SATIN CASES**  
FOR  
Jewelry and Silver Ware.  
New Trays for Lace, Shawl and Scarf Pins, Novelties in Brocade Silks,  
4 Great Jones Street,  
One door from Broadway, NEW YORK.

**JEWELRY PHOTOGRAPHED.**

In order to meet the demands of many of the Manufacturers of Jewelry, Silver Ware, &c. (Tiffany and others) I have erected a SPECIAL SKYLIGHT, for Mechanical Photography, viz:  
The Copying of Silver Ware, Statuary, Eric-a-Brac, Paintings, Models, &c.  
I propose to keep it busy by adopting the following rates:—8-10. Photographic negative \$1. Proofs 50 cents. Special rates for quantities.  
GEO. G. ROCKWOOD, Photographer, 17 Union Squ.  
Established 1859. (Above Tiffany's.)

**REPAIRING, COLORING AND GALVANIZING FOR THE TRADE.**

C. G. MALLIET,  
**Manufacturing Jeweler,**  
No. 9 JOHN STREET  
NEW YORK.

**EXCELSIOR'S**

ESSAY ON THE  
**BALANCE SPRING**  
Price \$3 50  
42 Nassau Street, N. Y.

**The Morse Diamond Cutting Company,**  
J. D. YERRINGTON, Agent.  
192 Broadway and 3 John Street.  
NEW YORK.

Rough Diamonds, Boart, Roses and Brilliants for sale.  
Fractured Diamonds repaired, and old stones improved; also Rough Diamonds cut and fashioned to order.

W. N. WALKER,  
**DIAMONDS,**  
Watches and Jewelry,  
No. 18 JOHN STREET, NEW YORK.  
IMPROVED JEWELERS' COTTON.  
JOHN J. ARMOUR.

**HENRY TROEMNER,**  
710 Market Street,  
PHILADELPHIA.  
Manufacturer of Fine Gold Scales,  
 DIAMOND SCALES,  
Bullion Balances and Weights, in use at all the U. S. Mints and Assay Offices.  
PRICED CATALOGUE ON APPLICATION.

Solid Gold Rings—a Specialty  
**WM. H. ELY,**  
**Solid Gold Rings**  
MANUFACTURER,  
Viz., Plain, Chased, Engraved, Enameled, Engine Turned, Shield & Scale. All qualities Warranted  
Orders Promptly Executed.  
58 Nassau Street, N. Y.

Established 1848. *Reliable and prompt.*  
**COOPER & BRO.**  
 Wholesale Jewelers,  
 Importers and dealers in WATCH & CLOCK-  
 MAKERS' TOOLS and MATERIALS; also, JEWEL-  
 ERS' SUPPLIES, SPECTACLES, OPTICAL GOODS,  
 &c. A complete Outfitting Establishment for the  
 trade.

Repairs Department established 1865. Every  
 description of work done for the trade. Watch  
 Repairing, Jewelry and Watch Case Repairing,  
 Gold and Silver-Plating, and Fire Gilding.  
 35 S. Fourth St. (1st floor). PHILADELPHIA

**E. HOERNER,**  
 Manufacturer of Jewelry,  
 Diamond and Black Onyx Goods,  
 15 Maiden Lane,  
 NEW YORK.

**DAVID PRINCE,**  
 Gold and Silver Refiner,  
*Assayer and Sweep Smelter,*  
 13 and 15 New Jersey Railroad Avenue,  
**NEWARK, N. J.**  
 Sole Agent for Comins' Improved Amalgamator.

LOWELL WRENCH CO., WORCESTER, Mass.



"The Jewelers' Pin Vise is a well-known tool advertised  
 in the CIRCULAR, by the Lowell Wrench Company, of Wor-  
 cester, Mass. and is a credit to them. The sample was in-  
 spected with high commendation by the members, many of  
 whom had used it and pronounced it far superior to the  
 imported article. It is of hardened steel, nickel-plated, the  
 handle is nicely milled, giving a firm grip for rolling in the  
 fingers, and the whole is turned true to centre. It holds  
 firmly anything placed in it, and altogether is a most excel-  
 lent tool for the bench."—*Proceedings Horological Club,*  
*April, 1879.*

**Vulcanite Jewelry Co.**

MANUFACTURERS OF

**WHITBY JET,**

Combination Whitby Jet and Vulcanite,  
 Byron's Patent, May 18, 1869.

Also a full line of Locketts—plain, gold mounted  
 and monogram.

No. 191 BROADWAY, N. Y.

Agents for the NEW RUBBER WATCH CASES,  
 fitting all American Movements.

Designs made and estimates given on all kinds  
 of Engraving for Jewelers.



Illustrations for Books, Mfg Catalogues, &c.  
 Labels and Show Cards Engraved on Metal for  
 Color Printing.

NEW YORK  
**Morocco Case Company,**  
 CASES FOR JEWELRY, WATCHES,  
 SILVER-WARE, &c., OF ANY  
 QUALITY AND STYLE.

Boxes and Trays for Jewelers' Travelers.  
 Show Cases and Window Fittings  
 a Specialty.

No. 69 NASSAU ST., cor. John, NEW YORK.

**O. SCHWENCKE,**

(Established over 30 years.)  
 [Successor to G. GUNZENHAUSER],  
 MANUFACTURER OF

**Fine Hair Jewelry,**

No. 43 MAIDEN LANE,  
 New York.

Solid Gold Mountings for Hair Jewelry, kept constantly  
 on hand, and made to order at shortest notice.  
 Orders for the country trade promptly attended to.

Leon Jeanne. Paul Jeanne.  
**JEANNE BROTHERS,**

MANUFACTURERS OF

**DIAMOND MOUNTINGS**  
**And RICH JEWELRY,**

Patentees of Jeanne's Ear Wires,  
 No. 1 Maiden Lane, New York.

Designs furnished and estimates given.

KETCHAM & McDOUGALL,  
 No. 4 LIBERTY PLACE, NEW YORK.  
 MANUFACTURERS OF  
 Improved Gold and Silver

**THIMBLES**



AND THE PATENT  
**AUTOMATIC EYE GLASS HOLDER,**  
 Which returns the Eye Glasses to their place on  
 or under the lapel of the vest by simply casting  
 them from the nose, combining all the conven-  
 iences of Cord, Hook and Case, without their  
 annoyances.

**J. B. LAURENCOT,**

IMPORTER OF

**WATCH GLASSES,**

**Optical and Fancy Goods**

French Clocks, Musical Boxes, &c.

No. 33 MAIDEN LANE.

15 Rue D'Enghien,  
 PARIS.

Box 2954, P. O.  
 NEW YORK.

**L. BONET,**

Medal at Centennial, 1876.

**CAMEO**

**Likenesses,**

889 Broadway, New York.

**C. B. WILKINSON & Co.**

212 Broadway,  
 NEW YORK,

**Manufacturing Jeweler,**

Masonic Pins, Rings & Charms,  
 School, Athletic, Fine  
 Presentation Medals,

—AND—  
**JEWELS OF EVERY DESCRIPTION**

Designs furnished free upon ap-  
 plication.



**GEO. W. DU BOIS,**

(Successor to Albert Landsberg.)

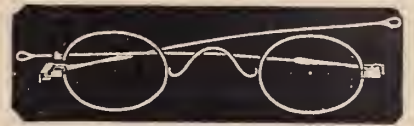

IMPORTER AND MANUFACTURER OF

**Optical Goods,**

No. 36 MAIDEN LANE,

Near Nassau Street, NEW YORK

Sole Agent for

**BLACK'S PATENT**

**Interchangeable Spectacles,**

AND

**EYE GLASSES.**

Jewelers and others who keep spectacles for  
 sale will please observe that, with these PATENT  
 SPECTACLES, it is only NECESSARY to have a full  
*Complete Assortment of Lenses and Pebbles,* which  
 being all of a UNIFORM SIZE, will FIT either the  
 Gold, Silver, or Steel Frames, of which but a  
 few of each kind are wanted; an advantage  
 which will give a complete assortment of the  
 finest Spectacles, for one-sixth the capital in-  
 vested in a like assortment of the same quality  
 goods of the old style frames.

For Particulars, price lists, &c., address

**GEO. W. DU BOIS,**

New York.

Established 1850.



**PETER L. KRIDER,**

MANUFACTURER OF

**STERLING**

**SILVER WARE,**

Medal and Diploma Awarded, &c.

Striking Society Medals in Gold, Silver or Bronze  
 A SPECIALTY!

ARTISAN HALL,

**618 Chestnut Street**

**PHILADELPHIA.**

# SPENCER Optical Manufacturing COMPANY.

Manufacturers of Spectacles and Eye Glasses,  
from all materials used for that purpose,  
and of all grades.

**SOMETHING NEW ! !**  
CELLULOID EYE GLASS FRAMES,  
Representing the Choicest Selected  
Tortoise Shell and Amber.



THEY HAVE GREAT ADVANTAGES

OVER ALL OTHER EYE GLASSES

(Turtles rejoicing over the discovery of Celluloid Tortoise Shell,  
Their Occupation Gone.)

They are much **Lighter** than any others. Twenty-five pairs of the frames weigh only one ounce.

They are much **Stronger** and more **Durable** than any others; they can be **Dropped Without Injury** upon the hardest substance.

Their **Beauty Far Surpasses** the ordinary Tortoise Shell Frames commonly in use.

They are **Not Affected by Atmospheric Changes**, being equally well adapted to either warm or cold climates.

They are made with **Different Sized Frames** to suit persons whose eyes are either near or far apart.

The Springs are made of a combination of metals which will neither **Rust** nor be effected by heat or frost.

These frames are set with **Fine Lenses**, accurately focused to suit all sights, which with the many other advantages, make them **Very Popular**.

**ASK YOUR OPTICIAN OR JEWELER TO SHOW THEM TO YOU.**  
Every Pair Stamped on Handle S. O. M. Co. Pat. Mar. 13, '77.

Parties ordering 3 doz. Celluloid Eye Glasses are furnished with 1,000 copies of circulars similar to this advertisement with name of dealer printed thereon.

**13 Maiden Lane, N. Y.**

Established 1853.

# L. H. KELLER & CO.

Successors to G. A. HUGUENIN,

IMPORTERS OF

## Fine Watch and Clock Materials, SWISS, ENGLISH, FRENCH & GERMAN FILES, TOOLS, &C.

FOR WATCH MAKERS, WATCH CASE MAKERS, JEWELERS  
SILVERSMITHS, ENGRAVERS, CHASERS, DIE  
SINKERS, MACHINISTS, &c.

SOLE AGENTS FOR HALL'S STAKING TOOLS AND  
ROLLER REMOVERS.

AGENTS FOR THE WHITCOMB AND OTHER AMERICAN LATHES.

GENERAL AGENTS FOR THE PHILADELPHIA  
WATCH COMPANY.

American Agents for the Horological Journal, (British).

A Monthly Paper for the advancement of Chronometer, Watch and Clock Making,  
and kindred Sciences. Published under the auspices of the British Horological  
Institute, London. Subscription \$2.50 per year, in advance. Also,

SAUNIER'S TREATISE ON MODERN HOROLOGY, IN  
THEORY AND PRACTICE,

BY M. CLAUDIUS SAUNIER The English Edition will appear in 26 monthly parts,  
Price 50 cents each. Whole Work, \$13 00, postage paid.

Special attention is directed to

### "OUR OWN" Celebrated Mainsprings Graduated

in thickness to equalize the power, with well rounded edges, and the  
*Highest Crocus Finish throughout*, insuring the least possible friction  
in the barrel, pronounced by expert judges to be the *best made*.

"JURGENSEN" Main Springs recoiling, suitable for the highest grades  
of Swiss Watches.

### "Lutz" Celebrated Hair Springs,

by numbers, of uniform diameter and strength, the best for  
"BREGUETING."

Fine Hole Jewels of Ruby, Sapphire, Chrysolite, Garnet, Beryl and  
Aqua Marine, with *gauged* (well shaped and polished) holes, numbered  
by the Swiss pivot gauge - also, neat black walnut cases, containing  
forty glass vials for assortments of same. The great advantage in hav-  
ing Jewels by numbers will readily be seen as a saving in time and an-  
noyance in selecting and in expense. Dealers once having an assort-  
ment, can replenish or stock up at a comparatively small outlay, as any  
desired quantity of No. and quality can be had of us at all times.  
our stock of jewels being the largest and most complete in the country.

Diamond Charged Broaches for opening and polishing jewel holes.

Diamond Powder and Bort for polishing and grinding 8 different  
grades, in  $\frac{1}{2}$ ,  $\frac{1}{4}$ ,  $\frac{1}{8}$ , and  $\frac{1}{16}$  K vials, bringing it into the reach of all.

Gold Diamond Set and other fine Geneva Hands.

The new Drills in Sets of 54 small, 126 small to medium, and 48  
large; also, sold separately if desired.

A FULL LINE OF MATERIALS FOR THE CELEBRATED WATCH  
MANUFACTURED BY PATEK, PHILLIPPE & CO OF GENEVA,  
FULLY FURNISHED AS FAR AS PRACTICABLE.

**No. 64 Nassau Street,**

Near Maiden Lane

**NEW YORK.**



## SPECIAL NOTICES.

Advertisements under this head, not to exceed six lines, \$1.00 each insertion.

**JEWELERS' Safe** for sale, low, Herring's. Cost \$2,000. Was exposed at the Centennial. Office JEWELERS' CIRCULAR, 42 Nassau St.

**WRIGHT'S ENGRAVING MACHINE** for sale cheap with alphabets all new and in good order. Enquire of H. E. Adams, Burlington, Vt.

**WANTED.**—Nos. 9, 10, 11 and 12 of Vol. VII of this journal. Address, stating price, E. L. THRALL, 2 West Bridge Street, Oswego, N. Y.

**FOR SALE.** A superior Ship's Chronometer, Frodsham make. Apply to C. A. GALLAGHER, Care SINNOCK & SHERRILL, 5 Maiden Lane, New York.

**WANTED.**—Four men who want to complete the trade in fine watch repairing. Ones that are willing to pay to be pushed through may address T. A. Ninot, Waltham, Mass.

**FOR SALE.**—One pair of 10 inch rollers made by Morgan & Orr, of Philadelphia, in good order, to be sold at a low figure. For particulars apply to PETER L. KRIDER, 618 Chestnut Street, Philadelphia.

**WANTED.**—A young man to attend to the watchwork and repair jewelry, etc. in a store in Georgia. Must be willing to sell goods and make himself generally useful. Address W. office Jewelers' Circular.

**FOR SALE.** A Jewellers' Factory, with ease and goodwill of the business. Tools, mills, dies and machinery in perfect order. Whole or part of front office to let. CHATTERTON & DODD, 19 John Street, New York.

**WANTED.**—A permanent situation either at bench or salesman by a watchmaker of eight years' experience accustomed to all kinds of jobbing and watch repairing. Can give good references. Address N. G. Taylor, Manchester, Vt.

**AMERICAN LATHE** for \$35, cost \$100. Large Size Watchmaker's American Lathe with universal head, pump center and adjustable chucks. Has been used but little and is in good condition. Address J. H. S., care of Jewelers' Circular.

**GEO. E. WILKINS.**—Importer of fine Tools for Watchmakers, cutting and dividing engines, rounding up tools and cutters, also cutters for stem winding wheels. Fine lathes with the American system of chucks. Dividing engine and rounding up tool combined. Marine chronometers for sale. Special tools imported to order. 21 South Salina St., Syracuse, N. Y.

**FOR SALE.**—We offer to sell a whole or half interest in our jewelry store, which in all departments is first class, with a reputation in this city of more than forty years, the senior partner from age and bad health desiring to retire from business. This affords an excellent opportunity for a man with moderate capital and business energy to enter upon a prosperous trade. Parties wishing to purchase please address Edward Mead Co., corner Fourth Street and Washington Avenue, St. Louis, Mo.

**IMPORTANT to Jewelers.**—By sending 25 Cents (in currency), I will forward to your address an INFALLIBLE Recipe for preserving all kinds of plated-ware from tarnishing. The ingredients are few, the cost trifling, the work of preparation very simple, and the result all that could be wished for. When prepared it need only be placed in the case where the ware is kept, and needs no further attention. F. H. MADDEN, Care United States Show Case Works, 327 Liberty St., Pittsburgh, Pa.

**WOODCOCK & CO.**—Manufacturers and repairers of difficult watch work for the trade, 1013 Chestnut Street, Philadelphia, Pa. Jeweling, adjusting to heat, cold and isochronism a specialty. Plates jeweled equal to American watches. American escapements put in English lever watches. Pivots, staffs, cylinders, verges, pinions of every description made to order, pallet jeweling put in very low, wheels cut to order, and in fact new pieces of every description made to order and fitted. Estimates given before doing work if not satisfactory. We pay expenses on returning it to you. Send for price list.

**FOR SALE.** A first-class Jewelry Store, established ten years, in a flourishing town on the Hudson of 7,000 inhabitants, beside 800 to 1,000 summer boarders; 1 hour's ride from New York; no other Jewelry Store within a circuit of several miles; store refitted 3 years ago, with seventeen feet of Silver-plated Show Cases, fire and burglar-proof safe, awnings, window shades, signs, reflectors, gas fixtures, etc.; also, large Mirror, and Heater, etc., etc., costing three years ago, \$1,200 will be sold for \$400. Buyer can purchase stock or not. No charge for good will. Lease of store, 2 years to run. Satisfactory reasons for selling. Address, M. SCHINDLER, Tarrytown, N. Y.

Attention is directed to the new designs of silver-plated ware manufactured by the Middletown Plate Company, illustrations of which appear in the advertisement on the fourth and fifth pages of the CIRCULAR. This enterprising establishment seem to have an inexhaustible wealth of new and original designs which they are constantly bringing out in the most attractive forms that cannot fail to give satisfaction.

## Buyer's Directory.

A Guide to the prominent Wholesale Houses in the Watch, Clock, Jewelry and kindred branches of Trade in New York, Philadelphia, Chicago, Providence and Newark.

## NEW YORK.

## Black Onyx Jewelry.

**Cox & Sedgwick.**—Manufacturers of Black Onyx Jewelry, No. 26 John St., New York.

**Unger, H. & Co.**—Manufacturing Jewelers. Fine Onyx and Pearl goods a specialty. Manufacturers of Patent Onyx Bracelet, with Lilly of the Valley mountings. No. 18 Crawford St., Newark, N. J. Box 63.

**Herbert, R. J.**—Importer and Broker in Diamonds, 16 Maiden Lane.

**Woglom & Miller.**—Manufacturers of (exclusively) Black Onyx Jewelry, 32 & 34 John St., New York.

## Bohemian Garnet Jewelry.

**Bissinger, Philip.**—Importer of Diamonds, Pearls and Precious Stones. Sole Agent for the Bohemian Garnet Jewelry, 22 John St.

## Clock Companies.

**New Haven Clock Co.**—62 Reade Street, N. Y.

**Seth Thomas Clock Co.**—20 Murray Street, N. Y.

**Waterbury Clock Co.**—M. Bailey, Treasurer, Manufs. and Jobbers, No. 4 Cortlandt Street, N. Y., and No. 197 State Street, Chicago.

**Kroeber, F.**—Manufacturer and Dealer in American and French Clocks, No. 8 Cortlandt St.

## Corals and Coral Jewelry.

**Cuppia, L. A.**—Importer of Coral and Silver Filigree Jewelry, 19 Union Square, N. Y.

**Errico Bros.**—Importers of Coral, Conch-Shell and Silver Filigree Jewelry, etc., 19 John St.

**Lawson, S.**—Manufacturer of Coral and Black Onyx Jewelry. All kinds of repairing solicited. Goods sent on Mem. 63 Nassau Street.

**Squadrioli, Ach.**—Manufacturer and Importer of Coral, Conch Shell and Silver Filigree, etc. No. 9 Maiden Lane, N. Y.

## Cameo Cutters, Etc.

**Bonet, L.**—Cameo Likenesses, No. 889 Broadway, N. Y.

**Peiter, Theodore.**—Cameo and Intaglio Engraver. Patantee of the new Cameo-Intaglio. No. 2 Bond Street, near Broadway, Room 4, New York.

**Wiederer, Peter.**—Late Habermeier & Wiederer, Engravers of Cameo Likenesses, Seal Stones. Cameos repaired. 23 John St.

## Charms &amp; Gold Watch Keys.

**Rupp & Held.**—Manufacturing Jewelers, Charms and Gold Watch Keys, with French and English Ratchets, a specialty. 15 John St., N. Y.

## Cutlery.

**Rogers Cutlery Co.**—Hartford, Conn.

**Harrison Bros. & Howson.**—Manufacturers of Fine Ivory and Pearl Table and Pocket Cutlery; Carvers in Cases; Nutpicks, Nutcracks and goods suitable for the jewelry trade. 26 Cliff street. W. C. Burkinshaw, Sole Agt.

## Diamonds.

**Anderson, Otis.**—Diamond Merchant and Broker, always ready to pay cash for bargains in Diamonds and Precious Stones, No. 9 Maiden Lane, N. Y.

**Bernhard, A. & Co.**—Manufacturing Jeweler & Importers of Diamonds and Precious Stones, also Diamond Mountings, 2 Maiden Lane.

**Bissinger, E.**—Importer of Diamonds, No. 192 Broadway, New York.

**Bissinger, Philip.**—Importer of Diamonds, Pearls and Precious Stones. Agent for the Bohemian Garnet Goods No. 22 John St., N. Y.

**Buckenham, Cole & Saunders.**—Importers of Diamonds and other Precious Stones, No. 10 Maiden Lane, N. Y.

**Fera, Henry.**—Importer of Diamonds, and Manufacturer of Fine Diamond Jewelry. No. 9 Maiden Lane, New York. Amsterdam, Holland, 23 Loojersgracht.

**Fox, M. & Co.**—Importers of Diamonds and other Precious Stones, No. 1 Maiden Lane,

**Hedges, Wm. S. & Co.**—Importers of Diamonds. No. 170 Broadway.

**Lyon & Hardy.**—Importers of Diamonds and Manufacturers of Diamond Jewelry. 30 Maiden Lane, New York.

**Neresheimer, E. Aug.**—Importer of Fine Diamonds. No. 21 Maiden Lane, New York.

**Prager, Morris.**—Importer of Diamonds and Fine Diamond Jewelry 8 Maiden Lane,

**Randel, Baremore & Co.**—Importers of Diamonds, corner Maiden Lane and Nassau St.

**Smith, Alfred H. & Co.**—Importers of Diamonds No. 14 John Street.

## Diamond Cutters.

**The Morse Diamond Cutting Co. of Boston.**—Henry D. Morse, General Manager. N. Y. Office, 192 Broadway, corner John street. J. D. Yerrington, Agent.

## Diamonds and Diamond Jewelry.

**Bissinger, Philip.**—Importer of Diamonds, 22 John street, N. Y. Agent for the Bohemian Garnet Goods.

**Heller & Bardel.**—Manufacturers of Diamond and Pearl Jewelry, and dealers in Diamonds, Pearls, &c. Also agents for Boss' Patent Stiffened Gold Watch Cases. 13 John St.

**Taylor & Brother.**—Importers of Diamonds and Diamond Jewelry, 676 Broadway.

## Diamond Setters, Etc.

**Asher, J.**—Jeweler and Diamond Setter, Precious Stones Inlaid and Incrusted with Diamonds, Nos. 880 and 882 Broadway.

**Wood, Chas. F.**—Engraver and Incruster of Precious Stones and Diamond Setter. No. 169 & 171 Broadway.

**Friend, S.**—Manufacturer of Fine Jewelry, and Diamond Setter. 33 John street. N. Y.

## Dials, &amp;c.

**Gold, John T.**—(Successor to the late T. Gold), Enamel Watch Dial Maker, 81 Nassau St.

## Enamellers, Etc.

**Nutt, J. D.**—Enameler on Gold, Silver and Copper, 32 and 34 John St. Birds, Flowers, etc., Enameled in colors.

**Orr, Jas. C.**—Enameler on Fine Jewelry, Flowers, Birds, &c., Enameled in colors. Band Bracelets (a specialty). 77 Nassau Street.

## Electroplaters, &amp;c.

**Jeandheur, F. & Son.**—Gold and Silver Electro Platers & Fire Gilders, coloring Russian and Gold Jewelry a specialty. 125 Fulton St.

## Engravers and Die Sinkers

**Fackner, Edward.**—Carver, Engraver and Chaser on Jewelry and Pencil Cases. Monograms Lettering, &c. 19 John Street.

**Park Wm.**—Stone Seal Engraver. Coats of Arms found and engraved. Initials and Monograms engraved. 26 John Street, New York.

**Schuller, J. Dan'l.**—Stone Seal Engraver Arms Crests, Initials and Monograms engraved on Stone Seals, &c. 71 Nassau street.

## Engraving Type.

**Ingersoll, H. S.**—Rubber Engraving Type, Patented December, 1872. Over 40,000 alphabets in use. Saves time and skill of designing before engraving silverware, etc. Also Engravers' Tools, etc. Catalogue free. 203 Broadway, N. Y.

## Fancy Goods, Clocks, Bronzes Etc.

**Magnin, Ve J. Guedin & Co.**—Importers of Clocks, Bronzes, Musical Boxes & Rich Fancy Goods etc., 29 Union Square.

**Le Boutillier & Co.**—Importers of Fancy Goods, Clocks, Bronzes, &c. 3 Union Square

## Gold Chains, Etc.

**Beck, J. & Son.**—Manufacturers of Fine Gold Chains and Chain Bracelets, 10 Liberty place, near Maiden lane, N. Y.

**Dorrance, Edge & Co.**—Manufacturers of the Celebrated Woven Fabric Gold Chain, No. 12 John street.

**Hamiltons & Hunt.**—Manufacturers of Fine Plated Chains and Patent Buckle Bracelets. Branch office, 176 Broadway. Factory, 226 Eddy street, Providence.

**Kaufmann Bros.**—Manufacturers of Gold Chains, and Chain Bracelets, 26 John street; Factory, 331 and 333 Bowery, N. Y.

**Nordt & Schlag.**—Manufacturers of Gold Chain No. 17 Maiden Lane, N. Y.

**Saxton, Smith & Co.**—Manufacturers of Fine Gold Chain. 15 Maiden Lane.

## Gold Pens, Etc.

**Aikin, Lambert & Co.**—Manufacturers of Choice Gold Pens, Cases, Holders, Toothpicks, etc., 23 Maiden Lane, N. Y.

**Clark, J. M.**—Manufacturer of Pen and Pencil Cases for the wholesale trade only. No. 61 Hudson Street, N. Y.

**Mabie, Todd & Bard.**—Manufacturers of Gold Pens, 180 Broadway.

**Todd, Edward & Co.**—Manufacturers of Gold Pens, Pencil Cases, Tooth Picks, &c., 44 East 14th St., Union Square.

**Coldsmiths, &c.**

**Greene Wm. C. & Co.**—Goldsmiths; Manufacturers of Rich Sets in Taper Wire Coral. Office, 192 Broadway.

**Cold Rings.**

**Bowden, J. B. & Co.**—Manufacturing Jeweler.—Solid Gold Rings a specialty, 1 Maiden Lane.  
**Ely, W. H.**—Manufacturer of Solid Gold Rings of every description. No. 58 Nassau Street.  
**Frankel & Folkart.**—Manufacturers of Seal, Cameo and Amethyst Rings a specialty, Also a full line of Gold White Stone goods and Diamond Settings. 21 John St., N. Y. etc., No. 4 Liberty Place.  
**Peckham, Wm. H. & Co.**—Manufacturers of Solid Gold Seamless Rings, and Fancy Embossed Rings, Patent Spectacles, Jewelry, etc. No. 4 Liberty Place, N. Y.  
**Sinnock & Sherrill.**—Manufacturers of Stone Rings. No. 5 Maiden Lane, N. Y.  
**Tingley, Joseph N.**—Manufacturer of Stone Rings and novelties in Stone Goods. No. 9 Maiden Lane, N. Y.

**Hair Jewelry.**

**Montoux, Wm. E.**—Leading Artist in Hair, and Manufacturing Jeweler, 81 Nassau St., New York. Pattern Books for the trade.  
**Sauter, L.**—Manufacturer of Fine Gold and Hair Jewelry and Device Work. Nos. 65 & 67 Nassau Street.

**Schwencke O.**—Manufacturer of Fine Hair Jewelry. Orders from the country promptly attended to. No. 43 Maiden Lane.

**Jewelry Cases, Fancy Boxes, Etc**

**Braun, Chr. E.**—Manufacturer of Jewelry Boxes, Trays for Show Cases, &c., 62 Chatham st.  
**Dahlem, W.**—Manufacturer of Cases for Jewelry and Silverware, No. 85 Nassau Street, N. Y. Show Case Trays, &c., at shortest notice.  
**Loehr & Koerner.**—Manufacturers of Morocco, Velvet, Satin, Jewelry, Watches and Silverware Cases, Glove, Handkerchief, Ladies' Jewel, Work Boxes, &c., Fancy Trays and Stone Fittings to order, Office and Salesroom 83 Nassau Street, New York.  
**New York Morocco Case Co.**—Makers of Cases for Jewelry, Watches, Silverware, etc. Boxes and Trays for Jewelry. No. 69 Nassau Street, N. Y.  
**Walker, Geo. W., Morocco Case Manufacturing Co.**—Manufacturers of Morocco Cases, 712 Broadway, N. Y.  
**Sturn, I.**—Manufacturer and Importer of Cases for Jewelry, Watches, Silverware, &c. No. 15 John street, N. Y.  
**Welch & Miller.**—Manufacturers of Morocco, Velvet, and Satin Jewelry Cases, Trays, &c. Telescope Simple Cases with flexible Trays. Complete stock on hand. 169 Broadway.  
**Wiggers & Froelick.**—No. 60 Nassau street.—Manufacturers of Cases for Jewelry, &c., of every description. Trays for Show-cases, Stands for Show-windows, etc. Jewelers' Traveling Cases, light, convenient and strong.

**Jewelry—Fine.**

**Aikin, Lambert & Co.**—Manufacturers. General stock of Reliable Jewelry, 23 Maiden Lane.  
**Alford, C. G. & Co.**, Manufacturers. General line fine and reliable goods. Specialties in Onyx goods and chain. 183 Broadway, New York.  
**Andrews, J. F.**—Manufacturer of Fine Jewelry, Locketts, Sleeve Buttons and Rings in Stone Cameo, etc., a specialty. 35 Maiden Lane.  
**Barthman & Straat.**—Manufacturers of Fine Jewelry. Seal and Stone Rings a Specialty Orders promptly attended to. 41 Maiden Lane.  
**Bernhard, A. & Co.**—Manufacturers of Fine Hair Jewelry and Device Work. The latest styles. 2 Maiden Lane, New York.  
**Bissinger, E.**—Importer of Fine Jewelry, Locketts, Crosses, Neck Chains, &c., No. 192 Broadway.  
**Brown, Thos. G.**—Manufacturer of Rich Jewelry Necklaces, Locketts, Bracelets, Sleeve Buttons, etc., 9 Bond street, N. Y.  
**Bryant & Bentley.**—Manufacturing Jewelers Rings a specialty. 12 Maiden Lane.  
**Brainerd & Steele.**—Successors to Brainerd, Steele & Co., Manufacturers of Fine Jewelry and Brainerd's Patent Locketts. No. 9 Maiden Lane, New York.  
**Burch, Geo. & Co.**—(Successors to Burch, De Mott & Coughlin.) Manufacturing Jewelers, 17 Maiden Lane, N. Y. Factory, Newark, N. J.  
**Carrow, Bishop & Co.**—Manufacturers of Fine Jewelry, Roman Band Bracelets, Locketts, Crosses, &c. 12 John Street, N. Y.

**Carter, Howkins & Sloan.**—Manufacturing Jewelers, Whiting Building, 4th St. & Broadway  
**Chatellier & Spence.**—Manufacturing Jewelers. No. 694 Broadway, N. Y.

**Champanois & Co.**—Manufacturing Jewelers, No. 1 Maiden Lane. Specialties—Jet Cluster Goods in Sets and Sleeve Buttons, Engraved and Enameled Goods in Sets, Studs, Sleeve and Collar Buttons, Lace, Shawl and Cuff Pins, Ear Knobs and Crosses.

**Cook, Groeschel & Co.**—Manufacturers of Fine Jewelry and Locketts, 191 Broadway (over Mercantile Bank), N. Y.

**Demmert Bros.**—Manufacturers and Importers of Fine Jewelry, Cameo and Onyx Locketts, Sleeve Buttons and Sets a specialty. Old No. 9 Maiden Lane, New York.

**Falkenau & Oppenheimer.**—Manufacturing Jewelers. Specialty—Knife Edge Work and Rings. 89 Nassau Street.

**Field & Co.**—Manufacturing Jewelers, 8 Maiden Lane, N. Y.

**Finkelmeier, Louis.**—Manufacturing Jeweler. Jobbing and ordered work for the trade at moderate prices. 73 Nassau Street, N. Y.

**Goddard, John M.**—Manufacturing Jeweler.—Seal Rings and Fine Locketts a specialty, No. 3 Maiden Lane, N. Y.

**Greason, Bogart & Pierce,** successors to Arthur, Rumrill & Co., 182 Broadway, manufacturers of fine jewelry and gold chains

**Hartmann, P.**—Manufacturer & Importer of Fine Gold, Diamond, and Filagree Silver Jewelry, No. 36 Maiden Lane. P. O. Box 2,454.

**Haskell, H. C.**—Manufacturing Jeweler. Seal Rings a specialty. Special attention to Jobbing of every description. 12 John street.

**Hellfenstein & Bourke.**—Manufacturers of the Patent Adjustable Sleeve Button, No. 202 Broadway, N. Y.

**Henderson & Winter.**—Jewelers, No. 15 Maiden Lane, New York. Specialties—Stone, Cameo, Onyx, Amethyst, Topaz, Pearl and Turquoise Rings.

**Hunt & Owen.**—Manufacturing Jewelers. Office 5 Maiden Lane.

**Hale & Mulford.**—Manufacturers Rich Jewelry, Whiting Building, Broadway and 4th Street.

**Jeanne Brothers.**—Manufacturers of Diamond Mountings & Rich Jewelry. 1 Maiden Lane.

**Kellei, Chas. & Co.**—Manufacturing Jewelers Locketts a Specialty. No. 18 John St., N. Y.

**Kremetz & Co.**—Manufacturing Jewelers, No. 13 John Street, N. Y.

**Kroll, H.**—Manufacturer of Fine Jewelry. Repairing (a specialty) done for the trade at moderate prices, 78 Nassau street.

**Kuhn & Doerflinger.**—Manufacturers of Enamel'd and Roman Band Bracelets, also Fine Locketts and Pendants, 18 John street.

**Lennon, John D.**—Manufacturing Jeweler, 142 Fulton street. Flat, and Half-rouned Gold Bracelets, Roman and Stone Locketts.

**Moore & Horton.**—11 Maiden Lane, Manufacturing Jewelers, Rings, Studs, Collar and Sleeve Buttons, Pins, Ear-rings, &c.

**Marx Kossuth & Co.**—Manufacturing Jewelers. 39 Maiden Lane.

**Owen, G. & S. & Co.**—Manufacturing Jewelers. Office, No. 5 Maiden Lane.

**Riker, William.**—Manufacturer of Jewelry. Inlaid Gold Jewelry a Specialty. No. 5 Maiden Lane, N. Y.

**Riley, J. A. & Co.**—Manufacturing Jewelers, Etruscan Gold and Coral Sets, Roman Bracelets, Necklaces, etc. Onyx Goods a specialty. 7 and 9 Bond street, New York.

**Richardson, Enos & Co.**—Manufacturers of Fine Gold Jewelry, Gold Chains, Locketts, Crosses and Necklaces. Colored and Etruscan Work. No. 23 Maiden Lane, New York.

**Richardson, J. W. & Co.**—Manufacturers of Jewelry, Masonic and other emblems. 196 Broadway, Manufactory, Providence, R. I.

**Ripley, Howland & Co.**—Manufacturers of Fine Jewelry and Diamond Mounting. 35 Maiden Lane, N. Y.

**Sexton & Cole.**—Manufacturing Jewelers, Colored Gold and Onyx Goods a specialty. No. 30 Maiden Lane.

**Shoemaker & Co.**—Manufacturing Jewelers, Cameo Buttons, and Locketts, Roman Gold Goods, etc. No. 21 Maiden Lane, N. Y.

**Stites, E.**—Manufacturer of Fine Jewelry. No. 12 Maiden Lane, N. Y.

**Stites, D. H. & Son.**—Manufacturers of Fine Jewelry, Rolled Plated Goods and Chains Parisian Diamond Rings, Studs and Ear-rings a specialty. 41 Maiden Lane, N. Y.

**Sturdy Bros & Co.**—Manufacturers of Jewelry. General line of fine and heavy Rolled Plate Goods. Specialties—enameling on gold plate; graduated wire coral work. 14 Maiden Lane, N. Y.

**Terhune, Charles F.**—Manufacturing Jeweler, 16 Maiden Lane, N. Y.

**Thoma, Ernest.**—Manufacturer of Fine Jewelry. Sleeve Buttons, Riugs, Ear-rings, &c. No. 173 Broadway, N. Y. Factory, Hackensack, N. J.

**Trier Bros. & Co.**—Jewelry. Optical, Rubber, Jet, Shell, Ivory, Amber and Pearl Goods. Silk Guards, Japausee Bamboo Watch Chains a Specialty. No. 15 Maiden Lane.

**Unger, H. & Co.**—Manufacturers of Fine Gold Jewelry, Colored and Etruscan work, Enameled Sets, etc. Office and Factory, 13 Crawford street, Newark, N. J. Box 63.

**Wadsworth, E. E.**—Manufacturer of Rich Jewelry and fine Rolled Plate. Fine Seal Rings a specialty. 35 Maiden Lane.

**Wheeler, Parsons & Hays.**—Manufacturers of Fine Jewelry, Watch Cases, Gold Chains, &c and Dealer in American and Swiss Watches, No. 2 Maiden Lane, N. Y.

**Wienhold, Joseph.**—Manufacturer of Fine Jewelry and Diamond Setter. 24 John St.

**Wogloom & Miller.**—Sole Agents for the "Prime" Thimbles in Gold and Silver, manufactured by Ezra C. Prime. 34 John Street, N. Y.

**Jewelers' Tools, etc.**

**Fraser & Co.**—Importers of Stubs, French, Swiss, German and Sheffield Tools, Files and Steel Wire for Watchmakers, Jewelers, etc., 62 Chatham street, N. Y.

**Hammel, L. & Co.**—Importers of Materials and Tools for Watchmakers, Jewelers and Engravers—also Optical Goods, &c., 9 Maiden Lane, N. Y.

**Hecht, Phil.**—Importers and dealers in Watch makers' materials, Tools, Optical Goods and Silk Guards, etc. 13 Maiden Lane, N. Y.

**Lapidaries.**

**Fox, M. & Co.**—Practical Lapidaries, No. 1 Maiden Lane, New York.

**Kordmann & Michel.**—Lapidaries, dealers in Precious Stones, Rubies, Sapphires and Peridots cut. No. 32 Maiden Lane.

**Masonic Jewelry.**

**Wilkinson, C. B. & Co.**—Manufacturers of Masonic, Odd Fellows, Athletic Clubs and other Jewelry, No. 212 Broadway, New York.

**Opticians.**

**Burbank Man'g Co.**—Manufacturers of Spectacles and Eye Glasses of all descriptions, in gold, silver, etc., 14 Maiden Lane, N. Y.

**Du Bois, Geo. W.**—Successor to A. Landsberg, Importer and Manufacturer of Optical Goods 36 Maiden Lane, Box 3993, N. Y.

**Hammel, L. & Co.**—Importers of Spectacles, Opera and Marine Glasses, Telescopes, Microscopes, Optical & Fancy Goods, 9 Maiden Lane.

**Laurencott, J. B.**—Importer of Watch Glasses, Optical and Fancy Goods, Clocks, Bronzes, etc., 33 Maiden Lane, N. Y.

**Lorsch, Albert.**—Manufacturer of the Patent Accommodating Spectacles and Eye Glasses in Gold, Silver and Steel, and other Optical Goods, 37 Maiden Lane, N. Y.

**Serin, A.**—Manufacturer of Spectacles and Eye-Glasses, in Steel, Shell and Rubber. Repairing of all kinds. Opera Glasses covered and re-gilt, etc. 169 and 171 Fulton street.

**Spencer Optical Manufacturing Co.**—Gold, Silver, Steel and Nickel Plated Spectacles, Eye Glasses, &c. 13 Maiden Lane, N. Y.

**Precious Stones, &c.**

**Bissinger, Philip.**—Importer of Diamonds, Pearls and Precious Stones. Agent for the Bohemian Garnet Goods. No. 22 John St., N. Y.

**Fox, M. & Co.**—Importers of Diamonds and other Precious Stones, No. 1 Maiden Lane, New York.

**Gruet, Jules.**—Importer of Precious and Imitation Stones, Amethysts, Topazes, Cameos, Garnets, Doublets, Imitation Diamonds, Pastes, etc., No. 14 John street. Manufactory at Septmoncel, France.

**Meyer, Francis Ed.**—Successors to John B. Behrmann, Importer of Imitation Precious Stones, all sizes and shapes constantly on hand. No. 53 Nassau st., P. O. Box, 1981.

**Silverware.**

**Gorham Manufacturing Co.**—Union Square.  
**Wood & Hughes.**—Manufacturers of Fine Silver ware. 16 John Street, N. Y.

**Silver Plated Ware.**

- Brown & Bros.**—Manufacturers of first quality of Electro Plated Flat Table Ware. No. 81 Chamber Street, N. Y.
- Hall, Elton & Co.**—Manufacturers of the Finest Electro-Plated Ware, salesroom, 75 Chambers street, N. Y.
- Holmes, Booth & Haydens**—Manufacturers of Silver-plated Ware. 47 Chambers street.
- Meriden Britannia Co.**—Manufacturers of Silver plated Ware, 46 East 14th Street, Union Square, N. Y.
- Middletown Plate Co.**—Manufacturers of Superior Electro-Plate. Factories, Middletown, Conn., Salesroom, 13 John Street
- Rogers Cutlery Co.**—Hartford, Conn.
- Reed & Barton**—Manufacturers of Fine Plated and Table Ware, of every description, 686 Broadway, N. Y.
- Rogers & Bro.**—Manufacturers of the finest quality of Electro-Plated Ware. 690 B'way.
- Simpson, Hall, Miller & Co.**—Manufacturers of Fine Silver Plated Ware, No. 36 E. 14th St.
- Schade, Henry.**—Manufacturer of White Metal and Plated Ware, No. 84 John Street, New York. Price list and catalogue furnished on application.
- Webster, E. G. & Bro.**—Manufacturers of Fine Silver Plated Ware. Office and Warerooms, 14 Maiden Lane, N. Y.

**Show Cases, Etc.**

- Kraft & Hoffmeister**—Manufacturers of Metal Show Cases, Jewelry Trays always on hand, No. 16 North William street, N. Y.
- Smith, B. & W. B.**—Patent Improved Counter Show Cases. Drawings furnished and estimates given for fitting stores in Cabinet Work complete.

**Spectacle Case Manufacturers.**

- Koenen, A. & Bro.**—Manufacturers of Leather Spectacle & Eye Glass Cases, 81 Nassau St., N. Y.

**Thermometers Etc.**

- Tagliabue, Giuseppe**—Thermometer, Barometer and Hydrometer Manufacturer, 302 Pearl street near Beekman, N. Y.

**Thimble Manufacturers.**

- Burbank Manufg Co.**—Manufacturers of Gold & Silver Thimbles, 14 Maiden Lane, N. Y.
- Ketcham & McDougall**—Improved Gold and Silver Thimbles, Nos. 4 and 6 Liberty Place, near Maiden Lane, N. Y.
- Woglom & Miller**—Sole Agents for the "Prince" thimble, in gold and silver, 34 John St.,

**Walking Canes.**

- Fradley, J. F.**—Manufacturer of Fine Gold and Silver-headed Walking Canes and Sterling Silverware. Office and Factory, 20 John st.

**Watch Companies.**

- American Watch Co.**—Robbins & Appleton, No. 9 Bond street, N. Y.
- Illinois Watch Co.**—Factory, Springfield, Ill. Office, 21 Maiden Lane.
- Hampden Watch Co.**—of Springfield, Mass. Office, No. 12 Maiden Lane, New York.
- Tiffany & Co.**—Makers of Fine and Complicated Watches. Office 694 Broadway, N. Y.
- The Howard Watch and Clock Co.**—No. 2 Maiden Lane, N. Y.

**Watch and Chronometer Jeweler.**

- Queen, James**—Watch and Chronometer Jeweler and Pallet Maker, 78 Nassau street, Room 8. Pivots inserted in Pinions, Balance, Staffs, &c.

**Watch Importers, Etc.**

- Aikin, Lambert & Co.**—Importers of Watches, Sole Agents for Paul Breton & Chas. Latour, Geneva. A general line of reliable Swiss Watches. Watch Cases of all styles made to order. 23 Maiden Lane, N. Y.
- Bynner, T. B.**—Importer and Jobber of Watches, Diamonds and Fancy Goods, and dealer in the best class of Rolled Plate Jewelry. 513 Broadway.
- Cross & Beguelin**—Importers of Watches, Watch Tools and Materials, dealers in American Watches, No. 21 Maiden Lane, N. Y.
- DuBois, Francis & Co.**—36 Maiden Lane, N. Y., Importers of Watches and Manufacturers of Watch Cases.
- Droz, Henry E.**—Importer of Watches and Watch Case manufacturer. Agent for the "E. Perregaux" Watch, and jobber in American Watches, No. 92 Fulton Street, N. Y.
- Freund Max & Co.**—Importers of Watches Jewelry and Precious Stones, 8 Maiden Lane
- Friedman, S.**—Importer of and dealer in Watches and Jewelry, 40 Maiden Lane.

**Gagnebin, Chas.**—Importer of all kinds of Watches, 4 Maiden Lane. Agent for Ulysse Breting's Fine Chronometers, Chronographs, Anchors, etc.

**Gallet, Julien**—Importer of Watches. No. 1 Maiden Lane.

**Ginnel, Henry**—Importer of Watches, Tools and Materials. No. 31 Maiden Lane, N. Y. P. O. Box, 2967

**Jandorf, P. & Bro.**—Importers of Watches and Jewelry. 182 Broadway, bet. John Street and Maiden Lane, New York.

**Keller, L. H. & Co.**—(Successors to G. A. Huguenin,) Importers of Fine Watch and French Clock Materials, No. 64 Nassau street, N. Y.

**Hirsch Bros.**—Dealers in Watches and Diamonds, and manufacturers of Jewelry. No. 23 Maiden Lane, New York

**Hyde's Sons, John E.**—Wholesale Commission Agents, only, for Jules Jurgensen, of Copenhagen, Ed. Perregaux, of Locle, Jules Monard, of Geneva, and for other makers of all qualities of watches, 22 Maiden Lane.

**Magnin, Ve J. Guedin & Co.**—Importers and Agents of the Nardin Watch, 29 Un. Square.

**Mathey, L. & A.**—Importers of Fine Watches and Sole Agents for the **H. L. Matile's** Watches, No. 16 Maiden Lane.

**Mathey, F. H.**—Importer of Watches. No. 5 Maiden Lane, N. Y.

**May & Stern**—Importers of Foreign Watches, Materials and Tools, etc. Manufacturing Jewelers. No. 19 John St., N. Y.

**Middleton & Brother.**—Importers of Swiss Watches and dealers in American Watches, Diamonds, Gold Chains, Jewelry, etc., 10 Maiden Lane, N. Y.

**Nicoud & Howard**—Importers and Manufacturers of Watches, No. 14 Maiden Lane.

**Oppenheimer Bros. & Veith**, Dealers in Watches and Diamonds, and Manufacturing Jewelers. No. 35 Maiden Lane, N. Y.

**Robert, J. Eugene**—No. 30 Maiden Lane, New York Agent for Louis Audemar's celebrated watches.

**Schwob, Adolphe**—Manufacturer & Importer of Watches, 11 Maiden Lane, N. Y.

**Stern Brothers & Co.**—Importers of Swiss Watches and wholesale dealers in American Watches, &c., 30 Maiden Lane.

**Scott, J. T. & Co.**—Importers of Watches, and Manufacturers of Jewelry, and Jobbers of all grades American Watches. No. 11 Maiden Lane, N. Y.

**Strasburger, Louis & Co.**—Importers and Makers of Watches of every description. No. 15 Maiden Lane.

**Tiffany & Co.**—Makers of Watches. General Agents for Patek, Philippe & Co. Wholesale office, 694 Broadway, N. Y.

**Watch Cases.**

**Brown, J. A. & Co.**—Manufacturers of The Ladd Patent Stiffened Gold Watch Cases, &c., 11 Maiden Lane, N. Y. Factory, 58 Eddy street, Providence, R. I.

**Watch and Chronometer Repairer.**

**Cert, B.**—Practical Watchmaker and Repairer, No. 10 John street, N. Y. Repairing and adjusting of Fine Watches done for the trade. All kinds of escape and stem winding wheels cut to order.

**Sirois, A.**—Practical Watchmaker, 89 Fulton street. Special attention paid to the repairing of Fine Watches. Pivots inserted.

**Watch Case Repairers.**

**Tarbox, Hiram**—Watch Case Repairing, Springing, Polishing and Engine Turning, 79 Nassau street, (room 22), N. Y.

**Renaud, F.**—Watch-Case Repairer.—Solid and Heavy Rolled Plate Bows and Pendants. Springer and Engine Turner of Cases and Jewelry, 36 Maiden Lane

**Watch Guards.**

**American Silk Guard Manufacturing Co.**—Our goods are warranted all silk.—Kossuth Marx & Co. No. 39 Maiden Lane, N. Y.

**Watch Glasses, Shades, Etc.**

**Brown, Edwin**—No. 85 Nassau Street, Imported and own Manufacture Watch Glasses, Flat, Flat Concave, Convex, Convex and fine Geneva's. Fine fitting solicited.

**Hill, Robert S.**—Manufacturer of Watch Glasses, &c., dealer in Imported Glasses, Flat Glasses a specialty; also, Jeweler's Glasses. Nos. 75 & 77 Nassau street, N. Y.

**BOSTON.**

**The Star Salt Caster Co.**—Sole Proprietors and Makers of the Celebrated Star Salts, 161 Franklin Street, Boston, Mass.

**PHILADELPHIA**

**Booz & Thomas.**—Manufacturers of Gold and Silver Watch Cases and Jewelry, 108 South 8th Street, Philadelphia.

**Bennett, Jacob & Son.**—Diamond Setters and Manufacturing Jewelers. 108 South 8th St.,

**Cooper & Bros.**—Wholesale Jewelers, and Importers of and Dealers in Watch and Clock-makers' Materials, etc. Spectacles and Optical Goods. No. 35 South 4th St., Phila.

**Conover David F. & Co.**—American Watches, Wholesale Salesroom, southeast corner 7th and Chestnut streets, Philadelphia.

**Hagstoz & Thorpe.**—Sole manufacturers of Boss' Stiffened Gold Watch Cases. Sixth and Chestnut Streets, Philadelphia.

**Herold, Chas. P.**—Successor to Hildebrandt, Herold & Co., Manufacturing Jeweler and Diamond Setter. Diamonds. 916 Chestnut St

**H. Muhr's Sons.**—Manufacturing Jewelers, Solid Gold Rings a specialty, 633 & 635 Market st. New York Office, 11 Maiden Lane.

**Krider, Peter L.**—Manufacturer of Sterling Silver Ware, Artisan Hall, No. 618 Chestnut street

**Levy, Bernard**—Manufacturers of gold and silver watch cases, and importers and dealers in Swiss and American watches, 402 Library street, Philadelphia.

**Morgan, Charles V.**—Manufacturer of Morocco and Hardwood Cases, 630 Chestnut Street, Philadelphia. Jewelry and Silverware Cases, Show Case Trays, Mathematical and Surgical Instrument Cases, etc.

**McCall & Newman**—Manufacturing Jewelers, Filled Plain Gold Rings a specialty, No. 625 Arch street.

**Morgan & Headly.**—Manufacturing Jewelers Cameo sets, Gold sets, Roman Locketts, Rings, Coral sets, and a general line of rich goods. 611 and 613 Sansom street, Philadelphia.

**Pierson, Edwin.**—Manufacturer of Fine Imitation Jewelry, Gold and Silver Electro-plater, Fire Gilder, Coloring, Etruscan and Gold Jewelry a specialty. 1300 Chestnut St.

**Rosenthal, G. F. C.**—Manufacturing Jeweler and Diamond Setter. Engraving and Designing of Monograms a Specialty. No. 924 Chestnut street, Philadelphia.

**Scherr, L. A. & Co.** Wholesale Dealer in Watches Silver Plated Ware, Spectacles, Fancy Goods, Watch Materials, etc., 726 Chestnut street.

**Sheafer, W. H. & Co.**—Makers of Fine Jewelry 908 Chestnut Street.

**Simons, Brother & Co.**—Manufacturers of Fine Jewelry, Canes, Thimbles, Chains. 611 & 613 Sansom St., Philadelphia.

**CHICAGO.**

**American Watch Company**, of Waltham, Mass. No. 170 State street, Chicago.

**Charpior & Wathier**—Watchmakers & Jewelers for the Trade, and Wholesale Dealers in Watch Material, Tools, &c., 61 West Kinzie Street, Chicago, Ill. Send for price list.

**Cogswell, Weber & Co.**—Watches, Jewelry and Silver Plated Ware, Watchmakers' Tools and Materials at whole sale only, 146 State st.

**Frese, B.**—Watchmaking and Repairing for the Trade promptly attended to. Stem-winding and escape wheels cut to order. No. 99 E. Madison St., Chicago, Ill.

**Purdy, J. H. & Co.**—Jobbers of large and small Tools and Materials, for the use of Watchmakers, Jewelers, and kindred Trades. Spectacles—Jewelry Boxes, Plated Chains, &c., &c. No. 170 State street.

**Stein & Ellbogen**—Wholesale Dealers in Watches and Jewelry, 127 State St., Chicago. Specialty, repairing for the Trade.

**PROVIDENCE**

**Irons, Chas. F.**—Manufacturer of Solid Gold Jewelry. Specialty Emblems, Pins and Charms Masonic, Odd Fellows, &c. 102 Friendship St.

**Perkins, C. H. & Co.**—Manufacturers of fine Gold and Plated Jewelry. 20 Conduit St.,

**NEWARK.**

**Lefort, Henry.**—Stem-winding Watch Crown Manufacturers. 80 & 82 Marshall St.

**Lelong, L. & Bro.**—Gold and Silver Refiners, Assayers and Sweep Smelters, S. W. corner Halsey & Marshall streets, Newark, N. J.

**Milne & Jourdan**—Manufacturers of Stem-winding Watch Crowns 13 & 15 Franklin Ave.

**Prince, David**—Gold and Silver Refiner, Assayer and Sweep Smelter. Sole Agent for Comin's Improved Amalgamator. 13 & 15 R. R. Av.

**DETROIT.**

**Black, L. & Co.**—Manufacturers of Spectacles and Eye-Glasses of every description.

**WESTON DYNAMO-ELECTRIC MACHINE CO**

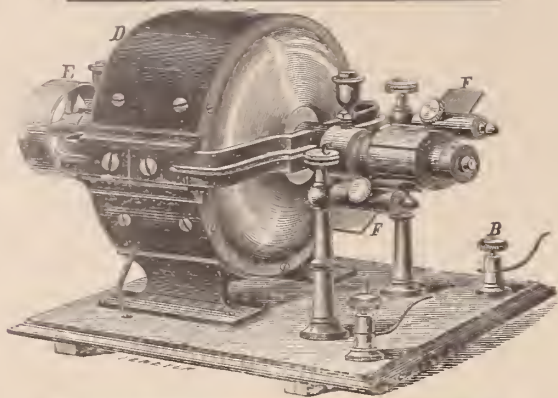

**CONDIT, HANSON & VAN WINKLE**  
Sole Agents **NEWARK, N.J. U.S.A.**

Machines for Electro-Plating, Electrotyping, Electric Light, Telegraphing, &c.

The Weston Dynamo-Electric Machine is constructed on a new principle giving the greatest amount of electricity with the least consumption of power. Its simplicity and ease of management has already made it the standard machine. The success attending its introduction has already had the effect of inducing parties building machines for similar uses to adopt some of the devices peculiar to our new construction. We beg to call attention to the various patents covering our machines, and to the fact that we guarantee purchasers against any infringement of existing patents, as well as to their adoption and endorsement by the largest manufacturers of the country, in many cases after a previous trial of all other machines.

In addition to the testimonials in our Catalogue of January 1, we beg to refer to the following houses:—Carter, Howkins & Sloan; Enos Richardson & Co.; Bates & Bacon; Short, Nevey & Co.; Stephen Richards & Co.; Meriden Britannia Co.; Russell & Erwin Manufacturing Co.; Reed & Barton; Hall, Elton & Co.; Richardson, Boynton & Co.; Wm. H. Jackson & Co.; Stanley Works; Rogers Cutlery Co.; Chas. Rogers Bros.; Edward Miller Co.; Mitchell, Vance & Co.; Norwalk Lock Co.; Hayden, Gere & Co.; Domestic Sewing Machine Co.; Eberhard Faber; Jos. Dixon Crucible Co.; Mumford & Hanson; Fagan & Son, and over 200 others. Outfits for NICKEL, SILVER, BRONZE PLATING, etc. The two highest Centennial Awards and three of the Centennial Medals of American Institute.

There are great advantages in the use of these Machines for Manufacturing Jewelers as they are always ready for use, avoiding the use of mercury and the annoyance of fitting up batteries, producing better colored work, and more durable; there are over 30 in use in Artleboro and vicinity alone, and are being rapidly adopted by the trade in Birmingham, Paris, Pforzheim, &c.

Machines from \$125, upward.  
The Machines may be seen in operation at our New York Office, 92 and 94 Liberty St., 2 doors west of Broadway.  
Catalogues of all our goods sent on application.

**FRASSE & COMPANY,**

Importers of P. S. STUBS',

French, Swiss, German & Sheffield Tools, Files,

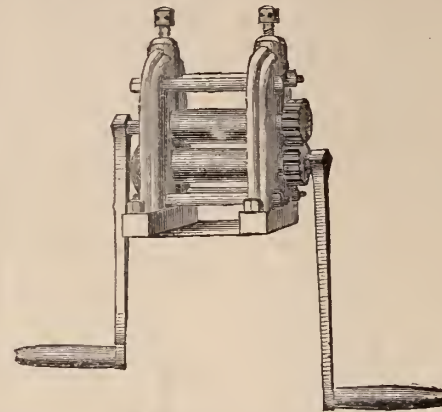

Steel Wire and Materials,  
For Watchmakers, Jewelers, Engravers,  
Die-Sinkers, Machinists, &c.

Turning Lathes, Drills & Chucks

Rolling Mills, Draw Plates,

The Celebrated Rodenbush  
Piercing Saws,

Horse Shoe Magnets, Nurls, In-  
go's, Chasing Tools, Engravers'  
Tools, Brush Wheels & Buffs,  
Hand Brushes and Buffs, Borax,  
Saltpetre, Beeswax, Rouge, Trip-  
oli, German Silver, Brass, &c.

**No. 62 Chatham Street,**  
Established 1816.

**New York.**  
P. O. Box 4627.

**CROSS & ADAMS,**

COUNSELLORS AT LAW,

ADVOCATES IN PATENT CAUSES.

No. 194 BROADWAY,

NELSON CROSS,  
JOHN P. ADAMS.

**NEW YORK.**

Particular attention given to Patents both with Departments and in the Courts.

More definite information relating to matters contained in the Patent Reports of this Journal furnished on application.

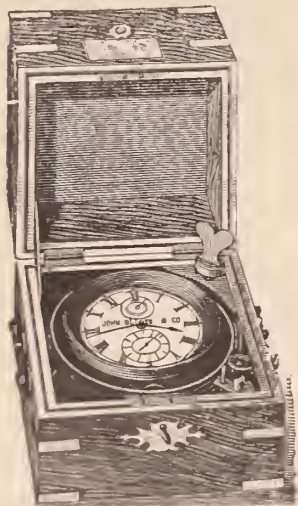

Standard Marine Chronometer  
FOR KEEPING CORRECT TIME.

**JOHN BLISS & CO.**

**STANDARD MARINE**

**Chronometers and Transits,**

FOR WATCHMAKERS' USE.

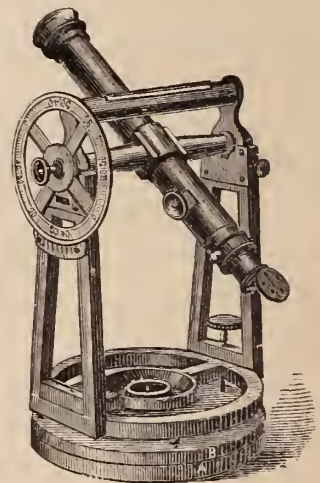

No. 10

**110 WALL STREET, NEW YORK.**

**IMPORTANT NOTICE.**—These Transits are readily set in position without the aid of strictly correct time as a basis for that purpose. Printed instructions, easily understood, accompany each Instrument, and no calculations are required preliminary to setting in position.

As a trial only is required to insure unqualified approval, we are induced to make the following **LIBERAL OFFER**—On receipt by us of satisfactory reference, and 10 per cent. of the price, we will send one of the foregoing Transit Instruments, on hire or trial, for one month, with full printed instructions for setting up and using the same, and if purchased after trial, we will allow the whole hire to apply in part payment, and sell the Instrument on approved note at four months for the balance. Special terms for payment by installments, after trial, on application. We do not make this offer merely to hire these instruments, but to insure a trial with a view to sales, the hire received being only sufficient to cover the cost of repolishing in case they are returned. Send for Illustrated Circular giving full description.

**JOHN BLISS & CO., 110 Wall Street, New York.**



HENRY HIRSH,

EDWARD HIRSH.

# HIRSH BROS.

## Dealers in Watches & Diamonds

AND MANUFACTURERS OF

### JEWELRY,

No. 23 Maiden Lane, New York.

Prompt attention given to filling orders for all kinds of goods pertaining to the trade.

**SILVER FILIGREE JEWELRY.**  
Splendid Silver Bridal Sets,  
Half Sets, Necklaces, Bracelets, &c.  
**P. HARTMANN,**  
P. O. BOX, 2454. 36 Maiden Lane, New York.  
Importer and Manufacturer of  
Fine Gold, Diamond & Filigree  
Silver Jewelry.

HENRY MAY.

Established 1854.

JOSEPH STERN.

# MAY & STERN,

IMPORTERS OF

## Foreign Watches, Materials and Tools

AGENTS FOR THE SALE OF ALL

DOMESTIC MOVEMENTS AND CASES.

### And MANUFACTURING JEWELERS

No. 19 John Street, New York.

SOLID GOLD SEAL RINGS, in Cameo, Amethyst, Topaz and Onyx, A SPECIALTY.

# ALBERT LORSCH,

IMPORTER AND DEALER IN

# WATCHES,

AND MANUFACTURER OF

# JEWELRY,

ALSO MANUFACTURER OF THE

PATENT ACCOMMODATING

# Spectacles and Eye Glasses,

In Gold, Silver, Steel, &c.

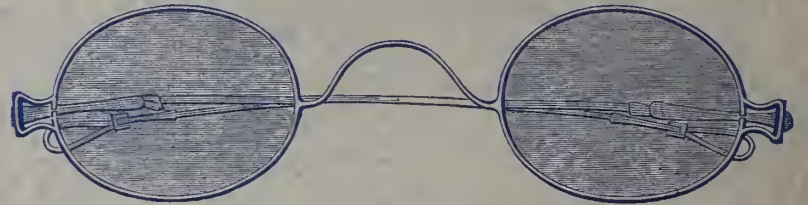

Would call the attention of the trade to the fact, that with the above Spectacles and Eye Glasses, which are constructed to form a Spring by which the lense is held, it is only necessary to have one complete assortment of lenses which being of uniform size, will interchange in all the different kinds of frames, thus giving a complete assortment for a comparatively small outlay. Notwithstanding the numerous advantages of these Spectacles, the prices will compare favorably with those of any other make.

ALBERT LORSCH, 37 Maiden Lane, New York.

LORSCH BROS., 120 Sutter St., San Francisco, Cal.

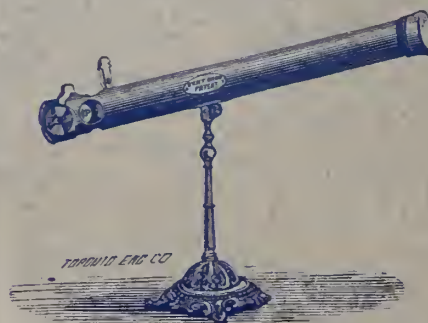

# L. BLACK & CO.'S Spectacle INDICATOR,

Patented in U. S., July 31, 1877.  
Canada, March 19, 1877.

Instruct the customer to place one eye closely against the open end of the tube; put the smallest letter opposite the small hole, and turn until the customer can distinguish a letter or figure. The strength of the spectacles required will be indicated on the index wheel. If the large letters are used, pull up the slide; if not, keep it down.

This instrument is easily adjusted, can not get out of order, is nickel plated, makes a nice appearance, and shows the correct number of lens required.

For particulars, address L. BLACK & CO., Detroit, Mich., or any wholesale Optical Establishment in New York.

# L. LELONG & BRO.

## GOLD and SILVER REFINERS,

## Assayers and Sweep Smelters,

Southwest Corner Halsey and Marshall Streets,

NEWARK, N. J.

SWEEPINGS A SPECIALTY.

# KELLER & UNTERMAYER,

ONLY AUTHORIZED AGENTS OF

# The International Watch Co.'s

## WATCHES.

A full and complete assortment of these goods in new and attractive Gold Cases constantly on hand.

No. 18 John Street, New York.

OCTOBER, 1879.



Established 1813.

# SETH THOMAS CLOCK CO.

THOMASTON, CONN.

No. 20 MURRAY STREET, New York.

16 Worship Street,  
LONDON, E. C.

172 State Street,  
CHICAGO.

132 Sutter Street,  
SAN FRANCISCO.

## F. KROEBER,

Manufacturer of CLOCKS,

No. 8 Cortlandt St., New York.



Birdie.



Velvet.



WASP.

1 Day, \$2.00. 8 Day, \$2.40.



Thistle.



Daisy.



Aurora.



Horseshoe.



Tulip.



Comtess.



# New Haven Clock Co.

117 & 119 State St., Chicago.

G. A. HARMOUNT, Agent.

62 Reade Street, New York.

L. EGERTON, Jr., Agent.

Manufacturers and Jobbers of

# AMERICAN CLOCKS,

## Movements and Clock Material,

Also, Black Walnut, Visible Pendulum Clocks, and Specialties  
in Brass and Nickel.

Agents for { JEROME & CO., - - - - - Of New Haven, Conn.  
E. INGRAHAM & CO.. - - - - - Of Bristol, Conn.

Liberal Discounts to the Trade.

# WATERBURY CLOCK CO.

## MANUFACTURERS OF AMERICAN CLOCKS,

4 CORTLANDT STREET,  
NEW YORK.

M. BAILEY, Treasurer.

63 WASHINGTON ST.  
CHICAGO.

—————  
FACTORIES, WATERBURY, CONN.

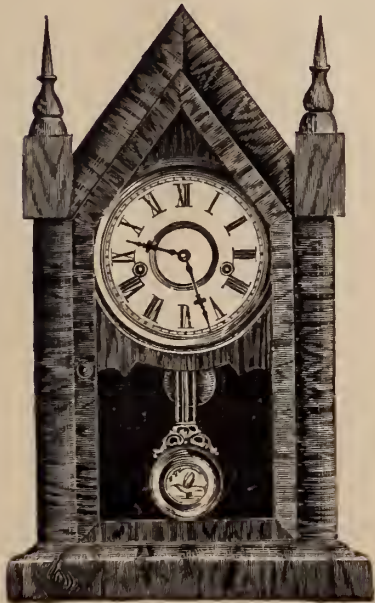

SHARP GOTHIC EXTRA.



CRICKET EXTRA.

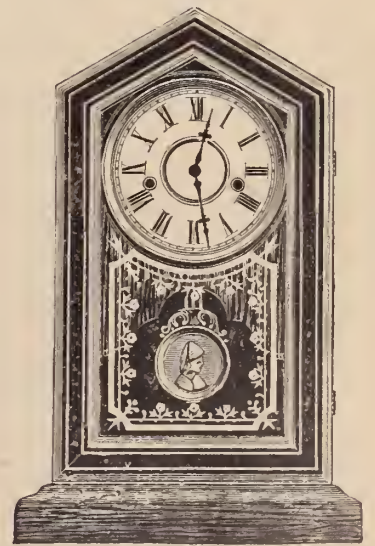

CHESTER.

**GEO. B. OWEN & CO.**

6 MURRAY STREET,

Factory, Winsted, Conn. **New York.**

MANUFACTURERS OF

**BLACK WALNUT CLOCKS,**

Clocks Manufactured by the following Companies will be furnished at lowest Market Rates:

- New Haven Clock Co.,
- Seth Thomas Clock Co.,
- E. N. Welch Man'f'g Co.,
- Welch, Spring & Co.,
- Waterbury Clock Company,
- Ansonia Clock Company,
- Wm. L. Gilbert Clock Company,
- E. Ingraham & Co.



**ARGUS.**

Eight day Strike. Height, 20 1/4 in



**AMPHITRITE.**

1 Day Time. Height 17 1/2 in.

Illustrated Catalogues and Price Lists furnished on application,

**E. N. WELCH MANUFACTURING CO.  
WELCH, SPRING & CO.**

MANUFACTURERS OF

**C L O C K S**

Factories at Forestville, Conn.

We announce the Removal of our New York Office and Salesroom to the commodious Store

No. 6 WARREN STREET, near Broadway,

where we invite the trade to call and examine our stock. Our line of Staple Clocks for the Export and Jobbing trade is full and complete, and we guarantee the quality of our goods equal to the best in the market.

We also offer for the Fall Trade many novelties, beautiful in design, and superior merit as time-keepers.

**E. N. WELCH M'F'G CO.  
WELCH, SPRING & CO.**

New York, September 1st, 1879.

Mr. E. C. HINE, late of the American Clock Company will have charge of our New York Office from and after October 1st, 1879.

We carry a full and large stock of our Clocks at our Office and Salesroom, 172 STATE STREET, CHICAGO, where Mr F. E. MORSE, long with the American Clock Co., will be found in charge and will be happy to accomodate WESTERN BUYERS, and furnish Catalogues and terms upon application.

# F. KROBER, IMPORTER,

8 Cortlandt Street,

New York.

MARBLE CLOCKS,

—WITH—

TIME, STRIKE AND VISIBLE MOVEMENTS,

WITH OR WITHOUT GONG.

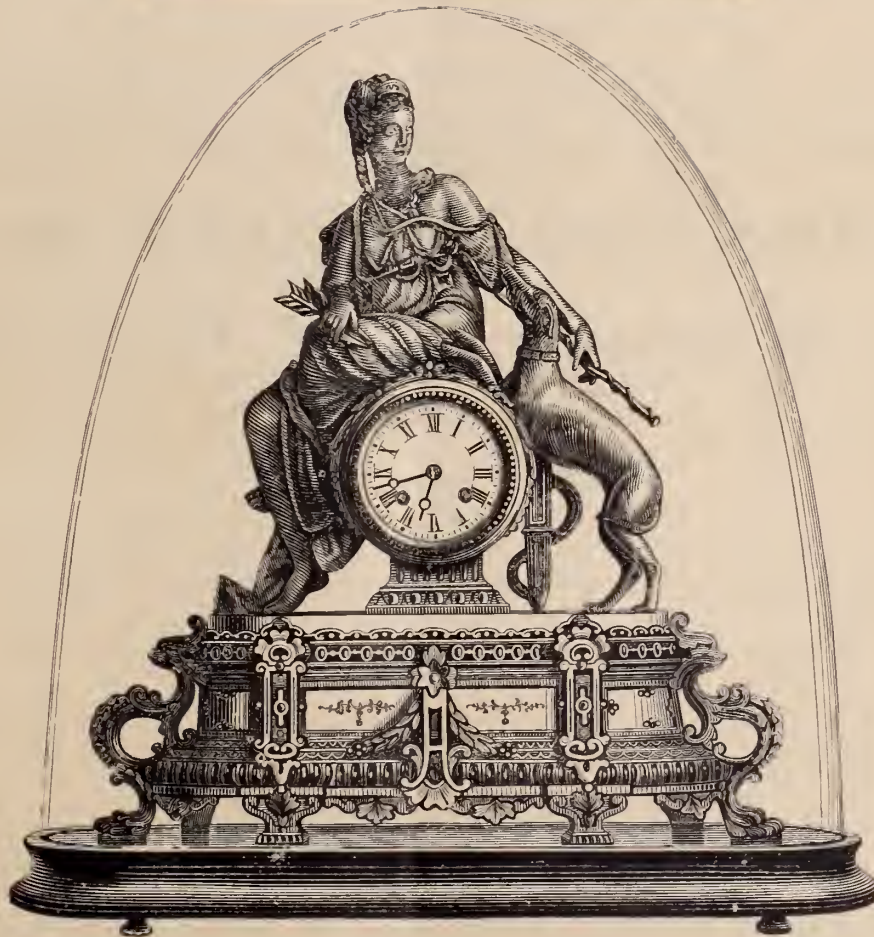

—WITH—

TIME OR STRIKE MOVEMENTS.

GILT AND ALABASTER CLOCKS,

PRICES REDUCED SEPTEMBER 1st.

# LOUIS STRASBURGER & CO.,

Importers of

# DIAMONDS.

We are direct Importers of Diamonds, dealers will therefore always find ORIGINAL parcels in our stock to select from.

MATCHED PAIRS, IN ALL GRADES AND WEIGHTS, A SPECIALTY!

NEW YORK, 15 MAIDEN LANE.

PARIS, 30 BOULEVARD HAUSSMANN.

Our complete stock of loose and mounted Diamonds enables us to send a full assortment for selection to any first-class house.

## LOUIS STRASBURGER & Co.

### Manufacturers of Watches,

From the finest Stem-Winding and Setting goods to the lowest price Watch in the market.

We manufacture and have continually in stock a complete assortment of the best COMMERCIAL WATCHES ranging from the lowest priced Metal and Silver Watches to the finest Gold Watches, such as REPEATERS, CHRONOGRAPHS (single and split) and all other Timing and Complicated Watches.

Also a full assortment of the INTERNATIONAL and all AMERICAN Movements. *Gold and Silver Cases*, constantly on hand.

We would call particular attention to our complete and varied assortment of NICKEL WATCHES, (black and fancy Dials,) in all grades, styles, and sizes.

THE RAIL-ROAD TIMEKEEPER A SPECIALTY.

SALESROOMS, No. 15 MAIDEN LANE, NEW YORK.

Watch Factory, Rue Leopold, Chaux de Fonds, Switzerland.

THE  
**MERIDEN BRITANNIA COMPANY**

46 East 14th Street, Union Square, New York,

MANUFACTURERS OF

**FINE ELECTRO SILVER-PLATE.**

Offer to the Trade the most extensive and attractive assortment of Fine Silver Plated Ware ever made in this country, consisting of Spoons, Forks and Table Ware of Every Description, also a Very Large Variety of Ornamental Articles Suitable for Gifts.

PARTICULAR ATTENTION IS INVITED TO OUR

**Sectional or XII Patent Process for Plating Spoons and Forks.**

By which the parts most exposed to wear receive an extra coat of Silver, three times the usual thickness, rendering the goods more economical than those of any other manufacture. TRADE MARK, 1847, ROGERS BROS., XII.

To Protect the Purchaser against Imitations, it should be observed that the Improved Spoons and Forks bear our Trade Mark, "1847, ROGERS BROS., XII."

MANUFACTORIES, - - WEST MERIDEN, CONN.

**THE WM. ROGERS MANUFACTURING COMPANY,**

—AND—

**THE ROGERS CUTLERY COMPANY,**

MANUFACTURERS OF

**Cutlery, and Silver Plated Table Ware.**

**Trade Marks:**

Established 1871.

On Spoons, &c., 1871 ROGERS  5 oz.

On Knives, - -



Established 1865.

 WM. ROGERS & Son, AA.



Our Knives are guaranteed

**TO STRIP**

12 dwts. of Silver per Dozen.

All our goods are put up

One Dozen in a Box.

Our Spoons, Forks, &c., are guaranteed

**TO STRIP**

On Tea Spoons - - 48 dwts. per gross

On Dessert Spoons & Forks, 72 dwts. per gross

On Table Spoons & Med. Forks 96 dwts. per gross

All other Goods in proportion.

All our Spoons, Forks, &c., are guaranteed to be plated upon

18 per cent. Nickel Silver.

the best known base for plating upon.

**OUR GOODS ARE PLATED 20 PER CENT. ABOVE STANDARD PLATE.**

**THE WM. ROGERS MANUFACTURING COMPANY,**

WM. H. WATROUS, President.  
F. WILLSON ROGERS, Secretary.

Address all communications to *Drawer 30, Hartford, Conn.*

# SIMPSON, HALL, MILLER & CO.

36 East 14th St., Union Square,  
NEW YORK.

Factories, Wallingford, Connecticut.

MANUFACTURERS OF THE FINEST QUALITY

## Silver-Plated Ware.

NEW DESIGNS OF SUPERIOR ARTISTIC MERIT NOW  
READY AND IN PREPARATION FOR  
THE FALL TRADE.



# The STAR SALT CASTER COMP'Y

Sole Proprietors and Manufacturers of  
CELEBRATED

## STAR SALTS

For convenience, neatness and utility the STAR SALTS have become a household necessity.

The pulverizer in the bottle, as shown by the cuts, keeps the salt pulverized, and obviates the disagreeable habit of spilling the salt by dipping out of an open salt cellar.

No. 161 Franklin Street  
BOSTON, MASS.

Place these in the family and Salt Cellars  
will be discarded.

MANUFACTURED IN ALL VARIETIES  
OF PLAIN AND FINE CUT  
GOODS, CASTERS, &c.

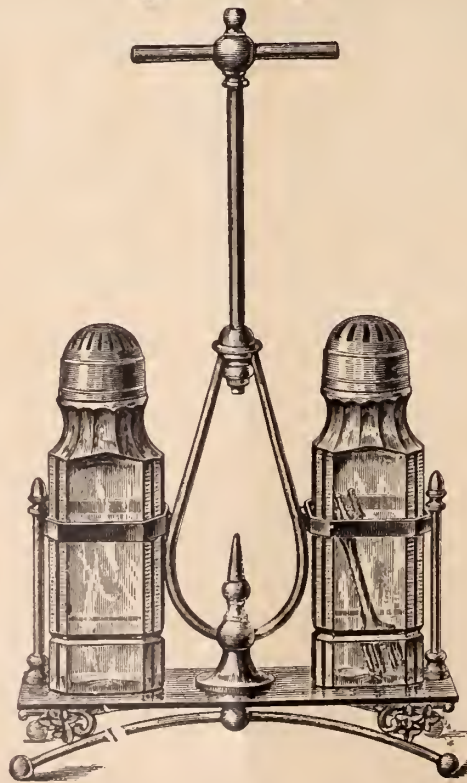

Special care given to orders for exportation.

Fine Diamond Cut, with  
Sterling Caps.

For full descriptions of the above goods see our Illustrated Catalogues, which will be mailed on application.

# SUPERIOR ELECTRO-PLATE!

MANUFACTURED BY

# THE MIDDLETOWN PLATE COMPANY,

Factories, MIDDLETOWN, Conn.



Salesrooms, { 13 John Street, New York,  
120 Sutter Street, San Francisco.

Our **ILLUSTRATED CATALOGUE** for the Trade Ready in September.

## CROSS & BEGUELIN,

21 MAIDEN LANE, . . . . . NEW YORK.

**IMPORTERS OF**

# SWISS WATCHES,

**Watch Tools, Materials, Glasses, Etc.,**

ALSO JOBBERS IN

All Grades of **AMERICAN WATCHES**

AND MAKERS OF THE

**CENTENNIAL WATCH,**

(Stem-Winding and Stem-Setting) so universally popular, and conceded to be the best made watch for the money in this market

We have recently added to our stock a full and complete line of

**FRENCH TRAVELING CLOCKS,**

With ordinary strike, also with Cathedral Chimes.

Also, **LEMAIRE'S OPERA AND FIELD GLASSES,**

The Most Reliable Glasses Made.

We are agents for the **AUBURNDALE TIMER**,  $\frac{1}{4}$  and  $\frac{1}{8}$  Seconds,

and **ROGERS & BRO., CELEBRATED FLAT & HOLLOW WARE.**



None Genuine without this Trade Mark.

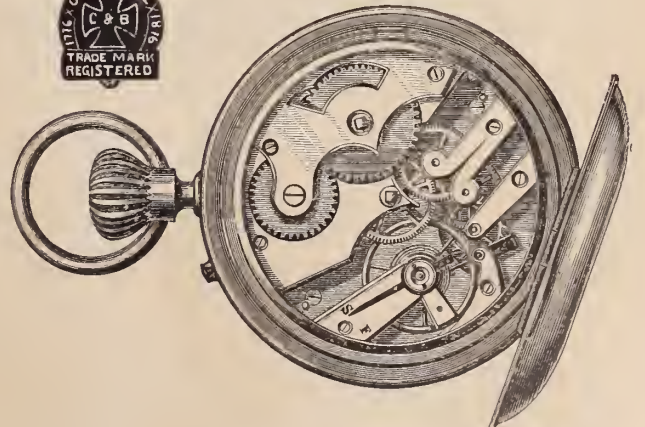

The above is a fac-simile of the Centennial Watch

JAS. T. SCOTT,  
S. CLEM SCOTT,  
J. T. SCOTT, JR.

# J. T. SCOTT & CO.

Established 1847.

SOLE EASTERN AGENTS FOR

## THE ROCKFORD WATCH COMPANY,

11 MAIDEN LANE,

NEW YORK.

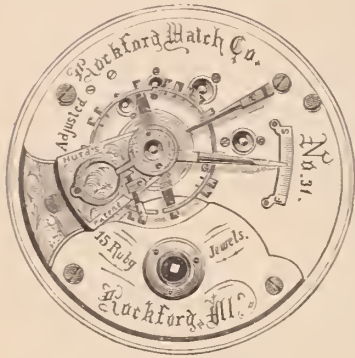

ROCKFORD WATCH.

This Company manufactures eight grades of superior 18 size key and stem wind

**QUICK TRAIN,**

Movements.

ALSO SOLE AGENTS FOR

**Abbott's Patent Open-Face**

18 size American stem-winders, with XII at pendant and seconds opposite



ABBOTT'S PATENT.

AND AGENTS FOR

The Auburndale

**CHRONOGRAPH**

TIMERS,

$\frac{1}{4}$  and  $\frac{1}{2}$  seconds, in 18 size Nickel-Plated Cases, designed for Sporting, Scientific and Mechanical purposes.

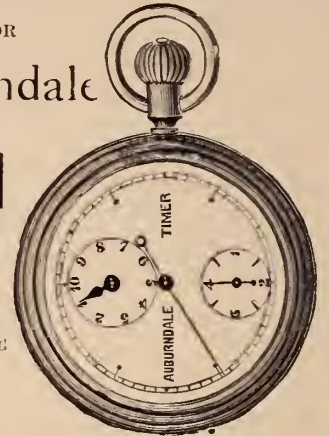

AUBURNDALE TIMER.

Manufacturers of Jewelry and Wholesale Dealers in all grades of American Movements.

WATCH CASES, DIAMONDS, CHAINS, SILVER WARE, &c.

*Price Lists furnished upon application to those regularly engaged in the Trade.*

J. C. AIKIN.

H. A. LAMBERT.

J. B. SHEA.

## AIKIN, LAMBERT & CO.,

Manufacturers of GOLD PENS,

Pen and Pencil Cases, Pencils, Tooth-picks, and "Novelties" in Pencil Goods.

No. 23 MAIDEN LANE,

NEW YORK.



Would call the attention of the Trade to our large and complete line of Pen and Pencil Goods in all styles and varieties, suitable for demand.

Our introduction last season of Pencils in NEW AND ENTIRELY NOVEL DESIGNS was marked by an unprecedented demand, which establishes the sale of these goods as STAPLES, and as being suited to any season of the year.

The Magic Charms (as per cuts shown below), inlaid with pearl and gold, in form of vines, flowers, birds, etc., on



celluloid of assorted colors, in imitation of malachite, tortoise shell, agate variegated marble, etc., are the LATEST and most novel pencils in the market.

Send for circular and new list.

Branch, No. 113 East Madison Street, Chicago.

### Also Importers of all grades of Watches,

Sole Agents for "PAUL BRETON" and "CHAS. LATOUR," GENEVA.

—SPECIALTIES.—

AGASSIZ Movements, Gilt and Nickel Stem-Winding, fitting Ladies' Riverside Case.

CHAS. LATOUR Movements, Gilt and Nickel Key-Winding, fitting 10 and 16 size Waltham Case.

PAUL BRETON Movements, Gilt and Nickel Key and Stem-Winding, a full line of these CELEBRATED TIMEPIECES in gold and silver cases of the most approved styles.

METAL OPEN FACE STEM-WINDING "LONGINES" and "EXCELSIOR", 16, 18 and 20 line, the BEST metal Watches in STYLE and QUALITY in the market.

Our assortment of Jewelry is very large and complete, consisting of a general line of RELIABLE goods, both in GOLD and ROLLED PLATE, of new and tasty patterns, and including almost any article a Jeweler would have calls for. Special attention given to ORDERED WORK and REPAIRS.

GOODS SENT ON APPROVAL and CORRESPONDENCE invited. Those not acquainted with us will oblige by giving references when ordering

JANUARY 1st, WE REVALUED OURENTIRE STOCK and HAVE REDUCED PRICES, and ARE OFFERING GREAT INDUCEMENTS TO PURCHASERS FOR THE SPRING TRADE.



# MULFORD & BONNET,

ARE OFFERING A SELECTION OF UNEXCEPTIONABLE GOODS ESPECIALLY DESIGNED FOR THE FALL  
TRADE, INCLUDING MANY NOVELTIES IN

## DIAMOND JEWELRY,

CONSISTING OF LACE PINS, RINGS, STUDS, EAR RINGS AND CLUSTER RINGS, OF ENTIRELY NEW DESIGN,  
MOUNTED IN BOTH PLATINUM AND GOLD. ALSO, AN UNCOMMONLY LARGE ASSORTMENT OF

Intaglio, Stone, Cameo,		Pearl, Turquoise, and Amethyst
-------------------------------	---	--------------------------------------

OF TASTEFUL PATTERNS, AT EXTREMELY LOW PRICES.

---

## ROLLED PLATED GOODS.

---

OUR STOCK OF THESE GOODS IS LARGER AND MORE EXTENSIVE THAN EVER BEFORE; THE PATTERNS  
MORE ATTRACTIVE, AND PRICES LOWER.

### MULFORD & BONNET,

MANUFACTURING JEWELERS,

21 MAIDEN LANE,

NEW YORK.

# MILLER BROS.

MANUFACTURING JEWELERS,

No. 11 MAIDEN LANE, NEW YORK.

Manufactory, 47, 49 & 51 Franklin Street, Newark, N. J

A  
Large Line  
of

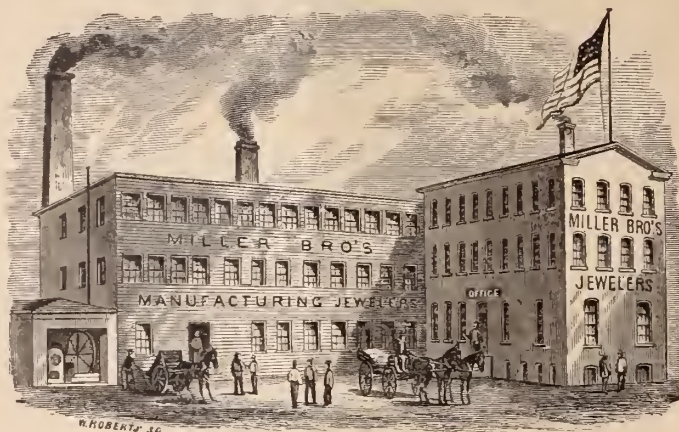

NOVELTIES.

ATTENTION IS INVITED TO OUR  
NEW STYLES OF ETRUSCAN SLEEVE BUTTONS,  
MOUNTED WITH

## RUSTIC LETTERS

BIRDS, ANIMAL HEADS AND FANCY ORNAMENTATIONS.  
Also a full line of Locketts, Sets, Pins, Ear Rings, Sleeve Buttons, Studs, &c.

All goods exclusively of our own manufacture, many of which are protected by MECHANICAL and DESIGN PATENTS.

# DAVID F. CONOVER & CO.

(SUCCESSORS TO W. M. B. WARNE & Co.)

Importers, Manufacturers and Wholesale Dealers in

## WATCHES AND JEWELRY,

Silver and Silver-Plated Ware,

AMERICAN WATCH WHOLESALE SALESROOM,

Southeast Corner Chestnut and 7th Streets,

(FIRST FLOOR.)

DAVID F. CONOVER,  
B. FRANK WILLIAMS,  
C. EDGAR RIGHTER.

PHILADELPHIA.



## Gorham Manufacturing Co.

PROVIDENCE }  
—AND— } Oct., 1879.  
NEW YORK. }

THE productions of our Factory the present season, while embodying some of the best features of those of preceding seasons, indicate the most thoughtful consideration and study of what is new in *DECORATIVE ART*.

The pleasing effects of color engraving, susceptible as it is of infinite variety, maintains its popularity. In other lines of decorative ware, the effects produced by various tints of gold in connection with other combinations of colors under the articles are eminently attractive.

Other forms of decoration are prominent in classes of goods especially adapted for specific methods of treatment.

Flower Vases, Tea Caddies, Berry Bowls, Fancy Spoon Ware, Etc.,

ARE ENRICHED BY APPLIED WORK.

Flowers, Ferns, Plants, Birds, Fishes, Reptiles, Etc.,

Are accurately modeled and attached to the body of the piece. Hammered or beaten surfaces, partially oxidized, lend an air of quiet elegance to the piece. "American Curios," exhibiting the most marked effects in form and surface decoration. Copies of the antique, and inlayings of various metals, and especially the characteristics of latest novelties and advanced thought in decoration.

These novel and attractive goods are meeting with the hearty approval of the leading houses in the trade, and liberal selections have been made unusually early in the season.

Our production in Hollow Ware include all articles for household use and presentation.

In Tea, Dessert, and Dinner Services our stock is large and varied; comprising plain, engraved, chased and decorative sets, which we are prepared to supply either on demand or at reasonable notice. Special attention has been given to small wares, such as

Napkin Rings, Cups, Fruit Knives, Peppers, Salts, Mustards, Card Cases, Portmonnaies, Tobacco Boxes, Snuff Boxes, Bells, Butter Plates, Match Boxes, Child's Bowls, Cigar and Cigarette Cases, Pickle or Olive Dishes, Flasks, Button or Glove Hooks, Knife Rests, Porringers, Ash Trays, Vases, etc., etc., etc.

In this line of production our stock is very complete and is eminently superior in design, finish and decoration.

New patterns have been added to our list of Napkin Rings and Fruit Knives, and in the latter we have improved the process of manufacture by entirely dispensing with the customary use of soft solder. By this improvement and by reason of an increased variety of patterns our stock is rendered still more desirable than heretofore.

Lithographic sheets of our popular Spoon and Fork patterns will be sent upon application, together with our twenty-four page circular recently issued.

Important reductions (taking effect Oct. 1) in the price of "Gorham Plate" Spoons and Forks have been made.

Our general stock of Gorham Plate, so favorably known for its characteristic designs, exquisite finish, best of plate, and silver soldered in every part, is very complete in every department.



Established 1843.

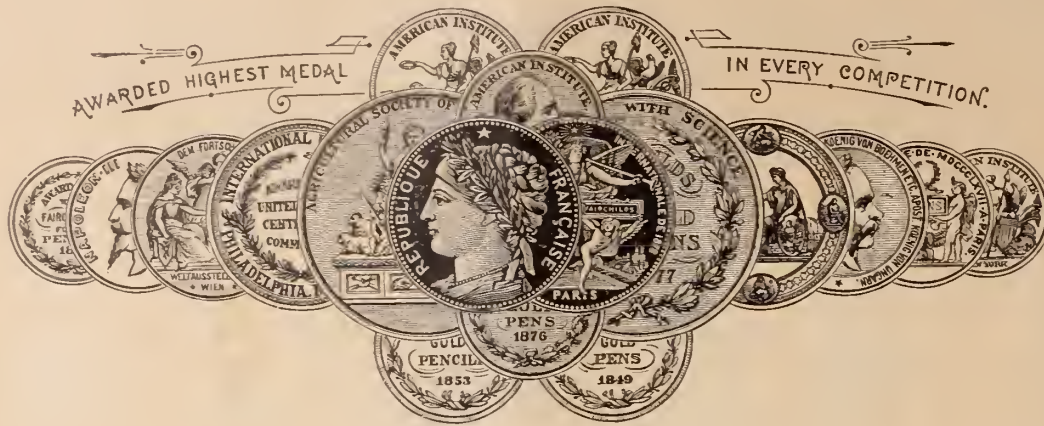

## TO THE TRADE.

I present, on the opposite page, a few specimens from my New Illustrated Catalogue of GOLD PENS, CASES, CHARM MAGIC PENCILS, CHAIN BARS, etc., etc., in Gold, Platina, Silver, Gold Plate, and various rich materials.

Being the owner of the most important patents, (over 30 in number) it enables me to omit from my list the articles that have been reproduced in common qualities and to offer the trade, only the choicest styles of the most elegant designs of practical goods at the most favorable prices.

Every article is fully warranted as represented, those in gold or silver, being solid throughout except the inside movements.

I take pleasure in announcing that MR. C. C. ADAMS, (late of The Adams & Shaw Company) has the entire supervision of my Pencil Case Factory and Office, cor. of 4th Street and Broadway, (Whiting Building) where a full line of samples can also be seen. Catalogue and Price List furnished on application.

Leroy W. Fairchild,  
110 William Street, New York.

FROM

**LE ROY W. FAIRCHILD'S**

**CATALOGUE.**

NOVELTIES (PATENTED) IN CHARM MAGIC PENCILS. ETC.

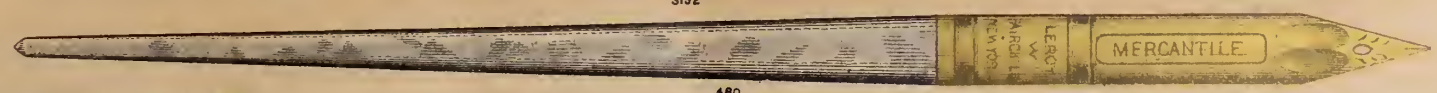
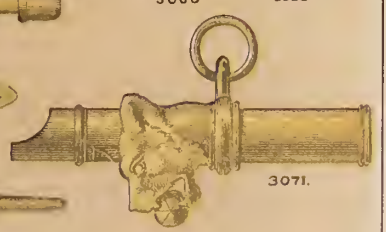
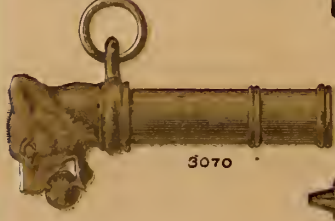
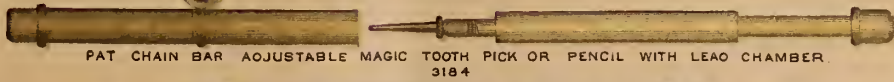
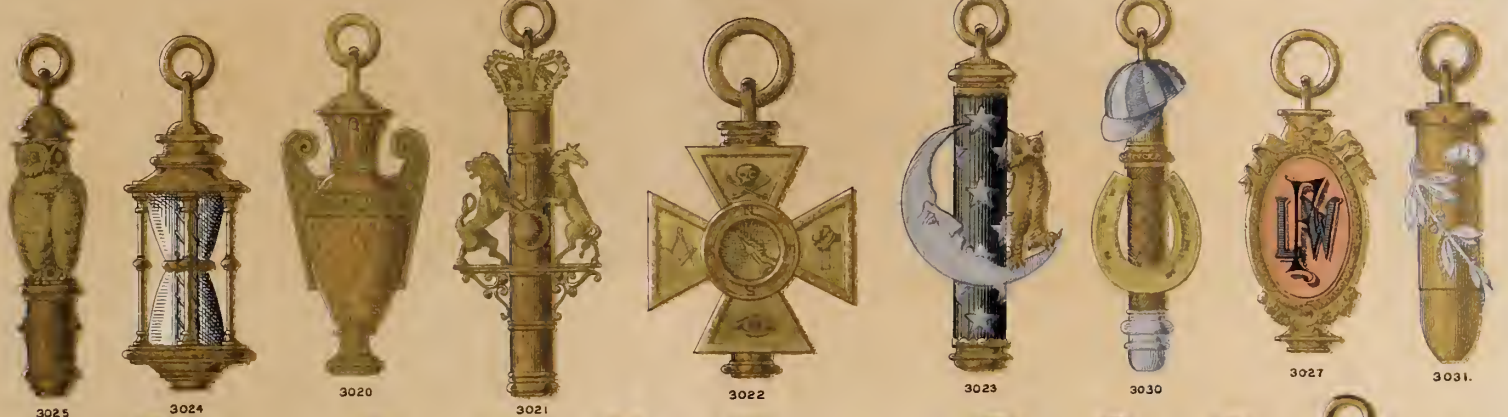
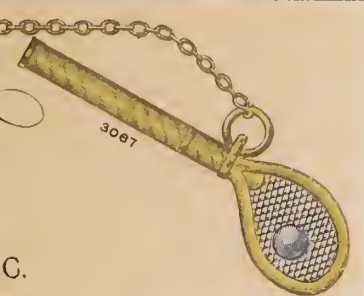
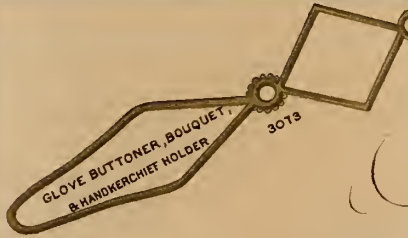

NEW YORK.

NO WILLIAM STREET.

**LE ROY W. FAIRCHILD.**

MANUFACTURER OF  
**GOLD PENS**

**PEN AND PENCIL CASES.**

AND AT PENCIL CASE FACTORY, 69 1/2 BROADWAY (WHITING BUILDING)

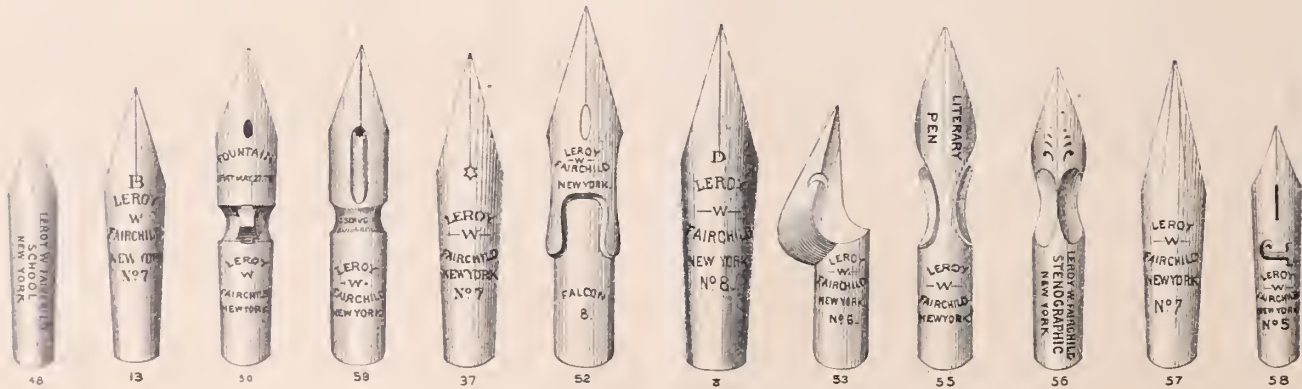

*The preceding page of this sheet of Illustrations will be found convenient to the Dealers, as it can be submitted to their Customers without exposing Trade Price.*

ESTABLISHED 1855.

D. LIECHTY & CO.,  
MANUFACTURERS OF

**Fine Gold Watch Cases**

No. 140 South Third Street,

Fourth Floor.

PHILADELPHIA

*Repairing neatly attended to.*

LOUIS A. SCHERR.

CHAS. H. O'BRYON.

G. W. SCHERR.

**LOUIS A. SCHERR & CO.**

Importers and Wholesale Dealers in

**Watches, Jewelry,**

WATCH MATERIALS, TOOLS, GLASSES, &C.

**Spectacles, Silk Guards, &c.**

Wholesale Agents for American Watches.

**No. 726 CHESTNUT STREET,**

FIRST FLOOR,

**PHILADELPHIA.**



**GUTMANN'S**

**Automatic Hammer and Punches**

Simplified and More Effective.

THIS TOOL takes the place of the third hand, therefore its manifold uses are quickly apparent, and I would only say that it is accompanied by six punches, to wit: 2 hand punches, 1 prick punch, 1 closing hole punch, 1 rivet punch, and 1 pinion punch, all of which fit neatly into the punch holder, and are fastened by the set screw. Its tap is alternately heavy and light, and the finger loops are assorted in sizes. The Tool is nickel-plated and boxed, ready to be mailed on receipt of price.

THE OPERATION IS AS FOLLOWS: First, set the hammer; next insert your forefinger through the loop at the top and place the punch with firmness on your work. When you are ready for the blow, push gently on the thumb-piece which produces the concussion on the punch. *Your left hand is entirely free to hold the work.*

Price, \$2.00; Reduced from \$2.50.

**MAX L. GUTMANN,**

Patentee and Manufacturer.

Also, Importer and Wholesale Dealer in

**Watch and Jobbing Materials, Tools, Glasses,**

*Chains, Guards, Jewelry and Watches.*

The Genuine American Silk Guards in all Styles a Specialty.

PLEASE SEND YOUR ORDERS.

**ROCHESTER, N. Y.**

AUBURNDALE, MASS.,

**CHRONOGRAPH TIMER**

WM. B. FOWLE, Maker.

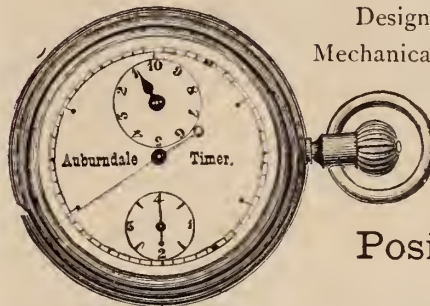

Designed for Sporting, Scientific and Mechanical purposes;  $\frac{1}{4}$  and  $\frac{1}{8}$  seconds, fly back.

List Price, - - \$15 00

**Positively Accurate.**

Put up in German Silver Cases, Nickel Plated, size of an ordinary watch. Very neat and handsome, supplying a want long felt by those desiring to measure the flight of time with scientific accuracy to the fraction of a second. It indicates positively minutes, seconds, quarters or eighths of seconds, the only instrument registering one eighth of a second made. It is substantially constructed, positive in its action and will not easily get out of order.

These Chronographs can be obtained from the principal Jobbing Houses in the Trade.

**BENJ. ALLEN & CO.**

WHOLESALE DEALERS IN

**American and Swiss Watches**

JEWELRY, DIAMONDS,

SILVER & PLATED WARE.

137 and 139 State Street, Chicago.

A full line of Howard Watches in stock. Catalogues sent upon application, to dealers only.

**CHAS. P. HEROLD,**  
**MANUFACTURING JEWELER,**  
**DIAMOND SETTER**  
AND DEALER IN  
**DIAMONDS.**

916 CHESTNUT ST. PHILA.

N.B. A LARGE STOCK OF 18 Kt. DIAMOND MOUNTINGS, SUCH AS CLUSTER AND SOLITAIRE RINGS, EARRINGS, LACE PINS, SHAWL PINS, CROSSES, STUDS, AND GENTS' PINS, &c. ALL OF WHICH ARE OF MY OWN DESIGNS, AND ARE MADE IN THE FINEST STYLE  $\frac{1}{10}$  FINISH.

# COLBY & JOHNSON,

17 Maiden Lane, New York.  
Exclusive Manufacturers of Open-face Stem-winding  
White, Gold, Silver,

Black,  
Malachite,  
or  
Marbleized



or  
Nickel  
Centers,  
Pendants  
and Bows.

SUITABLE FOR ALL 18-Size AMERICAN S. W. MOVEMENTS.

We call especial attention to the fact that Celluloid being a NON-CONDUCTOR, the cheaper grades of movements (not adjusted to heat and cold), cased in this material, are not affected by atmospheric changes, and can be relied upon as being much MORE ACCURATE TIME-KEEPERS than the same movements cased in metal of any kind.

# E. HOWARD & CO.,

MANUFACTURERS OF

## Fine Watches, Regulators, Office Clocks,

Electric Watch, Clocks & Tower Clocks,

**Office, No. 2 MAIDEN LANE**

**NEW YORK.**

No. 114 TREMONT STREET, BOSTON.

J. W. J. PIERSON, - - - AGENT.

# SHOEMAKER & CO.,

MANUFACTURERS OF

## Onyx, Cameo & Intaglio Buttons,

**AND LOCKETS.**

A full line of Roman Goods including Bracelets.

No. 21 MAIDEN LANE, NEW YORK.



# SPIESS & ROSSWOG,

MANUFACTURERS OF

## Fine Jewelry and Diamond Goods,

LOCKETS, CROSSES, SLEEVE BUTTONS AND NECKLACES.

Rich Sets in Coral Rose, Coral Cameo and Gold.

ENCRUSTED AMETHYST RINGS AND SILVER  
FILIGREE WORK,

Nos. 9 & 11 MAIDEN LANE, NEW YORK.

Also, a complete line in all Coral Goods, as formerly  
imported by A. SQUADRILLI.

DYER BRAINERD.

JOHN W. STEELE.

# BRAINERD & STEELE,

MANUFACTURERS OF

## Brainerd's Pat. Locket,

(Patented June 17, 1874.)



These Locketts combine both beauty and strength. They are made of solid 14kt. gold, and the stones used are the finest obtainable in the market. They cost no more than those of the old style, it indeed as much; and the combination of secrecy and durability renders them much more desirable. We make three sizes in four different shapes—round, oval, cushion and oblong squar.; and also Sleeve Buttons of the same style, containing a concealed box for miniatures, a novelty new to the Trade.



**FINE GOLD JEWELRY,**

**No. 9 Maiden Lane,**

**NEW YORK.**



ESTABLISHED 1837.

VICTOR BISHOP & CO.

IMPORTERS OF

**DIAMONDS,**  
PRECIOUS STONES

—AND—

CORAL JEWELRY,

Enamel Paintings, Copper and Platinum.

No. 47 NASSAU STREET, NEW YORK.

House in Paris, 66 Boulevard de Sebastopol.

SAXTON, SMITH & CO.

MANUFACTURERS OF

**Fine Gold Chain.**

No. 15 Maiden Lane,

New York.

Factory, No. 183 Eddy Street, Providence, R. I.

Sole Agents for the new PATENTED CHAIN BAR, containing a Detachable Pencil.

HELLER & BARDEL,

Manufacturers of

DIAMOND AND PEARL

**JEWELRY,**

And Dealers in Diamonds, Pearls, &c.



SHAWL AND LACE PINS IN GREAT VARIETY,

No. 18 John St., New York.

A full line of DIAMONDS, mounted and unmounted; also, a large assortment of first-class DIAMOND MOUNTINGS of our own make always on hand. Sketches submitted at any time upon application. We will send goods on selection to responsible houses.

ESTABLISHED 1848.

E. S. JOHNSON & CO.

MAKERS OF

Gold Pens, Pencil Cases, &c.

SUITABLE FOR THE REQUIREMENTS OF ALL CLASSES OF DEALERS.

These goods have achieved a high reputation and are universally acknowledged to be the best Pens and Pencil Cases made, and as low in price as is consistent with quality of Gold, workmanship and style of finish.

Intending purchasers will consult their interests by comparing prices. We are constantly introducing new and desirable goods that cannot fail to give satisfaction.

44 Nassau Street, New York.

PRICE LISTS SENT ON APPLICATION.

**WOOD & HUGHES,**

STERLING

Silverware Manufacturers

No. 16 JOHN STREET,

NEW YORK.

206 Kearney Street, San Francisco, Cal.

R. R. HASKELL, Agent.

KREMENTZ & CO.

MANUFACTURERS OF

**FINE JEWELRY,**

No. 13 John Street, New York.

FACTORY, 361 Mulberry Street, - - Newark, N. J.

GOODS OF OUR OWN MAKE EXCLUSIVELY.

CARTER, HOWKINS & SLOAN,  
**Makers of Fine Jewelry**

*Consisting of Chains, Bracelets, Sets, Pins, Studs, Sleeve Buttons,  
 Scarf Pins, Rings, &c., in Roman, Etruscan and Enamel,  
 and a full line of Jewelry generally.*

Whiting Building, Corner Broadway and Fourth Street,

A. CARTER JR.  
 WM. HOWKINS,  
 A. K. SLOAN.

**NEW YORK.**

C. E. HASTINGS,  
 GEO. R. HOWE,  
 W. T. CARTER.

**HALE & MULFORD,**  
**Manufacturing Jewelers,**

(WHITING BUILDING).

No. 694 Broadway, cor. 4th Street, New York.

Call attention of the Trade to their new style of

**BAND BRACELETS,**

We claim for these Bracelets, the following advantages over the old style, viz. :

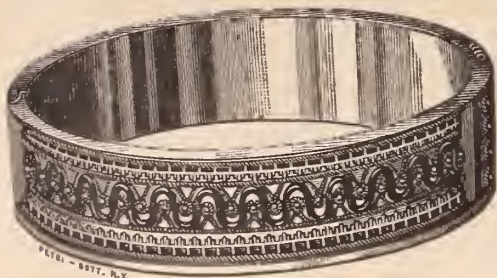

1st. The edge of the Bracelet being raised, forms a protection to the ornamentation.

2d. Less liability of getting damaged, and when damaged, are more easily repaired.

3d. More attractive in appearance.

Prices are as low as any FIRST CLASS 14 KARAT ALL GOLD Bracelet in the market.

Made in all sizes from  $\frac{1}{4}$  inch upwards.

—Established 1837.—

**TAYLOR & BROTHER,**

Late TAYLOR, OLMSTED & TAYLOR,

**Importers of Diamonds and Pearls,**

—AND—

**MANUFACTURERS OF DIAMOND JEWELRY,**

No. 676 BROADWAY,

**NEW YORK.**

**BALDWIN, SEXTON & PETERSON,**

MANUFACTURERS OF

**Fine Jewelry,**

Diamond and Stone Cameo Goods,

**GOLD CHAINS, &c.**

Importers of Diamonds, Pearls, Emeralds, Rubies, &c.

WHITING BUILDING,

**Cor. Broadway and Fourth Street,**

**NEW YORK.**

120 SUTTER STREET, San Francisco, Cal.

Established 1817.

**Ve. J. MAGNIN, GUÉDIN & CO.**

29 Union Square, New York.

Manufacturers and Importers,

FINE SWISS WATCHES,

REPEATERS, CHRONOGRAPHS & CALENDARS

GENEVA GOLD JEWELRY,

FRENCH CLOCKS AND BRONZES,

RICH FANCY GOODS,

HORSE-TIMERS & PEDOMETERS,

GOLD AND SILVER CHATELAINE WATCHES.

Gold Medal Awarded, Paris Exposition, 1875.

*Sole Agents for the James Nardin Watch.*

*House in Geneva, 14 Grand Quai.*

Established 1813.

**THOMAS G. BROWN,**

MANUFACTURER OF

**FINE JEWELRY.**

*Designs furnished for all kinds of Sporting  
 Badges and Medals for Schools & Colleges.*

**NEWARK, N. J.**

—AND—

**9 BOND STREET, NEW YORK.**



ALFRED H. SMITH  
AND CO  
IMPORTERS OF





**DIAMONDS**



14 JOHN ST.  
NEW YORK.

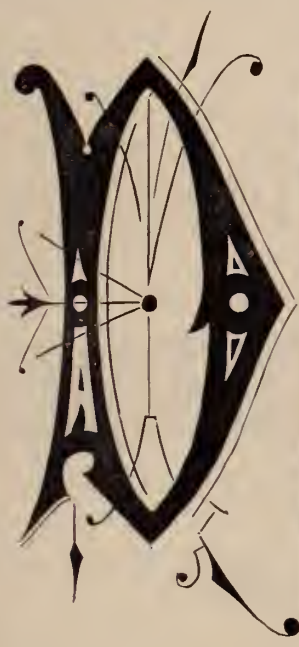
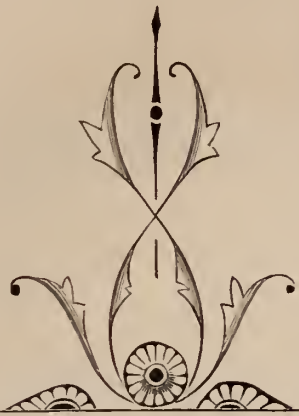

We are constantly receiving fresh invoices of desirable goods, in all grades,  
to which the attention of buyers is invited.



Established 1834.

# G. & S. OWEN & CO., Makers of Fine GOLD JEWELRY

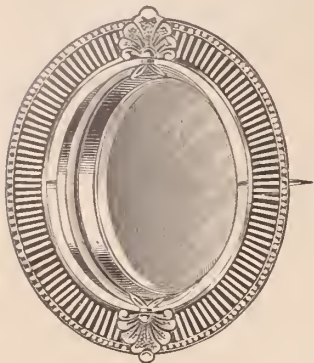

SPECIALTIES :

Black Onyx Goods,  
Roman & Polished Goods,  
Hair Chain Mountings  
Sole Makers

OF

**BOX AND GLASS GOODS.**

All our goods exclusively of our own manufacture.

5 MAIDEN LANE, NEW YORK.

## JOHN A. RILEY & CO.

MANUFACTURERS OF

### Rich Gold and Onyx Jewelry,

NOVELTIES IN HALF SETS. LACE PINS, SCARF  
PINS AND EAR RINGS,

Engagement Pad Lock Bands, Elastic Snake Bands and  
Chatelaines. Onyx Chatelaines with and  
without Watch Movements.

**Nos. 7 & 9 Bond Street, New York.**

No. 126 Kearney Street, San Francisco, Cal.

## MOORE & HORTON,

### JEWELERS,

No. 11 Maiden Lane, New York.

**SPECIALTIES!**

Stone Cameo, Onyx, Amethyst, Topaz and Pearl Rings.  
Studs, Collar and Sleeve Buttons.

Also our new fac simile of Fine African Diamonds, mounted in  
Rings, Studs, Pins, Ear-rings, Scarf Pins, Mc'allions.

Established 1846.

## WILLIAM RIKER, No. 5 Maiden Lane, New York.

Factory, 42 Court Street, Newark, N. J.

Would call the attention of the Trade to our Inlaid Bracelets.

**IMPORTER OF DIAMONDS**

**E. AUG. NERESHEIMER**

21 MAIDEN LANE,  
NEW YORK

№ 1 GAERTNER PLATZ  
MUNICH-GERMANY.

№ 24 DOELEN STRAIT  
AMSTERDAM-HOLL.

DIAMONDS LOOSE & MOUNTED SENT ON APPROVAL AND THE VALUE INSURED

**OWEN, SHAW & CO.**

**MAKERS OF FINE JEWELRY**

CONSISTING OF  
BRACELETS,  
SETS,  
LOCKETS,

PINS,  
STUDS,  
RINGS,  
SLEEVE BUTTONS  
ETC.

**SPECIALTY**  
**STIFFENED ROMAN BANDS.**

Nos. 612 & 614 CHESTNUT ST. PHILADELPHIA.  
BRANCH-OFFICE 15 JOHN ST. NEW-YORK.

# WM. S. HEDGES & CO.,

*Of the late firm of SMITH, HEDGES & Co.*

IMPORTERS OF

# DIAMONDS,

No. 170 Broadway, cor. Maiden Lane,

NEW YORK.

*Choice Brilliants in single stones and matched pairs a specialty.*

GOODS SENT ON APPROVAL.

## CHATELLIER & SPENCE,

### Manufacturing Jewelers,

694 BROADWAY, NEW YORK.

No. 1006 Chestnut Street, PHILADELPHIA, PA.

No. 12 West Street, BOSTON, MASS.

No. 120 Sutter Street, SAN FRANCISCO, CAL.

## NOTICE.

Manufacturing Jewelers are hereby notified that the undersigned have obtained Letters Patent, dated February 25th, 1879, No. 212,692, for Bracelets constructed of a single band, having ornamentation in relief permanently fixed upon its outer surface, with rigid marginal flanges or projection for the protection of the same, and all infringements, whether in cheap or fine goods, will be promptly and rigorously prosecuted according to law.

**HALE & MULFORD,**

Broadway & Fourth St.

New York, August 4th, 1879



## LYON & HARDY,

30 MAIDEN LANE, NEW YORK,

IMPORTERS OF

**DIAMONDS,**

AND MANUFACTURERS OF

## DIAMOND MOUNTINGS.

All goods ordered for stock or on approval are insured while in the hands of Express Companies.

## WHEELER, PARSONS & HAYES,

MANUFACTURERS OF

**Watch Cases, Gold Chains & Fine Jewelry,**

AND DEALERS IN

AMERICAN AND SWISS WATCHES,

No. 2 MAIDEN LANE, NEW YORK.

# ENOS RICHARDSON & CO.

MANUFACTURERS OF

## FINE GOLD JEWELRY,

Gold Chains, Locketts, Crosses and Necklaces,  
COLORED AND ETRUSCAN WORK.

ENGRAVED AND ENAMELLED GOODS IN GREAT VARIETY.

All Goods sold strictly of our own manufacture.

23 MAIDEN LANE, NEW YORK.

ENOS RICHARDSON,  
THOS. SLATER,

L. P. BROWN,

F. H. RICHARDSON  
W. P. MELCHER.

# A. J. HEDGES & Co.,

MAKERS OF

## FINE JEWELRY

*Of Every Description.*

No. 9 Maiden Lane, New York.

### FALL NOVELTIES.

We have recently introduced a new and attractive line of  
**FINE GOLD GOODS,**  
richly ornamented in illuminated gold upon a sunken sur-  
face, for which process we have been granted letters patent.

Buyers visiting the city are invited to examine these goods  
as they cannot fail to give satisfaction

NOTICE.--Any infringement of this patent will be vigor-  
ously prosecuted.

# HELFENSTEIN & BOURKE,

202 Broadway, New York.

OPEN.

EXCLUSIVE MANUFACTURERS OF

CLOSED.



## The Adjustable Sleeve Button

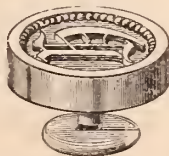

(PATENTED BY WM. BOURKE, JUNE 11, 1878.)

The only Perfect Style of Sleeve Button.

Can be quickly, easily, and securely adjusted without any  
strain on the forefinger and thumb, rumpling of the cuffs or  
wear of the button-holes. The durability, neatness and safety  
of its mechanism is unequalled.

EVERY PAIR OF BUTTONS WARRANTED AS REPRESENTED.

A large variety of handsome designs in Rolled Plate from \$4.50 to \$39.00  
per dozen pairs. Plain Pearl and Ivory Top, \$2.50 to \$4.50.

Samples Sent to Responsible Dealers.

# MAKERS OF FINE JEWELRY WALLING BROS. & CO. MAKERS OF FINE JEWELRY

Full Line of Roman and Mosaic Goods,  
Earrings, Buttons, Studs and Rings.

**SPECIALTIES:**

ENGRAVED AND ENAMELED BANDS,  
CAMEO GOODS.

170 BROADWAY, New York.

# BUCKENHAM, COLE & SAUNDERS,

SUCCESSORS TO

BUCKENHAM, COLE & HALL,

IMPORTERS OF

## Diamonds, Pearls

AND OTHER PRECIOUS STONES,

MANUFACTURERS OF FINE JEWELRY,  
10 Maiden Lane, New York

A large Stock of FINE DIAMONDS, Mounted and Unmounted,  
kept constantly on hand. Goods sent on approval to any part  
of the country on receipt of satisfactory references.

# RIPLEY, HOWLAND & CO.

383 Washington St., Boston, Mass.

## FINE JEWELRY,

DIAMOND MOUNTINGS, ETC.

OFFICE, 35 MAIDEN LANE,

NEW YORK.

**J. A. BROWN & CO.**

OFFICE AND SALEROOM: No. 11 Maiden Lane, N. Y. FACTORY: No. 104 Eddy St., Providence. R. I.  
SOLE MANUFACTURERS OF THE

**Ladd Patent Stiffened Gold Watch Cases**

The Best and most durable, and the

CHEAPEST STIFFENED Gold Watch Case FOR THE MONEY

MADE IN THE WORLD!

All genuine Watch Cases of our manufacture have "G. W. Ladd's Patent, June 11, 1867," stamped upon the side band underneath the glass bezel.

REFUSE ALL OTHERS.

Send for full Descriptive Circular to the

OFFICE AND SALESROOMS 11 Maiden Lane, N. Y.



KEY AND STEM WINDING

Hunting and Open-Face

IN FLAT BEVEL,

Mansard and Oval

SHAPES

Adapted to the various

AMERICAN-MADE MOVEMENTS,

IN

8, 10, 14, 16 & 18

SIZES.

Dealers can obtain them of the Wholesale Watch and Jewelry Houses, or their Travelling Agents throughout the United States and British Provinces,

**J. B. BOWDEN & CO.**

Manufacturer of

SOLID GOLD AND STONE

**RINGS**

All Styles of Children's

AND

**FANCY SOLID RINGS,**

A LARGE ASSORTMENT ALWAYS ON HAND.

No. 1 Maiden Lane, New York.

**LYON & HARDY,**

30 MAIDEN LANE, NEW YORK.

SOLE AGENTS FOR



Jeanne's Patent Diamond Exhibits, Made in Gold, Silver and Silver Gilt.

A Convenient and Practical Method for Exhibiting Loose Diamonds in a Portable Setting, showing to the best advantage how the Stones will look when Set.

**JOSEPH N. TINGLEY,**

Late of the firm of Tingley, Sincock & Sherrill,

MANUFACTURER OF

**STONE RINGS,**

—AND—

NOVELTIES IN STONE GOODS,

No 9 Maiden Lane, New York

Factory, Newark, N. J.

OPPENHEIMER BROS. & VEITH,  
MANUFACTURING JEWELERS

AND

Dealers in Watches and Diamonds,

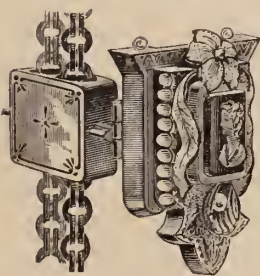

35 Maiden Lane,  
NEW YORK.



Patented June 3, 1879.

Combination Chain, Slide, Pendant and Locket.

**MAX FREUND & CO.**

Manufacturing Jewelers.

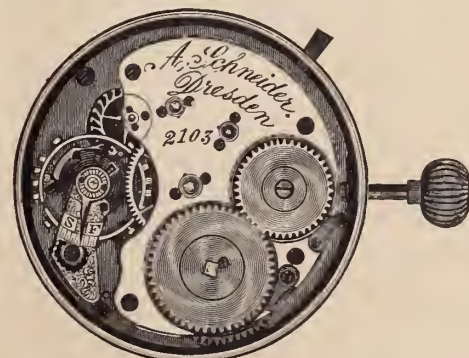

IMPORTERS OF

**Watches**

Jewelry and Precious Stones  
8 Maiden Lane

NEW YORK

Sole Agents for the Celebrated A. Schneider Watch, Dresden Also the Standard Watch Co. of New York.

HOPKINS' WATCH TOOL CO., Waltham, Mass.

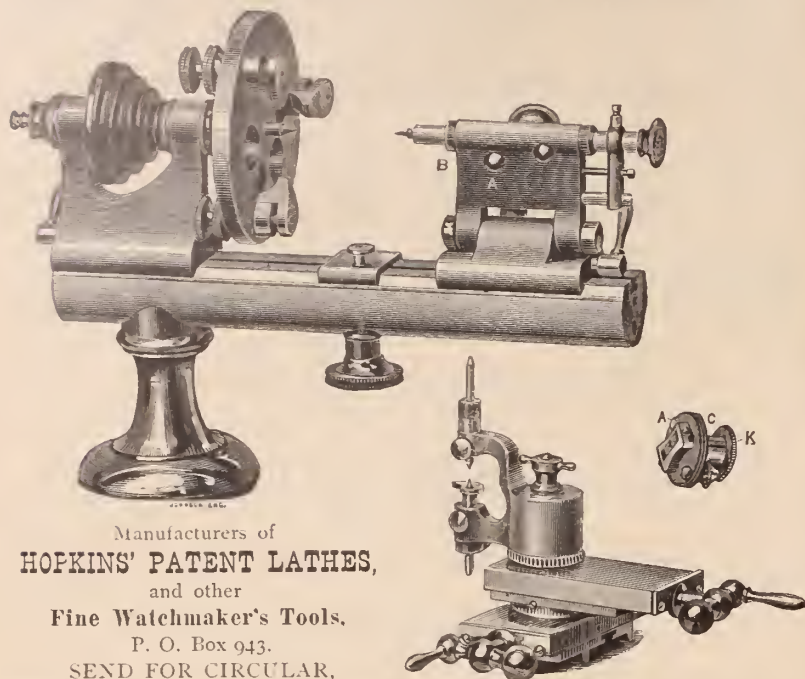

**Dorrance, Edge & Co.**

MANUFACTURERS OF

THE CELEBRATED WOVEN FABRIC  
**GOLD CHAIN.**

*Elegantly Mounted Bracelets, Opera, Leontine,*

VICTORIA WATCH GUARDS & NECKLACES, in all the Newest Designs.

Our stock is unusually complete, and, in addition to the above, a variety of Necklaces, from 1½ to 40 dwts. each, to which we invite the attention of buyers.

CHILDREN'S BRACELETS A SPECIALTY,  
 Weighing from 6 dwts. a pair upwards.

**No. 12 John Street, New York.**

Factory, 46 Greene Street, Newark, N.J.

**NOAH MITCHELL,**

*Manufacturer of all kinds of*

**Diamond Jewelry.**

DIAMOND MOUNTINGS A SPECIALTY.

A Full Assortment Constantly on Hand.

Nos. 692 & 694 BROADWAY,

Corner Fourth Street, New York.

ALL ORDERS WILL RECEIVE PROMPT ATTENTION.

**American Watch Tool Co.**

P. O. Box 999 WALTHAM MASS.

MANUFACTURERS OF THE WHITCOMB LATHE,  
 AND

Machinery for Watch, Watch Case and Clock Making  
 NEW YORK OFFICE, WITH

L. H. KELLER & CO., 64 Nassau Street.

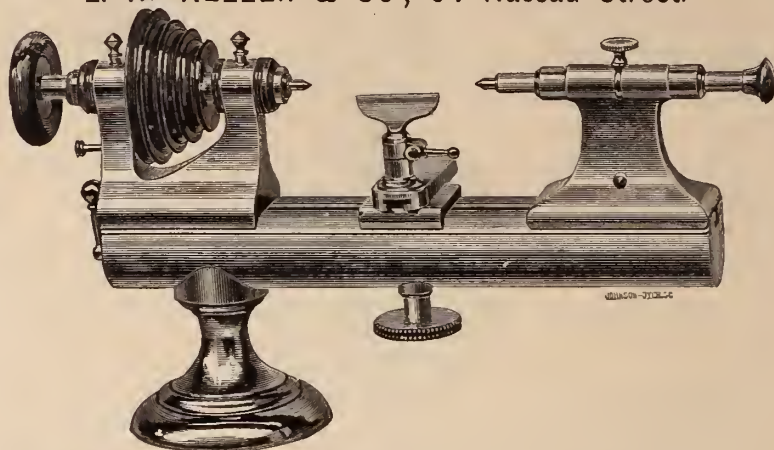

**LOUIS HERZOG & CO.**

DEALERS IN

**WATCHES,**

— AND —

Manufacturers of Jewelry,

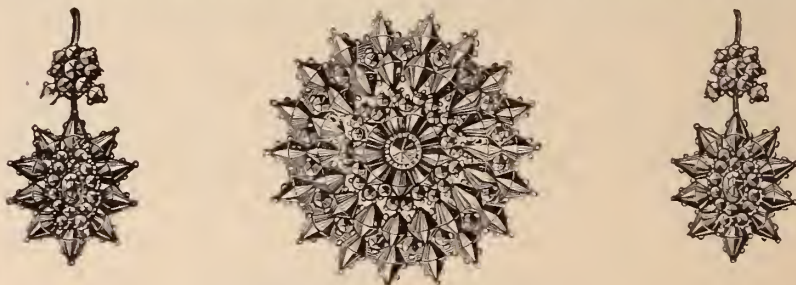

No. 33 MAIDEN LANE,

LOUIS HERZOG,  
 LOUIS KAUFMAN.

NEW YORK.

**FRASSE & COMPANY,**

Importers of P. S. STUBS',

French, Swiss, German & Sheffield Tools, Files,

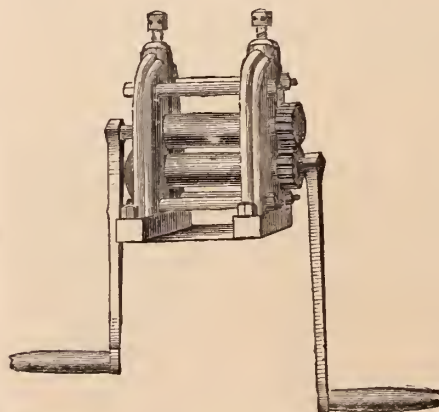

Steel Wire and Materials,  
 For Watchmakers, Jewelers, Engravers  
 Die Sinkers, Machinists, &c.

Turning Lathes, Drills & Chucks

Rolling Mills, Draw Plates,

The Celebrated Rodenbush

Piercing Saws,

Horse Shoe Magnets, Nurls, In-  
 gots, Chasing Tools, Engravers'  
 Tools, Brush Wheels & Buffs,  
 Hand Brushes and Buffs, Borax,  
 Saltpetre, Beeswax, Rouge, Trip-  
 oil, German Silver, Brass, &c.

**No. 62 Chatham Street,**

Established 181°.

**New York.**

P. O. Box 4627.



MANUFACTURERS  
OF  
EXCLUSIVELY  
**BLACK ONYX GOODS.**

The patented **DEEP MOURNING LOCKETS** are original with us, and have stood the test of years of wear. They meet the approval of the trade and the wearers for their superior make and finish, as well as for the correctness of the mechanical principle on which they are constructed.

**WOGLOM & MILLER,**  
32 & 34 JOHN STREET,  
NEW YORK.

**HENRY FERA,**  
Importer of **Diamonds,**  
No. 9 MAIDEN LANE,  
**New York.**

Having my own cutting and polishing establishment at Nos. 23 and 25 Looijersgracht, Amsterdam, Holland, constantly running 36 mills, I am able to offer to the trade a full assortment of Diamonds at very low prices.

Loose and Mounted Goods sent on approval to any part of the country on receipt of satisfactory references.

All goods ordered from or shipped to me, are insured while in the hands of express companies, and no valuation is needed on the parcels.

**BOOZ & THOMAS,**  
MANUFACTURERS OF

**Watch Cases**  **& Jewelry,**

108 South Eighth St., (2d Story) Philadelphia.

Samples of our goods sent on approval, when satisfactory reference is furnished.

**Old Gold & Silver Bought or Exchanged.**  
PARTICULAR ATTENTION PAID TO REPAIRING.

**HAMILTONS & HUNT,**  
MANUFACTURERS OF

**Fine Plated Chains**

AND PATENT BUCKLE BRACELETS,  
A Full Line of Ladies' and Gentlemen's Roman Stone Lockets,  
**Branch Office, 176 Broadway, New York**  
FACTORY, 226 EDDY STREET, PROVIDENCE, R. I.

GEO. W. PRATT. IRA GODDARD.

**GEO. W. PRATT & CO.**  
MANUFACTURERS AND DEALERS IN

**American and Swiss Watches,**  
**SOLID BAND AND SEAL RINGS,**  
Gold and Roll-Plated Jewelry,  
No. 14 JOHN STREET, NEW YORK.

  
**W. C. GREENE & CO.**  
GOLDSMITHS.

MANUFACTURERS OF  
RICH SETS IN TAPER WIRE CORAL

Factory 95 PINE ST. Providence, R. I. Office 192 BROADWAY, N. Y.

Stone Cameo Amethyst Coral Cameo Engraved Brooches Sleeve Sets Stud Buttons Ear Drops Crosses

WM. C. GREENE. B. W. GREENE. GEO. D. BRIGGS.

**M. FOX & CO.**  
**Practical Lapidaries,**  
IMPORTERS OF  
**DIAMONDS**  
AND OTHER PRECIOUS STONES,  
No. 1 Maiden Lane, New York.

**VANHOUTEN SAYRE & CO.**  
MANUFACTURERS  
OF  
**SOLID JEWELRY.**

ETRUSCAN ENAMEL  
AND  
FACET WORK.

OFFICE AND FACTORY, **53 CHESNUT STREET NEWARK, N. J.**

**E. STITES,**  
**Manufacturing Jeweler.**  
 No. 12 MAIDEN LANE,  
 New York.  
 COIFFEURETTES.

I. PFORZHEIMER.

D. KELLER.

**PFORZHEIMER & KELLER,**

IMPORTERS OF

**Watches and Diamonds**

*Dealers in American Watches,*

AND

**Manufacturers of Jewelry,**

No. 24 JOHN STREET,

**NEW YORK.**

P. O. Box 4144.

**Coral Cream Polishing Fluid**



IS SUPERIOR TO ANY IN USE FOR CLEANING AND POLISHING  
**SILVER, GOLD AND PLATED WARE,**  
 AND ALL FINE  
**Metallic and Glass Surfaces.**

**Free from Acid, Mercury, Ammonia,**  
 Or anything Poisonous or injurious to the Hands or Metal.

**CHEAPER THAN POWDERS.**

As there is no waste in using, and produces a more lasting  
 brilliancy without injury or Wear to the Metal.

Pronounced by Experts to be the finest and  
 most brilliant Pol'ish made.

Diploma awarded at American Institute Fair.

Bottle contains 4 fluid ounces.

IS THE BEST—SELS THE QUICKEST—AND COSTS THE LEAST.

Liberal Samples furnished on application.

For Sale by Wholesale Jewelers and Silverware Dealers.

**EDWARD BAXTER,**

*Cor. 8th St. & Broadway.*

CARTER BUILDING, (Room 25), NEW YORK.



HIGHEST AWARD TO

**SYLVANUS SAWYER,**

—FOR—

**WATCH MACHINERY,**

**Watch & Clock Making Machinery**

For sale or made to order, either in complete sets, including

**PUNCHES & DIES AND OTHER SPECIAL TOOLS,**

Or in parts of sets, to accommodate purchasers.

**ALSO, JEWELER'S LATHES AND TOOLS,**

AND OTHER FINE WORK,

**MAIN STREET, FITCHBURG, MASS.**

**BREITINGER & KUNZ,**

IMPORTERS OF

**Watchmakers' Tools and Materials,**

GLASSES, &C. &C.

**No. 107 N. 9th Street, Philadelphia.**

Agency in the U. S. for

**BÄHNI BROTHERS HARDENED & TEMPERED HAIRSPRINGS,**

**G. BECKER'S GOLD MEDAL REGULATORS,**

**DUDLEY'S ELECTRICALLY CORRECTED CLOCK.**

**WILLIAM BARBER'S PATENT ADJUSTABLE EYE-GLASS,**

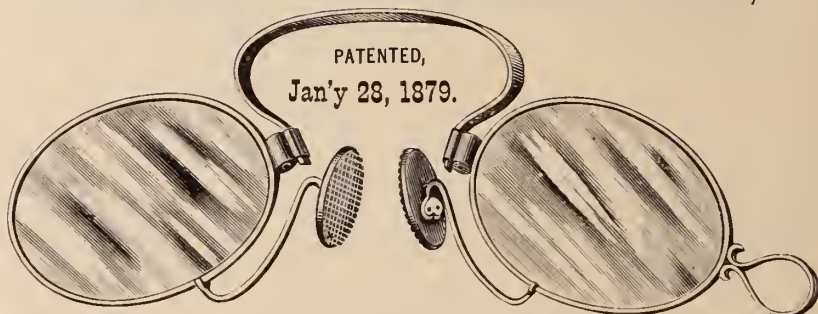

The above cut represents an Eye-glass possessing the convenience of an Eye-glass and the utility of a Spectacle combined, thereby rendering it practicable for everyone to avail themselves of their convenience, who have heretofore been deprived of their use. **TRY THEM, WILL RECOMMEND THEMSELVES.**

We manufacture them from Gold, Nickel, Steel, Shell and Rubber.

**WILLIAM BARBER,**

Inventor, Patentee and Manufacturer,

**L. A. CUPPIA,**

**19 UNION SQUARE, NEW YORK,**

MANUFACTURER OF

**Sterling Silver Jewelry.**

SETS, SCARF PINS, FANCY BRACELETS, CHATE-

LAINES, LACE PINS, BANGLES, BANDS, Etc.

**Silver Filigree and Conch Shell.**

**New Jewel Setting Cutter**

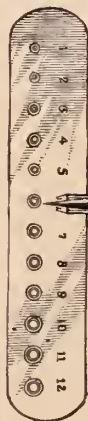

For cutting the bezel, or rim that holds the jewel to the plate of watch movements. In adjusting the jaws to the size of bezel to be cut, the gauge will be found very useful, there being twelve sizes of bezels made by this tool. A glance at the sketch will show the practicability and great

usefulness of the latest novelty in watchmakers' tools.

Sent with gauge, by mail, postpaid, on receipt of \$2.00.

**Lancaster (Pa.) Watch Co.'s Agent**

**New York, Pennsylvania and Ohio.** Information, Price Lists and Circulars cheerfully furnished upon enclosing business card.

Orders should be addressed,

**PHIL. HECHT, 13 Maiden Lane.**

ESTABLISHED 1853.

CLOCKS



CLOCKS

**B. J. COOKE'S SON,**  
137 N. 3d Street, Philadelphia  
Catalogues and Price Lists furnished to the Trade only, on application.

**GEO. W. WALKER MORROCCO CASE M'F'G CO.,**

MANUFACTURERS OF

*Cases for Silverware, Jewelry, &c.,*

FANCY MOROCCO GOODS OF EVERY DESCRIPTION.

*Chests in Fancy Woods, &c., &c., &c*

712 BROADWAY, - NEW YORK.

ESTABLISHED 1855.

**WELCH & MILLER,**  
MANUFACTURERS OF MOROCCO, VELVET AND SATIN  
**Jewelry Cases, Trays, &c.**

Telescope Sample Cases, with Flexible Trays.  
COMPLETE STOCK ON HAND.

**No. 1 69 BROADWAY, NEW YORK.**

CATALOGUES SENT ON APPLICATION.

**JAMES IRONS,**



CHEAPEST PLACE TO BUY GOOD

**SHOW CASES,**

Large Assortment.

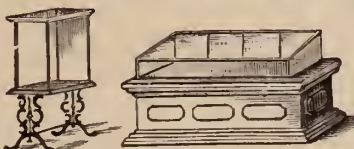

All kinds always on hand.

Cases packed securely to carry to any part of the world,

Factory and WAREHO

132 & 134

North 4th St.,

PHILADELPHIA.

**Charles F. Terhune & Co.,**  
Manufacturing Jewelers,

16 Maiden Lane,  
NEW YORK.

— Sole Manufacturers —



We beg to call the attention of the trade to the above cuts representing

**PATENT SLIDE BUTTON**

It is not separable, but works on a simple slide. It can be put in and taken out easier than any button made without soiling the cuff. Recommends itself at night.

A full line of Stone, Enamel, Ivory and Pearl goods in above patterns.

**BERNARD LEVY,**

**Manufacturer of Watch Cases**

—AND—

JOBBER OF AMERICAN MOVEMENTS.

No. 402 Library Street,

**PHILADELPHIA.**

ALSO, ORNAMENTAL ENGRAVER AND ENGINE TURNER.

**G. F. C. ROSENTHAL,**

**Manufacturing Jeweler,**

Removed from

924 Chestnut to 917 Sansom St.,

**PHILADELPHIA.**

The finest Diamond and Pearl Work exclusively.

Lubricating Oils, for Watch, Clock and Chronometer Makers.

The discovery of a Lubricator for FINE MACHINERY, such as Watches, Clocks and Chronometers, that is free from gum and corrosive substances, has taxed the ingenuity of hundreds of men whose efforts have proved a failure. But we are happy to say, (being largely interested) that such an article has been supplied by Mr. EZRA KELLY, of New Bedford Mass., who, after forty year study of the subject, has perfected a Lubricator, that recommends itself to all who have used the genuine, (there having been numerous counterfeits in the market,) as witness also the award of a

Diploma and Medal by the judges of the late Centennial Exhibition at Philadelphia. We have no hesitation in saying that his Oils are the BEST manufactured always uniform in quality and capable of standing all tests applied to lubricating oils. We cheerfully recommend it to all who may in their business require a FIRST CLASS LUBRICATOR

SETH THOMAS CLOCK COMPANY, SETH E. THOMAS, Agent

P. S.—The above Oils can be procured at all first-class wholesale Watch and Clock Establishments in the United States, as well as his only Agents, HENRY GINNEL, 31 Maiden Lane, New York, and GRIMSHAW & BAXTER, 35 Goswell Street, London, England.

New Bedford, October 15, 1877.



# “HILLSIDE,”

NEW THREE-QUARTER PLATE MOVEMENT

—MADE BY—

## The American Watch Company

OF WALTHAM,

The lowest price three-quarter plate Stem-Winding American movement ever made. We wish to call the attention of the trade to the following special advantages:

*They are made to wind at either the figure XII for Open Face Cases, or at figure III for Hunting Cases, in all three qualities, viz.:*

**Gilded Movement, Cut Expansion Balance, plain jeweled;**

“ “ “ “ “ with 3 pairs extra jewels in settings;

**Nickel Movement, Cut Expansion Balance, with 3 pairs extra jewels in settings.**

*These movements all have quick trains, Patent Pinions, with extra jewels in settings, and, at the very low price at which we offer them, are especially adapted for our New Patent Dust Proof Open-Face Cases. A good strong case can be made under our patents weighing not over*

**22 dwts., 14 karat gold,**

**24 “ 18 “ “**

*thus making altogether the lowest price three-quarter plate gentlemen's size stem-winding gold watch ever offered.*

Robbins & Appleton, 9 Bond St., New York.  
Robbins, Appleton & Co., 8 Summer St., Boston.  
Robbins & Appleton, 170 State St., Chicago. } *General Agents.*

AMERICAN WATCH COMPANY,  
OF WALTHAM, MASS.

*Note the prices of the following new movements made by*

# THE AMERICAN WATCH COMPANY

## OF WALTHAM, MASS.

### 14 Size, $\frac{3}{4}$ Plate.

AM. WATCH CO.	“HILLSIDE”	(NEW), 7 jewels, cut expansion balance, Stem Winder, for Hunter or Open Face, (Gilded Movement)	\$20 00
“	“	3 pairs extra jewels, in settings, cut expansion balance. Stem Winder, for Hunter or Open-Face, (Gilded Movement),.....	23 00
“	“	3 pairs extra jewels in settings, cut expansion balance, Stem Winder, for Hunter or Open Face, (Nickel Movement).....	30 00

### 18 Size, Full Plate, NICKEL Movements.

“WM. ELLERY,”	2	pairs, extra jewels, cut expansion balance.....	12 00
“	2	“ “ “ “ “ “ “ “ Stem Winder,.....	16 50
“P. S. BARTLETT,”	2	pairs, extra jewels in settings, cut expansion balance.....	18 50
“	2	“ “ “ “ “ “ “ “ “ Stem Winder	26 00
“WALTHAM WATCH CO.”	4	pairs, ex. jewels in settings, cut ex. balance.....	26 50
“	4	“ “ “ “ “ “ “ “ “ Stem Winder	34 50
“APPLETON, TRACY & CO.,”	4	pairs, extra jewels in settings, cut expansion balance, adjusted.....	37 00
“	4	pairs, extra jewels in settings, cut expansion balance, adjusted, Stem Winding.....	46 50

All the above are subject to the terms and discounts announced in our circular of the 8th Feb. last.

There will be no change in the quality of any of our grades, except as our constant efforts tend to their improvement. We decline altogether to take any part in the present unwise competition between Swiss and American manufacturers to see which shall make watches of the poorest quality. We intend to sell as low as any American company, but, however low the price, we do not intend to finish a grade of goods upon which it would be a disgrace for us to put our name.

Robbins & Appleton, 9 Bond St., New York.  
 Robbins, Appleton & Co., 8 Summer St., Boston, } General Agents.  
 Robbins & Appleton, 170 State St., Chicago.

American Watch Company,  
 OF WALTHAM, MASS.

*New York, September 1st, 1879.*

**T. B. BYNNER,**  
**Importer & Jobber of Watches**

DIAMONDS AND FINE JEWELRY,

And Dealer in the BEST CLASS OF ROLLED PLATE JEWELRY

And Key and Stem-Winding American Watches.

No. 513 Broadway, New York

**J. H. PURDY & Co.,**

128-170 STATE ST.

CHICAGO.

Jobbers of Imported and Domestic

**TOOLS & MATERIALS,**

For the use of Watchmakers, Jewelers, and kindred trades.

WATCH GUARDS, JEWELRY BOXES, SPECTACLES, CARDS  
 SPECTACLE CASES, PEARL GOODS, STEEL CHAINS,  
 TAGS, RUBBER TYPE, &c.

OFFICE WITH CHARLES WENDELL & CO.

**Clark's Grooved Case Springs.**



PAT. 677.

Made in four lengths, wide and narrow. The spring sets well away from the movement, the depressions obviate any tendency to move lengthwise. Steel rivets preferably used can be removed more easily than screws. In fitting file away the lower edge until the rivet can be pushed down in front of the spring in the grooves. These springs are made from fine steel, carefully tempered and warranted perfectly reliable. To be had of all jobbers in watch materials at manufacturers price—75 cts. per dozen.

**A. N. CARK,** Plainville, Ct.  
 Manufacturer of the Celebrated  
 FOUR HOLE CASE SPRINGS,  
 Watch Keys, Bench Tools, Crosby's  
 JEWELING TOOLS, &c.

**CROSS & ADAMS,**

COUNSELLORS AT LAW,

ADVOCATES IN PATENT CAUSES.

No. 194 BROADWAY,

NELSON CROSS,  
 JOHN P. ADAMS.

**NEW YORK,**

Particular attention given to Patents both with Departments and in the Courts.

More definite information relating to matters contained in the Patent Reports of this Journal furnished on application.

**A. W. MACERHANS,**  
**Manufacturing Jeweler,**

19 JOHN STREET, NEW YORK.

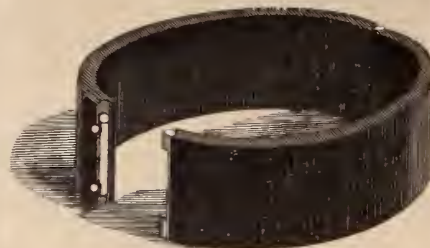

Patented May 7th, 1879.

These Bracelets, plain, with concaves for solitaire diamonds or with "lily of the valley" or other pearl ornaments, show less gold in mounting, and are lower in price than any other Onyx Band in the market.

They are made in widths running from  $\frac{3}{8}$  to 1 in. and from  $5\frac{3}{4}$  to  $6\frac{3}{4}$  in. wrist measure.

**Onyx Goods a Specialty.**

Onyx Lace Pins, Scarf Pins, Cuff Pins, Earrings, Lockets, Crosses, Ladies and Gents' Vest Chains.

APPROVAL ORDERS SOLICITED. REPAIRING CAREFULLY DONE.

**MILNE & JOURDAIN,**  
 Manufacturers of Stem-Winding Watch Crowns



13 & 15 Franklin Street,

**NEWARK, N. J.**

Gold Crowns, for Stem-winding Movements, to suit all sizes of Imported or American Watches, in four different styles and seven sizes.

Gold Pushers for Key Movements in every size. Also Gold Crowns for fine Chronograph Watches made to order.

Silver Stem winding Crowns and Key Pushers on hand or made to order. Send for card and samples.

A. MILNE.

A. JOURDAIN.



**RICKETT'S  
 PATENT EYE SHADE.**

It is simply a neat curved shade of hard rubber,  $\frac{3}{4}$  inch wide that fits under the eye brows, and flares out at the bottom so as to allow an angle of vision about level with the horizon. Having met with success in New York, Philadelphia and Boston, and wishing to extend our trade to other cities, we will for the next 30 days forward to any one in the trade ordering 2 dozen Spring Shades, an elegant Plaster Bust, life size, stands 17 $\frac{1}{2}$  inches high, and retails in New York for \$3.00. If placed in prominent window, will sell 2 dozen shades in 10 days.

We have first-class testimonials from M. GARDNER, Chief of Draftsman, U. S. Patent Office, H. OLMSTED, Secretary of New York Jewelers' Association, and from many other prominent men of the country. Order from any jobber or direct from us. Please state whether you want Bust.

PRICE.—Spring Shades, \$3.50 per doz.

RICKETT'S EYE SHADE CO.,

85 Nassau Street, New York.

**WILLIAM H. BALL,**

SUCCESSOR TO BALL & BARNARD,

MAKER OF

ORNAMENTED

Roman, Enameled and Engraved

**BRACELETS.**

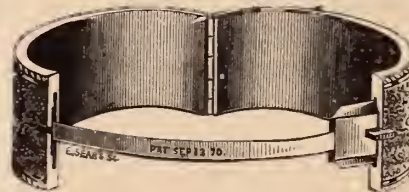

Having given the manufacture of Band Bracelets my entire attention for a number of years, it has been my desire to make a durable article, one that will give satisfaction to the seller as well as the wearer. I desire to call the attention of the trade to the reduction I have made in prices, still keeping up the standard as to QUALITY, FINISH and WORKMANSHIP. To each pair of BANDS is attached my patent guard without extra charge—thus saving the price of chain

No. 9 JOHN STREET, NEW YORK.

Factory, 30 & 32 Franklin Street, Newark, N. J.

# RANDEL, BAREMORE & CO. DIAMONDS,

Corner Maiden Lane and Nassau Street,

29 MAIDEN LANE,

58 NASSAU STREET,

**NEW YORK.**

No. 12 New Burlington Street, LONDON.

Established 1828.

## JACOB BENNETT & SON, Diamond Setters and Manufacturing Jewelers, No. 108 SOUTH EIGHTH STREET, PHILADELPHIA.

WE MANUFACTURE AND MAKE A SPECIALTY OF  
EVERY DESCRIPTION OF

**DIAMOND MOUNTINGS,**

SUPERIOR IN DESIGN AND WORKMANSHIP.



Dealers in

**DIAMONDS,**

And all kinds of Precious Stones.

Masonic Marks, Society and School Badges, Made to Order Only. Designs and Estimates Furnished.  
PARTICULAR ATTENTION GIVEN TO ALL KINDS OF JOBBING.

## L. & A. MATHEY,

No. 16 MAIDEN LANE,

IMPORTERS OF ALL GRADES OF

Plain and Complicated Watches and Movements,

SOLE AGENTS FOR THE WELL-KNOWN

# H. L. Matile

FINE WATCHES OF ASTRONOMICAL PRECISION.

AN ATTRACTIVE LINE OF CHATELAINES AND CHATELAINNE WATCHES.



## LOUIS AUDEMAR'S CELEBRATED STEM-WINDING WATCHES

*So well and favorably known all over the world, have achieved the highest honors ever accorded to any WATCH. They are the finest finished Watches made, consequently the most reliable time-keepers.*

### J. EUGENE ROBERT,

SOLE AGENT,

IMPORTER OF WATCHES AND WATCH MOVEMENTS,

30 MAIDEN LANE. N. Y.

Special attention is directed to my full and complete stock of **WATCHES OF ALL GRADES**, from the smallest size upwards especially designed for the requirements of this market, cased in Gold, Silver and Nickel. Several of these movements interchange in American cases. The above goods are fully warranted.

Medal and Diploma awarded at Centennial Exposition, for superior mechanical execution and artistic ornamentation.



Established in 1854.

# C. & A. PEQUIGNOT, MANUFACTURERS OF WATCH CASES,

DEALERS IN AMERICAN WATCHES AND IMPORTERS OF FINE KEY AND STEM-WINDING MOVEMENTS,

SALESROOM AND MANUFACTORY, 22 SOUTH FIFTH STREET,  
PHILADELPHIA.

A full stock of Key and Stem-Winding Gold Cases always on hand. Goods sent on approval when satisfactory references are furnished.

## HENRY C. HASKELL,

Manufacturing Jeweler,

No. 12 John Street,

New York

THE FINEST SEAL RING EVER OFFERED  
THE TRADE.

### The "MARQUIS"

*Must be seen to be fully appreciated.*

Four Sizes,  
CAMEO, INTAGLIO, ONYX or BLOOD STONE

*Every Stone Warranted  
not to come out.*



4040

*Samples sent on approval, express paid.*

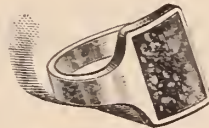

5223



7571

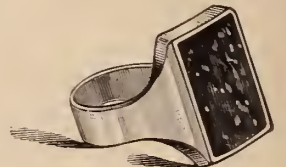

7572

*Price Lists to Trade only.*

# HAMPDEN WATCH CO.

Manufacturers of KEY AND STEM-WINDING

General Office and Factory,  
SPRINGFIELD, Mass.

## WATCHES.

New York Office,  
No. 12 MAIDEN LANE.

Established 1826.

Factory,  
27  
RUE DU PARC,  
Chaux de Fonds,  
Switzerland.

## JULIEN GALLET,

CHAS. PERRET, Sole Agent.

Sales Rooms,  
No. 1  
MAIDEN LANE,  
NEW YORK.  
P. O. Box, - 4420.

Importer of Watches & Watch Movements,

Would respectfully call the attention of the Trade to the annexed cuts of the Lady's size Watch, Stem-Winder and Stem-Setter, in Nickel, Silver and Gold, White and Black Dials.

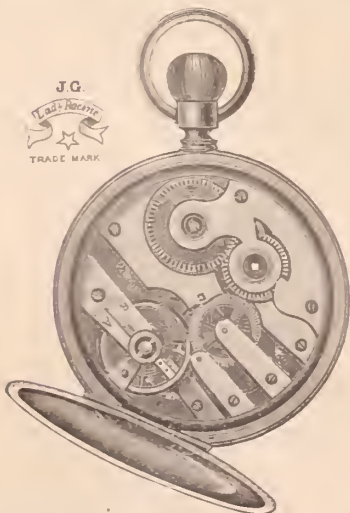



# HALL, ELTON & CO.,

## Manufacturers of the Finest Electro-Plated Ware.

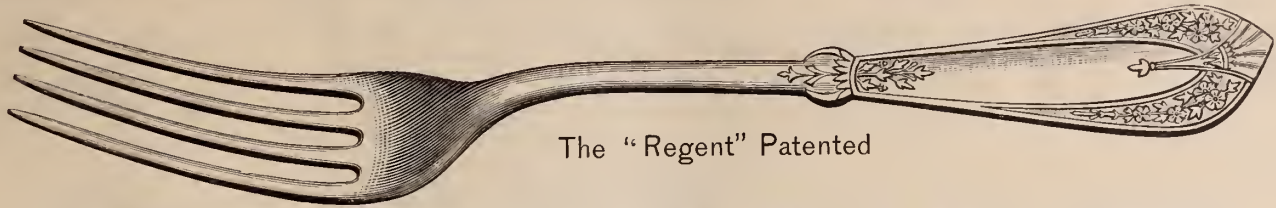

The "Regent" Patented

**UNSURPASSED IN QUALITY, STYLE AND FINISH!**

Factories, Wallingford, Conn. Salesroom, 75 Chambers St., New York.

# HOLMES, BOOTH & HAYDENS,

MANUFACTURERS OF

**ELECTRO-SILVER PLATED**

## Spoons, Forks, Ladles, Fancy Pieces,

**Solid Handle Steel Knives, &c., of the finest quality.**

No. 49 Chambers Street,  
**NEW YORK.**

No. 18 Federal Street,  
**BOSTON.**

Works at Waterbury, Conn.

# BROWN & BROTHER,

MANUFACTURERS OF

## Finest Quality of Electro-Plated Flat Table Ware

**PATENTED HEAVY SPRING TEMPERED SHANK ON FORKS AND SPOONS.**

ILLUSTRATED CATALOGUES FURNISHED ON APPLICATION.

**WAREROOMS, No. 81 CHAMBERS STREET, NEW YORK CITY.**

FACTORIES, WATERBURY, CONN.

P. O. BOX 5731.

## GUERRANT'S ELECTRO-ENGRAVING MACHINE.

It has baffled the skill of the inventive genius of the world for ages to produce a machine that would compete with the skillful hand engraver, and until this machine was invented, all engraving had to be done by hand. And, to-day, it is the only practical engraving machine in existence.

The construction of the machine is not complicated, but simple and durable. It is easily operated. The variety of work it will do is almost incredible, and to be fully appreciated, ought to be seen in operation.

We do not therefore, offer this machine to the public simply as a machine to aid the engraver, but as a perfect, practical engraver in itself, with which any person of ordinary skill can learn in a short time to do any piece of engraving that might be desired and in the very best manner.

It copies from the regular press type of any style of letter or design that is made of type, from the plainest to the finest german text letter or fancy design, at the same time it will reduce the letter or design from the original size to ten different sizes, or so small that it cannot be seen by the naked eye. It will shorten the letters or elongate them, also will lean them forward or backward, will either make a raised or sunken letter, will engrave on any surface, either plain, concave or convex—for instance, such things as Watch Cases, either in or outside; Finger Rings, either in or outside; Bracelets, Napkin Rings, Goblets, Pitchers, Mugs, Waiters, Spoons, Forks, and all kinds of Jewelry; or, in fact, on any article susceptible of being engraved or ornamented with scroll work or fancy designs, &c., either on Gold, Silver, Copper, Brass, Iron, hardened Steel, Glass, Stone, Pearl, Ivory, Bone, Gutta Percha.

No Jeweler or establishment that has engraving to be done should be without it. Machines are sold with limited territory to use them in; or, the exclusive rights to use them in certain town or territory can be purchased with the machine if desired.

For further information, address

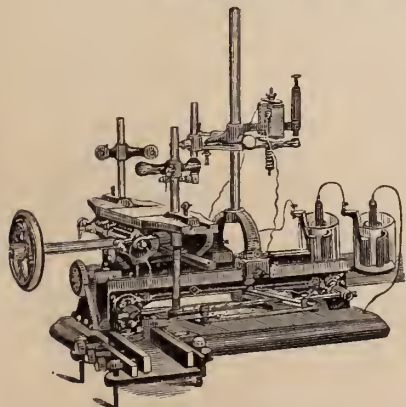

Size of Machine, 12 x 16 inches.

Patented Jan. 18, Oct. 31, 1876, & Mar. 4, 1879.

**WM. HICKSON, Gen. Agt.,**

**P. O. Box 1603, PHILADELPHIA, PA.**

**A. M. GUERRANT, Danville, Va.,** Agent for the Southern States.

**KARN & HICKSON,**

**LYNCHBURG, VA.**

Owners of the right of all the Northern States and Territories.

The accompanying cut illustrates the large size

## PIONEER WATCH,

The best pocket time-keeper ever offered the trade. Can be had of any first-class Jobbing House throughout the United States.

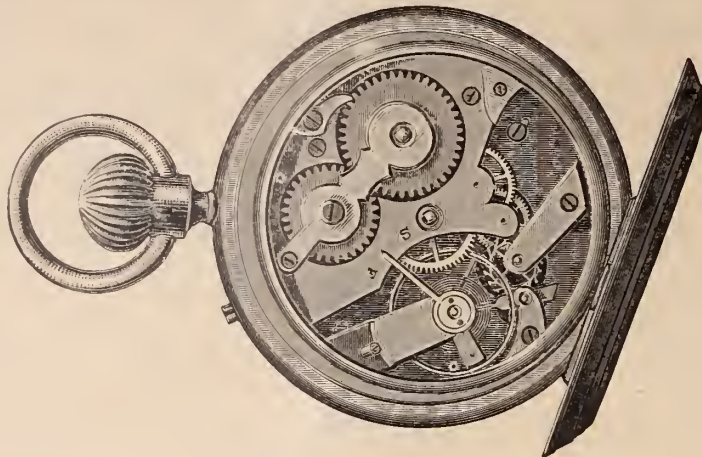

None genuine unless stamped

**"PIONEER"**

either inside or outside of case.

**H. GINNEL,**

Sole Manufacturer,

31 Maiden Lane,

NEW YORK.

P. O. Box 2967.



No. 5 A.

NICOUD WATCHES,  
NICOUD & HOWARD,  
SOLE IMPORTERS,  
14 MAIDEN LANE,  
P. O. BOX 2269. NEW YORK.

Goods sent on approval upon receipt of New York references.



No. 4.

## KOCH & DREYFUS,

IMPORTERS AND WHOLESALE DEALERS IN

# WATCHES, JEWELRY, CLOCKS,

SPECTACLES, JEWELRY BOXES, Etc.

Watchmakers' Jewelers', Engravers' and Mechanics' Tools and Supplies,

AGENTS of the PRINCIPAL WATCH AND CLOCK FACTORIES of the U. S.

18 CHARTRES STREET, New Orleans.

### New Jewel Setting Cutter

For cutting the bezel, or rim that holds the jewel to the plate of watch movements. In adjusting the jaws to the size of bezel to be cut, the gauge will be found very useful, there being twelve sizes of bezels made by this Tool. Sent with gauge, by mail, postpaid, on receipt of \$2.00.

Lancaster (Pa.) Watch Co.'s Agent

New York, Pennsylvania and Ohio. Information, Price Lists and Circulars cheerfully furnished upon enclosing business card.

Orders should be addressed,

PHIL. HECHT, 13 Maiden Lane.



WAVERLY, N. Y., August 30, 1879.

PHIL. HECHT: Dear Sir:—That little Jewel Cutter is a very handy little tool and saves lots of time. Every man who uses it cannot help but appreciate it.

Yours truly,

M. H. MANDEVILLE.

ROCK CREEK, August 25, 1879.

MR. PHILLIP HECHT,

Dear Sir:—The Jewel Setting Tool came to hand this morning. I am very much pleased with it. Five dollars would not buy it if I could not replace it.

J. C. KNOWLTON.

BETHLEHEM, August 27, 1879.

Dear Sir:—I send you briefly and most cheerfully my opinion of your "New Jewel Setting Cutter and Gauge." Having tried it thoroughly I can recommend it as a useful tool and doing its work correctly. No good workman ought to do without it.

Respectfully yours,

L. F. GIERING

Any Article in the Watch Material, Optical and Silk Guard Lines furnished at the Lowest Rates.

Gentlemen's Watches,  
Ladies Watches,  
Bridge Movement Watches,  
¾ Plate Movement Watches,  
¾ Plate Patent Reg. Watches,  
¾ Plate Movement Watches,  
Repeaters,  
Chronographs. (1-5 second)

**TIFFANY & Co.**  
NEW YORK, PARIS, LONDON, GENEVA.  
**MAKERS OF FINE AND COMPLICATED WATCHES,**  
Wholesale Office, 694 Broadway, New York.  
GEO. R. COLLIS, Manager.

Split-Second Chronographs,  
Minute and Sec'd Chronograph  
Chronograph and Repeaters,  
Minute Repeaters,  
Five Minute Repeaters,  
Quarter Hour Repeaters,  
Repeaters and Chronographs,  
&c., &c., &c.

All watches of our make have the firm name "TIFFANY & Co." engraved upon the movements, and the trade are cautioned against apparent fac-similes put upon the market by certain UNSCRUPULOUS dealers.

Our new "Bridge movement" watch for gentlemen is now ready, and conceded by experienced judges to be "the BEST watch ever made for the price." It is adjusted to temperature and position and fully guaranteed.

 Goods sent for selection or examination upon receipt of satisfactory references. Old nickel movements refinished for the trade. Orders for engraving and ornamenting movements, enameling and carving of inscriptions, Devices and Monograms on Cases promptly attended to.

ONLY WHOLESALE OFFICE for the sale of the AMERICAN PEDOMETER.

# HALL, NICOLL & GRANBERY,

Successors to SCHUYLER, HARTLEY & GRAHAM,

*Jobbers and Manufacturers of*

Imported and Domestic Fancy Goods,

## FAIENCE, PORCELAIN, BRASS, BRONZE & TABLE LAMPS,

These Goods are new, fashionable, and pay the retailer a large profit.

**AGENTS FOR FOLDING TRIPLICATE MIRRORS.**

Silver Jewelry, Genoese and English.

Amber Beads.

Opera and Field Glasses.

Carriage Clocks.

Terra Cotta Goods.

Odor Cases,

Nail Sets.

Scissors.

**MARBLE CLOCKS,**

**BRONZES,**

*AND VIENNA GOODS.*

*Of our own manufacture.*

**20 & 22 John St., New York.**

# THE "NEWPORT,"

(PATENTED.)

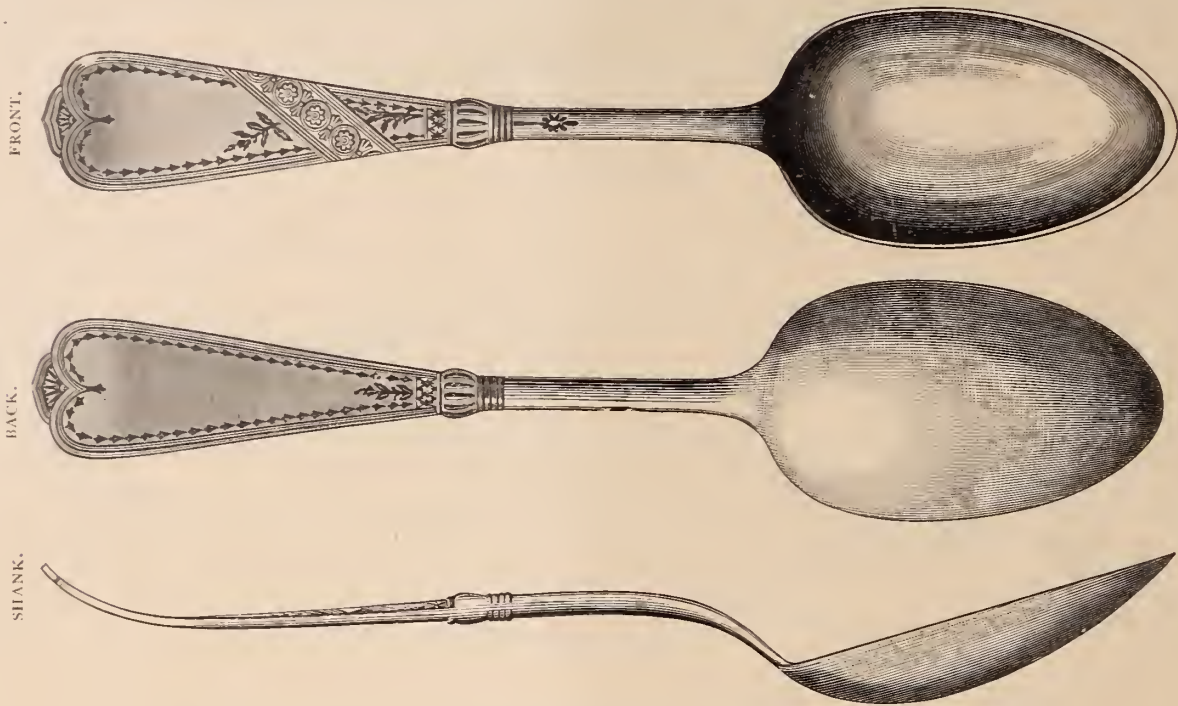

## TO THE TRADE.

We take pleasure in introducing the entirely new and beautiful pattern shown above.

**THE OUTLINE** . . . . is graceful and pleasing to the eye, having none of the sharp, angular points so objectionable in many of the recent patterns.

**THE ORNAMENTATION** is unique and fine, having the appearance of a Chased or Engraved Solid Silver Spoon.

**THE SHANK** . . . . is our well known heavy, spring-tempered, for which we hold letters patent.

*Every Care* has been taken to make this pattern as perfect as possible; first proofs of the die were submitted to many of the best experts and largest dealers in this country, and their unanimously expressed opinion is, that "the pattern is the handsomest ever made in plate," and predict for it a large sale.

Prices the same as "Crown" and other similar fancy patterns.

All dealers should add the desirable "Newport" to their stock.

Yours respectfully,

## ROGERS & BROTHER,

690 Broadway, New York,  
AND  
Waterbury, Conn.

N. B.—To correct erroneous impressions that exist in a few quarters, it is proper to say that the founders of "Rogers & Brother" first introduced electro-plating in this country in 1847. In 1858, this Company was incorporated by them, and at the present time is the only concern in the United States manufacturing Silver-plated ware under the name of "Rogers."



## THE GANTELINES.

THE ONLY NEW ARTICLE IN LADIES' JEWELRY IN A QUARTER CENTURY.

THE GANTELINES FACILITATES THE BUTTONING OF THE GLOVE.

It is formed of a hair-pin shaped link, connected by a chain to a charm of unique design.  
Or any suitable pencil, for memoranda.

It is worn pendant, by slipping the link through the button-hole of the dress; which allows the ornament to be displayed with pleasing effect.

We cite the following from the numerous press notices showing its merits.

"Of all the tasteful articles, nothing is so new or useful as the GANTELINES."—*N. Y. Evening Post.*  
 "A Pretty Ornament, and a very useful one, and the rage in fashion, is evinced by the number sold."—*N. Y. Mail.*  
 "It is really a clever device, uniting the useful with the beautiful, and is destined to become popular beyond a doubt."—*Home Journal.*  
 "A charming ornament of personal adornment, remarkable for simplicity, elegance, utility."—*N. Y. Trade Reporter.*

The above represents one of our elegant silvered Horse Shoe Trays, containing twelve GANTELINES, (Tray and Ganteline two-fifths size), and will be found a desirable acquisition to any Jeweler's stock. Nos. 653 and 655 show full size of GANTELINES.

These goods are of the **very best gold plate and finish.**

The GANTELINES can be ordered on approval in trays, which we have of different shapes, or singly if desired, from any of the above numbers.

We have spared no expense in producing new and beautiful ornaments for the GANTELINES.  
A tasteful Show Card will be furnished to every dealer who purchases one dozen or more.

**C. G. ALFORD & CO.,** Manufacturers, 183 BROADWAY, New York.



**Factory and Offices, 611 & 613 Sansom Street,**  
ARTISAN BUILDING.

THIS old and well-known firm manufacture a greater variety of *SPECIALTIES* than any other one house in the country.—**FINE TINTED AND ROMAN JEWELRY, IN SETS, BRACELTS, EAR RINGS, LOCKETS, &c., &c. GOLD CHAIN, SILVER CHAIN, GOLD THIMBLES, SILVER THIMBLES.**

In both *GOLD* and *SILVER THIMBLES*, in *Styles* and *Finish* we claim to excel all others.

## GOLD HEAD CANES.

These goods we were the *FIRST* to make to any extent, nearly all other makes are *copies of our patterns*, whilst some of our styles *have never yet been imitated*, we being *JEWELERS* as well as *CANE MAKERS*, are able to do more *elaborate* work than those not possessing this advantage.

### ILLUSTRATED CATALOGUE.

Our Illustrated Catalogue of these goods will be ready for gratuitous circulation by *September 15th*, and parties about to order *CANES* for Fall will do well to reserve orders until they have this *intelligent aid*.

**SIMONS BROTHER & CO.**  
**PHILADELPHIA.**

## THE "PAINLESS" EAR PIERCER.

PATENTED JUNE 25, 1878.

EARS PIERCED WITHOUT PAIN.

This Cut represents the Ear being pierced.



This Cut represents the Ear pierced, before the wire of the Ear-Ring is inserted in the tube of the needle.

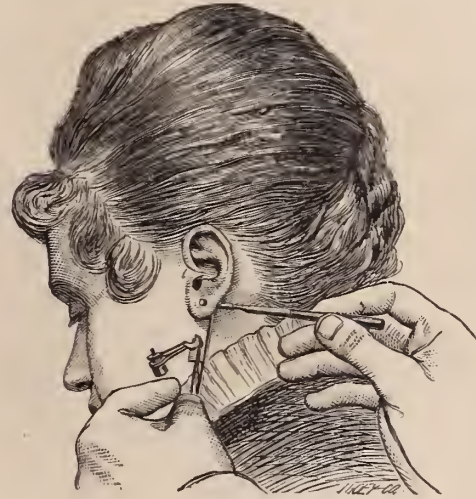

This Cut represents the Instrument and Piercer. A, is a needle with detachable point. C, a tubular guide through which the needle is forced. F, a gripper, with an aperture opposite that in the base B, between which the Ear-Lap or Lobe of the Ear is held. H, is a cork-holder, the cork receiving

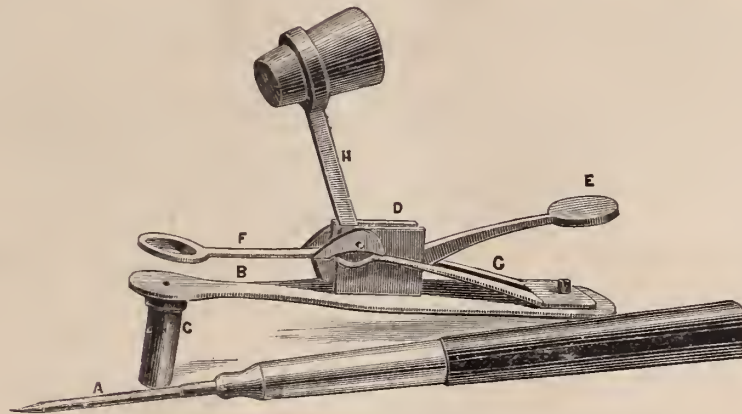

the point of the needle after the Ear is pierced. E, is the lever, by the pressure of which the gripper F, and the cork-holder H, are thrown completely back by the action of the spring G, after the Ear is pierced, as shown in the Cut No. 2.

The "Painless" Ear Piercer, patented and manufactured by Mulford & Bonnet, is an invention of real merit, which every jeweler should possess. By this simple and ingenious instrument the difficulty and *suffering* of piercing Ears is entirely overcome. The combination of the clamping device with the Piercer, as shown in the above cuts, enables the operation to be performed *without Pain*, and with *great rapidity*. This invention will commend itself to every intelligent jeweler for the following reasons:

The operation of piercing the Ear is rendered painless. The instrument holds the lobe of the Ear in such a position as to insure *perfect accuracy* in piercing. In piercing, the *tube* of the needle remains in the Ear, the wire of the Ear-Ring is inserted in the hollow of the tube, and is conveyed through the Ear as the tube is withdrawn.

The practical *importance* and *usefulness* of this invention is universally acknowledged, and its general adoption by the trade is confidently predicted.

*THE EAR CAN BE PIERCED AND THE EAR-RING INSERTED AT THE SAME TIME.*

The "Painless" Ear Piercers are nickel plated, fitted in a morocco case, and always ready for use.

MULFORD &amp; BONNET,

Sole Proprietors.

Manufacturing Jewelers,

21 MAIDEN LANE,

New York.

PRICE \$3.00 CASH.

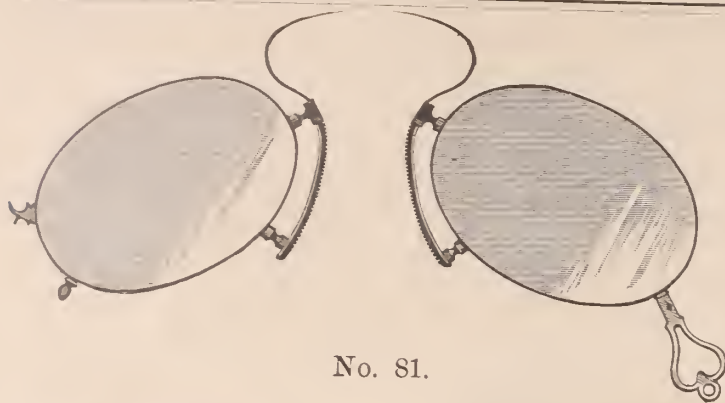

No. 81.

No. 9



No. 15. Gold Spectacles, Band Slides.  
Manufacturers of Gold, Silver & Steel

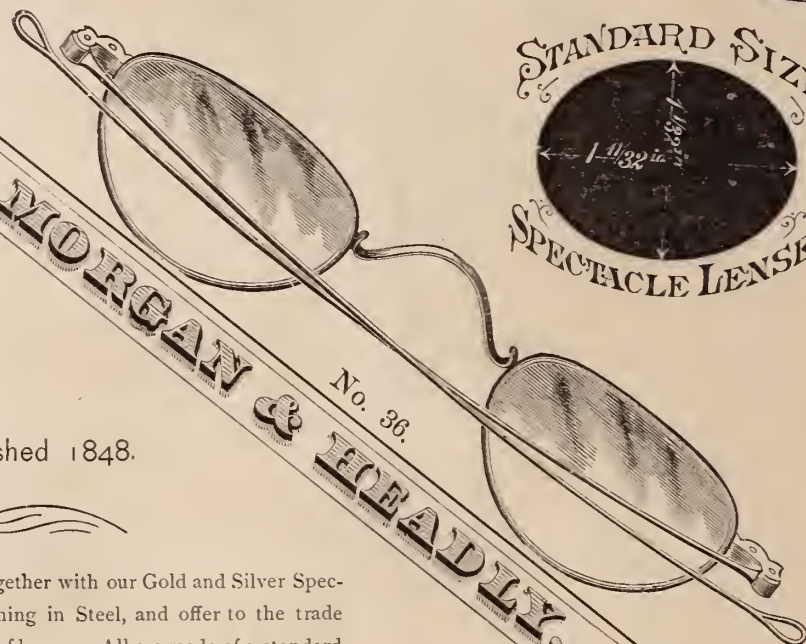

No. 36.

Established 1848.

WE are now manufacturing together with our Gold and Silver Spectacles, a full line of everything in Steel, and offer to the trade the advantage of a *uniform size* of lenses. All are made of a standard size and are interchangeable. The sizes are given in the cuts. We can only add that our reputation in gold work is our guarantee for the steel, and we shall spare no efforts to meet any competition in price as well as maintain our standard of quality.

Illustrated Catalogue mailed on application; from this dealers can order as well as if they had sample case before them.

Respectfully,

MORGAN & HEADLY.

Spectacles and Eye Glasses,  
611 & 613 Sansom Street, Philadelphia.



No. 88.

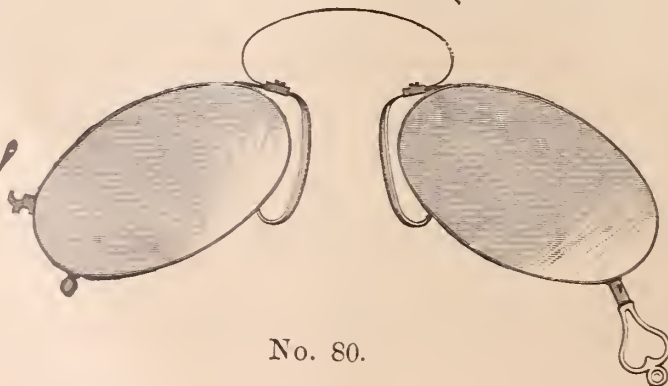

No. 80.



No. 2.



# THE STANDARD FILLED RING



## CROWN, 18. LION. FILLED RINGS

### PLAIN & CHASED



EVERY RING GUARANTEED  
BEWARE OF DIFFERENT STAMPS MADE TO IMITATE OUR TRADE MARK.

# ARROW BRAND,

INTERCHANGEABLE

## SPECTACLES & EYE GLASSES.



*The only line in the market of which all qualities interchange.*

The Steel and Gold Spectacles and Eye-Glasses, and the Steel bivocal specs being all made with lenses of one uniform size, a dealer can deliver any article such as Gold Spectacles or Eye-Glasses or Gold bivocal specs, while only carrying a very small stock of them. We guarantee these goods to interchange accurately and without trouble, and to be at least equal to any other goods of the kind in the market.

All dealers wishing to carry this, the most profitable item of their stock, in an economical manner will give our goods a trial.

*Catalogue with further particulars sent on receipt of application accompanied by business card to*

**W. B. CLAPP, YOUNG & CO.,**

WHOLESALE JEWELERS AND OPTICIANS.

149 & 151 STATE STREET,

CHICAGO, ILL.

**ESTABLISHED 1837.**

# FAIR TRADE

1879

Buyers will find it to their interest to examine our Line of Novelties in

## CLOCKS, MARBLE & BRONZE.

Vienna, Leather and Gilt Goods a Large and Choice Selection.

TRIPPLE MIRRORS, our Special Patterns, and many other new specialties of the season which we offer at close prices TO THE TRADE ONLY. Sole Agents LE COULTRE RAZORS.

**TAYLOR & BROTHER,**

No. 676 Broadway,

**NEW YORK**

# Marble Clocks,

The attention of buyers is directed to our **LINE** of this season's importations. New goods arriving weekly. Our stock will be kept full, so that early and late purchasers will have the advantage of the latest Novelties.

## Le Boutillier & Co.

IMPORTERS AND JOBBERS,

**No. 3 UNION SQUARE.**

**NEW YORK.**

Novelties in design and finish, in Silver Fancy Goods and Hollow Ware, with combinations of colors in gold, silver and niello-enamel, Testimonial and Presentation Goods, Spoons and Forks of patterns popular and desirable, and a choice line of Case goods, from single pieces to Cabinets for Wedding Gifts.

THE  
**Adams & Shaw Company,**  
**SILVERSMITHS,**

and Makers of Hard Metal Electro-Plate,

694 BROADWAY, . . . . . NEW YORK.

GEO. R. COLLIS, Manager.

Designs and estimates furnished, and particular attention paid to orders for racing, Field and Nautical Prizes, (small and large), Tea Sets, Berry Bowls, Fruit and Ice Cream Stands, Jelly Bowls and General Hollow-Ware, in Sterling Silver or Silver-soldered Electro-Plate.

A large assortment of new, ornamental and useful presents for the HOLIDAYS.

CHILDREN'S Cups, Rattles, Whistles, Paper Bowls, Catnip Warmers, Christening Sets, Knives, Forks, Spoons, Napkin Rings, Bib Pins, &c., &c.

LADIES' Portmonnies, Card Cases, Lace Pins, Hairpins, Tete-a-tetes, Shawl Pins, Card Stands, Vases, Caddies, Fruit Knives, Ice Cream Slicers, Sugar Scissors, Bells, and a great variety of other goods in new styles of decoration.

GENTLEMEN'S Cigar Cases, Match Boxes, Shaving Mugs, Cigarette Cases, Pocket Flasks, Wine Coolers, Cigar Lighters, Liquor Labels, Wine Goblets, After-dinner Coffee Sets, Ice Pitchers, Soap Boxes, Call Whistles, &c., &c.

# KEARNEY & SWARTCHILD,

Manufacturers and Jobbers of all kinds of  
*Watchmakers and Jewelers Supplies,*  
Watches, Jewelry, Etc.

113 & 115 STATE STREET,

**CHICAGO.**

300 Page Illustrated Catalogue sent upon application and Receipt of Business Card.

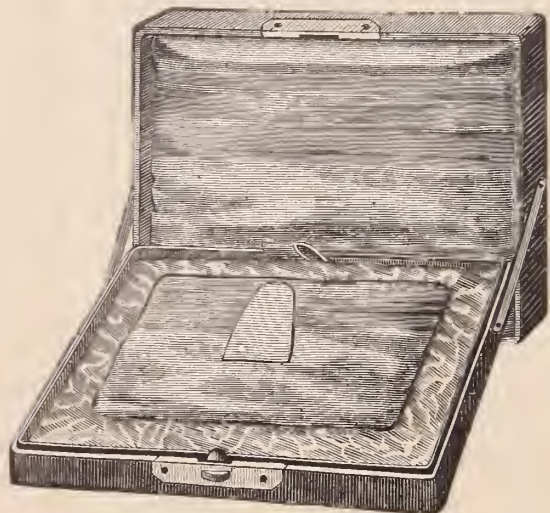

Set or Watch, \$9.00 per dozen.

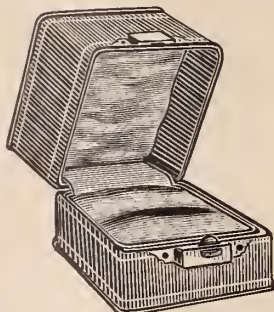

\$6.00 doz. Extra Fine, \$10.50 doz.



\$6.00 doz. Extra Fine, \$10.50 doz.



Set or Watch, \$12.00 per dozen.



Extra Fine, \$16.50 per dozen.



\$7.00 dozen. Extra Fine \$10.50 doz.

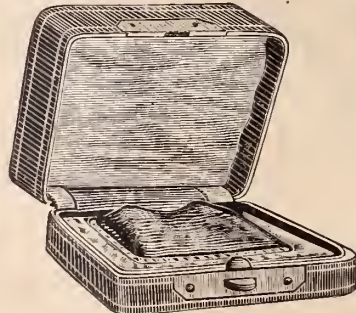

Extra Fine, \$10.50 dozen.



Extra Fine, \$16.50 per dozen.



\$7.00 doz. Extra Fine, \$10.50 doz.

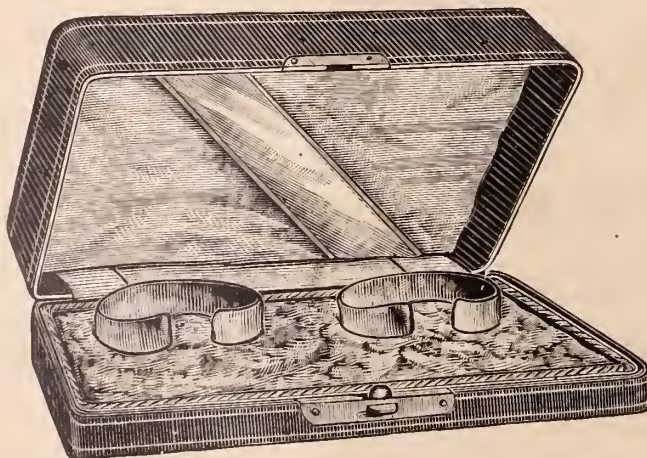

Extra Fine, \$18.00 per dozen.

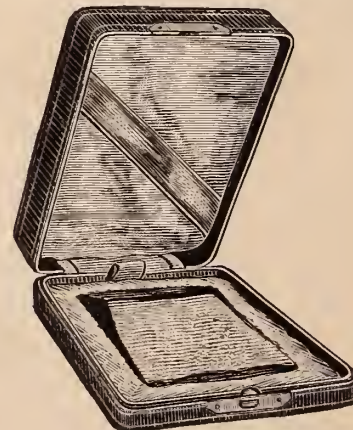

\$7.00 doz. Extra Fine, \$10.50 doz.

We have a splendid assortment of all kinds of case goods in medium and fine qualities and latest shades of lining. Name and address stamped in gold to order.

# GILES BROS. & CO.

Manufacturers and Jobbers of

**Fine and Rolled Plate Jewelry,**

Diamonds, Watches, Clocks, Materials,  
Tools and Optical Goods.

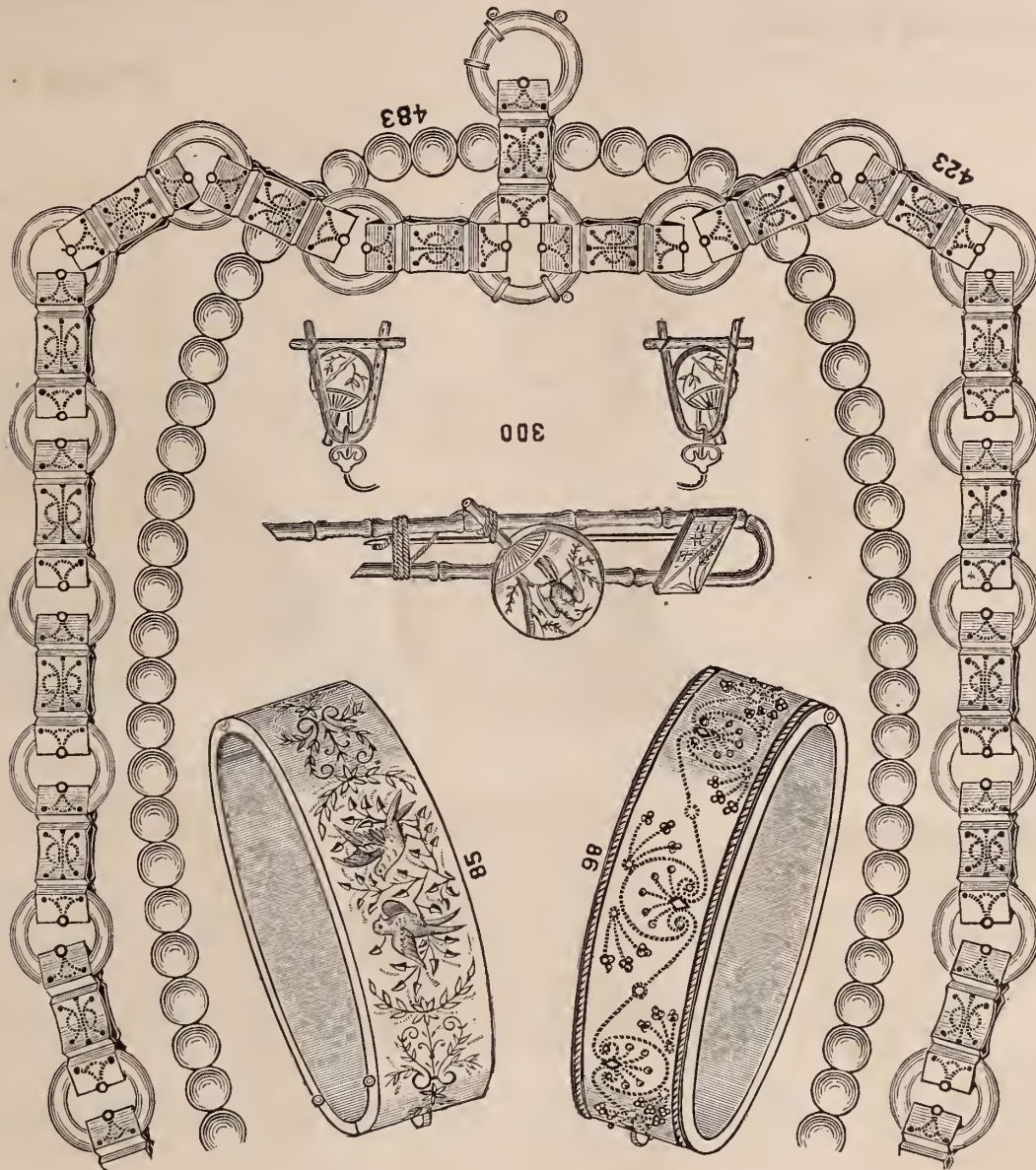

**Illustrated Catalogue Furnished**

Goods Sent for Selection.

— TO DEALERS ONLY. —

Corner State and Washington Streets, CHICAGO, Ills.

## CLOSING OUT.

THE ENTIRE STOCK OF

# JEWELRY

OF

## CHATTERTON & DODD,

To close the business.—Great inducements offered to purchasers.—Dealers visiting the city will find it to their interest to call and examine this stock.

No. 19 JOHN STREET, NEW YORK.

**CLAPP BROS. & CO.,**

**WHOLESALE JEWELERS,**

63 and 65 Washington Street, Chicago, Ill.

*We invite the attention of the trade to Our superior Stock and Uniformly Low Prices,  
Catalogues and Price Lists issued only to Watchmakers and Jewelers.  
Orders solicited.  
Promptness and Care Guaranteed.*

**JUERGENS & ANDERSEN,**

125 & 127 State Street, Chicago, Ill.,



No. 23.



No. 28a.



No. 28c.

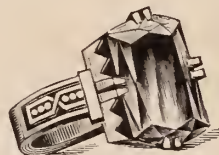

No. 42.



No. 40.



No. 47

**Manufacturers of Fine Jewelry, Diamond Work, Seal Rings, Etc., Etc.  
Special Attention Given to Watchwork and Repairing:**



**C. H. KNIGHTS & CO.,  
WHOLESALE JEWELERS,**

**125 & 127 STATE STREET,**

**CHICAGO, ILL.**

N. B.---We wish to call the attention of the Trade to our two new movements, "Enterprise," full jeweled, Nickel Key-wind, and "Queen," 11 jewels, full plate, open Bridge, Key and Stem-wind, with black dial. Also samples sent when requested.

**S. GLICKAUF & CO.,**

**Importers and Jobbers of**

**WATCH MATERIALS AND TOOLS,**

"W. B. & CO." WATCH GLASSES, SPECTACLES, CHAINS, SILK GUARDS, Etc., Etc.

WE CARRY A LARGE LINE OF NICKEL STEM-WINDERS.

79 & 81 Sate Street,

Chicago, Ill.

# B. F. NORRIS & CO.

MANUFACTURING AND  
**Wholesale Jewelers**

101 & 103 STATE ST.,  
CHICAGO.

We are the only Agents for the  
**ELGIN LATHE.**

Only Western Agents for  
Middletown Silver Plate Co.

Only Western Agents for the  
**CRESCENT SPECTACLES.**

A full Illustrated Catalogue furnished to Dealers.  
Send Business Card.

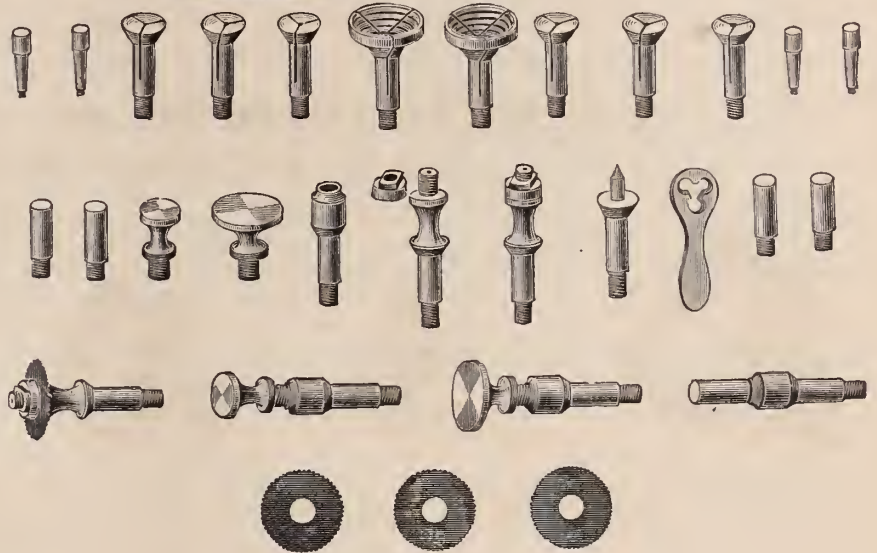
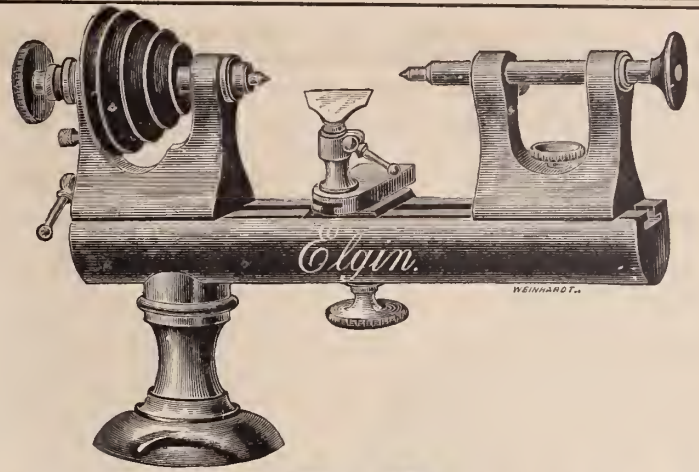

9.—LONG WOOD HANDLE BENCH KEY. (Nickel Plated.)

7.—BENCH KEY. (Brass Handle.)

1.—SLIDE KEY. (WILL WIND ANY WATCH)

2.—POCKET KEY. (Brass.) (A KEY THAT WILL WIND ANY WATCH)

3.—POCKET KEY. (Nickel Plated.) (A KEY THAT WILL WIND ANY WATCH)

4.—POCKET KEY. (Nickel Plated, Hexagon Shell.) (A KEY THAT WILL WIND ANY WATCH)

5.—POCKET KEY. (Heavy Rolled Gold Plate Mountings.) (WILL WIND ANY WATCH)

6.—CELLULOID MOUNTED KEY, (WILL WIND ANY WATCH)  
With Heavy Rolled Gold Plate Tips.

8.—SHORT WOOD HANDLE KEY. (Nickel Plated; for Bench or Pocket use.)

**BIRCH'S SELF-ADJUSTING WATCH KEYS**

WILL WIND ANY WATCH.

J. S. BIRCH & CO., 38 Dey St., N. Y.

ESTABLISHED 1869.

## The Jewelers' Circular and Horological Review,

*The recognized organ of the trade, the official representative of the Jewelers' League, the Watchmakers' and Jewelers' Guilds, and the various State Trade Societies.*

**SUBSCRIPTION, \$2.00 Per Annum.**

*Is published on the 15th of each month.*

This Journal is devoted to the interest of Watchmakers and Jewelers, and those engaged in kindred interests.

To the practical workman the JEWELERS' CIRCULAR is invaluable as a text-book and work of reference. Its pages furnish him with the latest scientific and mechanical ideas, set forth in plain, comprehensible language by specialists of ability and experience. The technical information contained in its columns represents the progress of the age, and every intelligent workman in the country acknowledges the advantages resulting from a study of its pages.

To the country dealer the JEWELERS' CIRCULAR affords thorough, correct and perfect information as to staple and original articles of trade. From it he can learn what to order and where to obtain supplies, he can discover the best source of materials in common use, while the latest novelties are without exception first announced in its columns. All communications should be addressed to

**D. H. HOPKINSON,**

42 Nassau Street, New York.

Or the regular Agents of the Circular.

Sample Copies sent on application.

**ARKELL & CO.**

IMPORTERS AND DEALERS IN

Watch Materials, Tools,  
**JEWELRY,**  
 AND ALL GRADES OF AMERICAN WATCHES.



We call the attention of Watchmakers to the "JEQUIER" Main Spring. This spring is the only one of all fabrications exhibited at the "Paris Exposition" that received FIRST and ONLY medal. We claim it is the best in this country, and invite a trial by the trade as a test of its merits. Send for sample and also descriptive catalogue of Columbus Watch, nickel  $\frac{3}{4}$  plate, full jeweled, stem-winding and setting, the most beautiful watch with the best results for least money, quality considered. No price list furnished unless requested and only to the trade.

BALDWIN'S BARREL CATCH INSERTER, indispensable to the Watch Repairer, saves time and labor, sent by mail on approval to the trade free of postage.

We are Sole Agents for the United States of these goods. We also manufacture the BOSS ENGRAVING BLOCK—there are features in its construction different from all others in the market, holds the work to be engraved, of any kind, without attachments. It is practical, simple, and reasonable in price. All these specialties enumerated, may be obtained of any regular Dealer in material and tools, or direct of us.



P. O. Box 8. Canajoharie, N. Y.



**ERRICO BROTHERS,**

19 JOHN STREET, N. Y.

MAKERS AND DIRECT IMPORTERS FROM OUR OWN MANUFACTORY IN NAPLES,

**CORAL, SILVER FILIGREE AND CONCH SHELL  
 JEWELRY,**

—OF THE LATEST DESIGNS.—

These goods are made under our own immediate supervision, and designed expressly for this market. Our stock, the largest in the city, is replete with the richest novelties in this line, and is offered to the trade at prices that will tempt buyers.

We would direct the especial attention to our recent importations of CORAL ROSES and CORAL CAMEOS in all the most desirable shades. Also to our new designs in SILVER FILIGREE goods, which we offer at unexceptionably low prices. Buyers, when in town, are invited to an examination of our stock.



# PATENT IMPROVEMENT IN COUNTER SHOW CASES,

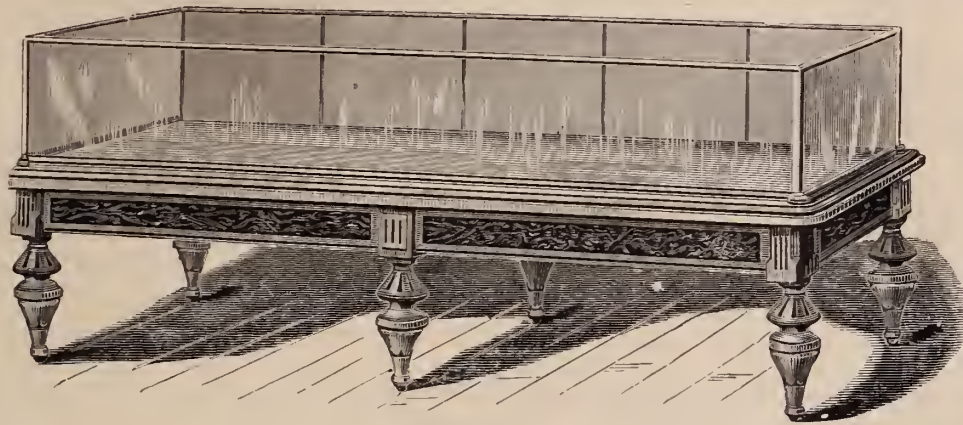

Perpendicular Sliding Door,

(DUST TIGHT.)

REAR VIEW OF CASE SHOWING SLIDING DOOR.

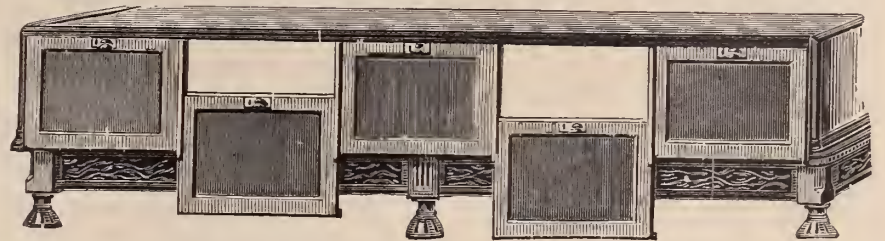

Its advantages are as follows:—The doors are more conveniently opened and closed, less liable to get out of repair or broken, articles are more easily reached in wide cases, mirrors are more safe, it dispenses with hinges, economizes room, excludes dust, and is air tight *when closed*.

Drawings furnished and estimates given for fitting stores in cabinet work complete.

REFERENCES:—Gorham Mfg Co., Rogers & Bro., Mitchell Vance & Co.,  
Meriden Britannia Co., M. S. Smith & Co. Detroit, Mich.  
D Valentine, Syracuse, N. Y.

**B. & W. B. SMITH,**

**220 West 29th Street, New York.**

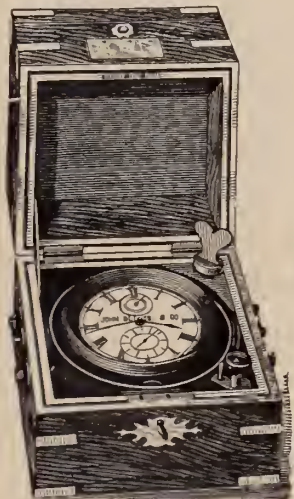

**JOHN BLISS & CO.**

**STANDARD MARINE**

**Chronometers and Transits,**

**FOR WATCHMAKERS' USE.**

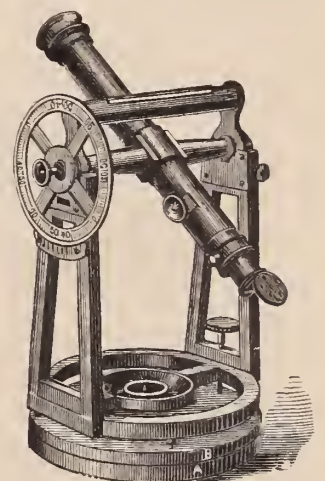

No. 10

Standard Marine Chronometer  
FOR KEEPING CORRECT TIME.

**110 WALL STREET, NEW YORK.**

**IMPORTANT NOTICE.**—These Transits are readily set in position without the aid of strictly correct time as a basis for that purpose. Printed instructions, easily understood, accompany each Instrument, and no calculations are required preliminary to setting in position.

As a trial only is required to insure unqualified approval, we are induced to make the following **LIBERAL OFFER**—On receipt by us of satisfactory reference, and 10 per cent. of the price, we will send one of the foregoing Transit Instruments, on hire or trial, for one month, with full printed instructions for setting up and using the same, and if purchased after trial, we will allow the whole hire to apply in part payment, and sell the Instrument on approved note at four months for the balance. Special terms for payment by installments, after trial, on application. We do not make this offer merely to hire these instruments, but to insure a trial with a view to sales, the hire received being only sufficient to cover the cost of repolishing in case they are returned. Send for Illustrated Circular giving full description.

**JOHN BLISS & CO., 110 Wall Street, New York.**

Established 1849.

Incorporated 1876

# BRADSTREET'S Improved Mercantile Agency,

Principal Office, 279, 281 & 283 Broadway, N. Y.

THE BRADSTREET COMPANY, PROPRIETORS.

BRANCH OFFICES IN ALL PRINCIPAL CITIES OF THE UNITED STATES AND CANADA,  
AND LONDON, ENGLAND. ALSO, A CONTINENTAL CORRESPONDENCE.

One Organization! One Management! One Interest!

## VOLUMES ISSUED QUARTERLY.

☞ SHEETS OF CHANGES SEMI-WEEKLY. CONSTANT REVISIONS AND PROMPT  
NOTIFICATIONS TO SUBSCRIBERS.

TO MERCHANTS, MANUFACTURERS AND BANKERS:—We shall issue the FORTY-SIXTH Volume of our REPORTS during the first weeks of July. We are confident that no previous issue of our work has been so complete, comprehensive, and reliable as this—for we have spared neither expense nor care in perfecting the reports, and have also revised and perfected the many improvements which have been so fully appreciated by our patrons.

We have compiled an Abstract of the Collection Laws of the several States, which we print under the proper headings. This feature will be appreciated by all who have occasion to grant credits covering different sections of the country.

We have also introduced under each town or village head, concise information, showing its actual or relative position—whether on a railroad, steamboat, or stage route—the population, and whether a telegraph, express or money-order office. As a Shipping guide, this will be almost invaluable, it being more comprehensive, and we intend that it shall be more reliable than any published otherwise. We have also tabulated the Banks and Bankers throughout the United States and Canada, giving their capital, etc., as well as their New York correspondent, which we shall publish as an Appendix to each volume, retaining, however, the names as they appear at present under their respective town or city, in the regular volume.

Owning and directing our whole business, from London to San Francisco, as from Montreal to New Orleans, we are able to control it in all its branches, so that it is not possible for the interest of our patrons to suffer from conflict with local managers.

Relying solely on the merits of our work, we respectfully solicit an examination of our system, with the assurance of our ability to substantiate all we claim, and with the knowledge that it is worthy of your earnest consideration.

CHARLES F. CLARK, President.

# The Burbank Manufacturing Company

Manufacturers of GOLD & SILVER



GOLD  
SILVER,  
STEEL,  
RUBBER,  
And SHELL,

## Thimbles,



EYE GLASS  
Self Adjusting.

## SPECTACLES AND EYE-GLASSES

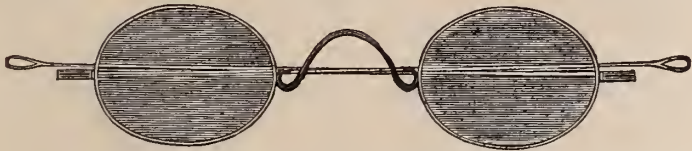

OF ALL DESCRIPTIONS.

## SOLID GOLD RINGS,

Office, 14 MAIDEN LANE. NEW YORK.

Manufactory, Springfield, Mass.

## S. C. JACKSON, MANUFACTURER OF

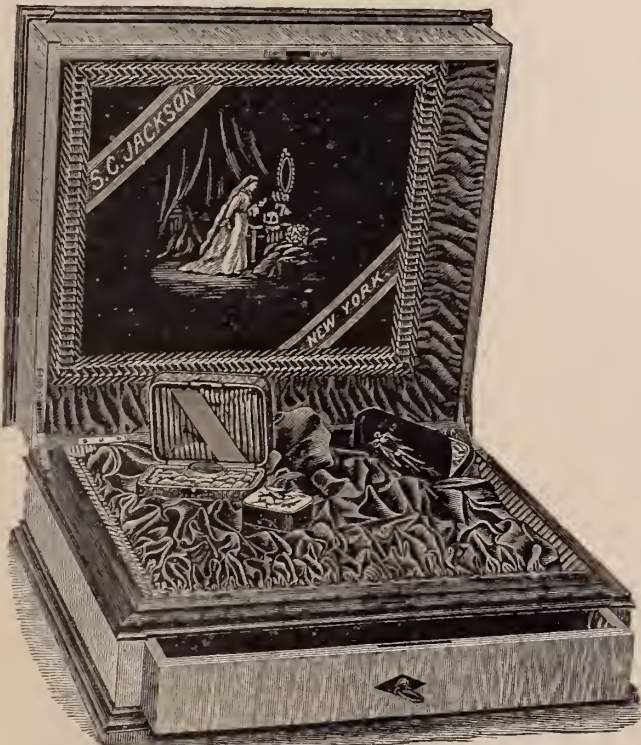

Fine Cases for Jewelry, Watches, Silverware, &c.

180 BROADWAY, N. Y.

A specialty in Show Case Trays, and Silver Cabinets, made from the finest hard woods, and polished.  
All kinds Sample Cases made to order A full assortment of a cheaper grade of Jewelry and Silverware cases in stock.  
New and elegant Styles now ready, including our paintings on silks, and satins, together with novelties from China and Japan, specially ordered.



## MABIE, TODD & BARD,

MANUFACTURERS OF

## GOLD PENS, PENCILS, CASES, HOLDERS

AND TOOTHPICKS,

Of 18kt., 14kt., 10kt., Solid Gold;

ALSO,

## Holders and Pencil Case

—OF—

Pearl, Ivory, Gold M'd Rubber, Sterling Silver,  
10kt. and 18kt. Plate.

180 BROADWAY, NEW YORK, U. S. A.



Correspondence Solicited in Reference to our Goods.  
Our new Catalogue will be sent to the trade upon application, when accompanied by a business card.

## J. F. FRADLEY.

MANUFACTURER OF



Fine Gold and Silver-Headed

## WALKING CANES

—AND—

STERLING

SILVER WARE.



OFFICE AND FACTORY,

20 JOHN STREET, NEW YORK.

Centennial Medal Awarded.

ESTABLISHED 1856

**WILLIAM PARK,**  
Stone, Seal & Game Engraver

26 John Street, New York.

**Arms, Crests, Monograms & Devices**

Engraved on Locketts, Sleeve Buttons, Rings, Etc.

*Masonic Engraving a Specialty*

ONE TRIAL SOLICITED.

**STERN BROS. & CO.**

Manufacturers of



**Fine Jewelry,**

30 MAIDEN LANE

FACTORY, 73 & 75 Fulton St., NEW YORK.

Gold Seal engraved Band-rings and Locketts a specialty. The attention of the trade is directed to our plain Gold filled Rings. Sections of which showing the construction and quality sent upon application. After February 1st, our plain filled rings will bear the above trade mark.

**F. W. C. Nieberg,**  
Repairer and Adjuster of  
**FINE WATCHES**  
and Marine Chronometers,  
No. 8 JOHN STREET  
New York.

**GUSTAV EPHRAIM,**

Successor to Ephraim Bros.

8 JOHN STREET, NEW YORK,

Importer and Manufacturer of

Bamboo, Silk Gaurds and Watch Chains of all Grades. Materials, Watch Glasses, Optical Goods and Jewelry.

Sole Agent for EAGLE SPECTS', CORNELL'S ANTI-OXYDIZER and COURVOSIER MAIN SPRINGS.

**H. M. RAYNOR,**

25 Bond Street, N. Y.

**PLATINUM**

FOR ALL

Laboratory & Manufacturing Purposes.

Native Platinum, Scrap, &c., purchased.

**Stephen J. Cox**  
DESIGNER & ENGRAVER  
of  
**WOOD**  
NO. 90 NASSAU STREET  
NEW YORK  
Jewelers' Work a Specialty.

**BLANCARD & OBERLANDER,**  
MANUFACTURERS OF

**Settings and Galleries**

Of every Carat of Gold or Silver, Platinum, Platinum-Lined and Fancy Settings a Specialty.

As we melt and refine Platinum ourselves.

36 & 38 JOHN STREET,  
NEW YORK.

Platinum Scraps Exchanged or Purchased. Send for Sample Card.

**VOSE & SOUTHWICK,**  
Manufacturers of Gold Jewelry



Sole Makers of the Separable Sleeve and Collar Buttons in Gold.

No. 183 Eddy Street, PROVIDENCE, R. I.



**HENRY LEFORT,**  
Stem-Winding Watch Crown Manufacturer,

Crowns and Pushers in gold, all sizes, quality and color, made to order. Silver crowns and pushers always on hand. Samples sent on application.

80 & 82 Marshall Street,  
NEWARK, N. J.

**ALBERT FRIEDENTHAL,**

Importer and Jobber of  
WATCHMAKERS' & JEWELERS'

Materials, Tools and Optical Goods

Real and Imitation Stones,

For Manufacturing and Repairing Purposes  
A SPECIALTY.

Agent for TISDALE'S Watch and Clock Oils.

No. 43 Maiden Lane, New York.

Orders by mail will receive prompt attention.

**JEWELRY PHOTOGRAPHED.**

In order to meet the demands of many of the Manufacturers of Jewelry, Silver Ware, &c. (Tiffany and others) I have erected a SPECIAL SKYLIGHT, for Mechanical Photography, viz:

The Copying of Silver Ware, Statuary, Eric-a-Brac, Paintings, Models, &c.

I propose to keep it busy by adopting the following rates:—8-10. Photographic negative \$1. Proofs 50 cents. Special rates for quantities.

GEO. G. ROCKWOOD, Photographer, 17 Union Squ

Established 1859.

(Above Tiffany's.)

THOMAS M. GUILBERT. J. CARROW DUBOSQ

**GUILBERT & DUBOSQ,**

Successors to Francis Dubosq & Son,

Manufacturers of

Fine Gold and Strung

**PEARL JEWELRY,**

No. 1031 Chestnut Street,

PHILADELPHIA.

**WILKINSON & LENNON.**

212 Broadway,  
NEW YORK,

**Manufacturing Jewelers**

Masonic Pins, Rings & Charms,

School, Athletic, Fine  
Presentation Medals,

—AND—  
JEWELS OF EVERY DESCRIPTION

Designs furnished free upon application.



**CHARPIER & WATHIER,**

**WATCHMAKERS & JEWELERS**

FOR THE TRADE,

And Wholesale Dealers in Watch Material, Tools, Glasses, Spectacles, Silk Guards, Etc.

61 West Kinzie Street, Chicago, Ill.

All work intrusted us will receive prompt attention and warranted satisfactory. Price List on application.

**The Morse Diamond Cutting Company,**

J. D. YERRINGTON, Agent.

192 Broadway and 3 John Street.

NEW YORK.

Rough Diamonds, Boart, Roses and Brilliants for sale.

Fractured Diamonds repaired, and old stones improved; also Rough Diamonds cut and fashioned to order.

**W. N. WALKER,**

**DIAMONDS,**

Watches and Jewelry,

No. 18 JOHN STREET, NEW YORK.

IMPROVED JEWELERS' COTTON.

JOHN J. ARMOUR.

**HENRY TROEMNER,**

710 Market Street,

PHILADELPHIA.

Manufacturer of Fine Gold Scales,

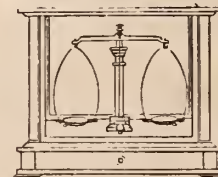

DIAMOND SCALES,

Bullion Balances and Weights, in use at all the U. S. Mints and Assay Offices.

PRICED CATALOGUE ON APPLICATION.

Solid Gold Rings—a Specialty

**WM. H. ELY,**

**Solid Gold Rings**

MANUFACTURER,

Viz., Plain, Chased, Engraved, Enameled, Engine Turned, Shield & Scale. All qualities Warranted Orders Promptly Executed.

58 Nassau Street, N. Y.

Established 1848. *Reliable and prompt.*

**COOPER & BRO.**  
Wholesale Jewelers,  
Importers and dealers in WATCH & CLOCK-  
MAKERS' TOOLS and MATERIALS; also, JEWEL-  
ERS' SUPPLIES, SPECTACLES, OPTICAL GOODS,  
&c. A complete Outfitting Establishment for the  
trade.

Repairs Department established 1865. Every  
description of work done for the trade. Watch  
Repairing, Jewelry and Watch Case Repairing,  
Gold and Silver-Plating, and Fire Gilding.

35 S. Fourth St. (1st floor). PHILADELPHIA

REPAIRING, COLORING AND GALVANI-  
ZING FOR THE TRADE.

C. G. MALLIET,  
*Manufacturing Jeweler,*  
No. 9 JOHN STREET  
NEW YORK.

DAVID PRINCE,  
*Gold and Silver Refiner,*  
*Assayer and Sweep Smelter,*  
13 and 15 New Jersey Railroad Avenue,  
NEWARK, N. J.

Sole Agent for Comins' Improved Amalgamator.

LOWELL WRENCH CO., WORCESTER, Mass.  
JEWELLERS' PIN VISE.



"The Jewelers' Pin Vise is a well-known tool advertised  
in the CIRCULAR by the Lowell Wrench Company of Wor-  
cester, Mass. and is a credit to them. The sample was in-  
spected with high commendation by the members, many of  
whom had used it and pronounced it far superior to the  
imported article. It is of hardened steel, nickel-plated, the  
handle is nicely milled, giving a firm grip for rolling in the  
fingers, and the whole is turned true to centre. It holds  
firmly anything placed in it, and altogether is a most excel-  
lent tool for the bench."—*Proceedings Horological Club,*  
*April, 18'9.*

L. BONET,  
Medal at Centennial, 1876.  
**CAMEO**  
**Likenesses,**  
889 Broadway. New York.

Designs made and estimates given on all kinds  
of Engraving for Jewelers.



Illustrations for Books, Mfg Catalogues, &c.  
Labels and Show Cards Engraved on Metal for  
Color Printing.

NEW YORK  
**Morocco Case Company,**  
CASES FOR JEWELRY, WATCHES,  
SILVER-WARE, &c., OF ANY  
QUALITY AND STYLE.

Boxes and Trays for Jewelers' Travelers.  
Show Cases and Window Fittings  
a Specialty.

No. 69 NASSAU ST., cor. John, NEW YORK.

Leon Jeanne. Paul Jeanne.  
**JEANNE BROTHERS,**  
MANUFACTURERS OF  
DIAMOND MOUNTINGS  
And RICH JEWELRY,  
Patentees of Jeanne's Ear Wires,  
No. 1 Maiden Lane, New York.  
Designs furnished and estimates given.



THIMBLES  
— ALSO —  
*THE AUTOMATIC EYE GLASS HOLDER*  
It Winds up the Cord when Not in Use.

**J. B. LAURENCOT,**  
IMPORTER OF  
WATCH GLASSES,  
**Optical and Fancy Goods**  
French Clocks, Musical Boxes, &c.  
No. 33 MAIDEN LANE.  
15 Rue D'Enghuen, Box 2954, P. O.  
PARIS. NEW YORK.

Established 1850.



**PETER L. KRIDER,**  
MANUFACTURER OF  
STERLING  
**SILVER WARE,**  
Medal and Diploma Awarded, &c.  
Striking Society Medals in Gold, Silver or Bronze  
A SPECIALTY!  
ARTISAN HALL,  
**618 Chestnut Street**  
PHILADELPHIA.

**GEO. W. DU BOIS,**  
(Successor to Albert Landsberg.)



IMPORTER AND MANUFACTURER OF

**Optical Goods,**

No. 36 MAIDEN LANE,  
Near Nassau Street, NEW YORK  
Sole Agent for

BLACK'S PATENT  
Interchangeable Spectacles,  
AND  
EYE GLASSES.

Jewelers and others who keep spectacles for  
sale will please observe that, with these PATENT  
SPECTACLES, it is only NECESSARY to have a full  
Complete Assortment of Lenses and Pebbles, which  
being all of a UNIFORM SIZE, will fit either the  
Gold, Silver, or Steel Frames, of which but a  
few of each kind are wanted; an advantage  
which will give a complete assortment of the  
finest Spectacles, for one-sixth the capital in-  
vested in a like assortment of the same quality  
goods of the old style frames.

For Particulars, price lists, &c., address

**GEO. W. DU BOIS,**  
New York.

**Fowler's Patent Watch Material Cabinet**

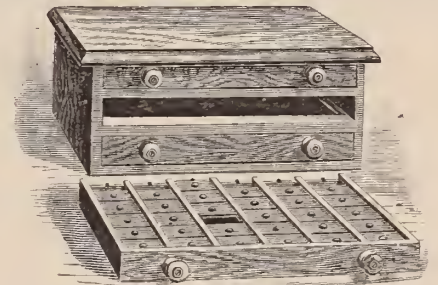

It is constructed of Black Walnut, highly finished,  
and contains three drawers, the first of which is di-  
vided into fifty-six compartments. The second drawer  
contains thirty compartments and the third twenty five  
Each compartment is protected by a separate sliding  
cover, and is so arranged that only one compartment in  
a row can be opened at a time, making it impossible to  
mix the different parts, etc., contained in them. It is  
also constructed that, by a series of stops arranged in  
the outside case, that if any of the compartments are  
open the movement of the drawer in closing, automatic-  
ally covers all the compartments. The cut is a fair illus-  
tration of this useful invention. The convenience and  
economy by its use in handling Watch Material, is testi-  
fied to by all the watchmakers who have them in use.  
The dimensions of this cabinet are 5 3/4 inches in height,  
11 inches in depth, and 12 1/2 inches in length.

Price, \$4.50.

PATENT CABINET FOR WATCH KEYS AND GLASSES.

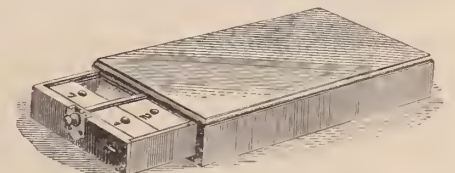

The Key Box is made with one drawer, divided in 12  
compartments, and each sliding cover is properly  
numbered to correspond with the different sizes of  
keys. The drawer also contains a self-acting catch  
which securely holds it in place when closed. It is the  
most complete key box that has ever been introduced  
to the trade and is sold at a very low price. For sale by  
the leading dealers of watch material in New York,  
Boston and Chicago. Price, \$2.00. Address,

Ambrose Fowler 532 Broadway, N. Y.

# SPENCER Optical Manufacturing COMPANY.

Manufacturers of Spectacles and Eye Glasses,  
from all materials used for that purpose,  
and of all grades.

**SOMETHING NEW !!**  
**CELLULOID EYE GLASS FRAMES,**  
Representing the Choicest Selected  
Tortoise Shell and Amber.



THEY HAVE GREAT ADVANTAGES

OVER ALL OTHER EYE GLASSES.



(Turtles rejoicing over the discovery of Celluloid Tortoise Shell,  
Their Occupation Gone.)

They are much **Lighter** than any others. Twenty-five pairs of the frames weigh only one ounce.

They are much **Stronger** and more **Durable** than any others; they can be **Dropped Without Injury** upon the hardest substance.

Their **Beauty Far Surpasses** the ordinary Tortoise Shell Frames commonly in use.

They are **Not Affected by Atmospheric Changes**, being equally well adapted to either warm or cold climates.

They are made with **Different Sized Frames** to suit persons whose eyes are either near or far apart.

The Springs are made of a combination of metals which will neither **Rust** nor be effected by heat or frost.

These frames are set with **Fine Lenses**, accurately focused to suit all sights, which with the many other advantages, make them **Very Popular**.

**ASK YOUR OPTICIAN OR JEWELER TO SHOW THEM TO YOU.**  
Every Pair Stamped on Handle S. O. M. Co. Pat. Mar. 13, '77.

Parties ordering 3 doz. Celluloid Eye Glasses are furnished with 1,000 copies of circulars similar to this advertisement with name of dealer printed thereon.

**13 Maiden Lane, N. Y.**

Established 1853.

# L. H. KELLER & CO.

Successors to G. A. HUGUENIN,

IMPORTERS OF

## Fine Watch and Clock Materials, SWISS, ENGLISH, FRENCH & GERMAN **FILES, TOOLS, & C.**

FOR WATCH MAKERS, WATCH CASE MAKERS, JEWELERS  
SILVERSMITHS, ENGRAVERS, CHASERS, DIE  
SINKERS, MACHINISTS, &c.

SOLE AGENTS FOR HALL'S STAKING TOOLS AND  
ROLLER REMOVERS.

**AGENTS FOR THE WHITCOMB AND OTHER AMERICAN LATHES.**

GENERAL AGENTS FOR THE PHILADELPHIA  
WATCH COMPANY.

American Agents for the Horological Journal, (British).

A Monthly Paper for the advancement of Chronometer, Watch and Clock Making,  
and kindred Sciences. Published under the auspices of the British Horological  
Institute, London. Subscription \$2.50 per year, in advance. Also,

SAUNIER'S TREATISE ON MODERN HOROLOGY, IN  
THEORY AND PRACTICE.

BY M. CLAUDIUS SAUNIER. The English Edition will appear in 26 monthly parts,  
Price 50 cents each. Whole Work, \$13 00, postage paid.

Special attention is directed to

### "OUR OWN" Celebrated Mainsprings Graduated

in thickness to equalize the power, with well rounded edges, and the  
*Highest Crocus Finish throughout*, insuring the least possible friction  
in the barrel, pronounced by expert judges to be the *best made*.

"JURGENSEN" Main Springs recoiling, suitable for the highest grades  
of Swiss Watches.

### "Lutz" Celebrated Hair Springs,

by numbers, of uniform diameter and strength, the best for  
"BREGUETING."

Fine Hole Jewels of Ruby, Sapphire, Chrysolite, Garnet, Beryl and  
Aqua Marine, with *gauged* (well shaped and polished) holes, numbered  
by the Swiss pivot gauge also, neat black walnut cases, containing  
forty glass vials for assortments of same. The great advantage in hav-  
ing Jewels by numbers will readily be seen as a saving in time and an-  
noyance in selecting and in expense. Dealers once having an assort-  
ment, can replenish or stock up at a comparatively small outlay, as any  
desired quantity of No. and quality can be had of us at all times.  
our stock of jewels being the largest and most complete in the country.

Diamond Charged Broaches for opening and polishing jewel holes.

Diamond Powder and Bort for polishing and grinding 8 different  
grades, in  $\frac{1}{2}$ ,  $\frac{1}{4}$ ,  $\frac{1}{8}$ , and  $\frac{1}{16}$  K vials, bringing it into the reach of all.

Gold Diamond Set and other fine Geneva Hands.

The new Drills in Sets of 54 small, 126 small to medium, and 48  
large; also, sold separately if desired.

A FULL LINE OF MATERIALS FOR THE CELEBRATED WATCHES  
MANUFACTURED BY **PATEK, PHILIPPE & CO.** OF GENEVA,  
FULLY FIRNISHED AS FAR AS PRACTICABLE.

**No. 64 Nassau Street,**

*Near Maiden Lane*

**NEW YORK.**

## SPECIAL NOTICES.

Advertisements under this head, not to exceed six lines, \$1.00 each insertion.

**FOR SALE.**—A small shop with tools, safe, and fixtures, complete, \$1,500. Apply at the office of this paper.

**A JEWELER'S Safe** for sale low. Cost \$2,000; as good as new, 3 combinations. Address A. B. C., Office of Jewelers Circular.

**WATCHMAKER** wanted in the city, must be a first-class workman. Address stating references and amount of salary wanted. Address JOHN, Office of Jewelers' Circular.

**FOR SALE.**—A splendid new cutting machine with complete set of cutters, suitable for cutting watch and clock wheels. Will be sold at a sacrifice. Address L. & A. Mathey, No. 16 Maiden Lane.

**WANTED** to treat with some responsible manufacturer of rolled plated jewelry, for the sole agency of the goods. Satisfactory references and ample security given. Address A. B. C. care of Jewelers' Circular.

**WANTED SITUATION.**—By young man to finish trade has had 4½ years experience in watch repairing and jobbing, is good Salesman, and can give first-class recommendations. Address WM. M. SIELDON, Shelbyville, Ind.

**FOR SALE.** Wight's improved engraving machine. Bureau of Geneva Watch Glasses; Small Swiss Regulator Polishing Lathe, Buffs and brushes, case for repaired watches, etc. Address J. E. DOWNES, Waterloo, N. Y.

**MOSELEY & CO.**, Elgin, Ill., Manufacturers of the "Moseley" Lathe, with full line of attachments. Designed especially for the watchmakers and repairers. Catalogue and price list furnished upon application.

**FOR SALE.**—An old established jewelry business with a good run of custom stock, reduced last year by fire, location has the best surroundings in the State, 20 miles from any other jewelry store. Address D. D., care Jewelers Circular.

**ONE** combination lathe, both Universal hand and pump center, slide rest, jeweler's rest, one split chuck accurate, and six cement chucks, for \$50. One rounding up wheel engine. \$20. Address Woodcock & Co., (Chronometer Raters), 1013 Chestnut Street, Phil.

**WILL** the party signing himself J. H. S. to a notice, which appeared in these columns, please forward his full address to the office as we have numerous letters for him, and have mislaid his communication.—Edit. Jewelers' Circular.

**SALESMAN** wanted in a first-class retail store 75 miles from New York City, must be familiar with watches, diamonds, and precious stones, silverware, clocks, bronzes, porcelains and fancy goods. Address with references F, care of Jewelers' Circular.

**FOR SALE.**—One Wight engraving machine complete, only been in use 3 months, with curve line and goblet attachment and ring bolder, book of instruction, and 204 patterns, will be sold very low for cash. Address Lock, Box 445, Johnstown, P. O., Cambria Co., Pa.

**GEO. E. WILKINS.**—Importer of fine Tools for Watchmakers, cutting and dividing engines, rounding-up tools and cutters, also cutters for stem-winding wheels. Fine lathes with the American system of chucks. Dividing engine and rounding up tool combined. Marine chronometers for sale. Special tools imported to order. 21 South Salina St., Syracuse, N. Y.

**WONDERFUL DISCOVERY.**—No more darkness! Articles which shine in the dark and with the assistance of which you may read numbers, advertisements, etc., and look at your watch during the night time without light or lamp, are manufactured by Mr. Nemitz, Inventor, 28 Rue Street Sebastien, Paris, France. Mailed to any country against remittance of the amount. Shining dial plates at same price as others. The way of manufacturing explained.

**FOR SALE.**—We offer to sell a whole or half interest in our jewelry store, which in all departments is first class, with a reputation in this city of more than forty years, the senior partner from age and bad health desiring to retire from business. This affords an excellent opportunity for a man with moderate capital and business energy to enter upon a prosperous trade. Parties wishing to purchase please address Edward Mead Co., corner Fourth Street and Washington Avenue, St. Louis, Mo.

**FOR SALE.**—A good opportunity is offered to any one who desires to purchase a jewelry establishment in a growing city of 40,000 population, but one competitor of any importance. Amount of stock and fixtures about \$10,000. Terms ½ cash, ½ time, or if preferred will give up location to any one who will pay cash for fixtures and \$500 horns, amounting to about \$2,500—everything is first-class, and in good condition. Corner store, plate-glass and iron front, fine show windows and low rent to any one wishing a location; it will pay to investigate. Address H. B. S., care of Jewelers' Circular.

**FOR SALE.** A first-class Jewelry Store, established ten years, in a flourishing town on the Hudson of 7,000 inhabitants, beside 800 to 1,000 summer boarders; 1 hour's ride from New York; no other Jewelry Store within a circuit of several miles; store refitted 3 years ago, with seventeen feet of Silver-plated Show Cases, fire and burglar-proof safe, awnings, window shades, signs, reflectors, gas fixtures, etc.; also, large Mirror, and Heater, etc., costing three years ago, \$1,200 will be sold for \$400. Buyer can purchase stock or not. No charge for good will. Lease of store, 2 years to run. Satisfactory reasons for selling. Address, M. SCHINDLER, Tarrytown, N. Y.

## Buyer's Directory.

A Guide to the prominent Wholesale Houses in the Watch, Clock, Jewelry and kindred branches of Trade in New York, Philadelphia, Chicago, Providence and Newark.

## NEW YORK.

## Black Onyx Jewelry.

**Cox & Sedgwick**—Manufacturers of Black Onyx Jewelry, No. 26 John St., New York.

**Unger, H. & Co.**—Manufacturing Jewelers. Fine Onyx and Pearl goods a specialty. Manufacturers of Patent Onyx Bracelet, with Lilly of the Valley mountings. No. 18 Crawford St., Newark, N. J. Box 63.

**Woglow & Miller**—Manufacturers of (exclusively) Black Onyx Jewelry, 32 & 34 John St., New York.

## Bohemian Garnet Jewelry.

**Bissinger, Philip**—Importer of Diamonds, Pearls and Precious Stones. Sole Agent for the Bohemian Garnet Jewelry, 22 John St.

## Clock Companies.

**New Haven Clock Co.**—62 Reade Street, N. Y.

**Seth Thomas Clock Co.**—20 Murray Street, N. Y.

**Waterbury Clock Co.**—M. Bailey, Treasurer, Manufs. and Jobbers, No. 4 Cortlandt Street, N. Y., and No. 197 State Street, Chicago.

**Kroeber, F.**—Manufacturer and Dealer in American and French Clocks, No. 8 Cortlandt St.

## Corals and Coral Jewelry.

**Cuppia, L. A.**—Importer of Coral and Silver Filigree Jewelry, 19 Union Square, N. Y.

**Errico Bros.**—Importers of Coral, Conch-Shell and Silver Filigree Jewelry, etc., 19 John St.

**Lawson, S.**—Manufacturer of Coral and Black Onyx Jewelry. All kinds of repairing solicited. Goods sent on Mem. 63 Nassau Street.

**Squadrioli, Ach.**—Manufacturer and Importer of Coral, Conch Shell and Silver Filigree, etc. No. 9 Maiden Lane, N. Y.

## Cameo Cutters, Etc.

**Bonet, L.**—Cameo Likenesses, No. 889 Broadway, N. Y.

**Peiter, Theodore**—Cameo and Intaglio Engraver. Patantee of the new Cameo-Intaglio. No. 2 Bond Street, near Broadway, Room 4, New York.

**Wiederer, Peter**—Late Habermeier & Wiederer, Engravers of Cameo Likenesses, Seal Stones. Cameos repaired. 23 John St.

## Charms &amp; Cold Watch Keys.

**Rupp & Held.**—Manufacturing Jewelers, Charms and Gold Watch Keys, with French and English Ratchets, a specialty. 15 John St., N. Y.

## Cutlery.

**Rogers Cutlery Co.**—Hartford, Conn.

**Harrison Bros. & Howson.**—Manufacturers of Fine Ivory and Pearl Table and Pocket Cutlery; Carvers in Cases; Nutpicks, Nutcracks and goods suitable for the jewelry trade. 26 Cliff street. W. C. Burkinshaw, Sole Agt.

## Diamonds.

**Anderson, Otis**—Diamond Merchant and Broker, always ready to pay cash for bargains in Diamonds and Precious Stones, No. 9 Maiden Lane, N. Y.

**Bernhard, A. & Co.**—Manufacturing Jeweler & Importers of Diamonds and Precious Stones, also Diamond Mountings, 2 Maiden Lane.

**Bissinger, E.**—Importer of Diamonds, No. 192 Broadway, New York.

**Bissinger, Philip**—Importer of Diamonds, Pearls and Precious Stones. Agent for the Bohemian Garnet Goods. No. 22 John St., N. Y.

**Buckenham, Cole & Saunders**—Importers of Diamonds and other Precious Stones, No. 10 Maiden Lane, N. Y.

**Fera, Henry**—Importer of Diamonds, and Manufacturer of Fine Diamond Jewelry. No. 9 Maiden Lane, New York. Amsterdam, Holland, 23 Loojersgracht.

**Fox, M. & Co.**—Importers of Diamonds and other Precious Stones, No. 1 Maiden Lane, Hedges, Wm. S. & Co.—Importers of Diamonds. No. 170 Broadway.

**Herbert, R. J.**—Importer and Broker in Diamonds, 16 Maiden Lane.

**Lyon & Hardy.**—Importers of Diamonds and Manufacturers of Diamond Jewelry. 30 Maiden Lane, New York.

**Neresheimer, E. Aug.**—Importer of Fine Diamonds. No. 21 Maiden Lane, New York.

**Prager, Morris.**—Importer of Diamonds and Fine Diamond Jewelry. 8 Maiden Lane

**Randel, Baremore & Co.**—Importers of Diamonds, corner Maiden Lane and Nassau St.

**Smith, Alfred H. & Co.**—Importers of Diamonds. No. 14 John Street.

## Diamond Cutters.

**The Morse Diamond Cutting Co. of Boston.**—Henry D. Morse, General Manager. N. Y. Office, 192 Broadway, corner John street.

J. D. Yerrington, Agent.

## Diamonds and Diamond Jewelry.

**Bissinger, Philip.**—Importer of Diamonds, 22 John street, N. Y. Agent for the Bohemian Garnet Goods.

**Heller & Bardel.**—Manufacturers of Diamond and Pearl Jewelry, and dealers in Diamonds, Pearls, &c. Also agents for Boss' Patent Stiffened Gold Watch Cases. 13 John St.

**Taylor & Brother**—Importers of Diamonds and Diamond Jewelry, 676 Broadway.

## Diamond Setters, Etc.

**Asher, J.**—Jeweler and Diamond Setter, Precious Stones Inlaid and Incrusted with Diamonds, Nos. 880 and 882 Broadway.

**Wood, Chas. F.**—Engraver and Incruster of Precious Stones and Diamond Setter. No. 169 & 171 Broadway.

**Friend, S.**—Manufacturer of Fine Jewelry, and Diamond Setter. 33 John street, N. Y.

## Dials, &amp;c.

**Gold, John T.**—(Successor to the late T. Gold), Enamel Watch Dial Maker, 81 Nassau St.

## Enamellers, Etc.

**Nutt, J. D.**—Enameler on Gold, Silver and Copper, 32 and 34 John St. Birds, Flowers, etc., Enameled in colors.

**Orr, Jas. C.**—Enameler on Fine Jewelry, Flowers, Birds, &c., Enameled in colors. Band Bracelets (a specialty). 77 Nassau Street.

## Electroplaters, &amp;c.

**Jeandheur, F. & Son.**—Gold and Silver Electro Platers & Fire Gilders, coloring Etruscan and Gold Jewelry a specialty. 125 Fulton St.

## Engravers and Die Sinkers

**Fackner, Edward**—Carver, Engraver and Chaser on Jewelry and Pencil Cases. Monograms Lettering, &c. 19 John Street.

**Park Wm.**—Stone Seal Engraver. Coats of Arms found and engraved. Initials and Monograms engraved. 26 John Street, New York.

**Schuller, J. Dan'l**—Stone Seal Engraver Arms Crests, Initials and Monograms engraved on Stone Seals, &c. 71 Nassau street.

## Engraving Type.

**Ingersoll, H. S.**—Rubber Engraving Type, Patented December, 1872. Over 40,000 alphabets in use. Saves time and skill of designing before engraving silverware, etc. Also Engravers' Tools, etc. Catalogue free. 203 Broadway, N. Y.

## Fancy Goods, Clocks, Bronzes Etc.

**Hall, Nicol & Granbery.**—Importers of Clocks, Bronzes, Folding Mirrors, Fancy Goods, &c. 20 & 22 John street.

**Magnin, Ve J. Guedin & Co.**—Importers of Clocks, Bronzes, Musical Boxes & Rich Fancy Goods etc., 29 Union Square.

**Le Boutillier & Co.**—Importers of Fancy Goods, Clocks, Bronzes, &c. 3 Union Square

## Gold Chains, Etc.

**Beck, J. & Son.** Manufacturers of Fine Gold Chains and Chain Bracelets, 10 Liberty place, near Maiden lane, N. Y.

**Dorrance, Edge & Co.**—Manufacturers of the Celebrated Woven Fabric Gold Chain, No. 12 John street.

**Hamiltons & Hunt.**—Manufacturers of Fine Plated Chains and Patent Buckle Bracelets. Branch office, 176 Broadway. Factory, 226 Eddy street, Providence.

**Kaufmann Bros.**—Manufacturers of Gold Chains, and Chain Bracelets, 26 John street; Factory, 331 and 333 Bowery, N. Y.

**Nordt & Schlag.**—Manufacturers of Gold Chain. No. 17 Maiden Lane, N. Y.

**Saxton, Smith & Co.**—Manufacturers of Fine Gold Chain. 15 Maiden Lane.

## Gold Pens, Etc.

**Aikin, Lambert & Co.**—Manufacturers of Choice Gold Pens, Cases, Holders, Toothpicks, etc., 23 Maiden Lane, N. Y.

**Clark, J. M.**—Manufacturer of Pen and Pencil Cases for the wholesale trade only. No. 61 Hudson Street, N. Y.

**Mable, Todd & Bard.**—Manufacturers of Gold Pens, 180 Broadway.

**Todd, Edward & Co.**—Manufacturers of Gold Pens, Pencil Cases, Tooth Picks, &c., 44 East 14th St., Union Square.

**Goldsmiths, &c.**

**Greene Wm. C. & Co.**—Goldsmiths; Manufacturers of Rich Sets in Taper Wire Coral. Office, 192 Broadway.

**Gold Rings.**

**Bowden, J. B. & Co.**,—Manufacturing Jeweler.—Solid Gold Rings a specialty, 1 Maiden Lane.  
**Ely, W. H.**—Manufacturer of Solid Gold Rings of every description. No. 58 Nassau Street.  
**Frankel & Folkart.**—Manufacturers of Seal, Cameo and Amethyst Rings a specialty. Also a full line of Gold White Stone goods and Diamond Settings. 21 John St., N. Y. etc., No. 4 Liberty Place.  
**Peckham, Wm. H. & Co.**—Manufacturers of Solid Gold Seamless Rings, and Fancy Embossed Rings, Patent Spectacles, Jewelry, etc. No. 4 Liberty Place, N. Y.  
**Sinnock & Sherrill**—Manufacturers of Stone Rings. No. 5 Maiden Lane, N. Y.  
**Tingley, Joseph N.**—Manufacturer of Stone Rings and novelties in Stone Goods. No. 9 Maiden Lane, N. Y.

**Hair Jewelry.**

**Montoux, Wm. E.**—Leading Artist in Hair, and Manufacturing Jeweler, 81 Nassau St., New York. Pattern Books for the trade.  
**Sauter, L.**—Manufacturer of Fine Gold and Hair Jewelry and Device Work. Pattern Book sent on application. Nos. 65 & 67 Nassau St.  
**Schwencke O.**—Manufacturer of Fine Hair Jewelry. Orders from the country promptly attended to. No. 43 Maiden Lane.

**Jewelry Cases, Fancy Boxes, Etc**

**Braun, Chr. E.**—Manufacturer of Jewelry Boxes, Trays for Show Cases, &c. 62 Chatham st.  
**Dahlem, W.**—Manufacturer of Cases for Jewelry and Silverware, No. 85 Nassau Street, N. Y. Show Case Trays, &c., at shortest notice.  
**Loehr & Koerner**—Manufacturers of Morocco, Velvet, Satin, Jewelry, Watches and Silverware Cases, Glove, Handkerchief, Ladies' Jewel, Work Boxes, &c., Fancy Trays and Stone Fittings to order, Office and Salesroom 83 Nassau Street, New York.  
**New York Morocco Case Co**—Makers of Cases for Jewelry, Watches, Silverware, etc. Boxes and Trays for Jewelry. No. 69 Nassau Street, N. Y.  
**Walker, Geo. W., Morocco Case Manufacturing Co.**—Manufacturers of Morocco Cases, 712 Broadway, N. Y.  
**Sturz, I.**—Manufacturer and Importer of Cases for Jewelry, Watches, Silverware, &c. No. 15 John street, N. Y.  
**Welch & Miller**—Manufacturers of Morocco, Velvet, and Satin Jewelry Cases, Trays, &c. Telescope Sample Cases with flexible Trays. Complete stock on hand. 169 Broadway.  
**Wiggers & Froelick**—No. 60 Nassau street.—Manufacturers of Cases for Jewelry, &c., of every description. Trays for Show-cases, Stands for Show-windows, etc. Jewelers' Traveling Cases, light, convenient and strong.

**Jewelry—Fine.**

**Aikin, Lambert & Co.**—Manufacturers. General stock of Reliable Jewelry, 23 Maiden Lane.  
**Alford, C. G. & Co.**, Manufacturers. General line fine and reliable goods. Specialties in Onyx goods and chain. 183 Broadway, New York.  
**Andrews, J. F.**—Manufacturer of Fine Jewelry, Lockets, Sleeve Buttons and Rings in Stone Cameo, etc., a specialty. 35 Maiden Lane.  
**Barthman & Straat**—Manufacturers of Fine Jewelry. Seal and Stone Rings a Specialty. Orders promptly attended to. 41 Maiden Lane.  
**Bernhard, A. & Co.**,—Manufacturers of Fine Hair Jewelry and Device Work. The latest styles. 2 Maiden Lane, New York.  
**Bissinger, E.**—Importer of Fine Jewelry, Lockets, Crosses, Neck Chains, &c., No. 192 Broadway.  
**Mulford & Bonet.**—Manufacturers of Diamond and Gold Jewelry. Dealers in Rolled Plated Goods, 21 Maiden Lane.  
**Brown, Thos. G.**—Manufacturer of Rich Jewelry Necklaces, Lockets, Bracelets, Sleeve Buttons, etc., 9 Bond street, N. Y.  
**Bryant & Bentley**—Manufacturing Jewelers Rings a specialty. 12 Maiden Lane.  
**Brainerd & Steele**—Successors to Brainerd, Steele & Co., Manufacturers of Fine Jewelry and Brainerd's Patent Lockets. No. 9 Maiden Lane, New York.  
**Burch & Fellows.**—Successors to Geo. Burch & Co., Manufacturing Jewelers, No. 17 Maiden Lane.

**Carrow, Bishop & Co.**—Manufacturers of Fine Jewelry, Roman Band Bracelets, Lockets, Crosses, &c. 12 John Street, N. Y.  
**Carter, Howkins & Sloan.**—Manufacturing Jewelers, Whiting Building, 4th St. & Broadway.  
**Chatellier & Spence**,—Manufacturing Jewelers. No. 694 Broadway, N. Y.  
**Champerois & Co.**—Manufacturing Jewelers, No. 1 Maiden Lane. Specialties—Jet Cluster Goods in Sets and Sleeve Buttons, Engraved and Enameled Goods in Sets, Studs, Sleeve and Collar Buttons, Lace, Shawl and Cuff Pins, Ear Knobs and Crosses.  
**Cook, Groeschel & Co.**—Manufacturers of Fine Jewelry and Lockets, 191 Broadway (over Mercantile Bank) N. Y.  
**Demmert Bros.**—Manufacturers and Importers of Fine Jewelry, Cameo and Onyx Lockets, Sleeve Buttons and Sets a specialty. Old No. 9 Maiden Lane, New York.  
**Falkenau & Oppenheimer**—Manufacturing Jewelers. Specialty—Knife Edge Work and Rings. 89 Nassau Street.  
**Field & Co.**—Manufacturing Jewelers, 8 Maiden Lane, N. Y.  
**Finkelmeier, Louis**—Manufacturing Jeweler. Jobbing and ordered work for the trade at moderate prices. 73 Nassau Street, N. Y.  
**Goddard, John M.**—Manufacturing Jeweler,—Seal Rings and Fine Lockets a specialty, No. 3 Maiden Lane, N. Y.  
**Greason, Bogart & Pierce**, successors to Arthur, Rumrill & Co., 182 Broadway, manufacturers of fine jewelry and gold chains  
**Hartmann, P.**—Manufacturer & Importer of Fine Gold, Diamond, and Filagree Silver Jewelry, No. 36 Maiden Lane. P. O. Box 2,454.  
**Haskell, H. C.**—Manufacturing Jeweler. Seal Rings a specialty. Special attention to Jobbing of every description. 12 John street.  
**Helfenstein & Bourke.**—Manufacturers of the Patent Adjustable Sleeve Button, No. 202 Broadway, N. Y.  
**Henderson & Winter**—Jewelers, No. 15 Maiden Lane, New York. Specialties—Stone, Cameo, Onyx, Amethyst, Topaz, Pearl and Turquoise Rings.  
**Hunt & Owen.**—Manufacturing Jewelers. Office 5 Maiden Lane.  
**Hale & Mulford**,—Manufacturers Rich Jewelry, Whiting Building, Broadway and 4th Street.  
**Jeanne Brothers.**—Manufacturers of Diamond Mountings & Rich Jewelry. 1 Maiden Lane.  
**Keller, Chas. & Co.**—Manufacturing Jewelers Lockets a Specialty. No. 18 John St., N. Y.  
**Kremetz & Co.**—Manufacturing Jewelers, No. 13 John Street, N. Y.  
**Kroll, H.**—Manufacturer of Fine Jewelry. Repairing (a specialty) done for the trade at moderate prices, 78 Nassau street.  
**Kuhn & Doerflinger**—Manufacturers of Enamel'd and Roman Band Bracelets, also Fine Lockets and Pendants, 18 John street.  
**Lennon, John D.**—Manufacturing Jeweler, 142 Fulton street. Flat, and Half-round Gold Bracelets, Roman and Stone Lockets.  
**Moore & Horton.**—11 Maiden Lane, Manufacturing Jewelers, Rings, Studs, Collar and Sleeve Buttons, Pins, Ear-rings, &c.  
**Marx Kossuth & Co.**—Manufacturing Jewelers 39 Maiden Lane.  
**Owen, G. & S. & Co.**—Manufacturing Jewelers. Office, No. 5 Maiden Lane.  
**Riker, William**—Manufacturer of Jewelry. Inlaid Gold Jewelry a Specialty. No. 5 Maiden Lane, N. Y.  
**Riley, J. A. & Co.**—Manufacturing Jewelers, Etruscan Gold and Coral Sets, Roman Bracelets, Necklaces, etc. Onyx Goods a specialty. 7 and 9 Bond street, New York.  
**Richardson, Enos & Co.**—Manufacturers of Fine Gold Jewelry, Gold Chains, Lockets, Crosses and Necklaces. Colored and Etruscan Work. No. 23 Maiden Lane, New York.  
**Richardson, J. W. & Co.**—Manufacturers of Jewelry, Masonic and other emblems. 196 Broadway, Manufacturing, Providence, R.I.  
**Ripley, Howland & Co.**—Manufacturers of Fine Jewelry and Diamond Mounting. 35 Maiden Lane, N. Y.  
**Sauter, L.**—Manufacturer of Fine Jewelry, Solid Stone Rings and Studs a specialty. Jobbing for the Trade. 65 & 67 Nassau st.  
**Sexton & Cole**—Manufacturing Jewelers, Colored Gold and Onyx Goods a specialty. No. 30 Maiden Lane.  
**Shoemaker & Co.**—Manufacturing Jewelers, Cameo Buttons, and Lockets, Roman Gold Goods, etc. No. 21 Maiden Lane, N. Y.

**Stites, E.**—Manufacturer of Fine Jewelry. No. 12 Maiden Lane, N. Y.  
**Stites, D. H. & Son**—Manufacturers of Fine Jewelry, Rolled Plated Goods and Chains Parisian Diamond Rings, Studs and Earrings a specialty. 41 Maiden Lane, N. Y.  
**Sturdy Bros & Co.**—Manufacturers of Jewelry. General line of fine and heavy Rolled Plate Goods. Specialties—enameling on gold plate; graduated wire coral work. 14 Maiden Lane, N. Y.  
**Terhune, Charles F.**—Manufacturing Jeweler, 16 Maiden Lane, N. Y.,  
**Thoma, Ernest**—Manufacturer of Fine Jewelry. Sleeve Buttons, Riugs, Ear-rings, &c. No. 173 Broadway, N. Y. Factory, Hackensack, N. J.  
**Trier Bros. & Co.**—Jewelry. Optical, Rubber, Jet, Shell, Ivory, Amber and Pearl Goods. Silk Guards, Japanese Bamboo Watch Chains a Specialty. No. 15 Maiden Lane.  
**Unger, H. & Co.**—Manufacturers of Fine Gold Jewelry, Colored and Etruscan work, Enameled Sets, etc. Office and Factory, 18 Crawford street, Newark, N. J. Box 63.  
**Wadsworth, E. E.**,—Manufacturer of Rich Jewelry and fine Rolled Plate. Fine Seal Rings a specialty. 35 Maiden Lane.  
**Wheeler, Parsons & Hays.**—Manufacturers of Fine Jewelry, Watch Cases, Gold Chains, &c and Dealer in American and Swiss Watches, No. 2 Maiden Lane, N. Y.  
**Wienhold, Joseph**—Manufacturer of Fine Jewelry and Diamond Setter. 24 John St.

**Jewelers' Tools, etc.**

**Frasse & Co.**—Importers of Stubs, French, Swiss, German and Sheffield Tools, Files and Steel Wire for Watchmakers, Jewelers, etc., 62 Chatham street, N. Y.  
**Hammel, L. & Co.**—Importers of Materials and Tools for Watchmakers, Jewelers and Engravers—also Optical Goods, &c., 9 Maiden Lane, N. Y.  
**Hecht, Phil.**—Importers and dealers in Watch makers' materials, Tools, Optical Goods and Silk Guards, etc. 13 Maiden Lane, N. Y.

**Lapidaries.**

**Fox, M. & Co.**—Practical Lapidaries, No. 1 Maiden Lane, New York.  
**Kordmann & Michel**—Lapidaries, dealers in Precious Stones, Rubics, Sapphires and Peridots cut. No. 59 Nassau Street.

**Masonic Jewelry.**

**Wilkinson, C. B. & Co.**—Manufacturers of Masonic, Odd Fellows, Athletic Clubs and other Jewelry, No. 212 Broadway, New York.

**Opticians.**

**Burbank Man'g Co.**—Manufacturers of Spectacles and Eye Glasses of all descriptions, in gold, silver, etc., 14 Maiden Lane, N. Y.  
**Du Bois, Geo. W.**—Successor to A. Laudsberg, Importer and Manufacturer of Optical Goods 36 Maiden Lane, Box 3993, N. Y.  
**Hammel, L. & Co.**—Importers of Spectacles, Opera and Marine Glasses, Telescopes, Microscopes, Optical & Fancy Goods, 9 Maiden Lane.  
**Laurencott, J. B.**—Importer of Watch Glasses, Optical and Fancy Goods, Clocks, Bronzes, etc., 33 Maiden Lane, N. Y.  
**Lorsch, Albert**—Manufacturer of the Patent Accommodating Spectacles and Eye Glasses in Gold, Silver and Steel, and other Optical Goods, 37 Maiden Lane, N. Y.  
**Serin, A.**—Manufacturer of Spectacles and Eye-Glasses, in Steel, Shell and Rubber. Repairing of all kinds. Opera Glasses covered and re-gilt, etc. 169 and 171 Fulton street.  
**Spencer Optical Manufacturing Co.**—Gold, Silver, Steel and Nickel Plated Spectacles, Eye Glasses, &c. 13 Maiden Lane, N. Y.

**Precious Stones, &c.**

**Bissinger, Philip**—Importer of Diamonds, Pearls and Precious Stones. Agent for the Bohemian Garnet Goods. No. 22 John St., N. Y.  
**Fox, M. & Co.**—Importers of Diamonds and other Precious Stones, No. 1 Maiden Lane, New York.  
**Gruet, Jules.**—Importer of Precious and Imitation Stones, Amethysts, Topazes, Cameos, Garnets, Doublets, Imitation Diamonds, Pastes, etc., No. 14 John street. Manufactory at Sept-moncel, France.  
**Meyer, Francis Ed.**—Successors to John B. Behmann, Importer of Imitation Precious Stones, all sizes and shapes constantly on hand. No. 53 Nassau st., P.O. Box, 1981.



**Silverware.**

**Cuppia, L. A.**—Manufacturer of Solid Silver Novelties, and importer of Silver Filigree, 19 Union Square.

**Gorham Manufacturing Co.**—Union Square.

**Wood & Hughes.**—Manufacturers of Fine Silver ware. 16 John Street, N. Y.

**Silver Plated Ware.**

**Brown & Bros.**—Manufacturers of first quality of Electro Plated Flat Table Ware. No. 81 Chamber Street, N. Y.

**Hall, Elton & Co.**—Manufacturers of the Finest Electro-Plated Ware, salesroom, 75 Chambers street, N. Y.

**Holmes, Booth & Haydens**—Manufacturers of Silver-plated Ware. 47 Chambers street.

**Meriden Britannia Co.**—Manufacturers of Silver plated Ware, 46 East 14th Street, Union Square, N. Y.

**Middletown Plate Co.**—Manufacturers of Superior Electro-Plate. Factories, Middletown, Conn., Salesroom, 13 John Street

**Rogers Cutlery Co.**—Hartford, Conn.

**Rogers & Bro.**—Manufacturers of the finest quality of Electro-Plated Ware. 690 B'way.

**Simpson, Hall, Miller & Co.**—Manufacturers of Fine Silver Plated Ware, No. 36 E. 14th St.

**Schade, Henry.**—Manufacturer of White Metal and Plated Ware, No. 84 John Street, New York. Price list and catalogue furnished on application.

**Webster, E. G. & Bro.**—Manufacturers of Fine Silver Plated Ware. Office and Warerooms, 14 Maiden Lane, N. Y.

**Show Cases, Etc.**

**Kraft & Hoffmeister**—Manufacturers of Metal Show Cases, Jewelry Trays always on hand, No. 20 North William street, N. Y.

**Smith, B. & W. B.**—Patent Improved Counter Show Cases. Drawings furnished and estimates given for fitting stores in Cabinet Work complete.

**Spectacle Case Manufacturers.**

**Koenen, A. & Bro.**—Manufacturers of Leather Spectacle & Eye Glass Cases, 81 Nassau St., N. Y.

**Thermometers Etc.**

**Tagliabue, Giuseppe**—Thermometer, Barometer and Hydrometer Manufacturer, 302 Pearl street near Beekman, N. Y.

**Thimble Manufacturers.**

**Burbank Manufg Co.**—Manufacturers of Gold & Silver Thimbles, 14 Maiden Lane, N. Y.

**Ketcham & McDougall**—Improved Gold and Silver Thimbles, Nos. 4 and 6 Liberty Place, near Maiden Lane, N. Y.

**Woglom & Miller**—Sole Agents for the "Prime" Thimbles in Gold and Silver, manufactured by Ezra C. Prime. 34 John Street, N. Y.

**Walking Canes.**

**Fradley, J. F.**—Manufacturer of Fine Gold and Silver-headed Walking Canes and Sterling Silverware. Office and Factory, 20 John st.

**Watch Companies.**

**American Watch Co.**—Robbins & Appleton, No. 9 Bond street, N. Y.

**Illinois Watch Co.**—Factory, Springfield, Ill. Office, 21 Maiden Lane.

**Hampden Watch Co.**—of Springfield, Mass. Office, No. 12 Maiden Lane, New York.

**The Howard Watch and Clock Co.**—No. 2 Maiden Lane, N. Y.

**Watch and Chronometer Jeweler.**

**Queen, James**—Watch and Chronometer Jeweler and Pallet Maker, 78 Nassau street, Room 8. Pivots inserted in Pinions, Balance, Staffs, &c.

**Watch Importers, Etc.**

**Aikin, Lambert & Co.**—Importers of Watches, Sole Agents for Paul Breton & Chas. Latour, Geneva. A general line of reliable Swiss Watches. Watch Cases of all styles made to order. 23 Maiden Lane, N. Y.

**Cross & Beguelin**—Importers of Watches, Watch Tools and Materials, dealers in American Watches, No. 21 Maiden Lane, N. Y.

**DuBois, Francis & Co.**—36 Maiden Lane, N. Y., Importers of Watches and Manufacturers of Watch Cases.

**Droz, Henry E.**—Importer of Watches and Watch Case manufacturer. Agent for the "E. Perregaux" Watch, and jobber in American Watches, No. 92 Fulton Street, N. Y.

**Freund Max & Co.**—Importers of Watches Jewelry and Precious Stones, 8 Maiden Lane

**Friedman, S.**—Importer of and dealer in Watches and Jewelry, 40 Maiden Lane.

**Gagnebin, Chas.**—Importer of all kinds of Watches, 4 Maiden Lane. Agent for Ulysse Brcting's Fine Chronometers, Chronographs, Anchors, etc.

**Gallet, Julien**—Importer of Watches. No. 1 Maiden Lane.

**Ginnel, Henry**—Importer of Watches, Tools and Materials. No. 31 Maiden Lane, N. Y. P. O. Box, 2967

**Jandorf, P. & Bro.**—Importers of Watches and Jewelry, 182 Broadway, bet. John Street and Maiden Lane, New York.

**Keller, L. H. & Co.**—(Successors to G. A. Huguenin,) Importers of Fine Watch and French Clock Materials, No. 64 Nassau street, N. Y.

**Hirsch Bros.**—Dealers in Watches and Diamonds, and manufacturers of Jewelry. No. 23 Maiden Lane, New York

**Hyde's Sons, John E.**—Wholesale Commission Agents, only, for Jules Jurgensen, of Copenhagen, Ed. Perregaux, of Loc'e, Jules Monard, of Geneva, and for other makers of all qualities of watches, 23 Maiden Lane.

**Magnin, Ve J. Guedin & Co.**—Importers and Agents of the Nardin Watch, 29 Un. Square.

**Mathey, L. & A.**—Importers of Fine Watches and Sole Agents for the H. L. Matile's Watches, No. 16 Maiden Lane.

**Mathey, J. F. H.**—Importer of Watches. No. 5 Maiden Lane, N. Y.

**May & Stern**—Importers of Foreign Watches, Materials and Tools, etc. Manufacturing Jewelers. No. 19 John St., N. Y.

**Middleton & Brother.**—Importers of Swiss Watches and dealers in American Watches, Diamonds, Gold Chains, Jewelry, etc., 10 Maiden Lane, N. Y.

**Nicoud & Howard**—Importers and Manufacturers of Watches, No. 14 Maiden Lane.

**Oppenheimer Bros. & Veith**, Dealers in Watches and Diamonds, and Manufacturing Jewelers. No. 35 Maiden Lane, N. Y.

**Robert, J. Eugene**—No. 30 Maiden Lane, New York Agent for Louis Audemar's celebrated watches.

**Schwob, Adolphe**—Manufacturer & Importer of Watches, 11 Maiden Lane, N. Y.

**Stern Brothers & Co.**—Importers of Swiss Watches and wholesale dealers in American Watches, &c., 30 Maiden Lane.

**Scott, J. T. & Co.**—Importers of Watches, and Manufacturers of Jewelry, and Jobbers of all grades American Watches. No. 11 Maiden Lane, N. Y.

**Strasburger, Louis & Co.**—Importers and Makers of Watches of every description. No. 15 Maiden Lane.

**Tiffany & Co.**—Makers of Watches. General Agents for Patek, Philippe & Co. Wholesale office, 694 Broadway, N. Y.

**Watch Cases.**

**Brown, J. A. & Co.**—Manufacturers of The Ladd Patent Stiffened Gold Watch Cases, &c., 11 Maiden Lane, N. Y. Factory, 58 Eddy street, Providence, R. I.

**Watch and Chronometer Repairer.**

**Cerf, B.**—Practical Watchmaker and Repairer, No. 10 John street, N. Y. Repairing and adjusting of Fine Watches done for the trade. All kinds of escape and stem winding wheels cut to order.

**Ludeman, W. H.**—Chronometer and Watchmaker. Repairing of every description for the Trade, 75 & 77 Nassau street.

**Sirois, A.**—Practical Watchmaker, 89 Fulton street. Special attention paid to the repairing of Fine Watches. Pivots inserted.

**Watch Case Repairers.**

**Tarbox, Hiram**—Watch Case Repairing, Springing, Polishing and Engine Turning, 79 Nassau street, (room 22), N. Y.

**Renaud, F.**—Watch-Case Repairer.—Solid and Heavy Rolled Plate Bows and Pendants. Springer and Engine Turner of Cases and Jewelry, 36 Maiden Lane

**Watch Glasses, Shades, Etc.**

**Brown, Edwin**—No. 85 Nassau Street, Imported and own Manufacture Watch Glasses, Flat, Flat Concave, Concave, Convex and fine Geneva's. Fine fitting solicited.

**Hill, Robert S.**—Manufacturer of Watch Glasses, &c, dealer in Imported Glasses, Flat Glasses a specialty; also, Jeweler's Glasses. Nos. 75 & 77 Nassau street, N. Y.

**PHILADELPHIA**

**Booz & Thomas.**—Manufacturers of Gold and Silver Watch Cases and Jewelry, 108 South 8th Street, Philadelphia.

**Bennett, Jacob & Son.**—Diamond Setters and Manufacturing Jewelers. 108 South 8th St.,

**Cooper & Bros.**—Wholesale Jewelers, and Importers of and Dealers in Watch and Clock-makers' Materials, etc. Spectacles and Optical Goods. No. 35 South 4th St., Phila.

**Conover David F. & Co.**—American Watches, Wholesale Salesroom, southeast corner 7th and Chestnut streets, Philadelphia.

**Herold, Chas P.**—Successor to Hildebrandt, Herold & Co., Manufacturing Jeweler and Diamond Setter. Diamonds, 916 Chestnut St

**Krider, Peter L.**—Manufacturer of Sterling Silver Ware, Artisan Hall, No. 618 Chestnut street

**Levy, Bernard**—Manufacturers of gold and silver watch cases, and importers and dealers in Swiss and Amer'n watches, 402 Library st

**Morgan, Charles V.**—Manufacturer of Morocco and Hardwood Cases, 630 Chestnut Street, Philadelphia. Jewelry and Silverware Cases, Show Case Trays, Mathematical and Surgical Instrument Cases, etc.

**McCall & Newman**—Manufacturing Jewelers, Filled Plain Gold Rings a specialty, No. 625 Arch street.

**Morgan & Heady.**—Manufacturing Jewelers Cameo sets, Gold sets, Roman Lockets, Rings, Coral sets, and a general line of rich goods. 611 and 613 Sansom street, Philadelphia.

**H. Muhr's Sons.**—Manufacturing Jewelers, Solid Gold an filled Rings a specialty, 633 & 635 Chestnut st. N. Y. Office, 11 Maiden Lane.

**Rosenthal, G. F. C.**—Manufacturing Jeweler and Diamond Setter. Engraving and Designing of Monograms a Specialty. No. 924 Chestnut street, Philadelphia.

**Rowe, Geo. A.**—Stone and Metal Seal Engraver, Die Sinker and Medalist. Intaglio cutting. Special rates for large quantities, to manufacturers, 1002 Walnut street.

**Scherr, L. A. & Co.**—Wholesale Dealer in Watches Silver Plated Ware, Spectacles, Fancy Goods, Watch Materials, etc., 726 Chestnut street.

**Sheafer, W. H. & Co.**—Makers of Fine Jewelry 908 Chestnut Street.

**Simons, Broth & Co.**—Manufacturers of Fine Jewelry, Canes, Thimbles, Chains. 611 & 613 Sansom St., Philadelphia.

**CHICAGO.**

**American Watch Company**, of Waltham, Mass. No. 170 State street, Chicago.

**Charpior & Wathier**—Watchmaker & Jewelers for the Trade, and Wholesale Dealers in Watch Material, Tools, &c., 61 West Kinzie Street, Chicago, Ill. Send for price list.

**Clapp, Bros. & Co.**—Wholesale Jewelers, 63 & 65 Washington st. Catalogue and Price List issued to Watchmakers and Jewelers.

**Frese, B.**—Watchmaking and Repairing for the Trade promptly attended to. Stem-winding and escape wheels cut to order. No. 99 E. Madison St., Chicago, Ill.

**Giles, Bros. & Co.**—Manufacturers and Jobbers in Watches, all classes of Jewelry, Materials, Clocks, Silver Ware, &c., &c. Illustrated Catalogues furnished to dealers upon application. State and Washington sts.

**Knights, C. H. & Co.**—Wholesale Jewelers, 125 & 127 State street.

**Kearney & Swartzchild.**—113 & 115 State st.—Importers and Jobbers of Watchmakers' and Jewelers Supplies, Watches, Jewelry, &c. Illustrated Catalogue and Price List sent on application and receipt of card.

**Norris, B. F. & Co.**—Wholesale Jewelers and and Dealers in Watchmakers' and Jewelers' Supplies. 101 & 103 State street.

**Stein & Ellbogen**—Wholesale Dealers in Watches and Jewelry, 127 State St., Chicago. Specialty, repairing for the Trade.

**PROVIDENCE**

**Irons, Chas. F.**—Manufacturer of Solid Gold Jewelry. Specialty Emblems, Pins and Charms Masonic, Odd Fellows, &c. 102 Friendship St.

**Perkins, C. H. & Co.**—Manufacturers of fine Gold and Plated Jewelry. 20 Conduit St.,

**NEWARK.**

**Lefort, Henry.**—Stem-winding Watch Crown Manufacturers. 80 & 82 Marshall St.

**Lelong, L. & Bro.**—Gold and Silver Refiners, Assayers and Sweep Smelters, S. W. corner Halsey & Marshall streets, Newark, N. J.

**Milne & Jourdan**—Manufacturers of Stem winding Watch Crowns 13 & 15 Frankli Ave.

MANUFACTURERS OF  
**GOLD AND FINE ROLLED PLATE  
 JEWELRY,**

**Standard Gold Stock Plate Chain,**

Bracelets, Necklaces, Locketts, Crosses,

A Specialty!

**SOLID GOLD RINGS**

IN LARGE VARIETY.

Goods sent to all parts of the U. S. on approval, without declaring values, and can be returned to us in the same manner, there by saving our patrons considerable expense by not being obliged to declare values to Express Co.'s.

Diamonds,  
 Pearls,  
 Cameos,  
 Amethysts,  
 Turquoise,  
 Garnets, &c.

In future the **DIAMOND** trade will receive our particular attention. **DIAMONDS** in original packages, singly, or in pairs, mounted or unmounted, will be found constantly on hand.

Manufacturers of the Celebrated

**American SILK GUARDS,**

**39**

**MAIDEN LANE,**

**New York.**

**Kossuth Marx & Co.**

Importers of all kinds of



Optical Goods.

French Clocks, strike, visible escapement, from \$20.00

## ALBERT BERGER & CO.

MANUFACTURERS AND IMPORTERS OF THE

W. B. & Co. Watch Glasses, Spectacles,  
FRENCH CLOCKS, REGULATORS, MUSICAL BOXES, &c.

Also Lemaire & Bardour & Sons' Opera and Field Glasses.

**No. 47 Maiden Lane, New York**

Factory at Goetzenbruck, Lorraine.

No. 21 Hatton Garden, London. No. 27 Rue-Paradis-Poissonniere, Paris.

J. S. BIRCH & CO., 38 Dey St., N. Y.

WATERBURY'S

BIRCH'S SELF-ADJUSTING



8.—SHORT WOOD HANDLE KEY.  
(Nickel Plated: for Bench or Pocket use.)

JOHN F. McINTYRE,  
73 Cortlandt Street, New York,

(Late of No. 19 Beekman Street,)

MANUFACTURER OF

## Fine Morocco Cases

For Jewelry, Silverware and Cutlery.

*Estimates for orders, however large, promptly furnished.*

*Having for years manufactured for the largest houses in the city, I am enabled to refer to a very large number of old patrons.*

*Prices lower than any other manufacturer.*

NE PLUS ULTRA.

## DUST-PROOF WATCH KEYS.

Patent Sept. 1st, 1874.



A



C



A

The Popular Name Key.

A. Nickel Plated Handle and Pipe, Swivel Top, per gross..... \$10.75

English Pattern Key.

C. Nickel Plated Handle and Pipe, Swivel Top, per gross..... \$7.50



BENCH KEYS.

Corrugated Gilt Handles, Tempered Steel Pipes, per Set of Six..... \$1.80  
per Set of Three..... .90

P. Style of Key.

Gilt Handle. Steel Pipe.

Per Gross..... \$8.50



Our Key Pipes are all warranted to be made of the finest quality of steel. One great advantage this key has over all others, is the mortice through the pipe, making it the most simple and thoroughly dust and moisture-proof, as well as the cheapest key in the market. Our sizes run from 1 to 12; 4, 5 and 6 ft Gents' American Watches; No. 8, Ladies' American.

For sale by the Trade generally.

**KENDRICK, DAVIS & CO., LEBANON, N. H.**

SOLE OWNERS AND MANUFACTURERS.

The advantage of our Name Key, as an advertising medium, will at once be seen.

HENRY HIRSH,

EDWARD HIRSH,

# HIRSH BROS.

Dealers in Watches & Diamonds

AND MANUFACTURERS OF

## JEWELRY,

No. 23 Maiden Lane, New York.

Prompt attention given to filling orders for all kinds of goods pertaining to the trade.

HENRY MAY.

Established 1854.

JOSEPH STERN.

# MAY & STERN,

IMPORTERS OF

Foreign Watches, Materials and Tools

AGENTS FOR THE SALE OF ALL

DOMESTIC MOVEMENTS AND CASES.

And MANUFACTURING JEWELERS

No. 19 John Street, New York.

SOLID GOLD SEAL RINGS, in Cameo, Amethyst, Topaz and Onyx, A SPECIALTY.

# L. LELONG & BRO.

GOLD and SILVER REFINERS,

Assayers and Sweep Smelters,

Southwest Corner Halsey and Marshall Streets,

NEWARK, N. J.

SWEEPINGS A SPECIALTY.

# KELLER & UNTERMAYER,

ONLY AUTHORIZED AGENTS OF

# The International Watch Co.'s

## WATCHES.

A full and complete assortment of these goods in new and attractive Gold Cases constantly on hand.

No. 18 John Street, New York.

**SILVER FILIGREE JEWELRY.**  
Splendid Silver Bridal Sets,  
Half Sets, Necklaces, Bracelets, &c.

**P. HARTMANN,**  
P. O. BOX, 2454. 36 Maiden Lane, New York.  
Importer and Manufacturer of  
Fine Gold, Diamond & Filigree  
Silver Jewelry.

# ALBERT LORSCH,

IMPORTER AND DEALER IN

# WATCHES,

AND MANUFACTURER OF

## JEWELRY,

ALSO MANUFACTURER OF THE

PATENT ACCOMMODATING

# Spectacles and Eye Glasses,

In Gold, Silver, Steel, &c.



Would call the attention of the trade to the fact, that with the above Spectacles and Eye Glasses, which are constructed to form a Spring by which the lense is held, it is only necessary to have one complete assortment of lenses which being of uniform size, will interchange in all the different kinds of frames, thus giving a complete assortment for a comparatively small outlay. Notwithstanding the numerous advantages of these Spectacles, the prices will compare favorably with those of any other make.

ALBERT LORSCH, 37 Maiden Lane, New York.

LORSCH BROS., 120 Sutter St., San Francisco, Cal.

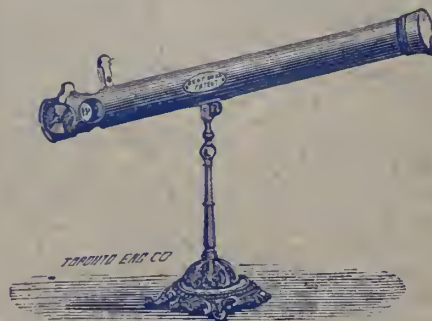

# L. BLACK & CO.'S Spectacle INDICATOR,

Patented in U. S., July 31, 1877.  
Canada, March 19, 1877.

Instruct the customer to place one eye closely against the open end of the tube; put the smallest letter opposite the small hole, and turn until the customer can distinguish a letter or figure. The strength of the spectacles required will be indicated on the index wheel. If the large letters are used, pull up the slide; if not, keep it down.

This instrument is easily adjusted, can not get out of order, is nickel plated, makes a nice appearance, and shows the correct number of lens required.

For particulars, address L. BLACK & CO., Detroit, Mich., or any wholesale Optical Establishment in New York.



Established 1813.

# SETH THOMAS CLOCK CO.

THOMASTON, CONN.

No. 20 MURRAY STREET, New York.

16 Worship Street,  
LONDON, E. C.

172 State Street,  
CHICAGO.

132 Sutter Street,  
SAN FRANCISCO.

## F. KROEBER

Manufacturer of CLOCKS,

No. 8 Cortlandt St., New York.



Birdie.



Velvet.



WASP.

1 Day, \$2.00. 8 Day, \$2.40.



Thistle.



Daisy.



Aurora.



Horseshoe.



Tulip.



Comtess.

# New Haven Clock Co.

117 & 119 State St., Chicago.

62 Reade Street, New York.

G. A. HARMOUNT, Agent.

L. EGERTON, Jr., Agent.

Manufacturers and Jobbers of

# AMERICAN CLOCKS,

## Movements and Clock Material,

Also, Black Walnut, Visible Pendulum Clocks, and Specialties in Brass and Nickel.

Agents for { JEROME & CO., - - - - - Of New Haven, Conn.  
E. INGRAHAM & CO., - - - - - Of Bristol, Conn.

Liberal Discounts to the Trade.

# WATERBURY CLOCK CO.

## MANUFACTURERS OF AMERICAN CLOCKS,

4 CORTLANDT STREET,  
NEW YORK.

M. BAILEY, Treasurer.

63 WASHINGTON ST.,  
CHICAGO.

—————  
factories, WATERBURY, CONN.

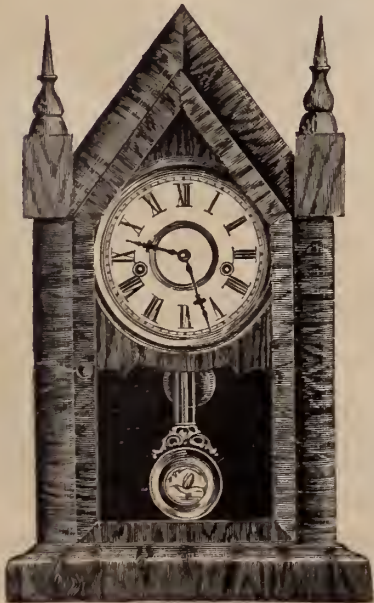

SHARP GOTHIC EXTRA.



CRICKET EXTRA.

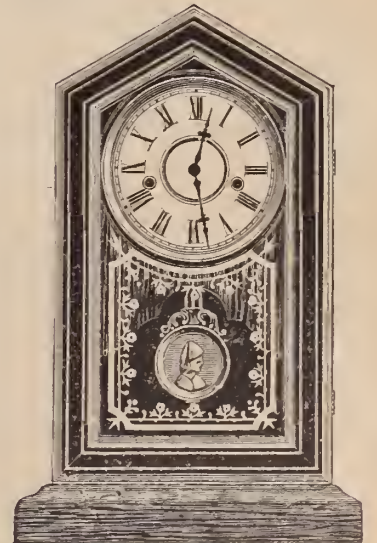

CHESTER.

**GEO. B. OWEN & CO.**

6 MURRAY STREET,

*Factory, Winsted, Conn.***New York.**

MANUFACTURERS OF

**BLACK WALNUT CLOCKS,**Clocks Manufactured by the following Companies will be  
furnished at lowest Market Rates:

New Haven Clock Co.,  
 Seth Thomas Clock Co.,  
 E. N. Welch Man'g Co.,  
 Welch, Spring & Co.,  
 Waterbury Clock Company,  
 Ansonia Clock Company,  
 Wm. L. Gilbert Clock Company,  
 E. Ingraham & Co.

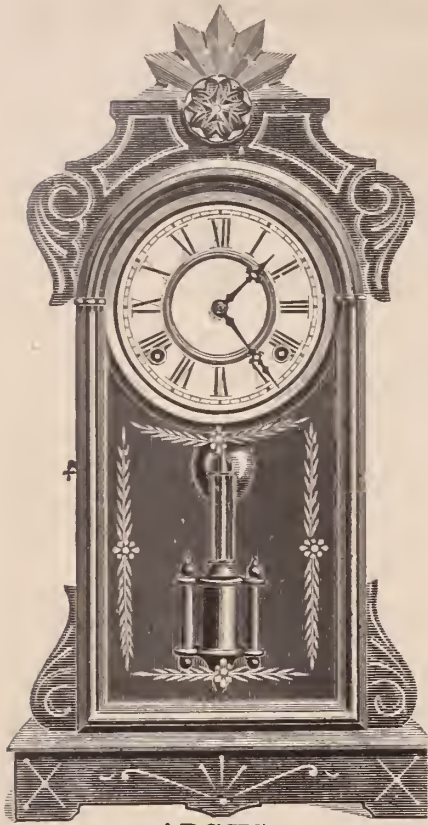
**ARGUS.**

Eight day Strike. Height, 20¼ in

**AMPHITRITE.**

1 Day Time. Height 17½ in.

Illustrated Catalogues and Price Lists furnished on application,

**E. N. WELCH MANUFACTURING CO.**  
**WELCH, SPRING & CO.**

MANUFACTURERS OF

**C L O C K S**

Factories at Forestville, Conn.

We announce the Removal of our New York Office and Salesroom to the commodious Store

No. 6 WARREN STREET, near Broadway,

where we invite the trade to call and examine our stock. Our line of Staple Clocks for the Export and Jobbing trade is full and complete, and we guarantee the quality of our goods equal to the best in the market.

We also offer for the Fall Trade many novelties, beautiful in design, and superior merit as time-keepers.

**E. N. WELCH M'F'G CO.**  
**WELCH, SPRING & CO.**

NEW YORK, September 1st, 1879.

Mr. E. C. HINE, late of the American Clock Company will have charge of our New York Office from and after October 1st, 1879.

We carry a full and large stock of our Clocks at our Office and Salesroom, 172 STATE STREET, CHICAGO, where Mr. F. E. MORSE, long with the American Clock Co., will be found in charge and will be happy to accommodate WESTERN BUYERS, and furnish Catalogues and terms upon application.



# F. KROEBER, IMPORTER,

8 Cortlandt Street,

New York.



GILT AND ALABASTER CLOCKS,

TIME OR STRIKE MOVEMENTS.

—WITH—

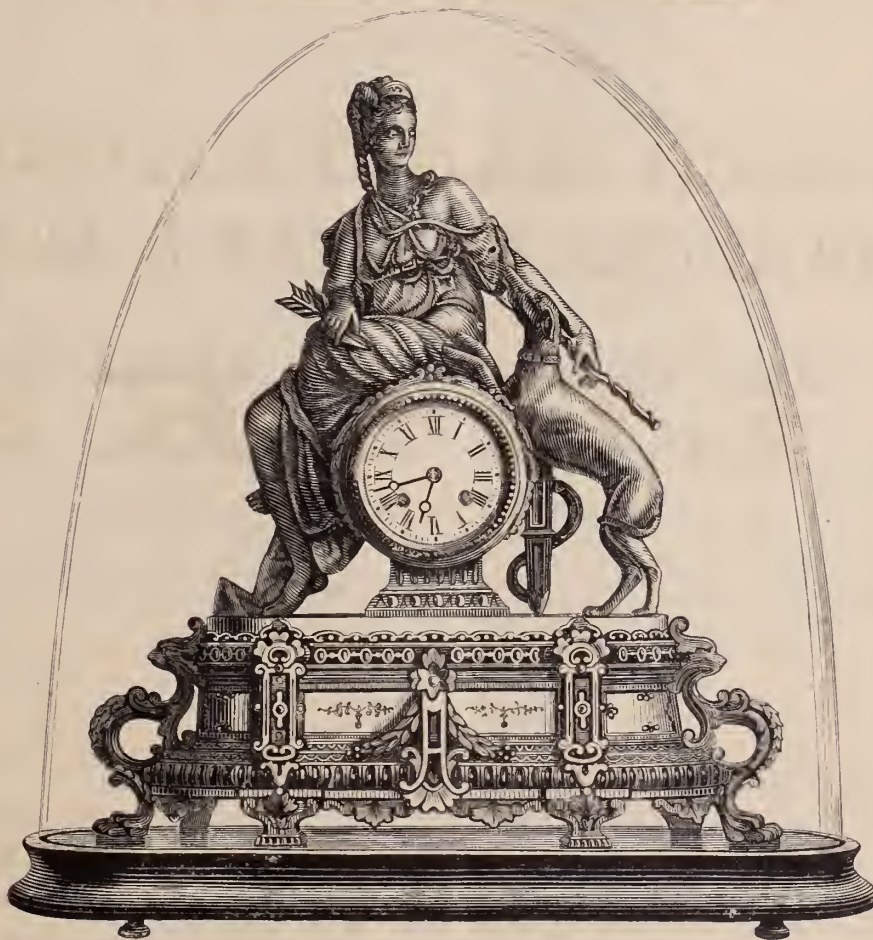

WITH OR WITHOUT GONG.

—WITH—

TIME, STRIKE AND VISIBLE MOVEMENTS,

MARBLE CLOCKS,

PRICES REDUCED SEPTEMBER 1st.

# LOUIS STRASBURGER & CO.,

Importers of

# DIAMONDS.

 We are direct Importers of Diamonds, dealers will therefore always find ORIGINAL parcels in our stock to select from.

**MATCHED PAIRS, IN ALL GRADES AND WEIGHTS, A SPECIALTY!**

**NEW YORK, 15 MAIDEN LANE.**

**PARIS, 30 BOULEVARD HAUSSMANN.**

Our complete stock of loose and mounted Diamonds enables us to send a full assortment for selection to any first-class house.

## LOUIS STRASBURGER & Co.

### **Manufacturers of Watches,**

From the finest Stem-Winding and Setting goods to the lowest price Watch in the market.

We manufacture and have continually in stock a complete assortment of the best COMMERCIAL WATCHES ranging from the lowest priced Metal and Silver Watches to the finest Gold Watches, such as REPEATERS, CHRONOGRAPHS (single and split) and all other Timing and Complicated Watches.

Also a full assortment of the INTERNATIONAL and all AMERICAN Movements. *Gold and Silver Cases,* constantly on hand.

We would call particular attention to our complete and varied assortment of NICKEL WATCHES, (black and fancy Dials,) in all grades, styles, and sizes.

THE RAIL-ROAD TIMEKEEPER A SPECIALTY.

**SALESROOMS, No. 15 MAIDEN LANE, NEW YORK.**

Watch Factory, Rue Leopold, Chaux de Fonds, Switzerland.

# BRADLEY & HUBBARD MF'G CO.

# BRONZES

CLOCKS, ORNAMENTS. CALL BELLS,

→☛☛☛ ALSO GAS, OIL FIXTURES AND LAMPS. ☛☛☛←

Bronze Goods in  
 Statuettes,  
 Animals,  
 Birds,  
 Vases,  
 Pitchers,  
 Card Receivers,  
 Card Tables,  
 Jardinieres, etc.  
 in all the popular styles  
 of finish, including Silver  
 and Gold, and Nickel  
 and Gold.



Polished Brass Goods in  
 Candlesticks,  
 Sconces,  
 Mirrors,  
 Vases,  
 Pitchers,  
 Card Tables,  
 Jardinieres,  
 and a large variety of other  
 Ornamental Goods.

*The attention of the trade is directed to our full and complete line of these goods, the largest and most comprehensive assortment to be found anywhere, and unsurpassed for quality, style and beauty of finish.*

**Bradley & Hubbard Mf'g Co.,**

**21 & 23 BARCLAY STREET,**

**FACTORIES, WEST MERIDEN, CONN.**

Near Post Office,

**NEW YORK.**



Factory and Offices, 611 & 613 Sansom Street,

ARTISAN BUILDING.

THIS old and well-known firm manufacture a greater variety of *SPECIALTIES* than any other one house in the country.—**FINE TINTED AND ROMAN JEWELRY, IN SETS, BRACELTS, EAR RINGS, LOCKETS, &c., &c. GOLD CHAIN, SILVER CHAIN, GOLD THIMBLES, SILVER THIMBLES.**

In both *GOLD* and *SILVER THIMBLES*, in *Styles* and *Finish* we claim to excel all others.

## GOLD HEAD CANES.

These goods we were the *FIRST* to make to any extent, nearly all other makes are *copies of our patterns*, whilst some of our styles *have never yet been imitated*, we being *JEWELERS* as well as *CANE MAKERS*, are able to do more *elaborate* work than those not possessing this advantage.

### ILLUSTRATED CATALOGUE.

Our Illustrated Catalogue of these goods will be ready for gratuitous circulation by *September 15th*, and parties about to order *CANES* for Fall will do well to reserve orders until they have this *intelligent aid*.

**SIMONS BROTHER & CO.**

**PHILADELPHIA.**

**CROSS & BEGUELIN,**

21 MAIDEN LANE - - - - - NEW YORK.

**IMPORTERS OF****SWISS WATCHES,****Watch Tools, Materials, Glasses, etc.**

ALSO JOBBERS IN

All Grades of **AMERICAN WATCHES**

AND MAKERS OF THE

**CENTENNIAL WATCH,**

(Stem-Winding and Stem-Setting) so universally popular and conceded to be the best made watch for the money in this market.

We have recently added to our stock a full and complete line of

**FRENCH TRAVELING CLOCKS,**

Also, LEMAIRE'S OPERA AND FIELD GLASSES,

We are wholesale agents for the CHARLES E. JACOT WATCHES,

and **ROGERS & BRO., CELEBRATED FLAT AND HOLLOW WARE.**

None Genuine without this Trade Mark.

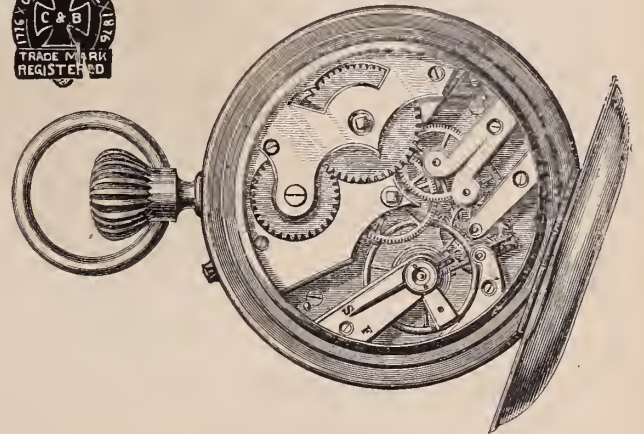

The above is a fac-simile of the Centennial Watch.

the AUBURNDALE TIMER,  $\frac{1}{4}$  and  $\frac{1}{8}$  Seconds.**BARAINS.**

We offer our entire stock of Fans, Opera Glasses, VIENNA GILT GOODS, Leather Jewel Boxes, Dressing Cases, Card Cases, Port Monnaies, Albums, Desks, Etc., Etc., Pearl and Shell Card Cases, Silver and Coral Rattles, Chattelaines, Bags and Notions to

**CASH BUYERS,**

at cost of importations.

We will clear our entire lines at less than cost, as we do not intend to carry a stock of these goods in future.

**Le Boutillier & Co.**

IMPORTERS AND JOBBERS,

**No. 3 UNION SQUARE.****NEW YORK.**

JAS. T. SCOTT,  
S. CLEM. SCOTT,  
J. T. SCOTT JR.

# J. T. SCOTT & CO.

Established 1847.

SOLE EASTERN AGENTS FOR

## THE ROCKFORD WATCH COMPANY,

11 MAIDEN LANE,

NEW YORK.

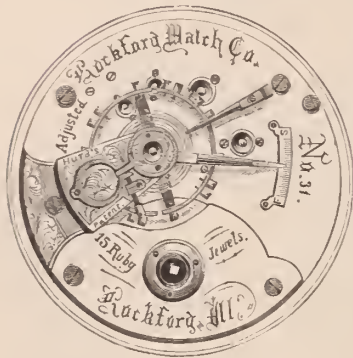

ROCKFORD WATCH.

This Company manufactures eight grades of superior 18 size key and stem wind

**QUICK  
TRAIN,**  
Movements.

ALSO SOLE AGENTS FOR  
**Abbott's Patent  
Open-Face**

18 size American stem-winders, with XII at pendant and seconds opposite



ABBOTT'S PATENT.

AND AGENTS FOR  
The Auburndale

### CHRONOGRAPH

TIMERS,

$\frac{1}{4}$  and  $\frac{1}{2}$  seconds, in 18 size  
Nickel-Plated Cases, designed  
for Sporting, Scientific and  
Mechanical purposes.

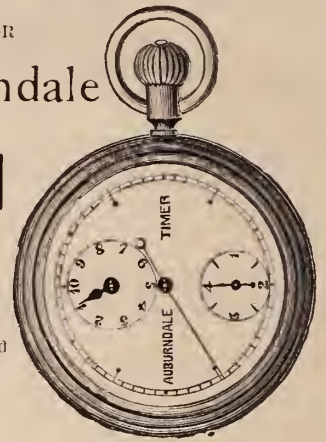

AUBURDALE TIMER.

Manufacturers of Jewelry and Wholesale Dealers in all grades  
of American Movements.

WATCH CASES, DIAMONDS, CHAINS, SILVER WARE, &c.

*Price Lists furnished upon application to those regularly engaged in the Trade.*

## DAVID F. CONOVER & CO.

(SUCCESSORS TO WM. B. WARNE & Co.)

Importers, Manufacturers and Wholesale Dealers in

### WATCHES AND JEWELRY,

### Silver and Silver-Plated Ware,

AMERICAN WATCH WHOLESALE SALESROOM,

### Southeast Corner Chestnut and 7th Streets,

(FIRST FLOOR.)

DAVID F. CONOVER,  
B. FRANK WILLIAMS,  
C. EDGAR RIGHTER.

### PHILADELPHIA.

## THE "PAINLESS" EAR PIERCER.

PATENTED JUNE 25, 1878.

EARS PIERCED WITHOUT PAIN.

This Cut represents the Ear being pierced.

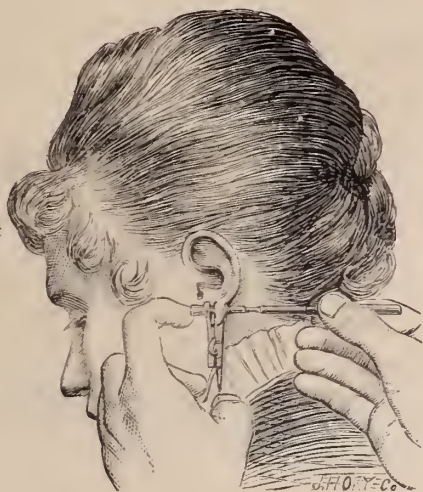

This Cut represents the Ear pierced, before the wire of the Ear-Ring is inserted in the tube of the needle.

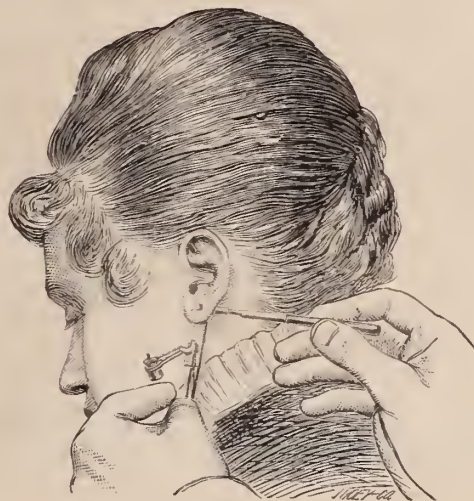

This Cut represents the Instrument and Piercer. A, is a needle with detachable point. C, a tubular guide through which the needle is forced. F, a gripper, with an aperture opposite that in the base B, between which the Ear-Lap or Lobe of the Ear is held. H, is a cork-holder, the cork receiving

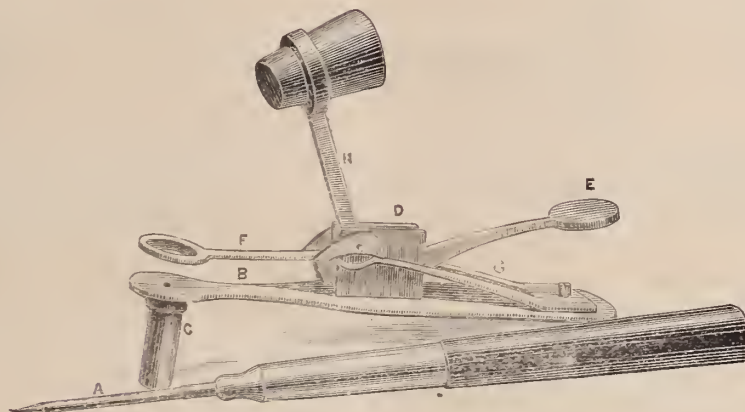

the point of the needle after the Ear is pierced. E, is the lever, by the pressure of which the gripper F, and the cork-holder H, are thrown completely back by the action of the spring G, after the Ear is pierced, as shown in the Cut No. 2.

The "Painless" Ear Piercer, patented and manufactured by Mulford & Bonnet, is an invention of real merit, which every jeweler should possess. By this simple and ingenious instrument the difficulty and *suffering* of piercing Ears is entirely overcome. The combination of the clamping device with the Piercer, as shown in the above cuts, enables the operation to be performed *without Pain*, and with *great rapidity*. This invention will commend itself to every intelligent jeweler for the following reasons:

The operation of piercing the Ear is rendered painless. The instrument holds the lobe of the Ear in such a position as to insure *perfect accuracy* in piercing. In piercing, the *tube* of the needle remains in the Ear, the wire of the Ear-Ring is inserted in the hollow of the tube, and is conveyed through the Ear as the tube is withdrawn.

The practical *importance* and *usefulness* of this invention is universally acknowledged, and its general adoption by the trade is confidently predicted.

*THE EAR CAN BE PIERCED AND THE EAR-RING INSERTED AT THE SAME TIME.*

The "Painless" Ear Piercers are nickel plated, fitted in a morocco case, and always ready for use.

MULFORD &amp; BONNET,

Sole Proprietors.

Manufacturing Jewelers,

21 MAIDEN LANE,

New York.

PRICE \$3.00 CASH.



# AIKIN, LAMBERT & CO.

MANUFACTURERS OF

GOLD PENS,

Ebony,	}	(PENCIL CASES,	}	Celluloid
Ivory.		DESK HOLDERS,		Rubber.
Rosewood,		PENCILS,		Pearl.
		TOOTH PICKS,		

—AND—



## NOVELTIES IN PENCIL CHARMS.

Many of which are protected by Letters Patent, and all at prices to meet the popular demand, being made and finished in our own factories under our own personal supervision, using the best materials with modern appliances (we guarantee our productions), unsurpassed in finish, style and price. Our patent inlaid Celluloid Pencils, Pencil Charms and Picks, in Black, Shell, Malachite, Red, White, Pink, Variegated light and dark blue colors, are the handsomest goods yet produced, and at reasonable prices, the inlaid work being of *solid gold* and pearl in form of flowers, birds, etc., and warranted durable.

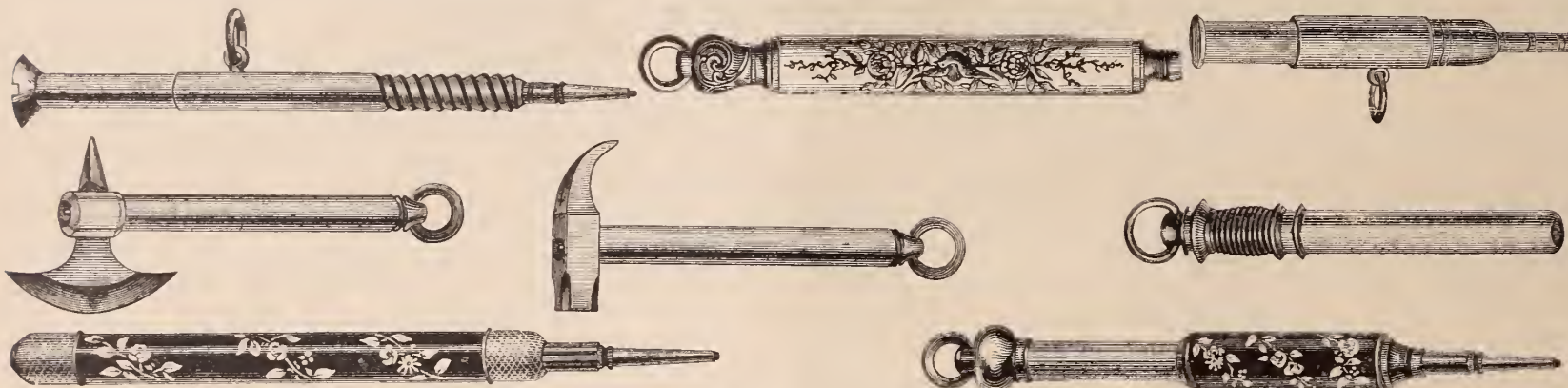

A full assortment of long and short nibs, stubs, falcon, oblique, commercial, fine and broad pointed Pens, in every style of holder, suitable for business or holiday trade.

To those purchasing assortments, we are furnishing the finest trays and show cases for their display, ever offered to the trade. Dealers are invited to call and examine, or particulars will be furnished to regular dealers only, upon application, when accompanied by business card, or satisfactory reference, and price lists, with Illustrated Catalogues sent. ALSO, A LINE OF GOODS SUITABLE FOR EXPORT TRADE. Goods sent for selection.

PARIS HOUSE,  
J. GLAENZER & CO  
35 Boulevard de Strasbourg.

Main Office, 23 Maiden Lane, New York.  
Branch Office, 113 E. Madison St., Chicago.

We are also Importers of all grades of watches, and would call attention to the following specialties :

**PAUL BRETON** Movements, of which we are sole Agents. A full line of these celebrated Watches in Gold and Silver Cases of the most approved styles.

**CHAS. LATOUR** Movements, Nickel  $\frac{3}{4}$  plate, handsome, showy watches at medium prices, good reliable time pieces. Key and Stem-Winders.

**AGASSIZ** Movements, Gilt and Nickel Stem Winders (fitting 8 size Riverside Case), accurate timepieces, and *lower priced* than American movements of same quality.

Metal Open Face Stem Winding **Longines, Excelsior and Champion**, 13, 15, 16, 18 and 20 lines, good timers and *attractive in style and finish*.

Jobbers in all kinds of **American Movements and Cases**, including the "DUEBER," Silver Cases, and BOSS' and LADD'S FILLED CASES.

MANUFACTURERS OF

**GOLD AND SILVER THIMBLES**, in various styles, and to order.

**STONE RINGS**, Onyx, Cameo, Intaglio, Topaz, Garnet, Amethyst, Pearl and Turquoise; also, Solid Band, Chased and Plain.

**BRACELETS**, an assortment in gold and rolled plate, including new and handsome designs.

**PLATED CHAINS**, a large assortment of Vest, Guard, Neck, &c. Also, SEALS, LOCKETS, &c. A GENERAL LINE OF RELIABLE JEWELRY IN GOLD AND PLATE.

We manufacture to order any article in the line; also do repairs, and will procure for regular customers any article required in the trade, whether kept in stock or not. Orders filled as promptly as possible.

**23 Maiden Lane, New York.**



1879. NEW FALL PATTERNS 1879.

—IN—

# FINE SILVER PLATED WARE,

MADE BY THE

## Meriden Britannia Company,

No. 46 East 14th Street, and No. 47 East 13th Street,

### UNION SQUARE.



Attention of the Trade is invited to a more complete assortment of Electro Plated Ware than ever before offered by this Company. Also, to the importance, more than for many years, in ordering earlier in the Season.

# SIMPSON, HALL, MILLER & CO.

36 East 14th St., Union Square,

NEW YORK.

Factories, Wallingford, Connecticut.

MANUFACTURERS OF THE FINEST QUALITY

## Silver-Plated Ware.



NEW DESIGNS OF SUPERIOR ARTISTIC MERIT NOW  
READY AND IN PREPARATION FOR  
THE FALL TRADE.

# The STAR SALT



# CASTER COMP'Y

Sole Proprietors and Manufacturers of  
CELEBRATED.

## STAR SALTS

No. 161 Franklin Street  
BOSTON, MASS.

Place these in the family and Salt Cellars  
will be discarded.

MANUFACTURED IN ALL VARIETIES  
OF PLAIN AND FINE CUT  
GOODS, CASTERS, &c.

For convenience, neatness and utility the STAR  
SALTS have become a household necessity.

The pulverizer in the bottle, as shown by the cuts, keeps  
the salt pulverized, and obviates the disagreeable habit of  
spilling the salt by dipping out of an open salt cellar.

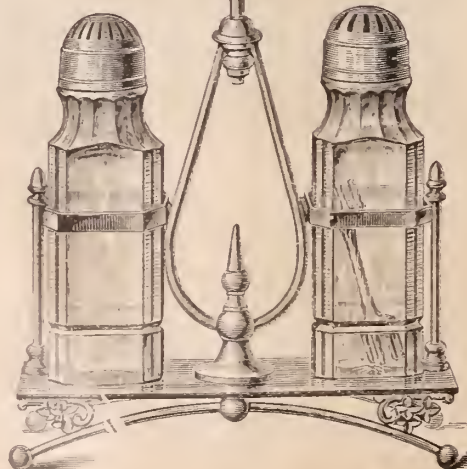
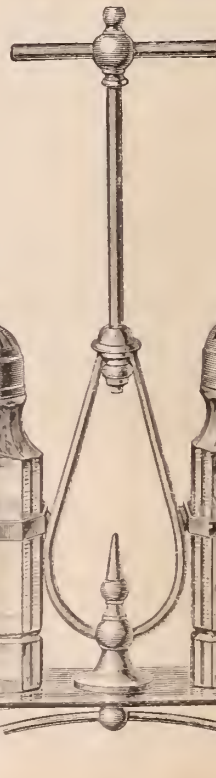

Special care given to orders for exportation.

Fine Diamond Cut, with  
Sterling Caps.

For full descriptions of the above goods see our Illustrated Catalogues, which will be mailed on application.

# SUPERIOR ELECTRO PLATE!

MANUFACTURED BY

# THE MIDDLETOWN PLATE COMPANY,

Factories, MIDDLETOWN, Conn.



## SALESROOMS:

13 John Street, N. Y. 101 & 103 State St., Chicago,  
120 Sutter St., San Francisco.

Our **ILLUSTRATED CATALOGUE** for the Trade Ready in September.

# WM. ROGERS & SON, HARTFORD, CONNECTICUT.

Trade Mark on Spoons:

⚓ WM. ROGERS & SON, A. A.

Established in 1865.

We call attention to our new pattern, the HARTFORD, it is the latest, noblest and best pattern in the market, and is *five per cent*, less than any pattern of the kind.



Trade Mark on Knives:



Established in 1865.

Silver Plated Knives, Forks,  
Spoons, Casters and  
Cake Baskets.



The HARTFORD. Pat. Sept. 23d, 1879.

# WM. ROGERS & SON,

Drawer 30, Hartford, Conn.

# MILLER BROS.

MANUFACTURING JEWELERS,

No. 11 MAIDEN LANE, NEW YORK.

Manufactory, 47, 49 & 51 Franklin Street, Newark, N. J.

A  
Large Line  
of

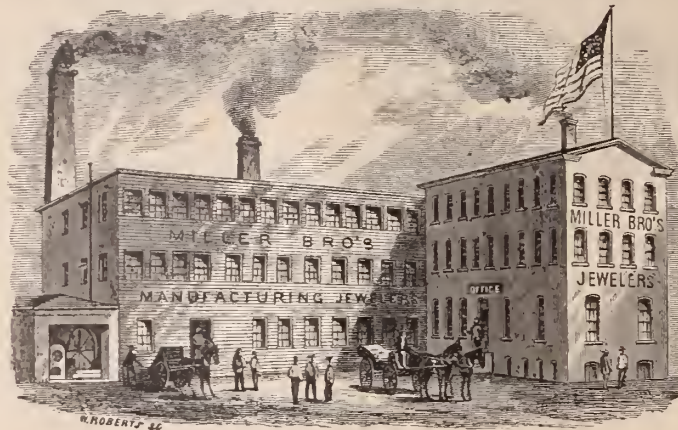

NOVELTIES.

ATTENTION IS INVITED TO OUR  
NEW STYLES OF ETRUSCAN SLEEVE BUTTONS,  
MOUNTED WITH

## RUSTIC LETTERS

BIRDS, ANIMAL HEADS AND FANCY ORNAMENTATIONS.

Also a full line of Locketts, Sets, Pins, Ear Rings, Sleeve Buttons, Studs, &c.

All goods exclusively of our own manufacture, many of which are protected by MECHANICAL and DESIGN PATENTS.

### ANNOUNCEMENT.

## HAMPDEN WATCHES.

KEY AND STEM-WINDING.

We desire to call the especial attention of the trade to the fact that our productions have been greatly improved in quality during the last two years, and shall so continue, notwithstanding the exceedingly **low prices** at which they are sold.

Yours respectfully,

HAMPDEN WATCH CO.

General Office,  
Springfield, - Mass.

New York Office,  
12 Maiden Lane.



## Gorham Manufacturing Co.

PROVIDENCE }  
—AND— } Oct., 1879.  
NEW YORK. }

THE productions of our Factory the present season, while embodying some of the best features of those of preceding seasons, indicate the most thoughtful consideration and study of what is new in *DECORATIVE ART*.

The pleasing effects of color engraving, susceptible as it is of infinite variety, maintains its popularity. In other lines of decorative ware, the effects produced by various tints of gold in connection with other combinations of colors under the articles are eminently attractive.

Other forms of decoration are prominent in classes of goods especially adapted for specific methods of treatment.

Flower Vases, Tea Caddies, Berry Bowls, Fancy Spoon Ware, Etc.,

ARE ENRICHED BY APPLIED WORK.

Flowers, Ferns, Plants, Birds, Fishes, Reptiles, Etc.,

Are accurately modeled and attached to the body of the piece. Hammered or beaten surfaces, partially oxidized, lend an air of quiet elegance to the piece. "American Curios," exhibiting the most marked effects in form and surface decoration. Copies of the antique, and inlayings of various metals, and especially the characteristics of latest novelties and advanced thought in decoration.

These novel and attractive goods are meeting with the hearty approval of the leading houses in the trade, and liberal selections have been made unusually early in the season.

Our production in Hollow Ware include all articles for household use and presentation.

In Tea, Dessert, and Dinner Services our stock is large and varied; comprising plain, engraved, chased and decorative sets, which we are prepared to supply either on demand or at reasonable notice. Special attention has been given to small wares, such as

Napkin Rings, Cups, Fruit Knives, Peppers, Salts, Mustards, Card Cases, Portmonnaies, Tobacco Boxes, Snuff Boxes, Bells, Butter Plates, Match Boxes, Child's Bowls, Cigar and Cigarette Cases, Pickle or Olive Dishes, Flasks, Button or Glove Hooks, Knife Rests, Porringers, Ash Trays, Vases, etc., etc., etc.

In this line of production our stock is very complete and is eminently superior in design, finish and decoration.

New patterns have been added to our list of Napkin Rings and Fruit Knives, and in the latter we have improved the process of manufacture by entirely dispensing with the customary use of soft solder. By this improvement and by reason of an increased variety of patterns our stock is rendered still more desirable than heretofore.

Lithographic sheets of our popular Spoon and Fork patterns will be sent upon application, together with our twenty-four page circular recently issued.

Important reductions (taking effect Oct. 1) in the price of "Gorham Plate" Spoons and Forks have been made.

Our general stock of Gorham Plate, so favorably known for its characteristic designs, exquisite finish, best of plate, and silver soldered in every part, is very complete in every department.



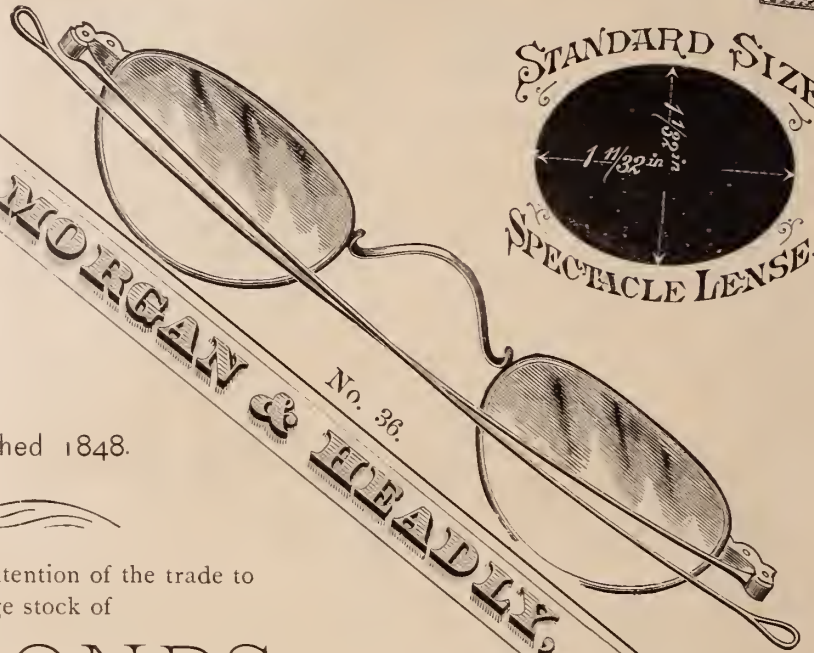
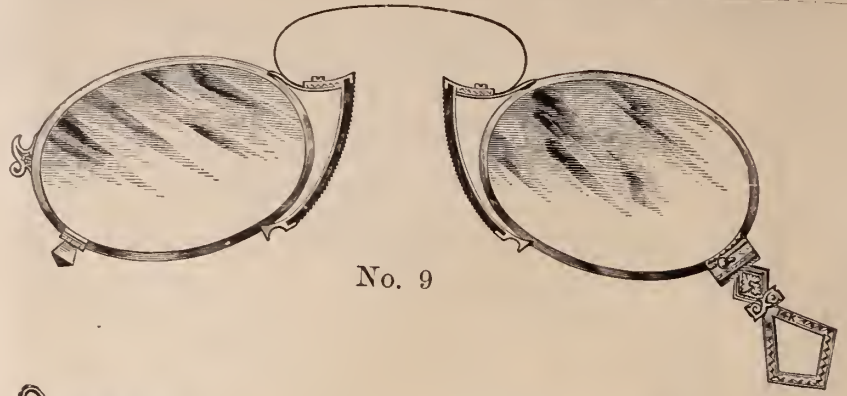
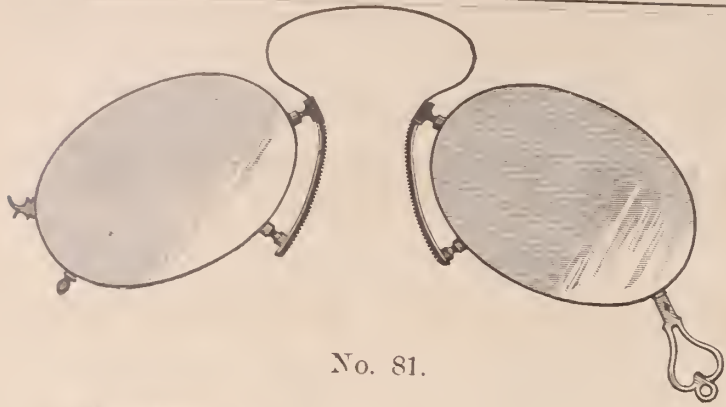

Established 1848.

We beg to call the attention of the trade to the large stock of

# DIAMONDS,

Set and unset, which we have on hand. Goods sent on approval where references are satisfactory. A rare collection of **F Old Mine Gems in Single Stones** and match pairs up to 16k. just received.

Respectfully,

MORGAN & HEADLY.

Spectacles and Eye Glasses,  
611 & 613 Sansom Street, Philadelphia.

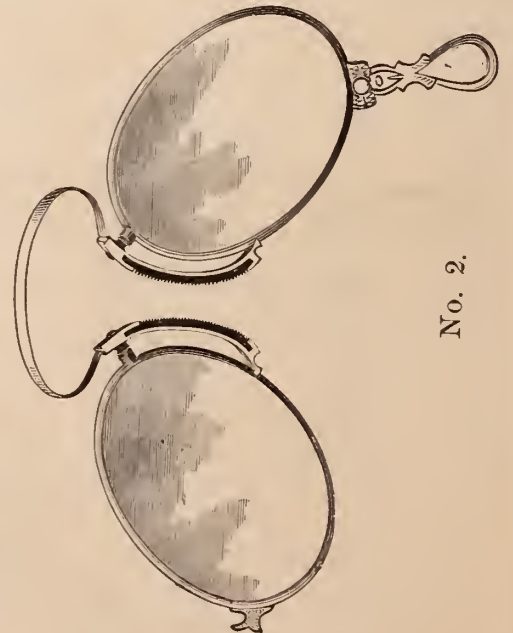
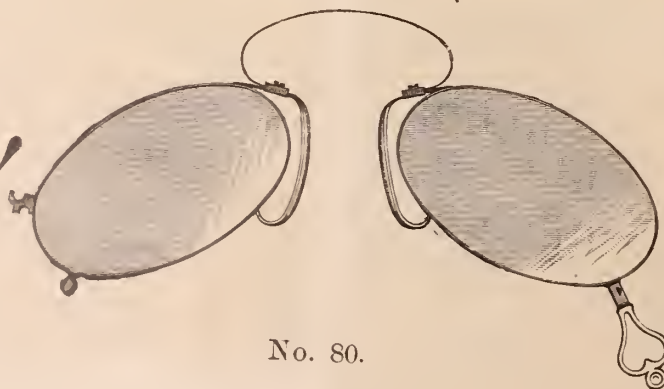

ESTABLISHED 1855.

D. LIECHTY & CO.,  
MANUFACTURERS OF

Fine Gold Watch Cases

No. 140 South Third Street,

Fourth Floor.

PHILADELPHIA

Repairing neatly attended to.

LOUIS A. SCHERR.

CHAS. H. O'BRYON.

G. W. SCHERR.

**LOUIS A. SCHERR & CO.**

Importers and Wholesale Dealers in

**Watches, Jewelry,**

WATCH MATERIALS, TOOLS, GLASSES, &C.

**Spectacles, Silk Guards, &c.**

Wholesale Agents for American Watches.

**No. 726 CHESTNUT STREET,**

FIRST FLOOR,

**PHILADELPHIA.**

**GUTMANN'S**

**Automatic Hammer and Punches**

Simplified and More Effective.

THIS TOOL takes the place of the third hand, therefore its manifold uses are quickly apparent, and I would only say that it is accompanied by six punches, to wit: 2 hand punches, 1 prick punch, 1 closing hole punch, 1 rivet punch, and 1 pinion punch, all of which fit neatly into the punch holder, and are fastened by the set screw. Its tap is alternately heavy and light, and the finger loops are assorted in sizes. The Tool is nickel-plated and boxed, ready to be mailed on receipt of price.

THE OPERATION IS AS FOLLOWS: First, set the hammer; next insert your forefinger through the loop at the top and place the punch with firmness on your work. When you are ready for the blow, push gently on the thumb-piece which produces the concussion on the punch. Your left hand is entirely free to hold the work.

Price, \$2.00; Reduced from \$2.50.

**MAX L. GUTMANN,**

Patentee and Manufacturer.

Also, Importer and Wholesale Dealer in

Watch and Jobbing Materials, Tools, Glasses,

Chains, Guards, Jewelry and Watches.

The Genuine American Silk Guards in all Styles a Specialty.

January 8th, 1878.

PLEASE SEND YOUR ORDERS.

ROCHESTER, N. Y.

AUBURNDALE, MASS..

**CHRONOGRAPH TIMER**

WM. B. FOWLE, Maker.

Designed for Sporting, Scientific and Mechanical purposes;  $\frac{1}{4}$  and  $\frac{1}{8}$  seconds, fly back.

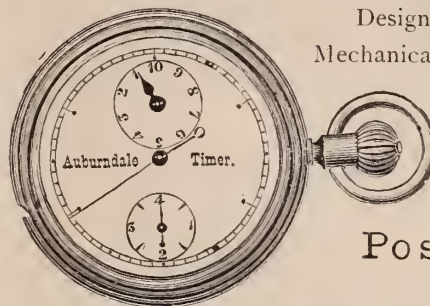

List Price, - - \$15 00

Positively Accurate.

Put up in German Silver Cases, Nickel Plated, size of an ordinary watch. Very neat and handsome, supplying a want long felt by those desiring to measure the flight of time with scientific accuracy to the fraction of a second. It indicates positively minutes, seconds, quarters or eighths of seconds, the only instrument registering one eighth of a second made. It is substantially constructed, positive in its action and will not easily get out of order.

These Chronographs can be obtained from the principal Jobbing Houses in the Trade.

**BENJ. ALLEN & CO.**

Nos. 137 & 139 State Street, Chicago.

**JEWELRY and DIAMONDS**

WALTHAM, ELGIN, HOWARD AND SPRINGFIELD, ILL.

**WATCHES,**

Rogers & Bro., Spoons, Forks, &c.

Western Agents for SIMPSON, HALL, MILLER & CO.

Our new Catalogue will be ready October 1st, and will be sent to the trade upon application.

**CHAS. P. HEROLD,**  
**MANUFACTURING JEWELER,**  
**DIAMOND SETTER**  
AND DEALER IN  
**DIAMONDS.**

916 CHESTNUT ST. PHILA.

N.B. A LARGE STOCK OF 18 Kt. DIAMOND MOUNTINGS, SUCH AS CLUSTER AND SOLITAIRE RINGS, EARRINGS, LACE PINS, SHAWL PINS, CROSSES, STUDS, AND GENTS' PINS, &c, ALL OF WHICH ARE OF MY OWN DESIGNS, AND ARE MADE IN THE FINEST STYLE AND FINISH.

**COLBY & JOHNSON,**

17 Maiden Lane, New York.

**FALL NOVELTIES.**

We will introduce about Nov 1st. two new sizes in

**Celluloid Watches,****No. 12,**

Gents' Stem-Winding Watch (18 Line) "Go'den Gate," Case of WHITE, BLACK or MARBLEIZED CELLULOID, with Nickel Center, Pendant and Bow.

**No. 22,**

Ladies' Stem-Winding Chantelaine Watch, (13 Line) in Cases of WHITE CELLULOID and GOLD, (Plain) or with inlayings of new and elegant designs in Illuminated Gold, (Hedges' Patent). The most attractive Chantelaine Watch ever offered to the trade.

**SPIESS & ROSSWOG,**

MANUFACTURERS OF

**Fine Jewelry and Diamond Goods,**

LOCKETS, CROSSES, SLEEVE BUTTONS AND NECKLACES.

Rich Sets in Coral Rose, Coral Cameo and Gold.

ENCRUSTED AMETHYST RINGS AND SILVER  
FILIGREE WORK,

Nos. 9 &amp; 11 MAIDEN LANE, NEW YORK.

Also, a complete line in all Coral Goods, as formerly  
imported by A. SQUADRILLI.**E. HOWARD & CO.,**

MANUFACTURERS OF

**Fine Watches, Regulators, Office Clocks,**

Electric Watch, Clocks &amp; Tower Clocks,

**Office, No. 2 MAIDEN LANE**

NEW YORK.

No. 114 TREMONT STREET, BOSTON.

J. W. J. PIERSON, - - - AGENT.

**SHOEMAKER & CO.,**

MANUFACTURERS OF

**Onyx, Cameo & Intaglio Buttons,****AND LOCKETS.**

A full line of Roman Goods including Bracelets.

No. 21 MAIDEN LANE, NEW YORK.

DYER BRAINERD.

JOHN W. STEELE.

**BRAINERD & STEELE,**

MANUFACTURERS OF

**Brainerd's Pat. Locket,**

(Patented June 17, 1874.)



These Locketts combine both beauty and strength. They are made of solid 14kt. gold, and the stones used are the finest obtainable in the market. They cost no more than those of the old style, if indeed as much; and the combination of secrecy and durability renders them much more desirable. We make three sizes in four different shapes—round, oval, cushion and oblong square; and also Sleeve Buttons of the same style, containing a concealed box for miniatures, a novelty new to the Trade.

**FINE GOLD JEWELRY,****No. 9 Maiden Lane,**

NEW YORK.



ESTABLISHED 1837.

VICTOR BISHOP & CO.

IMPORTERS OF

**DIAMONDS,**  
PRECIOUS STONES

—AND—

CORAL JEWELRY,

Enamel Paintings, Copper and Platinum.

No. 47 NASSAU STREET, NEW YORK.

House in Paris, 66 Boulevard de Sebastopol.

SAXTON, SMITH & CO.

MANUFACTURERS OF

**Fine Gold Chain.**

No. 15 Maiden Lane,

New York.

Factory, No. 183 Eddy Street, Providence, R. I.

Sole Agents for the new PATENTED CHAIN BAR, containing a Detachable Pencil.



HELLER & BARDEL,

Manufacturers of

DIAMOND AND PEARL

**JEWELRY,**

And Dealers in Diamonds, Pearls, &c.

SHAWL AND LACE PINS IN GREAT VARIETY,

No. 18 John St., New York.

A full line of DIAMONDS, mounted and unmounted; also, a large assortment of first-class DIAMOND MOUNTINGS of our own make always on hand. Sketches submitted at any time upon application. We will send goods on selection to responsible houses.

ESTABLISHED 1848.

E. S. JOHNSON & CO.

MAKERS OF

Gold Pens, Pencil Cases, Etc.

SUITABLE FOR THE REQUIREMENTS OF ALL CLASSES OF DEALERS

These goods have achieved a high reputation and are universally acknowledged to be the best Pens and Pencil Cases made, and as low in price as is consistent with quality of Gold, workmanship and style of finish.

Intending purchasers will consult their interests by comparing prices. We are constantly introducing new and desirable goods that cannot fail to give satisfaction.

44 Nassau Street, New York.



OPEN.

PRICE LISTS SENT ON APPLICATION.

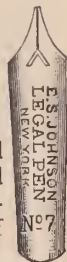

WOOD & HUGHES,

STERLING

Silverware Manufacturers

No. 16 JOHN STREET,

NEW YORK.

206 Kearney Street, San Francisco, Cal.

R. R. HASKELL, Agent.

KREMENTZ & CO.

MANUFACTURERS OF

**FINE JEWELRY,**

No. 13 John Street, New York.

FACTORY, 361 Mulberry Street, - - Newark, N. J.

GOODS OF OUR OWN MAKE EXCLUSIVELY.

CARTER, HOWKINS & SLOAN,  
**Makers of Fine Jewelry**

*Consisting of Chains, Bracelets, Sets, Pins, Studs, Sleeve Buttons,  
 Scarf Pins, Rings, &c., in Roman, Etruscan and Enamel,  
 and a full line of Jewelry generally.*

Whiting Building, Corner Broadway and Fourth Street,

A. CARTER JR.  
 WM. HOWKINS,  
 A. K. SLOAN.

**NEW YORK.**

C. E. HASTINGS,  
 GEO. R. HOWE,  
 W. T. CARTER.

**HALE & MULFORD,**  
**Manufacturing Jewelers,**

(WHITING BUILDING).

No. 694 Broadway, cor. 4th Street, New York.

Call attention of the Trade to their new style of

**BAND BRACELETS.**

We claim for these Bracelets, the following advantages over the old style, viz. :

1st. The edge of the Bracelet being raised, forms a protection to the ornamentation.

2d. Less liability of getting damaged, and when damaged, are more easily repaired.

3d. More attractive in appearance.

Prices are as low as any FIRST CLASS 14 KARAT ALL GOLD Bracelet in the market.

Made in all sizes from  $\frac{1}{4}$  inch upwards.

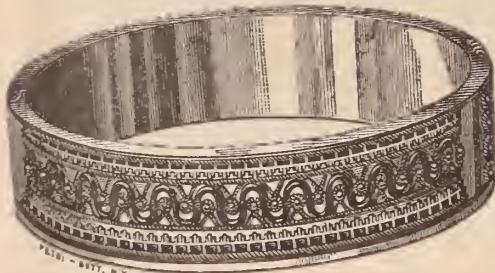

Patented Feb. 25th. Issued Oct. 19th, 1879

—Established 1837.—

**TAYLOR & BROTHER,**

Late TAYLOR, OLMSTED & TAYLOR,

**Importers of Diamonds and Pearls,**

—AND—

**MANUFACTURERS OF DIAMOND JEWELRY,**

No. 676 BROADWAY,

**NEW YORK.**

**BALDWIN, SEXTON & PETERSON,**

MANUFACTURERS OF

**Fine Jewelry,**

**Diamond and Stone Cameo Goods,**

**GOLD CHAINS, &c.**

**Importers of Diamonds, Pearls, Emeralds, Rubies, &c.**

WHITING BUILDING,

**Cor. Broadway and Fourth Street,**

**NEW YORK.**

120 SUTTER STREET, San Francisco, Cal.

Established 1817.

**Ve. J. MAGNIN, GUÉDIN & CO.**

29 Union Square, New York.

*Manufacturers and Importers,*

FINE SWISS WATCHES.

REPEATERS, CHRONOGRAPHS & CALENDARS

GENEVA GOLD JEWELRY,

FRENCH CLOCKS AND BRONZES,

RICH FANCY GOODS,

HORSE-TIMERS & PEDOMETERS,

GOLD AND SILVER CHATELAIN WATCHES.

Gold Medal Awarded, Paris Exposition, 1875.

*Sole Agents for the James Nardin Watch.*

*House in Geneva, 14 Grand Quai.*

Established 1813.

**THOMAS G. BROWN,**

MANUFACTURER OF

**FINE JEWELRY.**

*Designs furnished for all kinds of Sporting  
 Badges and Medals for Schools & Colleges.*

**NEWARK, N. J.**

—AND—

**9 BOND STREET, NEW YORK.**



ALFRED H. SMITH & CO.

IMPORTERS

14 JOHN ST., NEW YORK.

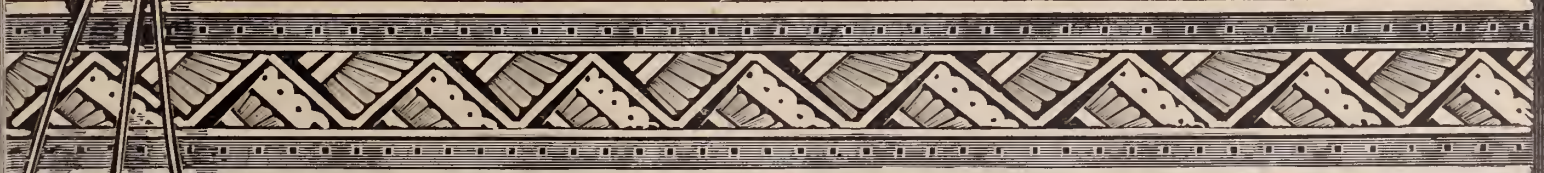

THROUGH CONSTANTLY ARRIVING INVOICES, OUR ASSORTMENT OF **Mounted** AND **Loose** GOODS WILL BE KEPT FULL, SO THAT DEALERS MAY FEEL SURE THAT THEIR ORDERS CAN BE FILLED WITHOUT DELAY.

Established 1834.

### G. & S. OWEN & CO.,

Makers of Fine GOLD JEWELRY

SPECIALTIES:

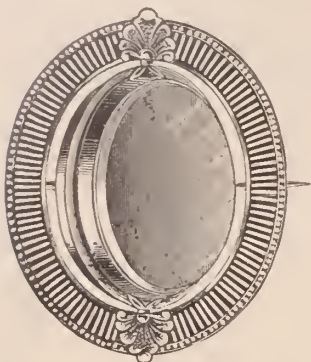

Black Onyx Goods,  
Roman & Polished Goods,  
Hair Chain Mountings  
Sole Makers  
OF

BOX AND GLASS GOODS.

All our goods exclusively of our own manufacture.

5 MAIDEN LANE, NEW YORK

### JOHN A. RILEY & CO.

MANUFACTURERS OF

Rich Gold and Onyx Jewelry,

NOVELTIES IN HALF SETS, LACE PINS, SCARF  
PINS AND EAR RINGS,

Engagement Pad Lock Bands, Elastic Snake Bands and  
Chatelaines. Onyx Chatelaines with and  
without Watch Movements.

Nos. 7 & 9 Bond Street, New York.

No. 126 Kearney Street, San Francisco, Cal.

### MOORE & HORTON,

### JEWELERS,

No. 11 Maiden Lane, New York.

SPECIALTIES!

Stone Cameo, Onyx, Amethyst, Topaz and Pearl Rings,  
Studs, Collar and Sleeve Buttons.

Also our new fac simile of Fine African Diamonds, mounted in  
Rings, Studs, Pins, Ear-rings, Scarf Pins, Medallions.

**OWEN, SHAW & CO.**

**MAKERS OF FINE JEWELRY**

CONSISTING OF  
BRACELETS,  
SETS,  
LOCKETS,



PINS,  
STUDS,  
RINGS,  
SLEEVE BUTTONS  
ETC.

**SPECIALTY**  
**STIFFENED ROMAN BANDS.**

Nos. 612 & 614 CHESTNUT ST. PHILADELPHIA.  
BRANCH-OFFICE 15 JOHN ST. NEW-YORK.

Established 1846.

WILLIAM RIKER,

No. 5 Maiden Lane, New York.

Factory, 42 Court Street, Newark, N. J.

Would call the attention of the Trade to our Inlaid Bracelets.

### COE, PINNEO & STEVENS,

MANUFACTURERS OF

### LOCKETS,

WHITE ENAMEL STUDS & BUTTONS,

Linca Finished and

### FINE JEWELRY,

Old No. 9 Maiden Lane, New York.

# ARROW BRAND,

INTERCHANGEABLE

SPECTACLES & EYE GLASSES.



*The only line in the market of which all qualities interchange.*

The Steel and Gold Spectacles and Eye-Glasses, and the Steel bifocal specs being all made with lenses of one uniform size, a dealer can deliver any article such as Gold Spectacles or Eye-Glasses or Gold bifocal specs. while only carrying a very small stock of them.

We guarantee these goods to interchange accurately and without trouble, and to be at least equal in qualities and prices to any other goods of the kind in the market.

All dealers wishing to carry this, the most profitable item of their stock, in an economical manner will give our goods a trial.

*Catalogue with further particulars sent on receipt of application accompanied by business card to*

**W. B. CLAPP, YOUNG & CO.,**

WHOLESALE JEWELERS AND OPTICIANS,

149 & 151 STATE STREET,

CHICAGO, ILL.

**ESTABLISHED 1837.**

**TRADE TRADE**

**1879**

Buyers will find it to their interest to examine our Line of Novelties in

**CLOCKS, MARBLE & BRONZE.**

Vienna, Leather and Gilt Goods a Large and Choice Selection.

TRIPPLE MIRRORS, our Special Patterns, and many other new specialties of the season which we offer at close prices TO THE TRADE ONLY. Sole Agents LE COULTRE RAZORS.

**TAYLOR & BROTHER,**

No. 676 Broadway,

**NEW YORK**

# GILES BRO. & CO.

Manufacturers and Jobbers of

## FINE AND ROLLED PLATE JEWELRY,

Diamonds, Watches, Clocks, Materials, Tools and Optical Goods.



273



628



629



438



Illustrated Catalogue Furnished to Dealers only.

GOODS SENT FOR SELECTION.

Corner State and Washington Streets, CHICAGO, Ills.

# CHARPIER & WATHIER,

## Watchmakers and Jewelers for the Trade,

AND WHOLESALE DEALERS IN

Watch Materials, Tools, Glasses, Spectacles, Silk Guards, &c.

61 WEST KINZIE STREET, CHICAGO.

All work intrusted to us will receive prompt attention and warranted satisfactory. Escape and Stem-Winding Wheels cut to order at lowest prices. Price List sent on application.

# N. MATSON & CO.

State and Monroe Sts., Chicago, Ill.

*Importers of Diamonds, Watches, Clocks, Opera Glasses,  
Materials, Tools, Etc., Etc.*

**General Jewelers and Furnishers of Jewelers Supplies.**

*Western Branch House for the Reed & Barton's Fine  
Electro Silver Plated Ware.*

All orders promptly filled, and every transaction warranted satisfactory  
to the buyer.

## CHATELLIER & SPENCE,

**Manufacturing Jewelers,**

694 BROADWAY, NEW YORK.

No. 1006 Chestnut Street, PHILADELPHIA, PA.

No. 12 West Street, BOSTON, MASS.

No. 120 Sutter Street, SAN FRANCISCO, CAL.

## CHURCHILL, LEWIS & CO.

**Manufacturing Jewelers,**

### SPECIALTIES :

TURQUOISE,	LACE PINS,
GARNET, and	EARRINGS,
ENAMELED	RINGS, and
PAINTINGS.	HALF SETS.

180 Broadway, New York.



## LYON & HARDY,

30 MAIDEN LANE, NEW YORK,

IMPORTERS OF

# DIAMONDS,

AND MANUFACTURERS OF

## DIAMOND MOUNTINGS.

All goods ordered for stock or on approval are insured while in  
the hands of Express Companies.

GEORGE W. FLATT,

IMPORTER AND JOBBER IN

## Watches, Jewelry, &c.

No. 20 Maiden Lane,

**NEW YORK.**

# ENOS RICHARDSON & CO.

MANUFACTURERS OF

## FINE GOLD JEWELRY,

Gold Chains, Locketts, Crosses and Necklaces,  
COLORED AND ETRUSCAN WORK.

ENGRAVED AND ENAMELED GOODS IN GREAT VARIETY

All Goods sold strictly of our own manufacture.

23 MAIDEN LANE, NEW YORK.

ENOS RICHARDSON,  
THOS. SLATER,

L. P. BROWN,

F. H. RICHARDSON  
W. P. MELCHER.

# A. J. HEDGES & Co.,

MAKERS OF

## FINE JEWELRY

*Of Every Description.*

No. 9 Maiden Lane, New York.

### FALL NOVELTIES.

We have recently introduced a new and attractive line of  
FINE GOLD GOODS.

richly ornamented in illuminated gold upon a sunken surface, for which process we have been granted letters patent.

Buyers visiting the city are invited to examine these goods as they cannot fail to give satisfaction

NOTICE.—Any infringement of this patent will be vigorously prosecuted.

# MIDDLETON & BROTHER,

IMPORTERS OF

## SWISS WATCHES,

AND DEALERS IN

## American Watches,

(KEY AND STEM WINDING.)

Diamonds, Gold Chains, Jewelry, Etc.

10 MAIDEN LANE, N. Y.

# WANTS OF FINE JEWELRY ALLING BROS. & CO. WANTS OF FINE JEWELRY

Full Line of Roman and Mosaic Goods,

Earrings, Buttons, Studs and Rings.

SPECIALTIES:

ENGRAVED AND ENAMELED BANDS,  
CAMEO GOODS.

170 BROADWAY, New York.

## NOTICE.

Manufacturing Jewelers are hereby notified that the undersigned have obtained Letters Patent, dated Feb. 25th, 1879 and re-issued Oct. 14, 1879, for Bracelets constructed of a single band, having ornamentation in relief permanently fixed upon its outer surface, with rigid marginal flanges or projection for the protection of the same, and all infringements, whether in cheap or fine goods, will be promptly and rigorously prosecuted according to law.

HALE & MULFORD,

Broadway & Fourth St.

New York, Oct. 14th, 1879

# RIPLEY, HOWLAND & CO.

383 Washington St., Boston, Mass.

MANUFACTURE

## FINE JEWELRY,

DIAMOND MOUNTINGS, ETC.

OFFICE, 35 MAIDEN LANE,

NEW YORK.



**J. A. BROWN & CO.**

OFFICE AND SALESROOM: No. 11 Maiden Lane, N. Y. FACTORY: No. 104 Eddy St., Providence, R. I.  
SOLE MANUFACTURERS OF THE

**Ladd Patent Stiffened Gold Watch Cases**

The Best and most durable, and the CHEAPEST STIFFENED Gold Watch Case FOR THE MONEY MADE IN THE WORLD!

All genuine Watch Cases of our manufacture have "G. W. Ladd's Patent, June 11, 1867," stamped upon the side band underneath the glass bezel.

REFUSE ALL OTHERS.

Send for full Descriptive Circular to the

OFFICE AND SALESROOMS

11 Maiden Lane, N. Y.

Dealers can obtain them of the Wholesale Watch and Jewelry Houses, or their Traveling Agents throughout the United States and British Provinces,



KEY AND STEM WINDING  
Hunting and Open-Face  
IN FLAT BEVEL,  
Mansard and Oval  
SHAPES  
Adapted to the various  
AMERICAN-MADE MOVEMENTS,  
IN  
8, 10, 14, 16 & 18  
SIZES.

**JOSEPH N. TINGLEY,**

Late of the firm of Tingley, Sinnock & Sherrill,

MANUFACTURER OF

**STONE RINGS,**

—AND—

NOVELTIES IN STONE GOODS,

No 9 Maiden Lane, New York

Factory, Newark, N. J.

**OPPENHEIMER BROS & VEITH,**

MANUFACTURING JEWELERS

AND

Dealers in Watches and Diamonds,

35 Maiden Lane,  
NEW YORK.

Patented June 3, 1879.

Combination Chain, Slide, Pendant and Locket.

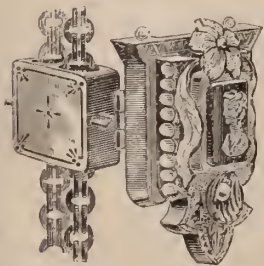

**J. B. BOWDEN & CO.**

Manufacturer of

SOLID GOLD AND STONE

**RINGS**

All Styles of Children's

AND

**FANCY SOLID RINGS,**

A LARGE ASSORTMENT ALWAYS ON HAND.

No. 1 Maiden Lane, New York.

**BUCKENHAM, COLE & SAUNDERS,**

SUCCESSORS TO

BUCKENHAM, COLE & HALL,

IMPORTERS OF

**Diamonds, Pearls**

AND OTHER PRECIOUS STONES,

MANUFACTURERS OF FINE JEWELRY,

10 Maiden Lane, New York.

A large Stock of FINE DIAMONDS, Mounted and Unmounted kept constantly on hand. Goods sent on approval to any part of the country on receipt of satisfactory references.

**MAX FREUND & CO.,**

Manufacturing Jewelers.

IMPORTERS OF

**Watches**

Jewelry and Precious Stones  
8 Maiden Lane

NEW YORK

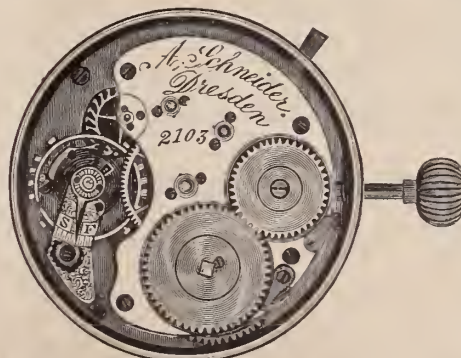

Sole Agents for the Celebrated A. Schneider Watch, Dresden Also the Standard Watch Co. of New York.

ESTABLISHED 1859.

**RINGS A SPECIALTY.****BRYANT & BENTLEY,**

No. 12 Maiden Lane, New York.

MANUFACTURE A LARGE VARIETY OF

**FINE SOLID RINGS,**

For Ladies and Gentlemen, in CAMEO, AMETHYST, ONYX, TOPAZ, TURQUOISE  
GARNET and other stones. FINE CAMEO, CORAL and ROMAN SETS of new  
and handsome designs. LOCFETS, MEDALLIONS, SHAWL and SCARF  
PINS, SLEEVE BUTTONS, STUDS, &c. All goods warranted.

We continue to manufacture several hundred patterns of **HARD SOLDER RINGS**, in every style, for men, women and children, stamped and warranted 16 karat fine.

**Dorrance, Edge & Co.**

MANUFACTURERS OF

THE CELEBRATED WOVEN FABRIC

**GOLD CHAIN.***Elegantly Mounted Bracelets, Opera, Leontine,*

VICTORIA WATCH GUARDS &amp; NECKLACES, in all the Newest Designs.

Our stock is unusually complete, and, in addition to the above, a variety  
of Necklaces, from 1½ to 40 dwts. each, to which we invite  
the attention of buyers.

CHILDREN'S BRACELETS A SPECIALTY,

Weighing from 6 dwts. a pair upwards.

No. 12 John Street, New York.

Factory, 46 Greene Street, Newark, N.J.

**KOCH & DREYFUS,**

IMPORTERS AND WHOLESALE DEALERS IN

**Watches, Jewelry, Clocks,**

SPECTACLES, JEWELRY BOXES, ETC.

Watchmakers', Jewelers', Engravers' and Mechanics'  
Tools and Supplies.

Agents for the Principal Watch and Clock Factories of the U. S.

18 Chartres St., New Orleans.

**LOUIS HERZOG & CO.**

DEALERS IN

**WATCHES,**

—AND—

**Manufacturers of Jewelry,**

GARNETS A SPECIALTY.

No. 33 MAIDEN LANE,

LOUIS HERZOG,  
LOUIS KAUFMAN.

NEW YORK.

**NOAH MITCHELL,***Manufacturer of all kinds of***Diamond Jewelry.**

DIAMOND MOUNTINGS A SPECIALTY.

A Full Assortment Constantly on Hand.

Nos. 692 &amp; 694 BROADWAY,

Corner Fourth Street, New York.

ALL ORDERS WILL RECEIVE PROMPT ATTENTION.

**FRASSE & COMPANY,**

Importers of P. S. STUBS',

*French, Swiss, German & Sheffield Tools, Files,*

Steel Wire and Materials,

For Watchmakers, Jewelers, Engravers,  
Die Sinks, Machinists, &c.

Turning Lathes, Drills &amp; Chucks

Rolling Mills, Draw Plates,

The Celebrated Rodebush

Piercing Saws,

Horse Shoe Magnets, Nurls, In-  
go's, Chasing Tools, Engravers'  
Tools, Brush Wheels & Buffs,  
Hand Brushes and Buffs, Borax,  
Saltpetre, Beeswax, Rouge, Tripoli,  
German Silver, Brass, &c.

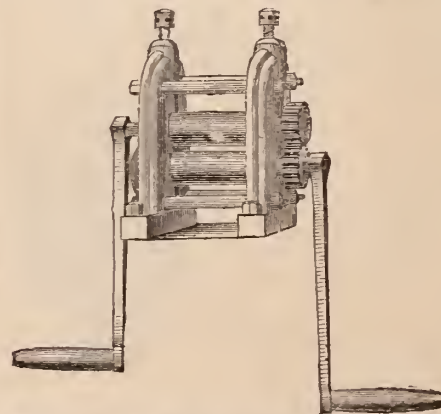

No. 62 Chatham Street,

New York.

Established 1816.

P. O. Box 462

# THE STANDARD FILLED RING

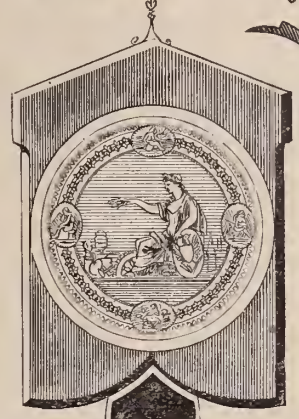
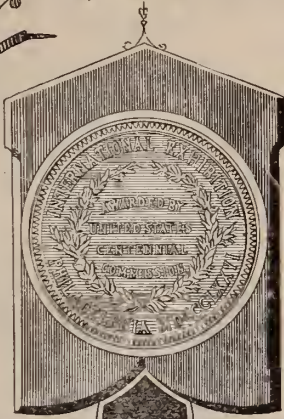

## CROWN, 18. LION FILLED RINGS

### PLAIN & CHASED



EVERY RING GUARANTEED

Beware of different stamps made to imitate our trade mark.



THE  
★ GANTELINE ★

THE GANTELINE.

THE ONLY NEW ARTICLE IN LADIES' JEWELRY IN A QUARTER CENTURY.

THE GANTELINE FACILITATES THE BUTTONING OF THE GLOVE.

It is formed of a hair-pin shaped link, connected by a chain to a charm of unique design.  
Or any suitable pencil, for memoranda.

It is worn pendant, by slipping the link through the button-hole of the dress;  
which allows the ornament to be displayed with pleasing effect.

We cite the following from the numerous press notices showing its merits.

"Of all the tasteful articles, nothing is so *new or useful* as the GANTELINE."—*N. Y. Evening Post.*  
 "A *Pretty Ornament*, and a very useful one, and the rage in fashion, is evinced by the number sold."—*N. Y. Mail.*  
 "It is really a clever device, *uniting the useful with the beautiful*, and is destined to become popular beyond a doubt."—*Home Journal.*  
 "A charming ornament of personal adornment, *remarkable for simplicity, elegance, utility*."—*N. Y. Trade Reporter.*

The above represents one of our elegant silvered Horse Shoe Trays, containing twelve GANTELINES, (Tray and Ganteline two-fifths size), and will be found a desirable acquisition to any Jeweler's stock. Nos. 653 and 655 show full size of GANTELINE.

These goods are of the *very best gold plate and finish*.

The GANTELINES can be ordered on approval in trays, which we have of different shapes, or singly if desired, from any of the above numbers.

We have spared no expense in producing new and beautiful ornaments for the GANTELINE.  
A tasteful Show Card will be furnished to every dealer who purchases one dozen or more.

C. G. ALFORD & CO., Manufacturers, 183 BROADWAY, New York.

MANUFACTURERS  
—OF—  
EXCLUSIVELY  
**BLACK ONYX GOODS.**

The patented **DEEP MOURNING LOCKETS** are original with us, and have stood the test of years of wear. They meet the approval of the trade and the wearers for their superior make and finish, as well as for the correctness of the mechanical principle on which they are constructed.

**WOGLOM & MILLER,**  
32 & 34 JOHN STREET,  
NEW YORK.

**HENRY FERA,**  
Importer of Diamonds,  
No. 9 MAIDEN LANE,  
New York.

Having my own cutting and polishing establishment at Nos. 23 and 25 Looijersgracht, Amsterdam, Holland, constantly running 36 mills, I am able to offer to the trade a full assortment of Diamonds at very low prices.

Loose and Mounted Goods sent on approval to any part of the country on receipt of satisfactory references.

All goods ordered from or shipped to me, are insured while in the hands of express companies, and no valuation is needed on the parcels.

**BOOZ & THOMAS,**  
MANUFACTURERS OF

Watch Cases  & Jewelry,

108 South Eighth St., (2d Story) Philadelphia.

Samples of our goods sent on approval, when satisfactory reference is furnished.  
**Old Gold & Silver Bought or Exchanged.**  
PARTICULAR ATTENTION PAID TO REPAIRING.

**HAMILTONS & HUNT,**  
MANUFACTURERS OF

**Fine Plated Chains**  
AND PATENT BUCKLE BRACELETS,  
Full Line of Ladies' and Gentlemen's Roman & Stone Lockets,  
**Branch Office, 176 Broadway, New York**  
FACTORY, 226 EDDY STREET, PROVIDENCE, R. I.

GEO. W. PRATT. IRA GODDARD.  
**GEO. W. PRATT & CO.**  
MANUFACTURERS AND DEALERS IN

**American and Swiss Watches,**  
**SOLID BAND AND SEAL RINGS,**  
Gold and Roll-Plated Jewelry,  
No. 14 JOHN STREET, NEW YORK.



**W. C. GREENE & CO.**  
GOLDSMITHS

MANUFACTURERS OF  
RICH SETS IN TAPER WIRE CORAL

Factory 95 PINE ST. Providence, R. I.      Stone Cameo      Engraved & Enamel Sets      Sleeve Buttons      Studs & Crosses      EAR & C. New York Office 192 BROADWAY.

WM. C. GREENE.      B. W. GREENE.      GEO. D. BRIGGS.

**M. FOX & CO.**  
**Practical Lapidaries,**  
IMPORTERS OF  
**DIAMONDS**  
AND OTHER PRECIOUS STONES,  
No. 1 Maiden Lane, New York.

**VANHOUTEN SAYRE & CO.**  
MANUFACTURERS  
OF  
**SOLID JEWELRY.**

ETRUSCAN ENAMEL  
AND  
FACET WORK.

SETS, REVENUTION, EAR-RINGS, LOCKETS, STUDS, COLLAR BUTTONS.

OFFICE AND FACTORY, **53 CHESNUT STREET NEWARK, N. J.**

**E. STITES,**  
*Manufacturing Jeweler.*  
 No. 12 MAIDEN LANE,  
 New York.  
 SCARF RINGS AND PINS.

Roman Band Bracelets.

I. PFORZHEIMER.

D. KELLER.

**PFORZHEIMER & KELLER,**

IMPORTERS OF

**Watches and Diamonds**

*Dealers in American Watches,*

AND

**Manufacturers of Jewelry,**

No. 24 JOHN STREET,

**NEW YORK.**

P. O. Box 4144.

**Coral Cream Polishing Fluid**

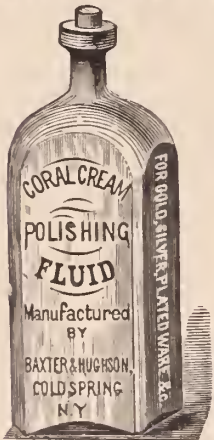

IS SUPERIOR TO ANY IN USE FOR CLEANING AND POLISHING  
 SILVER, GOLD AND PLATED WARE,  
 AND ALL FINE  
 Metallic and Glass Surfaces.

Free from Acid, Mercury, Ammonia,  
 Or anything Poisonous or injurious to the Hands or Metal.

**CHEAPER THAN POWDERS,**

As there is no waste in using, and produces a more lasting  
 brilliancy without injury or Wear to the Metal.

Pronounced by Experts to be the finest and  
 most brilliant Polish made.

Diploma awarded at American Institute Fair.

Bottle contains 4 fluid ounces.

IS THE BEST—SELLS THE QUICKEST—AND COSTS THE LEAST.  
 Liberal Samples furnished on application.

For Sale by Wholesale Jewelers and Silverware Dealers.

**EDWARD BAXTER,**

*Cor. 8th St. & Broadway.*

CARTER BUILDING, (Room 25), NEW YORK.

CHICAGO AGENT, J. H. PURDY & CO., 170 STATE STREET.



HIGHEST AWARD TO

**SYLVANUS SAWYER,**

—FOR—

**WATCH MACHINERY,**

**Watch & Clock Making Machinery**

For sale or made to order, either in complete sets, including

**PUNCHES & DIES AND OTHER SPECIAL TOOLS,**

Or in parts of sets, to accommodate purchasers.

**ALSO, JEWELER'S LATHES AND TOOLS,**

AND OTHER FINE WORK,

**MAIN STREET, FITCHBURG, MASS.**

**BREITINGER & KUNZ,**

IMPORTERS OF

**Watchmakers' Tools and Materials,**

GLASSES &C., &C.

**No. 107 N. 9th Street, Philadelphia.**

Agency in the U. S. for

**BÄHNI BROTHERS HARDENED & TEMPERED HAIRSPRINGS,  
 G. BECKER'S GOLD MEDAL REGULATORS,  
 DUDLEY'S ELECTRICALLY CORRECTED CLOCK.**

FINE ONYX AND PEARL NECKLACES AND PENDANTS.

**DOWNING & KELLER,**

MANUFACTURERS OF

**FINE JEWELRY,**

Onyx, Pearl Sets, Shawl Pins, Ear Rings, etc.

8 MAIDEN LANE,

**NEW YORK.**

**JEWELERS' AUCTIONEER:**

*Jewelers wishing to sell out, or reduce their  
 stock, retire from business, and being pushed  
 by creditors for obligations.*

I am a practical Jeweler, and conduct a good sale, being well  
 posted. Address, until further notice, care of Jewelers' Circular, and  
 letters will be forwarded to

**JOHN WIMMER,**

122 Spring Street,

**INDIANAPOLIS, IND.**

**STAR WATCH & CLOCK OIL,**

MANUFACTURED BY

**GEO. B. WHEELER,**

NEW BEDFORD, MASS.



This Oil is made from the best of stock, is free from gum or corro-  
 sive qualities, will stand the coldest weather, and is every way reliable.

L. HAMMEL & Co., 9 Maiden Lane, New York, Agents for the U. S.  
 KOCH & Co., Elberfeld, Prussia, Agents for Europe.



# ERRICO BROTHERS,

19 JOHN STREET, N. Y.

MAKERS AND DIRECT IMPORTERS FROM OUR OWN MANUFACTORY IN NAPLES,

## CORAL, SILVER FILIGREE AND CONCH SHELL JEWELRY,

—OF THE LATEST DESIGNS.—

These goods are made under our own immediate supervision, and designed expressly for this market. Our stock, the largest in the city, is replete with the richest novelties in this line, and is offered to the trade at prices that will tempt buyers.

We would direct the especial attention to our recent importations of CORAL ROSES and CORAL CAMEOS in all the most desirable shades. Also to our new designs in SILVER FILIGREE goods, which we offer at unexceptionably low prices. Buyers, when in town, are invited to an examination of our stock.

Novelties in design and finish, in Silver Fancy Goods and Hollow Ware, with combinations of colors in gold, silver and niello-enamel, Testimonial and Presentation Goods, Spoons and Forks of patterns popular and desirable, and a choice line of Case goods, from single pieces to Cabinets for Wedding Gifts.

THE  
Adams & Shaw Company,  
SILVERSMITHS,

and Makers of Hard Metal Electro-Plate,

694 BROADWAY, . . . . . NEW YORK.

GEO. R. COLLIS, Manager.

Designs and estimates furnished, and particular attention paid to orders for racing, Field and Nautical Prizes, (small and large), Tea Sets, Berry Bowls, Fruit and Ice Cream Stands, Jelly Bowls and General Hollow-Ware, in Sterling Silver or Silver-soldered Electro-Plate.

A large assortment of new, ornamental and useful presents for the HOLIDAYS.

LADIES' Portmonnies, Card Cases, Lace Pins, Hairpins, Tete-a-tetes, Shawl Pins, Card Stands, Vases, Caddies, Fruit Knives, Ice Cream Slicers, Sugar Scissors, Bells, and a great variety of other goods in new styles of decoration.

GENTLEMENS' Cigar Cases, Match Boxes, Shaving Mugs, Cigarette Cases, Pocket Flasks, Wine Coolers, Cigar Lighters, Liquor Labels, Wine Goblets, After-dinner Coffee Sets, Ice Pitchers, Soap Boxes, Call Whistles, &c., &c.

CHILDREN'S Cups, Rattles, Whistles, Pap Bowls, Catnip Warmers, Christening Sets, Knives, Forks, Spoons, Napkin Rings, Bib Pins, &c., &c.

**ROGERS & BROTHER,**

**Silver Plated Ware**

**FOR FALL AND HOLIDAY TRADE.**

*Dealers are reminded to give their orders IMMEDIATELY, if they desire the advantages of full stock to select from and early shipments.*

*As the Holidays approach and time for replenishing manufactured stock is shortened, (while orders are constantly accumulating) orders cannot then be filled with as much satisfaction to the manufacturer or the dealer.*

*Our stock is now complete with full lines of new, cheap and desirable goods. Dealers in town are invited to call and inspect the same. Dealers who do not intend to visit New York this Fall can have our Photographic Albums containing all the newest designs to date, sent them to make their selections from.*

*Parties unknown to us, desiring Albums sent, will kindly enclose business card and references.*

**ROGERS & BRO.,**

690 Broadway, New York



ESTABLISHED 1853.

CLOCKS



CLOCKS

B. J. COOKE'S SON,

137 N. 3d Street, Philadelphia.

Catalogues and Price Lists furnished to the Trade only, on application.

GEO. W. WALKER MOROCCO CASE M'FG CO.

MANUFACTURERS OF

Cases for Silverware, Jewelry, &c.,

FANCY MOROCCO GOODS OF EVERY DESCRIPTION.

Chests in Fancy Woods, &c., &c., &c

712 BROADWAY, - NEW YORK.

ESTABLISHED 1855.

WELCH & MILLER,

MANUFACTURERS OF MOROCCO, VELVET AND SATIN

Jewelry Cases, Trays, &c.

Telescope Sample Cases, with Flexible Trays.  
COMPLETE STOCK ON HAND.

No. 169 BROADWAY, NEW YORK.

CATALOGUES SENT ON APPLICATION.

JAMES IRONS,

THE "CONVEX"



SHOW CASE

CHEAPEST PLACE TO BUY GOOD

SHOW CASES,

Large Assortment.

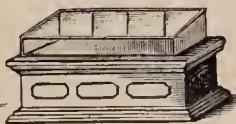

Factory and WAREROOMS,

132 & 134

North 4th St.,

PHILADELPHIA.

All kinds always on hand.

Cases packed securely to carry to any part of the world,

Charles F. Terhune & Co.,

Manufacturing Jewelers,

16 Maiden Lane,  
NEW YORK.



— Sole Manufacturers —



We beg to call the attention of the trade to the above cuts representing

PATENT SLIDE BUTTON

It is not separable, but works on a simple slide. It can be put in and taken out easier than any button made without soiling the cuff. Recommends itself at sight.

A full line of Stone, Enamel, Ivory and Pearl goods in above patterns.

BERNARD LEVY,

Manufacturer of Watch Cases

— AND DEALER IN —

AMERICAN WATCHES,

No. 402 Library Street,

PHILADELPHIA.

G. F. C. ROSENTHAL,

Manufacturing Jeweler,

917 SANSOM STREET.

PHILADELPHIA.

The finest Diamond and Pearl Work exclusively.

Lubricating Oils, for Watch, Clock and Chronometer Makers.

The discovery of a Lubricator for FINE MACHINERY, such as Watches, Clocks and Chronometers, that is free from gum and corrosive substances, has taxed the ingenuity of hundreds of men whose efforts have proved a failure. But we are happy to say, (being largely interested) that such an article has been supplied by Mr. EZRA KELLEY, of New Bedford, Mass., who, after forty year study of the subject, has perfected a Lubricator, that recommends itself to all who have used the genuine, (there having been numerous counterfeits in the market,) as witness also the award of a



Diploma and Medal by the judges of the late Centennial Exhibition at Philadelphia. We have no hesitation in saying that his Oils are the BEST manufactured always uniform in quality and capable of standing all test applied to lubricating oils. We cheerfully recommend it to all who may in their business require a FIRST CLASS LUBRICATOR

SETH THOMAS CLOCK COMPANY, SETH E. THOMAS, Agent



P. S.—The above Oils can be procured at all first-class wholesale Watch and Clock Establishments in the United States, as well as his only Agents, HENRY GINNEL, 31 Maiden Lane, New York, and GRIMSHAW & BAXTER, 35 Goswell Street, London, England.

New Bedford, October 15, 1877.

**T. B. BYNNER,**  
**Importer & Jobber of Watches**

DIAMONDS AND FINE JEWELRY,

And Dealer in the BEST CLASS OF ROLLED PLATE JEWELRY

And Key and Stem-Winding American Watches.

No. 513 Broadway, New York

**E. D. VOSBURY & CO.**  
**GOLD CHAINS,**

Rolled-Plate Chains and Locketts,

ELGIN WATCHES, BOSS FILLED CASES, STONE AND BAND RINGS OF EVERY DESCRIPTION,

25 Maiden Lane, New York.

**Clark's Grooved Case Springs.**

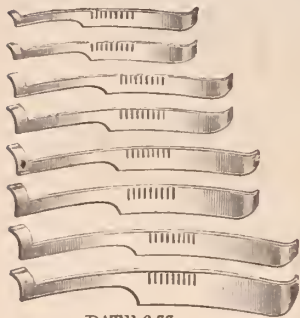

PAT. 677.

Made in four lengths, wide and narrow. The spring sets well away from the movement, the depressions obviate any tendency to move lengthwise. Steel rivets preferably used can be removed more easily than screws. In fitting file away the lower edge until the rivet can be pushed down in front of the spring in the grooves. These springs are made from fine steel, carefully tempered and warranted perfectly reliable. To be had of all jobbers in watch materials at manufacturers price—75 cts. per dozen.

**A. N. CARK,** Plainville, Ct.  
*Manufacturer of the Celebrated FOUR HOLE CASE SPRINGS, Watch Keys, Bench Tools, Crosby's JEWELING TOOLS, &c.*

**New Otto Silent Gas Engine.**

Working without Boiler, Steam, Coal, Ashes or Attendance.  
 Started instantly by a Match, it gives Full Power immediately.

No Explosion,  
 No Fires nor Cinders,  
 No Gauges,  
 No Pumps,

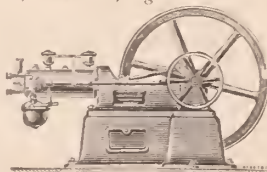

Perfectly Safe,  
 Easily Managed,  
 Durable, and  
 Simple in Construction.

**WHEN STOPPED, ALL EXPENSE CEASES.**  
**TESTIMONIAL.**

PHILADELPHIA, September 12, 1879.  
 Gents—The four horse power Gas Engine purchased from you for use in our polishing shop, has given us perfect satisfaction, holding its power, and giving little or no trouble in running. It has been in use for about nine months, and we are happy to say fulfills all that you promised for it. Yours, very truly,

JAS. E. CALDWELL & Co.

Sizes of Two, Four and Seven Horse made by  
**SCHLEICHER, SCHUMM & CO., 3045 CHESTNUT ST., PHILA.**

**A. W. MACERHANS,**  
**Manufacturing Jeweler,**

19 JOHN STREET, NEW YORK.

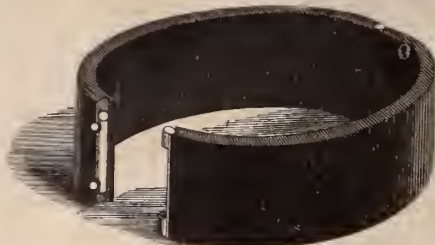

Patented May 7th, 1879.

These Bracelets, plain, with concaves for solitaire diamonds or with "lily of the valley" or other pearl ornaments, show less gold in mounting, and are lower in price than any other Onyx Band in the market.

They are made in widths running from 3/4 to 1 in. and from 5/4 to 6 3/4 in. wrist measure.

**Onyx Goods a Specialty.**  
 Onyx Lace Pins, Scarf Pins, Cuff Pins, Earrings, Locketts  
 Crosses, Ladies' and Gents' Vest Chains.

APPROVAL ORDERS SOLICITED. REPAIRING CAREFULLY DONE.

**MILNE & JOURDAIN,**  
 Manufacturers of Stem-Winding Watch Crowns



13 & 15 Franklin Street, NEWARK, N. J.

Gold Crowns, for Stem-winding Movements, to suit all sizes of Imported or American Watches, in four different styles and seven sizes.

Gold Pushers for Key Movements in every size. Also Gold Crowns for fine Chronograph Watches made to order.

Silver Stem winding Crowns and Key Pushers on hand or made to order. Send for card and samples.

A. MILNE.

A. JOURDAIN.



**RICKETT'S**  
**PATENT EYE SHADE.**

It is simply a neat curved shade of hard rubber, 3/4 inch wide that fits under the eye brows, and flares out at the bottom so as to allow an angle of vision about level with the horizon. Having met with success in New York, Philadelphia and Boston, and wishing to extend our trade to other cities, we will for the next 30 days forward to any one in the trade ordering 2 dozen Spring Shades, an elegant *Plaster Bust*, life size, stands 17 1/2 inches high, and retails in New York for \$3.00. If placed in prominent window, will sell 2 dozen shades in 10 days.

We have first-class testimonials from M. GARDNER, Chief of Draftsman, U. S. Patent Office, H. OLMSTED, Secretary of New York Jewelers' Association, and from many other prominent men of the country. Order from any jobber or direct from us. Please state whether you want Bust.

PRICE.—Spring Shades, \$3.50 per doz.

**RICKETT'S EYE SHADE CO.,**  
 85 Nassau Street, New York.

**WILLIAM H. BALL,**

SUCCESSOR TO BALL & BARNARD,

MAKER OF

ORNAMENTED

Roman, Enameled and Engraved  
**BRACELETS.**

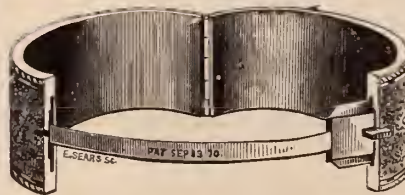

Having given the manufacture of Band Bracelets my entire attention for a number of years, it has been my desire to make a durable article, one that will give satisfaction to the seller as well as the wearer. I desire to call the attention of the trade to the reduction I have made in prices, still keeping up the standard as to QUALITY, FINISH and WORKMANSHIP. To each pair of BANDS is attached my patent guard without extra charge—thus saving the price of chain

No. 9 JOHN STREET, NEW YORK.

Factory, 30 & 32 Franklin Street, Newark, N. J.

# Clapp Bros. & Co.

## WHOLESALE JEWELERS,

63 and 65 Washington Street, Chicago, Ill.

*We invite the attention of the trade to Our superior Stock and Uniformly Low Prices.  
Catalogues and Price Lists issued only to Watchmakers and Jewelers.  
Orders solicited. Promptness and Care Guaranteed.*

## JUERGENS & ANDERSEN,

125 & 127 State Street, Chicago, Ill.,



No. 23.



No. 28a.



No. 28c.



No. 42.



No. 40.

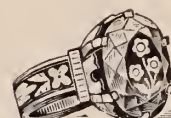

No. 47

Manufacturers of Fine Jewelry, Diamond Work, Seal Rings, Etc., Etc.

Special Attention Given to Matchwork and Repairing:

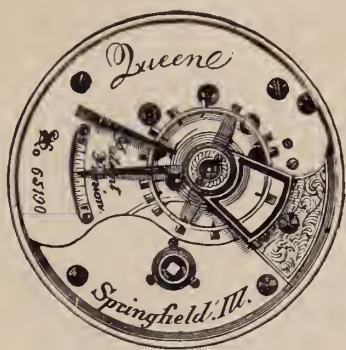

## C. H. KNIGHTS & CO.,

## WHOLESALE JEWELERS,

125 & 127 STATE STREET,

CHICAGO, ILL.

N. B.---We wish to call the attention of the Trade to our two new movements, "Enterprise," full jeweled, Nickel Key-wind, and "Queen," 11 jewels, full plate, open Bridge, Key and Stem-wind, with black dial. Also samples sent when requested.

## S. GLICKAUF & CO.,

Importers and Jobbers of

## WATCH MATERIALS AND TOOLS,

"W. B. & CO." WATCH GLASSES, SPECTACLES, CHAINS, SILK GUARDS, Etc., Etc.

WE CARRY A LARGE LINE OF NICKEL STEM-WINDERS.

79 & 81 State Street,

Chicago, Ill.



Whiting Manufacturing Company,

**SILVERSMITHS,**

BROADWAY AND FOURTH STREET,

**NEW YORK.**

# RANDEL, BAREMORE & CO. DIAMONDS,

Corner Maiden Lane and Nassau Street,

29 MAIDEN LANE,

58 NASSAU STREET,

**NEW YORK.**

No. 12 New Burlington Street, LONDON.

Established 1828.

## JACOB BENNETT & SON,

Diamond Setters and Manufacturing Jewelers,  
No. 108 SOUTH EIGHTH STREET, PHILADELPHIA.

WE MANUFACTURE AND MAKE A SPECIALTY OF  
EVERY DESCRIPTION OF

**DIAMOND MOUNTINGS,**

SUPERIOR IN DESIGN AND WORKMANSHIP.



Dealers in

**DIAMONDS,**

And all kinds of Precious Stones.

Masonic Marks, Society and School Badges, Made to Order Only. Designs and Estimates Furnished.  
PARTICULAR ATTENTION GIVEN TO ALL KINDS OF JOBBING.

## L. & A. MATHEY,

No. 16 MAIDEN LANE,

IMPORTERS OF ALL GRADES OF

Plain and Complicated Watches and Movements,

SOLE AGENTS FOR THE WELL-KNOWN

# H. L. Matile

FINE WATCHES OF ASTRONOMICAL PRECISION.

AN ATTRACTIVE LINE OF CHATELAINES AND CHATELAINNE WATCHES.



## LOUIS AUDEMAR'S CELEBRATED STEM-WINDING WATCHES

*So well and favorably known all over the world, have achieved the highest honors ever accorded to any WATCH. They are the finest finished Watches made, consequently the most reliable time-keepers.*

### J. EUGENE ROBERT,

SOLE AGENT,

IMPORTER OF WATCHES AND WATCH MOVEMENTS,

30 MAIDEN LANE. N. Y.

Special attention is directed to my full and complete stock of **WATCHES OF ALL GRADES**, from the smallest size upwards especially designed for the requirements of this market, cased in Gold, Silver and Nickel. Several of these movements interchange in American cases. The above goods are fully warranted.

Medal and Diploma awarded at Centennial Exposition, for superior mechanical execution and artistic ornamentation.



Established in 1854.

# C. & A. PEQUIGNOT, MANUFACTURERS OF WATCH CASES,

DEALERS IN AMERICAN WATCHES AND IMPORTERS OF FINE KEY AND STEM-WINDING MOVEMENTS,

## SALESROOM AND MANUFACTORY, 22 SOUTH FIFTH STREET, PHILADELPHIA.

A full stock of Key and Stem-Winding Gold Cases always on hand. Goods sent on approval when satisfactory references are furnished.

## HENRY C. HASKELL,

Manufacturing Jeweler,

No. 12 John Street,

New York

THE FINEST SEAL RING EVER OFFERED  
THE TRADE.

### The "MARQUIS"

*Must be seen to be fully appreciated.*

Four Sizes,  
CAMEO, INTAGLIO, ONYX or BLOOD STONE,

*Every Stone Warranted  
not to come out.*



4040

*Samples sent on approval, express paid.*



5223



7571

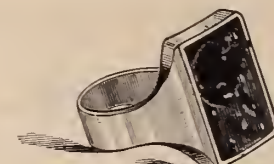

7572

*Price Lists to Trade only.*

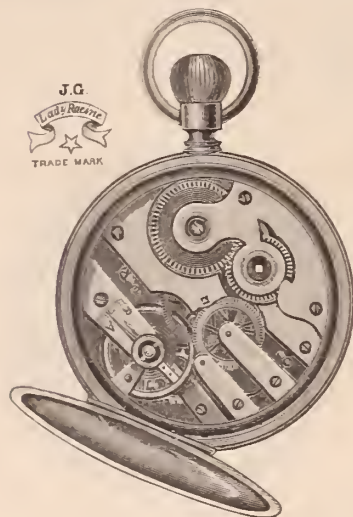

J.G.  
Lady's Reserve  
TRADE MARK

Factory,  
27  
RUE DU PARC,  
Chaux de Fonds,  
Switzerland.

Established 1826.

## JULIEN GALLET,

CHAS. PERRET, Sole Agent.

Sales Rooms,  
No. 1  
MAIDEN LANE,  
NEW YORK.  
P. O. Box, - 4420.

### Importer of Watches & Watch Movements,

Would respectfully call the attention of the Trade to the annexed cuts of the Lady's size Watch, Stem-Winder and Stem-Setter, in Nickel, Silver and Gold, White and Black Dials.



## New Jewel Setting Cutter

For cutting the bezel, or rim that holds the jewel to the plate of watch movements. In adjusting the jaws to the size of bezel to be cut, the gauge will be found very useful, there being twelve sizes of bezels made by this Tool. Sent with gauge, by mail, postpaid, on receipt of \$2.00.

Agent of Lancaster Pa. Watch Co.

for New York, Pennsylvania and Ohio. Information, Price Lists and Circulars cheerfully furnished upon application. Enclose business card. Orders should be addressed,

PHIL. HECHT, 13 Maiden Lane.



WAVERLY, N. Y., August 30, 1879.

PHIL. HECHT :

*Dear Sir* :—That little Jewel Cutter is a very handy little tool and saves lots of time. Every man who uses it cannot help but appreciate it.

Yours truly,

M. H. MANDEVILLE.

ROCK CREEK, August 25, 1879.

MR. PHILLIP HECHT,

*Dear Sir* :—The Jeweling Tool came to hand this morning. I am very much pleased with it. Five dollars would not buy it if I could not replace it.

J. C. KNOWLTON.

BETHLEHEM, August 27, 1879.

*Dear Sir* :—I send you briefly and most cheerfully my opinion of your "New Jewel Setting Cutter and Gauge." Having tried it thoroughly I can recommend it as a useful tool and doing its work correctly. No good workman ought to do without it.

Respectfully yours,

L. F. GIERING

*Any Article in the Watch Material, Optical and Silk Guard Lines furnished at the Lowest Rates.*

**HALL, ELTON & CO.,**  
**Manufacturers of the Finest Electro-Plated Ware.**



**UNSURPASSED IN QUALITY, STYLE AND FINISH!**  
 Factories, Wallingford, Conn.      Salesroom, 75 Chambers St., New York.

**HOLMES, BOOTH & HAYDENS,**  
 MANUFACTURERS OF  
**ELECTRO-SILVER PLATED**  
**Spoons, Forks, Ladles, Fancy Pieces,**  
**Solid Handle Steel Knives, &c., of the finest quality.**  
 No. 49 Chambers Street,      No. 18 Federal Street,  
**NEW YORK.**      **BOSTON.**  
 Works at Waterbury, Conn.

**BROWN & BROTHER,**  
 MANUFACTURERS OF  
**Finest Quality of Electro-Plated Flat Table Ware,**  
**PATENTED HEAVY SPRING TEMPERED SHANK ON FORKS AND SPOONS.**  
 ILLUSTRATED CATALOGUES FURNISHED ON APPLICATION.  
**WAREROOMS, No. 81 CHAMBERS STREET, NEW YORK CITY.**

FACTORIES, WATERBURY, CONN.

P. O. BOX 5731.

**GUERRANT'S ELECTRO-ENGRAVING MACHINE.**

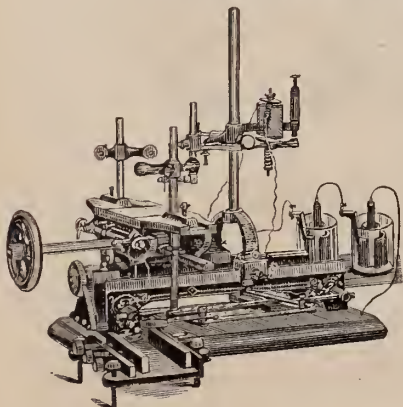

It has baffled the skill of the inventive genius of the world for ages to produce a machine that would compete with the skillful hand engraver, and until this machine was invented, all engraving had to be done by hand. And, to-day, it is the only practical engraving machine in existence.

The construction of the machine is not complicated, but simple and durable. It is easily operated. The variety of work it will do is almost incredible, and to be fully appreciated, ought to be seen in operation.

We do not therefore, offer this machine to the public simply as a machine to aid the engraver, but as a perfect, practical engraver in itself, with which any person of ordinary skill can learn in a short time to do any piece of engraving that might be desired and in the very best manner.

It copies from the regular press type of any style of letter or design that is made of type, from the plainest to the finest german text letter or fancy design, at the same time it will reduce the letter or design from the original size to ten different sizes, or so small that it cannot be seen by the naked eye. It will shorten the letters or elongate them, also will lean them forward or backward, will either make a raised or sunken letter, will engrave on any surface, either plain, concave or convex—for instance, such things as Watch Cases, either in or outside; Finger Rings, either in or outside; Bracelets, Napkin Rings, Goblets, Pitchers, Mugs, Waiters, Spoons, Forks, and all kinds of Jewelry; or, in fact, on any article susceptible of being engraved or ornamented with scroll work or fancy designs, &c., either on Gold, Silver, Copper, Brass, Iron, hardened Steel, Glass, Stone, Pearl, Ivory, Bone, Gutta Percha.

No Jeweler or establishment that has engraving to be done should be without it. Machines are sold with limited territory to use them in; or, the exclusive rights to use them in certain town or territory can be purchased with the machine if desired.

For further information, address

**WM. HICKSON, Gen. Agt.,**  
**P. O. Box 1603, PHILADELPHIA, PA.**

**KARN & HICKSON,**  
**LYNCHBURG, VA.**

Size of Machine, 12 x 16 inches.  
 Patented Jan. 18, Oct. 31, 1876, & Mar. 4, 1879.

**A. M. GUERRANT, Danville, Va.,** Agent for the Southern States.

Owners of the right of all the Northern States and Territories.

The accompanying cut illustrates the large size

# PIONEER WATCH,

The best pocket time-keeper ever offered the trade. Can be had of any first-class Jobbing House throughout the United States.

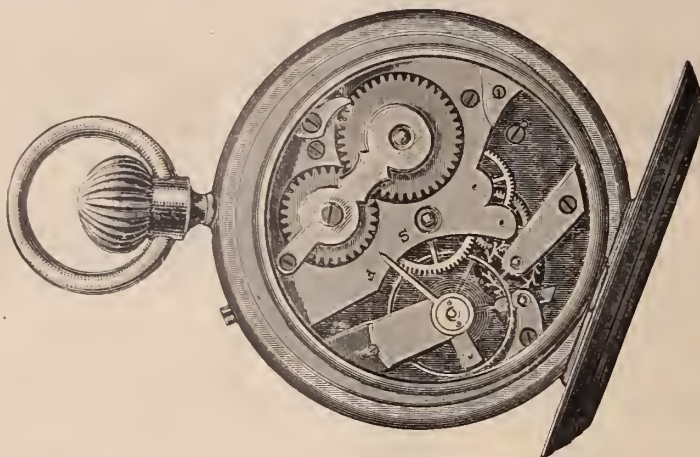

None genuine unless stamped  
**" PIONEER "**  
 either inside or outside of case.

**H. GINNEL,**

Sole Manufacturer,

31 Maiden Lane,

**NEW YORK.**

P. O. Box 2967.



No. 5 A.

NICOUD WATCHES,  
 NICOU D & HOWARD,  
 SOLE IMPORTERS,  
 14 MAIDEN LANE,  
 P. O. BOX 2269. NEW YORK.



No. 4.

Goods sent on approval upon receipt of New York references.

House Established since 1837.

# CHAS. LEO ABRY.

(SUCCESSOR TO J. A. ABRY.)

## Importer and Manufacturer of Swiss Watches,

OF ALL GRADES, AND DEALER IN AMERICAN WATCHES.

Sole Agent in the United States for the **Celebrated Vacheron and Constantin Geneva Watches.**

These unrivalled time-keepers are now made interchangeable in every respect. A full line (cased or uncased) always in stock—prices very much reduced from formerly. Specialties in O. F. Nickel Stem Winders Anchors with White, Black and Fancy Dials, 16, 18 and 20 lines. Also, Silver O. F. Hunting and 1/2 Hunters Stem Winding Anchors, 16 and 20 Lines. In liquidation—a large stock of Swiss Key and Stem Winder Watches, Gold and Silver Cases, must be sold and are offered cheap for cash. SEND FOR PRICES.

Factory, Neuchatel, Switzerland.

P. O. Box 611.

63 Nassau St., New York.

## CLOSING OUT.

THE ENTIRE STOCK OF

# JEWELRY

OF

## CHATTERTON & DODD,

To close the business.—Great inducements offered to purchasers.—Dealers visiting the city will find it to their interest to call and examine this stock.

No. 19 JOHN STREET, NEW YORK.



**W<sup>m</sup> S. HEDGES & CO**

OF THE LATE FIRM OF SMITH, HEDGES & CO.

**IMPORTERS OF**

**DIAMONDS**

**170 BROADWAY**

COR. OF MAIDEN LANE N. Y.

CHOICE BRILLIANTS IN SINGLE STONES  
AND MATCHED PAIRS A SPECIALTY

FRESH INVOICES OF GOODS IN ALL GRADES CONSTANTLY ARRIVING. ALSO, CHOICE PARCELS OF EXCEPTIONALLY FINE GEMS ESPECIALLY SELECTED FOR CRITICAL PURCHASERS. A Full Line of Mounted Goods Artistically Designed.

GOODS SENT ON APPROVAL.

# “HILLSIDE,”

NEW THREE-QUARTER PLATE MOVEMENT

—MADE BY—

## The American Watch Company

OF WALTHAM,

The lowest price three-quarter plate Stem-Winding American movement ever made. We wish to call the attention of the trade to the following special advantages:

*They are made to wind at either the figure XII for Open Face Cases, or at figure III for Hunting Cases, in all three qualities, viz.:*

- Gilded Movement, Cut Expansion Balance, plain jeweled;
- “ “ “ “ “ with 3 pairs extra jewels in settings;
- Nickel Movement, Cut Expansion Balance, with 3 pairs extra jewels in settings.

*These movements all have quick trains, Patent Pinions, with extra jewels in settings, and, at the very low price at which we offer them, are especially adapted for our New Patent Dust Proof Open-Face Cases. A good strong case can be made under our patents weighing not over*

22 dwts., 14 karat gold,  
24 “ 18 “ “

*thus making altogether the lowest price three-quarter plate gentlemen's size stem-winding gold watch ever offered.*

Robbins & Appleton, 9 Bond St., New York.  
Robbins, Appleton & Co., 8 Summer St., Boston.  
Robbins & Appleton, 170 State St., Chicago. } *General Agents.*

AMERICAN WATCH COMPANY,  
OF WALTHAM, MASS.

*Note the prices of the following new movements made by*

# THE AMERICAN WATCH COMPANY

## OF WALTHAM, MASS.

### 14 Size, $\frac{3}{4}$ Plate.

AM. WATCH CO.	"HILLSIDE"	(New), 7 jewels, cut expansion balance, Stem Winder, for Hunter or Open Face, (Gilded Movement)	\$20 00
"	"	"	3 pairs extra jewels, in settings, cut expansion balance. Stem Winder, for Hunter or Open-Face, (Gilded Movement),.....
			23 00
"	"	"	3 pairs extra jewels in settings, cut expansion balance, Stem Winder, for Hunter or Open Face, (Nickel Movement).....
			30 00

### 18 Size, Full Plate, NICKEL Movements.

" WM. ELLERY,"	2 pairs, extra jewels, cut expansion balance.....		12 00
"	2 " " " " " " " " Stem Winder,.....		16 50
"	2 " " " " " " " " " " Stem Winder		26 00
"	4 " " " " " " " " " " Stem Winder		34 50
"	4 pairs, extra jewels in settings, cut expansion balance, adjusted.....		37 00
"	4 pairs, extra jewels in settings, cut expansion balance, adjusted, Stem Winding.....		46 50

All the above are subject to the terms and discounts announced in our circular of the 8th Feb. last.

There will be no change in the quality of any of our grades, except as our constant efforts tend to their improvement. We decline altogether to take any part in the present unwise competition between Swiss and American manufacturers to see which shall make watches of the poorest quality. We intend to sell as low as any American company, but, however low the price, we do not intend to finish a grade of goods upon which it would be a disgrace for us to put our name.

Robbins & Appleton, 9 Bond St., New York.  
 Robbins, Appleton & Co., 8 Summer St., Boston, } General Agents.  
 Robbins & Appleton, 170 State St., Chicago.

American Watch Company,  
 OF WALTHAM, MASS.

*New York, September 1st, 1879.*



*A SELECT ASSORTMENT OF RINGS, EAR RINGS, EAR DROPS,  
STUDS, PINS, CROSSES, LACE PINS, AND OTHER*

*NOVELTIES,*

*ARTISTICALLY MOUNTED, AND ESPECIALLY DESIGNED*

*FOR THE HOLIDAY TRADE.*

*GOODS SENT ON APPROVAL.*

# New Haven Clock Co.

117 & 119 State St., Chicago.

G. A. HARMOUNT, Agent.

62 Reade Street, New York.

L. EGERTON, Jr., Agent.

Manufacturers and Jobbers of

# AMERICAN CLOCKS,

## Movements and Clock Material,

Also, Black Walnut, Visible Pendulum Clocks, and Specialties  
in Brass and Nickel.

Agents for { JEROME & CO., - - - - - Of New Haven, Conn.  
{ E. INGRAHAM & CO., - - - - - Of Bristol, Conn.

Liberal Discounts to the Trade.

# WATERBURY CLOCK CO.

MANUFACTURERS OF AMERICAN CLOCKS,

4 CORTLANDT STREET,  
NEW YORK.

M. BAILEY, Treasurer.

63 WASHINGTON ST.  
CHICAGO.

—————  
♦ ♦ ♦  
—————  
FACTORIES, WATERBURY, CONN.



SHARP GOTHIC EXTRA.



CRICKET EXTRA.

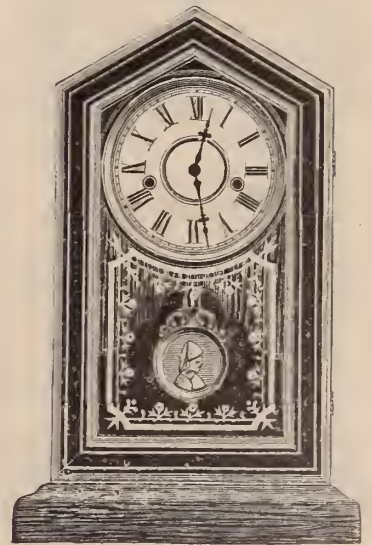

CHESTER.

# GEO. B. OWEN & CO.

6 MURRAY STREET,

Factory, Winsted, Conn.

New York.

MANUFACTURERS OF

## BLACK WALNUT CLOCKS,

Clocks Manufactured by the following Companies will be furnished at lowest Market Rates:

- New Haven Clock Co.,
- Seth Thomas Clock Co.,
- E. N. Welch Man'f'g Co.,
- Welch, Spring & Co.,
- Waterbury Clock Company,
- Ansonia Clock Company,
- Wm. L. Gilbert Clock Company,
- E. Ingraham & Co.

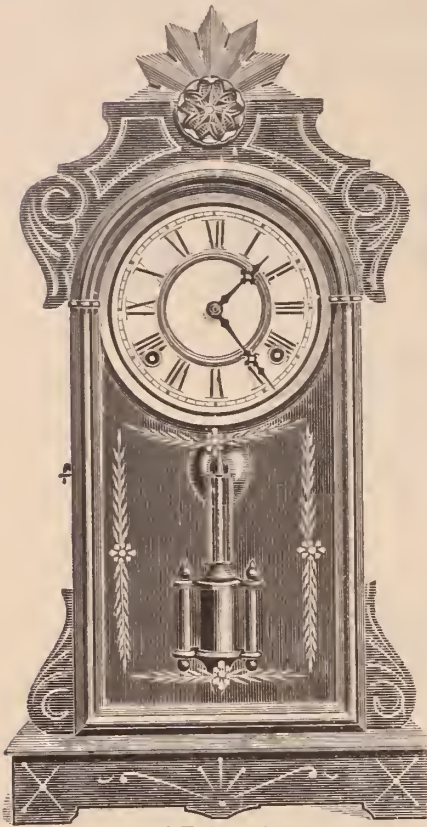

**ARGUS.**

Eight day Strike Height, 20 1/4 in



**AMPHITRITE.**

1 Day Time. Height 17 1/2 in

Illustrated Catalogues and Price Lists furnished on application,

# E. N. WELCH MFG. CO.

WELCH, SPRING & CO.

## Clock Manufacturers

FACTORIES, FORESTVILLE, CONN.

STORES AND WAREHOUSES:

6 Warren St., New York,

170 State St., Chicago.

STYLES OF OUR GOODS:

Original, Unique, Highly Finished,

Warranted Excellent Timekeepers, and Cheap.

Send for Catalogue, Price List and Discounts.

E. C. HINE, General Manager,

NEW YORK.

F. E. MORSE, Agent,

CHICAGO, ILL.

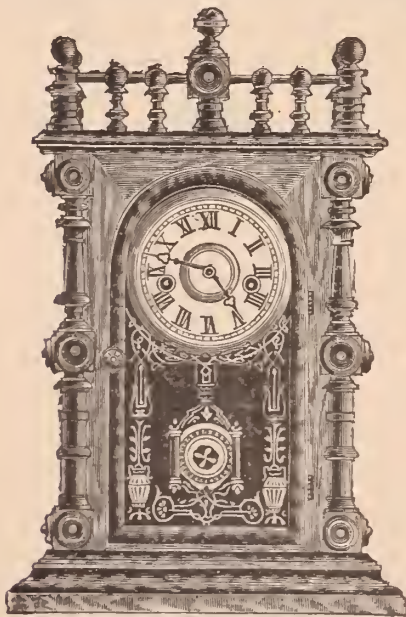

**GERSTER.**

SPRING STRIKE. VERY FINE MOVEMENT. HEIGHT, 18 INCHES. 8 DAY STRIKE. HIGHLY FINISHED ROSEWOOD CASE POLISHED. GLASS SIDES. SPRINGS BARRELED.



**GOODLUCK.**

(Patented Sept. 17, 1878. Height, 6 inches.)

Thirty hour Lever Time. This clock will run in any position. Is a stem winder. Winds and sets everything at the back. The movement is protected at front and back by close fitting caps, so that the dust can not get in. Made in Gold Gilt or Nickel, with and without alarm. Manufactured only by the E. N. WELCH MANUFACTURING CO., Forestville, Conn.

# LOUIS STRASBURGER & CO.

DIRECT IMPORTERS OF

## DIAMONDS.

OF ALL GRADES,

Especially selected for this market. Original parcels of new goods constantly arriving, so that dealers are always sure of finding a most desirable and ever-changing stock to select from.

FINE GEMS IN SINGLE STONES AND MATCHED PAIRS A SPECIALTY.

15 MAIDEN LANE, NEW YORK.

30 BOULEVARD HAUSSMANN, PARIS.

# LOUIS STRASBURGER & Co.

MAKERS AND IMPORTERS OF

## WATCHES.

From the finest Stem-Winding and Setting goods to the lowest price Watch in the market.

We have constantly in stock a complete and varied assortment of the best COMMERCIAL WATCHES ranging from the lowest priced Metal and Silver Watches to the finest Gold goods, including REPEATERS, CHRONOGRAPHS (single and split seconds) and other Timing and Complicated Watches of established reputation.

We would call the especial attention of the trade to our complete assortment of NICKEL WATCHES, with Black, Fancy and Luminous Dials, in all grades, styles and sizes.

Also a full assortment of the INTERNATIONAL and all grades of AMERICAN Movements, in *Gold and Silver Cases*, constantly in stock.

SALESROOM, No. 15 MAIDEN LANE, NEW YORK.

Watch Factory, Rue Leopold, Chaux de Fonds, Switzerland.

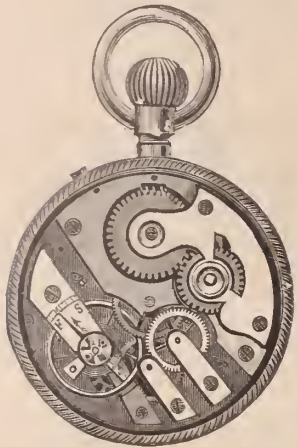

LADY RACINE,  
Open Back.



REGISTERED

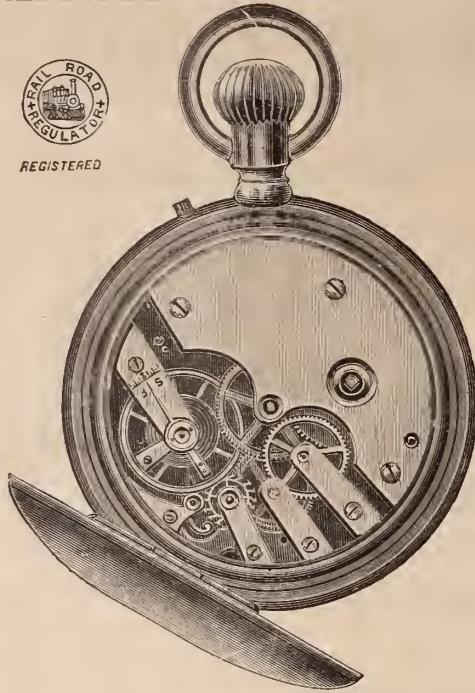

RAILROAD REGULATOR.

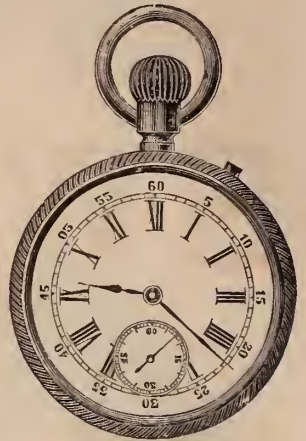

LADY RACINE,  
Open Face.



REGISTERED



CONTINENTAL.

THE CHEAPEST STEM-WINDING AND SETTING

# Swiss Watches,

IN THE MARKET.

These movements are carefully and substantially made—have White, Black, Luminous and Fancy dials—CASED IN NICKEL, and are the best imported Waches for the money.

## JULIEN GALLET,

No. 1 Maiden Lane, New York.

TRADE MARKS PATENTED.



CONTINENTAL.

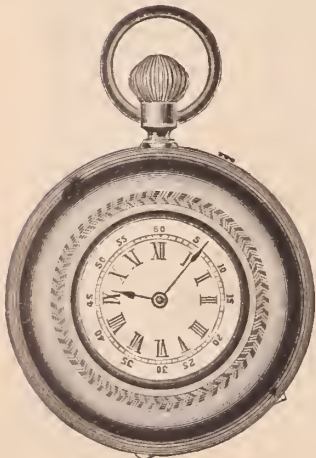

LADY RACINE.

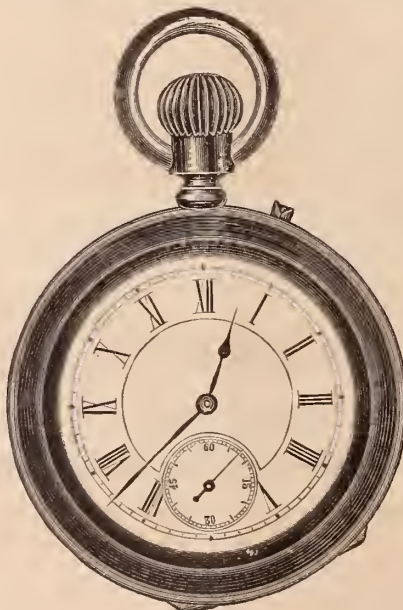

RAILROAD REGULATOR

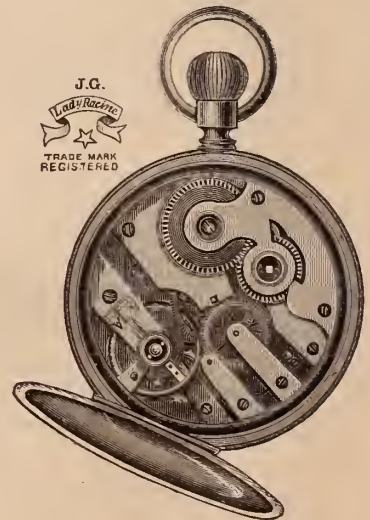

LADY RACINE.



# CROSS & BEGUELIN,

21 MAIDEN LANE - - - - - NEW YORK.

IMPORTERS OF

# SWISS WATCHES,

Watch Tools, Materials, Glasses, etc.

ALSO JOBBERS IN

All Grades of AMERICAN WATCHES

AND MAKERS OF THE

## CENTENNIAL WATCH,

(Stem-Winding and Stem-Setting) so universally popular and conceded to be the best made watch for the money in this market.

We have recently added to our stock a full and complete line of

## FRENCH TRAVELING CLOCKS,

Also, LEMAIRE'S OPERA AND FIELD GLASSES,

We are wholesale agents for the CHARLES E. JACOT WATCHES, and ROGERS & BRO., CELEBRATED FLAT AND HOLLOW WARE



None Genuine without this Trade Mark.

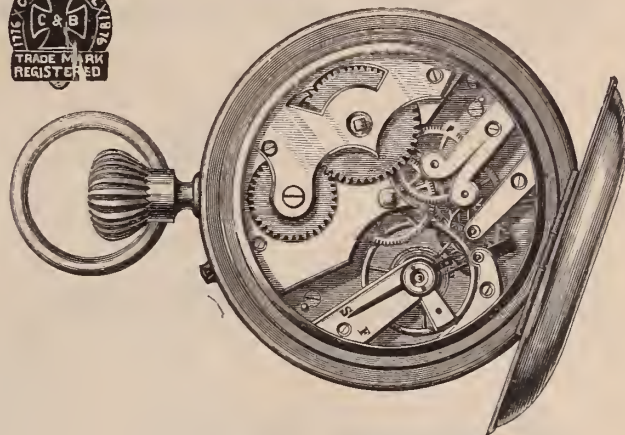

The above is a fac-simile of the Centennial Watch the AUBURNDALE TIMER, 1/4 and 1/8 Seco d

# WM. ROGERS & SON,

HARTFORD, CONNECTICUT.

Trade Mark on Spoons :

⚓ WM. ROGERS & SON, A. A.

Established in 1865.

We call attention to our new pattern, the HARTFORD, it is the latest, nob- biest and best pattern in the market, and is *five per cent*, less than any pattern of the kind.



Trade Mark on Knives :



Established in 1865.

Silver Plated Knives, Forks, Spoons, Casters and Cake Baskets.



The HARTFORD. Pat. Sept. 23d, 1879.

# WM. ROGERS & SON,

Drawer 30, Hartford, Conn.

WM. WATROUS, President.  
F. WILLSON ROGERS, Secretary.

# AIKIN, LAMBERT & CO.

MANUFACTURERS OF

GOLD PENS,

Ebony,	}	PENCIL CASES,	}	Celluloid
Ivory,		DESK HOLDERS,		Rubber.
Rosewood,		PENCILS,		Pearl.
		TOOTH PICKS,		

—AND—

## NOVELTIES IN PENCIL CHARMS.

Many of which are protected by Letters Patent, and all at prices to meet the popular demand, being made and finished in our own factories under our own personal supervision, using the best materials with modern appliances (we guarantee our productions), unsurpassed in finish, style and price. Our patent inlaid Celluloid Pencils, Pencil Charms and Picks, in Black, Shell, Malachite, Red, White, Pink, Variegated light and dark blue colors, are the handsomest goods yet produced, and at reasonable prices, the inlaid work being of *solid gold* and pearl in form of flowers, birds, etc., and warranted durable.

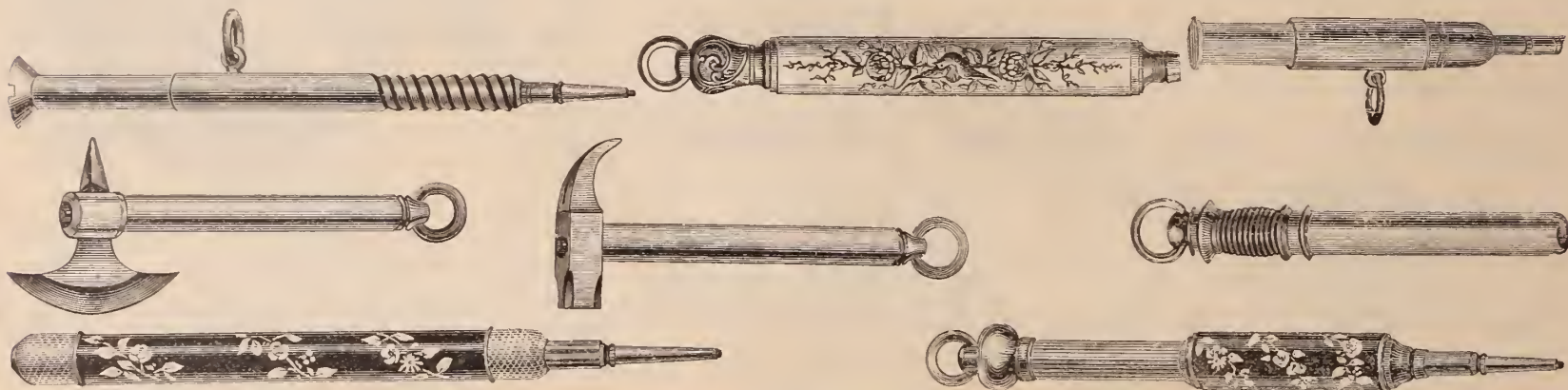

A full assortment of long and short nibs, stubs, falcon, oblique, commercial, fine and broad pointed Pens, in every style of holder, suitable for business or holiday trade.

To those purchasing assortments, we are furnishing the finest trays and show cases for their display, ever offered to the trade. Dealers are invited to call and examine, or particulars will be furnished to regular dealers only, upon application, when accompanied by business card, or satisfactory reference, and price lists, with Illustrated Catalogues sent. ALSO, A LINE OF GOODS SUITABLE FOR EXPORT TRADE.  Goods sent for selection.

PARIS HOUSE,

J. GLAENZER & CO

35 Boulevard de Strasbourg.

Main Office, 23 Maiden Lane, New York.

Branch Office, 113 E. Madison St., Chicago.

We are also Importers of all grades of watches, and would call attention to the following specialties :

**PAUL BRETON** Movements, of which we are sole Agents. A full line of these celebrated Watches in Gold and Silver Cases of the most approved styles.

**CHAS. LATOUR** Movements, Nickel  $\frac{3}{4}$  plate, handsome, showy watches at medium prices, good reliable time pieces. Key and Stem-Winders.

**AGASSIZ** Movements, Gilt and Nickel Stem Winders (fitting 8 size Riverside Case), accurate timepieces, and *lower priced* than American movements of same quality.

Metal Open Face Stem Winding **Longines, Excelsior and Champion**, 13, 15, 16, 18 and 20 lines, good timers and *attractive in style and finish*.

Jobbers in all kinds of **American Movements and Cases**, including the "DUEBER," Silver Cases, and BOSS' and LADD'S FILLED CASES.

MANUFACTURERS OF

**GOLD AND SILVER THIMBLES**, in various styles, and to order.

**STONE RINGS**, Onyx, Cameo, Intaglio, Topaz, Garnet, Amethyst, Pearl and Turquoise; also Solid Band, Chased and Plain.

**BRACELETS**, an assortment in gold and rolled plate, including new and handsome designs.

**PLATED CHAINS**, a large assortment of Vest, Guard, Neck, &c. Also, SEALS, LOCKETS, &c. A GENERAL LINE OF RELIABLE JEWELRY IN GOLD AND PLATE.

We manufacture to order any article in the line; also do repairs, and will procure for regular customers any article required in the trade, whether kept in stock or not. Orders filled as promptly as possible.

**23 Maiden Lane, New York.**

1879 NEW FALL PATTERNS IN FINE SILVER PLATED-WARE MADE BY 1879

## Meriden Britannia Company,

46 East 14th Street.

UNION SQUARE.

47 East 13th Street.

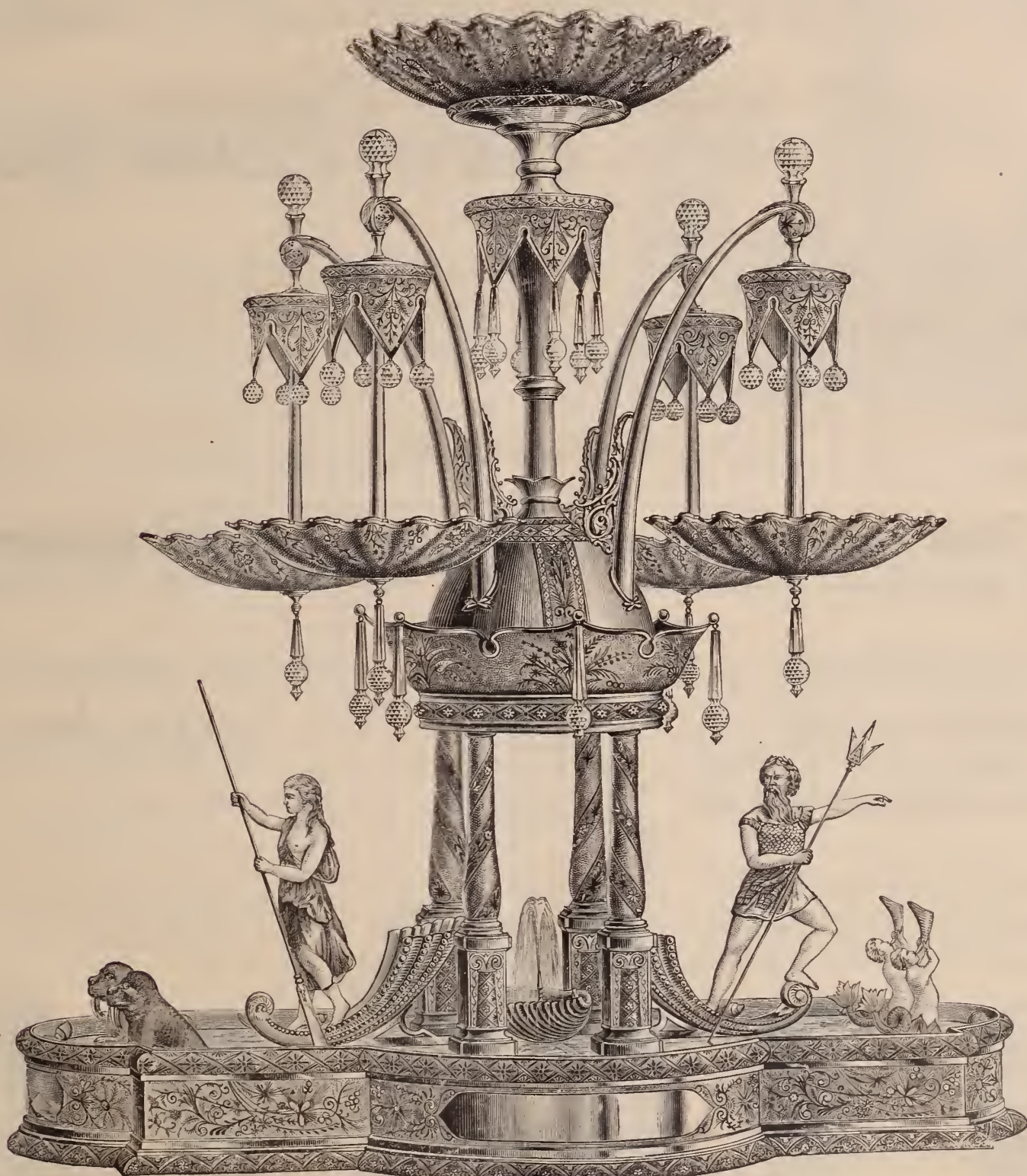

*From Gebbie & Barrie's "Masterpieces of the U. S. International Exhibition, 1876."*

Attention of the Trade is invited to a more complete assortment of Electro Plated Ware than ever before offered by this Company. Also, to the importance, more than for many years, in ordering earlier in the Season.

# SIMPSON, HALL, MILLER & CO.

36 East 14th St., Union Square,  
NEW YORK.

Factories, Wallingford, Connecticut.

MANUFACTURERS OF THE FINEST QUALITY

## Silver-Plated Ware.



NEW DESIGNS OF SUPERIOR ARTISTIC MERIT NOW  
READY AND IN PREPARATION FOR  
THE FALL TRADE.

# The STAR SALT



# CASTER COMP'Y

Sole Proprietors and Manufacturers of  
CELEBRATED

# STAR SALTS

For convenience, neatness and utility the STAR SALTS have become a household necessity.

The pulverizer in the bottle, as shown by the cuts, keeps the salt pulverized, and obviates the disagreeable habit of spilling the salt by dipping out of an open salt cellar.

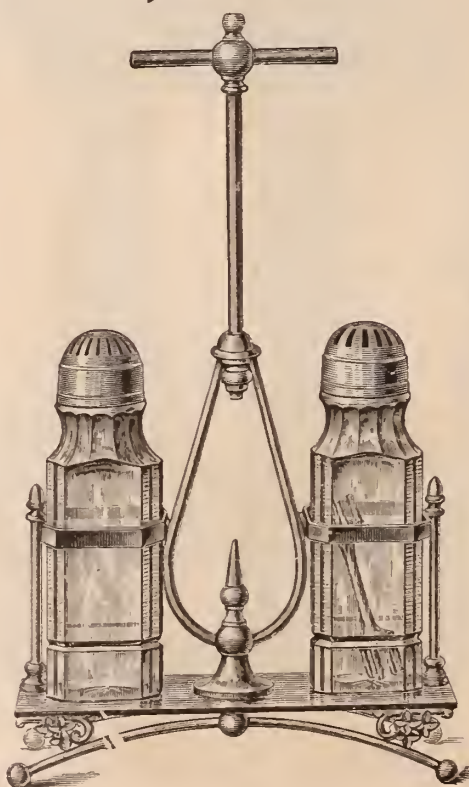

No. 161 Franklin Street  
BOSTON, MASS.

Place these in the family and Salt Cellars  
will be discarded.

MANUFACTURED IN ALL VARIETIES  
OF PLAIN AND FINE CUT  
GOODS, CASTERS, &c.

Special care given to orders for exportation.

For full descriptions of the above goods see our Illustrated Catalogues, which will be mailed on application

Fine Diamond Cut, with  
Sterling Caps.

New Designs for Fall of 1879,

— IN —

**MIDDLETOWN**



**PLATE CO.'S**

# Superior Silver-Plated Ware.

AN UNUSUALLY LARGE VARIETY OF

Patent Jewel Boxes, Card Receivers, Toilet Sets, Bon-Bon Boxes,

— AND OTHER —

**NOVELTIES.**

ATTRACTIVE FOR PRESENTS.

ALSO, THE LARGEST AND MOST ELEGANT ASSORTMENT OF

Tea Sets, Waiters, Baskets, Butter Dishes, Pitchers, Water Sets, Etc.

ORDERS SHOULD BE SENT PROMPTLY.

**Factories :**

**Middletown,**

CONN.

**Salesrooms :**

**120 Sutter Street,**

**San Francisco, Cal.**

**Salesrooms :**

**13 John Street,**

**NEW YORK.**

**101 & 103 State St.**

**Chicago, Illinois,**



No. 160 Card—Gilt, \$8.50.

# MILLER BROS.

MANUFACTURING JEWELERS,

No. 11 MAIDEN LANE, NEW YORK.

Manufactory, 47, 49 & 51 Franklin Street, Newark, N J

A  
Large Line  
of

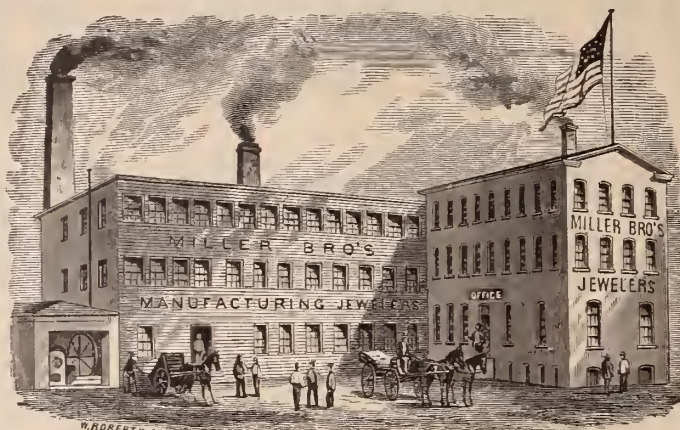

NOVELTIES.

ATTENTION IS INVITED TO OUR  
NEW STYLES OF ETRUSCAN SLEEVE BUTTONS,  
MOUNTED WITH

## RUSTIC LETTERS

BIRDS, ANIMAL HEADS AND FANCY ORNAMENTATIONS.  
Also a full line of Locketts, Sets, Pins, Ear Rings, Sleeve Buttons, Studs, &c.

All goods exclusively of our own manufacture, many of which are protected by MECHANICAL and DESIGN PATENTS.

Silver Case Factory, Milford, Pa.

Gold Case Factory, Brooklyn, N. Y.

## CHARLES GLATZ,

IMPORTER OF

# SWISS WATCHES.

MANUFACTURER OF

## Gold & Silver Watch Cases,

12 Maiden Lane, New York.

AGENT FOR ALL THE AMERICAN MOVEMENTS,

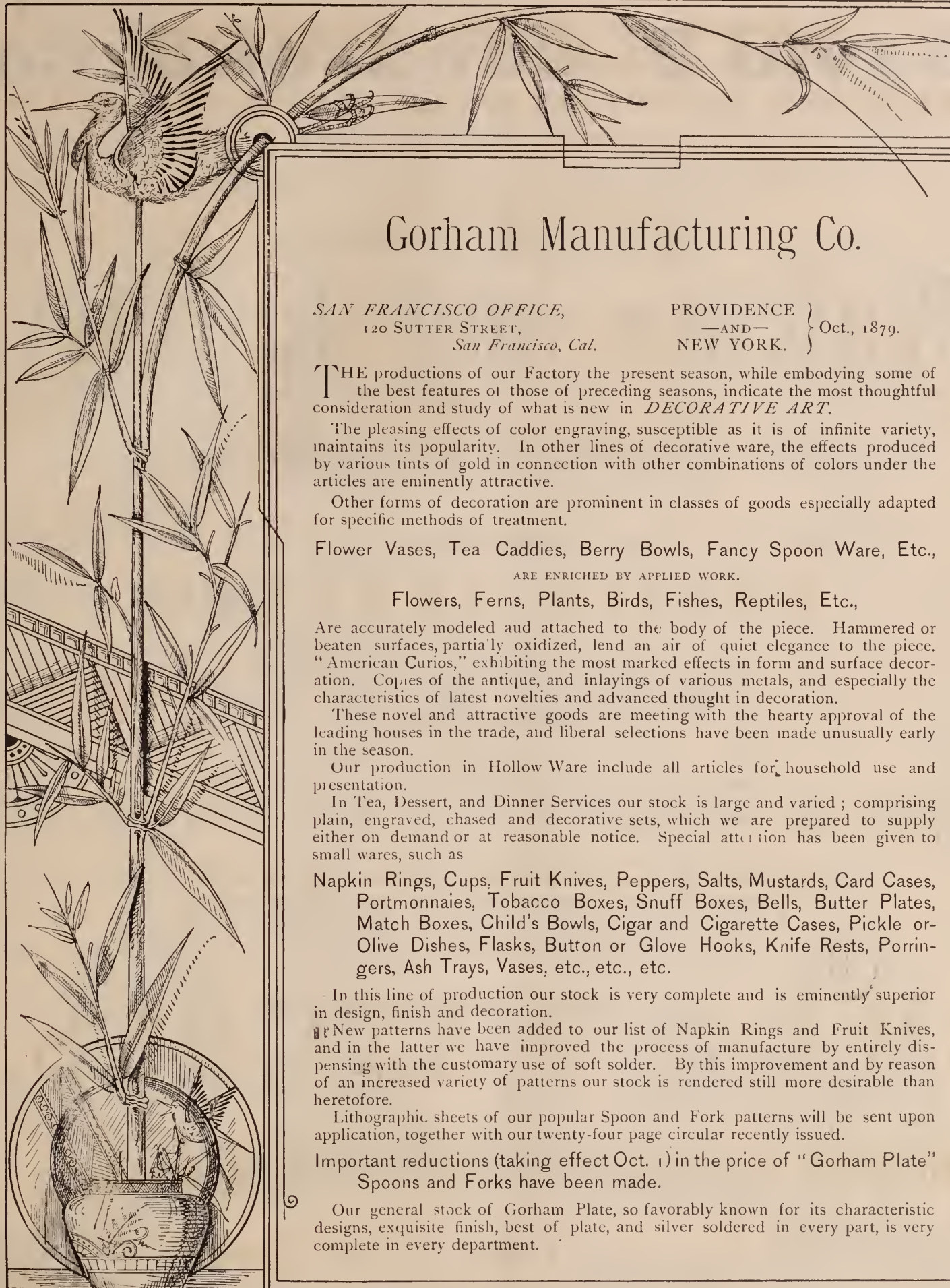

## Gorham Manufacturing Co.

SAN FRANCISCO OFFICE,  
120 SUTTER STREET,  
San Francisco, Cal.

PROVIDENCE }  
—AND— } Oct., 1879.  
NEW YORK. }

THE productions of our Factory the present season, while embodying some of the best features of those of preceding seasons, indicate the most thoughtful consideration and study of what is new in *DECORATIVE ART*.

The pleasing effects of color engraving, susceptible as it is of infinite variety, maintains its popularity. In other lines of decorative ware, the effects produced by various tints of gold in connection with other combinations of colors under the articles are eminently attractive.

Other forms of decoration are prominent in classes of goods especially adapted for specific methods of treatment.

Flower Vases, Tea Caddies, Berry Bowls, Fancy Spoon Ware, Etc.,

ARE ENRICHED BY APPLIED WORK.

Flowers, Ferns, Plants, Birds, Fishes, Reptiles, Etc.,

Are accurately modeled and attached to the body of the piece. Hammered or beaten surfaces, partially oxidized, lend an air of quiet elegance to the piece. "American Curios," exhibiting the most marked effects in form and surface decoration. Copies of the antique, and inlayings of various metals, and especially the characteristics of latest novelties and advanced thought in decoration.

These novel and attractive goods are meeting with the hearty approval of the leading houses in the trade, and liberal selections have been made unusually early in the season.

Our production in Hollow Ware include all articles for household use and presentation.

In Tea, Dessert, and Dinner Services our stock is large and varied; comprising plain, engraved, chased and decorative sets, which we are prepared to supply either on demand or at reasonable notice. Special attention has been given to small wares, such as

Napkin Rings, Cups, Fruit Knives, Peppers, Salts, Mustards, Card Cases, Portmonnaies, Tobacco Boxes, Snuff Boxes, Bells, Butter Plates, Match Boxes, Child's Bowls, Cigar and Cigarette Cases, Pickle or Olive Dishes, Flasks, Button or Glove Hooks, Knife Rests, Porringer, Ash Trays, Vases, etc., etc., etc.

In this line of production our stock is very complete and is eminently superior in design, finish and decoration.

New patterns have been added to our list of Napkin Rings and Fruit Knives, and in the latter we have improved the process of manufacture by entirely dispensing with the customary use of soft solder. By this improvement and by reason of an increased variety of patterns our stock is rendered still more desirable than heretofore.

Lithographic sheets of our popular Spoon and Fork patterns will be sent upon application, together with our twenty-four page circular recently issued.

Important reductions (taking effect Oct. 1) in the price of "Gorham Plate" Spoons and Forks have been made.

Our general stock of Gorham Plate, so favorably known for its characteristic designs, exquisite finish, best of plate, and silver soldered in every part, is very complete in every department.



# David F. Conover & Co.

(SUCCESSORS TO W. M. B. WARNE & CO.)

Importers, Manufacturers and Dealers in

## Watches and Jewelry,

AMERICAN WATCH WHOLESALE SALESROOM,

Southeast Cor. Chestnut and Seventh Streets, First Floor,

DAVID F. CONOVER,  
C. FRANK WILLIAMS,  
B. EDGAR RIGHTER.

**PHILADELPHIA.**

Wholesale Agents for

Rogers & Brother's Flat and Hollow Ware

**CELLULOID EYE GLASSES,**

**AND SOLE AGENTS FOR THE**

**Patent Railroad Train Watch Chains, Nickel.**

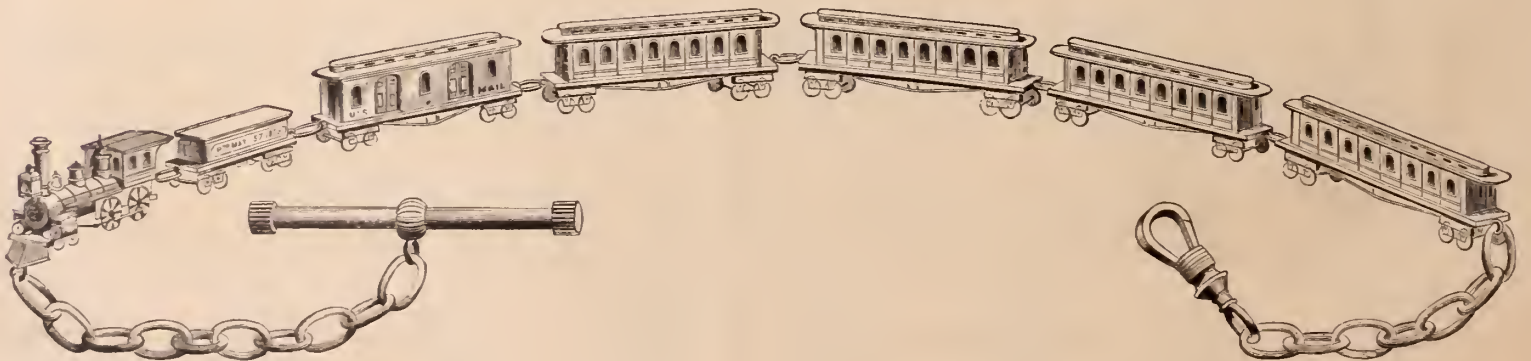



# THE STANDARD FILLED RING



## CROWN, 18. LION. FILLED RINGS

### PLAIN & CHASED



EVERY RING GUARANTEED  
BEWARE OF DIFFERENT STAMPS MADE TO IMITATE OUR TRADE MARK.

JAS. T. SCOTT,  
S. CLEM SCOTT,  
J. T. SCOTT, JR.

**J. T. SCOTT & CO.**

Established 1847.

**No. 11 Maiden Lane, New York,**

SOLE EASTERN AGENTS FOR

**THE ROCKFORD WATCH COMPANY,**



AND SOLE AGENTS FOR

**Abbott's Patent Open-Face, Full Plate, Stem-Wind Attachments.**

*These Stem-wind and hand-set attachments are applied to the regular 18-size full plate key movements of the Rockford, Waltham, Elgin and Illinois Watch Co.'s, making them wind at the figure XII in Open-Face Cases.*

Manufacturers of Jewelry and Wholesale Dealers in all grades of American Movements.

WATCH CASES, DIAMONDS, CHAINS, SILVER WARE, &c.

 Price Lists furnished upon application to those regularly engaged in the Trade. 

**ESTABLISHED 1837.**

**FALL TRADE**  
**1879**

Buyers will find it to their interest to examine our Line of Novelties in

**CLOCKS, MARBLE & BRONZE.**

Vienna, Leather and Gilt Goods a Large and Choice Selection.

TRIPLE MIRRORS, our Special Patterns, and many other new specialties of the season which we offer at close prices TO THE TRADE ONLY. Sole Agents LE COULTRE RAZORS.

**TAYLOR & BROTHER,**

No. 676 Broadway,

**NEW YORK**

# HAMPDEN WATCHES.

## The Superior Time Keepers.



E. W. BOND.—Beautifully finished, accurately adjusted, nickel movement, 17 fine Ruby jewels, 16 size, stem-winding, solid gold settings,  $\frac{3}{4}$  plate.

STATE STREET,  $\frac{3}{4}$  plate, nickel 16 size movement, Quick Train, gold settings.



Specially adapted to RAILROAD and all other uses where accurate time and adjustment is necessary.

18 size, full plate, nickel, beautifully finished, gold settings and gold trimmed.

Factories and General Office,  
**Springfield, Mass.**



NEW YORK OFFICE,  
**12 Maiden Lane.**

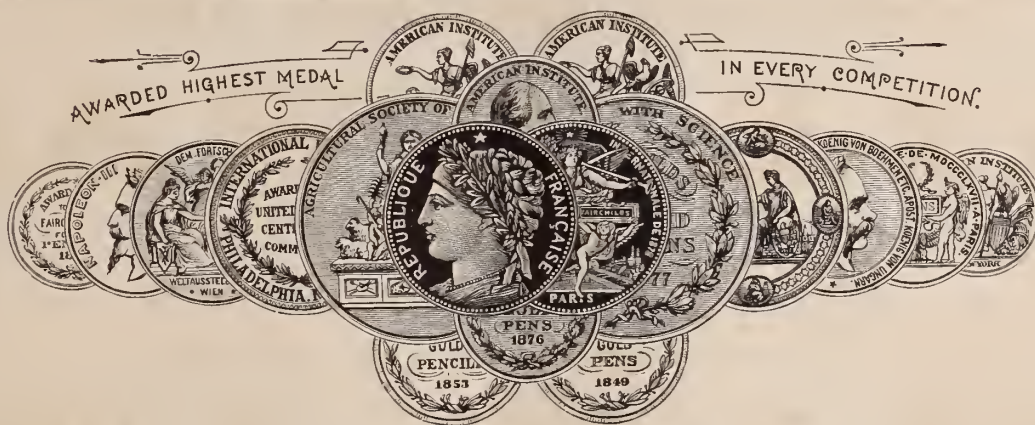

### TO THE TRADE.

My new Illustrated Catalogue, printed in colors, with accompanying Price List, is now ready to be forwarded on application.

New and fashionable

## NOVELTIES

of the most elegant designs, in Charms, Magic Pencils, in gold, platinum, silver, rolled gold plate and various rich materials.

Leroy W. Fairchild,  
110 William St., New York.

# BROWN & BROTHER,

MANUFACTURERS OF

Finest Quality of **Electro-Plated Flat Table Ware,**

**PATENTED HEAVY SPRING TEMPERED SHANK ON FORKS AND SPOONS.**

ILLUSTRATED CATALOGUES FURNISHED ON APPLICATION.

WAREROOMS, No. 81 CHAMBERS STREET, NEW YORK CITY.

FACTORIES, WATERBURY, CONN.

P. O. BOX 3731.

## ROSKOPH WATCH

J. D. HUGUENIN & CO.

General Agents,

12 Maiden Lane, New York.

The reputation of this Watch as an accurate timekeeper is fully established, and during the ten years that it has been before the Trade, has won an abiding reputation for fine Time-keeping qualities, and the **BEST WATCH** for the money in the world.

 Send business card for price list.

ESTABLISHED 1869.

### The Jewelers' Circular and Horological Review,

*The recognized organ of the trade, the official representative of the Jewelers' League, the Watchmakers' and Jewelers' Guilds, and the various State Trade Societies.*

**SUBSCRIPTION, \$2.00 Per Annum.**

*Is published on the 15th of each month.*

This Journal is devoted to the interest of Watchmakers and Jewelers, and those engaged in kindred interests.

To the practical workman the JEWELERS' CIRCULAR is invaluable as a text-book and work of reference. Its pages furnish him with the attest scientific and mechanical ideas, set forth in plain, comprehensible language by specialists of ability and experience. The technical information contained in its columns represents the progress of the age, and every intelligent workman in the country acknowledges the advantages resulting from a study of its pages.

To the country dealer the JEWELERS' CIRCULAR affords thorough, correct and perfect information as to staple and original articles of trade. From it he can learn what to order and where to obtain supplies, he can discover the best source of materials in common use, while the latest novelties are without exception first announced in its columns. All communications should be addressed to

**D. H. HOPKINSON,**

42 Nassau Street, New York.

Or the regular Agents of the Circular.

Sample Copies sent on application.

# Clapp Bros. & Co.

## WHOLESALE JEWELERS,

63 and 65 Washington Street, Chicago, Ill.

*We invite the attention of the trade to Our superior Stock and Uniformly Low Prices.  
Catalogues and Price Lists issued only to Watchmakers and Jewelers.  
Orders solicited. Promptness and Care Guaranteed.*

## JUERGENS & ANDERSEN,

125 & 127 State Street, Chicago, Ill.,



No. 23.



No. 28a.



No. 28c.

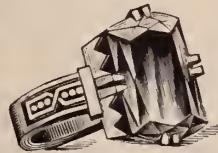

No. 42.



No. 40.



No. 47.

Manufacturers of Fine Jewelry, Diamond Work, Seal Rings, Etc., Etc.

Special Attention Given to Matchwork and Repairing:

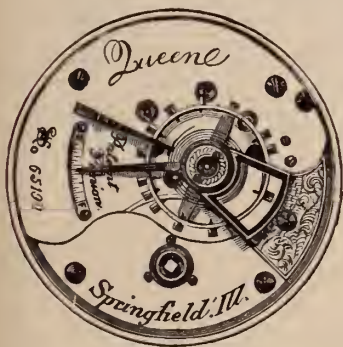

## C. H. KNIGHTS & CO.,

## WHOLESALE JEWELERS

125 & 127 STATE STREET,

CHICAGO, ILL.

N. B.---We wish to call the attention of the Trade to our two new movements "Enterprise," full jeweled, Nickel Key-wind, and "Queen," 11 jewels, full plate, open Bridge, Key and Stem-wind, with black dial. Also samples sent when requested.

## S. GLICKAUF & CO.,

Importers and Jobbers of

## WATCH MATERIALS AND TOOLS,

"W. B. & CO" WATCH GLASSES, SPECTACLES, CHAINS, SILK GUARDS, Etc., Etc.

WE CARRY A LARGE LINE OF NICKEL STEM-WINDERS.

79 & 81 State Street,

Chicago, Ill.

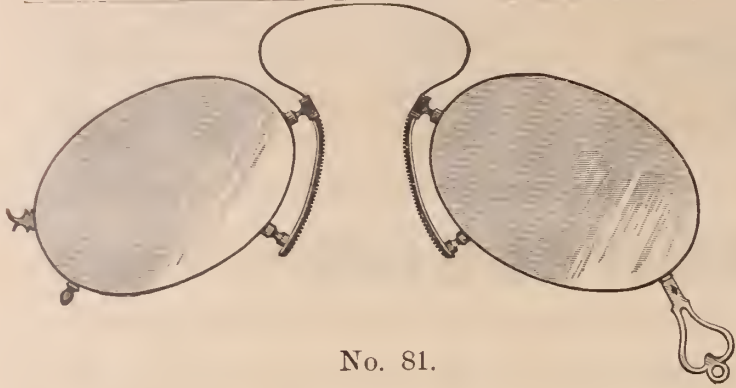

No. 81.

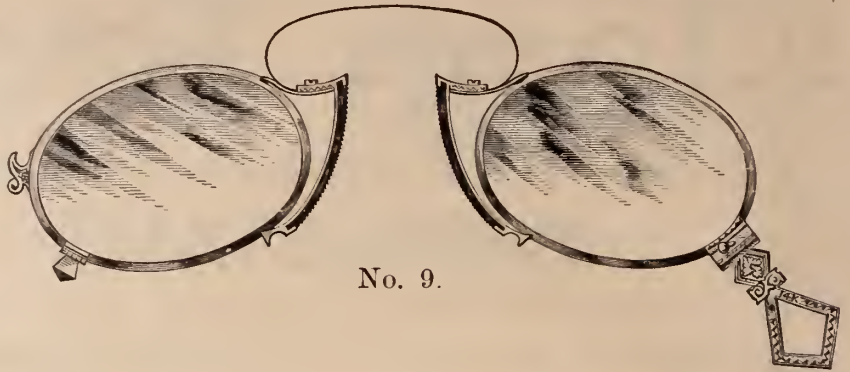

No. 9.



No. 15.



No. 36.

Manufacturers of  
GOLD, SILVER AND STEEL  
**MORGAN & HEADLY,**  
Spectacles and Eye Glasses.

We beg to call the attention of the trade to the large stock of

# DIAMONDS,

Set and unset, which we have on hand. Goods sent on approval where references are satisfactory. A rare collection of Fine Old Mine Gems in Single Stones and match pairs up to 16k. just received.

Nos. 611 & 613 Sansom Street,  
PHILADELPHIA.



No. 88.

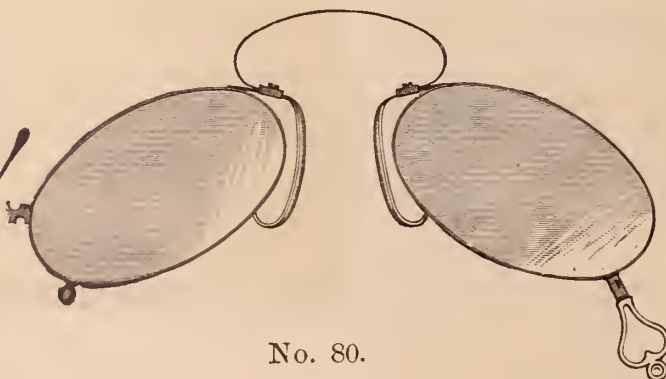

No. 80.

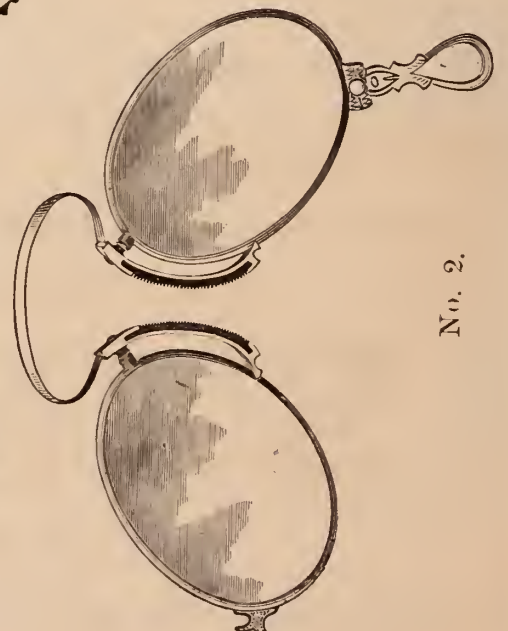

No. 2.

ESTABLISHED 1855.

D. LIECHTY & CO.,  
 MANUFACTURERS OF  
**Fine Gold Watch Cases**  
*No. 140 South Third Street,*  
 Fourth Floor. PHILADELPHIA  
*Repairing neatly attended to.*

LOUIS A. SCHERR.

CHAS. H. O'BRYON.

G. W. SCHERR

**LOUIS A. SCHERR & CO.**

Importers and Wholesale Dealers in

**Watches, Jewelry,**

WATCH MATERIALS, TOOLS, GLASSES, &C.

**Spectacles, Silk Guards, &c.**

Wholesale Agents for American Watches.

**No. 726 CHESTNUT STREET,**

FIRST FLOOR,

**PHILADELPHIA.**

**GUTMANN'S**

**Automatic Hammer and Punches**

Simplified and More Effective.



THIS TOOL takes the place of the third hand, therefore its manifold uses are quickly apparent, and I would only say, that it is accompanied by six punches, to wit: 2 hand punches, 1 prick punch, 1 closing hole punch, 1 rivet punch, and 1 pinion punch, all of which fit neatly into the punch holder, and are fastened by the set screw. Its tap is alternately heavy and light, and the finger loops are assorted in sizes. The Tool is nickel-plated and boxed, ready to be mailed on receipt of price.

THE OPERATION IS AS FOLLOWS: First, set the hammer; next insert your forefinger through the loop at the top and place the punch with firmness on your work. When you are ready for the blow, push gently on the thumb-piece which produces the concussion on the punch. *Your left hand is entirely free to hold the work.*

Price, \$2.00; Reduced from \$2.50.

**MAX L. GUTMANN,**

Patentee and Manufacturer.

Also, Importer and Wholesale Dealer in

**Watch and Jobbing Materials, Tools, Glasses,**

*Chains, Guards, Jewelry and Watches.*

The Genuine American Silk Guards in all Styles a Specialty.

January 8th, 1878.

PLEASE SEND YOUR ORDERS.

ROCHESTER, N. Y.

AUBURNDALE, MASS.

**CHRONOGRAPH TIMER**

WM. B. FOWLE, Maker.

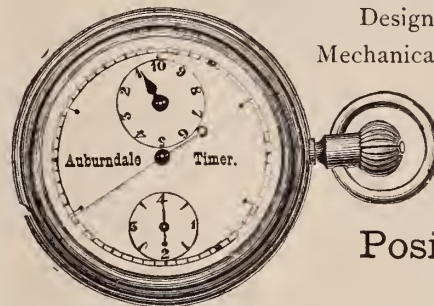

Designed for Sporting, Scientific and Mechanical purposes;  $\frac{1}{4}$  and  $\frac{1}{8}$  seconds, fly back.

List Price, - - \$15.00

Positively Accurate.

Put up in German Silver Cases, Nickel Plated, size of an ordinary watch. Very neat and handsome, supplying a want long felt by those desiring to measure the flight of time with scientific accuracy to the fraction of a second. It indicates positively minutes, seconds, quarters or eighths of seconds, the only instrument registering one eighth of a second made. It is substantially constructed, positive in its action and will not easily get out of order.

These Chronographs can be obtained from the principal Jobbing Houses in the Trade.

**BENJ. ALLEN & CO.**

Nos. 137 & 139 State Street, Chicago.

**JEWELRY and DIAMONDS**

WALTHAM, ELGIN, HOWARD AND SPRINGFIELD, ILL.

**WATCHES,**

Rogers & Bro., Spoons, Forks, &c.

Western Agents for SIMPSON, HALL, MILLER & CO.

Our new Catalogue will be ready October 1st, and will be sent to the trade upon application.

**CHAS. P. HEROLD,**  
**MANUFACTURING JEWELER,**  
**DIAMOND SETTER**  
 AND DEALER IN  
**DIAMONDS.**

916 CHESTNUT ST. PHILA.

N.B. A LARGE STOCK OF 18 Kt. DIAMOND MOUNTINGS, SUCH AS CLUSTER AND SOLITAIRE RINGS, EARRINGS, LACE PINS, SHAWL PINS, CROSSES, STUDS, AND GENTS' PINS, &c, ALL OF WHICH ARE OF MY OWN DESIGNS, AND ARE MADE IN THE FINEST STYLE AND FINISH.

**COLBY & JOHNSON,**

17 Maiden Lane, New York,

IMPORTERS AND JOBBERS OF

American and Swiss Watches,

MANUFACTURERS OF

**WATCH CASES AND FINE JEWELRY,**

PATENTEES AND SOLE MANUFACTURERS OF

White,  
Black, or  
Marbleized  
Celluloid  
Backs and  
Bezels.



Gold, Silver,  
or  
Nickel  
Centers,  
Pendants  
and Bows.

Suitable for all 18-Size American S. W. Movements.

**SINNOCK & SHERRILL,**

Stone Ring Manufacturers,

No. 5 Maiden Lane, N. Y.

Factory, Newark, N. J.

**SPIESS & ROSSWOG,**

MANUFACTURERS OF

**Fine Jewelry and Diamond Goods,**

LOCKETS, CROSSES, SLEEVE BUTTONS AND NECKLACES.

Rich Sets in Coral Rose, Coral Cameo and Gold.

ENCRUSTED AMETHYST RINGS AND SILVER  
FILIGREE WORK,

Nos. 9 & 11 MAIDEN LANE, NEW YORK.

Also, a complete line in all Coral Goods, as formerly  
imported by A. SQUADRILLI.

**COLBY & JOHNSON,**

17 Maiden Lane, New York.

**FALL NOVELTIES.**

We will introduce November 15th, two new sizes in

**Celluloid Watches,**

No. 12,

Gents' Stem-Winding Watch (18 Line) "Golden Gate," Case  
of WHITE, BLACK or MARBLEIZED CELLULOID,  
with Nickel Center, Pendant and Bow.

No. 22,

Ladies' Stem-Winding Chatelaine Watch, (13 Line) in Cases  
of WHITE CELLULOID and GOLD, (Plain) or with  
inlayings of new and elegant designs in Illuminated  
Gold, (Hedges' Patent). The most attractive  
Chatelaine Watch ever offered to the trade.

**E. HOWARD & CO.,**

MANUFACTURERS OF

**Fine Watches, Regulators, Office Clocks,**

Electric Watch, Clocks & Tower Clocks,

**Office, No. 2 MAIDEN LANE**

NEW YORK

No. 114 TREMONT STREET, BOSTON.

J. W. J. PIERSON, - - - AGENT.

DYER BRAINERD.

JOHN W. STEELE.

**BRAINERD & STEELE,**

MANUFACTURERS OF

**Brainerd's Pat. Locketts,**

(Patented June 17, 1874.)



These Locketts combine both beauty and strength.  
They are made of solid 14kt. gold, and the stones used  
are the finest obtainable in the market. They cost no  
more than those of the old style, if indeed as much; and  
the combination of secrecy and durability renders them  
much more desirable. We make three sizes in four di-  
fferent shapes—round, oval, cushion and oblong squar-;  
and also Sleeve Buttons of the same style, containing  
a concealed box for miniatures, a novelty new to the  
Trade.



**FINE GOLD JEWELRY,**

**No. 9 Maiden Lane,**

NEW YORK.



**ALFRED · H · SMITH**  
**· & Co. ·**  
**IMPORTERS**

**DIAMONDS**

**OF**

**14 JOHN ST.,**

**NEW YORK.**

The advertisement is framed by a decorative border with repeating patterns and floral motifs in the corners. The central text is arranged in a vertical hierarchy, with the company name at the top, followed by 'IMPORTERS', the word 'DIAMONDS' in large stylized letters, and the address '14 JOHN ST., NEW YORK.' at the bottom. Two diamond-tipped tools are positioned diagonally across the page, and several diamond shapes are scattered throughout the design.

**ALFRED H. SMITH & CO.**  
**IMPORTER OF DIAMONDS**  
 14 JOHN STREET, NEW YORK.

**TO THE TRADE.**

*In offering to you our RECENT HEAVY IMPORTATIONS of carefully selected Goods, we respectfully call your attention to a few facts bearing upon our ability to fill your orders, to your positive advantage.*

*We give to this business our EXCLUSIVE ATTENTION, admitting to our stock no other merchandise whatsoever.*

*We are DIRECT IMPORTERS of DIAMONDS, so that, with us, Dealers will find original parcels to select from.*

*Our foreign purchases are made by ourselves in person, thus insuring goods best adapted to the requirements of the Trade, and at the lowest possible figures.*

*Any goods you may be pleased to order from us, either for your stock, or on Memorandum, will be forwarded by us, without VALUE expressed thereon, and may be returned in like manner, (the same having been insured) thereby saving you the heretofore burdensome charges.*

*Exceptionally choice SINGLE STONES, and finely MATCHED PAIRS, will always be found with us, as well as a fine line of MOUNTED GOODS.*

*Very Respectfully*

ALFRED H. SMITH & CO.

*14 John Street, New York.*

Established 1834.

# G. & S. OWEN & CO.

MANUFACTURERS OF

## FINE GOLD JEWELRY

Consisting of { Roman and Polished Goods,  
Box and Glass Goods,  
Hair Chain Mountings,

*Specialty---Black Onyx and Pearl Goods Consisting of Lace, Chatelaine and Scarf Pins  
Ear Rings, Sleeve Buttons and Studs,  
Leontine and Vest Chains in  
great variety.*

All our goods exclusively of our own manufacture.

5 MAIDEN LANE, NEW YORK

# JOHN A. RILEY & CO.

MANUFACTURERS OF

Rich Gold and Onyx Jewelry,

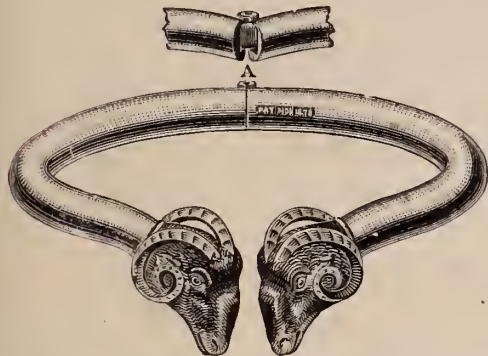

NOVELTIES IN HALF SETS, LACE PINS, SCARF PINS AND EAR RINGS

Engagement Pad, Lock Bands, Elastic Snake Bands and Chatelaines. Onyx Chatelaines with and without Watch Movements.

Nos. 7 & 9 Bond Street, New York.

No. 126 Kearney Street, San Francisco, Cal.

# MOORE & HORTON,

## JEWELERS,

No. 11 Maiden Lane, New York.

### SPECIALTIES!

Stone Cameo, Onyx, Amethyst, Topaz and Pearl Rings.  
Studs, Collar and Sleeve Buttons.

Also our new fac-simile of Fine African Diamonds, mounted in Rings, Studs, Pins, Ear-rings, Scarf Pins, Medallions.

**OWEN SHEAFER & CO.**

**MAKERS OF FINE JEWELRY**

CONSISTING OF  
BRACELETS,  
SETS,  
LOCKETS,

PINS,  
STUDS,  
RINGS,  
SLEEVE BUTTONS  
ETC.

**SPECIALTY**  
**STIFFENED ROMAN BANDS**

Nos. 612 & 614 CHESTNUT ST. PHILADELPHIA.  
BRANCH-OFFICE 15 JOHN ST. NEW-YORK.

Established 1846.

WILLIAM RIKER,

No. 5 Maiden Lane, New York.

Factory, 42 Court Street, Newark, N. J.

Would call the attention of the Trade to our Inlaid Bracelets.

# COE, PINNEO & STEVENS,

MANUFACTURERS OF

## LOCKETS,

WHITE ENAMEL STUDS & BUTTONS

Linen Finished and

## FINE JEWELRY,

Old No. 9 Maiden Lane, New York.

# ENOS RICHARDSON & CO.

MANUFACTURERS OF

## FINE GOLD JEWELRY,

Gold Chains, Locketts, Crosses and Necklaces,  
COLORED AND ETRUSCAN WORK.

ENGRAVED AND ENAMELED GOODS IN GREAT VARIETY.

All Goods sold strictly of our own manufacture.

23 MAIDEN LANE, NEW YORK.

ENOS RICHARDSON,  
THOS. SLATER,

L. P. BROWN,

F. H. RICHARDSON,  
W. P. MELCHER.

## SHOEMAKER & CO.,

MANUFACTURERS OF

## Onyx, Cameo & Intaglio Buttons,

AND LOCKETS.

A full line of Roman Goods including Bracelets,

No. 21 MAIDEN LANE, NEW YORK.

## Platinum-Tipped Diamond Settings

Patented April, 1878, by

RIPLEY, HOWLAND & CO.

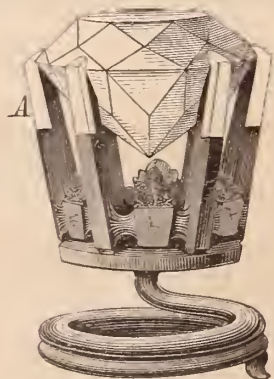

OFFICE, 35 MAIDEN LANE,  
NEW YORK.

Factory, 383 Washington St., Boston, Mass.

## WANTS OF FINE JEWELRY ALBING BROS. & CO. WANTS OF FINE JEWELRY

Full Line of Roman and Mosaic Goods,  
Earrings, Buttons, Studs and Rings.

SPECIALTIES:

ENGRAVED AND ENAMELED BANDS,  
CAMEO GOODS.

170 BROADWAY, New York.

## NOTICE.

Manufacturing Jewelers are hereby notified that the undersigned have obtained Letters Patent, dated Feb. 25th, 1879 and re-issued Oct. 14, 1879, for Bracelets constructed of a single band, having ornamentation in relief permanently fixed upon its outer surface, with rigid marginal flanges or projection for the protection of the same, and all infringements, whether in cheap or fine goods, will be promptly and rigorously prosecuted according to law.

HALE & MULFORD,

Broadway & Fourth St.

New York, Oct. 14th, 1879.

## A. J. HEDGES & Co.,

MAKERS OF

## FINE JEWELRY

*Of Every Description.*

No. 9 Maiden Lane, New York.

## FALL NOVELTIES.

We have recently introduced a new and attractive line of

FINE GOLD GOODS,

richly ornamented in illuminated gold upon a sunken surface, for which process we have been granted letters patent.

Buyers visiting the city are invited to examine these goods as they cannot fail to give satisfaction.

NOTICE.—Any infringement of this patent will be vigorously prosecuted.

WHEELER, PARSONS & HAYES,

MANUFACTURERS OF

Watch Cases, Gold Chains & Fine Jewelry,

AND DEALERS IN

AMERICAN AND SWISS WATCHES,

No. 2 MAIDEN LANE, NEW YORK



CHATELLIER & SPENCE,  
Manufacturing Jewelers,

694 BROADWAY, NEW YORK.

No. 1006 Chestnut Street, PHILADELPHIA, PA.

No. 12 West Street, BOSTON, MASS.

No. 120 Sutter Street, SAN FRANCISCO, CAL.

LYON & HARDY,

30 MAIDEN LANE, NEW YORK,

IMPORTERS OF

DIAMONDS,

AND MANUFACTURERS OF

DIAMOND MOUNTINGS.

All goods ordered for stock or on approval are insured while the hands of Express Companies.

CHURCHILL, LEWIS & CO.  
Manufacturing Jewelers,

SPECIALTIES:

TURQUOISE,	LACE PINS,
GARNET, and	EARRINGS,
ENAMELED	RINGS, and
PAINTINGS.	HALF SETS.

180 Broadway, New York.

GEORGE W. FLATT,

IMPORTER AND JOBBER IN

Watches, Jewelry, &c.

No. 20 Maiden Lane,

NEW YORK.

# J. B. BOWDEN & CO.

Manufacturers of

## RINGS

Have recently added to our stock a full line of

### NOVELTIES IN STONE RINGS.

*Camcos, Chevée, Intaglios, &c., Specially Designed for the HOLIDAYS.*

All Styles of Children's

AND

### FANCY SOLID RINGS,

No. 1 Maiden Lane, New York.

## JOSEPH N. TINGLEY,

Late of the firm of Tingley, Sinnock & Sherrill,

MANUFACTURER OF

## STONE RINGS,

—AND—

NOVELTIES IN STONE GOODS,

No 9 Maiden Lane, New York

Factory, Newark, N. J.

## OPPENHEIMER BROS & VEITH, MANUFACTURING JEWELERS

AND

Dealers in Watches and Diamonds,

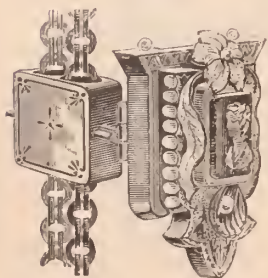

35 Maiden Lane,  
NEW YORK.



Patented June 3, 1879.

Combination Chain, Slide, Pendant and Locket.

# BUCKENHAM, COLE & SAUNDERS,

SUCCESSORS TO

BUCKENHAM, COLE & HALL,

IMPORTERS OF

## Diamonds, Pearls

AND OTHER PRECIOUS STONES,

MANUFACTURERS OF FINE JEWELRY,

10 Maiden Lane, New York.

A large Stock of FINE DIAMONDS, Mounted and Unmounted kept constantly on hand. Goods sent on approval to any part of the country on receipt of satisfactory references.

## JOHN M. GODDARD,

3 Maiden Lane, New York.

SPECIALTIES:

BRACELETS.

1st Quality Rolled Plate.

Gold and Rolled Plate, upwards 100 patterns.

CHAINS and LOCKETS  
Vests, Necks, Guards, Leontines  
in great variety.

*The Latest Designs in Gold and Fine Rolled Plate Jewelry always in stock.*

SEAL RINGS OF ALL KINDS.

Jewelry repaired, recolored, matched or made to order. Special attention given to the Job Department.

Orders from responsible Jewelers for goods on selection will be filled promptly and intelligently.

## LOUIS HERZOG & CO.

DEALERS IN

## WATCHES,

—AND—

Manufacturers of Jewelry,

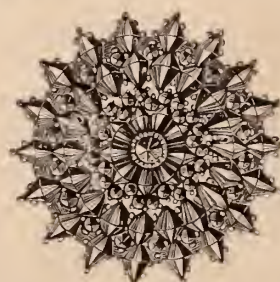

GARNETS A SPECIALTY.

No. 33 MAIDEN LANE,

LOUIS HERZOG,  
LOUIS KAUFMAN

NEW YORK.

**J. A. BROWN & CO.**

OFFICE AND SALEROOM: No. 11 Maiden Lane, N. Y. FACTORY: No. 104 Eddy St., Providence, R. I.  
SOLE MANUFACTURERS OF THE

**Ladd Patent Stiffened Gold Watch Cases**

The Best and most durable, and the

**CHEAPEST STIFFENED Gold Watch Case FOR THE MONEY**

MADE IN THE WORLD!

All genuine Watch Cases of our manufacture have "G. W. Ladd's Patent, June 11, 1867," stamped upon the side band underneath the glass bezel.

REFUSE ALL OTHERS.

Send for full Descriptive Circular to the

OFFICE AND SALESROOMS  
1 Maiden Lane, N. Y.



**KEY AND STEM WINDING**  
Hunting and Open-Face  
IN FLAT BEVEL,  
Mansard and Oval  
**SHAPES**  
Adapted to the various  
**AMERICAN-MADE MOVEMENTS,**  
IN  
**8, 10, 14, 16 & 18 SIZES.**

Dealers can obtain them of the Wholesale Watch and Jewelry Houses, or their Travelling Agents throughout the United States and British Provinces.

**MIDDLETON & BROTHER,**

IMPORTERS OF

**SWISS WATCHES,**

AND DEALERS IN

**American Watches**

(KEY AND STEM WINDING,)

Diamonds, Gold Chains, Jewelry, Etc.

10 MAIDEN LANE, N. Y.

**FRASSE & COMPANY,**

Importers of P. S. STUBS,

*French, Swiss, German & Sheffield Tools, Files,*

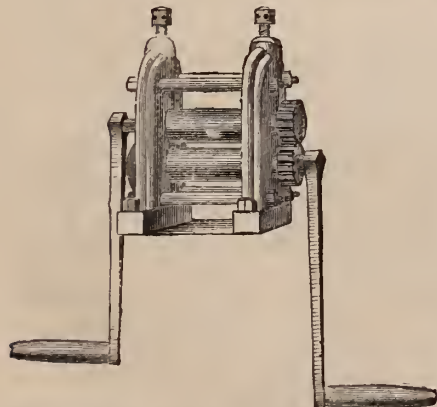

Steel Wire and Materials,  
For Watchmakers, Jewelers, Engraver  
Die-Sinkers, Machinists, &c.

**Turning Lathes, Drills & Chucks**

Rolling Mills, Draw Plates,

**The Celebrated Rodenbush Piercing Saw**

Horse Shoe Magnets, Nurls, Ingots, Chasing Tools, Engravers' Tools, Brush Wheels & Buffs, Hand Brushes and Buffs, Borax, Saltpetre, Beeswax, Rouge, Tripoli, German Silver, Brass, &c.

**No. 62 Chatham Street,**

Established 1816.

**New York.**

P. O. Box 462

**N. MATSON & CO.**

State and Monroe Sts., Chicago, Ill.

*Importers of Diamonds, Watches, Clocks, Opera Glasses, Materials, Tools, Etc., Etc.*

**General Jewelers and Furnishers of Jewelers Supplies.**

*Western Branch House for the Reed & Barton's Fine Electro Silver Plated Ware.*

All orders promptly filled, and every transaction warranted satisfactory to the buyer.

**NOAH MITCHELL,**

*Manufacturer of all kinds of*

**Diamond Jewelry.**

**DIAMOND MOUNTINGS A SPECIALTY.**

A Full Assortment Constantly on Hand.

Nos. 692 & 694 BROADWAY,

Corner Fourth Street, New York.

ALL ORDERS WILL RECEIVE PROMPT ATTENTION.

**MAX FREUND & CO.,**

**Manufacturing Jewelers**

IMPORTERS OF

**WATCHES**

**Jewelry and Precious Stones,**

**No. 8 Maiden Lane**

**NEW YORK**



This Movement fits Waltham Cases.

Sole Agents for the Celebrated A. Schneider Watch Dresden, Also the Standard Watch Co. of New York.

MANUFACTURERS  
OF  
EXCLUSIVELY  
**BLACK ONYX GOODS,**

The patented **DEEP MOURNING LOCKETS** are original with us, and have stood the test of years of wear. They meet the approval of the trade and the wearers for their superior make and finish, as well as for the correctness of the mechanical principle on which they are constructed.

**W O G L O M & M I L L E R,**  
32 & 34 JOHN STREET,  
NEW YORK.

**HENRY FERA,**  
Importer of **Diamonds,**  
No. 9 MAIDEN LANE,  
**New York.**

Having my own cutting and polishing establishment at Nos. 23 and 25 Looijersgracht, Amsterdam, Holland, constantly running 36 mills, I am able to offer to the trade a full assortment of Diamonds at very low prices.

Loose and Mounted Goods sent on approval to any part of the country on receipt of satisfactory references.

All goods ordered from or shipped to me, are insured while in the hands of express companies, and no valuation is needed on the parcels.

**BOOZ & THOMAS,**  
MANUFACTURERS OF

**Watch Cases & Jewelry,**

108 South Eighth St., (2d Story) Philadelphia.

Samples of our goods sent on approval, when satisfactory reference is furnished.  
**Old Gold & Silver Bought or Exchanged.**  
PARTICULAR ATTENTION PAID TO REPAIRING.

**HAMILTON & HUNT,**  
MANUFACTURERS OF

**Fine Plated Chains**  
AND PATENT BUCKLE BRACELETS,  
A Full Line of Ladies' and Gentlemen's Roman & Stone Locketts  
**Branch Office, 176 Broadway, New York**  
FACTORY, 226 EDDY STREET, PROVIDENCE, R. I.

GEO. W. PRATT. IRA GODDARD.  
**GEO. W. PRATT & CO.**  
MANUFACTURERS AND DEALERS IN

**American and Swiss Watches,**  
**SOLID BAND AND SEAL RINGS,**  
Gold and Roll-Plated Jewelry,  
No. 14 JOHN STREET, NEW YORK.

**W. C. GREENE & CO.**  
GOLDSMITHS

MANUFACTURERS OF  
RICH SETS IN TAPER WIRE CORAL

Factory 95 PINE ST. Providence, R. I. Office 192 BROADWAY.

Stone Cameo Amethyst Engraved & Enamel Sets Sleeve Buttons Studs & Ear Drops &c. New York

WM. C. GREENE. B. W. CREENE. GEO. D. BRIGGS.

**M. FOX & CO.**  
**Practical Lapidaries,**  
IMPORTERS OF  
**DIAMONDS**  
AND OTHER PRECIOUS STONES,  
No. 1 Maiden Lane, New York.

**VANHOUTEN SAYRE & CO.**  
MANUFACTURERS  
OF  
**SOLID JEWELRY.**

SETS  
EARRINGS  
ETRUSCAN ENAMEL AND FACET WORK.  
LOCKETS  
STUDS  
COLLAR BUTTONS

OFFICE AND FACTORY. **53 CHESNUT STREET NEWARK, N. J.**



**E. STITES,**  
*Manufacturing Jeweler,*  
 No. 12 MAIDEN LANE,  
 New York.  
 SCARF RINGS AND PINS.

Roman Band Bracelets.

I. PFORZHEIMER.

D. KELLER.

**PFORZHEIMER & KELLER,**  
 IMPORTERS OF  
**Watches and Diamonds**  
*Dealers in American Watches,*  
 AND  
*Manufacturers of Jewelry,*  
 No. 24 JOHN STREET,  
 NEW YORK.  
 P. O. Box 4144.

**WANTED.**

A First-Class Traveling Salesman  
 for a Western Jobbing Firm.

*Only those who have had experience on the road and can give the best of reference need apply. Good salary. Jewish preferred.*

Address CHICAGO, Care Jewelers' Circular.



HIGHEST AWARD TO

**SYLVANUS SAWYER,**  
 —FOR—  
**WATCH MACHINERY,**

Watch & Clock Making Machinery

For sale or made to order, either in complete sets, including

**PUNCHES & DIES AND OTHER SPECIAL TOOLS,**

Or in parts of sets, to accommodate purchasers.

ALSO, JEWELER'S LATHES AND TOOLS,  
 AND OTHER FINE WORK,

MAIN STREET, FITCHBURG, MASS.

**BREITINGER & KUNZ,**

IMPORTERS OF

**Watchmakers' Tools and Materials,**

GLASSES, &C., &C.

**No. 107 N. 9th Street, Philadelphia.**

Agency in the U. S. for

**BÄHNI BROTHERS HARDENED & TEMPERED HAIRSPRINGS,  
 G. BECKER'S GOLD MEDAL REGULATORS,  
 DUDLEY'S ELECTRICALLY CORRECTED CLOCK**

FINE ONYX AND PEARL NECKLACES AND PENDANTS.

**DOWNING & KELLER,**

MANUFACTURERS OF

**FINE JEWELRY,**

Onyx & Pearl Sets, Shawl Pins, Ear Rings, etc.

8 MAIDEN LANE,

NEW YORK.

**Dorrance, Edge & Co.**

MANUFACTURERS OF

THE CELEBRATED WOVEN FABRIC

**GOLD CHAIN.**

*Elegantly Mounted Bracelets, Opera, Leontine,*

VICTORIA WATCH GUARDS & NECKLACES, in all the Newest Designs.

Our stock is unusually complete, and, in addition to the above, a variety of Necklaces, from 1½ to 40 dwts. each, to which we invite the attention of buyers.

CHILDREN'S BRACELETS A SPECIALTY,

Weighing from 6 dwts. a pair upwards.

**No. 12 John Street, New York.**

Factory, 46 Greene Street, Newark, N.J.

**STAR WATCH & CLOCK OIL,**

MANUFACTURED BY

**GEO. B. WHEELER,**

NEW BEDFORD, MASS.



This Oil is made from the best of stock, is free from gum or corrosive qualities, will stand the coldest weather, and is every way reliable.

L. HAMMEL & Co., 9 Maiden Lane, New York, Agents for the U. S.

Koch & Co., Elberfeld, Prussia, Agents for Europe.

# T. B. BYNNER,

## Importer & Jobber of Watches

DIAMONDS AND FINE JEWELRY,

And Dealer in the BEST CLASS OF ROLLED PLATE JEWELRY

And Key and Stem-Winding American Watches.

No. 513 Broadway, New York

# E. D. VOSBURY & CO.

## GOLD CHAINS,

Rolled-Plate Chains and Locketts,

ELGIN WATCHES, BOSS FILLED CASES, STONE AND BAND RINGS OF EVERY DESCRIPTION,

25 Maiden Lane, New York.

## Clark's Grooved Case Springs.

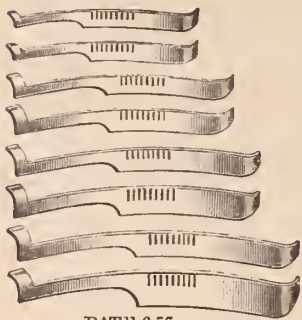

PAT. 116,77.

Made in four lengths, wide and narrow. The spring sets well away from the movement, the depressions obviate any tendency to move lengthwise. Steel rivets preferably used can be removed more easily than screws. In fitting file away the lower edge until the rivet can be pushed down in front of the spring in the grooves. These springs are made from fine steel, carefully tempered and warranted perfectly reliable. To be had of all jobbers in watch materials at manufacturers price—75 cts. per dozen.

**A. N. CLARK,** *Manufacturer of the Celebrated FOUR HOLE CASE SPRINGS, Watch Keys, Bench Tools, Crosby's JEWELING TOOLS, &c.* Plainville, Ct.

## New Otto Silent Gas Engine.

Working without Boiler, Steam, Coal, Ashes or Attendance.

Started instantly by a Match, it gives Full Power immediately.

No Explosion,  
No Fires nor Cinders,  
No Gauges,  
No Pumps,

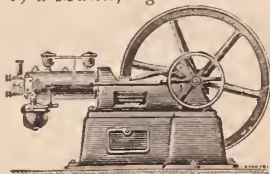

Perfectly Safe,  
Easily Managed,  
Durable, and  
Simple in Construction.

**WHEN STOPPED, ALL EXPENSE CEASES.**  
TESTIMONIAL.

PHILADELPHIA, September 12, 1879.

Gents:—The four horse power Gas Engine purchased from you for use in our polishing shop, has given us perfect satisfaction, holding its power, and giving little or no trouble in running. It has been in use for about nine months, and we are happy to say fulfills all that you promised for it. Yours, very truly,

JAS. E. CALDWELL & CO.

Sizes of Two, Four and Seven Horse made by  
**SCHLEICHER, SCHUMM & CO., 3045 CHESTNUT ST., PHILA.**

# A. W. MACERHANS, Manufacturing Jeweler,

19 JOHN STREET, NEW YORK.

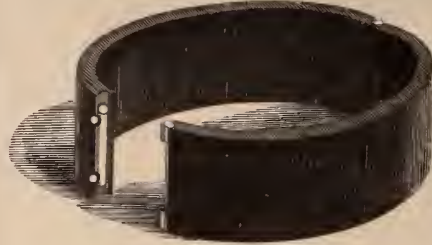

Patented May 7th, 1879.

These Bracelets, plain, with concaves for solitaire diamonds or with "lily of the valley" or other pearl ornaments, show less gold in mounting, and are lower in price than any other Onyx Band in the market.

They are made in widths running from  $\frac{3}{8}$  to 1 in. and from  $5\frac{1}{4}$  to  $6\frac{1}{4}$  in. wrist measure.

Onyx Goods a Specialty.

Onyx Lace Pins, Scarf Pins, Cuff Pins, Earrings, Locketts  
Crosses, Ladies' and Gents' Vest Chains.

APPROVAL ORDERS SOLICITED. REPAIRING CAREFULLY DONE.

# MILNE & JOURDAIN, Manufacturers of Stem-Winding Watch Crowns



13 & 15 Franklin Street, NEWARK, N. J.

Gold Crowns, for Stem-winding Movements, to suit all sizes of Imported or American Watches, in four different styles and seven sizes.

Gold Pushers for Key Movements in every size. Also Gold Crowns for fine Chronograph Watches made to order.

Silver Stem winding Crowns and Key Pushers on hand or made to order. Send for card and samples.

A. MILNE.

A. JOURDAIN.



## RICKETT'S PATENT EYE SHADE.

It is simply a neat curved shade of hard rubber,  $\frac{1}{4}$  inch wide that fits under the eye brows, and flares out at the bottom so as to allow an angle of vision about level with the horizon. Having met with success in New York, Philadelphia and Boston, and wishing to extend our trade to other cities, we will for the next 30 days forward to any one in the trade ordering 2 dozen Spring Shades, an elegant *Plaster Bust*, life size, stands  $17\frac{1}{2}$  inches high, and retails in New York for \$3.00. If placed in prominent window, will sell 2 dozen shades in 10 days.

We have first-class testimonials from M. GARDNER, Chief of Draftsman, U. S. Patent Office, H. OLMSTED, Secretary of New York Jewelers' Association, and from many other prominent men of the country. Order from any jobber or direct from us. Please state whether you want Bust.

PRICE.—Spring Shades, \$3.50 per doz.

RICKETT'S EYE SHADE CO.,  
85 Nassau Street, New York.

# WILLIAM H. BALL,

SUCCESSOR TO BALL & BARNARD,

MAKER OF

ORNAMENTED

Roman, Enameled and Engraved

**BRACELETS.**

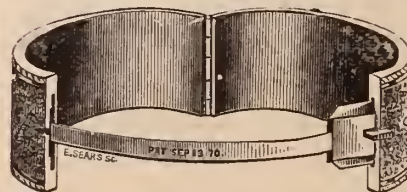

Having given the manufacture of Band Bracelets my entire attention for a number of years, it has been my desire to make a durable article, one that will give satisfaction to the seller as well as the wearer. I desire to call the attention of the trade to the reduction I have made in prices, still keeping up the standard as to QUALITY, FINISH and WORKMANSHIP. To each pair of BANDS is attached my patent guard without extra charge—thus saving the price of chain.

No. 9 JOHN STREET, NEW YORK.

Factory, 30 & 32 Franklin Street, Newark, N. J.

ESTABLISHED 1853.

CLOCKS



CLOCKS

**B. J. COOKE'S SON,**  
137 N. 3d Street, Philadelphia.  
Catalogues and Price Lists furnished to the Trade only, on application.



**KEYSTONE**  
**Jewelers' Forges,**

FOR HAND OR POWER.

Light, durable and noiseless.

SEND FOR CATALOGUE.

Keystone Portable Forge Co.,  
Philadelphia, Pa.

ESTABLISHED 1855.

**WELCH & MILLER,**  
MANUFACTURERS OF MOROCCO, VELVET AND SATIN  
**Jewelry Cases, Trays, &c.**

Telescope Sample Cases, with Flexible Trays.  
COMPLETE STOCK ON HAND.

**No. 169 BROADWAY, NEW YORK.**

CATALOGUES SENT ON APPLICATION.

**JAMES IRONS,**

PATENTEE  
AND  
Sole Manufacturer



CHEAPEST PLACE TO BUY GOOD

**SHOW CASES,**

Large Assortment.

All kinds always on hand.

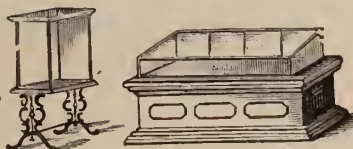

Factory and WAREHOUSES,

132 & 134

North 4th St.,

PHILADELPHIA.

Cases packed securely to carry to any part of the world,

**Charles F. Terhune & Co.,**  
Manufacturing Jewelers,

16 Maiden Lane,  
NEW YORK.

—Sole Manufacturers—



We beg to call the attention of the trade to the above cuts representing

**PATENT SLIDE BUTTON**

It is not separable, but works on a simple slide. It can be put in and taken out easier than any button made without soiling the cuff. Recommends itself at sight.

A full line of Stone, Enamel, Ivory and Pearl goods in above patterns.

**BERNARD LEVY,**  
Manufacturer of Watch Cases

—AND DEALER IN—

**AMERICAN WATCHES,**

No. 402 Library Street,

**PHILADELPHIA.**

**G. F. C. ROSENTHAL,**  
Manufacturing Jeweler,

917 SANSOM STREET.

PHILADELPHIA.

The finest Diamond and Pearl Work exclusively.

Lubricating Oils, for Watch, Clock and Chronometer Makers.

The discovery of a Lubricator for FINE MACHINERY, such as Watches, Clocks and Chronometers, that is free from gum and corrosive substances, has taxed the ingenuity of hundreds of men whose efforts have proved a failure. But we are happy to say, (being largely interested) that such an article has been supplied by MR. EZRA KELLEY, of New Bedford, Mass., who, after forty year study of the subject, has perfected a Lubricator, that recommends itself to all who have used the genuine, (there having been numerous counterfeits in the market,) as witness also the award of a



Diploma and Medal by the Judges of the late Centennial Exhibition at Philadelphia. We have no hesitation in saying that his Oils are the BEST manufactured always uniform in quality and capable of standing all tests applied to lubricating oils. We cheerfully recommend it to all who may in their business require a FIRST-CLASS LUBRICATOR

SETH THOMAS CLOCK COMPANY, SETH E. THOMAS, Agent



P. S.—The above Oils can be procured at all first-class wholesale Watch and Clock Establishments in the United States, as well as his only Agents, HENRY GINNEL, 31 Maiden Lane, New York, and GRIMSHAW & BAXTER, 35 Goswell Street, London, England.

New Bedford, October 15, 1877.

# RANDEL, BAREMORE & CO. DIAMONDS,

Corner Maiden Lane and Nassau Street,

29 MAIDEN LANE,

58 NASSAU STREET,

**NEW YORK.**

No. 12 New Burlington Street, LONDON.

Established 1828.

## JACOB BENNETT & SON,

Diamond Setters and Manufacturing Jewelers,  
No. 108 SOUTH EIGHTH STREET, PHILADELPHIA.

WE MANUFACTURE AND MAKE A SPECIALTY OF  
EVERY DESCRIPTION OF

**DIAMOND MOUNTINGS,**

SUPERIOR IN DESIGN AND WORKMANSHIP.



Dealers in

**DIAMONDS,**

And all kinds of Precious Stones.

Masonic Marks, Society and School Badges, Made to Order Only. Designs and Estimates Furnished.  
PARTICULAR ATTENTION GIVEN TO ALL KINDS OF JOBBING.

## L. & A. MATHEY,

No. 16 MAIDEN LANE,

IMPORTERS OF ALL GRADES OF

Plain and Complicated Watches and Movements,

SOLE AGENTS FOR THE WELL-KNOWN

# H. L. Matile

FINE WATCHES OF ASTRONOMICAL PRECISION.

AN ATTRACTIVE LINE OF CHATELAINES AND CHATELAINES WATCHES.

SOLE AGENTS FOR CHAS. MAYLAN'S IMPROVED MINUTE CHRONOGRAPHS.



## MATHEY'S TIME INSTRUCTOR.

*A pleasing Instrument for teaching Children Time. It consists of a neat black walnut box, about 8 inches square, by 1½ inches thick and contains a Time Dial with wheels to regulate the hands. The points of the Compass, Terrestrial Globe, Alphabet, Calendar and the Months of the Year, and other useful and interesting information conveyed in a simple, comprehensive way, to amuse children. This is the most pleasing instrument for the purpose designed ever introduced. It can also be used by the trade as an advertisement of their own by simply printing their business card on the Dial.*

Samples forwarded by mail, prepaid, on receipt of 60 Cents.

L. & A. MATHEY, 16 Maiden Lane, N. Y.

**W<sup>m</sup>. S. HEDGES & CO**

OF THE LATE FIRM OF SMITH, HEDGES & CO.

**IMPORTERS OF**

**DIAMONDS**

**170 BROADWAY**

COR. OF MAIDEN LANE N. Y.

CHOICE BRILLIANTS IN SINGLE STONES  
AND MATCHED PAIRS A SPECIALTY.

FRESH INVOICES OF GOODS IN ALL GRADES CONSTANTLY ARRIVING. ALSO, CHOICE PARCELS OF EXCEPTIONALLY FINE GEMS  
ESPECIALLY SELECTED FOR CRITICAL PURCHASERS. A Full Line of Mounted Goods Artistically Designed.

GOODS SENT ON APPROVAL.

# “HILLSIDE,”

NEW THREE-QUARTER PLATE MOVEMENT

—MADE BY—

## The American Watch Company

OF WALTHAM,

The lowest price three-quarter plate Stem-Winding American movement ever made. We wish to call the attention of the trade to the following special advantages:

*They are made to wind at either the figure XII for Open Face Cases, or at figure III for Hunting Cases, in all three qualities, viz.:*

Gilded Movement, Cut Expansion Balance, plain jeweled;  
 “ “ “ “ “ with 3 pairs extra jewels in settings;  
 Nickel Movement, Cut Expansion Balance, with 3 pairs extra jewels in settings.

*These movements all have quick trains, Patent Pinions, with extra jewels in settings, and, at the very low price at which we offer them, are especially adapted for our New Patent Dust Proof Open-Face Cases. A good strong case can be made under our patents weighing not over*

22 dwts., 14 karat gold,  
 24 “ 18 “ “

*thus making altogether the lowest price three-quarter plate gentlemen's size stem-winding gold watch ever offered.*

Robbins & Appleton, 9 Bond St., New York.  
 Robbins, Appleton & Co., 8 Summer St., Boston.  
 Robbins & Appleton, 170 State St., Chicago. } *General Agents.*

AMERICAN WATCH COMPANY,  
 OF WALTHAM, MASS.

Note the prices of the following new movements made by

# THE AMERICAN WATCH COMPANY

## OF WALTHAM, MASS.

### 14 Size, $\frac{3}{4}$ Plate.

AM. WATCH CO.	"HILLSIDE"	(New), 7 jewels, cut expansion balance, Stem Winder, for Hunter or Open Face, (Gilded Movement)	\$20 00
"	"	"	
		3 pairs extra jewels, in settings, cut expansion balance. Stem Winder, for Hunter or Open-Face, (Gilded Movement),.....	23 00
		3 pairs extra jewels in settings, cut expansion balance, Stem Winder, for Hunter or Open Face, (Nickel Movement).....	30 00

### 18 Size, Full Plate, NICKEL Movements.

"WM. ELLERY,"	2	pairs, extra jewels, cut expansion balance....	12 00
"	2	"	"
		Stem Winder,.....	16 50
"P. S. BARTLETT,"	2	pairs, extra jewels in settings, cut expansion balance....	18 50
"	2	"	"
		Stem Winder	26 00
"WALTHAM WATCH CO."	4	pairs, ex. jewels in settings, cut ex. balance....	26 50
"	4	"	"
		Stem Winder	34 50
"APPLETON, TRACY & CO.,"	4	pairs, extra jewels in settings, cut expansion balance, adjusted....	37 00
"	4	"	"
		4 pairs, extra jewels in settings, cut expansion balance, adjusted, Stem Winding.....	46 50

All the above are subject to the terms and discounts announced in our circular of the 8th Feb. last.

There will be no change in the quality of any of our grades, except as our constant efforts tend to their improvement. We decline altogether to take any part in the present unwise competition between Swiss and American manufacturers to see which shall make watches of the poorest quality. We intend to sell as low as any American company, but, however low the price, we do not intend to finish a grade of goods upon which it would be a disgrace for us to put our name.

Robbins & Appleton, 9 Bond St., New York.  
 Robbins, Appleton & Co., 8 Summer St., Boston,  
 Robbins & Appleton, 170 State St., Chicago.

American Watch Company,  
 OF WALTHAM, MASS.

*New York, September 1st, 1879.*



*A SELECT ASSORTMENT OF RINGS, EAR RINGS, EAR DROPS,  
STUDS, PINS, CROSSES, LACE PINS, AND OTHER*

NOVELTIES,

*ARTISTICALLY MOUNTED, AND ESPECIALLY DESIGNED*

FOR THE HOLIDAY TRADE.

*GOODS SENT ON APPROVAL.*





Medal and Diploma awarded at Centennial Exposition, for superior mechanical execution and artistic



Established in 1854.

**C. & A. PEQUIGNOT,  
MANUFACTURERS OF WATCH CASES,**

DEALERS IN AMERICAN WATCHES AND IMPORTERS OF FINE KEY AND STEM-WINDING MOVEMENTS,  
SALESROOM AND MANUFACTORY, 22 SOUTH FIFTH STREET,  
PHILADELPHIA.

A full stock of Key and Stem-Winding Gold Cases always on hand. Goods sent on approval when satisfactory references are furnished.

**Anti-Tarnish Silver Tissue Paper,**

FOR WRAPPING UP SILVER WARE, JEWELRY, &c. Patented.

Chemically prepared to resist the action of gases which tarnish Silver.

Endorsed by leading Chemists and Silver Ware Manufacturers, after being subjected to severe tests.

**H. V. BUTLER Jr., & CO.,**

SOLE MANUFACTURERS,

34 Reade St., New York.

Factory,  
27  
RUE DU PARC,  
Chaux de Fonds,  
Switzerland.

Established 1826.

**JULIEN GALLET,  
Importer of Watches & Watch Movements,  
OF EVERY DESCRIPTION.**

Sales Rooms,  
No 1  
MAIDEN LANE,  
NEW YORK.  
P. O. Box, - 4420.

Would respectfully call the attention of the trade to our page of Illustrations elsewhere in this Journal. These goods are of recent importation and embrace the latest novelties in Timepieces.

CHARLES PERRET, Sole Agent.

The accompanying cut illustrates the large size

**PIONEER WATCH,**

The best pocket time-keeper ever offered the trade. Can be had of any first-class Jobbing House throughout the United States.

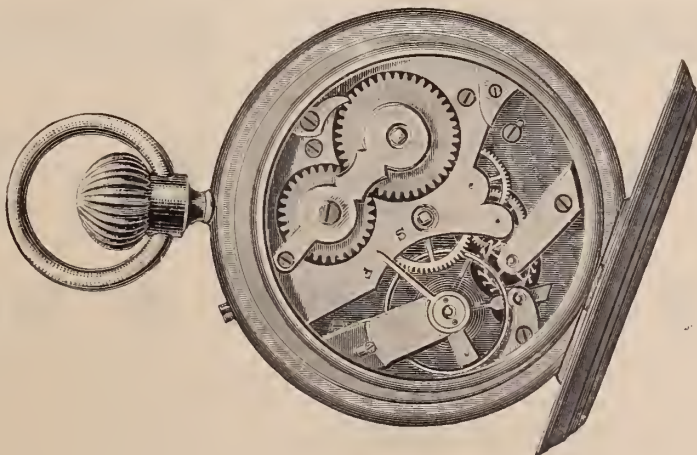

None genuine unless stamped  
**" PIONEER "**  
either inside or outside of case.

**H. GINNEL,**

Sole Manufacturer,

31 Maiden Lane,

NEW YORK.

P. O. Box 2967.

# HENRY C. HASKELL,

Manufacturing Jeweler,

No. 12 John Street,

New York

THE FINEST SEAL RING EVER OFFERED  
THE TRADE.

## The "MARQUIS"

*Must be seen to be fully appreciated.*

Four Sizes,  
CAMEO, INTAGLIO, ONYX or BLOOD STONE

*Every Stone Warranted*

*not to come out.*



4040



5223



7571

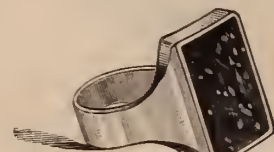

7572

*Samples sent on approval, express paid.*

*Price Lists to Trade only.*

# CHAS. F. WOOD,

No. 169 BROADWAY,

NEW YORK.



Designs Patented  
September 9th, 1879.



12



10



9



4



1



3



7



6

N. B.—Monograms, Birds, and all kinds of elaborate Devices incrustated with Gold of different colors, viz.: Yellow, Green and White.

The above colors present a very handsome appearance when incrustated either with or without Diamonds, in Onyx Rings, Scarf Pins, Lockets, Pins, Earrings, &c.

Stone Seal Engraving and Lapidary work promptly executed.

House Established since 1837.

# CHARLES LEO ABRVY,

(SUCCESSOR TO J. A. ABRVY.)

## Importer and Manufacturer of Swiss Watches

OF ALL GRADES, AND DEALER IN AMERICAN WATCHES.

Sole Agent in the United States for the **Celebrated Vacheron and Constantin Geneva Watches.**

These unrivalled time-keepers are now made interchangeable in every respect. A full line (cased or uncased) always in stock—prices very much reduced from formerly. Specialties in O. F. Nickel Stem Winders Anchors with White, Black and Fancy Dials, 16, 18 and 20 lines. Also, Silver O. F. Hunting and  $\frac{1}{2}$  Hunters Stem Winding Anchors, 16 and 20 Lines. In liquidation—a large stock of Swiss Key and Stem Winder Watches, Gold and Silver Cases, must be sold and are offered cheap for cash. SEND FOR PRICES.

Factory, Neuchatel, Switzerland.

P. O. Box 611.

63 Nassau St., New York.

## CLOSING OUT.

THE ENTIRE STOCK OF

# JEWELRY

OF

## CHATTERTON & DODD,

To close the business.—Great inducements offered to purchasers.—Dealers visiting the city will find it to their interest to call and examine this stock.

No. 19 JOHN STREET, NEW YORK.

Goods sent on selection to responsible parties.

**MULFORD & BONNET,**

Manufacturers of Gold Jewelry, Dealers in Diamonds,  
Jobbers of best Rolled Plated Goods.

Our stock is assorted with great care, and is kept replenished with the choicest and latest selections. We are introducing new designs and constantly receiving the newest patterns. The varied character of our stock, so comprehensive in all its details permits us to offer to buyers unusual advantages.

**MULFORD & BONNET,**

21 MAIDEN LANE, New York.

*Sole Proprietors of the PAINLESS EAR PIERCER,  
Patented June 25th, 1876.*

**HALL, ELTON & CO.,**

Manufacturers of the Finest Electro-Plated Ware.

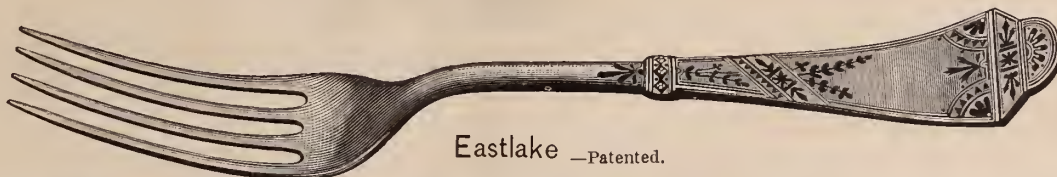
**UNSURPASSED IN QUALITY, STYLE AND FINISH!**

Factories, Wallingford, Conn. Salesroom, 75 Chambers St., New York.

**HOLMES, BOOTH & HAYDENS,**

MANUFACTURERS OF

**ELECTRO-SILVER PLATED****Spoons, Forks, Ladles, Fancy Pieces,****Solid Handle Steel Knives, &c., of the finest quality.**

No. 49 Chambers Street,  
**NEW YORK.**

No. 18 Federal Street,  
**BOSTON.**

Works at Waterbury, Conn.

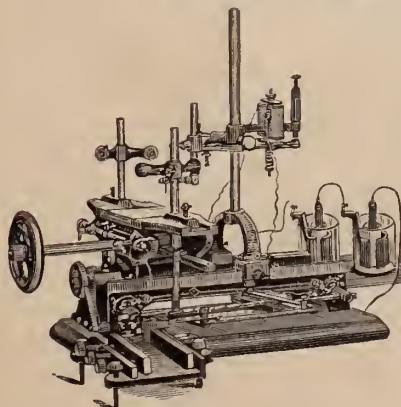
**GUERRANT'S ELECTRO-ENGRAVING MACHINE.**

Size of Machine, 12 x 16 inches.

Patented Jan. 18, Oct. 31, 1876, &amp; Mar. 4, 1879.

It has baffled the skill of the inventive genius of the world for ages to produce a machine that would compete with the skillful hand engraver, and until this machine was invented, all engraving had to be done by hand. And, to-day, it is the only practical engraving machine in existence.

The construction of the machine is not complicated, but simple and durable. It is easily operated. The variety of work it will do is almost incredible, and to be fully appreciated, ought to be seen in operation.

We do not therefore, offer this machine to the public simply as a machine to aid the engraver, but as a perfect, practical engraver in itself, with which any person of ordinary skill can learn in a short time to do any piece of engraving that might be desired and in the very best manner.

It copies from the regular press type of any style of letter or design that is made of type, from the plainest to the finest german text letter or fancy design, at the same time it will reduce the letter or design from the original size to ten different sizes, or so small that it cannot be seen by the naked eye. It will shorten the letters or elongate them, also will lean them forward or backward, will either make a raised or sunken letter, will engrave on any surface, either plain, concave or convex—for instance, such things as Watch Cases, either in or outside; Finger Rings, either in or outside; Bracelets, Napkin Rings, Goblets, Pitchers, Mugs, Waiters, Spoons, Forks, and all kinds of Jewelry; or, in fact, on any article susceptible of being engraved or ornamented with scroll work or fancy designs, &c., either on Gold, Silver, Copper, Brass, Iron, hardened Steel, Glass, Stone, Pearl, Ivory, Bone, Gutta Percha.

No Jeweler or establishment that has engraving to be done should be without it. Machines are sold with limited territory to use them in; or, the exclusive rights to use them in certain town or territory can be purchased with the machine if desired.

For further information, address

**WM. HICKSON, Gen. Agt.,**

P. O. Box 1603, PHILADELPHIA, PA.

A.M. GUERRANT, Danville, Va., Agent for the Southern States.

**KARN & HICKSON,**

LYNCHBURG, VA.

Owners of the right of all the Northern States and Territories.



WHITING MF'G COMPANY.

**SILVERSMITHS,**

BROADWAY AND FOURTH STREET,

**NEW YORK.**

Gentlemen's Watches,  
Ladies Watches,  
Bridge Movement Watches,  
¾ Plate Movement Watches,  
¾ Plate Patent Reg. Watches,  
¾ Plate Movement Watches,  
Repeaters,  
Chronographs. (1-5 second)

**TIFFANY & CO.**  
NEW YORK, PARIS, LONDON, GENEVA.  
**MAKERS OF FINE AND COMPLICATED WATCHES,**  
Wholesale Office, 694 Broadway, New York.  
GEO. R. COLLIS, Manager.

Split-Second Chronographs.  
Minute and Sec'd Chronograph  
Chronograph and Repeaters,  
Minute Repeaters,  
Five Minute Repeaters,  
Quarter Hour Repeaters,  
Repeaters and Chronographs,  
&c. &c., &c.

All watches of our make have the firm name "TIFFANY & CO." engraved upon the movements, and the trade are cautioned against apparent fac-similes put upon the market by certain unscrupulous dealers.

Our new "Bridge movement" watch for gentlemen is now ready, and conceded by experienced judges to be "the BEST watch ever made for the price." It is adjusted to temperature and position, and fully guaranteed.

☞ Goods sent for selection or examination upon receipt of satisfactory references. Old nickel movements refinished for the trade. Orders for engraving and ornamenting movements, enameling and carving of Inscriptions, Devices and Monograms on Cases promptly attended to.

Only Wholesale Office for the sale of the American Pedometer.

☞ Also General Agents for the United States for Messrs. PATEK, PHILIPPE & CO.'S Celebrated Watches.

# ROGERS & BRO.

MANUFACTURERS OF

## FINE ELECTRO SILVER PLATE,

### 690 BROADWAY, NEW YORK.

*N. B.—The only house manufacturing Silver-Plated Ware under the name of "ROGERS," although there are makers and sellers of plated-ware who stamp their goods "Rogers" and endeavor to live on the reputation we have been so many years in establishing.*

**ROGERS & BRO.,**

690 Broadway, New York.

Novelties in design and finish, in Silver Fancy Goods and Hollow Ware, with combinations of colors in gold, silver and niello-enamel, Testimonial and Presentation Goods, Spoons and Forks of patterns popular and desirable, and a choice line of Case goods, from single pieces to Cabinets for Wedding Gifts.

THE  
**Adams & Shaw Company,**  
**SILVERSMITHS,**

and Makers of Hard Metal Electro-Plate,

694 BROADWAY, . . . . . NEW YORK.

GEO. R. COLLIS, Manager.

Designs and estimates furnished, and particular attention paid to orders for racing, Field and Nautical Prizes, (small and large), Tea Sets, Berry Bowls, Fruit and Ice Cream Stands, Jelly Bowls and General Hollow-Ware, in Sterling Silver or Silver-soldered Electro-Plate.

A large assortment of new, ornamental and useful presents suitable for HOLIDAY OFFERINGS

LADIES' Portmonnies, Card Cases, Lace Pins, Hairpins, Tete-a-tetes, Shawl Pins, Card Stands, Vases, Caddies, Fruit Knives, Ice Cream Slicers, Sugar Scissors, Bells, and a great variety of other goods in new styles of decoration.

GENTLEMENS' Cigar Cases, Match Boxes, Shaving Mugs, Cigarette Cases, Pocket Flasks, Wine Coolers, Cigar Lighters, Liquor Labels, Wine Goblets, After-dinner Coffee Sets, Ice Pitchers, Soap Boxes, Call Whistles, &c., &c.

CHILDREN'S Cups, Rattles, Whistles, Pap Bowls, Catnip Warmers, Christening Sets, Knives, Forks, Spoons, Napkin Rings, Bib Pins, &c., &c.

# CARRIAGE, CABINET AND QUEEN ANNE CLOCKS !

**BRONZES FOR TOP PIECES, VASES FOR SIDE PIECES,**  
**TERRA COTTA STATUARY, Porcelain and Brass Mounted**  
**FIELD AND OPERA GLASSES, TABLE LAMPS.**  
**POLISHED BRASS SCONCES, FOLDING TRIPPLICATE MIRRORS,**  
 IN JAPANESE AND FRENCH DECORATIONS.

**Clean and attractive Holiday Stock.**

Illustrated Catalogue sent only to dealers enclosing Card.

## HALL, NICOLL & GRANBERY,

Successors to SCHUYLER, HARTLEY & GRAHAM,  
 As Importers and Manufacturers of Fancy Goods,

20 & 22 John St., New York.

# LE BOUTILLIER & CO.

Importers and Jobbers,

3 Union Square, New York.

Call the attention of the trade to their MYSTERIOUS CLOCK and Thermometer. Every clock GUARANTEED to run 21 days and keep accurate time. Will take back any clock not coming up to guarantee. Stands 31 inches high; vastly superior to the cheap American copy.

We have a full line of

**MARBLE**



**CATHEDRAL GONG**

striking on CATHEDRAL GONG at exceptional prices.

—ALSO—

The largest line of NOVELTIES in the City.

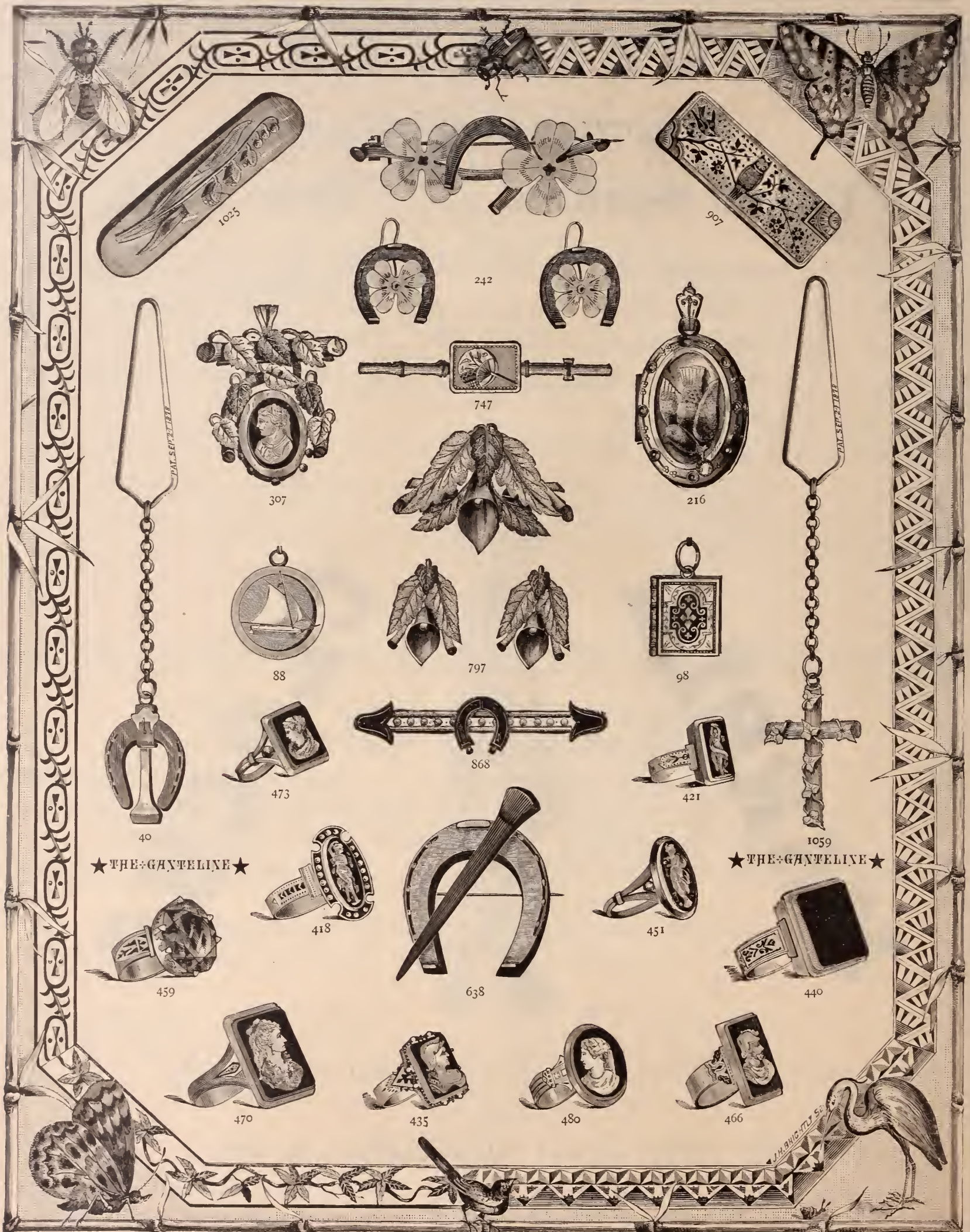

THE ABOVE REPRESENTS ONE PAGE OF OUR SUPPLEMENT OF FOUR PAGES OF NEW DESIGNS, WHICH WILL BE FURNISHED, TOGETHER WITH PRICES, TO THE LEGITIMATE JEWELRY TRADE ONLY, UPON APPLICATION.

**C. G. ALFORD & CO., 183 Broadway, New York.**



**F. KROEBER,**  
**IMPORTER,**  
 8 Cortlandt Street, New York.

**MARBLE CLOCKS,**

—WITH—

TIME, STRIKE AND VISIBLE MOVEMENTS,

**WITH OR WITHOUT GONG.**

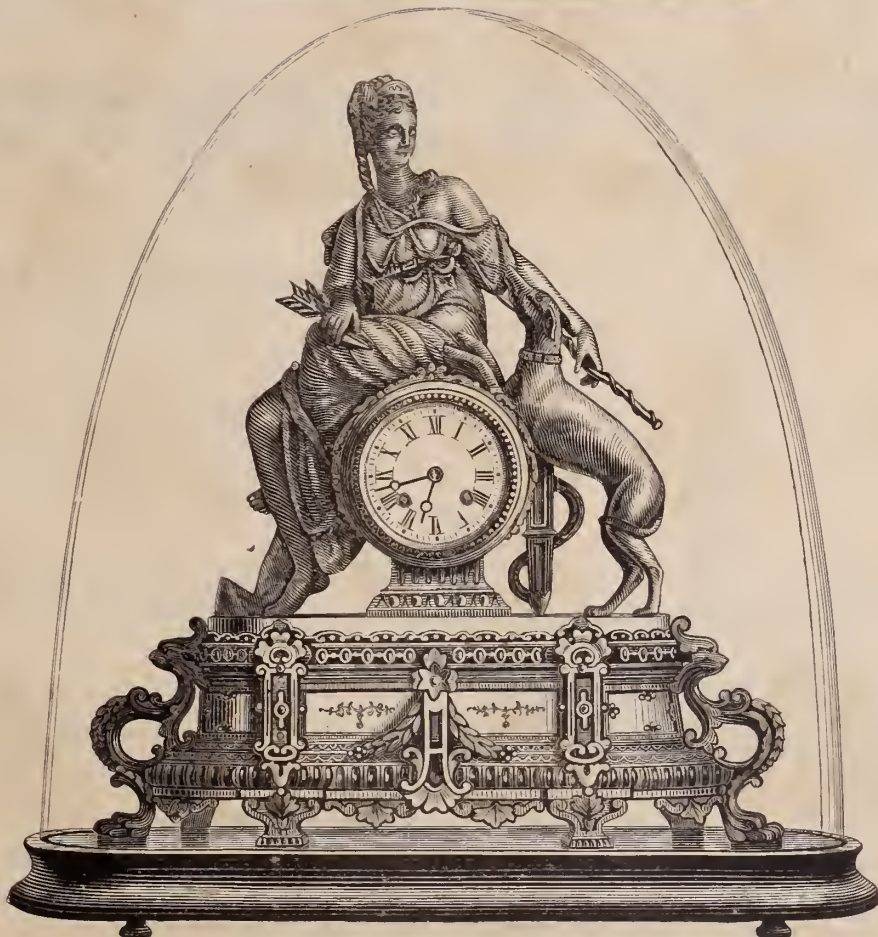

—WITH—

**TIME OR STRIKE MOVEMENTS.**

**GILT AND ALABASTER CLOCKS,**

**PRICES REDUCED SEPTEMBER 1st.**

# OPERA GLASSES

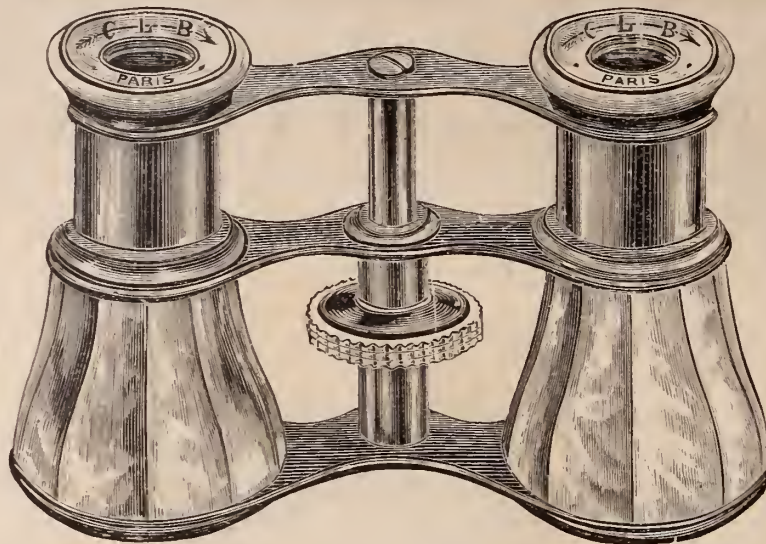

**OPTICAL**

**GOODS!**

And Arrow Brand Interchangeable Spectacles and Eye-Glasses.

*The most desirable line of the above goods in the market will be found in the*

**OPTICAL DEPARTMENT.**

—OF—

**W. B. CLAPP, YOUNG & CO.,**

149 & 151 STATE STREET,

CHICAGO, ILL

Illustrated Price Lists Sent to the Trade Only.

# REED & BARTON,

MANUFACTURERS OF

## Silver-Plated Ware.



Possessing the advantages of over half a century in manufacturing, employing only the highest skill and talent in every department, using only the most approved machinery in every department, we are enabled to produce goods of the most artistic design, finest finish, and quality, at the lowest prices. Our assortment is very extensive, including varied designs in

*COFFEE, TEA, DINNER, DESSERT AND WATER SETS; CAKE AND FRUIT STANDS; ENTREE, VEGETABLE AND BUTTER DISHES, TUREENS, SPOONS AND FORKS, CUTLERY, ETC.*

Also, a great variety of Fancy Articles, such as

*CARD CASES, CARD RECEIVERS, JEWEL BOXES, CHILDREN'S SETS, ORNAMENTED PIECES, ETC.*

Highest Premiums awarded our wares wherever exhibited: The World's Fair, New York, 1853; American Institute Fair, New York, 1838 to 1878; three awards at Centennial Exhibition, Philadelphia, 1876; and the only prize for Plated Ware at International Exhibition, Chile, 1875, was given to us.

**SALESROOM, 686 BROADWAY, N. Y.**

**Factories, - - Taunton, Mass.**

# GILES BRO. & CO.

Manufacturers and Jobbers of

## FINE AND ROLLED PLATE JEWELRY,

Diamonds, Watches, Clocks, Materials, Tools and Optical Goods.



273



628



629



438



Illustrated Catalogue Furnished to Dealers only.

GOODS SENT FOR SELECTION.

Corner State and Washington Streets, CHICAGO, Ills.

# CHARPIER & WATHIER,

## Watchmakers and Jewelers for the Trade,

AND WHOLESALE DEALERS IN

Watch Materials, Tools, Glasses, Spectacles, Silk Guards, &c.

61 WEST KINZIE STREET, CHICAGO.

All work intrusted to us will receive prompt attention and warranted satisfactory. Escape and StemWinding Wheels cut to order at lowest prices. Price List sent on application.



No. 3.



No. 4.

### NICOUD WATCHES,

STEM-WINDING,—HUNTING AND OPEN FACE.

GENTS' AND LADIES' SIZES.

## NICOUD & HOWARD,

SOLE IMPORTERS,

14 MAIDEN LANE,

P. O. BOX 2269.

NEW YORK.



No. 5 A.



No. 5 B.

*SMALL STEM WINDERS A SPECIALTY.*

Prices sent upon application accompanied by business card.



No. 7.



No. 8.

ESTABLISHED 1837.

VICTOR BISHOP & CO.

IMPORTERS OF

**DIAMONDS**  
PRECIOUS STONES

—AND—

CORAL JEWELRY,

Enamel Paintings, Copper and Platinum.

No. 47 NASSAU STREET, NEW YORK.

House in Paris, 66 Boulevard de Sebastopol.

SAXTON, SMITH & CO.

MANUFACTURERS OF

**Fine Gold Chain.**

No. 15 Maiden Lane,

New York.

Factory, No. 183 Eddy Street, Providence, R. I.

Sole Agents for the new PATENTED CHAIN BAR, containing a Detachable Pencil.

HELLER & BARDEL,

Manufacturers of

DIAMOND AND PEARL

**JEWELRY,**



13 John St., New York.

ESTABLISHED 1848.

E. S. JOHNSON & CO.

MAKERS OF

Gold Pens, Pencil Cases, Etc.

SUITABLE FOR THE REQUIREMENTS OF ALL CLASSES OF DEALERS

These goods have achieved a high reputation and are universally acknowledged to be the best Pens and Pencil Cases made, and as low in price as is consistent with quality of Gold, workmanship and style of finish.

Intending purchasers will consult their interests by comparing prices. We are constantly introducing new and desirable goods that cannot fail to give satisfaction.

44 Nassau Street, New York.

PRICE LISTS SENT ON APPLICATION.

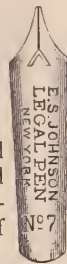

WOOD & HUGHES,

STERLING

Silverware Manufacturers

No. 16 JOHN STREET,

NEW YORK.

206 Kearney Street, San Francisco, Cal.

R. R. HASKELL, Agent.

KREMENTZ & CO.,

MANUFACTURERS OF

**FINE JEWELRY,**

No. 13 John Street, New York.

FACTORY, 361 Mulberry Street, - - Newark, N. J.

GOODS OF OUR OWN MAKE EXCLUSIVELY.

xx THE JEWELERS' CIRCULAR AND HOROLOGICAL REVIEW.

**CARTER, HOWKINS & SLOAN,**  
**Makers of Fine Jewelry**

*Consisting of Chains, Bracelets, Sets, Pins, Studs, Sleeve Buttons,  
 Scarf Pins, Rings, &c., in Roman, Etruscan and Enamel,  
 and a full line of Jewelry generally.*

Whiting Building, Corner Broadway and Fourth Street,

A. CARTER JR.  
 WM. HOWKINS,  
 A. K. SLOAN.

**NEW YORK.**

C. E. HASTINGS,  
 GEO. R. HOWE,  
 W. T. CARTER.

**HALE & MULFORD,**  
**Manufacturing Jewelers,**

(WHITING BUILDING).

No. 694 Broadway, cor. 4th Street, New York.

Call attention of the Trade to their new style of

**BAND BRACELETS,**

We claim for these Bracelets, the following advantages over the old style, viz. :

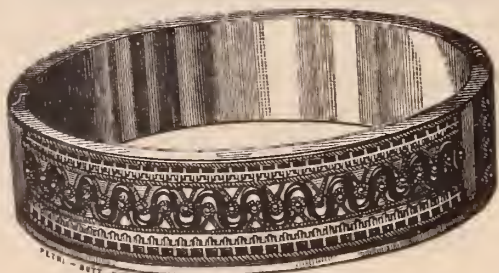

1st. The edge of the Bracelet being raised, forms a protection to the ornamentation.

2d. Less liability of getting damaged, and when damaged, are more easily repaired.

3d. More attractive in appearance.

Prices are as low as any FIRST CLASS 14 KARAT ALL GOLD Bracelet in the market.

Made in all sizes from  $\frac{1}{4}$  inch upwards.

Patented Feb. 25th, Re-issued Oct. 14th, 1879.

—Established 1837.—

**TAYLOR & BROTHER,**

Late TAYLOR, OLMSTED & TAYLOR,

**Importers of Diamonds and Pearls,**

—AND—

**MANUFACTURERS OF DIAMOND JEWELRY,**

No. 676 BROADWAY,

**NEW YORK.**

**BALDWIN, SEXTON & PETERSON,**

MANUFACTURERS OF

**Fine Jewelry,**

Diamond and Stone Cameo Goods,

**GOLD CHAINS, &c.**

Importers of Diamonds, Pearls, Emeralds, Rubies, &c.

WHITING BUILDING,

**Cor. Broadway and Fourth Street,**

**NEW YORK.**

120 SUTTER STREET, San Francisco, Cal.

Established 1817.

**Ve. J. MAGNIN, GUÉDIN & CO.**

29 Union Square, New York.

*Manufacturers and Importers,*

FINE SWISS WATCHES,

REPEATERS, CHRONOGRAPHS & CALENDARS

GENEVA GOLD JEWELRY,

FRENCH CLOCKS AND BRONZES,

RICH FANCY GOODS,

HORSE-TIMERS & PEDOMETERS,

GOLD AND SILVER CHATELAIN WATCHES.

Gold Medal Awarded, Paris Exposition, 1878.

*Sole Agents for the James Nardin Watch.*

*House in Geneva, 14 Grand Quai.*

Established 1813.

**THOMAS G. BROWN,**

MANUFACTURER OF

**FINE JEWELRY.**

*Designs furnished for all kinds of Sporting  
 Badges and Medals for Schools & Colleges.*

**NEWARK, N. J.**

—AND—

**9 BOND STREET, NEW YORK.**



Factory and Offices, 611 & 613 Sansom Street,

ARTISAN BUILDING.

THIS old and well-known firm manufacture a greater variety of *SPECIALTIES* than any other one house in the country.—**FINE TINTED AND ROMAN JEWELRY, IN SETS, BRACELTS, EAR RINGS, LOCKETS, &c., &c. GOLD CHAIN, SILVER CHAIN, GOLD THIMBLES, SILVER THIMBLES.**

In both *GOLD* and *SILVER THIMBLES*, in *Styles* and *Finish* we claim to excel all others.

## GOLD HEAD CANES.

These goods we were the *FIRST* to make to any extent, nearly all other makes are *copies of our patterns*, whilst some of our styles *have never yet been imitated*, we being *JEWELERS* as well as *CANE MAKERS*, are able to do more *elaborate* work than those not possessing this advantage.

### ILLUSTRATED CATALOGUE.

Our Illustrated Catalogue of these goods will be ready for gratuitous circulation by *September 15th*, and parties about to order *CANES* for Fall will do well to reserve orders until they have this *intelligent aid*.

## SIMONS BROTHER & CO.

SAMPLES AND PRICE LIST

Can be seen at

G. & S. OWEN & CO., 5 Maiden Lane, New York,  
OUR AGENTS.

PHILADELPHIA.

# KEARNEY & SWARTCHILD,

113 & 115 STATE STREET,

**CHICAGO.**

Manufacturers and Jobbers of all kinds of

*Watchmakers and Jewelers Supplies,*

Watches, Jewelry, Etc.

300 Page Illus. Catalogue sent upon application and Receipt of Business Card.



No. 15.



No. 7.



No. 10.



No. 20.



No. 1.



No. 2.



No. 3.



No. 5.



No. 1.



No. 8.



No. 9.



No. 12.



ESTABLISHED 1850.

The only establishment in the United States that is devoted exclusively to the sale of Musical Boxes.

**M. J. PAILLARD & CO.**

MANUFACTURERS, IMPORTERS AND DEALERS IN

## Musical Boxes,

SUITABLE FOR THE REQUIREMENTS OF ALL CLASSES, OFFER THEIR ENTIRE STOCK AT PRICES THAT WILL COMMAND THE ATTENTION OF BUYERS.

The Musical Boxes made by us, have achieved a world-wide reputation, and it is safe to say that two-thirds of the improvements in Musical Boxes, have originated in our establishment. The patents of which are owned exclusively by us.

Our stock is unusually complete and attractive and embraces many novelties, among which we may mention, the Sublime Harmony, the Harp Piccolo, and several others.

The double mainspring introduced by us is also a decided improvement, as it obviates the necessity of frequent winding. The greatest novelty in Musical Boxes is the interchangeable system of cylinders. These boxes are desirable goods for dealers as the cylinder can be increased to any extent, and a single instrument made to play an infinite variety of music. These cylinders can be ordered at pleasure, and all that is necessary to insure them fitting is to give the number of the box.

### Specialties for the Holidays,

Have just received an invoice of Musical novelties consisting of *WORKBOXES, ALBUMS, FOOT STOOLS, CIGAR CASES, DECANTERS, PLATES*, and other fancy articles appropriate for Holiday offerings.

**M. J. PAILLARD & CO.,**

*680 Broadway, New York.*

**A. E. JUILLERAT,**

Agent for the Pacific Coast,

**31 Post St., San Francisco, Cal.**

# B. F. NORRIS & CO.

MANUFACTURING AND

## Wholesale Jewelers

101 & 103 STATE ST.,

CHICAGO.

We are the only Agents for the

### ELGIN LATHE.

Only Western Agents for

Middletown Silver Plate Co.

Only Western Agents for the

### CRESCENT SPECTACLES.

—o—

A full Illustrated Catalogue furnished to Dealers.

Send Business Card.

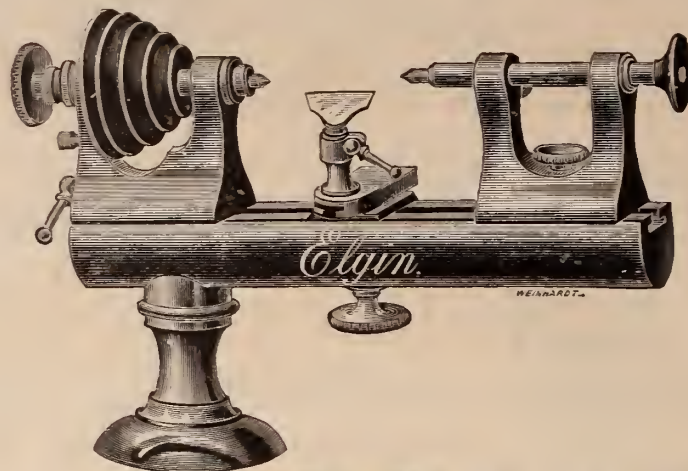

# ERRICO BROTHERS,

19 JOHN STREET, N. Y.

MAKERS AND DIRECT IMPORTERS FROM OUR OWN MANUFACTORY IN NAPLES,

## CORAL, SILVER FILIGREE AND CONCH SHELL JEWELRY,

—OF THE LATEST DESIGNS.—

These goods are made under our own immediate supervision, and designed expressly for this market. Our stock, the largest in the city, is replete with the richest novelties in this line, and is offered to the trade at prices that will tempt buyers.

We would direct the especial attention to our recent importations of CORAL ROSES and CORAL CAMEOS in all the most desirable shades. Also to our new designs in SILVER FILIGREE goods, which we offer at unexceptionably low prices. Buyers, when in town, are invited to an examination of our stock.

**L. A. CUPPIA**

MANUFACTURER OF

**STERLING SILVER JEWELRY,***Nickel and Silver Chatelaines a Specialty.*

Silver Filigree, Coral and Conch Shell THE NOVELTY of the Season.

*A Solid Nickel Chatelaine and Watch A Competition that will not tarnish. Send for Price List.***L. A. CUPPIA,**

Branch Office--180 Broadway, N. Y.

19 UNION SQUARE, N. Y.

S. C. JACKSON, Manager.

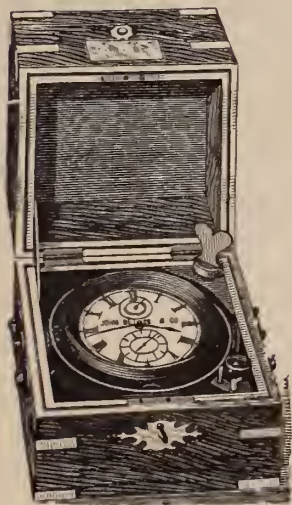
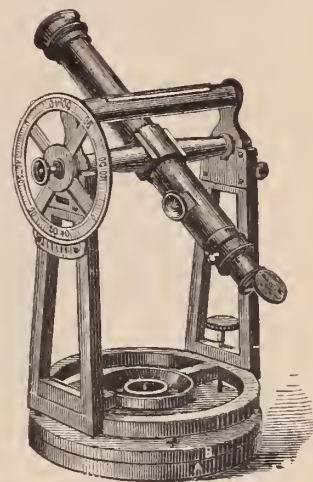
Standard Marine Chronometer  
FOR KEEPING CORRECT TIME.**JOHN BLISS & CO.****STANDARD MARINE****Chronometers and Transits,****FOR WATCHMAKERS' USE.**

No. 10

**110 WALL STREET, NEW YORK.****IMPORTANT NOTICE.**—These Transits are readily set in position without the aid of strictly correct time as a basis for that purpose. Printed instructions, easily understood, accompany each Instrument, and no calculations are required preliminary to setting in position.As a trial only is required to insure unqualified approval, we are induced to make the following **LIBERAL OFFER**—On receipt by us of satisfactory reference, and 10 per cent. of the price, we will send one of the foregoing Transit Instruments, on hire or trial, for one month, with full printed instructions for setting up and using the same, and if purchased after trial, we will allow the whole hire to apply in part payment, and sell the Instrument on approved note at four months for the balance. Special terms for payment by installments, after trial, on application. We do not make this offer merely to hire these instruments, but to insure a trial with a view to sales, the hire received being only sufficient to cover the cost of repolishing in case they are returned. Send for Illustrated Circular giving full description.**JOHN BLISS & CO., 110 Wall Street, New York.**

**ARHELL & CO.**

IMPORTERS AND DEALERS IN

Watch Materials, Tools,  
**JEWELRY,**  
 AND ALL GRADES OF AMERICAN WATCHES.

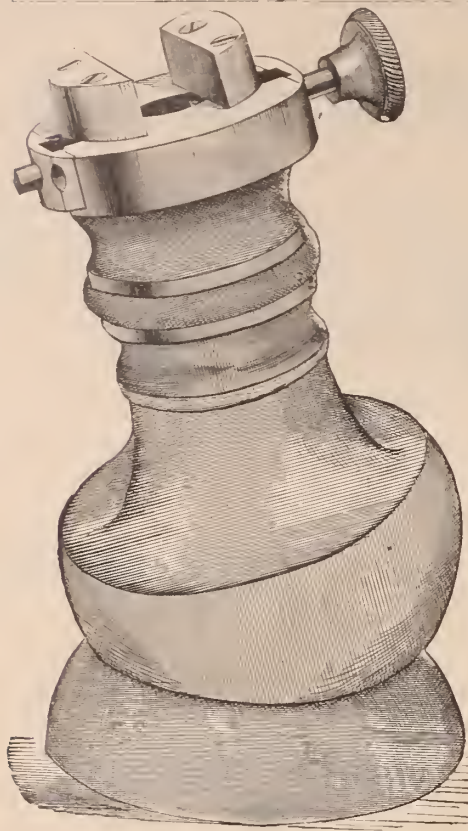
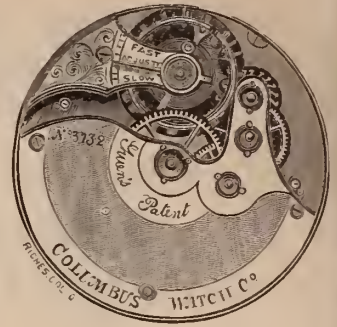

We call the attention of Watchmakers to the "JEQUIER" Main Spring. This spring is the only one of all fabrications exhibited at the "Paris Exposition" that received FIRST and ONLY medal. We claim it is the best in this country, and invite a trial by the trade as a test of its merits. Send for sample and also descriptive catalogue of Columbus Watch, nickel  $\frac{3}{4}$  plate, full jeweled, stem-winding and setting, the most beautiful watch with the best results for least money, quality considered. No price list furnished unless requested and only to the trade.

BALDWIN'S BARREL CATCH INSERTER, indispensable to the Watch Repairer, saves time and labor, sent by mail on approval to the trade free of postage.

We are Sole Agents for the United States of these goods. We also manufacture the BOSS ENGRAVING BLOCK—there are features in its construction different from all others in the market, holds the work to be engraved, of any kind, without attachments. It is practical, simple, and reasonable in price. All these specialties enumerated, may be obtained of any regular Dealer in materials and tools, or direct of us.



P. O. Box 8. Canajoharie, N. Y.



## PATENT IMPROVEMENT IN COUNTER SHOW CASES,

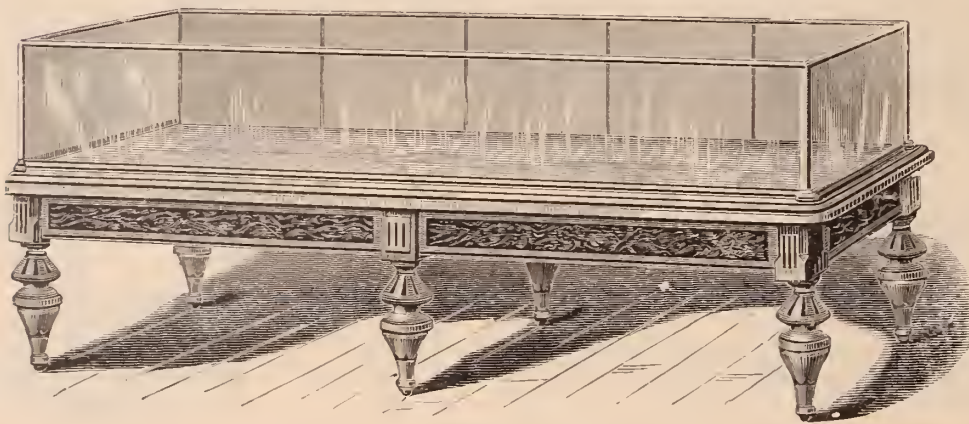

Perpendicular Sliding Door,

(DUST TIGHT.)

REAR VIEW OF CASE SHOWING SLIDING DOOR.

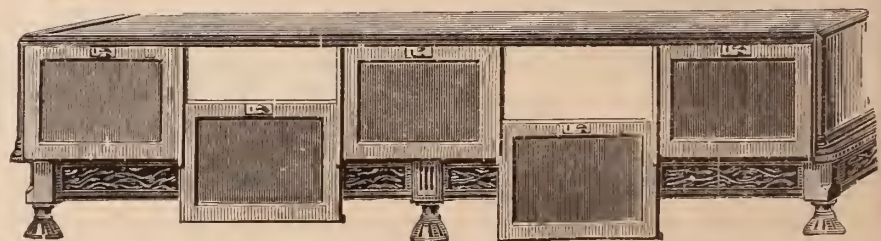

Its advantages are as follows:—The doors are more conveniently opened and closed, less liable to get out of repair or broken, articles are more easily reached in wide cases, mirrors are more safe, it dispenses with hinges, economizes room, excludes dust, and is air tight *when closed*.

Drawings furnished and estimates given for fitting stores in cabinet work complete.

REFERENCES:—Gorham Mfg Co., Rogers & Bro., Mitchell Vance & Co.,  
 Meriden Britannia Co., M. S. Smith & Co. Detroit, Mich.  
 D. Valentine, Syracuse, N. Y.

**B. & W. B. SMITH,**  
 220 West 29th Street, New York.

# American Watch Tool Co.

P. O. Box 999.

WALTHAM MASS.

MANUFACTURERS OF THE WHITCOMB LATHE,  
AND

Machinery for Watch, Watch Case and Clock Making

NEW YORK OFFICE, WITH

L. H. KELLER & CO., 64 Nassau Street.

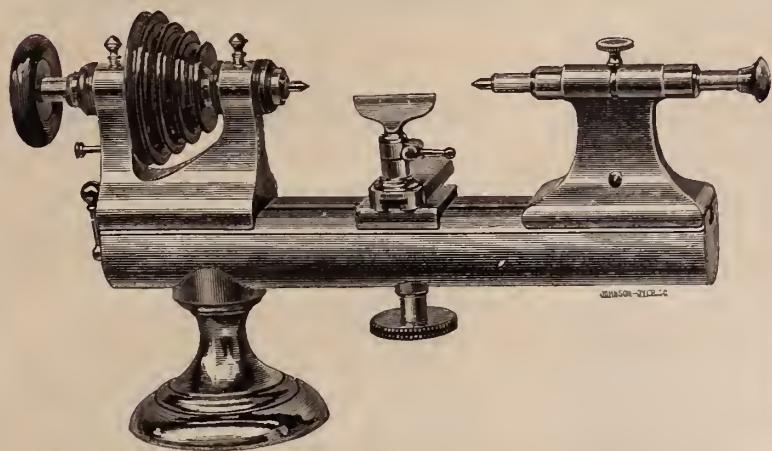

Chicago Office with Chas. Wendell & Co., No. 170 State Street.

# HOPKINS' WATCH TOOL CO.

WALTHAM, MASS.

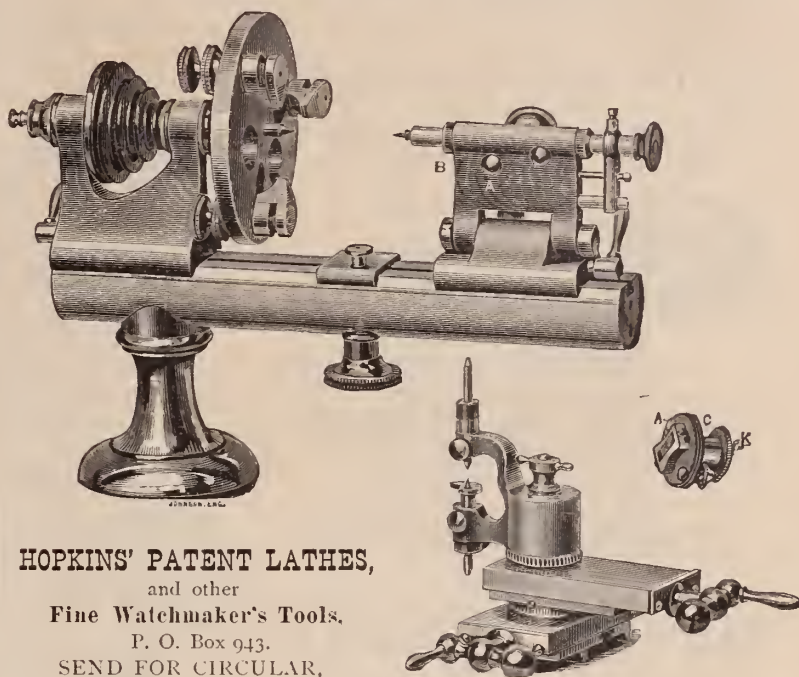

HOPKINS' PATENT LATHES,  
and other  
Fine Watchmaker's Tools.  
P. O. Box 943.  
SEND FOR CIRCULAR.

## S. C. JACKSON,

MANUFACTURER OF



Centennial Medal Awarded.

Fine Cases for Jewelry, Watches, Silverware, &c.

180 BROADWAY, N. Y.

A specialty in Show Case Trays, and Silver Cabinets, made from the finest hard woods, and polished.

All kinds Sample Cases made to order A full assortment of a cheaper grade of Jewelry and Silverware cases in stock.

New and elegant Styles now ready, including our paintings on silks, and satins, together with novelties from China and Japan, specially ordered.

## J. F. FRADLEY.

MANUFACTURER OF

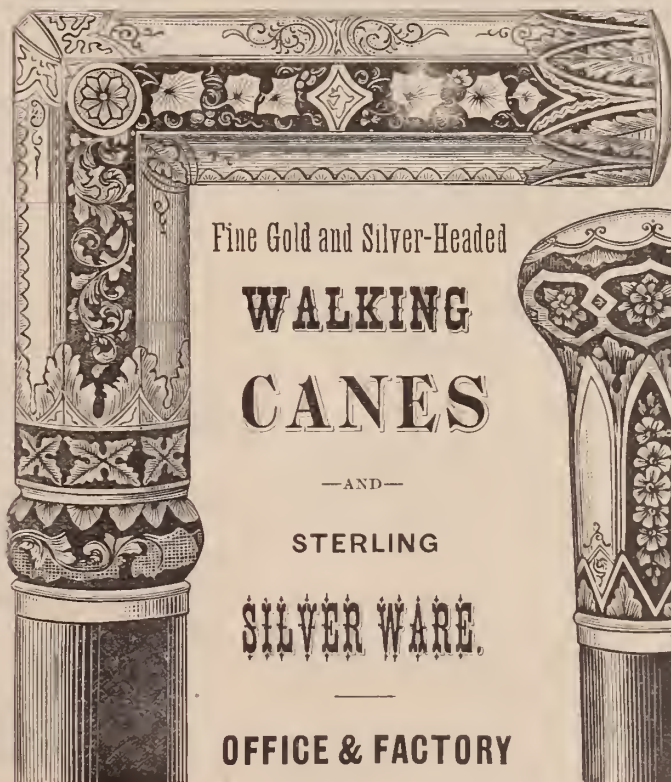

Fine Gold and Silver-Headed

**WALKING  
CANES**

—AND—

STERLING

**SILVER WARE.**

OFFICE & FACTORY

20 JOHN STREET, NEW YORK.

ESTABLISHED 1856

WILLIAM PARK,  
Stone, Seal & Cameo Engraver  
26 John Street, New York.  
Arms, Crests, Monograms & Devices,  
Engraved on Locketts, Sleeve Buttons,  
Rings, Etc.  
Masonic Engraving a Specialty  
ONE TRIAL SOLICITED.

STERN BROS. &amp; CO.



Manufacturers of

Fine Jewelry,

30 MAIDEN LANE,

FACTORY, 73 &amp; 75 Fulton St., NEW YORK.

Gold Seal engraved Band-rings and Locketts a specialty.  
The attention of the trade is directed to our plain Gold filled Rings. Sections of which showing the construction and quality sent upon application.  
After February 1st, our plain filled rings will bear the above trade mark.

LEIMBACH BROS.

Manufacturers of

DIAMOND JEWELRY

A full description constantly on hand.

LACE PINS A SPECIALTY.

51 NASSAU STREET,

P. H. Leimbach,  
F. E. Leimbach.

New York.

H. M. RAYNOR,

25 Bond Street, N. Y.

PLATINUM

FOR ALL

Laboratory &amp; Manufacturing Purposes.

Native Platinum, Scrap, &amp;c., purchased.

REPAIRING, COLORING AND GALVANI-  
ZING FOR THE TRADE.C. G. MALLIET,  
Manufacturing Jeweler,No. 9 JOHN STREET  
NEW YORK.

P. NEIDHARDT &amp; CO.

Manufacturers of

Diamond Mountings

—AND—

FINE JEWELRY

52 Nassau Street,

Cor. Maiden Lane,  
P. NEIDHARDT.NEW YORK.  
B. SCHILLING.L. M. LEBERTHON,  
IMPORTER OF  
DIAMONDS & WATCHES

AND

Manufacturer of Diamond Jewelry,

3 JOHN STREET, N. Y.

Fine Stones a Specialty.

BLANCARD &amp; OBERLANDER,

MANUFACTURERS OF

Settings and Galleries

Of every Carat of Gold or Silver,  
Platinum, Platinum-Lined and Fancy  
Settings a Specialty.

As we melt and refine Platinum ourselves.

36 & 38 JOHN STREET,  
NEW YORK.Platinum Scraps Exchanged or Purchased.  
Send for Sample Card.VOSE & SOUTHWICK,  
Manufacturers of Gold JewelrySole Makers of  
the Separable  
Sleeve and Col-  
lar Buttons in  
Gold.

No. 183 Eddy Street, PROVIDENCE, R. I.

Mansard English Geneve Louis XV.

HENRY LEFORT,  
Stem-Winding Watch Crown Manufacturer,Crowns and Pushers in gold, all sizes, quality and color,  
made to order. Silver crowns and pushers always on hand.  
Samples sent on application.80 & 82 Marshall Street,  
NEWARK, N. J.

ALBERT FRIEDENTHAL,

Importer and Jobber of  
WATCHMAKERS' & JEWELERS'Materials, Tools and Optical Goods  
Real and Imitation Stones,For Manufacturing and Repairing Purposes  
A SPECIALTY.

Agent for TISDALE'S Watch and Clock Oils.

No. 43 Maiden Lane, New York.

Orders by mail will receive prompt attention.

GUSTAV EPHRAIM,

Successor to Ephraim Bros.

8 JOHN STREET, NEW YORK,

Importer and Manufacturer of

Bamboo, Silk Guards and Watch Chains of all  
Grades. Materials, Watch Glasses,  
Optical Goods and Jewelry.Sole Agent for EAGLE SPECTS', CORNELL'S  
ANTI-OXYDIZER and COURVOSIER  
MAIN SPRINGS.

WILKINSON &amp; LENNON.

212 Broadway,  
NEW YORK,

Manufacturing Jewelers

Masonic Pins, Rings & Charms,  
School, Athletic, Fine  
Presentation Medals,—AND—  
JEWELS OF EVERY DESCRIPTION.Designs furnished free upon ap-  
plication.

The Morse Diamond Cutting Company,

J. D. YERRINGTON, Agent.

192 Broadway and 3 John Street.

NEW YORK.

Rough Diamonds, Boart, Roses and Brilliants  
for sale.Fractured Diamonds repaired, and old stones  
improved; also Rough Diamonds cut and  
fashioned to order.W. N. WALKER,  
DIAMONDS,

Watches and Jewelry,

No. 18 JOHN STREET, NEW YORK.  
IMPROVED JEWELERS COTTON

JOHN J. ARMOUR.

HENRY TROEMNER,  
710 Market Street,  
PHILADELPHIA.

Manufacturer of Fine Gold Scales,

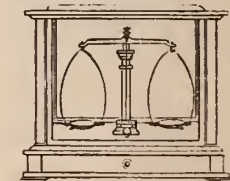

DIAMOND SCALES,

Bullion Balances and  
Weights, in use at all the  
U. S. Mints and Assay  
Offices.

PRICED CATALOGUE ON APPLICATION.

Solid Gold Rings—a Specialty

WM. H. ELY,  
Solid Gold Rings

MANUFACTURER,

Viz., Plain, Chased, Engraved, Enameled, Engine  
Turned, Shield & Scale. All qualities Warranted  
Orders Promptly Executed.

58 Nassau Street, N. Y.

AUGUST SCHWERTER'S  
PATENT  
JEWEL SETTING OPENERWill answer for straightening any kind of  
a Watch Jewel Setting without danger of  
breaking the hardened jaws, by observing  
the new directions which accompany each  
tool. Price \$1.00, or \$8.50 per doz.Address, AUG. SCHWERTER,  
51 Canal St., N. Y.

Established 1848. *Reliable and prompt.*

**COOPER & BRO.**

Wholesale Jewelers,  
Importers and dealers in WATCH & CLOCK-  
MAKERS' TOOLS and MATERIALS; also, JEWEL-  
ERS' SUPPLIES, SPECTACLES, OPTICAL GOODS,  
&c. A complete Outfitting Establishment for the  
trade.

Repairs Department established 1865. Every  
description of work done for the trade. Watch  
Repairing, Jewelry and Watch Case Repairing,  
Gold and Silver-Plating, and Fire Gilding.

35 S. Fourth St. (1st floor), PHILADELPHIA

THOMAS M. GUILBERT. J. CARROW DUBOSQ

**GUILBERT & DUBOSQ,**

*Successors to Francis Dubosq & Son,*

Manufacturers of

Fine Gold and Strung

**PEARL JEWELRY,**

No. 1031 Chestnut Street,

PHILADELPHIA.

**DAVID PRINCE,**

**Gold and Silver Refiner**

*Assayer and Sweep Smelter,*

13 and 15 New Jersey Railroad Avenue,

**NEWARK, N. J.**

Sole Agent for Comins' Improved Amalgamator.

**A. PICARD,**

Importer and Jobber of

**American and Swiss  
WATCHES,**

Jewelry, Optical Goods, Watchmakers' and  
Jewelers' Tools and Material,

No. 111 North Second Street,

**PHILADELPHIA.**

**W. H. LUDEMAN,**

*No. 75 & 77 Nassau Street,  
NEW YORK.*

**FINE AND COMPLICATED  
WATCHES**

Of every description repaired and regulated.

**Stem Winding and Escape Wheels**

Cut and finished to order with accuracy  
and promptness.

**Save your Gold and Silver  
From your waste Wash Water,**

Which can only be done completely by the use of the

**PATENT CHEMICAL FILTERS,**

Manufactured by us.

This apparatus occupies very little room, does not  
choke up, and is put up at our expense on shares, after  
the water has passed through the usual operations in  
use by Jewelers and others.

For further particulars, address,

**CYRUS O. BAKER, Jr. & CO.**

104 N. J. Rail Road Avenue,

**NEWARK, N. J.**

**NEW YORK**

**Morocco Case Company,**

CASES FOR JEWELRY, WATCHES,  
SILVER-WARE, &c., OF ANY  
QUALITY AND STYLE.

Boxes and Trays for Jewelers' Travelers.  
Show Cases and Window Fittings  
a Specialty.

No. 69 NASSAU ST., cor. John, NEW YORK.

Leon Jeanne.

Paul Jeanne.

**JEANNE BROTHERS,**

MANUFACTURERS OF

**DIAMOND MOUNTINGS  
And RICH JEWELRY,**

Patentees of Jeanne's Ear Wires,

No. 1 Maiden Lane, New York.

Designs furnished and estimates given.



Ketcham & McDougall

4 Liberty Place, N. Y.

Manufacturers of

**IMPROVED GOLD  
AND SILVER**



**THIMBLES**

—ALSO—



It Winds up the Cord when Not in Use.

**J. B. LAURENCOT,**

IMPORTER OF

**WATCH GLASSES,**

**Optical and Fancy Goods**

French Clocks, Musical Boxes, &c.

**No. 33 MAIDEN LANE.**

5 Rue D'Enghuen,

PARIS.

Box 2954, P. O.

NEW YORK.

*Established 1850.*



**PETER L. KRIDER,**

MANUFACTURER OF

**STERLING**

**SILVER WARE,**

Medal and Diploma Awarded, &c.

Striking Society Medals in Gold, Silver or Bronze

A SPECIALTY!

ARTISAN HALL,

**618 Chestnut Street**

**PHILADELPHIA.**

**SWIFT MANE'G CO.,**

12 CORTLANDT STREET,

NEW YORK,

—MANUFACTURERS OF—

**Jewelers' Wood Nested  
MAILING BOXES.**

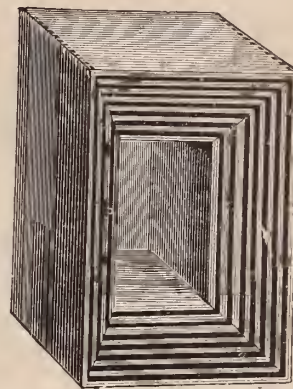

For Mailing and Express Purposes

**J. SPENCER TAYLOR,**

**Agent,**

Orders by mail promptly attended to.

**GEO. W. DU BOIS,**

(Successor to Albert Landsberg.)

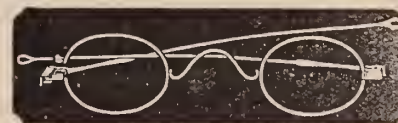

IMPORTER AND MANUFACTURER OF

**Optical Goods,**

**No. 36 MAIDEN LANE,**

Near Nassau Street, NEW YORK

Sole Agent for

**BLACK'S PATENT**

**Interchangeable Spectacles,**

AND

**EYE GLASSES.**

Jewelers and others who keep spectacles for  
sale will please observe that, with these PATENT  
SPECTACLES, it is only NECESSARY to have a full  
*Complete Assortment of Lenses and Pebbles*, which  
being all of a UNIFORM SIZE, will FIT either the  
Gold, Silver, or Steel Frames, of which but a  
few of each kind are wanted; an advantage  
which will give a complete assortment of the  
finest Spectacles, for one-sixth the capital in-  
vested in a like assortment of the same quality  
goods of the old style frames.

For Particulars, price lists, &c., address

**GEO. W. DU BOIS,**

New York.

# SPENCER

## Optical Manufacturing

### COMPANY,

Manufacturers of Spectacles and Eye Glasses,  
from all materials used for that purpose,  
and of all grades.

**SOMETHING NEW !!**  
**CELLULOID EYE GLASS FRAMES,**  
Representing the Choicest Selected  
Tortoise Shell and Amber.



(Turtles rejoicing over the discovery of Celluloid Tortoise Shell,  
Their Occupation Gone.)

They are much **Lighter** than any others. Twenty-five pairs of the frames weigh only one ounce.

They are much **Stronger** and more **Durable** than any others; they can be **Dropped Without Injury** upon the hardest substance.

Their **Beauty** far surpasses the ordinary Tortoise Shell Frames commonly in use.

They are **Not Affected** by Atmospheric Changes, being equally well adapted to either warm or cold climates.

They are made with **Different Sized Frames** to suit persons whose eyes are either near or far apart.

The Springs are made of a combination of metals which will neither **Rust** nor be affected by heat or frost. These frames are set with **Fine Lenses**, accurately focused to suit all sights, which with the many other advantages, make them **Very Popular**.

**ASK YOUR OPTICIAN OR JEWELER TO SHOW THEM TO YOU.**  
Every Pair Stamped on Handle S. O. M. Co. Pat. Mar. 13, '77.

Parties ordering 3 doz. Celluloid Eye Glasses are furnished with 1,000 copies of circulars similar to this advertisement with name of dealer printed thereon.

**13 Maiden Lane, N. Y.**

Established 1853.

## L. H. KELLER & CO.

Successors to G. A. HUGUENIN,

IMPORTERS OF

### Fine Watch and Clock Materials,

SWISS, ENGLISH, FRENCH & GERMAN  
**FILES, TOOLS, & C.**

FOR WATCH MAKERS, WATCH CASE MAKERS, JEWELERS  
SILVERSMITHS, ENGRAVERS, CHASERS, DIE  
SINKERS, MACHINISTS, &c.

SOLE AGENTS FOR HALL'S STAKING TOOLS AND  
ROLLER REMOVERS.

**AGENTS FOR THE WHITCOMB AND OTHER AMERICAN LATHES.**

GENERAL AGENTS FOR THE PHILADELPHIA  
WATCH COMPANY.

American Agents for the Horological Journal, (British).

A Monthly Paper for the advancement of Chronometer, Watch and Clock Making,  
and kindred Sciences. Published under the auspices of the British Horological  
Institute, London. Subscription \$2.50 per year, in advance. Also,

SAUNIER'S TREATISE ON MODERN HOROLOGY, IN  
THEORY AND PRACTICE,

BY M. CLAUDIUS SAUNIER. The English Edition will appear in 26 monthly parts,  
Price 50 cents each. Whole Work, \$13 00, postage paid.

Special attention is directed to

**"OUR OWN" Celebrated Mainsprings Graduated**

in thickness to equalize the power, with well rounded edges, and the  
*Highest Crocus Finish* throughout, insuring the least possible friction  
in the barrel, pronounced by expert judges to be the *best made*.

"JURGENSEN" Main Springs recoiling, suitable for the highest grades  
of Swiss Watches.

**"Lutz" Celebrated Hair Springs,**

by numbers, of uniform diameter and strength, the best for  
"BREGUETING."

Fine Hole Jewels of Ruby, Sapphire, Chrysolite, Garnet, Beryl and  
Aqua Marine, with *gauged* (well shaped and polished) holes, numbered  
by the Swiss pivot gauge - also, neat black walnut cases, containing  
forty glass vials for assortments of same. The great advantage in hav-  
ing Jewels by numbers will readily be seen as a saving in time and an-  
noyance in selecting and in expense. Dealers once having an assort-  
ment, can replenish or stock up at a comparatively small outlay, as any  
desired quantity of No. and quality can be had of us at all times,  
our stock of jewels being the largest and most complete in the country.

Diamond Charged Broaches for opening and polishing jewel holes.

Diamond Powder and Bort for polishing and grinding 8 different  
grades, in  $\frac{1}{2}$ ,  $\frac{1}{4}$ ,  $\frac{1}{8}$ , and  $\frac{1}{16}$  K vials, bringing it into the reach of all.

Gold Diamond Set and other fine Geneva Hands.

The new Drills in Sets of 54 small, 126 small to medium, and 48  
large; also, sold separately if desired.

A FULL LINE OF MATERIALS FOR THE CELEBRATED WATCHES  
MANUFACTURED BY

**Patek, Philippe & Co.**

OF GENEVA, FULLY FINISHED AS FAR AS PRACTICABLE.

**No. 64 Nassau Street,**

Near Maiden Lane

**NEW YORK.**



**SPECIAL NOTICES.**

Advertisements under this head, not to exceed six lines, \$1.00 each insertion.

**WANTED**—A permanent situation by a watchmaker of twenty years' experience, has held his present situation seven years. Address Circular, this office.

**WANTED**—A Practical Watchmaker with good references, wants to buy or rent a shop, either in the South or West of the Rocky Mountains. Address M., care Jewelers' Circular.

**WANTED**—A situation by a young man who has had four years' experience at the trade. A good engraver and jobber. Has worked at watches one year and six months. Address JEWELER, care J. W. Haight, Auburn, New York.

**A** RARE chance to any one desiring to open a jewelry business South. Well established, good run of work and sales. Satisfactory reasons for selling. Address P. O. Box 110, Brownville, Tenn., or J. H. Farby & Co., 170 State Street, Chicago.

**A** WATCHMAKER, 18 years experience, (German), wishes to change his position, understands watchmaking and jewelry jobbing thoroughly, well recommended. Address S., care of A. Lesser, Room 12 Larned Building, Syracuse, N. Y.

**W**ANTED—A young man of good habits and mechanical ingenuity, one who has had two or three years experience and can do easy jobs in watch repairing and engraving, also good jewelry repairing. To the right person we can offer a good chance to complete his trade, and steady employment. Address Hosmer Brothers, Opera House Jewelers, Quincy, Ill.

**F**OR SALE CHEAP—Two fine black walnut side show cases with drawers complete; one imitation walnut side case; these are substantially made, neatly finished, and just the thing for showing silver ware, and can be bought for less than half the original cost. Photographs sent to parties wishing to buy. Address Hosmer Brothers, Opera House, Quincy, Ill.

**G**EORGE E. WILKINS—Importer of fine Tools for Watchmakers, cutting and dividing engines, rounding up tools and cutters, also cutters for stem winding wheels. Fine lathes with the American system of chucks. Dividing engine and rounding up tool combined. Marine chronometers for sale. Special tools imported to order. 21 South Salina St., Syracuse, N. Y.

**Electric Clocks**

From 12 to 36 inch Dials.

SECOND & MINUTE JUMPERS,

Also ILLUMINATED DIALS

For Watchmakers Windows.

Constand Self-Feeding Batteries.

Sole Patentee and Manufacturer,

**VITALIS HIMMER,**

No. 107 Third Avenue,

Near 13th Street

NEW YORK.

**L. BONET,**

Medal at Centennial, 1876.

**CAMEO**

**Likenesses,**

889 Broadway, New York.



**Buyer's Directory.**

A Guide to the prominent Wholesale Houses in the Watch, Clock, Jewelry and kindred branches of Trade in New York, Philadelphia, Chicago, Providence and Newark.

**NEW YORK.**

**Black Onyx Jewelry.**

**Cox & Sedgwick**—Manufacturers of Black Onyx Jewelry, No. 26 John St. New York.  
**Downing & Keller**—Manufacturers of Onyx Jewelry, &c., 8 Maiden Lane, N. Y.  
**Woglom & Miller**—Manufacturers of (exclusively) Black Onyx Jewelry, 32 & 34 John St., N. Y.  
**Unger, H. & Co.**—Manufacturing Jewelers. Fine Onyx and Pearl goods a specialty. Manufacturers of Patent Onyx Bracelet, with Lily of the Valley mountings. No. 18 Crawford Street, Newark, N. J. Box 63.

**Bohemian Garnet Jewelry.**

**Bissinger, Philip**—Importer of Diamonds, Pearls and Precious Stones. Sole Agent for the Bohemian Garnet Jewelry, 22 John St.

**Clock Companies.**

**New Haven Clock Co.**—62 Reade Street, N. Y.  
**Seth Thomas Clock Co.**—20 Murray Street, N. Y.  
**Waterbury Clock Co.**—M. Bailey, Treasurer, Manuf. and Jobbers, No. 4 Cortland St., N. Y., and No. 197 State Street, Chicago.  
**Kroeber, F.**—Manufacturer and Dealer in American and French Clocks, No. 8 Cortland Street.  
**Owen, Geo. B. & Co.**—Manufacturers of Black Walnut Clocks, Factory, Winsted, Conn., New York Office, No. 6 Murray St.

**Corals and Coral Jewelry.**

**Cuppia, L. A.**—Importer of Coral and Silver Filigree Jewelry, 19 Union Square, N. Y.  
**Errico Bros.**—Importers of Coral, Conch-Shell and Silver Filigree Jewelry, etc., 19 John St.  
**Lawson, S.**—Manufacturer of Coral and Black Onyx Jewelry. All kinds of repairing solicited. Goods sent on Mem. 63 Nassau Street.

**Cameo Cutters, Etc.**

**Bonet, L.**—Cameo Likenesses, No. 889 Broadway.  
**Peiter, Theodore**—Cameo and Intaglio Engraver. Patentee of the new Cameo-Intaglio. No. 2 Bond Street, near Broadway, Room 4 New York.  
**Wiederer, Peter**—Late Habermeir & Wiederer, Engravers of Cameo Likenesses, Seal Stones. Cameos repaired. 23 John St.

**Charms & Gold Watch Keys.**

**Rupp & Held,**—Manufacturing Jewelers, Charms and Gold Watch Keys, with French and English Rachets, a specialty. 15 John St., N. Y.

**Cutlery.**

**Harrison Bros. & Howson,**—Manufacturers of Fine Ivory and Pearl Table and Pocket Cutlery; Carvers in Cases; Nutpicks, Nutcracks and goods suitable for the jewelry trade. 26 Cliff Street. W. C. Burkinshaw, Sole Agent.

**Diamonds.**

**Anderson, Otis**—Diamond Merchant and Broker, always ready to pay cash for bargains in Diamonds and Precious Stones, No. 9 Maiden Lane, N. Y.  
**Bernhard, A. & Co.**—Manufacturing Jeweler and Importers of Diamonds, Precious Stones, and Diamond Mountings, 2 Maiden Lane.  
**Bissinger, Philip**—Importer of Diamonds, Pearls and Precious Stones. Agent for the Bohemian Garnet Goods. No. 22 John St., N. Y.  
**Buckenham, Cole & Saunders**—Importers of Diamonds and Precious Stones, No. 10 Maiden Lane.  
**Fera, Henry**—Importer of Diamonds, and Manufacturer of Fine Diamond Jewelry. No. 9 Maiden Lane, New York. Amsterdam, Holland, 23 Loojersgracht.  
**Fox, M. & Co.**—Importers of Diamonds and other Precious Stones, No. 1 Maiden Lane.  
**Hedges, Wm. S. & Co.**—Importers of Diamonds, No. 170 Broadway.  
**Herbert, R. J.**—Importer and Broker in Diamonds, 16 Maiden Lane.  
**Lyon & Hardy**—Importers of Diamonds and Manufacturers of Diamond Jewelry, 30 Maiden Lane.  
**Leberthon, L. M.**—Importer of diamonds and watches. Manufacturer of jewelry. 3 John St. Fine stones a specialty.  
**Neresheimer, E. Aug.**—Importer of Fine Diamonds, No. 21 Maiden Lane, New York  
**Prager Morris.**—Importer of Diamonds and Fine Diamond Jewelry, 8 Maiden Lane.  
**Randel, Baremore & Co.**—Importers of Diamonds, corner Maiden Lane and Nassau St.  
**Smith, Alfred H. & Co.**—Importers of Diamonds, No. 14 John Street.

**Diamond Cutters.**

**The Morse Diamond Cutting Co. of Boston.**—Henry D. Morse, General Manager. N. Y. Office, 192 Broadway, corner John street. J. D. Verrington, Agent.

**Diamonds and Diamond Jewelry.**

**Bissinger, Philip.**—Importer of Diamonds, 22 John street, N. Y. Agent for the Bohemian Garnet Goods.  
**Heller & Bardel.**—Manufacturers of Diamond and Pearl Jewelry, and Dealers in Diamonds, Pearls, &c. Also agents for Boss' Patent Stiffened Gold Watch Cases. 13 John St.  
**Leimbach Bros.**—Manufacturers of Diamond Jewelry, 51 Nassau Street.  
**Neidhart, P. & Co.**—Manufacturers of Diamond Mountings and Fine Jewelry, 52 Nassau St., N. Y.  
**Taylor & Brother**—Importers of Diamonds and Diamond Jewelry, 676 Broadway.

**Diamond Setters, Etc.**

**Asher, J.**—Jeweler and Diamond Setter. Precious Stones Inlaid and Incrusted with Diamonds, Nos. 880 and 882 Broadway.  
**Wood, Chas. F.**—Engraver and Incruster of Precious Stones and Diamond Setter. No. 169 & 171 Broadway.  
**Friend, S.**—Manufacturer of Fine Jewelry, and Diamond Setter, 33 John Street, N. Y.

**Dials, &c.**

**Gold, John T.**—(Successor to the late T. Gold), Enamel Watch Dial Maker, 81 Nassau St.

**Enamelers, Etc.**

**Nutt, J. D.**—Enameler on Gold, Silver and Copper, 32 and 34 John St. Birds, Flowers, etc., Enameled in colors.  
**Orr, Jas. C.**—Enameler on Fine Jewelry, Flowers, Birds, &c., Enameled in colors. Band Bracelets (a specialty). 77 Nassau Street.

**Electroplaters, &c.**

**Jeandheur, F. & Son,**—Gold and Silver Electro Platers & Fire Gilders, coloring Etruscan and Gold Jewelry a specialty. 125 Fulton St.

**Engravers and Die Sinkers**

**Fackner, Edward**—Carver, Engraver and Chaser on Jewelry and Solid and Plated Pencil Cases, No. 19 John Street.  
**Park Wm.**—Stone Seal Engraver. Coats of Arms found and Engraved. Initials and Monograms engraved. 26 John Street, New York.  
**Schuller, J. Dan'l**—Stone Seal Engraver, Arms, Crests, Initials and Monograms engraved on Stone Seals, &c. 71 Nassau Street.

**Engraving Type.**

**Ingersoll, H. S.**—Rubber Engraving Type, Patented December, 1872. Over 40,000 alphabets in use. Saves time and skill of designing before engraving silverware, etc. Also Engravers' Tools, etc. Catalogue free 203 Broadway, N. Y.

**Fancy Goods, Clocks, Bronzes Etc.**

**Hall, Nicol & Granbery,**—Importers of Clocks, Bronzes, Folding Mirrors, Fancy Goods, &c. 20 and 22 John Street.  
**Magnin, Ve J. Guedin & Co.**—Importers of Clocks, Bronzes, Musical Boxes & Rich Fancy Goods, etc., 29 Union Square.  
**Le Boutillier & Co.**—Importers of Fancy Goods, Clocks, Bronzes, &c., 3 Union Square.

**Gold Chains, Etc.**

**Beck, J. & Son,** Manufacturers of Fine Gold Chains and Chain Bracelets, 10 Liberty Place, near Maiden Lane, N. Y.  
**Dorrance, Edge & Co.**—Manufacturers of the Celebrated Woven Fabric Gold Chain, No. 12 John Street.  
**Hamiltons & Hunt.**—Manufacturers of Fine Plated Chains and Patent Buckle Bracelets. Branch office, 176 Broadway. Factory, 226 Eddy Street, Providence.  
**Kaufmann Bros.**—Manufacturers of Gold Chains, and Chain Bracelets, 26 John Street; Factory, 331 and 333 Bowery, N. Y.  
**Nordt & Schlag,**—Manufacturers of Gold Chain, No. 17 Maiden Lane, N. Y.  
**Saxton, Smith & Co.**—Manufacturers of Fine Gold Chain. 15 Maiden Lane.

**Gold Pens, Etc.**

**Aikin, Lambert & Co.**—Manufacturers of Choice Gold Pens, Cases, Holders, Toothpicks, etc., 23 Maiden Lane, N. Y.  
**Clark, J. M.**—Manufacturer of Pen and Pencil Cases for the wholesale trade only. No. 61 Hudson Street, N. Y.  
**Mable, Todd & Bard**—Manufacturers of Gold Pens. 180 Maiden Lane.

**Goldsmiths, &c.**

**Greene, Wm. C. & Co.**—Goldsmiths; Manufacturers of Rich Sets in Taper Wire Coral. Office, 192 Broadway.

**Cold Rings.**

**Bowden J. E. & Co.**—Manufacturing Jeweler.—Solid Gold Rings a specialty, 1 Maiden Lane.  
**Ely, W. H.**—Manufacturer of Solid Gold Rings of every description. No. 58 Nassau Street,  
**Frankel & Folkart.**—Manufacturers of Seal, Cameo and Amethyst Rings a specialty. Also a full line of Gold White Stone goods and Diamond Settings. 21 John St., N. Y., and No. 4 Liberty Place.  
**Peckham, Wm. H. & Co.**—Manufacturers of Solid Gold Seamless Rings and Fancy Embossed Rings, Patent Spectacles, Jewelry, etc. No. 4 Liberty Place, N. Y.  
**Sinnock & Sherrill.**—Manufacturers of Stone Rings. No. 5 Maiden Lane, N. Y.  
**Tingley, Joseph N.**—Manufacturer of Stone Rings and novelties in Stone Goods. No. 9 Maiden Lane, N. Y.

**Hair Jewelry.**

**Bernhard A. & Co.**—Manufacturers of Hair Jewelry. Our new Pattern Book is now out up to 2724. No. 2 Maiden Lane, N. Y.  
**Montoux, Wm. E.**—Only *personal* leading Artist in Hair devises in U. S., and Manufacturer of Fine Hair Mountings in Gold. Grand catalogues for the trade. 81 Nassau St., Rooms 1 and 2. Finest work and lowest prices  
**Menge, C. T.**—Fine Hair Jewelry and Device Work, 32 John Street, N. Y.  
**Sauter, L.**—Manufacturer of Fine Gold and Hair Jewelry and Device Work. Pattern Book sent on application. Nos. 65 and 67 Nassau St.  
**Schwencke O.**—Manufacturer of Fine Hair Jewelry Orders from the country promptly attended to. No. 43 Maiden Lane.

**Jewelry Cases, Fancy Boxes, Etc**

**Braun, Chr. E.**—Manufacturer of Jewelry Boxes, Trays for Show Cases, &c., 62 Chatham St.  
**Dahlem, W.**—Manufacturer of Cases for Jewelry and Silverware, No. 85 Nassau St., N. Y. Show Case Trays, &c., at short notice.  
**Loehr & Koerner.**—Manufacturers of Morocco, Velvet, Satin, Jewelry, Watches and Silverware Cases, Glove, Handkerchief, Ladies' Jewel, Work Boxes, &c., Fancy Trays and Store Fittings to order. Office and Salesroom 83 Nassau St., N. Y.  
**New York Morocco Case Co.**—Makers of Cases for Jewelry, Watches, Silverware, etc. Boxes and Trays for Jewelry. No. 69 Nassau St., N. Y.  
**Sturn, I.**—Manufacturer and Importer of Cases for Jewelry, Watches, Silverware, &c. No. 15 John Street, N. Y.  
**Swift Manufacturing Co.**—Makers of Mailing Boxes for Mailing and Express purposes, 12 Courtland Street, N. Y.  
**Welch & Miller.**—Manufacturers of Morocco, Velvet, and Satin Jewelry Cases, Trays, &c., Telescope Sample Cases with flexible Trays. Complete stock on hand. 169 Broadway.  
**Wiggers & Froelick.**—No. 60 Nassau street—Manufacturers of Cases for Jewelry, &c., of every description. Trays for Show-cases, Stands for Show-windows, etc. Jewelers' Traveling Cases, light, convenient and strong.

**Jewelry—Fine.**

**Aikin, Lambert & Co.**—Manufacturers General stock of Reliable Jewelry, 23 Maiden Lane.  
**Alford, C. G. & Co.**—Manufacturers. General line fine and Reliable Goods. Specialties in Onyx Goods and Chain. 183 Broadway, New York.  
**Alling Bros. & Co.**—Manufacturing Jewelers, 170 Broadway.  
**Baldwin, Sexton & Peterson.**—Makers of Fine Jewelry and Importers of Diamonds, etc., corner Broadway and Fourth Street.  
**Barthman & Straat.** Manufacturers of Fine Jewelry. Seal and Stone Rings a specialty. Orders promptly attended to. 41 Maiden Lane.  
**Bissinger, E.**—Importer of Fine Jewelry, Locketts, Crosses, Neck Chains, &c., No. 192 Broadway.  
**Brown, Thos. G.**—Manufacturer of Rich Jewelry, Necklaces, Locketts, Bracelets, Sleeve Buttons, etc., 9 Bond Street, N. Y.  
**Bryant & Bentley.**—Manufacturing Jewelers. Rings a specialty. 12 Maiden Lane.  
**Brainerd & Steele.**—Successors to Brainerd, Steele & Co., Manufacturers of Fine Jewelry and Brainerd's Patent Locketts. No. 9 Maiden Lane, N. Y.  
**Burch & Fellows.**—Successors to Geo. Burch & Co., Manufacturing Jewelers, 17 Maiden Lane.  
**Cook, Groeschel & Co.**—Manufacturers of Fine Jewelry and Locketts, 191 Broadway (over Mercantile Bank,) N. Y.

**Carter, Howkins & Sloan.**—Manufacturing Jewelers, Whiting Building, 4th St. and Broadway.  
**Chatellier & Spence.**—Manufacturing Jewelers, No. 694 Broadway, N. Y.  
**Champerois & Co.**—Manufacturing Jewelers, No. 1 Maiden Lane. Specialties—Jet Cluster Goods in Sets, Sleeve Buttons, Studs and Collar Buttons, Lace, Shawl and Cuff Pins, Ear Knobs and Crosses.  
**Demmert Bros.**—Manufacturers and Importers of Fine Jewelry, Cameo and Onyx Locketts, Sleeve Buttons and Sets a specialty. Old No. 9 Maiden Lane, New York.  
**Downin & Keller.**—Manufacturers of Fine Jewelry, Onyx and Pearl Sets, Shawl Pins, Ear Rings, etc., 8 Maiden Lane.  
**Falkenau & Oppenheimer.**—Manufacturing Jewelers. Specialty—Knife Edge Work and Rings. 89 Nassau Street.  
**Field & Co.**—Manufacturing Jewelers, 8 Maiden Lane, N. Y.  
**Finkelmeier, Louis.**—Manufacturing Jeweler. Jobbing and ordered work for the trade at moderate prices. 73 Nassau Street, N. Y.  
**Goddard, John M.**—Manufacturing Jeweler.—Seal Rings and Fine Locketts a specialty, No. 3 Maiden Lane, N. Y.  
**Greason, Bogart & Pierce.** successors to Arthur, Rumrill & Co., 182 Broadway, Manufacturers of Fine Jewelry and Gold Chains.  
**Hartmann, P.**—Manufacturer & Importer of Fine Gold, Diamond, and Filigree Silver Jewelry, No. 36 Maiden Lane. P. O. Box 2,454.  
**Haskell, H. C.**—Manufacturing Jeweler. Seal Rings a specialty. Special attention to Jobbing of every description. 12 John street.  
**Henderson & Winter.**—Jewelers, No. 15 Maiden Lane, New York. Specialties—Stone, Cameo, Onyx, Amethysts, Topaz, Pearl and Turquoise Rings.  
**Hunt & Owen.**—Manufacturing Jeweler. Office 5 Maiden Lane.  
**Hale & Mulford.**—Manufacturers Rich Jewelry, Whiting Building, Broadway and 4th Street.  
**Jeanne Brothers.**—Manufacturers of Diamond Mountings & Rich Jewelry. 1 Maiden Lane.  
**Kellei, Chas. & Co.**—Manufacturing Jewelers. Locketts a Specialty. No. 18 John St., N. Y.  
**Kremetz & Co.**—Manufacturing Jewelers, No. 13 John Street. N. Y.  
**Kroll, H.**—Manufacturer of Fine Jewelry. Repairing (a specialty) done for the trade at moderate rates, 78 Nassau street.  
**Kuhn & Doerflinger.**—Manufacturers of Enameled and Roman Band Bracelets, also Fine Locketts and Pendants, 18 John street.  
**Lennon, John D.**—Manufacturing Jeweler, 142 Fulton Street. Stone Locketts and Rings; also Badges and Emblems of all kinds.  
**Miller Bros.**—Manufacturers of Fine Jewelry, Locketts, Sleeve Buttons, Studs, &c., 11 Maiden Lane, N. Y.  
**Mulford & Bonet.**—Manufacturers of Diamond and Gold Jewelry. Dealers in Rolled Plated Goods, 21 Maiden Lane.  
**Moore & Horton.**—11 Maiden Lane, Manufacturing Jewelers, Rings, Studs, Collars and Sleeve Buttons, Pins, Ear-rings, &c.  
**Marx Kossuth & Co.**—Manufacturing jewelers, 39 Maiden Lane.  
**Owen, G. & S. & Co.**—Manufacturing Jewelers. Office, No. 5 Maiden Lane.  
**Riker, William.**—Manufacturer of Jewelry. Inlaid Gold Jewelry a Specialty. No. 5 Maiden Lane, N. Y.  
**Riley, J. A. & Co.**—Manufacturing Jewelers, Etruscan Gold and Coral Sets, Roman Bracelets Necklaces, etc. Onyx Goods a specialty. 7 and 9 Bond street, New York  
**Richardson, Enos & Co.**—Manufacturers of Fine Gold Jewelry, Gold Chains, Locketts, Crosses and Necklaces. Colored and Etruscan Work. No. 23 Maiden Lane, New York.  
**Richardson, J. W. & Co.**—Manufacturers of Jewelry, Masonic and other emblems. 196 Broadway. Manufactory, Providence, R. I.  
**Ripley, Howland & Co.**—Manufacturers of Fine Jewelry and Diamond Mountings. 35 Maiden Lane, N. Y.  
**Sauter, L.**—Manufacturer of Fine Jewelry, Solid Stone Rings and Studs a specialty. Jobbing for the trade, 65 and 67 Nassau street.  
**Sexton & Cole.**—Manufacturing Jewelers, Colored Gold and Onyx Goods a specialty. No. 30 Maiden Lane.  
**Stites, D. H. & Son.**—Manufacturers of Fine Jewelry, Rolled Plated Goods and Chains, Parisian Diamond Rings, Studs and Earrings a specialty. 41 Maiden Lane, N. Y.

**Shoemaker & Co.**—Manufacturing Jewelers' Cameo Buttons, and Locketts, Roman Gold Goods, etc. No. 21 Maiden Lane, N. Y.  
**Stites, E.**—Manufacturer of Fine Jewelry. No. 12 Maiden Lane, N. Y.  
**Sturdy Bros & Co.**—Manufacturers of Jewelry. General line of fine and heavy Rolled Plate Goods. Specialties—enameling on gold plate; graduated wire coral work. 14 Maiden Lane, N. Y.  
**Terhune, Charles F.**—Manufacturing Jeweler, 16 Maiden Lane, N. Y.  
**Thoma, Ernest.**—Manufacturer of Fine Jewelry. Sleeve Buttons, Rings, Ear-rings, &c. No. 173 Broadway, N. Y. Factory, Hackensack, N. J.  
**Trier Bros. & Co.**—Jewelry. Optical, Rubber, Jet, Shell, Ivory, Amber and Pearl Goods, Silk Goods, Japanese Bamboo Watch Chains a Specialty. No 15 Maiden Lane.  
**Wadsworth, E. E.**—Manufacturer of Rich Jewelry and fine Rolled Plate. Fine Seal Rings a specialty. 35 Maiden Lane.  
**Wheeler, Parsons & Hays.**—Manufacturers of Fine Jewelry, Watch Cases, Gold Chains, &c. and Dealer in American and Swiss Watches, No. 2 Maiden Lane, N. Y.  
**Wienhold, Joseph.**—Manufacturer of Fine Jewelry and Diamond Setter. 24 John St.  
**Ward, Thos. M.**—Manufacturer of Fine Jewelry, Diamond Mountings a specialty. No. 25 John Street, N. Y.

**Jewelers' Tools, etc.**

**Frasse & Co.**—Importers of Stubb' French, Swiss, German and Sheffield Tools, Files and Steel Wire for Watchmakers, Jewelers, etc., 62 Chatham street, N. Y.  
**Hecht, Phil.**—Importers and Dealers in Watchmakers' materials, Tools, Optical Goods and Silk Goods etc. 13 Maiden Lane, N. Y.  
**Stanley & Company.**—Jobbers of Tools and Materials for use of Watchmakers and Jewelers. Spectacles, Jewelry Boxes, Plated Chains, &c., &c., 108 Wisconsin Street, Milwaukee, Wis.

**Lapidaries.**

**Fox, M. & Co.**—Practical Lapidaries, No. 1 Maiden Lane, New York.  
**Kordmann & Michel.**—Lapidaries, dealers in Precious Stones, Rubies, Sapphires and Periodots cut. No. 59 Nassau Street.

**Masonic Jewelry.**

**Luther, John F.**—79 Nassau Street. Manufacturer of Fine Presentation Jewels for All Societies. Knights Templars, Crosses, Badges, &c.  
**Wilkinson & Lenon.**—Manufacturers of Masonic, Odd Fellows, Athletic Clubs and other Jewelry, No. 212 Broadway, New York.

**Opticians.**

**Burbank Man'g Co.**—Manufacturers of Spectacles and Eye Glasses of all descriptions, in gold, silver, etc., 14 Maiden Lane, N. Y.  
**Du Bois, Geo. W.**—Successor to A. Landsberg, Importer and Manufacturer of Optical Goods, 36 Maiden Lane. Box 3993, N. Y.  
**Laurencott, J. B.**—Importer of Watch Glasses, Optical and Fancy Goods, Clocks, Bronzes, etc., 33 Maiden Lane, N. Y.  
**Lorsch, Albert.**—Manufacturer of the Patent Accommodating Spectacles and Eye Glasses in Gold, Silver and Steel, and other Optical Goods, 37 Maiden Lane, N. Y.  
**Serin, A.**—Manufacturer of Spectacles and Eye Glasses, in Steel, Shell and Rubber. Repairing of all kinds. Opera Glasses covered and re-gilt, etc. 169 and 171 Fulton street.  
**Spencer Optical Manufacturing Co.**—Gold Silver, Steel and Nickel Plated Spectacles, Eye Glasses, &c. 13 Maiden Lane, N. Y.

**Precious Stones, &c.**

**Fissinger, Philip.**—Importer of Diamonds, Pearls and Precious Stones. Agent for the Bohemian Garnet Goods. No. 22 John St. N. Y.  
**Fox, M. & Co.**—Importers of Diamonds and other Precious Stones, No. 1 Maiden Lane, N. Y.  
**Gruet, Jules.**—Importer of Precious and Imitation Stones, Amethysts, Topazes, Cameos, Garnets, Doublets, Imitation Diamonds, Pastes, etc., No. 14 John street. Manufactory at Septmoncel, France.

**Silverware.**

**Cuppia, L. A.**—Manufacturer of Solid Silver Novelties, and Importer of Silver Filigree, 19 Union Square.  
**Gorham Manufacturing Co.**—Union Square.  
**Wood & Hughes.**—Manufacturers of Fine Silverware 16 John Street, N. Y.

**N. Matson & Co.**—State and Monroe streets, Chicago, Ill. General Jewelers and Furnishers of Jewelers Supplies, Western Branch House for the Reed & Barton's Fine Electro Silver Plated Ware.

#### Silver Plated Ware.

**Brown & Bros.**—Manufacturers of first quality of Electro Plated Flat Table Ware. No. 81 Chambers Street, N. Y.

**Hall, Elton & Co.**—Manufacturers of the Finest Electro-Plated Ware, salesroom, 75 Chambers Street, N. Y.

**Holmes, Booth & Haydens**—Manufacturers of Silver-Plated Ware. 47 Chambers Street.

**Meriden Britannia Co.**—Manufacturers of Silver-Plated Ware. 46 East 14th Street, Union Square,

**Middletown Plate Co.**—Manufacturers of Superior Electro-Plate. Factories, Middletown, Conn., salesroom, 13 John Street.

**Rogers Wm. & Co.**—Hartford, Conn.

**Roger & Bro.**—Manufacturers of the finest quality of Electro-Plated Ware. 690 Broadway.

**Simpson, Hall, Miller & Co.**—Manufacturers of fine Silver-Plated Ware. No. 36 E. 14th Street.

**Schade, Henry.**—Manufacturer of White Metal and Plated Ware. No. 84 John St., N. Y. Price list and catalogue furnished on application.

**Webster, E. G. & Bro.**—Manufacturers of Fine Silver-Plated Ware. Office and warerooms, 14 Maiden Lane, N. Y.

#### Show Cases, Etc.

**Kraft & Hoffmeister.**—Manufacturers of Metal Show Cases, Jewelry Trays always on hand. No. 20 North William Street, N. Y.

**Smith, B. & W. B.**—Patent Improved Counter Show Cases. Drawings furnished and estimates given for fitting stores in Cabinet Work complete.

#### Spectacle Case Manufacturers.

**Koenen, A. & Bro.**—Manufacturers of Leather Spectacle and Eye-Glass Cases. 81 Nassau St., N. Y.

#### Thermometers Etc.

**Tagliabue, Giuseppe.**—Thermometer, Barometer, and Hydrometer manufacturer, 302 Pearl Street near Beekman, N. Y.

#### Thimble Manufacturers.

**Burbank Manufg Co.**—Manufacturers of Gold and Silver Thimbles, 14 Maiden Lane, N. Y.

**Ketcham & McDougall.**—Improved Gold and Silver Thimbles, Nos. 4 and 6 Liberty Place, near Maiden Lane, N. Y.

**Woglom & Miller.**—Sole Agents for the "Prime" Thimbles in Gold and Silver, manufactured by Ezra C. Prime. 34 John Street, N. Y.

#### Walking Canes.

**Fradley, J. F.**—Manufacturer of Fine Gold and Silver-headed Walking Canes and Sterling Silver Ware. Office and factory, 20 John Street, N. Y.

#### Watch Companies.

**American Watch Co.**—Robbins & Appleton, No. 9 Bond Street, N. Y.

**Hampden Watch Co.**—of Springfield Mass., office No. 12 Maiden Lane, N. Y.

**The Howard Watch and Clock Co.**—No. 2 Maiden Lane, N. Y.

#### Watch and Chronometer Jeweler.

**Queen, James.**—Watch and Chronometer Jeweler and Pallet Maker, 78 Nassau Street, room 8. Pivots inserted in Pinions, Balance, Staffs, etc.

#### Watch Importers, Etc.

**Aikin, Lambert & Co.**—Importers of Watches, Sole Agents for Paul Breton & Chas. Latour, Geneva. A general line of reliable Swiss Watches. Watch Cases of all styles made to order. 23 Maiden Lane, N. Y.

**Cross & Beguelin.**—Importers of Watches, Watch Tools and Materials, dealers in American Watches, No. 21 Maiden Lane, N. Y.

**DuBois, Francis & Co.**—36 Maiden Lane, N. Y., Importers of Watches and Manufacturers of Watch Cases.

**Droz, Henry E.**—Importer of Watches, and Watch Case Manufacturer. Agent for the "E. Perregaux" Watch, and jobber in American Watches, No. 92 Fulton Street, N. Y.

**Freund Max & Co.**—Importers of Watches, Jewelry and Precious Stones, 8 Maiden Lane, N. Y.

**Friedman, S.**—Importer of and dealers in Watches and Jewelry, 40 Maiden Lane.

**Gallet, Julien.**—Importer of Watches. No. 1 Maiden Lane.

**Ginnel, Henry.**—Importer of Watches, Tools and Materials, No. 31 Maiden Lane, N. Y. P.O. Box, 2907.

**Jandorf, P. & Bro.**—Importers of Watches and Jewelry, 182 B'way, bet. John St. & Maiden La.

**Keller, L. H. & Co.**—Successors to G. A. Huguenin, Importers of Fine Watch and French Clock Materials, No. 64 Nassau Street, N. Y.

**Hirsch Bros.**—Dealers in Watches and Diamonds and Manufacturers of Jewelry, No. 23 Maiden Lane, N. Y.

**Hyde's Sons, John E.**—Wholesale Commission Agents, only for Jules Jurgensen, of Copenhagen; Ed. Perregaux, of Locle; Jules Monard, of Geneva; and for other makers of all qualities of Watches, 22 Maiden Lane.

**Mathey, L. & A.**—Importers of Fine Watches and Sole Agents for the **H. L. Matile's** Watches, No. 16 Maiden Lane.

**May & Stern.**—Importers of Foreign Watches, Materials and Tools, etc. Manufacturing Jewelers, No. 19 John Street, N. Y.

**Middleton & Brother.**—Importers of Swiss Watches and dealers in American Watches, Diamonds, Gold chains, Jewelry, etc., 10 Maiden Lane, N. Y.

**Nicoud & Howard.**—Importers and Manufacturers of Watches, No. 14 Maiden Lane.

**Oppenheimer Bros. & Veith.**—Dealers in Watches and Diamonds, and Manufacturing Jewelers, No. 35 Maiden Lane.

**Schwob, Adolphe.**—Manufacturer and Importer of Watches, 11 Maiden Lane, N. Y.

**Stern Brothers & Co.**—Importers of Swiss Watches and wholesale dealers in American Watches, &c., 39 Maiden Lane.

**Scott, J. T. & Co.**—Importers of Watches, and Manufacturers of Jewelry, and Jobbers of all Grades, American Watches, No. 11 Maiden Lane.

**Strasburger, Louis & Co.**—Importers and Makers of Watches of every description, No. 15 Maiden Lane.

**Tiffany & Co.**—Makers of Watches. General agents for Patek, Philippe & Co. Wholesale office, 694 Broadway, N. Y.

#### Watch Cases.

**Brown, J. A. & Co.**—Manufacturers of the Ladd Patent Stiffened Gold Watch Cases, etc., 11 Maiden Lane, N. Y. Factory, 58 Eddy Street, Providence, R. I.

#### Watch and Chronometer Repairers.

**Cerf, B.**—Practical Watchmaker and Repairer, No. 10 John Street, N. Y. Repairing and adjusting of Fine Watches done for the trade. All kinds of escape and stem-winding wheels cut to order.

**Ludeman, W. H.**—Chronometer and Watch Maker. Repairing of every description for the trade, 75 and 77 Nassau Street.

**Sirois, A.**—Practical Watchmaker, 89 Fulton Street. Special attention paid to the repairing of Fine Watches. Pivots inserted.

#### Watch Case Repairers.

**Tarbox, Hiram.**—Watch Case Repairing, Springing, Polishing and Engine Turning, 79 Nassau Street, (room 22,) N. Y.

**Renaud, F.**—Watch Case Repairer.—Solid and Heavy Rolled Plate Bows and Pendants. Spring and Engine Turner of Cases and Jewelry, 36 Maiden Lane,

#### Watch Glasses, Shades, Etc.

**Brown, Edwin.**—No. 85 Nassau Street, Imported and Own Manufacture Watch Glasses, Flat, Flat Concave, Concave, Convex and fine Geneva's. Fine fitting solicited

**Hill, Robert S.**—Manufacturer of Watch Glasses, &c., dealer in Imported Glasses, Flat Glasses a specialty; also Jeweler's Glasses. Nos. 75 and 77 Nassau Street, N. Y.

## PHILADELPHIA

**Booz & Thomas.**—Manufacturers of Gold and Silver Watch Cases and Jewelry, 108 South 8th St., Philadelphia.

**Bennett, Jacob & Son.**—Diamond Setters and Manufacturing Jewelers, 108 South 8th St.

**Cooper & Bros.**—Wholesale Jewelers and Importers of and dealers in Watch and Clockmakers' Materials, etc., Spectacles and Optical Goods. No. 35 South 4th Street, Philadelphia.

**Conover David F. & Co.**—American Watches, Wholesale Salesroom, South 3rd corner 7th and Chestnut Streets, Philadelphia.

**Herold, Chas P.**—Successor to Hildebrandt, Herold & Co., Manufacturing Jeweler and Diamond Setter, Diamonds. 916 Chestnut Street.

**Levy, Bernard.**—Manufacturer of Gold and Silver Watch Cases, and Importers and Dealers in Swiss and American Watches. 402 Library Street.

**Morgan, Charles V.**—Manufacturer of Morocco and Hardwood Cases. 630 Chestnut Street, Philadelphia. Jewelry and Silverware Cases, Show Case Trays, Mathematical and Surgical Instrument Cases, etc.

**McCall & Newman.**—Manufacturing Jewelers, Filled Plain Gold Rings a Specialty. No. 625 Arch Street.

**Morgan & Headly.**—Manufacturing Jewelers, Cameo Sets, Gold Sets, Roman Lockets, Rings, Coral Sets and a general line of rich goods. 611 and 613 Sansom Street, Philadelphia.

**H. Muhr's Sons.**—Manufacturing Jewelers, Solid Gold and Filled Rings a Specialty. 633 and 635 Chestnut Street, N. V. Office. 11 Maiden Lane.

**Rosenthal, G. F. C.**—Manufacturing Jeweler and Diamond Setter. Engraving and Designing of Monograms a Specialty. No. 917 Sansom Street.

**Rowe, Geo. A.**—Stone and Metal Seal Engraver, Die Sinker and Medalist, Intaglio Cutting. Special rates for large quantities to manufacturers. 1002 Walnut Street.

**Echerr, L. A. & Co.**—Wholesale Dealers in Watches Silver-Plated Ware, Spectacles, Fancy Goods, Watch Materials, etc. 726 Chestnut Street.

**Sheafer, W. H. & Co.**—Makers of Fine Jewelry. 908 Chestnut Street.

**Simons, Brother & Co.**—Manufacturers of Fine Jewelry, Canes, Thimbles, Chains. 611 and 613 Sansom Street.

## CHICAGO.

**American Watch Company.**—of Waltham, Mass. No. 170 State Street, Chicago.

**Charpier & Wathier.**—Watchmakers and Jewelers for the trade, and Wholesale Dealers in Watch Materials, Tools, etc. 61 West Kinzie Street, Chicago, Ill. Send for price list.

**Clapp, Bros. & Co.**—Wholesale Jewelers. 63 and 65 Washington Street. Catalogue and price list issued to watchmakers and Jewelers.

**Frese, B.**—Watchmaking and Repairing for the Trade promptly attended to. Stem-winding and Escape Wheels cut to order. No. 99 E. Madison Street, Chicago, Ill.

**Giles, Bros. & Co.**—Manufacturers and Jobbers in Watches, all classes of Jewelry, Materials, Clocks, Silver Ware, &c. Illustrated catalogues furnished to dealers on application. State and Washington Streets.

**Glickauf, S. & Co.**—79 and 81 State Street. Importers of Watchmakers and Jewelers Supplies, Optical Goods, Watches, etc.

**Hahn, H. F. & Co.**—Wholesale Jewelers, 157 and 159 Franklin Street. Largest assortment and lowest prices. We do not issue any catalogue.

**Knights, C. H. & Co.**—Wholesale Jewelers, 125 and 127 State Street.

**Kearney & Swartchild.**—113 and 115 State Street. Importers and Jobbers of Watchmakers' and Jewelers' Supplies, Watches, Jewelry, etc. Illustrated catalogue and price list sent on application and receipt of card.

**Matson, N. & Co.**—State and Monroe Streets. General Jewelers and Furnishers of Jewelers' Supplies. Western Branch House for Reed & Barton's Fine Electro-Silver Plated Ware.

**Norris, B. F. & Co.**—Wholesale Jewelers, and Dealers in Watchmakers' and Jewelers' Supplies. 101 and 103 State Street.

**Richter, Jacob.**—Established 1868. Watch Repairer for the trade. Special attention given to complicated work, 528 State Street.

**Stein & Ellbogen.**—Wholesale Dealers in Watches and Jewelry, 127 State Street, Chicago, Ill. Specialty, repairing for the trade.

## PROVIDENCE

**Irons, Chas. F.**—Manufacturer of Solid Gold Jewelry. Specialty, Emblems, Pins and Charms, Masonic, Odd Fellows, etc. 102 Friendship St.

**Parkins, C. H. & Co.**—Manufacturers of Fine Gold and Plated Jewelry, 20 Conduit Street.

## NEWARK.

**Lefort, Henry.**—Stem-winding Watch Crown Manufacturer. 80 and 82 Marshall Street.

**Lelong, L. & Bro.**—Gold and Silver Refiners, Assayers and Sweep Smelters, Southwest corner of Halsey and Marshall Streets, Newark, N. J.

**Milne & Jourdan.**—Manufacturers of Stem-winding Watch Crowns. 13 and 15 Franklin Avenue.

**Prince, David.**—Gold and Silver Refiner, Assayer, and Sweep Smelter. Sole Agent for Comins' Improved Amalgamator. 63 Railroad Ave.

**Unger, H. & Co.**—Manufacturers of Fine Gold Jewelry, Colored and Etruscan work, Enamelled Sets. Office and factory, 18 Crawford street, Newark, N. J. Box 63.

MANUFACTURERS OF  
**GOLD AND FINE ROLLED PLATE  
 JEWELRY,**

**Standard Gold Stock Plate Chain,**

Bracelets, Necklaces, Locketts, Crosses,

A Specialty!

**SOLID GOLD RINGS**

IN LARGE VARIETY.

Goods sent to all parts of the U. S. on approval, without declaring values, and can be returned to us in the same manner, thereby saving our patrons considerable expense by not being obliged to declare values to Express Co.'s.

Diamonds,  
 Pearls,  
 Cameos,  
 Amethysts,  
 Turquoise,  
 Garnets, &c.

In future the **DIAMOND** trade will receive our particular attention. **DIAMONDS** in original packages, singly, or in pairs, mounted or unmounted, will be found constantly on hand.

Manufacturers of the Celebrated

**American SILK GUARDS,**

**39**

**MAIDEN LANE,**

**New York.**

**Kossuth Marx & Co.**

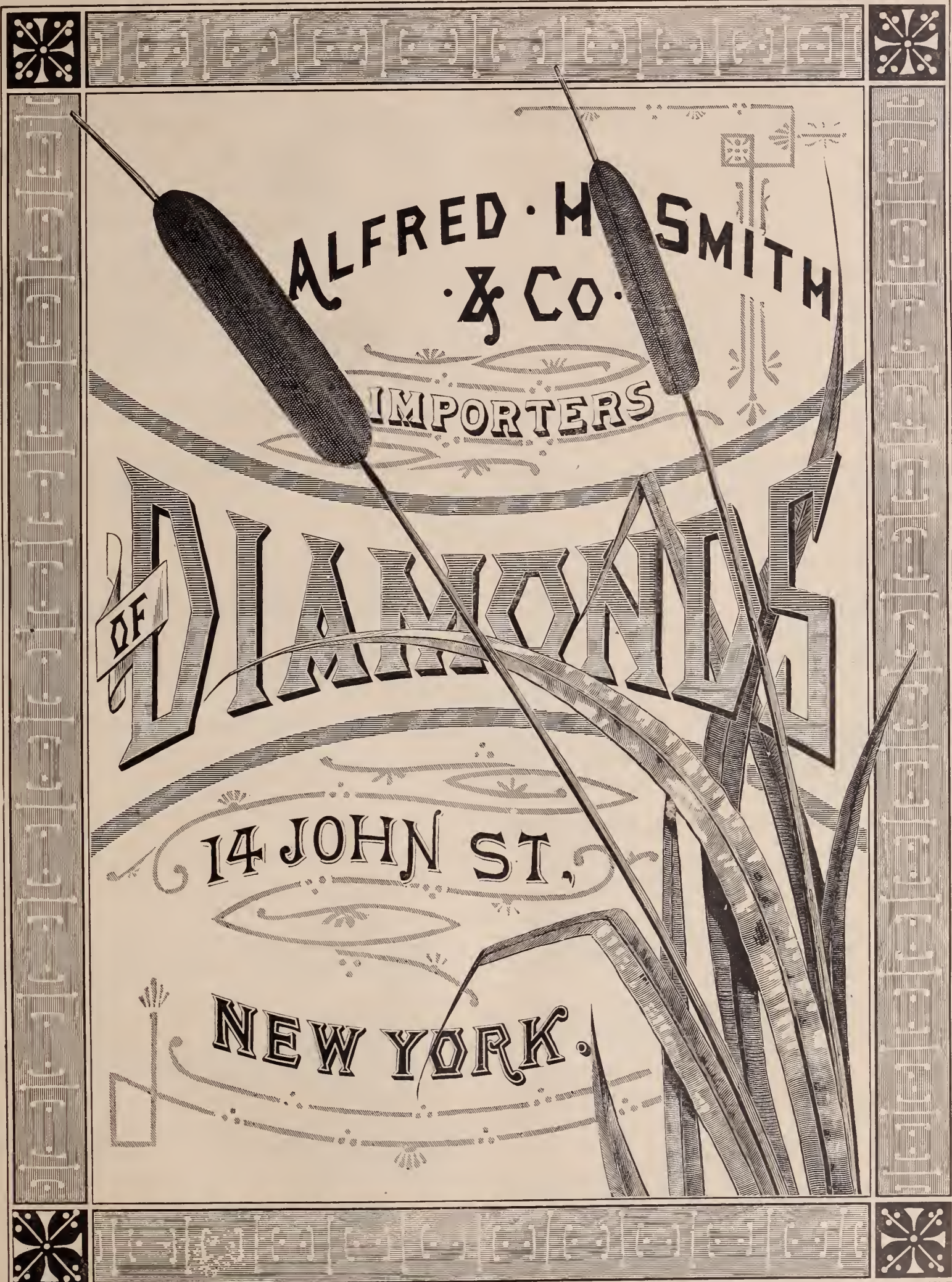

ALFRED · M · SMITH  
· & Co. ·

IMPORTERS

OF  
DIAMONDS

14 JOHN ST.

NEW YORK.

Established 1834.

# G. & S. OWEN & CO.

MANUFACTURERS OF

## FINE GOLD JEWELRY

Consisting of { Roman and Polished Goods,  
Box and Glass Goods,  
Hair Chain Mountings,

*Specialty---Black Onyx and Pearl Goods Consisting of Lace, Chatelaine and Scarf Pins  
Ear Rings, Sleeve Buttons and Studs,  
Leontine and Vest Chains in  
great variety.*

All our goods exclusively of our own manufacture.

5 MAIDEN LANE, NEW YORK

# JOHN A. RILEY & CO.

MANUFACTURERS OF

Rich Gold and Onyx Jewelry,

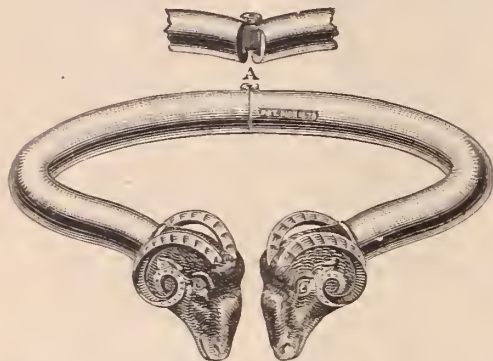

NOVELTIES IN HALF SETS. LACE PINS, SCARF PINS AND EAR RINGS

Engagement Pad, Lock Bands, Elastic Snake Bands and Chatelaines. Onyx Chatelaines with and without Watch Movements.

Nos. 7 & 9 Bond Street, New York.

No. 126 Kearney Street, San Francisco, Cal.

# MOORE & HORTON,

## JEWELLERS,

No. 11 Maiden Lane, New York.

### SPECIALTIES!

Stone Cameo, Onyx, Amethyst, Topaz and Pearl Rings.  
Studs, Collar and Sleeve Buttons.

Also our new fac-simile of Fine African Diamonds, mounted in Rings, Studs, Pins, Ear-rings, Scarf Pins, Medallions.

**OWEN, SHOWN & CO.**

**MAKERS OF FINE JEWELRY**

CONSISTING OF  
BRACELETS,  
SETTS,  
LOCKETS,

PINS,  
STUDS,  
RINGS,  
SLEEVE BUTTONS  
ETC.

**SPECIALTY**  
**STIFFENED ROMAN BANDS**

Nos. 612 & 614 CHESTNUT ST. PHILADELPHIA.  
BRANCH-OFFICE 15 JOHN ST. NEW-YORK.

Established 1846.

WILLIAM RIKER,

No. 5 Maiden Lane, New York.

Factory, 42 Court Street, Newark, N. J.

Would call the attention of the Trade to our Inlaid Bracelets.

# COE, PINNEO & STEVENS,

MANUFACTURERS OF

## LOCKETS,

## WHITE ENAMEL STUDS & BUTTONS

Linen Finished and

## FINE JEWELRY,

Old No. 9 Maiden Lane, New York.

# ENOS RICHARDSON & CO.

MANUFACTURERS OF

## FINE GOLD JEWELRY,

Gold Chains, Locketts, Crosses and Necklaces,  
COLORED AND ETRUSCAN WORK.

ENGRAVED AND ENAMELED GOODS IN GREAT VARIETY.

All Goods sold strictly of our own manufacture.

23 MAIDEN LANE, NEW YORK.

ENOS RICHARDSON,  
THOS. SLATER,

L. P. BROWN,

F. H. RICHARDSON,  
W. P. MELCHER.

# SHOEMAKER & CO.,

MANUFACTURERS OF

## Onyx, Cameo & Intaglio Buttons,

AND LOCKETS.

A full line of Roman Goods including Bracelets,

No. 21 MAIDEN LANE, NEW YORK.

## Platinum-Tipped Diamond Settings

Patented April, 1878, by

RIPLEY, HOWLAND & CO.



OFFICE, 35 MAIDEN LANE,  
NEW YORK.

Factory, 383 Washington St., Boston, Mass.

# WANTS OF FINE JEWELRY ALBING BROS. & CO. WANTS OF FINE JEWELRY

Full Line of Roman and Mosaic Goods,  
Earrings, Buttons, Studs and Rings.

SPECIALTIES:

ENGRAVED AND ENAMELED BANDS,  
CAMEO GOODS.

170 BROADWAY, New York.

## NOTICE.

Manufacturing Jewelers are hereby notified that the undersigned have obtained Letters Patent, dated Feb. 25th, 1879 and re-issued Oct. 14, 1879, for Bracelets constructed of a single band, having ornamentation in relief permanently fixed upon its outer surface, with rigid marginal flanges or projection for the protection of the same, and all infringements, whether in cheap or fine goods, will be promptly and rigorously prosecuted according to law.

HALE & MULFORD,

Broadway & Fourth St.

New York, Oct. 14th, 1879.

# A. J. HEDGES & Co.,

MAKERS OF

## FINE JEWELRY

*Of Every Description.*

No. 9 Maiden Lane, New York.

## FALL NOVELTIES.

We have recently introduced a new and attractive line of FINE GOLD GOODS, richly ornamented in illuminated gold upon a sunken surface, for which process we have been granted letters patent.

Buyers visiting the city are invited to examine these goods as they cannot fail to give satisfaction.

NOTICE.—Any infringement of this patent will be vigorously prosecuted.

# TO THE TRADE.

WE, THE UNDERSIGNED, have this day granted a license to  
Messrs. Carrow, Bishop & Co.

of this city giving them authority to manufacture Bracelets under our letters patent, (dated February 25th, 1879, reissued No. 8928), October 14th, 1879, for improvements in Bracelets.)

The trade is cautioned against dealing in bracelets covered by this patent made by other parties, as all infringement will be vigorously prosecuted according to law. All goods manufactured under this patent by CARROW, BISHOP & CO. and OURSELVES will be marked Patented October 14th, 1879.

**HALE & MULFORD,**

Dec. 6th, 1879.

692 Broadway, New York.

**CHATELLIER & SPENCE,**

**Manufacturing Jewelers,**

694 BROADWAY, NEW YORK.

No. 1006 Chestnut Street, PHILADELPHIA, PA.

No. 12 West Street, BOSTON, MASS.

No. 120 Sutter Street, SAN FRANCISCO, CAL.

**CHURCHILL, LEWIS & CO.**

**Manufacturing Jewelers,**

SPECIALTIES :

TURQUOISE,	LACE PINS,
GARNET, and	EARRINGS,
ENAMELED	RINGS, and
PAINTINGS.	HALF SETS.

180 Broadway, New York.



**LYON & HARDY,**

30 MAIDEN LANE, NEW YORK,

IMPORTERS OF

**DIAMONDS,**

AND MANUFACTURERS OF

**DIAMOND MOUNTINGS.**

All goods ordered for stock or on approval are insured while the hands of Express Companies.

**GEORGE W. PLATT,**

IMPORTER AND JOBBER IN

**Watches, Jewelry, &c.**

No. 20 Maiden Lane,

**NEW YORK.**



# J. B. BOWDEN & CO.

Manufacturers of

## RINGS

Have recently added to our stock a full line of

### NOVELTIES IN STONE RINGS.

*Cameos, Chevé, Intaglios, &c., Specially Designed for the HOLIDAYS.*

All Styles of Children's

AND

### FANCY SOLID RINGS,

No. 1 Maiden Lane, New York.

## J. A. BROWN & CO.

OFFICE AND SALEROOM:  
No. 11 Maiden Lane, N. Y.

FACTORY:  
No. 104 Eddy St., Providence. I. R.

SOLE MANUFACTURERS OF THE

## Ladd Patent Stiffened Gold Watch Cases

The Best and most durable, and the

CHEAPEST STIFFENED Gold Watch Case FOR THE MONEY

MADE IN THE WORLD!

All genuine Watch Cases of our manufacture have "G. W. Ladd's Patent, June 11, 1867," stamped upon the side band underneath the glass bezel.

REFUSE ALL OTHERS.

Send for full Descriptive Circular to the

OFFICE AND SALESROOMS

1 Maiden Lane, N. Y.



KEY AND STEM WINDING

Hunting and Open-Face

IN FLAT BEVEL,

Mansard and Oval

SHAPES

Adapted to the various

AMERICAN-MADE MOVEMENTS,

IN

8, 10, 14, 16 & 18

SIZES.

Dealers can obtain them of the Wholesale Watch and Jewelry Houses, or their Traveling Agents throughout the United States and British Provinces.

## OPPENHEIMER BROS. & VEITH, MANUFACTURING JEWELERS

AND

Dealers in Watches and Diamonds,

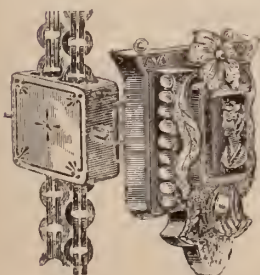

35 Maiden Lane,  
NEW YORK.



Patented June 3, 1879.

Combination Chain, Slide, Pendant and Locket.

## BUCKENHAM, COLE & SAUNDERS,

SUCCESSORS TO

BUCKENHAM, COLE & HALL,

IMPORTERS OF

## Diamonds, Pearls

AND OTHER PRECIOUS STONES,

MANUFACTURERS OF FINE JEWELRY,

10 Maiden Lane, New York.

A large Stock of FINE DIAMONDS, Mounted and Unmounted kept constantly on hand. Goods sent on approval to any part of the country on receipt of satisfactory references.

## JOHN M. GODDARD,

3 Maiden Lane, New York.

SPECIALTIES:

BRACELETS.

1st Quality Rolled Plate.

Gold and Rolled Plate, upwards 100 patterns.

CHAINS and LOCKETS  
Vests, Necks, Guards, Leontines  
in great variety.

The Latest Designs in Gold and Fine Rolled Plate Jewelry always in stock.

SEAL RINGS OF ALL KINDS.

Jewelry repaired, recolored, matched or made to order. Special attention given to the Job Department.

Orders from responsible Jewelers for goods on selection will be filled promptly and intelligently.

## MAX FREUND & CO.,

Manufacturing Jewelers

IMPORTERS OF

## WALTHAM

Jewelry and Precious Stones,

No. 8 Maiden Lane

NEW YORK



This Movement fits Waltham Cases.

Sole Agents for the Celebrated A. Schneider Watch Dresden, Also the Standard Watch Co. of New York.

MANUFACTURERS  
OF  
EXCLUSIVELY  
**BLACK ONYX GOODS,**

Bracelets,  
Brooches,  
Collar Buttons,  
Crosses,  
Cuff Pins,  
Ear Rings,  
Ear Studs,  
Half Sets,  
Lace Pins,  
Leontines,  
Sleeve Links,  
Lockets,  
Medallions,  
Necklaces,  
Scarf Pins,  
Shawl Pins,  
Sleeve Buttons,  
Studs and  
Vest Chains.

**WOGLOM & MILLER,**  
32 & 34 JOHN STREET,  
NEW YORK.

**HENRY FERA,**  
Importer of Diamonds,  
No. 9 MAIDEN LANE,  
New York.

Having my own cutting and polishing establishment at Nos. 23 and 25 Looijersgracht, Amsterdam, Holland, constantly running 36 mills, I am able to offer to the trade a full assortment of Diamonds at very low prices.

Loose and Mounted Goods sent on approval to any part of the country on receipt of satisfactory references

All goods ordered from or shipped to me, are insured while in the hands of express companies, and no valuation is needed on the parcels.

**BOOZ & THOMAS,**

MANUFACTURERS OF

Watch Cases  & Jewelry,

108 South Eighth St., (2d Story) Philadelphia.

Samples of our goods sent on approval, when satisfactory reference is furnished.

**Old Gold & Silver Bought or Exchanged.**

PARTICULAR ATTENTION PAID TO REPAIRING.

**HAMILTONS & HUNT,**

MANUFACTURERS OF

**Fine Plated Chains**

AND PATENT BUCKLE BRACELETS,

A Full Line of Ladies' and Gentlemen's Roman & Stone Lockets.

**Branch Office, 176 Broadway, New York**

FACTORY, 226 EDDY STREET, PROVIDENCE, R. I.

GEO. W. PRATT.

IRA GODDARD.

**GEO. W. PRATT & CO.**

MANUFACTURERS AND DEALERS IN

**American and Swiss Watches,**

**SOLID BAND AND SEAL RINGS,**

Gold and Roll-Plated Jewelry,

No. 14 JOHN STREET, NEW YORK.



**W. C. GREENE & CO.**  
GOLDSMITHS

MANUFACTURERS OF  
RICH SETS IN TAPER WIRE CORAL

Factory 95 PINE ST. Providence, R. I.      Stone Cameo      Amethyst      Coral Engraved & Enamel      Brooches & Sleeve Sets      Studs & Buttons      EAR DROPS & CROSSES      New York Office 192 BROADWAY.

WM. C. GREENE.      B. W. GREENE.      GEO. D. BRIGGS.

**M. FOX & CO.**

**Practical Lapidaries,**

IMPORTERS OF

**DIAMONDS**

AND OTHER PRECIOUS STONES.

No. 1 Maiden Lane, New York.

**VANHOUTEN SAYRE & CO.**  
MANUFACTURERS  
OF  
**SOLID JEWELRY.**

SETS      LEVER BUTTONS      EAR RINGS      ETRUSCAN ENAMEL AND FACET WORK.      LOCKETS      COLLAR BUTTONS      STUDS

OFFICE AND FACTORY, **53 CHESNUT STREET NEWARK, N.J.**

**E. STITES,**  
*Manufacturing Jeweler,*  
 No. 12 MAIDEN LANE,  
 New York.  
 SCARF RINGS AND PINS.  
 Roman Band and Le Gant  
 Bracelets.

**BREITINGER & KUNZ,**  
 IMPORTERS OF  
**Watchmakers' Tools and Materials,**  
 GLASSES &C. &C.  
**No. 107 N. 9th Street, Philadelphia.**

Agency in the U. S. for  
 BÄHNI BROTHERS HARDENED & TEMPERED HAIRSPRINGS,  
 G. BECKER'S GOLD MEDAL REGULATORS,  
 DUDLEY'S ELI CTRICALLY CORRECT'D CLOCK.

I. PFORZHEIMER. D. KELLER.  
**PFORZHEIMER & KELLER,**  
 IMPORTERS OF  
**Watches and Diamonds**  
*Dealers in American Watches,*  
 AND  
 Manufacturers of Jewelry,  
 No. 24 JOHN STREET,  
 NEW YORK.  
 P. O. Box 4144.

FINE ONYX AND PEARL NECKLACES AND PENDANTS.  
**DOWNING & KELLER,**  
 MANUFACTURERS OF  
**FINE JEWELRY,**  
 Onyx & Pearl Sets, Shawl Pins, Ear Rings, etc.  
 8 MAIDEN LANE,  
 NEW YORK.

**Dorrance, Edge & Co.**  
 MANUFACTURERS OF  
 THE CELEBRATED WOVEN FABRIC  
**GOLD CHAIN.**  
*Elegantly Mounted Bracelets, Opera, Leontine,*  
 VICTORIA WATCH GUARDS & NECKLACES, in all the Newest Designs.  
 Our stock is unusually complete, and, in addition to the above, a variety  
 of Necklaces, from 1½ to 40 dwts. each, to which we invite  
 the attention of buyers.  
 CHILDREN'S BRACELETS A SPECIALTY,  
 Weighing from 6 dwts. a pair upwards.  
**No. 12 John Street, New York.**  
 Factory, 46 Greene Street, Newark, N.J.

**WANTED.**  
 A First-Class Traveling Salesman  
 for a Western Jobbing Firm.  
*Only those who have had experience on the  
 road and can give the best of reference need  
 apply. Good Salary. Jewish preferred.*  
 Address CHICAGO, Care Jewelers' Circular.

**ROSKOPF WATCH**  
**J. D. HUGUENIN & CO.**  
 General Agents,  
 12 Maiden Lane, New York.

The reputation of this Watch as an accurate timekeeper is fully  
 established, and during the ten years that it has been before the  
 Trade, has won an abiding reputation for fine Time-keeping qual-  
 ities, and the BEST WATCH for the money in the world.  
 Send business card for price list.

**STAR WATCH & CLOCK OIL,**  
 MANUFACTURED BY  
**GEO. B. WHEELER,**  
 NEW BEDFORD, MASS.



This Oil is made from the best of stock, is free from gum or corro-  
 sive qualities, will stand the coldest weather, and is every way reliable.  
 L. HAMMEL & Co., 9 Maiden Lane, New York, Agents for the U. S.  
 KOCH & Co., Elberfeld, Prussia, Agents for Europe.

**T. B. BYINNER,**  
**Importer & Jobber of Watches**

DIAMONDS AND FINE JEWELRY,

And Dealer in the BEST CLASS OF ROLLED PLATE JEWELRY

And Key and Stem-Winding American Watches.

No. 513 Broadway, New York

**E. D. VOSBURY & CO.**  
**GOLD CHAINS,**

Rolled-Plate Chains and Locketts,

ELGIN WATCHES, BOSS FILLED CASES, STONE AND BAND RINGS OF EVERY DESCRIPTION,

25 Maiden Lane, New York.

**Clark's Grooved Case Springs.**

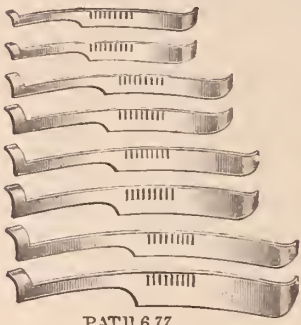

PAT. 116,777.

Made in four lengths, wide and narrow. The spring sets well away from the movement, the depressions obviate any tendency to move lengthwise. Steel rivets preferably used can be removed more easily than screws. In fitting file away the lower edge until the rivet can be pushed down in front of the spring in the grooves. These springs are made from fine steel, carefully tempered and warranted perfectly reliable. To be had of all jobbers in watch materials at manufacturers price—75 cts. per dozen.

**A. N. CLARK,** *Manufacturer of the Celebrated FOUR HOLE CASE SPRINGS, Watch Keys, Bench Tools, Crosby's JEWELING TOOLS, &c,* Plainville, Ct.

**New Otto Silent Gas Engine.**

Working without Boiler, Steam, Coal, Ashes or Attendance.  
*Started instantly by a Match, it gives Full Power immediately.*

No Explosion,  
 No Fires nor Cinders,  
 No Gauges,  
 No Pumps,

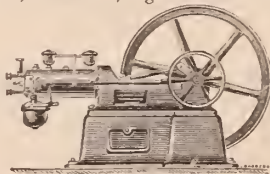

Perfectly Safe,  
 Easily Managed,  
 Durable, and  
 Simple in Construction.

**WHEN STOPPED, ALL EXPENSE CEASES.**  
**TESTIMONIAL.**

PHILADELPHIA, September 12, 1879,  
 Gents:—The four horse power Gas Engine purchased from you for use in our polishing shop, has given us perfect satisfaction, holding its power, and giving little or no trouble in running. It has been in use for about nine months, and we are happy to say it fulfills all that you promised for it. Yours, very truly,  
 JAS. E. CALDWELL & Co.

Sizes of Two, Four and Seven Horse made by  
**SCHLEICHER, SCHUMM & CO., 3045 CHESTNUT ST., PHILA.**

**A. W. MACERHANS,**  
**Manufacturing Jeweler,**  
 9 JOHN STREET, NEW YORK.



Patented May 7th, 1879.

These Bracelets, plain, with concaves for solitaire diamonds or with "lily of the valley" or other pearl ornaments, show less gold in mounting, and are lower in price than any other Onyx Band in the market.

They are made in widths running from  $\frac{3}{8}$  to 1 in. and from  $5\frac{3}{4}$  to  $6\frac{3}{4}$  in. wrist measure.

**Onyx Goods a Specialty.**

Onyx Lace Pins, Scarf Pins, Cuff Pins, Earrings, Locketts, Crosses, Ladies' and Gents' Vest Chains.

APPROVAL ORDERS SOLICITED. REPAIRING CAREFULLY DONE.

**MILNE & JOURDAIN,**  
 Manufacturers of Stem-Winding Watch Crowns



13 & 15 Franklin Street, NEWARK, N. J.

Gold Crowns for Stem-winding Movements, to suit all sizes of Imported or American Watches, in four different styles and seven sizes.

Gold Pushers for Key Movements in every size. Also Gold Crowns for fine Chronograph Watches made to order.

Silver Stem winding Crowns and Key Pushers on hand or made to order. Send for card and samples.

A. MILNE.

A. JOURDAIN.



**RICKETT'S**  
**PATENT EYE SHADE.**

It is simply a neat curved shade of hard rubber,  $\frac{3}{4}$  inch wide that fits under the eye brows, and flares out at the bottom so as to allow an angle of vision about level with the horizon. Having met with success in New York, Philadelphia and Boston, and wishing to extend our trade to other cities, we will for the next 30 days forward to any one in the trade ordering 2 dozen Spring Shades, an elegant *Plaster Bust*, life size, stands  $17\frac{1}{2}$  inches high, and retails in New York for \$3.00. If placed in prominent window, will sell 2 dozen shades in 10 days.

We have first-class testimonials from M. GARDNER, Chief of Draftsman, U. S. Patent Office, H. OLMSTED, Secretary of New York Jewelers' Association, and from many other prominent men of the country. Order from any jobber or direct from us. Please state whether you want Bust.

PRICE.—Spring Shades, \$3.50 per doz.

**RICKETT'S EYE SHADE CO.,**  
 85 Nassau Street, New York.

**WILLIAM H. BALL,**

SUCCESSOR TO BALL & BARNARD,

MAKER OF

ORNAMENTED

Roman, Enameled and Engraved  
**BRACELETS.**



Having given the manufacture of Band Bracelets my entire attention for a number of years, it has been my desire to make a durable article, one that will give satisfaction to the seller as well as the wearer. I desire to call the attention of the trade to the reduction I have made in prices, still keeping up the standard as to QUALITY, FINISH and WORKMANSHIP. To each pair of BANDS is attached my patent guard without extra charge—thus saving the price of chain.

No. 9 JOHN STREET, NEW YORK.

Factory, 30 & 32 Franklin Street, Newark, N. J.



W<sup>m</sup> S. HEDGES & CO

OF THE LATE FIRM OF SMITH, HEDGES & CO.

IMPORTERS OF

DIAMONDS

170 BROADWAY

COR. OF MAIDEN LANE N. Y.

CHOICE BRILLIANTS IN SINGLE STONES  
AND MATCHED PAIRS A SPECIALTY

# “HILLSIDE,”

NEW THREE-QUARTER PLATE MOVEMENT

—MADE BY—

## The American Watch Company

OF WALTHAM,

The lowest price three-quarter plate Stem-Winding American movement ever made. We wish to call the attention of the trade to the following special advantages:

*They are made to wind at either the figure XII for Open Face Cases, or at figure III for Hunting Cases, in all three qualities, viz.:*

**Gilded Movement, Cut Expansion Balance, plain jeweled;**

“ “ “ “ “ with 3 pairs extra jewels in settings;

**Nickel Movement, Cut Expansion Balance, with 3 pairs extra jewels in settings.**

*These movements all have quick trains, Patent Pinions, with extra jewels in settings, and, at the very low price at which we offer them, are especially adapted for our New Patent Dust Proof Open-Face Cases. A good strong case can be made under our patents weighing not over*

**22 dwts., 14 karat gold,**

**24 “ 18 “ “**

*thus making altogether the lowest price three-quarter plate gentlemen's size stem-winding gold watch ever offered.*

Robbins & Appleton, 9 Bond St., New York.  
 Robbins, Appleton & Co., 8 Summer St., Boston.  
 Robbins & Appleton, 170 State St., Chicago. } *General Agents.*

AMERICAN WATCH COMPANY,  
 OF WALTHAM, MASS.

*Note the prices of the following new movements made by*

## THE AMERICAN WATCH COMPANY OF WALTHAM, MASS.

### 14 Size, $\frac{3}{4}$ Plate.

AM. WATCH CO.	“HILLSIDE”	(NEW),	7 jewels,	cut expansion	balance,	Stem	Winder,	for Hunter or	Open Face,	(Gilded Movement)	\$20 00
“	“	“	3 pairs	extra jewels,	in settings,	cut expansion	balance.	Stem Winder,	for Hunter or	Open-Face,	23 00
				(Gilded Movement),							23 00
“	“	“	3 pairs	extra jewels	in settings,	cut expansion	balance,	Stem Winder,	for Hunter or	Open Face,	30 00
				(Nickel Movement)							30 00

### 18 Size, Full Plate, NICKEL Movements.

“WM. ELLERY,”	2 pairs,	extra jewels,	cut expansion	balance....							12 00
“	2 “	“	“	“	“	“	“	“	Stem Winder,		16 50
“P. S. BARTLETT,”	2 pairs,	extra jewels	in settings,	cut expansion	balance....						18 50
“	2 “	“	“	“	“	“	“	“	Stem Winder		26 00
“WALTHAM WATCH CO.”	4 pairs,	ex. jewels	in settings,	cut ex. balance....							26 50
“	4 “	“	“	“	“	“	“	“	Stem Winder		34 50
“APPLETON, TRACY & CO.,”	4 pairs,	extra jewels	in settings,	cut expansion	balance,	adjusted....					37 00
“	4 pairs,	extra jewels	in settings,	cut expansion	balance,	adjusted,	Stem Winding....				46 50

All the above are subject to the terms and discounts announced in our circular of the 8th Feb. last.

There will be no change in the quality of any of our grades, except as our constant efforts tend to their improvement. We decline altogether to take any part in the present unwise competition between Swiss and American manufacturers to see which shall make watches of the poorest quality. We intend to sell as low as any American company, but, however low the price, we do not intend to finish a grade of goods upon which it would be a disgrace for us to put our name.

Robbins & Appleton, 9 Bond St., New York.  
 Robbins, Appleton & Co., 8 Summer St., Boston,  
 Robbins & Appleton, 170 State St., Chicago.

American Watch Company,  
OF WALTHAM, MASS.

*New York, September 1st, 1879.*



*SELECT ASSORTMENT OF RINGS, EAR RINGS, EAR DROPS,  
STUDS, PINS, CROSSES, LACE PINS, AND OTHER*

NOVELTIES,

*ARTISTICALLY MOUNTED, AND ESPECIALLY DESIGNED*

FOR THE HOLIDAY TRADE.

*GOODS SENT ON APPROVAL.*



ESTABLISHED 1853.

CLOCKS



CLOCKS

**B. J. COOKE'S SON,**  
137 N. 3d Street, Philadelphia  
Catalogues and Price Lists furnished to the Trade only, on application.

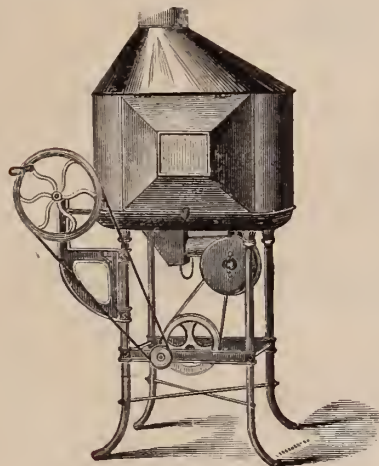

**KEYSTONE  
Jewelers' Forges,**

FOR HAND OR POWER.

Light, durable and noiseless.

SEND FOR CATALOGUE.

Keystone Portable Forge Co.,  
220 Carey Street,  
Philadelphia, Pa.

ESTABLISHED 1855.

**WELCH & MILLER,**  
MANUFACTURERS OF MOROCCO, VELVET AND SATIN  
**Jewelry Cases, Trays, &c.**

Telescope Sample Cases, with Flexible Trays.  
COMPLETE STOCK ON HAND.

**No. 169 BROADWAY, NEW YORK.**

CATALOGUES SENT ON APPLICATION.

**JAMES IRONS,**

PATENTEE  
AND  
Sole Manufacturer



CHEAPEST PLACE TO BUY GOOD

**SHOW CASES,**

Large Assortment.

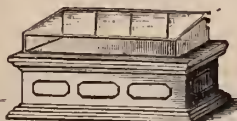

Factory and WAREHOUSES,

132 & 134

North 4th St.,

PHILADELPHIA.

All kinds always on hand.

Cases packed securely to carry to any part of the world,

**Charles F. Terhune & Co.,**  
Manufacturing Jewelers,

16 Maiden Lane,  
NEW YORK.

— Sole Manufacturers —



We beg to call the attention of the trade to the above cuts representing

**PATENT SLIDE BUTTON**

It is not separable, but works on a simple slide. It can be put in and taken out easier than any button made without soiling the cuff. Recommends itself at sight.

A full line of Stone, Enamel, Ivory and Pearl goods in above patterns

**BERNARD LEVY,**  
Manufacturer of Watch Cases

— AND DEALER IN —

**AMERICAN WATCHES,**

No. 402 Library Street,

**PHILADELPHIA.**

**G. F. C. ROSENTHAL,**  
Manufacturing Jeweler,

917 SANSOM STREET.

PHILADELPHIA.

The finest Diamond and Pearl Work exclusively.

**Lubricating Oils, for Watch, Clock and Chronometer Makers.**

The discovery of a Lubricator for FINE MACHINERY, such as Watches, Clocks and Chronometers, that is free from gum and corrosive substance, has taxed the ingenuity of hundreds of men whose efforts have proved a failure. But we are happy to say, (being largely interested) that such an article has been supplied by Mr. EZRA KELLEY, of New Bedford Mass., who, after forty years study of the subject, has perfected a Lubricator, that recommends itself to all who have used the genuine, (there having been numerous counterfeits in the market,) as witness also the award of a



Diploma and Medal by the judges of the late Centennial Exhibition at Philadelphia. We have no hesitation in saying that his Oils are the BEST manufactured always uniform in quality and of standing all test applied to lubricating oils. We cheerfully recommend it to all who may in their business require a FIRST-CLASS LUBRICATOR

SETH THOMAS CLOCK COMPANY, SETH E. THOMAS, Agent

P. S.—The above Oils can be procured at all first-class wholesale Watch and Clock Establishments in the United States, as well as his only Agents, HENRY GINNEL, 31 Maiden Lane, New York, and GRIMSHAW & BAXTER, 35 Goswell Street, London, England.

New Bedford, October 15, 1877.

# RANDEL, BAREMORE & CO. DIAMONDS,

Corner Maiden Lane and Nassau Street,

29 MAIDEN LANE,

58 NASSAU STREET,

**NEW YORK.**

No. 12 New Burlington Street, LONDON.

Established 1828.

## JACOB BENNETT & SON, Diamond Setters and Manufacturing Jewelers,

No. 108 SOUTH EIGHTH STREET, PHILADELPHIA.

WE MANUFACTURE AND MAKE A SPECIALTY OF  
EVERY DESCRIPTION OF

**DIAMOND MOUNTINGS,**

SUPERIOR IN DESIGN AND WORKMANSHIP.



Dealers in

**DIAMONDS**

And all kinds of Precious Stones.

Masonic Marks, Society and School Badges, Made to Order Only. Designs and Estimates Furnished.

PARTICULAR ATTENTION GIVEN TO ALL KINDS OF JOBBING.

## L. & A. MATHEY,

No. 16 MAIDEN LANE,

IMPORTERS OF ALL GRADES OF

Plain and Complicated Watches and Movements,

SOLE AGENTS FOR THE WELL-KNOWN

# H. L. Matile

FINE WATCHES OF ASTRONOMICAL PRECISION.

AN ATTRACTIVE LINE OF CHATELAINES AND CHATELAINE WATCHES.

SOLE AGENTS FOR CHAS. MAYLAN'S IMPROVED MINUTE CHRONOGRAPHS.

TABLE Showing the rate of a few of H. L. MATILE Fine, Plain and Timing Watches, just received by us after a competitive trial of four and six weeks, at the Observatory of Neuchatel.—(From the last official Report.

On Trial.	Movement Number.	Mean Daily Rate.	Mean Daily Variation.	For var'n of -1° Temperature	Before and after Oven.	Difference Hanging and Lying.	Hanging and Pend't Left.	Hanging and Pend't Right.	Dial up and Dial down	Diff. betw'n first and last Week.	Difference extreme rates.	
6 Weeks.	10075	-1.44	±0.31	+0.07	-0.4	+1.47	-1.96	-1.31	+0.48	-1.40	4.0	Received 3d Prize.
" "	10693	-4.07	±0.45	+0.22	+0.7	-0.59	+0.36	-0.14	-1.15	-0.73	6.9	
" "	10696	+4.51	±0.51	+0.20	-1.3	+1.21	+0.50	+2.40	-2.0	0.0	6.7	
" "	10694	-3.12	±0.57	+0.14	+0.1	-3.14	+5.41	+2.96	-2.99	+0.01	7.1	
" "	10526	+1.69	±0.80	+0.05	+0.3	-1.34	+0.40	+0.39	-2.28	-0.03	4.2	
" "	10525	-2.40	±0.42	+0.20	+0.3	-0.33	+5.29	-0.06	+0.29	-1.44	7.0	
" "	10695	+1.76	±0.49	0.0	-0.8	+0.22	+0.56	+3.71	+1.41	+0.98	5.0	Received 1st Prize.
4 "	530	-0.11	±0.26	+0.06	-0.3	+0.13					1.6	
" "	526	-0.26	±0.52	+0.08	+2.4	+0.47					3.1	
" "	10114	+0.8	±0.41	-0.10	+0.6	-0.89					5.8	
" "	10524	+1.66	±0.69	+0.16	-2.0	+1.27					5.3	
" "	10113	+8.04	±0.57	-0.12	-1.7	+2.42					5.7	

## MATHEY'S TIME INSTRUCTOR.

An Instrument for teaching Children how to tell the Time.

# HENRY C. HASKELL,

Manufacturing Jeweler,

No. 12 John Street,

New York

THE FINEST SEAL RING EVER OFFERED  
THE TRADE.

## The "MARQUIS"

*Must be seen to be fully appreciated.*

## NOVELTIES

In Great Variety,

FROM ORIGINAL DESIGNS



790

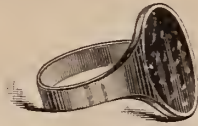

791



792



739



539



744

*Samples sent on approval.*

*New Holiday Catalogue supplied to Dealers by sending Card.*

# MULFORD & BONNET,

Manufacturers of Gold Jewelry, Dealers in Diamonds,  
Jobbers of best Rolled Plated Goods.

Our stock is assorted with great care, and is kept replenished with the choicest and latest selections. We are introducing new designs and constantly receiving the newest patterns. The varied character of our stock, so comprehensive in all its details permits us to offer to buyers unusual advantages.

## MULFORD & BONNET,

21 MAIDEN LANE, New York.

*Sole Proprietors of the PAINLESS EAR PIERCER,  
Patented June 25th, 1878.*

House Established since 1837.

# CHARLES LEO ABRY,

(SUCCESSOR TO J. A. ABRY.)

## Importer and Manufacturer of Swiss Watches

OF ALL GRADES, AND DEALER IN AMERICAN WATCHES.

Sole Agent in the United States for the **Celebrated Vacheron and Constantin Geneva Watches.**

These unrivalled time-keepers are now made interchangeable in every respect. A full line (cased or uncased) always in stock—prices very much reduced from formerly. Specialties in O. F. Nickel Stem Winders Anchors with White, Black and Fancy Dials, 16, 18 and 20 lines. Also, Silver O. F. Hunting and ½ Hunters Stem Winding Anchors, 16 and 20 Lines. In liquidation—a large stock of Swiss Key and Stem Winder Watches, Gold and Silver Cases, must be sold and are offered cheap for cash. SEND FOR PRICES.

Factory, Neuchatel, Switzerland.

*P. O. Box 611.*

**63 Nassau St., New York.**

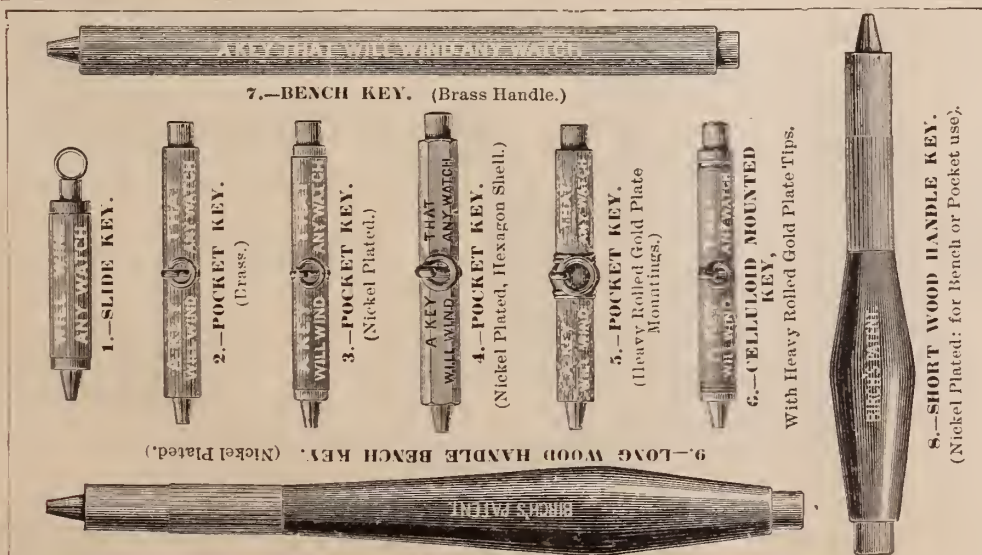

Birch's Self-Adjusting

# Watch Keys

**Will Wind any Watch.**

**J. S. BIRCH & CO.**

38 Dey Street, N. Y.

Medal and Diploma awarded at Centennial Exposition, for superior mechanical and artistic execution.



Established in 1854.

## C. & A. PEQUIGNOT, MANUFACTURERS OF WATCH CASES,



DEALERS IN AMERICAN WATCHES AND IMPORTERS OF FINE KEY AND STEM-WINDING MOVEMENTS,  
SALESROOM AND MANUFACTORY, 22 SOUTH FIFTH STREET,  
PHILADELPHIA.

A full stock of Key and Stem-Winding Gold Cases always on hand. Goods sent on approval when satisfactory references are furnished.

## Anti-Tarnish Silver Tissue Paper,

FOR WRAPPING UP SILVER WARE, JEWELRY, &c. Patented.

Chemically prepared to resist the action of gases which tarnish Silver.

Endorsed by leading Chemists and Silver Ware Manufacturers, after being subjected to severe tests.

H. V. BUTLER, Jr., & CO.,

SOLE MANUFACTURERS,

34 Reade St., New York.

Factory,  
27  
RUE DU PARC,  
Chaux de Fonds,  
Switzerland.

Established 1826.

## JULIEN GALLET,

### Importer of Watches & Watch Movements,

OF EVERY DESCRIPTION.

Sales Rooms,  
No. 1  
MAIDEN LANE  
NEW YORK.  
P. O. Box, - 4420.

Would respectfully call the attention of the trade to our page of Illustrations elsewhere in this Journal. These goods are of recent importation and embrace the latest novelties in Timepieces.

CHARLES PERRET, Sole Agent.

The accompanying cut illustrates the large size

## PIONEER WATCH,

The best pocket time-keeper ever offered the trade. Can be had of any first-class Jobbing House throughout the United States.

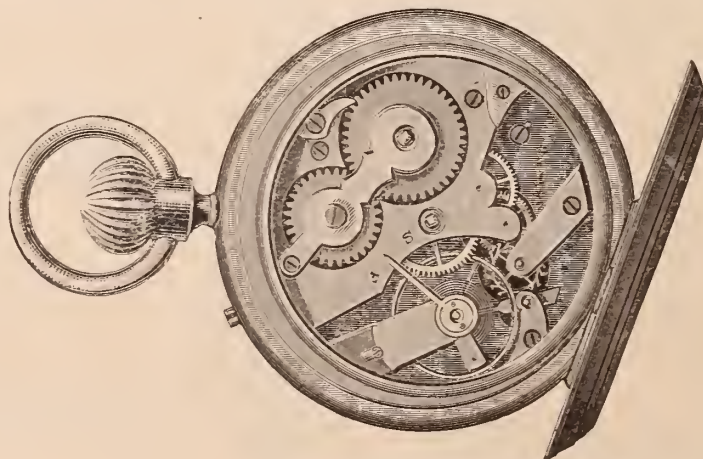

None genuine unless stamped

**"PIONEER"**

either inside or outside of case.

**H. GINNEL,**

Sole Manufacturer,

31 Maiden Lane,

NEW YORK.

P. O. Box 2967.

**HALL, ELTON & CO.,**  
**Manufacturers of the Finest Electro-Plated Ware.**



Eastlake - Patented.

**UNSURPASSED IN QUALITY, STYLE AND FINISH!**  
 Factories, Wallingford, Conn.      Salesroom, 75 Chambers St., New York.

**HOLMES, BOOTH & HAYDENS,**

MANUFACTURERS OF

**ELECTRO-SILVER PLATED**

**Spoons, Forks, Ladles, Fancy Pieces,**

**Solid Handle Steel Knives, &c., of the finest quality.**

No. 49 Chambers Street,  
**NEW YORK.**

No. 18 Federal Street,  
**BOSTON.**

Works at Waterbury, Conn.

**BROWN & BROTHER,**

MANUFACTURERS OF

**Finest Quality of Electro-Plated Flat Table Ware,**

**PATENTED HEAVY SPRING TEMPERED SHANK ON FORKS AND SPOONS.**

ILLUSTRATED CATALOGUES FURNISHED ON APPLICATION.

**WAREROOMS, No. 81 CHAMBERS STREET, NEW YORK CITY.**

FACTORIES, WATERBURY, CONN.

P. O. BOX 5731.

**J. EUGENE ROBERT,**  
**IMPORTER OF SWISS WATCHES,**

30 MAIDEN LANE, NEW YORK.

**SOLE AGENT FOR**

**LOUIS AUDEMAR'S FINE STEM-WINDING WATCHES**

**UNSURPASSED IN QUALITY AND TIME.**

*Novelties in Gold, Silver and Nickel Stem-Winders of all kinds, Sizes and Styles constantly Introduced*

# OPERA GLASSES

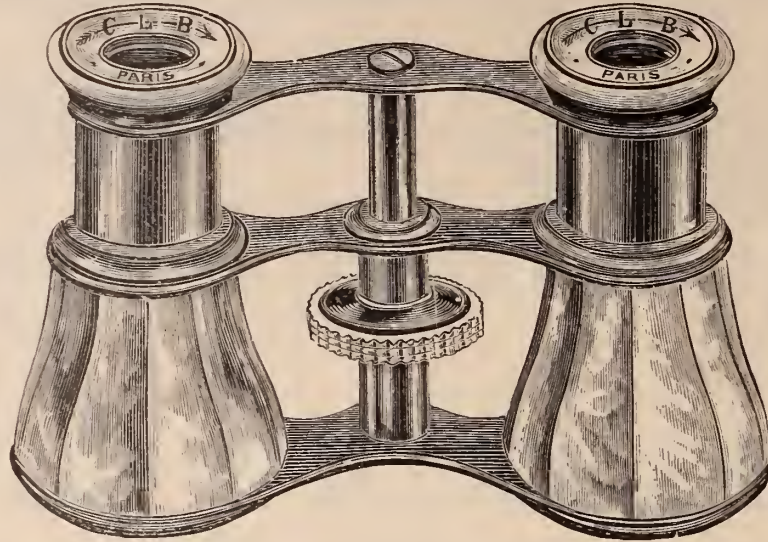

**OPTICAL**

**GOODS!**

And Arrow Brand Interchangeable Spectacles and Eye-Glasses.

*The most desirable line of the above goods in the market will be found in the*

**OPTICAL DEPARTMENT.**

—OF—

**W. B. CLAPP, YOUNG & CO.,**

149 & 151 STATE STREET,

CHICAGO, ILL.

Illustrated Price Lists Sent to the Trade Only.

Novelties in design and finish, in Silver Fancy Goods and Hollow Ware, with combinations of colors in gold, silver and niello-enamel, Testimonial and Presentation Goods, Spoons and Forks of patterns popular and desirable, and a choice line of Case goods, from single pieces to Cabinets for Wedding Gifts.

THE

**Adams & Shaw Company,**

**SILVERSMITHS,**

and Makers of Hard Metal Electro-Plate,

694 BROADWAY, . . . . . NEW YORK.

GEO. R. COLLIS, Manager.

Designs and estimates furnished, and particular attention paid to orders for racing, Field and Nautical Prizes, (small and large), Tea Sets, Berry Bowls, Fruit and Ice Cream Stands, Jelly Bowls and General Hollow-Ware, in Sterling Silver or Silver-soldered Electro-Plate.

A large assortment of new, ornamental and useful presents suitable for HOLIDAY OFFERINGS

LADIES' Portmonnies, Card Cases, Lace Pins, Hairpins, Tete-a-tetes, Shawl Pins, Card Stands, Vases, Caddies, Fruit Knives, Ice Cream Slicers, Sugar Scissors, Bells, and a great variety of other goods in new styles of decoration.

GENTLEMENS' Cigar Cases, Match Boxes, Shaving Mugs, Cigarette Cases, Pocket Flasks, Wine Coolers, Cigar Lighters, Liquor Labels, Wine Goblets, After-dinner Coffee Sets, Ice Pitchers, Soap Boxes, Call Whistles, &c., &c.

CHILDREN'S Cups, Rattles, Whistles, Pap Bowls, Catnip Warmers, Christening Sets, Knives, Forks, Spoons, Napkin Rings, Bib Pins, &c., &c.

# HAMPDEN WATCHES.

## The Superior Time Keepers.



E. W. BOND.—Beautifully finished, accurately adjusted, nickel movement, 17 fine Ruby jewels, 16 size, stem-winding, solid gold settings,  $\frac{3}{4}$  plate.

STATE STREET,  $\frac{3}{4}$  plate, nickel 16 size movement, Quick Train, gold settings.



Specially adapted to RAILROAD and all other uses where accurate time and adjustment is necessary.

18 size, full plate, nickel, beautifully finished, gold settings and gold trimmed.

Factories and General Office,  
**Springfield, Mass.**



NEW YORK OFFICE,  
**12 Maiden Lane.**

Gentlemen's Watches,  
Ladies Watches,  
Bridge Movement Watches,  
 $\frac{3}{4}$  Plate Movement Watches,  
 $\frac{3}{4}$  Plate Patent Reg. Watches,  
 $\frac{3}{4}$  Plate Movement Watches,  
Repeaters,  
Chronographs. (1-5 second)

**TIFFANY & Co.**  
NEW YORK, PARIS, LONDON, GENEVA.  
**MAKERS OF FINE AND COMPLICATED WATCHES,**  
Wholesale Office, 694 Broadway, New York.  
GEO. R. COLLIS, Manager

Split-Second Chronographs,  
Minute and Sec'd Chronograph  
Chronograph and Repeaters,  
Minute Repeaters,  
Five Minute Repeaters,  
Quarter Hour Repeaters,  
Repeaters and Chronographs,  
&c., &c., &c.

All watches of our make have the firm name "TIFFANY & CO." engraved upon the movements, and the trade are cautioned against apparent fac-similes put upon the market by certain unscrupulous dealers.

Our new "Bridge movement" watch for gentlemen is now ready, and conceded by experienced judges to be "the BEST watch ever made for the price." It is adjusted to temperature and position, and fully guaranteed.

Goods sent for selection or examination upon receipt of satisfactory references. Old nickel movements refinished for the trade. Orders for engraving and ornamenting movements, enameling and carving of Inscriptions, Devices and Monograms on Cases promptly attended to.

Only Wholesale Office for the sale of the American Pedometer.

Also General Agents for the United States for Messrs. PATEK, PHILIPPE & CO.'S Celebrated Watches.

NICOUD & HOWARD,

IMPORTERS OF

FINE SWISS WATCHES,

14 MAIDEN LANE,

NEW YORK.





Factory and Offices, 611 & 613 Sansom Street,

ARTISAN BUILDING.

THIS old and well-known firm manufacture a greater variety of *SPECIALTIES* than any other one house in the country.—**FINE TINTED AND ROMAN JEWELRY, IN SETS, BRACELTS, EAR RINGS, LOCKETS, &c., &c. GOLD CHAIN, SILVER CHAIN, GOLD THIMBLES, SILVER THIMBLES.**

In both *GOLD* and *SILVER THIMBLES*, in *Styles* and *Finish* we claim to excel all others.

## GOLD HEAD CANES.

These goods we were the *FIRST* to make to any extent, nearly all other makes are *copies of our patterns*, whilst some of our styles *have never yet been imitated*, we being *JEWELERS* as well as *CANE MAKERS*, are able to do more *elaborate* work than those not possessing this advantage.

### ILLUSTRATED CATALOGUE.

Our Illustrated Catalogue of these goods will be ready for gratuitous circulation by *September 15th*, and parties about to order *CANES* for Fall will do well to reserve orders until they have this *intelligent aid*.

## SIMONS BROTHER & CO.

SAMPLES AND PRICE LIST

Can be seen at

G. & S. OWEN & CO., 5 Maiden Lane, New York,  
OUR AGENTS.

PHILADELPHIA.

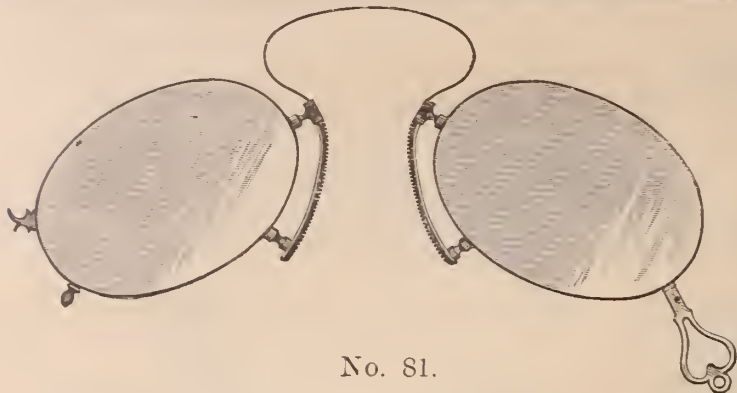

No. 81.

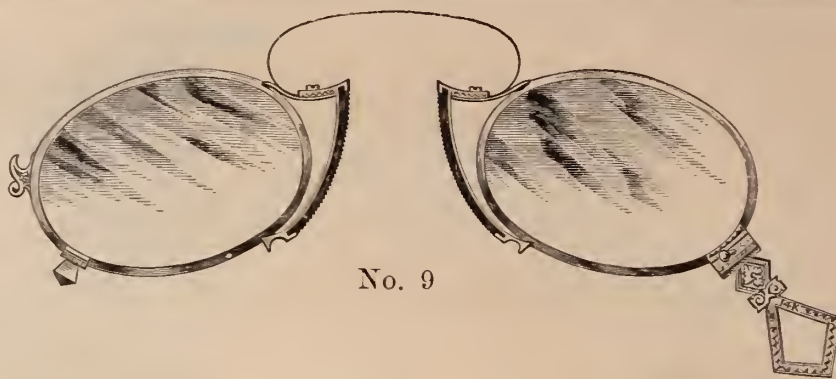

No. 9



No. 15.



No. 36.

Manufacturers of  
GOLD, SILVER AND STEEL  
**MORGAN & HEADLY,**  
Spectacles and Eye Glasses,  
We beg to call the attention of the trade to the large stock of  
**DIAMONDS,**  
Set and unset, which we have on hand. Goods sent on  
approval where references are satisfactory. A rare  
collection of **Fine Old Mine Gems in Single Stones**  
and match pairs up to 16k. just received.  
Nos. 611 & 613 Sansom Street,  
PHILADELPHIA.



No. 88.

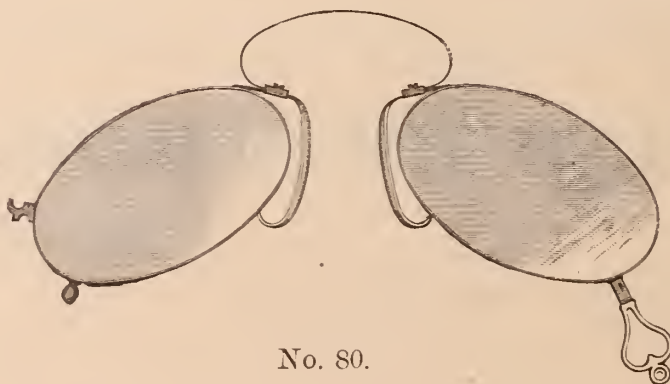

No. 80.

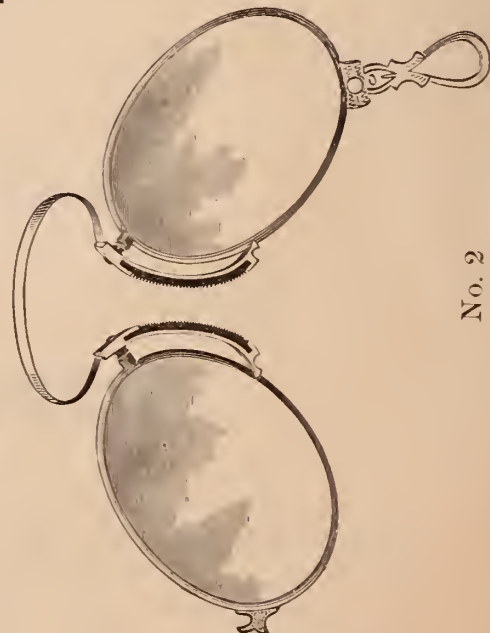

No. 2

# KEARNEY & SWARTCHILD,

Manufacturers and Jobbers of all kinds of  
**Watchmakers and Jewelers Supplies,**  
 Watches, Jewelry, Etc.

113 & 115 STATE STREET,

**CHICAGO.**

300 Page Illus. Catalogue sent upon application and Receipt of Business Card.

### Triumph, No. 1.

Nickel plated, 9½ inch bed.

- 15 Split Chucks,
- 4 Step Chucks,
- 1 Taper Chuck,
- 1 Screw Chuck,
- 1 Arbor or Saw Chuck,
- 1 Brass Cement " ½ inch,
- 1 " " " 1 "
- 6 " " pieces that go into Screw Chuck,
- 2 Steel and 2 Brass Pieces to go into Taper Chucks,
- 3 Circular Saws,
- 1 Screw Plate.

PRICE, - - - - \$75.00

No. 1 Lathe has hardened steel spindles and bearings, cone pulley of hard rubber, indexed sixty holes. Oil holes have brass shields to exclude dust and chips. The T rest has lever fastening. Head and tail stocks have lever fastenings, and rubber thumb pieces on spindles. All split chucks are tempered and ground perfectly true, and will take from No. 15 to No. 80 wire. Size of each chuck is marked on its face. The following split chucks go with No. 1 Lathe: Nos. 4, 6, 8, 10, 12, 14, 18, 22, 26, 30, 34, 38, 42, 46, 50. Other Nos. substituted for any of these when desired.

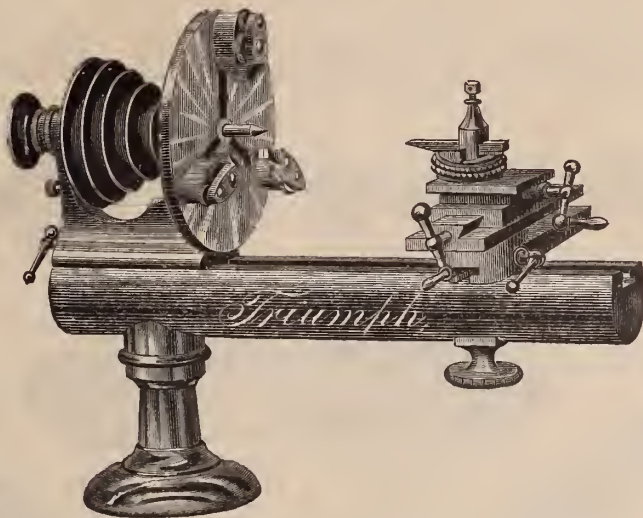

"TRIUMPH" Lathe, with Universal Head and Slide Rest.

Universal Head, Nickel Plated, - - - \$15 00  
 Slide Rest, Nickel Plated, - - - \$40 00

### Triumph, No. 2.

Nickel plated, 9½ inch bed.

- 6 Split Chucks,
- 2 Step Chucks,
- 1 Taper Chuck,
- 1 Screw Chuck,
- 1 Arbor or Saw Chuck,
- 1 Brass Cement Chuck, ½ inch,
- 1 " " " 1 "
- 4 " " pieces to go into Screw Chuck
- 2 Steel and 2 Brass pieces to go into Taper Chuck
- 3 Circular Saws,
- 1 Screw Plate.

PRICE, - - - - \$40 00

No. 2 Lathe has **Hardened Steel Spindles and Bearings**; cone pulley of hard rubber indexed 12 holes. Oil holes have brass shields to exclude dust and chips. The T rest and head stock have lever fastenings. All Split Chucks are tempered and ground perfectly true, and will take from No. 15 to No. 80 wire. Size of each chuck is marked on its face. The following split chucks go with No. 2 Lathe: Nos. 6, 10, 14, 18, 26, 34. Other numbers substituted for any of these when desired.

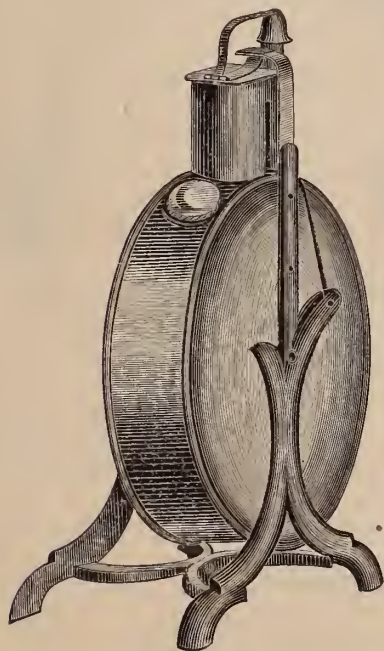

**Cooper's Patent Alcohol Lamps.**

Price, Nickel Plated, - - - - \$1.75

The above lamp consists of a reservoir pivoted in a supporting frame, and provided with two wick tubes, combining a large and small wick as desired, an extinguisher secured to a spring support which covers the large wick tube when in a vertical position, and an independent extinguisher for the small wick tube. Also a novel device for projecting the wick from the large tube as the reservoir is moved out of a vertical position.

We are Sole Manufacturers of these Lamps under J. W. Cooper's Patent.

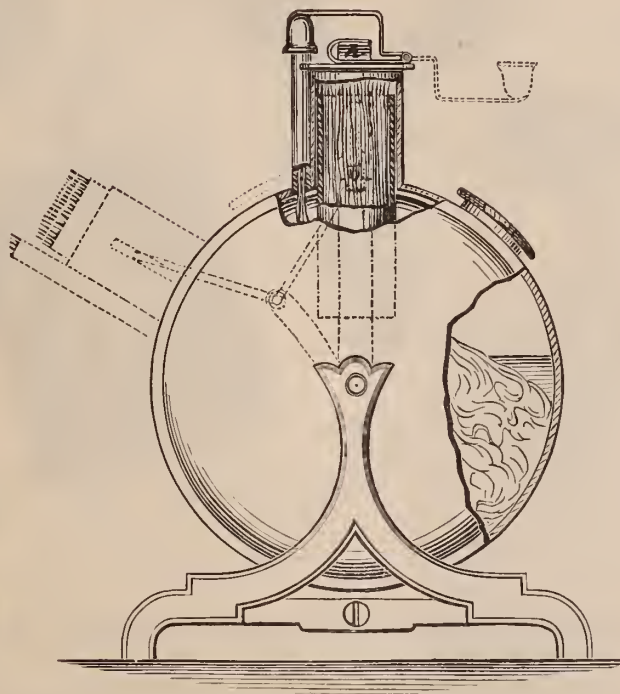

**Wilcox's Patent Engravers' Blocks.**

THE BEST ENGRAVERS' BLOCK IN THE MARKET.

Price, Japanned, - - - - \$4.75  
 " Japanned with Ring and Coin Holder, 6.50  
 " Nickel Plated, - - - - 6.75  
 " Nickel Plated with Ring & Coin Holder, 8.75

# GILES BRO. & CO.

Manufacturers and Jobbers of

## FINE AND ROLLED PLATE JEWELRY,

Diamonds, Watches, Clocks, Materials, Tools and Optical Goods.

### Fine Black Onyx, Mounted in Gold and Pearls.



LIST PRICES, FOR DISCOUNTS APPLY TO US.

Illustrated Catalogue Furnished to Dealers only.

GOODS SENT FOR SELECTION.

Corner State and Washington Streets,

Chicago, Ills.

# N. MATSON & CO.

State and Monroe Sts., Chicago, Ill.

Importers of *Diamonds, Watches, Clocks, Opera Glasses, Materials, Tools, Etc., Etc.*

General Jewelers and Furnishers of Jewelers Supplies.

Western Branch House for the Reed & Barton's Fine Electro Silver Plated Ware.

All orders promptly filled, and every transaction warranted satisfactory to the buyer.



January, 8th, 1878.

## GUTMANN'S

### Automatic Hammer and Punches

Simplified and More Effective.

THIS TOOL takes the place of the third hand, therefore its manifold uses are quickly apparent, and I would only say that it is accompanied by six punches, to wit: 2 hand punches, 1 prick punch, 1 closing hole punch, 1 rivet punch, and 1 pinion punch, all of which fit neatly into the punch holder, and are fastened by the screw. Its tap is alternately heavy and light and the finger loops are assorted in sizes. The Tool is nickel-plated and boxed, ready to be mailed on receipt of price.

THE OPERATION IS AS FOLLOWS: First, set the hammer; next insert your forefinger through the loop at the top and place the punch with firmness on your work. When you are ready for the blow, push gently on the thumb-piece which produces the concussion on the punch. *Your left hand is entirely free to hold the work.*

Price, \$2.00; Reduced from \$2.50.

MAX L. GUTMANN,

Patentee and Manufacturer.

Also, Importer and Wholesale Dealer in

Watch and Jobbing Materials, Tools, Glasses,

Chains, Guards, Jewelry and Watches.

The Genuine American Silk Guards in all Styles a Specialty.

PLEASE SEND YOUR ORDERS.

ROCHESTER, N. Y.

## BENJ. ALLEN & CO.

Nos. 137 & 139 State Street Chicago.

### JEWELRY and DIAMONDS

WALTHAM, ELGIN, HOWARD AND SPRINGFIELD, ILL.

WATCHES,

Rogers & Bro., Spoons, Forks, &c.

Western Agents for SIMPSON, HALL, MILLER & CO.

Our new Catalogue will be ready October 1st, and will be sent to the trade upon application.

LOUIS A. SCHERR.

CHAS. H. O'BRYON.

G. W. SCHERR

# LOUIS A. SCHERR & CO.

Importers and Wholesale Dealers in

## Watches, Jewelry,

WATCH MATERIALS, TOOLS, GLASSES, &C.

Spectacles, Silk Guards, &c.

Wholesale Agents for American Watches.

No. 726 CHESTNUT STREET

FIRST FLOOR,

PHILADELPHIA.

AGENTS FOR W. F. NYE'S WATCH AND CLOCK OILS.

AUBURNDALE, MASS.,

## CHRONOGRAPH TIMER

WM. B. FOWLE, Maker.

Designed for Sporting, Scientific and Mechanical purposes;  $\frac{1}{4}$  and  $\frac{1}{8}$  seconds, fly back.

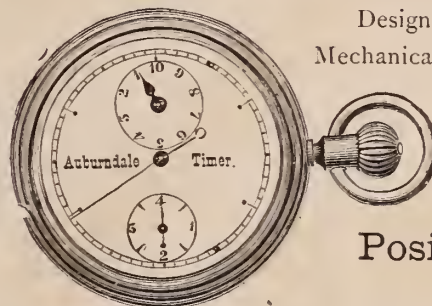

List Price, - - \$15.00

Positively Accurate.

Put up in German Silver Cases, Nickel Plated, size of an ordinary watch. Very neat and handsome, supplying a want long felt by those desiring to measure the flight of time with scientific accuracy to the fraction of a second. It indicates positively minutes, seconds, quarters or eighths of seconds, the only instrument registering one eighth of a second made. It is substantially constructed, positive in its action and will not easily get out of order.

These Chronographs can be obtained from the principal Jobbing Houses in the Trade.

**CHAS. P. HEROLD,**  
**MANUFACTURING JEWELER,**  
**DIAMOND SETTER**  
 AND DEALER IN  
**DIAMONDS.**

916 CHESTNUT ST. PHILA.

N.B. A LARGE STOCK OF 18 Kt. DIAMOND MOUNTINGS,  
 SUCH AS CLUSTER AND SOLITAIRE RINGS, EARRINGS, LACE PINS,  
 SHAWL PINS, CROSSES, STUDS, AND GENTS' PINS,  
 &c. ALL OF WHICH ARE OF MY OWN DESIGNS, AND  
 ARE MADE IN THE FINEST STYLE AND FINISH.

# Clapp Bros. & Co.

## WHOLESALE JEWELERS,

63 and 65 Washington Street, Chicago, Ill.

*We invite the attention of the trade to Our superior Stock and Uniformly Low Prices.  
Catalogues and Price Lists issued only to Watchmakers and Jewelers.  
Orders solicited. Promptness and Care Guaranteed.*



## G. H. KNIGHTS & CO., WHOLESALE JEWELERS

### 125 & 127 STATE STREET,

CHICAGO, ILL.

N. B.---We wish to call the attention of the Trade to our two new movements "Enterprise," full jeweled, Nickel Key-wind, and "Queen," 11 jewels, full plates open Bridge, Key and Stem-wind, with black dial. Also samples sent when requested.

## On the FIRST DAY of JANUARY, 1880,

### J. H. PURDY & CO.

## WATCH MATERIAL DEALERS,

170 STATE STREET, CHICAGO,

Will Remove to **125 STATE STREET,** Corner of Madison,

And Adopt the Name of J. H. PURDY & STEIN.

**YOUR ORDERS SOLICITED.**

## CHARPIER & WATHIER,

## Watchmakers and Jewelers for the Trade,

AND WHOLESALE DEALERS IN

Watch Materials, Tools, Glasses, Spectacles, Silk Guards, &c.

**61 WEST KINZIE STREET, CHICAGO.**

All work intrusted to us will receive prompt attention and warranted satisfactory. Escape and Stem Winding Wheels cut to order at lowest prices. Price List sent on application.

**WESTON DYNAMO-ELECTRIC MACHINE CO**

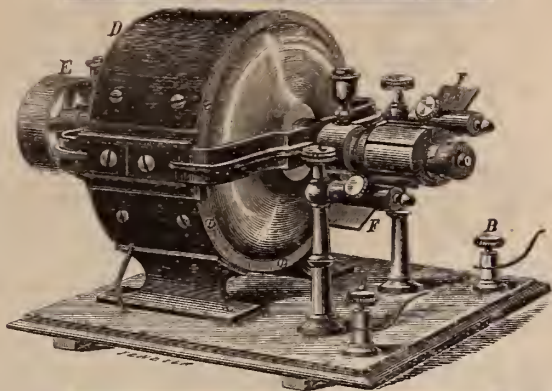

**CONDIT, HANSON & VAN WINKLE**  
Sole Agents NEWARK, N.J. U.S.A.

Machines for Electro-Plating, Electrotyping, Electric Light, Telegraphing, &c.

The Weston Dynamo-Electric Machine is constructed on a new principle giving the greatest amount of electricity with the least consumption of power. Its simplicity and ease of management has already made it the standard machine. The success attending its introduction has already had the effect of inducing parties building machines for similar uses to adopt some of the devices peculiar to our new construction. We beg to call attention to the various patents covering our machines, and to the fact that we guarantee purchasers against any infringement of existing patents, as well as to their adoption and endorsement by the largest manufacturers of the country, in many cases after a previous trial of all other machines.

In addition to the testimonials in our Catalogue of January 1, we beg to refer to the following houses—Carter, Howkins & Sloan; Enos Richardson & Co.; Bates & Bacon; Short, Nevey & Co.; Stephen Richards & Co.; Meriden Britannia Co.; Russell & Erwin Manufacturing Co.; Reed & Barton; Hall, Elton & Co.; Richardson, Boynton & Co.; Wm. H. Jackson & Co.; Stanley Works; Rogers Cutlery Co.; Chas. Rogers Bros.; Edward Miller Co.; Mitchell, Vance & Co.; Norwalk Lock Co.; Hayden, Gere & Co.; Domestic Sewing Machine Co.; Eberhard Faber; Jos. Dixon Crucible Co.; Mumford & Hanson; Fagan & Son, and over 200 others. Outfits for NICKEL, SILVER, BRONZE PLATING, etc. The two highest Centennial Awards and three of the Centennial Medals of American Institute.

There are great advantages in the use of these Machines for Manufacturing Jewelers as they are always ready for use, avoiding the use of mercury and the annoyance of fitting up batteries, producing better colored work, and more durable; there are over 30 in use in Attleboro and vicinity alone, and are being rapidly adopted by the trade in Birmingham, Paris, Pforzheim, &c.

Machines from \$125, upward.

The Machines may be seen in operation at our New York Office, 92 and 94 Liberty St., 2 doors west of Broadway.

Catalogues of all our goods sent on application.

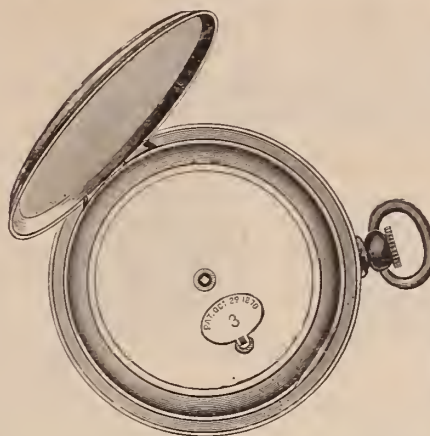

**THE ZINN**  
**PATENT**  
**Winding Attachment**  
—OR—  
“NATIONAL  
**WATCH-WINDER”**

**SIMPLE, PRACTICAL, EFFECTIVE.**

Adapted to nearly all Key-Wind Watches, Especially American. Adjustable with little or no trouble.

Increases practical value and salability of Watches in Stock. Salable at Sight for Watches in use.

An Indisputable Convenience and Real Practical Success.  
Trade--\$3.00 Per Dozen. Retail 50 Cents.

Send for Descriptive Circular.

**National Watch-Winder Company,**  
13 Avon Street, Boston, Mass.  
Agents for Pacific Coast—Henry Mayers & Co. San Francisco

**ARKELL & CO.**

IMPORTERS AND DEALERS IN

Watch Materials, Tools,  
**JEWELRY,**  
AND ALL GRADES OF AMERICAN WATCHES.

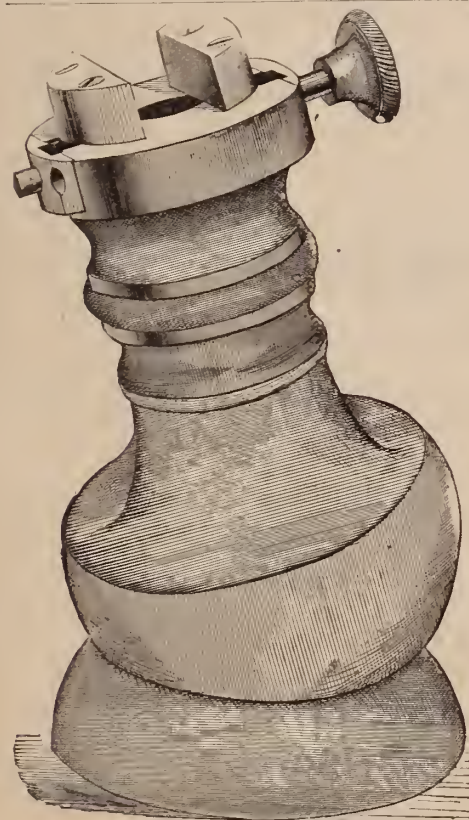

We call the attention of Watchmakers to the “JEQUIER” Main Spring. This spring is the only one of all fabrications exhibited at the “Paris Exposition” that received FIRST and ONLY medal. We claim it is the best in this country, and invite a trial by the trade as a test of its merits. Send for sample and also descriptive catalogue of Columbus Watch, nickel  $\frac{3}{4}$  plate, full jeweled, stem-winding and setting, the most beautiful watch with the best results for least money, quality considered. No price list furnished unless requested and only to the trade.

BALDWIN'S BARREL CATCH INSERTER, indispensable to the Watch Repairer, saves time and labor, sent by mail on approval to the trade free of postage.

We are Sole Agents for the United States of these goods. We also manufacture the BOSS ENGRAVING BLOCK—there are features in its construction different from all others in the market, holds the work to be engraved, of any kind, without attachments. It is practical, simple, and reasonable in price. All these specialties numerated, may be obtained of any regular Dealer in materials and tools, or direct of us.



P. O. Box 8. Canajoharie, N. Y.



# The Burbank Manufacturing Company

Manufacturers of GOLD & SILVER

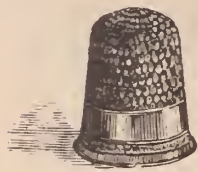

GOLD  
SILVER,  
STEEL,  
RUBBER,  
And SHELL,

## Thimbles,



EYE GLASS  
Self Adjusting.

## SPECTACLES AND EYE-GLASSES



OF ALL DESCRIPTIONS.

## SOLID GOLD RINGS,

Office, 14 MAIDEN LANE. NEW YORK.

Manufactory, Springfield, Mass.

Established 1854.

## CHAS. THEO. MENCE,

Fine Hair Jewelry and Device Work,  
Nos. 32 & 34 John Street, New York.



The attention of the trade is invited to the above designs of Hair Jewelry and Device Work, which are a few of the numerous designs contained in my Pattern Book. I will send a large Pattern Book and Price List, containing all the latest designs on receipt of 50 cts., which will be refunded on first order. I also fill orders taken from any other book upon advice of name and number of design. All orders will receive prompt attention, and repairing of Fine Jewelry in all its branches

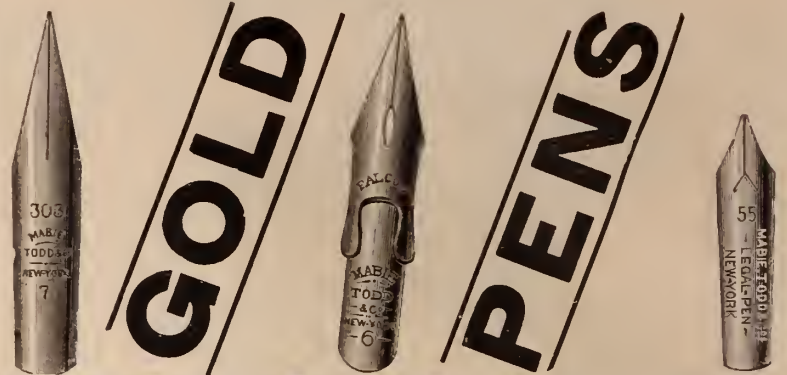

# GOLD

# PENS

## MABIE, TODD & BARD,

MANUFACTURERS OF

## GOLD PENS, PENCILS, CASES, HOLDERS

AND TOOTHPICK,

Of 18kt., 14kt., 10kt., Solid Gold;

ALSO,

## Holders and Pencil Cases

—OF—

Pearl, Ivory, Gold M'd Rubber, Sterling Silver,  
10kt. and 18kt. Plate.

180 BROADWAY, NEW YORK, U. S. A.



Correspondence Solicited in Reference to our Goods.  
Our new Catalogue will be sent to the trade upon application, when accompanied by a business card.

## New Jewel Setting Cutter

For cutting the bezel, or rim that holds the jewel to the plate of watch movements. In adjusting the jaws to the size of bezel to be cut, the gauge will be found very useful there being twelve sizes of bezels made by this Tool. Sent with gauge, by mail, postpaid, on receipt of \$2.00.



Agent of Lancaster Pa. Watch Co.

for New York, Pennsylvania and Ohio. Information, Price Lists and Circulars cheerfully furnished upon application. Enclose business card.

Orders should be addressed,

**PHIL. HECHT, 13 Maiden Lane.**

WAVERLY, N. Y., August 30, 1879.

PHIL. HECHT:

Dear Sir:—That little Jewel Cutter is a very handy little tool and saves lots of time. Every man who uses it cannot help but appreciate it.

Yours truly,

M. H. MANDEVILLE.

ROCK CREEK, August 25, 1879.

MR. PHILLIP HECHT,

Dear Sir:—The Jewel Setting Tool came to hand this morning. I am very much pleased with it. Five dollars would not buy it if I could not replace it.

J. C. KNOWLTON.

BETHLEHEM, August 27, 1879.

Dear Sir:—I send you briefly and most cheerfully my opinion of your "New Jewel Setting Cutter and Gauge." Having tried it thoroughly I can recommend it as a useful tool and doing its work correctly. No good workman ought to do without it.

Respectfully yours,

L. F. GIERING

Any Article in the Watch Material, Optical and Silk Guard Lines furnished at the Lowest Rates.



**S. C. JACKSON,**  
MANUFACTURER OF

Centennial Medal Awarded.

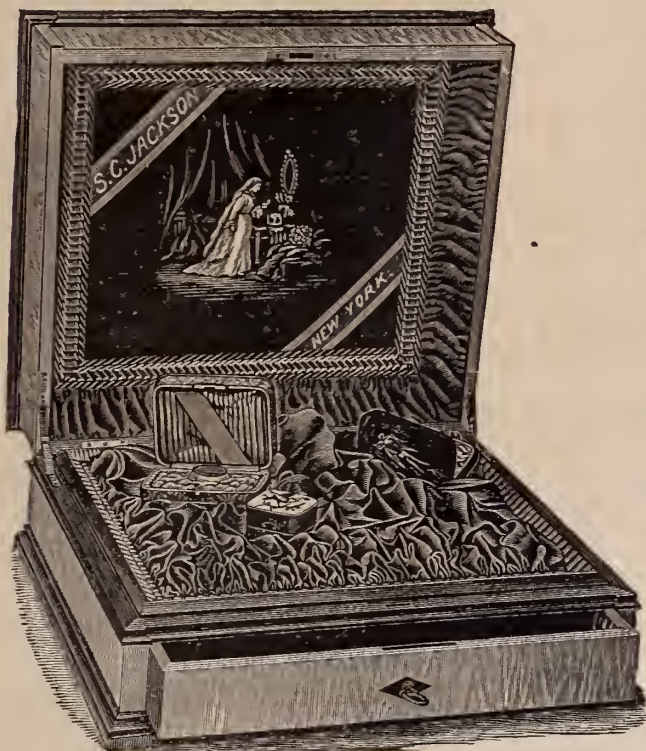

Fine Cases for Jewelry, Watches, Silverware, &c.

180 BROADWAY, N. Y.

A specialty in Show Case Trays, and Silver Cabinets, made from the finest hard woods, and polished.

All kinds Sample Cases made to order. A full assortment of a cheaper grade of Jewelry and Silverware cases in stock.

New and elegant Styles now ready, including our paintings on silks, and satins, together with novelties from China and Japan, specially ordered.

**FRASSE & COMPANY,**

Importers of P. S. STUBS'

*French, Swiss, German & Sheffield Tools, Files,*

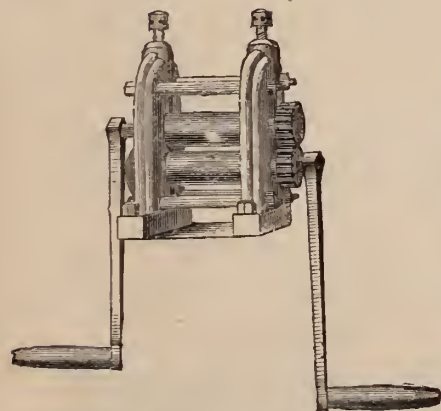

Steel Wire and Materials,  
For Watchmakers, Jewelers, Engravers  
Die-Sinkers, Machinists, &c.

**Turning Lathes, Drills & Chucks**

Rolling Mills, Draw Plates,

**The Celebrated Rodenbush  
Piercing Saws,**

Horse Shoe Magnets, Nurls, In-  
go's, Chasing Tools, Engravers'  
Tools, Brush Wheels & Buffs,  
Hand Brushes and Buffs, Borax,  
Saltpetre, Beeswax, Rouge, Trip-  
oli, German Silver, Brass, &c.

**No. 62 Chatham Street,**  
Established 1816.

**New York.**  
P. O. Box 462

**KOCH & DREYFUS,**

Importers and Wholesale Dealers in

**Watches, Jewelry, Clocks,**

**Spectacles, Jewelry Boxes, &c.**

*Watchmakers', Jewelers', Engravers' and Me-  
chanics' Tools and Supplies.*

Agents for the Principal Watch and Clock Factories of the  
United States.

18 Chartres Street, New Orleans.

**J. F. FRADLEY.**

MANUFACTURER OF

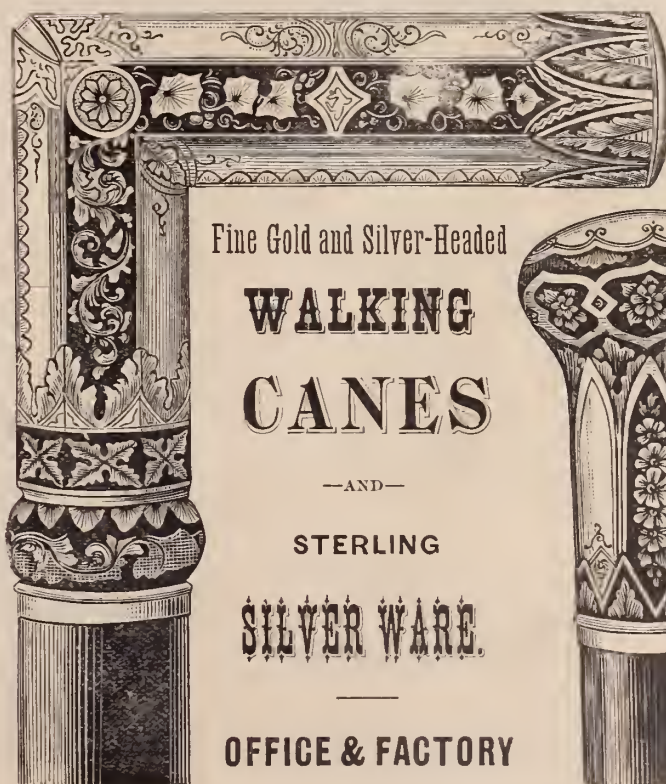

Fine Gold and Silver-Headed

**WALKING  
CANES**

—AND—

STERLING

**SILVER WARE.**

OFFICE & FACTORY

**20 JOHN STREET, NEW YORK.**

ESTABLISHED 1856

**WILLIAM PARK,**  
*Stone, Seal & Cameo Engraver*  
 26 John Street, New York.  
**Arms, Crests, Monograms & Devices,**  
 Engraved on Locketts, Sleeve Buttons,  
 Rings, Etc.  
*Masonic Engraving a Specialty*  
 ONE TRIAL SOLICITED.

**STERN BROS. & CO.**  
 Manufacturers of  
**Fine Jewelry,**  
**30 MAIDEN LANE,**  
 FACTORY, 73 & 75 Fulton St., NEW YORK.

Gold Seal engraved Band-rings and Locketts a specialty.  
 The attention of the trade is directed to our plain Gold filled Rings. Sections of which showing the construction and quality sent upon application.  
 After February 1st, our plain filled rings will bear the above trade mark.

**LEIMBACH BROS.**  
 Manufacturers of  
**DIAMOND JEWELRY**  
 A full description constantly on hand.  
 LACE PINS A SPECIALTY.  
**51 NASSAU STREET,**  
 P. H. Leimbach, New York.  
 F. E. Leimbach.

**H. M. RAYNOR,**  
 25 Bond Street, N. Y.  
**PLATINUM**  
 FOR ALL  
 Laboratory & Manufacturing Purposes.  
 Native Platinum, Scrap, &c., purchased.

**REPAIRING, COLORING AND GALVANI-  
 ZING FOR THE TRADE.**  
**C. G. MALLIET,**  
*Manufacturing Jeweler,*  
**No. 9 JOHN STREET**  
**NEW YORK.**

**P. NEIDHARDT & CO.**  
 Manufacturers of  
**Diamond Mountings**  
 —AND—  
**FINE JEWELRY**  
**52 Nassau Street,**  
 Cor. Maiden Lane, NEW YORK.  
 P. NEIDHARDT. B. SCHILLING.

**L. M. LEBERTHON,**  
 IMPORTER OF  
**DIAMONDS & WATCHES**  
 AND  
 Manufacturer of Diamond Jewelry,  
**3 JOHN STREET, N. Y.**  
 Fine Stones a Specialty.

**L. BONET,**  
 Medal at Centennial, 1876.  
**CAMEO**  
**Likenesses,**  
**889 Broadway, New York.**

**VOSE & SOUTHWICK,**  
 Manufacturers of Gold Jewelry  
  
 Sole Makers of  
 the Separable  
 Sleeve and Col-  
 lar Buttons in  
 Gold.  
**No. 183 Eddy Street, PROVIDENCE, R. I.**

Mansard English Geneve Louis XV.  
  
**HENRY LEFORT,**  
 Stem-Winding Watch Crown Manufacturer,  
 Crowns and Pushers in gold, all sizes, quality and color,  
 made to order. Silver crowns and pushers always on hand.  
 Samples sent on application.  
**80 & 82 Marshall Street,**  
**NEWARK, N. J.**

**ALBERT FRIEDENTHAL,**  
 Importer and Jobber of  
**WATCHMAKERS' & JEWELERS'**  
**Materials, Tools and Optical Goods**  
**Real and Imitation Stones,**  
 For Manufacturing and Repairing Purposes  
**A SPECIALTY.**  
 Agent for TISDALE'S Watch and Clock Oils.  
**No. 43 Maiden Lane, New York.**  
 Orders by mail will receive prompt attention.

**GUSTAV EPHRAIM,**  
 Successor to Ephraim Bros.  
**8 JOHN STREET, NEW YORK,**  
 Importer and Manufacturer of  
 Bamboo, Silk Guards and Watch Chains of all  
 Grades. Materials, Watch Glasses,  
 Optical Goods and Jewelry.  
 Sole Agent for EAGLE SPECTS', CORNELL'S  
 ANTI-OXYDIZER and COURVOISIER  
 MAIN SPRINGS.

**WILKINSON & LENNON.**  
 212 Broadway,  
**NEW YORK,**  
**Manufacturing Jewelers**  
 Masonic Pins, Rings & Charms.  
 School, Athletic, Fine  
 Presentation Medals.  
 —AND—  
**JEWELS OF EVERY DESCRIPTION.**  
 Designs furnished free upon ap-  
 plication.

**The Morse Diamond Cutting Company,**  
**J. D. YERRINGTON, Agent.**  
**192 Broadway and 3 John Street.**  
**NEW YORK.**

Rough Diamonds, Boart, Roses and Brilliants  
 for sale.  
 Fractured Diamonds repaired, and old stones  
 improved; also Rough Diamonds cut and  
 fashioned to order.

**W. N. WALKER,**  
**DIAMONDS,**  
 Watches and Jewelry,  
 No. 18 JOHN STREET, NEW YORK.  
**IMPROVED JEWELERS' COTTON**  
 JOHN J. ARMOUR.

**HENRY TROEMNER,**  
**710 Market Street,**  
**PHILADELPHIA.**  
 Manufacturer of Fine Gold Scales,  
  
**DIAMOND SCALES,**  
 Bullion Balances and  
 Weights, in use at all the  
 U. S. Mints and Assay  
 Offices.  
 PRICED CATALOGUE ON APPLICATION.

Solid Gold Rings—a Specialty  
**WM. H. ELY,**  
**Solid Gold Rings**  
 MANUFACTURER,  
 Viz., Plain, Chased, Engraved, Enameled, Engine  
 Turned, Shield & Scale. All qualities Warranted  
 Orders Promptly Executed.  
**58 Nassau Street, N. Y.**

**Stephen J. Cox**  
**DESIGNER & ENGRAVER**  
 For  
**WOOD**  
**NO. 90 NASSAU STREET.**  
**NEW YORK.**  
**Jewelers' Work A Specialty.**

Established 1848.

Reliable and prompt.

**COOPER & BRO.**

Wholesale Jewelers,

Importers and dealers in WATCH & CLOCK-MAKERS' TOOLS and MATERIALS; also, JEWELERS' SUPPLIES, SPECTACLES, OPTICAL GOODS, &c. A complete Outfitting Establishment for the trade.

Repairs Department established 1865. Every description of work done for the trade. Watch Repairing, Jewelry and Watch Case Repairing, Gold and Silver-Plating, and Fire Gilding.

35 S. Fourth St. (1st floor). PHILADELPHIA

THOMAS M. GUILBERT.

J. CARROW DUBOSQ

**GUILBERT & DUBOSQ,**

Successors to Francis Dubosq & Son,

Manufacturers of

Fine Gold and Strung

**PEARL JEWELRY,**

No. 1031 Chestnut Street,  
PHILADELPHIA.

**DAVID PRINCE,**

Gold and Silver Refiner

Assayer and Sweep Smelter,

13 and 15 New Jersey Railroad Avenue,

**NEWARK, N. J.**

Sole Agent for Comins' Improved Amalgamator.

**A. PICARD,**

Importer and Jobber of

American and Swiss  
**WATCHES,**

Jewelry, Optical Goods, Watchmakers' and Jewelers' Tools and Material,

No. 11 North Second Street,

**PHILADELPHIA.**

**W. H. LUDEMAN,**

No. 75 & 77 Nassau Street,  
**NEW YORK.**

**FINE AND COMPLICATED  
WATCHES**

Of every description repaired and regulated.  
Stem Winding and Escape Wheels  
Cut and finished to order with accuracy  
and promptness.

**Save your Gold and Silver**

From your waste Wash Water,

Which can only be done completely by the use of the

**PATENT CHEMICAL FILTERS,**

Manufactured by us.

This apparatus occupies very little room, does not choke up, and is put up at our expense on shares, after the water has passed through the usual operations in use by Jewelers and others.

For further particulars, address,

**CYRUS O. BAKER, Jr. & CO.**

104 N. J. Rail Road Avenue,  
**NEWARK, N. J.**

**BLANCARD & OBERLANDER,**  
MANUFACTURERS OF  
Settings and Galleries

Of every Carat of Gold or Silver,  
Platinum, Platinum-Lined and Fancy  
Settings a Specialty.

As we melt and refine Platinum ourselves.

**36 & 38 JOHN STREET,  
NEW YORK.**

Platinum Scraps Exchanged or Purchased.  
Send for Sample Card.

Leon Jeanne.

Paul Jeanne.

**JEANNE BROTHERS,**

MANUFACTURERS OF

**DIAMOND MOUNTINGS  
And RICH JEWELRY,**

Patentees of Jeanne's Ear Wires,  
No. 1 Maiden Lane, New York.

Designs furnished and estimates given.



Ketcham & McDougall  
4 Liberty Place, N.Y.



Manufacturers of  
**IMPROVED GOLD  
AND SILVER**

**THIMBLES**

— ALSO —



It Winds up the Cord when Not in Use.

**J. B. LAURENCOT,**

IMPORTER OF

WATCH GLASSES,

**Optical and Fancy Goods**

French Clocks, Musical Boxes, &c.

**No. 33 MAIDEN LANE.**

5 Rue D'Enghien,  
PARIS.

Box 2954, P. O.  
NEW YORK.

Established 1850.



**PETER L. KRIDER,**

MANUFACTURER OF

**STERLING  
SILVER WARE,**

Medal and Diploma Awarded, &c.

Striking Society Medals in Gold, Silver or Bronze  
A SPECIALTY!

ARTISAN HALL,

**618 Chestnut Street  
PHILADELPHIA.**

**SWIFT MANE'G CO.,**

12 CORTLANDT STREET,  
NEW YORK,

— MANUFACTURERS OF —

**Jewelers' Wood Nested  
MAILING BOXES.**

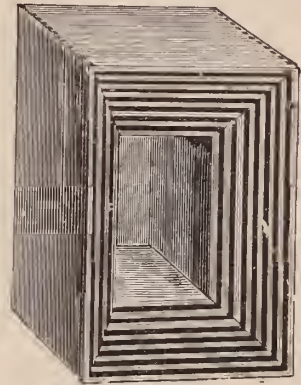

For Mailing and Express Purposes

**J. SPENCER TAYLOR,**  
Agent,

Orders by mail promptly attended to.

**GEO. W. DU BOIS,**

(Successor to Albert Landsberg.)

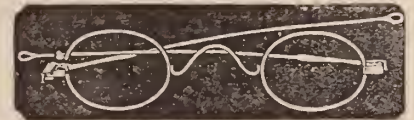

IMPORTER AND MANUFACTURER OF

**Optical Goods,**

**No. 36 MAIDEN LANE,**

Near Nassau Street, NEW YORK

Sole Agent for

**BLACK'S PATENT  
Interchangeable Spectacles,  
AND  
EYE GLASSES.**

Jewelers and others who keep spectacles for sale will please observe that, with these PATENT SPECTACLES, it is only NECESSARY to have a full Complete Assortment of Lenses and Pebbles, which being all of a UNIFORM SIZE, will FIT either the Gold, Silver, or Steel Frames, of which but a few of each kind are wanted; an advantage which will give a complete assortment of the finest Spectacles, for one-sixth the capital invested in a like assortment of the same quality goods of the old style frames.

For Particulars, price lists, &c., address

**GEO. W. DU BOIS,**

New York.

# SPENCER

## Optical Manufacturing

### COMPANY,

Manufacturers of Spectacles and Eye Glasses,  
from all materials used for that purpose,  
and of all grades.

**SOMETHING NEW !!**  
**CELLULOID EYE GLASS FRAMES,**  
Representing the Choicest Selected  
Tortoise Shell and Amber.



(Turtles rejoicing over the discovery of Celluloid Tortoise Shell,  
Their Occupation Gone.)

They are much **Lighter** than any others. Twenty-five pairs of these frames weigh only one ounce.

They are much **Stronger** and more **Durable** than any others; they can be **Dropped Without Injury** upon the hardest substance.

Their **Beauty** far surpasses the ordinary Tortoise Shell Frames commonly in use.

They are **Not Affected** by **Atmospheric Changes**, being equally well adapted to either warm or cold climates.

They are made with **Different Sized Frames** to suit persons whose eyes are either near or far apart.

The Springs are made of a combination of metals which will neither **Rust** nor be effected by heat or frost.

These frames are set with **Fine Lenses**, accurately focused to suit all sights, which with the many other advantages, make them **Very Popular**.

**ASK YOUR OPTICIAN OR JEWELER TO SHOW THEM TO YOU.**  
Every Pair Stamped on Handle S. O. M. Co. Pat. Mar. 13, '77.

Parties ordering 3 doz. Celluloid Eye Glasses are furnished with 1,000 copies of circulars similar to this advertisement with name of dealer printed thereon.

**13 Maiden Lane, N. Y.**

Established 1853.

## L. H. KELLER & CO.

Successors to G. A. HUGUENIN,

IMPORTERS OF

### Fine Watch and Clock Materials,

SWISS, ENGLISH, FRENCH & GERMAN

### FILES, TOOLS, & C.

FOR WATCH MAKERS, WATCH CASE MAKERS, JEWELERS  
SILVERSMITHS, ENGRAVERS, CHASERS, DIE  
SINKERS, MACHINISTS, &c.

SOLE AGENTS FOR HALL'S STAKING TOOLS AND  
ROLLER REMOVERS.

AGENTS FOR THE WHITCOMB AND OTHER AMERICAN LATHES.

GENERAL AGENTS FOR THE PHILADELPHIA  
WATCH COMPANY.

American Agents for the Horological Journal, (British).

A Monthly Paper for the advancement of Chronometer, Watch and Clock Making,  
and kindred Sciences. Published under the auspices of the British Horological  
Institute, London. Subscription \$2.50 per year, in advance. Also,

SAUNIER'S TREATISE ON MODERN HOROLOGY, IN  
THEORY AND PRACTICE,

BY M. CLAUDIUS SAUNIER. The English Edition will appear in 26 monthly parts,  
Price 50 cents each. Whole Work, \$13 00, postage paid.

Special attention is directed to

"OUR OWN" Celebrated Mainsprings Graduated

in thickness to equalize the power, with well rounded edges, and the  
*Highest Crocus Finish throughout*, insuring the least possible friction  
in the barrel, pronounced by expert judges to be the *best made*.

"JURGENSEN" Main Springs recoiling, suitable for the highest grades  
of Swiss Watches.

"Lutz" Celebrated Hair Springs,

by numbers, of uniform diameter and strength, the best for  
"BREGUETING."

Fine Hole Jewels of Ruby, Sapphire, Chrysolite, Garnet, Beryl and  
Aqua Marine, with *gauged* (well shaped and polished) holes, numbered  
by the Swiss pivot gauge; also, neat black walnut cases, containing  
forty glass vials for assortments of same. The great advantage in hav-  
ing Jewels by numbers will readily be seen as a saving in time and an-  
noyance in selecting and in expense. Dealers once having an assort-  
ment, can replenish or stock up at a comparatively small outlay, as any  
desired quantity of No. and quality can be had of us at all times,  
our stock of jewels being the largest and most complete in the country.

Diamond Charged Broaches for opening and polishing jewel holes.

Diamond Powder and Bort for polishing and grinding 8 different  
grades, in  $\frac{1}{2}$ ,  $\frac{1}{4}$ ,  $\frac{1}{8}$ , and  $\frac{1}{16}$  K vials, bringing it into the reach of all.

Gold Diamond Set and other fine Geneva Hands.

The new Drills in Sets of 54 small, 126 small to medium, and 48  
large; also, sold separately if desired.

A FULL LINE OF MATERIALS FOR THE CELEBRATED WATCHES  
MANUFACTURED BY

**Patek, Philippe & Co.**

OF GENEVA, FULLY FINISHED AS FAR AS PRACTICABLE.

**No. 64 Nassau Street,**

Near Maiden Lane

**NEW YORK.**

## SPECIAL NOTICES.

Advertisements under this head, not to exceed six lines, \$1.00 each insertion.

**FOR SALE**—One Banta & Harris engraving machine with all attachments complete, in use but a short time, for \$15, cost \$80. Address L. F. Giering, 4 South Main Street, Bethlehem, Pa.

**FOR SALE**—A jeweler's factory with lease and good will of the business. Tools, mills, dies and machinery in perfect order. Whole or part of front office to let. Chatterton & Dodd, 19 John Street, N. Y.

**JEWELRY FIXTURES** \$3,000. Best stand in Illinois (City of 2,300 inhabitants). Doing fine business. Rent \$1,000. Rare chance. Possession given next January. Address Meriden Britannia Co., Chicago.

**A RARE** chance to any one desiring to open a jewelry business South. Well established, good run of work and sales. Satisfactory reasons for selling. Address P. O. Box 110, Brownsville, Tenn., or J. H. Furdy & Co., 170 State Street, Chicago.

**WANTED**—A situation by an experienced watchmaker; Can also engrave. Has had charge of a jewelry store for the past year. Has a good set of tools, lathe &c. Can furnish the best of references; would prefer the city. Address "Lebanon" care Jewelers' Circular.

**WANTED** immediately, a watchmaker and engraver. A permanent job and fair wages to the right man. None but a first-class workman, sober, a single man, and one who can give first-class references need apply. Address with references—James M. Howe, Hopkinsville, Kentucky.

**SITUATION WANTED** as traveling salesman for a jewelry house. Has had ten years' experience at the bench and retail business. Can furnish best of references and is not afraid to work. Would take a permanent situation as watchmaker. Address D. H. Stites & Son, 41 Maiden Lane, N. Y.

**GEO. E. WILKINS**,—Importer of fine Tools for Watchmakers, cutting and dividing engines, rounding-up tools and cutters, also cutters for stem-winding wheels. Fine lathes with the American system of chucks. Dividing engine and rounding-up tool combined. Marine chronometers for sale. Special tools imported to order. 21 South Salina St., Syracuse, N. Y.

## Business Notes.

Kearney & Swartchild, of Chicago, whose card will be found elsewhere, are doing a thriving business with the trade in all sections of the country.

A. W. Magerhans, manufacturing jeweler of this city, has secured letters patent for a very attractive bracelet which is meeting with great success.

Breitinger & Kunz, of Philadelphia, importers of watch tools and materials, are the sole agents for Bahni Bros' celebrated hardened and tempered hairsprings, now so popular in the trade.

Booz & Thomas, manufacturers of watch cases and jewelry, 108 South Eighth Street, Philadelphia, are well and favorably known throughout the country as upright and honorable business men, whose productions are deservedly popular.

Morgan & Headly, of Philadelphia, offer a large line of Gold, silver and steel spectacles and eyeglasses. Also a choice and carefully selected stock of fine diamonds and diamond jewelry. We direct the attention of the trade to a perusal of their advertisement to be found elsewhere in the CIRCULAR.

D. F. Conover & Co. of Philadelphia, have assumed the sole agency for the Patent Railroad Train Watch Chains, a new and popular design that is meeting with great success. This enterprising firm is constantly presenting new and taking novelties which is creating for them a high reputation in the trade.

The old house of Simons Bros. & Co. of Philadelphia, whose productions are universally known as standard goods in their especial line of manufacture, continue to enjoy the confidence and esteem of a large clientele of customers. They this season offer an unusually fine assortment of gold and silver headed canes, fine gold jewelry, embracing the latest novelties, gold and silver thimbles and an extensive line of fine gold chains, etc.

## Buyer's Directory.

A Guide to the prominent Wholesale Houses in the Watch, Clock, Jewelry and kindred branches of Trade in New York, Philadelphia, Chicago, Providence and Newark.

## NEW YORK.

## Black Onyx Jewelry.

**Cox & Sedgwick**—Manufacturers of Black Onyx Jewelry, No. 26 John St. New York.

**Downing & Keller**—Manufacturers of Onyx Jewelry, &c., 8 Maiden Lane, N. Y.

**Woglom & Miller**—Manufacturers of (exclusively) Black Onyx Jewelry, 32 & 34 John St., N. Y.

**Unger, H. & Co.**—Manufacturing Jewelers. Fine Onyx and Pearl goods a specialty. Manufacturers of Patent Onyx Bracelet, with Lily of the Valley mountings. No. 13 Crawford Street, Newark, N. J. Box 63.

## Bohemian Garnet Jewelry.

**Bissinger, Philip**—Importer of Diamonds, Pearls and Precious Stones. Sole Agent for the Bohemian Garnet Jewelry, 22 John St.

## Clock Companies.

**New Haven Clock Co.**—62 Reade Street, N. Y.

**Seth Thomas Clock Co.**—20 Murray Street, N. Y.

**Waterbury Clock Co.**—M. Bailey, Treasurer, Manufs and Jobbers, No. 4 Cortland St., N. Y., and No. 197 State Street, Chicago.

**Kroeber, F.**—Manufacturer and Dealer in American and French Clocks, No. 8 Cortland Street.

**Owen, Geo. B. & Co.**—Manufacturers of Black Walnut Clocks, Factory, Winsted, Conn., New York Office, No. 6 Murray St.

## Corals and Coral Jewelry.

**Cuppia, L. A.**—Importer of Coral and Silver Filigree Jewelry, 19 Union Square, N. Y.

**Errico Bros.**—Importers of Coral, Conch-Shell and Silver Filigree Jewelry, etc., 19 John St.

**Lawson, S.**—Manufacturer of Coral and Black Onyx Jewelry. All kinds of repairing solicited. Goods sent on Mem. 63 Nassau Street.

## Cameo Cutters, Etc.

**Bonet, L.**—Cameo Likenesses, No. 839 Broadway, **Peiter, Theodore**—Cameo and Intaglio Engraver. Patentee of the new Cameo-Intaglio. No. 2 Bond Street, near Broadway, Room 4 New York.

**Wiederer, Peter**—Late Habermeir & Wiederer, Engravers of Cameo Likenesses, Seal Stones. Cameos repaired. 23 John St.

## Charms &amp; Gold Watch Keys.

**Rupp & Held**—Manufacturing Jewelers, Charms and Gold Watch Keys, with French and English Ratches, a specialty. 15 John St., N. Y.

## Cutlery.

**Harrison Bros. & Howson**—Manufacturers of Fine Ivory and Pearl Table and Pocket Cutlery; Carvers in Cases; Nutcracks, Nutcracks and goods suitable for the jewelry trade. 26 Cliff Street. W. C. Burkinshaw, Sole Agent.

## Diamonds.

**Anderson, Otis**—Diamond Merchant and Broker, always ready to pay cash for bargains in Diamonds and Precious Stones, No. 9 Maiden Lane, N. Y.

**Bernhard, A. & Co.**—Manufacturing Jeweler and Importers of Diamonds, Precious Stones, and Diamond Mountings, 2 Maiden Lane.

**Bissinger, Philip**—Importer of Diamonds, Pearls and Precious Stones. Agent for the Bohemian Garnet Goods. No. 22 John St., N. Y.

**Bickenham, Cole & Saunders**—Importers of Diamonds and Precious Stones, No. 10 Maiden Lane.

**Fera, Henry**—Importer of Diamonds, and Manufacturer of Fine Diamond Jewelry. No 9 Maiden Lane, New York. Amsterdam, Holland, 23 Loojersgracht.

**Fox, M. & Co.**—Importers of Diamonds and other Precious Stones, No. 1 Maiden Lane.

**Hedges, Wm. S. & Co.**—Importers of Diamonds, No. 170 Broadway.

**Herbert, R. J.**—Importer and Broker in Diamonds, 16 Maiden Lane.

**Lyon & Hardy**—Importers of Diamonds and Manufacturers of Diamond Jewelry, 30 Maiden Lane.

**Leberthon, L. M.**—Importer of diamonds and watches. Manufacturer of jewelry. 3 John St. Fine stones a specialty.

**Neresheimer, E. Aug.**—Importer of Fine Diamonds, No. 21 Maiden Lane, New York

**Prager, Morris.**—Importer of Diamonds and Fine Diamond Jewelry, 8 Maiden Lane.

**Randel, Baremore & Co.**—Importers of Diamonds, corner Maiden Lane and Nassau St.

**Smith, Alfred H. & Co.**—Importers of Diamonds, No 14 John Street.

## Diamond Cutters.

**The Morse Diamond Cutting Co. of Boston.**—Henry D. Morse, General Manager. N. Y. Office, 192 Broadway, corner John street. J. D. Verrington, Agent.

## Diamonds and Diamond Jewelry.

**Bissinger, Philip.**—Importer of Diamonds, 22 John street, N. Y. Agent for the Bohemian Garnet Goods.

**Heller & Bardel.**—Manufacturers of Diamond and Pearl Jewelry, and Dealers in Diamonds, Pearls, &c. Also agents for Boss' Patent Stiffened Gold Watch Cases. 13 John St.

**Leimbach Bros.**—Manufacturers of Diamond Jewelry, 51 Nassau Street.

**Neidhart, P. & Co.**—Manufacturers of Diamond Mountings and Fine Jewelry, 52 Nassau St., N. Y.

**Taylor & Brother**—Importers of Diamonds and Diamond Jewelry, 676 Broadway.

## Diamond Setters, Etc.

**Asher, J.**—Jeweler and Diamond Setter. Precious Stones Inlaid and Incrusted with Diamonds, Nos. 880 and 882 Broadway.

**Wood, Chas. F.**—Engraver and Incruster of Precious Stones and Diamond Setter. No 169 & 171 Broadway.

**Friend, S.**—Manufacturer of Fine Jewelry, and Diamond Setter, 33 John Street, N. Y.

## Dials, &amp;c.

**Gold, John T.**—(Successor to the late T. Gold), Enamel Watch Dial Maker, 81 Nassau St.

## Enamelers, Etc.

**Nutt, J. D.**—Enameler on Gold, Silver and Copper, 32 and 34 John St. Birds, Flowers, etc., Enameled in colors.

**Orr, Jas. C.**—Enameler on Fine Jewelry, Flowers, Birds, &c., Enameled in colors. Band Bracelets (a specialty). 77 Nassau Street.

## Electroplaters, &amp;c.

**Jeandheur, F. & Son.**—Gold and Silver Electro Platers & Fire Gilders, coloring Etruscan and Gold Jewelry a specialty. 125 Fulton St.

## Engravers and Die Sinkers

**Fackner, Edward**—Carver, Engraver and Chaser on Jewelry and Solid and Plated Pencil Cases, No 19 John Street.

**Park Wm.**—Stone Seal Engraver. Coats of Arms found and Engraved. Initials and Monograms engraved. 26 John Street, New York.

**Schuller, J. Dan'l.**—Stone Seal Engraver, Arms, Crests, Initials and Monograms engraved on Stone Seals, &c. 71 Nassau Street.

## Engraving Type.

**Ingersoll, H. S.**—Rubber Engraving Type, Patented December, 1872. Over 40,000 alphabets in use. Saves time and skill of designing before engraving silverware, etc. Also Engravers' Tools, etc. Catalogue free 203 Broadway, N. Y.

## Fancy Goods, Clocks, Bronzes Etc.

**Hall, Nicol & Granbery.**—Importers of Clocks, Bronzes, Folding Mirrors, Fancy Goods, &c. 20 and 22 John Street.

**Magnin, Ve J. Guedin & Co.**—Importers of Clocks, Bronzes, Musical Boxes & Rich Fancy Goods, etc., 29 Union Square.

**Le Boutillier & Co.**—Importers of Fancy Goods, Clocks, Bronzes, &c., 3 Union Square.

## Gold Chains, Etc.

**Beck, J. & Son.** Manufacturers of Fine Gold Chains and Chain Bracelets, 10 Liberty Place, near Maiden Lane, N. Y.

**Dorrance, Edge & Co.**—Manufacturers of the Celebrated Woven Fabric Gold Chain, No. 12 John Street.

**Hamiltons & Hunt.**—Manufacturers of Fine Plated Chains and Patent Buckle Bracelets. Branch office, 176 Broadway. Factory, 226 Eddy Street, Providence.

**Kaufmann Bros.**—Manufacturers of Gold Chains, and Chain Bracelets, 26 John Street; Factory, 331 and 333 Bowery, N. Y.

**Nordt & Schlag.**—Manufacturers of Gold Chain, No. 17 Maiden Lane, N. Y.

**Saxton, Smith & Co.**—Manufacturers of Fine Gold Chain. 15 Maiden Lane.

## Gold Pens, Etc.

**Aikin, Lambert & Co.**—Manufacturers of Choice Gold Pens, Cases, Holders, Toothpicks, etc., 23 Maiden Lane, N. Y.

**Clark, J. M.**—Manufacturer of Pen and Pencil Cases for the wholesale trade only. No. 61 Hudson Street, N. Y.

**Mabie, Todd & Bard**—Manufacturers of Gold Pens. 180 Maiden Lane.

**Goldsmiths, &c.**

**Greene, Wm. C. & Co.**—Goldsmiths; Manufacturers of Rich Sets in Taper Wire Coral. Office, 192 Broadway.

**Cold Rings.**

**Bowden J. F. & Co.**—Manufacturing Jeweler.—Solid Gold Rings a specialty, 1 Maiden Lane.

**Ely, W. H.**—Manufacturer of Solid Gold Rings of every description. No. 58 Nassau Street.

**Frankel & Folkart.**—Manufacturers of Seal, Cameo and Amethyst Rings a specialty. Also a full line of Gold White Stone goods and Diamond Settings. 21 John St., N. Y., and No. 4 Liberty Place.

**Peckham, Wm. H. & Co.**—Manufacturers of Solid Gold Seamless Rings, and Fancy Embossed Rings, Patent Spectacles, Jewelry, etc. No. 4 Liberty Place, N. Y.

**Sinnock & Sherrill.**—Manufacturers of Stone Rings. No. 5 Maiden Lane, N. Y.

**Tingley, Joseph N.**—Manufacturer of Stone Rings and novelties in Stone Goods. No. 9 Maiden Lane, N. Y.

**Hair Jewelry.**

**Bernhard A. & Co.**—Manufacturers of Hair Jewelry. Our new Pattern Book is now out up to 2724. No. 2 Maiden Lane, N. Y.

**Montoux, Wm. E.**—Only personal leading Artist in Hair devices in U. S., and Manufacturer of Fine Hair Mountings in Gold. Grand catalogues for the trade. 81 Nassau St., Rooms 1 and 2. Finest work and lowest prices.

**Merge, C. T.**—Fine Hair Jewelry and Device Work, 32 John Street, N. Y.

**Sauter, L.**—Manufacturer of Fine Gold and Hair Jewelry and Device Work. Pattern Book sent on application. Nos. 65 and 67 Nassau St.

**Schwencke O.**—Manufacturer of Fine Hair Jewelry Orders from the country promptly attended to. No. 43 Maiden Lane.

**Jewelry Cases, Fancy Boxes, Etc**

**Braun, Chr. E.**—Manufacturer of Jewelry Boxes, Trays for Show Cases, &c., 62 Chatham St.

**Dahlem, W.**—Manufacturer of Cases for Jewelry and Silverware, No. 85 Nassau St., N. Y. Show Case Trays, &c., at short notice.

**Loehr & Koerner.**—Manufacturers of Morocco, Velvet, Satin, Jewelry, Watches and Silverware Cases, Glove, Handkerchief, Ladies' Jewel, Work Boxes, &c., Fancy Trays and Store Fittings to order. Office and Salesroom 83 Nassau St., N. Y.

**New York Morocco Case Co.**—Makers of Cases for Jewelry, Watches, Silverware, etc. Boxes and Trays for Jewelry. No. 69 Nassau St., N. Y.

**Sturn, I.**—Manufacturer and Importer of Cases for Jewelry, Watches, Silverware, &c. No. 15 John Street, N. Y.

**Swift Manufacturing Co.**—Makers of Mailing Boxes for Mailing and Express purposes, 12 Courtland Street, N. Y.

**Welch & Miller.**—Manufacturers of Morocco, Velvet, and Satin Jewelry Cases, Trays, &c., Telescope Sample Cases with flexible Trays. Complete stock on hand. 169 Broadway.

**Wiggers & Froelick.**—No. 60 Nassau street—Manufacturers of Cases for Jewelry, &c., of every description. Trays for Show-cases, Stands for Show-windows, etc. Jewelers' Traveling Cases, light, convenient and strong.

**Jewelry—Fine.**

**Aikin, Lambert & Co.**—Manufacturers General stock of Reliable Jewelry, 23 Maiden Lane.

**Alford, C. G. & Co.**—Manufacturers. General line fine and Reliable Goods. Specialties in Onyx Goods and Chain. 183 Broadway, New York.

**Alling Bros. & Co.**—Manufacturing Jewelers, 170 Broadway.

**Baldwin, Sexton & Peterson.**—Makers of Fine Jewelry and Importers of Diamonds, etc., corner Broadway and Fourth Street.

**Barthman & Straat.**—Manufacturers of Fine Jewelry. Seal and Stone Rings a specialty. Orders promptly attended to. 41 Maiden Lane.

**Bissinger, E.**—Importer of Fine Jewelry, Locketts, Crosses, Neck Chains, &c., No. 192 Broadway.

**Brown, Thos. G.**—Manufacturer of Rich Jewelry, Necklaces, Locketts, Bracelets, Sleeve Buttons, etc., 9 Bond Street, N. Y.

**Bryant & Bentley.**—Manufacturing Jewelers. Rings a specialty. 12 Maiden Lane.

**Brainerd & Steele.**—Successors to Brainerd, Steele & Co., Manufacturers of Fine Jewelry and Brainerd's Patent Locketts. No. 9 Maiden Lane, N. Y.

**Burch & Fellows.**—Successors to Geo. Burch & Co., Manufacturing Jewelers, 17 Maiden Lane.

**Cook, Groeschel & Co.**—Manufacturers of Fine Jewelry and Locketts, 191 Broadway (over Mercantile Bank.) N. Y.

**Carter, Howkins & Sloan.**—Manufacturing Jewelers, Whiting Building, 4th St. and Broadway.

**Chatellier & Spence.**—Manufacturing Jewelers, No. 694 Broadway, N. Y.

**Champenois & Co.**—Manufacturing Jewelers, No. 1 Maiden Lane. Specialties—Jet Cluster Goods in Sets, Sleeve Buttons, Studs and Collar Buttons, Lace, Shawl and Cuff Pins, Ear Knobs and Crosses.

**Demmert Bros.**—Manufacturers and Importers of Fine Jewelry, Cameo and Onyx Locketts, Sleeve Buttons and Sets a specialty. Old No. 9 Maiden Lane, New York.

**Downin' & Keller.**—Manufacturers of Fine Jewelry, Onyx and Pearl Sets, Shawl Pins, Ear Rings, etc., 8 Maiden Lane.

**Falkenau & Oppenheimer.**—Manufacturing Jewelers. Specialty—Knife Edge Work and Rings. 89 Nassau Street.

**Field & Co.**—Manufacturing Jewelers, 8 Maiden Lane, N. Y.

**Finkelmeier, Louis.**—Manufacturing Jeweler. Jobbing and ordered work for the trade at moderate prices. 73 Nassau Street, N. Y.

**Goddard, John M.**—Manufacturing Jeweler.—Seal Rings and Fine Locketts a specialty, No. 3 Maiden Lane, N. Y.

**Greason, Bogart & Pierce,** successors to Arthur, Rumrill & Co., 182 Broadway, Manufacturers of Fine Jewelry and Gold Chains.

**Hartmann, P.**—Manufacturer & Importer of Fine Gold, Diamond, and Filigree Silver Jewelry, No. 36 Maiden Lane. P. O. Box 2,454.

**Haskell, H. C.**—Manufacturing Jeweler. Seal Rings a specialty. Special attention to Jobbing of every description. 12 John street.

**Henrich R.**—Manufacturing Jeweler, 35 Maiden Lane, New York.

**Henderson & W. t 1.**—Jewelers, No. 15 Maiden Lane, New York. Specialties—Stone, Cameo, Onyx, Amethyst, Topaz, Pearl and Turquoise Rings.

**Hunt & Owen.**—Manufacturing Jeweler. Office 5 Maiden Lane.

**Hale & Mulford.**—Manufacturers Rich Jewelry, Whiting Building, Broadway and 4th Street.

**Jeanne Brothers.**—Manufacturers of Diamond Mountings & Rich Jewelry. 1 Maiden Lane.

**Keller, Chas. & Co.**—Manufacturing Jewelers. Locketts a Specialty. No. 18 John St., N. Y.

**Krementz & Co.**—Manufacturing Jewelers, No. 13 John Street, N. Y.

**Kuhn & Doerflinger.**—Manufacturers of Enameled and Roman Band Bracelets, also Fine Locketts and Pendants, 18 John street.

**Lennon, John D.**—Manufacturing Jeweler, 142 Fulton Street. Stone Locketts and Rings; also Badges and Emblems of all kinds.

**Miller Bros.**—Manufacturers of Fine Jewelry, Locketts, Sleeve Buttons, Studs, &c., 11 Maiden Lane, N. Y.

**Mulford & Bonet.**—Manufacturers of Diamond and Gold Jewelry. Dealers in Rolled Plated Goods, 21 Maiden Lane.

**Moore & Horton.**—11 Maiden Lane, Manufacturing Jewelers, Rings, Studs, Collars and Sleeve Buttons, Pins, Ear-rings, &c.

**Marx Kossuth & Co.**—Manufacturing jewelers, 39 Maiden Lane.

**Cwen, G. & S. & Co.**—Manufacturing Jewelers. Office, No. 5 Maiden Lane.

**Riker, William.**—Manufacturer of Jewelry. Inlaid Gold Jewelry a Specialty, No. 5 Maiden Lane, N. Y.

**Riley, J. A. & Co.**—Manufacturing Jewelers, Etruscan Gold and Coral Sets, Roman Bracelets Necklaces, etc. Onyx Goods a specialty. 7 and 9 Bond street, New York

**Richardson. Enos & Co.**—Manufacturers of Fine Gold Jewelry, Gold Chains, Locketts, Crosses and Necklaces. Colored and Etruscan Work. No. 23 Maiden Lane, New York.

**Richardson, J. W. & Co.**—Manufacturers of Jewelry, Masonic and other emblems. 196 Broadway. Manufactory, Providence, R. I.

**Ripley, Howland & Co.**—Manufacturers of Fine Jewelry and Diamond Mountings. 35 Maiden Lane, N. Y.

**Sauter, L.**—Manufacturer of Fine Jewelry, Solid Stone Rings and Studs a specialty. Jobbing for the trade, 65 and 67 Nassau street.

**Sexton & Cole.**—Manufacturing Jewelers, Colored Gold and Onyx Goods a specialty. No. 30 Maiden Lane.

**Stites, D. H. & Son.**—Manufacturers of Fine Jewelry, Rolled Plated Goods and Chains, Parisian Diamond Rings, Studs and Earrings a specialty. 41 Maiden Lane, N. Y.

**Shoemaker & Co.**—Manufacturing Jewelers Cameo Buttons, and Locketts, Roman Gold Goods, etc. No. 21 Maiden Lane, N. Y.

**Stites, E.**—Manufacturer of Fine Jewelry. No. 12 Maiden Lane, N. Y.

**Sturdy Bros & Co.**—Manufacturers of Jewelry. General line of fine and heavy Rolled Plate Goods. Specialties—enameling on gold plate; graduated wire coral work. 14 Maiden Lane, N. Y.

**Terhune, Charles F.**—Manufacturing Jeweler, 16 Maiden Lane, N. Y.

**Thoma, Ernest.**—Manufacturer of Fine Jewelry. Sleeve Buttons, Rings, Ear-rings, &c. No. 173 Broadway, N. Y. Factory, Hackensack, N. J.

**Trier Bros. & Co.**—Jewelry. Optical, Rubber, Jet, Shell, Ivory, Amber and Pearl Goods, Silk Goods, Japanese Bamboo Watch Chains a Specialty. No 15 Maiden Lane.

**Wadsworth, E. E.**—Manufacturer of Rich Jewelry and fine Rolled Plate. Fine Seal Rings a specialty. 35 Maiden Lane.

**Wheeler, Parsons & Hays.**—Manufacturers of Fine Jewelry, Watch Cases, Gold Chains, &c. and Dealer in American and Swiss Watches, No. 2 Maiden Lane, N. Y.

**Wienhold, Joseph.**—Manufacturer of Fine Jewelry and Diamond Setter. 24 John St.

**Ward, Thos. M.**—Manufacturer of Fine Jewelry, Diamond Mountings a specialty. No. 25 John Street, N. Y.

**Woglom & Miller.**—Manufacturers of Black Onyx Goods exclusively. 32 & 34 John Street, N. Y.

**Jewelers' Tools, etc.**

**Fraser & Co.**—Importers of Stubb' French, Swiss, German and Sheffield Tools, Files and Steel Wire for Watchmakers, Jewelers, etc., 62 Chatham street, N. Y.

**Hecht, Phil.**—Importers and Dealers in Watchmakers' materials, Tools, Optical Goods and Silk Goods etc. 13 Maiden Lane, N. Y.

**Stanley & Company.**—Jobbers of Tools and Materials for use of Watchmakers and Jewelers, Spectacles, Jewelry Boxes, Plated Chains, &c., &c., 108 Wisconsin Street, Milwaukee, Wis.

**Lapidaries.**

**Fox, M. & Co.**—Practical Lapidaries, No. 1 Maiden Lane, New York.

**Kordmann & Michel.**—Lapidaries, dealers in Precious Stones, Rubies, Sapphires and Peridot cut. No. 59 Nassau Street.

**Masonic Jewelry.**

**Luther, John F.**—79 Nassau Street. Manufacturer of Fine Presentation Jewels for all Societies. Knights Templars, Crosses, Badges, &c.

**Wilkinson & Lenon.**—Manufacturers of Masonic, Odd Fellows, Athletic Clubs and other Jewelry, No. 212 Broadway, New York.

**Opticians.**

**Burbank Man'g Co.**—Manufacturers of Spectacles and Eye Glasses of all descriptions, in gold, silver, etc., 14 Maiden Lane, N. Y.

**Du Bois, Geo. W.**—Successor to A. Landsberg, Importer and Manufacturer of Optical Goods, 30 Maiden Lane. Box 3993, N. Y.

**Laurencott, J. B.**—Importer of Watch Glasses, Optical and Fancy Goods, Clocks, Bronzes, etc., 33 Maiden Lane, N. Y.

**Lorsch, Albert.**—Manufacturer of the Patent Accommodating Spectacles and Eye Glasses in Gold, Silver and Steel, and other Optical Goods, 37 Maiden Lane, N. Y.

**Spencer Optical Manufacturing Co.**—Gold Silver, Steel and Nickel Plated Spectacles, Eye Glasses, &c. 13 Maiden Lane, N. Y.

**Precious Stones, &c.**

**Bissinger, Philip.**—Importer of Diamonds, Pearls and Precious Stones. Agent for the Bohemian Garnet Goods. No. 22 John St. N. Y.

**Fox, M. & Co.**—Importers of Diamonds and other Precious Stones, No. 1 Maiden Lane, N. Y.

**Gruet, Jules.**—Importer of Precious and Imitation Stones, Amethysts, Topazes, Cameos, Garnets, Doublets, Imitation Diamonds, Pastes, etc., No. 14 John street. Manufactory at Septmoncel, France.

**Silverware.**

**Cappia, L. A.**—Manufacturer of Solid Silver Novelties, and Importer of Silver Filigree, 19 Union Square.

**Gorham Manufacturing Co.**—Union Square.  
**Wood & Hughes.**—Manufacturers of Fine Silverware 16 John Street, N. Y.

**N. Matson & Co.**—State and Monroe streets, Chicago, Ill. General Jewelers and Furnishers of Jewelers Supplies, Western Branch House for the Reed & Barton's Fine Electro Silver Plated Ware.

**Silver Plated Ware.**

**Brown & Bros.**—Manufacturers of first quality of Electro Plated Flat Table Ware. No. 81 Chambers Street, N. Y.

**Hall, Elton & Co.**—Manufacturers of the Finest Electro-Plated Ware, salesroom, 75 Chambers Street, N. Y.

**Holmes, Booth & Haydens**—Manufacturers of Silver-Plated Ware. 47 Chambers Street.

**Maiden Britannia Co.**—Manufacturers of Silver-Plated Ware. 46 East 14th Street, Union Square.

**Middletown Plate Co.**—Manufacturers of Superior Electro-Plate. Factories, Middletown, Conn., salesroom, 13 John Street.

**Rogers, Wm. & Son**—Hartford, Conn.

**Rogers & Bro.**—Manufacturers of the finest quality of Electro-Plated Ware. 690 Broadway.

**Simpson, Hall, Miller & Co.**—Manufacturers of fine Silver-Plated Ware. No. 36 E. 14th Street.

**Schade, Henry.**—Manufacturer of White Metal and Plated Ware. No. 84 John St., N. Y. Price list and catalogue furnished on application.

**Webster, E. G. & Bro.**—Manufacturers of Fine Silver-Plated Ware. Office and warehouses, 14 Maiden Lane, N. Y.

**Show Cases, Etc.**

**Kraft & Hoffmeister.**—Manufacturers of Metal Show Cases, Jewelry Trays always on hand. No. 20 North William Street, N. Y.

**Smith, B. & W. B.**—Patent Improved Counter Show Cases. Drawings furnished and estimates given for fitting stores in Cabinet Work complete.

**Spectacle Case Manufacturers.**

**Koenen, A. & Bro.**—Manufacturers of Leather Spectacle and Eye-Glass Cases. 81 Nassau St., N. Y.

**Thermometers Etc.**

**Tagliabue, Giuseppe.**—Thermometer, Barometer, and Hydrometer manufacturer, 302 Pearl Street near Beekman, N. Y.

**Thimble Manufacturers.**

**Burbank Manufg Co.**—Manufacturers of Gold and Silver Thimbles, 14 Maiden Lane, N. Y.

**Ketcham & McDougall.**—Improved Gold and Silver Thimbles, Nos. 4 and 6 Liberty Place, near Maiden Lane, N. Y.

**Woglom & Miller.**—Sole Agents for the "Prime" Thimbles in Gold and Silver, manufactured by Ezra C. Prime. 34 John Street, N. Y.

**Walking Canes.**

**Fradley, J. F.**—Manufacturer of Fine Gold and Silver-headed Walking Canes and Sterling Silver Ware. Office and factory, 20 John Street, N. Y.

**Watch Companies.**

**American Watch Co.**—Robbins & Appleton, No. 9 Bond Street, N. Y.

**Hampden Watch Co.**—of Springfield Mass., office No. 12 Maiden Lane, N. Y.

**The Howard Watch and Clock Co.**—No. 2 Maiden Lane, N. Y.

**Watch and Chronometer Jeweler.**

**Queen, James.**—Watch and Chronometer Jeweler and Pallet Maker, 78 Nassau Street, room 8. Pivots inserted in Pinions, Balance, Staffs, etc.

**Watch Importers, Etc.**

**Aikin, Lambert & Co.**—Importers of Watches, Sole Agents for Paul Breton & Chas. Latour, Geneva. A general line of reliable Swiss Watches. Watch Cases of all styles made to order. 23 Maiden Lane, N. Y.

**Cross & Beguelin.**—Importers of Watches, Watch Tools and Materials, dealers in American Watches, No. 21 Maiden Lane, N. Y.

**DuBois, Francis & Co.**—36 Maiden Lane, N. Y., Importers of Watches and Manufacturers of Watch Cases.

**Droz, Henry E.**—Importer of Watches, and Watch Case Manufacturer. Agent for the "E. Perregaux" Watch, and jobber in American Watches, No. 92 Fulton Street, N. Y.

**Freund Max & Co.**—Importers of Watches, Jewelry and Precious Stones, 8 Maiden Lane, N. Y.

**Friedman, S.**—Importer of and dealers in Watches and Jewelry, 40 Maiden Lane.

**Gallet, Julien.**—Importer of Watches. No. 1 Maiden Lane.

**Ginnel, Henry.**—Importer of Watches, Tools and Materials, No. 31 Maiden Lane, N. Y. P.O. Box, 2967.

**Jandorf, P. & Bro.**—Importers of Watches and Jewelry, 182 Broadway, bet. John St. & Maiden La.

**Keller, L. H. & Co.**—Successors to G. A. Huguenin, Importers of Fine Watch and French Clock Materials, No. 64 Nassau Street, N. Y.

**Hirsch Bros.**—Dealers in Watches and Diamonds and Manufacturers of Jewelry, No. 23 Maiden Lane, N. Y.

**Hyde's Sons, John E.**—Wholesale Commission Agents, only for Jules Jurgensen, of Copenhagen; Ed. Perregaux, of Locle; Jules Monard, of Geneva; and for other makers of all qualities of Watches, 22 Maiden Lane.

**Mathey, L. & A.**—Importers of Fine Watches and Sole Agents for the H. L. Matile's Watches, No. 16 Maiden Lane.

**May & Stern.**—Importers of Foreign Watches, Materials and Tools, etc. Manufacturing Jewelers, No. 19 John Street, N. Y.

**Middleton & Brother.**—Importers of Swiss Watches and dealers in American Watches, Diamonds, Gold chains, Jewelry, etc., 10 Maiden Lane, N. Y.

**Nicoud & Howard.**—Importers and Manufacturers of Watches, No. 14 Maiden Lane.

**Oppenheimer Bros. & Veith.**—Dealers in Watches and Diamonds, and Manufacturing Jewelers, No. 35 Maiden Lane.

**Schwob, Adolphe.**—Manufacturer and Importer of Watches, 11 Maiden Lane, N. Y.

**Stern Brothers & Co.**—Importers of Swiss Watches and wholesale dealers in American Watches, &c., 39 Maiden Lane.

**Scott, J. T. & Co.**—Importers of Watches, and Manufacturers of Jewelry, and Jobbers of all Grades, American Watches, No. 11 Maiden Lane.

**Strasburger, Louis & Co.**—Importers and Makers of Watches of every description, No. 15 Maiden Lane.

**Tiffany & Co.**—Makers of Watches. General agents for Patek, Phillippe & Co. Wholesale office, 694 Broadway, N. Y.

**Watch Cases.**

**Brown, J. A. & Co.**—Manufacturers of the Ladd Patent Stiffened Gold Watch Cases, etc., 11 Maiden Lane, N. Y. Factory, 58 Eddy Street, Providence, R. I.

**Watch and Chronometer Repairers.**

**Cerf, B.**—Practical Watchmaker and Repairer, No. 10 John Street, N. Y. Repairing and adjusting of Fine Watches done for the trade. All kinds of escape and stem-winding wheels cut to order.

**Ludeman, W. H.**—Chronometer and Watch Maker. Repairing of every description for the trade, 75 and 77 Nassau Street.

**Sirois, A.**—Practical Watchmaker, 89 Fulton Street. Special attention paid to the repairing of Fine Watches. Pivots inserted.

**Watch Case Repairers.**

**Tarbox, Hiram.**—Watch Case Repairing, Springing, Polishing and Engine Turning, 79 Nassau Street, (room 22,) N. Y.

**Renaud, F.**—Watch Case Repairer.—Solid and Heavy Rolled Plate Bows and Pendants. Springer and Engine Turner of Cases and Jewelry, 36 Maiden Lane.

**Watch Glasses, Shades, Etc.**

**Brown, Edw'n.**—No. 85 Nassau Street, Imported and Own Manufacture Watch Glasses. Flat, Flat Concave, Concave, Convex and fine Genevas. Fine fitting solicited.

**Hill, Robert S.**—Manufacturer of Watch Glasses, &c., dealer in Imported Glasses, Flat Glasses a specialty; also Jeweler's Glasses. Nos. 75 and 77 Nassau Street, N. Y.

**PHILADELPHIA**

**Booz & Thomas.**—Manufacturers of Gold and Silver Watch Cases and Jewelry, 108 South 8th St., Philadelphia.

**Bennett, Jacob & Son.**—Diamond Setters and Manufacturing Jewelers, 108 South 8th St.

**Cooper & Bros.**—Wholesale Jewelers and Importers of and dealers in Watch and Clockmakers' Materials, etc., Spectacles and Optical Goods. No. 35 South 4th Street, Philadelphia.

**Conover David F. & Co.**—American Watches, Wholesale Salesroom, South 5th corner 7th and Chestnut Streets, Philadelphia.

**Herold, Chas P.**—Successor to Hildebrandt, Herold & Co., Manufacturing Jeweler and Diamond Setter. Diamonds. 916 Chestnut Street.

**Levy, Bernard.**—Manufacturer of Gold and Silver Watch Cases, and Importers and Dealers in Swiss and American Watches. 402 Library Street.

**Morgan, Charles V.**—Manufacturer of Morocco and Hardwood Cases. 630 Chestnut Street, Philadelphia. Jewelry and Silverware Cases, Show Case Trays, Mathematical and Surgical Instrument Cases, etc.

**McCall & Newman.**—Manufacturing Jewelers Filled Plain Gold Rings a Specialty. No. 625 Arch Street.

**Morgan & Headly.**—Manufacturing Jewelers, Cameo Sets, Gold Sets, Roman Lockets, Rings, Coral Sets and a general line of rich goods. 611 and 613 Sansom Street, Philadelphia.

**H. Muhr's Sons.**—Manufacturing Jewelers, Solid Gold and Filled Rings a Specialty. 633 and 635 Chestnut Street, N. Y. Office. 11 Maiden Lane.

**Rosenthal, G. F. C.**—Manufacturing Jeweler and Diamond Setter. Engraving and Designing of Monograms a Specialty. No. 917 Sansom Street.

**Rowe, Geo. A.**—Stone and Metal Seal Engraver, Die Sinker and Medalist, Intaglio Cutting. Special rates for large quantities to manufacturers. 1002 Walnut Street.

**Scherr, L. A. & Co.**—Wholesale Dealers in Watches Silver-Plated Ware, Spectacles, Fancy Goods, Watch Materials, etc. 726 Chestnut Street.

**Sheaffer, W. H. & Co.**—Makers of Fine Jewelry. 908 Chestnut Street.

**Simons, Brother & Co.**—Manufacturers of Fine Jewelry, Canes, Thimbles, Chains. 611 and 613 Sansom Street.

**CHICAGO.**

**American Watch Company.**—of Waltham, Mass. No. 170 State Street, Chicago.

**Charpier & Wathier.**—Watchmakers and Jewelers for the trade, and Wholesale Dealers in Watch Materials, Tools, etc. 61 West Kinzie Street, Chicago, Ill. Send for price list.

**Clapp, Bros. & Co.**—Wholesale Jewelers. 63 and 65 Washington Street. Catalogue and price list issued to watchmakers and Jewelers.

**Frese, B.**—Watchmaking and Repairing for the Trade promptly attended to. Stem-winding and Escape Wheels cut to order. No. 99 E. Madison Street, Chicago, Ill.

**Giles, Bros. & Co.**—Manufacturers and Jobbers in Watches, all classes of Jewelry, Materials, Clocks, Silver-Ware, &c. Illustrated catalogues furnished to dealers on application. State and Washington Streets.

**Glickauf, S. & Co.**—79 and 81 State Street. Importers of Watchmakers and Jewelers Supplies, Optical Goods, Watches, etc.

**Hahn, H. F. & Co.**—Wholesale Jewelers, 157 and 159 Franklin Street. Largest assortment and lowest prices. We do not issue any catalogue.

**Knights, C. H. & Co.**—Wholesale Jewelers, 125 and 127 State Street.

**Kearney & Swartchild.**—113 and 115 State Street. Importers and Jobbers of Watchmakers' and Jewelers' Supplies, Watches, Jewelry, etc. Illustrated catalogue and price list sent on application and receipt of card.

**Matson, N. & Co.**—State and Monroe Streets General Jewelers and Furnishers of Jewelers' Supplies. Western Branch House for Reed & Barton's Fine Electro-Silver Plated Ware.

**Norris, B. F. & Co.**—Wholesale Jewelers, and Dealers in Watchmakers' and Jewelers' Supplies. 101 and 103 State Street.

**Richter, Jacob.**—Established 1868. Watch Repairer for the trade. Special attention given to complicated work, 528 State Street.

**Stein & Ellbogen.**—Wholesale Dealers in Watches and Jewelry, 127 State Street, Chicago, Ill. Specialty, repairing for the trade.

**PROVIDENCE**

**Irons, Chas. F.**—Manufacturer of Solid Gold Jewelry. Specialty, Emblems, Pins and Charms, Masonic, Odd Fellows, etc. 102 Friendship St.

**Perkins, C. H. & Co.**—Manufacturers of Fine Gold and Plated Jewelry, 20 Conduit Street.

**NEWARK.**

**Lefort, Henry.**—Stem-winding Watch Crown Manufacturer. 80 and 82 Marshall Street.

**Lelong, L. & Bro.**—Gold and Silver Refiners, Assayers and Sweep Smelters, Southwest corner of Halsey and Marshall Streets, Newark, N. J.

**Milne & Jourdan.**—Manufacturers of Stem-winding Watch Crowns. 13 and 15 Franklin Avenue.

**Prince, David.**—Gold and Silver Refiner, Assayer, and Sweep Smelter. Sole Agent for Comins' Improved Amalgamator. 63 Railroad Ave.

**Unger, H. & Co.**—Manufacturers of Fine Gold Jewelry, Colored and Etruscan work, Enameled Sets. Office and factory, 18 Crawford street, Newark, N. J. Box 63.



Standard Marine Chronometer  
FOR KEEPING CORRECT TIME.

**JOHN BLISS & CO.**  
**STANDARD MARINE**  
**Chronometers and Transits,**  
**FOR WATCHMAKERS' USE.**

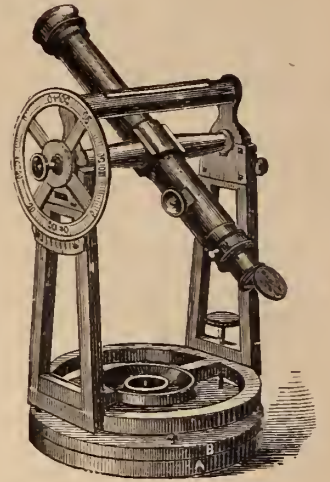

No. 10

**110 WALL STREET, NEW YORK.**

**IMPORTANT NOTICE.**—These Transits are readily set in position without the aid of strictly correct time as a basis for that purpose. Printed instructions, easily understood, accompany each Instrument, and no calculations are required preliminary to setting in position.

As a trial only is required to insure unqualified approval, we are induced to make the following **LIBERAL OFFER**—On receipt by us of satisfactory reference, and 10 per cent. of the price, we will send one of the foregoing Transit Instruments, on hire or trial, for one month, with full printed instructions for setting up and using the same, and if purchased after trial, we will allow the whole hire to apply in part payment, and sell the Instrument on approved note at four months for the balance. Special terms for payment by installments, after trial, on application. We do not make this offer merely to hire these instruments, but to insure a trial with a view to sales, the hire received being only sufficient to cover the cost of repolishing in case they are returned. Send for Illustrated Circular giving full description.

**JOHN BLISS & CO., 110 Wall Street, New York.**

**PATENT IMPROVEMENT IN COUNTER SHOW CASES,**

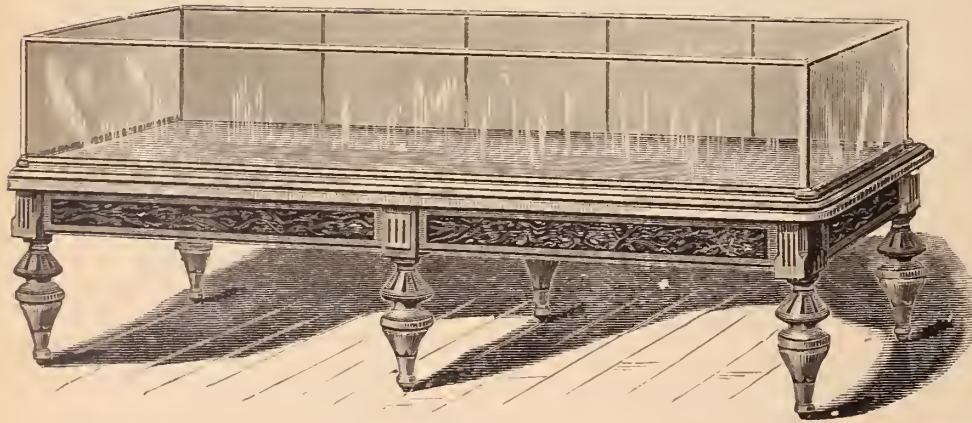

**Perpendicular Sliding Door,**

(DUST TIGHT.)

REAR VIEW OF CASE SHOWING SLIDING DOOR.

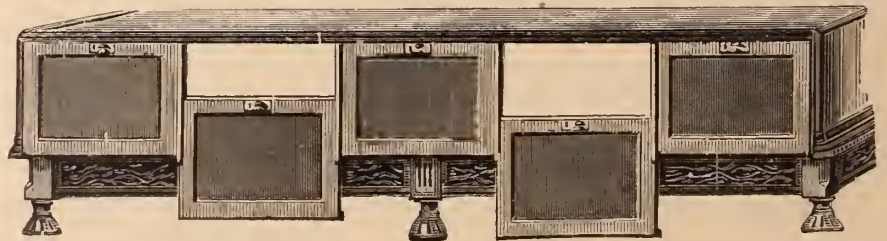

Its advantages are as follows:—The doors are more conveniently opened and closed, less liable to get out of repair or broken, articles are more easily reached in wide cases, mirrors are more safe, it dispenses with hinges, economizes room, excludes dust, and is air tight *when closed*.

Drawings furnished and estimates given for fitting stores in cabinet work complete.

REFERENCES:—Gorham Mfg Co., Rogers & Bro., Mitchell Vance & Co.,  
Meriden Britannia Co., M. S. Smith & Co. Detroit, Mich.  
D Valentine, Syracuse, N. Y.

**B. & W. B. SMITH,**  
**220 West 29th Street, New York.**



# F. JEANDHEUR, JR.

Old No. 117 Fulton Street, NEW YORK.  
New No. 125 Fulton Street,

For the last eleven years the firm of F. JEANDHEUR & SON have been known to the Wholesale Jewelry Trade of the United States as

## Electro-Platers and Fire Gilders.

Their increased business has now caused them to REMOVE from their old quarters to the large and spacious building, 125 Fulton Street, where they will be happy to see their patrons.

Mr. Jeandheur begs to notify the Trade, that by his NEW PROCESS of PLATING, Watch Cases, Jewelry, etc., can be finished with a far greater amount of depth of gold than has ever been accomplished, and also at less expense than the old process of fire-gilding. The Trade can rely on this statement, as a trial will abundantly prove, and their well-earned reputation is staked that they will in all cases give satisfaction.

NE PLUS ULTRA.

### DUST-PROOF WATCH KEYS.

Patent Sept. 1st, 1874.



The Popular Name Key.

A. Nickel Plated Handle and Pipe, Swivel Top, per gross..... \$10.75

English Pattern Key.

C. Nickel Plated Handle and Pipe, Swivel Top, per gross..... \$7.50



BENCH KEYS.

Corrugated Gilt Handles, Tempered Steel Pipes, per Set of Six.....\$1.80  
per Set of Three..... .90

P. Style of Key.

Gilt Handle.

Steel Pipe.

Per Gross.....\$8.50



Our Key Pipes are all warranted to be made of the finest quality of steel. One great advantage this key has over all others, is the mortice through the pipe, making it the most simple and thoroughly dust and moisture-proof, as well as the cheapest key in the market. Our sizes run from 1 to 12; 4, 5 and 6 fit Gents' American Watches; No. 8, Ladies' American.

For sale by the Trade generally.

**KENDRICK, DAVIS & CO., LEBANON, N. H.**

SOLE OWNERS AND MANUFACTURERS.

The advantage of our Name Key, as an advertising medium, will at once be seen.

ESTABLISHED 1849.

## O. SCHWENCKE,

Successor to C. Gunzenhausen,

MANUFACTURER OF

### FINE HAIR JEWELRY,

43 Maiden Lane, New York.

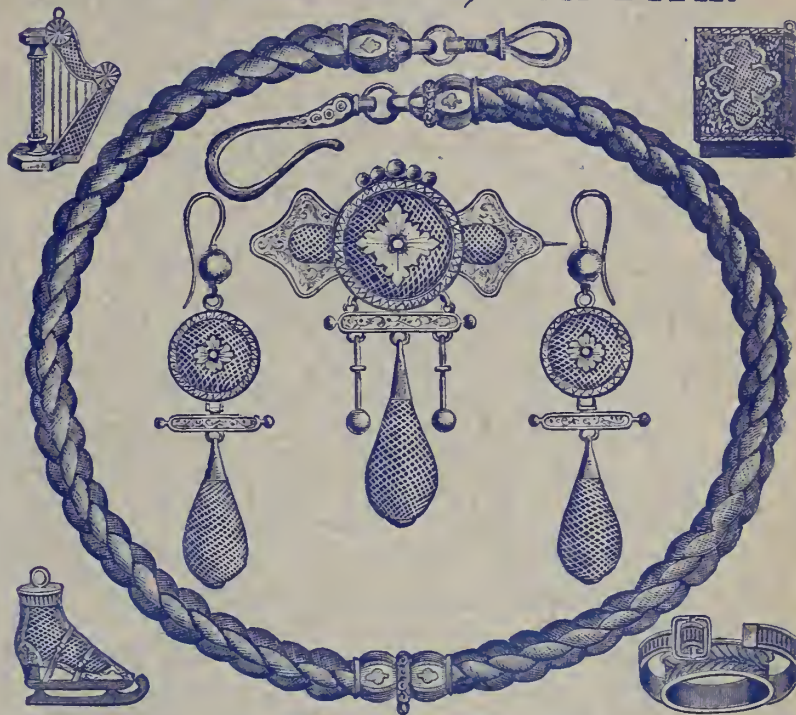

Solid Gold Mountings for Hair Jewelry, kept constantly on hand and made to order at short notice.

Orders from the country trade promptly attended to, and Price List and Catalogues furnished at 50 cents each, which will be refunded on first order.

ESTABLISHED, 1863.

## WIGGERS & FROELICK,

60 NASSAU STREET, NEW YORK,

MANUFACTURERS OF

### Cases for Jewelry,

EVERY DESCRIPTION.

Plain and Fancy Trays for Show Cases and Windows.

### Sample Cases & Trunk Trays

A SPECIALTY!

Trunks fitted with our Trays will carry more goods and carry them safer than by any other method; we having made it a special study to combine CHEAPNESS, LIGHTNESS, CONVENIENCE and DURABILITY.

The attention of the JOBBING TRADE is particularly invited.

HENRY HIRSH,

EDWARD HIRSH,

# HIRSH BROS.

Dealers in Watches & Diamonds

AND MANUFACTURERS OF

## JEWELRY,

No. 23 Maiden Lane, New York.

Prompt attention given to filling orders for all kinds of goods pertaining to the trade.

HENRY MAY.

Established 1854.

JOSEPH STERN.

# MAY & STERN,

IMPORTERS OF

Foreign Watches, Materials and Tools

AGENTS FOR THE SALE OF ALL

DOMESTIC MOVEMENTS AND CASES.

And **MANUFACTURING JEWELERS**

No. 19 John Street, New York.

SOLID GOLD SEAL RINGS, in Cameo, Amethyst, Topaz and Onyx, A SPECIALTY.

# L. LELONG & BRO.

**GOLD and SILVER REFINERS,**

Assayers and Sweep Smelters,

Southwest Corner Halsey and Marshall Streets,

NEWARK, N. J.

SWEEPINGS A SPECIALTY.

# KELLER & UNTERMAYER,

ONLY AUTHORIZED AGENTS OF

# The International Watch Co.'s

## WATCHES.

A full and complete assortment of these goods in new and attractive Gold Cases constantly on hand.

No. 18 John Street, New York.

**SILVER FILIGREE JEWELRY.**  
Splendid Silver Bridal Sets,  
Half Sets, Necklaces, Bracelets, &c.

**P. HARTMANN,**  
P. O. BOX, 2454. 36 Maiden Lane, New York.  
Importer and Manufacturer of  
Fine Gold, Diamond & Filigree  
Silver Jewelry.

# ALBERT LORSCH,

IMPORTER AND DEALER IN

# WATCHES,

AND MANUFACTURER OF

## JEWELRY,

ALSO MANUFACTURER OF THE

PATENT ACCOMMODATING

# Spectacles and Eye Glasses,

In Gold, Silver, Steel, &c.

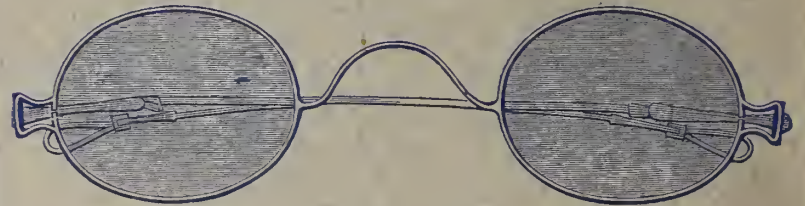

Would call the attention of the trade to the fact, that with the above Spectacles and Eye Glasses, which are constructed to form a Spring by which the lense is held, it is only necessary to have one complete assortment of lenses which being of uniform size, will interchange in all the different kinds of frames, thus giving a complete assortment for a comparatively small outlay. Notwithstanding the numerous advantages of these Spectacles, the prices will compare favorably with those of any other make.

ALBERT LORSCH, 37 Maiden Lane, New York.

LORSCH BROS., 120 Sutter St., San Francisco, Cal.

**L. BLACK & CO.'S  
Spectacle  
INDICATOR,**

Patented in U. S., July 31, 1877.  
Canada, March 19, 1877.

Instruct the customer to place one eye closely against the open end of the tube; put the smallest letter opposite the small hole, and turn until the customer can distinguish a letter or figure. The strength of the spectacles required will be indicated on the index wheel. If the large letters are used, pull up the slide; if not, keep it down.

This instrument is easily adjusted, can not get out of order, is nickel plated, makes a nice appearance, and shows the correct number of lens required.

For particulars, address L. BLACK & CO., Detroit, Mich., or any wholesale Optical Establishment in New York.



Established 1813.

# SETH THOMAS CLOCK CO.

THOMASTON, CONN.

No. 20 MURRAY STREET, New York.

16 Worship Street,  
LONDON, E. C.

172 State Street,  
CHICAGO.

132 Sutter Street,  
SAN FRANCISCO.

# F. KROEBER

Manufacturer of CLOCKS,

No. 8 Cortlandt St., New York.



Birdie.



Velvet.



Thistle.



Daisy.



Aurora.



Horseshoe.



Tulip.



Comtess.

WASP.  
1 Day, \$2.25      8 Day, \$2.50

# New Haven Clock Co.

62 Reade Street, New York.

117 & 119 State St., Chicago.

FRANK E. MORGAN, General Manager.

G. A. HARMOUNT, Agent.

Manufacturers of

## AMERICAN CLOCKS,

### MOVEMENTS & CLOCK MATERIALS

ALSO BLACK WALNUT

### VISIBLE PENDULUM CLOCKS

AND SPECIALTIES IN BRASS AND NICKEL.



Weser.



Sprite Alarm.

AGENTS FOR

Jerome & Co., of New Haven, Conn.

E. Ingraham & Co., of Bristol, Conn.



Sp ite T. P.



Tuscan D. R.

# WATERBURY CLOCK CO.

MANUFACTURERS OF AMERICAN CLOCKS,

4 CORTLANDT STREET,  
NEW YORK.

M. BAILEY, Treasurer.

63 WASHINGTON ST.  
CHICAGO.

—♦♦♦—  
FACTORIES, WATERBURY, CONN.



SHARP GOTHIC EXTRA.



CRICKET EXTRA.

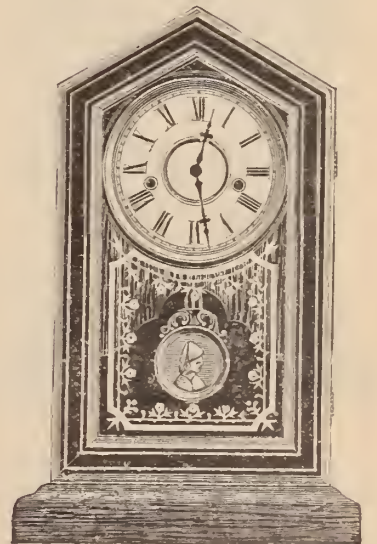

CHESTER

# GEO. B. OWEN & CO.

6 MURRAY STREET,

Factory, Winsted, Conn.

New York.

MANUFACTURERS OF

## BLACK WALNUT CLOCKS,

Clocks Manufactured by the following Companies will be furnished at lowest Market Rates:

- New Haven Clock Co.,
- Seth Thomas Clock Co.,
- E. N. Welch Man'f'g Co.,
- Welch, Spring & Co.,
- Waterbury Clock Company,
- Ansonia Clock Company,
- Wm. L. Gilbert Clock Company,
- E. Ingraham & Co.

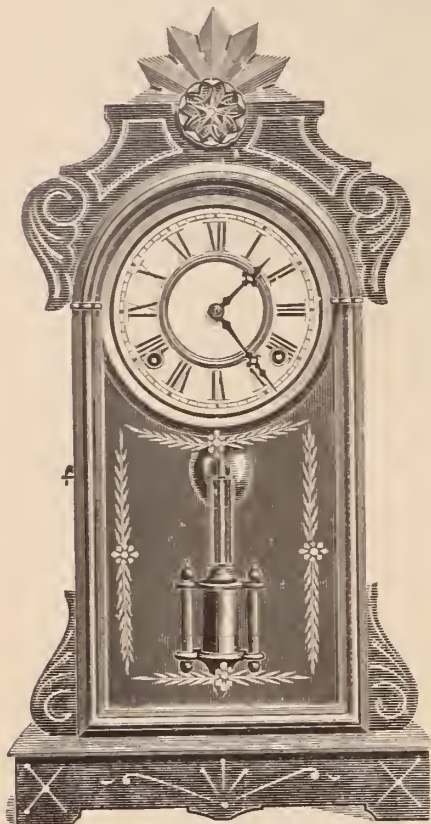

**ARGUS.**

Eight day Strike. Height, 20 1/4 in.



**AMPHITRITE.**

Day Time. Height 17 1/2 in.

Illustrated Catalogues and Price Lists furnished on application,

# E. N. WELCH MFG. CO.

WELCH, SPRING & CO.

## Clock Manufacturers

FACTORIES, FORESTVILLE, CONN.

STORES AND WAREHOUSES:

6 Warren St., New York,

170 State St., Chicago.

STYLES OF OUR GOODS:

Original, Unique, Highly Finished,

Warranted Excellent Timekeepers, and Cheap.

Send for Catalogue, Price List and Discounts.

E. C. HINE, General Manager,

NEW YORK.

F. E. MORSE, Agent,

CHICAGO, ILL.

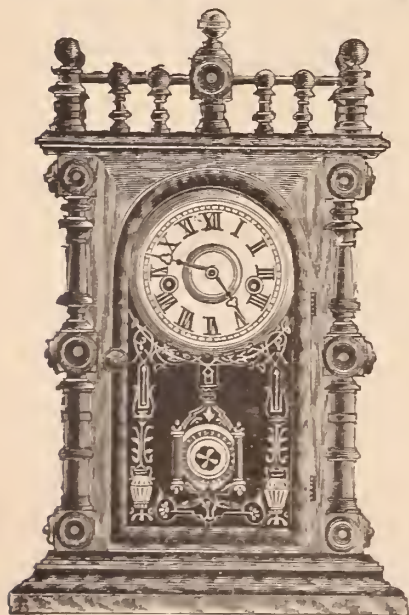

**CERSTER.**

SPRING STRIKE. VERY FINE MOVEMENT. HEIGHT, 18 INCHES. 8 DAY. STRIKE. HIGHLY FINISHED ROSEWOOD CASE POLISHED. GLASS SIDES. SPRINGS BARRELED.

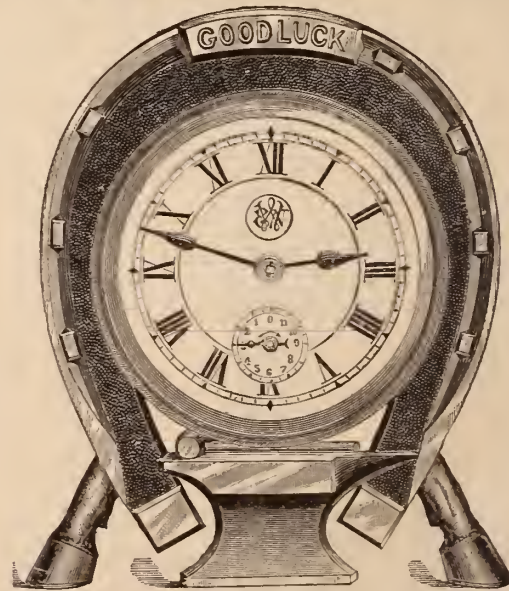

**GOOD LUCK.**

(Patented Sept. 17, 1878. Height, 6 inches.)

Thirty hour Lever Time. This clock will run in any position. Is a stem winder. Winds and sets everything at the back. The movement is protected at front and back by close fitting caps, so that the dust can not get in. Made in Gold Gilt or Nickel, with and without alarm. Manufactured only by the E. N. WELCH MANUFACTURING CO., Forestville, Conn.

# TO THE TRADE.

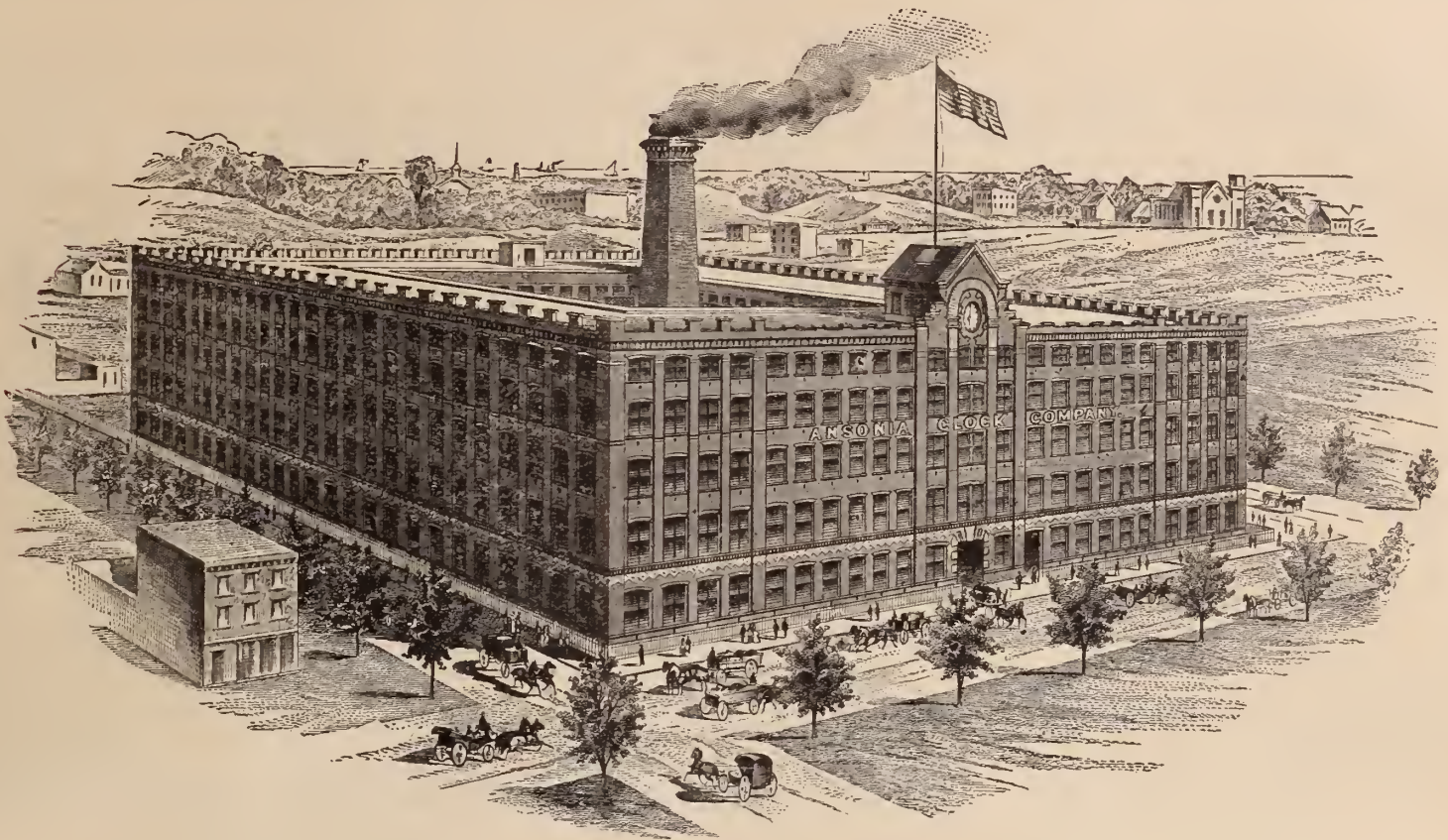

WE take pleasure in announcing that our NEW CLOCK FACTORY in the City of Brooklyn is now completed and in active operation.

Our machinery, which is new and improved, is especially adapted to a finer class of work than has heretofore been produced in this country, and embraces several principles quite original in their application to the manufacture of American Clocks. With these facilities we can produce Goods of the best workmanship in the most economical manner, and the fact that we now have the largest Clock Manufactories in this country, or in any other, is sufficient guarantee that orders will be promptly executed.

We have remodeled and refitted our Salesrooms at

11 TO 21 CLIFF STREET,

where we shall keep always on hand, inviting your attention, a full line of samples of our Improved Standard American Clocks, together with our popular novelties and specialties, also a large variety of French Clocks of our latest importations.

**ANSONIA CLOCK COMPANY.**

N. B.--An Entirely New Line of Original Styles will Shortly be Brought Out.  
Factories--Brooklyn, N. Y., and Ansonia, Conn.

# LOUIS STRASBURGER & CO.

DIRECT IMPORTERS OF

## DIAMONDS.

OF ALL GRADES,

Especially selected for this market. Original parcels of new goods constantly arriving, so that dealers are always sure of finding a most desirable and ever-changing stock to select from.

FINE GEMS IN SINGLE STONES AND MATCHED PAIRS A SPECIALTY.

15 MAIDEN LANE, NEW YORK.

30 BOULEVARD HAUSSMANN, PARIS.

# LOUIS STRASBURGER & Co.

MAKERS AND IMPORTERS OF

## WATCHES.

From the finest Stem-Winding and Setting goods to the lowest price Watch in the market.

We have constantly in stock a complete and varied assortment of the best COMMERCIAL WATCHES ranging from the lowest priced Metal and Silver Watches to the finest Gold goods, including REPEATERS, CHRONOGRAPHS (single and split seconds) and other Timing and Complicated Watches of established reputation.

We would call the especial attention of the trade to our complete assortment of NICKEL WATCHES, with Black, Fancy and Luminous Dials, in all grades, styles and sizes.

Also a full assortment of the INTERNATIONAL and all grades of AMERICAN Movements, in *Gold and Silver Cases*, constantly in stock.

SALESROOM, No. 15 MAIDEN LANE, NEW YORK.

Watch Factory, Rue Leopold, Chaux de Fonds, Switzerland.



# David F. Conover & Co.

(SUCCESSORS TO WM. B. WARNE & Co.)

Importers, Manufacturers and Dealers in

## Watches and Jewelry,

AMERICAN WATCH WHOLESALE SALESROOM,

Southeast Cor. Chestnut and Seventh Streets, First Floor,

**PHILADELPHIA.**

DAVID F. CONOVER,  
C. FRANK WILLIAMS,  
B. EDGAR RICHTER.

Wholesale Agents for

Rogers & Brother's Flat and Hollow Ware

**CELLULOID EYE GLASSES,**

**AND SOLE AGENTS FOR THE**

**Patent Railroad Train Watch Chains, Nickel.**



# AIKIN, LAMBERT & CO.

MANUFACTURERS OF

GOLD PENS,

Ebony, Ivory. Rosewood,	} (	PENCIL CASES,	} (	Celluloid
		DESK HOLDERS,		Rubber.
		PENCILS,		Pearl.
		TOOTH PICKS,		

—AND—

## NOVELTIES IN PENCIL CHARMS.

Many of which are protected by Letters Patent, and all at prices to meet the popular demand, being made and finished in our own factories under our own personal supervision, using the best materials with modern appliances (we guarantee our productions), unsurpassed in finish, style and price. Our patent inlaid Celluloid Pencils, Pencil Charms and Picks, in Black, Shell, Malachite, Red, White, Pink, Variegated light and dark blue colors, are the handsomest goods yet produced, and at reasonable prices, the inlaid work being of solid gold and pearl in form of flowers, birds, etc., and warranted durable.



A full assortment of long and short nibs, stubs, falcon, oblique, commercial, fine and broad pointed Pens, in every style of holder, suitable for business or holiday trade.

To those purchasing assortments, we are furnishing the finest trays and show cases for their display, ever offered to the trade. Dealers are invited to call and examine, or particulars will be furnished to regular dealers only, upon application, when accompanied by business card, or satisfactory reference, and price lists, with Illustrated Catalogues sent. ALSO, A LINE OF GOODS SUITABLE FOR EXPORT TRADE.  Goods sent for selection.

PARIS HOUSE,

J. GLAENZER & CO

35 Boulevard de Strasbourg.

Main Office, 23 Maiden Lane, New York.

Branch Office, 113 E. Madison St., Chicago.

We are also Importers of all grades of watches, and would call attention to the following specialties :

**PAUL BRETON** Movements, of which we are sole Agents. A full line of these celebrated Watches in Gold and Silver Cases of the most approved styles.

**CHAS. LATOUR** Movements, Nickel  $\frac{3}{4}$  plate, handsome, showy watches at medium prices, good reliable time pieces. Key and Stem-Winders.

**AGASSIZ** Movements, Gilt and Nickel Stem Winders (fitting 8 size Riverside Case), accurate timepieces, and *lower priced* than American movements of same quality.

Metal Open Face Stem Winding **Longines, Excelsior and Champion**, 13, 15, 16, 18 and 20 lines, good timers and *attractive in style and finish*.

Jobbers in all kinds of **American Movements and Cases**, including the "DUEBER," Silver Cases, and Boss' and LADD'S FILLED CASES.

MANUFACTURERS OF

**GOLD AND SILVER THIMBLES**, in various styles, and to order.

**STONE RINGS**, Onyx, Cameo, Intaglio, Topaz, Garnet, Amethyst, Pearl and Turquoise; also, Solid Band, Chased and Plain.

**BRACELETS**, an assortment in gold and rolled plate, including new and handsome designs.

**PLATED CHAINS**, a large assortment of Vest, Guard, Neck, &c. Also, SEALS, LOCKETS, &c. A GENERAL LINE OF RELIABLE JEWELRY IN GOLD AND PLATE.

We manufacture to order any article in the line; also do repairs, and will procure for regular customers any article required in the trade, whether kept in stock or not. Orders filled as promptly as possible.

**23 Maiden Lane, New York.**

LOUIS W. LEVY.

EDWARD DREYFUS.

PHILIP HECHT.

# LEVY, DREYFUS & CO.,

IMPORTERS AND DEALERS,

P. O. Box, 3567.

11 MAIDEN LANE, NEW YORK.

## WATCHMAKERS' TOOLS AND MATERIALS.

Consisting of Fine Geneva Mainsprings, Hair Springs, Hole Jewels, Wheels and Pinions, carefully selected with a view to accurate measurement by competent and skilled watchmakers. Also a selected assortment of Solid Case Springs, 4 holes, highly polished, and finely tempered; especially made for us.—Samples of which will be sent on approval.

### GENUINE AMERICAN MATERIALS.

A Full and Complete Line of all the leading Watch Companies' Materials (WARRANTED GENUINE.)

### FINE SWISS AND AMERICAN LATHES.

With the latest and most approved attachments. Staking tools in sets of 20, 24, and 42 punches; roller removers of 4 different styles. Stubs, Baumel, Vautier & Grobet, celebrated Tools, Files, &c., and all the leading Special Tools in this department.

### JEWELERS' AND ENGRAVERS' TOOLS.

Crescent Saw (square and flat) finely tempered, and uniform teeth; Wheels, Buffs and Brushes of every description, for all styles of work. Rollers, Polishing Heads and Stands of the most practical designs, Gold and Silver Enamel, Rouge, Polishing Powder, Vienna Lime, &c. ACCURATELY ADJUSTED DIAMOND AND GOLD SCALES.—POCKET AND UPRIGHT.

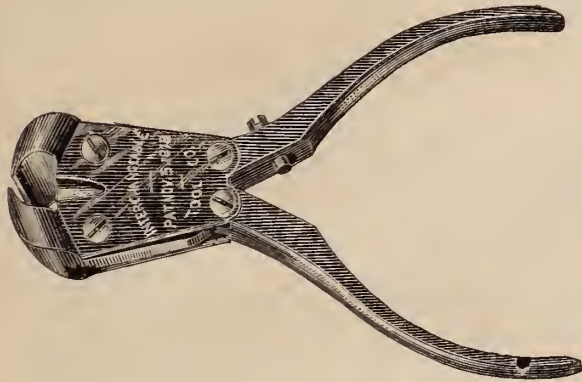

Patent Compound Lever Cutting Nippers made of tempered steel with interchangeable parts. Size, 5 inches. Price, \$1.25; Postage, 15 cents extra. Full descriptions sent on application.

### JEWELERS' JOBBING MATERIALS AND FINDINGS.

A Full and Complete Stock of every article in this line.

### REAL AND IMITATION STONES

For manufacturing and jobbing purposes.

Renard's, Stubs', Vautier's, Burt's, and other celebrated makes of jewelry, letter and wood gravers, and all other goods required for engravers' use.

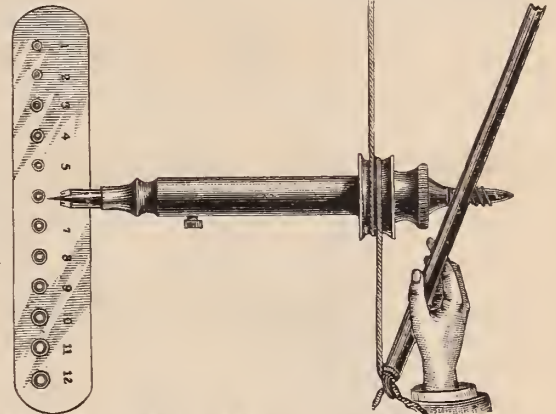

### NEW JEWEL SETTING CUTTER

For cutting the bezel or rim that holds the jewel to the plate of watch movements. The 12 sizes of bezels indicated on this gauge, are used for adjusting the jaws of the cutter. Price, \$2.00, postage paid.

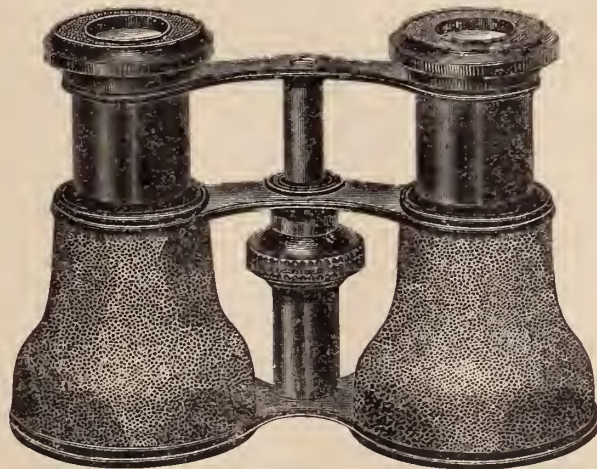

## OPTICAL GOODS IN GREAT VARIETY.

Consisting of Opera Glasses, of Bardou, Lemaire, and other standard makers, Marine and Field Glasses of all grades, Telescopes, Barometers, Microscopes, Thermometers, Compasses, Drawing Instruments, Spirit Levels, Linen Testers, &c.

### SPECTACLES AND EYE GLASSES OF ALL KINDS.

Also Spectacle Cases in great variety: Lenses, Grind Stones, and Opticians Supplies generally.

## WATCH GLASSES.

The Most Complete Assortment ever offered.

An Illustrated Book of Monograms and Alphabets. The most complete work ever published, containing over 1,500 designs of Monograms and crests, and the 35 series of Alphabets and numerals. Price bound in cloth, \$5.00.

Our prices will be found as low as any responsible house in the trade. All orders committed to our care will receive prompt and careful attention.

### WATCH CHAINS

In Bamboo, Leather, Horn, Shell, Rubber Berlin Wire, Steel, German Silver, Nickel Plate, Gilt, Rolled Plate and Fine Silk. Also SILK GUARDS, (round, square, tubular and flat) in great variety. Foreign and American makes of Ribbon Vest and Guard Chains, mounted in Gold, Rolled Plate and Silk trimmings.

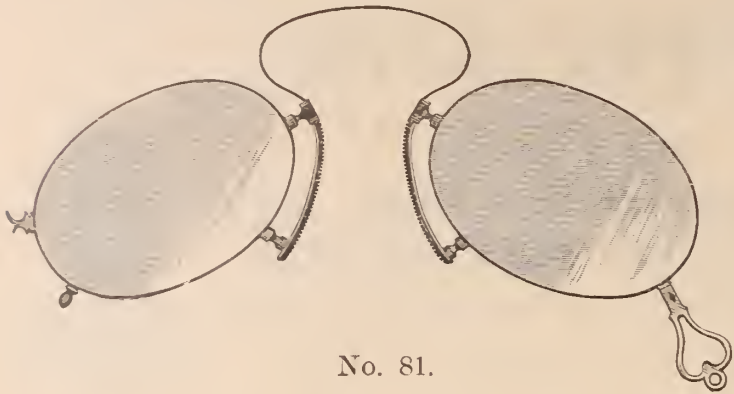

No. 81.

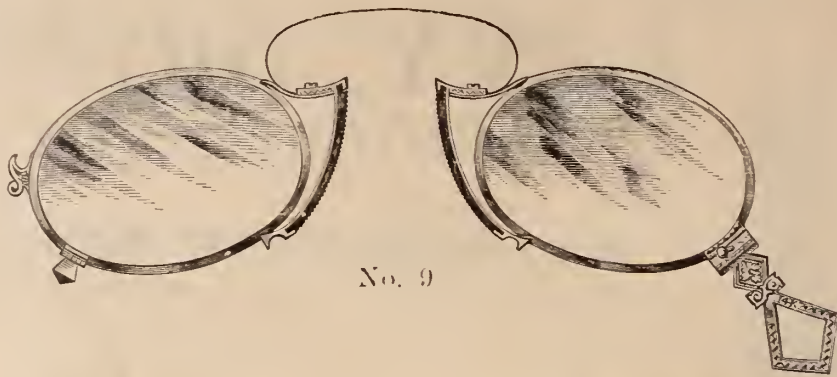

No. 9



No. 15.



No. 36.

Manufacturers of  
GOLD, SILVER AND STEEL  
**MORGAN & HEADLY,**  
Spectacles and Eye Glasses,  
We beg to call the attention of the trade to the large stock of  
**DIAMONDS,**  
Set and unset, which we have on hand. Goods sent on approval where references are satisfactory. A rare collection of Fine Old Mine Gems in Single Stones and match pairs up to 16k. just received.  
Nos. 611 & 613 Sansom Street,  
PHILADELPHIA.



No. 88.

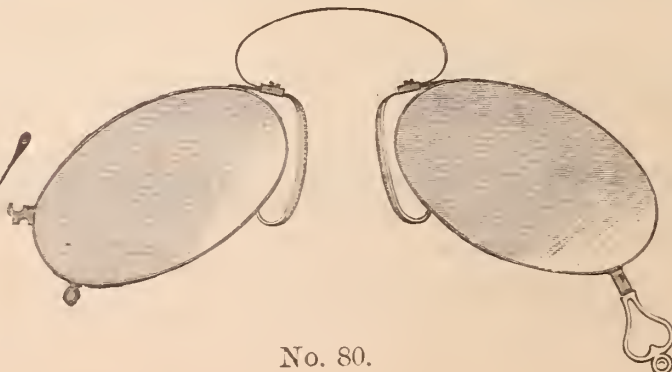

No. 80.

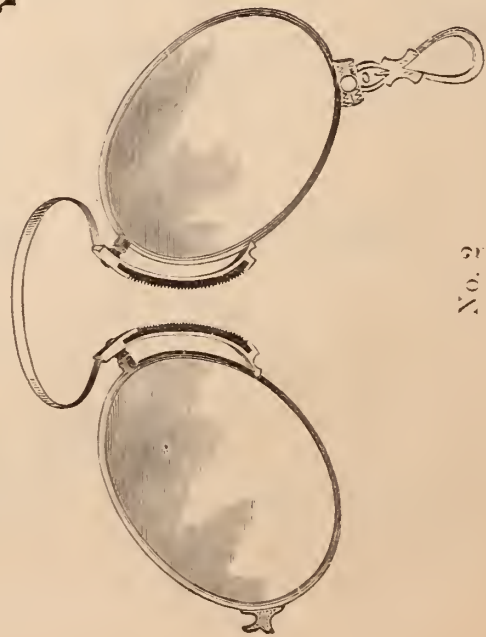

No. 2

# MILLER BROS.

MANUFACTURING JEWELERS,

No. 11 MAIDEN LANE, NEW YORK.

Manufactory, 47, 49 & 51 Franklin Street, Newark, N. J

A  
Large Line  
of

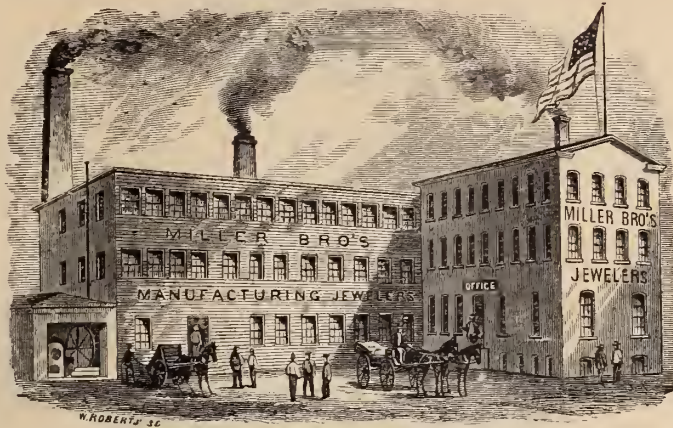

NOVELTIES.

ATTENTION IS INVITED TO OUR  
NEW STYLES OF ETRUSCAN SLEEVE BUTTONS,  
MOUNTED WITH

## RUSTIC LETTERS

BIRDS, ANIMAL HEADS AND FANCY ORNAMENTATIONS.

Also a full line of Locketts, Sets, Pins, Ear Rings, Sleeve Buttons, Studs, &c.

All goods exclusively of our own manufacture, many of which are protected by MECHANICAL and DESIGN PATENTS.

# SIMPSON, HALL, MILLER & CO

36 East 14th St., Union Square,

NEW YORK.

Factories, Wallingford, Connecticut.

MANUFACTURERS OF THE FINEST QUALITY

## Silver-Plated Ware.



NEW DESIGNS OF SUPERIOR ARTISTIC MERIT NOW  
READY AND IN PREPARATION.



# GORHAM MANUFACTURING COMPANY, Silversmiths,

NEW YORK AND PROVIDENCE, R. I.

California Office, 120 Sutter Street, San Francisco.

MAKERS OF STERLING SILVERWARES (925-1000 FINE), OF THE HIGHEST CHARACTER OF WORKMANSHIP AND DESIGN.

*We would call the attention of the trade to the Marked Reduction in our Prices of*

**GORHAM PLATED SPOONS AND FORKS,**

While the quality of these goods will be strictly maintained, we are now enabled to offer them at very moderate prices, which we feel confident will ensure for them a largely increased trade.

**SALESROOM, 37 UNION SQUARE, N. Y.**

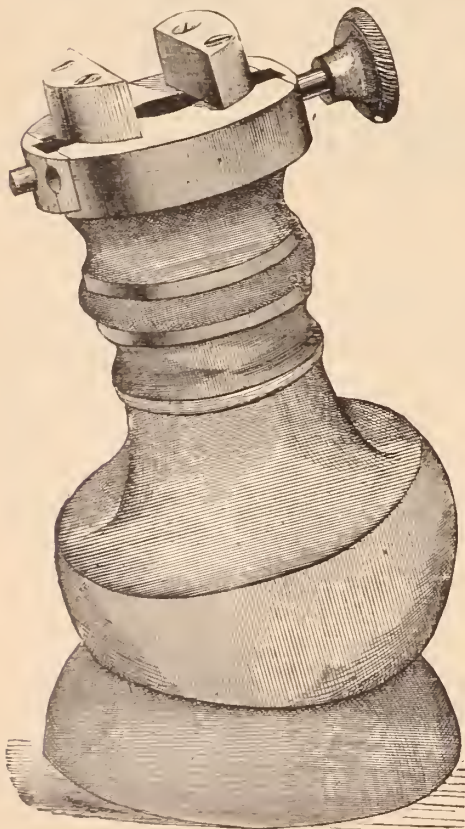

## ARKELL & CO.

IMPORTERS OF

### Watch Materials and Tools,

AND DEALERS IN

### ALL GRADES OF AMERICAN WATCHES

### And JEWELRY,

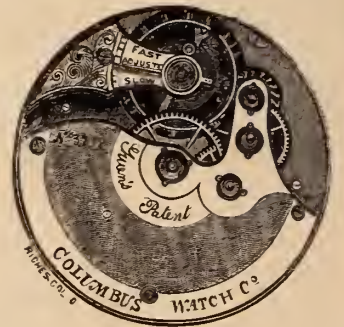

Sole agents for the "COLUMBUS" Watches, Nickel,  $\frac{1}{2}$  plate Stem-Winding, made in popular sizes. We call especial attention to our 8 Size Ladies' Watch, the best and lowest in price in the market.

We are manufacturers of the "BOSS" Engraving Block, and BALDWIN'S Barrel Catch Inserter; can be obtained of all dealers in Watch Materials. Sole agents for the JEQUIER MAIN SPRINGS for Swiss and American Watches. We claim they are the Best in the country, and are put up on strengths by Denison's Standard Gage.

We have constantly on hand rare specimens of BRAZIL BUGS at very low prices. All orders entrusted to us will receive prompt attention.

## ARKELL & CO.

Canajoharie, N. Y.



SPRING SEASON 1880.

MIDDLETOWN



PLATE CO.

MANUFACTURERS OF

# Superior Silver-Plated Ware.

OFFER NEW DESIGNS IN

Pitchers, Pitcher Sets, Water Sets, Casters, Baskets, Waiters, Tea Sets,  
Cups, Goblets, &c., &c.,

*Together with the Goods so popular during the past season. Our Illustrated Catalogues and  
Photograph Albums will be sent on application.*

---

**OFFICES.**

*Middletown, Conn.,  
120 Sutter Street, San Francisco, Cal.,*

*13 John Street, New York,  
101 & 103 State Street, Chicago, Illinois.*

# Silver Plated Ware

MADE BY THE

## MERIDEN BRITANNIA COMPANY,

46 East Fourteenth Street, Union Square,

NEW YORK.

# WM. ROGERS & SON,

HARTFORD, CONNECTICUT.

Trade Mark on Spoons :

⚓ WM. ROGERS & SON, A. A.

Established in 1865.

We call attention to our new pattern, the HARTFORD, it is the latest, noblest and best pattern in the market, and is *five per cent*, less than any pattern of the kind.



Trade Mark on Knives :



Established in 1865.

Silver Plated Knives, Forks,  
Spoons, Casters and  
Cake Baskets.

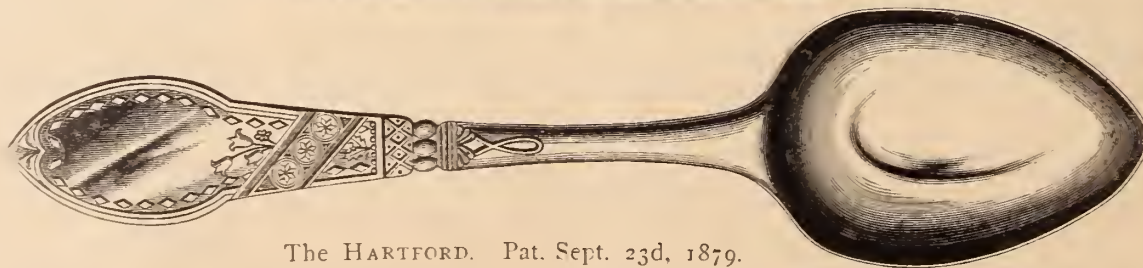

The HARTFORD. Pat. Sept. 23d, 1879.

# WM, ROGERS & SON,

Drawer 30, Hartford, Conn.

WM. WATROUS, President,  
F. WILLSON ROGERS, Secretary



# BENJ. ALLEN & CO.

Nos. 137 & 139 State Street Chicago.

## JEWELRY and DIAMONDS

WALTHAM, ELGIN, HOWARD AND SPRINGFIELD, ILL.

### WATCHES,

Rogers & Bro's., Spoons, Forks, &c.

Western Agents for SIMPSON, HALL, MILLER & CO.

Our new Catalogue will be ready October 1st, and will be sent to the trade upon application.

## L. H. SANDERSON,

Designer and Manufacturer of and Dealer in  
Watchmakers' and Jewelers' Tools & Supplies

New York House for Kendrick Davis & Co.'s Dust-proof Key, and T. A. Willson's Justly Celebrated Optical Goods.

I am also Keeping a Line of Hampden Watches.

NEW WATCH HAND FLYER.

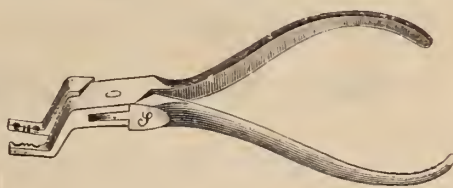

For removing second, minute and hour hands, also for holding to file, and to fit, and for a large variety of bench work. Watchmakers will find these tools invaluable. Price, \$1.25 Each.

66 NASSAU STREET

NEW YORK CITY.

P. O. Box 1965.

\$2.00 EACH.

New Roller Tool.  
Draws a roller on as well as off. Simple and effective and substantially made.



LOUIS A. SCHERR.

CHAS. H. O'BRYON.

G. W. SCHERR.

## LOUIS A. SCHERR & CO.

Importers and Wholesale Dealers in

### Watches, Jewelry,

WATCH MATERIALS, TOOLS, GLASSES, &c.

### Spectacles, Silk Guards, &c.

Wholesale Agents for American Watches.

No. 726 CHESTNUT STREET,

FIRST FLOOR.

### PHILADELPHIA.

AGENTS FOR W. F. NYE'S WATCH AND CLOCK OILS.

AUBURNDALE, MASS..

## CHRONOGRAPH TIMER

WM. B. FOWLE, Maker.

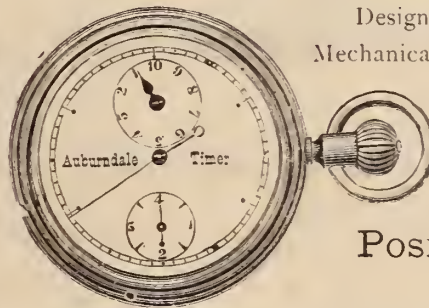

Designed for Sporting, Scientific and Mechanical purposes;  $\frac{1}{4}$  and  $\frac{1}{8}$  seconds, fly back.

List Price, - - \$15 00

Positively Accurate.

Put up in German Silver Cases, Nickel Plated, size of an ordinary watch. Very neat and handsome, supplying a want long felt by those desiring to measure the flight of time with scientific accuracy to the fraction of a second. It indicates positively minutes, seconds, quarters or eighths of seconds, the only instrument registering one eighth of a second made. It is substantially constructed, positive in its action and will not easily get out of order.

These Chronographs can be obtained from the principal Jobbing Houses in the Trade.

## FRASSE & COMPANY,

Importers of P. S. STUBS'

French, Swiss, German & Sheffield Tools, Files,

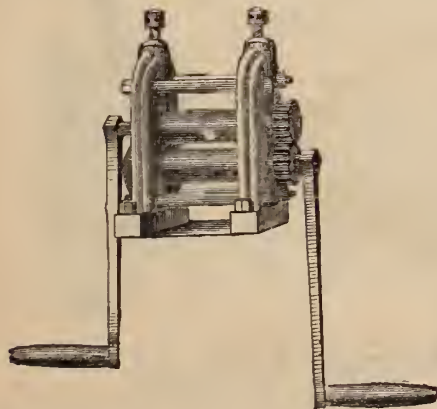

Steel Wire and Materials,  
For Watchmakers, Jewelers, Engravers  
Die-Sinkers, Machinists, &c.

Turning Lathes, Drills & Chucks

Rolling Mills, Draw Plates,

The Celebrated Rodenbush  
Piercing Saws,

Horse Shoe Magnets, Nurls, Ingo's, Chasing Tools, Engravers' Tools, Brush Wheels & Buffs, Hand Brushes and Buffs, Borax, Saltpetre, Beeswax, Rouge, Tripoli, German Silver, Brass, &c.

No. 62 Chatham Street,

Established 1816.

New York.

P. O. Box 462

**CHAS. P. HEROLD,**  
**MANUFACTURING JEWELER,**  
**DIAMOND SETTER**  
AND DEALER IN  
**DIAMONDS.**

916 CHESTNUT ST. PHILA.

N.B. A LARGE STOCK OF 18 Kt DIAMOND MOUNTINGS,  
SUCH AS CLUSTER AND SOLITAIRE RINGS, EARRINGS, LACE PINS,  
SHAWL PINS, CROSSES, STUDS, AND GENTS' PINS,  
&c. ALL OF WHICH ARE OF MY OWN DESIGNS AND  
ARE MADE IN THE FINEST STYLE AND FINISH.

# COLBY & JOHNSON,

17 Maiden Lane, New York,  
IMPORTERS AND JOBBERS OF

## American and Swiss Watches,

MANUFACTURERS OF

### WATCH CASES AND FINE JEWELRY,

PATENTEES AND SOLE MANUFACTURERS OF

White,  
Black, or  
Marbleized  
Celluloid  
Backs and  
Bezels.



Gold, Silver,  
or  
Nickel  
Centers,  
Pendants  
and Bows.

Suitable for all 18-Size American S. W. Movements.

## SINNOCK & SHERRILL,

### Stone Ring Manufacturers,

No. 5 Maiden Lane, N. Y.

Factory, Newark, N. J.

## JOSEPH N. TINGLEY,

Late of the firm of Tingley, Sinnock & Sherrill,

MANUFACTURER OF

# STONE RINGS,

—AND—

NOVELTIES IN STONE GOODS,

No 9 Maiden Lane, New York.

Factory, Newark, N. J.

## E. HOWARD & CO.,

MANUFACTURERS OF

### Fine Watches, Regulators, Office Clocks,

Electric Watch, Clocks & Tower Clocks,

**Office, No. 2 MAIDEN LANE**

**NEW YORK**

No. 114 TREMONT STREET, BOSTON.

J. W. J. PIERSON, - - - AGENT.

To Watch Case Manufacturers and Jewelers.

### FOR SALE

## TWO ENGINE TURNING LATHES

*But little used and in perfect order. One a "Straight Line" and the other "Circular." Cost when new, \$2,500. A bargain as they will be sold at a great sacrifice. Address,*

**HODENPYL, TUNISON & CO.,**

170 Broadway, N. Y.

DYER BRAINERD.

JOHN W. STEELE.

## BRAINERD & STEELE,

MANUFACTURERS OF

### Brainerd's Pat. Lockets,

(Patented June 17, 1874)

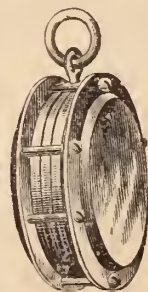

These Lockets combine both beauty and strength. They are made of solid 14kt. gold, and the stones used are the finest obtainable in the market. They cost no more than those of the old style, if indeed as much; and the combination of secrecy and durability renders them much more desirable. We make three sizes in four different shapes—round, oval, cushion and oblong square; and also Sleeve Buttons of the same style, containing a concealed box for miniatures, a novelty new to the Trade.



### FINE GOLD JEWELRY,

**No. 9 Maiden Lane,**

**NEW YORK.**

**NOTICE.**

Manufacturing Jewelers are hereby notified that the undersigned have obtained Letters Patent, dated Feb. 25th, 1879 and re-issued Oct. 14, 1879, for Bracelets constructed of a single band, having ornamentation in relief permanently fixed upon its outer surface, with rigid marginal flanges or projection for the protection of the same, and all infringements, whether in cheap or fine goods, will be promptly and rigorously prosecuted according to law.

**HALE & MULFORD,**  
Broadway & Fourth St.

New York, Oct. 14th, 1879.

**SAXTON, SMITH & CO.**  
MANUFACTURERS OF

**Fine Gold Chain.**

No. 15 Maiden Lane,  
**New York.**

Factory, No. 183 Eddy Street, Providence, R. I.

Sole Agents for the new PATENTED CHAIN BAR, containing a Detachable Pencil.

**HELLER & BARDEL,**

Manufacturers of

DIAMOND AND PEARL

**JEWELRY,**

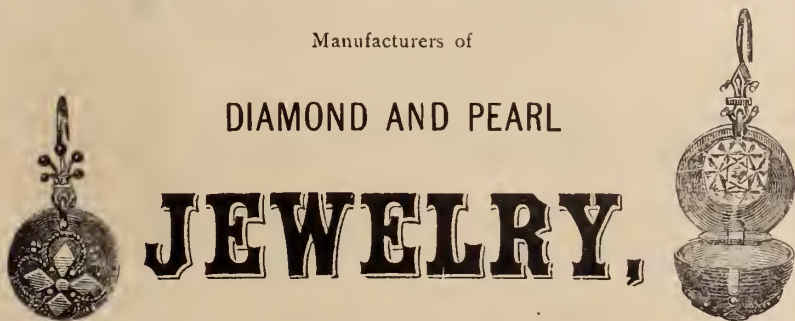

13 John St., New York.

ESTABLISHED 1848.

**E. S. JOHNSON & CO.**

MAKERS OF

**Gold Pens, Pencil Cases, Etc.**

SUITABLE FOR THE REQUIREMENTS  
OF ALL CLASSES OF DEALERS

These goods have achieved a high reputation and are universally acknowledged to be the best Pens and Pencil Cases made, and as low in price as is consistent with quality of Gold, workmanship and style of finish.

Intending purchasers will consult their interests by comparing prices. We are constantly introducing new and desirable goods that cannot fail to give satisfaction.

44 Nassau Street, New York.

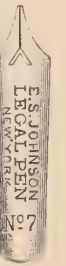
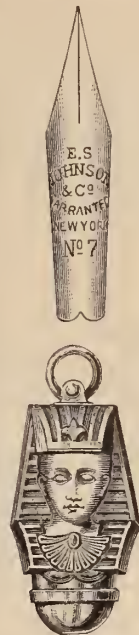

PRICE LISTS SENT ON APPLICATION.

**WOOD & HUGHES,**

STERLING

**Silverware Manufacturers**

No. 16 JOHN STREET,

NEW YORK.

206 Kearney Street, San Francisco, Cal.

R. R. HASKELL, Agent.

**KREMENTZ & CO**

RINGS IN  
CAMEO, TURQUOISE & C.

JEWELERS

MEDALLIONS & NECKLACES

LACE TRIMS

SETS & EARRINGS

ONYX GOODS.

Office 13 John St.  
NEW YORK.  
FACTORY NEWARK, N. J.

CARTER, HOWKINS & SLOAN,  
**Makers of Fine Jewelry**

*Consisting of Chains, Bracelets, Sets, Pins, Studs, Sleeve Buttons,  
 Scarf Pins, Rings, &c., in Roman, Etruscan and Enamel,  
 and a full line of Jewelry generally.*

Whiting Building, Corner Broadway and Fourth Street,

A. CARTER JR.  
 WM. HOWKINS,  
 A. K. SLOAN.

**NEW YORK.**

C. E. HASTINGS,  
 GEO. R. HOWE,  
 W. T. CARTER.

**HALE & MULFORD,**  
**Manufacturing Jewelers,**

(WHITING BUILDING).

No. 694 Broadway, cor. 4th Street, New York.

Call attention of the Trade to their new style of

**BAND BRACELETS,**

We claim for these Bracelets, the following advantages over the old style, viz. .

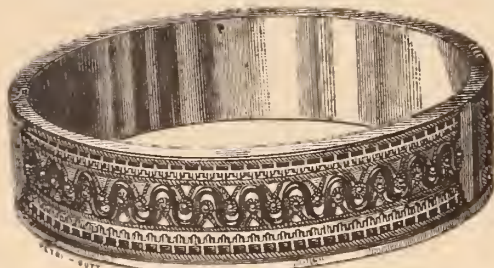

Patented Feb. 25th    Re-issued Oct. 14th, 1879.

1st. The edge of the Bracelet being raised, forms a protection to the ornamentation.

2d. Less liability of getting damaged, and when damaged, are more easily repaired.

3d. More attractive in appearance.

Prices are as low as any FIRST CLASS 14 KARAT ALL GOLD Bracelet in the market.

Made in all sizes from  $\frac{1}{4}$  inch upwards.

—Established 1837.—

**TAYLOR & BROTHER,**

Late TAYLOR, OLMSTED & TAYLOR,

**Importers of Diamonds and Pearls,**

—AND—

**MANUFACTURERS OF DIAMOND JEWELRY,**

No. 676 BROADWAY,

**NEW YORK.**

**BALDWIN, SEXTON & PETERSON.**

MANUFACTURERS OF

**Fine Jewelry,**

Diamond and Stone Cameo Goods,

GOLD CHAINS, &c.

Importers of Diamonds, Pearls, Emeralds, Rubies, &c.

WHITING BUILDING,

**Cor. Broadway and Fourth Street,**

**NEW YORK.**

120 SUTTER STREET, San Francisco, Cal.

Established 1817.

**Ve. J. MAGNIN, GUÉDIN & CO.**

29 Union Square, New York.

Manufacturers and Importers,

FINE SWISS WATCHES.

REPEATERS, CHRONOGRAPHS & CALENDARS

GENEVA GOLD JEWELRY,

FRENCH CLOCKS AND BRONZES,

RICH FANCY GOODS,

HORSE-TIMERS & PEDOMETERS,

GOLD AND SILVER CHATELAIN WATCHES.

Gold Medal Awarded, Paris Exposition, 1878.

*Sole Agents for the James Nardin Watch.*

*House in Geneva, 14 Grand Quai.*

Established 1818.

**THOMAS G. BROWN,**

MANUFACTURER OF

**FINE JEWELRY.**

*Designs furnished for all kinds of Sporting  
 Badges and Medals for Schools & Colleges.*

**NEWARK, N. J.**

—AND—

**9 BOND STREET, NEW YORK.**

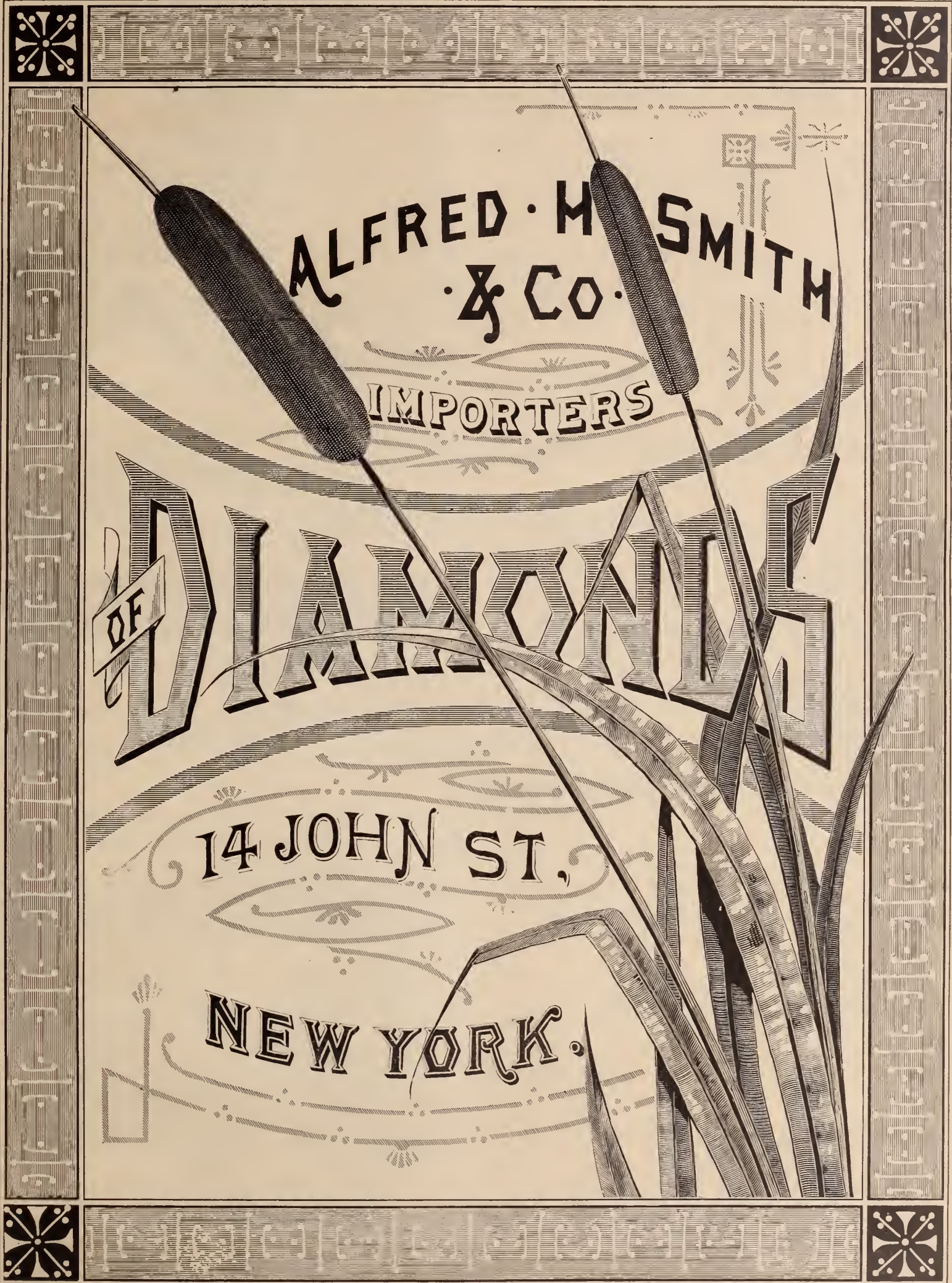

ALFRED · M · SMITH  
· & Co. ·

IMPORTERS

OF DIAMONDS

14 JOHN ST.,

NEW YORK.

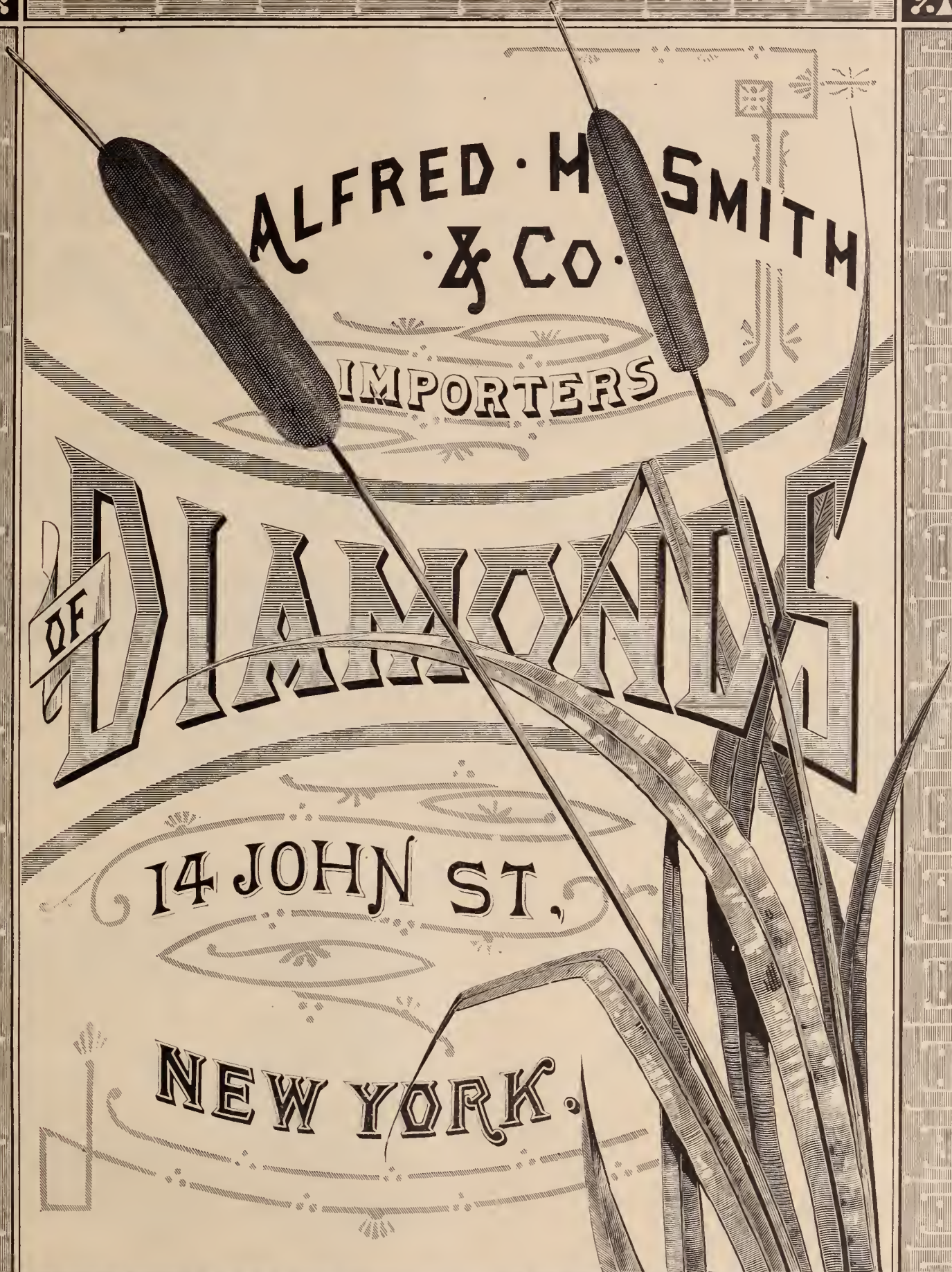

Established 1834.

# G. & S. OWEN & CO.

MANUFACTURERS OF

## FINE GOLD JEWELRY

Consisting of { Roman and Polished Goods,  
 { Box and Glass Goods,  
 { Hair Chain Mountings,

*Specialty---Black Onyx and Pearl Goods Consisting of Lace, Chatelaine and Scarf Pins Ear Rings, Sleeve Buttons and Studs, Leontine and Vest Chains in great variety.*

All our goods exclusively of our own manufacture.

5 MAIDEN LANE, NEW YORK

# JOHN A. RILEY & CO.

MANUFACTURERS OF

## Rich Gold and Onyx Jewelry,

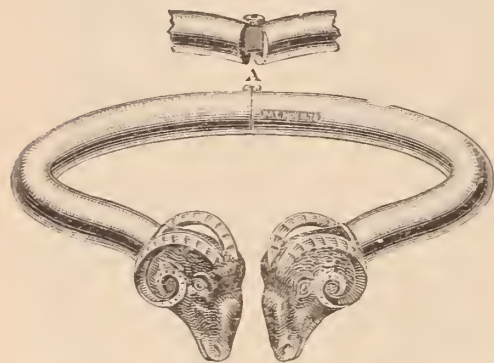

NOVELTIES IN HALF SETS. LACE PINS, SCARF PINS AND EAR RINGS

Engagement Pad, Lock Bands, Elastic Snake Bands and Chatelaines. Onyx Chatelaines with and without Watch Movements.

Nos. 7 & 9 Bond Street, New York.

No. 126 Kearney Street, San Francisco, Cal.

# MOORE & HORTON,

## JEWELLERS,

No. 11 Maiden Lane, New York.

### SPECIALTIES!

Stone Cameo, Onyx, Amethyst, Topaz and Pearl Rings.  
 Studs, Collar and Sleeve Buttons.

Also our new fac simile of Fine African Diamonds, mounted in Rings, Studs, Pins, Ear-rings, Scarf Pins, Medallions.

26  
 John  
 STREET,  
 New York.

**S**

COY & SEDGWICK,  
 MAKERS OF  
 FINE JEWELRY.

**IMPORTER OF DIAMONDS**

**E. AUG. NERESHEIMER**

21 MAIDEN LANE,  
 NEW YORK

№1 GAERTNER PLATZ  
 MUNICH-GERMANY.

№24 DOELEN STRAIT  
 AMSTERDAM-HOLL.

DIAMONDS LOOSE & MOUNTED SEPTON APPROVAL AND THE VALUE INSURED

**OWEN SHEPHERD & CO**

**MAKERS OF FINE JEWELRY**

CONSISTING OF  
 BRACELETS,  
 SETTS,  
 LOCKETS,

PINS,  
 STUDS,  
 RINGS,  
 SLEEVE BUTTONS  
 ETC.

**SPECIALTY**  
**STIFFENED ROMAN BANDS.**

Nos 612 & 614 CHESTNUT ST. PHILADELPHIA.  
 BRANCH-OFFICE 15 JOHN ST. NEW-YORK.

# ENOS RICHARDSON & CO.

MANUFACTURERS OF

## FINE GOLD JEWELRY,

Gold Chains, Locketts, Crosses and Necklaces,  
COLORED AND ETRUSCAN WORK.

ENGRAVED AND ENAMELED GOODS IN GREAT VARIETY.

All Goods sold strictly of our own manufacture.

23 MAIDEN LANE, NEW YORK.

ENOS RICHARDSON,  
THOS. SLATER,

L. P. BROWN,

F. H. RICHARDSON,  
W. P. MELCHER.

# CHATELLIER & SPENCE,

## Manufacturing Jewelers,

694 BROADWAY, NEW YORK.

No. 1006 Chestnut Street, PHILADELPHIA, PA.

No. 12 West Street, BOSTON, MASS.

No. 120 Sutter Street, SAN FRANCISCO, CAL.

## Platinum-Tipped Diamond Settings

Patented April, 1878, by

### RIPLEY, HOWLAND & CO.



OFFICE, 35 MAIDEN LANE,  
NEW YORK.

Factory, 383 Washington St., Boston, Mass.

# LYON & HARDY,

30 MAIDEN LANE, NEW YORK,

IMPORTERS OF

## DIAMONDS,

AND MANUFACTURERS OF

## DIAMOND MOUNTINGS.

All goods ordered for stock or on approval are insured while in the hands of Express Companies.

# E. A. CUPPIA,

MANUFACTURER OF

## Sterling Silver Jewelry,

19 Union Square, N. Y.

## CHATELAINES

In Solid Nickel Metal and Sterling Silver of New and Original Designs at Greatly Reduced Prices.

## SILVER FILAGREE.

Imported Direct from Genoa, Embracing Novelties never before introduced, and offered at prices that will compel the attention of buyers.

# A. J. HEDGES & Co.,

MANUFACTURING

## JEWELERS.

No. 9 Maiden Lane, New York.

Factory, No. 90 Mechanic Street, Newark, N. J.

**J. A BROWN & CO.**

OFFICE AND SALEROOM:  
No. 11 Maiden Lane, N. Y.

FACTORY:  
No. 104 Eddy St., Providence, I. R.

SOLE MANUFACTURERS OF THE

**Ladd Patent Stiffened Gold Watch Cases**

The Best and most durable, and the

CHEAPEST STIFFENED Gold Watch Case

FOR THE MONEY  
MADE IN THE WORLD!

All genuine Watch Cases of our manufacture have "G. W. Ladd's Patent, June 11, 1867," stamped upon the side band underleath the glass bezel.

REFUSE ALL OTHERS.

Send for full Descriptive Circular to the

OFFICE AND SALEROOMS  
1 Maiden Lane, N. Y.

Dealers can obtain them of the Wholesale Watch and Jewelry Houses, or their Traveling Agents throughout the United States and British Provinces.



KEY AND STEM WINDING

Hunting and Open-Face

IN FLAT BEVEL.

Mansard and Oval

SHAPES

Adapted to the various

AMERICAN-MADE MOVEMENTS,

IN

8, 10, 14, 16 & 18

SIZES.

THOS. COGSWELL.

O. W. WALLIS.

**COGSWELL & WALLIS,**

(AGENTS.)

WHOLESALE

**Watches, Clocks, Jewelry,**

**Silver and Plated Ware,**

**WATCHMAKERS' TOOLS AND MATERIALS.**

146 STATE STREET.

SECOND FLOOR.

CHICAGO

**OPPENHEIMER BROS. & VEITH.**

MANUFACTURING JEWELERS

AND

Dealers in Watches and Diamonds,

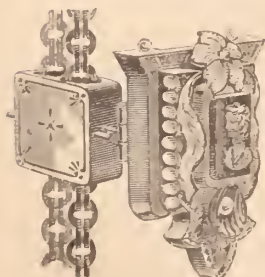

35 Maiden Lane,

NEW YORK.



Patented June 3, 1879.

Combination Chain, Slide, Pendant and Locket.

ESTABLISHED 1839.

**BUCKENHAM, COLE & SAUNDERS,**

SUCCESSORS TO

**BUCKENHAM, COLE & HALL,**

IMPORTERS OF

**Diamonds, Pearls**

AND OTHER PRECIOUS STONES,

MANUFACTURERS OF FINE JEWELRY,

**10 Maiden Lane, New York.**

A large Stock of FINE DIAMONDS, Mounted and Unmounted kept constantly on hand. Goods sent on approval to any part of the country on receipt of satisfactory references.

*New York, December 31st, 1879.*

AUGUSTUS A. JEANNOT and ANDREW K. SHIEBLER have this day formed a co-partnership under the firm name of

**Jeannot & Shiebler,**

Who will continue the manufacture of

**FINE WATCH CASES**

At their Factory,

Nos. 42 and 44 State Street, Brooklyn, N. Y.

Office, 20 Maiden Lane, N. Y.

The partnership heretofore existing and known as A. A. JEANNOT & Co., composed of A. A. Jeannot, T. F. Ball, William Parker, George L. Waters and C. Lindemeyer expires this day by its own limitation.

The undersigned have exclusive control and authority to settle and collect all outstanding claims of the late Firm.

**JEANNOT & SHIEBLER,**

20 Maiden Lane, N. Y.

**MAX FREUND & CO.,**

**Manufacturing Jewelers**

IMPORTERS OF

**WALTHAM'S**

Jewelry and Precious Stones,

No. 8 Maiden Lane

NEW YORK



This Movement fits Waltham Cases.

Sole Agents for the Celebrated A. Schneider Watch, Dresden.

Also the Standard Watch Co. of New York.



MANUFACTURERS  
OF  
EXCLUSIVELY  
**BLACK ONYX GOODS,**

**WOGLOM & MILLER,**  
32 & 34 JOHN STREET,  
NEW YORK.

Bracelets,  
Brooches,  
Collar Buttons,  
Crosses,  
Cuff Pins,  
Ear Rings,  
Ear Studs,  
Half Sets,  
Lace Pins,  
Leontines,  
Sleeve Links,  
Lockets,  
Medallions,  
Necklaces,  
Scarf Pins,  
Shawl Pins,  
Sleeve Buttons,  
Studs and  
Vest Chains.

**HENRY FERA,**  
Importer of Diamonds,  
No. 9 MAIDEN LANE,  
New York.

Having my own cutting and polishing establishment at Nos. 23 and 25 Looijersgracht, Amsterdam, Holland, constantly running 36 mills, I am able to offer to the trade a full assortment of Diamonds at very low prices.

Loose and Mounted Goods sent on approval to any part of the country on receipt of satisfactory references.

All goods ordered from or shipped to me, are insured while in the hands of express companies, and no valuation is needed on the parcels.

**BOOZ & THOMAS,**

MANUFACTURERS OF



Watch Cases & Jewelry,

108 South Eighth St., (2d Story) Philadelphia.

Samples of our goods sent on approval, when satisfactory reference is furnished.

**Old Gold & Silver Bought or Exchanged.**

PARTICULAR ATTENTION PAID TO REPAIRING.

**HAMILTONS & HUNT,**

MANUFACTURERS OF

**Fine Plated Chains**

AND PATENT BUCKLE BRACELETS,

A Full Line of Ladies' and Gentlemen's Roman & Stone Locketts.

**Branch Office, 176 Broadway, New York**

FACTORY, 226 EDDY STREET, PROVIDENCE, R. I.

**M. FOX & CO.**  
**Practical Lapidaries,**

IMPORTERS OF

**DIAMONDS**

AND OTHER PRECIOUS STONES,

No. 1 Maiden Lane, New York.

**W. C. GREENE & CO.**  
GOLDSMITHS

MANUFACTURERS OF  
RICH SETS IN TAPER WIRE CORAL

Factory 95 PINE ST. Providence, R. I.  
 Stone Cameo Amethyst Coral Cameo Engraved & Enamel Brooches Sleeve Buttons Studs & Crosses EAR & C. New York Office 192 BROADWAY.

WM. C. GREENE. B. W. GREENE. GEO. D. BRIGGS.

**MILNE & JOURDAIN,**  
Manufacturers of Stem-Winding Watch Crowns



13 & 15 Franklin Street, NEWARK, N. J.

Gold Crowns, for Stem-winding Movements, to suit all sizes of Imported or American Watches, in four different styles and seven sizes.

Gold Pushers for Key Movements in every size. Also Gold Crowns for fine Chronograph Watches made to order.

Silver Stem winding Crowns and Key Pushers on hand or made to order. Send for card and samples.

A. MILNE.

A. JOURDAIN.

**VANHOUTEN SAYRE & CO.**  
MANUFACTURERS  
OF  
**SOLID JEWELRY.**

SETS, REVERBITON, EAR RINGS, ETRUSCAN ENAMEL AND FACET WORK, LOCKETS, COLLAR BUTTONS, STUDS.

OFFICE AND FACTORY, 53 CHESNUT STREET NEWARK, N. J.

**E. STITES,**  
**Manufacturing Jeweler,**  
 No. 12 MAIDEN LANE,  
 New York.  
 SCARF RINGS AND PINS.  
 Roman Band and Le Gant  
 Bracelets.

**WILLIAM H. BALL,**

SUCCESSOR TO BAILL & BARNARD,

MAKER OF

ORNAMENTED

Roman, Enameled and Engraved  
**BRACELETS.**

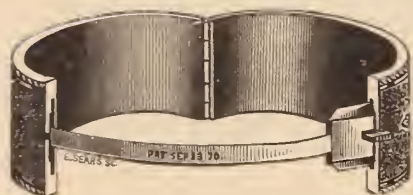

Having given the manufacture of Band Bracelets my entire attention for a number of years, it has been my desire to make a durable article, one that will give satisfaction to the seller as well as the wearer. I desire to call the attention of the trade to the reduction I have made in prices, still keeping up the standard as to QUALITY, FINISH and WORKMANSHIP. To each pair of BANDS is attached my patent guard without extra charge—thus saving the price of chain.

No. 9 JOHN STREET, NEW YORK.

Factory, 30 & 32 Franklin Street, Newark, N. J.

**NEW OTTO SILENT GAS ENGINE**

Working without Boiler, Steam, Coal, Ashes or Attendance.  
 Started instantly by a Match, it gives Full Power immediately.

No Explosion,  
 No Fires nor Cinders,  
 No Gauges,  
 No Pumps,

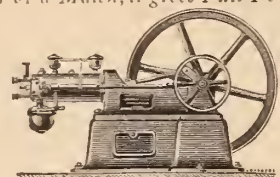

Perfectly Safe,  
 Easily Managed,  
 Durable, and  
 Simple in Construction.

**WHEN STOPPED, ALL EXPENSE CEASES.**  
**TESTIMONIAL.**

PHILADELPHIA, September 12, 1879,  
 Gents:—The four horse power Gas Engine purchased from you for use in our polishing shop, has given us perfect satisfaction, holding its power, and giving little or no trouble in running. It has been in use for about nine months, and we are happy to say fulfills all that you promised for it. Yours, very truly,  
 JAS. E. CALDWELL & CO.

Sizes of Two, Four and Seven Horse made by  
**SCHLEICHER, SCHUMM & CO., 3045 CHESTNUT ST., PHILA.**

**Clark's Grooved Case Springs.**

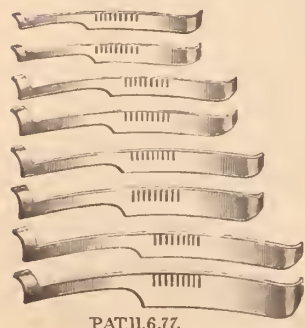

PAT. 116,77.

Made in four lengths, wide and narrow. The spring sets well away from the movement, the depressions obviate any tendency to move lengthwise. Steel rivets preferably used can be removed more easily than screws. In fitting file away the lower edge until the rivet can be pushed down in front of the spring in the grooves. These springs are made from fine steel, carefully tempered and warranted perfectly reliable. To be had of all jobbers in watch materials at manufacturers price—75 cts. per dozen.

**A. N. CLARK,** Manufacturer of the Celebrated **Plainville, Ct.**  
 FOUR HOLE CASE SPRINGS,  
 Watch Keys, Bench Tools, Crosby's  
 JEWELING TOOLS, &c.

**Dorrance, Edge & Co.**

MANUFACTURERS OF

THE CELEBRATED WOVEN FABRIC

**GOLD CHAIN.**

*Elegantly Mounted Bracelets, Opera, Leontine,*

VICTORIA WATCH GUARDS & NECKLACES, in all the Newest Designs.

Our stock is unusually complete, and, in addition to the above, a variety of Necklaces, from 1½ to 40 dwts. each, to which we invite the attention of buyers.

CHILDREN'S BRACELETS A SPECIALTY,

Weighing from 6 dwts. a pair upwards.

No. 12 John Street, New York.

Factory, 46 Greene Street, Newark. N. J.

**T. B. BYNNER,**

**Importer & Jobber of Watches**

DIAMONDS AND FINE JEWELRY,

And Dealer in the BEST CLASS OF ROLLED PLATE JEWELRY

And Key and Stem-Winding American Watches.

No. 513 Broadway, New York



**RICKETT'S  
 PATENT EYE SHADE.**

It is simply a neat curved shade of hard rubber, ¼ inch wide that fits under the eye brows, and flares out at the bottom so as to allow an angle of vision about level with the horizon. Having met with success in New York, Philadelphia and Boston, and wishing to extend our trade to other cities, we will for the next 30 days forward to any one in the trade ordering 2 dozen Spring Shades, an elegant *Plaster Bust*, life size, stands 17½ inches high, and retails in New York for \$3.00. If placed in prominent window, will sell 2 dozen shades in 10 days.

We have first-class testimonials from M. GARDNER, Chief of Draftsman, U. S. Patent Office, H. OLMSTED, Secretary of New York Jewelers' Association, and from many other prominent men of the country. Order from any jobber or direct from us. Please state whether you want Bust.

PRICE.—Spring Shades, \$3.50 per doz.

**RICKETT'S EYE SHADE CO.,**  
 85 Nassau Street, New York.

**STAR WATCH & CLOCK OIL,**

MANUFACTURED BY

**GEO. B. WHEELER,**

NEW BEDFORD, MASS.



This Oil is made from the best of stock, is free from gum or corrosive qualities, will stand the coldest weather, and is every way reliable. L. HAMMEL & Co., 9 Maiden Lane, New York, Agents for the U. S. KOCH & Co., Elberfeld, Prussia, Agents for Europe.

**W<sup>m</sup> S. HEDGES & CO**  
OF THE LATE FIRM OF SMITH, HEDGES & CO.  
IMPORTERS OF  
**DIAMONDS**  
**170 BROADWAY**  
COR. OF MAIDEN LANE. N. Y.  
CHOICE BRILLIANTS IN SINGLE STONES  
AND MATCHED PAIRS A SPECIALTY.

Fresh invoices of Goods in all Grades constantly arriving. Also, choice parcels of exceptionally Fine Gems, ESPECIALLY Selected for critical purchasers. A full line of Mounted Goods, Artistically Designed.

GOODS SENT ON APPROVAL.

# “HILLSIDE,”

NEW THREE-QUARTER PLATE MOVEMENT

—MADE BY—

## The American Watch Company

OF WALTHAM,

The lowest price three-quarter plate Stem-Winding American movement ever made. We wish to call the attention of the trade to the following special advantages:

*They are made to wind at either the figure XII for Open Face Cases, or at figure III for Hunting Cases, in all three qualities, viz.:*

**Gilded Movement, Cut Expansion Balance, plain jeweled;**

“ “ “ “ “ with 3 pairs extra jewels in settings;

**Nickel Movement, Cut Expansion Balance, with 3 pairs extra jewels in settings.**

*These movements all have quick trains, Patent Pinions, with extra jewels in settings, and, at the very low price at which we offer them, are especially adapted for our New Patent Dust Proof Open-Face Cases. A good strong case can be made under our patents weighing not over*

22 dwts., 14 karat gold,

24 “ 18 “ “

*thus making altogether the lowest price three-quarter plate gentlemen's size stem-winding gold watch ever offered.*

Robbins & Appleton, 9 Bond St., New York.  
Robbins, Appleton & Co., 8 Summer St., Boston.  
Robbins & Appleton, 170 State St., Chicago. } *General Agents.*

AMERICAN WATCH COMPANY,  
OF WALTHAM, MASS.

NEW WALTHAM WATCHES FOR 1880.

THE AMERICAN WATCH COMPANY

OF

WALTHAM, MASS.

*Be g to announce that they now manufacture the following qualities of Stem-Winding Movements, with quick train, in Brass and Nickel.*

**18 Size, Full Plate, Stem Winders and Stem Setters,  
To Wind at Figure XII for Open Face Cases.**

		GILDED MOVEMENT.	NICKEL MOVEMENT.
“ WM. ELLERY,”	with 2 pairs, extra jewels and compensation balance, to wind at Figure XII for Open Face Cases.....	\$12 00	\$16 00
“ P. S. BARTLETT,”	with 2 pairs, extra jewels in settings and compensation balance, to wind at figure XII for Open Face Cases.....	19 00	23 00
“ APPLETON, TRACY & CO.,”	with 4 pairs, extra fine jewels in settings, pensation balance, adjusted to temperature, to wind at figure XII for Open Face Cases...	36 00	46 50

These movements are made to fit all regular full plate stem winding cases, and our new patent dust proof cases.

They have all the merits of our 18 size new model watches, and none of the demerits which are so conspicuous in so-called interchangeable and extra-pinion movements.

**Fine Nickel Movement, 16 Size.**

With 4 pairs extra ruby jewels, exposed pallets, patent regulator, compensation balance, adjusted to temperature; named “ AM. WATCH Co. WALTHAM, MASS.” It is now ready for hunting cases, and will soon be completed so AS TO WIND AT FIGURE XII FOR OPEN FACE CASES.....

\$75 00

**Fine Nickel Movement, 14 Size.**

With 4 pairs extra ruby jewels, exposed pallets, patent regulator, compensation balance, adjusted to temperature; named “ AMER'N WATCH Co., RIVERSIDE, WALTHAM, MASS.” TO WIND AT BOTH FIGURES XII AND III FOR OPEN FACE AND HUNTING CASES.,.....

\$50 00

Robbins & Appleton, 9 Bond St., New York.  
Robbins, Appleton & Co., 8 Summer St., Boston.  
Robbins & Appleton, 170 State St., Chicago. } General Agents.

American Watch Company,  
OF WALTHAM, MASS.

*New York, January 1st, 1880.*

# ROSKOPF WATCH

J. D. HUGUENIN & CO.

General Agents,

12 Maiden Lane New York.

The reputation of this Watch as an accurate timekeeper is fully established, and during the ten years that it has been before the Trade, has won an abiding reputation for fine Time-keeping qualities, and the BEST WATCH for the money in the world.

Send business card for price list.

J. J. COHN & CO.,

Importers and Manufacturers of

Whitby Jet, Rubber and Pearl Goods,

Gold and Roll Plated Jewelry.

Bamboo and Silk Guards, Watch Keys, Etc.  
Silver Filigree Jewelry.

12 Maiden Lane, New York.

# American Watch Tool Co.

P. O. Box 999.

WALTHAM MASS.

MANUFACTURERS OF THE WHITCOMB LATHE,

AND

Machinery for Watch, Watch Case and Clock Making

NEW YORK OFFICE, WITH

L. H. KELLER & CO., 64 Nassau Street.

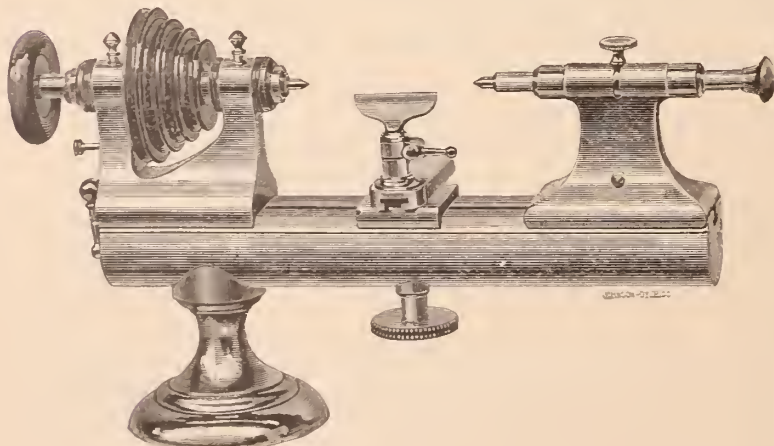

Chicago Office with Chas. Wendell & Co., No. 170 State Street.

COE, PINNEO & STEVENS,

MANUFACTURERS OF

# LOCKETS,

LINEN FINISHED

# ENAMEL GOODS,

AND

# FINE JEWELRY,

Old No. 9 Maiden Lane, New York.

THE WATCH KEY SUPERSEDED.



THE ZINN

PATENT

Winding Attachment

—OR—

“NATIONAL

# WATCH-WINDER”

**SIMPLE, PRACTICAL, EFFECTIVE.**

An Indisputable Convenience and Real Practical Success.

Adapted to nearly all Key-Wind Watches, Especially American. Adjustable with little or no trouble.

Salable at Sight.

Trade, \$3.00 per doz., 6 Sizes Assorted. Retail, 50 Cts.

Send for Descriptive Circular.

National Watch-Winder Company,

13 Avon Street, Boston, Mass.

Agents for Pacific Coast—Henry Mayers & Co. San Francisco

ESTABLISHED 1853.

CLOCKS



CLOCKS

**B. J. COOKE'S SON,**  
137 N. 3d Street, Philadelphia  
Catalogues and Price Lists furnished to the Trade only, on application.

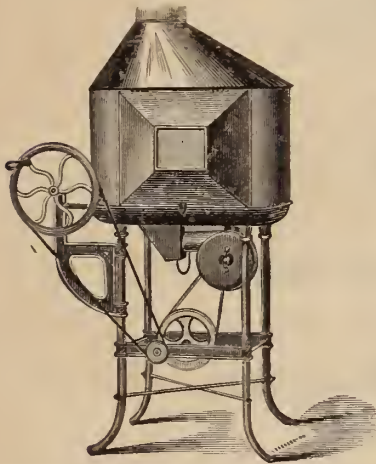

**KEYSTONE  
Jewelers' Forges,**

FOR HAND OR POWER.  
Light, durable and noiseless.

SEND FOR CATALOGUE.  
Keystone Portable Forge Co.,  
220 Carter Street,  
Philadelphia, Pa.

ESTABLISHED 1855.

**WELCH & MILLER,**  
MANUFACTURERS OF MOROCCO, VELVET AND SATIN  
**Jewelry Cases, Trays, &c.**

Telescope Sample Cases, with Flexible Trays.  
COMPLETE STOCK ON HAND.

**No. 169 BROADWAY, NEW YORK.**

CATALOGUES SENT ON APPLICATION.

**JAMES IRONS,**

PATENT AND Sole Manufacturer OF **"THE CONVEX"**

**SHOW CASE**  
CHEAPEST PLACE TO BUY GOOD  
**SHOW CASES,**

Large Assortment. All kinds always on hand. Cases packed securely to carry to any part of the world,  
Factory and WAREROOMS,  
132 & 134 North 4th St., PHILADELPHIA.

**Charles F. Terhune & Co.,**  
Manufacturing Jewelers,



**16 Maiden Lane,**  
NEW YORK.



— Sole Manufacturers —

We beg to call the attention of the trade to the above cuts representing  
**PATENT SLIDE BUTTON**

It is not separable, but works on a simple slide. It can be put in and taken out easier than any button made without soiling the cuff. Recommends itself at sight.

A full line of Stone, Enamel, Ivory and Pearl goods in above patterns.

**BERNARD LEVY,**  
Manufacturer of Watch Cases

— AND DEALER IN —

**AMERICAN WATCHES,**

No. 402 Library Street,

**PHILADELPHIA.**

**G. F. C. ROSENTHAL,**  
Manufacturing Jeweler,

917 SANSOM STREET.

PHILADELPHIA.

The finest Diamond and Pearl Work exclusively.

Lubricating Oils, for Watch, Clock and Chronometer Makers.

The discovery of a Lubricator for FINE MACHINERY, such as Watches, Clocks and Chronometers, that is free from gum and corrosive substance, has taxed the ingenuity of hundreds of men whose efforts have proved a failure. But we are happy to say, (being largely interested) that such an article has been supplied by Mr. EZRA KELLEY, of New Bedford Mass., who, after forty years study of the subject, has perfected a Lubricator, that recommends itself to all who have used the genuine, (there having been numerous counterfeits in the market,) as witness also the award of a



Diploma and Medal by the judges of the late Centennial Exhibition at Philadelphia. We have no hesitation in saying that his Oils are the BEST manufactured always uniform in quality and capable of standing all tests applied to lubricating oils. We cheerfully recommend it to all who may in their business require a FIRST CLASS LUBRICATOR

SETH THOMAS CLOCK COMPANY, SETH E. THOMAS, Agent



P. S.—The above Oils can be procured at all first-class wholesale Watch and Clock Establishments in the United States, as well as his only Agents, HENRY GINNEL, 31 Maiden Lane, New York, and GRIMSHAW & BAXTER, 35 Goswell Street, London, England.

New Bedford, October 15, 1877.

# RANDEL, BAREMORE & CO. DIAMONDS,

Corner Maiden Lane and Nassau Street,

29 MAIDEN LANE,

58 NASSAU STREET,

**NEW YORK.**

No. 12 New Burlington Street, LONDON.

Established 1828.

## JACOB BENNETT & SON, Diamond Setters and Manufacturing Jewelers,

No. 108 SOUTH EIGHTH STREET, PHILADELPHIA.

WE MANUFACTURE AND MAKE A SPECIALTY OF  
EVERY DESCRIPTION OF

**DIAMOND MOUNTINGS,**

SUPERIOR IN DESIGN AND WORKMANSHIP.



Dealers in

**DIAMONDS**

And all kinds of Precious Stones.

Masonic Marks, Society and School Badges, Made to Order Only. Designs and Estimates Furnished.  
PARTICULAR ATTENTION GIVEN TO ALL KINDS OF JOBBING.

House Established since 1837.

## CHARLES LEO ABRY,

(SUCCESSOR TO J. A. ABRY.)

### Importer and Manufacturer of Swiss Watches,

OF ALL GRADES, AND DEALER IN AMERICAN WATCHES.

Sole Agent in the United States for the **Celebrated Vacheron and Constantin Geneva Watches.**

These unrivalled time-keepers are now made interchangeable in every respect. A full line (cased or uncased) always in stock—prices very much reduced from formerly. Specialties in O. F. Nickel Stem Winders Anchors with White, Black and Fancy Dials, 16, 18 and 20 lines. Also, Silver O. F. Hunting and  $\frac{1}{2}$  Hunters Stem Winding Anchors, 16 and 20 Lines. In liquidation—a large stock of Swiss Key and Stem Winder Watches, Gold and Silver Cases, must be sold and are offered cheap for cash. SEND FOR PRICES.

Factory, Neuchatel, Switzerland.

P. O. Box 611.

63 Nassau St., New York.

## CROSS & BEGUELIN,

21 MAIDEN LANE . . . . . NEW YORK.

Offer a Full and Complete **STOCK** of Watch Tools and Materials, Watch Glasses, Silk Guards, &c., &c. Close Attention Given to **ALL** Orders.

### Importers of Swiss Watches and Dealer in all Grades of American Watches

ROGERS & BRO'S. HOLLOW AND FLAT WARE.



# HENRY C. HASKELL,

Manufacturing Jeweler,

No. 12 John Street,

New York

THE FINEST SEAL RING EVER OFFERED  
THE TRADE.

## The "MARQUIS"

*Must be seen to be fully appreciated.*

## NOVELTIES

In Great Variety,

FROM ORIGINAL DESIGNS.



790



791

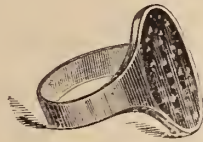

792



739



539



744

*Samples sent on approval.*

*New Holiday Catalogue supplied to Dealers by sending Card.*

# HOLMES, BOOTH & HAYDENS,

MANUFACTURERS OF

**ELECTRO-SILVER PLATED**

**Spoons, Forks, Ladles, Fancy Pieces,**

**Solid Handle Steel Knives, &c., of the finest quality.**

No. 49 Chambers Street,  
**NEW YORK.**

No. 18 Federal Street,  
**BOSTON.**

Works at Waterbury, Conn.

# BROWN & BROTHER,

MANUFACTURERS OF

**Finest Quality of Electro-Plated Flat Table Ware,**

**PATENTED HEAVY SPRING TEMPERED SHANK ON FORKS AND SPOONS.**

ILLUSTRATED CATALOGUES FURNISHED ON APPLICATION.

**WAREROOMS, No. 81 CHAMBERS STREET, NEW YORK CITY.**

*FACTORIES, WATERBURY, CONN.*

*P. O. BOX 5731.*

## HENRY ZIMMERN,

IMPORTER OF

**Watch Materials, Tools**

AND

**OPTICAL GOODS,**

No. 8 MAIDEN LANE.

First Floor)

NEW YORK.

SOLE AGENT FOR

**A. Hugenin & Gravier Spring.**

SOLE AGENT FOR

**The Celebrated U. S. Spectacles  
and Eye Glasses.**

WHITE METAL CHAINS A SPECIALTY.

Medal and Diploma awarded at Centennial Exposition, for superior mechanical and artistic execution.



Established in 1854.

C. & A. PEQUIGNOT,  
MANUFACTURERS OF WATCH CASES,

DEALERS IN AMERICAN WATCHES AND IMPORTERS OF FINE KEY AND STEM-WINDING MOVEMENTS,

SALESROOM AND MANUFACTORY, 22 SOUTH FIFTH STREET,  
PHILADELPHIA.

A full stock of Key and Stem-Winding Gold Cases always on hand. Goods sent on approval when satisfactory references are furnished.

**Anti-Tarnish Silver Tissue Paper,**

FOR WRAPPING UP SILVER WARE, JEWELRY, &c. Patented.

Chemically prepared to resist the action of gases which tarnish Silver.

Endorsed by leading Chemists and Silver-Ware Manufacturers, after being subjected to severe tests.

H. V. BUTLER, Jr. & CO.,

SOLE MANUFACTURERS,

34 Reade St., New York.

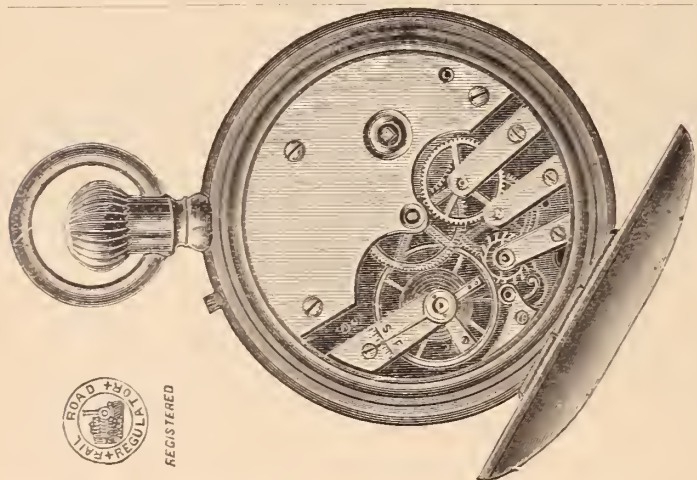

Factory,  
27  
RUE DU PARC,  
Chaux de Fonds,  
Switzerland.

Established 1826.  
**JULIEN GALLET,**  
Importer of Watches and  
Watch Movements  
OF EVERY DESCRIPTION.

Sales Rooms,  
No. 1  
MAIDEN LANE  
NEW YORK.  
P. O. Box, - 4420.

CHARLES PERRET, Sole Agent.

The accompanying Cut Illustrates our  
*Open Face Nickel Stem-Winder "Rail Road Regulator,"*  
The best Stem-Winding and Setting Watch in the Market for the  
Price. Can be had of any first-class Jobber in the Country.

The accompanying cut illustrates the large size

**PIONEER WATCH,**

The best pocket time-keeper ever offered the trade. Can be had of any first-class Jobbing House throughout the United States.

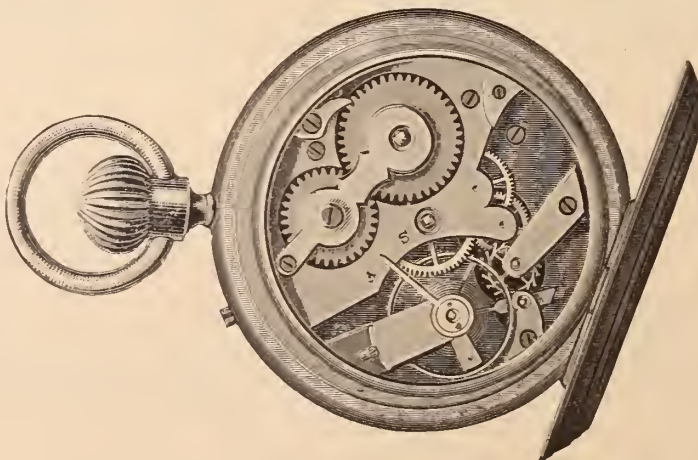

None genuine unless stamped  
**"PIONEER"**  
either inside or outside of case.

**H. GINNEL,**

Sole Manufacturer,

31 Maiden Lane,

NEW YORK.

P. O. Box 2967.

# L. & A. MATHIEY,

No. 16 MAIDEN LANE,

IMPORTERS OF ALL GRADES OF

Plain and Complicated Watches and Movements,

SOLE AGENTS FOR THE WELL-KNOWN

# H. L. Matile

FINE WATCHES OF ASTRONOMICAL PRECISION.

AN ATTRACTIVE LINE OF CHATELAINES AND CHATELAINE WATCHES.

SOLE AGENTS FOR CHAS. MAYLAN'S IMPROVED MINUTE CHRONOGRAPHS.

TABLE Showing the rate of a few of **H. L. MATILE** Fine, Plain and Timing Watches, just received by us after a competitive trial of four and six weeks, at the Observatory of Neuchatel.—(From the last official Report.

On Trial.	Movement Number.	Mean Daily Rate.	Mean Daily Variation.	For var'n of -1° Temperature	Before and after Oven.	Difference Hanging and Lying.	Hanging and Pend't Lett.	Hanging and Pend't Right.	Dial up and Dial down	Diff. betw'n first and last Week.	Difference extreme rates.	
6 Weeks.	10075	-1.44	±0.31	+0.07	-0.4	+1.47	-1.96	-1.31	+0.48	-1.40	4.0	Received 3d Prize.
" "	10693	-4.07	±0.45	+0.22	+0.7	-0.59	+0.36	-0.14	-1.15	-0.73	6.9	
" "	10696	+4.51	±0.51	+0.20	-1.3	+1.21	+0.50	+2.40	-2.0	0.0	6.7	
" "	10694	-3.12	±0.57	+0.14	+0.1	-3.14	+5.41	+2.96	-2.99	+0.01	7.1	
" "	10526	+1.69	±0.80	+0.03	+0.3	-1.34	+0.40	+0.39	-2.28	-0.03	4.2	
" "	10525	-2.40	±0.42	+0.20	+0.3	-0.33	+5.29	-0.06	+0.29	-1.44	7.0	
" "	10695	+1.76	±0.49	0.0	-0.8	+0.22	+0.56	+3.71	+1.41	+0.98	5.0	Received 1st Prize.
4 "	530	-0.11	±0.26	+0.06	-0.3	+0.13					1.6	
" "	526	-0.26	±0.52	+0.08	+2.4	+0.47					3.1	
" "	10114	+0.8	±0.41	-0.10	+0.6	-0.89					5.8	
" "	10524	+1.66	±0.69	+0.16	-2.0	+1.27					5.3	
" "	10113	+8.04	±0.57	-0.12	-1.7	+2.42					5.7	

## MATHIEY'S TIME INSTRUCTOR.

An Instrument for teaching Children how to tell the Time.

Novelties in design and finish, in Silver Fancy Goods and Hollow Ware, with combinations of colors in gold, silver and niello-enamel, Testimonial and Presentation Goods, Spoons and Forks of patterns popular and desirable, and a choice line of Case goods, from single pieces to Cabinets for Wedding Gifts.

THE

# Adams & Shaw Company,

SILVERSMITHS,

and Makers of Hard Metal Electro-Plate,

694 BROADWAY, . . . . . NEW YORK.

GEO. R. COLLIS, Manager.

Designs and estimates furnished, and particular attention paid to orders for racing, Field and Nautical Prizes, (small and large), Tea Sets, Berry Bowls, Fruit and Ice Cream Stands, Jelly Bowls and General Hollow-Ware, in Sterling Silver or Silver-soldered Electro-Plate.

LADIES' Portmonnies, Card Cases, Lace Pins, Hairpins, Tete-a-tetes, Shawl Pins, Card Stands, Vases, Caddies, Fruit Knives, Ice Cream Slicers, Sugar Scissors, Bells, and a great variety of other goods in new styles of decoration.

GENTLEMENS' Cigar Cases, Match Boxes, Shaving Mugs, Cigarette Cases, Pocket Flasks, Wine Coolers, Cigar Lighters, Liquor Labels, Wine Goblets, After-dinner Coffee Sets, Ice Pitchers, Soap Boxes, Call Whistles, &c., &c.

CHILDREN'S Cups, Rattles, Whistles, Pap Bowls, Catnip Warmers, Christening Sets, Knives, Forks, Spoons, Napkin Rings, Bib Pins, &c., &c.

Gentlemen's Watches,  
Ladies Watches,  
Bridge Movement Watches,  
¾ Plate Movement Watches,  
¾ Plate Patent Reg. Watches,  
¾ Plate Movement Watches,  
Repeaters,  
Chronographs. (1-5 second)

**TIFFANY & CO.**  
NEW YORK, PARIS, LONDON, GENEVA.  
**MAKERS OF FINE AND COMPLICATED WATCHES,**  
Wholesale Office, 694 Broadway, New York.  
GEO. R. COLLIS, Manager.

Split-Second Chronographs,  
Minute and Sec'd Chronograph  
Chronograph and Repeaters,  
Minute Repeaters,  
Five Minute Repeaters,  
Quarter Hour Repeaters,  
Repeaters and Chronographs  
&c. &c. &c.

All watches of our make have the firm name "TIFFANY & CO." engraved upon the movements, and the trade are cautioned against apparent fac-similes put upon the market by certain unscrupulous dealers.

Our new "Bridge movement" watch for gentlemen is now ready, and conceded by experienced judges to be "the BEST watch ever made for the price." It is adjusted to temperature and position, and fully guaranteed.

Goods sent for selection or examination upon receipt of satisfactory references. Old nickel movements refinished for the trade. Orders for engraving and ornamenting movements, enameling and carving of Inscriptions, Devices and Monograms on Cases promptly attended to.

Only Wholesale Office for the sale of the American Pedometer.

Also General Agents for the United States for Messrs. PATEK, PHILIPPE & CO.'S Celebrated Watches.

**ESTABLISHED 1837.**

**SPRING TRADE**

**1880**

Buyers will find it to their interest to examine our Line of Novelties in

**CLOCKS, MARBLE & BRONZE.**

Vienna, Leather and Gilt Goods a Large and Choice Selection.

TRIPLE MIRRORS, our Special Patterns, and many other new Specialties of the season which we offer at close prices TO THE TRADE ONLY. Sole Agents LE COULTRE RAZORS.

**TAYLOR & BROTHER,**

No. 676 Broadway,

**NEW YORK**



**Factory and Offices, 611 & 613 Sansom Street,**

ARTISAN BUILDING.

THIS old and well-known firm manufacture a greater variety of *SPECIALTIES* than any other one house in the country.—**FINE TINTED AND ROMAN JEWELRY, IN SETS, BRACELETS, EAR RINGS, LOCKETS, &c., &c. GOLD CHAIN, SILVER CHAIN, GOLD THIMBLES, SILVER THIMBLES.**

In both *GOLD* and *SILVER THIMBLES*, in *Styles* and *Finish* we claim to excel all others.

## GOLD HEAD CANES.

These goods we were the *FIRST* to make to any extent, nearly all other makes are *copies of our patterns*, whilst some of our styles *have never yet been imitated*, we being *JEWELERS* as well as *CANE MAKERS*, are able to do more *elaborate* work than those not possessing this advantage.

### ILLUSTRATED CATALOGUE.

Our Illustrated Catalogue of these goods will be ready for gratuitous circulation by *September 15th*, and parties about to order *CANES* for Fall will do well to reserve orders until they have this *intelligent aid*.

## SIMONS BROTHER & CO.

SAMPLES AND PRICE LIST

Can be seen at

G. & S. OWEN & CO., 5 Maiden Lane, New York,  
OUR AGENTS.

PHILADELPHIA.

# The Burbank Manufacturing Company

Manufacturers of GOLD & SILVER



## Thimbles,



EYE GLASS  
Self Adjusting.

GOLD  
SILVER,  
STEEL,  
RUBBER,  
And SHELL,

## SPECTACLES AND EYE-GLASSES

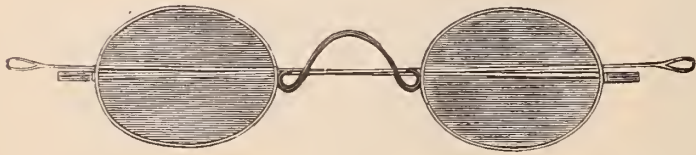

OF ALL DESCRIPTIONS.

## SOLID GOLD RINGS,

Office, 14 MAIDEN LANE. NEW YORK.

Manufactory, Springfield, Mass.

## S. C. JACKSON, MANUFACTURER OF

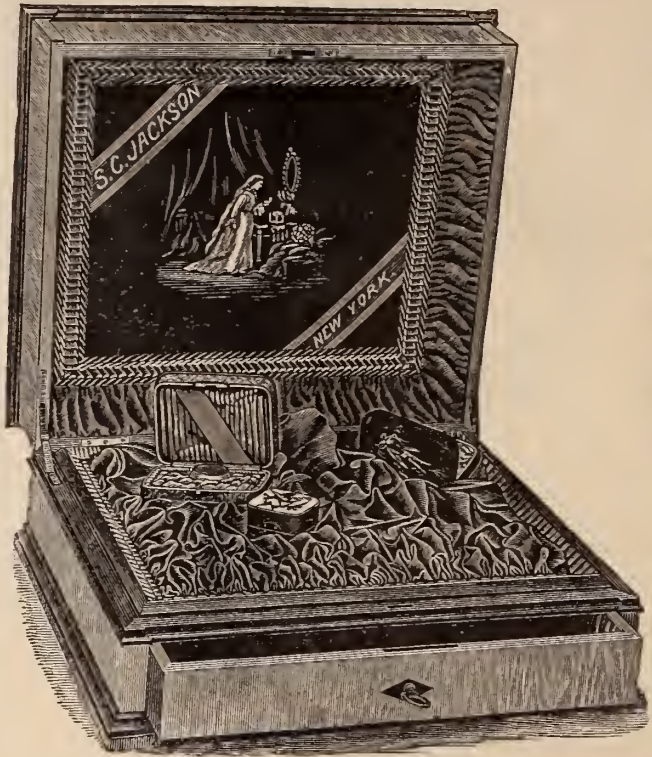

Centennial Medal Awarded.

Fine Cases for Jewelry, Watches, Silverware, &c.

180 BROADWAY, N. Y.

A specialty in Show Case Trays, and Silver Cabinets, made from the finest hard woods, and polished.

All kinds Sample Cases made to order. A full assortment of a cheaper grade of Jewelry and Silverware cases in stock.

New and elegant Styles now ready, including our paintings on silks, and satins, together with novelties from China and Japan, specially ordered.

# J. F. FRADLEY.

MANUFACTURER OF



Fine Gold and Silver-Headed

## WALKING CANES

—AND—

STERLING

## SILVER WARE.



OFFICE & FACTORY

20 JOHN STREET, NEW YORK.

Birch's Self-Adjusting

# Watch Keys

Will Wind any Watch.

## J. S. BIRCH & CO.

38 Dey Street, N. Y.

---

ESTABLISHED 1869.

---

VOLUME XI BEGINS WITH THE FEBRUARY NUMBER.

---

NOW IS THE TIME TO SUBSCRIBE.

---

**T**HE JEWELERS' CIRCULAR AND HOROLOGICAL REVIEW, established in 1869, has improved in variety and quality of its contents, increased in size, strengthened in power and influence, and enlarged its circulation until it is now recognized as the representative organ of the trade, and appreciated as the most complete and valuable periodical of its class published in any country. It reaches every branch of the jewelry, watch, clock, silverware and kindred trades throughout the United States, and is the only publication representative of the trade which has secured by its intrinsic merits and acknowledged benefits, a legitimate and *bona fide* patronage of paying subscribers, including many of the leading firms in England, France, Germany, Switzerland, Mexico, the West Indies, Brazil, the South American Republics, and other foreign countries.

THE JEWELERS' CIRCULAR is regarded throughout this wide circle of interested and careful readers as a *reliable authority* and *independent chronicle* with regard to all matters connected with the trade, in its moral, mercantile and mechanical aspects, while its decided, straightforward and consistent course of conduct in relation to commercial questions has won widespread and unanimous approval.

To the practical workman the JEWELERS' CIRCULAR is invaluable as a text book and work of reference. Its pages furnish him with the latest scientific and mechanical ideas, set forth in plain comprehensible language by specialists of ability and experience. The technical information contained in its columns represents the progress of the age, and every intelligent workman in the country acknowledges the advantages resulting from a study of its pages.

To the country dealer the JEWELERS' CIRCULAR affords thorough, correct and perfect information as to staple and original articles of trade. From it he can learn what to order and where to obtain supplies, he can discover the best source of materials in common use, while the latest novelties are without exception first announced in its columns.

The JEWELERS' CIRCULAR has acquired an enviable reputation by its undeviating advocacy of the highest standard of commercial integrity, and its persistent opposition to those who dishonor and demoralize business by trickery and fraud. It has always been ready to promulgate and further plans and enterprises tending to the public good, and its columns have always been open to the honest expression of private opinion concerning matters which needed to be mended. Its information on commercial matters, much of which is nowhere else to be obtained, is of great importance and benefit, while the completeness of its trade directory and business columns render it indispensable to those concerned in the trade.

The JEWELERS' CIRCULAR is an art journal worthy of the artistic interests and industries which it represents. Its elegant and tasteful typography is apparent in its advertising pages, where every announcement is rendered attractive and conspicuous.

The JEWELERS' CIRCULAR is a welcome visitor and powerful influence in the workshop, in the store and in the counting room. The best testimony to its merits is to be found in the goods to sell finds that *it pays to advertise* in the JEWELERS' CIRCULAR, because all who buy goods seek and find their information in its pages, while every dealer and workman finds that *it pays to subscribe*, because they obtain a return in intelligence and instruction of infinitely greater pecuniary value. In the future, as in the past, no expense or care will be spared to improve the JEWELERS' CIRCULAR, and render it attractive, beneficial, instructive and indispensable; while it is hoped that the continuance of the subscription price at \$2 per annum (a rate far beneath that of any monthly publication of its size and contents), will obtain for it the widest possible circulation both at home and abroad.

*D. H. HOPKINSON, Editor and Proprietor.*

42 Nassau Street, New York.

**L. OLLENDORFF.**

Wholesale Dealer in

**WATCHES,  
JEWELRY, MATERIALS.**

37 Maiden Lane, New York

Orders by Mail will receive prompt attention.

**STERN BROS. & CO.**

Manufacturers of



**Fine Jewelry,**

30 MAIDEN LANE,

FACTORY, 73 & 75 Fulton St., NEW YORK.

Gold Seal engraved Band-rings and Locketts a specialty. The attention of the trade is directed to our plain Gold filled Rings. Sections of which showing the construction and quality sent upon application. After February 1st, our plain filled rings will bear the above trade mark.

**LEIMBACH BROS.**

Manufacturers of

**DIAMOND JEWELRY**

A full description constantly on hand.

LACE PINS A SPECIALTY.

51 NASSAU STREET,

P. H. Leimbach,  
F. E. Leimbach.

New York.

**H. M. RAYNOR.**

25 Bond Street, N. Y.

**PLATINUM**

FOR ALL

Laboratory & Manufacturing Purposes.

Native Platinum, Scrap, &c., purchased.

REPAIRING, COLORING AND GALVANIZING FOR THE TRADE.

C. G. MALLIET,

Manufacturing Jeweler,

No. 9 JOHN STREET

NEW YORK.

**P. NEIDHARDT & CO.**

Manufacturers of

Diamond Mountings

—AND—

**FINE JEWELRY**

52 Nassau Street,

Cor. Maiden Lane,  
P. NEIDHARDT.

NEW YORK.  
B. SCHILLING.

Particular attention paid to Remounting. Price list furnished on application.



Full line of new and original mountings on hand.

**L. M. LEBERTHON,**

IMPORTER OF

**DIAMONDS & WATCHES**

AND

Manufacturer of Diamond Jewelry,

3 JOHN STREET, N. Y.

Fine Stones a Specialty.

**VOSE & SOUTHWICK,  
Manufacturers of Gold Jewelry**



Sole Makers of the Separable Sleeve and Collar Buttons in Gold.

No. 183 Eddy Street, PROVIDENCE, R. I.



**HENRY LEFORT,  
Stem-Winding Watch Crown Manufacturer,**

Crowns and Pushers in gold, all sizes, quality and color, made to order. Silver crowns and pushers always on hand. Samples sent on application.

80 & 82 Marshall Street,  
NEWARK, N. J.

**ALBERT FRIEDENTHAL,**

Importer and Jobber of  
WATCHMAKERS' & JEWELERS'

Materials, Tools and Optical Goods  
Real and Imitation Stones,

For Manufacturing and Repairing Purposes  
A SPECIALTY.

Agent for TISDALE'S Watch and Clock Oils.  
No. 43 Maiden Lane, New York.  
Orders by mail will receive prompt attention.

**GUSTAV EPHRAIM,**

Successor to Ephraim Bros.

8 JOHN STREET, NEW YORK,

Importer and Manufacturer of

Bamboo, Silk Guards and Watch Chains of all Grades. Materials, Watch Glasses, Optical Goods and Jewelry.

Sole Agent for EAGLE SPECTS', CORNELL'S ANTI-OXYDIZER and COURVOSIER MAIN SPRINGS.

**WILKINSON & LENNON.**

212 Broadway,  
NEW YORK,

Manufacturing Jewelers

Masonic Pins, Rings & Charms,  
School, Athletic, Fine  
Presentation Medals,

—AND—  
JEWELS OF EVERY DESCRIPTION.

Designs furnished free upon application.



**The Morse Diamond Cutting Company,**

J. D. YERRINGTON, Agent.

192 Broadway and 3 John Street.

NEW YORK.

Rough Diamonds, Boart, Roses and Brilliants for sale.  
Fractured Diamonds repaired, and old stones improved; also Rough Diamonds cut and fashioned to order.

W. N. WALKER,

**DIAMONDS,**

Watches and Jewelry,

No. 18 JOHN STREET, NEW YORK.

**IMPROVED JEWELERS' COTTON**

JOHN J. ARMOUR.

**HENRY TROEMNER,  
710 Market Street,**

PHILADELPHIA.

Manufacturer of Fine Gold Scales,

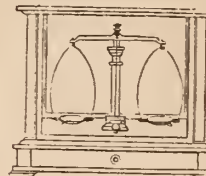

DIAMOND SCALES,

Bullion Balances and Weights, in use at all the U. S. Mints and Assay Offices.

PRICED CATALOGUE ON APPLICATION.

Solid Gold Rings—a Specialty

WM. H. ELY,

**Solid Gold Rings**

MANUFACTURER.

Viz., Plain, Chased, Engraved, Enameled, Engine Turned, Shield & Scale. All qualities Warranted Orders Promptly Executed.

58 Nassau Street, N. Y.





Established 1848.

Reliable and prompt.

**COOPER & BRO.**

Wholesale Jewelers,

Importers and dealers in WATCH & CLOCK-MAKERS' TOOLS and MATERIALS; also, JEWELERS' SUPPLIES, SPECTACLES, OPTICAL GOODS, &c. A complete Outfitting Establishment for the trade.

Repairs Department established 1865. Every description of work done for the trade. Watch Repairing, Jewelry and Watch Case Repairing, Gold and Silver-Plating, and Fire Gilding.

35 S. Fourth St. (1st floor) PHILADELPHIA

THOMAS M. GUILBERT.

J. CARROW DUBOSQ

**GUILBERT & DUBOSQ,**

Successors to Francis Dubosq & Son,

Manufacturers of

Fine Gold and Strung

**PEARL JEWELRY,**

No. 1031 Chestnut Street,  
PHILADELPHIA.

**DAVID PRINCE,**

Gold and Silver Refiner

Assayer and Sweep Smelter,

13 and 15 New Jersey Railroad Avenue,  
NEWARK, N. J.

Sole Agent for Comins' Improved Amalgamator.

**W. H. LUDEMAN,**

No. 75 & 77 Nassau Street,  
NEW YORK.

**FINE AND COMPLICATED  
WATCHES**

Of every description repaired and regulated.  
Stem Winding and Escape Wheels  
Cut and finished to order with accuracy  
and promptness.

**WM. MORRIS,**

Direct Importer of

**Watch Materials and Tools**

Glasses and Optical Goods.

Wholesale Agent for

Celebrated Paradise Mainspring.

No. 706 CHESTNUT ST., PHILADELPHIA

Send for Price List.

**L. BONET,**

Medal at Centennial, 1876.

**CAMEO  
Likenesses,**

889 Broadway, New York.

**BLANCARD & OBERLANDER,**

MANUFACTURERS OF

**Settings and Galleries**

Of every Carat of Gold or Silver,  
Platinum, Platinum-Lined and Fancy  
Settings a Specialty.

As we melt and refine Platinum ourselves.

36 & 38 JOHN STREET,  
NEW YORK.

Platinum Scraps Exchanged or Purchased.  
Send for Sample Card.

Leon Jeanne.

Paul Jeanne.

**JEANNE BROTHERS,**

MANUFACTURERS OF

**DIAMOND MOUNTINGS  
And RICH JEWELRY,**

Patentees of Jeanne's Ear Wires,

No. 1 Maiden Lane, New York.

Designs furnished and estimates given.



Ketcham & McDougall

4 Liberty Place, N. Y.

Manufacturers of

**GOLD AND SILVER THIMBLES.**



(A) Shows position of glasses with cord reeled up.



ALSO  
**AUTOMATIC  
EYE GLASS  
HOLDER.**

It reels up the cord when not in use.

**J. B. LAURENCOT,**

IMPORTER OF

**WATCH GLASSES,**

**Optical and Fancy Goods**

French Clocks, Musical Boxes, &c.

No. 33 MAIDEN LANE.

5 Rue D'Enghen,  
PARIS.

Box 2954, P. O.  
NEW YORK.

Established 1850.



**PETER L. KRIDER,**

MANUFACTURER OF

**STERLING  
SILVER WARE,**

Medal and Diploma Awarded, &c.

Striking Society Medals in Gold, Silver or Bronze  
A SPECIALTY!

ARTISAN HALL,

**618 Chestnut Street  
PHILADELPHIA.**

**GEO. W. DU BOIS,**

(Successor to Albert L. Landsberg.)

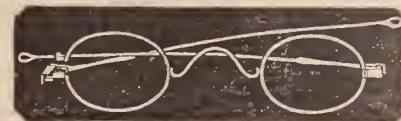

IMPORTER AND MANUFACTURER OF

**Optical Goods,**

No. 36 MAIDEN LANE,

Near Nassau Street, NEW YORK

Sole Agent for

**BLACK'S PATENT**

**Interchangeable Spectacles,**

AND

**EYE GLASSES.**

Jewelers and others who keep spectacles for sale will please observe that, with these PATENT SPECTACLES, it is only NECESSARY to have a full Complete Assortment of Lenses and Pebbles, which being all of a UNIFORM SIZE, will FIT either the Gold, Silver, or Steel Frames, of which but a few of each kind are wanted; an advantage which will give a complete assortment of the finest Spectacles, for one-sixth the capital invested in a like assortment of the same quality goods of the old style frames.

For Particulars, price lists, &c., address

**GEO. W. DU BOIS,**

New York.

Eugen J. Baur.

John H. Kocher

George Klinkel

**E. J. BAUR & CO.**

(Successors to the late F. Waaser)

Importers of and Dealers in

**Watches, Jewelry,**

Watchmakers', Jewelers' and Engravers' Tools,  
Materials, Etc.

52 Nassau Street,

Cor. Maiden Lane,

NEW YORK

Wheels Cut, Watches Jeweled and Repaired.

**IMPORTANT INFORMATION  
FOR \$1.00.**

Upon the receipt of \$1.00 I will send enough material (post paid) to make half a pint of anti-oxidizer, which will positively preserve the color and prevent oxidizing of gold, silver, or any other metal, when red hot or while being hard soldered. Also tell what the material is and how to prepare it at a cost of not over 25 cents a pint.

**RICHARD OLIVER,**

23 JOHN STREET, NEW YORK.

Maker of the Original McLane's Anti-Oxidizer, refers to Editor of JEWELERS' CIRCULAR.

**JEWELRY PHOTOGRAPHED.**

In order to meet the demands of many of the manufacturers of Jewelry, Silverware, &c., (Tiffany and others), I have erected a Special Skylight for mechanical Photography, viz :

The Copying of Silverware, Statuary, Eric-a-Brac, Paintings, Models, &c.

I propose to keep it busy by adopting the following rates: 8-10 Photographic negative \$1.00. Proofs 50 cts. Special rates for quantities.

**GEO. G. ROCKWOOD,** Photographer, 17 Union Square  
Established 1859. (Above Tiffany's)

# SPENCER

## Optical Manufacturing

### COMPANY,

Manufacturers of Spectacles and Eye Glasses,  
from all materials used for that purpose,  
and of all grades.

**SOMETHING NEW !!**  
**CELLULOID EYE GLASS FRAMES,**  
Representing the Choicest Selected  
Tortoise Shell and Amber.

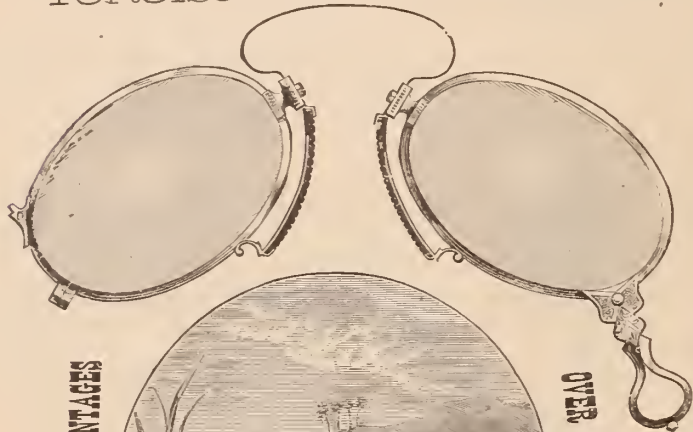

(Turtles rejoicing over the discovery of Celluloid Tortoise Shell,  
Their Occupation Gone.)

They are much **Lighter** than any others. Twenty-five pairs of the frames weigh only one ounce.

They are much **Stronger** and more **Durable** than any others; they can be **Dropped Without Injury** upon the hardest substance.

Their **Beauty** far surpasses the ordinary Tortoise Shell Frames commonly in use.

They are **Not Affected** by Atmospheric Changes, being equally well adapted to either warm or cold climates.

They are made with **Different Sized Frames** to suit persons whose eyes are either near or far apart.

The Springs are made of a combination of metals which will neither **Rust** nor be effected by heat or frost.

These frames are set with **Fine Lenses**, accurately focused to suit all sights, which with the many other advantages, make them **Very Popular**.

**ASK YOUR OPTICIAN OR JEWELER TO SHOW THEM TO YOU.**  
Every Pair Stamped on Handle S. O. M. Co. Pat. Mar. 13, '77-

Parties ordering 3 doz. Celluloid Eye Glasses are furnished with 1,000 copies of circulars similar to this advertisement with name of dealer printed thereon.

**13 Maiden Lane, N. Y.**

Established 1853.

## L. H. KELLER & CO.

Successors to G. A. HUGUENIN,

IMPORTERS OF

### Fine Watch and Clock Materials,

SWISS, ENGLISH, FRENCH & GERMAN

## FILES, TOOLS, & C.

FOR WATCH MAKERS, WATCH CASE MAKERS, JEWELERS  
SILVERSMITHS, ENGRAVERS, CHASERS, DIE  
SINKERS, MACHINISTS, &c.

SOLE AGENTS FOR HALL'S STAKING TOOLS AND  
ROLLER REMOVERS.

AGENTS FOR THE WHITCOMB AND OTHER AMERICAN LATHES.

GENERAL AGENTS FOR THE PHILADELPHIA  
WATCH COMPANY.

American Agents for the Horological Journal, (British).

A Monthly Paper for the advancement of Chronometer, Watch and Clock Making,  
and kindred Sciences. Published under the auspices of the British Horological  
Institute, London. Subscription \$2.50 per year, in advance. Also,

SAUNIER'S TREATISE ON MODERN HOROLOGY, IN  
THEORY AND PRACTICE,

BY M. CLAUDIUS SAUNIER. The English Edition will appear in 26 monthly parts,  
Price 50 cents each. Whole Work, \$13 00, postage paid.

Special attention is directed to

"OUR OWN" Celebrated Mainsprings Graduated

in thickness to equalize the power, with well rounded edges, and the  
*Highest Crocus Finish* throughout, insuring the least possible friction  
in the barrel, pronounced by expert judges to be the *best made*.

"JURGENSEN" Main Springs recoiling, suitable for the highest grades  
of Swiss Watches.

"Lutz" Celebrated Hair Springs,

by numbers, of uniform diameter and strength, the best for  
"BREGUETING."

Fine Hole Jewels of Ruby, Sapphire, Chrysolite, Garnet, Beryl and  
Aqua Marine, with *gauged* (well shaped and polished) holes, numbered  
by the Swiss pivot gauge; also, neat black walnut cases, containing  
forty glass vials for assortments of same. The great advantage in hav-  
ing Jewels by numbers will readily be seen as a saving in time and an-  
noyance in selecting and in expense. Dealers once having an assort-  
ment, can replenish or stock up at a comparatively small outlay, as any  
desired quantity of No. and quality can be had of us at all times,  
our stock of jewels being the largest and most complete in the country.

Diamond Charged Broaches for opening and polishing jewel holes.

Diamond Powder and Bort for polishing and grinding 8 different  
grades, in  $\frac{1}{2}$ ,  $\frac{1}{4}$ ,  $\frac{1}{8}$ , and  $\frac{1}{16}$  K vials, bringing it into the reach of all.

Gold Diamond Set and other fine Geneva Hands.

The new Drills in Sets of 54 small, 126 small to medium, and 48  
large; also, sold separately if desired.

A FULL LINE OF MATERIALS FOR THE CELEBRATED WATCHES  
MANUFACTURED BY

**Patek, Philippe & Co.**

OF GENEVA, FULLY FINISHED AS FAR AS PRACTICABLE.

**No. 64 Nassau Street,**

Near Maiden Lane

**NEW YORK.**

## SPECIAL NOTICES.

Advertisements under this head, not to exceed six lines, \$1.00 each insertion.

**WANTED**—An experienced Gold Pen Agent. Apply to John Foley.

**P. MEERLENDER, S.**, Sudbury, Mass., Manufacturer of Mainsprings, for all kinds of Swiss and American movements. Send for samples and price list.

**FOR SALE**—One Banta & Harris engraving machine with all attachments complete, in use but a short time, for \$15, cost \$80. Address L. F. Giering, 4 South Main Street, Bethlehem, Pa.

**WANTED**—A situation by a young man repairer of Watches and Jewelry. Can engrave, speak German, and has good business qualities. Reference and security if necessary. Address Z. care Jewelers' Circular.

**A RARE** chance to any one desiring to open a jewelry business South. Well established, good run of work and sales. Satisfactory reasons for selling. Address P. O. Box 110, Brownville, Tenn., or J. H. Purdy & Co., 170 State Street, Chicago.

**WANTED**—A situation by an experienced watchmaker. Can also engrave. Has had charge of a jewelry store for the past year. Has a good set of tools, lathe &c. Can furnish the best of references; would prefer the city. Address "Lebanon" care Jewelers' Circular.

**WANTED**—A first-class traveling salesman for a Western jobbing house. One who is acquainted with Ohio and Michigan trade and can furnish unquestionable reference. Address with reference and state salary expected. "Jobber," care this office.

**SITUATION WANTED** as traveling salesman for a jewelry house. Has had ten years' experience at the bench and retail business. Can furnish best of references and is not afraid to work. Would take a permanent situation as watchmaker. Address D. H. Stites & Son, 41 Maiden Lane, N. Y.

**WANTED**—Situation as watchmaker and Engraver, is a good salesman. Has American Combination Lathe with all attachments for first-class work. Understands general jobbing. To the right parties would take an interest in the business. Can give good references. Address Experience, care Jewelers' Circular.

**FOR SALE**—A nice Jewelry Store in a thriving town in Delaware. Have a large run of custom work and jobbing. Over one hundred and fifty custom watches now on hand which will be turned over to purchaser; also good will. Good reasons for selling. This is a rare chance for a good man. Address A. Bird, care JEWELERS' CIRCULAR.

**GEO. E. WILKINS**—Importer of fine Tools for Watchmakers, cutting and dividing engines, rounding up tools and cutters, also cutters for stem-winding wheels. Fine lathes with the American system of chucks. Dividing engine and rounding up tool combined. Marine chronometers for sale. Special tools imported to order. 21 South Salina St., Syracuse, N. Y.

**FOR SALE**—Four Jewelers' Safes—Herring's make. Dimensions—height 64 inches; width 51 inches; depth, 18 inches. These safes were made expressly to order and fitted up for the jewelry business. Combination locks and all the late improvements to make them secure against burglary. Will be sold at a sacrifice. Chatterton & Dodd, 19 John Street.

**AN AMERICAN**—single—29 years of age, 12 years' experience in wholesale jewelry business, and in kindred lines—watches and gold pens—having some trade in New England, Middle and Southern States, Atlantic Coast, desires good paying position. No preference as to locality. Speaks the Spanish language. P. O. Address, J. E. S., Station G., New York.

**FOR SALE OR EXCHANGE**—An entirely new Grossman Watch Lathe, with a very large number of attachments, a Wheel Cutting Machine with fifty cutters, and also two works on escapements, Martins and Grossman's. These instruments and books have never been used. They are for sale at a reasonable price, or will be exchanged for a regulator clock with sweep seconds, and a seconds compensated pendulum. Address, Engineer, care Jewelers' Circular.

**FOR SALE**—Very cheap; a nice Jewelry Store in a thriving and growing town in Delaware, the location is the very best in the town, and the proprietor does the very largest business in our line in the County and the store and the proprietor are free of debt. Good reasons for selling; good will given to purchaser, and will turn over the jobbing which is very large. Have now over one hundred and fifty custom watches besides jewelry, jobbing, etc., etc. Terms cash, and none need apply only those meaning business. Address A. Bird, care Jewelers' Circular.

Levy, Dreyfus & Co., is the name of a firm recently established in this city for supplying the trade with jewelers' and watchmakers' tools, materials and supplies generally. These gentlemen open with a complete stock of fresh goods, everything new and embracing all the novelties. An idea of their line of goods will be obtained by reference to their advertisement on another page. The firm will also deal in optical instruments of all kinds, and will make a specialty of this branch of their business. The partners are all young men, who are well known in the trade, full of life and enterprise, and their friends will be glad to learn that they have embarked in business for themselves.

## Buyer's Directory.

A Guide to the prominent Wholesale Houses in the Watch, Clock, Jewelry and kindred branches of Trade in New York, Philadelphia, Chicago, Providence and Newark.

## NEW YORK.

## Black Onyx Jewelry.

**Cox & Sedgwick**—Manufacturers of Black Onyx Jewelry, No. 26 John St. New York.  
**Downing & Keller**—Manufacturers of Onyx Jewelry, &c., 8 Maiden Lane, N. Y.  
**Woglom & Miller**—Manufacturers of (exclusively) Black Onyx Jewelry, 32 & 34 John St., N. Y.  
**Unger, H. & Co.**—Manufacturing Jewelers. Fine Onyx and Pearl goods a specialty. Manufacturers of Patent Onyx Bracelet, with Lily of the Valley mountings. No. 18 Crawford Street, Newark, N. J. Box 63.

## Bohemian Garnet Jewelry.

**Bissinger, Philip**—Importer of Diamonds, Pearls and Precious Stones. Sole Agent for the Bohemian Garnet Jewelry, 22 John St.

## Clock Companies.

**New Haven Clock Co.**—62 Reade Street, N. Y.  
**Seth Thomas Clock Co.**—20 Murray Street, N. Y.  
**Waterbury Clock Co.**—M. Bailey, Treasurer, Manufs and Jobbers, No. 4 Cortland St., N. Y., and No. 197 State Street, Chicago.

**Kroeber, F.**—Manufacturer and Dealer in American and French Clocks, No. 8 Cortland Street.

**Owen, Geo. B. & Co.**—Manufacturers of Black Walnut Clocks, Factory, Winsted, Conn., New York Office, No. 6 Murray St.

## Corals and Coral Jewelry.

**Cuppia, L. A.**—Importer of Coral and Silver Filigree Jewelry, 19 Union Square, N. Y.  
**Errico Bros.**—Importers of Coral, Conch-Shell and Silver Filigree Jewelry, etc., 19 John St.  
**Lawson, S.**—Manufacturer of Coral and Black Onyx Jewelry. All kinds of repairing solicited. Goods sent on Mem. 63 Nassau Street.

## Cameo Cutters, Etc.

**Bonet, L.**—Cameo Likenesses, No. 889 Broadway.  
**Peifer, Theodore**—Cameo and Intaglio Engraver. Patentee of the new Cameo-Intaglio. No. 2 Bond Street, near Broadway, Room 4 New York.  
**Wiederer, Peter**—Late Habermair & Wiederer, Engravers of Cameo Likenesses, Seal Stones. Cameos repaired. 23 John St.

## Charms &amp; Gold Watch Keys.

**Rupp & Held**—Manufacturing Jewelers, Charms and Gold Watch Keys, with French and English Ratchets, a specialty. 15 John St., N. Y.

## Cutlery.

**Harrison Bros. & Howson**—Manufacturers of Fine Ivory and Pearl Table and Pocket Cutlery; Carvers in Cases; Nutcracks, Nutcracks and goods suitable for the jewelry trade. 26 Cliff Street. W. C. Burkinshaw, Sole Agent.

## Diamonds.

**Anderson, Otis**—Diamond Merchant and Broker, always ready to pay cash for bargains in Diamonds and Precious Stones, No. 9 Maiden Lane, N. Y.  
**Bernhard, A. & Co.**—Manufacturing Jeweler and Importers of Diamonds, Precious Stones, and Diamond Mountings, 2 Maiden Lane.  
**Bissinger, Philip**—Importer of Diamonds, Pearls and Precious Stones. Agent for the Bohemian Garnet Goods. No. 22 John St., N. Y.  
**Buckenham, Cole & Saunders**—Importers of Diamonds and Precious Stones, No. 10 Maiden Lane.  
**Fera, Henry**—Importer of Diamonds, and Manufacturer of Fine Diamond Jewelry. No. 9 Maiden Lane, New York. Amsterdam, Holland, 23 Loojersgracht.

**Fox, M. & Co.**—Importers of Diamonds and other Precious Stones, No. 1 Maiden Lane.

**Hedges, Wm. S. & Co.**—Importers of Diamonds, No. 170 Broadway.

**Herbert, R. J.**—Importer and Broker in Diamonds, 16 Maiden Lane.

**Lyon & Hardy**—Importers of Diamonds and Manufacturers of Diamond Jewelry, 30 Maiden Lane.

**Leberthon, L. M.**—Importer of diamonds and watches. Manufacturer of jewelry. 3 John St. Fine stones a specialty.

**Neresheimer, E. Aug.**—Importer of Fine Diamonds, No. 21 Maiden Lane, New York.

**Prager Morris**—Importer of Diamonds and Fine Diamond Jewelry, 8 Maiden Lane.

**Randel, Baremore & Co.**—Importers of Diamonds, corner Maiden Lane and Nassau St.

**Smith, Alfred H. & Co.**—Importers of Diamonds, No. 14 John Street.

## Diamond Cutters.

**The Morse Diamond Cutting Co. of Boston**—Henry D. Morse, General Manager. N. Y. Office, 192 Broadway, corner John street. J. D. Verrington, Agent.

**Diamonds and Diamond Jewelry.**  
**Bissinger, Philip**—Importer of Diamonds, 22 John street, N. Y. Agent for the Bohemian Garnet Goods.

**Heller & Bardel**—Manufacturers of Diamond and Pearl Jewelry, and Dealers in Diamonds, Pearls, &c. Also agents for Boss' Patent Stiffened Gold Watch Cases. 13 John St.

**Leimbach Bros**—Manufacturers of Diamond Jewelry, 51 Nassau Street.

**Neidhart, P. & Co.**—Manufacturers of Diamond Mountings and Fine Jewelry, 52 Nassau St., N. Y.

**Taylor & Brother**—Importers of Diamonds and Diamond Jewelry, 676 Broadway.

## Diamond Setters, Etc.

**Asher, J.**—Jeweler and Diamond Setter. Precious Stones Inlaid and Incrusted with Diamonds, Nos. 880 and 882 Broadway.

**Wood, Chas. F.**—Engraver and Incruster of Precious Stones and Diamond Setter. No. 169 & 171 Broadway.

**Friend, S.**—Manufacturer of Fine Jewelry, and Diamond Setter, 33 John Street, N. Y.

## Dials, &amp;c.

**Gold, John T.**—(Successor to the late T. Gold), Enamel Watch Dial Maker, 81 Nassau St.

## Enamellers, Etc.

**Nutt, J. D.**—Enameler on Gold, Silver and Copper, 32 and 34 John St. Birds, Flowers, etc., Enameled in colors.

**Orr, Jas. C.**—Enameler on Fine Jewelry, Flowers, Birds, &c., Enameled in colors. Band Bracelets (a specialty). 77 Nassau Street.

## Electroplaters, &amp;c.

**Jeandheur, F. & Son**—Gold and Silver Electro Platers & Fire Gilders, coloring Etruscan and Gold Jewelry a specialty. 125 Fulton St.

## Engravers and Die Sinkers

**Farkner, Edward**—Carver, Engraver and Chaser on Jewelry and Solid and Plated Pencil Cases, No. 19 John Street.

**Park Wm.**—Stone Seal Engraver. Coats of Arms found and Engraved. Initials and Monograms engraved. 26 John Street, New York.

**Schuller, J. Dan'l**—Stone Seal Engraver, Arms, Crests, Initials and Monograms engraved on Stone Seals, &c. 71 Nassau Street.

## Engraving Type.

**Ingersoll, H. S.**—Rubber Engraving Type, Patented December, 1872. Over 40,000 alphabets in use. Saves time and skill of designing before engraving silverware, etc. Also Engravers' Tools, etc. Catalogue free 203 Broadway, N. Y.

## Fancy Goods, Clocks, Bronzes Etc.

**Hall, Nicol & Granbery**—Importers of Clocks, Bronzes, Folding Mirrors, Fancy Goods, &c. 20 and 22 John Street.

**Magnin, Ve J. Guedin & Co.**—Importers of Clocks, Bronzes, Musical Boxes & Rich Fancy Goods, etc., 29 Union Square.

**Le Boutillier & Co.**—Importers of Fancy Goods, Clocks, Bronzes, &c., 3 Union Square.

## Gold Chains, Etc.

**Beck, J. & Son**—Manufacturers of Fine Gold Chains and Chain Bracelets, 10 Liberty Place, near Maiden Lane, N. Y.

**Dorrance, Edge & Co.**—Manufacturers of the Celebrated Woven Fabric Gold Chain, No. 12 John Street.

**Hamiltons & Hunt**—Manufacturers of Fine Plated Chains and Patent Buckle Bracelets. Branch office, 176 Broadway. Factory, 226 Eddy Street, Providence.

**Kaufmann Bros.**—Manufacturers of Gold Chains, and Chain Bracelets, 26 John Street; Factory 331 and 333 Bowery, N. Y.

**Nordt & Schlag**—Manufacturers of Gold Chain, No. 17 Maiden Lane, N. Y.

**Saxton, Smith & Co.**—Manufacturers of Fine Gold Chain. 15 Maiden Lane.

## Gold Pens, Etc.

**Aikin, Lambert & Co.**—Manufacturers of Choice Gold Pens, Cases, Holders, Toothpicks, etc., 23 Maiden Lane, N. Y.

**Clark, J. M.**—Manufacturer of Pen and Pencil Cases for the wholesale trade only. No. 61 Hudson Street, N. Y.

**Mabie, Todd & Bard**—Manufacturers of Gold Pens. 180 Maiden Lane.

**Goldsmiths, &c.**

**Greene, Wm. C. & Co.**—Goldsmiths; Manufacturers of Rich Sets in Taper Wire Coral. Office, 192 Broadway.

**Gold Rings.**

**Bowden, J. B. & Co.**—Manufacturing Jeweler.—Solid Gold Rings a specialty, 1 Maiden Lane.  
**Ely, W. H.**—Manufacturer of Solid Gold Rings of every description. No. 58 Nassau Street.  
**Frankel & Folkart.**—Manufacturers of Seal, Cameo and Amethyst Rings a specialty. Also a full line of Gold White Stone goods and Diamond Settings. 21 John St., N. Y., and No. 4 Liberty Place.  
**Peckham, Wm. H. & Co.**—Manufacturers of Solid Gold Seamless Rings, and Fancy Embossed Rings, Patent Spectacles, Jewelry, etc. No. 4 Liberty Place, N. Y.  
**Sinnock & Sherrill**—Manufacturers of Stone Rings. No. 5 Maiden Lane, N. Y.  
**Tingley, Joseph N.**—Manufacturer of Stone Rings and novelties in Stone Goods. No. 9 Maiden Lane, N. Y.

**Hair Jewelry.**

**Bernhard A. & Co.**—Manufacturers of Hair Jewelry. Our new Pattern Book is now out up to 2724. No. 2 Maiden Lane, N. Y.  
**Montoux, Wm. E.**—Only personal leading Artist in Hair devises in U. S., and Manufacturer of Fine Hair Mountings in Gold. Grand catalogues for the trade. 81 Nassau St., Rooms 1 and 2. Finest work and lowest prices.  
**Menge, C. T.**—Fine Hair Jewelry and Device Work, 32 John Street, N. Y.  
**Sauter, L.**—Manufacturer of Fine Gold and Hair Jewelry and Device Work. Pattern Book sent on application. Nos. 65 and 67 Nassau St.  
**Schwencke O.**—Manufacturer of Fine Hair Jewelry Orders from the country promptly attended to. No. 43 Maiden Lane.

**Jewelry Cases, Fancy Boxes, Etc**

**Braun, Chr. E.**—Manufacturer of Jewelry Boxes, Trays for Show Cases, &c., 62 Chatham St.  
**Dahlem, W.**—Manufacturer of Cases for Jewelry and Silverware, No. 85 Nassau St., N. Y. Show Case Trays, &c., at short notice.  
**Loehr & Koerner**—Manufacturers of Morocco, Velvet, Satin, Jewelry, Watches and Silverware Cases, Glove, Handkerchief, Ladies' Jewel, Work Boxes, &c., Fancy Trays and Store Fittings to order. Office and Salesroom 83 Nassau St., N. Y.  
**New York Morocco Case Co**—Makers of Cases for Jewelry, Watches, Silverware, etc. Boxes and Trays for Jewelry. No. 69 Nassau St., N. Y.  
**Sturm, I.**—Manufacturer and Importer of Cases for Jewelry, Watches, Silverware, &c. No. 15 John Street, N. Y.  
**Welch & Miller**—Manufacturers of Morocco, Velvet, and Satin Jewelry Cases, Trays, &c., Telescope Sample Cases with flexible Trays. Complete stock on hand, 169 Broadway.  
**Wiggers & Froelick**—No. 60 Nassau street—Manufacturers of Cases for Jewelry, &c., of every description. Trays for Show-cases, Stands for Show-windows, etc. Jewelers' Traveling Cases, light, convenient and strong.

**Jewelry—Fine.**

**Aikin, Lambert & Co.**—Manufacturers General stock of Reliable Jewelry, 23 Maiden Lane.  
**Alford, C. G. & Co.**—Manufacturers. General line fine and Reliable Goods. Specialties in Onyx Goods and Chain. 183 Broadway, New York.  
**Alling Bros. & Co.**—Manufacturing Jewelers, 170 Broadway.  
**Baldwin, Sexton & Peterson**—Makers of Fine Jewelry and Importers of Diamonds, etc., corner Broadway and Fourth Street.  
**Ball, W. H.**—Manufacturer of Gold Band Bracelets. 9 John Street, N. Y.  
**Barthman & Straat**, Manufacturers of Fine Jewelry. Seal and Stone Rings a specialty. Orders promptly attended to. 41 Maiden Lane.  
**Bissinger, E.**—Importer of Fine Jewelry, Lockets, Crosses, Neck Chains, &c., No. 192 Broadway.  
**Brown, Thos. G.**—Manufacturer of Rich Jewelry, Necklaces, Lockets, Bracelets, Sleeve Buttons, etc., 9 Bond Street, N. Y.  
**Bryant & Bentley**—Manufacturing Jewelers. Rings a specialty. 12 Maiden Lane  
**Brainerd & Steele**—Successors to Brainerd, Steele & Co., Manufacturers of Fine Jewelry and Brainerd's Patent Lockets. No. 9 Maiden Lane, N. Y.  
**Burch & Fellows.**—Successors to Geo. Burch & Co., Manufacturing Jewelers, 17 Maiden Lane.  
**Cook, Groeschel & Co.**—Manufacturers of Fine Jewelry and Lockets, 191 Broadway (over Mercantile Bank,) N. Y.

**Carter, Howkins & Sloan.**—Manufacturing Jewelers, Whiting Building, 4th St. and Broadway.  
**Chatellier & Spence.**—Manufacturing Jewelers, No. 694 Broadway, N. Y.  
**Champenois & Co.**—Manufacturing Jewelers, No. 1 Maiden Lane. Specialties—Jet Cluster Goods in Sets, Sleeve Buttons, Studs and Collar Buttons, Lace, Shawl and Cuff Pins, Ear Knobs and Crosses  
**Demmert Bros.**—Manufacturers and Importers of Fine Jewelry, Cameo and Onyx Lockets, Sleeve Buttons and Sets a specialty. Old No. 9 Maiden Lane, New York.  
**Downin & Keller**—Manufacturers of Fine Jewelry, Onyx and Pearl Sets, Shawl Pins, Ear Rings, etc., 8 Maiden Lane.  
**Falkenau & Oppenheimer**—Manufacturing Jewelers. Specialty—Knife Edge Work and Rings. 89 Nassau Street.  
**Field & Co.**—Manufacturing Jewelers, 8 Maiden Lane, N. Y.  
**Finkelmeier, Louis**—Manufacturing Jeweler. Jobbing and ordered work for the trade at moderate prices. 73 Nassau Street, N. Y.  
**Goddard, John M.**—Manufacturing Jeweler.—Seal Rings and Fine Lockets a specialty, No. 3 Maiden Lane, N. Y.  
**Greason, Bogart & Pierce,** successors to Arthur, Rumrill & Co., 182 Broadway, Manufacturers of Fine Jewelry and Gold Chains.  
**Hartmann, P.**—Manufacturer & Importer of Fine Gold, Diamond, and Filigree Silver Jewelry, No. 36 Maiden Lane. P. O. Box 2,454.  
**Haskell, H. C.**—Manufacturing Jeweler. Seal Rings a specialty. Special attention to Jobbing of every description. 12 John street.  
**Hedges & A. J. Co.**—Makers of Fine Jewelry of every description. No. 9 Maiden Lane, N. Y.  
**Henrich, R.**—Manufacturing Jeweler, 35 Maiden Lane, New York.  
**Henderson & Winter**—Jewelers, No. 15 Maiden Lane, New York. Specialties—Stone, Cameo, Onyx, Amethyst, Topaz, Pearl and Turquoise Rings.  
**Hunt & Owen.**—Manufacturing Jeweler. Office 5 Maiden Lane.  
**Hale & Mulford,**—Manufacturers Rich Jewelry, Whiting Building, Broadway and 4th Street.  
**Jeanne Brothers.**—Manufacturers of Diamond Mountings & Rich Jewelry. 1 Maiden Lane.  
**Keller, Chas. & Co.**—Manufacturing Jewelers. Lockets a Specialty. No. 18 John St., N. Y.  
**Kremetz & Co.**—Manufacturing Jewelers, No. 13 John Street, N. Y.  
**Kuhn & Doerflinger**—Manufacturers of Enameled and Roman Band Bracelets, also Fine Lockets and Pendants, 18 John street.  
**Lennon, John D.**—Manufacturing Jeweler, 142 Fulton Street. Stone Lockets and Rings; also Badges and Emblems of all kinds.  
**Miller Bros.**—Manufacturers of Fine Jewelry, Lockets, Sleeve Buttons, Studs, &c., 11 Maiden Lane, N. Y.  
**Mulford & Bonet.**—Manufacturers of Diamond and Gold Jewelry. Dealers in Rolled Plated Goods, 21 Maiden Lane.  
**Moore & Horton.**—11 Maiden Lane, Manufacturing Jewelers, Rings, Studs, Collars and Sleeve Buttons, Pins, Ear-rings, &c.  
**Marx Kossuth & Co.**—Manufacturing jewelers, 39 Maiden Lane.  
**Owen, G. & S. & Co.**—Manufacturing Jewelers. Office, No. 5 Maiden Lane.  
**Riker, William**—Manufacturer of Jewelry. In-laid Gold Jewelry a Specialty, No. 5 Maiden Lane, N. Y.  
**Riley, J. A. & Co.**—Manufacturing Jewelers. Etruscan Gold and Coral Sets, Roman Bracelets Necklaces, etc. Onyx Goods a specialty. 7 and 9 Bond street, New York  
**Richardson, Enos & Co.**—Manufacturers of Fine Gold Jewelry, Gold Chains, Lockets, Crosses and Necklaces. Colored and Etruscan Work. No. 23 Maiden Lane, New York.  
**Richardson, J. W. & Co.**—Manufacturers of Jewelry, Masonic and other emblems. 196 Broadway. Manufactory, Providence, R. I.  
**Ripley, Howland & Co.**—Manufacturers of Fine Jewelry and Platinum Tipped Diamond Settings. No. 35 Maiden Lane, N. Y.  
**Sauter, L.**—Manufacturer of Fine Jewelry, Solid Stone Rings and Studs a specialty. Jobbing for the trade, 65 and 67 Nassau street.  
**Sexton & Cole**—Manufacturing Jewelers, Colored Gold and Onyx Goods a specialty. No. 30 Maiden Lane.  
**Stites, D. H. & Son**—Manufacturers of Fine Jewelry, Rolled Plated Goods and Chains, Parisian Diamond Rings, Studs and Earrings a specialty. 41 Maiden Lane, N. Y.

**Shoemaker & Co.**—Manufacturing Jewelers Cameo Buttons, and Lockets, Roman Gold Goods, etc. No. 21 Maiden Lane, N. Y.  
**Stites, E.**—Manufacturer of Fine Jewelry. No. 12 Maiden Lane, N. Y.  
**Sturdy Bros & Co.**—Manufacturers of Jewelry. General line of fine and heavy Rolled Plate Goods. Specialties—enameling on gold plate; graduated wire coral work. 14 Maiden Lane, N. Y.  
**Terhune, Charles F.**—Manufacturing Jeweler, 16 Maiden Lane, N. Y.  
**Thoma, Ernest**—Manufacturer of Fine Jewelry. Sleeve Buttons, Rings, Ear-rings, &c. No. 173 Broadway, N. Y. Factory, Hackensack, N. J.  
**Trier Bros. & Co.**—Jewelry. Optical, Rubber, Jet, Shell, Ivory, Amber and Pearl Goods, Silk Goods, Japanese Bamboo Watch Chains a Specialty. No 15 Maiden Lane.  
**Wadsworth, E. E.**—Manufacturer of Rich Jewelry and fine Rolled Plate. Fine Seal Rings a specialty. 35 Maiden Lane.  
**Wheeler, Parsons & Hays.**—Manufacturers of Fine Jewelry, Watch Cases, Gold Chains, &c. and Dealer in American and Swiss Watches, No. 2 Maiden Lane, N. Y.  
**Wienhold, Joseph**—Manufacturer of Fine Jewelry and Diamond Setter. 24 John St.  
**Ward, Thos. M.**—Manufacturer of Fine Jewelry, Diamond Mountings a specialty. No. 25 John Street, N. Y.  
**Woglom & Miller**—Manufacturers of Black Onyx Goods exclusively. 32 & 34 John Street, N. Y.

**Jewelers' Tools, etc.**

**Frasse & Co.**—Importers of Stubb' French, Swiss, German and Sheffield Tools, Files and Steel Wire for Watchmakers, Jewelers, etc., 62 Chatham street, N. Y.  
**Friedenthal, A.**—Importer and jobber of Watchmakers' and Jewelers' Tools and Materials, etc. 43 Maiden Lane, N. Y.  
**Stanley & Company**—Jobbers of Tools and Materials for use of Watchmakers and Jewelers. Spectacles, Jewelry Boxes, Plated Chains, &c., &c., 108 Wisconsin Street, Milwaukee, Wis.

**Lapidaries.**

**Fox, M. & Co.**—Practical Lapidaries, No. 1 Maiden Lane, New York.  
**Kordmann & Michel**—Lapidaries, dealers in Precious Stones, Rubies, Sapphires and Periodots cut. No. 59 Nassau Street.

**Masonic Jewelry.**

**Luther, John F.**—79 Nassau Street. Manufacturer of Fine Presentation Jewels for all Societies. Knights Templars, Crosses, Badges, &c.  
**Wilkinson & Lenon.**—Manufacturers of Masonic, Odd Fellows, Athletic Clubs and other Jewelry, No. 212 Broadway, New York.

**Opticians.**

**Burbank Man'g Co.**—Manufacturers of Spectacles and Eye Glasses of all descriptions, in gold, silver, etc., 14 Maiden Lane, N. Y.  
**Du Bois, Geo. W.**—Successor to A. Landsberg, Importer and Manufacturer of Optical Goods, 36 Maiden Lane. Box 3993, N. Y.  
**Laurencott, J. B.**—Importer of Watch Glasses, Optical and Fancy Goods, Clocks, Bronzes, etc., 33 Maiden Lane, N. Y.  
**Lorsch, Albert**—Manufacturer of the Patent Accommodating Spectacles and Eye Glasses in Gold, Silver and Steel, and other Optical Goods, 37 Maiden Lane, N. Y.  
**Spencer Optical Manufacturing Co.**—Gold Silver, Steel and Nickel Plated Spectacles, Eye Glasses, &c. 13 Maiden Lane, N. Y.

**Precious Stones, &c.**

**Bissinger, Philip**—Importer of Diamonds, Pearls and Precious Stones. Agent for the Bohemian Garnet Goods. No. 22 John St. N. Y.  
**Fox, M. & Co.**—Importers of Diamonds and other Precious Stones, No. 1 Maiden Lane, N. Y.  
**Gruet, Jules.**—Importer of Precious and Imitation Stones, Amethysts, Topazes, Cameos, Garnets, Doubles, Imitation Diamonds, Pastes, etc., No. 14 John street. Manufactory at Septmoncel, France.

**Silverware.**

**Cuppia, L. A.**—Manufacturer of Solid Silver Novelties, and Importer of Silver Filigree, 19 Union Square.  
**Rieder, Peter L.**—Manufacturer of Sterling Silver Ware. 618 Chestnut Street, Philadelphia.  
**Gorham Manufacturing Co.**—Union Square.  
**Wood & Hughes.**—Manufacturers of Fine Silverware 16 John Street, N. Y.

**N. Matson & Co.**—State and Monroe streets, Chicago, Ills. General Jewelers and Furnishers of Jewelers Supplies, Western Branch House for the Reed & Barton's Fine Electro Silver Plated Ware.

#### Silver Plated Ware.

**Brown & Bros.**—Manufacturers of first quality of Electro Plated Flat Table Ware. No. 81 Chambers Street, N. Y.

**Hall, Elton & Co.**—Manufacturers of the Finest Electro-Plated Ware, salesroom, 75 Chambers Street, N. Y.

**Holmes, Booth & Haydens**—Manufacturers of Silver-Plated Ware. 47 Chambers Street.

**Meriden Britannia Co.**—Manufacturers of Silver-Plated Ware. 46 East 14th Street, Union Square, Middletown Plate Co.—Manufacturers of Superior Electro-Plate. Factories, Middletown, Conn., salesroom, 13 John Street.

**Rogers, Wm. & Son**—Hartford, Conn.

**Rogers & Bro.**—Manufacturers of the finest quality of Electro-Plated Ware. 690 Broadway.

**Simpson, Hall, Miller & Co.**—Manufacturers of fine Silver-Plated Ware. No. 36 E. 14th Street.

**Schade, Henry.**—Manufacturer of White Metal and Plated Ware. No. 84 John St., N. Y. Price list and catalogue furnished on application.

**Webster, E. G. & Bro.**—Manufacturers of Fine Silver-Plated Ware. Office and warerooms, 14 Maiden Lane, N. Y.

#### Show Cases, Etc.

**Kraft & Hoffmeister.**—Manufacturers of Metal Show Cases, Jewelry Trays always on hand. No. 20 North William Street, N. Y.

**Smith, B. & W. B.**—Patent Improved Counter Show Cases. Drawings furnished and estimates given for fitting stores in Cabinet Work complete.

#### Spectacle Case Manufacturers.

**Koenen, A. & Bro.**—Manufacturers of Leather Spectacle and Eye-Glass Cases. 81 Nassau St., N. Y.

#### Thermometers Etc.

**Tagliabue, Giuseppe.**—manufacturer of Thermometers, Barometers and Hydrometers. Patentee and sole manufacturer of the U. S. Standard Hydrometer. No. 302 Pearl Street, near Beekman, N. Y. All instruments in my line repaired with neatness and dispatch.

#### Thimble Manufacturers.

**Burbank Manufg Co.**—Manufacturers of Gold and Silver Thimbles, 14 Maiden Lane, N. Y.

**Ketcham & McDougall.**—Improved Gold and Silver Thimbles, Nos. 4 and 6 Liberty Place, near Maiden Lane, N. Y.

**Woglom & Miller.**—Sole Agents for the "Prime" Thimbles in Gold and Silver, manufactured by Ezra C. Prime. 34 John Street, N. Y.

#### Walking Canes.

**Fradley, J. F.**—Manufacturer of Fine Gold and Silver-headed Walking Canes and Sterling Silver Ware. Office and factory, 20 John Street, N. Y.

#### Watch Companies.

**American Watch Co.**—Robbins & Appleton, No. 9 Bond Street, N. Y.

**Hampden Watch Co.**—of Springfield Mass., office No. 12 Maiden Lane, N. Y.

**The Howard Watch and Clock Co.**—No. 2 Maiden Lane, N. Y.

#### Watch and Chronometer Jeweler.

**Queen, James.**—Watch and Chronometer Jeweler and Pallet Maker, 78 Nassau Street, room 8. Pivots inserted in Pinions, Balance, Staffs, etc.

#### Watch Importers, Etc.

**Aikin, Lambert & Co.**—Importers of Watches, Sole Agents for Paul Breton & Chas. Latour, Geneva. A general line of reliable Swiss Watches, Watch Cases of all styles made to order. 23 Maiden Lane, N. Y.

**Cross & Beguelin.**—Importers of Watches, Watch Tools and Materials, dealers in American Watches, No. 21 Maiden Lane, N. Y.

**DuBois, Francis & Co.**—36 Maiden Lane, N. Y., Importers of Watches and Manufacturers of Watch Cases.

**Droz, Henry E.**—Importer of Watches, and Watch Case Manufacturer. Agent for the "E. Perregaux" Watch, and jobber in American Watches, No. 92 Fulton Street, N. Y.

**Freund Max & Co.**—Importers of Watches, Jewelry and Precious Stones, 8 Maiden Lane, N. Y.

**Friedman, S.**—Importer of and dealers in Watches and Jewelry, 40 Maiden Lane.

**Gallet, Julien.**—Importer of Watches. No. 1 Maiden Lane.

**Ginnel, Henry.**—Importer of Watches, Tools and Materials, No. 31 Maiden Lane, N. Y. P.O. Box, 2067.

**Jandorf, P. & Bro.**—Importers of Watches and Jewelry, 182 B'way, bet. John St. & Maiden La.

**Keller, L. H. & Co.**—Successors to G. A. Huguenin, Importers of Fine Watch and French Clock Materials, No. 64 Nassau Street, N. Y.

**Hirsch Bros.**—Dealers in Watches and Diamonds and Manufacturers of Jewelry, No. 23 Maiden Lane, N. Y.

**Hyde's Sons, John E.**—Wholesale Commission Agents, only for Jules Jurgensen, of Copenhagen; Ed. Perregaux, of Locle; Jules Monard, of Geneva; and for other makers of all qualities of Watches, 22 Maiden Lane.

**Mathey, L. & A.**—Importers of Fine Watches and Sole Agents for the H. L. Matile's Watches, No. 16 Maiden Lane.

**May & Stern.**—Importers of Foreign Watches, Materials and Tools, etc. Manufacturing Jewelers, No. 19 John Street, N. Y.

**Nicoud & Howard.**—Importers and Manufacturers of Watches, No. 14 Maiden Lane.

**Oppenheimer Bros. & Veith.**—Dealers in Watches and Diamonds, and Manufacturing Jewelers, No. 35 Maiden Lane.

**Schwob, Adolphe.**—Manufacturer and Importer of Watches, 11 Maiden Lane, N. Y.

**Stern Brothers & Co.**—Importers of Swiss Watches and wholesale dealers in American Watches, &c., 39 Maiden Lane.

**Scott, J. T. & Co.**—Importers of Watches, and Manufacturers of Jewelry, and Jobbers of all Grades, American Watches, No. 11 Maiden Lane.

**Strasburger, Louis & Co.**—Importers and Makers of Watches of every description, No. 15 Maiden Lane.

**Tiffany & Co.**—Makers of Watches. General agents for Patek, Philippe & Co. Wholesale office, 694 Broadway, N. Y.

#### Watch Cases.

**Brown, J. A. & Co.**—Manufacturers of the Ladd Patent Stiffened Gold Watch Cases, etc., 11 Maiden Lane, N. Y. Factory, 58 Eddy Street, Providence, R. I.

#### Watch and Chronometer Repairers.

**Cerf, B.**—Practical Watchmaker and Repairer, No. 10 John Street, N. Y. Repairing and adjusting of Fine Watches done for the trade. All kinds of escape and stem-winding wheels cut to order.

**Ludeman, W. H.**—Chronometer and Watch Maker. Repairing of every description for the trade, 75 and 77 Nassau Street.

**Sirois, A.**—Practical Watchmaker, 89 Fulton Street. Special attention paid to the repairing of Fine Watches. Pivots inserted.

#### Watch Case Repairers.

**Tarbox, Hiram.**—Watch Case Repairing, Springing, Polishing and Engine Turning, 79 Nassau Street, (room 22,) N. Y.

**Renaud, F.**—Watch Case Repairer.—Solid and Heavy Rolled Plate Bows and Pendants. Springing and Engine Turner of Cases and Jewelry, 36 Maiden Lane.

#### Watch Glasses, Shades, Etc.

**Brown, Edwin.**—No. 85 Nassau Street, Imported and Own Manufacture Watch Glasses, Flat, Flat Concave, Concave, Convex and fine Genevas. Fine fitting solicited

**Hill, Robert S.**—Manufacturer of Watch Glasses, &c., dealer in Imported Glasses, Flat Glasses a specialty; also Jeweler's Glasses. Nos. 75 and 77 Nassau Street, N. Y.

#### Wood Mailing and Nested Boxes.

**Swift Manufacturing Co.**—Makers of Mailing Boxes for Mailing and Express purposes, 12 Courtland Street, N. Y.

## PHILADELPHIA

**Booz & Thomas.**—Manufacturers of Gold and Silver Watch Cases and Jewelry, 108 South 8th St., Philadelphia.

**Bennett, Jacob & Son.**—Diamond Setters and Manufacturing Jewelers, 108 South 8th St.

**Cooper & Bros.**—Wholesale Jewelers and Importers of and dealers in Watch and Clockmakers' Materials, etc., Spectacles and Optical Goods. No. 35 South 4th Street, Philadelphia.

**Conover David F. & Co.**—American Watches, Wholesale Salesroom, South 5th corner 7th and Chestnut Streets, Philadelphia.

**Herold, Chas P.**—Successor to Hildebrandt, Herold & Co., Manufacturing Jeweler and Diamond Setter. Diamonds. 916 Chestnut Street.

**Levy, Bernard.**—Manufacturer of Gold and Silver Watch Cases, and Importers and Dealers in Swiss and American Watches. 402 Library Street.

**Morgan, Charles V.**—Manufacturer of Morocco and Hardwood Cases. 630 Chestnut Street, Philadelphia. Jewelry and Silverware Cases, Show Case Trays, Mathematical and Surgical Instrument Cases, etc.

**Pequinot, C. & A.**—Manufacturers of Watch Cases and dealers in American Watches, etc. 22 South 5th Street, Philadelphia.

**McCall & Newman.**—Manufacturing Jewelers Filled Plain Gold Rings a Specialty. No. 625 Arch Street.

**Morgan & Headly.**—Manufacturing Jewelers, Cameo Sets, Gold Sets, Roman Locketts, Rings, Coral Sets and a general line of rich goods. 611 and 613 Sansom Street, Philadelphia.

**H. Muhr's Sons.**—Manufacturing Jewelers, Solid Gold and Filled Rings a Specialty. 633 and 635 Chestnut Street, N. Y. Office. 11 Maiden Lane.

**Rosenthal, G. F. C.**—Manufacturing Jeweler and Diamond Setter. Engraving and Designing of Monograms a Specialty. No. 917 Sansom Street.

**Rowe, Geo. A.**—Stone and Metal Seal Engraver, Die Sinker and Medalist, Intaglio Cutting. Special rates for large quantities to manufacturers. 1002 Walnut Street.

**Scherr, L. A. & Co.**—Wholesale Dealers in Watches Silver-Plated Ware, Spectacles, Fancy Goods, Watch Materials, etc. 726 Chestnut Street.

**Sheafer, W. H. & Co.**—Makers of Fine Jewelry. 908 Chestnut Street.

**Simons, Brother & Co.**—Manufacturers of Fine Jewelry, Canes, Thimbles, Chains. 611 and 613 Sansom Street.

## CHICAGO.

**American Watch Company.**—of Waltham, Mass. No. 170 State Street, Chicago.

**Charpier & Wathier.**—Watchmakers and Jewelers for the trade, and Wholesale Dealers in Watch Materials, Tools, etc. 61 West Kinzie Street, Chicago, Ill. Send for price list.

**Clapp, Bros. & Co.**—Wholesale Jewelers. 63 and 65 Washington Street. Catalogue and price list issued to watchmakers and Jewelers.

**Frese, B.**—Watchmaking and Repairing for the Trade promptly attended to. Stem-winding and Escape Wheels cut to order. No. 99 E. Madison Street, Chicago, Ill.

**Giles, Bros. & Co.**—Manufacturers and Jobbers in Watches, all classes of Jewelry, Materials, Clocks, Silver Ware, &c. Illustrated catalogues furnished to dealers on application. State and Washington Streets.

**Glickauf, S. & Co.**—79 and 81 State Street. Importers of Watchmakers and Jewelers Supplies, Optical Goods, Watches, etc.

**Hahn, H. F. & Co.**—Wholesale Jewelers, 157 and 159 Franklin Street. Largest assortment and lowest prices. We do not issue any catalogue.

**Knights, C. H. & Co.**—Wholesale Jewelers, 125 and 127 State Street.

**Kearney & Swartzchild.**—113 and 115 State Street. Importers and Jobbers of Watchmakers' and Jewelers' Supplies, Watches, Jewelry, etc. Illustrated catalogue and price list sent on application and receipt of card.

**Matson, N. & Co.**—State and Monroe Streets. General Jewelers and Furnishers of Jewelers' Supplies. Western Branch House for Reed & Barton's Fine Electro-Silver Plated Ware.

**Norris, B. F. & Co.**—Wholesale Jewelers, and Dealers in Watchmakers' and Jewelers' Supplies. 101 and 103 State Street.

**Richter, Jacob.**—Established 1868. Watch Repairer for the trade. Special attention given to complicated work, 528 State Street.

**Stein & Ellbogen.**—Wholesale Dealers in Watches and Jewelry, 127 State Street, Chicago, Ill. Specialty, repairing for the trade.

## PROVIDENCE

**Irons, Chas. F.**—Manufacturer of Solid Gold Jewelry. Specialty, Emblems, Pins and Charms, Masonic, Odd Fellows, etc. 102 Friendship St.

**Perkins, C. H. & Co.**—Manufacturers of Fine Gold and Plated Jewelry, 20 Conduit Street.

## NEWARK.

**Lefort, Henry.**—Stem-winding Watch Crown Manufacturer. 80 and 82 Marshall Street.

**Lelong, L. & Bro.**—Gold and Silver Refiners, Assayers and Sweep Smelters, Southwest corner of Halsey and Marshall Streets, Newark, N. J.

**Milne & Jourdan.**—Manufacturers of Stem-winding Watch Crowns. 13 and 15 Franklin Avenue.

**Prince, David.**—Gold and Silver Refiner, Assayer, and Sweep Smelter. Sole Agent for Comins' Improved Amalgamator. 63 Railroad Ave.

**Unger, H. & Co.**—Manufacturers of Fine Gold Jewelry, Colored and Etruscan work, Enameled Sets. Office and factory, 18 Crawford street, Newark, N. J. Box 63.

**JOHN BLISS & CO.**

**STANDARD MARINE**

**Chronometers and Transits,**

**FOR WATCHMAKERS' USE.**



Standard Marine Chronometer  
FOR KEEPING CORRECT TIME.

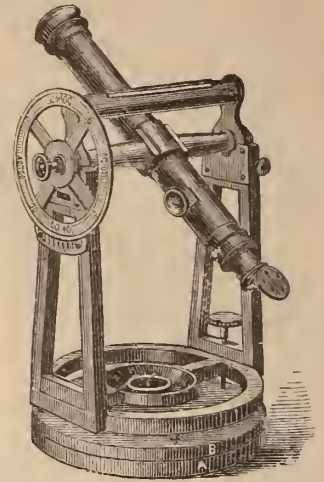

No. 10

**110 WALL STREET, NEW YORK.**

**IMPORTANT NOTICE.**—These Transits are readily set in position without the aid of strictly correct time as a basis for that purpose. Printed instructions, easily understood, accompany each Instrument, and no calculations are required preliminary to setting in position.

As a trial only is required to insure unqualified approval, we are induced to make the following **LIBERAL OFFER**—On receipt by us of satisfactory reference, and 10 per cent. of the price, we will send one of the foregoing Transit Instruments, on hire or trial, for one month, with full printed instructions for setting up and using the same, and if purchased after trial, we will allow the whole hire to apply in part payment, and sell the Instrument on approved note at four months for the balance. Special terms for payment by installments, after trial, on application. We do not make this offer merely to hire these instruments, but to insure a trial with a view to sales, the hire received being only sufficient to cover the cost of repolishing in case they are returned. Send for Illustrated Circular giving full description.

JOHN BLISS & CO., 110 Wall Street, New York.

**PATENT IMPROVEMENT IN COUNTER SHOW CASES,**

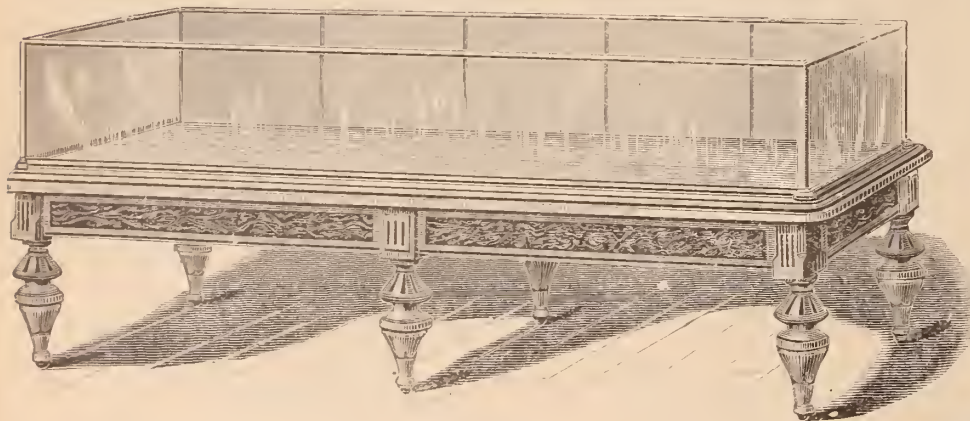

**Perpendicular Sliding Door,**

(DUST TIGHT.)

REAR VIEW OF CASE SHOWING SLIDING DOOR.

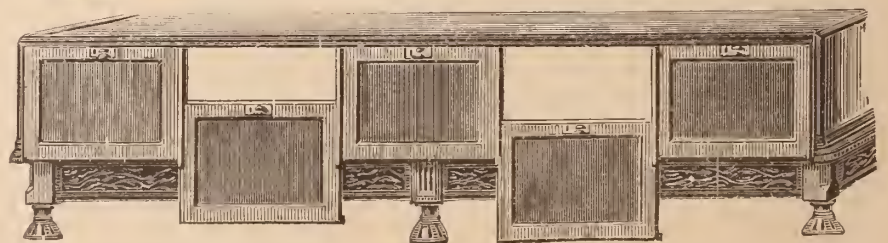

Its advantages are as follows:—The doors are more conveniently opened and closed, less liable to get out of repair or broken, articles are more easily reached in wide cases, mirrors are more safe, it dispenses with hinges, economizes room, excludes dust, and is air tight *when closed*.

Drawings furnished and estimates given for fitting stores in cabinet work complete.

REFERENCES:—Gorham Mfg Co., Rogers & Bro., Mitchell Vance & Co.,  
Meriden Britannia Co., M. S. Smith & Co. Detroit, Mich.  
D Valentine, Syracuse, N. Y.

**B. & W. B. SMITH,**

**220 West 29th Street, New York.**

ESTABLISHED, 1863.

# WIGGERS & FROELICK,

60 NASSAU STREET, NEW YORK,

MANUFACTURERS OF

## Cases for Jewelry,

EVERY DESCRIPTION.

Plain and Fancy Trays for Show Cases and Windows.

## Sample Cases & Trunk Trays

A SPECIALTY!

Trunks fitted with our Trays will carry more goods and carry them safer than by any other method; we having made it a special study to combine CHEAPNESS, LIGHTNESS, CONVENIENCE and DURABILITY.

The attention of the **JOBGING TRADE** is particularly invited.

NE PLUS ULTRA.

## DUST-PROOF WATCH KEYS.

Patent Sept. 1st, 1874.



The Popular Name Key.

A. Nickel Plated Handle and Pipe, Swivel Top, per gross..... \$10.75

English Pattern Key.

C. Nickel Plated Handle and Pipe, Swivel Top, per gross..... \$7.50

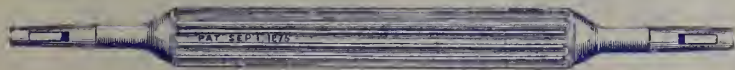

BENCH KEYS.

Corrugated Gilt Handles, Tempered Steel Pipes, per Set of Six.....\$1.80  
per Set of Three..... .90

P. Style of Key.

Gilt Handle.

Steel Pipe.

Per Gross.....\$8.50



Our Key Pipes are all warranted to be made of the finest quality of steel. One great advantage this key has over all others, is the mortice through the pipe, making it the most simple and thoroughly dust and moisture-proof, as well as the cheapest key in the market. Our sizes run from 1 to 12; 4, 5 and 6 fit Gents' American Watches; No. 8, Ladies' American.  
For sale by the Trade generally.

**KENDRICK, DAVIS & CO., LEBANON, N. H.**

SOLE OWNERS AND MANUFACTURERS.

The advantage of our Name Key, as an advertising medium, will at once be seen.

ESTABLISHED 1849.

# O. SCHWENCKE,

Successor to C. Gunzenhausen,

MANUFACTURER OF

## FINE HAIR JEWELRY,

43 Maiden Lane, New York.

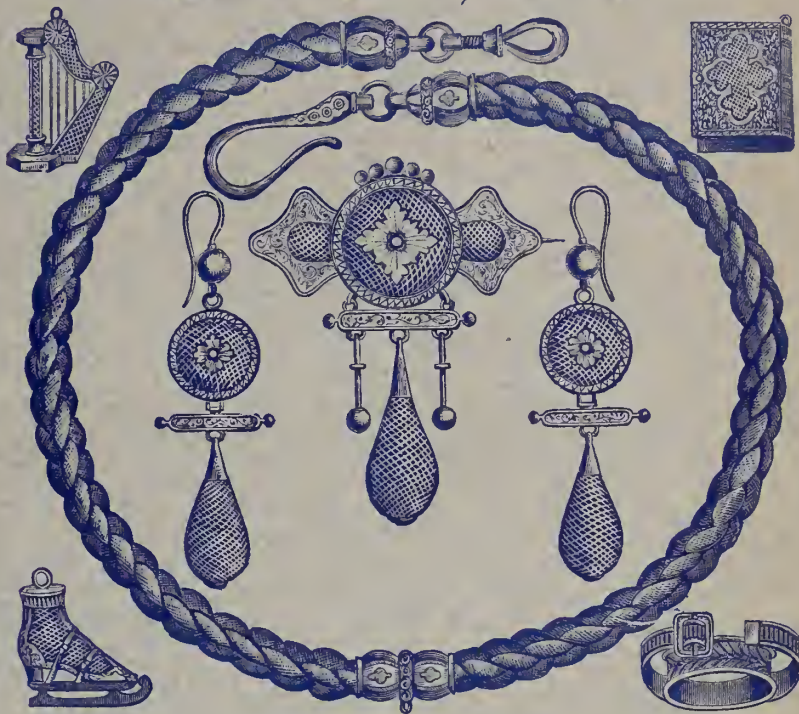

Solid Gold Mountings for Hair Jewelry, kept constantly on hand and made to order at short notice.

Orders from the country trade promptly attended to, and Price List and Catalogues furnished at 50 cents each, which will be refunded on first order.

# HOPKINS' WATCH TOOL CO.

WALTHAM, MASS.

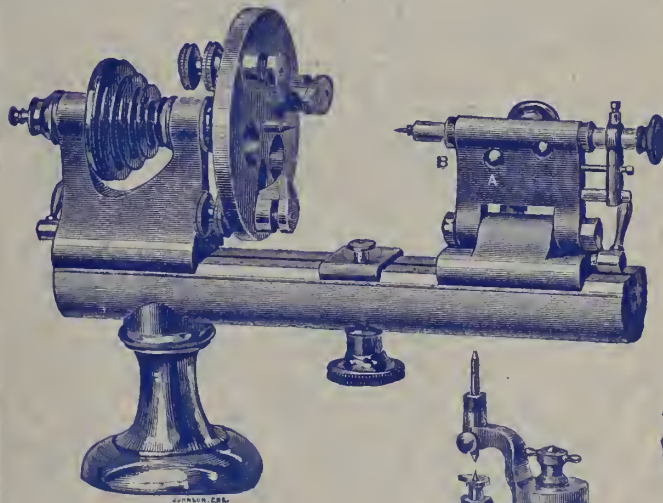

HOPKINS' PATENT LATHES,

and other

Fine Watchmaker's Tools,

P. O. Box 943.

SEND FOR CIRCULAR.

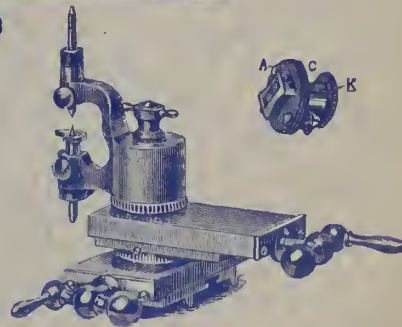

HENRY HIRSH,

EDWARD HIRSH,

# HIRSH BROS.

## Dealers in Watches & Diamonds

AND MANUFACTURERS OF

### JEWELRY,

No. 23 Maiden Lane, New York.

Prompt attention given to filling orders for all kinds of goods pertaining to the trade.

HENRY MAY.

Established 1854.

JOSEPH STERN.

# MAY & STERN,

IMPORTERS OF

## Foreign Watches, Materials and Tools

AGENTS FOR THE SALE OF ALL

DOMESTIC MOVEMENTS AND CASES,

### And MANUFACTURING JEWELERS

No. 19 John Street, New York.

SOLID GOLD SEAL RINGS, in Cameo, Amethyst, Topaz and Onyx, A SPECIALTY.

# L. LELONG & BRO.

## GOLD and SILVER REFINERS,

### Assayers and Sweep Smelters,

Southwest Corner Halsey and Marshall Streets,

NEWARK, N. J.

SWEEPINGS A SPECIALTY.

# KELLER & UNTERMAYER,

ONLY AUTHORIZED AGENTS OF

## The International Watch Co.'s

### WATCHES.

A full and complete assortment of these goods in new and attractive Gold Cases constantly on hand.

No. 18 John Street, New York.

**SILVER FILIGREE JEWELRY.**  
Splendid Silver Bridal Sets,  
Half Sets, Necklaces, Bracelets, &c.

**P. HARTMANN,**  
P. O. BOX, 2454. 36 Maiden Lane, New York.  
Importer and Manufacturer of  
Fine Gold, Diamond & Filigree  
Silver Jewelry.

# ALBERT LORSCH,

IMPORTER AND DEALER IN

## WATCHES,

AND MANUFACTURER OF

### JEWELRY,

ALSO MANUFACTURER OF THE

### PATENT ACCOMMODATING

## Spectacles and Eye Glasses,

In Gold, Silver, Steel, &c.

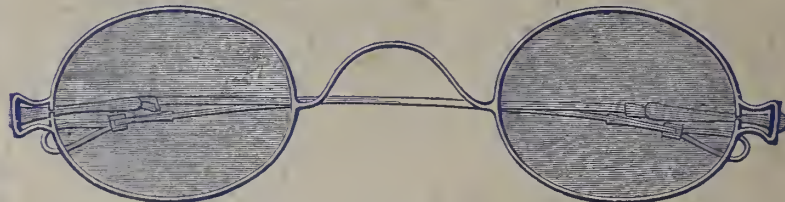

Would call the attention of the trade to the fact, that with the above Spectacles and Eye Glasses, which are constructed to form a Spring by which the lense is held, it is only necessary to have one complete assortment of lenses which being of uniform size, will interchange in all the different kinds of frames, thus giving a complete assortment for a comparatively small outlay. Notwithstanding the numerous advantages of these Spectacles, the prices will compare favorably with those of any other make.

ALBERT LORSCH, 37 Maiden Lane, New York.

LORSCH BROS., 120 Sutter St., San Francisco, Cal.

I. PFORZHEIMER.

D. KELLER.

# PFORZHEIMER & KELLER,

IMPORTERS OF

## Watches and Diamonds

Dealers in American Watches,

AND

### Manufacturers of Jewelry,

No. 24 JOHN STREET,

P. O. Box 4144.

NEW YORK.



# New Haven Clock Co.

117 & 119 State St., Chicago.

62 Reade Street, New York.

G. A. HARMOUNT, Agent.

L. EGERTON, Jr., Agent.

Manufacturers and Jobbers of

## AMERICAN CLOCKS,

### Movements and Clock Materials,

Also, Black Walnut, Visible Pendulum Clocks, and Specialties in Brass and Nickel.

Agents for { JEROME & CO., - - - - - Of New Haven, Conn.  
E. INGRAHAM & CO., - - - - - Of Bristol, Conn.

Liberal Discounts to the Trade.

# WATERBURY CLOCK CO.

MANUFACTURERS OF AMERICAN CLOCKS,

4 CORTLANDT STREET,  
NEW YORK.

M. BAILEY, Treasurer.

63 WASHINGTON ST.,  
CHICAGO.

—♦♦♦—  
FACTORIES, WATERBURY, CONN.



SHARP GOTHIC EXTRA.



CRICKET EXTRA.

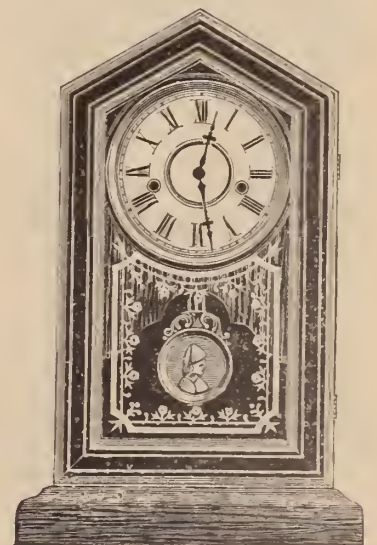

CHESTER

# GEO. B. OWEN & CO.

6 MURRAY STREET,

Factory, Winsted, Conn.

New York.

MANUFACTURERS OF

## BLACK WALNUT CLOCKS,

Clocks Manufactured by the following Companies will be furnished at lowest Market Rates:

- New Haven Clock Co.,
- Seth Thomas Clock Co.,
- E. N. Welch Man'g Co.,
- Welch, Spring & Co.,
- Waterbury Clock Company,
- Ansonia Clock Company,
- Wm. L. Gilbert Clock Company,
- E. Ingraham & Co.

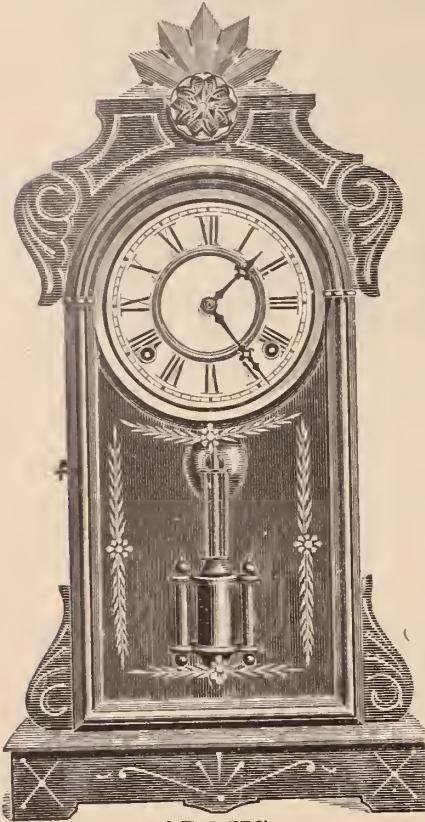

**ARGUS.**

Eight day Strike. Height, 20 1/4 in.



**AMPHITRITE.**

1 Day Time. Height 17 1/2 in.

Illustrated Catalogues and Price Lists furnished on application,

# E. N. WELCH MFG. CO.

WELCH, SPRING & CO.

## Clock Manufacturers

FACTORIES, FORESTVILLE, CONN.

STORES AND WAREHOUSES:

6 Warren St., New York,

170 State St., Chicago.

STYLES OF OUR GOODS:

Original, Unique, Highly Finished,

Warranted Excellent Timekeepers, and Cheap.

Send for Catalogue, Price List and Discounts.

E. C. HINE, General Manager,  
NEW YORK.

F. E. MORSE, Agent,  
CHICAGO, ILL.



**CERSTER.**

SPRING STRIKE. VERY FINE MOVEMENT. HEIGHT, 18 1/2 INCHES. 8 DAY STRIKE. HIGHLY FINISHED ROSEWOOD CASE FOLISHED, GLASS SIDES. SPRINGS BARRELED.

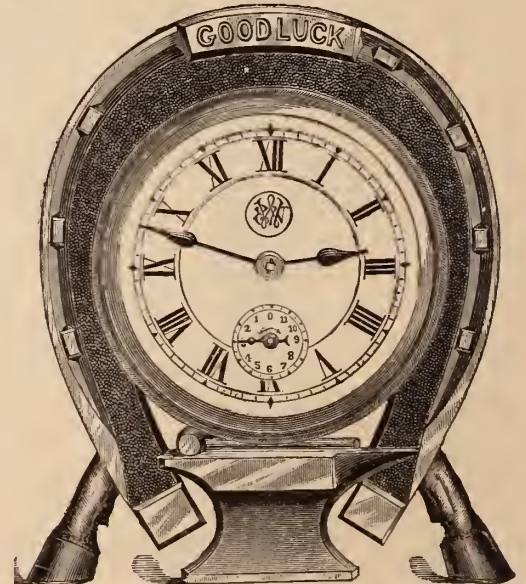

**GOOD LUCK.**

(Patented Sept. 17, 1878. Height, 6 inches.)

Thirty hour Lever Time. This clock will run in any position. Is a stem winder. Winds and sets everything at the back. The movement is protected at front and back by close fitting caps, so that the dust can not get in. Made in Gold Gilt or Nickel, with and without alarm. Manufactured only by the E. N. WELCH MANUFACTURING CO., Forestville, Conn.

# LOUIS STRASBURGER & CO.

DIRECT IMPORTERS OF



## DIAMONDS.



OF ALL GRADES,

Especially selected for this market. Original parcels of new goods constantly arriving, so that dealers are always sure of finding a most desirable and ever-changing stock to select from.

FINE GEMS IN SINGLE STONES AND MATCHED PAIRS A SPECIALTY.

15 MAIDEN LANE, NEW YORK.

30 BOULEVARD HAUSSMANN, PARIS.

# LOUIS STRASBURGER & Co.

MAKERS AND IMPORTERS OF

## WATCHES.

From the finest Stem-Winding and Setting goods to the lowest price Watch in the market.

We have constantly in stock a complete and varied assortment of the best COMMERCIAL WATCHES ranging from the lowest priced Metal and Silver Watches to the finest Gold goods, including REPEATERS, CHRONOGRAPHS (single and split seconds) and other Timing and Complicated Watches of established reputation.

We would call the especial attention of the trade to our complete assortment of NICKEL WATCHES, with Black, Fancy and Luminous Dials, in all grades, styles and sizes.

Also a full assortment of the INTERNATIONAL and all grades of AMERICAN Movements, in *Gold and Silver Cases*, constantly in stock.

SALESROOM, No. 15 MAIDEN LANE, NEW YORK.

Watch Factory, Rue Leopold, Chaux de Fonds, Switzerland.



LADY RACINE,  
Open Back.



REGISTERED



RAILROAD REGULATOR.



LADY RACINE,  
Open Face.



REGISTERED



CONTINENTAL.

THE CHEAPEST STEM-WINDING AND SETTING

# Swiss Watches,

IN THE MARKET.

These movements are carefully and substantially made—have White, Black, Luminous and Fancy dials—CASED in NICKEL, and are the best imported Watches for the money.

## JULIEN GALLET,

No. 1 Maiden Lane, New York.

TRADE MARKS PATENTED.

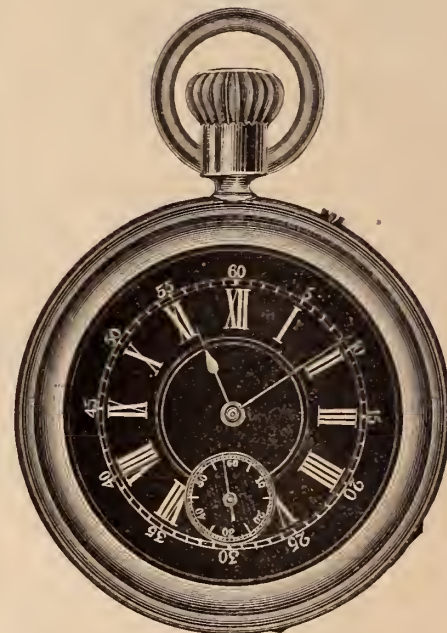

CONTINENTAL.

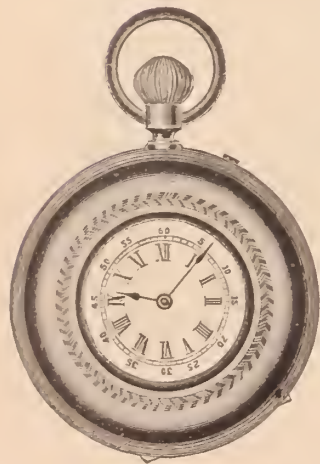

LADY RACINE.

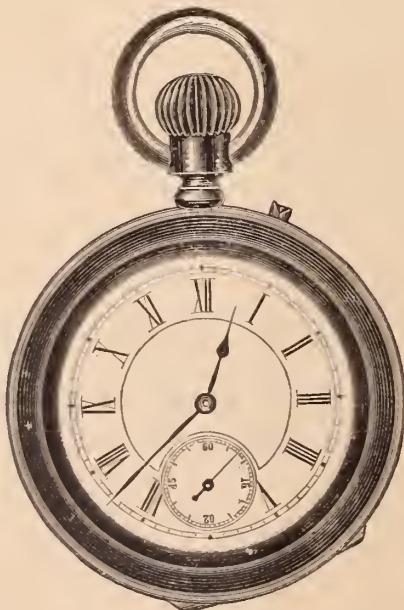

RAILROAD REGULATOR

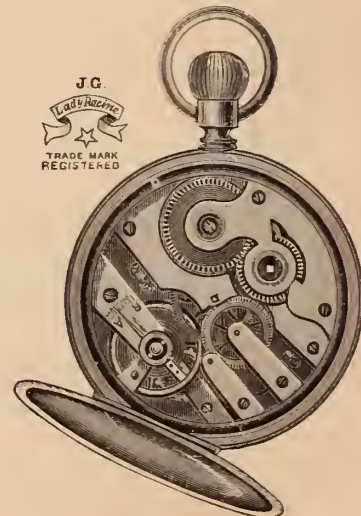

TRADE MARK REGISTERED

LADY RACINE.

# CROSS & BEGUELIN,

21 MAIDEN LANE . . . . . NEW YORK.

— IMPORTERS OF —

## SWISS WATCHES,

Watch Tools, Materials, Glasses, Etc.

**JOBBERS IN ALL GRADES OF AMERICAN WATCHES**

AND AGENTS FOR THE FOLLOWING WELL-KNOWN MAKERS:

### A. HUGUENIN & SON'S

Fine and Complicated Watches, consisting of Repeaters,  $\frac{1}{4}$  Split Seconds, Fly-back, Chronometer and Revolving Escapement.

These Goods are among the finest imported.

### THE AUBURNDALE TIMER,

Now successfully introduced in this market, has been adopted by sporting authorities. It is a Fly-back, registering quarter and eighth seconds.

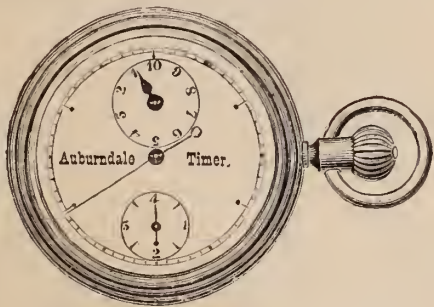

Three-fourths size of Timer.

Are carefully made and accurate time-keepers.

### CHARLES E. JACOT

Watches, in Ladies' and Gents' sizes, have an established reputation in the trade.

### DROZ & PERRET.

Well-known watch, are generally considered by practical workmen to be among the best medium-price watches made.

### HENRY BEGUELIN.

The watches bearing this maker's name have been before the trade for over 30 years and are among the most reliable goods imported.

### LEMAIRE'S

## Celebrated Opera and Field Glasses.

SO UNIVERSALLY POPULAR,

THEY ARE AMONG THE STANDARD GOODS MADE.

We are also Wholesale Agents for

## ROGERS & BROS'. CELEBRATED FLAT AND HOLLOW WARE.

These Goods are Deservedly Popular and enjoy a Standard Reputation.

THE

## Centennial Watch

Of which we are the Makers,

HAS BECOME QUITE POPULAR

As a Cheap Watch,

**AND GIVES UNIVERSAL SATISFACTION.**



None Genuine without this Trade Mark.

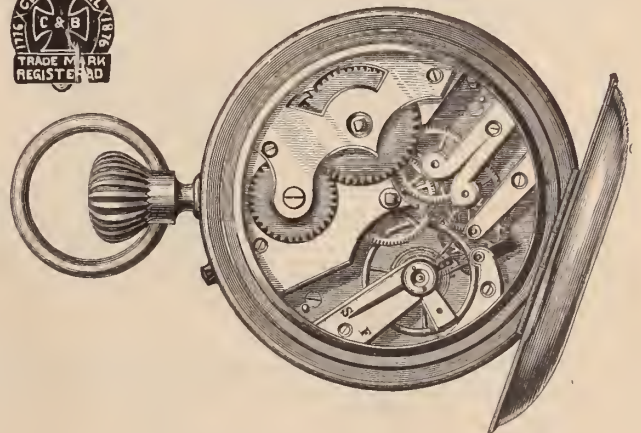

The above is a fac-simile of the Centennial Watch

ALSO AN ATTRACTIVE LINE OF

Valuable French Traveling Clocks, with Common Strike and Cathedral Chimes.

# David F. Conover & Co.

(SUCCESSORS TO WM. B. WARNE & Co.)

Importers, Manufacturers and Dealers in

## Watches and Jewelry,

AMERICAN WATCH WHOLESALE SALESROOM,

Southeast Cor. Chestnut and Seventh Streets, First Floor,

PHILADELPHIA.

DAVID F. CONOVER,  
C. FRANK WILLIAMS,  
B. EDGAR RIGHTER.

Wholesale Agents for

Rogers & Brother's Flat and Hollow Ware

CELLULOID EYE GLASSES,

AND SOLE AGENTS FOR THE

Patent Railroad Train Watch Chains, Nickel.

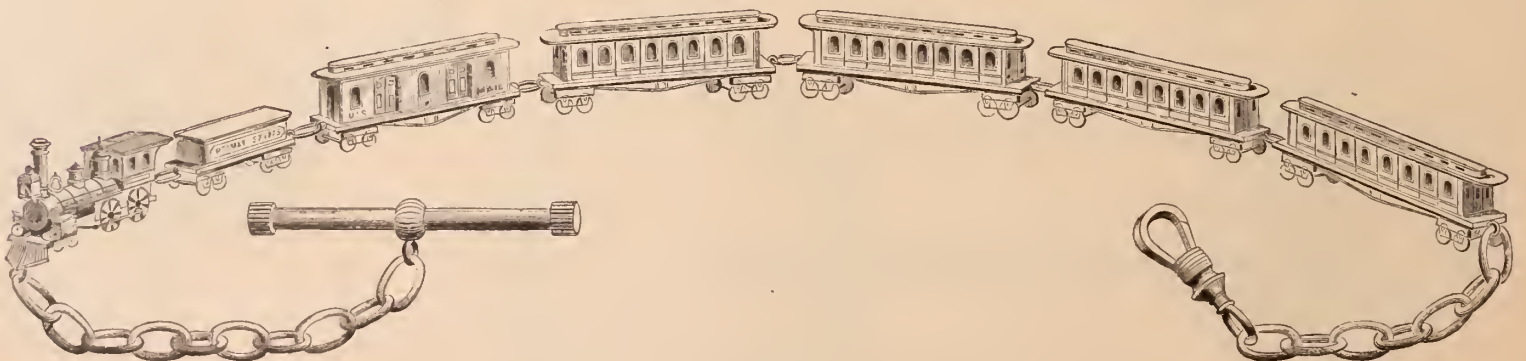

# THE STANDARD FILLED RING



## CROWN, 18. LION. FILLED RINGS PLAIN & CHASED



EVERY RING GUARANTEED  
BEWARE OF DIFFERENT STAMPS MADE TO IMITATE OUR TRADE MARK.

# AIKIN, LAMBERT & CO.

MANUFACTURERS OF

GOLD PENS,

Ebony,	}	PENCIL CASES,	}	Celluloid
Ivory.		DESK HOLDERS,		Rubber.
Rosewood,		PENCILS,		Pearl.
		TOOTH PICKS,		

—AND—

## NOVELTIES IN PENCIL CHARMS.

Many of which are protected by Letters Patent, and all at prices to meet the popular demand, being made and finished in our own factories under our own personal supervision, using the best materials with modern appliances (we guarantee our productions), unsurpassed in finish, style and price. Our patent inlaid Celluloid Pencils, Pencil Charms and Picks, in Black, Shell, Malachite, Red, White, Pink, Variegated light and dark blue colors, are the handsomest goods yet produced, and at reasonable prices, the inlaid work being of *solid gold* and pearl in form of flowers, birds, etc., and warranted durable.



A full assortment of long and short nibs, stubs, falcon, oblique, commercial, fine and broad pointed Pens, in every style of holder, suitable for business or holiday trade.

To those purchasing assortments, we are furnishing the finest trays and show cases for their display, never offered to the trade. Dealers are invited to call and examine, or particulars will be furnished to regular dealers only, upon application, when accompanied by business card, or satisfactory reference, and price lists, with Illustrated Catalogues sent. ALSO, A LINE OF GOODS SUITABLE FOR EXPORT TRADE.  Goods sent for selection.

PARIS HOUSE,

J. GLAENZER & CO

35 Boulevard de Strasbourg.

Main Office, 23 Maiden Lane, New York.

Branch Office, 113 E. Madison St., Chicago.

We are also Importers of all grades of watches, and would call attention to the following specialties :

**PAUL BRETON** Movements, of which we are sole Agents. A full line of these celebrated Watches in Gold and Silver Cases of the most approved styles.

**CHAS. LATOUR** Movements, Nickel  $\frac{3}{4}$  plate, handsome, showy watches at medium prices, good reliable time pieces. Key and Stem-Winders.

**AGASSIZ** Movements, Gilt and Nickel Stem Winders (fitting 8 size Riverside Case), accurate timepieces, and *lower priced* than American movements of same quality.

Metal Open Face Stem Winding **Longines, Excelsior and Champion**, 13, 15, 16, 18 and 20 lines, good timers and *attractive in style and finish*.

Jobbers in all kinds of **American Movements and Cases**, including the "DUEBER," Silver Cases, and Boss' and LADD'S FILLED CASES.

MANUFACTURERS OF

**GOLD AND SILVER THIMBLES**, in various styles, and to order.

**STONE RINGS**, Onyx, Cameo, Intaglio, Topaz, Garnet, Amethyst, Pearl and Turquoise; also, Solid Band, Chased and Plain.

**BRACELETS**, an assortment in gold and rolled plate, including new and handsome designs.

**PLATED CHAINS**, a large assortment of Vest, Guard, Neck, &c. Also, SEALS, LOCKETS, &c. A GENERAL LINE OF RELIABLE JEWELRY IN GOLD AND PLATE.

We manufacture to order any article in the line; also do repairs, and will procure for regular customers any article required in the trade, whether kept in stock or not. Orders filled as promptly as possible.

**23 Maiden Lane, New York.**



New Designs for Fall of 1879,

— IN —

MIDDLETOWN



PLATE CO.'S

Superior Silver-Plated Ware.

—A—

“Merry Christmas”

—AND—

“Happy New Year”

TO THE TRADE.

MIDDLETOWN PLATE CO.

WM. ROGERS & SON,

HARTFORD, CONNECTICUT.

Trade Mark on Spoons :

⚓ WM. ROGERS & SON, A. A.

Established in 1865.

We call attention to our new pattern, the HARTFORD, it is the latest, nobbiest and best pattern in the market, and is *five per cent*, less than any pattern of the kind.



Trade Mark on Knives :



Established in 1865.

Silver Plated Knives, Forks, Spoons, Casters and Cake Baskets.

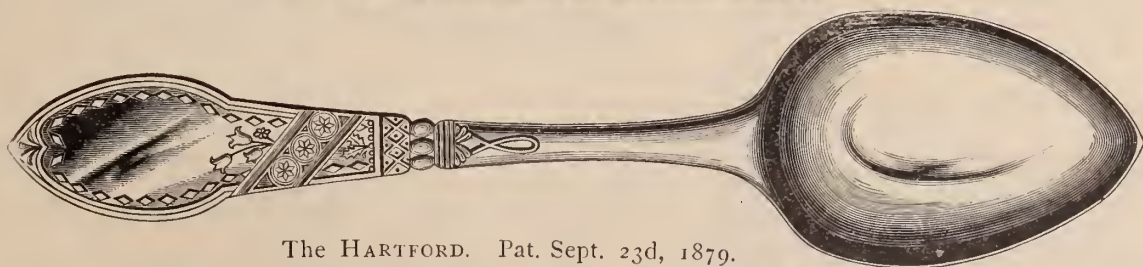

The HARTFORD. Pat. Sept. 23d, 1879.

WM, ROGERS & SON,

Drawer 30, Hartford, Conn.

WM. WATROUS, President.  
F. WILLSON ROGERS, Secretary.



**GORHAM MANUFACTURING COMPANY,**  
*Silversmiths,*

NEW YORK AND PROVIDENCE, R. I.

California Office, 120 Sutter Street, San Francisco.

**MAKERS OF STERLING SILVERWARES (925-1000 FINE), OF THE HIGHEST CHARACTER OF WORKMANSHIP AND DESIGN.**

**W**E have prepared for this Season's Trade Demands a special line of Articles suitable for WEDDING and HOLIDAY GIFTS, varied in Decoration and Novel in Design, introducing new methods of Decorative Ornament, and including

TEA SETS,  
 COLOGNE BOTTLES,  
 Etc.,

TETE-A-TETE SETS,  
 TEA CADDIES,  
 Etc.,

PITCHERS,  
 CAKE STANDS,  
 Etc.

TRAYS,  
 FRUIT STANDS,  
 Etc.

Besides a Complete Line of Smaller Articles for Holiday Trade.

*The attention of the Trade is solicited.*

**SALESROOM, 37 UNION SQUARE.**

**SIMPSON, HALL, MILLER & CO.**

**36 East 14th St., Union Square,**

**NEW YORK.**

**Factories, Wallingford, Connecticut.**

MANUFACTURERS OF THE FINEST QUALITY

**Silver-Plated Ware.**



NEW DESIGNS OF SUPERIOR ARTISTIC MERIT NOW  
 READY AND IN PREPARATION FOR  
 THE FALL TRADE.

# Silver Plated Ware

MADE BY THE

MERIDEN BRITANNIA COMPANY,

46 East Fourteenth Street, Union Square,

NEW YORK.

ESTABLISHED 1837.

**FAIR TRADE**  
 1879

Buyers will find it to their interest to examine our Line of Novelties in

**CLOCKS, MARBLE & BRONZE.**

Vienna, Leather and Gilt Goods a Large and Choice Selection.

TRIPLE MIRRORS, our Special Patterns, and many other new Specialties of the season which we offer at close prices TO THE TRADE ONLY. Sole Agents LE COULTRE RAZORS.

**TAYLOR & BROTHER,**

No. 676 Broadway,

**NEW YORK**

JAS. T. SCOTT,  
S. CLEM SCOTT,  
J. T. SCOTT, JR.

**J. T. SCOTT & CO.**

Established 1847.

**No. 11 Maiden Lane, New York,**

SOLE EASTERN AGENTS FOR

**THE ROCKFORD WATCH COMPANY,**



AND SOLE AGENTS FOR

**Abbott's Patent Open-Face, Full Plate, Stem-Wind Attachments.**

*These Stem-wind and hand-set attachments are applied to the regular 18-size full plate key movements of the Rockford, Waltham, Elgin and Illinois Watch Co.'s, making them wind at the figure XII in Open-Face Cases.*

Manufacturers of Jewelry and Wholesale Dealers in all grades of American Movements.

WATCH CASES, DIAMONDS, CHAINS, SILVER WARE, &c.

 Price Lists furnished upon application to those regularly engaged in the Trade. 

Silver Case Factory, Milford, Pa.

Gold Case Factory, Brooklyn, N. Y.

**CHARLES GLATZ,**

IMPORTER OF

**SWISS WATCHES.**

MANUFACTURER OF

**Gold & Silver Watch Cases,**

**12 Maiden Lane, New York.**

**AGENT FOR ALL THE AMERICAN MOVEMENTS.**

**MILLER BROS.****MANUFACTURING JEWELERS,**

No. 11 MAIDEN LANE, NEW YORK.

Manufactory, 47, 49 &amp; 51 Franklin Street, Newark, N. J

A  
Large Line  
of

NOVELTIES.

ATTENTION IS INVITED TO OUR  
NEW STYLES OF ETRUSCAN SLEEVE BUTTONS,  
MOUNTED WITH

**RUSTIC LETTERS**

BIRDS, ANIMAL HEADS AND FANCY ORNAMENTATIONS.  
Also a full line of Locketts, Sets, Pins, Ear Rings, Sleeve Buttons, Studs, &c.  
All goods exclusively of our own manufacture, many of which are protected by MECHANICAL and DESIGN PATENTS.

**L. A. CUPPIA**

MANUFACTURER OF

**STERLING SILVER JEWELRY,***Nickel and Silver Chatelaines a Specialty.*

Silver Filigree, Coral and Conch Shell THE NOVELTY of the Season.

*Æ Solidā Nickei Chatelaine and Watch A Composition that will not tarnish. Send for Price List.***L. A. CUPPIA,**

Branch Office--180 Broadway, N. Y.

19 UNION SQUARE, N. Y.

S. C. JACKSON, Manager.

# COLBY & JOHNSON,

17 Maiden Lane, New York,  
IMPORTERS AND JOBBERS OF

## American and Swiss Watches,

MANUFACTURERS OF

### WATCH CASES AND FINE JEWELRY,

PATENTEES AND SOLE MANUFACTURERS OF

White,  
Black, or  
Marbleized  
Celluloid  
Backs and  
Bezels.



Gold, Silver,  
or  
Nickel  
Centers,  
Pendants  
and Bows.

Suitable for all 18-Size American S. W. Movements.

## SINNOCK & SHERRILL,

### Stone Ring Manufacturers,

No. 5 Maiden Lane, N. Y.

Factory, Newark, N. J.

## JOSEPH N. TINGLEY,

Late of the firm of Tingley, Sinnock & Sherrill,

MANUFACTURER OF

# STONE RINGS,

—AND—

NOVELTIES IN STONE GOODS,

No 9 Maiden Lane,

New York

Factory, Newark, N. J.

## E. HOWARD & CO.,

MANUFACTURERS OF

### Fine Watches, Regulators, Office Clocks,

Electric Watch, Clocks & Tower Clocks,

**Office, No. 2 MAIDEN LANE**

NEW YORK

No. 114 TREMONT STREET, BOSTON.

J. W. J. PIERSON, - - - AGENT.

## MIDDLETON & BROTHER,

IMPORTERS OF

### SWISS WATCHES,

AND DEALERS IN

## American Watches

(KEY AND STEM WINDING,)

Diamonds, Gold Chains, Jewelry, Etc.

10 MAIDEN LANE, N. Y.

DYER BRAINERD.

JOHN W. STEELE.

## BRAINERD & STEELE,

MANUFACTURERS OF

### Brainerd's Pat. Locketts,

(Patented June 17, 1874.)



These Locketts combine both beauty and strength. They are made of solid 14kt. gold, and the stones used are the finest obtainable in the market. They cost no more than those of the old style, if indeed as much; and the combination of secrecy and durability renders them much more desirable. We make three sizes in four different shapes—round, oval, cushion and oblong square; and also Sleeve Buttons of the same style, containing a concealed box for miniatures, a novelty new to the Trade.



### FINE GOLD JEWELRY,

**No. 9 Maiden Lane,**

NEW YORK.

ESTABLISHED 1837.

VICTOR BISHOP & CO.

IMPORTERS OF

**DIAMONDS**  
PRECIOUS STONES

—AND—

CORAL JEWELRY,

Enamel Paintings, Copper and Platinum.

No. 47 NASSAU STREET, NEW YORK.

House in Paris, 66 Boulevard de Sebastopol.

SAXTON, SMITH & CO.

MANUFACTURERS OF

**Fine Gold Chain.**

No. 15 Maiden Lane,

New York.

Factory, No. 183 Eddy Street, Providence, R. I.

Sole Agents for the new PATENTED CHAIN BAR, containing a Detachable Pencil.

**HELLER & BARDEL,**

Manufacturers of

DIAMOND AND PEARL

**JEWELRY,**



13 John St., New York.

ESTABLISHED 1848.

E. S. JOHNSON & CO.

MAKERS OF

Gold Pens, Pencil Cases, Etc.

SUITABLE FOR THE REQUIREMENTS  
OF ALL CLASSES OF DEALERS

These goods have achieved a high reputation and are universally acknowledged to be the best Pens and Pencil Cases made, and as low in price as is consistent with quality of Gold, workmanship and style of finish.

Intending purchasers will consult their interests by comparing prices. We are constantly introducing new and desirable goods that cannot fail to give satisfaction.

44 Nassau Street, New York.

PRICE LISTS SENT ON APPLICATION.

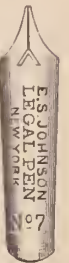

**WOOD & HUGHES,**

STERLING

Silverware Manufacturers

No. 16 JOHN STREET,

NEW YORK.

206 Kearney Street, San Francisco, Cal.

R. R. HASKELL, Agent.

KREMENTZ & CO.

MANUFACTURERS OF

**FINE JEWELRY,**

No. 13 John Street, New York.

FACTORY, 361 Mulberry Street, - - Newark, N. J.

GOODS OF OUR OWN MAKE EXCLUSIVELY.

CARTER, HOWKINS & SLOAN,  
**Makers of Fine Jewelry**

*Consisting of Chains, Bracelets, Sets, Pins, Studs, Sleeve Buttons,  
 Scarf Pins, Rings, &c., in Roman, Etruscan and Enamel,  
 and a full line of Jewelry generally.*

Whiting Building, Corner Broadway and Fourth Street,

A. CARTER JR.  
 WM. HOWKINS,  
 A. K. SLOAN.

**NEW YORK.**

C. E. HASTINGS,  
 GEO. R. HOWE,  
 W. T. CARTER.

**HALE & MULFORD,**  
**Manufacturing Jewelers,**

(WHITING BUILDING).

No. 694 Broadway, cor. 4th Street, New York.

Call attention of the Trade to their new style of

**BAND BRACELETS,**

We claim for these Bracelets, the following advantages over the old style, viz. .



Patented Feb. 25th Re-issued Oct. 14th, 1879.

1st. The edge of the Bracelet being raised, forms a protection to the ornamentation.

2d. Less liability of getting damaged, and when damaged, are more easily repaired.

3d. More attractive in appearance.

Prices are as low as any FIRST CLASS 14 KARAT ALL GOLD Bracelet in the market.

Made in all sizes from  $\frac{1}{4}$  inch upwards.

—Established 1837.—

**TAYLOR & BROTHER,**

Late TAYLOR, OLMSTED & TAYLOR,

**Importers of Diamonds and Pearls,**

—AND—

**MANUFACTURERS OF DIAMOND JEWELRY,**

No. 676 BROADWAY,

**NEW YORK.**

**BALDWIN, SEXTON & PETERSON,**

MANUFACTURERS OF

**Fine Jewelry,**

Diamond and Stone Cameo Goods,

GOLD CHAINS, &c.

Importers of Diamonds, Pearls, Emeralds, Rubies, &c.

WHITING BUILDING,

Cor. Broadway and Fourth Street,

**NEW YORK.**

120 SUTTER STREET, San Francisco, Cal.

Established 1817.

**Ve. J. MAGNIN, GUÉDIN & CO.**

29 Union Square, New York.

Manufacturers and Importers,

FINE SWISS WATCHES,

REPEATERS, CHRONOGRAPHS & CALENDARS  
 GENEVA GOLD JEWELRY,

FRENCH CLOCKS AND BRONZES,

RICH FANCY GOODS,

HORSE-TIMERS & PEDOMETERS,

GOLD AND SILVER CHATELAINE WATCHES.

Gold Medal Awarded, Paris Exposition, 1878.

*Sole Agents for the James Nardin Watch.*

*House in Geneva, 14 Grand Quai.*

Established 1813.

**THOMAS G. BROWN,**

MANUFACTURER OF

**FINE JEWELRY.**

*Designs furnished for all kinds of Sporting  
 Badges and Medals for Schools & Colleges.*

**NEWARK, N. J.**

—AND—

**9 BOND STREET, NEW YORK.**



**NE PLUS ULTRA.**  
**DUST-PROOF WATCH KEYS.**

Patent Sept. 1st, 1874.



- The Popular Name Key.  
 A. Nickel Plated Handle and Pipe, Swivel Top, per gross..... \$10.75  
 English Pattern Key.  
 C. Nickel Plated Handle and Pipe, Swivel Top, per gross..... \$7.50



**BENCH KEYS.**

Corrugated Gilt Handles, Tempered Steel Pipes, per Set of Six..... \$1.80  
 per Set of Three..... .90

**P. Style of Key.**

Gilt Handle. Steel Pipe.   
 Per Gross..... \$8.50

Our Key Pipes are all warranted to be made of the finest quality of steel. One great advantage this key has over all others, is the mortice through the pipe, making it the most simple and thoroughly dust and moisture-proof, as well as the cheapest key in the market. Our sizes run from 1 to 12: 4, 5 and 6 ft Gents' American Watches; No. 3, Ladies' American.  
 For sale by the Trade generally.

**KENDRICK, DAVIS & CO., LEBANON, N. H.**  
 SOLE OWNERS AND MANUFACTURERS.

The advantage of our Name Key, as an advertising medium, will at once be seen.

**American Watch Tool Co.**

P. O. Box 999. WALTHAM MASS.

**MANUFACTURERS OF THE WHITCOMB LATHE,**  
 AND

**Machinery for Watch, Watch Case and Clock Making**

NEW YORK OFFICE, WITH

L. H. KELLER & CO., 64 Nassau Street.

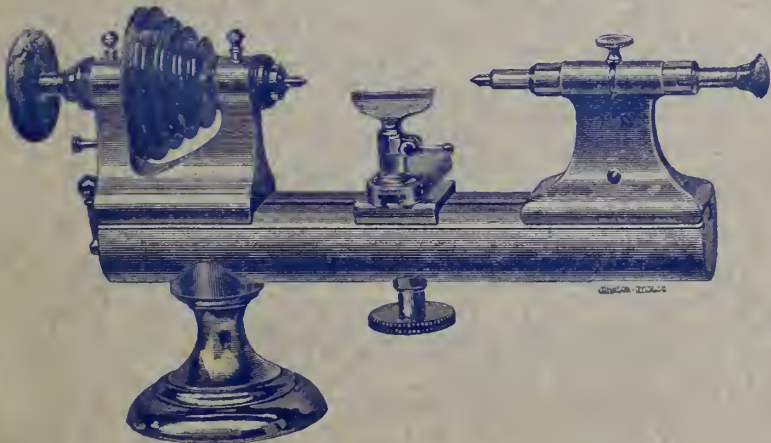

Chicago Office with Chas. Wendell & Co., N. 170 State Street.

ESTABLISHED 1849.

**O. SCHWENCKE,**

Successor to C. Gunzenhausen,  
 MANUFACTURER OF

**FINE HAIR JEWELRY,**  
 43 Maiden Lane, New York.



Solid Gold Mountings for Hair Jewelry, kept constantly on hand and made to order at short notice.

Orders from the country trade promptly attended to, and Price List and Catalogues furnished at 50 cents each, which will be refunded on first order.

**HOPKINS' WATCH TOOL CO.**

WALTHAM, MASS.

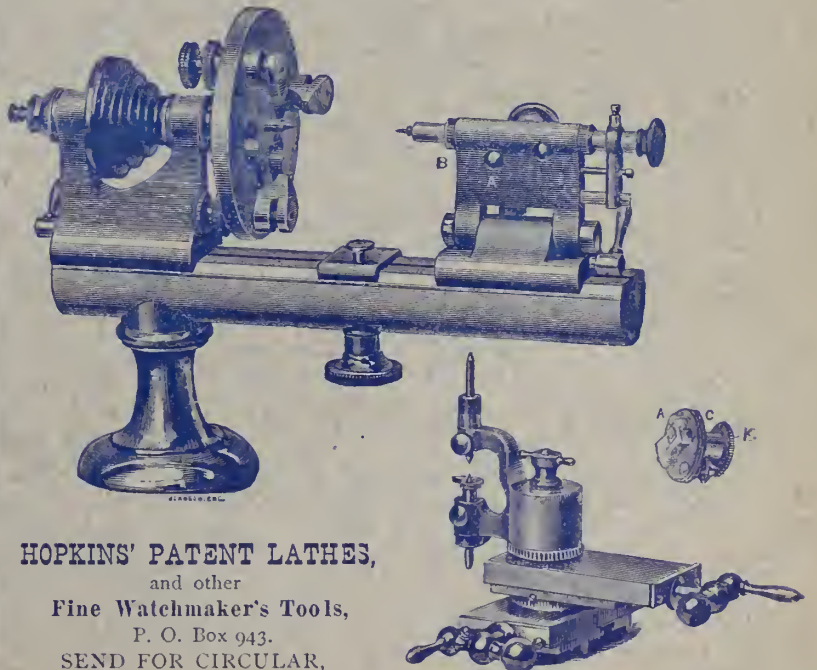

**HOPKINS' PATENT LATHES,**  
 and other  
 Fine Watchmaker's Tools,  
 P. O. Box 943.  
 SEND FOR CIRCULAR.

HENRY HIRSH,

EDWARD HIRSH,

# HIRSH BROS.

## Dealers in Watches & Diamonds

AND MANUFACTURERS OF

### JEWELRY,

No. 23 Maiden Lane, New York.

☞ Prompt attention given to filling orders for all kinds of goods pertaining to the trade.

HENRY MAY.

Established 1854.

JOSEPH STERN.

## MAY & STERN,

IMPORTERS OF

### Foreign Watches, Materials and Tools

AGENTS FOR THE SALE OF ALL

DOMESTIC MOVEMENTS AND CASES.

### And MANUFACTURING JEWELERS

No. 19 John Street, New York.

☞ SOLID GOLD SEAL RINGS, in Cameo, Amethyst, Topaz and Onyx, A SPECIALTY.

## L. LELONG & BRO.

### GOLD and SILVER REFINERS,

### Assayers and Sweep Smelters,

Southwest Corner Halsey and Marshall Streets,

NEWARK, N. J.

SWEEPINGS A SPECIALTY.

## KELLER & UNTERMAYER,

ONLY AUTHORIZED AGENTS OF

# The International Watch Co.'s

### WATCHES.

☞ A full and complete assortment of these goods in new and attractive Gold Cases constantly on hand.

No. 18 John Street, New York.

**SILVER FILIGREE JEWELRY.**  
Splendid Silver Bridal Sets,  
Half Sets, Necklaces, Bracelets, &c.

**P. HARTMANN,**  
P. O. BOX, 2454. 36 Maiden Lane, New York.  
Importer and Manufacturer of  
Fine Gold, Diamond & Filigree  
Silver Jewelry.

## ALBERT LORSCH,

IMPORTER AND DEALER IN

# WATCHES,

AND MANUFACTURER OF

### JEWELRY,

ALSO MANUFACTURER OF THE

### PATENT ACCOMMODATING

## Spectacles and Eye Glasses,

In Gold, Silver, Steel, &c.

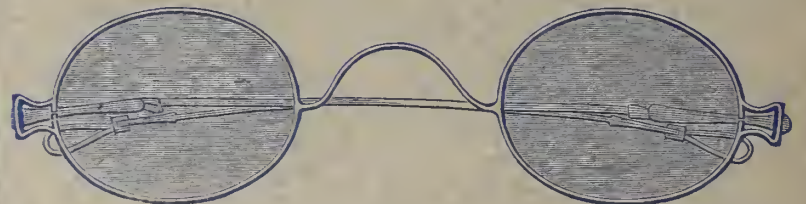

Would call the attention of the trade to the fact, that with the above Spectacles and Eye Glasses, which are constructed to form a Spring by which the lense is held, it is only necessary to have one complete assortment of lenses which being of uniform size, will interchange in all the different kinds of frames, thus giving a complete assortment for a comparatively small outlay. Notwithstanding the numerous advantages of these Spectacles, the prices will compare favorably with those of any other make.

ALBERT LORSCH, 37 Maiden Lane, New York.

LORSCH BROS., 120 Sutter St., San Francisco, Cal.

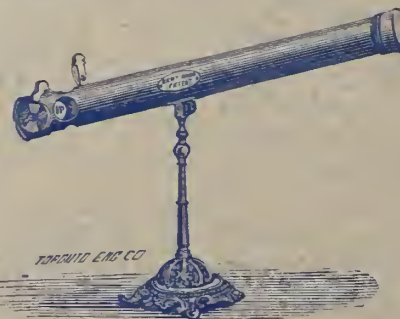

## L. BLACK & CO.'S Spectacle INDICATOR,

Patented in U. S., July 31, 1877.  
Canada, March 19, 1877.

Instruct the customer to place one eye closely against the open end of the tube; put the smallest letter opposite the small hole, and turn until the customer can distinguish a letter or figure. The strength of the spectacles required will be indicated on the index wheel. If the large letters are used, pull up the slide; if not, keep it down.

This instrument is easily adjusted, can not get out of order, is nickel plated, makes a nice appearance, and shows the correct number of lens required.

☞ For particulars, address L. BLACK & CO., Detroit, Mich., or any wholesale Optical Establishment in New York.





