

Gems and Gemology

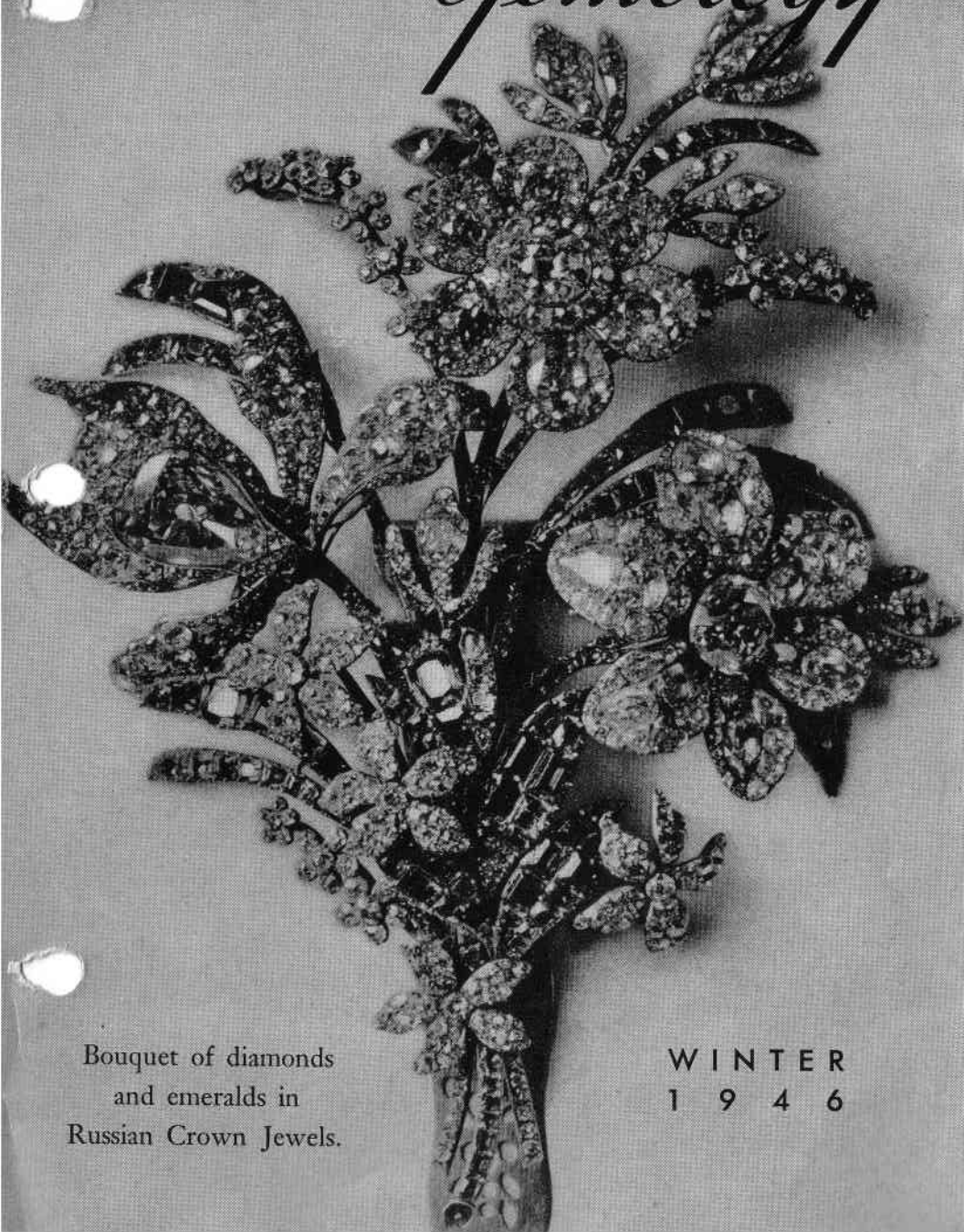

Bouquet of diamonds
and emeralds in
Russian Crown Jewels.

W I N T E R
1 9 4 6

Gems & Gemology

GEMS & GEMOLOGY is the quarterly official organ of the Gemological Institute of America. In harmony with its position of maintaining an unbiased and uninfluenced position in the jewelry trade, no advertising is accepted. Any opinions expressed in signed articles are understood to be the views of the author and not of the publishers. Subscription price: \$3.50 a year.

Robert M. Shipley, Editor

VOLUME V

WINTER, 1946

NUMBER 8

<i>In This Issue:</i>	<i>Page</i>
<i>Color Plate I. Opals from Australia</i>	Opposite 364
<i>Radiographic Examination of Pearl,</i> <i>William H. Barnes, Ph.D.</i>	359
<i>Jewels of the Russian Diamond Fund,</i> <i>Alexander E. Fersman</i>	363
<i>New Australian Opal Fields</i>	364
<i>Contributors in This Issue</i>	366
<i>Apparatus for the Identification of Gems by X-rays,</i> <i>George Switzer, Ph.D. and Ralph J. Holmes, Ph.D.</i>	367
<i>Gemological Digests</i>	377
<i>Diamond Glossary</i>	379

Identification of Synthetic Gems, Part II, by Edward Gübelin, Ph.D., C.G., will appear in the Spring issue of Gems & Gemology.

Cover: Figure 5 in "Jewels of the Russian Diamond Fund"; flowers of diamonds with emerald leaves, Middle XVIII century (full size). Reproduced from "Russia's Treasure of Diamonds and Precious Stones."

Copyright, 1947, by

THE GEMOLOGICAL INSTITUTE OF AMERICA
(UNITED STATES AND CANADA)

Established 1931

541 South Alexandria Ave.



Los Angeles 5, California

Radiographic Examination of Pearl

Mappin's Gemmological Laboratories, Montreal

by

WILLIAM H. BARNES, Ph.D.†

Associate Professor of Chemistry, McGill University

ABSTRACT

The great advantage of the radiographic examination of pearls by X-rays lies in the large number of pearls that can be photographed at one time. Attention is drawn, however, to the fact that some pearls give ambiguous radiographs. In such cases, X-ray diffraction photographs of the individual pearls should be obtained.

During the X-ray radiographic examination of several pearl necklaces and loose pearls, using Alexander's technique* of partially immersing the pearls in carbon tetrachloride in a plastic dish during the exposure, a number of individual pearls in strings of natural ones showed more

tion depends on the appearance of a dark line corresponding to the outline of the mother-of-pearl core. As a test, therefore, of the natural origin of the four pearls shown in Figure 1, X-ray diffraction photographs of each were taken. The results are presented in Figures 2, 3, 4 and 5. No "ray catcher" was employed to absorb the undiffracted beam so that there is appreciable fogging of the centres of the X-ray photographs from this cause but even so the patterns (except for P-66-1 and P-66-2)

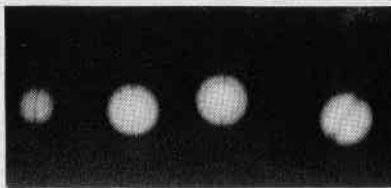
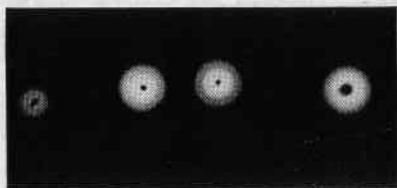

Figure 1

X-ray Radiographs of Natural Pearls

X-ray beam along drill holes.

X-ray beam normal to drill holes.

Left to right: P-66, P-67, P-68, P-69.

or less continuous dark lines inside the outer edge. Examples are reproduced in Figure 1 in which two sets of radiographs of the same four pearls, with the X-rays parallel and perpendicular, respectively, to the drill holes, are shown. Now the diagnosis of a pearl as cultured by the method of X-radiographic examina-

show an abnormal amount of small angle scattering. No trace of a "cultured" pattern appears in any of the negatives so that these pearls would be identified unequivocally as "natural" on the basis of their X-ray diffraction effects. The following notes summarize the data on Figures 1 to 5, inclusive.

†Editor's note: For biographical sketch of Dr. Barnes, see Page 372.

*Described in *Gems & Gemology*, Winter, 1941, Vol. III, No. 12, p. 184, et seq.

P-66 (See Figures 1 and 2): The radiographs show an irregular imperfectly centred line around the centre. X-ray diffraction photographs (P-66-1, P-66-2) taken with the

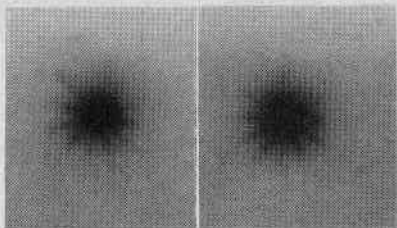

P-66-1 P-66-2
Figure 2

X-ray beam in each of two directions at 90° through the pearl are of the hexagonal "spoke" or "ray" type. Unfiltered tungsten radiation and a specimen-to-film distance of about 3 cms. were employed.

P-67 (See Figures 1 and 3): The radiographs show a very distinct line almost perfectly circular with the beam along the drill hole but

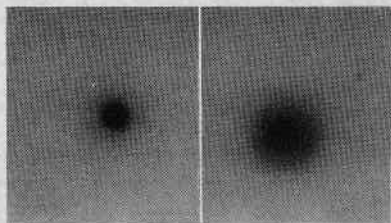

P-68-1 P-68-2

perimposed on a broad halo. The specimen-to-film distance was about 3 cms. Unfiltered tungsten radiation was used.

P-68 (See Figures 1 and 4): The

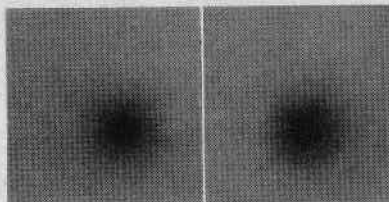

P-67-1 P-67-2
Figure 3

radiographs show a clear-cut, almost perfectly circular line with the X-ray beam either parallel or perpendicular to the drill hole. This indicates an almost perfectly spherical discontinuity between the core and the outer layers of the pearl. In the absence of much experience with radiographs of natural and cultured pearls, such a picture gives rise to

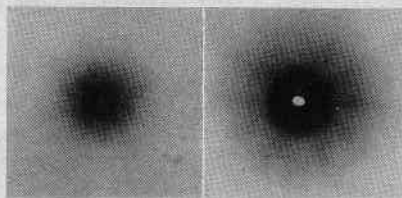

P-68-3 P-68-5

Figure 4

somewhat irregular with the beam perpendicular to the drill hole. The diffraction photographs (P-67-1, P-67-2) with the X-ray beam passing through the pearl along each of two directions at 90° show faintly the hexagonal "spoke" pattern su-

doubts as to whether the pearl is natural or cultured.

The diffraction photographs (P-68-1, P-68-2, P-68-3, P-68-5), however, definitely indicate that the pearl is a natural one. The first three were obtained with a specimen-to-film dis-

tance of about 3 cms. while for the fourth (P-68-5) a distance of about 6 cms. was used. All were taken with unfiltered radiation from a tungsten target. The photographs are characterized by excessive fogging near the centre due to small angle scat-

X-ray beam at about 45° to those in which P-69-1 and P-69-2 were obtained and a crystal-to-film distance of only 3 cms. was used. The pattern is of the hexagonal "spoke" type superimposed on an intense broad halo.

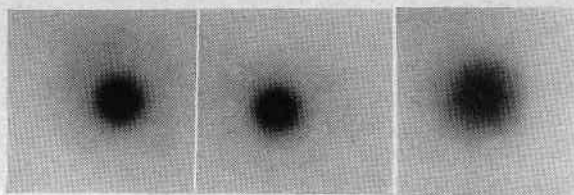

P-69-1

P-69-2

P-69-3

Figure 5

tering. P-68-2 was obtained with the pearl at 90° to the position it occupied relative to the X-ray beam for P-68-1; for P-68-3 the pearl was rotated about 45° from its positions for P-68-1 and P-68-2, respectively. P-68-5 is a repetition of P-68-2 but with about double the specimen-to-film distance and a very long exposure time. All photographs show a broad diffuse halo with a more or less distinct hexagonal pattern (somewhat distorted in P-68-1) superimposed.

P-69 (See Figures 1 and 5): The radiographs show a line of discontinuity similar to that in P-67 but apparently not spherically complete in the pearl. The diffraction photographs P-69-1 and P-69-2 were taken with tungsten radiation, a specimen-to-film distance of about 6 cms. and with the pearl orientated in each of two directions at right angles. Faint haloes at a radius of about 8mm. with indications of hexagonal "spokes" are present in the photographs. For P-69-3 the pearl occupied a position relative to the

Radiographs of three other pearls (P-70, P-71, P-72) are shown in Figure 6. The centre one (P-71) was believed to be cultured; the other two, natural.

Pearl P-70 had been broken and the centre was exposed; no mother-of-pearl bead was present. Examined



Left to right: P-70, P-71, P-72

Figure 6

under a pocket (12 x) magnifier, the exposed cross-section of P-70 had an ivory white outer layer merging into lemon yellow towards the centre. This white to yellow region was translucent and horny in appearance. It was separated from the centre by several chalky white rings. The centre was purplish grey with a distinct grey ring about one-third of the distance from the white rings

to the centre of the pearl. The structure of the outer layers appeared to be circular while that of the core showed both circular and radial markings. It is hoped that this pearl will be examined microscopically in thin section. Through the courtesy of a friend, an X-ray powder photograph of scrapings from P-70 (largely from the centre) was obtained. It is of interest to note that this photograph showed the presence of both calcite and aragonite.

The line of separation between the mother-of-pearl core and the outer nacre in the radiograph of the cultured pearl (P-71) is not as distinct as one would wish, although it is more definitely outlined in the original negative than in Figure 6. There was little doubt from the original radiograph that the pearl was cultured.

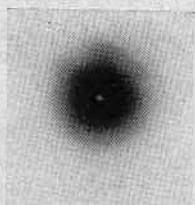

P-70-1
Figure 7

The radiograph of the small pearl (P-72) shows not only a distinct line of separation between the outer layers and the core but a rather less dense centre than usual.

Diffraction photographs of the three pearls are reproduced in Figures 7, 8, 9. Unfiltered tungsten radiation and a specimen-to-film distance of about 3 cms. were used in each case.

Only one orientation of the broken pearl relative to the X-ray beam was possible, but the two photo-

graphs of P-71 and of P-72 represent in each case two mutually perpendicular positions of the pearl relative

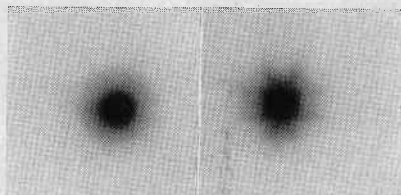

P-71-1 P-71-2
Figure 8

graphs of P-71 and of P-72 represent in each case two mutually perpendicular positions of the pearl relative to the X-ray beam. Diffraction photograph P-70-1 shows broad hexagonal "spokes" on a diffuse background. In the original negative traces of what appear to be powder rings (possibly due to the calcite present) are visible towards the outer edge of the diffuse centre; two are discernible on the left of the centre in Figure 7.

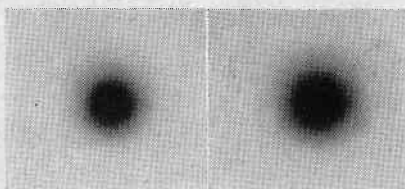

P-72-1 P-72-2
Figure 9

The diffraction photographs (P-71-1; P-71-2) of pearl P-71 indicate clearly that the specimen is cultured. A typical rectangular (fibre) diagram appears in P-71-1; a broad halo with faint hexagonal "spokes" superimposed in P-71-2. The pearl was mounted, therefore, by chance normal to the direction of the pseudo-hexagonal axes of the mother-of-pearl core for P-71-1 and approximately parallel to these axes for P-71-2.

(Continued on Page 376)

Jewels of the Russian Diamond Fund †

by

ALEXANDER E. FERSMAN

(Translated by Marie Pavlovna Warner)

"... I gave many years to the scientific investigations of the diamond crystals. . . . My friend and comrade at the Heidelberg University, famous South African scientist Percy Wagner, just started his classical investigations of nature and diamonds of Kimberley.

"... Studying the least details in the structure of hundreds and thousands of crystals, myself, and Prof. V. Goldschmidt, my teacher, soon noticed that the cuts of diamonds are of unusual structure, and instead of straight geometrical lines, here we met rounded surfaces . . ."

"I started to love precious stones more than 30 years ago, when fate brought me to the far-off island Elba. Then for many years my mind was occupied by diamonds. Thou-

sands, tens of thousands of crystals passed through my hands. While looking for noted diamonds I visited all the largest commercial firms of the world, and on the large tables, tightly covered by cloth, there were in front of me heaps of crystals from Southern Africa and from the Eastern shores of the Atlantic. The problems of crystallography brought me to the study of other precious stones—colored stones of Uruguay and Brazil, stones of India and Indo-China. I studied thousands of kilos of the most precious stones in the small town of Idar, in the warehouses and cutting rooms of hundreds of stone manufacturing places in Central France in Rouaille. Then for almost 20 years I studied the riches of Altai, Trans-Baikal and Urals. Since 1919 I divided my time between Petergof (Peterhoff) and old Ekaterinburg. . . . For three years I studied the stones which comprise the Diamond Fund of the U.S.S.R.*

"... All known birthplaces of diamonds are represented in the Russian Diamond Fund. There are stones of Brazil found in the middle of XVIIIth century; products of South Africa of XIXth century. There are also Russian stones found in 1838 on the river Kushaika on the Urals.

"I am not going to speak of all the riches of the Diamond Fund, which comprises 25,000 carats in

(Continued on Page 372)

†*Editor's Note:* In 1925 the People's Commissariat of Finances in Moscow published "Russia's Treasure of Diamonds and Precious Stones," one of the authors of which was the late Alexander E. Fersman, renowned Russian academician. Much of that material has already been incorporated in the G.I.A. gemological courses, and Fersman's opinions concerning the "Orloff," the "Shah," and the "Mogul" diamonds appeared in the first edition of Shipley's "Famous Diamonds of the World." The above previously unpublished chapters from "The History of Stone in the History of Culture" and other popular scientific works by Fersman have been translated for the Gemological Institute of America, from the Russian magazine, *Novyi mir* (No. 3, 1946, Moscow, U.S.S.R.). The numerals in the text refer to the accompanying illustrations made from plates reproduced in the above-mentioned "Russia's Treasure of Diamonds and Precious Stones." Figure 5 on cover.

Brief biographical sketch of Prof. Fersman in *Gems & Gemology*, Summer 1946, Vol. V, No. 6.

New Australian Opal Fields

Further discoveries of opal in Australia have recently been announced: an additional site in the Coober Pedy district, and an entirely new field, Amberooka, 300 miles north of Coober Pedy.

The Amberooka locality is of especial interest because opal from that area is very different in appearance from most of the Australian opal. Amberooka opal is semi-transparent with a blue body color and strong play of color in green. Typical Amberooka opal is shown in the accompanying color plate.

The new opal field at Amberooka was made known to the Gemological Institute of America by Mr. Athol L. Spring of Sydney, Australia. During his visit in Los Angeles, Mr. Spring exhibited a fine collection of over 7,000 carats of Australian opal from all of the well-known localities, including many beautiful specimens from Amberooka, Coober Pedy, White Cliffs and Lightning Ridge.

Regarding present conditions in the Australian opal fields, Mr. Spring stated that there are now about 150 active miners and that buyers (including many Americans) now outnumber the miners. He further reported that good rough opal is becoming increasingly scarce.

The specimens illustrated in the accompanying color plate were made available to the Gemological Institute through the courtesy of Mr. Spring. In choosing opals for the photograph, Mr. Spring selected stones typical in appearance of the four principal localities: Lightning Ridge, White Cliffs, Coober Pedy and Amberooka. The approximate location of each of the fields is shown on the map.

The other new opal site in the Coober Pedy district has been described recently in a report received from the Australian Consulate General at San Francisco.



Outline map of Australia, showing approximate locations of main opal fields.

(Courtesy of Australian News & Information Bureau, San Francisco.)

The new find was made in February, 1945, at a point about nine miles northwest of Coober Pedy. First news of the locality was brought back by Oswald Grayson, a young Melbourne tailor, who had undertaken a desert mapping tour as a vacation.

The discovery is attributed to an aboriginal cattle hand named Momphey, who with his friends have shared in the wealth along with the white diggers who rushed to the new field. Opals from the new site are said to be of rare size and beauty—one shown to Mr. Grayson was six inches long and four inches wide, and as much as £1000 has been paid for a single stone.



(Opal from collection of Mr. Athol L. Spring)

Opals from Australia

Lightning Ridge
Lightning Ridge
Lightning Ridge

Cooper Pedy
White Cliffs
Amberooka

Cooper Pedy
White Cliffs
Amberooka

Composition and Genesis of Opal

The composition of opal is $\text{SiO}_2 \cdot n\text{H}_2\text{O}$, that is, hydrated silica. The content of water varies from 1 to 21 per cent, but in precious opal is generally 6 to 10 per cent. Impurities such as compounds of calcium, iron, magnesium, sodium and aluminum are frequently present.

Opal is formed from gelatinous silica, deposited in cracks and fissures in various types of rocks by water solutions. In hardening, the silica gel loses some of its water, thus forming opal. During this process of dehydration and hardening, cracks often form. These cracks are sometimes later filled with additional thin films of opal, having a different refractive index from the main ground mass. Interference of light waves in passing through these thin films of opal results in the familiar play of color, or "fire," which makes opal a valuable gem.

Opal is a very common mineral, found in almost innumerable localities all over the world. Only rarely, however, has Nature filled the cracks formed during the dehydration with that thin opal film necessary for sufficient beauty to be classed as a gem. In its common varieties opal may be colorless, white, gray, brown and various other tints.

Varieties of Opal

Opal is commonly classified as either *precious opal* or *common opal*. The following are the important varieties of precious opal:

White Opals are those having a light or white body color with fine play of color.

Black Opals have a black, dark blue, dark green, or dark gray body color with fine play of color.

Harlequin Opals are those which show play of color in regular, close-set angular patches. Harlequin opals having very small patches of color are known as *pin fire opals*.

Flash Fire Opals are those displaying play of color in more or less irregular streaks. According to Schlossmacher, a *flame opal* is a variety of flash fire opal in which red is the predominant color.

Girasol Opals show no play of color but instead have a moving billowy blue light.

Fire Opals are those which are transparent to translucent with an orange red to red body color. They may or may not show a play of color. *Cherry Opal* is a name given to the cherry-colored variety.

Gold Opal is a variety which exhibits an over-all color of golden yellow.

Onyx Opal is defined by most authorities to be opal made up of alternate layers of precious and common opal, or of alternate layers of opal and chalcedony.

Occurrence of Opal

By far the greatest proportion of precious opal is found in Australia. Australian opal is classified as follows, according to the type of matrix in which it is found:

Boulder Opal is an occurrence of Australian opal in which the opal is found as thin veins in brown iron-stone boulders of concretionary origin.

Sandstone Opal is a type of occurrence where the opal is found in pipe-like masses up to one inch or more in diameter running through sandstone.

(Continued on Page 378)

Contributors in This Issue

Dr. William H. Barnes, whose article, "Radiographic Examination of Pearl," we are pleased to present in this issue, is Associate Professor of Chemistry at McGill University, Montreal, and is associated with Mappin's, Ltd., Montreal, in a consultative capacity. He received his Ph.D. at McGill; studied at the Royal Institute, London, England, as a Ramsay Memorial fellow; is a fellow of the Royal Society of Canada; has done research work in adiabatic calorimetry and x-ray crystallography.

Dr. Barnes is at present at Massachusetts Institute of Technology, working with Dr. M. J. Buerger, under a Guggenheim fellowship.

Dr. Ralph J. Holmes (co-author of "Apparatus for the Identification of Gems by X-rays") majored in geology at Columbia University where he received his B.S. and Ph.D. degrees. He was awarded the University's Research fellowship in Geology in 1935, and since 1936 has been a staff member of the Columbia Department of Geology, first as lecturer and then as instructor in mineralogy and crystallography. Dr.

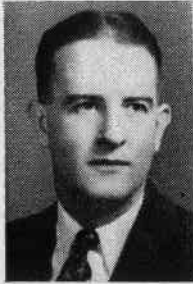

Dr. Holmes

Holmes conducts the mineralogy course at Columbia as well as mineralogy and geology courses in the University's School of Engineering. He is also instructor in the University's extension classes on Gems and Precious Stones. In 1946, Dr. Holmes was one of the instructors in the Institute's summer classes.

Dr. George Switzer joined the staff of the Institute some months ago and as Director of Research is conducting some valuable experiments, results of which will appear in *Gems & Gemology* from time to time. He is co-author of "Apparatus for the Identification of Gems by X-rays" in this issue.

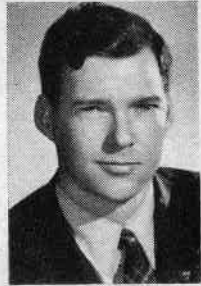

Dr. Switzer

Receiving his A.B. degree at the University of California and his Ph.D. at Harvard, he was at first student instructor at Stanford; then instructor of mineralogy at Yale for four years. Prior to joining the staff of the Gemological Institute, he was electronics engineer for the Majestic Radio and Television Corp., of Chicago. Dr. Switzer is a fellow of the Mineralogical Society of America and a member of the Stanford Chapter, Sigma Xi, honorary scientific fraternity.

Apparatus for the Identification of Gems by X-Rays

by

GEORGE SWITZER, Ph.D.

Director of Research, Gemological Institute of America

and

RALPH J. HOLMES, Ph.D.

Instructor in Mineralogy, Columbia University, New York City

Abstract

A new type x-ray diffraction camera has been developed in the laboratories of the Gemological Institute of America. By means of the new instrument it is possible to obtain a *powder-type* diffraction pattern without damaging the specimen in any way, whereas previously it was necessary to remove a portion of the specimen and powder it. These diffraction patterns, which are the most useful type for purposes of identification, are obtained by imparting to the specimen a combination rotatory and oscillatory motion. The new instrument will be used for especially difficult or disputed identifications, since with it a positive determination may be made of a gem of any size whether transparent or opaque, with plane or curved surfaces, mounted or unmounted.

Introduction

The present known methods of gem testing in certain unusual cases make it impossible for one to positively identify an unknown stone without powdering a portion of it for chemical or x-ray analysis. This is especially true of opaque substances, where the only property that can be determined without the possibility of damaging the gem is that of specific gravity, and if the gem is mounted, even this test cannot be made without first removing it from the setting.

To a lesser extent non-opaque materials can prove to be very troublesome, especially if they are cut with all curved surfaces, so that their index of refraction cannot be determined with accuracy. With curved surface gems, even the property of

single or double refraction cannot be determined by either the polariscope or the polarizing microscope if the gem is in a solid-backed mounting, or if it is semi-translucent.

There has been a definite need, therefore, for a method of gem identification which will yield positive results on all gems, and especially on opaque or semi-translucent materials, mounted or unmounted. Hence at the suggestion of Robert M. Shipley, such a method of gem identification by means of x-rays has been developed in the laboratory of the Gemological Institute of America which fulfills this need.

The design of the instrument to be described in the following pages is based upon a suggestion made by Dr. Samuel G. Gordon, Associate Curator, Academy of Natural Sciences of Philadelphia, at the January 1946 meeting of the Educational Advisory Board of the Gemological Institute. Acting upon Dr. Gordon's suggestion, work was begun in the Los Angeles laboratory in April 1946 to develop and construct an x-ray camera of a special type that would make it possible to identify gemstones by a method of x-ray diffraction. After preliminary work by Switzer the problem became the joint effort of Switzer

and Holmes in the summer of 1946 during Holmes' tenure as instructor in the Gemological Institute summer classes in Los Angeles. The camera has gradually evolved to its present form after nearly eight months of modification and testing.

Requirements to Be Met

Before describing the actual camera design it will be advantageous to review briefly the requirements that must be met by an instrument which will make it possible to identify an unknown gem by means of x-rays. It will be well at this time to re-read the article on "Introduction to X-ray Method of Gem Identification" in *Gems & Gemology*, Vol. 5, No. 7, Fall, 1946, since this article was written expressly to provide background material to aid in the better understanding of the present article. The article on pearls elsewhere in this issue of *Gems & Gemology*, and others to follow will aid in understanding of the application of x-ray methods to gem identification.

Crystalline substances, and all gem materials except opal, jet, amber, obsidian, moldavite, glass and some plastics, are made up of atoms having an orderly arrangement. This orderly atomic arrangement causes a crystalline substance to act as a three dimensional diffraction grating, with the result that when an x-ray beam strikes it, secondary beams of x-rays are generated. This diffraction effect, for simplicity, may be thought of as reflection of the x-ray beam by planes of atoms within the crystal.

Any crystalline substance will produce a diffraction pattern if placed before a narrow x-ray beam and a sheet of film is put in proper position to record the secondary

x-ray beams generated by the orderly atomic arrangement of the specimen. In the general case, when the specimen is stationary and having a random orientation, a pattern is obtained consisting of an unsymmetrical network of spots. A pattern of this type is known as a Laue pattern.

In general a Laue pattern is taken of a *single crystal*. A single crystal is a homogeneous crystalline body and may be one having natural crystal faces, or a cut gem where the natural crystal faces have been removed by the lapidary. In any case, to be most useful a Laue pattern must be taken with the x-ray beam parallel to an axis of the crystal. Then a symmetrical pattern is obtained which indicates the crystal system to which the material belongs. In other words, to obtain a usable diffraction pattern from a stationary cut gem (single crystal) such as corundum, topaz, or beryl, it must be set before the x-ray beam with one of its crystal axes parallel to the x-ray beam. Since in cut gems the naturally occurring crystal faces (which lie parallel to the crystal axes) have been removed, to locate the direction of a crystal axis is extremely difficult or in some cases impossible, and therefore impractical.

A more useful type of diffraction pattern is obtained if the specimen is rotated or oscillated about an axis of the crystal. Here again, however, unless the position of a crystal axis is known, and the crystal carefully placed before the x-ray beam in a particular position, the resultant pattern is useless for purposes of identification.

The most useful type of x-ray diffraction pattern for the identifica-

tion of minerals is the so-called powder pattern, first developed by Debye and Sherrer in 1916. A pattern of this type is ordinarily obtained by finely powdering the material under investigation and cementing the powder into a small rod-shaped specimen. The sample thus prepared is made up of a large number of randomly oriented crystals, so that the position of the sample in the x-ray camera is now of no consequence. Powder patterns consist of

a *powder-type* diffraction pattern may be obtained from a cut gem, whether it be cut from a single crystal, or from an aggregate of many crystals.

As stated above, a large number of randomly oriented grains are required in order to obtain a powder-type pattern. In the new instrument an analogous condition is obtained *without powdering the sample* by giving to the specimen a combination rotatory and oscillatory mo-

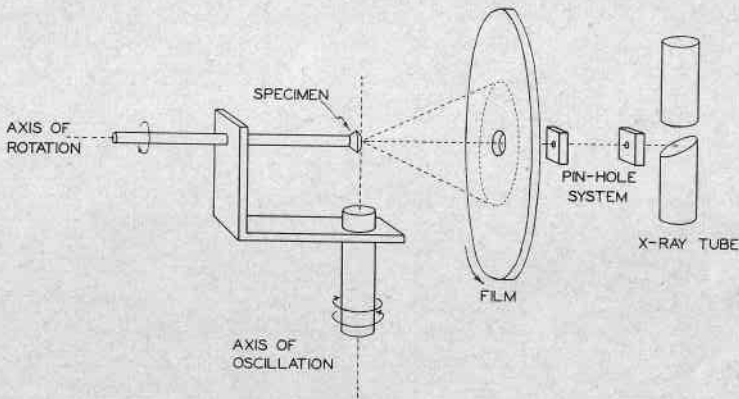

Figure 1

Schematic diagram of apparatus for identification of gems by x-rays.

a group of concentric circles recorded on the film, and are in a sense a "fingerprint" since every crystalline material gives its own characteristic grouping of circles or lines.

It is evident from the foregoing discussion, that the ideal condition for identification work is to have available a powdered sample. However, this cannot be done without damaging the specimen, and cannot be considered as a practicable method of identification of a cut and polished gem. The new x-ray camera was therefore developed at the Gemological Institute of America, so that

tion. The manner in which this is accomplished is described below.

The Instrument

The new instrument, or *x-ray diffraction camera*, is shown schematically in Figure 1. On the extreme right is indicated the x-ray tube, which in actual practice in the G.I.A. laboratory is a North American Philips Diffraction Unit having a copper target tube. The x-ray beam passes through a pin-hole system which serves to confine it to a narrow pencil of essentially parallel x-rays. The x-ray beam then passes through a hole in the

film holder and film and strikes the specimen. Secondary x-ray beams are generated by reflection of the primary beam from planes of atoms within the specimen and are reflected back to the film to produce an x-ray diffraction pattern. The primary x-ray beam in Figure 1 is shown as a dotted line passing through the pin-hole system, through the center of the film, and striking the specimen. The secondary x-rays generated by the orderly atomic structure of the specimen are shown as dotted lines leading back to the film. The dotted circle on the film indicates the manner in which the concentric

less, or if it is given a simple rotatory or oscillatory motion. However, *powder-type* patterns are obtained when the specimen is simultaneously rotated about one axis and oscillated about another axis at 90 degrees to the first. Referring to Figure 1, the specimen is rotated continuously about the horizontal *axis of rotation*. At the same time it is oscillated to and fro through a 90-degree arc about a vertical axis, the *axis of oscillation*.

The motive power is supplied by clock motors, the horizontal rotation taking place at the rate of one revolution per minute, and the ver-

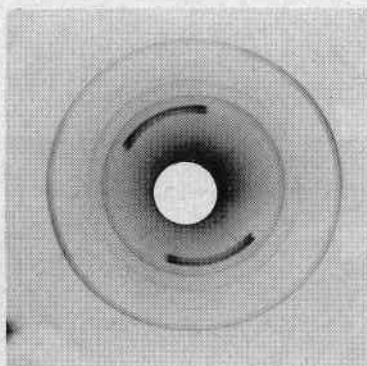

Corundum

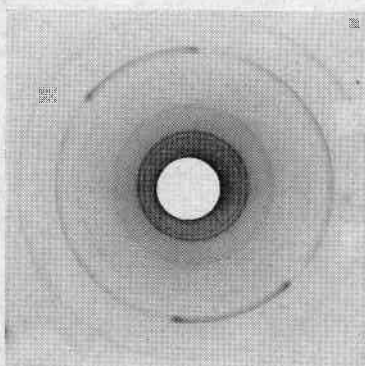

Spinel

Figure 2

X-ray diffraction patterns taken with new x-ray camera. Filtered copper x-radiation, exposure time 6 hours. Film to specimen distance, 4 cm.

circles (see Figure 2) are recorded on the film. A pattern obtained in this way is referred to as a *back-reflection* diffraction pattern, since the secondary x-rays are reflected from the specimen back to the film.

The motion imparted to the specimen is of particular importance. As has already been pointed out, diffraction patterns usable for identification work cannot in general be obtained if the specimen is motion-

tical oscillation at one degree per minute. As a result of this "oscillating fan" type of motion given to the specimen, a large number of atomic planes are brought into reflecting position, with diffraction patterns such as those shown in Figure 2 being the result.

A third motion may be introduced, this being a rotation of the *film* about the x-ray beam as an axis.

Results and Uses

Typical results obtained with the new x-ray diffraction camera are shown in Figure 2. These are *powder-type* diffraction patterns but were obtained from single cut gems. Note that they each consist of a family of concentric circles, but that the spacings and intensities of the circles in the two patterns are very different, as is to be expected since one pattern was obtained from a brilliant-cut ruby, and the other from a brilliant-cut spinel. Just as these two patterns differ, so will all patterns obtained from different gem materials.

The x-ray method of gem identification described in the foregoing pages is intended for use primarily in especially difficult cases, or in cases where identification by all other means has led to dispute as to the gem's true identity. Its advantages are as follows: (1) It can be *used on all specimens regardless of size*, depending on camera design. The present model can accommodate specimens up to 10 centimeters in diameter. (2) It can be used on any specimen, *regardless of shape*

or contour of surface. (3) It can be *used on mounted or unmounted gems*. (4) It will give a positive identification of *opaque as well as non-opaque material*. (5) It will work equally well on a *single crystal* such as ruby, emerald, or marcasite, or upon *fine grained crystalline aggregates* such as onyx, lapis, hematite, jadeite or nephrite.

Conclusion

The results described herein are the first obtained with the new x-ray camera. Eventually a catalog of standard patterns will be made, one for each gem mineral species, and routine identifications will be made by direct comparison of the standard film with those obtained from unknown specimens. Since this is a back-reflection camera, it is not possible to make a direct comparison of these patterns with those obtained in an ordinary type powder camera.

Construction of another x-ray camera is being planned for installation in the New York laboratory of the Gemological Institute at the time of its opening.

Color Reproductions of Gems

It is the purpose of the Editors to accompany future issues of *Gems & Gemology* with color reproductions of gemstones, the one included

in this issue being a result of early experiments and very inferior to those which will appear later.

Jewels of the Russian Diamond Fund

(Continued from Page 363)

diamonds. I am going to note the most famous diamonds: 'Orlov' weighing 194.75 carats; 'Shakh' (Shah)—88.70 carats, the stone being of Indian ancestry; the octagonal diamond of Katherine the Great—about 57 carats; a diamond solitaire weighing about 55 carats; a high rose-diamond of Indian cut with a bluish tinge, 47 carats; a large bracelet of Indian cut weighing 40 carats, etc. Over 70 diamonds, exceptional in their size and weight, should be included in this group.

"Here also are colored diamonds, which are especially valued in world collections. Such are pink diamonds of deep and brilliant tinge weighing $3\frac{3}{16}$ carats; delicately violet diamond weighing approximately 10 carats; large self-colored [samotzviet**] with pinkish tinge, weighing $40\frac{1}{32}$ carats, and finally a large pink diamond in a brooch weighing more than 17 carats. It is interesting to note that in literature often is mentioned a pink diamond⁴, ruby-colored, weighing 10 carats, which was bought by Paul I for 100,000 rubles. It is a rather flat diamond, mounted in a diamond diadem. It is very clear, of delicately pinkish water, but it has its ruby color only due to underlying foil and to coloring of the stone on the reverse side.

"Much more precious are blue diamonds: a deep blue one in a pin; the white one with blue overcoloring in a large riviére; and a beautiful, delicately violet, the equal to which we do not know in any collection. Such are the main diamonds in the Diamond Fund. It is almost impossible to describe them by words.

"After the diamonds, emeralds

take next place in the Diamond Fund. Here are two stones weighing 174 carats; large dark green cabochons, 153 carats each; a beautiful flat stone of the clearest water with a Persian inscription²; and blue-green stones of Colombia; several Russian stones from the emerald mines of the Urals, including a large stone of irregular form, wrongly faceted, weighing 250 carats. But the best stone in this collection and at the same time a first class historical exemplar—a colossal square tablet¹, edged by exquisite leaves which are studded with diamonds, and weighing 136 carats; the diamonds are of the clearest, deep, beautiful water; only in one corner of this tablet are noticed very tiny cracks, the results of some careless stroke. Who owned this stone and what is its history? The answer is lost in the fog of the past; yet there is no doubt but that it is one of the stones which in XVIth century were stolen from the idol temples of South America, and under the false name of Indian stones and with Indian cutting, for several centuries were the pride of the palaces of the Moguls and rajás. There is no collection in the world which can compare with the emeralds of the Diamond Fund.

"The third place in our sea of fire and light [Russian Diamond Fund] is occupied by a sapphire, dark blue stone from Himalayas and Kashmir. There are also cornflower blue stones* from the island of Ceylon. The large sapphires alone constitute about 1700 carats. The most significant of them all is a deep cabochon, covered with tiny hexagonal facets,

Figure 1

Large square emerald mounted as a brooch, 136.25 m.c. (full size).

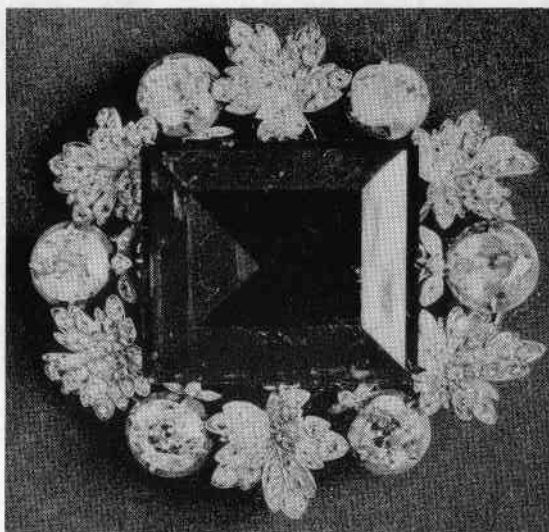
*Figure 2*

Brooch decorated with large emerald, covered with an Arabian inscription, 40 m.c. (full size).

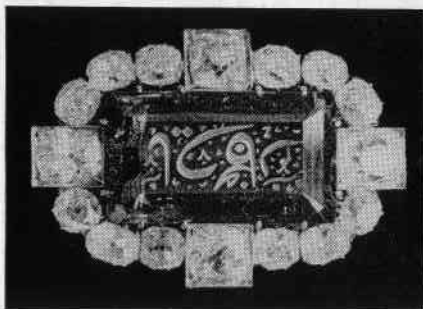
*Figure 3*

Brooch-coulant with large emeralds; rectangular, 6 m.c.; pendant, 110 m.c. (full size). Not mentioned in text.

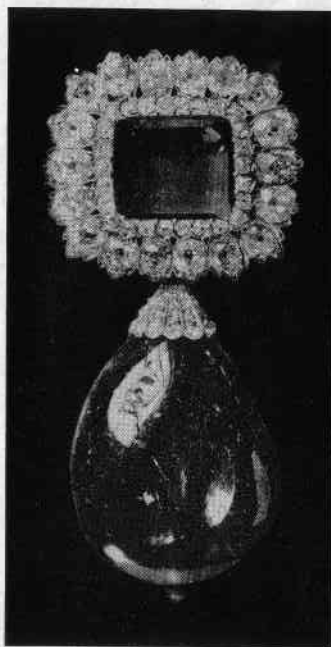

*Reproduced from
"Russia's Treasure of Diamonds and Precious Stones."*

resembling a honeycomb. If we will compare these stones with other known sapphires, we will see that they occupy the first place in world collections. It must be said, however, that we do not know anything about the beautiful Kashmir stones of the English crown, nor do we know how truthful are the stories of the colossal sapphires of Indian rajahs, but what we do know cannot be compared in beauty and size of stones with the sapphires of the Diamond Fund.

"Now let us speak about the red stones. It is significant that the red stones, so greatly favored in the East, and especially India, were never liked by the Russian tzars. However, there are several unique stones in this collection. Here is a violet-red ruby weighing 18 carats; then the largest stone from far-off Burma, almost 40 carats. Such rubies are very rare, and it is easy to name them; ruby of the Persian shah, 175 carats; the stone of the great Mogul Jahangir, 430 carats; ruby described by Boetz de Boot in the beginning of the XVIIIth century was said to be the size of an egg. There is also a known mineralogical find of large, cracked and foggy rubies weighing as much as 2000 carats. But we do not know what were the qualities of these stones, and it is difficult to believe the fairy tales of the East. Most probably these stones are only called rubies, but in reality are beautiful spinels or pink tourmalines from Tai. However, in the Diamond Fund these spinels have a significant place. One of such stones, weighing 100 carats, speaks to us of the sands of Ceylon, but the majority of them come from Afghanistan, from the mountains of the province of Badakhshan. In old Russian manu-

scripts it was called "lal Badakhshan." Let us note that among the pink tourmalines the best known is the famous stone which usually in literature is called a ruby, and which was presented to Katherine the Great by Swedish King Gustav in 1777.

"Of special value in the Diamond Fund are pieces of jewelry. . . . It is especially interesting to note that the magnificent pieces of jewelry of the middle of XVIIIth century were not always made from the best of stones. On the contrary, many of the most significant pieces of that epoch were made of stones of little value, but the artist knew how to place the stones, how to combine them in an artistic design, so that the faults of the stone became its best points . . . Here is the description of several artistic pieces from the great number which are in the Diamond Fund. . . . Here is the famous large bouquet⁵ with emerald leaves and diamond flowers. It was made by a French jeweler of Duval's school, probably not later than 1760. This bouquet consists of small emeralds from Colombia, cut roughly and irregularly, and of not expensive Brazilian (but not Indian) diamonds. This bouquet is one of the world's most remarkable pieces of jewelry of the XVIIIth century. Not only among Russian pieces of jewelry, but in the whole world, it occupies the first place as to the combination of colors, lightness and at the same time definiteness of design, nobility of workmanship and richness of the shades of the stones. Thin golden leaves and stems are covered by tablets of emeralds forming continuous green threads. Flowers are made of diamonds, mounted on foil and pure



Figure 4

*Diamond Diadem
probably containing
Famous Paul I
"Red" Diamond.
(Reduced half)*

Old literature listed the Paul I diamond as a "flat blood-red brilliant of 10 carats"; probably an erroneous description of the flat diamond in this diadem, which the author states here appears red only because it is backed with red foil.

*Reproduced from
"Russia's Treasure of Diamonds and Precious Stones."*

silver. All parts of the bouquet are movable; they tremble and play with the least motion, displaying colors of magnificent shades.

"Old Indian stones of rare beauty are remarkable for their exceptional variety. Here are incomparable solitaires of bluish and even delicately pink water; there are several defective stones with black dots; but all these stones with their shades, combination, and beauty of cut, make one brilliant scale and are of the greatest artistic value."

(To Be Continued)

**Diamond Fund of U.S.S.R.* "In April, 1922, a committee composed of professors and experts was appointed and on its first meeting emphasized the necessity of preserving 'as national property never to be sold or done away with' the regalia and the Romanov jewels. This proposition met with full approval from the members of the government and then, once again, the strong boxes were transferred to the 'National Department of State Valuables' (now the National Fund of Metals and Precious Stones) where, to the present day, they are safely kept." *Russia's Treasure of Diamonds and Precious Stones*; published by People's Commissariat of Finances, Moscow, 1925; Part I, p. 12.

**Mr. Fersman calls many stones "samotzviet," literal translation of which is self-colored stone. All dictionaries give as translation "precious stone." It is logical to suppose that this word means such self-colored stones as rubies, etc., but occasionally he also applies it to diamonds. (Translator's note.)

Radiographic Examination of Pearl

(Continued from Page 362)

The natural origin of P-72 is shown by the diffraction photographs P-72-1 and P-72-2 in each of which the hexagonal "spoke" pattern appears more or less faintly on a diffuse background.

The present study, while limited and somewhat superficial, indicates the importance of supplementing radiographic examination of pearls with the X-ray diffraction method. Radiography has the distinct advantage of permitting examination of a large number of pearls in a relatively short time. Doubtful cases of individual pearls arise, however, in the case of cultured pearls through an indistinct line of demarcation between core and nacre and in the case of natural pearls through internal flaws that appear in the radiograph as circular discontinuities between

the centre and the outer layers. Such doubtful pearls may be recognized in a group by direct comparison between the original group of pearls and the radiograph. They should then be removed and photographed individually by the X-ray diffraction method in order to identify them with greater certainty. The present photographs also suggest that the broad diffuse diffraction haloes with or without traces of hexagonal "spokes" or "rays" so commonly encountered with natural pearls are associated, as one might expect, with irregularity of the internal structure of the pearl. It is hoped eventually to correlate perfection and imperfection of X-ray diffraction photographs of natural pearls with microscopic examination of thin sections of the same specimens.

Editor's Note: The work described in the foregoing article was carried out in the summer of 1946 for Mr. K. G. Mappin, F.G.A., C.G., Director of the Gemmological Laboratory, Mappin's Limited, at the suggestion of Mr. H. R. Cox, F.G.A. The x-ray diffraction photographs were taken in the laboratory of the Department of Chemistry, McGill University, Montreal.

Another article will appear in the next issue of *Gems & Gemology*.

GEMOLOGICAL DIGESTS

Reopening of Premier and Jagersfontein Diamond Mines

The Premier mine, the only diamond pipe in Transvaal, South Africa, has come back into the news because of the fact that it is soon to be reopened, after being shut down since March 1932.

The Premier diamond pipe is the largest known, although the recently discovered Williamson mine in Tanganyika is reputed to be larger. The Premier mine is unusual in that it was worked as an open pit to the depth of 600 feet.

The work of reopening the Premier mine was begun in 1944, when the enormous task was undertaken of pumping out 740,000,000 gallons of accumulated water. Installation of new pumping machinery permitted the de-watering to be done in about twelve months' time. In the future, the Premier mine will be operated through underground workings rather than as an open pit. For this purpose a five-compartment shaft is being sunk to a depth of 1200 feet in the country rock alongside the open pit. A new processing plant is being installed, capable of handling 8000 loads of ore per shift. It is expected that actual production of diamond will be resumed sometime in 1948. (*The Diamond News*, Sept. 1946, Vol. 9, No. 12.)

It was decided early in 1946 to reopen the Jagersfontein mine, in

Orange Free State, as soon as possible. Much of the original equipment is still available and inspection and overhaul work has begun. The previous washing plant had been dismantled during the war years and a new plant is being designed and will be constructed as soon as materials are available. Work has begun on reconditioning the underground workings, and the main shaft will be sunk an additional 600 feet. The diamonds produced from the Jagersfontein mine are noted for their exceptional quality. (*The Diamond News*, July 1946, Vol. 9, No. 10.)

G.S.

New Pearl Essence Factories

News of the establishment of a new pearl essence factory in Lubec, Maine, has been announced in the October issue of *Trader and Canadian Jeweller*. There are now four pearl essence factories in Maine, just south of the New Brunswick border. Two more new plants are soon to be opened on the Canadian side. The essence is made from the iridescence on fish scales, and after this extraction is made, the scales are worthless and must be discarded. The pearl essence manufacturers are searching for further channels for their product, now used chiefly in the manufacture of imitation pearls.

G.S.

New Australian Opal Fields

(Continued from Page 365)

Seam Opal is a term describing opal which is found in thin, flat cakes or seams in sandstone. These seams may vary in thickness up to one inch or more and are without adhering matrix.

The main opal fields in Australia, aside from the new ones mentioned in the earlier part of this article, are described below and indicated on the accompanying map.

New South Wales. There are three general localities in New South Wales where opal has been mined extensively. These are Lightning Ridge, the Tintenbar district, and White Cliffs district.

South Australia. The Coober

Pedy field, about 70 miles west of Anna Creek Station, is the most important producer in this region. The new field of Amberooka, approximately 300 miles north of Coober Pedy, is also in South Australia.

Queensland. Production from this district is far less than in New South Wales and South Australia. A large district in Western Queensland is known to contain opal, but the working has been restricted to a few localities.

Precious opal is found in lesser quantity in numerous places besides Australia, other localities of note being Czechoslovakia, Mexico, United States and Honduras.

Government Control in Colombia

The Republic of Colombia, the world's largest producer of emerald, is placing the mining and export of all its precious stones under control of the national bank. (*Jewelry*, 11-18-46.)

Brazilian Amethyst

"A new discovery of amethyst at Campo Formosa in the State of Baia, north of Brejinho, the former chief amethyst-producing center, has depressed the price [of that gemstone]." (*From Report of Bureau of Mines, U. S. Dept. Interior, Nov. 20, 1946.*)

Gübelin Article Held Over

Owing to lack of space in this issue, "Identification of Synthetic Gems," Part II, by Edward Gübelin, C.G., will appear in the Spring Number of *Gems & Gemology*.

The article, "The Diamond Industry in 1945," by Sidney H. Ball, Ph.D. (condensed in the Fall, 1946 issue of *Gems & Gemology*), appeared through the courtesy of *Jewelers' Circular-Keystone*.

DIAMOND GLOSSARY

(Continued from Page 356 of last issue)

properties. The following are the important physical, optical, and chemical properties of diamond. Abbreviations used: A.U., Angstrom Units; C., Centigrade; F., Fahrenheit.

atomic spacing. 3.5669 ± 0.0002 A.U.

breaking load. 25 kilograms for 0.18 mm. point radius.

breaking strength. 790,000 (corundum on same scale has breaking strength=130,000).

bulk modulus. 10^{12} dynes per square centimeter.

chemical composition. C (pure carbon) for gem varieties. Some bort yields up to 20% ash consisting principally of oxides of silicon, iron, magnesium, aluminum, calcium and titanium.

chemical properties. Burns in oxygen between 700 and 900 degrees C. (1500 to 1650 degrees F.) In powder form can be burned by a bunsen burner. Not attacked by any known acids or alkalies, with the exception of very strong alkalies in powder form.

crystal class. Hextetrahedral $\bar{4}3m$, perhaps hexoctahedral $4/m\bar{3}2/m$.

crystal system. Isometric.

dielectric constant. 5.5 (air=1).

dispersion. Value equals difference between indices of refraction for red and blue light. Exact value depends upon wave lengths used: H-B=0.058, G-B=0.044, F-C=0.025. (See *refractive index*.)

electrical conductivity. 0.211×10^{14} to 0.309×10^{13} ohm centimeters at 15°C.

hardness, indentation (Knoop). 6000-6300 (corundum on Knoop scale has value of 1600-2000).

hardness, scratch (Mohs). 10.

melting point. $3700^\circ \pm 100^\circ\text{C}$. (6698°F.)

refractive index.

2.465 (violet H=3968 A.U.)

2.4513 (violet G=4308 A.U.)

2.4354 (blue F=4861 A.U.)

2.4175 (yellow D=5893 A.U.)

2.4103 (red C=6563 A.U.)

2.4076 (red B=6876 A.U.)

Average value for white light 2.417.

space group. $Fd\bar{3}m$.

specific gravity (density). Purest white 3.511, ranges from 3.4-3.52. Calculated from x-ray measurements 3.511.

thermal conductivity. 0.35 gram calories per centimeter per second per degree Centigrade.

thermal expansion (linear). 0.6 to 1.18×10^{-6} per degree Centigrade.

wear resistance (Rosiwal). 90,000. (Corundum on same scale has wear resistance=1000.)

Young's Modulus. 10^{12} dynes per square centimeter.

"Punch" Jones Diamond. Largest alluvial diamond found in U.S.A. on Rich Creek, Peterstown, W. Va., by Grover and Wm. P. ("Punch") Jones. A transparent hexoctahedron of 34.46 metric carats. It is of a grayish green

tint and is one of a number of isolated diamonds found in the Appalachian Mts. At present on display in National Museum, Washington, D.C.

pure. *In diamond grading.* Term rarely used to indicate comparative perfection; more or less synonymous with clean. See clean.

purest water. A term used in describing the quality of a diamond. See water.

quartz-diamond intergrowth. An intergrowth of quartz and diamond. A rare occurrence reported from Diamantina, Brazil. It suggests the presence of a lower temperature during the formation of diamond than has been generally assumed.

quin facet. Term used in England and elsewhere for **top corner facet**.

radium treated diamonds. See **treated diamonds**.

radioactivity (in diamonds). See **treated diamonds**.

Rajah of Mattan Diamond. Same as **Mattan Diamond**.

Raman, Sir (Chandrasekhara) Venkata. Kt. cr. 1929; F.R.S.; M.A.; Hon. D. Sc.; Hon. Ph.D.; Hon. LL.D.; Nobel Laureate in Physics; Director, Indian Institute of Science, Bangalore.

recovery plant. Plant in which the blue ground from a mine is treated in order to recover the diamonds.

Red Cross Diamond. A large, canary-yellow, square-shaped South African diamond given by the Diamond Syndicate in 1918 to assist the British Red Cross Society. It weighed 370 to 380 m.c. and contained a series of black inclusions

in the form of a maltese cross, which was to be seen through the table of the 205 m.c. brilliant into which the rough stone was cut. (G. F. H. Smith.)

red diamonds. Rarest of all fancy colored diamonds. However, the term is often used to mean red-brown or rose-colored diamonds. Diamonds of the full red color of ruby or garnet are perhaps unknown. The often mentioned Ruby Red Diamond of Paul I has recently been revealed as being a rose-colored diamond backed with red foil. See **Paul I Diamond**.

reef. A term used in South Africa to mean the original country rock through which the diamond-bearing volcanic pipes penetrated. Thus when **kimberlite** has been removed, the remaining rock walls are called *reef walls*; and any mass of the original country rock which was enveloped by the outpouring lava and then solidified in the kimberlite is known as *floating reef*.

Regent Diamond (formerly called the Pitt Diamond). One of the last large diamonds to be found in India, said to have come from the Partial mines on the Kistna River about the year 1701. Weight in the rough, 410 carats. Sold to Governor Thomas Pitt for approximately \$100,000, who had it cut into a cushion-shaped brilliant $1\frac{1}{16}$ inches long, 1 inch wide, and $\frac{3}{4}$ of an inch deep and weighing 143.2 mc. The cut stone has only one very small imperfection and remains to this day one of the finest and most brilliant of the known large diamonds.

(To Be Continued)