

# Gems & Gemology



WINTER 1976-1977



RICHARD T. LIDDICOAT, JR.  
*Editor*

ROBERT A. P. GAAL, Ph.D.  
*Assoc. Editor*

ISSN 0016-62X

GEMS & GEMOLOGY is the quarterly journal of the Gemological Institute of America, an educational institution originated by jewelers for jewelers. In harmony with its position of maintaining an unbiased and uninfluenced position in the jewelry trade, no advertising is accepted. Any opinions expressed in signed articles are understood to be the views of the authors and not of the publishers. Subscription price \$8.50 each four issues. Copyright 1976 by Gemological Institute of America, 1660 Stewart Street, Santa Monica, California 90404, U.S.A.

GEMS & GEMOLOGY

---

---

# Gems & Gemology

VOLUME XV

NUMBER 8

---

---

WINTER 1976-1977

## IN THIS ISSUE

- 226 . . . . . **A Critical Examination of Synthetic Turquoise**  
By J. D. Williams, Ph.D., and K. Nassau, Ph.D.
- 233 . . . . . **Developments and Highlights at GIA's Lab in Santa Monica**  
By Richard T. Liddicoat, Jr.
- 238 . . . . . **Cathodoluminescence of Gem Materials: A Short Review**  
By Robert A. P. Gaal, Ph.D., G.G.
- 245 . . . . . **Developments and Highlights at GIA's Lab in New York**  
By Robert Crowningshield
- 252 . . . . . **Observations on the Slocum Stone**  
By Pete J. Dunn, M.A., F.G.A.

# A Critical Examination of Synthetic Turquoise

By

J. D. WILLIAMS, Ph.D.  
Mercyhurst College  
Erie, PA 16501

K. NASSAU, Ph.D.  
Bell Laboratories  
Murray Hill, N.J. 07974

## ABSTRACT

Several synthetic and imitation turquoise specimens have been examined and compared with natural turquoise with respect to five criteria: elemental composition, X-ray diffraction pattern, possible presence of a binder, and conventional gemological tests.

"Gilson Created Turquoise" (P. Gilson S. A. Lapidaries) appears to meet all five criteria and can therefore be considered a "synthetic" turquoise. "Turquite" (Turquite Minerals) did not correspond to turquoise either by elemental composition or by X-ray diffraction pattern. "Simulated Turquoise" or "True Synthetic Turquoise" (Syntho Gem Co.) and "Reconstituted Turquoise" (Adco Products) had approximately the right composition, but did not have the turquoise structure. These three products should accordingly be designated "imitation" or "simulated" turquoise.

## Introduction

Turquoise is a hydrated copper aluminum hydroxy phosphate  $\text{CuAl}_6$

$(\text{PO}_4)_4(\text{OH})_8 \cdot 5\text{H}_2\text{O}$  (triclinic, PT) with a calculated composition 19.90% Al, 15.23% P, 7.81% Cu and 1.97% H; some iron is usually present, as little as 0.15% Fe in the crystalline material from Virginia.<sup>(1)</sup> In view of a considerable demand for quality material, a number of imitations and syntheses are commercially available and partial descriptions have been given in various publications.<sup>(2,3,4,5)</sup>

Many turquoise substitutes are sold as simulations or imitations, implying by these designations only a similarity in appearance. Some products claim to be "synthetic" turquoise, i.e., a man-made exact equivalent of natural turquoise, or "reconstituted" or "reconstructed" turquoise, implying a natural turquoise raw material source which is processed to end up as the equivalent of natural turquoise.

In this study the five "turquoise" materials shown in *Figure 1* were compared. They are:

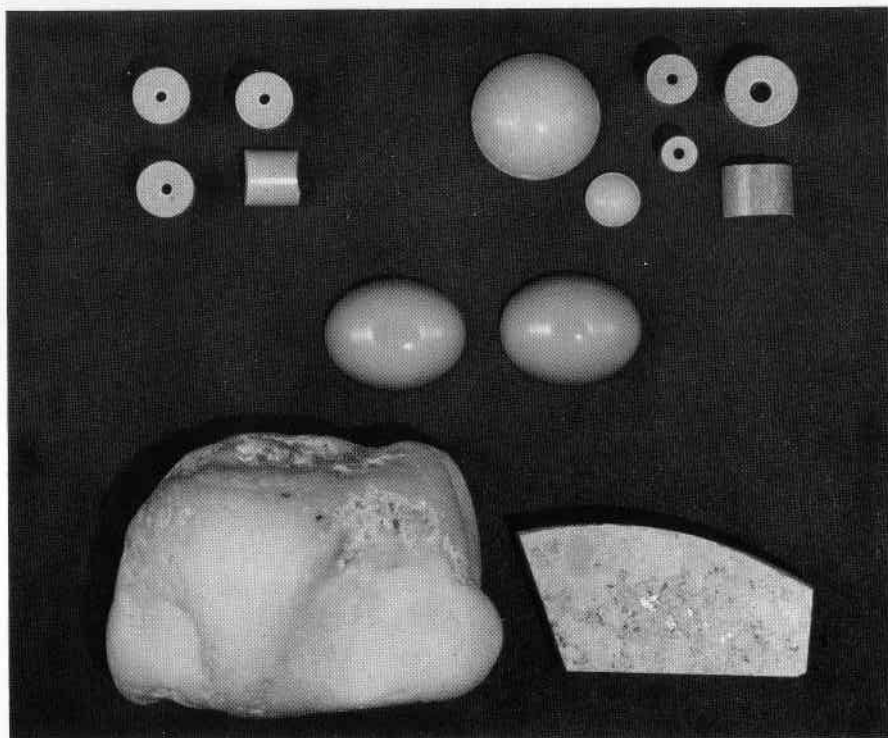

Figure 1. Bottom row: natural turquoise (left), and Turquite (right); center: two Gilson cabochons; top: Adco (left) and Syntho (right).

Sample 1: Natural turquoise, a nugget from Nevada;

Sample 2: "Gilson Created Turquoise" from Pierre Gilson S.A. Lapidaries, Chateau de Campagne Les Wardrecques, 62120, Aires, France;

Sample 3: "Simulated Turquoise" (advertised as "True Synthetic Turquoise" at the time of this study) from the Syntho Gem Co., Reseda, CA 91335;

Sample 4: "Reconstituted Turquoise" from Adco

Products, P.O. Box 67, Buena Park, CA 90621 (this material was in the form of "heishi" beads; slabs for cabochons tested as plastic with an S.G. 1.44, R.I. 1.57); and

Sample 5: "Turquite" simulated turquoise from Turquite Minerals, Deming, NM 88030.

#### Criteria of Distinction

In a recent account one of us<sup>(6)</sup> has published a set of criteria against

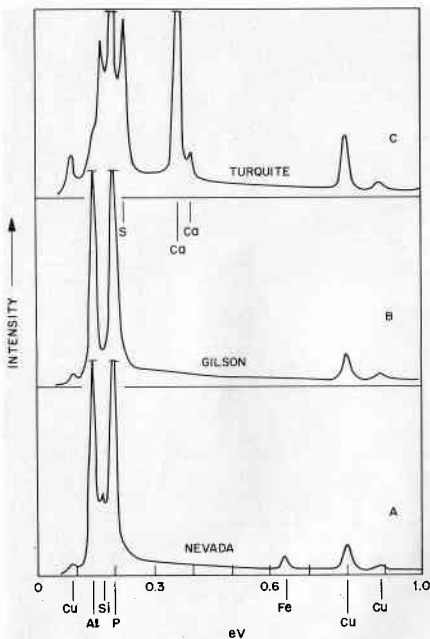

Figure 2. Scanning Electron Microscope elemental analysis curves (energy dispersive mode); Syntho and Adco are similar to the Gilson curve.

which the designation "synthetic" may be judged for non-single crystal

gem materials. It is proposed that the synthetic should duplicate the natural at the atomic level (chemical composition, cause of color, etc.); at the X-ray diffraction level (crystal structure); at the electron microscope level (optical effects, if any), and at the visual level (appearance to the unaided eye). At the microscopic level (100 nm to 1 nm) there may be some variability, as there is in fact among different species of any natural material (and hence some variability in the many conventional gemological tests, by which these materials are distinguished).

A scanning electron microscope, SEM (ETEC Autoscan operated at 20 kV) was used for detailed examination including semi-quantitative comparative analysis in conjunction with an X-ray energy spectrometer (KEVEX model 5100C) and also for elemental mapping.

The relevant elements not accessible to this technique (carbon and hydrogen) were analyzed for separately by combustion and gravimetry.

TABLE I  
Composition of the Various Turquoise Specimens Studied

Sample	Major Elements <sup>a</sup> (over 10%)	Minor Elements <sup>a</sup> (10% to 1%)	Impurity Elements <sup>a</sup> (about 1% or less)	Carbon Wt. % <sup>b</sup>	Hydrogen Wt. % <sup>b</sup>
#1 Natural	A1,P	Cu	Fe,Si	0.34	2.1
#2 Gilson	A1,P	Cu	—	0.69	2.1
#3 Syntho	A1,P	Cu	—	2.6	2.1
#4 Adco	A1,P	Cu	—	2.8	3.0
#5 Turquoise Theory <sup>c</sup>	Si,P,S A1,P	Cu,A1 Cu	— —	6.9 —	1.9 2.0

<sup>a</sup> by SEM

<sup>b</sup> by combustion and gravimetry.

<sup>c</sup> for  $\text{CuAl}_6(\text{PO}_4)_4(\text{OH})_8 \cdot 5\text{H}_2\text{O}$

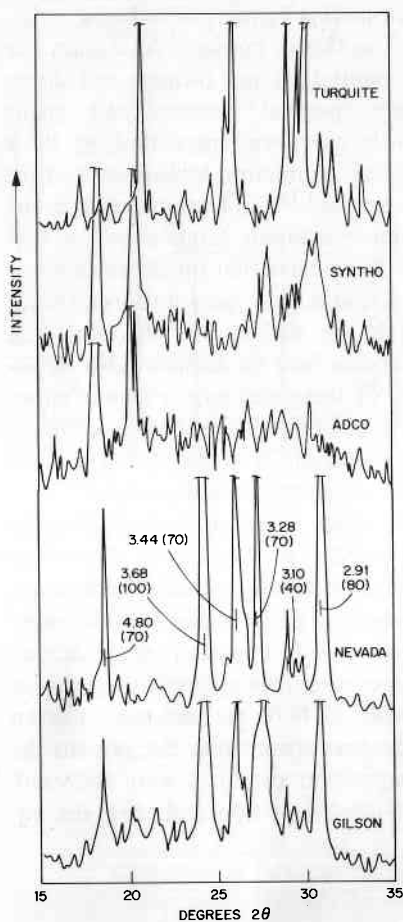

Figure 3. Powder X-ray diffraction curves; the numbers on the Nevada curve are the  $\alpha$  spacing in Å and the intensity in parentheses taken from the ASTM File Card 6-0214.

Pyrolysis was performed at a rate of 2°C/min in an inert atmosphere (flowing nitrogen) and the products analyzed in a UTC-100 mass-spectrometer.

Gemological parameters were determined by the usual techniques<sup>(7)</sup> (R.I. by the spot method; specific

gravity by hydrostatic weighing; short and long-wave ultra violet fluorescence, and examination under magnification).

## Results

Elemental compositions from the SEM in the energy dispersive mode are shown for three of the materials in Figure 2. The Adco and Syntho products gave curves similar to the Gilson curve of Figure 2B. It can be seen immediately that the Turquoise material does not have the turquoise composition, containing little, if any, Al and much Si, S, and Ca. The natural turquoise contains small amounts of Fe and Si, the former as expected,<sup>(1)</sup> the latter indicating some trace silicate contamination.

Table 1 contains these results together with C and H analyses. It can be seen that the Gilson product analysis is very close to the natural turquoise results; the absence of significant amounts of iron indicates it is probably made from fairly pure ingredients. The low iron content also explains why the weak iron spectrum seen in natural turquoise is absent in the Gilson product.

Syntho and Adco contain considerable excess carbon, and Turquoise just does not fit the turquoise composition.

Results of powder X-ray diffraction add further information. Here, as shown in Figure 3, only the Gilson product has the same crystal structure as natural turquoise. Syntho and Adco are very similar to each other, with the correct chemical composition, but not the turquoise crystal structure. The Turquoise product also does not have

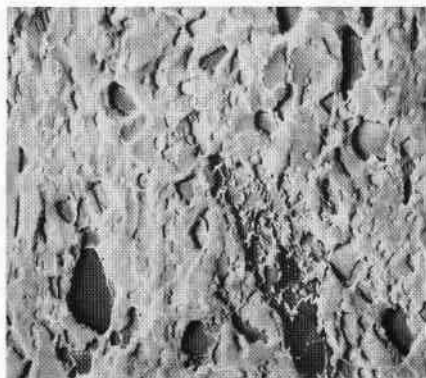

Figure 4. Scanning Electron Microscope view of the Syntho product; field of view is 3 mm across.

the correct crystal structure for turquoise.

Microscopic and SEM examinations show a very coarse structure for Turquoise, visible even in *Figure 1*. Syntho and Adco have a finer structure, shown for Syntho in *Figure 4*. SEM analysis showed the dark grain in the lower left hand corner to have a higher P and lower Al content than the

surrounding lighter colored area.

The Gilson product has a grain size of about 0.04  $\mu\text{m}$  (40  $\mu\text{m}$ ) and shows some material between the grains which has been speculated to be a gel-like aluminum hydroxide cement by Eppler.<sup>(3)</sup> SEM examination in the element mapping mode shown in *Figure 5* indicates that the distribution of P, Al, and Cu is quite uniform. Grains would be slightly less than half the reference bars in diameter. No depletion of these elements is seen in either grain or intergrain regions; accordingly the grains and intergrain filling all have the same turquoise composition.

Another question that needs to be answered is whether any of the carbon in the Gilson product could derive from an organic binder (plastic, polymer) or is present as inorganic carbonate as in the natural turquoise. A sample of 6.70 mg was heated in an inert gas stream and the gaseous decomposition products were analyzed. Only H<sub>2</sub>O and CO<sub>2</sub> and their decom-

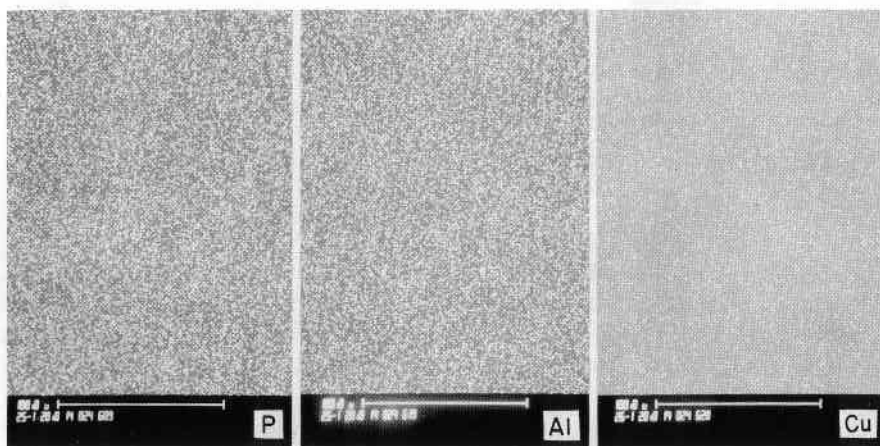

Figure 5. Scanning Electron Microscope views in the elemental mapping mode of Gilson synthetic turquoise for phosphorous (P), aluminum (Al), and copper (Cu).



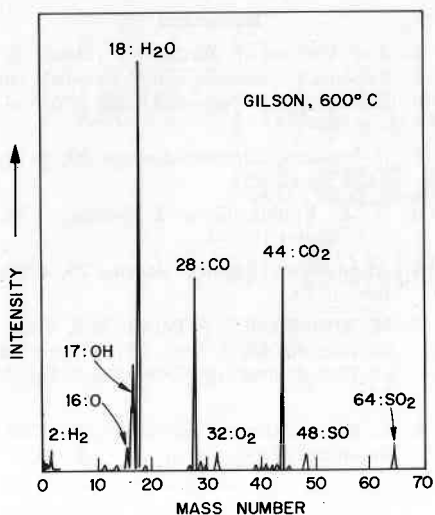

Figure 6.

position products were observed (together with a trace of  $\text{SO}_2$ , probably a contamination). Figure 6 shows the curve at  $600^\circ\text{C}$ . Quite similar curves were obtained up to  $1000^\circ\text{C}$ , indicating the absence of any organic binder.

We are grateful to Dr. P. K. Gallagher for these pyrolysis results.

The infrared reflection spectra published by Arnaud and Poirot<sup>(5)</sup> show the spectrum of the Gilson material to have the same peak positions as the natural, however with much less sharpness. The other products examined by them were quite different.

The results of gemological examinations are given in Table 2. These clearly permit the imitations to be distinguished from the natural and synthetic materials. Examination under magnification should permit the distinction between natural turquoise and the Gilson product.<sup>(2,3,4)</sup>

### Summary

The "Gilson Created Turquoise" is shown to meet all the criteria proposed<sup>(6)</sup> for a synthetic non-single crystal equivalent of a natural gem material. It appears to be the only true synthetic turquoise so far examined.

TABLE 2  
Gemological Data for the Various Turquoise Specimens Studied

Sample	S.G.	Refractive Index	Fluorescence under	
			lw uv	sw uv
Natural (range)	2.60-2.90	1.61-1.65	Greenish-Yellow to Blue	Inert
Nevada (Natural)	2.66	1.61	Grey Blue	Inert
Gilson (Synthetic)	2.70	1.61	Grey Blue	Inert
Syntho (Imitation)	2.10-2.40	1.56-1.59	Inert	Inert
Adco (Imitation)	2.20	1.58	Inert	Inert
Turquoise (Imitation)	2.26	1.56	Patchy Yellow Green	Patchy Yellow Green

Turquoise was found to be a simulation, as claimed by the manufacturer. The name is true of the Syntho product, which had previously been advertised as "True Synthetic Turquoise," however. The Adco product does not appear to be a "reconstituted" turquoise, since it does not contain any significant amount of iron, which is always present in natural turquoise. Neither does it appear to be a "synthetic" turquoise, since it does not have the turquoise crystal structure. These three products are correctly designated "imitation" or "simulated" turquoise.

Conventional gemological testing appears to be adequate to distinguish synthetic, imitation, and natural turquoise.

## References

1. *The System of Mineralogy (Dana)*, C. Palache, H. Berman, and C. Frondel, 7th Edition, John Wiley and Sons, NY, Vol. 2, p. 947.
2. R. Webster, *Lapidary Journal* 29, 1412, 1428, Nov. 1975.
3. W. F. Eppler, *Gems & Gemology* 14, 226, Winter 1973-4.
4. Anonymous, *Lapidary Journal* 29, 1760, Dec. 1975.
5. M. Arnaud and J. P. Poirot, *Bull. Assoc. Fr. Gemm.* 44, 9, Sept. 1975, reprinted in *The Journal of Gemmology* 14, 8, 375.
6. K. Nassau, *Gems & Gemology*, XV, 168, Summer 1976.
7. *Handbook of Gem Identification*, 10th Edition, R.T. Liddicoat, Jr., Gemological Institute of America, Los Angeles, California, pp. 16, 35.
8. R. T. Liddicoat, *Gems & Gemology* XIV, 248, Winter 1973-4.

---

## The Adiel Steacy Memorial Scholarship in Gemology

An annual scholarship is open to a resident of the city of Brockville, Ontario, Canada, or surrounding area who is in need of assistance to enable him to pursue the study of gemology. The scholarship provides actual costs up to a maximum of \$2,500 to enable the recipient to attend the Gemological Institute of America or any Institute in Canada of equivalent status.

If there is no applicant from the

city of Brockville or the surrounding area, the scholarship may be awarded to a person ordinarily resident in Ontario. It is a condition of the scholarship that the recipient must seek employment in the jewelry industry in Canada.

Applications should be submitted to the Assistant Registrar (Student Awards), Queen's University, Kingston, Ontario, Canada prior to July 1 of the year of application.

# Developments and Highlights at **GIA**'s Lab in Santa Monica

By RICHARD T. LIDDICOAT, JR.

In the interim since the last laboratory report, we have seen some interesting things.

## Laser Drilling Gone Mad

A diamond was sent to the Santa Monica Laboratory for identification. This pear-shaped brilliant caused some doubts in the minds of the people who sent it because obviously they were not sure it was a diamond. The stone

boggled the minds of those who saw it because they found between 25 and 30 laser drill holes in the table. Many of these are discernible in *Figure 1*. When a diamond is laser drilled through the table, the drill holes are much less apparent than when they are drilled through the pavilion facet. Pavilion drill holes appear as obvious white lines. If the diamond is drilled through the table, the drill holes are much less evident to a viewer who examines the diamond from a direction perpendicular to the table. When this diamond was examined from the side, the appearance seen in *Figure 2* became evident. Many drill holes can be readily seen in *Figure 2*.

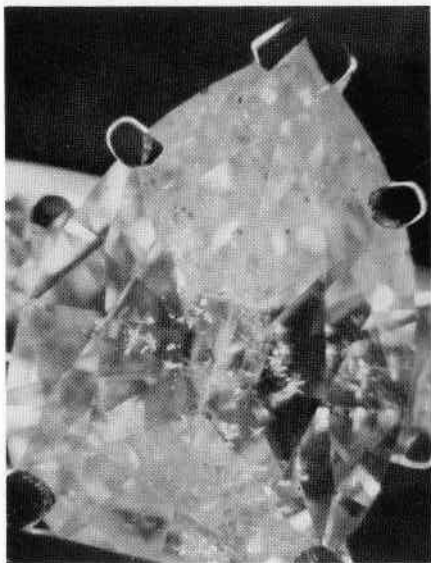

Figure 1.

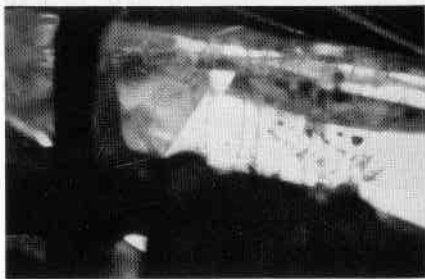

Figure 2.



Figure 3.

### Imitation Bloodstone

Occasionally we see imitations that have been made of relatively inexpensive materials. It makes one wonder why the imitator bothered to do the job. We received a really beautiful imitation of bloodstone for identification. It was unquestionably glass but so beautifully done that there is no doubt but that it had been done intentionally and seemingly at great expense.

Figure 3 shows a view of a portion of a carving purported to be bloodstone. The light areas in the photograph are the red spots that would characterize a bloodstone. However, since it was actually glass, it was surprising that the amount of effort that went into the making of the piece would have been expended on such an inexpensive item. Obviously, the purpose was that the material could be molded instead of having to be carved, so it made more sense than it would have had it not contained a carving. Figure 4 shows a magnification at 63x of one of the red spots and the pointer shows a bubble beside a flow structure within the red spot that makes it clearly a glass imitation.

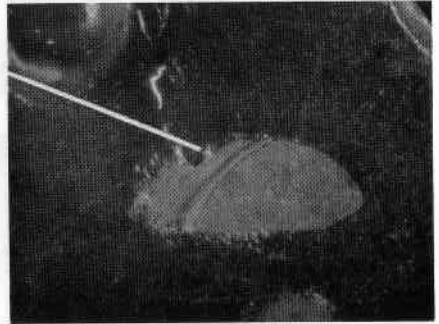

Figure 4.

### Barion Cuts

Figures 5 and 6 show two Barion cut diamonds, one a square and the other rectangular. These were very attractive stones that used this relatively new style of cutting.

### Repairs and Alterations of Jade Carvings

We received in for identification a two-piece carving on which damage has been sustained on the top piece.

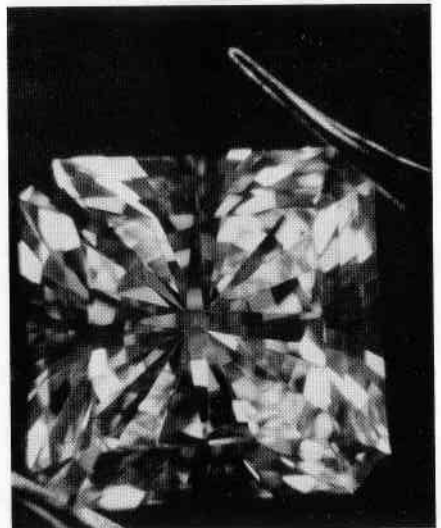

Figure 5.

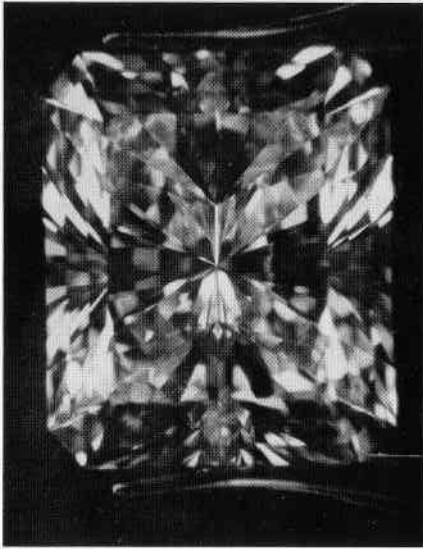

Figure 6.

To repair the break, plastic material had been added, which is shown in *Figure 7*. The right hand portion and the ring surrounding the left hand portion were of nephrite jade but the plastic addition to replace the broken piece is shown as the shinier left hand top portion in *Figure 7*. Another

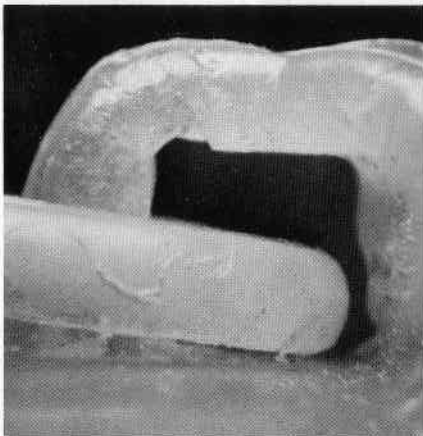

Figure 7.

nephrite jade carving in the form of the disc had a drill hole through it originally to take care of a chain. The hole had been filled in and is seen as the gray area at the center of *Figure 8*. This was very obvious to the eye in the examining of the stone.

### True Canary

A truly lovely square-cut canary diamond in a turn-of-the-century platinum mounting was received for identification and a determination as to whether the color was natural. It had a beautiful orangy fluorescence to both short-wave and long-wave ultraviolet and was totally without the usual cape spectrum of a canary diamond. This is what Basil Anderson, longtime director of the London Laboratory, referred to frequently as a true canary. It was a very lovely stone. We do not see these very often.

### Rare and Unusual Stones

Recently, we received for identification a 6.07 oval-mixed cut brown stone which proved to be sinhalite. It showed all of the four absorption lines we expect from this relatively rare gemstone and was a very attractive stone. We also received as a gift from

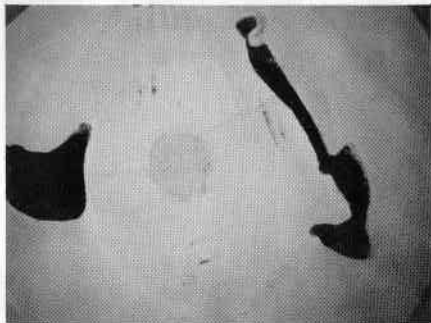

Figure 8.

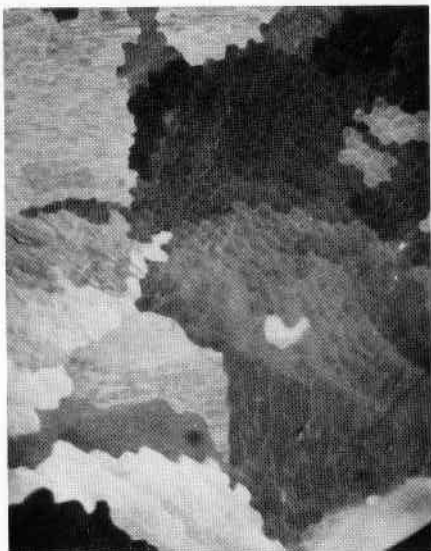

Figure 9.

our old friend, Edward R. Swoboda, two crystals of a very rare gem material — jeremejevite. One was colorless and the other blue. Another interesting identification was a color-

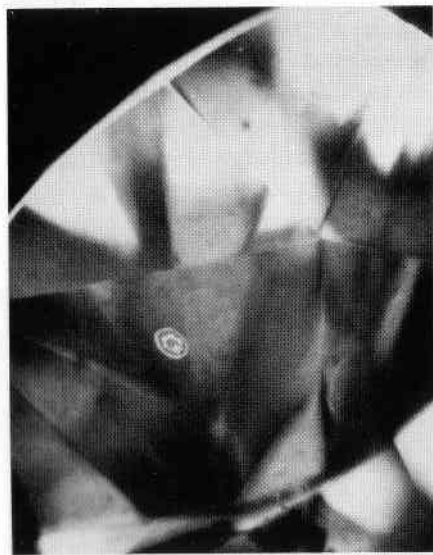

Figure 10.

less brilliant that the sender suspected of being a new diamond imitation. The specific gravity turned out to be 5.57, the hardness of 6 to 6½. It was singly refractive and inert to both short-wave and long-wave ultraviolet. The 1.17-carat round brilliant showed a faint yellow fluorescence to X-rays. We were asked to do an X-ray diffraction study on it, and found that it conformed best in structure to a dysprosium gallium oxide. In view of the fact that all the figures we have for this compound give much higher specific gravity values, we doubt that this is exactly what it is, but it is obviously a rare earth synthetic with a garnet structure.

#### A New Use of Gilson Synthetic Opal

A really spectacular black opal triplet was received by our Laboratory for identification. This turned out to have a glass top and a good solid opal back, but the black opal portion showed the usual mosaic structure of the Gilson synthetic opal. We learned from our New York Laboratory that they too had recently encountered such a use for Gilson synthetic opal. See *Figure 9*.

#### More Notes on Diamond Inclusions

Again, we encountered some very interesting inclusions in diamond. What appeared to be an oval bubble is portrayed in *Figure 10*. This was actually a very flat inclusion in a cleavage plane with a separation away from a tiny crystal inclusion. But in this view, it does look very much like an oval bubble. In a pink diamond sent in for identification, a number of needlelike inclusions were observed and are seen in *Figure 11*. Such inclu-

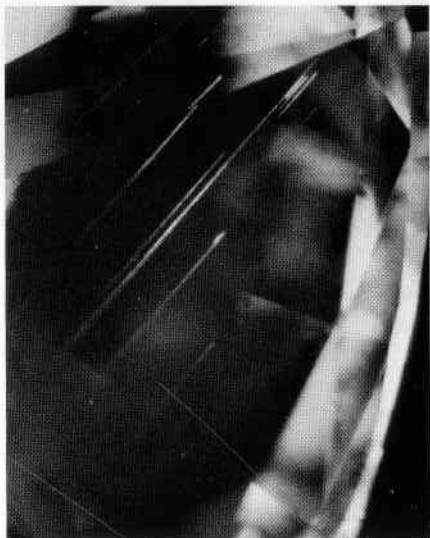

Figure 11.

sions are not exceedingly rare in a pink diamond but they showed up rather more clearly than usual in this illustration.

#### "Bubble" in Natural Sapphire

What appears at first glance to be a circular bubble in a natural sapphire is seen in *Figure 12*. A second look at it from the side indicates that it is actually flattened and that it is neither spherical nor a bubble (*Figure 13*.)

#### Acknowledgements

We wish to express our sincere ap-



Figure 12.

preciation for the following gifts:

To *Arnold Baron, C.G.*, of *Arnold Baron, Inc.*, Los Angeles, California, for three faceted natural blue sapphires and four faceted natural rubies of great use in residence classes.

To *E. Braunschweiger, GIA* Correspondence Student, Braunschweiger Jewelers, Morristown, New Jersey, for a large assortment of stones including garnet and glass doublets, YAG, GGG, natural emeralds, citrine, aquamarine, moonstone, and synthetic spinel, ruby and sapphire.

To *Karen and Thomas Harrelson, GIA* Santa Monica Resident students, of Miami, Florida, for a useful selection of rough pink tourmaline crystals from the Stewart Mine, Pala, California.

To *Frank Miley, GIA* Correspondence student, Los Alamos, New Mexico, for a nice group of opal and turquoise cabochons and a selection of tumbled agates, peridots, and garnets.

To *Irving Setterberg, R.J.*, Paul Jones Jewelers, Sun City, Arizona, for an interesting heat-cracked 0.64-carat natural emerald.

To *Edward Swoboda, Pala* Properties, Fallbrook, California, for donating two rare and unusual jereimejevite crystals, one blue and one colorless.



Figure 13.

# Cathodoluminescence of Gem Materials

## A Short Review

BY  
ROBERT A. P. GAAL, PH.D., G.G.  
Research Scientist, GIA  
Santa Monica, California

### Abstract

Gem materials containing activator ions or structural defects luminesce in an electron beam and reveal features not visible to the eye when using ordinary light. This phenomenon called cathodoluminescence (CL) has been known in diamonds for nearly 100 years. The technique has only recently been resurrected by mineralogists as a fallout from the development of the electron microprobe analyzer. Results obtained so far promise versatile possibilities of applications to gemology and the jewelry trade, especially when coupled to a scanning micro-spectrophotometer. This technique can produce luminescent colors and spectra useful in research which in turn can be used to detect and identify gem materials, show crystal structural defects not observed by other means, separate natural, synthetic, and imitation gemstones, exhibit zoning, detect certain dyes and enhancement processes, and be used by the prospector, miner, sorter, cutter, and gem synthesizer in separations, sorting and quality control functions. The structural and compositional variations reveal potential genetic implications.

### Introduction

Mineralogists and gemologists have used UV excited fluorescence for identification for many years, yet little attention has been given to the application of electron excited luminescence by microscopic examination until recently in the study of dia-

monds. How paradoxical this is since diamond was one of the first crystals in which cathodoluminescence was observed. Crookes in 1879 initially reported the phenomenon of cathodoluminescence (CL) in gemstones. As one of the pioneers in the use of luminescence as a gemological technique, Crookes, along with Maskelyne, studied the effect in diamond, sapphire, ruby, emerald, zircon and other minerals nearly 100 years ago. They found that when gemstones were subjected to the negative discharge in vacuum, they "shine with a great splendor."

In the 1920's, H. Michel and G. Riedl of Vienna investigated the luminescence of gemstones using cathode rays and later B. W. St. Clair studied cathodoluminescence of natural and synthetic sapphires. He was able to detect and identify the phosphorescent synthetics from the natural stones.

Although the phenomenon of CL has been known for many years, the "modern" period of development of luminescence microscopy perhaps only began in the early 1960's when J. V. Smith (1965) at the University of Chicago and J.V.P. Long and S.O. Agrell (1965) of Cambridge University published papers on the use of luminescence as a petrologic technique.



The renewal of the method was a result of the development of the electron-bombardment-stimulated X-ray microprobe analyzer (EMP) of the late 1950's and early 1960's, in which cathodoluminescence was commonly observed as a by-product of studies undertaken for other purposes.

Some of the most recent studies with CL involve "lunar rocks," emeralds from Colombia and CL scanning electron microscope studies of diamond by the De Beers Diamond Research Laboratory and various universities in England, Germany, and Holland. See Escobar and Mariano, 1976.

In 1965, the Nuclide Corporation developed an inexpensive device that could be attached to an ordinary microscope for observing specimens under electron bombardment having energies of up to 20,000 volts. The resulting instrument was called the Luminoscope<sup>®</sup>. See Mariano, 1975.

Recently, the Gemological Institute of America acquired a Nuclide Luminoscope<sup>®</sup> ELM-2A, a new third-generation cathodoluminescence instrument for the convenient and economical observation of specimens under electron bombardment. This unit is compatible with almost all microscopes so that the CL phenomenon can be seen at various magnifications.

### Luminoscope<sup>®</sup>

What is the Luminoscope<sup>®</sup> and what does it do that other instruments cannot do for gemology? First, it can be visualized as a miniature TV tube in which the TV screen can be considered to be the gem sample. It resembles a horizontally mounted electron micro-

scope in that an anode draws electrons from a cold cathode, then passes them along a column consisting of a metal tube with magnetic condenser objective lenses. These lenses (magnets) focus the electron beam onto a small sample area. The electrons then excite the sample and cathodoluminescence, thermoluminescence and some X-rays are produced.

The basic instrument and its components shown in *Figure 1* consists of a high voltage power supply control unit, and vacuum specimen chamber with attached electron gun. *Figure 2* illustrates its schematic arrangement.

The control unit consists of a high voltage power supply (0-18 keVDC) current monitor (8 $\mu$ A-2mA) and focusing controls (system). The vacuum specimen chamber has an observation window and holds 2" x 3" x 1/2" specimens. The GIA instrument (specimen chamber and electron gun) is mounted on a stereomicroscope. An internal X-Y translating stage allows specimen positioning within the chamber. A variable leak valve is attached to the chamber to maintain a glow discharge. The electron gun attached to the vacuum specimen chamber uses a cold cathode discharge at mechanical pump pressures (10-25 millitorr). Details of the specimen chamber and electron gun are shown in *Figure 3*. Because of the cold cathode discharge environment, specimens do not require a conductive coating.

### Theory of Cathodoluminescence . . . or Why Do Gem Materials Light Up

Cathodoluminescence (CL) simply means electron stimulated luminescence. Luminescence is the term used

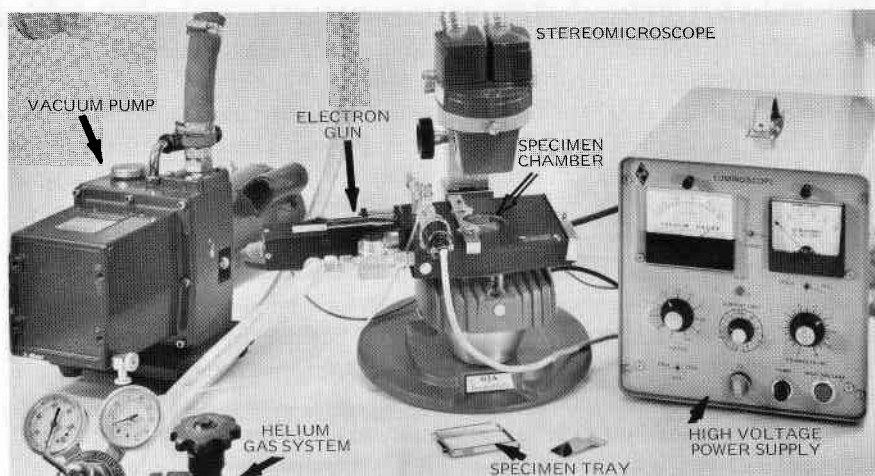

Figure 1. The Luminoscope®, Model ELM 2A, with specimen chamber installed on a Gemolite stereomicroscope, with vacuum pump, helium system, and power supply attached.

for light emission that cannot be attributed purely to thermal origin. When it is produced by ultraviolet or visible light, it is called photoluminescence. This is the classical or common type of optical fluorescence seen by gemologists. If, however, the luminescence or visible radiation is produced by high speed electron bombardment, the phenomenon is called cathodoluminescence.

The most familiar used of catho-

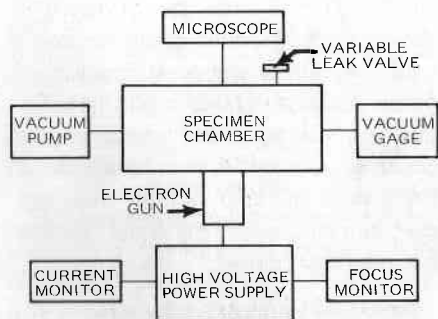

Figure 2. Schematic diagram of cathodoluminescence system.

doluminescence is in the picture tube of television sets. Let's look at the analogy of the TV picture tube as shown in *Figure 4*. An electric current flowing through the heater filament causes the cathode, a metal cylinder, to get hot and a continuous cloud of electrons is "boiled off" which passes through the anode on its way to the screen where it strikes the inside phosphor coating of the tube and causes it to "light up." The screen of a television picture tube consists of many crystals of phosphor capable of producing luminescence when bombarded by electrons. When a fast-moving electron strikes one of the crystals, its molecules absorb the energy of impact and some of the electrons, bound in the crystal, are raised to higher than normal energy levels. As they drop back to the unexcited or ground state, the electrons give off visible light, with an intensity depending upon the energy from the impinging electrons. Similarly, the Luminoscope® works

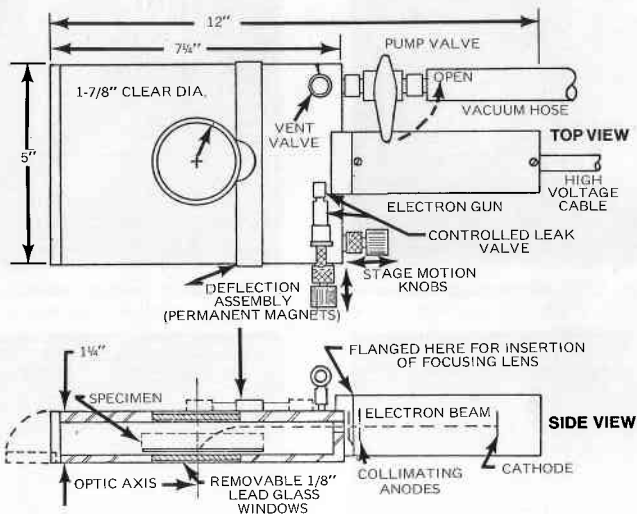

Figure 3. Luminoscope® Model ELM-2A specimen chamber showing features (plan and section). Courtesy of Nuclide Corporation, Acton, Mass.

in much the same way, except the gem material lights up and becomes the glowing screen. Instead of using a heater to produce electrons, the Luminoscope® uses a cold-cathode emission technique to produce an electron beam. A high potential difference of several thousand volts is placed between the anode and cathode to pull the electrons free from the cathode. The gem material is bombarded in a vacuum chamber to permit passage and minimize attenuation of the electron beam.

Since the physics of CL can become quite complex very quickly, the reader is referred to references on color in gem materials by Nassau in *Gems and Gemology* 1975-1976, Loeffler and Burns (1976), and for an in-depth presentation of the theory of luminescence, see Garlick (1958), Leverenz (1950), and Burns (1970). Numerous other papers discussing the details

of the electronic processes involving transitions from excited states to ground states, and other solid state phenomena, are listed in the aforementioned references. However, I believe that the conceptual analogy of the TV picture tube will suffice for the practicing gemologists.

Although the theory of CL is quite complex, the effect is readily seen when the electron beam current is a few micro-amps ( $\mu\text{A}$ ) and the high voltage is about 5 to 18 keV. This voltage is sufficient to accelerate the electrons to speeds of almost a quarter

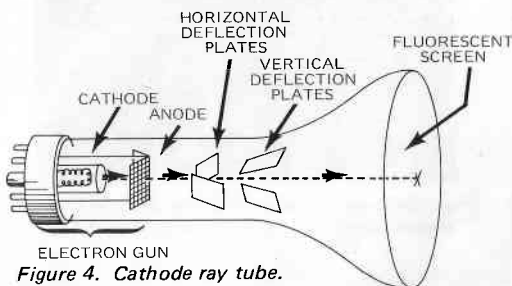

Figure 4. Cathode ray tube.



a. Labradorite, left, calcite, right, showing CL suppression by iron.



b. Benitoite with characteristic intrinsic blue CL.



c. Natural ruby with disrupted structures suggesting interrupted growth.

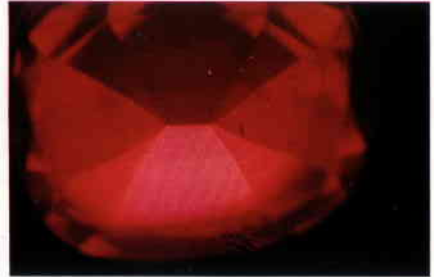

d. Synthetic ruby (Kashan) with characteristic parallel zonation in CL.

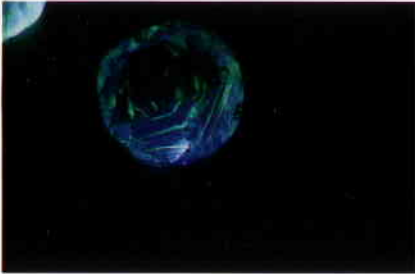

e. Diamond with complex growth zones, slip and dislocation bands.

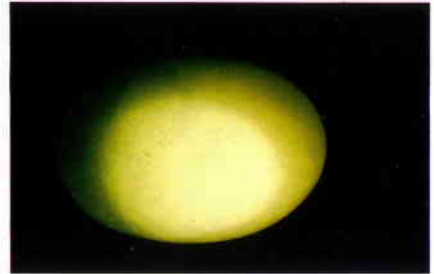

f. Natural white jadeite in CL.



g. Diamond melee of two different diamond types.

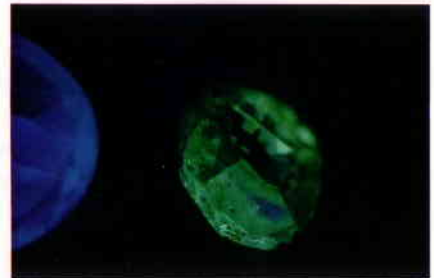

h. Diamond exhibiting complex structures and diamond type mixtures.



*a. Synthetic alexandrite with growth banding showing changes in composition.*

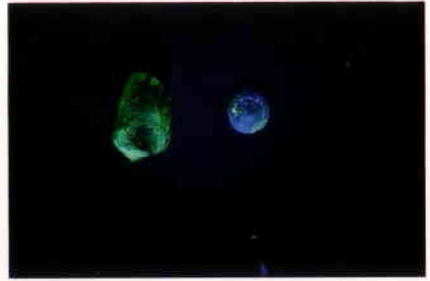

*b. Natural green diamond showing different compositional types in CL.*



*c. Diamond with floating disrupted structures of different types.*

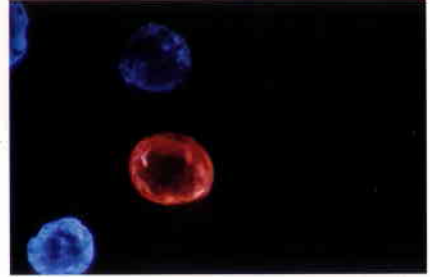

*d. Diamonds with red and blue CL.*



*e. Dyed green jadeite.*



*f. Dyed lavender jadeite.*



*g. Natural green jadeite spot at initial CL.*



*h. Green jadeite spot in 2-g turns red after 10 secs (thermoluminescence).*

of the speed of light. When the electrons strike the gem material, they are brought to rest and their kinetic energy is dissipated, mostly as heat, in the atomic structure of the bombarded material. Depending on lattice distortions, imperfections, intrinsic features, or impurity ions, some of this energy is radiated back as light — this is cathodoluminescence.

Minerals owe their CL to the presence of impurity activators, structural defect centers, or to intrinsic properties. Variations in intensity of luminescence may be due to variations in activators and/or quenching ions. Activators are imperfections such as impurities or defects in structures that cause luminescence as a result of changes in electronic states. CL appears to be generated only in a very thin layer in or near the surface.

### Experimental Method

Gem materials analyzed with the Luminoscope<sup>®</sup> included faceted, cabochons, crystals, and rough materials. There is no need for coating the samples with a conductive paint since charge neutralization occurs rapidly and there is very little charging at the low pressure in the chamber. The chamber and electron gun unit is attached to a stereomicroscope for viewing. CL was induced by 5 to 18 keV electrons in an irradiation chamber; the specimens were examined microscopically during irradiation and luminescence observed visually. Ideally these data also should be recorded spectrophotometrically. Spectra of the new diamond simulant cubic zirconia quickly identify it. Zirconia has a broad

band in CL peaking at about 475 nm with a small satellite peak at 612 nm which is different than diamond (personal communication, A. Mariano, 1977). Two micro-spectrophotometer systems were tested, one of which was computerized and data output (spectra) was plotted on an X-Y recorder.

Energies used in this study cause electron penetration depths of 1 to 2  $\mu\text{m}$  (Garlick, 1966). Davies (1975) has calculated the depth of penetration in diamonds and shown it to be a near surface effect. For 10 keV, the depth of penetration is 1.4  $\mu\text{m}$  and for 50 keV about 20  $\mu\text{m}$ . Therefore, CL excites a very small volume of the gemstone. The size of the energized volume is equal to the area of the spot diameter, 1 cm. ( $10^4 \mu\text{m}$ ) for the unfocused beam and 1 mm. for the focused beam and depth about 10  $\mu\text{m}$ .

Samples are first cleaned in distilled water where applicable and wiped dry with a lint free absorbent tissue whereupon they are placed in the specimen tray and their position is plotted on a sheet of paper so that their response to CL can be identified and recorded. The samples are placed in the vacuum chamber which is pumped down to a pressure of 15-30 mtorr in less than 3 minutes. Once this vacuum has been reached, the cold cathode discharge source is turned on and the beam voltage adjusted to produce luminescence. The electron beam can be focused at a diameter from 1 mm. to 1 cm. on the desired specimen. The response of the gem material is recorded as to color, intensity, patterns, phosphorescence or no apparent reaction. See Goebel and Patzelt, 1976.

Specimens with dimensions up to 2" x 3" x 1/2" can be placed into the chamber and are examined at magnification up to 90x with a stereomicroscope. Samples can be changed and analyzed in less than 5 minutes once the unit has been pumped down initially.

CL color data are summarized in *Table I*. High concentrations of iron or other elemental impurities tend to suppress luminescence.

All photographs were taken on high-speed Ektachrome (160 ASA) with a 35-mm Nikon F2 Photomic camera attached to an AO stereomicroscope at magnifications of 10x to 63x, 5-18 keV, 0.5-1ma, 40-50 mtorr, for 30 to 60 seconds. See *Plates 1 and 2*.

### Results

Preliminary study of various gem materials indicates that several can be rapidly identified, and suggests that much can be learned about gemstone treatment, crystal defects, origins, etc., based upon the features revealed by CL. Structural and compositional variations may reveal potential genetic implications. Crystal-zoning, sometimes revealed only by CL, was quite pronounced in some crystals such as diamonds and synthetic alexandrite (*Plates 1d, 1e and 2a*). The zoning suggests that the composition and environment of crystallization was changing with time.

Most diamonds have a blue CL color. Some specimens luminesced a very weak blue-yellow-green (*Plate 2b*), but did not show any obvious structural relationships by microscope examination. However, when the speci-

men was photographed, excellent structural defects become apparent. Other diamonds which originally luminesced various shades of blue turned a pink color at higher beam current densities and exhibited weak linear zonations. Since rubies and emeralds luminesce in the red end of the spectrum, an interesting speculation is to consider the use of IR photography during CL. Examination of some dyed lavender and green jadeite suggests another useful application of CL. The dyed luminescing areas seen in *Plates 2e and 2f* displayed by CL appear to be discontinuous and irregular, apparently following the crystal boundaries and cracks.

The variety of color of some gemstones may be of diagnostic value (*Plate 1b*). Carbonates usually show red or orange luminescence; those that did not apparently were iron bearing. See *Plate 1a*. Zoning is detected from variations in color or intensity of luminescence, possibly indicating areas of weakness in a stone. CL is a quick qualitative way of revealing chemical variations which could be especially useful in checking the homogeneity of synthetic or natural gem materials. Supplemental investigation with EMP or EDS would help confirm this interpretation. Because of the heating effect of the electron beam on (insulating materials) the specimen, the observed luminescence in some specimens was seen to change with time. A spot of green jadeite mixed in white jadeite was observed to turn red in a matter of a few seconds (*Plates 2g and 2h*). This may be a thermoluminescent effect due to heating.

**Table 1**  
Selected Gem Materials and their Cathodoluminescent colors\*

GEM MATERIAL	Red	Orange	Yellow	Blue	Green	Indigo	Violet	Brown	No Reaction	REMARKS
ALEXANDRITE	●							●		DULL TO N.R.
AMBER			●		●					DULL YEL-GRN
AQUAMARINE									●	
AXINITE	●	●								VERY DARK
BENITOITE				●						INTENSE
BERYLLONITE				●						LIGHT
BRAZILIANITE									●	
CALCITE		●								INTENSE
CHRYSOBERYL (yel.)			●							LIGHT
CHRYSOPTASE	●									DULL PURP-RED
CORAL (pink)						●				DULL
DANBURITE				●						PALE PINK-BLUE
DIAMOND	●		●	●	●		●	●	●	INTENSE BLUE; STRUCTURES
CHROME DIOPSIDE	●									DULL BRN-RED
DATOLITE				●						INTENSE LT. BLUE
DIOPTASE									●	
EMERALD									●	
GROSSULAR (green)		●								INTENSE
IOLITE	●									V. DULL RED
KYANITE	●									DULL RED
LABRADORITE				●				●		BRN-LAMELLAE
LAPIS		●		●			●			MOTTLED
ORTHOCLASE (cat's-eye)				●						
PEARL (Biwa; Chinese)			●							FRESH WATER CULTURED
PERIDOT									●	
PETALITE		●								INTENSE
PHENAKITE				●						INTENSE
PLAGIOCLASE				●						PHOSPHORESCENT
RHODOCHROSITE		●								DULL
RUBY	●									INTENSE
SANIDINE				●						
SPESSARTITE	●									DULL
SPHALERITE		●								INTENSE
SPHENE								●		DULL
SPODUMENE (pink)		●								INTENSE
STRONTIUM TITANATE	●									
TANZANITE					●					PALE
TEKTITE (moldavite)								●		DULL
TREMOLITE		●	●							
WOLLASTONITE (white)		●								INTENSE
ZIRCON (green)			●			●				DULL YEL & PURP BANDS
YAG (colorless)				●			●			
SYN. RUBY	●									KASHAN WEAK, OTHERS INT
SYN. EMERALD	●									CHATHAM, LINDE INTENSE
SYN. DIAMOND			●	●	●					INTENSE

\*Most commonly observed color(s).



Diamonds proved to be one of the most interesting materials observed in GIA lab studies. Several CL examples of diamonds are seen in *Plates 1g and 2d*. Studies by G. Davies (1975) indicated that only diamonds with "imperfections" can radiate visible CL. These imperfections include impurity ions or their aggregates and vacant lattice sites. The particular CL colors produced suggest the type of defect. Note that not all defects, in diamonds, for example N3 and ND1 centers, produce CL. The blue CL seen in type Ia and IIb diamond may be due to donor-acceptor spectra. Furthermore, Davies (1975) believed that CL is a near surface phenomenon since no luminescence comes from the true surface of the diamond and no information is obtained below a 20  $\mu\text{m}$  depth of penetration for the electrons.

Collins (1974) has studied CL in diamonds and reported that natural type Ia and IIb diamonds often show two different contrasting shades of blue. This distribution of blue color within a specimen indicates the inhomogeneity of natural diamonds and that they are mixtures of type I and II material. See *Plates 1e and 2c*. The blue CL is due to Band A spectrum. Blue CL can be seen from all types of natural diamonds. We found that upon prolonged excitation the color of the diamond may change from blue to green, suggesting this variation in color may be due to changes in specimen temperature. This effect was also noted in some other gemstones, e.g., the green areas in natural jadeite turn red. Some type IIb diamonds turn an intense pink. Red CL is reported to be characteristic

of some type II or type Ib diamonds which have undergone radiation damage (see *Plate 2d*). Some synthetic diamonds CL green, others blue. Seal (1976) has discussed the structure of type I and II diamonds using CL and other methods.

An excellent recent paper on CL of synthetic diamonds by Woods and Lang (1975) discusses growth sectors and dislocations and their characteristic luminescent colors and brightness as a function of current density. They reported that some green CL from cube growth sectors are linearly polarized. This writer found similar effects for certain gem materials. More recently, Woods (1976) in a stimulating paper on "nitrogen platelets" in diamonds used CL in conjunction with other techniques. He now believes that the so-called "platelets" are *not* of nitrogen, but rather of aggregates of interstitial carbon atoms in puckered layers parallel to [100] planes.

The most intriguing aspect of this writer's study was the observation of the complex internal structures and inhomogeneities of the diamond types. These features indicate interesting potential genetic relationships. For example, the complex bending and dislocations of parallel growth zones in some diamonds suggest plastic deformation in a dynamic stress field; the sum of the thicker multiple growth zones followed by much thinner growth zones of differing composition suggests a fluctuating growth rate of relatively long and short duration in a changing environment; apparent disrupted structures of different compositions and angular shapes suggest violent dis-

ruptions followed by extremely rapid growth (see *Plates 1e, 1h, and 2c*).

### Summary

CL color can be used for the detection and identification of many gem materials. It shows variations in trace concentrations of activator elements in zoned materials. CL can be used in quality control in synthetic crystal growth. By using a broad beam, one can examine and sort parcels of mixed stones or rough material. Also, mounted goods can be studied.

CL may aid in the study of dyed or even plastic enhanced materials and reveal features not detectable by other visible methods. It may also be seen in gem materials in which UV produces no effect.

Its use can be applied by the research and practicing gemologist, gem prospector, in initial mine separation and sorting, synthetic gem manufacturing in quality control, diamond and colored stone gem sorters and cutters, etc. See Potosky and Kopp, 1970.

Future research will include (1) creating defect centers within various gemstones possibly by X-rays to determine any measurable changes for test purposes, (2) study of the change in CL variations of color and intensity with temperature and time, (3) study emission spectra to obtain quantitative spectra, (4) study suites of specimens from known localities to establish a baseline for future work, (5) study the relationships of the various types of zonations, bands, dislocations, and patterns to crystallographic parameters.

### References

Burns, R. G. (1970) *Mineralogic Applications of Crystal Field Theory*, Cambridge

University Press, 224 p.

Collins, A. T. (1974) Visible luminescence from diamond, *Industrial Diamond Review*, April, 131-137.

Davies, G. (1975) Cathodoluminescence of diamond: a short review, *Diamond Research 1975*, Industrial Diamond Information Bureau, 13-17.

Escobar, R. and Mariano, A. N. (1976) On the Origin of Colombian Emeralds (*abstract*), Mineralogical Society of America - F.M. Symposium on Crystal Chemistry and Paragenesis of Gem Minerals, Tucson, Arizona.

Gaal, Robert (1976) Recent Research at the Gemological Institute of America (*abstract*), Mineralogical Society of America - F.M. Symposium on the Chemistry and Paragenesis of the Gem Minerals, Tucson, Arizona.

Gaal, Robert (1976) Cathodoluminescence by the Luminoscope, *Guilds - Conclave Issue*, Boston, Mass., 13-15.

Garlick, G. F. J. (1966) *Luminescence of Inorganic Solids*, Academic Press, 688 p.

Goebel, V. W. and Patzelt, W. J. (1976) Cathodo-luminescence - Investigations of Solids with the LEITZ Contrasting Device, *Scientific and Technical Information*, Leitz Wetzlar, VI, No. 7, 263-267.

Leverenz, H. W. (1950) *Introduction to Luminescence of Solids*, J. Wiley, 88 p.

Long, J. V. P. and Agrell, S. O. (1965) The cathodoluminescence of minerals in thin-section, *Mineral. Mag.*, 34, 318-326.

Mariano, A. N. and Ring, P. J. (1975) Europium-activated cathodoluminescence in minerals, *Geochemica et Cosmochimica Acta*, 39, 649-660.

Potosky, R. A. and Kopp, O. (1970) Application of cathodoluminescence to petrographic studies, *The Compass*, 47, 63-69.

Seal, M. (1976) Type I/Type II Structure and Inhomogeneity of Diamonds, MSA-F.M. Symposium on the Chemistry and Paragenesis of the Gem Minerals, Tucson, Arizona (*abstract*).

Smith, J. V. and Stenstrom, R. C. (1965) Electron excited luminescence as a petrologic tool, *Jour. Geology*, 73, 627-635.

Woods, G. S. and Lang, A. R. (1975) Cathodoluminescence, optical absorption and X-ray topographic studies of synthetic diamonds, *Journal of Crystal Growth*, 28, 215-226.

Woods, G. S. (1976) Electron microscopy of 'giant' platelets on cube planes in diamonds, *Philosophical Magazine*, 34, No. 6, 993-1012.

# Developments and Highlights at **GIA**'s Lab in New York

By ROBERT CROWNINGSHIELD

## Diamonds Toujours Diamonds

In the early days of our investigations into the problems of identifying irradiated diamonds we had the impression that definite color banding in a fancy color diamond was an indica-

tion of its natural color. *Figure 1* illustrates pronounced color banding in a natural brown diamond. Later we read that one of the early problems in cyclotron treatment of first, greens, then browns and yellows was the production of color banding when none was visible before. This problem must have been solved as we rarely

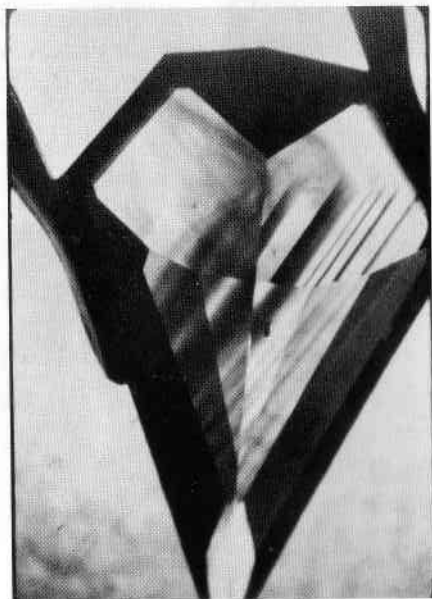

*Figure 1.*

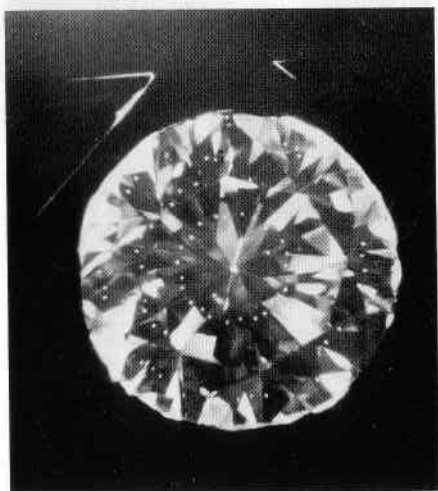

*Figure 2*

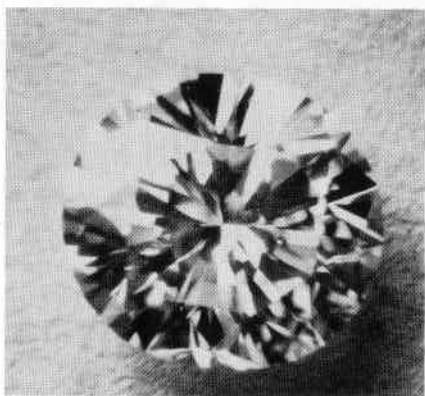

Figure 3.

encounter strong color zoning in treated stones today.

Although the diamond illustrated in Figure 2 is also a brown diamond, the reason for reproducing the slide is the unusually precise location of an included crystal which reflects in nearly every facet. Placed only slightly away

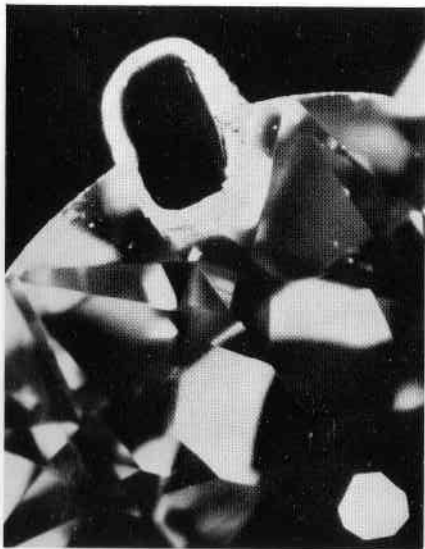

Figure 4.

from its position the stone would be graded fairly high – perhaps VS<sub>2</sub>. It is a problem to grade the stone fairly but surely SI<sub>2</sub> comes to mind.

Figure 3 shows just one of the faults in symmetry that can occur in the pursuit of excellence – in color and clarity. The stone was originally submitted for quality grading and found to be E color, VVS<sub>2</sub> with a weight of 2.14 carats. The flaw accounting for the clarity grade was a feather at the girdle. The stone was finally completed after five examinations as a Flawless, E color stone but with symmetry noted “poor.” The final weight was 2.01 cts! The Gem Trade Laboratories are quite aware of the perhaps unwitting part they play in producing less than good make and symmetry. The nearly oval shape of this stone is a good example.

We are also aware over the past few months of a growing tendency to produce round brilliant cut diamonds with main crown angles 30° or less. It was about 18 months ago that we first began to note on laboratory reports when a stone had such a deficiency.

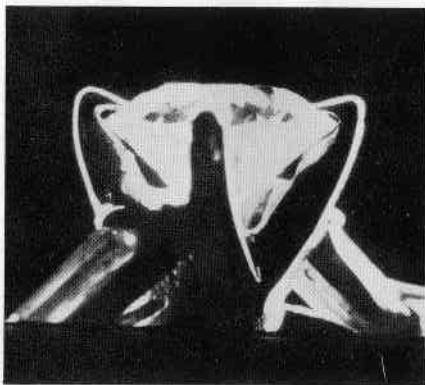

Figure 5.



Figure 6.

We have noted in this column before that we have seen crown angles less than  $30^\circ$  together with thin girdles in at least 75% of the cases of damaged stones which come to our attention, usually through insurance adjusters. The damage can occur during normal wear or during setting as shown in *Figure 4*. Although this particular damaged stone was an old European brilliant, the thin girdle and improper bearing in the prongs (*Figure 5*) could have been responsible for similar damage in a thin crowned stone.

We rarely see a green diamond that we feel sure is of natural color. Certainly, in the past 25 years we can recall only one or two dark tourmaline green stones whose history could establish the natural color. Also, each such stone had dark brown to greenish-brown naturals. We have seen several very light almost aquamarine color bluish-green diamonds which we feel are natural in color by virtue of the presence of brown "stains" in naturals. *Figure 6* illustrates this. On at least two occasions cutters who know that these important clues may be cut away in polishing have shown us rough crystals which have a brownish-green skin but are very transparent and a

most attractive color even before cutting.

Over the years there have been several photographic techniques developed for the purpose of "fingerprinting" diamonds. The most recent has been reported to make use of a simple laser beam. The resulting pattern when reflected from the facets of a polished diamond is unique to that stone and supposedly provides a means of identification. The twofold problem still remains, however; in recall, how does one catalog the millions of smaller diamonds that may one day be photographed and what means does the device have to detect that a stone has been recut — a favorite method employed in disposing of stolen stones? One suggested means of truly capturing a significant identifying characteristic of important diamonds is to photograph the strain patterns under polarized light. Almost all diamonds have strain when seen under crossed polarizers though not usually as distinct and attractive as that shown in *Figure 7*. The photograph does not indicate the beautiful blue and red colors present nor the

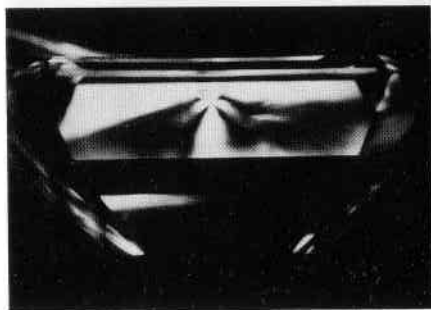

Figure 7.



Figure 8

fact that a small pinpoint inclusion is present in the center. Of interest to cutters, is the fact that sawing through such a strain center may cause fractures to develop and many use a polariscope to avoid doing so.

We show *Figure 8* only to remind our readers that coated diamonds are still around though certainly in the New York Laboratory we have not seen many in the past few years. The coating on the diamond in this photograph was quite resistant and appeared as tiny bluish spots all across the pavilion.

It would be difficult to disguise the

identifying characteristics of the orange-brown natural color diamond shown in *Figure 9*. The cottony cloud is characteristic of many of these lovely stones, though usually not so pronounced. In the last issue we did show a similar diamond, though very much smaller, with a similar central cloud. The last issue also showed the picture of a diamond with an unusual spiral scratch. Reader Eugene S. Love, Newport News, Virginia, offers the suggestion that it could have occurred if the stone were in a spinning device such as a Flexshaft hand tool while being polished on the diamond scribe. This is a technique the writer has seen used with star sapphires but was unaware of its use with diamond.

Diamonds with no other fault than surface grain lines may be graded "Internally Flawless." However, there has to be a limit to the visibility of this characteristic. When they are numerous and reflect in the opposite facets of a round brilliant, the trade generally will not accept such a stone as flawless. In *Figure 10* the arrow points to

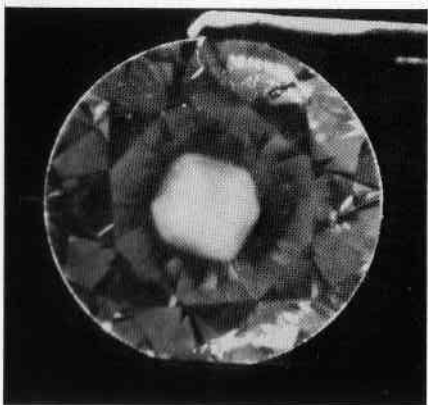

Figure 9.

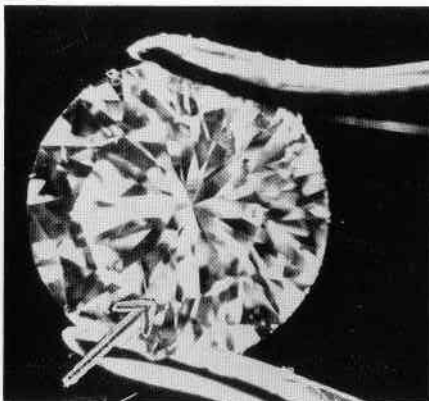

Figure 10.

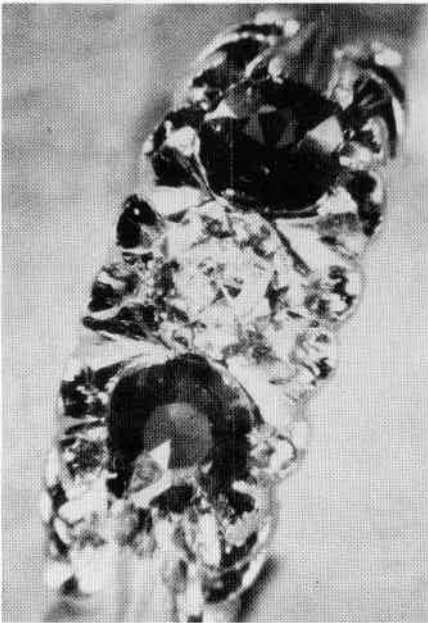

Figure 11.

surface grain lines which in the photo appear white and reflect in the opposite facets. This stone was graded VVS<sub>2</sub> — certainly the grain lines were much more obvious and detracting than a minute pinpoint inclusion.

#### **Tricky Rubies and a Synthetic Emerald**

Figure 11 illustrates a three stone antique ring with two rubies flanking a diamond. With the loupe, one of the rubies appears immediately to be synthetic since it has the typical strain cracks at facet junctions and even across whole facets due to rapid polishing (Figure 12). In fact, it is a natural ruby and of the two stones has much the better color but much the poorer make and polish.



Figure 12.

Another natural ruby is shown in Figure 13. Here one would swear he is looking at gas bubbles. However, the stone shows no fluorescence under ultra-violet and under high magnification the bubbles are seen to have a



Figure 13.



Figure 14

“halo” (Figure 14). The black crystals in the ruby shown in Figure 15 appear to be natural but are in reality metallic inclusions in a flux synthetic – of which we are seeing many more in recent months. The stones shown in Figure 16 appear to be carved with the typical motifs used to enhance opaque Mysore ruby. They are, in fact, dyed quartz.



Figure 16

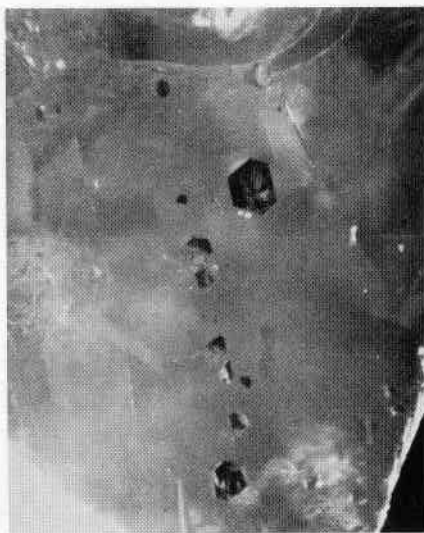

Figure 15

Occasionally we see very pronounced banding in Gilson’s synthetic emeralds and have referred to them as “Venetian blinds.” The photograph (Figure 17) caught this effect better than any we have yet seen. This type of banding has also been noted in the synthetic alexandrite made by the flux method by David Patterson in California.

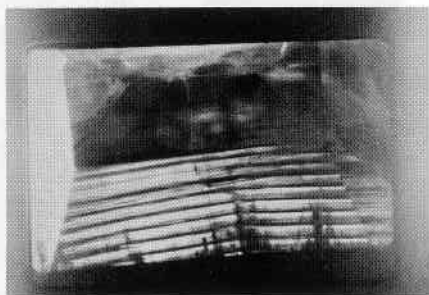

Figure 17





Figure 18.

### Insects In?

We have had a flurry of inquiries about insect-bearing amber and have had occasion to identify several specimens. In *Figure 18* the insect is quite distinct and has extremely long legs, well preserved. The ungainly insect shown in *Figure 19* surrounded by distinct gas bubbles met its fate only recently in a very good plastic imitation of amber.

### Acknowledgements

We wish to express our sincere thanks for the following gifts:

To *Mrs. Ella Freitas*, GIA student and collector of beautiful gems, for a fine rough specimen of #1 quality Kingman turquoise which she and her husband collected at the mine. It makes a handsome addition to our gem collection.

To GIA student *Morris Greene*, for an "M" master color diamond for class use.

To Gem Trade Laboratory member *Arthur Reik* for the catalog of a current jewelry exhibition at the British Museum entitled "7000 Years of Jewellery." It is beautifully illustrated and most inspiring.

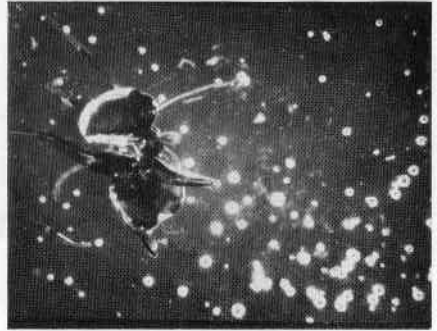

Figure 19.

To *Mr. Paul S. Rogell* of Rogell Associates, Inc., Stamford, Conn., for a selection of chatoyant cabochons made of fiberglass and soon to be marketed (*Figure 20*). Although similar stones have appeared on the market in colors more reminiscent to chrysoberyl than these gray stones, their potential would appear to be in the field of fashion rather than as an imitation. Currently Mr. Rogell is pondering a trade name for the product.

To *Mr. Leon Trecker*, GIA Graduate and sometime lapidary, for several fine examples of fire agate from Mexico.

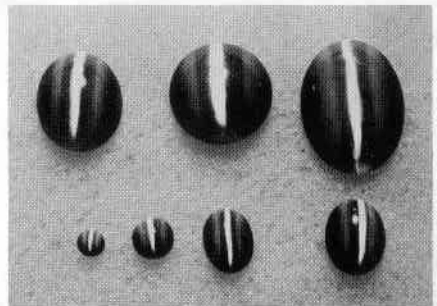

Figure 20.

# Observations on the Slocum Stone

By PETE J. DUNN, M.A., F.G.A.  
Department of Mineral Sciences  
Smithsonian Institution  
Washington, D.C. 20560

## Introduction

During the last two years, a new imitation opal gem material has appeared on the gem market in the U.S.A. This material is an opal simulant which is a sodium calcium magnesium silicate glass. When viewed from a distance of three feet, the material has a striking similarity to gem opal. This material is called THE SLOCUM STONE after its creator, J.L. Slocum. This imitation opal is sold by MDI Corporation, 3417 Rochester Road, Royal Oak, Michigan 48073, U.S.A. It is manufactured in at least five colors which are termed "white, crystal, amber, semi-black, and black" according to a brochure from the manufacturer. An initial report on the material was published by Crowningshield (1974).

## Physical Description

The author examined two of the simulated gems; one with black body color and one with no body color. The clear material is the one described

herein. It is quite attractive and might pass for opal in the eye of an untrained casual observer.

The material is quite transparent in transmitted light and one could easily read this printed page through the gemstone, were it not for the opalescent effect which returns much light to the eye and cuts down the effective transparency. To an experienced gemologist, some of the Slocum stones, particularly the black colored material, exhibit a vague resemblance to crinkled cellophane under crown-glass. However, a careful observation indicates that the color-causing medium is indeed distributed through the material in a rather uniform manner.

The opal simulant studied herein was about 20 x 12 mm and cut *en cabochon*. Upon examining the imitation opal from directly above the crown, one sees an "opalescence" of violetish blue, orangish red, and yellowish green. As the stone is moved, the character of the light changes in a manner similar to opal,

and the individual color-spots, sheets, and veils change from one color to another and back again. There are no localized color-concentrations or patchy effects.

Two salient features aid the gemologist in visually recognizing the Slocum stone. *First*, there is a preferred orientation for the "opal-escence" and when the stone is viewed from the side, there is a marked reduction in the opalescent effect. The *second* noteworthy feature is that when the material is viewed with transmitted light passing normal to the plane of the orientation, a patchwork of very small green splotches is very obvious. The splotches do change color upon tilting the stone, but in a peculiar manner not identical to the effect seen under reflected illumination. This effect, quite unlike opal, is rather peculiar.

The examined Slocum Stone has a density of  $2.47 \text{ g/cm}^3 (\pm 0.03)$  compared with the manufacturer's range of 2.41 – 2.50. The refractive index is  $n_D = 1.514 (\pm 0.003)$  compared with the range of 1.49 – 1.51 offered by the manufacturer. The material is isotropic and the effect seen in crossed polars is kaleidoscopic. It is not fluorescent in either long- or short-wave length ultraviolet radiation. The material does not diffract X-rays coherently, is amorphous, and is not affected by heating to 200°F. The *Slocum Stone* is a glass.

A notable feature of this material among other simulants is its extreme toughness. Its resistance to chipping and breaking is quite high. The author spent about 15 minutes bouncing this

imitation gem on floors with no effect to the stone whatsoever. It might be added in passing that this very tenacious material has a rather lively bounce; greater than that of normal glass gems. Breaking the material for analysis using a device comprised of opposing chisels was quite difficult and confirmed the toughness of the material.

The Mohs hardness is about 5-5½. Several measurements were made with a Vickers micro-hardness tester. Eight impressions with a 100-gram load gave an average hardness number of 509 ( $\pm 38$ ). Five impressions made with a 50-gram load gave an average hardness number of 465 ( $\pm 50$ ). This Vickers hardness confirms the Mohs hardness value. The observed variation in micro-hardness of the material (not of concern in evaluating its gem potential) is also seen as a differential resistance to polishing. A careful examination of a polished surface (*Figure 1*) reveals a subtle, irregular, "suturing" between adjacent grains of the glass. The presence of these grains suggests a gross granular or lamellar texture with

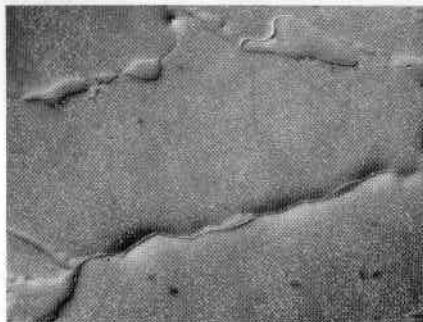

*Figure 1. Irregular suturing between grains of the Slocum stone. (Photo taken with Nomarski phase-contrast technique at 44x.)*

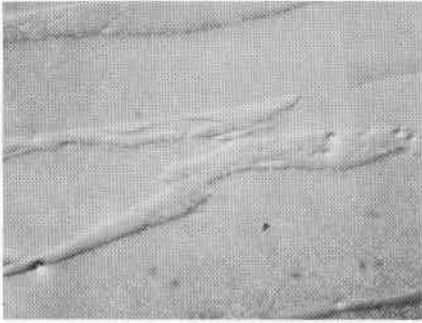

*Figure 2. Lenticular-aggregate texture of the Slocum stone. (Photo taken with Nomarski phase-contrast technique at 44x.)*

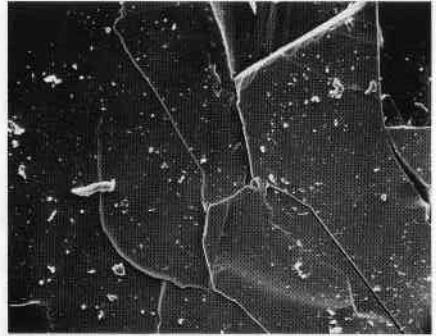

*Figure 3. Photograph showing the irregular fracture of the Slocum stone. (Photo taken with the Scanning Electron Microscope (SEM) at 130x.)*

a grain size varying up to 1.5 mm. The highly polished surface of a thin section of the material was coated with carbon and then coated with platinum and photographed in reflected light. Photographs of this section are shown in *Figure 2*. The section is cut normal to the base of the cabochon and shows the irregularity of the texture very well. The preferred orientation of the grains is obvious and the grains are lying with their tabular direction parallel to the normal line of sight of the viewer, assuming the stone

was cut in the manner suggested by the manufacturer's pre-orienting of the material. This irregularity of the grains is also likely the cause of the extreme toughness of this material. The fracture of the glass is irregular and random (*Figure 3*), with no diagnostic features.

#### **High Magnification Observations**

In an effort to attempt to explain the "opalescent" effect seen in the



*Figure 4. Photograph of a large fracture surface of the Slocum stone. (Photo taken with the Scanning Electron Microscope (SEM) at 53x.)*



*Figure 5. High magnification photo of the lenticular texture of the Slocum stone. (Photo taken with the Scanning Electron Microscope (SEM) at 680x.)*

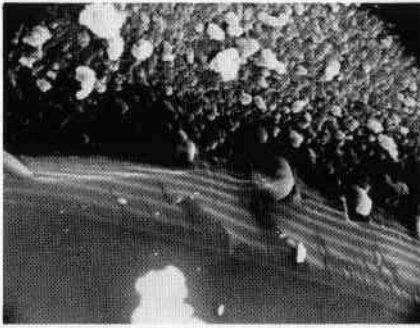

Figure 6. High magnification photograph of the border between the two different textures in the Slocum stone. (Photo taken with the Scanning Electron Microscope (SEM) at 10,500x.)

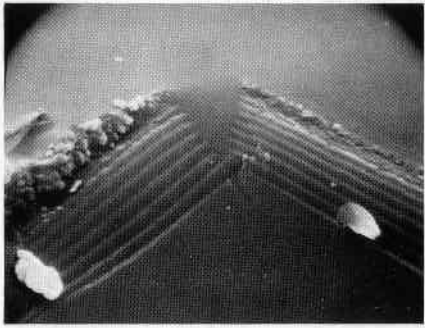

Figure 7. High magnification photograph of the border between two grains of similar smooth texture. (Photo taken with the Scanning Electron Microscope (SEM) at 10,500x.)

material, small fragments were examined by means of a Scanning Electron Microscope (SEM). It was thought that the effect might be due to a thin film of organic material lying between the individual lamellae. No film was observed, however, even at magnifications of 10,500 x, nor was any other intergranular material noted.

Figure 4 illustrates a very small section of a fractured surface magnified 53 times. Scattered bits of particulate matter are dust and glass fragments and should be ignored. A small portion of Figure 4 (designated by arrow 5) was examined at 680 magnifications and is shown as Figure 5. The lamellar texture seen in Figure 2 is also quite obvious here, although here it is seen on a very small scale. In this photograph the material is seen to consist of two separate textures; one extremely fine-grained, and the other of a micro-granular nature. It is possible that the "opalescent" effect is generated at the juncture of these two texturally inhomogeneous materials.

Two small sections of Figure 5 (designated by arrows 6 and 7) were photographed at a magnification of 10,500 x to generate Figures 6 and 7. It is readily apparent from Figure 6 that there is quite a variation in the texture of individual lamellae in the material. Here the border between the truly homogeneous glassy and micro-granular portions is clearly seen. This textural difference is also likely responsible for the differential micro-hardness of the Slocum stone, as noted earlier in this paper. Figure 7 is a photograph (at 10,500 x) of the "sutured" junctures where two glassy portions appear (see Figure 1) to join without any intervening lamellae of the coarser-grained material. Here a chevron-like banding occurs which may be due to a compositional variation below the limits of detection of the microprobe or, more likely, due to a gradual change in grain size between the two textures. This banded effect is also seen in Figure 6, but is less pronounced.

TABLE I

## Microprobe analyses of the Slocum Stone

	#1	#2
SiO <sub>2</sub>	71.85	73.20
TiO <sub>2</sub>	0.00	0.00
Al <sub>2</sub> O <sub>3</sub>	1.95	0.07
FeO	0.00	0.00
MgO	4.37	4.28
MnO	0.00	0.00
CaO	7.59	8.98
K <sub>2</sub> O	0.60	0.02
Na <sub>2</sub> O	13.22	14.08
TOTAL	99.58*	100.63*

accuracy of data  $\pm$  2% relative

\* plus 0.29 % H<sub>2</sub>O by the Penfield method.

## Chemistry

This imitation opal material is a sodium calcium magnesium potassium aluminum silicate glass. The manufacturer states that it is composed of "SiO<sub>2</sub>, Al<sub>2</sub>O<sub>3</sub>, and alkalis, and is anhydrous."

The sample was analyzed with an ARL-SEMQ electron microprobe using an operating voltage of 15 kV and a beam current of 0.15  $\mu$ A. Standards used were SiO<sub>2</sub> for silicon, hornblende for aluminum, iron, calcium, potassium, magnesium, and titanium. Manganite was used for manganese and anorthoclase for sodium. Separate analyses with different standards have verified the composition. A microprobe scan indicated the absence of other elements. The data were corrected by computer using Bence-Albee correction factors.

Two analyses of the material are presented in *Table I*. Analysis #1 is representative of the bulk of the glass examined. The material is very rich in silicon, sodium, calcium, and mag-

nesium. During the course of analyzing the material, it was noted that the base of the imitation opal was deficient in aluminum and enriched in calcium and sodium relative to the bulk of the material. Analysis #2 is representative of the composition of the base. Water was determined by the Penfield method and found to be a miniscule 0.29% by weight. When compared to the water content of gem opal, this water is negligible. The Slocum stone is also, aside from the aluminum-deficient base noted above, quite homogeneous in composition.

In summary, the Slocum stone is a sodium calcium magnesium glass of extremely high tenacity. The cause of the "opalescence" is not known with certainty since the observations herein are subject to several interpretations.

## Acknowledgements

This investigation was initiated at the suggestion of Robert Crowningshield and Paul Holt of the GIA of New York. The author is indebted to them for the impetus. Deep appreciation is due Dr. Edward Henderson for hardness measurements. Thanks are due Paul Desautels for helpful suggestions. Ms. Mary-Jacque Mann and Walter Brown were of great assistance in the production of SEM photographs. Drs. Daniel Appleman and William Melson made very constructive criticisms.

## References

- Crowningshield, R. (1974). Developments and highlights at GIA's Lab in New York. *Gems & Gemology* 14, #12, 362-363.