

**biology**



## **EDITORIAL BOARD**

### **Editor in Chief**

Richard Robinson  
rrobinson@nasw.org  
*Tucson, Arizona*

### **Advisory Editors**

Peter Bruns, *Howard Hughes Medical Institute*  
Rex Chisholm, *Northwestern University Medical School*  
Mark A. Davis, *Department of Biology, Macalester College*  
Thomas A. Frost, *Trout Lake Station, University of Wisconsin*  
Kenneth S. Saladin, *Department of Biology, Georgia College and State University*

### **Editorial Reviewer**

Ricki Lewis, *State University of New York at Albany*

### **Students from the following schools participated as consultants:**

Pocatello High School, Pocatello, Idaho  
Eric Rude, *Teacher*  
Swiftwater High School, Swiftwater, Pennsylvania  
Howard Piltz, *Teacher*  
Douglas Middle School, Box Elder, South Dakota  
Kelly Lane, *Teacher*  
Medford Area Middle School, Medford, Wisconsin  
Jeanine Staab, *Teacher*

## **EDITORIAL AND PRODUCTION STAFF**

Linda Hubbard, *Editorial Director*  
Diane Sawinski, Christine Slovey, *Senior Editors*  
Shawn Beall, Bernard Grunow, Michelle Harper, Kate Millson, Carol Nagel, *Contributing Editors*  
Kristin May, Nicole Watkins, *Editorial Interns*  
Michelle DiMercurio, *Senior Art Director*  
Rhonda Williams, *Buyer*  
Robyn V. Young, *Senior Image Editor*  
Julie Juengling, Lori Hines, *Permissions Assistants*  
Deanna Raso, *Photo Researcher*

### **Macmillan Reference USA**

Elly Dickason, *Publisher*  
Hélène G. Potter, *Editor in Chief*  
Ray Abruzzi, *Editor*

# biology

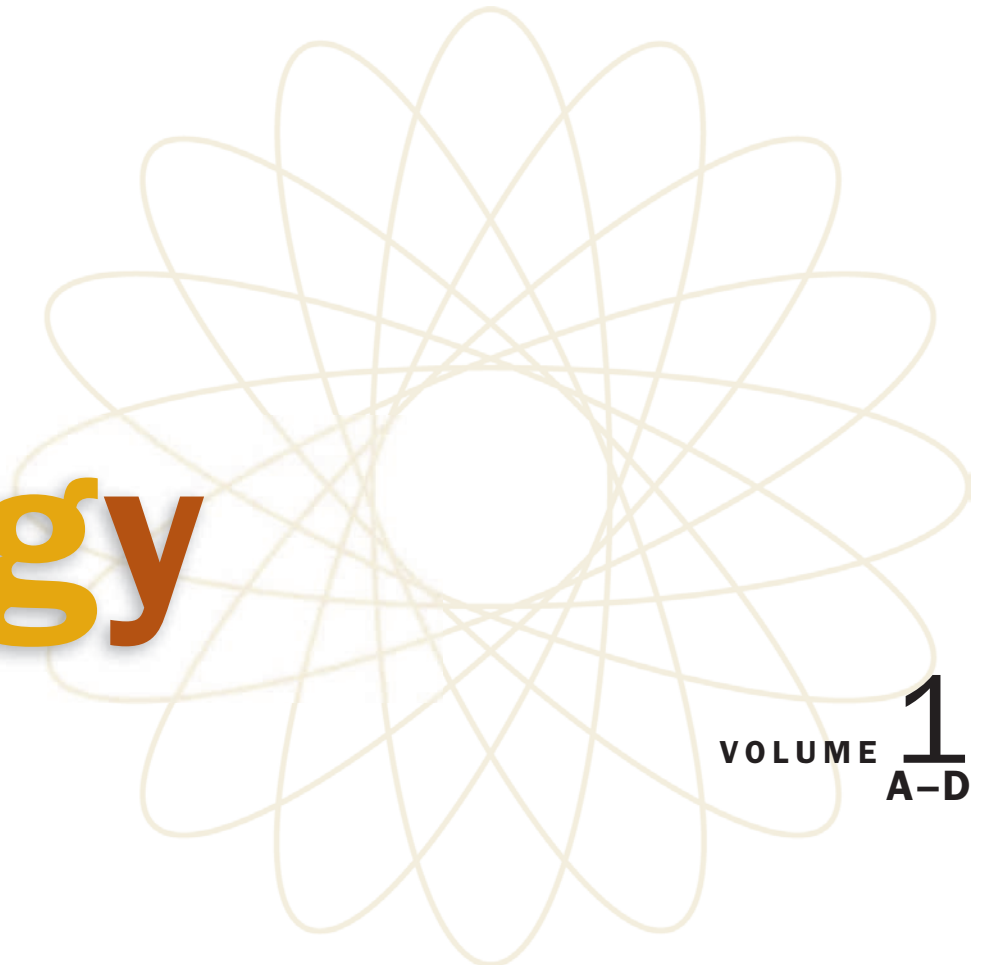

VOLUME **1**  
A-D

**Richard Robinson, Editor in Chief**

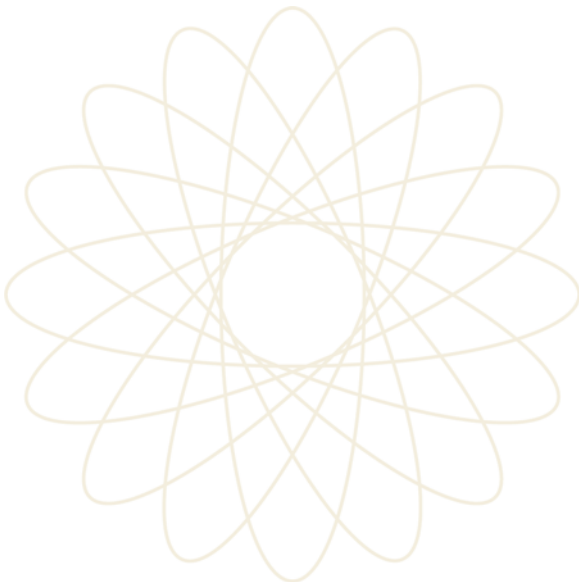

**MACMILLAN  
REFERENCE  
USA™**

**THOMSON**  
★  
**GALE™**

---

**Copyright © 2002 by Macmillan Reference USA**

All rights reserved. No part of this book may be reproduced or transmitted in any form or by any means, electronic or mechanical, including photocopying, recording, or by any information storage and retrieval system, without permission in writing from the Publisher.

Macmillan Reference USA  
300 Park Avenue South  
New York, NY 10010

Gale Group  
27500 Drake Rd.  
Farmington Hills, 48331-3535

Printed in the United States of America

1 2 3 4 5 6 7 8 9 10

**Library of Congress Catalog-in-Publication Data**

Biology / Richard Robinson, editor in chief.

p. cm.

Includes bibliographical references and index.

ISBN 0-02-86551-6 (set: hardcover) — ISBN 0-02-86-5552-4 (vol. 1) — ISBN 0-02-865556-7 (vol. 2) — ISBN 0-02-865554-0 (vol. 3) — ISBN 0-02-865555-9 (vol. 4)

1. Biology. I. Robinson, Richard, 1956–  
QH07.2.B556 2001

570-dc21  
2001040211

# Preface

The scope of biology is so vast it can be dizzying. Upwards of 50 million species of living things exist on Earth. Within each species, the number of creatures can range from the alarming (only a handful of Yangtze River dolphins exist), to the worrisome (our own species numbers six billion and counting), to the astonishing (five hundred quadrillion individual wheat plants emerge and die every year). But numbers alone can't tell the tale, because life at every level is a process and a pattern, from the development of a single creature to the evolution of a whole species, and from the expression of a single gene to the nutrient cycling of an entire ecosystem. The human body contains about fifty trillion cells, every one of which draws on its store of thirty thousand genes to make the pattern of proteins that control it and make it unique. Within the human brain, one hundred billion neurons make one hundred trillion connections, which combine to make the pattern of thoughts, memories, and feelings that make each of us unique.

## Central Ideas and Vital Details

How can a single book, or even a four-volume encyclopedia, encompass so vast a subject? It can't. And in producing *Biology*, we didn't try to cover every topic from Aardvark to *Zyzyva*. Instead, in our 432 entries we present as broad an introduction as possible to the many facets of biology, while concentrating in depth on a smaller number of central ideas and phenomena that are at the heart of all biological processes.

One of our major themes is molecular genetics, which in the last two decades has taken center stage in biology, along with its offspring, biotechnology. In these volumes, students will find detailed and accessible descriptions of the many aspects of these growing disciplines, from genes and chromosomes to cloning and the Human Genome Project. Genes exert their effects through proteins in cells, and we discuss both individual cell processes and the rapidly growing understanding of control mechanisms. Throughout, our emphasis is on clear explanation of the underlying principles, so that students can prepare to understand phenomena that may yet remain undiscovered.

Understanding of human physiology is central to medicine and health, and in *Biology*, we discuss almost every aspect of the human system, including bones, brains, and behavior. We devote special attention to several health issues especially important to students, including smoking, alcohol, and sexually transmitted diseases. Comparative animal physiology and plant physiology are also featured.

★ Explore further in DNA, Nucleus, and Clone

★ Explore further in Development, Immune Response, and Smoking and Health

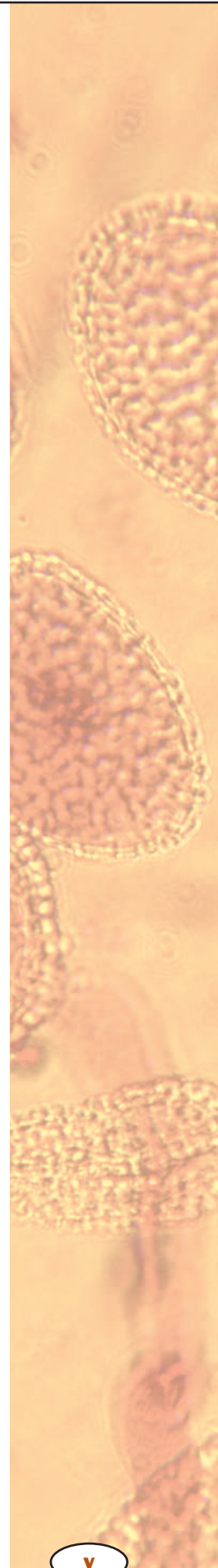



★Explore further in  
Eubacteria, Conifers, and  
Conservation

★Explore further in  
Grasslands, Population  
Dynamics, and Sexual  
Selection

The world's biodiversity is being revealed even as it is increasingly threatened, and we survey both of these crucial aspects within our pages. Animal and plant diversity is discussed in many separate entries, and major entries are provided on archaea, eubacteria, fungi, and protists. Up-to-date classification systems are used throughout. We examine the major environmental challenges facing the world today, including global climate change, extinction, desertification, and the growing human population.

“The ecological theater and the evolutionary play” was how one notable biologist described the vital connection between these two major areas in biology. This interplay is explored in entries that range from physiological ecology to human evolution, and in environments from the Arctic tundra to the depths of the oceans. Finally, we examine the history of biology through major entries and capsule biographies, and we look at careers in biology at every level in every field.

### Organization of the Material

To aid students and teachers in exploring this vast territory, *Biology* includes individual volume indexes as well as a cumulative index at the end of Volume 4. We also provide a glossary of more than 550 terms with definitions both in the page margin and collected at the end of each volume. Each entry contains suggestions for further reading. A topical index provides a guide to entries by subject, and useful references are provided as frontmatter, including a geologic time scale and tables of metric conversions.

### Acknowledgments and Thanks

A work of this scope would be impossible without the dedication and hard work of many people. Our contributors are biologists who have devoted their careers to understanding the living world, and have now devoted many hours to explaining it carefully and clearly enough for a beginning audience. H el ene Potter of Macmillan Library Reference charted a challenging and inspiring course in launching this encyclopedia, and Linda Hubbard, Michelle Harper, Diane Sawinski, and Christine Slovey of the Gale Group provided a sure hand on the tiller during rough weather. Ricki Lewis offered invaluable editorial review when it mattered most.

The editorial advisors for this project have given their time and expertise unstintingly, often far beyond the call of duty. As will be clear from the list of authors, several of them are also gifted and generous authors. They have my deep gratitude for all their work on this encyclopedia. Sadly, Tom Frost, an aquatic ecologist of national stature, did not live to see the completion of this work. His loss was a blow to this project, and even more so to the world of ecology. But he has left his mark on *Biology*, and we dedicate this work to him.

*Richard Robinson*  
Tucson, Arizona  
rrobinson@nasw.org

# For Your Reference

The following section provides information that is applicable to a number of articles in this reference work. Included are a metric measurement and conversion table, geologic timescale, diagrams of an animal cell and a plant cell, illustration of the structure of DNA nucleotides, detail of DNA nucleotides pairing up across the double helix, and a comparison of the molecular structure of DNA and RNA.

## METRIC MEASUREMENT

### Definitions

Kilo = 1000  
 Hecto = 100  
 Deka = 10  
 Deci = 0.10 (1/10)  
 Centi = 0.01 (1/100)  
 Milli = 0.001 (1/1000)  
 Micro = 0.000001 (1/1,000,000)  
 Nano = 0.000000001 (1/1,000,000,000)

### Conversions

To convert	Into	Multiply by
Acres	Hectares	0.4047
Centimeters	Inches	0.3937
Feet	Meters	0.3048
Gallons	Liters	3.7853
Grams	Ounces	0.0353
Grams	Pounds	0.0022
Hectares	Acres	2.4710
Inches	Centimeters	2.5400
Kilograms	Pounds	2.2046
Kilometers	Miles	0.6214
Liters	Gallons]	0.2642
Meters	Feet	3.2808
Miles	Kilometers	1.6093
Ounces	Grams	28.3495
Pounds	Kilograms	0.4536
Pounds	Grams	453.59

### Temperature Conversion

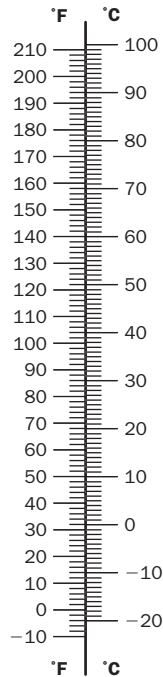

100°C = water boils  
 0°C = water freezes

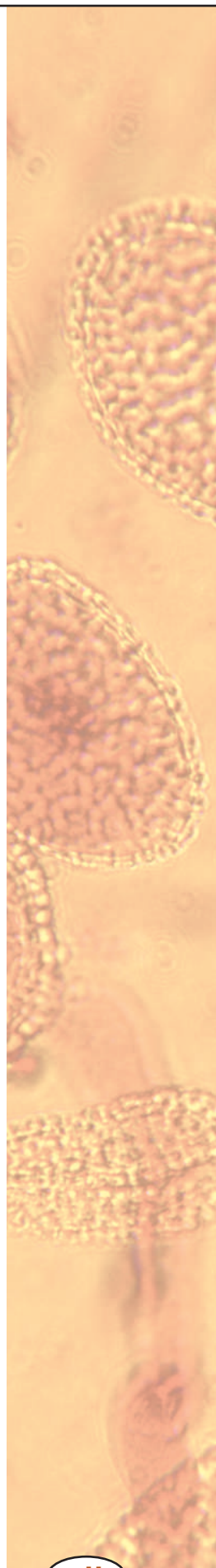

## GEOLOGIC TIMESCALE

ERA	PERIOD	EPOCH	STARTED (millions of years ago)	
<b>Cenozoic:</b> 66.4 millions of years ago–present time	<b>Quaternary</b>	Holocene	0.01	
		Pleistocene	1.6	
	<b>Tertiary</b>	<b>Neogene</b>	Pliocene	5.3
			Miocene	23.7
		<b>Paleogene</b>	Oligocene	36.6
			Eocene	57.8
			Paleocene	66.4
<b>Mesozoic:</b> 245–66.4 millions of years ago	<b>Cretaceous</b>	Late	97.5	
		Early	144	
	<b>Jurassic</b>	Late	163	
		Middle	187	
		Early	208	
	<b>Triassic</b>	Late	230	
		Middle	240	
		Early	245	
	<b>Paleozoic:</b> 570–245 millions of years ago	<b>Permian</b>	Late	258
Early			286	
<b>Carboniferous</b>		<b>Pennsylvanian</b>	Late	320
		<b>Mississippian</b>	Early	360
<b>Devonian</b>		Late	374	
		Middle	387	
		Early	408	
<b>Silurian</b>		Late	421	
		Early	438	
<b>Ordovician</b>		Late	458	
		Middle	478	
		Early	505	
<b>Cambrian</b>		Late	523	
		Middle	540	
	Early	570		
<b>Precambrian time:</b> 4500–570 millions of years ago			4500	



**A TYPICAL ANIMAL CELL**

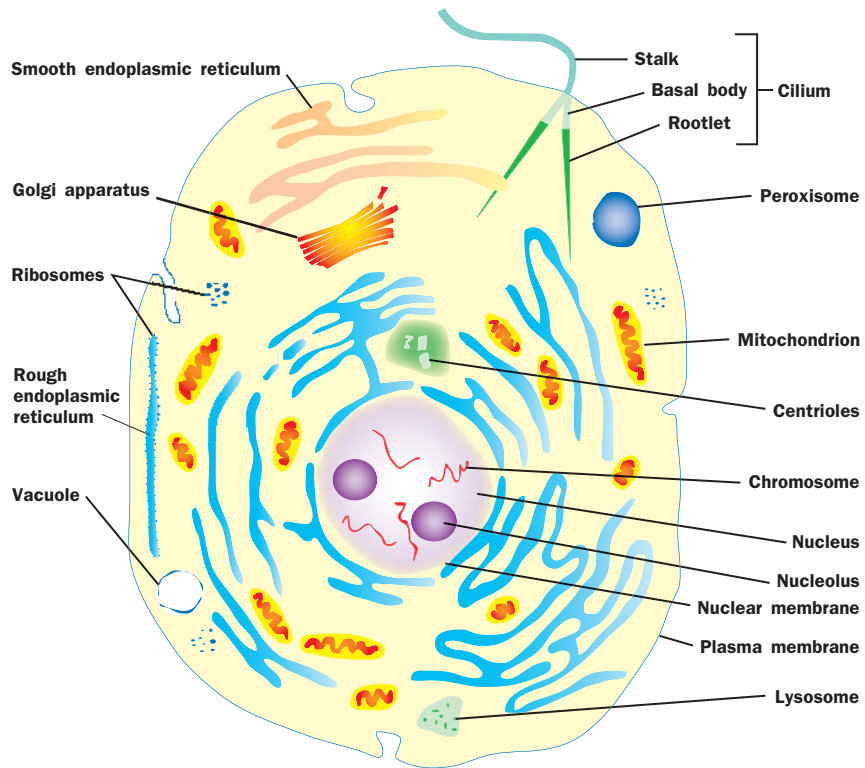

**A TYPICAL PLANT CELL**

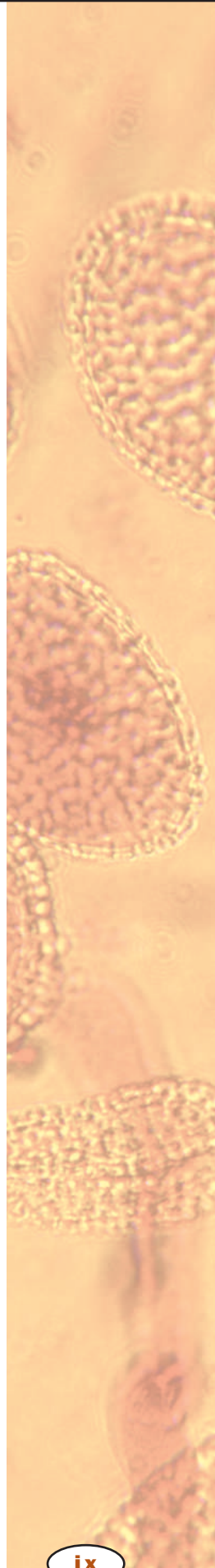
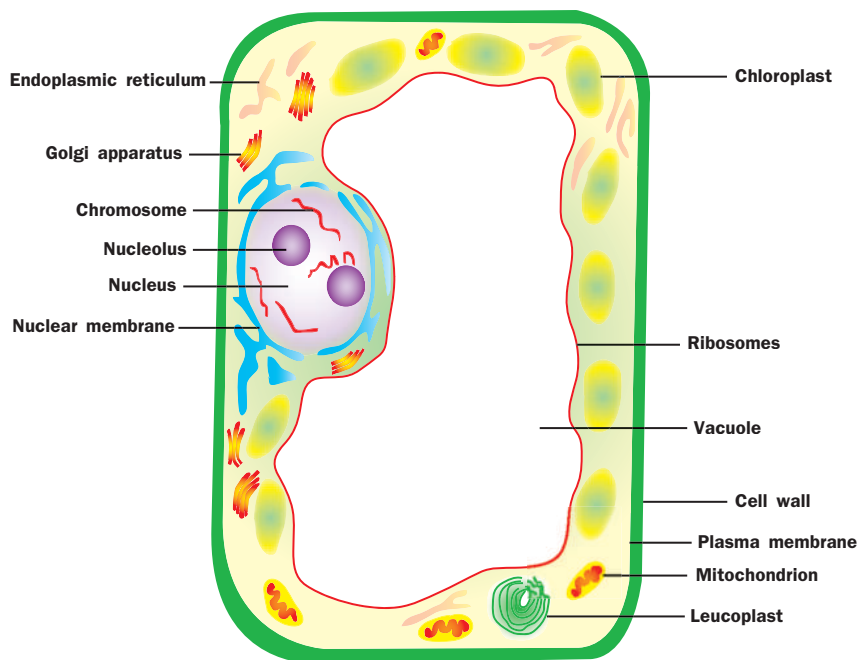

## STRUCTURE OF DNA NUCLEOTIDES

### Components of a nucleotide

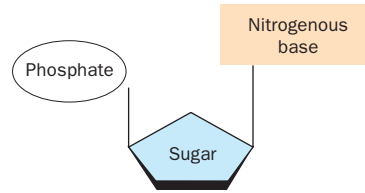

### Purine-containing nucleotides

Adenine

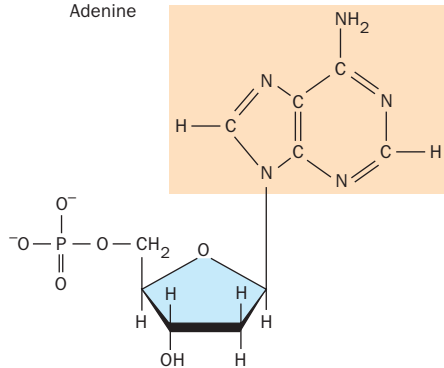

### Pyrimidine-containing nucleotides

Thymine

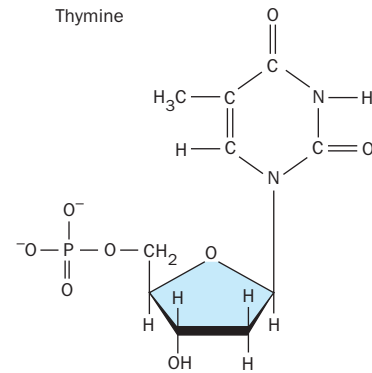

Guanine

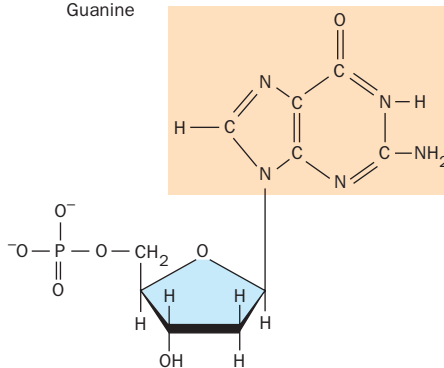

Cytosine

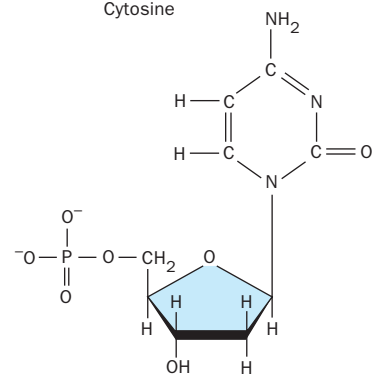

# DNA NUCLEOTIDES PAIR UP ACROSS THE DOUBLE HELIX

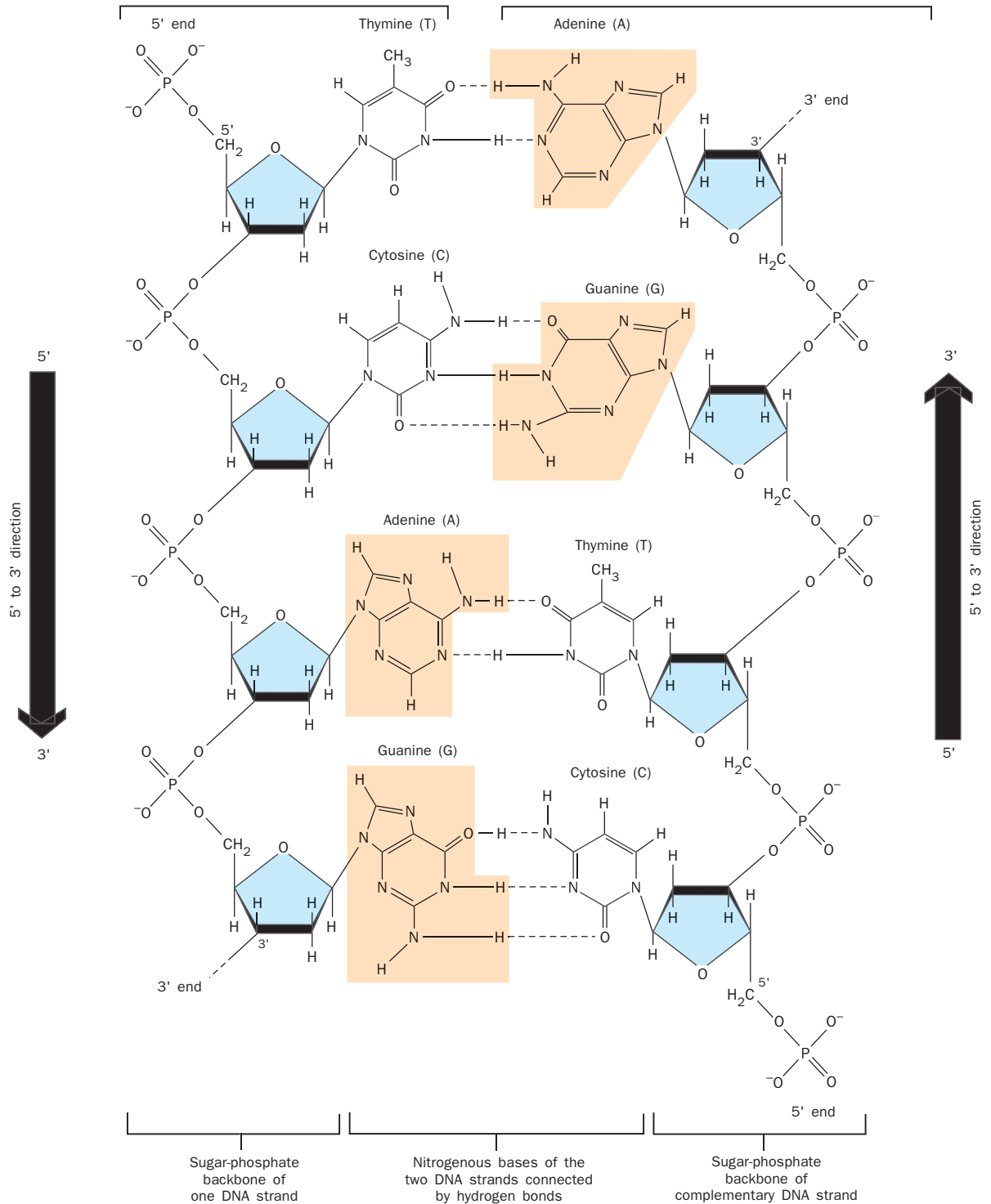

# COMPARISON OF DNA AND RNA

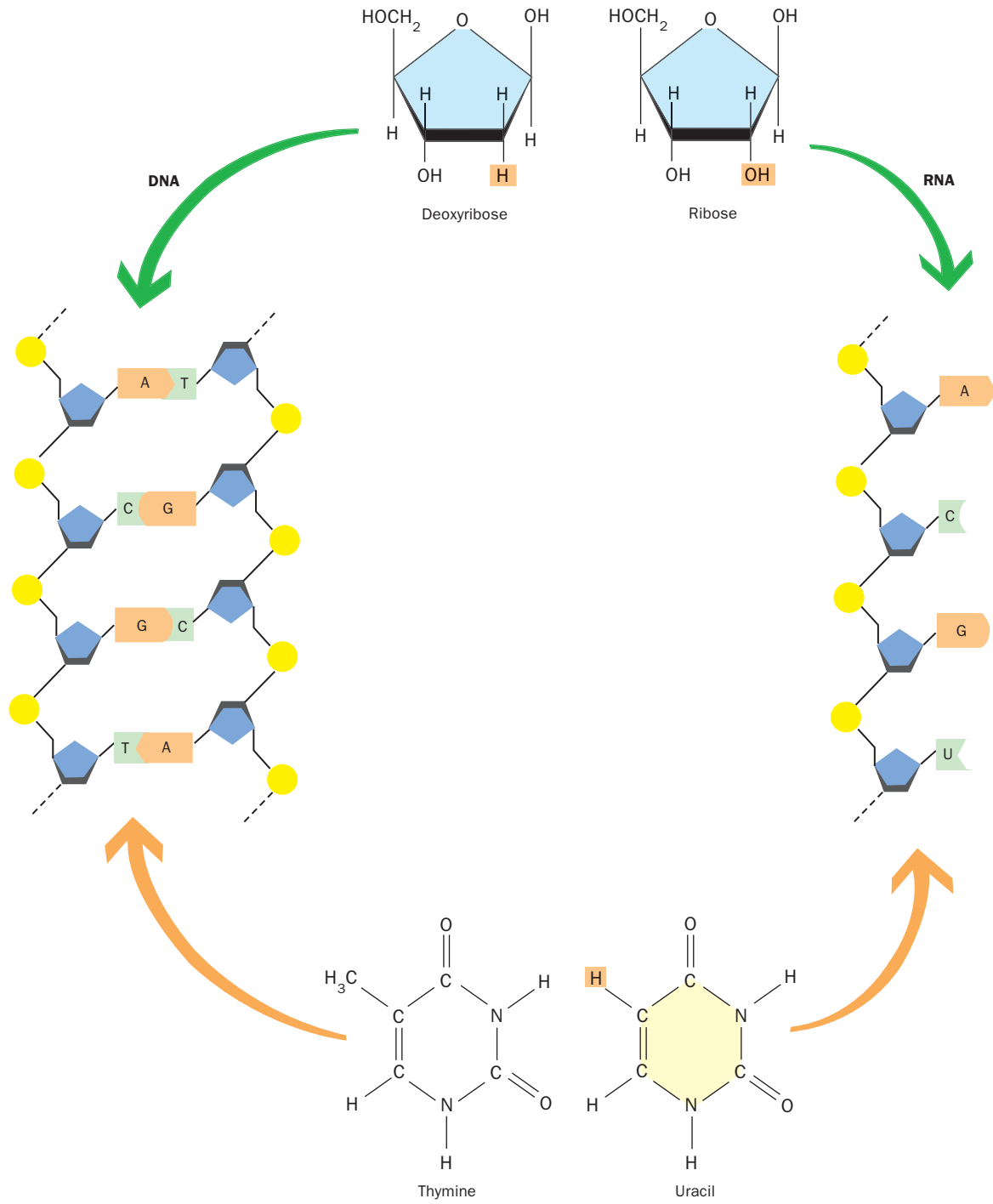

# Contributors

- Stephen A. Adam  
*Northwestern University Medical School*  
Active Transport  
Mitochondrion  
Organelle  
Radionuclides
- Dennis M. Allen  
*University of South Carolina*  
Estuaries
- Byron Anderson  
*Northwestern University Medical School*  
Protein Structure
- Wayne F. Anderson  
*Northwestern University Medical School*  
Amino Acid  
Structure Determination
- Diane K. Angell  
*St. Olaf College*  
Sociobiology
- Karen Gunnison Ballen  
*Augsburg College*  
Biology
- Maureen E. Basha  
*Macalester College*  
Physiological Ecology
- Mary Beckman  
*Idaho Falls, ID*  
Genetic Code  
Hybridization  
Transposon
- J. Derek Bewley  
*University of Guelph*  
Seed Germination and  
Dormancy
- Theresa Stouter Bidle  
*Hagerstown Community College*  
Muscle
- Richard E. Bir  
*Mountain Horticulture Crops  
Research and Extension Center*  
Propagation
- James E. Blankenship  
*Cornell University*  
Electrophoresis  
RNA  
RNA Processing  
Transfer RNA
- Michele D. Blum  
*Rockefeller University*  
Cell  
Mitosis  
Vitamins and Coenzymes
- Patricia S. Bowne  
*Milwaukee, WI*  
Stress Response
- Sheri L. Boyce  
*Messiah College*  
Nervous Systems  
Spinal Cord
- John M. Briggs  
*Arizona State University*  
Remote Sensing
- Nicholas Brokaw  
*Harvard University*  
Forest  
Forest, Tropical
- Clifford Brunk  
*University of California, Los Angeles*  
DNA Sequencing
- Alvin M. Burt  
*Hendersonville, TN*  
Brain  
History of Medicine  
Synaptic Transmission
- Jackie Butler  
*Grayson County College*  
Bacterial Diseases
- Paul R. Cabe  
*Washington and Lee University*  
Population Genetics
- Virginia Card  
*Metropolitan State University*  
Algae  
Cartilaginous Fish
- James Cardelli  
*Louisiana State University*  
Endoplasmic Reticulum  
Exocytosis  
Golgi
- Leslie R. Carlson  
*Iowa State University*  
Limnologist  
Psychiatric Disorders, Biology of
- Stephen W. Carmichael  
*Mayo Clinic*  
Adrenal Gland
- Dennis Carnes  
*Imperial Valley College*
- Nicholas C. Carpita  
*Purdue University*  
Cell Wall
- C. M. Sean Carrington  
*University of the West Indies*  
Fruits  
Seeds
- Walter P. Carson  
*University of Pittsburgh*  
Competition
- Susan B. Chaplin  
*St. Thomas University*  
Growth  
Scaling
- Marisa K. Chelius  
*University of Wisconsin*  
Eubacteria
- Rex L. Chisholm  
*Northwestern University Medical School*  
Cell Motility  
Cytokinesis  
Cytoskeleton
- Suzette F. Chopin  
*Texas A&M University-Corpus Christi*  
Development
- Donald F. Cipollini  
*Wright State University*  
Tropisms and Nastic Movements
- Corey L. Cleland  
*James Madison University*  
Pain
- Craig Clifford  
*Northeastern State University*  
Clinical Trials
- Barbara Cocanour  
*University of Massachusetts, Lowell*  
Central Nervous System  
Circulatory Systems
- Dean Cocking  
*James Madison University*  
Agriculture  
Agronomist  
Bryophytes  
Forester  
Leaves

- Seedless Vascular Plants  
Soil
- Allen G. Collins  
*University of California*  
Chordata
- Joseph T. Collins  
*Center for North American  
Herpetology*  
Crocodilians  
Reptile  
Tuatara  
Turtle
- Scott Collins  
*National Science Foundation*  
Amphibian  
Community
- Christopher S. Cronan  
*University of Maine*  
Carbon Cycle
- James Cronin  
*University of Pittsburgh*  
Competition
- James A. Crowder  
*Brookdale Community College*  
Organ
- James L. Culbertson  
*West Virginia University*  
Hypothalamus  
Touch
- Scott N. Daigle  
*Schering-Plough Research Institute*  
Endocytosis  
Lysosomes
- Cynthia K. Damer  
*Vassar College*  
Endocytosis  
Lysosomes
- Lynnette Danzl-Tauer  
*Rock Valley College*  
Biological Weapons  
Reproductive Technology
- Mark A. Davis  
*Macalester College*  
Behavior Patterns  
Ecological Research, Long-Term  
Endangered Species  
Ethnobotany  
Field Studies in Plant Ecology  
Invasive Species  
Microbiologist  
Migration  
Mimicry, Camouflage, and  
Warning Coloration  
Predation and Defense  
Social Behavior  
Theoretical Ecology
- Mark S. Davis  
*University of Evansville*  
Epidemiologist
- David W. Deamer  
*University of California*  
Life, What Is  
Origin of Life
- Patricia L. Dementi  
*Randolph-Macon College*  
Autoimmune Disease  
Thyroid Gland
- Nancy G. Dengler  
*University of Toronto*  
Differentiation in Plants  
Plant Development
- Dana Desonie  
*Phoenix, AZ*  
Global Climate Change  
Ocean Ecosystems: Hard  
Bottoms  
Ocean Ecosystems: Open Ocean  
Ocean Ecosystems: Soft Bottoms
- Tanya A. Dewey  
*University of Michigan*  
Animalia  
Marsupial  
Monotreme
- Arne Dietrich  
*Georgia College & State University*  
Neurologic Diseases  
Psychoactive Drugs
- Jennie Dusheck  
*Santa Cruz, CA*  
Amniote Egg  
Carson, Rachel  
Ecology  
Ecosystem  
Life Cycle, Human  
Medical/Science Illustrator  
Science Writer  
Zoology Researcher
- Christopher J. Earle  
*Seattle, WA*  
Conifers  
Gymnosperms
- Joel C. Eissenberg  
*Saint Louis University Medical  
School*  
Chromosome, Eukaryotic
- Simon K. Emms  
*University of St. Thomas*  
Evolution of Plants
- Robert Engelman  
*Population Action International*  
Human Population
- David L. Evans  
*Pennsylvania College of Technology*  
Entomologist  
Skin  
Vision
- Robert C. Evans  
*Rutgers University*  
Photoperiodism
- Susan Evarts  
*University of St. Thomas*  
Mating Systems
- Frank Ewers  
*Michigan State University*  
Water Movement in Plants
- Larry Fink  
*Boynton Beach, FL*  
Pollution and Bioremediation
- Janet M. Fischer  
*Franklin and Marshall College*  
Lakes and Ponds  
Plankton  
Population Dynamics
- Lee E. Frelich  
*University of Minnesota*  
Fire Ecology  
Forest, Boreal  
Forest, Temperate
- Daniel D. Gallaher  
*University of Minnesota*  
Nutritionist
- Orin G. Gelderloos  
*University of Michigan-Dearborn*  
College Professor
- Susan P. Gilbert  
*University of Pittsburgh*  
Enzymes
- Michael L. Gleason  
*Georgia College & State University*  
Biochemist  
Chemoreception
- Harold J. Grau  
*Christopher Newport University*  
Eye  
Hearing
- John Hanson  
*Urbana, IL*  
History of Plant Physiology
- C. Leon Harris  
*State University of New York*  
Body Cavities  
Evolution  
Excretory Systems  
Kidney  
Locomotion  
Skeleton
- Edward Harris  
*Louisiana State University Health  
Sciences Center*  
Endoplasmic Reticulum  
Golgi
- Robbie Hart  
*Port Angeles, WA*  
Arachnid  
Bony Fish  
Exocytosis  
Flight
- David C. Hartnett  
*Kansas State University*  
Symbiosis
- Christopher Haufler  
*University of Kansas*  
Pteridophytes

- Robert Hay  
*American Type Culture Collection*  
Cell Culture
- Verna J. Higgins  
*University of Toronto*  
Plant Pathogens and Pests
- Greg A. Hoch  
*Kansas State University*  
Remote Sensing
- Katja Hoehn  
*Mount Royal College*  
Neuron
- Roger F. Horton  
*University of Guelph*  
Senescence
- Laura F. Huenneke  
*New Mexico State University*  
Desert  
Desertification
- Angie Kay Huxley  
*University of Arizona*  
Biology of Race  
Bone  
Lymphatic System
- Elisa Izaurralde  
*European Molecular Biology  
Laboratory*  
Nuclear Transport
- Karen E. Jensen  
*Western State College*  
Health  
Musculoskeletal System  
Public Health Careers
- Nancy Johnson  
*Northern Arizona University*  
Mycorrhizae
- Jonathan Jones  
*Northwestern University Medical  
School*  
Cell Junctions  
Extracellular Matrix
- John R. Jungck  
*Beloit College*  
Gene  
Mutation
- Anthony R. Kaney  
*King of Prussia, PA*  
Genetic Analysis  
Sex Chromosomes
- Harold P. Katner  
*Macon, GA*  
AIDS
- Angela D. Kent  
*University of Wisconsin—Madison*  
Eubacteria
- Ann E. Kessen  
*University of Minnesota*  
Bird  
Speciation  
Species
- Karen E. Kirk  
*Lake Forest College*  
Patterns of Inheritance
- Christine Klein  
*Medical University of Luebeck*  
Pedigrees and Modes of  
Inheritance  
Radiation Hybrid Mapping
- Karynne L. M. Kleine  
*Georgia College & State University*  
High School Biology Teacher
- Alan K. Knapp  
*Kansas State University*  
Grasses  
Grassland
- Timothy K. Kratz  
*University of Wisconsin, Trout  
Lake Station*  
Landscape Ecology
- Lynda Paulson LaBounty  
*Macalester College*  
Learning
- Jonathan Leis  
*Northwestern University Medical  
School*  
Retrovirus  
Reverse Transcriptase
- David S. Lester  
*U.S. Food and Drug  
Administration*  
Drug Testing  
Pharmacologist
- Ricki Lewis  
*University at Albany*  
Anabolic Steroids  
Archaea  
Behavior, Genetic Basis of  
Coral Reef  
Digestion  
Genetic Counselor  
Herbal Medicine  
History of Agriculture  
Lichen  
Model Organisms: Physiology  
and Medicine  
Oncogenes and Cancer Cells  
Smoking and Health  
Taxonomy, History of
- Jennifer Lippincott-Schwartz  
*National Institute of Health*  
Protein Targeting
- Richard Longnecker  
*Northwestern University Medical  
School*  
DNA Viruses  
Virus
- Jon Lorsch  
*Johns Hopkins School of  
Medicine*  
Protein Synthesis  
Ribosome
- Dawn B. Ludwig  
*Augsburg College*  
Physician Assistant
- Rocco L. Mancinelli  
*NASA/Ames Research Center*  
Extreme Communities
- Amy L. Massengill  
*Middle Tennessee State University*  
Veterinarian
- A. Gregory Matera  
*Case Western University*  
Nucleolus
- Brian Maurer  
*Michigan State University*  
Biogeography
- Robert P. McIntosh  
*University of Notre Dame*  
Ecology, History of
- Robert McSorley  
*University of Florida*  
Nematode
- Roberta M. Meehan  
*Greeley, CO*  
Alcohol and Health  
Disease  
Fungal Diseases  
Sexually Transmitted Diseases
- John Merriam  
*University of California, Los  
Angeles*  
Chromosome Aberrations  
Linkage and Gene Mapping  
Recombinant DNA  
Replication
- Ralph Meyer  
*University of Cincinnati*  
Biotechnology  
Genome  
Human Genome Project
- Sara E. Miller  
*Duke University*  
Electron Microscopy  
Light Microscopy  
Microscopist
- Cristina G. Mittermeier  
*Great Falls, VA*  
Biodiversity  
Biome
- Russell A. Mittermeier  
*Great Falls, VA*  
Biodiversity  
Biome
- Carol L. Moberg  
*Rockefeller University*  
Dubos, René  
Porter, Keith
- Mary K. Montgomery  
*Macalester College*  
Cell Evolution

- Richard Mooi  
*California Academy of Sciences*  
Echinoderm
- Derek Bishop Munro  
*Eastern Cereal and Oilseed Research Centre*  
Poisonous Plants
- Molly Nepokroeff  
*National Museum of Natural History*  
Angiosperms  
Eudicots
- Lorelei L. Norvell  
*Pacific Northwest Mycology Service*  
Fungi
- Lynn K. Nyhart  
*University of Wisconsin-Madison*  
History of Biology: Inheritance
- Mark H. Olson  
*Franklin and Marshall College*  
Life Cycles
- Margaret G. Ott  
*Tyler Junior College*  
Gas Exchange
- Hans Paerl  
*University of North Carolina*  
Cyanobacteria
- Michael A. Palladino  
*Monmouth University*  
Endocrine System  
Male Reproductive System
- Margaret Palmer  
*University of Maryland*  
Community
- Cynthia A. Paszkowski  
*University of Alberta*  
Habitat  
Kingdom
- Izak Paul  
*Mount Royal College*  
Blood Sugar Regulation  
Digestive System  
Liver  
Pancreas
- Martha Phillips  
*The College of St. Catherine*  
Wetlands
- Eric R. Pianka  
*University of Texas at Austin*  
Adaptation  
Convergent Evolution  
Natural Selection
- John Prebble  
*University of London*  
History of Biology: Biochemistry
- Richard B. Primack  
*Boston University*  
Conservation
- Jeffrey L. Ram  
*Wayne State University*  
Heart and Circulation
- Wendy E. Raymond  
*Williams College*  
Cell Cycle  
Meiosis
- Kurt Redföberg  
*Coe College*  
Pheromone
- Janardan Reddy  
*Northwestern University Medical School*  
Peroxisomes
- Peter B. Reich  
*University of Minnesota*  
Fire Ecology  
Forest, Boreal  
Forest, Temperate
- Anthony Ricciardi  
*Dalhousie University*  
Porifera
- John M. Ripper  
*Butler County Community College*  
Antibody  
Immune Response  
Nonspecific Defense  
Physical Therapist and  
Occupational Therapist  
T Cells
- Aimee M. Roberson  
*Edina, MN*  
Field Studies in Animal Behavior
- Richard Robinson  
*Tucson, AZ*  
Alternation of Generations  
Antibodies in Research  
Arthropod  
Beer Making, Biology of  
Biogeochemical Cycles  
Blood  
Blood Clotting  
Botanist  
Buffon, Count (Georges-Louis Leclerc)  
C4 and CAM Plants  
Clone  
Coffee, Botany of  
Darwin, Charles  
De Saussure, NicolasThéodore  
Doctor, Family Practice  
Gene Therapy  
Genetic Diseases  
Grain  
Gray, Asa  
History of Biology: Cell Theory and Cell Structure  
Hormones  
Human Nutrition  
Ingenhousz, Jan  
Insect  
Lamarck, Jean-Baptiste  
Leakey Family  
Linnaeus, Carolus  
McClintock, Barbara  
Medical Assistant
- Model Organisms: Cell Biology and Genetics  
Monocots  
Nitrogen Cycle  
Nitrogen Fixation  
Nurse  
Pasteur, Louis  
Pituitary Gland  
Plant  
Poisons  
Torrey, John  
Vacuole  
van Helmont, Jan  
Vavilov, Nikolay  
von Humboldt, Alexander  
Water  
Winemaking, Biology of
- John H. Roese  
*Lake Superior State University*  
Wildlife Biologist
- Kristina Curry Rogers  
*Macalester College*  
Evolution, Evidence for
- Raymond R. Rogers  
*Macalester College*  
Cambrian Explosion  
Paleontology
- Martha S. Rosenthal  
*Florida Gulf Coast University*  
Sleep  
Temperature Regulation
- Lynn J. Rothchild  
*NASA/Ames Research Center*  
Extreme Communities
- Susan T. Rouse  
*Emory University*  
Anatomy of Plants  
Dentist  
Doctor, Specialist  
Emergency Medical Technician  
Genetic Control of Development  
Meristems  
Psychiatrist  
Roots  
Shoots
- Scott D. Russell  
*University of Oklahoma*  
Flowers  
Pollination and Fertilization
- Margaret Somosi Saha  
*College of William and Mary*  
Birth Control
- Kenneth S. Saladin  
*Georgia College & State University*  
Behavior, Genetic Basis of  
Cancer  
Cnidarian  
Connective Tissue  
Creationism  
Crustacean  
Electron Microscopy  
Feeding Strategies  
Harvey, William



- Homeostasis  
Imaging in Medicine  
Leeuwenhoek, Antony van  
Light Microscopy  
Marine Biologist  
Metabolism, Human  
Microscopist  
Mollusk  
Osmoregulation  
Parasitic Diseases  
Platyhelminthes  
Protista  
Protozoan Diseases  
Respiration  
Rivers and Streams  
Sex Determination  
Tunicate  
Vesalius, Andreas
- Lisa Nicole Saladin  
*University of Miami*  
Marine Biologist
- Kirstie Saltsman  
*Baltimore, MD*  
Control of Gene Expression  
Control Mechanisms  
Signaling and Signal  
Transduction  
Transcription
- Robert W. Sanders  
*Temple University*  
Protozoa
- Alexander Sandra  
*University of Iowa*  
Fetal Development, Human
- Jack C. Schultz  
*Pennsylvania State University*  
Herbivory and Plant Defenses  
Secondary Metabolites in Plants
- Stewart T. Schultz  
*University of Miami*  
Reproduction in Plants
- Michael G. Scott  
*Lincoln University*  
Epithelium  
Laboratory Technician  
Tissue
- Hank Seifert  
*Northwestern University*  
Bacterial Cell  
Bacterial Genetics  
Bacterial Viruses
- Hanna Rose Shell  
*Yale University*  
Crick, Francis  
Pauling, Linus  
Watson, James
- David Shier  
*Ann Arbor, MI*  
Blood Vessels  
Cardiovascular Diseases
- Brian R. Shmaefsky  
*Kingwood College*
- Environmental Health  
Vaccines
- Rubin Shmulsky  
*University of Minnesota*  
Wood and Wood Products
- Carl J. Shuster  
*Amarillo College*  
Viral Diseases
- Margaret Simpson  
*Sweet Briar College*  
Zoology
- Cassandra L. Smith  
*Boston University*  
Genomics
- Kevin Smith  
*University of Minnesota*  
Nurse Practitioners
- Vassiliki Betty Smocovitis  
*University of Florida*  
History of Evolutionary Thought
- Michelle J. Solensky  
*University of Minnesota*  
Sexual Reproduction, Evolution of  
Sexual Selection
- Jane Sooby  
*Organic Farming Research  
Foundation*  
Organic Agriculture
- Theodore L. Steck  
*The University of Chicago*  
Membrane Proteins  
Membrane Transport
- John R. Steele  
*Ivy Tech State College*  
Plant Pathologist
- Steven A. Sullivan  
*National Institutes of Health*  
DNA
- Michelle Tallquist  
*Seattle, WA*  
Transgenic Techniques
- David W. Tapley  
*Salem State College*  
Carbohydrates  
Glycolysis and Fermentation  
Krebs Cycle  
Metabolism, Cellular  
Nucleotides  
Oxidative Phosphorylation  
Photosynthesis
- Martha Tappen  
*University of Minnesota*  
Human Evolution  
Primate
- Alyson K. Tobin  
*University of St. Andrews*  
Chloroplast
- Linda G. Tolstoi  
*Uniontown, PA*  
Genomics
- Steven N. Trautwein  
*Southeast Missouri State University*  
Aging, Biology of
- Eric W. Triplett  
*University of Wisconsin—Madison*  
Eubacteria
- Robert Turgeon  
*Cornell University*  
Translocation
- Richard J. Vetter  
*Mayo Clinic*  
Health and Safety Officer
- Tom Volk  
*University of Wisconsin-La Crosse*  
Slime Molds
- Curt Walker  
*Dixie State College*  
Peripheral Nervous System
- Skip Walker  
*University of Alaska Fairbanks*  
Tundra
- William P. Wall  
*Georgia College & State University*  
Extinction  
Hardy-Weinberg Equilibrium  
Mammal
- Tim Watkins  
*Dartmouth College*  
Sexual Reproduction
- Chris Watters  
*Middlebury College*  
Lipids  
Membrane Structure  
Plasma Membrane
- Katherine E. Webster  
*Wisconsin Department of Natural  
Resources*  
Water Cycle
- Margaret A. Weck  
*St. Louis College of Pharmacy*  
Female Reproductive System  
Pharmaceutical Sales  
Representative
- B. S. Weir  
*North Carolina State University*  
Forensic DNA Analysis
- William R. Wellnitz  
*Augusta College*  
Antisense Nucleotides  
Mendel, Gregor  
Polymerase Chain Reaction
- Zhiping Weng  
*Boston University*  
Bioinformatics
- David Westaway  
*University of Toronto*  
Prion
- Mark J. Wetzel  
*Center for Biodiversity*  
Annelid

Gabriele K. Wienhausen  
*University of California at San Diego*  
Separation and Purification of Biomolecules

Katherine L. Wilson  
*Johns Hopkins University School of Medicine*  
Nucleus

George H. Wittler  
*Ripon College*  
Hormones, Plant

Hybridization, Plant  
Plant Nutrition  
Rhythms of Plant Life

David A. Woodman  
*University of Nebraska, Lincoln*  
Transplant Medicine

Chau H. Wu  
*Northwestern University*  
Ion Channels

Anthony C. Yannarell  
*University of Wisconsin—Madison*  
Eubacteria

Katharine E. Yoder  
*Franklin and Marshall College*  
Lakes and Ponds

Elizabeth A. Zimmer  
*Smithsonian Institution*  
Angiosperms

Robert M. Zink  
*University of Minnesota*  
Bird  
Speciation  
Species

# Table of Contents

## VOLUME 1

PREFACE .....	v
FOR YOUR REFERENCE .....	vii
LIST OF CONTRIBUTORS .....	xiii

## A

Active Transport .....	1
Adaptation .....	3
Adrenal Gland .....	5
Aging, Biology of .....	7
Agriculture .....	10
Agronomist .....	13
AIDS .....	14
Alcohol and Health .....	17
Algae .....	20
Alternation of Generations .....	22
Amino Acid .....	24
Amniote Egg .....	25
Amphibian .....	26
Anabolic Steroids .....	27
Anatomy of Plants .....	29
Angiosperms .....	31
Animalia .....	34
Annelid .....	36
Antibodies in Research .....	37
Antibody .....	39
Antisense Nucleotides .....	41
Arachnid .....	42
Archaea .....	43
Arthropod .....	46
Autoimmune Disease .....	47

## B

Bacterial Cell .....	48
Bacterial Diseases .....	52
Bacterial Genetics .....	53
Bacterial Viruses .....	58
Beer-making, Biology of .....	59

Behavior, Genetic Basis of .....	60
Behavior Patterns .....	63
Biochemist .....	65
Biodiversity .....	66
Biogeochemical Cycles .....	68
Biogeography .....	70
Bioinformatics .....	71
Biological Weapons .....	74
Biology .....	76
Biology of Race .....	77
Biome .....	79
Biotechnology .....	80
Bird .....	80
Birth Control .....	82
Blood .....	84
Blood Clotting .....	86
Blood Sugar Regulation .....	87
Blood Vessels .....	89
Body Cavities .....	91
Bone .....	93
Bony Fish .....	95
Botanist .....	96
Brain .....	97
Bryophytes .....	104
Buffon, Count (Georges-Louis Leclerc) .....	106

## C

C4 and CAM Plants .....	107
Cambrian Explosion .....	108
Cancer .....	110
Carbohydrates .....	112
Carbon Cycle .....	114
Cardiovascular Diseases .....	115
Carson, Rachel .....	117
Cartilaginous Fish .....	118
Cell .....	119
Cell Culture .....	122

Cell Cycle .....	124	DNA Sequencing .....	224
Cell Division .....	127	DNA Viruses .....	227
Cell Evolution .....	127	Doctor, Family Practice .....	228
Cell Junctions .....	129	Doctor, Specialist .....	229
Cell Motility .....	130	Drug Testing .....	232
Cell Wall .....	132	Dubos, René .....	233
Central Nervous System .....	134	PHOTO AND ILLUSTRATION	
Chemoreception .....	135	CREDITS .....	235
Chloroplast .....	137	GLOSSARY .....	243
Chordata .....	138	TOPIC OUTLINE .....	263
Chromosome Aberrations .....	139	INDEX .....	273
Chromosome, Eukaryotic .....	143		
Circulatory Systems .....	149	<b>VOLUME 2</b>	
Clinical Trials .....	151	FOR YOUR REFERENCE .....	v
Clone .....	152	<b>E</b>	
Cnidarian .....	155	Echinoderm .....	1
Coffee, Botany of .....	155	Ecological Research, Long-Term .....	3
College Professor .....	156	Ecology .....	4
Community .....	157	Ecology, History of .....	5
Competition .....	159	Ecosystem .....	7
Conifers .....	162	Electron Microscopy .....	10
Connective Tissue .....	164	Electrophoresis .....	13
Conservation .....	165	Emergency Medical Technician .....	15
Control of Gene Expression .....	170	Endangered Species .....	16
Control Mechanisms .....	177	Endocrine System .....	18
Convergent Evolution .....	181	Endocytosis .....	22
Coral Reef .....	183	Endoplasmic Reticulum .....	25
Creationism .....	185	Entomologist .....	27
Crick, Francis .....	187	Environmental Health .....	28
Crocodylians .....	188	Enzymes .....	29
Crustacean .....	189	Epidemiologist .....	36
Cyanobacteria .....	190	Epithelium .....	37
Cytokinesis .....	191	Estuaries .....	38
Cytoskeleton .....	193	Ethnobotany .....	40
<b>D</b>		Eubacteria .....	41
Darwin, Charles .....	197	Eudicots .....	43
De Saussure, Nicolas-Théodore .....	199	Evolution .....	44
Dentist .....	200	Evolution, Evidence for .....	52
Desert .....	201	Evolution of Plants .....	55
Desertification .....	204	Excretory Systems .....	60
Development .....	205	Exocytosis .....	62
Differentiation in Plants .....	212	Extinction .....	64
Digestion .....	217	Extracellular Matrix .....	68
Digestive System .....	219	Extreme Communities .....	69
Disease .....	221	Eye .....	72
DNA .....	222		

<b>F</b>	
Feeding Strategies	74
Female Reproductive System	77
Fetal Development, Human	81
Field Studies in Animal Behavior	85
Field Studies in Plant Ecology	87
Fire Ecology	89
Flight	91
Flowers	93
Forensic DNA Analysis	94
Forest, Boreal	97
Forest, Temperate	99
Forest, Tropical	101
Forester	105
Fruits	105
Fungal Diseases	108
Fungi	109
<b>G</b>	
Gas Exchange	114
Gene	117
Gene Therapy	124
Genetic Analysis	125
Genetic Code	129
Genetic Control of Development	131
Genetic Counselor	135
Genetic Diseases	136
Genome	140
Genomics	141
Global Climate Change	145
Glycolysis and Fermentation	148
Golgi	150
Grain	153
Grasses	155
Grassland	156
Gray, Asa	158
Growth	158
Gymnosperms	161
<b>H</b>	
Habitat	163
Hardy-Weinberg Equilibrium	164
Harvey, William	166
Health	167
Health and Safety Officer	169
Hearing	169
Heart and Circulation	172
Herbal Medicine	176
Herbivory and Plant Defenses	178
High School Biology Teacher	180
History of Agriculture	180
History of Biology: Biochemistry	182
History of Biology: Cell Theory and Cell Structure	186
History of Biology: Inheritance	189
History of Evolutionary Thought	192
History of Medicine	196
History of Plant Physiology	198
Homeostasis	201
Hormones	203
Hormones, Plant	206
Horticulturist	208
Human Evolution	208
Human Genome Project	212
Human Nutrition	217
Human Population	219
Hybridization	220
Hybridization, Plant	221
Hypothalamus	222
PHOTO AND ILLUSTRATION CREDITS	
CREDITS	227
GLOSSARY	235
TOPIC OUTLINE	255
INDEX	265
<b>VOLUME 3</b>	
FOR YOUR REFERENCE	
	v
<b>I</b>	
Imaging in Medicine	1
Immune Response	4
Ingenhousz, Jan	7
Insect	7
Invasive Species	10
Ion Channels	12
<b>K</b>	
Kidney	15
Kingdom	17
Krebs Cycle	18
<b>L</b>	
Laboratory Technician	20
Lakes and Ponds	21

Lamarck, Jean-Baptiste	23	Mollusk	105
Landscape Ecology	24	Monocots	106
Leakey Family	26	Monotreme	108
Learning	26	Muscle	108
Leaves	28	Musculoskeletal System	112
Leeuwenhoek, Antony von	30	Mutation	115
Lichen	31	Mycorrhizae	119
Life Cycle, Human	32		
Life Cycles	34	<b>N</b>	
Life, What Is	37	Natural Selection	121
Light Microscopy	38	Nematode	124
Limnologist	42	Nervous Systems	125
Linkage and Gene Mapping	42	Neurologic Diseases	129
Linnaeus, Carolus	47	Neuron	131
Lipids	48	Nitrogen Cycle	135
Liver	50	Nitrogen Fixation	136
Locomotion	50	Nonspecific Defense	138
Lymphatic System	52	Nuclear Transport	140
Lysosomes	54	Nucleolus	142
		Nucleotides	144
<b>M</b>		Nucleus	145
Male Reproductive System	56	Nurse	148
Mammal	59	Nurse Practitioners	148
Marine Biologist	60	Nutritionist	149
Marsupial	62		
Mating Systems	62	<b>O</b>	
McClintock, Barbara	64	Ocean Ecosystems: Hard Bottoms	150
Medical Assistant	65	Ocean Ecosystems: Open Ocean	151
Medical/Science Illustrator	65	Ocean Ecosystems: Soft Bottoms	153
Meiosis	66	Oncogenes and Cancer Cells	154
Membrane Proteins	70	Organ	158
Membrane Structure	73	Organelle	159
Membrane Transport	76	Organic Agriculture	159
Mendel, Gregor	80	Origin of Life	161
Meristems	81	Osmoregulation	165
Metabolism, Cellular	84	Oxidative Phosphorylation	168
Metabolism, Human	87		
Microbiologist	90	<b>P</b>	
Microscopist	91	Pain	170
Migration	92	Paleontology	171
Mimicry, Camouflage, and Warning		Pancreas	173
Coloration	93	Parasitic Diseases	174
Mitochondrion	94	Pasteur, Louis	176
Mitosis	98	Patterns of Inheritance	177
Model Organisms: Cell Biology and		Pauling, Linus	184
Genetics	101	Pedigrees and Modes of Inheritance	186
Model Organisms: Physiology and		Peripheral Nervous System	189
Medicine	102	Peroxisomes	191

Pharmaceutical Sales Representative . . .	192	Protozoan Diseases . . . . .	26
Pharmacologist . . . . .	192	Psychiatric Disorders, Biology of . . . . .	27
Pheromone . . . . .	193	Psychiatrist . . . . .	30
Photoperiodism . . . . .	195	Psychoactive Drugs . . . . .	31
Photosynthesis . . . . .	196	Pteridophytes . . . . .	33
Physical Therapist and Occupational Therapist . . . . .	200	Public Health Careers . . . . .	35
Physician Assistant . . . . .	201	<b>R</b>	
Physiological Ecology . . . . .	202	Radiation Hybrid Mapping . . . . .	36
Pituitary Gland . . . . .	205	Radionuclides . . . . .	38
Plankton . . . . .	205	Recombinant DNA . . . . .	38
Plant . . . . .	207	Remote Sensing . . . . .	46
Plant Development . . . . .	208	Replication . . . . .	47
Plant Nutrition . . . . .	214	Reproduction in Plants . . . . .	52
Plant Pathogens and Pests . . . . .	216	Reproductive Technology . . . . .	60
Plant Pathologist . . . . .	219	Reptile . . . . .	62
Plasma Membrane . . . . .	220	Respiration . . . . .	63
Platyhelminthes . . . . .	222	Retrovirus . . . . .	66
Poisonous Plants . . . . .	223	Reverse Transcriptase . . . . .	68
Poisons . . . . .	224	Rhythms of Plant Life . . . . .	69
Pollination and Fertilization . . . . .	227	Ribosome . . . . .	71
Pollution and Bioremediation . . . . .	228	Rivers and Streams . . . . .	73
Polymerase Chain Reaction . . . . .	232	RNA . . . . .	75
Population Dynamics . . . . .	233	RNA Processing . . . . .	77
Population Genetics . . . . .	235	Roots . . . . .	78
Porifera . . . . .	239	<b>S</b>	
Porter, Keith . . . . .	240	Scaling . . . . .	81
<b>PHOTO AND ILLUSTRATION</b>		Science Writer . . . . .	83
<b>CREDITS</b> . . . . .	243	Secondary Metabolites in Plants . . . . .	84
<b>GLOSSARY</b> . . . . .	251	Seed Germination and Dormancy . . . . .	86
<b>TOPIC OUTLINE</b> . . . . .	271	Seedless Vascular Plants . . . . .	88
<b>INDEX</b> . . . . .	281	Seeds . . . . .	89
		Senescence . . . . .	91
<b>VOLUME 4</b>		Separation and Purification of Biomolecules . . . . .	93
<b>FOR YOUR REFERENCE</b> . . . . .	v	Sex Chromosomes . . . . .	94
<b>P</b>		Sex Determination . . . . .	96
Predation and Defense . . . . .	1	Sexual Reproduction . . . . .	98
Primate . . . . .	4	Sexual Reproduction, Evolution of . . . . .	101
Prion . . . . .	5	Sexual Selection . . . . .	104
Propagation . . . . .	6	Sexually Transmitted Diseases . . . . .	106
Protein Structure . . . . .	7	Shoots . . . . .	110
Protein Synthesis . . . . .	13	Signaling and Signal Transduction . . . . .	112
Protein Targeting . . . . .	19	Skeletons . . . . .	118
Protista . . . . .	21	Skin . . . . .	120
Protozoa . . . . .	23	Sleep . . . . .	121
		Slime Molds . . . . .	124

Smoking and Health ..... 126  
 Social Behavior ..... 127  
 Sociobiology ..... 131  
 Soil ..... 132  
 Speciation ..... 134  
 Species ..... 136  
 Spinal Cord ..... 137  
 Stress Response ..... 139  
 Structure Determination ..... 141  
 Symbiosis ..... 142  
 Synaptic Transmission ..... 145

**T**

T Cells ..... 148  
 Taxonomy, History of ..... 151  
 Temperature Regulation ..... 154  
 Theoretical Ecology ..... 157  
 Thyroid Gland ..... 158  
 Tissue ..... 159  
 Torrey, John ..... 160  
 Touch ..... 161  
 Transcription ..... 162  
 Transfer RNA ..... 166  
 Transgenic Techniques ..... 167  
 Translocation ..... 168  
 Transplant Medicine ..... 172  
 Transposon ..... 174  
 Tropisms and Nastic Movements ..... 175  
 Tuatara ..... 176  
 Tundra ..... 177  
 Tunicate ..... 178  
 Turtle ..... 179

**V**

Vaccines ..... 180  
 Vacuole ..... 182  
 van Helmont, Jan ..... 183  
 Vavilov, Nikolay ..... 183  
 Vesalius, Andreas ..... 184  
 Veterinarian ..... 185  
 Viral Diseases ..... 186  
 Virus ..... 187  
 Vision ..... 188  
 Vitamins and Coenzymes ..... 190  
 von Humboldt, Alexander ..... 192

**W**

Water ..... 192  
 Water Cycle ..... 193  
 Water Movement in Plants ..... 193  
 Watson, James ..... 196  
 Wetlands ..... 197  
 Wildlife Biologist ..... 199  
 Wine-making, Botany of ..... 200  
 Wood and Wood Products ..... 201

**Z**

Zoology ..... 204  
 Zoology Researcher ..... 204

PHOTO AND ILLUSTRATION

CREDITS ..... 207  
 GLOSSARY ..... 215  
 TOPIC OUTLINE ..... 235  
 CUMULATIVE INDEX ..... 245

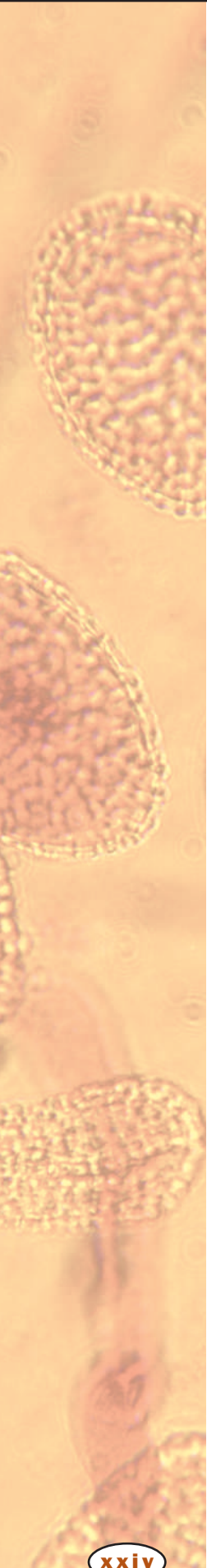



**biology**



## Active Transport

Active transport is the movement of molecules up their concentration **gradient**, using energy.

### Concentration Gradients

The concentration of most molecules inside a cell is different than the concentration of molecules in the surrounding environment. The plasma membrane separates the internal environment of the cell from the fluid bathing the cell and regulates the flow of molecules both into and out of the cell. The second law of thermodynamics states that molecules, whether in the gas or liquid state, will move spontaneously from an area of higher concentration to an area of lower concentration or down their concentration gradient.

A concentration gradient can be likened to water stored behind a dam. The water behind the dam will flow through the dam via any available channel to the other side. The energy from the water moving through the dam can be harnessed to make electricity. Water can also be pumped in the opposite direction from the river below the dam up to the reservoir behind the dam, with an expenditure of energy. Cellular membranes act somewhat like a dam. They block the movement of many types of molecules and have specific channels, transporters and pumps to provide pathways for the movement of certain molecules across the membrane.

When a molecule moves *down* its concentration gradient using one of these membrane channels or transporters, the process is called facilitated diffusion. In facilitated diffusion, no input of energy is needed to move the molecules. Instead, the potential energy of the concentration gradient powers the movement, just like water flowing out of a dam. For further diffusion, the channel or transporter does not determine in which direction the molecules will move, it only provides a pathway for the movement.

In cells, some molecules must be moved against their concentration gradient to increase their concentration inside or outside the cell. This process requires the input of energy and is known as active transport. As with facilitated diffusion, special transporters in the membrane are used to move the molecules across the membrane. The plasma membrane is not the only cellular membrane that requires active transport. All **organelles** surrounded by



**gradient** difference in concentration between two places

**organelle** membrane-bound cell compartment

Diagram of carrier protein, which actively pumps  $\text{Na}^+$  out of and  $\text{K}^+$  into a cell. For every molecule of ATP hydrolyzed inside the cell, three  $\text{Na}^+$  are pumped out and two  $\text{K}^+$  are pumped in.

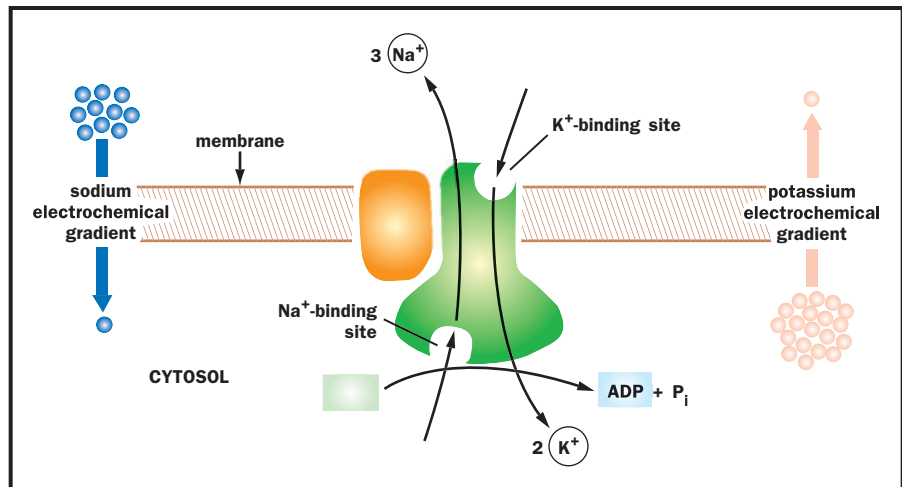

membranes must concentrate some molecules against their concentration gradients.

### Types of Active Transporters

There are three types of active transporters in cells: (1) Coupled transporters link the “downhill” transport of one molecule to the “uphill” transport of a different molecule; (2) **ATP-driven pumps** use the energy stored in adenosine triphosphate (ATP) to move molecules across membranes; (3) **Light-driven pumps** use the energy from photons of light to move molecules across membranes. Light driven pumps are found mainly in certain types of bacterial cells.

Most of the energy expended by a cell in active transport is used to pump **ions** out of the cell across the plasma membrane. Because ions have an electrical charge, they do not easily cross membranes. This phenomenon allows large ion concentration differences to be built up across a membrane. Highly selective transporters are present in membranes that pump certain ions up their concentration gradients, but ignore other ions.

**The  $\text{Na}^+\text{-K}^+$  Pump.** One of the best understood active transport systems is the sodium-potassium pump, or  $\text{Na}^+\text{-K}^+$  pump. This carrier **protein** is a coupled transporter that moves sodium ions out of the cell while simultaneously moving potassium ions into the cell. Because of the pump, the sodium ion concentration inside the cell is about ten to thirty times lower than the concentration of sodium ions in the fluid surrounding the cell. The concentration of potassium ions inside the cell is almost exactly the opposite, with a ten- to thirtyfold higher concentration of potassium ions inside the cell than outside.

Because the cell is pumping sodium from a region of lower concentration (inside) to a region of higher concentration (outside), the  $\text{Na}^+\text{-K}^+$  pump must use energy to carry out its pumping activity, and this energy is supplied by ATP. For this reason, the  $\text{Na}^+\text{-K}^+$  pump is also considered an **enzyme**. It belongs to a class of enzymes known as ATPases that use the energy stored in ATP to carry out another action. Other membrane transporters use the energy from ATP to pump ions like calcium, **amino acids**, and other electrically charged molecules either into or out of the cell.

**ATP** adenosine triphosphate, a high-energy nucleotide used by cells to power most energy-requiring reactions

**ion** an electrically charged particle

**protein** complex molecule made from amino acids; used in cells for structure, signaling, and controlling reactions

**enzyme** protein that controls a reaction in a cell

**amino acid** a building block of protein

Ions carry a positive or negative electrical charge so that these gradients have two components: a concentration gradient and a voltage or electrical gradient. For instance, sodium ions are positively charged. The higher concentration of sodium ions outside of the cell than inside means that outside of the cell will have a positive charge and the inside of the cell will have a negative charge. This potential difference, or voltage, across the membrane can be used as an energy source to move other charged molecules. Positively charged molecules will be attracted towards the inside of the cell and negatively charged molecules will be attracted to the outside of the cell. It is, in fact, this electrical potential that causes positively charged potassium ions to enter the cell through the Na-K pump, even though they are moving up their concentration gradient.

The potential energy of the gradient can be used to produce ATP or to transport other molecules across membranes. One of the most important uses of the  $\text{Na}^+$  gradient is to power the transport of **glucose** into the cell. The  $\text{Na}^+$ -glucose cotransporter moves sodium down its concentration gradient, and glucose up its gradient, as both move into the cell. SEE ALSO MEMBRANE TRANSPORT; NEURON; OXIDATIVE PHOSPHORYLATION; PHOTOSYNTHESIS

*Stephen A. Adam*

### Bibliography

Alberts, Bruce, et al. *The Molecular Biology of the Cell*, 4th ed. New York: Garland Publishing, 2000.

Bray, Dennis. *Cell Movements*. New York: Garland Press, 1992.

Lodish, Harvey, et al. *Molecular Cell Biology*, 3rd ed. New York: Scientific American Books, 1995.

**glucose** simple sugar that provides energy to animal cells and is the building block of cellulose in plants

## Adaptation

To survive and reproduce, all living organisms must adjust to conditions imposed on them by their environments. An organism's environment includes everything impinging upon it, as well as everything that is affected by that organism. Conformity between an organism and its environment constitutes what biologists call adaptation.

### Biotic and Abiotic Environments

Plants and animals have adapted to their environments genetically and by means of physiological, behavioral, or developmental flexibility, including both instinctive behavior and learning. Adaptation has many dimensions in that most organisms must conform simultaneously to numerous different aspects of their environments. Adaptation involves coping not only with the physical **abiotic** environment (light, dark, temperature, water, wind), but also with the complex **biotic** environment (other organisms such as mates, competitors, **parasites**, predators, and escape tactics of prey). Conflicting demands of these various environmental components often require that an organism compromise in its adaptations to each.

Conformity to any given dimension requires a certain amount of energy that is then no longer available for other adaptations. The presence of predators, for example, may require that an animal be wary, which in turn is likely to reduce its feeding efficiency and hence its competitive ability.

**abiotic** nonliving

**biotic** living

**parasite** organism living in close association with another from which it derives most of its nutrition



A willow ptarmigan in winter color.

**nocturnal** characterized by activity at night, or related to the night

**hormone** molecule released by one cell to influence another

**avian** concerning birds

For a small bird, trees are an important part of its environment: They offer vital shade during the heat of a hot summer day, places to forage for insects, safety from ground-dwelling predators, and safe places to build nests and raise chicks. Blades of grass or hairs used to line a bird's nest are also important components of a bird's environment. During the dangerous night, a bird copes with **nocturnal** predators such as raccoons by sleeping perched on a small twig high above the ground. While gleaning tiny insects from tree leaves during the day, a bird remains alert for diurnal predators like hawks.

Many birds cope with changing seasonal conditions by migrating to warmer places at lower latitudes where there is more food. Over eons of time, natural selection has molded birds to make them effective at escaping from the predictable dire consequences of winter (a time of high mortality). Birds that did not successfully evade winter's icy clutches died without leaving any surviving offspring, whereas those that migrated survived to pass on their genes. Natural selection has endowed birds with a built-in biological clock, which they compare against day length, effectively giving them a built-in calendar. Changing day length affects a bird's pituitary gland, causing it to secrete **hormones** that control **avian** behavior. Short autumn days elicit a "wanderlust," ultimately leading to migratory behavior. Experiments with migrating birds in planetaria have shown that tiny bird brains have been hard-wired so that they contain a map of the stars. Indeed, natural selection "invented" celestial navigation.

### Factors that Affect Adaptation

Organisms can conform to and cope with a highly predictable environment relatively easily, even when it changes in a regular way, as long as the changes are not too extreme. Adaptation to an unpredictable environment is usually more difficult; adapting to extremely erratic environments may even prove impossible. Many organisms have evolved dormant stages that allow them to survive unfavorable periods, both predictable and unpredictable. Brine shrimp in deserts and annual plants everywhere are good examples. Brine shrimp eggs survive for years in the salty crust of dry desert lakes; when a rare desert rain fills one of these lakes, the eggs hatch, the shrimp grow rapidly to adults, and they produce many eggs. Some plant seeds known to be many centuries old are still viable and have been germinated.

Very small undirected changes in the physical environment can sometimes improve the level of adaptation between an organism and its environment, but large changes are almost always detrimental. Changes in the environment that reduce overall adaptation are collectively termed the "deterioration of environment." Such changes cause directional selection resulting in accommodation to the new environment, or adaptation. Changes in biotic environments (such as the hunting efficiency of an organism's predator) are usually directed and typically reduce the level of adaptation.

Every individual is simultaneously a member of a population, a species, and a community; therefore, it must be adapted to cope with each and must be considered in that context. An individual's fitness—its ability to perpetuate itself as measured by its reproductive success—is greatly influenced by its status within its own population. An individual might be a resident or a vagrant, mated or unmated, or high or low in a pecking order, all factors

that strongly affect its fitness. Any given individual's fitness is also influenced by various **interspecific** associations of its species and especially by the particular community in which it finds itself embedded.

### “Arms Races”

Individuals and species must “track” their environments in ecological and evolutionary time, adapting and evolving as their environments change. Natural selection acting on natural enemies (prey, parasites, and predators) will always result in a deterioration of an organism's biotic environment, diminishing fitness. Every prey-predator or host-parasite interaction constitutes an escalating “arms race,” in which moves alternate with countermoves.

Prey that are better able to escape from their predators, or hosts that can better resist infection by parasites, will enjoy a fitness advantage. But better predators and better parasites are also favored by natural selection themselves, assuring that the arms race will continue to escalate indefinitely. Indeed, most species are probably evolving rapidly just to maintain a given current level of adaptation in the face of a continually deteriorating environment. Still other interactions between species are mutually beneficial, resulting in increased fitness for both parties, such as between plants and their pollinators.

Any genetically based physiological, behavioral, or ecological trait that enables an organism to cope with, and to survive and reproduce in, its environment represents an adaptation. Some traits may not be adaptive but simply leftover vestiges of traits that once were adaptive. A given trait can also be “preadapted” if it was formerly adaptive under some prior set of conditions now gone but is later co-opted as the basis of a new adaptation under some new environmental conditions. For instance, it is likely that bird feathers were initially important for temperature regulation, rather than for flying. SEE ALSO COMMUNITY; CONVERGENT EVOLUTION; EVOLUTION; NATURAL SELECTION; PARASITIC DISEASES; PITUITARY GLAND; POPULATION DYNAMICS; PREDATION AND DEFENSE; SEXUAL SELECTION; SYMBIOSIS

*Eric R. Pianka*

#### Bibliography

Fisher, Ronald A. *The Genetical Theory of Natural Selection*. Oxford: Clarendon Press, 1930.

Pianka, Eric. R. *Evolutionary Ecology*, 6th ed. San Francisco: Addison-Wesley-Longman, 2000.

## Adrenal Gland

The adrenal glands are located on the upper pole of each kidney. In fact, their name designates their location: the prefix *ad* means “adjacent,” and *renal* refers to the kidney. In the human body, they are small yellowish glands that weigh about five grams (0.175 ounces) each.

The adrenal gland is actually two organs in one. The outer portion, called the adrenal cortex (*cortex* means “bark,” as in the bark of a tree), is about nine-tenths of the gland's total weight. The inner part, called the adrenal medulla (*medulla* means “marrow,” as found in the inside of a bone),



A willow ptarmigan in summer color.

**interspecific** between different species

Cross section of a human adrenal gland.

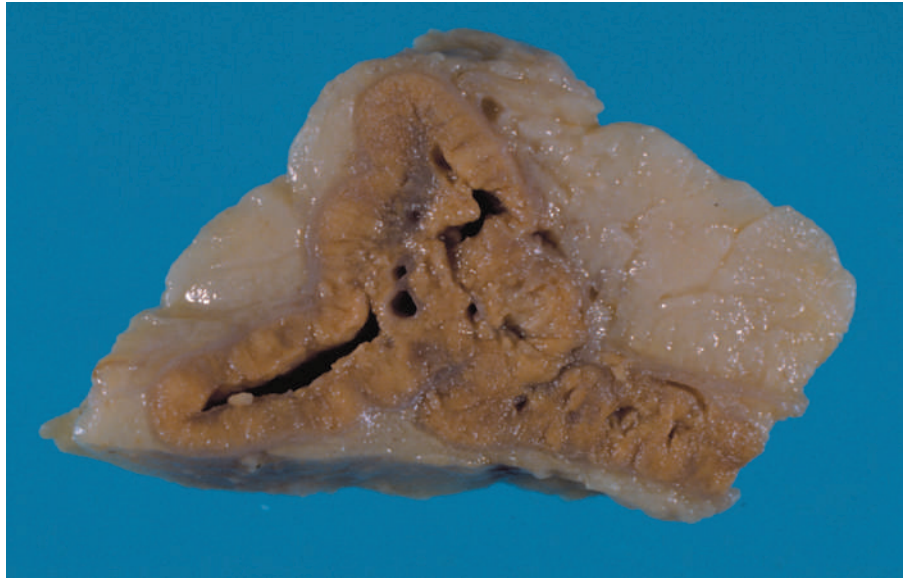

**endocrine** related to the system of hormones and glands that regulate body function

**hormone** molecule released by one cell to influence another

**aggregate** clump together

**steroids** hormones such as testosterone or estrogens that control many aspects of physiology

**excrete** deposit outside of

**minerals** iron, calcium, sodium, and other elements needed by living organisms

**metabolism** chemical reactions within a cell

**carbohydrates** sugars, starches, and other molecules combining carbon, hydrogen, and oxygen and serving as fuel or structural components

**glucose** simple sugar that provides energy to animal cells and is the building block of cellulose in plants

is about one-tenth. They are both **endocrine** glands, meaning that they secrete chemical messengers called **hormones** into the bloodstream. However, the adrenal cortex and medulla are different in their embryological development, their tissue structure, the types of hormones they secrete, and the way they are regulated. So why is one located inside the other?

### Adrenal Cortex

The adrenal cortex develops from the mesoderm (middle layer) of the embryo. The tissue destined to become the adrenal cortex **aggregates** near the developing kidney and becomes organized into three zones. The outer zone is called the zona glomerulosa (meaning that the cells are arranged in little balls called glomeruli), the middle zone is the zona fasciculata (the cells are in parallel fascicles or bundles), and the zona reticularis (reticular means network) is innermost.

The hormones secreted from each zone all resemble the molecule cholesterol and are called **steroids**, but each zone secretes slightly different hormones. The zona glomerulosa secretes hormones that influence the kidneys to **excrete** or retain sodium and potassium, depending on the needs of the body. These hormones are called mineralocorticoids (sodium and potassium are **minerals**). The zona fasciculata secretes hormones called glucocorticoids that influence the **metabolism** of **carbohydrates**, including **glucose**. The glucocorticoids include hydrocortisone, corticosterone, and cortisone.

In addition to regulating metabolism, these steroids provide resistance to stress and suppress the inflammatory response and some allergic reactions. Steroids such as these are often rubbed onto inflamed and itchy skin to make it feel better. The zona reticularis secretes steroids that resemble the sex hormones secreted by the ovary in the female and testes in the male.

The adrenal cortex is regulated by the pituitary gland in the head. The pituitary gland secretes a hormone called adrenocorticotropic hormone (ACTH). *Tropic* (pronounced with a long o) is from a Greek word meaning

“nourishment,” so ACTH simply refers to this hormone’s ability to produce a change in the adrenal cortex. ACTH is necessary for cell growth and maintenance and stimulates glucocorticoid synthesis.

## Adrenal Medulla

The adrenal medulla forms from ectoderm (outer layer) very near the embryonic spinal cord. From its beginnings, the adrenal medulla is part of the nervous system. These cells migrate into the middle of the developing adrenal cortex and form into a solid ball. The cells of the adrenal medulla secrete a class of hormones called catecholamines, adrenaline (or epinephrine) being the best known. Norepinephrine is also secreted.

In times of acute stress, the brain and spinal cord send a signal to the adrenal medulla, and it secretes adrenaline into the bloodstream. This causes the heart to beat faster, opens up the airways, and gets the body ready for physical activity. This “fight or flight” reaction is a survival mechanism, allowing people (and other animals) to escape from a dangerous situation. A person experiences the effects of the adrenal medulla when he or she gets scared or excited.

Why is the adrenal medulla inside the cortex? Steroids in the adrenal cortex activate the **enzyme** that puts the final atoms onto adrenaline. Therefore, the adrenal cortex helps the adrenal medulla to synthesize adrenaline, allowing the medulla to do its job. SEE ALSO ANABOLIC STEROIDS; ENDOCRINE SYSTEM; HOMEOSTASIS; HORMONES; PITUITARY GLAND; STRESS RESPONSE

*Stephen W. Carmichael*

### Bibliography

Carmichael, Stephen W., and Hans Winkler. “The Adrenal Chromaffin Cell.” *Scientific American* 253 (August 1985): 40–49.

Ross, Michael H., Lynn J. Rommerell, and Gordon I. Kaye. *Histology: A Text and Atlas*, 3rd ed. Baltimore: Williams & Wilkins, 1995.

## Aging, Biology of

Human life span, or longevity, has two components: mean longevity (also called life expectancy) and maximum longevity. Mean longevity is the average age at death of all members of a population. Throughout history, human life expectancy has increased. For example, life expectancy in the United States in the late eighteenth century was thirty-five years. By the last quarter of the twentieth century, it had increased to seventy-two years. The second component of life span, maximum longevity, is the age at which the most long-lived individuals of a population will die. This is difficult to determine in humans but is generally accepted to fall between 110 and 120 years.

The trend for life expectancy to get closer to maximum longevity has been attributed to improvements in nutrition, sanitation, and medical care. Maximum longevity, in actuality, appears to be independent of these environmental factors and is an absolute limit, probably determined by the action of genes. The genes that determine maximum longevity are believed to be responsible for repairing errors in the genetic information, repairing mistakes in the process of **protein** synthesis, and determining the time of death.

**enzyme** protein that controls a reaction in a cell

**protein** complex molecule made from amino acids; used in cells for structure, signaling, and controlling reactions



Improvements in nutrition, sanitation, and medical care have contributed to increased life expectancy.



### Aging Changes that Occur in Humans

Some of the most easily observed age-related changes in humans are found in the skin and its derivatives. These include a loss of pigment in the hair, wrinkling of the skin, an increase in pigment in the skin, and thickening of the nails. Other observable changes are a decrease in size, due to loss of muscle and bone mass; a decrease in muscle strength; a decrease in mobility in the joints; and a variety of neurological changes, including diminished sensory function (vision, hearing, smell, and taste), increased response time, and diminished capacity for learning and memory. The latter have been attributed to a loss in brain mass, due at least in part to a loss of brain cells.

Less easily observed changes include a decrease in metabolic rate; diminished function of the kidneys, lungs, and pancreas; cardiovascular disease; diminished immune function; increased susceptibility to cancer; and a decrease (in males) or termination (in females) of reproductive function. All of these changes have been attributed to cellular events and processes that are described by various theories of aging.

### Theories of Aging

It is widely accepted that the process of aging cannot be traced to a single cause. A number of theories have been proposed to explain the changes observed during aging. In order to be a valid candidate for an explanation of the aging process, the changes proposed by the theory must meet the following criteria: (1) they will commonly occur in all or most humans; (2) as an individual ages, these changes will become more pronounced; and (3) the changes will lead to cellular or organ dysfunction that ultimately cause failure of the organ or system. The following explanations are the most commonly accepted ones for the aging process.

**Free Radicals.** Free radicals are chemical particles that contain an unpaired electron and are extremely reactive. They are produced by **aerobic metabolism** and by radiation and other environmental agents. Their effects

**aerobic** with air, or requiring it

**metabolism** chemical reactions within a cell

are widespread. They alter or break down the structure of many other molecules in the cell and thus impair their functions. Free radicals react with proteins, which have **enzymatic**, structural, and control functions. They cause breaks in deoxyribonucleic acid (DNA) and thus alter the information necessary for synthesizing proteins. They cause **lipids** to stick together, which causes cell membranes to break down.

Their effects on **carbohydrates** are less well documented. Free radicals are most abundant in the cellular **organelles** called **mitochondria**, where **oxidative** reactions occur. Mitochondrial damage, including damage to mitochondrial DNA, has been proposed as a contributing factor to the aging process. The effects of free radicals are diminished by certain **enzymes** (superoxide dismutase and catalase) that interrupt the cycle of reactions that cause their damage. **Antioxidants** such as vitamins C and E also protect against free radical damage by quenching the reactions.

**Crosslinkage of Proteins.** In addition to the effects of free radicals, proteins can be altered by the spontaneous and uncontrolled joining of protein molecules to one another by **glucose**. The cumulative effect of this glycosylation is to cause the proteins to stick together. For example, the fibrous extracellular protein collagen, found in **connective tissue**, becomes stiff via this process, which contributes to the wrinkling of the skin and the loss of joint mobility.

**Events Affecting the Genetic Material.** Mutations, or changes in the DNA, are common and can lead to changes in the structure and function of proteins. There are a number of mechanisms that can repair these changes, but it is possible that these mechanisms diminish in their effectiveness with age, since they are carried out by enzymatic proteins, which are themselves damaged by the aging process. Another suggestion is that there are specific genes responsible for the death of individual cells.

Also, it is known that cells in tissue culture will undergo only a certain number of cell divisions. In human cells, this limit is approximately fifty cell divisions. This so-called Hayflick limit (after the scientist who first described it) has been tentatively explained by the progressive shortening of the telomere, the section of each DNA molecule that is responsible for initiating replication of DNA. As the telomere becomes too short, an increasing number of mistakes occur in the replicated DNA.

**The Effects of Hormones.** These chemical messengers normally have well-regulated effects on body tissues. Abnormally high levels of some hormones (which may be caused by other changes described here) can change the sensitivity of tissues to the hormones, as well as stimulate the **secretion** of other hormones whose uncontrolled effects could be deleterious. Insulin, growth hormone, glucocorticoid hormones, and reproductive hormones have been suggested as candidates in this mechanism.

**Changes in the Immune System.** This major defense system of the body may experience two kinds of change, either one of which could contribute to the aging process. First, the immune system may gradually lose its ability to distinguish cells of the body from foreign cells, resulting in immune attack on the body itself. Second, the immune system appears to be less able to respond to microbes or foreign molecules, thus rendering the cells

**enzymatic** related to function of an enzyme

**lipid** fat or waxlike molecule, insoluble in water

**carbohydrates** sugars, starches, and other molecules combining carbon, hydrogen, and oxygen and serving as fuel or structural components

**organelle** membrane-bound cell compartment

**mitochondria** subcellular organelle that creates ATP used for energy-requiring processes in a cell

**oxidative** characterized by oxidation, or loss of electrons

**enzyme** protein that controls a reaction in a cell

**antioxidant** substance that prevents damage from oxidation

**glucose** simple sugar that provides energy to animal cells and is the building block of cellulose in plants

**connective tissue** one of four types of body tissue, characterized by few cells and extensive extracellular material

**secretion** material released from the cell

of the body more susceptible to the effects of these noxious agents. SEE ALSO AUTOIMMUNE DISEASE; LIFE CYCLE, HUMAN; MITOCHONDRION; PEROXISOMES

Steven N. Trautwein

### Bibliography

- Christiansen, James L., and John M. Grzybowski. *Biology of Aging: An Introduction to the Biomedical Aspects of Aging*. New York: McGraw-Hill, 1999.
- Clark, William R. *A Means to an End: The Biological Basis of Aging and Death*. New York: Oxford University Press, 1999.
- DiGiovanna, Augustine Gaspar. *Human Aging: Biological Perspectives*, 2nd ed. Boston: McGraw-Hill, 2000.
- Spence, Alexander P. *Biology of Human Aging*, 2nd ed. Englewood Cliffs, NJ: Prentice Hall, 1995.

## Agriculture

Agriculture is both an occupational practice and a subject to be studied. Farmers, horticulturists, and ranchers are examples of individuals who grow things for human use. Scientific researchers who experiment to improve plant and animal productivity; historians who examine the development of agrarian processes and the industry; and ecologists who study fields and fish ponds as managed **ecosystems** are examples of those who pursue agriculture as an area of academic interest. Decision making, leadership, research, and many other roles in modern agriculture require a college education in fields such as agronomy, animal husbandry, pathology, floriculture, agricultural economics, and mariculture.

Farming began early in the development of human society. The earliest ancestors of modern humans were scavengers, hunters, and gatherers. The search for food was an ongoing process, and the collected items were consumed shortly after being found. The abundance of food was very dependent on periodic variations in weather and natural disasters such as flood, fire, drought, and severe cold. The beginnings of agriculture rest with individuals who learned to plant seeds of edible crops or keep a small herd of goats or maintain a flock of chickens.

The transition to sustainability involved using the milk of the goats, or gathering eggs, rather than butchering animals as soon as possible for meat. Some cultures were ingenious in developing ways to obtain multiple sustainable resources from a single species. Examples of this are the cattle herded by the Masai of present-day Kenya and Tanzania, and reindeer managed by many indigenous peoples of northern Eurasia. These animals provide resources such as milk, meat from excess calves, and even blood as food, plus leather and bone for clothes, tools, and ornaments.

Globally, a variety of cultural patterns developed as family units grew into villages, villages into towns, and ultimately towns grew into the complex urban cultures present throughout the world today. With the concentration of humans into cities, the ability of the individual to produce food for a family unit declined to the point where as of the twenty-first century a large number of individuals are totally dependent on others for their nourishment. In some societies this involves a daily trip to the marketplace where

**ecosystem** an ecological community and its environment

family farmers sell the products of their efforts. In many less-developed countries a great deal of the food consumed is still self-produced or obtained from small agricultural units in this manner. In more developed and industrialized countries, the local market has been extensively replaced by large chain stores that distribute packaged and processed foods that are produced by large commercial farms, ranches, and orchards. However, even in these highly developed areas, there are many who prefer locally grown foods and flock to farmers markets, **organic** food stores, and other small businesses.

Modern agriculture is now a big business, which is driven by ever-increasing scientific knowledge. The family farm found throughout America during the twentieth century is disappearing. These traditional, somewhat self-contained operations, where field crops were grown to produce grain, and gardens cultivated for vegetables, and a mixture of animals including cows, pigs, chickens, and sheep produced food and necessary materials such as leather and wool, are no longer economically practical. They have, in the industrialized world, given way to corporate farms that operate in much the same way as other large businesses. These agricultural units include not only the obvious specialized food-producing dairy farms, poultry operations, apple orchards, cattle ranches, and expansive wheat, corn, and soybean fields, but also such industries as catfish farms, shrimp nurseries, and oyster cultures. Agriculture also produces nonedible products such as tobacco and cotton, and grain for the production of methanol, a substitute for fossil fuels.

The agricultural operations of the past depended greatly on the intuition and experience of the family unit concerning when to plant, how to recognize a disease in the herd, and the best time to harvest. This information was passed from generation to generation. Decisions are now based on research and development carried out by university and private industry scientists. At one time it was a matter of knowing which farmer in the township had the best bull and bartering with him or her to bring this fine specimen to one's herd of females. Today genetic research has resulted in the development of the best bull in the country, and a farmer can order frozen sperm from across the continent. In fact, in this new millennium, the commercial distribution of cloned embryos of individual livestock specimens with the best possible characteristics is at hand.

Genetic engineering has virtually unlimited potential for producing frost- and disease-resistant crops, high-yield animals, products with a longer shelf life and a better flavor, and a multitude of other advances. Biotechnology, which has the great promise of advancing agriculture, has potential deleterious effects. For example, it could result in the herbicide-resistant gene inserted in a grain variety being transferred through unintended hybridization into a natural population of a related "weedy" or deleterious species, allowing it to prosper out of control.

Not only has modern agriculture introduced additional science into the barnyard, it has also brought in the economists, the lawyers, the television commentators for agri-business shows, and a multitude of businesspeople who advertise and market the product. This is a far cry from a farmer selling his best calf at the end of the summer at the county fair.

Finally, there is another element of modern agriculture. When farms were spread out across the countryside interspersed with wood lots, or when cattle production involved letting the herd range over hundreds of acres



A wild rice plant growing in Ocala, Florida. For the earliest ancestors of modern humans, the search for food was an ongoing process.

**organic** a type of agriculture stressing soil fertility and avoidance of synthetic pesticides and fertilizers

A herd of Holsteins eat silage from troughs on a Minnesota farm. Modern agriculture is now a big business, which is driven by ever increasing scientific knowledge.

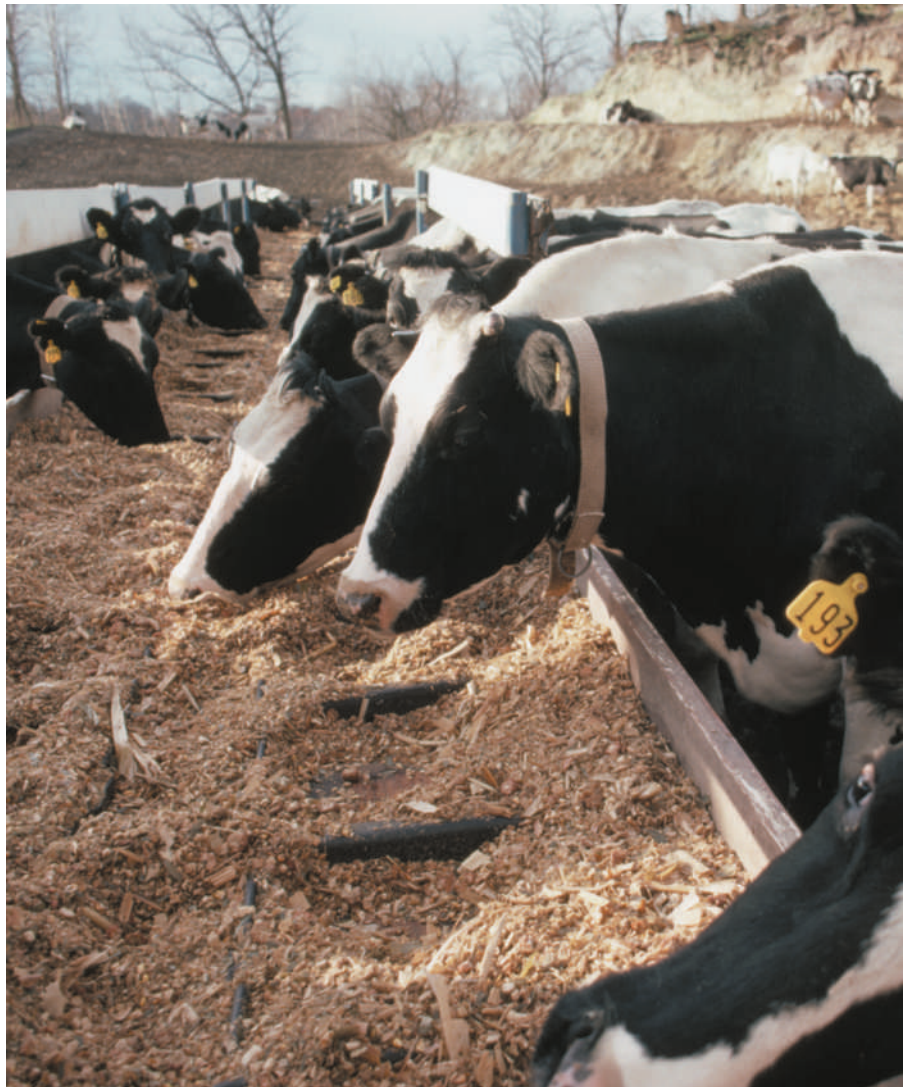

during the summer, the local impact on the land and environment was relatively low (although the total impact was high, given the large number of acres devoted to agriculture). Modern, high-intensity agriculture with fields cultivated using tractors as large as elephants, fertilizers, pesticides, and irrigation systems is a potential threat to the environment. These techniques can place high demands on freshwater sources and have the potential for introducing toxic contaminants and excess nutrients into streams and rivers or promoting soil erosion. High-density animal production, such as hog farms in North Carolina, cattle feed lots in the Midwest, and turkey and dairy farms in the Shenandoah Valley, produce fecal contamination that can pollute waterways with bacteria and cause cultural **eutrophication** of aquatic ecosystems due to excess nutrients. Even the best planned containment of animal wastes can break down under the flood conditions of hurricanes and high rainfall years.

**eutrophication** process by which waters become enriched in dissolved nutrients that promote plant growth, which results in depletion of dissolved oxygen

The human population is growing at such a high rate that humans in less-developed countries will surely starve and die without pulses of progress such as the green revolution that produced high-quality rice for underdeveloped countries in the 1960s. Prevention of this situation is the hope of

industrial and biological technology advances that are sure to happen during the twenty-first century. However, this is a double-edged sword. Agricultural progress without due attention to environmental impacts has the potential for creating a world that will not be desirable to live in for the people supported by its products. SEE ALSO AGRONOMIST; GRAIN; HISTORY OF AGRICULTURE; HORTICULTURIST; ORGANIC AGRICULTURE

Dean Cocking

### Bibliography

Cooper, Elmer L., and L. Devere Burton. *Agriscience: Fundamentals and Applications*, 3rd ed. Albany, NY: Delmar Publishers, 2000.

National Research Council. *Genetically Modified Pest-Protected Plants*. Report by Committee on Genetically Modified Pest-Protected Plants. Washington, DC: National Academy Press, 2000.

Smith, Bruce D. *Emergence of Agriculture*. New York: Freeman and Company/Worth Publishers, 1999.

## Agronomist

An agronomist is a professional who practices, or does research in the area of, agronomy, which is the art and science of managing field crops and the soils beneath them. Agronomy emerged early in the twentieth century when this component of agriculture involving the growing of plants was separated from animal husbandry. It has continued to evolve as subcategories develop within the crop and soil sciences, such as the study of forage crops, tropical cropping systems, weed science, and turf science and management (the growth of grasses for golf courses and parks).

Seed science and technology, agro-forestry (the growth of timber in plantations), agricultural economics and engineering, and the nutrition, **physiology**, and ecology of crop plants are other interests of agronomists. They also often concentrate on soil conservation and the structural, chemical, and physical properties of soil that affect the growth of crops. Because of this extensive diversification, professionals working in these fields now often use the specialty to define their occupation rather than the broader designation of agronomist. All of these disciplines contribute toward increasing the productivity of farmlands, enhancing the quality of the agricultural product, and improving the economic efficiency of farming practices.

Because farming cannot always occur under optimal plant growth conditions, many agronomists focus on the utilization of marginal habitats and problems occurring in the less-industrialized countries. These include conditions such as fields under frequent water deficiency, where dry-land farming practices can be utilized, and farming on nutrient-poor soils. Others seek to make plants grow under **saline** conditions; in extremely hot or cold environments; or in habitats with abbreviated growing seasons. Many of these challenges can be resolved through traditional plant breeding or the application of biotechnology.

These scientifically based aspects of the profession require undergraduate college study. In the United States, this is frequently at federally established land-grant universities. Many of these individuals become farm managers or owners, county agricultural agents, or work in industry or the

**physiology** branch of biology that deals with the functions and activities of living matter

**saline** of, relating to salt

federal government. Students interested in these subjects need to follow a college preparatory track focusing on science, computer, and writing skills and, where possible, courses covering practices in business and agriculture. Internships or applied experience in agricultural operations can provide practical information that is very useful in making career decisions. Furthermore, the continually increasing emphasis on scientific research by agronomists provides opportunities for trained scientists to contribute to the growth of knowledge in agronomy. Masters degree and doctorate programs can be entered as a continuation of undergraduate applied study, or following liberal arts degrees, particularly in biology or geology with an emphasis on soil science. SEE ALSO BIOTECHNOLOGY; PLANT NUTRITION; SOIL

*Dean Cocking*

### Bibliography

Hillel, Daniel J. *Out of the Earth: Civilization and the Life of the Soil*. Berkeley, CA: University of California Press, 1992.

## AIDS

AIDS (acquired immunodeficiency syndrome) is defined as the stage of infection with HIV-1, or HIV (human immunodeficiency virus), in which an infected person's immune system has become so weak that he or she is at risk of developing other infections or cancers (or has already developed them) that can potentially lead to death. Though all people with AIDS are infected with HIV-1, not all people with HIV-1 infection have AIDS, nor will all of them develop AIDS.

### HIV Pathogenesis

The cause of AIDS is human immunodeficiency virus-1 (HIV-1), a member of a group of viruses called retroviruses. Retroviruses are enveloped ribonucleic acid (RNA) viruses that contain an **enzyme** (reverse transcriptase) that will **transcribe** viral RNA to deoxyribonucleic acid (DNA). In the case of HIV-1, this DNA (now called a DNA provirus) is then integrated into the infected person's DNA. When the infected person's DNA is then transcribed, or read by the cell's molecular machinery, the proviral DNA is also read, leading to the creation of new virus and release from the infected cell.

The **pathogenesis** of HIV-1 infection is complex. HIV-1 binds to cells that have specific types of molecular receptors on their surface, such as CD4 and chemokine receptors. Cells that have these receptors include CD4 lymphocytes, macrophages, and microglial cells in the brain. CD4 lymphocytes are a kind of helper **T cell**. Macrophages are immune cells that consume infected cells, and microglial cells perform certain immune functions in the brain. After the virus binds and enters the cell, it will replicate as discussed above. In the course of a day, as many as ten billion virus particles can be produced in an infected person.

CD4 lymphocytes are one of the main targets of HIV-1. These cells are essential in the functioning of the immune system. The CD4 lymphocytes are destroyed by direct viral killing, by other lymphocytes that destroy HIV-infected cells, and probably by other mechanisms. As the CD4 lymphocytes

**enzyme** protein that controls a reaction in a cell

**transcribe** to create an RNA copy of a DNA gene

**pathogenesis** pathway leading to disease

**T cell** white blood cell that controls the immune response

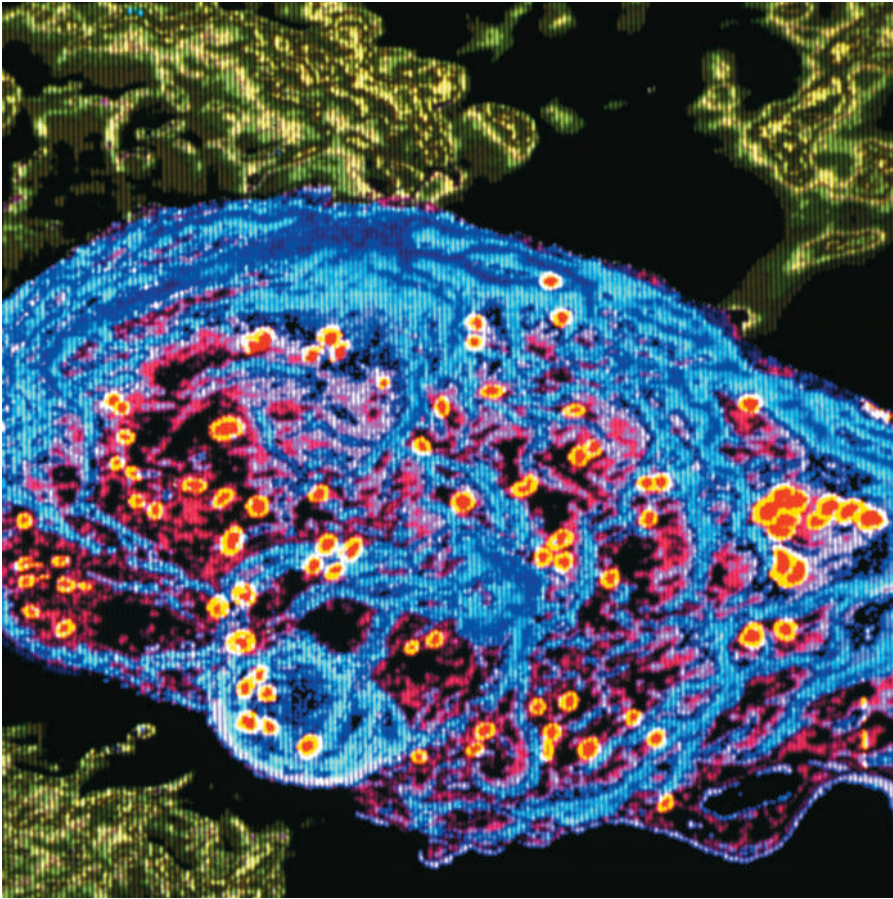

A scanning electron micrograph of the AIDS virus attacking T4 lymphocytes.

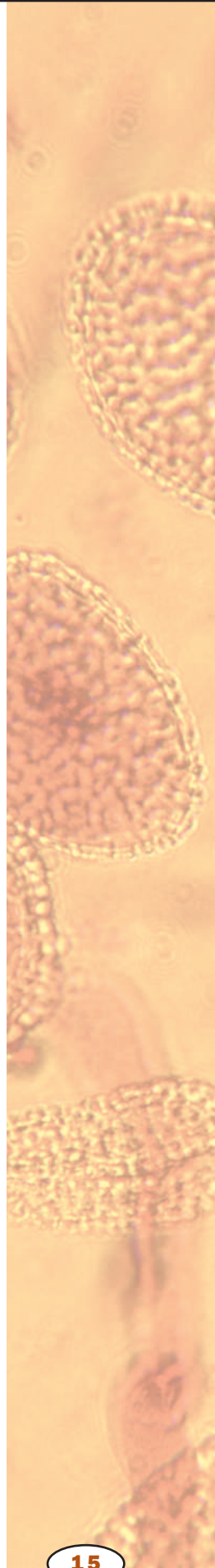

become depleted, the immune system's ability to fight off infections and certain types of cancers is lost. When the loss becomes severe enough, these infections and cancers can occur, and may kill the HIV-infected person. At this stage of depleted CD4 cells, medical professionals say that the infected person has full-blown AIDS.

### Transmission

The epidemiology of HIV infection/AIDS has changed over the years. When the disease was first recognized in the early 1980s, men who had sex with men were by far the largest affected risk group, followed by intravenous drug users who were sharing needles, individuals who received HIV-infected blood, and hemophiliacs who received infected clotting factors. Women who had sexual contact with infected men were recognized as being at high risk of contracting HIV, and if they were pregnant, passing it on to their unborn children.

Though this disease was first recognized in the United States, cases soon appeared in many countries of the world. Particularly hard hit were countries in sub-Saharan Africa, the Caribbean, and Asia. At the turn of the twenty-first century, it is estimated that more than forty million people are infected worldwide and as many as one million in the United States alone.

Transmission of HIV-1 occurs through infected bodily fluids. Sexual contact by far is the most common mode of transmitting HIV. Anal sex is the most efficient sexual manner of transmitting the virus. Vaginal intercourse



poses the next highest risk, but more to the female than the male. In other words, it is much easier for an infected man to infect a woman through penile-vaginal intercourse than the other way around, especially if the man is circumcised and has no sores or ulcers on his penis. Since HIV is a blood-borne infection, those individuals engaging in intravenous drug use and sharing needles can easily transmit the virus in this manner. Prior to testing for the virus in the blood supply, there was a risk of acquiring HIV from transfusion of blood or a blood product, but this risk is now extremely small. Vertical transmission, or transmission from mother to child during pregnancy, occurs in about one-third of HIV-infected pregnant women who are not treated with anti-HIV medications.

## Prevention

Prevention of HIV transmission is both a behavioral and medical problem. Abstinence from sexual behavior is promoted as the only sure way of preventing transmission of HIV. Though this of course is true, premarital and extramarital sexual behavior is common in most societies. Condoms provide an effective barrier to sexual transmission. Social, religious, political, and cultural issues, however, enter into the education of youth on the use of condoms, and lead to controversies over education about sexual behavior in general. With as many as one-third or more of HIV infections occurring during adolescence, aggressive and honest educational approaches must be implemented. One can only make an informed decision about one's behavior if one understands the consequences and has knowledge of how to prevent transmission.

Beyond all of this, there are the medical areas of transmission prevention. As mentioned above, HIV-infected pregnant women who are treated with anti-HIV medications can reduce their risk of transmitting the virus to their baby. Health care workers who are stuck with needles contaminated with blood from HIV-positive patients can reduce their risk of infection by using anti-HIV medications. Medical studies in the early twenty-first century are looking at the possibility of reducing the risk of HIV transmission following a sexual contact by treating the uninfected contact with anti-HIV medications. Vaccines against HIV are being researched in many parts of the world, but as of yet, have not been shown to be protective.

## Treatment

Treatment of HIV/AIDS is both complicated and expensive. The medications that are available inhibit the **reverse transcriptase** enzyme, and inhibit an enzyme that helps the virus mature into one that can infect other cells. By using a combination of at least three different medications that are active at these various sites, one can clear the blood stream completely of virus. Once this occurs, the patient's immune system often improves, and in some cases, returns to normal. If the patient takes medications as directed and the virus stays suppressed, there is a chance that the patient may never become ill. The virus, however, is still present in the lymph nodes and probably other tissues. If the patient stops taking medications or takes them erratically, the virus will return to the bloodstream. Once the virus is actively produced again, there is a high probability that it will

**reverse transcriptase**  
enzyme that copies RNA  
into DNA

mutate to a form resistant to the medications that the patient was previously on. When this occurs, especially if the patient has been on more than one regimen of medicines, a virus resistant to all available medications can be selected for. At this point, little else can be done. One major concern about these individuals is that if they are still sexually active or continue to share needles, they will transmit resistant virus. This is being documented more frequently.

New medications are being studied that may be able to overcome this resistance problem by attacking different sites of viral production, or those that are not affected by mutations in the resistant virus. The problems here include the possibility that the patient could die before the new medicines are available; that if the patient is still alive, he or she will be unable to tolerate the side effects of the new medicines; and, finally, that the patient will be unable to afford the medicines. Anti-HIV or anti-retroviral medications are very expensive, costing over \$10,000 per year in the United States. This, plus the costs of blood tests and doctor visits, makes treatment beyond the means of most of the infected people in the world.

HIV/AIDS is and will continue to be one of the greatest medical challenges medical professionals have ever faced. Prevention and education are the only means that public health professionals currently have to stem the tide of this ever-growing **epidemic**. SEE ALSO BIRTH CONTROL; RETROVIRUS; REVERSE TRANSCRIPTASE; SEXUALLY TRANSMITTED DISEASES; T CELLS; VIRAL DISEASES

*Harold P. Katner*

### Bibliography

- “Defeating AIDS: What Will It Take?” *Scientific American* 279, no. 1 (July 1998): 81–107.
- Jasny, Barbara, ed. “AIDS: The Unanswered Questions.” *Science* (special AIDS issue), 260 (28 May 1993): 1253–1293.
- Mandell, G. L., J. E. Bennett, and R. Dolin, eds. *Principles and Practice of Infectious Diseases*, 5th ed. Philadelphia, PA: Churchill Livingstone, 2000.
- Sande, M. A., and P. A. Volberding, eds. *The Medical Management of AIDS*, 6th ed. Philadelphia, PA: W. B. Saunders, Co., 1999.
- World Health Organization. “WHO Global AIDS Statistics.” *AIDS Care* 2000 12, no. 798.

## Alcohol and Health

Ethanol, C<sub>2</sub>H<sub>5</sub>OH, also known as ethyl alcohol or grain alcohol, is the only common alcohol that humans are able to digest. Alcohol is readily absorbed by the body when consumed in an **aqueous** solution. All common alcoholic drinks are aqueous solutions of ethanol.

Alcohol absorption generally begins in the stomach, although most absorption takes place from the small intestine. Because alcohol is distributed to all body fluids (in proportion to the water content of that fluid), alcohol can be detected and quantitatively measured in the blood, urine, cerebrospinal fluid, and water vapor from the lungs. Drug testing for alcohol level relies on this fact.

**epidemic** rapid spread of disease through a population, or a disease that spreads in this manner

**aqueous** watery or water-based



A Santa Monica police officer administers a breathalyzer test to a man to determine the alcohol level in his bloodstream.

**excrete** deposit outside of

**oxidation** reaction characterized by loss of electrons, or reaction with oxygen

**enzyme** protein that controls a reaction in a cell

**catalyze** aid in the reaction of

## Metabolism

Only about 2 percent of consumed alcohol is **excreted** unchanged by the lungs or kidneys. The rest is metabolized by the body through biological **oxidation** with the aid of the **enzymes** alcohol dehydrogenase and acetaldehyde dehydrogenase. These are induced enzymes (produced in response to need), and are found in larger quantities in heavy drinkers than in nondrinkers.

Alcohol dehydrogenase **catalyzes** the oxidation of ethyl alcohol to acetaldehyde. Acetaldehyde is moderately toxic and is believed to be a major cause of headaches and hangovers.

The second enzyme, acetaldehyde dehydrogenase, catalyzes the oxidation of acetaldehyde to acetate. A small amount of acetate enters the Krebs (cellular digestion) cycle, while other acetate molecules enter other energy-conversion pathways of the body. The remainder of the acetate is stored as long-chain fatty acids and is ultimately oxidized to form carbon dioxide and water.

Although some human variation exists, the body can metabolize only about one drink (1¼ fluid ounces [0.036 liters]) per hour. Because the oxidation reactions are enzyme-catalyzed, little can be done to speed up the reactions.

Alcohol is processed by the liver. However, excessive quantities of alcohol cannot be processed during a single pass through the liver. Thus, alcohol can have a direct effect on other parts of the body. Most tissue effects are a part of an intricate, interrelated series of events.

## Physiological Effects

Alcohol is a vasodilator (the blood vessels dilate or enlarge). Chronically dilated veins are often associated with liver disease, and the “enlarged red nose” of the chronic alcoholic is usually the result of permanently dilated blood vessels. **Dilation** of the veins of the **esophagus** can lead to hematemesis (vomiting blood). Late-stage alcoholics have been known to drown in their own blood because of ruptured esophageal blood vessels.

Edema, the accumulation of tissue fluid, occurs with alcohol consumption because when the blood vessels expand, the **proteins** as well as the fluids within the capillaries leak into the **interstitial space**. This accumulation between the cells leads to tissue swelling. Because the fluid is not within the blood vessels, apparent dehydration exists. Jaundice (yellowing of the body tissues) is generally caused by excessive bilirubin (a normal body pigment) in the extracellular fluids, and may indicate liver disease.

Alcohol is a **central nervous system** (CNS) depressant, meaning that with alcohol the central nervous system is operating at decreased efficiency. Alcohol is also a depressant of all major systems of the body. High quantities of alcohol function as an anesthetic. Alcohol also depresses the psychological inhibition and thus may appear to be a stimulant. Because of this apparent stimulation of certain behaviors, psychologists call alcohol a biphasic drug. The combination of CNS depression and inhibition release leads to the symptoms of drunkenness. Drunkenness, a term for which there is no precise definition, varies with body size, metabolic rate, individual absorption, and individual tolerance.

## Chronic Alcoholism

Prolonged use of alcohol can lead to compensatory mechanisms for the depressed normal nervous system activity. The nervous system tends to “work harder” to maintain equilibrium and therefore, upon withdrawal of alcohol, the nervous system may experience excessive excitement which may lead to convulsions, seizures, and ultimately delirium tremens (the DT’s), a state of restlessness, disorientation, and **hallucinations**.

Mental impairment in chronic alcohol use is difficult to quantify because some impairment is reparable either by itself or by the construction of alternate nervous routes in the brain. Perhaps the most noticeable of the reparable impairments is personality loss.

Other physiological involvements include **sleep apnea**, decreased REM (restful) sleep, headaches, inhibition of testosterone synthesis, pancreatic inflammation, and electrolyte imbalance in the blood.

**dilation** expansion or swelling

**esophagus** tube connecting throat to stomach

**protein** complex molecule made from amino acids; used in cells for structure, signaling, and controlling reactions

**interstitial space** space between cells in a tissue

**central nervous system** brain and spinal cord

**hallucination** altered sensory experience

**sleep apnea** difficulty breathing while asleep

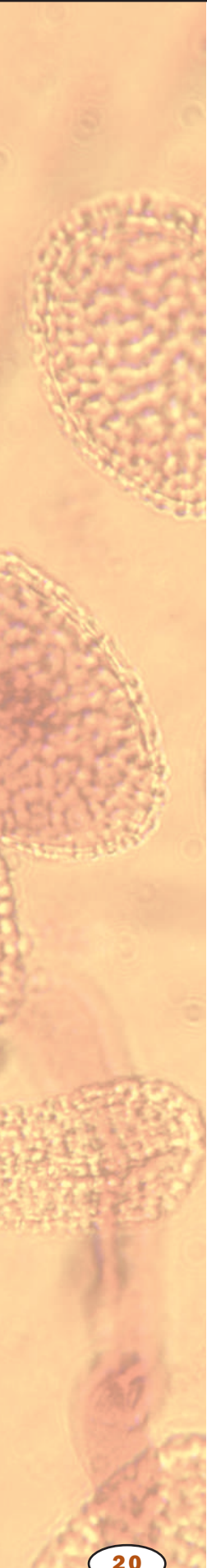

**ecosystem** an ecological community and its environment

**phytoplankton** microscopic floating creatures that photosynthesize

**prokaryote** single-celled organism without a nucleus

The major nutritional problem with alcohol is poor diet. Also, excessive alcohol ingestion often leads to gastrointestinal irritation, and this can lead to ulcers, colitis (inflamed colon), and other chronic ailments.

It is estimated that about 10 percent of the human population is addicted to alcohol. Probably no single cause of alcohol addiction exists. Certain genetic markers have been discovered, and the genetic component of alcoholism is well documented. Nevertheless, genetics alone does not explain all alcohol addiction. Psychological components to alcohol addiction have also been identified. For most alcohol addicts, the only treatment is total abstinence from alcohol and participation in a program such as Alcoholics Anonymous. The alcoholic's body does not "forget" alcohol, and the induced enzymes mentioned earlier remain ready to continue their metabolic actions if alcohol use resumes. SEE ALSO DIGESTIVE SYSTEM; DRUG TESTING; KREBS CYCLE; LIVER

*Roberta M. Meehan*

### Bibliography

*Alcoholics Anonymous*. <[www.alcoholics.anonymous.org](http://www.alcoholics.anonymous.org)>.

Blum, K. and J. E. Payne. *Alcohol and the Addictive Brain*. New York: The Free Press, 1991.

*National Institute of Alcohol Abuse and Alcoholism*. <[www.niaaa.gov/](http://www.niaaa.gov/)>.

## Algae

Algae are a diverse group of all photosynthetic organisms that are not plants. Algae are important in marine, freshwater, and some terrestrial **ecosystems**. Seaweeds are large marine algae. The study of algae is called phycology.

Algae may be unicellular, colonial, or multicellular. Some algae, like the diatoms, are microscopically small. Other algae, like kelp, are as big as trees. Some algae, the **phytoplankton**, drift in the water. Other algae, the epiphytic or benthic algae, grow attached to rocks, docks, plants, and other solid objects.

### Classification

The major groups of eukaryotic algae are the green algae, diatoms, red algae, brown algae, and dinoflagellates. They are classified as protista. Another group, the blue-green algae, is the cyanobacteria. Some authorities do not consider the blue-green algae to be true algae because they are **prokaryotes**, not eukaryotes.

**Green Algae.** Green algae are the algae most closely related to plants. They have the same pigments (chlorophyll a and b and carotenoids), the same chemicals in their cell walls (cellulose), and the same storage product (starch) as plants. Green algae may be unicellular or form filaments, nets, sheets, spheres, or complex mosslike structures. There are both freshwater and marine species. Some species of green algae live on snow, or in symbiotic associations as lichens, or with sponges or other aquatic animals. Edible green algae include Chlorella and sea lettuce. There are at least seventeen thousand species of green algae.

**Diatoms.** Diatoms are often regarded as the most beautiful of the algae. Each diatom has a cell wall made of glass that is very finely etched with a species-specific pattern of dots and lines. The patterns on the diatom cell walls are so precise that they were used for years to test the optics of new microscopes. Diatoms are also the most abundant algae in the open ocean and responsible for about one-quarter of all the oxygen gas produced on the earth each year. Diatom populations often bloom in lakes in the spring, providing a major food for zooplankton, forming the base of the aquatic food chain. There are over one hundred thousand species of diatoms.

**Red Algae.** Red algae are almost exclusively marine and include many edible and economically important species, including nori and laver. Red algae are also the source of carageenan and **agar**, which are used as food thickeners and stabilizers. Red algae are mostly large, complex seaweeds. There are four thousand to six thousand species.

**Brown Algae.** Brown algae are almost exclusively marine and include the largest and most complex seaweeds. Kelp, for example, may be more than 60 meters (200 feet) tall, and forms dense underwater forests off the California coast. Other important brown algae include the rockweeds and Sargassum, for which the Sargasso Sea is named. There are about fifteen hundred species of brown algae.

**Dinoflagellates.** Dinoflagellates are unicellular algae with armor made of **cellulose** and flagella that cause them to spin as they swim. Dinoflagellates are found in both freshwater and marine ecosystems. Some species of dinoflagellates emit an eerie blue light when disturbed, called **bioluminescence**. Other dinoflagellates are toxic and responsible for red tides and outbreaks of shellfish poisoning. There are two thousand to four thousand species of dinoflagellates.

## Life Cycles

Life cycles among the algae are incredibly varied. In fact, almost any type of life cycle one can imagine is displayed by some member of the algae. In an asexual life cycle, individuals reproduce by splitting. Some dinoflagellates reproduce primarily by asexual division. There are three types of sexual life cycles, which involve at some stage the fusion of **gametes**: gametic **meiosis**, zygotic meiosis, and sporic meiosis.

**Gametic Meiosis.** In the gametic meiosis life cycle (which is employed by humans), meiosis produces the gametes, so the only **haploid** cells in the life cycle are the gametes. The individual that one sees is made of **diploid** cells. Diatoms have gametic meiosis.

**Zygotic Meiosis.** In zygotic meiosis, the **zygote** undergoes meiosis, so the only cell that is diploid is the zygote. All the other cells in the organism are haploid. Many of the green algae, including sea lettuce, have zygotic meiosis.

**Sporic Meiosis.** In sporic meiosis, there are both haploid individuals and diploid individuals within the life cycle. Meiosis produces haploid spores, which then divide to produce an individual that is made entirely of haploid cells. This individual produces gametes by **mitosis**. Two gametes unite and form a diploid zygote. The zygote divides to produce an individual that is made entirely of diploid cells. This individual produces spores by meiosis



Algae on a pond. Algae are important in freshwater as well as in marine and some terrestrial ecosystems.

**agar** gel derived from algae

**cellulose** carbohydrate made by plants and some other organisms; part of the cell wall

**bioluminescence** production of light by biochemical reactions

**gamete** reproductive cell, such as sperm or egg

**meiosis** cell division that forms eggs or sperm

**haploid** having single, non-paired chromosomes in the nucleus

**diploid** having pairs of chromosomes in the nucleus

**zygote** fertilized egg

**mitosis** separation of replicated chromosomes

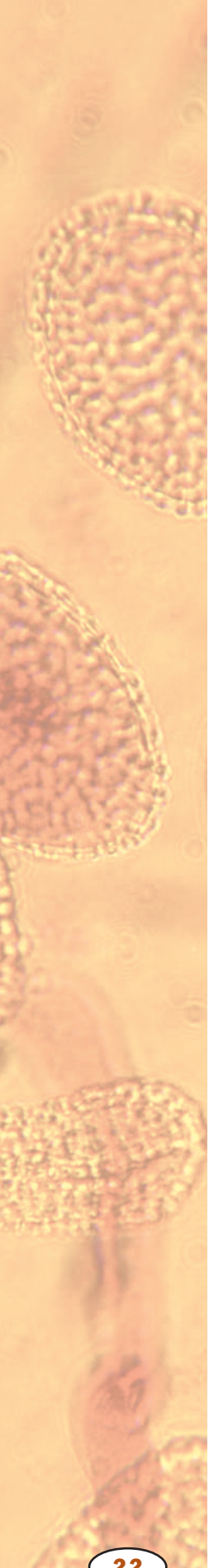

**protein** complex molecule made from amino acids; used in cells for structure, signaling, and controlling reactions

**diploid** having pairs of chromosomes in the nucleus

**meiosis** cell division that forms eggs or sperm

**haploid** having single, non-paired chromosomes in the nucleus

to complete the cycle. Because the life cycle includes two generations of individuals, a haploid generation and a diploid generation, it is called “alternation of generations.” Plants and many of the green, red, and brown algae have sporic meiosis.

In Japan, Korea, and China, the production of nori is a billion-dollar-a-year industry, but because the two generations in the nori life cycle look completely unlike each other it was not until the early twentieth century that the second generation was discovered. This discovery radically improved the ability of humans to grow nori, and there is a memorial park in Japan dedicated to the British scientist, Kathleen Drew Baker, who discovered it.

### Economic and Ecological Importance

Algae are the base of the aquatic food chain. Humans also eat many types of algae. The marine algae nori and kelp have been harvested in China for over two thousand years. *Spirulina*, a blue-green algae that is rich in **protein** and vitamin B, is harvested from Lake Chad in Africa. The photosynthesis done by algae is very important to the biosphere because it reduces the amount of carbon dioxide and increases the amount of oxygen in the atmosphere.

Some types of algae can cause environmental problems such as red tides and fishy-tasting water. These problems are usually caused by the excessive release of nutrients from farms, sewage, and other human activities. The outbreak of the nerve-toxin-producing *Pfiesteria* (a dinoflagellate) on the Atlantic coast, for example, has been linked to overflowing sewage lagoons. SEE ALSO ALTERNATION OF GENERATIONS; CELL WALL; CHLOROPLAST; EVOLUTION OF PLANTS; LICHEN; LIFE CYCLES; LIMNOLOGIST; OCEAN ECOSYSTEMS: HARD BOTTOMS; OCEAN ECOSYSTEMS: OPEN OCEAN; OCEAN ECOSYSTEMS: SOFT BOTTOMS; PHOTOSYNTHESIS; PLANKTON; PLANT; PROTISTA

Virginia Card

#### Bibliography

Lembi, Carole A., and J. Robert Waaland. *Algae and Human Affairs*. Cambridge: Cambridge University Press, 1988.

Raven, Peter H., Ray F. Evert, and Susan E. Eichorn. *Biology of Plants*, 6th ed. New York: W. H. Freeman and Company, 1999.

## Alternation of Generations

For sexually reproducing multicellular organisms such as plants and animals, the life cycle requires that **diploid** cells divide by **meiosis** to create **haploid** cells. Haploid cells then fuse to recreate the diploid number and a new organism. Alternation of generations refers to the occurrence in the plant life cycle of both a multicellular diploid organism and a multicellular haploid organism, each giving rise to the other. This is in contrast to animals, in which the only multicellular phase is the diploid organism (such as the human man or woman), whereas the haploid phase is a single egg or sperm cell.

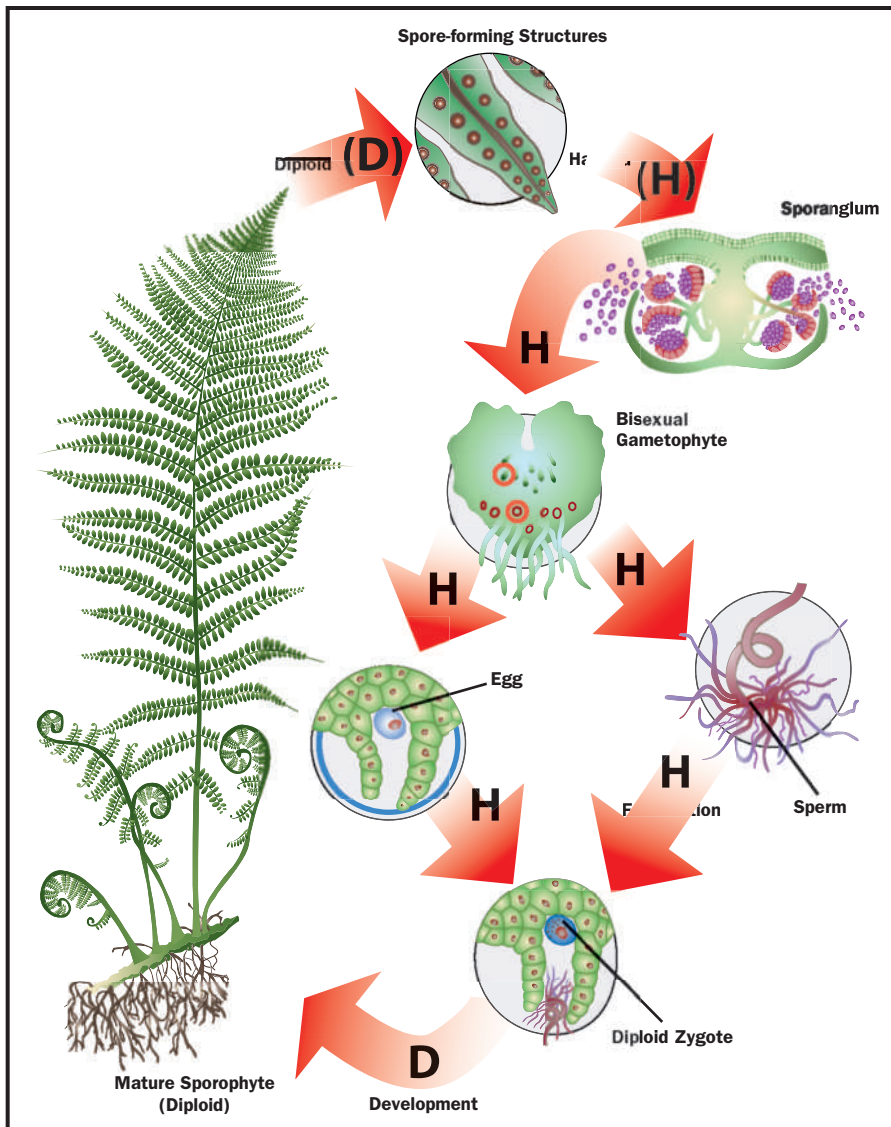

The fern is an example of alternation of generations, in which both a multicellular diploid organism and a multicellular haploid organism occur and give rise to the other.

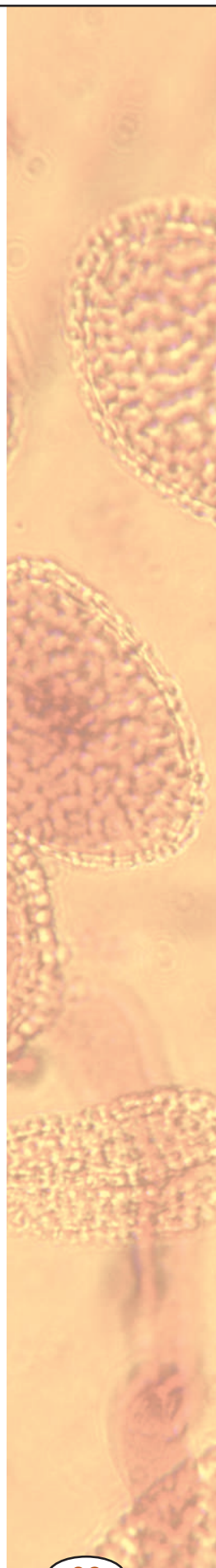

Alternation of generations is easiest to understand by considering the fern. The large, leafy fern is the diploid organism. On the undersurface of its fronds or leaves, its cells undergo meiosis to create haploid cells. However, these cells do not immediately unite with others to recreate the diploid state. Instead, they are shed as spores and germinate into small haploid organisms. Because the diploid organism creates spores, it is called the sporophyte generation of the life cycle. Upon reaching maturity, the haploid organism creates haploid egg and sperm cells (gametes) by **mitosis**. Because the haploid organism creates **gametes**, it is called the **gametophyte** generation of the life cycle. The male gametes (sperm) are then released and swim to the female egg. Fusion of the gametes creates the new diploid sporophyte, completing the life cycle.

Whereas the fern gametophyte and sporophyte generations are completely independent, in some types of plants one generation lives on or in the other and depends on it for nutrition. In mosses, the familiar lush carpet of moss is the gametophyte, and its gametes require a moist environment for short-distance swimming before fusing. The sporophyte lives as a

**mitosis** separation of replicated chromosomes

**gamete** reproductive cell, such as sperm or egg

**gametophyte** a haploid plant that makes gametes by mitosis



**ovule** multicellular structure that develops into a seed after fertilization

**fertilization** union of sperm and egg

**zygote** fertilized egg

**triploid** possessing three sets of chromosomes

**endosperm** nutritive tissue within a seed

thin stalk attached to the gametophyte. Spores are released into the air and can travel on the slightest breezes to other habitats.

In contrast, in flowering plants (angiosperms), the sporophyte is the dominant form. The male gametophyte has been reduced to just three cells, two of which are sperm. These together form the pollen grain, which is formed from the anther, part of the sporophyte. Similarly, the female gametophyte has been reduced to just seven cells, one of which is the egg cell. These are retained inside the **ovule**, which is part of the sporophyte. In angiosperms, two **fertilization** events take place: one sperm fertilizes the egg to form the diploid **zygote** of the new individual, and the other sperm fertilizes the so-called polar nuclei to form the **triploid endosperm**, a nutritive tissue. Together with maternal sporophyte tissue, these make up the seed. SEE ALSO ANGIOSPERMS; BRYOPHYTES; LIFE CYCLES; MEIOSIS; POLLINATION AND FERTILIZATION; PTERIDOPHYTES; REPRODUCTION IN PLANTS

*Richard Robinson*

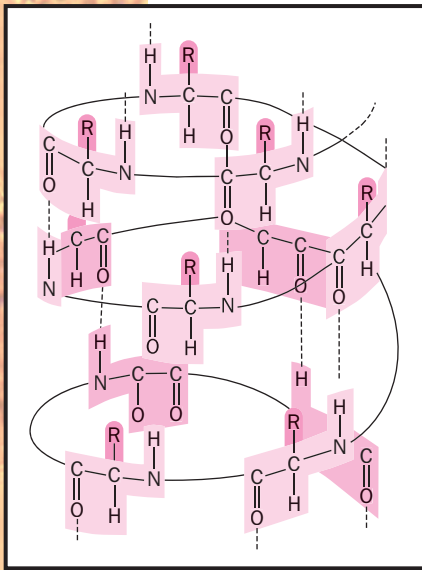

Amino acids link together to form alpha-helices and other fundamental structures, which interact to give proteins their ultimate three-dimensional shape.

$\alpha$  the Greek letter alpha

**protein** complex molecule made from amino acids; used in cells for structure, signaling, and controlling reactions

**peptide bond** bond between two amino acids

**polypeptide** chain of amino acids

**gene** portion of DNA that codes for a protein or RNA molecule

## Amino Acid

Amino acids are molecules that have both an amino group ( $-\text{NH}_2$ ) and a carboxylic acid group ( $-\text{COOH}$ ), hence the name. The most common amino acids are the  $\alpha$ -amino acids, the building blocks of **proteins**. These have the amino group, the carboxylic acid group, a hydrogen, and a characteristic side chain all attached to one carbon atom, designated the  $\alpha$ -carbon. Each type of  $\alpha$ -amino acid has a unique side chain that determines its properties and its role in proteins. The side chains (or “R” groups) can range from a hydrogen atom, as in glycine, to the more complicated side chains of tryptophan or arginine.

The  $\alpha$ -carbon atom has four different groups attached to it arranged at the points of a tetrahedron. This arrangement is asymmetric and can occur in two different forms, or enantiomers, that are related to each other in the same way as an object and its image in a mirror. These two enantiomers are called L and D. Only L-amino acids occur in proteins made by living systems. D-amino acids and amino acids other than  $\alpha$ -amino acids occur in biological systems but are not incorporated into proteins.

Many organisms can synthesize all of the amino acids they require from compounds present in the metabolic pathways they use for energy production. Humans, however, are not able to synthesize all of the necessary amino acids, and a number of them must be obtained from the diet.

The major use of amino acids is to construct proteins. A protein is a linear chain of amino acids linked together by **peptide bonds**. A peptide bond is formed when the amino group attached to the  $\alpha$ -carbon of one amino acid is joined to the carboxyl group of a second amino acid with the elimination of water. The side chain of each amino acid residue protrudes from the **polypeptide** backbone. The sequence of amino acids in the chain is determined by the deoxyribonucleic acid (DNA) sequence of the **gene** that codes for that protein.

The three-dimensional structure and the properties of a specific protein, and therefore its biological role, are determined by the sequence of

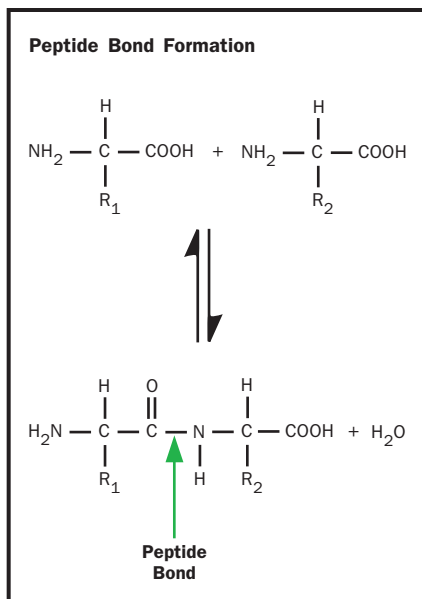
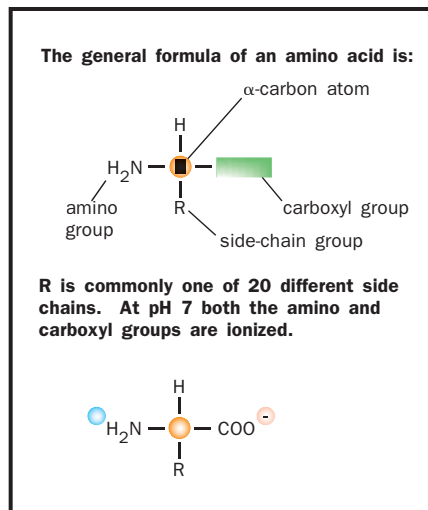

amino acid side chains. In proteins, **acidic** amino acid side chains are negatively charged, and **basic** ones are positively charged. The **polar** and charged amino acids are hydrophilic, meaning they like to interact with water (or are water-loving). The nonpolar, **aromatic**, and sulfur-containing amino acid side chains prefer to interact with themselves or each other (they are hydrophobic, or water-avoiding).

A protein folds so that nonpolar side chains tend to be buried within the protein while polar and charged side chains tend to be exposed to the water around the protein. The biological function of a protein is generally highly dependent on its three-dimensional structure. SEE ALSO ENZYMES; PROTEIN STRUCTURE

Wayne F. Anderson

### Bibliography

Alberts, Bruce, et al. *Molecular Biology of the Cell*, 4th ed. New York: Garland Publishing, 2000.

Stryer, Lubert. *Biochemistry*, 4th ed. New York: W. H. Freeman and Company, 1995.

## Amniote Egg

The amniotic egg was an evolutionary invention that allowed the first reptiles to colonize dry land more than 300 million years ago. Fishes and amphibians must lay their eggs in water and therefore cannot live far from water. But thanks to the amniotic egg, reptiles can lay their eggs nearly anywhere on dry land.

The amniotic egg of reptiles and birds is surrounded by a tough outer shell that protects the egg from predators, **pathogens**, damage, and drying. Oxygen passes through tiny pores in the shell, so the embryo doesn't suffocate. Inside the shell are four sacs. The first sac inside the shell is the chorion, which carries oxygen from the shell to the embryo and waste carbon dioxide from the embryo to the shell. Within the chorion is the

**acidic** having an excess of H<sup>+</sup> ions and a low pH

**basic** having an excess of OH<sup>-</sup> ions and a high pH

**polar** partially charged, and usually soluble in water

**aromatic** compound including a double-bonded carbon ring

**pathogen** disease-causing organism

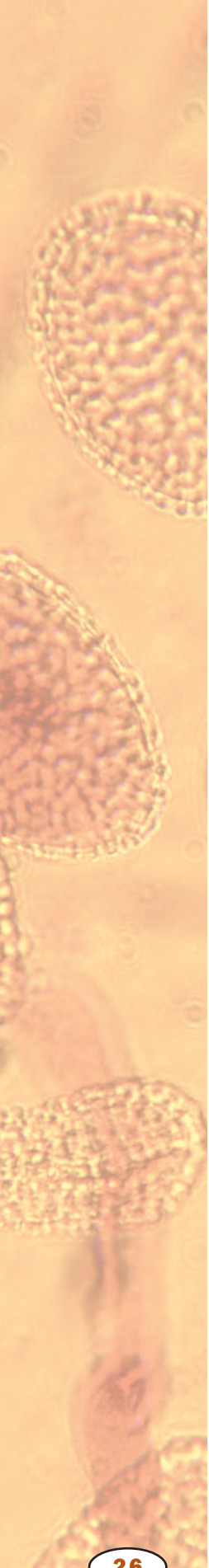

amnion, the membrane for which the amniotic egg is named. The amnion keeps the embryo from drying out, so it's critical to living on land. A third sac, the allantois, stores wastes from the embryo and also fuses with the chorion to form the chorioallantoic membrane, which carries oxygen and carbon dioxide to and from the embryo, just like a lung. A fourth membrane, the yolk sac, holds and digests nutritious yolk for the developing embryo.

Together, the shell and membranes create a safe watery environment in which an embryo can develop from a few cells to an animal with eyes and ears, brain, and heart. Because reptiles, birds, and mammals all have amniotic eggs, they are called amniotes.

The duck-billed platypus and some other mammals also lay eggs. But most mammals have evolved amniotic eggs that develop inside the mother's womb, or uterus, and so lack a shell. In humans and other mammals, the chorion fuses with the lining of the mother's uterus to form an organ called the placenta. The placenta transports oxygen and carbon dioxide to and from the embryo and delivers nutrients from the mother's blood. SEE ALSO BIRD; EVOLUTION; FETAL DEVELOPMENT, HUMAN; MAMMAL; REPTILE

*Jennie Dusbeck*

#### Bibliography

Browder, Leon W., Carol A. Erickson, and William R. Jeffery. *Developmental Biology*, 3rd ed. Philadelphia, PA: Harcourt College Publishing, 1991.

Dorit, Robert L., Warren F. Walker, and Robert D. Barnes. *Zoology*. Philadelphia, PA: Harcourt College Publishing, 1991.

## Amphibian

The class Amphibia consists worldwide of nearly 4,700 species, contained in three major orders: Caudata (salamanders), Gymnophiona (caecilians), and Anura (frogs and toads). Salamanders are composed of about 415 species worldwide, and are typically characterized by their long tails and four limbs of nearly equal size. They first appeared in the fossil record over 190 million years ago in the late Triassic.

The caecilians consist of about 165 species. They have a mostly pantropical distribution, and are characterized by their elongated, annulated (ringed) bodies and lack of legs, resembling worms. These amphibians first appeared in the fossil record nearly 190 million years ago in the early Jurassic.

By far the most successful of the three orders with about 4,100 species worldwide, frogs and toads are characterized by lack of a true tail and by generally having comparatively enlarged hind limbs. The order Anura first surfaced in the fossil record about 230 million years ago in the early Triassic.

Amphibians have relatively moist, scaleless skin and rely heavily on **cutaneous respiration** and/or the presence of a buccopharyngeal pump (a muscular pump in the throat) to force air into their mouth and lungs, features not found in other classes of terrestrial vertebrates. In addition, most amphibians produce eggs that develop and hatch outside their bodies laying gelatinous, unshelled eggs in water or moist places. Many undergo a larval aquatic existence before **metamorphosis** into adults (unlike other classes

**cutaneous respiration** gas exchange through the skin

**metamorphosis** development process that includes a larval stage with a different form from the adult



A strawberry poison arrow frog in Costa Rica.

of terrestrial vertebrates). In a few species, the female retains the eggs in her body where they are nourished directly by her before she gives birth to her young, or they develop by absorbing their own yolk (a phenomenon also known to occur in at least one species of sea snake, class Reptilia).

Some populations of amphibians have disappeared or begun to decline, and this has raised concern among biologists worldwide. It is unknown if this phenomenon is uniformly widespread across all continents, or is occurring only in selected areas. SEE ALSO CROCODYLIANS; REPTILE; TUATARA; TURTLE

*Joseph T. Collins*

### Bibliography

Halliday, Tim R., and Kraig Adler. *The Encyclopedia of Reptiles and Amphibians*. Facts on File, Inc., 1986.

Pough, F. Harvey, R. M. Andrews, J. E. Cadle, M. L. Crump, A. H. Savitzky, and K. D. Wells. *Herpetology*. Upper Saddle River, NJ: Prentice Hall, 1998.

Stebbins, Robert C., and Nathan W. Cohen. *A Natural History of Amphibians*. Princeton, NJ: Princeton University Press, 1995.

## Anabolic Steroids

Anabolic steroids are synthetic chemicals that mimic the effects of the male sex **hormone** testosterone. Some athletes seeking increased muscular strength and size abuse anabolic steroids. They may reach their goal of increased strength in the short term but risk serious medical complications in the long term.

“Anabolic” denotes the ability to induce **protein** synthesis, particularly in muscle cells. As a result, **isometric** muscle strength increases. These steroids are also androgenic, which means that they cause changes characteristic of males, such as growth of facial hair, loss of scalp hair, deepening of the voice, skin oiliness, and aggressive behavior.

**hormone** molecule released by one cell to influence another

requires energy

**protein** complex molecule made from amino acids; used in cells for structure, signaling, and controlling reactions

**isometric** relating to contraction without movement

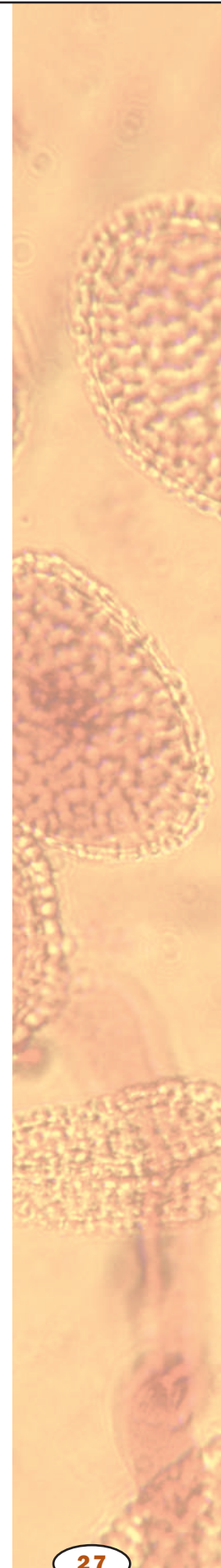



Anabolic steroids increase muscular strength and size, but put their abusers at risk for serious medical complications.

**anemia** lack of oxygen-carrying capacity in the blood

A female taking anabolic steroids experiences irregular menstrual periods and atrophy of the breasts and uterus, and develops the male-associated characteristics. A male may develop an enlarged prostate and atrophy of the testicles.

Steroid abuse stunts height, increases weight, dampens immunity, and can damage the kidneys, liver, and heart. Blood vessels may become blocked with fatty plaque. The liver may develop tumors, and infertility is common. Psychiatric symptoms include depression, delusions, and violent tendencies, sometimes called “roid rage.”

Athletes call anabolic steroids ‘roids, juice, pump, or hype. Some of the one hundred varieties are oxymetholone, oxandrolone, and stanozolol (taken orally) and nandrolone and boldenone (taken by injection). Abusers may take one huge dose seeking instant strength, slowly build up the dose (pyramiding), or “stack” different types of steroids. Whatever the delivery route, the message to the body is the same: there’s too much testosterone; halt normal production.

Despite the well-known side effects of anabolic steroids, use among athletes is widespread, perhaps because of the example set by professional baseball, basketball, and hockey players who use them. However, the National Football League, International Olympic Committee, and National Collegiate Athletic Association ban their use. Still, about 30 percent of college and professional athletes use anabolic steroids, as do 10 to 20 percent of high school athletes. Among U.S. bodybuilders, studies show that steroid use exceeds 80 percent.

Olympic athletes have often been punished for steroid use. After Canadian Ben Johnson flew past his competitors in the 100-meter run in the 1988 summer Olympics, officials rescinded his gold medal when a urine test revealed stanozolol in Johnson’s system. His natural testosterone level was only 15 percent of a normal male’s. Shot-putters, discus throwers, wrestlers, and swimmers have also been known to use anabolic steroids. In 2000, a urine test on U.S. shot-putter C. J. Hunter revealed one thousand times the allowable limit of nandrolone.

Anabolic steroids do have legitimate medical uses. They were first synthesized in the 1930s to treat underdeveloped testes and resulting testosterone deficiency. In the 1950s, they were used to treat **anemia** and muscle-wasting disorders and to bulk up patients whose muscles had atrophied from extended bed rest. In the 1960s, anabolic steroids were used to treat some forms of dwarfism. Today anabolic steroids are being studied for their ability to alleviate the extreme body wasting associated with acquired immunodeficiency syndrome (AIDS). Their most common use, however, remains among athletes seeking a quick competitive edge. SEE ALSO ENDOCRINE SYSTEM; HORMONES; MALE REPRODUCTIVE SYSTEM; MUSCLE

*Ricki Lewis*

### Bibliography

- American Academy of Pediatrics. *Steroids: Play Safe, Play Fair*. <<http://www.aap.org/family/steroids.htm>>.
- Dobs, Adrian Sandra. “Is There a Role for Androgenic Anabolic Steroids in Medical Practice?” *The Journal of the American Medical Association* 281, no. 14 (1999):1326.
- National Institute of Drug Abuse. *Anabolic Steroid Abuse*. <<http://www.nida.nih.gov/ResearchReports/Steroids/anabolicsteroids2.html>>.

## Anatomy of Plants

Plants are the primary producers in Earth's **ecosystem**. Plants are autotrophic, meaning that they produce their own food (via photosynthesis), and as a result ultimately produce food for the ecosystem's consumers (such as humans). Understanding plant function is the key to enhancing crop production, preserving plant biodiversity, producing medicines, and much more. However, in order to understand plant function, one must understand plant form.

### General Anatomical Organization of Plants

Like animals, plant bodies are made up of a variety of cell types that are organized into tissues. Tissues are organized into organs, and organs function together within systems. Within this hierarchy of structure, emergent properties arise at each level. An emergent property is a characteristic or function that can be found at one level that is not present at lower levels. For example, an individual cell of a leaf cannot perform all of the functions of the leaf, but the cells of the leaf collectively perform the function of a leaf. Therefore, the function of each lower level is best understood in the context of the system in which it exists. For this reason, this article begins by exploring the gross anatomical features of a plant and proceeds to examine the anatomy in progressive detail.

Plants are made up of two organ systems: the shoot system and the root system. For terrestrial plants the shoot system is above ground and consists of a number of organs. These include stems, leaves, and flowers. On the other hand, the root system is most often underground and consists of organs such as roots, underground stems (tubers), and rhizomes.

Each of these organs performs a different function. Stems are support structures and mediate the growth of the plant. Shoot tips contain actively dividing regions called meristems, which produce auxin, a **hormone** that regulates the growth and shape of the plant. Leaves are the primary sites of photosynthesis, so they are the food production centers of the plant. Flowers are reproductive structures, where eggs and sperm (pollen) are produced and where pollination and **fertilization** occur. Roots, tubers, and rhizomes are the main system for nutrient and water acquisition and storage. All of these organs are made up of cells that can be categorized into three major tissue types: dermal, ground, and vascular tissue.

### Dermal Tissue

Dermal tissue makes up the outer layers of the plant and contains epidermal cells that secrete and are coated with a waxy layer. This waxy coating, the cuticle, prevents excessive water loss from the plant. While the dermal tissue primarily serves a protective role, it also has a variety of other specialized functions depending on the particular organ where it is located.

In leaves, dermal tissue contains specialized cells called **guard cells** that make up structures called **stomata**. Stomata facilitate the exchange of gases in the leaf. Carbon dioxide (CO<sub>2</sub>) diffuses into the leaf through the stomata for use in photosynthesis, and oxygen (O<sub>2</sub>), the waste product of photosynthesis, diffuses out of the leaf through stomata. Stomata are also crucial for water transport through the **xylem**. Stomatal opening results in the evap-

**ecosystem** an ecological community and its environment

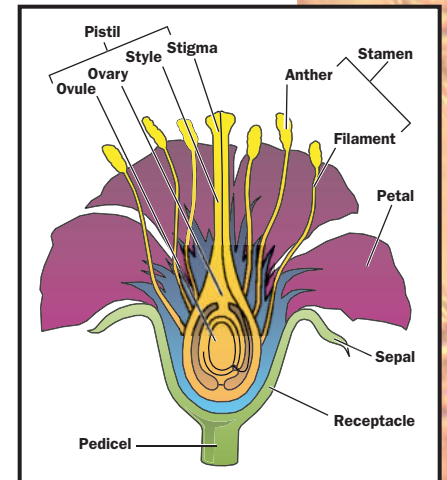

Structure of angiosperm flowers. Redrawn from Van de Graaff et al., 1994.

**hormone** molecule released by one cell to influence another

**fertilization** union of sperm and egg

**guard cells** paired cells on leaves that control gas exchange and water loss

**stomata** openings in leaves for gas exchange, surrounded and regulated by guard cells

**xylem** water-transporting system in plants

**mycorrhizae** symbioses between soil fungus and plant root to maximize absorption

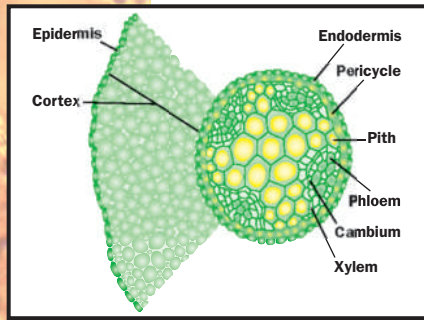

Transverse section of tissues of a dicot root. Redrawn from Van de Graaff et al., 1994.

**lignin** organic molecule used in plant cell walls to add stiffness to cellulose

**protoplasm** fluid portion of a plant cell within the cell wall

**organelle** membrane-bound cell compartment

**minerals** iron, calcium, sodium, and other elements needed by living organisms

**phloem** plant tissue that conducts sugars from leaves to roots and other tissues

**amino acid** a building block of protein

oration of water from the air spaces of the leaf. This creates negative water pressure that pulls on the column of water in the xylem. The evaporation of water from the stomata is the main driving force for water transport through the water. In roots, epidermal cells have a specialized structure that facilitates water and nutrient absorption, the main function of the root. Some of the root epidermal cells have long membranous extensions called root hairs that increase the absorptive surface area of the root. Root epidermis also interacts with symbiotic fungi that form **mycorrhizae**, which increase nutrient absorption.

## Ground Tissue

Many different functions are performed by ground tissue including photosynthesis, storage, and support. Ground tissue makes up the majority of the plant structure and is composed of three cell types: parenchyma, collenchyma, and sclerenchyma cells.

Parenchyma cells are the least specialized cells in a plant. These cells are responsible for the production and storage of nutrients. Photosynthesis occurs in the chloroplasts of parenchyma cells in leaves. Parenchyma cells in stems, roots, and fruits have structures that store starch. Most developing plant cells are structurally similar to parenchyma cells. During their differentiation, they become specialized in form and function and lose the potential to divide. Mature parenchyma cells do not usually divide, but they retain the ability to divide and differentiate into different cell and tissue types in the event of an injury to the plant.

Collenchyma and sclerenchyma cells provide structural support for the plant. Collenchyma cells have thick, yet pliable, cell walls. These cells give structural support to newly formed portions of a plant without restricting growth. Collenchyma cells are stacked end on end and are oriented in strands just beneath the epidermis of the young structure. The relatively soft cell wall allows the collenchyma cells to elongate as the structure grows.

On the other hand, sclerenchyma cells provide support to mature plant structures. Like collenchyma cells, they have very thick cell walls. However, the cell walls of sclerenchyma cells contain **lignin**, a molecule that makes the cell wall hard. This provides strength to the cell wall, but restricts the ability of the cells to elongate and grow. Since a sclerenchyma cell functions solely to provide structural support, many sclerenchyma cells are actually dead at functional maturity. The cell membrane, **protoplasm** (cytoplasm) and **organelles** are gone, leaving only the rigid cell wall that serves as a scaffolding system for that structure.

## Vascular Tissue

Vascular tissues make up the organs that transport water, **minerals**, and food throughout the plant. Vascular tissue can be divided into two functional units. Xylem transports water and minerals from root to shoot. **phloem** transports nutrients (such as sugar and **amino acids**) from leaves and other production sites to roots, flowers, stems, and other tissues that need them. The cells that make up vascular tissue are unique in their structure. Their specialized characteristics allow them to transport material through the plant efficiently while providing structural support to the plant.

Xylem tissue contains two types of cells: tracheids and vessel elements. Like sclerenchyma, both of these cell types are dead at functional maturity and therefore lack protoplasm. Tracheids are long, thin cells that have tapered ends. They overlap on another, and water passes from tracheid to tracheid via small pores. Vessel elements are shorter and are stacked end to end, forming more of a tube structure. Water flows in the tube by passing through perforated end walls between cells.

Phloem tissue is made up of two different types of cells: sieve tube members and companion cells. Sieve tube members are the main conducting cells, and are named for the sievelike areas along their cell walls through which the phloem sap moves from cell to cell. Unlike cells of the xylem, sieve tube members are alive at functional maturity, but do not have nuclei. For this reason, companion cells are closely associated with sieve tube members. These cells do have nuclei and serve to support the sieve tube members. The **cytoplasm** of sieve tube members and companion cells is connected through numerous pores called plasmodesmata. These pores allow the companion cells to regulate the content and activity of the sieve tube member's cytoplasm. Moreover, the companion cells help to load the sieve tube members with sugar and the other metabolic products that they transport throughout the plant. SEE ALSO ALGAE; ANGIOSPERMS; BRYOPHYTES; CELL WALL; CONIFERS; FRUITS; GYMNASPERMS; LEAVES; MERISTEMS; MYCORRHIZAE; PTERIDOPHYTES; ROOTS; SHOOTS; TRANSLOCATION; WATER MOVEMENT IN PLANTS

Susan T. Rouse

### Bibliography

*Atlas of Plant Anatomy*. <<http://atlasveg.ib.usp.br/English/>>.

Moore, Randy, et al. *Botany*, 2nd ed. New York: McGraw-Hill, 1999.

*Plant Anatomy Images*. University of Rhode Island. <[http://www.uri.edu/artsci/bio/plant\\_anatomy/images.html](http://www.uri.edu/artsci/bio/plant_anatomy/images.html)>.

## Angiosperms

The angiosperms, or flowering plants, are the largest and most species-rich **phylum** of plants, with more than 250,000 species estimated.

### Defining Characteristics

The term “angiosperm” derives from two Greek words: *angeion*, meaning “vessel,” and *sperma*, meaning “seed.” The angiosperms are those plants whose seeds develop within a surrounding layer of plant tissue, called the carpel, with seeds attached around the margins. This arrangement is easily seen by slicing into a tomato, for example. Collectively, carpels together with the style and stigma are termed the ovary, and these plus associated structures develop into the mature fruit. The enclosed seeds and the presence of carpels distinguish angiosperms from their closest living relatives, the **gymnosperms**, in which the seed is not enclosed within a fruit, but rather sits exposed to the environment. Some defining characteristics of angiosperms include flowers, carpels, and the presence of endosperm, a nutritive substance found in seeds, produced via a second **fertilization** event.

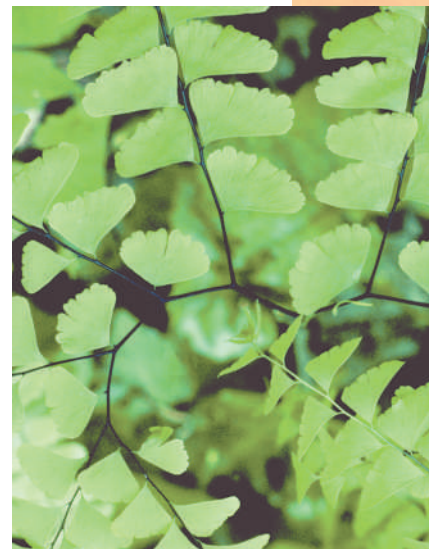

A photograph of a maidenhair fern, showing its shoot system of stems and leaves.

**cytoplasm** material in a cell, excluding the nucleus

**phylum** taxonomic level below kingdom, e.g., arthropod or chordate

**gymnosperms** “naked seed” plants, including conifers

**fertilization** union of sperm and egg





An iris. Angiosperms, or flowering plants, are quite diverse in morphology, growth form, and habitat.

**sepal** whorl of flower organs outside of the petals, usually green and serving to protect the flower before it opens

**pistil** female reproductive organ of a flower

**lineage** ancestral line

**phylogenetic** related to phylogeny, the evolutionary development of a species

**basal** lowest level

**monocot** any of various flowering plants, such as grasses and orchids, that have a single cotyledon in the seed

**eudicot** “true dicot”; plants with two seed leaves that originated from the earliest of flowering plants

However, some current studies suggest that endosperm is not unique to angiosperms.

Angiosperm flowers are generically characterized by having four whorls, or sets of organs: **sepals**, petals, stamens, and carpels. The carpels may be united or fused to form a compound **pistil**, and the number of stigma lobes may then be indicative of the number of carpels. The pistil also includes the stigma, on which pollen lands, and style, the tube leading to the egg. Stamens are separated into anthers, which produce pollen, and filaments. The mature ovary (part of the pistil containing the seeds) is termed a “fruit.” Sepals and petals may be showy and colorful to attract pollinators, or may be quite reduced in wind-pollinated plants, such as grasses. Likewise, fruits may assume a wide variety of forms associated with mode of dispersal, such as fleshy fruits (for example, berries) dispersed by animals, and dry, winged fruits adapted for wind dispersal, such as the samaras of maple trees, which twirl like helicopters as they fall.

## Evolution and the Angiosperms

The angiosperms are a relatively recent group of land plants, and are thought to have originated in the early Cretaceous, only 130 million years ago. The angiosperms increased dramatically in abundance during the Cretaceous. This sudden, dramatic appearance of large numbers of very diverse flowering plant species in the fossil record was referred to by English naturalist Charles Darwin as an “abominable mystery.” It is postulated that coevolution with animal pollinators, especially insects, may have contributed to the explosion and abundance of angiosperm species which characterize the modern earth’s flora. However, even today, it is not clear what group of non-flowering plants the angiosperms are most closely related to, or what the relationships of the early **lineages** of flowering plants are to one another. This is in part due to the extremely fast evolution of this group of plants, over a relatively short period of time, and the extinction of many closely related lineages of seed plants, some of which may be more closely related to the modern angiosperms than extant seed plant lineages.

Most contemporary studies, which are based on **phylogenetic** analysis of deoxyribonucleic acid (DNA) sequence data from as many as six different genes, suggest that the closest relatives of the angiosperms are the gymnosperms, which include cycads, *Ginkgo*, conifers (the group that contains the pines, spruces, firs, and relatives), and Gnetales (a group containing three ancient genera: *Ephedra*, the Mormon tea; *Welwitschia*, a bizarre plant of southwest African deserts; and *Gnetum*, a genus of mostly tropical vines). The origins of angiosperms are not well understood and remain problematic, in part because many seed plant lineages have already gone extinct. However, studies indicate that the earliest lineage of flowering plants, or **basal** angiosperms, may include the family Amborellaceae (with the single living species *Amborella trichopoda*, a shrub from the South Pacific island of New Caledonia). Other early diverging lineages of angiosperms include Nymphaeales, the water lilies; Illiciales, or star anise; a group called the magnoliids, which includes magnolias, laurels, and black pepper; and the very large group called the **monocots**. A final lineage, the **eudicots**, contains all other flowering plants and comprises the bulk (approximately three-quarters) of the flowering plant species.

## Monocots, Dicots, and Eudicots

The angiosperms have historically been divided into two groups: the monocotyledons (monocots) and the dicotyledons (dicots). These terms derive from the number of seed leaves, or **cotyledons**, the plants have upon germination. Dicots have recently been shown not to be an evolutionarily natural group.

The monocots do form an evolutionarily natural, or **monophyletic**, group, and include familiar plants such as lilies, grasses, and palm trees. The monocots are characterized by having a single cotyledon, an **adventitious** root system, stems with scattered vascular bundles, absence of woody growth, leaves with parallel venation, flower parts usually in sets of threes, and monoaperturate pollen (that is, pollen with one large, groovelike aperture).

The dicots have historically included all those plants with two cotyledons, tap root systems, stems with vascular bundles in a ring, leaf venation forming a netlike pattern, and flower parts in fours or fives. Current studies indicate that the dicots do not form an evolutionarily monophyletic group, but instead include several different lineages, some of which are more closely related to the monocots.

Two groups that are well supported in contemporary studies are the eudicots (“true dicots”), characterized by having triaperturate pollen (that is, pollen with three long, groovelike apertures), and the noneudicots, which are characterized by having inaperturate pollen; that is, pollen lacking apertures. Noneudicot, basal angiosperms include the monocots, the laurels and avocados, the magnolias, black pepper, *Amborella*, water lilies and Illiciaceae (the star anise family). Evolutionary relationships among these noneudicot groups are not well understood. The eudicots include many familiar plants, including most trees, and include two major groups of flowering plants, the asterids (including the composite family, and the economically important Solanaceae, the potato family) and the rosids (including the rose family and the economically important legume family).

## Diversity and Symbioses

Some of the most species-rich families of flowering plants include the monocot species of Orchidaceae, the orchids (19,500 species), the Poaceae or grass family (8,700), the Cyperaceae or sedge family (4,500), and the eudicot families of Euphorbiaceae or spurge family (6,900), the Fabaceae or legume family (18,000), the Rosaceae or rose family (3,000), Brassicaceae or mustard family (4,130), Rubiaceae or coffee family (9,000), the Lamiaceae or mint family (6,970), the Apiaceae or carrot family (4,250), and the Asteraceae or composite family (23,000).

The angiosperms are of great ecological importance and are principal components of nearly all of the major land habitats. Correspondingly, flowering plants are quite diverse in **morphology**, growth form, and habitat, and range from the minute aquatic plants in the duckweed family (genus *Lemna*) to the massive forest trees, such as oak and maple. Angiosperm flowers can be quite reduced, as in the grasses, where the most visible floral parts are the stamens and stigmas, to quite elaborate floral structures exhibiting fusion of parts and development of complex shapes, such as those evolved to attract insect pollinators in the orchids, mints, and snapdragons.

**cotyledon** seed leaf, which stores food and performs photosynthesis after germination

**monophyletic** a group that includes an ancestral species and all its descendants

**adventitious** growing from a nonstandard location

**morphology** related to shape and form

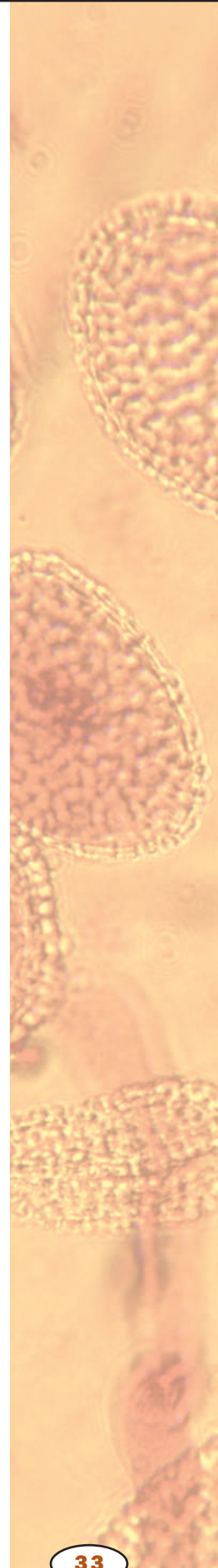

**symbionts** organisms living in close association with another organism

**eukaryotic** of, relating to a cell with a nucleus

**protein** complex molecule made from amino acids; used in cells for structure, signaling, and controlling reactions

**diploid** having pairs of chromosomes in the nucleus

**motile** able to move

**zygote** fertilized egg

**metamorphosis** development process that includes a larval stage with a different form from the adult

An important aspect of angiosperm evolution is their well-documented relationships with other organisms such as animal pollinators, mycorrhizal (fungal) root associations, and even bacteria. Indeed, one of the most successful families of flowering plants, in terms of number of species, are the orchids, which have very specialized relationships with both pollinators and mycorrhizal interactions. Another highly successful family, the legume family, has evolved symbiotic relationships with nitrogen-fixing bacterial **symbionts**. Some flowering plants, such as the acacias of the legume family, obtain protection from herbivores via symbiotic relationships with ants. Through agriculture, humans have developed their own complex relationship with angiosperms. It is these relationships with other organisms that is the hallmark of angiosperms, and as such have contributed to the success of the flowering plants in the modern earth's flora. SEE ALSO CONIFERS; FRUITS; GYMNOSPERMS; MONOCOTS; NITROGEN FIXATION; POLLINATION AND FERTILIZATION; ROOTS; SYMBIOSIS

*Molly Nepokroeff and Elizabeth A. Zimmer*

### Bibliography

- Crane, P. R., E. M. Friis, and K. R. Pederson. "The Origin and Early Diversification of Angiosperms." *Nature* 374 (1995): 27–33.
- Judd, Walter S., Christopher S. Campbell, Elizabeth A. Kellogg, and Peter F. Stevens. *Plant Systematics: A Phylogenetic Approach*. Sunderland, MA: Sinauer Associates, Inc., 1999.
- Kenrick, Paul. "The Family Tree Flowers." *Nature* 402 (1999): 358–359.
- Parkinson, C. L., K. L. Adams, and J. D. Palmer. "Multigene Analyses Identify the Three Earliest Lineages of Flowering Plants." *Current Biology* 9 (1999): 1485–1488.

## Animalia

The kingdom Animalia, or Metazoa, includes all animals. Animals are multicellular, **eukaryotic** organisms, which are heterotrophic, meaning they obtain nutrition from organic sources. Most animals obtain nutrition by ingesting other organisms or decomposing organic material.

Animal cells are characterized by their lack of a rigid cell wall exhibited by fungi and plants. Instead, animal cells are held together by structural **proteins** such as collagen. All animals, except for the sponges, are made up of cells organized into tissues that are specialized for some function. As a result, most animals are capable of complex behavioral responses and rapid movement.

Most animals are **diploid**, meaning they have two copies of all genetic information for most of their life cycle. Most animals reproduce sexually with differentiated sex cells. These cells (large, nonmotile eggs and small, **motile** sperm) fuse to form a new diploid individual called a **zygote**. The zygote undergoes a series of cell divisions, called cleavage, to form a hollow, multicellular ball known as a blastula. The blastula then folds in on itself to form a gastrula, a double-walled structure with an opening to the outside called the blastopore. Some animals (including all mammals) develop and mature directly into adults but the development of most animals includes larval stages. Larvae are immature forms that are morphologically distinct from adults. The process of **metamorphosis** transforms larvae into



A jellyfish is a radially symmetric animal with internal organs that are visible through its transparent, gelatinous body.

their adult form. A familiar example is the metamorphosis of a tadpole into a frog.

Although taxonomists disagree about the identity of major animal groups and the relationships among them, most agree that Animalia is monophyletic. This means that all animals can trace their descent to a single common ancestor. There are approximately thirty-two living animal groups, or phyla, each with a distinctive body plan and biological properties.

All of these are the survivors of the one hundred or so animal phyla that evolved during the Cambrian explosion. This incredible diversity of animal body plans and lifestyles arose in the relatively short period of 40 million years, between 565 and 525 million years ago. All of today's remarkably diverse animal forms are variations on the basic body plans that evolved during the Cambrian.

The most primitive animal group is the phylum Porifera, the sponges. The remaining animal groups can be divided into radial and **bilaterally symmetric** animals. **Radially symmetric** animals are the cnidarians, including jellyfish, corals, and anemones, and ctenophores, or comb jellies.

**bilaterally symmetric** symmetric, or similar, across a central line

**radially symmetric** symmetric, or similar, about a central point (a wheel is radially symmetric)

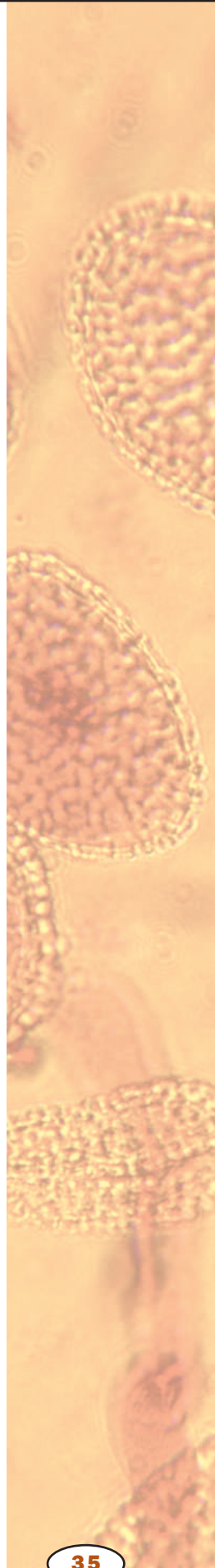

**nematode** worm of the Nematoda phylum, many of which are parasitic

**protostome** “mouth first”; referring to the early development of the oral pore during gut tube formation

**deuterostome** “mouth second”; referring to the early development of the anal pore during gut tube formation

**ecosystem** an ecological community and its environment

**phylogenetic** related to phylogeny, the evolutionary development of a species

**bilaterally symmetric** symmetric, or similar, across a central line

Bilaterally symmetric animals (which include all vertebrates) are further divided based on types of body cavities and variations on the pattern of gastrula formation during development. Flatworms, phylum Platyhelminthes, have no body cavity. Ten phyla of animals, including **nematodes** and rotifers, have a primitive type of body cavity.

All other animals have a true body cavity and are divided into two major groups. **Protostomes** include Mollusca (clams, snails, and octopi), Annelida (segmented worms), Arthropoda (spiders, crustaceans, and insects), and several minor phyla. **Deuterostomes** include Echinodermata (sea stars and sea urchins), two proto-chordate phyla, and Chordata (tunicates, lancelets, sharks, fish, amphibians, snakes and lizards, birds, and mammals). SEE ALSO ANNELID; ARTHROPOD; CAMBRIAN EXPLOSION; CELL; CHORDATA; CNIDARIAN; ECHINODERM; MOLLUSK; NEMATODE; PLATYHELMINTHES; PORIFERA; PROTEIN STRUCTURE; TUNICATE

Tanya A. Dewey

### Bibliography

Campbell, Neil A., Jane B. Reece, and Lawrence G. Mitchell. *Biology*. Menlo Park, CA: Benjamin/Cummings, 1999.

Hickman, Cleveland P. Jr., Larry S. Roberts, and Allan Larson. *Animal Diversity*. New York: McGraw-Hill, 2000.

## Annelid

Annelids, or true-segmented worms, are members of the animal phylum Annelida, the most complex of all wormlike groups of organisms. Annelids are commonly found in terrestrial, as well as marine, brackish, estuarine, and freshwater **ecosystems** worldwide. Most annelids are free-living, although several species have parasitic, mutualistic, or commensal relationships with other animals, and many species are commonly associated with aquatic and terrestrial plants.

Six major classes comprise this phylum: Polychaeta (polychaete, or many-bristled worms; primarily marine; more than 15,000 species [spp.]); Oligochaeta (oligochaete worms; freshwater, terrestrial, marine; more than 8,000 spp.), Hirudinea (leeches; freshwater, terrestrial, marine; more than 700 spp.), Branchiobdellida (crayfish worms; freshwater, live on crayfishes; more than 100 spp.), Aphanoneura (suction-feeding worms; freshwater; more than 30 spp.), and Acanthobdellida (bristle leech; parasitic on Arctic marine fishes; 1 sp.). As with any group of organisms, the **phylogenetic** relationships of the diverse groups within annelids, and of the phylum to others within the animal kingdom, is the subject of continuing debate. The marine invertebrate groups Echiura and Sipunculida recently were aligned with the annelids.

All annelids are **bilaterally symmetrical**, with an elongated, cylindrical body shape divided both externally and internally by a regular, linear series of segments. The highly developed digestive, circulatory, nervous, and excretory systems within the body cavity, or coelom, reflect external segmentation and generally are repeated serially; this is called metameric segmentation, and distinguishes annelids from all other wormlike groups. Annelids range in size from less than 0.7 millimeters (0.019 inch) to over 3

meters (9.8 feet) in length. The number of segments is relatively fixed in some groups (Branchiobdellida, Hirudinea), but indeterminate in others. External form of annelids is diverse, even within each group; the polychaetes may have distinct body regions, with limblike parapodia, chaetae (hairs), tentacles, and antennae, while others may appear similar to an earthworm, with few if any external **appendages**. Most oligochaete species have chaetae arranged in bundles on each segment. Several aquatic oligochaetes and many polychaetes have gills.

Leeches are usually flattened, with a posterior sucker and **anterior** suckerlike mouth; several species have jaws, others have an extendable proboscis. The branchiobdellidans have a posterior sucker and an anterior end with several fused segments and distinct teeth. Chaetae are absent in leeches and branchiobdellidans. The single species of Acanthobdellida is shaped like an elongate leech, with a few hooked chaetae located ventrally on a few anterior segments. Annelids are hermaphroditic; reproduction is commonly sexual, but many species reproduce asexually by budding or fragmentation. Annelids are important components of their respective habitats, whether it be the bottom of freshwater or marine environments, or the soil. The feeding habits of many species are important in the decomposition of **organic** matter and recycling of nutrients in terrestrial and aquatic environments. Many annelids feed on algae, insects, carrion, and other worms, and several leech species consume the blood of turtles, birds, fishes, and mammals. SEE ALSO NEMATODE; PLATYHELMINTHES

Mark J. Wetzel

### Bibliography

- Brusca, Richard C., and Gary J. Brusca. *Invertebrates*. Sunderland, MA: Sinauer Associates, Inc., 1990.
- Dindal, Daniel L., ed. *Soil Biology Guide*. New York: John Wiley & Sons, 1990.
- Fauchald, Kristian. "Worms, Annelida." In *Encyclopedia of Biodiversity*, Vol. 5. Edited by S. A. Levin. San Diego, CA: Academic Press, 2001.
- Ruppert, Edward E., and Robert D. Barnes. *Invertebrate Zoology*, 6th ed. Philadelphia, PA: Saunders College Publishing, 1994.
- Thorp, James H., and Alan P. Covich. *Ecology and Classification of North American Freshwater Invertebrates*, 2nd ed. San Diego, CA: Academic Press, 2001.

## Antibodies in Research

Antibodies are **proteins** made by B cells, part of the body's immune system. The normal function of antibodies is to latch onto foreign substances (antigens) and flag them for destruction, thus helping to fight infection. This ability to bind to specific molecules makes them ideal probes in cell research, where they are used to latch onto, and thus help isolate and identify, molecules of interest in and on cells. Antibodies have become one of the most important tools for studying protein function in cells.

To see how antibodies are used, consider the challenge of determining where actin is located in a nerve cell. Actin is a protein that forms part of the **cytoskeleton**, giving internal structure to the cell much like the human skeleton does. First, purified actin is used to trigger an immune reaction in a rabbit. The B cells that make the anti-actin antibodies are then isolated

**appendage** attached organ or structure

**anterior** toward the front

**organic** composed of carbon, or derived from living organisms

**protein** complex molecule made from amino acids; used in cells for structure, signaling, and controlling reactions

**cytoskeleton** internal scaffolding in a cell, composed of protein

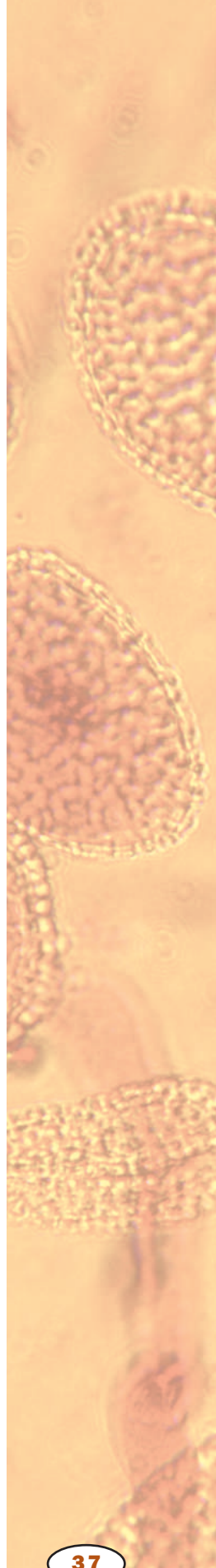

An enzyme-linked immunosorbent assay (ELISA) plate, an immunologic test that can be used to indicate pregnancy or HIV infection by detecting very small quantities of antigens and antibodies (HTLV-III viral antibodies, in this case).

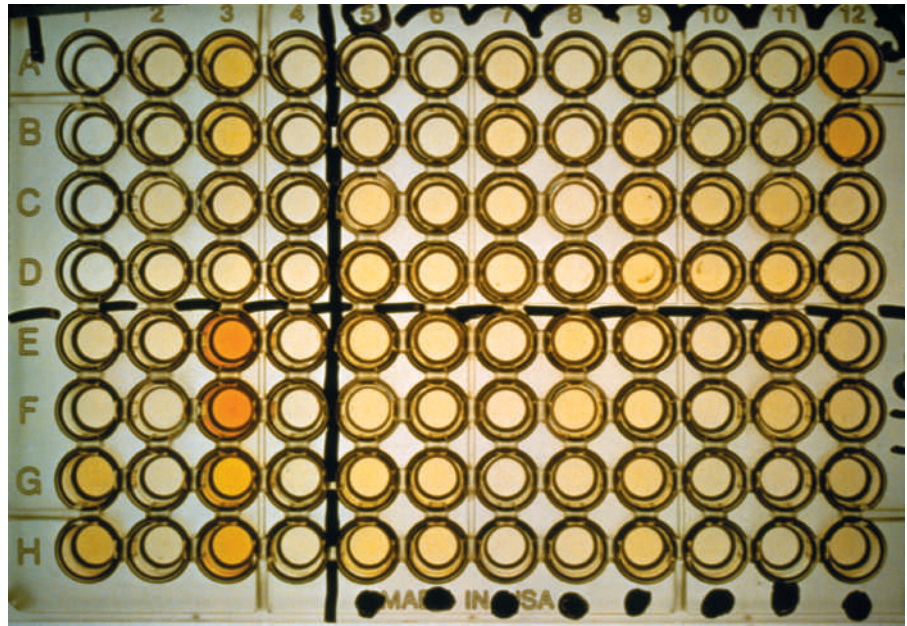

and fused with tumor cells. Unlike B cells, tumor cells will grow forever in the lab, and thus can supply large amounts of anti-actin antibodies indefinitely. These can be harvested from the cells in large quantities. The resulting antibodies are called “monoclonal” antibodies, because they derive from identical (cloned) cells.

Next, in order to make the antibodies visible once inside the cell, a fluorescent molecule is attached to them. They are then injected into the cell using a very fine glass needle. Once an antibody encounters actin, it attaches to it. The cell can then be examined under the light microscope, where the fluorescent molecules will light up, revealing the location of the actin. Of course it is not just actin that can be found this way; any protein to which we can make an antibody can be located in the cell.

Several modifications and extensions of this basic procedure are possible. To mark more than one protein at a time, a set of different antibodies is used, each marked with a differently colored fluorescent tag. In this way, for instance, the spatial relations between actin and other cytoskeleton proteins can be visualized. Instead of fluorescent tags, antibodies can be attached to gold particles, which will show up under the electron microscope. Outside of cells, antibodies attached to glass beads can grab proteins out of a homogenized cell puree, allowing the protein to be isolated for further study. In one widely used technique called western blotting, fluorescently tagged antibodies are used to locate proteins of interest that have been separated in **electrophoresis** gels.

Antibodies are also used in a test, or assay, called the **enzyme**-linked immunosorbent assay (ELISA). This is the assay used in the home pregnancy test, which detects the presence of human chorionic gonadotropin (HCG), produced by human embryos. The test kit contains an antibody to HCG, which traps HCG if it is present in a woman’s urine. Next, a second antibody to HCG is added, which will bind to the HCG if it is trapped. This antibody is linked to an enzyme called peroxidase. Chemicals are then

**electrophoresis** technique that uses electricity to separate molecules based on size and electric charge

**enzyme** protein that controls a reaction in a cell

added which the peroxidase will cause to react, making a color change. The color change will only occur if the enzyme is present, and the enzyme will only be present if the HCG is present. Therefore, a color change indicates pregnancy. An ELISA test is also used to screen for HIV (human immunodeficiency virus) infection. In this case, the test kit contains HIV proteins, which bind to anti-HIV antibodies in the patient's blood.

It is the specificity of the antibody-antigen reaction, combined with the ability to link one or the other to fluorescent tags, enzymes, or other markers, that makes antibodies such versatile tools in both basic and clinical research. SEE ALSO ANTIBODY; CLONE; CYTOSKELETON; ELECTROPHORESIS; FEMALE REPRODUCTIVE SYSTEM

*Richard Robinson*

### Bibliography

*ELISA at the Biology Project.* <<http://www.biology.arizona.edu/immunology/activities/elisa/main.html>>.

Roitt I., D. Male, and J. Brostoff. *Immunology*, 5th ed. New York: Mosby, 1998.

### YALOW, ROSALYN SUSSMAN (1921–)

U.S. biologist who developed a technique, called “radioimmunoassay,” for detecting and measuring tiny amounts of biological substances using radioactive antibodies. Her technique led to enormous numbers of medical breakthroughs, but most notably it opened up the entire field of endocrinology, the study of hormones. Dr. Yalow was awarded the 1977 Nobel Prize in medicine for her research.

## Antibody

In 1890 scientists transferred blood from animals with diphtheria to animals never exposed to the disease. The second group of animals became resistant (or immune) to diphtheria. Over the next decade, investigators such as Emil von Behring, Shibasaburo Kitasato, Karl Landsteiner, and Paul Ehrlich studied this phenomenon and discovered that this transfer of immunity occurred because of **proteins** called antibodies. This type of immunity was called humoral immunity. The word “humoral” refers to body fluids, and antibodies are found in the liquid part of the blood. Antibodies are an extremely important part of the body's defense against infection.

Antibodies are also called gamma globulins and **immunoglobulins** (abbreviated “Ig”). Vertebrate animals make antibodies, but invertebrate animals do not. They are made by white blood cells called B lymphocytes (or B cells). Antibodies are capable of attaching to foreign invaders, targeting them for destruction. They can do this because of their structure.

### Structure

Antibodies are Y-shaped molecules. At the end of each arm of the Y is a pocket called an antigen binding site. An antigen is a piece of a foreign invader that starts an immune response. An antigen fits inside the antigen binding site of an antibody because the structures match, like a key in a lock. Each antibody has antigen binding sites different from other antibodies. Consequently, each antibody recognizes a different piece of a foreign invader. This explains how the immune system specifically identifies a wide variety of foreign invaders.

Each antibody is composed of four chains of **amino acids**. There are two light chains and two heavy chains. The arms of the antibody contain both light and heavy chains. They are called the *variable regions* because this is where antigen binding sites are located. The **genes** that determine the variable region's structure undergo a series of rearrangements as a B cell

**protein** complex molecule made from amino acids; used in cells for structure, signaling, and controlling reactions

**immunoglobulin** an immune protein, also called an antibody

**amino acid** a building block of protein

**gene** portion of DNA that codes for a protein or RNA molecule



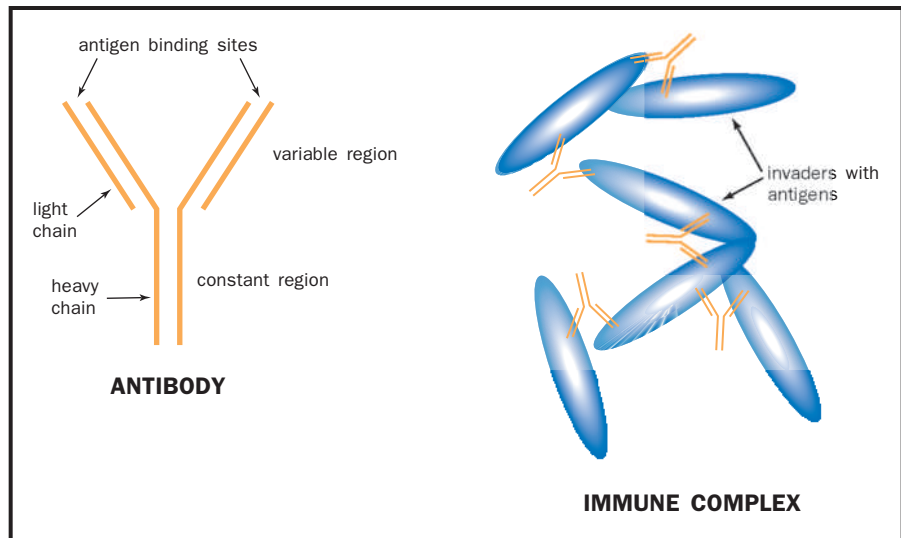

matures. Millions of possible antibodies can be produced by this rearrangement. However, once the genes are rearranged, the B cell is committed to making only one type of antibody.

The base of the Y contains only heavy chains and is called the *constant region*. The constant region determines the antibody's class. Mammals make five main classes of antibodies. Each class works differently to protect the body from disease.

### Classes of Antibodies

IgM and IgD are two classes of antibodies. They are found on the surface of mature B cells. If a B cell encounters an invader with antigens that match its antibodies (like a key in a lock), the antigen is brought inside and then displayed on the surface, akin to waving the enemy's captured flag. This alerts other immune cells that it is ready to be activated. If the B cell gets the appropriate signals from **T cells**, it becomes activated, dividing rapidly and secreting antibodies into the surrounding fluid. B cells that release antibodies are also called plasma cells. The first class of antibodies secreted by B cells is IgM. Like all antibodies, IgM travels through the body's fluids, binding to antigens to eliminate the invader. IgM antibodies are often found in groups of five, forming a structure called a pentamer.

The B cell may then switch the class of antibodies it is secreting to more effectively remove the invader. It will most likely start producing the IgG class of antibodies. Unlike other antibodies, IgG can be transferred across the placenta from mother to fetus.

B cells may also produce IgA antibodies. Because IgA is found in **secretions** such as milk, tears, saliva, sweat, and mucus, it represents an important first line of defense against invaders trying to enter the body. IgA antibodies are often found in groups of two, forming a structure called a dimer.

Finally, B cells may produce IgE antibodies. IgE provides protection against parasitic infections. IgE binds to white blood cells called mast cells and basophils. When an antigen is encountered, IgE signals these cells to

**T cell** white blood cell that controls the immune response

**secretions** materials released from the cell

release chemicals that cause inflammation. This process is responsible for the symptoms of many allergies.

The binding of antibodies to antigens protects the body in several ways. The invader may simply be neutralized, unable to infect healthy cells. Secondly, large numbers of antibodies can bind large numbers of antigens, forming an immune complex. Immune complexes are large and precipitate out of solution, increasing the chance that white blood cells called phagocytes will destroy them. In fact, any antigen with an attached antibody is likely to be phagocytosed. This is because phagocytes can bind to antibodies, allowing phagocytes to more easily recognize the antigen. Finally, blood proteins called complement can destroy the membranes of foreign cells. Complement proteins do this more easily when antibodies are attached to the target. **Phagocytosis** and complement proteins are both examples of nonspecific immunity.

As the research since the late 1800s has shown, interactions between specific antibodies and nonspecific defenses give the immune system a powerful tool to eliminate invaders. SEE ALSO AUTOIMMUNE DISEASE; IMMUNE RESPONSE; NONSPECIFIC DEFENSE; T CELL

*John M. Ripper*

### Bibliography

- Beck, Gregory, and Gail S. Habicht. "Immunity and the Invertebrates." *Scientific American* 275, no. 5 (1996): 60–65.
- Friedlander, Mark P., Jr., and Terry M. Phillips. *The Immune System: Your Body's Disease-Fighting Army*. Minneapolis, MN: Lerner Publications Company, 1998.
- National Institutes of Health. *Understanding the Immune System*. Washington, DC: National Institutes of Health, 1993.
- Nossel, Gustav J. "Life, Death, and the Immune System." *Scientific American* 269, no. 3 (1993): 53–62.
- Paul, William E. "Infectious Diseases and the Immune System." *Scientific American* 269, no. 3 (1993): 90–97.

## Antisense Nucleotides

Antisense nucleotides are either ribonucleic acid (RNA) or deoxyribonucleic acid (DNA) molecules that are **complementary** to a messenger RNA (mRNA) molecule. Because these molecules are complementary to given mRNA, they will bind to the RNA and form a free double-stranded molecule or double-stranded region of a **chromosome**. The double-stranded molecules are not able to interact with **ribosomes** and, as a result, a particular **protein** is unable to be made. Inhibiting the production of a given protein may be important in the control and treatment of many diseases such as cancer.

Two approaches to antisense nucleotides have been tried: (1) direct introduction of antisense nucleotides into cells and (2) synthesis of antisense nucleotides within the cell. In the first approach, short antisense oligonucleotides are introduced directly into cells in hopes that they will interact with the appropriate mRNA. Scientists are using different nucleotides that are complementary to different regions of the mRNA—beginning, middle, or end—in an attempt to determine the most effective sequence.

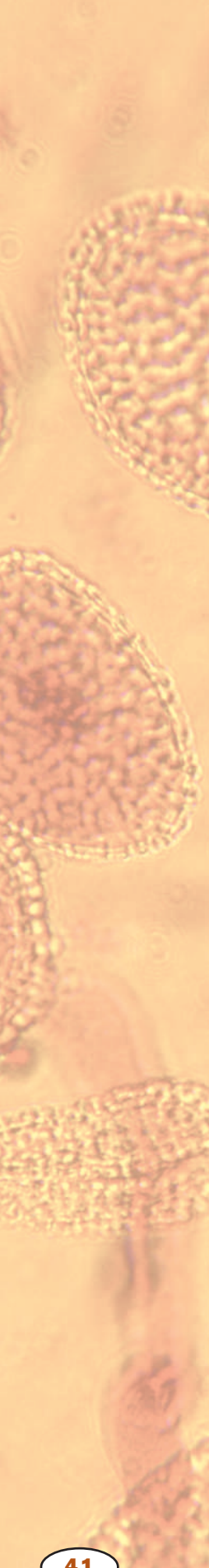

**phagocytosis** engulfing of cells or large fragments by another cell, including immune system cells

**complementary** matching opposite

**chromosome** "colored body" in the cell nucleus; made of DNA and protein, and divided functionally into genes and non-gene regions

**ribosome** protein-RNA complex in cells that synthesizes protein

**protein** complex molecule made from amino acids; used in cells for structure, signaling, and controlling reactions

**enzyme** protein that controls a reaction in a cell

**transcription** messenger RNA formation from a DNA sequence

**phylum** taxonomic level below kingdom, e.g., arthropod or chordate

**exoskeleton** external skeleton

**metamorphosis** development process that includes a larval stage with a different form from the adult

**enzyme** protein that controls a reaction in a cell

Unfortunately, **enzymes** within cells often degrade these short oligonucleotides before they can interact with the target mRNA. Replacing the phosphate linkages in the nucleotides with sulfur or other linkages seems to prevent degradation.

The second approach involves using a vector (a vehicle for transferring genetic material) containing the entire gene to transfer DNA into the cells. This DNA will theoretically integrate into the chromosome, duplicate at each cell division, and remain within the cells. These vectors are constructed so that the control sequences for **transcription** are on the DNA strand opposite to the one that is usually used for transcription. Therefore, when inducers are added, the cells make the antisense RNA, which then binds to mRNA from the normal gene. In many cases, the amount of an undesirable protein is reduced.

The use of antisense nucleotides is in its infancy, but the results have been promising in reducing certain types of cancer in animals. The procedure has the potential of becoming widely used in the future to treat a variety of diseases, provided that it has low risks associated with it. **SEE ALSO** DNA; GENE; HYBRIDIZATION; RNA

*William R. Welnitz*

#### **Bibliography**

Campbell, Neil A., Jane B. Reece, and Lawrence G. Mitchell. *Biology*, 5th ed. Menlo Park, CA: Benjamin Cummings, 1999.

Pasternak, Jack J. *An Introduction to Human Molecular Genetics*. Bethesda, MD: Fitzgerald Science Press, Inc., 1999.

## **Arachnid**

Spiders, mites, ticks, and scorpions make up the class Arachnida. Arachnids are members of the **phylum** Arthropoda, which also includes crustaceans (such as crabs and shrimp), insects, and other animals with an **exoskeleton** and jointed legs. Although arachnids vary in form and behavior, they share certain characteristics. All arachnids have two body segments, eight legs, and no antennae or wings. Unlike many insects, arachnids do not go through **metamorphosis** but hatch from eggs as miniature adults. Most arachnids are carnivores, often delivering digestive **enzymes** to their victims externally (by squirting it onto or injecting it into the dead or paralyzed prey), and then sucking in the liquefied food. Most arachnids have poor vision and rely mostly on sensing chemicals and vibrations. The jumping spiders, an exception, have excellent vision.

The most common arachnids are mites (order Acari) and spiders (order Araneae). Although mites outnumber spiders in sheer numbers, and likely also in numbers of species, mites are all very small (often microscopic) and hard to observe. They usually parasitize plants or animals, and are very abundant in most terrestrial environments. Spiders, although less widely distributed, are found on all continents except Antarctica, and in almost all habitats except the ocean. (Sea spiders are neither true spiders nor arachnids.) Because of their greater physical size, spiders have been studied more, and have played more of a role in human society throughout history.



Newly hatched green lynx spiders.

The most interesting, distinctive, and useful adaptation of the spiders is their silk. Spiders secrete silk (a kind of **protein**) using organs on their abdomens called spinnerets. Spiders put the silk to a multitude of uses: building webs, covering egg sacs, lining their burrows, constructing safety tethers, even making “parachutes” for the dispersal of young spiders on a windy day. Some jumping spiders have even been observed attaching a thread to a wall like a bungee cord and then jumping into the air to catch an insect in flight. SEE ALSO ARTHROPOD; CRUSTACEAN; INSECT

*Robbie Hart*

#### **Bibliography**

Levi, Herbert W., and Lorna R. Levi. *Spiders and Their Kin*. New York: St. Martin's Press, 2001.

Mason, Adrienne. *The World of the Spider*. San Francisco: Sierra Club Books, 1999.

## **Archaea**

Much of human knowledge of the diversity of life has been based on what can be seen. Early attempts at classifying life considered just plants and animals, with fungi part of the plant kingdom. Once microscopes revealed microbial life, biologists could distinguish the bacteria and cyanobacteria, whose cells lack nuclei, from the more complex Protista, single-celled organisms that have nuclei and other **organelles**. However, lumping together

**protein** complex molecule made from amino acids; used in cells for structure, signaling, and controlling reactions

**organelle** membrane-bound cell compartment

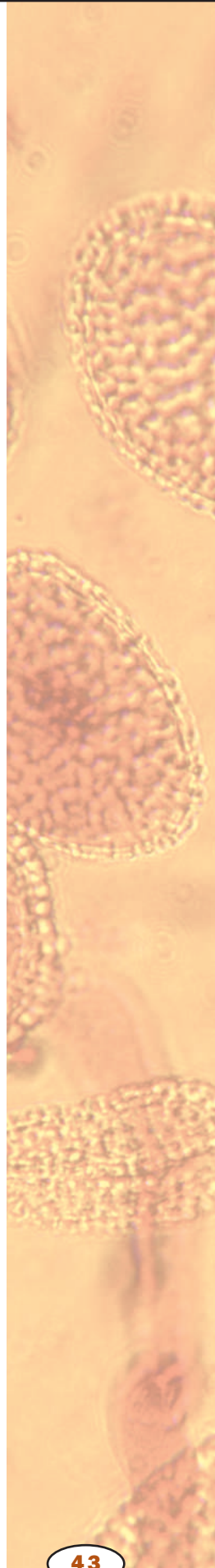

A scanning electron micrograph of a ten-million-year-old Archaea.

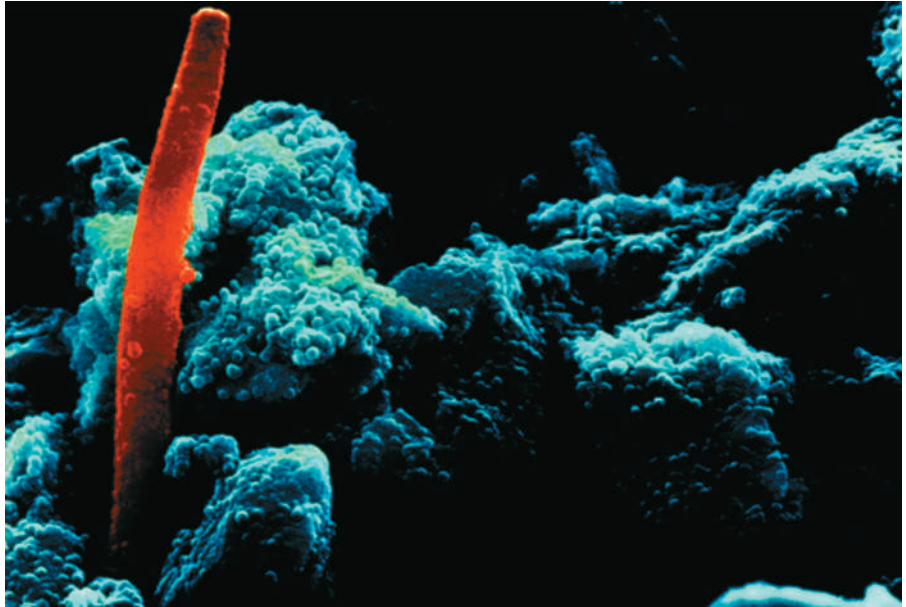

**prokaryote** single-celled organism without a nucleus

all unicellular organisms lacking nuclei—the **prokaryotes**—as bacteria proved inaccurate too.

**lineage** ancestral line

It took a different way of looking at life to recognize that a group of prokaryotes, the Archaea, actually represent a third major form of life, necessitating invention of a term to supersede kingdom, the domain. The three domains of life are the Bacteria, the Archaea, and the Eukarya. Evidence obtained so far indicates that the Bacteria and Archaea diverged from a common ancestor about 3.7 billion years ago, and somewhat later the Archaea diverged from the **lineage** that would become the Eukarya. Carl Woese, a microbiologist at the University of Illinois, identified the Archaea and proposed the three-domain system of classifying life in 1977.

**superficial** on the surface; not deep

### Considering Different Characteristics

Traditionally, microbial classifications were based on **superficial** similarities, such as shape, habitat, or method of acquiring energy. This approach did not necessarily group organisms that are the most recently descended from shared ancestors. That is, traditional classification considered similarities, but not evolutionary relationships. For example, *Thermus aquaticus* and *Thermoplasma volcanium* both are thermophiles, thriving in hot springs, but the former is a bacterium, and the latter an archaeon. They are not closely related at all, but live in similar surroundings.

**enzyme** protein that controls a reaction in a cell

In the early 1970s, Woese and others began comparing nucleic acid sequences to discover the evolutionary relationships among microorganisms. Woese focused on ribosomal ribonucleic acid (rRNA) because these are very important molecules that are therefore unlikely to have changed much over evolutionary time. The more alike the rRNA sequences were between two microbes, the more recently they shared an ancestor. Because nucleic acid sequencing had not yet been invented, Woese used an indirect method to compare rRNA sequences. He cut rRNA molecules into pieces with **enzymes**, then visualized the pieces in size order using a technique called autoradiography.

Different patterns of rRNA pieces characterized the prokaryotes known at the time (bacteria), and the eukaryotes. At the suggestion of a colleague, Woese ventured beyond probing the rRNAs of common laboratory strains of bacteria and analyzed a microbe that a graduate student had collected from a nearby septic system. These microorganisms were methanogens; they produced methane (swamp gas) from hydrogen and carbon dioxide in the environment. Surprisingly, the rRNA pattern for the septic system microbe lacked some of the pieces that had been identified in more than forty types of bacteria, and had some mysterious spots of its own.

Woese found other methanogens that didn't fit the expected **prokaryotic** pattern or rRNA fragments. By 1977, he and his colleagues published a landmark paper that described ten species of methanogens that "appear to be only distantly related to typical bacteria" (Woese 1977, p. 5088). Even though further publications continued to make the case for two types of prokaryotes, the idea of domains in general, and of the newly distinguished archaea in particular, took a long time to gain acceptance. Confusion arose over the initial naming of the "new" organisms as "archaebacteria." They are not bacteria; they are archaea.

## Describing Archaea

Since 1977, microbiologists have identified and described several more members of domain Archaea. An initial misnomer was that these microbes are only found in what scientists call extreme environments, such as hot springs and deep-sea hydrothermal vents. Continued research showed that this is not the case. Archaea have been found in rice paddies, soils, swamps, freshwater, and throughout the oceans.

As more microbiologists came to accept the idea that archaea are not bacteria, more distinctions emerged. Archaeal transfer RNA (tRNA) molecules differ in sequence from their bacterial or eukaryotic counterparts. Archaeal cell walls lack the **peptidoglycans** that are part of bacterial cell walls, yet archaeal cell membranes include **lipid** molecules not seen in other types of organisms. Archaea make methane using different enzymes than do bacterial methanogens.

Archaeans are sensitive to different antibiotic drugs than are bacteria, indicating a basic difference in cell structure. However, archaea also share characteristics with members of the other two domains. They have some of the same surface molecules as bacteria and transport **ions** in much the same way. But archaea have **proteins** associated with their DNA that resemble the **histone** proteins of eukaryotes and synthesize proteins in a way similar to that of eukaryotes. Also like eukaryotes, archaeal **genomes** have more genes interrupted with **intron** sequences, and more repeated sequences, than do bacterial genomes.

## Comparing Genomes

Genome studies confirm that the archaea mix characteristics of the other two domains of life, and much more. A team from The Institute of Genomic Research (TIGR), which included Carl Woese, published the first genome sequence of an archaeon in 1996. The researchers collected samples of *Methanococcus jannaschii* from a "white smoker" chimney 2,600 meters (over 8,500 feet) deep in the Pacific Ocean, an environment that lacks

**prokaryotic** without a nucleus

**peptidoglycans** amino acid chains with linked sugars

**lipid** fat or waxlike molecule, insoluble in water

**ion** an electrically charged particle

**protein** complex molecule made from amino acids; used in cells for structure, signaling, and controlling reactions

**histone** protein around which DNA wraps to form chromosomes

**genome** total genetic material in a cell or organism

**intron** untranslated portion of a gene that interrupts coding regions

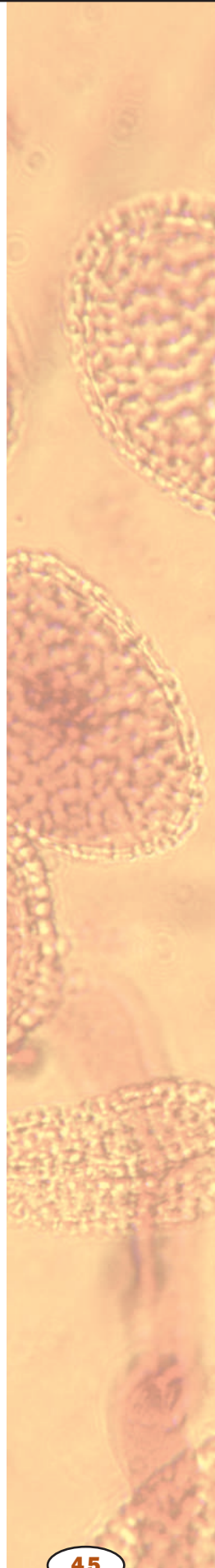

**metabolism** chemical reactions within a cell

**biosynthetic** forming a complex molecule from simpler ones

**phylum** taxonomic level below kingdom, e.g., arthropod or chordate

**appendage** attached organ or structure

**protein** complex molecule made from amino acids; used in cells for structure, signaling, and controlling reactions

**chitin** nitrogen-containing carbohydrate found in arthropod exoskeletons and fungus cell walls

oxygen and has extremely high temperature (near 85 degrees Celsius [185 degrees Fahrenheit]) and pressure (exceeding 200 atmospheres). Of *M. jannaschii*'s 1,738 protein-encoding genes, more than half are unknown in other organisms. Analysis of its genes revealed that its **metabolism**, cell surface, and ion transport mechanisms resemble those of bacteria, yet its DNA replication and protein synthesis mechanisms are more like those of eukaryotes.

Two years later, TIGR sequenced a second archaeon, *Archaeoglobus fulgidus*. Now researchers could compare archaea. Although *A. fulgidus* resembles *M. jannaschii* in DNA replication, protein synthesis, and **biosynthetic** pathways, it differs markedly in how it senses the environment, moves substances into and out of cells, and regulates metabolism. One quarter of *A. fulgidus*' genes encode proteins that are uncharacterized, but two-thirds of them are also found in *M. jannaschii*. Half of *A. fulgidus*' proteins are known in other organisms. However, one-quarter of its genes are not known, even in *M. jannaschii*. *A. fulgidus* is a thermophilic anaerobe like *M. jannaschii*, but also leads a very different lifestyle in that it metabolizes sulfur. In 1999, TIGR introduced the genome sequence of another archaeon, *Aeropyrum pernix* K1. It differs from the other two in that it lives in the presence of oxygen, but it also has many unique genes.

Compared to other types of organisms, biologists know very little about the archaea. However, the diversity seen among the few known types indicate that not only are the members of this third domain of life quite distinctive from members of the others, but they also differ from each other. SEE ALSO BACTERIAL CELL; CELL WALL; EUBACTERIA; EXTREME COMMUNITIES; KINGDOM; RNA; TAXONOMY, HISTORY OF

Ricki Lewis

### Bibliography

Bult, C. J., et al. "Complete Genome Sequence of the Methanogenic Archaeon, *Methanococcus jannaschii*." *Science* 273 (1996): 1058–1073.

*The Institute for Genomic Research*. <<http://www.tigr.org>>.

Lewis, Ricki. "Going Out On a Limb for the Tree of Life." In *Discovery: Windows on the Life Sciences*. Malden, MA: Blackwell Science, 2001.

Woese, Carl R., and George E. Fox. "Phylogenetic Structure of the Prokaryotic Domain: The Primary Kingdoms." *Proceedings of the National Academy of Sciences* 74 (1977): 5088–5090.

## Arthropod

Arthropods are a **phylum** within the animal kingdom. They include four classes: Chelicerates (such as spiders, mites, ticks, scorpions, and horseshoe crabs), the extinct Trilobites, Crustaceans (such as lobsters, crabs, and shrimp), and Uniramians (millipedes, centipedes, and the most numerous group of all, the insects). The defining features of arthropods are their exoskeletons (hard outer coverings), segmented bodies, and jointed **appendages**, from which they derive their name (*arthro* means "joint," *pod* means "foot").

The exoskeleton, secreted by the outer tissue layer, is composed of **protein** and a nitrogenous carbohydrate called **chitin**, which in crustaceans is fortified with calcium carbonate crystals. To grow, most arthropods either

shed (molt) the exoskeleton periodically or grow as soft-bodied larvae before undergoing **metamorphosis** into the adult, hard-bodied form. Some arthropods (such as millipedes) have legs on nearly every segment. However, most arthropods have evolved reduced numbers of legs, with many other appendages taking on highly specialized roles. Examples include the antennae and hardened mouth parts on head segments, and egg-clasping ovipositors on rear segments.

Arthropods are the most numerous of all animal phyla, both in numbers of species and numbers of individuals, primarily due to insect diversity and numbers. There are at least one million recorded species of arthropods, with the actual number probably ten or even twenty times that amount. SEE ALSO ARACHNID; CRUSTACEAN; INSECT

*Richard Robinson*

### Bibliography

Daly, H. V., J. T. Doyen, and A. H. Purcell. *Introduction to Insect Biology and Diversity*. New York: Oxford University Press, 1998.

## Autoimmune Disease

In order for the immune system to protect the body against attack by foreign organisms, it must be able to distinguish between the body's own **proteins** (autoantigens) and proteins from foreign cells (foreign **antigens**). When the immune system turns against autoantigens, thus attacking its own tissues, the resulting condition is an autoimmune disease.

Common autoimmune diseases include:

- glomerulonephritis, which compromises the filtering ability of the kidney tubules
- Graves' disease, which stimulates the thyroid to overproduce thyroid hormone
- rheumatoid arthritis, which destroys joint tissue
- myasthenia gravis, which interferes with nerve-muscle communication
- multiple sclerosis, which destroys the fatty myelin coating of nerves
- systemic lupus erythematosus, which attacks deoxyribonucleic acid (DNA), causing widespread damage in kidneys, heart, lungs, and skin
- juvenile onset (Type I) diabetes mellitus, which destroys the insulin-producing beta cells of the pancreas, resulting in inability to regulate blood sugar properly.

### Theories of Autoimmunity

The cells involved in immune reactions are B lymphocytes (B cells), which develop in the bone marrow, and T lymphocytes (**T cells**), which develop in the thymus. Each lymphocyte carries a recognition site for a specific antigen and becomes activated when that antigen is encountered. During development, most of the lymphocytes that could recognize and destroy widely

**metamorphosis** development process that includes a larval stage with a different form from the adult



A digitally enhanced X ray of the left hand of a sufferer of rheumatoid arthritis, an autoimmune disease that destroys joint tissue.

**protein** complex molecule made from amino acids; used in cells for structure, signaling, and controlling reactions

**antigen** foreign substance that provokes an immune response

**T cell** white blood cell that controls the immune response



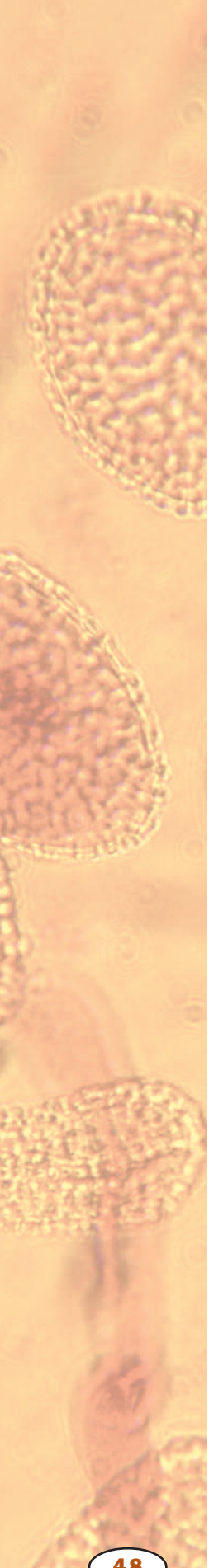

**B lymphocyte** white blood cell that makes antibodies



**alkaline** chemically basic, with an excess of OH<sup>-</sup> ions

**prokaryote** single-celled organism without a nucleus

**eukaryotic cell** a cell with a nucleus

**nucleus** membrane-bound portion of cell containing the chromosomes

**organelle** membrane-bound cell compartment

occurring autoantigens are deleted. Tissues bearing these autoantigens are generally safe from subsequent attack by the immune system unless either the autoantigen mutates or the immune system confuses the autoantigen with a foreign antigen. However, some tissue-specific autoantigens are unavailable when lymphocytes are developing in the bone marrow or thymus, and so lymphocytes with receptors for those autoantigens remain viable, posing the threat of tissue destruction in autoimmune diseases.

It is not yet clear why these lingering, self-reactive lymphocytes do not trigger autoimmunity more often, or why autoimmunity occurs when it does. However, there is strong suspicion that infection may play an important role in genetically susceptible individuals. An infection causes the production of inflammatory chemicals. If these are present at the same time that a lymphocyte is presented with its autoantigen by an antigen-presenting cell, the combination could activate self-reactive lymphocytes that were not deleted during development. Destruction of body tissues bearing those autoantigens would follow.

In another possible process, termed “molecular mimicry,” a foreign protein bears such similarity to an autoantigen that B cell antibodies or cytotoxic T cells specific for that foreign antigen cross-react with autoantigens, causing tissue destruction. Alternatively, the combination of a foreign antigen with a self-protein can form a new complex capable of activating appropriate T or **B lymphocytes** to destroy tissues containing the complex. SEE ALSO ANTIBODY; BLOOD SUGAR REGULATION; IMMUNE RESPONSE; T CELLS

*Patricia L. Dementi*

### Bibliography

Janeway, Charles A., Jr., Paul Travers, Mark Walport, and J. Donald Capra. *Immunobiology: The Immune System in Health and Disease*, 4th ed. New York: Elsevier Science Ltd./Garland Publishing, 1999.

Marieb, Elaine Nicpon. *Human Anatomy and Physiology*, 5th ed. San Francisco: Benjamin Cummings, 2001.

## Bacterial Cell

Hundreds of thousands of bacterial species exist on Earth. They can be found in very diverse environments ranging from cold to hot and **alkaline** to acid. They live in soil, in water, and on rocks. They exist deep in the earth, high on mountains, and in deep-sea vents. They grow on and in other bacteria, worms, insects, plants, animals, and people.

Bacteria are **prokaryotes**. Prokaryotic cells possess simpler structures than **eukaryotic cells**, since they do not have a **nucleus**, other membrane bound **organelles**, or a **cytoskeleton**. Bacterial cells have two major compartments, the **cytoplasm** and cell envelope, and may also have exterior **appendages**, such as flagella or pili. There are two major types of prokaryotes: bacteria and archaea. Archaea (also called archaeobacteria) are often found in extreme environments, and while they are clearly prokaryotic, they have evolved separately from bacteria. **Mitochondria** and chloroplasts are two membrane-bound organelles carried within eukaryotic cells that are thought to have been derived from free-living prokaryotic organisms that became irreversibly engulfed by ancestral eukaryotes.

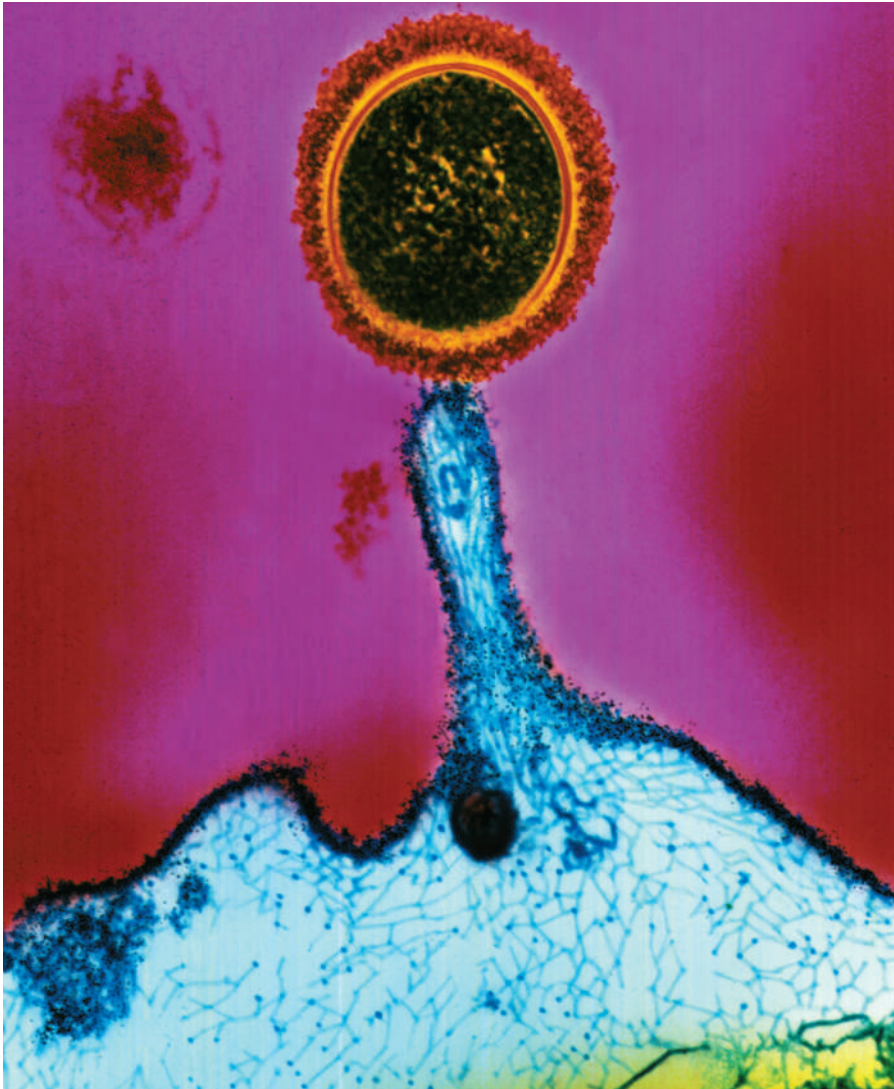

A colored transmission electron micrograph of *Streptococcus* bacteria attached to a human tonsil cell.

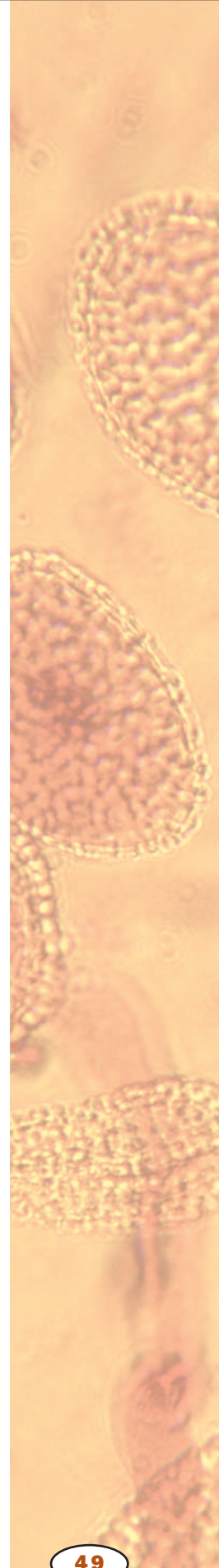

## Growth and Reproduction

Bacterial cells grow by a process called binary fission: One cell doubles in size and splits in half to produce two identical daughter cells. These daughter cells can then double in size again to produce four sibling cells and these to produce eight, and so on. The time it takes for a bacterial cell to grow and divide in two is called the doubling time. When nutrients are plentiful, the doubling time of some bacterial species can be as short as twenty minutes. However, most bacterial species show a doubling time between one and four hours. A single bacterial cell with a one-hour doubling time will produce over 1 million offspring within twenty hours. If left unchecked, a single *E. coli* bacterium replicating once every twenty minutes could replicate to equal the mass of Earth in twenty-four hours. The enormous increase in cell numbers that accompanies this exponential growth provides these simple unicellular organisms with an incredible growth advantage over other unicellular or multicellular organisms. Luckily, there are always limits to bacterial growth.

**cytoskeleton** internal scaffolding in a cell, composed of protein

**cytoplasm** material in a cell, excluding the nucleus

**appendage** attached organ or structure

**mitochondria** subcellular organelle that creates ATP used for energy-requiring processes in a cell

**genome** total genetic material in a cell or organism

**transcriptional** of, relating to messenger RNA formation from a DNA sequence

**ribosome** protein-RNA complex in cells that synthesizes protein

**protein** complex molecule made from amino acids; used in cells for structure, signaling, and controlling reactions

**chromosome** “colored body” in the cell nucleus; made of DNA and protein, and divided functionally into genes and non-gene regions

**bilayer** composed of two layers

**amino acid** a building block of protein

**peptidoglycan** polymer that is composed of polysaccharide and peptide chains

**lipid** fat or waxlike molecule, insoluble in water

**polymer** molecule composed of many similar parts

The cytoplasm of a bacterial cell contains the deoxyribonucleic acid (DNA) molecules that make up the bacterial **genome** (or nucleoid), the **transcriptional** machinery that copies DNA into ribonucleic acid (RNA), and the **ribosomes** that translate the messenger RNA information into **protein** sequence. Since there is no nucleus, all of these processes occur simultaneously. The rapid growth rate of the bacterial cell requires constant DNA replication and ways to segregate the two new **chromosomes** into the two daughter cells without tangling them.

## Structure and Diversity

Bacterial cells express a variety of shapes and sizes. The smallest bacteria are the *Mycoplasmas*, which range from about 0.1 to 0.25 micrometers in diameter, while the gigantic *Epulopiscium fishelsoni* is 250 micrometers long and visible to the naked eye. Some bacteria have a coccid (spherical) shape. Others are shaped as bacilli (rods), vibrio (curved rods), or spirochetes (spirals).

Bacterial cells are often classified by the structure of their cell envelope. All bacteria have a **bilayer** membrane that surrounds the cytoplasm. Integral membrane proteins within the cytoplasmic membrane are required to transport nutrients (sugars and **amino acids**) into the cell for growth. Most bacteria have a cell wall that is made up of **peptidoglycan**. The exceptions are the *Mycoplasma* species, which only have a cytoplasmic membrane that is unique in the prokaryotic world due to the presence of the **lipid** cholesterol. The peptidoglycan molecule is made up of chains of sugars (glycans) that are attached to one another by peptide (amino acid) cross-links. This is a naturally occurring **polymer**, similar to chemicals that make up plastics and synthetic fabrics. Peptidoglycan it is only found in bacterial cells. The beta-lactam antibiotics (penicillin, ampicillin, amoxicillin) act to prevent the peptide cross-links from forming, which makes them active in preventing the growth of a diverse number of bacteria.

Most bacteria are classified by how they react to a defined series of colored dyes (the Gram stain). The Gram stain is the basis of one major classification scheme for bacteria. Gram-positive bacteria have a thick cell wall with many peptide cross-links that allow a dark purple color to remain after the Gram stain procedure. The Gram-positive cell wall acts as a molecular barrier to prevent access to the cytoplasmic membrane and to keep large, harmful molecules from damaging the cell. In contrast, Gram-negative bacteria have a thin layer of peptidoglycan that makes up their cell wall that is surrounded by a second bilayer membrane called the outer membrane. The purple dye used in the Gram stain does not penetrate the outer membrane, and these cells do not stain purple. Gram-negative cells are instead identified by a pink color contributed by a different chemical stain during the Gram stain procedure. The Gram-negative outer membrane functions to protect the cytoplasmic membrane. The outer membrane contains porin proteins that form holes in the outer membrane to allow small molecules (sugars, peptides, salts) to enter the area between the two membranes (the periplasm).

The Gram-negative outer membrane is made up of a molecule called lipopolysaccharide (LPS). LPS has a unique chemical structure that is only found in Gram-negative bacteria and is recognized by the mammalian im-

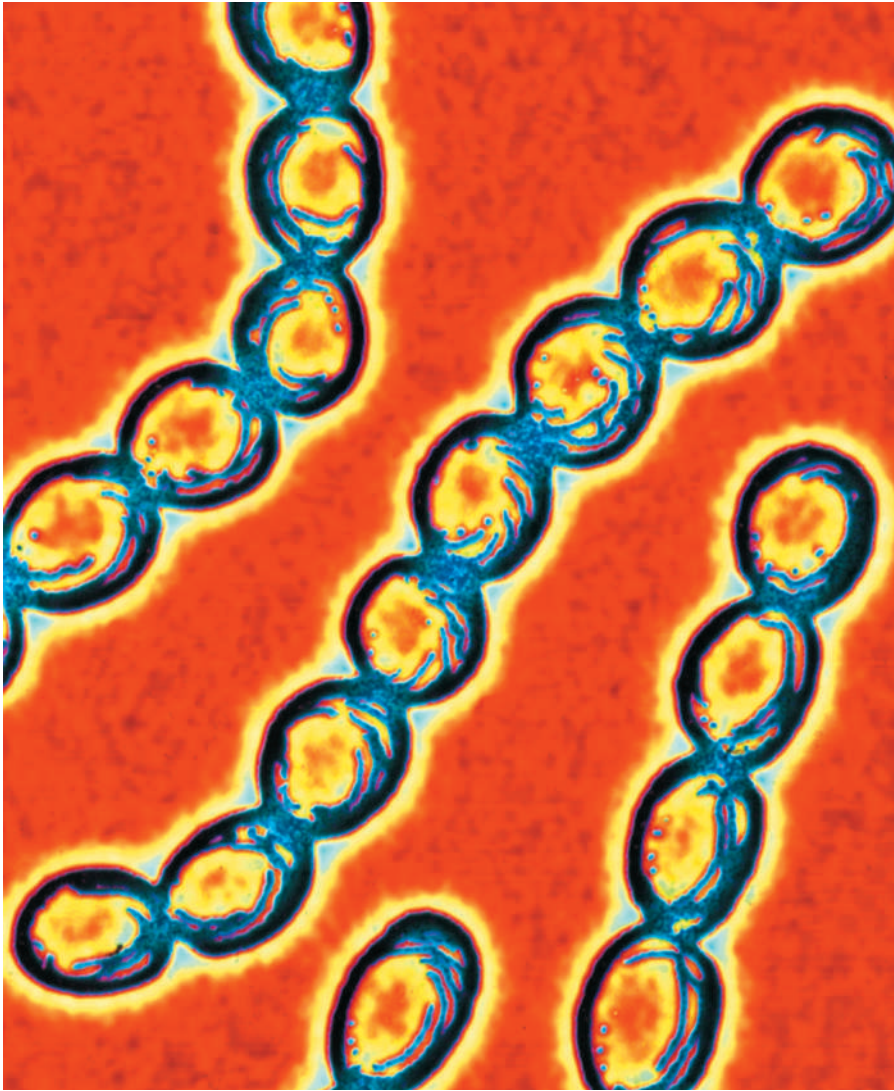

A colored transmission electron micrograph of *Streptococcus pyogenes* bacteria.

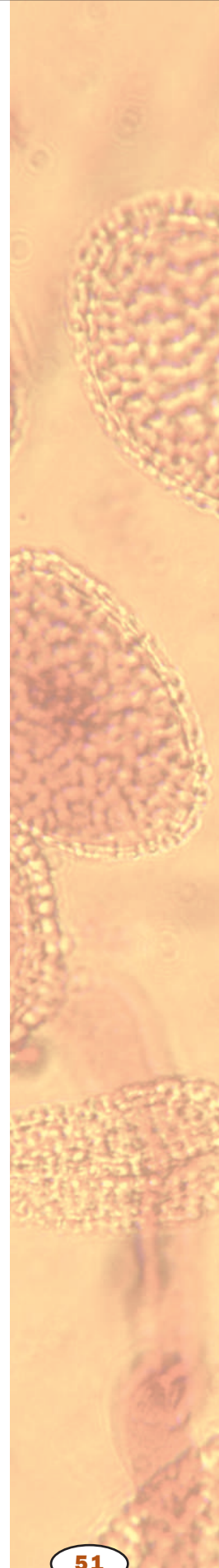

immune system as a microbial product (endotoxin). Since LPS in the blood stream can be fatal to mammals, all products that are used clinically within the bloodstream (such as insulin) must be endotoxin-free to prevent septic shock. Gram-positive bacteria express lipoteichoic acids in their cell walls that act similar to LPS on the mammalian immune system.

Most bacterial species express other molecules and structures outside of their cell envelope that are important for interactions with the environment. **Polysaccharide** postmortem capsules prevent **desiccation** of environmental microbes and allow **pathogens** to resist **phagocytosis** by mammalian white blood cells. Most bacterial species have flagella, which allow the bacteria cells to move around in **aqueous** environments. Most Gram-negative bacteria express hairlike appendages called pili or fimbriae that allow them to adhere to other bacteria, bacterial viruses, eukaryotic cells, or other physical surfaces. Both Gram-negative and Gram-positive bacteria can express afimbrial **adhesions** that also allow adherence to a variety of molecules or surfaces. These exterior appendages help bacteria get to where they want to go, and then keep them there to facilitate growth.

**polysaccharide** carbohydrate composed of many individual units of sugar

**desiccation** drying out

**pathogen** disease-causing organism

**phagocytosis** engulfing of cells or large fragments by another cell, including immune system cells

**aqueous** watery or water-based

**adhesion** attachment; sticking to the surface of

## Beneficial Bacteria

Most bacteria do not directly influence humans. However, a small number of bacterial species can cause human or animal diseases and are a major focus of scientific study. Other bacteria can be beneficial to humans by contributing to human nutrition and protecting the body from pathogens. The *E. coli* bacteria in our colons are an example. Bacterial cells such as *E. coli* are widely used in laboratories as factories to produce commercially or medically important proteins through the use of genetic engineering or recombinant DNA technologies. Other bacteria are important for agriculture since they take nitrogen from the air and replace it in the soil (nitrogen fixation). Bacteria are used to clean up oil spills and toxic chemicals in the environment. There are as many beneficial bacteria as there are destructive germs. SEE ALSO ARCHAEA; BACTERIAL GENETICS; BACTERIAL VIRUSES; CELL WALL; EUBACTERIA; NITROGEN FIXATION; RECOMBINANT DNA; REPLICATION; TRANSCRIPTION

*Hank Seifert*

### Bibliography

Neidhardt, Frederick C., John L. Ingraham, and Moselio Schaechter. *Physiology of the Bacterial Cell: A Molecular Approach*. Sunderland, MA: Sinauer Associates, 1990.

Tortora, Gerard J., Berdell R. Funke, Christine L. Case. *Microbiology: An Introduction*. Redwood City, CA: Benjamin/Cummings Publishing Company, Inc., 2001.

## Bacterial Diseases

Bacteria get a bad reputation for causing disease when, in reality, very few species of bacteria infect humans. The ones that do, however, are the ones most often written about in magazines and newspapers. These bacteria inhabit the human body because of the constant source of nourishment, moist environment, relatively stable pH and body temperature, and extensive surface area.

Contamination with bacteria from the environment can lead to colonization, taking up residence on or in the human body. The mixed collection of bacteria that are adapted to the body and reside in it for extended periods of time are called normal flora. Some bacteria inhabit the body only as transients, soon destroyed by human (host) defense mechanisms or removed by cleaning. Bacteria that evade host defenses and cause infection are described as virulent. Under certain circumstances, such as an imbalance in normal flora or lowered host resistance, even normal flora can cause infection.

Infection may proceed to disease if host defenses do not arrest the infection before tissue damage occurs. Bacterial disease can have several outcomes. The immune system may arrest the infection and stop progression of the disease. In other cases, the body may be unable to repair damaged tissues and permanent dysfunction or even death may result. For this reason, treatments are designed to stop the infection before permanent damage has occurred.

Most bacterial diseases are treated with antibiotics to kill the organisms. In recent years, more and more bacteria have become resistant to the avail-

pH measure of acidity or alkalinity; numbers below 7 are acid, above are basic

### WILLIAM, ANNA WESSELS (1863–1954)

Physician and bacteriologist who isolated a strain of the bacterium that causes diphtheria, from which she made an antitoxin that could be used to treat the disease. She also discovered a way to diagnose rabies in a few minutes instead of a few days, thus saving many more lives.

able antibiotics. This has forced the scientific community to examine the use of antibacterial agents in soaps and cleansers, the use of antibiotics in animal feeds, and the inappropriate prescription of antibiotics. Patients who terminate the treatment prematurely because they feel better, even though the infection is not yet eliminated, compound the problem of antibiotic resistance. All of these situations lead to the killing off of susceptible bacteria while leaving the resistant ones to multiply. The best “medicine” is still prevention of infection. SEE ALSO DISEASE; EUBACTERIA

*Jackie Butler*

### Bibliography

Berkow, Robert, et al. *The Merck Manual of Diagnosis and Therapy*, 17th ed. Rahway, NJ: Merck & Co., 1999.

Levy, Stuart B. “The Challenge of Antibiotic Resistance.” *Scientific American* (March 1998). <[www.sciam.com/1998/0398issue/0398levy.html](http://www.sciam.com/1998/0398issue/0398levy.html)>.

Murray, Patrick R., et al. *Medical Microbiology*, 3rd ed. St. Louis: Mosby-Year Book, 1998.

Staley, James T., et al. *Bergey’s Manual of Systematic Bacteriology*, 4 vols. Philadelphia, PA: Lippincott, Williams & Wilkins, 1984–1989.

### KOCH, ROBERT (1843–1910)

German physician who discovered the three bacteria that cause the deadly diseases tuberculosis, cholera, and anthrax, and who won the 1905 Nobel Prize in medicine. His most enduring work was a set of guidelines, called Koch’s postulates, for telling which pathogens (bacteria or viruses) cause which diseases.

## Bacterial Genetics

There are hundreds of thousands of bacterial species in existence on Earth. They grow relatively quickly, and most reproduce by binary fission, the production of two identical daughter cells from one mother cell. Therefore, each replication cycle doubles the number of cells in a bacterial population. The bacterial **chromosome** is a long circle of deoxyribonucleic acid (DNA) that is attached to the membrane of the cell. During replication, the chromosome is copied, and the two copies are divided into the two daughter cells. Transfer of genetic information from the mother cell to offspring is called vertical transmission.

Beneficial mutations that develop in one bacterial cell can also be passed to related bacteria of different **lineages** through the process of horizontal transmission. There are three main forms of horizontal transmission used to spread genes between members of the same or different species: conjugation (bacteria-to-bacteria transfer), transduction (viral-mediated transfer), and transformation (free DNA transfer). These forms of genetic transfer can move **plasmid**, bacteriophage, or genomic DNA sequences. A plasmid is a small circle of DNA separate from the chromosome; a bacteriophage is a virus that reproduces in bacteria by injecting its DNA; the **genome** is the total DNA of the bacterial organism.

After transfer, the DNA molecules can exist in two forms, either as DNA molecules separate from the bacterial chromosome (an episome), or can become part of the bacterial chromosome. The study of basic mechanisms used by bacteria to exchange genes allowed scientists to develop many of the essential tools of modern molecular biology.

### Conjugation

Bacterial conjugation refers to the transfer of DNA between bacterial cells that requires cell-to-cell contact. Joshua Lederberg and Edward Tatum first

**chromosome** “colored body” in the cell nucleus; made of DNA and protein, and divided functionally into genes and non-gene regions

**lineage** ancestral line

**plasmid** small ring of DNA found in many bacteria

**genome** total genetic material in a cell or organism

A laboratory technician performing an Analytical Profile Index (API) test on bacteria.



described conjugation in 1946 when they discovered the F factor (an episome) that can move between *Escherichia coli* cells. The F factor is one of the most well studied conjugative plasmids (plasmids are circular episomes) and is the most well studied conjugative system. There are many different conjugal plasmids carried by members of most bacterial species. Conjugal plasmids that carry antibiotic resistance genes are called R factors. The F factor and R factors usually exist as episomes and each carries functions that allow it to replicate its DNA and thus be inherited by the daughter cells after binary fission. However, conjugative plasmids also express transfer functions that allow the movement of DNA from a donor to a recipient cell; this is the process of conjugation.

The steps of bacterial conjugation are: mating pair formation, conjugal DNA synthesis, DNA transfer, and maturation. The main structure of the F factor that allows mating pair formation is the F pilus or sex pilus (a long thin fiber that extends from the bacterial cell surface). There are one to three pili expressed on an *E. coli* cell that carries the F factor, and one pilus will specifically interact with several molecules on the recipient cell surface (attachment). About twenty genes on the F factor are required to produce

a functional pilus, but the structure is mainly made up of one **protein**, pilin. To bring the donor and recipient cell into close proximity, the F pilus retracts into the donor cell by removing pilin protein **monomers** from the base of the pilus to draw the bacterial cells together.

Once a stable mating pair is formed, a specialized form of DNA replication starts. Conjugal DNA synthesis produces a single-stranded copy of the F factor DNA (as opposed to a double-stranded DNA that is formed by normal replication). This DNA strand is transferred into the recipient cell. Once in the recipient cell, the single-stranded copy of the F plasmid DNA is copied to make a double-stranded DNA molecule, which then forms a mature circular plasmid. At the end of conjugation the mating pair is broken and both the donor and the recipient cells carry an identical episomal copy of the F factor. All of the approximately one hundred genes carried on the F factor can now be expressed by the recipient cell and will be inherited by its offspring.

In addition to transferring itself, the F factor can also transfer chromosomal genes between a donor and recipient cell. The F factor can be found inserted (integrated) into the bacterial chromosome at many locations in a small fraction of bacterial cells. An integrated F factor is replicated along with the rest of the chromosome and inherited by offspring along with the rest of the chromosome. When a mating pair is formed between the donor cell carrying an integrated F factor and a recipient cell, DNA transfer occurs as it does for the episomal F factor, but now the chromosomal sequences adjacent to the integrated F factor are transferred into the recipient. Since these DNA sequences encode bacterial genes, they can recombine with the same genes in the recipient. If the donor gene has minor changes in DNA sequence from the recipient gene, the different sequence can be incorporated into the recipient gene and inherited by the recipient cell's offspring. Donor cells that have an integrated copy of the F factor are called Hfr strains (High frequency of recombination).

## Transduction

The second way that DNA is transferred between bacterial cells is through a **phage** particle in the process of transduction. Joshua Lederberg and Norton Zinder first discovered transduction in 1956. When phage inject their DNA into a recipient cell, a process occurs that produces new bacteriophage particles and kills the host cell (lytic growth). Some phage do not always kill the host cell (temperate phage), but instead can be inherited by daughter host cells. Therefore acquisition of a so-called temperate “prophage” by a recipient cell is a form of transduction. Many phage also have the ability to transfer chromosomal or plasmid genes between bacterial cells. During generalized transduction any gene can be transferred from a donor cell to a recipient cell. Generalized transducing phage are produced when a phage packages bacterial genes into its capsid (protein envelope) instead of its own DNA. When a phage particle carrying bacterial chromosomal genes attaches to a recipient cell, the DNA is injected into the **cytoplasm** where it can recombine with a **homologous** DNA sequences.

Some bacteriophage can pick up a subset of chromosomal genes and transfer them to other bacteria. This process is called specialized transduc-

**protein** complex molecule made from amino acids; used in cells for structure, signaling, and controlling reactions

**monomer** “single part”; monomers are joined to form a polymer

**phage** short for bacteriophage

**cytoplasm** material in a cell, excluding the nucleus

**homologous** similar in structure

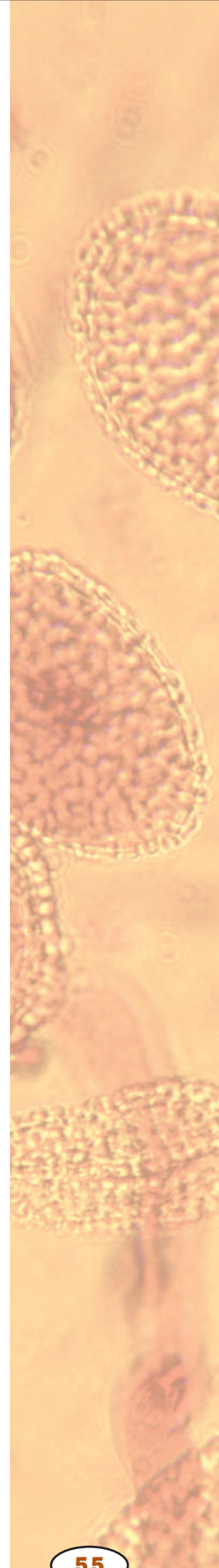



Bacterial conjugation. The bacterium on the left passes a copy of the F plasmid to the bacterium on the right, converting it from an F<sup>-</sup> cell to an F<sup>+</sup> cell.

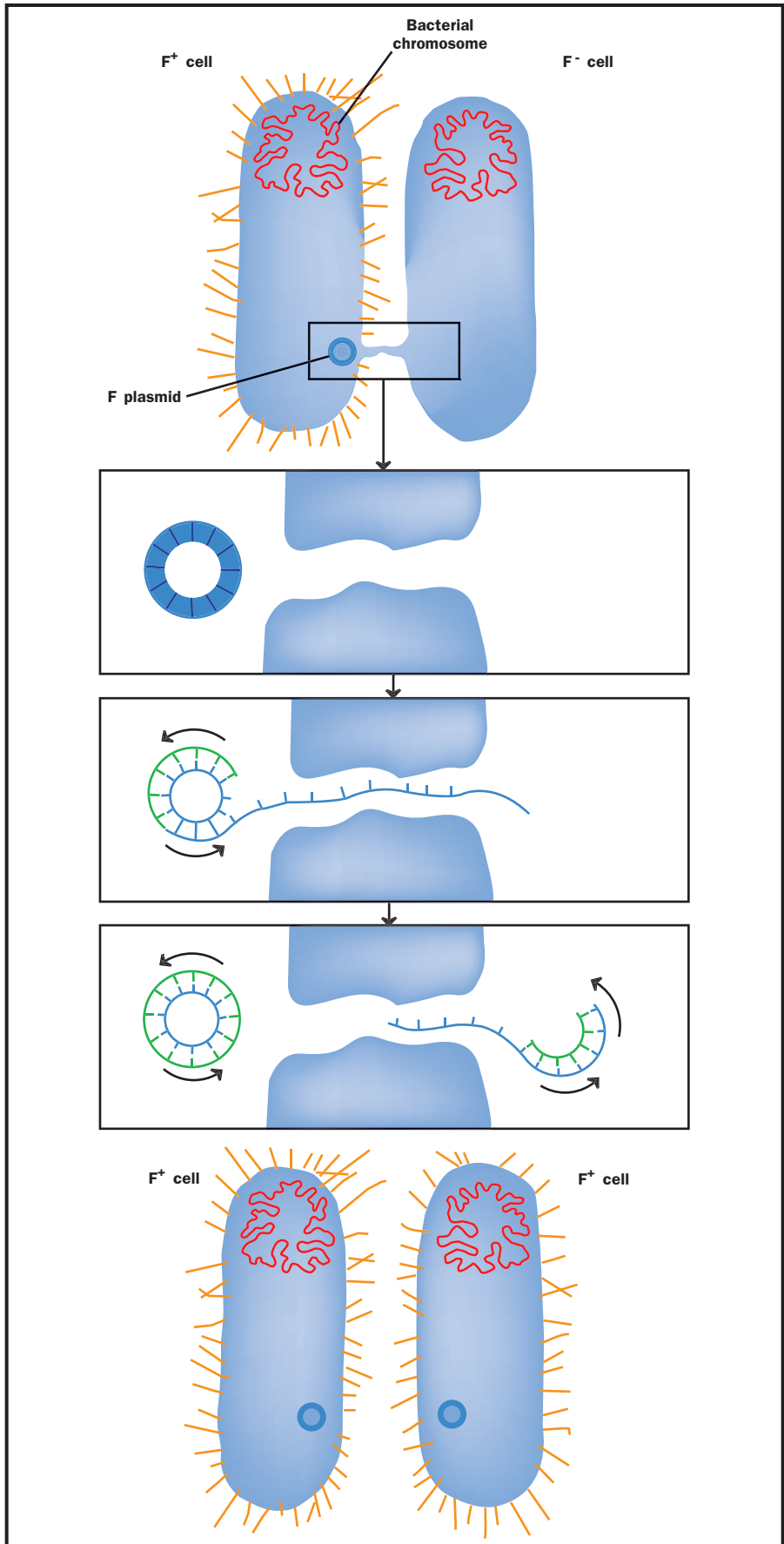

tion since only a limited set of chromosomal genes can be transferred between bacterial cells.

## Transformation

The third main way that bacteria exchange DNA is called DNA transformation. Some bacteria have evolved systems that transport free DNA from the outside of the bacterial cell into the cytoplasm. These bacteria are called “naturally competent” for DNA transformation. Natural DNA transformation of *Streptococcus pneumoniae* provided the first proof that DNA encoded the genetic material in experiments by Oswald Avery and colleagues. Some other naturally competent bacteria include *Bacillus subtilis*, *Haemophilus influenzae*, and *Neisseria gonorrhoeae*. Other bacterial species such as *E. coli* are not naturally competent for DNA transformation. Scientists have devised many ways to physically or chemically force noncompetent bacteria to take up DNA. These methods of artificial DNA transformation form the basis of plasmid cloning in molecular biology.

Most naturally competent bacteria regulate transformation competence so that they only take up DNA into their cells when there is a high density of cells in the environment. The ability to sense how many other cells are in an area is called quorum sensing. Bacteria that are naturally competent for DNA transformation express ten to twenty proteins that form a structure that spans the bacterial cell envelope. In some bacteria this structure also is required to form a particular type of pilus different than the F factor pilus. Other bacteria express similar structures that are involved in secreting proteins into the exterior **medium** (Type II secretion). Therefore, it appears that DNA transformation and protein secretion have evolved together.

During natural DNA transformation, doubled-stranded DNA is bound to the recipient cell surface by a protein receptor. One strand of the DNA is transported through the cell envelope, where it can recombine with similar sequences present in the recipient cell. If the DNA taken up is not homologous to genes already present in the cell, the DNA is usually broken down and the **nucleotides** released are used to synthesize new DNA during normal replication. This observation has led to the speculation that DNA transformation competence may have originally evolved to allow the acquisition of nucleic acids for food.

The source of DNA for transformation is thought to be DNA released from other cells in the same population. Most naturally competent bacteria spontaneously break apart by expressing **enzymes** that break the cell wall. Autolysis will release the genomic DNA into the environment where it will be available for DNA transformation. Of course, this results in the death of some cells in the population, but usually not large numbers of cells. It appears that losing a few cells from the population is counterbalanced by having the possibility of gaining new traits by DNA transformation. **SEE ALSO** BACTERIAL CELL; BACTERIAL VIRUSES; CLONE; RECOMBINANT DNA

Hank Seifert

## Bibliography

Tortora, Gerard J., Berdell R. Funke, Christine L. Case. *Microbiology: An Introduction*. Redwood City, CA: Benjamin/Cummings Publishing Company, Inc., 2001.

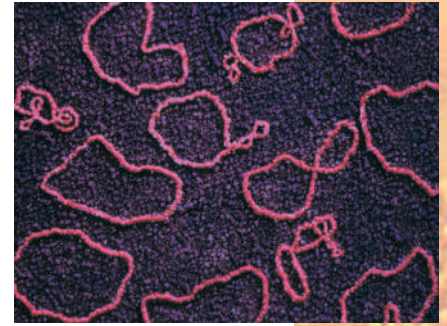

A scanning electron micrograph of bacterial DNA plasmids.

**medium** nutrient source

**nucleotide** the building block of RNA or DNA

**enzyme** protein that controls a reaction in a cell

## Bacterial Viruses

There are viruses that infect all types of cells: animal cells, plant cells, and unicellular organisms. Those that infect bacteria are called bacteriophage or just phage (*phage* means “to eat”). Bacteriophage exist as inert particles when they are outside of bacterial cells. They possess complex **protein** coats with defined structure and may also have tail structures. The protein coat, or capsid, surrounds the deoxyribonucleic acid (DNA) or ribonucleic acid (RNA) molecules that make up the bacteriophage **genome**. Phage genomes can be single stranded or double stranded, and are either circular or linear. Different bacteriophage can encode as few as four proteins or as many as one hundred in their genome.

Phage are similar to animal and plant viruses in that they are not alive, since they cannot replicate themselves or conduct metabolic processes. All phage require bacterial cells for reproduction, but each phage type exhibits a defined host range. Some phage are very specific for one or two closely related bacterial species, while others can infect and replicate in a variety of bacterial cells. The host cell functions required for bacteriophage reproduction define host range. These include attachment to specific molecules on the bacterial cell surface, injection of the bacteriophage DNA into the bacterial cell **cytoplasm**, avoidance of host cell defenses, proper expression and regulation of bacteriophage **genes**, production and assembly of the capsid, replication of the phage nucleic acid (DNA or RNA), packaging the nucleic acid into the capsid, and exit from the bacterial cell.

The bacteriophage that infect the bacterium *Escherichia coli* can be used to illustrate many of the properties of different bacteriophage. One of the most well-studied bacteriophage is bacteriophage  $\lambda$ . The  $\lambda$  genome exists as a linear, double-stranded DNA molecule in the bacteriophage particle. There are 48,514 **base pairs** of DNA that encode about 50 genes that define the  $\lambda$  genome.  $\lambda$  phage bind to a receptor on the *E. coli* cell surface that includes a protein involved in transporting the sugar molecule, maltose. (It is common for viruses to use cellular molecules designed for another function for their own ends.)

The  $\lambda$  genome is injected through the cell envelope into the cytoplasm, where it is converted from a linear to circular form. At this point a choice is made between two different programs: a lytic or lysogenic state. When  $\lambda$  phage undergo lytic growth, replication produces hundreds of copies of its genome and phage genes produce the proteins that make up the capsid, in which the phage genome is inserted to make the mature phage particles. These phage particles are released by **enzymes** that break open the bacterial cell. Lysogeny is a dormant state, where the  $\lambda$  genome becomes part of the bacterial genome and is inherited by the bacterial offspring as a prophage. Bacteriophage that produce lysogeny, like  $\lambda$ , are called temperate since they do not harm the bacteria, while those that can only replicate are called virulent, since they commonly kill the host cell.

There are many virulent phage in *E. coli*. The T even phage (such as T2, T4) and T odd phage (such as T1, T3) always replicate themselves and **lyse** the bacterial cell. In contrast, filamentous phage (for example, M13, fd) always replicate but produce new phage particles by extruding out of the bacterial membrane and never destroy the bacterial cell. When a prophage

**protein** complex molecule made from amino acids; used in cells for structure, signaling, and controlling reactions

**genome** total genetic material in a cell or organism

**cytoplasm** material in a cell, excluding the nucleus

**gene** portion of DNA that codes for a protein or RNA molecule

$\lambda$  the Greek letter lambda

**base pair** two nucleotides (either DNA or RNA) linked by weak bonds

**enzyme** protein that controls a reaction in a cell

**lyse** break apart

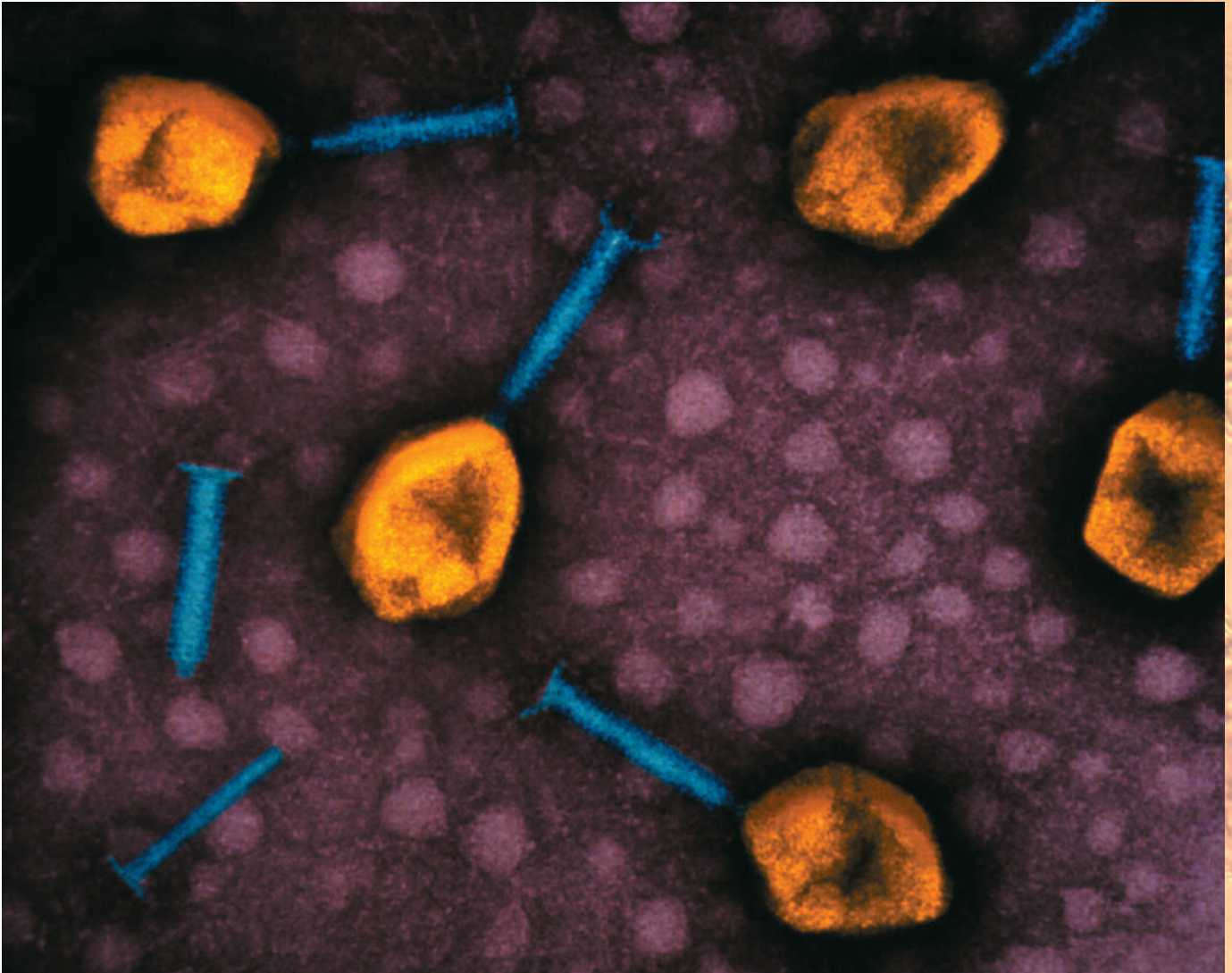

carries one or more genes that provide a selective advantage for the host bacterial cell, this is called lysogenic conversion. SEE ALSO BACTERIAL CELL; BACTERIAL GENETICS; DNA; DNA VIRUSES; REPLICATION; RETROVIRUS; VIRUS

A scanning electron micrograph of T4 cells, a virulent phage in *E. coli*.

*Hank Seifert*

#### **Bibliography**

Tortora, Gerard J., Berdell R. Funke, Christine L. Case. *Microbiology: An Introduction*. Redwood City, CA: Benjamin/Cummings Publishing Company, Inc., 2001.

## **Beer-making, Biology of**

Beer is made by fermentation of grains, principally barley (*Hordeum vulgare*). Other grains, including wheat and rice, may be added to develop particular flavors. The grain is first allowed to germinate by soaking it in water. As part of its germination process, the grain produces amylase **enzymes** that break down the starches of the **endosperm** (part of the seed) into sugars.

**enzyme** protein that controls a reaction in a cell

**endosperm** nutritive tissue within a seed

At a certain point, germination is halted by rapidly drying the grain, in a process called kilning, to produce “malt.” More prolonged kilning produces a darker beer. The malt is then ground and mixed with more water to re-activate the amylases and complete the liberation of the sugars.

The resin-filled flowers of the hops plant (*Humulus lupulus*, Cannabaceae family), are added for aroma and bitter flavor, and the mixture is boiled to bring out the flavor. Boiling also kills unwanted microorganisms that might spoil the fermentation that follows. Yeast is then added to ferment the sugars to ethyl alcohol. Ales are made at room temperature using the yeast *Saccharomyces cerevisiae*, whereas lagers use *Saccharomyces uvarum* at cooler temperatures. The final alcohol concentration of most beers is about 5 percent. Some beers are naturally carbonated by bottling before fermentation is complete, but most commercial beers require addition of carbon dioxide after fermentation.

Beer is probably the oldest of alcoholic beverages and has been made for thousands of years, at least as far back as classical Egyptian civilization of five thousand years ago. Modern beer styles originated in Germany, the Czech Republic, and the United Kingdom, which still claim production of some of the finest beers in the world. SEE ALSO AGRICULTURE; COFFEE, BOTANY OF; ENZYMES; GLYCOLYSIS AND FERMENTATION; WINE-MAKING, BOTANY OF

*Richard Robinson*

#### **Bibliography**

Jackson, Michael. *The New World Guide to Beer*. Philadelphia, PA: Running Press, 1997.

## **Behavior, Genetic Basis of**

A debate raged throughout the twentieth century, and probably will continue, about the relative influences of heredity and experience on human behavior. Behavioral scientists today largely regard this “nature versus nurture” debate as an outmoded dichotomy. Most scientists now believe that behavior results from a combination of these influences, never entirely from one or the other.

### **Genetic Influences in Animal Behavior**

Clearly, **genes** significantly influence animal behavior. This is the only reasonable conclusion in cases where animals born and reared in isolation nevertheless develop age-appropriate, species-specific behaviors that they could not have possibly learned from other individuals. Such instincts that occur even in isolated animals include insect mating behavior; courtship, nesting, and brood-rearing behavior of pigeons; the songs of some (not all) birds; bird flight; and nut-cracking and nut-burying by squirrels. Animals are born “knowing” how to do certain things. Experiments that rule out social learning and trial-and-error learning leave heredity—that is, genes—as the only logical explanation for such behaviors.

People have long used artificial selection to produce animal breeds with desirable behavioral traits, such as dogs that herd sheep or hunt. Artificial

**gene** portion of DNA that codes for a protein or RNA molecule



Experiments with honeybees have confirmed the relationship between genes and behaviors.

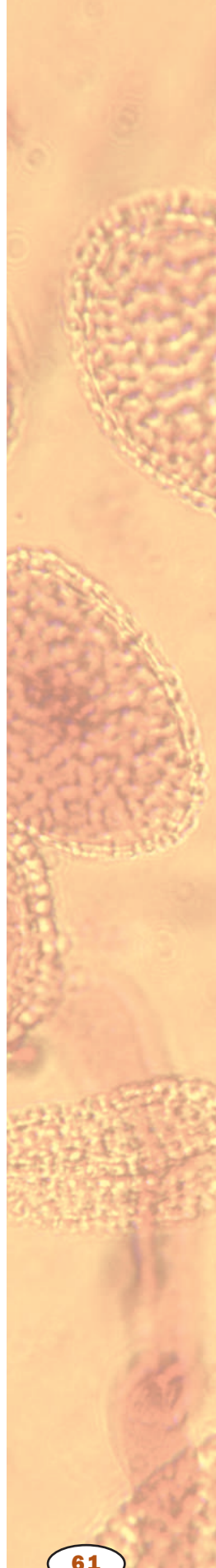

selection can also shape the reactions of fruit flies (*Drosophila*) to light and gravity and the ability of rats to learn mazes. Such results would not be possible if genes did not influence behavior. The fact that X rays and chemicals can induce mutations that alter behavior strengthens the link to genetics. Mutations have changed obstacle-avoidance behavior of *Paramecium* and biological clocks and several behaviors in *Drosophila*.

### Experimental Evidence of Gene-Behavior Links

Breeding experiments confirm the relationship between genes and behaviors. For example, worker honeybees normally react to diseased or dead pupae by uncapping the honeycomb cell containing the pupa, dragging the pupa out, and removing it from the hive. This helps to prevent the spread of infections through the colony. Experiments in which normal honeybees were crossed with bees that do not bring out their dead traced the behavior to two genes: one that induces workers to uncap the diseased cell, and the other that induces the insects to remove the diseased pupa.

Hybrids between behaviorally different strains and species of animals exhibit behaviors intermediate between those of the parents, or combine the parental behaviors. This has been seen for aggression in honeybees, courtship in *Drosophila*, breeding behaviors of cichlid fishes, food preferences in garter snakes, bird migratory and nesting behaviors, and bird distress calls.

### Genes and Human Behavior

The foregoing observations and experiments, and many others like these, no longer leave room for doubt that genes significantly influence animal behavior. The subject becomes very controversial, however, when we come to the behavior of the most complex of animals, *Homo sapiens*. Behavioral geneticists find evidence of a genetic influence on schizophrenia, alcoholism,

sleep disorders, depression, sexual orientation, intelligence quotient, and many personality traits.

Consider, for example, sexual orientation, an intensely heated issue in which one side argues that people are born with a hereditary predisposition to become homosexual or heterosexual, and the other side argues that homosexuals simply “choose to be that way” and could change if they wanted to, or that this behavior was caused by childhood influences and can be “corrected” by such means as psychotherapy. J. M. Bailey and R. C. Pillard studied families with two or more male siblings, at least one of whom was homosexual. In 52 percent of the cases where the brothers were monozygotic (genetically identical) twins, the other brother was also homosexual; in 22 percent of dizygotic (nonidentical) twin pairs, the second brother was homosexual; and in only 9 percent of nontwin brothers, the second brother was homosexual. The 52 percent figure shows that genes do not inevitably determine sexual orientation; if they did, this figure would be 100 percent. But the contrast between this datum and the other two does suggest that heredity significantly increases the likelihood of a given adult sexual orientation.

**genome** total genetic material in a cell or organism

**nucleotide** the building block of RNA or DNA

The sequencing of the human **genome** will provide a new tool to assess the genetic underpinnings of behaviors in the human species. A shortcut to sequencing the genomes of many people is to identify places in the genome where people tend to differ in the particular DNA base found. These sites are called single **nucleotide** polymorphisms, or SNPs, and already an international consortium of researchers has identified more than two million of them among the three billion bases of the human genome. Many research groups are now correlating specific SNP patterns to disease susceptibilities, and these include conditions that have behavioral components. One company, for example, is amassing SNP patterns among six hundred families in which two or more members have eating disorders. The researchers look at SNPs in genes known to be associated with eating behaviors and satiety, such as leptin and neuropeptide Y, and other, as yet unknown places in the genome where certain SNPs are statistically more common in people with these types of disorders. Even with this powerful new technology, it will be difficult to separate inherited tendencies from learned behaviors.

### Political and Philosophical Issues

Much of the opposition to the idea of a genetic influence on human behavior stems from political and social philosophies that are reluctant to accept the idea that not all human behavior can be shaped by experience or changed at will. It would be discouraging to think that tendencies toward war, racism, or marital infidelity were genetic and unchangeable. Hereditary theories of human behavior were taken to despicable extremes in the twentieth century, including a eugenics movement in America that argued that some races and classes of people were genetically inferior to others and, most horrendously, the racial philosophy of Nazi Germany, which extolled the fictitious “white Aryan race” while trying to systematically exterminate another. In light of this horrific history, it is understandable that some people recoil from any latter-day suggestions that human behavior is hereditary.

#### **PAVLOV, IVAN PETROVICH (1849–1936)**

Russian biologist who won the 1904 Nobel Prize in physiology for his demonstration of the idea of a “conditioned reflex.” Pavlov trained dogs to drool at the sound of a bell by feeding them immediately after sounding the bell.

Yet scientific evidence cannot be rejected simply because it does not conform to a political philosophy. In evaluating the influence of genes on human behavior, several points must be kept in mind. One is that behavioral geneticists are not arguing for genetic determinism: they are saying genes influence behavior, not that they rigidly determine it and destine people to behave in certain ways. Genes may influence human behavior, but they do not enslave people. All behaviors require at least some contribution from genes (to build sense organs, nervous systems, muscles, and the other equipment of behavior) and environment (to provide the raw materials to build this equipment and the experiences that sway **gene expression**). As evolutionary theorist Richard Dawkins puts it, behavior is like a chocolate cake, needing both a recipe and ingredients. Genes provide the behavioral recipe, and the environment the ingredients.

Finally, there is no such thing as a gene for any behavior. There is no aggression gene, no gay gene, no gene for bird song or nut-burying. Genes encode **proteins**, nothing more; but through proteins, they can influence behavior. Aggression and sexual behavior, for example, are influenced by testosterone, and testosterone is synthesized by **enzymes**, which are proteins encoded by deoxyribonucleic acid (DNA). Thus one can see how genes would influence these behaviors. All behavior, furthermore, depends on chemical signals (neurotransmitters) that are released by one **neuron** and bind to receptors on the next neuron. **Neurotransmitters**, too, are synthesized by enzymes encoded by DNA, and their receptors are proteins as well. Neurotransmitter levels control mood and probably aspects of personality. The list goes on and on. Indeed, it is impossible to see how genes could *not* play a role in behavior. SEE ALSO BIOLOGY OF RACE; EVOLUTION; SOCIOBIOLOGY

*Kenneth S. Saladin and Ricki Lewis*

### Bibliography

- Alcock, John. *Animal Behavior*, 7th ed. Sunderland, MA: Sinauer Associates, Inc., 2001.
- Bailey, J. M., and R. C. Pillard. "A Genetic Study of Male Sexual Orientation." *Archives of General Psychiatry* 48 (1991): 1089–1096.
- Clark, William R., and Michael Grunstein. *Are We Hardwired? The Role of Genes in Human Behavior*. New York: Oxford University Press, 2000.
- Lewis, Ricki. *Human Genetics: Concepts and Applications*, 4th ed. Dubuque, IA: McGraw-Hill Higher Education, 2001.
- Plomin, Robert, et al., eds. *Behavioral Genetics*, 4th ed. San Francisco: W. H. Freeman and Company, 2000.
- Wilson, Edward O. *On Human Nature*. Cambridge, MA: Harvard University Press, 1978.

## Behavior Patterns

There are millions of different species of animals, and each species behaves somewhat differently. Nevertheless, there are common patterns of behavior exhibited by many species, and a few behavior patterns that are exhibited by all species. Since all species need to reproduce, eat, and try not to be eaten by someone else, all species exhibit some type of reproductive behavior, foraging (eating) behavior, and defensive behavior. Over time, natural selection has also favored other behavior patterns that help species

### LORENZ, KONRAD (1903–1989)

Austrian biologist who founded the study of animal behavior, or ethology. Lorenz said that animal behavior evolves in the same way as physical structures, such as wings. Lorenz shared the Nobel Prize in physiology with fellow ethologists Karl von Frisch and Nikolaas Tinbergen.

**gene expression** use of a gene to create the corresponding protein

**protein** complex molecule made from amino acids; used in cells for structure, signaling, and controlling reactions

**enzyme** protein that controls a reaction in a cell

**neuron** nerve cell

**neurotransmitters** molecules released by one neuron to stimulate or inhibit another neuron or cell



Elk fighting for dominance in a Wyoming herd. Common patterns of behavior are exhibited by many species.



accomplish these basic goals, including communication behavior, territorial behavior, dispersal behavior, and social behavior.

### Reproductive Behavior

Although some animals are able to reproduce asexually (such as some insects and a few species of lizards), most animals must find a mate in order to reproduce. In many cases, one of the individuals, usually the male, tries to attract a mate by performing a courtship display. This is often a visual display, as is the case with the peacock and many species of coral reef fish. Studies have shown that the females select males partly on the basis of their courtship displays. Scientists believe that vigorous and brightly colored displays might signal to the female that the male is strong and healthy. Thus, mating behavior plays an important role in determining which **genes** get passed on to the next generation.

### Foraging Behavior

Animals exhibit several different types of foraging behavior. Some animals are quite selective in what they eat. These animals are called foraging specialists. For example, the diet of the lynx consists primarily of snowshoe hares. Some species of insects feed only on a single plant species; they are the ultimate feeding specialists. Other animals are generalists, eating a wide variety of food types. An example of a foraging generalist is the opossum, which eats everything from insects and berries to garbage. It is thought that natural selection has favored many animals to forage in an efficient manner. This means that the animals make feeding choices that maximize the amount of energy they can obtain in the shortest time possible. This type of foraging, sometimes referred to as “optimal foraging,” leaves the animal with more time and energy for other important activities, such as finding a mate or caring for offspring.

### Defensive Behavior

Virtually all animals are vulnerable to predation (being eaten by another animal) at least some time during their lives. Even wolves and lions can be

**gene** portion of DNA that codes for a protein or RNA molecule

prey for other animals when they are very young. As a result, animals from worms to whales have evolved ways to reduce the likelihood they are eaten. This behavior, often referred to as defensive, or antipredator, behavior, can take many forms. Some animals, such as many moths and lizards, try to blend in with their surroundings so the predator cannot see them. This is called cryptic behavior. Other species have evolved effective escape behaviors, such as fast-running antelope and fast-swimming fish. Others fight back with stinging or biting behavior. In many cases, prey can deter predators with a threat display. Threat displays are special behaviors that tell the predator that the prey may fight back ferociously. A raccoon that bares its teeth and growls when cornered by a predator is giving such a threat display.

### Communication Behavior

As illustrated above, effective communication behavior is vital for an animal. Besides communicating with sight and sound, some animals communicate using chemicals. For example, male moths find mates by detecting special chemicals called **pheromones** that the females release into the air. Ants also use pheromones to determine if another ant is an intruder or a member of the colony.

**pheromone** molecule released by one organism to influence another organism's behavior

### Territorial Behavior

Setting up and maintaining a territory is another common pattern of behavior exhibited by many species of insects, fish, birds, reptiles, and mammals. Territories are used for a variety of purposes, including feeding, mating, and caring for offspring. The territory owner normally tries to keep other individuals of its species out of the territory.

### Dispersal and Social Behavior

Other patterns of behavior include dispersal behavior, exhibited when individuals move away from the area in which they were born, and many types of social behavior. Social behavior is particularly common in animals that live in groups, such as ants, penguins, and primates. In all cases, scientists believe that these patterns of behavior have evolved over time because they have increased the ability of animals to survive and reproduce. **SEE ALSO FEEDING STRATEGIES; HERBIVORY AND PLANT DEFENSES; MATING SYSTEMS; MIGRATION; MIMICRY, CAMOUFLAGE AND WARNING COLORATION; PREDATION AND DEFENSE; SEXUAL SELECTION; SOCIAL BEHAVIOR**

*Mark A. Davis*

#### Bibliography

Alcock, John. *Animal Behavior: An Evolutionary Approach*, 6th ed. Sunderland, MA: Sinauer Associates, Inc., 1997.

**protein** complex molecule made from amino acids; used in cells for structure, signaling, and controlling reactions

**carbohydrates** sugars, starches, and other molecules combining carbon, hydrogen, and oxygen and serving as fuel or structural components

**lipid** fat or waxlike molecule, insoluble in water

## Biochemist

A biochemist is a scientist primarily concerned with the chemistry of biological processes. The four main branches of biochemistry are: a) nucleic acids, b) **proteins**, c) **carbohydrates**, and d) **lipids**. Most biochemists will generally specialize in one of these areas. The training and scientific focus of a biochemist is what distinguishes him or her from others in related

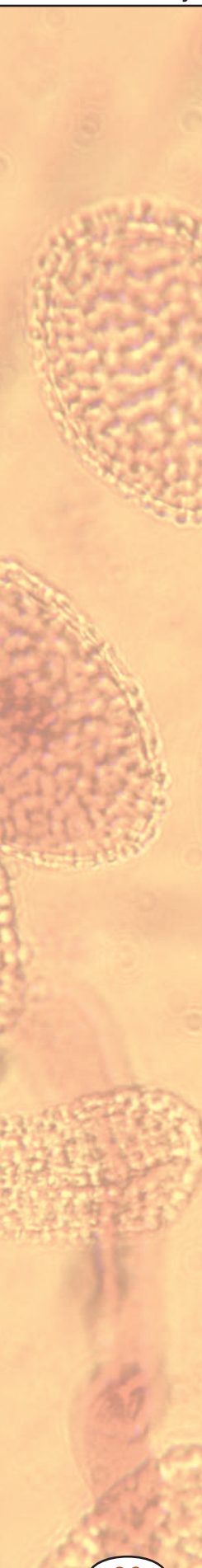

**ecosystem** an ecological community and its environment

disciplines (molecular genetics, cell biology, analytic chemistry, and biophysics). Biochemists deal chiefly with scientific research of specific biochemical structures, interactions, or reactions. Two specific examples of research biochemists are enzymologists, who study catalytic proteins, and analytical biochemists, who may, for example, develop new DNA separation technologies.

Minimal training for a technician-level position in biochemistry generally requires a B.S. in biochemistry or chemistry, while those wishing more professional autonomy should attain a graduate degree. Ph.D.-level biochemists achieve the greatest autonomy. Before attaining their first independent position they will usually undergo additional training after completion of their in Ph.D., a postdoctoral position.

Biochemists work in the biopharmaceutical and agricultural biotechnology industries, academia, clinical laboratories, and a variety of regulatory and military posts in government. SEE ALSO BIOTECHNOLOGY; CARBOHYDRATES; DNA; LIPIDS; PHARMACOLOGIST

*Michael L. Gleason*

#### **Bibliography**

*American Chemical Society: ChemCenter.* <<http://www.acs.org/servlet/ACSHomePage>>.

## **Biodiversity**

Biodiversity is the sum total of life on Earth; the entire global complement of terrestrial, marine, and freshwater biomes and **ecosystems**, and the species—plants, animals, fungi, and microorganisms—that live in them, including their behaviors, interactions, and ecological processes. Biodiversity is linked directly to the nonliving components of the planet—atmosphere, oceans, freshwater systems, geological formations, and soils—forming one great, interdependent system, the biosphere.

### **Humankind's Relationship to Biodiversity**

Humans depend entirely on this biodiversity and are an integral part of it. Directly or indirectly, be it from wild or domesticated components of biodiversity, humankind derives many goods critical to its sustenance, well-being, health, and enjoyment, such as food, medicine, building materials, and industrial products. Also, people enjoy many ecosystem services, including water regulation and supply, erosion control, soil formation, nutrient storage and cycling, pollination, pollution breakdown and absorption, climate stability, protection and recovery from natural disasters, and buffering against the spread of disease. These services, provided by nature free of charge, have an estimated value of \$33 trillion per year.

Even though continued human welfare depends on it, our knowledge of biodiversity is seriously inadequate. As of 1998, scientists have described between 1.4 and 1.8 million species. However, later estimates indicate that the total number of species ranges between 5 and 30 million, and some scientists believe it may be higher than 100 million.

Clearly, much more work is needed to quantify and describe all biodiversity at three main levels: genetic diversity, or the variation of genes

within species; species diversity, or the variety of species within a biome or ecosystem, measured in species richness, species abundance, and taxonomic diversity; and ecosystem diversity, or the broad differences between ecosystem structures and biome types, and the diversity of habitats and ecological processes occurring within each of them. Taxonomists and other scientists in fields such as zoology, botany, ecology, and genetics study biodiversity.

### Threats to Biodiversity

Species are becoming extinct faster than scientists can discover them. The loss of biodiversity is an irreversible process: once a species becomes extinct its loss is permanent and irrevocable. Late-twentieth-century estimates cite the extinction rate between one thousand and ten thousand times greater than it would be naturally. This means that Earth is losing species at the fastest rate in the planet's 4.5 billion-year history and, unlike prior extinction episodes (such as the mass extinction of dinosaurs 65 million years ago), this extinction spasm is mainly the result of human activity and not of a cosmic event. If extinctions continue at the current rate, in the next one hundred years humankind runs the risk of losing half of the planet's biodiversity.

Most threats to biodiversity have to do with pressures on natural resources due to human activities. These include habitat destruction and conversion of natural ecosystems to agriculture; flooding for hydroelectric projects; large-scale extraction of natural resources such as mining and logging; excessive hunting and overfishing; pollution from agricultural pesticides, human waste, and industrial processes; and poorly planned urban and suburban sprawl.

### Conserving Biodiversity

Conserving biodiversity is an urgent matter of common concern and should be an integral part of the development process, as was outlined in the Convention on Biological Diversity. This global, comprehensive agreement was drafted at the 1992 Rio de Janeiro Earth Summit and signed by 160 nations to address all aspects of biological diversity. Its objectives include "the conservation of biodiversity, its sustainable use and the fair sharing of the benefits derived from the utilization of genetic resources."

One conservation strategy aimed at reaching this goal recognizes that biodiversity is not evenly distributed over the planet: certain regions have higher species richness (the number of species in an area) and endemism (the number of species in that area that occur nowhere else) than others. Ironically, many of these sensitive areas are also preferred by humans to inhabit, placing tremendous pressure on local biodiversity. These areas are called the "biodiversity hotspots"; twenty-five of them have been described thus far, including Madagascar, the tropical Andes, the Philippines, and the Atlantic forest of Brazil. Conservationists believe that urgent conservation efforts should be targeted at these regions. Equally important are the so-called wilderness areas: Amazonia, the Congo Basin, and Papua New Guinea. These areas are also high in biodiversity but are not so immediately threatened. SEE ALSO BIOME; CONSERVATION; ECOSYSTEM; ENDANGERED SPECIES; EXTINCTION; INVASIVE SPECIES

*Cristina G. Mittermeier and Russell A. Mittermeier*

#### **WILSON, E. O. (1829–)**

U.S. evolutionary biologist and Pulitzer Prize-winning author. Wilson is the world's authority on ants and biodiversity and was an early advocate of studying the behavior of humans and other animals in the context of evolution and adaptation, so-called "sociobiology."

### Bibliography

- Costanza, Robert, et al. "The Value of the World's Ecosystem Services and Natural Capital." *Nature* 387, no. 15 (May 1997): 253–260.
- May, R. M. "How Many Species Are There on Earth?" *Science* 241 (1998): 1441–1449.
- Mittermeier, Russell A., P. Robles Gil, and Cristina G. Mittermeier. *Megadiversity: Earth's Biologically Wealthiest Countries*. Mexico: Cemex, 1997.
- . *Hotspots: Earth's Biologically Richest and Most Endangered Terrestrial Ecoregions*. Mexico: Cemex, 1999.
- Stuart, S. *Species: Unprecedented Extinction Rate, and It's Increasing*. Gland, Switzerland: IUCN, 1999.

## Biogeochemical Cycles

Biogeochemical cycles refer to the movement of chemical elements between living (biotic) and nonliving (abiotic) forms in the environment. Although many elements undergo this type of cycling to some extent, four elements—carbon, nitrogen, phosphorus, and sulfur—are most commonly discussed because of their importance (along with hydrogen and oxygen) for living organisms. The extent and rate of the cycling of these elements has important consequences, such as influencing the amount of phosphate available to forests and the ability of the oceans to slow down global warming by absorbing carbon dioxide.

### Common Compounds

All the elements that undergo cycling are incorporated into compounds. Carbon may be found as **inorganic**  $\text{CO}_2$  gas, carbonate **ions** ( $\text{CO}_3^{2-}$ ) in rocks or the oceans, or in **organic** compounds, such as sugars and **proteins**, within living organisms. Nitrogen exists in the atmosphere as  $\text{N}_2$  or ammonia ( $\text{NH}_3$ ), in the soil as an ion such as nitrate ( $\text{NO}_3^-$ ), and in living organisms in a variety of organic compounds, including proteins and nucleic acids. Wherever it occurs, phosphorus is largely bound to oxygen to make a phosphate ion ( $\text{PO}_4^{3-}$ ). Sulfur exists as sulfur dioxide gas ( $\text{SO}_2$ ), sulfate ions ( $\text{SO}_4^{2-}$ ) in rocks, and in living organisms incorporated into proteins.

The atmosphere, oceans, fresh water, rocks, soil, and living organisms can each be thought of as a "pool" for storing these compounds. The time spent in any one pool is quantified as the mean residence time (MRT). For instance, the MRT for phosphate in rock may be thousands of years, whereas the MRT for the phosphate in a stand of corn is less than one year.

### Transport Mechanisms

Elements move from one pool to another through meteorological, geologic, biological, or anthropogenic mechanisms. Meteorological mechanisms revolve around precipitation, such as rain carrying  $\text{SO}_2$  into the soil. Geologic mechanisms include erosion, which can bring rock ions into solution, as well as sedimentation and volcanoes.

Biological mechanisms are those carried on by living organisms, such as photosynthetic conversion of  $\text{CO}_2$  to sugar, or conversion of soil  $\text{NH}_3$  to gaseous  $\text{N}_2$  by soil bacteria. Marine birds can have a significant local impact on transport of phosphate and nitrogen from ocean to land. Many islands off

**inorganic** not bonded to carbon

**ion** an electrically charged particle

**organic** composed of carbon, or derived from living organisms

**protein** complex molecule made from amino acids; used in cells for structure, signaling, and controlling reactions



Soil erosion on a trail in the Adirondack mountains. Erosion is a geologic mechanism that helps to move chemical compounds between biotic and abiotic forms in the environment.

the western coast of South America, for instance, are covered with a layer of white guano, dropped by generations of birds feasting on anchovies. Harvest of this rich fertilizer forms part of the economies of Peru, Chile, and Ecuador.

**Anthropogenic** mechanisms are those carried on by humans and are therefore a subset of biological mechanisms. Humans have a profound effect on biogeochemical cycles through agriculture (for example, adding nitrogen to the global nitrogen cycle through fertilizer applications), forestry, and especially the use of carbon-based fossil fuels. The release of vast amounts of carbon from stored pools is likely to raise the world's temperature by at least several degrees over the coming decades, with the potential for significant consequences on many forms of life. An important, yet unanswered, question is whether the forests, soil, and especially the ocean can absorb this extra CO<sub>2</sub> and thereby reduce the extent of global warming. SEE ALSO CARBON CYCLE; ECOSYSTEM; GLOBAL CLIMATE CHANGE; NITROGEN CYCLE; PHOTOSYNTHESIS; PLANKTON

*Richard Robinson*

### **Bibliography**

Berner Elizabeth Kay, and Robert A. Berner. *Global Environment: Water, Air, and Geochemical Cycles*. Upper Saddle River, NJ: Prentice Hall, 1996.

**anthropogenic** of, relating to the influence of human beings or nature

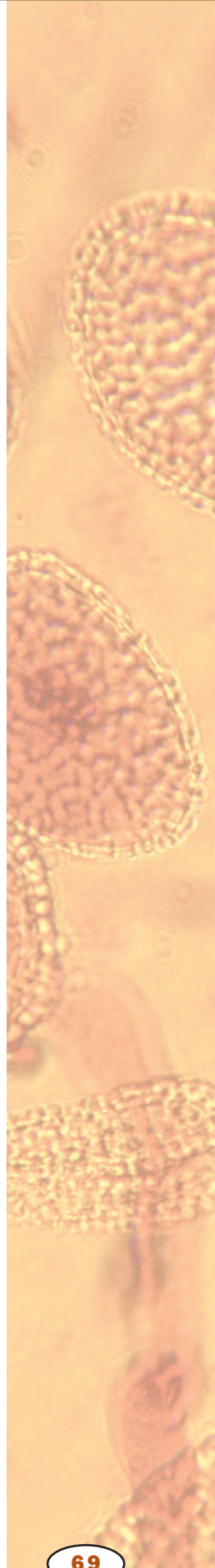

## Biogeography

An enormous variety of species live in the thin layer on Earth's surface that makes up the biosphere. None of these species is found everywhere on Earth's surface. Instead, the number and kinds of species change dramatically as one moves from one place to the next. The science that studies the past and present distribution patterns of organisms and seeks to understand the mechanisms that underlie these patterns is called biogeography.

Biogeographers explain the distributions of species using four basic principles regarding the nature of Earth and the organisms that live on it:

1. **Environmental variability:** For a variety of reasons, the conditions that organisms experience change dramatically across Earth's surface. Climate and elevation are two major influences.
2. **Ecological limitation:** Every organism has a limited range of conditions that must be met in order to allow it to live and reproduce. Since a species is a population of reproductively compatible organisms that have similar biological properties, no species can be found everywhere.
3. **Continental drift:** The locations of landmasses across Earth's surface have not remained the same, but have changed slowly over the course of Earth's history. Therefore, the conditions experienced by organisms change over long periods of Earth's history.
4. **Evolutionary change:** Species do not stay the same over time, but are in a constant state of change as individuals best able to survive and reproduce within certain environments become more frequent, while others less capable die or fail to produce offspring. The ability of a species to evolve allows it to persist over long periods of time and track the changes occurring on Earth's surface.

The first two principles indicate that the current geographic distribution of a species is determined by how its ecological limitations are related to the environmental conditions it encounters. Species with similar requirements will be found together in the same locations. Regions on continents or in oceans where the species share similar ecological limitations are called biomes. For example, deserts are biomes where the species are all able to withstand relatively hot, dry climates.

The third and fourth principles indicate that as continents move about across the face of Earth, they carry with them the species that inhabit them. When continents that were once connected separate, populations are fragmented, and subsequent evolutionary changes in related species will occur independently. The timing of such independent evolutionary changes provides clues about the timing of Earth's history. Much of the history of continental drift, for example, can be reconstructed by examining the geographical distribution of fossils and of related groups of living species.

All four principles suggest that as the conditions on Earth change over long periods of time, each species will respond to these changes in one of three distinct ways. First, a species may change its geographic distribution to track changes in the location of its favored set of ecological conditions. For instance, during ice ages, many species moved southward. Second, a

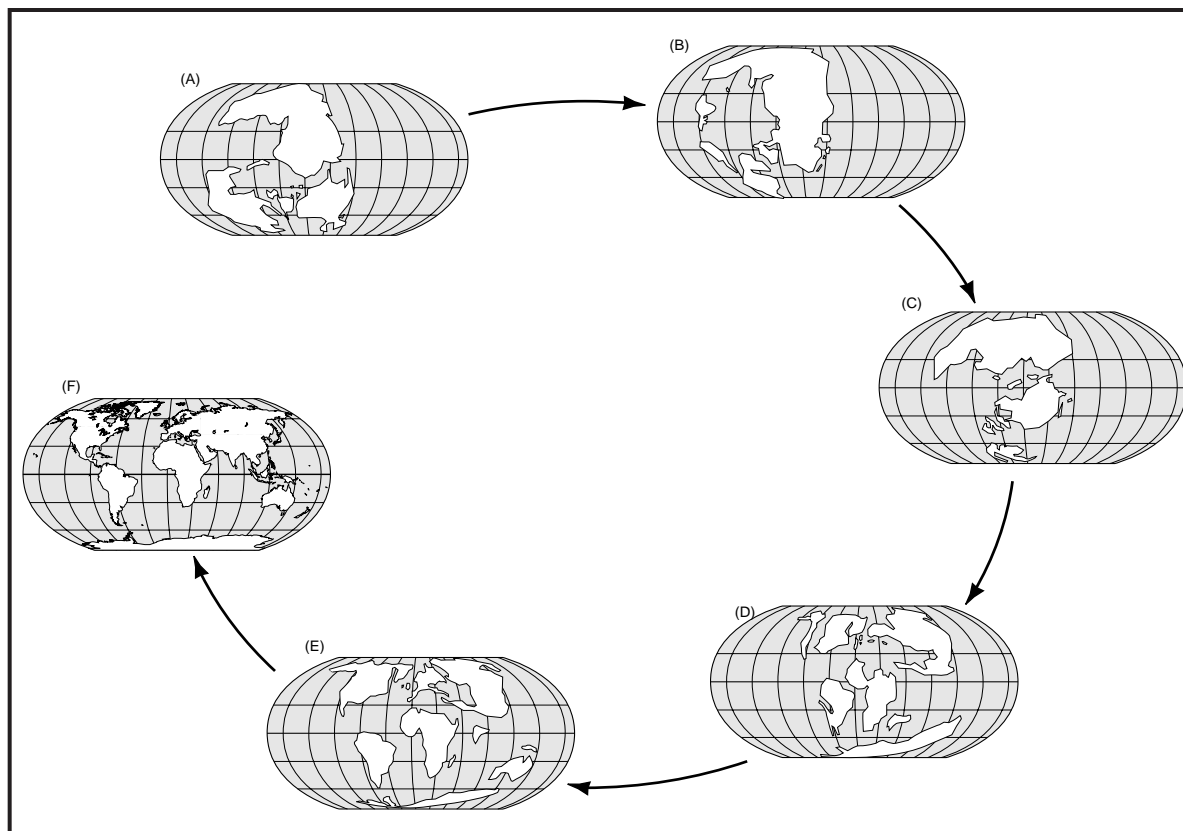

species may undergo evolutionary change to adapt to changing conditions. Third, if a species cannot shift its geographic range or undergo evolutionary change, the species will go extinct. Over the history of Earth, no species has been able to persist unchanged as the biosphere has changed. SEE ALSO BIODIVERSITY; BIOME; EVOLUTION

Brian Maurer

### Bibliography

Brown, J. H., and M. V. Lomolino. *Biogeography*. Sunderland, MA: Sinauer Associates, Inc., 1998.

Cox, B. C., and P. D. Moore. *Biogeography: An Ecological and Evolutionary Approach*. Boston: Blackwell Scientific Publications, 1985.

The distribution of landmasses at points in Earth's history, illustrating the theory of continental drift and the changing conditions organisms experienced due to it: (A) 320 million years ago; (B) 250 million years ago; (C) 135 million years ago; (D) 100 million years ago; (E) 45 million years ago; (F) present.

## Bioinformatics

Bioinformatics is a new field that centers on the development and application of computational methods to organize, integrate, and analyze **gene**-related data. The Human Genome Project (HGP) was an international effort to determine the deoxyribonucleic acid (DNA) base sequence of the entire human genome, which includes about thirty thousand **protein**-encoding genes, their regulatory elements, and many highly repeated noncoding sections. In 1985, a group of visionary scientists led by Charles DeLisi, who was then the director of the office of health and environmental research at the U.S. Department of Energy (DOE), realized that having the entire human genome in hand would provide the foundation for a revolution in biology and medicine. As a result, the 1988 presidential budget submission to

**gene** portion of DNA that codes for a protein or RNA molecule

**protein** complex molecule made from amino acids; used in cells for structure, signaling, and controlling reactions



A scientist at the Whitehead Institute in Cambridge, Massachusetts, studies a map of the human Y chromosome.



U.S. Congress requested funds to start the HGP. Momentum built quickly and by 1990, DOE and the U.S. National Institutes of Health had laid out plans for a fifteen-year project. An international public consortium and a private company announced completion of a rough draft of the human genome sequence on June 26, 2000, with papers describing the data published eight months later. This is the first generation bestowed with the “parts list” of life, as well as the daunting task of making sense out of it.

### Data Management

The Human Genome Project and other genome projects have generated massive data on genome sequences, disease-causing gene variants, protein three-dimensional structures and functions, protein-protein interactions, and gene regulation. Bioinformatics is closely tied to two other new fields: genomics (identification and functional characterization of genes in a massively parallel and high-throughput fashion) and proteomics (analysis of the biological functions of proteins and their interactions), which have also resulted from the genome projects. The fruits of the HGP will have major impacts on understanding evolution and developmental biology, and on scientists’ ability to diagnose and treat diseases. Areas outside of traditional biology, such as anthropology and **forensic** medicine, are also embracing genome information.

**forensic** related to legal proceedings

Knowing the sequence of the billions of bases in the human genome does not tell scientists where the genes are (about 1.5 percent of the human genome encodes protein). Nor does it tell scientists what the genes do, how genes are regulated, how gene products form a cell, how cells form organs, which mutations underlie genetic diseases, why humans age, and how to develop drugs. Bioinformatics, genomics, and proteomics try to answer these questions using technologies that take advantage of as much gene sequence information as possible. In particular, bioinformatics focuses on computational approaches.

Bioinformatics includes development of databases and computational algorithms to store, disseminate, and rapidly retrieve genomic data. Biologi-

cal data are complex and abundant. For example, the U.S. National Center for Biotechnology Information (NCBI), a division of the National Institutes of Health, houses central databases for gene sequences (GenBank), disease associations (OMIM), and protein structure (MMDB), and publishes biomedical articles (PubMed). The best way to get a feeling for the magnitude and variety of the data is to access the homepage of NCBI via the World Wide Web (<http://ncbi.nlm.nih.gov>). A bioinformatics team at NCBI works on the design of the databases and the development of efficient algorithms for retrieving data and comparing DNA sequences.

## Applications

Bioinformatics also covers the design of genomics and proteomics experiments and subsequent analysis of the results. For instance, disease tissues (such as those from cancer patients) express different sets of proteins than their normal counterparts. Therefore protein abundance can be used to diagnose diseases. Moreover, proteins that are highly (or uniquely) expressed in disease tissues may be potential drug targets.

Genomics and proteomics generate protein abundance data using different approaches. Genomics determines gene abundance (which is a good indicator of protein abundance) using DNA microarrays, also known as DNA chips, which are high-density arrays of short DNA sequences, each recognizing a particular gene. By **hybridizing** a tissue sample to a DNA chip, one can determine the activities of many genes in a single experiment. The design of DNA chips—that is, which gene fragments to use in order to achieve maximum sensitivity and specificity, as well as how to interpret the results of DNA chip experiments—are difficult problems in bioinformatics.

Proteomics measures protein abundance directly using mass **spectroscopy**, which is a way to measure the mass of a protein. Since mass is not unique enough for identifying a protein, one usually cuts the protein with **enzymes** (that cut at specific places according to the protein sequence) and measures the masses of the resulting fragments using mass spectroscopy. Such “mass distributions” for all proteins with known sequences can be generated using computers and stored. By comparing the mass distribution of an unknown protein sample to those of known proteins, one can identify the sample. Such comparisons require complex computational algorithms, especially when the sample is a mixture of proteins. Although not as efficient as DNA chips, mass spectroscopy can directly measure protein abundance. In fact, spectrometric identification of proteins has been the one of the most significant advances in proteomics.

Bioinformatics can lead to discovery of new proteins. When the cystic fibrosis gene (CF) was first identified in 1989, for example, researchers compared its DNA sequence computationally to all sequences known at that time. The comparison revealed striking homology (sequence similarity) to a large family of proteins involved in active transport across cell membranes. Indeed, the CF gene encodes a membrane-spanning chloride **ion** channel, called the cystic fibrosis transmembrane regulator, or CFTR. The identification of gene function by searching for sequence homology is a widely used bioinformatics method. When no homology is found, one may still be able to tell if a gene codes for membrane-spanning channels using computational

**hybridizing** combining two different types

**spectroscopy** process using light or other emitted radiation to determine properties of a sample

**enzyme** protein that controls a reaction in a cell

**ion** an electrically charged particle

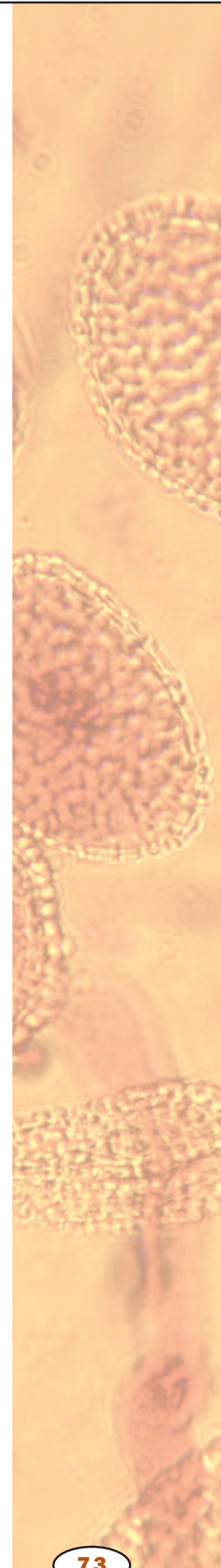

**bilayer** composed of two layers

**lipid** fat or waxlike molecule, insoluble in water

**rickettsia** (pl. -sias or siae) any of a family of polymorphic microorganisms that cause various diseases

**protozoa** any of a phylum of minute protoplasmic animals present in almost every kind of habitat, some of which pose serious threats to humans and animals

**fungi** major group of parasitic, lower plants that obtain their food from the products of organic decay (e.g. molds, smuts, etc.)

tools. Membranes are **bilayers** of **lipid** molecules, which are water insoluble. An ion channel typically has regions outside the membrane (water soluble) and regions inside the membrane (water insoluble) arranged in a certain pattern. Computer algorithms have been developed to capture such patterns in a gene sequence.

By thinking boldly and by setting ambitious goals, the Human Genome Project has brought about a new era in biological and biomedical research. Many revolutionarily new technologies are being developed, most of which have significant computational components. The avalanche of genomic data also enables model-based reasoning. The bright future of bioinformatics calls for individuals who can think quantitatively and in the meantime love biology—an unusual combination. SEE ALSO BIOTECHNOLOGY; GENOME; HUMAN GENOME PROJECT

*Zhiping Weng*

### **Bibliography**

- Butler, Declan. "Are You Ready for the Revolution?" *Nature* 409 (15 February 2001): 758–760.
- DeLisi, Charles. "The Human Genome Project." *American Scientist* 76 (1988): 488–493.
- Marshall, Eliot. "Bioinformatics: Hot Property: Biologists Who Compute." *Science* 272 (1996): 1730–1732.
- Roos, D. S. "Bioinformatics: Trying to Swim in a Sea of Data." *Science* 291 (16 February 2001): 1260–1261.

## **Biological Weapons**

Biological weapons are organisms or their by-products used to deliberately spread disease. They include bacteria, viruses, **rickettsiae**, **protozoa**, **fungi**, and their toxins. The effects of biological warfare agents are diverse, but they generally incapacitate or kill their victims, or destroy crops or livestock.

Biological weapons have been used for centuries. The Tartar army catapulted plague-ridden corpses over city walls in the 1346 siege of Kaffa. All major participants in World War II developed biological weapons, however Japan, which dropped bubonic plague-infested debris on Chinese cities, was the only country known to have used them. In 1969 the United States abandoned research and production of biological weapons. Within three years, remaining U.S. stockpiles were destroyed. In 1975, 118 countries signed the Biological Weapons Convention that outlawed the development, possession, and stockpiling of biological weapons.

Biological weapons are often called "the poor man's weapon of mass destruction" because they are cheap and easy to produce. The production processes used to make biological weapons are similar to those used to develop medicines or make yogurt. Since facilities, equipment, and supplies resemble those for biotechnical and medical research, they can be hidden within legitimate facilities, making it difficult to track development of biological weapons. Compared to chemical or nuclear weapons, biological weapons are easily handled and effective in small amounts.

Exposure to most biological weapons occurs by inhaling an aerosolized agent. The most difficult part of producing the weapon is getting the agent into a small, stable form for dispersal. Agents can be dispersed as part of a



An American soldier receiving an anthrax vaccine before shipping out to Korea in February 2000. Inhalation of anthrax spores causes severe respiratory distress, shock, and death in about five days.

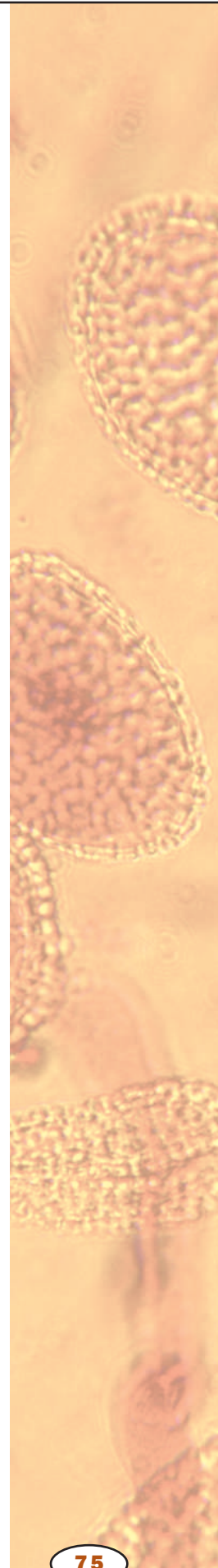

**cutaneous** related to the skin

conventional warhead or sprayed from a plane or a small canister. Attacks are nearly impossible to detect in early stages and may not become known until symptoms of disease appear. Defense against biological weapons may include protective clothing and masks, vaccinations, and antibiotic or antiviral therapy. Quick identification of biological agents is essential to save lives and maintain military effectiveness.

There are more than sixty potential biological warfare agents. Two of the most common are anthrax and botulism. The anthrax bacteria, *Bacillus anthracis*, commonly cause disease in cattle, horses, and sheep. In humans, **cutaneous** anthrax, which causes skin ulcers, accounts for about 95 percent of U.S. cases, with little mortality. However, inhalation of anthrax spores destroys lung and intestinal membranes, causing severe respiratory distress, shock, and death in about five days. Although antibiotics can be used, the mortality rate for inhaled anthrax is nearly 100 percent after symptoms appear. Anthrax is easy to cultivate and forms highly resistant spores that can remain active and potentially lethal for at least forty years.

Botulism is caused by *Clostridium botulinum* neurotoxin. Inhaling a very small amount of this bacterial toxin blocks electrical signal transmission in the nervous system and causes progressive muscular paralysis. Paralysis of respiratory muscles leads to asphyxiation and death. Tracheostomy and use of a ventilator reduce mortality, but recovery may take months of intensive nursing care.

Advances in biotechnology may produce biological weapons that are even more toxic, fast acting, and resilient. Genetic engineering may produce new organisms or toxins designed to target specific populations. Cloning techniques may allow for mass production. SEE ALSO NERVOUS SYSTEMS; NEURON; POISONS

*Lynnette Danzl-Tauer*

#### **Bibliography**

*Biological Weapons*. Special Edition of the *Journal of the American Medical Association* 278, no. 5 (1997).

Solomon, Brian, ed. *Chemical and Biological Warfare*. New York: H. W. Wilson Company, 1999.

## Biology

Biology is defined as the “study of life.” The term life refers to all organisms (plants, animals, bacteria, fungi, and protists) inhabiting Earth and its atmosphere. Both scientists and laypeople are drawn to biology because it seeks to answer the question of how life began. All of the acquired evidence points to a single origin for all living things.

The study of evolution shows that there are significant similarities among organisms that are not obviously related. Virtually every organism uses the same **genetic code** to build its **proteins**, from the tiniest bacterium to the blue whale and the giant sequoia. A fungus and a horse break down sugar to release energy using (more or less) the same **enzymes**. Indeed, evolution, the gradual change in a population over time, serves as a unifying concept in biology.

The more related two species of multicellular organisms are, the more similar their anatomies in almost all cases. Species that rely heavily on one another for life evolve in response to each other’s habits and characteristics. Researchers use animals closely related to humans in order to predict the effects of new drugs or surgical techniques on human subjects, taking advantage of evolutionary relationships that yield similar anatomies and physiologies in different organisms.

### Biology’s Subdisciplines

Biology encompasses many diverse subdisciplines. Systematics is the study of the diversity and classification of organisms. Cell biology is concerned with the structure and function of cells but also includes the interactions that occur between cells (for example, the signaling that occurs among different cells of the human body). The field of ecology considers interactions among organisms that inhabit the same area. For example, ecologists might study the changes in population size of a group of birds in response to the presence of a predator, or the impact of pollution on frog populations. Someone interested in medicine would need a solid background in anatomy, the study of the structure of the bodies of animals and how different components of the body relate to one another.

Physiology, which is closely related to anatomy, describes the mechanisms by which these different components perform. One might also study the anatomy and physiology of plants to learn how different tissues within a plant perform and interact. Microbiology, a field driven largely by the study of disease, is concerned with the structure, function, and interactions of microorganisms. Genetics is concerned with the inheritance of characteristics from parents to offspring, and the expression of genes to create the living organism.

Much emphasis in biology is in biotechnology, the use of organisms to create products. This field opens unimaginable possibilities for the diagnosis and treatment of hereditary diseases, production of drugs, and advancement of agriculture. At the same time, these prospects will challenge scientists with serious ethical considerations in the years to come, as the use of biotechnology requires scientists to manipulate the course of evolution. SEE ALSO BIODIVERSITY; BIOTECHNOLOGY; ECOLOGY; EVOLUTION

*Karen Gunnison Ballen*

**genetic code** relationship between triples of RNA nucleotides and the amino acids they code for during protein synthesis

**protein** complex molecule made from amino acids; used in cells for structure, signaling, and controlling reactions

**enzyme** protein that controls a reaction in a cell

### Bibliography

Krogh, David. *Biology: A Guide to the Natural World*. Upper Saddle River, NJ: Prentice Hall, 2000.

## Biology of Race

The biological definition of race is a geographically isolated breeding population that shares certain characteristics in higher frequencies than other populations of that species, but has not become reproductively isolated from other populations of the same species. (A population is a group of organisms that inhabit the same region and interbreed.) Human racial groups compose a number of breeding units that in the past remained geographically and perhaps temporally isolated, yet could interbreed and produce viable offspring within the species *Homo sapiens sapiens*. **Paleoanthropological** evidence suggests that these units have been interbreeding between populations for at least the last two hundred thousand years or longer in what may once have been considered racial groups.

More recently, molecular techniques have developed to examine genetic differences between individuals and populations, including karyotypes providing chromosomal number and patterns, deoxyribonucleic acid (DNA) hybridization, **protein** sequences, and nuclear and **mitochondrial** base sequences from ancient and modern DNA. From all this evidence, it is clear that populational, but not racial, differences do exist within the human species. Race should not be equated with ethnicity, which has a sociological meaning. Ethnicity is a self-described category that has three components—ancestry, language, and culture—that all have affinities to certain ancestral groups.

Early racial classification systems for humans used specific phenotypic characteristics that occurred in higher frequencies in certain populations. Initially, three classes were identified by anthropologists: Caucasoids, Mongoloids, and Negroids; later, Australoids and Capoids (Bushmen) were added. Following this, even more classifications were made, with no consensus among biological anthropologists. Difficulties with these early classification systems stem from the immense genotypic and phenotypic human variation found in modern living populations. While the genotypic variation was not studied in great detail in the early part of the twentieth century, phenotypic variation in skin color, body height, hair type, nasal width, and other characteristics was studied in great detail.

Some genetic differences do exist between groups, but these by and large do not correspond to historical racial categories. For instance, there are populational differences in the frequency of ABO blood types. Native North and South Americans have an incidence of nearly 100 percent type O (less than 1 percent have type AB), while Asians have a lower incidence of O (60 percent) and higher incidence of type B (22 percent). Some characteristics, such as skin color and body height, are considered to be polygenic traits. Skin color has a clinal distribution, with indigenous peoples with darker skin colors found in native peoples at the equator and lighter skin colors found in natives from higher latitudes.

**paleoanthropological** of, related to the branch of anthropology (the study of human beings) that is concerned with “fossil man”

**protein** complex molecule made from amino acids; used in cells for structure, signaling, and controlling reactions

**mitochondrial** of, relating to subcellular organelle that creates ATP used for energy-requiring processes in a cell

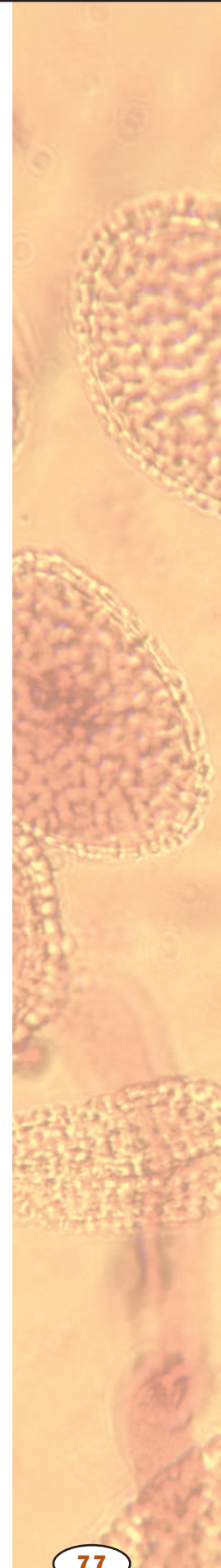

The very large amount of variation within groups dwarfs the small differences between groups, therefore race in humans does not have a biological meaning.



Skin color is an adaptation to sunlight that provides protection from skin cancer, yet at the same time allows for vitamin D production for calcium absorption. Darker skin provides more protection, while lighter skin allows more penetration of the weaker sun in temperate regions. While body height is also considered a polygenic trait, it is very much affected by inheritance, as well as environmental stressors (such as malnutrition and infectious disease).

Some differences between populations may correlate with historical exposure to different infectious diseases. For example, certain genetic variants of **hemoglobin** (for example, those causing sickle-cell **anemia** in people of African descent and thalassemia in people of Mediterranean descent) were strongly selected because they provide defensive mechanisms against infection by the organism that causes malaria (*Plasmodium*). Such environmental selection pressures have caused more than three hundred variants of the hemoglobin molecule. Cystic fibrosis (CF), a disorder of a gene that produces a protein that forms a chloride pump in cell membranes, allows for the buildup of mucus in the respiratory tract, thereby leading to death from **pathogenic** invasion. Yet the **heterozygous** condition for CF protects against extreme dehydration due to cholera. Tay-Sachs disease, a disorder of an **enzyme** that breaks down a molecule in the myelin sheath of nerve fibers, is found more commonly in people of eastern European Jewish descent than in other populations. Whether the Tay-Sachs gene protects against an infectious disease is unknown, though some have made a connection to tuberculosis exposure.

The molecular techniques outlined above now allow anthropologists to study the migration patterns of ancient peoples. Genetic diversity has resulted from the extensive hybridization that has occurred in the last two hundred thousand years, hiding any clear evidence for typological classification of race. Moreover, when selection pressures (temperature, altitude) are coupled with phenotypic variation, phenotypic expression defies taxonomic assignment of race. The genetic diversity *within* any histori-

**hemoglobin** oxygen-carrying protein complex in red blood cells

**anemia** lack of oxygen-carrying capacity in the blood

**pathogenic** causing, or capable of causing, disease

**heterozygous** characterized by possession of two different forms (alleles) of a particular gene

**enzyme** protein that controls a reaction in a cell

cally defined race swamps the small amount of difference between such groups, making the boundaries of these categories entirely arbitrary. Therefore, race in humans does not have a biological meaning. SEE ALSO GENETIC DISEASES; HUMAN EVOLUTION; HYBRIDIZATION; SEXUAL SELECTION

Angie K. Huxley

### Bibliography

- Brues, A. M. *People and Races*. New York: Macmillan Publishing Company, 1977.
- Dobzhansky, T. *Genetics and the Origin of Species*. New York: Columbia University Press, 1951.
- Jackson, F. L. "Race and Ethnicity as Biological Constructs." *Ethnicity & Disease* 2, no. 2 (Spring 1992): 120–125.
- "Sickle Cell, Thalassemia, Tay Sacs, Cystic Fibrosis." *HealthlinkUSA*. <<http://www.healthlinkusa.com/>>.

## Biome

Earth's major terrestrial, marine, and freshwater **ecosystems** are known as biomes. They are classified according to similarities in species composition of plants and animals, and by environmental attributes. These attributes include temperature, precipitation, and soil type in terrestrial biomes and temperature, depth, and salinity in aquatic biomes. There are no hard boundaries between biomes and there is much intermixing of species between them.

Biomes are divided into many kinds of ecosystems and habitats, according to local variations in species composition and physical environment (a cloud forest, mud flat, and meadow, to name a few). However, scientists generally recognize between twelve and fifteen major natural terrestrial biomes, including tropical rain forest, tropical deciduous forest, thorn woodland, tropical **savanna**, desert, **sclerophyllous** woodland, subtropical evergreen forest, temperate deciduous forest, temperate rain forest, temperate grassland, boreal forest, and tundra. Some scientists consider cultivated land to be a biome. There are seven major freshwater biomes: ice, spring, river, swamp, marsh, lake, and stream. There are six major marine biomes: coral reef; algal bed; estuary; upwelling zone; **continental shelf**; and open ocean.

Significant changes in the global environment and climate are causing major shifts in some biomes, such as glacier movement and polar cap melting, and are threatening the survival of others, such as the deforestation of tropical and temperate rain forests. SEE ALSO BIODIVERSITY; DESERT; ESTUARIES; FOREST, TEMPERATE; GRASSLAND; HABITAT; OCEAN ECOSYSTEMS; TUNDRA

Cristina G. Mittermeier and Russell A. Mittermeier

### Bibliography

- Brown, James H. and M. V. Lomolino. *Biogeography*, 2nd ed. Sunderland, MA: Sinauer Associates, Inc., 1998.

**ecosystem** an ecological community and its environment

**savanna** open grassland with sparse trees

**sclerophyll** small, tough evergreen leaves

**continental shelf** submerged offshore area demarcated by land on one side and deep sea on the other

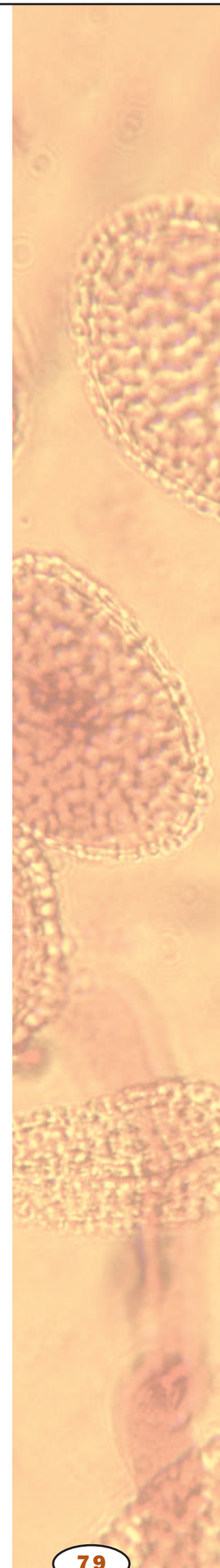



## Biotechnology

The term “biotechnology” was coined in 1919 by Hungarian scientist Karl Ereky to mean “any product produced from raw materials with the aid of living organisms.” In its broadest sense, biotechnology dates from ancient times. Approximately 6000 B.C.E., the Sumarians and Babylonians discovered the use of yeast in making beer. About 4000 B.C.E., the Egyptians employed yeast to make bread and the Chinese bacteria to make yogurt.

The modern sense of biotechnology dates from the mid-1970s, when molecular biologists developed techniques to isolate, identify, and clone individual **genes**. These genes could then be manipulated in the test tube, and could be inserted into other organisms by “recombinant technology.” The dawn of modern biotechnology dates from 1977 when the biotechnology company Genetech reported the production in bacteria of the first human **protein, somatostatin**, by recombinant technology. Shortly thereafter, human insulin and human growth **hormone** (hGH) were also produced by similar techniques.

Biotechnology promises dramatic discoveries in the twenty-first century, particularly in the areas of new drugs, antibiotics, and medicines. Plants and animals are being genetically manipulated (“plant and animal pharms”) to produce useful reagents such as antibodies in milk and vaccines in potatoes. A new “green revolution” in biotechnology is taking place to improve food crops. Plants are being developed that produce their own nitrogen fertilizer and pesticides. Others are resistant to herbicides to eradicate weeds and improve crop yield. Rice, the primary foodstuff of one-third of the world’s population, is deficient in vitamin A. By the insertion of a gene from a flower into rice, a new strain of “golden rice,” rich in vitamin A, promises to alleviate vitamin A-deficient blindness in these populations. On the negative side, biotechnology, unfortunately, is being used to develop biological weapons by increasing the virulence of **pathogens** or creating new “superbugs.” SEE ALSO CLONE; DNA SEQUENCING; GENE THERAPY; GENOMICS; HUMAN GENOME PROJECT; POLYMERASE CHAIN REACTION; RECOMBINANT DNA

*Ralph Meyer*

### Bibliography

Alcamo, I. Edward. *DNA Technology: The Awesome Skill*, 2nd ed. San Diego, CA: Academic Press, 2001.

Bud, Robert, and Mark. F. Cantley. *The Uses of Life: A History of Biotechnology*, New York: Cambridge University Press, 1993.

## Bird

Birds are warm-blooded vertebrates with feathers. They are thought to have evolved over 150 million years ago from a Mesozoic reptilian ancestor. Indeed, they share many characteristics with reptiles, including **nucleated** red blood cells, females as the heterogametic sex (having two different sex **chromosomes**), numerous skeletal features, and similar eggs. However, birds have evolved many unique characteristics.

**gene** portion of DNA that codes for a protein or RNA molecule

**protein** complex molecule made from amino acids; used in cells for structure, signaling, and controlling reactions

**somatostatin** hormone produced by the hypothalamus that influences growth

**hormone** molecule released by one cell to influence another

**pathogen** disease-causing organism

**nucleated** having a nucleus

**chromosome** “colored body” in the cell nucleus; made of DNA and protein, and divided functionally into genes and non-gene regions

## Characteristics of Birds

The most remarkable of the bird's characteristics is the feather. Feathers are the diagnostic trait of birds. No other living animal has feathers. The contours and strength of feathers make bird flight possible. At the same time they are lightweight and provide excellent insulation and physical protection to the bird's body. Feather coloration provides both concealment and a means of communicating with rivals and mates. Feathers are energetically inexpensive to produce, and a bird can grow at least a partial new feather coat each year.

Birds are highly skilled, powerful flyers. Flying, however, is an energetically costly activity, and there is hardly any aspect of **avian** anatomy that has not been influenced by the demands of flight. In the interest of weight reduction, some avian bones have been fused or reduced in size, and many of the bones in a bird's body are hollow and filled with air (pneumatized).

Birds have lightweight beaks instead of jaws filled with heavy teeth, and some internal organs are reduced in size or absent. Stability in flight is increased by the bird's overall body plan, which places its greatest mass in the centralized area between the wings, providing a compact center of gravity. To provide the power for flight, birds have exceptionally efficient circulatory and respiratory systems, the latter including a system of air sacs that assist with **thermoregulation** and buoyancy as well as offering some protection to internal organs. Control and rapid adjustments during flight are aided by the bird's sophisticated **central nervous system** and exceptional visual acuity.

## The Evolution of Birds

There are two primary theories about bird origins. One theory suggests that birds arose from early (nondinosaur) reptiles, possibly those called thecodonts. The other proposes that birds evolved from a common ancestor with theropod dinosaurs. If the latter idea is true, then modern birds are "living dinosaurs."

Proponents of the thecodont theory point out that there are skeletal similarities between birds and thecodonts, most notably the presence of **clavicles**, which dinosaurs were thought to lack. However, fossil finds and re-examination of previously collected dinosaur fossils show that many groups of dinosaurs did, indeed, have clavicles. Proponents of the dinosaur theory point out that *Archaeopteryx*, the earliest fossil to be conclusively identified as having a close affinity to birds, has many anatomical features in common with theropod dinosaurs.

However, one argument against the dinosaur origin of birds has to do with the digits. In the avian wing, the bones of the "hand" include only three fingers. The "hand" of a theropod dinosaur also has only three fingers, but many paleontologists think that they are a different three than those that birds have retained.

## Birds and the Environment

Birds range in size from the Cuban bee hummingbird, which is approximately 5.7 centimeters (2.25 inches) from bill tip to tail tip and weighs less than 31 grams (about 1 ounce), to the ostrich, which may stand 2.7 meters



A red-tailed hawk. Aside from birds, no other living animal has feathers.

**avian** concerning birds

**thermoregulation** temperature regulation

**central nervous system** brain and spinal cord

**clavicle** collar bone

(9 feet) tall and weigh over 136 kilograms (300 pounds). Birds are represented in the breeding fauna of all seven continents, and exploit habitats ranging from rainforests to deserts to oceans. The high mobility conferred by flight permits birds to colonize even the most remote areas. Some birds, however, particularly those residing on islands where there are few terrestrial predators, have secondarily evolved flightlessness.

Because birds are everywhere and highly visible, the health of bird populations can be valuable indicators of environmental health. Habitat destruction and/or fragmentation is probably the most important current threat to bird populations worldwide. Reducing a large area of **contiguous** habitat to several smaller parcels means that birds requiring large breeding territories will not be able to find them. Birds that can breed in the smaller parcels may also experience reduced breeding success because proximity of a nest to a habitat edge may increase the likelihood that it will be found by a predator or **parasite**.

Pesticides have also been implicated in reductions of bird populations. In particular, poisons may accumulate in the tissues of predatory birds at the top of the food chain, such as eagles, which consume many smaller predators that have been exposed to pesticides. An example is DDT, which results in the thinning of eggshells and consequent egg breakage during incubation. Some bird species have also been threatened by the introduction of non-native competitors and predators. SEE ALSO AMNIOTE EGG; CARSON, RACHEL; CHORDATA; EVOLUTION; FLIGHT; REPTILE; RESPIRATION

*Ann E. Kessen and Robert M. Zink*

#### Bibliography

Ehrlich, Paul R., David S. Dobkin, and Darryl Wheye. *The Birder's Handbook: A Field Guide to the Natural History of North American Birds*. New York: Simon & Schuster, Inc., 1988.

Gill, Frank B. *Ornithology*, 2nd ed. New York: W. H. Freeman and Company, 1995.

Proctor, Noble S., and Patrick J. Lynch. *Manual of Ornithology*. New Haven, CT: Yale University Press, 1993.

## Birth Control

Birth control refers to the practice of deliberately controlling the number of children born, especially by reducing or eliminating the possibility of conception. While there are many forms of birth control, they can be broadly classified as follows: behavioral methods; surgical methods; barrier methods; hormonal methods; and methods that prevent the continuation of pregnancy, namely abortion.

Behavioral methods include the practice of abstinence from intercourse, particularly during the fertile period of the woman's menstrual cycle, commonly known as the rhythm method. While the fertile days generally occur in the three to four days before and after ovulation, this particular method of birth control is frequently ineffective because of the difficulty in predicting ovulation with the necessary accuracy. Other behavioral methods include withdrawal of the penis from the vagina prior to male orgasm. This depends on complete and timely withdrawal, with no sperm deposited anywhere near the **vulva**. It is *not* an effective method of birth control.

**contiguous** adjacent to or touching

**parasite** organism living in close association with another from which it derives most of its nutrition

**vulva** external female genitalia

Surgical methods of birth control can be used by both males and females. In males, this involves a vasectomy in which the **vas deferens** is severed. In females, a tubal ligation ties off the **fallopian tubes**, thus preventing sperm from reaching the egg. These methods offer a high degree of effectiveness but have the disadvantage of being difficult to reverse should the individuals ever want to regain fertility.

Barrier methods of birth control involve preventing the sperm from reaching and fertilizing the egg. For males, this entails the use of condoms to prevent the sperm from entering the vagina. In females, sponges, spermicides, or diaphragms are used to prevent the sperm from entering the uterus and ultimately the fallopian tubes. When used in combination and consistently, these methods can be highly effective, but they frequently fail due to inconsistent usage or failure of the barrier (for example, a broken condom or improperly inserted diaphragm).

Hormonal methods are among the most common and effective means of birth control worldwide. These methods rely on the use of **hormones** (usually a combination of progesterone and estrogen) that disrupt the normal menstrual cycle in the female, resulting in a suppression of ovulation and hence conception. While the birth control pill is the most common of these methods, other common hormonal methods of birth control are implants (such as Norplant) that release hormone continuously or injections of hormones every few months that likewise suppress ovulation.

All of these hormonal methods are highly effective means of birth control with generally minor side effects. Major side effects, such as stroke, are rare and generally associated with increasing female age and smoking. The “morning after” pill is also hormonal in nature. It is often referred to as an “emergency form” of birth control, and is taken following intercourse. It prevents the embryo from successfully implanting in the uterine wall.

Another effective means of birth control is the intrauterine device (IUD), plastic and metal (often copper) device that is inserted into the uterus. While earlier versions were linked to side effects including pelvic inflammatory disease, the currently available forms have few serious side effects and have the advantage of being easily removed when a restoration of fertility is desired. It remains unclear how exactly the IUD exerts its contraceptive effects, but it is thought that it alters the uterine environment to prevent sperm passage or to prevent implantation of the fertilized egg.

The final category of birth control is abortion, which involves the cessation of a pregnancy. It is not a contraceptive technique, given that it does not prevent conception from occurring, but rather, one that terminates an existing pregnancy. This could be performed surgically by removing the fetus from the womb. More recently, drugs that induce a medical abortion such as Ru486 have become available in certain countries, including the United States. This drug, taken during the first trimester of pregnancy, inhibits the effects of progesterone, a hormone that is essential to the continuation of the pregnancy. Thus the fetus is ultimately expelled from the uterus.

While a wide variety of alternatives exist for or birth control, the selection of an appropriate method depends on a wide array of individual circumstances and should be made in conjunction with a knowledgeable health

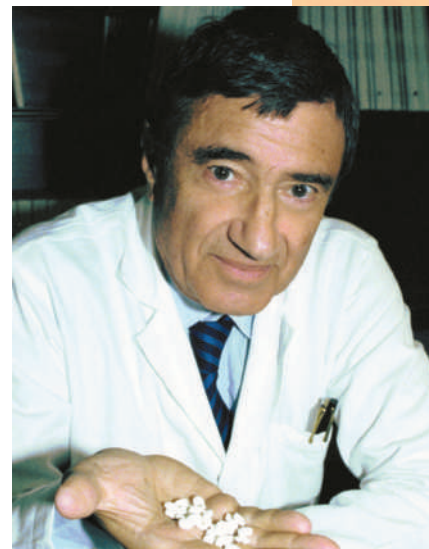

Emile-Etienne Beaulieu,  
inventor of Ru486.

**vas deferens** tube through which sperm travel from testes to urethra

**fallopian tubes** tubes through which eggs pass to the uterus

**hormone** molecule released by one cell to influence another

care provider. SEE ALSO FEMALE REPRODUCTIVE SYSTEM; MALE REPRODUCTIVE SYSTEM; SEXUAL REPRODUCTION; SEXUALLY TRANSMITTED DISEASES

Margaret Somosi Saba

### Bibliography

Bullough, Vern, and Bonnie Bullough. *Contraception: A Guide to Birth Control Methods*. Amherst, NY: Prometheus Books, 1997.

Knowles, Jon, and Marcia Ringel. *All About Birth Control: A Personal Guide*. New York: Crown Publishers, 1998.

Peacock, Judith. *Birth Control and Protection: Choices for Teens (Perspectives on Healthy Sexuality)*. Mankato, MN: Capstone, 2000.

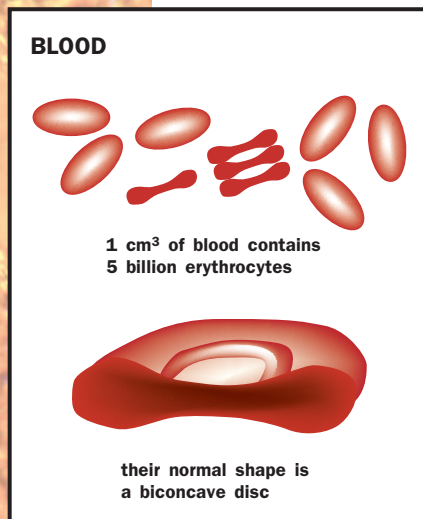

Erythrocytes (red blood cells) are very small cells, usually with no nucleus or internal membranes, and are stuffed full of the oxygen-binding protein hemoglobin.

**pH** measure of acidity or alkalinity; numbers below 7 are acid, above are basic

**thermoregulation** temperature regulation

**protein** complex molecule made from amino acids; used in cells for structure, signaling, and controlling reactions

**nucleus** membrane-bound portion of cell containing the chromosomes

**hemoglobin** oxygen-carrying protein complex in red blood cells

## Blood

Blood is the bodily fluid responsible for transport of materials and waste products throughout the body. It carries oxygen from and carbon dioxide to the lungs, nutrients from the digestive system or storage sites to tissues that require them, and waste products from the tissues to the liver for detoxification and to the kidneys for disposal. Blood delivers hormones to their sites of action and circulates numerous critical parts of the immune system throughout the body. Blood regulates its own **pH**, as well as that of the intercellular fluid in the body, and aids in **thermoregulation** by redistributing heat. Blood also carries the **proteins** and other factors it needs to clot, thereby preventing its own loss in the event of injury to the vessels in which it travels.

A human adult has 4 to 6 liters (1 to 1.5 gallons) of blood, approximately 92 percent of which is water. Nearly half its volume is red blood cells (RBCs, or erythrocytes). Proteins, sugars, salts, white blood cells, and platelets make up the remainder. The noncellular portion is termed plasma, while the cellular parts are collectively referred to as the formed elements. Blood forms in the bone marrow, a spongy tissue contained in the bones.

### Red Blood Cells and Hemoglobin

Only a small amount of the oxygen needed for life can dissolve directly in plasma. Oxygen transport instead relies on red blood cells. At any one time, there are more than 25 trillion RBCs in circulation in an adult, more than the combined total of all other cell types in the body. As RBCs develop, they extrude their cell **nucleus**, so that at maturity they have almost nothing inside their membranes except the oxygen-carrying protein, **hemoglobin**. The absence of a nucleus contributes to the RBC's short life, as does the constant physical stress it experiences squeezing through capillaries that are narrower than it is. The average RBC circulates for approximately 120 days before being destroyed in the liver, bone marrow, or spleen. The iron from hemoglobin is recycled, while the cyclic nitrogen compound that holds it, called heme, is converted to bilirubin. Bilirubin is transported to the liver for elimination from the body as bile. Liver disease can cause jaundice, a yellowing of the skin due to bilirubin in the blood.

The iron in hemoglobin is critical for oxygen transport. Lack of dietary iron is one cause of anemia, a condition in which the blood cannot carry enough oxygen. The heme group binds oxygen tightly when the concen-

tration of  $O_2$  is high (as it is in the lungs), but quickly releases it when the concentration is low, as it is in the tissues. The iron can also bind carbon monoxide (CO), which is produced by car engines and other combustion sources. CO binds much more tightly than oxygen does and prevents oxygen binding, making CO a deadly poison.

A genetic variant of the hemoglobin gene causes a single **amino acid** change in the hemoglobin molecule. This change causes the red blood cell to become sickle-shaped at low oxygen concentrations, so that it tends to become lodged in small capillaries, depriving tissues of oxygen. A person with one such variant hemoglobin gene does not suffer ill effects, but with two variants will develop sickle-cell anemia. Despite this, the sickling variant is common in populations historically exposed to malaria, because having one variant helps protect against malaria infection.

## CO<sub>2</sub> Transport and Blood Buffering

Carbon dioxide (CO<sub>2</sub>) does not bind to iron, but rather to the protein portion of hemoglobin. CO<sub>2</sub> is a product of cell respiration, and is picked up in the tissues and transported to the lungs. Most of the CO<sub>2</sub> transported is actually in the form of bicarbonate **ion**, HCO<sub>3</sub><sup>-</sup>. Bicarbonate is formed by the **enzyme** carbonic anhydrase, which is present in the red blood cells. This enzyme **catalyzes** the conversion of CO<sub>2</sub> and H<sub>2</sub>O to carbonic acid (H<sub>2</sub>CO<sub>3</sub>), which immediately splits to form H<sup>+</sup> and HCO<sub>3</sub><sup>-</sup>. Besides serving as a transport form of CO<sub>2</sub>, HCO<sub>3</sub><sup>-</sup> also participates in blood buffering. It can react with excess H<sup>+</sup> (acid ion) formed in other reactions. In this way, it prevents excess acidity in the blood. Similarly, HCO<sub>3</sub><sup>-</sup> can react with excess OH<sup>-</sup> (base ion) to form water and CO<sub>3</sub><sup>2-</sup>, absorbing excess base. Along with phosphate, bicarbonate keeps the blood buffered at a pH of 7.4.

## Nutrient Transport, Regulation, and Clotting

Blood also transports nutrients, hormones, and immune system components. Nutrients from the gut are dissolved directly in the plasma for transport, but are quickly shuttled to the liver for processing and storage of excess. Insulin and glucagon, hormones produced by the pancreas, control the level of blood sugar by promoting storage or release of **glucose**. The kidney performs the vital function of excreting excess salts and water, as well as metabolic wastes, helping to maintain blood levels of these substances within narrow limits. One waste product the kidneys cannot **excrete** is heat, produced by cell **metabolism** through out the body. Blood performs the vital function of carrying heat from the body core to the periphery, where it can be cooled before returning.

Hormones are released by **endocrine** organs directly into the bloodstream for wide and rapid circulation. White blood cells also use the circulatory system as a highway through the body, traveling in the blood until they exit in response to chemical signals from wounded or infected tissues. Platelets and clotting proteins in the blood work together to prevent blood loss when a vessel is broken. Clotting relies on chemical signals from damaged tissue and from platelets, and the activation of a complex cascade of more than a dozen different plasma proteins. SEE ALSO BLOOD CLOTTING; HEART AND CIRCULATION; HORMONES; RESPIRATION

*Richard Robinson*

**amino acid** a building block of protein

**ion** an electrically charged particle

**enzyme** protein that controls a reaction in a cell

**catalyze** aid in the reaction of

**glucose** simple sugar that provides energy to animal cells and is the building block of cellulose in plants

**excrete** deposit outside of

**metabolism** chemical reactions within a cell

**endocrine** related to the system of hormones and glands that regulate body function

### DREW, CHARLES (1904–1950)

African-American surgeon who invented a way to preserve blood plasma so that it could be stored. Drew's plasma saved the lives of thousands of Londoners during the Nazi bombings in World War II. But when the U.S. military refused to accept blood donated by black Americans, Drew resigned from his post as head of the Red Cross's "Plasma for Britain" program.

**Bibliography**

Guyton, Arthur C., and John E. Hall. *Textbook of Medical Physiology*, 10th ed. Philadelphia, PA: W. B. Saunders, Co., 2000.

Stiene-Martin, E. Anne, Cheryl A. Lotspeich-Steininger, and John A. Koepke. *Clinical Hematology: Principles, Procedures, Correlations*, 2nd ed. Philadelphia, PA: Lippincott Williams & Wilkins, 1998.

**Blood Clotting**

Blood clotting (coagulation) is the process by which blood vessels repair ruptures after injury. Injury repair actually begins even before clotting does, through vascular spasm, or muscular contraction of the vessel walls, which reduces blood loss. Clotting itself is a complex cascade of reactions involving platelets, **enzymes**, and structural **proteins**.

Platelets are not whole cells, but rather small packets of membrane-bounded **cytoplasm**. There are approximately one million platelets in a drop of blood. Damage to the lining of a blood vessel (the endothelial lining) exposes materials that cause platelets to stick to the endothelial cells; additional platelets then stick to these. These aggregating platelets release factors that promote accumulation of fibrin, a circulating protein. A blood clot is a meshwork of platelets and blood cells woven together by fibrin.

Accumulation of fibrin must be tightly regulated, of course, to prevent clot formation where there is no wound. Thrombosis is an abnormal localized activation of the clotting system. Disseminated intravascular coagulation is a **pathological** condition in which the clotting system is activated throughout the circulatory system in response to bacterial toxins, trauma, or other stimuli. A clot may break off, forming an embolus, which can lodge in a small blood vessel, cutting off circulation. If this occurs in the heart, it may cause ischemia (lack of blood flow) or myocardial infarction (heart attack). In the lungs, it causes pulmonary embolism, with loss of capacity for oxygen exchange. In the brain, it can cause stroke.

Because of this need for tight regulation, and the need for rapid response, the clotting mechanism involves a multistep cascade of enzymes, most of whose jobs are to activate the next enzyme in the cascade. In this way, the effect of the initial stimulus (the damaged blood vessel) can be quickly magnified, as a single enzyme at the first stage activates many copies of another enzyme at the next stage, each of which activates many more at the next, and so on. At the same time, the many levels of interaction provide many points of control over the process. This coagulation cascade begins from thirty seconds to several minutes after the injury.

Coagulation can begin with either of two pathways, called the extrinsic and intrinsic pathway, both of which feed into a common pathway that completes the process. The extrinsic pathway begins with a substance called tissue factor (tissue thromboplastin) released by damaged blood vessels and surrounding tissues. In the presence of other plasma proteins (clotting factors) and calcium **ions**, this leads to the activation of a protein called factor X. The intrinsic pathway begins with a substance called factor XII, released by blood platelets. Through a series of additional clotting factors, and again in the presence of calcium ions, this pathway also leads to the activation of

**enzyme** protein that controls a reaction in a cell

**protein** complex molecule made from amino acids; used in cells for structure, signaling, and controlling reactions

**cytoplasm** material in a cell, excluding the nucleus

**pathological** related to disease

**ion** an electrically charged particle

factor X. One of the necessary factors of the intrinsic pathway is called factor VIII. A mutation in the **gene** for this factor is the most common cause of hemophilia.

The common pathway begins with the activation of factor X. In the presence of calcium ions and other clotting factors, factor X activates an enzyme called prothrombin activator. This enzyme then converts the plasma protein prothrombin into thrombin. Thrombin is an enzyme that, in turn, converts fibrinogen to fibrin. Here the cascade ends, because fibrin is not an enzyme, but a fibrous protein. It forms strands that stick to the platelets and endothelial cells at the wound, forming a meshwork that, in turn, traps other cells.

Once the clot forms, contraction of the platelets pulls the edges of the wound closer together, and fresh endothelial cells then grow across it, repairing the damaged blood vessel. Over time, fibrin is degraded by plasmin. This enzyme is formed from circulating plasminogen by tissue plasminogen activator (t-PA). Synthetic t-PA is used to dissolve blood clots in stroke, myocardial infarction, pulmonary embolism, and other conditions. **SEE ALSO** BLOOD; BLOOD VESSELS; CONTROL MECHANISMS

*Richard Robinson*

### Bibliography

Guyton, Arthur C., and John E. Hall. *Textbook of Medical Physiology*, 10th ed. Philadelphia, PA: W. B. Saunders, Co., 2000.

Stiene-Martin, E. Anne, Cheryl A. Lotspeich-Steininger, and John A. Koepke. *Clinical Hematology: Principles, Procedures, Correlations*, 2nd ed. Philadelphia, PA: Lippincott Williams & Wilkins, 1998.

## Blood Sugar Regulation

Most cells in the human body use the sugar called **glucose** as their major source of energy. Glucose molecules are broken down within cells in order to produce adenosine triphosphate (ATP) molecules, energy-rich molecules that power numerous cellular processes. Glucose molecules are delivered to cells by the circulating blood and therefore, to ensure a constant supply of glucose to cells, it is essential that blood glucose levels be maintained at relatively constant levels. Level constancy is accomplished primarily through negative **feedback** systems, which ensure that blood glucose concentration is maintained within the normal range of 70 to 110 milligrams (0.0024 to 0.0038 ounces) of glucose per **deciliter** (approximately one-fifth of a pint) of blood.

*Negative feedback systems* are processes that sense changes in the body and activate mechanisms that reverse the changes in order to restore conditions to their normal levels. Negative feedback systems are critically important in homeostasis, the maintenance of relatively constant internal conditions. Disruptions in homeostasis lead to potentially life-threatening situations. The maintenance of relatively constant blood glucose levels is essential for the health of cells and thus the health of the entire body.

Major factors that can increase blood glucose levels include glucose absorption by the small intestine (after ingesting a meal) and the production of new glucose molecules by liver cells. Major factors that can decrease blood

**gene** portion of DNA that codes for a protein or RNA molecule

**glucose** simple sugar that provides energy to animal cells and is the building block of cellulose in plants

**feedback** process in which the output or result influences the rate of the process

**deciliter** one-tenth of a liter; a unit of volume

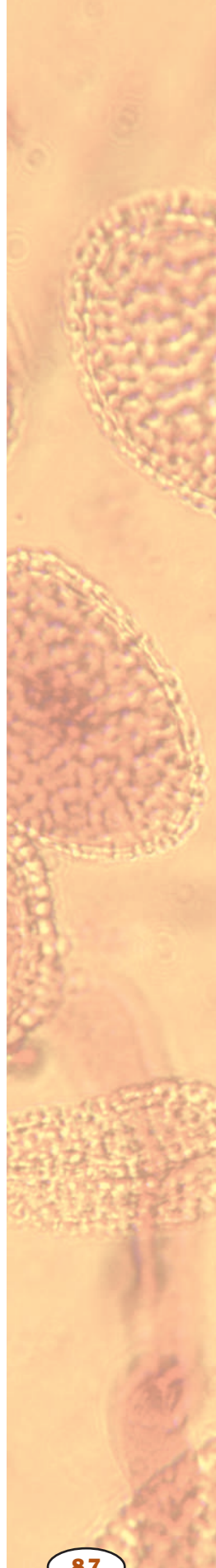



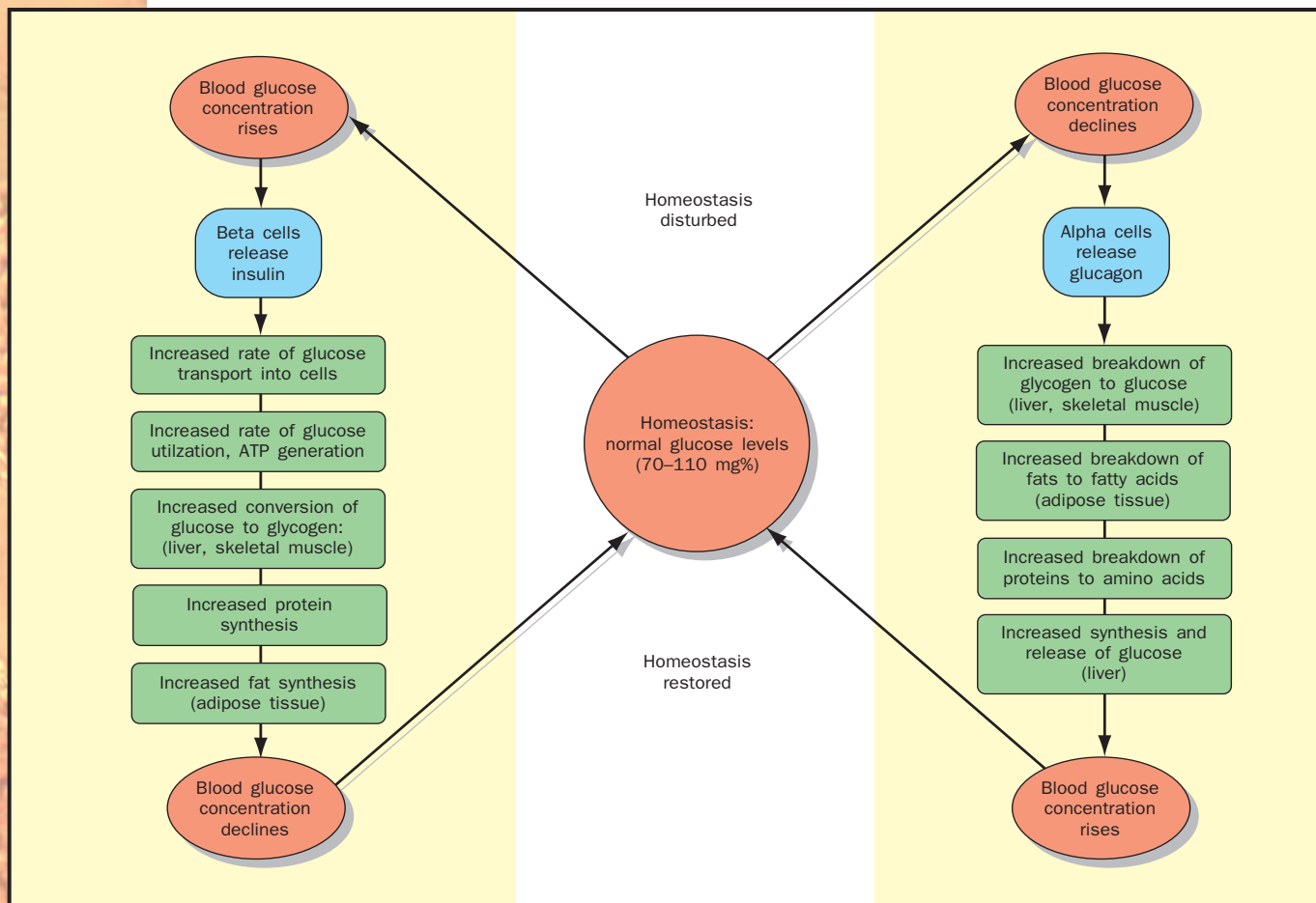

The homeostatic regulation of glucose concentrations.

**hormone** molecule released by one cell to influence another

**glycogen** complex carbohydrate used as storage in animals and some other organisms

**secretion** material released from the cell

glucose levels include the transport of glucose into cells (for use as a source of energy or to be stored for future use) and the loss of glucose in urine (an abnormal event that occurs in diabetes mellitus).

### Insulin and Glucagon

In a healthy person, blood glucose levels are restored to normal levels primarily through the actions of two pancreatic **hormones**, namely insulin and glucagon. If blood glucose levels rise (for example, during the fed or absorptive state, when a meal is digested and the nutrient molecules are being absorbed and used), the beta cells of the pancreas respond by secreting insulin. Insulin has several notable effects: (1) it stimulates most body cells to increase their rate of glucose uptake (transport) from the blood; (2) it increases the cellular rate of glucose utilization as an energy source; (3) it accelerates the formation of **glycogen** from glucose in liver and skeletal muscle cells; and (4) it stimulates fat synthesis (from glucose) in liver cells and adipose (fat) tissue. These effects collectively cause a decrease in blood glucose levels back to normal levels.

If blood glucose levels fall below normal levels (for instance, during the post-absorptive or fasting state, when nutrients from a recently digested meal are no longer circulating in the blood, or during starvation), insulin **secretion** is inhibited and, at the same time, the alpha cells of the pancreas respond by secreting glucagon, a hormone that has several important effects:

(1) it accelerates the breakdown of glycogen to glucose in liver and skeletal muscle cells; (2) it increases the breakdown of fats to fatty acids and glycerol in adipose tissue and, consequently, the release of these substances into the blood (which cells can thus use for energy); and (3) it stimulates liver cells to increase glucose synthesis (from glycerol absorbed from the blood) and glucose release into the blood. These effects collectively cause an increase in blood glucose levels back to normal levels.

In addition to insulin and glucagon, there are several other hormones that can influence blood glucose levels. The most important ones are epinephrine, cortisol, and growth hormone, all of which can increase blood glucose levels.

## Diseases and Blood Sugar Regulation

Glucose levels above or below the normal range are indicative of the presence of disease states. For example, elevated glucose levels are present in diabetes mellitus, Cushing's syndrome, liver disease, and hyperthyroidism, while decreased glucose levels are present in Addison's disease, hyperinsulinism, and hypothyroidism.

The most prevalent of these diseases is diabetes mellitus. There are two types of this disease: Type I (insulin-dependent or juvenile-onset) diabetes mellitus, and Type II (noninsulin-dependent or maturity-onset) diabetes mellitus. In Type I diabetes, pancreatic beta cells are destroyed by an erroneous attack by the body's own immune system, and thus insulin secretion is reduced to negligible levels. In Type II diabetes, insulin secretion is not reduced; however, there is a reduced sensitivity of target cells to insulin, a phenomenon known as insulin resistance. SEE ALSO AUTOIMMUNE DISEASE; DIGESTION; DIGESTIVE SYSTEM; HOMEOSTASIS; HORMONE; LIVER; PANCREAS; THYROID GLAND

*Izak Paul*

### Bibliography

Saladin, Kenneth S. *Anatomy & Physiology: The Unity of Form and Function*, 2nd ed. New York: McGraw-Hill, 2001.

## Blood Vessels

The cardiovascular system includes the heart (cardio) and blood vessels (vascular). The heart pumps blood throughout the body. Sixty thousand miles of blood vessels transport the blood, enough to encircle Earth more than twice. Arteries carry blood away from the heart; capillaries reach all of the body's seventy trillion cells; and veins carry blood back to the heart. Because blood vessels form a circular route, this system is also called the circulatory system.

The cardiovascular system has two main parts. In the pulmonary circuit, blood is pumped from the right **ventricle** of the heart through the pulmonary arteries, which lead to the lungs. Here the blood gives up carbon dioxide and picks up oxygen. The oxygen-rich blood returns to the left atrium of the heart through pulmonary veins. From the left atrium, blood passes to the left ventricle of the heart, which pushes the blood through the **systemic** circuit beginning with the aorta, which branches to all body parts.

### HODGKIN, DOROTHY CROWFOOT (1910–1994)

English chemist who won the 1964 Nobel Prize in chemistry for describing the structure of vitamin B<sub>12</sub>. In 1969, she completed a thirty-four-year effort to decipher the three-dimensional structure of insulin, the protein that helps people regulate blood sugar levels.

**ventricle** fluid-filled chamber

**systemic** throughout the body

A scanning electron micrograph of red and white blood cells flowing through a vein.

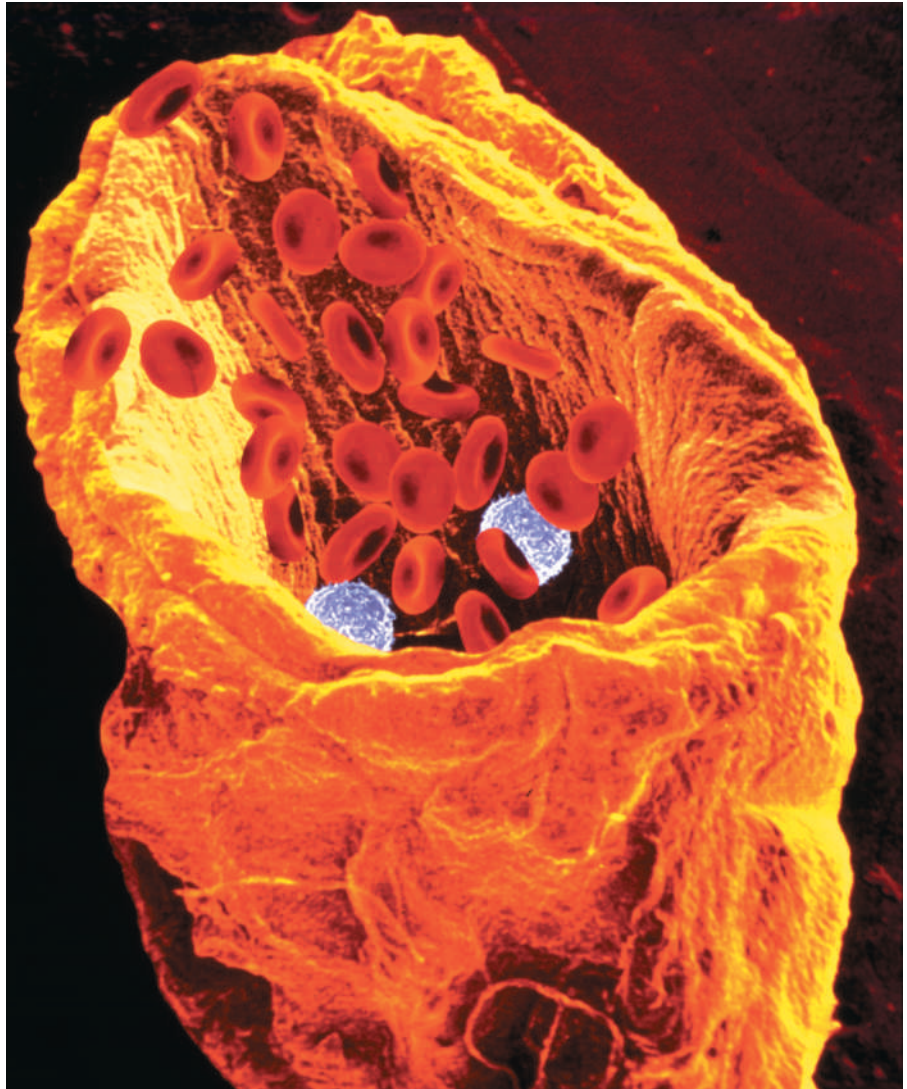

After delivering oxygen and picking up carbon dioxide, blood returns to the right atrium of the heart and then to the right ventricle. The journey begins anew.

### Arteries

Thick walls enable arteries to withstand the pressure created by the pumping of the heart (blood pressure). The pulmonary arteries and the aorta are the largest arteries (the aorta is as wide as a thumb!). Some arteries are named for the organ that they supply, such as the hepatic artery (liver) and the coronary arteries (heart). Others have special names, such as the carotid arteries that supply the head and brain. Arteries branch many times into smaller arteries and eventually into minute branches called arterioles.

Arteries consist of an inner lining, one cell thick, called endothelium, a middle layer of smooth muscle and elastic tissue, and an outer layer that is mostly loose **connective tissue**, which holds the multilayered tube together. The muscle layer in arteries and arterioles is thick and the overall structure quite elastic, enabling these vessels to withstand greater blood pressure than can veins.

**connective tissue** one of four types of body tissue, characterized by few cells and extensive extracellular material

## Veins

Veins and arteries are so similar that portions of veins are used to replace damaged arteries in **coronary artery** bypass surgery. Veins have the same three layers as arteries and are elastic, but they have a less-muscular middle layer, making their walls thinner. Also, unlike arteries, some veins have valves (tissue flaps) that permit blood to flow in only one direction, back to the heart. Valves help maintain blood flow in places such as the legs where the blood pressure has to push blood uphill, against the force of gravity. Despite the valves, accumulation of blood in leg veins can stretch the thin walls, resulting in varicose veins.

Veins are named in much the same way as arteries. Pulmonary veins return blood from the lungs to the heart, and a hepatic vein returns blood from the liver. Some veins have special names. The jugular veins return blood from the head, and the great saphenous veins return blood from the legs; these are used as grafts in coronary artery bypass surgery. The median cubital vein, which extends from side to side in the bend of the elbow, is a common site for drawing blood. The smallest veins arise from minute venules, and then merge to form larger and larger veins.

## Capillaries

Capillaries are the shortest, narrowest, and thinnest blood vessels. They connect **arterioles** to **venules** to complete the circuit. Capillaries consist only of endothelium with some connective tissue binding the cells. Red blood cells squeeze through capillaries single file. Unlike arteries and veins, capillaries do not have specific names, but are named collectively for the region that they supply. Capillaries in the lungs, for example, are called pulmonary capillaries, and those in the stomach are the gastric capillaries.

The body will always have one heart, but the number of blood vessels may change. Because blood vessels bring oxygen-rich blood to cells, areas that have increased oxygen demands actually develop more blood vessels, primarily capillaries. New blood vessel growth is called angiogenesis. For example, new capillaries permeate the muscles of a conditioned athlete. Cancerous tumors also grow new capillary networks. One approach to fight cancer is to starve it with drugs that block angiogenesis. SEE ALSO BLOOD; BLOOD CLOTTING; CARDIOVASCULAR DISEASES; CIRCULATORY SYSTEMS; HEART AND CIRCULATION

*David Shier*

### Bibliography

*The Centers for Disease Control and Prevention, Cardiovascular Disease.* <[www.cdc.gov/nccdphp/cardiov.htm](http://www.cdc.gov/nccdphp/cardiov.htm)>.

Lewis, Ricki. "Homing in on Homocysteine." *The Scientist* 14 (2000): 1.

*The Mayo Clinic's Heart and Blood Vessel Center.* <[www.mayo.edu](http://www.mayo.edu)>.

Shier, D., J. Butler, and R. Lewis. *Hole's Human Anatomy and Physiology*, 8th ed. Dubuque, IA: McGraw-Hill Higher Education, 2000.

**coronary artery** artery supplying blood to the heart

**arterioles** any of the small, terminal twigs of an artery that ends in capillaries

**venule** any of the minute veins connecting the capillaries with the larger systemic veins

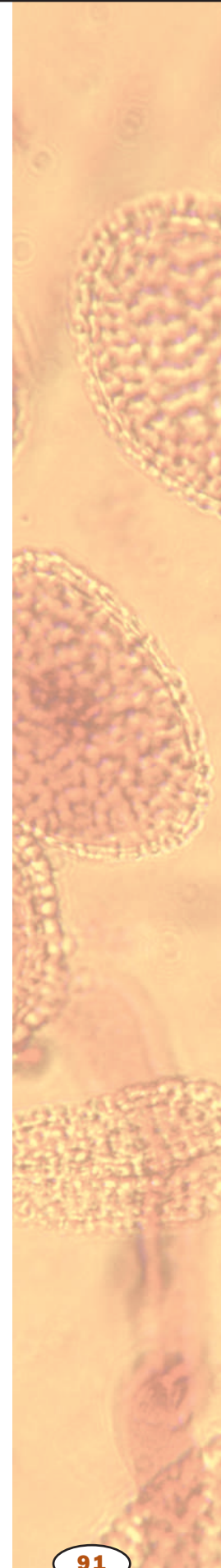

## Body Cavities

A body cavity can be defined as the space that remains after the organs inside it are removed, but this definition does not do justice to the variety and

Schematic diagrams of the bodies of animals with coeloms, with pseudocoeloms, or without body cavities.

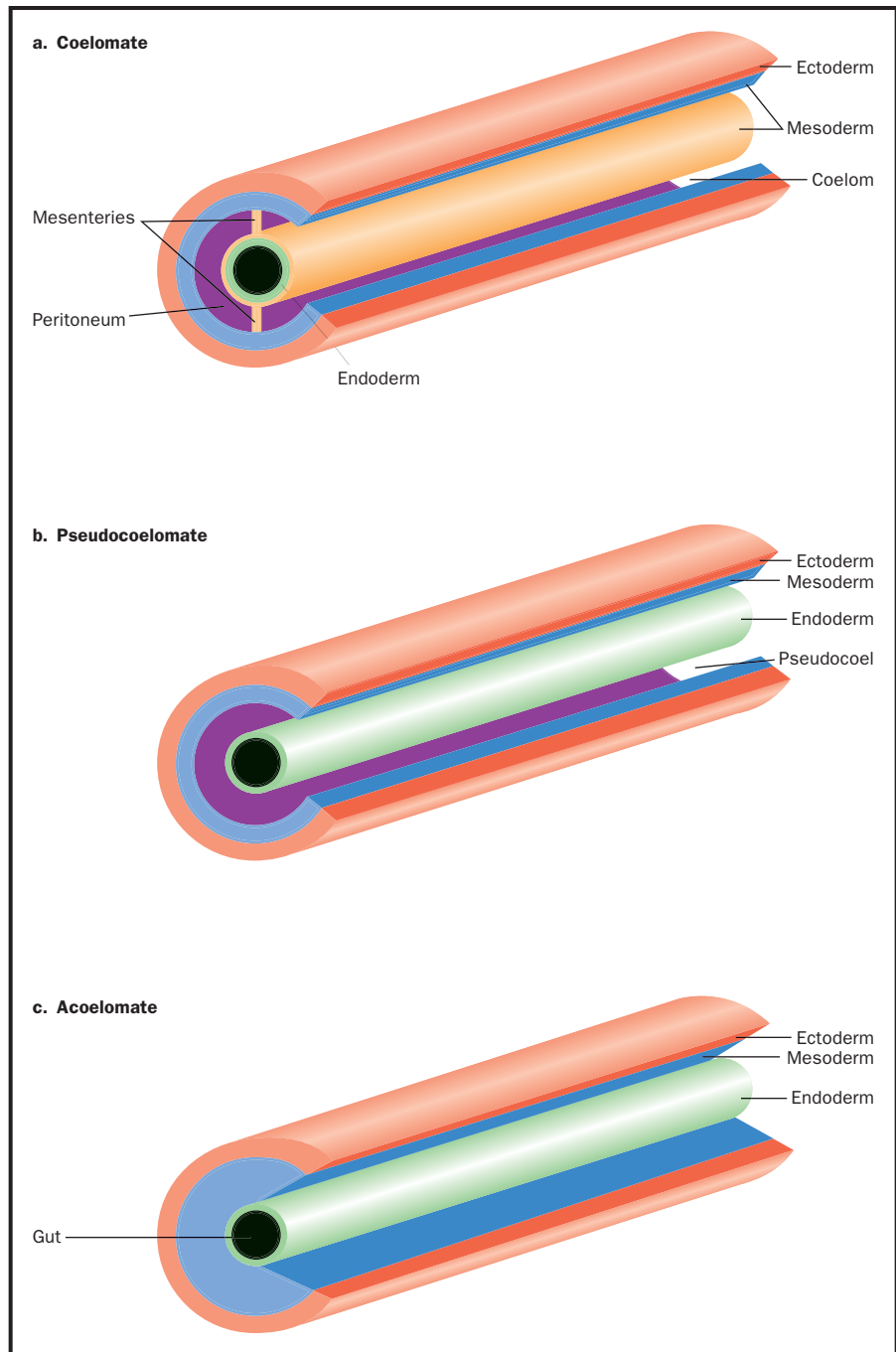

functions of body cavities. Humans have four body cavities: (1) the dorsal body cavity that encloses the brain and spinal cord; (2) the thoracic cavity that encloses the heart and lungs; (3) the abdominal cavity that encloses most of the digestive organs and kidneys; and (4) the pelvic cavity that encloses the bladder and reproductive organs. The **cranial** cavity cushions and protects the brain within a rigid skull. The other body cavities also cushion internal organs, but instead of being rigid, they have to be flexible for the heart, lungs, digestive organs, and reproductive organs to expand.

In humans all but the cranial cavity develop from the coelom (pronounced SEE-lum). A coelom is a cavity that is entirely enclosed within cells

**cranial** related to the cranium, or brain cavity

derived from the middle layer of embryonic tissue. A few groups of animals, such as roundworms (Nematoda), have a body cavity that is only partly enclosed by tissue from the middle layer. Such a body cavity is called a pseudocoelom (pronounced SOO-doe-SEE-lum). In a few other groups, such as flatworms (Platyhelminthes), there is no body cavity. SEE ALSO DEVELOPMENT; PLATYHELMINTHES

C. Leon Harris

### Bibliography

Pechenik, Jan A. "Classification by Developmental Pattern." In *Biology of the Invertebrates*, 4th ed. Boston: McGraw-Hill Higher Education, 2000.

Saladin, Kenneth S. "Body Cavities and Membranes." In *Anatomy and Physiology*. Boston: McGraw-Hill, 1998.

## Bone

Bone serves many important functions. Bones support the body, protect underlying organs, and provide a movable skeleton against which the muscles can work. In addition, bone forms all the cells of the blood, plus takes part in calcium and acid-base balance, and storage of trace elements (such as zinc) needed by cells elsewhere.

### Bone Structure

Bone is created from **osseous connective tissue**. Like other types of connective tissue, osseous tissue is composed of relatively sparse cells surrounded by an extracellular network, or **matrix**. Bone matrix is a tough, resilient mixture of **protein** and **minerals**. Osteoblasts, a type of bone cell, secrete proteins into the matrix, which provide tensile strength (resistance to stretching and twisting). The principal protein of the bone matrix is collagen, which accounts for almost one-third of the dry weight of bone. Most of the rest of the bone's weight is due to the minerals of the matrix. These are mainly calcium phosphate and calcium carbonate. Embedded in the protein network, the minerals provide hardness and compressive strength.

Bone cells remain alive and, like other cells in the body, must be nourished by blood. In order to deliver nutrients to and remove waste from the bone interior, the hard, compact surface is pierced by "canals" through which blood vessels can travel. Once inside, these canals branch, allowing blood vessels to reach cells throughout the bone. This canal system gives bone its characteristic appearance under the microscope, with bone cells embedded in concentric rings (lamellae) of calcified matrix, all surrounding a hollow canal. These units of structure, called osteons, all run parallel in compact bone, but form a looser and less-ordered network in spongy bone. Compact bone forms in the perimeter of long bone shafts, such as those of the legs and arms, where stress forces tend to be all in the same direction. In contrast, spongy bone is found in the ends of bones, where forces come from many different directions. Spongy bone also occurs where bone is not subject to significant stress.

### Formation and Growth

Ossification (bone formation) occurs in one of two ways. Intramembranous ossification occurs within parts of the skull and part of the **clavicles**. In this process, osteoblasts deposit matrix on a membranous network within the

**osseous** related to bone

**connective tissue** one of four types of body tissue, characterized by few cells and extensive extracellular material

**matrix** a network, usually of threadlike fibers

**protein** complex molecule made from amino acids; used in cells for structure, signaling, and controlling reactions

**minerals** iron, calcium, sodium, and other elements needed by living organisms

**clavicle** collar bone

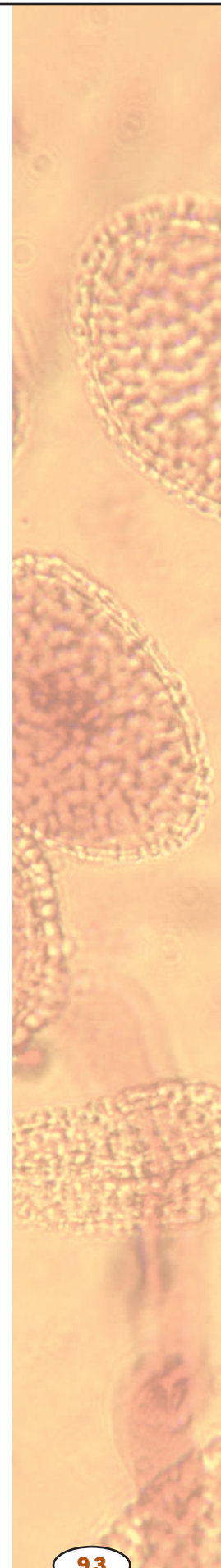

A false-color scanning electron micrograph of cancellous bone tissue affected by osteoporosis.

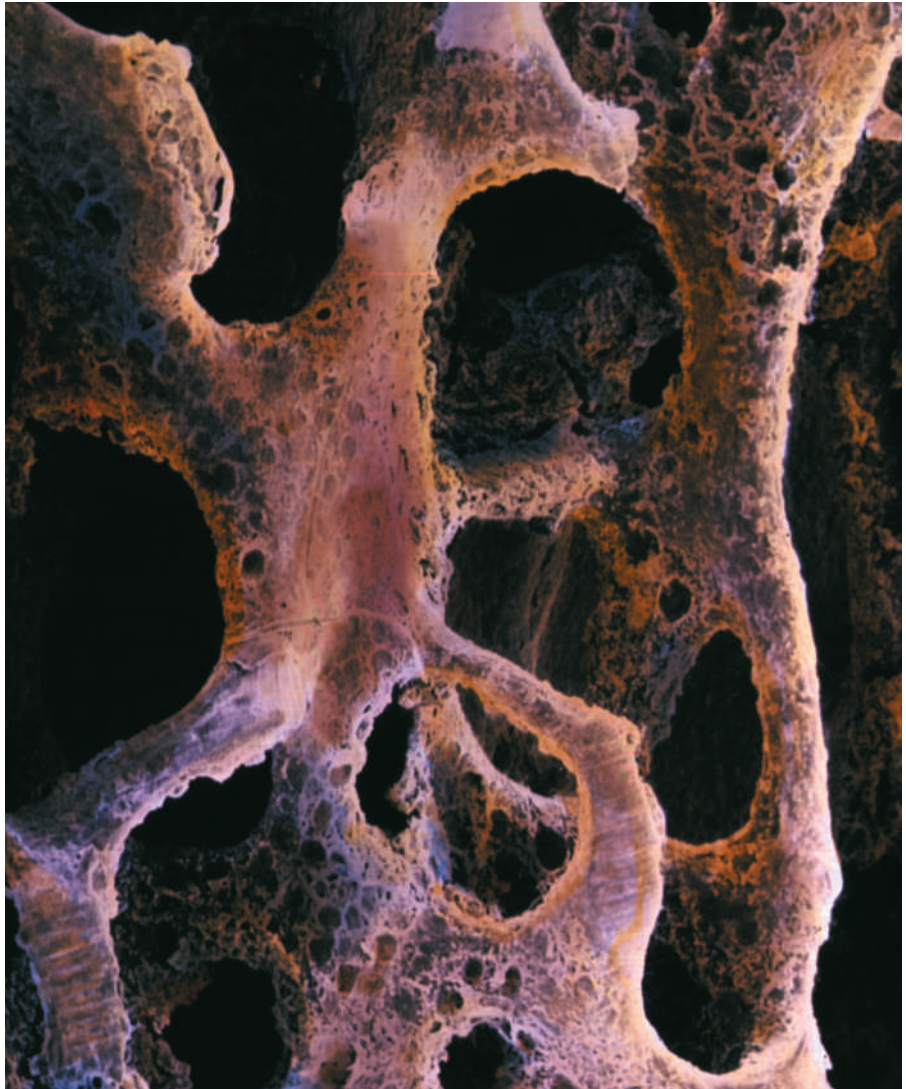

future bone. Once their own extracellular matrix traps the osteoblasts, they become fully mature osteocytes.

By contrast, most of the body's bones form by endochondral (within cartilage) ossification. In this process, a temporary model in the shape of the future bone is made from cartilage laid down by chondrocytes (cartilage-forming cells), which later die within the shaft of the future bone. The space created by the death of these cells is invaded by osteogenic (bone-forming) cells. These cells differentiate into osteoblasts and secrete the matrix. As osteoblasts build bone, another type of cell, the osteoclast, dissolves older matrix, enlarging the cavity within. Osteoclasts dissolve matrix by secreting hydrochloric acid, which attacks the mineral portion, and **enzymes** that digest the collagen and other proteins. Within the shafts of the long bones, the spaces created are filled with blood-forming tissue, the bone marrow.

**enzyme** protein that controls a reaction in a cell

**hormone** molecule released by one cell to influence another

### Hormonal Control

Growth in bone length is stimulated by sex **hormones** and growth hormone during puberty, accounting for the pubertal growth spurt. Growth is later

halted, and bones cannot grow in length during adulthood. However, bone is constantly remodeled by the combined action of osteoblasts and osteoclasts, and can grow in width in response to mechanical stresses such as weight lifting. When a bone is fractured, chondrocytes, osteoblasts, and osteoclasts go to work repairing it and cleaning up the damage.

The interactions of three hormones—parathyroid hormone, calcitonin, and calcitriol—control bone growth and remodeling, as well as the calcium concentration in the blood serum. Calcium is necessary for a variety of critical functions outside of bone, including muscle contraction, **neuron** function, glandular **secretion**, and blood clotting. Because of this, serum calcium is kept within very narrow limits, 9.2 to 10.4 milligrams per **deciliter** of blood. Calcium excesses and deficiencies are prevented by using bone as a storage pool.

Calcitriol promotes calcium absorption from the gut and prevents its loss through the kidneys. Calcitriol is made from vitamin D, either supplied from the diet or manufactured by skin cells exposed to sunlight. A lack of vitamin D can lead to rickets in childhood, osteomalacia in adulthood, or osteoporosis later in life. Once calcium is absorbed by the gut, it enters the blood, and, if in high concentration, is deposited in bone by osteoblasts, stimulated by calcitonin. When serum calcium levels drop, parathyroid hormone indirectly causes osteoclasts to break down bone and release calcium into the blood. Bone, therefore, is constantly cycling between deposition and resorption, and about one-fifth of the skeleton is built and demolished each year. **SEE ALSO** BLOOD; CONNECTIVE TISSUE; MUSCULOSKELETAL SYSTEM; VITAMINS AND COENZYMES

Angie Kay Huxley

### Bibliography

- Alexander, R. M. *Bones: The Unity of Form and Function*. New York: Macmillan, 1994.
- Ross, M. H., L. J. Romrell, and G. I. Kaye. *Histology: A Text and Atlas*, 3rd ed. Baltimore, MD: Williams & Wilkins, 1995.
- Turner, C. H. "Homeostatic Control of Bone Structure: An Application of Feedback Theory." *Bone* 12 (1991): 203–217.
- Zaleske, D. J. "Cartilage and Bone Development." *Instructional Course Lectures* 47 (1998): 461–468.

## Bony Fish

The class Osteichthyes (literally "bony fish") gets its name from the bony skeleton and scales of its members. The group comprises nearly all living fish, with notable exceptions being sharks and other cartilaginous fish, and the primitive lampreys and their kin. Bony skeletons and scales are the primary features that differentiate these fish from other cartilaginous fish, whose skeleton is composed of cartilage and whose skin is leathery. Other important differences include the swim bladder, a lunglike, gas-filled organ that helps bony fish to regulate their buoyancy.

Osteichthyes is the most numerous and diverse group of vertebrates, occupying virtually all large bodies of water, from polar seas to hot undersea vents to land-locked lakes. Because of their numbers (more than 20,000 species), diversity, and range, the bony fish play a major role in virtually all

Some forms of osteoporosis (brittle bones) are caused by overactive osteoclasts.

**neuron** nerve cell

**secretion** material released from the cell

**deciliter** one-tenth of a liter; a unit of volume

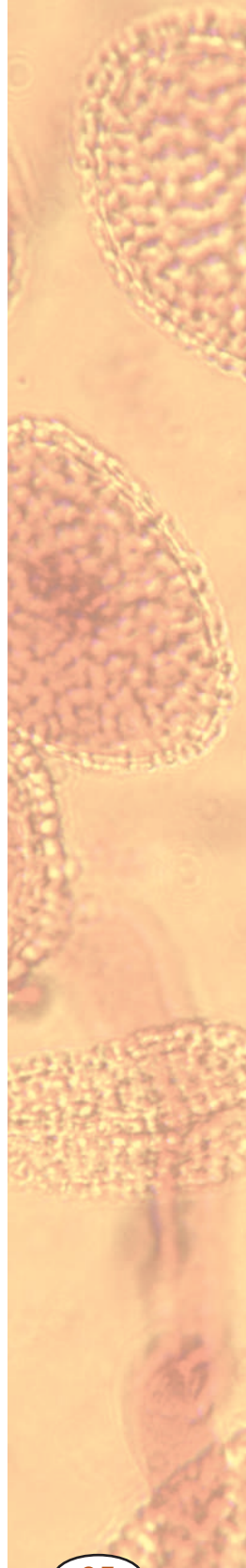



**ecosystem** an ecological community and its environment

marine and freshwater **ecosystems**. They range from the tiny seahorses to giant sunfish (weighing thousands of pounds) to the salmon on one's dinner plate.

Most of the bony fish—thirty-nine of the forty-two orders—are ray-finned fish; subclass Actinopterygii. The other three orders are fleshy-finned fish, members of the subclass Sacropterygii. Although much less numerous and diverse than the ray-fins, the fleshy finned fish are still interesting and important. In two orders, the fleshy finned fish have lungs instead of swim bladders, and can survive their ponds drying up by burrowing into the mud. The final order contains only one species: the coelacanth (pronounced SEE-low-kanth), an ancient species of fish once thought to be long extinct. Living coelacanths, virtually identical to its fossil relatives that lived 20 million years ago, were first found in 1938. This discovery was doubly important because the coelacanth is a close relative of the fish from which amphibians evolved, making it closely related to the ancestors of all terrestrial vertebrates. SEE ALSO CARTILAGINOUS FISH; LIMNOLOGIST; OCEAN ECOSYSTEM

Robbie Hart

#### Bibliography

Bond, Carl E. *Biology of Fishes*, 2nd ed. Fort Worth, TX: Saunders, 1997.

Moyle, Peter. B., and Joseph J. Cech, Jr. *Fishes: An Introduction to Ichthyology*, 4th ed. Englewood Cliffs, NJ: Prentice Hall, 1999.

## Botanist

A botanist is a scientist who studies plants. The study of plants encompasses their evolution, classification, anatomy, physiology, development, genetics, diversity, ecology, and economic uses. Professional botanists typically specialize in one of these areas, or more likely in a smaller subspecialty, such as the evolution of the angiosperms (flowering plants), the biochemistry of photosynthesis, or the cultivation of roses for the wholesale market. Botanists may be employed by universities as professors or researchers; by the government to (for instance) conduct field studies of plant diversity in a national park or to compare crop planting systems; by agricultural industries to perform research on crops or to breed new types of plant varieties; or by pharmaceutical companies to discover new sources of plant-based drugs in the tropical rain forest, or to develop them in the lab from plant sources.

Botanists may work in laboratories or greenhouses performing experiments, or they may work outside in fields, forests, or other plant habitats. For many botanists, the opportunity to work with plants in their natural settings is a principal attraction of the discipline, along with an intellectual curiosity about how plants work, or a desire to improve their usefulness to humans. A career in botany requires at least a bachelor's degree from a four-year college. This would enable someone to begin work as a research assistant, for instance. Most professional botanists entering the field today earn a Ph.D., which gives them the qualifications and credentials to conduct research or manage a plant breeding program, for example. To pursue botany as a major in college, high school students should take courses in biology, chemistry, physics, and math, and would benefit from getting hands-on experience with plants, either by gardening, farming, working in a nursery or

greenhouse, or simply exploring the natural world around them. SEE ALSO ANGIOSPERMS; AGRONOMIST; ANATOMY OF PLANTS; CONIFERS; EVOLUTION OF PLANTS; PHOTOSYNTHESIS; PLANT

*Richard Robinson*

### Bibliography

*Careers in Botany from the Botanical Society of America.* <<http://www.botany.org/bsa/careers/>>.

## Brain

The vertebrate brain is the large **anterior** portion of the **central nervous system**. The “cranial vault” of the skull encases the brain in most vertebrates. In invertebrates, the enlarged and specialized anterior ganglion of the central nervous system is often referred to as a brain, although not all scientists regard it as a true brain.

The brain receives and processes sensory information, initiates and controls movement, and executes **cognitive** (thought) processes. The human brain has an extraordinary capacity, correlated with the great enlargement

**anterior** toward the front

**central nervous system** brain and spinal cord

**cognitive** related to thought or awareness

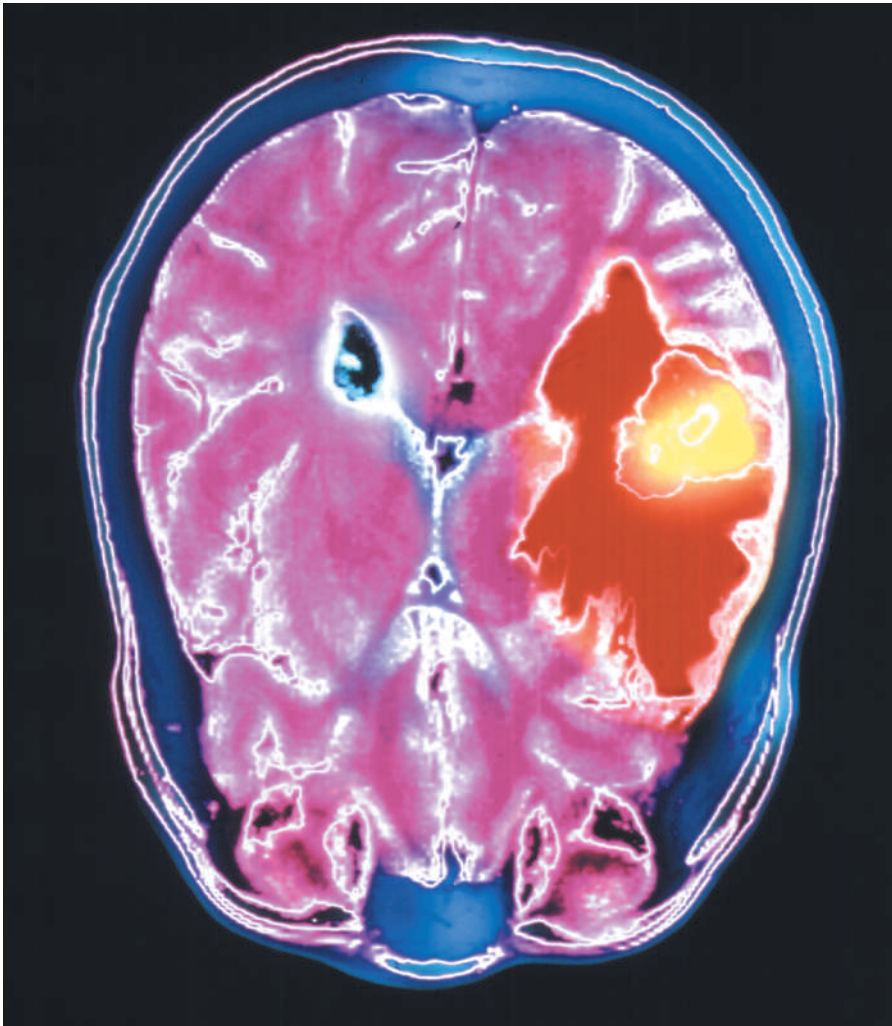

A colored magnetic resonance imaging (MRI) scan of the axial section of the human brain showing a metastatic tumor (yellow).

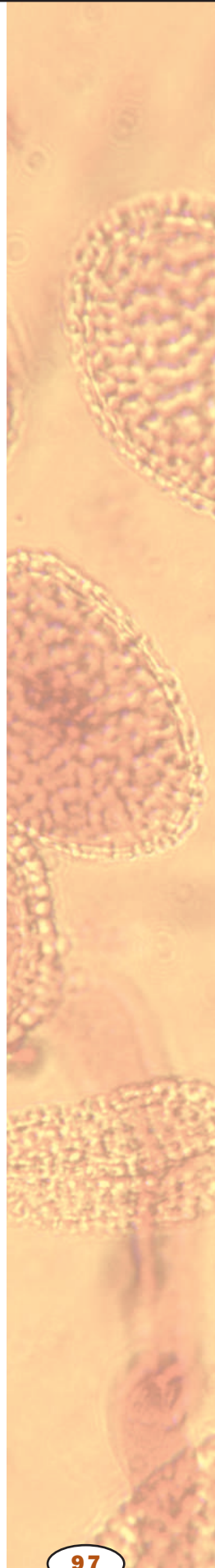

of the cerebrum, for information storage and retrieval, thought, emotions, and initiation of behavior.

## Gross Anatomy

The mammalian brain has three primary subdivisions: the cerebrum (including the outer, wrinkled cortex), cerebellum, and brainstem. The brainstem is further divided into the diencephalon, midbrain, pons, and medulla. The human brain is about 85 percent cerebrum, 11 percent cerebellum, and 4 percent brainstem.

The human brain has more than 100 billion **neurons**, with 14 to 16 billion in the **cerebral cortex** and nearly 100 billion in the cerebellum alone. In addition, there are perhaps nine times as many glial cells, whose exact roles are unclear, but which help to support and maintain neurons. Most neurons are present shortly after birth, and as the brain continues to grow, the number and complexity of neuronal connections increases. These neurons are arranged into gray matter and white matter. Gray matter composes areas rich in neurons, their dendrites, and synapses. White matter is tissue rich in **axons** (nerve fibers), but with a few cell bodies or dendrites. It gets its color from an insulating wrap called myelin around the nerve fibers. The high **lipid** content of white matter makes it light and easily distinguished from gray matter in fresh, unstained tissue.

The cerebrum and cerebellum each have a multilayered sheet of cells on the surface called the cortex, composed of gray matter. The white matter lies deep to this and consists of axons that send information to and from the cortex or connect different regions of the cortex to each other. Deeper masses of gray matter are also found embedded in the white matter.

The central nervous system (brain and spinal cord) develops as a hollow tube whose internal space eventually forms a system of fluid-filled cavities called **ventricles**. The first two ventricles are a pair of C-shaped lateral ventricles, one in each cerebral hemisphere. Each of these communicates through a small pore with a slitlike third ventricle between the two hemispheres, surrounded by the diencephalon. From here, a slender canal, the cerebral aqueduct, passes down the middle of the midbrain and leads to a triangular fourth ventricle, between the cerebellum and the brainstem. Pores from the fourth ventricle open into a subarachnoid space that surrounds the brain. These ventricles are filled with a liquid, the cerebrospinal fluid (CSF), which also bathes the outside of the brain and cushions the organ in the cranial cavity. The CSF is secreted in part by a complex of blood vessels, the choroid plexus, in each ventricle.

Around the brain and spinal cord, between the nervous tissue and bone, are found three membranes called meninges: the dura mater just under the bone; a middle arachnoid; and a delicate pia mater on the surface of the tissue.

The brain receives most of its input from, and sends most of its output to, the spinal cord, which merges with the brainstem at the base of the brain. The twelve cranial nerves provide input and output pathways to and from the structures in the head.

**neuron** nerve cell

**cerebral cortex** outer-most wrinkled portion of the brain

**axon** long extension of a nerve cell down which information flows

**lipid** fat or waxlike molecule, insoluble in water

Multiple sclerosis is an autoimmune disease in which myelin degenerates.

**ventricle** fluid-filled chamber

Inflammation of the meninges occurs in meningitis, which may be caused by a viral or bacterial infection.

## The Cerebrum

The cerebrum, the largest subdivision of the human brain, consists of a pair of cerebral hemispheres. Each hemisphere consists of an outer mantle of gray matter (the cerebral cortex), an extensive underlying of white matter, and deep aggregations of gray matter, the basal nuclei, or **ganglia**. Each hemisphere develops from a lateral outgrowth of the embryonic forebrain. Near its attachment to the forebrain, immature neurons **aggregate** to form the basal nuclei. As the basal nuclei grow, the remainder of the hemisphere continues to balloon outward and posteriorly, forming the cerebral cortex. This outgrowth is hollow, and its cavity becomes the lateral ventricle.

In adults, the right and left hemispheres are separated from each other by a deep midline cleft, the longitudinal fissure, and are separated from the cerebellum by a deep horizontal groove, the **transverse** fissure. The hemispheres are connected to each other by a massive bundle of nerve fibers, the corpus callosum, on the floor of the longitudinal fissure. Many of these fibers connect regions of one hemisphere to corresponding points in the opposite hemisphere.

As the cortex continues to grow, it is thrown into folds called gyri (singular, gyrus), separated by shallow grooves called sulci (singular, sulcus). A few especially prominent sulci appear early in development and are consistent from brain to brain. They serve as landmarks to divide the cortex into areas called lobes. (Gyri are not as numerous or pronounced in most other mammals.)

The frontal, parietal, temporal, and occipital lobes are visible on the surface of the brain. The frontal lobe extends from the region of the forehead to a groove called the central sulcus at the top of the head. The parietal lobe begins there and progresses posteriorly as far as the parieto-occipital sulcus, which is visible only on the medial surface of the brain. The occipital lobe extends from there to the rear of the head. A conspicuous lateral fissure separates the temporal lobe, in the region of the ear, from the frontal and parietal lobes above it. The insula is a fifth lobe of the cerebrum not visible from the surface. It lies deep to the lateral fissure between portions of the frontal, parietal, and temporal lobes.

The limbic system is a ring of tissue on the medial surface of each hemisphere, surrounding the corpus callosum and diencephalon and incorporating parts of the frontal, parietal, and temporal lobes. A major component of this system is the hippocampal formation, deep in the temporal lobe.

## Functional Areas of the Cerebral Cortex

Considerable knowledge of **cortical** function has come from patients with damage to specific cortical areas, and from electrical stimulation and recording from the cortex, often as a necessary prelude to neurosurgery. Imaging procedures developed in the 1980s and 1990s, such as positron emission tomography (PET), enable neuroscientists to follow changes in cortical activity over time. PET scans can show sequential changes in brain activity during such tasks as planning and executing movement and learning and storing information.

**ganglia** cluster of nerve cell bodies

**aggregate** clump together

**transverse** situated or lying across

Imbalance between production and drainage of cerebrospinal fluid can lead to hydrocephalus, a potentially fatal disorder.

**cortical** related to the cortex, or outer portion

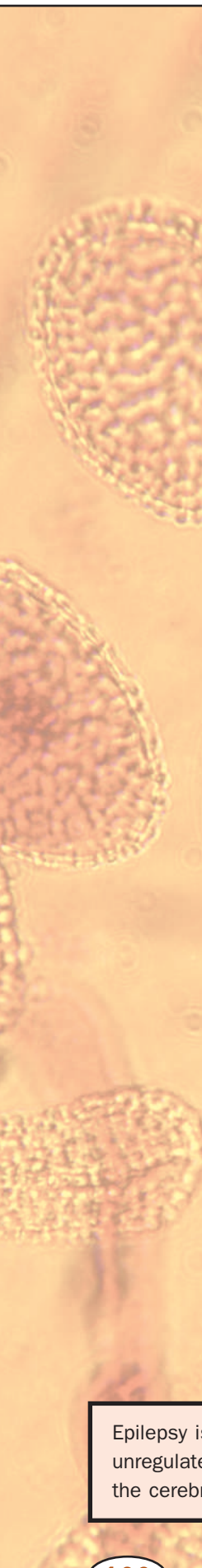

**feedback** process in which the output or result influences the rate of the process

**Motor Areas.** Four motor areas collectively occupy almost half of the frontal lobe. One of these, the primary motor cortex, is the precentral gyrus just anterior to the central sulcus. The motor areas are extensively connected to the basal ganglia and cerebellum. Working together in complex **feedback** loops, these areas are essential for motor coordination, postural stability and balance, learned movements, and the planning and execution of voluntary movement.

**Sensory Areas.** Primary sensory areas receive incoming sensory information. One of these, the primary somatosensory cortex, receives input for pain, temperature, touch, and pressure. It is located in the postcentral gyrus, the first gyrus of the parietal lobe posterior to the central sulcus. The primary auditory cortex, for hearing, is on the super (upper) margin of the temporal lobe, deep in the lateral fissure. The primary visual cortex, for sight, is in the occipital lobe, especially the medial surface.

Primary sensory areas are organized into precise sensory maps of the body. The primary somatosensory cortex, for example, has a point-for-point correspondence with the opposite (contralateral) side of the body, so that, for instance, the first and second fingers of the left hand send sensory information to adjacent areas of the right primary somatosensory cortex. Similarly, the primary visual cortex has a point-for-point map of the contralateral visual field. The primary auditory cortex has a tonotopic map of the cochlea of the inner ear, with different points in the cortex representing different sound frequencies.

**Association Areas.** Once received by a primary sensory area, information is sorted and relayed to adjacent sensory association areas for processing. Association areas identify specific qualities of a stimulus and integrate stimulus information with memory and other input. To hear a piece of music, for example, involves the primary auditory cortex, but to recognize that music as Mozart or Elvis Presley involves the auditory association area just below the primary auditory cortex.

The human brain differs from that of other primates in its large amount of association cortex. Association areas not only integrate immediate sensory data with other information, but are also responsible for human ingenuity, personality, judgment, and decision making.

### Cortical Lesions

The posterior region of the parietal lobe integrates motor and sensory information. Damage to this region often results in neglect or unawareness of the contralateral side of the body and the space around that side of the body. This can be reflected in such oversights as forgetting to shave one side of the face or dress one side of the body. The degree of behavioral dysfunction depends on the specific areas of the brain that are damaged and the extent of the damage. Temporal lobe lesions often cause difficulty performing tasks that require keen visual discrimination. Damage of the inferior (lower) area of the temporal lobe may produce short-term memory loss, while damage of the inferior and anteromedian (front-middle) regions may cause long-term memory loss. Lesions in the prefrontal cortex (far anterior portions of the frontal lobe) may produce problem-solving deficits, inability to make informed decisions, unpredictable emotional states, and bizarre, socially unacceptable behaviors.

Epilepsy is associated with unregulated electrical activity in the cerebrum.

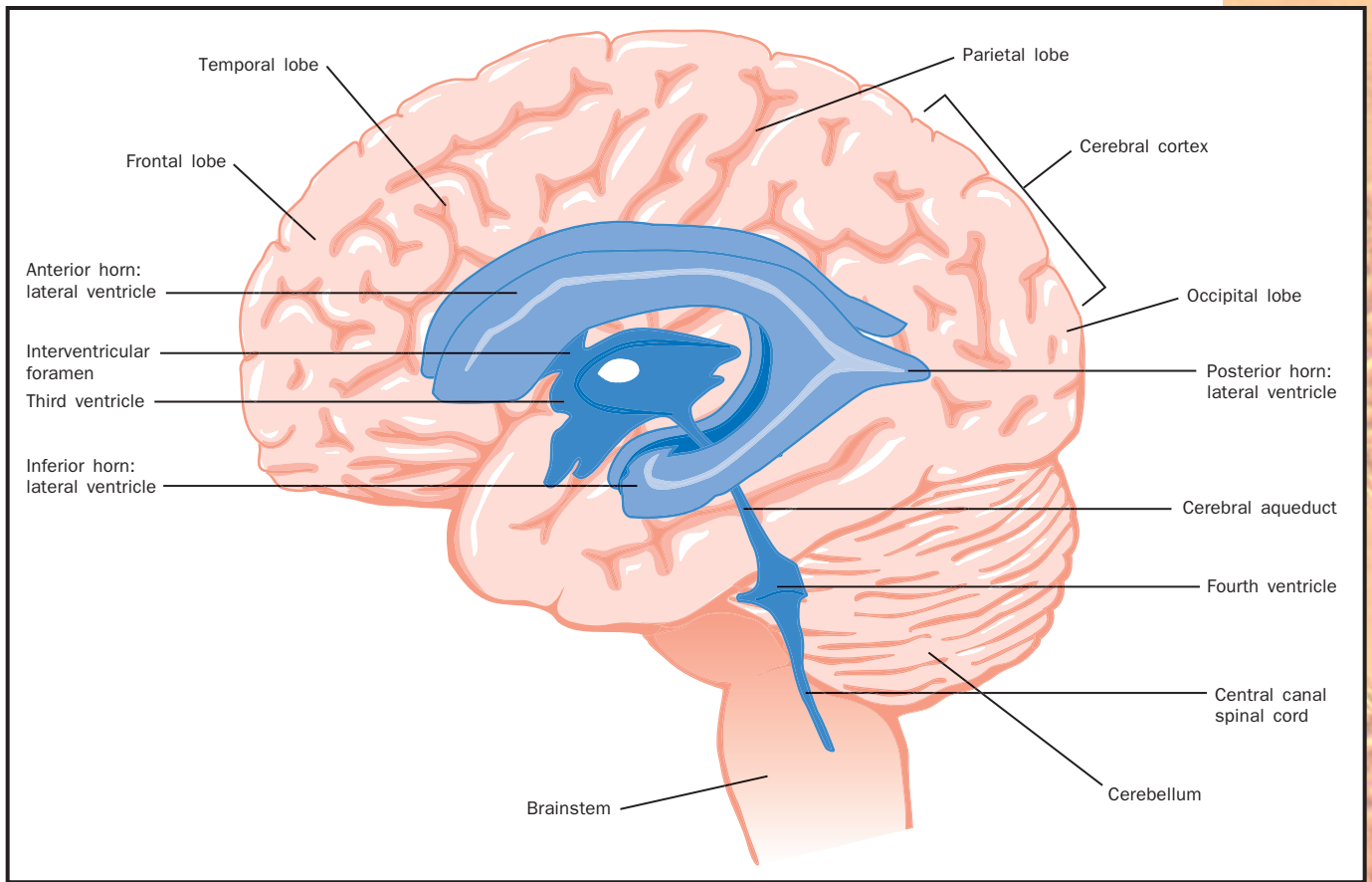

### “Left Brain” and “Right Brain”

The two cerebral hemispheres are neither anatomically nor functionally identical. Cortical functions are said to be lateralized when one hemisphere is dominant over the other for a particular function. The side containing the speech centers is called the dominant hemisphere, and is usually the left hemisphere. Most people are highly lateralized for language skills, and lesions in the dominant cortex can cause complete loss of specific language functions. The posterior, superior part of the dominant temporal lobe is important for understanding spoken and written language. Lesions in the language centers produce various forms of aphasia, difficulty understanding or using written or spoken language. The language-dominant hemisphere is also a site of mathematical skills, and intellectual decision making and problem solving using rational, symbolic thought processes.

The nondominant hemisphere is more adept at recognition of complex, three-dimensional structures and patterns of both visual and tactile kinds. It is also the site for recognition of faces and other images, and for non-verbal, intuitive thought processes. Creative and artistic abilities reside in the nondominant hemisphere. Thus, the dominant hemisphere tends to be the more analytical one, and the nondominant hemisphere more intuitive.

### The Basal Nuclei

The basal nuclei, or basal ganglia, are four masses of gray matter deep in the cerebrum: the **caudate nucleus**, putamen, globus pallidus, and amygd-

Anatomy of the brain.

**caudate** toward the tail

**nucleus** group of cell bodies in the central nervous system

Parkinson's disease, due to degeneration of the substantia nigra, causes slowed movements and tremor.

**ventral to** toward the belly side

**endocrine** related to the system of hormones and glands that regulate body function

**visceral** related to the viscera, or internal organs

**autonomic** independent; regulating involuntary actions

**hormone** molecule released by one cell to influence another

**reticular** netlike

### LEVI-MONTALCINI, RITA (1909–)

Biologist with dual U.S. and Italian citizenship who received, with Stanley Cohen, the 1986 Nobel Prize in physiology for her discovery of a substance ("nerve growth factor") that stimulates and guides the growth of nerve cells. During World War II, the Jewish Levi-Montalcini continued her research on the nervous system of chick embryos while hiding from the Germans.

dala. Functionally related nuclei of the midbrain, such as the substantia nigra, are sometimes considered to belong to the basal nuclei as well. The basal nuclei receive nerve fibers from all areas of the cerebral cortex and are important in motor skills and processing a broad range of cortical information. Skilled motor tasks such as tying one's shoes—things learned and now done with little thought—are controlled by the basal nuclei.

## The Brainstem

The brainstem occupies the base of the brain and includes the diencephalon, midbrain, pons, and medulla.

**Diencephalon.** The diencephalon is a paired structure with right and left halves. The largest component is the egg-shaped thalamus, which relays incoming information from lower levels of the brain to the cerebral cortex. Little information reaches the cerebral cortex without passing through synapses (neural junctions) in the thalamus. Some information processing occurs here, but the thalamus functions more as a dynamic filter for incoming information.

Immediately **ventral to** the thalamus is the smaller hypothalamus, the control center for the **endocrine** system and involuntary **visceral** motor system. The hypothalamus regulates diverse functions ranging from body temperature to gastrointestinal motility. All functions of the **autonomic** nervous system are regulated by the hypothalamus, although the hypothalamus can be overridden by input from the cerebrum; for example, in rage, fright, or sexual arousal. The hypothalamus also synthesizes the **hormones** released by the posterior lobe of the pituitary gland and produces other hormones that control the anterior lobe of the pituitary. The small epithalamus, containing the pineal gland, is posterior to the thalamus. One cranial nerve, the optic nerve (cranial nerve II), is associated with the diencephalon.

**Midbrain.** The midbrain is the smallest division of the brainstem. Four small humps, the two inferior and two superior colliculi, form the roof of the midbrain. They are involved in auditory and visual reflexes, respectively. Ventral to the cerebral aqueduct is a region of midbrain called the tegmentum. The floor of the midbrain is formed by two massive cerebral peduncles, stalks that attach the cerebrum and lower brainstem. The midbrain gives rise to two cranial nerves associated with eye movements: the oculomotor nerve (III) and trochlear nerve (IV).

**Pons.** The most striking feature of the pons is a large, rounded, ventral mass, the basal pons, which relays information from the cerebrum to the cerebellum. The tegmentum of the pons lies between the basal pons and the fourth ventricle. It contains nuclei for several cranial nerves, although only cranial nerve (V), the trigeminal nerve, exits and enters the pons itself.

**Medulla.** The medulla oblongata forms a transition from brain to spinal cord. Many columns of nerve fibers pass vertically through the medulla, going between the spinal cord and higher levels of the brain. The ventral surface of the medulla has a pair of ridges, the medullary pyramids, that contain motor nerve fibers carrying signals down to the spinal cord. Lateral to each pyramid is a mound, the inferior olive, containing neurons that relay information to the cerebellum. A central core of neurons, the **reticular** formation, contains control centers for the heartbeat and respiration. Three cranial

nerves enter or leave the brainstem at the junction between the pons and medulla: the abducens nerve (VI), involved in eye movements; the facial nerve (VII), which controls the muscles of facial expression; and the vestibulocochlear nerve (VIII), which carries signals for hearing and balance. Motor rootlets of the hypoglossal nerve (XII) leave the ventrolateral surface of the medulla and supply muscles of the tongue. **Dorsal to** the olive are rootlets of the glossopharyngeal nerve (IX) and vagus nerve (X). The glossopharyngeal nerve is involved in taste, salivation, swallowing, and other functions. The vagus nerve supplies many organs of the thoracic and abdominal cavities. Inferior to the rootlets of the vagus nerve are those of the spinal accessory nerve (XI), which **innervates** several neck and shoulder muscles.

**dorsal to** to the back of

**innervates** supplies with nerves

## The Cerebellum

The cerebellum, located beneath the occipital lobe and posterior to the medulla and pons, is an important regulator of motor function. It connects to the brainstem by three paired bundles of nerve fibers called the superior, middle, and inferior cerebellar peduncles. Integrity of the cerebellum is necessary to perform smooth, accurate, coordinated movements; to maintain posture; and to learn and regulate complicated motor patterns. Damage to the cerebellum does not produce muscle paralysis or paresis (weakness), but rather a loss of muscle coordination called ataxia.

## Comparative Anatomy of the Brain

During the course of vertebrate evolution, the control of body functions other than simple reflexes has become concentrated in the brain. Neurons with related functions have become clustered in specific regions, and axons with similar functions have become bundled into discrete tracts. However, the primitive reticular formation of the brainstem is retained in even the most complex brains. More recently evolved centers and tracts have been added to this primitive core.

Lateral views of four brains illustrate this evolutionary trend in vertebrates. The frog has a relatively simple brain. Its cerebrum and cerebellum are small, but its olfactory and visual centers are well developed. These centers trigger reflexive activity needed for survival. The alligator brain shows a growth of both the cerebrum and cerebellum without significant reduction of the visual or olfactory centers. The cerebrum and cerebellum are more developed in the goose, and the visual and olfactory centers remain well developed. These differences reflect higher levels of cortical function and more complex, coordinated motor functions.

There is extensive enlargement of the cerebrum in the horse. Extensive cortical enlargement throws the cortex into gyri and sulci, accommodating a greater cortical area within the cranial vault. The cerebellum also is larger and more convoluted. Human brains have the most extensive cerebral and cerebellar development. The vertebrate brains have the same twelve pairs of cranial nerves, with the same functions. SEE ALSO CENTRAL NERVOUS SYSTEM; HEARING; HYPOTHALAMUS; NERVOUS SYSTEMS; NEUROLOGIC DISEASES; NEURON; PAIN; PERIPHERAL NERVOUS SYSTEM; PITUITARY GLAND; SYNAPTIC TRANSMISSION; TOUCH

### RAMON Y CAJAL, SANTIAGO (1852–1934)

Spanish biologist who received, with Camillo Golgi, the 1906 Nobel Prize in physiology for showing that the nerve cell is the basic unit of the nervous system, a discovery that suggested how nerves could send signals to one another. Ramon y Cajal improved Golgi's silver stain, which revealed how the long threads (dendrites) of nerve cells connect to form a network.

*Alvin M. Burt*



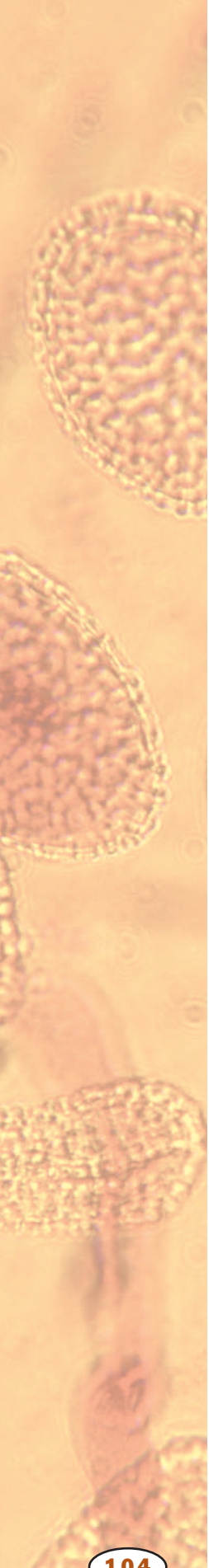

**superficial** on the surface; not deep

**xylem** water-transporting system in plants

**phloem** plant tissue that conducts sugars from leaves to roots and other tissues

**osmosis** passage of water through a membrane in response to concentration differences

**substrate** the molecule acted on by an enzyme

### Bibliography

Burt, Alvin M. "Organization and Development of the Nervous System," "Brain Stem and Cerebellum," "Telencephalon," and "Cerebral Cortex." In *Textbook of Neuroanatomy*. Philadelphia, PA: W. B. Saunders, Co., 1993.

Saladin, Kenneth S. "The Central Nervous System." In *Anatomy and Physiology: The Unity of Form and Function*. New York: McGraw-Hill, 2001.

## Bryophytes

Bryophytes are seedless plants without specialized water-conducting tissues. Bryophytes include mosses (phylum Bryophyta), liverworts (phylum Marchantiophyta Hepatophyta), and hornworts (phylum Anthoceroophyta). They are plants that virtually everyone has seen, but many have ignored. The most commonly encountered group is the green mosses that cover rotting logs, anchor to the bark of trees, and grow in the spray of waterfalls, along streams and in bogs. Even though mosses often thrive in wet habitats, many mosses and some liverworts can survive in relatively dry environments such as sandy soils and exposed rock outcrops.

The liverworts can take leafy forms, which are very similar **superficially** to mosses, but differ in the details of leaf size and arrangement. Other liverwort genera are characterized by a thallus made up of relatively small, flattened, ribbonlike segments of photosynthetic tissue, which have the general appearance of short, branched pieces of rich dark green egg noodles or linguini.

The leafy liverworts and the mosses differ in the appearance of their spore-forming structures. The mosses have thin stalks called seta extending from the ends of leafy branches. Seta bear capsules, which produce spores. The leafy and thalloid liverworts have very small, balloon-shaped spore-producing stages that remain virtually hidden within, and totally dependent upon, the photosynthetic plant tissues. The third major group of bryophytes is the hornworts. They received this common name because their spore producing structures, called sporangia, are generally long, slender, hornlike, and without capsules. More than eighteen thousand different bryophyte species have been identified throughout the world, and there are perhaps ten thousand species of moss, approximately eight thousand liverwort species, and only a little more than one hundred species of hornworts.

### Characteristics of Bryophytes

There are several characteristic features of bryophytes. First, the green tissue that makes up most of the plant body is not vascularized; it does not have **xylem** and **phloem** cells. This absence of specialized tissues for transporting water and dissolved food throughout the organism limits terrestrial forms to being very short plants, since the only way to move substances through the plant body is by **osmosis** and diffusion from surface moisture.

Second, bryophytes do not have roots, but have rhizoids, which are relatively simple, sometimes multicellular filaments of thin-walled cells that extend from the photosynthetic tissue into the soil or other **substrate**. They anchor the plant somewhat and in some cases facilitate water and nutrient uptake.

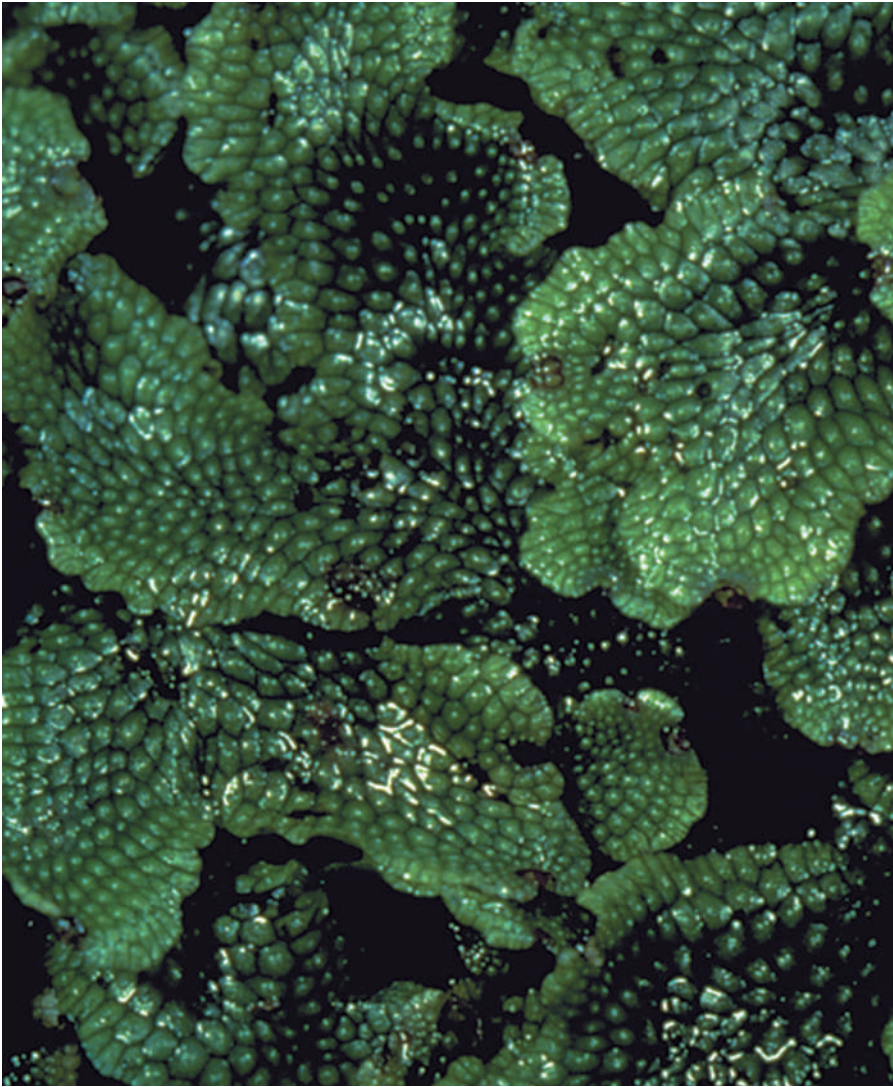

Liverworts can either resemble mosses or have the general appearance of short, branched pieces of rich, dark green egg noodles.

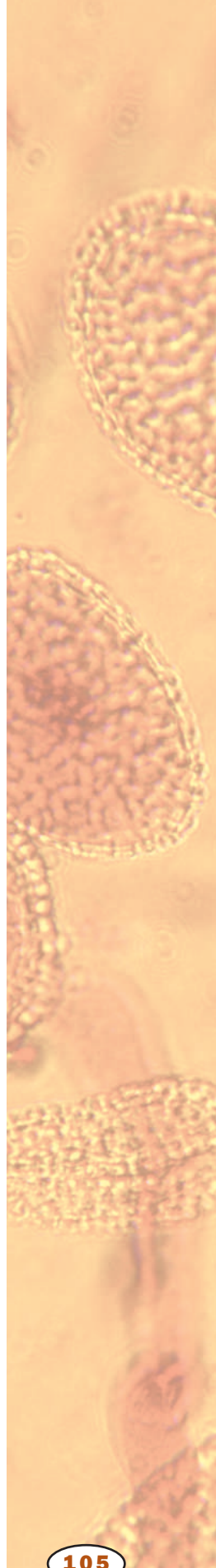

## Sexual Reproduction

The third characteristic of bryophytes is something that one could not guess by just looking at the conspicuous green tissue. Unlike other plants (and indeed most other multicellular organisms), the conspicuous portion of bryophytes is composed of **haploid** cells, containing only one set of **chromosomes**.

Sexual reproduction in animals involves the union of an egg and a sperm to form a fertilized egg (zygote). This **diploid** ( $2n$ ) cell divides mitotically to produce an embryo, and ultimately a mature adult organism. These adults have specialized cells, which divide meiotically to produce haploid ( $n$ ) sperm or eggs depending on the sex of the individual. In the plant kingdom, this cycle of **fertilization** and **meiosis** involves an alternation of generations between the haploid **gamete**-producing stage (gametophyte) and the diploid organism (sporophyte).

Vascular plants, including flowering plants, conifers, and many, such as ferns, that do not produce seeds, have life cycles with the diploid sporophyte being the predominant generation. In the bryophytes, it is the haploid

**haploid** having single, non-paired chromosomes in the nucleus

**chromosome** “colored body” in the cell nucleus; made of DNA and protein, and divided functionally into genes and non-gene regions

**diploid** having pairs of chromosomes in the nucleus

**fertilization** union of sperm and egg

**meiosis** cell division that forms eggs or sperm

**gamete** reproductive cell, such as sperm or egg

**gametophyte** a haploid plant that makes gametes by mitosis

**zygote** fertilized egg

**Enlightenment** eighteenth-century philosophical movement stressing rational critique of previously accepted doctrines in all areas of thought

**gametophyte** that produces the leaves and thali and therefore predominates. This change from predominant gametophyte to sporophyte was a major evolutionary advancement, which along with the development of vascular tissue facilitated the ultimate success of plants in a diversity of terrestrial habitats.

In order to accomplish sexual reproduction, bryophyte gametophytes produce eggs (n) in the archegonium, a vase-shaped structure that is the female reproductive organ. The sperm (n) are produced in antheridia, which may occur on the same gametophyte, but are often located on separate male plants. Water is generally required for them to swim to the eggs for fertilization. The resulting **zygote** (2n) develops into the sporophyte (2n). The sporophytes remain attached to and dependent on the female gametophyte. These parasitic sporophytes produce spores (n) by meiosis that then divide mitotically to produce the obvious multicellular gametophyte. SEE ALSO ALTERNATION OF GENERATIONS; ANGIOSPERMS; PLANT; PTERIDOPHYTES; SEEDLESS VASCULAR PLANTS; TRANSLOCATION; WATER MOVEMENT IN PLANTS

Dean Cocking

#### Bibliography

- Conard, Henry Shoemaker, et al. *How to Know the Mosses and Liverworts*, 2nd ed. New York: McGraw-Hill, 1980.
- Malcolm, Bill, and Nancy Malcolm. *Mosses and Bryophytes: An Illustrated Glossary*. Portland, OR: Timber Press/Micro-Optics Press, 2000.
- Shaw, A. Jonathan, and Bernard Goffinet, eds. *Bryophyte Biology*. New York: Cambridge University Press, 2000.

## Buffon, Count (Georges-Louis Leclerc)

**French naturalist and philosopher**  
**1707–1788**

Georges-Louis Leclerc, Comte de Buffon (Count Buffon), was one of the greatest French naturalists and a key philosopher of the **Enlightenment**. Born to a wealthy family, Buffon became interested in Newton's physics before turning to biology.

Buffon's life's work was a monumental encyclopedia of all that was known about the natural world, from astronomy to zoology. The first three volumes of his *Histoire Naturelle* were published in 1749. The work eventually grew to 44 volumes, the last of which was published after his death. Buffon's clear writing gave the encyclopedia a broad audience, and his ideas were widely discussed in the salons of Paris. Buffon's influence spread to America as well, and he corresponded with the statesmen Benjamin Franklin and Thomas Jefferson.

Buffon was one of the first philosophers to grapple with the questions of evolution, both of Earth and of living creatures. At the time, church doctrine insisted that Earth was only six thousand years old and that each type of creature had been made independently by the Creator. Volume 1 of the *Histoire* proposed instead that Earth was much older and that the seven days of biblical creation could be understood as seven epochs, each many thou-

sands of years long. Buffon was chastised by French authorities and published a recantation in volume 4.

Elsewhere in the encyclopedia, Buffon recognized the existence of change in species. He proposed that embryos were guided in their development by an “internal mold,” fueled by “organic molecules,” which recombine into the form of the developing organism. He thought that a change in the environment might lead to a change in the fuel molecules, and therefore cause a change in the form of the species. These ideas were advanced for their time, although they were later shown to be incorrect in their particulars. Buffon also proposed, in sharp contrast to his contemporary Carolus Linnaeus, that species are defined not by simple similarity of appearance but by reproductive fertility over time. SEE ALSO DARWIN, CHARLES; LAMARCK, JEAN-BAPTISTE; LINNAEUS, CAROLUS

*Richard Robison*

### Bibliography

- Magner, Lois E. *History of the Life Sciences*, 2nd ed. New York: Marcel Dekker, 1994.
- Mayr, E. *The Growth of Biological Thought*. Cambridge, MA: Harvard University Press, 1982.

## C4 and CAM Plants

C4 and CAM plants are plants that use certain special compounds to gather carbon dioxide (CO<sub>2</sub>) during photosynthesis. Using these compounds allows these plants to extract more CO<sub>2</sub> from a given amount of air, helping them prevent water loss in dry climates.

All photosynthetic plants need carbon to build sugars, and all get their carbon from CO<sub>2</sub> in the air. CO<sub>2</sub> must first be bound, or “fixed,” to another molecule inside the plant cell in order to begin its transformation into sugar. In most plants, carbon fixation occurs when CO<sub>2</sub> reacts with a five-carbon compound called RuBP (ribulose 1,5-bisphosphate). The product splits immediately to form a pair of three-carbon compounds, and therefore this pathway is called the C3 pathway. Further reaction leads to the creation of a sugar (glyceraldehyde-3-phosphate) and the regeneration of RuBP. This series of reactions is known as the Calvin-Benson cycle after the two scientists who elucidated it.

The **enzyme** that **catalyzes** the joining of RuBP and CO<sub>2</sub> is known as RuBP carboxylase, also called Rubisco. Rubisco is believed to be the most abundant **protein** in the world. However, Rubisco is not very efficient at grabbing CO<sub>2</sub>, and it has an even worse problem. When the concentration of CO<sub>2</sub> in the air inside the leaf falls too low, Rubisco starts grabbing oxygen instead. The ultimate result of this process, called photorespiration, is that sugar is burned up instead of being created. Photorespiration becomes a significant problem for plants during hot, dry days, when they must keep their stomates (leaf pores) closed to prevent water loss.

Diverse groups of plants have evolved different systems for coping with the problem of photorespiration. These plants, called C4 plants and CAM plants, initially bind carbon dioxide using a much more efficient enzyme. This allows a more efficient harvest of CO<sub>2</sub>, allowing the plant to trap suf-



**enzyme** protein that controls a reaction in a cell

**catalyze** aid in the reaction of

**protein** complex molecule made from amino acids; used in cells for structure, signaling, and controlling reactions

efficient CO<sub>2</sub> without opening its stomates too often. Each then uses the CO<sub>2</sub> in the Calvin-Benson cycle.

C4 (“four-carbon”) plants initially attach CO<sub>2</sub> to PEP (phosphoenolpyruvate) to form the four-carbon compound OAA (oxaloacetate) using the enzyme PEP carboxylase. This takes place in the loosely packed cells called mesophyll cells. OAA is then pumped to another set of cells, the bundle sheath cells, which surround the leaf vein. There, it releases the CO<sub>2</sub> for use by Rubisco. By concentrating CO<sub>2</sub> in the bundle sheath cells, C4 plants promote the efficient operation of the Calvin-Benson cycle and minimize photorespiration. C4 plants include corn, sugar cane, and many other tropical grasses.

CAM (“crassulacean acid metabolism”) plants also initially attach CO<sub>2</sub> to PEP and form OAA. However, instead of fixing carbon during the day and pumping the OAA to other cells, CAM plants fix carbon at night and store the OAA in large vacuoles within the cell. This allows them to have their stomates open in the cool of the evening, avoiding water loss, and to use the CO<sub>2</sub> for the Calvin-Benson cycle during the day, when it can be driven by the sun’s energy. CAM plants are more common than C4 plants and include cacti and a wide variety of other succulent plants. SEE ALSO LEAVES; PHOTOSYNTHESIS; WATER MOVEMENT IN PLANTS

*Richard Robinson*

## Cambrian Explosion

Scientists agree that the Cambrian explosion is one of the most significant events in the history of life. It is marked by a series of biological changes that took place over a relatively short period of geologic time during the early Cambrian, 543 to 520 million years ago. (The entire Cambrian period ranged from 543 to approximately 490 million years ago.) First and foremost, the Cambrian explosion is marked by the global appearance of organisms with skeletal hard parts in the fossil record in contrast to the strictly soft-bodied creatures prior to this. Initially, these skeletal structures were simple in design, such as minute cylindrical tubes, tiny cones, and rudimentary jawlike **appendages**. However, they evolved rapidly into larger and more elaborate structures comparable to the **exoskeletons** of many living invertebrate groups. These early skeletons were constructed from a diverse array of materials that form the building blocks of skeletons to this day, including calcium carbonate, calcium phosphate, and silica.

Coincident with the appearance of skeletons was the phenomenal diversification of metazoan life. Paleontologists Stephen Jay Gould in *Wonderful Life* (1989) and Simon Conway Morris in *Crucible of Creation* (1998) provide detailed, popular accounts of the amazing evolution of Cambrian animals, though they reach somewhat different conclusions with regard to the implications for the subsequent history of life.

However, all paleontologists agree that virtually all of the modern invertebrate groups made their first definitive appearance in the early Cambrian, including **phylum** Annelida (worms), **phylum** Mollusca (clams, snails, cephalopods), **phylum** Echinodermata (starfish, urchins, sea lilies), **phylum**

**appendage** attached organ or structure

**exoskeleton** external skeleton

**phylum** taxonomic level below kingdom, e.g., arthropod or chordate

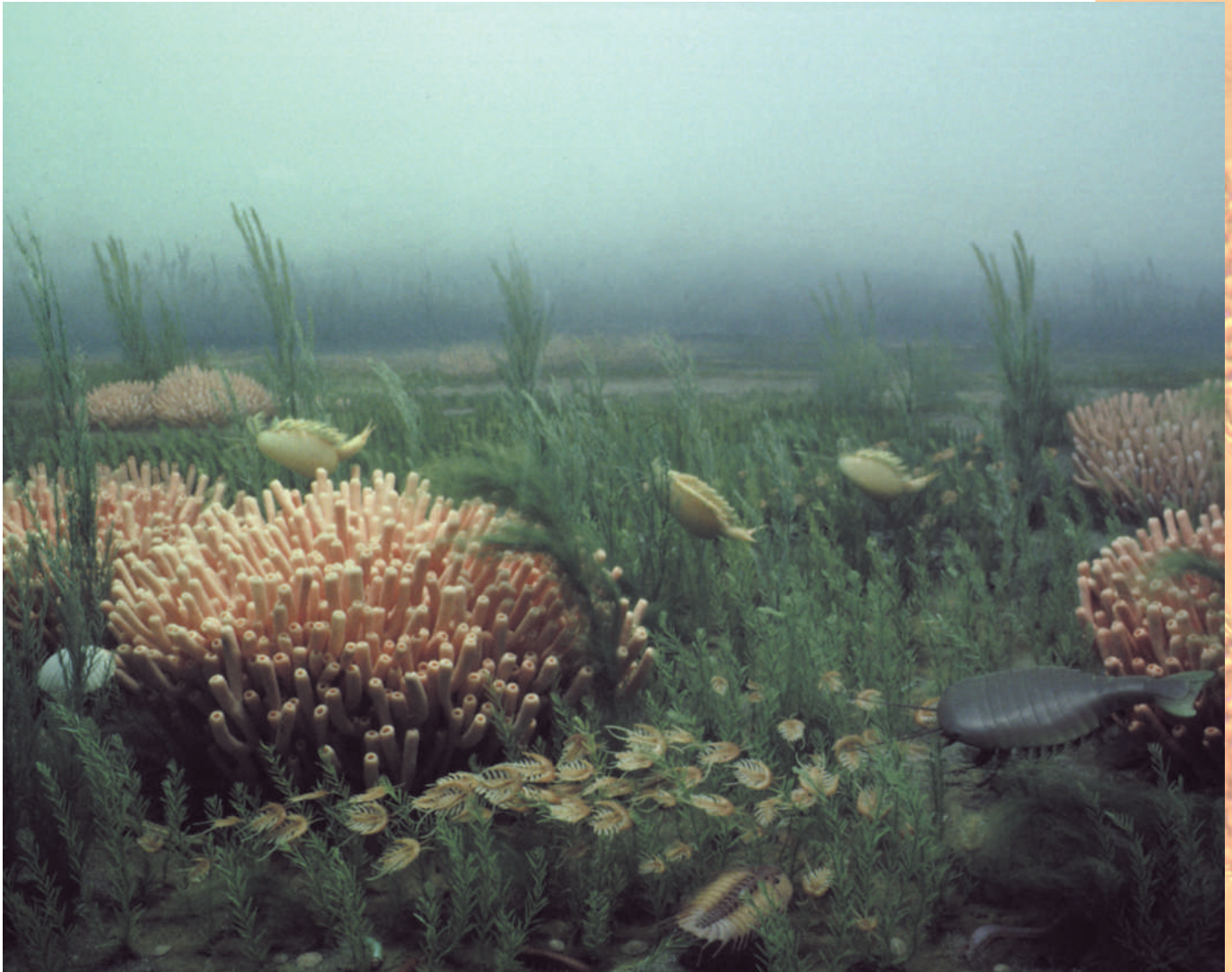

Arthropoda (trilobites, crabs, lobsters, insects), and phylum Brachiopoda (lamp shells). Along with these familiar groups came more obscure animals such as the Archaeocyatha, which are an interesting assemblage of sponge-like fossils that presumably led a quiet existence on the Cambrian seafloor filtering food particles from the water column. The Archaeocyatha became extinct by the middle Cambrian. A significant geological phenomenon associated with this great diversification of metazoan life is the enhanced record of bioturbation (the mixing of sediments by organisms seeking food and/or shelter) in rocks of Cambrian age. Prior to the Cambrian, most marine sediments were relatively undisturbed by animal activity.

Many scientists correlate the abrupt appearance of skeletons and the burst of **biotic** evolution in the early Cambrian with chemical changes in the world ocean, specifically an increase in the concentration of oxygen. Many scientists also point to the evolutionary first appearance of predatory lifestyles, with organisms adapting to this new ecological pressure with the construction of protective skeletons and the selection of burrowing habits. (An animal residing beneath the sediment surface is far less likely to be preyed upon.) Still others suggest that the relatively wide-open

Marine life from the Cambrian period. Virtually all of the modern invertebrate groups made their first definitive appearance in the early Cambrian period.

**biotic** living

Cambrian oceans were an ideal setting for large-scale evolutionary experimentation and the origin of Phyla. Regardless of the driving mechanisms, the Cambrian explosion will forever remain one of the defining episodes in the history of life on Earth. SEE ALSO EVOLUTION

*Raymond R. Rogers*

### Bibliography

Conway Morris, Simon. *The Crucible of Creation*. Oxford: Oxford University Press, 1998.

Cowan, Richard. *History of Life*. Boston: Blackwell Science Inc., 2000.

Gould, Stephen J. *Wonderful Life*. New York: W. W. Norton and Company, 1989.

## Cancer

Normal tissue development depends on a balance between cell multiplication and cell death. When cells multiply faster than they die, the result is an abnormal tissue growth called a tumor (neoplasm). The study and treatment of tumors is a branch of medicine called oncology.

Not all tumors are cancerous. Benign tumors are surrounded by a fibrous capsule, grow slowly, and do not spread to other organs; although they are nevertheless sometimes fatal. A wart is a benign tumor. Malignant tumors have no capsule, grow rapidly, and shed cells that can “seed” new tumors in other organs, a phenomenon called **metastasis**. The word *cancer* refers only to malignant tumors. The word literally means “crab.” It was coined by the ancient Greek physician Hippocrates when the tangle of blood vessels in a breast tumor reminded him of the legs of a crab.

Cancers are classified according to the type of tissues or cells in which they originate (see Table on page 112). A primary tumor is a tumor in the site of origin, and a secondary (metastatic) tumor is a tumor in a new site resulting from the spread of cells from the original tumor, for example, a brain tumor resulting from cells that originated in colon cancer.

### Causes of Cancer

Most cancer is caused by environmental agents called carcinogens. Carcinogens include chemicals such as cigarette tar, nitrites (used as food preservatives), and many industrial chemicals; viruses such as the hepatitis B and herpes simplex 2 viruses; and **ionizing radiation** such as X rays and gamma rays. All of these agents are mutagens; that is, they cause mutations, or changes in deoxyribonucleic acid (DNA) and chromosome structure, which in turn result in uncontrolled cell division.

### Cancer Genes

The risk of cancer is often hereditary, and many forms of cancer have been traced to two types of **genes**: **oncogenes** and tumor-suppressor genes.

**Oncogenes.** Oncogenes are mutated, “misbehaving” genes that normally code for growth factors or their receptors. Growth factors are chemical signals that trigger cell division. Some oncogenes cause excessive **secretion** of growth factors, and thus excessive cell division. Other oncogenes code for

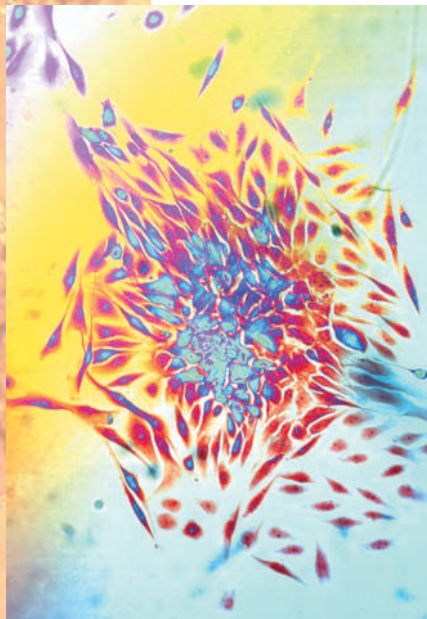

Human breast cancer cells metastasizing and spreading outward in a culture (blue).

**metastasis** breaking away of cancer cells from a solid tumor to travel elsewhere in the body

**ionizing radiation** high-energy radiation that destroys chemical bonds

**gene** portion of DNA that codes for a protein or RNA molecule

**oncogene** gene that causes cancer

**secretion** material released from the cell



Colored barium enema X ray of a human abdomen showing cancer of the ascending colon. The tumor appears over the right pelvic bone (left on image).

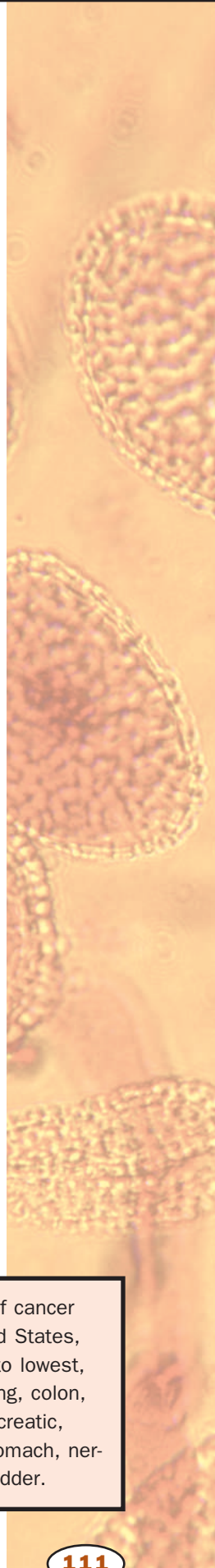

dysfunctional receptors that act like switches stuck in the “on” position, sending signals for cell division even when there is no growth factor bound to them. Many cases of breast and ovarian cancer are due to an oncogene called *erbB2*.

**Tumor-Suppressor Genes.** Tumor-suppressor (TS) genes normally inhibit cancer by opposing the action of oncogenes, promoting the repair of mutated DNA, or controlling tissue development. When TS genes are mutated, these protections are lost. A TS gene called *p53* has been implicated in leukemia and colon, lung, breast, liver, brain, and esophageal cancer.

Thus, oncogenes promote cancer and TS genes suppress it. They can be loosely compared to the accelerator and brake on a car, respectively. A defect in either one causes the “car,” cell division, to run out of control. Cancers typically require more than one mutation before they develop; thus, colon cancer involves damage to at least three TS genes on chromosomes 5, 17, and 18, plus activation of an oncogene on chromosome 12. It may take many years for so many mutations to accumulate in a single cell, which is one reason cancer is more common among the elderly than among young people.

The top ten causes of cancer mortality in the United States, ranked from highest to lowest, are cancers of the lung, colon, breast, prostate, pancreatic, leukemic, ovarian, stomach, nervous system, and bladder.



Type of cancer	Site of origin
Carcinoma	Epithelial cells
Melanoma	Pigment-producing skin cells (melanocytes)
Sarcoma	Bone, other connective tissues, or muscle
Leukemia	Blood-producing tissues (bone marrow and lymphatic tissue)
Lymphoma	Lymph nodes

## Effects of Cancer

Cancer is almost always fatal if it is not treated. Four ways in which cancer can kill are:

1. By displacing normal tissue, so the function of an organ deteriorates; an example of this is when a lung tumor replaces so much lung tissue that the blood can no longer get enough oxygen, or a brain tumor compresses and kills brain tissue
2. By invading blood vessels, causing fatal hemorrhages
3. By compressing vital passages, for example shutting off air flow into the lung or obstructing blood flow through a major vein or artery
4. By competing with healthy tissues for nutrients, often causing the body to break down its own proteins (muscle, for example) to feed the “hungry” tumor, or failing to make enough red blood cells and platelets because stem cells are diverted into producing the abnormal white blood cells of leukemia.

Cancer is normally treated by surgery, chemotherapy, or both, depending on its location, type, and extent. Other approaches are radiotherapy (using radiation to destroy tumors) and immunotherapy (providing antibodies or immune cells to attack cancer cells). Some forms of cancer are highly treatable, such as skin cancer, whereas others offer much less hope of recovery, such as pancreatic cancer. SEE ALSO CELL CYCLE; GENETIC DISEASES; MUTATION; ONCOGENES AND CANCER CELLS

*Kenneth S. Saladin*

### Bibliography

American Cancer Society. <<http://www.cancer.org/>>.

Fauci, Anthony S., et al. *Harrison's Principles of Internal Medicine*, 14th ed. New York: McGraw-Hill, 1998.

McCance, Kathryn L., and Sue E. Huether. *Pathophysiology*, 3rd ed. St. Louis: Mosby, 1998.

Varmus, H., and R. A. Weinberg. *Genes and the Biology of Cancer*. San Francisco: W. H. Freeman and Company, 1993.

**lipid** fat or waxlike molecule, insoluble in water

**protein** complex molecule made from amino acids; used in cells for structure, signaling, and controlling reactions

## Carbohydrates

Carbohydrates are one of four major classes of biological molecules, along with nucleic acids, **lipids**, and **proteins**. They are the most abundant biological molecules, and are an important nutritional component of many foods. Carbohydrates are usually composed solely of carbon,

hydrogen, and oxygen, although some also contain nitrogen, sulfur, or phosphorus.

Carbohydrates are classified according to size. The smallest carbohydrates are called monosaccharides (*mono* means “one”; *saccharide* means “sugar”). As the name implies, these are single sugar molecules. The most common monosaccharides, such as fructose and **glucose**, have six carbon atoms, but monosaccharides can have as few as three or as many as seven. Monosaccharides with five or more carbons usually have a ring-shaped structure when they are in a solution.

Oligosaccharides (*oligo* means “few”) are more **complex carbohydrates** composed of chains of two or a few (up to about twenty) simple sugars joined with a type of covalent bond called a glycosidic bond. The longer **oligosaccharides** may be linear or branched. The most common oligosaccharides, composed of only two sugars, are called disaccharides (*di* means “two”). The most common disaccharide, sucrose, or cane sugar, consists of a glucose molecule bonded to a fructose molecule. Other important disaccharides are maltose (two glucoses joined together) and lactose, or milk sugar (glucose joined to galactose). Longer oligosaccharides are usually bound to other molecules, such as lipids or proteins, to form glycolipids and glycoproteins, respectively (*glyco* means “sweet”), rather than being free in solution. These kinds of molecules are important in cell recognition, signaling, and **adhesion**, and are commonly found on the outer surface of cell membranes.

Polysaccharides (*poly*, means “many”) are important energy-storage and structural molecules. They are formed of long chains of sugars, most commonly glucose. Like oligosaccharides, they may be linear or branched. Important **polysaccharides** are starch, glycogen (animal starch), **cellulose**, and **chitin**. Starch and glycogen are similar energy-storage molecules found in plants and animals, respectively. Both are made of glucose molecules that are bonded in the same manner; however, glycogen has a higher degree of branching compared to starch.

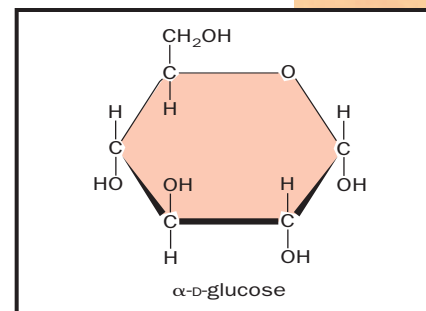

Glucose, a common monosaccharide

**glucose** simple sugar that provides energy to animal cells and is the building block of cellulose in plants

**complex carbohydrate** molecules formed by linking simpler carbohydrates such as sugars

**oligosaccharide** chain of several sugar molecules

**adhesion** attachment; sticking to the surface of

**polysaccharide** carbohydrate composed of many individual units of sugar

**cellulose** carbohydrate made by plants and some other organisms; part of the cell wall

**chitin** nitrogen-containing carbohydrate found in arthropod exoskeletons and fungus cell walls

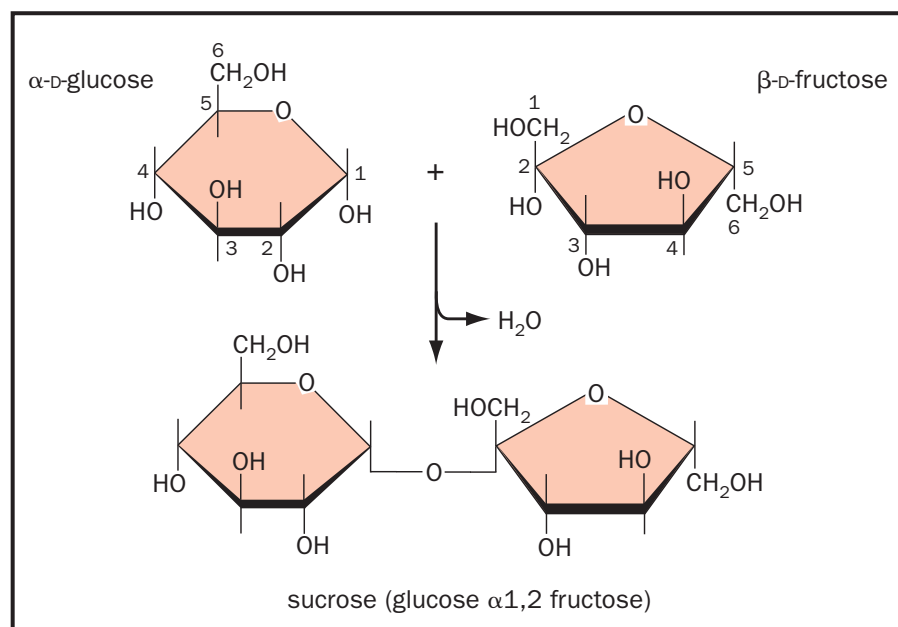

Sucrose, a common disaccharide.

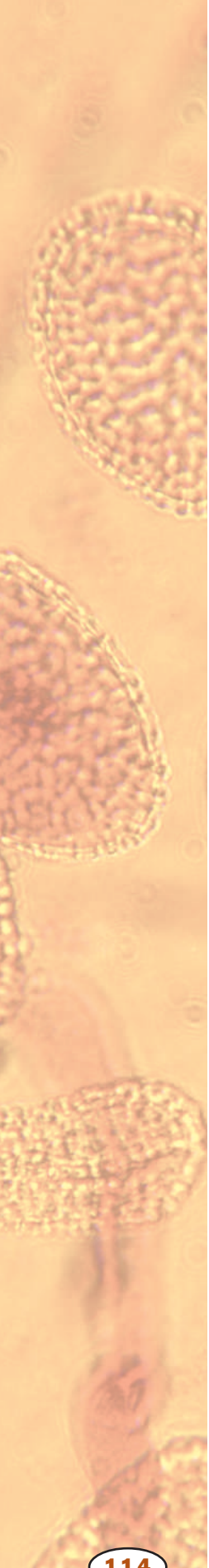

**exoskeleton** external skeleton

**matrix** a network, usually of threadlike fibers

**connective tissue** one of four types of body tissue, characterized by few cells and extensive extracellular material

**glycolysis** initial stages of sugar breakdown in a cell

**organic** composed of carbon, or derived from living organisms

**inorganic** not bonded to carbon

**metabolism** chemical reactions within a cell

**ecosystem** an ecological community and its environment

Cellulose is also made of glucose, but the individual glucose units are linked differently, resulting in a long, fibrous structure that is not soluble in water. Cellulose is the main structural component of most plant and some protozoan and bacterial cell walls. Wood is largely cellulose, and paper is an almost-pure sheet of cellulose prepared from wood. Cotton is also nearly pure cellulose.

Chitin is similar to cellulose, but its sugar subunits are a modified form of glucose called *N*-acetyl glucosamine. Chitin is the main structural component of fungal cell walls and of animal **exoskeletons**, such as the shells of insects and crustaceans. Other important structural polysaccharides form the **matrix** of cartilage and other **connective tissues** of animals. Carbohydrates are at the center of cellular metabolic pathways. The most fundamental process, **glycolysis**, uses glucose to produce energy for cellular needs. SEE ALSO CELL WALL; EXTRACELLULAR MATRIX; GLYCOLYSIS AND FERMENTATION

*David W. Tapley*

### Bibliography

Sharon, N. "Carbohydrates." *Scientific American* 243 (1980): 90–102.

## Carbon Cycle

The carbon cycle involves the circulation of carbon dioxide (CO<sub>2</sub>) from the atmosphere into plants and other living organisms; the transfer of carbon from these organisms into other temporary storage pools, living or nonliving, containing **organic** and **inorganic** carbon compounds; and the return of CO<sub>2</sub> to the atmosphere through respiration or combustion processes. The carbon cycle provides a unifying framework for examining exchanges or storage of carbon associated with photosynthesis and energy assimilation by organisms, respiration and **metabolism**, productivity and biomass accumulation, and the decay and recycling of organic matter at the level of a single organism, an **ecosystem**, or the global biosphere.

Analysis of the carbon cycle in a forest ecosystem, for example, requires the estimation of pools of carbon in live biomass, dead wood, decaying litter (branches and leaves), and soil organic matter. This information is combined with estimates of major transfers within the cycle such as carbon fixation via photosynthesis, CO<sub>2</sub> release by respiration, carbon flow to the soil as litterfall and root turnover, and carbon flow through grazing and decomposer food chains.

On a global scale, the primary carbon storage pools are the oceans and marine sediments, fossil fuels and shale deposits, terrestrial plants and soils, and the atmosphere. The global carbon cycle is characterized by large exchanges of carbon between Earth and its atmosphere. Photosynthesis and ocean uptake processes remove CO<sub>2</sub> from the atmospheric carbon pool, whereas CO<sub>2</sub> is returned to the atmosphere by biological respiration, deforestation and land clearing, forest fires, and fossil fuel combustion associated with human activities. As of 2001, the atmosphere is experiencing a net gain of 3 billion tons of carbon per year from CO<sub>2</sub> emissions derived from human combustion of coal, oil, and gas, as well as from deforestation and land clearing activities. This imbalance in the global carbon cycle is

reflected in the rising concentration of atmospheric CO<sub>2</sub>, which has increased 15 percent from 320 ppm (parts per million) to 368 ppm since the mid-1960s. SEE ALSO BIOGEOCHEMICAL CYCLES; ECOSYSTEM; GLOBAL CLIMATE CHANGE; PLANKTON

*Christopher S. Cronan*

### Bibliography

Botkin, Daniel, and Edward Keller. *Environmental Science*. New York: John Wiley & Sons, 1995.

Schlesinger, William H. *Biogeochemistry: An Analysis of Global Change*. New York: Academic Press, 1991.

## Cardiovascular Diseases

Cardiovascular diseases affect the heart or the blood vessels. Because the cardiovascular system provides oxygen and nutrients to cells and removes wastes from them, these diseases have profound impacts on health.

### Arrhythmias

Heart dysfunction can range from mild abnormalities to complete failure. The heart beats almost forty million times a year. Variants of the heartbeat can affect health and are called arrhythmias. A persistent resting heart rate above one hundred beats per minute is called tachycardia, and below sixty, bradycardia. If the cause is in the **ventricles**, the condition is termed ventricular tachycardia or bradycardia. If the cause is in the **atria**, it is termed supraventricular.

A number of factors can cause arrhythmias, including abnormal circulating levels of **electrolytes**, particularly potassium and calcium, and damage to the heart from insufficient blood flow (ischemia). An electrocardiogram (ECG) may be helpful in determining the cause. An ECG measures the electrical activity of the heart from the skin, even though the heart is deep within the thoracic (chest) cavity.

### Heart Failure

In heart failure, the heart is unable to contract with sufficient force to pump blood to all body parts. Eventually, the lack of adequate blood flow causes death. Heart failure has several causes. Disease of the heart muscle, called cardiomyopathy, is one cause that can be inherited, or have no known origin. More commonly heart failure is associated with insufficient blood flow, which may reflect a blockage in the circulatory pathway.

Heart failure is commonly associated with hypertension (high blood pressure), in which the muscular walls of blood vessels contract, impeding blood flow. The heart must work harder to pump the blood and may hypertrophy, or overgrow, to meet the challenge. Eventually, the increased mass requires more oxygen than blood flow to the heart can provide, and the heart muscle begins to fail.

### Hypertension

Hypertension may stretch and weaken areas of blood vessel walls, leading to an **aneurysm**, in which the weakened area balloons out and may burst. In a major blood vessel, this can be rapidly fatal. If such a ruptured vessel

**ventricles** fluid-filled, lower chambers of the heart

**atria** two upper chambers of the heart (singular, atrium)

**electrolytes** ions in body fluids

**aneurysm** bulging of the wall of a blood vessel

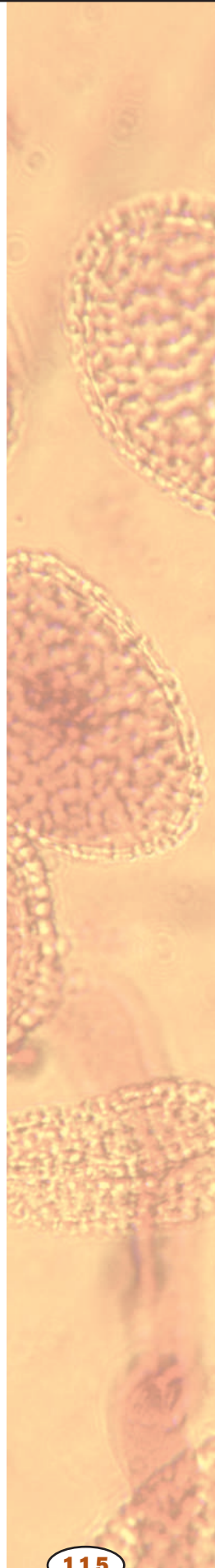

An image of a human heart undergoing angiography to repair a massive aneurysm of the aortal arch.

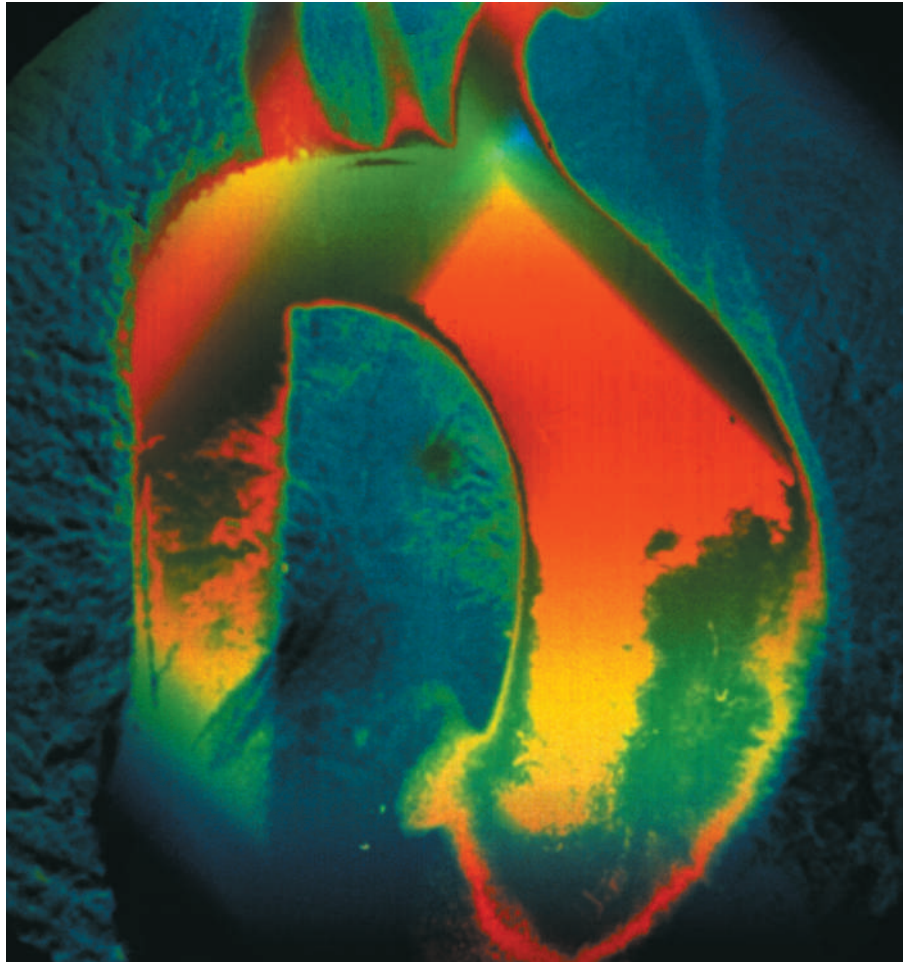

occurs in the brain, brain cells are killed and a stroke results. Stroke may also occur when a blood clot blocks blood flow to part of the brain, a condition called an embolism. Embolisms can occur in any blood vessel, but those in the brain can be especially devastating.

### Heart Attack

Decreased blood flow to heart muscle cells can result in a heart attack, or myocardial infarction. This is more likely to occur when heart oxygen demands increase, as during exercise, or if blood vessels to the heart are partially blocked, as in atherosclerosis, in which fatty deposits form on the inner linings of coronary arteries. Initially, decreased blood flow causes angina pectoris, which is a sensation of heavy pressure or squeezing in the chest that may be accompanied by sweating, difficulty breathing, nausea, and vomiting. Complete blockage causes a heart attack, in which heart muscle cells die. It can be fatal.

### Valve Disorders

Valves in the heart ensure that pumped blood always leaves through the arteries, and does not reverse direction through the veins. Valve defects can seriously impair the heart's ability to pump blood. Mitral valve prolapse is a common abnormality in which the valve separating the atrium and ven-

tricle bulges back into the atrium when the ventricle contracts. It produces a distinctive type of heart murmur that can be heard through a stethoscope. Symptoms include chest pain, fatigue, and anxiety. Infection by certain species of *Streptococcus* bacteria can lead to mitral valve damage. The bacteria and the mitral valve have similar surface chemistry. When the immune system attacks the bacteria, it may also attack the valve. SEE ALSO AUTOIMMUNE DISEASE; BLOOD CLOTTING; BLOOD VESSELS; CIRCULATORY SYSTEMS; HEART AND CIRCULATION; SMOKING AND HEALTH

David Shier

### Bibliography

*The Centers for Disease Control and Prevention, Cardiovascular Disease.* <[www.cdc.gov/nc-cdphp/cardio.htm](http://www.cdc.gov/nc-cdphp/cardio.htm)>.

*The Mayo Clinic's Heart and Blood Vessel Center.* <[www.mayo.edu](http://www.mayo.edu)>.

McCance, K. L., and S. E. Huether. *Pathophysiology: The Biologic Basis for Disease in Adults and Children*, 3rd ed. St. Louis: Mosby, 1998.

Sandeep, Jauhar. "Saving the Heart Can Sometimes Mean Losing the Memory." *New York Times* (19 September 2000): F1.

## Carson, Rachel

**American science writer and naturalist  
1907–1964**

Rachel Louise Carson was a career government biologist and author who forever changed public attitudes about the environment. Her eloquent writing about environmental pollution and the natural history of the oceans earned Carson the title "founder of the modern environmental movement."

Carson was the youngest of three children and grew up near the western Pennsylvania town of Springdale. Her mother inspired in Rachel a lifelong love of nature and biology. In 1929, Carson graduated with honors from the Pennsylvania College for Women, and in 1932 earned a master's degree in zoology from Johns Hopkins University.

Soon after, the U.S. Bureau of Fisheries hired Carson to write radio scripts, and the *Baltimore Sun* newspaper published her feature articles about natural history. In 1936, when she was twenty-nine, Carson began working as a biologist for the U.S. Fish and Wildlife Service, eventually becoming editor in chief for all its publications. Carson also wrote lyric prose about nature for national magazines and published a half dozen books. Among these were *The Sea Around Us* (1951), which won a National Book Award, and *Silent Spring* (1962), which created a worldwide awareness of the dangers of pesticides.

Carson was attacked by the chemical industry as an hysterical alarmist who didn't know what she was talking about. But history has proved that she was right. At the time, her calm demeanor, impeccable credentials, and articulate arguments persuaded the world that human-made chemicals could indeed drive birds and other animals to extinction. President John F. Kennedy read Carson's book, and was inspired to call for safety testing of pesticides. These tests eventually lead to the banning of DDT, a pesticide that persists in the environment and harms humans as well as most other animals. SEE ALSO ENDANGERED SPECIES; POLLUTION AND BIOREMEDIATION

Jennie Dusbeck

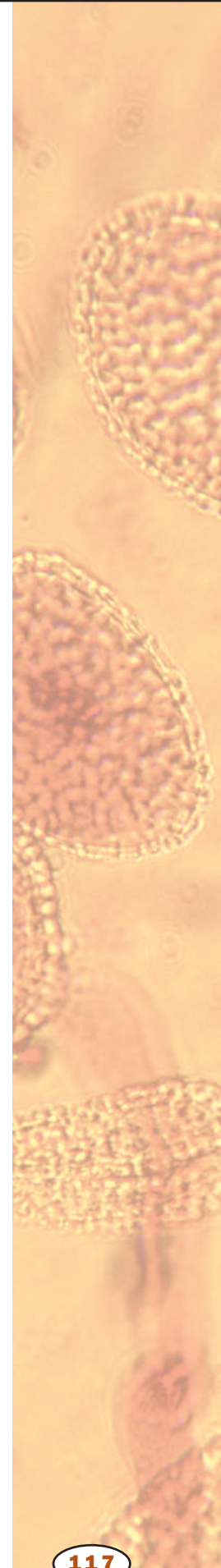

### Bibliography

- Carson, Rachel. *The Sea Around Us*. New York: Oxford University Press, 1951.
- . *Silent Spring*. Boston: Houghton Mifflin, 1962.
- Kudlinski, Kathleen V. *Rachel Carson: Pioneer of Ecology*. New York: Puffin Books, 1989.
- Lear, Linda. *Rachel Carson: Witness for Nature*. New York: Henry Holt & Co., 1997.

## Cartilaginous Fish

The cartilaginous fish, or Chondrichthyes, include the sharks, rays, skates, and chimaeras. There are over eight hundred living species of sharks and rays, and about thirty species of chimaeras. Cartilaginous fish are true fish. They have fins and breathe with gills. Unlike the more familiar bony fish, the Osteichthyes, the skeletons of the cartilaginous fish are made of cartilage. Other features that distinguish the cartilaginous fish from the bony fish are multiple gill slits, tiny toothlike scales, nostrils on the side of the head, teeth that are not fused to the jaw, and internal **fertilization**. Internal fertilization also occurs in some bony fish such as sea horses, guppies, and mollies. The ancestors of cartilaginous fish and bony fish diverged in the late Silurian, more than 400 million years ago.

**fertilization** union of sperm and egg

Sharks are large, long-lived, slow-growing ocean predators. The whale shark (*Rhincodon typhus*) is the world's largest fish; adults can be as long as 18 meters (59 feet). The spiny dogfish shark (*Squalus acanthias*) is the most studied shark, and while it rarely grows longer than 1.2 meters (almost 4 feet), it matures at 35 years and lives to be 70 or 80 years old. Sharks have internal fertilization and many shark species bear live young after a **gestation** of six or more months. The number of sharks in a clutch is often low, but can range from one or two to hundreds, depending on the species. The combination of slow maturity, long gestation, and small clutches means that shark populations cannot increase very rapidly. As a result, shark populations are very vulnerable to overfishing.

**gestation** period of fetal development within the mother

Sharks are tremendous predators, with their mouths full of ever-sharp teeth and jaw strength capable of exerting over 2,500 kg/cm<sup>2</sup> (30,000 psi) of pressure at the tooth tips. (A single shark may produce over ten thousand teeth in its lifetime, and as a result, the most common fossils of the cartilaginous fish are their teeth.) Sharks also have excellent senses of smell, waterborne vibrations, and the ability to sense the faint magnetic fields generated by the muscles of their prey. The large white shark (*Carcharodon carcharias*) preys on seals, sea lions, and large fish, and has been known to attack swimmers and boats.

Rays are bottom-dwelling fishes that are able to “fly” through the water with their enlarged and flattened pectoral fins. Stingrays can cause excruciating pain using a venomous stinger at the base of their tail. Electric rays can generate a shock of 200 volts. The manta ray has a wing span of up to 7 meters (almost 23 feet) and is sometimes seen following ships in the open ocean.

Chimaeras, also known as ratfishes, are a small group of rarely seen bottom-dwelling cartilaginous fish with large platelike teeth, no scales, and long skinny tails. SEE ALSO BONY FISH; OCEAN ECOSYSTEMS

Virginia Card

### Bibliography

Carl, E. *Biology of Fishes*, 2nd ed. Philadelphia, PA: W. B. Saunders, Co., 1997.

Moyers, Peter B., and Joseph J. Cech, Jr. *Fishes: An Introduction to Ichthyology*, 4th ed. Englewood Cliffs, NJ: Prentice Hall, 1999.

## Cell

A cell is the smallest unit of living matter. Cells were first identified in Europe in the seventeenth century by Antoni van Leeuwenhoek and others. They were named by Robert Hooke, an Englishman, who said they reminded him of the rooms or “cells” in a monastery. The cell theory describes some fundamental characteristics of all cells and is one of the unifying concepts in biology. It states that: (1) all organisms are made of cells, a cell is the structural and functional unit of organs, and therefore cells are organisms; and (2) cells are capable of self-reproduction and come only from preexisting cells.

### Prokaryotic Cells

Cells come in many shapes and sizes and have different structural features. Bacteria are single-celled organisms approximately 1 to 10 micrometers (.00004 to .0004 inch) in size and can be spherical, rod-shaped, or spiral-shaped. They are known as **prokaryotes** (from the Greek *pro*, meaning “before” and *karyon*, meaning “kernel” or “nucleus”) because they contain a nucleoid region rather than a true **nucleus** where their **genetic** material is found. All bacteria have cell walls that may be surrounded by a capsule and/or a gelatinous slime layer.

Beneath the cell wall is the plasma membrane responsible for regulating the flow of materials into and out of the cell’s **cytoplasm** within the interior of the cell. The cytoplasm is composed of fluid known as **cytosol** and solid materials. Within the cytosol are **ribosomes**, granular bodies that di-

**prokaryote** single-celled organism without a nucleus

**nucleus** membrane-bound portion of cell containing the chromosomes

**genetic** of, relating to the portion of DNA that codes for a protein or RNA molecule

**cytoplasm** material in a cell, excluding the nucleus

**cytosol** fluid portion of a cell, not including the organelles

**ribosome** protein-RNA complex in cells that synthesizes protein

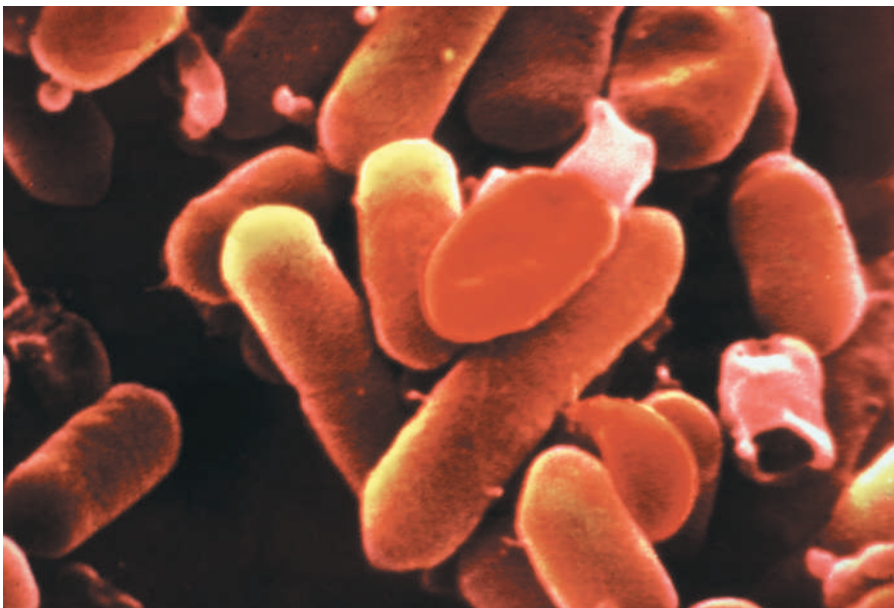

A scanning electron micrograph of *Listeria monocytogenes* cells.

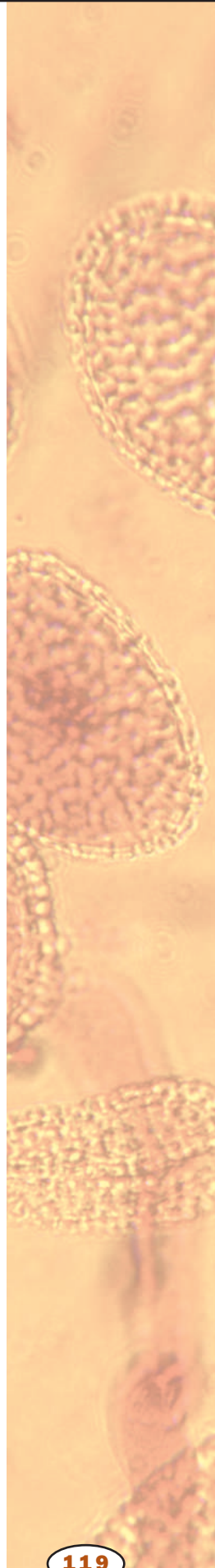



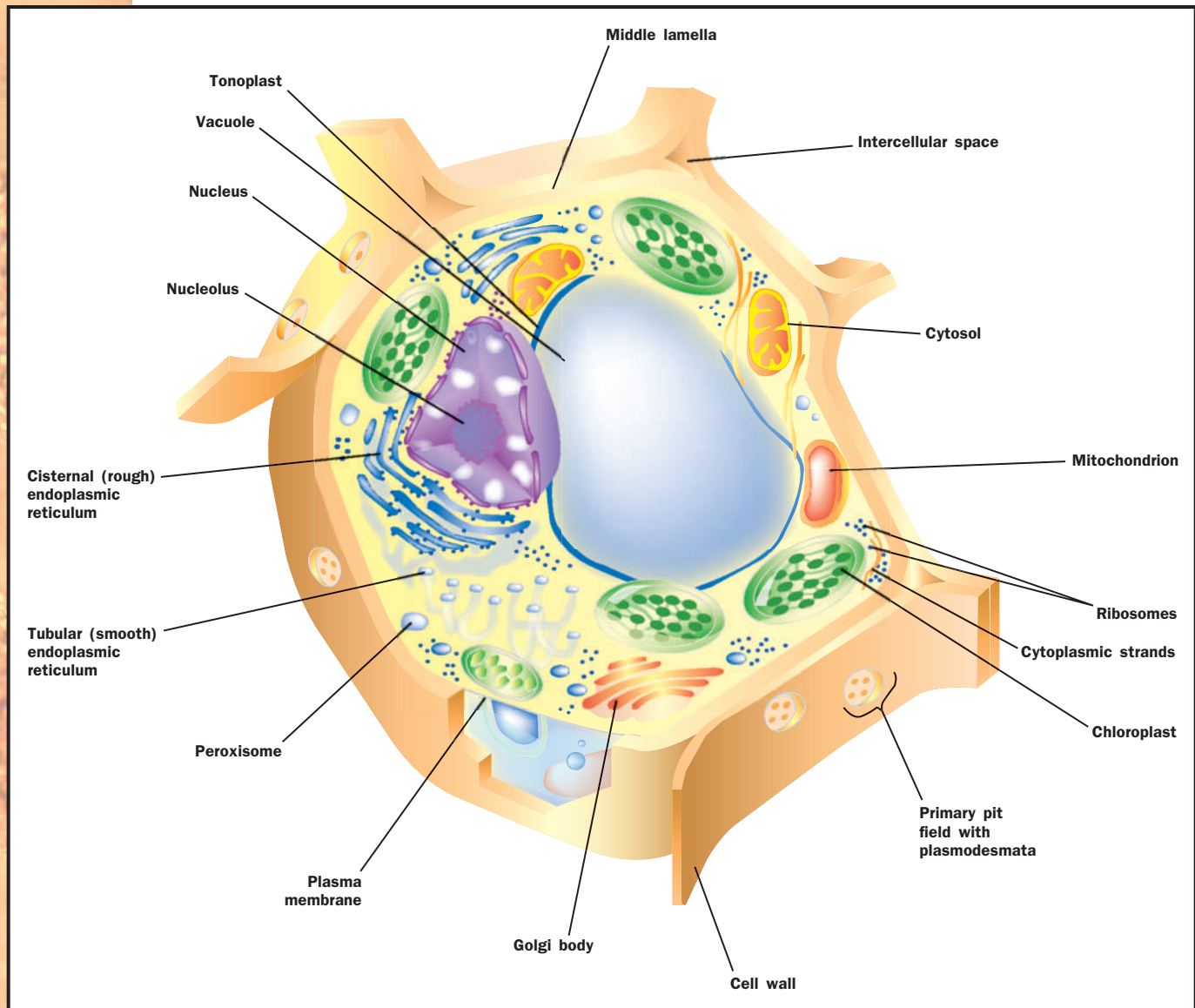

Components of a plant cell.

**protein** complex molecule made from amino acids; used in cells for structure, signaling, and controlling reactions

**appendage** attached organ or structure

**chromosome** “colored body” in the cell nucleus; made of DNA and protein, and divided functionally into genes and non-gene regions

rect the synthesis of all bacterial **proteins**. Some bacteria have whiplike **appendages** called flagella that enable them to move. The genetic material of bacteria is deoxyribonucleic acid (DNA), which is contained within a single circular **chromosome** in the nucleoid region and sometimes also in a smaller ring called a **plasmid**.

### Eukaryotic Cells

Eukaryotic cells (from the Greek *eu*, meaning “true” and *karyon*, meaning “kernel” or “nucleus”) are more complex than prokaryotic cells and are found in both unicellular organisms like the **amoeba** and multicellular organisms like sunflowers, mushrooms, and humans. They are generally larger than prokaryotic cells, ranging from about 10 to 100 micrometers (.0004 to .004 inch) in size. In multicellular organisms, there are many different types of cells that perform specialized functions. In animals, for instance, pancreatic cells make and secrete **hormones**, whereas red blood cells are specialized

for transporting oxygen throughout the body. Cells with specialized functions such as these are called “differentiated.”

All eukaryotic cells share specific structural characteristics. These include a true nucleus that is bounded by a double-layered membrane known as the nuclear membrane. Within the nucleus is housed the cell’s genetic material in the form of linear chromosomes of DNA contained in thread-like structures called **chromatin**. All eukaryotic cells have a plasma membrane that encloses the cytoplasm. Cells of plants, fungi, and many protists have an additional outer boundary called a cell wall that differs significantly in structure and composition from that of a prokaryotic cell.

Eukaryotic cells have many different kinds of small membrane-bound structures called **organelles** that, with the exception of ribosomes, are absent from prokaryotic cells. Eukaryotic ribosomes (which are not enclosed by a membrane) float freely in the cytosol or are attached to another organelle known as the **endoplasmic reticulum** (ER). The ER is a series of membrane-bound, fluid-filled spaces in contact with the nuclear membrane. Its function is to synthesize and/or modify proteins, phospholipids, and cholesterol and to transport substances from the nucleus to the rest of the cell.

When the ER is studded with ribosomes it is called the rough ER. When ribosomes are absent it is called the smooth ER. The Golgi apparatus is a system of membrane-enclosed sacs responsible for transporting newly synthesized proteins and **lipids** from the ER to other organelles and the plasma membrane. It is also the site of **polysaccharide** synthesis and modification of proteins and lipids by addition of sugars.

Both animal and plant cells have **mitochondria**, power houses that convert energy stored in the chemical bonds of nutrients like **carbohydrates**, proteins, and fats into adenosine triphosphate (ATP), a high-energy chemical compound that is required for many cellular processes. Many plant cells also have chloroplasts, organelles that contain the pigment chlorophyll. Chloroplasts conduct photosynthesis, in which plants use sunlight, water, and carbon dioxide to synthesize the sugar **glucose**.

**plasmid** small ring of DNA found in many bacteria

**amoeba** a single-celled protist that moves by crawling and can cause diarrhea

**hormone** molecule released by one cell to influence another

**chromatin** complex of DNA, histones, and other proteins making up chromosomes

**organelle** membrane-bound cell compartment

**endoplasmic reticulum** network of membranes within the cell

**lipid** fat or waxlike molecule, insoluble in water

**polysaccharide** carbohydrate composed of many individual units of sugar

**mitochondria** subcellular organelle that creates ATP used for energy-requiring processes in a cell

**carbohydrates** sugars, starches, and other molecules combining carbon, hydrogen, and oxygen and serving as fuel or structural components

**glucose** simple sugar that provides energy to animal cells and is the building block of cellulose in plants

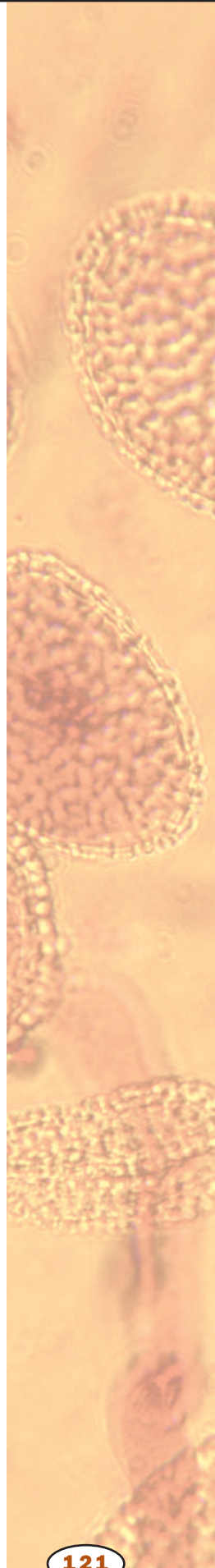

**Organelles in Eukaryotic Cells**

Structure	Function
Nucleus	Contains genetic material
Ribosomes	Protein synthesis
Endoplasmic reticulum	Synthesis/modification and transport of proteins and lipids
Golgi apparatus	Processing, distribution of proteins, lipids
Lysosomes	Digestion of substances in cell
Peroxisomes	Digestion and detoxification
Chloroplasts	Photosynthesis
Flagella/Cilia	Cell movement
Vacuole and vesicle	Storage of cellular substances
Centriole	Cytoskeletal organization

**enzyme** protein that controls a reaction in a cell

**intracellular** within a cell

**cytoskeleton** internal scaffolding in a cell, composed of protein

**cilia** short, hairlike cell extensions of the cell membrane formed by the cytoskeleton

**enzyme** protein that controls a reaction in a cell

**dissociate** break apart

**medium** nutrient source

**hormone** molecule released by one cell to influence another

**biopharmaceuticals** drugs produced by and harvested from living organisms

Lysosomes are membrane-enclosed bodies in plant and animal cells that contain **enzymes** responsible for digesting substances within the cell. In animal cells, peroxisomes contain enzymes that metabolize lipids and alcohol. In plants, peroxisomes also convert fatty acids into molecules that are precursors of sugars. Both plant and animal cells have vacuoles, membranous sacs that store substances such as water, sugars, and salts. Protozoans, a type of unicellular protist, have specialized contractile vacuoles for removing excess water from the cell.

Most organelles do not flow freely in the cytoplasm but are anchored to a complex **intracellular** framework known as the **cytoskeleton**, which is made of three different types of protein fibers: microfilaments, intermediate filaments, and microtubules. The cytoskeleton is involved in maintaining cell shape and participates in cell movement and cell division. The centrosome contains a pair of organelles called centrioles close to the nucleus of animal cells. It is responsible for organizing some of the cytoskeletal components.

Some plant and animal cells have projections from the plasma membrane known as flagella or **cilia** that are capable of movement. For example, a single flagellum is responsible for the movement of sperm cells. SEE ALSO CELL WALL; CHLOROPLAST; CYTOSKELETON; DNA; GOLGI; HISTORY OF BIOLOGY: CELL THEORY AND CELL STRUCTURE; MITOCHONDRION; NUCLEUS; RIBOSOME; VACUOLE

*Michele D. Blum*

### Bibliography

Mader, Sylvia S. *Biology*, 6th ed. Boston: McGraw-Hill, 1998.

McFadden, Carol, H., and William T. Keeton. *Biology: An Exploration of Life*. New York: W. W. Norton and Company, Inc., 1995.

## Cell Culture

Cell culture describes the laboratory growth of cells derived from plants or animals. To put cells into culture, the tissue of interest is exposed to **enzymes** that **dissociate** the tissue to release the component cells. In some cases, for example with blood-forming tissues, suspensions can be produced more simply by mechanical means, such as forcing them through a syringe. Dispersed cells are then transferred to a suitable growth **medium** and allowed to attach to the surface of culture flasks. When cells have grown (by dividing) to cover the flasks' surface, the process of enzymic dissociation can be repeated and the cells replanted to additional flasks. This process is referred to as subcultivation or "splitting."

Cell culture requires careful attention to the growth medium to ensure cells are given all the components they require to grow. Often the culture medium requires growth factors or **hormones** to stimulate growth.

The general process of cell culture has been used extensively since the early 1900s for research on tissue growth and development, virus biology, properties of cancer cells, studies relating to aging, genetics, and gene therapy. More recently, large-scale cell culture systems have been developed to produce **biopharmaceuticals** in quantities, another facet of the broad field of biotechnology.

A central advantage of the cell culture technique is its simplicity compared to the difficulties of studies using whole plant or animal organs, which are usually composed of many different cell types. With cell culture, it is possible to observe, in a well-defined environment, small numbers of cells of a single type derived by expanding an original population. In contrast, with an intact organ, one could be working with forty or more differing cell types, a nondefined fluid, and literally billions of cells.

The limitations of cell culture include the finite doubling potential of most normal cells, the possibilities for unexpected infection with viruses or microorganisms, or even cross-contamination with other cell types. Media used to propagate cells are rich in nutrients and, therefore, support growth of a multitude of organisms. Accordingly, most culture methods require sterile conditions. Often antibiotics are used to inhibit growth of unwanted microbial contaminants. Another difficulty with some cultured cells is their tendency to change their **morphology**, functions, or the range of genes they express.

Cell culture has had a tremendous impact on human health. The ability to culture cells allowed the laboratory growth of polio virus to produce vaccines that nearly eliminated polio as a disease. Two of the many areas of scientific study where uses of cell culture techniques have had major impact are human aging and cancer research. In the 1960s, biologists found that normal human fibroblasts, cells derived from **connective tissue**, had a predictable limit in their ability to proliferate in culture. Subsequently, the observation was extended to other normal cell types and species. Furthermore, the number of subcultivations that could be achieved was age related. Cells from young donors were able to divide more times than those isolated from older donors. After extensive research on this phenomenon, in the 1990s it was determined that the telomeres, small segments at the end of human **chromosomes**, become shorter with age both in cultured cells and in cells taken directly from individuals. An enzyme, telomerase, which acts to maintain telomeres, decreased in activity with age. Interestingly, cells engineered to express more telomerase retained telomeres and the ability for extended proliferation. Cancer cell lines, which can grow indefinitely in culture, also retain long telomeres.

Scientists have also learned much about cancer initiation and progression through the use of cells in culture. Normal fibroblasts from mouse embryos generally declined in proliferation rate with subcultivation. After an extended, so-called “crisis” phase, they seemed to recover and eventually returned to active division. However, the chromosome number of the resultant cell population was abnormal. Furthermore, if the cells were subcultivated extensively, they acquired malignant properties characteristic of cancer cells. This change results when normal genes are expressed under inappropriate circumstances. Their products overcome the normal controls of the cell division cycle to allow abnormal proliferation. SEE ALSO CELL CYCLE; CHROMOSOME, EUKARYOTIC

*Robert Hay*

### **Bibliography**

- Hay, Robert J., J. G. Park, and A. Gazdar, eds. *Atlas of Human Tumor Cell Lines*. San Diego: Academic Press, 1994.
- Hunter-Cevera, J. C., and A. Belt, eds. *Preservation and Maintenance of Cultures Used in Biotechnology*. San Diego: Academic Press, 1996.

### **FELL, HONOR BRIGET (1900–1986)**

British biologist who developed ways to grow cells outside the body (“tissue culture”) in order to more closely study the cells and the effects of hormones, vitamins, and other chemicals. The vigorous Fell worked until the end of her life. Three weeks before she died, she called out from her lab bench, “It’s worked, isn’t it exciting, come see the results!”

**morphology** related to shape and form

**connective tissue** one of four types of body tissue, characterized by few cells and extensive extracellular material

**chromosome** “colored body” in the cell nucleus; made of DNA and protein, and divided functionally into genes and non-gene regions

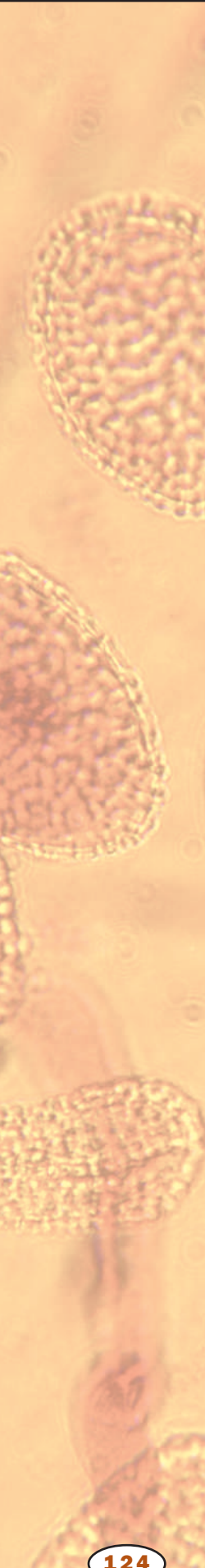

**eukaryotic cell** a cell with a nucleus

**chromosome** “colored body” in the cell nucleus; made of DNA and protein, and divided functionally into genes and non-gene regions

**mitosis** separation of replicated chromosomes

**cytoplasm** material in a cell, excluding the nucleus

**organelle** membrane-bound cell compartment

**cytosol** fluid portion of a cell, not including the organelles

**genome** total genetic material in a cell or organism

**chromatid** a replicated chromosome before separation from its copy

**synchronously** at the same time

**neuron** nerve cell

## Cell Cycle

The cell cycle is the ordered series of events required for the faithful duplication of one **eukaryotic cells** into two genetically identical daughter cells. In a cell cycle, precise replication of deoxyribonucleic acid (DNA) duplicates each **chromosome**. Subsequently, the duplicated chromosomes separate away from each other by **mitosis**, followed by division of the **cytoplasm**, called cytokinesis.

These monumental transformations in the chromosomes are accompanied by general cell growth, which provides enough material of all sorts (membranes, **organelles**, **cytosol**, nucleoplasm) required for the resultant doubling of cell number. This cycle continues indefinitely in specialized cells called stem cells, found in skin or bone marrow, causing constant replenishment of cells discarded by natural physiological processes.

Repetition of the cell cycle may produce a clone of identical cells, such as a colony of baker’s yeast on a petri dish, or it may be accompanied by intricate changes that led to differentiation into distinctive cell types, or ultimately to the development of a complex organism. In all cases, the DNA sequence of each cell’s **genome** remains unchanged, but the resultant cellular forms and functions may be quite varied.

### Stages of the Cell Cycle

From the viewpoint of chromosomes, four distinct, ordered stages constitute a cell cycle. DNA synthesis (S) and mitosis (M) alternate with one another, separated by two “gap” phases ( $G_2$  and  $G_1$ ) of preparation and growth. Though a generic cell cycle possesses no definitive starting stage, the term “start” of the cell cycle has nonetheless been given to the initiation of chromosomal DNA replication or synthesis. During S phase, every chromosome replicates to yield two identical sister chromosomes (called **chromatids**) that remain attached at their kinetochores.  $G_2$ , a period of apparent chromosomal inactivity, follows S phase. In  $G_2$ , cells prepare for the dynamic chromosomal movements of mitosis. In mitosis, the duplicated chromosomes separate into two equal groups through a series of highly coordinated events. First, condensed sister chromatids attach to the mitotic spindle at the center of the cell. The mitotic spindle, a fanlike array of microtubules, mediates the separation of all sister chromatid pairs as the chromatids, now called chromosomes, **synchronously** move to opposite poles of the cell.

Cytokinesis follows, in which the cytoplasm pinches apart and two new intact daughter cells are formed, each with the correct complement of chromosomes.  $G_1$ , a phase of cellular growth and preparation for DNA synthesis, occurs next. Thus a cell cycle proceeds from S to  $G_2$  to M to  $G_1$ , and the two new cells’ cycles continue to S and onward through the same series of stages. Cells that no longer undergo mitosis are said to be in  $G_0$ . Such cells include most **neurons** and mature muscle cells.

### Checkpoints

Both internal and external inputs trigger molecular events that regulate normal progress through the stages of the cell cycle. The precisely choreographed movements of chromosomes during mitosis provide one example

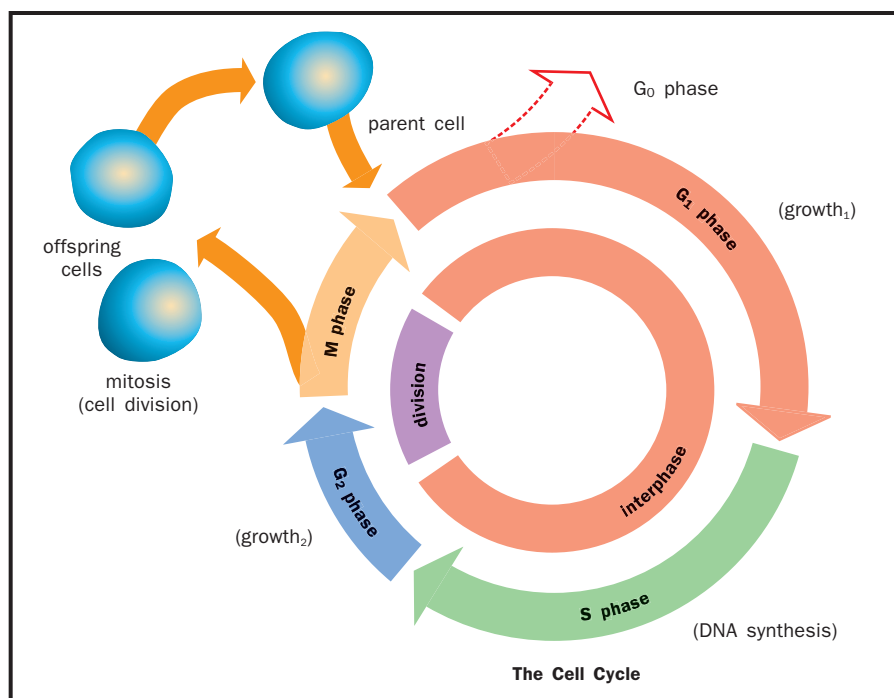

Transition between stages is triggered by cyclin-dependent kinases (CDK).

of this intrinsically faithful, careful regulation. The apparent simplicity of the particular alignment, division, and locomotion of chromosomes in each normal cell division belies the many levels of regulation that guarantee such precision. For example, without complete and proper DNA replication, the events of mitosis are not initiated. This control of cell-cycle order is maintained through an **intracellular** “checkpoint” that monitors the integrity and completion of DNA synthesis before authorizing the initiation of mitosis. This S-phase checkpoint responds to various forms of DNA damage, such as single- and double-strand breaks in the DNA backbone or incorporation of unusual **nucleotides**, and halts the progression of the cell cycle until effective repairs have occurred. The S-phase checkpoint also responds to stalled DNA replication forks, making the cell cycle pause until replication is completed. Ted Weinert and Lee Hartwell were the first to report experimental evidence of such a cell-cycle checkpoint in 1988. Since then, checkpoints have been discovered that regulate many aspects of cell-cycle progression in all organisms studied. Initiation of DNA synthesis, assembly and integrity of the mitotic spindle, and chromosome attachment to the mitotic spindle are all regulated by checkpoints. Mutations in checkpoint genes can lead to cancer, because of the resultant deregulation of cell division.

### Regulation by CDK Proteins

Remarkably, the coordinated transitions between cell cycle stages depend on one family of evolutionarily conserved **proteins**, called cyclin-dependent **kinases**. Cyclin-dependent kinases (CDKs) act as oscillating driving forces to direct the progression of the cell cycle. Each CDK consists of two parts, an **enzyme** known as a kinase and a modifying protein called a cyclin. Kinases are regulatory enzymes that **catalyze** the addition of phosphate groups to protein **substrates**. Adding one or more phosphate groups to a substrate protein can change that substrate’s ability to do its cellular job: One partic-

**intracellular** within a cell

**nucleotide** the building block of RNA or DNA

**protein** complex molecule made from amino acids; used in cells for structure, signaling, and controlling reactions

**kinase** enzyme that adds a phosphate group to another molecule, usually a protein

**enzyme** protein that controls a reaction in a cell

**catalyze** aid in the reaction of

**substrate** the molecule acted on by an enzyme

**phosphorylation** addition of the phosphate group  $\text{PO}_4^{3-}$

**transcription** messenger RNA formation from a DNA sequence

**hormone** molecule released by one cell to influence another

ular substrate may be inhibited by such a modification, while a different substrate may be activated by the same type of modification. Cyclins, so named because their activity cycles up and down during the cell cycle, restrict the action of their bound kinase to particular substrates. Together, the two integral parts of a CDK target specific cellular proteins for **phosphorylation**, thereby causing changes in cell-cycle progression.

Each CDK, consisting of a particular kinase bound by a particular cyclin, directs a critical transition in the cell cycle. For example, one CDK controls the initiation of DNA synthesis, while another CDK controls the onset of mitosis. Inactivation of the mitotic CDK is necessary for a subsequent cell-cycle transition, when cells exit mitosis and proceed to  $G_1$ . CDKs are also the ultimate targets of most cell-cycle checkpoint activity. So that all cell-cycle events occur at the proper time during each cell cycle, CDK activity itself is tightly controlled by regulating the activity of every cyclin. Each cyclin is active only periodically during the cell cycle, with its peak of activity limited to the period during which it is needed. Regulated **transcription** of cyclin genes and regulated degradation of cyclin proteins provides this oversight.

### Extrinsic Controls

In addition to intrinsic controls exerted by CDKs and checkpoints, many external controls affect cell division. Both normal and abnormal cell cycles can be triggered by such extrinsic controls. For example, the **hormone** estrogen affects the development of a wide variety of cell types in women. Estrogen exerts its effects on a receptive cell by binding to a specific receptor protein on the cell's nuclear membrane. By binding to an estrogen receptor, estrogen initiates a cascade of biochemical reactions that lead to changes in the cell-cycle program. Normally, estrogen moves cells out of a resting stage into an active cell cycle.

In a different context, however, even normal levels of estrogen encourage the growth of some forms of breast cancer. In these cases, estrogen increases the speed with which the cancerous cells complete their cell cycles, leading to more rapid growth of the tumor. The most effective current drug therapies for such breast cancers block the estrogen receptor's estrogen-binding ability, making cells unresponsive to estrogen's proliferation signal. Thus, while estrogen itself does not cause breast cancer, it plays an important role in stimulating the growth of some cancers once they initiate by other mechanisms, such as by an unregulated CDK or a defect in a cell-cycle checkpoint. **SEE ALSO CONTROL MECHANISMS; GENETIC CONTROL OF DEVELOPMENT; HORMONES; ONCOGENES AND CANCER CELLS; SIGNALING AND SIGNAL TRANSDUCTION**

Wendy E. Raymond

### Bibliography

- Hartwell, Leland H., et al. *Genetics: From Genes to Genomes*. New York: McGraw-Hill, 2000.
- Hartwell, Leland H., and T. A. Weinert. "Checkpoints: Controls That Ensure the Order of Cell Cycle Events." *Science* 246 (1989): 629–634.
- Murray, Andrew, and Tim Hunt. *The Cell Cycle: An Introduction*. New York: W. H. Freeman and Company, 1993.

## Cell Division *See Cytokinesis, Mitosis*

## Cell Evolution

Approximately 3.5 billion years ago, cellular life emerged on Earth in the form of primitive bacteria. Bacteria or “prokaryotes” organize their genes into a circular chromosome that lies exposed within the fluid environment of the cell. Within a billion years, bacterial cell types had flourished and diversified, evolving numerous ways of extracting energy from the environment. These types included first the fermenting **anaerobic** archaeobacteria, then the oxygen-producing photosynthetic cyanobacteria, and finally respiring **aerobic** bacteria able to utilize the new oxygen-rich atmosphere. In addition some bacteria had become **motile**, such as the corkscrew-shaped wriggling spirochetes. All of these bacterial cell types have descendants living today.

Eukaryotes, whose deoxyribonucleic acid (DNA) is sequestered within a separate membrane-bound **nucleus**, first emerged perhaps 2 billion years ago. **Eukaryotic cells** also contain an extensive internal membrane system, a **cytoskeleton**, and different kinds of membrane-bound **organelle**, including **mitochondria** (the “power factories”) and, in algae and plants, plastids (sites of photosynthesis). All multicellular life, including plants, animals, and fungi, are composed of eukaryotic cells; some microbes, such as unicellular algae and protozoa, are also eukaryotes. So how did this great diversity of eukaryotic organisms evolve from **prokaryotic** ancestors?

### Serial Endosymbiosis

The most widely accepted explanation is known as the Serial **endosymbiosis** theory (SET), articulated and championed by scientist Lynn Margulis. In 1905 Russian scientist Konstantin Merezhkovsky proposed that new organs or organisms could form through **symbiosis** (“the living together of different kinds of organisms”). In the 1920s researcher Ivan Wallin suggested that organelles such as chloroplasts and mitochondria originated as symbiotic bacteria. His theory was rejected by his colleagues, leading him to abandon his laboratory investigations.

However, in 1967 the theory was resuscitated by Margulis to explain observations by geneticists of “cytoplasmic genes,” DNA found outside the nucleus. Margulis proposed that cytoplasmic organelles with a bacterial origin were the source of the extranuclear genes. Margulis’s SET begins with the merger of an archaeobacterium, lacking a rigid cell wall, with motile spirochetes to form the first eukaryotic cell. The archaeobacterium’s flexible membrane pinched inwards to enclose the DNA within a double-membrane nucleus and the spirochetes provided cytoskeletal support, ultimately giving rise to motile structures known as microtubules.

This new cell type then engulfed an aerobic (needing oxygen) bacterium, which was retained within a membrane vesicle inside the host cell. Over many generations, this new cell component evolved into what scientists now call “mitochondrion” and allowed eukaryotes to thrive in an oxygen-rich environment by harnessing the metabolic capabilities of its newest partner. Over time, many of the proto-mitochondrion’s genes were transferred to

**anaerobic** without oxygen, or not requiring oxygen

**aerobic** with oxygen, or requiring it

**motile** able to move

**nucleus** membrane-bound portion of cell containing the chromosomes

**eukaryotic cell** a cell with a nucleus

**cytoskeleton** internal scaffolding in a cell, composed of protein

**organelle** membrane-bound cell compartment

**mitochondria** subcellular organelle that creates ATP used for energy-requiring processes in a cell

**prokaryotic** without a nucleus

**endosymbiosis** symbiosis in which one partner lives within the other

**symbiosis** close relationship between two species in which at least one benefits

### MARGULIS, LYNN (1938–)

U.S. biologist famous for her widely accepted theory that a cell is a community of tiny organisms that have evolved to live together. A member of the prestigious National Academy of Science, Margulis has won the National Medal of Science for her outstanding work on “the development, structure, and evolution of living things, for inspiring new research in the biological, climatological, geological, and planetary sciences, and for her extraordinary abilities as a teacher and communicator of science to the public.”



Suggested evolutionary pathway for the origin of mitochondria.

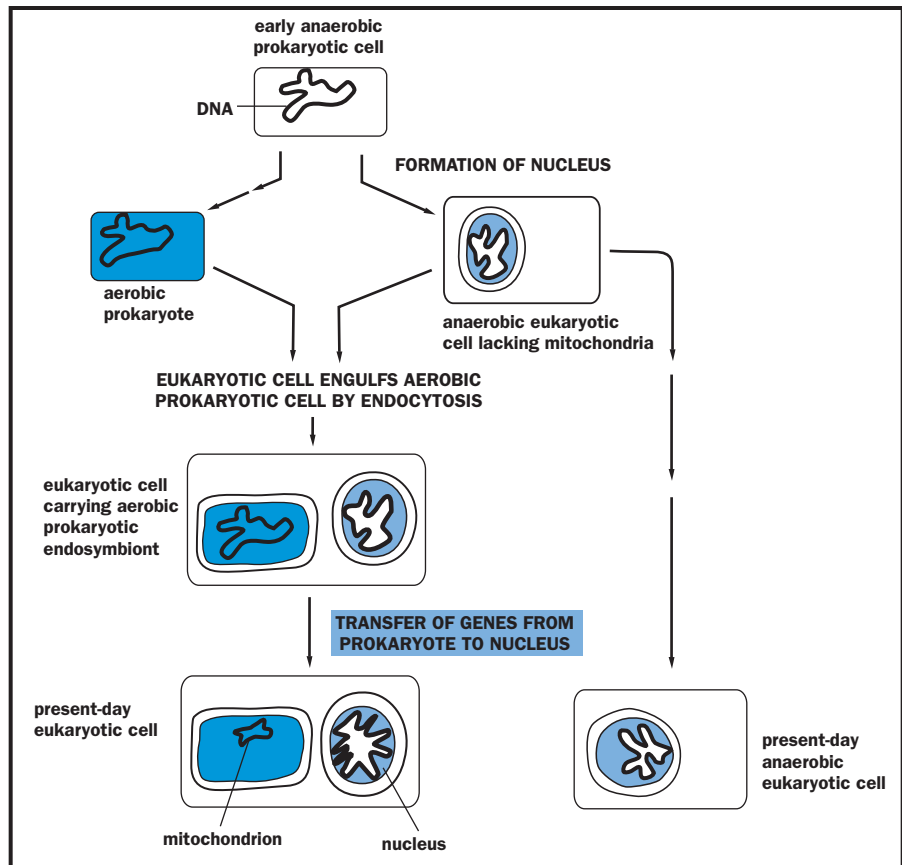

**nucleated** having a nucleus

**intracellular** within a cell

**symbionts** organisms living in close association with another organism

the host nucleus, making the mitochondrion dependent upon the host cell for its survival. In a similar fashion, some of these aerobic **nucleated** cells established symbiotic associations with **intracellular** cyanobacteria, leading to the evolution of photosynthetic eukaryotes.

The view that the eukaryotic cell evolved from an intimately associated consortium of bacteria initially met with sharp criticism. Some, including Margulis, argued that the discovery that both mitochondria and plastids contain bacteria-like circular chromosomes, the source of the “cytoplasmic genes,” was evidence for the bacterial origins of these double-membrane-bound organelles. Others argued, however, that these organelles and their genes originated by pinching off from the nucleus.

Eventually researchers accumulated more and more supporting evidence for the main premise of SET: the symbiotic origin of mitochondria and plastids. The size, gene structure and sequences, biochemistry, and fission-style reproduction of these organelles all imply a closer evolutionary relationship to free-living aerobic bacteria and cyanobacteria than to the “host” archaeobacteria-derived cell encoded by genes in the nucleus. The origin of microtubules from spirochete **symbionts**, however, is not as well supported and remains controversial. One of the reasons the theory met with such initial skepticism is that it challenged the prevailing ideas about how evolution occurs: that is, through slow accumulations of changes in vertically transmitted sets of genes, resulting in speciation events in which branches of the tree of life are forever splitting, never joining. SET describes the wholesale

fusion of two (three, four, or more) **genomes**, a process that joined previously diverging branches into one. SEE ALSO ARCHAEA; CELL; CHLOROPLAST; CYTOSKELETON; EUBACTERIA; MITOCHONDRION

Mary K. Montgomery

### Bibliography

de Duve, Christian. "The Birth of Complex Cells." *Scientific American* 274 (1996): 50–57.

Margulis, Lynn. *Symbiotic Planet: A New Look at Evolution*. New York: Basic Books, 1998.

## Cell Junctions

Cell junctions can be divided into two types: those that link cells together, also called intercellular junctions (tight, gap, adherens, and desmosomal junctions), and those that link cells to the extracellular **matrix** (focal contacts/adhesion plaques and hemidesmosomes). These junctions play a prominent role in maintaining the integrity of tissues in multicellular organisms and some, if not all of them, are involved in signal **transduction**.

Intercellular junctions and hemidesmosomes were first identified in tissues examined by electron microscopy. In contrast, the **focal** contact was first observed in cultured cells in the light microscope by a technique called interference reflection. This procedure revealed specific sites where cells closely adhere to their **substrate**. These were called focal contacts or **adhesion** plaques.

### Tight Junctions

The tight junction (also referred to as a zonula occludens) is a site where the membranes of two cells come very close together. In fact, the outer leaflets of the membranes of the contacting cells appear to be fused. Tight junctions, as their name implies, act as a barrier so that materials cannot pass between two interacting cells. The protein components of the tight junction are arranged like beads on a string that span the adjacent membranes of each tight junction.

Tight junctions often occur in a belt completely encircling the cell. In a sheet of such cells, material cannot pass from one side of the sheet to the other by squeezing between cells. Instead, it must go through a cell, and hence the cell can regulate its passage. Such an arrangement is found in the gut, to regulate absorption of digested nutrients.

### Gap Junctions

In contrast to the tight junction, there is a channel between the membranes of contacting cells in the gap junction so that the **cytoplasm** of the two is connected. The basic building block of each gap junction is the connexin subunit. Six of these in each of the membranes of two neighboring cells come together, and then the group of six connexins in one cell interact with a comparable **hexamer** in the other cell resulting in the formation of a channel. This channel allows direct cytoplasmic communication among the cells; small molecules of 1,500 daltons or less can pass through the channel of

**genome** total genetic material in a cell or organism

**matrix** a network, usually of threadlike fibers

**transduction** conversion of a signal of one type into another type

**focal** at a point

**substrate** the molecule acted on by an enzyme

**adhesion** attachment; sticking to the surface of

**cytoplasm** material in a cell, excluding the nucleus

**hexamer** a structure composed of six parts

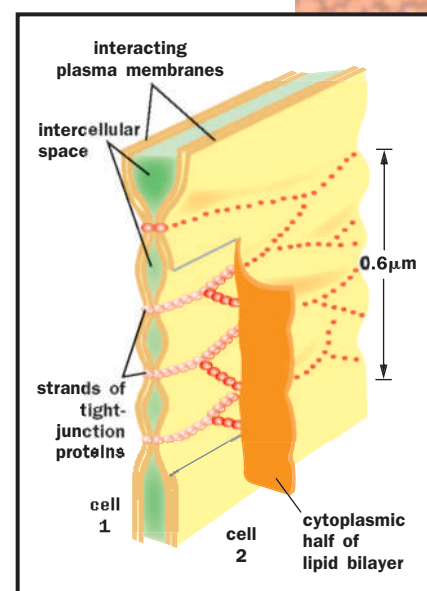

A model of a tight junction. It is thought that the strands that hold adjacent plasma membranes together are formed by continuous strands of transmembrane junctional proteins across the intercellular space, creating a seal.

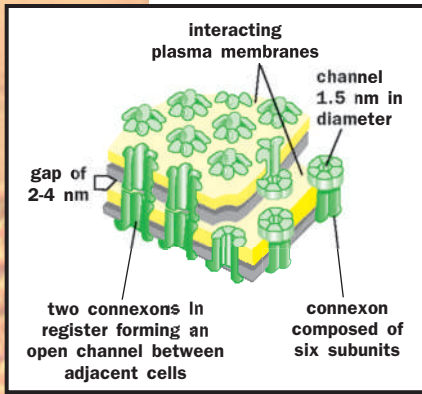

Model of a gap junction. The lipid bilayers are penetrated by protein assemblies called connexons. Two connexons join across the intercellular space to form a continuous aqueous channel that links the two cells.

**cytoskeleton** internal scaffolding in a cell, composed of protein

**transduce** to convert a signal of one type into another type

**keratin** a major structural protein

**integrins** a family of transmembrane linking proteins

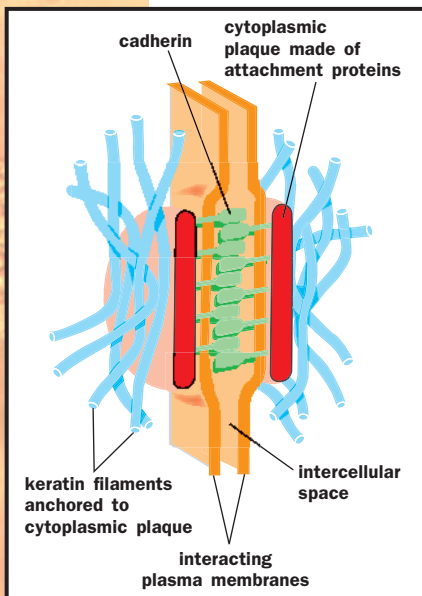

Schematic drawing of a desmosome.

each gap junction whose opening or closing can be controlled locally in the cell. Gap junctions unite muscle cells in the heart to help coordinate their contraction.

### Adherens Junctions and Focal Contacts

Adherens junctions (sometimes called zonula adherens) are found at sites of cell-cell interaction. Focal contacts mediate association of cells with the extracellular matrix. Both associate with the actin **cytoskeleton** and both are involved in adhesion (sticking cells together or sticking cells to surfaces). Focal contacts possess specific transmembrane receptors of the integrin family that link the cell to the extracellular matrix on the outside of the cell and the microfilament system on the inside. Conversely, members of a family of calcium ion-dependent cell adhesion molecules, called cadherins, mediate attachment between cells at adherens junctions. Adherens junctions and focal contacts not only tether cells together or to the extracellular matrix, but they also **transduce** signals into and out of the cell, influencing a variety of cellular behaviors including proliferation, migration, and differentiation. In fact some protein components of these junctions can shuttle to and from the nucleus where they are thought to play a role in regulating gene expression.

### Desmosomes and Hemidesmosomes

Desmosomes (the macula adherens) and hemidesmosomes are distinguished by their association with the **keratin**-based cytoskeleton. Despite their names, desmosomes and hemidesmosomes are distinct at the molecular level. Both are primarily involved in adhesion. The desmosome, like the adherens junction, possesses calcium ion-dependent cell adhesion molecules that interact with similar molecules in the adjacent cell. Meanwhile, **integrins** at the core of the hemidesmosome mediate its interaction with the extracellular matrix. The hemidesmosome and, most likely, the desmosome are also sites of signal transduction. SEE ALSO CYTOSKELETON; EXTRACELLULAR MATRIX; PLASMA MEMBRANE

*Jonathan Jones*

#### Bibliography

Alberts, Bruce, et al. *Molecular Biology of the Cell*, 4th ed. New York: Garland Publishing, 2000.

## Cell Motility

Cells exhibit a wide range of movement. These movements include migration of cells along a surface or through a tissue, or movement of components within cells. Specific examples of cell motility include:

- movement of cells from one location in an embryo to another during embryonic development
- migration of cells into a wound during wound healing
- contraction of a muscle cell that is the fundamental process responsible for muscle contraction
- separation of a cell into two daughter cells during cell division

- movement of membrane-bound **vesicles** into cells during **phagocytosis** or endocytosis
- movement of membrane-bound vesicle from the cell interior to the cell surface during **secretion**
- movement of **chromosomes** during **mitosis**

The first four bulleted points are examples of cell movement, while the last three bulleted points are examples of “intracellular motility.” All of these movements have in common the fact that they are mediated by filamentous structures in the cell called the **cytoskeleton** and are powered by molecular motors that move along these filamentous structures. The simplest example is the movement of membrane-bound vesicles. These vesicles bind to a molecular motor just like a boxcar attaches to a railroad locomotive. The vesicle represents the cargo and the molecular motor represents the locomotive. The molecular motor then moves along the cytoskeletal filament as a locomotive moves along a railroad track. Most forms of **intracellular** movement occur using this mechanism.

A second mechanism is called contraction. This mechanism is responsible for contraction of muscle cells and the separation of daughter cells during cell division. Contraction works through the action of molecular motors pulling on the cytoskeletal filaments, drawing them toward each other. A third mechanism involves the rapid polymerization of the cytoskeleton. In this case the filamentous structures (usually the microfilament cytoskeleton) extend by the addition of subunits to the end. This growth of filaments then pushes out the membrane. This mechanism is responsible for protrusion of the front end of migrating cells.

Moving cells exhibit a special kind of directional movement called “chemotaxis.” This mechanism accounts for the ability of cells to migrate in a specific direction. During chemotaxis, cells move in response to an external signal, most frequently a small molecule or short peptide, called a chemoattractant. Cells sense the concentration of the chemical and move in the direction of increasing concentration of the signal. This directional movement is responsible for much of the cell migration required for tissue formation and for wound healing. Wounded cells, for instance, release chemoattractants that attract immune system cells called macrophages and **connective tissue** cells called **fibroblast**.

For most **eukaryotic cells**, the process of cell movement occurs in several coordinated steps. First, cells extend a structure called a pseudopod (“false foot”) using the polymerization mechanism. Next the pseudopod makes an attachment to the surface along which the cell is moving. This establishes the new front of the cell. A contraction-mediated process provides the force that moves the rest of the cell toward the front and leads to detachment of the trailing end of the cell. When cells are exhibiting chemotaxis they extend pseudopods in several directions, but only make the attachment to the surface in the direction of the highest concentration of the chemical signal.

In contrast, bacterial cells move by the action of an amazing rotary motor called a bacterial flagellum. This flagellum spins like a propeller propelling the cell forward. Bacteria undergo chemotaxis by a process called

**vesicle** membrane-bound sac

**phagocytosis** engulfing of cells or large fragments by another cell, including immune system cells

**secretion** release from the cell

**chromosome** “colored body” in the cell nucleus; made of DNA and protein, and divided functionally into genes and non-gene regions

**mitosis** separation of replicated chromosomes

**cytoskeleton** internal scaffolding in a cell, composed of protein

**intracellular** within a cell

**connective tissue** one of four types of body tissue, characterized by few cells and extensive extracellular material

**fibroblasts** undifferentiated cell normally giving rise to connective tissue cells

**eukaryotic cell** a cell with a nucleus

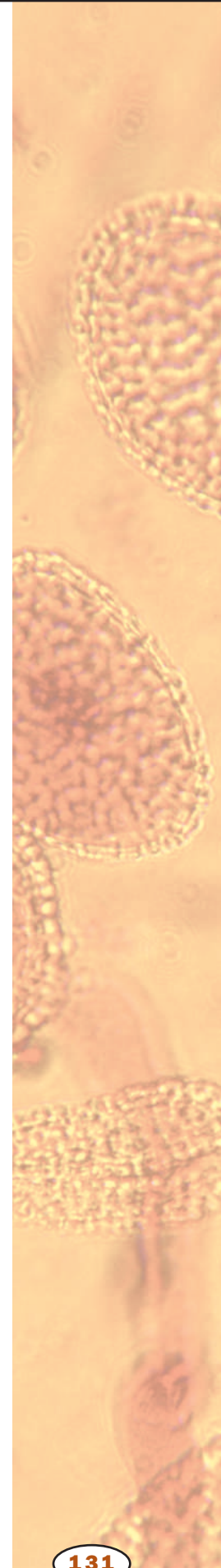

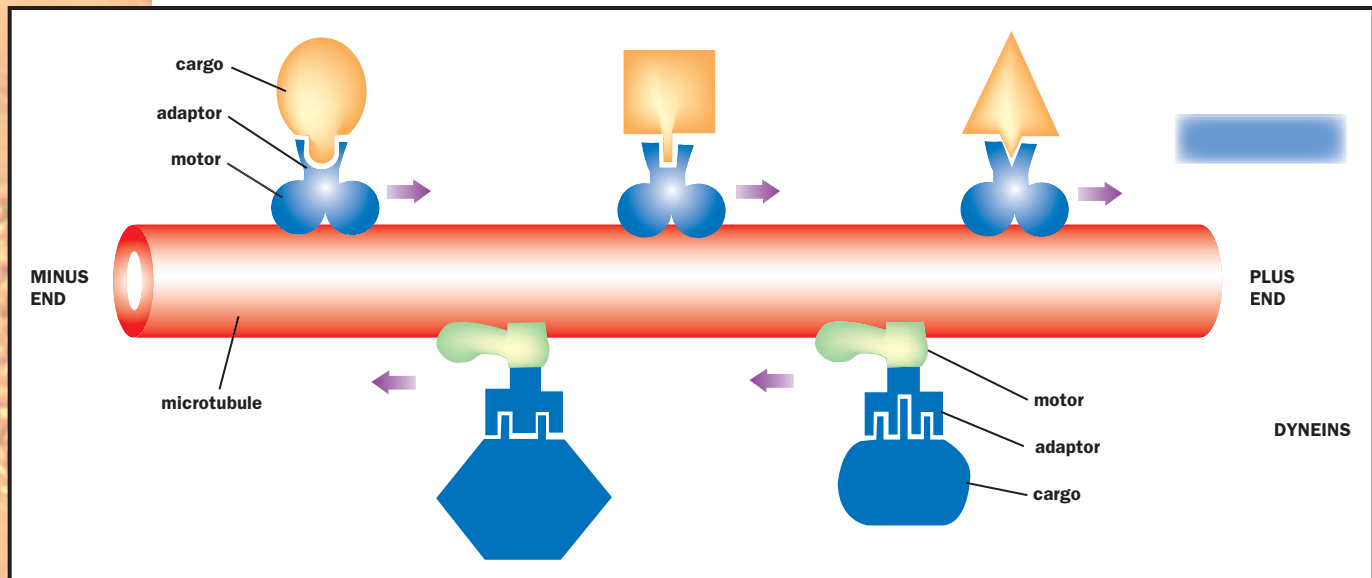

The motor proteins that move along microtubules. Kinesins move toward the plus end, whereas dyneins move toward the minus end.

“tumble and run.” In this process, a bacterial cell tumbles end over end and then “runs,” moving in a single (random) direction for a defined period of time. At the end of that period the cell stops, tumbles again, and measures the concentration of the chemoattractant. If the concentration of chemoattractant is higher than at the last sampling the cell runs for an increased distance. If the chemoattractant concentration is lower, the run distance is shortened and the cell tumbles more frequently. Through this biased process cells preferentially migrate in the direction of higher chemoattractants. SEE ALSO CONNECTIVE TISSUE; CYTOKINESIS; CYTOSKELETON; ENDOCYTOSIS; EXOCYTOSIS; IMMUNE RESPONSE; MITOSIS; MUSCLE

*Rex L. Chisholm*

#### Bibliography

Alberts, Bruce, et al. *The Molecular Biology of the Cell*, 4th ed. New York: Garland Publishing, 2000.

Bray, Dennis. *Cell Movements*. New York: Garland Press, 1992.

Lodish, Harvey, et al. *Molecular Cell Biology*, 3rd ed. New York: Scientific American Books, 1995.

**matrix** a network, usually of threadlike fibers

**protein** complex molecule made from amino acids; used in cells for structure, signaling, and controlling reactions

**carbohydrates** sugars, starches, and other molecules combining carbon, hydrogen, and oxygen and serving as fuel or structural components

**ion** an electrically charged particle

## Cell Wall

With very few exceptions, all cells are enveloped by an extracellular **matrix** composed of **proteins**, **carbohydrates**, and other substances. Owing to its exceptional strength and its ability to control cell shape, the extracellular matrix of eubacteria, algae, fungi, and plants is called the cell wall. The composition of cell walls varies widely among these kingdoms and the species within them, but the central functions are similar for most organisms.

Cell walls provide rigidity and protection. For multicellular organisms, the cell wall also binds different cells together. Plants use their cell wall as part of their system for maintaining their shape and stiffness. The plant concentrates **ions** and other substances within the cell, which pulls in wa-

ter by **osmosis**. The cell swells, pressing tightly against the cell wall. The swelling increases rigidity, or **turgor**, while the wall keeps the cell from bursting.

## Eukaryotic Cell Walls

Eukaryotic organisms, such as algae, fungi, and higher plants, have multi-layered cell walls composed in large part of either **cellulose** or **chitin**. Cellulose and chitin are **polysaccharides**, meaning they are composed of many linked sugar molecules. Cellulose is a **polymer** of **glucose**, which contains only carbon, hydrogen, and oxygen, while chitin is a polymer of N-acetylglucosamine, a sugar that contains nitrogen as well. Both cellulose and chitin are linear, unbranched polymers of their respective sugars, and several dozen of these polymers are assembled into large crystal-like cables, called microfibrils, that spool around the cells.

Cellulose microfibrils form the scaffold of all plant cell walls. At least two types of primary walls are found among the species of flowering plants (angiosperms). In the Type I walls of **eudicots** and some monocots, the microfibrils are tethered together by sugars called xyloglucans, and this framework is embedded in a gel of **pectins**, another type of polysaccharide. The pectins establish several of the wall's physical characters, such as electrical charge, density, porosity, **enzyme** and protein distribution, and cell-to-cell **adhesions**. Pectins are used commercially to thicken jellies and jams. The Type II walls of cereal grains and other monocot relatives tether the microfibrils with different sugars, and is relatively pectin-poor. The hardness of wood comes from **lignin**, which is impregnated between the cellulose microfibrils. Lignin is a phenolic compound, chemically related to benzene.

The cell walls of fungi are diverse among the taxonomic groups, but most contain chitin microfibrils embedded in a polysaccharide matrix and covered with a loose coating of additional molecules combining sugars and peptides (amino acid chains). However, the cell walls of the Oomycetes contain cellulose instead of chitin. Different groups of fungi can be distinguished partly by the composition of their cell wall components.

Cellulose forms a substantial part of the microfibrillar framework of most algae, although some contain other polysaccharides instead. These microfibrillar networks are embedded in a thick gel of polysaccharides of immense diversity. Three important classes of algae, the Chlorophyceae (green), Rhodophyceae (red), and Phaeophyceae (brown), can be distinguished to a certain extent based on their polysaccharide constituents. Alginic acid and fucans are found in brown algae, whereas agarose and carrageenan are found predominately in red algae. Several of these polysaccharides are used as thickening and stabilizing agents in a variety of foods.

## Bacterial Cell Walls

In eubacteria, the cell wall is composed of one or more layers of a peptidoglycan, called murein. A peptidoglycan is a combination of peptides and sugars. Murein is composed of the sugars N-acetylglucosamine and N-acetylmuramic acid. To murein are linked peptide extensions that are cross-linked to form the netlike wall. The antibiotic penicillin shuts down the enzyme that creates these cross-links, thus preventing bacterial growth.

**osmosis** passage of water through a membrane in response to concentration differences

**turgor** internal pressure

**cellulose** carbohydrate made by plants and some other organisms; part of the cell wall

**chitin** nitrogen-containing carbohydrate found in arthropod exoskeletons and fungus cell walls

**polysaccharide** carbohydrate composed of many individual units of sugar

**polymer** molecule composed of many similar parts

**glucose** simple sugar that provides energy to animal cells and is the building block of cellulose in plants

**eudicot** "true dicot"; plants with two seed leaves that originated from the earliest of flowering plants

**pectin** carbohydrate in plants that forms crosslinks to stabilize cell walls

**enzyme** protein that controls a reaction in a cell

**adhesion** attachment; sticking to the surface of

**lignin** organic molecule used in plant cell walls to add stiffness to cellulose

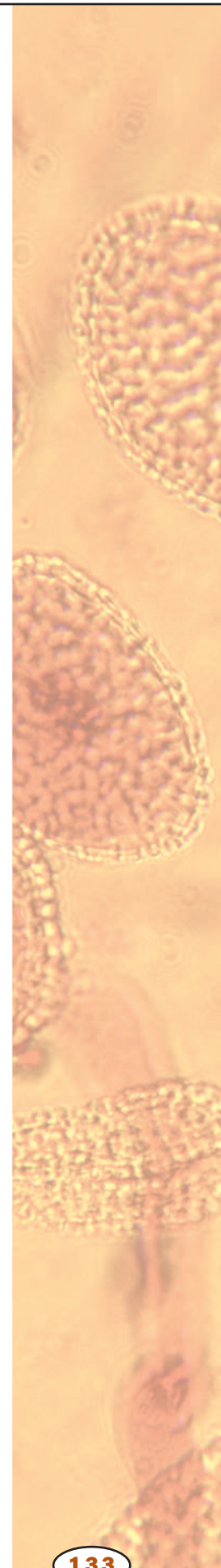

**polypeptide** chain of amino acids

**complex carbohydrates** molecules formed by linking simpler carbohydrates such as sugars

**motor neuron** nerve cell that controls a muscle or gland

**ventral to** toward the belly side

**dorsal to** to the back of

**efferent** conducting outward or directing away from

**peripheral** outside the central nervous system (brain and spinal cord)

**neuron** nerve cell

Many bacteria produce a capsule to the exterior of the murein wall, composed of a diverse selection of molecules, including **polypeptides** and several **complex carbohydrates**, which may include cellulose. Bacteria with this outer capsule do not absorb a particular dye, called Gram stain, and therefore known as Gram-negative bacteria. Bacteria lacking the outer capsule do absorb the dye and are called Gram-positive bacteria. The Gram stain is a basic tool for identifying bacteria. *Escherichia coli* bacteria in the human large intestine are Gram-negative bacteria.

In contrast to eubacteria, archaea possess a pseudomurein wall, with a different set of sugars, no D-amino acids, and exterior layers of proteins, glycoproteins, and polysaccharides similar to those found in higher organisms. SEE ALSO AMINO ACID; ANGIOSPERMS; ARCHAEA; EUBACTERIA; EXTRACELLULAR MATRIX; FUNGI, PLANT; HOMEOSTASIS; PROTISTA

*Nicholas C. Carpita*

**Bibliography**

Alberts, Bruce, et al. *Molecular Biology of the Cell*, 4th ed. New York: Garland Publishing, 2000.

**Cellular Respiration** See *Glycolysis, Krebs Cycle, Oxidative Phosphorylation*

**Central Nervous System**

The central nervous system (CNS) consists of a brain and spinal (nerve) cord. Most invertebrates and all vertebrates have sensory and **motor neurons** that are linked by way of a CNS. Most invertebrates have a CNS that is organized into a brain and a longitudinal nerve cord that is **ventral to** the digestive system, whereas chordates have a spinal cord that is hollow and **dorsal to** the digestive system. The CNS processes input from the internal and external environments, integrates information, and controls the body's responses through **efferent** pathways to the body.

The brain is protected by the skull in vertebrates. The head is usually first to make contact with changes in the environment (for example, changes in light through the eyes, sound through the ears, and olfactory encounters through the nose), so it is beneficial to have the information-processing tissues of the nervous system concentrated there.

The nerve cord, or spinal cord, serves as a connection between the **peripheral** nerves and the brain. It receives sensory information from the periphery, relays it to the brain for interpretation and feedback, and coordinates many reflexes. It also contains the cell bodies of many of the **neurons** that control the body's glandular and muscular responses by way of the peripheral nervous system. SEE ALSO BRAIN; NERVOUS SYSTEMS; NEURON; PERIPHERAL NERVOUS SYSTEM; SPINAL CORD

*Barbara Cocanour*

**Bibliography**

Raven, Peter H., and George B. Johnson. *Biology*, 5th ed. Boston: McGraw-Hill, 1999.  
Walker, Jr., Warren F., and Karel F. Liem. *Functional Anatomy of the Vertebrates: An Evolutionary Perspective*, 2nd ed. Orlando, FL: Saunders College Publishing, 1994.

## Chemoreception

The detection of chemicals by smell, taste, or other means is generally known as chemoreception. A phenomenon that occurs widely in nature, chemoreception is found in the simple chemotaxis of a **motile** bacterium toward food as well as the more complex interpretative pathways associated with an animal's ability to smell and taste.

Chemicals detected by chemoreception are small molecules that can readily diffuse through a fluid. Airborne odor molecules must be small enough to become **volatile** (less than 400 molecular mass), and taste molecules are generally soluble in **aqueous** solutions. Detection of a specific molecule occurs on the outer surface of a receptor cell at a plasma membrane **protein** known as chemoreceptor. Generally, a chemoreceptor will detect just a single chemical or a small range of structurally similar chemicals. Detection elicits a series of biochemical changes inside the receptor cell. The response of the receptor cell may signal yet other cells in multicellular organisms such as animals or cause a response unique to the sensing cell.

### Chemotaxis

Chemoreception that leads to movement of a cell or organism is known as chemotaxis. For example, a simple motile bacterium responds by swimming toward food molecules released by a decomposing organism. In this example of chemoattraction, the bacterium follows an increasing concentration of food molecules to their source. Conversely, the same bacterium might swim away from repellant chemicals released from an unfavorable environment.

In other cases a cell's movement may simply be a change in its shape. For example, in the mating of the single-celled yeast, the nonmotile yeast cells of opposite mating types respond to their mutual detection of **complementary pheromones** by elongating toward each other. Chemotaxis also plays an important role in chemically directed movement of cells during mammalian development and in human immune cells as they migrate toward invading bacteria near the site of an infected wound.

### Smell

The ability to smell odor molecules is known as olfaction. Scientists have estimated that humans can sense over ten thousand different types of smells and that their detection can influence mood, memory, emotions, mate choices, and the immune and **endocrine** systems.

Olfaction begins with the extremely sensitive detection of odor molecules by one or more of the 12 million receptor cells that line the nasal cavity. Covering this olfactory **epithelium** is a mucous **secretion** that may hold some of the more **hydrophobic** odors to be detected. The chemoreceptors of the olfactory receptor cells are located on nonmotile **cilia** projecting into the mucous layer. At the other end of these receptor cells are **axons** that project up through the skull and terminate in the two olfactory bulbs near the front and base of the cerebral hemispheres. From there, olfactory nerve tracts project to the limbic system (an ancient region of the brain concerned

**motile** able to move

**volatile** easily vaporized

**aqueous** watery or water-based

**protein** complex molecule made from amino acids; used in cells for structure, signaling, and controlling reactions

**complementary** matching opposite

**pheromone** molecule released by one organism to influence another organism's behavior

**endocrine** related to the system of hormones and glands that regulate body function

**epithelium** one of four tissue types found in the body, characterized by thin sheets and usually serving a protective or secretory function

**secretion** material released from the cell

**hydrophobic** "water hating," such as oils

**cilia** short hairlike cell extensions of the cell membrane formed by the cytoskeleton

**axon** long extension of a nerve cell down which information flows

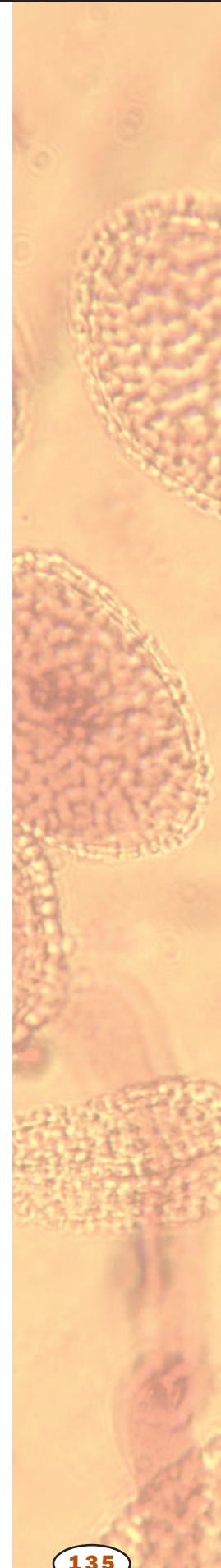



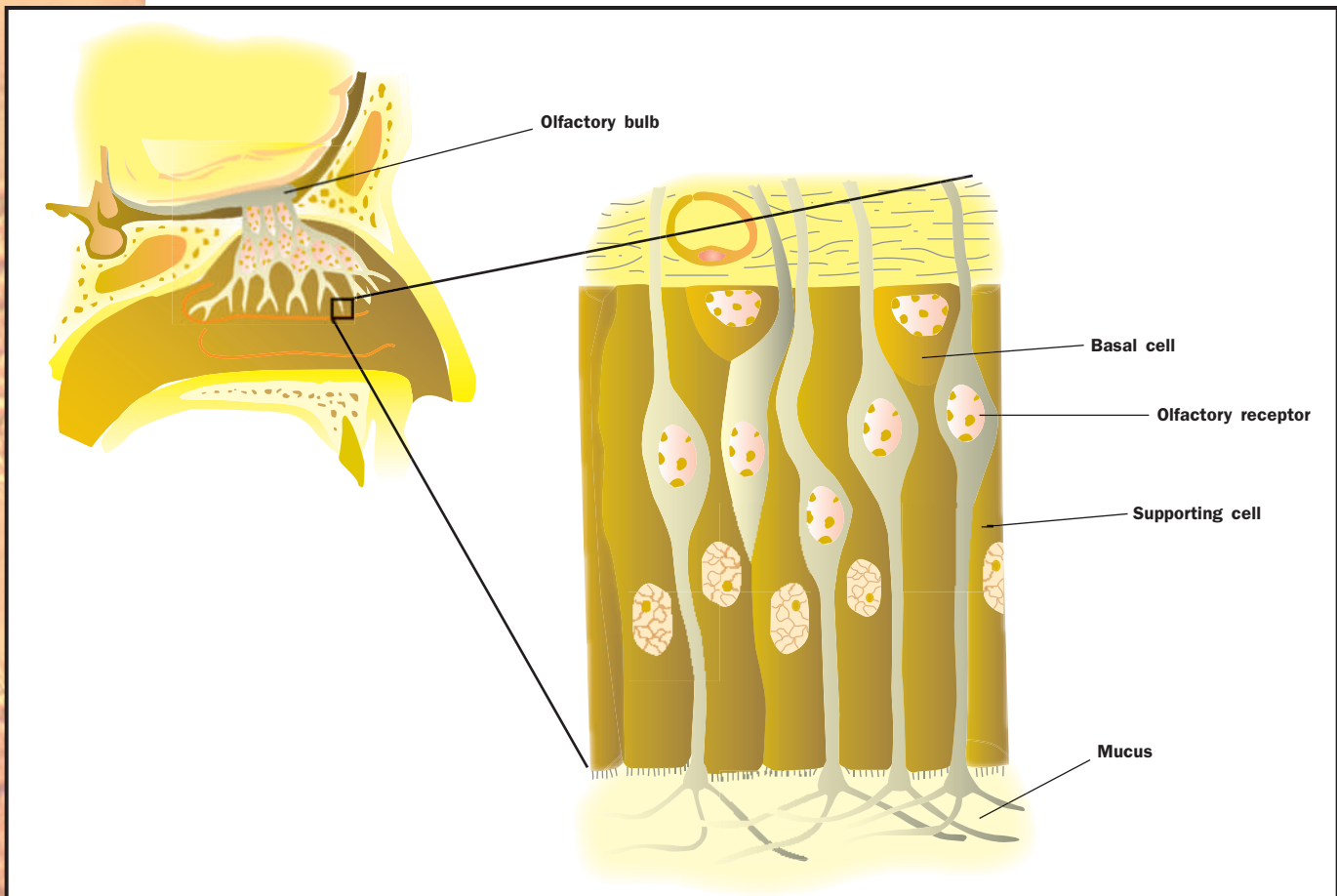

The olfactory epithelium.

**cranial** related to the cranium, or brain cavity

**anterior** toward the front

**posterior** toward the back

**pharynx** throat

with motivation, emotion, and certain kinds of memory) and to the thalamus and then to the frontal cortex for recognition of the odor.

## Taste

Gustation is the sense of taste. The tongue is the major organ associated with gustation, and it is the tongue's taste buds that sense the majority of chemicals dissolved in saliva. During gustation receptor cells in taste buds and elsewhere respond and make synaptic contact with **cranial** nerves VII (serving the **anterior** two-thirds of the tongue), IX (serving the **posterior** one-third of the tongue), or X (serving parts other than the tongue, for example, the epiglottis and **pharynx**). From there cranial nerve fibers project to the thalamus and then the primary gustatory cortex in the lower parietal lobe of the cerebrum. It is at this final location that the taste is recognized. Commonly recognized tastes are salty, sweet, bitter, sour, and umami (a meaty taste). The flavor of food and drink, often associated solely with taste, is actually a combination of the gustatory and olfactory processes. SEE ALSO BRAIN; IMMUNE RESPONSE; SIGNALING AND SIGNAL TRANSDUCTION

*Michael L. Gleason*

## Bibliography

Finger, Thomas E., Wayne L. Silver, and Diego Restrepo. *The Neurobiology of Taste and Smell*, 2nd ed. New York: John Wiley & Sons, 2000.

*Gustation: The Sense of Taste*. North Carolina State University Online. <<http://www.csa.com/crw/web/web-taste.html>>.

*Olfaction: The Sense of Smell.* North Carolina State University Online. <<http://www.csa.com/crw/web/web-smol.html>>.

Smith, David V., and Robert F. Margolskee. "Making Sense of Taste." *Scientific American* 284, no. 3 (March 2001): 32–39.

## Chloroplast

Chloroplasts are the source of virtually all of the world's food and fuel and much of its oxygen supply, and as such life on Earth depends on them. They are a vital component of all photosynthetic cells in plants and algae, and are unique to them. What makes them so important is that they are the sites of photosynthesis, from the absorption of light by chlorophyll through to the production of the first simple sugars. It is chlorophyll that gives them their characteristic green color. They are present in all green-colored cells of a plant; not only in leaves, but also in green stems and green parts of a fruit (for example, in an apple peel).

Chloroplasts are approximately 4 to 6 micrometers in diameter and shaped like a satellite dish with the concave face toward the light. This shape, together with their alignment along the inner surface of the cell, maximizes their ability to capture light. Depending on the plant species there can be as many as two hundred chloroplasts in a cell.

A chloroplast is enclosed by two membranes, which together are termed the "envelope." Inside are two distinct features: a complex organization of folded and interconnecting membranes, called the thylakoids, and a **protein**-rich fluid region called the stroma. The proteins and pigments (chlorophyll and carotenoids) involved in the light reactions of photosynthesis are located on the thylakoid membranes. The **enzymes** involved in the conversion of carbon dioxide to simple sugars (the "dark reactions") are found in the stroma. Together these reactions convert carbon dioxide and water to sugars and oxygen.

As well as in making sugars, chloroplasts are important in making other essential plant products, such as fats, oils, scents, and proteins. They can

**protein** complex molecule made from amino acids; used in cells for structure, signaling, and controlling reactions

**enzyme** protein that controls a reaction in a cell

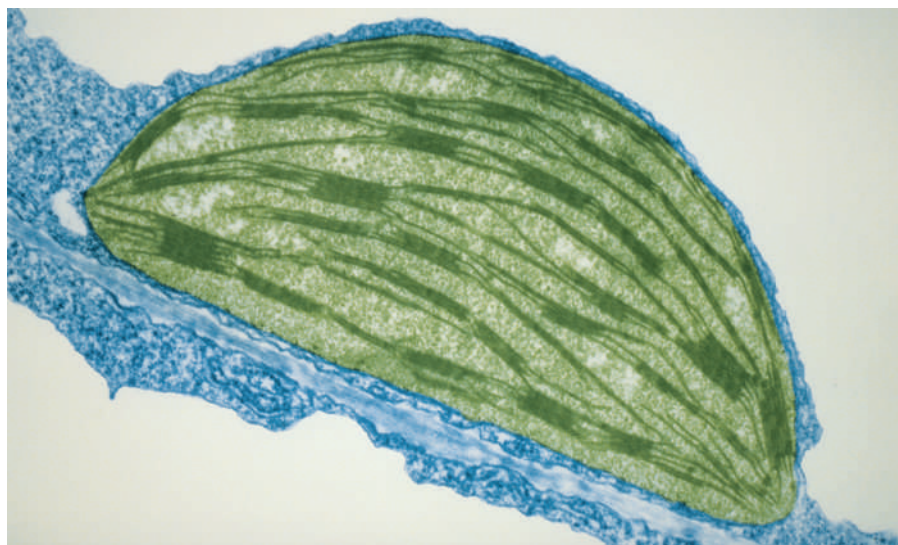

A false-color transmission electron micrograph of a chloroplast from a tobacco leaf.

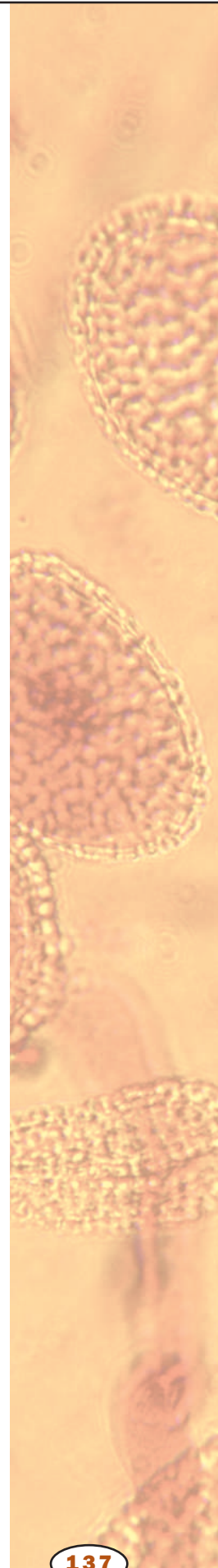

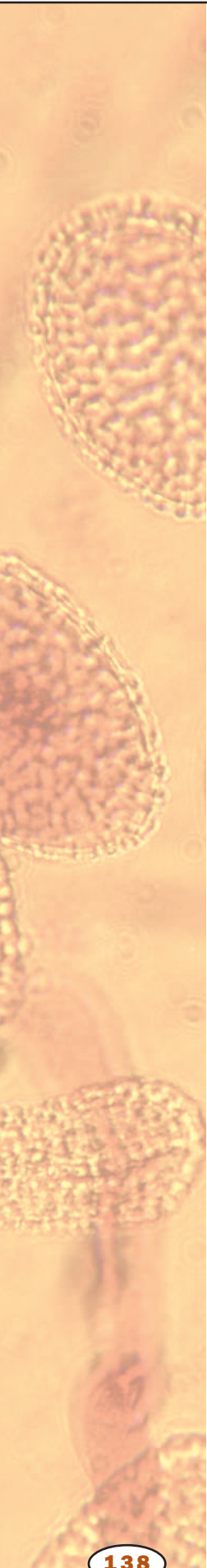

**nucleus** membrane-bound portion of cell containing the chromosomes

**gene** portion of DNA that codes for a protein or RNA molecule

even make many of the proteins needed to produce another chloroplast. They are thought to have been originally free-living, single-celled photosynthetic bacteria, which became engulfed in a nonphotosynthetic host cell. At first, the two cells lived symbiotically, where each was an individual organism that derived some benefit from the other. Eventually, through evolution, the bacteria lost more and more of their ability to live independently and became the chloroplasts we recognize today.

Many pieces of evidence support the endosymbiotic theory. Chloroplasts, for example, contain deoxyribonucleic acid (DNA), the entire sequence of which has been determined in a number of species. Chloroplast DNA codes for a number of essential chloroplast proteins. Over time, large parts of the DNA of the original bacterium have found their way into the **nucleus** of the host cell, giving it control over many of the functions and features of the chloroplast. **Genes** involved in controlling the division, and hence “reproduction,” of the chloroplast are now present in the nucleus. The composition of the DNA and the way in which it is translated resembles that of bacterial cells, adding further support to the endosymbiotic origin of chloroplasts. SEE ALSO CELL EVOLUTION; LEAVES; PHOTOSYNTHESIS

*Alyson K. Tobin*

#### **Bibliography**

Raven, Peter H., Ray F. Evert, and Susan E. Eichhorn. *Biology of Plants*, 6th ed. New York: W. H. Freeman and Company, 1999.

## **Chordata**

Chordata is a large and diverse group of animals, with roughly 50,000 living species included. The majority of chordates belong to a group called Vertebrata. Vertebrates have backbones that are composed of vertebrae. Some examples of vertebrates are sharks, fish, dinosaurs, and human beings.

A second group of chordates, called Urochordata, consists of animals found mostly in oceans. Urochordates include sock-shaped pyrosomes that grow up to 10 meters (32.8 feet) long, sack-shaped sea squirts that live attached to the seafloor, and tadpole-shaped larvaceans that build their floating houses out of mucus.

All of these assorted chordates are united because they are descended from a common ancestor that had three features that were passed on to all of its descendants. These three characteristics can be used to distinguish chordates from other animals.

First, chordates have a collection of nerve fibers, called a nerve cord, which runs down their back sides connecting the brain to the organs and muscles. The second characteristic is a notochord, which is a stiffened rod that runs underneath the nerve cord. The notochord is used by many chordates as an aid for swimming. Muscles pull the notochord one way and then it springs back, propelling the chordate forward through the water.

Finally, all chordates have pharyngeal slits, a set of openings behind the head that connect directly to the throat. Some chordates use their pharyngeal slits to filter food out of water sucked in through their mouths. Other chordates have modified pharyngeal slits, called gills, that are used to get oxygen out of water. Human beings, like other land-dwelling chordates, only have pharyngeal slits as an embryo. During a baby's development they are modified into parts of the inner ear. SEE ALSO ANIMALIA; TAXONOMY

Allen G. Collins

### Bibliography

Newman, H. H. *The Phylum Chordata: Biology of Vertebrates and Their Kin*. New York: Macmillan, 1939.

Ruppert, Edward E., and Robert D. Barnes. *Invertebrate Zoology*, 6th ed. Fort Worth, TX: Saunders College Publishing, 1996.

Weichert, Charles K. *Elements of Chordate Anatomy*, 3rd ed. New York: McGraw-Hill, 1967.

## Chromosome Aberrations

Chromosome aberrations are departures from the normal set of chromosomes either for an individual or from a species. They can refer to changes in the number of sets of chromosomes (ploidy), changes in the number of individual chromosomes (somy), or changes in appearance of individual chromosomes through mutation-induced rearrangements. They can be associated with genetic diseases or with species differences.

### Trisomy

Chromosome number, size, and shape (X-shaped or V-shaped) are fixed for each species. In most animals, chromosomes are present in pairs, called **homologous** pairs, carrying similar genes. Each chromosome pair carries a distinctive set of genes. Genes code for **proteins**, and the amount of protein produced in a cell from a particular gene is proportional to the number of functional gene copies present.

Trisomy refers to having three copies of one chromosome. It arises through the chromosomal accident of nondisjunction during **meiosis**, which sends two copies of a particular chromosome into a sperm or egg, rather than one. An individual with a trisomy who survives to be born produces more of the gene products encoded on the trisomic chromosome. The resulting genic imbalance almost always severely impairs growth. Trisomy of the twenty-first chromosome, the smallest in humans, is the cause of Down syndrome, which is associated with mental retardation, **congenital** heart disease, accelerated aging, and characteristic facial features. Trisomy that occurs after **fertilization**, during fetal development, results in a "mosaic" individual with only some trisomic cells in the body. Such individuals may display some but not all of the features of the syndrome.

Trisomics for different chromosomes result in different abnormal characteristics. In humans, trisomies 13 and 18 are associated with different birth defects. While these individuals do not live long after birth, trisomies for

**homologous** similar in structure

**protein** complex molecule made from amino acids; used in cells for structure, signaling, and controlling reactions

**meiosis** cell division that forms eggs or sperm

**congenital** present at birth; inherited

**fertilization** union of sperm and egg

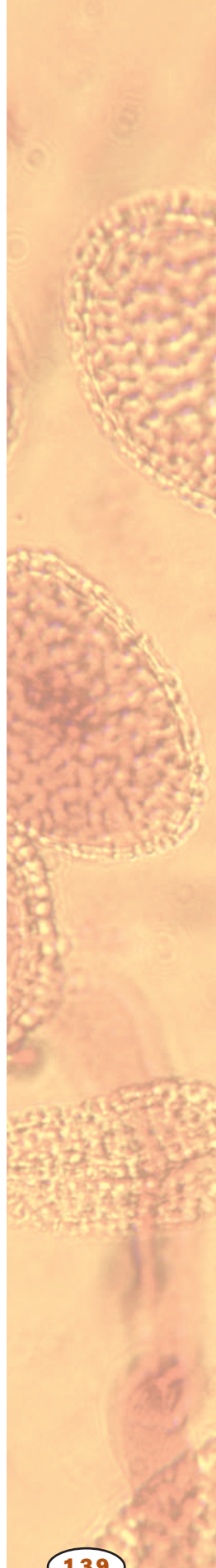

**phenotype** observable characteristics of an organism

**oncogene** gene that causes cancer

**progeny** offspring

**heterozygous** characterized by possession of two different forms (alleles) of a particular gene

**gamete** reproductive cell, such as sperm or egg

**centromere** region of the chromosome linking chromatids

**zygote** fertilized egg

any of the other non-sex chromosomes die before birth. Monosomies (having only one copy) for any chromosome also do not survive fetal existence, except for the sex chromosomes X and Y. Sex chromosome trisomies and monosomy for the X chromosome are associated with less severe effects on the **phenotype**.

## Translocations

Translocations are the result of a chromosomal-level mutation, with two different (nonhomologous) chromosomes breaking and rejoining, placing the genes from one part of the one chromosome with part of the second chromosome, and vice versa. The number of genes is unchanged. Occasionally, the breakpoint mutation interrupts and inactivates the gene located at that chromosomal site. In other cases, the juxtaposition of new deoxyribonucleic acid (DNA) sequences from the other chromosome next to a gene at the breakpoint results in inappropriate expression. This action may activate an **oncogene**, for example. The “Philadelphia chromosome” is a translocation that fuses parts of chromosomes 9 and 22, which produces a new gene product that functions as an oncogene called Abl, which is implicated in chronic myelogenous leukemia.

Inherited translocations are passed through generations in a codominant fashion. Since one copy of each chromosome remains normal, both parent and **progeny** with such a translocation are **heterozygous**, or “balanced” carriers. Half their **gametes** will include one copy of each gene, either on the translocated chromosomes or their normal homologs. The other half, however, are unbalanced with some combination of translocated and normal homologs. The result is that the gamete has two copies of some genes, but no copies of other genes, from the translocated chromosomes. Such an “unbalanced” gamete, if it takes part in fertilization, often disrupts development so greatly that the individual does not survive to be born. If the number of unbalanced genes is low, however, children may be born, but often they have growth defects and mental retardation. Couples with recurrent spontaneous abortions may have one partner carrying a balanced translocation. Thus, gene copy number determines the specific phenotypes associated with a translocation, or with any chromosome aberration. Extreme examples of the importance of gene number are triploidy ( $3n = 69$  for humans) and tetraploidy ( $4n = 92$ ). These individuals nearly always die early in fetal life and are detected only in the remains of early spontaneous abortions. However, intolerance of polyploidy may be a mammalian phenomenon. It is common among plants, and frogs that are triploid are both viable and fertile.

Robertsonian translocations are a special class that result from the fusion of two V-shaped chromosomes at their **centromere** ends to form a single X-shaped chromosome. Individuals who are balanced for this translocation have forty-five chromosomes, but are otherwise normal. However, during gamete formation, some gametes will become unbalanced, and their progeny are at risk for being aneuploid (without the correct set of genes). If the two fused chromosomes are homologs, then the risk is 100 percent that the **zygote** will be aneuploid since it will either have too few or too many genes. If nonhomologs are fused, the risk is usually 50 percent. About 5 percent of Down syndrome cases are caused by Robertsonian translocations.

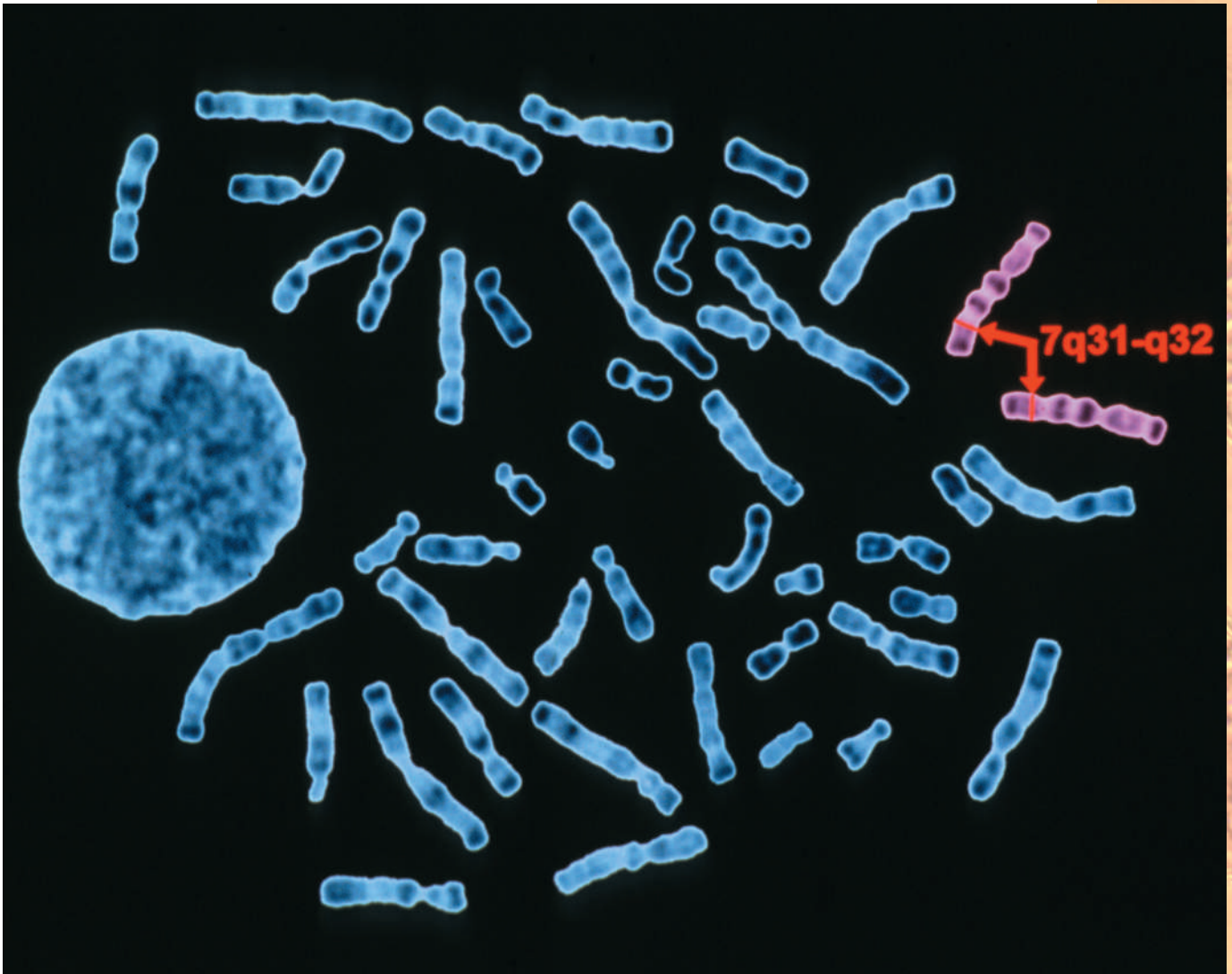

Chromosome fusions or exchanges at the centromere position can often be correlated with differences between closely related species. The great apes (chimpanzees and gorillas) have forty-eight chromosomes, for example. Their chromosome constitution differs from humans only in having one fewer small X-shaped chromosome pair and two additional small V-shaped pairs. At some point in our past, the V-shaped pairs fused at the centromeres to form the X-shaped pairs. Using DNA sequences that are conserved among vertebrate species as position markers, it is possible to create comparative maps of conserved blocks of genes. All mammalian X chromosomes are alike in the genes present, for instance. Thus, changes visible at the chromosome level are useful markers to follow the evolutionary relatedness of different species. Further comparison of conserved sequences suggests the vertebrate **genome** is a tetraploid (four-copy) version of the invertebrate genome.

### Polyploidy

Changes in ploidy are of evolutionary importance in the flowering plants (angiosperms). Tetraploid plants often grow faster and larger than the **diploid** plants they derive from, and tend to be selected for agriculture. Alfalfa, cof-

A photomicrograph of human chromosomes showing a mutation on gene 7, which is responsible for cystic fibrosis.

**genome** total genetic material in a cell or organism

**diploid** having pairs of chromosomes in the nucleus

A digital image of multipolar and bipolar spindles from T84 colonic cancer cell cultures.

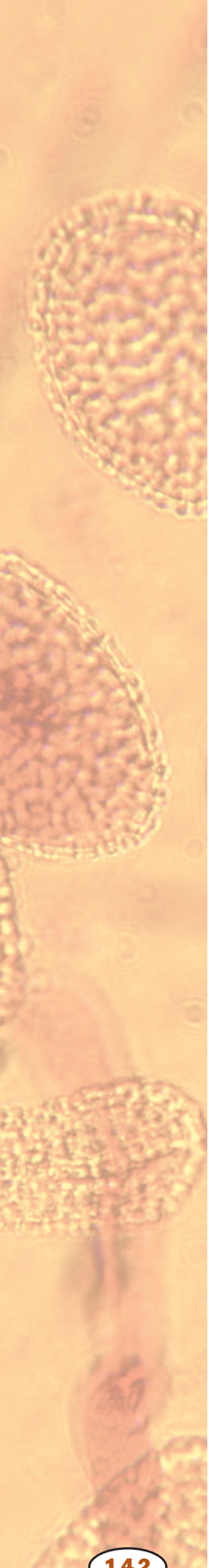
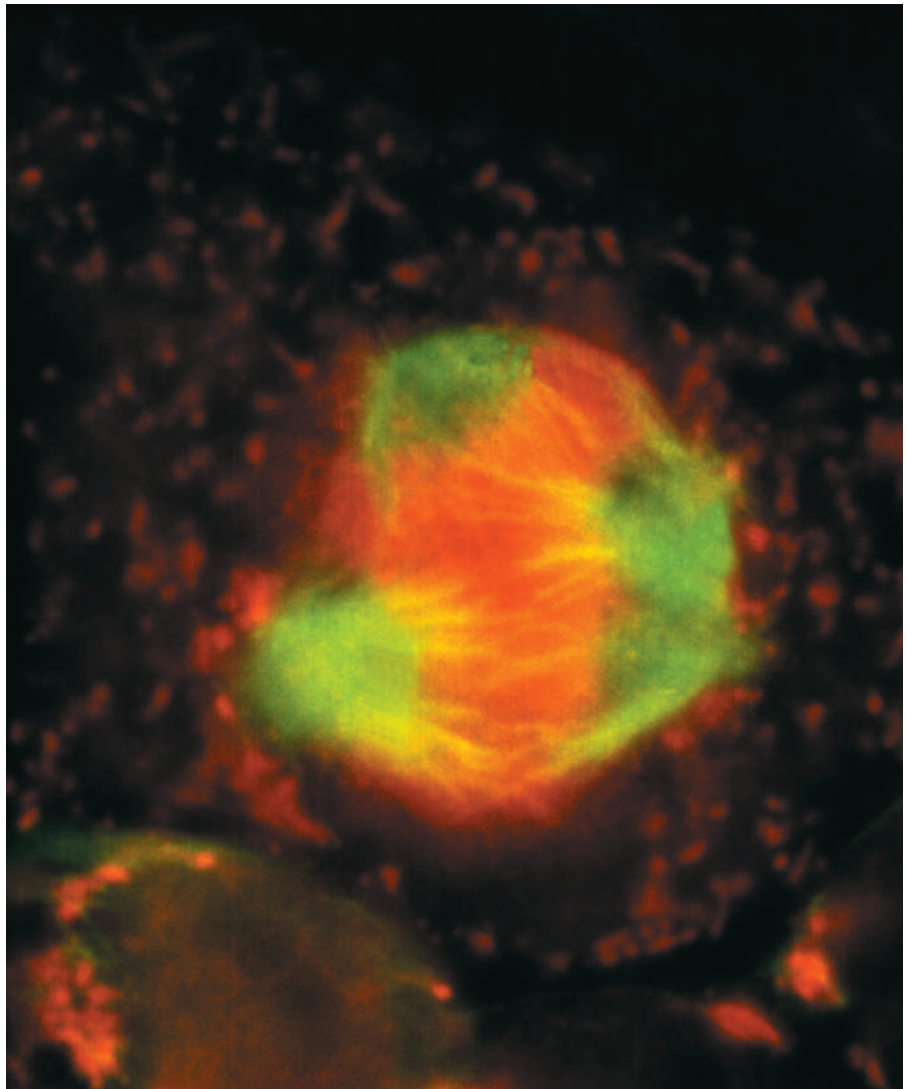

**hybrid** combination of two different types

**lysine** an amino acid

fee, wheat, peanuts, and potatoes are some examples. Commercially grown strawberries are octaploids (eight chromosome sets). Triploid plants, formed by crossing tetraploid with related diploid species, are almost always sterile because their aneuploid seeds abort. Seedless watermelons and bananas are examples of this technique used to improve fruit for human consumption.

An example of plant polyploidy that affected human civilization and history is the origin of wheat. Modern bread wheat, cultivated for about eight thousand years, is a hexaploid with  $2n = 42$ , formed by sequential **hybrids** formed among three related grass species, each with  $2n = 14$ . To complete the circle, modern hybridizers have created a new species, *Triticale*, by crossing the ancestral Emmer wheat ( $2n = 28$ ) with rye ( $2n = 14$ ) and then doubling the chromosome number to 42 to take advantage of strong wheat growth with the high **lysine** content of rye. DNA analysis is scrutinizing the hybrid origins of many cultivated plants to identify their ancestors. SEE ALSO ANGIOSPERMS; CHROMOSOME, EUKARYOTIC; GENE; GENETIC DISEASES; MUTATION; ONCOGENES AND CANCER CELLS; PATTERNS OF INHERITANCE

*John Merriam*

**Bibliography**

Gardner, R. J. McKinlay, and G. R. Sutherland. *Chromosome Abnormalities and Genetic Counseling*. Oxford: Oxford University Press, 1996.

John, Bernard. *Meiosis*. New York: Cambridge University Press, 1990.

## Chromosome, Eukaryotic

The deoxyribonucleic acid (DNA) of eukaryotic cells carries the blueprint for the biosynthesis of cellular **proteins** and the control of cellular assembly and regulation. If all the DNA in a single human cell were stretched out straight and the strands representing all the chromosomes laid end-to-end, they would extend for well over 1 meter (3 feet). This meter of DNA must fit into a **nucleus** whose diameter is on the order of 10 **microns** ( $10^{-5}$  meter)! The dual problem of how to store this large amount of **genetic** information but also to keep it accessible for use and for faithful maintenance, copying, and distribution to daughter cells during cell division, is solved by using proteins to package the DNA into chromosomes.

During the **cell cycle**, the cell grows (during G1 phase), replicates its DNA (during S phase), prepares for cell division (during G2 phase), and divides by **mitosis** (during M phase). During M phase, each chromosome is duplicated, and each replica remains attached to its original at the **centromere** portion of the chromosome. The two identical strands, called **chromatids**, wind up and become visible under the microscope at the beginning of mitosis. During the portion of mitosis known as **metaphase**, spindle fibers (which attach to the centromeres) jostle the chromatid pairs to the middle of the cell. The two chromatids are then pulled apart and segregated into different daughter cells, ensuring that each new cell has identical genetic information. The cells then enter G1 phase again. The combination of G1, S, and G2 is known as interphase. During interphase, the genes carried on the chromosomes are **transcribed**, to form proteins needed by the cell.

Various proteins act to stabilize DNA in interphase, while additional proteins are required to condense the chromosomes over a thousandfold to form the compact chromosomes required for mitosis and cell division. The sections that follow summarize key concepts concerning the structure of eukaryotic chromosomes.

### Histones and Nucleosomes

Nearly all of the DNA in eukaryotic cells is complexed with a set of small basic proteins called **histones**. (As its name suggests, DNA is acidic, and is attracted to the basic histones.) The complexes form a repeating unit, the nucleosome, which consists of an **octomeric** disc of histones with about two turns of DNA wrapped around the outside. Thus, chromosomal DNA is organized as a string of nucleosome beads with a small amount of DNA connecting each bead. This first level of organization helps to compact the DNA so it can fit into the nucleus while still affording the necessary flexibility to fold the chromosome further; for example, in the **condensation** of chromosomes at metaphase.

The structure of the nucleosome is known at the atomic level through **X-ray crystallography**. The histone proteins interact extensively with one

**protein** complex molecule made from amino acids; used in cells for structure, signaling, and controlling reactions

**nucleus** membrane-bound portion of cell containing the chromosomes

**micron** one-millionth of a meter; also called a micrometer

**genetic** of, relating to the portion of DNA that codes for a protein or RNA molecule

**cell cycle** sequence of growth, replication, and division that produces new cells

**mitosis** separation of replicated chromosomes

**centromere** region of the chromosome linking chromatids

**chromatid** a replicated chromosome before separation from its copy

**metaphase** intermediate stage in cell division, in which chromosomes line up before separating

**transcribe** creation of an RNA copy of a DNA gene

**histone** protein around which DNA wraps to form chromosomes

**octomeric** composed of eight parts

**condensation** compaction of chromosome strands into a tight structure

**X-ray crystallography** use of X rays to determine the structure of a molecule

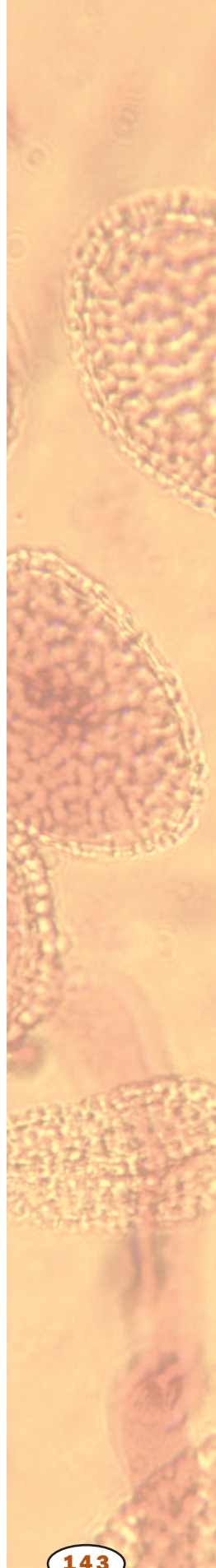



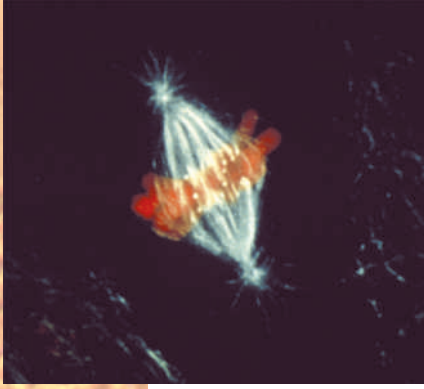

An immunofluorescence photomicrograph of the mitosis metaphase in an animal cell.

**template** master copy

**transcription** messenger RNA formation from a DNA sequence

**catalyze** aid in the reaction of

**acetylation** addition of an acetyl group,  $\text{CH}_3\text{-COO-}$

**lysine** an amino acid

**RNA polymerase** enzyme complex that creates RNA from DNA template

**promoter** DNA sequence to which RNA polymerase binds to begin transcription

**phosphorylation** addition of the phosphate group  $\text{PO}_4^{3-}$

**genome** total genetic material in a cell or organism

**solenoid** cylindrical coiled structure

another to form the compact central disc of the nucleosomes, while specific amino acids have been identified that hold the DNA tightly onto the nucleosome surface. However, about fifteen to twenty-five amino acids at the end of each histone extend outside the compact limits of the central protein core. These tails are invisible in the X-ray structure of the nucleosome, indicating that they are relatively unstructured. (X-ray crystallography can only utilize structures with a high degree of order.) This indicates they can accommodate dynamic interactions with DNA or with adjacent nucleosomes in living chromosomes.

The sequence information encoded in DNA must be accessible to ribonucleic (RNA) polymerases in order to be useful as a **template** for **transcription**. Since the binding of DNA by histones interferes with this access, cells have evolved specific mechanism to destabilize nucleosomes in chromosome regions that must be transcribed. While the details of this important process are still being deciphered, it is clear that there are enzymes in eukaryotic nuclei that can modify nucleosome structure or the structure of individual histones to loosen the histone-DNA contacts, thereby making the DNA available for transcription.

One class of enzyme believed to modify nucleosomes for transcription is the histone acetyltransferases, which **catalyze acetylation** of specific **lysines** in the N-terminal tails of histones. Acetylation of lysines reduces the overall positive charge of the histone protein; since DNA has a net negative charge, histone acetylation may reduce the electrostatic forces holding the DNA on the nucleosome. This is thought to make the DNA more accessible to other DNA-binding proteins such as **RNA polymerase**.

In addition, some transcription regulatory proteins bind more easily to their DNA target sites if the nucleosomes associated with those sites are acetylated. A critical part of the transcription activation mechanism in eukaryotic cells appears to be the specific recruitment of nucleosome remodeling enzymes, such as histone acetyltransferases to **promoters**, thus allowing those promoters to be used more efficiently by RNA polymerase. Histone acetylation, therefore, can increase the transcription rate for a gene. Conversely, cells also possess histone deacetylases. Histone deacetylases may be specifically recruited to shut off genes when they are no longer required.

Another type of histone modification is addition of a phosphate group called **phosphorylation**. Phosphorylation typically causes significant changes in protein structure and activity. Increased histone phosphorylation is correlated with chromosome condensation at the onset of mitosis. The mechanism by which phosphorylation promotes condensation is unclear, but may involve nucleosome-nucleosome interactions, or the binding of nonhistone proteins to nucleosomal DNA as part of the folding of chromosomes for metaphase.

### 30 Nanometer Fiber

The nucleosomal organization of DNA in chromosomes cannot fully account for the degree of compaction necessary to fit the **genome** into the compact nucleus. The nature of these additional levels of DNA folding is controversial, but is believed to include the coiling of nucleosome arrays to form a **solenoidal** structure. Such solenoids have been visualized in elec-

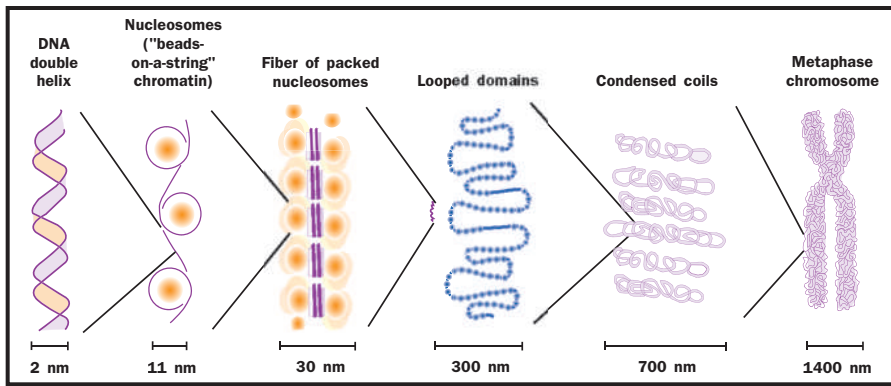

DNA is highly organized and has a structure that allows tight compaction while still allowing access for gene expression.

tron micrographs of eukaryotic chromosomes as fibers of 30 **nanometers** (a nanometer equals one billionth of a meter) in diameter, in contrast to the 10-nanometer diameter of the nucleosome particle itself. In **somatic** nuclei, the 30-nanometer fiber appears to be stabilized by a specific histone, histone H1, which interacts with the DNA-linking adjacent nucleosomes.

**nanometer**  $10^{-9}$  meters; one-billionth of a meter

**somatic** nonreproductive; not an egg or sperm

### Domains and Higher Order Structures

Early electron micrograph images of eukaryotic metaphase chromosomes gave the impression of looped fibers extending out from the central axis of each chromatid. Subsequent analysis by microscopic and biochemical techniques suggests that stretches of chromosome approximately forty thousand to eighty thousand **nucleotide** pairs long may be anchored to a nuclear scaffold or **matrix**. These points of anchorage may serve to organize or spatially restrict chromosomes during interphase. These same anchor points may coalesce at metaphase to condense chromosomes for mitotic segregation.

**nucleotide** the building block of RNA or DNA

**matrix** a network, usually of threadlike fibers

Chromosomes exist to hold genes, of course, and some structural features of the chromosome may serve to separate genes from one another to help regulate transcription. Gene transcription in higher eukaryotes is controlled by regulatory elements that, in some cases, are located hundreds of thousands of nucleotides away from their target promoters. How can such elements be prevented from activating other nearby promoters? Experiments suggest that there are DNA sequences that act as boundaries or barriers to prevent the distant regulatory elements from one gene from contacting the promoters of genes located elsewhere on the same chromosome. In some cases, these genetic domain borders may be equivalent to the nuclear scaffold/matrix anchorage points, but in other cases these activities appear separable.

An average human chromosome contains approximately 240 million base pairs.

### Telomeres, Telomerase, and Cancer

In his studies of chromosome structure, geneticist Herman Muller recognized that the natural ends of chromosomes were peculiar in that they could not be placed at internal sites in chromosomes, and that if they were detached (by breakage with **ionizing radiation**), the resulting chromosome behaved abnormally. He recognized the special properties of chromosome ends by giving them a special name: "telomeres." Scientists now know that the ends of chromosomes have a unique structure and are maintained by a unique mechanism.

**ionizing radiation** high-energy radiation that destroys chemical bonds

A karyotype of human male chromosomes (XY karyotype) with G banding.



**germ line** cells creating eggs or sperm

**ribonucleoprotein** combination of RNA and protein

**reverse transcriptase** enzyme that copies RNA into DNA

**metazoans** animals other than sponges

**in vitro** "in glass"; in lab apparatus, rather than within a living organism

The chromosomes of eukaryotic cells are linear DNA molecules. Because of this fact, and because of the mechanics of normal DNA replication by DNA-dependent DNA polymerases, a small amount of DNA at each end of every chromosome fails to be replicated with every cell cycle in somatic cells. If this loss occurred in the **germ line** as well, all eukaryotes would become extinct after a few generations, as important genes located near the chromosome ends would eventually be lost by the gradual chipping away at the ends. The major way that living cells offset this loss is by adding extra DNA onto one strand using a special enzyme for this purpose called "telomerase." Telomerase is a **ribonucleoprotein** complex, consisting of an RNA-dependent DNA polymerase (also known as a **reverse transcriptase**) and an RNA molecule that serves as a template for DNA synthesis, giving rise to the characteristic repeated DNA sequence of most eukaryotic telomeres. (The fruit fly *Drosophila* is a notable exception to this; it uses transposable elements to maintain its telomeres.)

Telomerase activity in **metazoans** is found primarily in germ cells and at low levels in a few somatic tissues (stem cells that give rise to blood and skin cells that have to be replenished constantly throughout adult life). Normal animal somatic cells that are cultured **in vitro** usually lack telomerase activity. Such cells typically can divide only a finite number of times before they stop proliferating, go into a quiescent state, and eventually die, a process called senescence. Senescence in cultured cells is correlated with loss of telomeric repeats. In general, cancer cells escape senescence and often can proliferate indefinitely in culture; this phenomenon, called immortalization,

is accompanied by the activation of telomerase activity. Although cancer cells are often found to have unusually short telomeres, the length of their telomeres remains stable as the cells continue to proliferate. It is believed that telomerase activation in cancer is essential to continuous tumor growth and **metastasis**. Since most somatic cells have low or undetectable telomerase activity, drugs that specifically inactivate telomerase activity should be potent anticancer drugs with minimal side effects on healthy normal tissue.

**metastasis** breaking away of cancer cells from a solid tumor to travel elsewhere in the body

## Condensation and Decondensation

While chromosomes undergo cycles of condensation and decondensation with entry into and exit from mitosis during the cell cycle, some regions of chromosomes remain condensed throughout most of interphase. This chronically condensed material in the nuclei of all eukaryotic cells was recognized by German cytogeneticist Emil Heitz, who named it “heterochromatin” (in contrast with the “euchromatin,” or “true chromatin”), which disperses with the onset of interphase. The regions surrounding most eukaryotic centromeres is composed of heterochromatin.

Heterochromatin is distinguished from euchromatin by other properties. It replicates late in S phase while euchromatin replicates early in S, and it has the ability to silence euchromatic genes. Biochemical analysis shows that the DNA in heterochromatin is less accessible to a variety of DNA-binding proteins, suggesting that heterochromatin condensation inactivates regions of chromosomes by interfering with the accessibility of DNA for transcription. In mammalian females, one X chromosome is inactivated by heterochromatinization. This is thought to ensure that both males (who have only one X) and females (who have two) have equal “doses” of the many genes carried on the X chromosome.

In mealybugs, the entire paternal genome set is inactivated by heterochromatinization early in development, and therefore mealybugs express only maternally derived genes.

## Classes of DNA

The chromosomes of higher eukaryotes contain classes of DNA sequences that differ in the number of times they are presented in the genome. Much of the DNA in higher eukaryotes is unique, in the sense that the exact linear sequence of nucleotides is found only once per **haploid** chromosome complement. But some DNA sequences are found in a few dozen or a few hundred identical or nearly identical copies in each haploid chromosome set. These are considered “moderately repetitive” DNA sequences, and in most higher eukaryotes include the genes encoding the histones and the ribosomal RNA (rDNA), as well as certain classes of transposable elements. In the case of the repeated histone and rDNA, having many copies of these genes may be important at certain stages of development to allow biosynthesis of large amounts of histone proteins (during S phase) and ribosomal RNA (during ribosomal synthesis) in a short period of time.

**haploid** having single, non-paired chromosomes in the nucleus

The third broad class of DNA found in higher eukaryotic chromosomes is represented in many thousands of copies, and is thus termed “highly repetitive.” Because of the relative abundance and sequence homogeneity of highly repetitive DNA sequences, they were initially isolated from fragmented eukaryotic DNA as “satellites” easily separated from the main mass of DNA. This satellite DNA includes tandem arrays—many copies, one right after another—of a 171-nucleotide pair repeat called “alphoid satellite.” Alphoid satellite DNA is found in tandem arrays of thousands of copies

Extra X chromosomes, as in XXY males or XXX females, are also condensed, to leave only one active X chromosome.

in the centromeres of all human chromosomes. The alphoid repeats are sufficient to confer centromeric properties on artificial human chromosomes. (The centromere region forms the “pinched waist” so characteristic of metaphase chromosomes, and is the site to which the spindle fibers attach to separate daughter chromatids in mitosis.)

The function of other types of highly repetitive sequence DNA is unknown; indeed, some repetitive DNA sequences are thought to be “junk DNA,” present in chromosomes simply because there is no evolutionarily efficient way to eliminate it. Approximately 500,000 copies of a 300-nucleotide-pair sequence called an “Alu sequence” are found in the human genome. Unlike the alphoid satellite, Alu sequences are interspersed throughout all human chromosomes. Alu sequences are **homologous** to portions of the 7SL RNA, a structural component of the signal recognition particle that targets **ribosomes** to the **endoplasmic reticulum**. Alu sequences are probably relics of **reverse transcription** of this RNA into 7SL DNA, which then recombined randomly into chromosomes. Such dispersed repeated DNA sequences are potential sites for **homologous recombination**, not only between noncorresponding positions on the same chromosome or on different chromosomes. Indeed, recombination between Alu elements is probably responsible for some deletion or rearrangement of mutations leading to inherited human diseases, since Alu sequences are often found at deletion/rearrangement breakpoints.

Throughout all chromosomes of all living organisms, short, simple sequence repeats may be found. For example, short stretches of guanosine-cytosine **base pairs**, alternating adenosine-thymidine and cytosine-guanosine, occur randomly, both within and outside of protein-coding sequences, and are sometimes referred to as “microsatellite repeats.” In such regions, there is a higher tendency for the DNA polymerase to make errors by skipping a nucleotide or adding a couple of nucleotides. Such errors create sites of mismatched bases, which could lead to mutation—and cancer—if they are inherited by daughter cells after cell division. Most living cells have a way of detecting and correcting such mismatches shortly after they occur, using a mechanism termed “mismatch repair.” Patients that lack one of the components of the mismatch repair machinery have a much higher chance of being victims of certain types of cancers.

## Identifying Chromosomes

Numbers and sizes of chromosomes vary widely in eukaryotes, and neither correlates with genome size. The classification of chromosomes within a given species was made possible initially by the use of stains that revealed variation in the DNA sequence composition along the length of the chromosome, resulting in a banded staining pattern characteristic for each chromosome. Using the criteria of overall chromosome length, relative centromere position and banding pattern, chromosomes of any species can be identified as a characteristic ordered set called a karyotype. With advent of **molecular hybridization** and extensive molecular cloning of unique-sequence DNAs, DNA sets representing sequences unique to individual chromosomes have been identified. By coupling the cloned DNA to fluorescent dyes and hybridizing the fluorescently labeled DNA directly to chromosomal preparations or whole cells, fluorescent *in situ* hybridization

**homologous** similar in structure

**ribosome** protein-RNA complex in cells that synthesizes protein

**endoplasmic reticulum** network of membranes within the cell

**reverse transcription** creation of DNA from an RNA template

**homologous recombination** exchange of DNA segments between chromosomes

**base pair** two nucleotides (either DNA or RNA) linked by weak bonds

Hereditary nonpolyposis colon cancer is associated with defects in mismatch repair.

**molecular hybridization** base-pairing among DNAs or RNAs of different origins

(FISH) enables rapid, efficient, and reliable identification of whole chromosomes or chromosome fragments. FISH has found widespread clinical application in the identification of chromosome rearrangements underlying inherited disease and many tumors.

## Cytosine Methylation and Gene Regulation

When cellular DNA is first replicated, it consists of four nucleotide subunits: deoxyadenosine, deoxycytidine, deoxyguanosine, and thymidine. Following DNA replication, though, chemical modifications can occur to DNA. One of the most commonly encountered modifications found in the DNA of mammalian cells is the **methylation** of cytidine at carbon number 5 of the cytosine base. In human cells, about 3 to 5 percent of the cytosines are so methylated. The distribution of methylated sites is not uniform, but occurs only at cytosine residues that precede a guanosine (so-called CpG motifs, where the “p” symbolizes the intervening phosphate in the sugar-phosphate DNA backbone). Clusters of CpG dinucleotides—called CpG islands—preferentially occur near the promoters of many mammalian genes. When the cytosines in such islands are extensively methylated, the gene associated with that island is usually found to be transcriptionally silent. Thus, cytosine methylation is inversely correlated with **gene expression**. The mechanism of methylation-dependent silencing involves proteins that specifically recognize and bind to methylated DNA

Cytosine methylation is also found in plants, where it is also inversely correlated with gene activity. Interestingly, many fungi and insects have no detectable DNA methylation at all, yet they seem to be able to regulate their genes adequately. One theory is that DNA methylation arose in evolution as a secondary mechanism to ensure faithful gene silencing in organisms that undergo many cell divisions in development between **fertilization** and adulthood. It may also have evolved to inactivate certain types of viruses. SEE ALSO CELL CYCLE; CHROMOSOME ABERRATIONS; CONTROL OF GENE EXPRESSION; DNA; GENE; NUCLEOTIDES; ONCOGENES AND CANCER CELLS; SEX CHROMOSOMES; TRANSPOSON

*Joel C. Eissenberg*

### Bibliography

- Greider, Carol W., and Elizabeth H. Blackburn. “Telomeres, Telomerase and Cancer.” *Scientific American* 274, no. 2 (1996): 92–97.
- Grunstein, Michael. “Histones as Regulators of Genes.” *Scientific American* 267, no. 4 (1992): 68–74B.
- Moxon, E. Richard, and Christopher Wills. “DNA Microsatellites: Agents of Evolution?” *Scientific American* 280, no.1 (1999): 94–99.

## Circulatory Systems

Animal circulatory systems consist of a blood or a bloodlike fluid, a system of tubular blood vessels, and one or more pulsating hearts that pump the blood through the vessels. Animals that are only a few cell layers thick do not need or possess circulatory systems, because they can rely on diffusion through the body surface to exchange materials with the environment. Larger animals, however, require a circulatory system to transport nutrients

Rett syndrome is a rare genetic disorder resulting from defects in a methylcytosine-binding protein, MeCP2. Rett syndrome affects girls, and causes slowed development, mutism, and seizures.

**methylation** addition of the methyl group  $\text{CH}_3$

**gene expression** use of a gene to create the corresponding protein

**fertilization** union of sperm and egg

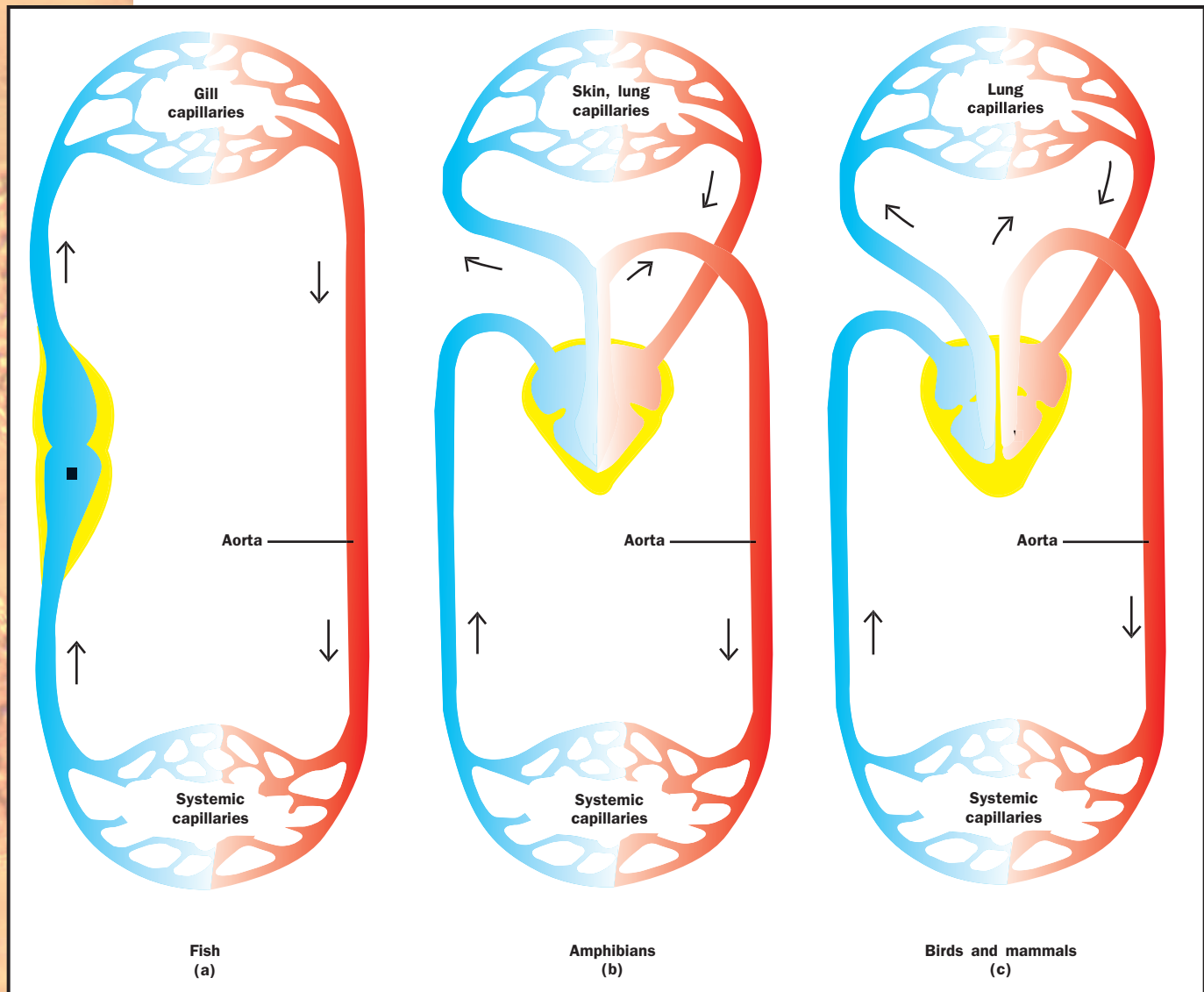

Vertebrate circulatory systems. Oxygen-rich blood is shown as red and oxygen-poor blood as blue. (a) In fish, the heart has one atrium (A) and one ventricle (V). Blood oxygenated in the gill capillaries flows directly to the capillaries of the systemic circulation without first returning to the heart. (b) In amphibians, the single atrium is divided into two separate chambers. Oxygen-rich blood from the lungs enters one atrium, and oxygen-poor blood enters the other. Oxygen-rich blood is pumped from one ventricle to the body tissues, while oxygen-poor blood is sent from the lungs to the skin, which is a major respiratory organ in amphibians. (c) In birds and mammals, the atrium and ventricle are divided into two separate chambers, forming two hearts. One pumps oxygen-rich blood through the body, and one pumps oxygen-poor blood through the lungs.

**hormone** molecule released by one cell to influence another

**arthropods** organisms with jointed appendages and exoskeletons, including insects, spiders, and crustaceans

and oxygen to their tissues, remove wastes, transport **hormones**, equalize body temperature, and maintain homeostasis.

Circulatory systems are classified as open or closed. In an open circulatory system, the heart pumps a fluid through arteries that empty into a large space, the hemocoel. The fluid bathes the organs in the hemocoel, and returns through veins to the heart. Since there is no distinction between blood and tissue fluid in such a system, the fluid is called hemolymph. Open circulatory systems are found in most mollusks and **arthropods**.

In a closed circulatory system, blood never leaves the blood vessels, and is thus separated from the tissue fluid. Blood flows away from the heart by

way of arteries and returns to the heart by way of veins. Arteries are connected to veins by tiny, thin-walled capillaries. Arteries and veins have a wall made of elastic and muscular tissue, and an inner lining of thin **epithelium** called endothelium. Capillaries are made of endothelium only. This thin wall allows for exchange of substances between the blood and tissue fluid.

Closed systems have a relatively high blood pressure. This enables nutrients and oxygen to be delivered quickly to their tissues and supports the high metabolic rate associated with the relatively high mobility of some animals. Squids, for example, have closed circulatory systems with three hearts, one to serve each gill and one for the rest of the body. Earthworms, although not highly mobile, have a closed circulatory system with five pairs of hearts.

Vertebrates independently evolved closed circulatory systems in close association with the respiratory systems. In fish, blood flows from the heart to the gills for gas exchange, then to the rest of the body, and finally back to the heart. This is called a single circulation since the blood flows through the heart only once during each complete trip around the body. Amphibians evolved a double circulation; blood flows from the heart to the gills or lungs for gas exchange, then back to the heart to be repressurized before flowing to the rest of the body. The vessels that serve the respiratory organs are called the branchial circuit (for gills) or pulmonary circuit (for lungs). Vessels that serve the rest of the body are called the **systemic** circuit.

The amphibian heart and most reptilian hearts have only three chambers—two **atria** and one **ventricle**—and there is some mixing of oxygen-rich and oxygen-poor blood in the single ventricle. **Endothermic** vertebrates, the birds and mammals, have higher metabolic rates and require stricter separation of the pulmonary and systemic blood. Thus, they have four-chambered hearts. Oxygen-rich blood flows through the other ventricle to the systemic circuit. **SEE ALSO** ARTHROPODS; BLOOD; BLOOD VESSELS; HEART AND CIRCULATION; TISSUE

*Barbara Cocanour*

### Bibliography

- Raven, Peter H., and George B. Johnson. *Biology*, 5th ed. Boston: McGraw-Hill, 1999.
- Walker, Warren F., Jr., and Karel F. Liem. *Functional Anatomy of the Vertebrates: An Evolutionary Perspective*, 2nd ed. Orlando, FL: Saunders College Publishing, 1994.

## Clinical Trials

A clinical trial is a prospective study of the effectiveness of a new treatment, such as a drug, surgical technique, or medical device. The term prospective indicates that there is a well-defined starting point from which the subjects are tracked for some definite period of time. Before a clinical trial is conducted, laboratory experimentation and animal trials on the proposed treatment is performed.

Clinical trials must meet strict government guidelines established by the U. S. Food and Drug Administration (FDA) to assure the safety of subjects and the scientific validity of the trial. Prior to admission to a clinical trial, subjects must meet the study requirements and be sufficiently informed re-

**epithelium** one of four tissue types found in the body, characterized by thin sheets and usually serving a protective or secretory function

**systemic** throughout the body

**atria** two upper chambers of the heart (singular, atrium)

**ventricle** fluid-filled chamber

**endothermic** characterized by regulation of body temperature through metabolic activity

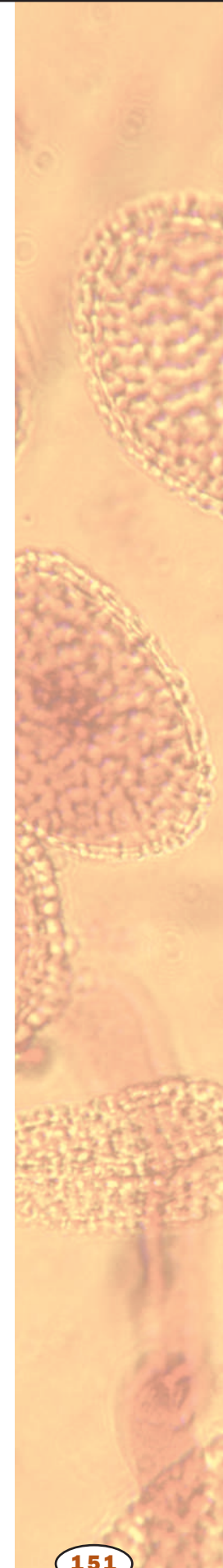



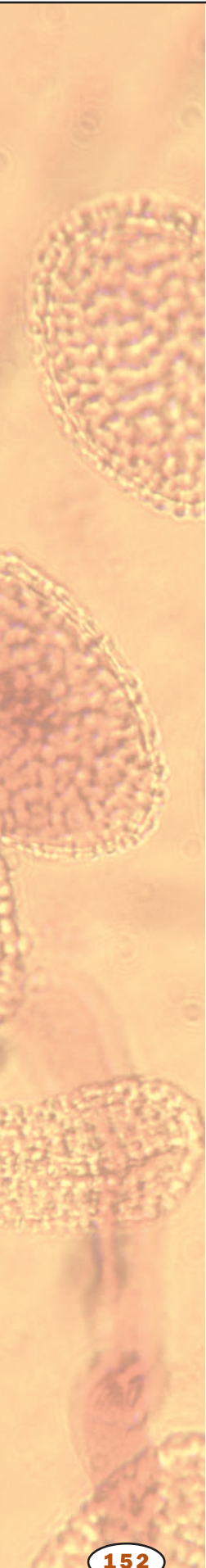

**mitosis** separation of replicated chromosomes

**protein** complex molecule made from amino acids; used in cells for structure, signaling, and controlling reactions

**hormone** molecule released by one cell to influence another

**kilobase** one thousand DNA bases; a measure of size of a piece of DNA

garding the purpose of the trial. A new treatment may have major benefits but may also have significant side effects for the type of patient that it could help. Careful screening and examination help select persons who meet the trial's design and intent. Informed consent, required of all participants, will alert the subjects not only to the purpose and design of trial with its potential benefits but to any known or suspected side effects or complications.

A phase I trial is a small-scale test in healthy volunteers to determine the general safety of the treatment with human subjects. Phase II tests the safety and effectiveness of the new treatment in a small group of patients who might benefit. A phase III trial is a large-scale study to scientifically document the value of the proposed drug, technique, or device. Phase IV studies allow the long-term follow-up of patients to determine side effects and continued effectiveness after a treatment reaches the market.

The expense involved in clinical trials is due to the extensive development and research costs, initial laboratory testing, and their large-scale nature. Conducted at multiple sites around the country, clinical trials have significant infrastructure for record-keeping, follow-up, dissemination, and safety.

*Craig Clifford*

### Bibliography

Friedman, L. M., C. D. Furberg, and D. L. DeMets. *Fundamentals of Clinical Trials*, 3rd ed. New York: Springer-Verlag, 1998.

Whitehead, John. *The Design and Analysis of Sequential Clinical Trials*, 2nd ed. New York: John Wiley & Sons, 1997.

## Clone

The word “clone” has several different meanings in biology. As a noun, a clone is an identical genetic copy of either a piece of deoxyribonucleic acid (DNA), a cell, or a whole organism. Identical twins are clones, as are two daughter cells produced by **mitosis**. As a verb, “to clone” means to produce identical genetic copies of either pieces of DNA, cells, or whole organisms.

### Cloning DNA

DNA cloning is usually performed for one of two reasons: either to produce a lot of identical DNA for further study, or to use the DNA in an intact organism to produce useful **proteins**. In the first case, for example, a researcher might want to determine the DNA sequence of the gene or study the factors that control its expression (transcription). In the second case, one might want to produce large amounts of a medically useful protein, such as insulin or growth **hormone**.

Large quantities of identical DNA can be produced via the polymerase chain reaction (PCR), but only if the DNA pieces are rather short (less than about 40 **kilobases** [kb], and usually closer to 1 kb). For larger pieces, or for protein production, DNA is almost always cloned in bacteria.

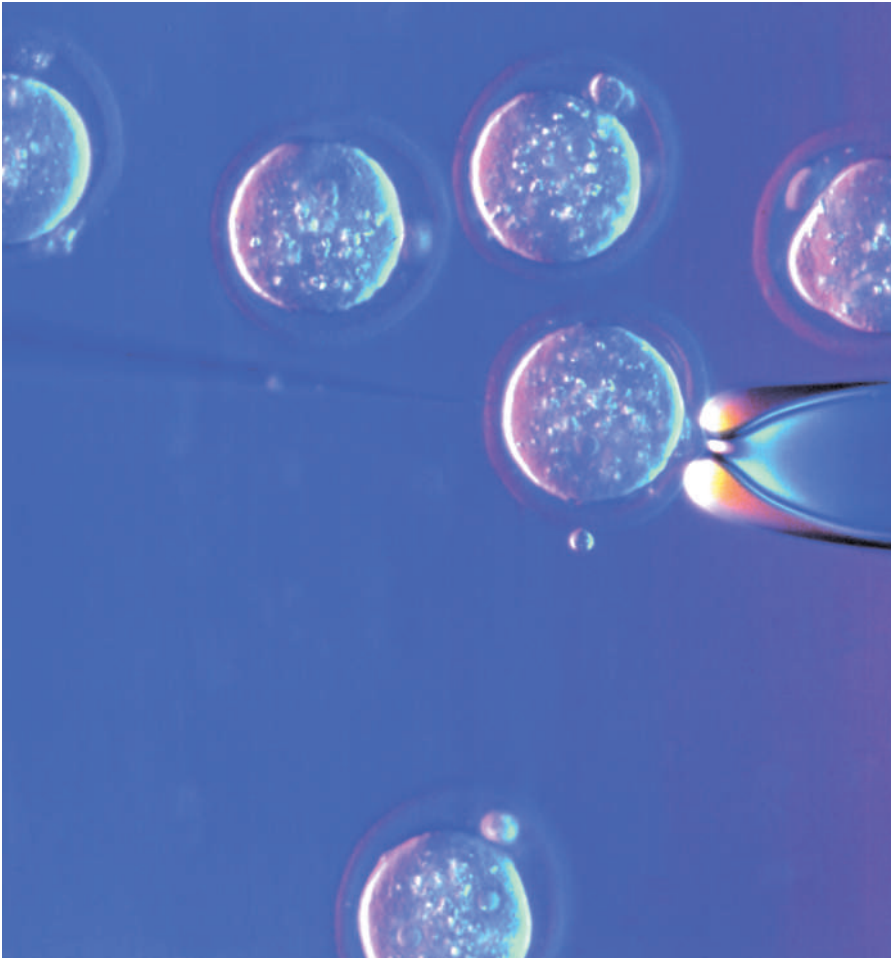

A micro injection of foreign genes into animal cells. Similar techniques are used to insert an entire nucleus into a host egg cell.

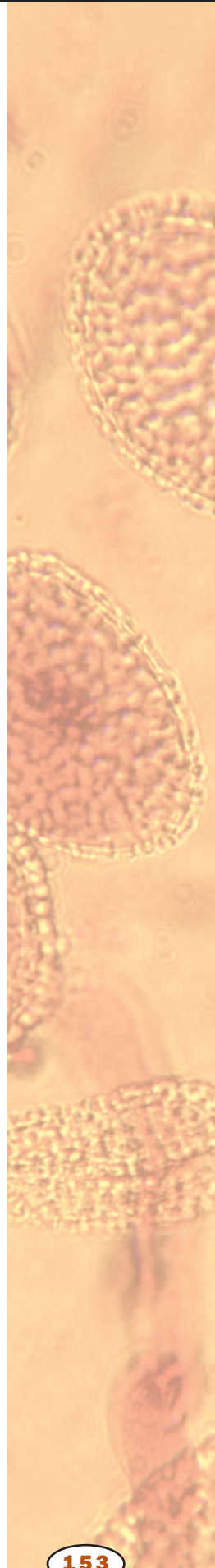

Techniques for cloning change rapidly, but the overall picture is as follows, using the insulin gene as an example:

- Isolate and purify all the DNA from a sample of human cells. Break apart the cells and then wash, centrifuge, and use other purification techniques.
- Cut the DNA into millions of small fragments using **restriction enzymes**. Each DNA piece may be as large as 10 kb, but is more commonly 1 to 5 kb.
- Mix the DNA fragments with **plasmids** that have been cut with the same restriction enzymes. Add DNA ligase, an **enzyme** that joins the human DNA fragments to the plasmids and seals the circles up again. By using the right ratio of plasmid to fragment, a researcher can ensure that each plasmid harbors at most one human DNA fragment. With luck, one DNA fragment will contain the insulin gene.
- Cause a bacterial culture to take up the plasmids. This can be done by ionic shock. Again, adjusting the ratio can ensure one plasmid per bacterium. The plasmid used usually carries a gene for antibiotic resistance.
- Grow the bacteria on antibiotic-containing **agar** plates, spread very thinly. The antibiotic will kill bacteria that didn't take up the plas-

**restriction enzyme**  
enzyme that cuts DNA at a particular sequence

**plasmid** small ring of DNA found in many bacteria

**enzyme** protein that controls a reaction in a cell

**agar** gel derived from algae

**complementary** matching opposite

**promoter** DNA sequence to which RNA polymerase binds to begin transcription

$\lambda$  the Greek letter lambda

**vector** carrier

**chromosome** “colored body” in the cell nucleus; made of DNA and protein, and divided functionally into genes and non-gene regions

**nucleus** membrane-bound portion of cell containing the chromosomes

**genome** total genetic material in a cell or organism

**pipette** lab instrument for precise measurement and transfer of small volumes of liquids

**somatic** nonreproductive; not an egg or sperm

**transgenic** characterized by presence of one or more genes from a different organism

mid. Single bacteria give rise to colonies, which will appear as small spots on the plate. The resulting bacterial colonies are called a genomic library.

- To find which of the colonies includes the human insulin gene, use a probe. This is typically a radioactive segment of DNA whose sequence is **complementary** to part of the insulin gene, allowing it to bind. Apply the probe, and see where it sticks.
- Isolate that colony, and let it multiply in a rich broth. Each bacterium will replicate the insulin gene, providing many copies to work with. Including the appropriate **promoters** and other regulatory factors will prompt the bacteria to synthesize the human insulin protein, which can then be purified for medical use.

Several modifications of this technique allow cloning of even larger DNA fragments. Cloning into the bacterial virus bacteriophage  $\lambda$  allows use of fragments up to about 20 kb. In this scheme, the bacteriophage infects cultured bacteria and directs production of the gene of interest. Cosmid **vectors** can package about 44 kb. These are plasmids containing special sequences from bacteriophage ( $\lambda$ ) that promote very efficient sealing of the plasmid circle. Bacterial artificial **chromosomes** (BACs) can contain up to 300 kb, and yeast artificial chromosomes (YACs), grown in yeast cells, can handle up to 2,000 kb, or 2 megabases.

## Cloning an Animal

Since the **nucleus** of virtually every animal cell contains the entire **genome** of the animal, it might seem easy enough to clone an animal by placing the nucleus in an egg cell from which the nucleus has been removed. While this was tried many times, it was never successfully accomplished until 1996, in the creation of the sheep Dolly by Ian Wilmut and colleagues in Scotland. Dolly was the first mammal created using the nucleus from a cell of a mature adult mammal. Prior to this feat, it had been thought that normal mammalian development caused irreversible changes in some portion of the DNA that prevented it from acting as embryonic DNA does.

Amphibians have long been cloned from adult cells, but they invariably die in the tadpole stage. Adult amphibians, though, have been successfully cloned for many years from embryo nuclei. In this technique, nuclei from cells of an early embryo are extracted using a very fine glass **pipette** and placed in egg cells that have been shed by a female amphibian such as a frog (after removing the unfertilized egg cell nucleus). In 1998, mice were cloned from adult **somatic** cell nuclei, using the same technique as was used for Dolly. This technique may become especially important for producing large numbers of **transgenic** animals, for use in research or production of specialized proteins. However, cloned mammals are generally not very healthy. Apparently development is not quite normal when it begins with a nucleus that has already existed in another animal, compared to a genome derived from a sperm and an egg. SEE ALSO BACTERIAL VIRUSES; GENETIC CONTROL OF DEVELOPMENT; POLYMERASE CHAIN REACTION; REPRODUCTIVE TECHNOLOGY

*Richard Robinson*

**Bibliography**

Drlica, Karl. *Understanding DNA: A Guide for the Curious*. New York: John Wiley & Sons, 1997.

Strachan, Tom, and Andrew Read. *Human Molecular Genetics*, 2nd ed. New York: John Wiley & Sons, 1999.

**Cnidarian**

The Cnidaria (pronounced ny-DARE-ee-ah) are a **phylum** of simple animals including the hydras, jellyfish, sea anemones, and corals. Any swimmer who has suffered a jellyfish sting has painfully encountered the feature for which the phylum is named: the venomous, stinging **organelles** called nematocysts or cnidae (pronounced NID-ee). Nematocysts are used for defense and to sting and paralyze prey, ranging from **plankton** to fish.

Cnidarians have a simple body plan with two epithelial cell layers: the epidermis and gastrodermis, separated by a gelatinous mesoglea (“middle glue”). The mesoglea ranges from a thin, glue-like layer in the freshwater hydras to a thick, gelatinous layer in the jellyfish. The simple body wall encloses a water-filled space, the gastrovascular cavity, responsible for the digestion of food and the distribution of digested nutrients.

Many cnidaria have a life cycle that alternates between a **sessile** polyp stage and a swimming medusa. The polyp may consist of a single stalklike body, attached to the **substrate** below and with a mouth surrounded by a ring of tentacles above; or it may be a branching colony, easily mistaken for a plant until one looks at it under the microscope. The medusa (jellyfish) is typically umbrella shaped, with a mouth-bearing stalk where the handle of the umbrella would be, and stinging, nematocyst-laden tentacles around the margin. Hydras, corals, and sea anemones, however, have only the hydroid stage, and some medusae have no polyp stage in the life cycle. **SEE ALSO** ANIMALIA; CORAL REEF; OCEAN ECOSYSTEMS; PLANKTON

*Kenneth S. Saladin*

**Bibliography**

Pechenik, Jan A. *Biology of the Invertebrates*, 4th ed. Boston: McGraw-Hill, 2000.

Rupert, Edward E., and Robert D. Barnes. *Invertebrate Zoology*, 6th ed. Fort Worth, TX: Saunders College Publishing, 1994.

**Coffee, Botany of**

Coffee is made from the bean of the coffee plant, *Coffea arabica* or *Coffea canephora*, in the Rubiaceae family. It is native to the forest understory of the east African highlands. It grows best with frequent rains, warm but not extreme temperatures, and hilly ground 600 to 1,200 meters (2,000 to 4,000 feet) above sea level and therefore has been cultivated in high tropical regions around the globe.

The coffee plant is a woody shrub, and it grows in the wild as high as 12 meters (39 feet), but cultivated trees are pruned to 2 meters (6.5 feet) to make harvesting easier. Small, white flowers give rise to a red, fleshy fruit, the “coffee cherry,” which contains a pair of beans. A single coffee tree pro-

**phylum** taxonomic level below kingdom, e.g., arthropod or chordate

**organelle** membrane-bound cell compartment

**plankton** microscopic floating organisms

**sessile** attached and remaining in one place

**substrate** surface for attachment

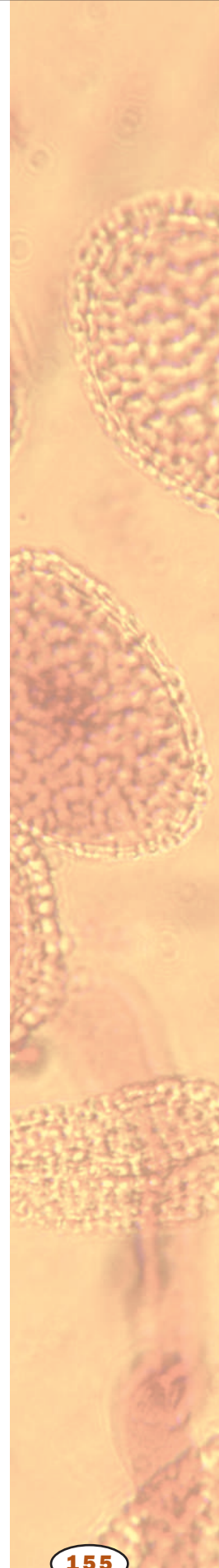

duces enough beans for about forty cups of coffee per year. Because fruit does not all set at once, most coffee cherries are harvested by hand, rather than by machine. The bean is removed from the fruit for drying. Dried beans can be stored for a year or more before roasting. Once roasted, the bean begins to lose flavor and is best used within several weeks.

Though native to Africa, the majority of coffee is now grown in South and Central America, with Brazil being the single largest producer. In 2000 world coffee production was more than 6 billion kilograms (6.6 million tons), almost all of which was exported, making coffee one of the largest commodities traded on the international market. Almost one-quarter of the world's coffee is imported by the countries of North America.

Desire to increase yield has led some growers to cut back the forest trees under which most coffee is grown. This has the undesirable effect of reducing biodiversity, especially of birds, and increasing soil erosion. Some coffees are labeled as “shade-grown” to alert consumers to its more environmentally sensitive origins. SEE ALSO AGRICULTURE; BEER-MAKING, BIOLOGY OF; BIODIVERSITY; WINE-MAKING, BOTANY OF

*Richard Robinson*

#### **Bibliography**

Dicum, Gregory, and Nina Luttinger. *The Coffee Book: Anatomy of an Industry*. New York: New Press, 1999.

Pendergrast, Mark. *Uncommon Grounds: The History of Coffee and How It Transformed Our World*. New York: Basic Books, 1999.

## **College Professor**

College and university professors have satisfying careers because they work in an intellectually stimulating environment and with people who want to learn more about the world around them. Professors need to have many qualities and skills such as excellent teaching abilities, inquisitive minds, a love of learning, and a willingness to dedicate their lives to their profession.

Science professors need to have a great deal of education. A bachelor's degree (bachelor of science or bachelor of arts) is earned after completing a minimum of four years of college. A master's degree can be earned in about two years of study. To teach in a college or university, the minimum requirement is a doctor of philosophy (Ph.D.) degree in one of the sciences, such as biology, chemistry, or geology. The doctorate is primarily a research degree, which takes three to five years to complete, depending on the topic which is chosen for research. The research topics in science are sharply focused and require experimental study in the field or a laboratory on a subject that has previously never been explored.

In addition to these three degrees, it is common for professors to have post-doctoral (“post-doc”) experience doing research full time for one or more years before they are accepted for a position as a professor.

A professor may teach a variety of courses, which is for many the most exciting part of this career. Usually professors teach two to four courses per semester. Each course requires a great deal of preparation by reading much material about the subject, especially new discoveries, and designing ways

to teach the materials so that the students understand it well. Professors are expected to advise students about courses and careers available to them. Faculty members are required to conduct research and publish the results in journals. However, not everything that is written by a faculty member gets published in a journal.

Faculty members make decisions on a wide variety of subjects, such as the curriculum, the selection of new faculty members, the cultural events on the campus, the supervision of athletic programs, and many more topics. Often, faculty members provide service to their professional organizations and to the community by serving on boards and councils.

Students can prepare themselves to be a professor by doing extremely well in school, reading and studying a great deal, and getting to know professors and their work. SEE ALSO HIGH SCHOOL BIOLOGY TEACHER

*Orin G. Gelderloos*

## Community

An ecological community is a collection of organisms occurring together in a location and interacting to varying degrees. A community is often defined by the most common or prominent species found in it (a beech-maple forest) or by its environment (a wetland community).

### Species Diversity

Community ecologists study what determines membership in communities and how and why communities change in space and time. One of the most important characteristics of an ecological community is species diversity. Species diversity is a measure that combines the number of species in a community with the relative abundances of those species. Understanding why some species are more abundant than others is particularly important because communities that are strongly dominated by one or a few species often have low species diversity overall. Differences in species diversity among communities occur because of differences in environment, differences in the kinds and strengths of species interactions, or both.

### Interactions

There are many kinds of species interactions in communities, all of which affect species diversity. Predation, parasitism, and herbivory are interactions in which one species benefits at the expense of another. Competition involves a mutually negative interaction among species. **Mutualism** involves an interaction in which both species derive benefit.

Some of these interactions may lower diversity, while others increase diversity. In addition, the strengths of these interactions change as the environment changes. For example, competition may be more intense when resources are severely limited. In streams, for instance, different species of fish compete for insect prey. When prey are scarce, competition among fish species is strong, and when prey are abundant, competition is weak.

**mutualism** symbiosis between two organisms in which both benefit

A second-growth birch forest with an evergreen understory in northern Wisconsin. One of the most important characteristics of an ecological community is species diversity.



Ecological communities are complex because many different factors affect species interactions in communities. Moreover, the different types of interactions among species in communities interact. For example, high predation rates can reduce competition among prey species. Because of this complexity, ecologists are keenly interested in understanding the complex web of interactions among the various plants, herbivores, carnivores, and decomposers in a community.

In fact, one of the challenging questions in community ecology is whether the web of interactions in a community is controlled primarily by resources or by top predators. Human activities are changing the abundance of resources in the environment, which in turn changes the types and strengths of interactions among species in communities. Ultimately, these changes could alter species interactions and patterns of species diversity.

**CLEMENTS, FREDERICK  
(1874–1945)**

American plant ecologist who defined early-twentieth-century ecology by introducing the concept of climax communities. In the 1910s, before many paved roads existed, Clements and his wife drove across the American West describing and photographing every major ecosystem in North America.

**Disturbance and Succession**

Ecological communities are dynamic. An ecological community may change as a result of species interactions, but other phenomena, such as dispersal or the movement of an individual from one place to another, also cause communities to change. Dispersal is important because it means that a community in one area can influence community composition some place far away.

In the Caribbean, for example, the composition and abundance of lizards on islands change suddenly and dramatically following hurricanes. Flooding during hurricanes kills animals on some islands while some animals float from one island to another during and after the storm. Hurricanes are an example of ecological disturbance, an event that destroys living organisms and frees space for new individuals to colonize. Disturbances—including

fires, floods, and volcanoes—are natural occurrences, and they are one of the primary forces that create change in ecological communities.

The study of how disturbances affect communities is an important aspect of community ecology. Many disturbances, like forest fires, may appear harmful or destructive, but they are natural phenomena that initiate change. **Succession** is the change in species composition at a site over time. Primary succession occurs in previously unoccupied habitats, such as the lava produced by a volcano. Secondary succession, which is much more common, occurs following a disturbance in an area that was previously occupied by a community. Successional change occurs as species disperse to a newly disturbed site and interact over time. Eventually, the rate of community change during succession decreases.

Stability is a measure of a community's ability to return to a condition that existed before disturbance. The question "Does diversity increase stability?" is hotly debated by ecologists. Some think that diversity increases stability because when many different species occupy an area, they use the resources more fully. In doing so, the diverse community is resilient because when the abundance of one species declines, for example during a drought, the abundance of a more drought-tolerant species increases.

Other ecologists think there is little relationship between diversity and stability. Rather, they believe that any response is really a function of the dominant species in the community. This issue is not likely to be resolved for some time.

Ecological communities are complex assemblages of organisms that undergo a rich array of interactions. These interactions affect the kinds and abundances of species found in a community. Understanding how species coexist and why communities change over time are exciting and challenging questions in ecology. Knowledge about community ecology becomes increasingly valuable as human activity alters the global environment. Thus, as the human population increases, ecologists will provide key information needed to help manage and conserve species diversity and ecological communities. **SEE ALSO** COMPETITION; ECOSYSTEM; PREDATION AND DEFENSE; SYMBIOSIS

*Scott Collins and Margaret Palmer*

### **Bibliography**

- Molles, Manual C., Jr. *Ecology: Concepts and Applications*. Boston: McGraw-Hill, 2000.
- Shahid Naeem, et al. "Biodiversity and Ecosystem Functioning: Maintaining Natural Life Support Processes." *Issues in Ecology*, no. 4. Washington, DC: Ecological Society of America.

## **Competition**

Competition is a negative interaction that occurs among organisms whenever two or more organisms require the same limited resource. All organisms require resources to grow, reproduce, and survive. For example, animals require food (such as other organisms) and water, whereas plants require soil nutrients (for example, nitrogen), light, and water. Organisms, however, cannot acquire a resource when other organisms consume or defend that

**succession** series of changes seen in some plant communities over time, in which low-growing, rapidly reproducing species are replaced by taller and more slowly reproducing ones

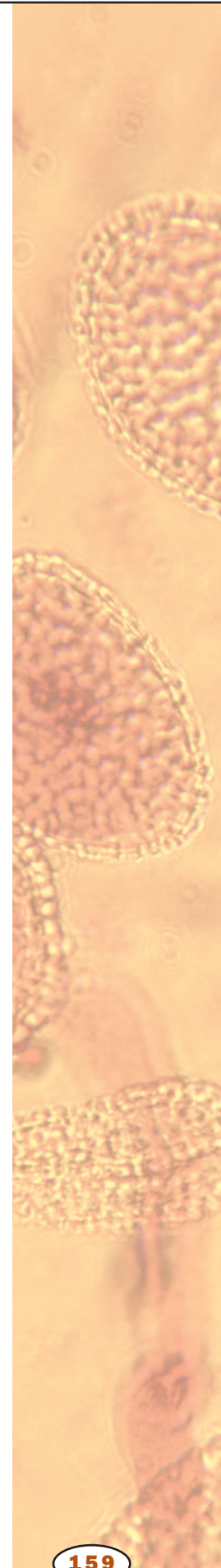



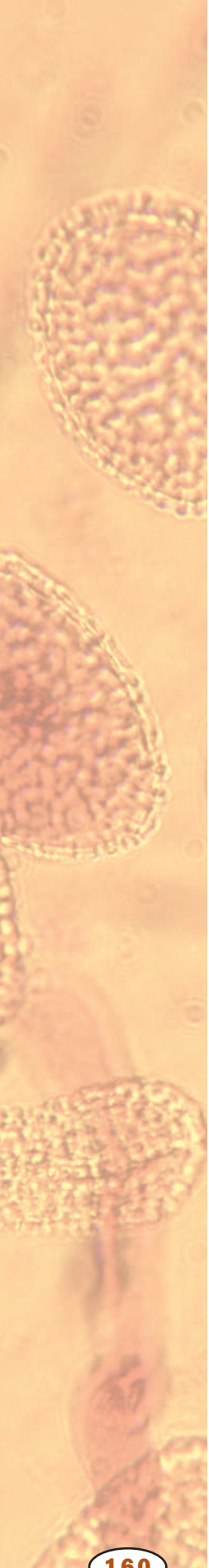

**pH** measure of acidity or alkalinity; numbers below 7 are acid, above are basic

resource. Therefore, competitors reduce each other’s growth, reproduction, or survival.

### Interference and Exploitation

Biologists typically recognize two types of competition: interference and exploitative competition. During interference competition, organisms interact directly by fighting for scarce resources. For example, large aphids (insects) defend feeding sites on cottonwood leaves by kicking and shoving smaller aphids from better sites. In contrast, during exploitative competition, organisms interact indirectly by consuming scarce resources. For example, plants consume nitrogen by absorbing it into their roots, making nitrogen unavailable to nearby plants. Plants that produce many roots typically reduce soil nitrogen to very low levels, eventually killing neighboring plants.

### Within Species and Between Species

Competition can occur between individuals of the same species, called intraspecific competition, or between different species, called interspecific competition. Studies show that intraspecific competition can regulate population dynamics (changes in population size over time). This occurs because individuals become crowded as a population grows. Since individuals within a population require the same resources, crowding causes resources to become more limited. Some individuals (typically small juveniles) eventually do not acquire enough resources and die or do not reproduce. This reduces population size and slows population growth.

Species also interact with other species that require the same resources. Consequently, interspecific competition can alter the sizes of many species’ populations at the same time. Experiments demonstrate that when species compete for a limited resource, one species eventually drives the populations of other species extinct. These experiments suggest that competing species cannot coexist (they cannot live together in the same area) because the best competitor will exclude all other competing species. Why then do communities seem to have many competing species that coexist in the same area?

### The Competitive Exclusion Principle

To explain how species coexist, in 1934 G. F. Gause proposed the competitive exclusion principle: species cannot coexist if they have the same niche. The word “niche” refers to a species’ requirements for survival and reproduction. These requirements include both resources (like food) and proper habitat conditions (like temperature, **pH**). Gause reasoned that if two species had identical niches (required identical resources and habitats) they would attempt to live in the exact same area and would compete for the exact same resources. If this happened, the species that was the best competitor would always exclude its competitors from that area. Therefore, species must at least have slightly different niches in order to coexist.

Peter Grant and colleagues tested Gause’s principle by studying seed-eating finches (birds) that live on the Galapagos Islands in the Pacific Ocean. They found that different finch species can coexist if they have traits that allow them to specialize on particular resources. For example, two finch species, *Geospiza fuliginosa* and *Geospiza fortis*, vary in a key trait: beak size.

Beak size is a critical trait because it determines the size of a seed that a finch can eat: Individuals with small beaks eat small seeds, individuals with intermediate sized beaks can eat intermediate size seeds and individuals with large beaks can eat large seeds. *G. fuliginosa* and *G. fortis* do compete for intermediate sized seeds because each species has some individuals with intermediate sized beaks. However, *G. fuliginosa* specializes upon smaller seeds because it has more individuals with small beaks. Conversely, *G. fortis* specializes upon larger seeds because it has more individuals with large beaks. Thus, these species niches differ slightly because a specific trait, beak size, allows them to specialize upon a particular seed size.

Joe Connell also tested Gause's principle by studying barnacles (shelled marine organisms) that live on rocks along European coastlines. In 1961, Connell found that two barnacle species, *Balanus* and *Chthamalus*, can coexist because they differ in two traits: growth rate and vulnerability to **desiccation**. *Balanus*'s growth is rapid, which allows it to smother and crush the slower-growing *Chthamalus*. *Balanus*, however, dies close to shore because it gets too dry during low tide. In contrast, *Chthamalus* tolerates these dry conditions. Consequently, even though *Balanus* is a better competitor for space, these barnacles coexist because *Chthamalus* can survive in areas that *Balanus* cannot survive. These and many other examples support the competitive exclusion principle: Species can only coexist if they have different niches.

## Character Displacement

Competition can cause species to evolve differences in traits. This occurs because the individuals of a species with traits similar to competing species always experience strong interspecific competition. These individuals have less reproduction and survival than individuals with traits that differ from their competitors. Consequently, they will not contribute many offspring to future generations. For example, the finches previously discussed can be found alone or together on the Galapagos Islands. Both species' populations actually have more individuals with intermediate-sized beaks when they live on islands without the other species present. However, when both species are present on the same island, competition is intense between individuals that have intermediate-sized beaks of both species because they all require intermediate sized seeds. Consequently, individuals with small and large beaks have greater survival and reproduction on these islands than individuals with intermediate-sized beaks.

Studies show that when *G. fortis* and *G. fuliginosa* are present on the same island, *G. fuliginosa* tends to evolve a small beak and *G. fortis* tends to evolve a large beak. The observation that competing species' traits are more different when they live in the same area than when competing species live in different areas is called character displacement. For the two finch species, beak size was displaced: Beaks became smaller in one species and larger in the other species. Studies of character displacement are important because they provide evidence that competition plays a very important role in determining ecological and evolutionary patterns in nature. SEE ALSO ADAPTATION; COMMUNITY; EVOLUTION; EXTINCTION; NATURAL SELECTION; POPULATION DYNAMICS; SYMBIOSIS

*J. P. Cronin and Walter P. Carson*

**desiccation** drying out



A ground finch on Santa Cruz Island in the Galapagos. Different finch species can coexist if they have traits—for instance, beak size—that allow them to specialize on particular resources.

### Bibliography

- Connell, Joseph. "The Influence of Interspecific Competition and Other Factors on the Distribution of the Barnacle *Chthamalus stellatus*." *Ecology* 42, no. 4 (1961): 710–723.
- Gause, G. F. *The Struggle for Existence*. Baltimore: Williams & Wilkins, 1934.
- Grant, Peter R. *Ecology and Evolution of Darwin's Finches*. Princeton, NJ: Princeton University Press, 1986.
- Wedin, David, and David Tilman. "Competition Among Grasses Along a Nitrogen Gradient: Initial Conditions and Mechanisms of Competition." *Ecological Monographs* 63, no. 2 (1993): 199–229.
- Whitham, Thomas G. "Costs and Benefits of Territoriality: Behavioral and Reproductive Release by Competing Aphids." *Ecology* 67, no. 1 (1986): 139–147.

## Conifers

The conifers are a group of about 588 species of trees and shrubs that include many of the best-known plants in the world. All conifers bear seeds inside cones, woody protective structures. There are seven families of conifers. The largest is the Pine family (232 species), which includes such familiar trees as pine, spruce, fir, and larch. Most plants in this family have needlelike foliage and bear their seeds in a cone formed of papery or woody scales whorled about a central axis. The Pine family includes the oldest known trees, the bristlecone pines, many of which are known to be more than four thousand years old.

The next largest family (147 species) is the Podocarps. Most Podocarps are tropical trees, many of them native to the Southern Hemisphere. Generally, they have broad leaves and bear their seeds in a structure similar to a berry. Nonetheless, their flowers, the anatomy of their wood, and the details of seed development all show that Podocarps are closely related to the Cypress family (141 species).

Most trees in the Cypress family bear scalelike foliage and have cones that have only a few scales. Besides cypress, this diverse family includes juniper, a common tree or shrub in desert areas; giant sequoia, which is the world's largest tree; and coast redwood, the tallest tree in the world. The remaining 68 species of conifers include a wide variety of less well-known trees, such as the yews, which are common garden plants, and the araucarias, which are important timber trees in some tropical countries.

Although the 588 species of conifers are not a very abundant group compared with the 250,000 species of flowering plants, the conifers are ecologically and economically one of the most important plant groups. A few species in the Pine family form the most extensive forest on Earth, the boreal forest, which covers thousands of miles across Russia, Canada, and Scandinavia. One species, the Siberian larch, is the most numerous and widespread of all trees.

Almost all conifers are trees, and so they create forests that provide habitat for wildlife and a wide variety of insects, fungi, and smaller plants. Some conifer forests support extremely complex **ecosystems** with very high levels of biodiversity. Conifers are also very important economically because they provide wood and wood products that are used to make buildings, furniture, and paper. Before petroleum was widely used, conifers were also the

**ecosystem** an ecological community and its environment



All conifers bear seeds inside cones, woody protective structures.

source of many important **organic** chemicals used to make paint and other finishes, solvents, and oils used by industry. Native peoples have used conifers to make houses and necessary implements, and some peoples have even used them for clothing (from woven bark) and food (seeds).

Conifers are one of the oldest groups of plants, with araucaria-like trees first appearing about 290 million years ago, and primitive representatives of most of the conifer families appearing during the Mesozoic era, from 230 to 68 million years ago. Therefore, conifers, and other types of **gymnosperms**, are generally regarded as being more evolutionarily primitive than angiosperms. SEE ALSO FOREST, BOREAL; GYMNOSPERMS; WOOD AND WOOD PRODUCTS

*Christopher J. Earle*

#### **Bibliography**

Dallimore, William, Albert Bruce Jackson, and S. G. Harrison. *A Handbook of Coniferae and Ginkgoaceae*, 4th ed. New York: St. Martin's Press, 1967.

Earle, C. J. *The Gymnosperm Database*. <<http://www.conifers.org>>.

van Gelderen, D. M., and J. R. P. van Hoey Smith. *Conifers*, 2nd ed. Portland: Timber Press, 1986.

**organic** composed of carbon, or derived from living organisms

**gymnosperms** "naked seed" plants, including conifers

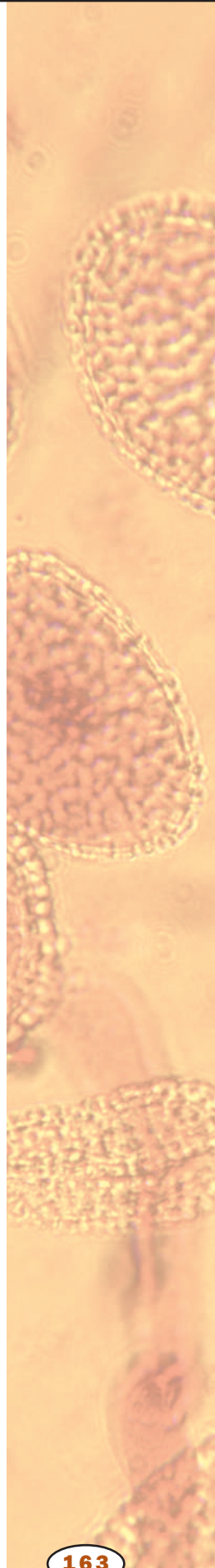

## Connective Tissue

The human body is composed of just four basic kinds of tissue: nervous, muscular, epithelial, and connective tissue. Connective tissue is the most abundant, widely distributed, and varied type. It includes fibrous tissues, fat, cartilage, bone, bone marrow, and blood. As the name implies, connective tissues often bind other organs together, hold organs in place, cushion them, and fill space.

Connective tissue is distinguished from the other types in that the extracellular material (matrix) usually occupies more space than the cells do, and the cells are relatively far apart. Fat is an exception, having cells in close contact with each other; but with large, nonliving, **intracellular lipid** droplets, fat contains much more nonliving material than living material.

The **matrix** of connective tissue typically consists of fibers and a featureless ground substance. The most abundant fiber in connective tissues is a tough **protein** called collagen. Tendons, ligaments, and the white stringy tissue (fascia) seen in some cuts of meat are composed almost entirely of collagen, as is leather, which consists of the connective tissue layer (dermis) of animal skins. Collagen also strengthens bone and cartilage. Elastic and **reticular** fibers are less abundant connective tissue proteins with a more limited distribution.

The ground substance may be liquid, as in blood; gelatinous, as in **areolar** tissue; rubbery, as in cartilage; or calcified and stony, as in bone. It consists mainly of water and small dissolved **ions** and **organic** molecules, but the gelatinous to rubbery consistency of some tissues results from enormous protein-carbohydrate complexes in the ground substance. The hard consistency of bone results mainly from calcium phosphate salts in the ground substance.

Some of the cells of connective tissue are **fibroblasts** (which produce collagen fibers and are the only cell type in tendons and ligaments); adipocytes (fat cells); leukocytes (white blood cells, also found outside the

**intracellular** within a cell

**lipid** fat or waxlike molecule, insoluble in water

**matrix** a network, usually of threadlike fibers

**protein** complex molecule made from amino acids; used in cells for structure, signaling, and controlling reactions

**reticular** netlike

**areolar** related to a small space within a tissue

**ion** an electrically charged particle

**organic** composed of carbon, or derived from living organisms

**fibroblast** undifferentiated cell normally giving rise to connective tissue cells

### CONNECTIVE TISSUE

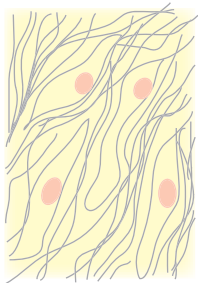

fibroblasts in loose connective tissue

Two main types of extracellular protein fiber are collagen and elastin.

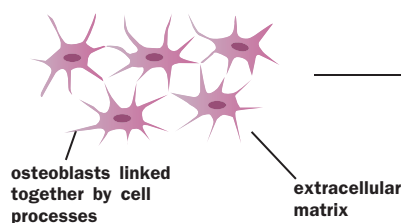
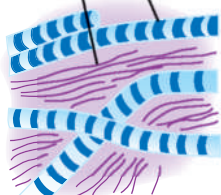

osteoblasts linked together by cell processes

extracellular matrix

Calcium salts are deposited in the extracellular matrix.

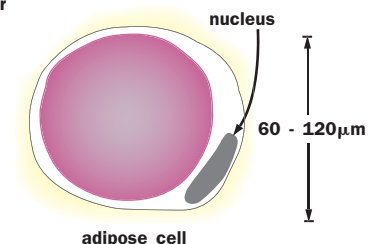
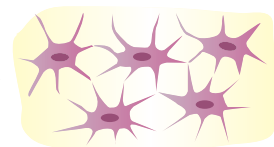

adipose cell

Connective tissue type and characteristics	Functions	Locations
<b>Areolar (loose) connective tissue.</b> Loose array of random fibers with a wide variety of cell types	Nourishes and cushions epithelia, provides arena for immune defense against infection, binds organs together, allows passage for nerves and blood vessels through other tissues	Under all epithelia; outer coverings of blood vessels, nerves, esophagus, and other organs; fascia between muscles; pleural and pericardial sacs
<b>Adipose tissue (fat).</b> Large fat-filled adipocytes and scanty extracellular matrix.	Stores energy, conserves body heat, cushions and protects many organs, fills space, shapes body	Beneath skin; around kidneys, heart, and eyes; breast; abdominal membranes (mesenteries)
<b>Dense irregular connective tissue.</b> Densely spaced, randomly arranged fibers and fibroblasts.	Toughness; protects organs from injury; provides protective capsules around many organs	Dermis of skin; capsules around liver, spleen, and other organs; fibrous sheath around bones
<b>Dense regular connective tissue.</b> Densely spaced, parallel collagen fibers and fibroblasts.	Binds bones together and attaches muscle to bone; transfers force from muscle to bone	Tendons and ligaments
<b>Cartilage (gristle).</b> Widely spaced cells in small cavities (lacunae); rubbery matrix.	Eases joint movements; resists compression at joints; holds airway open; shapes outer ear; moves vocal cords; forerunner of fetal skeleton; growth zone of children's bones	External ear, larynx, rings around trachea, joint surfaces and growth zones of bones, between ribs and sternum, intervertebral discs
<b>Bone (osseous tissue).</b> Widely spaced cells in lacunae; much of matrix in concentric onionlike layers; hard mineralized matrix.	Physically supports body, provides movement, encloses and protects soft organs, stores and releases calcium and phosphorus	Skeleton
<b>Blood.</b> Erythrocytes, leukocytes, and platelets in	Transports nutrients, gases, wastes, hormones,	Circulates in cardiovascular system

bloodstream in fibrous connective tissues); macrophages (large phagocytic cells descended from certain leukocytes); erythrocytes (red blood cells, found only in the blood and bone marrow); chondrocytes (cartilage cells); and osteocytes (bone cells).

The table above lists representative locations and functions of the major types of connective tissue. Further details on connective tissue can be found in textbooks of **histology** and human anatomy. SEE ALSO BLOOD; BONE; MUSCULOSKELETAL SYSTEM; ORGAN; SKIN; TISSUE

**histology** study of tissues

*Kenneth S. Saladin*

### Bibliography

- Gartner, Leslie P., and James L. Hiatt. *Color Textbook of Histology*. Philadelphia, PA: W. B. Saunders, Co., 1997.
- Ross, Michael H., Lynn J. Romrell, and Gordon I. Kaye. *Histology: A Text and Atlas*, 3rd ed. Philadelphia, PA: Lippincott Williams & Wilkins, 1994.
- Saladin, Kenneth S. *Anatomy & Physiology: The Unity of Form and Function*, 2nd ed. Dubuque, IA: McGraw-Hill Higher Education, 2001.

## Conservation

Biological diversity throughout the world is being threatened by human activity: species are being driven to the edge of extinction; biological com-

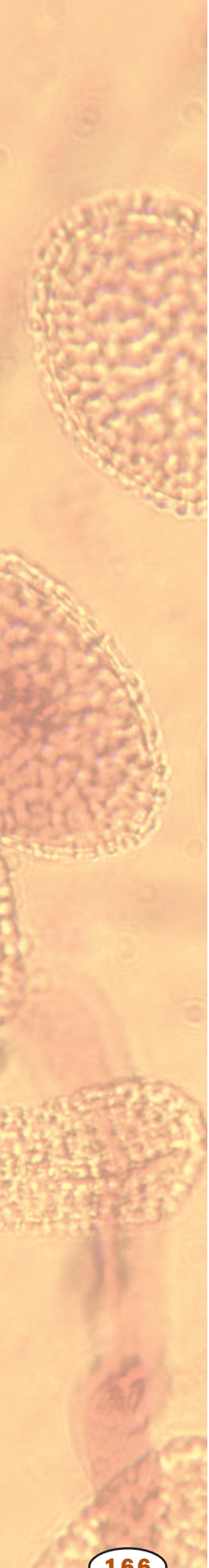

**ecosystem** an ecological community and its environment

munities are being degraded, fragmented, and destroyed; and the genetic variation within species is being lost as populations are reduced in size and lost. Conservation biology is a multidisciplinary science that has developed in response to this biodiversity crisis. Conservation biology has three goals: (1) to investigate and describe the diversity of the living world; (2) to understand the effects of human activities on species, communities, and **ecosystems**; and (3) to develop practical interdisciplinary approaches to protecting and restoring biological diversity.

Conservation biology arose because none of the applied disciplines, such as forestry, fisheries and wildlife management, zoo and park management, and agriculture, were comprehensive enough individually to address the critical threats to biological diversity. In general, these applied disciplines have developed methods for managing a small range of species for the marketplace and recreation. Conservation biology complements these applied disciplines by providing a broader approach and by having the long-term preservation of biological diversity as its primary goal, with economic factors often secondary. The academic disciplines of population biology, ecology, taxonomy, landscape ecology, and genetics constitute the core of conservation biology, with increasing inputs from economics, law, philosophy, anthropology, and other related fields.

### Origins in the United States

The need for the conservation of biological diversity has been recognized for centuries in North America, Europe, and other regions of the world. Religious and philosophical beliefs concerning the value of protecting species and wilderness are found in many cultures. In the United States, philosophers such as Ralph Waldo Emerson and Henry David Thoreau saw wild nature as an important element in human moral and spiritual development. Wilderness advocates such as John Muir and Aldo Leopold argued for preserving natural landscapes and maintaining the health of natural ecosystems.

The influential forester Gifford Pinchot developed the idea that commodities and qualities found in nature, including timber, clean water, wildlife, species diversity, and even beautiful landscapes, can be considered as natural resources, and that the goal of management is to use these natural resources to obtain the greatest good for the greatest number of people for the longest time. In the twenty-first century, the concepts of ecosystem management and sustainable development have extended these ideas by emphasizing management practices that maintain ecosystem health and wild species now and for future generations.

### Conservation at Many Levels

All levels of biological diversity are necessary for the continued survival of species and natural communities, and all are important for people. The diversity of species includes the full range of organisms on Earth, from bacteria and protists, through the multicellular kingdoms of fungi, plants, and animals. The diversity of species provides people with resources and resource alternatives.



The polluted Swazambhunath River in Kathmandu, Nepal. Sewage, industrial waste, and agricultural runoff can severely damage aquatic communities.

At the finest scale, genetic variation within species allows species to survive in the face of a changing environment; this genetic variation is also crucial for the continued efforts to improve domestic plants and animals, and for the rapidly developing biotechnology industry. On a larger scale, biological diversity includes the range of biological communities in which species live, and the ecosystem-level interactions with the physical and chemical environment. Biological communities provide beneficial services such as flood control, protection from soil erosion, the production of new plant material, and the filtering of air and water. As each one of these levels of biological diversity is degraded and destroyed, the natural fabric of the living world unravels and its value to people also diminishes.

### Threats to Biological Diversity

The major threats to biological diversity are all caused directly or indirectly by an ever-increasing use of the world's resources by the exponentially expanding human population. Because more people require more resources for their livelihood, many scientists have argued that controlling human numbers is the key to protecting biological diversity. A more equitable distribution of natural resources throughout the world, and reducing the excessive consumption of natural resources by wealthy countries, such as the United States, are also important targets for conservation efforts.

The major threat to biological diversity is loss of habitat, and the most important means of protecting biological diversity is habitat preservation. Eighty-one percent of the endangered species in the United States are threatened by habitat destruction. Tropical rain forests, wetlands, coral reefs, and temperate grasslands are all being eliminated by human activity. Even when habitat still remains, it is increasingly fragmented by roads, power lines, fences, farms, ranches, residences, and other human activities that restrict wildlife movement and alter the local environment.

Air and water pollution can also eliminate susceptible species, even where the basic habitat structure remains. Sewage, industrial waste, and agricultural runoff can severely damage aquatic communities.

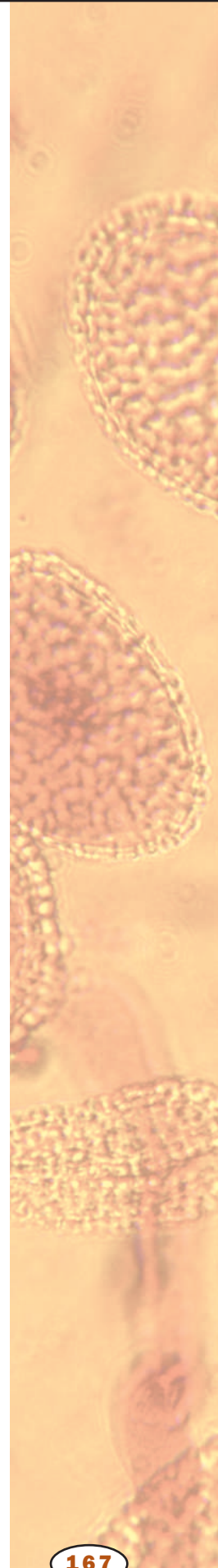



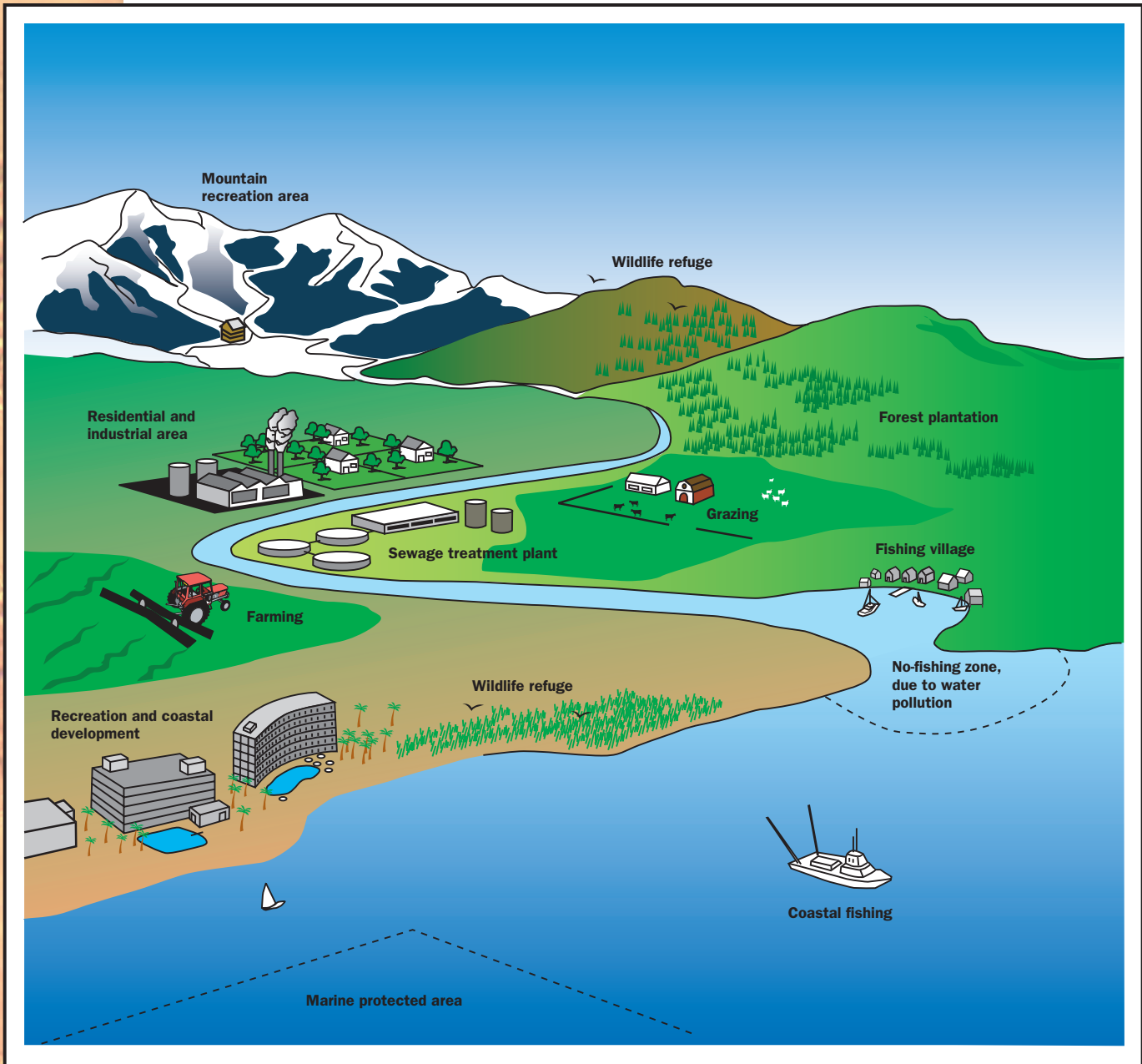

Land-use planning is a critical component of conservation. A well-planned community provides sufficient resources for a variety of uses, while preserving large areas for conservation.

Biological communities can be harmed when exotic species are transported by people to a new place deliberately or accidentally. In many areas of the world introduced sheep, cattle, pigs, and goats have driven native plants to extinction; introduced invasive grasses, agricultural weeds, and ornamental plants have escaped into the surrounding landscapes, replacing the native species. Diseases spreading from one continent to another are a significant threat decimating important tree species in North America and birds in Hawaii.

Global climate change is an emerging threat to biological diversity. If Earth's climate continues to change and warm as scientists predict, many species will not be able to migrate or adapt and will go extinct.

Numerous bird, mammal, and fish species continue to be overharvested. Entire communities of large animals have been removed for consumption or sale resulting in “empty” forests, lakes, and oceans. Certain species have been targeted by collectors and represent special conservation problems, such as shellfish, butterflies, tropical and coral reef fish, orchids, and cacti and other succulent plants.

## Conservation Efforts

The single most important method to protect biological diversity is to establish national parks, nature reserves, and other protected areas. Such efforts to protect biological diversity in their natural habitats are referred to as *in situ* or on-site conservation. Approximately 6 percent of the world’s land surface is designated as protected, with more national parks being designated each year. Many new marine reserves are being established to protect the nursery grounds for commercial fish species and maintain high-quality areas for recreation and tourism.

To be effective at preserving biological diversity, protected areas must be well-designed, be as large as possible, and contain a variety of vegetation types and water sources. Management practices—such as regulating hunting, removing exotic species, and employing controlled burning to maintain habitat diversity—need to be developed and put into practice. One of the most rapidly developing areas of conservation management involves restoring native biological communities on degraded lands, often by planting the original species. Protected areas must be periodically monitored to make sure they are meeting their objectives.

Where species can no longer live in the wild due to continuing threats, they can be maintained in zoos and botanical gardens. In such places, information can be gathered about the biology of the species and the public can be educated about conservation issues. The goal of such captive breeding programs is to return species back into their original habitat, known as “reintroductions,” once the original threat to the species has been identified and eliminated.

The greatest challenge involves developing projects in which conservation efforts are integrated with rural economic development. If local people benefit from conservation efforts through obtaining jobs, improved **infrastructure**, or new business and education opportunities, they will contribute to conservation objectives. But if local people perceive that the establishment of a protected area is harming their livelihood, they may actively oppose conservation efforts and damage the area.

Since the 1980s, conservation biology has become one of the most vibrant subject areas within biology. Enormous interest has led to whole new fields of knowledge being developed. However, conservation biologists are not simply content with developing new knowledge. The field of conservation biology will only be judged a success if this knowledge is used in a practical way to protect and restore the world’s fragile biological diversity. SEE ALSO BIODIVERSITY; ENDANGERED SPECIES; EXTINCTION; GLOBAL CLIMATE CHANGE; INVASIVE SPECIES

*Richard B. Primack*

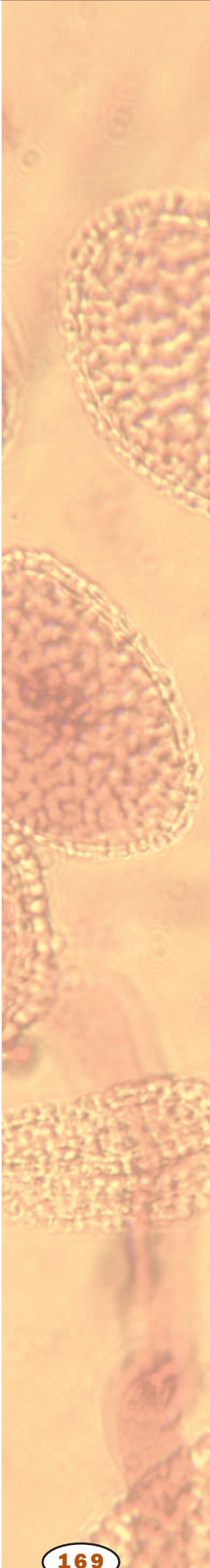

**infrastructure** roads, phone lines, and other utilities that allow commerce

**Bibliography**

- Akçakaya, H. Resit, Mark A. Burgman, and Lev R. Ginzburg. *Applied Population Ecology: Principles and Computer Exercises Using RAMAS EcoLab*. Sunderland, MA: Sinauer Associates, 1999.
- Meffe, Gary C., and C. Ron Carroll. *Principles of Conservation Biology*. Sunderland, MA: Sinauer Associates, 1997.
- Primack, Richard. *A Primer of Conservation Biology*, 2nd ed. Sunderland, MA: Sinauer Associates, 2000.
- Wilson, Edward O. *The Diversity of Life*. Cambridge, MA: Belknap Press of Harvard University, 1992.
- , and Daniel L. Perlmann. *Conserving Earth's Biodiversity*. Washington, DC: Island Press, 1999.

**Control of Gene Expression**

All cells contain a set of genes, which can be thought of as a set of instructions for making each of a very large number of **proteins**. The creation of a protein from its gene is called gene expression. However, for a given cell not all of these instructions are actually used, and among those that are, some are used more than others or only under certain circumstances. Controlling gene expression is critical to a cell because it allows it to avoid wasting energy and raw materials in the synthesis of proteins it does not need. Thus, it allows a cell to be a more streamlined and versatile entity that can respond to changing conditions by adjusting its physiology.

To understand the control of gene expression, two key concepts should be understood. First, gene expression requires **transcription**, the process of making a messenger ribonucleic acid (mRNA) copy of the deoxyribonucleic acid (DNA) gene. Transcription can only occur if RNA polymerase first attaches, or binds, to the DNA. Controlling this binding process is the major way that gene expression is controlled, and proteins are the major controllers of binding.

The second important concept is that a protein molecule that helps regulate binding can itself be regulated. This usually occurs when some other molecule binds to the protein, causing the protein to undergo a structural change, in other words, to change shape. In some cases this shape change will help **RNA polymerase** to bind to DNA, and in other cases it will prevent it from doing so.

**Control in Prokaryotes**

**Negative Control.** The concept that gene expression could be controlled originated with studies done in the 1950s by French scientists François Jacob and Jacques Monod. They were studying the **metabolism** of a sugar, called lactose, by the *E. coli* bacterium. **β**-Lactose metabolism requires three proteins. Galactosidase and lactose permease are both involved directly in lactose metabolism; **β**-galactosidase **hydrolyzes** lactose into galactose and **glucose**, and lactose permease transports lactose across the bacterial cell membrane. The physiologic role of the third protein, thiogalactoside acetylase, is unclear. Jacob and Monod found that the amount of the three proteins all increased when *E. coli* were cultured in lactose-containing medium

**protein** complex molecule made from amino acids; used in cells for structure, signaling, and controlling reactions

**transcription** messenger RNA formation from a DNA sequence

**RNA polymerase** enzyme complex that creates RNA from DNA template

**metabolism** chemical reactions within a cell

**β** the Greek letter beta

**hydrolyze** to split apart using water

**glucose** simple sugar that provides energy to animal cells and is the building block of cellulose in plants

(a nutrient source). This led to the hypothesis that the three genes were regulated together as a single unit.

This type of multigene unit was dubbed an “operon” and consists of the structural genes, which encode proteins, plus regulatory sequences lying upstream on the DNA. The structural genes in an operon are **transcribed** as a single mRNA, and the mRNA is thus polygenic (or polycistronic). An elegant series of experiments showed that transcription was begun when a lactose derivative, Allolactose, caused a repressor to be removed from the transcription initiation site. Thus, lactose regulates the synthesis of the **enzymes** necessary for its own metabolism by releasing the transcriptional repression imposed upon them. This type of regulation is called negative regulation, since it employs a repression to prevent transcription. The use of activator proteins in the positive control of gene expression is also common in **prokaryotes**. In this system, the activator protein promotes transcription.

**Positive Control.** Positive control of gene expression is illustrated by the transcriptional activator, catabolite gene activator protein (CAP). CAP activates transcription of the lac operon, in addition to many other **inducible** operons. Because glucose is a preferred food source, the lac operon is not activated in *E. coli* cells cultured in medium containing both glucose and lactose until the glucose is used up. However, since lactose is present, one might expect the lac operon to be derepressed and hence active. But experiments have shown that glucose itself represses the activity of the lac operon, such that only when lactose is the only source of energy is it activated. This glucose repression is observed for a number of other operons that encode enzymes for the utilization of alternative energy sources. Glucose repression occurs via a positive mechanism. As glucose is consumed, its level in the cell drops. Low glucose levels stimulate the production of a small molecule called cyclic-AMP (cAMP), which then binds CAP. CAP undergoes a structural change that allows it to bind DNA and activate transcription. Thus, regulation of the lac operon is achieved by a collaboration between the negative control of the lac repressor and the positive control of CAP.

The lac repressor and CAP are examples of regulators of initiation of transcription. Although most regulators act at this level, some act at the level of elongation of the mRNA, after transcription has started. The tryptophan operon (trp operon) consists of five structural genes necessary for the biosynthesis of the **amino acid** tryptophan. It is regulated at the level of initiation via a negative regulatory scheme much like that for the lac operon; however, an additional mechanism, called transcriptional **attenuation**, is also at work. Part of the mRNA generated from the trp operon spontaneously folds into a stem-loop structure that exposes a termination sequence, causing transcription to terminate prematurely. However, when tryptophan is lacking, the **ribosome** works more slowly (since tryptophan is needed to make protein). This allows time for the formation of a different structure, the stem-loop, which hides the termination sequence, with the result being that transcription continues and a full-length transcript is produced. Thus, the end product of the operon, tryptophan, actively participates in the regulation of its own synthesis. This is a common theme in prokaryotic transcriptional regulation. Transcriptional attenuation can occur in prokaryotes

**transcribe** creation of an RNA copy of a DNA gene

**enzyme** protein that controls a reaction in a cell

**prokaryote** single-celled organism without a nucleus

**inducible** able to be switched on

**AMP** adenosine monophosphate, form of ATP after removal of two phosphate groups

**amino acid** a building block of protein

**attenuation** lessening over time

**ribosome** protein-RNA complex in cells that synthesizes protein

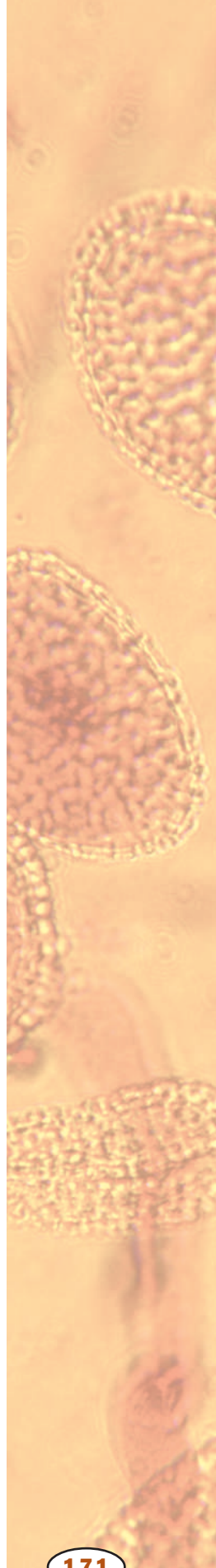

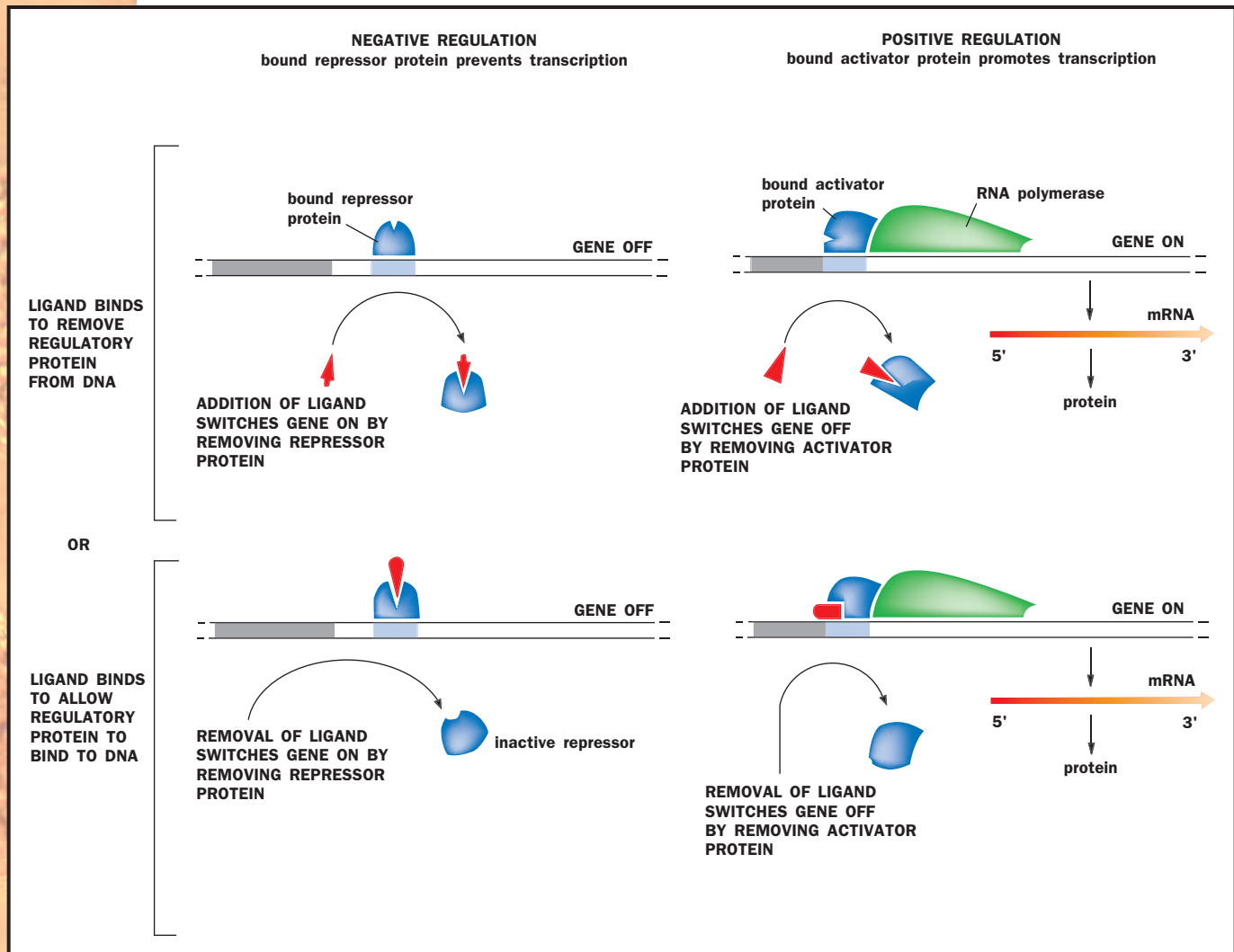

The mechanisms by which gene regulatory proteins control gene transcription in prokaryotes. A ligand is a small molecule that binds to a protein.

**translation** synthesis of protein using mRNA code

**nucleus** membrane-bound portion of cell containing the chromosomes

**chromosome** "colored body" in the cell nucleus; made of DNA and protein, and divided functionally into genes and non-gene regions

because **translation** of an mRNA begins before its synthesis is complete. In eukaryotes it does not occur because transcription and translation are completely separate processes that do not occur simultaneously.

## Eukaryotic Transcription

Regulation of transcription is by necessity far more complex in eukaryotic cells (cells with a **nucleus**) than in prokaryotic cells. Not only are eukaryotic cells larger and more highly compartmentalized, but multicellular eukaryotes pass through a number of developmental stages, each requiring different proteins, on the road to their final differentiated state. Also, multicellular organisms contain many different cell types, each of which expresses distinct sets of proteins.

Certain basic features of transcriptional regulation are shared between prokaryotes and eukaryotes; in both cases it involves an interplay between activators and repressors that bind cis-acting sequences on DNA. However, one major difference is that, unlike prokaryotic DNA, eukaryotic **chromosomes** are wrapped around proteins called **histones**, to form a condensed form of DNA called **chromatin**. This tends to repress gene transcription,

and several transcriptional activators have been found to function by relieving chromatin-induced repression. Another feature that distinguishes eukaryotic from prokaryotic transcription is that RNA polymerase does not bind directly to DNA but instead binds via a set of proteins called the basic **transcription factor**. Thus, in many cases the role of activators is to recruit these transcription factors to the **promoter** site rather than to directly recruit the polymerase itself. Finally, whereas prokaryotic genes are often controlled by only one or two regulatory proteins, eukaryotic genes are typically controlled by a multiplicity of factors. This added complexity allows for the fine-tuning of gene activity in response to multiple stimuli.

### Structure of Transcriptional Activators

Many transcriptional activators are essentially modular in structure in that the DNA-binding domain and the transactivation (or activation) domain can almost be thought of as two distinct proteins that are physically linked. The DNA-binding domain is the part of the molecule that contacts DNA at the promoter site. The transactivation domain is the part that recruits other factors to the promoter such that the rate of transcription of the gene increases. Although transcription factor DNA-binding domains vary in amino acid sequence, many can be placed into structural categories based on their three-dimensional structures. Among these are the zinc finger, helix-loop-helix,

**histone** protein around which DNA wraps to form chromosomes

**chromatin** complex of DNA, histones, and other proteins making up chromosomes

**transcription factor** protein that increases the rate of transcription of a gene

**promoter** DNA sequence to which RNA polymerase binds to begin transcription

#### REGULATION OF THE LAC OPERON

*E. coli* with defects in the regulation of the lac operon were found to have mutations in one of two loci, called *o* and *i*, located upstream of the structural genes. Mutations in *o* yielded cells that constitutively (continually) expressed the lac operon, whereas mutations in *i* fell into two categories; one in which the lac operon was constitutively expressed, and the other in which it was uninducible (could not be expressed). Subsequent experiments showed that *i* was a gene for a diffusible protein that was the repressor of the lac operon, whereas *o* was a DNA sequence to which a repressor bound.

This was consistent with the mutant results: A mutation in *o* would disrupt the binding of the repressor protein, leading to constitutive expression of the lac operon, and a mutation in *i* would either prevent the repressor from binding to *o*, resulting in constitutive activation, or render the repressor unresponsive to the inducer, lactose, which would cause uninducibility. Because *i* was diffusible (could move within the cell) and could interact with any piece of DNA containing its target sequence, it was called a trans-acting factor (*trans* means “across”). In contrast, *o* only affects the genes to which it is physically linked and so has been called a cis-acting factor (*cis* means “together”). These elegant genetic studies paved the way for biochemical studies carried out in the 1960s by Walter Gilbert and Benno Müller-Hill. They purified the *lac repressor*, encoded by *i*, and found that it bound to a 30 base-pair region of DNA spanning the transcription initiation site, consistent with the location of *o*. In addition, they found that the lac repressor released its hold on *o* when bound to allolactose, a derivative of lactose.

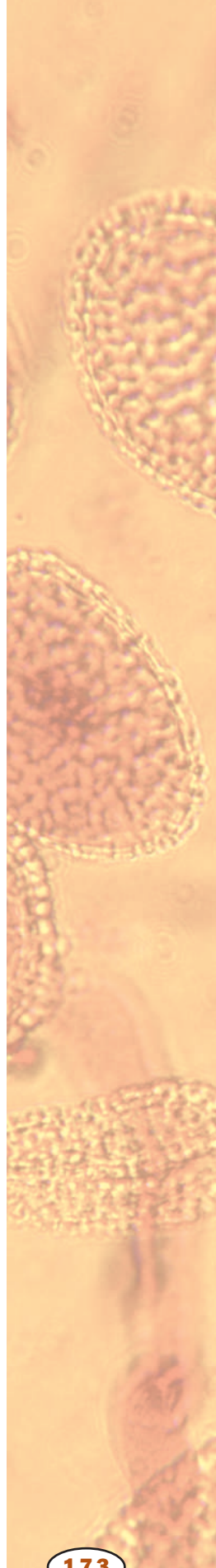

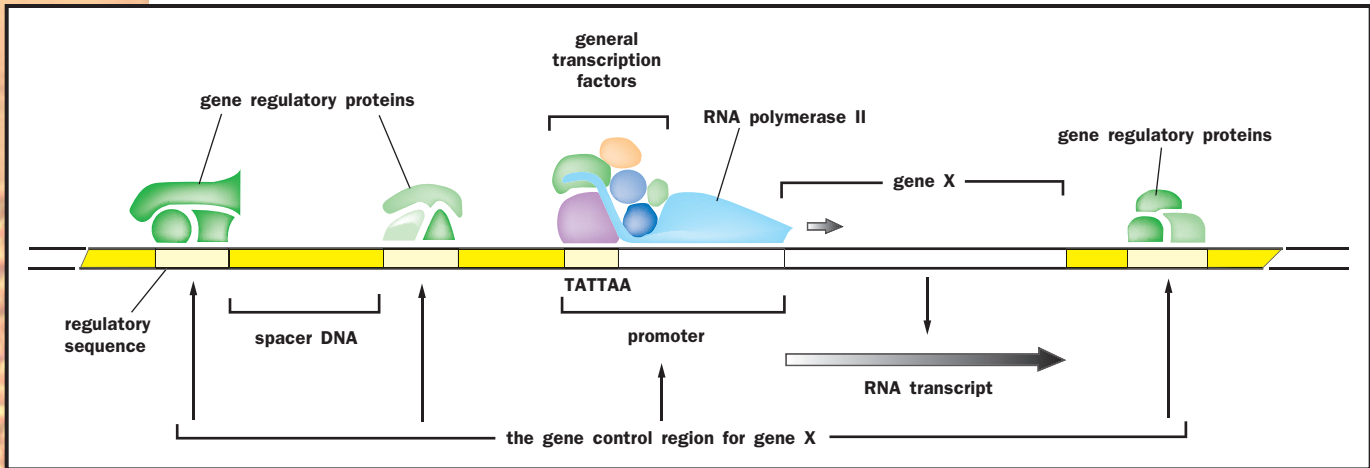

The gene control region of a eukaryotic gene.

**acidic** having an excess of  $H^+$  ions, and a low pH

**antibody** immune system protein that binds to foreign molecules

**B lymphocyte** white blood cell that makes antibodies

**cytoplasm** material in a cell, excluding the nucleus

**phosphorylate** add a phosphate group to

and helix-turn-helix classes. Although the three-dimensional structures within a class are similar, each individual binding domain can recognize a different DNA sequence due to specific amino acid differences and different amino acid–DNA contacts. Many transcriptional activation domains can also be placed into categories, the most common of which is the **acidic** activation domain category. Others include the glutamine-rich and proline-rich classes.

### Regulation of Transcriptional Activators

Regulation of transcription sometimes occurs via the simple presence or absence of transcription factors. An example of this is in the regulation of the immunoglobulin (an immune protein, also called **antibody**) heavy chain gene, which is expressed in B lymphocytes (white blood cells that make antibodies) but not other cell types. This gene's enhancer (a region distant from the promoter) contains at least nine binding sites for regulatory proteins. The enhancer is acted on by activators present in **B lymphocytes**, while in nonlymphocyte cells repressors are present that inhibit transcription. This limits expression of the gene to lymphocytes.

Often, however, regulation does not occur at the level of presence or absence of a regulatory protein but rather by modulation of its activity. Thus, many transcription factors are always present in the cell, awaiting the specific signals that will convert them from an inactive to an active form. How is this achieved? The three most common mechanisms are regulation of nuclear localization, regulation of DNA binding, and regulation of transactivation.

**Regulation of Nuclear Localization.** In many cases a protein is kept in the **cytoplasm**, well away from its target genes, until a stimulus signals it to enter the nucleus and activate transcription. This mode of regulation works because transport into the nucleus is regulated, such that only proteins possessing a special tag are allowed to enter. The transcription factor  $NF-\kappa B$ , which regulates a number of genes in immune cells that help fight infections, is regulated in this way.  $NF-\kappa B$  is present in the cytoplasm of unstimulated immune cells as a complex with an inhibitory protein called  $\kappa B$ . Upon receiving a stimulus, such as a viral infection,  $\kappa B$  becomes **phosphorylated** and is sub-

sequently degraded, leaving NF- $\kappa$ B free to enter the nucleus and activate its target genes to help fight infection. Interestingly, one of these target genes is the  $\kappa$ B gene, and thus inhibition of NF- $\kappa$ B is reestablished shortly thereafter. This kind of negative **feedback** mechanism, bringing the cell back to its unstimulated state, is common among inducible genes. In addition, NF- $\kappa$ B activation illustrates another common feature of transcription factor regulation in eukaryotes: **phosphorylation** is often used as a switch that interconverts a transcription factor back and forth between inactive and active forms.

**Regulation of DNA Binding.** A second common mechanism by which the activity of a transcription factor is controlled is through alteration of its DNA-binding ability. The **steroid hormone** receptor family is a good example of this. This family of transcription factors has many members, all related in structure, yet binding to distinct steroid hormones on the one hand, and activating distinct sets of genes on the other. Some of these hormone receptors reside in the cytoplasm and others in the nucleus, but all are unable to bind their target DNA sequence until they first bind to their corresponding steroid hormone. This causes them to undergo a conformational change that increases their **affinity** for DNA, allowing them to bind. It is through their action on hormone receptors and DNA that steroid hormones exert their powerful effects on the body's cells.

Another way to increase the DNA-binding ability of a transcription factor is to induce it to multimerize. Many factors are inactive by themselves, but when induced to bind other factors, they can bind their target sequences and activate transcription. The other factors can either be identical molecules of the same factor, thus forming homo-multimers, or different proteins, forming hetero-multimers. An example of this occurs with heat shock factor (HSF) in mammalian cells, which upon stimulation forms homotrimers. The DNA-binding affinity of a single molecule of HSF for its binding site is too low to be physiologically significant; however, a complex of three molecules binds the target site very tightly, making HSF one of the most inducible transcription factors known.

**Regulation of Transactivation.** Finally, some transcriptional activators are already bound to their target sites in gene promoters but remain transcriptionally inactive until they are stimulated. In yeast, HSF is already trimerized and bound to some of its target genes in unstimulated cells. Heat shock (a rise in temperature) results in phosphorylation of HSF at multiple sites, which induces a structural change in the protein that unleashes the transactivation domain.

The aforementioned examples illustrate a number of ways in which a transcriptional activator may be regulated. However, it should be kept in mind that many are regulated in more than one way. For example, both nuclear localization and DNA-binding ability of an activator may be controlled. Thus, even if a few molecules should happen into the nucleus by mistake, they would not be able to bind and activate their target genes. This kind of tight control is important because sometimes even small levels of a protein can set off a cascade of reactions that can dramatically change the physiology of the cell. It is critical to avoid these types of false alarms in order for the cell not to waste valuable energy and resources, and so that it remains poised to respond to a genuine stimulus.

**feedback** process in which the output or result influences the rate of the process

**phosphorylation** addition of the phosphate group  $\text{PO}_4^{3-}$

**steroid hormone** group of hormones that include estrogen, testosterone, and progesterone

**affinity** attraction

In the laboratory the DNA-binding domain and the transactivation domain—the two functional domains—can be mixed and matched between different transcription factors to yield hybrid molecules that still function, albeit differently from the original proteins. This feature has been exploited experimentally. For example, the relative strengths of various activation domains can be assessed by fusing each to the same DNA-binding domain and determining the rate at which each promotes transcription.



## Transcriptional Repression

Transcriptional repressors, like activators, bind cis-acting sequences in the genes they regulate and are modular in structure, possessing distinct DNA-binding and repressor domains. However, as their name implies, their role is in the repression of gene activity rather than their activation. Some repressors function by simply binding upstream regions of genes and blocking the binding of either activator proteins or the polymerase itself, much like the repressor in the lac operon. Some extremely versatile proteins can function either as repressors or activators, depending on the proteins with which they interact. An example is the Mcm1 protein in yeast. Yeast can be one of two mating types, called  $\alpha$  and (“alpha”), each of which expresses mating type-specific sets of genes. Mcm1 **dimerizes** with one protein to repress the  $\alpha$ -specific genes in  $\alpha$  cells, and with another to activate the  $\alpha$ -specific genes.

$\alpha$  the Greek letter alpha  
**dimerizes** forms a pair

## The Role of Chromatin

Although transcriptional repressors often participate in gene regulation, it must be kept in mind that the very nature of DNA in eukaryotic cells tends to keep genes in the repressed state. Eukaryotic DNA is wrapped around protein complexes called histone octamers, which has the effect of packaging the DNA into a compact form such that it fits inside the nucleus. However, this also limits access of regulatory factors to their target sites. As the mechanisms of transcriptional activators are being uncovered, more and more are being found that act by relieving chromatin-induced repression. An example is the Swi/Snf protein complex, first identified in yeast. Mutations in components of the complex resulted in decreased activity of certain target genes. It was later found that mutations in the histone genes restored normal activity to those target genes; in other words, the mutations in the histone genes somehow compensated for the mutations in Swi/Snf. This was an indication that histones and Swi/Snf interact in some way and suggested that Swi/Snf might function by disrupting histone binding to DNA. Biochemical experiments carried out later on showed that this was indeed the case. Although Swi/Snf does not completely **dissociate** histones from DNA, it loosens them, which is sufficient to allow many activators to bind. Swi/Snf is only involved in activating a subset of genes, and the question of why it functions at some promoters and not others is a topic of intense research.

**dissociate** break apart

Mutations in the MeCP2 cause Rett syndrome, an X-linked dominant disorder marked by seizures, abnormal movements, and mutism.

A second mechanism by which chromatin-induced repression is relieved is by histone **acetylation**. Histones are positively charged proteins and hence interact tightly with DNA, which is negatively charged. Acetylation of histones reduces their net positive charge, which loosens their interaction with DNA and increases transcription factor binding. Several transcription factors in a variety of organisms have now been found to be acetyltransferases; in effect, they can acetylate histones.

**acetylation** addition of an acetyl group, CH<sub>3</sub>-CHOO-

**methylation** addition of the methyl group CH<sub>3</sub>

In addition, some transcriptional repressors in yeast and mammals have been found to be histone deacetylases. In fact, the protein MeCP2, which binds to methylated DNA, has been found to function in a complex with a histone deacetylase. Thus, **methylation** would lead to binding of this complex, causing deacetylation of histones and a more condensed chromatin structure. Methylated DNA has long been known to be associated with tran-

scriptionally inactive genes, and inroads into the study of histone acetylation have finally provided an explanation for this. SEE ALSO CHROMOSOME, EUKARYOTIC; CONTROL MECHANISMS; DNA; GENE

Kirstie Saltsman

### Bibliography

Stryer, Lubert. "Control of Gene Expression in Prokaryotes." In *Biochemistry*, 4th ed. New York: W. H. Freeman and Company, 1995.

———. "Eukaryotic Chromosomes and Gene Expression." In *Biochemistry*, 4th ed. New York: W. H. Freeman and Company, 1995.

## Control Mechanisms

The cell possesses an extraordinary array of **enzymes**, each specialized to carry out an important function in the cell. However, in many cases it is critical that the enzymes only be active at certain times and not others. For example, the digestive enzymes secreted by cells lining the stomach and intestine must only be active once they have been secreted and not before. If they were active prior to secretion they would degrade the **proteins** within the very cells that synthesized them. Or consider the enzymes that carry out the many activities of cell division. If these are not held in tight control, a cell will divide inappropriately and may become cancerous.

Thus, it is critical for the cell to be able to control the activities of many of its enzymes, and a number of intricate mechanisms have evolved to do just that. In most cases the activity of an enzyme is achieved via changes in its conformation, or shape, and the four most common ways of achieving this are regulation by small molecules; regulation by **phosphorylation**; regulation by protein-interactions; and regulation by proteolytic cleavage.

### Regulation by Small Molecules

Regulation of an enzyme can occur by the binding of a small molecule to a site distant from the **active site**, which is the binding site for the enzyme's **substrate**. This is called allosteric regulation (from the Greek *allo*, meaning "other," and *steric*, meaning "site"). Because the small molecule does not bind the active site, it does not function by blocking access to the substrate. Instead, it acts by changing the conformation of the protein. A classic example of this occurs with an enzyme called aspartate transcarbamoylase (ATCase) from the bacterium *E. coli*.

ATCase is the first enzyme in a series of enzymes whose end product is cytidine triphosphate (CTP), which is used to make ribonucleic acid (RNA) and deoxyribonucleic acid (DNA). CTP has been found to bind to ATCase and inhibit its activity. The binding of CTP to ATCase changes the conformation of the active site such that the **affinity** for substrates is decreased by up to 90 percent. Thus, the buildup of CTP shuts the entire pathway off, thereby maintaining a fairly constant supply. This type of inhibition, in which the end product of a reaction inhibits its own synthesis, is called feedback inhibition and is a common regulatory mechanism in biologic pathways. In a more extreme case, the **amino acid** tryptophan goes so far as to inhibit the synthesis of the mRNAs encoding the **biosynthetic**

**enzyme** protein that controls a reaction in a cell

**protein** complex molecule made from amino acids; used in cells for structure, signaling, and controlling reactions

**phosphorylation** addition of the phosphate group  $\text{PO}_4^{3-}$

**active site** surface region of an enzyme where it catalyzes its reaction

**substrate** the molecule acted on by an enzyme

**affinity** attraction

**amino acid** a building block of protein

**biosynthetic** forming a complex molecule from simpler ones

Although G-proteins have intrinsic GTPase activity, this activity can often be further stimulated by a protein called a GTPase activating protein (GAP).

enzymes that synthesize it. Thus, in that case, the enzymes themselves are not even synthesized until they are needed.

An important class of proteins regulated by small molecules are the G-proteins. They are called G-proteins because they bind and are activated by guanosine triphosphate (GTP). G-proteins have intrinsic GTPase activity, meaning they convert the bound GTP molecule to GDP (guanosine diphosphate). Typically, when GDP is bound, the conformation of the protein is such that the molecule is inactive. A protein called a GTP exchange factor (GEF) stimulates the exchange of GDP for GTP, thus reactivating the G-protein.

The ras protein is a G-protein found in a number of different organisms. Research has shown that ras activates proteins involved in cell growth and division. It was first discovered in a virus that causes tumors in mice. It causes tumors when it is mutated such that its GTPase activity is defective. This causes the protein to always be bound to GTP (instead of GDP) and hence it remains active. Thus, overactive ras causes uncontrolled cell proliferation and cancer. It has since been found that up to 15 percent of human cancers involve a mutation in ras that inhibits its GTPase activity, making it an important protein in human disease. The normal protein is only activated when stimulants outside the cell, such as growth factors, signal it to grow and proliferate. Following a short period of activity, inherent GTPase activity of the ras returns it to the inactive form.

Interestingly, in the fruit fly, *Drosophila melanogaster*, ras serves a different function. The structure and regulation of ras in *D. melanogaster* is similar to that in mammalian cells, but instead of participating in a pathway signaling cell proliferation, it is involved in a pathway leading to the differentiation of a certain type of cell in the eye, the photoreceptor cell. The regulation of protein activity by a GTP-GDP switch is apparently evolutionarily ancient and has been adapted to serve a variety of different cellular functions.

## Regulation by Phosphorylation

Phosphorylation means the addition of a phosphate group,  $\text{PO}_4^{3-}$ . Phosphorylation of certain amino acids in a protein can occur via the action of a group of proteins called **kinases**. Kinases are classified into two broad classes based on the amino acid they phosphorylate: the serine/threonine class and the tyrosine class. All three of these amino acids contain a **hydroxyl** (-OH) side chain, to which a phosphate group can be attached. Phosphorylation often occurs on more than one amino acid in a protein, and the result is a conformational change that affects the protein's activity. A second class of proteins, called phosphatases, reverses the activity of kinases by removing the phosphates, returning the proteins to their original forms. Phosphatases are also categorized by their substrate specificities, either serine/threonine or tyrosine, however, a few have the ability to dephosphorylate all three amino acid side chains. In the example of regulation by phosphorylation described below, dephosphorylation leads to activation. This is not always the case, and equally as many proteins are activated by phosphorylation.

Nuclear factor of activated **T cells** (NFAT) is a protein regulated by phosphorylation. NFAT is a **transcription factor** that is found in the

**kinase** enzyme that adds a phosphate group to another molecule, usually a protein

**hydroxyl** chemical group consisting of -OH

**T cell** white blood cell that controls the immune response

**transcription factor** protein that increases the rate of transcription of a gene

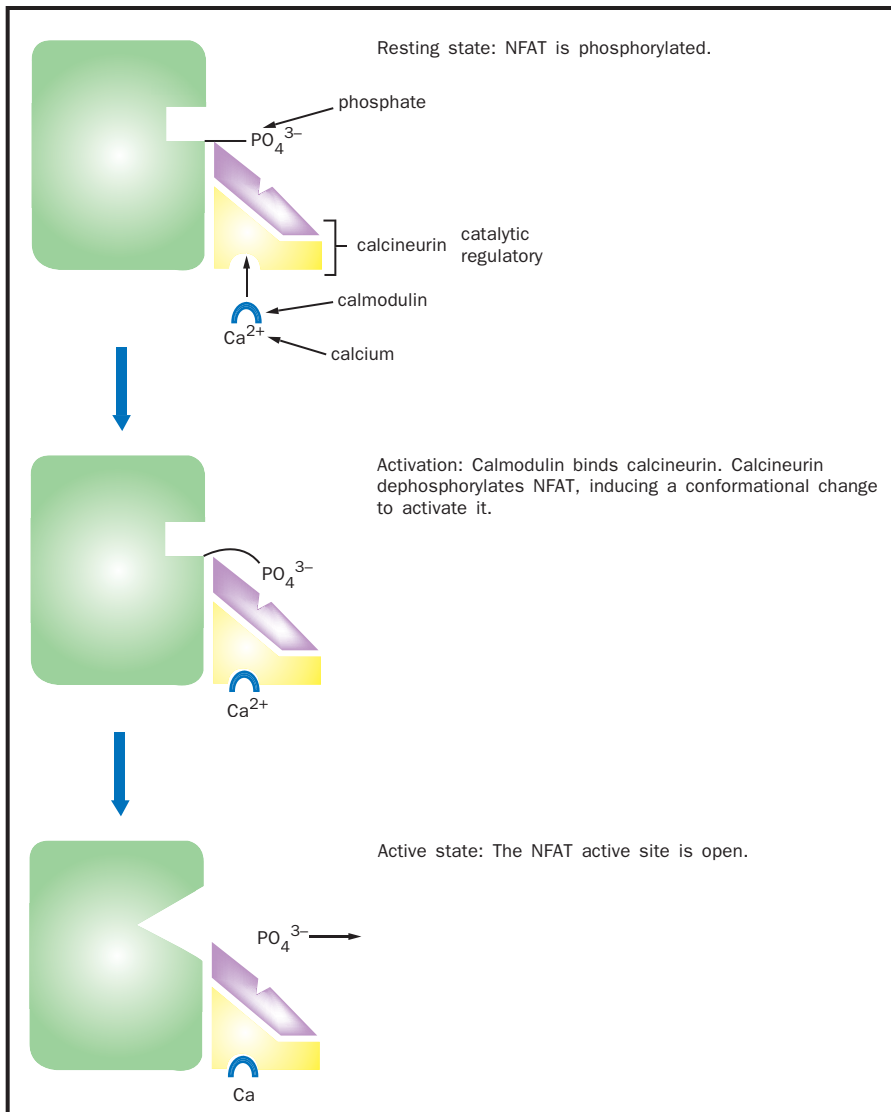

**cytoplasm** and is phosphorylated in resting cells. Dephosphorylation causes a conformational change that allows it to be transported to the **nucleus**, where it binds other transcription factors to activate **gene transcription**. NFAT was first found to activate genes in T cells (an immune cell); however, it has since been found in a number of other cell types as well.

The phosphatase that dephosphorylates and activates NFAT is called calcineurin, which is of the serine/threonine class. Even when inactive, calcineurin is bound to NFAT, ensuring a rapid response upon activation. Stimulation by an inducer such as a viral infection or perhaps an organ transplant causes the activation of calcineurin, which then makes additional contacts with NFAT via its active site and dephosphorylates it. This activates NFAT, aiding the immune response by the T cell.

### Regulation by Protein-Protein Interactions

Many enzymes are regulated by binding to another protein. For example, transcription factors, such as heat shock factor (HSF), can be activated by

**cytoplasm** material in a cell, excluding the nucleus

**nucleus** membrane-bound portion of cell containing the chromosomes

**gene** portion of DNA that codes for a protein or RNA molecule

**transcription** messenger RNA formation from a DNA sequence

Phosphorylation or dephosphorylation causes a conformational change that affects the protein's activity.

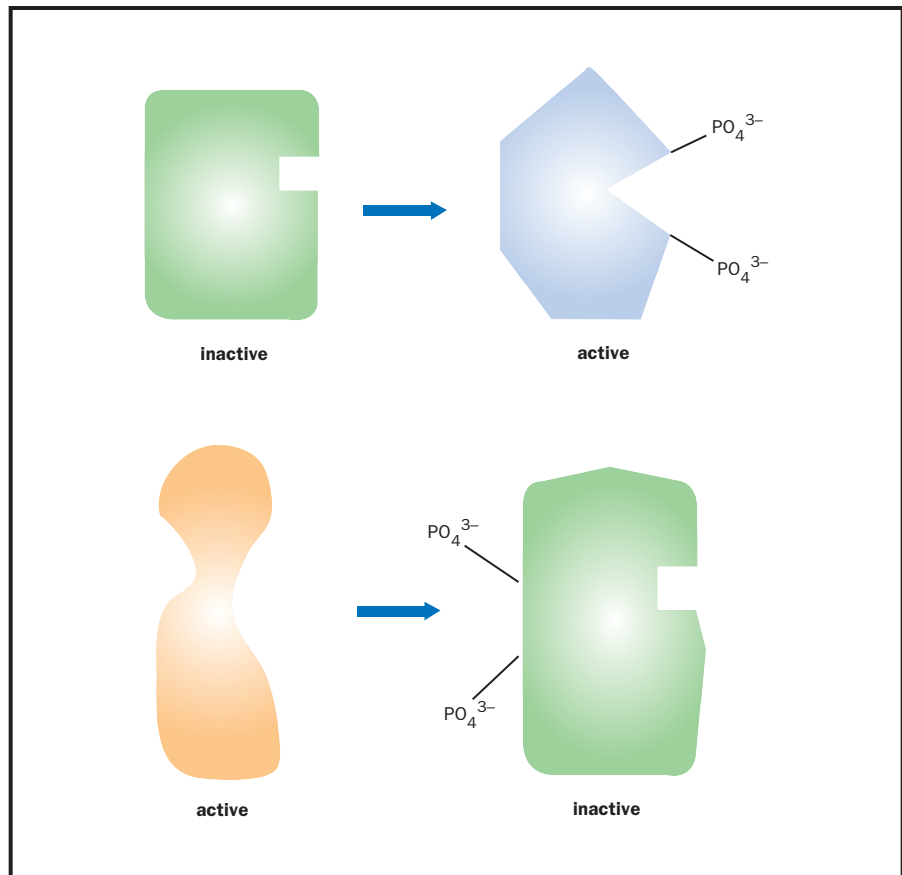

binding to other copies of itself (homomultimerization). In addition, inactivation of a protein can also occur by protein-protein interactions.

Although HSF activation occurs by binding of identical molecules to one another, often regulation by protein-protein interactions occurs between different proteins. For example, calcineurin, the phosphatase that activates NFAT, is itself regulated by protein-protein interactions. Calcineurin is composed of two **polypeptide** subunits, one catalytic and one regulatory. The catalytic subunit contains the active site and is the part of the enzyme that dephosphorylates NFAT. The regulatory subunit binds the catalytic subunit and keeps it inactive by blocking the active site until a stimulus is detected.

The stimulus for calcineurin activation is increased cytoplasmic calcium levels. Calcium, together with a small protein called calmodulin, binds calcineurin, which results in the displacement of the regulatory subunit, exposing the active site and allowing it to dephosphorylate NFAT. Thus, calcineurin is an example of an enzyme that is regulated by both small molecules (calcium) and proteins (the regulatory subunit and calmodulin).

Another example of this occurs with a kinase called cAMP-dependent protein kinase, which in resting cells consists of a complex of two catalytic and two regulatory subunits. As with calcineurin, the regulatory subunits keep the kinase inactive until cyclic AMP (cAMP), a small molecule derived from adenosine monophosphate (**AMP**), binds and activates the kinase. In this case, however, the regulatory subunits completely **dissociate**

**polypeptide** chain of amino acids

**AMP** adenosine monophosphate, form of ATP after removal of two phosphate groups

**dissociate** break apart

from the catalytic subunits, rather than simply shifting their position as in calcineurin.

### Regulation by Proteolytic Cleavage

A number of proteins are activated by **proteolytic** cleavage, that is, they are synthesized as a longer protein that is inactive and are later cleaved into a smaller, active form. The inactive precursor is called a zymogen, or proenzyme. For example, the **hormone** insulin is derived from proinsulin by proteolytic cleavage, as are many of the proteins involved in blood clotting. In addition, many digestive enzymes are activated by cleavage. Trypsinogen is a zymogen that upon cleavage becomes the digestive enzyme trypsin. Trypsinogen is made in the pancreas and secreted into the duodenum (the small intestine) where it is cleaved by an enzyme called enteropeptidase. The small amount of trypsin made by enteropeptidase then goes on to cleave other molecules of trypsinogen to make more trypsin as well as cleaving the other pancreatic zymogens into their active forms, and thus trypsin can be thought of as a master switch in the digestive process.

Unlike the other control mechanisms described above, proteolytic cleavage is irreversible, and thus once cleavage has occurred the enzyme cannot be returned to its inactive form. Thus, enzymes activated in this way may need to be turned off via other mechanisms. In the case of trypsin, there exists a small protein called pancreatic trypsin inhibitor that binds to trypsin's active site and inhibits its activity. It binds the active site so tightly that even very harsh conditions used to dissociate proteins in the laboratory are ineffective at removing it. This extremely effective inhibitor has probably evolved to target trypsin because of its role as a master switch in the regulation of digestion in the small intestine. Once trypsin has been inactivated, proteolytic soon ceases, and digestion comes to a halt. **SEE ALSO CELL CYCLE; CONTROL OF GENE EXPRESSION; DIGESTION; DIGESTIVE SYSTEM; ENZYMES; ONCOGENES AND CANCER CELLS; SIGNALING AND SIGNAL TRANSDUCTION**

*Kirstie Saltsman*

#### Bibliography

Cooper, Geoffrey. "Protein Synthesis, Processing and Regulation." In *The Cell: A Molecular Approach*. Sunderland, MA: Sinauer Associates, Inc., 1997.

Stryer, Lubert. "Regulatory Strategies." In *Biochemistry*, 4th ed. New York: W. H. Freeman and Company, 1995.

**proteolytic** breakdown of proteins

**hormone** molecule released by one cell to influence another

Calcineurin is the target of immunosuppressive drugs used to treat patients following an organ transplant.

## Convergent Evolution

Convergent evolution is the process by which unrelated or distantly related organisms evolve similar adaptations. Organisms displaying these similarities usually live in similar environments, and the force driving convergence is natural selection. Similar environments pose similar challenges to survival, and traits that aid in survival are selected for in each environment. Convergent evolution is seen in the fusiform (tapering toward the end) shapes and similar countershading coloration of sharks and dolphins, both of which are adapted to marine environments. Their shape facilitates rapid and effi-

A sand skink in Polk County, Florida. Some of the most striking examples of convergent evolution are found in desert lizards throughout the world.



cient movement through water, and their light underbelly and a gray upper surface make them less visible from both below and above.

### Convergent Evolution in Desert Lizards

Some of the most striking examples of convergent evolution are found in desert lizards throughout the world. Australian and North American deserts each support a cryptically colored lizard species that is specialized to eat ants and is protected by sharp spines. The Australian species, the thorny devil (*Moloch horridus*, Agamid family) is only distantly related to the American species, the desert horned lizard (*Phrynosoma platyrhinos* Iguanid family), as shown by sequencing deoxyribonucleic acid (DNA). They are much more similar anatomically than either is to its closest living relatives. Clearly, the desert environment has posed strong challenges for survival, which have been met by evolution of similar external characteristics.

Open sandy deserts pose severe problems for their inhabitants: (1) wind-blown sands are loose and provide little traction; (2) surface temperatures at midday rise to lethal levels; and (3) open sandy areas offer little food or shade or shelter for evading predators. Even so, natural selection over eons of time has enabled lizards to cope fairly well with such sandy desert conditions. Subterranean lizards simply bypass most problems by staying underground and actually benefit from the loose sand because underground locomotion is facilitated. Burrowing is also made easier by evolution of a pointed, shovel-shaped head and a countersunk lower jaw, as well as by small limbs and muscular bodies and tails.

During the hours shortly after sunrise, but before sand temperatures climb too high, **diurnal** lizards scurry about above ground in such sandy desert habitats. Sand-specialized lizards provide some of the most striking examples of convergent evolution. Representatives of many different families of lizards scattered throughout the world's deserts have found a similar solution for getting better traction on loose sand: enlarged scales on the toes, or lamellae, have evolved independently in six different families of lizards: skinks, lacertids, iguanids, agamids, gerrhosaurids, and geckos.

**diurnal** active during the daytime

A skink (*Scincus philbyi*), appropriately dubbed the “sand fish”, literally swims through sandy seas in search of insect food in the Sahara. These sandy desert regions also support lacertid lizards (*Acanthodactylus*) with fringed toes and shovel noses. Far away in the Southern Hemisphere, on windblown dunes of the Namib desert of southwestern Africa, an independent **lineage** of lacertids has evolved a similar life form, *Meroles anchietae*. Such organisms that fill similar ecological **niches** in different regions have undergone convergent evolution and are called “ecological equivalents.”

In North America, this body form has been adopted by members of the iguanid genus *Uma*, which usually forage by waiting in the open and eat a fairly diverse diet of various insects, such as sand roaches, beetle larvae, and other burrowing **arthropods**. They also listen intently for insects buried in the sand and dig them up. Sometimes they dash, dig, and paw through a patch of sand and then watch the disturbed area for movements.

All of these lizards have flattened, duckbill-like, shovel-nosed snouts, which enable them to make remarkable “dives” into the sand even while running at full speed. The lizards then wriggle along under the surface, sometimes for over a meter. **SEE ALSO** ADAPTATION; DESERT; EVOLUTION; NATURAL SELECTION

*Eric R. Pianka*

### Bibliography

Pianka, E. R. *Evolutionary Ecology*, 6th ed. San Francisco, CA: Addison-Wesley-Longman, 2000.

## Coral Reef

A coral reef is a living community built around the accumulated mineralized remains of coral animals, which belong to **phylum** Cnidaria. The hardened calcium carbonate **secretion** from coral animals, with mineralized algal cells and other secretions, create nooks and crannies that shelter up to sixty thousand species, including hundreds of types of corals, as well as eels, lobsters, sea slugs, sea horses, sea urchins, turtles, and a huge variety of fishes. A coral reef houses some permanent occupants, and others that come and go. Often life lives within life. For example, snapping shrimp dwell in sponges that occupy crevices in layers of coral.

A living coral animal, called a polyp, is small and soft. Polyps collect atop their preserved ancestors, using their waving tentacles to capture prey that floats by. The sticky calcium carbonate **exoskeletons** that polyps secrete meld them to each other and to the graveyard below.

The tides deliver nutrients to coral polyps. Algal and dinoflagellate **symbionts** live inside the corals and actively photosynthesize, providing nutrients to their hosts and contributing the vibrant colors that give coral reefs their rainbow hues. These guests remove wastes from polyps and maintain water **pH** at a level that stimulates deposition of the exoskeletons. A million such symbionts may occupy a mere 2 cubic inches of coral reef. Were it not for the photosynthesis that the algae and dinoflagellates provide, the coral could not survive.

**lineage** ancestral line

**niche** the habitat supplying the right environment for a particular species

**arthropods** organisms with jointed appendages and exoskeletons, including insects, spiders, and crustaceans

**phylum** taxonomic level below kingdom, e.g., arthropod or chordate

**secretion** material released from the cell

**exoskeleton** external skeleton

**symbionts** organisms living in close association with another organism

**pH** measure of acidity or alkalinity; numbers below 7 are acid, above are basic

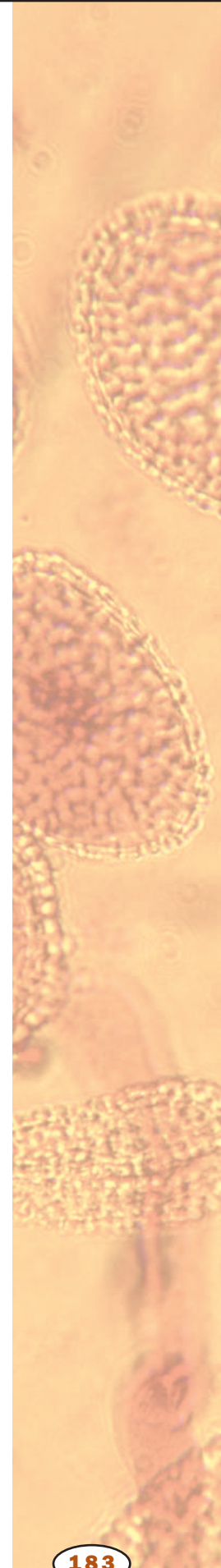





An aerial view of the Great Barrier Reef, between Cairns and Townsville, Australia.

### Extent and Diversity

Corals cover 242,000 square kilometers (232,000 square miles) of ocean. Most reefs lie between 25 degrees north and south latitude, with more isolated growths in cooler waters farther from the equator. Most species require clear, warm water of about 20 degrees Celsius (68 degrees Fahrenheit). Less massive corals are found in colder waters that hug continents, including the fjords in Norway and along vertical banks of the coasts of England, New Zealand, Japan, and the western United States.

Biologists distinguish types of coral reefs by shape and organization. An atoll is a ring-shaped coral colony that encloses a lagoon, whereas a fringing reef forms next to shores where there isn't much rain, such as on one side of a tropical island. Barrier reefs surround islands or run alongside shorelines, enclosing lagoons. The Australian Great Barrier Reef is 1,303 square kilometers (1,250 square miles) long.

### Threats to Coral Reefs

Many coral reefs are threatened, either by nature, human activity, or both. Winds destroy the delicate substructure of reefs, which have been damaged

both by the large-scale, long-lasting winds of El Niño and more localized but dramatic hurricanes. When stressed by climatic extremes, polyps disgorge their dinoflagellate symbionts, bleaching the coral. In addition, many corals in recent years have fallen victim to bacterial and viral infections. A dozen different viruses, for example, have decimated populations of elkhorn and staghorn corals in the Caribbean.

Building near shores threatens corals. Nitrogen and phosphorus fertilizer and soil in runoff from construction upsets the species balance of photosynthesizing symbionts.

Snorkelers are warned not to sample the coral, which many people erroneously think are plants or nonliving. In some areas, people catch fish by infiltrating living coral with explosives or cyanide, which often kills the coral and humans along with the fish. With all of these insults, ecologists estimate that by the middle of the twenty-first century, up to two-thirds of coral reefs may be gone. SEE ALSO ALGAE; BIOME; BONY FISH; CNIDARIAN; OCEAN ECOSYSTEMS; SOFT BOTTOMS; PORIFERA; SYMBIOSIS

*Ricki Lewis*

### **Bibliography**

Bryant, Dirk, Laretta Burke, John McManus, and Mark Spalding. *Reefs at Risk: A Map-Based Indicator of Threats to the World's Coral Reefs*. Washington, DC: World Resources Institute, 1998.

Crossette, Barbara. "World's Imperiled Shores and Coral Reefs to Get Millions in Aid." *The New York Times* (15 March 2001): F1.

Humann, Paul, and Ned DeLoach, eds. *The Reef Set*. Lancaster, CA: New World Publications, 1994.

Steene, Roger. *Coral Seas*. Willowdale, Ontario: Firefly Books, 1998.

## **Creationism**

In the broad sense, creationism is the belief that the universe and life were created by God. Within this definition are a broad range of beliefs. At one extreme are biblical literalists who believe that all life was created in its present form, including Adam and Eve as the first humans, as described in Genesis and with little or no evolutionary change since then (special creation). At the other end are creationists who have no quarrel with evolution and believe it is God's method of creating life (theistic evolution), the view accepted today by most Christian denominations.

In the United States, the creationism controversy began in earnest with the birth of Protestant fundamentalism in the 1910s. Fundamentalists, as they began calling themselves, argued for the literal truth of every word in the Bible, and thus rejected evolution and other philosophies of "modernism." They waged a campaign to outlaw the teaching of evolution and succeeded in getting five states to pass such laws from 1923 to 1929.

In Tennessee, this resulted in the famous Scopes trial of 1925, in which teacher John T. Scopes was convicted of teaching evolution. His fine was overturned on a technicality, but the Tennessee statute remained in effect until the legislature repealed it in 1967, both to improve the image of the state and to head off a threatened lawsuit. A similar law that had passed in 1928 in Arkansas was challenged by biology teacher Susan Epperson in 1965.

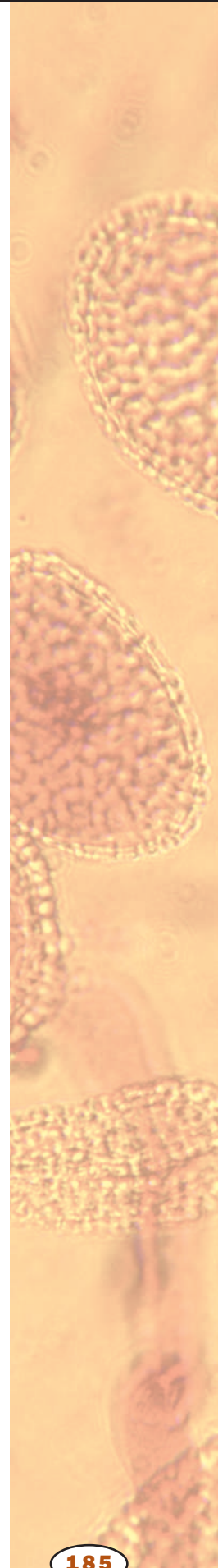

The U.S. Supreme Court ruled in her favor in 1968, stating that these anti-evolution statutes violated the First Amendment of the U.S. Constitution, which prohibits an entanglement of church and state. The last anti-evolution statute was repealed in 1969.

Creationists therefore changed their strategy. Briefly, they campaigned for laws to require “equal time for Genesis” if evolution was to be taught. Tennessee was the only state to pass such a law, in 1973, but it was overturned in court in 1975.

Failing at this tactic, creationists tried to have their views recognized as an alternative scientific theory and thus taught in the science curriculum. Many called their doctrine “scientific creationism,” and founded such organizations as the Creation Research Society and Institute for Creation Research to promote their views. “Scientific creationists,” as they called themselves, attacked the evidence for evolution, arguing over gaps in the fossil record, questioning the validity of radiometric dating, disputing the significance of human fossil remains, arguing that statistical probability or the laws of thermodynamics make evolution impossible, and claiming that geological features such as the Grand Canyon were evidence of Noah’s flood, among many other lines of attack.

The scientific community never took the claims of creationists seriously but did publish numerous books to educate the public on why the claims were fallacious and why creationism was not a science. They founded organizations such as the National Center for Science Education and state Committees of Correspondence to counter the strategies of creationists in legislatures, school boards, and the media.

Despite their failure to convince many scientists of their views, creationists were more successful at the political level. Arkansas and Louisiana passed laws requiring the teaching of “creation science” in 1981. The Arkansas law was quickly struck down in a federal district court in 1982, whereas the Louisiana case dragged out until 1987, when the law was finally struck down by the U.S. Supreme Court. Both courts ruled that creationism had no reason to be part of a science curriculum; they recognized that these laws represented merely fundamentalist religion in disguise and were therefore in violation of the First Amendment. Creationists continue to press their case with some success, however, in local school boards, state boards of education, and textbook adoption committees. The result is often a watering down of the curriculum to include less (often much less) about evolution.

The eminent geneticist Theodosius Dobzhansky declared, “Nothing in biology makes sense except in the light of evolution.” Because of the political efforts of creationists, evolution remains widely censored in biology courses today, and countless students are being kept in the dark about the facts of evolution. SEE ALSO DARWIN, CHARLES; EVOLUTION; EVOLUTION, EVIDENCE FOR; NATURAL SELECTION

*Kenneth S. Saladin*

#### **Bibliography**

Larson, Edward J. *Summer for the Gods*. New York: Basic Books, 1997.

National Center for Science Education. <<http://www.natcensci.ed.org>>.

Strahler, Arthur N. *Science and Earth History: The Evolution/Creation Controversy*. Buffalo, NY: Prometheus Books, 1987.

## Crick, Francis

### **British biophysicist**

**1916–**

Francis Harry Compton Crick, a British biophysicist, was co-winner of the Nobel Prize in physiology and medicine in 1962, for his work in genetics. This award was shared with American biologist James D. Watson and British biophysicist Maurice Wilkins.

Francis Crick, the son of a local shoe factory owner, was born on June 8, 1916, in Northampton England. He did his undergraduate work at University College, London, where he studied physics. Crick's science education was interrupted by World War II. After the war, in 1946, Crick's interest in chemical research was awakened after he attended a lecture given by American chemist Linus Pauling. Crick remained fascinated with **organic** molecules, and with quantum mechanics and the chemistry of genetics.

Crick went on to conduct research at the Cambridge Medical Research Council Unit at the famous Cavendish physics laboratory. He received his doctorate in 1953 from Cambridge University during the beginning of his collaboration with American biologist James Watson.

In 1952, at Cambridge, Crick and James Watson began to investigate the molecular structure, and significance to genetics, of nucleic acids. They began by looking specifically at earlier X-ray diffraction analyses of deoxyribonucleic acid (DNA), by Maurice Wilkins. DNA was already then considered to be the substance of which genes were made.

Watson and Crick used Wilkins's data, part of which came from co-worker Rosalind Franklin, to create a three-dimensional model of the DNA molecule. The model included known facts, such as the chemical constituents (nitrogen bases, sugar, and phosphate), and took into account data from Wilkins's X-ray diffraction experiments.

Watson and Crick tried out various ways of arranging model molecules in space, finally settling on the aptly named double helix. Their model, afterwards referred to as the Watson-Crick model, showed DNA as a two-stranded twisted "helix." The two strands contain **complementary** nitrogen bases. This model both matched chemical facts previously known about DNA, and provided a viable explanation for how DNA could replicate, and thus for how genetic information could pass from one generation to the next generation of living organisms.

Crick's discoveries revolutionized biology. After the acceptance of the Watson-Crick model, biologists could begin to understand living things at the molecular level. Living organisms could be related to one another according to their genetic similarities and dissimilarities.

Following the elucidation of the structure of DNA, Crick turned his attention to how genetic information is stored and used in a cell, and formulated the "central dogma" of molecular biology: that DNA dictates the



Francis Crick.

**organic** composed of carbon, or derived from living organisms

**complementary** matching opposite

**amino acid** a building block of protein

**protein** complex molecule made from amino acids; used in cells for structure, signaling, and controlling reactions

**ventricle** fluid-filled chamber

**cloacal** of, relating to the common exit cavity for intestinal, genital, and urinary tracts

**transverse** situated or lying across

**lineage** ancestral line

sequence of ribonucleic acid (RNA), which dictates the sequence of **amino acids** in **proteins**, without the possibility of a reverse flow of information. He continued to make important theoretical contributions to genetics with a particular interest in development, until he turned his attention to neuroscience in the late 1970s. Crick's focus since then has been on the biology of consciousness and the nature of visual processing in the brain.

Among Crick's well-known publications are *Of Molecules and Men* (1996) and *Life Itself* (1982). SEE ALSO DNA; GENE; HISTORY OF BIOLOGY: INHERITANCE; NUCLEOTIDES; WATSON, JAMES

Hanna Rose Shell

### Bibliography

Crick, Francis. *What Mad Pursuit?* New York: Basic Books, 1988.

Sherborn, Victoria. *James Watson and Francis Crick: Decoding the Secrets of DNA*. Woodbridge, CT: Blackbirch Press, 1995.

Strathern, Paul. *The Big Idea: Crick, Watson, and DNA*. New York: Anchor, 1997.

Watson, James. *The Double Helix*. New York: Norton Press, 1968.

## Crocodilians

The class Crocodylia consists of twenty-two species of alligators, caimans, gharials, and crocodiles worldwide, and is most closely related to birds (class Aves). Like birds (and mammals), crocodilians have the **ventricle** of their heart divided into left and right compartments (unlike amphibians, turtles, and reptiles, whose ventricles have but a single, undivided compartment). In addition, like mammals and birds, crocodilians demonstrate much parental care of their young, a behavior not found in amphibians, turtles, reptiles, and tuataras.

Crocodilians are covered with scales, a trait they share with reptiles (and to some extent with turtles, but not with amphibians, whose skin is scaleless and permeable), and their **cloacal** opening is a longitudinal slit (not **transverse** as in the classes Reptilia and Rhynchocephalia). Crocodilians are no longer classified as reptiles, but are considered a distinct and unique evolutionary **lineage**, the class Crocodylia. Crocodilians are tropical and subtropical in distribution. Some species, such as the saltwater crocodile, can attain lengths of up to 7 meters (23 feet). Crocodilians are carnivorous in diet, and females build nests in which to lay eggs.

During their 215-million-year evolutionary history, beginning in the middle Triassic, these magnificent beasts invaded diverse habitats, from ocean to swamp, from wet tropical forest to cascading mountain rivers. Today's comparatively small remnant of this once diverse group still live in these areas, but their numbers grow smaller with poaching and the continuing, unstoppable destruction of their habitat by world overpopulation. SEE ALSO AMPHIBIAN; CIRCULATORY SYSTEMS; REPTILE; TUATARA; TURTLE

Joseph T. Collins

### Bibliography

Conant, Roger, and Joseph T. Collins. *A Field Guide to Reptiles and Amphibians: Eastern and Central North America*, 3rd ed. Boston: Houghton Mifflin, 1998.

Halliday, Tim R., and Kraig Adler. *The Encyclopedia of Reptiles and Amphibians*. New York: Facts on File, 1986.

Pough, F. Harvey, R. M. Andrews, J. E. Cadle, M. L. Crump, A. H. Savitzky, and K. D. Wells. *Herpetology*. Upper Saddle River, NJ: Prentice Hall, 1998.

Ross, Charles A., ed. *Crocodiles and Alligators*. New York: Facts on File, 1989.

## Crustacean

The Crustacea are a subphylum of the animal **phylum** Arthropoda. This is a large and diverse group with more than forty thousand species, including crabs, shrimp, lobsters, crayfish, barnacles, and many near-microscopic members of the zooplankton community. The subphylum is characterized especially by having mandibles and compound eyes and living in mostly aquatic habitats, although the “pillbugs” found under rocks and boards are also crustaceans, and many crabs spend much of their time on land.

The Crustacea are named for their hard, crusty **exoskeletons**, well known to anyone who has dined on lobster or crab. The hardness of the exoskeleton comes partly from **chitin**, but moreover from a heavy deposit of

**phylum** taxonomic level below kingdom, e.g., arthropod or chordate

**exoskeleton** external skeleton

**chitin** nitrogen-containing carbohydrate found in arthropod exoskeletons and fungus cell walls



A horseshoe crab on Fire Island National Seashore, New York. The Crustacea are a large and diverse group with more than forty thousand species.

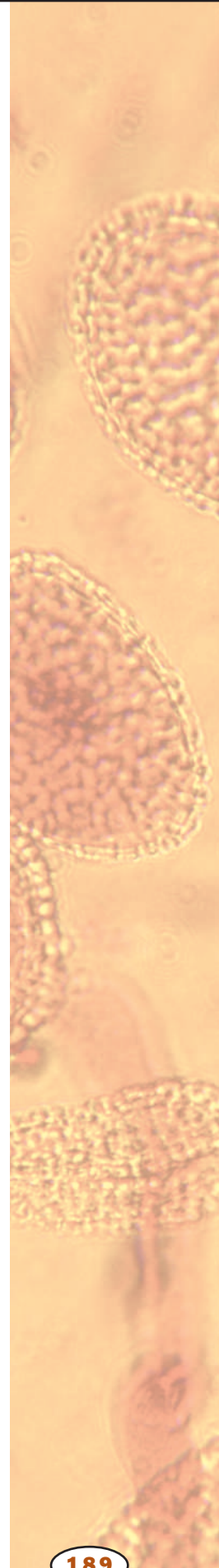

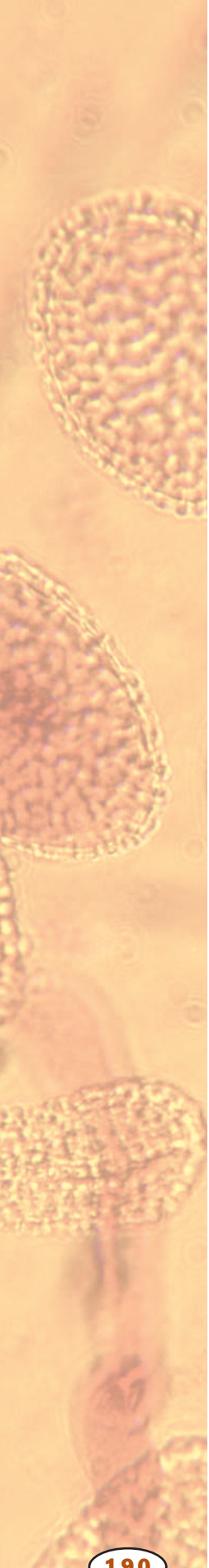

**plankton** microscopic floating organisms

**nucleus** membrane-bound portion of cell containing the chromosomes

**organelle** membrane-bound cell compartment

**ecosystem** an ecological community and its environment

**plankton** microscopic floating organisms

**vesicle** membrane-bound sac

**desiccation** drying out

**hypersalinity** very high level of salt

calcium carbonate. The edible blue crab, for example, has as much calcium carbonate in its exoskeleton as four sticks of chalk. The rigid exoskeleton requires crustaceans to molt, or shed it periodically, in order to grow. Some crustaceans can mate only during the brief time just after they have molted and the new exoskeleton is still soft. This is also a time of great vulnerability to predators, so crustaceans often seek a place to hide before molting.

Some crustaceans resemble miniature adults from the moment they hatch, but many species have larval forms with little or no resemblance to the adult. These larvae, and some adult crustaceans, such as krill and copepods, are very important members of the freshwater and oceanic **plankton** community and are a major source of food for corals, fish, baleen whales, and other animals. A few crustaceans turn the tables on these predators by parasitizing the skin of fishes. These parasitic crustaceans are often wormlike and scarcely recognizable as relatives of shrimp and crabs. SEE ALSO ANIMALIA; ARTHROPOD; LAKES AND PONDS; OCEAN ECOSYSTEMS; PLANKTON

Kenneth S. Saladin

### Bibliography

Pechenik, Jan A. *Biology of the Invertebrates*, 4th ed. Boston: McGraw-Hill, 2000.

Ruppert, Edward E., and Robert D. Barnes. *Invertebrate Zoology*, 6th ed. Fort Worth, TX: Saunders College Publishing, 1994.

## Cyanobacteria

Cyanobacteria (blue-green algae) are microorganisms that structurally resemble bacteria (they lack a **nucleus** and **organelles**). However, unlike other bacteria, cyanobacteria contain chlorophyll *a* and conduct oxygenic photosynthesis. Cyanobacteria are approximately 2.5 billion years old and thus are the oldest oxygenic phototrophs on Earth. The early evolution of Earth's oxygen-rich atmosphere is most likely due to cyanobacterial photosynthesis.

Cyanobacteria are morphologically and physiologically diverse and broadly distributed in terrestrial and aquatic environments. Morphological groups include coccoid, filamentous nonheterocystous, and heterocystous genera. Heterocysts are specialized cells harboring nitrogen fixation, a process by which atmospheric nitrogen ( $N_2$ ) is converted to a biologically useful form ( $NH_3$ ). All heterocystous and some coccoid/filamentous cyanobacteria fix nitrogen. This enables cyanobacteria to exploit **ecosystems** devoid of nitrogen compounds, including those located in polar, open ocean, and desert regions. Cyanobacterial nitrogen fixation can be a significant source of biologically available nitrogen in these ecosystems.

Cyanobacteria move by gliding, using mucilaginous excretions as propellant, or, in the case of **planktonic** genera, by altering buoyancy through gas **vesicle** formation and collapse. Cyanobacteria exhibit remarkable eco-physiological adaptations to global change. They tolerate **desiccation**, **hypersalinity**, hyperthermal, and high ultraviolet light conditions, often for many years. Over their long evolutionary history, they have formed numerous endosymbiotic and mutualistic associations with microorganisms, higher plants, and animals, including lichens (fungi), ferns, cycads, diatoms, seagrasses, sponges, and even polar bears. Cyanobacteria have also exploited

man-made pollution of aquatic environments, especially nutrient-stimulated primary productivity or **eutrophication**.

Cyanobacterial blooms are highly visible, widespread indicators of eutrophication. Because of the toxicity of some bloom taxa, blooms can pose serious water quality and animal and human health problems. Foul odors and tastes, oxygen depletion, fish kills, and drinking/recreational impairment are symptoms of bloom-infested waters. Finally, the large contribution of cyanobacterial blooms to **phytoplankton** biomass and ecosystem nutrient fluxes can alter biogeochemical cycling and **food web** dynamics. SEE ALSO EUBACTERIA; PHOTOSYNTHESIS; WETLANDS

Hans Paerl

### Bibliography

Fogg, G. E., William D. P. Stewart, Peter Fay, and Anthony E. Walsby. *The Blue-Green Algae*. London: Academic Press, 1973.

Whitton, Brian A., and Malcolm Potts. *The Ecology of Cyanobacteria*. Dordrecht, Netherlands: Kluwer Academic Publishers, 2000.

## Cytokinesis

Cytokinesis is the process by which a cell divides its **cytoplasm** to produce two daughter cells. As the final step in cell division after **mitosis**, cytokinesis is a carefully orchestrated process that signals the start of a new cellular generation. The separation of one cell into two is accomplished by a structure called the contractile ring. The contractile ring is a structure believed to operate in a way similar to muscle. A molecular motor, myosin, contracts the actin filaments that form the contractile ring tighter and tighter until the cell is pinched in two. The contraction of the contractile ring has been likened to tightening a purse string to close the top of a pouch. The furrow created by this pinching process is also called the “cleavage furrow,” as it is the site at which cleavage of one cell into two cells occurs.

Cytokinesis consists of four major steps. The first step is to define the position at which the contractile ring will form. The spindle, the structure responsible for segregating the **chromosomes** into what will become the daughter cells, also appears to be responsible for defining where the contractile ring forms. The contractile ring forms perpendicular to the long axis of the spindle at its midpoint. Components of the spindle that come in contact with the plasma membrane, called astral microtubules, are believed to transmit a signal to the cell periphery that tells actin and other components of the contractile ring to assemble at that location. Actin and microtubules are both part of the **cytoskeleton**.

The second step in cytokinesis is to assemble the actin filaments that form the contractile ring. Additional **proteins**, including the molecular motor myosin, which powers contraction, also assemble in this same domain. The third step is the actual contraction of the contractile ring. In this step, the myosin motor, powered by adenosine triphosphate, moves the actin filaments past each other, much in the same way as myosin interacts with actin to power the contraction of muscle. This step also requires the removal of actin subunits to allow the ring to decrease in size. The final step, breaking and refusion of the plasma membrane, occurs once the ring has contracted

**eutrophication** process by which waters become enriched in dissolved nutrients that promote plant growth, which results in depletion of dissolved oxygen

**phytoplankton** microscopic floating creatures that photosynthesize

**food web** set of feeding relations in an ecosystem

**cytoplasm** material in a cell, excluding the nucleus

**mitosis** separation of replicated chromosomes

**chromosome** “colored body” in the cell nucleus; made of DNA and protein, and divided functionally into genes and non-gene regions

**cytoskeleton** internal scaffolding in a cell, composed of protein

**protein** complex molecule made from amino acids; used in cells for structure, signaling, and controlling reactions

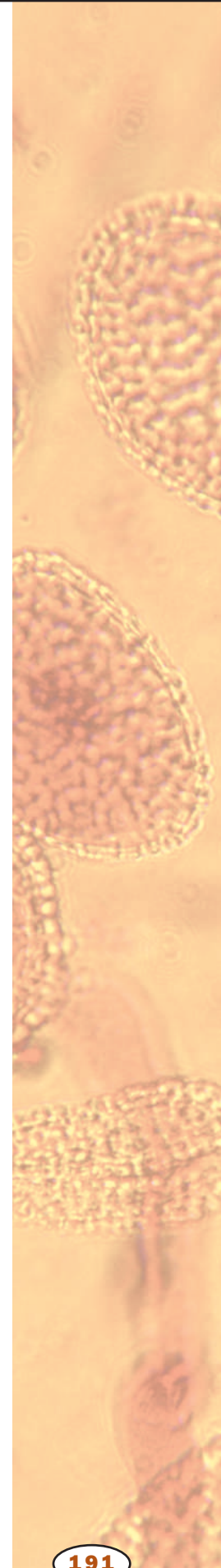



A colored scanning electron micrograph of a breast cancer cell dividing.

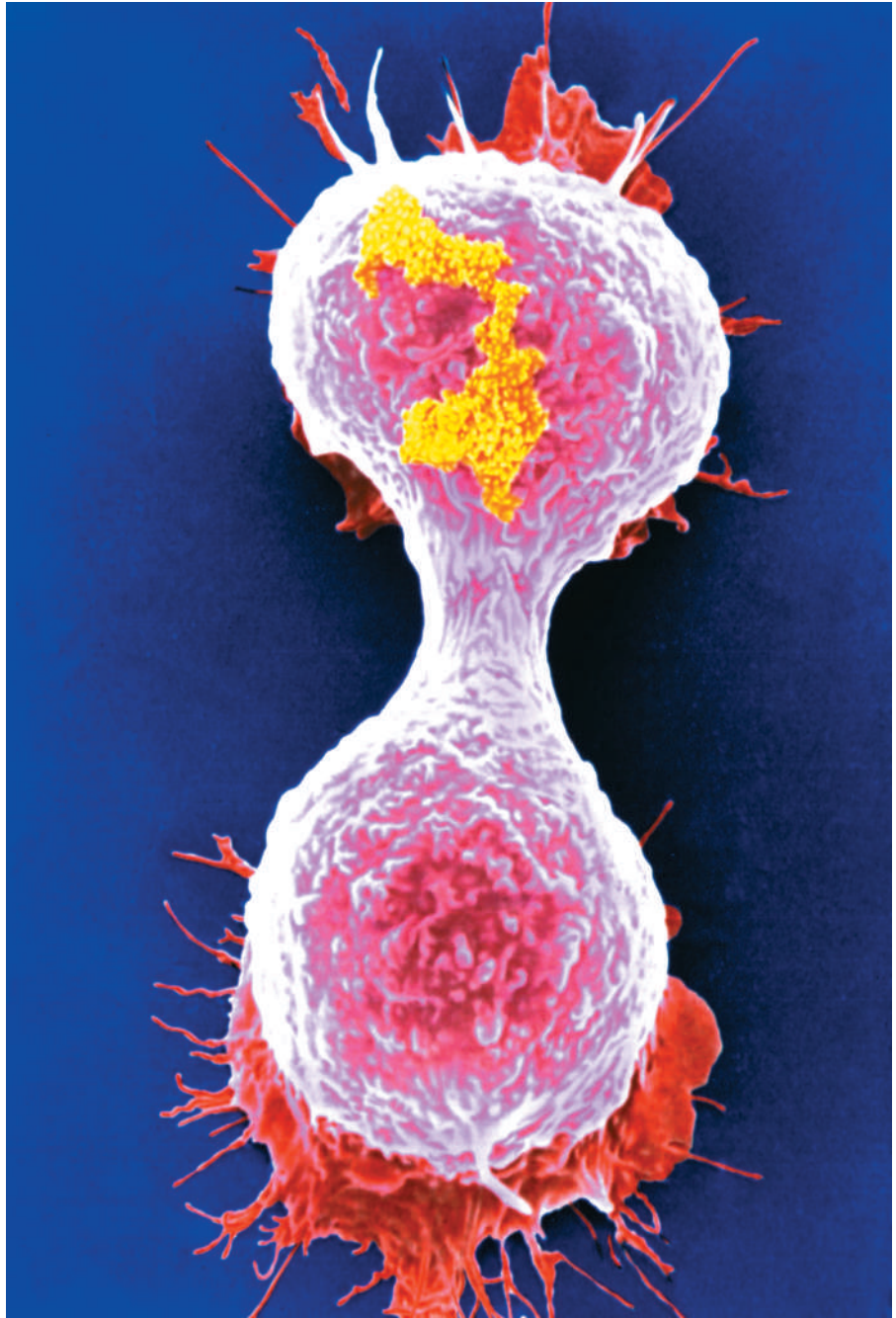

to its minimum size. This breaking and fusion finally separates the two daughter cells from each other.

As with each of the steps in mitosis, cytokinesis is highly regulated. If the cell were to divide its cytoplasm prior to the completion of duplication and segregation of the chromosomes, it is unlikely that each of the **progeny** cells would receive the proper genetic information. Thus the cell employs several regulatory mechanisms to assure that cytokinesis occurs only after all of the chromosomes have been properly segregated. There is, for example, a “spindle checkpoint” that assures that each and every chromosome has attached to the spindle. The entire process of cell division waits at the checkpoint until the conditions of the checkpoint have been satisfied.

**progeny** offspring

Once they have been, the process continues and concludes with cytokinesis. SEE ALSO CELL CYCLE; CYTOSKELETON; MITOSIS; MUSCLE

Rex L. Chisholm

### Bibliography

Alberts, Bruce, et al. *The Molecular Biology of the Cell*, 4th ed. New York: Garland Publishing, 2000.

Bray, Dennis. *Cell Movements*. New York: Garland Press, 1992.

Lodish, Harvey, et al. *Molecular Cell Biology*, 3rd ed. New York: Scientific American Books, 1995.

## Cytoskeleton

The cytoskeleton is responsible for cell shape, motility (movement) of the cell as a whole, and motility of **organelles** within a cell. There are three types of filaments in the **cytoplasm** of most vertebrate cells: microfilaments, microtubules, and intermediate filaments. All of these filament systems share a critical feature: They are composed of proteins that have the unique property of being able to self-assemble into a filamentous network. Imagine a pile of bricks that could assemble by themselves into a wall; the proteins that make up the fibers of the cytoskeleton are able to do just this. The proteins that make each of the three different filament systems assemble into only the structure characteristic of that filament.

Unlike the human skeleton, the cytoskeleton is extremely dynamic, meaning the filament systems are able to lengthen or shorten very rapidly. This dynamic nature of the cytoskeleton is necessary for cells to be able to change shape, complete cell division, or migrate, and represents one of the cytoskeleton's most important features. Each of the self-assembling proteins has a characteristic concentration, called the "critical concentration," below which the **monomer** state is favored and above which the **polymer** state is favored. Increasingly, the subunit concentration favors filament building, and decreasing it favors filament deconstruction. This property allows the cell to rapidly control cytoskeleton structure.

### Microfilaments

The microfilament system is a network of filaments 6 **nanometers** (nm) in diameter that are important for anchoring plasma membrane proteins, for producing cell movement, and for cell division. The base filament is composed of a protein called actin that is 42 kilodaltons (kd) in weight. Actin is also the protein that forms the thin filaments found in muscle. When purified actin is incubated in a test tube, 6 **nm** filamentous structures are formed. These threads consist of side-by-side actin monomers that twist around each other in a helix. Inside cells, actin exists in two states, the monomeric protein, called G-actin (for globular actin) and the 6 nm filament, called F-actin (for filamentous actin). The factor that determines the relative proportions of F-actin and G-actin is the concentration of actin protein. Each microfilament has a fast-growing, or "plus," end, and a slow-growing, or "minus," end. In most cells the plus ends of the filaments are oriented toward the edge of the cell. In this way rapid polymerization of actin monomers onto the plus ends of microfilaments can produce protrusions on the cell surface

**organelle** membrane-bound cell compartment

**cytoplasm** material in a cell, excluding the nucleus

**monomer** "single part"; monomers are joined to form a polymer

**polymer** molecule composed of many similar parts

**nanometer**  $10^{-9}$  meters; one-billionth of a meter

**nm** nanometer; one-billionth of a meter

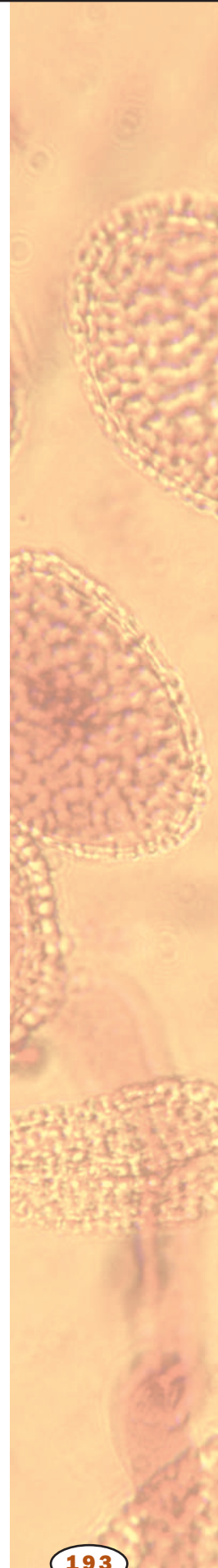

**pseudopod** “false foot”; an extension of the plasma membrane during locomotion by an amoeba or similar crawling cell

**progeny** offspring

**enzyme** protein that controls a reaction in a cell

**vesicle** membrane-bound sac

called **pseudopods**. These extensions are critical for the ability of cells to migrate in a directional fashion.

Microfilaments exist in their highest concentration in association with the cell periphery, where they are believed to play an important role in anchoring membrane proteins. Microfilaments can also be organized into bundles, called stress fibers, which serve as contractile elements, somewhat like little muscles, within cells. These structures are important for maintaining connections between the cell and the surface on which it grows. In addition, these structures may be important for producing contractility to generate directional force during cell motility. A third microfilament-based structure, the contractile ring, is critical for the separation of a cell into its two **progeny** during cytokinesis.

In most cells the concentration of actin exceeds the critical concentration for microfilament assembly, yet the actin is not entirely assembled into filaments. This occurs because cells make a variety of “actin-associated” or “actin-binding” proteins. One example of an actin binding protein is the G-actin-binding protein profilin. When bound to profilin, actin monomers cannot assemble into filaments. Binding of actin by profilin can effectively reduce the concentration of free actin monomer to below the critical concentration. The actin-binding activity of profilin is regulated in cells. Certain stimuli will cause profilin molecules to release their bound actin monomers, effectively increasing the concentration of actin and thereby stimulating actin assembly. Thus cells can control the relative proportions of G-actin and F-actin.

In general, the functions of actin-associated proteins are to modify the properties of the microfilament network in cells. Some filament-associated proteins, for example the protein tropomyosin, bind along the length of the filament to stiffen it. There are also proteins such as villin or filamin that bind microfilaments together side by side to produce bundles of actin filaments. Other actin-binding proteins cross-link actin filaments to form mesh-like structures such as those found in association with the cell membrane. Cells can also control the length of filaments through the action of proteins that can cut filaments to produce two shorter filaments. To keep the filaments a certain length, cells produce “capping” proteins that bind to the ends and prevent the addition of new actin subunits. By modulating the state of the microfilament network the cell can control the physical properties of the cytoplasm such as rigidity and viscosity.

One of the most interesting types of actin-associated proteins is a family of **enzymes**, called myosins, which have the ability to convert chemical energy into movement. The characteristic property of these so-called myosin molecular motors is their ability to bind actin in an adenosine triphosphate-sensitive fashion and to produce movement of actin filaments. Over fifteen different types of myosin motors have been identified. Some of them, such as those involved in cytokinesis and cell motility, are two headed, meaning they have two actin-binding motor domains, while others have only one head. Some of these myosins are involved in the movement of membrane-bound **vesicles** along actin tracks. The best characterized of these molecular motors, myosin II, slides actin filaments past each other either to power contraction of the contractile ring or to produce cell migration. A different version of this myosin motor forms the thick filaments that are responsible for the contraction of muscle.

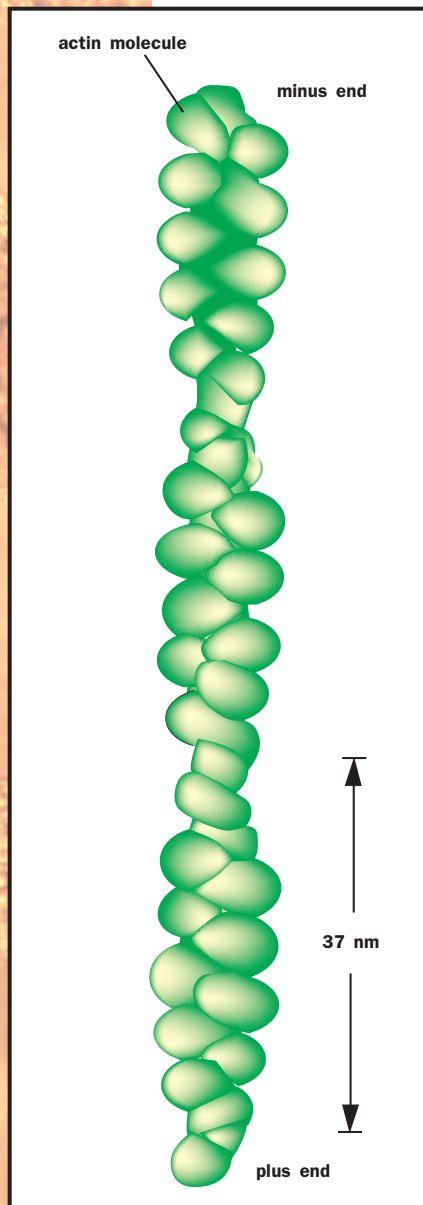

Helical structure of actin molecules.

## Microtubules

Microtubules are the largest of the cytoskeletal filaments with a diameter of 25 nm. There are many parallels between the microfilament cytoskeletal system and the microtubule system. Like microfilaments, microtubules are produced by the self-assembly of a subunit, which in the case of microtubules is a **heterodimer** composed of one alpha tubulin and one beta tubulin bound together. Alpha and beta subunits alternate to form a protofilament. Thirteen protofilaments line up side by side, forming the hollow tube of the microtubule.

Microtubules also have a fast-growing, or plus, end and a slow-growing, or minus, end. In most cells microtubules are organized in a radial array extending from a single site termed the microtubule organizing center (MTOC), generally positioned near the **nucleus**. This organization produces a network of microtubule tracks where the plus ends of the microtubules are near the cell surface and the minus ends are associated with the MTOC. This structure is well suited for the primary function of microtubules, which is to serve as tracks along which membrane-bound vesicles are moved. Vesicles transported include organelles such as **mitochondria**, as well as secretory vesicles destined for exocytosis.

Another parallel with microfilaments is the highly dynamic nature of microtubules. Microtubules exhibit a phenomenon called “dynamic instability.” Individual microtubules constantly grow and shorten, often shortening dramatically in a process called “catastrophe.” This rapid turnover of microtubules allows cells to change shape quickly and facilitates reorganization of the tracks important for delivery of vesicles to sites throughout the cell. Like the microfilament cytoskeleton, the dynamics of microtubules can be modified by microtubule associated proteins, called MAPs. Some MAPs stabilize microtubules, while others cross-link microtubules, both with other microtubules as well as with microfilaments and the third cytoskeletal system, intermediate filaments (see below).

The dynamics of microtubules are also important for **mitosis**. Each time the cell goes through division the microtubule network is completely disassembled and the tubulin subunits are reassembled into a new structure called the spindle. The spindle is responsible for the segregation of **chromosomes** into each daughter cell and also plays an important role in specifying the position of the cleavage plane that will separate the two daughter cells (during cytokinesis).

The functions of microtubules in vesicle transport and chromosome segregation are dependent on molecular motors that bind to and move along microtubule tracks. These motors are divided into two families, kinesin and cytoplasmic dynein. Kinesin was the first microtubule motor to be identified. It is responsible for moving vesicles (the cargo of the motor) toward the plus ends of microtubules, that is, from the center of the cell toward the plasma membrane. Since discovery of the first kinesin, the family has been shown to consist of many members, some of which are important for spindle function during mitosis. Some of these kinesins move toward the minus ends of microtubules. In contrast, the other type of microtubule motor, cytoplasmic dynein, appears to move cargo exclusively toward the minus ends of microtubules, that is, from the cell periphery back towards the center.

**heterodimer** complex molecule composed of two different parts

**nucleus** membrane-bound portion of cell containing the chromosomes

**mitochondria** subcellular organelle that creates ATP used for energy-requiring processes in a cell

**mitosis** separation of replicated chromosomes

**chromosome** “colored body” in the cell nucleus; made of DNA and protein, and divided functionally into genes and non-gene regions

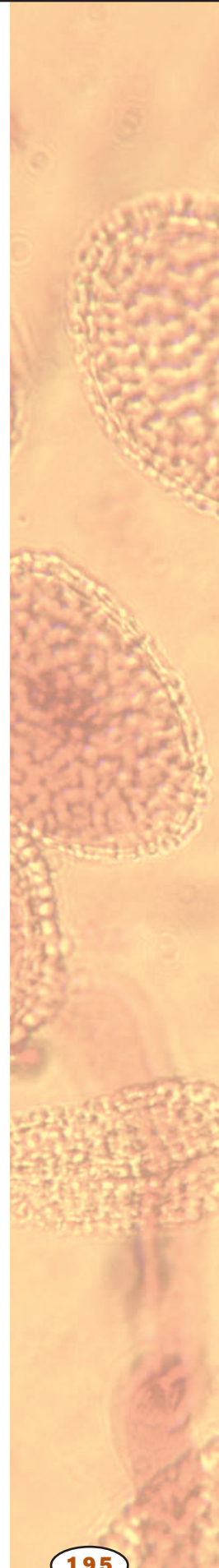

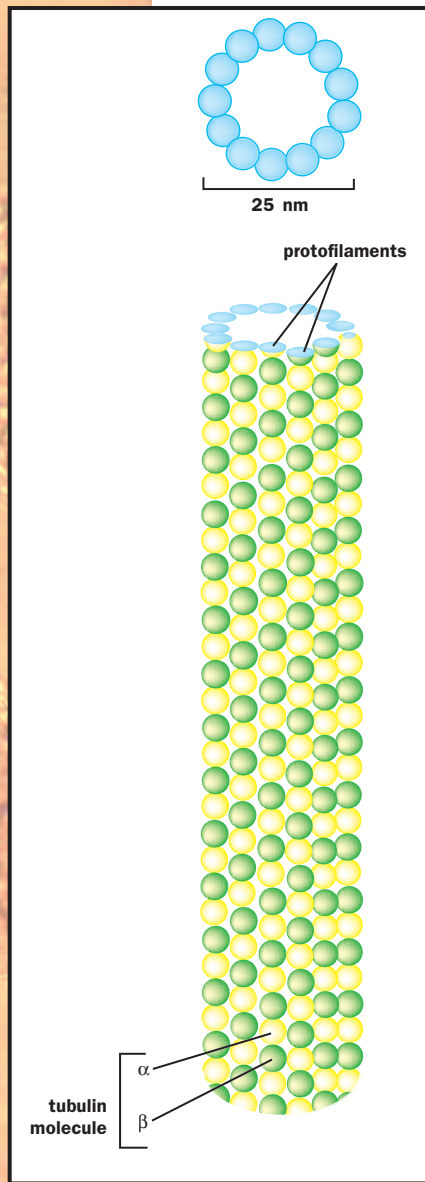

Top: Illustration of the ring of 13 distinct subunits in a microtubule, each of which corresponds to a tubulin molecule. Bottom: A side view of a section of a microtubule, with the tubulin molecules in long, parallel rows called protofilaments.

**hormone** molecule released by one cell to influence another

**secretion** material released from the cell

**keratin** a major structural protein

The ability of these motors to move organelles around inside of cells is critical for processes such as **hormone secretion**, transmission of nerve impulses and recycling of membrane.

## Intermediate Filaments

The third cytoskeletal system is called the intermediate filament system because the filaments, which are 10 nm in diameter, are intermediate in size between microfilaments and microtubules. There are many other features that set the intermediate filaments system apart from the other cytoskeletal systems. Unlike the other systems, which are composed of one or two different proteins, intermediate filaments can be formed by a relatively large number of different proteins. For example, the primary intermediate filaments found in epithelial cells (such as skin) are formed from pairs of **keratins**, one **basic** and one **acidic**. There are a large number of different keratin pairs, found in different tissues, that produce 10-nm filaments. Wool, hair, and nails are examples of structures formed from intermediate filaments. The different filament-forming keratins are developmentally regulated, and the keratins expressed early in embryos differ from those expressed later in development.

In contrast, a different cell type, **fibroblasts**, have intermediate filaments that are formed from a single protein, vimentin. In heart tissue, the intermediate filaments can be formed from a different single protein, desmin. In nervous tissue the intermediate filaments are formed from yet another family of **intermediate filament proteins** called neurofilament proteins. There are even structures in the nucleus formed from intermediate filament protein family members called nuclear lamins.

Although intermediate filaments can also self-assemble from their constituent subunits, the filaments differ from microtubules and microfilaments in that they do not have an obvious polarity. Structurally, intermediate filaments are formed from a bundle of subunit proteins which themselves are extended in structure, as compared to the more globular-shaped protein subunits that form microfilaments and microtubules. Intermediate filaments are generally more stable structures than the other cytoskeletal systems, although recently it has been shown that subunits are capable of exchanging in and out of the filament all across their length. Like other filament systems, intermediate filaments have associated proteins, but interestingly no molecular motors that use intermediate filaments as their track have been identified.

Intermediate filaments are organized within cells so that they link the cell surface and the nucleus. Intermediate filaments are believed to play an important role in cells by stabilizing structural integrity. Of all the cytoskeletal systems, intermediate filaments are best suited to play this structural role since they have the highest tensile strength (resistance to stretch). At the cell surface, intermediate filaments attach to specific junctions called desmosomes and hemidesmosomes. These junctions attach cells to neighboring cells or the extracellular **matrix**.

Mutations in intermediate filament subunit proteins have been shown to cause human diseases. For example, mutations in keratins cause blistering diseases that result from a loss of cellular integrity, causing cells to lit-

erally split in half. Similarly, mutations in the neurofilament proteins produce neurological diseases called neuropathies.

## Cytoskeleton-Based Cellular Structures

Several cellular structures are built around a core of cytoskeletal proteins. Perhaps the best known examples are **cilia** and flagella. Flagella provide the motive force for sperm motility through their waving motion. Cilia line the surfaces of cells in the respiratory tract where their motion constantly moves mucus along the airway surface. The core of both flagella and cilia is composed of a highly organized bundle of specialized microtubules. Around a “central pair” of microtubules, there are nine pairs of modified microtubules called “doublet microtubules.” The central pair and the outer doublet microtubules are connected by a number of different specialized proteins. The characteristic waving motion of cilia and flagella is generated by the action of a microtubule-based motor called axonemal dynein that moves the microtubules in the flagellum relative to each other. Axonemal dynein is related to the minus end directed motor cytoplasmic dynein that moves vesicles along microtubules. Dynein mutation causes cilia dysfunction, leading to respiratory illness and sperm immotility. Curiously, about half of the people with these mutations also have “situs inversus,” in which the internal organs are reversed left for right.

Another microtubule-based cellular structure is the centriole. The centriole is a somewhat mysterious cylindrical structure containing vanes formed from microtubules that run the length of the cylinder. Centrioles together with the associated pericentriolar material form a somewhat larger structure called a centrosome. Centrosomes function as microtubule organizing centers during interphase of the **cell cycle**, and become the center of the spindle poles during mitosis.

Finally, several cell types such as intestinal epithelial cells have protrusions from their surface called microvilli. At the core of the microvilli are bundles of actin filaments. These protrusions are believed to increase the surface area of the intestinal cells to maximize their ability to absorb nutrients. SEE ALSO CELL JUNCTIONS; CELL MOTILITY; CYTOKINESIS; ENDOCYTOSIS; MEMBRANE PROTEINS; MITOSIS; MUSCLE; NUCLEUS; PLASMA MEMBRANE; SLIME MOLDS

Rex L. Chisholm

### Bibliography

Alberts, Bruce et al. *The Molecular Biology of the Cell*, 4th ed. New York: Garland Publishing, 2000.

Bray, Dennis. *Cell Movements*. New York: Garland Press, 1992.

Lodish, Harvey, et al. *Molecular Cell Biology*, 3rd ed. New York: Scientific American Books, 1995.

## Darwin, Charles

**English naturalist**  
**1809–1882**

Charles Darwin was the founder of modern evolutionary thought, and the developer, along with Alfred Russel Wallace, of the theory that natural se-

**basic** having an excess of OH<sup>-</sup> ions, and a high pH

**acidic** having an excess of H<sup>+</sup> ions, and a low pH

**fibroblast** undifferentiated cell normally giving rise to connective tissue cells

**intermediate filament protein** one type of cytoskeleton protein

**matrix** a network, usually of threadlike fibers

**cilia** short, hairlike cell extensions of the cell membrane formed by the cytoskeleton

**cell cycle** sequence of growth, replication, and division that produces new cells



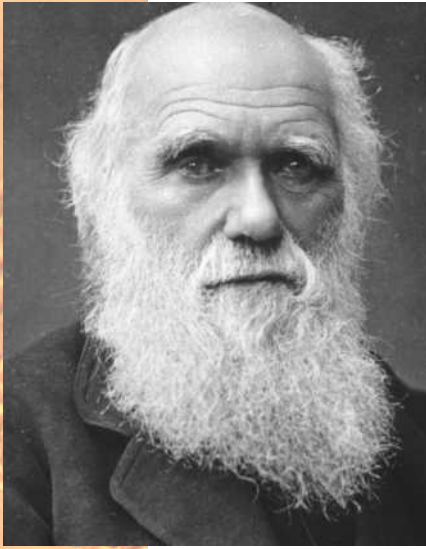

Charles Darwin.

lection is a principle driving force in evolution. Darwin is generally recognized as the single greatest thinker in the history of biology, whose contributions provided the basis for understanding the immense diversity that characterizes the natural world.

Darwin was born February 12, 1809, into a wealthy English family. A lifelong interest in natural history led him to embark, at age twenty-two, on a five-year voyage to South America aboard the HMS *Beagle* as the ship's naturalist. Darwin collected a wealth of specimens and made observations of both living species and fossils he encountered. Darwin was particularly struck by similarities he observed between the species found on the Galapagos Islands off the western coast of South America, and species of the mainland. He also noted differences and similarities among species found on the numerous islands of the Galapagos. The evidence suggested each species had not been independently formed by the Creator, but rather had diverged from a smaller group of common ancestors.

Upon returning home, Darwin pondered these ideas in conjunction with two other streams of thought. The first was the theory of uniformitarianism of geologist Charles Lyell. Uniformitarianism held that major geologic features, such as mountains and canyons, were formed not by rapid and short-lived catastrophic events such as floods, but rather by the slow, steady action of forces such as erosion. This mechanism suggested that Earth was much older than previously believed, a fact which Darwin saw provided the requisite time for the steady accumulation of change that would turn one species into another. The second idea was from *An Essay on the Principle of Population*, in which economist Thomas Malthus contrasted the potential for exponential increase in human population with the much slower increase in food supply. Malthus suggested that competition, disease, war, and famine kept the human population in check. Darwin saw that this principle provided the selective force needed to bring about change in a species.

### Natural Selection

Between 1837 and 1838, Darwin developed his ideas into the principle of natural selection, which combines struggle, heritable variation, and differential reproduction. He proposed that in all species, limited resources leads to a struggle for existence, either against other members of the species, or against the environment. Members of a species differ from one another, and some of those variations influence the success of an organism's struggle. Organisms with more useful variations will leave more offspring, who inherit those variations and so are better able to cope with the environment. As this process continues over time, with successive rounds of struggle, variation, and differential reproduction, the population will become increasingly well adapted to the environment. Organisms of one species who become separated into different environments, such as the birds of the Galapagos, could develop over time into separate species through the accumulation of differences best adapted for their separate environments.

For the next decade, Darwin collected evidence to support his theory, and discussed his ideas only with a small circle of colleagues. But in 1858, he learned that naturalist Alfred Russel Wallace had developed a similar theory. Urged on by friends, Darwin agreed in 1858 to jointly submit papers

with Wallace to the *Journal of the Linnaean Society*, and this was how the world first learned of the principle of natural selection. A year later, Darwin published *On the Origin of Species, or the Preservation of Favored Races in the Struggle for Life*. It is no exaggeration to call this the most important book ever published in biology. In it, Darwin provided so convincing an argument for natural selection that it became widely accepted by scientists shortly after publication. With natural selection, Darwin had provided a mechanism for evolution and an explanation for the diversity of life.

Despite the power of the arguments Darwin provided, numerous problems remained with the theory, especially with the mechanism of inheritance. Critics argued that blending of traits (for instance, tall with short to give medium height) would ultimately dilute out any variations. It was not until the particulate nature of inheritance was discovered, from the work of Gregor Mendel, that this problem was resolved.

Darwin continued to explore the ramifications of natural selection in a series of books published over the next twenty years. In 1871, he published *The Descent of Man, and Selection in Relation to Sex*, in which he applied the theory of natural selection to argue that humans evolved from earlier ape-like creatures, and suggested sexual selection as an important adjunct to natural selection.

On his death in 1882, in recognition of his scientific achievements, Darwin was buried in Westminster Abbey, along with Isaac Newton, Michael Faraday, and other great English scientists. SEE ALSO ADAPTATION; BUFFON, COUNT (GEORGES-LOUIS LECLERC); CREATIONISM; EVOLUTION, EVIDENCE FOR; LAMARCK, JEAN-BAPTISTE; MENDEL, GREGOR; NATURAL SELECTION; SEXUAL SELECTION; SPECIES

*Richard Robinson*

### **Bibliography**

Browne, Janet. *Charles Darwin*. Princeton, NJ: Princeton University Press, 1996.

Miller, Jonathan. *Darwin for Beginners*. New York: Pantheon Books, 1990.

## **De Saussure, Nicolas-Théodore**

**Swiss botanist**  
**1767–1845**

Nicolas de Saussure was an early pioneer in plant physiology. He was born and lived in Geneva, Switzerland, and later became professor of mineralogy and geology at the Geneva Academy. De Saussure's most famous book was *Recherches chimiques sur la végétation*, or "Chemical Research on Plant Matter," published in 1804.

De Saussure studied gas and nutrient uptake in plants, using the scientific method of controlled experimentation. By enclosing plants in glass containers and weighing the plants and enclosed carbon dioxide before and after, de Saussure demonstrated that plants absorb carbon dioxide during photosynthesis. This showed that carbon in plants comes from the atmosphere (not the soil, as some believed). Extending the work of Jan Ingenhousz, who showed oxygen was released during photosynthesis, de Saussure proved that

### **HUXLEY, THOMAS HENRY (1825–1895)**

English biologist and paleontologist famous for his enthusiastic public debates in support of English naturalist Charles Darwin's theory of evolution. Huxley never finished college, but went to work as an assistant surgeon aboard a British frigate. When he returned to England four years later, he had sent home so many specimens and scientific papers that he was immediately elected to the Royal Society. He never returned to college.



the volume of carbon dioxide absorbed is approximately equal to the volume of oxygen consumed. Because the weight of carbon absorbed was less than the total weight increase of the plant, de Saussure reasoned that water is absorbed, and in so doing correctly outlined the major chemical transformations in photosynthesis.

De Saussure also studied oxygen consumption in germinating seeds and plants grown in the dark, and argued (correctly) that the use of oxygen by plants was similar to that of animals. Later in life, he analyzed plant ashes to show that the mineral composition differed from that of the soil, thereby demonstrating that plants absorb nutrients selectively. SEE ALSO VAN HELMONT, JAN; HISTORY OF PLANT PHYSIOLOGY; INGENHOUSZ, JAN; PHOTOSYNTHESIS

*Richard Robinson*

### **Bibliography**

Morton, Alan G. *History of Botanical Science*. New York: Academic Press, 1981.

## **Dentist**

A dentist is a medical professional who cares for the oral health of his patients. Dentists administer both prophylactic (preventative) care and corrective treatments for teeth and gums. Dentists in a general practice perform procedures such as cavity filling, root canals, gingivitis (gum disease) correction, and much more. Specialties in dentistry include orthodontics (structural correction), oral surgery, pediatric dentistry, endodontics (complex root canals and dental implants), oral surgery, periodontics (advanced gum care), and prosthodontics (reconstructive dentistry).

The most familiar work setting for a dentist is private practice. Traditionally, dentists in private practice provide oral health services for families. However, dentists are also employed in a variety of other situations. For example, many hospitals (especially those that specialize in long-term care, such as geriatric and psychiatric hospitals) employ dentists to attend to the oral health of their patients. Additionally, public health agencies that organize relief efforts for inner cities, the rural poor, or developing nations employ dentists to provide dental care to people groups that cannot normally afford it. Many insurance companies also employ dentists as consultants that help review and process dental claims.

In order to become a dentist, one must attend four years of dental school after obtaining a bachelor's degree from an undergraduate college. To gain admittance into dental school, a strong high school and college background in biology, chemistry, math, and physics is required. SEE ALSO DOCTOR, FAMILY PRACTICE; MEDICAL ASSISTANT

*Susan T. Rouse*

### **Bibliography**

*American Dental Student Dental Association*. <<http://www.asdanet.org/>>.

*Cox/Bond Dental Group*. "So You Want to Become a Dentist?" <<http://www.vvm.com/~bond/home.htm>>.

*List of Dental Schools*. <[http://dir.yahoo.com/Health/Medicine/Dentistry/Schools\\_\\_Departments\\_\\_and\\_Programs/](http://dir.yahoo.com/Health/Medicine/Dentistry/Schools__Departments__and_Programs/)>.

## Desert

Deserts are environments shaped by aridity, or dryness. Aridity reflects the balance between precipitation and potential evapotranspiration (PET), or the air's ability to absorb water (determined by temperature and water content). In arid zones, precipitation may be 5 to 20 percent of PET; semi-arid regions receive more precipitation, and hyper-arid regions less, in relation to PET.

### Features of a Desert

Roughly one-third of Earth's land surface is arid or semi-arid. The major desert regions are: Australia, western North America, western South America (Atacama), southern Africa (Namib), and Asia-northern Africa. There are so-called polar deserts; however, most arid lands are in the warm subtropics.

There are two primary causes of aridity. One is the subtropical high-pressure belts, where high altitude air masses move away from the tropics. Tropical heat causes air to rise and cool, and therefore drop moisture as it moves away from the equator. The air then becomes more cool and dense. This air then sinks, warms as it nears the surface, and regains the ability to absorb water, thus creating zones of aridity. A second cause is the rainshadow effect caused by mountain ranges. Continental interiors are dry because most air masses have moved long distances or over mountains and in doing so have lost water.

Desert conditions may be quite harsh. Intense solar radiation and lack of shade cause surface temperatures as high as 50 degrees Celsius (130 degrees Fahrenheit). Limited precipitation and rapid evaporation greatly limit plant growth, and water is rarely available for animal consumption. Precipitation is predictable in some systems (such as winter rains in California's Mojave) but nonseasonal in others. Many sites experience long rain-free periods; in portions of the Atacama, rainfall has never been recorded.

Variability is another characteristic of deserts. Precipitation is episodic; rainstorms may be quite intense, with much of the annual total falling in just minutes. Similarly, resources may be spatially patchy. Arroyos or erosion channels and low spots may collect runoff from surrounding areas; rockiness and soil surface crusts contribute to runoff. Seeds and litter accumulate and support plant growth in low, relatively moist locations. Permanent water sources (desert springs or oases) are rare but important.

Evaporation draws water from the surface, leaving dissolved **minerals** as a salty crust. Sparse plant growth adds little **organic** material to the soil; thus the soil has limited capacity to retain water and minerals. Sparse vegetation also increases the erosional influences of high wind, runoff, and extreme temperatures. Sand dunes are accumulations of eroded materials; their instability makes them harsh environments for most organisms.

### Desert Life

Desert organisms adapt to arid environments either by tolerating extreme conditions or by escaping them. Tolerant is survival under stress. Many adaptations are related to water acquisition. Plants may have shallow, extensive root systems to absorb rainfall from the largest area possible. Animals obtain moisture from live food. Tenebrionid beetles of the Namib

**minerals** iron, calcium, sodium, and other elements needed by living organisms

**organic** composed of carbon, or derived from living organisms



Shadows form on the El Oued dunes in the Sahara Desert in Algeria.

**oxidation** reaction characterized by loss of electrons, or reaction with oxygen

**cryptobiosis** when a plant or animal becomes so inactive that its life processes nearly come to a stop

**aestivating** remaining dormant for the summer

extract water from coastal fogs: The beetles do “headstands” on dune ridges, and moisture condensing on the beetle’s textured carapace trickles down to the mouth. Kangaroo rats obtain virtually all of their water by **oxidation** of fats in dry seeds (metabolic water). Other adaptations involve water retention: storage of water in succulent tissues; specialized photosynthetic processes minimizing water loss; leaflessness, small leaves, or leaf loss during drought, also reducing plant water use; and animal use of burrows or shade. Finally, some organisms simply tolerate tissue dehydration.

Escape or avoidance results in activity only during favorable periods. Annual plants, completing their life cycle in a single year, are abundant in many deserts. They may spend years as dormant seeds; only after sufficient rainfall do they germinate and grow, reproducing quickly before the soil redries. Some invertebrates and amphibians remain dormant up to several years, the invertebrates as eggs or in the “suspended animation” of **cryptobiosis**, the amphibians as **aestivating**, or dormant adults, beneath the surface. When temporary ponds form after rain, these organisms hatch or awaken; feeding, reproduction, and growth of juveniles are all a race against time so that at least some mature before the ponds dry. Some organisms are



A high desert oasis in Sedona, Arizona.

nomadic or migratory, finding temporary patches created by local rainfall: These include large mammals such as antelope, birds, and even insects (for example, desert locusts or grasshoppers).

Arid and semiarid regions have been important for livestock grazing throughout history. As energy sources have made irrigation feasible, some regions have been converted to cultivation. Urban populations are increasing rapidly where groundwater or river water is available and affordable; the southwestern United States, for example, contains several rapidly growing metropolitan areas in desert, such as Phoenix, Arizona. Depletion of underlying groundwater is a major environmental consequence in such areas. SEE ALSO BIOME; GRASSLAND; WATER CYCLE

*Laura F. Huenneke*

#### **Bibliography**

- Cooke, R. U., A. Warren, and A. S. Goudie. *Desert Geomorphology*. London: UCL Press, 1993.
- Louw, G. N. and M. K. Seeley. *Ecology of Desert Organisms*. New York: Longman, 1982.
- Mares, M. A., ed. *Encyclopedia of Deserts*. Norman: University of Oklahoma Press, 1999.

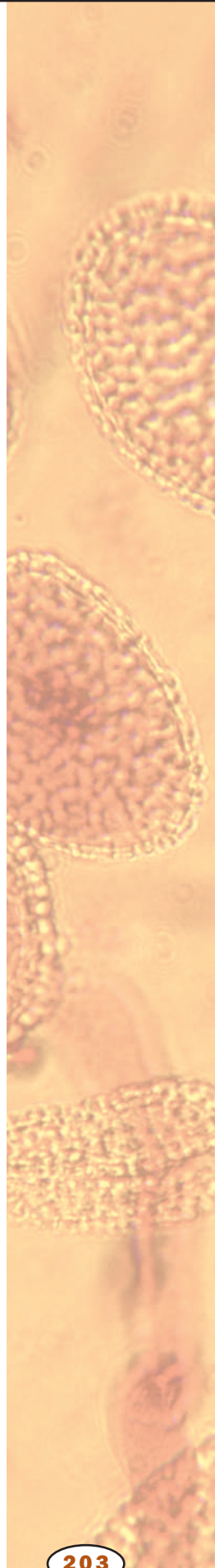

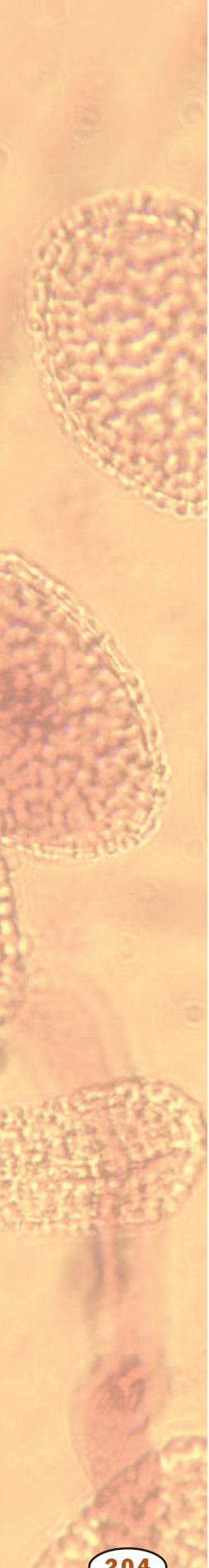

**savanna** open grassland with sparse trees

**ecosystem** an ecological community and its environment

## Desertification

Desertification is the degradation of grasslands, **savannas**, and woodlands to a more desert-like condition, with resulting decrease in plant production and the land's ability to support livestock grazing or other human uses. Vegetation becomes sparse; exposed soil becomes more vulnerable to erosion; and yields from cropland or grazing are reduced. The margins of most semi-arid regions (in North and South America, much of central Asia, the African Sahel, South Africa, and Australia) are at high risk of desertification. Estimates of land degradation rates range from 50,000 to 120,000 square kilometers per year, affecting up to 60 percent of semi-arid rangeland and cropland.

Multiple causes may trigger desertification. Climatic shifts, especially long-lasting drought cycles, can drive **ecosystems** to more desert-like conditions. Over the past 40,000 years many regions have experienced repeated shifts in vegetation from semiarid to desert and back again in response to natural environmental variation. Semiarid ecosystems contain organisms well adapted to tolerate drought under natural conditions. Human activities such as woodland clearance, severe soil disturbance, or inappropriate cultivation practices have clearly contributed to desertification in many regions, and human disturbance makes semi-arid systems vulnerable to further degradation.

Frequently, desertification is marked by the decline of grasses and the replacement of continuous grasslands by scattered shrubs and thorny vegetation, leaving much bare soil. One result is that soil resources become more concentrated around the large plants, and conditions grow increasingly difficult for most organisms in the bare areas. These exposed surfaces are then vulnerable to further degradation through erosion, evaporation, and high temperatures. Desertification can also result when cultivated areas are abandoned and soil conditions have been so altered as to impede recovery of natural ecosystems. Such alterations include erosion, increased salt from irrigation, and loss of soil organisms.

Desertification is a challenge to developed as well as developing nations. Because semi-arid ecosystems have historically been important as livestock-producing areas, desertification has negative consequences for human populations. Desertification may also trigger further aspects of global environmental change. The increased proportion of bare soil relative to green vegetation can change Earth's radiation balance (the balance between absorbed and reflected solar energy) and thus temperatures. Dust eroded from exposed soil can be transported long distances, affecting other ecosystems and altering air quality.

Minor changes in average climate may have potentially large effects on semi-arid vegetation; hence "global warming" could exacerbate desertification. Because air temperature, carbon dioxide (CO<sup>2</sup>) concentrations, and relative humidity affect plant growth and water use in complex, interacting ways, it is difficult to predict the net effect of atmospheric and climatic changes on dryland vegetation. Even if warming climate were to result in greater moisture and hence more precipitation in some areas, some areas, such as continental interiors, would likely experience warming without significant additions of precipitation; hence concerns about desertification may

be well founded. However, intensified land use, higher numbers of grazing livestock, and other pressures resulting from growing human populations are likely to be far more significant drivers of desertification in the near future than any climatic shifts. SEE ALSO DESERT; GLOBAL CLIMATE CHANGE; GRASSLAND

Laura F. Huenneke

### Bibliography

Allan, T., and A. Warren, eds. *Deserts: The Encroaching Wilderness*. New York: Oxford University Press, 1993.

Schlesinger, William H., et al. "Biological Feedbacks in Global Desertification." *Science* 247 (1990): 1043–1048.

United Nations Environment Program. *World Atlas of Desertification*. London: Edward Arnold, 1992.

## Development

Reproduction and development are integral factors of life. Multicellular organisms arise through a process that begins with the fertilized egg and ends with a new individual. The fertilized egg undergoes cell divisions to increase the number of cells; simultaneously, the cells produced differentiate into the organs and organ systems of the fully formed organism. The scientific study of these developmental processes is called embryology. Aristotle (384–322 B.C.E.), considered the first embryologist, described the growth of a chick embryo from a small dot of tissue to a fully formed bird.

### Early Ideas in Embryology

Prior to the mid-1800s, scientists believed that development was the result of preformation. Preformation means that animals develop from an already existing miniature animal that merely required the right conditions to unfold and grow into a new organism. Scientific debates over whether the miniature animal was contained in the egg (ovum) or the sperm raged for decades. Scientists who believed that the miniature animal was in the egg were called ovists; those who believed that the miniature animal was in the sperm were called spermists.

In 1675, Marcello Malpighi (1628–1694), an ovist, reported seeing a miniature chick in the chicken egg. Anton Leeuwenhoek (1632–1723), a spermist, reported seeing a miniature human (homunculus) in each sperm (see Figure 1). In 1775, Lazzaro Spallanzani (1729–1799) demonstrated that both egg and seminal fluid were needed to produce a new individual. He conducted a series of experiments using amphibian eggs and seminal fluid. When the eggs were exposed to seminal fluid, they began to develop. However, if the eggs were exposed to filtered seminal fluid, fewer eggs developed. The more highly the seminal fluid was filtered, the fewer eggs developed. If the eggs were combined with the material left on the filter paper, they began to develop. Although Spallanzani correctly concluded that both egg and seminal fluid were necessary for development, he believed that the sperm seen in the seminal fluid were **parasites**. He postulated that the fertilizing agent was composed of the **proteins** and fats in the fluid.

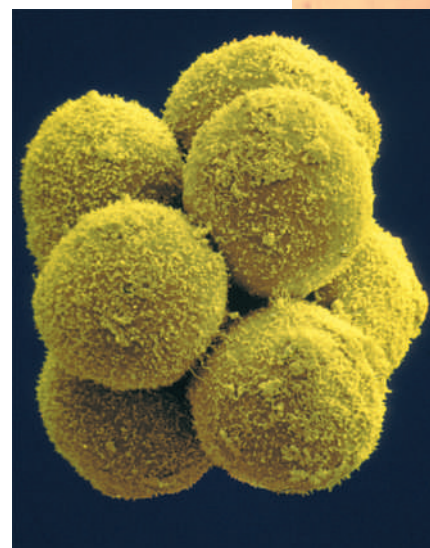

A scanning electron micrograph of a human embryo at the eight-cell stage (day three).

**parasite** organism living in close association with another from which it derives most of its nutrition

**protein** complex molecule made from amino acids; used in cells for structure, signaling, and controlling reactions

**appendage** attached organ or structure

**gamete** reproductive cell, such as sperm or egg

**motile** able to move

**fertilization** union of sperm and egg

**zygote** fertilized egg

**haploid** having single, non-paired chromosomes in the nucleus

**chromosome** “colored body” in the cell nucleus; made of DNA and protein, and divided functionally into genes and non-gene regions

**diploid** having pairs of chromosomes in the nucleus

**cytoplasm** material in a cell, excluding the nucleus

**organelle** membrane-bound cell compartment

William Harvey (1578–1657) viewed embryological development as a continuing process of remodeling and growth from unspecialized tissues to specialized structures. This theory, which is termed epigenesis, was largely ignored until 1759 when Kaspar Friedrich Wolff (1733–1794) offered empirical evidence of epigenesis from his detailed studies of chick development. In 1828, Karl von Baer (1792–1876) described four fundamental concepts of development. These four concepts, referred to as von Baer’s law, are: (1) general features such as **appendages** appear earlier in the embryo than specialized features such as fingers; (2) development proceeds from general to specific characteristics; (3) as an embryo develops, it becomes increasingly different from other species; and (4) the early embryo of a higher animal is never like an adult of a lower animal, but only similar to the lower animal’s embryo. Because they delineated the basic concepts of development, Wolff and von Baer are considered founders of modern embryology.

## Fertilization

The process of development begins with the fusion of **gametes**: egg (ovum) and sperm. The **motile** sperm swims to the egg, pierces its cell membrane and enters the cell. **Fertilization** is the fusion of the nuclei of the egg and sperm, and the single cell that results from this fusion is called the fertilized egg or **zygote** (see Figure 2). During fertilization, the genetic material of the sperm and egg are combined. Each gamete is **haploid**, that is, it contains one-half of the normal number of **chromosomes** for the species. At fertilization, the gametes combine to produce a zygote with the full number of chromosomes for that particular species. Another way to say this is that fertilization restores the **diploid** number. For example, haploid human gametes have twenty-three chromosomes; when the egg and sperm fuse, the diploid state of forty-six chromosomes is restored to the zygote. Thus, each parent contributes one-half of the chromosomal complement of the new individual, resulting in a new organism with genetic characteristics of both parents. This single cell, the fertilized egg, gives rise to all the organs of the individual—muscles, brain, liver, eyes—through highly regulated and timed processes.

The stages from fertilization to the birth or hatching of an individual organism are identical to those of all individuals of the same species. Developmental stages include rapid cell division or cleavage; formation of the germ layers through the process of gastrulation; and differentiation and growth of the organs and organ systems. These stages are categorized as the periods of embryogenesis (cleavage and gastrulation) and organogenesis (formation of organs and organ systems).

## Cleavage

As soon as the sperm enters the egg, the cell membrane of the egg undergoes changes that prevent the entrance of additional sperm. Meanwhile, the chromosomes from each parent come together and, within a few hours, the first cell division begins. The egg degrades the **cytoplasm** and **organelles** of the sperm; only the chromosomes of the sperm contribute to the fertilized egg.

The early cell divisions of the fertilized egg are called cleavage. The fertilized egg divides into two daughter cells called blastomeres. These two

blastomeres divide into four blastomeres, the four blastomeres divide into eight, and so on. During cleavage, the total number of cells increases, but the size of each cell decreases. The reason for this strange situation is that cell division occurs so rapidly that there is not enough time for the individual cells to grow bigger. The constant doubling of cells during cleavage results in a multicellular embryo very quickly.

In a short period, the embryo has over one hundred cells arranged as a solid ball of blastomeres called a morula. The cells of the morula rearrange themselves into a single layer of cells surrounding a fluid-filled central cavity; the embryo at this stage is called a blastula (see Figure 2).

## Gastrulation

The next step in development is the formation of the gastrula by invagination, the folding in of the cells of the blastula at a point called the blastopore. The resulting gastrula is a double-layer cup of cells. The outer layer of cells is termed the ectoderm and the inner layer of cells is termed the endoderm. The inner endodermal layer surrounds a new cavity, the primitive gut. A third layer of cells, the mesoderm, develops between the ectoderm and endoderm in most animals. Ectoderm, mesoderm and endoderm are the three germ layers from which all cells, tissues and organs develop (see Figure 2).

Cells of the ectoderm differentiate into the epidermis, hair, nails, claws, sweat glands, tooth enamel, brain, and spinal cord. Mesoderm differentiates into muscles, blood, blood vessels, heart, spleen, reproductive organs, and kidneys. Endoderm differentiates into the cells lining the digestive and respiratory systems, the liver, gallbladder, and pancreas.

## Induction

One of the more fascinating aspects of development is the determination of body form, pattern, and differentiation. Put simply, how does a cell know what it is supposed to grow up to be? How do cells of the endoderm know they are supposed to form the digestive and respiratory systems? Induction is the process during which individual cells are “told” what they are supposed to become. A modern understanding of molecular events in development is discussed in the article *Genetic Control of Development* in volume 2 of this reference work. This essay outlines some pioneering work by Hans Spemann and Hilde Mangold.

Hans Spemann (1869–1941) received the Nobel Prize in 1935 for over twenty years of research on development in amphibians. In a series of elegant and delicate “baby hair loop” experiments, he demonstrated that when cells invaginate during gastrulation, they are induced to form specific cells and organs and that the primary inducer is a specific region of the blastopore. Spemann tied a strand of baby’s hair around a fertilized newt egg so that the **nucleus** and some cytoplasm were on one side of the ligature while the other side contained only cytoplasm. After several cell divisions, Spemann loosened the ligature and allowed a nucleus to pass over into the other side. When cell divisions began on the side with the transported nucleus, the ligature was again tightened to separate the two masses of cells. The result was the production of two newt larvae, one a bit older than the other.

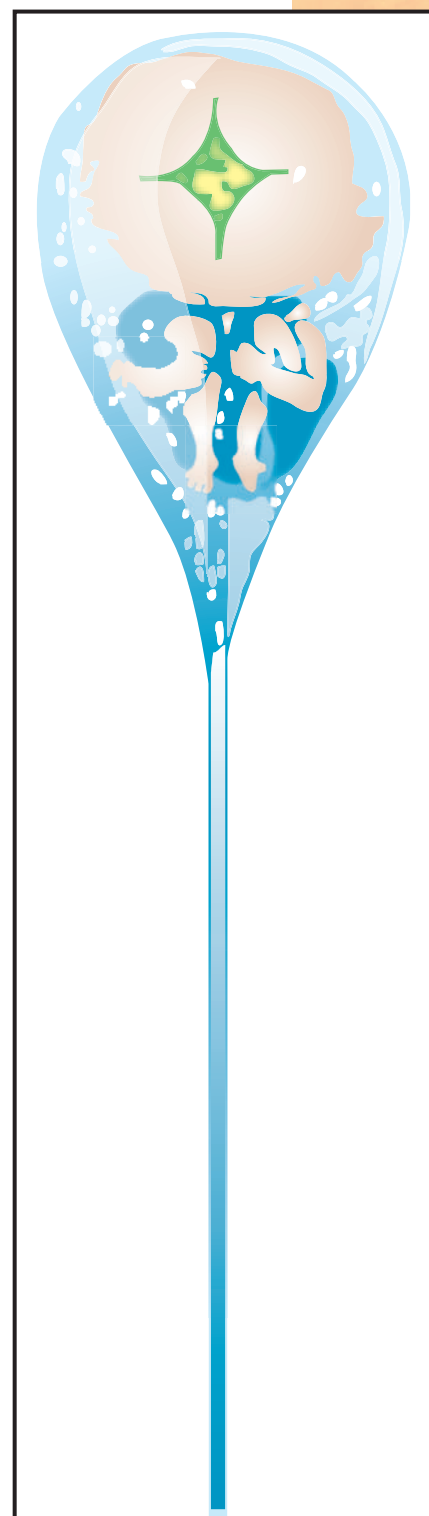

Figure 1. The human infant preformed in the sperm as depicted by Nicholas Haartsoecker (1694).

**nucleus** membrane-bound portion of cell containing the chromosomes



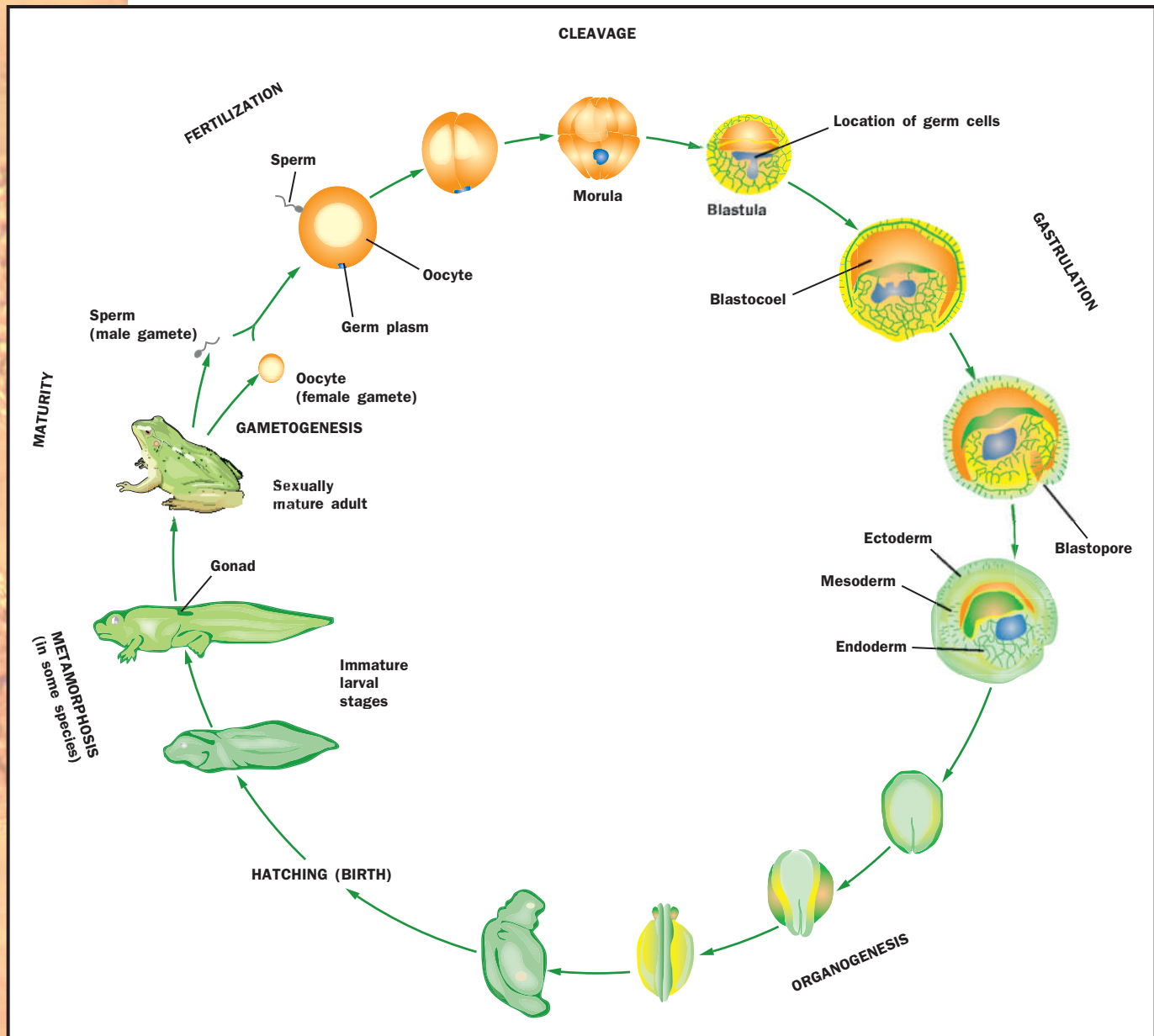

Figure 2. Developmental history of the frog. The stages from fertilization through hatching are known collectively as embryogenesis.

These experiments demonstrated that all the nuclei of an early embryo are capable of producing embryos. This ability is the basis for much current practice of cloning agriculture or lab animals.

In later experiments, Spemann found that the location of the ligature was important. If the ligature were placed so that each half of the fertilized egg contained the certain cells (called the gray crescent because of their color) from the region destined to become the blastopore, two newts would develop. However, if the ligature were placed so that the gray crescent was only on one half of the cell, that part would form a newt, but the half without the gray crescent would remain a formless mass of cells he called the belly piece. Further experimentation demonstrated that during gastrulation cells became committed to their developmental fates.

Spemann and his graduate student Hilde Mangold (1898–1924) demonstrated that specific cells of the blastopore are the only determining region



Frog embryos begin their development inside eggs.

in the gastrula. When these cells were transplanted to other embryos, the embryos were induced to undergo gastrulation and form a second embryo. These experiments that Mangold performed for her doctoral dissertation formed the foundation for much of Spemann's later work. Mangold died at age twenty-six when the heater in her apartment exploded. She could not share the Nobel Prize awarded to Spemann eleven years later because the prize is not awarded posthumously.

### Protostomes and Deuterostomes

The fate of the blastopore is used to classify animals that have three germ layers into two large categories, **protostomes** and **deuterostomes**. Most adult animals have two external openings, the mouth and the anus, into the digestive tract. During gastrulation, the blastopore is the opening into the primitive gut. During further development, the blastopore becomes the mouth in animals classified as protostomes; the blastopore becomes the anus in deuterostomes. Organisms belonging to the phyla Mollusca (clams and snails), Arthropoda (insects and crustaceans) and Annelida (earthworms) are protostomes; members of the phyla Echinodermata (starfish) and Chordata (fish and humans) are deuterostomes. The type of cleavage and the development of the body cavity are other important differences between the protostomes and deuterostomes.

Protostomes exhibit spiral cleavage in which the blastomeres divide at acute angles to one another and are not aligned over one another. If one of these blastomeres is removed from the embryo, neither the removed blastomere nor the remaining cells develop into an individual. This type of determinate cleavage indicates that the fate of the daughter cells is determined early in development. A final characteristic of protostomes is that the body cavity, or coelom, develops as a split within the middle of the mesodermal layer. This type of coelom formation is termed schizocoelous development.

Deuterostomes, on the other hand, exhibit radial cleavage in which the blastomeres divide perpendicular or parallel to one another and are

**protostome** "mouth first"; referring to the early development of the oral pore during gut tube formation

**deuterostome** "mouth second"; referring to the early development of the anal pore during gut tube formation

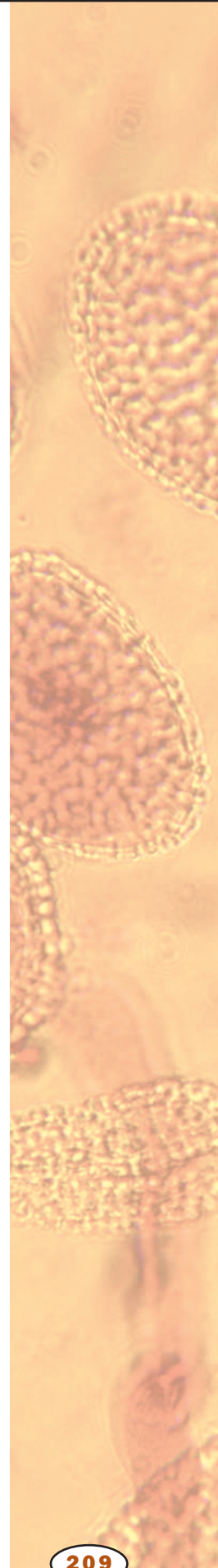

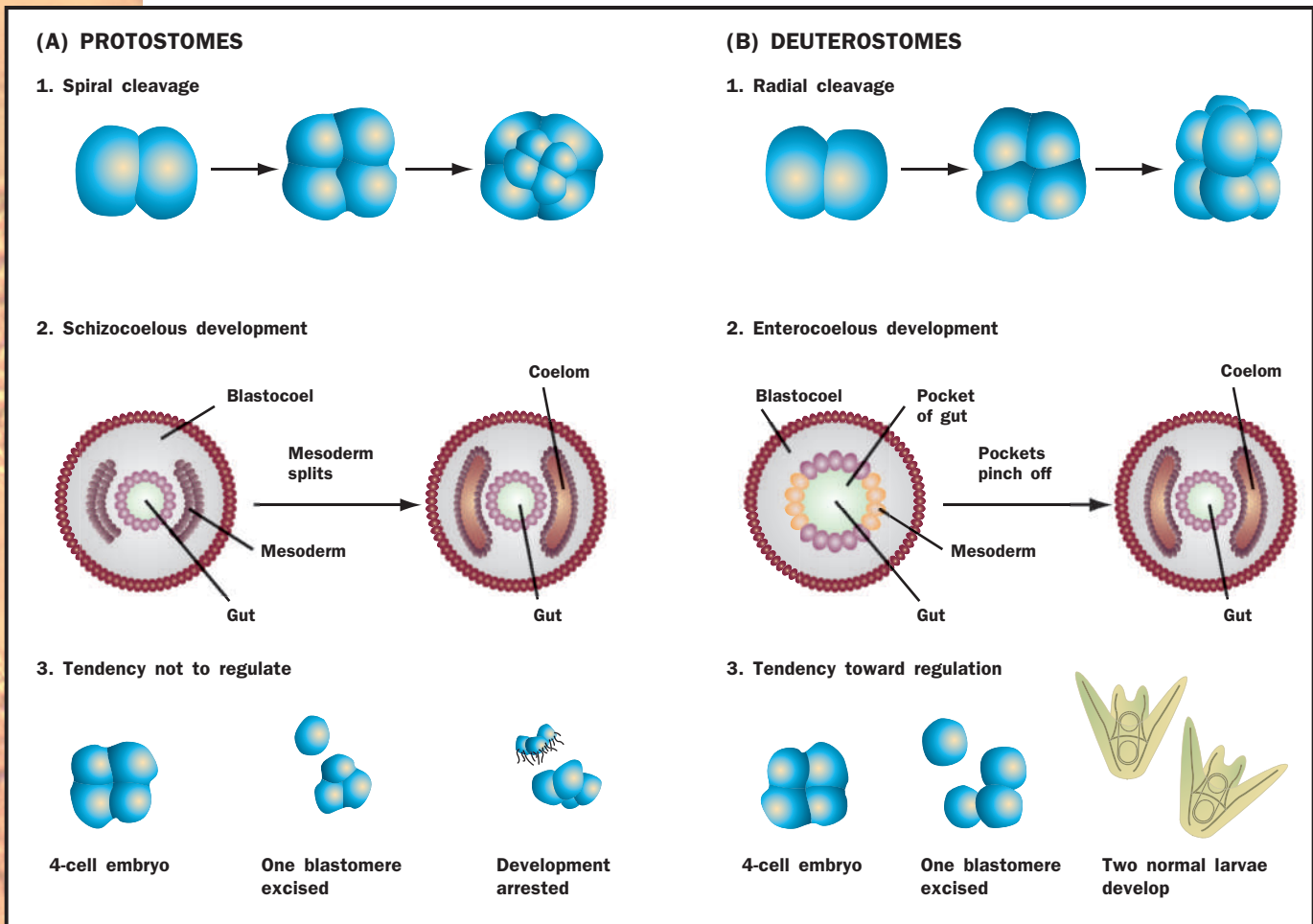

Development in protostomes and deuterostomes.

aligned over one another. If one of these blastomeres is removed from the embryo, both the removed blastomere and the remaining cells can develop into individual organisms. This type of indeterminate cleavage indicates that the fate of the daughter cells is determined later in development. Identical twins are possible because of indeterminate cleavage. Genetic testing of human embryos is possible because of indeterminate cleavage: One blastomere can be removed from an eight-celled embryo and tested without interfering with the normal development of the remaining seven cells. In deuterostomes the coelom develops as buds from the primitive gut. This type of coelom formation is termed enterocoelous development.

### Biogenetic Law

Ernst Haeckel (1834–1919), a physician, was so influenced by Charles Darwin’s *The Origin of Species* that he gave up medicine and devoted himself to comparative anatomy. He disagreed with Darwin’s theory of natural selection, and suggested that the environment acted directly on organisms, producing new species. In 1868, he proposed the biogenetic law, which sought to explain evolution as a series of stages in which the new characteristics of the next animal to evolve are simply added on to the lower animal. Briefly put, his biogenetic law stated that ontogeny recapitulates phylogeny (the

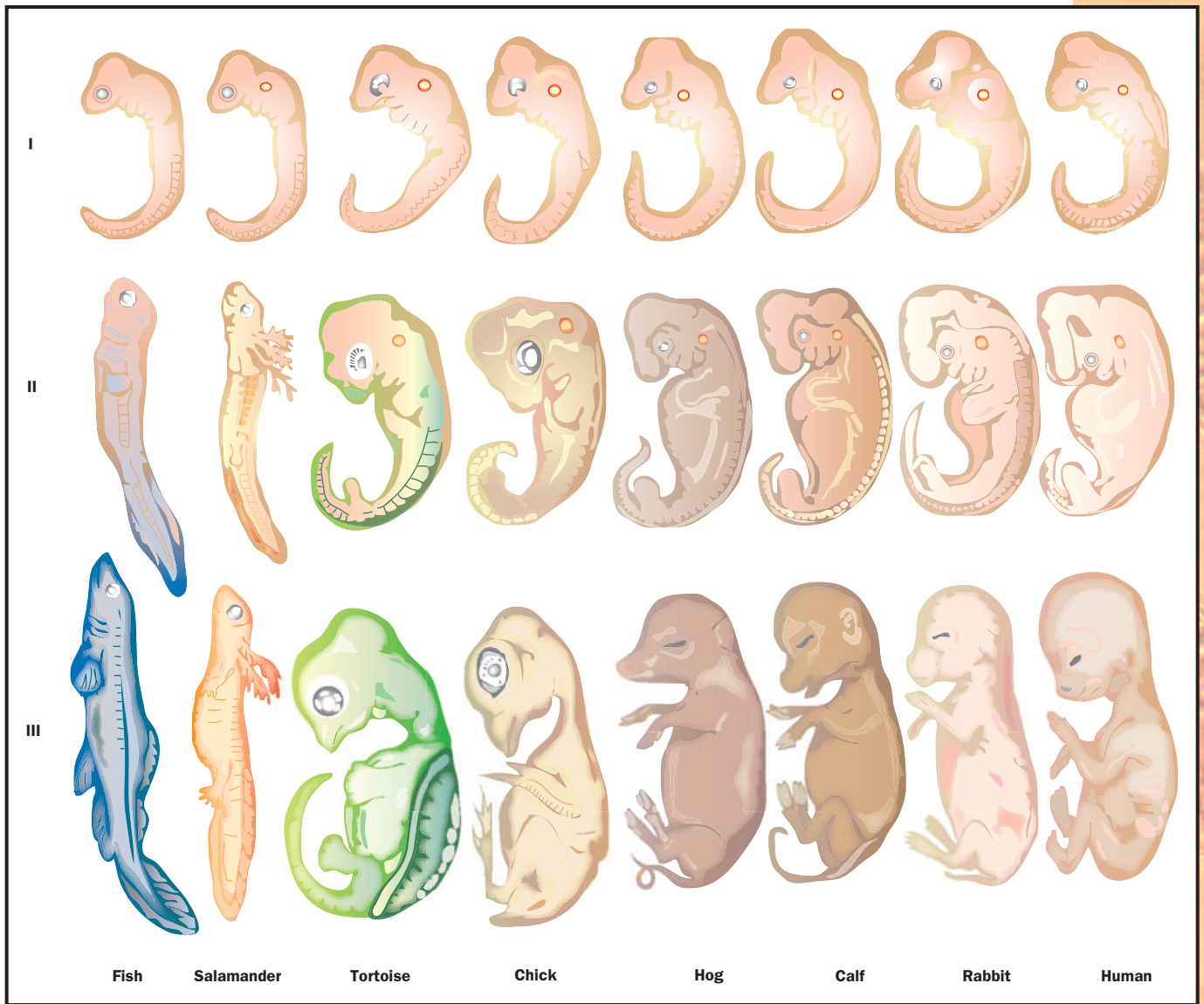

embryological development of a particular species repeats the evolutionary history of that species). Although Haeckel is best remembered for his “ontogeny recapitulates phylogeny” statement, he also coined the terms **phylum**, ecology, and phylogeny.

Modern scientists do not subscribe to the biogenetic law as postulated by Haeckel. However, there are elements of recapitulation that are important in comparative embryology. In 1828, Karl von Baer pointed out that vertebrates share common characteristics during development (see Fig. 3). Examination of vertebrate embryos reveals that during corresponding stages of early development, the embryos appear to be very similar. For example, all vertebrate embryos pass through stages in which they have gill pouches. The pouches eventually develop into the gill apparatus in fish; in later-evolving vertebrates that do not have gills, the gill pouches undergo further refinement and develop into structures associated with the head and neck. Similarly, all early vertebrate embryos have

Figure 3. Illustration of von Baer's law.

**phylum** taxonomic level below kingdom, e.g., arthropod or chordate

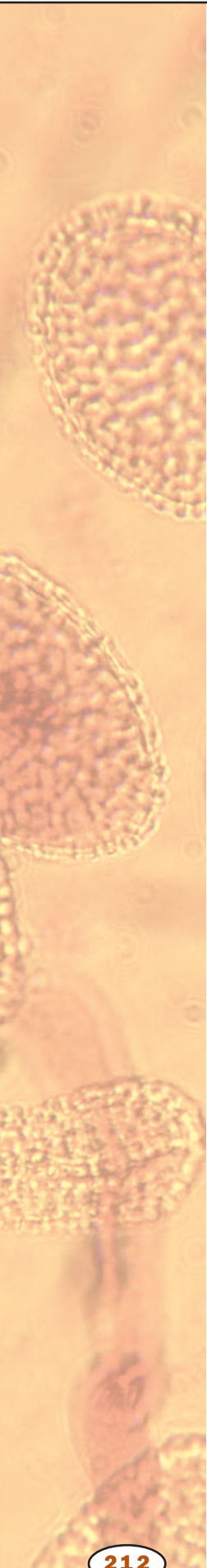

**apical meristem** growing tip from which all plant tissues arise

**nucleus** membrane-bound portion of cell containing the chromosomes

**cytoplasm** material in a cell, excluding the nucleus

**ribosome** protein-RNA complex in cells that synthesizes protein

tails, which persist in some animals but regress during the later stages of development of humans. Thus, the individual development of an animal occurs through a series of stages that paint a broad picture of the evolutionary stages (phylogeny) of the species to which it belongs. SEE ALSO ANNELID; ARTHROPOD; CLONE; ECHINODERM; FETAL DEVELOPMENT, HUMAN; GENETIC CONTROL OF DEVELOPMENT; GROWTH; MEIOSIS; MOLLUSK; REPRODUCTIVE TECHNOLOGY

Suzette F. Chopin

### Bibliography

Carlson, Bruce M. *Human Embryology and Developmental Biology*, 2nd ed. New York: Mosby, 1999.

———. *Patten's Foundation of Embryology*, 6th ed. New York: McGraw-Hill, Inc., 1996.

Gilbert, Scott F. *Developmental Biology*, 3rd ed. Sunderland, MA: Sinauer Associates, Inc., 1991.

Gould, Stephen J. *Ontogeny and Phylogeny*. Cambridge, MA: The Belknap Press, 1977.

Moore, Keith L., and T. V. N. Persaud. *Before We Are Born: Essentials of Embryology and Birth Defects*, 5th ed. Philadelphia, PA: W. B. Saunders, Co., 1998.

**Dicot** See *Eudicot*

## Differentiation in Plants

Differentiation in plants refers to the processes by which distinct cell types arise from precursor cells and become different from each other. Plants have about a dozen basic cell types that are required for everyday functioning and survival. Additional cell types are required for sexual reproduction. While the basic diversity of plant cell types is low compared to animals, these cells are strikingly different. For example, some cells such as parenchyma cells retain the potential to respond to environmental and/or hormonal signals throughout their life and, under the right conditions, can be transformed into another cell type (transdifferentiation). Other cells such as the water-conducting vessel elements undergo cell death as part of their differentiation pathway and thus can never transdifferentiate to another cell type.

### Meristem Origins

Despite the differences among mature cells, all are ultimately derived from the **apical meristems**, populations of embryonic cells at the tips of the shoots and roots. Meristem cells are uniform in appearance: they are small and cuboidal in shape, and have a thin, flexible cell wall, a high **nucleus** to **cytoplasm** ratio, and dense cytoplasm with numerous **ribosomes**. The first step in the differentiation pathway is the formation of the precursors of the three tissue systems: protoderm (dermal tissue system), ground meristem (ground tissue system), and procambium (vascular tissue system).

### Plant Tissue Systems

Each of the three tissue systems is found in a predictable location and consists of one or more multicellular tissues that carry out a unique function. For instance, the dermal tissue system is found at the surface of the plant and consists of a single tissue type, the epidermis. The epidermis functions

to protect the plant from water loss, to permit gas exchange, and to provide a barrier to the invasion of harmful fungi and other microorganisms. The ground tissue system occurs internally to dermal tissue and may consist of three tissue types: parenchyma tissue, collenchyma tissue, and sclerenchyma tissue.

Parenchyma tissue is a multipurpose tissue that functions in photosynthesis and storage, while both collenchyma and sclerenchyma function to support the aboveground parts of the plant against the pull of gravity. The vascular tissue system occurs at the center of roots, stems, and leaves and functions in the long-distance transport of water and **solutes**. It consists of two tissues: **xylem** tissue and **phloem** tissue. Xylem provides a conduit for the movement of water and dissolved mineral elements from the roots to the shoot system. In contrast, phloem transports an **aqueous** solution of the products of photosynthesis from the green photosynthetic shoots to the roots and other parts of the plant that are using or storing food energy.

## Overview of Plant Cell Types

**Epidermal Cell Types.** Epidermal cells are the most common cell type in the epidermis. These cells are often called “pavement cells” because they are flat polygonal cells that form a continuous layer, with no spaces between individual cells. Epidermal cells secrete the waxy **hydrophobic** substance cutin that polymerizes on the surface, forming a barrier to water evaporation. Epidermal cells are transparent because their plastids remain small and undifferentiated; hence light readily penetrates through to the photosynthetic tissues beneath the epidermis.

Two more specialized cell types are also found in the epidermis: **guard cells** and trichomes. Guard cells are kidney-shaped cells that are filled with chloroplasts. They always occur in pairs and form a small pore between them. The pair of guard cells and their pore is called a stomate and functions in gas exchange. Typically, the guard cells open the pore during daylight hours to allow CO<sub>2</sub> to diffuse into the photosynthetic tissues below. At night, however, the guard cells close the pore, preventing the diffusion of water vapor from internal tissues. The green chloroplasts of the guard cells function to provide the energy that fuels the opening and closing process.

Trichomes are long, narrow epidermal cells that grow perpendicular to the surface. Trichomes are either unicellular or multicellular and come in an amazing array of shapes. Some are branched and some are shield- or umbrella-shaped. Trichomes form a hairlike covering on the surface of leaves, stems, and roots and perform several important functions. The simple, unbranched trichomes of roots are called root hairs and function in the absorption of water from the soil. Trichomes on the surface of leaves and stems function primarily to retain water vapour and reduce the evaporative loss of water. Some trichomes secrete defense compounds that repel insect herbivores.

**Ground Tissue Cell Types.** Parenchyma cells are relatively unspecialized cells that make up the bulk of the soft internal tissues of leaves, stems, roots, and fruits. Parenchyma cells have thin, flexible cell walls and their cytoplasm typically contains a large, water-filled vacuole that fills 90 percent of the cell’s volume. The vacuole may also contain compounds such as sugars (in

**solute** dissolved substance

**xylem** water-transporting system in plants

**phloem** plant tissue that conducts sugars from leaves to roots and other tissues

**aqueous** watery or water-based

**hydrophobic** “water hating,” such as oils

**guard cells** paired cells on leaves that control gas exchange and water loss

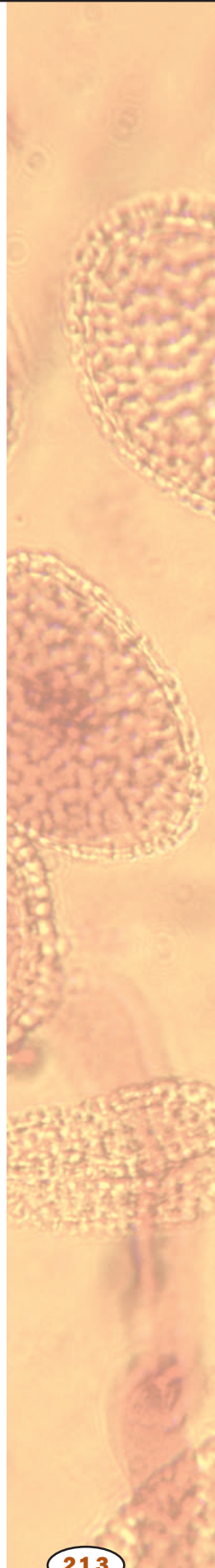
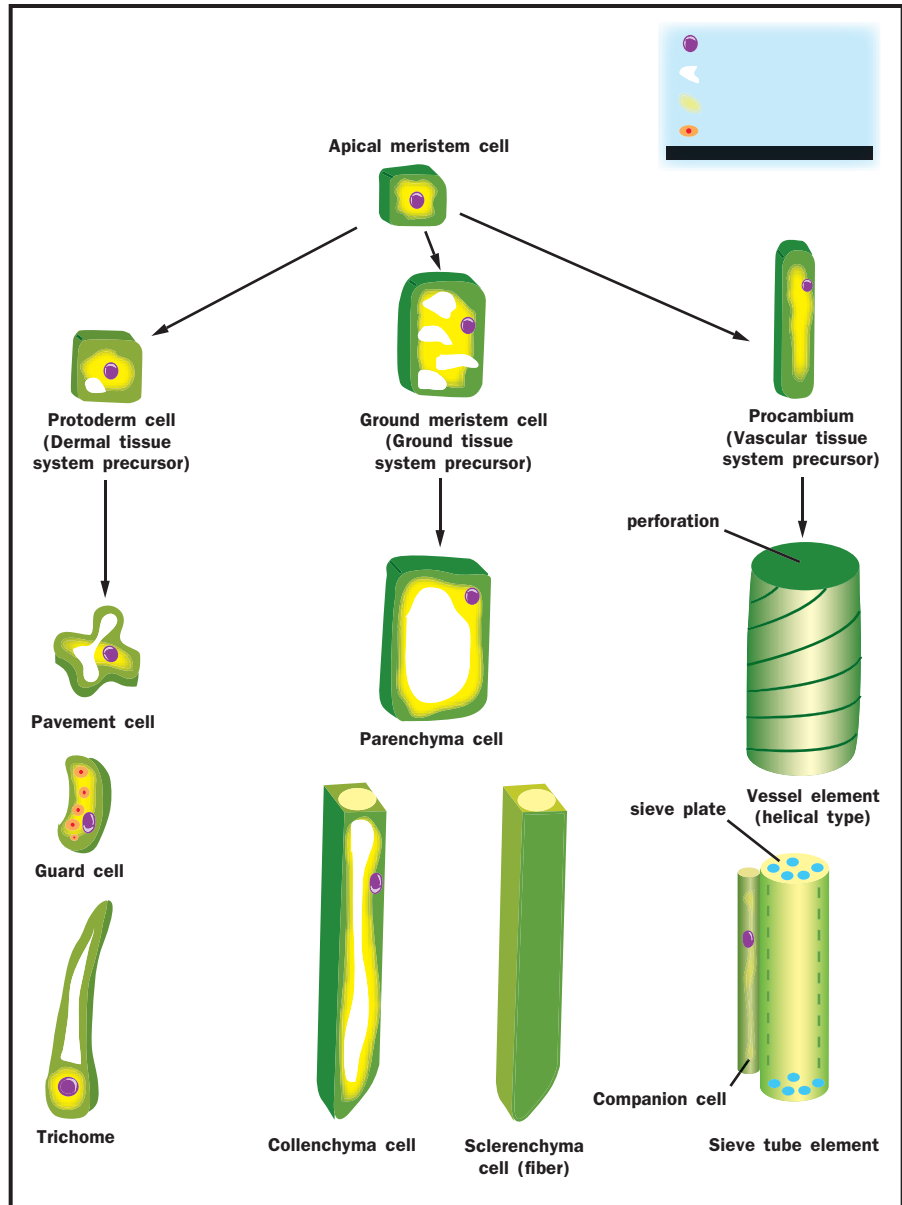

Figure 1. Distinct plant cell types are all ultimately derived from apical meristems.



**organic** composed of carbon, or derived from living organisms

**lignin** organic molecule used in plant cell walls to add stiffness to cellulose

sweet fruits such as apples), **organic** acids (as in oranges), or defense compounds such as the tannins found in tea leaves. Other specialized parenchyma cells may have starch-containing plastids such as those of potato tubers.

Collenchyma cells are long narrow cells with thick, strong, yet extensible, cell walls. Collenchyma cells are found in strands or sheets beneath the epidermis and function to provide support while a stem or leaf is still expanding. When growth is complete, sclerenchyma cells take over the role of providing mechanical support. Typical sclerenchyma cells are also long narrow cells (called fibers) with thick strong walls. Unlike collenchyma, the cell walls of sclerenchyma fibers are hard and rigid due to the deposition of **lignin** within the wall.

Fibers contribute more than half the volume of woody tissues and are found in all stems and leaves that are hard and tough. Other specialized sclerenchyma cells are shorter (sclereids) and have a protective function such as

those of seed coats, walnut shells, or peach pits. Since the supportive or protective functions of sclerenchyma are carried out by the **lignified** cell walls, there is no requirement for living cytoplasm and these cells typically die as part of the differentiation process.

**Vascular Tissue Cell Types.** The vascular tissues are complex tissues, each consisting of a number of distinct cell types. The xylem contains conducting cells called vessel elements, as well as sclerenchyma fibers and parenchyma cells.

Vessel elements are highly specialized cells. Like sclerenchyma fibers, they form a thick cell wall that is impregnated with lignin. This cell wall can take many forms, depending on the time and location of its formation within the plant. In tissues that are growing, the lignified part of the cell wall is formed in rings or a helix, allowing the vessel elements to extend as the plant grows. In nonexpanding parts of the plant the cell wall forms as a netlike or pitted structure; these patterns contribute to the mechanical support of the plant and prevent cell collapse. Vessel elements are aligned end to end within the xylem. The part of the cell wall between adjacent cells is degraded, so that the interior of all the vessel elements in a file becomes continuous, forming a vessel. Vessel elements are dead at maturity, leaving a hollow tube for the flow of water upward from the roots to the shoot system.

Phloem is also a complex tissue, containing two unique cell types, the sieve tube elements and companion cells, as well as parenchyma and sclerenchyma cells. Sieve tube elements are elongate cells with thick flexible cell walls. Adjacent cells are aligned end to end, forming the sieve tube. The end walls between adjacent cells have numerous pores; the sievelike appearance of these end walls led early microscopists to give these cells their name.

Sieve tubes transport the products of photosynthesis from the leaves to all parts of the plant where energy is needed or stored. The mechanism of transport requires that the sieve tube elements have a living cell membrane, but not other large components of the protoplast that might block the pores on the sieve plate. Thus mature sieve tube elements lack a vacuole, a nucleus, rough **endoplasmic reticulum**, and golgi. Sieve tube elements often live for years, but only because each is associated with a specialized parenchyma cell called a companion cell. The nucleus and cytoplasm of the companion cell must do the work for two cells, making and exporting the **proteins** required for sieve tube element function.

## Examples of Cell Differentiation

**Trichomes.** The distinctive branched unicellular trichomes of plants such as *Arabidopsis* differentiate from undistinguished precursor cells in the protoderm. These precursor cells initiate the differentiation pathway by undergoing deoxyribonucleic acid (DNA) synthesis without accompanying cytokinesis, so that trichome precursors typically have eight or sixteen times the amount of DNA of adjacent pavement cells. Next, trichome precursors begin cell expansion in the plane perpendicular to the epidermis, forming a tubular extension. Once this stalk is formed, the nucleus migrates from the base of the stalk to its tip, using the cell's **cytoskeleton** to pull it to a new location. The trichome then undergoes an unusual pattern of cell wall growth, in which the cell wall balloons out at three locations, forming the

**lignified** hardened by impregnation with lignin, a compound formed in plants

**endoplasmic reticulum** network of membranes within the cell

**protein** complex molecule made from amino acids; used in cells for structure, signaling, and controlling reactions

**cytoskeleton** internal scaffolding in a cell, composed of protein

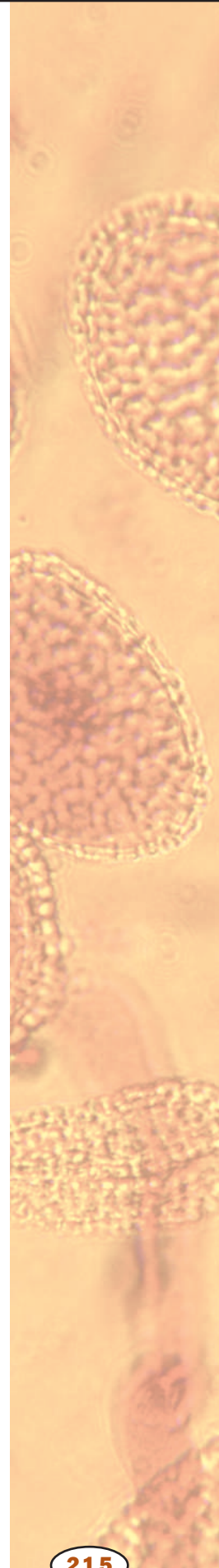



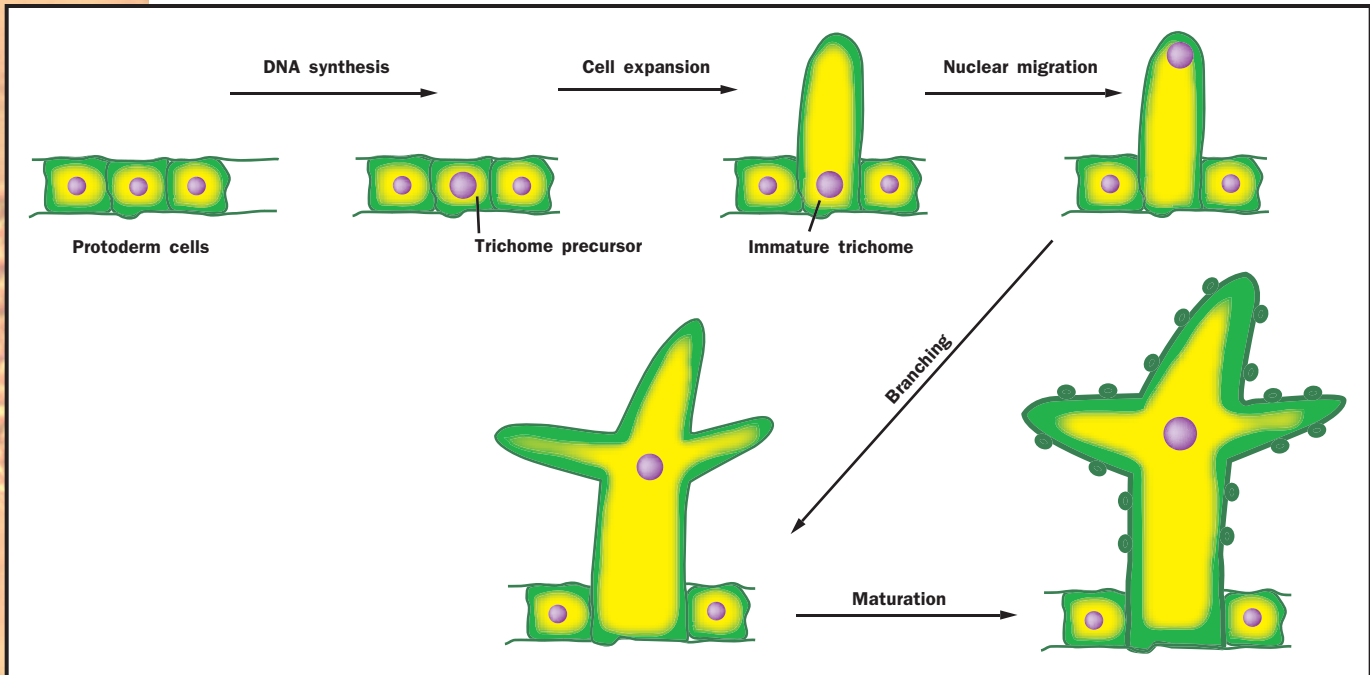

Figure 2. Trichome differentiation.

three trichome branches. When the trichome cell has reached its full size and shape, it adds thickness to its cell wall and deposits sharp crystals of calcium oxalate on the surface of the trichome, adding to its effectiveness in defense against herbivores (see Figure 2).

**enzyme** protein that controls a reaction in a cell

**gene** portion of DNA that codes for a protein or RNA molecule

**Vessel Elements.** Vessel elements differentiate from cells of the procambium. Vessel elements are first differentiated from other procambial cells because they expand more than their neighbors. Vessel element precursors next begin to deposit the thickened, lignified parts of their cell walls in either the ringlike, helical, netlike, or pitted pattern. The pattern can be predicted by the location of elements of the cytoskeleton within the cytoplasm that help guide wall precursor to the proper location. When cell wall synthesis is complete, special wall-degrading **enzymes** attack the end walls of the cell, forming the perforation between adjacent elements in a vessel. Finally, the vessel elements undergo programmed cell death. The cell makes protease enzymes and nuclease enzymes that reduce proteins and nucleic acids to their simple building blocks. Surrounding parenchyma cells absorb these small molecules, leaving an empty vessel (see Figure 3).

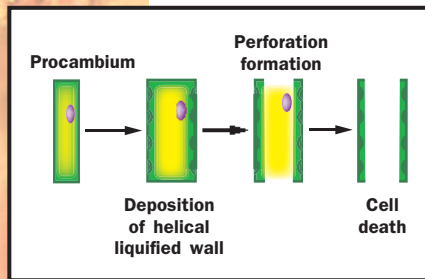

Figure 3. Vessel element differentiation.

**Bundle Sheath Cells.** In most plants, the cells of the photosynthetic ground tissue are uniform in size, shape, and chloroplast development. Two types of photosynthetic parenchyma cells are sharply differentiated in plants that have the C4 photosynthetic pathway, however. These two cell types, the mesophyll and bundle sheath cells, begin differentiation as similar-appearing ground meristem cells. During leaf expansion, the bundle sheath cells begin to enlarge first. The cell wall becomes thickened and impermeable to the diffusion of gases. Their plastids replicate, grow, and become asymmetrically placed within the cell. In contrast, the mesophyll cells undergo a minimal amount of enlargement and have thin, permeable cell walls. The number of plastids is low and the plastids remain small. During cell differentiation the **genes** encoding the enzymes of the C4 biochemical path-

way are expressed exclusively in the mesophyll cells, whereas the genes encoding the enzymes of the C3 pathway are expressed only in the bundle sheath cells (see Figure 4).

## Cell Differentiation and Development

Cell differentiation is only part of the larger picture of plant development. As plant organs develop (the process of organogenesis), the precursors of the tissue systems form in response to positional signals. Then, within each tissue system precursor, cell types must be specified in the proper spatial pattern. For instance, the spacing of trichomes and stomates within the protoderm must be specified before their precursor cells begin differentiation. Exchange of signals among neighboring cells is an important aspect of the processes of spatial patterning and cell differentiation. In addition, long distance signals are required so that the strands of xylem and phloem cells within the leaf vascular bundles connect perfectly with those in the stem.

## Hormonal Influences

Many aspects of differentiation are controlled by **hormones**. The hormone auxin, for example, plays an important role in the differentiation of vessel elements, both in intact and wounded plants. This role was first demonstrated in experiments where small incisions were made in stem internodes that cut through the phloem and xylem of a single vascular bundle. Auxin produced by the apical meristem and young leaves above the wound induces parenchyma cells to regenerate the damaged vascular tissue. Parenchyma cells undergo transdifferentiation.

Although they already had differentiated as parenchyma cells from ground meristem precursors, they now repeat the steps that procambial cells take when they differentiate as vessel elements. Cells are induced to do this in a chainlike pattern, so that a new continuous strand of vascular tissue is formed as a detour around the original incision. Scientists know that auxin is involved, since transdifferentiation is blocked when the sources of natural auxin (young leaves and buds) are removed or when auxin transport inhibitors are applied. If natural sources of auxin are removed, and artificial sources added, transdifferentiation of parenchyma cells will occur, regenerating the vascular bundle. SEE ALSO C4 AND CAM PLANTS; CELL WALL; FRUITS; HORMONES, PLANT; LEAVES; MERISTEMS; ROOTS; SECONDARY METABOLITES IN PLANTS; SHOOTS; VACUOLE; WATER MOVEMENT IN PLANTS

Nancy G. Dengler

### Bibliography

- Howell, S. H. *Molecular Genetics of Plant Development*. New York: Cambridge University Press, 1998.
- Lyndon, R. F. *Plant Development: The Cellular Basis*. London: Unwin-Hyman, 1990.
- Raven, Peter H., Ray F. Evert, and Susan E. Eichhorn. *Biology of Plants*. New York: W. H. Freeman and Company, 1999.

## Digestion

Digestion breaks down foods into nutrient molecules that are small enough to be absorbed into an animal's circulatory system. Following digestion, nu-

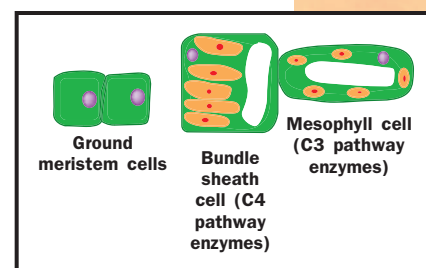
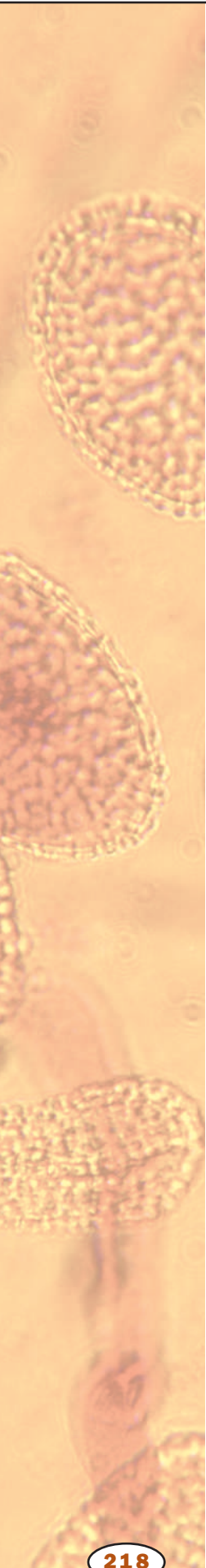

Figure 4. Bundle sheath cell differentiation.

**hormone** molecule released by one cell to influence another



**enzyme** protein that controls a reaction in a cell

**cellulose** carbohydrate made by plants and some other organisms; part of the cell wall

**esophagus** tube connecting throat to stomach

**protein** complex molecule made from amino acids; used in cells for structure, signaling, and controlling reactions

**sphincter** ring of muscle regulating passage of material through a tube such as the gastrointestinal tract

**amino acid** a building block of protein

**electrolytes** ions in body fluids

**minerals** iron, calcium, sodium, and other elements needed by living organisms

trients are delivered to cells, where energy is extracted from their chemical bonds. Digestion often begins with a mechanical tearing apart of food into smaller pieces, which are then chemically dismantled in a stepwise fashion.

Because digestive chemicals are harsh, food processing in an animal's body takes place in compartments. Some single-celled organisms, such as protista, sequester food particles in food vacuoles, where **enzymes** break them down. Simple multicellular organisms, such as hydra and flatworms, have one-opening digestive systems. They must digest the nutrients and expel the waste before eating anew. Digestive systems of more complex animals have two openings, allowing simultaneous ingestion, digestion, and excretion. Roundworms have the simplest two-opening digestive system, which is little more than a tube. Enzymes in the tube break down the food, and nutrients are absorbed from there into the body fluids. More complex animals, such as vertebrates, have a gastrointestinal tract that is specialized into compartments where digestive enzymes and other substances process the food. Waves of muscular contraction called peristalsis help to move the food along.

Digestive system specializations reflect the lifestyles of their owners. Birds eat and digest nearly all the time. They can store food in an enlarged sac called a crop, and have a muscular organ called a gizzard that uses small pebbles to grind food. In some migratory species, the intestines actually enlarge before a long flight, enabling the animal to obtain energy throughout the journey. Ruminants such as cows have several stomachs, which contain **cellulose**-digesting bacteria, enabling them to digest grasses.

In humans, digestion begins at the mouth, where teeth tear food into small pieces, and the enzyme salivary amylase begins the breakdown of starch. During swallowing, food travels quickly through the **esophagus**, landing in the stomach. Here, the food is churned and further mechanically broken down as it mixes with gastric juice into a slurry called chyme. Each day, 40 million cells that line the stomach's interior release up to three quarts of gastric juice, which consists of water, mucus, salts, hydrochloric acid, and the enzyme pepsin, which breaks down **protein** into peptides. Hydrochloric acid unwinds proteins and kills many microorganisms.

After a length of time that reflects the components of the meal, a drawstringlike muscular structure called the pyloric **sphincter** at the stomach's exit opens, and chyme squirts into the duodenum, the first ten inches of the small intestine. The next two segments are the jejunum and the ileum. In addition to peristalsis, the small intestine undergoes localized muscle contractions that slosh the chyme back and forth, exposing it to several types of digestive enzymes. Trypsin and chymotrypsin continue the breakdown of peptides, and then peptidases break these down further into **amino acids**. Carbohydrases and pancreatic amylase continue the carbohydrate digestion that began in the mouth, and nucleases break down deoxyribonucleic acid (DNA) and ribonucleic acid (RNA). Bile, which is produced in the liver and stored in the gallbladder, emulsifies fats, which are then chemically digested by lipases into fatty acids and monoglycerides. The pancreas secretes trypsin, chymotrypsin, amylase, lipase, and nucleases.

Absorption of most of the products of digestion occurs in the small intestine. Water, **electrolytes**, and **minerals** are absorbed in the large in-

testine. The remaining material, which consists mostly of bacteria, bile, cellulose and shed intestinal lining cells, is compacted into feces in the rectum, and exits the body through the anus. **SEE ALSO** DIGESTIVE SYSTEM

*Ricki Lewis*

### Bibliography

Alexander, R. McNeill. "News of Chews: The Optimization of Mastication." *Nature* 391 (1998): 329–331.

Johnson, Leonard R., and Thomas A. Gerwin. *Gastrointestinal Physiology*. New York: Mosby, 2001.

## Digestive System

The human digestive system is responsible for food ingestion and digestion as well as the absorption of digested food molecules and the elimination of undigested molecules. It consists of a long tube called the gastrointestinal tract or GI tract (alimentary canal) and several accessory organs. The major components of the GI tract are the mouth, **pharynx**, **esophagus**, stomach, small intestine, and large intestine. The major accessory organs are the teeth, salivary glands, liver, gallbladder, and pancreas.

### Mastication and Swallowing

Ingestion (the intake of food) occurs in the mouth where food is chewed and mixed with saliva. The teeth have different shapes to perform different tasks; the incisors (chisel-shaped **anterior** teeth) are used to cut into food, the canines (pointed teeth located lateral to the incisors) are used to tear or pierce food, and the premolars and molars (having broad surfaces) are used for crushing and grinding food. Chewing (mastication) of food is accompanied by mixing of the food with saliva. The mouth is normally kept moist by the continual production of small quantities of saliva by numerous tiny intrinsic salivary glands located in the inner lining of the mouth.

During chewing, much greater quantities of saliva are secreted by three pairs of extrinsic salivary glands, namely the parotid glands (located under the skin anterior to each earlobe), the submandibular glands (located under the base of the tongue), and the sublingual glands (located in the floor of the mouth). Saliva is a watery fluid containing several components including lysozyme, an **enzyme** that kills bacteria, and salivary amylase, an enzyme that begins the digestion of starch.

Once the food has been chewed into a soft, flexible mass called a bolus, it is swallowed for delivery to the stomach. On its journey, the bolus passes through the pharynx and then through the esophagus, a straight muscular tube that descends through the thoracic (chest) cavity, anterior to the spine. Each bolus of food is propelled through the esophagus by gravity, and by the process of peristalsis, a wave of muscular contraction that pushes the bolus downward. The lower end of the esophagus, which passes through a hole in the diaphragm to meet the stomach within the abdominal cavity, has a lower esophageal (or gastroesophageal or cardiac) **sphincter** which briefly relaxes to allow the bolus of food to enter the stomach.

**pharynx** throat

**esophagus** tube connecting throat to stomach

**anterior** toward the front

**enzyme** protein that controls a reaction in a cell

**sphincter** ring of muscle regulating passage of material through a tube such as the gastrointestinal tract

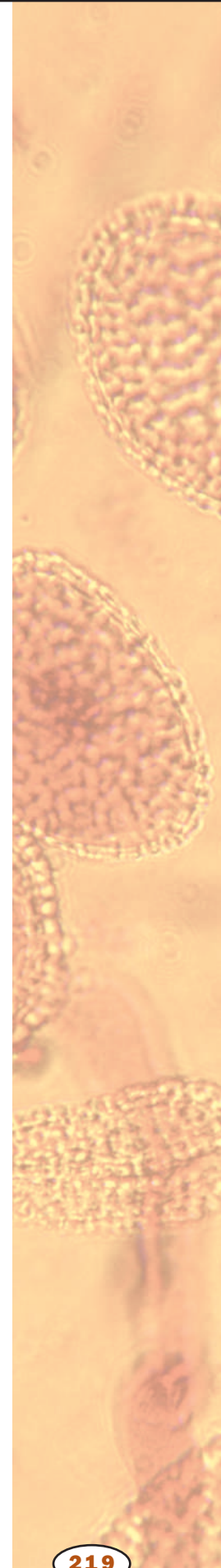

Parts of the digestive system.

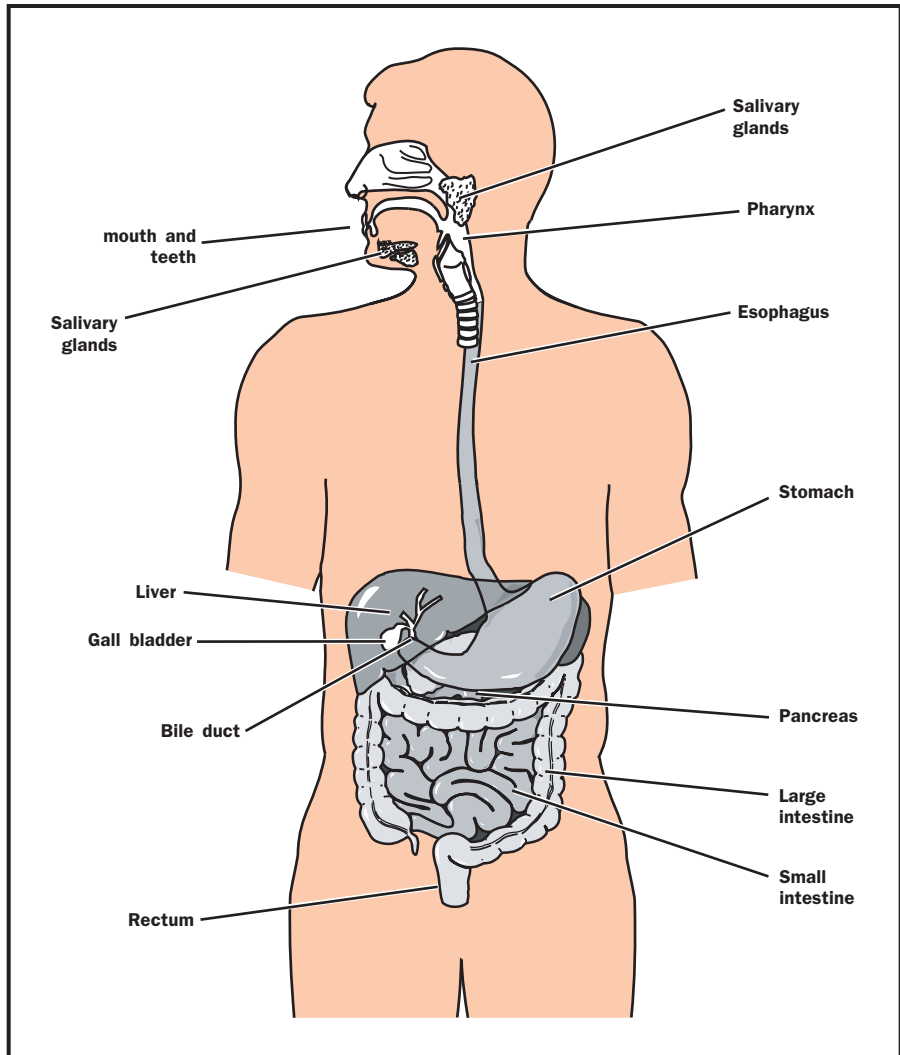

## Stomach and Intestines

The stomach is a muscular sac that is located in the upper left portion of the abdominal cavity. The inner lining of the stomach wall contains millions of tiny gastric glands that secrete gastric juice, which dissolves the food to form a thick liquid called chyme. Gastric juice contains several substances including hydrochloric acid, intrinsic factor (which is essential for the intestinal absorption of vitamin B<sub>12</sub>) and pepsinogen (an inactive **protein**-digesting enzyme). The hydrochloric acid has several functions including destroying ingested bacteria, and converting pepsinogen into its active form, pepsin, in order to initiate the digestion of protein.

At the lower end of the stomach is the pyloric sphincter, a valve through which chyme must flow to enter the small intestine. Most meals are gradually emptied into the small intestine after two to six hours due to peristaltic contractions that travel toward the lower end of the stomach. Most digestion and absorption occur within the small intestine. The small intestine consists of three segments named the duodenum, jejunum and ileum. The duodenum receives chyme from the stomach as well as pancreatic juice from the pancreas and bile from the liver (and stored in the gallbladder).

**protein** complex molecule made from amino acids; used in cells for structure, signaling, and controlling reactions

Pancreatic juice contains digestive enzymes capable of digesting proteins, **carbohydrates**, and **lipids**. Bile emulsifies lipids to increase the efficiency of lipid digestion and absorption. Once digestion has been completed, the digested nutrients are absorbed into blood vessels and lymphatic vessels within the wall of the small intestine.

Peristaltic contractions move chyme through the small intestine and into the large intestine. The large intestine consists of three major segments, the cecum (which receives chyme from the small intestine), the colon, and the rectum. As peristalsis moves chyme through the colon, water is absorbed to gradually convert the chyme into semisolid material called feces. The feces contain indigestible food molecules (primary **cellulose**) and intestinal bacteria that live in the colon (primarily *Escherichia coli*). Peristalsis delivers the feces into the rectum where they are stored until they are expelled through the anus by the process of defecation. SEE ALSO DIGESTION; LIVER; PANCREAS

Izak Paul

### Bibliography

Saladin, Kenneth S. *Anatomy & Physiology: The Unity of Form and Function*, 2nd ed. New York: McGraw-Hill, 2001.

## Disease

Disease (or “lack of ease”) is any damage or injury that impairs an organism’s function. Diseases (sometimes called deviations from the norm) can be classified in numerous ways. Generally, an acute disease comes on quickly and lasts for only a relatively short time. A chronic disease usually begins slowly and lasts for a longer time.

Diseases can also be classified according to type. Common disease types or categories include: infectious, genetic (hereditary), psychiatric, deficiency, degenerative, **congenital** (whether genetic or not), neurological, cardiovascular, metabolic, chemical, and occupational.

Infectious or microbial diseases (the pathogenic diseases) are often classified by their causative agents: bacteria, fungi, protozoans, viruses, or prions. Progressive diseases, particularly those caused by microbes, have several clinical stages: infection, incubation, acute, decline, and convalescent. “Prodromal” refers to the initial stages when perhaps only one or two early characteristics of the disease can be observed. **Communicable** diseases are transmitted either directly or indirectly (via carriers or **vectors**) from one organism to another. Contagious diseases are rapidly transmitted infectious diseases. Malignant diseases usually progress quite rapidly and are potentially life threatening.

In contrast to disease (the deviation itself), “illness” is feeling of being sick, or suffering some effect of the disease. Many people have hypertension (the disease), for example, without feeling any illness until it is so far advanced that it causes a stroke or kidney failure. This is why hypertension is sometimes called “the silent killer.” SEE ALSO AUTOIMMUNE DISEASE; BACTERIAL DISEASES; CARDIOVASCULAR DISEASES; GENETIC DISEASES; HISTORY OF MEDICINE;

**carbohydrates** sugars, starches, and other molecules combining carbon, hydrogen, and oxygen and serving as fuel or structural components

**lipid** fat or waxlike molecule, insoluble in water

**cellulose** carbohydrate made by plants and some other organisms; part of the cell wall

**congenital** present at birth; inherited

**communicable** transmissible from person to person

**vector** carrier

HOMEOSTASIS; NEUROLOGIC DISEASES; PARASITIC DISEASES; PSYCHIATRIC DISORDERS, BIOLOGY OF; SEXUALLY TRANSMITTED DISEASES; VIRAL DISEASES

Roberta M. Meehan

### Bibliography

Madigan, Michael T., John M. Martinko, and Jack Parker. *Brock Biology of Microorganisms*, 9th ed. Upper Saddle River, NJ: Prentice Hall, 2000.

Thomas, Clayton L., ed. *Taber's Cyclopedic Medical Dictionary*, 18th ed., Philadelphia, PA: F. A. Davis Company, 1997.

## DNA

DNA (deoxyribonucleic acid) is the molecule that stores genetic information in living systems. Like other **organic** molecules, DNA mostly consists of carbon, along with hydrogen, oxygen, nitrogen, and phosphorus. The fundamental structural unit of DNA is the **nucleotide**, which has two parts: an unvarying portion composed of sugar and phosphate, attached to one of four nitrogen-containing bases named adenine, cytosine, guanine, or thymine (abbreviated A, C, G, T).

### The Double Helix

The structure of DNA, deduced in 1953 by James Watson, Francis Crick, and Rosalind Franklin, resembles that of a twisted ladder or spinal staircase composed of two long chains of nucleotides that are coiled around each other to form a double helix. The DNA ladder's two sidepieces (its double-stranded backbone) are made of alternating units of sugar and phosphate. The sugar is deoxyribose, which contains a ring of four carbons and one oxygen. A phosphate is an atom of phosphorus bonded to four oxygens. Bases attached to opposing sugars project inward toward each other to form rungs or steps, called **base pairs**. In contrast to the strong covalent (electron-sharing) bonds between nucleotides in a strand, the two bases in a base pair are held together only by much weaker **hydrogen bonds**. However, the cumulative attractive force of the hydrogen bonds in a chain of base pairs maintains DNA as a double-stranded molecule under physiological conditions. In the cell **nucleus**, DNA is bound to **proteins** to form **chromosomes**, and is coated with a layer of water molecules.

To make a sturdy rung, the two bases in a base pair have to interlock like pieces of a jigsaw puzzle, which only happens if their shapes and hydrogen-bonding characteristics are compatible. Only two combinations fulfill these requirements in DNA: G–C and A–T. This rule makes the two strands of a DNA molecule **complementary**, so that if the bases of one strand are ordered GGTACAT, the bases of the opposite strand must be ordered CCATGTA. The order of the bases on a strand (mirrored in the complementary strand) is called the sequence of the DNA, and embodies coded instructions for making new biomolecules: proteins, ribonucleic acid (RNA), and DNA itself.

### Complementarity and Replication

Each strand of DNA has a direction in which it can be read by the cellular machinery, arising from the arrangement of phosphates and sugars in the

**organic** composed of carbon, or derived from living organisms

**nucleotide** the building block of RNA or DNA

**base pair** two nucleotides (either DNA or RNA) linked by weak bonds

**hydrogen bond** weak bond between the H of one molecule or group and a nitrogen or oxygen of another

**nucleus** membrane-bound portion of cell containing the chromosomes

**protein** complex molecule made from amino acids; used in cells for structure, signaling, and controlling reactions

**chromosome** “colored body” in the cell nucleus; made of DNA and protein, and divided functionally into genes and non-gene regions

**complementary** matching opposite

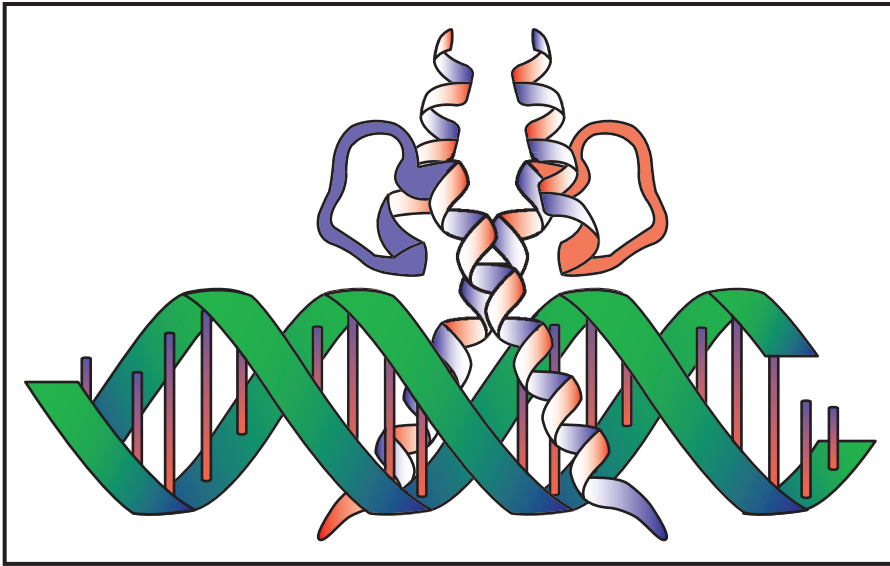

A helix-loop-helix dimer bound to DNA.

backbone. The two strands of DNA are oriented antiparallel to each other, that is, they lie parallel to each other but are decoded in opposite directions. Because of the numbering convention for the combinations in sugar, the directions along the backbone are called  $5' \rightarrow \rightarrow \rightarrow 3'$  (“five-prime to three-prime”) or  $3' \rightarrow 5'$ . The complementary nature of the two strands means that instructions for making new DNA can be read from both strands.

When DNA replicates, the weak hydrogen bonds of base pairs are broken and the two strands separate. Each strand acts as a **template** for the synthesis of a new complementary strand. Since the resulting new double-stranded molecule always contains one “old” (template) strand and one newly made strand, DNA replication is said to be semiconservative; it would be termed conservative if the two original template strands rejoined. By a similar mechanism (transcription), a DNA strand can be a template for the synthesis of RNA, which is a single-stranded nucleic acid that carries coded information from the DNA to the protein synthesizing machinery of the cell. During protein synthesis, the **genetic code** is used to translate the order of bases originally found in the DNA sequence into the order of **amino acid** building blocks in a protein.

### Genes, Noncoding Sequences, and Methylation

DNA exists in nature as a macromolecule millions of base pairs long. In multicelled organisms, the complete set of genetic information—the **genome**—is divided among several DNA **macromolecules** (called chromosomes) in the cell nucleus. In contrast, the genomes of many one-celled organisms consist of a single, often circular, chromosome. The human genome contains 3.2 billion base pairs distributed among twenty-three chromosomes. Laid end to end, these would make a macromolecule 1.7 meters (5.5 feet) long; printed out, they would fill one thousand one-thousand-page telephone books. Furthermore, two copies of the genome are in almost every cell of humans and other **diploid** organisms. This vast amount of DNA packs into a cell nucleus, whose volume is only a few millionths of a cubic meter, by first spooling around globular proteins called **histones**. The DNA/histone complex then coils and curls up into even denser configura-

**template** master copy

**genetic code** relationship between triples of RNA nucleotides and the amino acids they code for during protein synthesis

**amino acid** a building block of protein

**genome** total genetic material in a cell or organism

**macromolecules** large molecules such as proteins, carbohydrates, and nucleic acids

**diploid** having pairs of chromosomes in the nucleus

**histone** protein around which DNA wraps to form chromosomes

A defect in the gene for a methylating enzyme causes Rett syndrome, a disorder responsible for mental retardation and movement disorders in young girls.



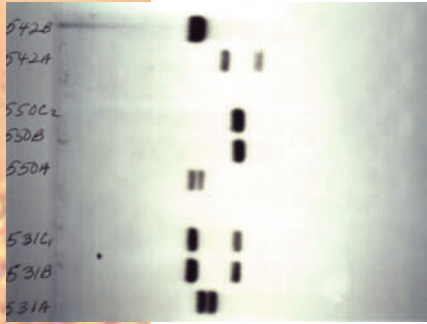

A human DNA fingerprint taken from blood to match donor and patient in an organ transplantation.

**neuron** nerve cell

**methylation** addition of the methyl group  $\text{CH}_3$

### WILKINS, MAURICE (1916- )

New Zealand-born British biologist who helped James Watson and Francis Crick deduce the structure of deoxyribonucleic acid (DNA), for which the three men received a 1962 Nobel Prize. Wilkins secretly showed Watson an x-ray diffraction photo of DNA taken by researcher Rosalind Franklin. Watson and Crick later used Franklin's extensive unpublished data to build a model of DNA.

**genome** total genetic material in a cell or organism

tions, like a rubber band does when one holds one end and rolls the other end between one's fingers. Yet the human genome isn't nearly nature's biggest: the genome of a lily is just over ten times larger than a human's, although its nuclei are not significantly larger.

The information storage capacity of DNA is vast; a microgram (one-millionth of a gram) of DNA theoretically could store as much information as 1 million compact discs. The "useful" information contained in genomes consists of the coded instructions for making proteins and RNA. These information-containing regions of a genome are called genes. However, genes comprise less than 5 percent of the human genome. Most genomes consist largely of repetitive, noncoding DNA (sometimes called junk DNA) that is interspersed with genes and whose only apparent function is to replicate itself. Perhaps it helps to hold the chromosome together. The tenfold greater size of the lily genome compared to humans' is due to the presence of enormous amounts of repetitive DNA of unknown function.

While most cells of higher organisms contain all the genes in the genome, specialized cells such as **neurons** or muscle require expression from only some of the genes. One strategy for silencing unneeded genes is **methylation**. A methyl group ( $-\text{CH}_3$ ) is added to cytosine nucleotides, but only if they are followed by a guanine in the sequence, that is, CG. Adding methyl groups to a region of DNA attracts repressive DNA-binding proteins to it and may also cause the region to compact even further, making it inaccessible to proteins that make RNA from DNA (the first step of protein synthesis). During DNA replication the pattern of methylation is preserved by specific proteins that add methyl groups to the new strand based on the location of CG methyl groups in the template strand. The most extreme case of repression by methylation is X-inactivation, in which one of the two X chromosomes in cells of a female mammal is entirely shut down, presumably because expression from one X provides enough protein in females, as it does in males (who have only one X chromosome). SEE ALSO CHROMOSOME, EUKARYOTIC; CONTROL OF GENE EXPRESSION; CRICK, FRANCIS; GENE; MUTATION; NUCLEOTIDES; REPLICATION; RNA; WATSON, JAMES

Steven A. Sullivan

### Bibliography

- Alberts, Bruce, et al. *Molecular Biology of the Cell*. New York: Garland Publishing, 2000.
- Felsenfeld, Gary. "DNA." *Scientific American* 253 (1985): 58–67.
- Levin, Benjamin. *Genes VII*. New York: Oxford University Press, 1999.
- Watson, James D., and Francis H. Crick. "A Structure for Deoxyribose Nucleic Acid." *Nature* 171 (1953): 737.

## DNA Sequencing

The **genome** of an organism is the sum total of its genetic information. The genome is not only a blueprint for the organism it also contains historical notes on the evolution of the organism. The ability to determine the sequence of deoxyribonucleic acid (DNA) and thus read the messages in the genome is of immense biological importance because it not only describes the organism in detail but also indicates its evolutionary history.

DNA is a linear chain of four **nucleotides**: adenosine (A), thymidine (T), cytidine (C), and guanosine (G). The genetic information in DNA is encoded in the sequence of these nucleotides much like the information in a word is encoded in a sequence of letters. The technique for determining the sequence of nucleotides in DNA is based on the same mechanism by which DNA is replicated in the cell. DNA is composed of two **complementary** strands in which the As of one strand are paired with the Ts of the complementary strand and the Cs of one strand are paired with the Gs of the complementary strand. When DNA is replicated, a new DNA strand (primer strand) is extended by using the information in the complementary (template) strand. The DNA has a direction (polarity); the growing end of a DNA strand is the end that is 3' and the other end is the 5'. An **enzyme**, DNA polymerase, replicates DNA by adding nucleotides to the 3' end of the **primer** strand, which complement the **template** strand. (Figure 2.)

DNA polymerase has an absolute requirement for a **hydroxyl** group (OH) on the 3' end of the template strand. If the 3' hydroxyl group is missing no further nucleotides can be added to the template strand. This termination of the elongation of the template strand is the basis for determining the DNA sequence. If the DNA polymerase is presented with a mixture of nucleotides, some of which have 3' OH groups and others of which have no 3' OH group (and are bound to a colored dye), both types of nucleotides are added to the growing template strand. When a nucleotide with no OH group is added to the primer strand, elongation is terminated with the colored dye at the 3' end of the strand.

All essential elements for determining the sequence of nucleotides in the primer DNA strand are in place. A DNA synthesis reaction is set up in a test tube (in vitro), including DNA polymerase, a template DNA strand, a short uniform primer DNA strand, and a mixture of the four nucleotides (A, T, C, and G). The short primer DNA strands are synthesized chemically and are identical so they pair with a specific sequence in the template DNA strand. Each of the nucleotides is present in two forms, the normal form with a 3' hydroxyl group and the terminating form with a colored dye and no 3' hydroxyl group. Each different terminating nucleotide (A, T, C, and G) has a different colored dye attached.

The amount of normal nucleotides present in the reaction is much larger than the terminating nucleotides so that DNA synthesis proceeds almost normally, and only occasionally is the elongation of the primer strand terminated by the incorporation of a dye labeled nucleotide lacking a 3' hydroxyl group. However, eventually all of the primer strands do incorporate a dye labeled nucleotide and their elongation is terminated. Thus, at the end of the reaction there is a vast collection of primer strands of varying lengths each terminated with a nucleotide that has a colored dye specific to the terminal nucleotide.

All of the primer strands start at the same point, specified by the sequence of the short uniform primer DNA. Thus, the *length* of the primer strand corresponds to the position of the terminal nucleotide in the DNA sequence relative to the starting position of the primer DNA strand. The *color* of the dye on the primer strand identifies the terminal nucleotide as an A, T, C, or G. Once the primer strands are arranged according to length, the DNA sequence will be indicated by the series of colors on progressively longer primer strands.

**nucleotide** the building block of RNA or DNA

**complementary** matching opposite

**enzyme** protein that controls a reaction in a cell

**primer** short nucleotide sequence that helps begin DNA replication

**template** master copy

**hydroxyl** chemical group consisting of -OH

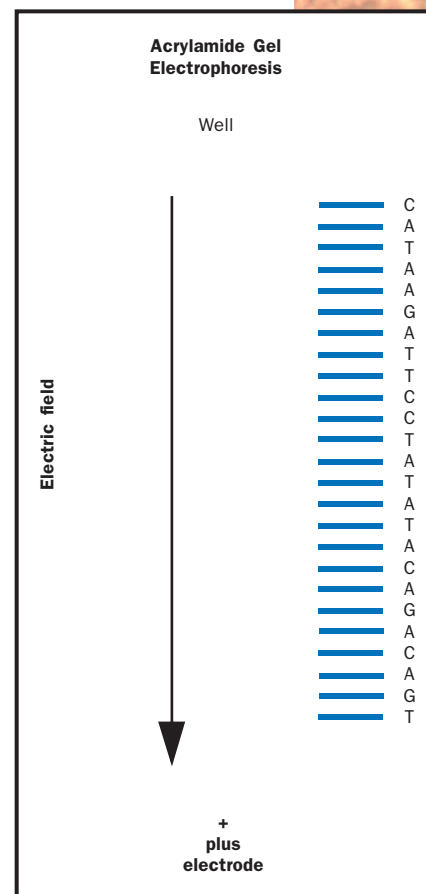

Figure 1. DNA strands can be separated according to length by acrylamide gel electrophoresis.

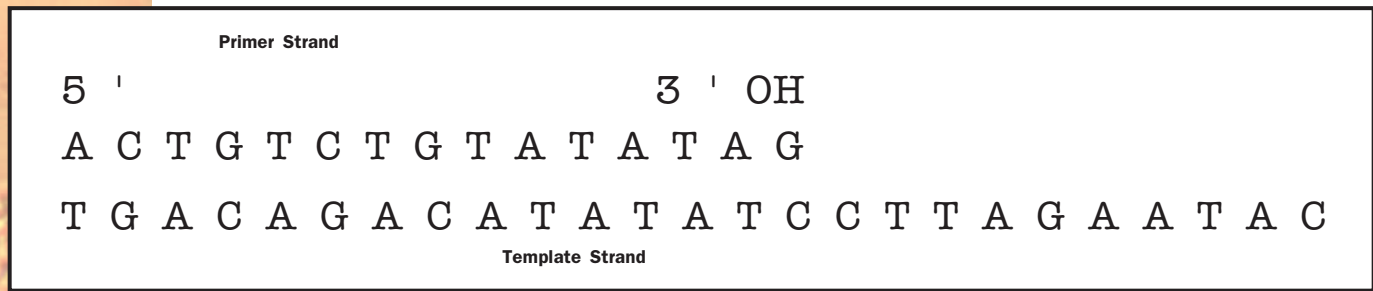

Figure 2. DNA polymerase replicates DNA by adding nucleotides that complement the template strand to the 3' end of the primer strand.

**electrophoresis** technique that uses electricity to separate molecules based on size and electric charge

**matrix** a network, usually of threadlike fibers

The DNA strands can be readily separated according to length by acrylamide gel **electrophoresis** (see Figure 1). The acrylamide gel is a loose **matrix** of fibers through which the DNA can migrate. The DNA molecules have a large negative charge and thus are pulled toward the plus electrode in an electric field. The whole collection of primer strand DNA molecules is placed in a well at the top of an acrylamide gel with the plus electrode at the bottom of the gel. When the electric field is applied the DNA molecules are drawn toward the plus electrode, with shorter molecules passing through the gel matrix more easily than longer molecules. Thus the smaller DNA molecules move the fastest.

After a fixed period of time, the DNA molecules are separated according to length with the shortest molecules moving furthest down the gel. All of the molecules of a given length will form a band and will have the same terminal nucleotide and thus the same color. The DNA sequence can be read from the colors of the bands. One reads the sequence of the DNA from the 5' end starting at the bottom of the gel to the 3' end at the top of the gel.

In practice the whole process is automated; the bands are scanned with a laser as they pass a specific point in the gel. These scans produce profiles for each nucleotide, as shown in the lower portion of Figure 3. A computer program then determines the DNA sequence from these colored profiles, as shown in the upper portion of Figure 3. A single automated DNA sequencing instrument can determine more than 100,000 nucleotides of DNA sequence per day and a large sequencing facility can often produce over 10 million nucleotides of sequence per day. This high sequencing capacity has made it feasible to determine the complete DNA sequence of large genomes including the human genome. SEE ALSO DNA; ELECTROPHORESIS; HUMAN GENOME PROJECT; SEPARATION AND PURIFICATION OF BIOMOLECULES

Figure 3. Laser scans produce profiles for nucleotides, as shown in the lower portion of the figure. A computer program then determines the DNA sequence, as shown in the upper portion of the figure.

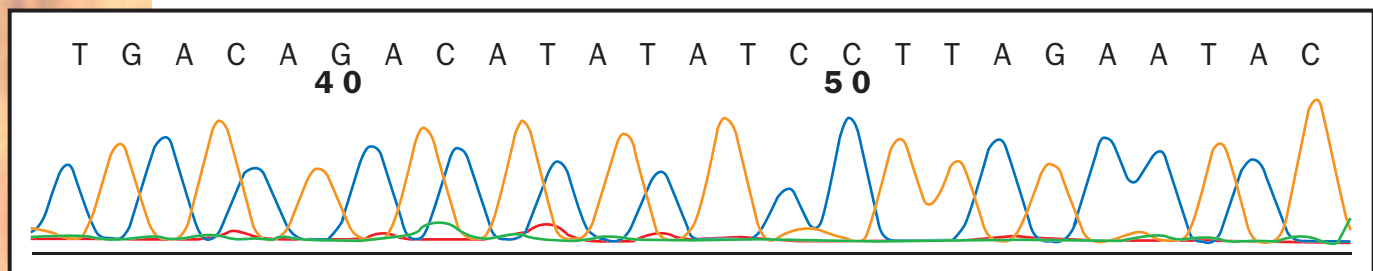

### Bibliography

Hartl, Daniel L., and Elizabeth W. Jones. *Genetics: Principles and Analysis*, 4th ed. Sudbury, MA: Jones and Bartlett, 1998.

Raven, Peter H., and George B. Johnson. *Biology*. New York: McGraw-Hill, 1999.

Watson, James D., Michael Gilman, Jan Witkowski, and Mark Zoller. *Recombinant DNA*, 2nd ed. New York: Scientific American Books, 1992.

## DNA Viruses

Viruses can be classified based on **proteins** encoded within the viral genetic material or **genome**. Viruses with deoxyribonucleic acid (DNA) genomes are called DNA viruses. Like all viruses, DNA viruses are small when compared to the cells they infect and as such are obligate intracellular parasites (parasites that can only replicate within cells). In the appropriate cell, DNA viruses are able to program the cell to replicate the virus using the genes contained within the viral DNA genome.

The extracellular form of a virus is known as a virion. For a DNA virus, the virion is composed of a set of DNA genes protected by a protein-containing coat called a capsid. The coat is often characterized by regularity and symmetry in its structure and is capable of binding to and invading cells. In the case of some DNA viruses, the capsid can be surrounded by a membrane that is formed from cellular membranes. On invasion of a susceptible cell the virion is disassembled to release the viral genome into the cell, at which time the genes within the viral DNA are transcribed, producing viral messenger ribonucleic acid (mRNA).

The viral mRNA is translated into protein. These “early” proteins are responsible for altering normal cellular functions which in some cases allow the infected cell to evade the immune system. These “early” proteins are also important for promoting “late” viral gene synthesis and preparing the cell for the production of **progeny** virus. Following late gene synthesis, which includes proteins that are important for replicating and encasing the virus, progeny virions are then released by the infected cell to invade other cells so that the process can be repeated.

There are six different DNA virus families that infect and may cause significant disease in humans. These can be further subdivided into those with “small” DNA genomes or “large” DNA genomes. DNA viruses with small DNA genomes have genome sizes of less than 10 **kilobasepairs**, whereas DNA viruses with large genomes are over 30 kilobasepairs. Small DNA viruses generally have less than ten genes encoded within the viral genome, whereas large DNA viruses can have anywhere from fifty genes to well over one hundred genes. Viruses with small DNA genomes include human papillomavirus (HPV). HPV infects epithelial cells of the skin. It causes common warts on hands and feet and in some cases is important for the development of cervical cancer in women. Hepatitis B is another small DNA virus that infects the liver, causes hepatitis, and is associated with liver cancer. Adenovirus, herpesvirus, and poxvirus are all examples of large DNA viruses that infect humans. Adenoviruses, of which there are many types, cause **gastroenteritis** and respiratory disease in humans.

Herpesviruses are a very diverse family of viruses. There are a total of eight herpesviruses that infect humans and establish latent infection. Her-

**protein** complex molecule made from amino acids; used in cells for structure, signaling, and controlling reactions

**genome** total genetic material in a cell or organism

**progeny** offspring

**kilobasepair** one thousand DNA base pairs; a measure of size of a piece of DNA

**gastroenteritis** inflammation of the gastrointestinal tract, often from infection

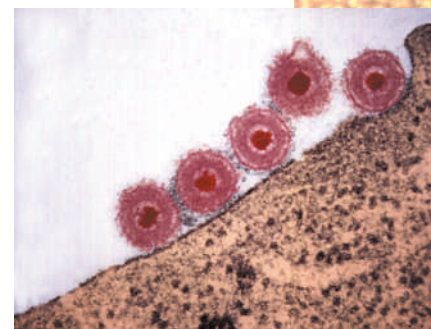

A scanning electronic micrograph of herpes simplex virus (HSV6).

**epithelium** one of four tissue types found in the body, characterized by thin sheets and usually serving a protective or secretory function

**neuron** nerve cell

pes simplex viruses I (HSV-1 and HSV-2) typically cause lesions in the oral or genital **epithelium**. Following productive infection at an epithelial site, HSV-1 and HSV-2 then establish a latent (“resting”) infection in sensory **neurons**, which may erupt in times of stress.

Other herpes viruses that infect humans include Epstein-Barr virus, which causes mononucleosis and is important in a variety of human cancers, and varicella-zoster virus, which causes chickenpox in children and shingles in adults. The final large DNA virus that can infect humans is smallpox. Prior to vaccination and eradication of smallpox in 1970s, smallpox caused significant morbidity in human populations with anywhere from 1 to 25 percent of the cases resulting in death. **SEE ALSO** CANCER; DNA; VIRAL DISEASES; VIRUS

*Richard Longnecker*

#### **Bibliography**

Flint, S. Jane, et al., eds. *Principles of Virology: Molecular Biology, Pathogenesis, and Control*. Washington, DC: ASM Press, 2000.

Knipe, David M., and Peter M. Howley, eds. *Fields' Virology*, 4th ed. Philadelphia, PA: Lippincott Williams & Wilkins, 2001.

## **Doctor, Family Practice**

A family practice doctor is the primary health care professional responsible for treating people for most conditions. Family physicians work in private offices, group practices, and hospitals, caring for every family member from before birth until the time of death. Under America’s health insurance system, most people go first to their family practice doctor for all complaints, from infections to chronic illnesses to preventive medicine.

Family practice doctors approach the treatment of the family as a unit, focusing on health promotion, disease prevention, and psychological issues affecting health, as well as treatment of disease. Depending on the condition, treatment may include prescribing medicines, recommending lifestyle changes such as exercise and diet, or referral for other types of treatment, including surgery, physical therapy, or psychotherapy. The doctor works in partnership with other health care professionals, including nurse practitioners, nurses, and medical assistants.

To become a family practice doctor, one must first earn a bachelor’s degree (either a bachelor of arts or bachelor of science) from a four-year college, and then earn a doctorate of medicine (M.D.) degree from a medical school. This usually takes four years, and combines classes and clinical experience. Following this, doctors undergo three years of postgraduate training, called internship and residency. During residency, they receive training in the full range of medical disciplines, including pediatrics, obstetrics/gynecology, internal medicine, preventive medicine, surgery, and psychiatry. Family practice doctors often choose this career because they enjoy participating in the comprehensive care of people of all ages, and they desire to help people attain and maintain good health. **SEE ALSO** DOCTOR, SPECIALIST; NURSE; NURSE PRACTITIONERS

*Richard Robinson*

#### **Bibliography**

*American Academy of Family Physicians*. <<http://www.aafp.org>>.

### **DELBRÜCK, MAX (1906–1981)**

German-born U.S. biologist who received, with Salvador Luria and Alfred Hershey, the 1969 Nobel Prize in physiology for his work on bacteriophages, viruses that infect bacteria. In 1939, Delbrück invented an easy way to grow bacteriophages in the lab, and in 1949 he and Hershey showed that the genetic material of different viruses can combine to make entirely new viruses.

## Doctor, Specialist

A medical specialist focuses on diagnosis and treatment of a particular organ or body system, a specific patient population, or a particular procedure. Medical care of humans is a complicated task due to the many different organ systems that comprise the human body. Each stage of life presents a variety of health issues that need to be addressed as well. Moreover, males and females also have very different medical needs through puberty and adulthood. This complexity of life necessitates a high degree of specialization in the physicians that care for people's medical needs. There are many types of medical specialties.

### General Educational Requirements for Medical Specialists

All physicians, regardless of their ultimate specialization, must obtain a bachelor's degree from an undergraduate college and graduate from medical school (four years). During the last two years of medical school, students perform clinical rotations in which they are exposed to a wide variety of medical specialties. This provides broad training for all medical professionals, as well as gives the students an opportunity to choose a specialty.

After medical school, all physicians are required to do a residency. The purpose of the residency is to provide specific, detailed training in the chosen specialty. The length of the residency is determined by the specialty. The tables on page 231 include the average residency length for each of the specialties listed. Oftentimes, physicians will have a particular expertise within their specialized area. For example, most surgeons are subspecialized in the organ system on which they operate (neurosurgeons, cardiac surgeons, and orthopedic surgeons are examples). These subspecialties are obtained during a fellowship period that lasts one to two years after the residency is completed. It is not uncommon for a highly specialized doctor (such as a pediatric neurosurgeon) to invest ten years or more in his or her medical education after graduating from college.

### Job Duties and Educational Requirements for Sample Specialties

**Cardiologist.** A cardiologist is a physician who cares for people with heart disease. Cardiologists treat conditions such as myocardial infarction (heart attack) and angina (chest pain). They use diagnostic tools such as an electrocardiogram (EKG) and ultrasound to visualize the electrical and structural functioning of the heart. Cardiologists are employed by hospitals but also work in private practice. Since cardiology is considered a subspecialty of internal medicine, cardiologists must first complete a residency in internal medicine that lasts about three years after medical school. Cardiologists then complete a subspecialty residency in cardiology (another three years).

**Neurologist.** A neurologist is a physician who treats patients with neurological disorders (involving the brain, spinal cord, and **peripheral** nervous system). Conditions that would necessitate treatment by a neurologist include, Parkinson's disease, multiple sclerosis, myasthenia gravis, Alzheimer's

**peripheral** outside the central nervous system (brain and spinal cord)

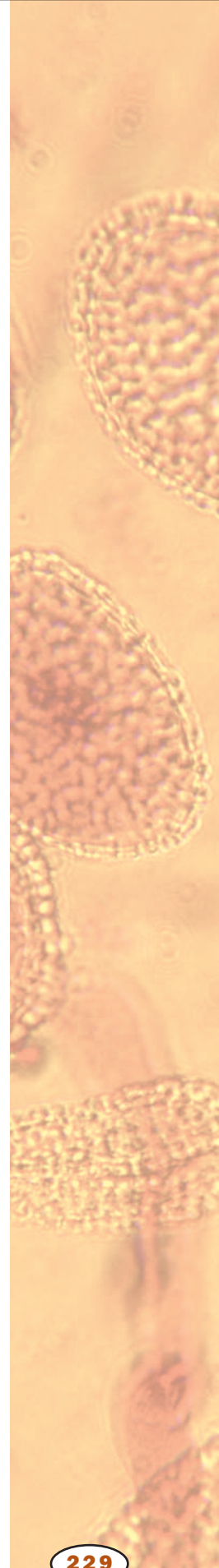

A surgeon reviewing CAT scans.



disease, traumatic brain or spinal cord injury, epilepsy, or stroke. Diagnostic techniques used by neurologists to detect these disorders include (but are not limited to) sensory and motor skills assessments, memory tests, magnetic resonance imaging (MRI) scans, and positron emission tomography (PET). To treat these types of disorders, neurologists may prescribe medication, physical therapy, occupational therapy, or surgery. There are several new and very effective surgical treatments for diseases such as Parkinson's disease. Neurologists must complete at least four years of residency in an accredited neurology program before being eligible for certification by the American Board of Psychiatry and Neurology.

**Obstetrician/Gynecologist (OB/GYN).** An OB/GYN specializes in the care of women from puberty through pregnancy and menopause. An obstetrician focuses on the care of pregnant women and the delivery of babies. Although some doctors choose to specialize in either obstetrics or gynecology, it is very common for a physician to specialize in both since the two fields are so closely linked. In addition to delivering babies, OB/GYNs perform diagnostic tests such as pelvic exams (to look for ovarian cysts and other abnormalities), pap smears (to screen for cervical cancer), and obstetrical ultrasound (to assess the development of a fetus). After medical school, OB/GYNs must complete a four-year residency. Many OB/GYNs practice their specialty in private practices that are closely affiliated with hospitals in which they deliver babies. However, most hospitals employ OB/GYNs directly as well.

**Oncologist.** An oncologist cares for patients with cancer. Cancer is a very complex disease that demands very specialized attention and intensive treatment. It is common for an oncologist to specialize in a particular type of cancer, such as lung or colon cancer. Oncologists may work in private practices that are closely affiliated with a particular hospital or may be directly employed by a hospital. Like cardiology, oncology is considered a subspecialty of internal medicine. Oncologists must first complete a residency in internal medicine that lasts about three years after medical school. They then must complete a subspecialty residency in oncology (another three years).

Doctors who have expertise in a particular disease/condition			
Specialist	Oncologist	Emergency physician	Allergist
<b>Area of expertise</b>	Cancer	Urgent and crisis medical needs	Allergies
<b>Sample disease/disorders treated</b>	AIDS-related lymphoma, leukemia, Hodgkin's disease, lung cancer, breast cancer, skin cancer, colon cancer, etc.	Traumatic brain injury, emergency births, cardiac arrest, gunshot wounds, poisoning, etc.	Asthma, hay fever, contact eczema, etc.
<b>Average # of years of residency</b>	6 years (3 years-internal medicine; 3-years oncology)	3 years	5-6 years (3 years in internal medicine or pediatrics and 2-3 years in allergy, asthma, and immunology)

**Pediatrician.** Infants and children have very specialized medical needs due to their rapidly changing and maturing bodies. Pediatricians are experts in the developmental stages of children and medical treatments of childhood diseases. In addition to treating childhood illnesses such as ear infections, jaundice, and respiratory infections, pediatricians also perform periodic exams of healthy children to ensure their proper development, administer immunizations to prevent disease, and advise parents on the proper care for each developmental stage. Pediatricians commonly work in private practice, but many are employed by children's hospitals as well. They are required to complete three years of residency before they are eligible for certification by the American Board of Pediatrics.

**Radiologist.** The ability to visualize internal organs revolutionized twentieth-century medicine. A radiologist is a doctor who has expertise in a variety of diagnostic imaging technologies. These technologies include

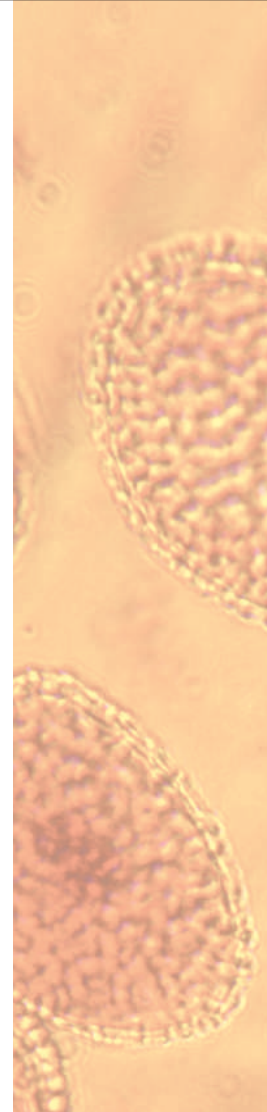

Doctors who have expertise in a particular organ system										
Specialist	Cardiologist	Neurologist	Dermatologist	Ophthalmologist	Podiatrist	ENT	Orthopedist	Endocrinologist	Urologist	Gastroenterologist
<b>Area of expertise</b>	Heart	Brain (nervous system)	Skin	Eyes	Feet	Ear, nose, throat	Bones	Hormone imbalances	Urinary tract, kidneys	Digestive system
<b>Sample disease/disorders treated</b>	Angina, atrial fibrillation, congestive heart failure, heart attack, high cholesterol, etc.	Stroke, epilepsy, Alzheimer disease, Bell's palsy, epilepsy, fibromyalgia, migraine, Lou Gehrig's disease, Parkinson's disease, multiple sclerosis, vertigo, etc.	Acne, birthmarks, eczema, fungal infections, moles, psoriasis, skin cancer, etc.	Glaucoma, cataracts, etc.	Achilles tendonitis, athlete's foot, bunions, corns, gout, heel pain, rheumatoid arthritis, osteoarthritis, etc.	Middle ear infections, sinus infections, allergies, balance disorders, strep throat, etc.	Broken bones, bone malformations, joint problems	Thyroid disorders, infertility, diabetes, hypoglycemia	Bladder control problems, erectile dysfunction, incontinence, kidney stones, Peyronie's disease, urinary tract infections, etc.	Peptic and duodenal ulcers, acid reflux, impacted bowels, colon cancer, etc.
<b>Average # of years of residency</b>	6 years (3 years-internal medicine; 3 years-cardiology)	4 years	4 years	3 years	2-4 years	5 years	5-6 years	5 years	4-6 years	5 years



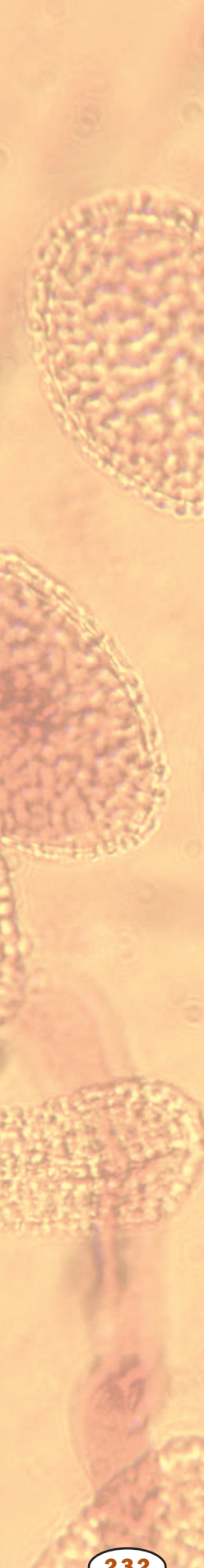

**forensic** related to legal proceedings

**metabolism** chemical reactions within a cell

**metabolite** molecule involved in a metabolic pathway

**excreted** deposited outside of

x ray, ultrasound, and MRI. All of these procedures produce a picture of the internal organs. Radiologists often serve as consultants to other specialists who need to visualize a specific organ in a patient that they are treating. However, radiologists do participate in treatments such as unblocking arteries in the legs and trunk that eliminate the need for more invasive procedures like surgery. Although most radiologists work within hospitals, they are rarely employed by the hospital itself. Instead, they are employed by private practices and contract with the hospital to provide services. Radiologists must complete a residency of at least four years, and oftentimes they complete additional years of a fellowship to become an expert in a particular type of imaging technique. SEE ALSO CARDIOVASCULAR DISEASES; DOCTOR, FAMILY PRACTICE; IMAGING IN MEDICINE; NEUROLOGIC DISEASES; NURSE PRACTITIONERS; REPRODUCTIVE TECHNOLOGY; TRANSPLANT MEDICINE

*Susan T. Rouse*

### Bibliography

*American Board of Medical Specialties.* <<http://www.healthcommunities.com/>>.

## Drug Testing

Drug testing refers to the process of detecting “drugs” in human or animal specimens. Drug testing may be performed in the contexts of sports, workplace safety, therapeutic drug monitoring, **forensics**, toxicology, and drug abuse prevention.

Human drug testing is most commonly performed by analysis of urine or hair samples. Blood may provide a more appropriate source in certain circumstances, for example, monitoring doses of pharmaceuticals. In some cases, testing can be done on excised (removed) tissue samples.

Drug testing is complex because most foreign chemicals taken into the body and entering the blood system, either by injection or ingestion through the digestive system, undergo some form of **metabolism** or chemical transformation. This generally occurs in the liver. One or more **metabolites** (transformed chemicals) are produced that may be removed via filtration through the kidneys and ultimately **excreted**. Although the drug in its native chemical form may be rapidly broken down, its metabolites may persist for extended periods of time.

Some metabolites accumulate in tissue. For example, if a metabolite or drug transported in the blood manages to penetrate the barrier surrounding the brain, it tends to accumulate, often resulting in some pharmacologic (desired) or toxic (undesired) response.

Technical approaches used in drug testing have undergone significant advancement. When a drug-testing laboratory performs such analyses, the specimen is fractionated, or divided, into its components. The compound of interest and its metabolites are characterized based on specific physical and/or chemical properties, which allow subsequent identification. For example, the charge and molecular weight of a compound often provides a specific “signature” of that chemical.

There are numerous separation techniques, with the simplest being liquid chromatographic (LC) procedures and the most complex being a com-

bination of two analytical methodologies such as gas chromatography (GC) with mass spectrometry (MS). Liquid chromatography can also be combined with mass spectrometry. For optimal sensitivity, GC-MS and LC-MS may be done as complementary procedures, providing the most convincing identification of a particular chemical. The sensitivity of MS is significantly greater than that of LC or GC procedures; consequently MS can identify trace amounts of material. Analytical chemists develop and test these procedures. The sophistication of these methods makes it extremely difficult to intentionally fool the test.

Home drug testing kits for a number of drugs of abuse are now available by online purchase but are not as sensitive as laboratory methods. They generally work by producing a color reaction demonstrating the presence of a specific drug of interest. The application of laboratory and home testing procedures provides safer workplaces and ultimately leads to a safer environment. SEE ALSO ANABOLIC STEROIDS; KIDNEY; LIVER; PSYCHOACTIVE DRUGS

David S. Lester

### Bibliography

*American Toxicology Institute, Inc.* <<http://www.atilab.com>>.

Boclaer, Jan F. Van, Karine M. Clauwaert, Willy E. Lambert, Dieter L. Deforce, Elfriede G. Van den Eeckhout, Andre P. De Leenheer. "Liquid Chromatography–Mass Spectrometry in Forensic Toxicology." *Mass Spectrometry Reviews* 19, no. 4 (2000): 165–214.

Cook, J. D., et al. "The Characterization of Human Urine for Specimen Validity Determination in Workplace Drug Testing: A Review." *Journal of Analytical Toxicology* 24 (2000): 579–588.

*Drug Detective.* <<http://www.drugdetective.com>>.

Kerns, Dennis L., and William I. Stopperan. "Keys to a Successful Program." *Occupational Health and Safety* 69, no. 10 (2000): 230–234.



A technician performing a density test from urine samples at the Australian Sports Drug Testing Laboratory in Sydney.

## Dubos, René

### American bacteriologist 1901–1982

In 1939 René Dubos launched the antibiotic era by reporting the discovery of gramicidin after the first systematic search for antimicrobial agents. Following this discovery he warned of microbial resistance to antibiotics, completed innovative studies of tuberculosis, expanded investigations into the nature of disease and, ultimately, examined the question of health.

Born near Paris in 1901, Dubos studied agronomy in France and, through a chance meeting with biochemist Selman Waksman, was invited to study soil science at Rutgers University. In his Ph.D. studies, Dubos discovered that local soil characteristics determine which microbes decompose **cellulose**.

By good fortune again, Dubos joined Oswald Avery of the Rockefeller Institute (now University) who was trying to decompose the **polysaccharide** capsule surrounding the deadly pneumococcus bacterium. Dubos succeeded by using a soil enrichment technique to find a specific microbial **enzyme**.

**cellulose** carbohydrate made by plants and some other organisms; part of the cell wall

**polysaccharide** carbohydrate composed of many individual units of sugar

**enzyme** protein that controls a reaction in a cell

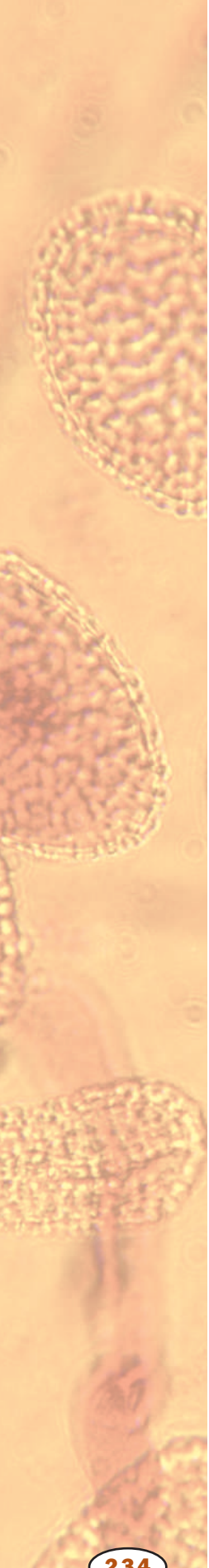

**polypeptide** chain of amino acids

**medium** nutrient source

He further discovered this enzyme was produced only if the polysaccharide capsule was the microbe's sole food, a phenomenon now known as an induced enzyme. He described this as "his greatest hour in science . . . one of the most important biological laws I have ever been in contact with."

In 1939, using the same techniques, he found *Bacillus brevis*, a microbe that digests and destroys other microbes. From it he extracted an antibacterial agent he named tyrothricin that contains two **polypeptides** he called gramicidin and tyrocidine. Within a few months, he and organic chemist Rollin Hotchkiss described the bacterial, chemical, clinical, and pharmaceutical properties of these antibiotics. This work stimulated two English scientists, Howard Florey and Ernst Chain, to revive the stalled research on penicillin, found accidentally in 1929 by Scottish bacteriologist Alexander Fleming.

In 1942 Dubos warned that bacterial resistance to antibiotics should be expected, saying, "In the analysis of . . . antibacterial agents . . . susceptible bacterial species often give rise with 'training' to variants endowed by great resistance to these agents."

Dubos turned his interest to tuberculosis in 1944. He began a renaissance in studying this disease by creating a culture **medium** to produce rapid, luxuriant, and well-dispersed growth of bacilli. He pioneered international standards for the BCG vaccination against tuberculosis and described social aspects of the disease in "The White Plague" (1952). Later he investigated how environmental effects of crowding, malnutrition, pesticides, toxins, and stress increase susceptibility to disease.

Dubos observed that people coexist with both good and bad microbes and that disease-producing microbes reside quiescently (dormant) in the body until stress alters resistance. He restated the germ theory, saying a microbe is necessary but not sufficient to cause disease. He concluded that in order to improve one's physical and spiritual well-being, one must first understand and then control one's impact on one's own surroundings.

When he won the Pulitzer prize in 1969 for *So Human an Animal*, Dubos was thrust into the swelling environmental debate. He became well known for balancing views between those who believe that humans can improve on nature and those who advocate wilderness preservation. Hundreds of lectures and two dozen books evolved from medical considerations of environment and health, to cultural and scientific aspects of medicine, to an ecological philosophy encompassing health of Earth. He coined many aphorisms such as "think globally, act locally" to explain complex issues. SEE ALSO BACTERIAL DISEASES; HISTORY OF MEDICINE; NATURAL SELECTION

Carol L. Moberg

### Bibliography

- Dubos, René. *So Human an Animal*. New York: Charles Scribner's Sons, 1968.
- , and Jean Dubos. *The White Plague: Tuberculosis, Man, and Society*. Boston: Little, Brown, 1952.
- Moberg, Carol L., and Zanvil A. Cohn. "René Jules Dubos." *Scientific American* 264, no. 5 (1991): 66–74.

# Photo and Illustration Credits

*Unless noted below, the illustrations and tables featured in Biology were created by GGS Information Services. The photographs appearing in the text were reproduced by permission of the following sources:*

## Volume 1

**p. 4** Willow ptarmigan in summer color, photograph. © JLM Visuals; **p. 5** Willow ptarmigan in winter color, photograph. © Marypat Zitzer/JLM Visuals; **p. 6** Cross section of human adrenal gland, triangular shape, photograph by Martin M. Rotker. Phototake NYC; **p. 8** Elderly married couple, photograph. © Kevin R. Morris/Corbis; **p. 11** Wild rice plant grows in Ocala, Florida, photograph. © Jonathan Blair/Corbis; **p. 12** Herd of Holsteins eat silage from troughs on a Minnesota farm, photograph. © Richard Hamilton Smith/Corbis; **p. 15** AIDS virus attacking T4 lymphocytes, scanning electron micrograph image. ©Wagner/Seifert, Inc./Phototake; **p. 18** Santa Monica police officer, administering Breathalyzer test, photograph. © Shelley Gazin/Corbis; **p. 21** Algae on Pond, photograph. © Charles Mauzy/Corbis; **p. 27** Strawberry poison arrow frog, photograph. © Alex Kerstitch/JLM Visuals; **p. 28** Weightlifting with a dumbbell, photograph. © Duomo/Corbis; **p. 31** Maidenhair fern with fan-shaped leaves, photograph by Robert J. Huffman/Field Mark Publications; **p. 32** Light blue iris against black background, photograph. JLM Visuals; **p. 35** Transparent jellyfish with short tentacles, photograph by Mark A. Johnson/Stock Market; **p. 38** Enzyme-lined immunoabsorbent assay, ELISA plate, photograph. © Lester V. Bergman/Corbis; **p. 43** Newly hatched Green Lynx spiders, photograph. © J. C. Cokendolpher/JLM Visuals;

**p. 44** Ten million year old Archeobacteria, scanning electron micrograph by Eurelios. © Eurelios/Phototake; **p. 47** Digitally enhanced X ray of left hand showing rheumatoid arthritis, photograph. © 1994 Michael English, M.D. Custom Medical Stock Photo; **p. 49** Streptococcus bacteria attached to a human tonsil cell, colored transmission electron micrograph by Dr. Immo Rantala. © Dr. Immo Rantala/SPL/Photo Researchers, Inc; **p. 51** Streptococcus pyogenes bacteria, colored transmission electron micrograph by Alfred Pasiaka. © Alfred Pasiaka/Science Photo Library, Photo Researchers, Inc.; **p. 54** Laboratory technician performing Analytical Profile Index (API), photograph by Geoff Tompkinson. © Geoff Tompkinson/Science Photo Library, Photo Researchers, Inc; **p. 57** DNA circles of bacterial plasmid, scanning electron micrograph. © Gopal Murti/Phototake; **p. 59** Electron micrograph of T4 Cells, or bacteriophage, photograph. © Dr. Dennis Kunkel/Phototake; **p. 61** Honey bees around Queen in hive, photograph. © J. C. Cokendolpher/JLM Visuals. Reproduced by permission; **p. 64** Elk fighting, Wyoming, photograph. © Breck P. Kent/JLM Visuals; **p. 69** Soil erosion on the trail, Adirondack, photograph by Yoav Levy/Phototake; **p. 71** Continental Drift, illustration by Accurate Art, Inc., Gale Group; **p. 72** Mary Pat Reeves-Daly, mapping human Y chromosome, as part of Human Genome Mapping Project, photograph. © Roger Ressimyer/Corbis; **p. 75** Immunization technician Sgt. Louis Rios giving 2nd Lieutenant Clayton Bland a vaccination for anthrax, photograph. AP/Wide World Photos; **p. 78** Smiling school girls,

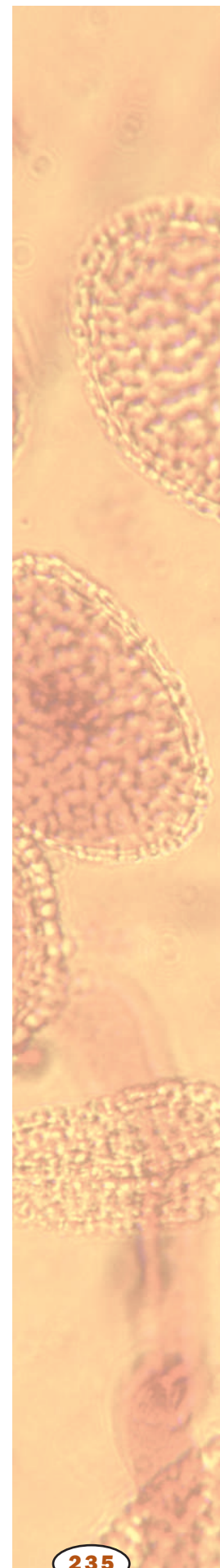

photograph. © The Purcell Team/Corbis; **p. 81** Red-tailed hawk perched on stump, photograph by Robert J. Huffman/Field Mark Publications; **p. 83** Beaulieu, Emile-Etienne, holding handful of the RU-486 abortion drug/pills, which he invented, photograph. AP/Wide World Photos; **p. 90** Red and white blood cells flowing through saphenous vein, scanning electron micrograph. © Image Shop/Phototake; **p. 94** Cancellous bone tissue affected by osteoporosis, false-color scanning electron micrograph. © Professor P. Motta/Dept. of Anatomy/University of La Sapienza, Rome/Science Photo Library, Photo Researchers, Inc.; **p. 97** Axial section of human brain showing metastatic tumor, MRI by Simon Fraser. © Simon Fraser/Science Photo Library, Photo Researchers, Inc.; **p. 101** Human brain with hypothalamus highlighted, green dot, MRI scan by Scott Camazine & Sue Trainor; © Scott Camazine & Sue Trainor/Photo Researchers, Inc.; **p. 105** Liverwort, plant with leaf-like structures covered with tiny capsules, photograph. JLM Visuals; **p. 109** Marine life from Cambrian Period, photograph by Robert J. Huffman/Field Mark Publications; **p. 110** Human breast cancer cells growing in culture, photograph by Cecil Fox. © Cecil Fox/Photo Researchers, Inc; **p. 111** Human abdomen showing cancer of the ascending colon, colored barium enema X ray. © Science Photo Library/Photo Researchers, Inc.; **p. 116** Electronic image of human heart undergoing angiography; indicates massive aneurism of aortal arch, photograph. © CNRI/Phototake; **p. 119** *Listeria monocytogenes*, scanning electron micrograph image. © CNRI/Phototake; **p. 137** Tobacco leaf chloroplast, micrograph, photograph. © Dr. Jeremy Burgess/Science Photo Library, National Audubon Society Collection/ Photo Researchers, Inc. Reproduced with permission; **p. 141** Human chromosomes showing male mutation on gene 7, which determines cystic fibrosis, photomicrograph by Jean Claude Revy. © Jean Claude Revy/Phototake; **p. 142** Digital image of multipolar and bipolar spindles from T84 colonic cancer cell cultures, photograph. © Albert Tousson/Phototake; **p. 144** Mitosis metaphase of an animal cell, immunofluorescence photomicrograph. © CNRI/Phototake; **p. 146** Human male chromosomes, XY karyotype, with G banding, karotype. © CNRI/Phototake; **p. 153** Micro injection introducing foreign genes into animal cells, photograph by M. Baret. © M. Baret/Rapho, Photo Researchers, Inc; **p. 158** Second growth birch forest, photograph. © Richard P. Jacobs/JLM Visuals; **p. 161** Ground finch with dark feathers and bill, photograph by Tim Davis. Photo Researchers, Inc; **p. 163** Pine cones, photograph. JLM Visuals; **p. 167** People along polluted Swazambhunath River, in Kathmandu, Nepal, photograph. © Charlie Crangle/JLM Visuals; **p. 182** Sand skink on top of shiny dark green leaf, 1985, Florida, photograph by Joseph T. Collins/Photo Researchers, Inc.; **p. 184** Stretch of the great coral reef, between Cairns and Townsville, photograph. © Yann Arthus-Bertrand/Corbis; **p. 187** Crick, Francis, photograph. The Library of Congress; **p. 189** Horseshoe crab, photograph. © John M. Burnley/The National Audubon Society Collection/Photo Researchers, Inc; **p. 192** Breast cancer cell dividing, colored scanning electron micrograph. © Quest/Science Photo Library, Photo Researchers, Inc.; **p. 198** Darwin, Charles, photograph. Popperfoto/Archive Photos. © Archive Photos, Inc.; **p. 202** Shadows form on the El Oued dunes, The Algerian Sahara Desert, Algeria, photograph. © Adam Woolfitt/Corbis; **p. 203** High desert oasis, photograph. © Richard P. Jacobs/JLM Visuals; **p. 205** Human embryo, 8-cell stage, day 3, scanning electron micrograph, SEM, scan by Dr. Yorgos Nikas. © Dr. Yorgos Nikas/Phototake; **p. 209** Frog embryos complete their metamorphoses inside their eggs, photograph. Michael & Patricia Fogden/Corbis; **p. 224** Human DNA fingerprint taken from blood to match donor and patient in organ transplantation, photograph. © Index Stock/Phototake; **p. 227** Herpes simplex virus, HSV6, scanning electronic micrograph. © Dr. Dennis Kunkel/Phototake; **p. 230** Surgeon looking at CAT scans, photograph. © Steve Chenn/Corbis; **p. 233** Lab technician Li Zhang performing a density test from urine samples at the Australian Sports Drug Testing Laboratory, photograph. AP/Wide World Photos.

## Volume 2

**p. 6** Professor Ernst Haeckel, the German naturalist and philosopher, poses as if in a jungle scene, photograph. © Hulton-Deutsch Collection/Corbis; **p. 9** Lush growth, mossy tree, temperate rain forest, photograph by Robert J. Huffman/Field Mark Publications; **p. 12** Scientist sitting at scanning transmission electron microscope, STEM, photograph by Sinclair Stammers/Science Photo Library/Photo Researchers, Inc.; **p. 14** Gloved hands holding a sheet/culture, electrophoresis gel, photograph. © Eurelios/Phototake; **p. 17** White tiger in the zoo, photograph. © Shawn Gerrits/JLM Visuals; **p. 21** Scintigram of normal human thyroid, front view, photograph. © CNRI/Phototake; **p. 23** Phagocytosis, color enhanced transmission electron micrograph. © Biophoto Associates/Science Source/Photo Researchers, Inc; **p. 27** Entomologist Elidia Fernandez sorts an insect collection for the Institute for Biodiversity, photograph. © Gary Braasch/Corbis; **p. 39** Ravenglass Estuary curving to the sea, Cumbria, England, photograph. Corbis/Genevieve Leaper; **p. 41** Chlamydia pneumonia, photograph by Dr. Kari Lounatmaa. Custom Medical Stock Photo; **p. 42** Escherichia Coli, photograph by Kari Lounatmaa. Photo Researchers; **p. 44** Bumble bee, photograph. © Lloyd R. Brockus III/JLM Visuals; **p. 46** Darwin's Large Cactus Finch, © Breck P. Kent/ JLM Visuals; **p. 50** Antibiotic Staphylococcus aureus, photograph by Hank Morgan. © Hank Morgan/Science Photo Library, Photo Researchers, Inc.; **p. 53** Fossil fish, photograph. © Richard P. Jacobs/JLM Visuals; **p. 58** Ginkgo tree, photograph. JLM Visuals; **p. 60** X ray, color enhanced normal intravenous pyelogram. © Biophoto Associates/Science Source/Photo Researchers, Inc; **p. 65** Dinosaur skeleton on display at the Royal Terrell Museum, photograph. © Paul A. Souders/Corbis; **p. 67** Carolina parakeets lie in bags with tags, photograph. © Jonathan Blair/Corbis; **p. 73** Rod cells in the retina of the human eye, colored scanning electron micrograph. © Quest/Science Photo Library, Photo Researchers, Inc.; **p. 77** Normal human uterus and fallopian tubes, hysterosalpinograph. © GCA/CNRI/Phototake; **p. 83** Human fetus, 10 weeks old, inside amniotic sac, photograph. © CNRI/Phototake; **p. 86** Gray wolves exhibiting submissive behaviors, photograph. © Mary Ann McDonald/Corbis; **p. 88** Agronomists place a plastic greenhouse over crops, photograph. © Ted Spiegel/Corbis; **p. 90** Despain, Don, measures Lodgepole Pine Seedlings, photograph. © Raymond Gehman/Corbis; **p. 94** Snapdragons in flower, photograph by Eric Kamp. © Eric Kamp/Phototake; **p. 95** Lab Agent Kathy Dressel works on DNA evidence in the murder of JonBenet Ramsey at the Colorado Bureau of Investigation, Boulder, Colorado, photograph. AP/Wide World Photos; **p. 98** Boreal forest, evergreen trees, Michigan, photograph. JLM Visuals; **p. 100** Oak/hickory trees in autumn, photograph by Robert J. Huffman/Field Mark Publications; **p. 102** Moss-covered lianas in the Daintree National Park, Queensland, Australia, photograph. © Paul A. Souders/Corbis; **p. 103** Agile gibbon hanging from tree branch with baby at waist, photograph. © Breck P. Kent/JLM Visuals; **p. 105** Strawberry plants with fruit and blossoms, photograph. © Ed Young/Corbis; **p. 111** Dark yellow Witches' Butter jelly fungus, photograph. © Richard P. Jacobs/JLM Visuals; **p. 113** Detail that shows the gills of a mushroom, photograph. © Laura Sivell; Papilio/Corbis; **p. 114** Salmon gills showing the filaments of the gills, photograph. © Ron Boardman; Frank Lane Picture Agency/Corbis; **p. 124** Cancer cells infected with bioengineered adenovirus, photograph by Jean Claude Revy. © Jean Claude Revy/Phototake; **p. 132** Chicken embryo, 96-hours old, photograph. © Richard P. Jacobs/JLM Visuals; **p. 142** Man using computer to design complex proteins, photograph by Richard Nowitz. © Richard Nowitz/Phototake; **p. 147** Mexico City, photograph. Reuters/Archive Photos; **p. 154** Piles of wheat during harvest, Polouse Valley, Washington, photograph. © Vince Streano/Corbis; **p. 157** Grassland, photograph. © Richard P. Jacobs/JLM Visuals; **p. 159** Baby smiling, photograph. © Simon Dearden/Corbis; **p. 160** Hand development of a 2, 6, and 19 year old male, computer color enhanced X ray by Scott Camazine. © Scott Camazine, Photo Researchers, Inc.; **p. 162** Cycad, photograph. JLM Visuals;

**p. 166** Harvey, William, photograph. U.S. National Library of Science; **p. 167** Bicyclist sitting under a shade tree, photograph by Robert J. Huffman/Field Mark Publications; **p. 170** Hearing, human system, diagram by Hans & Cassidy. Gale Group; **p. 173** Heart, diagram by Hans & Cassidy. Gale Group. **p. 178** Close-up of branch with very long thorns, photograph. © Richard P. Jacobs/JLM Visuals; **p. 181** Close-up of genetically manipulated corn, photograph. © Carolina Biological Supply Company/Phototake; **p. 183** Buchner, Eduard, photograph. Hulton-Deutsch Collection/Corbis; **p. 186** Microscope used by Robert Hooke, 17th century, photograph. © Bettmann/Corbis; **p. 189** Young girl on her father's shoulders, photograph. © Raoul Minsart/Corbis; **p. 193** Cuvier, Georges Leopold, photograph. The Library of Congress; **p. 199** Hales, Stephen, engraving. The Library of Congress; **p. 209** Beginnings of Civilization, map by XNR Productions Inc. Gale Research; **p. 213** Female researcher loading an automated DNA sequencer at the Joint Genome Institute, photograph. Photo Researchers; **p. 215** Computer print-out of sequence of DNA, placed below multi-well sample tray, upper left, and automated pipettes, lower right, illustration by © James King-Holmes/Science Photo Library. Photo Researchers; **p. 217** Ingredients that should make up the bulk of a healthy diet, including fruits, vegetables, whole grains, photograph. © Nathan Benn/Corbis; **p. 221** Tomatoes ripen on vine for market, photograph. © Ed Young/Corbis.

### Volume 3

**p. 2** Human brain, cervical spine, and spinal marrow, magnetic resonance imaging (MRI). © GCA/CNRI/Phototake; **p. 6** Cancer cell attacked by tumor infiltrating lymphocytes, scanning electron micrograph by Jean Claude Revy. © Jean Claude Revy/Phototake; **p. 8** Katydid on human hand, photograph. JLM Visuals; **p. 11** House and hill overgrown with kudzu, photograph. JLM Visuals; **p. 22** Canadian Rockies, Ben My Chreem, Yukon, photograph. © Lowell R. Laudon/JLM Visuals; **p. 26** Leakey, Dr. L.S.B and Mary, photograph. AP/Wide World Photos, Inc; **p. 27**

Young girl fits blocks of different shapes through similarly shaped holes in a red box, photograph. © Robert Kozma/Corbis; **p. 30** Spine of Cleistocactus, close-up, photograph. © Peggy Morsch/JLM Visuals; **p. 32** Golden lichen, photograph. © Don Blegen/JLM Visuals; **p. 33** Grandmother holding her grandson, Philadelphia, PA, photograph. © Ed Eckstein/Corbis; **p. 36** Spawning sockeye salmon run the Fraser River from Shushwap Lake to Adams River, photograph. © Stuart Westmorland/Corbis; **p. 38** Chicken embryo, 56-hours old, photograph. © Richard P. Jacobs/JLM Visuals; **p. 40** Microscope, parts labeled, photograph. Carolina Biological Supply Company/Phototake; **p. 52** Two Ceratium tripos, photomicrograph by Eric Grave. © Eric Grave/Phototake; **p. 53** Lymphangiography, diagram of man's body, illustration. Electronic Illustrators Group; **p. 57** Human testis showing spermatogenesis, photomicrograph by Ken Wagner. © Ken Wagner/Phototake; **p. 61** Marine biologist in diving suit inspecting coral reef damaged by illegal fishing practices, photograph. AP/Wide World Photos; **p. 63** Male frigatebird with its red throat pouch inflated, photograph. © Wolfgang Kaehler/Corbis; **p. 64** McClintock, Barbara, photograph. UPI/Corbis-Bettmann; **p. 70** Transmission Electron Micrograph, TEM, image of Golgi apparatus, photograph. © Dr. Dennis Kunkel/Phototake; **p. 80** Mendel, Gregor, photograph. Archive Photos, Inc; **p. 86** Two lysosomes that contain digestive enzymes which destroy damaged molecules; in an intestinal epithelial cell, colored high resolution scanning electron micrograph. P. Motta & T. Naguro/Science Photo Library/Photo Researchers, Inc; **p. 89** Fat cells that make up adipose connective tissue, colored scanning electron micrograph. © Quest/Science Photo Library, Photo Researchers, Inc; **p. 90** Quality control microbiologist Kim Egger inspects a bacteria culture from ground meat processed at Excel Corporation's slaughterhouse, photograph. AP/Wide World Photos; **p. 93** Spring tide of surfbirds surge from the mud flats of Alaska's Copper River delta, photograph. © Jonathan Blair/Corbis; **p. 94** Indian leaf butterfly, photograph. © Richard P. Jacobs/JLM Visuals; **p.**

**99** Mitosis of an animal cell, early prophase, photograph. © CNRI/Phototake; **p. 100** Mitosis of an animal cell, early metaphase, photograph. © CNRI/Phototake; mitosis of an animal cell, immunofluorescence photomicrograph. © CNRI/Phototake; mitosis telophase of an animal cell, photograph. © CNRI/Phototake; **p. 101** Fruit fly head, magnified 200 times, scanning electron micrograph. © Dr. Dennis Kunkel, Phototake; **p. 104** Hands holding lab mouse, photograph. © Mario Beauregard/Corbis; **p. 107** Eastern prairie fringed orchid, photograph. U.S. Fish and Wildlife Service; **p. 114** Human knee joint with patella, X ray. © CNRI/Phototake; **p. 116** White American alligator shows a genetic mutation known as ieucism, Miami Zoo, photograph. © W. Perry Conway/Corbis; **p. 118** African clawed frog, *Xenopus laevis*, mutated, with three hind legs, photograph by Mark Smith. © Mark Smith/Science Source/Photo Researchers, Inc.; **p. 120** Endotrophic mycorrhizae in orchid root, magnified 100x, photograph. © Carolina Biological Supply Company/Phototake; **p. 122** Eggs and spiderlings of Uloborid Spider, photograph. © J. C. Cokendolpher/JLM Visuals; **p. 130** Human brain with Parkinson's Disease showing atrophy, Computerized Axial Tomography, CAT, scan. © GJLP/CNRI/Phototake; **p. 134** Two types of neurons; top of image shows a bipolar neuron, bottom of image is a developing neuron, scanning electron micrograph. © Dr. Dennis Kunkel/Phototake; **p. 137** Nitrogen fixation, bacteria, plants, photograph. © Adam Hart-Davis, National Audubon Society Collection/Photo Researchers, Inc.; **p. 139** Macrophage engulfing a *Leishmania* sp. parasite, colored scanning electron micrograph. © Juergen Berger, Max-Planck Institute/Science Photo Library, Photo Researchers, Inc.; **p. 142** Single mammalian tissue culture cell, color transmission electron micrograph. Dr. Gopal Murti/Science Photo Library/Photo Researchers, Inc.; **p. 149** Loh, Dan, photograph. AP/Wide World Photos; **p. 151** Anemone, Tunicate, Oyster, and Sponge, photograph. © Stephen Frink/Corbis; **p. 152** Bottlenosed dolphin playing, photograph. © Stephen Frink/Corbis; **p. 155** Blood smear showing leukemia cells, photomicrograph. ©

Margaret Cubberly/Phototake; **p. 160** Hand wearing glove, holding worms, compost sits below, photograph by Robert J. Huffman/Field Mark Publications; **p. 164** Meteorite ALH84001, from Mars, 4.5 billion years old, photograph. National Aeronautics and Space Administration (NASA); **p. 172** Larson, Peter, running fingers over teeth of a *Tyrannosaurus rex* skeleton, photograph. AP/Wide World Photos; **p. 175** Dog hookworms in small intestines, photograph. © Michael L. Wolmack/JLM Visuals; **p. 178** Young native boy with blonde hair trait, Lubarria Island, Solomon Islands, photograph. © Wolfgang Kaehler/Corbis; **p. 183** Micrograph comparing healthy red blood cells with a sickle cell, photograph by Dr. Gopal Murti. National Audubon Society Collection/Photo Researchers, Inc.; **p. 190** Diagram showing the central and peripheral nervous systems, left, and the autonomic nervous system, right, illustration by Frank Forney; **p. 192** Scientist performing pharmacological research, photograph. © Bob Krist/Corbis; **p. 194** Cecropia moth, photograph. Robert J. Huffman/Field Mark Publications; **p. 203** Dromedary camel, photograph. © Leonard Lee Rue, III/The National Audubon Society Collection/Photo Researchers, Inc.; **p. 206** Marine Plankton, green organisms with orange spots, 1960-1995, photograph by Douglas P. Wilson. Corbis/Dougals P. Wilson; Frank Lane Picture Agency; **p. 226** Digitalis, photograph. © Ken Wagner/Phototake; **p. 227** Release of pollen from anther of a black walnut, photograph. © Yoav Levy/Phototake; **p. 230** Closed General Electric plant in Pittsfield, Massachusetts, on the Housatonic River, photograph. AP/Wide World Photos; **p. 237** Cheetah, photograph. Robert J. Huffman/Field Mark Publications.

## Volume 4

**p. 2** Peregrine falcon with wings outstretched, photograph by Tim Davis. Photo Researchers, Inc.; **p. 3** School of fish swimming above blue and green coral reef, Indian Ocean, off Pemba Island, 1991, photograph by Stephen Frink. Corbis/Stephen Frink; **p. 21** Dinoflagellate *gambierdiscus toxicus*, scanning electron micrograph by Dr. Dennis



Kunkel. © Dr. Dennis Kunkel/Phototake; **p. 22** Diatoms, photograph. © Richard P. Jacobs/JLM Visuals; **p. 24** Euglena protozoa, photomicrograph by Eric Grave. © Eric Grave/Phototake; **p. 27** Plasmodium flaciparum, malaria parasite, electron micrograph. © Institut Pasteur/Phototake; **p. 28** Brain scans of a schizophrenic patient, bottom, versus a normal patient, top, colored positron emission tomography. © Wellcome Dept. of Cognitive Neurology/Science Photo Library, Photo Researchers, Inc.; **p. 32** Man shows the milky juice of unripe seedpods used to make opium from the opium poppy plant, photograph. © Michael S. Yamashita/Corbis; **p. 33** Sensitive fern, close-up of single leaf, photograph by Robert J. Huffman/Field Mark Publications; **p. 39** Slade, Dennis, photograph. AP/Wide World Photos; **p. 53** Structure of Hibiscus flower, photograph by Ken Wagner. © Ken Wagner/Phototake; **p. 57** Bumblebee pollinating flower, photograph by Robert J. Huffman/Field Mark Publications; **p. 61** *In vitro* fertilization, photograph. © CC Studio/Science Photo Library, Photo Researchers, Inc.; **p. 64** Respiratory system, diaphragm, photograph by Hans & Cassidy. Gale Group; **p. 67** Model of HIV virus, photograph. Corbis-Bettmann; **p. 70** Old-growth forest with understory of wood sorrel in Mt. Hood National Forest in Oregon, photograph by William H. Mullins. Photo Researchers, Inc.; **p. 71** Color-coded cryo-EM map of the *E. coli* ribosome, photograph. Courtesy of Joachim Frank/Health Research, Inc.; **p. 74** Farmland on the banks of the Nile, Egypt, photograph. © Yann Arthus-Bertrand/Corbis; **p. 79** Cross-section of plant in soil, photograph. © Premium Stock/Corbis; **p. 86** Kidney bean sprouting into a seedling, photograph. Photo Researchers, Inc.; **p. 90** Arabidopsis sp. seed pods, scanning electron micrograph, SEM. © Dr. Dennis Kunkel/Phototake; **p. 92** Autumn scene with man, photograph by Robert J. Huffman/Field Mark Publications; **p. 93** Purified adenovirus, photograph by Jean Claude Revy. © Jean Claude Revy/Phototake; **p. 95** Barr body in a female squamous epithelium cell, photograph. © Lester V. Bergman/Corbis; **p. 97** Normal human female chromosomes (XX) in karyotype. © Leonard Lessin, FBPA/Photo Researchers, Inc.; **p. 99** Common frogs in amplexus, photograph. © John Tinning; Frank Lane Picture Agency/Corbis; **p. 102** Rainbow trout eggs hatching, photograph. JLM Visuals; **p. 105** Male and female black widow spiders, photograph. © J. C. Cockendolpher/JLM Visuals; **p. 107** Gonorrhea cells, photograph. Custom Medical Stock Photo; **p. 108** Syphilitic infection, sexually transmitted disease, photograph. © CNRI/Phototake; **p. 111** Fiddlehead ferns, close-up, photograph by Robert J. Huffman/Field Mark Publications; **p. 113** Lymphocytes, T-cells, and 3 red cells, scanning electron micrograph. © NYU Franklin Research Fund/Phototake; **p. 118** Snake skeleton, photograph. © Richard P. Jacobs/JLM Visuals; **p. 125** Pillows of coral colored Myxomycetes grow on damp wood, photograph. © Steve Austin; Papilio/Corbis; **p. 128** Two gannets greeting each other on Bonaventure Island, Quebec, photograph. © Breck P. Kent/JLM Visuals; **p. 130** Olive baboon grooming papio cynocephalus, photograph. © Joe McDonald/Corbis; **p. 131** Wilson, Edward O., 1991, photograph. AP/Wide World Photos; **p. 143** Cleaner shrimp, cleaner moray, photograph. JLM Visuals; **p. 149** Three T-lymphocytes, scanning electron micrograph, SEM, image. © Microworks/Phototake; **p. 152** Linnaeus, Carolus, engraving. The Library of Congress; **p. 153** Archeobacteria, scanning electron micrograph by Eurelios. © Eurelios/Phototake; **p. 155** Pit Bull Panting, photograph. © Lawrence Manning/Corbis; **p. 159** Thyroid Nuclear Medicine Scan, enhanced Scintigram, photograph by Oliver Meckes. Photo Researchers, Inc.; **p. 161** Close-up of a human fingerprint, macrophotograph by Martin Dohrn. © Martin Dohrn/Science Photo Library, Photo Researchers, Inc.; **p. 173** Surgeons clean a human kidney in preparation for transport into a patient at the University of Pittsburgh Medical Center, photograph. © Nathan Benn/Corbis; **p. 177** Cook Strait Tutuata, photograph by Tom McHugh. Photo Researchers, Inc.; **p. 178** Sea-peach tunicate, photograph. JLM Visuals; **p. 181** Vaccination process, illustration. Electronic Illustrators Group. **p. 185** Veterinarian technicians check the blood pressure of a dog, photograph.

AP/Wide World Photos; **p. 188** T4 bacteriophage virus, colored transmission electron micrograph. © Department of Microbiology, Biozentrum/Science Photo Library/Photo Researchers, Inc.; **p. 189** Compound eye of a fruit fly, scanning electron micrograph, SEM. © Dr. Dennis Kunkel; **p. 194** Drop of guttation, water extruded by a plant's root pressure, on a blade of grass. Alpine Lakes Wilderness Area, Washington, photograph. © Pat O'Hara/Corbis; **p. 196** Watson, Dr. James Dewey, with DNA model, 1962, photograph. UPI/Corbis-Bettmann; **p. 198** Dead

tree trunks, stumps in deep blue water, golden leaves, photograph by Robert J. Huffinan/Field Mark Publications; **p. 199** Biologists take samples from drugged polar bears for data about pesticides, photograph. © Galen Rowell/Corbis; **p. 201** Man walks across giant rollers used to crush wood pulp at the Ketchikan Pulp Company, photograph. © Kevin Fleming/Corbis; **p. 205** Zoo veterinarian Don Janssen examining the San Diego Zoo's 2-week old giant panda cub, photograph. AP/Wide World Photos.

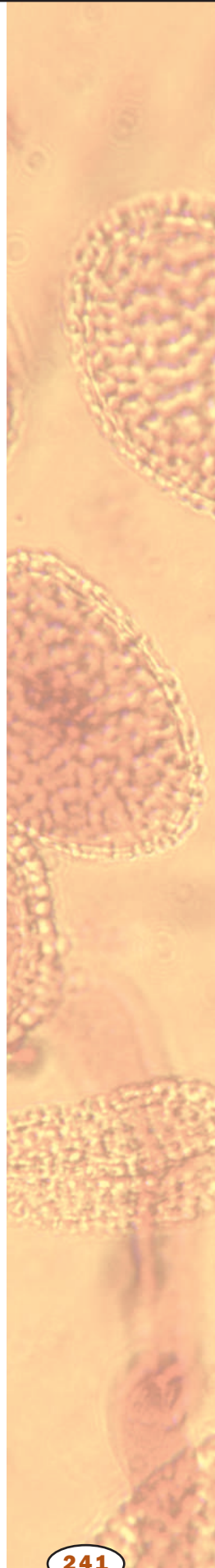

# Glossary

**abiotic** nonliving

**abscission** shedding of leaves; falling off

**acetylation** addition of an acetyl group,  $\text{CH}_3\text{-CHOO-}$

**acidic** having an excess of  $\text{H}^+$  ions and a low pH

**acinus** one of the small divisions of a fruit such as a raspberry

**action potential** wave of ionic movement down the length of a nerve cell

**active site** surface region of an enzyme where it catalyzes its reaction

**adaptive radiation** diversification of a group of organisms into several different forms that adapt to different environments

**adhesion** attachment; sticking to the surface of

**ADP** adenosine diphosphate, the low-energy form of ATP

**adventitious** growing from a nonstandard location

**aerobe** organism that needs oxygen

**aerobic** with oxygen, or requiring it

**aestivating** remaining dormant for the summer

**affinity** attraction

**aflatoxin** toxic compound produced by a mold fungus

**agar** gel derived from algae

**agnosia** “not knowing”; loss of ability to recognize familiar objects

**agroecosystem** agricultural ecosystem

**alkaline** chemically basic, with an excess of  $\text{OH}^-$  ions

**allele** a particular form of a gene

**allelopathy** inhibition of one plant’s growth by another plant

**amino acid** a building block of protein

**amoeba** a single-celled protist that moves by crawling

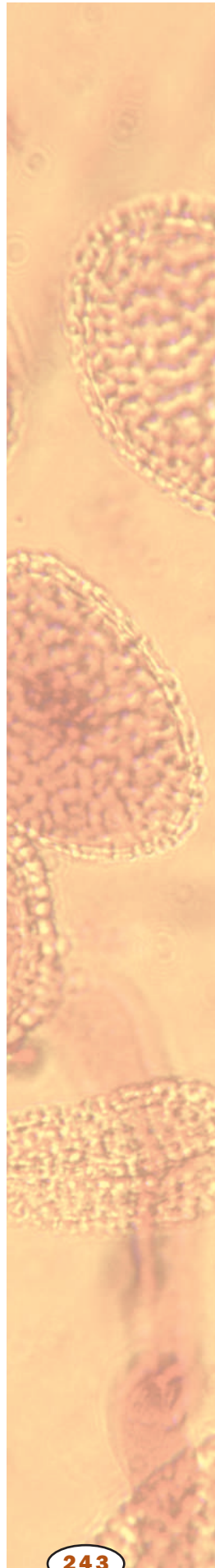

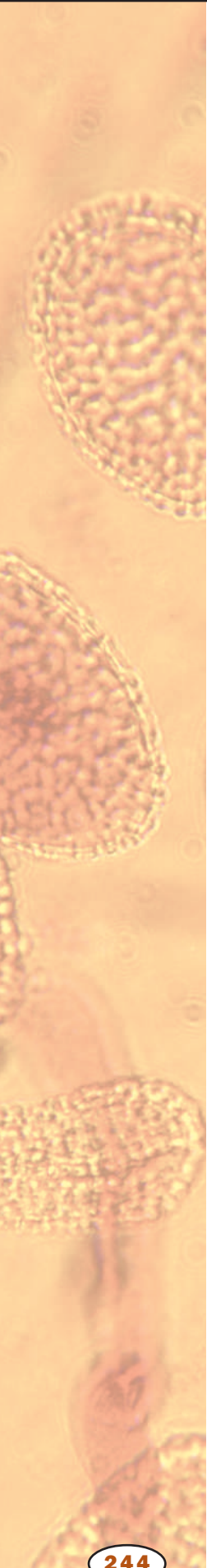

**amoeboid** like an amoeba, especially in movement via extension of portions of the membrane

**AMP** adenosine monophosphate, form of ATP after removal of two phosphate groups

**amphipathic** having both polar and nonpolar regions

**anabolic** characteristic of a reaction that builds complex molecules from simpler ones, and requires energy

**anadromous** describes fish that return to the rivers where they were born in order to breed

**anaerobe** organism not needing oxygen

**anaerobic** without oxygen, or not requiring oxygen

**anemia** lack of oxygen-carrying capacity in the blood

**aneurysm** bulging of the wall of a blood vessel

**antagonism** working against

**antagonist muscle** muscle that works against the action undertaken

**anterior** toward the front

**anterograde** forward

**anthocyanins** colored compounds made by plants

**anthropogenic** of, or relating to, the influence of human beings or nature

**antibody** immune system protein that binds to foreign molecules

**antigen** foreign substance that provokes an immune response

**antioxidant** substance that prevents damage from oxidation

**antitoxin** molecule used to inactivate a toxin

**aphasia** loss of the ability to form ideas into words

**apical** at the tip

**apical meristem** growing tip from which all plant tissues arise

**appendage** attached organ or structure

**aqueous** watery or water-based

**areolar** related to a small space within a tissue

**aromatic** compound including a double-bonded carbon ring

**arterioles** any of the small, terminal twigs of an artery that ends in capillaries

**arthropods** organisms with jointed appendages and exoskeletons, including insects, spiders, and crustaceans

**asymptomatic** without symptoms

**ATP** adenosine triphosphate, a high-energy nucleotide used by cells to power most energy-requiring reactions

- atria** two upper chambers of the heart (singular, atrium)
- attenuation** lessening over time
- autoimmune disease** disease in which the immune system attacks the body's own tissues
- autonomic** independent; regulating involuntary actions
- autonomic nervous system** one of the branches of the motor system, controlling involuntary muscles and glands
- autosomal dominant** pattern of inheritance in which inheritance of a single allele from either parent results in expression of the trait
- avian** concerning birds
- axon** long extension of a nerve cell down which information flows
- B lymphocyte** white blood cell that makes antibodies
- B.C.E.** before the Common Era, equivalent to B.C.
- basal** lowest level
- base pair** two nucleotides (either DNA or RNA) linked by weak bonds
- basic** having an excess of  $\text{OH}^-$  ions and a high pH
- bilaterally symmetric** symmetric, or similar, across a central line
- bilayer** composed of two layers
- bioaccumulate** build up within organisms
- bioluminescence** production of light by biochemical reactions
- biopharmaceuticals** drugs produced by and harvested from living organisms
- biosynthetic** forming a complex molecule from simpler ones
- biotic** living
- bolting** sudden spurt of growth
- boreal** of, relating to, or located in northern regions
- brood parasite** organism of one species that lays its eggs in the nest of another species
- C4 and CAM plants** plants that employ accessory systems for trapping carbon for photosynthesis
- cadherins** family of calcium-dependent adhesion proteins
- carbohydrates** sugars, starches, and other molecules combining carbon, hydrogen, and oxygen and serving as fuel or structural components
- cardiomyopathy** heart muscle disease
- catalysis** aiding in the reaction of
- catalyst** substance that aids in a reaction without being used up

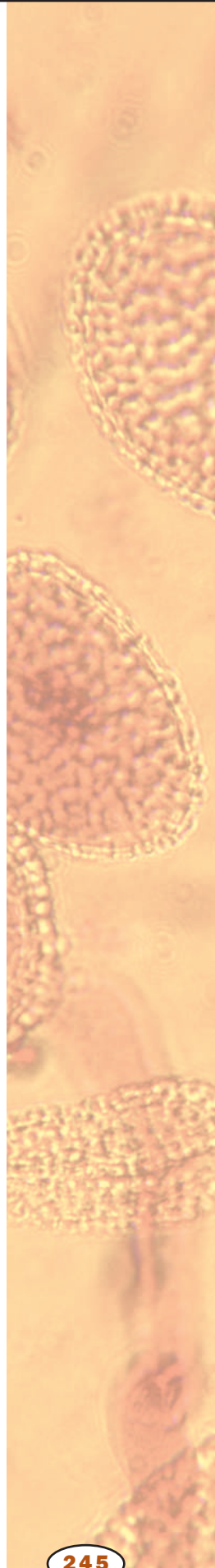

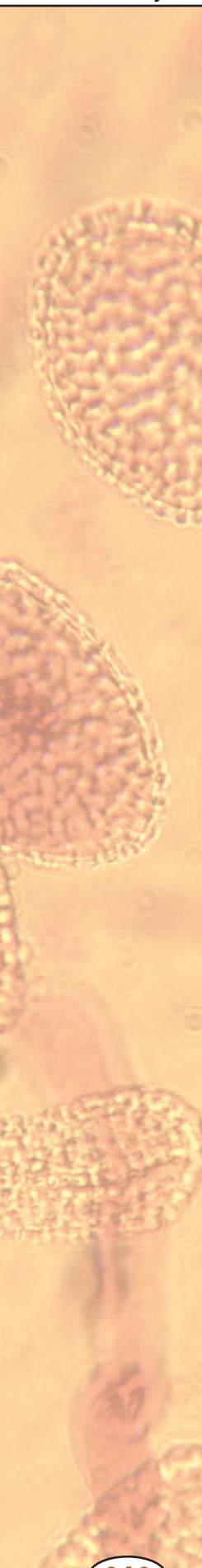
- 
- catalyze** aid in the reaction of
- caudate** toward the tail
- C.E.** Common Era; equivalent to AD
- cell cycle** sequence of growth, replication, and division that produces new cells
- cellulose** carbohydrate made by plants and some other organisms; part of the cell wall
- central nervous system** brain and spinal cord
- centromere** region of the chromosome linking chromatids
- cerebral cortex** outermost wrinkled portion of the brain
- chemiosmosis** use of proton gradients to make ATP
- chitin** nitrogen-containing carbohydrate found in arthropod exoskeletons and fungus cell walls
- chromatid** a replicated chromosome before separation from its copy
- chromatin** complex of DNA, histones, and other proteins making up chromosomes
- chromosomal analysis** staining, banding, and other techniques for detection of chromosomal abnormalities
- chromosome** “colored body” in the cell nucleus; made of DNA and protein, and divided functionally into genes and non-gene regions
- cilia** short, hairlike cell extensions of the cell membrane formed by the cytoskeleton
- ciliated** possessing cilia, which are short, hairlike extensions of the cell membrane
- circadian** related to a day or daylength
- clavicle** collar bone
- cloaca** common exit cavity for intestinal, genital, and urinary tracts
- codon** sequence of three mRNA nucleotides coding for one amino acid
- cognition** mental processes of thought and awareness
- cognitive** related to thought or awareness
- communicable** transmissible from person to person
- complementary** matching opposite
- complex carbohydrate** molecules formed by linking simpler carbohydrates such as sugars
- condensation** compaction of chromosome strands into a tight structure
- conformation** three-dimensional shape
- congenital** present at birth; inherited

- conjunctiva** eye membrane that helps seal the eye socket
- connective tissue** one of four types of body tissue, characterized by few cells and extensive extracellular material
- consanguineous** descended from the same ancestor
- constitutive** at a constant rate or continually
- contiguous** adjacent to or touching
- continental shelf** submerged offshore area demarcated by land on one side and deep sea on the other
- coralloid** resembling coral
- coronary artery** artery supplying blood to the heart
- cortical** related to the cortex, or outer portion
- cotyledon** seed leaf, which stores food and performs photosynthesis after germination
- cranial** related to the cranium, or brain cavity
- cryptobiosis** when a plant or animal becomes so inactive that its life processes nearly come to a stop
- cutaneous** related to the skin
- cutaneous respiration** gas exchange through the skin
- cytology** study of cells
- cytoplasm** material in a cell, excluding the nucleus
- cytoskeleton** internal scaffolding in a cell, composed of protein
- cytosol** fluid portion of a cell, not including the organelles
- Darwinian fitness** capacity to survive and reproduce
- deciduous** trees that shed their leaves in the fall
- deciliter** one-tenth of a liter; a unit of volume
- dementia** neurological illness characterized by impaired thought or awareness
- desiccation** drying out
- desynchronized** not happening at the same time
- deuterostome** “mouth second”; referring to the early development of the anal pore during gut tube formation
- dialysis** cleansing by partial filtration
- dicot** plant having two cotyledons, or seed leaves
- dikaryotic cell** cell with a pair of nuclei
- dilation** expansion or swelling
- dimer** polymer formed from two molecules of a simple compound

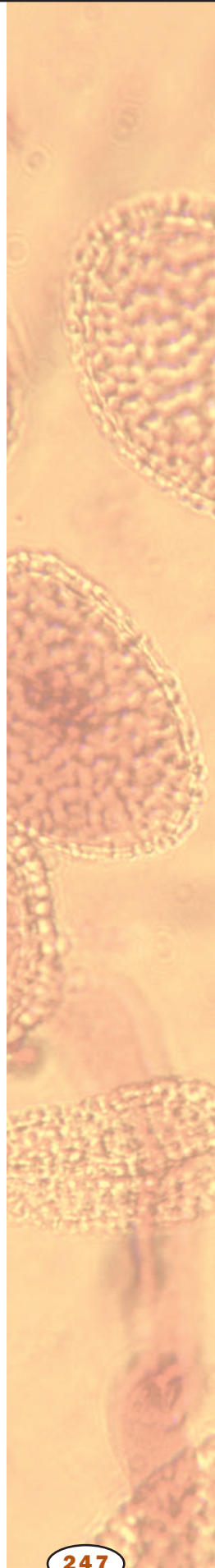

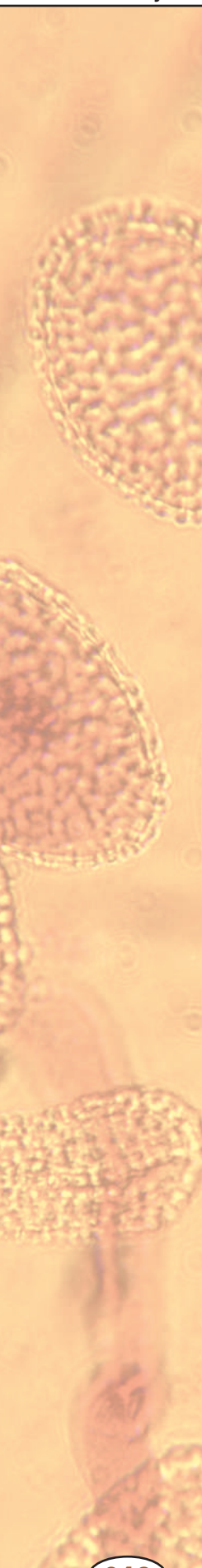
- 
- dimerizes** forms a pair
- diploid** having pairs of chromosomes in the nucleus
- dissociate** break apart
- distal** away from
- diurnal** active during the daytime
- dorsal** to the back of
- ecosystem** an ecological community and its environment
- effector** organ at the end of a nerve, such as a muscle or gland
- efferent** conducting outward or directing away from
- electrolytes** ions in body fluids
- electromagnetic radiation** light, X rays, and other forms of radiant energy
- electron transport system** membrane-bound system of proteins that extracts energy from high-energy electrons, found in mitochondria and chloroplasts
- electrophoresis** technique that uses electricity to separate molecules based on size and electric charge
- electrophoresis gel** porous medium through which molecules can be separated using an electric current
- embalming** treating a dead body to protect it from decay
- embryology** development of the embryo
- emulsify** suspend in solution through interaction with soap or similar molecules
- endocrine** related to the system of hormones and glands that regulate body function
- endogenous** caused by factors inside the organism
- endometriosis** disorder of the endometrium, the lining of the uterus
- endoplasmic reticulum** network of membranes within the cell
- endosperm** nutritive tissue within a seed
- endosymbiosis** symbiosis in which one partner lives within the other
- endothermic** characterized by regulation of body temperature through metabolic activity
- Enlightenment** eighteenth-century philosophical movement stressing rational critique of previously accepted doctrines in all areas of thought
- enzymatic** related to the function of an enzyme
- enzyme** protein that controls a reaction in a cell
- epidemic** rapid spread of disease through a population, or a disease that spreads in this manner



- epistasis** suppression of a characteristic of one gene by the action of another gene
- epithelium** one of four tissue types found in the body, characterized by thin sheets and usually serving a protective or secretory function
- esophagus** tube connecting the throat to the stomach
- eudicot** “true dicot”; plants with two seed leaves that originated from the earliest of flowering plants
- eukaryotic cell** a cell with a nucleus
- eutrophication** process by which waters become enriched in dissolved nutrients that promote plant growth which results in depletion of dissolved oxygen
- evapotranspiration** loss of water from a plant by evaporation within the leaf
- evidentiary DNA profile** analyzed DNA from a sample used as evidence
- excrete** deposit outside of
- exocrine gland** gland that secretes substances to an external or internal surface rather than into the bloodstream
- exoskeleton** external skeleton
- extensibility** ability to expand or grow larger
- fallopian tubes** tubes through which eggs pass to the uterus
- fecundity** ability to reproduce
- feedback** process in which the output or result influences the rate of the process
- fertilization** union of sperm and egg
- fibroblast** undifferentiated cell normally giving rise to connective tissue cells
- filtrate** material passing through a filter
- focal** at a point
- follicle** a vesicle that contains a developing egg surrounded by a covering of cells
- food web** set of feeding relations in an ecosystem
- forb** broad-leaved herbaceous plant
- forensic** related to legal proceedings
- fulcrum** pivot point of a lever
- fungi** major group of parasitic, lower plants that obtain their food from the products of organic decay (e.g. molds, smuts, etc.)
- gamete** reproductive cell, such as sperm or egg
- gametophyte** a haploid plant that makes gametes by mitosis
- ganglia** cluster of nerve cell bodies

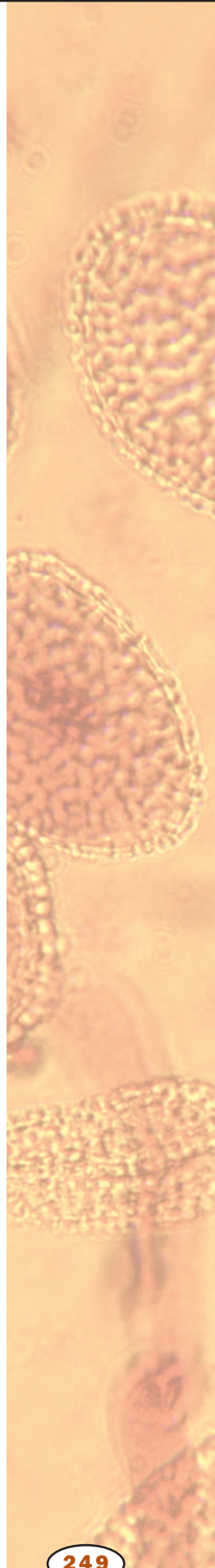

**gastroenteritis** inflammation of the gastrointestinal tract, often from infection

**gene** portion of DNA that codes for a protein or RNA molecule

**gene expression** use of a gene to create the corresponding protein

**genetic code** relationship between triples of RNA nucleotides and the amino acids they code for during protein synthesis

**genitalia** reproductive organs

**genome** total genetic material in a cell or organism

**germ line** cells creating eggs or sperm

**gestation** period of fetal development within the mother

**glial** supporting tissue of the elements of nervous tissue, including the brain, spinal cord, and ganglia

**glucose** simple sugar that provides energy to animal cells; it is the building block of cellulose in plants

**glycogen** complex carbohydrate used as storage in animals and some other organisms

**glycolysis** initial stages of sugar breakdown in a cell

**gradient** difference in concentration between two places

**grafting** attachment and fusing of parts from different plants

**guard cells** paired cells on leaves that control gas exchange and water loss

**gymnosperms** “naked seed” plants, including conifers

**hallucination** altered sensory experience resulting in the perception of objects that are not real

**haploid** having single, nonpaired chromosomes in the nucleus

**hectare** 10,000 square meters (2.47 acres)

**heme** the deep red, iron containing, nonprotein portion of hemoglobin and myoglobin

**hemicellulose** complex carbohydrate related to cellulose and found in cell walls of plants and some other organisms

**hemoglobin** oxygen-carrying protein complex in red blood cells

**herbarium** a collection of dried plant specimens systematically arranged for reference

**hermaphrodite** organism possessing both male and female reproductive structures

**heterodimer** complex molecule composed of two different parts

**heterogeneous** composed of, or containing, different parts or types

**heterozygous** characterized by possession of two different forms (alleles) of a particular gene

- hexamer** a structure composed of six parts
- histogenesis** origin or production of tissues
- histology** study of tissues
- histone** protein around which DNA wraps to form chromosomes
- homologous** similar in structure
- homologous chromosomes** chromosomes carrying similar genetic information
- homologous recombination** exchange of DNA segments between chromosomes
- homozygous** containing two identical copies of a particular gene
- hormone** molecule released by one cell to influence another
- hybrid** combination of two different types
- hydrocarbon** molecule or group composed only of C and H
- hydrogen bond** weak bond between the H of one molecule or group and a nitrogen or oxygen of another
- hydrolyze** to split apart using water
- hydrophilic** “water loving”
- hydrophobic** “water hating,” such as oils
- hydroponics** growing of plants without soil
- hydroxyl** chemical group consisting of -OH
- hypersalinity** very high level of salt
- hypersecretion** excess secretion
- hypersensitivity reaction** immune reaction characterized by rapid and severe response, often with swelling of airways
- hyphae** threadlike part of the vegetative portion of the fungus
- hyposcretion** lack of secretion
- hypothermia** subnormal temperature of the body
- ice-out** a thawing of ice covering a lake or other body of water
- immunoglobulin** an immune protein, also called an antibody
- immunosuppressant** inhibition of the immune response
- in utero** inside the uterus
- in vitro** “in glass”; in lab apparatus, rather than within a living organism
- inbred** repeatedly bred with close relatives, creating organisms with very little genetic variation

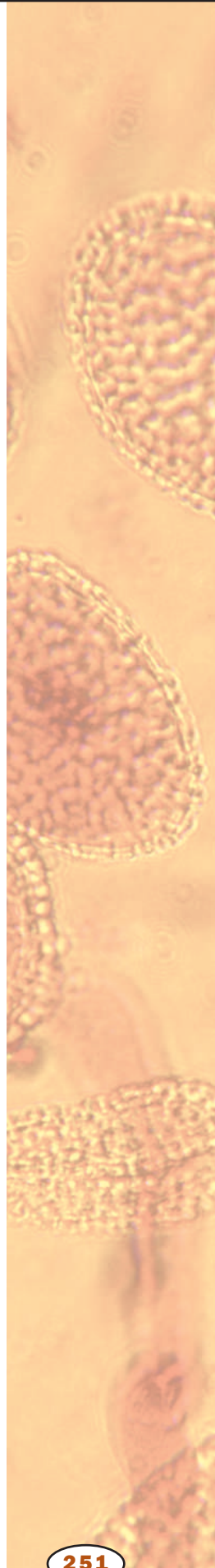

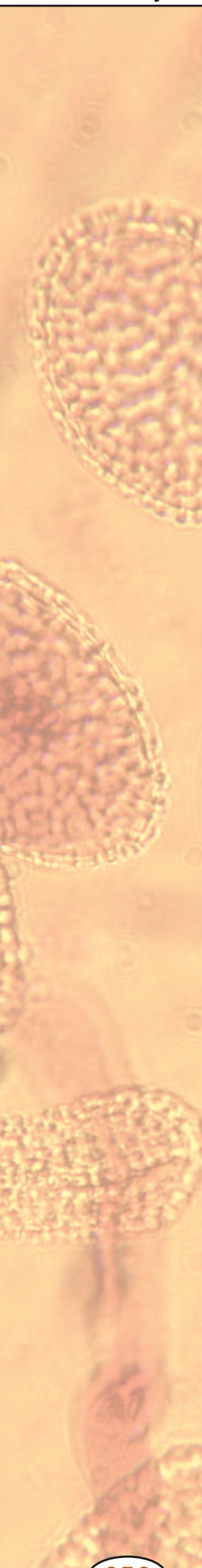
- 
- inducible** able to be switched on
- inflorescence** characteristic arrangement of flowers on a stalk
- infrastructure** roads, phone lines, and other utilities that allow commerce
- inorganic** not bonded to carbon
- insectivorous** insect-eating
- integrins** a family of transmembrane linking proteins
- interferons** signaling molecules of the immune system
- intermediate filament protein** one type of cytoskeleton protein
- interspecific** between different species
- interstitial space** space between cells in a tissue
- intracellular** within a cell
- intraocular** within the eyeball
- intrinsic to** intimate part of; within
- intron** untranslated portion of a gene that interrupts coding regions
- ion** an electrically charged particle
- ionic** based on or functioning by means of ions
- ionizing radiation** high-energy radiation that destroys chemical bonds
- isometric** relating to contraction without movement
- isotopes** forms of an atom that differ by the number of neutrons in the nucleus
- keratin** a major structural protein
- kilobase** one thousand DNA bases; a measure of size of a piece of DNA
- kilobasepair** one thousand DNA base pairs; a measure of size of a piece of DNA
- kinase** enzyme that adds a phosphate group to another molecule, usually a protein
- Krebs cycle** central metabolic pathway in mitochondria
- lactation** production of milk by the mammary glands
- laparoscopic surgery** surgery in which an instrument is inserted through a very small incision, usually guided by some type of imaging technique
- larynx** “voice box”; muscles at the top of the trachea that control pitch and loudness
- lateral** side-to-side
- lethargy** lack of excitability; torpor
- lignified** hardened by impregnation with lignin, a compound formed in plants

- lignin** organic molecule used in plant cell walls to add stiffness to cellulose
- lineage** ancestral line
- lipid** fat or waxlike molecule, insoluble in water
- lipoprotein** combination of protein and lipid, or fatlike molecule
- locus** site on a chromosome (plural, loci)
- lotic** of, relating to, or living in actively moving water
- lymph** pale fluid that circulates in the lymphatic system, principally composed of blood plasma and cell fluid
- lymphatic system** network of tubes that permeates the body for transport of lymph and combat of infection
- lymphocyte** white blood cell found in lymph nodes
- lyse** break apart
- lysine** an amino acid
- lysing** disintegration or dissolution of cells
- macromolecules** large molecules such as proteins, carbohydrates, and nucleic acids
- marsupials** kangaroos and other mammals that gestate young in an external pouch
- materialism** the belief that life is due entirely to biochemical interactions, without the intervention of supernatural forces
- matrix** a network, usually of threadlike fibers
- medium** nutrient source
- meiosis** cell division that forms eggs or sperm
- membrane potential** electrical and chemical differences across a membrane leading to storage of energy and excitability
- metabolism** chemical reactions within a cell
- metabolite** molecule involved in a metabolic pathway
- metamorphosis** development process that includes a larval stage with a different form from the adult
- metaphase** intermediate stage in cell division, in which chromosomes line up before separating
- metastasis** breaking away of cancer cells from a solid tumor to travel elsewhere in the body
- metazoans** animals other than sponges
- methylation** addition of the methyl group  $\text{CH}_3$
- micron** one-millionth of a meter; also called a micrometer
- mid-dorsal** middle of the back

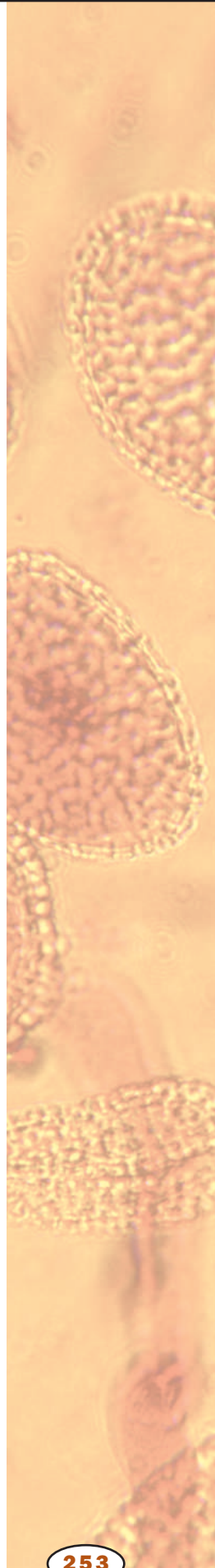

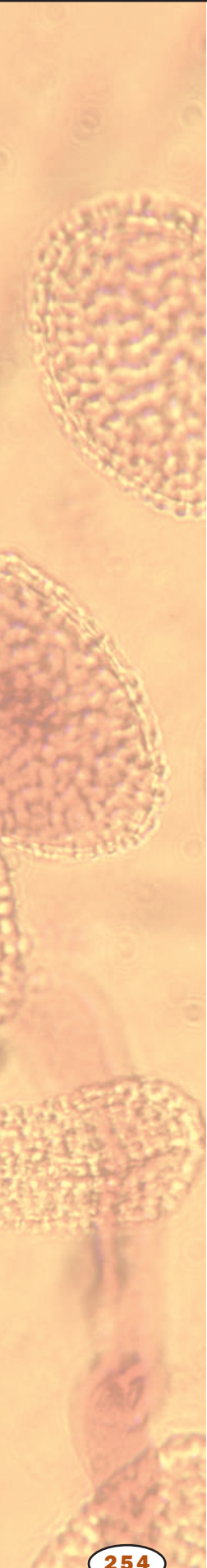

**middle lamella** layer of material between two plant cells that holds them together

**minerals** iron, calcium, sodium, and other elements needed by living organisms

**missense mutation** nucleotide change that causes a change in the amino acid normally added to the protein

**mitochondria** subcellular organelle that creates ATP used for energy-requiring processes in a cell

**mitogen** substance that stimulates mitosis

**mitosis** separation of replicated chromosomes

**molecular hybridization** base-pairing among DNAs or RNAs of different origins

**monocot** any of various flowering plants, such as grasses and orchids, that have a single cotyledon in the seed

**monoculture** cultivation of a single type of crop in a large area

**monomer** “single part”; monomers are joined to form a polymer

**monophyletic** a group that includes an ancestral species and all its descendants

**montane** mountainous region

**morphology** related to shape and form

**motile** able to move

**motor neuron** nerve cell that controls a muscle or gland

**mucous membrane** outer covering designed to secrete mucus, often found lining cavities and internal surfaces

**multimer** composed of many similar parts

**multinucleate** having many nuclei within a single cell membrane

**muscle tone** low level, constant muscle contraction

**mutualism** symbiosis between two organisms in which both benefit

**mycorrhizae** symbiosis between soil fungus and plant root to maximize absorption

**myxedema** thyroid disorder characterized by dry skin, swelling in the face, and mental deterioration

**nanometer**  $10^{-9}$  meters; one-billionth of a meter

**natural selection** process by which organisms best suited to their environments achieve greater reproductive success thus creating more “fit” future generations

**nematode** worm of the Nematoda phylum, many of which are parasitic

**nephron** functional unit of the kidney that performs filtration, reabsorption, and excretion

- neritic** zone near the shore
- neural** related to nerve cells or the nervous system
- neurologist** doctor who treats brain disorders
- neuron** nerve cell
- neurotransmitters** molecules released by one neuron to stimulate or inhibit another neuron or cell
- niche** the habitat supplying the right environment for a particular species
- nm** nanometer; one-billionth of a meter
- nocturnal** characterized by activity at night, or related to the night
- nondisjunction** failure of separation of homologous chromosomes during meiosis
- nuclear envelope** double membrane surrounding the cell nucleus
- nucleated** having a nucleus
- nucleotide** the building block of RNA or DNA
- nucleus** membrane-bound portion of cell containing the chromosomes
- obligate** required or necessary, especially referring to a metabolic process or mode of nutrition
- octomer** composed of eight parts
- oligosaccharide** chain of several sugar molecules
- oncogene** gene that causes cancer
- oocyte** unfertilized egg
- opportunistic** caused by a microorganism that is usually harmless but which causes infection in an immunosuppressed person
- organelle** membrane-bound cell compartment
- organic** composed of carbon, or derived from living organisms; also, a type of agriculture stressing soil fertility and avoidance of synthetic pesticides and fertilizers
- osmosis** passage of water through a membrane in response to concentration differences
- osseous** related to bone
- outcross** fertilization between two different plants
- ovipary** production of eggs that hatch outside the body
- ovovivipary** production of eggs that hatch within the female's body
- ovule** multicellular structure that develops into a seed after fertilization
- oxidation** reaction characterized by loss of electrons, or reaction with oxygen

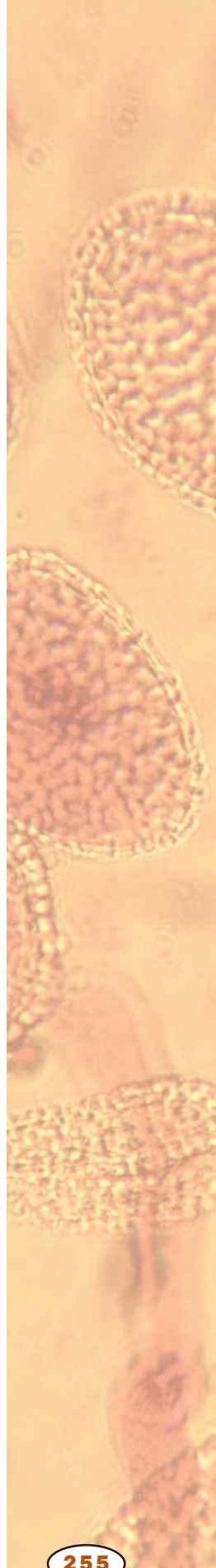

**oxidation-reduction** oxidation is loss of electrons, and reduction is gain of electrons

**oxidative** characterized by oxidation, or loss of electrons

**oxidative phosphorylation** use of oxygen to make ATP

**oxidize** to react or make react with oxygen

**palatine bone** bone of the hard palate at the roof of the mouth

**paleoanthropology** study of ancient humans

**palindromic** reading the same forward and backward

**pandemic** disease spread throughout an entire population

**papillate** small, nipplelike projection

**parasite** organism living in close association with another from which it derives most of its nutrition

**parasitology** study of parasites

**parasympathetic nervous system** branch of the nervous system promoting nutrient absorption and other maintenance activities

**pathogen** disease-causing organism

**pathogenesis** pathway leading to disease

**pathologic** related to disease

**pectin** carbohydrate in plants that forms crosslinks to stabilize cell walls

**peptide bond** bond between two amino acids

**peptidoglycans** polymer that is composed of polysaccharides and peptic chains

**perianth** combined sepals and petals

**peripheral** outside the central nervous system (brain and spinal cord)

**pH** measure of acidity or alkalinity; numbers below 7 are acid, above are basic

**phage** short for bacteriophage

**phagocytosis** engulfing of cells or large fragments by another cell, including immune system cells

**pharynx** throat

**phase-contrast microscopy** technique that manipulates passage of light through transparent specimens to reveal internal features

**phenotype** observable characteristics of an organism

**pheromone** molecule released by one organism to influence another organism's behavior

**phloem** plant tissue that conducts sugars from leaves to roots and other tissues



- phosphodiester** the link between two nucleotides in DNA or RNA
- phosphorylate** add a phosphate group to
- phosphorylation** addition of the phosphate group  $\text{PO}_4^{3-}$
- phyletic gradualism** the belief that evolutionary change is slow and steady
- phylogenetic** related to phylogeny, the evolutionary development of a species
- phylum** taxonomic level below kingdom, e.g., arthropod or chordate
- physiology** branch of biology that deals with the functions and activities of living matter
- phytoplankton** microscopic floating creatures that photosynthesize
- pinnate** featherlike
- pinocytosis** introduction of fluids into a cell by enclosing it and pinching off the plasma membrane
- pipette** lab instrument for precise measurement and transfer of small volumes of liquids
- pistil** female reproductive organ of a flower
- placental** related to mammals that nourish the fetus with a placenta, an exchange organ in the uterus
- plankton** microscopic floating organisms
- plant hybridization** creation of offspring by union of two different types of plants, such as wheat and rye
- plasmid** small ring of DNA found in many bacteria
- plasticity** change form
- plate tectonics** the movement of large plates of Earth's crust
- polar** partially charged, and usually soluble in water
- polar covalent** bond in which electrons are unevenly shared
- polymer** molecule composed of many similar parts
- polymerase** enzyme complex that synthesizes DNA or RNA from individual nucleotides
- polymerization** linking together of similar parts to form a polymer
- polypeptide** chain of amino acids
- polysaccharide** carbohydrate composed of many individual units of sugar
- posterior** toward the back
- postmortem** after death
- prebiotic** before the origin of life
- Precambrian** before the Cambrian era; before 600 million years ago

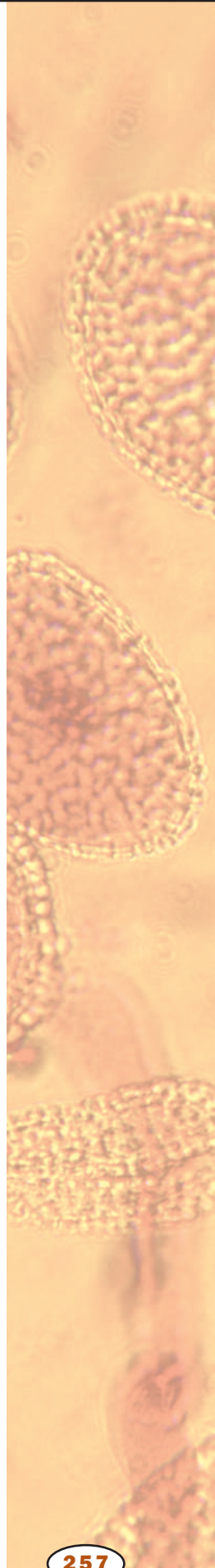

**primer** short nucleotide sequence that helps begin DNA replication

**progeny** offspring

**prokaryote** single-celled organism without a nucleus

**promoter** DNA sequence to which RNA polymerase binds to begin transcription

**prostaglandins** hormonelike molecules released by one cell that affect nearby cells, including smooth muscle

**prostrate** face downward

**protein** complex molecule made from amino acids; used in cells for structure, signaling, and controlling reactions

**proteolysis** breakdown of proteins

**protoecology** early ecology

**protoplasm** fluid portion of a plant cell within the cell wall

**protostome** “mouth first”; referring to the early development of the oral pore during gut tube formation

**protozoa** any of a phylum of minute protoplasmic animals present in almost every kind of habitat, some of which pose serious threats to humans and animals

**pseudopod** “false foot”; an extension of the plasma membrane during locomotion by an amoeba or similar crawling cell

**psychosis** severe mental disorder characterized by diminished connection with reality

**psychotropic** affecting consciousness, thought, or emotion

**punctuated equilibrium** pattern of evolution in which long periods of relatively little change are punctuated by rapid change

**pyruvate** the ionized form of pyruvic acid, a key intermediate in cell metabolism

**quaternary** fourth level

**radially symmetric** symmetric, or similar, about a central point (a wheel is radially symmetric)

**reproductive isolation** isolation of a population from other populations of the same species due to inability to successfully reproduce; an early stage in species formation

**respire** use oxygen to burn cellular fuel

**restriction enzyme** enzyme that cuts DNA at a particular sequence

**restriction fragments** fragments of DNA created by restriction enzymes

**reticular** netlike

**retrograde** backward

- reverse transcriptase** enzyme that copies RNA into DNA
- reverse transcription** creation of DNA from an RNA template
- ribonucleoprotein** combination of RNA and protein
- ribosome** protein-RNA complex in cells that synthesizes protein
- rickettsia** (pl. -sias or siae) any of a family of polymorphic microorganisms that cause various diseases
- RNA polymerase** enzyme complex that creates RNA from DNA template
- saline** of, or relating to, salt
- saprophyte** plant that feeds on decaying parts of other plants
- savanna** open grassland with sparse trees
- sclerophyll** small, tough evergreen leaves
- secretion** material released from the cell
- secretory pathway** series of events within a cell by which molecules are brought to the plasma membrane for release from the cell
- sepals** whorls of flower organs outside of the petals, usually green and serving to protect the flower before it opens
- serotinous** developing late in the season
- serotype** identity of an organism or virus based on reaction to an antibody
- sessile** attached and remaining in one place
- silviculture** cultivation of forest trees
- sleep apnea** difficulty breathing while asleep
- solenoid** cylindrical coiled structure
- solute** dissolved substance
- solvation** the process of dissolving
- somatic** nonreproductive; not an egg or sperm
- somatostatin** hormone produced by the hypothalamus that influences growth
- spasticity** of, or relating to, spasms
- spectroscopy** process using light or other emitted radiation to determine properties of a sample
- sphincter** ring of muscle regulating passage of material through a tube such as the gastrointestinal tract
- spontaneous generation** the theory that life began from nonliving matter
- stasis** state of no change
- steroid hormone** group of hormones that includes estrogen, testosterone, and progesterone

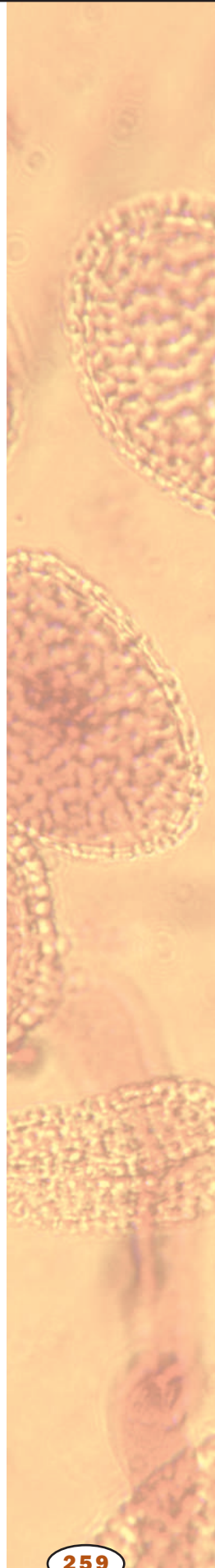

**steroids** hormones such as testosterone or estrogens that control many aspects of physiology

**stomata** openings in leaves for gas exchange, surrounded and regulated by guard cells

**strong bond** high-energy arrangement between two atoms involving electron-sharing; strong bonds require more energy to break than weak bonds

**subcutaneous** below the skin

**substrate** the molecule acted on by an enzyme; also a surface for attachment

**succession** series of changes seen in some plant communities over time, in which low-growing, rapidly reproducing species are replaced by taller and more slowly reproducing ones

**superficial** on the surface; not deep

**symbiont** organism living in close association with another organism

**symbiosis** close relationship between two species in which at least one benefits

**sympathetic nervous system** branch of the nervous system that promotes heightened awareness, increased nutrient consumption, and other changes associated with “fight or flight”

**synaptic transmission** passage of chemicals between nerve cells to send messages or alter neuron firing

**synchronously** at the same time

**synergism** working together to create a larger product rather than a simple sum

**systemic** throughout the body

**T cell** white blood cell that controls the immune response

**taxon** a level of classification, such as kingdom or phylum

**tectonic plate** large segment of Earth’s crust that moves in relation to other similar plates

**template** master copy

**teratogens** substances that cause birth defects

**tertiary** third level

**thermoregulation** temperature regulation

**transcribe** creation of an RNA copy of a DNA gene

**transcription** messenger RNA formation from a DNA sequence

**transcription factor** protein that increases the rate of transcription of a gene

**transduction** conversion of a signal of one type into another type

**transgenic** characterized by presence of one or more genes from a different organism

**translation** synthesis of protein using mRNA code

**translocation** movement of sugars and other nutrients throughout a plant

**transverse** situated or lying across

**trimer** a structure composed of three parts

**triploid** possessing three sets of chromosomes

**trophic** related to feeding

**trophic level** feeding level in an ecosystem

**true breeding** giving only offspring identical to the parents

**turgor** internal pressure

**ubiquitous** found everywhere

**ultrasonography** use of sound waves to produce an image

**ungulate** hoofed mammals such as cattle

**uninucleate** possessing one nucleus

**vas deferens** tube through which sperm travel from testes to urethra

**vector** carrier

**ventral to** toward the belly side

**ventricle** fluid-filled chamber

**venule** any of the minute veins connecting the capillaries with the larger systemic veins

**vesicle** membrane-bound sac

**vestigial** no longer functional

**visceral** related to the viscera, or internal organs

**viscous** thick

**vivipary** production of live young

**volatile** easily vaporized

**vulva** external female genitalia

**weak bond** low-energy arrangement between two atoms involving electron-sharing; weak bonds require less energy to break than strong bonds

**X-ray crystallography** use of X rays to determine the structure of a molecule

**xylem** water-transporting system in plants

**zygote** fertilized egg

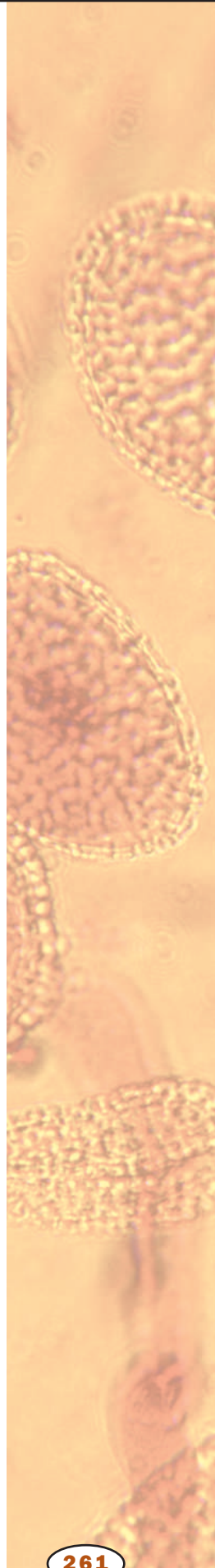

# Topic Outline

## **AGRICULTURE AND ECONOMIC BOTANY**

---

Agriculture  
Agronomist  
Beer-making, Botany of  
Coffee, Botany of  
Desertification  
Ethnobotany  
Forester  
Grain  
Grasses  
History of Agriculture  
Horticulturist  
Hybridization-Plant  
Landscape Ecology  
Nitrogen Cycle  
Nitrogen Fixation  
Organic Agriculture  
Plant Pathogens and Pests  
Pollution and Bioremediation  
Soil  
Vavilov, Nikolay  
Wine-making, Botany of

## **ANIMAL ANATOMY AND PHYSIOLOGY**

---

Amniote egg  
Animalia  
Circulatory Systems  
Connective Tissue  
Digestion  
Epithelium  
Excretory Systems  
Gas Exchange  
Growth  
Life Cycles  
Locomotion  
Model Organisms in Physiology and Medicine  
Muscle  
Nervous Systems  
Neuron  
Organ

Osmoregulation  
Physiological Ecology  
Respiration  
Scaling  
Sex Determination  
Skeletons  
Social Behavior  
Temperature Regulation  
Vision  
Zoology

## **ANIMAL BEHAVIOR**

---

Behavior, Genetic Basis of  
Behavior Patterns  
Feeding Strategies  
Field Studies in Animal Behavior  
Migration and Animal Navigation  
Mimicry, Camouflage, and Warning Coloration  
Pheromone  
Physiological Ecology  
Population Dynamics  
Predation and Defense  
Sexual Selection  
Symbiosis  
Temperature Regulation  
Wildlife Biologist

## **ANIMAL DIVERSITY**

---

Amphibian  
Animalia  
Annelid  
Arachnid  
Arthropod  
Biodiversity  
Bird  
Bony Fish  
Cambrian Explosion  
Cartilaginous Fish  
Chordata  
Cnidarian

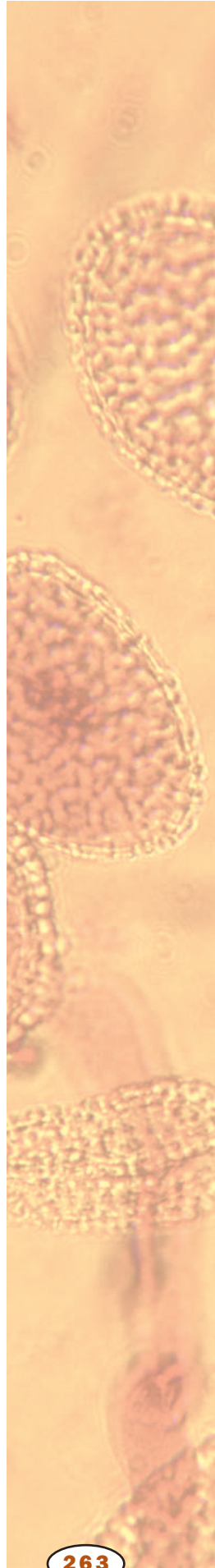

Coral Reef  
Crocodilian  
Crustacean  
Echinoderm  
Endangered Species  
Entomologist  
Extinction, Mammals  
Human Evolution  
Insect  
Mammal  
Marsupial  
Mollusk  
Monotreme  
Nematode  
Parasitic Diseases  
Platyhelminthes  
Porifera  
Primate  
Reptile  
Tuatara  
Tunicate  
Turtle  
Zoology  
Zoology Researcher

### **AQUATIC BIOLOGY**

---

Algae  
Amphibian  
Bony Fish  
Cartilaginous Fish  
Cnidarian  
Coral Reef  
Crustacean  
Echinoderm  
Estuaries  
Extreme Communities  
Lakes and Ponds  
Limnologist  
Marine Biologist  
Mollusk  
Ocean Ecosystems: Hard Bottoms  
Ocean Ecosystems: Open Ocean  
Ocean Ecosystems: Soft Bottoms  
Platyhelminthes  
Porifera  
Rivers and Streams  
Water

### **BACTERIA AND ARCHAEA**

---

Archaea  
Bacterial Cell  
Bacterial Diseases  
Bacterial Genetics  
Bacterial Viruses

Biotechnology  
Cell Evolution  
Cell Wall  
Chloroplast  
Clone  
Control of Gene Expression  
Cyanobacteria  
Dubos, René  
Ecosystem  
Eubacteria  
Microbiologist  
Mitochondrion  
Model Organisms: Cell Biology and Genetics  
Plant Pathogens and Pests  
Poisons  
Recombinant DNA  
Sexually Transmitted Diseases  
Transgenic Techniques

### **BEHAVIOR**

---

Behavior, Genetic Basis of  
Behavior Patterns  
Brain  
Competition  
Feeding Strategies  
Field Studies in Animal Behavior  
Flight  
Learning  
Locomotion  
Migration and Animal Navigation  
Mimicry, Camouflage, and Warning Coloration  
Pheromone  
Predation and Defense  
Sexual Reproduction  
Sexual Selection  
Sleep  
Social Behavior  
Sociobiology

### **BIOCHEMISTRY**

---

Amino Acid  
Antibodies in Research  
Biochemist  
Biogeochemical Cycles  
Carbohydrates  
Carbon Cycle  
DNA  
DNA Sequencing  
Drug Testing  
Electrophoresis  
Enzymes  
Glycolysis and Fermentation  
History of Biology: Biochemistry  
Krebs Cycle

Lipids  
 Lysosomes  
 Membrane Proteins  
 Metabolism  
 Mitochondrion  
 Nitrogen Cycle  
 Nitrogen Fixation  
 Nucleotides  
 Origin of Life  
 Oxidative Phosphorylation  
 Pauling, Linus  
 Peroxisomes  
 Pharmacologist  
 Poisons  
 Polymerase Chain Reaction  
 Prion  
 Protein Structure  
 Protein Synthesis  
 Radionuclides  
 RNA  
 Secondary Metabolites in Plants  
 Separation and Purification  
 Structure Determination  
 Vitamins and Coenzymes  
 Water

### **BIOLOGY AND SOCIETY**

---

Alcohol and Health  
 Anabolic Steroids  
 Behavior, Genetic Basis of  
 Biological Weapons  
 Biology of Race  
 Carson, Rachel  
 Creationism  
 Desertification  
 Doctor, Specialist  
 Dubos, René  
 Endangered Species  
 Ethnobotany  
 Evolution, Evidence for  
 Extinction, Mammals  
 Fire Ecology  
 Gene Therapy  
 Global Climate Change  
 Human Genome Project  
 Human Population  
 Invasive Species  
 Organic Agriculture  
 Pauling, Linus  
 Pollution and Bioremediation  
 Psychiatric Disorders, Biology of  
 Psychoactive Drugs  
 Recombinant DNA  
 Reproductive Technology  
 Sexually Transmitted Diseases

Smoking and Health  
 Sociobiology  
 Transgenic Techniques

### **BIOMES**

---

Biogeography  
 Biome  
 Coral Reef  
 Desert  
 Field Studies in Plant Ecology  
 Forest, Boreal  
 Forest, Temperate  
 Forest, Tropical  
 Global Climate Change  
 Grassland  
 Remote Sensing  
 Tundra

### **BIOTECHNOLOGY**

---

Antibodies in Research  
 Antisense Nucleotides  
 Bacterial Genetics  
 Bioinformatics  
 Biological Weapons  
 Biotechnology  
 Clone  
 Electrophoresis  
 Forensic DNA Analysis  
 Genomics  
 Human Genome Project  
 Hybridization  
 Polymerase Chain Reaction  
 Recombinant DNA  
 Reproductive Technology  
 Reverse Transcriptase  
 Separation and Purification  
 Structure Determination  
 Transgenic Techniques

### **CAREERS**

---

Agronomist  
 Biochemist  
 Botanist  
 College Professor  
 Dentist  
 Doctor, Family Practice  
 Doctor, Specialist  
 Emergency Medical Technician  
 Entomologist  
 Epidemiologist  
 Forester  
 Health and Safety Officer  
 High School Biology Teacher  
 Horticulturist



Laboratory Technician  
 Marine Biologist  
 Medical Assistant  
 Microbiologist  
 Microscopist  
 Nurse  
 Nurse Practitioner  
 Nutritionist  
 Pharmaceutical Sales Representative  
 Pharmacologist  
 Physician Assistant  
 Plant Pathologist  
 Psychiatrist  
 Public Health Careers  
 Science Writer  
 Veterinarian  
 Wildlife Biologist  
 Zoology Researcher

**CELL FUNCTION**

---

Active Transport  
 Cancers  
 Cell Cycle  
 Cell Motility  
 Control Mechanisms  
 Control of Gene Expression  
 Cytokinesis  
 Endocytosis  
 Enzymes  
 Exocytosis  
 Glycolysis and Fermentation  
 History of Plant Physiology  
 Hormones  
 Ion Channels  
 Krebs Cycle  
 Lysosomes  
 Meiosis  
 Membrane Proteins  
 Membrane Transport  
 Metabolism  
 Mitochondrion  
 Model Organisms: Cell Biology and Genetics  
 Nuclear Transport  
 Oxidative Phosphorylation  
 Peroxisomes  
 Protein Synthesis  
 Protein Targeting  
 Replication  
 Ribosome  
 RNA Processing  
 Signaling and Signal Transduction  
 Synaptic Transmission  
 Transcription

**CELL STRUCTURE**

---

Archaea  
 Bacterial Cell  
 Cell  
 Cell Evolution  
 Cell Junctions  
 Cell Motility  
 Cell Wall  
 Chloroplast  
 Connective Tissue  
 Cyanobacteria  
 Cytoskeleton  
 Electron Microscopy  
 Endoplasmic Reticulum  
 Epithelium  
 Eubacteria  
 Extracellular Matrix  
 Golgi  
 History of Biology: Cell Theory and Cell Structure  
 Ion Channels  
 Life, What Is  
 Light Microscopy  
 Lysosomes  
 Membrane Proteins  
 Membrane Structure  
 Membrane Transport  
 Microscopist  
 Mitochondrion  
 Model Organisms: Cell Biology and Genetics  
 Muscle  
 Neuron  
 Nuclear Transport  
 Nucleolus  
 Nucleus  
 Organelle  
 Origin of Life  
 Peroxisomes  
 Plasma Membrane  
 Porter, Keith  
 Ribosome  
 T Cells  
 Tissue  
 Vacuole

**CIRCULATION AND RESPIRATION**

---

Blood  
 Blood Clotting  
 Blood Sugar Regulation  
 Blood Vessels  
 Cardiovascular Diseases  
 Circulatory Systems  
 Gas Exchange  
 Harvey, William  
 Heart and Circulation

Lymphatic System  
 Physiological Ecology  
 Respiration  
 Smoking and Health  
 Temperature Regulation

### **DIGESTION AND EXCRETION**

---

Digestion  
 Digestive System  
 Excretory Systems  
 Human Nutrition  
 Kidney  
 Liver  
 Metabolism  
 Osmoregulation  
 Physiological Ecology

### **DISEASE AND HEALTH**

---

AIDS  
 Alcohol and Health  
 Anabolic Steroids  
 Autoimmune Disease  
 Bacterial Diseases  
 Birth Control  
 Blood Sugar Regulation  
 Cancers  
 Cardiovascular Diseases  
 Clinical Trials  
 Disease  
 Environmental Health  
 Female Reproductive System  
 Fungal Diseases  
 Gene Therapy  
 Health  
 Health and Safety Officer  
 Herbal Medicine  
 History of Medicine  
 Human Nutrition  
 Imaging in Medicine  
 Immune Response  
 Male Reproductive System  
 Model Organisms in Physiology and Medicine  
 Neurologic Diseases  
 Oncogenes and Cancer Cells  
 Pain  
 Parasitic Diseases  
 Poisonous Plants  
 Prion  
 Protozoan Diseases  
 Psychiatric Disorders, Biology of  
 Psychoactive Drugs  
 Sex Determination  
 Sexual Reproduction  
 Sexually Transmitted Diseases

Sleep  
 Smoking and Health  
 Stress Response  
 Transplant Medicine  
 Vaccines  
 Viral Diseases  
 Vitamins and Coenzymes

### **DNA, RNA, CHROMOSOMES**

---

Antisense Nucleotides  
 Chromosome Aberrations  
 Chromosome, Eukaryotic  
 Crick, Francis  
 DNA  
 DNA Sequencing  
 Gene  
 Genome  
 Medical/Science Illustrator  
 Meiosis  
 Mitosis  
 Mutation  
 Nucleotides  
 Polymerase Chain Reaction  
 Recombinant DNA  
 Replication  
 Sex Chromosomes  
 Transfer RNA  
 Watson, James

### **ECOLOGY**

---

Biogeochemical Cycles  
 Biogeography  
 Biome  
 Carbon Cycle  
 Community  
 Competition  
 Conservation  
 Coral Reef  
 Desert  
 Desertification  
 Ecological Research, Long-term  
 Ecology  
 Ecology, History of  
 Ecosystem  
 Endangered Species  
 Estuaries  
 Extinction, Mammals  
 Feeding Strategies  
 Field Studies in Plant Ecology  
 Fire Ecology  
 Forest, Boreal  
 Forest, Temperate  
 Forest, Tropical  
 Global Climate Change

Grassland  
 Habitat  
 Invasive Species  
 Lakes and Ponds  
 Landscape Ecology  
 Limnologist  
 Marine Biologist  
 Mimicry, Camouflage, and Warning Coloration  
 Nitrogen Cycle  
 Ocean Ecosystems: Hard Bottoms  
 Ocean Ecosystems: Open Ocean  
 Ocean Ecosystems: Soft Bottoms  
 Physiological Ecology  
 Pollution and Bioremediation  
 Population Dynamics  
 Predation and Defense  
 Remote Sensing  
 Rivers and Streams  
 Symbiosis  
 Theoretical Ecology  
 Tundra  
 Water Cycle  
 Wetlands

**ENDOCRINE SYSTEM**

Adrenal Gland  
 Anabolic Steroids  
 Birth Control  
 Blood Sugar Regulation  
 Endocrine System  
 Female Reproductive System  
 Hormones  
 Hypothalamus  
 Pancreas  
 Pituitary Gland  
 Sex Determination  
 Stress Response  
 Thyroid Gland

**EVOLUTION AND ADAPTATION**

Adaptation  
 Amniote Egg  
 Angiosperms  
 Biodiversity  
 Biogeography  
 Buffon, Count (Georges-Louis Leclerc)  
 Cambrian Explosion  
 Cell Evolution  
 C4 and CAM Plants  
 Convergent Evolution  
 Creationism  
 Darwin, Charles  
 Evolution  
 Evolution, Evidence for

Evolution of Plants  
 Extinction, Mammals  
 Extreme Communities  
 Hardy-Weinberg Equilibrium  
 Herbivory and Plant Defenses  
 History of Evolutionary Thought  
 Human Evolution  
 Lamarck, Jean-Baptiste  
 Leakey Family  
 Mimicry, Camouflage, and Warning Coloration  
 Natural Selection  
 Origin of Life  
 Osmoregulation  
 Paleontology  
 Physiological Ecology  
 Population Genetics  
 Predation and Defense  
 Scaling  
 Secondary Metabolites in Plants  
 Sociobiology  
 Speciation  
 Species

**EXPERIMENTAL TECHNIQUES**

Antibodies in Research  
 Antisense Nucleotides  
 Biochemist  
 Bioinformatics  
 Biotechnology  
 Cell Culture  
 Clinical Trials  
 Clone  
 Crick, Francis  
 DNA Sequencing  
 Drug Testing  
 Ecological Research, Long-term  
 Electron Microscopy  
 Electrophoresis  
 Field Studies in Animal Behavior  
 Field Studies in Plant Ecology  
 Forensic DNA Analysis  
 Gene Therapy  
 Genetic Analysis  
 Genomics  
 Hardy-Weinberg Equilibrium  
 History of Biology: Biochemistry  
 History of Plant Physiology  
 Human Genome Project  
 Hybridization  
 Imaging in Medicine  
 Ingenhousz, Jan  
 Laboratory Technician  
 Leeuwenhoek, Anton  
 Light Microscopy  
 Linkage and Gene Mapping

Microbiologist  
 Microscopist  
 Model Organisms: Cell Biology and Genetics  
 Model Organisms: Physiology and Medicine  
 Pasteur, Louis  
 Pauling, Linus  
 Pharmacologist  
 Polymerase Chain Reaction  
 Porter, Keith  
 Radiation Hybrid Mapping  
 Radionuclides  
 Recombinant DNA  
 Reproductive Technology  
 Reverse Transcriptase  
 Scaling  
 Separation and Purification  
 Structure Determination  
 Theoretical Ecology  
 Transgenic Techniques  
 Transplant Medicine  
 Van Helmont, J. B.  
 Watson, James  
 Zoology Researcher

## **FUNGI**

---

Biodiversity  
 Cell  
 Cell Wall  
 Fungal Diseases  
 Fungi  
 Lichen  
 Mycorrhizae  
 Plant Pathogens and Pests  
 Symbiosis  
 Taxonomy, History of

## **GENE—PROTEIN**

---

Antisense Nucleotides  
 Chromosome, Eukaryotic  
 Control Mechanisms  
 Control of Gene Expression  
 DNA  
 Endoplasmic Reticulum  
 Gene  
 Genetic Code  
 Genetic Control of Development  
 Genetic Diseases  
 Hormones  
 McClintock, Barbara  
 Mutation  
 Nuclear Transport  
 Nucleolus  
 Nucleotides  
 Nucleus

Prion  
 Protein Structure  
 Protein Synthesis  
 Protein Targeting  
 Recombinant DNA  
 Retrovirus  
 Reverse Transcriptase  
 Ribosome  
 RNA  
 RNA Processing  
 Transcription  
 Transfer RNA  
 Transposon  
 Virus

## **GENETICS**

---

Bacterial Genetics  
 Bacterial Viruses  
 Behavior, Genetic Basis of  
 Biology of Race  
 Chromosome Aberrations  
 Chromosome, Eukaryotic  
 Clone  
 Control of Gene Expression  
 Crick, Francis  
 DNA  
 DNA Sequencing  
 DNA Viruses  
 Forensic DNA Analysis  
 Gene  
 Gene Therapy  
 Genetic Analysis  
 Genetic Code  
 Genetic Control of Development  
 Genetic Counselor  
 Genetic Diseases  
 Genome  
 Genomics  
 Hardy-Weinberg Equilibrium  
 History of Biology: Inheritance  
 Human Genome Project  
 Hybrid  
 Hybridization  
 Hybridization, Plant  
 Linkage and Gene Mapping  
 McClintock, Barbara  
 Meiosis  
 Model Organisms: Cell Biology and Genetics  
 Nucleotides  
 Patterns of Inheritance  
 Pedigrees and Modes of Inheritance  
 Population Genetics  
 Prion  
 Radiation Hybrid Mapping  
 Recombinant DNA

Replication  
 Retrovirus  
 Reverse Transcriptase  
 Transgenic Techniques  
 Transposon  
 Virus  
 Watson, James

### **HISTORY OF BIOLOGY**

---

Buffon, Count (Georges-Louis Leclerc)  
 Carson, Rachel  
 Crick, Francis  
 Darwin, Charles  
 De Saussure, Nicolas  
 Dubos, René  
 Ecology, History of  
 Gray, Asa  
 Harvey, William  
 History of Agriculture  
 History of Biology: Biochemistry  
 History of Biology: Cell Theory and Cell Structure  
 History of Biology: Inheritance  
 History of Evolutionary Thought  
 History of Medicine  
 History of Plant Physiology  
 Ingenhousz, Jan  
 Lamarck, Jean-Baptiste  
 Leakey Family  
 Leeuwenhoek, Anton  
 Linnaeus, Carolus  
 McClintock, Barbara  
 Mendel, Gregor  
 Pasteur, Louis  
 Pauling, Linus  
 Porter, Keith  
 Taxonomy, History of  
 Torrey, John  
 Van Helmont, J. B.  
 Vavilov, Nikolay  
 Vesalius, Andreas  
 Von Humboldt, Alexander  
 Watson, James

### **IMMUNE SYSTEM**

---

AIDS  
 Antibodies in Research  
 Antibody  
 Autoimmune Disease  
 Immune Response  
 Lymphatic System  
 Nonspecific Defense  
 Stress Response  
 T Cells

Transplant Medicine  
 Vaccines

### **INHERITANCE**

---

Bacterial Genetics  
 Behavior, Genetic Basis of  
 Biology of Race  
 Cell Cycle  
 Chromosome Aberrations  
 Clone  
 DNA  
 Feeding Strategies  
 Genetic Counselor  
 Genetic Diseases  
 History of Biology: Inheritance  
 Hybridization-Plant  
 Life Cycles  
 Linkage and Gene Mapping  
 Meiosis  
 Mendel, Gregor  
 Mitosis  
 Model Organisms: Cell Biology and Genetics  
 Mutation  
 Patterns of Inheritance  
 Pedigrees and Modes of Inheritance  
 Radiation Hybrid Mapping  
 Replication  
 Transgenic Techniques

### **INTERACTIONS, POPULATIONS, AND COMMUNITIES**

---

Behavior Patterns  
 Biogeography  
 Community  
 Competition  
 Ecological Research, Long-term  
 Ecology, History of  
 Ecosystem  
 Feeding Strategies  
 Field Studies in Animal Behavior  
 Field Studies in Plant Ecology  
 Fire Ecology  
 Habitat  
 Herbivory and Plant Defenses  
 Human Population  
 Invasive Species  
 Landscape Ecology  
 Lichen  
 Mimicry, Camouflage, and Warning Coloration  
 Mycorrhizae  
 Pheromone  
 Population Dynamics  
 Population Genetics  
 Predation and Defense

Symbiosis  
Theoretical Ecology  
Von Humboldt, Alexander

### **LIFE CYCLES**

---

Aging, Biology of  
Alternation of Generations  
Amniote Egg  
Cell Cycle  
Cnidarian  
Development  
DNA Sequencing  
Female Reproductive System  
Ferns  
Fetal Development, Human  
Growth  
Life Cycle, Human  
Life Cycles  
Male Reproductive System  
Reproduction in Plants  
Seedless Vascular Plants  
Seeds  
Sexual Reproduction  
Slime Molds

### **NERVOUS SYSTEM**

---

Biological Weapons  
Brain  
Central Nervous System  
Chemoreception  
Eye  
Hearing  
Hypothalamus  
Ion Channels  
Nervous Systems  
Neurologic Diseases  
Neuron  
Pain  
Peripheral Nervous System  
Psychiatric Disorders, Biology of  
Psychiatrist  
Psychoactive Drugs  
Spinal Cord  
Stress Response  
Synaptic Transmission  
Touch  
Vision

### **PLANT ANATOMY AND PHYSIOLOGY**

---

Alternation of Generations  
Anatomy of Plants  
Beer-making, Botany of  
C4 and CAM Plants  
Cell Wall

Chloroplast  
De Saussure, Nicolas  
Differentiation in Plants  
Flowers  
Fruits  
Grain  
History of Plant Physiology  
Hormones, Plant  
Hybridization-Plant  
Ingenhousz, Jan  
Leaves  
Meristems  
Mycorrhizae  
Nitrogen Fixation  
Photoperiodism  
Photosynthesis  
Plant Development  
Plant Nutrition  
Plant Pathogens and Pests  
Poisonous Plants  
Pollination and Fertilization  
Propagation  
Reproduction in Plants  
Rhythms of Plant Life  
Roots  
Secondary Metabolites in Plants  
Seed Germination & Dormancy  
Seeds  
Senescence  
Shoots  
Soil  
Translocation  
Tropisms and Nastic Movements  
Van Helmont, J. B.  
Water Cycle  
Water Movement in Plants  
Wine-making, Botany of  
Wood and Wood Products

### **PLANT DIVERSITY**

---

Angiosperms  
Biodiversity  
Biogeography  
Bryophytes  
C4 and CAM Plants  
Conifers  
Eudicots  
Evolution of Plants  
Ferns  
Grasses  
Gray, Asa  
Gymnosperms  
Hybridization-Plant  
Monocots

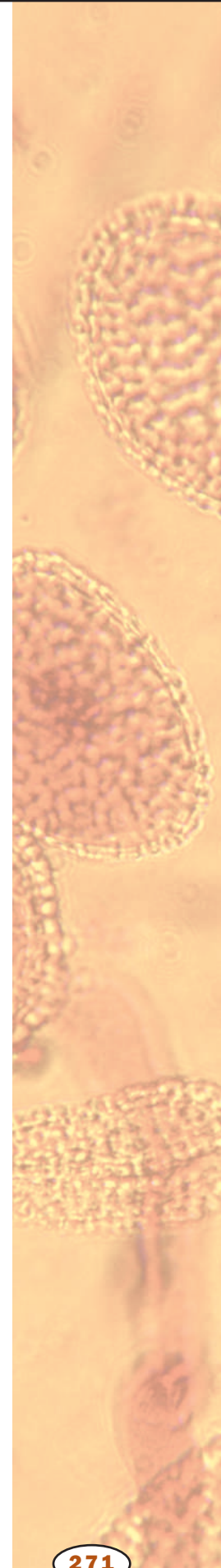

Plant  
Seedless Vascular Plants  
Torrey, John  
Vavilov, Nikolay  
Von Humboldt, Alexander

---

**PROTISTS**

Algae  
Beer-making, Botany of  
Cell  
Coral Reef  
Evolution of Plants  
History of Biology: Cell Theory and Cell Structure  
Leeuwenhoek, Anton  
Lichen  
Model Organisms: Cell Biology and Genetics  
Plankton  
Protista  
Protozoa  
Protozoan Diseases  
Slime Molds

---

**REPRODUCTION AND DEVELOPMENT**

Aging, Biology of  
Birth Control  
Cell Cycle  
Cytokinesis  
Development  
Female Reproductive System  
Fetal Development, Human  
Genetic Diseases  
Life Cycle, Human  
Life Cycles  
Male Reproductive System  
Meiosis  
Mitosis  
Reproductive Technology  
Sexual Reproduction  
Sexually Transmitted Diseases

---

**SKIN, MUSCLE, AND BONE**

Body Cavities  
Bone  
Connective Tissue  
Epithelium  
Growth  
Locomotion  
Muscle  
Musculoskeletal System  
Skeletons  
Skin

---

**TAXONOMY AND BIODIVERSITY (SEE ALSO ANIMAL DIVERSITY AND PLANT DIVERSITY)**

Animalia  
Archaea  
Biodiversity  
Eubacteria  
Evolution of Plants  
Fungi  
Kingdom  
Lamarck, Jean-Baptiste  
Leeuwenhoek, Anton  
Linnaeus, Carolus  
Plant  
Protista  
Speciation  
Species  
Taxonomy, History of

---

**VIRUSES AND PRIONS**

AIDS  
Bacterial Viruses  
Plant Pathogens and Pests  
Prion  
Retrovirus  
Reverse Transcriptase  
Sexually Transmitted Diseases  
Viral Diseases  
Virus

**biology**





## **EDITORIAL BOARD**

### **Editor in Chief**

Richard Robinson  
rrobinson@nasw.org  
*Tucson, Arizona*

### **Advisory Editors**

Peter Bruns, *Howard Hughes Medical Institute*  
Rex Chisholm, *Northwestern University Medical School*  
Mark A. Davis, *Department of Biology, Macalester College*  
Thomas A. Frost, *Trout Lake Station, University of Wisconsin*  
Kenneth S. Saladin, *Department of Biology, Georgia College and State University*

### **Editorial Reviewer**

Ricki Lewis, *State University of New York at Albany*

### **Students from the following schools participated as consultants:**

Pocatello High School, Pocatello, Idaho  
Eric Rude, *Teacher*  
Swiftwater High School, Swiftwater, Pennsylvania  
Howard Piltz, *Teacher*  
Douglas Middle School, Box Elder, South Dakota  
Kelly Lane, *Teacher*  
Medford Area Middle School, Medford, Wisconsin  
Jeanine Staab, *Teacher*

## **EDITORIAL AND PRODUCTION STAFF**

Linda Hubbard, *Editorial Director*  
Diane Sawinski, Christine Slovey, *Senior Editors*  
Shawn Beall, Bernard Grunow, Michelle Harper, Kate Millson, Carol Nagel, *Contributing Editors*  
Kristin May, Nicole Watkins, *Editorial Interns*  
Michelle DiMercurio, *Senior Art Director*  
Rhonda Williams, *Buyer*  
Robyn V. Young, *Senior Image Editor*  
Julie Juengling, Lori Hines, *Permissions Assistants*  
Deanna Raso, *Photo Researcher*

### **Macmillan Reference USA**

Elly Dickason, *Publisher*  
Hélène G. Potter, *Editor in Chief*  
Ray Abruzzi, *Editor*

# biology

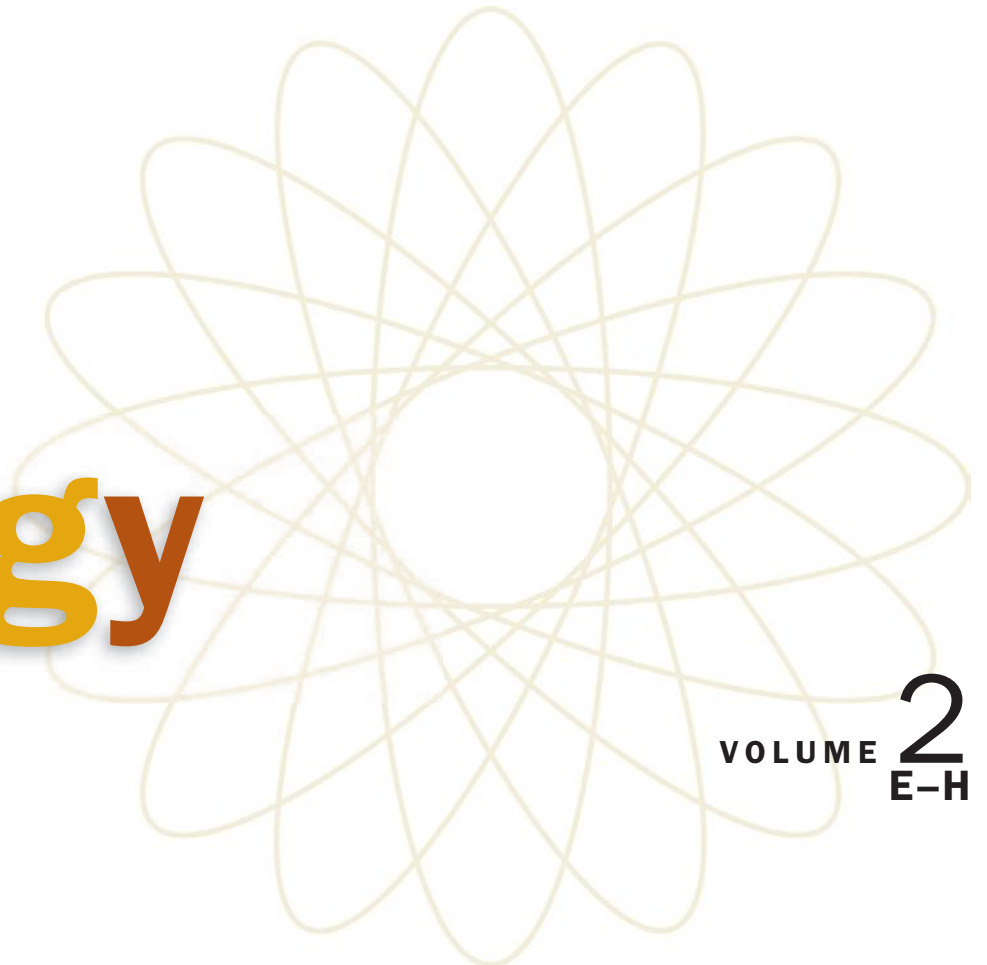

VOLUME **2**  
E-H

**Richard Robinson, Editor in Chief**

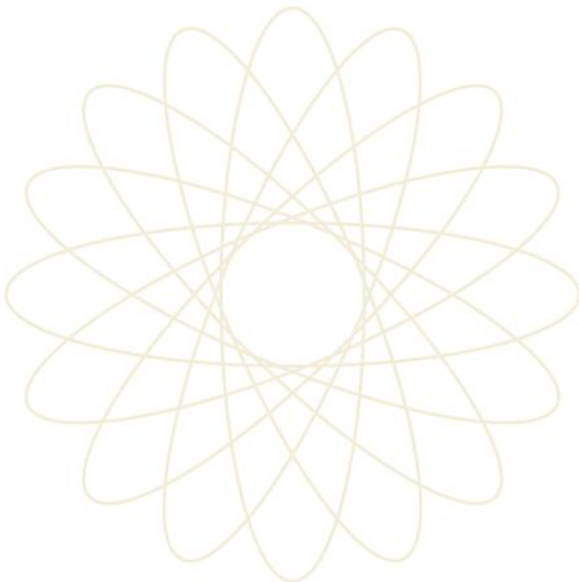

**MACMILLAN  
REFERENCE  
USA™**

**THOMSON**  
★  
**GALE™**

**Copyright © 2002 by Macmillan Reference USA**

All rights reserved. No part of this book may be reproduced or transmitted in any form or by any means, electronic or mechanical, including photocopying, recording, or by any information storage and retrieval system, without permission in writing from the Publisher.

Macmillan Reference USA	Gale Group
300 Park Avenue South	27500 Drake Rd.
New York, NY 10010	Farmington Hills, 48331-3535

Printed in the United States of America

1 2 3 4 5 6 7 8 9 10

**Library of Congress Catalog-in-Publication Data**

Biology / Richard Robinson, editor in chief.

p. cm.

Includes bibliographical references and index.

ISBN 0-02-86551-6 (set: hardcover) — ISBN 0-02-86-5552-4 (vol. 1) — ISBN 0-02-865556-7 (vol. 2) — ISBN 0-02-865554-0 (vol. 3) — ISBN 0-02-865555-9 (vol. 4)

1. Biology. I. Robinson, Richard, 1956–  
QH07.2.B556 2001

570-dc21  
2001040211

# For Your Reference

The following section provides information that is applicable to a number of articles in this reference work. Included are a metric measurement and conversion table, geologic timescale, diagrams of an animal cell and a plant cell, illustration of the structure of DNA nucleotides, detail of DNA nucleotides pairing up across the double helix, and a comparison of the molecular structure of DNA and RNA.

## METRIC MEASUREMENT

### Definitions

Kilo = 1000  
 Hecto = 100  
 Deka = 10  
 Deci = 0.10 (1/10)  
 Centi = 0.01 (1/100)  
 Milli = 0.001 (1/1000)  
 Micro = 0.000001 (1/1,000,000)  
 Nano = 0.000000001 (1/1,000,000,000)

### Conversions

To convert	Into	Multiply by
Acres	Hectares	0.4047
Centimeters	Inches	0.3937
Feet	Meters	0.3048
Gallons	Liters	3.7853
Grams	Ounces	0.0353
Grams	Pounds	0.0022
Hectares	Acres	2.4710
Inches	Centimeters	2.5400
Kilograms	Pounds	2.2046
Kilometers	Miles	0.6214
Liters	Gallons]	0.2642
Meters	Feet	3.2808
Miles	Kilometers	1.6093
Ounces	Grams	28.3495
Pounds	Kilograms	0.4536
Pounds	Grams	453.59

### Temperature Conversion

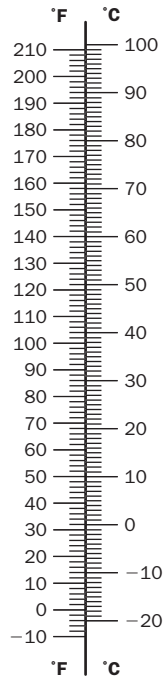

100°C = water boils  
 0°C = water freezes

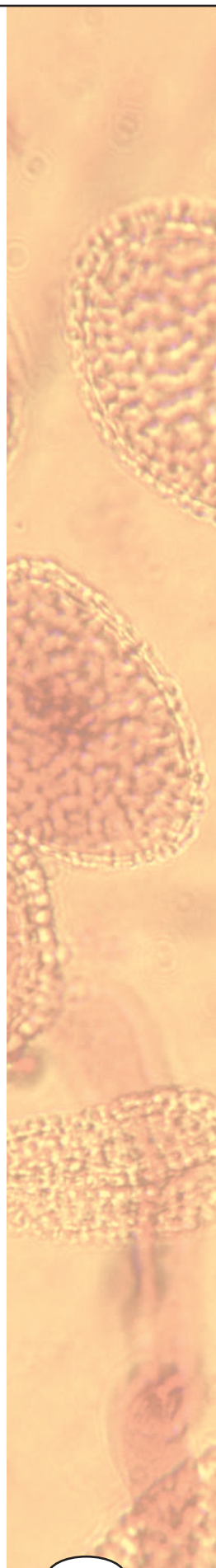

## GEOLOGIC TIMESCALE

ERA	PERIOD	EPOCH	STARTED (millions of years ago)	
<b>Cenozoic:</b> 66.4 millions of years ago–present time	<b>Quaternary</b>	Holocene	0.01	
		Pleistocene	1.6	
	<b>Tertiary</b>	<b>Neogene</b>	Pliocene	5.3
			Miocene	23.7
		<b>Paleogene</b>	Oligocene	36.6
			Eocene	57.8
			Paleocene	66.4
<b>Mesozoic:</b> 245–66.4 millions of years ago	<b>Cretaceous</b>	Late	97.5	
		Early	144	
	<b>Jurassic</b>	Late	163	
		Middle	187	
		Early	208	
	<b>Triassic</b>	Late	230	
		Middle	240	
		Early	245	
	<b>Paleozoic:</b> 570–245 millions of years ago	<b>Permian</b>	Late	258
Early			286	
<b>Carboniferous</b>		<b>Pennsylvanian</b>	Late	320
		<b>Mississippian</b>	Early	360
<b>Devonian</b>		Late	374	
		Middle	387	
		Early	408	
<b>Silurian</b>		Late	421	
		Early	438	
<b>Ordovician</b>		Late	458	
		Middle	478	
		Early	505	
<b>Cambrian</b>		Late	523	
		Middle	540	
		Early	570	
<b>Precambrian time:</b> 4500–570 millions of years ago			4500	

**A TYPICAL ANIMAL CELL**

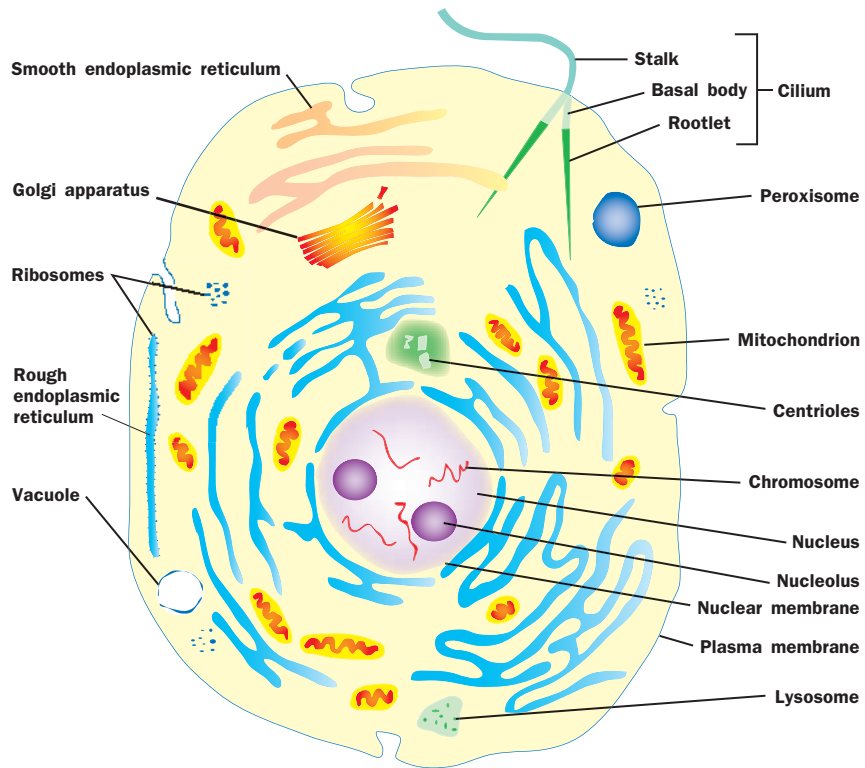

**A TYPICAL PLANT CELL**

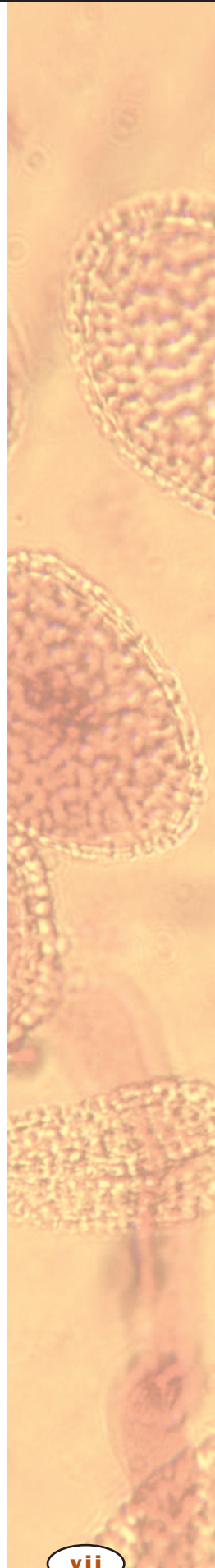
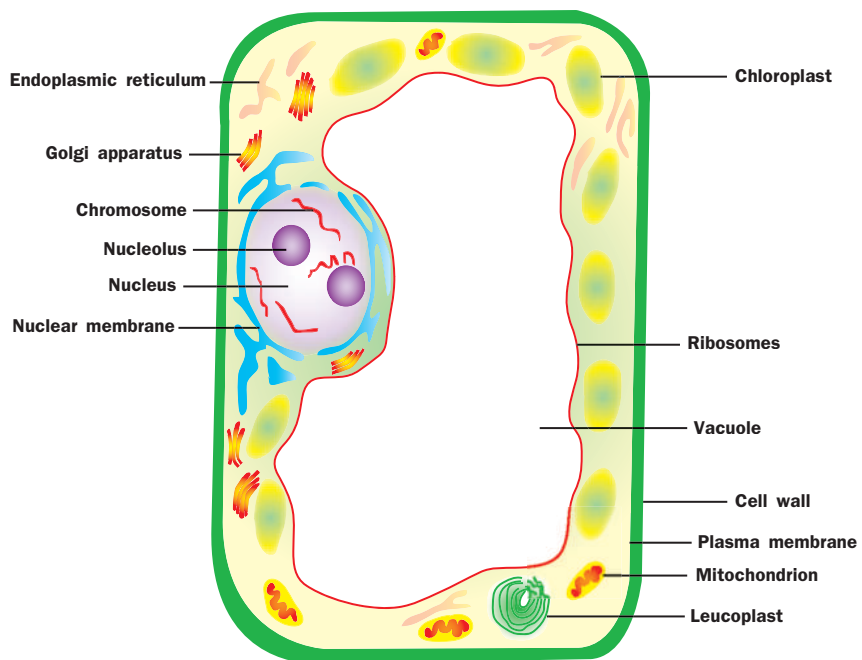

## STRUCTURE OF DNA NUCLEOTIDES

### Components of a nucleotide

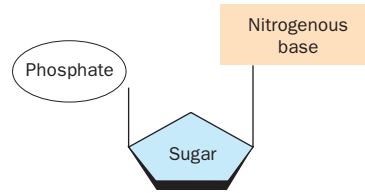

### Purine-containing nucleotides

Adenine

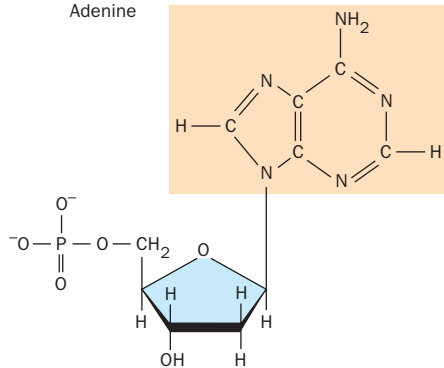

### Pyrimidine-containing nucleotides

Thymine

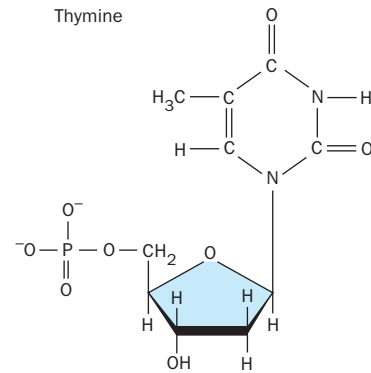

Guanine

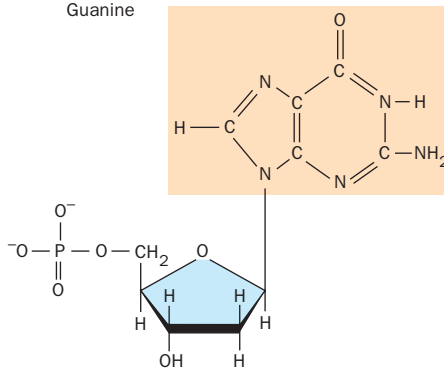

Cytosine

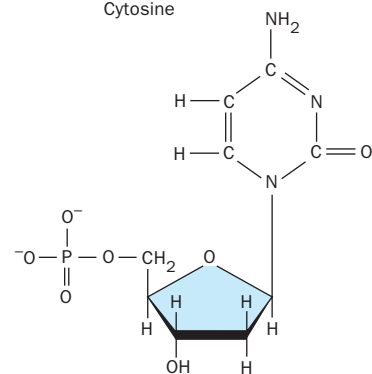

# DNA NUCLEOTIDES PAIR UP ACROSS THE DOUBLE HELIX

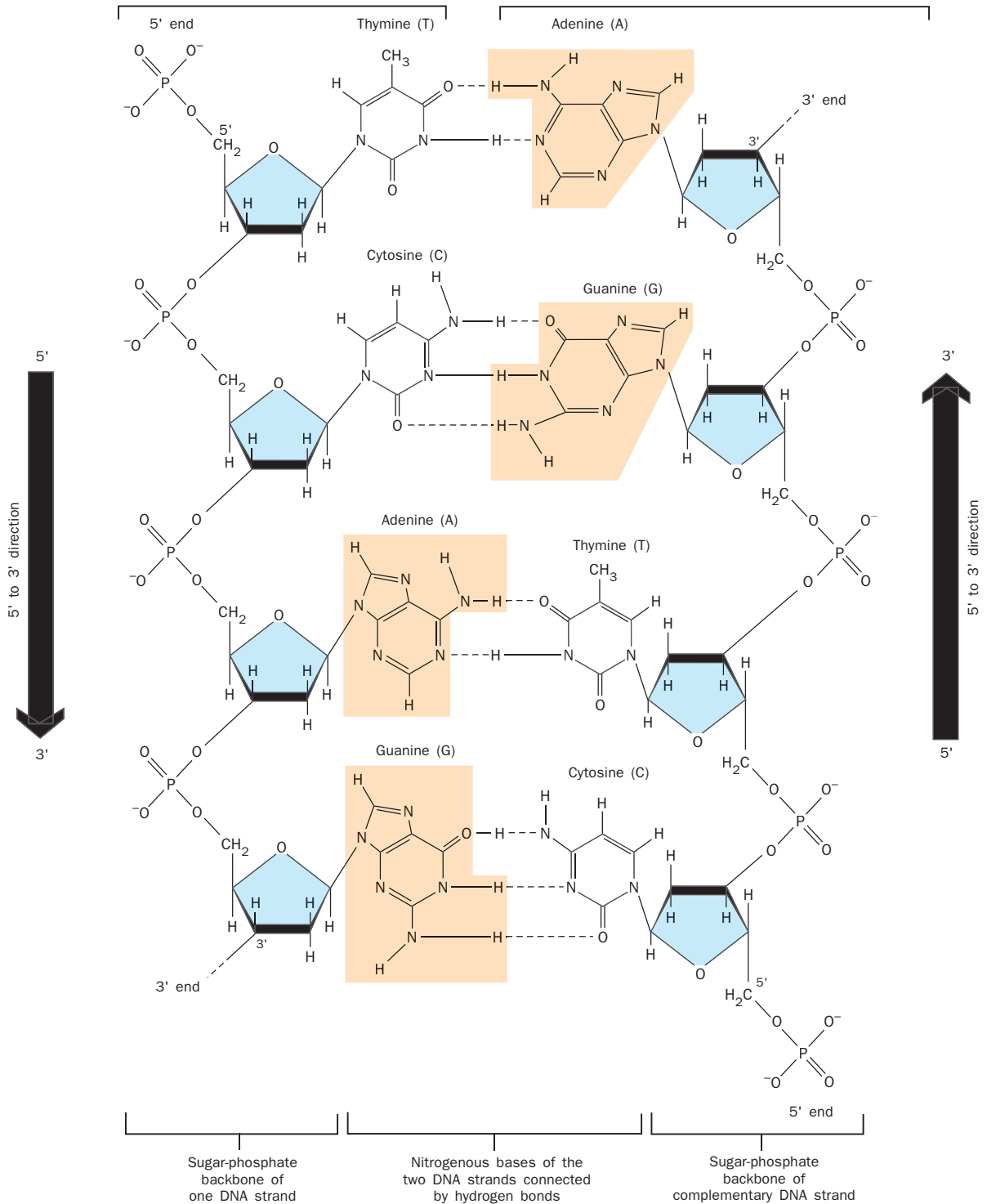



# COMPARISON OF DNA AND RNA

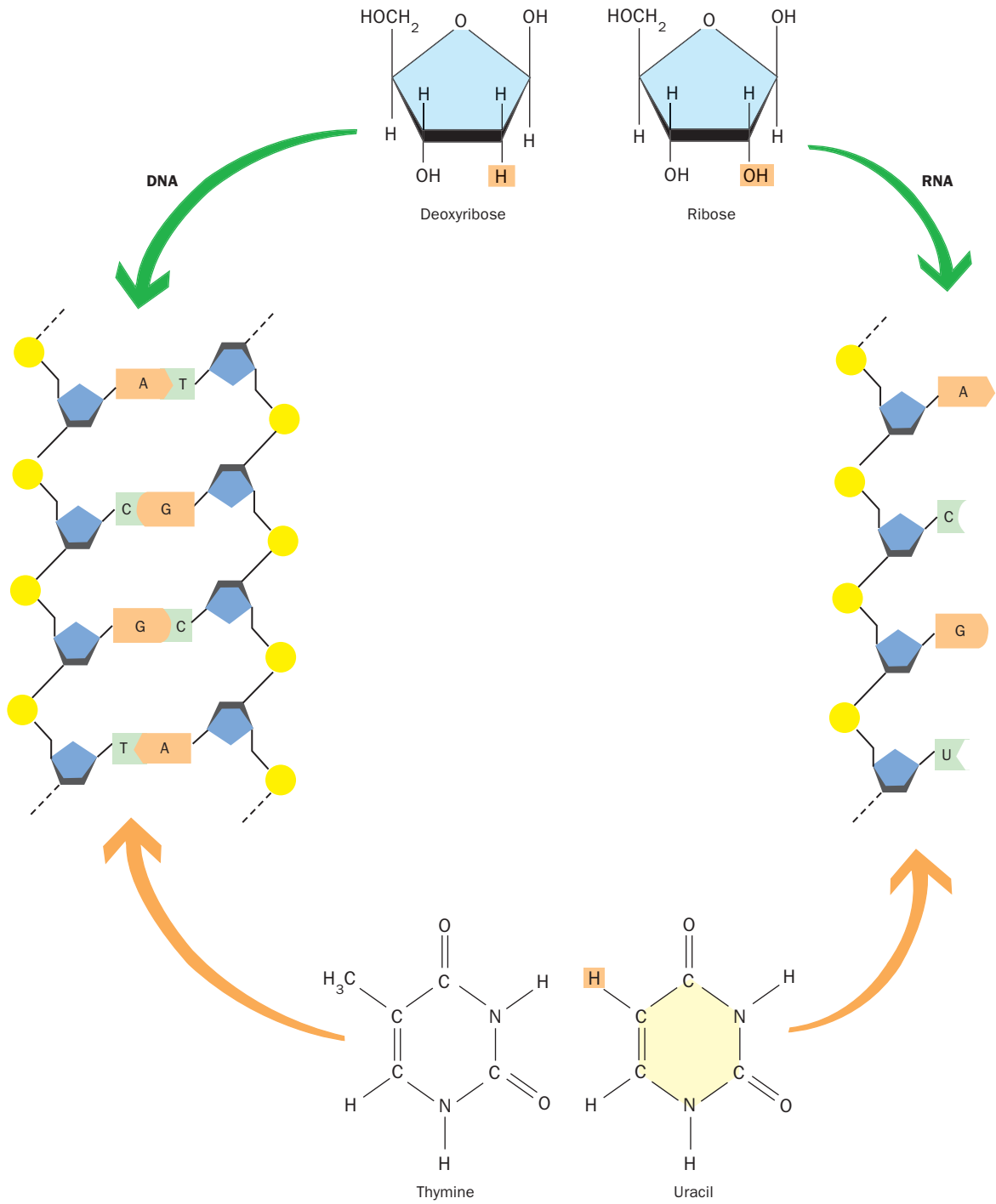

# Table of Contents

## VOLUME 1

PREFACE .....	v
FOR YOUR REFERENCE .....	vii
LIST OF CONTRIBUTORS .....	xiii

## A

Active Transport .....	1
Adaptation .....	3
Adrenal Gland .....	5
Aging, Biology of .....	7
Agriculture .....	10
Agronomist .....	13
AIDS .....	14
Alcohol and Health .....	17
Algae .....	20
Alternation of Generations .....	22
Amino Acid .....	24
Amniote Egg .....	25
Amphibian .....	26
Anabolic Steroids .....	27
Anatomy of Plants .....	29
Angiosperms .....	31
Animalia .....	34
Annelid .....	36
Antibodies in Research .....	37
Antibody .....	39
Antisense Nucleotides .....	41
Arachnid .....	42
Archaea .....	43
Arthropod .....	46
Autoimmune Disease .....	47

## B

Bacterial Cell .....	48
Bacterial Diseases .....	52
Bacterial Genetics .....	53
Bacterial Viruses .....	58
Beer-making, Biology of .....	59

Behavior, Genetic Basis of .....	60
Behavior Patterns .....	63
Biochemist .....	65
Biodiversity .....	66
Biogeochemical Cycles .....	68
Biogeography .....	70
Bioinformatics .....	71
Biological Weapons .....	74
Biology .....	76
Biology of Race .....	77
Biome .....	79
Biotechnology .....	80
Bird .....	80
Birth Control .....	82
Blood .....	84
Blood Clotting .....	86
Blood Sugar Regulation .....	87
Blood Vessels .....	89
Body Cavities .....	91
Bone .....	93
Bony Fish .....	95
Botanist .....	96
Brain .....	97
Bryophytes .....	104
Buffon, Count (Georges-Louis Leclerc) .....	106

## C

C4 and CAM Plants .....	107
Cambrian Explosion .....	108
Cancer .....	110
Carbohydrates .....	112
Carbon Cycle .....	114
Cardiovascular Diseases .....	115
Carson, Rachel .....	117
Cartilaginous Fish .....	118
Cell .....	119
Cell Culture .....	122

Cell Cycle .....	124	DNA Sequencing .....	224
Cell Division .....	127	DNA Viruses .....	227
Cell Evolution .....	127	Doctor, Family Practice .....	228
Cell Junctions .....	129	Doctor, Specialist .....	229
Cell Motility .....	130	Drug Testing .....	232
Cell Wall .....	132	Dubos, René .....	233
Central Nervous System .....	134	PHOTO AND ILLUSTRATION	
Chemoreception .....	135	CREDITS .....	235
Chloroplast .....	137	GLOSSARY .....	243
Chordata .....	138	TOPIC OUTLINE .....	263
Chromosome Aberrations .....	139	INDEX .....	273
Chromosome, Eukaryotic .....	143		
Circulatory Systems .....	149	<b>VOLUME 2</b>	
Clinical Trials .....	151	FOR YOUR REFERENCE .....	v
Clone .....	152	<b>E</b>	
Cnidarian .....	155	Echinoderm .....	1
Coffee, Botany of .....	155	Ecological Research, Long-Term .....	3
College Professor .....	156	Ecology .....	4
Community .....	157	Ecology, History of .....	5
Competition .....	159	Ecosystem .....	7
Conifers .....	162	Electron Microscopy .....	10
Connective Tissue .....	164	Electrophoresis .....	13
Conservation .....	165	Emergency Medical Technician .....	15
Control of Gene Expression .....	170	Endangered Species .....	16
Control Mechanisms .....	177	Endocrine System .....	18
Convergent Evolution .....	181	Endocytosis .....	22
Coral Reef .....	183	Endoplasmic Reticulum .....	25
Creationism .....	185	Entomologist .....	27
Crick, Francis .....	187	Environmental Health .....	28
Crocodylians .....	188	Enzymes .....	29
Crustacean .....	189	Epidemiologist .....	36
Cyanobacteria .....	190	Epithelium .....	37
Cytokinesis .....	191	Estuaries .....	38
Cytoskeleton .....	193	Ethnobotany .....	40
<b>D</b>		Eubacteria .....	41
Darwin, Charles .....	197	Eudicots .....	43
De Saussure, Nicolas-Théodore .....	199	Evolution .....	44
Dentist .....	200	Evolution, Evidence for .....	52
Desert .....	201	Evolution of Plants .....	55
Desertification .....	204	Excretory Systems .....	60
Development .....	205	Exocytosis .....	62
Differentiation in Plants .....	212	Extinction .....	64
Digestion .....	217	Extracellular Matrix .....	68
Digestive System .....	219	Extreme Communities .....	69
Disease .....	221	Eye .....	72
DNA .....	222		

<b>F</b>			
Feeding Strategies	74	Herbivory and Plant Defenses	178
Female Reproductive System	77	High School Biology Teacher	180
Fetal Development, Human	81	History of Agriculture	180
Field Studies in Animal Behavior	85	History of Biology: Biochemistry	182
Field Studies in Plant Ecology	87	History of Biology: Cell Theory and Cell Structure	186
Fire Ecology	89	History of Biology: Inheritance	189
Flight	91	History of Evolutionary Thought	192
Flowers	93	History of Medicine	196
Forensic DNA Analysis	94	History of Plant Physiology	198
Forest, Boreal	97	Homeostasis	201
Forest, Temperate	99	Hormones	203
Forest, Tropical	101	Hormones, Plant	206
Forester	105	Horticulturist	208
Fruits	105	Human Evolution	208
Fungal Diseases	108	Human Genome Project	212
Fungi	109	Human Nutrition	217
		Human Population	219
<b>G</b>		Hybridization	220
Gas Exchange	114	Hybridization, Plant	221
Gene	117	Hypothalamus	222
Gene Therapy	124		
Genetic Analysis	125	PHOTO AND ILLUSTRATION	
Genetic Code	129	CREDITS	227
Genetic Control of Development	131	GLOSSARY	235
Genetic Counselor	135	TOPIC OUTLINE	255
Genetic Diseases	136	INDEX	265
Genome	140		
Genomics	141	<b>VOLUME 3</b>	
Global Climate Change	145		
Glycolysis and Fermentation	148	FOR YOUR REFERENCE	v
Golgi	150		
Grain	153	<b>I</b>	
Grasses	155	Imaging in Medicine	1
Grassland	156	Immune Response	4
Gray, Asa	158	Ingenhousz, Jan	7
Growth	158	Insect	7
Gymnosperms	161	Invasive Species	10
		Ion Channels	12
<b>H</b>			
Habitat	163	<b>K</b>	
Hardy-Weinberg Equilibrium	164	Kidney	15
Harvey, William	166	Kingdom	17
Health	167	Krebs Cycle	18
Health and Safety Officer	169		
Hearing	169	<b>L</b>	
Heart and Circulation	172	Laboratory Technician	20
Herbal Medicine	176	Lakes and Ponds	21

Lamarck, Jean-Baptiste	23	Mollusk	105
Landscape Ecology	24	Monocots	106
Leakey Family	26	Monotreme	108
Learning	26	Muscle	108
Leaves	28	Musculoskeletal System	112
Leeuwenhoek, Antony von	30	Mutation	115
Lichen	31	Mycorrhizae	119
Life Cycle, Human	32		
Life Cycles	34	<b>N</b>	
Life, What Is	37	Natural Selection	121
Light Microscopy	38	Nematode	124
Limnologist	42	Nervous Systems	125
Linkage and Gene Mapping	42	Neurologic Diseases	129
Linnaeus, Carolus	47	Neuron	131
Lipids	48	Nitrogen Cycle	135
Liver	50	Nitrogen Fixation	136
Locomotion	50	Nonspecific Defense	138
Lymphatic System	52	Nuclear Transport	140
Lysosomes	54	Nucleolus	142
		Nucleotides	144
<b>M</b>		Nucleus	145
Male Reproductive System	56	Nurse	148
Mammal	59	Nurse Practitioners	148
Marine Biologist	60	Nutritionist	149
Marsupial	62		
Mating Systems	62	<b>O</b>	
McClintock, Barbara	64	Ocean Ecosystems: Hard Bottoms	150
Medical Assistant	65	Ocean Ecosystems: Open Ocean	151
Medical/Science Illustrator	65	Ocean Ecosystems: Soft Bottoms	153
Meiosis	66	Oncogenes and Cancer Cells	154
Membrane Proteins	70	Organ	158
Membrane Structure	73	Organelle	159
Membrane Transport	76	Organic Agriculture	159
Mendel, Gregor	80	Origin of Life	161
Meristems	81	Osmoregulation	165
Metabolism, Cellular	84	Oxidative Phosphorylation	168
Metabolism, Human	87		
Microbiologist	90	<b>P</b>	
Microscopist	91	Pain	170
Migration	92	Paleontology	171
Mimicry, Camouflage, and Warning		Pancreas	173
Coloration	93	Parasitic Diseases	174
Mitochondrion	94	Pasteur, Louis	176
Mitosis	98	Patterns of Inheritance	177
Model Organisms: Cell Biology and		Pauling, Linus	184
Genetics	101	Pedigrees and Modes of Inheritance	186
Model Organisms: Physiology and		Peripheral Nervous System	189
Medicine	102	Peroxisomes	191

Pharmaceutical Sales Representative . . .	192	Protozoan Diseases . . . . .	26
Pharmacologist . . . . .	192	Psychiatric Disorders, Biology of . . . . .	27
Pheromone . . . . .	193	Psychiatrist . . . . .	30
Photoperiodism . . . . .	195	Psychoactive Drugs . . . . .	31
Photosynthesis . . . . .	196	Pteridophytes . . . . .	33
Physical Therapist and Occupational Therapist . . . . .	200	Public Health Careers . . . . .	35
Physician Assistant . . . . .	201	<b>R</b>	
Physiological Ecology . . . . .	202	Radiation Hybrid Mapping . . . . .	36
Pituitary Gland . . . . .	205	Radionuclides . . . . .	38
Plankton . . . . .	205	Recombinant DNA . . . . .	38
Plant . . . . .	207	Remote Sensing . . . . .	46
Plant Development . . . . .	208	Replication . . . . .	47
Plant Nutrition . . . . .	214	Reproduction in Plants . . . . .	52
Plant Pathogens and Pests . . . . .	216	Reproductive Technology . . . . .	60
Plant Pathologist . . . . .	219	Reptile . . . . .	62
Plasma Membrane . . . . .	220	Respiration . . . . .	63
Platyhelminthes . . . . .	222	Retrovirus . . . . .	66
Poisonous Plants . . . . .	223	Reverse Transcriptase . . . . .	68
Poisons . . . . .	224	Rhythms of Plant Life . . . . .	69
Pollination and Fertilization . . . . .	227	Ribosome . . . . .	71
Pollution and Bioremediation . . . . .	228	Rivers and Streams . . . . .	73
Polymerase Chain Reaction . . . . .	232	RNA . . . . .	75
Population Dynamics . . . . .	233	RNA Processing . . . . .	77
Population Genetics . . . . .	235	Roots . . . . .	78
Porifera . . . . .	239	<b>S</b>	
Porter, Keith . . . . .	240	Scaling . . . . .	81
<b>PHOTO AND ILLUSTRATION</b>		Science Writer . . . . .	83
CREDITS . . . . .	243	Secondary Metabolites in Plants . . . . .	84
<b>GLOSSARY</b> . . . . .	251	Seed Germination and Dormancy . . . . .	86
<b>TOPIC OUTLINE</b> . . . . .	271	Seedless Vascular Plants . . . . .	88
<b>INDEX</b> . . . . .	281	Seeds . . . . .	89
		Senescence . . . . .	91
<b>VOLUME 4</b>		Separation and Purification of Biomolecules . . . . .	93
<b>FOR YOUR REFERENCE</b> . . . . .	v	Sex Chromosomes . . . . .	94
<b>P</b>		Sex Determination . . . . .	96
Predation and Defense . . . . .	1	Sexual Reproduction . . . . .	98
Primate . . . . .	4	Sexual Reproduction, Evolution of . . . . .	101
Prion . . . . .	5	Sexual Selection . . . . .	104
Propagation . . . . .	6	Sexually Transmitted Diseases . . . . .	106
Protein Structure . . . . .	7	Shoots . . . . .	110
Protein Synthesis . . . . .	13	Signaling and Signal Transduction . . . . .	112
Protein Targeting . . . . .	19	Skeletons . . . . .	118
Protista . . . . .	21	Skin . . . . .	120
Protozoa . . . . .	23	Sleep . . . . .	121
		Slime Molds . . . . .	124

Smoking and Health ..... 126  
 Social Behavior ..... 127  
 Sociobiology ..... 131  
 Soil ..... 132  
 Speciation ..... 134  
 Species ..... 136  
 Spinal Cord ..... 137  
 Stress Response ..... 139  
 Structure Determination ..... 141  
 Symbiosis ..... 142  
 Synaptic Transmission ..... 145

**T**

T Cells ..... 148  
 Taxonomy, History of ..... 151  
 Temperature Regulation ..... 154  
 Theoretical Ecology ..... 157  
 Thyroid Gland ..... 158  
 Tissue ..... 159  
 Torrey, John ..... 160  
 Touch ..... 161  
 Transcription ..... 162  
 Transfer RNA ..... 166  
 Transgenic Techniques ..... 167  
 Translocation ..... 168  
 Transplant Medicine ..... 172  
 Transposon ..... 174  
 Tropisms and Nastic Movements ..... 175  
 Tuatara ..... 176  
 Tundra ..... 177  
 Tunicate ..... 178  
 Turtle ..... 179

**V**

Vaccines ..... 180  
 Vacuole ..... 182  
 van Helmont, Jan ..... 183  
 Vavilov, Nikolay ..... 183  
 Vesalius, Andreas ..... 184  
 Veterinarian ..... 185  
 Viral Diseases ..... 186  
 Virus ..... 187  
 Vision ..... 188  
 Vitamins and Coenzymes ..... 190  
 von Humboldt, Alexander ..... 192

**W**

Water ..... 192  
 Water Cycle ..... 193  
 Water Movement in Plants ..... 193  
 Watson, James ..... 196  
 Wetlands ..... 197  
 Wildlife Biologist ..... 199  
 Wine-making, Botany of ..... 200  
 Wood and Wood Products ..... 201

**Z**

Zoology ..... 204  
 Zoology Researcher ..... 204

PHOTO AND ILLUSTRATION

CREDITS ..... 207  
 GLOSSARY ..... 215  
 TOPIC OUTLINE ..... 235  
 CUMULATIVE INDEX ..... 245

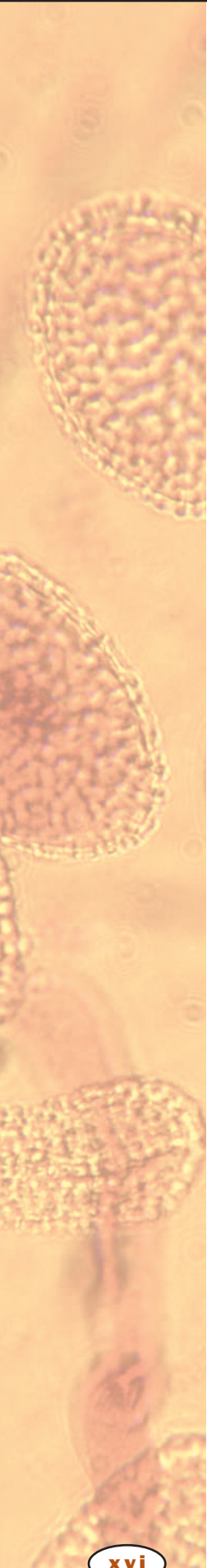

**biology**





## Echinoderm

The echinoderms (*echino* means “spiny;” *derm* means “skin”) are large, conspicuous, entirely marine invertebrates. Today, this group inhabits virtually every conceivable oceanic environment, from sandy beaches and coral reefs to the greatest depths of the sea. They are also common as fossils dating back 500 million years. These less-familiar fossil types are represented by a bizarre variety of animals, some of which reveal their relationship to the living echinoderms only at close inspection.

### Diversity

The species living today are generally regarded as belonging to five subgroups: sea lilies and feather stars (Crinoidea, 650 species); starfish (Asteroidea, 1,500 species), brittlestars and basket stars (Ophiuroidea, 1,800 species), sea cucumbers (Holothuroidea, 1,200 species); and sea urchins and sand dollars (Echinoidea, 1,200 species).

Sea lilies have a central body, or calyx, surrounded by feathery, usually heavily branched arms. This whole arrangement sits at the end of a stem-like stalk attached to the sea bottom. The feather stars lack this stalk. Starfish (also called sea stars) have a central disk that is not marked off from the unbranched arms, of which there are usually five. Occasionally, one will encounter starfish species with more than five arms. Brittlestars also typically have five relatively long, flexible arms, but these are well differentiated from the central disk.

Sea cucumbers are soft-bodied and wormlike, with a cluster of tentacles around the mouth at one end. Sea urchins usually have a rigid body of joined plates upon which is mounted a dense forest of spines. The sea urchin body can be almost spherical, with long spines, or flattened to varying degrees with very short spines in types such as the sand dollars.

### Anatomy and Physiology

In general, echinoderms are characterized by several unique features not found in any other animal **phylum**. They have a limestone (calcium carbonate) skeletal meshwork called “stereom” in their tissues, especially the body wall. The porous structure of stereom makes the skeleton light yet resistant to breakage. Echinoderms possess a special kind of ligament that can be stiffened or

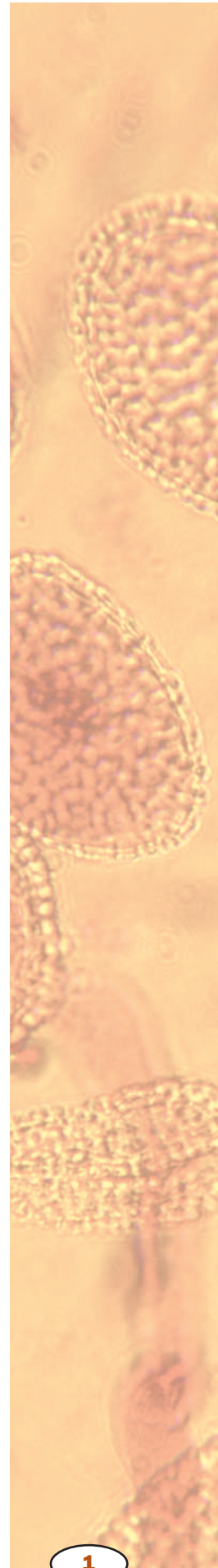

**phylum** taxonomic level below kingdom, e.g., arthropod or chordate

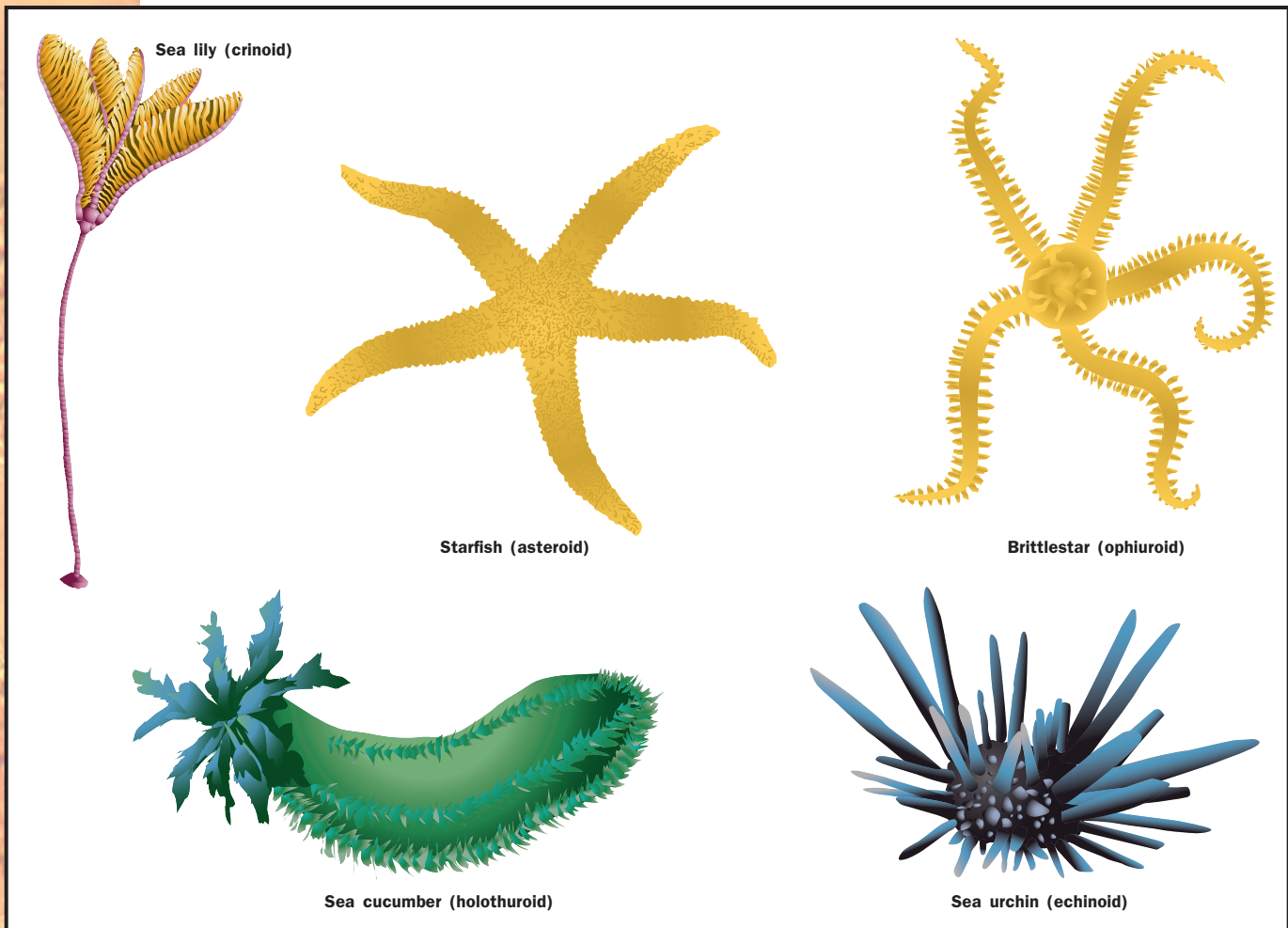

Echinoderms are marine invertebrates that inhabit every conceivable ocean environment. They are divided into five subgroups: Crinoidea, Asteroidea, Ophiuroidea, Holothuroidea, and Echinoidea.

**bilaterally symmetric**  
symmetric, or similar,  
across a central line

loosened at will so that these animals can maintain a posture without expending energy by muscular contraction. Echinoderms have an internal set of plumbing tubes, the “water vascular system” that manipulate flexible external tube feet. Tube feet are the “hands” and “feet” of echinoderms, and are involved in sensory, locomotory, feeding, and respiratory activities.

Males and females are separate, and fertilized eggs develop into a typically free-swimming larva that changes (or “metamorphoses”) from a **bilaterally symmetric** form to an adult possessing a body structure with the five radiating rays that makes adult echinoderms so distinctive. Even the worm-like sea cucumbers and sea lilies show this five-part structure because the feeding tentacles and arms are usually present in multiples of five.

Echinoderms are relatives, although distant ones, of the vertebrates. Like vertebrates, and unlike other animal phyla, echinoderms are “denterostomes,” meaning the mouth pore forms after the anal pore during early development. This makes them ideal subjects for studies that shed light on human development and evolution. In addition, the ecological importance of echinoderms, combined with their sensitivity to environmental degradation, gives them a key role to play in environmental research. SEE ALSO ANIMALIA; CORAL REEF; DEVELOPMENT

*Richard Mooi*

### Bibliography

- Hyman, Libbie Henrietta. *The Invertebrates, Vol. 4: Echinodermata*. New York, McGraw-Hill, 1955.
- Lawrence John M. *A Functional Biology of Echinoderms*. Baltimore, MD: Johns Hopkins, 1987.
- Mooi, R., and B. David. "Skeletal Homologies of Echinoderms." *Paleontological Society Papers* 3: 305–335.
- Nichols, David. *Echinoderms*. London: Hutchinson, 1962.

## Ecological Research, Long-Term

Many ecological studies last just one or a few years. There are many reasons for this. Sometimes people are doing the study as part of their research in graduate school and they want a project they can finish in a few years. Much ecological research is funded by various federal and state agencies, and these grants are normally for only one to three years. The problem with this approach is many important ecological processes occur over longer time frames than this. For example, droughts and fires play a very important role in determining what trees can grow in certain environments, such as **savannas**. If one studied a savanna for three years, and no drought or fire occurred during this time, one would never discover the importance of fire and drought in that habitat. Some animals such as snow shoe hares and ruffed grouse experience dramatic fluctuations in the size of their populations. If one conducted a study of just a few years on these species, one would never learn the fascinating fact that these populations experience regular population cycles approximately ten years in length.

Thus, although much important ecological information can be learned from short-term studies, long-term studies are essential to understanding many processes that occur over a longer period of time. Fortunately, organizations like the National Science Foundation (NSF), a federal agency that funds much ecological research, have recognized the need to support some long-term ecological studies. In 1980, the NSF instituted a special funding program called the Long Term Ecological Research (LTER) program. Instead of funding projects for just one to three years, this program funds research for at least five years and usually for much longer. Some projects have been funded for as long as twenty years, and funding is expected to continue for these projects into the future. More than twenty LTER research sites are located throughout North America in almost all the major habitats, including prairies, forests, deserts, mountains, tundra, freshwater lakes, and ocean coastal environments. This funding has enabled scientists to study such important issues as the long-term effects of acid rain on forests and aquatic organisms, the long-term effects of pollution on native prairie plants, and the possible impacts of rising atmospheric carbon dioxide levels on forest growth.

Ecologists are particularly interested in the possible ecological effects of global warming. Since this is a process that occurs over decades, and even centuries, very long studies are needed. Some of these studies are now underway and are expected to continue for decades. In other cases, ecologists have made use of data collected in the past to answer certain questions involving global warming. For example, century-old scientific notes and



**savanna** open grassland with sparse trees

**ice-out** a thawing of ice covering a lake or other body of water

journals containing the spring arrival dates of migrating birds and blooming dates of wildflowers have shown that spring is occurring about ten days earlier in Europe and North America than it was 150 years ago. Some churches in Europe have recorded the dates of **ice-out** in nearby lakes for several hundred years. These continuous monitoring efforts represent some of the longest ecological data sets in existence. **SEE ALSO** COMMUNITY; ECOLOGY; ECOSYSTEM; FIRE ECOLOGY; GLOBAL CLIMATE CHANGE; LANDSCAPE ECOLOGY

Mark A. Davis

### Bibliography

Bowman, W. D., and T. R. Seastedt. *Structure and Function of an Alpine Ecosystem*. Oxford: Oxford University Press, 2001.

Knapp, A. K., J. M. Briggs, D. C. Hartnett, and S. L. Collins. *Grassland Dynamics: Long-Term Ecological Research in Tallgrass Prairie*. Oxford: Oxford University Press, 1998.

## Ecology

Ecology is the study of how plants, animals, and other organisms interact with each other and with their environment, or “home.” The word “ecology” comes from the Greek word *oikos*, which means “home.” Ecology is also the study of the abundance and distribution of organisms. An ecologist, for example, might try to find out why a species of frog that used to be common is now rare, or why fir trees are rare in a dry pine forest but common in a moister habitat.

Ecologists study living organisms in different ways. One might study a population, a group of individuals that can interbreed with each other; a community, the many species that inhabit an area; or an ecosystem, a community of organisms along with the nonliving parts of their environment. The nonliving parts, which ecologists refer to as “abiotic” components, include air, water, soil, and weather.

Population ecologists study what makes populations go extinct, what regulates populations at intermediate densities, and what makes populations increase in size. A major cause of extinction is loss of habitat or the break up of habitat into patches. Community ecologists study the relationships among different species; for instance, how groups of predators and prey affect one another.

The study of ecosystems means examining how all the parts fit together. An example of this is carbon in the atmosphere, which is taken up by plants during photosynthesis. Animals eat the plants, or eat the animals that ate the plants, and then exhale the carbon as carbon dioxide. The carbon cycles through networks of organisms, the atmosphere, and the Earth itself. Another example are shellfish, which make their shells from carbon. These shells drop to the bottom of the ocean to form thick sediments. Millions of years later, geological processes lift them up as mountains. The study of ecosystems is truly the study of life on the Earth. **SEE ALSO** COMMUNITY; ECOLOGY, HISTORY OF; ECOLOGICAL RESEARCH, LONG-TERM; ECOSYSTEM; PLANKTON; POPULATION DYNAMICS; THEORETICAL ECOLOGY

Jennie Dusbeck

Founded in 1915, the Ecological Society of America is a non-profit organization of scientists that aims to promote ecological science, increase the resources available for the conduct of ecological science, and ensure the proper use of ecological science in environmental decision-making by improving communication between the ecological community and policy-makers.

### Bibliography

*Ecological Society of America*. <<http://esa.sdsc.edu/>>.

Molles, Manuel C. *Ecology, Concepts and Applications*. 3rd ed. Boston: McGraw-Hill, 1999.

## Ecology, History of

Ecology descended from a tradition of natural history beginning in antiquity. What has been called **protoecology** is seen in the writings of Carolus Linnaeus, a Swedish botanist, who, in the eighteenth century, wrote of interactions of plants and animals, which he called *The Economy of Nature*. In the early nineteenth century a German biogeographer, Alexander von Humboldt, stimulated the study of the distribution of vegetation as communities of plants and their environment that was pursued into the twentieth century by such European botanists as Oscar Drude and Eugene Warming. Edward Forbes, a British marine biologist, studied seashore communities early in the nineteenth century and was among the first to use quantitative methods for measuring water depth and counting individual organisms.

**protoecology** early ecology

### Early Roots

The name *ecology*, however, was coined in 1866 by German biologist Ernst Haeckel, a prominent proponent of Darwinism. In 1870 Haeckel wrote, "Ecology is the study of all those complex interactions referred to by Darwin as the conditions of the struggle for existence." (Darwin himself figures prominently in protoecology.) Ecology emerged as a recognized science in the 1890s and early 1900s as a mix of oceanography, its freshwater counterpart limnology, and plant and animal ecology. It departed from the late-nineteenth-century emphasis on laboratory studies of physiology and genetics to return to the field emphasis of traditional natural history. Premier British animal ecologist Charles Elton defined ecology as scientific natural history.

In the United States, ecology flourished particularly in the Midwest. S. A. Forbes of the Illinois Laboratory of Natural History initiated studies of lakes and streams in the 1880s. In the 1890s Edward A. Birge pioneered lake studies at the University of Wisconsin. Frederic Clements initiated vegetation studies at the University of Nebraska and formulated ideas of ecological communities in the 1890s that dominated American ecology for fifty years. In the same decade Henry C. Cowles, from the University of Chicago, studied the vegetation of the dunes of Lake Michigan.

Clements and Cowles, among the first to earn advanced degrees in ecology, examined the changes of plant species populations, communities, and environments over time, a process they called **succession**, adapting the term from poet-naturalist Henry D. Thoreau. Clements's concept of succession, which dominated ecology until the 1950s, was of communities developing progressively to a relatively stable state, or climax, that he said had properties of a superorganism. Ecology became institutionalized in British and American ecological societies in 1913 and 1915, respectively.

**succession** series of changes seen in some plant communities over time, in which low-growing, rapidly reproducing species are replaced by taller and more slowly reproducing ones



Ernst Haeckel, the German biologist who coined the term "ecology."

## Integration and Quantification

Charles Elton wrote the first book on animal ecology in 1927 and provided organizing ideas that served to integrate population and community ecology and remain as key concepts. These were:

1. Food chain or cycle (later called food web or trophic structure): the sequence by which nutrients and energy passed from plants to herbivores to predators then to various forms of decomposers and back to the inorganic environment.
2. Niche: Each species had adaptations that fitted it to a particular status in a community.
3. Pyramid of numbers: More small animals are required to support fewer large organisms in a food chain because some nutrients and energy are lost from the food chain.

The 1920s and 1930s also produced early developments in quantitative ecology and mathematical theory. Ecological studies increasingly used quantitative samples of populations and communities to assess the numbers and kinds of organisms in a habitat and to measure the physical environment. Theoretical, mathematical, population ecology was an attempt, particularly by a physicist, Alfred Lotka, and a mathematical biologist, Vito Volterra, to extend principles of physical chemistry into ecology in the form of a differential equation, the logistic, that describes the growth of a population over time.

Ecological theory flourished in the 1950s in the work of George Evelyn Hutchinson and Robert MacArthur, who formulated a niche theory of animal communities predicated on competition among species. Also in the 1950s, the long-ignored, individualistic concept of community of Henry A. Gleason, which held that organisms responded individually to the physical environment and other organisms, was resurrected and became widely accepted as alternative to the superorganism theory of Clements. Ecologists became increasingly aware of the significance of historical and chance events for developing ecological theory.

## Ecosystems and Human Influences

British ecologist Sir Arthur Tansley recognized that it was not possible to consider organisms apart from their physical environment, as ecologists conventionally did, and in 1935 coined the term "ecosystem." Ecosystems are integrated systems of living organisms (biotic) and inorganic (abiotic) conditions. The ecosystem concept was integrated with the trophic concept and succession in 1942 by a young American limnologist, Raymond Lindeman. Ecosystem ecology focused on the movements of matter and energy through the food web. Partly through the influence of American ecologist Eugene Odum, ecosystem ecology became one of the principal forces in ecology in the 1960s and 1970s and the basis of a new theoretical ecology termed "systems ecology."

As ecology developed as a science it became evident that its concepts of population, community, environment, and ecosystem must incorporate human beings and their effects on Earth. This, too, had antecedents in nineteenth-century natural history. In 1864 George Perkins Marsh argued that

human actions have profound, reciprocal, and commonly destructive effects on the earth on which humanity depends. Early ecologists were acutely aware of the implications of ecology for human environments and worked on agricultural, fisheries, wildlife, disease, and conservation problems. This insight became widely evident to the American public and politicians with the recognition in the 1970s of the environmental crisis. In 1962 marine biologist Rachel Carson provided an early warning of the threat of herbicides and pesticides to the environment, a warning for which she was castigated by the chemical industry that produced them and the agricultural industry that used them injudiciously.

Aldo Leopold, an American forester turned animal ecologist, published the *Sand County Almanac* in 1949 as a plea for an ecological view of the earth and of humanity. Leopold wrote: "That land is a community is the basic concept of ecology, but that land is to be loved and respected is an extension of ethics." Leopold's ideas influenced conservationists and philosophers, especially ethicists, and extended ecological ideas to a concerned public. SEE ALSO BIOGEOCHEMICAL CYCLES; BIOGEOGRAPHY; CARSON, RACHEL; COMMUNITY; ECOLOGY; ECOSYSTEM; LINNAEUS, CAROLUS; THEORETICAL ECOLOGY; VON HUMBOLDT, ALEXANDER

Robert P. McIntosh

### Bibliography

- Carson, Rachel. *Silent Spring*. Boston: Houghton Mifflin, 1962.
- Kingland, Sharon E. *Modeling Nature: Episodes in the History of Population Ecology*. Chicago: The University of Chicago Press, 1985.
- Leopold, Aldo. *Sand County Almanac*. Oxford: Oxford University Press, 1949.
- McIntosh, Robert P. *The Background of Ecology: Concept and Theory*. Cambridge: Cambridge University Press, 1985.
- Worster, Donald. *The Wealth of Nature: Environmental History and the Ecological Imagination*. Oxford: Oxford University Press, 1993.

## Ecosystem

An ecosystem is all the living organisms in an area along with the nonliving, or abiotic, parts of their environment. The abiotic parts of an ecosystem include physical substances such as soil, air, and water; forces such as gravity and wind; and conditions such as temperature, light intensity, humidity, or salinity.

### Components and Boundaries

Physical substances can include **organic** materials that were once alive, such as bits of wood from trees, rotting plant material, and animal wastes and dead organisms. The physical substance of an ecosystem also includes **inorganic** materials such as **minerals**, nitrogen, and water, as well as the overall landscape of mountains, plains, lakes, and rivers.

The organisms and the physical environment of an ecosystem interact with one another. The atmosphere, water, and soil allow life to flourish and limit what kind of life can survive. For example, a freshwater lake provides a home for certain fish and aquatic plants. Yet, the same lake would kill plants and animals adapted to a saltwater estuary.

**organic** composed of carbon, or derived from living organisms

**inorganic** not bonded to carbon

**minerals** iron, calcium, sodium, and other elements needed by living organisms

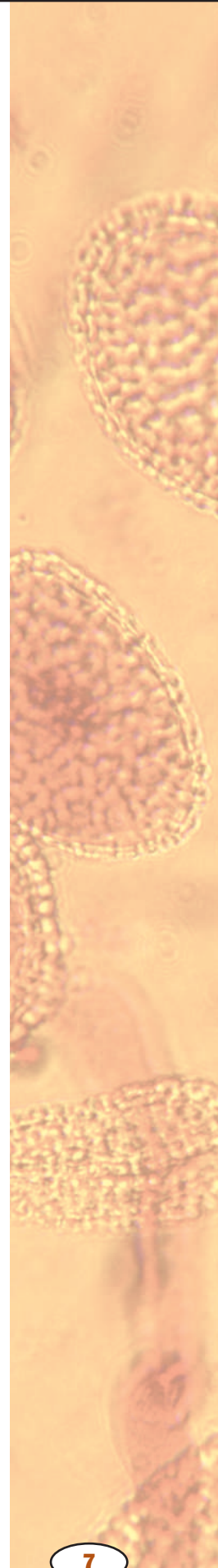

Just as the environment affects organisms, organisms affect their environment. Lichens break down rock. Trees block sunlight, change the acidity and moisture content of soil, and release oxygen into the atmosphere. Elephants may uproot whole trees in order to eat their leaves, beavers dam streams and create meadows, and rabbits nibble grasses right down to the ground.

Ecosystems are not closed; in fact, an ecosystem's boundaries are usually fuzzy. A pond, for example, blends little by little into marsh, and then into a mixture of open meadow and brush. A stream brings nutrients and organisms from a nearby forest and carries away materials to other ecosystems. Even large ecosystems interact with other ecosystems. Seeds blow from place to place, animals migrate, and flowing water and air carry organisms—and their products and remains—from ecosystem to ecosystem.

All ecosystems taken together make up the biosphere, all living organisms on the earth and their physical environment. The biosphere differs from other ecosystems in having fixed boundaries. The biosphere covers the whole surface of the earth. It begins underground and extends into the highest reaches of the atmosphere.

### Feeding Relations

Ecologists divide the living, biotic part of an ecosystem into two groups of organisms: the autotrophs and the heterotrophs. Autotrophs, also called primary producers, are organisms that make their own food. The vast majority of autotrophs (literally self-nourishers) are either plants, algae, or bacteria that use sunlight to make sugars from carbon dioxide in the air through photosynthesis.

Heterotrophs (which means “nourished by others”), also called consumers, are organisms that consume other organisms. Heterotrophs include animals, protists, and bacteria, or fungi. Animals that eat plants, such as deer and caterpillars, are called herbivores. Animals that eat other animals, such as mountain lions and wasps, are called carnivores.

Decomposers are heterotrophs that feed from the carcasses of dead animals or dead plants. If they are animals, such as millipedes, lobsters, starfish, clams, and catfish, scientists sometimes call them scavengers. Many animals, including starfish, lions, hyenas, and humans, change from carnivore to scavenger and back, depending on what food source is available.

Some of the most important decomposers are nearly invisible. These are the detritivores: fungi, bacteria, and other organisms that feed on the remains of dead plants and other organisms. Each year, detritivores break down the remains of millions of tons of dead plant and animal material, recycling nutrients back into ecosystems around the world.

Because animals eat one another, they can be linked in food chains, where, for example, a hawk eats a snake, which has eaten a ground squirrel, which has eaten a seed. Every ecosystem has numerous food chains that interlink to form a **food web**. A food web can change over time. In one year, a population explosion of oak moths means that insect predators focus on oak moth caterpillars. In another year, oak moths are rare, and predators eat a diversity of other herbivores.

Ecologists assign the organisms in a food web to different **trophic** levels, depending on where they get their energy. Plants, which get their en-

**food web** set of feeding relations in an ecosystem

**trophic** related to feeding





A temperate rain forest. Rain forests have more organisms per square meter than any other ecosystem.

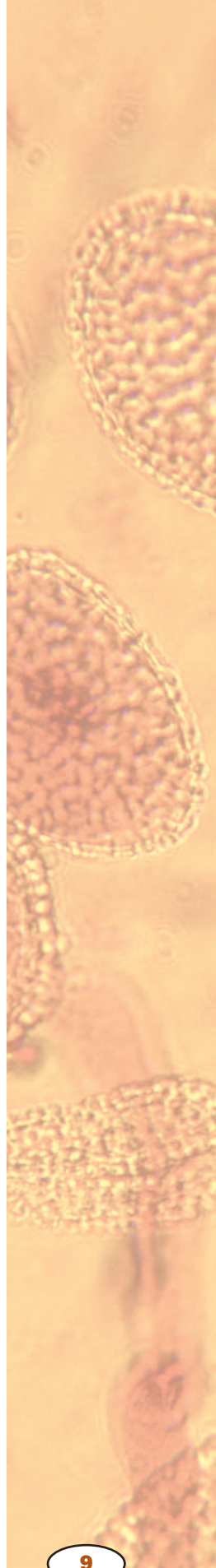

ergy directly from the sun, are in the first trophic level; caterpillars, which get their energy from plants, are in the second; birds that eat caterpillars are in the third. Predators that eat the birds would be in a fourth trophic level. Predators may eat at more than one level. (Humans are an example.)

### **Productivity and Nutrient Cycling**

Every ecosystem is unique, yet similar ecosystems share fundamental characteristics, including climate, productivity, total mass of living organisms, and numbers of species. For example, tropical rain forests have higher species diversity than temperate forests.

In the same way, marshes all have high productivity and deserts all have low productivity. Primary productivity is the amount of energy captured by primary producers during photosynthesis on a square meter of land each year. One factor that determines productivity is latitude and its effect on sunshine. A square meter of land near the North Pole, for example, receives about 700,000 kcals (kilocalories) of sunshine per year, while the same area at the equator receives nearly 2.5 times that much sunshine. So all things

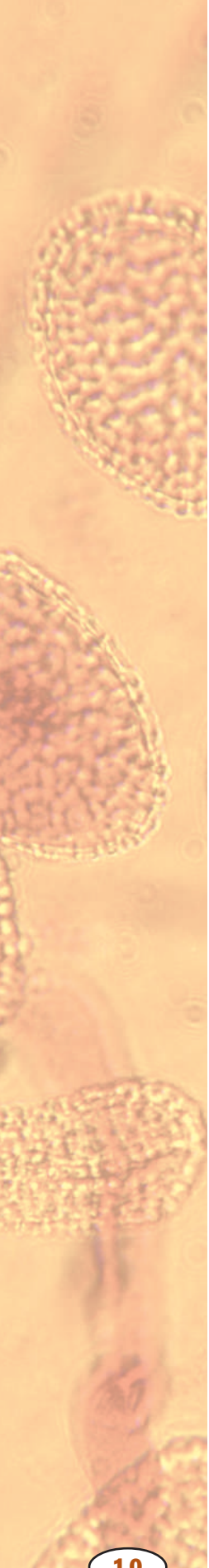

being equal, the tropical region has the potential for higher productivity. However, even in the same latitude, primary productivity varies enormously from ecosystem to ecosystem. A marsh, for example, is twice as productive as a temperate forest, four times as productive as a wheat field, and thirty-five times as productive as a desert.

Another important characteristic of ecosystems is total biomass, the dry weight of all the organisms living in it. Rain forests have more organisms per square meter and therefore more total biomass than other ecosystems, more even than the superproductive marshes.

On land, the biomass of plants is usually greater than the biomass of herbivores, which is greater than the biomass of carnivores. The reason for this is that every chemical process releases energy in the form of heat. So producers can use only part of the energy from the sun to build their bodies; the rest is lost as heat. In the same way, consumers can use only part of the energy in plants to build their own bodies; the rest is lost as heat. Each trophic level passes along only about 10 percent of the energy from the one below. This generalization is called the 10 percent law.

The 10 percent law explains why ecosystems have so few trophic levels and so few individuals at the highest trophic levels. If on a square meter of land, primary consumers store 15,000 kcal/year, herbivores will be able to consume only about 1,500 kcal/year from that meter, and herbivore-eating carnivores will only get 150 kcals, about as many calories as are in a cup of spaghetti. Carnivores must, therefore, roam over large areas to obtain enough to eat.

All sunlight energy eventually escapes from the biosphere in the form of heat. In contrast, the biosphere constantly recycles water, carbon, and other materials. As materials move from one trophic level to another, they may change form, but they rarely escape from the biosphere entirely. A single carbon atom in a fingernail may have been, at different times, part of an apple, part of a trilobite in the ocean, part of a mountain range, part of a dinosaur, or part of the oil in a Texas oil well. Carbon, oxygen, nitrogen, phosphorus, and other materials all pass through many forms—both biotic and abiotic—in a system called a biogeochemical cycle. The biogeochemical cycles of materials such as carbon and oxygen involve the whole biosphere. SEE ALSO BIOGEOCHEMICAL CYCLES; COMMUNITY; DESERT; ESTUARIES; FOREST, BOREAL; FOREST, TEMPERATE; FOREST, TROPICAL; LANDSCAPE ECOLOGY; PLANKTON; POPULATION DYNAMICS

*Jennie Dusbeck*

#### **Bibliography**

Brewer, Richard. *The Science of Ecology*, 2nd ed. Philadelphia, PA: W. B. Saunders, Co., 1988.

Kareiva, Peter M., ed. *Exploring Ecology and Its Applications: Readings from American Scientists*. Sunderland, MA: Sinauer Associates, Inc., 1982–97.

Molles, Manuel C. *Ecology: Concepts and Applications*. Boston: WCB/McGraw-Hill, 1999.

## **Electron Microscopy**

The light microscope (LM) is limited in its resolution to about 0.25 micrometers. If two objects are closer together than that, they blur together

and cannot be distinguished by the LM. The electron microscope (EM) overcomes this limitation and achieves resolutions down to 0.2 **nanometers**, allowing useful magnifications of biological material up to several hundred thousand times, and even more for nonbiological specimens. The EM achieves this by using a beam of electrons instead of visible light. Resolution is governed by the wavelength of illumination, and an electron beam has a much shorter wavelength (about 0.005 nanometers) than visible light (about 400 to 750 nanometers). Electron microscopes can therefore resolve objects as small as individual **protein** and deoxyribonucleic acid (DNA) molecules and pores in cell membranes.

The electron beam of an EM is generated by a heated tungsten wire (cathode) and accelerated down an evacuated column by a charge difference of typically 60,000 to 100,000 volts between the cathode and a grounded, mushroom-shaped anode. After passing through a hole in the center of the anode, it is focused on the specimen by electromagnets, which take the place of the glass lenses of a light microscope.

### The Transmission Electron Microscope

In the transmission electron microscope (TEM), the electron beam passes through ultrathin tissue sections or small specimens, such as viruses. After passing through the specimen, the electrons strike a fluorescent screen and produce an image. The image can also be captured on photographic film or with a camera that digitizes it for storage on a computer.

Specimens for the TEM are typically fixed with aldehyde and stained with heavy metals, such as osmium, that will absorb or scatter electrons. The specimen is then dehydrated and embedded in a plastic resin. When it hardens, the resin is cut into sections 60 to 90 nanometers thick with a glass or diamond knife. Very tiny particles such as viruses and purified cell **organelles** can be viewed without sectioning by depositing them on a thin membrane. This membrane is treated with a heavy metal “negative stain” so that the specimen stands out as a light image against a dark background.

Areas of a specimen that bind the most osmium absorb the most energy from an electron beam, and are called electron-dense regions. Areas that bind less of the stain allow electrons to pass through more freely and are described as electron-lucent regions. Electrons that pass through the lightly stained, electron-lucent regions lose relatively little energy and produce relatively bright spots of light when they strike the screen. The more heavily stained, electron-dense regions cause some electrons to lose energy and others to be deflected from the beam, and thus produce dimmer spots on the screen. TEM images are essentially shadows caused by accumulations of the heavy metal on cellular structures or, in the case of negative staining, on the supporting membrane.

### The Scanning Electron Microscope

The scanning electron microscope (SEM) is used to examine a specimen coated with vaporized metal **ions** (usually gold or palladium). An electron beam sweeps across the specimen surface and discharges secondary electrons from the metal coating. These electrons produce an image on a monitor similar to a television screen. The image on the monitor can be

**nanometer**  $10^{-9}$  meters; one-billionth of a meter

**protein** complex molecule made from amino acids; used in cells for structure, signaling, and controlling reactions

**organelle** membrane-bound cell compartment

**ion** an electrically charged particle

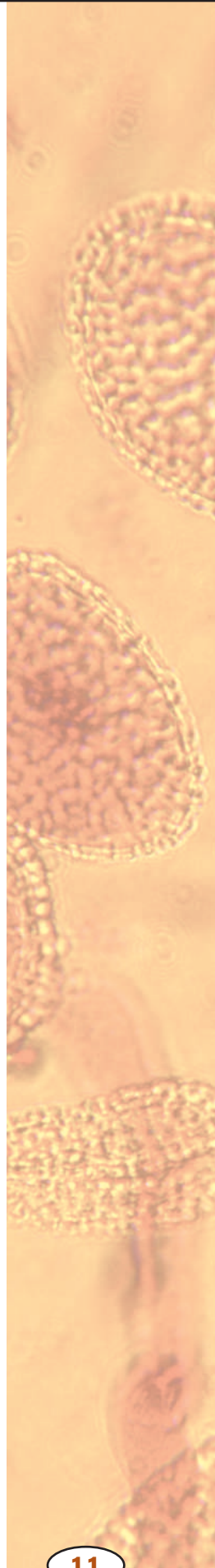

A scientist operating a scanning transmission electron microscope.

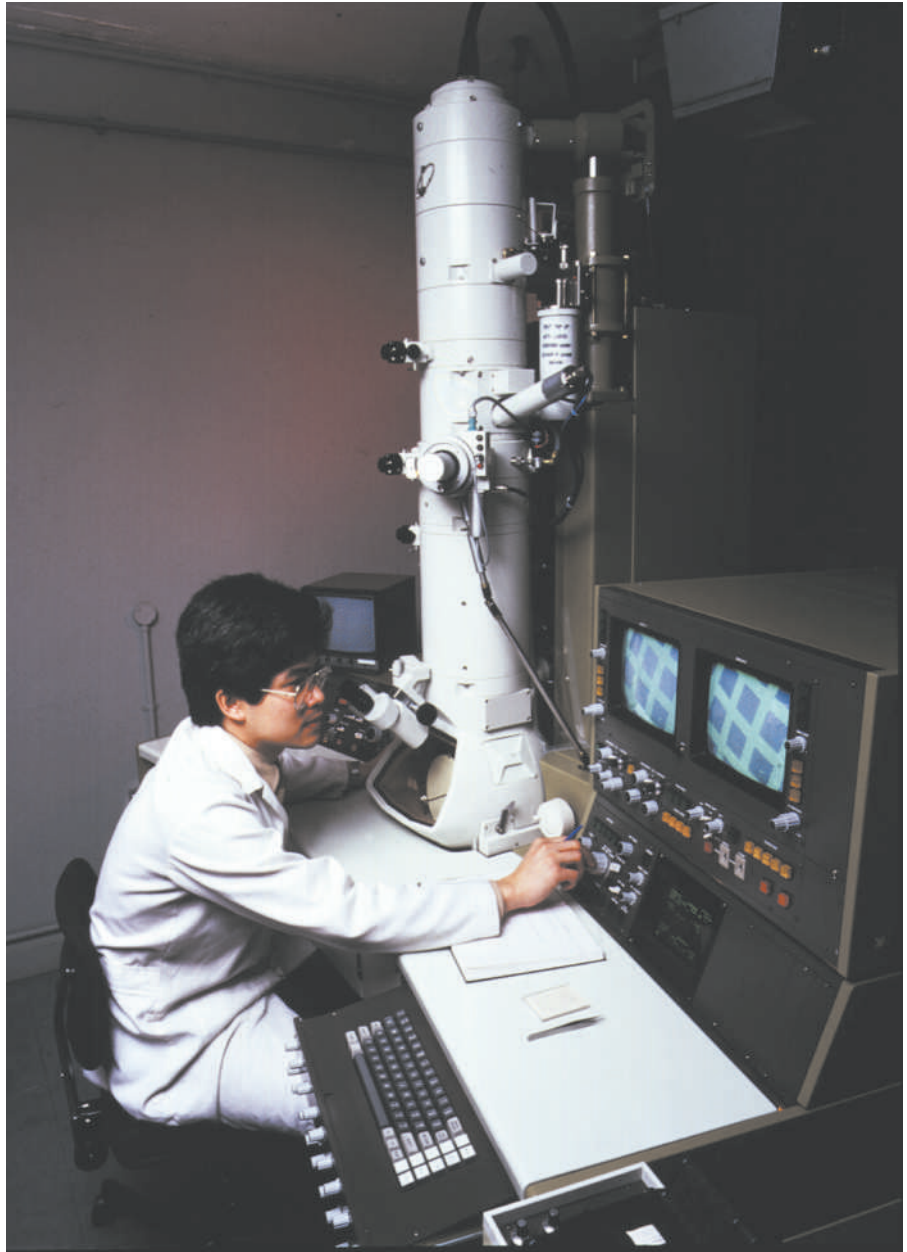

photographed or recorded with a digital camera. The SEM cannot see through a specimen as the TEM does, but can see only the surface where the metal coating is.

The SEM is capable of less resolution and useful magnification than the TEM. However, it produces dramatic three-dimensional images that can yield more information about surface topography than the flat images usually produced by TEM.

### **Other Variations in Electron Microscopy**

Both SEMs and TEMs can be equipped with a detector that monitors X rays given off by a specimen when it is bombarded by electrons. Other types of microscopes irradiate the specimen with ions or X rays and record ions,

electrons, or X rays given off by the specimen. In both cases, the emitted particles and radiation yield information about the chemical composition of the specimen.

A scanning tunneling microscope measures the vertical movement of a tiny probe that is dragged over a specimen, producing a line representation of that movement. An atomic force microscope operates on a similar principle, but measures forces of attraction and repulsion between the specimen and the probe as the probe moves across the surface. In either case, multiple scan lines side by side produce images of the specimen surface, revealing details as small as the “atomic terrain” of individual molecules. SEE ALSO LIGHT MICROSCOPY; MICROSCOPIST

Sara E. Miller and Kenneth S. Saladin

### Bibliography

Berger, Dee. *Journeys in Microspace: The Art of the Scanning Electron Microscope*. New York: Columbia University Press, 1995.

Gilmore, C. P. *The Scanning Electron Microscope: World of the Infinitely Small*. Greenwich, NY: Graphic Society, 1972.

*Microworld Internet Guide to Microscopy*. <[mwrn.com/guide/electron\\_microscopy/microscope.htm](http://mwrn.com/guide/electron_microscopy/microscope.htm)>. Includes lecture notes and guides to EM techniques and instrumentation.

Slayter, Elizabeth M., and Henry S. Slayter. *Light and Electron Microscopy*. New York: Cambridge University Press, 1992.

*WWW Virtual Library: Microscopy*. <<http://www.ou.edu/research/electron/mirror/>>. Numerous links to other sites on all aspects of microscopy.

## Electrophoresis

Electrophoresis is one of the most important techniques used by molecular biologists. To name only a few applications, deoxyribonucleic acid (DNA) electrophoresis is used to map the order of **restriction fragments** within **chromosomes**, to analyze DNA variation within a population by restriction fragment length polymorphisms (RFLPs), and to determine the **nucleotide** sequence of a piece of DNA.

Electrophoresis refers to the migration of a charged molecule through a restrictive **matrix**, or gel, drawn by an electrical force. As the force drags the molecule through the gel, it encounters resistance from the strands of the gel, retarding its rate of migration. In gel electrophoresis, larger molecules migrate more slowly than smaller ones, and so the distance of migration within a gel can be used to determine a molecule's size.

Although it is possible to separate whole chromosomes using specialized electrophoresis techniques, DNA that is to be analyzed by electrophoresis is usually cut into smaller pieces using **restriction enzymes**. Fragments of DNA prepared by treatment with restriction enzymes are commonly separated from one another, and their sizes determined, using a gel of agarose electrophoresis, a **complex carbohydrate**. DNA is negatively charged due to the **phosphodiester** bonds that join the individual nucleotide building blocks. DNA will therefore electrophorese toward the positive electrode when placed in an electrical field. To visualize the results after electrophoresis, the gel is soaked in a solution that causes DNA to fluoresce when exposed to ultraviolet light.

### restriction fragments

fragments of DNA created by restriction enzymes

**chromosome** “colored body” in the cell nucleus; made of DNA and protein, and divided functionally into genes and non-gene regions

**nucleotide** the building block of RNA or DNA

The rate of migration is inversely proportional to the logarithm of a molecule's size.

**matrix** a network, usually of threadlike fibers

**restriction enzyme** enzyme that cuts DNA at a particular sequence

**complex carbohydrate** molecules formed by linking simpler carbohydrates such as sugars

**phosphodiester** the link between two nucleotides in DNA or RNA

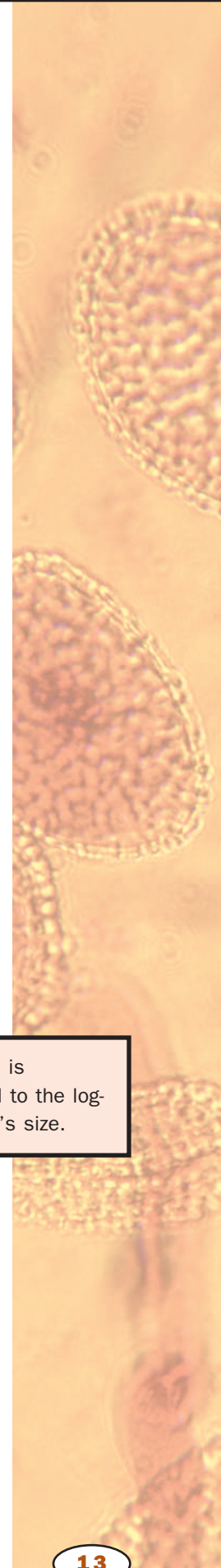

An electrophoresis gel, which can be used to determine a molecule's size.

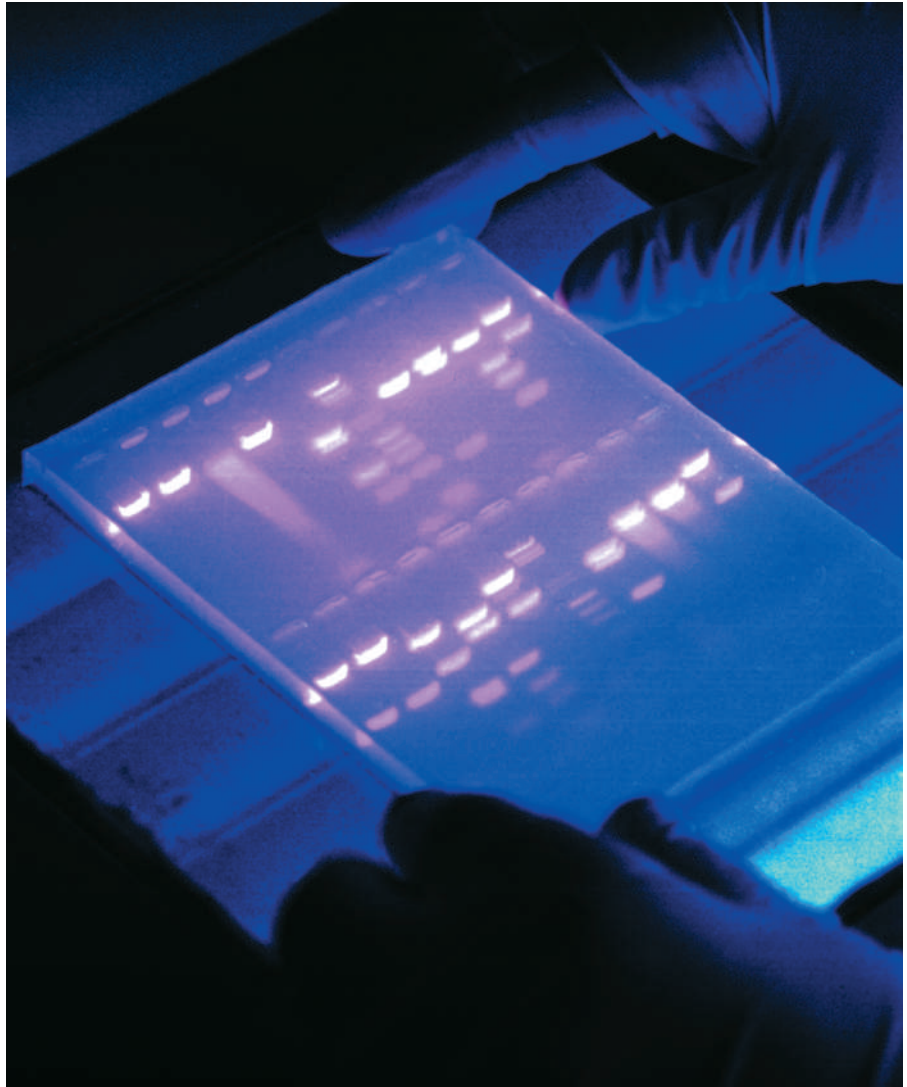

Treatment of the DNA sample with multiple restriction enzymes in various combinations enables the researcher to generate a restriction map of the original DNA fragment, which identifies the sites at the DNA where the restriction enzymes are.

Many research questions require a detailed analysis of one specific DNA fragment in a complex mixture. In such cases, a radioactive DNA probe can be used to identify the fragment based on its nucleotide sequence. The method, known as hybridization, is based on the rules of **complementary base pairing** (A bonds to T, G bonds to C). A probe is designed whose sequence is complementary to the piece of DNA to be detected. The gel-separated DNA is first transferred to a nylon membrane using a technique called a Southern blot.

During the blotting procedure, the strands within the DNA double helix are separated from each other, or denatured, by treatment with a base. Because double-stranded DNA is more stable than single-stranded, during the hybridization the single-stranded probe will locate and bind to the single-stranded gel-separated fragment with complementary sequence.

**complementary** matching opposite

**base pair** two nucleotides (either DNA or RNA) linked by weak bonds

Agarose, which is used to make electrophoresis gel, is derived from the seaweed agar.

Being fluorescent or radioactive, the position of the probe can be determined using photographic methods. The target sequence can then be removed by cutting at the piece of the gel that contains it.

The most common technique for determining DNA sequence is the Sanger method, which generates fragments that differ in length by a single nucleotide. High-resolution polyacrylamide gel electrophoresis is then used to separate the fragments and to allow the sequence to be determined.

Electrophoresis of ribonucleic acid (RNA) is an integral procedure in many studies of **gene expression**. RNA is isolated, separated by electrophoresis, and then the gel-separated RNA fragments are transferred to a nylon membrane using a technique called a Northern blot. Hybridization with a single-stranded DNA probe is then used to determine the position of a specific RNA fragment.

DNA and RNA are relatively simple in terms of structure and composition. **Proteins**, however, are composed of twenty different **amino acids** in various combinations, and proteins vary significantly in their three-dimensional structure. The composition of amino acids will affect the charge on the protein, which ultimately will affect its electrophoretic behavior. The shape of a protein similarly will affect its rate of migration. As a result, a specialized technique, SDS-polyacrylamide gel electrophoresis (SDS-PAGE), is usually used to analyze proteins. In this method, protein samples are heated and then treated with the detergent sodium dodecyl sulfate (SDS). Proteins treated in this way are unfolded, linear, and uniformly coated by negatively charged detergent molecules. The rate of migration of treated proteins is inversely proportional to the logarithm of molecular weight. Following electrophoresis, the protein in the gel can be stained to visualize all the proteins in a sample, or the proteins in the gel can be transferred to a nylon membrane (Western blot) and specific ones detected with the use of **enzyme**-linked antibodies.

Regardless of the macromolecule being studied, gel electrophoresis is a crucial technique to the molecular biologist. Many scientific questions can be answered using electrophoresis, and as a result an active molecular biology research lab will have several benches that are devoted to the required specialized reagents and equipment. SEE ALSO DNA SEQUENCING

*James E. Blankenship*

### Bibliography

Alberts, Bruce, et al. *Molecular Biology of the Cell*, 4th ed. New York: Garland Publishing, 2000.

Stryer, Lubert. *Biochemistry*, 4th ed. New York: W. H. Freeman and Company, 1995.

### SANGER, FREDERICK (1918–)

English biochemist who received two Nobel Prizes in chemistry. The first came in 1958, for finding the amino sequence of insulin, the protein that helps regulate blood sugar levels, and the second, in 1980, for inventing a technique to sequence the nucleotides in a strand of deoxyribonucleic acid (DNA).

**gene expression** use of a gene to create the corresponding protein

**protein** complex molecule made from amino acids; used in cells for structure, signaling, and controlling reactions

**amino acid** a building block of protein

**enzyme** protein that controls a reaction in a cell

## Emergency Medical Technician

An emergency medical technician (EMT) is a person who delivers the initial medical treatment to persons in crisis situations. Traditionally, EMTs are part of the medical team that travels by ambulance or helicopter to the site of the emergency situation. The most common medical crises to which EMTs are called include: injuries acquired during automobile accidents and roadway and home births; sudden myocardial infarctions (heart attacks); and wounds resulting from interpersonal violence (such as gun shots and stab wounds).

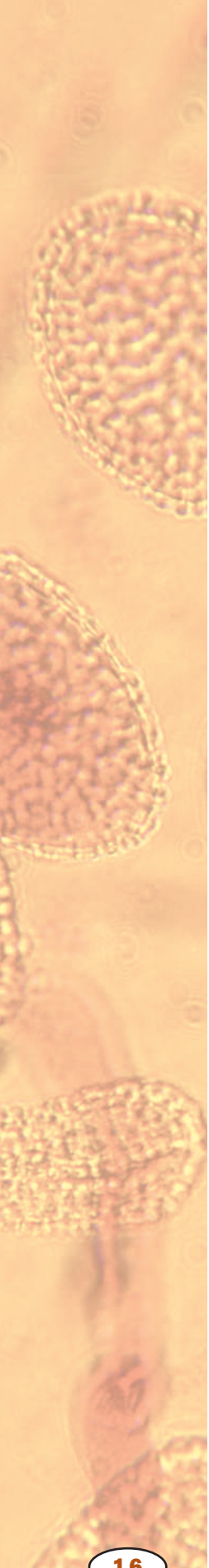

Emergency medical technicians must be trained and certified. There are five levels of EMT training, from First Responders, who are certified in basic emergency medical care, to EMT-4 (paramedics), who are certified to administer drugs, read electrocardiograms, and use other advanced equipment in providing prehospital care. The training process is progressive, starting with EMT 1 (which includes First Responder training), requiring approximately 120 hours of training, through the paramedic level, requiring up to two years of training. Hospitals, trauma centers, private ambulance companies, and fire and police departments employ emergency medical technicians. In fact, many firefighters are also certified EMTs.

In order to be well prepared for EMT training, a strong background in the sciences is important. High school courses such as biology, chemistry, mathematics, and physics are essential prerequisites for EMT training. A good driver's education class is crucial as well, since many EMTs are also ambulance drivers who must negotiate challenging roadway situations in order to reach the crisis scene quickly and safely.

A career in emergency medicine can be very challenging. EMTs must maintain the difficult balance between compassion and emotional fortitude. Strong leadership and interpersonal skills are a must for an emergency medical technician. However, despite the challenges, it is very rewarding to help people and save lives daily. SEE ALSO DOCTOR, FAMILY PRACTICE; DOCTOR, SPECIALIST; MEDICAL ASSISTANT, NURSE

*Susan T. Rouse*

**Bibliography**

- New York Department of Labor.* CareerZone. <<http://www.explore.cornell.edu/newcareerzone/profile.asp?onet=32508&cluster=4>>.
- U.S. Department of Labor.* "Occupational Outlook Handbook." Washington, DC: Government Printing Office, annually. <<http://stats.bls.gov/oco/ocos101.htm>>.

---

## Endangered Species

---

Endangered species are species of plants or animals (or other life forms such as fungi) that are threatened with extinction. As well as being a biological term, "endangered" has a formal political meaning: nations, states, and other organizations evaluate the status of species and determine which are in the greatest danger of going extinct; these species are designated as endangered species. Other species that are declining rapidly in numbers, but are not yet believed to be on the brink of extinction, are designated as threatened species. In the United States, the Endangered Species Act protects such species.

Several factors can cause a species to become endangered. The most common cause is loss of habitat. Much of the world's forests, grasslands, and wetlands are being transformed into agricultural and urban areas, and many species that lived in those habitats are unable to adapt to the new environment. As a result, their numbers can drop greatly in a very short time. In some cases, human hunting or gathering of particular species can drive a species to the brink of extinction. This is the case of the rhinoceros, which has been killed in large numbers during the past century to meet market needs in certain areas of the world. The horn of the rhino is prized for dagger handles in the Middle East and for medicinal uses in parts of Asia. Tigers





A white tiger (*Panthera tigris*) in a zoo. For some species, the only feasible way to preserve the species is to bring all the remaining individuals into captivity.

and sun bears in Asia have likewise been driven to the brink of extinction due to the huge market for animal parts that are believed by many to have potent medicinal powers.

### Protection and Reestablishment

There are several ways that people can try to protect endangered species and to keep them from going extinct. One important way is to set up special protected areas around some of the last remaining populations of a species. China has created such reserves for the giant panda. However, for these reserves to be successful, they need to have the support of the resident people that live around the reserve. In some cases, the reserves provide the local people with jobs, and in other cases, some agricultural and even hunting activities are permitted within the reserve.

For some species, their habitat has essentially disappeared, or the species has declined to only a few individuals. In these instances, the only feasible way to try to preserve the species is to bring all the remaining individuals into captivity. One important function of zoos today is to house such endangered species. In some cases, captive breeding programs are initiated to

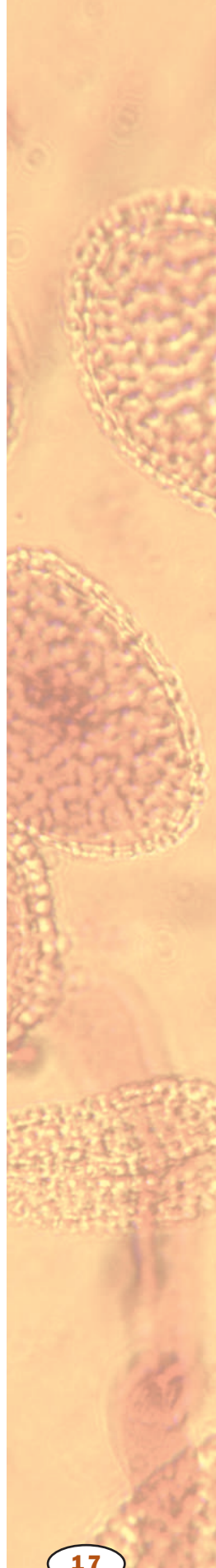

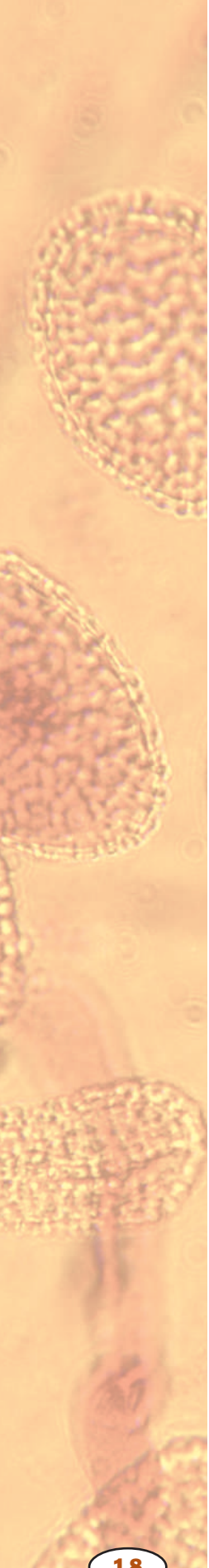

**hormone** molecule released by one cell to influence another

increase the number of individuals of the endangered species. The ultimate goal of many of these captive breeding programs is to reintroduce the species back into the wild at some future date.

There are several ongoing reintroductions. In the 1980s, when the California condor had declined almost to the point of extinction, the few remaining individuals were captured and placed in captivity. A successful captive breeding program increased the numbers to several dozen individuals, and some have been released back into the wild. Reintroductions of endangered species are not always successful because the reintroduced animals usually have lived only in captivity. Thus, it is often necessary to prepare these animals for their new life in the wild by teaching them how to catch their food and to avoid predators.

Probably the greatest success story of the recovery of an endangered species involves the national bird of the United States, the bald eagle. The bald eagle, like many other birds of prey, fell victim to the heavy use of pesticides by farmers in the 1950s, including DDT. Much of the DDT that was sprayed onto agricultural fields ran off into streams and rivers and lakes when it rained. Small aquatic life consumed some of this DDT, and it remained in their body tissue. When a small fish ate these small aquatic organisms, DDT accumulated in their bodies too and was passed on when a larger fish ate the smaller fish. This process has been referred to as bioaccumulation, or biomagnification.

Thus, by the time the bald eagle ate the larger fish, it was eating contaminated food, and the eagles' own tissues accumulated high concentrations of DDT. One unfortunate consequence of these high concentrations of DDT was the severe weakening of the eggshell laid by the eagle. They were so weak they would often break during the normal parental brooding of the eggs. As a result, the birth rates of the eagles plummeted at the same time the death rates from DDT poisoning rose.

In response to environmentalists like Rachel Carson, who saw how the use of these sorts of chemicals was harming wildlife, the United States banned further use of DDT and provided the bald eagle with special protection under its endangered species status. The eagle populations responded slowly, but in the 1990s the populations began to increase at a rapid rate. In the early twenty-first century, the bald eagle is seen commonly in many parts of the United States and Canada, and its numbers have increased substantially enough that it is no longer considered an endangered species. SEE ALSO BIODIVERSITY; CARSON, RACHEL; EXTINCTION; POLLUTION AND BIOREMEDIATION

*Mark A. Davis*

### **Bibliography**

Primack, Richard B. *Essentials of Conservation Biology*. Sunderland, MA: Sinauer Associates, 1998.

## **Endocrine System**

The endocrine system is the interacting group of glands that secrete **hormones**, helping to control cells and organs throughout the body. How do cells and organs at different locations in the body communicate with each

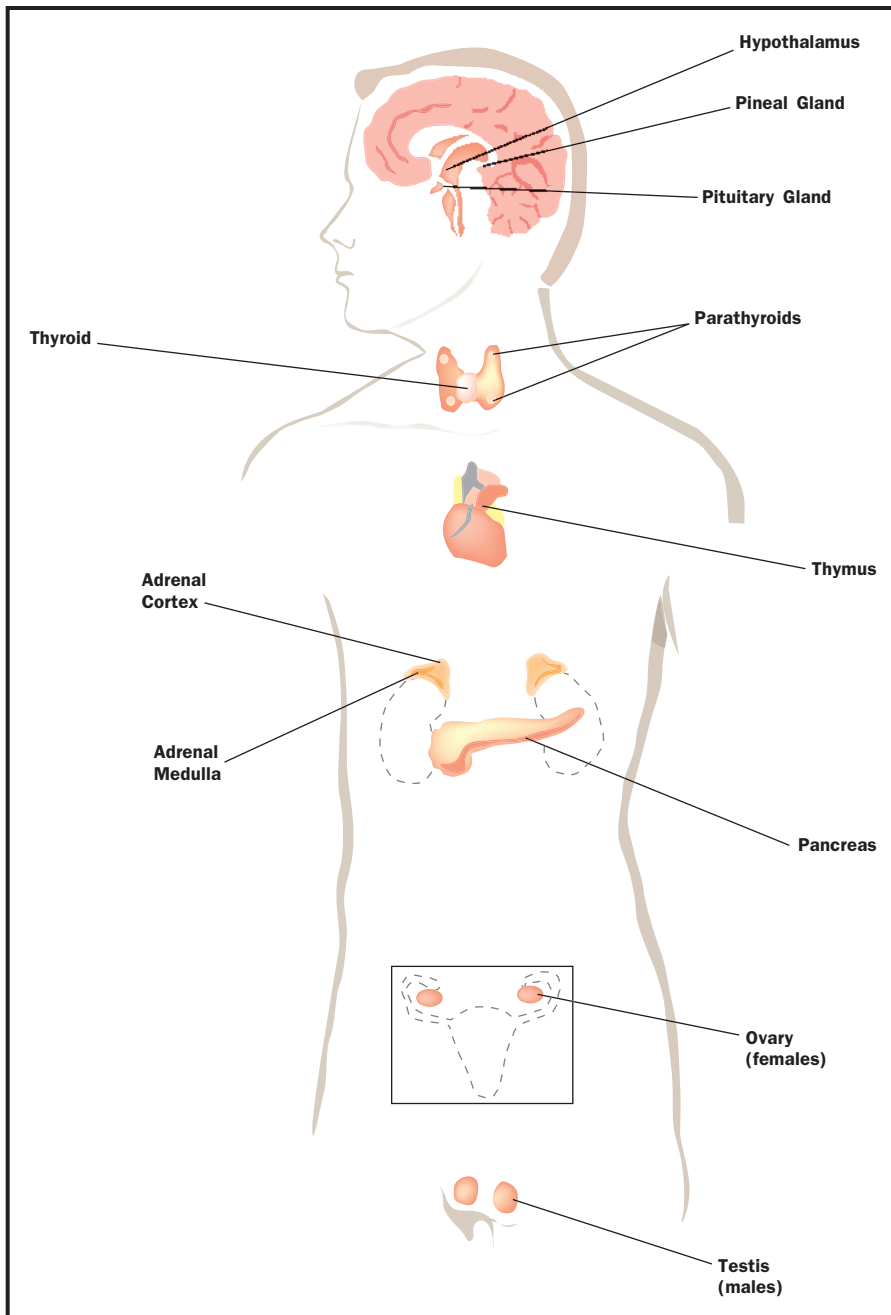

The endocrine organs in the human body.

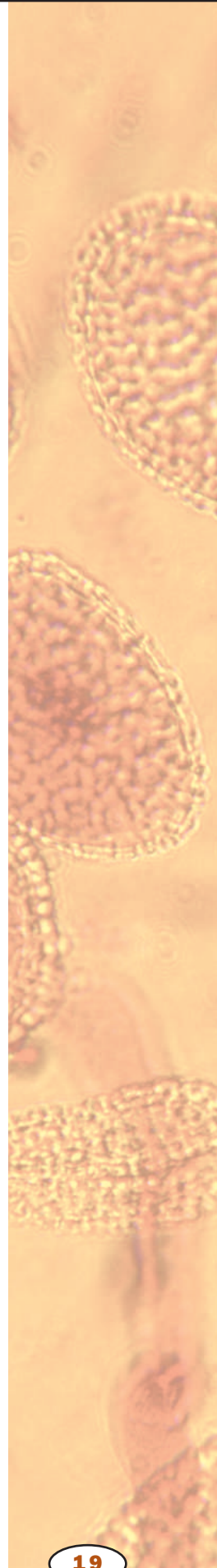

other to maintain the physiology of healthy living organisms? What happens if organs do not communicate properly? These questions can be answered by understanding how organs of the nervous system and endocrine system function.

There are similarities and differences between how the human nervous system and endocrine system communicate with and control other organs. For example, the nervous system relies on electrical impulses and chemical **neurotransmitters**. Most endocrine organs do not transmit electrical information but instead secrete hormones (from the Greek, meaning “to arouse or excite”), which are molecules that act as chemical messengers.

**neurotransmitters** molecules released by one neuron to stimulate or inhibit another neuron or cell

**metabolism** chemical reactions within a cell

**gamete** reproductive cell, such as sperm or egg

**protein** complex molecule made from amino acids; used in cells for structure, signaling, and controlling reactions

**secretion** material released from the cell

**amino acid** a building block of protein

**steroids** hormones such as testosterone or estrogens that control many aspects of physiology

**feedback** process in which the output or result influences the rate of the process

Hormones are released into the bloodstream whereby they travel to organs they affect, known as target organs.

Endocrine organs are located throughout the body, and they have diverse functions controlling events such as cell **metabolism**, blood sugar concentration, digestion, the menstrual cycle in females, and the production of male and female **gametes**. Primary endocrine organs include the hypothalamus, pituitary gland, pineal gland, thyroid and parathyroid glands, thymus, adrenal glands, pancreas, and male and female gonads, the testes and ovaries respectively. Other tissues serve endocrine functions through the hormones they produce. For example, the kidneys produce erythropoietin that stimulates formation of red blood cells, and the skin produces vitamin D, a steroid derivative required for calcium absorption by the small intestine.

## Hormones

Hormones are “signaling” molecules because they influence the activity of other cells that may be far from where the hormone was produced. For a hormone to affect a target cell, it must attach to a receptor **protein** on the target cell membrane or inside the cell. Hormone binding to a receptor triggers an intricate set of biochemical interactions that can affect the target cell in myriad ways. For example, hormones can influence cell metabolism, cell division, electrical activity, ribonucleic acid (RNA) and protein synthesis, or cell **secretion**.

There are several different types of hormones that vary in their chemical organization and functions. The majority of hormones are peptides. These consist of short sequences of **amino acids**; examples include insulin and growth hormone. The class of hormones called **steroids** are synthesized from cholesterol—examples include male sex steroids such as testosterone and female sex steroids such as estrogen and progesterone.

Hormone production by an endocrine organ is regulated by complex interactions, called **feedback** loops, between the endocrine organ and its target organs. Feedback loops are two-way modes of communication in which a target organ also releases molecules that regulate the endocrine organ. Feedback loops are designed to maintain hormone concentration within a normal range. Endocrine disorders in which hormone concentration becomes abnormal can be difficult to diagnose and treat because of the complexity of feedback loops. One simple way to classify endocrine disorders is based on whether a condition is due to excess production (hypersecretion) or underproduction (hyposecretion) of hormone.

## The Major Endocrine Glands

Located at the base of the brain, the pituitary gland produces many hormones that regulate other organs. Because of this, the pituitary is often referred to as the “master” endocrine gland, although the term “central” endocrine gland is more correct because hormone release by the pituitary is primarily regulated by a brain structure called the hypothalamus, which acts to connect the nervous system to the endocrine system. The hypothalamus produces hormones that stimulate or inhibit the release of pituitary hormones. The hypothalamus also produces antidiuretic hormone, which regulates water balance in the body by inhibiting urine formation by the

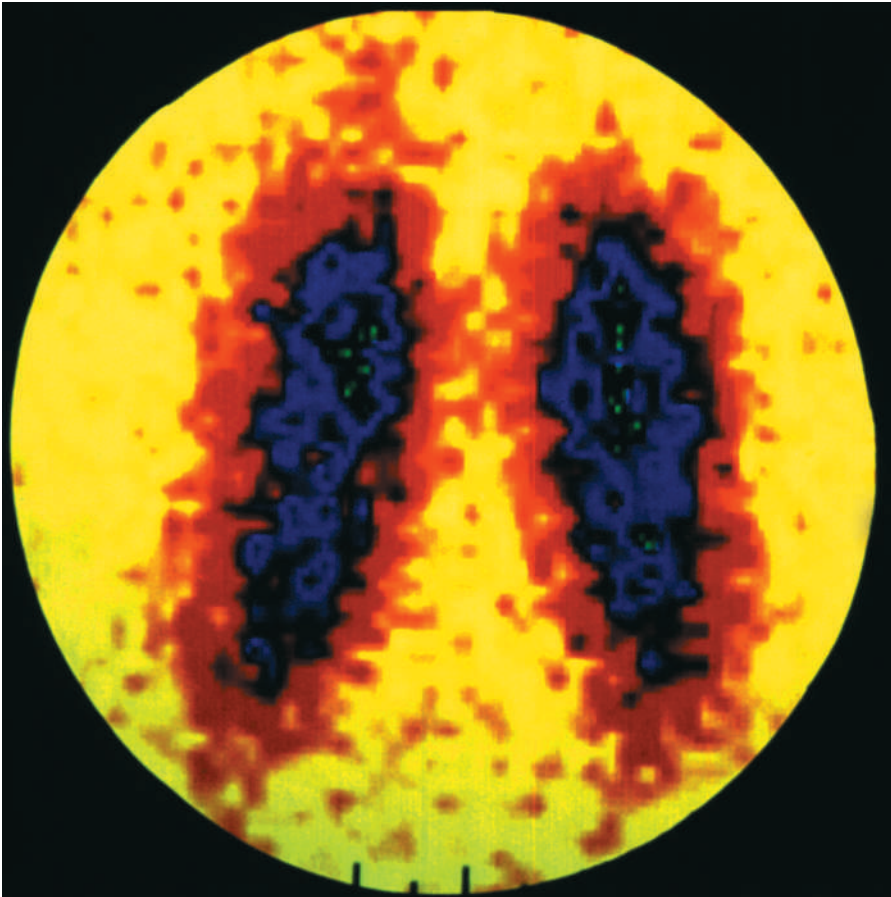

A frontal-view scintigram of a normal human thyroid. Part of the endocrine system, the thyroid controls basal metabolic rate.

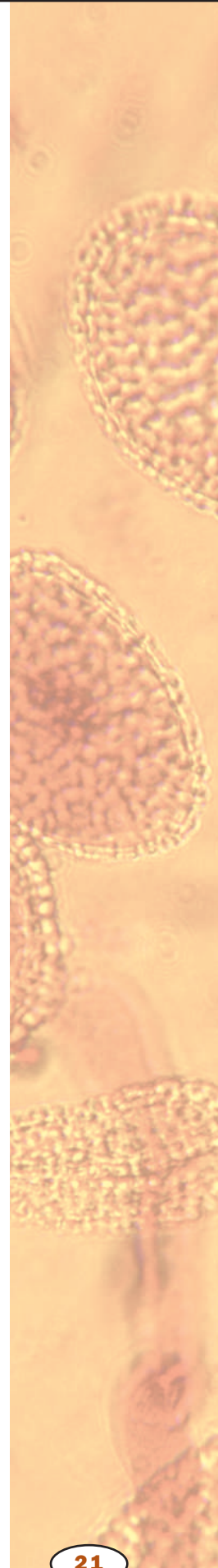

kidneys, and a hormone called oxytocin, which stimulates uterine contractions during childbirth and releases milk during breast-feeding.

Hormones released by the pituitary include growth hormone, which increases during childhood and stimulates the growth of muscle, bone, and other tissues. Sporadic bursts in growth hormone release often result in rapid growth “spurts” associated with adolescence. Hyposecretion of growth hormone can result in dwarfism, whereas hypersecretion of growth hormone can cause gigantism and other disorders. The pituitary also produces follicle-stimulating hormone and luteinizing hormone, which stimulate gamete production and sex steroid production in male and female reproductive organs, and prolactin, which stimulates milk formation in the mammary glands.

Located adjacent to the **larynx**, the thyroid gland primarily produces thyroxine and triiodothyronine, collectively referred to as thyroid hormone. Thyroid hormone stimulates growth of muscles and bones, carbohydrate metabolism, and basal metabolic rate. Its production requires iodine; the lack of dietary iodine causes goiter, a thyroid gland that is overly enlarged in an effort to compensate for the thyroid hormone deficiency.

Effects of thyroid disorders in children and adults can differ widely. For example, hyposecretion of thyroid hormone in infants causes **congenital** hypothyroidism, a disease characterized by mental retardation and poor body growth; hyposecretion in adults produces myxedema, with symptoms such as **lethargy**, weight gain, and dry skin. Conversely, hypersecretion of

**larynx** “voice box”; muscles at the top of the trachea that control pitch and loudness

**congenital** present at birth; inherited

**lethargy** lack of excitability; torpor

**sympathetic nervous system** branch of the nervous system that promotes heightened awareness, increased nutrient consumption, and other changes associated with “fight or flight”

**glucose** simple sugar that provides energy to animal cells and is the building block of cellulose in plants

**glycogen** complex carbohydrate used as storage in animals and some other organisms

**eukaryotic cell** a cell with a nucleus

thyroid hormone in adults causes Graves’ disease, a condition characterized by weight loss, nervousness, and dramatic increases in body metabolism. The thyroid also produces calcitonin, a hormone that regulates blood calcium concentration.

The adrenal glands are small organs on the apex of each kidney. The outer layers of cells in the adrenal gland, called the adrenal cortex, produce several hormones that affect reproductive development; mineral balance; fat, protein, and carbohydrate balance; and adaptation to stress. The inner part, called the adrenal medulla, secretes epinephrine and norepinephrine, which activate the **sympathetic nervous system** and stimulate the “fight-or-flight” response that helps the body cope with stressful situations, such as fear.

The pancreas produces insulin and glucagon, which function in opposing fashion to regulate blood sugar (glucose) concentration. When blood **glucose** level rises—for example, after eating a sugar-rich meal—insulin lowers it by stimulating glucose storage in liver and muscle cells as long chains of glucose called **glycogen**. Conversely, between meals, blood glucose level decreases. In response, the pancreas releases glucagon, which stimulates glycogen breakdown and subsequent release of glucose into the bloodstream. One of the most well characterized endocrine disorders is diabetes mellitus, resulting from hyposecretion of insulin or, more commonly, target cell insensitivity to it.

Endocrine functions of the gonads are addressed in articles on the male and female reproductive systems. The sex hormone testosterone regulates sperm production in males. Estrogen and progesterone influence egg maturation and release (ovulation) and control the uterine (menstrual) cycle in females.

Although the many hormones produced by human endocrine organs have a wide variety of actions, the common purpose of all hormones is to facilitate organ-to-organ communication necessary for body physiology. **SEE ALSO** ADRENAL GLAND; ANABOLIC STEROIDS; BLOOD SUGAR REGULATION; FEMALE REPRODUCTIVE SYSTEM; GROWTH; HOMEOSTASIS; HORMONES; HYPOTHALAMUS; NERVOUS SYSTEMS; PANCREAS; PITUITARY GLAND; STRESS RESPONSE; THYROID GLAND

*Michael A. Palladino*

### Bibliography

Hadley, Mac E. *Endocrinology*, 5th ed. Upper Saddle River, NJ: Prentice Hall, 2000.

Marieb, Elaine Nicpon. *Human Anatomy and Physiology*, 5th ed. San Francisco: Benjamin Cummings, 2000.

## Endocytosis

The ability to internalize material from outside the cell is important for several cellular processes including the ingestion of essential nutrients, removal of dead or damaged cells from the body, and defense against microorganisms. **Eukaryotic cells** internalize fluid, large and small molecules, and even other cells from their surroundings by a process called endocytosis. During endocytosis, the plasma membrane of the cell forms a pocket around the material to be internalized. The pocket closes and then separates from the

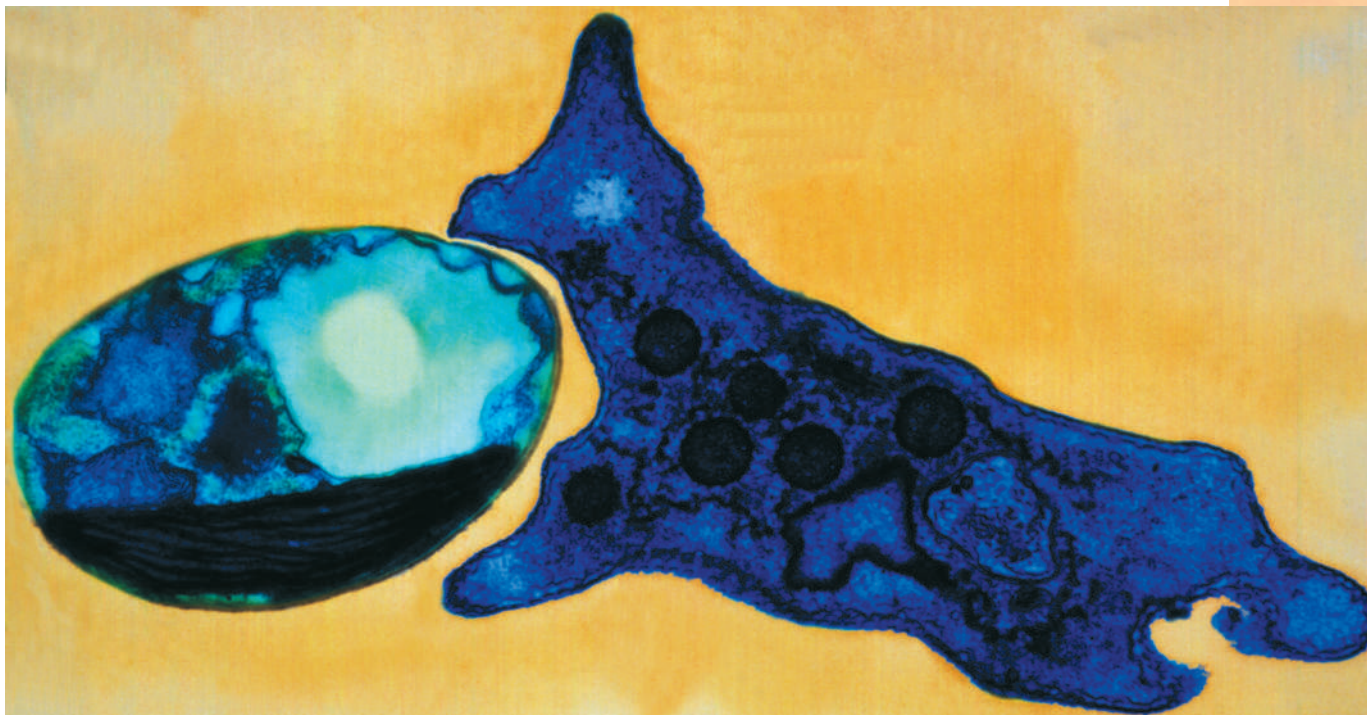

inside surface of the plasma membrane to form a membrane-enclosed bubble, or vesicle, containing the ingested material.

There are two main types of endocytosis that are distinguished by the size of the vesicle formed and the cellular machinery involved. Pinocytosis (cell drinking) describes the internalization of extracellular fluid and small **macromolecules** by means of small vesicles. **Phagocytosis** (cell eating) describes the ingestion of large particles such as cell debris and whole microorganisms by means of large vesicles. While all eukaryotic cells are continually ingesting fluid and molecules by pinocytosis, only specialized phagocytic cells ingest large particles.

### Specialized Phagocytic Cells Engulf Large Particles

Phagocytosis begins with the extension of large, handlike projections from the plasma membrane. The projections surround the particle and fuse together so that the particle is completely engulfed in a large vesicle within the cell called a phagosome. Inside the cell, the phagosome fuses with another membranous **organelle** called a lysosome, forming a single membranous organelle and mixing their contents in the process. Lysosomes, acting as the “stomach” of the cell, carry digestive **enzymes** that break down all types of biological molecules. Consequently, after a phagosome fuses with a lysosome, the digestive enzymes break down the ingested material into small molecules that are transported into the **cytosol** and made available for cell use. Many single-celled organisms like **amoebas** and ciliates use phagocytosis as a means to acquire food. In multicellular animals, only specialized types of cells use phagocytosis. For example, in humans, specialized white blood cells called macrophages use phagocytosis to defend the body against infection by engulfing invading microorganisms and to remove cell debris from the body by ingesting damaged or old cells.

A color-enhanced transmission electron micrograph of an amoeba engulfing green algal cell for food. In phagocytosis, a type of endocytosis, large vesicles ingest whole microorganisms.

**macromolecules** large molecules such as proteins, carbohydrates, and nucleic acids

**phagocytosis** engulfing of cells or large fragments by another cell, including immune system cells

**organelle** membrane-bound cell compartment

**enzyme** protein that controls a reaction in a cell

**cytosol** fluid portion of a cell, not including the organelles

**amoeba** a single-celled protist that moves by crawling and can cause diarrhea

## All Eukaryotic Cells Constantly Ingest Fluid and Molecules by Pinocytosis

**pinocytosis** introduction of fluids into a cell by enclosing it and pinching off of the plasma membrane

**hormone** molecule released by one cell to influence another

**protein** complex molecule made from amino acids; used in cells for structure, signaling, and controlling reactions

**cytoplasm** material in a cell, excluding the nucleus

In contrast to phagocytosis, **pinocytosis** begins with small, convex pits on the cell surface that collect material or fluid to be internalized. The convex pits expand into the interior of the cell forming small vesicles that pinch from the inside of the plasma membrane. All eukaryotic cells have a continuous stream of vesicles budding from the plasma membrane. The constant removal of membrane from the plasma membrane would quickly deplete the plasma membrane if not for the balancing effects of another continual process called exocytosis. Exocytosis is the process by which vesicles from inside the cell fuse with the plasma membrane to secrete material and fluid. So, pinocytosis brings fluid and material into the cell and removes membrane from the plasma membrane, while exocytosis expels fluid and material from the cell while adding membrane to the plasma membrane. Thus, the two processes work together to continuously recycle the plasma membrane.

The most thoroughly understood form of pinocytosis is receptor-mediated endocytosis. Receptor-mediated endocytosis selectively internalizes specific molecules that are found in low concentrations in the extracellular space, such as **hormones**, growth factors, antibodies, iron, enzymes, vitamins, and cholesterol. The specific molecules to be internalized bind to **proteins** called receptors on the outside surface of the cell. Receptors are proteins that are embedded in the plasma membrane with portions of the protein extending outside the cell to form a binding site for a specific molecule. Once molecules bind to their receptors, the receptors move within the plasma membrane and become concentrated in small depressions called clathrin-coated pits. Clathrin-coated pits are formed when many clathrin protein molecules interact with each other to form a convex, basketlike structure on the inside of the plasma membrane that molds the membrane into a pit. The coated pits then progressively invaginate, or form inward, to form clathrin-coated vesicles that pinch off the plasma membrane into the **cytoplasm**. Hence, the clathrin-coated vesicles carry the receptor proteins taken from the plasma membrane and their bound molecules taken from the extracellular space.

Once a clathrin-coated vesicle pinches from the inner surface of the plasma membrane, the clathrin coat is removed. The “uncoated” vesicle, still carrying receptor proteins and their bound cargo molecules, fuses with another membranous organelle called an endosome. Endosomes function as “sorting stations.” In an endosome, molecules are sorted and packaged into new vesicles for transportation to various locations within the cell.

Receptors brought into the cell by receptor-mediated endocytosis have one of several fates after unloading their cargo and leaving the endosome: (1) they can be recycled back to the same area of plasma membrane from which they came; (2) they can be transported to another region of the plasma membrane; or (3) they can be transported to the lysosome where they are degraded. Thus, in contrast to phagocytosis, not all material brought into the cell by receptor-mediated endocytosis ends up in the lysosome for digestion.



## Endocytosis of Cholesterol

Receptor-mediated endocytosis was discovered by Michael Brown and Joseph Goldstein, who were investigating the internalization of cholesterol by cells from the bloodstream. Brown and Goldstein won the Nobel Prize in medicine in 1985 for their discovery. Cholesterol, a type of **lipid**, is insoluble and is transported in the bloodstream bound to protein in particles called low-density **lipoproteins** (LDL). The LDL particles bind to LDL receptors on cell surfaces, and the LDL/receptor complexes are concentrated into clathrin-coated pits. The clathrin-coated pits develop into clathrin-coated vesicles that move into the interior of the cell, lose their clathrin coats, and fuse with an endosome. The **acidic** environment of the endosome causes the LDL particles to detach from the LDL receptors, and the two are sorted from each other. The LDL particles are transported to the lysosome where they are broken down by digestive enzymes; the cholesterol is released into the cytosol where it is used in the synthesis of new membrane. The LDL receptors are packaged into membrane vesicles that travel back to and fuse with the plasma membrane (via exocytosis) so that the receptors once again face the exterior of the cell and can pick up more LDL particles to start the cycle again. SEE ALSO EXOCYTOSIS; HORMONES; LIPIDS; LYSOSOMES; MEMBRANE PROTEINS

*Cynthia K. Damer and Scott N. Daigle*

### Bibliography

- Aderem, Alan, and David M. Underhill. "Mechanisms of Phagocytosis in Macrophages." *Annual Review of Immunology* 17 (1999): 593–623.
- Alberts, Bruce, et al. *Molecular Biology of the Cell*, 4th ed. New York: Garland Publishing, 2000.
- Mukherjee, Sushmita, Richik N. Ghosh, and Frederick R. Maxfield. "Endocytosis." *Physiological Reviews* 77 (1997): 759–803.
- Schmid, Sandra L. "Clathrin-Coated Vesicle Formation and Protein Sorting: An Integrated Process." *Annual Review of Biochemistry* 66 (1997): 511–548.

## Endoplasmic Reticulum

The endoplasmic reticulum (ER) is a series of interconnected membranes or flattened sacs adjacent and connected to the nuclear membrane. The ER comes in two different morphological forms: smooth endoplasmic reticulum (sER) and rough endoplasmic reticulum (rER). The primary function of the sER is to serve as a platform for the synthesis of lipids (fats), carbohydrate (sugars) **metabolism**, and the detoxification of drugs and other toxins.

Tissues and organs that directly participate in these activities, such as the liver, are enriched in sER. Morphologically, the rER is studded with **ribosomes** that participate in **protein** synthesis giving its "rough" appearance when viewed with the electron microscope. The proteins synthesized on the ER are transported from the ER membranes by small **vesicles** that pinch off the surface and enter the Golgi membrane stack (cisternae). From the Golgi, the proteins are transported to the cell surface or to other **organelles**.

### The Rough Endoplasmic Reticulum (rER)

The rER is a series of stacked membranes closest to the **nucleus** that is the site for synthesis and maturation of proteins destined for the plasma

**lipid** fat or waxlike molecule, insoluble in water

**lipoprotein** combination of protein and lipid, or fatlike molecule

**acidic** having an excess of H<sup>+</sup> ions, and a low pH

**metabolism** chemical reactions within a cell

**ribosome** protein-RNA complex in cells that synthesizes protein

**protein** complex molecule made from amino acids; used in cells for structure, signaling, and controlling reactions

**vesicle** membrane-bound sac

**organelle** membrane-bound cell compartment

**nucleus** membrane-bound portion of cell containing the chromosomes

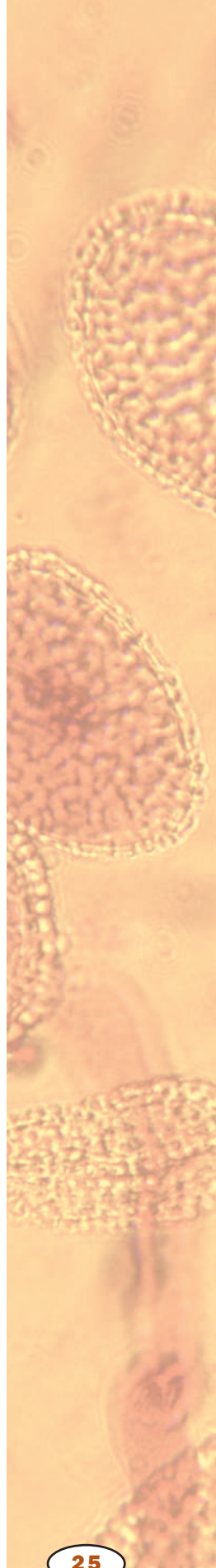

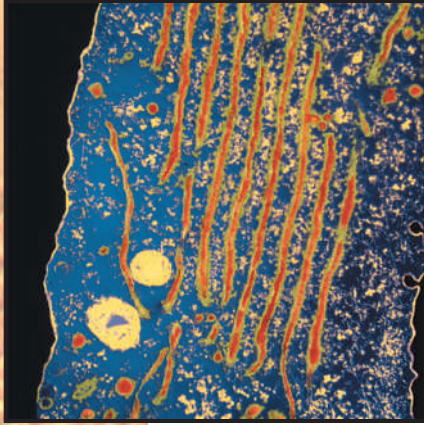

Rough endoplasmic reticulum in an animal cell. The ER membranes are seen running from the top to the bottom of the image. The small granules attached to the membrane of the ER are ribosomes.

**transcribe** creation of an RNA copy of a DNA gene

**translation** synthesis of protein using mRNA code

**amino acid** a building block of protein

**carbohydrates** sugars, starches, and other molecules combining carbon, hydrogen, and oxygen and serving as fuel or structural components

**oligosaccharide** chain of several sugar molecules

**conformation** three-dimensional shape

**enzyme** protein that controls a reaction in a cell

**hydrophobic** “water hating,” such as oils

**cytosol** fluid portion of a cell, not including the organelles

membrane, secretory vesicles, or endocytic vesicles. Many ribosomes stud the cytoplasmic face of the rER, as well as populating the surrounding cytoplasm. Messenger ribonucleic acid (mRNA) **transcribed** in the nucleus leaves the nucleus via the nuclear pores and is transported into the cytoplasm. Docking sites on the head or “N-terminus” of the mRNA allow the ribosome to bind to it and initiate **translation**, decoding the linear sequences of bases in the RNA to an **amino acid** sequence that will constitute a protein.

**Translocation into the Lumen.** The first segment of the growing peptide consists of a “signal sequence” that binds to a pre-existing signal recognition particle (SRP) from the cytoplasm. The SRP is a small protein/RNA complex that acts as a targeting guide and is essential for protein **translocation** into the rER lumen (interior chamber). The cytoplasmic surface of the rER contains a protein called the SRP receptor that binds to the SRP, anchoring the ribosome with its growing peptide to the rER membrane. As translation proceeds, the peptide is fed into the lumen of the rER where the signal sequence is cut off and additional changes called post-translational modifications proceed immediately.

**Glycosylation.** Proteins are modified by the addition of **carbohydrates** (glycosylation) to specific amino acids in the peptide chain. One of the most common modifications is to attach an **oligosaccharide** (*oligo* means “few”; *saccharide* means “sugar” or “carbohydrate”) to the growing peptide. The branched oligosaccharide is composed of a combination of three sugars: glucose, mannose, and N-acetylglucosamine that can be further modified in the rER and, later, in the Golgi complex. The oligosaccharide modifications on proteins assist in the correct folding of the protein and help stabilize it. The oligosaccharide may also assist in targeting the protein to the correct location in the cell.

**Protein Folding.** The ER lumen maintains a chemical environment that ensures that proteins are folded into the correct **conformation**. Misfolded proteins are useless and may cause problems if they are detected as “foreign structures” by the immune system of the body. How does the ER ensure that proteins are folded correctly? Newly synthesized proteins are quickly associated with ER “chaperone proteins” and folding **enzymes** that assist in the folding of the proteins into their correct conformations. A protein that is misfolded is retained by the ER and degraded. It is not known exactly how the ER recognizes misfolded proteins, but it may be able to recognize specific domains or segments on the proteins. For example, a **hydrophobic** domain (water-avoiding segment) should be tucked away inside the protein, but a misfolded protein may have this domain protruding outward. Such a protein would be retained and degraded.

### Smooth Endoplasmic Reticulum (sER)

Lipid synthesis takes place at the interface of the sER membrane and the **cytosol**. The initial starting material is embedded in the membrane while cytosolic enzymes and building materials continually modify it until the lipid product is complete. How do these lipids, which are made in the sER, get to the plasma membrane or other organelle membranes? There are two models. According to the membrane budding model, a patch of membrane pinches off the ER and forms a vesicle that finds its way to its destination.

In the phospholipid exchange model, water-soluble proteins remove the lipid from the ER membrane and release it into the target membrane.

The ER is also involved in cell signaling by releasing stored calcium ions ( $\text{Ca}^{2+}$ ) into the cytosol. This serves to amplify signals from molecules in very low concentrations, such as extracellular **hormones**, thus triggering a response in cells. Without amplification of the initial signal, the cells will not respond to the hormone. The chain of events can be summarized as follows: (1) a hormone binds to a specific receptor on the plasma membrane; (2) the receptor interacts with several other membrane-bound signaling proteins to produce a molecule called inositol 1,4,5-trisphosphate ( $\text{IP}_3$ ), which is released into the cytoplasm; and (3)  $\text{IP}_3$  interacts with its own receptor on the ER membrane and passes the signal on to a  $\text{Ca}^{2+}$  pump. Once the pump is activated, it releases a massive amount of calcium from the ER lumen into the cytoplasm. The  $\text{Ca}^{2+}$  ions act as “second messengers” that turn on several cellular systems ranging from cell motility to protein synthesis. SEE ALSO GOLGI; LIPIDS; NUCLEAR TRANSPORT; NUCLEUS; PROTEIN SYNTHESIS; RIBOSOME SIGNALING AND SIGNAL TRANSDUCTION

*Edward Harris and James Cardelli*

### Bibliography

Ellgaard, Lars, et al. “Setting the Standard: Quality Control in the Secretory Pathway.” *Science* 286 (December 3, 1999): 1882–1887.

Lodish, Harvey F., et al. *Molecular Cell Biology*, 4th ed. New York: W. H. Freeman and Co., 2000.

Putney, James W., Jr. “Kissin’ Cousins’: Intimate Plasma Membrane-ER Interactions Underlie Capacitative Calcium Entry.” *Cell* 99 (1999): 5–8.

## Entomologist

Entomologists study insects and their relatives and use their findings to help people, animals, and plants. Of the many branches of entomology, one of the most interesting is that related to **forensics**. Forensic entomologists help to solve crimes by identifying insects and insect remains at crime scenes. For example, some flies are found only in specific times and places. The police can use such information to determine where and when a crime occurred.

Other entomologists study insects that spread diseases in people. For example, malaria, an infectious disease that affects more people than any other, is spread by a mosquito. Entomologists’ specialized knowledge has helped to trace the spread of West Nile virus and Lyme disease in North America.

Entomologists specializing in nervous systems test new brain drugs on cockroaches. Since their nerves work very similarly to those in humans, one can tell if a drug has potential to work on illnesses such as Parkinson’s disease. Other entomologists use the existence of specific types of aquatic insects as indicators of water pollution. Many entomologists work in agriculture, helping prevent crop damage while minimizing the amount of pesticide used.

Most entomologists need to have at least a bachelor’s degree in entomology. With this degree, a person can work for private companies or the

**ion** an electrically charged particle

**hormone** molecule released by one cell to influence another

**forensic** related to legal proceedings



An entomologist sorts an insect collection from Guanacaste, Costa Rica, for the Institute for Biodiversity, which plans to inventory all living things in Costa Rica.

federal and state governments. Entomologists also work in sales and insecticide application. Usually an additional certification is needed for the latter.

If a student has done well academically while working for the bachelor's, then he or she may start work on the doctor of philosophy (Ph.D.) at any of a number of excellent universities worldwide. With this degree, the entomologist can get jobs as a director of research program or in college teaching. SEE ALSO AGRICULTURE; ARTHROPOD; EPIDEMIOLOGIST; INSECT

David L. Evans

### Bibliography

Romoser, William S., and John G. Stoffolano, Jr. *The Science of Entomology*, 4th ed. Boston: WCB/McGraw-Hill, 1998.

## Environmental Health

Environmental health describes the effects of civilization, culture, personal habits, pollution, population growth, and travel on human health. It is a new science that measures a variety of factors leading to acquired and **congenital** diseases. Acquired diseases are illnesses people get from exposure to harmful chemicals, injurious activities, and **pathogenic** organisms. Congenital diseases are caused by genetic defects or factors that harm fetal development.

Throughout history people have witnessed the increase in human disease with the growth of agriculture and cities. It was not until the late nineteenth century that people had scientific explanations for the cause of the diseases. Urban growth and overpopulation are associated with higher incidences of **communicable** diseases spread by insects, rats, and humans. Agriculture also resulted in a host of new human diseases. A variety of diseases, such as influenza, measles, and smallpox, may have been developed from diseases originally found in agricultural animals.

The role of pollution and health was not well known to the public until the publication of *Silent Spring*, written by Rachel Carson in 1962. She alerted people to the health effects of pesticides and other pollutants on humans and wildlife. Many scientists supported her views, and this resulted in the formation of the Environmental Protection Agency by the U.S. government in 1970. The National Institutes of Health was later set up to look at other environmental health issues. This agency focuses on illnesses associated with household and work environments. In 1948 the World Health Organization was formed by the United Nations to deal with international environmental health problems.

Occupational health and wellness includes health issues related to the work environment. Some issues include injuries due to certain activities or illness due to handling certain chemicals. Ergonomics is a field of study that has linked conditions such as carpal tunnel syndrome to repetitive hand actions such as continuous typing on a keyboard or handling automobile parts on an assembly line.

Mental health is also a concern of public health agencies working in environmental health. Abuse, poverty, violence, and stressful work environ-

**congenital** present at birth; inherited

**pathogenic** causing or capable of causing disease

**communicable** transmissible from person to person

In the past twenty years, plastics have become the most popular material for manufacturing a variety of products including automobiles, household goods, and medical devices. Plastics have replaced many traditional uses of glass, metal, and wood. They have permitted the development of fuel-efficient automobiles, lightweight airplanes, durable furniture, and safer food containers. With all these benefits comes a high environmental cost. Many scientists are discovering that many plastics leak pollutants capable of altering the body's endocrine system, which is responsible for body maintenance, growth, and reproduction.

ments are associated with mental illnesses. Public health agencies seek ways of changing the social environment in attempts to reduce mental disease.

Today, scientists are continuously conducting research linking environmental factors to human illness. There are two types of environmental health research: experimental research and epidemiological research.

Environmental health experiments involve laboratory and field tests that show how an environmental factor can cause a particular disease. For example, animal experiments are showing that many types of water pollution will cause birth defects, cancer, and reproductive disorders. Epidemiological research techniques involve collecting data associating a particular illness to a certain activity or environmental factor. The data are gathered through surveys, public medical records, and field studies. Air pollution has been linked to increases in asthma and emphysema in epidemiology human studies. This was determined by comparing high rates of asthma and emphysema to increased levels of air pollution in an area.

Laws prohibiting smoking in many public areas are recent examples of government policy based on environmental health research. Food safety regulations controlling the amount of pesticides in foods are another example. The Environmental Protection Agency set laws that limit pollution to levels that do not cause illness to humans and wildlife. SEE ALSO CARSON, RACHEL; DISEASE; EPIDEMIOLOGIST

*Brian R. Shmaefsky*

### Bibliography

Miller, Tyler. *Environmental Science, Sustaining the Earth*, 4th ed. Belmont, CA: Wadsworth Publishing Company.

U.S. Environmental Protection Agency. <[www.epa.gov](http://www.epa.gov)>.

U.S. National Institutes of Health. <[www.nih.gov](http://www.nih.gov)>.

World Health Organization. <[www.who.int](http://www.who.int)>.

## Enzymes

Enzymes are incredibly efficient and highly specific biological **catalysts**. In fact, the human body would not exist without enzymes because the chemical reactions required to maintain the body simply would not occur fast enough.

Think about the soda you drank moments ago before hitting the books. The sugar in the soda was converted to CO<sub>2</sub>, H<sub>2</sub>O, and chemical energy within seconds of being absorbed by your cells, and this chemical energy enabled you to see, think, and move. However, the 2.2-kilogram (5-pound) bag of sugar in your kitchen cabinet can sit for years and still not be converted to CO<sub>2</sub> and H<sub>2</sub>O. The net reaction (glucose + 6 O<sub>2</sub> → 6 CO<sub>2</sub> + 6 H<sub>2</sub>O) is the same in both cases, and both pathways are thermodynamically favorable. However, the human body speeds the overall reaction through a series of enzyme-mediated steps. The key is in the catalytic power of enzymes to drive reactions on a time scale required to digest food, relay signals via the nervous system, and contract muscles.

How do enzymes do what they do? They create an environment to make the reaction energetically more favorable. This environment, the **active site**,

**catalyst** substance that aids in a reaction without being used up

**active site** surface region of an enzyme where it catalyzes its reaction

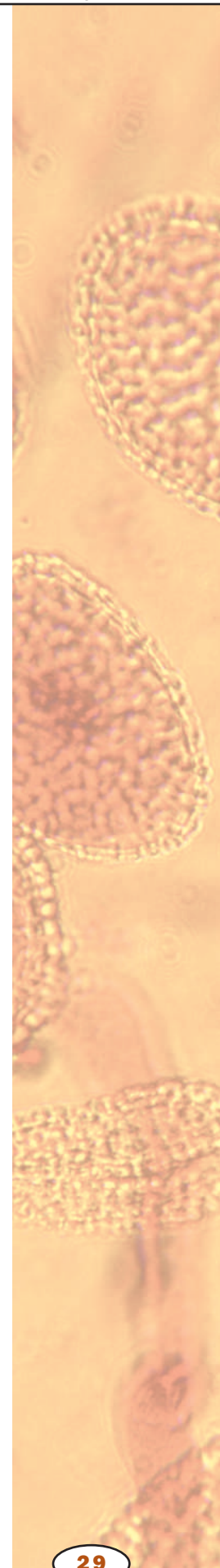

**amino acid** a building block of protein

**substrate** the molecule acted on by an enzyme

**protein** complex molecule made from amino acids; used in cells for structure, signaling, and controlling reactions

**pH** measure of acidity or alkalinity; numbers below 7 are acid, above are basic

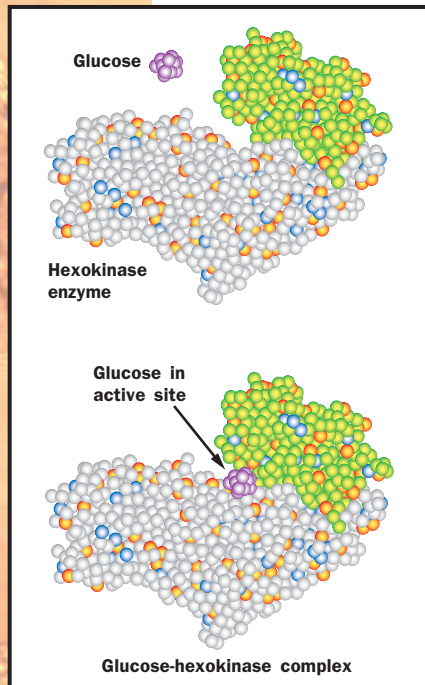

Figure 1. The active site is a groove or pocket on the enzyme surface, into which the substrate (here, a glucose molecule) binds and undergoes reaction.

**catalyze** aid in the reaction of

**glucose** simple sugar that provides energy to animal cells and is the building block of cellulose in plants

is typically a pocket or groove that is lined with **amino acids** whose side chains bind the **substrate** (such as sugar) and aid in its chemical transformation to products (see Figure 1). Therefore, the amino acids that form the active site provide the specificity of substrate binding and the proper chemical environment so that the reaction occurs more rapidly than it otherwise would.

Enzymes are central to every biochemical process that occurs in the body. Most enzymes are **proteins**. There are exceptions, however. For example, there are catalytic ribonucleic acid (RNA) molecules called ribozymes that are involved in RNA processing, and, in 1994, the first DNA enzyme was engineered. Although no naturally occurring deoxyribozymes have been identified, these laboratory-generated DNA enzymes are being developed as therapeutic agents to fight infectious disease and cancer.

All enzymes are characterized by having a high degree of specificity for their substrates, and they accelerate the rate of chemical reactions tremendously, often by a factor of a million times or more. Most enzymes function in the cellular environment at mild conditions of temperature, **pH**, and salt. There are few nonbiological catalysts that can be so efficient in this type of environment.

Enzymes play a critical role in everyday life. Many heritable genetic disorders (diabetes, Tay-Sachs disease) occur because there is a deficiency or total absence of one or more enzymes. Other disease conditions (cancer) result because there is an excessive activity of one or more enzymes. Routine medical tests monitor the activity of enzymes in the blood, and many of the prescription drugs (penicillin, methotrexate) exert their effects through interactions with enzymes. Enzymes and their inhibitors can be important tools in medicine, agriculture, and food science.

## Four Common Features of Enzymes

Enzymes exhibit four fundamental characteristics. First, enzymes do not make a reaction occur that would not occur on its own, they just make it happen much faster. Second, the enzyme molecule is not permanently altered by the reaction. It may be changed transiently, but the enzyme at the end of the reaction is the same molecule it was at the beginning. Therefore, a single enzyme molecule can be used over and over to **catalyze** the same reaction. Third, an enzyme can catalyze both the forward and the reverse reaction. One direction may be more favorable than the other, but the unfavorable direction of the reaction can occur. Fourth, enzymes are highly specific for the substrates they bind, meaning they catalyze only one reaction.

## How Enzymes Work

Take a look at Figure 2. Note that **glucose** ( $C_6H_{12}O_6$ ) in the presence of oxygen ( $6O_2$ ) will generate carbon dioxide ( $6CO_2$ ) and water ( $6H_2O$ ). The forward reaction from glucose to the top of the energy hill to carbon dioxide and water at the base is energetically favorable, as indicated by the “down-hill” position of the products. Because energy is released, the forward reaction sequence is called exergonic. Conversely, to synthesize glucose from  $CO_2$  and  $H_2O$  requires energy input to surmount the energy hill and drive the reaction in reverse; therefore, glucose synthesis is called endergonic.

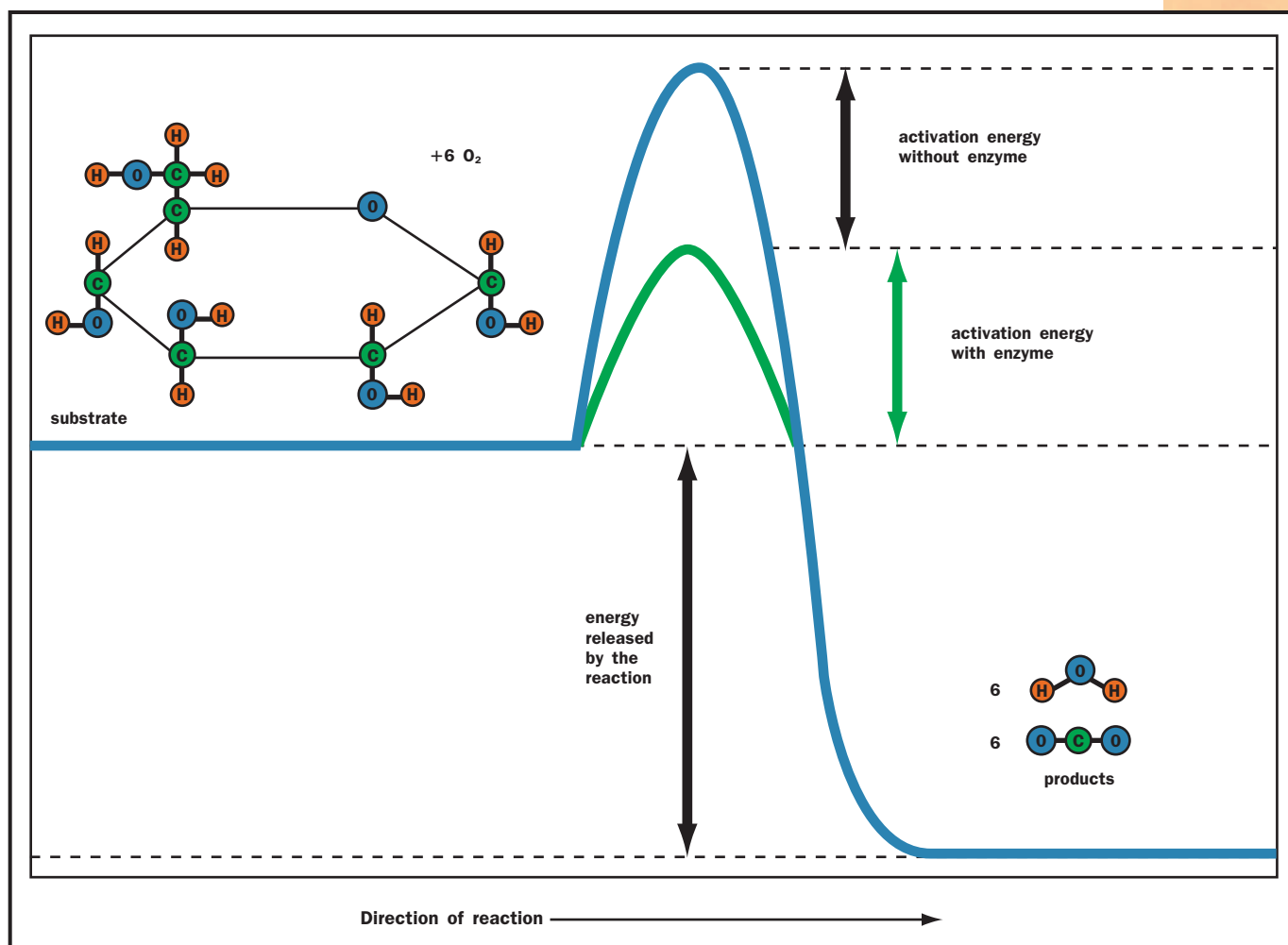

Every biochemical reaction involves both bond breaking and bond forming. The reactant molecules or substrates must absorb enough energy from their surroundings to start the reaction by breaking bonds in the reactant molecules. This initial energy investment is called the activation energy. The activation energy is represented by the uphill portion of the graph with the energy content of the reactants increasing. It is the height of this hilltop that is lowered by enzymes. At the top of the energetic hill, the reactants are in an unstable condition known as the transition state. At this fleeting moment, the molecules are energized and poised for the reaction to occur. As the molecules settle into their new bonding arrangements, energy is released to the surroundings (the downhill portion of the curve). At the summit of the energy hill, the reaction can occur in either the forward or the reverse direction.

Look again at Figure 2. The products  $\text{CO}_2$  and  $\text{H}_2\text{O}$  can form spontaneously or through a series of enzyme-catalyzed reactions in the cell. What enzymes do to accelerate reactions is to lower the energy activation barrier (green) to allow the transition state to be reached more rapidly. What is so special about the active site that allows it to accomplish this goal? Several mechanisms are involved.

Figure 2. An energy profile for the glucose reaction. An enzyme (green) enhances the reaction rate by lowering the amount of activation energy required to boost the reactants to the transition state at the summit of the energy barrier.

**ion** an electrically charged particle

**hydrolysis** splitting with water

**hydrophobic** “water hating,” such as oils

**catalysis** aiding in the reaction of

**complementary** matching opposite

**Proximity Effect.** Substrate molecules collide infrequently when their concentrations are low. The active site brings the reactants together for collision. The effective concentration of the reactants is increased significantly at the active site and favors transition state formation.

**Orientation Effect.** Substrate collisions in solution are random and are less likely to be the specific orientation that promotes the approach to the transition state. The amino acids that form the active site play a significant role in orienting the substrate. Substrate interaction with these specific amino acid side chains promotes strain such that some of the bonds are easier to break and thus the new bonds can form.

**Promotion of Acid-Base Reactions.** For many enzymes, the amino acids that form the active site have functional side chains that are poised to donate or accept hydrogen **ions** from the substrate. The loss or the addition of a proton ( $H^+$ ) can destabilize the covalent bonds in the substrate to make it easier for the bonds to break. **Hydrolysis** and electron transfers also work by this mechanism.

**Exclusion of Water.** Most active sites are sequestered and somewhat **hydrophobic** to exclude water. This nonpolar environment can lower the activation energy for certain reactions. In addition, substrate binding to the enzyme is mediated by many weak noncovalent interactions. The presence of water with the substrate can actually disrupt these interactions in many cases.

Enzymes can use one or more of these mechanisms to produce the strain that is required to convert substrates to their transition state. Enzymes speed the rate of a reaction by lowering the amount of activation energy required to reach the transition state, which is always the most difficult step in a reaction.

### Lock and Key or Induced Fit Model

The first ideas about substrate binding to the active site of an enzyme were based on a lock and key model, with the active site being the keyhole and the substrate being the key. When the right substrate entered the active site, **catalysis** occurred because the substrate was perfectly **complementary** to the active site. This model described some enzymes, but not all. For others, binding leads to conformational, or shape changes, in the enzyme active site to enhance the bond breakage and formation required to reach the transition state. In both models, the active site provides the tightest fit for the transition state, and the substrate is drawn into the transition state configuration as a result.

### The Cellular Environment Affects Enzyme Activity

**Temperature and pH.** Enzymes are sensitive to their environmental conditions. Up to a point, the rate of the reaction will increase as a function of temperature because the substrates will collide more frequently with the enzyme active site. At extremes of pH or temperature, either high or low, the native structure of the enzyme will be compromised, and the molecule will become inactive (see Figure 3). Note that there is a sharp decrease in the temperature optimum for typical human enzymes at approximately 40 degrees Celsius (104 degrees Fahrenheit). At temperatures greater than 40



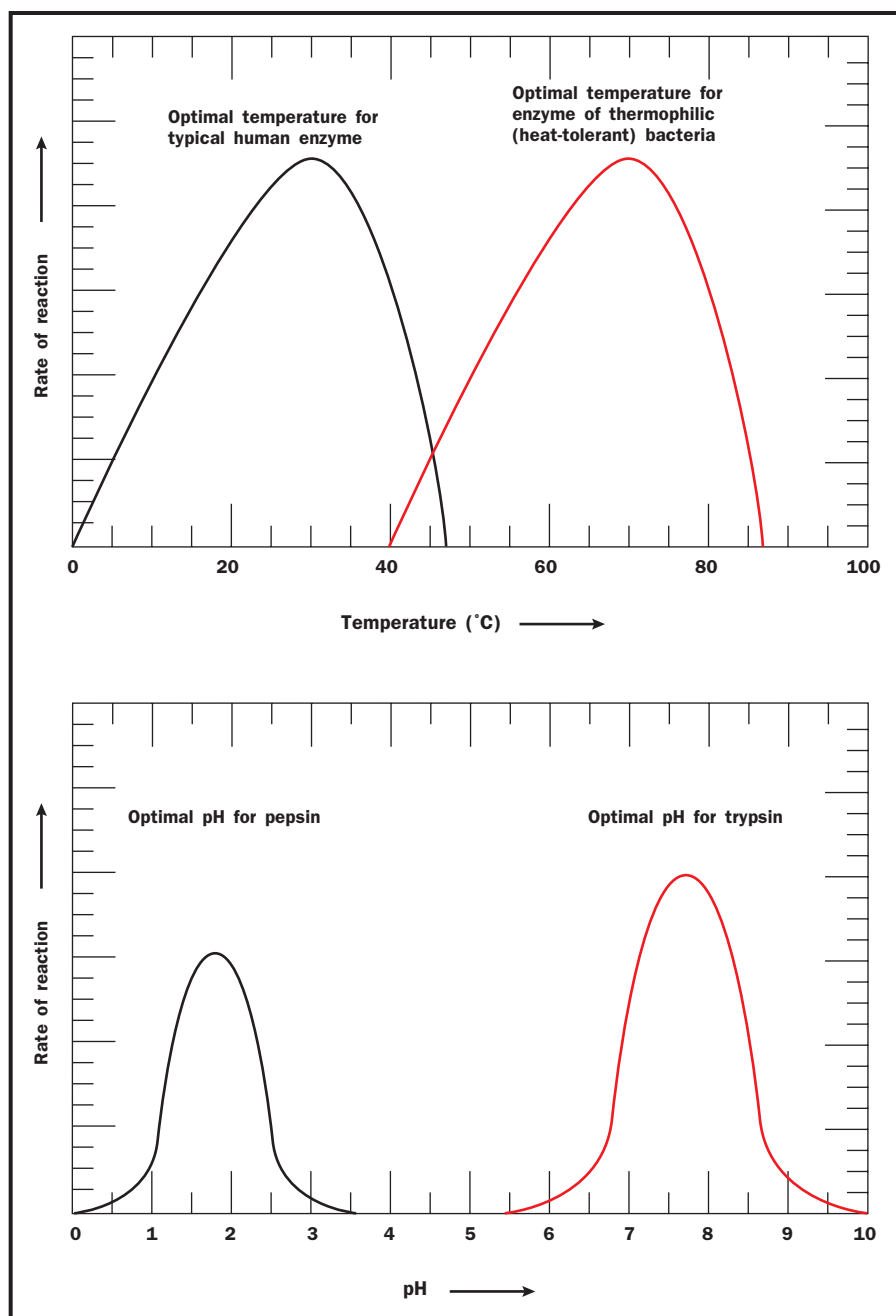
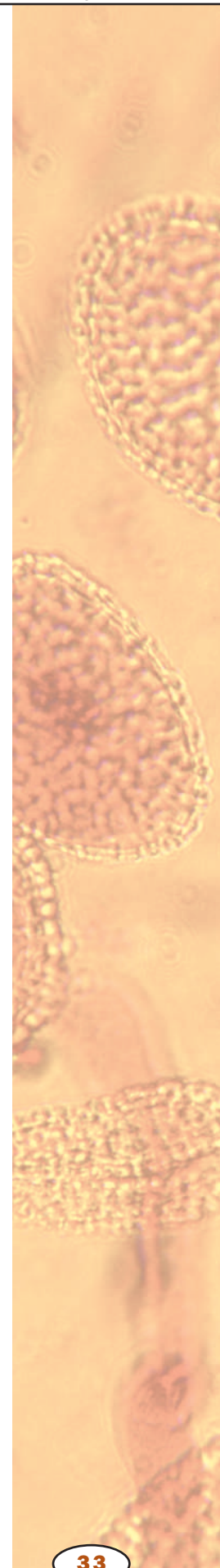

Figure 3. Temperature and pH profiles. Each enzyme has an optimal pH and temperature that favor the native conformation for maximum activity.



degrees Celsius, the enzyme degrades because the noncovalent interactions that stabilize the native conformation of the enzyme are disrupted. The enzyme in essence falls apart, and the active site is no longer able to function. In contrast, the optimal temperature for enzymes of the thermophilic bacteria (extremophiles) that live in hot springs is quite high at 70 degrees Celsius (158 degrees Fahrenheit), a temperature that would instantly scald skin.

Enzymes also show a pH range at which they are most active (see Figure 3). The pH effect results because of critical amino acids at the active site of the enzyme that participate in substrate binding and catalysis. The ionic or electric charge on the active site amino acids can enhance and stabilize interactions with the substrate. In addition, the ability of the substrate

**acidic** having an excess of  $H^+$  ions, and a low pH

**inorganic** not bonded to carbon

**organic** composed of carbon, or derived from living organisms

**eukaryotic cell** a cell with a nucleus

**intracellular** within a cell

**organelle** membrane-bound cell compartment

**lipid** fat or waxlike molecule, insoluble in water

**cytoplasm** material in a cell, excluding the nucleus

**mitochondria** subcellular organelle that creates ATP used for energy-requiring processes in a cell

**phosphorylation** addition of the phosphate group  $PO_4^{3-}$

**kinase** enzyme that adds a phosphate group to another molecule, usually a protein

and enzyme to donate or receive an  $H^+$  is affected by pH. The pH optimum differs for different enzymes. For example, pepsin is a digestive enzyme in the stomach, and its pH optimum is pH 2. In contrast, trypsin is a digestive enzyme that works in the small intestine where the environment is much less **acidic**. Its pH optimum is pH 8.

**Cofactors and Coenzymes.** Many enzymes require additional factors for catalytic activity. The cofactors are **inorganic** such as the metal atoms, zinc, iron, and copper. **Organic** molecules that function to assist an enzyme are referred to as coenzymes. Vitamins are the precursors of many essential coenzymes. Cofactors and coenzymes may remain at the active site of the enzyme in the absence of the substrate, or they may be present transiently during catalysis.

**Allosteric Inhibitors and Activators.** In addition to the active site where the substrate binds, an enzyme may have separate sites, called allosteric sites, where specific molecules can bind to increase or decrease the activity of the enzyme. The allosteric inhibitors and activators bind the enzyme through weak, noncovalent interactions and exert their effects by changing the conformation of the enzyme, a change that is transmitted to the active site. Typically, the allosteric modulators regulate enzyme activity by affecting substrate binding at the active site.

## Control of Metabolism

Although biochemical reactions are controlled in part by the specificity of substrate binding and by allosteric regulation, the human body could not function if all enzymes were present together and all operating maximally with no regulation. There would be biochemical chaos with substances being synthesized and degraded at the same time. Instead, the body tightly regulates enzymes through metabolic pathways and by controlling specific enzymes within a pathway. This approach allows an entire pathway to be turned on or off by simply regulating one or a few enzymes. Metabolic pathways can also be regulated by switching specific genes on or off.

**Compartmentation.** One of the major characteristics of **eukaryotic cells** is the presence of membrane-bound **intracellular organelles**. These structures help to segregate specific enzymes and metabolic pathways, especially when the pathways are competing with each other. For example, the enzymes that catalyze synthesis of fatty acids (a type of **lipid**) are located in the **cytoplasm**, while the enzymes that breakdown fatty acids are located in the **mitochondria**.

**Covalent Modification.** Enzymes can be activated or inactivated by covalent modification. A common example is **phosphorylation** of an enzyme (addition of a phosphate group to the amino acids serine, threonine, or tyrosine) mediated by another enzyme called a **kinase**. The phosphorylation is reversible, and other enzymes called phosphatases typically catalyze the removal of the phosphate group from the enzyme. The phosphorylated form of the enzyme is often, but not always, the active form. For some enzymes, the dephosphorylated form is active, and the phosphorylated state is inactive. Enzymes can also be activated by removing a fragment of the protein. Many of the digestive enzymes (trypsin, chymotrypsin) are synthesized and stored in the pancreas. They are secreted to the small intestine where

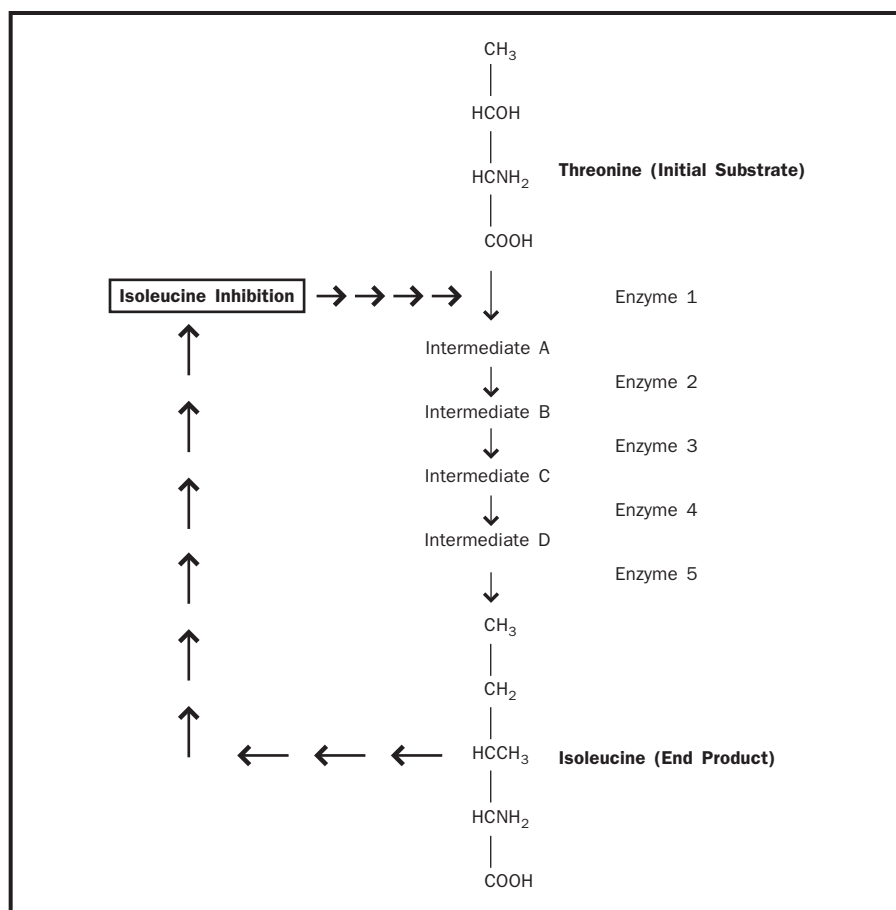

Figure 4. Feedback inhibition. Many metabolic pathways can be down regulated or turned off by an end product acting as an allosteric inhibitor of an enzyme earlier in the pathway. In this example, the product, isoleucine, inhibits the first enzyme in the pathway, threonine deaminase.

they are activated by removing or cleaving off a small portion of the protein. This “proteolytic” cleavage to activate an enzyme is irreversible but serves an important function to prevent the digestive enzymes from digesting the pancreas.

**Allosteric Regulation.** Allosteric modulators can increase or decrease the activity of an entire metabolic pathway by altering the conformation of a single enzyme. Sometimes, the end product of the metabolic pathway acts as an allosteric inhibitor by binding to the enzyme at its allosteric site, causing a conformational change in the enzyme to decrease the activity of the enzyme. This type of regulation is called **feedback** inhibition (see Figure 4).

**Cooperativity.** Frequently, enzymes are multisubunit complexes with more than one active site. Binding of the first substrate molecule may lead to conformational changes that are communicated to the other subunit(s) such that the binding of each additional substrate molecule is enhanced. Positive cooperativity can amplify the response of enzymes to substrates and provides an additional mechanism to regulate enzyme activity.

### Molecular Motors

Finally, enzymes can be thought of as nanomachines, powering the reactions of the cell to enable the human body to be the entity it is. There is a special class of enzymes called molecular motors that drive all the movements that occur in the body, including muscle contraction (myosin/actin),

**feedback** process in which the output or result influences the rate of the process

**cilia** short, hairlike cell extensions of the cell membrane formed by the cytoskeleton

**vesicle** membrane-bound sac

**neuron** nerve cell

flagella and **cilia** beating (dynein/microtubule), and **vesicle** movements in **neurons** (kinesin/microtubule). These molecular motors harness the energy from adenosine triphosphate (ATP) to drive actin-based or microtubule-based movements. SEE ALSO CELL MOTILITY; CONTROL MECHANISMS; CYTOSKELETON; GENETIC DISEASES; LIPIDS; MITOCHONDRION; VITAMINS AND COENZYMES

Susan P. Gilbert

### Bibliography

Breaker, Ronald R. "Making Catalytic DNAs." *Science* 290 (2000): 2095–2096.

Campbell, Neil A., Jane B. Reece, and Lawrence G. Mitchell. *Biology*, 5th ed. Menlo Park, CA: Benjamin/Cummings, 1999.

Deeth, Robert J. "Chemical Choreography." *New Scientist* 155 (1997): 24–27.

Koshland, Daniel E., Jr. "Protein Shape and Biological Control." *Scientific American* 229 (1973): 52–64.

Madigan, Michael R., and Barry L. Marrs. "Extremophiles." *Scientific American* 276 (1997): 82–87.

## Epidemiologist

An epidemiologist is a scientist who studies how diseases interact with populations. Most epidemiologists study the relationships between germs and people, but some investigate animal or plant diseases. These scientists study the factors involved in every aspect of a disease, including the start, spread, and treatment.

Three primary types of studies/reports are performed by epidemiologists: descriptive, analytical, and experimental. In descriptive studies epidemiologists determine the physical aspects of existing diseases. For example, they might record the number of cases of chicken pox in a given locale. Analytical studies report on the cause/effect relationships in a disease, such as the reasons behind increased numbers of cholera cases in a flood ravaged area or a decrease in influenza cases due to a mild winter. In experimental studies, epidemiologists test hypotheses about treatment of diseases such as the efficacy (success rate) of a hepatitis vaccine or testing experimental cures for HIV (human immunodeficiency virus) infections on animal models.

Epidemiologists work in a variety of settings, including the field (from urban health clinics to villages in Africa), the laboratory (testing vaccines), or the office (organizing and interpreting data).

In addition, epidemiologists work for a wide range of employers. Governmental services ranging from the Centers for Disease Control (CDC) to local city and county health departments employ many epidemiologists. International health centers such as the World Health Organization (WHO) track worldwide **pandemics** to localized **epidemics** across the globe. Hospitals often employ epidemiologists to assist them in disease control within the hospital. Epidemiologists also work in the private sector, often for pharmaceutical companies tracking the success rate of newly introduced drugs.

The degrees held by people working in epidemiology vary from associate degrees in health sciences to doctoral degrees specializing in epidemiology. Important secondary classes that could be taken to prepare for

**pandemic** disease spread throughout an entire population

**epidemic** rapid spread of disease through a population, or a disease that spreads in this manner

epidemiology training include microbiology, biology (advanced and general), medical terminology, biochemistry, and statistics. SEE ALSO BACTERIAL DISEASES; DOCTOR, SPECIALIST; HEALTH AND SAFETY OFFICER; SEXUALLY TRANSMITTED DISEASES; VIRAL DISEASES

Mark S. Davis

### Bibliography

Black, Jacquelyn G. *Microbiology Principles and Explorations*, 4th ed. Upper Saddle River, NJ: Prentice Hall, 1999.

## Epithelium

Epithelium is a tissue composed of sheets of cells that are joined together in one or more layers. Epithelia cover the body surface, line body cavities and hollow organs, and form glands. Epithelial tissue forms a barrier between the body and the external environment and plays important roles in protection, filtration, absorption, excretion, and sensation. The rapid regeneration of epithelial cells is important to their protective function. Impervious barriers between cells (tight junctions) allow some epithelia (as in the gut) to tightly regulate flow of materials across them. Glands typically contain clusters of epithelial cells that either secrete their products (such as **hormones**) into the bloodstream or secrete products (such as digestive **enzymes**) by way of ducts onto an epithelial surface, such as the epidermis or stomach lining.

Epithelia are classified on the basis of cell shape and number of layers: Squamous cells are thin and flat, cuboidal cells are cubical to round, and columnar cells are tall and cylindrical. A simple epithelium is composed of a single layer of cells, all of which contact a nonliving basement membrane below. A stratified epithelium is composed of two or more cell layers. Each of these classes has four types of epithelium (see table below).

Simple squamous epithelium is a single layer of flat cells, simple cuboidal epithelium has a single layer of cubical cells, and simple columnar epithelium has a single layer of columnar cells. Pseudostratified columnar epithelium is a simple epithelium that looks stratified because some of its cells are shorter than others and do not reach the free surface.

Stratified epithelia are named for the shape of the cells at the surface; the deeper cells may or may not have a different shape. In stratified

**hormone** molecule released by one cell to influence another

**enzyme** protein that controls a reaction in a cell

Type of Epithelium	Typical Locations	Typical Functions
Simple Squamous	lining of heart, blood vessels, and lungs	filtration and secretion
Simple Cuboidal	lining of kidney tubules and other ducts	secretion and absorption
Simple Columnar	lining of gastrointestinal tract	secretion and absorption
Stratified Squamous	epidermis of skin	protection
Stratified Cuboidal	lining of sweat gland ducts	protection
Stratified Columnar	lining of large ducts	protection
Transitional	lining of urinary bladder	elastic properties
Pseudostratified Columnar	lining of the upper respiratory tract	secretion and movement

**basal** lowest level

squamous epithelium, the surface cells are flat; in stratified cuboidal epithelium, the surface cells are cubical or round; and in stratified columnar epithelium, surface columnar cells rest on a **basal** layer of cuboidal cells. Transitional epithelium, a stratified type found only in the urinary tract, has cells that change shape and move across each other as an organ, such as the bladder, expands and contracts. SEE ALSO DIGESTIVE SYSTEM; GAS EXCHANGE; SKIN; TISSUE

Michael G. Scott

### Bibliography

Gartner, Leslie P., and James L. Hiatt. *Color Textbook of Histology*. Philadelphia, PA: W. B. Saunders, Co., 1997.

Tortora, Gerard J., and Sandra R. Grabowski. *Principles of Anatomy and Physiology*, 9th ed. New York: John Wiley & Sons, Inc, 2000.

## Estuaries

Estuaries are partially enclosed bodies of water that occur where the land meets the ocean. The world's largest estuaries are at the ocean ends of rivers that deliver freshwater from surrounding and sometimes remote upland areas. Estuaries may be configured as sounds, bays, lagoons, or networks of tidal creeks and marshes. Many estuaries are separated from the ocean by barrier islands and do not have major sources of freshwater inflow. Estuaries are more common on coasts with wide and shallow continental shelves than on coasts close to **tectonic plate** boundaries.

**tectonic plate** large segment of Earth's crust that moves in relation to other similar plates

**ecosystem** an ecological community and its environment

Estuaries are physically and chemically dynamic and complex **ecosystems**. Annual, seasonal, and daily fluctuations in freshwater input, tidal inundation, temperature, wind, and other hydrological and meteorological factors are responsible for the highly changeable character of estuaries. Due to variations in tidal height, currents, wave exposure, sediment types, salinity, and depth within estuaries, many different types of submerged and intertidal habitats exist. The diversity and interrelatedness of habitats contributes to the biological richness of estuaries.

**organic** composed of carbon, or derived from living organisms

**phytoplankton** microscopic floating creatures that photosynthesize

Temperate and tropical estuaries are among the most biologically productive ecosystems on Earth. Salt marshes dominated by *Spartina* grasses can produce 5 to 10 tons of **organic** matter per acre per year, which is more than most agricultural crops. In tropical estuaries, mangroves are the dominant producers. Submerged seagrass beds, macroalgae ("seaweeds"), and **phytoplankton** also produce organic material that supports abundant and diverse populations of animals. Direct consumption of estuarine plants is important, but many small estuarine animals process decomposing plant material and associated microbes known as detritus. Rich populations of invertebrates living in the sediments and water provide food for shrimps, crabs, fishes, birds, and mammals.

Estuaries support large commercial and recreational fisheries. Crabs, clams, oysters, herrings, drums, striped bass, and other harvested species reproduce and grow within estuaries and rivers. In addition, major fishery species such as shrimps, flounders, mullets, and menhaden, which spawn in the ocean, rely on estuaries as nurseries for juveniles. At least 70 percent of the species harvested in the United States requires a period of estuarine res-



An aerial view of the sandy Ravenglass Estuary in Cumbria, England.

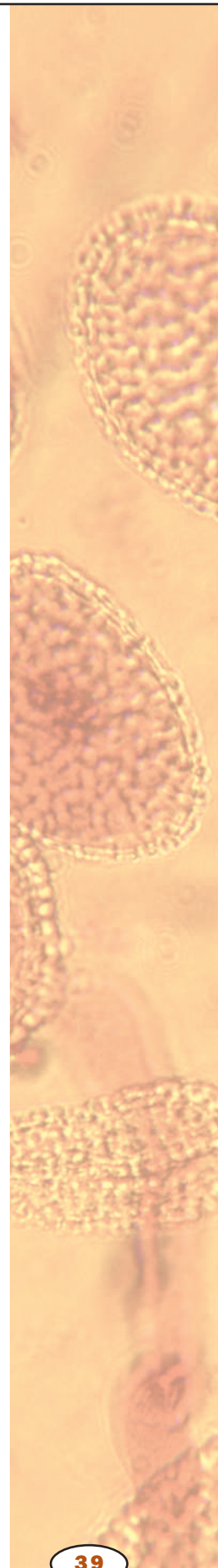

idency to complete their life cycles. Adult fish, marine mammal, and bird migrations are often timed to coincide with best conditions for reproduction and feeding in estuaries.

Coastal areas, especially estuaries, have always attracted and supported human populations. About 40 percent of the world's population lives within 60 miles of the coast, and 22 of the 32 largest cities are located on estuaries. Human impacts associated with agricultural, industrial, and residential development in coastal watersheds have resulted in changes in freshwater inflow, increases in nutrients, and the destruction of wetlands. Dredging, diversion, and damming have also altered estuarine habitats. Reductions in water and habitat quality and overharvesting have reduced resources and changed biological communities.

Healthy estuaries help to regulate flooding and decompose contaminants. Increasing awareness of impacts and advances in scientific knowledge and technology have led to some success in reducing impacts and restoring water quality. Education and long-term planning are keys to achieving a balance between sustaining economies and preserving the ecological

integrity of estuaries. SEE ALSO BIODIVERSITY; OCEAN ECOSYSTEMS: HARD BOTTOMS; OCEAN ECOSYSTEMS: SOFT BOTTOMS; PLANKTON; RIVERS AND STREAMS; WETLANDS

Dennis M. Allen

#### Bibliography

Day, John W., Jr., Charles A. S. Hall, W. Michael Kemp, and Alejandro Yanez-Arancibia. *Estuarine Ecology*. New York: John Wiley & Sons, 1989.

Teal, John, and Mildred Teal. *Life and Death of the Salt Marsh*. New York: Ballantine Books, 1969.

## Ethnobotany

Ethnobotany is a field of study that combines botany (the study of plants), anthropology (the study of human cultures), and medicine. Plants have been the original sources of many medicines used in all past and current societies. Many species of plants are biochemically quite complex, in part because they have had to evolve chemical defenses to deter herbivores and protect against attack from fungal, viral, and bacterial diseases. Thus, many of these same chemicals have been exploited by humans as treatment or prevention of diseases.

Ethnobotanists visit and learn from traditional healers in order to try to identify plants with valuable uses, particularly medicinal uses. Sometimes referred to as shamans, healers of every traditional culture are still using specific plants to treat specific health conditions based on generations of traditional knowledge and experience. In many cases, subsequent research by scientists has shown that the plant extracts used by the shamans contain chemical compounds that have natural healing or disease-fighting effects. In some cases, once the active chemical compound has been identified, scientists are able to synthesize, or create, it in the laboratory, and the plant is no longer needed. In other cases, the chemical or chemicals are too complex for easy synthesis, and the plant remains the raw material for the drug.

One controversial issue associated with ethnobotany is who should share the money that is produced when a plant compound, identified with the help of a traditional healer, is used by a major drug company to produce a very profitable drug. In many cases, the traditional peoples believe that they should receive some compensation since their knowledge was used by the drug companies for financial gain. In addition, sometimes the government of the country in which the plant grows believes that it should receive compensation since the plant species grows within their national boundaries. Compensation arrangements may be worked out in some cases. Another problem is that the culturally transmitted knowledge base of many traditional cultures is disappearing at a very rapid rate, as the traditional cultures themselves disappear or begin to adopt a more technology-based form of health care using manufactured medicines. Ethnobotanists may be in a race against time to preserve the knowledge of traditional healing systems before the practitioners die. SEE ALSO HERBAL MEDICINE; PHARMACOLOGIST

Mark A. Davis

#### Bibliography

Plotkin, Mark J. *Tales of a Shaman's Apprentice*. New York: Viking Penguin Books, 1993.



## Eubacteria

Bacteria are microscopic organisms that comprise the domain Eubacteria. A domain is the highest grouping of organisms, superseding the level of kingdom in the classical Linnaean system of biological classification. There are three domains, two of which, Eubacteria and Archaea, are composed entirely of **prokaryotic** organisms; the third domain, Eucarya, encompasses all other (**eukaryotic**) life forms, including the single-cell and multicellular protists, as well as animals, green plants, and fungi. Unlike eukaryotic cells, prokaryotic cells lack nuclei and other **organelles**, and tend to be less complex.

Eubacteria are differentiated from archaea primarily based on chemical composition of cellular constituents. For example, bacterial cell walls are composed of **peptidoglycan** (though there are examples of bacteria that lack cell walls) while archaeal cell walls are composed of a **protein-carbohydrate** molecule called pseudopeptidoglycan or other molecules. Bacterial cell membranes are composed of fatty acids joined to glycerol by ester bonds (COOC), while archaeal membranes are composed of isoprenoids rather than glycerol, linked to fatty acids by ether bonds (COC). In addition, the archaea have a more complex ribonucleic acid (RNA) polymerase than bacteria.

### Life Cycle

Reproduction in bacteria involves duplicating the genetic material and dividing the cell into two daughter cells, a process known as binary fission. Under very favorable conditions, certain bacterial cells can divide as often as once every twenty minutes. Some bacteria, such as *Clostridium* and *Bacillus* species, possess the ability to form a resting state, or “spore,” when unfavorable conditions are encountered. These spores are very resistant to heat, drying, radiation, and toxic chemicals. Bacterial spores have reportedly been reawakened from a 250-million-year-old salt crystal that existed before the time of the dinosaurs. Sterilization techniques used in medicine must overcome these resistant properties.

### Size and Shape

Prokaryotes range in size from 0.2 micrometers to more than 50 micrometers, although the average prokaryote is around 1 to 3 micrometers in size. Eukaryotic cells are approximately one order of magnitude larger, ranging in size from 5 to 20 micrometers in diameter, with an average size of 20 micrometers.

The bacteria come in a number of distinct shapes as well. Common shapes include spherical (coccus), cylindrical (rod), and spiral forms (spirilla). While bacteria are generally regarded as unicellular organisms, there are also examples of bacteria that exist as multicellular colonies, aggregates, or filaments. In addition, bacteria can aggregate on surfaces. Called biofilms, these assemblages can consist of a single species or communities of microorganisms that can participate in metabolic cooperation.

### Origin of Bacteria

It is not known whether the ancestor of bacteria originated on Earth or elsewhere. Some scientists believe that a life form existed extraterrestrially in

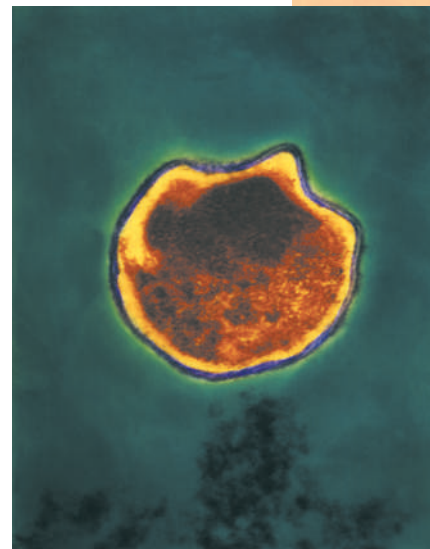

The spherical-shaped *Chlamydia pneumoniae* bacteria.

**prokaryotic** without a nucleus

**eukaryotic** with a nucleus

**organelle** membrane-bound cell compartment

**peptidoglycan** polymer that is composed of polysaccharide and peptide chains

**protein** complex molecule made from amino acids; used in cells for structure, signaling, and controlling reactions

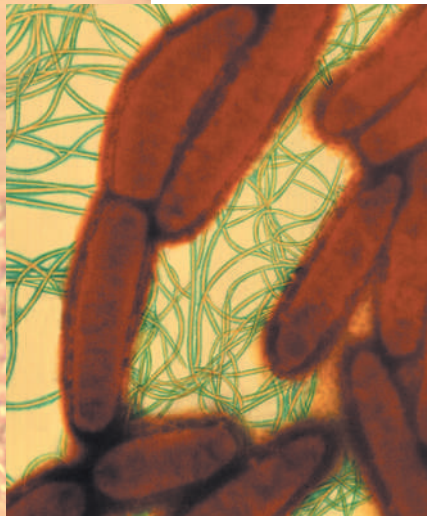

Colored transmission electron micrograph of the rod-shaped *E. coli* bacteria, showing its long flagellae.

**organic** composed of carbon, or derived from living organisms

**inorganic** not bonded to carbon

**pH** measure of acidity or alkalinity; numbers below 7 are acid, above are basic

**obligate** required or necessary, especially referring to a metabolic process or mode of nutrition

**aerobe** organism that needs oxygen

**anaerobe** organism not needing oxygen

$\alpha$  the Greek letter alpha

**genome** total genetic material in a cell or organism

the Martian meteorite ALH84001. Whether primitive life originated on Earth or elsewhere, current consensus is that bacteria were present on Earth 3.8 billion years ago.

## Diversity

Bacteria show an incredible range of metabolic diversity. Some bacteria can get their energy from light (these are referred to as phototrophic organisms), **organic** compounds (organotrophic), or **inorganic** compounds such as hydrogen ( $H_2$ ), sulfur compounds ( $H_2S$ ), inorganic nitrogen compounds or ferrous iron compounds (chemolithotrophic). Some bacteria can make all of their organic compounds by fixing carbon (autotrophic), while others need to break down organic compounds to provide a carbon source (heterotrophic). Many bacteria are capable of fixing atmospheric nitrogen as a nitrogen source, in addition to organic and inorganic sources of nitrogen. Because of this metabolic diversity, bacteria play an important role in biogeochemical cycles such as the carbon, nitrogen, and phosphorous cycles.

This metabolic diversity also permits them to occupy a wide range of habitats. Bacteria can thrive in extremes of temperature, **pH**, salt, pressure, or toxic substances. Some bacteria can survive these conditions by spore formation, while other bacteria are able to multiply under extreme conditions. The most primitive bacteria extant today are thermophiles, leading to the consensus view that life arose under extreme conditions. Within and between these extremes, bacteria are found in marine, aquatic, terrestrial and subterranean environments. There are bacteria that are **obligate aerobes** and some that are obligate **anaerobes**, and many that fall somewhere in between.

In recent years, highly conserved genes such as the gene coding for the small subunit ribosomal RNA have been used as principal taxonomic characters. As bacteria evolve over time the sequence of this molecule changes, allowing taxonomic relationships between bacteria to be discerned.

Many divisions exist within the Bacteria. An example of this diversity is the subdivision  $\alpha$ -proteobacteria, whose members are more diverse from each other than are plants from animals. More recently, full **genome** sequencing has revealed that genes can move between cells and even between species. Thus, bacterial genomes are in constant flux driven by gene acquisition from other species as well as evolutionary forces. The known bacterial tree of life is remarkable, but as 99 percent of bacterial life remains uncultured, this tree will undoubtedly expand greatly over time.

## Associations

While most bacteria are free living at some point of their life cycles, many bacteria are capable of living in close associations with other organisms, including eukaryotes. Some of these so-called symbiotic associations are so highly evolved as to be obligate, while other associations are facultative, meaning the symbiotic partners can live apart from each other. In some symbioses, the eukaryotic host provides a highly specialized structure within which the bacteria reside, such as the nitrogen-fixing root nodules found on leguminous plants, such as clover, or the rumen possessed by some herbiv-

orous mammals. Looser symbiotic associations exist where the host provides no specialized structure for the symbiotic bacteria. Organisms that populate the root zone of plants can provide growth benefits; these bacteria are in turn making use of plant products exuded through the roots.

There are also bacteria that are very harmful or even fatal to eukaryotic hosts. An example of this is *Yersinia pestis*, causative agent of the bubonic plague. Not all associations between bacteria and their eukaryotic hosts have such a drastic result. Many bacteria exist in relatively benign associations with their hosts, such as the *Escherichia coli* bacteria in the human large intestine. Some resident bacteria can become pathogenic under certain circumstances. These **opportunistic** pathogens can cause serious infection in hosts whose defenses are compromised by age or previous illness.

Some association can be very intimate, occurring on the **intracellular** level. It is generally accepted that the eukaryotic chloroplasts and **mitochondria** arose from associations between bacteria and other cells. These organelles are similar in size to bacteria and contain remnants of bacterial genomes. SEE ALSO ARCHAEA; BACTERIAL DISEASES; BACTERIAL GENETICS; BIOGEOCHEMICAL CYCLES; CELL WALL; CHLOROPLAST; EXTREME COMMUNITIES; MITOCHONDRION; NITROGEN FIXATION; SYMBIOSIS

Marisa K. Chelius, Angela D. Kent, Anthony C. Yannarell, and Eric W. Triplett

### Bibliography

- Friedmann, E. I., J. Wierzchos, C. Ascaso, and Michael Winklhofer. "Chains of Magnetite Crystals in the Meteorite ALH84001: Evidence Of Biological Origin." *Proc. Natl. Acad. Sci. USA* 98, no. 5 (2001): 2176–2181.
- Madigan, M. T., J. T. Martinko, and J. Parker. *Brock Biology of Microorganisms*, 9th ed. Upper Saddle River, NJ: Prentice Hall, 2000.
- Perry, J. J., and J. T. Staley. *Microbiology: Dynamics and Diversity*. Philadelphia, PA: W. B. Saunders, Co., 1997.
- Vreeland, R. H., W. D. Rosenzweig, and D. W. Powers. "Isolation of a 250-Million-Year-Old Halotolerant Bacterium from a Primary Salt Crystal." *Nature* 407 (2000): 897–900.

## Eudicots

The eudicots are the largest group of flowering plants (angiosperms). The term *eudicots* derives from the term "dicotyledons." Historically, **dicots** were the group of flowering plants characterized by having two seeds leaves upon germination, presence of woody or secondary growth, tap root system, reticulate (netlike) venation in the leaves, and flower parts in groups of four or five. Recent studies based on molecular **phylogenetic** evidence suggest that the dicotyledons are an evolutionarily natural, or **monophyletic**, group. However, a smaller, monophyletic, well-supported **lineage** termed the eudicots or "true dicots" contains the majority, but not all, of the former dicots.

There are approximately 319 families of plants within the eudicots, and these include about three-quarters of all flowering plant species. One of the most important defining morphological features of the eudicots is the presence of pollen grains having three, long, grooved apertures or openings, and in recognition of that fact, the eudicots are also known as the tricolpates.

**opportunistic** caused by a microorganism that is usually harmless but which causes an infection in an immunosuppressed person

**intracellular** within a cell

**mitochondria** subcellular organelle that creates ATP used for energy-requiring processes in a cell

**dicot** plant having two cotyledons, or seed leaves

**phylogenetic** related to phylogeny, the evolutionary development of a species

**monophyletic** a group that includes an ancestral species and all its descendants

**lineage** ancestral line

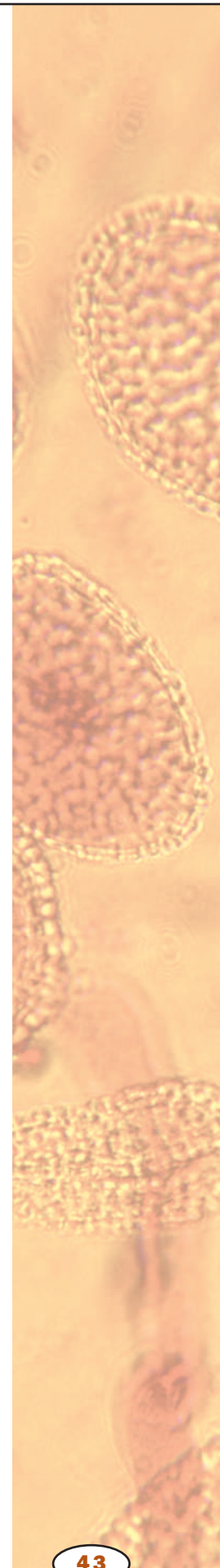



Some eudicots have evolved highly specialized associations with animal pollinators.

**organelle** membrane-bound cell compartment

**sepals** whorl of flower organs outside of the petals, usually green and serving to protect the flower before it opens

Many eudicots also exhibit a specific cell ultrastructure: The sieve elements (sap-conducting cells) contain **organelles** called plastids, which contain starch grains.

The eudicots are believed to represent one of the early radiations, or evolutionary expansions, of flowering plants, but the relationship of the eudicots to other flowering plant lineages is not well known. The eudicots include many familiar flowering plants. The earliest diverging lineage includes a group called the Ranunculales (including *Ranunculus*, the buttercups; *Podophyllum*, the mayapples; and *Papaver*, the poppies). Other groups within the eudicots include *Proteas* (grown as an ornamental) and related plants, the sycamore or plane tree family (Platanaceae), and the so-called “core eudicots.” The core eudicots are the largest group of eudicots and include a number of diverse plant families, such as the following groups and their relatives: the carnations, sandalwoods, saxifrages, geraniums, roses, and asters. The eudicots include many economically important plants, such as *Nicotiana tabacum* (tobacco), *Brassica oleracea* (cabbage, kale, and broccoli), the legumes (which include beans, peas, lentils, chickpeas, peanuts, and soybeans, among other crops), and *Solanum tuberosum* (potato).

The eudicots are one of the most diverse groups of flowering plants in terms of floral and vegetative shape, growth form, habitat, and association with animals for pollination, seed dispersal, or nutrition. Some eudicots, for example many woody trees (oaks, maples, hickories, and birches in the Northern Hemisphere), are wind-pollinated and have very reduced petals and **sepals**, while producing copious amounts of pollen. Others have evolved highly specialized associations with animal pollinators including many species of insects (including bees, butterflies, and moths), birds (especially hummingbirds) and even bats (some species of cactus are pollinated by bats).

Floral modifications characteristic of some eudicots include fusion of sepal and petal parts, and zygomorphic (asymmetrical) shape (for example, *Antirrhium*, the snapdragon and its relatives, and many flowers of the mint family). This trait often provides a “landing pad” projecting from the flower, and is often associated with insect pollination. The aster or composite family (for example, the common daisy, dandelion, and sunflower) has a unique type of inflorescence that is composed of many tiny flowers, some of which form the rays and look like petals, and others which form the disk flowers in the center of the composite head. SEE ALSO ANGIOSPERMS; FRUITS; MONOCOTS

Molly Neprokroeff

### Bibliography

- Judd, W. S., C. S. Campbell, E. A. Zimmer, and P. F. Stevens. *Plant Systematics: A Phylogenetic Approach*. Sunderland, MA: Sinauer Associates, 1999.
- Magallon, Susana, Peter R. Crane, and Patrick S. Herendeen. “Phylogenetic Pattern, Diversity, and Diversification of Eudicots.” In *Annals of the Missouri Botanical Garden* 86 (1999): 297–372.

## Evolution

The remains of stadiums, temples, and aqueducts indicate as clearly as any ancient document that the Roman Empire once existed. Likewise, fossils

speak eloquently of a time when dinosaurs and not humans dominated Earth. Even without ancient ruins, similarities in appearance, language, customs, and genetic makeup show that the Italians, Spanish, English, and French all came from the same ancestral culture. Likewise, similarities in structure and genetic makeup persuade humankind that algae and plants, insects and crustaceans, chimpanzees and humans came from the same ancestral species.

Evolution, which can be defined as the natural change in the inherited characteristics of groups of organisms, is as well established as the Roman Empire or any other event that is accepted as fact. Unfortunately, the common phrase “theory of evolution” has misled many people into believing that evolution is “only” a theory. To biologists, “theory of evolution” refers to a proposal about *how* evolution occurs, not *whether* it occurs. There are, in fact, several theories of evolution. Like evolution itself, some of these theories are well supported by observations and experiments.

### Development of Evolutionary Theory

Evolution is generally associated with Charles Darwin (1809–1882), but by the time he wrote about it in 1858, it had already been suggested by many people. In fact, Charles Darwin’s grandfather, Erasmus Darwin (1731–1802), was one of many who suggested that living species had descended from different species that had lived in the past. His theory of how evolution occurred was similar to that of French biologist Jean-Baptiste Lamarck (1744–1829) and was based on the belief that characteristics that develop in an adult can be passed on to its offspring. Thus, for example, giraffes could have evolved because their short-necked ancestors stretched their necks to reach higher leaves and therefore had offspring with longer necks. Both Lamarck and Erasmus Darwin were ignored, scorned, and ridiculed for this idea.

Charles Darwin was well aware of the controversy over evolution. As a theology student at Cambridge University with a passion for biology, he heard his professors dismiss evolution as nonsense, and he saw no reason to doubt them. Between 1831 and 1836, however, while serving as naturalist on an around-the-world voyage of *The Beagle*, young Darwin made observations that convinced him that evolution had, in fact, occurred. He saw that the fossil animals in parts of South America were different from, but similar to, the animals still living there. This gave Darwin the idea that living organisms were descendants of extinct ones that had lived in the same place in the past.

Darwin also observed that regions isolated from each other often had different but similar species. He noted, for example, that each of the Galapagos Islands had distinct species of mockingbirds. This suggested that all were descendants of the same ancestral species, and each had taken its own evolutionary path after being separated from the others. Darwin was also influenced by reading *Principles of Geology* by Charles Lyell (1797–1875). Lyell argued convincingly that geological changes were not caused by sudden global catastrophes, as most geologists then thought, but by gradual processes like erosion. This made Darwin realize that evolution must also have been gradual, otherwise organisms could not have remained adapted to their changing environments.

While in the Galapagos, Darwin did not come up with any answers as to why the forms of life were so different in those remote islands from the rest of the world. But a couple of years later, in 1837, he wrote the following in his journal: “In July opened first notebook on transmutation of species. Had been greatly struck from about the month of previous March on character of South American fossils, and species on Galapagos Archipelago. These facts (especially the latter) are the origin of all my views.”

A cactus finch in the Galapagos Islands, where Charles Darwin began to formulate his theory of evolution. Darwin observed that regions isolated from each other often had different but similar species.



Darwin eventually returned to England convinced of the reality of evolution. He knew, however, that no one else would believe it unless he could find a better theory to explain it than his grandfather and Lamarck had proposed. Since some of his relatives owned estates on which they had successfully altered domesticated animals by selective breeding, it occurred to Darwin that something like this artificial selection might explain evolution. But how could unconscious nature select which individuals would breed and which would not? Darwin studied agricultural journals, conducted breeding experiments, and pondered the question for months. Then one day in 1838 he decided to read (“for amusement,” he says in his autobiography) the famous piece *Essay on the Principle of Population* (1798) by Thomas Malthus (1766–1834).

### Natural Selection

The essential idea of this essay is now called the Malthusian Principle. It proposes that human population has a tendency to increase much faster than the food supply. Consequently, there will always be competition between those who can get food and those who cannot. Darwin saw in a

flash that the same principle applies to all organisms. Virtually all species have the natural ability to produce many more offspring than can survive with the available resources. Within any species there will be some individuals that are better able to compete for food, mates, and other resources, and they will be more likely than others to produce more offspring. Scientists would now say that they have a greater fitness. To the extent that their fitness is hereditary, their offspring will also be better able to compete, and so on, generation after generation. In this way the fitter individuals become increasingly numerous, and the species gradually evolves. Darwin gave his theoretical mechanism of evolution the name “natural selection.”

Natural selection may be the simplest yet most powerful theory in science. With it one can immediately see that evolution is not only possible but, given enough time, inescapable. All that is required is that there be competition among individuals of the same species, and that individual organisms have inherited traits that make some better able than others to compete. Darwin must have realized the importance of his theory. Rather than risk his budding reputation with a hasty report to a scientific journal, however, he began to accumulate supporting evidence for a book. Twenty years later he was still at work on his book when a remarkable coincidence forced him to publish. In 1858 he received a manuscript from an English collector in the East Indies, Alfred Russel Wallace (1823–1913).

As Darwin read the manuscript he was stunned to see that Wallace had hit upon the same theory of natural selection that he had been laboring over for two decades. Darwin reluctantly agreed to publish an outline of his ideas along with Wallace’s paper. (It was discovered later that the basic concept of evolution by natural selection had already been proposed almost thirty years earlier by a little-known Scotsman named Patrick Matthew [1790–1874]. Matthew had also been ignored.) Ultimately, what finally made the words “evolution” and “Darwinism” well known was Darwin’s book, *On the Origin of Species by Means of Natural Selection*, which was published in 1859. Its vast documentation and powerful arguments soon convinced the majority of biologists that evolution is a fact, and natural selection is one of the reasons why it occurs.

Since the publication of *On the Origin of Species*, few biologists have doubted that evolution occurs. By the early twentieth century, however, natural selection appeared to be heading toward extinction. One criticism of natural selection was that any adaptation that made an individual only slightly more fit would be diluted when the individual mated. For example, if a giraffe ancestor with a slightly longer neck mated with a normal member of its species, their offspring would have necks with lengths between that of the two parents. This reduction in neck length would continue with each generation. Thus any adaptation would be blended out of the species before natural selection would have a chance to favor it. In addition, beginning in 1900, genetic mutation seemed to provide an alternative theory that was better than natural selection. The discovery of the work of Gregor Mendel and further research on genetics suggested that new species resulted from large mutations occurring within a single generation instead of small mutations being selected over many generations.

**WALLACE, ALFRED  
RUSSEL (1823–1913)**

English-born naturalist and explorer who helped formulate the principles of biological evolution and natural selection. Wallace traveled more than 14,000 miles in the area that is now known as Indonesia and Malaysia and catalogued more than 125,000 biological specimens.

**HARDY, GODFREY HAROLD (1877–1947)**

Professor of mathematics at Trinity College and the University of Oxford and a leading mathematician who recognized, shortly after Weinberg, the relevance of Mendel's laws of inheritance to the study of population genetics.

**Neo-Darwinism**

By the middle of the twentieth century, however, biologists saw that Darwin's theory of natural selection was not really in conflict with genetics. They synthesized the two views, resulting in what is now called the neo-Darwinian or Synthetic Theory of Evolution. The neo-Darwinian theory was aided by a shift in thinking about the scale of evolution. Rather than conceiving of evolution as something that happened to entire species, biologists began to think of it as occurring within smaller groups of interbreeding organisms, called populations. Most species comprise many populations.

The neo-Darwinian Theory was also made possible by a mathematical proof called the Hardy-Weinberg equilibrium. The Hardy-Weinberg equilibrium showed that adaptations would not be blended out of populations, and it also showed that natural selection was indeed a possible cause of evolution. This proof, which was proposed in 1908 independently by English mathematician G. H. Hardy (1877–1947) and German physician Wilhelm Weinberg (1862–1937), shows that under certain conditions even rare mutations persist indefinitely. In modern terms, scientists would say that the Hardy-Weinberg equilibrium shows that the gene frequency—the proportion of a particular type of gene in a population—will remain constant if certain conditions occur. These conditions are as follows:

1. The size of the population is practically infinite.
2. Individuals in the population mate at random.
3. All individuals in the population have the same fitness, regardless of their genes.
4. There is no gain or loss of genes due to immigration into or emigration out of the population.
5. There is no new mutation in the population.

Violating any one of these conditions can lead to a change in gene frequency. This is important because changes in gene frequency can result in evolution. In fact, many biologists now define evolution as any change in gene frequency. As an example, suppose a genetic mutation had caused an ancestor of giraffes to have a slightly longer neck. A departure from the Hardy-Weinberg conditions could continually increase the frequency of that mutated gene in the population. Gradually the entire population would have longer necks. This process repeated over thousands of generations could cause that population to evolve into the giraffe. The Hardy-Weinberg equilibrium therefore amounts to a list of conditions that, if absent, can cause evolution. The potential causes of evolution include small population size, nonrandom mating, natural selection, immigration and emigration, and mutation.

**Small Population Size.** A change in gene frequency due to small population size is called genetic drift. Genetic drift is now recognized as one of the major causes of evolution, although its results are usually random rather than adaptive. Chance events operating in small populations can have huge effects on gene frequency. Imagine, for instance, an isolated population of a very rare, endangered species of mountain sheep, whose males have horns that are either curved or straight. If a severe snowstorm happened to kill

**WEINBERG, WILHELM (1862–1937)**

German physician, geneticist, medical statistician, and early founder of population genetics who demonstrated the importance of Mendel's laws to the genetic composition of populations.



the few sheep with genes for curved horns, the proportion of sheep with straight horns would increase greatly in future generations.

A related phenomenon, called a population bottleneck, occurs when a large population is decimated by disease, predation, or habitat destruction. The few surviving members constitute the “bottleneck” through which the species passes. The genes of those few members dominate the gene pool of future generations. Similarly, a population of organisms could differ from others simply because the few founders of the population happened to have a gene frequency different from that of the species as a whole. This is called the founder effect. The wide differences in blood group frequencies between the Old Order Amish of Pennsylvania and other U.S. populations of European ancestry is due to the founder effect operating in the Amish population. The role of genetic drift in species formation is an important area of research in evolution.

**Nonrandom Mating.** A second potential cause of evolution is nonrandom mating. Nonrandom mating usually occurs when individuals choose their mates. Animals often select mates on the basis of fitness, and the results of such sexual selection are indistinguishable from natural selection. On the other hand, mate selection can be based on characteristics that have nothing to do with fitness. For example, the tail feathers of the peacock or the bright coloration of the male pheasant are not thought to confer selective advantage in any arena other than mate selection. But because females choose the showier bird, the trait is selected for in males. This is called sexual selection.

**Natural Selection.** Natural selection, which is due to hereditary differences in fitness, is a third potential cause of evolution, as Charles Darwin argued. Natural selection is now considered to be the main, if not the only, cause of the evolution of adaptations that increase fitness. For example, the speed of the gazelle and the cheetah that chases it are both due to natural selection.

**Immigration and Emigration.** Immigration and emigration can bring in or remove particular genes. The global travel of human beings has increased the importance of these forces not only in human populations, but in many other species that travel with humans, such as Africanized honey bees. The so-called killer bees from Africa are currently changing the gene frequencies of bee populations in the southern United States.

**Mutation.** Finally, mutation can obviously change the frequency of a gene. Mutation can be especially potent when combined with genetic drift in small populations.

## Mutation

As noted earlier, many biologists once thought that mutation by itself was the major cause of evolution. In the 1920s, however, British biologist J. B. S. Haldane (1892–1964), British statistician Ronald A. Fisher (1890–1962), and American geneticist Sewall Wright (1889–1988) published three different mathematical proofs showing that mutation by itself is insufficient. They showed that a rate of mutation fast enough to cause evolution would also be fast enough to undo any evolution that had happened in the past. Scientists now know that mutations are too rare (about one per billion

A vertical strip on the right side of the page shows a microscopic view of honey bee cells, likely from a honeycomb. The cells are hexagonal and filled with a textured, golden-brown substance, possibly honey or wax. The lighting is warm and focused, highlighting the intricate patterns of the cells.

The Africanized honey bee was first found in the United States near Brownsville, Texas, in 1990. Since that time, the bees have spread throughout the state. They've also been found in Arizona, California and New Mexico.

A petri dish culture of antibiotic-resistant *Staphylococcus aureus*. Resistance to antibiotics evolves when antibiotics are used improperly, allowing the survival of a few bacteria with mutated genes that confer resistance.



**nucleotide** the building block of RNA or DNA

**nucleotides** per human lifetime) to account for most evolutionary change without the help of natural selection. Also, contrary to what Erasmus Darwin and Lamarck thought, scientists know of no way that the efforts or experience of an organism can induce specific, adaptive mutations in its offspring.

For a time, many biologists thought that natural selection was so rigorous that it would eliminate most mutations since most mutations were presumed to be harmful. Starting in the 1950s, however, it was found that genetic variations resulting from past mutations are quite abundant in most species. Most mutations have little effect on fitness, and they can accumulate generation after generation with little selection against them. With increased competition or some change in the environment, however, some of these mutations may result in differences in fitness. Natural selection can then bring about evolution by increasing the frequency of the beneficial mutations. Natural selection therefore seldom has to sit and wait for just the right mutation to come along and make an individual more fit. The mutations are usually already present in most populations.

### Microevolution and Macroevolution

Changes in gene frequency that occur within a population without producing a new species are called microevolution. As microevolution continues, a population may become so different that it is no longer able to reproduce with members of other populations. At that point, the population becomes a new species. As the new species continues to evolve, biologists might eventually consider it to be a new genus, order, family, or higher level of classification. Such evolution at the level of species or higher is called macroevolution.

Microevolution can occur very quickly; indeed, it is probably always occurring. For example, in less than half a century after the discovery of antibiotics, many bacteria evolved resistance to them. Resistance to antibiotics evolves when antibiotics are used improperly, allowing the survival of a few

bacteria with mutated genes that confer resistance. Natural selection then leads to the evolution of antibiotic-resistant strains. Pesticide-resistant insects and herbicide-resistant weeds are additional examples of rapid microevolution.

Macroevolution occurs over much longer periods and is seldom observed within the human life span. Occasionally, however, scientists do see evidence that new species have recently evolved. There are species of parasitic insects, for example, that are unable to reproduce except in domesticated plants that did not even exist a few centuries ago. The pace of evolution can be quite variable, with long periods in which there is little change being punctuated by relatively brief periods of tens of thousands of years in which most changes occur. This idea that the pace of evolution is not always slow and constant is referred to as **punctuated equilibrium**. It was first proposed by paleontologists Niles Eldredge and Stephen Jay Gould in 1979, and it is one of many examples of how scientists' views of evolution are continually changing.

Several possible mechanisms exist for rapid evolution. Chromosomal aberrations, such as breakages and rejoining of chromosomal parts, can introduce large changes in genes and the sequences that regulate them. This may lead to changes much larger than that brought about by simple point mutations.

Environmental catastrophes can set the stage for rapid evolution as well. It is thought that the extinction of the dinosaurs was triggered by a large comet impact. This rapid loss of the dominant fauna in many **ecosystems** opened up many new niches for mammals, which at the time were a small group of fairly unimportant creatures. The sudden appearance of many new opportunities led to rapid and widespread speciation, in a process called **adaptive radiation**.

Other areas of biology are also continually changing under the influence of evolution. For example, as Charles Darwin predicted in *The Origin of Species*, classification has become more than simply the grouping of organisms into species, genera, families, and so on based on how physically similar they are. Classification now aims to group species according to their evolutionary history. Thus two species that diverged recently from the same ancestor should be in the same genus, whereas species that shared a more distant common ancestor might be in different genera or higher taxonomic levels.

Until the 1980s, evolutionary history, or phylogeny, of organisms could only be inferred from anatomical similarities. Since that time, however, it has been possible to determine phylogeny from comparisons of molecules. Often this molecular phylogeny agrees with the phylogeny based on anatomy. For example, about 99 percent of the sequence of bases in the deoxyribonucleic acid (DNA) of chimpanzees and humans is identical. This finding confirms the conclusion from anatomy that chimpanzees and humans evolved from the same ancestor only a few million years ago. Such agreement between anatomical and molecular phylogeny would not be expected if each species were a totally different creation unrelated to other species, but it makes sense in light of evolution. It is one of many examples of the famous saying by the geneticist Theodosius Dobzhansky (1900–1975):

**punctuated equilibrium**  
pattern of evolution in which long periods of relatively little change are punctuated by rapid change

**ecosystem** an ecological community and its environment

**adaptive radiation**  
diversification of a group of organisms into several different forms that adapt to different environments

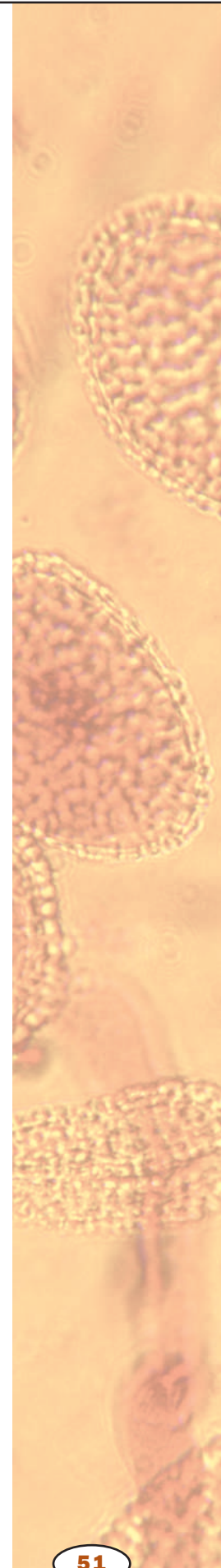

“Nothing in biology makes sense except in light of evolution.” SEE ALSO ADAPTATION; BUFFON, COUNT (GEORGES-LOUIS LECLERC); CONVERGENT EVOLUTION; DARWIN, CHARLES; ENDANGERED SPECIES; EVOLUTION, EVIDENCE FOR; EXTINCTION; HARDY-WEINBERG EQUILIBRIUM; LAMARCK, JEAN-BAPTISTE; NATURAL SELECTION; SPECIATION

C. Leon Harris

### Bibliography

- Dawkins, Richard, *The Selfish Gene*. Oxford: Oxford University Press, 1990.
- Freeman, Scott, and Jon C. Herron. *Evolutionary Analysis*, 2nd ed. Upper Saddle River, NJ: Prentice Hall, 2001.
- Futuyma, Douglas J. *Evolutionary Biology*, 3rd ed. Sunderland, MA: Sinauer Associates, 1998.
- Stanhope, Judith. *Hardy-Weinberg Equilibrium*. <[www.accessexcellence.org/AE/AEPC/WWC/1994/hwintro.html](http://www.accessexcellence.org/AE/AEPC/WWC/1994/hwintro.html)>.

## Evolution, Evidence for

Evolution is the unifying principle in biology. It explains the overwhelming diversity of life on Earth, as well as the constancy of molecular and morphological attributes observed in diverse assemblages of plants and animals. Charles Darwin’s publication of *On the Origin of Species by Means of Natural Selection* in 1859 marks the beginning of scientific understanding of how evolution has molded the history of life.

Darwin, along with his contemporary Alfred Russel Wallace, provided convincing and abundant evidence that all organisms, living and fossil, have descended with modification from a common ancestor and that the chief agent of modification is **natural selection**. Shortly after the publication of *The Origin of Species*, nearly all biologists accepted the premise that organisms have changed over time. However, the exact mechanisms of natural selection and the rates at which evolutionary changes occur are still subject to scientific discussion.

### Evidence from Living Organisms

Evidence for evolution comes in many forms, with some of the strongest derived from observations of living animals. First, there is the striking similarity among vertebrate embryos. Despite great variation in adult forms, early stages of embryonic development are virtually indistinguishable: the human embryo is not easily distinguished from the embryo of a fish or an elephant. This embryological similarity is consistent with a common ancestry among all vertebrates.

Second, there is the phenomenon of homology. Structures in two or more species are termed **homologous** if they can be traced back to a common origin. Clues to homology usually lie in the skeletal structure and its connections to surrounding parts, rather than to a similar function.

For instance, the forelimbs of a human, a seal, and a bird are all used for different types of locomotion, so one should not expect them to be identical. However, if one searches beyond the **superficial** structure of wings, fins, and arms and looks at the structural relationships of each bone, one will see that they are very similar. Each humerus is connected to a radius

**natural selection**  
process by which organisms best suited to their environments achieve greater reproductive success, thus creating more “fit” future generations

**homologous** similar in structure

**superficial** on the surface; not deep



and ulna, which are in turn connected to the bones of the hand. So, even though organs and bones may look drastically different and may serve very different functions, the fact that they can be identified as the same organ with modification supports evolution.

Finally, **vestigial** organs provide an indication of biological modification and change, in that they remain even when their original function is lost. For instance, whales are now fully marine organisms, but they evolved from terrestrial carnivores tens of millions of years ago. Whales retain remnants of pelvic elements situated near their “hips” that no longer have any clear function in hindlimb activity.

Additional evidence for evolution comes from the study of living populations. Some scientists take a macroscopic approach by documenting morphological and behavioral changes in natural laboratories. A good example of this type of work can be found in Jonathan Weiner’s *The Beak of the Finch* (1994). In this account of evolution in action, scientists visit island populations where they measure morphological attributes of animals and plants (for example, the beak size of finches in the Galapagos) and correlate those changes to environmental changes. They can follow the breeding patterns of populations over many generations and record changes that are passed along, thus developing an hypothesis of adaptation and natural selection.

On a molecular level, some of the strongest support for evolution lies in the deoxyribonucleic acid (DNA) of organisms. New techniques allow

Fossil of a fish, *Xiphactinus (Portheus) molossus*. Evolution cannot be understood without studying the fossil record.

**vestigial** no longer functional

**morphology** related to shape and form

**punctuated equilibrium** pattern of evolution in which long periods of relatively little change are punctuated by rapid change

**stasis** state of no change

scientists to extract and replicate DNA sequences that can then be compared to sequences from other animals. Because DNA ultimately controls both morphological and behavioral features in organisms, similarities and differences among DNA sequences can clearly reveal the path of evolution.

## Fossil Evidence

The distribution, **morphology**, and genetics of living populations all provide evidence for evolution, but the complete picture cannot be understood by the study of living populations alone. The origin of major new structures and body plans must be studied through the archive of evolution, the fossil record. In the sedimentary rocks deposited over the last several billion years of Earth's history the ancestry of living organisms can be traced, and the mysteries of species origination and extinction can be explored.

The 3.5-billion-year time frame for biologic evolution provided by the rock record is great enough for even the most improbable of events, such as rare mutations, to have occurred repeatedly. This archive of evolution was calibrated with the discovery of radioactive decay and the advent of radiometric dating in the mid-twentieth century. The absolute dates that define the modern geological time scale serve to guide scientific estimates of the time necessary for new genera and species to evolve by providing rates of change.

One of the main conceptual differences that continues to plague the scientific understanding of the evolutionary process is the question of evolutionary rates. Two main schools of thought have developed over the years. The traditional view is one of gradualism, with evolution proceeding slowly, through intermediate forms lost from the fossil record (missing links). There is some support for this view in the fossil record.

The alternative view of evolution is termed **punctuated equilibrium**, and it too is supported by patterns in the fossil record. Those who promote punctuated equilibrium hold that species evolution is driven largely by chance and occurs in pulses, whereas the maintenance of a species during its longevity is driven by selection and is viewed in the fossil record as relative **stasis**.

These ideas, both of which no doubt hold some credence, have revitalized debate extending across evolutionary topics, from the level of change within isolated populations to longer-term patterns. Most important, they have signified a general acceptance of the concept of evolution among biologists and have provided the impetus for paleontologists and biologists to probe deeper into the remaining mysteries of evolutionary pattern and process. SEE ALSO CONVERGENT EVOLUTION; CREATIONISM; DARWIN, CHARLES; EVOLUTION; PALEONTOLOGY; SPECIATION

*Kristina Curry Rogers*

### Bibliography

Carroll, Robert J. *Patterns and Processes of Vertebrate Evolution*. Cambridge, MA: Cambridge University Press, 1997.

Futuyma, Douglas J. *Evolutionary Biology*, 2nd ed. Sunderland, MA: Sinauer Associates, 1986.

Weiner, Jonathan. *The Beak of the Finch*. New York: Vintage Books, 1994.

## Evolution of Plants

Modern classification systems, based largely on molecular evidence, divide living organisms into three domains: Bacteria (also called Eubacteria), Archaea, and Eukarya. Plants are classified as a kingdom (Plantae) within the Eukarya; organisms that possess a **nucleus**, **mitochondria**, an internal **cytoskeleton**, and, in photosynthetic species, chloroplasts. Most scientists recognize three other eukaryotic kingdoms: Protista (most of which are single-celled organisms), Fungi, and Animalia (animals). The fungi, plants, and animals are thought to have evolved from different groups of protists.

Plants are multicellular organisms that have evolved the ability to live on land. The vast majority can carry out photosynthesis, but they are not the only organisms with this ability: many protists can photosynthesize too, as can several important groups of bacteria.

### Algae in Plant Evolution

Photosynthetic protists (commonly called algae) are a diverse group of organisms and are divided into several phyla. Many are unicellular, including most euglenoids (phylum Euglenophyta) and dinoflagellates (Dinophyta), and some diatoms (Bacillariophyta) and green algae (Chlorophyta). These, along with the cyanobacteria (often misleadingly called blue-green algae), form the **phytoplankton** of aquatic **ecosystems**. Others, including all brown algae (Phaeophyta), most red algae (Rhodophyta), and many green algae are multicellular. The large marine forms of these phyla are usually called seaweeds.

Plants are thought to have evolved from a class of freshwater green algae called the charophytes. Two particular groups of charophyte, the Coleochaetales and the Charales, resemble the earliest land plants (bryophytes) in a variety of ways, including the structure of their chloroplasts and sperm cells, and the way their cells divide during **mitosis**.

### The Importance of Vascular Tissue

Plants are classified into two main groups: the bryophytes (nonvascular plants) and the tracheophytes (vascular plants). Both groups have multicellular embryos, which indicates that they are closely related to each other and distinguishes them from the green algae. Indeed, true plants are often referred to as embryophytes because of this feature. The bryophytes consist of the liverworts, hornworts, and mosses, and as their name implies none of these plants possess vascular tissues.

All other plants, including the ferns, gymnosperms, and angiosperms, are classified as tracheophytes. These possess specialized vascular tissues—**phloem** and **xylem**—to transport sugars, water, and **minerals** throughout their bodies. The oldest known vascular plants appeared in the middle Silurian period (439–409 million years ago); the oldest known bryophytes appeared later, in the Devonian (409–354 million years ago). Despite this, most scientists believe that bryophytes evolved before vascular plants, and that the earliest bryophytes have not been found because they fossilize poorly. This belief is supported by a variety of evidence, including morphological traits, ultrastructural features visible under the electron microscope, and molecular information obtained from **gene** sequencing.

**nucleus** membrane-bound portion of cell containing the chromosomes

**mitochondria** subcellular organelle that creates ATP used for energy-requiring processes in a cell

**cytoskeleton** internal scaffolding in a cell, composed of protein

**phytoplankton** microscopic floating creatures that photosynthesize

**ecosystem** an ecological community and its environment

**mitosis** separation of replicated chromosomes

**phloem** plant tissue that conducts sugars from leaves to roots and other tissues

**xylem** water-transporting system in plants

**minerals** iron, calcium, sodium, and other elements needed by living organisms

**gene** portion of DNA that codes for a protein or RNA molecule

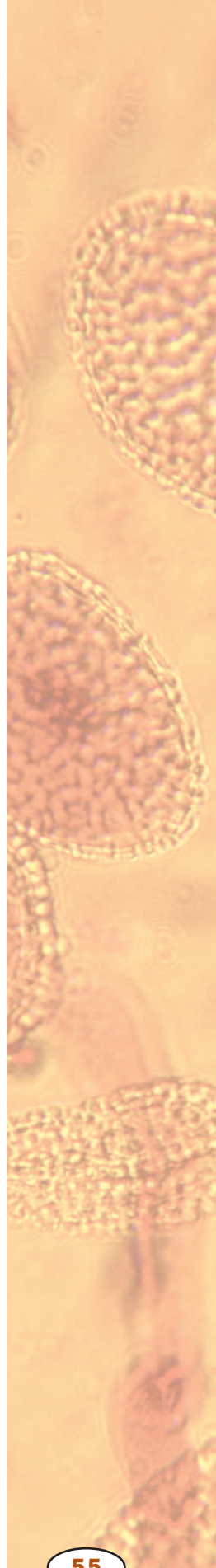

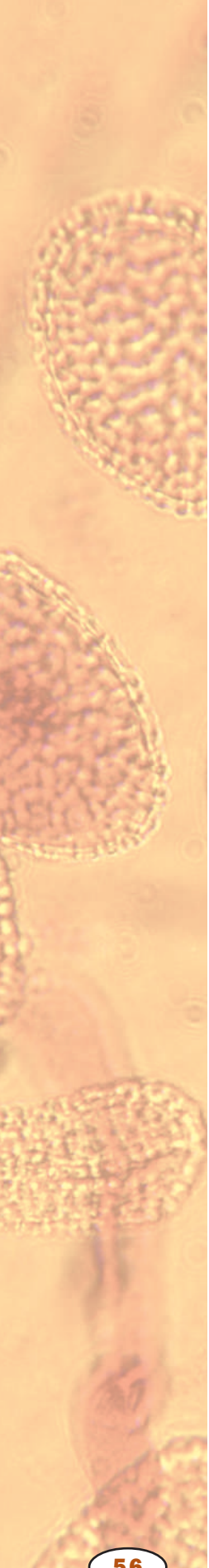

**lignified** hardened by impregnation with lignin, a compound formed in plants

**turgor** internal pressure

**gamete** reproductive cell, such as sperm or egg

**stomata** openings in leaves for gas exchange, surrounded and regulated by guard cells

**lignin** organic molecule used in plant cell walls to add stiffness to cellulose

**phylum** taxonomic level below kingdom, e.g., arthropod or chordate

## Bryophytes

Since bryophytes are land plants, they need to support themselves in air. However, because they lack **lignified** vascular tissues, this support must be provided largely by the **turgor** pressure of their cells. Consequently, they cannot grow to be very tall, and most bryophytes are small and rather inconspicuous. An additional important feature of their lifestyle is their reproductive system. The male **gametes**, produced by reproductive structures called antheridia, are free-swimming sperm cells that need water to transport them to the female gametes, which are enclosed within structures called archegonia. Because of the need for water, bryophytes are especially common in wet habitats such as bogs, streambanks, and in moist forests. However, they are not restricted to these habitats, and some mosses thrive in deserts, above the treeline, and in the Arctic tundra.

Among the living bryophytes, liverworts are probably most closely related to the earliest land plants, since unlike hornworts, mosses, and all vascular plants they do not possess **stomata**. Indeed, the fact that stomata first appeared in hornworts and mosses is evidence that vascular plants evolved from one of these two groups. Vascular plants appear to be more closely related to mosses than to hornworts, because some mosses possess food-conducting cells (leptoids) and water-conducting cells (hydroids) that resemble the phloem and xylem of vascular plants.

## Early Vascular Plants

The first detailed vascular plant fossils appear in rocks from middle Silurian, about 425 million years ago. The oldest of these, including a plant called *Aglaophyton*, appear to have possessed conducting cells similar to the hydroids of mosses. These ancient plants, which are sometimes called proto-tracheophytes, may have been an evolutionary link between the bryophytes and the true tracheophytes. Early vascular plants possessed two features that made them especially well adapted to life on land. First, their vascular tissues transported sugars, nutrients, and water far more efficiently than the conducting cells of mosses. Second, they evolved the ability to synthesize **lignin**, which made the cell walls of their vascular tissues rigid and supportive. Taken together, these features allowed them to grow much larger than their bryophyte ancestors and considerably reduced their dependence on moist habitats.

There are three major groups of tracheophytes: seedless vascular plants, gymnosperms, and angiosperms. Since the first appearance of tracheophytes in the Silurian, the fossil record shows three major evolutionary transitions, in each of which a group of plants that were predominant before the transition is largely replaced by a different group that becomes predominant afterward. The first such transition occurred in the late Devonian, approximately 375 million years ago. Prior to this time the most common plants were simple, seedless vascular plants in various phyla, several of which are now extinct. However, one **phylum** from this time, the Psilophyta, still has two living genera, including a greenhouse weed called *Psilotum*.

From the late Devonian until the end of the Carboniferous period (290 million years ago) larger, more complex seedless plants were predominant. The main phyla were the Lycophyta, the Sphenophyta, and the Pterophyta.



All three groups contain living relatives, including club mosses (Lycopodiaceae) in the Lycopphyta, *Equisetum* (the only living genus of sphenophytes), and ferns, which are pterophytes. Only the ferns, which have about 11,000 living species, are common today, but in the Carboniferous these three phyla comprised a large fraction of the vegetation on the planet. Many grew to the size of trees and dominated the tropical and subtropical swamps that covered much of the globe at this time.

The second major transition was the decline of the lycophytes, sphenophytes, and pterophytes at the end of the Carboniferous and their replacement by gymnosperms in the early Permian. Gymnosperms dominated the vegetation of the land for the next 200 million years until they themselves began to decline and were replaced by angiosperms in the middle of the Cretaceous. Although one group of gymnosperms (the conifers) is still abundant, the angiosperms have been the most diverse and widespread group of plants on Earth for the last 100 million years.

## Gymnosperms

The gymnosperms probably evolved from an extinct phylum of seedless vascular plants, the progymnosperms, that appeared about 380 million years ago. The fossils of these plants, some of which were large trees, appear to form a link between the trimerophytes (another extinct phylum of seedless vascular plants) and true gymnosperms. Progymnosperms reproduced by means of spores like the former, but their vascular tissues were very similar to those of living conifers. The oldest true gymnosperms, which produce seeds rather than spores, first appeared about 365 million years ago. The evolution of seeds, with their hard, resilient coats, was almost certainly a key factor in the success of the group. A second factor was the evolution of pollen grains to protect and transport the male gametes. As a consequence of this, gymnosperms, unlike seedless vascular plants, were no longer dependent on water for successful **fertilization** and could broadcast their male gametes on the wind.

Several early gymnosperm groups are now extinct, but there are four phyla with living representatives: the cycads, the gnetophytes, the conifers, and one phylum (Ginkgophyta) that has only a single living species, the ginkgo tree (*Ginkgo biloba*). Of these, the conifers are by far the most abundant and diverse, and many species are of considerable ecological and economic importance. Most conifers are well adapted to dry environments, particularly in their leaf **morphology**, and some can withstand severe cold. These features may have enabled them to thrive in the Permian, when Earth became much drier and colder than it had been in the Carboniferous.

## Angiosperms

The angiosperms, or flowering plants, are all members of the phylum Anthophyta. There are at least 250,000 species, making the group easily the most diverse of all plant phyla. They share a number of features that distinguish them from other plant groups. The most obvious of these is the possession of flowers, highly modified shoots that carry the male and female reproductive structures. They also carry out a process called double fertilization, in which two male gametes (sperm nuclei) are released from the pollen tube into the **ovule**. One of these sperm nuclei fuses with an egg cell

**fertilization** union of sperm and egg

**morphology** related to shape and form

**ovule** multicellular structure that develops into a seed after fertilization

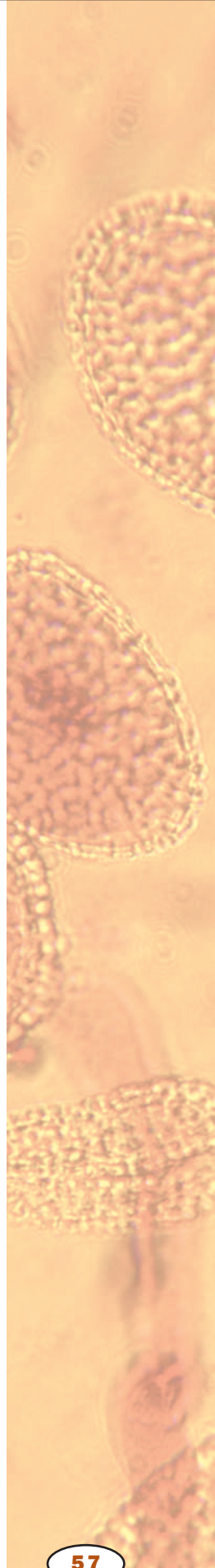

The ginkgo tree (*Ginkgo biloba*) is the only living species of the early gymnosperm phylum Ginkgophyta.



**triploid** possessing three sets of chromosomes

**endosperm** nutritive tissue within a seed

in a similar way to gymnosperms. The second nucleus (which degenerates in most gymnosperms) fertilizes other cells in the ovule called polar nuclei. Most commonly, two polar nuclei fuse with the sperm nucleus to form a **triploid endosperm** nucleus. The tissue that forms from this fusion is called endosperm, which in most angiosperms provides nutrients for the developing embryo.

A third feature that separates angiosperms from gymnosperms is that angiosperm embryos are protected by an ovary wall, which develops into a fruit after fertilization has taken place. In contrast, gymnosperm embryos are held relatively unprotected on the surfaces of ovule-bearing scales in the female cones.

### Angiosperm Evolution

Angiosperms first appear in the fossil record about 130 million years ago, and by 90 million years ago they had become the predominant group of plants on the planet. English naturalist Charles Darwin considered the sudden appearance of angiosperms to be an “abominable mystery,” and scien-

tists have debated about the origin of the group for many years. Comparative studies of living species suggest that angiosperms evolved from the gnetophytes, a group of gymnosperms with three living genera of rather strange plants: *Ephedra*, *Gnetum*, and *Welwitschia*. Double fertilization has been shown to occur in both *Ephedra* and *Gnetum*, and the reproductive structures (strobili) of all three genera are similar to the flowering stalks of some angiosperms. Some gene sequencing studies also indicate that gnetophytes and angiosperms are closely related to each other and to an extinct group of gymnosperms called the Bennettitales. However, more recent molecular studies suggest that gnetophytes are more closely related to conifers than they are to angiosperms.

In 1998, the discovery of an angiosperm-like fossil called *Archaeofructus*, which apparently existed 145 million years ago, also cast some doubt on the idea that angiosperms descended from gnetophytes or Bennettitales. Although a great deal of information has been obtained since the time of Darwin, the origin of angiosperms is still something of a mystery.

### Early Angiosperms, Monocots, and Eudicots

The oldest known angiosperms were a diverse group of plants called magnoliids. Some of these were herbs with simple flowers; others were woody plants with more complex flowers that were very similar to living magnolias. Magnoliids, probably those with small, inconspicuous flowers, gave rise to the two main groups of angiosperms, **monocots** and **eudicots**, although a few angiosperm families, including the water lilies, may have evolved earlier.

These plants possessed a number of adaptations that were probably crucial to their eventual success. Their vascular tissues were particularly efficient, their embryos were enclosed in a protective seed coat, their leaves were resistant to **desiccation**, and they were pollinated by insects, rather than by the wind. This last feature made pollen transfer much more efficient and was almost certainly a key innovation in the diversification of the group, as coevolution of plants and their pollinators, particularly bees, gave rise to increasing specialization of both flowers and insects.

The orchid family contains some of the most specialized insect-pollinated flowers of all and has more species (at least 24,000) than any other plant family. Other groups of angiosperms re-evolved the ability to be pollinated by wind. One of these groups—the grasses—appeared about 50 million years ago, diversified rapidly, and became the dominant plants over many regions of the planet. They still thrive and are crucial to human well-being. Approximately 54 percent of the food eaten by people is provided by grain (seed) from cultivated varieties of just three grasses: rice, wheat, and corn. SEE ALSO ALGAE; ANGIOSPERMS; ARCHAEA; BRYOPHYTES; CONIFERS; CYANOBACTERIA; EUBACTERIA; EUDICOTS; FRUITS; FUNGI; GYMNOSPERMS; MONOCOTS; PHOTOSYNTHESIS; PLANT; PROTISTA; PTERIDOPHYTES; SEEDLESS VASCULAR PLANTS; SEEDS

*Simon K. Emms*

#### Bibliography

Friedman, W. E., and S. K. Floyd. "The Origin of Flowering Plants and Their Reproductive Biology." *Evolution* 55 (2001): 217–231.

**monocot** plants having a single cotyledon, or leaf, in the embryo

**eudicot** "true dicot"; plants with two seed leaves that originated from the earliest of flowering plants

**desiccation** drying out

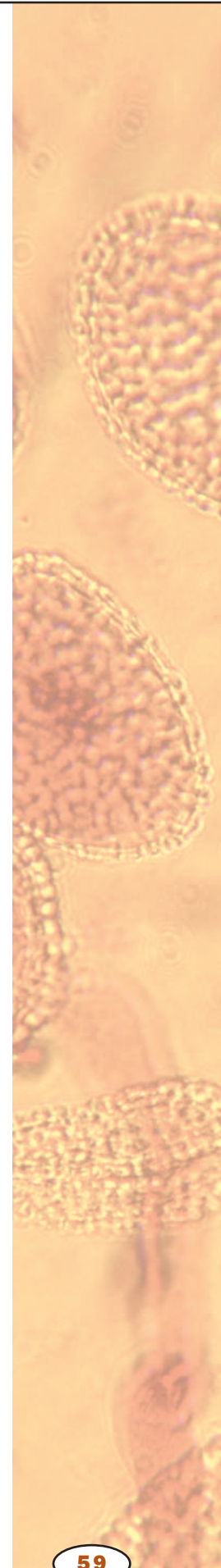

- Iwatsuki, K., and P. H. Raven, eds. *Evolution and Diversification of Land Plants*. Berlin, Germany: Springer-Verlag, 1997.
- Kenrick, P., and P. R. Crane. "The Origin and Early Evolution of Plants on Land." *Nature* 389 (1997): 33–39.
- Pryer, K. M., et al. "Horsetails and Ferns Are a Monophyletic Group and the Closest Living Relatives to Seed Plants." *Nature* 409 (2001): 618–622.
- Qiu, Y. L., et al. "The Earliest Angiosperms: Evidence from Mitochondrial, Plastid, and Nuclear Genomes." *Nature* 402 (1999): 404–407.
- Raven, Peter H., Ray F. Evert, and Susan E. Eichhorn. *Biology of Plants*, 6th ed. New York: W. H. Freeman and Company, 1999.
- Stewart, W. N., and G. W. Rothwell. *Paleobotany and the Evolution of Plants*, 2nd ed. Cambridge: Cambridge University Press, 1993.
- Sun, G., et al. "In Search of the First Flower: A Jurassic Angiosperm, *Archaeofructus*, from Northeast China." *Science* 282 (1998): 1692–1695.

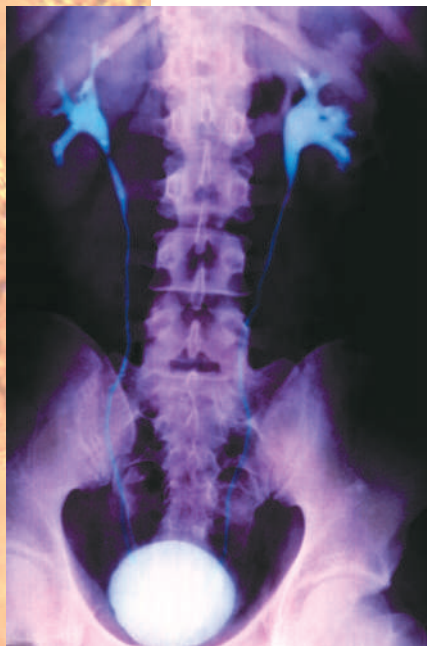

A color-enhanced normal intravenous pyelogram X ray displaying the drainage of urine from the kidneys through the ureter toward the bladder.

**excrete** deposit outside of

**metabolism** chemical reactions within a cell

**ion** an electrically charged particle

**osmosis** passage of water through a membrane in response to concentration differences

## Excretory Systems

Most animals require some system to **excrete** the waste products of **metabolism** from the body fluids. Kidneys are the major organs of the excretory systems of humans and other vertebrates, but several other kinds of excretory organs occur in other kinds of animals.

### Functions and Principles

Besides metabolic wastes, kidneys and other excretory organs also eliminate excess water, **ions**, or other substances that are taken in with food. Moreover, although they are referred to as excretory systems, what they retain in the body fluids is just as important as what they excrete. They are best viewed as systems that maintain a constant, or homeostatic, composition of the body fluids.

Water and ions are among the important components of the body fluids that must be maintained homeostatically. Cells will shrink if placed in a fluid that has too high an ion concentration because water will be drawn out of the cell by **osmosis**. Cells will swell in a fluid that is too dilute because water will be drawn into them by osmosis. Maintaining a balance of water and ions—osmoregulation—is another major homeostatic function of the excretory organs of most animals.

With few exceptions, the osmoregulatory and excretory functions are combined in the same organ, which generally works in two stages. First the organ filters blood or another body fluid into a tubule. Then as the **filtrate** passes through the tubule, needed molecules are pumped out of it and back into the body fluid. At the same time, metabolic wastes and excess water and other molecules in the body fluids are pumped into the filtrate by active transport. The resulting fluid, called urine, is eliminated through the open end of the tubule outside the body.

### Variety in the Animal Kingdom

In flatworms and a few kinds of invertebrates the excretory/osmoregulatory organ is a protonephridium. By definition, the protonephridium has a tubule that is open only at the end leading outside the body. The other end of the protonephridium has **cilia** or a flagellum that draws body fluid in to form

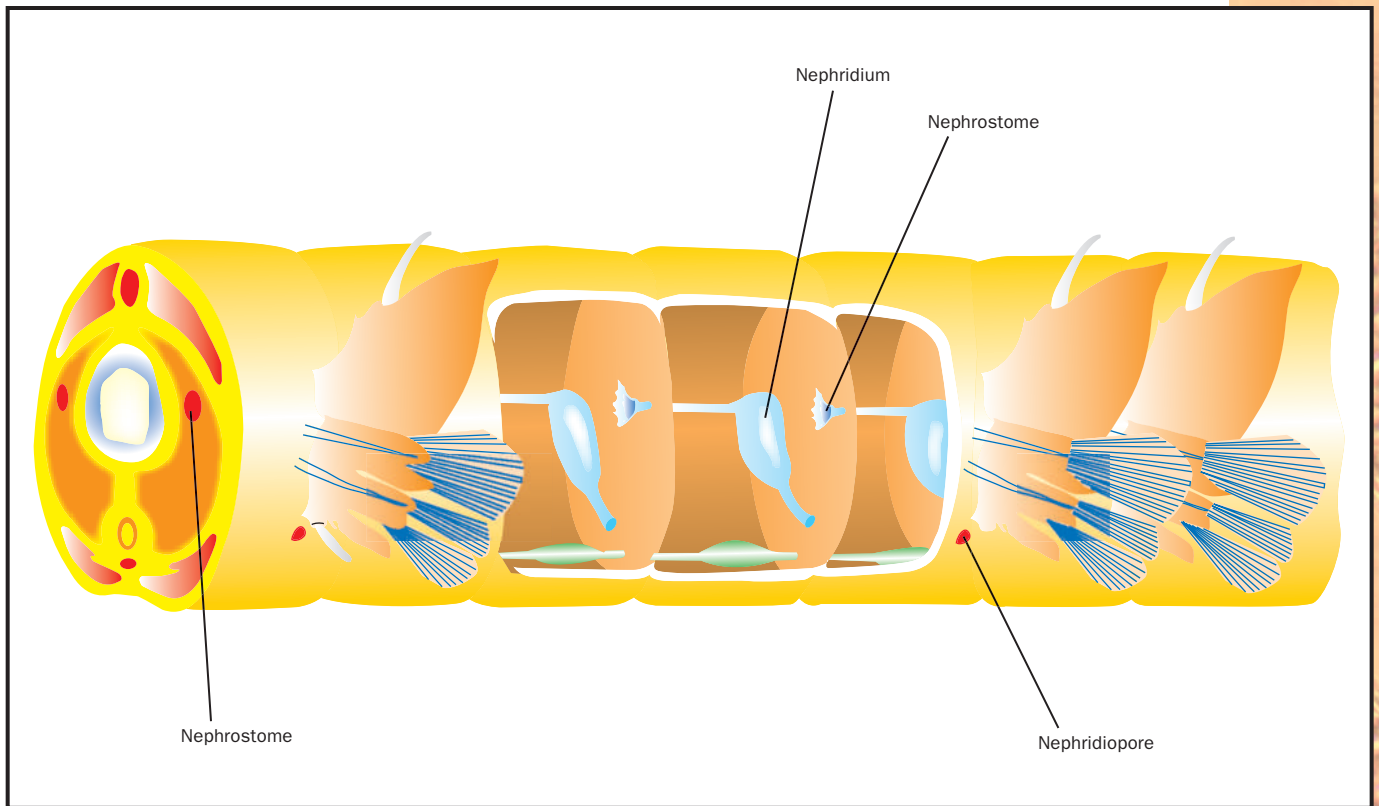

the filtrate. In most kinds of invertebrates, including earthworms, the organ is called the metanephridium (or sometimes simply nephridium). In the metanephridium the tubule is open at both ends, and the pressure of the body fluid forces the filtrate into the tubule.

Insects, crustaceans, spiders, and other **arthropods** have different types of excretory/osmoregulatory organs, but they too operate by filtration and active transport. In insects and spiders the main organs are Malpighian (pronounced mal-PIG-ee-yan) tubules, which are attached to the gut. For these terrestrial animals the problem is to conserve water, rather than eliminate it. Water, containing metabolic wastes and excess ions, is filtered into the Malpighian tubules and then joins the feces in the hind part of the gut. As the feces passes through the rectum, the water is pumped back into the body fluid.

In vertebrates the excretory/osmoregulatory organ is the kidney. The vertebrate kidney contains thousands or even millions of tubules, called **nephrons**, each one of which uses the same principles of filtration and active transport. One difference between kidneys and most other excretory/osmoregulatory organs is that kidneys filter blood rather than some other body fluid. Nephrons form a filtrate consisting of water, nutrients, ions, and other components of blood except cells and very large molecules. As the filtrate passes along the nephron tubule, nutrients, water, and other needed molecules are transported back into the bloodstream. Ions, metabolic wastes, and other excess molecules go into the resulting fluid. Finally, more water is removed from the fluid, transforming it into urine.

Metanephridia, the excretory organ in most invertebrates, including earthworms.

**filtrate** material passing through a filter

**cilia** short, hairlike cell extensions of the cell membrane formed by the cytoskeleton

**arthropods** organisms with jointed appendages and exoskeletons, including insects, spiders, and crustaceans

**nephron** functional unit of the kidney that performs filtration, reabsorption, and excretion

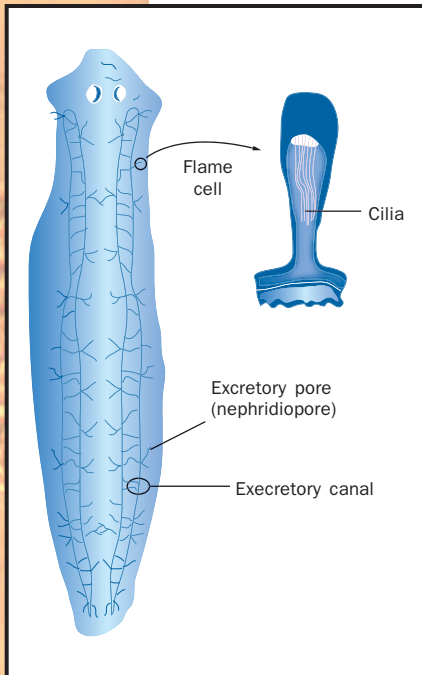

A protonephridia, the excretory organ of flatworms and some invertebrates.

**intracellular** within a cell

**vesicle** membrane-bound sac

**cytoplasm** material in a cell, excluding the nucleus

**constitutive** at a constant rate or continually

**protein** complex molecule made from amino acids; used in cells for structure, signaling, and controlling reactions

**endoplasmic reticulum** network of membranes within the cell

## Exceptions

There are two exceptions to the generalization that excretion and osmoregulation are performed by the same systems. The first exception occurs in animals that spend their entire lives in the fairly constant environment of the ocean. For them, osmoregulation is not needed because the balance of water and ions in the oceans is osmotically suitable for cells. (This is not surprising, considering that life most likely evolved in the oceans.) A starfish, for example, does not have or normally need an osmoregulatory system. If a starfish is placed in water with a higher concentration of salts than in the ocean, however, water will be drawn out of it by osmosis, and it will shrink. Conversely, if the starfish is placed in fresh water, it will swell and burst as water is drawn into the more concentrated body fluids.

The second exception to the rule that osmoregulation and excretion are performed by the same system occurs in some sponges and other relatively simple animals that live in fresh water. These animals osmoregulate by collecting excess water in each cell within a chamber called the contractile vacuole. When full, the contractile vacuole contracts and expels the water through the plasma membrane of the cell. The contractile vacuole is also called the water expulsion vesicle. SEE ALSO INSECT; KIDNEY; OSMOREGULATION; PORIFERA

*C. Leon Harris*

## Bibliography

Hickman, Cleveland P., Jr., Larry S. Roberts, and Allan Larson. "Homeostasis." In *Integrated Principles of Zoology*, 11th ed. Boston: McGraw-Hill Higher Education, 2001.

Saladin, Kenneth S. "The Urinary System" and "Water, Electrolyte, and Acid-Base Balance." In *Anatomy and Physiology*. Boston: McGraw-Hill Higher Education, 2001.

## Exocytosis

Exocytosis is the cellular process in which **intracellular vesicles** in the **cytoplasm** fuse with the plasma membrane and release or "secrete" their contents into the extracellular space. Exocytosis can be **constitutive** (occurring all the time) or regulated. Constitutive exocytosis is important in transporting **proteins** like receptors that function in the plasma membrane. Regulated exocytosis is triggered when a cell receives a signal from the outside.

Many of the products that cells secrete function specifically for the tissue type in which the cells reside or are transmitted to more distant parts of the body. Most of these products are proteins that have gone through rigorous quality control and modification processes in the **endoplasmic reticulum** and Golgi membranes. It is in the *trans*-Golgi network, the "downstream" end of the Golgi apparatus, where cellular products are sorted and accumulate in exocytic vesicles.

## Mechanisms

The mechanisms controlling regulated exocytosis were largely discovered in the 1990s. Contrary to early ideas, membranes normally do not fuse together spontaneously. This is due to the negative charges associated with

the phospholipids that make up the **lipid bilayer** of the membranes of vesicles and **organelles**.

Membrane fusion requires energy and the interaction of special “adaptor” molecules present on both the vesicle and plasma membrane. The adapter molecules are highly selective and only allow vesicles to fuse with membranes of particular organelles, thus preventing harm to the cell. Once the appropriate adapter molecules bind to each other (docking), energy stored and released by **ATP** forms a fusion pore between the vesicle membranes and plasma membrane. The contents of the vesicle are released to the exterior of the cell (or the interior of an organelle) as the fusion pore widens. The vesicle ultimately becomes part of the plasma membrane or is recycled back to the cytoplasm.

## Purpose of Exocytosis

Many cells in the body use exocytosis to release **enzymes** or other proteins that act in other areas of the body, or to release molecules that help cells communicate with one another. For instance, clusters of **α**- and **β**-cells in the islets of Langerhans in the pancreas secrete the **hormones** glucagon and insulin, respectively. These enzymes regulate **glucose** levels throughout the body. As the level of glucose rises in the blood, the **β**-cells are stimulated to produce and secrete more insulin by exocytosis. When insulin binds to liver or muscle, it stimulates uptake of glucose by those cells. Exocytosis from other cells in the pancreas also releases digestive enzymes into the gut.

Cells also communicate with each other more directly through the products that they secrete. For instance, a **neuron** cell relays an electrical pulse through the use of **neurotransmitters**. The neurotransmitters are stored in vesicles and lie next to the cytoplasmic face of the plasma membrane. When the appropriate signal is given, the vesicles holding the neurotransmitters must make contact with the plasma membrane and secrete their contents into the synaptic junction, the space between two neurons, for the other neuron to receive those neurotransmitters.

Components of the vesicle and extra neurotransmitter molecules are quickly taken up and recycled by the neuron to form new vesicles that are ready to send another pulse to an adjacent neuron. Neurons need to send many signals each second, which indicates how tight the controls are that regulate exocytosis.

The immune system also uses exocytosis to communicate information between cells. An immune cell can tell a virally infected cell that it must destroy itself to preserve other cells around it. A cell that is infected with a virus displays viral by-products on its surface, which is equivalent to the cell turning on red warning lights to attract immune cells.

Immune cells, such as the killer **T cells** that wander throughout the body, recognize the viral by-products and position themselves very close to the infected cell so that there is very little space between their plasma membranes. In a rapid succession, the killer T cells mobilize secretory vesicles filled with enzymes like perforin and granzyme B adjacent to the inner side of their plasma membranes. In response to a signal, the vesicles undergo exocytosis and release their contents. These enzymes then punch holes in the

**lipid** fat or waxlike molecule, insoluble in water

**bilayer** composed of two layers

**organelle** membrane-bound cell compartment

**ATP** adenosine triphosphate, a high-energy nucleotide used by cells to power most energy-requiring reactions

**enzyme** protein that controls a reaction in a cell

**α** the Greek letter alpha

**β** the Greek letter beta

**hormone** molecule released by one cell to influence another

**glucose** simple sugar that provides energy to animal cells and is the building block of cellulose in plants

**neuron** nerve cell

**neurotransmitters** molecules released by one neuron to stimulate or inhibit another neuron or cell

Botulinum toxin, responsible for botulism poisoning, paralyzes muscles by disabling one of the adapter proteins in nerve cells.

**T cell** white blood cell that controls the immune response

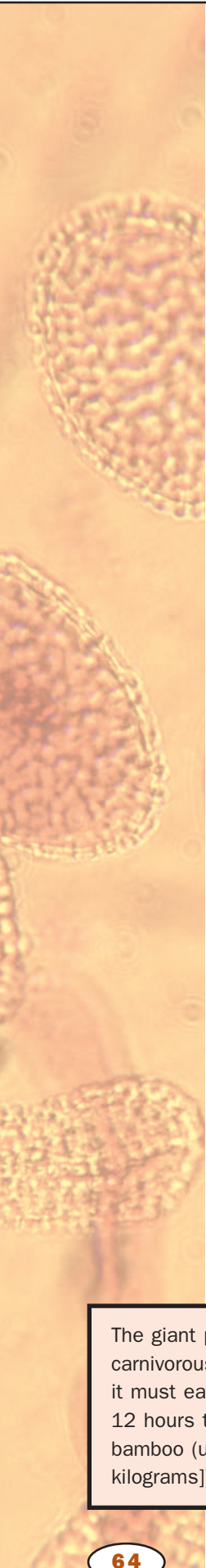

**lineage** ancestral line

plasma membrane of the infected cell. This causes the cell to undergo self-destruction or apoptosis, also known as programmed cell death, to prevent further spread of the virus. SEE ALSO BLOOD SUGAR REGULATION; ENDOCYTOSIS; ENDOPLASMIC RETICULUM; GOLGI; PROTEIN TARGETING

*Edward Harris and James Cardelli*

### **Bibliography**

Cooper, Geoffrey M. *The Cell: A Molecular Approach*, 2nd ed. Sunderland, MA: Sinauer Associates Inc., 2000.

Lodish, Harvey F., et al. *Molecular Cell Biology*, 4th ed. New York: W. H. Freeman, 2000.

## **Extinction**

Extinction is the termination of evolutionary **lineage**. The most common extinction event is the loss of a species. There are many reasons why a species might die out. Human intervention (either directly or indirectly) has become the leading cause of species extinction (possibly for the last fifteen thousand years).

### **Species and Populations**

An important distinction must be made between true extinction and extirpation. Extirpation is the loss of a population, or loss of a species from a particular geographic region. A famous twentieth-century example is the extirpation of wolves from the Yellowstone region of Wyoming. The park service reintroduced wolves to Yellowstone in the 1990s, and these predators appear to be adapting well to their new home. True extinction must also be differentiated from pseudoextinction. Biologists studying the changes that take place in a lineage over time often designate distinct morphological stages as separate species. The extinction of a species in this context is not the result of the termination of a lineage, but rather the transformation into a new form.

A clear understanding of the definition of a species is necessary in order to discuss extinction. This is not a simple question, but one view defines a species as a population of potentially interbreeding individuals that is reproductively isolated from other such populations. By this definition the relatively common mating between coyotes and domestic dogs raises the question of the validity of their separate species status.

### **Environmental Change**

Species go extinct primarily because they are unable to adapt to a changing environment. Animals with specialized food or habitat requirements, such as the giant panda (which feeds almost exclusively on bamboo), are particularly susceptible to environmental changes. Generalist species that feed on many types of food and live in a variety of settings are much more able to survive in a changing environment. For example, raccoons are common city dwellers, where they forage from trash cans instead of from streams. In addition, species with long generation times that produce few offspring are often vulnerable to extinction. If a population of animals is very small, it is subject to extinction from a variety of factors, such as disturbances and dis-

The giant panda actually has a carnivorous digestive system, so it must eat voraciously for 10 to 12 hours to consume enough bamboo (up to 66 pounds [30 kilograms]) each day.





A dinosaur skeleton on display at the Royal Terrell Museum in Dinosaur Provincial Park in Alberta, Canada.

eases. Organisms with short generation times that produce a lot of offspring, for example, many rodents and insect species, are often capable of increasing their populations quickly and therefore become less vulnerable to extinction. However, animals such as the rhinoceros or Siberian tiger take several years to mature and when they do reproduce only give birth to one or two offspring. Thus, species such as these cannot rebound from low populations quickly and thus are more likely to go extinct.

A firm grasp of ecological principles is crucial to an understanding of how species interactions can lead to extinction. Two species with significantly overlapping niches are unlikely to coexist over time unless some mechanism prevents either species from reaching its carrying capacity (the maximum number of individuals the habitat can sustain). Typically the species that is better adapted will drive the other species to extinction. This phenomenon is particularly important because of the widespread introduction of exotic species by humans. Many studies have shown the impact of domestic cats and dogs on native prey species. Less obvious, however, is their competitive impact on native predators.

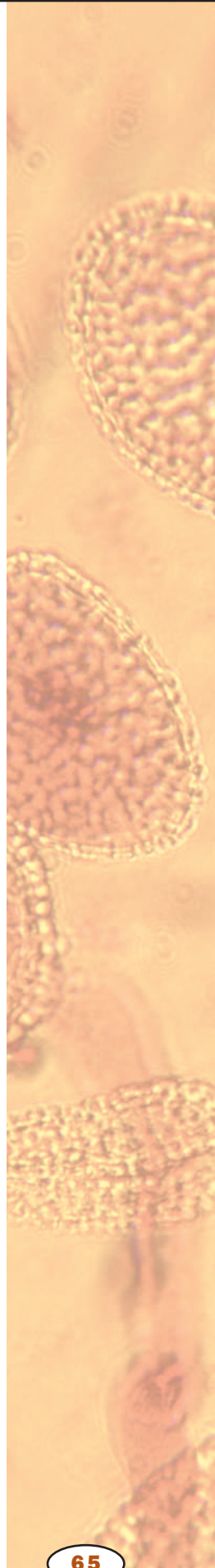

**placental** related to mammals that nourish the fetus with a placenta, an exchange organ in the uterus

**marsupial** kangaroos and other mammals that gestate young in an external pouch

**adaptive radiation** diversification of a group of organisms into several different forms that adapt to different environments

The extinction of the Tasmanian wolf in the twentieth century is probably the best-known example of this negative impact on biodiversity. Typically whenever there is considerable overlap between the niches of a **placental** and a **marsupial** the placental will win out. The reasons for placental superiority are not entirely clear (relatively greater intelligence and reproductive physiology are possibilities), but this fact probably accounts for the existence of only one successful species of marsupial in North America, the opossum, a broad generalist with a very high reproductive rate.

## Mass Extinctions

Mass extinction events have occurred periodically in Earth's history. Three of these events are particularly relevant to mammalian history. The first was the Cretaceous-Tertiary extinction 65 million years ago that led to the demise of the dinosaurs. Mammals and dinosaurs coexisted for approximately 140 million years, during which time dinosaurs dominated the majority of large terrestrial vertebrate niches. This extinction most likely was the result of a large meteor impact that eliminated over half of all species on the planet. Mammals survived that extinction event relatively well, probably because the majority of Mesozoic mammals were species with short generation times and large litters. During the Tertiary period, mammals underwent a rapid **adaptive radiation**, filling niches similar to those vacated by dinosaurs.

A second major extinction event occurred during the Eocene-Oligocene period, 30 to 35 million years ago. This extinction was the result of global cooling due to changes in ocean current patterns. Prior to this period modern families of mammals comprised only about 15 percent of the mammalian fauna; after cooling modern mammals made up more than 50 percent of the fauna at the family level.

The third mass extinction event began around 15,000 years ago and is still ongoing. Large species (mammoth, ground sloth, horses, camels, and lions) were more adversely impacted by the most recent extinction event than other taxa. In the twenty-first century, there are only about a dozen species of large mammals (over 100 pounds) in North America. As recently as 11,000 years ago there may have been three times that number.

There is controversy about what caused the extinction of these large mammals. Three possibilities include global warming at the end of the last major glaciation, overkill by early North American humans, and contagious diseases. The timing of each of these events correlates with the time of extinction, therefore determining which hypothesis is most likely must be based on the merits of each argument. Reduction in size of suitable habitat is the most likely factor if the extinction is due to climatic change. Much of North America was covered by a grassland habitat during the last glacial period. As this habitat declined the largest species may have been unable to adapt to the new conditions. Migration of humans into North America is the causative agent for the other two hypotheses. According to these models, the megafauna went extinct either directly through predation by a highly efficient hunter or indirectly by the introduction of exotic, infectious organisms.



Carolina parakeets collected in 1870 and housed in the British Museum of Natural History in Tring, England. Many of these birds were shot because they were eating fruit crops. Within a few decades, the species was extinct.

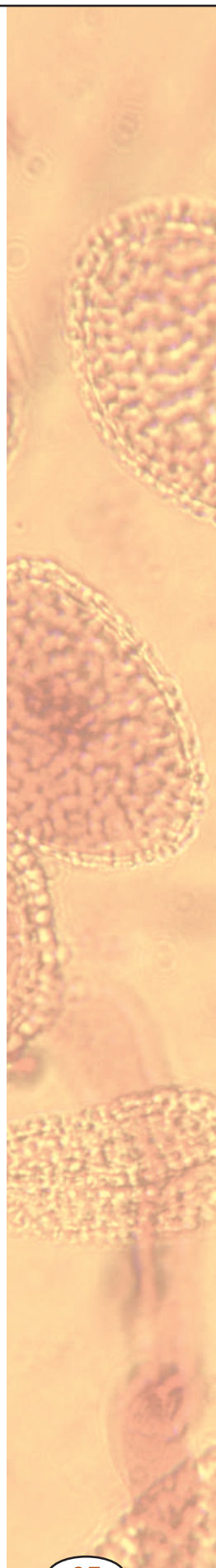

In the late twentieth and early twenty-first centuries, large-scale habitat destruction in tropical forests and elsewhere has caused extinction of significant numbers of species, many not fully identified. Pressures from population increase, agricultural expansion, and forest cleaning threaten many thousands of species throughout the world. SEE ALSO BIODIVERSITY; CONSERVATION; ENDANGERED SPECIES; EVOLUTION; FOREST, TROPICAL; POPULATION DYNAMICS; SPECIES

*William P. Wall*

### **Bibliography**

- Courtillot, V. *Evolutionary Catastrophes: The Science of Mass Extinction*. New York: Cambridge University Press, 1999.
- Lewin, R. *The Sixth Extinction: Patterns of Life and the Future of Humankind*. New York: Anchor Books, 1996.
- Pianka, Eric. R. *Evolutionary Ecology*. San Francisco, CA: Benjamin Cummings, 2000.
- Raup, David. *Extinction: Bad Genes or Bad Luck*. New York: W. W. Norton & Company, 1992.
- Vaughan, Terry A., James M. Ryan, and Nicholas J. Czaplewski. *Mammalogy*. Fort Worth, TX: Saunders College Publishing, 2000.

**protein** complex molecule made from amino acids; used in cells for structure, signaling, and controlling reactions

**carbohydrates** sugars, starches, and other molecules combining carbon, hydrogen, and oxygen and serving as fuel or structural components

**connective tissue** one of four types of body tissue, characterized by few cells and extensive extracellular material

**basal** lowest level

$\alpha$  the Greek letter alpha

**gene** portion of DNA that codes for a protein or RNA molecule

**amino acid** a building block of protein

**trimer** a structure composed of three parts

**secretion** material released from the cell

**nanometer**  $10^{-9}$  meters; one-billionth of a meter

## Extracellular Matrix

The extracellular matrix is a meshwork of **proteins** and **carbohydrates** that binds cells together or divides one tissue from another. The extracellular matrix is the product principally of **connective tissue**, one of the four fundamental tissue types, but may also be produced by other cell types, including those in epithelial tissues. In the connective tissue, matrix is secreted by connective tissue cells into the space surrounding them, where it serves to bind cells together. The extracellular matrix forms the **basal lamina**, a complex sheet of extracellular matrix molecules that separates different tissue types, such as binding the epithelial tissue of the outer layer of skin to the underlying dermis, which is connective tissue. Cartilage is a connective tissue type that is principally composed of matrix, with relatively few cells.

### Collagens

Collagens are the principal proteins of the extracellular matrix. They are structural proteins that provide tissues with strength and flexibility, and serve other essential roles as well. They are the most abundant proteins found in many vertebrates. There are at least nineteen collagen family members whose subunits, termed  $\alpha$  chains, are encoded by at least twenty-five **genes**. The primary protein sequence of all collagen subunits contains repeating sequences of three **amino acids**, the first being glycine with the second and third being any amino acid residue (sometimes referred to as a GLY-X-Y motif).

Most, if not all, collagens assemble as **trimers**, with three  $\alpha$  subunits coming together to form a tightly coiled helix that confers rigidity on each collagen molecule. Assembly of the collagen trimer occurs in the cell by a self-assembly process, which is mediated by short amino acid sequences at both ends of each  $\alpha$  subunit, called propeptides. Some collagens, most notably collagen types I, II, III, and V, assemble into large, ropelike macrofibrils once they are secreted into the extracellular matrix. In these cases, the propeptides are cleaved off following **secretion**, permitting the trimeric molecules to undergo further self-assembly into fibrils. In the electron microscope each of these macrofibrils has a characteristic banded appearance and can be very large (up to 300 **nanometers** in diameter).

Type IV collagen, which is found in the basal lamina, does not assemble into a fibril since its  $\alpha$  subunits retain their propeptides following secretion from a cell. Its triple helix has a series of interruptions in the GLY-X-Y repeating motif, preventing the subunits from binding quite as tightly, and giving the molecule more flexibility. Type IV collagen forms a scaffold around which other basal lamina molecules assemble. In contrast to the fibril-forming collagens and type IV collagen, type XVII collagen is membrane-spanning protein. It is a component of a cell/matrix junction called the hemidesmosome.

The fibrillar collagens are also associated with a class of collagen molecules that themselves do not form fibrils but that appear to play an important role in organizing the highly ordered arrays of collagen fibrils that occur in some connective tissues. Examples of this collagen class include type IX and type XII collagen.

Collagens do not simply provide filler for tissues. Both fibrillar and basal lamina collagens interact with other extracellular matrix proteins and play important roles in regulating the activities of the cells with which they interact. Cells associate with collagen via cell surface receptors, and through such interactions collagens may have a profound impact on cell proliferation, migration, and differentiation. Fibers and meshworks of collagen molecules also act as a repository of growth factors and matrix-degrading **enzymes**. These are often present in inactive form and become activated in order for tissues to undergo remodeling, for example in development, during cyclical changes in the female reproductive system, and in **pathological** conditions such as cancer. SEE ALSO AMINO ACID; CONNECTIVE TISSUE; EPITHELIUM; PROTEIN STRUCTURE

*Jonathan Jones*

### Bibliography

Alberts, Bruce, et al. *Molecular Biology of the Cell*, 4th ed. New York: Garland Publishing, 2000.

**enzyme** protein that controls a reaction in a cell

**pathologic** related to disease

## Extreme Communities

The environments of Earth include conditions in which physical and chemical extremes make it very difficult for organisms to survive. Conditions that can destroy living cells and biomolecules include high and low temperatures; low amounts of oxygen and water; and high levels of salinity, acidity, alkalinity, and radiation. Examples of extreme environments on Earth are hot geysers and oceanic thermal vents, Antarctic sea ice, and oxygen-depleted rivers and lakes. Organisms that have evolved special adaptations that permit them to live in extreme conditions are called “extremophiles.”

### Cellular Adaptations

Some organisms survive in extreme environments by keeping the extreme environment outside their cell walls. For example, organisms that live at the extremes of **pH** are often able to do so by maintaining their **cytoplasm** at near-neutral levels of pH, thus eliminating the need for other adaptive physiology. Where it is impossible to keep the extreme environmental conditions outside the cells, in very hot environments, for example, extremeophiles have evolved special physiological mechanisms and repair abilities.

High temperatures increase the fluidity of membranes, whereas low temperatures decrease membrane fluidity. To counter these changes, some extremeophile organisms change the ration of unsaturated to saturated fatty acids. As temperatures decrease, the proportion of unsaturated fatty acids in the membrane increases. The increase in the proportion of unsaturated fatty acids is also often a response to increased pressure, which also reduces the fluidity of cell membranes. To withstand below-freezing temperatures, some organisms protect cell fluids from freezing by producing chemicals that act like antifreeze, lowering the temperature at which the cell fluids will freeze (crystallize) to as low as -40 degrees Celsius. Other organisms are freeze tolerant, permitting freezing of up to 65 percent of their body water, as in the case of the wood frog.

**pH** measure of acidity or alkalinity; numbers below 7 are acid, above are basic

**cytoplasm** material in a cell, excluding the nucleus

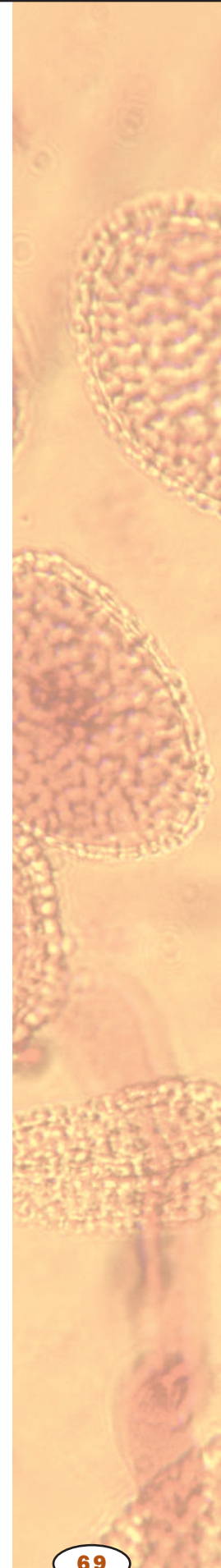

A hydrothermal vent on the East Pacific Rise. Life forms ranging from microbes to invertebrates have adapted to the extreme conditions around these underwater geysers.

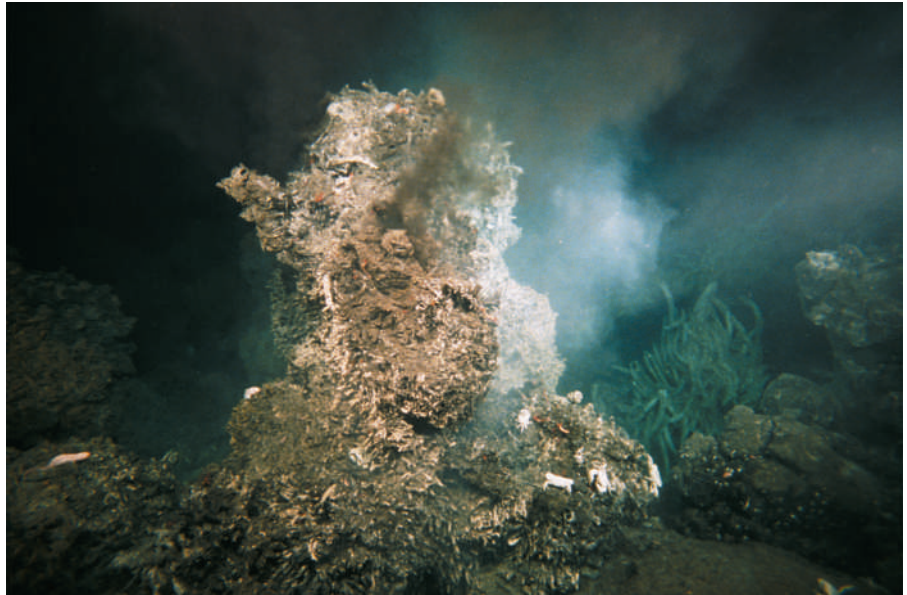

**protein** complex molecule made from amino acids; used in cells for structure, signaling, and controlling reactions

**enzyme** protein that controls a reaction in a cell

**oxidative** characterized by oxidation, or loss of electrons

**antioxidant** substance that prevents damage from oxidation

**ion** an electrically charged particle

**amino acid** a building block of protein

**cytosol** fluid portion of a cell, not including the organelles

**desiccation** drying out

**prokaryote** single-celled organism without a nucleus

High temperatures destroy the delicate **proteins** of unadapted organisms. Extremeophiles have protein structures stabilized against the disruptive effects of heat. One Archean thermophile, *Thermus aquaticus*, which lives in hot springs, is the source of the heat-stable deoxyribonucleic acid (DNA) polymerase **enzyme** used in polymerase chain reaction (PCR). PCR forms part of the foundation of much of the biotechnology industry.

Radiation and **oxidative** damage have always been common on Earth. Mechanisms evolved to cope with these conditions include the production of **antioxidants** and detoxifying enzymes and the ability to repair damage to cells. Many microorganisms respond to increases in osmolarity (concentration of dissolved substances in the environment) by accumulating osmotica (**ions**, **amino acids**, or other small molecules) in their **cytosol** to protect them from dehydration and **desiccation**. With the exception of the Halobacteriaceae, which use  $K^+$  (potassium ion) as their osmoticum, glycine-betaine is the most common effective osmoticum in most **prokaryotes**. During desiccation, osmotic concentration increases, and thus responses are similar to those in a cell in a saline environment.

### Examples of Extreme Communities

**Deep Sea.** The deep sea environment has high pressure and cold temperatures (1 to 2 degrees Celsius [33.8 to 35.6 degrees Fahrenheit]), except in the vicinity of hydrothermal vents, which are a part of the sea floor that is spreading, creating cracks in the earth's crust that release heat and chemicals into the deep sea environment and create underwater geysers. In these vents, the temperature may be as high as 400 degrees Celsius (752 degrees Fahrenheit), but water remains liquid owing to the high pressure. Hydrothermal vents have a pH range from about 3 to 8 and unusual chemistry. In 1977, the submarine *Alvin* found life 2.6 kilometers (1.6 miles) deep near vents along the East Pacific Rise. Life forms ranged from microbes to invertebrates that were adapted to these extreme conditions. Deep sea environments are home to psychrophiles (organisms that like cold tempera-

tures), hyperthermophiles (organisms that like very high temperatures), and piezophiles (organisms adapted to high pressures).

**Hypersaline Environments.** Hypersaline environments are high in salt concentration and include salt flats, evaporation ponds, natural lakes (for example, Great Salt Lake), and deep sea hypersaline basins. Communities living in these environments are often dominated by halophilic (salt-loving) organisms, including bacteria, algae, diatoms, and protozoa. There are also halophilic yeasts and other fungi, but these normally cannot tolerate environments as saline as other taxa.

**Deserts.** Deserts can be hot or cold, but they are always dry. The Atacama desert in Chile is one of the oldest, driest hot deserts, sometimes existing for decades without any precipitation at all. The coldest, driest places are the Antarctic Dry Valleys, where primary inhabitants are cyanobacteria, algae, and fungi that live a few millimeters beneath the sandstone rock surface. Although these endolithic (living in rocks) communities are based on photosynthesis, the organisms have had to adapt to long periods of darkness and extremely dry conditions. Light dustings of snow that may melt in the Antarctic summer are often the only sources of water for these organisms.

**Ice, Permafrost, and Snow.** From high-altitude glaciers, often colored pink from red-colored algae, to the polar permafrost, life has evolved to use frozen water as a habitat. In some instances, the organisms, such as bacteria, protozoa, and algae, are actually living in liquid brine (very salty water) that is contained in pockets of the ice. In other cases, microorganisms found living on or in ice are not so much ice lovers as much as ice survivors. These organisms may have been trapped in the ice and simply possessed sufficient adaptations to enable them to persist.

**Atmosphere.** The ability for an organism to survive in the atmosphere depends greatly on its ability to withstand desiccation and exposure to ultraviolet radiation. Although microorganisms can be found in the upper layers of the atmosphere, it is unclear whether these constitute a functional **ecosystem** or simply an aerial suspension of live but largely inactive organisms and their spores.

**Outer Space.** The study of extremeophiles and the ability of some to survive exposure to the conditions of outer space has raised the possibility that life might be found elsewhere in the universe and the possibility that simple life forms may be capable of traveling through space, for example from one planet to another. SEE ALSO ARCHAEA; EUBACTERIA; POLYMERASE CHAIN REACTION

*Rocco L. Mancinelli and Lynn J. Rothschild*

### Bibliography

- Horikoshi, K., and W. D. Grant. *Extremophiles: Microbial Life in Extreme Environments*. New York: Wiley-Liss, 1998.
- Madigan, M. T., and B. L. Mairs. "Extremophiles." *Scientific American* 276, no. 4 (1997): 82–87.
- Rothschild, L. J., and R. L. Mancinelli. "Life in Extreme Environments." *Nature* 409 (2001): 1092–1101.
- Seckbach, J., ed. *Journey to Diverse Microbial Worlds: Adaptation to Exotic Environments*. Dordrecht, Netherlands: Kluwer Academic Publishers, 2000.

**ecosystem** an ecological community and its environment

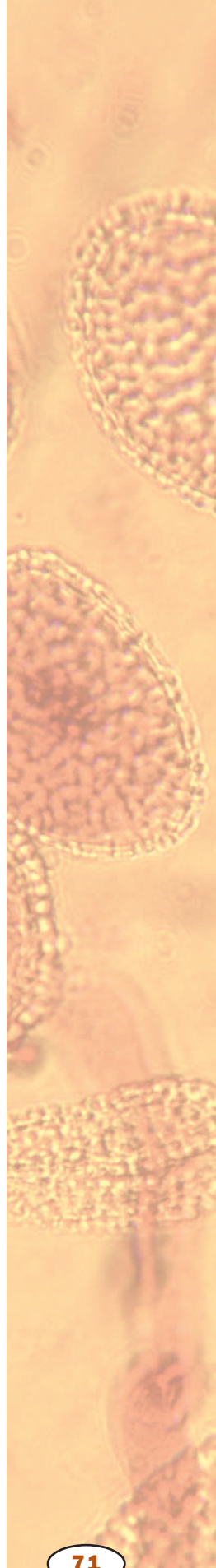

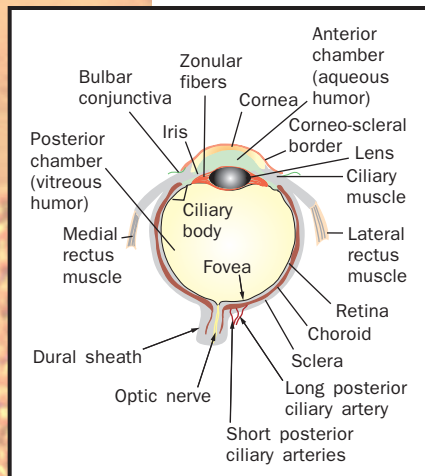

Structure of the human eye.

**protein** complex molecule made from amino acids; used in cells for structure, signaling, and controlling reactions

**aqueous** watery or water-based

**intraocular** within the eyeball

**dilation** expansion or swelling

**neural** related to nerve cells or the nervous system

**nocturnal** characterized by activity at night, or related to the night

## Eye

The human eye is an amazing instrument. It is the body's camera, capturing images of the world with striking clarity in a virtual instant. The eye and the typical camera share many of the same structural features. A camera needs an operator, a housing (box) to hold onto and to contain the working parts and film, an aperture to let the light in (preferably one that allows for different light conditions), a lens for focusing the image, and film for capturing the image. Then the film must be developed (or the digital images downloaded). The following description illustrates how the eye performs these same functions.

### Anatomy of the Eye

The eye consists mainly of three layers, or tunics. The bulk of the outermost layer (fibrous tunic) is the white of the eye, or sclera. Like a camera's housing, the sclera is the eye's skeleton, giving structure to the eye and protecting the internal components; it also provides an attachment site for the eye muscles that position the eye under the control of the brain. In the very front of the eye, where the light must pass through, the fibrous tunic is a transparent structure called the cornea. The cornea is responsible for approximately 70 percent of the focusing power of the eye; without a cornea, vision would be impossible. (One can, however, see without a lens, just not very keenly.) Because it must be transparent, there are no blood vessels in the cornea. The tissue must get all of its oxygen and nutrients by diffusion; the cornea actually "breathes" across its surface (hence "gas-permeable" contact lenses can be worn for longer periods than "hard contacts").

The middle layer (vascular tunic) mostly provides for internal maintenance functions, as well as for aperture and fine focusing control. In the posterior two-thirds, the vascular tunic consists of the choroid, a layer of nutritive and supporting tissue. Toward the front, it forms the ciliary body and the iris.

The ciliary body contains the smooth muscles that pull on suspensory ligaments attached to the lens, changing its shape and thus adjusting its focusing power. (Sometimes the **proteins** that make up the lens become cloudy, a condition called a cataract.) The ciliary body also secretes **aqueous** humor, the watery fluid that fills the space between the cornea and lens (anterior cavity). This fluid provides a sort of circulatory system for the front of the eye. When excess fluid accumulation causes excess **intraocular** pressure, the vision-threatening condition known as glaucoma occurs.

The iris, the colored portion of the eye surrounding the dark opening (pupil), sits in front of the lens. The iris is made of two sets of smooth muscle that contract to produce pupil **dilation** or constriction; this brainstem reflex controls the intensity of the light reaching the innermost sensory layer, the retina.

The retina makes up the inner layer, or **neural** tunic, and occupies only the posterior two-thirds of the eye. The retina consists of several layers of cells, including the rods and cones, the sensory cells that respond to light. The tips of the rods and cones are embedded in a pigmented layer of cells on the very back of the retina. The pigment helps prevent light from scattering in the back of the eye. (Some **nocturnal** animals have a reflective



layer instead of pigment, called the tapetum lucidum, which increases their sensitivity to low light and makes their eyes “shine” when a bright light strikes them.) When light strikes a rod or cone cell, it passes the signal to a bipolar cell, which passes it on to the ganglion cells, which perform the first level of information processing. The **axons** of the ganglion cells also form the “cables” that make up the optic nerve, carrying visual information to the brain. (There are no rods and cones where the optic nerve leaves the eye; this is called the “blind spot.”) The retina is pressed flat against the inner wall of the eye by a thick, gel-like substance called vitreous humor, which fills the space behind the lens (posterior cavity).

### Accessory Structures

There are accessory structures associated with the eye. The eye is protected by being located in the orbit of the skull. Eyelashes help prevent foreign matter from reaching the sensitive surface. The eyelids help protect the exposed **anterior** part of the eye. The eyelids have glands that produce lubricating **secretions**. Infection of the glands at the base of the eyelash produces a painful localized swelling called a sty. A thin membrane called the **conjunctiva** lines the inside of both eyelids and covers the exposed eye surface (except the cornea); when this membrane gets irritated, blood vessels beneath it become dilated, resulting in a condition called conjunctivitis (“pinkeye”).

Tear (lacrimal) glands located on the upper lateral (outside) region of the eye provide secretions (tears) that lubricate the surface, remove debris, help prevent bacterial infection, and deliver oxygen and nutrients to the conjunctiva; blinking of the eyelids provides a wiping action across the surface that keeps the eye “polished” and distributes the tears. These tears then drain into the tear ducts in the lower inner corner of the eye, draining into the nasal cavity. Another gland, the lacrimal caruncle (the pinkish blob in the inner corner), produces thick secretions that sometimes accumulate during sleep (the “sand” from the “sandman”).

Most vertebrate animals have eyes that are essentially the same as the human eye. Among invertebrates, there is a wide variety of eyes. Some have simple eyespots that do not form images, detecting only the presence of light. Others, like the cephalopod mollusks (octopus, squid), have a camera eye very similar to that of vertebrates. Perhaps the most unusual eye is the compound eye found in **arthropods** such as insects and crustaceans. These eyes actually consist of hundreds of individual eye units, called ommatidia (up to thirty thousand in dragonflies). Each ommatidium has its own lens and set of receptor and supporting cells; each forms its own tiny picture of only a small part of the visual field. The insect’s brain thus receives a mosaic of hundreds of individual images that it uses to make a somewhat “grainy” composite image of the entire visual field. **SEE ALSO VISION**

*Harold J. Grau*

### Bibliography

- Eden, John. *The Physician’s Guide to Cataracts, Glaucoma, and Other Eye Problems*. Yonkers, NY: Consumer Reports Books, 1992.
- Tucker, Lael. *The Eye: Window to the World*. Washington, DC: U.S. News Books, 1981.
- Ward, Brian R. *The Eye and Seeing*. New York: Franklin Watts, 1981.

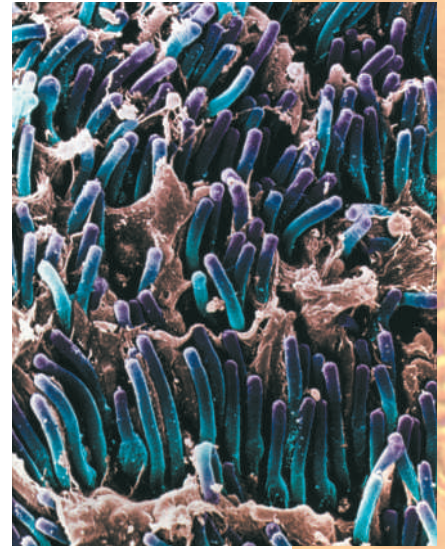

A colored scanning electron micrograph of rod cells (blue and purple) in the retina of a human eye.

**axon** long extension of a nerve cell down which information flows

**anterior** toward the front

**secretion** material released from the cell

**conjunctiva** eye membrane that helps seal the eye socket

**arthropods** organisms with jointed appendages and exoskeletons, including insects, spiders, and crustaceans



**organic** composed of carbon, or derived from living organisms

## Feeding Strategies

All animals are heterotrophic, meaning they must eat other organisms, living or dead, to acquire **organic** nutrients. A large percentage of an animal's life is occupied with acquiring food. Almost every living species is eaten by something else, but food varies in its spatial distribution, seasonal availability, predictability, how well hidden or easily detected it is, how much competition for it exists, and whether or not it can resist being eaten. Consequently, animals have a variety of feeding strategies to meet these challenges.

Some animals are food generalists (euryphagous); that is, they eat a wide variety of foods. Coyotes, opossums, and humans are good examples. Others are food specialists (stenophagous), feeding on a narrow range of foods. For example, the Everglades kite (a small hawk) feeds on just one species of snail, and many feather mites can survive on just one species of bird.

Behavioral ecologists who study feeding strategies are often concerned with theories of optimal foraging. Obviously, animals must gain more energy from their food than they expend in searching for it, capturing it, and consuming it. In addition to energy, they must acquire specific nutrients, such as certain salts, which provide no energy but are crucial for survival. Thus, theories of feeding are concerned with such issues as food choice, prey switching, sensory mechanisms for recognizing and locating food, optimal search strategies, overcoming the defenses of food organisms, and how to compromise between finding food and not carelessly falling prey to some other hunter.

Following are some of the basic methods that animals use to acquire food. Many animals use mixed strategies, shifting from one method to another as different kinds of food become available, or using combinations of methods simultaneously.

### Grazing

Grazers crop grasses and other ground plants on land or scrape algae and other organisms from surfaces in the water. They include animals as diverse as snails, grasshoppers, geese, rodents, kangaroos, and hoofed mammals. Grass and algae are palatable foods that offer little or no resistance to being eaten, but are adapted to survive grazing and quickly replace the lost biomass. A disadvantage of such food, however, is that it is nutrient poor. Grazers therefore must consume a large quantity of it and spend a larger percentage of their time eating than predators do. While eating, they are vulnerable to attack. To eat without being eaten requires alertness and quick escape responses. Grazing mammals tend to form herds: There is safety in numbers, and the abundance of grass supports the high population density of grazing herds.

### Browsing

Terrestrial browsers nip foliage from trees and shrubs. They include caterpillars, tortoises, grouse, giraffes, goats, antelopes, deer, pandas, koalas, and monkeys. In aquatic habitats, browsers feed on algae, aquatic plants, and corals, and include sea slugs, sea urchins, parrot fish, ducks,

and manatees. Browsers depend on food that is less abundant and widespread than grass, so they tend to form smaller groups or to be solitary and secretive.

### Eating Nectar, Fruits, Pollen, and Seeds

Plants provide an abundance of food other than foliage, some of it for the purpose of rewarding animals. Sweet nectar rewards bees, flies, moths, butterflies, and bats that spread pollen from one flower to another, and sugary fruits entice birds, monkeys, fruit bats, bears, elephants, and humans to eat them and spread the indigestible seeds throughout the countryside. Pollen and seeds, being a plant's reproductive capital, are not meant to be eaten, but many bees, flies, and beetles nevertheless consume pollen, while birds, squirrels, and harvester ants take their toll on the seed crop.

### Burrowing

Some animals burrow into their food, eating a tunnel as they go. These include many herbivores such as bark beetles, fly and moth larvae called leaf miners, and wood-boring termites. In the sea, unusual clams and crustaceans called shipworms and gribbles, respectively, burrow through wooden piers and ships, causing enormous destruction. Earthworms and many marine worms burrow in soil and sediment, eating indiscriminately as they go, digesting the organic matter and defecating the indigestible sand and other particles. Burrowing animals not only have the benefit of being surrounded by food, but also are less exposed to predators.

### Filter-feeding

Filter-feeding is a common strategy in aquatic habitats, especially the ocean. It uses anatomical devices that act as strainers to remove small food items from the water. **Sessile** filter-feeders, such as barnacles, oysters, fanworms, brachiopods, and tunicates sit in one place, pumping sea water and straining **plankton** from it. Other filter-feeders are mobile. Herring swim with their mouths open, letting water flow through the gill rakers, which strain small particles of food from it. Flamingoes take in mouthfuls of water and mud, then force the water through the fringed edges of their bills, which serve as strainers that retain food such as brine shrimp, aquatic insects, and plankton in the mouth. Small and even microscopic food in the water may not seem very abundant, yet the largest animals on Earth—the basking sharks, whale sharks, manta rays, and baleen whales, including the largest species alive today, the great blue whale—nourish themselves entirely in this way. Filter-feeding is more common in the ocean than in fresh water, because plankton is less concentrated in fresh water.

### Suspension and Deposit Feeding

Another form of small particulate food in aquatic habitats is the steady “rain” of organic matter that settles to the bottom: living and dead plankton and bits of dead animal, plant, and algal tissue. Suspension feeders pick this material from the water as it falls and deposit feeders consume it after it settles on the bottom. Many sea anemones, corals, marine worms, and crinoids, for example, spread out an array of tentacles and capture whatever settles

Fruit bats consume both fruit and flowers. They normally suck on the flowers and fruit, then swallow the nectar or juice and spit out the rest. Because fruit bats disperse seeds and pollinate the flowers of many plants, many of the fruits and vegetables we eat every day would not exist without these bats.

**sessile** attached and remaining in one place

**plankton** microscopic floating organisms

**substrate** surface for attachment

**ciliated** possessing cilia, short, hairlike extensions of the cell membrane

on them. Other worms, some bivalves, brittle stars, and sea cucumbers spread sticky palps, arms, or tentacles over the **substrate**, picking up the organic matter that has settled there. The feeding arms or tentacles of many of these animals have **ciliated**, sticky grooves. Food becomes caught in mucus, and cilia steadily propel the mucus strand toward the mouth. Sea cucumbers, however, reach out and pick up sediment on their sticky tentacles, then draw the tentacles into their mouths and remove the food, like licking jam off one's fingers.

### Predation

Predators are animals that depend on killing other animals outright. Since the other animals have evolved defenses against predation—hard shells, toxins, the ability to fight back, or simply running or flying away—predators have evolved a wide range of strategies for capturing their prey. Some hunt in packs (wolves), some collaborate to ambush prey (lions), some are stalkers (solitary cats), some use lures to attract unsuspecting prey (snapping turtles and angler fish), some employ camouflage so their prey does not notice them until it is too late (praying mantids), and some use snares (spiders, jellyfish).

### Symbiosis

Symbionts are animals that live in a close physical relationship with another animal, the host, from which they benefit. Unlike predators, symbionts do not benefit from the death of their hosts; ideally, they steal food or consume host tissue at a rate that the host can tolerate, allowing the host to survive. Symbiosis includes mutually beneficial relationships (mutualism); relationships in which one partner benefits, typically by stealing food from the host or eating its tissues, but the host is neither benefited nor harmed (commensalism); and relationships in which the host is harmed, usually because the symbiont consumes nutrients or tissue faster than the host can replace it (parasitism). The host is often both food and shelter for its symbiont.

### Scavenging

Finally, and fortunately for the planet's "hygiene," many animals belong to a community of scavengers that feed on organic refuse such as manure (dung beetles, flies), leaf litter (snails, millipedes, earthworms), and dead animals (blowflies, vultures, hyenas, storks). The family name of the vultures, Cathartidae, is from the Greek *katharos*, meaning "to cleanse." Disgusting as some people may find their habits, we would be infinitely more disgusted with an environment from which such scavengers were lacking. SEE ALSO ECOSYSTEM; HERBIVORY AND PLANT DEFENSES; OCEAN ECOSYSTEMS: HARD BOTTOMS; OCEAN ECOSYSTEMS: OPEN OCEAN; OCEAN ECOSYSTEMS: SOFT BOTTOMS; PARASITIC DISEASES; PREDATION AND DEFENSE; PROTOZOAN DISEASES; SYMBIOSIS

*Kenneth S. Saladin*

### Bibliography

Alcock, John. *Animal Behavior*, 7th ed. Sunderland, MA: Sinauer Associates, Inc., 2001.  
Owen, Jennifer. *Feeding Strategy*. Chicago: University of Chicago Press, 1980.

## Female Reproductive System

Like the male reproductive system, a primary function of the female reproductive system is to make **gametes**, the specialized cells that contribute half of the total genetic material of a new person. The female reproductive system has several additional functions: to be the location for joining of the male and female gametes, to protect and nourish the new human during the period of **gestation**, and to nourish the newborn infant for some time after birth, though **lactation** and nursing.

### Basic Anatomy

The parts of the female reproductive tract normally include two ovaries, two uterine tubes (also called **fallopian tubes**), a single pear-shaped uterus, and a single vagina. Gamete production is the responsibility of the ovaries, whereas protection and nourishment of the growing embryo and fetus before birth are functions of the uterus. The two uterine tubes, one from each ovary, provide pathways for the female gametes (eggs) to get from the ovaries to the uterus.

The portion of the reproductive tract called the vagina is between the narrow uterine cervix and the outside of the body. In female humans there is a second opening where the urethra from the urinary bladder connects to the outside of the body. The urethral opening is normally separate from, and in front of, the vagina. Both the urethra and the vagina are located between two outer folds of skin called the labia majora and two inner folds, the labia minora. The structure called the clitoris is located where the two folds of the labia minora join each other at the front. The organs of the female reproductive tract are kept in place internally by ligaments that attach the ovaries and uterus to the body wall and by the peritoneal membrane that lines the body cavity containing the intestines and other digestive organs.

**gamete** reproductive cell, such as sperm or egg

**gestation** period of fetal development within the mother

**lactation** production of milk by the mammary glands

**fallopian tubes** tubes through which eggs pass to the uterus

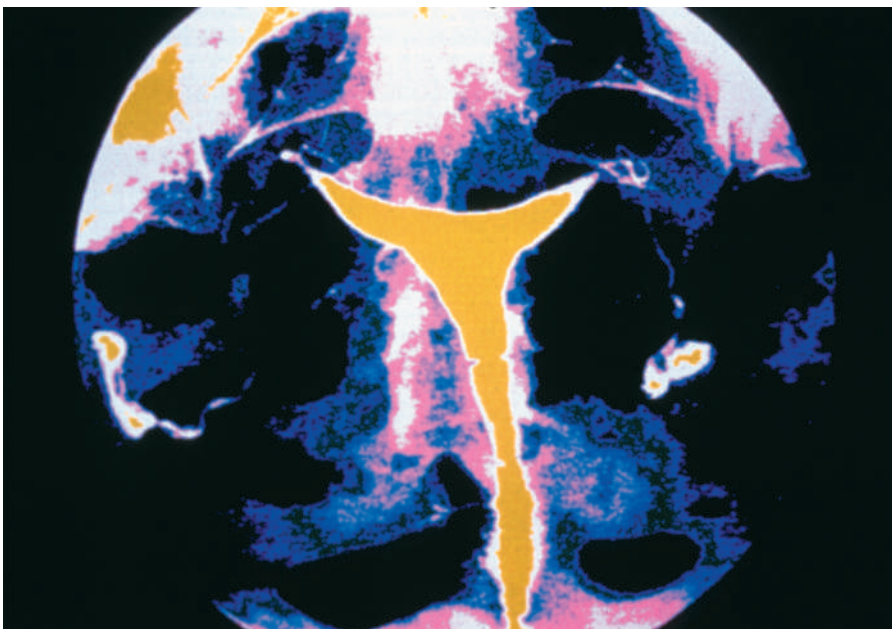

A hysterosalpinograph (X ray) of a normal human uterus and fallopian tubes.

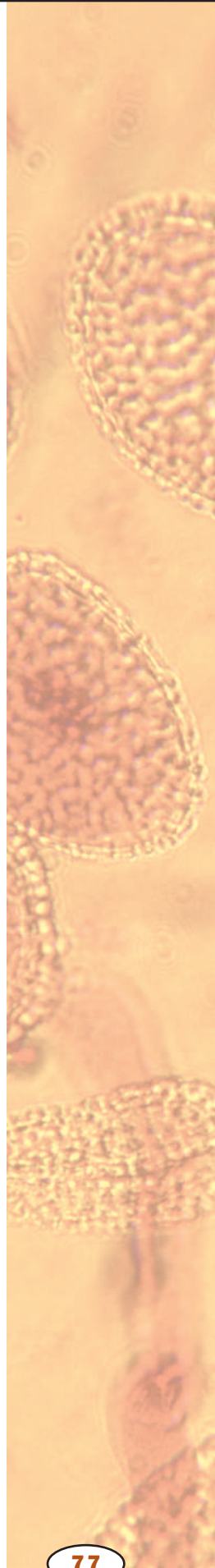

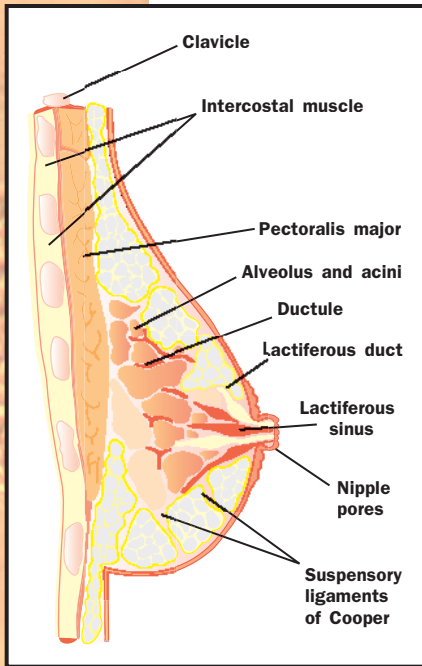

A cross-section of a breast showing the structure of the mammary gland and its placement on the surface muscles of the chest.

**follicle** a vesicle that contains a developing egg surrounded by a covering of cells

**hormone** molecule released by one cell to influence another

**fertilization** union of sperm and egg

The mammary glands are not part of the female reproductive tract but are important secondary reproductive organs. The mammary glands develop in the tissue underneath the skin but on top of the muscles of the chest. Both males and females start with the same tissues, but normally only females generate the correct hormonal signals to promote development of the mammary glands at puberty. The full ability of mammary glands to synthesize and secrete milk does not occur unless a woman is exposed to the hormonal changes of pregnancy.

### The Menstrual Cycle

The primary **follicles** located in the ovary contain the only cells in the female that can complete the special form of cell division (meiosis) that produces gametes. In females the mature gametes are called egg cells or ova. The production of mature ova is not continuous. Each twenty-eight days or so, one primary follicle (containing one ovum) matures under the influence of **hormones** from the anterior pituitary, hypothalamus, and the ovary itself. The process of release of a mature ovum from a mature follicle is called ovulation.

While the follicle and ovum are maturing, the follicle secretes hormones that prepare the uterine lining (the endometrium). The endometrium gets thicker and is well supplied with blood vessels. If there are no viable sperm present in the uterine tube as the ovum moves along from the ovary to the uterus, then the ovum will not be fertilized. If **fertilization** does not occur, or for any other reason a blastocyst (future embryo) fails to implant within the endometrium, the built-up endometrial lining degenerates and is shed. Some bleeding accompanies this process, and the menstrual flow that leaves the woman's body through her vagina is made of blood and the cells that lined the uterus. Following menstruation, the cycle normally begins again with maturation of a new ovum and buildup of the uterine lining once more.

Women do not have menstrual cycles their entire lives. The first menstrual flow (the menarche) actually means that a female's first menstrual cycle has just been completed; the first menstrual flow is one commonly used outward sign that a female has entered the transition time called puberty. During puberty, a reproductively immature "girl" becomes a reproductively capable "woman." With an adequate diet and general good health, puberty typically begins early in a girl's second decade of life; a first menstrual cycle at eleven or twelve years of age is not unusual. Women also eventually stop having menstrual cycles sometime in their fifth or sixth decade (forty-five to fifty-five years of age). The last menstrual period that a woman experiences is referred to as her menopause. The exact time of menarche and menopause varies significantly from one woman to another.

### Hormonal Control of Female Reproduction

Hormones typically coordinate functions in several different organs at the same time. Considerable coordination among the organs of the female reproductive tract is required. Reproduction will not be successful unless ovulation at the ovary occurs near the time when the uterus is prepared to receive the pre-embryo and, soon thereafter, begin forming the placenta. Without a functional placenta the pregnancy will not continue very long after implantation of the blastocyst.

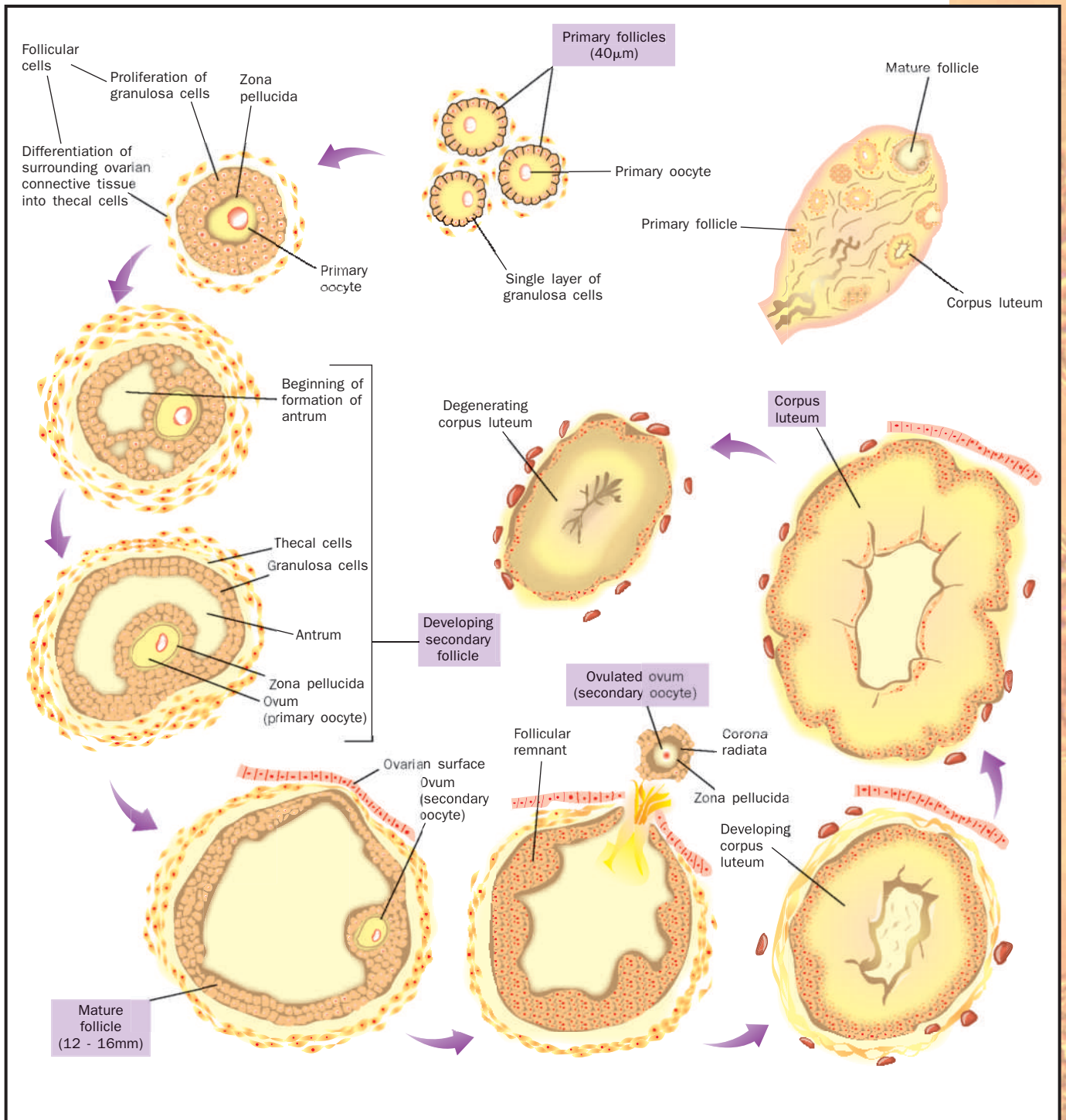

A suite of hormones begin preparing the uterus to receive a fertilized egg and control the development of the next ovum. The ovaries, the anterior pituitary, and the hypothalamus all have **endocrine secretions** involved in the control of female reproduction.

At puberty, the hypothalamus begins its first cyclic release of the peptide hormone gonadotropin releasing hormone (GnRH), which increases the secretion of peptide hormones called luteinizing hormone (LH) and

The ovarian cycle.

**endocrine** related to the system of hormones and glands that regulate body function

**secretion** material released from the cell

Hormonal profiles throughout the ovarian and uterine cycles with basal body temperature.

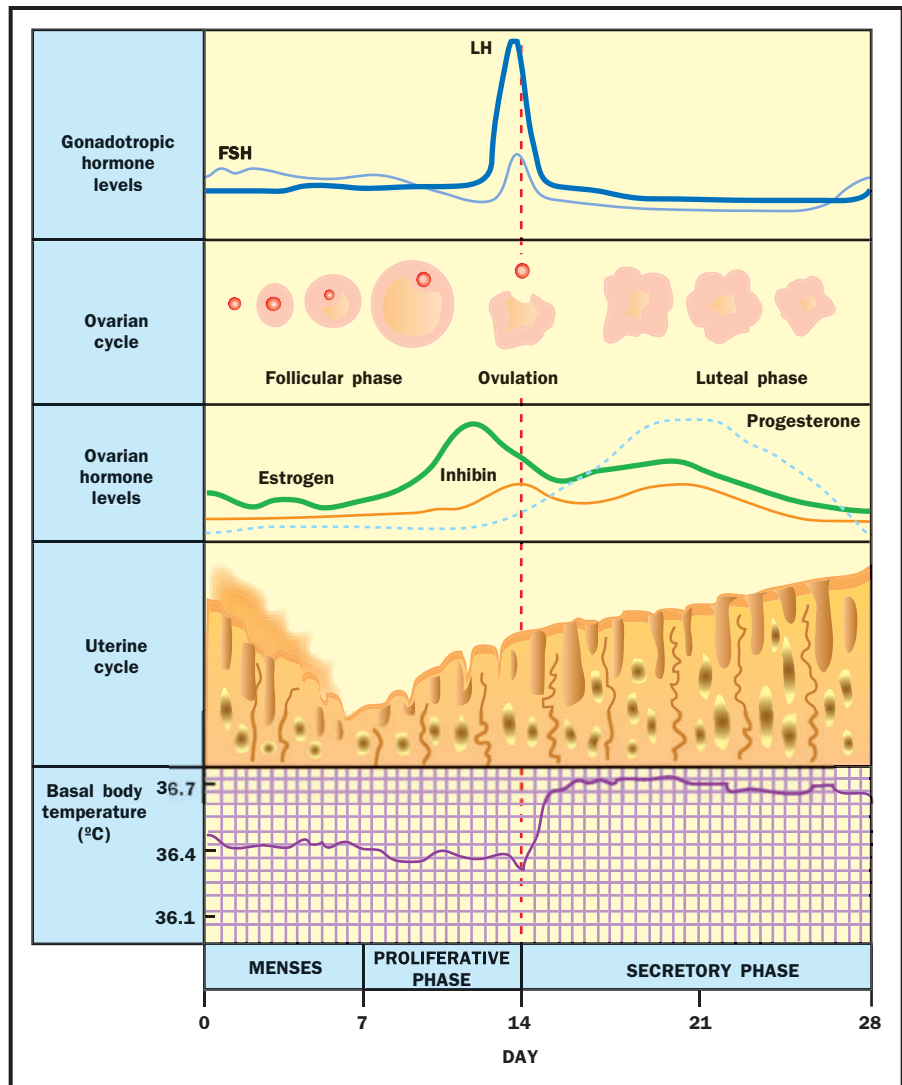

**steroids** hormones such as testosterone or estrogens that control many aspects of physiology

follicle stimulating hormone (FSH) from the anterior pituitary. More FSH and LH are then in the blood flowing through the ovaries. The ovarian cells making up follicles respond to FSH by maturing an ovum. Some of these follicular cells also begin producing their own hormonal signals that prevent other follicles from maturing (the **steroids** called estrogens) and inhibit the further release of FSH from the anterior pituitary (low levels of estrogens and the peptide hormone inhibin).

About halfway through the cycle on average, fourteen days since the last menstrual flow began, there is a measurable decrease in the woman's basal body temperature followed by a rapid increase in temperature and in her blood level of LH. This LH surge appears to be the biochemical signal for starting ovulation. Following ovulation, the follicular cells that remain in the ovary become the corpus luteum. The cells of the corpus luteum secrete steroid hormones (progesterone and estrogen). If fertilization and implantation are not successful, the corpus luteum begins to degenerate within ten days of being formed. The decreased levels of progesterone then allow the degeneration and shedding of the endometrium and the next menstrual flow.



## Changes Associated with Conception and Pregnancy

In a normal menstrual cycle, only one fertilizable ovum is released. It remains capable of being fertilized for only about twenty-four hours following ovulation, whereas sperm cells may remain capable of fertilizing an ovum for as long as seventy-two hours after they have been deposited into the woman's reproductive tract by sexual intercourse. Once deposited, the male's gametes must swim upward through the fluids within the vagina and uterus to arrive at a freshly ovulated ovum in the uterine tube.

A fertilized ovum divides by **mitosis**, and in about a week produces the blastocyst that implants into the endometrium. If the blastocyst successfully implants in the uterine lining, then a pregnancy occurs. At the start of pregnancy, the corpus luteum continues secreting progesterone under the influence of human chorionic gonadotropin (HCG) secreted by the implanted embryo. The continuous secretion of progesterone maintains the endometrial lining. As the pregnancy continues, the placenta gradually takes over the reproductive endocrine functions that were performed in the nonpregnant woman by the ovaries. In addition to its endocrine function, the placenta is vitally important in providing nourishment and waste removal for the growing embryo/fetus throughout gestation.

**mitosis** separation of replicated chromosomes

## Mammary Glands and Lactation

Newborn infants are not able to feed themselves. The same hormones that are responsible for the changes in the ovaries and uterus during the pregnancy also alter the internal function of the woman's mammary glands. The synthesis of mother's milk begins after the delivery of the newborn. An additional peptide hormone called prolactin is secreted from the anterior pituitary. Prolactin helps maintain the secretory capability of the mammary glands for as long as the baby continues to suckle. SEE ALSO DEVELOPMENT; HORMONES; HYPOTHALAMUS; LIFE CYCLE, HUMAN; MALE REPRODUCTIVE SYSTEM; PITUITARY GLAND; SEXUAL REPRODUCTION

*Margaret A. Weck*

### Bibliography

- Boston Women's Health Collective. *Our Bodies Ourselves for the New Century*. New York: Simon and Schuster, 1998.
- Byer, Curtis O., Louis W. Shainberg, and Grace Galliano. *Dimensions of Human Sexuality*, 5th ed. Dubuque, IA: McGraw-Hill, 1998.
- Mader, Sylvia. *Human Reproductive Biology*. Dubuque, IA: McGraw-Hill, 1992.
- Medscape's Women's Health MedPulse*. <<http://womenshealth.medscape.com>>.
- Saladin, Kenneth S. *Anatomy and Physiology: The Unity of Form and Function*, 2nd ed. Dubuque, IA: McGraw-Hill, 2001.
- Wilcox, Allen J., Clarice R. Weinberg, and Donna D. Baird. "Timing of Sexual Intercourse in Relation to Ovulation." *New England Journal of Medicine* 333 (1995): 1517-1521.

## Fetal Development, Human

The miracle of the renewal of human life takes place in well-defined stages, from the union of the egg and sperm to the birth of the baby. Fetal development is the longest and clinically the most important phase of this process.

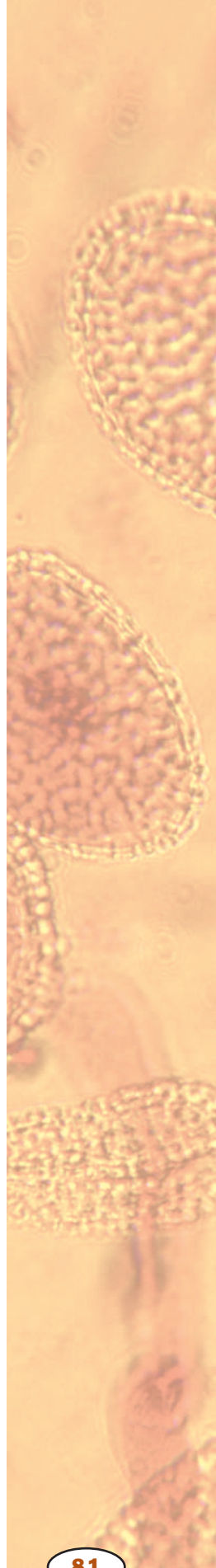

## Early Development

Early human development may be summarized by the following four phases: (1) fertilization; (2) implantation; (3) gastrulation; and (4) embryogenesis.

**embryology** development of the embryo

**nucleus** membrane-bound portion of cell containing the chromosomes

**meiosis** cell division that forms eggs or sperm

**haploid** having single, non-paired chromosomes in the nucleus

**diploid** having pairs of chromosomes in the nucleus

**chromosome** “colored body” in the cell nucleus; made of DNA and protein, and divided functionally into genes and non-gene regions

**Fertilization.** This stage takes place during the first week of human **embryology**. Fertilization occurs when the cell membrane of a sperm fuses with the cell membrane of the oocyte (egg), injecting its **nucleus**. The egg then undergoes its second division of **meiosis**, and the resulting **haploid** nucleus fuses with the haploid sperm nucleus to re-form the **diploid** number of **chromosomes**. These events occur in the oviduct, or fallopian tube. The fertilized egg, now termed a “zygote,” continues to move down the oviduct to the uterus, where it lodges in the wall.

**Implantation.** After the conceptus is implanted in the uterine wall, the cells that will form the embryo proper divide and organize themselves into a bilaminar (two-layered) disc. This disc is surrounded by an outer ring of cells, the trophoblast, which does not contribute to the new organism’s tissues. After implantation, trophoblast cells multiply rapidly and invade the endometrium (uterine wall). Together, the trophoblast and endometrium form the placenta, through which all the nutrition for the developing embryo will pass. This rich mass of tissue is filled with blood vessels, allowing rapid exchange of nutrients and waste. Another group of cells separates from the developing embryo near this time, and these cells also do not form part of the new organism. Instead, they develop into the amnion, the membrane that will surround the fetus to form the embryonic sac. This fluid-filled sac helps to cushion the fetus during later development. This phase begins during the second week of development.

**Gastrulation.** During the third week, the embryo undergoes the process of gastrulation, forming a trilaminar (three-layered) disc. Gastrulation establishes the three germ layers—the endoderm, ectoderm, and centrally placed mesoderm—all of which will give rise to the various organ systems. Mesoderm also combines with trophoblast tissue to form the umbilical cord, which transports nutrients and wastes between the fetal circulation and the placenta.

**Embryogenesis.** At this point, the developing human enters the actual embryonic phase, which lasts from the third week through the eighth week after conception. The organ systems differentiate at greatly varying rates during this phase. For example, the circulatory system is largely functional at the end of this period, whereas the nervous system is still engaged in massive cell division and only beginning to establish functional connections. Most embryological malformations occur during this embryonic phase.

The remainder of human development, from weeks nine to thirty-eight, is called the fetal period, the time during which the embryo first acquires human appearance. (The medical definition of the fetal period extends to forty weeks because it is measured not from conception but from the onset of the woman’s last menstrual period, usually two weeks earlier.) Fertilization takes place around the middle of the average four-week cycle, hence the two week discrepancy between the biological and medical **gestation** period.

**gestation** period of fetal development within the mother



A human fetus at ten weeks.

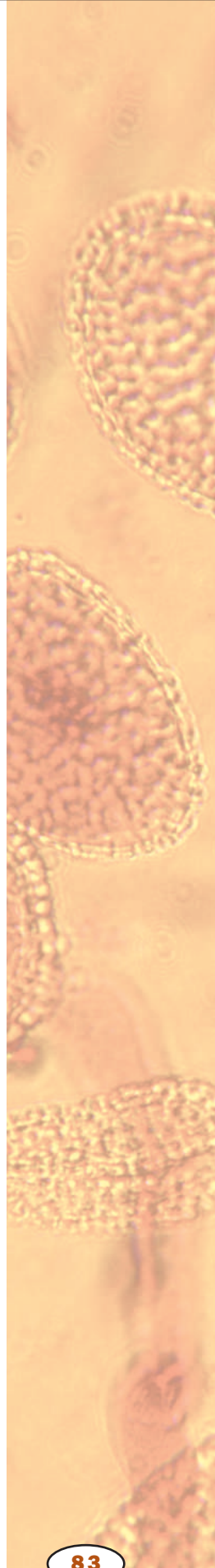

## The Fetal Period

The fetal period is characterized by two processes. The first is rapid growth (increase in size and cell number) and the second is continued tissue and organ differentiation (specialization of cells to perform distinct functions).

**Rapid growth.** Fetal growth rate is greatest at the beginning of the fetal period (through week sixteen), during which time the fetus increases twenty-five-fold in weight. The largest increase in absolute weight gain, however, takes place during the final month of gestation. In these four weeks the fetus gains as much weight (500 grams [a little over 1 pound]) as it does during its first twenty weeks of development. Normal full-term babies weigh about 3,500 grams (7.7 pounds). Newborns weighing 500 grams or less rarely survive, although medical advances are improving their chances. Infants weighing between 500 and 1,000 grams (2.2 pounds) are classified as immature and those between 1,000 and 2,500 grams (5.5 pounds) are premature.

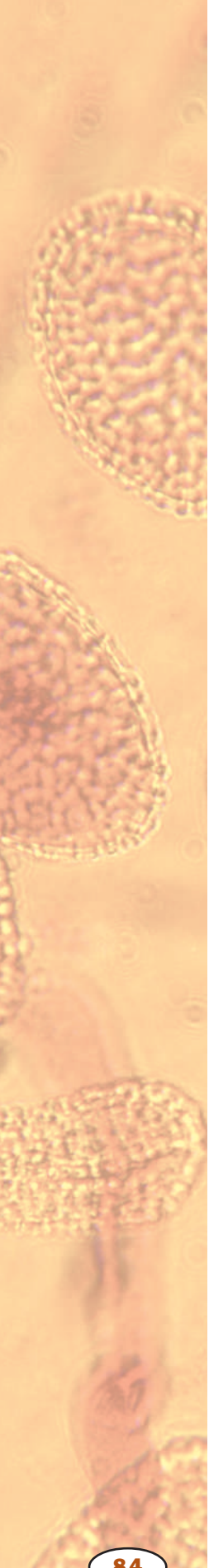

**placental** related to the placenta, an exchange organ in the uterus

**viability** ability to live

**metabolite** molecule involved in a metabolic pathway

**chromosomal analysis** staining, banding, and other techniques for detection of chromosomal abnormalities

**ultrasonography** use of sound waves to produce an image

**genitalia** reproductive organs

**excrete** deposit outside of

**lipid** fat or waxlike molecule, insoluble in water

**secretion** material released from the cell

**protein** complex molecule made from amino acids; used in cells for structure, signaling, and controlling reactions

**in utero** inside the uterus

Besides weight, the length of the fetus is also used to estimate age and survivability. Specifically, the obstetrician can use ultrasonic probes to determine fetal crown-rump length, the distance from the top of the head to the bottom of the rump.

Many factors affect fetal growth, including the nutritional state and social habits (e.g., smoking, drug use) of the mother, the state of **placental** function, and the genetic makeup of the fetus. Perinatology is the medical subspecialty concerned with the mother and fetus from the time of **viability** outside the uterus, generally the last three months of normal gestation (the third trimester) to about one month after birth. A perinatologist uses a variety of methods to assess the fetus. Amniocentesis is the technique by which amniotic fluid is withdrawn by a needle inserted through the mother's abdomen into the amniotic sac. The fluid itself can be analyzed for various **metabolites**, and fetal cells that have been shed into the fluid can be isolated and grown in culture for **chromosomal analysis**.

The fetus itself can be visualized by two general methods. **Ultrasonography** is noninvasive. An instrument emitting ultrasonic waves is placed on the mother's abdomen and the reflected signals are rendered into images of the fetus by computer enhancement. Fetoscopy is an invasive technique in which a fiber-optic probe is inserted like an amniocentesis needle into the amnion. Fetoscopy can be used to both directly visualize the fetus and take a sample (biopsy) of specific fetal tissues.

**Tissue and organ development.** Early in fetal development the head dominates the body, constituting half its length. The face is broad and flat, eyes are still wide apart, and ears are low. The intestines temporarily protrude through the abdominal wall until the tenth week, and the external **genitalia** appear similar between the sexes. The fetus also starts to **excrete** urine into the amniotic cavity. By the end of the fourth month, the rest of the body has caught up to the head and the limbs have grown to give the fetus proportions more nearly like those of a newborn. The fifth month is marked by the first fetal movements perceived by the mother, known as quickening. The skin of the fetus secretes a **lipid**-rich covering substance, the vernix caseosa. It also exhibits a temporary covering of fine hair, the lanugo.

By the sixth month, the fetus acquires the capacity for independent existence because the lungs have finally matured to the point where the fetus can breathe. This depends on the **secretion** from specific lung cells of a **protein**-lipid complex known as surfactant. Surfactant lowers the surface tension in the lungs at the air-liquid interface thereby aiding gas exchange. Without adequate surfactant, infants born prematurely succumb to hyaline membrane disease (respiratory distress syndrome). Modern medicine has had some success in saving such babies by providing them with an external source of surfactant.

During the seventh month the nervous system develops many basic reflex responses, including the constriction of the pupils in response to light. Other reflexes controlling breathing, swallowing, and general movement can be detected much earlier, around the middle of the third month, although the effective coordination of such movements requires several more months **in utero**.

The cardiovascular system undergoes dramatic changes at the time of birth. Because the placenta provides for gaseous exchange *in utero*, blood flow to the lungs is largely bypassed through a hole known as the foramen ovale within the wall between the left and right **atria**. In addition, a shunt (bypass) called the ductus arteriosus occurs between the aorta and pulmonary artery. Upon birth, the foramen ovale is functionally closed by the higher blood pressure on the left side of the heart. This is in part caused by the closure of the ductus arteriosus, which becomes a fibrous remnant, the ligamentum arteriosum. The umbilical arteries and vein also degenerate after birth to become ligamentous structures on the inside of the abdominal wall.

As the fetus approaches term, substantial adipose (fat) tissue is deposited. The circumference of the abdomen slightly exceeds that of the head. Passage of the head through the birth canal is facilitated by the fact that the flat bones of the skull are widely separated by **connective tissue** called fontanelles. This allows a degree of compression of the head at birth, called molding. The often misshapen head of the newborn quickly returns to normal. The process of birth, or parturition (labor), occurs in three stages. The first is the **dilation** of the cervix, the second is the actual delivery of the fetus, and the third ends with the expulsion of the placenta. The entire process may take from only a few hours to well over a day to complete. SEE ALSO AMNIOTE EGG; DEVELOPMENT; FEMALE REPRODUCTIVE SYSTEM; HEART AND CIRCULATION; MALE REPRODUCTIVE SYSTEM; MEIOSIS

Alexander Sandra

### Bibliography

- Kolata, Gina. *The Baby Doctors: Probing the Limits of Fetal Medicine*. New York: Delcorte Press, 1990.
- Lagercrantz, H., and T. A. Slotkin. "The 'Stress' of Being Born." *Scientific American* (April 1986): 100–107.
- Mehren, Elizabeth. *Born Too Soon*. New York: Kensington Books, 1991.
- Van De Graaf, Kent. *Human Anatomy*, 5th ed. New York: McGraw-Hill, 2000.

## Field Studies in Animal Behavior

Field studies of animals help scientists understand the complexities and causes of animal behavior. Wild animals interact with their physical surroundings and the biological world while breeding, eating, and moving within their habitat. Although some behavioral studies are conducted in laboratories or zoos, many of the behaviors that animals exhibit in the wild are closely interconnected with the plants and animals around them and can only be observed during field studies.

Charles Darwin, an English naturalist, presented his theory of evolution by **natural selection** in 1859, after observing the correlation between beak sizes and feeding behavior of ground finches in the Galapagos Islands. This theory has helped to shape a conceptual framework for modern biology.

Between 1930 and 1950, Konrad Lorenz, an Austrian naturalist, and Nikolas Tinbergen, a Dutch-born zoologist, developed the field of ethology, the modern science of animal behavior. Their field studies of animals,

**atria** two upper chambers of the heart (singular, atrium)

**connective tissue** one of four types of body tissue, characterized by few cells and extensive extracellular material

**dilation** expansion or swelling

**natural selection** process by which organisms best suited to their environments achieve greater reproductive success, thus creating more "fit" future generations

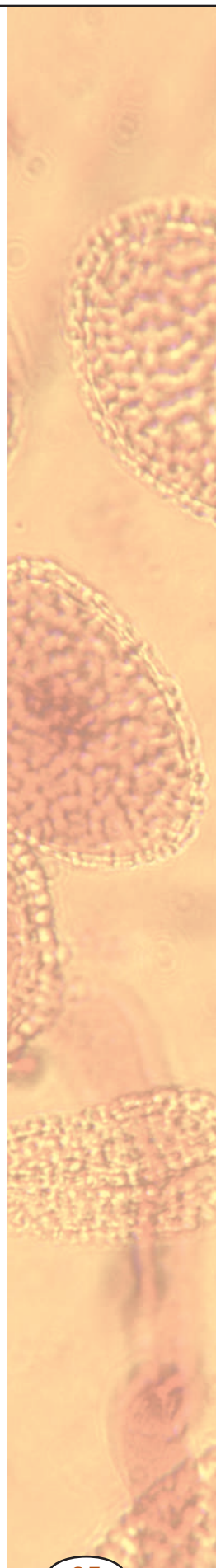

Gray wolves (*Canis lupis*) exhibiting submissive behavior. Studies of animal behavior seek the causes of behavior, how it has evolved over time, and how it contributes to a species' survival.



**NICE, MARGARET MORSE  
(1883–1974)**

American biologist and psychologist who published over 250 papers and books. Nice was one of the first scientists to study the behavior of individual animals living in the wild, much as later biologists would study chimpanzees, gorillas, hyenas, and other species. In the late 1920s and early 1930s, Nice captured and marked individual song sparrows in her backyard, then studied them for their entire lives.

such as ducks, geese, gulls, butterflies, fish, wasps, and bees, led to studies of animal behavior becoming more organized and systematic in seeking the causes of instinctive behavior, how it has evolved over time, and how it contributes to a species' survival.

Lorenz and Tinbergen used little more than binoculars and a notebook for documenting careful and detailed descriptions of animal behaviors. Today, modern technology also plays a role in studies of animal behavior. For example, radio telemetry is used to track the movements and behavior of various animals from reptiles and amphibians to large mammals, satellite telemetry is used to document bird and sea turtle migration routes, and depth recorders are placed on diving seals and whales.

Field investigations address many different types of behavior, including social behavior, mating systems, sheltering and feeding habits, predator-prey relationships, migration, and navigation. Although field studies have taught scientists many things about animal behavior, questions still remain. The study of these questions helps reveal the roles individuals play within a

species, the niches a species fills in relation to other species, including humans, and even how humans behave and how their actions affect other species. For example, the apparent grieving rituals of elephants and the environment of mutual care in which they rear their young continue to fascinate many people, and the “self-sacrificing” behavior of bees and ants have contributed to the science of sociobiology.

Field studies of animal behavior have the practical value of increasing researchers’ understanding of how to conserve threatened and endangered species, as well as how to control pest species. English zoologist Jane Goodall is known for her work with chimpanzees in Tanzania, which began in 1960. Through her extensive fieldwork and detailed reports, she has greatly increased human understanding of primate behavior and has documented behaviors, such as tool use and warfare, which were previously believed to be unique to humans. Goodall’s efforts have helped to prolong the survival of chimpanzees in the wild and have brought the issues of wildlife conservation to the attention of the world. SEE ALSO CONSERVATION; DARWIN, CHARLES; ENDANGERED SPECIES; MATING SYSTEMS; MIGRATION; SOCIAL BEHAVIOR; SOCIOBIOLOGY; WILDLIFE BIOLOGIST

*Aimee M. Roberson*

### **Bibliography**

Goodall, Jane. *Through a Window: My Thirty Years with the Chimpanzees of Gombe*. New York: Soko Publications Limited, 1990.

Halliday, Tim, ed. *Animal Behavior*. Norman: University of Oklahoma Press, 1994.

## **Field Studies in Plant Ecology**

Some of the most important ecological research taking place today is in field studies in plant ecology. These are studies undertaken to answer such important questions as: How much carbon dioxide do plants take up from the atmosphere? Does the number of plant species in a community such as a prairie or forest affect productivity? How much carbon dioxide is taken up by these communities? Why do some plant communities such as tropical forests have so many species, whereas others like salt water marshes have so few? What effects are introduced species having on native plant communities? Although laboratory experiments are useful in trying to understand how individual plants respond to different conditions, only studies conducted in the field can answer questions such as these.

Field plant studies vary in the degree of experimental manipulation that is imposed on the environment under investigation. Some field studies are strictly observational with no experimental manipulation at all. Long-term monitoring studies of patterns of tree growth and mortality are examples of observational studies. At the other end of the spectrum are studies in which entire plant communities are created by the investigator. In these studies, the scientist tills and prepares the soil, sows the seeds of the target species, and then often imposes various experimental treatments on portions of the vegetation. These treatments can include altering the vegetation’s water and nutrient regimes to excluding certain herbivores (animals that eat plants). In the middle of the spectrum are studies conducted in natural environments

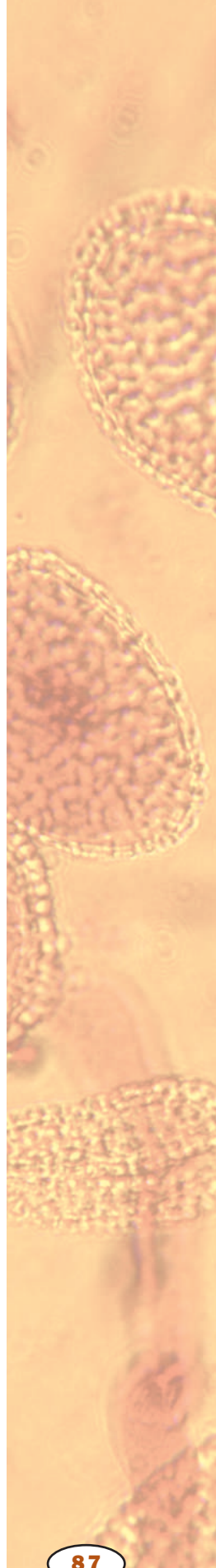

Agronomists place a plastic greenhouse over crops that will be exposed to simulated rain with varying pH levels. The greenhouse provides a closed environment that will allow scientists to assess the plants' reaction to the rain.



in which the investigator manipulates only a single or a few variables, such as fire frequency.

The advantage of field experiments over strict observational studies is that the investigator has more control over the variables of interest, and hence it is often easier to test specific hypotheses. The potential pitfall of field experiments is that the investigator may so alter the natural environment that the findings may not be relevant beyond the experiment itself. Often, scientists will employ both field experiments and field observational studies in order to answer important plant ecological questions.

Field studies in plant ecology serve two major purposes. First, they help researchers understand how the natural world functions, thereby satisfying human curiosity. Second, they provide information that can be of great practical value. For example, some plant studies show how plant species are affected if their habitat is reduced in size. Others show how certain plant species are dependent on particular animals for their pollination or seed dispersal. These findings aid conservation biologists who are trying to preserve plant species diversity in natural areas and in urban and suburban environ-



ments. Many ongoing field plant studies are trying to increase scientists' understanding of global climate change. It is hoped that findings from these studies will help scientists better predict the nature and extent of future climate change. In turn, these field studies may show how changes and elimination of plant communities (for example, through deforestation and urbanization) might be affecting global and regional climate patterns. SEE ALSO ESTUARIES; FOREST, TROPICAL; GLOBAL CLIMATE CHANGE; NATURAL SELECTION; THEORETICAL ECOLOGY

Mark A. Davis

### Bibliography

Grime, J. P. *Plant Strategies, Vegetation Processes, and Ecosystem Properties*, 2nd ed. New York: Wiley & Sons, 2001.

## Fire Ecology

Fire is one of the leading natural forces that has shaped nearly all land-based **ecosystems** for several thousand years. Fire is especially important in regulating the species composition of vegetation. Fire is particularly important in forests of cold northern regions, such as Canada and Siberia, and in **savannas**, grasslands, and shrubby vegetation types in temperate and tropical regions, such as Australia and California.

Fire has become more important in tropical forests due to human disturbance. Fires are caused naturally by lightning and by people both accidentally and intentionally for management purposes. Native peoples around the world have used fire to maintain favored vegetation types and manage wildlife.

### Surviving Fire

Some plant species have adaptations that allow them to survive or reproduce after fire. Survival adaptations include sprouting from underground roots (aspen, grasses), sprouting from stumps (birches, oaks), and growing thick bark that insulates trees from fire (many species of pine and oak). Adaptations that lead to reproduction after fire include serotinous cones on species such as jack pine and lodgepole pine. **Serotinous** cones are held high in the forest canopy in closed condition and do not shed their seeds unless scorched by fire. Buried seeds of some species survive in the forest floor until fire kills the tree canopy, allowing sufficient light to stimulate seed germination (pin cherry and some geraniums).

Some plant species have none of these adaptations to fire. They survive fire in refuges, such as rocky areas without continuous fuel to carry fires, or wetlands that rarely burn. They may also grow in parts of the world where rainfall is frequent and fires are rare.

Natural vegetation types of the world experience several "fire regimes," or characteristic occurrence of fire in terms of the frequency and intensity of fire. A fire regime with very frequent, low-intensity fire (two- to ten-year recurrence) occurs in moderately dry climates supporting grasslands and savannas around the world. Frequent, low-intensity fires (ten- to forty-year recurrence) constitute the fire regime in many temperate and **boreal** forests

**ecosystem** an ecological community and its environment

**savanna** open grassland with sparse trees

**serotinous** developing late in the season

**boreal** of, relating to, or located in northern regions

A plant ecologist measures lodgepole pine seedling growth in Yellowstone National Park in Wyoming. Seven years after the fire of 1988, there were ten times as many seedlings in the area than before the fire.



dominated by tree species with thick bark, especially oaks and pines. The fires kill invading tree species with thin bark while allowing oak and pine to survive.

A fire regime of moderately frequent, high-intensity fire (thirty- to one-hundred-year recurrence) occurs in oak and manzanita-dominated chaparral in California and in dry boreal forests dominated by trees with serotinous cones, such as jack pine in North America. These high-intensity fires kill the forest from the ground up and initiate a new, young forest. Infrequent, high-intensity fires (one-hundred- to five-hundred-year recurrence) occur in many conifer forests of the Rocky Mountains and wetter parts of the boreal forest.

### “Helpful” Fire

A number of ecosystems have a regime in which fires are rare, including hemlock and sugar maple forests of eastern North America, arctic tundra, and very dry deserts. Surprisingly, fire may still be important in these systems. For example, lightning strikes in maple forests of Michigan sometimes burn a fraction of an acre of forest, called a spot fire. These spot fires are usually invaded by oak trees, which then live for up to three hundred years. These spot fires have a long-lasting impact where they occur and they enhance biodiversity by maintaining fire-dependent oak as a component of the forest landscape where big fires never occur.

Many vegetation types around the world require fire for their maintenance over time, and they are replaced by different vegetation in the absence of fire. People have suppressed fire during the nineteenth and twentieth centuries in many parts of the world. Fire suppression in savannas and prairie remnants has allowed invasion by forest in many cases. Restoration of prairies requires the use of “prescribed fire,” purposely set by people, to reestablish the fire regime required by the prairie plants.

Pine forests throughout the United States (ponderosa pine in the west, white pine in the east) were formerly kept in a parklike condition with open understories by the occurrence of surface fires. After several decades of fire

suppression, these forests have accumulated a high density of trees, including the invasion of other species such as spruce and fir. The buildup of high fuel loads and smaller trees that can function as a ladder to carry fire into the crowns of large pines means that fires become more intense than in the past, possibly too intense to be controlled by fire fighters, and intense enough to kill the old pines.

## Fire and Wildlife

Fires kill relatively few numbers of wildlife species directly. The major impact of fires on wildlife is that it alters their habitat. Any substantial alteration in habitat is sure to affect some species positively and others negatively. For example, if an old-growth boreal forest of pine, spruce, and fir is replaced by a young aspen forest after a fire, then a whole suite of conifer-dependent birds, such as spruce grouse, gray jay, and boreal chickadee, will fare poorly after the fire. Conversely, birds that prefer young aspen forest such as ruffed grouse will increase in population.

Forest fires generally only consume 10 to 20 percent of the wood in tree trunks, leaving many standing dead trunks referred to as snags. Snags are good habitat for woodpeckers that seek insects living within the dead wood and cavity-nesting birds that use the cavities excavated by the woodpeckers. Deer and elk also prefer young post-fire forests, whereas the pine marten prefers mature forests.

If a major forest fire were to burn an entire forest, for example, an entire national park or wildlife refuge, then all of the habitat after the fire would be young forest, and those species that lived in mature forests could be excluded from the park. Conversely, if there were never any fires, those species of wildlife that require young, regenerating forests would be excluded.

An ideal solution to this problem is to have relatively small fires occur on a regular basis so that a mix of young, middle-aged, and mature habitat is always present to accommodate all species of wildlife that could live in the area. This concept is known as landscape diversity. The distribution and size of fires on the landscape over time is, together with human disturbance such as logging, the most important factor in determining landscape diversity and the consequent ability of the landscape to provide for a variety of wildlife. SEE ALSO ADAPTATION; FOREST, TEMPERATE; GRASSLAND

*Lee E. Frelich and Peter B. Reich*

### Bibliography

- Johnson, Edward A. *Fire and Vegetation Dynamics: Studies from the North American Boreal Forest*. Cambridge, UK: Cambridge University Press, 1992.
- Pyne, Stephen, J. *Fire in America: A Cultural History of Wildland Fire and Rural Fire*. Princeton, NJ: Princeton University Press, 1982.
- Whelan, Robert J. *The Ecology of Fire*. Cambridge, UK: Cambridge University Press, 1995.

According to the National Office of Fire and Aviation, more than 57,000 acres of land in the United States burned as a result of prescribed fires in 2000. Oregon and Idaho had the most, with an estimated 12,400 and 10,300, respectively.

## Flight

Flying organisms include insects, birds, and bats, all of which evolved the ability to fly (and the wings that flight requires) independently. Flying squirrels, flying fish, and other animals that only glide are not considered

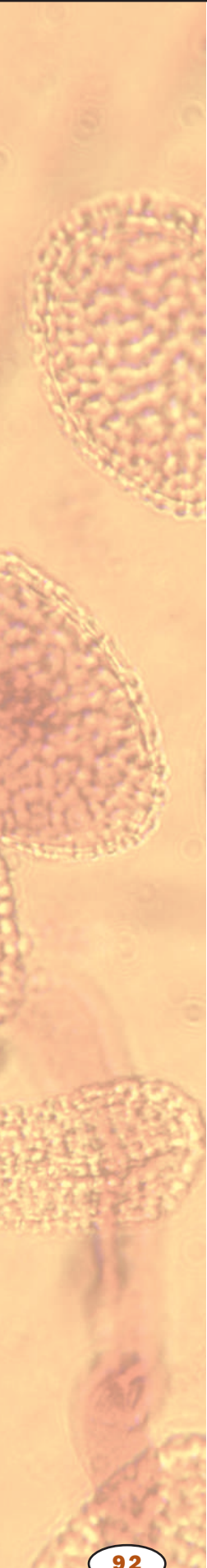

**appendage** attached organ or structure

**fulcrum** pivot point of a lever

capable of true flight. In general, flight requires an animal to generate enough lift to overcome the force of gravity. Unless it is hovering, the animal also needs to generate directional thrust, to move once it is in the air. The different groups of animals manage these tasks in different ways.

## Insects

Among the many other titles insects hold (including being the most numerous and diverse group of animals) they can claim the title of the first flying organisms, having taken to the air tens of millions of years before the pterosaurs (extinct flying dinosaurs), and hundreds of millions of years before birds and bats. Most insects can fly, or are descended from flying ancestors, and are grouped in the subclass Pterygota (“having wings”). The more primitive, nonflying insects are grouped in the class Apterygota (“not having wings”). Unlike wings of the other flying animals, insect wings are not modifications of legs but rather separate **appendages**, outgrowths of the thorax. It is not known how insect wings evolved—the fossil record is not that complete—but there are many hypotheses, including the ideas that wings first evolved for gliding, as solar collectors, or as gills on aquatic juvenile insects.

Insects manipulate their wings using two kinds of muscles: direct, which are attached to the wing, and indirect, which alter the shape of the thorax. In flight with the indirect muscles, the wing acts as a lever, with a part of the thorax as its **fulcrum**, and tilts up or down as the thorax changes shape.

Many insects are so small that the relative thickness of the air is too great for them to fly as birds, bats, and airplanes do. Instead, because of the viscosity of the air, they move in a way more akin to swimming than gliding or soaring.

## Vertebrates

Flight has evolved independently in vertebrates at least three times: in pterosaurs, birds, and bats. Although scientists know that pterosaurs, like bats, flew on wings consisting of skin stretched from the hand to the body, it is not known how they kept such large bodies airborne. Bird wings, on the other hand are made up of flight feathers. Both birds and bats provide most of the thrust for flight with their wing tips, tilting them on both the down stroke and the upstroke so that they cut into the air at an angle and pull the body forward. Most of the lift, however, is provided by the base of the wing. In both birds and bats, as in airplanes, the wing is thicker at the front, convex on the top, and concave or flat on the bottom. As this shape slices through the air, a low-pressure zone is formed by the faster-moving air on top of the wing, and the higher pressure air beneath the wing pushes up on the wing, creating lift. To lighten their bodies and minimize the amount of lift they have to create, both birds and bats are usually relatively small, and birds have hollow bones. SEE ALSO BIRD; INSECT; EVOLUTION; SCALING

*Robbie Hart*

### Bibliography

Borror, Donald J., Dwight M. DeLong, and Charles A. Triplehorn. *An Introduction to the Study of Insects*. Philadelphia, PA: W. B. Saunders, Co., 1989.

Brock, Fenton M. *Bats*. New York: Facts on File, 1992.

Ehrlich, Paul R., David S. Dobkin, and Darryl Wheye. *The Birder's Handbook*. New York: Simon & Schuster, 1988.

## Flowers

Flowers are the typically showy reproductive organs of angiosperms (flowering plants). Their diverse blooms generate countless horticultural products; functionally flowers are essential for sexual reproduction. Flowers may occur individually on the plant or together with other flowers forming inflorescences. Their flowers and inflorescences are: (1) highly adapted to the plant's ecology and pollination strategy; (2) highly variable among the flowering plants; (3) critically important to plant identification; and (4) subject to their own rich and specialized terminology.

Morphologically and evolutionarily, the flower is regarded as a terminal shoot with variably leaflike **lateral appendages**. The stem of the flower, known as a pedicel, is connected to the other floral parts via the receptacle. From the outside rim of the receptacle, the first appendages are typically green, leaflike **sepals**, collectively called the calyx. The next whorl is composed of variously colored and often complex petals, collectively called the corolla.

The androecium forms the next whorl, formed of stamens, each made of a filament and anther. Anther sacs are filled with pollen at maturity. Anthers release the pollen timed to match the receptivity of the female of either the same flower or others of the same species.

The center of the flower is occupied by the gynoecium, which is formed of one or more carpels. Carpels may fuse to form a compound **pistil** or may remain separate and unfused. The carpel is divided into three regions, from the tip: the stigma, a receptive surface for pollen; the style, a specialized region for pollen tube elongation; and the ovary, a location where immature seeds called **ovules** occur, containing the female **gametophyte** or embryo sac. **Meiosis** occurs deep within the anther to produce many **haploid** male gametophytes (which become pollen) and deep within the ovule to produce the female gametophyte (or embryo sac).

The group of angiosperms known as monocotyledons typically have floral organs in multiples of three, whereas dicotyledons have floral organs in multiples of four or five. Fusion of floral organs often occurs obscuring these parts and increasing the diversity of floral form. Similar organs fuse in the example of the corolla tube (as in the morning glory), but dissimilar organs fuse in the example of apple flowers.

Organs may also be modified to perform different functions. For example, roses have five petals (as do most dicots), but some or all of the numerous stamens form petal-like staminodes, sterile petal-like stamens that give horticultural roses the appearance of having many more petals. Symmetry of individual flowers may be radial (forming mirror images around the center), or bilateral (forming mirror images along only one plane).

The flower is the focus of considerable metabolic activity for the plant, producing reproductive organs with high energy content. Flowers attract

**lateral** side-to-side

**appendage** attached organ or structure

**sepal** whorl of flower organs outside of the petals, usually green and serving to protect the flower before it opens

**pistil** female reproductive organ of a flower

**ovule** multicellular structure that develops into a seed after fertilization

**gametophyte** a haploid plant that makes gametes by mitosis

**meiosis** cell division that forms eggs or sperm

**haploid** having single, non-paired chromosomes in the nucleus

The largest flowers are species of *Rafflesia*, a carrion flower measuring up to 2 meters (6 feet) wide. This flower, native to the tropical rain forests of Sumatra, has no leaves or aboveground organs except for the flower. Living up to its name, *Rafflesia* attracts and is pollinated by carrion flies.

Snapdragons in bloom. Insects and other animal pollinators that visit flowers are often rewarded in return with pollen or nectar to assure this continued relationship.



The smallest flower is a duckweed. The smallest duckweeds are members of the genus *Wolffia*, with the whole plant measuring less than 1 millimeter (.039 inch) across. The flower of this plant is reduced to one pistil and one anther, which are borne on different plants. Other floral parts are vestigial or fail to form.

insects and other animal pollinators to visit the flower. In return, pollinators are often provided with a food reward of pollen or nectar to assure this continued relationship. After the flower is fertilized, floral organs, including petals, stigma, and style, die back while seeds form inside the carpels. The tissues surrounding the ovary are dramatically modified to become the fruit. SEE ALSO ANGIOSPERMS; FRUITS; POLLINATION AND FERTILIZATION; SEEDS

*Scott D. Russell*

**Bibliography**

- Uno, Gordon E., Richard Storey, and Randy Moore. *Principles of Botany*. Boston: McGraw-Hill, 2001.
- Young, Paul G., and Jacquelyn Giuffre. *The Botany Coloring Book*. New York: Harper Perennial, 1982.

**Forensic DNA Analysis**

Forensic DNA analysis is the use of deoxyribonucleic acid (DNA) specimens in legal proceedings. Just as people can leave fingerprints when they touch

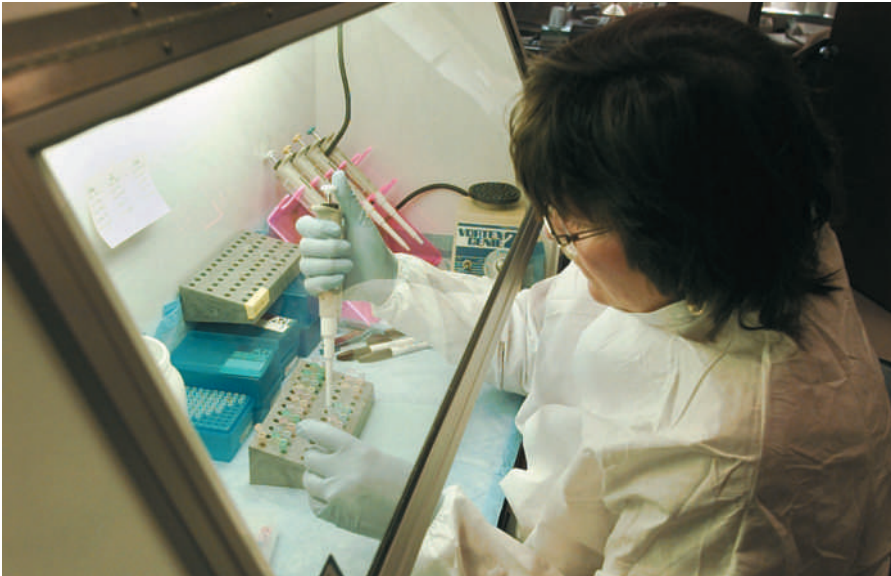

An agent works on DNA evidence at the Colorado Bureau of Investigation forensic lab in Lakewood.

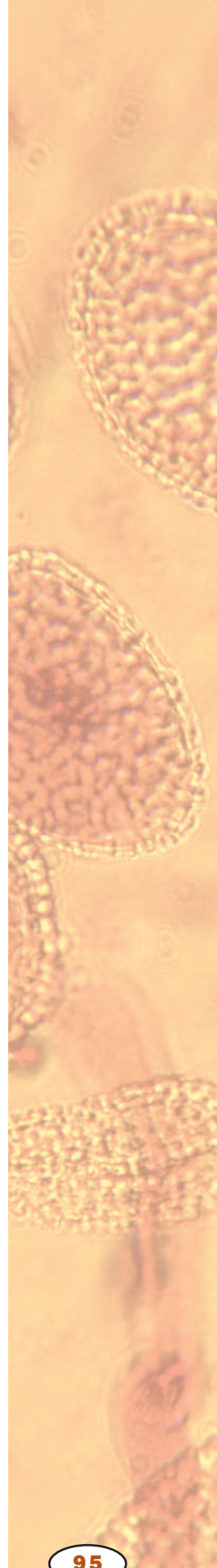

a surface, so too can they leave biological material that contains DNA. When a person's fingerprint matches the latent print found at the scene of a crime, the match provides evidence linking the person to the crime. Similarly, DNA recovered from stains of blood, saliva, or semen or from material such as bone, hair, or skin can be matched to a person's DNA. DNA can even be recovered from fingerprints.

A man could be associated with a rape in a private home by several types of evidence: he may have smoked a cigarette and left the butt outside the house; he may have cut his hand while breaking a window to get inside; or he may have left semen on the victim's body. For each type of evidence, DNA could be used to strengthen the case against a suspect identified by the police by some other means. If the DNA profile from a blood sample or cheek cell scrape is found to match that at the scene of the crime, the suspect is implicated in the crime. If the police have no suspect, they can take the crime scene profiles and use them to search a database of profiles of previously convicted offenders, in the same way that fingerprint records can be searched.

Not only can DNA be used to associate people with crimes, but it can also be used to exonerate them. Several people have been released from prison because DNA testing, not available when they were convicted, has since shown that it could not have been their blood, for example, on an item of evidence.

These forensic uses of DNA rest on the fact that DNA is found in every **nucleated** cell in the body and is the same in all those cells. The other great advantage for DNA as a means of identification is that it is transmitted from parent to child. Paternity disputes can be settled by comparisons of the DNA profiles of mother, child, and alleged father. Just one or two components of the child's DNA profile may be sufficient to exclude a man from being the father, whereas if the man and child match paternal **alleles** at many loci (sites on a **chromosome**), it may be highly probable that the man is the child's father.

**nucleated** having a nucleus

**allele** a particular form of a gene

**chromosome** "colored body" in the cell nucleus; made of DNA and protein, and divided functionally into genes and non-gene regions

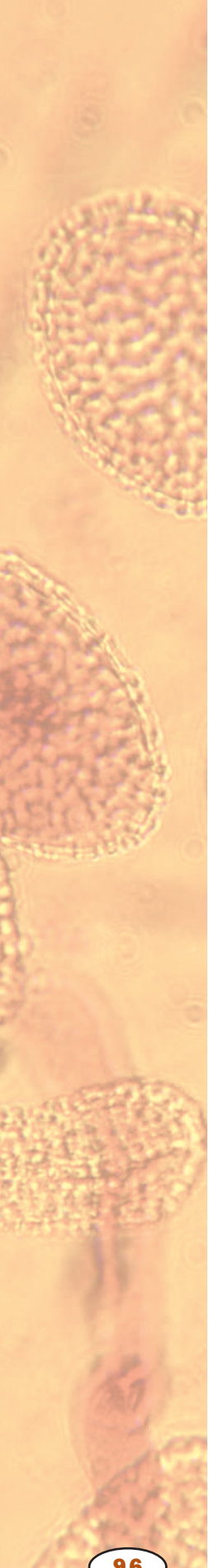

**mitochondria** subcellular organelle that creates ATP used for energy-requiring processes in a cell

**base pair** two nucleotides (either DNA or RNA) linked by weak bonds

**evidentiary DNA profile** analyzed DNA from a sample used as evidence

The sharing of some aspects of DNA profiles among family members is also used to identify remains after mass disasters, such as aircraft crashes or battles of war. Particularly when bone or hair is used for identification, **mitochondrial** DNA may be preferred over nuclear DNA because it is more abundant in the cell and because its smaller size means that it is less susceptible to degradation over time.

Exclusion by DNA is taken to be absolute. If the DNA profile from a bloodstain is different from that of a suspect in a crime, that person could not be the source of the stain. Failure to exclude a “match” is not absolute, however, because two people may have the same profile. On average, two people are expected to differ at the DNA level about once per 1,000 **base pairs**. This means that they have about three million differences, and this would certainly be detected if complete DNA sequences were used in forensic science. Current technology, however, limits DNA profiles to just a few genetic markers, often thirteen in the United States, and coincidental matches have been found for up to six markers.

When a person is not excluded as being the source of an **evidentiary DNA profile**, the strength of the evidence is given in terms of probabilities. Although the evidentiary profile may *match* the DNA of the suspect, this is not proof that the stain *came from* the suspect. All that can be said is that there is a certain probability that it did. Because related people share more markers, the probabilities may need to allow for the suspect being a close relative to the person who was the source of the evidence, and the calculations should also allow for the chance of people in the same subpopulation having the same DNA profiles because of a shared ancestry or evolutionary history.

There are two probabilities the forensic scientist can determine. The first probability is for obtaining a match between the suspect’s profile and the evidentiary profile if the suspect *is* the source of the evidentiary profile. Obtaining a match in this case is usually taken as certain. This probability has a value of one. The second probability is for obtaining a match between the suspect’s profile and the evidentiary profile if the suspect *is not* the source of the evidentiary profile. This probability varies with the tests done and the characteristics of the population in the area of the crime scene. In many cases, it has the value of one in one million, or much less.

Thus, what the forensic scientist reports is: “If the suspect is innocent, there is a one in one million chance of obtaining this match.” Far too often that statement is misinterpreted as, “If this DNA matches, there is a one in one million chance the suspect is innocent.” The reversal of proposition and conclusion is known as the Prosecutor’s Fallacy. It is a very common misinterpretation of DNA forensic evidence by prosecutors, juries, and the press.

To understand why it is wrong to reverse these clauses, consider this analogous example. If one is a citizen of Spain, there is a 95 percent probability that one speaks Spanish. However, if one speaks Spanish, it does not follow that there is a 95 percent probability that one is a citizen of Spain—there are many other likely sources of Spanish speakers. Similarly, if the DNA matches, it does not follow that the suspect is the source. In a city of ten million people, there are, on average, nine other people whose DNA



would match the evidentiary sample to the same degree of certainty that the suspect's did (one in one million). With only the DNA evidence, each of them might be regarded as being equally suspect. Many other circumstances, including age and sex, could be evidence against such equal probabilities, of course, and the exact number of people with the same profile in the city is unknown. Only by considering other incriminating evidence can the prosecutor proceed with the case against the suspect. **SEE ALSO** DNA; DNA SEQUENCING; ELECTROPHORESIS; MITOCHONDRION; POLYMERASE CHAIN REACTION; SEPARATION AND PURIFICATION OF BIOMOLECULES

B. S. Weir

### Bibliography

Evetts, Ian W., and Bruce S. Weir. *Interpreting DNA Evidence: Statistical Genetics for Forensic Scientists*. Sunderland, MA: Sinauer Associates, 1998.

## Forest, Boreal

Boreal forests are the northernmost forests in the world. These are vast forests that include 29 percent of all the world's forest area in a belt around the Northern Hemisphere, including Scandinavia, Russia, and Canada. In the United States, boreal forests occur in central Alaska and northeastern Minnesota. Boreal forests are dominated by species of spruce, fir, pine, larch, birch, and aspen. Their forest floors are usually covered with mosses and many species of wildflowers.

The distinguishing climatic features are long winters with five to seven months of snow cover and a short cool summer. July mean temperatures fall between 13 and 18 degrees Celsius (55 to 64 degrees Fahrenheit). If summers are cooler than this temperature range, trees are unable to complete their summer growth cycle, and tundra is the dominant vegetation. If summers are warmer, temperate forest trees such as maples and oaks become dominant.

Boreal forests can be divided into southern and northern zones. Southern boreal forests have a high density of trees 15 to 30 meters (50 to 100 feet) in height and are productive enough to produce timber and fiber for paper pulp. Those southern boreal forests in the interior of North America and Asia, away from the oceans, periodically experience very large, high-intensity crown fires that range from 40,485 to 404,858 **hectares** (100,000 to 1 million acres). These forests are composed of species that reproduce well after fires, such as jack pine, aspen, and black spruce. Some southern boreal forests change little in species composition over time, even after fire.

For example, central North American jack pine forests on shallow rocky soils burn in high-intensity crown fires and regenerate directly back to jack pine. In other regions, with deeper more fine-textured soils, boreal forests of spruce and fir are replaced by aspen and birch after fire, and the conifers take several decades to regain dominance. Northern boreal forests occur on permanently frozen ground so that they are stunted (6 to 15 meters [20 to 50 feet] in height), with low tree density. These forests, also called taiga, have thick mats of water-soaked moss and burn infrequently.

**hectare** 10,000 square meters (2.47 acres)

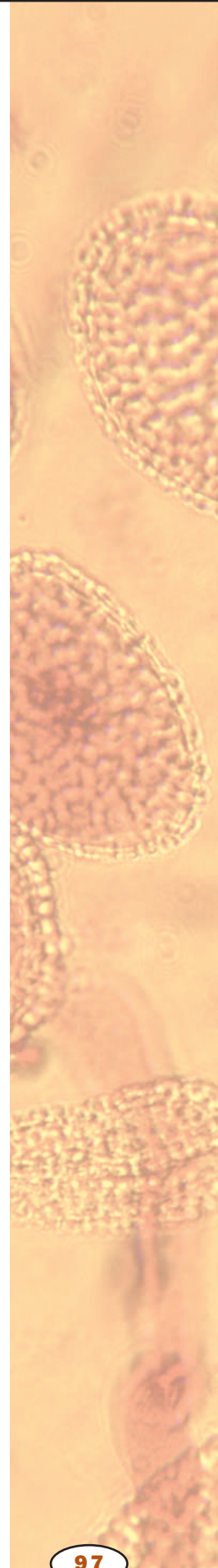

Boreal forests are dominated by species of spruce, fir, pine, larch, birch, and aspen.



**niche** the habitat supplying the right environment for a particular species

Tree and plant species in boreal forests have broader environmental **niches** than in temperate or tropical forests. For example, black spruce can grow in poorly drained bogs and on well-drained rocky hills. It can reproduce well after major forest fires and in older forests that have not burned for some time. Thus, it is both a lowland and upland species and a pioneer and old-growth species.

Characteristic wildlife in the boreal forests includes bear, moose, woodland caribou, wolves, lynx, and wolverine. Deer are restricted to the southern margin of the boreal forest. Many migratory birds use the boreal forest during summer, including warblers, pelicans, seagulls, and hawks. Species of owls and ravens are year-round residents.

The North American boreal forest is still mostly primary forest (first growth) but is now being logged for timber and paper pulp. The Russian boreal forest has seen much less logging, but that began to change in the 1990s. Logging often changes dominance of boreal forests from conifers to aspen and birch. Global warming also has the potential to change boreal forests more than most other forest types; the predicted temperature change

for the boreal forest is greater in magnitude than for temperate and tropical forests. SEE ALSO BIOME; FOREST, TEMPERATE; FOREST, TROPICAL; TUNDRA; WOOD AND WOOD PRODUCTS

*Lee E. Frelich and Peter B. Reich*

### Bibliography

Heinselman, Miron L. *The Boundary Waters Wilderness Ecosystem*. Minneapolis: University of Minnesota Press, 1996.

Johnson, Edward A. *Fire and Vegetation Dynamics: Studies from the North American Boreal Forest*. Cambridge, UK: Cambridge University Press, 1992.

Larsen, James A. *The Boreal Ecosystem*. New York: Academic Press, 1980.

Olson, Sigurd F. *Sigurd F. Olson's Wilderness Days*. New York: Alfred A. Knopf, 1972.

## Forest, Temperate

Temperate forests occur in a latitudinal belt between tropical and boreal forests. Most of the world's temperate forests are in the Northern Hemisphere, although Southern Hemisphere occurrences are found in Chile, Argentina, Australia, and New Zealand.

North American temperate forests fall into six main groups: (1) temperate evergreen rain forests along the West Coast from California to Alaska, dominated by sitka spruce, western red cedar, and western hemlock; (2) **montane** evergreen forests of the western mountains, dominated by Douglas-fir, several species of true fir, spruce, and pine; (3) southeastern evergreen pine forests with longleaf and other pines; (4) central deciduous oak-hickory forest; (5) northeastern **deciduous** beech-maple-hemlock forests; and (6) northern pine forests with red, white, and jack pines.

Disturbance regimes include frequent fire in forests on sandy soils (oak and pine), to rare fire (hemlock, maple, and beech-dominated forests). Wind is a common form of disturbance in temperate forests. Mid-latitude, low-pressure systems hit the Pacific Coast, hurricanes traverse the southern and eastern coast of the United States, and severe thunderstorms and tornadoes often form in the interior of the country. On rare occasions hurricanes and severe thunderstorms can level hundreds of square miles of forest. Many species of trees can sprout from the stump after such blowdowns, and seedlings of shade-tolerant species present on the forest floor are also free to grow when the large trees above them blow down.

Small gaps caused by the felling of single or small groups of trees by ordinary storms are very common. These gaps are important for maintaining a diversity of tree species in the forest. For example, yellow birch, green ash, and basswood enter the forest primarily through gaps. Deciduous temperate forests are known for their diverse understory of spring-blooming wildflowers, including trillium, violets, bluebells, bloodroot, and many others.

Deer, elk, squirrels, and black bear are characteristic wildlife species. All of these animals eat acorns produced by oak trees. Deer also browse tree seedlings during the winter. When a given area is settled by humans the deer population usually rises and is high enough in some areas to change

**montane** mountainous region

**deciduous** trees that shed their leaves in the fall

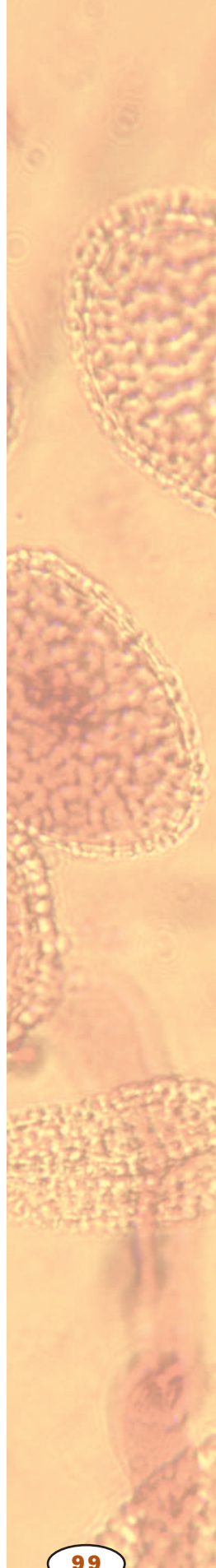

A temperate forest in autumn. The central deciduous oak-hickory forest is just one of the six main North American temperate forest groups.



the composition of the future forest. In mixed hemlock-maple forests of eastern North America, for example, deer prefer hemlock seedlings and effectively prevent them from successful regeneration. Such forests will eventually be dominated solely by maple.

A vast majority of the world's temperate forests have been logged, and nearly half have been converted to croplands, highways, and cities. For example, less than 1 percent of all temperate forest in eastern North America remains in primary (never logged) condition. Logging by clear-cutting is common in coniferous forests and selection cutting—whereby small groups of trees are cut—is common in deciduous forests. Woods from the deciduous forest, such as cherry, walnut, oak, and maple, are used for furniture, woodwork, and flooring. Douglas-fir, longleaf pine, and other conifers are used primarily for lumber.

Much of the secondary temperate forest is fragmented in small farmers' woodlots, city parks, and nature reserves. These small fragments (4 to 40 **hectares** [10 to 100 acres]) face problems from invasive exotic species, high deer populations, and fire exclusion. The combination of these forces can

**hectare** 10,000 square meters (2.47 acres)

cause massive changes to forest species composition. SEE ALSO BIOME; FIRE ECOLOGY; FOREST, BOREAL

*Lee E. Frelich and Peter B. Reich*

### Bibliography

Bormann, F. Herbert, and Gene E. Likens. *Pattern and Process in a Forested Ecosystem*. New York: Springer-Verlag, 1979.

Davis, Mary B., ed. *Eastern Old-Growth Forests: Prospects for Rediscovery and Recovery*. Washington, DC: Island Press, 1996.

Hunter, Malcolm, L., Jr., ed. *Maintaining Biodiversity in Forest Ecosystems*. Cambridge, UK: Cambridge University Press, 1999.

## Forest, Tropical

With their towering trees and tiny orchids, great apes and minute insects, tropical forests are magnificent expressions of nature. Tropical forests may contain half the species on Earth, but many of those species will disappear because of continuous deforestation. More than half the original forests have already been lost, and therefore conserving tropical forests is an urgent concern for ecologists.

Tropical forests include many forest types. True tropical rain forest is warm and wet, occurring mainly near the equator, where the monthly temperature never dips below 18 degrees Celsius (64 degrees Fahrenheit), rainfall exceeds 1700 millimeters (66 inches) per year, and no month gets less than 100 millimeters (almost 4 inches). Away from the equator one usually finds drier tropical forests, and on mountains one finds cooler and wetter, **montane** tropical forests. At sites with extreme conditions such as flooding or very poor soils, specialized tropical forests, such as mangrove, occur.

**montane** mountainous region

### Tree and Plant Species

True rain forest usually has 100 to 250 different tree species in 1 **hectare** (2.47 acres), including palms and stranglers (which germinate in a tree crown then grow up and down, eventually surrounding the host). These trees are mostly evergreen and come in many forms: with round, fluted, deeply furrowed, or spiny trunks; with swollen base or buttresses (flanges extending from lower trunk to the ground) or perched on stilt roots; with large leaves or tiny leaflets.

**hectare** 10,000 square meters (2.47 acres)

Added to this tree diversity are other plant types: shrubs, giant vines, herbs large and small, epiphytes (plants growing on other plants and not rooted in the ground), hemi-epiphytes (which begin life as epiphytes then extend roots to the ground), lichens, and mosses. With all these kinds of plants, and with trees falling and making gaps where regrowth proliferates, the three-dimensional structure of the forest is complex. Despite the fairly uniform climate, flowering, fruiting, and leaf production are somewhat seasonal.

In the other tropical forest types that are drier or cooler than true rain forest, or on extreme sites, there is more seasonal plant behavior, shorter trees, more **deciduous** trees, and fewer species, but plant diversity is still higher than outside the tropics.

**deciduous** trees that shed their leaves in the fall

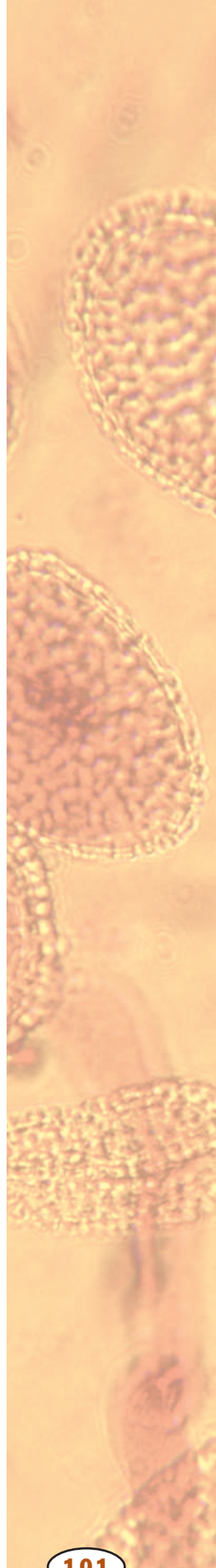

## Animals

Tropical forest animals are also diverse. In Borneo there are squirrels the size of mice and squirrels 75 centimeters (29.5 inches) long. Fourteen monkey species and 230 bird species frequent 100 hectares (247 acres) of mature forest at Cocha Cashu, Peru. Eighty-six frog and toad species and fifty-three snake species inhabited Santa Cecilia, Ecuador, before that forest was destroyed. Insects are the most diverse of all; a scientist found forty-six ant species in one large Brazilian tree, as many as inhabit all of Canada. A major goal of tropical forest scientists has been to describe and explain this tropical diversity.

The diversity of plants is not completely understood but is due to a combination of many factors: a long growing season; variety in growth form; specialization on particular light levels, soil types, or topography (such as slopes versus ridges); **mutualisms** with animals; variable conditions created by disturbances such as hurricanes; chance results of reproduction; and the tendency for common species to attract many animals to eat them, creating space for many less common ones.

**mutualism** symbiosis between two organisms in which both benefit

Moss-covered lianas in the Daintree National Park in Queensland, Australia.





An Agile gibbon (*Hylobates agilis*) with a baby in a Borneo rain forest.

Animal diversity stems mainly from specialization. Many animals specialize on the different resources provided by the great variety of plants and complex forest structure. For example, different plant species are food for different insect species, and flowers and fruit of many types support various kinds of nectar, pollen, fruit, and seed eaters, including insects, birds, bats, and monkeys. Birds catch insects in specialized ways that reflect forest structure and the activities of other species. For instance, different flycatcher species launch themselves from characteristically different perch heights to catch aerial prey; antwrens search the undersides of leaves; woodcreepers glean tree trunks; leaftossers scour the ground; hummingbirds steal prey from spider webs; and antbirds pluck insects fleeing swarming army ants.

Many animals survive in tropical forest through specialized mutualisms, in which animals and plants interact for mutual benefit. This happens, for example, when insects gather nectar from individual plants of one species and transfer pollen among them. These plants often have special features to attract particular insect species. Mutualism also occurs when animals eat fruits and scatter the seeds within, promoting plant reproduction. Some

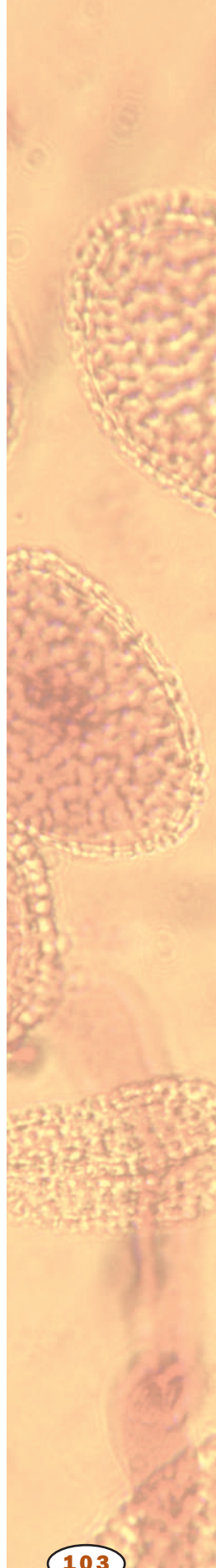

plants and animals truly live together. Cecropia trees house Azteca ants within hollow stems and feed them nectar; in return the Azteca exclude leaf-eating insects and vines from the tree.

### The Effects of Deforestation

Humans have inhabited and used tropical forests for millennia, but widespread deforestation only began in the late twentieth century. Forest loss varies among countries and, depending on location, results from small-scale farming, ranching, logging followed by farming, fuelwood gathering, and other causes. At many places the cleared land is used briefly before soil nutrients are exhausted, and natural reforestation is hindered by the unsuitable conditions created for trees, especially by repeated burning, which also eats into remaining forest stands.

When the forest is cleared, the marvelous variety of plants and animals it contained is lost. Some can survive in small forest patches, but many cannot because light and moisture conditions are changed, critical mutualists are absent, or too few individuals of a given species are present to breed successfully. In addition to this loss of biological diversity, other consequences of tropical deforestation, depending on location, are the loss of native forest peoples, reduced rainfall, increased erosion, silting of coastal **ecosystems**, and possible net release of carbon dioxide and other gases that lead to global warming.

Concerned with these negative effects, local, national, and international groups are trying to stem tropical forest loss. Conservation strategies range from completely protecting remaining forest to promoting sustainable economic uses that leave the forest mostly intact to reforesting degraded lands. Sustainable means using a resource in such a way that future uses are not impaired, which requires sound knowledge of tropical forest ecology. Sustainable timber harvest is one such possibility, which can succeed only if management plans are properly implemented. The success of all conservation efforts depends on ensuring that local people benefit economically, which requires strong cooperation among peoples and nations. **SEE ALSO** BIODIVERSITY; BIOME; CARBON CYCLE; ETHNOBOTANY; WOOD AND WOOD PRODUCTS

*Nicholas Brokaw*

#### Bibliography

- Caulfield, Catherine. *In the Rainforest*. Chicago: University of Chicago Press, 1984.
- Forsyth, Adrian, and Ken Miyata. *Tropical Nature*. New York: Scribner's and Sons, 1984.
- Kellman, Martin, and Rosanne Tackaberry. *Topical Environments: The Functioning and Management of Tropical Ecosystems*. New York: Routledge, 1997.
- Kricher, John C. *A Neotropical Companion: An Introduction to the Animals, Plants, and Ecosystems of the New World Tropics*, 2nd ed. Princeton, NJ: Princeton University Press, 1999.
- Richards, Paul W. *The Tropical Rain Forest: An Ecological Study*, 2nd ed. Cambridge, UK: Cambridge University Press, 1996.
- Terborgh, John. *Diversity and the Tropical Rain Forest*. New York: W. H. Freeman and Company, 1992.
- Whitmore, Timothy C. *An Introduction to Tropical Rain Forests*, 2nd ed. Oxford: Oxford University Press, 1998.

**ecosystem** an ecological community and its environment



## Forester

In common parlance any person who has something to do with raising and managing forest timber resources is in some sense a forester. Foresters go back in history to individuals responsible for managing the harvest of trees on the property of castles and estates and for the management and disposition of the valuable timber asset. Their intuition, practical experience, and natural history knowledge contributed greatly to decision making.

In the twenty-first century, the field has changed, and for the most part a professional forester has a college education and academic credentials, ranging from an associate degree in forest technology to a graduate degree from a school of forestry with specialization in a particular subject area. In addition to the traditional implements of forestry such as shovels, axes, meter sticks, and cruising prisms (which allow the rapid estimation of the number of board feet of timber in a wood lot), foresters now depend on global positioning systems, computer models, and sophisticated research tools in their work. These are used to evaluate such properties of the forest as the quality of wood, the site conditions of the habitat, and fire susceptibility during dry seasons.

Many tasks carried out by foresters involve applications of **silviculture**, chemistry, plant physiology, and biotechnology. Some professional areas, such as forest and paper engineering and scientific resource management, require quantitative skills, while others, such as forest biochemistry, natural products chemistry, and forest ecology, depend on an extensive basic science background. The work environment can be a private practice as a consulting forester, or with industries, government, or academic institutions. While much of the work time is spent outdoors in forests, office and laboratory work is often involved as well. As is the case with virtually all professions, strong writing, verbal, and management skills all place an individual in a favorable position for advancement. SEE ALSO FOREST, BOREAL; FOREST, TEMPERATE; FOREST, TROPICAL

*Dean Cocking*

### Bibliography

Wille, Christopher M., and Mark Rowh. *Opportunities in Forestry Careers*. Chicago: NTC/Contemporary Publishing Group, 1998.

## Fruits

Fruits are produced only by flowering plants (angiosperms). Following pollination of the flower, the fertilized ovules develop into seeds while the surrounding ovary wall forms the fruit tissue, or pericarp.

### Types of Fruits

The botanical definition of a fruit is an organ that contains seeds, protecting these as they develop and often aiding in their dispersal. This may be at odds with everyday usage of the word “fruit.” Botanically, pineapples, oranges, and apples are fruits, but so too are “vegetables” like tomatoes and cucumbers. The pods that contain peas and beans are fruits, as are the dry, inedible structures that bear the seeds of many wild plants.

**silviculture** cultivation of forest trees



A strawberry plant with blossoms and fruit. The true fruit of the strawberry is not the fleshy tissue but the tiny seedlike achenes on the surface of the berry.

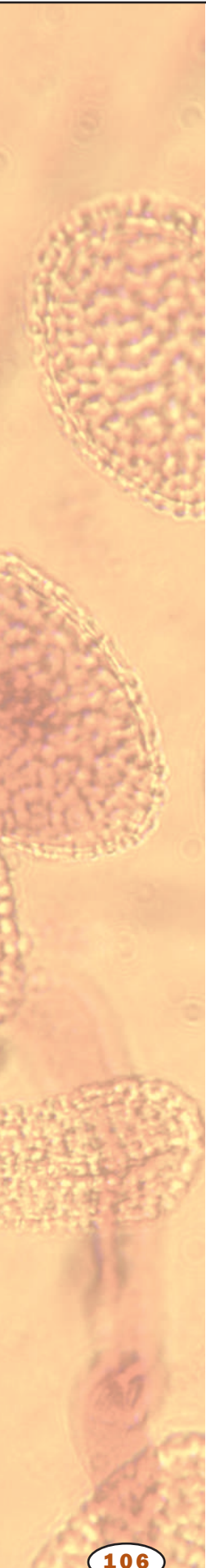

**pistil** female reproductive organ of a flower

MAJOR FRUIT TYPES		
Type	Definition	Examples
<b>SIMPLE</b>	From a single pistil	
<b>DRY INDEHISCENT</b>	At maturity dry; does not split open	
<b>Achene</b>	Close-fitting pericarp surrounding a single seed	Sunflower
<b>Grain</b>	Close-fitting pericarp fused to a single seed	Corn, wheat
<b>Nut</b>	Thick, woody pericarp surrounding a single seed	Walnut, hazelnut
<b>DRY DEHISCENT</b>	At maturity dry and splits open	
<b>Legume</b>	Pod that splits along two opposite sides	Beans, peas
<b>Capsule</b>	Fruit opening by several splits or pores	Cotton, poppy
<b>Schizocarp</b>	Fruit splitting into 1-seeded segments	Dill
<b>FLESHY</b>	Mostly fleshy at maturity; do not usually split open	
<b>Drupe</b>	1- to 2-seeded; the innermost pericarp layer, stony and enclosing the seed(s)	Plum, peach
<b>Berry</b>	1- to many-seeded; no stony innermost layer of pericarp	Tomato, grape, (all citrus fruit are berries of a special type termed a hesperidium)
<b>AGGREGATE</b>	Formed by fusion of several separate pistils of one flower	Raspberry, cherimoya
<b>MULTIPLE</b>	Formed by fusion of several separate pistils of several grouped flowers	Pineapple, fig

There are many ways to classify fruits, but the simplest distinction is between fleshy and dry fruits. Fleshy fruits are made of living cells and are often juicy and sweet (oil-rich olives and avocados are exceptions). Dry fruits at maturity are made up of dead cells and are divided into those that split open (dehiscent fruit) and those that do not (indehiscent fruit). Within these broad categories many specialized fruit types are recognized. Nuts (for example, hazelnuts and pecans) are one such category, defined as dry, indehiscent fruits with a hard, stony wall. Everyday usage of the word “nut” is, however, quite different, and includes cashew nuts and peanuts (which are actually seeds not fruits).

True fruits are formed by the ovary, which is the lower region of the **pistil** and the female sex organ of the flower. Sometimes the bulk of the fruit is not derived from the ovary but from some other part(s) of the flower. Such fruits are termed false fruits or accessory fruits. Strawberry is a good example of this. The fleshy tissue people consider the fruit is derived from the receptacle (the swollen tip of the flower stalk), and the true fruits are the tiny, seedlike achenes on the surface.

Apart from strawberry, all the fruit types discussed so far are simple fruits derived from single pistils. In contrast to simple fruits are aggregate and multiple fruits, which are formed from many pistils and, in turn, many

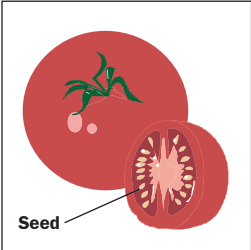
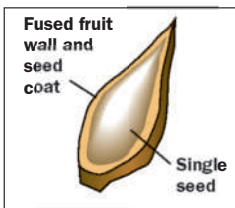
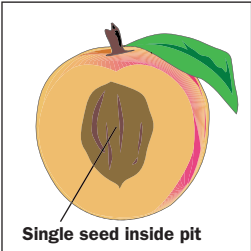
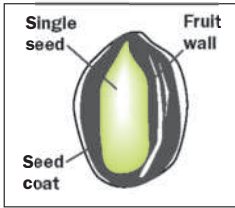
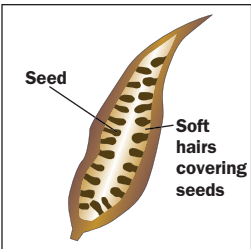
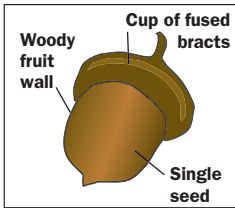
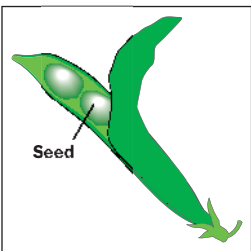
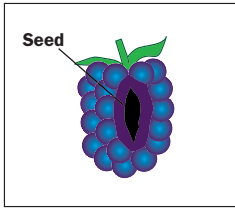
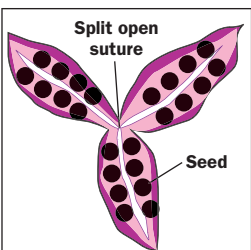
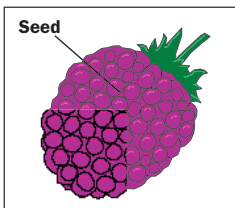
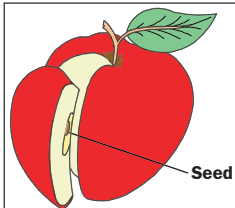
	<p><b>Berry-</b> A simple, fleshy fruit in which the fruit wall is soft throughout.</p> <p>Tomato (<i>Lycopersicon lycopersicum</i>)</p>		<p><b>Grain-</b> A simple, dry fruit in which the fruit wall is fused to the seed coat.</p> <p>Wheat (<i>Triticum</i> sp.)</p>
	<p><b>Drupe-</b> A simple, fleshy fruit in which the inner wall of the fruit is hard and stony (the pit).</p> <p>Peach (<i>Prunus persice</i>)</p>		<p><b>Achene-</b> A simple, dry fruit in which the fruit wall is separate from the seed coat.</p> <p>Sunflower (<i>Helianthus annuus</i>)</p>
	<p><b>Follicle-</b> A simple, dry fruit that splits open along one suture to release its seeds.</p> <p>Milkweed (<i>Asclepias synaca</i>)</p>		<p><b>Nut-</b> A simple, dry fruit that has a stony wall, is usually large, and does not split open at maturity.</p> <p>Oak (<i>Quercus</i> sp.)</p>
	<p><b>Legume-</b> A simple, dry fruit that splits open along two sutures to release its seeds.</p> <p>Green bean (<i>Phaseolus vulgaris</i>)</p>		<p><b>Aggregate fruit-</b> A fruit that develops from a single flower with several to many pistils (i.e., carpels are not fused into a single pistil).</p> <p>Blackberry (<i>Rubens</i> sp.)</p>
	<p><b>Capsule-</b> A simple, dry fruit that splits open along three or more sutures or pores to release its seeds.</p> <p>Iris (<i>Iris</i> sp.)</p>		<p><b>Multiple fruit-</b> A fruit that develops from the ovaries of a group of flowers.</p> <p>Mulberry (<i>Morus</i> sp.)</p>
			<p><b>Accessory fruit-</b> A fruit composed primarily of tissue (such as the receptacle) other than ovary tissue.</p> <p>Apple (<i>Malus sylvestris</i>)</p>

ovaries. Aggregate fruits like raspberries and blackberries are formed from the several ovaries of a single flower. Multiple fruits like pineapples and mulberries develop from the fusion of the ovaries of several flowers. Interestingly, some fruits (such as banana) develop without seed formation, a phenomenon termed parthenocarpy.

## Dispersal

Fleshy, edible fruits serve as food for animals. Animals in turn spread the enclosed seeds of the fruits they eat and so disperse what will be the next

Examples of the many classifications of fruits. The botanical definition of a fruit may be at odds with everyday usage of the word.

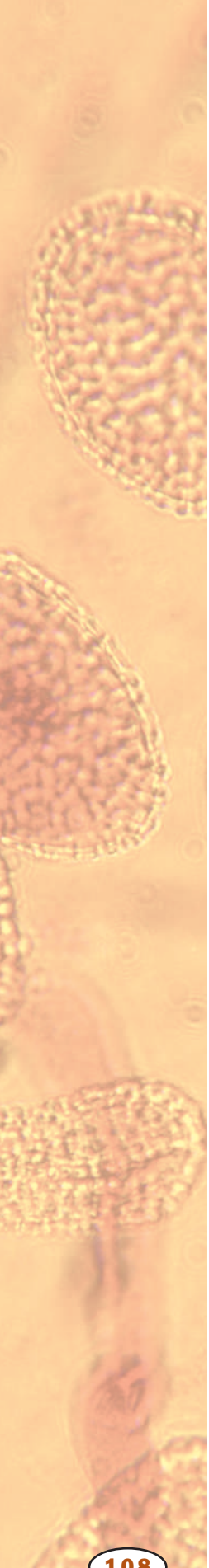

**hormone** molecule released by one cell to influence another

**antigen** foreign substance that provokes an immune response

generation of that plant. The coconut provides a good example of a fruit adapted for dispersal by water. Its corky, buoyant outer layer allows this fruit to be carried great distances by ocean currents before the seed within germinates on the seashore. Many dry, dehiscent fruits split explosively, flicking their seeds into the air where they are carried by the wind. Some fruits may have spines for attachment to animal fur, whereas others are winged or feathery for wind dispersal.

### Economic Importance

Many fleshy fruit are major food crops of great economic importance. Prime areas of cultivation may be far removed from the original “home” of that particular plant; for example, *Citrus* species like orange are native to Asia, as are apples. Fruits, like other types of produce, comprise living tissue and require special handling and storage to ensure optimal quality for the consumer. Ripening of fruit involves a range of processes that ultimately make the fruit more attractive for consumption, such as color change, softening, sweetening, and aroma production.

Physiologically, fleshy fruit fall into two categories: climacteric and non-climacteric. Climacteric fruit can be picked mature but unripe and then stored for extended periods at low temperature before being ripened and sold. Such fruit include mangoes, bananas, papayas, avocados, and tomatoes. Special methods for handling such fruits allow tropical fruits grown thousands of miles away to be on sale weeks later in supermarkets in temperate regions with no apparent loss of quality. Ripening of climacteric fruit is triggered by the gaseous plant **hormone** ethylene, and this is exploited by shippers to artificially induce fruit ripening. In several fruit crops, including tomato, it has been possible to use genetic engineering to knock out ethylene production thus preventing ripening and extending the shelf life of the fruit.

Nonclimacteric fruits such as grapes, citrus, and strawberries do not respond dramatically to ethylene as is the case of climacteric fruits. These fruits ripen only while still attached to the parent plant and so cannot be picked early and stored for later ripening. SEE ALSO ANGIOSPERMS; FLOWERS; HORMONES, PLANT; POLLINATION AND FERTILIZATION; SEEDS

C. M. Sean Carrington

### Bibliography

Simpson, Beryl Brintnall, and Molly Conner Ogorzaly. *Economic Botany: Plants in Our World*. New York: McGraw-Hill, 1986.

## Fungal Diseases

About fifty fungal species cause human disease, usually by one of three major mechanisms. First, some fungi cause an immune response, resulting in hypersensitivity (allergic) reactions to the fungi. (The fungi themselves thus act as **antigens**.) For example, several *Aspergillus* species can cause asthma and other allergic reactions. The second mechanism is found in fungal species producing poisons or mycotoxins. *Aspergillus flavus* grows on improperly stored grain and can produce aflatoxins that cause tumors in birds and various other animals.

The third disease mechanism is infection. Mycoses (singular, mycosis) are fungal infections found in or on the body. Most mycoses are “nuisance” diseases, although some can be quite serious or even life-threatening. Many of the mycoses are caused by **opportunistic** organisms, organisms taking advantage of the patient whose defense mechanisms are down (such as persons suffering from AIDS [acquired immunodeficiency syndrome]). Examples of opportunistic mycoses include histoplasmosis (usually respiratory), cryptococcosis (affecting any organ, often the brain), coccidioidomycosis (often respiratory), and candidiasis (the common yeast infection affecting any part of the body). (Candidiasis in the mouth and throat of newborns is called thrush.)

Superficial mycoses affecting the skin, scalp, hair, or nails are spread by contact with infected persons or contaminated objects. These common mycoses are generally self-limiting. Tinea is a categorical term used to describe fungal infections by their location, such as tinea capitis (head, also known as ringworm), tinea barbae (beard), tinea corporis (body), tinea cruris (genital and anal areas, also known as jock itch), tinea pedis (foot, also known as athlete’s foot).

**Subcutaneous** mycoses develop in wounds and often resemble ulcers or chancres. Sporotrichosis (caused by *Sporothrix schenckii*) is a common subcutaneous mycosis.

The **systemic** mycoses, which develop when a fungus invades the internal organs (or systems), are extremely difficult to treat, particularly in immunocompromised patients. Yeast, classified as a type of fungus, can cause infection of the urinary tract. SEE ALSO FUNGI; SEXUALLY TRANSMITTED DISEASES

Roberta M. Meehan

### Bibliography

Madigan, Michael T., John M. Martinko, and Jack Parker. *Brock Biology of Microorganisms*, 9th ed. Upper Saddle River, NJ: Prentice Hall, 2000.

Thomas, Clayton L., ed. *Taber’s Cyclopedic Medical Dictionary*, 18th ed. Philadelphia, PA: F. A. Davis Company, 1997.

## Fungi

Fungi are **eukaryotic** organisms distinct from plants and animals and members of several other smaller kingdoms. Common fungi include mushrooms, conks, corals, jellies, puffballs, stinkhorns, morels, cups, truffles, lichens, yeasts, rusts, smuts, bread molds, mildews, and molds on bathroom tiles.

In 1959, R. H. Whittaker introduced a five-kingdom taxonomy that granted fungi equal status with plants and animals. The five-kingdom system has been supplanted by a multiple-kingdom classification, and species traditionally treated as fungi are now distributed across several kingdoms. Those believed to form a **monophyletic lineage** are assigned to kingdom Eumycota (often called kingdom Fungi). Mycology, the science devoted to fungi, still covers all traditional fungi.

**opportunistic** infectious in an immunosuppressed person but not a healthy person

**subcutaneous** below the skin

**systemic** throughout the body

**eukaryotic** cell with a nucleus

**monophyletic** a group that includes an ancestral species and all its descendants

**lineage** ancestral line

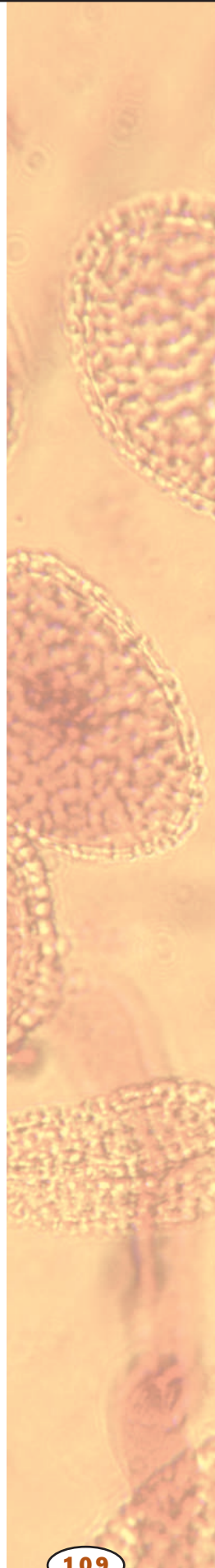

**organic** composed of carbon, or derived from living organisms

**chitin** nitrogen-containing carbohydrate found in arthropod exoskeletons and fungus cell walls

**glycogen** complex carbohydrate used as storage in animals and some other organisms

**exoskeleton** external skeleton

**multinucleate** having many nuclei within a single cell membrane

**haploid** having single, non-paired chromosomes in the nucleus

**diploid** having pairs of chromosomes in the nucleus

**superficial** on the surface; not deep

**enzymatic** related to function of an enzyme

**parasite** organism living in close association with another from which it derives most of its nutrition

**enzyme** protein that controls a reaction in a cell

**mycorrhizae** symbioses between soil fungus and plant root to maximize absorption

## Characteristics of Fungi

The Eumycota consist of eukaryotic, nonchlorophyllous heterotrophs that absorb nutrients from dead or living **organic** matter, have cell walls composed of **chitin**, and store excess energy as **glycogen**. The kingdom contains four phyla: Chytridiomycota, Zygomycota, Ascomycota, and Basidiomycota. All true fungi have a definite cell wall throughout all developmental stages. Fungal cell walls are composed of chitin, the compound also found in arthropod **exoskeletons** (for example, lobster shells). Most fungi produce a vegetative mycelium (filamentous thallus) composed of hyphae that branch and extend via tip elongation, although some groups (like yeasts) consist only of individual cells. Hyphae (singular, hypha) are tube-like filaments with either single **multinucleate** cells (coenocytes) that lack septa (cross-walls) separating nuclei, or many septate cells containing one, two, or more nuclei.

## Fungal Nutrition: Saprobies, Parasites, and Mutualists

A fungal thallus may be as small as a single microscopic cell (baker's yeast, *Saccharomyces cerevisiae*) or exceedingly large (*Armillaria gallica*, the several-acre-sized "humungous fungus" reported in 1992 as the world's largest organism). Sporocarp (fruit body, or "mushroom" size) also ranges from microscopic to meters in diameter (*Bridgeoporus nobilissimus*, an endangered bracket fungus found on noble fir trees).

Not unexpectedly, such a diverse kingdom manifests several different life cycles. Virtually all fungi produce spores. Both asexual and sexual spores may germinate to form vegetative thalli from primary and secondary mycelia. Thalli may be **haploid** dominant, **diploid** dominant, or exhibit haplo-diploid alternation of generations. Here it is important not to confuse the chromosomal state of individual nuclei (haploid versus diploid) with the number of nuclei per cell (monokaryotic versus dikaryotic). Fungi are unusual in that they often exhibit dikaryotamy, wherein hyphal cells contain two (usually haploid) nuclei that migrate, multiply, and divide together.

Although **superficially** similar to plants, fungi are probably more closely related to animals. Like animals, fungi lack chlorophyll and do not photosynthesize, must obtain nutrients from organic sources, and store energy as glycogen instead of starch. Unlike animals, however, fungi do not engulf, but rather absorb, their nutrients after breaking them down via **enzymatic** action, earning them the nickname "absorbotrophs."

Fungi absorb their nutrients in three different ways: (1) saprobies decompose dead organic matter; (2) **parasites** feed on living hosts; and (3) mutualists live in symbiotic unions with other living organisms. Saprophytic fungi, such as edible meadow mushrooms (*Agaricus campestris*), shiitake (*Lentinula edodes*), and oyster mushrooms (*Pleurotus ostreatus*), decompose dead plant and animal tissue by releasing **enzymes** from hyphal tips, thereby recycling organic materials back into the surrounding environment. Parasitic fungi also use enzymes to break down living tissue, usually sapping the energy of the host and frequently causing its demise.

Lichens and **mycorrhizae** are two important mutualistic associations. Lichens represent partnerships between a fungus (mycobiont) and one or more algae (phycobiont). Although there are a few basidiolichens, almost all



Dark yellow Witches' Butter (*Tremella* species) jelly fungus.

lichen mycobionts are Ascomycota (approximately 20,000 ascolichens described thus far). Mycorrhizae are symbiotic or non to slightly **pathogenic** fungus-plant unions formed with approximately 85 percent of the vascular plants. Mycorrhizae are identified as ectomycorrhizal, arbuscular mycorrhizal (AM), ericoid, orchid, arbutoid, and monotropoid based on anatomical form and association. Ectomycorrhizal fungi (predominantly basidiomycetes such as boletes, amanitas, and coral fungi) form thick mycelial mantles around rootlets of many trees (oaks, firs, pines, poplars) to which they transport water and **minerals** from the soil, receiving sugars and other organic nutrients in return. AM fungi (in the Zygomycota order Glomales) form an endo-infection by penetrating rootlets to form coils and **vesicles** or finely branched arbuscules. The last four mycorrhizal types are specific to individual plant groups.

**pathogenic** disease-causing

**minerals** iron, calcium, sodium, and other elements needed by living organisms

**vesicle** membrane-bound sac

### Ecological and Economic Importance

Fungi have a profound biological and economic impact. As decomposers, plant pathogens, and symbiotic partners, their ability to grow anywhere, on anything, makes them both beneficial and harmful recyclers of carbon and nitrogen. Beneficially, they are used as food (mushrooms, truffles) and in baking and brewing (yeasts). They are being developed to detoxify pollutants (soil fungi), control insects (pathogenic Zygomycota), and regulate plant growth (pathogenic Ascomycota). Detrimentally, rusts, smuts, and molds cost billions of dollars through crop disease and spoilage while forest pathogens such as the honey mushroom (*Armillaria ostoyae*) and root-butt rot (*Heterobasidion annosum*) similarly threaten the timber industry. Some are toxic when eaten, such as the infamous destroying angel (*Amanita phalloides*). Natural LSD, a hallucinogen produced by ergot (*Claviceps purpurea*), is associated with medieval hysterical frenzies produced by consumption of infected grain, and the **aflatoxin** produced by *Aspergillus flavus* in improperly stored grain is one of the most potent carcinogens yet discovered. As human and animal pathogens, fungi cause infections that range from the vexing (athlete's foot, yeast infections) to life threatening (histoplasmosis). Fortunately,

**aflatoxin** toxic compound produced by a mold fungus

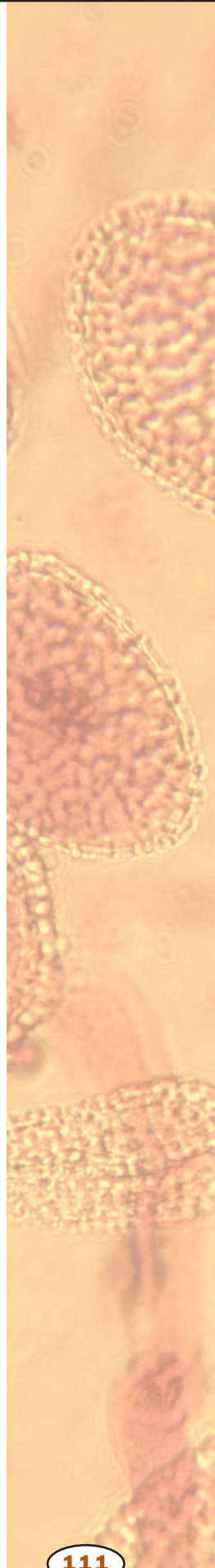

**immunosuppressants**  
inhibition of the immune response

**hyphae** threadlike part of the vegetative portion of a fungus

**dikaryotic** cell with a pair of nuclei

**motile** able to move

**phylum** taxonomic level below kingdom, e.g., arthropod or chordate

**mitochondria** subcellular organelle that creates ATP used for energy-requiring processes in a cell

**anaerobic** without oxygen, or not requiring oxygen

**appendage** attached organ or structure

other fungi (such as *Penicillium*) have been used to develop modern antibiotics and beneficial **immunosuppressants**.

## Classification

With the introduction of deoxyribonucleic acid (DNA) sequence analyses, previous fungal evolutionary theory is undergoing rapid transformation, not surprising when one considers the extremely fragmentary fungal fossil record. Mycologists generally agree that true fungi (with animals and plants) diverged from the protozoan fungi (for example, slime molds and Oomycota) before fungi and animals diverged from plants. The chytrids separated from the remaining phyla approximately 550 million years ago, followed by splintering of the Zygomycota from the other two phyla, which share septate **hyphae** and **dikaryotic** stages in their life cycles. The Ascomycota split from the Basidiomycota approximately 400 million years ago, followed by an increase in fungal diversity throughout the Paleozoic. Most yeasts and “asco-molds” are thought to have evolved in approximately the last 200 million years.

While most plants and vertebrates appear to have been described, most fungi have yet to be discovered or named. The 1995 edition of the *Dictionary of Fungi* counts 566,360 described species (about 100,000 in the Eumycota) but notes that there may be approximately 1.5 million species of fungi in the world. Elias Fries (1794–1878), often regarded as the “father of mycology,” classified fungi based primarily on spore print color and sporocarp appearance. Friesian-based nomenclature, reflecting similarity of form (phenetic) rather than genetic relationships, is still used in many field guides. Now, however, taxonomists are integrating molecular and morphological characters to develop natural classifications that more adequately reflect evolutionary relationships. Realizing that fungal taxonomy and nomenclature will remain somewhat fluid until new species and data are analyzed and integrated, most mycologists generally accept the classification below.

**Chytridiomycota.** The fact that chytrids alone among the Eumycota produce **motile** zoospores explains why their **phylum** is sometimes assigned with the flagellate oomycetes to kingdom Chromista. Chytrids possess posteriorly unflagellate spores, **mitochondria** with flattened cristae, and cell walls composed of glucan and chitin. Among the simplest and smallest fungi, they live as saprobes in water and damp organic-rich habitats, or as parasites on invertebrates, plants, and other fungi. The so-called “frog chytrids” (such as *Batrachochytrium dendrobatidis*) are implicated in the current worldwide decline of amphibian species. Other chytrids are host-specific “rumen fungi” (such as *Piromyces communis*) that thrive in **anaerobic** conditions in the guts of herbivores, such as cattle and sheep. There are five orders and about 800 species of chytrids recognized thus far.

Unicellular members of the order Chytridiales lack a mycelial stage and consist of a central body with a few rudimentary **appendages** (haustoria) that attach to and invade the host tissue. Other chytrids, such as the Blastocladales, develop true mycelia with sporangia and male/female gametangia that produce unflagellate zoospores. Chytrid thalli may be either haploid or diploid, and some, like the aquatic chytrid *Allomyces*, exhibit an isomorphic alternation of generations with similar appearing sexual and asexual zoospores.



**Zygomycota.** The chytrids and this phylum are assigned the two “bottom” branches of the fungal evolutionary tree. There are more than 1,000 species in two classes (Trichomycetes, Zygomycetes) and ten orders, representing a diverse assemblage of saprobes, soil fungi, **obligate** insect and fungal parasites, and mycorrhizal formers. Common representatives of the saprobic order Mucorales include the dung-inhabiting “cap-thrower” (*Pilobolus*), the black bread mold (*Rhizopus stolonifera*), and *Phycomyces blakesleeanus*, sometimes referred to as the “body in the basement” because of the rapid growth of long, hairlike sporangiophores over a substrate under the right conditions.

Zygomycota are characterized by large, thick-walled, coenocytic zygospores and hyphae with relatively thin walls composed of chitin and chitosan. Both asexual sporangiospores and sexual zygospores germinate into haploid mycelia, with the hyphae functioning as gametangia during the sexual stage. In *Rhizopus*, for instance, close proximity of two hyphal strands of different mating types chemically triggers each to grow branches toward the other to form septate suspensor cells and gametangia. Eventual fusion produces a diploid zygosporangium that undergoes **meiosis** to become a thick-walled zygospore with large numbers of haploid nuclei.

**Ascomycota.** In addition to most lichens and so-called “imperfect fungi,” about 33,000 species of unicellular yeasts, green and black molds, powdery mildews, morels, cup fungi, and ascotruffles (“true” truffles) belong to this phylum. The phylum is characterized by ascospores produced within a saclike sporangium called an ascus. Mycelia (more complex than Zygomycota mycelia) are composed of septate hyphae with chitin-glucan hyphal walls. Most species produce specialized fruiting bodies called ascocarps whose details of structure help define different species, classes, or orders. Nonascocarpic representatives (such as unicellular yeasts and mildews that reproduce primarily by budding) do not form mycelia. Both sexual and asexual reproduction are found within this phylum.

**Basidiomycota.** This phylum, which also features septate hyphae and chitin-glucan cell walls, is characterized by basidiospores borne upon a club-like structure called a basidium. Approximately 22,500 species are assigned to three classes: Basidiomycetes, Teliomycetes, and Ustomycetes. Basidiomycetes include mushrooms, polypores, crusts, corals, clubs, basidiolichens, and jellies, which propel their spores, and “gastromycetes” (or “stomach fungi”) that passively release their spores (puffballs, basidiotruffles [“false truffles”], stinkhorns, and birds’ nests). Teliomycetes (rusts) and Ustomycetes (smuts) are obligate parasites of insects or plants. Rusts and smuts have exceedingly complex cycles involving up to five separate spore stages and multiple hosts. This ability to produce spores on different hosts in multiple ways presents a significant economic challenge to agriculture.

**Oomycota.** Oomycetes (kingdom Chromista) are distinguished from true fungi by having glucan-cellulose cell walls that only occasionally incorporate small amounts of chitin. These algae-like fungi occur in aquatic or moist terrestrial habitats as single cells or mycelial mats composed of multinucleate, nonseptate hyphae. Their life cycle generally mirrors that of plants, with a transitory haploid stage. Both resting oospores and motile zoospores are diploid, the latter propelled by two unequal flagella (insel type plus whiplash). This phylum contains about 700 species in nine orders, including

**obligate** required or necessary, especially referring to a metabolic process or mode of nutrition

**meiosis** cell division that forms eggs or sperm



The gills of a mushroom. Although superficially similar to plants, fungi are members of a distinct kingdom.

the generally saprophytic water molds (Saprolegniales) and the pathogenic Peronosporales and Pythiales. Most water molds are saprophytic, but there are a number of parasites that invade plants (white rusts, downy mildews, tobacco blue mold) or fish. Among the economically significant wilts, blights, and pathogens are *Phytophthora infestans* (responsible for the Irish potato famine in the 1850s), *Plasmopara viticola* (the causative agent of downy mildew of grapes), and the fish parasite *Saprolegnia parasitica*, a twenty-first-century threat to salmon migrating through dams in western North America. SEE ALSO ALTERNATION OF GENERATIONS; KINGDOM; MYCORRHIZAE; PLANT PATHOGENS AND PESTS; SYMBIOSIS

Lorelei L. Norvell

### Bibliography

Alexopoulos, C. J., C. W. Mims, and M. Blackwell. *Introductory Mycology*, 4th ed. New York: John Wiley & Sons, 1996.

Arora, D. *Mushrooms Demystified: A Comprehensive Guide to the Fleshy Fungi*. Berkeley, CA: Ten Speed Press, 1986.

Hanlin, R.T., and M. Ulloa. *Atlas of Introductory Mycology*, 2nd ed. Winston-Salem, MA: Hunter Textbooks Inc., 1978.



## Gas Exchange

Gas exchange is the process by which oxygen and carbon dioxide (the respiratory gases) move in opposite directions across an organism's respiratory membranes, between the air or water of the external environment and the body fluids of the internal environment. Oxygen is needed by cells to extract energy from organic molecules, such as sugars, fatty acids, and amino acids. Carbon dioxide is produced in the process and must be disposed.

### Principles of Gas Exchange

The random movement of molecules is called diffusion. Although individual molecules move randomly, a substance can have directed movement, or net diffusion. The net diffusion of a substance occurs because of a difference in its concentration, or **gradient**, along its course. Within an animal's body as oxygen is used up and carbon dioxide produced, the concentration gradient of the two gases provides the direction for their diffusion. For example, as air or water nears the respiratory membrane, the oxygen concentration on the outside of the membrane is higher than on the internal side so oxygen diffuses inward. The concentration gradient for carbon dioxide is in the opposite direction, and so net diffusion of carbon dioxide keeps it diffusing out of the body.

The solubility of the respiratory gases in water is low, and the solubility of oxygen is only about one-twentieth that of carbon dioxide. Special transport molecules within body fluids increase the oxygen content by holding oxygen molecules within circulating fluids. These molecules are called respiratory pigments and include **hemoglobin**, which is red, and hemocyanin, which is blue. These molecules combine with oxygen at the respiratory membrane, where oxygen concentrations are relatively high and easily release the oxygen in deeper tissues, which are low in oxygen.



Filaments of a salmon's gills. In fish, water is pumped across gills to enable gas exchange.

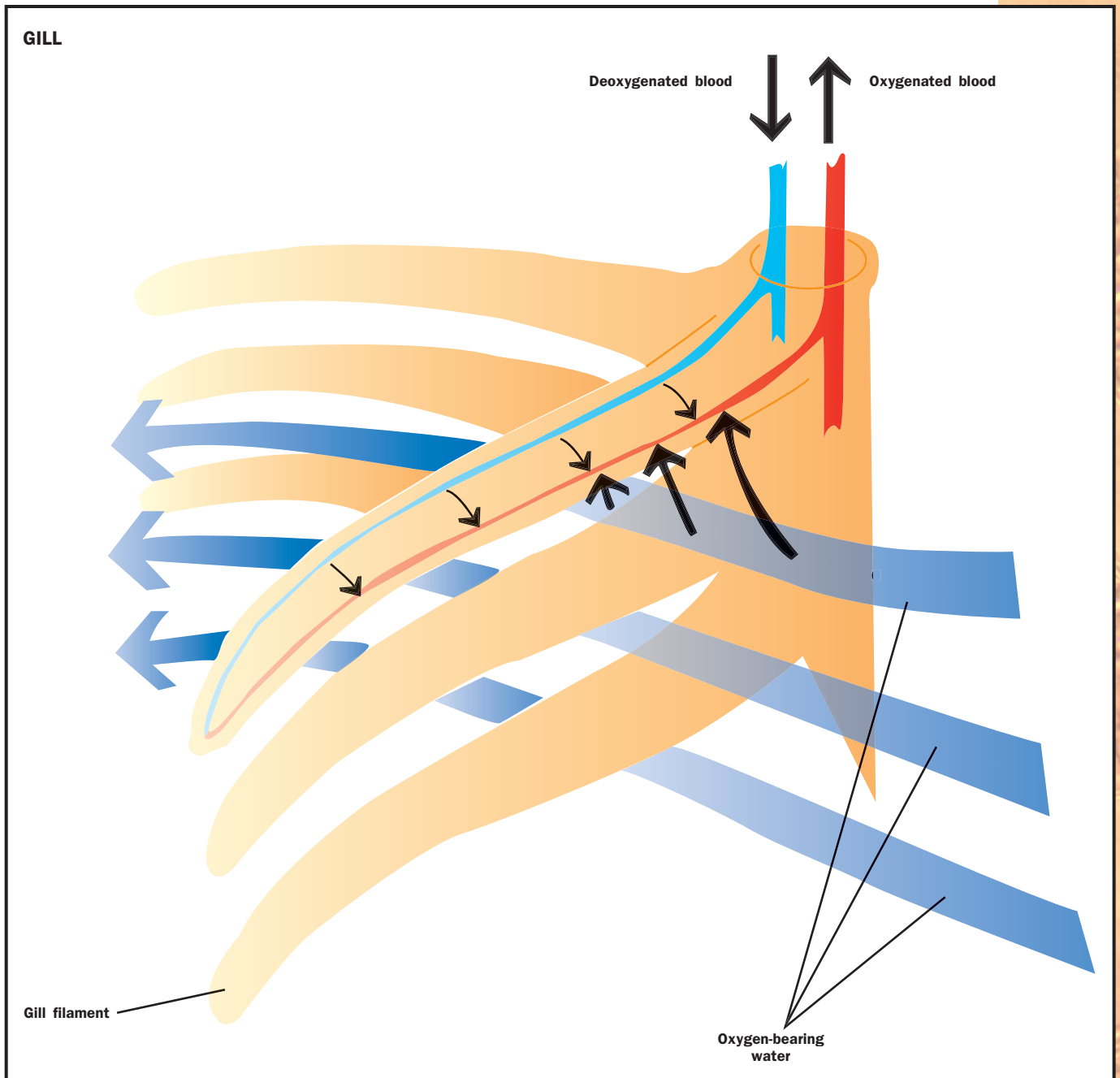

### Variety in the Animal Kingdom

Animals with small bodies exchange respiratory gases sufficiently through the body surface without specialized respiratory membranes. Even some vertebrates, such as small, slender salamanders, exchange respiratory gases solely across the skin, which is richly supplied with blood vessels. Larger animals require an extended surface for gas exchange. This specialized respiratory membrane is often folded to increase its surface area without occupying excessive space. For most fish, many aquatic invertebrates, and some terrestrial invertebrates the specialized respiratory organs are the gills. In crustaceans, gills are often found where the legs attach to the body; moving

Gills are respiratory organs that absorb oxygen from water as it flows over the gill surface.

**gradient** difference in concentration between two places

**hemoglobin** oxygen-carrying protein complex in red blood cells

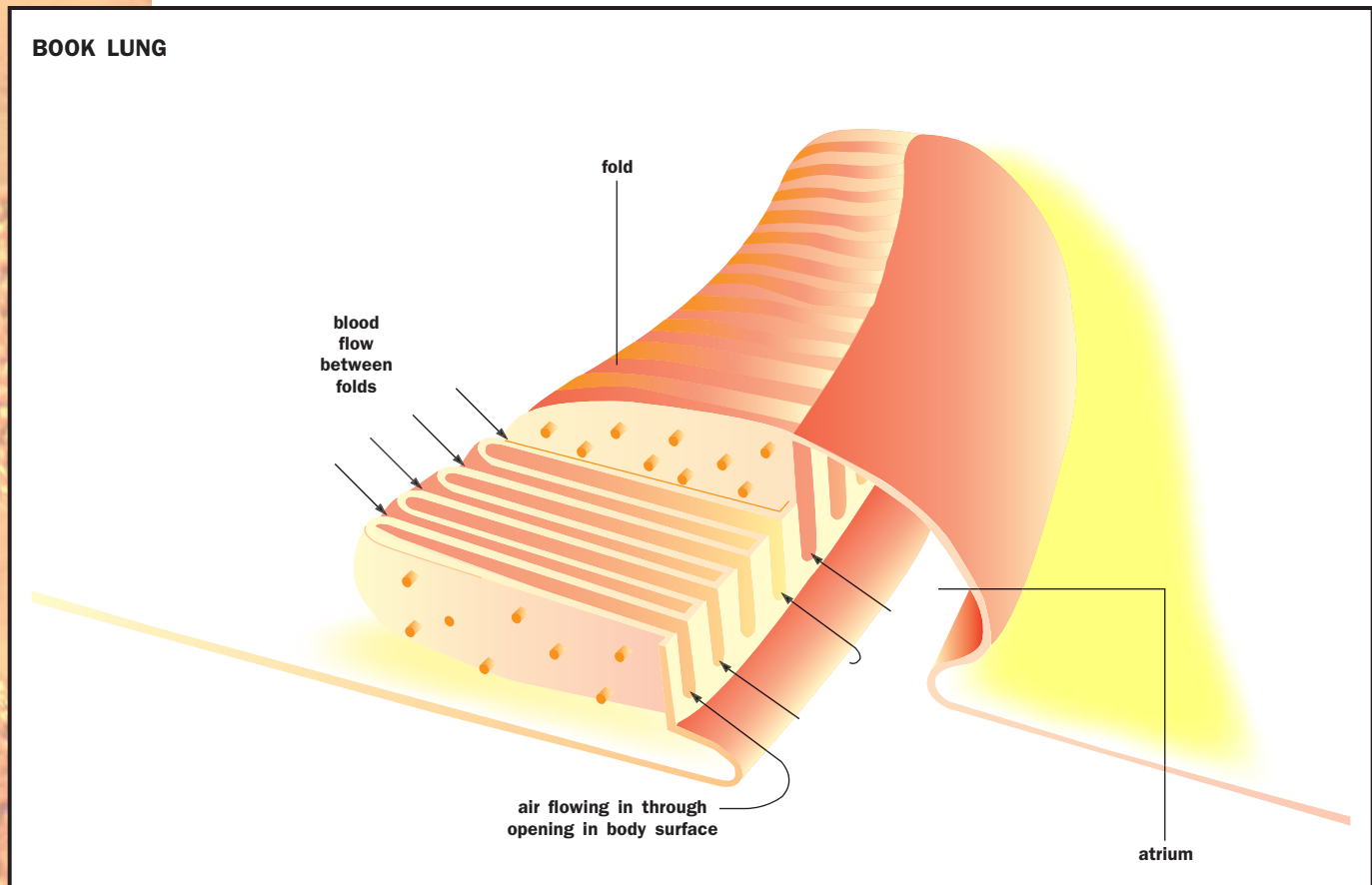

Book lungs are specialized, leaf-shaped, inward folds of the cuticle, surrounded by an air chamber that can be ventilated with muscular contractions.

the legs sweeps water across the gill surfaces. In fish and some mollusks, gills are ventilated by muscular contractions that pump water across the respiratory surface.

Terrestrial animals must protect their respiratory membranes from drying out. Many spiders have book lungs, which are specialized, leaf-shaped, inward folds of the cuticle, surrounded by an air chamber that can be ventilated with muscular contractions. In larger terrestrial insects, the respiratory organs are inward, branching, tubular extensions of the body wall called tracheae. The system is so extensive that most cells are in close proximity to a tracheal branch and the tissues do not depend on blood circulation for gas transport.

Terrestrial vertebrates generally have lungs. The surface area for gas exchange is correlated with metabolic rate. Endotherms, such as birds and mammals, have a high metabolic rate and a correspondingly high respiratory surface area. Birds have one-way flow through their lungs, enabled by a complex system of air-storing sacs. Since fresh air is always flowing through the lung, the oxygen concentration can be maintained at a constant, high level.

Mammals, reptiles, and amphibians have saclike lungs with tidal (two-way) air flow. This results in residual air remaining in the lungs, reducing the concentration of available oxygen in comparison to bird lungs. Reptile lungs have fewer air sacs and less respiratory surface area than mammals, and

amphibian lungs have less surface area than reptilian lungs. SEE ALSO BLOOD; AMPHIBIAN; ARTHROPOD; BIRD; CIRCULATORY SYSTEMS; INSECT; KREBS CYCLE; MAMMAL; OXIDATIVE PHOSPHORYLATION; REPTILE; RESPIRATION

Margaret G. Ott

### Bibliography

Guyton, Arthur C., and John E. Hall. *Textbook of Medical Physiology*. Philadelphia, PA: W. B. Saunders, Co., 2000.

Hickman, Cleveland P. *Biology of the Invertebrates*. St. Louis, MO: C. V. Mosby Co., 1973.

Schmidt-Nielsen, Knut. *Animal Physiology Adaptation and Environment*. New York: Cambridge University Press, 1997.

## Gene

Considering the central role that genes play in the understanding of biology, it is surprising that no single, simple definition of a gene exists. This is partly because genes are under multiple evolutionary constraints, and partly because the concept of a gene has both structural and functional aspects that do not always align perfectly. A modern description of a gene must consider not only its structure, as a length of DNA, but also its function, as a unit of heredity in transmission from one generation to the next and in development as a carrier of coded information of the sequence of a **protein** or RNA molecule. In addition, the description should recognize the multiple roles a single gene can play in different tissues during various stages of development and over the course of evolution.

In the table on page 118, some different sorts of geneticists are listed along with the aspects of genes on which they focus and what kinds of phenomena they investigate. In order to understand someone who is discussing genes, it is critical for the listener or reader to know sufficient context such that s/he can ferret out which of the possible interpretations of “gene” in this list is most likely implied.

### Units of Heredity

The modern conception of genes begins with the work of Gregor Mendel (1822–1884), who showed that inheritance involved discrete factors passed from parent to offspring. (While Mendel is given credit as the originator of modern genetics, the word “gene” was not coined until well after his death.) In this view, genes are those elements responsible for the “phenotype,” the set of observable traits that make up the organism. In the original Mendelian conception, genes came in pairs, as did possible **phenotypes**. Classic examples include round versus wrinkled seeds in peas, or presence or absence of hairs on the middle section of the fingers in humans.

The competing school of thought for the first thirty years of the twentieth century was Darwinism, which considered characters with a continuous distribution such as speed, strength, skin color, height, weight, number of **progeny**, etc., for which no simple paired set of elements could account. By 1930, these seemingly incompatible views had been combined in the “neo-Darwinian synthesis,” which incorporated features of both sides of the debate. This involved a transformation of the “one gene, one trait”

**protein** complex molecule made from amino acids; used in cells for structure, signaling, and controlling reactions

**phenotype** observable characteristics of an organism

**progeny** offspring

### WEISMANN, AUGUST (1834–1914)

German biologist who kept alive English naturalist Charles Darwin’s theory of natural selection as the mechanism for evolution, when most biologists were looking for other mechanisms. Weismann also predicted the existence of deoxyribonucleic acid (DNA), arguing that parents pass traits, such as eye color, to their children by means of molecules of some kind.

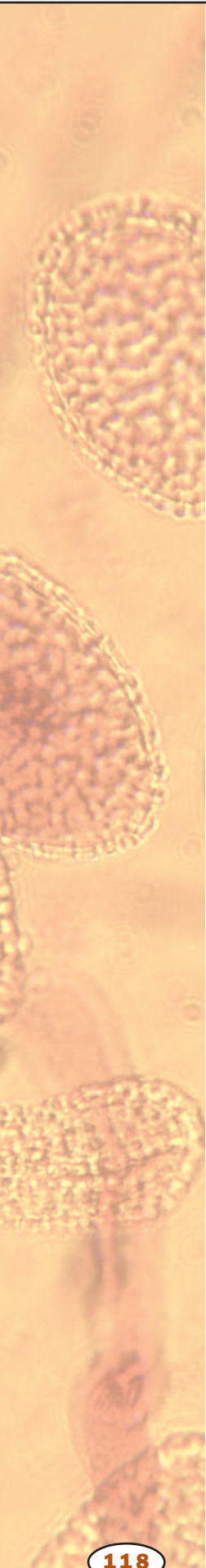

**hemoglobin** oxygen-carrying protein complex in red blood cells

**epistasis** suppression of a characteristic of one gene by the action of another gene

**homozygous** containing two identical copies of a particular gene

### Ways of Investigating Genes

Kind of Biologist	Aspects of Genes of Major Concern	Phenomena Investigated
Molecular Biologist	A piece of DNA	Physical isolation; knock-out experiments
Classical Geneticist	A mapped position on a chromosome; a new mutant; a functional unit	% recombination; mappable and unique; satisfy complementation or cis-trans test
Cytogeneticist	A band or knob on a stained chromosome (insertions, deletions, translocations)	Presence or absence of genetic function and occurrence of physical chromosome feature
Quantitative Geneticist	Contributing alleles in an additive or multiplicative fashion	Polygenic ratios; inbreeding effects; path analysis
Population Geneticist	Selection, mutation, migration, genetic drift	Multigenerational change in allele or genotype frequency, polymorphism, heterozygosity
Molecular Evolutionist or Phylogenetic Systematicist	Evolutionary tree of changes in DNA sequence	A traceable molecular character inherited by all progeny
Bioinformatician	One of six reading frames of DNA with a particular pattern	"Gene finding" by computer algorithms and heuristics
Developmental Geneticist	Homeotic mutant	Embryonic changes
Genetic Epidemiologist	Marker	Can be studied for spatial distribution and diffusion
Sociobiologist	Selfish genes; "junk DNA"	Replication without function
X-ray Crystallographer	Geometry	Relationship of three-dimensional structure to function
Mathematical Biologist	Topology	Knots, Catenanes
Biotechnology Entrepreneur	Commodity	Commercial value
Genetic Therapist	Surgically insertable piece or "fixable" DNA	Alleviation of cause of symptoms

relationship to a recognition that single inheritable genes could influence many different observable traits (called pleiotropy), and a single definable trait could be influenced by many different genes called polygenes.

Pleiotropy is a one-to-many genetic phenomenon. If a human has two copies of the gene for **hemoglobin S**, then with high probability the individual is likely to develop a broad constellation of symptoms that constitute sickle cell disease. Complications of swelled heart, ulcerated skin, spleen failure, and shortness of breath are all associated with this single gene.

On the other hand, polygenic inheritance, **epistasis**, gene interaction, operons, and regulatory circuits all involve a many-to-one relationship between genotype and phenotype. Wheat color provides a good example of polygenic inheritance, the contribution of more than one gene to a single trait. When a very dark red, completely **homozygous** individual is crossed with a white, completely homozygous individual, all of their progeny are

phenotypically red. When these red progeny are self-crossed, their offspring include individuals that are very dark red, dark red, red, light red, and white, in a ratio of 1:4:6:4:1. The inference drawn by geneticists is that two independently assorting genes are interacting to determine color, and that each gene has two **alleles**, one that contributes red color and the other that does not. Hence, the genotypes range from four contributing alleles (making very dark red) to zero (making white). Involvement of more genes can give even more complex and more continuous distributions.

It is important to realize that in none of these cases is any information provided about the physical nature of the gene. In classical genetics, a gene is a unit of heredity, and understanding inheritance patterns does not require knowledge of gene structure.

However, without an understanding of structure, it is tempting to think of genes as being “for” the trait they influence, in the sense that a hammer is “for” pounding nails or a CD player is “for” listening to music. However, the whole notion of “for” is an unacceptable concept to most research biologists. “For” connotes a determinism that is inconsistent with our understanding of the complexities of cellular processes. There is no gene for intelligence, although many genes influence intelligence through their actions within individual cells. Intelligence, like any other complex trait, arises as the result of many genes interacting.

## Genes Are Carried on Chromosomes

Long before the discovery that genes were made of DNA, geneticists realized that hereditary factors—genes—were carried on **chromosomes**. Unlike genes themselves, chromosomes can be easily seen under the microscope, and their movements can be followed during the processes of **mitosis** and **meiosis**. Beginning around 1910, Thomas Morgan and colleagues showed that the patterns of Mendelian inheritance could be correlated with the patterns of movement and recombination of the chromosomes. Morgan’s group showed that one of the central events of meiosis is crossing over, in which genes trade places between maternal and paternal chromosomes. In this way, Morgan and colleagues developed the chromosomal theory of inheritance and gave a physical reality to the abstract concept of the gene.

From this point, much work was devoted to discovering the physical nature of the gene. Throughout the next several decades, a series of experiments showed that genes were made of DNA (deoxyribonucleic acid), and finally that the double-helical structure of DNA accounted for the faithful replication and inheritance of genes.

## Genes Encode Enzymes and Other Proteins

Parallel to the growing understanding of the structure of the gene came discoveries about how genes affect the phenotype. From patients who suffered from Mendelian diseases and from experiments on bread mold, early researchers inferred that mutant genes were frequently associated with dysfunctional **enzymes** that could not **catalyze** particular metabolic steps. Thus, they concluded that enzymes perform the actual functions in a cell that lead to phenotype. These observations led to the first definition of a

**allele** a particular form of a gene

**chromosome** “colored body” in the cell nucleus; made of DNA and protein, and divided functionally into genes and non-gene regions

**mitosis** separation of replicated chromosomes

**meiosis** cell division that forms eggs or sperm

**enzyme** protein that controls a reaction in a cell

**catalyze** aid in the reaction of

### CHASE, MARTHA (1927–)

American biologist who, with Alfred Hershey, used a friend’s blender to show that genes are made of deoxyribonucleic acid (DNA). In their ingenious experiment, Chase and Hershey labeled virus proteins with one radioactive label and virus DNA with another label. When the viruses then infected bacteria, Hershey and Chase found DNA, not protein, inside the bacteria.

Figure 1. This simplified gene is composed of four regions. The promoter binds to an RNA polymerase in an on-off fashion and controls whether mRNA can be made. The beginning stretch of RNA is not ultimately translated into protein at the ribosome, and neither is the terminal region.

**polypeptide** chain of amino acids

**transcription factor** protein that increases the rate of transcription of a gene

**nucleotide** the building block of RNA or DNA

**amino acid** a building block of protein

**transcribe** creation of an RNA copy of a DNA gene

**ribosome** protein-RNA complex in cells that synthesizes protein

**genetic code** relationship between triples of RNA nucleotides and the amino acids they code for during protein synthesis

**genome** total genetic material in a cell or organism

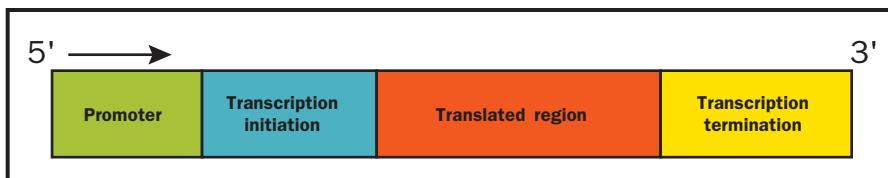

gene that combined structure and function, stated as “one gene, one enzyme.” In this formulation, a gene was thought to be enough DNA to bring about the production of one enzyme. This view had to be modified slightly with the realization that many enzymes are composed of several subunits, called **polypeptides**, whose corresponding DNA sequences (genes) may be on entirely different chromosomes. In addition, not all proteins are enzymes; there are structural proteins, **transcription factors**, and other types. This led to the reformulation “one gene, one polypeptide.”

### Information Sequences that Code for Production of RNA

The discovery of the structure of DNA led quickly to an unraveling of the means by which it controls protein production. RNA was discovered to be an intermediate between DNA and protein, and this led Francis Crick to formulate the “central dogma of molecular genetics”:



The sequence of DNA subunits, called **nucleotides**, was found to correspond to the sequence of **amino acids** in the resulting protein. This led to the explicit formulation of a gene as a coded instruction.

Three major aspects of DNA as a code—a sequence of symbols that carry information—are widely employed. First, molecular biologists describe genes as messages that can be decoded or translated. The letters in the DNA alphabet (A, C, G, T) are **transcribed** into an RNA alphabet (A, C, G, U), which in turn is translated at the **ribosome** into a protein alphabet (twenty amino acids). A word in DNA or RNA is a sequence of three nucleotides that corresponds to a particular amino acid. Thus, translating the messenger RNA word AUG via the standard **genetic code** yield the amino acid methionine.

In this conception, the gene is a DNA molecule with instructions written within it. The analogy to words, books, and libraries has been drawn repeatedly, because it offers a way to understand the hierarchy of information contained in the **genome**.

Further work showed that not all DNA sequences are ultimately translated into protein. Some are used only for production of RNA molecules, including transfer RNA (tRNA) and ribosomal RNA (rRNA). This led to yet another formulation of the gene definition, as the code for an RNA molecule. This encompasses tRNA, rRNA, and the mRNA that ultimately is used to make proteins.

### Genes Have Complex Structures

A surprising fact about gene structure was revealed in 1977 with the discovery of intron. Introns are segments of DNA within the gene that are not ultimately translated into protein. The introns alternate with exons, seg-

#### TONEGAWA, SUSUMU (1939– )

Japanese molecular biologist and immunologist who won the 1987 Nobel Prize in physiology for discovering how the immune system makes billions of unique antibodies to fight disease and other unwanted intruders of the human body. Tonegawa showed that white blood cells mix and match a few genes to make billions of combinations that are then translated into billions of unique antibodies.



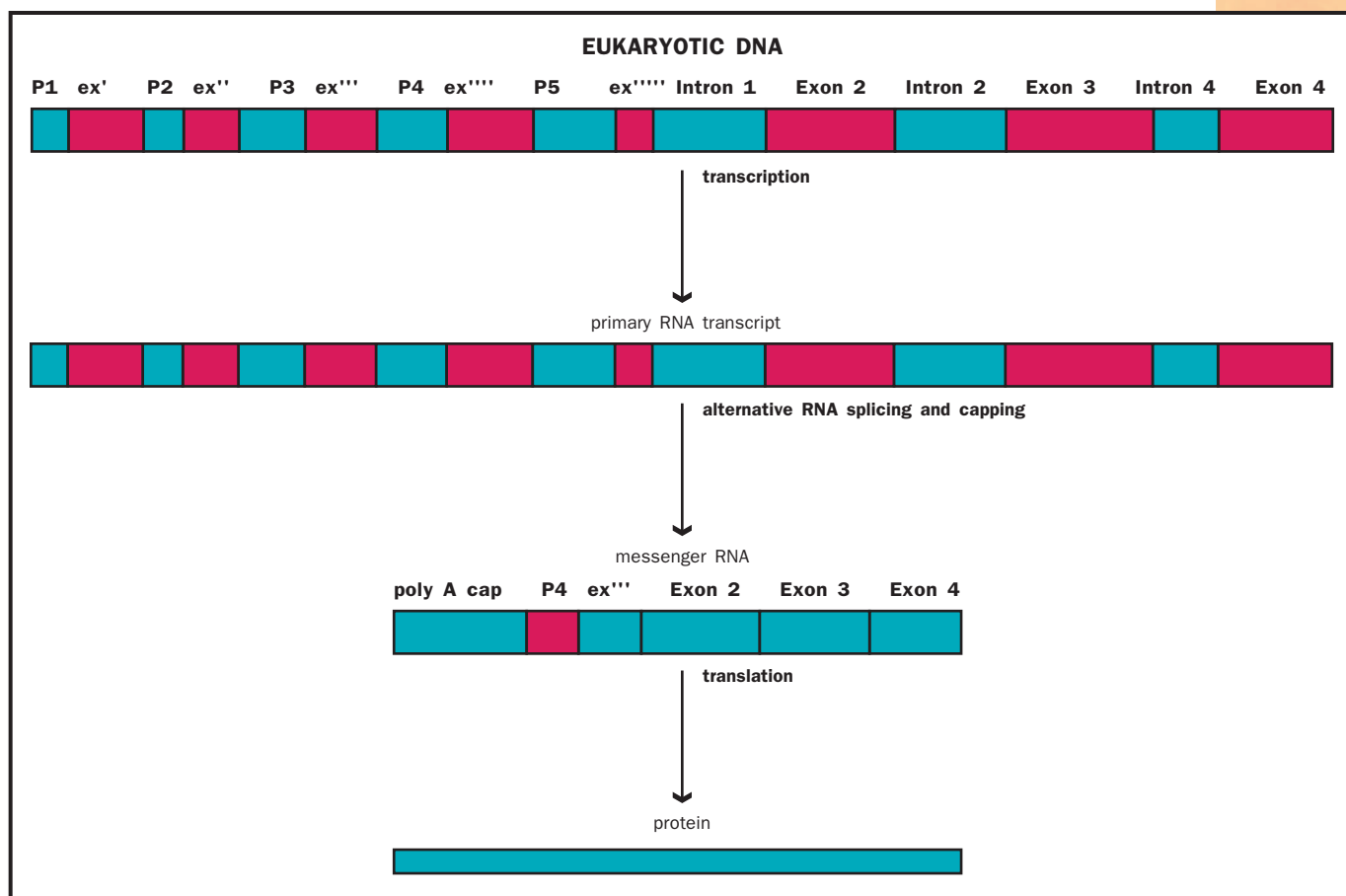

ments that are translated. The entire gene is first transcribed to make RNA, but then the intronic sections are removed, and the RNA exons are spliced together to form mature mRNA. The transcribed DNA of a gene is also flanked by nontranslated and nontranscribed regions that are essential to its function. These include the **promoter** region, a section of “upstream” DNA that binds RNA polymerase, the enzyme that forms the RNA copy. In Figure 1, an overly simplified version of a genetic message is presented. Other DNA segments called enhancers also regulate gene transcription, and these may be located upstream, downstream, within the gene, or far from it.

## Genes Have Complex Functions

Further complexity arose with the discovery of alternative splicing and multiple promoters. In many eukaryotic genes, the exons can be combined in different ways to make closely related but slightly different proteins, called isoforms. There can be multiple promoters, some within the gene, that begin transcription at different sites within the gene. Such an example is illustrated in Figure 2. The dystrophin gene codes for a muscle protein that, when absent, causes Duchenne muscular dystrophy. Other isoforms of dystrophin are expressed in white blood cells, **neurons**, and the Schwann cells that wrap neurons with insulation.

Thus, it is difficult to speak of “the” dystrophin gene because the alternative splicing of noncontiguous pieces of RNA produces a variety of

Figure 2. The dystrophin gene codes for slightly different proteins—isoforms—in a variety of differentiated cell types. A simplified version is illustrated above. The dystrophin gene is thought to have eight promoters, each with its own initial exon and as many as seventy-eight downstream exons.

**promoter** DNA sequence to which RNA polymerase binds to begin transcription

**neuron** nerve cell

Figure 3. Gene tree illustrating the transfer of genes from one biological ancestor to descendants.

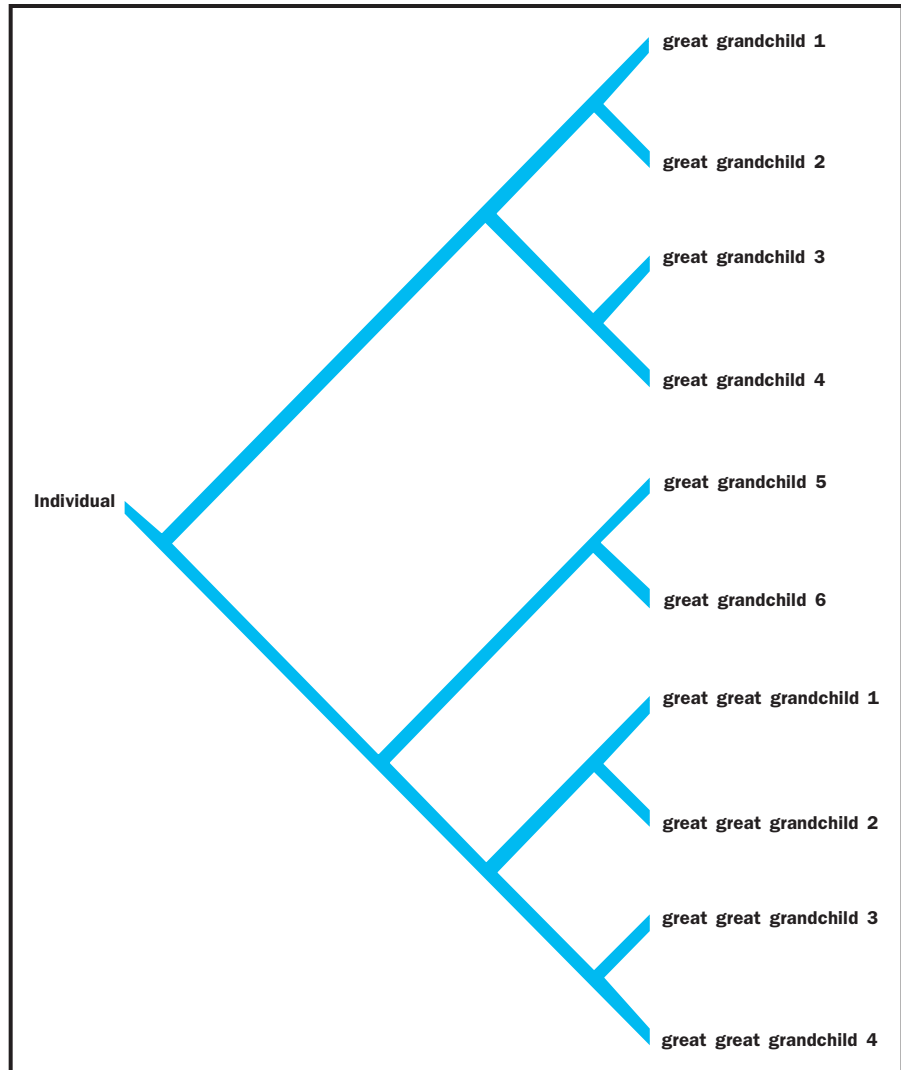

different proteins. Isoforms help generate the differences between tissues, and are thus partly responsible for the complexity of the fully differentiated organism. Similarly, the vast variety of antibodies we produce are coded for a much smaller number of exons, shuffled and expressed in a combinatorial fashion.

With these complications, defining a gene becomes yet more complicated. While it would be possible to describe the set of dystrophin isoforms as arising from an equal-numbered set of genes, most biologists find that unnecessarily complex. Instead, the gene is defined as a DNA sequence that is transcribed as a single unit, and one that encodes one set of closely related polypeptides or RNA molecules. Thus there is one dystrophin gene, which at various times in various tissues codes for each of the known dystrophin isoforms. This has been summarized as “one gene, many polypeptides.”

### Genes Act in Evolution, Heredity, and Development

Finally, some fruitful connections can be made by looking at genes in three different contexts and from three different points of view. First, develop-

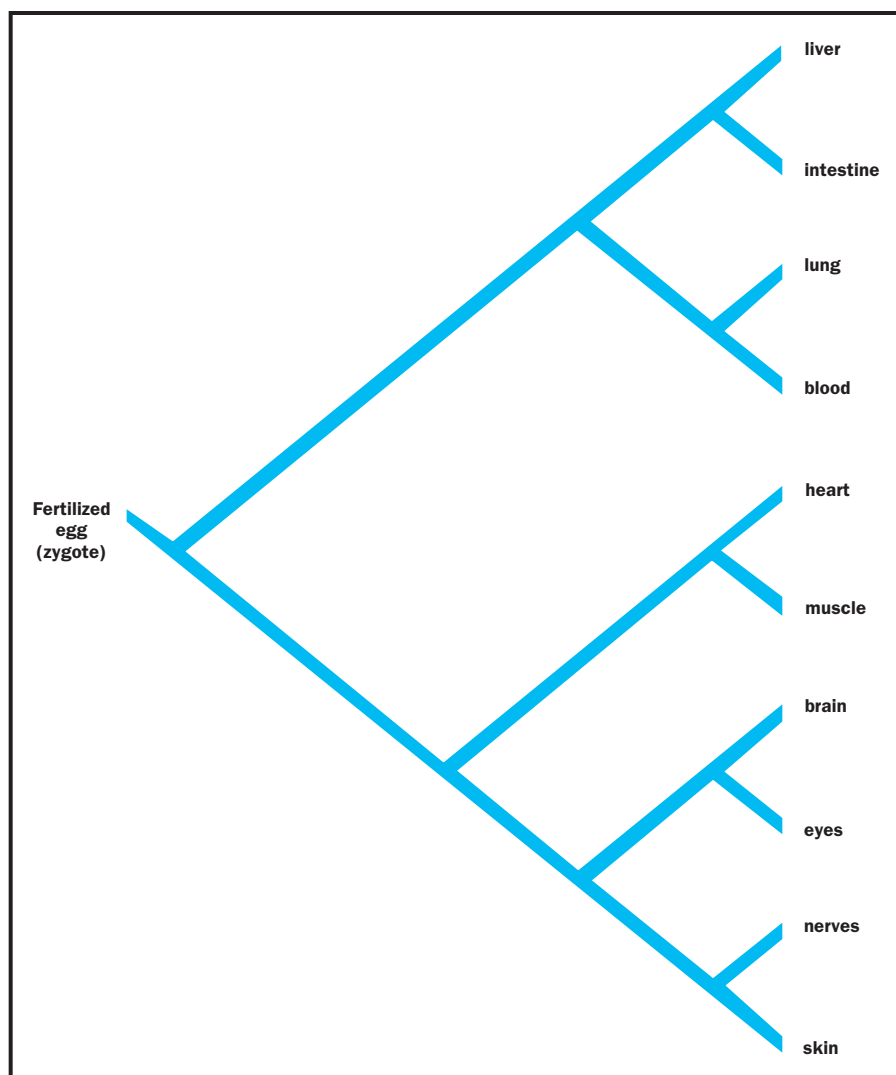
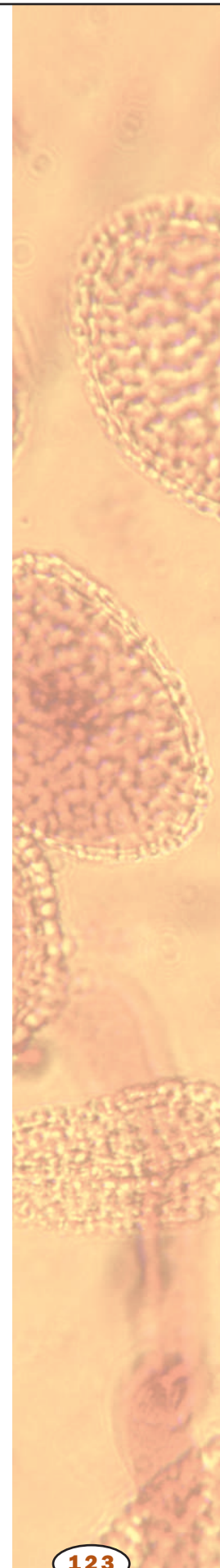

Figure 4. Gene tree illustrating the different cell types that arise by division of one original cell (a zygote; fertilized egg) and differentiation of subsequent daughter cells.



mental biologists focus on the action of genes at different times and places over the life history of an individual from conception to death. Over time, a particular gene will be expressed or silenced depending on stage of development and the tissue it is in. Second, geneticists focus on transmission of information, assortment and recombination of markers, and reproduction within families and populations within one species. Over time, a particular gene will be copied and transmitted to offspring and may accumulate mutations in the process. Third, evolutionary biologists focus on history, mutation, variability, and gene duplication. Over time in different species, as mutation and natural selection have their effects, there is divergence of each duplicate's structure and function.

These perspectives can be understood by displaying multiple views as graphs called trees. In Figures 3 and 4, the general form of the tree, representing the transfer of genes from one biological ancestor to descendants, can be identical, yet the diagrams illustrate a passage of genes with a variety of spatial, temporal, and biological changes in different contexts.

A gene is a unit of both structure and function, whose exact meaning and boundaries are defined by the scientist in relation to the experiment he

or she is doing. Despite an inability to define a gene precisely, the concept of gene has been a fruitful one for a century. In fact, these ambiguities have helped scientists to develop a concept of “gene” that has attained a robustness. This dynamic richness of meaning has contributed to the endurance of “the gene” in biologists’ vocabulary. All of these meanings will have value as we face genetic problems in the future and try to establish wise policy in using our knowledge of genes. SEE ALSO GENE THERAPY; GENETIC ANALYSIS; GENETIC CODE; GENETIC CONTROL OF DEVELOPMENT; GENETIC DISEASES; HISTORY OF BIOLOGY: INHERITANCE; MENDEL, GREGOR; PROTEIN SYNTHESIS

John R. Jungck

### Bibliography

- Condit, Celeste Michelle. *The Meanings of the Gene: Public Debates About Human Heredity*. Madison, WI: The University of Wisconsin Press, 2000.
- Dawkins, Richard. *The Selfish Gene*. Oxford: Oxford University Press, 1989.
- Fowler, C., and P. Mooney. *The Threatened Gene: Food, Politics, and the Loss of Genetic Diversity*. Cambridge: Lutterworth Press, 1990.
- Jones, Steve. *The Language of Genes: Solving the Mysteries of Our Genetic Past, Present and Future*. New York: Anchor Books, 1993.
- Jungck, John R., and John N. Calley. “Genotype as Phenotype: How Genetic Engineering Has Changed Our Fundamental Concepts of Biology.” *American Biology Teacher* 46 (1984): 357, 405.
- Mulligan, R.C. “The Basic Science of Gene Therapy.” *Science* 60 (1993): 926–932.
- Olby, Robert. *Origins of Mendelism*, 2nd edition. Chicago: University of Chicago Press, 1985.
- Singer, Maxine, and Paul Berg. *Genes and Genomes*. Mill Valley, CA: University Science Books, 1991.
- Wallace, Bruce. *The Search for the Gene*. Ithaca, NY: Cornell University Press, 1992.

## Gene Therapy

Gene therapy is an experimental disease treatment in which a gene is delivered to cells in the body. The **protein** made by the new gene compensates for the absence of normal proteins or interacts with some abnormal protein already in the cell to interrupt its function. Gene therapy is not yet a routine treatment for any disease, but it may become so as researchers solve the many technical problems it presents.

Humans are prey to numerous diseases due to single-gene defects, such as adenosine deaminase deficiency (defective **enzyme**), cystic fibrosis (defective **ion** channel), and Duchenne muscular dystrophy (defective muscle protein). Replacement of the defective gene is conceptually simple, but practically very difficult. Effective gene therapy requires delivering the gene to each cell in which it acts, integrating the gene with the thousands of others on the **chromosomes** and regulating the expression of the gene.

Gene delivery is a major hurdle. Viruses are the most commonly used vehicle, or **vector**, since they have been designed by evolution to deliver their own genes to our cells. Adenovirus (a type of cold virus) has been the most commonly used vector, since it can carry a very large gene and will infect most cell types. However, the immune system is designed to prevent this type of infection, and immune rejection has so far thwarted most gene therapy efforts. While most patients have not been harmed by this prob-

**protein** complex molecule made from amino acids; used in cells for structure, signaling, and controlling reactions

**enzyme** protein that controls a reaction in a cell

**ion** an electrically charged particle

**chromosome** “colored body” in the cell nucleus; made of DNA and protein, and divided functionally into genes and non-gene regions

**vector** carrier

lem, one gene therapy patient has died from immune response to the adenovirus. Modifications of the virus, using fewer immunogenic viruses (such as adeno-associated virus, herpes virus, or retrovirus), immune-suppressive drugs, and nonviral delivery systems are all possible solutions. Curiously, the brain does not mount a strong immune response, and as such, represents a promising site for gene delivery in neurological diseases.

Getting the gene to enough target cells is also a significant challenge. Adenosine deaminase deficiency affects white blood cells and causes severe combined immune deficiency (“bubble boy” disease). This disease can be treated by removing white blood cells, inserting the adenosine deaminase gene into them, and returning the cells to the bone marrow. Cystic fibrosis presents a much bigger challenge, since it affects the airways and pancreas. Inhalation of the vector may treat the lungs, but the pancreas is more difficult to reach without injecting vector into the bloodstream. Duchenne muscular dystrophy is an even bigger challenge, since it affects all muscles, and muscles make up 45 percent of the body. The only realistic treatment option in this case is **systemic** delivery, which poses the added challenge of preventing delivery to nonmuscle tissue.

Once inside the target tissue, genes usually become active whether or not they are integrated into the host chromosome. However, long-term expression requires that the gene join the host chromosome. Directing the gene to do so, and to integrate in a way that doesn’t disrupt other genes, is still a significant challenge. Regulating its expression, so that enough of the protein (but not too much) is made, is also a problem. Currently, most virally delivered genes do not integrate successfully, and stop making protein after several weeks to months.

While correction of gene defects was the original inspiration for gene therapy research, treatment of other diseases is now being explored. Cancers are an appealing target, and several strategies are possible. Currently the most promising is delivering a so-called “suicide gene,” whose protein product renders a tumor more sensitive to cell-killing drugs, allowing lower doses of chemotherapy to be effective. This works well for solid tumors, which can be injected with the gene. Delivery to more diffuse locations is still problematic. Further research on cellular properties of cancer cells may broaden the reach of this and similar cancer-targeting strategies. SEE ALSO CHROMOSOME, EUKARYOTIC; CRICK, FRANCIS; GENE; GENETIC DISEASES; MENDEL, GREGOR; RECOMBINANT DNA

*Richard Robinson*

### **Bibliography**

- Lemoine, N. R. *Understanding Gene Therapy*. Oxford: BIOS Scientific Publishers, 1999.
- Lewis, Ricki. *Human Genetics: Concepts and Applications*, 4th ed. New York: McGraw-Hill, 2001.
- Stolberg, Sheryl Gay. “The Biotech Death of Jesse Gelsinger.” *New York Times Magazine* (28 November 1999): 17.

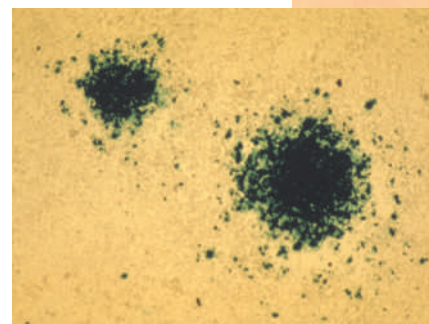

Cancer cells infected with a bioengineered adenovirus.

**systemic** throughout the body

## **Genetic Analysis**

Genetic analysis refers to experimental procedures designed to identify the genes influencing physical characteristics in organisms and to study their

### Punnett Square for Mendelian Cross of Pure-bred Purple with Pure-bred White

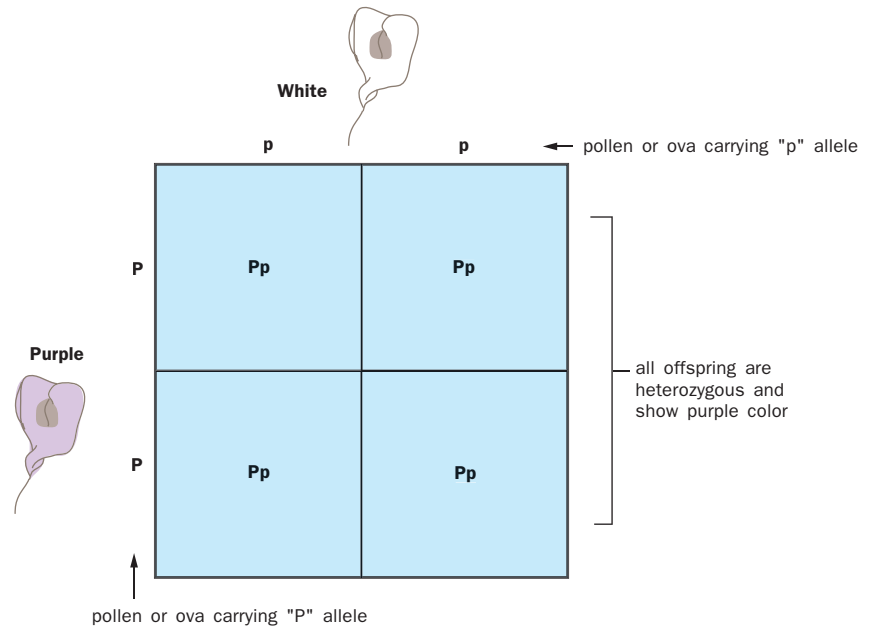

### Punnett Square for Cross of Two Heterozygous Purples from the First Cross

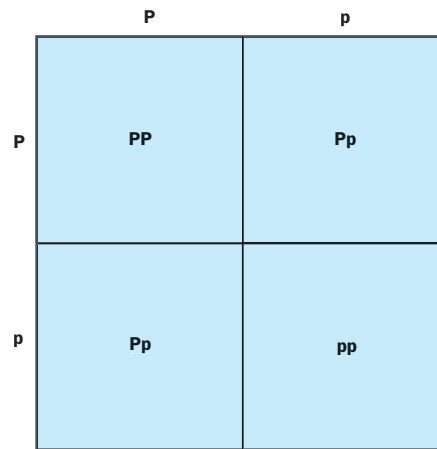

Ratio of Purple to White is 3:1

**chromosome** "colored body" in the cell nucleus; made of DNA and protein, and divided functionally into genes and non-gene regions

patterns of inheritance. Historically, genetic analysis originated as a standard program of breeding experiments, first performed and interpreted in a systematic quantitative manner by the Austrian monk Gregor Mendel, the founder of the science of genetics. In 1865, Mendel's experiments provided the first clear evidence of the discrete units of inheritance that are now called genes, although Mendel himself had no knowledge of genes or the **chromosomes** on which they are carried.

## Mendelian Genetics

Mendel performed his experiments with the common garden pea, a species that shows well-defined variation in several characteristics, such as flower

color, seed color, and seed shape. Mendel followed the inheritance of such characteristics, including flower color, which in peas has two easily distinguished alternative forms, white or purple. In preparation for performing his crosses, Mendel was careful to establish genetically uniform stocks by repeatedly inbreeding or self-fertilizing his stocks for many generations to ensure that all of the plants had flowers of the same color. He also began his analysis by following the inheritance of only one trait at a time.

In a typical experiment, he crossed white-flowered with purple-flowered peas and found that all of the **progeny** from the cross had purple flowers. When these second-generation purple-flowered plants were then self-fertilized, the third generation included both purple- and white-flowered plants in the ratio of one to three.

The mathematical regularity and the reproducibility of the pattern of transmission of the trait, and the reappearance of white flower color in the third generation convinced Mendel that the trait of flower color, as well as the other traits he analyzed, were carried by physical particles that were passed along unchanged from one generation to the next. Mendel called these particles unit factors, later renamed genes.

Mendel proposed that each adult plant had two genes (factors) for flower color and that each parent randomly passed on only one of its two genes to its offspring during reproduction. For the following discussion, let us use the capital letter  $P$  to symbolize the gene for purple flower color and the lowercase letter  $p$  to symbolize the gene for white flower color. Such different forms of a particular gene are called **alleles**.

Since Mendel's first-generation plants were true-breeding, the purple-flowered plants had two "purple" alleles (PP), and the white-flowered plants had two "white" alleles (pp). (Each is "homozygous" for the alleles they carry.) If each parent passed one of its alleles to its offspring, all of the second-generation plants would therefore have had one "purple" and one "white" allele (Pp). (These offspring are "heterozygous.") Since all of the second-generation plants had purple flowers, Mendel hypothesized that the "purple" allele masked, or was dominant to, the "white" allele, which he therefore called the "recessive" allele. The **phenotype**, or outward appearance, of these purple-flowered plants is the same as that produced by PP, even though the genotype, or genetic makeup, is different.

When the second-generation, purple-flowered peas (Pp) were allowed to reproduce by self-fertilization, they passed on one of their two alleles for flower color at random in each of the male and female reproductive cells. This means that half of the male reproductive cells (pollen) and of the female reproductive cells (ova) carried a "white" allele and half carried a "purple" allele. The process of this separation and random distribution of one member of each pair of alleles into each reproductive cell is known as Mendel's Law of Segregation.

Since **fertilization** of eggs by sperm occurs randomly, one-quarter of the third-generation progeny inherit two "purple" alleles (PP), one-half inherit one "purple" and one "white" allele (Pp), and one-quarter inherit two "white" alleles (pp). Because of the dominance of the purple allele to the white allele, Mendel observed a three-to-one ratio of purple-flowered to white-flowered progeny.

**progeny** offspring

**allele** a particular form of a gene

**phenotype** observable characteristics of an organism

**fertilization** union of sperm and egg

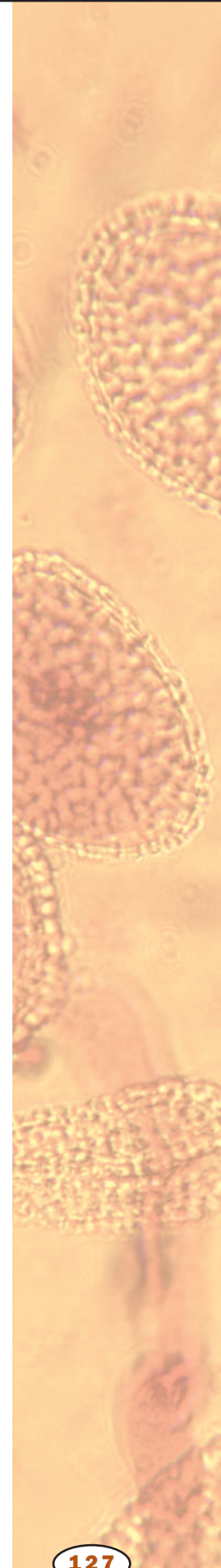

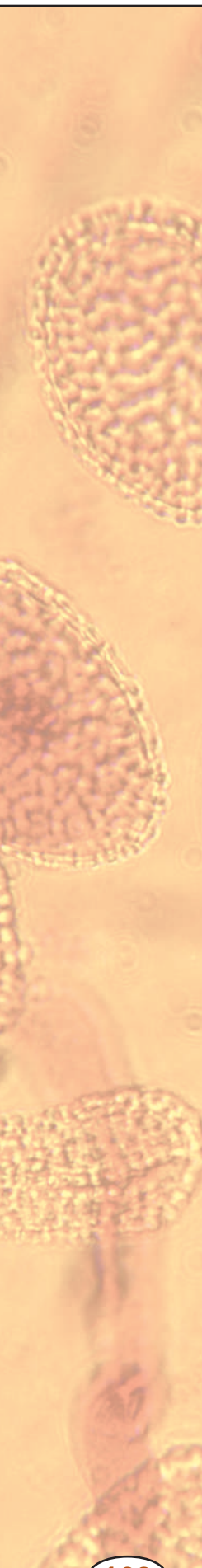

**meiosis** cell division that forms eggs or sperm

**homologous chromosomes** chromosomes carrying similar genetic information

**protein** complex molecule made from amino acids; used in cells for structure, signaling, and controlling reactions

Mendel made another important observation in which he analyzed the simultaneous inheritance of two pairs of alternate alleles, such as purple or white flower color and yellow or green seed color, in the same set of crosses. He found that each pair of alleles was inherited independently. This observation is known as Mendel's Law of Independent Assortment.

About fifty years after Mendel performed his experiments with peas, improvements in the microscope led to the discovery of chromosomes and the description of their behavior during **meiosis**, the type of cell division that occurs during the formation of eggs and sperm. It was observed that the behavior of chromosomes during meiosis was parallel to the behavior of genes as proposed by Mendel. Further work confirmed that allele pairs, such as purple versus white flowers, are carried on **homologous chromosomes**. Homologous chromosomes are separated during meiosis, accounting for the Law of Segregation.

### Modifying Mendel

Although Mendel's studies established most of the important general principles of inheritance, some important extensions of his laws have since been discovered. The discovery of chromosomes led to an important exception to Mendel's laws. Mendel assumed that any two pairs of traits would sort independently. However, two traits carried on the same chromosome cannot separate as freely as two traits carried on different chromosomes, thus limiting the Law of Independent Assortment. Traits carried on the same chromosome are said to be linked. If the chromosomal locations (loci) for the two traits are very close together, a particular pair of alleles (for example, purple flowers and thick stems) is likely to remain together. If the loci are far apart, the two alleles may become separated during the crossing over phase of meiosis. In that case, Mendel's assortment law will be more likely to hold. The frequency with which a particular pair of alleles on a chromosome is separated during meiosis can be used to determine their distance apart, and is a first step in mapping chromosomes.

The simple Mendelian concepts of dominance and recessiveness have also undergone important refinements and extensions. In many cases, recessiveness is known to be due to a mutation that makes the genes or resulting **protein** nonfunctional. Presence of one functional allele is often enough to produce adequate levels of protein, and so the functional allele has a dominant effect on the phenotype of the organism. Only when both alleles are defective does the recessive phenotype appear. In some cases, a gene will become mutated to take on a new, harmful function. Such "toxic gain-of-function" mutations are often dominant.

In the case of all of the pairs of allelic genes studied by Mendel, one of the two alleles was completely dominant to the other. However, it is more often the case that an organism with two different alleles of a gene will exhibit characteristics that are intermediate between those determined by either allele separately. For example, the progeny of a cross between red-flowered and white-flowered snapdragons have pink flowers. This type of interaction between alleles is called incomplete dominance. In a related phenomenon, co-dominance, both alleles present affect the phenotype.

The discovery around 1950 that genes are made of deoxyribonucleic acid (DNA), and the elucidation of the structure of DNA in 1953 by James



Watson and Francis Crick, led to a virtual explosion of scientific and technical advances in the analysis and manipulation of the genetic material. Thanks to these developments, Mendelian analysis has been largely replaced by techniques in which the analysis is carried out at the cellular and molecular level. Individual genes can simply be identified, isolated, and copied, and their precise molecular structure and function can usually be determined. An example of this type of analysis is represented in the Human Genome Project, in which the structure of all of the genes in human chromosomes is being elucidated. The origins of all of this sophisticated technology, however, can be traced back to the nineteenth-century pioneering methodical studies on inheritance in peas by Gregor Mendel. SEE ALSO GENE; HUMAN GENOME PROJECT; MENDEL, GREGOR; PATTERNS OF INHERITANCE

*Anthony R. Kaney*

### Bibliography

Audesirk, Teresa, and Gerald Audesirk. *Biology: Life on Earth*. Upper Saddle River, NJ: Prentice Hall, 1996.

## Genetic Code

The genetic code allows an organism to translate the genetic information found in its **chromosomes** into usable **proteins**. Stretches of deoxyribonucleic acid (DNA) are built from four different **nucleotide** bases, while proteins are made from twenty unique subunits called **amino acids**. This numerical disparity presents an interesting problem: How does the cell translate the genetic information in the four-letter alphabet of DNA into the twenty-letter alphabet of protein? The conversion code is called the genetic code.

### Requirements of a Code

The information transfer from DNA to protein, called **gene expression**, occurs in two steps. In the first step, called **transcription**, a DNA sequence is copied to make a **template** for protein synthesis called messenger ribonucleic acid (messenger RNA, or mRNA). During protein synthesis, **ribosomes** and transfer RNA (tRNA) use the genetic code to convert genetic information contained in mRNA into functional protein. (Formally speaking, the genetic code refers to the RNA-amino acid conversion code and not to DNA, though usage has expanded to refer more broadly to DNA.)

Mathematics reveals the minimum requirements for a genetic code. The ribosome must convert mRNA sequences that are written in four bases—A, G, U, and C—into proteins, which are made up of twenty different amino acids. A one base to one amino acid correspondence would code for only four amino acids ( $4^1$ ). Similarly, all combinations of a two-base code (for example, AA, AU, AG, AC, etc.) will provide for only sixteen amino acids ( $4^2$ ). However, blocks of three RNA bases allow sixty-four ( $4^3$ ) combinations of the four nucleotides, which is more than enough combinations to correspond to the twenty distinct amino acids. So, the genetic code must use blocks of at least three RNA bases to specify each amino acid. (This reasoning assumes that each amino acid is encoded by the same size block of RNA.)

In addition, a ribosome must know where to start synthesizing a protein on an mRNA molecule and where to stop, and start and stop signals

**chromosomes** “colored body” in the cell nucleus; made of DNA and protein, and divided functionally into genes and non-gene regions

**protein** complex molecule made from amino acids; used in cells for structure, signaling, and controlling reactions

**nucleotide** the building block of RNA or DNA

**amino acid** a building block of protein

**gene expression** use of a gene to create the corresponding protein

**transcription** messenger RNA formation from a DNA sequence

**template** master copy

**ribosome** protein-RNA complex in cells that synthesizes protein

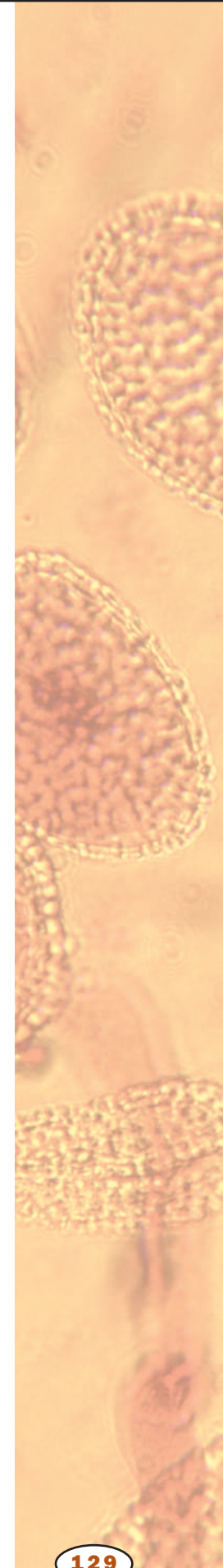

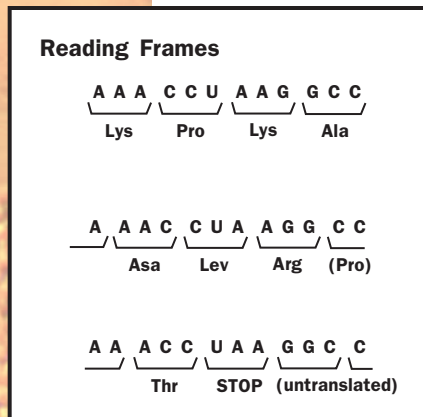

Figure 1. The genetic code reads codons of three bases each and builds a chain of amino acids accordingly.

**codon** sequence of three mRNA nucleotides coding for one amino acid

**prokaryote** single-celled organism without a nucleus

**complementary** matching opposite

**enzyme** protein that controls a reaction in a cell

**cytosol** fluid portion of a cell, not including the organelles

require their own RNA sequences. A series of experiments carried out in the 1960s confirmed these mathematical speculations, and went on to determine which triplet sequence (called a **codon**) specifies which amino acid.

Indeed, the genetic code uses codons of three bases each, such as ACC or CUG. Therefore, the protein synthesis machinery reads every triplet of bases along the mRNA and builds a chain of amino acids—a protein—accordingly. Reading triplets, however, would allow a ribosome to start at any one of three positions within a given triplet (see Fig. 1). The position that the ribosome chooses is based on the location of the start signal and is called the “reading frame.”

Experiments have shown all but three of the sixty-four possible codons that A, G, U, and C specify code for one amino acid each. This means that most amino acids are encoded by more than one codon. In other words, the genetic code is said to be redundant or degenerate. This redundancy allows the protein-synthesizing machinery of the cell to get by with less, as will be seen below. The three that don’t, the “nonsense” codons, indicate the end of the protein-coding region of an mRNA, and are termed stop codons.

## Starting, Stopping, and Making Protein

In any mRNA molecule, one codon always marks the beginning of a protein. That “start” codon is usually AUG in both eukaryotes and **prokaryotes**, although eukaryotes use GUG on rare occasions. AUG codes for the amino acid methionine. To start synthesizing at an AUG, however, ribosomes require more information besides a start codon; this information is found in the sequence surrounding the initial AUG. AUG codons in the middle of a protein-coding sequence are translated like any other codon.

Three codons signal the end of the mRNA template. These so-called stop codons, UAA, UAG, and UGA, do not code for any amino acid. Instead, the ribosome gets stuck, waiting for the tRNA that never comes, and eventually falls off, releasing the newly synthesized protein.

The **complementary** sequence of a codon found on a tRNA molecule is called its anticodon. The tRNA molecule matches up its anticodon with the correct codon on the mRNA. A tRNA molecule holds an amino acid in one of its molecular arms and works with the ribosome to add its amino acid to the protein being synthesized. Each tRNA is then reloaded with its specific amino acid by an **enzyme** in the **cytosol**.

Codons that code for the same amino acid are called redundant codons. The first two bases of redundant codons are usually the same and the third is either U or C, or alternatively A or G. For example, two redundant codons for the amino acid arginine are CGU and CGC, both of which pair with the same tRNA, despite having different third bases. This characteristic of the codon-anticodon interaction is called “wobble,” and it allows organisms to have fewer than sixty-four distinct tRNA genes. In some tRNAs, wobble is made possible by a modified base within the anticodon. This modified base is called inosine (designated by I) and is made from adenine.

## Evidence for Evolution

For almost all organisms tested, including humans, flies, yeast, and bacteria, the same codons are used to code for the same amino acids. Therefore,

1st position (5' end)	2nd position				3rd position (3' end)
	U	C	A	G	
U	Phe Phe Leu Leu	Ser Ser Ser Ser	Tyr Tyr STOP STOP	Cys Cys STOP Trp	U C A G
C	Leu Leu Leu Leu	Pro Pro Pro Pro	His His Gln Gln	Arg Arg Arg Arg	U C A G
A	Ile Ile Ile Met	Thr Thr Thr Thr	Asn Asn Lys Lys	Ser Ser Arg Arg	U C A G
G	Val Val Val Val	Ala Ala Ala Ala	Asp Asp Glu Glu	Gly Gly Gly Gly	U C A G

Figure 2. The universal genetic code.

the genetic code is said to be universal. The universality of the genetic code strongly implies a common evolutionary origin to all organisms, even those in which the small differences have evolved. These include a few bacteria and protozoa that have a few variations, usually involving stop codons.

Mammalian **mitochondria**, which contain DNA, use the codon UGA not as a stop signal but instead to specify the amino acid tryptophan, and they have four stop codons instead of three. Also, the modified base inosine is not used in mitochondrial anticodons. Mitochondrial genetic codes from different organisms can also be distinct from each other as well as from the universal code, reflecting both their ancient bacterial origins and their long isolation within their host species. SEE ALSO ARCHAEA; CELL EVOLUTION; DNA; EUBACTERIA; GENE; MITOCHONDRION; NUCLEOTIDES; PROTEIN SYNTHESIS; PROTISTA; RIBOSOME; TRANSCRIPTION

Mary Beckman

### Bibliography

- Alberts, Bruce, et al. *Molecular Biology of the Cell*, 4th ed. New York: Garland Publishing, 2000.
- Creighton, Thomas E. *Proteins: Structures and Molecular Properties*, 2nd ed. New York: W. H. Freeman, 1993.
- Freifelder, David. *Molecular Biology*, 2nd ed. Boston: Jones & Bartlett, 1987.
- Lehninger, Albert L. *Principles of Biochemistry*, New York: Worth Publishers, 1982.

## Genetic Control of Development

The transformation of a single-celled **zygote** (product of the union between egg and sperm) to a multicellular embryo and then to an adult organism is a complex and amazing process. A fully developed organism has many different cell types that serve many different functions. For example, red blood cells carry oxygen, muscle cells contract, fat cells store nutrients, and nerve cells transmit information. In fact, a human has about 350 different types

**mitochondria** subcellular organelle that creates ATP used for energy-requiring processes in a cell

**zygote** fertilized egg

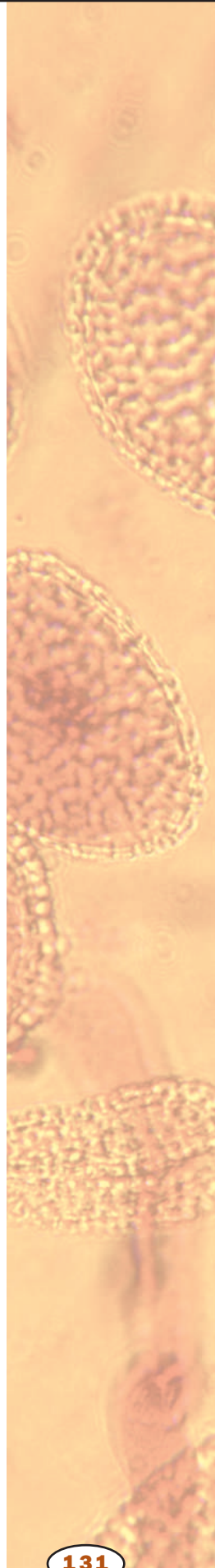

A chicken embryo. During pattern formation, communication between cells of a developing embryo is crucial, so that each cell will “know” its position within the emerging body plan.

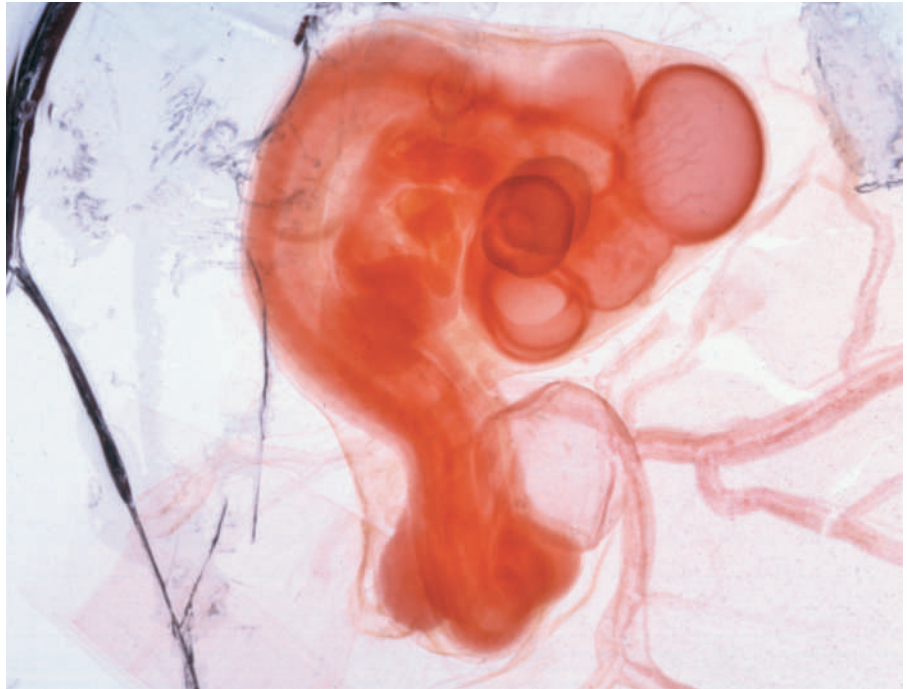

**protein** complex molecule made from amino acids; used in cells for structure, signaling, and controlling reactions

**nucleus** membrane-bound portion of cell containing the chromosomes

**lineage** ancestral line

**genome** total genetic material in a cell or organism

of cells that are distinguishable in both form and function. However, all of the cells of a very early embryo appear to be identical. How, then, do cells become specialized as they divide?

### Differentiation

The process of cell specialization during development is called differentiation. The differentiation process proceeds by the progressive specialization of the **protein** contents of a cell. Each type of cell in a mature organism has a unique collection of proteins. The blueprints for making these proteins are found in the **nucleus** of each cell in the form of deoxyribonucleic acid (DNA). Therefore, the starting place for understanding the process of differentiation lies in the nucleus of the original zygote, which contains all of the genetic instructions (DNA) to make all of the cell type repertoire of the mature organism. The original cell is totipotent, which means that it can give rise to any cell type. As the embryo develops, some cells differentiate, while others, called stem cells, remain pluripotent, which means that they can give rise to a certain subset of cell types called a **lineage**.

One hypothesis to explain how differentiated cells have a specialized pool of proteins is that differentiating cells retain only the genes (DNA) that encode the proteins they need, and they lose all the other genes. Such a mechanism would produce mature cell types with a different **genome**. Experiments, however, disproved this hypothesis. In 1968, John Gurdon removed the nucleus of an unfertilized frog egg and replaced it with the nucleus from a fully differentiated tadpole epithelial cell. The egg developed into a normal tadpole. Gurdon’s classic experiment demonstrated that the nucleus of the differentiated cell still retains the full genome: no genes are lost as a cell’s descendants specialize.

#### MANGOLD, HILDA (1898–1924)

German biologist who discovered that a small part of an embryo determines the organization of the entire embryo. When Mangold moved this bit of tissue, called the “primary organizer,” in a frog embryo, it developed a second backbone and other organs. Mangold died young in an accident, but her professor, Hans Spemann, received the Nobel prize for their work on the primary organizer.

Other experiments supported an alternative hypothesis: that cell specialization reflects the differential regulation of the full set of genes in each cell type. This means that all cells in a mature organism (muscle cells, brain cells) all have the same set of genes, but only a subset of those genes are turned “on” in any specific cell type. Therefore, the process of differentiation involves the activation (turning on) of some genes and the inactivation (turning off) of other genes, in order to get the specific collection of proteins that characterizes that cell type.

The point during development at which a cell becomes committed to a particular fate is called determination. Differentiation (specialization) is the end product of determination. Determination happens when certain genes are activated or inactivated, and differentiation completes when the cell synthesizes all of the tissue-specific proteins that the activated genes encode. For example, when particular cells in a mammalian embryo activate the gene for the protein MyoD and thus begin making MyoD protein, they are determined to be muscle cells. As it turns out, the MyoD protein is a **transcription factor** that controls the expression of several other genes. Therefore, MyoD activates and inactivates many of the genes that encode muscle-specific proteins.

What is it, then, that activates MyoD in some cells and not in others during development? Two important types of signals “tell” the developing organism which genes to express and when to express them. Firstly, the uneven distribution of substances (such as messenger RNA, protein, **organelles**) in the **cytoplasm** of the unfertilized egg is important to the initial stages of determination. Once the egg is fertilized and the nucleus begins to divide (via **mitosis**), the resulting nuclei are exposed to different cytoplasmic surroundings. These different internal environments contain different sets of molecules (collectively called cytoplasmic determinants) that regulate the expression of certain genes. Secondly, as the embryo enlarges and increases in cell number, molecules in the extracellular environment can act as signals to developing cells. More often than not, these signal molecules are released from other cells in the embryo and affect target cells by regulating the expression of certain genes in those cells. This process is called induction, and is the process by which cells of the embryo communicate and spur on the processes of determination and differentiation. Induction was discovered in the 1920s by the embryologist Hans Spemann and Hilde Mangold.

## Morphogenesis

As cells become specialized they organize into a hierarchy of tissues, organs, and organ systems in which they work as a set, providing a certain function. Morphogenesis is the process by which differentiated cells are organized into these functional groups. In many species, morphogenesis begins before differentiation is completed. For example, in the sea urchin embryo, cells begin to migrate and the embryo changes shape long before the cells are fully differentiated. The process of morphogenesis reflects the differential expression of genes in different cells. The complex interactions of actively differentiating cells actually drives the process of morphogenesis. It is useful to look at the **gene expression** patterns that characterize one component of morphogenesis.

**transcription factor** protein that increases the rate of transcription of a gene

**organelle** membrane-bound cell compartment

**cytoplasm** material in a cell, excluding the nucleus

**mitosis** separation of replicated chromosomes

**gene expression** use of a gene to create the corresponding protein

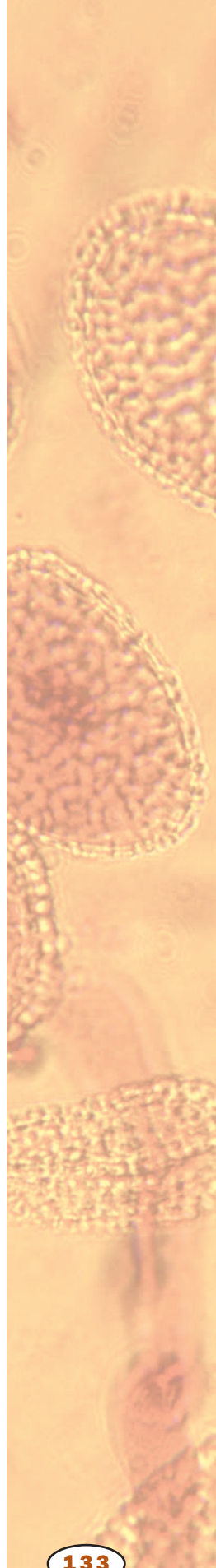

## Pattern Formation

During morphogenesis, a process called pattern formation drives the spatial organization of tissues and organs into a defined body plan, or final shape. For example, both dogs and humans have legs made up of bone, muscle, and skin. During development, differentiation produces muscle cells, bone cells, and skin cells from an unspecialized set of embryo cells. Morphogenesis then organizes the bone cells into bone tissue to form bones and the muscle cells into muscle tissue to form muscles. However, it is the process of pattern formation that organizes those bones and muscles into the specific spatial organization that makes a dog look like a dog and a human look like a human.

**The Role of Positional Cues in Pattern Formation.** During pattern formation, it is crucial for cells of the developing embryo to communicate with one another so that each cell will “know” its relative position within the emerging body plan. The intercellular molecular signals that ultimately drive the process of pattern formation provide positional information. These signals may be chemicals released by certain embryonic cells that diffuse through the embryo and bind to other cells. These diffusible signals are called morphogens. Oftentimes it is the concentration of the morphogen the target cell senses that provides information about the target cell’s proximity to the releasing cell.

The development of a chicken wing is a good example of this phenomenon. During development, the chick wing develops from a structure called the limb bud. Lewis Wolpert discovered a small collection of cells that lie along the rear margin of the limb bud and that specify the position of cells along the front-rear axis of the bud. Ultimately, these cells control the pattern of digit development in the wing (chicken digits are like human fingers). Wolpert named these cells the polarizing region. They release a morphogen that diffuses through the limb bud. The cells that are exposed to the highest concentration of morphogen (the ones closest to the polarizing region) develop into a particular digit, the cells that are exposed to an intermediate concentration of morphogen develop into a differently shaped digit, etc. Ultimately the positional cue directs differentiation of the target cell by changing its pattern of gene expression.

**The Role of *Hox* Genes in Pattern Formation.** The basic three-dimensional layout of an organism is established early in embryonic development. Even an early embryo body has dorsal and ventral axes (top and bottom) as well as anterior and posterior axes (front and back). The differential expression of certain genes in different cells of the embryo controls the emergence of this organization. Interestingly, while different types of organisms have dramatically different morphological features, a similar family of genes controls differential gene expression during pattern formation. The *Hox* family of genes (also called homeotic genes) is found in many different organisms (including plants and animals), and is important in controlling the anatomical identity of different parts of a body along its anterior/posterior axis. Many species have genes that include a nearly identical DNA sequence, called the homeobox region. These genes comprise the *Hox* family of genes, and they encode proteins that function as transcription factors. In fruit flies, for example, homeotic genes specify the types of **appendages** that develop on each body segment. The homeotic genes antennal and leg development

**appendage** attached organ or structure

### WAELSCH, SALOME (1907– )

German-born U.S. biologist whose work helped lay the foundation for modern genetics. Waelsch overcame anti-Semitism and sexism both in Nazi Germany and later in the United States in her efforts to continue studying the genetics of development in mammals. In 1993, she was awarded the National Medal of Science.

by regulating the expression of a variety of other genes. The importance of the *Hox* genes is vividly evident when one of these genes is mutated: the wrong body part forms. For example, mutation in the *Antennapedia* gene causes fruit flies to develop legs in place of antennae on the head segment. SEE ALSO CELL CYCLE; CONTROL OF GENE EXPRESSION; DEVELOPMENT; GENE; TRANSCRIPTION

Susan T. Rouse

### Bibliography

- Akam, Michael. "Hox Genes: From Master Genes to Micromanagers." *Current Biology* 8 (1998): R676–R678.
- Beardsley, Tim. "Smart Genes." *Scientific American* 265 (1991): 86–95.
- Fletcher, J. C., and Elliott M. Meyerowitz. "Cell Signaling Within the Shoot Meristem." *Current Opinions in Plant Biology* 3 (2000): 23–30.
- Gellon, Gabriel, and William McGinnis. "Shaping Animal Body Plans in Development and Evolution by Modulation of *Hox* Expression Patterns." *Bioessays* 20 (1998): 116–125.
- Wolpert, Lewis. "Pattern Formation in Biological Development." *Scientific American* 239 (1978): 154–164.
- . *Triumph of the Embryo*. Oxford: Oxford University Press, 1991.

## Genetic Counselor

A genetic counselor is a medical professional who serves as a liaison between an individual or family and a physician or medical team. The counselor interprets genetic test results and provides information to help patients make medical or lifestyle choices, based on knowledge gained from genetic tests.

Genetic counselors are trained in genetics, statistics, and psychology, and usually have master's degrees from genetic counseling programs. Nurses, social workers, physicians, and Ph.D. geneticists also do genetic counseling. The job requires a combination of technical expertise and compassion—a genetic counselor must love working with people and be able to offer comfort under stressful circumstances.

During a typical session, the counselor asks many questions from which he or she constructs a pedigree, which is a family tree that depicts certain traits or illnesses. From this information, he or she can recognize or deduce the mode of inheritance (dominant or recessive, sex-linked or autosomal), predict which family members are likely to be affected, and suggest specific medical tests.

The first genetic counselors graduated from Sarah Lawrence College in Bronxville, New York, in 1971, against a backdrop of concern over such medical matters as test tube babies, heart transplants, and recombinant DNA (deoxyribonucleic acid) technology. At that time, genetic testing for sickle cell disease and Tay-Sachs disease was a prelude to the more widespread testing of the twenty-first century.

Until the early twenty-first century, patients seeking genetic counseling either had family histories of rare, single-gene disorders or were at high risk of carrying a fetus with a chromosomal or **congenital** problem, due to "advanced maternal age" or exposure to harmful substances (teratogens), respectively. With the sequencing of the human **genome**, the spectrum of

**congenital** present at birth; inherited

**genome** total genetic material in a cell or organism

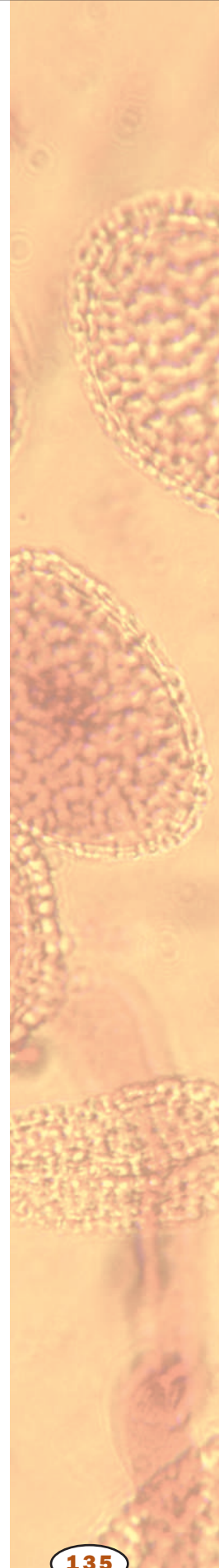

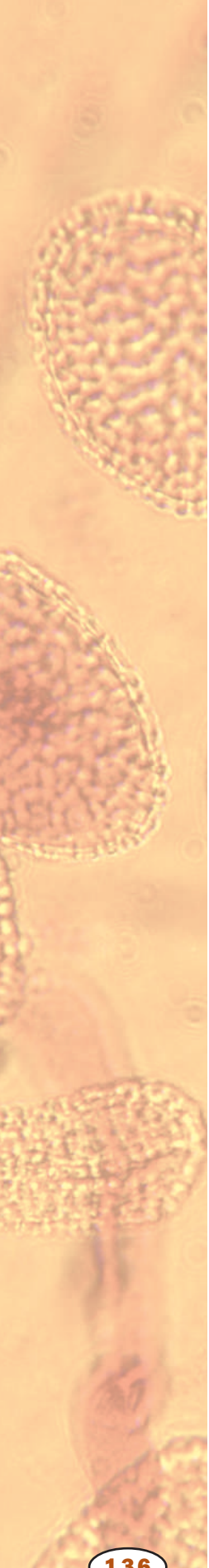

**protein** complex molecule made from amino acids; used in cells for structure, signaling, and controlling reactions

**nucleotide** the building block of RNA or DNA

**chromosome** “colored body” in the cell nucleus; made of DNA and protein, and divided functionally into genes and non-gene regions

**nucleus** membrane-bound portion of cell containing the chromosomes

conditions that a genetic counselor confronts is broadening considerably to include much more common disorders, such as cancers and cardiovascular disease, that reflect the input of several genes and the environment. Rather than offering definitive diagnoses based on detecting single abnormal genes, genetic information is more likely to take the form of elevated risk estimates. SEE ALSO GENE; GENETIC ANALYSIS; HUMAN GENOME PROJECT; PATTERNS OF INHERITANCE

*Ricki Lewis*

### Bibliography

Kling, James. “Genetic Counseling: The Human Side of Science.” *The Scientist* 13 (19 July 1999): 1.

Lewis, Ricki. “Genetic Counselors Struggle for Status.” *The Scientist* 6 (31 August 1992): 1.

———. *Human Genetics: Concepts and Applications*, 4th ed. St. Louis: McGraw-Hill Higher Education, 2001.

## Genetic Diseases

A genetic disease is due to a faulty gene or group of genes. While not all gene defects cause disease, many do. New genetic diseases are discovered every month; as of 2001, there are estimated to be approximately 1,100 genetic diseases.

### How Gene Defects Cause Disease

A gene is a recipe for making a **protein**. Proteins control cell functions, and defects in the instructions for making a protein can prevent the cell from functioning properly. Genes are made of deoxyribonucleic acid (DNA), a chemical composed of units called **nucleotides**, and are carried on **chromosomes** within the cell **nucleus**. Most genes are present in pairs (corresponding to the two sets of chromosomes inherited from one’s parents). As well as coding for proteins, genes are the hereditary material. Therefore, genetic diseases can be inherited.

Genetic defects cause diseases in a variety of ways. The simplest way is through a “loss-of-function” mutation. In this type of defect, a change in the DNA nucleotides prevents the gene from making protein, or prevents the protein from functioning once it is made. Genetic diseases due to loss-of-function mutations are very common, and include cystic fibrosis (which affects the lungs and pancreas), Duchenne muscular dystrophy, and the hemophilias, a group of blood-clotting disorders.

A second mechanism for causing disease is called a “toxic-gain-of-function” mutation. In this type of defect, the gene takes on a new function that is harmful to the organism—the protein produced may interfere with cell functions, or may no longer be controllable by its normal regulatory partners, for instance. Many degenerative diseases of the brain are due to this type of mutation, including Huntington disease.

More complex mechanisms are possible. Most traits are multifactorial, meaning they are determined by many different genes. In the human population, there are several variants (alleles) of most genes, each form of which



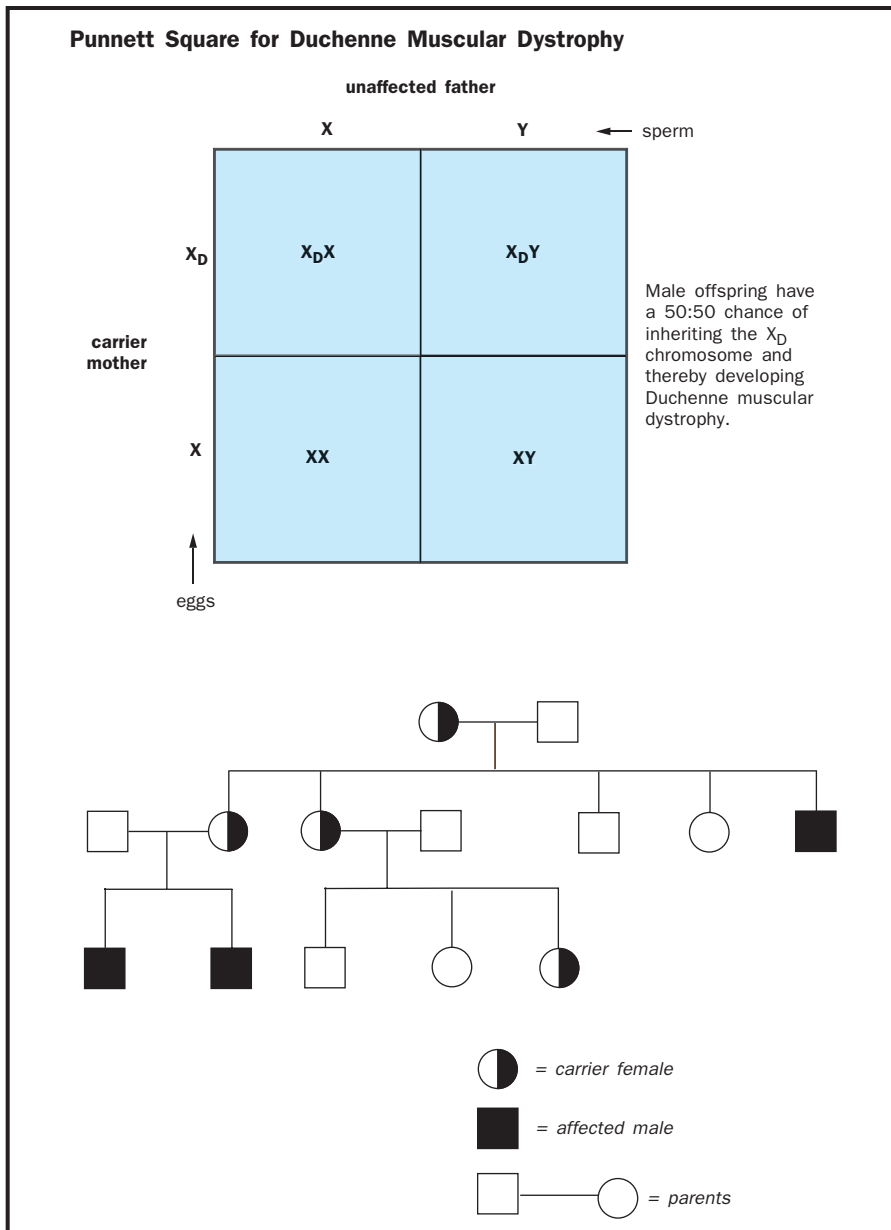

Duchenne muscular dystrophy is a genetic disease due to the loss-of-function mutation. The bottom diagram shows a typical pedigree for inheritance of an x-linked trait such as Duchenne muscular dystrophy.

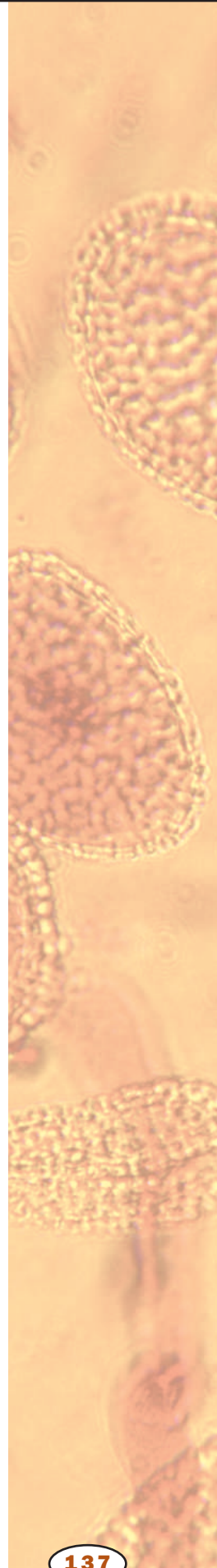

is functional and does not cause disease by itself. However, some **alleles** may predispose a person to a certain disease, especially in combination with other alleles or environmental factors that influence the same trait. Such susceptibility alleles have been found in breast cancer and colon cancer, for instance. Carriers of these alleles have an increased likelihood of developing that disease, a risk that can be increased or decreased by such factors as diet, exposure to environmental toxins, or presence of particular alleles for other genes. As more is learned about the human **genome**, a large number of susceptibility genes are likely to be discovered for a wide variety of conditions.

Disease can also be caused by chromosome abnormalities rather than gene defects. Down syndrome is due to having three copies of chromosome 21, instead of the normal two copies. It is likely the extra protein from the extra gene copies lead directly to the disease symptoms, but this is not yet clear.

**allele** a particular form of a gene

**genome** total genetic material in a cell or organism

Condition	Chromosome Location and Inheritance Pattern	Protein Affected	Symptoms and Comments
Gaucher Disease	1, recessive	glucocerebrosidase, a lipid metabolism enzyme	Common among European Jews. Lipid accumulation in liver, spleen, and bone marrow. Treat with enzyme replacement
Achondroplasia	4, dominant	fibroblast growth factor receptor 3	Causes dwarfism. Most cases are new mutations, not inherited
Huntington's Disease	4, dominant	huntingtin, function unknown	Expansion of a three-nucleotide portion of the gene causes late-onset neurodegeneration and death
Juvenile Onset Diabetes	6,11,7, others	IDDM1, IDDM2, GCK, other genes	Multiple susceptibility alleles are known for this form of diabetes, a disorder of blood sugar regulation. Treated with dietary control and insulin injection
Hemochromatosis	6, recessive	HFE protein, involved in iron absorption from the gut	Defect leads to excess iron accumulation, liver damage. Menstruation reduces iron in women. Bloodletting used as a treatment
Cystic Fibrosis	7, recessive	cystic fibrosis transmembrane regulator, an ion channel	Sticky secretions in the lungs impair breathing, and in the pancreas impair digestion. Enzyme supplements help digestive problems
Friedreich's Ataxia	9, recessive	frataxin, mitochondrial protein of unknown function	Loss of function of this protein in mitochondria causes progressive loss of coordination and heart disease
Best Disease	11, dominant	VMD2 gene, protein function unknown	Gradual loss of visual acuity
Sickle Cell Disease	11, recessive	hemoglobin beta subunit, oxygen transport protein in blood cells	Change in hemoglobin shape alters cell shape, decreases oxygen-carrying ability, leads to joint pain, anemia, and infections. Carriers are resistant to malaria. About 8% of US black population are carriers
Phenylketonuria	12, recessive	phenylalanine hydroxylase, an amino acid metabolism enzyme	Inability to break down the amino acid phenylalanine causes mental retardation. Dietary avoidance can minimize effects. Postnatal screening is widely done
Marfan Syndrome	15, dominant	fibrillin, a structural protein of connective tissue	Scoliosis, nearsightedness, heart defects, and other symptoms
Tay-Sachs Disease	15, recessive	beta-hexosaminidase A, a lipid metabolism enzyme	Accumulation of the lipid GM2 ganglioside in neurons leads to death in childhood
Breast Cancer	17, 13	BRCA1, BRCA2 genes	Susceptibility alleles for breast cancer are thought to involve reduced ability to repair damaged DNA
Myotonic Dystrophy	19, dominant	dystrophia myotonica protein kinase, a regulatory protein in muscle	Muscle weakness, wasting, impaired intelligence, cataracts
Familial Hypercholesterolemia	19, incomplete dominance	low-density lipoprotein (LDL) receptor	Accumulation of cholesterol-carrying LDL in the bloodstream leads to heart disease and heart attack
Severe Combined Immune Deficiency ("Bubble Boy" Disease)	20, recessive	adenosine deaminase, nucleotide metabolism enzyme	Immature white blood cells die from accumulation of metabolic products, leading to complete loss of the immune response. Gene therapy has been a limited success
Adrenoleukodystrophy	X	lignoceroyl-CoA ligase, in peroxisomes	Defect causes build-up of long-chain fatty acids. Degeneration of the adrenal gland, loss of myelin insulation in nerves. Featured in the film <i>Lorenzo's Oil</i>
Duchenne Muscular Dystrophy	X	dystrophin, muscle structural protein	Lack of dystrophin leads to muscle breakdown, weakness, and impaired breathing
Hemophilia A	X	Factor VIII, part of the blood clotting cascade	Uncontrolled bleeding, can be treated with injections or replacement protein
Rett Syndrome	X	methyl CpG-binding protein 2, regulates DNA transcription	Most boys die before birth. Girls develop mental retardation, mutism, and movement disorder
Leber's Hereditary Optic Neuropathy	mitochondria, maternal inheritance	respiratory complex proteins	Degeneration of the central portion of the optic nerve, loss of central vision
Mitochondrial Encephalopathy, Lactic Acidosis, and Stroke (MELAS)	mitochondria, maternal inheritance	transfer RNA	Recurring, stroke-like episodes in which sudden headaches are followed by vomiting and seizures; muscle weakness

## Inheritance Patterns in Genetic Disease

Genetic diseases are heritable, meaning they may be passed from parent to child. A disease gene is called *recessive* if both copies of the gene must be defective to cause the disease. Loss-of-function mutations are often recessive. If the second copy of the gene is healthy, it may be able to serve adequately even if the first copy suffers a loss-of-function mutation. In this case, the carrier of the disease gene will not have the disease.

All humans are thought to carry a number of such defective genes. Close relatives are likely to carry similar genes and gene defects, and are therefore more likely to bear children with recessive genetic diseases if they mate. Because of this, a prohibition against marriage of close relatives is found in virtually every culture in the world.

A disease gene is called *dominant* if inheriting one copy of it causes the disease. Toxic gain-of-function mutations often create dominant genes, as in the case of Huntington disease.

If having one defective gene causes a different condition than having two, the gene is called *incompletely dominant*. In familial hypercholesterolemia, having two disease genes leads to very high blood cholesterol levels and death in childhood or early adulthood. Having one disease gene and one normal gene leads to less-elevated cholesterol and a longer but still reduced life span.

Most genes are carried on autosomes, the twenty-two pairs of chromosomes that do not determine sex. Males and females are equally likely to inherit disease genes on autosomes and develop the related diseases, called *autosomal disorders*. Unlike autosomes, the pair of chromosomes that determine sex (called X and Y) have almost no genes in common. While the Y carries very few genes, the very large X chromosome contains many genes for proteins unrelated to sex determination. Males have one X and one Y, and are more likely than females to develop diseases due to recessive X-linked genes, since they do not have a backup copy of the normal gene. Such disorders are termed *X-linked disorders*. Females have two X chromosomes, and so usually do not develop recessive X-linked disorders. Duchenne muscular dystrophy, for instance, is an X-linked condition due to a defective muscle protein. It affects boys almost exclusively. Females are carriers for the condition, meaning they have the gene but seldom develop the disease.

The cell energy **organelles** called **mitochondria** also contain a small number of genes. Mitochondria are inherited only from the mother, and so mitochondrial gene defects show *maternal inheritance*. Leber's hereditary optic neuropathy is a maternally inherited mitochondrial disorder causing partial blindness.

In some diseases, not every person who inherits the gene will develop the disease. Such genes are said to show *incomplete penetrance*. For instance, fragile X syndrome does not affect about one-fifth of boys who inherit it. This syndrome is due to a large increase in the number of CCG nucleotides at the tip of the X chromosome and leads to characteristic facial features, mental retardation, and behavioral problems.

## Unique Features of Genetic Diseases

If a parent is known to carry a disease gene, it is possible to predict the likelihood that an offspring will contract the disease, based on simple laws of

**organelle** membrane-bound cell compartment

**mitochondria** subcellular organelle that creates ATP used for energy-requiring processes in a cell

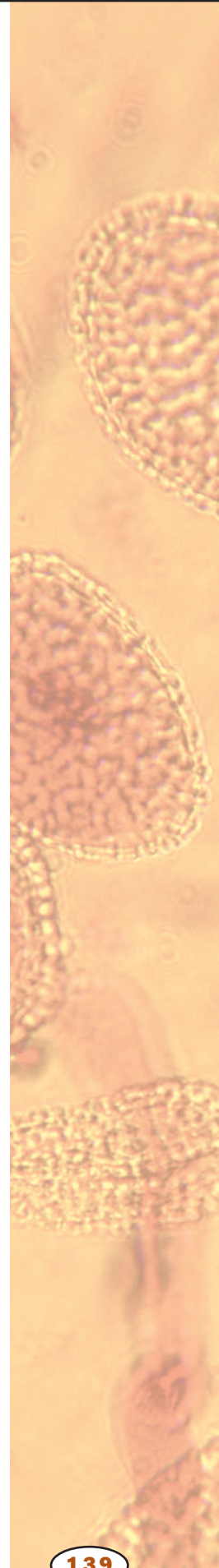

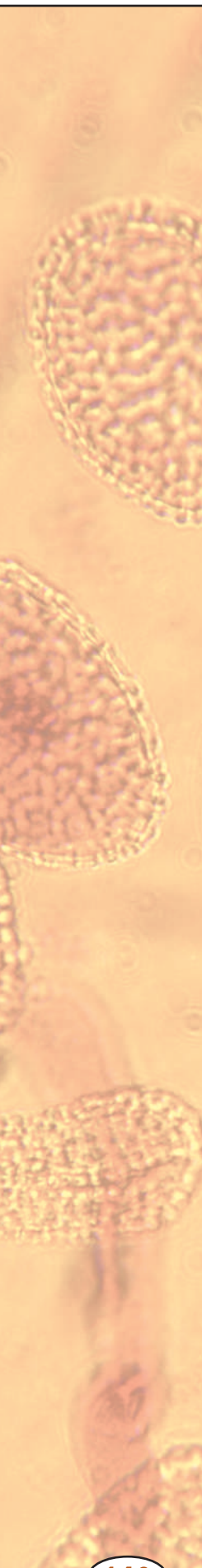

**lipid** fat or waxlike molecule, insoluble in water

**metabolism** chemical reactions within a cell

**enzyme** protein that controls a reaction in a cell

**amino acid** a building block of protein

**protein** complex molecule made from amino acids; used in cells for structure, signaling, and controlling reactions

**chromosome** “colored body” in the cell nucleus; made of DNA and protein, and divided functionally into genes and non-gene regions

**nucleus** membrane-bound portion of cell containing the chromosomes

probability. In Duchenne muscular dystrophy, for instance, if the mother carries the defective gene, there is a 50 percent chance that each male child will develop the disease, since she will give the child one of her two X chromosomes. It is also possible with many disorders to test the fetus to determine if the gene was in fact inherited. Such information can be used for purposes of family planning.

Different populations may have different frequencies of disease alleles because of long periods of relative genetic isolation. For instance, Jews of European ancestry are much more likely to carry the gene for Tay-Sachs disease, a fatal autosomal recessive disorder of **lipid metabolism**. Healthy adults in such populations may choose to be tested to see if they carry one Tay-Sachs allele. A person with one disease allele might use this information to avoid choosing a mate who also has one disease allele.

Treatment of genetic diseases is possible in some but not all cases. Missing proteins can be supplied relatively easily to the blood, as for hemophilia, but not to most other organs. The effects of phenylketonuria, which is due to a defect in an **enzyme** that breaks down phenylalanine, can be partially avoided by reducing the amount of the **amino acid** phenylalanine in the diet. (This is the reason some diet soft drinks carry a notice that phenylalanine is used in the artificial sweetener.) Most genetic diseases can't be treated, though, except by supplying the missing gene to the tissues in which it acts. This treatment, called gene therapy, is still experimental, but may become an important type of therapy for genetic diseases in the coming decades. SEE ALSO GENE THERAPY; GENETIC ANALYSIS; GENETIC COUNSELOR; MUTATION; PATTERNS OF INHERITANCE; PEDIGREES AND MODES OF INHERITANCE; SEX CHROMOSOMES

*Richard Robinson*

### Bibliography

Bellenir, Karen. *Genetic Disorders Sourcebook*. Detroit, MI: Omnigraphics, 1996.

*Genes and Disease—Information and Chromosome Maps from National Institutes of Health*. <<http://www.ncbi.nlm.nih.gov/disease/>>.

Lewis, Ricki. *Human Genetics: Concepts and Applications*, 4th ed. New York: McGraw-Hill, 2001.

## Genome

The genetic material of an organism consists of deoxyribonucleic acid (DNA). A gene is a segment of DNA that encodes a **protein** (or a structural ribonucleic acid [RNA] for example, ribosomal RNA), along with the regulatory elements that control expression of that gene. The entire complement of DNA within the **chromosomes** of an organism is called the genome. The more complex organisms, that is, eukaryotes, contain much more DNA in their genomes than is found in genes. This nongene DNA has often been called “junk DNA,” as scientists have yet to find a specific function for it. The junk DNA can amount to 90 to 99 percent of the total DNA in the cell **nucleus**.

Within the nucleus the DNA is part of the chromosomes. The number of chromosomes varies with species but is generally about twenty to forty pairs. However, there are exceptions: The round worm *Ascaris megalocephala*

has but one pair of chromosomes, while the fern *Ophioglossum reticulatum* has six hundred thirty. Humans have twenty-three pairs. In **prokaryotes**, such as bacteria, the DNA is found in a single chromosome, and this constitutes the bacterial genome.

The concept of a genome can be extended. **Mitochondria**, the cellular **organelles** found in all eukaryotes, as well as plastids such as the chloroplast found in plants, originally evolved from bacteria-like ancestors that took up residence within the primitive **eukaryotic cell**. These are called endosymbionts. Mitochondria and chloroplasts retain some of the genes of these ancestral endosymbionts, and one can then speak of the mitochondrial or chloroplast genome. In addition, many bacteria harbor **plasmids**, small circular pieces of DNA containing a few genes that form a plasmid genome.

Genomes do not have to consist of double-stranded DNA. Indeed, it is among the viruses that one finds a wide variety of genome forms. These genomes may be composed of double-stranded or single-stranded DNA. The DNA molecules may be linear or form a circle. Other viruses use RNA as their genetic material. These RNA genomes may be single-stranded or double-stranded. Viroids are another interesting group. Viroids are disease-causing entities in plants, such as the tomato stunt viroid or the avocado sunblotch viroid. Viroids resemble viruses, but unlike viruses they lack a coat protein(s) and consist of a genome of only approximately 240 to 400 bases of RNA.

The study of genomes has been made possible by the development of automated DNA sequencers and high-powered computers that can overlap pieces of genome sequence to derive the entire DNA base sequence. This led to the development in the late 1990s of a new field of study called genomics. Genomics uses genome sequence data to identify genes, to predict the structure of gene products, to study the evolution of individual genes, or to examine the genetic relationships among species. With this technology, genome sequencing is progressing rapidly. The National Institutes of Health maintains a genome database ([www.ncbi.nlm.nih.gov](http://www.ncbi.nlm.nih.gov)). As of May 2001, more than six hundred complete genomes have been deposited in the database. Most of these are viruses, along with four eukaryotes and almost fifty prokaryotes. Several hundred more partial sequences are also available. A first draft of the entire three-billion-plus bases of the human genome was completed in early 2000 and announced on June 26 of that year. The work is expected to be completed in 2003. **SEE ALSO** CELL EVOLUTION; CHLOROPLAST; CHROMOSOME, EUKARYOTIC; DNA; DNA VIRUSES; GENE; HUMAN GENOME PROJECT; MITOCHONDRION

*Ralph R. Meyer*

### Bibliography

National Institutes of Health. <<http://www.ncbi.nlm.nih.gov>>.

Singer, Maxine, and Paul Berg. *Genes and Genomes*. Mill Valley, CA: University Science Books, 1991.

**prokaryote** single-celled organism without a nucleus

**mitochondria** subcellular organelle that creates ATP used for energy-requiring processes in a cell

**organelle** membrane-bound cell compartment

**eukaryotic cell** a cell with a nucleus

**plasmid** small ring of DNA found in many bacteria

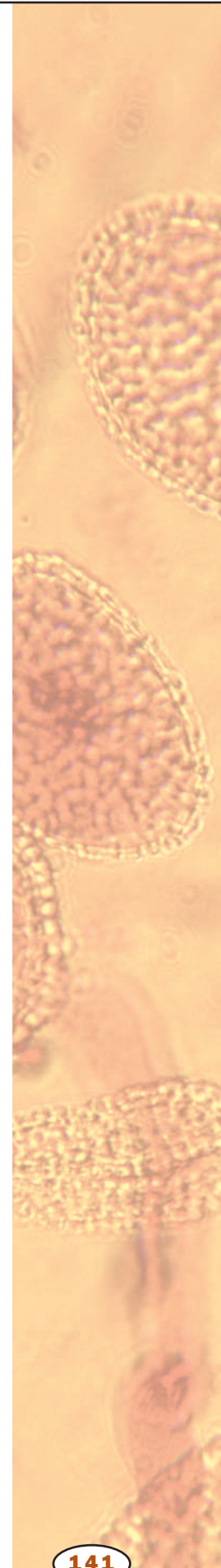

## Genomics

Genomics is the study of the **genome**, or deoxyribonucleic acid (DNA), of an organism and associated technologies. Genomics evolved from a series

**genome** total genetic material in a cell or organism

A scientist using a computer to design complex proteins. Proteins are more difficult to manipulate than DNA, and each must be approached individually.

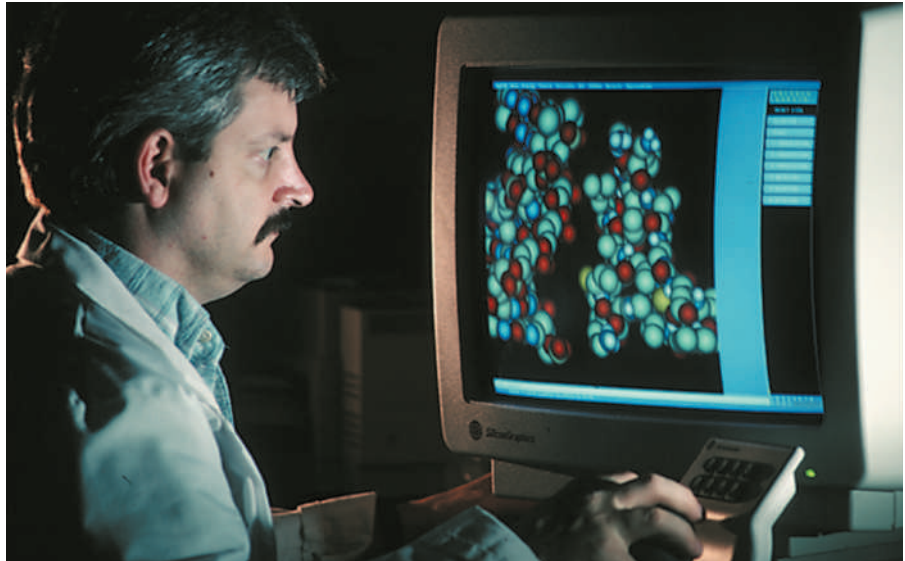

of experimental and conceptual advances that allowed researchers to decipher the DNA sequences of whole genomes from virtually any organism, including humans. Single experiments can scrutinize many genes and compare genomes of different species.

Before the development of genomics, DNA studies in humans were mostly relegated to observing highly condensed **chromosomes** under a microscope. Many human studies were done in medical centers where families with visible chromosomal mutations came for evaluation. While it was possible in a few cases to determine on which chromosome a gene was located or whether two genes were located on the same chromosome, without molecular techniques these were difficult tasks at best.

### Tools of Genomics

Genomics developed from advances in recombinant DNA technology, while in turn, developed from earlier progress in biochemistry and genetics. Recombinant DNA technology is the set of tools that make it possible for researchers to study and manipulate DNA, ribonucleic acid (RNA), and **protein** from any source, both outside of the cells (*in vitro*) and inside of the cells (*in vivo*) of the well-studied model organisms.

Relatively few techniques are used to study DNA. The basic methods that underlie genomic technologies include DNA sequencing, **polymerase chain reaction (PCR)**, **electrophoresis**, cloning, and hybridization. The fact that all DNA molecules can be manipulated using a few basic techniques is a major advantage of working with DNA. In contrast, proteins are much more difficult to manipulate, and each must be approached individually.

DNA sequencing determines the order of bases in a segment of DNA, a gene, a chromosome, or an entire genome. PCR can increase the number of copies (even a millionfold) of a single gene or fragment of DNA *in vitro* within hours. Electrophoresis separates DNA by size in the presence of an electrical field. This is a simple technique used to follow changes in DNA size through different recombinant manipulations.

**chromosomes** “colored body” in the cell nucleus; made of DNA and protein, and divided functionally into genes and non-gene regions

**proteins** complex molecule made from amino acids; used in cells for structure, signaling, and controlling reactions

**polymerase** enzyme complex that synthesizes DNA or RNA from individual nucleotides

**electrophoresis** technique that uses electricity to separate molecules based on size and electric charge

## Cloning

The process of isolating a piece of DNA for recombinant DNA studies is called cloning. Cloning increases the number of copies of a single gene or fragment of DNA *in vivo*. Large amounts of DNA are needed for sequencing and manipulation experiments. The purified, unknown DNA is combined with another well-characterized piece of DNA called a cloning **vector**. The vector DNA has the DNA sequences needed to form an artificial mini-chromosome. A cell that contains the cloned DNA is called a clone. The clone is used to produce more copies of the DNA of interest and to produce protein encoded by the DNA. In some experiments, a modified DNA segment is returned to the original organism for further studies.

Cloning can be used to isolate and scrutinize a small part of the genome, such as a gene. For example, consider the cloning of an **oncogene**, which is a gene that, when overexpressed, causes cancer. DNA fragments from human cancer cells were introduced into the cells of a normal mouse. Some of the cells received a piece of human DNA that caused them to develop into cancerous cells. Recombinant DNA techniques were used to identify which piece of human DNA was responsible for converting the normal cells to cancerous cells. DNA methods enabled researchers to isolate the specific human gene that causes the cancer.

## Hybridization

Hybridization, which is also known as renaturation or annealing, is the coming together of two **complementary**, single strands of DNA to form double-stranded DNA. Denaturation is the reverse process, which separates double-stranded DNA into two single strands (see Fig. 1). Double-stranded DNA is denatured when it is incubated at a high temperature. In hybridization experiments, single-stranded DNA of unknown sequence (test DNA) is hybridized to single-stranded DNA of known sequence (probe DNA). Hybridization takes place only when the test DNA contains a complementary DNA sequence.

Hybridization experiments can be used to sequence the test DNA a “word” at a time. A word is equal to the length of the probe sequence, which is usually greater than eight bases. This technique makes it possible to obtain information more rapidly than from ordinary sequencing methods.

DNA hybridization experiments are also used to study the expression of thousands of genes at the same time. In expression studies, messenger RNA (mRNA) from a cell is hybridized to an array (display) of complementary single-stranded DNA probe sequences unique for each test mRNA. Test mRNA hybridizes to DNA probes in the same manner as test DNA. The amount of test mRNA hybridized to each probe is measured to determine the amount of complementary mRNA present. Since the hybridization is done to the entire array simultaneously, information about all test mRNA sequences is obtained in a single experiment. The DNA probes arrayed on a microchip are recorded and the hybridization results are analyzed automatically using computers.

DNA array experiments identify and analyze mRNAs solely on the basis of their sequence. No information is needed about the proteins encoded

**vector** carrier

**oncogene** gene that causes cancer

**complementary** matching opposite

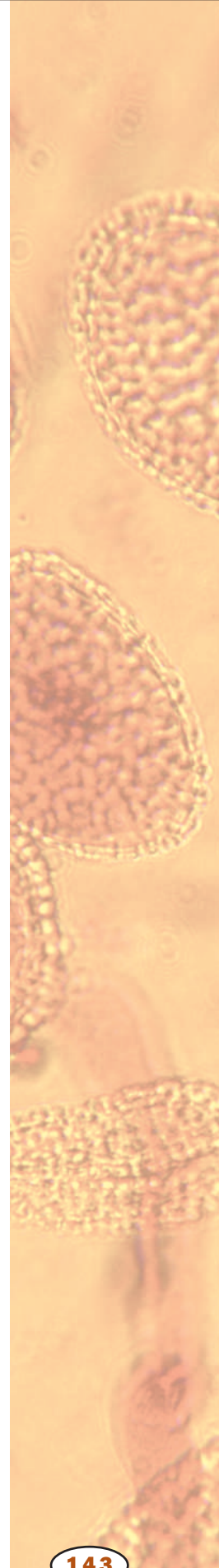
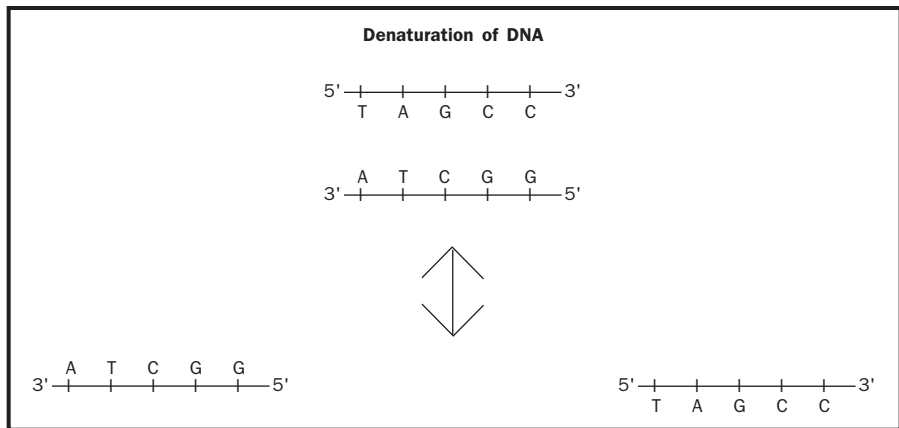

Figure 1. Denaturation uses heat or chemicals to separate the two strands of DNA in the double helix. Hybridization experiments begin by denaturing different DNAs, and then allowing them to reassemble.



by the mRNA or their function. However, ultimately, information about the proteins and their functions is the real goal of these experiments. The array experiment is used to identify important mRNAs, which indicate which genes a particular cell is expressing. This may be related to a cell specialization (for example, brain versus heart), or to a disease state. This “whole genome” approach can lead to the discovery of new genes and identify unexpected functions of known genes.

### Finding Disease Genes

Positional cloning experiments isolate genes responsible for a specific genetic disease, such as cystic fibrosis, by first identifying their location (position) in the genome (which chromosome they are on). Genetic mapping techniques locate a gene or a DNA sequence among the chromosomes by identifying which regions of the genome are inherited in the same manner as the trait of interest, such as a disease. Once the chromosomal region is found, molecular and computational methods are used to identify all genes in the region and to pick up “candidate” genes for further testing. Some of the candidate genes are identified by determining whether their encoded proteins fit the trait or disease of interest. For example, the isolation and determination of the DNA sequence of the cystic fibrosis gene made it possible to identify its product, a large protein molecule that regulates the transport of chloride across the cell membrane. Researchers were able to explain the clinical symptoms when they discovered that the protein was nonfunctional.

The power of focusing on genetic causes of disease is due to several factors. First, positional cloning is guaranteed to produce results provided enough money is available to do the experiment and large families inheriting the trait of interest are known. It is very rare in research to be sure of success. Second, the identification of a gene responsible for a disease uncovers pathways and genes that are unknown and may play a role in non-inherited forms of the same or a similar disease.

### Future Directions

The first stage of genomic research is coming to an end as the entire human DNA sequence is known. An understanding of that blueprint will likely take many more years of research. That understanding will require sequencing



many genomes to determine how variations in DNA sequences affect protein and cell function. Further, each gene must be understood in the context of the entire repertoire of thirty-five thousand human genes. Because of advances in genomics, scientists are no longer forced to study single genes out of context. Consequently, experiments and the information gathered in each experiment are becoming more complex. New computational tools are needed to understand the massive amount of information that is now being generated. This has developed into the field of bioinformatics.

The DNA sequences of any two individuals can differ in at least one million places. In medicine, variations in the DNA sequences will be used to develop individualized drug treatments. This new field, known as pharmacogenomics, is in its infancy, but already DNA profiles are being used to subtype different cancers, enabling physicians to prescribe the drugs most likely to be effective for a particular patient in the course of treatment.

Genomic studies are not confined to humans, but are used to learn about all organisms. The lessons that nature will provide from all these studies will have an impact on fields far beyond biology and medicine. The tools and knowledge needed to accomplish these cross-traditional boundaries of scientific disciplines. The solutions to future scientific problems will require an immense amount of collaboration and will need to take advantage of talents and knowledge of a large number of individuals. **SEE ALSO** BIOINFORMATICS; CLONE; DNA SEQUENCING; HUMAN GENOME PROJECT; HYBRIDIZATION; MODEL ORGANISMS: CELL BIOLOGY AND GENETICS; ONCOGENES AND CANCER CELLS; POLYMERASE CHAIN REACTION; RECOMBINANT DNA

*Cassandra L. Smith and Linda G. Tolstoi*

### Bibliography

- Biomedicine Promises for Health*. Washington, DC: Pharmaceutical Research and Manufacturers of America (PHRMA), 1998. <<http://www.phrma.org/publications/publications/brochure/biomed/>>.
- Casey, Denise. *Primer on Molecular Genetics*. Washington, DC: U.S. Department of Energy, Office of Energy Research, Office of Health and Environmental Research, 1992.
- Hamadeh, Hisham, and Cynthia A. Afshari. "Gene Chips and Functional Genomics." *American Scientist* 88, no. 6 (2000): 508–515.
- Haseltine, William A. "Discovering Genes for New Medicines." *Scientific American* 276, no. 3 (1997): 92–97.
- Lewis Ricki. *Human Genetics: Concepts and Applications*, 3rd ed. Boston: WCB/McGraw-Hill, 1999.
- Tolstoi, Linda, and Cassandra L. Smith. "Human Genome Project and Cystic Fibrosis — a Symbiotic Relationship." *Journal of the American Dietetic Association* 99, no. 11 (1999): 1421 – 1427.
- Vaughan, Douglas. *To Know Ourselves*. Washington, DC: U.S. Department of Energy and the Human Genome Project, 1996. <<http://www.ornl.gov/hgmis/>>.

## Global Climate Change

Energy from the Sun passes through the atmosphere as light and is absorbed by soil, rock, and water at the surface of Earth. The energy is reradiated as heat and absorbed in the atmosphere by greenhouse gases, including carbon dioxide (CO<sub>2</sub>), water vapor, methane, ozone, nitrous oxide, and the

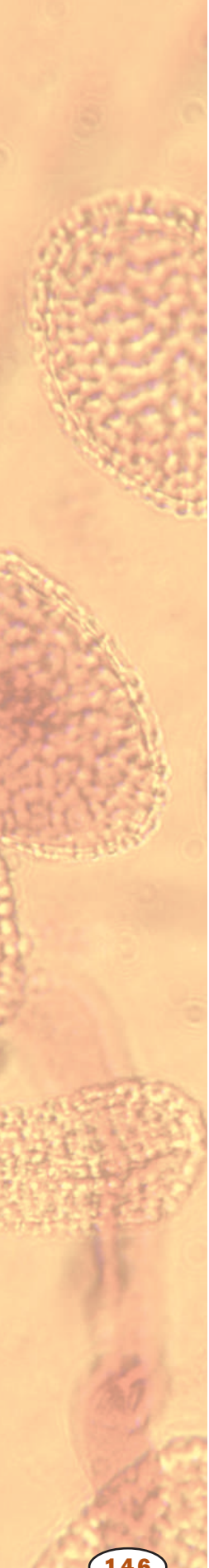

**organic** composed of carbon, or derived from living organisms

human-made chemicals chlorofluorocarbons (CFCs). This atmospheric warming is called the greenhouse effect; without it Earth's average global temperature would be about  $-18$  degrees Celsius ( $0$  degrees Fahrenheit). Greenhouse gases are added to the atmosphere by natural events including volcanic eruptions, the decay and burning of **organic** matter, and respiration by animals. They are also removed from the atmosphere.  $\text{CO}_2$  is absorbed by seawater and stored in plant tissue. When plants die and gradually are transformed into fossil fuels—coal, oil, natural gas—deep in the earth, their  $\text{CO}_2$  is stored with them. The removal of greenhouse gases from the atmosphere keeps the planet from overheating.

## Climate History

Besides the concentrations of greenhouse gases in the atmosphere, other factors affect global climate including Earth's orbital behavior, the positions and topography of the continents, the temperature structure of the oceans, and the amount and types of life. During much of Earth's history the climate was warm and humid with ice-free poles; global average temperatures were about  $5$  degrees Celsius ( $9$  degrees Fahrenheit) higher than today. Several times glaciers covered the higher latitudes, most recently during the Pleistocene (1.6 million to 10,000 years ago), when up to 30 percent of the land was covered by ice. During the four glacial advances of the Pleistocene, average global temperature was  $5$  degrees Celsius lower than today and  $10$  degrees Celsius ( $18$  degrees Fahrenheit) lower than the ancient global average. During the three interglacial periods, global temperature was a degree or two warmer than today. Many scientists think that Earth is in an interglacial period, and the ice sheets will return.

Since the peak of the last glacial advance 18,000 years ago, average global temperature has risen  $4$  degrees Celsius ( $7$  degrees Fahrenheit), including  $1$  degree Celsius ( $1.8$  degrees Fahrenheit) since the beginning of the Industrial Revolution. It is difficult to know how much of the recent warming is the result of the end of the Pleistocene and how much is the result of human activities that add greenhouse gases to the atmosphere.  $\text{CO}_2$  is the most abundant greenhouse gas, a by-product of burning fossil fuels and modern forests. In the early twenty-first century, there is greater than 30 percent more  $\text{CO}_2$  in the atmosphere than in 1850. There have also been significant increases in methane and CFCs. Some projections show a doubling of  $\text{CO}_2$  over preindustrial levels by 2050 and additional increases in methane. (CFCs are being phased out by international agreement because they destroy Earth's protective ozone layer.)

Adding greenhouse gases to the atmosphere is like throwing another blanket on Earth; the consequent rise in global temperature is known as global warming. Since climate is a complex system and climate models are difficult to construct, scientists can only speculate on the effect large increases in greenhouse gases will have on global climate. Some models show average global temperature increasing as much as  $5$  degrees Celsius by 2100. Any temperature increase will not be uniform. Since ocean water absorbs more heat than land, the Southern Hemisphere (which has more water) will warm less than the Northern. Atmospheric circulation patterns will bring the greatest warming, as much as  $8$  to  $10$  degrees Celsius ( $14$  to  $18$  degrees Fahrenheit), to the poles.



Pollution over Mexico City. Concentrations of greenhouse gases in the atmosphere have a great impact on global climate.

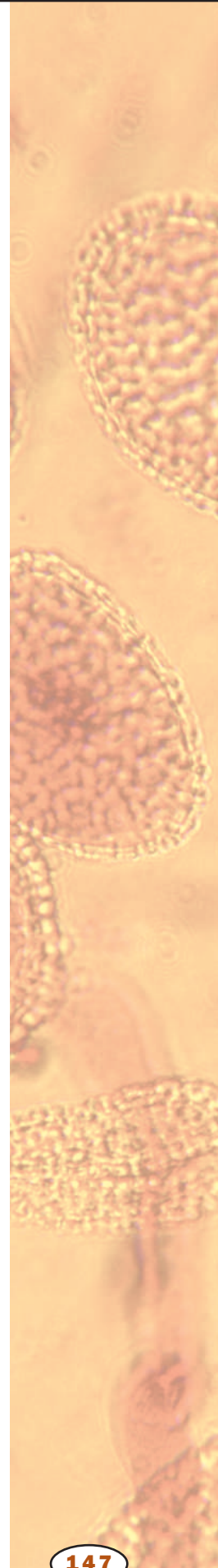

## Possible Consequences

A rapid increase in global average temperature could have profound effects on social and natural systems. Warmer temperatures would cause ocean water to expand and polar ice caps to melt, increasing sea level by as much as 50 centimeters (1.6 feet) by 2100. This would flood coastal regions, where about one-third of the world's population lives and where an enormous amount of economic **infrastructure** is concentrated. It would destroy coral reefs, accelerate coastal erosion, and increase salinity to coastal groundwater aquifers. Warmer temperatures would allow tropical and subtropical insects to expand their ranges, bringing tropical diseases such as malaria, encephalitis, yellow fever, and dengue fever to larger human populations. There would be an increase in heat-related diseases and deaths. Agricultural regions might become too dry to support crops, and food production all over the world would be forced to move north; this would result in a loss of current cropland of 10 to 50 percent and a decline in the global yield of key food crops of from 10 to 70 percent.

**infrastructure** roads, phone lines, and other utilities that allow commerce

Wild plant and animal species would need to move poleward 100 to 150 square kilometers (60 to 90 miles) or upward 150 meters (500 feet) for each 1 degree Celsius rise in global temperature. Since most species could not migrate that rapidly and since development would stop them from colonizing many new areas, much biodiversity would be lost. The decrease in the temperature difference between the poles and the equator would alter global wind patterns and storm tracks. Regions with marginal rainfall levels could experience drought, making them uninhabitable. Overall, since warmer air holds more moisture, an increase in global air and sea temperatures would increase the numbers of storms. Higher sea surface temperatures would increase the frequency and duration of hurricanes and El Niño events.

Many scientists believe that global warming is the most serious threat to our planet. By 2025 the world's energy demand is projected to be 3.5 times greater than in 1990, with annual CO<sub>2</sub> emissions nearly 50 percent higher. Thus far, attempts at international agreements to curb the emissions of greenhouse gases (for example, the Kyoto Protocol) have failed. This is due to several factors: (1) the scientific uncertainty of the role humans play in global warming; (2) the lifestyle changes necessary to reduce fossil fuel consumption in developed nations; (3) the possible slowdown in the economic development of developing nations; and (4) the need for true international cooperation. A high-technology alternative to decreasing greenhouse gas emissions is to sequester CO<sub>2</sub>. Experiments are underway to inject liquid CO<sub>2</sub> deep into the earth, thereby effectively removing it from Earth's carbon cycle. SEE ALSO BIOGEOCHEMICAL CYCLES; CARBON CYCLE; ECOLOGICAL RESEARCH, LONG-TERM; ECOSYSTEM; EXTINCTION; TUNDRA

Dana Desonie

**anaerobic** without oxygen, or not requiring oxygen

**cytosol** fluid portion of a cell, not including the organelles

**ATP** adenosine triphosphate, a high-energy nucleotide used by cells to power most energy-requiring reactions

**glucose** simple sugar that provides energy to animal cells and is the building block of cellulose in plants

**metabolism** chemical reactions within a cell

**ADP** adenosine diphosphate, the low-energy form of ATP

**phosphorylate** add a phosphate group to

**oxidize** to react or make react with oxygen

**chemiosmosis** use of proton gradients to make ATP (see Oxidative Phosphorylation entry)

### Bibliography

Drake, Frances. *Global Warming: The Science of Climate Change*. Edward Arnold, 2000.

Stevens, William K. *The Change in the Weather: People, Weather, and the Science of Climate*. Delta, 2001.

## Glycolysis and Fermentation

Glycolysis is an **anaerobic** metabolic pathway, found in the **cytosol** of all cells, which forms adenosine triphosphate (**ATP**) by degrading **glucose**. It also serves as a source of precursors for other pathways, and as a recipient of products of various pathways for use as metabolic fuels. Its universal and central role in **metabolism** suggests that glycolysis evolved early in the history of life.

In the overall reaction for glycolysis, one molecule of glucose is converted to two molecules of pyruvic acid. Along the way, two molecules of adenosine diphosphate (**ADP**) are **phosphorylated** to **ATP**, and two molecules of NAD<sup>+</sup> (the **oxidized** form of NAD, or nicotinamide adenine dinucleotide) are reduced to NADH. **ATP** serves as an energy carrier and can be used to power many cellular processes. The NADH carries high-energy electrons, which can be used to produce more **ATP** by **chemiosmosis**. Like-

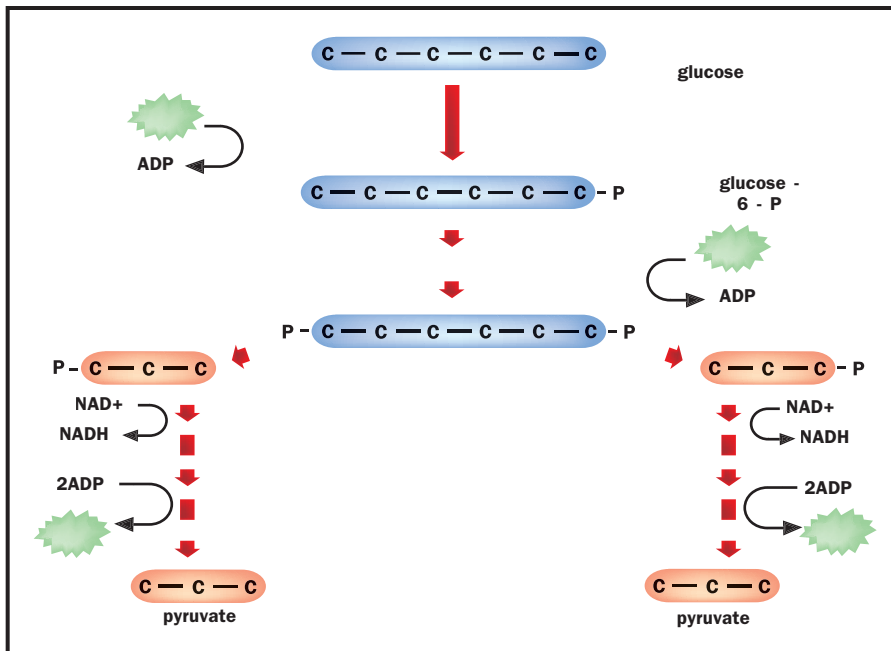

The process of glycolysis. In glycolysis, the six-carbon glucose (shown without its hydrogens or oxygens) is first destabilized by the addition of ATP, and then split. Further transformations create NADH and new ATP, leaving a pair of three-carbon pyruvates.

wise, the pyruvic acid can be further oxidized by the **Krebs cycle** to yield additional ATP.

The ten steps of glycolysis can be divided into two stages. The first five steps, the preparatory, or priming, phase of glycolysis, prepare the glucose by phosphorylating it twice, using two molecules of ATP as sources of phosphate. This increases the energy content of the glucose, so the preparatory phase is also sometimes called the investment stage, reflecting the need to invest two ATP molecules before a net yield of energy can be achieved. During the second five reactions, the payoff phase, the fructose-1,6-bisphosphate formed during the preparatory phase is dephosphorylated and cleaved, forming two molecules of **pyruvate** and four of ATP. Because two ATPs are used and four are produced during glycolysis, there is a net production of two molecules of ATP for every glucose consumed.

Since glycolysis plays a central role in cellular metabolism, it has several control points. Like most pathways, it is regulated during its early steps. Hexokinase, the **enzyme** that **catalyzes** the first reaction, is inhibited by its product, glucose-6-phosphate (G-6-P). The third enzyme, phosphofructokinase (PFK), is regulated in a complex manner by several **metabolites**, and is also under indirect hormonal control. The last glycolytic enzyme, pyruvate **kinase**, is regulated by several metabolites, including ATP, which inhibits it. These control mechanisms have the effect of maintaining a constant supply of ATP for the cell, since production of ATP inhibits the process, and depletion of ATP activates it.

Aerobically respiring cells will produce even more ATP through **oxidative phosphorylation**. However, cells that cannot **respire aerobically**, either because they lack the necessary metabolic pathways or because they live in anaerobic environments, cannot do this. This presents a problem since all cells must continually regenerate the  $\text{NAD}^+$  needed during the

**Krebs cycle** central metabolic pathway in mitochondria

**pyruvate** the ionized form of pyruvic acid, a key intermediate in cell metabolism

**enzyme** protein that controls a reaction in a cell

**catalyze** aid in the reaction of

**metabolite** molecule involved in a metabolic pathway

**kinase** enzyme that adds a phosphate group to another molecule, usually a protein

**oxidative phosphorylation** use of oxygen to make ATP

**respire** use oxygen to burn cellular fuel

**aerobic** with oxygen, or requiring it

In the absence of oxygen the pyruvate is converted to  $\text{NAD}^+$  in reactions collectively referred to as fermentations.

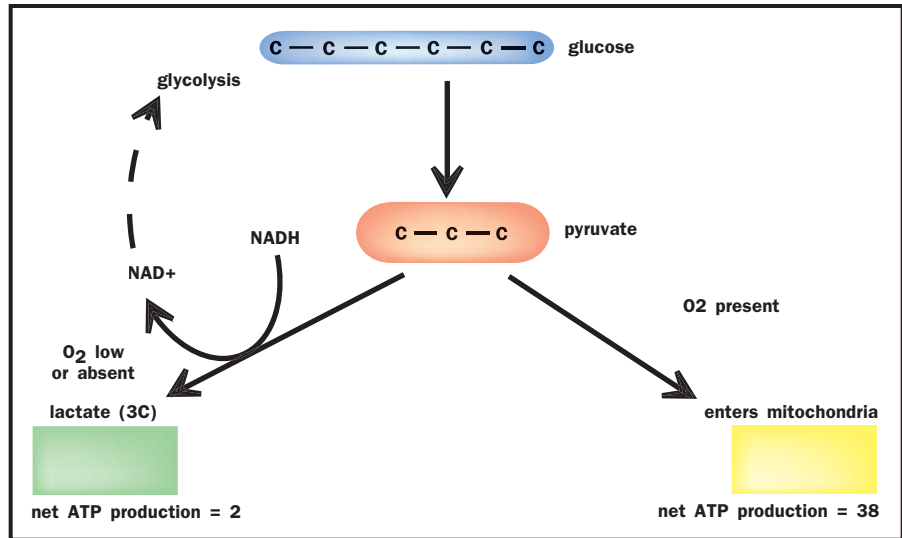

**organic** composed of carbon, or derived from living organisms

preparatory phase of glycolysis. All such cells accomplish this by converting the pyruvate to another product, oxidizing  $\text{NADH}$  to  $\text{NAD}^+$  in the process. These reactions are collectively referred to as fermentations. Animals, some plants, and most bacteria produce lactic acid, whereas yeast and a few bacteria produce carbon dioxide and ethanol. Rarer fermentations produce a variety of **organic** molecules such as other alcohols and organic acids. Fermentations are used extensively by industry to produce these compounds cheaply, as well as to produce foods such as yogurt, bread, wine, and beer. SEE ALSO CARBOHYDRATES; KREBS CYCLE; OXIDATIVE PHOSPHORYLATION

David W. Tapley

#### Bibliography

Bodner, G. M. "Metabolism: Part I, Glycolysis." *Journal of Chemical Education* 63 (1986): 566–570.

Sparks, S. "The Purpose of Glycolysis." *Science* 277 (1997): 459–460.

## Golgi

The Golgi (pronounced GOL-jee) complex (or Golgi apparatus or Golgi body) was discovered by Camillo Golgi (1844–1926), an Italian physician. While Dr. Golgi was staining **neurons** with silver nitrate (Golgi stain), he noticed small **intracellular** structures made up of **vesicles** and fibers known today as the Golgi complex.

### Structure

The Golgi complex is composed of several layers of cisternae (fluid-filled membrane sacs) arranged like stacked pancakes near the outer edges of the **endoplasmic reticulum** (ER) near the **nucleus**. The Golgi complex is organized into three biochemically distinct compartments: the *cis* Golgi, the *medial* Golgi, and *trans* Golgi; the *cis* Golgi is closest to the ER.

**neuron** nerve cell

**intracellular** within a cell

**vesicle** membrane-bound sac

**endoplasmic reticulum** network of membranes within the cell

**nucleus** membrane-bound portion of cell containing the chromosomes

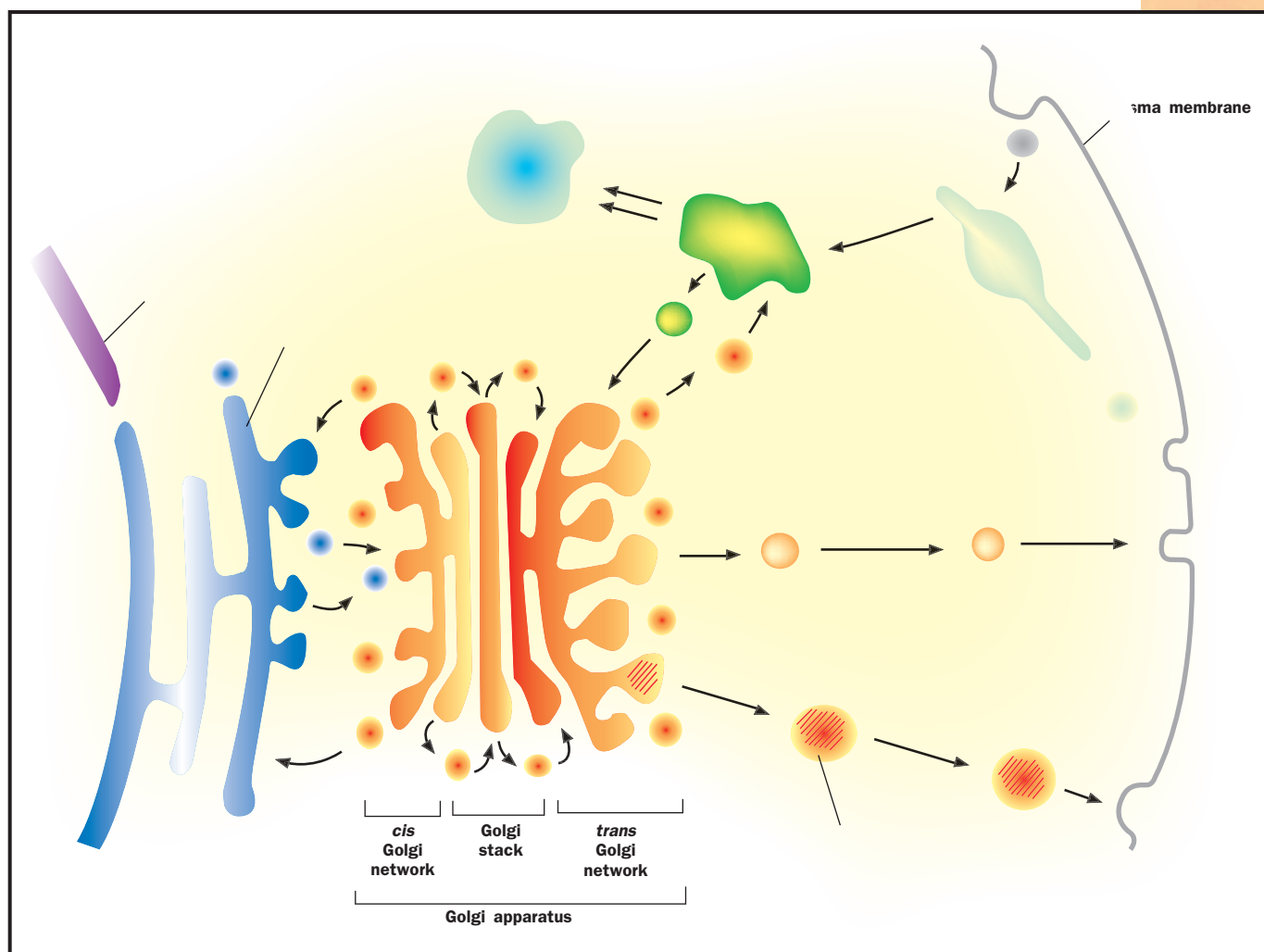

## Protein Processing

The primary function of the Golgi complex is to modify, process, and sort newly produced **proteins** that arrive from the ER. These modifications include adding or deleting specific sugar molecules to modify the branched sugar structures found on newly formed proteins. For example, some of the mannose sugars are cut from the **oligosaccharide** branch in the cis Golgi. Upon completion of this step, the protein travels to the medial Golgi where other sugars like N-acetylglucosamine and fucose are added to the oligosaccharide branches on the protein. Further modifications to the **carbohydrates** are completed in the trans Golgi. Carbohydrate additions may aid in the stability, transport, and/or function of the proteins.

## Transport

Two models have been proposed to explain how newly produced proteins travel from the ER to the Golgi complex and travel among Golgi stacks. One model suggests that proteins are transported enclosed in vesicles. Another model proposes that one stack of the Golgi “matures” into the next stack. This is called the cisternal progression model. Regardless of which

The intracellular structures known as the Golgi complex are involved in protein processing and secretion.

**protein** complex molecule made from amino acids; used in cells for structure, signaling, and controlling reactions

**oligosaccharide** chain of several sugar molecules

**carbohydrates** sugars, starches, and other molecules combining carbon, hydrogen, and oxygen and serving as fuel or structural components

Camillo Golgi is most noted for his studies with the human nervous system and shared the 1906 Nobel prize with Santiago Ramon y Cajal in the field of medicine.

**retrograde** backward

**enzyme** protein that controls a reaction in a cell

**organelle** membrane-bound cell compartment

**aggregate** clump together

**acidic** having an excess of  $H^+$  ions and a low pH

**macromolecules** large molecules such as proteins, carbohydrates, and nucleic acids

**endocrine** related to the system of hormones and glands that regulate body function

**hormone** molecule released by one cell to influence another

**constitutive** at a constant rate or continually

**secretion** material released from the cell

model is correct, the question remains as to how the cell maintains the size, shape, and biochemical uniqueness of the Golgi complex.

One answer is **retrograde** transport or recycling of **enzymes** and molecules from one Golgi stack back to their original stacks. Each of the vesicles that travel between the ER and Golgi stacks is coated with proteins that have “addressing tags” on them. For example, the vesicle that buds off of the ER has coat proteins that specifically direct it to the cis Golgi instead of the medial Golgi or some other **organelle**. Sometimes, enzymes and proteins that reside in the ER accidentally get caught in a vesicle going to the Golgi. When this happens, they return (retrograde transport) from the cis Golgi back to the ER in a vesicle coated with different proteins that are addressed to the ER. Therefore, the Golgi has two sets of vesicles flowing in opposite directions. The first set of vesicles are filled with newly made proteins awaiting further modifications traveling in a forward or anterograde direction. The second set of vesicles are filled with enzymes and matured proteins seeking their resident organelle traveling in the reverse or retrograde direction.

### The Trans-Golgi Network (TGN)

The trans-Golgi network (TGN) is an extension of the trans Golgi where different types of vesicles are formed. The TGN can be thought of as a major protein sorting station inside the cell. Proteins maturing in the Golgi are sorted in the TGN for transport to several locations in the cell depending upon the biochemical tags that are found on the individual proteins. It is thought that proteins in the TGN are concentrated by linking up with receptor molecules in the lumen of the TGN. As proteins find their proper receptors, they may **aggregate** in one or few locations within the TGN and then bud off to form immature secretory vesicles: (1) secretory granules (vesicles that undergo further maturation and sorting of specialized cargo); (2) secretory vesicles targeted to the plasma membrane; and (3) vesicles carrying degradative enzymes to lysosomes (small, **acidic** organelles that degrade **macromolecules**). Some selectivity and sorting of proteins may exist in these secretory vesicles before they get to the plasma membrane.

First, secretory vesicles are packaged with a high concentration of a specific protein that has been transported to the TGN. For example, **endocrine** cells produce large amounts of specialized proteins called **hormones** that are packaged into secretory granules. When endocrine cells receive the correct “signal” that triggers fusion of the secretory granules with the plasma membrane, these proteins are released into the circulatory system.

Second, some proteins are produced and secreted in a **constitutive** or constant manner; these proteins do not rely on extracellular signals for release and are not sorted to secretory granules. Instead, constitutive **secretion** involves vesicles originating at the TGN and traveling directly to the plasma membrane for exocytosis.

Finally, the TGN is a sorting station for the delivery of degradative enzymes to lysosomes, vesicles containing nutrients that originated outside of the cell. Cells need to target these proteins to acidic lysosomes to assist in the digestion of internalized nutrients. Proteins destined for the lysosome



have been modified with a unique sugar called mannose 6-phosphate. These lysosomal proteins are sorted in the TGN by binding to the mannose 6-phosphate receptor that then buds off in a vesicle that fuses with a lysosome. The low pH in the lysosome causes the mannose 6-phosphate bearing protein to **dissociate** from the receptor. The empty receptor buds off from the lysosome in a small vesicle and is recycled to the TGN.

The Golgi complex plays an essential role in the sorting and targeting of proteins to various parts of the cell. Despite what is known, there are still many unanswered questions concerning the exact mechanisms involved with sorting and transporting cellular cargo throughout the cell. This is an important area of investigation since many diseases such as I cell disease, Alzheimer Disease, Batten's disease, and a host of other protein and **lipid** storage diseases are a result of cells misrouting protein and lipids to the wrong locations in the cell. **SEE ALSO** ENDOPLASMIC RETICULUM; EXOCYTOSIS; LYSOSOMES; PROTEIN STRUCTURE; PROTEIN TARGETING

*Edward Harris and James Cardelli*

### Bibliography

Balch W. E., and B. A. Bernard. "Protein Sorting by Directed Maturation of Golgi Compartments." *Science* 285 (2 July 1999): 63–66.

## Grain

Grains are seeds of grasses. More particularly, the term "grains" usually refers to the cereal grains, those that are used as food or fodder by humans. Three grains—rice, wheat, and corn—are the major source of calories in the human diet throughout the world, both through direct consumption or by providing animal feed. In addition, corn is a significant source of raw materials for some segments of the chemical industry.

Like other seeds of flowering plants, grain contains both the embryo and **endosperm**. The **diploid** embryo, often called the germ, contains the tissues that develop into the new individual after germination. The **triploid** endosperm is a rich nutritive tissue formed by the fusion of a second sperm and the two nuclei of the central cell in the embryo sac. Surrounding both endosperm and embryo is the **protein-** and oil-rich aleurone layer. This layer plus several thin outer coverings and the remains of the seed coat make up the bran.

### Rice

Rice (*Oryza sativa*) is grown throughout the world, but principally in the countries of Asia, where it forms the basis of the diet. Most rice is grown under flooded conditions, with fields drained two to three weeks before harvest. Removal of the hull (remnant floral parts) leaves brown rice. Further milling removes the bran and embryo to give white rice, by far the most popular form of rice. White rice is high in **carbohydrates** but low in protein or vitamins.

Both traditional breeding and genetic engineering have been used to improve the qualities of rice. In the 1960s, shorter semidwarf varieties were

A defect in the enzyme that tags proteins with mannose 6-phosphate causes I cell disease, marked by skeletal deformities, movement difficulty, and early death.

**dissociate** break apart

**lipid** fat or waxlike molecule, insoluble in water

**endosperm** nutritive tissue within a seed

**diploid** having pairs of chromosomes in the nucleus

**triploid** possessing three sets of chromosomes

**protein** complex molecule made from amino acids; used in cells for structure, signaling, and controlling reactions

**carbohydrates** sugars, starches, and other molecules combining carbon, hydrogen, and oxygen and serving as fuel or structural components



A wheat harvest in Polouse Valley, Washington. Wheat is the top food crop consumed by humans.

bred. This allowed farmers to increase yields with fertilizers without having the long thin stems of full-height rice fall over before harvest. This development was a major part of the “green revolution” in the 1960s, in which grain yields kept pace with a skyrocketing world population, preventing widespread famine. More recently, genetic engineering techniques have been used to introduce a gene for a precursor of vitamin A, lacking in white rice. This so-called “golden rice” may help prevent blindness due to vitamin deficiencies, although the quantity of vitamin A available from the rice alone is insufficient by itself for this purpose.

## Wheat

Wheat (*Triticum sativum*) is the top food crop consumed directly by humans. Wheat consumption is supplementing or even replacing rice and corn consumption for many people in developing countries. Wheat is grown as a cool-weather annual, with some varieties even requiring a cold period to produce grain. Wheat is less profitable on a per-acre basis than other grains, but requires comparatively little labor and fewer inputs of fertilizer and pesticide. Wheat is milled to remove the hull to give “whole wheat,” which can be ground into flour. Removal of the germ and bran before grinding gives white flour. Wheat is unique among the major grains in having a high level of the protein gluten in the endosperm. The elastic gluten protein allows dough to stretch. As yeasts added to dough release gas, the gluten expands, trapping the gas bubbles and allowing the bread to rise.

## Corn

Corn or maize (*Zea mays*) is a native of the New World and is grown primarily in South, Central, and North America. It still provides the major source of calories for most people south of the United States. Ancient corn was similar to modern popcorn, with a hard seed coat that trapped heated steam until the coat burst suddenly, exposing the puffy white endosperm. Traditionally, corn has been dried and ground into meal, using the entire kernel. The meal is then used for tortillas, tamales, and other foods. The entire kernel of sweet corn is also consumed, but the harvest occurs before seed maturity and before the sugars in the endosperm have been converted to starches. Removal of the seed coat leaves primarily endosperm, which is boiled to make grits, or rolled and baked to make corn flakes. Corn is a major feed for livestock, and provides the starting materials for a number of chemical products, including a variety of alcohols, acetone, polyurethane, and acetic acid.

## Other Grains

Several other grains are consumed in small quantities. The handful of species of millet are consumed mainly in Africa and Asia, with U.S. use primarily for birdseed. Rye (*Secale cereale*) is used in rye breads mainly in temperate areas in the Northern Hemisphere, and oats (*Avena sativa*) are grown for breads, breakfast cereals, and animal feed in these same regions. Barley (*Hordeum vulgare*) provides the source of carbohydrate for fermentation in beer. SEE ALSO AGRICULTURE; GRASSES

*Richard Robinson*

### Bibliography

Leonard, Warren H., and John H. Martin. *Cereal Crops*. New York: Macmillan, 1963.

## Grasses

Grasses belong to one of the largest and most economically and ecologically important families of plants: the Poaceae, formerly called the Gramineae. There are over nine thousand species of grasses recognized by botanists. Grasses can be found on every continent and in a wide variety of habitats, both as the dominant plant type (in prairies and tundra) or as minor components of the plant community. Collectively, grasses domesticated as crops represent the world's most important source of food.

Grasses share a number of characteristics that differentiate them from other plant species. They typically have long, narrow leaves. The stems may be either flattened or round, and they are often hollow. Grasses can grow very tall (tropical bamboos can reach up to 100 meters [328 feet]) or they can grow **prostrate** along the ground. The root systems of grasses are highly branched (fibrous) and do not have a well-defined central taproot. Many grasses spread horizontally through the production of underground stems known as rhizomes, or prostrate stems aboveground known as stolons. New grass shoots can emerge from either rhizomes or stolons.

Grasses have evolved in environments where drought, grazing by large herbivores, and fires were common. Unlike many plants, the growing points (or meristems) of grasses are located near the base of the plant or below the ground, rather than at the tips of the plant. This characteristic allows grass plants to be grazed or burned without damage to the growing points. Additionally, grasses have large root systems that can store substantial food reserves that allow grasses to regrow quickly if aboveground parts are removed. These features also make grasses drought resistant and ideal for lawns that are repeatedly mowed. The large and fibrous root system of grasses has additional value for preventing soil erosion.

The flowers of grasses are small and inconspicuous. Grass flowers lack petals and other floral parts common in other plant families. Grass flowers are typically wind pollinated and therefore do not produce nectar, but they do produce pollen in large amounts. Grass flowers are so simple and small that they are sometimes referred to individually as florets. Florets are typically grouped or clustered along a central axis into units known as spikelets. The arrangement of florets and spikelets varies greatly among grasses, and individual grass species are often defined by these differences. The fruit of a grass flower is termed a caryopsis or a grain.

Grasses make up many of the most important crop species grown for human consumption. Three cereal crops—corn, wheat, and rice—are the most important source of calories in all diets throughout the world. Sugarcane is a grass that supplies most of the world's sugar. Grasses, including several species of reed and bamboo, are used in many countries as construction material and as thatch for roofs, and the fiber from many grasses is used in making paper. Finally, native and planted grasslands are used worldwide in hay production and as grazing lands for animal production.

**prostrate** face downward

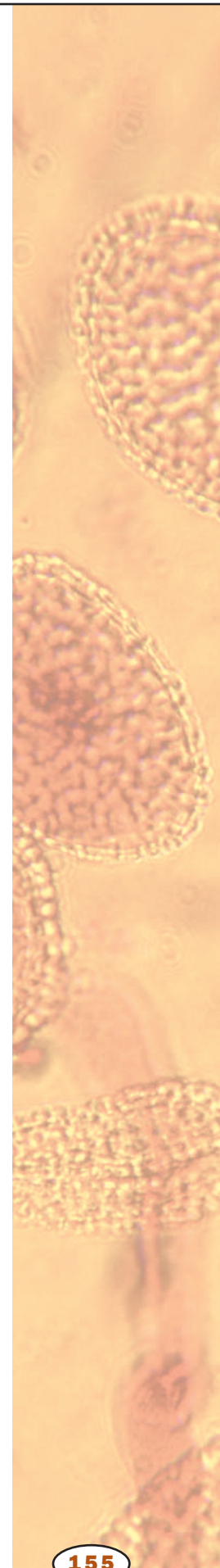

### Economically Important Cereal Grasses

Global and U.S. production estimates (in millions of metric tons, 1998/1999) and the value of those crops produced in the United States (in millions of U.S. dollars, 1997). Data are from the U.S. Census Bureau and the U.S. Department of Agriculture.

	World Production	U.S. Production	Value
<b>Corn</b>	605.5	247.9	20,456
<b>Wheat</b>	588.4	69.3	8,926
<b>Rice</b>	394.0	5.8	1,657
<b>Barley</b>	136.8	7.7	799
<b>Sorghum</b>	59.2	13.2	1,619
<b>Oats</b>	26.0	2.4	—
<b>Rye</b>	20.3	0.3	—

As economically valuable as grasses are, the grass family, like all large plant families, also contains species that are considered pests or weeds and as such incur an economic cost. Crabgrass is a familiar example in lawns, but there are many agricultural weeds that are grasses and these consume resources meant for planted species, interfere with the harvest, and, ultimately, reduce crop yield. SEE ALSO AGRICULTURE; GRAIN; HISTORY OF AGRICULTURE; MONOCOTS

*Alan K. Knapp*

#### Bibliography

Chapman, G. P., and W. E. Peat. *An Introduction to the Grasses*. Melksham, UK: CAB International, Redwood Press, Ltd., 1992.

Heiser, Charles Bixler. *Seed to Civilization*. Cambridge, MA: Harvard University Press, 1990.

## Grassland

Grasslands are environments in which grasses and grasslike plants dominate the vegetation. Grasslands once covered up to 25 to 40 percent of the earth's land surface, but many of these grasslands have been plowed for crop production. Prior to the European settlement of North America, the largest grasslands in the United States stretched across the Great Plains from the Rocky Mountains and deserts of the southwestern states to the Mississippi River. Other extensive grasslands are, or were, found in Europe, South America, Asia, and Africa.

Grasslands can be categorized as temperate or tropical. Temperate grasslands have cold winters and warm to hot summers and often have deep, fertile soils. In North America, other names for temperate grasslands include prairies and steppes. Tallgrass prairies in the Midwestern United States receive the most rainfall (75 to 90 centimeters [29.5 to 35 inches]) and are the most productive grasslands with grasses growing to 3 meters (almost 10 feet) in height. Historically, these were most abundant in Iowa, Illinois, Minnesota, and Kansas.

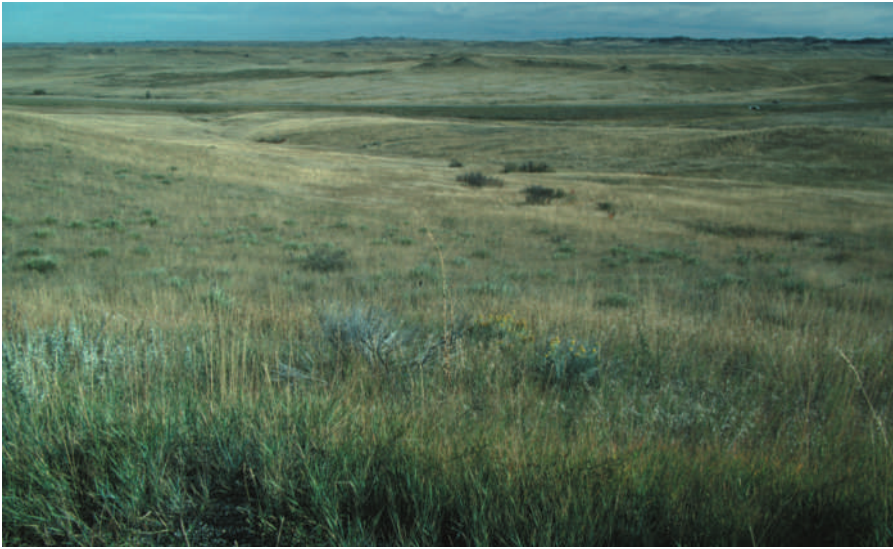

A Montana grassland. Temperate grasslands—also known as prairies—have cold winters and warm to hot summers.

The driest grasslands (25 to 35 centimeters [9.8 to 13.7 inches] of rainfall) are termed shortgrass prairie, or steppe, with grasses seldom taller than 25 centimeters. These grasslands are found in Texas, Colorado, Wyoming, and New Mexico. Temperate grasslands are also called steppes in most of Europe and Asia, veld in Africa, and the pampas in South America.

Tropical grasslands are warm throughout the year but have pronounced wet and dry seasons with annual rainfall amounts of 50 to 130 centimeters (19.6 to 51 inches). Most tropical grasslands have a greater density of woody shrubs and trees than temperate grasslands. Other names for tropical grasslands include velds in Africa, and the campos and llanos in South America.

Grass-dominated **ecosystems** that contain a significant number of widely spaced trees are termed **savannas**. Trees may cover 5 to 30 percent of savanna landscapes, but grasses form a continuous ground cover. Africa, Australia, and South America have extensive savannas.

Fire, drought, and herds of large grazing animals are common features in most grasslands, and most plant and animal life is well adapted to these forces. Fires are most common in grasslands with high levels of plant productivity. Fires are important for keeping trees from encroaching into grasslands—many tree species are killed by fire because their active growing parts are aboveground. Grassland plants survive and even thrive after fire because their buds are below the ground and protected from lethal temperatures. Typically, grassland animals are not harmed by fire. Those animals living below the ground are well protected, and most grassland birds and mammals are mobile enough to avoid direct contact with fire.

Years of extreme drought are more common in grassland than in forested areas, and such droughts may kill even mature trees. But grasses and other grassland plants have extensive root systems that help them survive drought periods. The most conspicuous animals in grasslands are large grazers such as bison and antelope in North America and zebras, gazelles, and wildebeest in Africa. Grasshoppers also can be important consumers of plants, but **nematodes** (roundworms) and root-feeding invertebrates below the ground

**ecosystem** an ecological community and its environment

**savanna** open grassland with sparse trees

**nematode** worm of the Nematoda phylum, many of which are parasitic

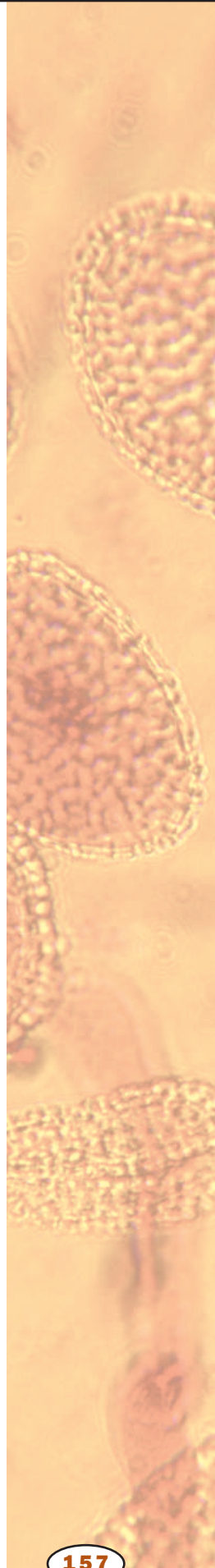

are actually the most significant consumers of plant biomass in many grasslands. SEE ALSO BIOME; TUNDRA

Alan K. Knapp

### Bibliography

- Archibald, O. W. *Ecology of World Vegetation*. New York: Chapman and Hall, 1995.
- Cole, Monica M. *The Savannas: Biogeography and Geobotany*. New York: Academic Press, 1986.
- Lauenroth, W. K., I. C. Burke, and M. P. Gutmann. "The Structure and Function of Ecosystems in the Central North American Grassland Region." *Great Plains Research* 9 (1999): 223–259.

## Gray, Asa

### American botanist 1810–1888

Asa Gray was one of the central figures in American botany in the nineteenth century. Through his writing, teaching, collection, and correspondence, he had a major influence on the study of plants in the United States. Born in New York, Gray earned a medical degree before going to work for the famed American botanist John Torrey in 1833. By 1843 Torrey and Gray had published two volumes of the *Flora of North America*. A planned third volume was never completed. During this time Gray traveled extensively in Europe, where he met with Charles Darwin. Gray later became an important proponent of Darwin's ideas in the United States. In 1842 Gray became a professor at Harvard University, founding an **herbarium** there that still bears his name. Gray worked at a time when the American West was being explored systematically, and through his correspondence with collectors he greatly influenced where and how plants were collected, and how the information gleaned was used and disseminated. His prolific writings from this period include *Manual of Botany of the Northern United States*, a highly popular textbook *Elements of Botany*, and the first half of *Synoptical Flora of North America*, which was completed by others after Gray died. SEE ALSO TORREY, JOHN

Richard Robinson

**herbarium** a collection of dried plant specimens systematically arranged for reference

## Growth

Growth implies development, from the time of emergence or birth to the time of maturity and for many species, beyond maturity to eventual senescence or death. Growth also implies increase in size resulting from cell multiplication and cell expansion, as well as maturation of tissues. However, growth, while accentuating increased cell number and size, also necessitates programmed cell death, leading to the production of the final body form. Thus, growth is an incredibly complex phenomenon, which involves changes in body form, **metabolism**, and body processes.

**metabolism** chemical reactions within a cell

### Patterns of Growth

In most animals, the growth pattern follows an S-shaped curve. Slow early growth occurs from first emergence, or birth, which is followed by a long

phase of rapid increase in body mass and maturation of organs, especially structural or **somatic** tissue that support the individual, up to about the time of puberty or reproductive maturity. Finally, growth slows, and in some species stops altogether after reproductive maturation. In many animals and most plants, however, growth continues throughout life, so that the oldest individuals in the population are generally the largest.

In many animals, young emerge looking like miniature adults, and gradually enlarge throughout their lifetime, going through alternating stages of rapid growth and plateaus. In contrast, in some vertebrate as well as many invertebrate species, the young emerge looking completely different from the adults and spend their early lives acquiring body mass as a larva, then go through a **metamorphosis** (complete rearrangement of body pattern) to emerge in the adult form. This is typical of some insects, such as butterflies and moths, and some amphibians, such as frogs.

In birds and mammals, young generally emerge looking vaguely like adults, but the body proportions are very different, characterized by an enlarged head and reduced supportive limb elements. During the rapid growth phase of these individuals, the head grows much less than the body, limbs elongate, and skin maturation results in the typical adult feather or fur patterns. Since young birds and mammals are usually dependent on their parents for a time after birth, the incomplete development at birth is not a disadvantage.

The pattern of human growth provides a good example of the change in body proportions throughout development from birth to adult (the ultimate size of the individual). At two months past conception, the head of the embryo makes up approximately 50 percent of its total length, and the limbs less than 25 percent. At birth, the head size makes up about 25 percent of the total length and the limbs approximately 37 percent. Throughout childhood, the head size to limb length ratio continues to decrease toward the adult pattern of head size about 12 percent of body length and limb size over 50 percent of body length.

## Bone Growth

The increase in body size is supported by increased skeletal structure in vertebrates, as a soft and pliable cartilage **matrix** becomes invested with hard and resistive bone. In the early newborn, the cartilage model of the eventual skeletal structure serves as the **template** for bone deposition. Bone-forming cells called osteoblasts lay down a “collar” of calcium and phosphate crystals in a lattice matrix around the shaft of the cartilage. This provides the strength for the bone to bear weight. At the same time, the terminal ends of the cartilaginous model also develop centers of osteoblastic activity, called epiphyses (singular, epiphysis). As the bone elongates, the collar elongates and the epiphyses in the ends of the bones continue to deposit calcium and phosphate. Eventually, the cartilage between these two bony centers of ossification, called the epiphyseal plate, is completely replaced with the bony matrix, and growth (limb elongation) ceases.

The epiphyseal plate is maintained under the influence of a **hormone** from the pituitary gland (the master **endocrine** gland at the base of the brain) called growth hormone (GH). However, at puberty, the hormones



In birds and mammals, the young emerge looking vaguely like adults, but with different body proportions.

**somatic** nonreproductive; not an egg or sperm

**metamorphosis** development process that includes a larval stage with a different form from the adult

**matrix** a network, usually of threadlike fibers

**template** master copy

**hormone** molecule released by one cell to influence another

**endocrine** related to the system of hormones and glands that regulate body function



Computer color-enhanced X ray depicting the hand development of a two, six, and nineteen year old male.

associated with reproductive maturity (estrogen and testosterone) cause an initial surge in GH release and in elongation of limbs, and then cause closure of the epiphyseal plate, causing growth to cease. This “growth spurt” tends to happen earlier in human females than in human males.

### Hormonal Control

Growth hormone is essential to normal growth and development. It is regulated by two hormones released from the brain (in the hypothalamus) which cause daily peaks of GH in the blood. The peaks are most closely associated with the sleep cycle, large peaks appearing right after going to sleep and right before waking. Since growth hormone is associated not only with growth and differentiation but also tissue maintenance and repair, it makes sense that the peak of GH activity would occur during the nonactive period. In fact, the hypothalamic hormone that induces the release of GH (GH-releasing hormone) is a sleep inducer. Some researchers have suggested that the disappearance of deep sleep as we age and associated reduction of GH release may contribute to the physical decline that humans experience in old age.



GH represents about one-half the total hormone content of the **anterior** pituitary gland. GH stimulates the absorption of **amino acids** and **protein** synthesis necessary for development of skeletal muscle; stimulates breakdown of fat for energy utilization by cells of the body; stimulates the formation and maintenance of the epiphyseal plate in bone, and encourages lengthening of the long bones by stimulation of osteoblast cellular deposition of bone; and it stimulates the liver to make growth stimulating proteins, called insulin-like growth factors (IGF), which then affect the cellular metabolism of all cells in the body.

## Growth Disorders

Abnormal **secretion** of GH can lead to growth disorders. Oversecretion of GH can lead to gigantism, marked by extreme limb elongation especially in the terminal elements (hands and feet) and enlargement of the face, especially the chin, nose, and ears, a condition called *acromegaly*. This condition can occur either because of a tumor of specific cells that manufacture GH or GH-like proteins or because of insufficient regulation by the hypothalamic releasing factors that control GH release. Not only are body proportions distorted with acromegaly, but **hypersecretion** of GH causes excessive sweating and secretion by the skin, enlargement of the heart, and sometimes high blood pressure. As a result of the many physiological effects of excessive GH secretion, life expectancy is shortened.

In contrast, lack of sufficient GH, especially during early years of development, can produce short stature or dwarfism. However, short stature with normal body proportions can be found throughout the human population and is probably associated with deficient production of IGF from the liver. For example, African pygmies are short, but normally proportioned people who have normal GH levels, but exhibit low levels of one form of IGF. Low GH release after birth can result in retarded growth, and these individuals are at risk for hypoglycemia (low blood sugar) as well. This condition severely impairs normal development, and these individuals are not only short but exhibit greatly retarded maturation of all tissues. SEE ALSO BONE; DEVELOPMENT; FETAL DEVELOPMENT, HUMAN; HYPOTHALAMUS; INSECT; PITUITARY GLAND; SCALING

Susan B. Chaplin

### Bibliography

Tanner, James M. *Foetus into Man: Physical Growth from Conception to Maturity*. Cambridge, MA: Harvard University Press, 1990.

Vlijasek, Stanley J., et al., eds. *The Cambridge Encyclopedia of Human Growth and Development*. New York: Cambridge University Press, 1998.

## Gymnosperms

Gymnosperms are a group of plants that share one common characteristic: they bear seeds, but their seeds do not develop within an ovary. For this reason, gymnosperms were long thought to be an evolutionary precursor to the angiosperms, which are seed plants that enclose their seeds in an ovary and that are vastly more diverse than gymnosperms. Studies of their de-

**anterior** toward the front

**amino acid** a building block of protein

**protein** complex molecule made from amino acids; used in cells for structure, signaling, and controlling reactions

**secretion** material released from the cell

**hypersecretion** excess secretion

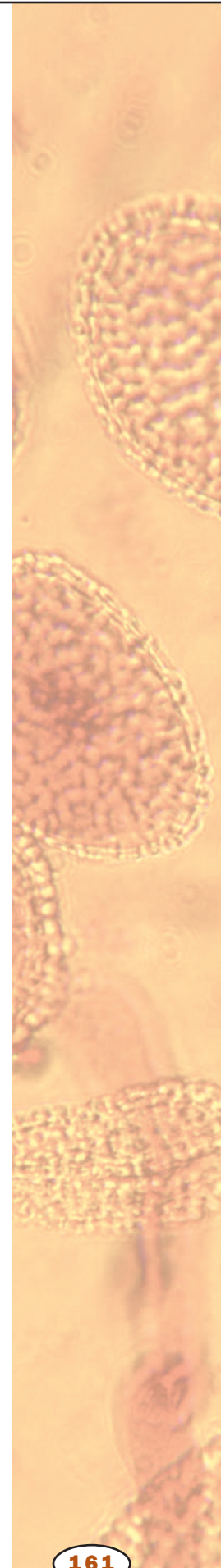

A cycad. Most cycads superficially resemble ferns, but they differ in that they develop distinctive male and female cones.



oxyribonucleic acid (DNA) has shown that the gymnosperms consist of four major, related groups: conifers, cycads, ginkgo, and gnetophytes.

### Conifers

With approximately 588 living species, this is the most diverse and by far the most ecologically and economically important gymnosperm group. Conifers grow in all climate zones and on all continents except Antarctica. They all bear their seeds within a cone or a structure **superficially** resembling a berry (true berries only exist among angiosperms). Most conifers are trees. Conifers appeared in the fossil record about 290 million years ago and have been an ecologically important, widespread group ever since then.

### Cycads

The 220 species of cycads are widely distributed through the tropical and subtropical regions. Most of them superficially resemble ferns, having a cluster of long **pinnate** (rarely bipinnate) fronds growing from a central stalk, but they differ in developing distinctive male and female cones. Cycads are

**superficially** on the surface; not deep

**pinnate** featherlike

woody, long-lived, unisexual plants. All species have **coralloid** roots, which support symbiotic cyanobacteria that can fix atmospheric nitrogen. The cycads and ginkgo are unique among seed plants in having **motile** sperm; this is often taken as evidence of their evolutionary primitiveness. Cycads appeared in the fossil record about 230 million years ago and attained their greatest ecological importance during the Jurassic period, about 193 million to 136 million years ago, when they formed extensive forests.

**coralloid** resembling coral

**motile** able to move

## Ginkgo

There is one surviving species of ginkgo. It is a tree, sometimes attaining large size, native to China but widely planted around the world. Ginkgo is often referred to as a “living fossil” because nearly identical plants are known from fossils nearly 200 million years old. The fossil record shows that they were formerly a widespread, abundant, and diverse group.

## Gnetophytes

The gnetophytes are one of the most peculiar plant groups. They include three highly distinct groups totaling 68 species. One group, the genus *Ephedra*, is composed of shrubs native to deserts and semiarid areas. The second group, the genus *Gnetum*, is composed of climbing vines (and one tree species) native to tropical rainforests. The third group contains a single species, *Welwitschia mirabilis*. It lives in the desert of Southwest Africa, produces two leaves that grow throughout the life of plant, and lives an estimated two thousand years. Although the fossil record is virtually nonexistent, studies suggest that the Gnetales are a relatively young group that evolved from the angiosperms and thus are unrelated to the other gymnosperms. SEE ALSO CONIFERS; CYANOBACTERIA; NITROGEN FIXATION; PLANT

*Christopher J. Earle*

### Bibliography

- Earle, Christopher J. *The Gymnosperm Database*. 2001. <<http://www.conifers.org>>.
- Farabee, M. J. *On-Line Biology Book: Biological Diversity: Seed Plants*. <[http://gened.emc.maricopa.edu/bio/bio181/BIOBK/BioBookDiversity\\_6.html](http://gened.emc.maricopa.edu/bio/bio181/BIOBK/BioBookDiversity_6.html)>.
- Norstog, Knut J., and Trevor J. Nicholls. *The Biology of the Cycads*. Ithaca, NY: Cornell University Press, 1997.

## Habitat

In its simplest sense, a habitat is where an organism lives and thus is a concrete physical location like a stand of trees or a pool of water. A broader concept of habitat encompasses the general set of living and nonliving features typical of a particular environment, for example, “desert habitat” or “coral reef habitat.”

Ecologists can measure environmental conditions where a species normally occurs to define its habitat more rigorously. Appropriate habitat can be defined in terms of its temperature regime, the availability of light and water, the chemical environment (acidity, salinity), and the strength of physical forces (waves, wind). Species can vary substantially in the suite of



**niche** way an organism uses its environment

environmental conditions that they tolerate and can be classified as flexible habitat generalists or narrow habitat specialists.

Ecologist G. Evelyn Hutchinson developed the related concept of the species **niche**, which is a “living space” delineated by the entire range of environmental conditions that an organism can tolerate and by all the resources it requires for survival, growth, and reproduction. The niche of a species is where it lives and what it does. A cactus, tarantula, and roadrunner may share a common desert habitat, but each occupies a unique niche. SEE ALSO BIOME; COMMUNITY; ECOLOGY; ECOSYSTEM

*Cynthia A. Paszkowski*

### Bibliography

Krohne, David T. *General Ecology*. New York: Wadsworth Publishing, 1997.

## Hardy-Weinberg Equilibrium

**allele** a particular form of a gene

The Hardy-Weinberg equilibrium is the fundamental concept in population genetics (the study of genetics in a defined group). It is a mathematical equation describing the distribution and expression of **alleles** (forms of a gene) in a population, and it expresses the conditions under which allele frequencies are expected to change.

Mendelian genetics demonstrated that the phenotypic (observable) expression of some traits is based on a simple dominant-recessive relationship between the alleles coding for the trait. In Mendel’s original work for instance, green pea pods were dominant to yellow pods, meaning that a heterozygote (an individual with one allele for green and one for yellow) would show the green trait. (A common misunderstanding is that a dominant allele should also be common. This is not the case. Frequency of an allele in a population is independent of its dominance or recessiveness. Either type of allele may be common or rare.)

### Allele Frequencies

**phenotype** observable characteristics of an organism

A significant question in population genetics, therefore, is determining the frequency of the dominant and recessive alleles in a population (for example, the frequency of blood type O allele in the United States), given the frequency of the **phenotypes**. Note that phenotypic and allelic frequencies are related but are not equal. Heterozygotes show the dominant phenotype, but carry a recessive allele. Therefore, the frequency for the recessive allele is higher than the frequency of the recessive phenotype.

Early in the twentieth century mathematician Godfrey Hardy and physician Wilhelm Weinberg independently developed a model describing the relationship between the frequency of the dominant and recessive alleles (hereafter,  $p$  and  $q$ ) in a population. They reasoned that the combined frequencies of  $p$  and  $q$  must equal 1, since together they represent all the alleles for that trait in the population:

$$p + q = 1$$

Hardy and Weinberg represented random mating in the population as the product  $(p + q)(p + q)$ , which can be expanded to  $p^2 + 2pq + q^2$ . This

corresponds to the biological fact that, as a result of mating, some new individuals have two  $p$  alleles, some one  $p$  and one  $q$ , and some two  $q$  alleles.  $P^2$  then represents the fraction of the population that is **homozygous dominant** while  $2pq$  and  $q^2$  represent the **heterozygous** and homozygous recessive fractions, respectively.

Mathematically, since  $p + q = 1$ ,  $(p + q)^2$  must also equal 1, and so:

$$p^2 + 2pq + q^2 = 1$$

The usefulness of this final form is that  $q^2$ , the fraction of the population that is homozygous recessive, can be determined with relative ease, and from that value all of the other frequencies can be calculated. For instance, if 1 percent of the population is found to be homozygous recessive,  $q^2 = 0.01$ , then  $q = 0.1$ ,  $p = 0.9$ ,  $p^2 = 0.81$ , and  $2pq = 0.09$ .

One value of the Hardy-Weinberg equilibrium equation is that it allows population geneticists to determine the proportion of each genotype and phenotype in a population. This may be useful for genetic counseling in the case of a genetic disease, for example, or for measuring the genetic diversity in a population of endangered animals.

### Implications for Evolution

A significant implication of the Hardy-Weinberg relationship is that the frequency of the dominant and recessive alleles will remain unchanged from one generation to the next, given certain conditions. These conditions are: (1) a sufficiently large population to eliminate change due to chance alone; (2) random mating (the phenotypic trait being examined cannot play a role in mate selection); (3) no migration of individuals either into or out of the population under study; (4) the genes under consideration are not subject to mutational change; and (5) the dominant or recessive phenotype must not have an adaptive advantage; in other words natural selection must not be favoring one trait over another.

If any of these constraints are not satisfied then the Hardy-Weinberg equilibrium does not hold true. When a population geneticist finds a change in allele frequency over time, therefore, he or she may be confident that one or more of these factors is at work. In fact, one definition of evolution is a change in allele frequencies over time.

J. B. S. Haldane was the first person to adapt the Hardy-Weinberg relationship to model evolutionary change. He introduced a selection coefficient to represent a disadvantage for the homozygous recessive. His equation was later shown to successfully model the impact of industrial pollution on peppered moths in England. SEE ALSO ADAPTATION; EVOLUTION; GENETIC DISEASES; NATURAL SELECTION; POPULATION GENETICS

*William P. Wall*

### Bibliography

- Gillespie, John H. *Population Genetics: A Concise Guide*. Baltimore, MD: Johns Hopkins University Press, 1998.
- Kingsland, Sharon E. *Modeling Nature: Episodes in the History of Population Ecology*. Chicago: University of Chicago Press, 1995.
- Pianka, Eric R. *Evolutionary Ecology*. San Francisco, CA: Benjamin Cummings, 2000.
- Stearns, Stephen C., and Rolf F. Hoekstra. *Evolution: An Introduction*. New York: Oxford University Press, 2000.

**homozygous** containing two identical copies of a particular gene

**heterozygous** characterized by possession of two different forms (alleles) of a particular gene

### DOBZHANSKY, THEODOSIUS (1900–1975)

Dobzhansky is a Ukrainian-born U.S. biologist and author who showed that ongoing change in gene frequencies in natural populations was the rule, not the exception. He also showed that individuals with two different versions of the same gene (“heterozygotes”) could be better adapted than individuals with identical copies of a gene (“homozygotes”).



William Harvey (right) with Charles I (seated, left).

## Harvey, William

**English physician and physiologist  
1578–1657**

William Harvey was an English physician, a pioneer in the study of blood circulation and embryology, and the founder of experimental physiology. Educated in Cambridge, England, and Padua, Italy, he practiced medicine in London and was court physician to King James I and King Charles I.

The Roman physician Galen (129–c. 199 C.E.) had argued that the liver received food from the small intestine and converted it to blood, the heart pumped this blood to the other organs, and those organs consumed it. Harvey, refusing to accept this, measured the amount of blood pumped by the hearts of snakes and other animals. He concluded that (1) the heart pumps more blood in half an hour than there is in the entire body; (2) animals do not consume enough food to account for so much blood; and (3) the blood must be continually recirculated around the body, since the planets orbit the Sun and (he believed) the human body is modeled after the solar system. So for a mixture of scientific and superstitious reasons, Harvey correctly deduced that after blood leaves the heart it returns there rather than being consumed. He predicted that there must be a connection between the arteries and veins so blood could get back to the heart. Such connections, the capillaries, were first seen by Antony van Leeuwenhoek and Marcello Malpighi after Harvey's death.

Harvey published his conclusions in the book *Anatomical Studies on the Motion of the Heart and Blood in Animals* (a translation of its Latin title) in 1628. Harvey's contemporaries were so wedded to the ancient beliefs of Aristotle and Galen, however, that they ridiculed his conclusions. How could the blood serve any purpose, they argued, if the organs did not consume it? Harvey's reputation survived this skepticism, however, and he went on to do important work in embryology.

Harvey was forced to flee for his life in 1642, and his home was ransacked and his records destroyed in a rebellion against the British monarchy that ended with the beheading of his patron, King Charles. Depressed by this turn of events, Harvey gave up his medical practice and retired to the countryside. Nevertheless, at the urging of friends, he resumed work. Harvey rejected the belief that animals can arise from decaying flesh, and argued that every animal, including humans, arises from the union of sperm and egg. In 1651 he published this theory of animal development, with a detailed account of the embryology of the chick, as *Studies on the Generation of Animals*. The frontispiece of his book bore the inscription *ex ovo omnia*—everything [comes] from an egg.

Harvey died of a stroke in 1657, honored by his country and wealthy from the income on his books. SEE ALSO BLOOD VESSELS; CIRCULATORY SYSTEMS; HEART AND CIRCULATION; HISTORY OF MEDICINE

*Kenneth S. Saladin*

### Bibliography

Durant, Will, and Ariel Durant. *The Story of Civilization, Vol. VII*. New York: Simon & Schuster, 1961.

Marcus, Rebecca. *William Harvey, Trailblazer of Scientific Medicine*. New York: Franklin Watts, 1962.

Moore, John A. *Science as a Way of Knowing*. Cambridge, MA: Harvard University Press, 1993.

## Health

For many years, health was defined merely as the absence of disease. However, it has become clear that health is an active process that depends on the supportive interaction of all the body's systems. Reflecting this concept, the World Health Organization (WHO) defines health as "the state of complete physical, mental, and social well-being and not merely the absence of disease or infirmity." Many groups, such as the American Public Health Association, Worksite Health Promotion, and the National Wellness Association, have expanded the concept of health further to encompass wellness: the spiritual, social, mental, physical, and occupational needs for one to live life to the fullest.



The World Health Organization defines health as "the state of complete physical, mental, and social well-being and not merely the absence of disease or infirmity."

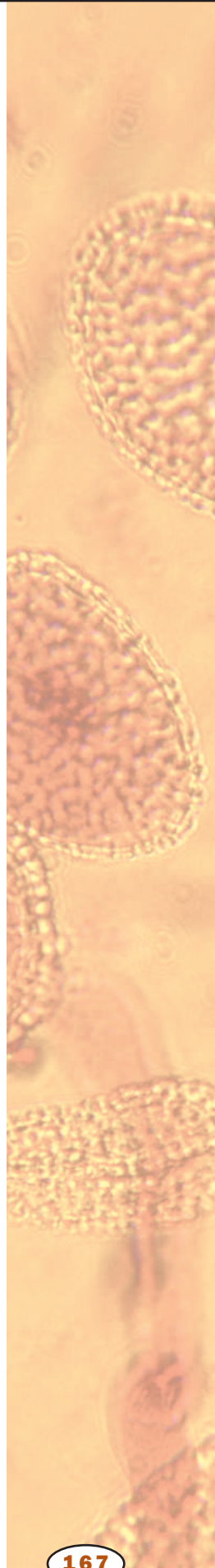

In either sense, health is a state of action that includes prevention, care, and individual responsibility to achieve optimal health. The U.S. Department of Health and Human Services (HHS), in *Healthy People 2010*, divides the ten leading factors affecting health into two major themes. The first, lifestyle challenges, includes physical activity, avoidance of excess weight and obesity, abstinence from tobacco use or substance abuse, and responsible sexual behavior. The second, system enhancement challenges, include mental health, freedom from injury and violence, good environmental quality, immunization, and equal access to health care.

## Homeostasis

The state of health reflects the body's homeostasis, its attempt to maintain a relatively stable internal environment while confronted with changes in the external environment. One's ability to handle stress depends on the body's success in maintaining or returning to homeostasis. Failure to do so can result in abnormal function and disease.

Homeostasis involves negative **feedback** systems. The analogy to home heating and cooling systems is often made. When a house falls below a certain temperature, the system turns on to heat the house back to the set level. If it gets too warm, another system effects a change to cool the home off. Similarly, the human body senses changes from ideal conditions in variables, such as blood **glucose**, dehydration, blood calcium, carbon dioxide, heart rate, breathing rate, and fat deposition. The body also detects the presence of **pathogens** that alter homeostasis. When such factors disturb homeostasis, the body releases substances such as **hormones**, **neurotransmitters**, and antibodies to return conditions to normal.

Why is health important? The WHO states that it is fundamental to world peace and security as political strife can stem from inadequate food, medicine, or other resources. For the United States and other industrialized nations, the large increase in the older population calls for strategies to increase the number of quality years as people age. Living longer is not a positive goal if it means living longer with disease. HHS has made this one of two major goals in *Healthy People 2010*. The other is to eliminate disparities in health based on race or ethnicity. Too many segments of American society are not reaping the benefits from advances in medicine, technology, and health care.

Individual choices are important to health outcomes. Preventive medicine includes stress reduction, good nutrition, exercise, wearing seat belts and helmets, and having routine dental and physical screenings (for cholesterol level and blood pressure, for example). As science progresses in genetic engineering, important choices will be made about changing genes, thus altering the inheritance of many diseases. SEE ALSO ALCOHOL AND HEALTH; CARDIOVASCULAR DISEASES; DISEASE; ENVIRONMENTAL HEALTH; HISTORY OF MEDICINE; HOMEOSTASIS; PUBLIC HEALTH CAREERS; SEXUALLY TRANSMITTED DISEASES; SMOKING AND HEALTH

Karen E. Jensen

**feedback** process in which the output or result influences the rate of the process

**glucose** simple sugar that provides energy to animal cells and is the building block of cellulose in plants

**pathogen** disease-causing organism

**hormone** molecule released by one cell to influence another

**neurotransmitters** molecules released by one neuron to stimulate or inhibit another neuron or cell

The National Institutes of Health (NIH) is one of eight health agencies of the U.S. Public Health Service. The NIH was founded in 1887 with the goal to acquire new knowledge to help prevent, detect, diagnose, and treat diseases and disabilities. As one of the world's foremost medical research centers, the NIH conducts research, supports research elsewhere, helps train researchers, and fosters communication about medical and health sciences information.

### Bibliography

- Donatelle, Rebecca J. *Health: The Basics*. Boston: Allyn and Bacon, 2001.  
*National Institutes of Health*. <<http://www.nih.gov>>.  
*World Health Organization*. <<http://www.who>>.



## Health and Safety Officer

Most companies, universities, and academic medical centers employ a health and safety officer (HSO). The HSO promotes the health and safety of employees and is in charge of the company's formal health and safety program. The HSO writes policies and procedures that the company and its employees must follow to assure a safe work environment. The program is based on state and federal regulations but may be stricter. Work includes measuring hazardous agents, observing workers accomplish their tasks, and making recommendations on ways to reduce injuries. Measurements may include chemicals in laboratory air, noise levels in production areas, and levels of radiation in facilities that use radiation or radioactive substances.

The HSO often observes workers to determine causes of injuries and recommends ways to avoid injuries or exposure to hazardous materials. The HSO provides personal protective equipment for eye and hearing protection, requires machine guards to prevent injuries, and requires protective clothing to guard against chemicals and bacteria. Sometimes the HSO works with a physician to determine the cause of a worker's illness. The HSO at a small company often has a biology or engineering background (depending on the company and hazards to employees). Usually a bachelor of science (B.S.) degree and a few years of experience in health and safety are adequate. Large companies and organizations often require formal graduate training in safety and certification, for example a Certified Safety Professional. The HSO at a large company often has a B.S. degree in a biological or physical science, plus a master's degree or doctorate, depending on the needs of the company. The best way to prepare to become an HSO is to obtain a B.S. degree in science or engineering and a graduate degree in a safety discipline such as safety engineering or industrial hygiene. SEE ALSO EPIDEMIOLOGIST

*Richard J. Vetter*

### Bibliography

La Follette, S. E., T. Bellinger, and P. Ronczkowski. "On the Path from Student to Practitioner: Testing the Water Before the Internship." *Environmental Health* 63 (2001): 15-19.

## Hearing

Hearing is the process by which humans, using ears, detect and perceive sounds. Sounds are pressure waves transmitted through some medium, usually air or water. Sound waves are characterized by frequency (measured in cycles per second, cps, or hertz, Hz) and amplitude, the size of the waves. Low-frequency waves produce low-pitched sounds (such as the rumbling sounds of distant thunder) and high-frequency waves produce high-pitched sounds (such as a mouse squeak). Sounds audible to most humans range from as low as 20 Hz to as high as 20,000 Hz in a young child (the upper range especially decreases with age). Loudness is measured in decibels (dB), a measure of the energy content or power of the waves proportional to amplitude. The decibel scale begins at 0 for the lowest audible sound, and increases logarithmically, meaning that a sound of 80 db is not just twice as loud as a sound of 40 db, but has 10,000 times more power! Sounds of 100

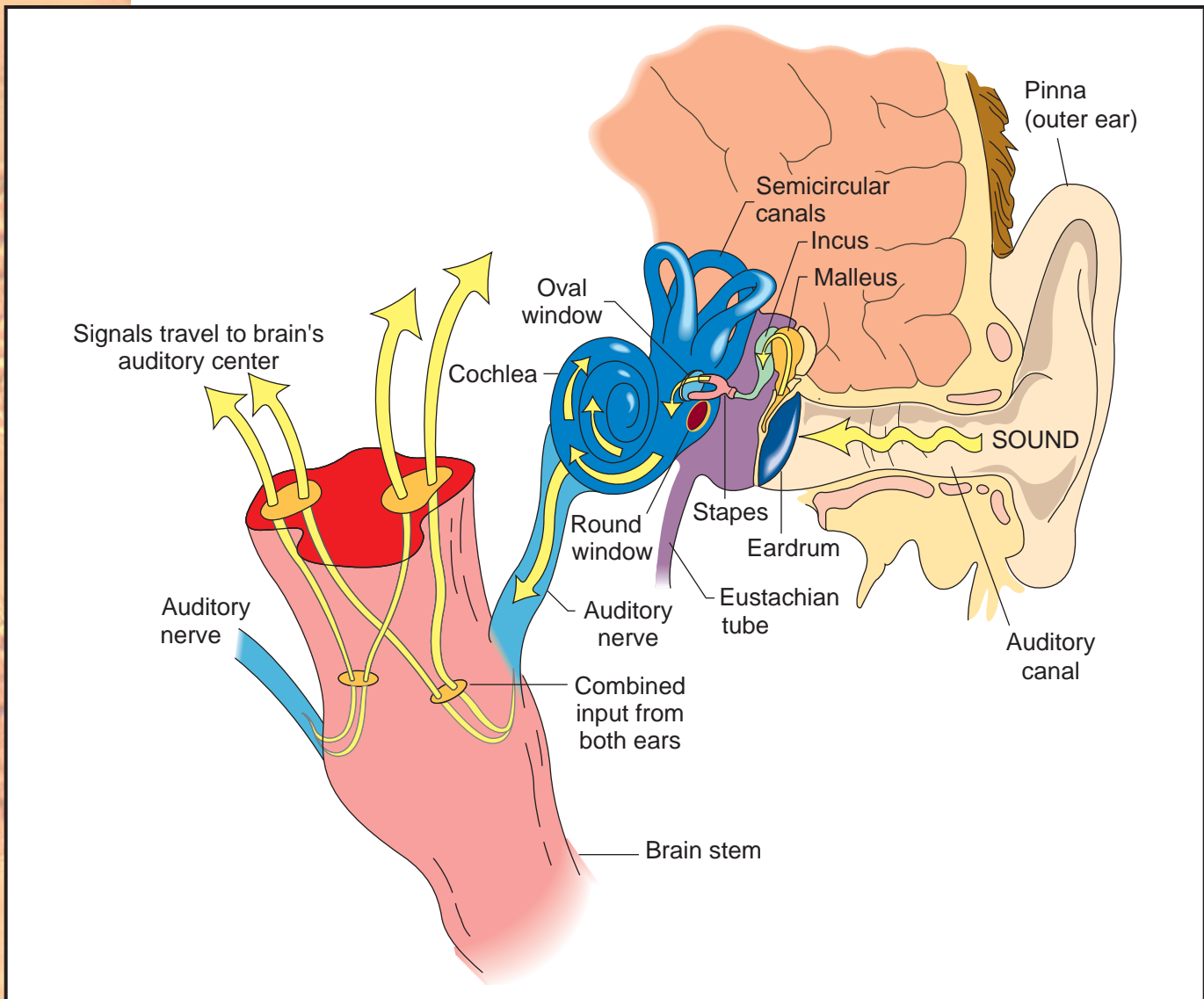

Anatomy of the human ear and the hearing process.

db are so intense that they can severely damage the inner ear, as many jack-hammer operators and rock stars have discovered.

The ear is a complex sensory organ, divided into three parts: external (outer) ear, middle ear, and inner ear. The outer and middle ear help to protect and maintain optimal conditions for the hearing process and to direct the sound stimuli to the actual sensory receptors, hair cells, located in the cochlea of the inner ear.

### Outer Ear and Middle Ear

The most visible part of the ear is the pinna, one of two external ear structures. Its elastic cartilage framework provides flexible protection while collecting sound waves from the air (much like a funnel or satellite dish); the intricate pattern of folds helps prevent the occasional flying insect or other particulate matter from entering the ear canal, the other external ear component. The ear (auditory) canal directs the sound to the delicate eardrum (tympanic membrane), the boundary between external and middle ear. The

ear canal has many small hairs and is lined by cells that secrete ear wax (cerumen), another defense to keep the canal free of material that might block the sound or damage the delicate tympanic membrane.

The middle ear contains small bones (auditory ossicles) that transmit sound waves from the eardrum to inner ear. When the sound causes the eardrum to vibrate, the malleus (hammer) on the inside of the eardrum moves accordingly, pushing on the incus (anvil), which sends the movements to the stapes (stirrup), which in turn pushes on fluid in the inner ear, through an opening in the cochlea called the oval window. Small muscles attached to these ossicles prevent their excessive vibration and protect the cochlea from damage when a loud sound is detected (or anticipated). Another important middle ear structure is the auditory (eustachian) tube, which connects the middle ear to the pharynx (throat). For hearing to work properly, the pressure on both sides of the eardrum must be equal; otherwise, the tight drum would not vibrate. Therefore, the middle ear must be connected to the outside.

Sometimes, when there are sudden changes in air pressure, the pressure difference impairs hearing and causes pain. In babies and many young people, fluid often builds up in the middle ear and pushes on the eardrum. The stagnant fluids can also promote a bacterial infection of the middle ear, called otitis media (OM). OM also occurs when upper respiratory infections (colds and sore throats) travel to the middle ear by way of the auditory tube. Sometimes the pressure can be relieved only by inserting drainage tubes in the eardrum.

### Inner Ear

The inner ear contains the vestibule, for the sense of balance and equilibrium, and the cochlea, which converts the sound pressure waves to electrical impulses that are sent to the brain. The cochlea is divided into three chambers, or ducts. The cochlear duct contains the hair cells that detect sound. It is sandwiched between the tympanic and vestibular ducts, which are interconnected at the tip. These ducts form a spiral, giving the cochlea a snail shell appearance. Inside the cochlear duct, the hair cells are anchored on the basilar membrane, which forms the roof of the vestibular duct. The tips of the hair cells are in contact with the tectorial membrane, which forms a sort of awning. When the stapes pushes on the fluid of the inner ear, it creates pressure waves in the fluid of the tympanic and vestibular ducts (like kicking the side of a wading pool). These waves push the basilar membrane up and down, which then pushes the hair cells against the tectorial membrane, bending the “hairs” (stereocilia). When stereocilia are bent, the hair cell is excited, creating impulses that are transmitted to the brain.

How does the cochlea differentiate between sounds of different pitches and intensities? Pitch discrimination results from the fact that the basilar membrane has different vibrational properties along its length, such that the base (nearest the oval window) vibrates most strongly to high frequency sounds, and the tip to low frequencies. The hair cells along the length of the cochlea each make their own connection to the brain, just like the keys on an electric piano are each wired for a certain note. Loud (high-amplitude) sounds cause the basilar membrane to vibrate more vigorously than soft

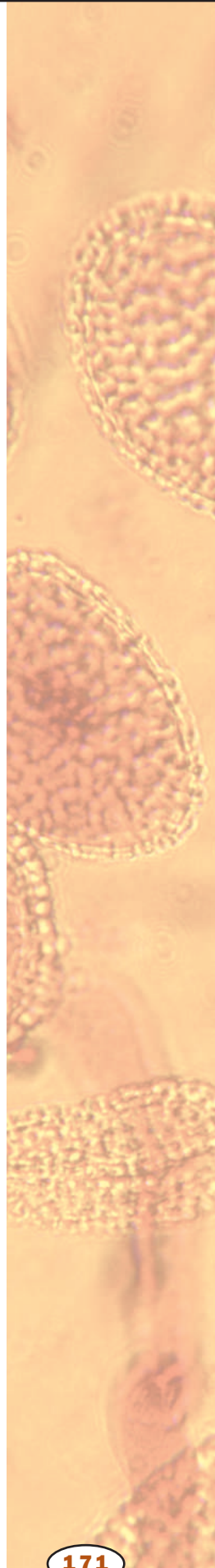

**central nervous system**  
brain and spinal cord

**cranial** related to the  
cranium, or brain cavity

(low-amplitude) sounds. The brain thus distinguishes loud from soft sounds by differences in the intensity of nerve signaling from the cochlea.

Hair cells themselves do not make the impulses that are transmitted to the **central nervous system** (CNS); they stimulate nerve fibers to which they are connected. These nerve fibers form the cochlear branch of the eighth **cranial** (vestibulocochlear) nerve. In the CNS, the information is transmitted both to the brainstem, which controls reflex activity, and to the auditory cortex, where perception and interpretation of the sound occur. By comparing inputs from two ears, the brain can interpret the timing of sounds from right and left to determine the location of the sound source. This is called binaural hearing. SEE ALSO BRAIN; NEURON

*Harold J. Grau*

### Bibliography

Carmen, Richard. *Our Endangered Hearing*. Emmaus, PA: Rodale Press, 1977.

Stebbins, William C. *The Acoustic Sense of Animals*. Cambridge, MA: Harvard University Press, 1983.

Stevens, S. S., and Fred Warshofsky. *Sound and Hearing* (Life Science Library). New York: Time, 1967.

## Heart and Circulation

“It is absolutely necessary to conclude that the blood in the animal body is impelled in a circle, and is in a state of ceaseless motion; that this is the act or function which the heart performs by means of its pulse.” William Harvey’s description of the circulation of the blood and the motive force of the heart in *de Motu Cordis* (1628) is considered the beginning of modern physiology. In the adult human body, the heart beats about 70 times per minute, or approximately 100,000 beats per day. During exercise or intense emotion the human heart rate can increase to 200 beats per minute. Thus, in a life span of seventy-five years, with everyday stresses and emotions, a human heart may beat more than 3 billion times.

The heart pumps approximately 100 milliliters per beat. In seventy-five years, this amounts to 300 million liters of blood. The pumping action of the heart and the changes in its activity in response to body needs are necessary for life, so much so that up to one-third of all deaths in the United States result from heart disease.

In humans and other mammals, the heart consists of two pumps. The right side of the heart pumps blood to the lungs, where the blood is oxygenated and then returns to the heart. This circuit is called the pulmonary circulation. The left side of the heart receives oxygenated blood from the lungs and pumps it to the rest of the body. Then, as was first described by Harvey in 1628, blood is pumped throughout the body and returns to the heart, to be pumped again to the lungs. The circuit of blood from the left side of the heart, to the periphery, and then back to the heart is known as the **systemic** circulation.

Contraction of the heart underlies its pumping action. Most heart cells are muscle cells. Contraction of the muscle cells and coordination of their pumping action is controlled by electrical activity in the heart cells.

**systemic** throughout  
the body

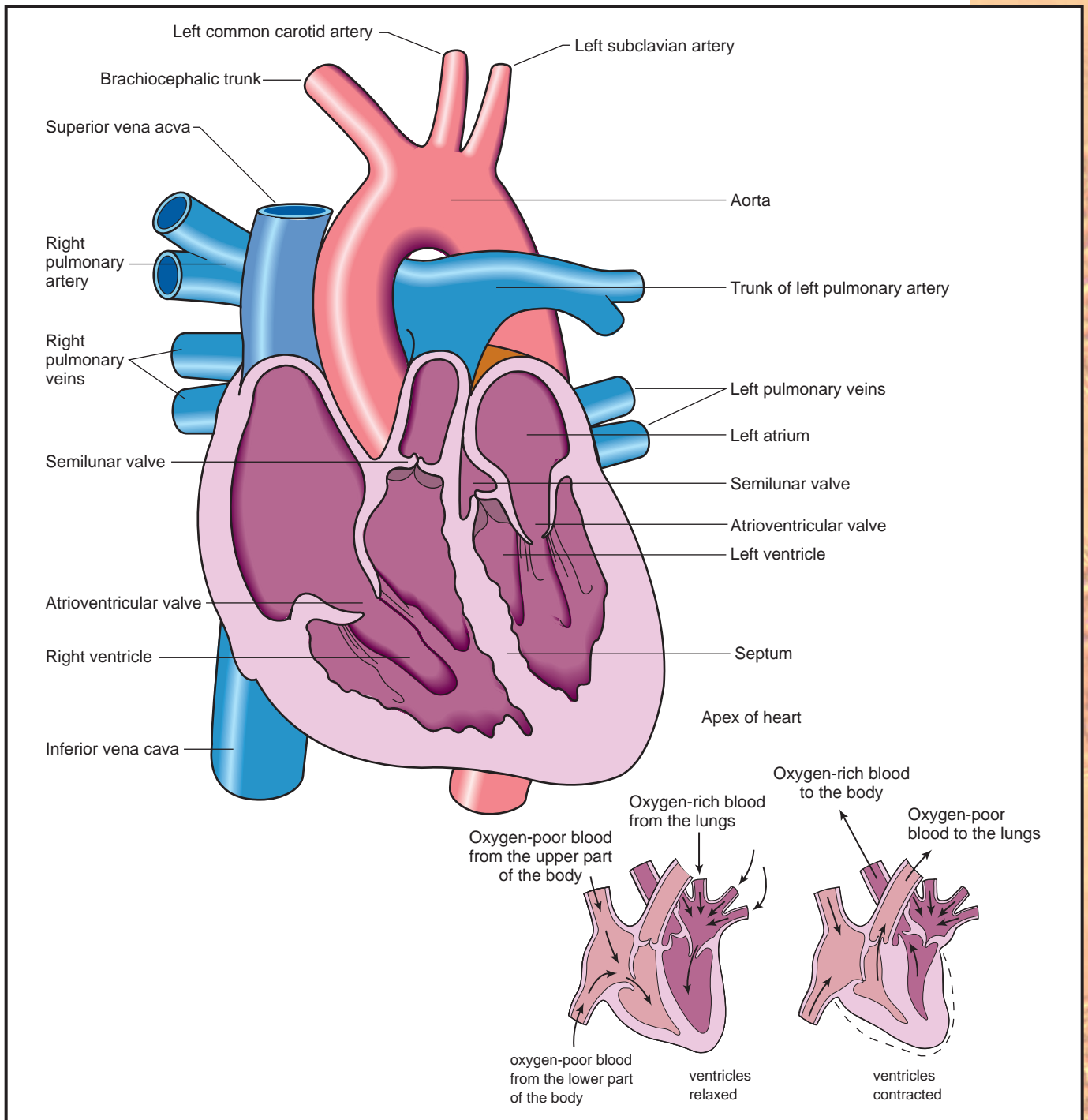

## Heart Structure

The heart is located in a lubricated sac (the pericardium) in the left center of the thorax (chest). Blood returning from the body enters the right side of the heart from the superior vena cava, which carries blood from the head and other parts of the body above the heart, and the inferior vena cava, which carries blood from parts of the body below the heart. These veins merge as they enter the upper chamber on the right side of the heart, the right atrium, which acts as a “receiving room” for blood entering the heart.

Anatomy of the human heart.

**ventricle** lower chamber of the heart

Blood in the right atrium flows into the right **ventricle**, the lower chamber on the right side of the heart, through the tricuspid valve, a one-way valve.

The tricuspid valve allows blood to flow into the right ventricle but prevents its return to the right atrium when the ventricle contracts. Instead, ventricular contraction pumps blood out through another one-way valve, the pulmonary valve, into the pulmonary artery, which carries blood to the lungs. All of the blood that is pumped to the lungs by the right side of the heart returns to the heart through four pulmonary veins that empty into the upper chamber on the left side of the heart, the left atrium.

From the left atrium, blood flows into the lower chamber on the left side of the heart, the left ventricle, through another one-way valve, the mitral valve. Similar in function to the tricuspid valve on the right side, the mitral valve prevents blood from reentering the left atrium and pulmonary veins when the ventricle contracts. Contraction of the left ventricle pumps blood out of the heart through the one-way aortic valve, into the largest artery of the body, the aorta. As the aorta curves over the top of the heart, large arteries branch off to the head, arms, and upper thorax.

The aorta descends through the lower part of the thorax and abdomen, where arteries branch off carrying blood to the liver, spleen, intestine, kidneys, gonads, and legs. After passing through smaller arteries and then capillaries, the blood returns to the heart through the veins. Also branching off the aorta as it leaves the heart is a pair of coronary arteries. These arteries supply blood to the heart and are considered part of the systemic circulation. After passing through capillaries in the heart, blood in the coronary circuit returns to the right side of the heart through veins that empty directly into the right atrium. Heart attacks are caused by clots in coronary arteries, depriving the heart muscle of oxygen.

### The Cardiac Cycle

When the heart is relaxed, blood pressure in the veins is higher than the **atria**, which in turn are higher than the pressures in the ventricles. Hence, blood flows from the veins into the atria and from the atria into the ventricles.

Contraction of the heart (systole) begins first with the atria. As atria contract on both sides of the heart, atrial pressures increase, pushing more blood into the ventricles; however, after a delay of about 0.1 second, the ventricles begin to contract. When the blood pressure in the ventricles becomes greater than in the atria, the tricuspid and mitral valves close. Contraction continues, increasing pressure in the ventricles still further until it exceeds the blood pressure in the exit artery (the pulmonary artery for the right side, the aorta for the left side), at which point the arterial valves open, and blood flows into the arteries.

As contraction of ventricles continues, blood pressure in the pulmonary artery and aorta reaches a maximum, the systolic blood pressure. Blood pressure then falls slowly as blood flows away from the heart into the lungs and periphery, respectively. Diastole begins when the heart relaxes, and the blood pressure continues to fall. The lowest blood pressure reached in the arteries before the next contraction is the diastolic pressure. For a healthy young adult, an aortic systolic pressure of 120 mil-

**atria** two upper chambers of the heart (singular, atrium)

limeters of mercury (mm Hg) and a diastolic pressure of 70 mm Hg are normal. Since blood pressures in the aorta and the arteries in the arm are approximately the same, measurement of blood pressure using an arm cuff is a reasonably accurate method of estimating the aortic systolic and diastolic blood pressures. Pressures in the pulmonary circulation are lower than in the systemic circulation.

## Electrical Activity

Contraction of heart muscle cells is caused by the movement of **ions** into and out of the muscle cells. This movement of ions is an electric current that can be observed by placing electrodes on the skin. Measurement of the electrical activity of the heart is known as an electrocardiogram.

The inside of relaxed muscle cells is negatively charged. When channels permeable to sodium open up, sodium rushes into heart muscle cells, making the inside more positive. This causes calcium channels to open, and calcium rushes in. Calcium causes contractile **proteins** (actin and myosin) to attach and pull on one another, producing force. Calcium is the most important ion for activating contraction. Potassium going out of the cell makes the muscle cell negative again and terminates the contraction. This cycle of electrical activity, going from negative to positive to negative again, is called an action potential.

Action potentials in one muscle cell can excite adjacent muscle cells. This process spreads and coordinates contraction over the entire heart. Some muscle cells are adapted for conducting the electrical activity from one part of the heart to another. Other muscle cells initiate action potentials spontaneously and are known as pacemaker cells.

Pacemaker cells in the sinoatrial node, located over the right atrium, initiate the cardiac cycle. Systole begins when excitation spreads over both atria, activating atrial contraction. Excitation spreads to the atrioventricular node, near the atrioventricular border, from which excitation is conducted by the bundle of His and the Purkinje system (groups of specialized muscle cells) to the bottom of the ventricles. Excitation spreads upward in the ventricles, contracting them from the bottom up, like squeezing a toothpaste tube from the bottom. When the action potentials end, diastole (relaxation) begins, until excitation is again initiated by the pacemaker cells of the sinoatrial node.

Five waves in the normal electrocardiogram correspond to the movement of ions into and out of muscle cells and the direction of conduction over the heart. P is due to activation of atrial cells. Q, R, and S waves correspond to activation of ventricular muscle cells. (The positive or negative direction of QRS waves depends on whether activity is spreading towards the electrode or away from it.) The T wave corresponds to the end of the ventricular action potential. No wave for the end of the atrial action potential is seen because it occurs at the same time as QRS. Abnormalities in the size or duration of the electrocardiogram waves can be used to diagnose heart attacks and other forms of heart disease. In abnormal hearts, waves may be missing or out of sequence. SEE ALSO BLOOD; BLOOD VESSELS; CARDIOVASCULAR DISEASES; CIRCULATORY SYSTEMS

**ion** an electrically charged particle

**protein** complex molecule made from amino acids; used in cells for structure, signaling, and controlling reactions

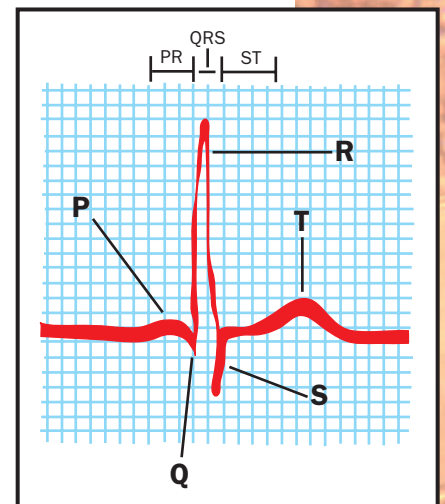

Electrical activity of the heart is recorded in an electrocardiogram. Here, one complete cycle is shown, comprising contraction and relaxation of the atria and the ventricles.

*Jeffrey L. Ram*

### Bibliography

Ganong, William F. *Review of Medical Physiology*, 19th ed. Stamford, CT: Appleton & Lange, 1999.

Harvey, William. "On the Motion of the Heart and Blood in Animals, 1628," trans. Robert Willis. In *The Harvard Classics, Vol. 38: Scientific Papers; Physiology, Medicine, Surgery, Geology, with Introduction, Notes and Illustrations*. New York: P. F. Collier & Son, 1910. Obtained from <<http://www.fordham.edu/halsall/mod/1628harvey-blood.html>>.

*National Vital Statistics System, NCHS, CDC*. "10 Leading Causes of Death, United States 1993–1995." <<http://www.cdc.gov/ncipc/osp/leadcaus/ustable.htm>>.

Vander, Arthur, James Sherman, and Dorothy Luciano. *Human Physiology: The Mechanisms of Body Function*, 7th ed. Boston: McGraw-Hill, 1998.

## Herbal Medicine

Using medicines derived from plants is a practice probably as old as humankind itself. Prehistoric peoples likely noted when consuming a particular plant part provided relief, such as willow bark "tea" lowering a fever. Sumatran clay tablets engraved forty centuries ago list plant-based remedies for common ills, as do ancient writings from Egypt and China. In nineteenth-century United States, St. John's wort and *Echinacea* were just two of many commonly used herbal remedies.

Many modern medicines are synthetic versions of plant-derived "natural products." A compound from a periwinkle plant, for example, served as the basis for a powerful drug that fights leukemia. Poppies provide alkaloids such as morphine that are potent painkillers.

In the U.S. today, one-third of all adults have tried herbal treatments, creating a multibillion-dollar market. The resurgence of interest in herbal medicine is largely due to the Dietary Supplements Health and Education Act (DSHEA) of 1994, which expanded the definition of "dietary supplement" beyond essential nutrients to include "herbs and botanicals," thus removing them from regulation as drugs. This designation means that labels can only mention ways that the herbal product can promote health, not cure disease. For example, valerian root "promotes restful sleep," St. John's wort "may help enhance mood," and *Echinacea* and goldenseal "may help support the immune system." Table 1 lists some herbal products marketed as food supplements that are currently being tested for efficacy in treating specific illnesses. Many physicians and biochemists argue that active ingredients in many herbal remedies are indeed drugs, and should be regulated as such.

The U.S. Food and Drug Administration does not require food supplements to be tested for safety and efficacy in treating illness, or even that a product be consistent in concentration of the active ingredient, or the plant part from which it is derived. Two-thirds of individuals who take herbal supplements do so without consulting a physician, which can be dangerous. St. John's wort, for example, interacts with **enzymes** that control blood levels of many drugs, including anesthetics and drugs that transplant recipients must take. Some herbal supplements may be dangerous if taken in large

**enzyme** protein that controls a reaction in a cell



**Herbal Supplements and Conditions They Treat**

<b>Product</b>	<b>Condition</b>
Cannabis	migraine
Echinacea	respiratory infection
Garlic	cardiovascular disease
Ginger root	nausea and vomiting
Ginkgo biloba	memory impairment intermittent claudication glaucoma tinnitus altitude sickness
Horse chestnut	chronic venous insufficiency
Kava	anxiety
Oregon grape	psoriasis
Red clover	elasticity of large arteries
Red grape juice	coronary artery disease
Saw palmetto	frequent urination due to enlarged prostate
Valerian root	insomnia
Willow bark	lower back pain

doses or by individuals with particular illnesses. For example, *Ginkgo biloba* has been linked to intracranial bleeds, and *Ephedra* to seizures, hypertension, stroke, and death.

Studies to test effects of herbal substances may be flawed or yield inconsistent results. Some reports are actually studies of studies, selected in a way that prejudices the results. Many trials are too small or not well enough controlled to yield meaningful conclusions. Consider an investigation on whether fruits of the chastetree can prevent symptoms of premenstrual syndrome. For three months, 1,634 women took two capsules a day of the extract, and reported their symptoms before and after the trial period—with no control group not receiving the drug. For St. John's wort, one large investigation found it to be just as effective as a standard antidepressant drug, yet another large study published a few months later found it to be useless.

Not all herbal remedies lack scientific backing due to the peculiarities of regulatory law or variations in experimental design. For example, people have drunk cranberry juice to ease symptoms of urinary tract infections for many years. The effect was thought to be due to increasing acidity of urine, but a 1998 study found that compounds called proanthocyanidins prevent bacterial outgrowths from adhering to the wall of the uterine tract.

It is wise to consult a physician when considering use of an herbal product. Even for a well-understood remedy such as cranberry extract, additional therapy may be required, or drug interactions a possibility. The law may not currently consider herbal ingredients to be drugs, but science indicates

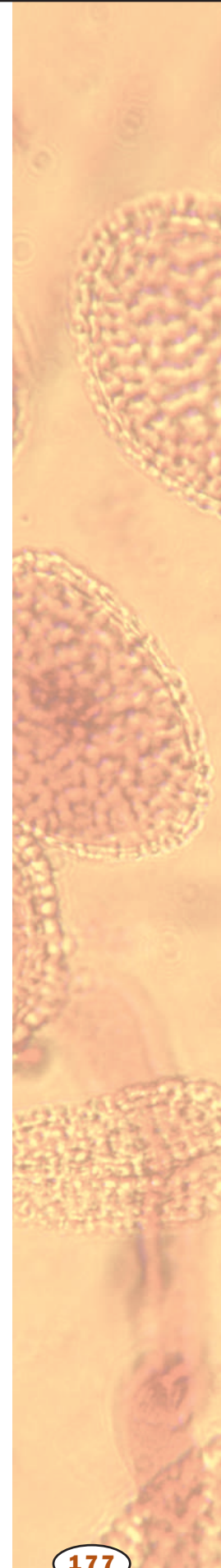

otherwise. SEE ALSO CLINICAL TRIALS; ETHNOBOTANY; PSYCHOACTIVE DRUGS; SECONDARY METABOLITES IN PLANTS

Ricki Lewis

### Bibliography

Attenborough, David. *The Private Life of Plants*. Princeton, NJ: Princeton University Press, 1995.

Fleming, G. Alexander. "The FDA, Regulation, and the Risk of Stroke." *The New England Journal of Medicine* 343, no. 25 (21 December 2000): 1886–1887.

Shelton, Richard C., et al. "Effectiveness of St. John's Wort in Major Depression." *The Journal of the American Medical Association* 285, no. 15 (18 April 2001): 1978–1986.

Simpson, Beryl Brintnall, and Molly Conner Ogorzaly. *Economic Botany: Plants in Our World*, 3rd ed. New York: McGraw-Hill Higher Education, 2000.

## Herbivory and Plant Defenses

Herbivory is the consumption of plant tissues by animals. This usually has a negative impact on plant growth and reproduction, and so imposes natural selection on plants, thereby favoring the evolution of traits that reduce losses (defenses).

Terrestrial plants generally lose less than 10 percent of annual production to herbivores. Fish can consume 100 percent in some shallow-water marine systems in days or weeks, and single-celled algae are often eaten as fast as they reproduce. A few terrestrial herbivores (gypsy moths or locusts, for example) occasionally experience population explosions during which they may totally defoliate their preferred food plants over wide areas. A loss of even 15 percent of annual production can reduce plant growth and fitness.

The fact that some herbivores occasionally can consume most or all vegetation suggests that something prevents this most of the time. Two dominant opposing hypotheses are that "top-down" forces (predators, **parasites**, disease) limit herbivore populations so all plants are not consumed, or that "bottom-up" forces (plant quality) prevent herbivores from eating some plant tissues. In reality both forces combine to limit herbivores and herbivory. Herbivore damage is greater in simplified managed systems, reflecting the loss of these interactions.

Plants have developed numerous physical (spines, thorns, tough tissues, sticky resins, and hairs) and chemical defenses that may reduce herbivory. Some of these are fixed (constitutive), whereas others are only produced (induced) when the plant is attacked. A tremendous diversity of plant biochemicals are toxic, repellent, or antinutritive for herbivores of all types. Many of these chemicals have been called "secondary **metabolites**" because roles have not been found for them in primary plant functions like growth and reproduction. Examples include alkaloids (such as caffeine and nicotine), terpenoids (terpene and pinene), glucosinolates (sinigrin), and phenolics (tannin and chlorogenic acid).

Although many of these compounds appear to have specific activity in animal systems, such as interfering with neurotransmission, recent research suggests that they may have other functions in plants. Nonetheless, it is



Plants have developed physical defenses that reduce the likelihood of herbivory.

**parasite** organism living in close association with another from which it derives most of its nutrition

**metabolite** molecule involved in a metabolic pathway

clear that plant chemistry is a major barrier to herbivory. It is also exploited by humans in medicinal plant use and pharmaceutical development.

While all plants produce chemical defenses continuously, all plants so far studied also change or increase production of both physical and chemical defenses when attacked by herbivores. Defenses can be induced throughout a plant, even in unattacked tissues or tissues produced after the attack, producing **systemic** resistance. New physical and chemical defenses may be synthesized, **enzymes** may activate preexisting defenses, or tissues may be dropped (abscised) to remove pests. This requires detection, coordination, and response. Plants can discriminate among and respond differentially to wounding (such as wind damage) and herbivores, or even among herbivores.

Chemicals found in insect regurgitant (mouth juices) trigger plant responses; these cues may be produced by the insect or by bacteria living in their guts. Fatty acid signals made by the plant (especially jasmonic acid) in response to attack circulate widely, stimulating defense **gene expression** and providing systemic resistance. Methyl jasmonate is **volatile** and escapes wounded plants, triggering defense responses in nearby unwounded plants.

Because producing defenses requires materials (such as carbon and nitrogen) and energy that presumably could be used for growth or reproduction, many believe that defense may be costly for plants. Clear evidence of this is difficult to obtain, but some plants grow or reproduce less when producing maximum defenses, providing indirect support. The types of defenses employed by fast-growing versus slow-growing, or early- versus late-successional plant species differ in consistent ways, but why this is so is not clear. One benefit of induced defenses could be cost-saving, since they are only produced when needed. Induced or **constitutive**, plant defense chemistry influences litter quality, decomposition and nutrient cycling in **ecosystems**.

Herbivores, especially insects, have developed behavioral and biochemical mechanisms that reduce the effects of plant defenses. Plant evolution includes ongoing development of new defenses, which is thought to favor the evolution of new herbivore adaptations and promote speciation in both plants and herbivores. This kind of reciprocal evolutionary impact is called coevolution. While all plants gain some protection from defenses, no plant escapes herbivory by at least some adapted herbivores. Plant defenses and consumer adaptation can limit consumption, and thus can determine the length and shape of **food webs**. SEE ALSO HERBAL MEDICINE; HORMONES, PLANT; PLANT PATHOGENS AND PESTS; POISONOUS PLANTS; SECONDARY METABOLITES IN PLANTS

*Jack C. Schultz*

### Bibliography

- Agosta, William C. *Thieves, Deceivers and Killers: Tales of Chemistry in Nature*. Princeton, NJ: Princeton University Press, 2000.
- Karban, Rick, and Ian T. Baldwin. *Induced Responses to Herbivory*. Chicago: University of Chicago Press, 1997.
- Rosenthal, Gerald, and May R. Berenbaum. *Herbivores: Their Interaction with Secondary Plant Metabolites*. San Diego, CA: Academic Press, 1991.

**systemic** throughout the structure

**enzyme** protein that controls a reaction in a cell

**gene expression** use of a gene to create the corresponding protein

**volatile** easily vaporized

**constitutive** at a constant rate or continually

**ecosystem** an ecological community and its environment

**food web** set of feeding relations in an ecosystem

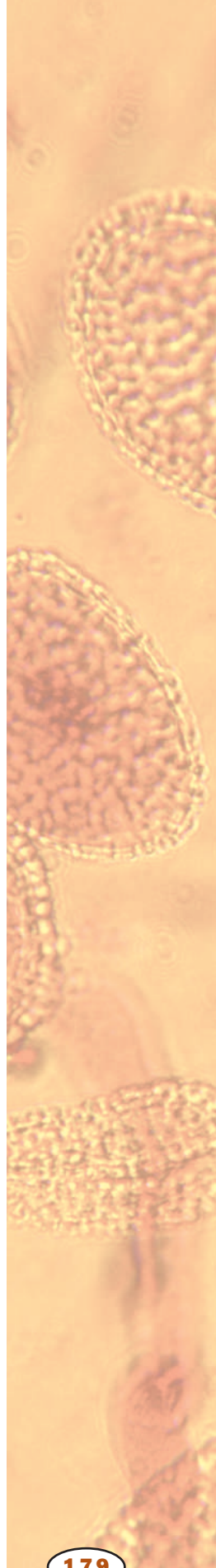

## High School Biology Teacher

Those with a broad knowledge of life science, strong interpersonal and decision-making skills, and an understanding of human development can become high school biology teachers. To prepare for this career, a student should have four years each of science and mathematics coursework, pursue outside interests in science and nature, and spend considerable time working with young people.

Biology teachers work independently and with others to select the material to be taught, apply effective teaching methods for conveying that material to adolescents, and evaluate students' knowledge of the subject. Responsible for the production of scientifically literate citizens and future scientists, they should be able to inspire and instruct.

Teaching generally requires a bachelor of science degree in biology and an additional year of college preparation to learn how students acquire knowledge as well as ways that are effective for promoting learning. Once prepared, individuals seek approval from the state's certifying body, which will attest that the candidate has met the content and pedagogical requirements to teach biology to high school students. Having a criminal-free background, completing a period of supervised practice teaching, and passing a licensure exam are among the requirements. Certified teachers are employed by public school districts and private schools throughout the state of licensure. SEE ALSO COLLEGE PROFESSOR

*Karynne L. M. Kleine*

### Bibliography

*National Science Teachers Association.* <<http://www.nsta.org>>.

*National Association of Biology Teachers.* <<http://www.nabt.org>>.

## History of Agriculture

Agriculture is the raising of domesticated animals and the planting, cultivation, and preservation of crops. Agriculture entails selective breeding of organisms with combinations of inherited characteristics that benefit humans (and not necessarily the organisms themselves), and so these practices have over time greatly influenced the course of evolution of these animals. Agriculture arose thousands of years ago in different parts of the world. The steps were similar in different places, but the types of organisms that were raised or cultivated differed. Underlying all of agriculture is human control of the environment.

### From Hunting and Gathering to Intentional Intervention

Preparing a feast today is as easy as visiting the local supermarket, farm stand, or garden. However, fifteen thousand years ago, conditions were quite different. Isolated bands of people hunted and gathered on the parts of the earth not covered in ice, seeking wild game and edible plants. They had to find food, or starve.

Cultivation of plants may have arisen accidentally. According to the "dump heap hypothesis," wandering peoples discarded remains of plant

foods in piles in cleared areas, then returned to the sites and discovered that the same types of plants they had eaten the year before grew again. Eventually, people connected the leaving of seed one season to finding of edible plants the next. Farming began when people intentionally saved and planted seeds of their favorite plants.

By selecting characteristics that make a plant a good crop, early farmers altered the genetic makeups of plant populations. Corn, for example, is a product of human intervention. Corn's ancestor, a grass called teosinte, had small ears with sparse kernels. As humans selected teosinte ears bearing the most plump kernels, they gradually edged evolution towards forming a new species, corn. A reminder today of this ancient intervention is that the jackets formed by the leaves covering an ear of corn (husks) are so tight that the plant cannot naturally release its seed. Other plant species were also changed by humans selecting variants that held onto seeds more tightly, a trait that would not benefit a plant in the wild.

### Multiple Origins of Agriculture

Some of the earliest archeological evidence for agriculture comes from the Yellow River region of China, where the people raised rice and millet some fifteen thousand years ago. By thirteen thousand years ago, when warmer and wetter weather followed the end of the Pleistocene ice age, people in the Fertile Crescent, an area that today includes Iran, Iraq, Turkey, Syria, Israel, and Lebanon, cultivated wild grasses, which were the ancestors of barley and emmer and einkorn wheat, as well as lentils and chickpeas. The fields of grasses supported grazing animal populations.

Striking evidence of early agriculture is a ten thousand-year-old farming village in Jericho in the Jordan Valley built over the remains of a hunter-gatherer settlement. The farm was larger and supported more people, and included permanent homes and evidence of irrigation, including walls to hold back floods and ditches. Barley flourished in nearby fields.

By eight thousand years ago, farming settlements and villages ringed by crop fields had spread from the Middle East to Eastern Europe. People raised wheat, barley, legumes, goats, sheep, pigs, cattle, and many other species. By seven thousand years ago, people in central Europe and the western Mediterranean region were actively farming, and by four thousand years ago, the change came to the British Isles. Tombs, mummy wrappings, and paintings and hieroglyphics from Assyria and Egypt from this time herald a diet, at least among the well-to-do, that included figs, dates, grapes, olives, pomegranate, and several cereals. Meanwhile, agriculture was spreading in the Americas. By eight thousand years ago, people there were eating kidney beans, peanuts, lima beans, cocoa, avocados, pumpkins, squashes, tomatoes, chili peppers, and corn. Potatoes were a staple in settlements in the Andes Mountains in South America about four thousand years ago. On the African continent, cassava, yams, coffee, cotton, millet, and sorghum were among the first crops, grown about five thousand years ago.

### Modern Agriculture and Biotechnology

The work of Charles Darwin and Gregor Mendel in the late nineteenth century, in evolution and genetics, respectively, revealed the biological

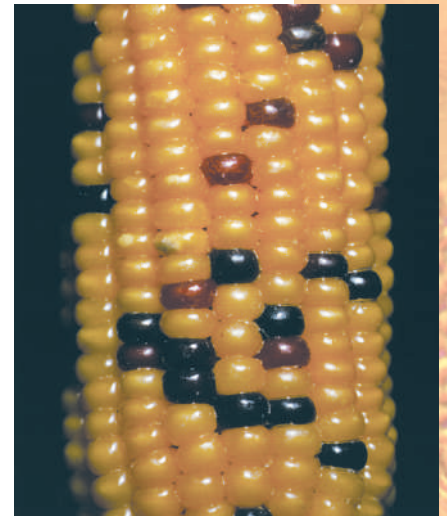

Genetically engineered corn. Humans have intervened with the growth of corn since ancient times.

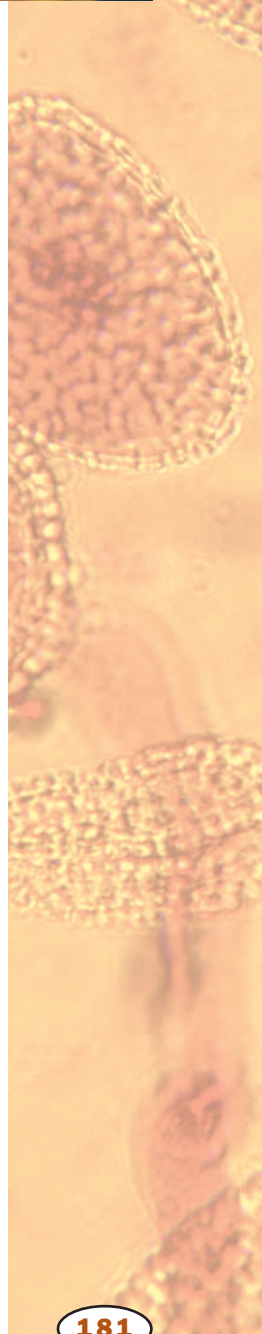

**inbred** repeatedly bred with close relatives, creating organisms with very little genetic variation

**hybrid** combination of two different types

**monoculture** cultivation of a single type of crop in a large area

**pathogen** disease-causing organism

**transgenic** characterized by presence of one or more genes from a different organism

**genetic code** relationship between triples of RNA nucleotides and the amino acids they code for during protein synthesis

**protein** complex molecule made from amino acids; used in cells for structure, signaling, and controlling reactions

**metabolism** chemical reactions within a cell

basis of the selective breeding that is agriculture. Cultivation approaches could therefore become more directed. For example, in the early twentieth century, George Shull, at the Station for Experimental Evolution in Cold Spring Harbor, New York, crossed highly **inbred** strains of corn, and produced very robust **hybrids**. Use of hybrids ushered in a new era in agriculture, with many fields planted with the same strains of crop plants (**monocultures**). But this set the stage for disaster, such as arrival of a **pathogen** to which all of the plants were equally vulnerable. In the twenty-first century, farmers plant several varieties of the same crop to avoid the weakness of monocultures.

Traditional agriculture selects valuable variants among individual organisms, and breeding is between members of the same or very closely related species. Conventional breeding therefore mixes up many traits at a time. In contrast is agricultural biotechnology, in which addition or modification of specific genes creates valuable variants. Specifically, a **transgenic** plant or animal has an added gene in each of its cells. The transgene can come from a different type of organism, which is possible because all species use the same **genetic code** to manufacture **protein**. To return to the example of corn, plants that are transgenic for a gene from the bacterium *Bacillus thuringiensis* produce a protein that kills certain caterpillars, including the devastating European corn borer. Use of such “bt corn” enables a farmer to avoid using chemical pesticides, but has potential consequences of its own, such as promoting selection of borers resistant to the poison, and harm to nearby insect populations.

Agricultural biotechnology began in the 1970s, and people in the United States have been eating genetically modified foods since the mid-1990s. The goals of agricultural biotechnology are the same as traditional agriculture: improved appearance, flavor, and nutritional content of foods, and ease of cultivation. SEE ALSO AGRICULTURE; AGRONOMIST; GRAIN; ORGANIC AGRICULTURE; PLANT PATHOGENS AND PESTS

Ricki Lewis

### Bibliography

Brintnall Simpson, Beryl, and Molly Conner Ogorzaly. *Economic Botany: Plants in Our World*, 3rd ed. New York: McGraw-Hill Higher Education, 2000.

McCully, Kilmer. “The Significance of Wheat in the Dakota Territory, Human Evolution, Civilization, and Degenerative Diseases.” *Perspectives in Biology and Medicine* 44, no. 1 (Winter 2001): 52–61.

Smith, Bruce D. *The Emergence of Agriculture*. New York: Scientific American Library, 1995.

## History of Biology: Biochemistry

Biochemistry as a recognizably distinct discipline emerged at the beginning of the twentieth century. Initially it focused on the chemical changes of cellular **metabolism**.

### Roots of Biochemistry

Biochemistry had its roots in nineteenth-century physiological chemistry, animal chemistry, and the chemistry of biological materials. The earliest

views on the chemistry of life posited that it was fundamentally different from nonliving chemistry. From around 1835, the view had developed that **protoplasm**, seen as a jellylike single homogeneous form of matter within organisms, carried out all the processes of **intracellular** breakdown of foods, respiration, and biosynthesis. Despite this general belief, neither Justus Liebig nor Ernst Hoppe-Seyler, two eminent chemists, accepted this view. Hydrolytic enzymes such as amylase, maltase, and pepsin were known in the nineteenth century, but were not thought to act within cells.

Probably the single most important experiment that initiated the study of biochemistry was the preparation by Eduard Buchner in 1897 of a cell-free extract of yeast, called zymase, which fermented **glucose** and produced carbon dioxide and ethanol. Buchner regarded zymase as a single enzyme, although others soon showed that it contained several. This work confirmed fermentation as a chemical process and discredited the protoplasm theory. Furthermore, the distinction between **catalysis** by hydrolytic extracellular enzymes and by intracellular enzymes disappeared.

## Enzymes

The nature of catalysis began to be explored early in the twentieth century with the realization that enzymes bind their **substrates** during the reaction. At the beginning of the twentieth century, Emil Fischer proposed that a substrate fits its enzyme like a key fits a lock. Mathematical analysis of enzyme action enabled Leonor Michaelis and Maud Menten to formulate the classic equations for enzyme action in 1913. The chemical nature of enzymes as proteins remained uncertain until James Sumner crystallized urease from Jack bean meal in 1926. Several other enzymes were crystallized in the following years and were all shown to be proteins. In 1959, Sanford Moore and William Stein determined the first primary sequence (the **amino acid** sequence) of an enzyme, ribonuclease. The path was now open, using X-ray crystallography to reveal the catalytic process in three-dimensional models of enzymes.

## Metabolism

Part of the significance of Buchner's work lay in initiating the study of fermentation as a metabolic pathway. Otto Meyerhof demonstrated that muscle juice had similar properties, although producing lactic acid rather than ethanol. Thus, the glycolytic pathway, associated with the names of Gustav Embden, Meyerhof, and Otto Warburg, was elucidated over the first four decades of the twentieth century.

In the first years of the twentieth century, Franz Knoop and also Henry Dakin outlined the basis of fatty acid **oxidation**, although this pathway was not fully formulated until the 1950s. The cyclical nature of some metabolic pathways became apparent to Hans Krebs in his study of the synthesis of urea, which led to the description of the urea cycle in 1931. In 1937, building on much work on cell oxidation reactions, Krebs formulated the citric acid cycle (often called the **Krebs cycle** in his honor). Identification of acetyl coenzyme A in the early 1950s facilitated the understanding of **pyruvate** oxidation, fatty acid oxidation, and the citric acid cycle.

During the 1930s, biochemists began to use radioactive **isotopes** such as deuterium ( $^2\text{H}$ ),  $^{32}\text{P}$ , and  $^{35}\text{S}$  in studies of metabolism. After World War



Eduard Buchner, whose experiments with zymase initiated the study of biochemistry.

**protoplasm** fluid portion of a plant cell within the cell wall

**intracellular** within a cell

**glucose** simple sugar that provides energy to animal cells and is the building block of cellulose in plants

**catalysis** aiding in the reaction of

**substrate** the molecule acted on by an enzyme

**amino acid** a building block of protein

**oxidation** reaction characterized by loss of electrons, or reaction with oxygen

**Krebs cycle** central metabolic pathway in mitochondria

**pyruvate** the ionized form of pyruvic acid, a key intermediate in cell metabolism

**isotopes** forms of an atom that differ by the number of neutrons in the nucleus

II,  $^{14}\text{C}$  became readily available, and together with the use of microbial mutants, enabled researchers to elucidate metabolic pathways, particularly from 1945 to 1975.

## Bioenergetics and Membranes

**ATP** adenosine triphosphate, a high-energy nucleotide used by cells to power most energy-requiring reactions

**glycolysis** initial stages of sugar breakdown in a cell

**phosphorylation** addition of the phosphate group  $\text{PO}_4^{3-}$

**gradient** difference in concentration between two places

**ion** an electrically charged particle

**membrane potential** electrical and chemical differences across a membrane leading to storage of energy and excitability

**oxidative phosphorylation** use of oxygen to make ATP

**lipid** fat or waxlike molecule, insoluble in water

**bilayer** composed of two layers

**hemoglobin** oxygen-carrying protein complex in red blood cells

The importance of adenosine triphosphate (**ATP**) emerged slowly from a study of the cofactors necessary for **glycolysis** in yeast and muscle. In 1939, Vladimir Engelhardt and Militsa Lyubimova showed ATP to be a substrate for myosin that participates in muscular contraction. In 1941, Fritz Lipmann set out the essential role of ATP as the energy currency of the cell. Initially ATP synthesis was thought to be associated only with glycolysis, but during the 1930s a number of studies showed that much of ATP production was associated with oxygen uptake, linking oxygen consumption with **phosphorylation**.

During the 1920s and 1930s, David Keilin outlined the steps of the respiratory chain, through which oxygen is consumed in the mitochondrion. By the 1950s, it was clear that the respiratory chain was coupled to the synthesis of ATP. In 1961, Peter Mitchell formulated the chemiosmotic theory of ATP production, based on a **gradient** of  $\text{H}^+$  **ions** and **membrane potential**. This not only resolved the issue of **oxidative phosphorylation** but also gave a firm foundation for studies of transport across membranes. Jonathon Singer and Garth Nicholson resolved problems of membrane structure by proposing in 1972 the fluid mosaic model in which proteins are embedded in a fluid **lipid bilayer**.

At the beginning of the twentieth century, the basic process of photosynthesis had already been defined. From 1954 to 1956, Melvin Calvin and Andrew Benson formulated the metabolic pathway for carbon dioxide fixation, which would be named the Calvin-Benson cycle in their honor. In 1937, Robin Hill and others had progressively elaborated the workings of the electron transport chain of the chloroplast. In the second half of the 1950s, Daniel Arnon showed that the electron transport chain drives ATP synthesis in the chloroplast. Many researchers in the twentieth century explored the basic photochemistry of photosynthesis, but the determination of the structure of a bacterial reaction center complex by Johann Deisenhofer in 1984 has helped to clarify the field.

## Proteins

The theory that proteins were composed of linear chains of amino acids had been enunciated at the beginning of the twentieth century, while the amino acid constituents of proteins were still being identified. However, it was not until Fred Sanger obtained the first complete primary structure of a protein, insulin, in 1955 that the theory was confirmed. A model of the three-dimensional structure of a protein (whale myoglobin) was determined by John Kendrew and colleagues between 1958 and 1960 based on X-ray analysis. Concurrently Max Perutz described the structure of **hemoglobin**. Among other issues, these achievements confirmed the predictions made in 1950 by Linus Pauling and Robert Corey that the amino acid chain could coil into a spiral staircase-like structure called the alpha helix. Researchers have described the three-dimensional structures of many proteins since that time.



Improved techniques of crystallography, X-ray analysis, and other skills in protein chemistry are bringing new insights to many areas of classical biochemistry, including enzymology. For example, the elucidation of the structure and mechanism of the bacterial **mitochondrial** and chloroplast ATP synthase (ATPase) in the 1990s, based on the work of Paul Boyer and John Walker, has revealed an enzyme that involves a rotating core to carry out ATP synthesis. This molecule is used by both mitochondria and chloroplasts to make ATP.

## DNA and Protein Synthesis

Work on bacteria led Oswald Avery to suggest in the 1940s that deoxyribonucleic acid (DNA) was the genetic material of the cell. Francis Crick and James Watson elucidated the structure of DNA in 1953. The structure they proposed suggested immediately the way in which genes might be replicated. More importantly, Crick suggested that the sequence of bases determines the sequence of amino acids in proteins, and that the amino acid sequence in itself determined the three-dimensional structure of these proteins. By 1960, it was believed that a sequence of three DNA bases encodes an individual amino acid. Marshall Nirenberg, Severo Ochoa, and Gobind Khorana “cracked” the **genetic code**—the specific DNA base triplets that specify particular amino acids—in a series of experiments conducted in the 1960s.

In 1961, François Jacob and Jacques Monod introduced the concept of regulatory genes, which control the expression of structural genes that encode for proteins. Other methods of control were discovered later. By the 1970s, it was possible to synthesize proteins *in vitro*.

## Manipulation of DNA and Elucidation of Protein Structure

The sequencing of significant lengths of DNA remained a problem until in 1977 Fred Sanger sequenced a bacteriophage **genome** of 5,375 **nucleotides**. This achievement led the way to Sanger’s sequencing of the DNA of the human mitochondrial genome of more than 16,000 nucleotides in 1981. These early sequencing successes contributed to the idea that arose in the mid-1980s to sequence the human genome, which researchers expect to complete in 2003 (a draft sequence was published in 2001).

Parallel to DNA sequencing efforts was the use of **restriction enzymes**, which cut DNA at specific sequences. Restriction enzymes made possible DNA sequencing, recombinant DNA technology, **transgenic** technology, and other tools, giving rise to the rapid development in the 1990s of biotechnology based on gene splicing. SEE ALSO CRICK, FRANCIS; ENZYMES; GLYCOSIS AND FERMENTATION; HISTORY OF BIOLOGY: CELL THEORY AND CELL STRUCTURE; HISTORY OF BIOLOGY: INHERITANCE; KREBS CYCLE; METABOLISM, CELLULAR; MUSCLE; OXIDATIVE PHOSPHORYLATION; PROTEIN STRUCTURE; WATSON, JAMES

*John Prebble*

### Bibliography

- Crick, Francis. *What Mad Pursuit: A Personal View of Scientific Discovery*. New York: Basic Books, 1988.
- Florkin, Marcel, and Stotz, Elmer H. *Comprehensive Biochemistry*, Section VI (Volumes 30–39): *A History of Biochemistry*. Amsterdam: Elsevier, 1970–95.

**mitochondria** subcellular organelle that creates ATP used for energy-requiring processes in a cell

**genetic code** relationship between triples of RNA nucleotides and the amino acids they code for during protein synthesis

**in vitro** “in glass”; in lab apparatus, rather than within a living organism

**genome** total genetic material in a cell or organism

**nucleotide** the building block of RNA or DNA

**restriction enzyme** enzyme that cuts DNA at a particular sequence

**transgenic** characterized by presence of one or more genes from a different organism

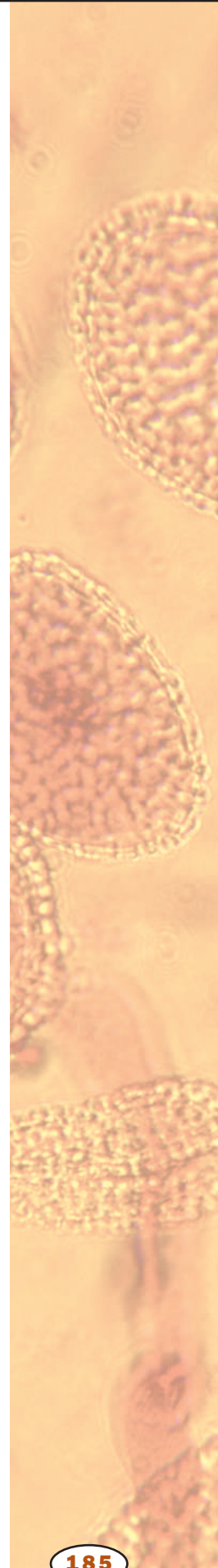

Fruton, Joseph S. *Proteins, Enzymes, Genes: The Interplay of Chemistry and Biology*. New Haven, CT: Yale University Press, 1999.

Judson, Horace F. *The Eighth Day of Creation*. New York: Simon & Schuster, 1979.

Kohler, Robert E. "The Enzyme Theory and the Origin of Biochemistry." *Isis* 64 (1973): 181–196.

Krebs, Hans A. *Reminiscences and Reflections*. Oxford: Oxford University Press, 1981.

Watson, James D. *The Double Helix*. London: Weidenfeld & Nicolson, 1968.

## History of Biology: Cell Theory and Cell Structure

All living organisms are composed of cells, and all cells arise from other cells. These simple and powerful statements form the basis of the cell theory, first formulated by a group of European biologists in the mid-1800s. So fundamental are these ideas to biology that it is easy to forget they were not always thought to be true.

### Early Observations

The invention of the microscope allowed the first view of cells. English physicist and microscopist Robert Hooke (1635–1702) first described cells in 1665. He made thin slices of cork and likened the boxy partitions he observed to the cells (small rooms) in a monastery. The open spaces Hooke observed were empty, but he and others suggested these spaces might be used for fluid transport in living plants. He did not propose, and gave no indication that he believed, that these structures represented the basic unit of living organisms.

Marcello Malpighi (1628–1694), and Hooke's colleague, Nehemiah Grew (1641–1712), made detailed studies of plant cells and established the presence of cellular structures throughout the plant body. Grew likened the cellular spaces to the gas bubbles in rising bread and suggested they may have formed through a similar process. The presence of cells in animal tissue was demonstrated later than in plants because the thin sections needed for viewing under the microscope are more difficult to prepare for animal tissues. The prevalent view of Hooke's contemporaries was that animals were composed of several types of fibers, the various properties of which accounted for the differences among tissues.

At the time, virtually all biologists were convinced that organisms were composed of some type of fundamental unit, and it was these "atomistic" preconceptions that drove them to look for such units. While improvements in microscopy made their observations better, it was the underlying belief that there was some fundamental substructure that made the microscope the instrument of choice in the study of life.

In 1676 the Dutch microscopist Antony van Leeuwenhoek (1632–1723) published his observations of single-cell organisms, or "little animalcules" as he called them. It is likely that Leeuwenhoek was the first person to observe a red blood cell and a sperm cell. Leeuwenhoek made numerous and detailed observations on his microorganisms, but more than one hundred years passed before a connection was made between the obviously cellular structure of these creatures and the existence of cells in animals or plants.



Robert Hooke's microscope. Hooke first described cells in 1665.

## The Development of the Cell Theory

In 1824 Frenchman Henri Milne-Edwards suggested that the basic structure of all animal tissues was an array of “globules,” though his insistence on uniform size for these globules puts into question the accuracy of his observations. Henri Dutrochet (1776–1847) made the connection between plant cells and animal cells explicit, and he proposed that the cell was not just a structural but also a physiological unit: “It is clear that it constitutes the basic unit of the organized state; indeed, everything is ultimately derived from the cell” (Harris 1999, p. 29). Dutrochet proposed that new cells arise from within old ones, a view that was echoed by his contemporary François Raspail (1794–1878). Raspail was the first to state one of the two major tenets of cell theory: *Omnis cellula e cellula*, which means “Every cell is derived from another cell.” However, despite this ringing and famous phrase, his proposed mechanism of cell generation was incorrect. Raspail was also the founder of cell biochemistry, making experiments on the chemical composition of the cell and their response to changing chemical environments.

In 1832 Barthélemy Dumortier (1797–1878) of France described “binary fission” (cell division) in plants. He observed the formation of a midline partition between the original cell and the new cell, which, Dumortier noted, “seems to us to provide a perfectly clear explanation of the origin and development of cells, which has hitherto remained unexplained” (Harris 1999, p. 66). These observations led him to reject the idea that new cells arise from within old ones, or that they form spontaneously from noncellular material. The discovery of cell division is usually attributed to Hugo von Mohl (1805–1872), but Dumortier preceded him in this regard. Von Mohl did coin the word “protoplasm” for the material contained in the cell.

The first unequivocal description of the cell **nucleus** was made by a Czech, Franz Bauer, in 1802 and was given its name in 1831 by Robert Brown (1773–1858) of Scotland, who is best remembered for discovering the random “Brownian” motion of molecules. The first accurate description of the nucleolus was made in 1835.

Schleiden and Schwann, who are usually given credit for elucidating the cell theory, made their marks in 1838 and 1839. In 1838 Matthias Schleiden (1804–1881) proposed that every structural element of plants is composed of cells or the products of cells. However, Schleiden insisted on priority for several ideas that were not his and clung to the idea that cells arise by a crystallization-like process either within other cells or from outside, which Dumortier had dispensed with some years earlier. (In Schleiden’s defense, it should be remembered that drawing incorrect conclusions from limited observations is a risk inherent in science, especially when working on the frontier of a new field.)

In 1839 a fellow German, Theodor Schwann (1810–1882), proposed that in animals too every structural element is composed of cells or cell products. Schwann’s contribution might be regarded as the more groundbreaking, since the understanding of animal structure lagged behind that of plants. In addition, Schwann made the explicit claim that the fundamental laws governing cells were identical between plants and animals: “A common principle underlies the development of all the individual elementary subunits of all organisms” (Harris 1999, p. 102).

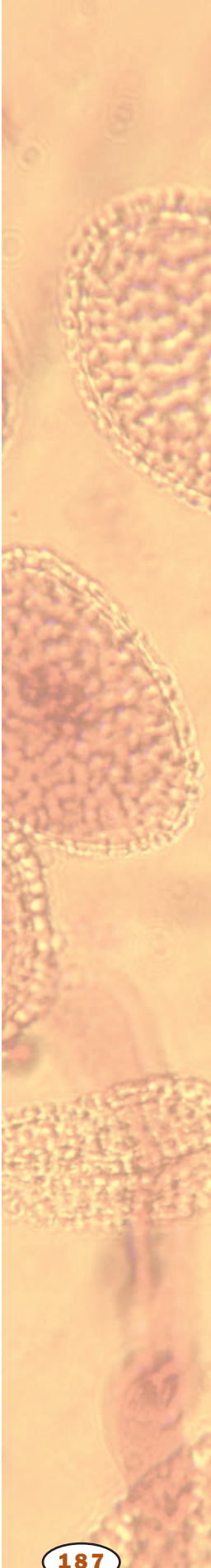

**nucleus** membrane-bound portion of cell containing the chromosomes

**cytologist** scientist who studies cells

**chromosomes** “colored body” in the cell nucleus; made of DNA and protein, and divided functionally into genes and non-gene regions

**mitosis** separation of replicated chromosomes

**endoplasmic reticulum** network of membranes within the cell

**cytoskeleton** internal scaffolding in a cell, composed of protein

### WILSON, EDMUND B. (1865–1939)

Premier cell biologist of the early twentieth century, Wilson described how a fertilized egg divides up into hundreds of cells to form an embryo and which parts of the body develop from which cells. His student Walter Sutton discovered the role of chromosomes as the units of heredity.

A special word should be said here about the Czech Jan Purkyňe (1787–1869), or Purkinje, as his name is usually given. Purkinje was the premiere **cytologist** of his day, and one of the most influential formulators of the cell theory. He gave his name to structures throughout the body, including the Purkinje cells of the cerebellum. Purkinje, in fact, deserves much of the credit that usually goes to Schwann, for in 1837 he proposed not only that animals were composed principally of cells and cell products (though he left room for fibers) but also that the “basic cellular tissue is again clearly analogous to that of plants” (Harris 1999, p. 92). Unfortunately, Schwann did not credit Purkinje in his influential publication.

## Reproduction and Inheritance

Despite the work of Dumortier, the origins of new cells remained controversial and confused. In 1852 a German, Robert Remak (1852–1865), published his observations on cell division, stating categorically that the generation schemes proposed by Schleiden and Schwann were wrong. Based on his observations of embryos, Remak stated instead that binary fission was the means of reproduction of new animal cells. This view was widely publicized not by Remak but by Rudolf Virchow (1821–1902), unfortunately without crediting Remak. Virchow is also usually given the credit for the phrase *Omnis cellula e cellula*, indicating the importance of cell division in the creation of new cells.

The understanding of the central importance of **chromosomes** lagged well behind their discovery. In 1879 Walther Flemming (1843–1905) noted that the chromosomes split longitudinally during **mitosis** (a term he introduced). Wilhelm Roux (1850–1924) proposed that each chromosome carried a different set of heritable elements and suggested that the longitudinal splitting observed by Flemming ensured the equal division of these elements. This scheme was confirmed in 1904 by Theodor Boveri (1862–1915). Combined with the rediscovery of Gregor Mendel’s 1866 paper on heritable elements in peas, these results highlighted the central role of the chromosomes in carrying genetic material. The chemical nature of the gene was determined in a series of experiments over the next fifty years, culminating in the determination of the structure of deoxyribonucleic acid (DNA) in 1953 by James Watson and Francis Crick.

## Modern Advances

The modern understanding of cellular substructure began with the use of the electron microscope. Keith Porter (1912–1997) was a pioneer in this field and was the first to identify the **endoplasmic reticulum** and many elements of the **cytoskeleton**. The explosion of knowledge brought about by improvements in microscopy, biochemistry, and genetics has led to a depth of understanding of cell structure and function undreamed of by the earliest cell biologists. SEE ALSO CELL; ELECTRON MICROSCOPY; LEEUWENHOEK, ANTON VON; LIGHT MICROSCOPY; PORTER, KEITH

*Richard Robinson*

### Bibliography

Harris, Henry. *The Birth of the Cell*. New Haven, CT: Yale University Press, 1999.  
Magner, Lois N. *History of Life Sciences*, 2nd ed. New York: Marcel Dekker, 1994.

## History of Biology: Inheritance

Heredity (colloquially synonymous with “inheritance”) refers to the process by which certain features (heritable characteristics) are transmitted from parent to offspring. This process has long been a source of intense interest to scientists. Just why do children look like their parents, but not exactly? This question can be separated into two parts: (1) In sexually reproducing organisms, how do the features of the parents get combined and transmitted to the offspring? (2) What actually gets transmitted? To ask these questions requires the materialist belief that some physical substance is transmitted that corresponds to particular traits, an assumption that was not widely held before the late nineteenth century.

### From Aristotle to Weismann

Before the nineteenth century, questions about offspring looking like their parents were asked within a conceptual framework that embraced very different assumptions than scientists do today. The contributions of the parents to the offspring were not necessarily assumed to be equal, or even to be purely material. The ancient Greek philosopher Aristotle, for example, thought that the male semen contributed the “active element” to the offspring, bringing it to life, while the female contributed only nutritional material for the offspring.

Theorists who did think both parents contributed some material elements generally assumed that *blending inheritance* held true: the parental contributions were believed to blend together so that the offspring’s characteristics were usually intermediate between those of the parents. If one parent had a short nose and another a long one, the child could be expected to have a nose somewhere in between. Moreover, in this conceptual framework, heredity was not separated sharply from environment; it was “common sense” that environmental effects on parental characteristics could reappear in their offspring. (This would later be called “the inheritance of acquired characters,” or “Lamarckism,” after the early-nineteenth-century biologist Jean-Baptiste Lamarck.) Thus, if parents were well educated, it was assumed that their children would be smart.

In the late nineteenth century, this framework was gradually abandoned. Two shifts in outlook were especially important. First, spurred on by new observations, scientists came to view hereditary transmission as a purely material process (possibly exempt from the effects of the environment). Starting in the 1860s, biologists developed new microscopic techniques to study the physical processes of the cell (a branch of biology called **cytology**). In 1875, the German anatomist Oscar Hertwig was the first to observe a sperm penetrating an egg (of a sea urchin), thereby lending credence to the idea that a material substance was actually physically transferred via the sperm.

In the 1870s, new structures in the **nucleus** were discovered, called **chromosomes** (which means “colored bodies”) because they absorbed dyes more intensely than the surrounding nuclear material. Although their function was mysterious, the fact that they came in pairs (perhaps one from each parent) suggested a possible role in heredity. As cytologists raced to sort out the complex and confusing cell-division events of **mitosis** and **meiosis** from



Heredity refers to the process by which certain features are transmitted from parents to offspring.

**cytology** study of cells

**nucleus** membrane-bound portion of cell containing the chromosomes

**chromosome** “colored body” in the cell nucleus; made of DNA and protein, and divided functionally into genes and non-gene regions

**mitosis** separation of replicated chromosomes

**meiosis** cell division that forms eggs or sperm

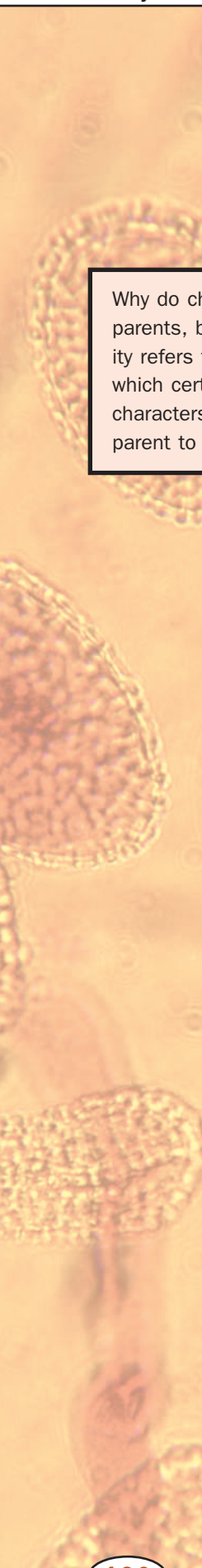

**fertilization** union of sperm and egg

Why do children look like their parents, but not exactly? Heredity refers to the process by which certain features (heritable characters) are transmitted from parent to offspring.

the late 1870s to the early 1900s, they constructed innovative theories of heredity to accommodate these new observations. In contrast with earlier work, most of these theories postulated that some physical substance carried by the sperm and egg combined during **fertilization** to produce the offspring.

**August Weismann.** At the same time, theorists began to challenge a second fundamental assumption of the old framework: blending inheritance. Instead, they suggested that inheritance was *particulate*: each parent contributed to the offspring its own share of discrete units corresponding to some hereditary trait (such as height or eye color), which were somehow then combined and sorted in the offspring. In the 1880s and 1890s, the German zoologist August Weismann influentially combined the two new concepts (material transfer and particulate inheritance), postulating a substance called the “germ plasm” that was carried in the chromosomes of the reproductive cells from generation to generation, and that was made up of invisible particles corresponding to particular body structures. Though Weismann’s theory was highly speculative, by the early 1900s studies of chromosomal action during fertilization and early development seemed to confirm important parts of it, especially the role of the chromosomes as bearers of particulate hereditary material.

Weismann was not the only theorist to propose that the hereditary material was made up of discrete particles: Charles Darwin had conceived of heredity as particulate in the late 1860s (though his theory of heredity was not well regarded), and the Dutch plant breeder Hugo de Vries theorized a hereditary particle he called the “pangene.” Thus, in 1900 scientists were already thinking about hereditary particles when de Vries and the German botanist Carl Correns rediscovered an obscure paper published in 1865 by the Austrian monk Gregor Mendel.

**Gregor Mendel.** Describing his breeding experiments on the common garden pea, Mendel developed his basic concept of paired, discrete hereditary “factors” (he did not call them “genes” or “alleles”). Each parent contributed one factor for each trait, and each trait came in one of two forms, dominant or recessive. Although only the dominant form would be visible in any combination of dominant and recessive, the recessive factor was still there, hidden, and could be passed to the next generation. If two recessives combined together, then the recessive form would be “expressed.” Mendel’s results also supported the idea that traits such as height and seed texture were not generally linked but recombined randomly during reproduction, showing independent assortment. A tall pea plant could thus have either smooth or wrinkled seeds; so could a short pea plant. In 1909, the Danish Mendelian Wilhelm Johannsen named these presumed hereditary particles “genes.”

Mendel’s ideas commanded immediate, widespread interest. His pea-breeding experiments, which ran over many generations of plants to yield impressively stable statistical ratios of hereditary traits, provided biological theorists with compelling new evidence for the hypothesis of paired hereditary characters that sorted independently. Mendel’s results appeared to offer practical guidance as well. Animal and plant breeders believed that they would help them develop rational systems for combining desirable traits in livestock and agriculturally important plants. Eugenicists, who sought to improve the human race through breeding “the best” traits together (such as

strength and intelligence), thought Mendelism would provide rules for rational human breeding.

**Thomas Hunt Morgan.** By the early 1900s, then, the existence of discrete genes that governed heredity seemed plausible to most biologists. However, the location and the physical nature of these theoretical entities was still uncertain. In particular, the relation between genes (which seemed to come in pairs) and chromosomes (which also came in pairs) was still a matter of some debate. Then in the 1910s, Thomas Hunt Morgan at Columbia University united the cytological focus on chromosome activity with the Mendelian breeding approach.

Combining breeding experiments on fruit flies (*Drosophila*) with microscopic study of their chromosomes, Morgan and his students established beyond any doubt that hereditary material was carried on the chromosomes and that the theoretical entity known as the gene corresponded to particular identifiable traits. They also refined the theory of the gene substantially, developing explanations for “linked” traits that did not sort randomly (genes near each other on the same chromosome), positing the existence of more than two forms of a gene (multiple **alleles**), and developing the idea that some genes could act as modifiers on others, changing their effect.

Morgan’s student Alfred H. Sturtevant combined breeding experiments, statistical analysis, and the study of chromosomes under the microscope to draw up chromosome “maps” that showed how far apart the genes for various traits must be on the chromosome. Although some scientists outside Morgan’s powerful circle—especially in Europe—contested the view that the chromosomal gene was the sole bearer of hereditary material (arguing, for example, that the **cytoplasm** surrounding the nucleus might also play a role in heredity), the views established by Morgan and his school in the 1910s and 1920s largely prevailed, and have come to be known as classical genetics.

**Biochemistry.** Biologists in the Morgan tradition, however, were unequipped to answer the question, What is the gene made of? Answering this question required attention to biochemistry. In the 1930s and 1940s, the leading candidate was **protein**, though a minority view held that it might be deoxyribonucleic acid, or DNA. In 1944, Oswald Avery, Colin MacLeod, and Maclyn McCarty published results of their experiments with the pneumonia-causing bacterium *Streptococcus pneumoniae* that indicated that DNA was the right pick, and in 1952 this view gained strong verification by the famous “Waring blender” experiments of Alfred Hershey and Martha Chase, which showed that the protein of the bacteriophage virus was a mere protective coating, while the stuff that created genetic transformation was DNA.

In 1953, James Watson and Francis Crick went further, postulating a double-helical structure for DNA, arguing that the four **nucleotide** bases guanine, cytosine, thymine, and adenine were its building blocks. The parallel structure of the helices suggested the possibility that it “unzipped” in replication, such that each side of the zipper, each helix, could then act as a **template** for the synthesis of a **complementary** strand of DNA, thus creating a perfect replica, ideally suited for passing on to offspring. Finally, in the early 1960s, scientists interpreted the sequence of nucleotides along the chromosome as a code for the sequence of **amino acids** in protein. This insight illuminated the means by which the gene dictates the physical characteristics

**allele** a particular form of a gene

**cytoplasm** material in a cell, excluding the nucleus

**protein** complex molecule made from amino acids; used in cells for structure, signaling, and controlling reactions

**nucleotide** the building block of RNA or DNA

**template** master copy

**complementary** matching opposite

**amino acid** a building block of protein

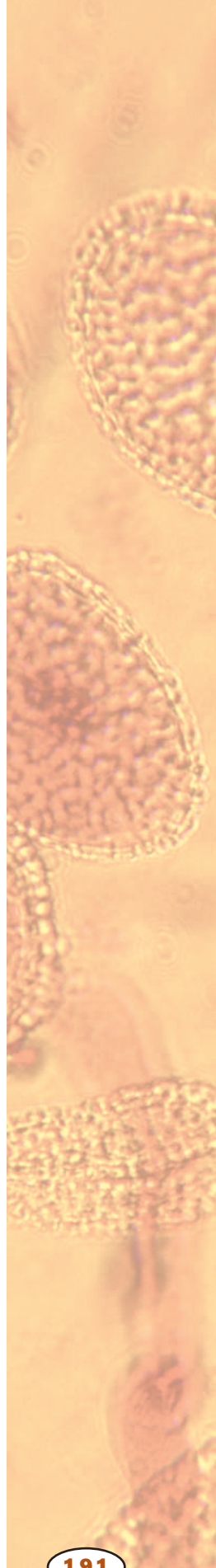

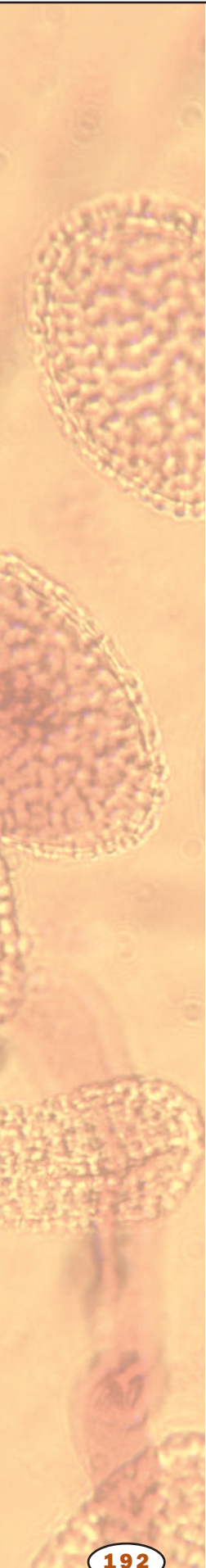

**polypeptide** chain of amino acids

**gene expression** use of a gene to create the corresponding protein

**embryology** study of development

**B.C.E.** before the Common Era, equivalent to BC

of the organism possessing it. Although many details needed to be resolved, it seemed to many that the most basic keys to heredity had been discovered.

By the late twentieth century, then, biologists had come to view the gene from two directions. Working from the “outside in,” organismal and population biologists continued to operate with the classical concept that a gene (or some combination of genes) corresponds to a trait (as in “a gene for X”). Working from the “inside out,” biochemists and molecular biologists defined the gene as the amount of DNA that codes for one protein or one **polypeptide**. Since a protein is not the same as a trait, much work continues to aim at unravelling the complex nature of **gene expression**. As research continues to develop, and the field of genomics continues to expand, the idea of the gene continues to evolve. SEE ALSO CRICK, FRANCIS; DNA; GENE; GENOMICS; HISTORY OF BIOLOGY: CELL THEORY AND CELL STRUCTURE; MENDEL, GREGOR; WATSON, JAMES

Lynn K. Nyhart

### Bibliography

- Allen, Garland E. *Life Science in the Twentieth Century*. New York: John Wiley & Sons, 1975.
- Bowler, Peter J. *The Mendelian Revolution: The Emergence of Hereditarian Concepts in Modern Science and Society*. Baltimore, MD: The Johns Hopkins University Press, 1989.
- Coccos, Alain F., and Floyd V. Monaghan, eds. *Gregor Mendel's Experiments on Plant Hybrids: A Guided Study*. New Brunswick, NJ: Rutgers University Press, 1993.
- Crick, Francis. *What Mad Pursuit: A Personal View of Scientific Discovery*. New York: Basic Books, 1988.
- Judson, Horace Freeland. *The Eighth Day of Creation: Makers of the Revolution in Biology*. New York: Simon & Schuster, 1979.
- Morgan, Thomas Hunt. *The Theory of the Gene*. Originally published in 1926. Reprint: New York: Garland Publishing, 1988.
- Weismann, August. *The Germ-Plasm. A Theory of Heredity*, translated by W. Newton Parker and Harriet Ronnfeldt. London: W. Scott, 1893.

## History of Evolutionary Thought

Although Charles Darwin's name is virtually synonymous with the word evolution, he was not the first person to recognize the phenomenon of species change nor did he even use the word “evolution” in the original theory he set forth in *On the Origin of Species* (1859). In fact, only the very last word of his book was *evolve*. The word *evolution* was introduced after Darwin published his book and by commentators like English biologist Thomas Henry Huxley (1825–1895) who borrowed the term from **embryology**.

### Antiquity

The history of evolution long predates Darwin and his theory. The belief in a changing or dynamic universe can be first seen in ancient Greek philosophy. Heraclitus (c. 500 B.C.E.), also known as the “flux philosopher,” believed that change was a fundamental property of the universe. His successor, Empedocles (c. 392–432 B.C.E.), first articulated a crude but dynamic theory that postulated that the origin of life had taken place in a manner that suggested evolution.



## From Aristotle to Linnaeus

However, beginning with the philosophical worldview established by Aristotle (384–322 B.C.E.), the belief in a changing universe fell into disfavor. Aristotle and his numerous medieval and Renaissance translators, commentators, and supporters, instead believed in a static universe which held that living organisms were created initially and then remained essentially unchanged. These ideal types or species were arranged hierarchically in what came to be known as the “scala naturae,” or the ladder of creation. Like rungs on a ladder, each species took its place with lower forms of life on the bottom and higher forms of life on the top.

During the Renaissance, the ladder of creation gave way to the popular metaphor of the “great chain of being,” which referred to a progression of living forms linked in an orderly chainlike arrangement. Extinction, the sudden disappearance of a species, in such a scheme, was unthinkable since it meant that the chain would lose a vital link. Belief in the fixity of species, therefore dominated biological thought and was most clearly demonstrated in the modern classification scheme that originated with Carolus Linnaeus (1707–1778).

## Buffon, Lamarck, and Transmutationism

Belief in species change, or transmutationism, slowly began to emerge during the **Enlightenment**. This period saw the emergence of the belief in a progressive world, both scientific and social. It also saw the beginnings of the new science of geology. Geological theories suggested that fossils were of **organic** (once-living) origin and that uniform or constant processes rather than catastrophic or one-time events had shaped Earth’s history.

The French naturalist Comte de Buffon (Count Buffon, 1707–1788) was one of the first to question the fixity of species and to suggest a transmutationist theory with a startling resemblance to Darwinian evolution. Although he was a respected naturalist, his theoretical explanations for the origin of life and of species change were not accepted during his time. Buffon’s transmutationist ideas were also not accepted because they opposed the philosophical teachings of his French colleague Georges Cuvier, the great comparative anatomist and the father of modern paleontology. Cuvier upheld the fixity of species despite fossil evidence of species change. Ironically, though he opposed transmutationism strongly, Cuvier was the first to recognize the phenomenon of extinction, or the view that species had disappeared from the biological record.

The first to suggest a viable theory of species change was Frenchman Jean-Baptiste Lamarck. Lamarck was interested in adaptation, or the manner and process by which organisms are able to adapt physiologically and morphologically to their environment. He was especially interested in how well-adapted organs like the neck of the giraffe had originated. According to Lamarck, the use or, in many cases, disuse of such a vital organ could lead to the development of novel but well-adapted traits. The cumulative effect of these adaptations could eventually lead to a new species. Lamarck never provided a cogent mechanism by which this physical transformation took place, however, though he did draw on contemporary theories from



Georges Léopold Cuvier opposed evolutionary theories, even though he was the first to recognize the phenomenon of extinction.

### Enlightenment

eighteenth-century philosophical movement stressing rational critique of previously accepted doctrines in all areas of thought

**organic** composed of carbon, or derived from living organisms

animal physiology to suggest that the body heat generated by physical exercise could lead to structural transformation.

Sometimes called “the inheritance of acquired characters,” Lamarckian transmutationism, also later called Lamarckian evolution, was subsequently shown to be erroneous because changes acquired as a result of use and disuse were shown to be not heritable. Lamarck’s ideas were, however, very popular throughout much of the nineteenth century and well into the twentieth century. Darwin himself relied heavily on the inheritance of acquired characters to explain many adaptations that he later outlined in laying out his own transmutationist theory.

Transmutationism itself became increasingly acceptable by the early nineteenth century. It captured the interest of Darwin’s own grandfather, Erasmus Darwin (1731–1802), who suggested that life had originated from “one living filament.” Other transmutationists included French anatomist Isidore Geoffroy Sainte Hilaire (1805–1861), who studied birth defects. He suggested that through such “monstrous births” new species might suddenly arise.

In 1844 the work of one transmutationist in particular drew the attention of a wide audience. Writing anonymously at first, Robert Chambers (1802–1871) outlined a transmutationist theory under the title *Vestiges of the Natural History of Creation*. The book drew such heavy criticism that it dissuaded Charles Darwin from setting forth his own controversial transmutationist views for nearly fifteen years.

### **Darwin and *On the Origin of Species***

Charles Darwin was the leading transmutationist of the nineteenth century. Darwin had developed the major features of his theory as early as 1837 after returning from his five year voyage of the HMS *Beagle* and after reading the famous *Essay on the Principle of Population* by Thomas Malthus (1766–1834). However, Darwin did not make his work public until much later. He felt that he needed to collect solid evidence to his support what he knew would be a contentious theory. He was finally forced into joint publication of an abbreviated version of his theory in 1858, shortly after English naturalist Alfred Russel Wallace (1823–1913) independently formulated his own nearly identical theory.

It took Darwin less than a year to outline in book form his theory of species change that he called “descent with modification” by means of the mechanism of natural selection. The full title of his famous book was *On the Origin of Species or the Preservation of Favored Races in the Struggle for Life*. The book appeared in bookstores on November 24, 1859, and sold out on the first day. It went through six editions as Darwin modified his theory in response to his many critics. It is generally thought that the first edition is a more accurate account of the workings of evolution because subsequent editions included a watered-down version of his original theory.

Darwin thought “descent with modification” took place primarily through the mechanism he termed natural selection. Natural selection occurs when an organism with a favorable variation in some trait reproduces more as a result, thereby increasing the frequency of the variation in the next generation. In addition to this mechanism for driving species change, Darwin included

some four or five other mechanisms that he thought could account for species change including the inheritance of acquired characters. Though he did not address human evolution in this book, Darwin's readers quickly made the connection between humans and other primates. Darwin eventually turned to the human evolution in 1871 when he wrote *The Descent of Man*. In this book, Darwin corrected earlier misconceptions of his work and made it clear that humans had not evolved from modern-day monkeys, but that both had shared a common ancestor.

### Criticisms and Controversies

Darwin's theory did face notable criticism in his day. One problem had to do with the absence of any viable mechanism of inheritance in Darwin's work. This led to the criticism that novel characters would be diluted out in subsequent generations. This problem was not solved until the particulate nature of heredity was elucidated during the "rediscovery of Mendel" in 1900. Another problem was the age of the earth, which was then thought to be only about 400 million years old. This was an insufficient amount of time to account for the slow, gradual process that Darwin envisioned. This problem was solved after the discovery of radioactivity in the late nineteenth century which showed the age of the earth to be nearly 5 billion years, an estimate of time long enough to account for evolution.

Yet another difficulty was that Darwin had no direct proof for a process that took place over such a long stretch of time. This proof of evolution by means of natural selection was finally provided beginning in the 1920s, with the example of industrial melanism in the peppered moth, *Biston betularia*.

More difficult to resolve were the theological and philosophical questions that followed from the mechanism of natural selection. Even though Darwin had only one line in his 1859 book on human evolution, the theory implied that humans were subject to the same mechanistic process as plants and animals. Because natural selection provides a means to develop highly complex structures without divine intervention, it challenged one argument for God's existence (namely that complex designs require a complex creator).

### The Evolutionary Synthesis

Despite a storm of controversy over the mechanism, the fact of evolution was rapidly accepted by scientists. Only after the mechanism of heredity was understood and only after the science of genetics was integrated with natural history was the debate over the mechanism of natural selection extinguished. This took place between 1920 and 1950 and was part of the event called the "evolutionary synthesis." The evolutionary synthesis drew on the work of genetics, systematics, botany, paleontology, **cytology**, and **morphology** to create what contemporary scientists call the "synthetic theory of evolution" or the "Neo-Darwinian theory of evolution."

The evolutionary synthesis drew on the work of twentieth-century biologists like Theodosius Dobzhansky (1900–1975), Ernst Mayr (b. 1904), Julian Huxley (1887–1975), George Ledyard Stebbins (1906–2001), and George Gaylord Simpson (1902–1984). It endorses the view that natural selection is the dominant mechanism that drives evolutionary change. In 1975,

**cytology** study of cells

**morphology** related to shape and form

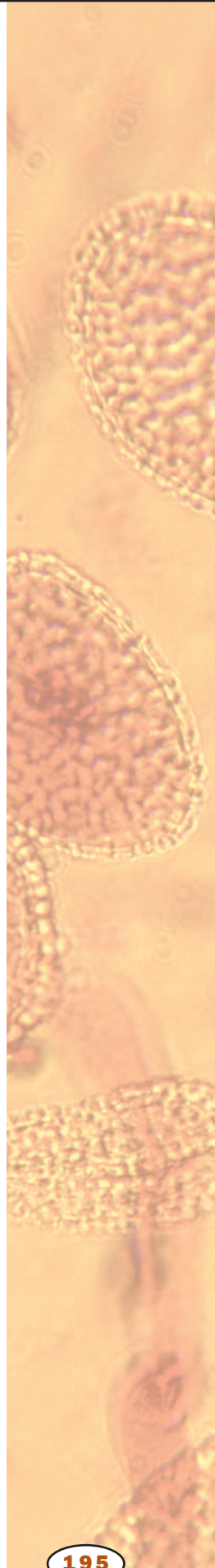

Dobzhansky stated the important fact that “nothing in biology makes sense except in the light of evolution.” In stating this, he was stressing the fact that evolution by means of natural selection serves as the central, unifying principle of the modern science of biology. SEE ALSO ADAPTATION; BUFFON, COUNT (GEORGES-LOUIS LECLERC); DARWIN, CHARLES; EVOLUTION; EVOLUTION, EVIDENCE FOR; LAMARCK, JEAN-BAPTISTE; LINNAEUS, CAROLUS; MENDEL, GREGOR; NATURAL SELECTION; PALEONTOLOGY

*Vassiliki Betty Smocovitis*

### Bibliography

- Bowler, Peter. *Evolution: The History of an Idea*. Berkeley, CA: University of California Press, 1989.
- Dobzhansky, Theodosius. “Nothing in Biology Makes Sense Except in the Light of Evolution.” *American Biology Teacher* 35 (1973): 125–129.
- Greene, John C. *The Death of Adam: Evolution and Its Impact on Western Thought*. Ames, IA: Iowa State University Press, 1959.
- Mayr, Ernst. *The Growth of Biological Thought*. Cambridge: Cambridge University Press, 1980.
- Ruse Michael. *The Darwinian Revolution*. Chicago: University of Chicago Press, 1979.

## History of Medicine

Medical history reflects a gradual transition from supernatural to natural explanations of human diseases and disorders. Speculation with few facts characterized prehistoric medicine; that is, “supernatural” medicine men blending magic, religion, and social customs with variably effective herbal medicines. The earliest “medical text” (1550 B.C.E.), containing spells, incantations, and herbal remedies, was found in a tomb in Thebes on the Nile. Many rules of hygiene and health, some with bases in science and others in tradition, are in the Hebrew Torah (1200 B.C.E.). Medical advances came as technology and social beliefs permitted; for example, cellular biology required the development of the compound microscope, and anatomy could not develop until dissecting the human body was no longer considered a sacrilege.

Hippocrates (460–377 B.C.E.) is known for his writings and the founding of a Grecian “medical school.” Physicians today still take the Hippocratic oath, an ethical code for care of the ill and dying. Greek “medicine” was mostly caring for and comforting the ill and appealing to gods. Aristotle (384–324 B.C.E.) inherited the traditions of Socrates, Plato, and Hippocrates, and perpetuated a theory of disease based on four humors and four qualities. This theory was accepted for almost two thousand years. Alexander the Great spread Grecian teachings as far as Afghanistan and Egypt.

During Roman dominance, Galen (C.E. 131–201), dissected animals (such as pigs and monkeys) because human dissection was forbidden. His experiments defined many neurological deficits, but he based his physiology on natural, vital, and animal “spirits” that reflected his religious views. Roman engineering contributed greatly to hygiene and sanitation with sewer systems and aqueducts.

Many eminent universities were founded during the Middle Ages, notably in Paris (1110), Bologna (1158), Oxford (1167), Montpellier (1181),

**B.C.E.** before the Common Era, equivalent to BC

**C.E.** Common Era, equivalent to AD

Cambridge (1209), Padua (1222), and Naples (1224). In London, St. Bartholomew's hospital (1123) and St. Thomas's hospital (1215) opened. With the human body less sacrosanct, **postmortem** examinations and dissections occurred. Medicine grew to be based on a better knowledge of anatomy, recorded in accurate drawings by Vesalius (1514–1564) and others during late Middle Ages and early Renaissance.

William Harvey's studies (1628) functionally defined the cardiovascular system, although he lacked a knowledge of capillaries. Zacharias Jansen (1590) introduced the compound microscope and subsequent improvements by Galileo Galilei and Antony van Leeuwenhoek accelerated microscopic study. Marcello Malpighi (1661) described capillaries and Leeuwenhoek described spermatozoa (1679) and bacteria (1683). Robert Boyle's chemical studies (1661) finally dispelled Aristotelian concepts of elements.

The Hunter brothers founded the Hunter School of Anatomy in London (1770). Crawford Long and William Morton invented ether anesthesia for surgery and Robert Liston amputated patients' limbs under ether anesthesia in 1846. Surgery blossomed thanks to anesthesia, but surgeons still depended on daylight and lacked sterile technique. The "golden age of surgery" began when such limitations were overcome in the twentieth century. Later highlights include heart-lung machines (1951), heart valve replacement (1952), kidney transplantation (1954), liver transplantation (1964), and heart transplantation and coronary bypass surgery (1967). Non-invasive imaging, ultrasound (1950s), and computerized axial tomography (CAT, 1972), followed later by nuclear magnetic resonance (NMR) tomography, dramatically reduced exploratory surgery.

In 1858 Rudolf Virchow published his renowned *Cellular Pathology* and Louis Pasteur proved there was no spontaneous generation of life. By 1879, Pasteur grew streptococci from a case of puerperal (childbed) fever and vaccinated sheep for anthrax (1881) while Robert Koch discovered the tuberculosis bacillus (1882). Alexander Fleming (1928) noted that *Penicillium* mold killed staphylococci, however, it took Howard Florey and Ernst Chain until 1938 to purify it. It was in general use by 1944. Viruses were first isolated and chemically defined in the 1950s and Albert Sabin's polio virus vaccine appeared in 1957. The U.S. Centers for Disease Control recognized HIV (human immunodeficiency virus) and AIDS (acquired immunodeficiency syndrome) in 1981.

In the nineteenth century, the **central nervous system** was believed to be a syncytium with all **neurons** structurally continuous. Proponents of the "neuron doctrine" (especially Santiago Ramon y Cajal) challenged this (1890s), believing the nervous system contained individual nerve cells, distinct anatomically and functionally. Ramon y Cajal and Camillo Golgi (a supporter of the syncytial theory) shared the 1906 Nobel Prize. Charles Scott Sherrington (1906) published *Integrative Action of the Nervous System* and shared the Nobel Prize with Edgar Douglas Adrian for nerve impulse work (1932). Electron microscopic studies (1960s) demonstrated points of "near contact" between neurons called synapses, final proof for the neuron doctrine.

Hormones were described by William Bayliss and Ernest Starling (1902), and Earl Sutherland described their molecular mechanisms of action in

**postmortem** after death

**central nervous system**  
brain and spinal cord

**neuron** nerve cell

### **SEMMEIWEIS, IGNAZ PHILIPP (1818–1865)**

Hungarian physician who discovered that doctors were the cause of childbed fever, which killed up to 30 percent of women who delivered a baby in a hospital. Semmelweis showed that the fever was an infection spread by doctors who did not wash their hands. The doctors and their students dissected the bodies of women who had died of the disease, then moved directly to examine and infect healthy mothers.

the 1950s. James Watson and Francis Crick discovered deoxyribonucleic acid (DNA) structure in 1953, but the Human Genome Project wasn't initiated until 1986. Human genetic sequencing is expected to be complete in 2003 (a draft of the human genome was completed in 2001). Genetic engineering and cloning are ethical issues for the twenty-first century. SEE ALSO CRICK, FRANCIS; HARVEY, WILLIAM; HUMAN GENOME PROJECT; IMAGING IN MEDICINE; HORMONES; NEURON; PASTEUR, LOUIS; TRANSPLANT MEDICINE; LEEUWENHOEK, ANTON VON; VESALIUS, ANDREAS; WATSON, JAMES

*Alvin M. Burt*

### Bibliography

Porter, Roy, ed. *The Cambridge Illustrated History of Medicine*. Cambridge, England: Cambridge University Press, 1996.

Rhodes, Philip. *An Outline History of Medicine*. London: Butterworths, 1985.

## History of Plant Physiology

Plant physiology is concerned with the life processes of plants, and from the beginning has been focused largely on the higher green terrestrial plants, the autotrophic (self-feeding) plants that feed us animals. In part, plant physiology has roots in agriculture.

The central question of plant physiology is how do plants grow, develop, and reproduce? When primitive humans collected seeds and began raising food plants they must have noted that plants need sunlight, warmth and moist (but not wet) soil of good tilth, and that seeds from vigorous plants produced vigorous plants. They observed the beneficial effects of manuring (mentioned in the Bible; Luke 13:8). Centuries of agricultural practice produced improved varieties and cultural practices, and early studies of physiology drew on this basic knowledge of plant growth and gross anatomy.

### Early Experiments on Growth

An early physiological question was where a plant gets the material with which it grows. In the early 1600s, Jan van Helmont, a Belgian physician, decided the source must be water alone. Van Helmont grew a willow seedling in 200 pounds of soil, and only added rainwater. A 164-pound tree was produced with only 57.1 grams (2 ounces) of soil lost. He knew of carbon dioxide but never dreamed that a diffuse gas could produce willow wood.

In the next century Antoine Lavoisier found **organic** matter to be largely formed of carbon and oxygen. Joseph Priestley, Jan Ingenhousz, and Jean Senebier demonstrated that plant leaves in light take up carbon dioxide and emit equivalent amounts of oxygen. Later, Nicholas de Saussure noted that water was involved in the process. The reverse occurred in the dark—plants **respired** like animals, taking up oxygen and emitting carbon dioxide. J. R. Mayer observed that the process converted light energy into the chemical energy of organic carbon. Thus growth of seedlings in the dark or of roots in the soil was at the expense of this energy. Therefore, by the nineteenth century, photosynthesis, although not understood bio-

**organic** composed of carbon, or derived from living organisms

**respire** use oxygen to burn cellular fuel

chemically, was established as the primary and essential synthetic process in plant growth.

## Nutrition and Transportation

In his experiment, van Helmont assigned no importance to the two ounces of soil lost. However, starting in the late 1700s and extending into the mid 1800s, Julius Sachs and others used chemical assays to establish that quantitatively minor soil constituents of nitrogen, potassium, phosphate, sulfur, and other elements had major importance in plant growth. The long-recognized importance of manure lay with its content of these **inorganic** nutrients, especially nitrogen. It was discovered these could be added to the soil as inorganic salts, such as potassium nitrate. The organic material of manure, or the residue of its decay, contributed to improved tilth, or soil structure, but did not provide nutrients. From these discoveries came the modern agricultural use of chemical fertilizers.

What about the extensive loss of water from the soil? Van Helmont had to continuously water his willow tree with many more pounds of water than were ultimately incorporated by the tree. In 1727 an English clergyman and amateur physiologist, Stephen Hales, published *Vegetable Staticks*, an account of his pioneering studies on the transpiration, growth, and gas exchanges of plants. Hales demonstrated that water from the soil moves up the stems to the leaves where it is lost as water vapor, a process called transpiration. Subsequent research of the nineteenth and early twentieth centuries showed that the water diffuses out through **stomata** (singular stoma), pores in the leaf epidermis (outer layer of leaf cells).

With light and adequate water the two cells bounding the stoma inflate, opening the pore to gas diffusion; under dry conditions the cells grow flaccid and the pore closes, conserving water. Capillary forces originating in the microscopic pores of the leaf mesophyll (internal green photosynthetic cells), with some contribution from **osmosis**, pull columns of water up the open vessels and tracheids of the **xylem** (wood) carrying nutrient salts from the roots. The coherence between water molecules and their adherence to cell walls prevents the taut water columns from breaking even in trees of great height. This scheme was first proposed in 1895 by Henry Dixer and John Joly. Numerous researchers in the twentieth century confirmed and refined this “cohesion-tension” theory of transportation.

Hales also measured the root pressure (forced bleeding) of decapitated plants. Subsequent work showed that under conditions of good soil moisture and aeration, roots actively secrete high concentrations of salt into the root xylem creating a high osmotic pressure that forces water up the stem and out pores at the tips of leaves (guttation). In 1926, E. Munch proposed a similar mechanism for **translocation**, the movement of sugars from leaves to roots and other plant parts. This mechanism is known as the pressure-flow model.

## Cellular and Molecular Plant Physiology

By the twentieth century, plant physiologists increasingly turned to chemistry and physics for assistance with fundamental questions. They also



Stephen Hales conducted pioneering experiments on the transpiration, growth, and gas exchanges of plants.

**inorganic** not bonded to carbon

**stomata** openings in leaves for gas exchange, surrounded and regulated by guard cells

**osmosis** passage of water through a membrane in response to concentration differences

**xylem** water-transporting system in plants

**translocation** movement of sugars and other nutrients through a plant

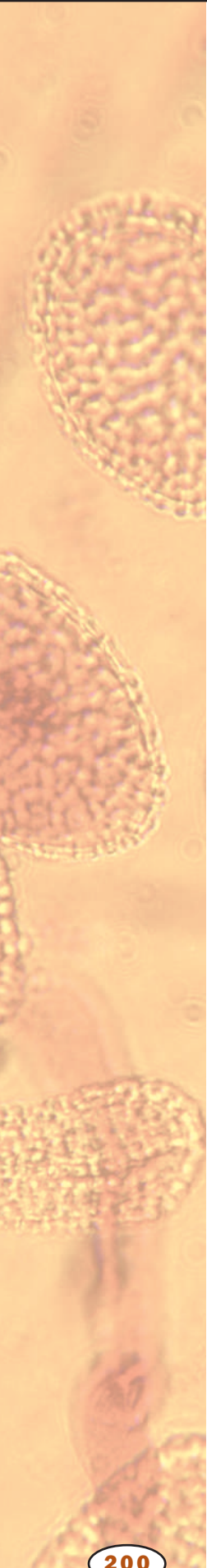

**ion** an electrically charged particle

**hormone** molecule released by one cell to influence another

**enzyme** protein that controls a reaction in a cell

**abscission** shedding of leaves; falling off

**circadian** related to a day or daylength

**organelle** membrane-bound cell compartment

**carbohydrates** sugars, starches, and other molecules combining carbon, hydrogen, and oxygen and serving as fuel or structural components

**glucose** simple sugar that provides energy to animal cells and is the building block of cellulose in plants

established their own societies with journals to publish their findings, which had a catalytic effect in increasing the level and amount of research. A great deal of the fundamental biochemistry of cell growth and function, known from the more extensive medical, animal, and microbiological research, was found to apply to plant cells. Anatomical studies gave structural details to support physiological findings, and submicroscopic cell structure was revealed by the electron microscope.

All the mineral nutrients required for plant growth were established. The key to their selective uptake from the soil and transport into the root xylem proved to lie with an energy-requiring proton (hydrogen **ion**) pumping mechanism in the cell membranes.

Environmental, hormonal, and genetic controls on growth and development have been extensively explored, but there is still more to learn. Ethylene, a simple two-carbon gas generated by plants initiates fruit ripening and regulates aspects of seed germination. Phototropisms (bending in response to unilateral light, investigated by Charles Darwin), and geotropisms (root growth down, stem growth up) were found to be due to displacement of a cell growth **hormone**, or auxin. In some circumstances, auxins could also elicit cell division (root formation in stem cuttings). Other hormones, the gibberellins, regulate cell division at the stem apex and activate **enzyme** formation in seed germination.

Attempts to culture plant tissues led to discovery of more cell division hormones, the cytokinins. Another type of hormone, abscisic acid, initiates the senescence and **abscission** of leaves in the fall, and causes the stomata to close under water stress. Additional growth regulating compounds are being found and investigated but a coordinated picture of hormone interaction is lacking.

Photoperiodism, the regulation of flowering by day length was discovered. Sleep movements, such as the drooping of bean leaves in the evening, were found to be controlled by a biological “clock,” a **circadian** rhythm, not by the onset of darkness. In 1952, phytochrome was discovered and found to be the pigment at the center of photoperiodism.

In recent years there has been a major shift to molecular genetics in attempts to locate the genes responsible for physiological processes. In photosynthesis chlorophyll structure was determined and localized in the internal membranes of the chloroplasts of the mesophyll cells. Red and blue portions of the light spectrum were found effective, leading to the discovery that two light reactions are required. In the 1930s, C. B. van Neil used radioactive water to show that water, not carbon dioxide, was the source of oxygen released during photosynthesis. Sugar was found to be synthesized in the stroma (fluid part) of the chloroplast, and the molecular details of its creation were worked out by Melvin Calvin and Andrew Benson. All plant cells were found to respire, an energy-yielding process essentially the same as that in animals, involving another membranous **organelle**, the mitochondrion, and yielding metabolic energy available for transport reactions and synthesis of cell substance.

The formation of fats and oils from **carbohydrates** was found to be similar to that in animals, but plants had the added ability to transform oils in germinating seeds into carbohydrates such as the **glucose** used in **cellu-**



**lose** wall formation. The symbiotic relationships of plants and microorganisms was explored, notably in the cases of reduced nitrogen formation from atmospheric nitrogen by nodule bacteria.

At the end of twentieth century, the small mustard plant *Arabidopsis thaliana* took center stage in the attempt of scientists to understand plant **genomes**. The full sequence of this genome was elucidated in 2000 by an international consortium of plant geneticists. SEE ALSO C4 AND CAM PLANTS; DE SAUSSURE, NICOLAS THÉODORE; HORMONES, PLANT; INGENHOUSZ, JAN; PHOTOPERIODISM; RHYTHMS OF PLANT LIFE; WATER MOVEMENT IN PLANTS

*John Hanson*

### Bibliography

Dennis, D. T., and D. H. Turpin. *Plant Physiology, Biochemistry and Molecular Biology*. Harlow, Essex, UK: Longman Group, 1990.

Salisbury, F. B., and C. W. Ross. *Plant Physiology*, 3rd ed. Belmont, CA: Wadsworth Publishing, 1985.

Taiz Lincoln, and Eduardo Zeiger. *Plant Physiology*, 2nd ed. Sunderland, MA: Sinauer Associates, 1998.

## Homeostasis

Living cells can function only within a narrow range of such conditions as temperature, **pH**, **ion** concentrations, and nutrient availability, yet living organisms must survive in an environment where these and other conditions vary from hour to hour, day to day, and season to season. Organisms therefore require mechanisms for maintaining internal stability in spite of environmental change. American physiologist Walter Cannon (1871–1945) named this ability homeostasis (*homeo* means “the same” and *stasis* means “standing or staying”). Homeostasis has become one of the most important concepts of physiology, physiological ecology, and medicine. Most bodily functions are aimed at maintaining homeostasis, and an inability to maintain it leads to disease and often death.

The human body, for example, maintains blood pH within the very narrow range of 7.35 to 7.45. A pH below this range is called acidosis and a pH above this range is alkalosis. Either condition can be life-threatening. One can live only a few hours with a blood pH below 7.0 or above 7.7, and a pH below 6.8 or above 8.0 is quickly fatal. Yet the body’s metabolism constantly produces a variety of acidic waste products that challenge its ability to maintain pH in a safe range.

Body temperature also requires careful homeostatic control. On a spring or fall day in a temperate climate, the outdoor Fahrenheit temperature may range from the thirties or forties at night to the eighties in the afternoon (a range of perhaps 4 to 27 degrees Celsius). In spite of this environmental fluctuation, our core body temperature is normally 37.2 to 37.6 degrees Celsius (99.0 to 99.7 degrees Fahrenheit) and fluctuates by only 1 degree or so over the course of 24 hours. Indeed, if core body temperatures goes below 33 degrees Celsius (91 degrees Fahrenheit) a person is likely to die of **hypothermia**, and if it goes above 42 degrees Celsius (108 degrees Fahrenheit), death from hyperthermia is likely.

**cellulose** carbohydrate made by plants and some other organisms; part of the cell wall

**genome** total genetic material in a cell or organism

**pH** measure of acidity or alkalinity; numbers below 7 are acid, above are basic

**ion** an electrically charged particle

**hypothermia** subnormal temperature of the body

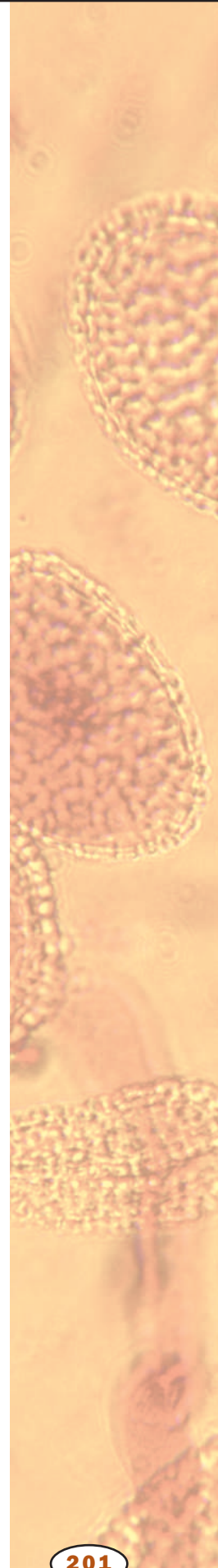

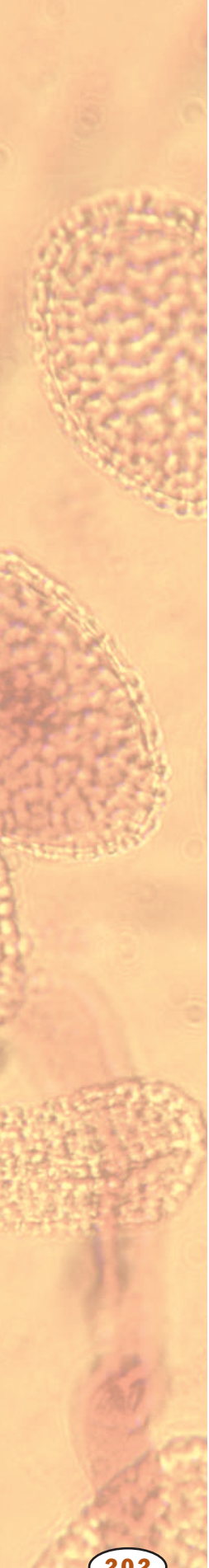

**feedback** process in which the output or result influences the rate of the process.

**enzyme** protein that controls a reaction in a cell.

**protein** complex molecule made from amino acids; used in cells for structure, signaling, and controlling reactions

**catalytic** aiding in the reaction of

**hormone** molecule released by one cell to influence another

Internal conditions are not absolutely stable but fluctuate within a narrow range around an average called the set point. The set point for core body temperature, for example, is about 37.4 degrees Celsius, but the temperature fluctuates within about ( $\pm 0.5$  degrees Celsius). Thus, it is more accurate to say the body maintains an internal dynamic equilibrium than to say it maintains absolute stability.

### Negative Feedback and Stability

The usual means of maintaining homeostasis is a general mechanism called a negative **feedback** loop. The body senses an internal change and activates mechanisms that reverse, or negate, that change.

An example of negative feedback is body temperature regulation. If blood temperature rises too high, this is sensed by specialized neurons in the hypothalamus of the brain. They signal other nerve centers, which in turn send signals to the blood vessels of the skin. As these blood vessels dilate, more blood flows close to the body surface and excess heat radiates from the body. If this is not enough to cool the body back to its set point, the brain activates sweating. Evaporation of sweat from the skin has a strong cooling effect, as we feel when we are sweaty and stand in front of a fan.

If the blood temperature falls too low, on the other hand, this is also sensed by the hypothalamus and signals are sent to the cutaneous arteries (those supplying the skin) to constrict them. Warm blood is then retained deeper in the body and less heat is lost from the surface. If this is inadequate, then the brain activates shivering. Each muscle tremor in shivering releases heat energy and helps warm the body back toward its 37 degrees Celsius set point.

In both cases, specialized neurons sense the abnormal body temperature and activate corrective negative feedback loops that return the temperature to normal. As a result, body temperature seldom goes more than 0.5 degrees Celsius above or below its set point. Other negative feedback loops regulate blood sugar concentration, water balance, pH, and countless other variables. Many such loops are regulated by the nervous system, and others by the hormones of the endocrine system.

### Positive Feedback and Rapid Change

The counterpart to negative feedback is the positive feedback loop, a process in which the body senses a change and activates mechanisms that accelerate or increase that change. This can also aid homeostasis, but in many cases it produces the opposite effect and can be life-threatening.

An example of its beneficial effect is seen in blood clotting. Part of the complex biochemical pathway of clotting is the production of an **enzyme** that forms the matrix of the blood clot, but also speeds up the production of still more thrombin. That is, it has a self-**catalytic**, self-accelerating effect, so that once the clotting process begins, it runs faster and faster until, ideally, bleeding stops. Thus, this positive feedback loop is part of a larger negative feedback loop, one that is activated by bleeding and ultimately works to stop the bleeding.

Another example of beneficial positive feedback is seen in childbirth, where stretching of the uterus triggers the secretion of a **hormone**, oxytocin,

which stimulates uterine contractions and speeds up labor. Yet another is seen in protein digestion, where the presence of partially digested protein in the stomach triggers the secretion of hydrochloric acid and pepsin, the enzyme that digests protein. Thus, once digestion begins, it becomes a self-accelerating process.

Often, however, positive feedback produces the very opposite of homeostasis: rapid loss of internal stability with potentially fatal consequences. For example, if the death of a small area of heart tissue triggers a heart attack (myocardial infarction), the heart pumps an inadequate amount of blood. Thus, the heart muscle itself is deprived of blood flow, and still more begins to die. This can lead to a rapid worsening of cardiac function until a person dies. Many diseases involve dangerous positive feedback loops.

Homeostasis, while described here with examples from human physiology, is a fundamental property of life and a necessity for survival of all living things—not just humans but all other animals as well as bacteria, plants, fungi, and protists. It enables all living organisms to maintain internal stability in spite of a ceaselessly changing and challenging environment. SEE ALSO BLOOD CLOTTING; BLOOD SUGAR REGULATION; BRAIN; ENDOCRINE SYSTEM; HORMONES; HYPOTHALAMUS; NERVOUS SYSTEMS; OSMOREGULATION; PHYSIOLOGICAL ECOLOGY; TEMPERATURE REGULATION

*Kenneth S. Saladin*

### Bibliography

- Blessing, William W. *The Lower Brainstem and Bodily Homeostasis*. New York: Oxford University Press, 1997.
- Cannon, Walter B. *The Wisdom of the Body*. New York: W. W. Norton, 1932.
- Saladin, Kenneth S. *Anatomy and Physiology—The Unity of Form and Function*, 2nd ed. Dubuque, IA: McGraw-Hill Higher Education, 2001.
- Willmer, P., G. Stone, and I. Johnson. *Environmental Physiology of Animals*. Oxford: Blackwell Science, 2000.

## Hormones

Hormones are molecules released by a group of cells in the body that influence the behavior of another group of cells. Hormones are the chemical signals of the **endocrine** system, the group of glands that, along with the nervous system, controls the body's responses to internal and external stimuli. Hormones are carried to their target cells in the bloodstream.

All hormones bind at the target cell to a specific receptor, a **protein** made by the target cell. When the hormone binds to the receptor, it causes a change in the receptor's **conformation**, or shape. This conformation change allows the receptor to fit with other cell molecules in a way it could not before, thus triggering new activities in the cell. While a hormone such as testosterone (produced in the testes) reaches all cells in the body, only some cells have testosterone receptors, and therefore only those cells are sensitive to testosterone's effects. Similarly, different receiving cells make different sets of molecules to interact with the testosterone receptor, and this controls the exact response the target cell exhibits.

**endocrine** related to the system of hormones and glands that regulate body function

**protein** complex molecule made from amino acids; used in cells for structure, signaling, and controlling reactions

**conformation** three-dimensional shape

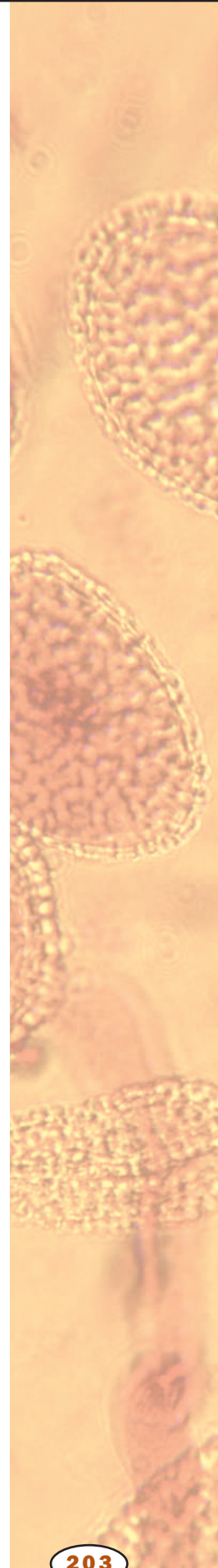

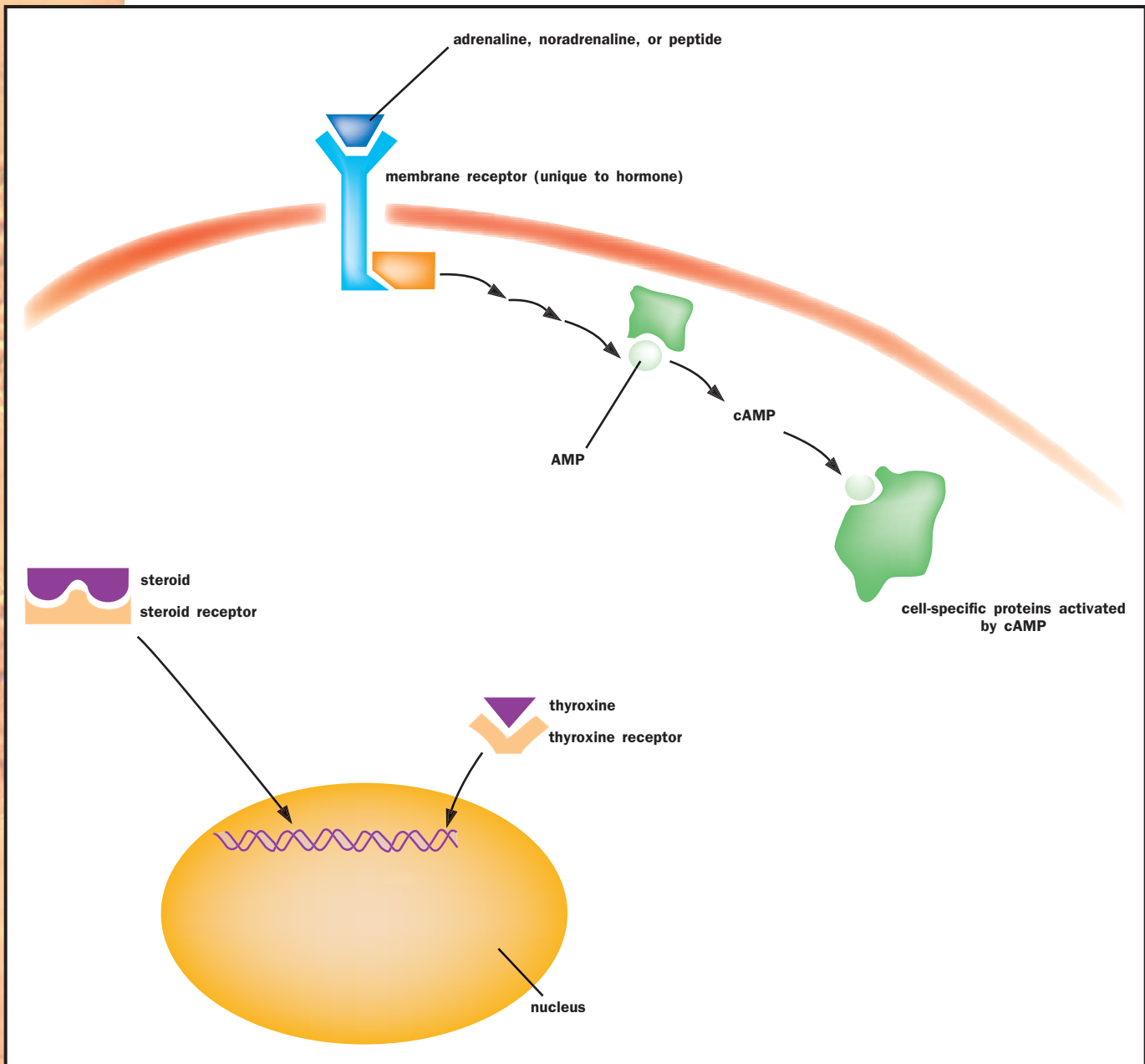

Hormones differ in where their receptors are found in the target cell. Some are located in the nucleus, some in the cell cytoplasm, and still others bind to a receptor on the membrane surface.

**amino acid** a building block of protein

Hormones are classified based on their chemical structures. Peptide hormones are chains of **amino acids**. Insulin and glucagon, which help control blood sugar, are peptide hormones, as are the hormones of the hypothalamus and the pituitary gland. **Steroid hormones** are **lipids** (fatlike molecules) whose structures are derived from cholesterol. Hormones of the sex organs and the adrenal cortex (part of the adrenal gland) are steroids. Monoamine hormones are made by modifying amino acids. These hormones include adrenaline and noradrenaline made by the adrenal medulla, thyroid hormone (thyroxine), and melatonin from the pineal gland in the brain.

Hormones also differ in where their receptors are found in the target cell, and the type of effect they cause when they bind to their receptors.

The receptor for thyroxine is located in the **nucleus**, while the receptors for steroid hormones are found in the cell's **cytoplasm**. In both cases, the hormone binds to the receptor to form a complex, and then the hormone-receptor complex activates specific **genes** within the nucleus, leading to synthesis of new proteins.

Adrenaline, noradrenaline, and the peptide hormones do not enter the target cell. Instead, they bind to a receptor on the membrane surface. The receptor extends through the membrane, and when the outside portion binds to the hormone, the inside portion of the receptor undergoes a conformation change. This change sets off a cascade of reactions inside the cell, ultimately leading to an increase in concentration of one or another internal messenger molecules. The most common of these so-called “second messengers” (the hormone is the “first messenger”) are calcium **ion** and cyclic **AMP** (cAMP), a type of **nucleotide**. The second messenger then triggers other activities in the cell, depending on the cell type. In muscle, adrenaline causes cAMP buildup, which causes breakdown of **glycogen** to release **glucose**, which the muscle cell uses to support increased activity.

Hormones that bind to external receptors and work through second messengers affect pre-existing proteins within the cell. Because of this, they typically cause much faster effects than those that bind to internal receptors, which influence creation of new proteins. For example, adrenaline's effects last from minutes to hours at the most, while testosterone's effects last from days to months or more. SEE ALSO ADRENAL GLAND; AMINO ACID; BLOOD SUGAR REGULATION; ENDOCRINE SYSTEM; FEMALE REPRODUCTIVE SYSTEM; HOMEOSTASIS; HYPOTHALAMUS; MALE REPRODUCTIVE SYSTEM; NUCLEOTIDES; PANCREAS; PITUITARY GLAND; THYROID GLAND; TRANSCRIPTION

Richard Robinson

### Bibliography

Alberts, Bruce, et al. *Molecular Biology of the Cell*, 4th ed. New York: Garland Publishing, 2000.

Saladin, Kenneth S. *Anatomy and Physiology: The Unity of Form and Function*. Dubuque, IA: McGraw-Hill Higher Education, 2001.

## Hormones, Plant

Plant hormones are chemical messengers that are produced in one part of the plant and have a physiological effect on a target tissue that may be distant from the site of production. When hormones reach the target tissue they can: (1) have a direct effect on the target tissue causing a rapid metabolic response; (2) involve the use of a second messenger within target cells; and/or (3) affect **transcription** of nuclear deoxyribonucleic acid (DNA). Unlike animals, plants have no specialized organs designed solely for hormone synthesis and **secretion**. Leaves, stem tips, root tips, flowers, seeds, and fruits all produce hormones. Most plant hormones are functional at very low concentrations.

Auxins, cytokinins, gibberellins, abscisic acid, and ethylene are the best known plant hormones. All are in some way involved in regulating plant growth and development. Some promote growth by stimulating cell enlargement or division while others inhibit growth by inducing dormancy or promoting senescence. Recently brassinolides, jasmonates, and salicylic acid have been shown to have hormonal function.

**steroid hormone** group of hormones that include estrogen, testosterone, and progesterone

**lipid** fat or waxlike molecule, insoluble in water

**nucleus** membrane-bound portion of cell containing the chromosomes

**cytoplasm** material in a cell, excluding the nucleus

**gene** portion of DNA that codes for a protein or RNA molecule

**ion** an electrically charged particle

**AMP** adenosine monophosphate, form of ATP after removal of two phosphate groups

**nucleotide** the building block of RNA or DNA

**glycogen** complex carbohydrate used as storage in animals and some other organisms

**glucose** simple sugar that provides energy to animal cells and is the building block of cellulose in plants

**transcription** messenger RNA formation from a DNA sequence

**secretion** material released from the cell

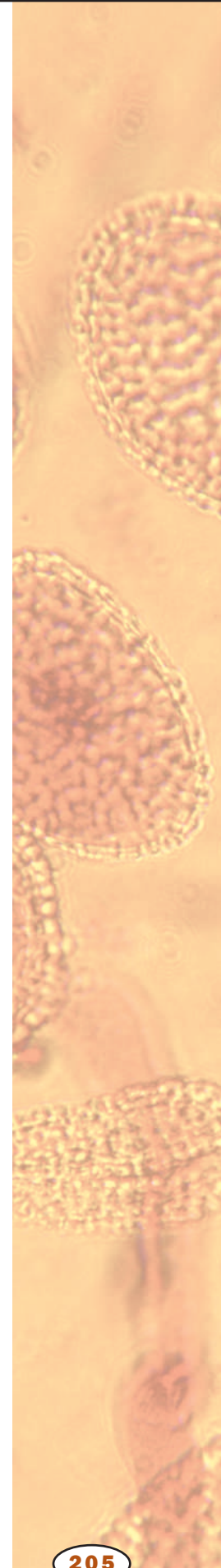

## Principles of Hormone Function

Often two or more hormones work synergistically. In a classic 1957 experiment, Skoog and Miller provided evidence that auxins and cytokinins work together in the differentiation of plant organs. Using tobacco tissue culture, they showed that when a tissue culture medium contains low concentrations of auxin *and* optimal cytokinin levels, then formation of shoots is favored. In contrast, when the culture medium is supplied with optimal concentrations of auxin combined with low concentrations of cytokinins, root formation is favored.

Hormones sometimes work antagonistically. **Apical** dominance is a process in which **lateral** buds of stems remain dormant as long as the stem apex remains intact. It has been shown that auxin produced in the stem apex is responsible for maintaining lateral bud dormancy by causing cells in the lateral buds to produce another hormone, ethylene, which is a growth inhibitor. During early spring, rapidly growing root tips will generate a high concentration of cytokinin that counteracts the effect of ethylene on the lateral buds of the stem. The lateral buds released from dormancy by cytokinins can then begin growth on their own.

## Auxins

Auxins were the first class of plant hormones to be identified. Many auxins, both natural and synthetic, are now known and all have similar effects on plant growth and development. The most widely studied naturally occurring auxin is indol-3-acetic acid (IAA), which is chemically related to the **amino acid** tryptophan. IAA can be synthesized from tryptophan in intact cells but other synthetic pathways are available. Because auxins can have an effect in very low concentrations, plants regulate synthesis and disassembly of auxin very precisely. Auxins are produced in young shoots and always travel downward in the plant from shoot to root. This polar movement of auxin is not well understood but requires calcium **ions** ( $\text{Ca}^{2+}$ ) and most likely involves special carriers in cell membranes. Naturally occurring auxins promote cell enlargement, are important in tropisms, prevent **abscission**, promote fruit development, and are involved in apical dominance. Synthetic auxins such as naphthalene acetic acid are used as rooting hormones. Other synthetic auxins include 2,4-D (2,4-dichlorophenoxyacetic acid) and 2,4,5-T (2,4,5-trichlorophenoxyacetic acid) that are used as weed killers.

The effect of IAA on cell enlargement has been well studied. IAA stimulates special pumps in the cell membrane of target cells to release  $\text{H}^+$  ions into the cell wall, resulting in a **pH** drop to approximately 5.0 in the cell wall. **Enzymes** that are pH-dependent then break down important structural bonds between **cellulose** microfibrils causing an increase in cell wall **plasticity**. As the cell wall becomes more plastic, water is able to flow in and the cell enlarges. Auxin also may have an effect on transcription of nuclear DNA that can contribute to cell enlargement.

Calcium acts as a second messenger in processes involving auxin. Auxin stimulates the release of  $\text{Ca}^{2+}$  from the vacuole and **endoplasmic reticulum** in target tissues which affects Ca-dependent enzymes, including **kinases**, phosphatases, and phospholipases.

**apical** at the tip

**lateral** side-to-side

**amino acid** a building block of protein

**ion** an electrically charged particle

**abscission** shedding of leaves; falling off

**pH** measure of acidity or alkalinity; numbers below 7 are acid, above are basic

**enzyme** protein that controls a reaction in a cell

**cellulose** carbohydrate made by plants and some other organisms; part of the cell wall

**plasticity** change form

**endoplasmic reticulum** network of membranes within the cell

**kinase** enzyme that adds a phosphate group to another molecule, usually a protein

Plant Hormones: Roles	
Hormone	Role
<b>Auxins</b>	Involved in differentiation of vascular tissue, control cellular elongation, prevention of abscission, involved in apical dominance and various tropisms, stimulate the release of ethylene, enhance fruit development
<b>Cytokinins</b>	Affect cell division, delay senescence, activate dormant buds
<b>Gibberellins</b>	Initiate mobilization of storage materials in seeds during germination, cause elongation of stems, stimulate bolting in biennials, stimulate pollen tube growth
<b>Abscisic Acid</b>	Maintains dormancy in seeds and buds, stimulates the closing of stomata
<b>Ethylene</b>	Causes ripening of climacteric fruits, promotes abscission, causes formation of aerenchyma tissue in submerged stems, determines sex in cucurbits
<b>Jasmonates</b>	Involved in response to environmental stresses, control germination of seeds
<b>Brassinolides</b>	Promote of elongation, stimulate flowering, promote cell division, can affect tropic curvature
<b>Salicylic Acid</b>	Activates genes involved with plant's defense mechanisms

Auxins are involved in tropisms, which are growth responses to directional environmental stimuli such as light, gravity, and touch. In phototropism, unidirectional light will cause auxin to move toward the darkened side of the organ and stimulate enlargement of cells on the darkened side. This causes the organ to bend toward the light. This effect is often seen in potted plants growing in windowsills.

## Other Plant Hormones

Cytokinins (for example, zeatin, isopentenyl adenine) have an effect on cell division. As previously mentioned, cytokinins work synergistically with auxin in the control of tissue and organ differentiation. Cytokinins are produced in root tips and may be transported in the **xylem** toward the shoot.

Gibberellins are a very large class of compounds, all with a similar chemical makeup. There have been as many as eighty-four gibberellins identified (named GA1 through GA84), but GA3, called gibberellic acid, has been the most studied. Gibberellins promote cell elongation, overcome genetic dwarfism, stimulate **bolting** in biennials, and are involved in seed germination. During the germination of grass seeds the imbibition (intake) of water stimulates the production of gibberellins by the embryo that diffuse throughout the seed. A **protein**-rich layer just internal to the seed coat, the aleurone layer, responds to gibberellins by synthesizing hydrolytic enzymes that aid in mobilization of stored food in the **endosperm** for use by the embryo.

Abscisic acid (ABA), is a growth inhibitor that, despite its name, is probably not involved in leaf or fruit abscission. One role of ABA is the stimulation of **stomatal** closure. When ABA binds to receptors on guard cell membranes, chloride ion channels open, letting chloride ions move out of the **guard cells**. The resulting depolarization of the membrane stimulates the movement of potassium ions ( $K^+$ ) ions out of guard cells, which then lose water, causing the stomata to close.

Ethylene is the only plant hormone that is a gas. Ethylene is also considered a growth inhibitor as it may have a role in causing bud dormancy, and it is involved with leaf abscission, causes fruit ripening, may determine

**xylem** water-transporting system in plants

**bolting** sudden spurt of growth

**protein** complex molecule made from amino acids; used in cells for structure, signaling, and controlling reactions

**endosperm** nutritive tissue within a seed

**stomata** openings in leaves for gas exchange, surrounded and regulated by guard cells

**guard cells** paired cells on leaves that control gas exchange and water loss

**steroids** hormones such as testosterone or estrogens that control many aspects of physiology

**pathogen** disease-causing organism

sex in cucurbits (melon family), and stimulates formation of aerenchyma (gas transport tissue) in submerged roots and stems.

Brassinolides are plant **steroids** (many animal hormones are steroids) that may be involved in the light-induced expression of genes. SEE ALSO CELL WALL; MERISTEMS; PLANT DEVELOPMENT; SENESCENCE

*George Wittler*

#### **Bibliography**

Raven, Peter H., Ray F. Evert, and Susan E. Eichhorn. *Biology of Plants*, 6th ed. New York: W. H. Freeman and Company, 1999.

Taiz, Lincoln, and Eduardo Zeiger. *Plant Physiology*, 2nd ed. Sunderland, MA: Sinauer Associates, Inc., 1998.

## **Horticulturist**

Horticulturists find work in two distinct areas: agriculture and landscape design. The training for both of these specialties is the same but the day-to-day activities are different. People with a Bachelor of Science degree in botany, biology, or agriculture may find employment as horticulturists after college. A strong training in the basic sciences, especially chemistry and biology, is necessary.

An agricultural horticulturist is responsible for investigating the best techniques for managing the aboveground aspects of agriculture. These include pruning, mulching, trellising, plant spacing, and pollination. His or her partners in this endeavor are the agronomist, who is concerned with fertilization, irrigation, and drainage, and the integrated pest manager who is concerned with plant **pathogens** and pests. Each must know the essentials of the others' fields and all must work together to produce profitable food and fiber crops.

The landscape horticulturist is concerned with all aspects of plant growth: aboveground aspects and fertilization, irrigation, and drainage. The landscape horticulturist must also have training in art and architecture. It is essential to know the requirements of decorative plants. Horticulturists work for commercial nurseries; schools or businesses with a "campus" or landscaped grounds; entertainment centers such as theme parks; and local, state, and federal governmental agencies (such as public works departments) for the creation of green spaces and color spots along highways, in city parks, or in residential areas. SEE ALSO AGRICULTURE; AGRONOMIST; PROPAGATION

*Dennis Carnes*

#### **Bibliography**

Acquaah, George. *Horticulture: Principles and Practice*. Upper Saddle River, NJ: Prentice Hall, 1997.

Garner, Jerry. *Careers in Horticulture and Botany*. New York: Barnes and Noble, 1999.

## **Human Evolution**

It is remarkable that the unique qualities of humans—language, advanced thought, and culture—evolved through the same processes that shaped the adaptations of all other creatures on earth: natural selection. How this came



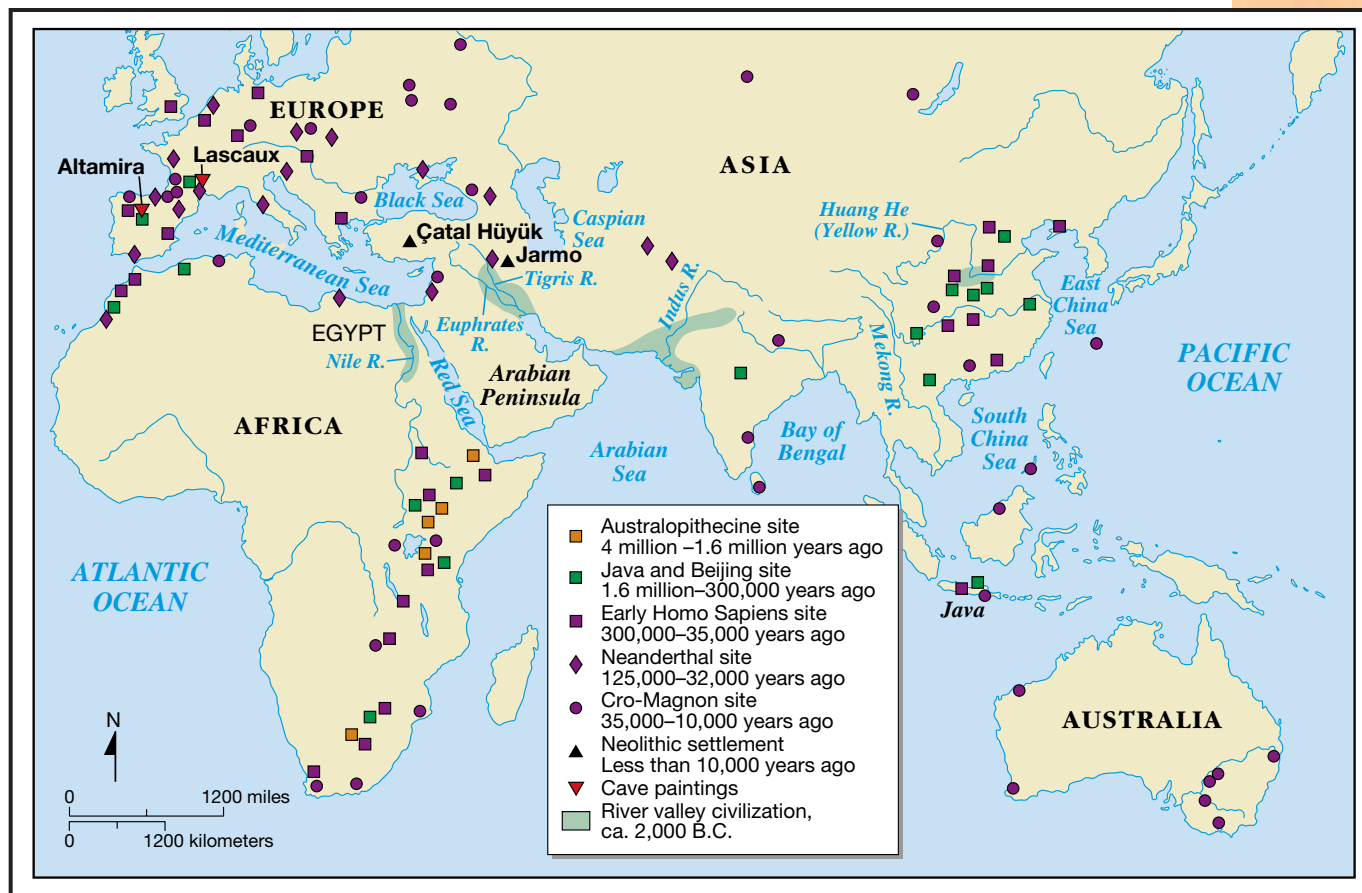

about is perhaps the most fascinating question of all time. The direct evidence for human evolution has increased enormously since the early 1990s via the discovery of hundreds of new fossils, including three new genera and even more new species; and via the comparisons of modern and ancient deoxyribonucleic acid (DNA). Great leaps forward are being made in science because of this proliferation of information.

Humans and our ancestors are called *hominins*, going back to the time of the split from the **lineage** of human's closest relatives, the chimpanzees. (Until recently the term *hominid* was used, but based on genetic relatedness and the rules of zoological nomenclature, the word *hominid* should apply to *both* the chimpanzee and human clades [lineages].) Humans have evolved various traits that have diverged from the typical great ape collection of characters; notable is human's commitment to standing on two legs (bipedalism) rather than four, increased fine motor dexterity making possible extensive use of tools, prolonged period of infancy and childhood, increased brain size, language, great cultural complexity and economic interdependence.

## Ape Ancestors

During the Miocene epoch (23 to 5 million years ago), when our superfamily, the Hominoidea (apes) flourished and speciated, more than twenty genera and about twice that number of species in the Hominoidea family. Many of these species went extinct, and today there are only five genera of apes: gibbons, orangutans, gorillas, chimpanzees/bonobos, and humans. The

Sites of early civilizations.

**lineage** ancestral line

**savanna** open grassland with sparse trees

The newly discovered *Kenyanthropus platyops* dates from the same era as the *Australopithecus* but belongs to a previously unknown species. The new skull has a more humanlike face with much smaller teeth. Its name means “the flat-faced human from Kenya.”

origins of the hominins remain obscure. Genetic comparisons and the molecular clock suggest that the human-chimp lines split in the late Miocene about 6 million years ago. The fossil record is very incomplete at this time, and neither fossils of ancestral chimpanzees nor fossils that are clearly ancestral to both lines are known. However, field research since the mid-1990s has resulted in several fossils from this time period, and researchers hope that this trend of discovery will continue and scientists’ understanding of the origin of hominins will improve over the twenty-first century.

Scientists do know this: Hominins evolved from an ape that was similar to the living African apes, and the human lineage did not spread beyond Africa into Eurasia until about 1.8 million years ago. The early hominins lived in an array of habitats, but most evidence points to wooded **savannas** (a type of grassland) as a principal one. There is solid evidence that significant amounts of bipedal behavior preceded other major events such as increased brain size or tool use.

### Earliest Hominins

The earliest named hominin, *Orrorin tugenensis*, was discovered in 2000 in eastern Kenya, and is believed to have lived 6 million years ago. Thigh bones suggest that this species spent a significant amount of time bipedally. In the 5-million-year time range there are several fragmentary fossils from East Africa, but they are difficult to associate with particular species. At 4.4 million years ago, another genus and species, *Ardipithecus ramidus*, is present. This species has many traits, especially in the teeth, that are between chimpanzees and later hominins (australopithecines) in size and character (for example canine size, enamel thickness, and size of the cheek teeth). Discovery of a third new early hominin, *Kenyanthropus platyops*, was published in 2001 by Meave Leakey and colleagues.

Between 3.9 and 2.0 million years ago there was a proliferation of australopithecine species, including the “gracile” australopithecines of the genus *Australopithecus*, with five commonly recognized species, and the robust australopithecines of the genus *Paranthropus*, with three commonly recognized species. These australopithecine species are variable, but general trends include: significant amounts of terrestrial bipedalism, with some species also retaining significant arboreal adaptations; brains still very close to chimpanzees’ in size; tool use generally minimal; very large grinding cheek teeth and chewing muscles, consistent with a largely vegetarian diet including many tough foods; canine teeth reduced in size; and male body size much larger than females (that is, high degrees of sexual dimorphism).

### Origins of Homo

The origins of the human genus *Homo* is also being reexamined in the early twenty-first century. There are many fossils in the 2.4- to 1.6-million-year time range in Africa that have variously been assigned to *Homo habilis*, *Homo rudolfensis*, or *Homo* species, but many still have large cheek teeth, smallish brains, and faces shaped like australopithecines. Some of these fossils even retain many arboreal adaptations. Thus the majority of these specimens will probably be moved into the genus *Australopithecus*; reserving the genus *Homo* to include only those specimens which are clearly more closely related to humans.

Considered this way, the human genus evolved nearly 2 million years ago with the appearance of *Homo ergaster*. *Homo ergaster*, personified by the amazingly well-preserved West Turkana skeleton of a twelve-year-old boy, is a markedly different creature than australopithecines, though still not modern. They were tall, lanky, long-legged with body proportions nearly the same as modern humans, committed to efficient terrestrial bipedalism at the expense of arboreality, and larger—about the size of modern humans. This increase in body size was accompanied by an increase in brain size—the largest examples having **cranial** capacities (brain cavities) of about 900 cubic centimeters (cc), the smaller examples closer to 650 cc. (Modern human brains are about 1300 cc, chimpanzees are about 400 cc.) Because of the increase in body size, this is not a large relative increase in brain size over earlier hominids. The trend toward increasingly large cheek teeth is reversed in our lineage: There is a reduction in cheek tooth size, generally thought to reflect consumption of higher quality foods and/or more food preparation.

*Homo ergaster* also used tools. The earliest archaeological sites, which contain the debris of stone tool manufacture and animal bones eaten by hominins, date to 2.6 million years ago in Ethiopia. The earliest stone tools are simply sharp flakes broken off rocks that were used as cutting tools. It is difficult to say which species made and used these earliest tools, in fact it probably included some of the australopithecine species. By 1.5 million years ago the stone tool industries include more elaborate, symmetrically flaked rocks, called Acheulian hand axes.

### Spread Beyond Africa

Immediately after the evolution of *Homo ergaster* there was an initial, but probably short-lived, spread beyond Africa into the Near East, Far East (Java), and southern Spain. Either something about *H. ergaster* or the environment must have facilitated this spread. Was it the increase in body size? Did their ecological position shift up as they became more successful at acquiring meat, and therefore their home ranges needed to increase to encompass more and more space? Was it learning to control fire? Or changes in social organization? More research will focus on these questions, but whatever caused this initial spread, there is very little evidence for *Homo* outside of Africa again for about 1 million years, when more sites are found around Europe and Asia.

The populations in the Far East (China and Indonesia) evolved into a local species called *Homo erectus*, which may have survived until into the Late Pleistocene (approximately 50,000 years ago). These fossils have long low skulls with thick brows and cranial capacities near 1000 cc. Interestingly, *H. erectus* seems to have been contemporary with other species of archaic *Homo*, specifically species that evolved into *Homo neanderthalensis* in Europe and the Near East, and another that evolved into anatomically modern humans (AMH) in Africa. All of these species have long, low skulls, big faces, and large brow ridges, but differ in details of the cranial anatomy, and some have larger cranial capacities. They are robust with massive skeletons and muscles, reflecting a large dependency on brawn to cope with the world. Archaeological evidence for accomplished hunting in the form of wooden spears is clear by 400,000 years ago.

**cranial** related to the cranium, or brain cavity

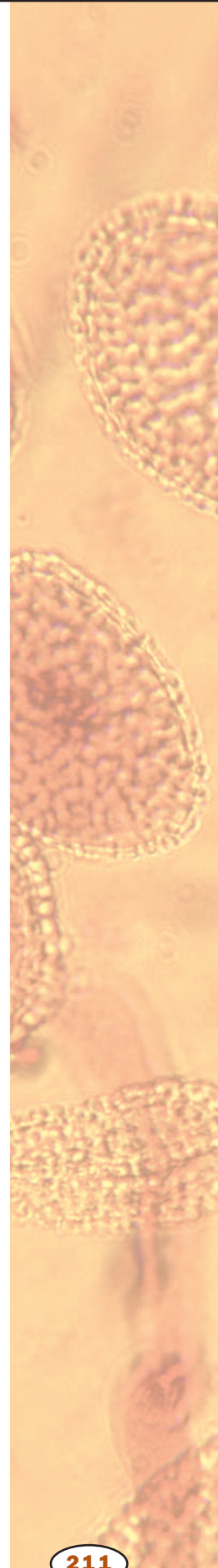

In Europe Neanderthals evolve into their classic form: extremely strong, stocky, and robust, with large eyes and noses and jutting faces; their bodies seem well adapted to the cold Pleistocene. Their tool kit was more elaborate, including stone-tipped spears, and archeological and isotopic evidence indicates a great reliance on meat in the diet. Nonetheless, except in a very few instances when Neanderthals were contemporary with modern humans, there is little to no evidence for art. For this reason, many anthropologists believe Neanderthals did not have modern language.

### Anatomically Modern Humans

Meanwhile, archaic *Homo* evolved into anatomically modern humans in Africa. Throughout this time range (between 200,000 and 100,000 years ago) there are increasing bits of evidence for art and symbolism in the form of red ochre, beads, and composite tools in Africa while they are still absent in Europe, and it is during this period that genetic evidence from modern humans suggests that anatomically modern humans evolved. Indeed, the earliest anatomically modern humans fossils come from Africa and the Near East, just over 100,000 years ago. Anatomically modern humans are characterized by a reduction in skeletal robustness and strength, probably related to greater reliance on technology and culture rather than brute strength. Cranial capacity remains about the same as in the more robust predecessors, but the face and teeth are smaller, the forehead becomes high and the chin juts out. Cultural elaboration is evident in increased number of tools types, regional variation in style, more composite tools, and notably, art.

There is a minority of anthropologists who consider all the *Homo* specimens to be from one diverse species. In the early twenty-first century, the majority of anthropologists believe that the fossil, archaeological, and genetic evidence concur that anatomically modern humans evolved in Africa about 200,000 to 150,000 years ago, and spread out from there to Europe and Asia as recently 100,000 to 25,000 years ago (depending on where), replacing the archaic *Homo* species, for example, Neanderthals and *Homo erectus*, and these later species may have contributed relatively little genetic diversity to the human gene pool. The information scientists have thus suggests that all humans across the globe today are very closely related to one another. SEE ALSO BIOLOGY OF RACE; EVOLUTION; GRASSLAND; LEAKEY FAMILY; NATURAL SELECTION; POPULATION GENETICS; PRIMATE

*Martha Tappen*

#### Bibliography

- Jones, S., R. Martin, and D. Pilbeam. *The Cambridge Encyclopedia of Human Evolution*. New York: Cambridge University Press, 1992.
- Klein, Richard. *The Human Career*, 2nd ed. Chicago: The University of Chicago Press, 1999.
- McBrearty, S., and A. S. Brooks. "The Revolution That Wasn't: A New Interpretation of the Origin of Modern Human Behavior." *Journal of Human Evolution* 39 (2000): 453–563.

**nucleotide** the building block of RNA or DNA

**base pair** two nucleotides (either DNA or RNA) linked by weak bonds

## Human Genome Project

The Human Genome Project (HGP), the determination of the complete **nucleotide** sequence of all of the more than three billion **base pairs** of de-

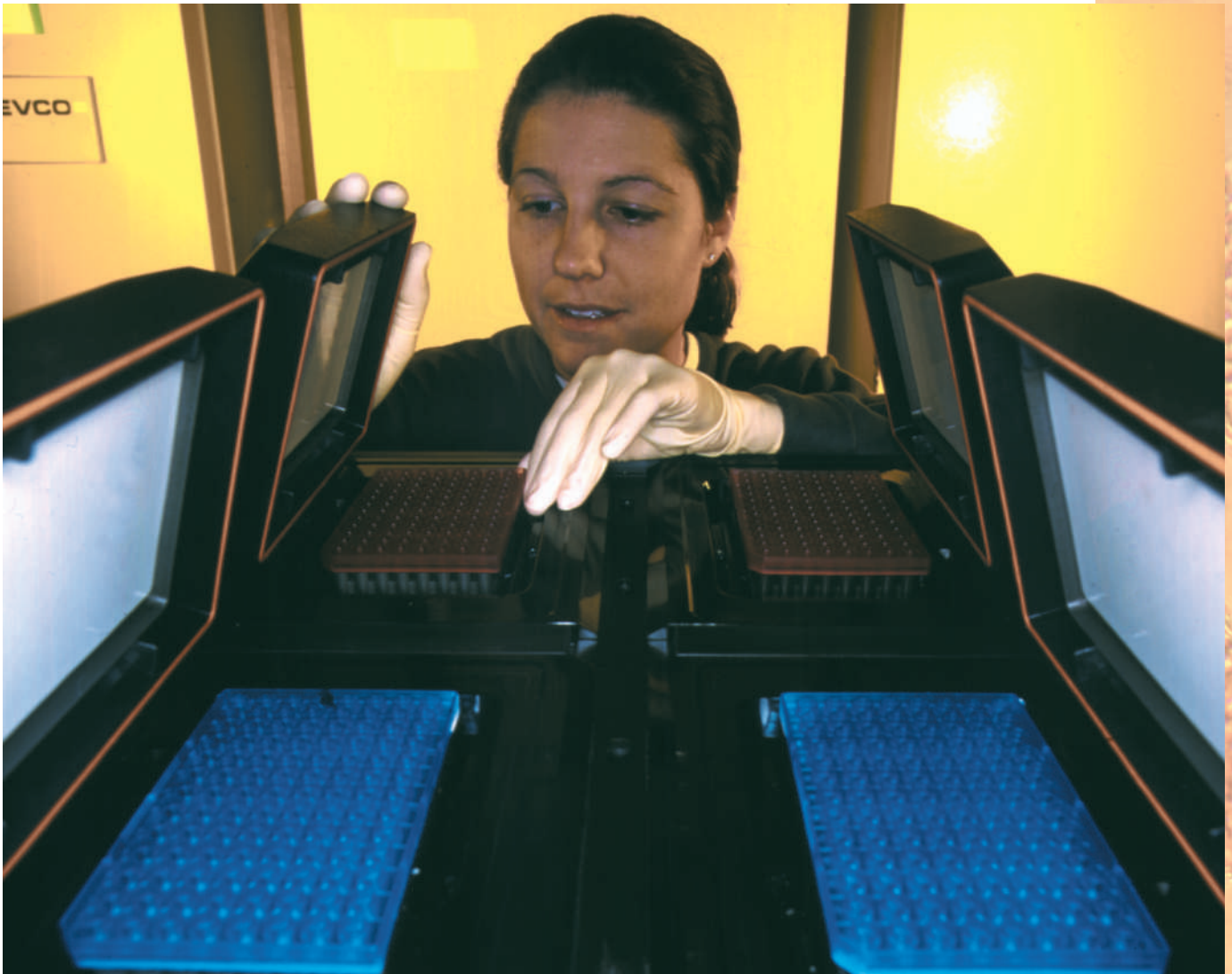

oxyribonucleic acid (DNA) in the **nucleus** of a human cell, is one of the greatest scientific undertakings in the history of humankind. The project reached an important milestone in 2001 with the completion of the “first draft” of the entire sequence. The HGP promises to bring unprecedented scientific rewards in the discovery of disease-causing **genes**, design of new drugs, understanding developmental processes, and determining the origin and evolution of the human race. It has also raised many ethical issues.

### Origins

The original impetus for the HGP came from the U.S. Department of Energy (DOE) shortly after World War II. In 1945 there were many survivors of the atomic bombs dropped on Hiroshima and Nagasaki who had been exposed to high levels of radiation. In 1946 geneticist and Nobel Prize winner H.J. Müller opined in the *New York Times* that “if they could foresee the results [mutations among their descendants] 1,000 years from now . . . they might consider themselves more fortunate if the bomb had killed them.” Müller, who had studied the biological effects of radiation on the fruit fly *Drosophila melanogaster*, had firsthand experience with the devastating effects

A researcher loading an automated DNA sequencer at the Joint Genome Institute in Walnut Creek, California.

**nucleus** membrane-bound portion of cell containing the chromosomes

**gene** portion of DNA that codes for a protein or RNA molecule

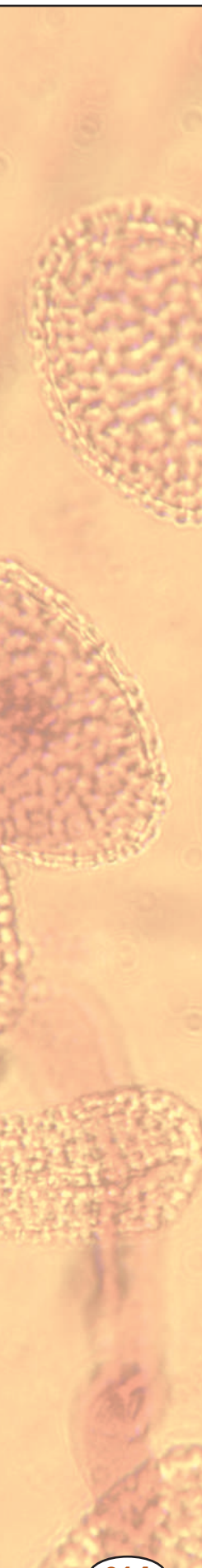

of radiation. The survivors of the bomb were considered poor marriage prospects, because of the potential of carrying mutations and were often ostracized by Japanese society. Thus the Atomic Energy Commission (AEC) of the DOE set up an Atomic Bomb Casualty Commission in 1947 to address the issue of potential mutations among the survivors. The problem they faced, though, was how to experimentally determine such mutations. It would be many years before the technology was developed to do so.

During the mid-1970s, molecular biologists developed techniques for the isolation and cloning of individual genes. In 1977 Walter Gilbert and Fred Sanger independently developed methods for the sequencing of DNA, for which they received the Nobel Prize. In 1980, the polymerase chain reaction (PCR) was invented by a scientist at Cetus Corporation. This technique allowed one to take minute samples of DNA and amplify them a billionfold for analysis. In 1986, an automated DNA sequencer was developed, increasing the number of bases sequenced per day. Thus, by the mid-1980s, there was a feeling among molecular biologists that it might now be feasible to sequence the entire human genome. The first major impetus came in June 1985 when Robert Sinsheimer, chancellor of the University of California at Santa Cruz, called a meeting among leading scientists to discuss the possibility of sequencing the human genome. Meanwhile, the DOE, led by Charles Delisi, was a strong supporter of the initiative, for the DOE had a continuing interest in identifying radiation-caused mutations. Sequencing the entire genome would clearly provide the best way to analyze such mutations.

Many biologists were interested in this “Holy Grail of Molecular Biology.” Most notably was Walter Gilbert who, through his interest, personality, and academic ties, developed enormous enthusiasm for the project. The initial goals were to develop:

- genetic linkage maps
- a physical map of ordered clones of DNA sequences
- the capacity for large-scale sequencing, as faster and cheaper machines and great leaps in technology would be necessary.

By 1990 the Human Genome Project had received the endorsement of the National Academy of Sciences, the National Research Council, the DOE, the National Institutes of Health (NIH), the National Science Foundation, the U.S. Department of Agriculture, and the Howard Hughes Medical Institute. Sequencing of the human genome was now officially begun. Nobel Prize winner James Watson agreed to head the project at the NIH. It was estimated to cost \$3 billion and be completed by September 30, 2005. However, Watson resigned as the director of the HGP over the issue of patenting the genome. Francis Collins succeeded him as director. Just as important was the establishment of projects seeking to sequence several model organisms, that is, those organisms of genetic, biochemical, or medical importance.

### Rapid Progress

Thousands of scientists, in more than one hundred laboratories in nineteen different countries around the world, are contributing to the HGP. The sequencing progressed well ahead of schedule and well under budget, a rare

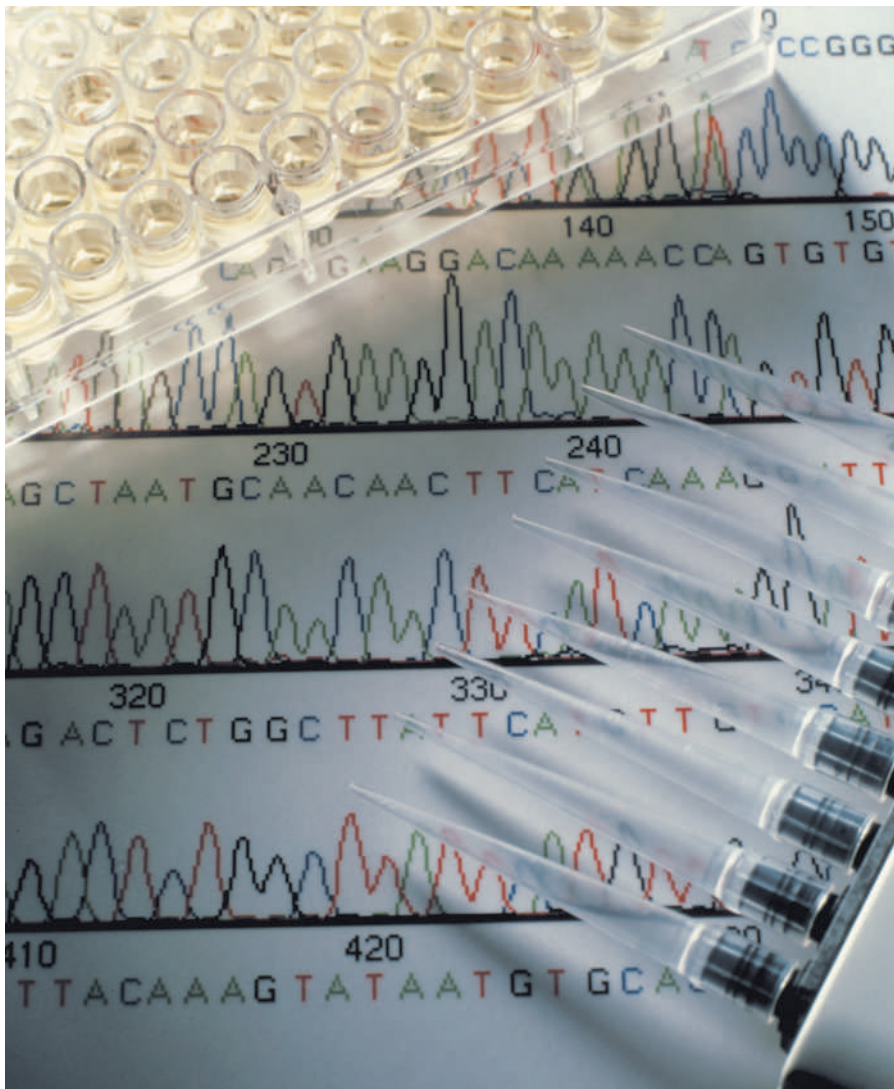

A computer printout of a DNA sequence.

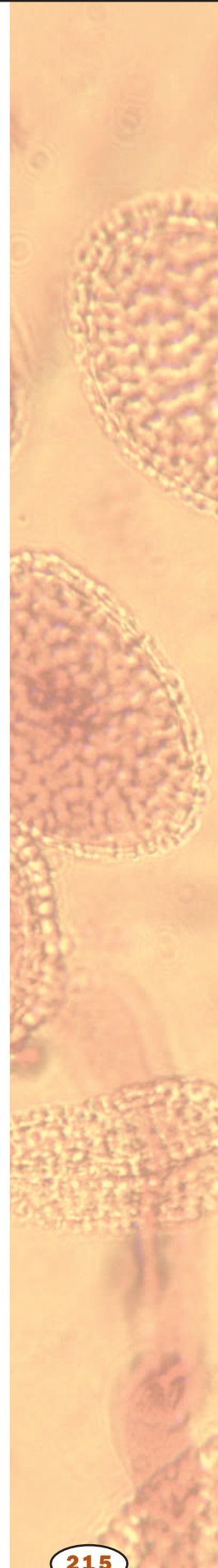

phenomenon in government-sponsored endeavors. In 1995, the first complete genome, that of the bacterium *Haemophilus influenzae*, was published by the biotech company TIGR (The Institute for Genome Research). Several of the model organisms have subsequently been completed, including the yeast *Saccharomyces cerevisiae*, the first eukaryote sequenced.

The human genome consists of twenty-two pairs of **chromosomes** plus the X and Y sex chromosomes. On December 2, 1999, more than one hundred scientists working together in laboratories in the United Kingdom, Japan, United States, Canada, and Sweden announced the complete sequence of the first human chromosome, chromosome #22, the smallest of the autosomes. In 1998, J. Craig Venter, along with Perkin Elmer (PE) Corporation, founded the private biotech company Celera Genomics with the goal of privately sequencing the human genome, in direct competition with the public efforts supported by the NIH and DOE. Celera had available three hundred of the world's fastest PE automatic DNA sequencers along with one of the world's most powerful supercomputers. With remarkable speed Celera sequenced several of the model genomes and, in April 2000,

**chromosome** “colored body” in the cell nucleus; made of DNA and protein, and divided functionally into genes and non-gene regions

announced that it had preliminary sequence of the human genome. In February 2001 Celera and the public consortium jointly announced completion of the draft human sequence.

### Whose Genome?

To assure the accuracy of the sequence, each segment will be sequenced at least ten times. Although all humans share a 99.99 percent or more of their sequences, each human is unique. Geneticists estimate that each person carries many, perhaps hundreds or thousands, mutations. Moreover, it is anticipated that there will be distinct differences among different populations. No single person's genome will be identical to that in the databank as "the human genome." The Human Genome Diversity Project was proposed in 1997 to catalog such variations among racial and/or geographic groups. Samples from four thousand to eight thousand individuals in dozens of populations are to be analyzed. Similarly, a Human Cancer Genome Anatomy Project was initiated in 1997 to catalog all genes expressed in cancer cells to aid in the detection and treatment of cancers.

**protein** complex molecule made from amino acids; used in cells for structure, signaling, and controlling reactions

Most of the genome does not code for **proteins**. Indeed, perhaps only 5 percent of the DNA will be found to encode a gene. Estimates by scientists of the number of genes in the human genome have ranged from 35,000 to 140,000. Using the sequence data already available, scientists can anticipate that the final number will be approximately 120,000.

### Patenting the Genome

From the outset there has been considerable debate among scientists, politicians, and entrepreneurs as to whether the human gene sequences can or should be patented. As of the year 2000, the U.S. Patent and Trademark Office is granting patents to genes that have been identified, rather than just random sequenced fragments. The data will be an invaluable resource, particularly in the area of developing new medical treatments. This has given rise to the new field of genomics (the study of gene sequences), and is resulting in the "mining of the genome" for valuable sequence data. Similarly, proteomics (the study of protein sequences) is a new, rapidly expanding field, as protein sequences can be predicted from the gene sequence. The folding of the proteins (secondary and **tertiary** structures) can be predicted by computers as well, leading to a three-dimensional view of the protein encoded by a particular gene.

**tertiary** third level

### Ethical Issues

From the outset, many have been concerned with ethical issues raised by the HGP, which need to be addressed by society as a whole. These including the following:

- confidentiality of an individual's DNA information
- insurance denial for pre-existing conditions if a person carries a gene that predisposes one to a particular disease
- stigmatization due to carrying certain genes
- genetic testing required for employment
- prenatal testing and abortion issues



- genetic manipulation
- challenges to self-understanding, given the knowledge of one's genes
- psychological burdens resulting from the knowledge that one carries a detrimental gene.

SEE ALSO BIOINFORMATICS; DNA SEQUENCING; GENOME; GENOMICS

Ralph Meyer

### Bibliography

- Collins, Francis S., and Karin G. Jégalian. "Deciphering the Code of Life." *Scientific American* 281, no. 6 (1999): 86–91.
- Cook-Deegan, Robert. *The Gene Wars: Science, Politics and the Human Genome Project*. New York: Norton, 1994.
- Kevles, Daniel J., and Leroy Hood, eds. *The Code of Codes: Scientific and Social Issues in the Human Genome Project*. Cambridge, MA: Harvard University Press, 1992.
- Koshland, Daniel E., Jr. "Sequences and Consequences of the Human Genome." *Science*, 246 (1989): 189.
- Nature* (Special Issue). The Human Genome (15 February 2001).
- Roberts, Leslie. "The Gene Hunters. Unlocking the Secrets of DNA to Cure Disease, Slow Aging." *U.S. News and World Report* (January 3–10, 2000): 34–38.
- Science* (Special Issue). The Human Genome (16 February 2001).
- Shostak, Stanley. *Evolution of Sameness and Difference. Perspectives on the Human Genome Project*. Amsterdam, The Netherlands: Harwood Academic Publishers, 1999.
- Sloan, Phillip R., ed. *Controlling Our Destinies. Historical, Philosophical, Ethical and Theological Perspectives on the Human Genome Project*. Notre Dame, IN: Notre Dame Press, 2000.
- Watson, James D., and Robert M. Cook-Deegan. "Origins of the Human Genome Project." *FASEB Journal* 5 (1991): 8–11.

## Human Nutrition

Nutrition is a broad topic that includes the components of food, food intake, what happens to the food once in the body, elimination of the residue, and how nutrients are related to health and disease. Research, education, and advertising combine to bombard the public with massive amounts of information or misinformation on what to eat, how much, and when. A strong understanding of nutrition will help people make better and healthier choices about nutrition.

### Nutrients

A nutrient is an ingested chemical that is absorbed and made part of the human tissues. Substances in the food that are not absorbed are not considered nutrients, but may nevertheless be essential to one's health, such as dietary fiber. A chemical need not be digested (chemically modified) to be considered a nutrient. Water, vitamins, minerals, and cholesterol are all important nutrients, for example, that are absorbed into the tissues without requiring chemical breakdown. Foods can confer health benefits beyond their nutritional value. For example, fiber helps prevent colon cancer, and cranberries and blueberries promote urinary tract health.

Nutrients include macronutrients (carbohydrates, **lipids**, proteins, and water) that are consumed in large quantities and micronutrients (vitamins



Foods can confer health benefits beyond their nutritional value.

**lipid** fat or waxlike molecule, insoluble in water

**glucose** simple sugar that provides energy to animal cells and is the building block of cellulose in plants

**complex carbohydrate** molecules formed by linking simpler carbohydrates such as sugars

**polysaccharide** carbohydrate composed of many individual units of sugar

**glycogen** complex carbohydrate used as storage in animals and some other organisms

**cellulose** carbohydrate made by plants and some other organisms; part of the cell wall

**carbohydrates** sugars, starches, and other molecules combining carbon, hydrogen, and oxygen and serving as fuel or structural components

**steroid hormone** group of hormones that include estrogen, testosterone, and progesterone

**amino acid** a building block of protein

**connective tissue** one of four types of body tissue, characterized by few cells and extensive extracellular material

**hormone** molecule released by one cell to influence another

**enzyme** protein that controls a reaction in a cell

**excrete** deposit outside of

**electrolytes** ions in body fluids

**dissociate** break apart

**osmosis** passage of water through a membrane in response to concentration differences

**hemoglobin** oxygen-carrying protein complex in red blood cells

and minerals) that are consumed in much smaller quantities, although they are no less essential to health. The macronutrients provide raw material for building tissues, as well as energy. The energy stored in the nutrient is measured in kilocalories (simply called calories in dietetics). A positive energy balance means one is consuming more kilocalories than one is using; the excess stored mostly as fat. A negative energy balance means that one is “burning” more calories than are being eaten; this results in weight loss.

## Macronutrients

Carbohydrates are the most important source of quick energy, but they also function in cell-membrane structure. They include the simple sugars **glucose**, fructose, and galactose; the disaccharides maltose, lactose, and sucrose; and the **complex carbohydrates** or **polysaccharides**, which are **glycogen** in human tissues and **cellulose** (fiber) and starch in plant tissues.

Lipids provide the body with more stored energy than **carbohydrates** do. They are also important as cell membrane components, **steroid hormones**, and visual pigments. Adipose tissue, which is mostly stored lipid, provides insulation and protection for the organs. About 95 percent of the body’s lipid is in the form of triglycerides (fats).

Proteins are chains of **amino acids**. They are important structural components of cell membranes and the extracellular materials of bones, tendons, and other **connective tissues**, and all muscle contraction results from the action of proteins. Proteins also function as **hormones**, **enzymes**, and antibodies.

Water makes up most of the body. It is the body’s major solvent, and it serves in lubrication, temperature control, and waste removal. A water deficiency can kill more quickly than a deficiency of any other nutrient.

## Micronutrients

Vitamins serve a wide variety of functions in enabling enzymes to work (thus contributing to the synthesis of the body), and in vision, immunity, protection from harmful free radicals, and absorption of other nutrients. The fat-soluble vitamins (A,D,E, and K) are absorbed with dietary fat and stored mainly in the liver. Water-soluble vitamins (vitamin C and the B vitamins) are not stored in the body (except for vitamin B12), since they mix freely with the body fluids and are quickly **excreted** by the kidneys.

Minerals are chemical elements such as sodium, potassium, chlorine, calcium, iron, magnesium, manganese, and phosphorus. They come ultimately from the soil and pass up the food chain from plants to humans. Some minerals serve as **electrolytes**—salts that **dissociate** in water to form charged particles (ions), whose movements through cell membranes produce nerve signals and muscle contractions (including the heartbeat). Minerals have a major effect on **osmosis** and thus strongly affect the body’s water balance. They act as co-factors that enable many enzymes to function.

Calcium and phosphorus are important components of bones and teeth. Phosphorus is also a part of deoxyribonucleic acid (DNA), ribonucleic acid (RNA), adenosine triphosphate (ATP), and the phospholipids that compose cell membranes. Iodine is needed to make thyroid hormone, and iron to make **hemoglobin**.

Good nutrition hinges on the senses of hunger and thirst, which are both controlled by centers in the hypothalamus of the brain. Thirst is triggered by dehydration and hunger by a low blood glucose concentration. Long-term satiety (satisfaction) of thirst and hunger results when the water and glucose content of the blood return to normal. The hypothalamus thus regulates eating and drinking patterns, although these are also subject to factors such as habit, stress, time of day, social obligations, and availability of food and drink. The food pyramid is a chart of the relative amounts of different food categories recommended for a healthy daily diet. SEE ALSO CARBOHYDRATES; DIGESTION; LIPIDS; VITAMINS AND COENZYMES

Richard Robinson

### Bibliography

*International Food Information Council*. <<http://ificinfo.health.org>>.

Johnson, Rachel, and Eileen Kennedy. "The 2000 Dietary Guidelines for Americans: What Are the Changes and Why Were They Made?" *Journal of the American Dietetic Association* 100, no. 7 (2000): 769–774.

Lachance, Paul A. "Overview of Key Nutrients: Micronutrient Aspects." *Nutrition Reviews* 56, no. 4 (98): 534–539.

U.S. Department of Agriculture. <<http://www.nal.usda.gov:8001/py/pmap.htm>>. Explains the food pyramid as a guideline for good nutrition.

Wardlaw, Gordon, and Paul Insel. *Perspectives in Nutrition*. St Louis, MO: Mosby, 1993.

## Human Population

Human population refers to the number of people living in a particular area, from a village to the world as a whole. A secondary meaning of population is the inhabitants themselves, but in most uses population means numbers.

No one knows the population of the earliest humans, but there may have been only a few tens of thousands of individuals when the species *Homo sapiens* first emerged 200,000 years ago. Today more than 6 billion human beings inhabit the earth. Three-fifths of them live in one continent, Asia, with the rest occupying every continent except Antarctica.

The overwhelming bulk of human population growth has occurred since the Industrial Revolution began, more than half since 1950. All but a small percentage of the roughly 80 million people added to world population each year live in the world's developing countries, which are home to 80 percent of humanity and more than 95 percent of world population growth. In Europe and Japan, small average family size and relatively modest immigration levels are leading to a leveling of, and even decreases in, population. In the United States, Canada, and Australia, slightly larger families and higher levels of immigration make for continued population growth.

World population grows because births significantly outpace deaths on average. This imbalance occurs not because women are having more children than they once did—quite the reverse—but because improved sanitation and health mean that many more children than in the past survive to become parents themselves. Human reproduction is such a success story that some analysts believe that today's large and ever-increasing population growth threatens the earth's support systems and contributes to global poverty.

Debate on this question has raged since at least the 1800s. Some economists and other social scientists argue that higher populations provide more human resources for solving problems and producing wealth. Most physical and biological scientists, by contrast, argue that key natural resources—fresh water, cropland, forests, and fisheries, for example—are increasingly strained by burgeoning human demands. Rising natural resource consumption by individuals also boosts these demands. The long-term growth of human population clearly has been an especially significant factor in human-induced climate change, species extinction, the loss of forests, and other environmental problems. But scientists and other analysts have been unable to agree on population's exact role in environmental change. Many other factors, from consumption patterns to government policies to the unequal distribution of power and wealth, also influence the environment.

One clear trend in human population is that its growth is slowing down. Women and men increasingly want to have later pregnancies and smaller families than did their own parents. Governments increasingly provide the health services that allow couples to plan their families. For some countries, this trend raises questions about how societies will cope with lower proportions of young and working people. For the world as a whole, however, births are likely to outnumber deaths for decades to come, and human population will continue to grow. **SEE ALSO** BIODIVERSITY; DESERTIFICATION; EXTINCTION; GLOBAL CLIMATE CHANGE

*Robert Engelman*

### Bibliography

- Cohen, Joel E. *How Many People Can the Earth Support?* New York: Norton, 1995.
- Mazur, Laurie, ed. *Beyond the Numbers: A Reader on Population, Consumption, and the Environment*. Washington, DC: Island Press, 1995.
- Robey, Bryant, et al. "Fertility Decline in Developing Countries." *Scientific American* 269, no. 6 (December 1993): 60–67.

## Hybridization

Hybridization is a technique in which molecules of single-stranded deoxyribonucleic acid (DNA) or ribonucleic acid (RNA) are bound to **complementary** sequences of either single-stranded DNA or RNA. Complementary **base pairs** are adenine (A) with thymine (T) or uracil (U) and vice versa, and guanine (G) with cytosine (C) and vice versa. Although the DNA double helix is relatively stable at body temperatures, high temperatures can split, or "melt," the double helix into single, complementary strands. After disrupting the double helix in this way, lowering the temperature then causes the single-stranded DNA to base-pair, or anneal, to other single strands that have complementary sequences.

Single-stranded DNA can hybridize to either single-stranded DNA or single-stranded RNA. Two complementary single-stranded DNA molecules can reform the double helix after annealing. In DNA-RNA hybridization, the RNA base uracil pairs with adenine in DNA. Single-stranded RNA that is complementary to a messenger RNA (mRNA) sequence is called "antisense" RNA. Antisense RNA and mRNA form a double helix that is slightly different from a DNA double helix.

**complementary** matching opposite

**base pair** two nucleotides (either DNA or RNA) linked by weak bonds

Researchers use hybridization for many purposes. Overall genetic relatedness of two species can be determined by hybridizing their DNA. Due to sequence similarity between closely related organisms, higher temperatures are required to melt such DNA hybrids when compared to more distantly related organisms. In **forensic** DNA testing, a variety of different methods use hybridization to pinpoint the origin of a DNA sample, including the polymerase chain reaction (PCR). PCR produces many copies of a particular nucleic acid sequence and is also used to clone genes. In another technique, short DNA sequences are hybridized to cellular mRNAs to identify expressed genes. Pharmaceutical drug companies are exploring the use of antisense RNA to bind to undesired mRNA, preventing the **ribosome** from translating the mRNA into **protein**. SEE ALSO DNA; POLYMERASE CHAIN REACTION; RNA

Mary Beckman

### Bibliography

Alberts, Bruce, et al. *Molecular Biology of the Cell*, 4th ed. New York: Garland Publishing, 2000.

Freifelder, David. *Molecular Biology*, 2nd ed. Boston: Jones & Bartlett, 1987.

## Hybridization, Plant

Hybridization is the process of interbreeding between individuals of different species (interspecific hybridization) or genetically divergent individuals from the same species (intraspecific hybridization). Offspring produced by hybridization may be fertile, partially fertile, or sterile.

Plants hybridize much more frequently and successfully than animals do. Pollen from flowering plants disperses widely and may land on flowers of other species. Chromosomal doubling (polyploidy) occurs more frequently in plants and facilitates the fertility of the hybrid offspring. Finally, plant forms are less stringently controlled than animal forms, and so the intermediate form of a plant hybrid is more likely to be physiologically successful.

One of the first persons to study plant hybridization was Josef Kölrueter, who published the results of his experiments on tobacco in 1760. Kölrueter concluded that **interspecific** hybridization in nature is rare unless humans disturb the habitat. Since that time, many instances of hybridization among various plant species have been documented.

One good example of plant hybridization involves hybridization between the elegant sego lily (*Calochortus selwayensis*) and a mariposa lily (*C. apiculatus*) in western Montana. The sego lily, with purple-spotted petals, lives in dry sites at mid-elevations in the Rocky Mountains under the somewhat open canopy of ponderosa pine forests. The mariposa, with its cream-colored petals, lives in moister sites at higher elevations under the more closed Douglas-fir canopies. Interspecific hybrids between the elegant sego and mariposa lilies are found in great abundance on ski slopes where Douglas-fir canopies have been opened and kept clear of trees and tall shrubs.

The ski slope is a habitat that is too dry and too open for the mariposa to thrive and too moist for the elegant sego, but just right for the hybrids.

**forensic** related to legal proceedings

**ribosome** protein-RNA complex in cells that synthesizes protein

**protein** complex molecule made from amino acids; used in cells for structure, signaling, and controlling reactions



Crop yields increase dramatically when hybridization is used to exceed one or more of the parents in size and reproductive potential.

**interspecific** between different species

**allele** a particular form of a gene

**chromosome** “colored body” in the cell nucleus; made of DNA and protein, and divided functionally into genes and non-gene regions

**inbred** repeatedly bred with close relatives, creating organisms with very little genetic variation

**neural** related to nerve cells or the nervous system

**endocrine** related to the system of hormones and glands that regulate body function

Such an intermediate habitat is called a hybrid habitat. Human disturbance can generate hybrid habitats of many types and thus can foster interspecific hybridization.

Backcrossing, which is the interbreeding between hybrids and their parental species, can transfer **alleles** from one parent to the other using the interspecific hybrids as a genetic bridge in a process called introgression. Introgression increases the genetic variation of one or both of the parents. In the previous example, there is extensive backcrossing between the hybrids and mariposa lily. The result of this introgression is that some mariposa lilies now display petals with some of the purple spotting characteristic of the elegant sego, and theoretically they can live in slightly drier habitats.

Often interspecific hybrids are sterile or for some other reason cannot interbreed with the parental species. Occasionally sterile interspecific hybrids can undergo a doubling of their **chromosome** set and become fertile tetraploids (four sets of chromosomes). For example, the bread wheats that humans use today are a result of two hybridizations each followed by chromosome doubling to produce fertile hexaploids (six sets of chromosomes). In such instances the hybrids can become new species with characteristics different from either of the parents.

Humans have used intraspecific hybridization, hybridization between strains of a single species, to develop high-yielding crops. In corn, continually **inbred** varieties will often exhibit inbreeding depression, which is a reduction in vitality and yield. Hybridization between inbred lines can result in hybrids that exceed one or more of the parents in size and reproductive potential. This increased vitality is called hybrid vigor and has been studied since the time of English naturalist Charles Darwin. Crop yields increase dramatically (as much as 100 percent) when hybridization is used in this way. In the twenty-first century, over 90 percent of the corn grown is of hybrid origin. SEE ALSO GRAIN

George H. Wittler

### Bibliography

Anderson, Edgar. *Introgressive Hybridization*. New York: John Wiley & Sons, Inc., 1949.

Grant, Verne. *Plant Speciation*. New York: Columbia University Press, 1971.

Wagner, Warren. “Reticulate Evolution in the Appalachian *Asplenium*s.” *Evolution* 8 (1954): 103–118.

## Hypothalamus

The hypothalamus is a tiny part of the brain of vertebrate animals; in humans it weighs about four grams in a brain that weighs on average 1,400 grams (49 ounces). Despite its small size, the hypothalamus plays a pivotal role in an astounding number of functional and behavioral activities that are essential for day-to-day survival of the individual animal (or person) and for continuing survival of its species. Its overall role is to collect and integrate a huge variety of information from the body and to organize **neural** and **endocrine** responses that maintain homeostasis (constant internal environment).

Carrying out this single overriding task requires coordinating the activity of the **autonomic** nervous system and the endocrine system, and ultimately influences several important behaviors. Thus energy **metabolism** is regulated by control of feeding, drinking, and digestion. Body temperature is monitored and maintained at a constant level (37 to 38°C [98.6 to 100.4°F] in humans) by a complex interplay of behavior and activity in several body systems, and reproductive behavior is coordinated with endocrine regulation of the reproductive organs. Blood pressure and composition of the blood plasma are regulated by hypothalamic mechanisms. The expression of emotions such as fear, rage, and anger are partly controlled by the hypothalamus, and it even helps regulate sleep and levels of consciousness.

### Location/Anatomy

The hypothalamus is a thin (3 to 4 millimeters [.118 to .157 inches] in thickness) plate of neural tissue found along either side of the front end of the third **ventricle** (one of the fluid-filled cavities inside the brain). Deeply buried in the brain, near the center of the **cranial** cavity, it lies just below the thalamus (a relay center for sensory and motor pathways in the brain). It is almost completely hidden by the overlying cerebral hemisphere, although when a brain is removed for study, the hypothalamus is visible on the **basal** surface.

The hypothalamus has a special structural and functional relationship with the pituitary gland, which dangles below it, attached by a thin stalk of nerve fibers. Important information passes along both the nerve fibers and the blood vessels of this stalk.

### Working Principles

About ten or eleven small, indistinct nuclei (nerve cell groups) are packed into the hypothalamus. Reflecting their complex and highly specialized functions, the cells here use several unusual means of cell-to-cell communication.

Some hypothalamic cells are specialized to detect the presence and the concentration of large molecules such as **hormones** circulating in the blood and tissue fluids. They are able to do this because even the capillaries here are specialized. Unlike other brain vessels, they permit large molecules like hormones to leak into the tissues and carry signals to the **neurons**.

Hypothalamic neurons also receive information from other body and brain areas by way of electrical impulses conducted from many sensory sources (signaling pain, vision, and blood pressure, for example) scattered through the body. Other hypothalamic neurons respond by changing their firing pattern when there are changes in the desired values of variables such as blood (body) temperature, **glucose** concentration, or salt concentrations in the body fluids.

When the hypothalamus, using signals like those just described, establishes a need for response, hypothalamic cells influence other cells in two ways. Like other neurons, they send electrical signals (action potentials) to stimulate or inhibit cells in other regions of the brain and body. In addition, some release chemicals (hormones), usually small **proteins** called peptides, into the bloodstream so they can act on target cells at a considerable distance.

**autonomic** independent; regulating involuntary actions

**metabolism** chemical reactions within a cell

**ventricle** fluid-filled chamber

**cranial** related to the cranium, or brain cavity

**basal** lowest level

**hormone** molecule released by one cell to influence another

**neuron** nerve cell

**glucose** simple sugar that provides energy to animal cells and is the building block of cellulose in plants

**protein** complex molecule made from amino acids; used in cells for structure, signaling, and controlling reactions

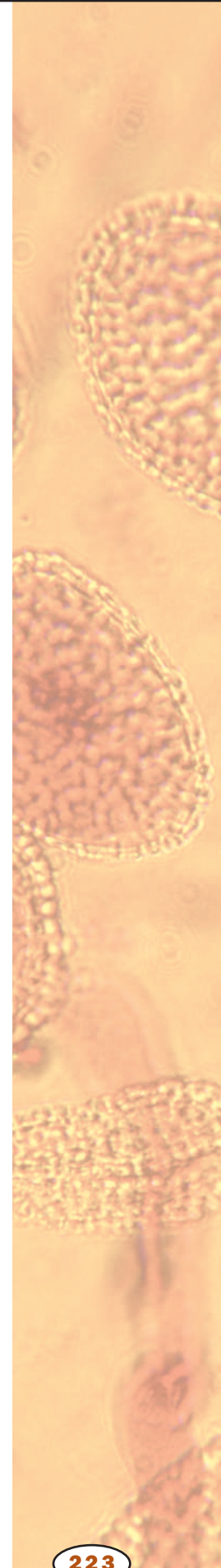

Anatomic location of the hypothalamus, in relation to the thalamus and pituitary gland.

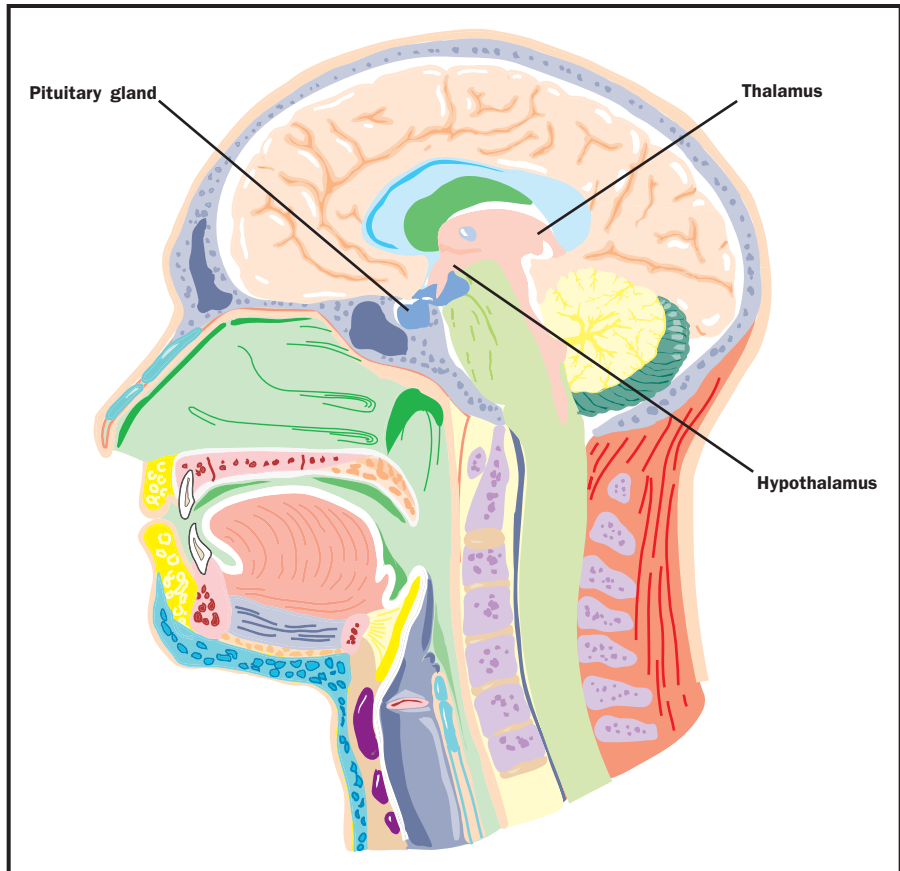

### Localized Hypothalamic Functions

Two of the most prominent hypothalamic nuclei (because their neurons are large) are the paraventricular **nucleus** and supraoptic nucleus. Upon appropriate stimulation, cells in these nuclei secrete (release) two hormones into the bloodstream. Oxytocin causes uterine contraction during birth and induces milk release in females with young. Antidiuretic hormone (ADH) travels to the kidneys to help the body retain water by decreasing urinary output.

Several other hypothalamic nuclei, mostly located in the **anterior** area, respond to several different hormones circulating in the body. When hormone levels change, cells in these nuclei release peptide signaling molecules into a special system of blood vessels that carry them to the anterior lobe of the pituitary. These peptides cause pituitary cells to either increase or decrease the **secretion** of one of about eight specific hormones into the bloodstream. This basic mechanism regulates blood levels of growth hormone, adrenocorticotrophic hormone (for response to stress), thyrotropin (regulating basal metabolism), and the several hormones that regulate the reproductive organs and sexual behavior.

Also in the anterior hypothalamus, the tiny suprachiasmatic nuclei sit atop the optic chiasm. A few optic nerve fibers from the eyes end here, informing these cells about cycles of light and darkness. Through their expansive projections to other brain areas, especially the pineal organ, these cells evoke release of the hormone melatonin into the bloodstream and thus

**nucleus** cluster of cell bodies in the central nervous system

**anterior** toward the front

**secretion** material released from the cell



help to regulate the body's **circadian** rhythms. Circadian rhythms are the cyclic, often subtle, fluctuations in many body functions that reoccur at intervals of about twenty-four hours.

**circadian** related to a day or daylength

Cells in the anterior and posterior hypothalamic areas detect blood temperature and have connections that allow them to adjust abnormal body temperature. Neural activity in the anterior area activates systems for heat loss, dilating blood vessels of the skin and causing sweating and panting. Neurons in the posterior hypothalamus help to preserve heat by constricting blood vessels of the skin, causing shivering and slowed breathing. Still other hypothalamic nuclei work together to balance food intake. Activity in the **lateral** hypothalamic area encourages eating while the ventromedial nucleus (VMN) suppresses food intake. Damage to the VMN results in animals (and humans) that overeat to excess and become obese.

**lateral** side-to-side

In the preoptic area at the front end of the hypothalamus are cells that use several of the hormonal mechanisms already described to drive and regulate the menstrual cycles and other aspects of reproductive organ function and behavior. Finally, a range of behaviors characterized as rage or aggression represent physiological responses to stress; these can be seen following experimental stimulation of the dorsomedial nucleus of animals. Blood pressure and heart rate are elevated, muscles are tensed, the animals show signs of strong internal, emotional feeling. SEE ALSO BRAIN; CENTRAL NERVOUS SYSTEM; ENDOCRINE SYSTEM; FEMALE REPRODUCTIVE SYSTEM; HOMEOSTASIS; HORMONES; MALE REPRODUCTIVE SYSTEM; PITUITARY GLAND; TEMPERATURE REGULATION; THYROID GLAND

*James L. Culbertson*

### **Bibliography**

- Beardsley, Tim. "Waking Up." *Scientific American* 275, no. 1 (2000): 14–16.
- Delcomyn, Fred. *Foundations of Neurobiology*. New York: W. H. Freeman and Company, 1998.
- Goldstein, Irwin. "Male Sexual Circuitry." *Scientific American* 282, no. 8 (2000): 70–75.
- Kandel, Eric R., James H. Schwartz, and Thomas M. Jessell, eds. *Essentials of Neural Science and Behavior*. Norwalk, CT: Appleton and Lange, 1995.
- Moore, Robert Y. "A Clock for the Ages." *Science* 284, no. 5423 (1999): 2102–2103.

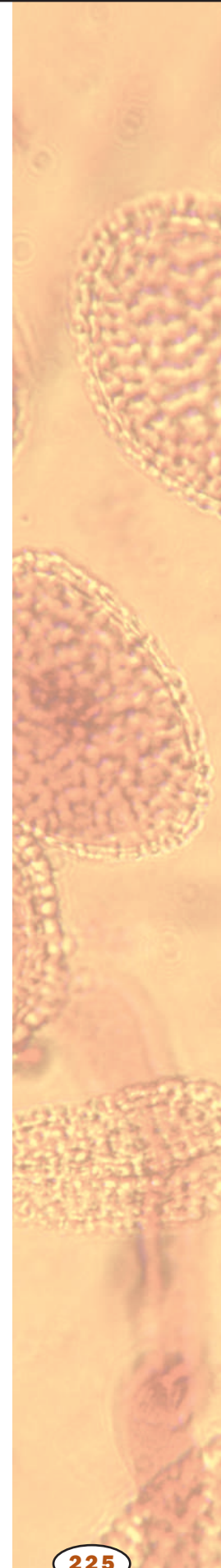

# Photo and Illustration Credits

*Unless noted below, the illustrations and tables featured in Biology were created by GGS Information Services. The photographs appearing in the text were reproduced by permission of the following sources:*

## Volume 1

**p. 4** Willow ptarmigan in summer color, photograph. © JLM Visuals; **p. 5** Willow ptarmigan in winter color, photograph. © Marypat Zitzer/JLM Visuals; **p. 6** Cross section of human adrenal gland, triangular shape, photograph by Martin M. Rotker. Phototake NYC; **p. 8** Elderly married couple, photograph. © Kevin R. Morris/Corbis; **p. 11** Wild rice plant grows in Ocala, Florida, photograph. © Jonathan Blair/Corbis; **p. 12** Herd of Holsteins eat silage from troughs on a Minnesota farm, photograph. © Richard Hamilton Smith/Corbis; **p. 15** AIDS virus attacking T4 lymphocytes, scanning electron micrograph image. ©Wagner/Seifert, Inc./Phototake; **p. 18** Santa Monica police officer, administering Breathalyzer test, photograph. © Shelley Gazin/Corbis; **p. 21** Algae on Pond, photograph. © Charles Mauzy/Corbis; **p. 27** Strawberry poison arrow frog, photograph. © Alex Kerstitch/JLM Visuals; **p. 28** Weightlifting with a dumbbell, photograph. © Duomo/Corbis; **p. 31** Maidenhair fern with fan-shaped leaves, photograph by Robert J. Huffman/Field Mark Publications; **p. 32** Light blue iris against black background, photograph. JLM Visuals; **p. 35** Transparent jellyfish with short tentacles, photograph by Mark A. Johnson/Stock Market; **p. 38** Enzyme-lined immunoabsorbent assay, ELISA plate, photograph. © Lester V. Bergman/Corbis; **p. 43** Newly hatched Green Lynx spiders, photograph. © J. C. Cokendolpher/JLM Visuals;

**p. 44** Ten million year old Archeobacteria, scanning electron micrograph by Eurelios. © Eurelios/Phototake; **p. 47** Digitally enhanced X ray of left hand showing rheumatoid arthritis, photograph. © 1994 Michael English, M.D. Custom Medical Stock Photo; **p. 49** Streptococcus bacteria attached to a human tonsil cell, colored transmission electron micrograph by Dr. Immo Rantala. © Dr. Immo Rantala/SPL/Photo Researchers, Inc; **p. 51** Streptococcus pyogenes bacteria, colored transmission electron micrograph by Alfred Pasioka. © Alfred Pasioka/Science Photo Library, Photo Researchers, Inc.; **p. 54** Laboratory technician performing Analytical Profile Index (API), photograph by Geoff Tompkinson. © Geoff Tompkinson/Science Photo Library, Photo Researchers, Inc; **p. 57** DNA circles of bacterial plasmid, scanning electron micrograph. © Gopal Murti/Phototake; **p. 59** Electron micrograph of T4 Cells, or bacteriophage, photograph. © Dr. Dennis Kunkel/Phototake; **p. 61** Honey bees around Queen in hive, photograph. © J. C. Cokendolpher/JLM Visuals. Reproduced by permission; **p. 64** Elk fighting, Wyoming, photograph. © Breck P. Kent/JLM Visuals; **p. 69** Soil erosion on the trail, Adirondack, photograph by Yoav Levy/Phototake; **p. 71** Continental Drift, illustration by Accurate Art, Inc., Gale Group; **p. 72** Mary Pat Reeves-Daly, mapping human Y chromosome, as part of Human Genome Mapping Project, photograph. © Roger Ressmeyer/Corbis; **p. 75** Immunization technician Sgt. Louis Rios giving 2nd Lieutenant Clayton Bland a vaccination for anthrax, photograph. AP/Wide World Photos; **p. 78** Smiling school girls,

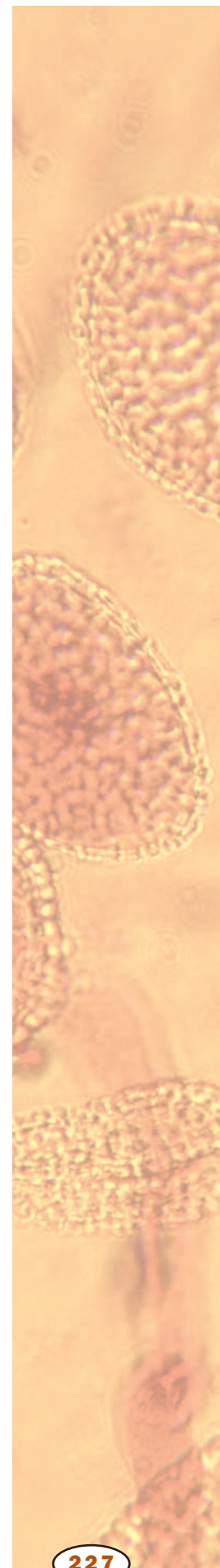

- photograph. © The Purcell Team/Corbis; **p. 81** Red-tailed hawk perched on stump, photograph by Robert J. Huffman/Field Mark Publications; **p. 83** Beaulieu, Emile-Etienne, holding handful of the RU-486 abortion drug/pills, which he invented, photograph. AP/Wide World Photos; **p. 90** Red and white blood cells flowing through saphenous vein, scanning electron micrograph. © Image Shop/Phototake; **p. 94** Cancellous bone tissue affected by osteoporosis, false-color scanning electron micrograph. © Professor P. Motta/Dept. of Anatomy/University of La Sapienza, Rome/Science Photo Library, Photo Researchers, Inc.; **p. 97** Axial section of human brain showing metastatic tumor, MRI by Simon Fraser. © Simon Fraser/Science Photo Library, Photo Researchers, Inc.; **p. 101** Human brain with hypothalamus highlighted, green dot, MRI scan by Scott Camazine & Sue Trainor; © Scott Camazine & Sue Trainor/Photo Researchers, Inc.; **p. 105** Liverwort, plant with leaf-like structures covered with tiny capsules, photograph. JLM Visuals; **p. 109** Marine life from Cambrian Period, photograph by Robert J. Huffman/Field Mark Publications; **p. 110** Human breast cancer cells growing in culture, photograph by Cecil Fox. © Cecil Fox/Photo Researchers, Inc; **p. 111** Human abdomen showing cancer of the ascending colon, colored barium enema X ray. © Science Photo Library/Photo Researchers, Inc.; **p. 116** Electronic image of human heart undergoing angiography; indicates massive aneurism of aortal arch, photograph. © CNRI/Phototake; **p. 119** *Listeria monocytogenes*, scanning electron micrograph image. © CNRI/Phototake; **p. 137** Tobacco leaf chloroplast, micrograph, photograph. © Dr. Jeremy Burgess/Science Photo Library, National Audubon Society Collection/ Photo Researchers, Inc. Reproduced with permission; **p. 141** Human chromosomes showing male mutation on gene 7, which determines cystic fibrosis, photomicrograph by Jean Claude Revy. © Jean Claude Revy/Phototake; **p. 142** Digital image of multipolar and bipolar spindles from T84 colonic cancer cell cultures, photograph. © Albert Tousson/Phototake; **p. 144** Mitosis metaphase of an animal cell, immunofluorescence photomicrograph. © CNRI/Phototake; **p. 146** Human male chromosomes, XY karyotype, with G banding, karotype. © CNRI/Phototake; **p. 153** Micro injection introducing foreign genes into animal cells, photograph by M. Baret. © M. Baret/Rapho, Photo Researchers, Inc; **p. 158** Second growth birch forest, photograph. © Richard P. Jacobs/JLM Visuals; **p. 161** Ground finch with dark feathers and bill, photograph by Tim Davis. Photo Researchers, Inc; **p. 163** Pine cones, photograph. JLM Visuals; **p. 167** People along polluted Swazambhunath River, in Kathmandu, Nepal, photograph. © Charlie Crangle/JLM Visuals; **p. 182** Sand skink on top of shiny dark green leaf, 1985, Florida, photograph by Joseph T. Collins/Photo Researchers, Inc.; **p. 184** Stretch of the great coral reef, between Cairns and Townsville, photograph. © Yann Arthus-Bertrand/Corbis; **p. 187** Crick, Francis, photograph. The Library of Congress; **p. 189** Horseshoe crab, photograph. © John M. Burnley/The National Audubon Society Collection/Photo Researchers, Inc; **p. 192** Breast cancer cell dividing, colored scanning electron micrograph. © Quest/Science Photo Library, Photo Researchers, Inc.; **p. 198** Darwin, Charles, photograph. Popperfoto/Archive Photos. © Archive Photos, Inc.; **p. 202** Shadows form on the El Oued dunes, The Algerian Sahara Desert, Algeria, photograph. © Adam Woolfitt/Corbis; **p. 203** High desert oasis, photograph. © Richard P. Jacobs/JLM Visuals; **p. 205** Human embryo, 8-cell stage, day 3, scanning electron micrograph, SEM, scan by Dr. Yorgos Nikas. © Dr. Yorgos Nikas/Phototake; **p. 209** Frog embryos complete their metamorphoses inside their eggs, photograph. Michael & Patricia Fogden/Corbis; **p. 224** Human DNA fingerprint taken from blood to match donor and patient in organ transplantation, photograph. © Index Stock/Phototake; **p. 227** Herpes simplex virus, HSV6, scanning electronic micrograph. © Dr. Dennis Kunkel/Phototake; **p. 230** Surgeon looking at CAT scans, photograph. © Steve Chenn/Corbis; **p. 233** Lab technician Li Zhang performing a density test from urine samples at the Australian Sports Drug Testing Laboratory, photograph. AP/Wide World Photos.

## Volume 2

- p. 6** Professor Ernst Haeckel, the German naturalist and philosopher, poses as if in a jungle scene, photograph. © Hulton-Deutsch Collection/Corbis; **p. 9** Lush growth, mossy tree, temperate rain forest, photograph by Robert J. Huffman/Field Mark Publications; **p. 12** Scientist sitting at scanning transmission electron microscope, STEM, photograph by Sinclair Stammers/Science Photo Library/Photo Researchers, Inc.; **p. 14** Gloved hands holding a sheet/culture, electrophoresis gel, photograph. © Eurelios/Phototake; **p. 17** White tiger in the zoo, photograph. © Shawn Gerrits/JLM Visuals; **p. 21** Scintigram of normal human thyroid, front view, photograph. © CNRI/Phototake; **p. 23** Phagocytosis, color enhanced transmission electron micrograph. © Biophoto Associates/Science Source/Photo Researchers, Inc; **p. 27** Entomologist Elidia Fernandez sorts an insect collection for the Institute for Biodiversity, photograph. © Gary Braasch/Corbis; **p. 39** Ravenglass Estuary curving to the sea, Cumbria, England, photograph. Corbis/Genevieve Leaper; **p. 41** Chlamydia pneumonia, photograph by Dr. Kari Lounatmaa. Custom Medical Stock Photo; **p. 42** Escherichia Coli, photograph by Kari Lounatmaa. Photo Researchers; **p. 44** Bumble bee, photograph. © Lloyd R. Brockus III/JLM Visuals; **p. 46** Darwin's Large Cactus Finch, © Breck P. Kent/ JLM Visuals; **p. 50** Antibiotic Staphylococcus aureus, photograph by Hank Morgan. © Hank Morgan/Science Photo Library, Photo Researchers, Inc.; **p. 53** Fossil fish, photograph. © Richard P. Jacobs/JLM Visuals; **p. 58** Ginkgo tree, photograph. JLM Visuals; **p. 60** X ray, color enhanced normal intravenous pyelogram. © Biophoto Associates/Science Source/Photo Researchers, Inc; **p. 65** Dinosaur skeleton on display at the Royal Terrell Museum, photograph. © Paul A. Souders/Corbis; **p. 67** Carolina parakeets lie in bags with tags, photograph. © Jonathan Blair/Corbis; **p. 73** Rod cells in the retina of the human eye, colored scanning electron micrograph. © Quest/Science Photo Library, Photo Researchers, Inc.; **p. 77** Normal human uterus and fallopian tubes, hysterosalpinograph. © GCA/CNRI/Phototake; **p. 83** Human fetus, 10 weeks old, inside amniotic sac, photograph. © CNRI/Phototake; **p. 86** Gray wolves exhibiting submissive behaviors, photograph. © Mary Ann McDonald/Corbis; **p. 88** Agronomists place a plastic greenhouse over crops, photograph. © Ted Spiegel/Corbis; **p. 90** Despain, Don, measures Lodgepole Pine Seedlings, photograph. © Raymond Gehman/Corbis; **p. 94** Snapdragons in flower, photograph by Eric Kamp. © Eric Kamp/Phototake; **p. 95** Lab Agent Kathy Dressel works on DNA evidence in the murder of JonBenet Ramsey at the Colorado Bureau of Investigation, Boulder, Colorado, photograph. AP/Wide World Photos; **p. 98** Boreal forest, evergreen trees, Michigan, photograph. JLM Visuals; **p. 100** Oak/hickory trees in autumn, photograph by Robert J. Huffman/Field Mark Publications; **p. 102** Moss-covered lianas in the Daintree National Park, Queensland, Australia, photograph. © Paul A. Souders/Corbis; **p. 103** Agile gibbon hanging from tree branch with baby at waist, photograph. © Breck P. Kent/JLM Visuals; **p. 105** Strawberry plants with fruit and blossoms, photograph. © Ed Young/Corbis; **p. 111** Dark yellow Witches' Butter jelly fungus, photograph. © Richard P. Jacobs/JLM Visuals; **p. 113** Detail that shows the gills of a mushroom, photograph. © Laura Sivell; Papilio/Corbis; **p. 114** Salmon gills showing the filaments of the gills, photograph. © Ron Boardman; Frank Lane Picture Agency/Corbis; **p. 124** Cancer cells infected with bioengineered adenovirus, photograph by Jean Claude Revy. © Jean Claude Revy/Phototake; **p. 132** Chicken embryo, 96-hours old, photograph. © Richard P. Jacobs/JLM Visuals; **p. 142** Man using computer to design complex proteins, photograph by Richard Nowitz. © Richard Nowitz/Phototake; **p. 147** Mexico City, photograph. Reuters/Archive Photos; **p. 154** Piles of wheat during harvest, Polouse Valley, Washington, photograph. © Vince Streano/Corbis; **p. 157** Grassland, photograph. © Richard P. Jacobs/JLM Visuals; **p. 159** Baby smiling, photograph. © Simon Dearden/Corbis; **p. 160** Hand development of a 2, 6, and 19 year old male, computer color enhanced X ray by Scott Camazine. © Scott Camazine, Photo Researchers, Inc.; **p. 162** Cycad, photograph. JLM Visuals;

**p. 166** Harvey, William, photograph. U.S. National Library of Science; **p. 167** Bicyclist sitting under a shade tree, photograph by Robert J. Huffman/Field Mark Publications; **p. 170** Hearing, human system, diagram by Hans & Cassidy. Gale Group; **p. 173** Heart, diagram by Hans & Cassidy. Gale Group. **p. 178** Close-up of branch with very long thorns, photograph. © Richard P. Jacobs/JLM Visuals; **p. 181** Close-up of genetically manipulated corn, photograph. © Carolina Biological Supply Company/Phototake; **p. 183** Buchner, Eduard, photograph. Hulton-Deutsch Collection/Corbis; **p. 186** Microscope used by Robert Hooke, 17th century, photograph. © Bettmann/Corbis; **p. 189** Young girl on her father's shoulders, photograph. © Raoul Minsart/Corbis; **p. 193** Cuvier, Georges Leopold, photograph. The Library of Congress; **p. 199** Hales, Stephen, engraving. The Library of Congress; **p. 209** Beginnings of Civilization, map by XNR Productions Inc. Gale Research; **p. 213** Female researcher loading an automated DNA sequencer at the Joint Genome Institute, photograph. Photo Researchers; **p. 215** Computer print-out of sequence of DNA, placed below multi-well sample tray, upper left, and automated pipettes, lower right, illustration by © James King-Holmes/Science Photo Library. Photo Researchers; **p. 217** Ingredients that should make up the bulk of a healthy diet, including fruits, vegetables, whole grains, photograph. © Nathan Benn/Corbis; **p. 221** Tomatoes ripen on vine for market, photograph. © Ed Young/Corbis.

### Volume 3

**p. 2** Human brain, cervical spine, and spinal marrow, magnetic resonance imaging (MRI). © GCA/CNRI/Phototake; **p. 6** Cancer cell attacked by tumor infiltrating lymphocytes, scanning electron micrograph by Jean Claude Revy. © Jean Claude Revy/Phototake; **p. 8** Katydid on human hand, photograph. JLM Visuals; **p. 11** House and hill overgrown with kudzu, photograph. JLM Visuals; **p. 22** Canadian Rockies, Ben My Chreem, Yukon, photograph. © Lowell R. Laudon/JLM Visuals; **p. 26** Leakey, Dr. L.S.B and Mary, photograph. AP/Wide World Photos, Inc; **p. 27**

Young girl fits blocks of different shapes through similarly shaped holes in a red box, photograph. © Robert Kozma/Corbis; **p. 30** Spine of Cleistocactus, close-up, photograph. © Peggy Morsch/JLM Visuals; **p. 32** Golden lichen, photograph. © Don Blegen/JLM Visuals; **p. 33** Grandmother holding her grandson, Philadelphia, PA, photograph. © Ed Eckstein/Corbis; **p. 36** Spawning sockeye salmon run the Fraser River from Shushwap Lake to Adams River, photograph. © Stuart Westmorland/Corbis; **p. 38** Chicken embryo, 56-hours old, photograph. © Richard P. Jacobs/JLM Visuals; **p. 40** Microscope, parts labeled, photograph. Carolina Biological Supply Company/Phototake; **p. 52** Two Ceratium tripos, photomicrograph by Eric Grave. © Eric Grave/Phototake; **p. 53** Lymphangiography, diagram of man's body, illustration. Electronic Illustrators Group; **p. 57** Human testis showing spermatogenesis, photomicrograph by Ken Wagner. © Ken Wagner/Phototake; **p. 61** Marine biologist in diving suit inspecting coral reef damaged by illegal fishing practices, photograph. AP/Wide World Photos; **p. 63** Male frigatebird with its red throat pouch inflated, photograph. © Wolfgang Kaehler/Corbis; **p. 64** McClintock, Barbara, photograph. UPI/Corbis-Bettmann; **p. 70** Transmission Electron Micrograph, TEM, image of Golgi apparatus, photograph. © Dr. Dennis Kunkel/Phototake; **p. 80** Mendel, Gregor, photograph. Archive Photos, Inc; **p. 86** Two lysosomes that contain digestive enzymes which destroy damaged molecules; in an intestinal epithelial cell, colored high resolution scanning electron micrograph. P. Motta & T. Naguro/Science Photo Library/Photo Researchers, Inc; **p. 89** Fat cells that make up adipose connective tissue, colored scanning electron micrograph. © Quest/Science Photo Library, Photo Researchers, Inc; **p. 90** Quality control microbiologist Kim Egger inspects a bacteria culture from ground meat processed at Excel Corporation's slaughterhouse, photograph. AP/Wide World Photos; **p. 93** Spring tide of surfbirds surge from the mud flats of Alaska's Copper River delta, photograph. © Jonathan Blair/Corbis; **p. 94** Indian leaf butterfly, photograph. © Richard P. Jacobs/JLM Visuals; **p.**

**99** Mitosis of an animal cell, early prophase, photograph. © CNRI/Phototake; **p. 100** Mitosis of an animal cell, early metaphase, photograph. © CNRI/Phototake; mitosis of an animal cell, immunofluorescence photomicrograph. © CNRI/Phototake; mitosis telophase of an animal cell, photograph. © CNRI/Phototake; **p. 101** Fruit fly head, magnified 200 times, scanning electron micrograph. © Dr. Dennis Kunkel, Phototake; **p. 104** Hands holding lab mouse, photograph. © Mario Beaugard/Corbis; **p. 107** Eastern prairie fringed orchid, photograph. U.S. Fish and Wildlife Service; **p. 114** Human knee joint with patella, X ray. © CNRI/Phototake; **p. 116** White American alligator shows a genetic mutation known as ieucism, Miami Zoo, photograph. © W. Perry Conway/Corbis; **p. 118** African clawed frog, *Xenopus laevis*, mutated, with three hind legs, photograph by Mark Smith. © Mark Smith/Science Source/Photo Researchers, Inc.; **p. 120** Endotrophic mycorrhizae in orchid root, magnified 100x, photograph. © Carolina Biological Supply Company/Phototake; **p. 122** Eggs and spiderlings of Uloborid Spider, photograph. © J. C. Cokendolpher/JLM Visuals; **p. 130** Human brain with Parkinson's Disease showing atrophy, Computerized Axial Tomography, CAT, scan. © GJLP/CNRI/Phototake; **p. 134** Two types of neurons; top of image shows a bipolar neuron, bottom of image is a developing neuron, scanning electron micrograph. © Dr. Dennis Kunkel/Phototake; **p. 137** Nitrogen fixation, bacteria, plants, photograph. © Adam Hart-Davis, National Audubon Society Collection/Photo Researchers, Inc.; **p. 139** Macrophage engulfing a *Leishmania* sp. parasite, colored scanning electron micrograph. © Juergen Berger, Max-Planck Institute/Science Photo Library, Photo Researchers, Inc.; **p. 142** Single mammalian tissue culture cell, color transmission electron micrograph. Dr. Gopal Murti/Science Photo Library/Photo Researchers, Inc.; **p. 149** Loh, Dan, photograph. AP/Wide World Photos; **p. 151** Anemone, Tunicate, Oyster, and Sponge, photograph. © Stephen Frink/Corbis; **p. 152** Bottlenosed dolphin playing, photograph. © Stephen Frink/Corbis; **p. 155** Blood smear showing leukemia cells, photomicrograph. ©

Margaret Cubberly/Phototake; **p. 160** Hand wearing glove, holding worms, compost sits below, photograph by Robert J. Huffman/Field Mark Publications; **p. 164** Meteorite ALH84001, from Mars, 4.5 billion years old, photograph. National Aeronautics and Space Administration (NASA); **p. 172** Larson, Peter, running fingers over teeth of a *Tyrannosaurus rex* skeleton, photograph. AP/Wide World Photos; **p. 175** Dog hookworms in small intestines, photograph. © Michael L. Wolmack/JLM Visuals; **p. 178** Young native boy with blonde hair trait, Lubarria Island, Solomon Islands, photograph. © Wolfgang Kaehler/Corbis; **p. 183** Micrograph comparing healthy red blood cells with a sickle cell, photograph by Dr. Gopal Murti. National Audubon Society Collection/Photo Researchers, Inc.; **p. 190** Diagram showing the central and peripheral nervous systems, left, and the autonomic nervous system, right, illustration by Frank Forney; **p. 192** Scientist performing pharmacological research, photograph. © Bob Krist/Corbis; **p. 194** *Cecropia* moth, photograph. Robert J. Huffman/Field Mark Publications; **p. 203** Dromedary camel, photograph. © Leonard Lee Rue, III/The National Audubon Society Collection/Photo Researchers, Inc.; **p. 206** Marine Plankton, green organisms with orange spots, 1960-1995, photograph by Douglas P. Wilson. Corbis/Dougals P. Wilson; Frank Lane Picture Agency; **p. 226** *Digitalis*, photograph. © Ken Wagner/Phototake; **p. 227** Release of pollen from anther of a black walnut, photograph. © Yoav Levy/Phototake; **p. 230** Closed General Electric plant in Pittsfield, Massachusetts, on the Housatonic River, photograph. AP/Wide World Photos; **p. 237** Cheetah, photograph. Robert J. Huffman/Field Mark Publications.

## Volume 4

**p. 2** Peregrine falcon with wings outstretched, photograph by Tim Davis. Photo Researchers, Inc.; **p. 3** School of fish swimming above blue and green coral reef, Indian Ocean, off Pemba Island, 1991, photograph by Stephen Frink. Corbis/Stephen Frink; **p. 21** Dinoflagellate *gambierdiscus toxicus*, scanning electron micrograph by Dr. Dennis

Kunkel. © Dr. Dennis Kunkel/Phototake; **p. 22** Diatoms, photograph. © Richard P. Jacobs/JLM Visuals; **p. 24** Euglena protozoa, photomicrograph by Eric Grave. © Eric Grave/Phototake; **p. 27** Plasmodium flaciparum, malaria parasite, electron micrograph. © Institut Pasteur/Phototake; **p. 28** Brain scans of a schizophrenic patient, bottom, versus a normal patient, top, colored positron emission tomography. © Wellcome Dept. of Cognitive Neurology/Science Photo Library, Photo Researchers, Inc.; **p. 32** Man shows the milky juice of unripe seedpods used to make opium from the opium poppy plant, photograph. © Michael S. Yamashita/Corbis; **p. 33** Sensitive fern, close-up of single leaf, photograph by Robert J. Huffman/Field Mark Publications; **p. 39** Slade, Dennis, photograph. AP/Wide World Photos; **p. 53** Structure of Hibiscus flower, photograph by Ken Wagner. © Ken Wagner/Phototake; **p. 57** Bumblebee pollinating flower, photograph by Robert J. Huffman/Field Mark Publications; **p. 61** *In vitro* fertilization, photograph. © CC Studio/Science Photo Library, Photo Researchers, Inc.; **p. 64** Respiratory system, diaphragm, photograph by Hans & Cassidy. Gale Group; **p. 67** Model of HIV virus, photograph. Corbis-Bettmann; **p. 70** Old-growth forest with understory of wood sorrel in Mt. Hood National Forest in Oregon, photograph by William H. Mullins. Photo Researchers, Inc.; **p. 71** Color-coded cryo-EM map of the *E. coli* ribosome, photograph. Courtesy of Joachim Frank/Health Research, Inc.; **p. 74** Farmland on the banks of the Nile, Egypt, photograph. © Yann Arthus-Bertrand/Corbis; **p. 79** Cross-section of plant in soil, photograph. © Premium Stock/Corbis; **p. 86** Kidney bean sprouting into a seedling, photograph. Photo Researchers, Inc.; **p. 90** Arabidopsis sp. seed pods, scanning electron micrograph, SEM. © Dr. Dennis Kunkel/Phototake; **p. 92** Autumn scene with man, photograph by Robert J. Huffman/Field Mark Publications; **p. 93** Purified adenovirus, photograph by Jean Claude Revy. © Jean Claude Revy/Phototake; **p. 95** Barr body in a female squamous epithelium cell, photograph. © Lester V. Bergman/Corbis; **p. 97** Normal human female chromosomes (XX) in karyotype. © Leonard Lessin, FBPA/Photo Researchers, Inc.; **p. 99** Common frogs in amplexus, photograph. © John Tinning; Frank Lane Picture Agency/Corbis; **p. 102** Rainbow trout eggs hatching, photograph. JLM Visuals; **p. 105** Male and female black widow spiders, photograph. © J. C. Cockendolpher/JLM Visuals; **p. 107** Gonorrhea cells, photograph. Custom Medical Stock Photo; **p. 108** Syphilitic infection, sexually transmitted disease, photograph. © CNRI/Phototake; **p. 111** Fiddlehead ferns, close-up, photograph by Robert J. Huffman/Field Mark Publications; **p. 113** Lymphocytes, T-cells, and 3 red cells, scanning electron micrograph. © NYU Franklin Research Fund/Phototake; **p. 118** Snake skeleton, photograph. © Richard P. Jacobs/JLM Visuals; **p. 125** Pillows of coral colored Myxomycetes grow on damp wood, photograph. © Steve Austin; Papilio/Corbis; **p. 128** Two gannets greeting each other on Bonaventure Island, Quebec, photograph. © Breck P. Kent/JLM Visuals; **p. 130** Olive baboon grooming papio cynocephalus, photograph. © Joe McDonald/Corbis; **p. 131** Wilson, Edward O., 1991, photograph. AP/Wide World Photos; **p. 143** Cleaner shrimp, cleaner moray, photograph. JLM Visuals; **p. 149** Three T-lymphocytes, scanning electron micrograph, SEM, image. © Microworks/Phototake; **p. 152** Linnaeus, Carolus, engraving. The Library of Congress; **p. 153** Archeobacteria, scanning electron micrograph by Eurelios. © Eurelios/Phototake; **p. 155** Pit Bull Panting, photograph. © Lawrence Manning/Corbis; **p. 159** Thyroid Nuclear Medicine Scan, enhanced Scintigram, photograph by Oliver Meckes. Photo Researchers, Inc.; **p. 161** Close-up of a human fingerprint, macrophotograph by Martin Dohrn. © Martin Dohrn/Science Photo Library, Photo Researchers, Inc.; **p. 173** Surgeons clean a human kidney in preparation for transport into a patient at the University of Pittsburgh Medical Center, photograph. © Nathan Benn/Corbis; **p. 177** Cook Strait Tutuata, photograph by Tom McHugh. Photo Researchers, Inc.; **p. 178** Sea-peach tunicate, photograph. JLM Visuals; **p. 181** Vaccination process, illustration. Electronic Illustrators Group. **p. 185** Veterinarian technicians check the blood pressure of a dog, photograph.

AP/Wide World Photos; **p. 188** T4 bacteriophage virus, colored transmission electron micrograph. © Department of Microbiology, Biozentrum/Science Photo Library/Photo Researchers, Inc.; **p. 189** Compound eye of a fruit fly, scanning electron micrograph, SEM. © Dr. Dennis Kunkel; **p. 194** Drop of guttation, water extruded by a plant's root pressure, on a blade of grass. Alpine Lakes Wilderness Area, Washington, photograph. © Pat O'Hara/Corbis; **p. 196** Watson, Dr. James Dewey, with DNA model, 1962, photograph. UPI/Corbis-Bettmann; **p. 198** Dead

tree trunks, stumps in deep blue water, golden leaves, photograph by Robert J. Huffinan/Field Mark Publications; **p. 199** Biologists take samples from drugged polar bears for data about pesticides, photograph. © Galen Rowell/Corbis; **p. 201** Man walks across giant rollers used to crush wood pulp at the Ketchikan Pulp Company, photograph. © Kevin Fleming/Corbis; **p. 205** Zoo veterinarian Don Janssen examining the San Diego Zoo's 2-week old giant panda cub, photograph. AP/Wide World Photos.

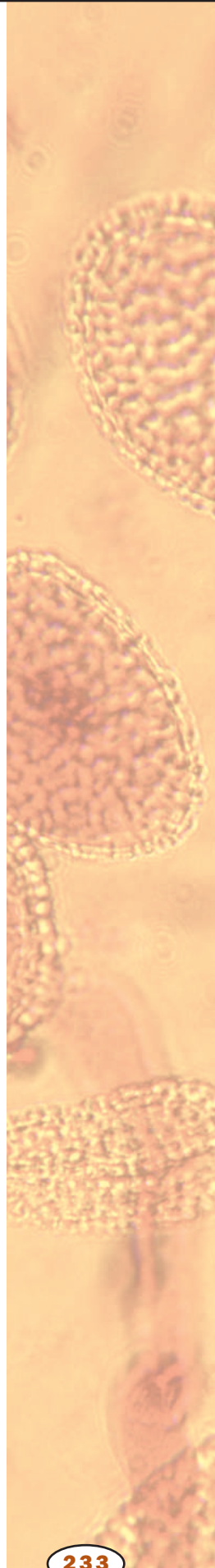



# Glossary

**abiotic** nonliving

**abscission** shedding of leaves; falling off

**acetylation** addition of an acetyl group,  $\text{CH}_3\text{-CHOO-}$

**acidic** having an excess of  $\text{H}^+$  ions and a low pH

**acinus** one of the small divisions of a fruit such as a raspberry

**action potential** wave of ionic movement down the length of a nerve cell

**active site** surface region of an enzyme where it catalyzes its reaction

**adaptive radiation** diversification of a group of organisms into several different forms that adapt to different environments

**adhesion** attachment; sticking to the surface of

**ADP** adenosine diphosphate, the low-energy form of ATP

**adventitious** growing from a nonstandard location

**aerobe** organism that needs oxygen

**aerobic** with oxygen, or requiring it

**aestivating** remaining dormant for the summer

**affinity** attraction

**aflatoxin** toxic compound produced by a mold fungus

**agar** gel derived from algae

**agnosia** “not knowing”; loss of ability to recognize familiar objects

**agroecosystem** agricultural ecosystem

**alkaline** chemically basic, with an excess of  $\text{OH}^-$  ions

**allele** a particular form of a gene

**allelopathy** inhibition of one plant’s growth by another plant

**amino acid** a building block of protein

**amoeba** a single-celled protist that moves by crawling

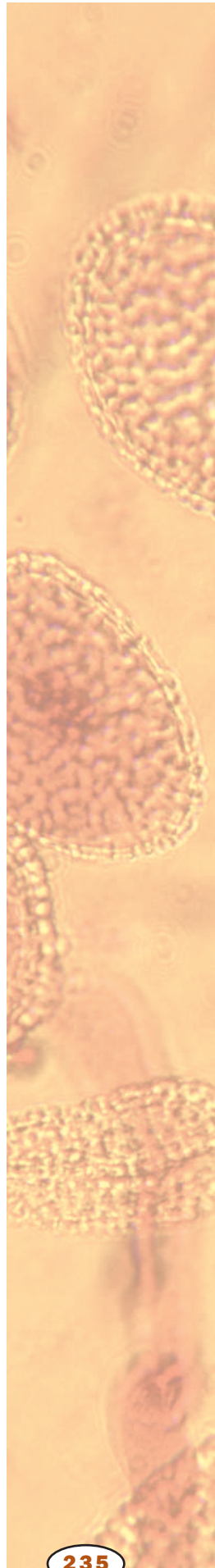

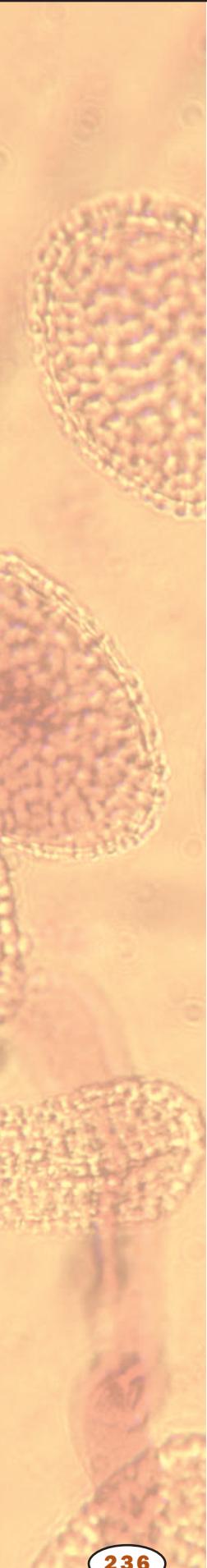

**amoeboid** like an amoeba, especially in movement via extension of portions of the membrane

**AMP** adenosine monophosphate, form of ATP after removal of two phosphate groups

**amphipathic** having both polar and nonpolar regions

**anabolic** characteristic of a reaction that builds complex molecules from simpler ones, and requires energy

**anadromous** describes fish that return to the rivers where they were born in order to breed

**anaerobe** organism not needing oxygen

**anaerobic** without oxygen, or not requiring oxygen

**anemia** lack of oxygen-carrying capacity in the blood

**aneurysm** bulging of the wall of a blood vessel

**antagonism** working against

**antagonist muscle** muscle that works against the action undertaken

**anterior** toward the front

**anterograde** forward

**anthocyanins** colored compounds made by plants

**anthropogenic** of, or relating to, the influence of human beings or nature

**antibody** immune system protein that binds to foreign molecules

**antigen** foreign substance that provokes an immune response

**antioxidant** substance that prevents damage from oxidation

**antitoxin** molecule used to inactivate a toxin

**aphasia** loss of the ability to form ideas into words

**apical** at the tip

**apical meristem** growing tip from which all plant tissues arise

**appendage** attached organ or structure

**aqueous** watery or water-based

**areolar** related to a small space within a tissue

**aromatic** compound including a double-bonded carbon ring

**arterioles** any of the small, terminal twigs of an artery that ends in capillaries

**arthropods** organisms with jointed appendages and exoskeletons, including insects, spiders, and crustaceans

**asymptomatic** without symptoms

**ATP** adenosine triphosphate, a high-energy nucleotide used by cells to power most energy-requiring reactions

- atria** two upper chambers of the heart (singular, atrium)
- attenuation** lessening over time
- autoimmune disease** disease in which the immune system attacks the body's own tissues
- autonomic** independent; regulating involuntary actions
- autonomic nervous system** one of the branches of the motor system, controlling involuntary muscles and glands
- autosomal dominant** pattern of inheritance in which inheritance of a single allele from either parent results in expression of the trait
- avian** concerning birds
- axon** long extension of a nerve cell down which information flows
- B lymphocyte** white blood cell that makes antibodies
- B.C.E.** before the Common Era, equivalent to B.C.
- basal** lowest level
- base pair** two nucleotides (either DNA or RNA) linked by weak bonds
- basic** having an excess of  $\text{OH}^-$  ions and a high pH
- bilaterally symmetric** symmetric, or similar, across a central line
- bilayer** composed of two layers
- bioaccumulate** build up within organisms
- bioluminescence** production of light by biochemical reactions
- biopharmaceuticals** drugs produced by and harvested from living organisms
- biosynthetic** forming a complex molecule from simpler ones
- biotic** living
- bolting** sudden spurt of growth
- boreal** of, relating to, or located in northern regions
- brood parasite** organism of one species that lays its eggs in the nest of another species
- C4 and CAM plants** plants that employ accessory systems for trapping carbon for photosynthesis
- cadherins** family of calcium-dependent adhesion proteins
- carbohydrates** sugars, starches, and other molecules combining carbon, hydrogen, and oxygen and serving as fuel or structural components
- cardiomyopathy** heart muscle disease
- catalysis** aiding in the reaction of
- catalyst** substance that aids in a reaction without being used up

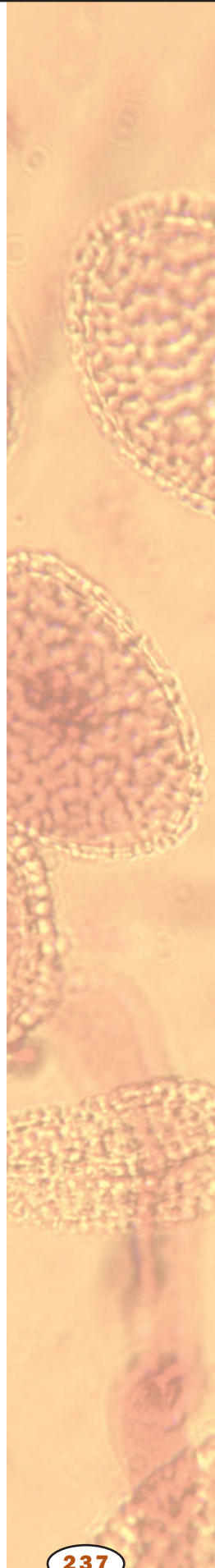

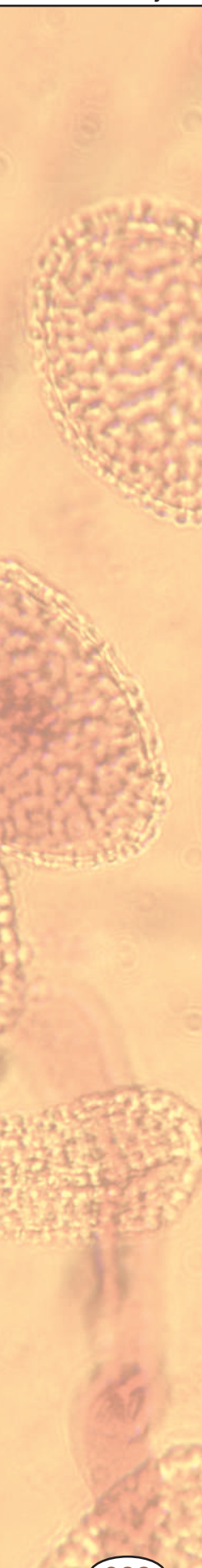
- 
- catalyze** aid in the reaction of
- caudate** toward the tail
- C.E.** Common Era; equivalent to AD
- cell cycle** sequence of growth, replication, and division that produces new cells
- cellulose** carbohydrate made by plants and some other organisms; part of the cell wall
- central nervous system** brain and spinal cord
- centromere** region of the chromosome linking chromatids
- cerebral cortex** outermost wrinkled portion of the brain
- chemiosmosis** use of proton gradients to make ATP
- chitin** nitrogen-containing carbohydrate found in arthropod exoskeletons and fungus cell walls
- chromatid** a replicated chromosome before separation from its copy
- chromatin** complex of DNA, histones, and other proteins making up chromosomes
- chromosomal analysis** staining, banding, and other techniques for detection of chromosomal abnormalities
- chromosome** “colored body” in the cell nucleus; made of DNA and protein, and divided functionally into genes and non-gene regions
- cilia** short, hairlike cell extensions of the cell membrane formed by the cytoskeleton
- ciliated** possessing cilia, which are short, hairlike extensions of the cell membrane
- circadian** related to a day or daylength
- clavicle** collar bone
- cloaca** common exit cavity for intestinal, genital, and urinary tracts
- codon** sequence of three mRNA nucleotides coding for one amino acid
- cognition** mental processes of thought and awareness
- cognitive** related to thought or awareness
- communicable** transmissible from person to person
- complementary** matching opposite
- complex carbohydrate** molecules formed by linking simpler carbohydrates such as sugars
- condensation** compaction of chromosome strands into a tight structure
- conformation** three-dimensional shape
- congenital** present at birth; inherited

- conjunctiva** eye membrane that helps seal the eye socket
- connective tissue** one of four types of body tissue, characterized by few cells and extensive extracellular material
- consanguineous** descended from the same ancestor
- constitutive** at a constant rate or continually
- contiguous** adjacent to or touching
- continental shelf** submerged offshore area demarcated by land on one side and deep sea on the other
- coralloid** resembling coral
- coronary artery** artery supplying blood to the heart
- cortical** related to the cortex, or outer portion
- cotyledon** seed leaf, which stores food and performs photosynthesis after germination
- cranial** related to the cranium, or brain cavity
- cryptobiosis** when a plant or animal becomes so inactive that its life processes nearly come to a stop
- cutaneous** related to the skin
- cutaneous respiration** gas exchange through the skin
- cytology** study of cells
- cytoplasm** material in a cell, excluding the nucleus
- cytoskeleton** internal scaffolding in a cell, composed of protein
- cytosol** fluid portion of a cell, not including the organelles
- Darwinian fitness** capacity to survive and reproduce
- deciduous** trees that shed their leaves in the fall
- deciliter** one-tenth of a liter; a unit of volume
- dementia** neurological illness characterized by impaired thought or awareness
- desiccation** drying out
- desynchronized** not happening at the same time
- deuterostome** “mouth second”; referring to the early development of the anal pore during gut tube formation
- dialysis** cleansing by partial filtration
- dicot** plant having two cotyledons, or seed leaves
- dikaryotic cell** cell with a pair of nuclei
- dilation** expansion or swelling
- dimer** polymer formed from two molecules of a simple compound

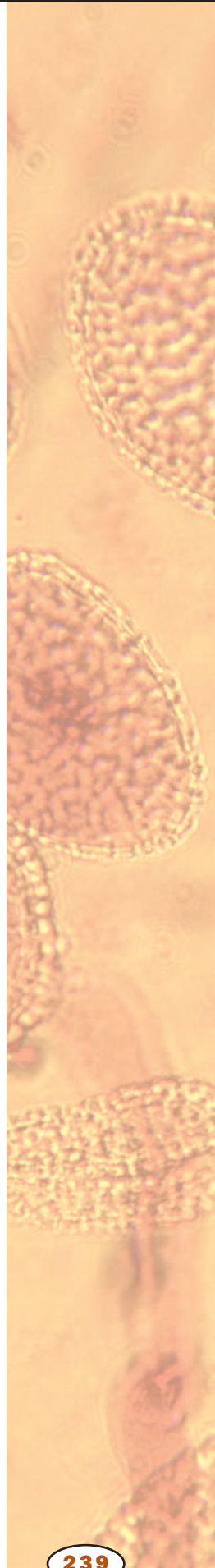

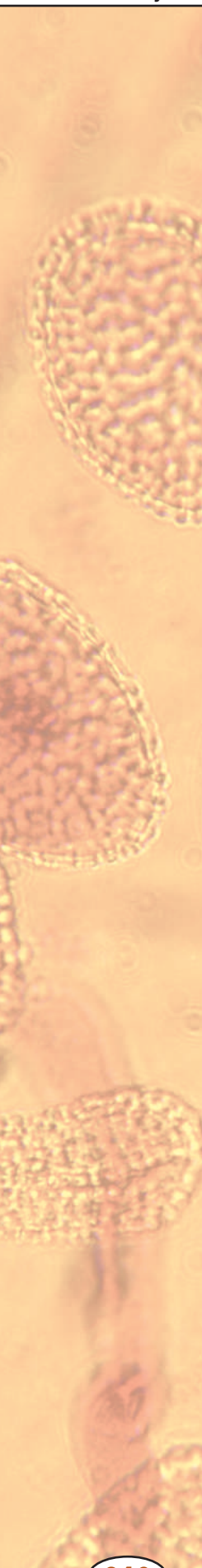
- 
- dimerizes** forms a pair
- diploid** having pairs of chromosomes in the nucleus
- dissociate** break apart
- distal** away from
- diurnal** active during the daytime
- dorsal** to the back of
- ecosystem** an ecological community and its environment
- effector** organ at the end of a nerve, such as a muscle or gland
- efferent** conducting outward or directing away from
- electrolytes** ions in body fluids
- electromagnetic radiation** light, X rays, and other forms of radiant energy
- electron transport system** membrane-bound system of proteins that extracts energy from high-energy electrons, found in mitochondria and chloroplasts
- electrophoresis** technique that uses electricity to separate molecules based on size and electric charge
- electrophoresis gel** porous medium through which molecules can be separated using an electric current
- embalming** treating a dead body to protect it from decay
- embryology** development of the embryo
- emulsify** suspend in solution through interaction with soap or similar molecules
- endocrine** related to the system of hormones and glands that regulate body function
- endogenous** caused by factors inside the organism
- endometriosis** disorder of the endometrium, the lining of the uterus
- endoplasmic reticulum** network of membranes within the cell
- endosperm** nutritive tissue within a seed
- endosymbiosis** symbiosis in which one partner lives within the other
- endothermic** characterized by regulation of body temperature through metabolic activity
- Enlightenment** eighteenth-century philosophical movement stressing rational critique of previously accepted doctrines in all areas of thought
- enzymatic** related to the function of an enzyme
- enzyme** protein that controls a reaction in a cell
- epidemic** rapid spread of disease through a population, or a disease that spreads in this manner

- epistasis** suppression of a characteristic of one gene by the action of another gene
- epithelium** one of four tissue types found in the body, characterized by thin sheets and usually serving a protective or secretory function
- esophagus** tube connecting the throat to the stomach
- eudicot** “true dicot”; plants with two seed leaves that originated from the earliest of flowering plants
- eukaryotic cell** a cell with a nucleus
- eutrophication** process by which waters become enriched in dissolved nutrients that promote plant growth which results in depletion of dissolved oxygen
- evapotranspiration** loss of water from a plant by evaporation within the leaf
- evidentiary DNA profile** analyzed DNA from a sample used as evidence
- excrete** deposit outside of
- exocrine gland** gland that secretes substances to an external or internal surface rather than into the bloodstream
- exoskeleton** external skeleton
- extensibility** ability to expand or grow larger
- fallopian tubes** tubes through which eggs pass to the uterus
- fecundity** ability to reproduce
- feedback** process in which the output or result influences the rate of the process
- fertilization** union of sperm and egg
- fibroblast** undifferentiated cell normally giving rise to connective tissue cells
- filtrate** material passing through a filter
- focal** at a point
- follicle** a vesicle that contains a developing egg surrounded by a covering of cells
- food web** set of feeding relations in an ecosystem
- forb** broad-leaved herbaceous plant
- forensic** related to legal proceedings
- fulcrum** pivot point of a lever
- fungi** major group of parasitic, lower plants that obtain their food from the products of organic decay (e.g. molds, smuts, etc.)
- gamete** reproductive cell, such as sperm or egg
- gametophyte** a haploid plant that makes gametes by mitosis
- ganglia** cluster of nerve cell bodies

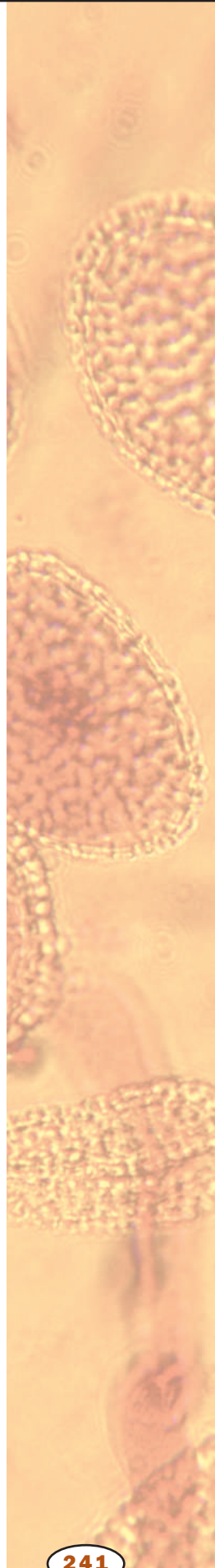

**gastroenteritis** inflammation of the gastrointestinal tract, often from infection

**gene** portion of DNA that codes for a protein or RNA molecule

**gene expression** use of a gene to create the corresponding protein

**genetic code** relationship between triples of RNA nucleotides and the amino acids they code for during protein synthesis

**genitalia** reproductive organs

**genome** total genetic material in a cell or organism

**germ line** cells creating eggs or sperm

**gestation** period of fetal development within the mother

**glial** supporting tissue of the elements of nervous tissue, including the brain, spinal cord, and ganglia

**glucose** simple sugar that provides energy to animal cells; it is the building block of cellulose in plants

**glycogen** complex carbohydrate used as storage in animals and some other organisms

**glycolysis** initial stages of sugar breakdown in a cell

**gradient** difference in concentration between two places

**grafting** attachment and fusing of parts from different plants

**guard cells** paired cells on leaves that control gas exchange and water loss

**gymnosperms** “naked seed” plants, including conifers

**hallucination** altered sensory experience resulting in the perception of objects that are not real

**haploid** having single, nonpaired chromosomes in the nucleus

**hectare** 10,000 square meters (2.47 acres)

**heme** the deep red, iron containing, nonprotein portion of hemoglobin and myoglobin

**hemicellulose** complex carbohydrate related to cellulose and found in cell walls of plants and some other organisms

**hemoglobin** oxygen-carrying protein complex in red blood cells

**herbarium** a collection of dried plant specimens systematically arranged for reference

**hermaphrodite** organism possessing both male and female reproductive structures

**heterodimer** complex molecule composed of two different parts

**heterogeneous** composed of, or containing, different parts or types

**heterozygous** characterized by possession of two different forms (alleles) of a particular gene



- hexamer** a structure composed of six parts
- histogenesis** origin or production of tissues
- histology** study of tissues
- histone** protein around which DNA wraps to form chromosomes
- homologous** similar in structure
- homologous chromosomes** chromosomes carrying similar genetic information
- homologous recombination** exchange of DNA segments between chromosomes
- homozygous** containing two identical copies of a particular gene
- hormone** molecule released by one cell to influence another
- hybrid** combination of two different types
- hydrocarbon** molecule or group composed only of C and H
- hydrogen bond** weak bond between the H of one molecule or group and a nitrogen or oxygen of another
- hydrolyze** to split apart using water
- hydrophilic** “water loving”
- hydrophobic** “water hating,” such as oils
- hydroponics** growing of plants without soil
- hydroxyl** chemical group consisting of -OH
- hypersalinity** very high level of salt
- hypersecretion** excess secretion
- hypersensitivity reaction** immune reaction characterized by rapid and severe response, often with swelling of airways
- hyphae** threadlike part of the vegetative portion of the fungus
- hyposcretion** lack of secretion
- hypothermia** subnormal temperature of the body
- ice-out** a thawing of ice covering a lake or other body of water
- immunoglobulin** an immune protein, also called an antibody
- immunosuppressant** inhibition of the immune response
- in utero** inside the uterus
- in vitro** “in glass”; in lab apparatus, rather than within a living organism
- inbred** repeatedly bred with close relatives, creating organisms with very little genetic variation

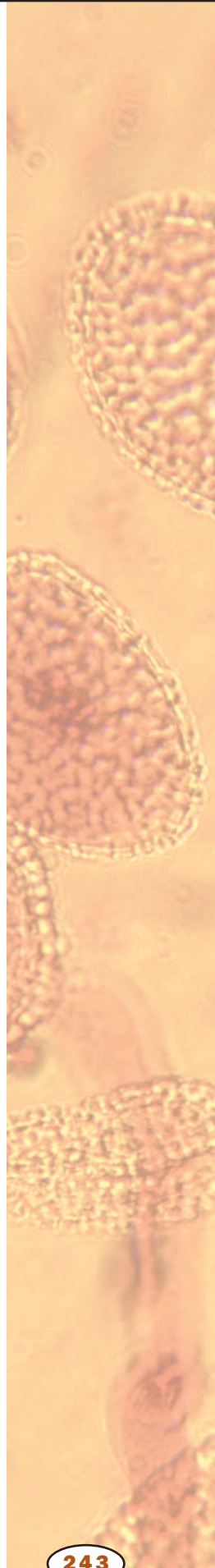

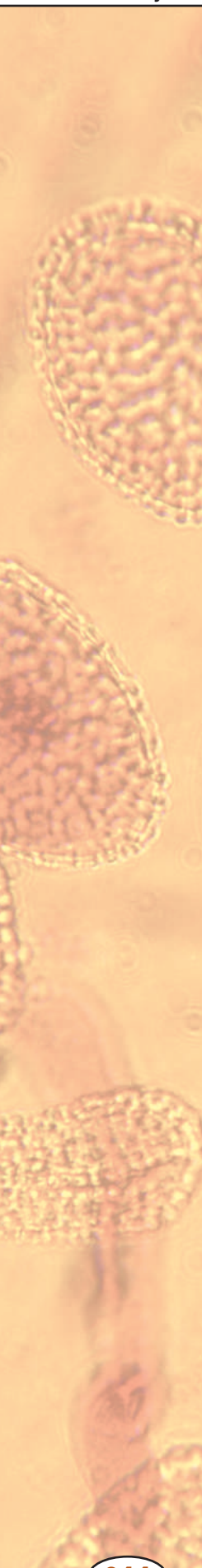
- 
- inducible** able to be switched on
- inflorescence** characteristic arrangement of flowers on a stalk
- infrastructure** roads, phone lines, and other utilities that allow commerce
- inorganic** not bonded to carbon
- insectivorous** insect-eating
- integrins** a family of transmembrane linking proteins
- interferons** signaling molecules of the immune system
- intermediate filament protein** one type of cytoskeleton protein
- interspecific** between different species
- interstitial space** space between cells in a tissue
- intracellular** within a cell
- intraocular** within the eyeball
- intrinsic to** intimate part of; within
- intron** untranslated portion of a gene that interrupts coding regions
- ion** an electrically charged particle
- ionic** based on or functioning by means of ions
- ionizing radiation** high-energy radiation that destroys chemical bonds
- isometric** relating to contraction without movement
- isotopes** forms of an atom that differ by the number of neutrons in the nucleus
- keratin** a major structural protein
- kilobase** one thousand DNA bases; a measure of size of a piece of DNA
- kilobasepair** one thousand DNA base pairs; a measure of size of a piece of DNA
- kinase** enzyme that adds a phosphate group to another molecule, usually a protein
- Krebs cycle** central metabolic pathway in mitochondria
- lactation** production of milk by the mammary glands
- laparoscopic surgery** surgery in which an instrument is inserted through a very small incision, usually guided by some type of imaging technique
- larynx** “voice box”; muscles at the top of the trachea that control pitch and loudness
- lateral** side-to-side
- lethargy** lack of excitability; torpor
- lignified** hardened by impregnation with lignin, a compound formed in plants

**lignin** organic molecule used in plant cell walls to add stiffness to cellulose

**lineage** ancestral line

**lipid** fat or waxlike molecule, insoluble in water

**lipoprotein** combination of protein and lipid, or fatlike molecule

**locus** site on a chromosome (plural, loci)

**lotic** of, relating to, or living in actively moving water

**lymph** pale fluid that circulates in the lymphatic system, principally composed of blood plasma and cell fluid

**lymphatic system** network of tubes that permeates the body for transport of lymph and combat of infection

**lymphocyte** white blood cell found in lymph nodes

**lyse** break apart

**lysine** an amino acid

**lysing** disintegration or dissolution of cells

**macromolecules** large molecules such as proteins, carbohydrates, and nucleic acids

**marsupials** kangaroos and other mammals that gestate young in an external pouch

**materialism** the belief that life is due entirely to biochemical interactions, without the intervention of supernatural forces

**matrix** a network, usually of threadlike fibers

**medium** nutrient source

**meiosis** cell division that forms eggs or sperm

**membrane potential** electrical and chemical differences across a membrane leading to storage of energy and excitability

**metabolism** chemical reactions within a cell

**metabolite** molecule involved in a metabolic pathway

**metamorphosis** development process that includes a larval stage with a different form from the adult

**metaphase** intermediate stage in cell division, in which chromosomes line up before separating

**metastasis** breaking away of cancer cells from a solid tumor to travel elsewhere in the body

**metazoans** animals other than sponges

**methylation** addition of the methyl group  $\text{CH}_3$

**micron** one-millionth of a meter; also called a micrometer

**mid-dorsal** middle of the back

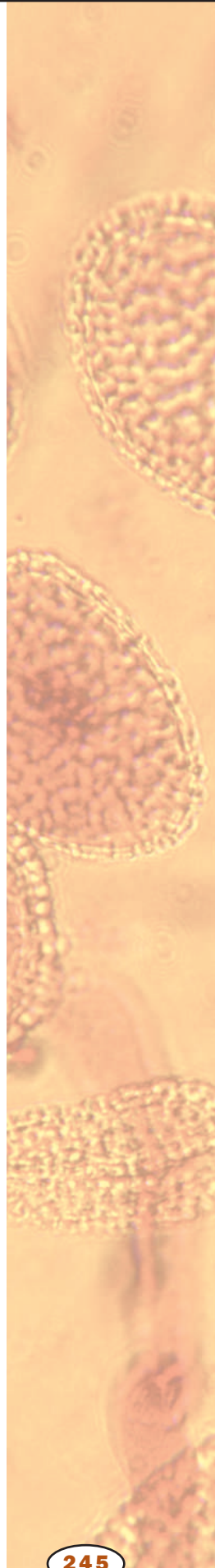

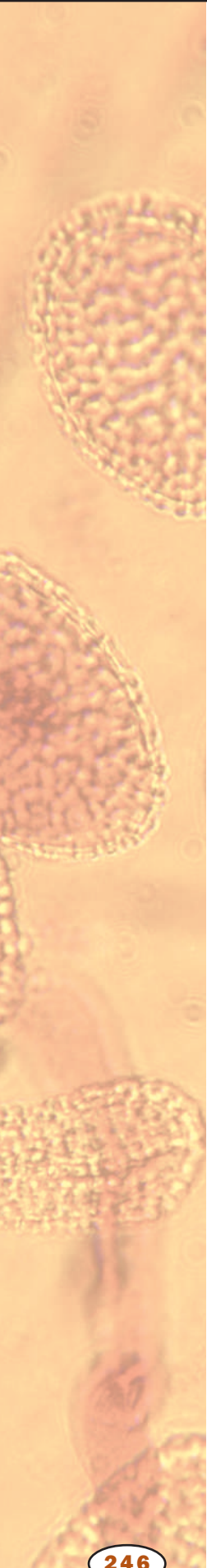

**middle lamella** layer of material between two plant cells that holds them together

**minerals** iron, calcium, sodium, and other elements needed by living organisms

**missense mutation** nucleotide change that causes a change in the amino acid normally added to the protein

**mitochondria** subcellular organelle that creates ATP used for energy-requiring processes in a cell

**mitogen** substance that stimulates mitosis

**mitosis** separation of replicated chromosomes

**molecular hybridization** base-pairing among DNAs or RNAs of different origins

**monocot** any of various flowering plants, such as grasses and orchids, that have a single cotyledon in the seed

**monoculture** cultivation of a single type of crop in a large area

**monomer** “single part”; monomers are joined to form a polymer

**monophyletic** a group that includes an ancestral species and all its descendants

**montane** mountainous region

**morphology** related to shape and form

**motile** able to move

**motor neuron** nerve cell that controls a muscle or gland

**mucous membrane** outer covering designed to secrete mucus, often found lining cavities and internal surfaces

**multimer** composed of many similar parts

**multinucleate** having many nuclei within a single cell membrane

**muscle tone** low level, constant muscle contraction

**mutualism** symbiosis between two organisms in which both benefit

**mycorrhizae** symbiosis between soil fungus and plant root to maximize absorption

**myxedema** thyroid disorder characterized by dry skin, swelling in the face, and mental deterioration

**nanometer**  $10^{-9}$  meters; one-billionth of a meter

**natural selection** process by which organisms best suited to their environments achieve greater reproductive success thus creating more “fit” future generations

**nematode** worm of the Nematoda phylum, many of which are parasitic

**nephron** functional unit of the kidney that performs filtration, reabsorption, and excretion

- neritic** zone near the shore
- neural** related to nerve cells or the nervous system
- neurologist** doctor who treats brain disorders
- neuron** nerve cell
- neurotransmitters** molecules released by one neuron to stimulate or inhibit another neuron or cell
- niche** the habitat supplying the right environment for a particular species
- nm** nanometer; one-billionth of a meter
- nocturnal** characterized by activity at night, or related to the night
- nondisjunction** failure of separation of homologous chromosomes during meiosis
- nuclear envelope** double membrane surrounding the cell nucleus
- nucleated** having a nucleus
- nucleotide** the building block of RNA or DNA
- nucleus** membrane-bound portion of cell containing the chromosomes
- obligate** required or necessary, especially referring to a metabolic process or mode of nutrition
- octomer** composed of eight parts
- oligosaccharide** chain of several sugar molecules
- oncogene** gene that causes cancer
- oocyte** unfertilized egg
- opportunistic** caused by a microorganism that is usually harmless but which causes infection in an immunosuppressed person
- organelle** membrane-bound cell compartment
- organic** composed of carbon, or derived from living organisms; also, a type of agriculture stressing soil fertility and avoidance of synthetic pesticides and fertilizers
- osmosis** passage of water through a membrane in response to concentration differences
- osseous** related to bone
- outcross** fertilization between two different plants
- ovipary** production of eggs that hatch outside the body
- ovovivipary** production of eggs that hatch within the female's body
- ovule** multicellular structure that develops into a seed after fertilization
- oxidation** reaction characterized by loss of electrons, or reaction with oxygen

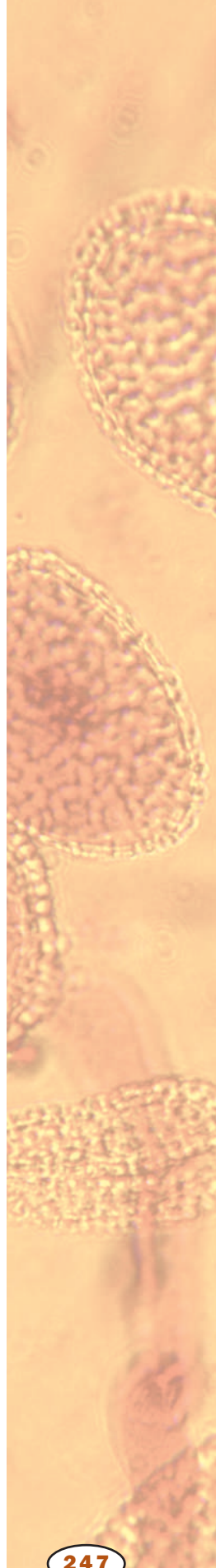

**oxidation-reduction** oxidation is loss of electrons, and reduction is gain of electrons

**oxidative** characterized by oxidation, or loss of electrons

**oxidative phosphorylation** use of oxygen to make ATP

**oxidize** to react or make react with oxygen

**palatine bone** bone of the hard palate at the roof of the mouth

**paleoanthropology** study of ancient humans

**palindromic** reading the same forward and backward

**pandemic** disease spread throughout an entire population

**papillate** small, nipplelike projection

**parasite** organism living in close association with another from which it derives most of its nutrition

**parasitology** study of parasites

**parasympathetic nervous system** branch of the nervous system promoting nutrient absorption and other maintenance activities

**pathogen** disease-causing organism

**pathogenesis** pathway leading to disease

**pathologic** related to disease

**pectin** carbohydrate in plants that forms crosslinks to stabilize cell walls

**peptide bond** bond between two amino acids

**peptidoglycans** polymer that is composed of polysaccharides and peptic chains

**perianth** combined sepals and petals

**peripheral** outside the central nervous system (brain and spinal cord)

**pH** measure of acidity or alkalinity; numbers below 7 are acid, above are basic

**phage** short for bacteriophage

**phagocytosis** engulfing of cells or large fragments by another cell, including immune system cells

**pharynx** throat

**phase-contrast microscopy** technique that manipulates passage of light through transparent specimens to reveal internal features

**phenotype** observable characteristics of an organism

**pheromone** molecule released by one organism to influence another organism's behavior

**phloem** plant tissue that conducts sugars from leaves to roots and other tissues

- phosphodiester** the link between two nucleotides in DNA or RNA
- phosphorylate** add a phosphate group to
- phosphorylation** addition of the phosphate group  $\text{PO}_4^{3-}$
- phyletic gradualism** the belief that evolutionary change is slow and steady
- phylogenetic** related to phylogeny, the evolutionary development of a species
- phylum** taxonomic level below kingdom, e.g., arthropod or chordate
- physiology** branch of biology that deals with the functions and activities of living matter
- phytoplankton** microscopic floating creatures that photosynthesize
- pinnate** featherlike
- pinocytosis** introduction of fluids into a cell by enclosing it and pinching off the plasma membrane
- pipette** lab instrument for precise measurement and transfer of small volumes of liquids
- pistil** female reproductive organ of a flower
- placental** related to mammals that nourish the fetus with a placenta, an exchange organ in the uterus
- plankton** microscopic floating organisms
- plant hybridization** creation of offspring by union of two different types of plants, such as wheat and rye
- plasmid** small ring of DNA found in many bacteria
- plasticity** change form
- plate tectonics** the movement of large plates of Earth's crust
- polar** partially charged, and usually soluble in water
- polar covalent** bond in which electrons are unevenly shared
- polymer** molecule composed of many similar parts
- polymerase** enzyme complex that synthesizes DNA or RNA from individual nucleotides
- polymerization** linking together of similar parts to form a polymer
- polypeptide** chain of amino acids
- polysaccharide** carbohydrate composed of many individual units of sugar
- posterior** toward the back
- postmortem** after death
- prebiotic** before the origin of life
- Precambrian** before the Cambrian era; before 600 million years ago

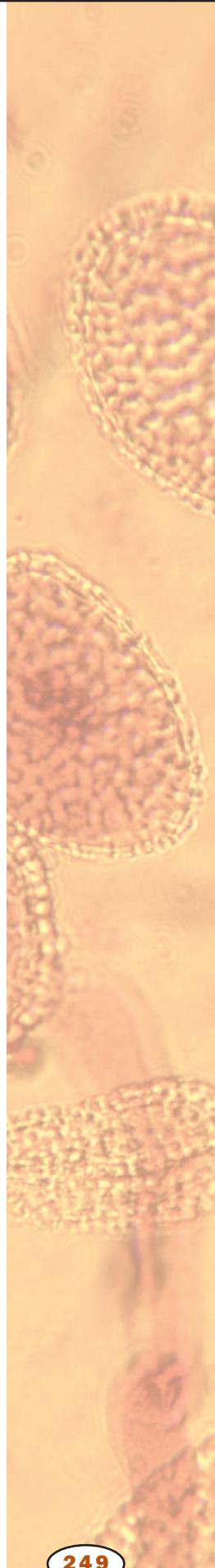

**primer** short nucleotide sequence that helps begin DNA replication

**progeny** offspring

**prokaryote** single-celled organism without a nucleus

**promoter** DNA sequence to which RNA polymerase binds to begin transcription

**prostaglandins** hormonelike molecules released by one cell that affect nearby cells, including smooth muscle

**prostrate** face downward

**protein** complex molecule made from amino acids; used in cells for structure, signaling, and controlling reactions

**proteolysis** breakdown of proteins

**protoecology** early ecology

**protoplasm** fluid portion of a plant cell within the cell wall

**protostome** “mouth first”; referring to the early development of the oral pore during gut tube formation

**protozoa** any of a phylum of minute protoplasmic animals present in almost every kind of habitat, some of which pose serious threats to humans and animals

**pseudopod** “false foot”; an extension of the plasma membrane during locomotion by an amoeba or similar crawling cell

**psychosis** severe mental disorder characterized by diminished connection with reality

**psychotropic** affecting consciousness, thought, or emotion

**punctuated equilibrium** pattern of evolution in which long periods of relatively little change are punctuated by rapid change

**pyruvate** the ionized form of pyruvic acid, a key intermediate in cell metabolism

**quaternary** fourth level

**radially symmetric** symmetric, or similar, about a central point (a wheel is radially symmetric)

**reproductive isolation** isolation of a population from other populations of the same species due to inability to successfully reproduce; an early stage in species formation

**respire** use oxygen to burn cellular fuel

**restriction enzyme** enzyme that cuts DNA at a particular sequence

**restriction fragments** fragments of DNA created by restriction enzymes

**reticular** netlike

**retrograde** backward



- reverse transcriptase** enzyme that copies RNA into DNA
- reverse transcription** creation of DNA from an RNA template
- ribonucleoprotein** combination of RNA and protein
- ribosome** protein-RNA complex in cells that synthesizes protein
- rickettsia** (pl. -sias or siae) any of a family of polymorphic microorganisms that cause various diseases
- RNA polymerase** enzyme complex that creates RNA from DNA template
- saline** of, or relating to, salt
- saprophyte** plant that feeds on decaying parts of other plants
- savanna** open grassland with sparse trees
- sclerophyll** small, tough evergreen leaves
- secretion** material released from the cell
- secretory pathway** series of events within a cell by which molecules are brought to the plasma membrane for release from the cell
- sepals** whorls of flower organs outside of the petals, usually green and serving to protect the flower before it opens
- serotinous** developing late in the season
- serotype** identity of an organism or virus based on reaction to an antibody
- sessile** attached and remaining in one place
- silviculture** cultivation of forest trees
- sleep apnea** difficulty breathing while asleep
- solenoid** cylindrical coiled structure
- solute** dissolved substance
- solvation** the process of dissolving
- somatic** nonreproductive; not an egg or sperm
- somatostatin** hormone produced by the hypothalamus that influences growth
- spasticity** of, or relating to, spasms
- spectroscopy** process using light or other emitted radiation to determine properties of a sample
- sphincter** ring of muscle regulating passage of material through a tube such as the gastrointestinal tract
- spontaneous generation** the theory that life began from nonliving matter
- stasis** state of no change
- steroid hormone** group of hormones that includes estrogen, testosterone, and progesterone

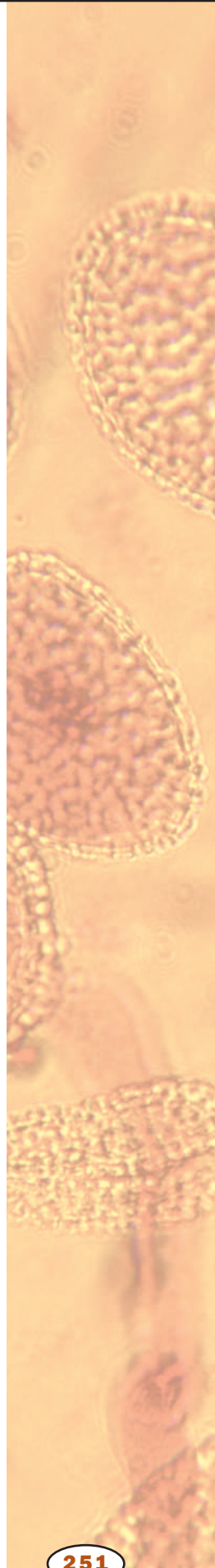

**steroids** hormones such as testosterone or estrogens that control many aspects of physiology

**stomata** openings in leaves for gas exchange, surrounded and regulated by guard cells

**strong bond** high-energy arrangement between two atoms involving electron-sharing; strong bonds require more energy to break than weak bonds

**subcutaneous** below the skin

**substrate** the molecule acted on by an enzyme; also a surface for attachment

**succession** series of changes seen in some plant communities over time, in which low-growing, rapidly reproducing species are replaced by taller and more slowly reproducing ones

**superficial** on the surface; not deep

**symbiont** organism living in close association with another organism

**symbiosis** close relationship between two species in which at least one benefits

**sympathetic nervous system** branch of the nervous system that promotes heightened awareness, increased nutrient consumption, and other changes associated with “fight or flight”

**synaptic transmission** passage of chemicals between nerve cells to send messages or alter neuron firing

**synchronously** at the same time

**synergism** working together to create a larger product rather than a simple sum

**systemic** throughout the body

**T cell** white blood cell that controls the immune response

**taxon** a level of classification, such as kingdom or phylum

**tectonic plate** large segment of Earth’s crust that moves in relation to other similar plates

**template** master copy

**teratogens** substances that cause birth defects

**tertiary** third level

**thermoregulation** temperature regulation

**transcribe** creation of an RNA copy of a DNA gene

**transcription** messenger RNA formation from a DNA sequence

**transcription factor** protein that increases the rate of transcription of a gene

**transduction** conversion of a signal of one type into another type

- transgenic** characterized by presence of one or more genes from a different organism
- translation** synthesis of protein using mRNA code
- translocation** movement of sugars and other nutrients throughout a plant
- transverse** situated or lying across
- trimer** a structure composed of three parts
- triploid** possessing three sets of chromosomes
- trophic** related to feeding
- trophic level** feeding level in an ecosystem
- true breeding** giving only offspring identical to the parents
- turgor** internal pressure
- ubiquitous** found everywhere
- ultrasonography** use of sound waves to produce an image
- ungulate** hoofed mammals such as cattle
- uninucleate** possessing one nucleus
- vas deferens** tube through which sperm travel from testes to urethra
- vector** carrier
- ventral to** toward the belly side
- ventricle** fluid-filled chamber
- venule** any of the minute veins connecting the capillaries with the larger systemic veins
- vesicle** membrane-bound sac
- vestigial** no longer functional
- visceral** related to the viscera, or internal organs
- viscous** thick
- vivipary** production of live young
- volatile** easily vaporized
- vulva** external female genitalia
- weak bond** low-energy arrangement between two atoms involving electron-sharing; weak bonds require less energy to break than strong bonds
- X-ray crystallography** use of X rays to determine the structure of a molecule
- xylem** water-transporting system in plants
- zygote** fertilized egg

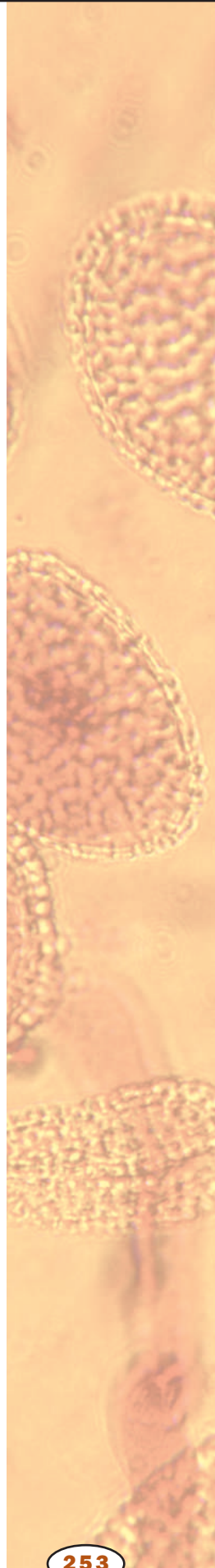

# Topic Outline

## **AGRICULTURE AND ECONOMIC BOTANY**

---

Agriculture  
Agronomist  
Beer-making, Botany of  
Coffee, Botany of  
Desertification  
Ethnobotany  
Forester  
Grain  
Grasses  
History of Agriculture  
Horticulturist  
Hybridization-Plant  
Landscape Ecology  
Nitrogen Cycle  
Nitrogen Fixation  
Organic Agriculture  
Plant Pathogens and Pests  
Pollution and Bioremediation  
Soil  
Vavilov, Nikolay  
Wine-making, Botany of

## **ANIMAL ANATOMY AND PHYSIOLOGY**

---

Amniote egg  
Animalia  
Circulatory Systems  
Connective Tissue  
Digestion  
Epithelium  
Excretory Systems  
Gas Exchange  
Growth  
Life Cycles  
Locomotion  
Model Organisms in Physiology and Medicine  
Muscle  
Nervous Systems  
Neuron  
Organ

Osmoregulation  
Physiological Ecology  
Respiration  
Scaling  
Sex Determination  
Skeletons  
Social Behavior  
Temperature Regulation  
Vision  
Zoology

## **ANIMAL BEHAVIOR**

---

Behavior, Genetic Basis of  
Behavior Patterns  
Feeding Strategies  
Field Studies in Animal Behavior  
Migration and Animal Navigation  
Mimicry, Camouflage, and Warning Coloration  
Pheromone  
Physiological Ecology  
Population Dynamics  
Predation and Defense  
Sexual Selection  
Symbiosis  
Temperature Regulation  
Wildlife Biologist

## **ANIMAL DIVERSITY**

---

Amphibian  
Animalia  
Annelid  
Arachnid  
Arthropod  
Biodiversity  
Bird  
Bony Fish  
Cambrian Explosion  
Cartilaginous Fish  
Chordata  
Cnidarian

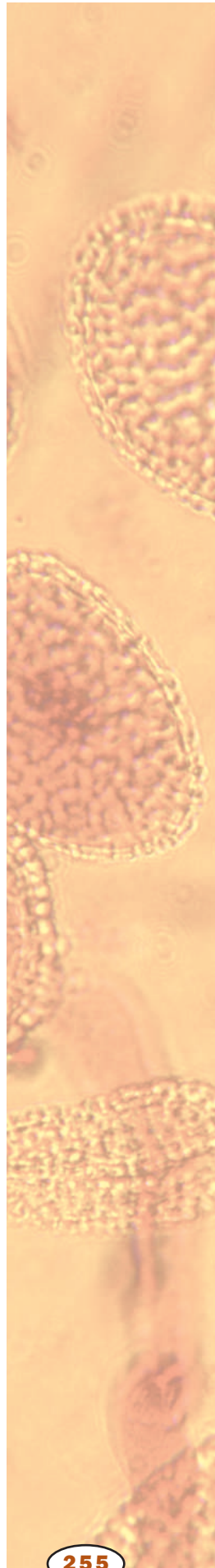

Coral Reef  
Crocodilian  
Crustacean  
Echinoderm  
Endangered Species  
Entomologist  
Extinction, Mammals  
Human Evolution  
Insect  
Mammal  
Marsupial  
Mollusk  
Monotreme  
Nematode  
Parasitic Diseases  
Platyhelminthes  
Porifera  
Primate  
Reptile  
Tuatara  
Tunicate  
Turtle  
Zoology  
Zoology Researcher

### **AQUATIC BIOLOGY**

---

Algae  
Amphibian  
Bony Fish  
Cartilaginous Fish  
Cnidarian  
Coral Reef  
Crustacean  
Echinoderm  
Estuaries  
Extreme Communities  
Lakes and Ponds  
Limnologist  
Marine Biologist  
Mollusk  
Ocean Ecosystems: Hard Bottoms  
Ocean Ecosystems: Open Ocean  
Ocean Ecosystems: Soft Bottoms  
Platyhelminthes  
Porifera  
Rivers and Streams  
Water

### **BACTERIA AND ARCHAEA**

---

Archaea  
Bacterial Cell  
Bacterial Diseases  
Bacterial Genetics  
Bacterial Viruses

Biotechnology  
Cell Evolution  
Cell Wall  
Chloroplast  
Clone  
Control of Gene Expression  
Cyanobacteria  
Dubos, René  
Ecosystem  
Eubacteria  
Microbiologist  
Mitochondrion  
Model Organisms: Cell Biology and Genetics  
Plant Pathogens and Pests  
Poisons  
Recombinant DNA  
Sexually Transmitted Diseases  
Transgenic Techniques

### **BEHAVIOR**

---

Behavior, Genetic Basis of  
Behavior Patterns  
Brain  
Competition  
Feeding Strategies  
Field Studies in Animal Behavior  
Flight  
Learning  
Locomotion  
Migration and Animal Navigation  
Mimicry, Camouflage, and Warning Coloration  
Pheromone  
Predation and Defense  
Sexual Reproduction  
Sexual Selection  
Sleep  
Social Behavior  
Sociobiology

### **BIOCHEMISTRY**

---

Amino Acid  
Antibodies in Research  
Biochemist  
Biogeochemical Cycles  
Carbohydrates  
Carbon Cycle  
DNA  
DNA Sequencing  
Drug Testing  
Electrophoresis  
Enzymes  
Glycolysis and Fermentation  
History of Biology: Biochemistry  
Krebs Cycle

Lipids  
 Lysosomes  
 Membrane Proteins  
 Metabolism  
 Mitochondrion  
 Nitrogen Cycle  
 Nitrogen Fixation  
 Nucleotides  
 Origin of Life  
 Oxidative Phosphorylation  
 Pauling, Linus  
 Peroxisomes  
 Pharmacologist  
 Poisons  
 Polymerase Chain Reaction  
 Prion  
 Protein Structure  
 Protein Synthesis  
 Radionuclides  
 RNA  
 Secondary Metabolites in Plants  
 Separation and Purification  
 Structure Determination  
 Vitamins and Coenzymes  
 Water

### **BIOLOGY AND SOCIETY**

---

Alcohol and Health  
 Anabolic Steroids  
 Behavior, Genetic Basis of  
 Biological Weapons  
 Biology of Race  
 Carson, Rachel  
 Creationism  
 Desertification  
 Doctor, Specialist  
 Dubos, René  
 Endangered Species  
 Ethnobotany  
 Evolution, Evidence for  
 Extinction, Mammals  
 Fire Ecology  
 Gene Therapy  
 Global Climate Change  
 Human Genome Project  
 Human Population  
 Invasive Species  
 Organic Agriculture  
 Pauling, Linus  
 Pollution and Bioremediation  
 Psychiatric Disorders, Biology of  
 Psychoactive Drugs  
 Recombinant DNA  
 Reproductive Technology  
 Sexually Transmitted Diseases

Smoking and Health  
 Sociobiology  
 Transgenic Techniques

### **BIOMES**

---

Biogeography  
 Biome  
 Coral Reef  
 Desert  
 Field Studies in Plant Ecology  
 Forest, Boreal  
 Forest, Temperate  
 Forest, Tropical  
 Global Climate Change  
 Grassland  
 Remote Sensing  
 Tundra

### **BIOTECHNOLOGY**

---

Antibodies in Research  
 Antisense Nucleotides  
 Bacterial Genetics  
 Bioinformatics  
 Biological Weapons  
 Biotechnology  
 Clone  
 Electrophoresis  
 Forensic DNA Analysis  
 Genomics  
 Human Genome Project  
 Hybridization  
 Polymerase Chain Reaction  
 Recombinant DNA  
 Reproductive Technology  
 Reverse Transcriptase  
 Separation and Purification  
 Structure Determination  
 Transgenic Techniques

### **CAREERS**

---

Agronomist  
 Biochemist  
 Botanist  
 College Professor  
 Dentist  
 Doctor, Family Practice  
 Doctor, Specialist  
 Emergency Medical Technician  
 Entomologist  
 Epidemiologist  
 Forester  
 Health and Safety Officer  
 High School Biology Teacher  
 Horticulturist

Laboratory Technician  
 Marine Biologist  
 Medical Assistant  
 Microbiologist  
 Microscopist  
 Nurse  
 Nurse Practitioner  
 Nutritionist  
 Pharmaceutical Sales Representative  
 Pharmacologist  
 Physician Assistant  
 Plant Pathologist  
 Psychiatrist  
 Public Health Careers  
 Science Writer  
 Veterinarian  
 Wildlife Biologist  
 Zoology Researcher

**CELL FUNCTION**

---

Active Transport  
 Cancers  
 Cell Cycle  
 Cell Motility  
 Control Mechanisms  
 Control of Gene Expression  
 Cytokinesis  
 Endocytosis  
 Enzymes  
 Exocytosis  
 Glycolysis and Fermentation  
 History of Plant Physiology  
 Hormones  
 Ion Channels  
 Krebs Cycle  
 Lysosomes  
 Meiosis  
 Membrane Proteins  
 Membrane Transport  
 Metabolism  
 Mitochondrion  
 Model Organisms: Cell Biology and Genetics  
 Nuclear Transport  
 Oxidative Phosphorylation  
 Peroxisomes  
 Protein Synthesis  
 Protein Targeting  
 Replication  
 Ribosome  
 RNA Processing  
 Signaling and Signal Transduction  
 Synaptic Transmission  
 Transcription

**CELL STRUCTURE**

---

Archaea  
 Bacterial Cell  
 Cell  
 Cell Evolution  
 Cell Junctions  
 Cell Motility  
 Cell Wall  
 Chloroplast  
 Connective Tissue  
 Cyanobacteria  
 Cytoskeleton  
 Electron Microscopy  
 Endoplasmic Reticulum  
 Epithelium  
 Eubacteria  
 Extracellular Matrix  
 Golgi  
 History of Biology: Cell Theory and Cell Structure  
 Ion Channels  
 Life, What Is  
 Light Microscopy  
 Lysosomes  
 Membrane Proteins  
 Membrane Structure  
 Membrane Transport  
 Microscopist  
 Mitochondrion  
 Model Organisms: Cell Biology and Genetics  
 Muscle  
 Neuron  
 Nuclear Transport  
 Nucleolus  
 Nucleus  
 Organelle  
 Origin of Life  
 Peroxisomes  
 Plasma Membrane  
 Porter, Keith  
 Ribosome  
 T Cells  
 Tissue  
 Vacuole

**CIRCULATION AND RESPIRATION**

---

Blood  
 Blood Clotting  
 Blood Sugar Regulation  
 Blood Vessels  
 Cardiovascular Diseases  
 Circulatory Systems  
 Gas Exchange  
 Harvey, William  
 Heart and Circulation

Lymphatic System  
 Physiological Ecology  
 Respiration  
 Smoking and Health  
 Temperature Regulation

### **DIGESTION AND EXCRETION**

---

Digestion  
 Digestive System  
 Excretory Systems  
 Human Nutrition  
 Kidney  
 Liver  
 Metabolism  
 Osmoregulation  
 Physiological Ecology

### **DISEASE AND HEALTH**

---

AIDS  
 Alcohol and Health  
 Anabolic Steroids  
 Autoimmune Disease  
 Bacterial Diseases  
 Birth Control  
 Blood Sugar Regulation  
 Cancers  
 Cardiovascular Diseases  
 Clinical Trials  
 Disease  
 Environmental Health  
 Female Reproductive System  
 Fungal Diseases  
 Gene Therapy  
 Health  
 Health and Safety Officer  
 Herbal Medicine  
 History of Medicine  
 Human Nutrition  
 Imaging in Medicine  
 Immune Response  
 Male Reproductive System  
 Model Organisms in Physiology and Medicine  
 Neurologic Diseases  
 Oncogenes and Cancer Cells  
 Pain  
 Parasitic Diseases  
 Poisonous Plants  
 Prion  
 Protozoan Diseases  
 Psychiatric Disorders, Biology of  
 Psychoactive Drugs  
 Sex Determination  
 Sexual Reproduction  
 Sexually Transmitted Diseases

Sleep  
 Smoking and Health  
 Stress Response  
 Transplant Medicine  
 Vaccines  
 Viral Diseases  
 Vitamins and Coenzymes

### **DNA, RNA, CHROMOSOMES**

---

Antisense Nucleotides  
 Chromosome Aberrations  
 Chromosome, Eukaryotic  
 Crick, Francis  
 DNA  
 DNA Sequencing  
 Gene  
 Genome  
 Medical/Science Illustrator  
 Meiosis  
 Mitosis  
 Mutation  
 Nucleotides  
 Polymerase Chain Reaction  
 Recombinant DNA  
 Replication  
 Sex Chromosomes  
 Transfer RNA  
 Watson, James

### **ECOLOGY**

---

Biogeochemical Cycles  
 Biogeography  
 Biome  
 Carbon Cycle  
 Community  
 Competition  
 Conservation  
 Coral Reef  
 Desert  
 Desertification  
 Ecological Research, Long-term  
 Ecology  
 Ecology, History of  
 Ecosystem  
 Endangered Species  
 Estuaries  
 Extinction, Mammals  
 Feeding Strategies  
 Field Studies in Plant Ecology  
 Fire Ecology  
 Forest, Boreal  
 Forest, Temperate  
 Forest, Tropical  
 Global Climate Change



Grassland  
 Habitat  
 Invasive Species  
 Lakes and Ponds  
 Landscape Ecology  
 Limnologist  
 Marine Biologist  
 Mimicry, Camouflage, and Warning Coloration  
 Nitrogen Cycle  
 Ocean Ecosystems: Hard Bottoms  
 Ocean Ecosystems: Open Ocean  
 Ocean Ecosystems: Soft Bottoms  
 Physiological Ecology  
 Pollution and Bioremediation  
 Population Dynamics  
 Predation and Defense  
 Remote Sensing  
 Rivers and Streams  
 Symbiosis  
 Theoretical Ecology  
 Tundra  
 Water Cycle  
 Wetlands

**ENDOCRINE SYSTEM**

Adrenal Gland  
 Anabolic Steroids  
 Birth Control  
 Blood Sugar Regulation  
 Endocrine System  
 Female Reproductive System  
 Hormones  
 Hypothalamus  
 Pancreas  
 Pituitary Gland  
 Sex Determination  
 Stress Response  
 Thyroid Gland

**EVOLUTION AND ADAPTATION**

Adaptation  
 Amniote Egg  
 Angiosperms  
 Biodiversity  
 Biogeography  
 Buffon, Count (Georges-Louis Leclerc)  
 Cambrian Explosion  
 Cell Evolution  
 C4 and CAM Plants  
 Convergent Evolution  
 Creationism  
 Darwin, Charles  
 Evolution  
 Evolution, Evidence for

Evolution of Plants  
 Extinction, Mammals  
 Extreme Communities  
 Hardy-Weinberg Equilibrium  
 Herbivory and Plant Defenses  
 History of Evolutionary Thought  
 Human Evolution  
 Lamarck, Jean-Baptiste  
 Leakey Family  
 Mimicry, Camouflage, and Warning Coloration  
 Natural Selection  
 Origin of Life  
 Osmoregulation  
 Paleontology  
 Physiological Ecology  
 Population Genetics  
 Predation and Defense  
 Scaling  
 Secondary Metabolites in Plants  
 Sociobiology  
 Speciation  
 Species

**EXPERIMENTAL TECHNIQUES**

Antibodies in Research  
 Antisense Nucleotides  
 Biochemist  
 Bioinformatics  
 Biotechnology  
 Cell Culture  
 Clinical Trials  
 Clone  
 Crick, Francis  
 DNA Sequencing  
 Drug Testing  
 Ecological Research, Long-term  
 Electron Microscopy  
 Electrophoresis  
 Field Studies in Animal Behavior  
 Field Studies in Plant Ecology  
 Forensic DNA Analysis  
 Gene Therapy  
 Genetic Analysis  
 Genomics  
 Hardy-Weinberg Equilibrium  
 History of Biology: Biochemistry  
 History of Plant Physiology  
 Human Genome Project  
 Hybridization  
 Imaging in Medicine  
 Ingenhousz, Jan  
 Laboratory Technician  
 Leeuwenhoek, Anton  
 Light Microscopy  
 Linkage and Gene Mapping

Microbiologist  
 Microscopist  
 Model Organisms: Cell Biology and Genetics  
 Model Organisms: Physiology and Medicine  
 Pasteur, Louis  
 Pauling, Linus  
 Pharmacologist  
 Polymerase Chain Reaction  
 Porter, Keith  
 Radiation Hybrid Mapping  
 Radionuclides  
 Recombinant DNA  
 Reproductive Technology  
 Reverse Transcriptase  
 Scaling  
 Separation and Purification  
 Structure Determination  
 Theoretical Ecology  
 Transgenic Techniques  
 Transplant Medicine  
 Van Helmont, J. B.  
 Watson, James  
 Zoology Researcher

## **FUNGI**

---

Biodiversity  
 Cell  
 Cell Wall  
 Fungal Diseases  
 Fungi  
 Lichen  
 Mycorrhizae  
 Plant Pathogens and Pests  
 Symbiosis  
 Taxonomy, History of

## **GENE—PROTEIN**

---

Antisense Nucleotides  
 Chromosome, Eukaryotic  
 Control Mechanisms  
 Control of Gene Expression  
 DNA  
 Endoplasmic Reticulum  
 Gene  
 Genetic Code  
 Genetic Control of Development  
 Genetic Diseases  
 Hormones  
 McClintock, Barbara  
 Mutation  
 Nuclear Transport  
 Nucleolus  
 Nucleotides  
 Nucleus

Prion  
 Protein Structure  
 Protein Synthesis  
 Protein Targeting  
 Recombinant DNA  
 Retrovirus  
 Reverse Transcriptase  
 Ribosome  
 RNA  
 RNA Processing  
 Transcription  
 Transfer RNA  
 Transposon  
 Virus

## **GENETICS**

---

Bacterial Genetics  
 Bacterial Viruses  
 Behavior, Genetic Basis of  
 Biology of Race  
 Chromosome Aberrations  
 Chromosome, Eukaryotic  
 Clone  
 Control of Gene Expression  
 Crick, Francis  
 DNA  
 DNA Sequencing  
 DNA Viruses  
 Forensic DNA Analysis  
 Gene  
 Gene Therapy  
 Genetic Analysis  
 Genetic Code  
 Genetic Control of Development  
 Genetic Counselor  
 Genetic Diseases  
 Genome  
 Genomics  
 Hardy-Weinberg Equilibrium  
 History of Biology: Inheritance  
 Human Genome Project  
 Hybrid  
 Hybridization  
 Hybridization, Plant  
 Linkage and Gene Mapping  
 McClintock, Barbara  
 Meiosis  
 Model Organisms: Cell Biology and Genetics  
 Nucleotides  
 Patterns of Inheritance  
 Pedigrees and Modes of Inheritance  
 Population Genetics  
 Prion  
 Radiation Hybrid Mapping  
 Recombinant DNA

Replication  
 Retrovirus  
 Reverse Transcriptase  
 Transgenic Techniques  
 Transposon  
 Virus  
 Watson, James

### **HISTORY OF BIOLOGY**

---

Buffon, Count (Georges-Louis Leclerc)  
 Carson, Rachel  
 Crick, Francis  
 Darwin, Charles  
 De Saussure, Nicolas  
 Dubos, René  
 Ecology, History of  
 Gray, Asa  
 Harvey, William  
 History of Agriculture  
 History of Biology: Biochemistry  
 History of Biology: Cell Theory and Cell Structure  
 History of Biology: Inheritance  
 History of Evolutionary Thought  
 History of Medicine  
 History of Plant Physiology  
 Ingenhousz, Jan  
 Lamarck, Jean-Baptiste  
 Leakey Family  
 Leeuwenhoek, Anton  
 Linnaeus, Carolus  
 McClintock, Barbara  
 Mendel, Gregor  
 Pasteur, Louis  
 Pauling, Linus  
 Porter, Keith  
 Taxonomy, History of  
 Torrey, John  
 Van Helmont, J. B.  
 Vavilov, Nikolay  
 Vesalius, Andreas  
 Von Humboldt, Alexander  
 Watson, James

### **IMMUNE SYSTEM**

---

AIDS  
 Antibodies in Research  
 Antibody  
 Autoimmune Disease  
 Immune Response  
 Lymphatic System  
 Nonspecific Defense  
 Stress Response  
 T Cells

Transplant Medicine  
 Vaccines

### **INHERITANCE**

---

Bacterial Genetics  
 Behavior, Genetic Basis of  
 Biology of Race  
 Cell Cycle  
 Chromosome Aberrations  
 Clone  
 DNA  
 Feeding Strategies  
 Genetic Counselor  
 Genetic Diseases  
 History of Biology: Inheritance  
 Hybridization-Plant  
 Life Cycles  
 Linkage and Gene Mapping  
 Meiosis  
 Mendel, Gregor  
 Mitosis  
 Model Organisms: Cell Biology and Genetics  
 Mutation  
 Patterns of Inheritance  
 Pedigrees and Modes of Inheritance  
 Radiation Hybrid Mapping  
 Replication  
 Transgenic Techniques

### **INTERACTIONS, POPULATIONS, AND COMMUNITIES**

---

Behavior Patterns  
 Biogeography  
 Community  
 Competition  
 Ecological Research, Long-term  
 Ecology, History of  
 Ecosystem  
 Feeding Strategies  
 Field Studies in Animal Behavior  
 Field Studies in Plant Ecology  
 Fire Ecology  
 Habitat  
 Herbivory and Plant Defenses  
 Human Population  
 Invasive Species  
 Landscape Ecology  
 Lichen  
 Mimicry, Camouflage, and Warning Coloration  
 Mycorrhizae  
 Pheromone  
 Population Dynamics  
 Population Genetics  
 Predation and Defense

Symbiosis  
Theoretical Ecology  
Von Humboldt, Alexander

### **LIFE CYCLES**

---

Aging, Biology of  
Alternation of Generations  
Amniote Egg  
Cell Cycle  
Cnidarian  
Development  
DNA Sequencing  
Female Reproductive System  
Ferns  
Fetal Development, Human  
Growth  
Life Cycle, Human  
Life Cycles  
Male Reproductive System  
Reproduction in Plants  
Seedless Vascular Plants  
Seeds  
Sexual Reproduction  
Slime Molds

### **NERVOUS SYSTEM**

---

Biological Weapons  
Brain  
Central Nervous System  
Chemoreception  
Eye  
Hearing  
Hypothalamus  
Ion Channels  
Nervous Systems  
Neurologic Diseases  
Neuron  
Pain  
Peripheral Nervous System  
Psychiatric Disorders, Biology of  
Psychiatrist  
Psychoactive Drugs  
Spinal Cord  
Stress Response  
Synaptic Transmission  
Touch  
Vision

### **PLANT ANATOMY AND PHYSIOLOGY**

---

Alternation of Generations  
Anatomy of Plants  
Beer-making, Botany of  
C4 and CAM Plants  
Cell Wall

Chloroplast  
De Saussure, Nicolas  
Differentiation in Plants  
Flowers  
Fruits  
Grain  
History of Plant Physiology  
Hormones, Plant  
Hybridization-Plant  
Ingenhousz, Jan  
Leaves  
Meristems  
Mycorrhizae  
Nitrogen Fixation  
Photoperiodism  
Photosynthesis  
Plant Development  
Plant Nutrition  
Plant Pathogens and Pests  
Poisonous Plants  
Pollination and Fertilization  
Propagation  
Reproduction in Plants  
Rhythms of Plant Life  
Roots  
Secondary Metabolites in Plants  
Seed Germination & Dormancy  
Seeds  
Senescence  
Shoots  
Soil  
Translocation  
Tropisms and Nastic Movements  
Van Helmont, J. B.  
Water Cycle  
Water Movement in Plants  
Wine-making, Botany of  
Wood and Wood Products

### **PLANT DIVERSITY**

---

Angiosperms  
Biodiversity  
Biogeography  
Bryophytes  
C4 and CAM Plants  
Conifers  
Eudicots  
Evolution of Plants  
Ferns  
Grasses  
Gray, Asa  
Gymnosperms  
Hybridization-Plant  
Monocots

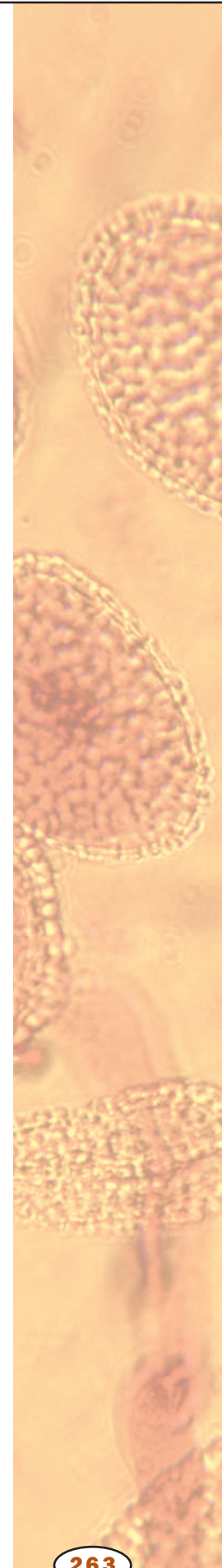

Plant  
Seedless Vascular Plants  
Torrey, John  
Vavilov, Nikolay  
Von Humboldt, Alexander

---

**PROTISTS**

Algae  
Beer-making, Botany of  
Cell  
Coral Reef  
Evolution of Plants  
History of Biology: Cell Theory and Cell Structure  
Leeuwenhoek, Anton  
Lichen  
Model Organisms: Cell Biology and Genetics  
Plankton  
Protista  
Protozoa  
Protozoan Diseases  
Slime Molds

---

**REPRODUCTION AND DEVELOPMENT**

Aging, Biology of  
Birth Control  
Cell Cycle  
Cytokinesis  
Development  
Female Reproductive System  
Fetal Development, Human  
Genetic Diseases  
Life Cycle, Human  
Life Cycles  
Male Reproductive System  
Meiosis  
Mitosis  
Reproductive Technology  
Sexual Reproduction  
Sexually Transmitted Diseases

---

**SKIN, MUSCLE, AND BONE**

Body Cavities  
Bone  
Connective Tissue  
Epithelium  
Growth  
Locomotion  
Muscle  
Musculoskeletal System  
Skeletons  
Skin

---

**TAXONOMY AND BIODIVERSITY (SEE ALSO ANIMAL DIVERSITY AND PLANT DIVERSITY)**

Animalia  
Archaea  
Biodiversity  
Eubacteria  
Evolution of Plants  
Fungi  
Kingdom  
Lamarck, Jean-Baptiste  
Leeuwenhoek, Anton  
Linnaeus, Carolus  
Plant  
Protista  
Speciation  
Species  
Taxonomy, History of

---

**VIRUSES AND PRIONS**

AIDS  
Bacterial Viruses  
Plant Pathogens and Pests  
Prion  
Retrovirus  
Reverse Transcriptase  
Sexually Transmitted Diseases  
Viral Diseases  
Virus

**biology**



## **EDITORIAL BOARD**

### **Editor in Chief**

Richard Robinson  
rrobinson@nasw.org  
*Tucson, Arizona*

### **Advisory Editors**

Peter Bruns, *Howard Hughes Medical Institute*  
Rex Chisholm, *Northwestern University Medical School*  
Mark A. Davis, *Department of Biology, Macalester College*  
Thomas A. Frost, *Trout Lake Station, University of Wisconsin*  
Kenneth S. Saladin, *Department of Biology, Georgia College and State University*

### **Editorial Reviewer**

Ricki Lewis, *State University of New York at Albany*

### **Students from the following schools participated as consultants:**

Pocatello High School, Pocatello, Idaho  
Eric Rude, *Teacher*  
Swiftwater High School, Swiftwater, Pennsylvania  
Howard Piltz, *Teacher*  
Douglas Middle School, Box Elder, South Dakota  
Kelly Lane, *Teacher*  
Medford Area Middle School, Medford, Wisconsin  
Jeanine Staab, *Teacher*

## **EDITORIAL AND PRODUCTION STAFF**

Linda Hubbard, *Editorial Director*  
Diane Sawinski, Christine Slovey, *Senior Editors*  
Shawn Beall, Bernard Grunow, Michelle Harper, Kate Millson, Carol Nagel, *Contributing Editors*  
Kristin May, Nicole Watkins, *Editorial Interns*  
Michelle DiMercurio, *Senior Art Director*  
Rhonda Williams, *Buyer*  
Robyn V. Young, *Senior Image Editor*  
Julie Juengling, Lori Hines, *Permissions Assistants*  
Deanna Raso, *Photo Researcher*

### **Macmillan Reference USA**

Elly Dickason, *Publisher*  
Hélène G. Potter, *Editor in Chief*  
Ray Abruzzi, *Editor*

# biology

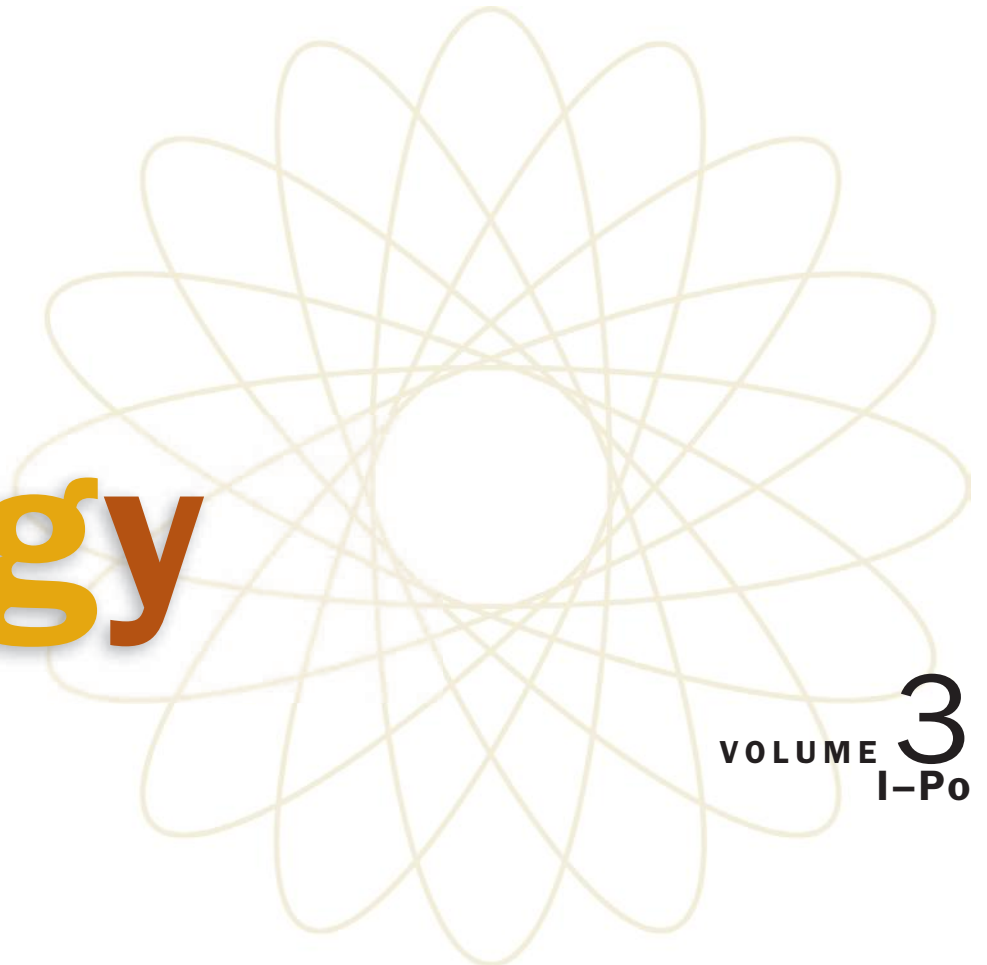

VOLUME **3**  
I-Po

**Richard Robinson, Editor in Chief**

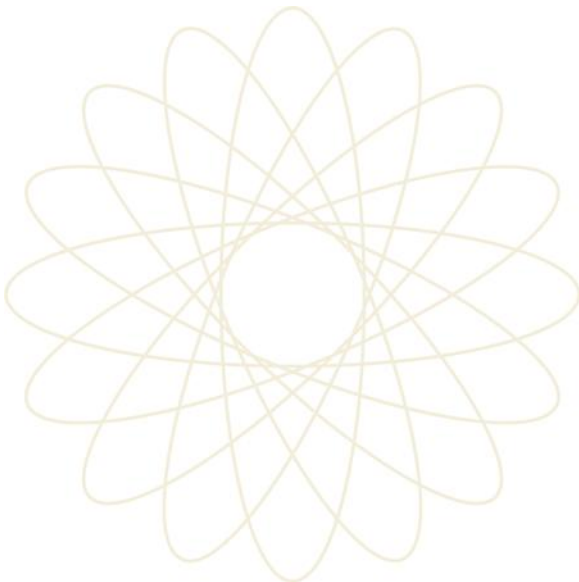

**MACMILLAN  
REFERENCE  
USA™**

**THOMSON**  
★  
**GALE™**



**Copyright © 2002 by Macmillan Reference USA**

All rights reserved. No part of this book may be reproduced or transmitted in any form or by any means, electronic or mechanical, including photocopying, recording, or by any information storage and retrieval system, without permission in writing from the Publisher.

Macmillan Reference USA  
300 Park Avenue South  
New York, NY 10010

Gale Group  
27500 Drake Rd.  
Farmington Hills, 48331-3535

Printed in the United States of America

1 2 3 4 5 6 7 8 9 10

**Library of Congress Catalog-in-Publication Data**

Biology / Richard Robinson, editor in chief.

p. cm.

Includes bibliographical references and index.

ISBN 0-02-86551-6 (set: hardcover) — ISBN 0-02-86-5552-4 (vol. 1) — ISBN 0-02-865556-7 (vol. 2) — ISBN 0-02-865554-0 (vol. 3) — ISBN 0-02-865555-9 (vol. 4)

1. Biology. I. Robinson, Richard, 1956–  
QH07.2.B556 2001

570-dc21  
2001040211

# For Your Reference

The following section provides information that is applicable to a number of articles in this reference work. Included are a metric measurement and conversion table, geologic timescale, diagrams of an animal cell and a plant cell, illustration of the structure of DNA nucleotides, detail of DNA nucleotides pairing up across the double helix, and a comparison of the molecular structure of DNA and RNA.

## METRIC MEASUREMENT

### Definitions

Kilo = 1000  
 Hecto = 100  
 Deka = 10  
 Deci = 0.10 (1/10)  
 Centi = 0.01 (1/100)  
 Milli = 0.001 (1/1000)  
 Micro = 0.000001 (1/1,000,000)  
 Nano = 0.000000001 (1/1,000,000,000)

### Conversions

To convert	Into	Multiply by
Acres	Hectares	0.4047
Centimeters	Inches	0.3937
Feet	Meters	0.3048
Gallons	Liters	3.7853
Grams	Ounces	0.0353
Grams	Pounds	0.0022
Hectares	Acres	2.4710
Inches	Centimeters	2.5400
Kilograms	Pounds	2.2046
Kilometers	Miles	0.6214
Liters	Gallons]	0.2642
Meters	Feet	3.2808
Miles	Kilometers	1.6093
Ounces	Grams	28.3495
Pounds	Kilograms	0.4536
Pounds	Grams	453.59

### Temperature Conversion

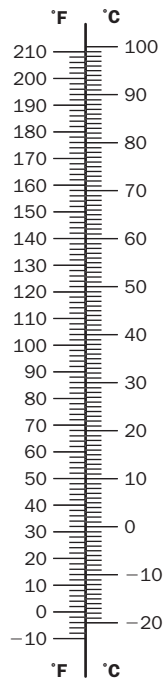

100°C = water boils  
 0°C = water freezes

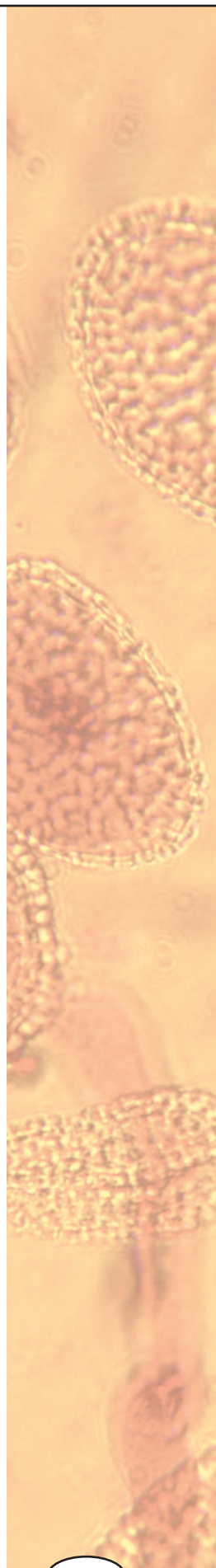

## GEOLOGIC TIMESCALE

ERA	PERIOD	EPOCH	STARTED (millions of years ago)	
<b>Cenozoic:</b> 66.4 millions of years ago–present time	<b>Quaternary</b>	Holocene	0.01	
		Pleistocene	1.6	
	<b>Tertiary</b>	<b>Neogene</b>	Pliocene	5.3
			Miocene	23.7
		<b>Paleogene</b>	Oligocene	36.6
			Eocene	57.8
			Paleocene	66.4
<b>Mesozoic:</b> 245–66.4 millions of years ago	<b>Cretaceous</b>	Late	97.5	
		Early	144	
	<b>Jurassic</b>	Late	163	
		Middle	187	
		Early	208	
	<b>Triassic</b>	Late	230	
		Middle	240	
		Early	245	
	<b>Paleozoic:</b> 570–245 millions of years ago	<b>Permian</b>	Late	258
Early			286	
<b>Carboniferous</b>		<b>Pennsylvanian</b>	Late	320
		<b>Mississippian</b>	Early	360
<b>Devonian</b>		Late	374	
		Middle	387	
		Early	408	
<b>Silurian</b>		Late	421	
		Early	438	
<b>Ordovician</b>		Late	458	
		Middle	478	
		Early	505	
<b>Cambrian</b>		Late	523	
		Middle	540	
		Early	570	
<b>Precambrian time:</b> 4500–570 millions of years ago			4500	

**A TYPICAL ANIMAL CELL**

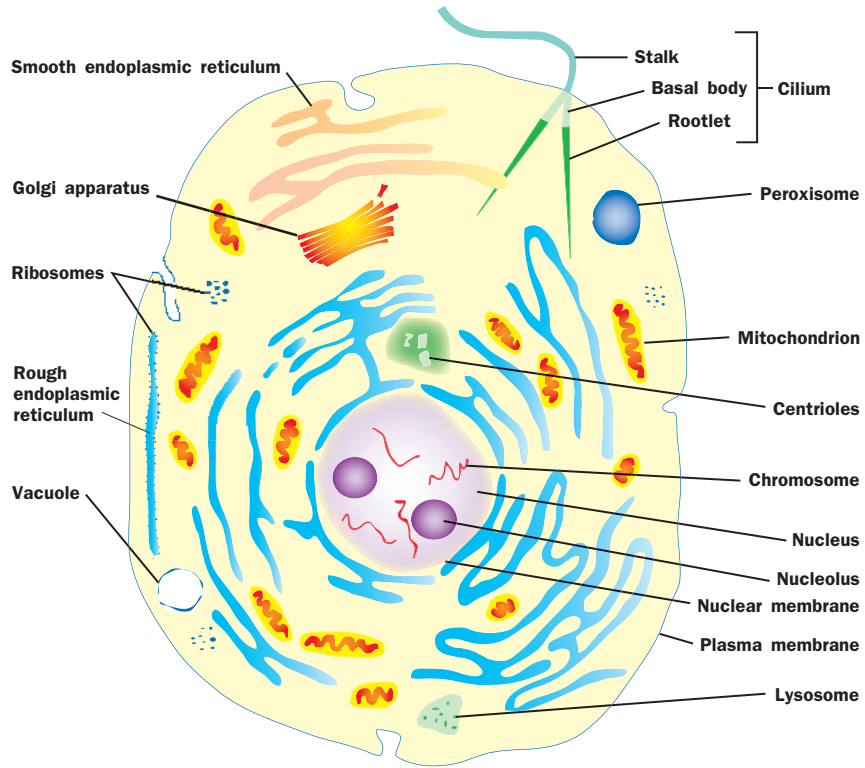

**A TYPICAL PLANT CELL**

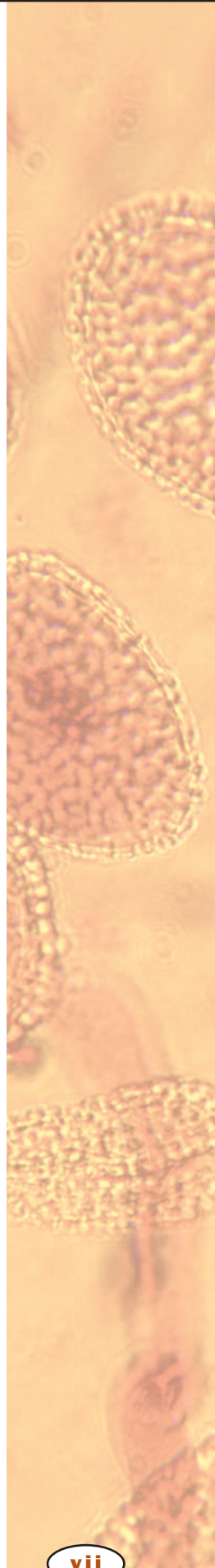
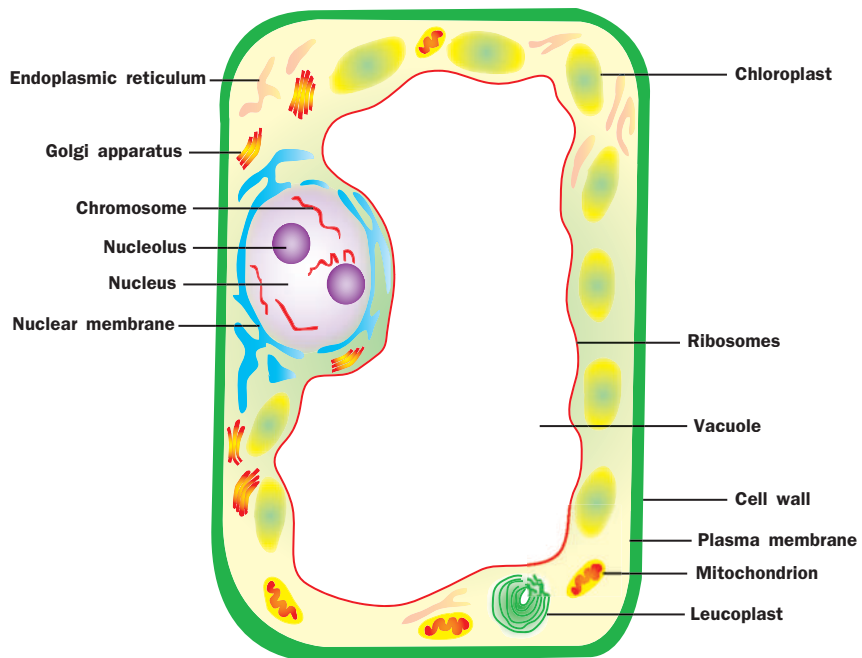

## STRUCTURE OF DNA NUCLEOTIDES

### Components of a nucleotide

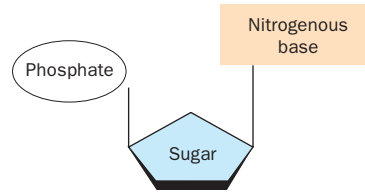

### Purine-containing nucleotides

Adenine

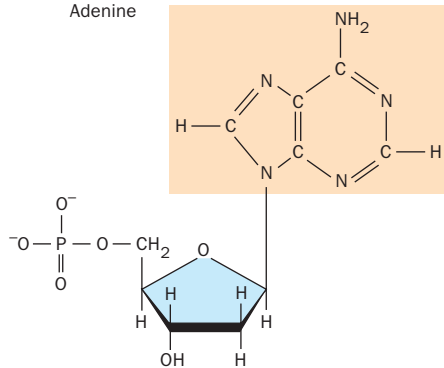

### Pyrimidine-containing nucleotides

Thymine

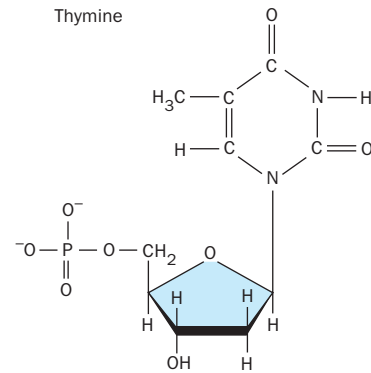

Guanine

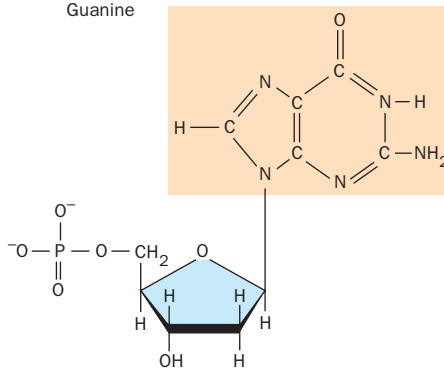

Cytosine

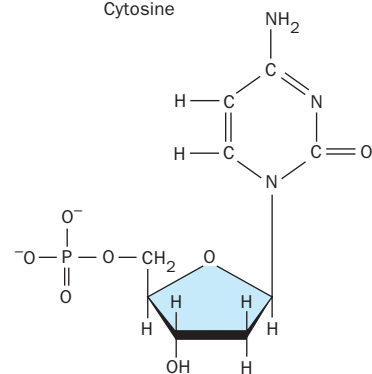

# DNA NUCLEOTIDES PAIR UP ACROSS THE DOUBLE HELIX

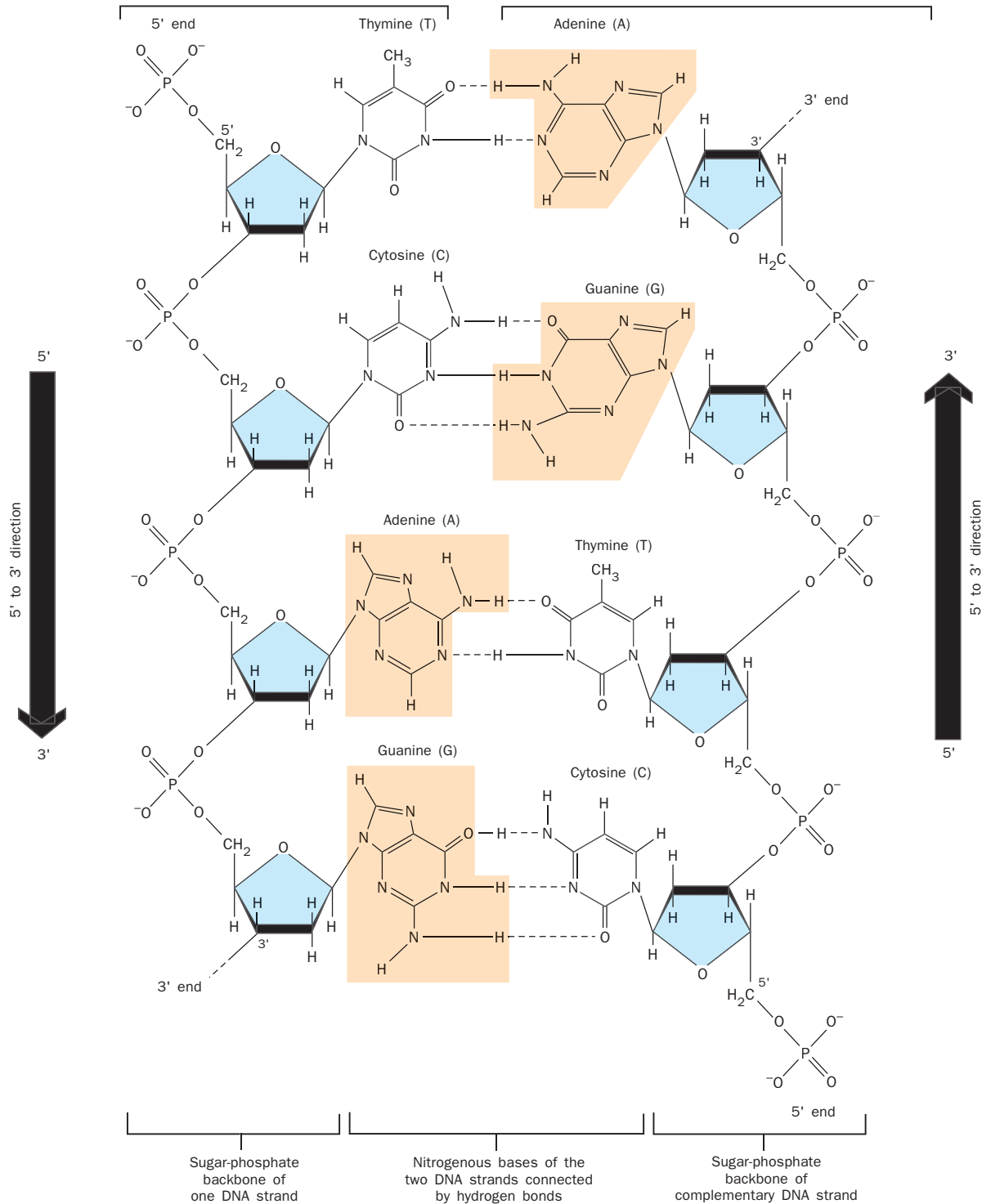

# COMPARISON OF DNA AND RNA

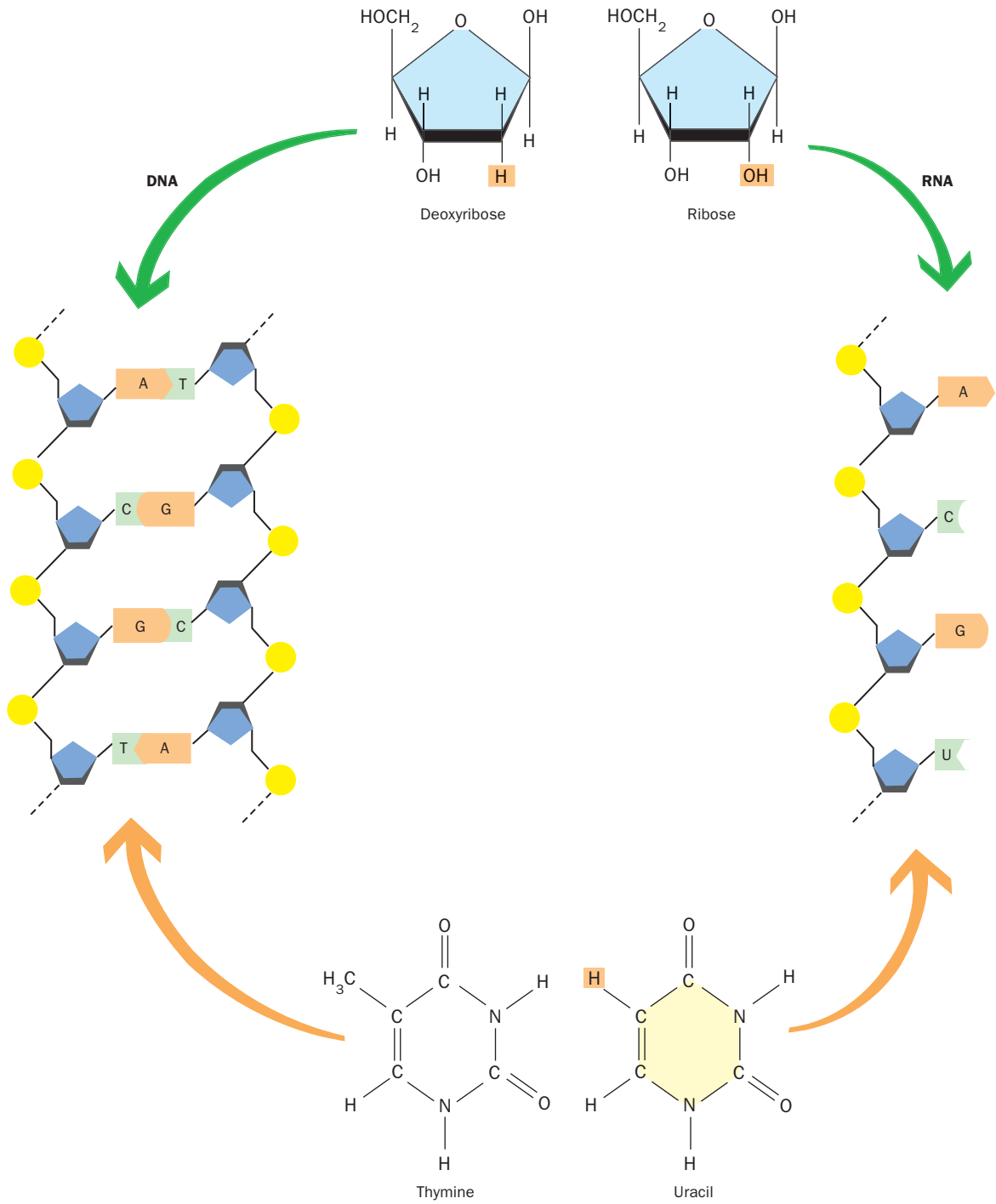

# Table of Contents

## VOLUME 1

PREFACE .....	v
FOR YOUR REFERENCE .....	vii
LIST OF CONTRIBUTORS .....	xiii

## A

Active Transport .....	1
Adaptation .....	3
Adrenal Gland .....	5
Aging, Biology of .....	7
Agriculture .....	10
Agronomist .....	13
AIDS .....	14
Alcohol and Health .....	17
Algae .....	20
Alternation of Generations .....	22
Amino Acid .....	24
Amniote Egg .....	25
Amphibian .....	26
Anabolic Steroids .....	27
Anatomy of Plants .....	29
Angiosperms .....	31
Animalia .....	34
Annelid .....	36
Antibodies in Research .....	37
Antibody .....	39
Antisense Nucleotides .....	41
Arachnid .....	42
Archaea .....	43
Arthropod .....	46
Autoimmune Disease .....	47

## B

Bacterial Cell .....	48
Bacterial Diseases .....	52
Bacterial Genetics .....	53
Bacterial Viruses .....	58
Beer-making, Biology of .....	59

Behavior, Genetic Basis of .....	60
Behavior Patterns .....	63
Biochemist .....	65
Biodiversity .....	66
Biogeochemical Cycles .....	68
Biogeography .....	70
Bioinformatics .....	71
Biological Weapons .....	74
Biology .....	76
Biology of Race .....	77
Biome .....	79
Biotechnology .....	80
Bird .....	80
Birth Control .....	82
Blood .....	84
Blood Clotting .....	86
Blood Sugar Regulation .....	87
Blood Vessels .....	89
Body Cavities .....	91
Bone .....	93
Bony Fish .....	95
Botanist .....	96
Brain .....	97
Bryophytes .....	104
Buffon, Count (Georges-Louis Leclerc) .....	106

## C

C4 and CAM Plants .....	107
Cambrian Explosion .....	108
Cancer .....	110
Carbohydrates .....	112
Carbon Cycle .....	114
Cardiovascular Diseases .....	115
Carson, Rachel .....	117
Cartilaginous Fish .....	118
Cell .....	119
Cell Culture .....	122



Cell Cycle .....	124	DNA Sequencing .....	224
Cell Division .....	127	DNA Viruses .....	227
Cell Evolution .....	127	Doctor, Family Practice .....	228
Cell Junctions .....	129	Doctor, Specialist .....	229
Cell Motility .....	130	Drug Testing .....	232
Cell Wall .....	132	Dubos, René .....	233
Central Nervous System .....	134	PHOTO AND ILLUSTRATION	
Chemoreception .....	135	CREDITS .....	235
Chloroplast .....	137	GLOSSARY .....	243
Chordata .....	138	TOPIC OUTLINE .....	263
Chromosome Aberrations .....	139	INDEX .....	273
Chromosome, Eukaryotic .....	143		
Circulatory Systems .....	149	<b>VOLUME 2</b>	
Clinical Trials .....	151	FOR YOUR REFERENCE .....	v
Clone .....	152	<b>E</b>	
Cnidarian .....	155	Echinoderm .....	1
Coffee, Botany of .....	155	Ecological Research, Long-Term .....	3
College Professor .....	156	Ecology .....	4
Community .....	157	Ecology, History of .....	5
Competition .....	159	Ecosystem .....	7
Conifers .....	162	Electron Microscopy .....	10
Connective Tissue .....	164	Electrophoresis .....	13
Conservation .....	165	Emergency Medical Technician .....	15
Control of Gene Expression .....	170	Endangered Species .....	16
Control Mechanisms .....	177	Endocrine System .....	18
Convergent Evolution .....	181	Endocytosis .....	22
Coral Reef .....	183	Endoplasmic Reticulum .....	25
Creationism .....	185	Entomologist .....	27
Crick, Francis .....	187	Environmental Health .....	28
Crocodylians .....	188	Enzymes .....	29
Crustacean .....	189	Epidemiologist .....	36
Cyanobacteria .....	190	Epithelium .....	37
Cytokinesis .....	191	Estuaries .....	38
Cytoskeleton .....	193	Ethnobotany .....	40
<b>D</b>		Eubacteria .....	41
Darwin, Charles .....	197	Eudicots .....	43
De Saussure, Nicolas-Théodore .....	199	Evolution .....	44
Dentist .....	200	Evolution, Evidence for .....	52
Desert .....	201	Evolution of Plants .....	55
Desertification .....	204	Excretory Systems .....	60
Development .....	205	Exocytosis .....	62
Differentiation in Plants .....	212	Extinction .....	64
Digestion .....	217	Extracellular Matrix .....	68
Digestive System .....	219	Extreme Communities .....	69
Disease .....	221	Eye .....	72
DNA .....	222		

<b>F</b>	
Feeding Strategies	74
Female Reproductive System	77
Fetal Development, Human	81
Field Studies in Animal Behavior	85
Field Studies in Plant Ecology	87
Fire Ecology	89
Flight	91
Flowers	93
Forensic DNA Analysis	94
Forest, Boreal	97
Forest, Temperate	99
Forest, Tropical	101
Forester	105
Fruits	105
Fungal Diseases	108
Fungi	109
<b>G</b>	
Gas Exchange	114
Gene	117
Gene Therapy	124
Genetic Analysis	125
Genetic Code	129
Genetic Control of Development	131
Genetic Counselor	135
Genetic Diseases	136
Genome	140
Genomics	141
Global Climate Change	145
Glycolysis and Fermentation	148
Golgi	150
Grain	153
Grasses	155
Grassland	156
Gray, Asa	158
Growth	158
Gymnosperms	161
<b>H</b>	
Habitat	163
Hardy-Weinberg Equilibrium	164
Harvey, William	166
Health	167
Health and Safety Officer	169
Hearing	169
Heart and Circulation	172
Herbal Medicine	176
Herbivory and Plant Defenses	178
High School Biology Teacher	180
History of Agriculture	180
History of Biology: Biochemistry	182
History of Biology: Cell Theory and Cell Structure	186
History of Biology: Inheritance	189
History of Evolutionary Thought	192
History of Medicine	196
History of Plant Physiology	198
Homeostasis	201
Hormones	203
Hormones, Plant	206
Horticulturist	208
Human Evolution	208
Human Genome Project	212
Human Nutrition	217
Human Population	219
Hybridization	220
Hybridization, Plant	221
Hypothalamus	222
PHOTO AND ILLUSTRATION	
CREDITS	227
GLOSSARY	235
TOPIC OUTLINE	255
INDEX	265
<b>VOLUME 3</b>	
FOR YOUR REFERENCE	
	v
<b>I</b>	
Imaging in Medicine	1
Immune Response	4
Ingenhousz, Jan	7
Insect	7
Invasive Species	10
Ion Channels	12
<b>K</b>	
Kidney	15
Kingdom	17
Krebs Cycle	18
<b>L</b>	
Laboratory Technician	20
Lakes and Ponds	21

Lamarck, Jean-Baptiste	23	Mollusk	105
Landscape Ecology	24	Monocots	106
Leakey Family	26	Monotreme	108
Learning	26	Muscle	108
Leaves	28	Musculoskeletal System	112
Leeuwenhoek, Antony von	30	Mutation	115
Lichen	31	Mycorrhizae	119
Life Cycle, Human	32		
Life Cycles	34	<b>N</b>	
Life, What Is	37	Natural Selection	121
Light Microscopy	38	Nematode	124
Limnologist	42	Nervous Systems	125
Linkage and Gene Mapping	42	Neurologic Diseases	129
Linnaeus, Carolus	47	Neuron	131
Lipids	48	Nitrogen Cycle	135
Liver	50	Nitrogen Fixation	136
Locomotion	50	Nonspecific Defense	138
Lymphatic System	52	Nuclear Transport	140
Lysosomes	54	Nucleolus	142
		Nucleotides	144
<b>M</b>		Nucleus	145
Male Reproductive System	56	Nurse	148
Mammal	59	Nurse Practitioners	148
Marine Biologist	60	Nutritionist	149
Marsupial	62		
Mating Systems	62	<b>O</b>	
McClintock, Barbara	64	Ocean Ecosystems: Hard Bottoms	150
Medical Assistant	65	Ocean Ecosystems: Open Ocean	151
Medical/Science Illustrator	65	Ocean Ecosystems: Soft Bottoms	153
Meiosis	66	Oncogenes and Cancer Cells	154
Membrane Proteins	70	Organ	158
Membrane Structure	73	Organelle	159
Membrane Transport	76	Organic Agriculture	159
Mendel, Gregor	80	Origin of Life	161
Meristems	81	Osmoregulation	165
Metabolism, Cellular	84	Oxidative Phosphorylation	168
Metabolism, Human	87		
Microbiologist	90	<b>P</b>	
Microscopist	91	Pain	170
Migration	92	Paleontology	171
Mimicry, Camouflage, and Warning		Pancreas	173
Coloration	93	Parasitic Diseases	174
Mitochondrion	94	Pasteur, Louis	176
Mitosis	98	Patterns of Inheritance	177
Model Organisms: Cell Biology and		Pauling, Linus	184
Genetics	101	Pedigrees and Modes of Inheritance	186
Model Organisms: Physiology and		Peripheral Nervous System	189
Medicine	102	Peroxisomes	191

Pharmaceutical Sales Representative . . .	192	Protozoan Diseases . . . . .	26
Pharmacologist . . . . .	192	Psychiatric Disorders, Biology of . . . . .	27
Pheromone . . . . .	193	Psychiatrist . . . . .	30
Photoperiodism . . . . .	195	Psychoactive Drugs . . . . .	31
Photosynthesis . . . . .	196	Pteridophytes . . . . .	33
Physical Therapist and Occupational Therapist . . . . .	200	Public Health Careers . . . . .	35
Physician Assistant . . . . .	201	<b>R</b>	
Physiological Ecology . . . . .	202	Radiation Hybrid Mapping . . . . .	36
Pituitary Gland . . . . .	205	Radionuclides . . . . .	38
Plankton . . . . .	205	Recombinant DNA . . . . .	38
Plant . . . . .	207	Remote Sensing . . . . .	46
Plant Development . . . . .	208	Replication . . . . .	47
Plant Nutrition . . . . .	214	Reproduction in Plants . . . . .	52
Plant Pathogens and Pests . . . . .	216	Reproductive Technology . . . . .	60
Plant Pathologist . . . . .	219	Reptile . . . . .	62
Plasma Membrane . . . . .	220	Respiration . . . . .	63
Platyhelminthes . . . . .	222	Retrovirus . . . . .	66
Poisonous Plants . . . . .	223	Reverse Transcriptase . . . . .	68
Poisons . . . . .	224	Rhythms of Plant Life . . . . .	69
Pollination and Fertilization . . . . .	227	Ribosome . . . . .	71
Pollution and Bioremediation . . . . .	228	Rivers and Streams . . . . .	73
Polymerase Chain Reaction . . . . .	232	RNA . . . . .	75
Population Dynamics . . . . .	233	RNA Processing . . . . .	77
Population Genetics . . . . .	235	Roots . . . . .	78
Porifera . . . . .	239	<b>S</b>	
Porter, Keith . . . . .	240	Scaling . . . . .	81
<b>PHOTO AND ILLUSTRATION</b>		Science Writer . . . . .	83
CREDITS . . . . .	243	Secondary Metabolites in Plants . . . . .	84
<b>GLOSSARY</b> . . . . .	251	Seed Germination and Dormancy . . . . .	86
<b>TOPIC OUTLINE</b> . . . . .	271	Seedless Vascular Plants . . . . .	88
<b>INDEX</b> . . . . .	281	Seeds . . . . .	89
		Senescence . . . . .	91
		Separation and Purification of Biomolecules . . . . .	93
<b>VOLUME 4</b>		Sex Chromosomes . . . . .	94
<b>FOR YOUR REFERENCE</b> . . . . .	v	Sex Determination . . . . .	96
<b>P</b>		Sexual Reproduction . . . . .	98
Predation and Defense . . . . .	1	Sexual Reproduction, Evolution of . . . . .	101
Primate . . . . .	4	Sexual Selection . . . . .	104
Prion . . . . .	5	Sexually Transmitted Diseases . . . . .	106
Propagation . . . . .	6	Shoots . . . . .	110
Protein Structure . . . . .	7	Signaling and Signal Transduction . . . . .	112
Protein Synthesis . . . . .	13	Skeletons . . . . .	118
Protein Targeting . . . . .	19	Skin . . . . .	120
Protista . . . . .	21	Sleep . . . . .	121
Protozoa . . . . .	23	Slime Molds . . . . .	124

Smoking and Health ..... 126  
 Social Behavior ..... 127  
 Sociobiology ..... 131  
 Soil ..... 132  
 Speciation ..... 134  
 Species ..... 136  
 Spinal Cord ..... 137  
 Stress Response ..... 139  
 Structure Determination ..... 141  
 Symbiosis ..... 142  
 Synaptic Transmission ..... 145

**T**

T Cells ..... 148  
 Taxonomy, History of ..... 151  
 Temperature Regulation ..... 154  
 Theoretical Ecology ..... 157  
 Thyroid Gland ..... 158  
 Tissue ..... 159  
 Torrey, John ..... 160  
 Touch ..... 161  
 Transcription ..... 162  
 Transfer RNA ..... 166  
 Transgenic Techniques ..... 167  
 Translocation ..... 168  
 Transplant Medicine ..... 172  
 Transposon ..... 174  
 Tropisms and Nastic Movements ..... 175  
 Tuatara ..... 176  
 Tundra ..... 177  
 Tunicate ..... 178  
 Turtle ..... 179

**V**

Vaccines ..... 180  
 Vacuole ..... 182  
 van Helmont, Jan ..... 183  
 Vavilov, Nikolay ..... 183  
 Vesalius, Andreas ..... 184  
 Veterinarian ..... 185  
 Viral Diseases ..... 186  
 Virus ..... 187  
 Vision ..... 188  
 Vitamins and Coenzymes ..... 190  
 von Humboldt, Alexander ..... 192

**W**

Water ..... 192  
 Water Cycle ..... 193  
 Water Movement in Plants ..... 193  
 Watson, James ..... 196  
 Wetlands ..... 197  
 Wildlife Biologist ..... 199  
 Wine-making, Botany of ..... 200  
 Wood and Wood Products ..... 201

**Z**

Zoology ..... 204  
 Zoology Researcher ..... 204

PHOTO AND ILLUSTRATION

CREDITS ..... 207  
 GLOSSARY ..... 215  
 TOPIC OUTLINE ..... 235  
 CUMULATIVE INDEX ..... 245

**biology**



## Imaging in Medicine

---

As recently as in the 1970s, the diagnosis of some diseases often required exploratory surgery, opening a body cavity to “have a look around” for visible disorders. The risks of infection, anesthesia, and imperfect healing weigh against exploratory surgery, but the diagnostic benefit may make the risk worth taking. In the last few decades, however, a variety of medical imaging techniques has made most exploratory surgery unnecessary and has greatly accelerated progress in medicine. Although the basic principles of some of these techniques have been known for much longer, they did not become clinically useful until computer technology had advanced enough to process data into clear images of the body, mostly since the 1970s.

### Radiography

Radiography, use of X rays, is the oldest imaging technique. The term “X ray” can refer either to the type of radiation used or to the photographic image produced (the radiogram). X rays were discovered in 1885, and Marie Curie (1867–1934) trained military doctors in the use of X-ray machines in World War I. X rays are relatively simple and inexpensive to make, and they are commonly used in dentistry, mammography, chest examinations, and diagnosis of fractures. They are best used for dense structures such as bone, but hollow organs can be visualized by filling them with a radiopaque substance such as barium, given by swallow or enema to X ray the stomach or colon. Angiography is the X-ray visualization of blood vessels after injection with a radiopaque dye.

### Sonography

Sonography, or ultrasound imaging, is the second oldest imaging method, and the second most widely used. An outgrowth of the sonar technology developed in World War II, it uses a handheld probe to “bombard” the body with ultrasound waves and a computer to analyze the reflected signal into an image. Sonography avoids the harmful effects of X rays and is commonly used to examine fetuses.

### Computed Tomography (CT)

Formerly called a CAT scan, computed tomography (CT) is a more sophisticated use of X rays to produce more finely detailed images. The

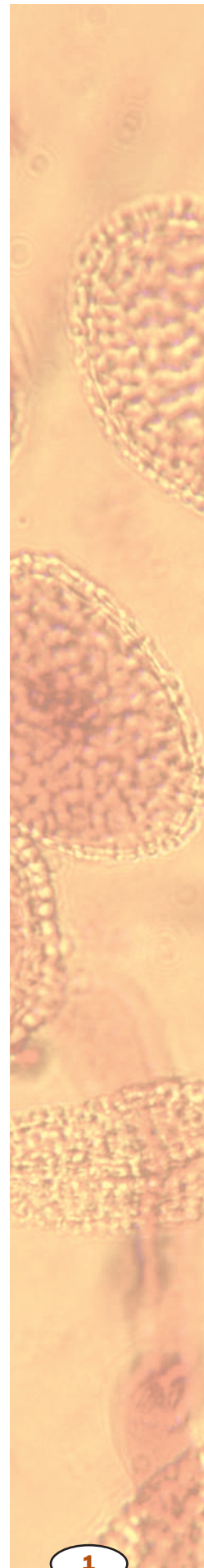

A magnetic resonance imaging (MRI) scan of a human brain, cervical spine, and spinal marrow.

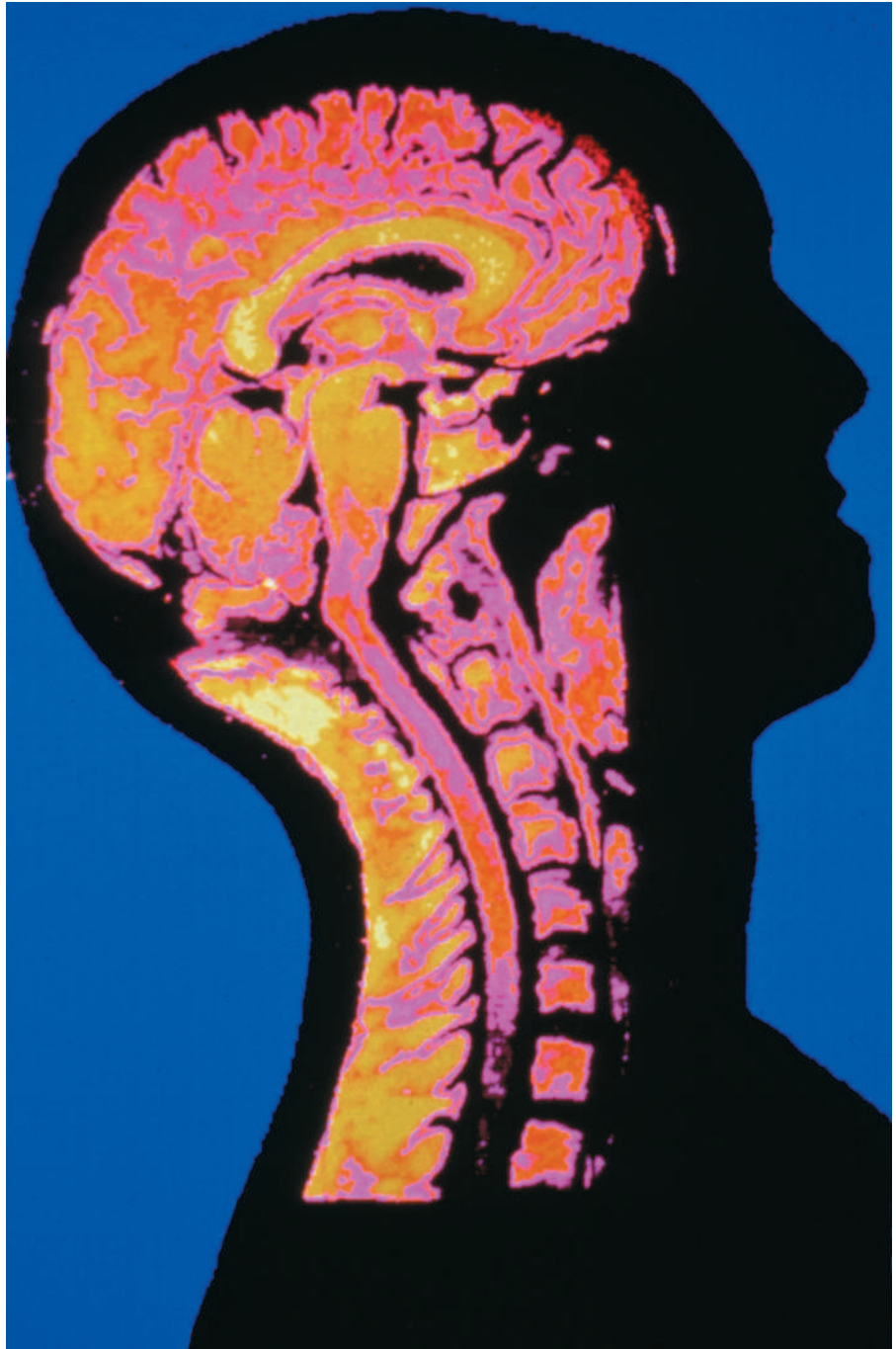

**aneurysm** bulging of the wall of a blood vessel

patient is moved through a machine that emits low-intensity X rays on one side and receives them with a detector on the other side. By imaging body slices as thin as a coin, CT scans show less overlap of organs than conventional X rays and thus produce sharper images. CT scans are useful for identifying tumors, **aneurysms**, cerebral hemorrhages, kidney stones, and other disorders.

### **Magnetic Resonance Imaging (MRI)**

With magnetic resonance imaging (MRI), a cylindrical device surrounds the body with a magnetic field three thousand to sixty thousand times as



strong as Earth's. Hydrogen atoms align themselves with this field. The patient is then irradiated with radio waves. Hydrogen **ions** absorb this energy and align in a new direction. When the radio waves are turned off, they realign to the magnetic field and emit energy at rates that vary with the type of tissue. This emitted energy is received by a detector and analyzed by a computer into an image of the body's interior. MRI can see through **cranial** and vertebral bone to visualize brain and spinal cord tissue in finer detail than CT.

### Positron Emission Tomography (PET)

Positron emission tomography (PET) is used to visualize the metabolic state of a tissue. The patient receives an injection of radioactively labeled **glucose**, which emits charged particles called positrons. When a positron and electron meet, they annihilate each other and give off gamma rays that are picked up by a detector and analyzed by computer. The result is a color-coded image that shows which tissues were using the most glucose (that is, were most metabolically active) at the time. In cardiology, a PET scan can show the location and extent of dead heart tissue. In neuroscience, it can show which parts of the brain are active from moment to moment as a person engages in various sensory, motor, or intellectual tasks.

### Functional MRI (fMRI)

A new variation of MRI, functional MRI (fMRI) detects the **anaerobic** activity of active **neurons** of the brain. It can pinpoint brain activity to within 1 or 2 millimeters, and is even more precise and useful than PET scans for studies of brain function. It also has the advantage of requiring no injections or radioactive **isotopes**, and it is much quicker than a PET scan. The PET and fMRI techniques not only have been valuable for clinical diagnosis but have added enormously to our knowledge of brain function, pinpointing abnormalities correlated with depression, schizophrenia, and attention deficit disorder. They have also provided images of the mind at work, so to speak, identifying areas involved in consciousness, memory, thought, musical perception, reading, motor control, and speech.

Radiology is the medical specialty that embraces all of these imaging techniques. Nuclear medicine is a branch of medicine that uses radioisotopes in the making of medical images, as in PET scans, and in the treatment of diseases such as cancer. Noninvasive techniques are those that require no break in the body surface whatsoever: conventional X rays; sonography; and CT, MRI, and fMRI scans. If a technique involves even such a slight invasion of the body as an injection or a barium swallow, it is considered an invasive procedure (angiography and PET scans, for example). SEE ALSO BRAIN; DOCTOR, SPECIALIST

*Kenneth S. Saladin*

#### Bibliography

Brant, William E., and Clyde A. Helms, eds. *Fundamentals of Diagnostic Radiology*, 2nd ed. Philadelphia, PA: Lippincott, Williams and Wilkins, 1999.

National Institutes of Health, National Library of Medicine. *Visible Human Project*. <[http://www.nlm.nih.gov/research/visible/visible\\_human.html](http://www.nlm.nih.gov/research/visible/visible_human.html)>.

Weisslader, Ralph, Mark J. Rieumont, and Jack Wittenberg. *Primer of Diagnostic Imaging*, 2nd ed. St. Louis, MO: Mosby, 1997.

**ion** an electrically charged particle

**cranial** related to the cranium, or brain cavity

**glucose** simple sugar that provides energy to animal cells and is the building block of cellulose in plants

**anaerobic** without oxygen, or not requiring oxygen

**neuron** nerve cell

**isotopes** forms of an atom that differ by the number of neutrons in the nucleus

## Immune Response

Among the many threats organisms face are invasion and infection by bacteria, viruses, fungi, and other foreign or disease-causing agents. All organisms have nonspecific defenses (or innate defenses) that provide them with some of the protection they need. This type of defense exists throughout the animal kingdom, from sponges to mammals. Vertebrate animals, however, have an additional line of defense called specific immunity. Specific immunity is also called acquired immunity, adaptive immunity, or, most simply, an immune response.

### Overview

One characteristic of specific immunity is recognition. Immune responses begin when the body recognizes the invader as foreign. This occurs because there are molecules on foreign cells that are different from molecules on the body's cells. Molecules that start immune responses are called **antigens**. The body does not usually start an immune response against its own antigens because cells that recognize self-antigens are deleted or inactivated. This concept is called self-tolerance and is a key characteristic that defines immune responses.

A second characteristic is specificity. Although all immune responses are similar, each time the body is invaded by a different antigen, the exact response is specific to that antigen. For example, infection with a virus that causes the common cold triggers a response by a different set of cells than infection with bacteria that causes strep throat.

A third characteristic is memory. After an antigen is cleared from the body, immunological memory allows an antigen to be recognized and removed more quickly if encountered again.

### Antigen Presentation

Three groups of white blood cells are involved in starting an immune response. Although immune responses can occur anywhere in the body these cells are found, they primarily occur in the **lymph** nodes and spleen. These organs contain large numbers of antigen-presenting cells (APCs), T lymphocytes (or **T cells**), and **B lymphocytes** (or B cells).

APCs include macrophages, dendritic cells, and B cells. These cells encounter the foreign invader and present the invader's antigens to a group of T cells called helper T cells ( $T_H$  cells). APCs do this by first engulfing an invader and bringing it inside the cell. The APC then breaks the invader apart into its antigens and moves these antigens to its cell surface.

Receptors are cell surface **proteins** that can attach to antigens. Each  $T_H$  cell has a different receptor, allowing each cell to recognize a different antigen. The APC "shows" the antigen to the  $T_H$  cells until there is a match between a  $T_H$  cell receptor and the antigen. The contact between the two cells stimulates the  $T_H$  cell to divide rapidly. This process is called clonal selection because only the  $T_H$  cells that recognize the foreign invader are selected to reproduce. Stimulated  $T_H$  cells also produce chemical messengers called cytokines. Cytokines are made by all immune cells and control the immune response.

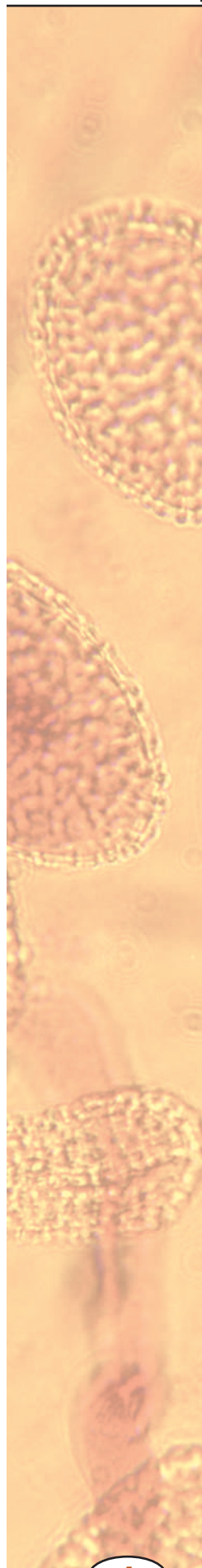

**antigen** foreign substance that provokes an immune response

**lymph** pale fluid that circulates in the lymphatic system, principally composed of blood plasma and cell fluid

**T cell** white blood cell that controls the immune response

**B lymphocyte** white blood cell that makes antibodies

**protein** complex molecule made from amino acids; used in cells for structure, signaling, and controlling reactions

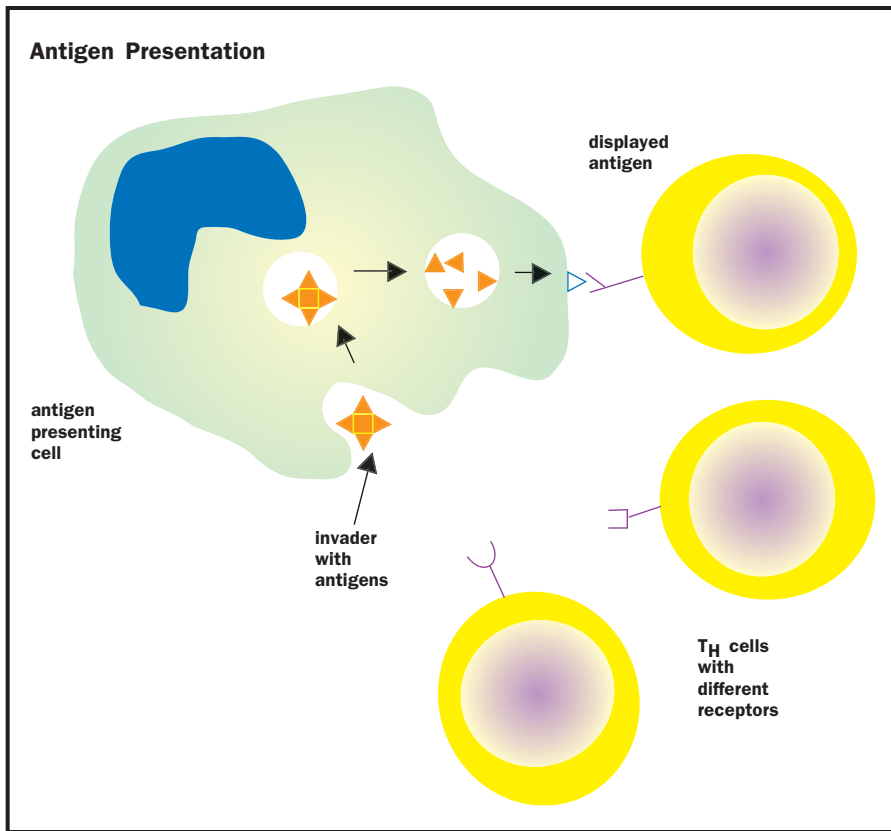

Immune responses occur primarily in the lymph nodes and spleen, which contain large numbers of antigen presenting cells (APCs).

## Antigen Clearance

The large numbers of T<sub>H</sub> cells activate two other populations of white blood cells: cytotoxic T cells (T<sub>C</sub> cells) and B cells. Like T<sub>H</sub> cells, each T<sub>C</sub> cell and B cell has receptors that match one antigen. This is why the immune system can recognize millions of antigens with specificity. The cells with the appropriate receptor encounter the antigen, preparing them for activation. They receive the final signal necessary for clonal selection from T<sub>H</sub> cells and cytokines.

Cloned T<sub>C</sub> cells attach to invaders they recognize and release a variety of chemicals that destroy the foreign cell. Because this must happen through cell-to-cell contact, it is called cell-mediated immunity (or cellular immunity). It is especially effective at destroying abnormal body cells, such as cancerous cells or virus-infected cells.

Cloned B cells destroy foreign invaders differently. After activation by T<sub>H</sub> cells, B cells release proteins called antibodies. Antibodies travel through the body's fluids and attach to antigens, targeting them for destruction by nonspecific defenses. This type of immune response is called **antibody-mediated immunity** (or humoral immunity). It is especially effective at destroying bacteria, extracellular viruses, and other antigens found in body fluids.

**antibody** immune system protein that binds to foreign molecules

## Immunologic Memory

A primary immune response happens the first time that the body encounters a specific antigen. It takes several days to begin and one or two

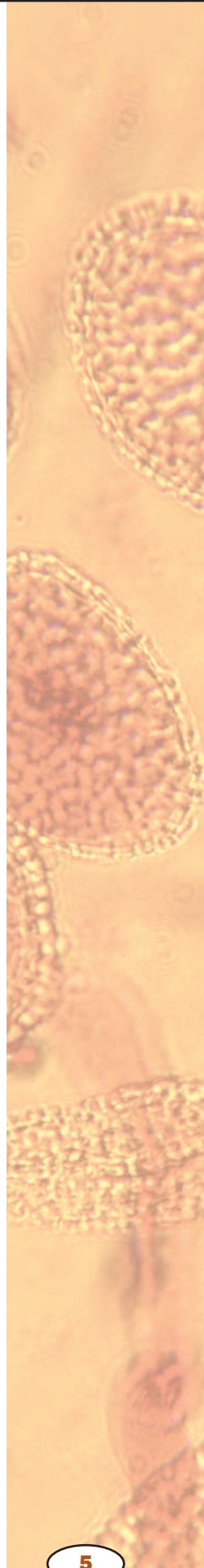

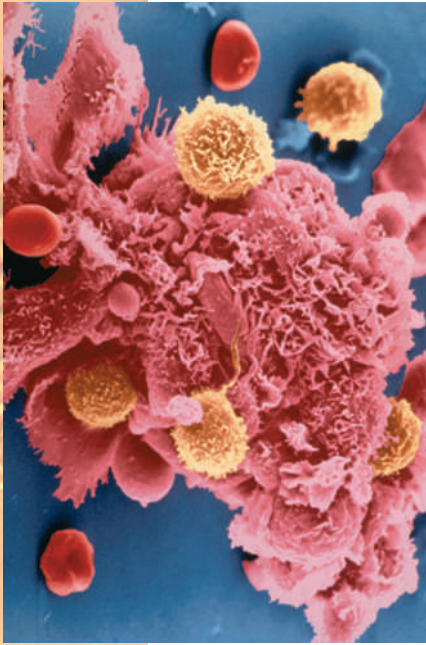

A scanning electron micrograph of a cancer cell (red in image) being attacked by tumor-infiltrating lymphocytes.

**pathogen** disease-causing organism

**autoimmune disease** disease in which the immune system attacks the body's own tissues

weeks to reach maximum activity. A secondary immune response occurs if the body encounters the same antigen at a later time. It takes only hours to begin and may peak within a few days. The invader is usually removed before it has a chance to cause disease. This is because some of the cloned  $T_C$  cells and B cells produced during a primary immune response develop into memory cells. These cells immediately become activated if the antigen appears again. The complex interactions among cells described above are not necessary.

In fact, this is what happens when an individual is immunized against a disease. The vaccination (using weakened or killed **pathogens**) causes a primary immune response (but not the disease) and the production of memory cells that will provide protection if exposed to the disease-causing agent.

### Immune System Disorders

Studying immune responses also allows scientists to understand immune system diseases. For example, hypersensitivity disorders occur when the immune system overreacts to an antigen, causing damage to healthy tissues. The result of this excessive antibody and  $T_C$  cell activity can be relatively harmless (as with allergies to pollen, poison ivy, or molds) or deadly (as with **autoimmune diseases** or allergies to bee venom and antibiotics).

At the opposite end of the spectrum are immunodeficiency diseases, conditions in which the body does not respond effectively against foreign invaders. HIV (human immunodeficiency virus) infection causes AIDS (acquired immunodeficiency syndrome) by attacking  $T_H$  cells. Occasionally an individual is born with a deficient immune system, but these disorders are usually acquired (for example, from radiation treatment, chemotherapy, or infection with HIV). Whatever the cause, the individual has a more difficult time fighting infections.

Because immune responses exhibit the characteristics of self-tolerance, specificity, and memory, a healthy body is well equipped to remove foreign invaders and prevent recurrent infections. Age, nutrition, exercise, and stress all affect the ability of the body to fight disease. SEE ALSO AIDS; ANTIBODY; AUTOIMMUNE DISEASE; NONSPECIFIC DEFENSE

*John M. Ripper*

#### Bibliography

- Beck, Gregory, and Gail S. Habicht. "Immunity and the Invertebrates." *Scientific American* 275, no. 5 (1996): 60–65.
- Friedlander, Mark P., Jr., and Terry M. Phillips. *The Immune System: Your Body's Disease-Fighting Army*. Minneapolis, MN: Lerner Publications Company, 1998.
- Gustav, J. V. "Life, Death, and the Immune System." *Scientific American* 269, no. 3 (1993): 53–62.
- National Institutes of Health. *Understanding the Immune System*. Washington, DC: National Institutes of Health, 1993.
- Paul, William. E. "Infectious Diseases and the Immune System." *Scientific American* 269, no. 3 (1993): 90–97.

## Ingenhousz, Jan

**Dutch physician and plant physiologist**  
1730–1799

Jan Ingenhousz was a pioneer in plant physiology and demonstrated that oxygen is produced during photosynthesis. Born in the Netherlands, Ingenhousz practiced medicine in several European countries and served as a court physician to Empress Maria Theresa of Austria for twenty years. Ingenhousz promoted vaccination against smallpox and helped develop a new vaccination procedure.

Ingenhousz used the gas-measuring techniques of his friend Joseph Priestley to study how plants alter the air. Priestley had shown that animals or burning candles “spoil” air, making it unfit for breathing. He had also reported that plants restore the air, but other experimenters could not replicate his results.

Ingenhousz attacked this problem systematically and meticulously. By placing different plant parts in sealed containers either exposed to or hidden from sunlight, Ingenhousz showed that plants do restore the air by the production of oxygen (a gas that Priestley had recently discovered) and that the green leaves must be exposed to sunlight for this to occur. In this way, Ingenhousz began the scientific understanding of photosynthesis, a process elucidated further by Swiss agriculturist Nicolas de Saussure and others. Ingenhousz contemplated using oxygen to treat patients but did not develop the equipment to do so. SEE ALSO DE SAUSSURE, NICOLAS; PHOTOSYNTHESIS; VAN HELMONT, J. B.

*Richard Robinson*

## Insect

Insects are a class of **arthropods**. Like other arthropods, they have **exoskeletons** made from the carbohydrate **chitin**, segmented bodies, and jointed **appendages**. Insects are distinguished by having three major body segments (head, thorax, and abdomen), with three pairs of legs attached to the thorax. Ancestral head appendages have been modified to form antennae and mouth parts, while abdominal appendages are either absent or modified to aid in reproduction. Most insects possess wings as adults, also attached to the thorax.

### Sensory Systems

The insect head bears a single pair of compound eyes, composed of many individual units, called ommatidia, each of which senses a small portion of the visual field. Hunting insects such as the dragonfly may have thousands of ommatidia per eye, while others, such as ants, have many fewer. A single pair of antennae serves as chemical sensors to help find food or mates. In many species, including the tobacco hornworm moth, the female releases airborne chemicals called **pheromones** that attract the male. The highly branched antennae of the male moth can detect the molecules of the female pheromone, and can track the scent to find the female over very long

**arthropods** organisms with jointed appendages and exoskeletons, including insects, spiders, and crustaceans

**exoskeleton** external skeleton

**chitin** nitrogen-containing carbohydrate found in arthropod exoskeletons and fungus cell walls

**appendage** attached organ or structure

**pheromone** molecule released by one organism to influence another organism's behavior

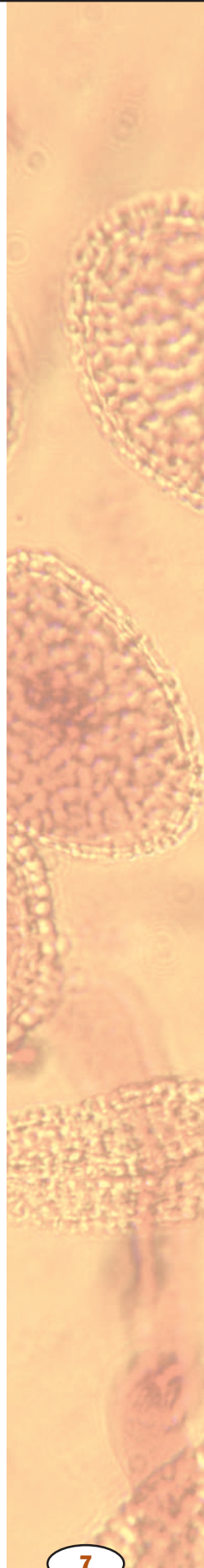

A katydid. Insects are distinguished by having three major body segments (head, thorax, and abdomen), with three pairs of legs attached to the thorax.



distances. Chemoreceptors are also located on the feet, allowing an insect to taste its food as it walks across a leaf or a table. The numerous hairs covering the insect body are linked to mechanoreceptors, which aid its sense of touch. Some mechanoreceptors can sense changes in air pressure, useful for flying or evading a swooping predator. Receptors for carbon dioxide, water, and temperature also exist.

### **Ingestion, Digestion, and Excretion**

Insect mouth parts vary tremendously in their shapes, reflecting adaptations to a wide variety of feeding habits. Mosquitoes, for instance, have a long hypodermic needlelike stylet, perfect for piercing skin to suck blood. Butterflies and moths, among others, have a very long, flexible strawlike mouth part, the proboscis, which they unfold to sip nectar from the base of flowers. Houseflies have a spongy tonguelike labrum for sopping up a variety of foods. Grasshoppers and beetles have small, sharp mouth parts adapted for chewing. The insect gut is divided into three regions, with most digestion occurring in the midgut. Suspended into the midgut are the Malpighian tubules, which filter nitrogenous waste from the blood and deposit it as crys-

tals within the gut, avoiding the water loss that urine formation would entail. In termites, the hindgut houses a complex group of protists and bacteria that digest wood.

## Legs and Wings

Insect legs are used for walking and climbing. In some predatory species such as the praying mantis, the front pair of legs has been modified for capturing prey, with barbed surfaces that hold other insects tightly. Almost all insects have wings, although a few primitive forms do not. In the ants, only the reproductive members of the colony have wings, which they shed after their “nuptial flight,” in which they mate with members of the opposite sex.

## Respiration and Circulation

Insects do not have lungs, but instead employ a highly branched network of internal tubes, called tracheae, to deliver oxygen to the tissues. Tracheae connect with the atmosphere through openings in the exoskeleton called spiracles. Insect circulatory systems transport nutrients and wastes in a fluid called hemolymph, which is pumped into and out of internal chambers surrounding the organs, an arrangement called an open circulatory system.

## Reproduction and Development

Most insects reproduce sexually, although the aphids are a notable exception. Aphids reproduce by parthenogenesis, in which the egg develops into a new organism without **fertilization**. In honey bees and some other social insects, only one female per colony reproduces, and males are **haploid**, whereas females are **diploid**, a system called haplodiploidy. The queen produces new (diploid) females (workers, soldiers, and future queens) from fertilized eggs. Males are produced from eggs that are not fertilized, and thus males are haploid.

Insects vary in their degree of **metamorphosis** during development. Butterflies, beetles, and flies, for example, undergo complete metamorphosis, in which the egg hatches into a feeding larva, which then pupates. Within the pupa, the larval tissues dissolve and rearrange into the adult form. In contrast, grasshoppers, cockroaches, and cicadas undergo incomplete metamorphosis, emerging from the egg as a miniature adult, but minus the wings and genitals. To grow, all insects must molt, or shed their exoskeleton, which then reforms around the larger individual.

Metamorphosis often allows juvenile and adult individuals of the same species to avoid competition for food. Larval moths feed voraciously and can be significant agricultural pests, while adult moths either don't feed or consume only nectar.

## Diversity

Insects are the most diverse of all groups of organisms, with over 800,000 species named and many thousands, probably millions, yet to be discovered. Insect diversity may be linked to their close association with the angiosperms (flowering plants). The Coleoptera (beetles) are the most diverse of all insect orders, with at least 350,000 species, representing one fourth of all known animal species. (Asked what could be inferred about the work of the

**fertilization** union of sperm and egg

**haploid** having single, nonpaired chromosomes in the nucleus

**diploid** having pairs of chromosomes in the nucleus

**metamorphosis** development process that includes a larval stage with a different form from the adult

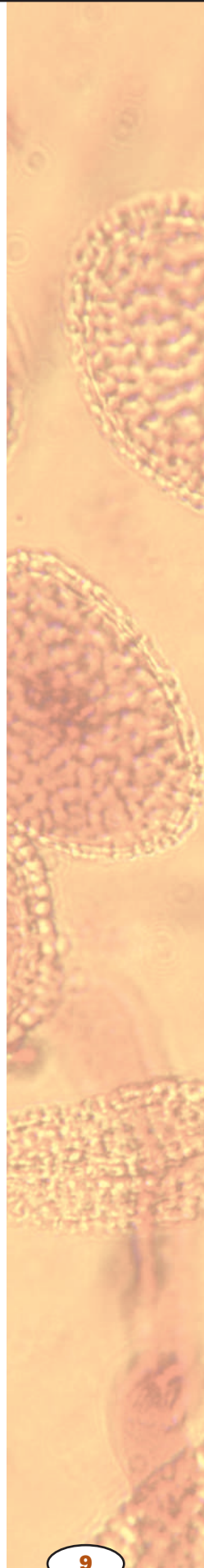

Creator from a study of His works, British scientist J. B. S. Haldane is reported to have quipped, “an inordinate fondness for beetles.”) The evolutionary reasons for the mind-boggling diversity of this single order are not clear. Other major orders of insects include the Diptera (flies), Hymenoptera (bees and wasps), Hemiptera (true bugs), and Lepidoptera (moths and butterflies). Note that each name describes the wing (*ptera* means “wing”). For instance, Diptera means “two wings,” referring to the presence of only one wing pair in this order. In the Coleoptera (“sheath wings”), the first pair of wings is modified into a hard covering for the rear pair, which is easily observed in a lady beetle, for instance. SEE ALSO ANGIOSPERMS; ARACHNID; ARTHROPOD; BIODIVERSITY; OSMOREGULATION; PHYSIOLOGICAL ECOLOGY; PLANT PATHOGENS AND PESTS; SYMBIOSIS

Richard Robinson

### Bibliography

- Berenbaum, May. *Bugs in the System*. New York: Addison-Wesley, 1995.
- Daly, H. V., J. T. Doyen, and A. H. Purcell. *Introduction to Insect Biology and Diversity*. New York: Oxford University Press, 1998.
- Evans, Arthur V., and Charles L. Bellamy. *An Inordinate Fondness for Beetles*. New York: Henry Holt & Company, 1996.
- Fabre, Jean Henri. *Fabre's Book of Insects*. Mineola, NY: Dover Publications, 1998.

## Invasive Species

Animals, plants, and other organisms that are newly introduced into an area from another part of the world are sometimes referred to as “alien” or “exotic” species. These words are used to distinguish newly arrived species from the native species that have lived in the environment for very long periods of time. Although some people refer to all exotic species as invaders, some scientists believe it makes more sense to use the term “invasive species” only when referring to new species that are spreading rapidly and having a large negative impact on the environment, economic activities, or human health.

Many of these invasive species have been introduced into new environments by human activities. Sometimes they are introduced intentionally, such as European starlings, kudzu, and purple loosestrife, three species that spread very rapidly across the United States beyond their initial range of introduction and are believed to have reduced the abundance of native bird and plant species in many areas. However, most species introductions probably occur inadvertently by humans, a byproduct of frequent movements around the globe. For example, small ocean organisms are commonly picked up in the ballast water of ocean ships. When the ships release their ballast water at a port in another part of the world, these organisms are introduced into a new environment. Logs and other wood and fiber products imported into the United States sometimes contain insects from their country of origin, which accounts for the introduction of Chestnut Blight fungus in the United States.

In many cases, the new species do not spread very much nor do they have a large impact. However, many of these new species have created huge problems. Zebra mussels are reducing populations of native mussels in many





Kudzu overgrowing a house in Tennessee. Kudzu was intentionally introduced in the United States, but it spread very rapidly beyond its initial range of introduction.

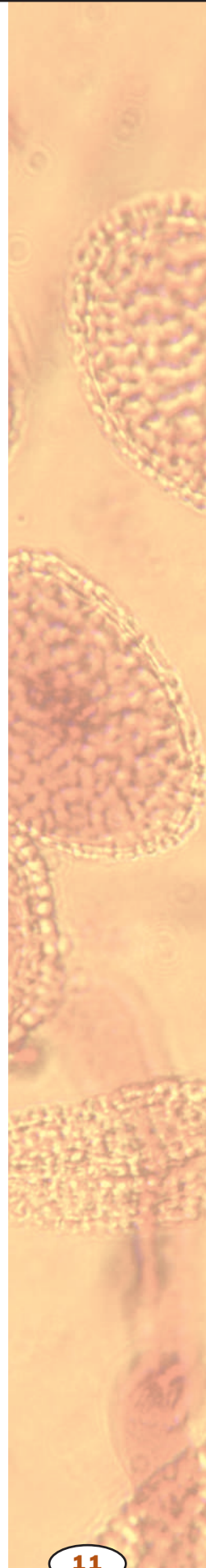

areas of the United States, and they are so numerous in places that they are clogging up water intake pipes of power plants and municipal water supplies. Leafy spurge, an introduced poisonous plant of grassland, has covered large regions of the northern Great Plains and threatens many of the livestock operations in these areas.

One of the most famous ecological disasters associated with invasive species is the brown tree snake that was accidentally introduced on to the Pacific island of Guam. In just a few decades, through its hunting habits, the snake was responsible for the extinction of several of the island's bird species that were found nowhere else on Earth. Problems produced by invasive species are believed to cost billions of dollars every year.

Scientists are working very hard to find out what factors facilitate these biological invasions in hopes of providing some help to those trying to control their negative effects. It is clear that trying to prevent the introduction of new species into an area in the first place is the primary step to take. Some scientists are also trying to determine why some environments seem to be invaded more easily than others, or why some environments are

invaded only at certain times. Some think that environments that have a high diversity of native species may be more resistant to invasions by new species, while others believe that disturbances and other factors that free up new resources are more important to opening an environment to invaders. There is still much work that needs to be done to increase scientists' understanding of the causes and effects of invasive species. **SEE ALSO** BIODIVERSITY; CONSERVATION; EXTINCTION; GLOBAL CLIMATE CHANGE

Mark A. Davis

### Bibliography

Elton, Charles S. *The Ecology of Invasions by Animals and Plants*. Chicago: University of Chicago Press, 2000.

Pimental, D., L. Lach, R. Zuniga, and D. Morrison. "Environmental and Economic Costs of Nonindigenous Species in the United States." *Bioscience* 50: 53–65.

## Ion Channels

Ions are charged particles such as  $\text{Na}^+$ ,  $\text{H}^+$ ,  $\text{K}^+$ ,  $\text{Ca}^{2+}$ , and  $\text{Cl}^-$ . Ions have a significant effect on many cell processes and also influence the amount of water in the cell. Cells use **inorganic** ions for transmitting signals across the cell membrane or along the surface of the cell. Other cellular functions as diverse as **secretion** of **hormones** to **fertilization** of egg cells require ion transport across the cell membrane. However, ions have great difficulty passing through the membrane by simple diffusion because cell membranes are composed of **hydrophobic** phospholipids that oppose the passage of **hydrophilic** ions. Furthermore, the negatively charged phosphate head groups of the phospholipids tend to repel negatively charged anions and trap positively charged cations. Therefore, an ion as small as a hydrogen ion ( $\text{H}^+$ ) requires a specific portal **protein** to facilitate its transport through the membrane. Such a protein molecule is called an ion channel.

### Molecular Structure of Potassium and Sodium Channels

An ion channel is usually equipped with four basic parts: a central conduction pathway (opening) for ions to pass through, an ion recognition site to allow passage of specific ions (selectivity filter), one or more gates that may open or close, and a sensor that senses the triggering signal and transmits it to the gate.

The Shaker-type voltage-gated potassium channel of nerve and muscle provides a good example of the four parts of the ion channel. The name *Shaker* arises from the **gene** coding for this channel in the fruitfly (*Drosophila melanogaster*), whose mutation causes the fly to shake. Humans have many potassium channels belonging to the Shaker family. This channel is composed of four identical subunits arranged like a four-leaf clover, with the center serving as the ion conduction pathway. Each subunit has six segments that cross the membrane and are termed S1 through S6. The region between S5 and S6 segments from each subunit contributes to form the ion conduction pathway; hence, it is called the "pore" or "P-region."

**inorganic** not bonded to carbon

**secretion** material released from the cell

**hormone** molecule released by one cell to influence another

**fertilization** union of sperm and egg

**hydrophobic** "water hating," such as oils

**hydrophilic** "water loving"

**protein** complex molecule made from amino acids; used in cells for structure, signaling, and controlling reactions

**gene** portion of DNA that codes for a protein or RNA molecule

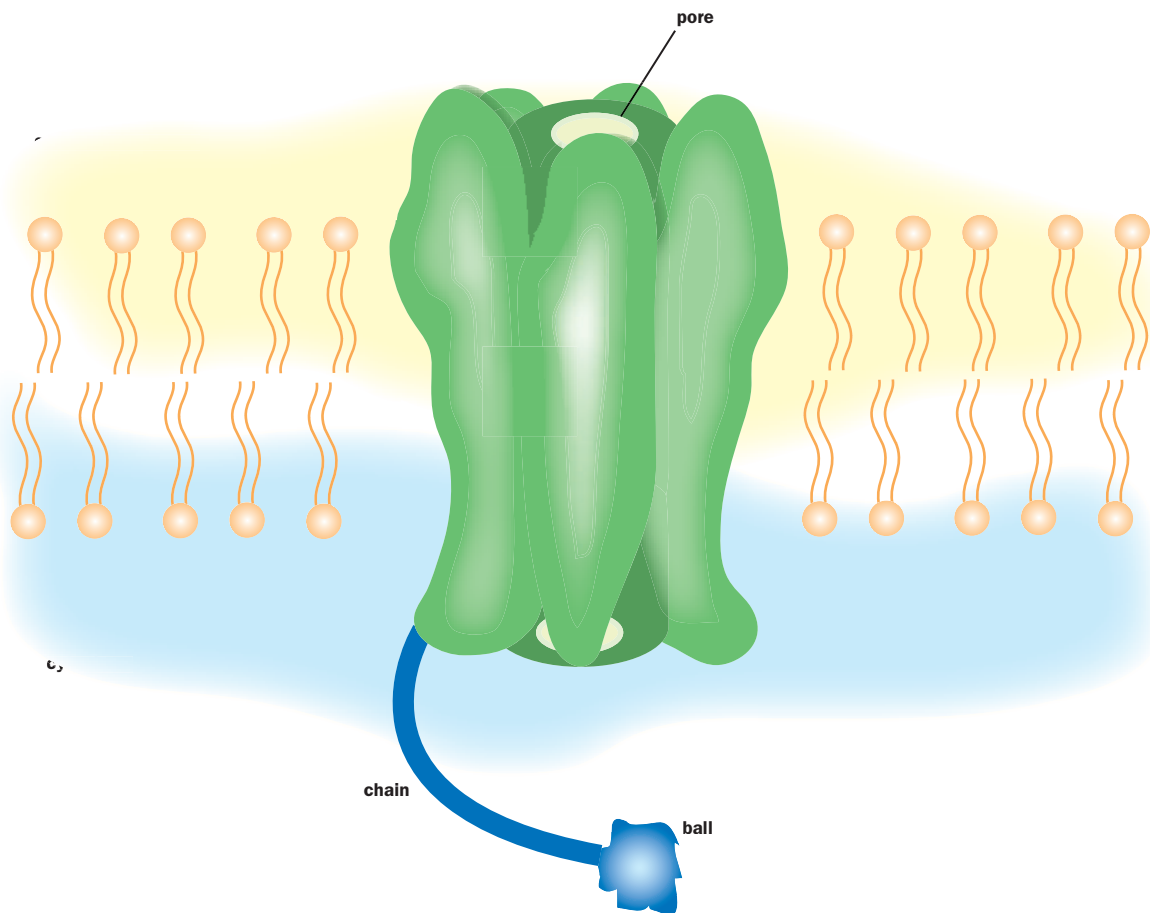
Shaker Voltage-gated K<sup>+</sup> Ion Channel

In the P-region, a few critical **amino acids** from each subunit gather to form the selectivity filter that specifically recognizes only potassium ions. The S4 segment contains positively charged amino acids on every third position and serves as a voltage sensor. When the potential on the internal surface of the membrane becomes more positive, the potential drives the S4 segment toward the outside. This movement triggers a channel gate to open. The voltage-gated sodium channel has a similar architecture, except that the four subunits are strung together in a long peptide chain like a train of parading elephants linking up trunk-to-tail. This channel is highly selective for sodium ions.

### Biophysics

As the charged ions flow across the membrane, they generate an electric current. The amount of current flow is determined by three factors. First, when the gate of an ion channel opens, ions flow down the concentration **gradient** from high to low across the membrane, which is typical of the passive transport mechanism. Second, the flow of ions is controlled by the voltage difference across the membrane. For instance, if the cell interior is

The shaker-type voltage-gated potassium channel of nerve and muscle provides a good example of the parts of the ion channel.

**amino acid** a building block of protein

**gradient** difference in concentration between two places

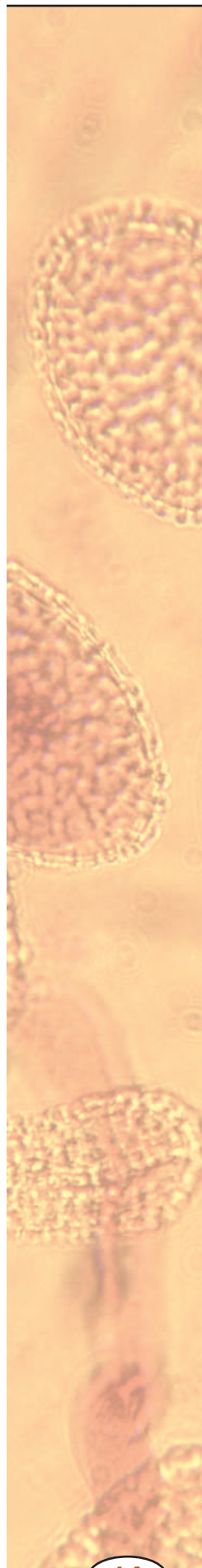

**conformation** three-dimensional shape

already highly positive, less  $K^+$  will flow in. Third, a channel may be highly selective for a specific ion (such as the voltage-gated sodium channel) or rather nonselective (such as the mechano-sensitive channel). Thus, the total ion flow is influenced by the concentration gradient of the ions, the voltage difference across the membrane, and the permeability of the ions.

The patch clamp technique developed in 1980 has enabled scientists to record current flow through a single ion channel. This technique uses extremely fine glass electrodes attached to membranes to measure electrical activity in a very small part of the membrane. One of the most exciting results from the development of the patch clamp technique is direct observation of the opening and closing of a single channel, like observing the twinkle of a little star in the night sky. The opening of a channel represents a **conformational** change of the channel molecule from a closed state to an open state. If the rate for such a conformational change is dependent on voltage, then the channel is said to be voltage-gated. A channel may stay in the open state for less than a millisecond to tens of seconds. The current flow through a single channel may range from less than a picoampere to hundreds of picoamperes (a picoampere is  $10^{-12}$  ampere).

### Drugs and Toxins Acting on Ion Channels

Nature produces a wide variety of highly potent toxins that target specific ion channels. The toxins are usually packaged in venom and delivered by stings or fangs. A large number of toxins have been isolated from scorpions, sea anemones, cone snails, and snakes. They have been used for studying various ion channels. One of the most famous toxins is tetrodotoxin, which selectively blocks the sodium channel. It is contained in the poisonous puffer fish, which ironically is the most expensive delicacy served in Japanese restaurants. Only chefs who have passed rigorous licensing examinations are allowed to prepare the fish. Tetrodotoxin is also commonly portrayed in fictions and movies; it almost killed the fictitious Agent 007 James Bond in *From Russia with Love*. Drugs have been developed to target ion channels and to prevent the channels from conducting ions. They are widely used as local anesthetics, antiarrhythmic drugs to prevent irregular heartbeats, antihypertensive drugs to lower blood pressure, and anti-epileptic drugs to prevent seizures.

### Genetic Defects of Ion Channels

Several genetic diseases exhibiting defects in the physiological functions of ion channels have now been shown to be caused by mutations in the genes coding for specific ion channels. For example, a cardiac potassium channel named HERG (human ether-a-go-go-related gene) acts to protect the heart against inappropriate rhythmicity. People lacking a functional HERG gene exhibit an abnormality on their electrocardiogram called “long Q-T syndrome,” which predisposes them to sudden cardiac arrest when they are under stress. Cystic fibrosis results from mutations of a particular chloride channel called the cystic fibrosis transmembrane conductance regulator. **SEE ALSO** MEMBRANE PROTEINS; MEMBRANE TRANSPORT; NEURON; SYNAPTIC TRANSMISSION

*Chau H. Wu*

**Bibliography**

Hille, Bertil. *Ionic Channels of Excitable Membranes*, 2nd ed. Sunderland, MA: Sinauer Associates Inc., 1992.

Neher, Erwin, and Bert Sakmann. "The Patch Clamp Technique." *Scientific American* 266 (1992): 44-51.

**Kidney**

The kidneys of vertebrates have the vital function of removing metabolic wastes from the blood and otherwise maintaining its normal composition. The two kidneys of a normal human adult produce 1 to 2 liters (about 30 to 70 fluid ounces) of urine each day that contain wastes, excess water, and other unneeded molecules. Production of less than 0.4 liter (13.5 fluid ounces) of urine per day is insufficient to eliminate wastes and regulate the composition of blood. Such a condition is always fatal within a few weeks unless the underlying cause is corrected, a new kidney is transplanted, or the blood is artificially cleared by **dialysis**.

The human kidney belongs to one of three kinds of kidneys that occur among different vertebrates at various developmental stages. The first type, called the pronephros, lies toward the front of some fishes and the embryos of many vertebrates. The mesonephros lies more posteriorly and occurs in most adult fishes and amphibians and in the embryo of humans and other mammals. The metanephros occurs still farther posteriorly and is the type of kidney in adult reptiles, birds, and mammals, including humans.

Each human kidney is about the size of a fist, shaped like a kidney bean, and located on one side of the lower abdomen toward the back. At any given



**dialysis** cleansing by partial filtration

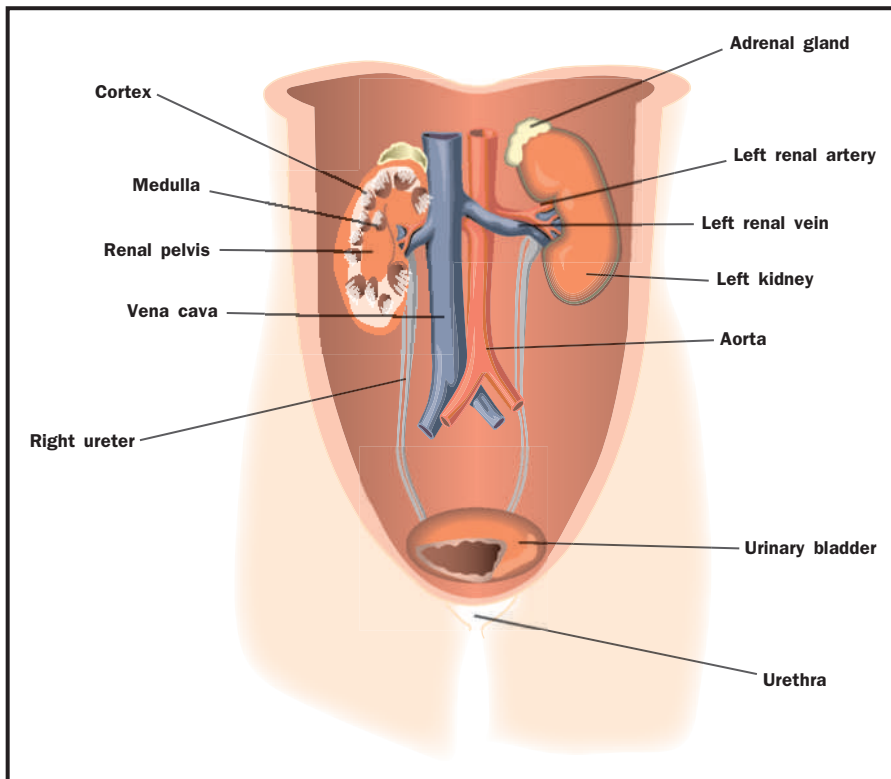

Location and gross anatomy of the human kidneys. Blood enters the kidney via the renal artery, and almost all of it leaves the kidney through the renal vein. The kidney removes excess ions, water, and other molecules, which are excreted through the ureters as urine.

Alcohol suppresses antidiuretic hormone (ADH), which normally reabsorbs water in the kidneys, and so increases urine volume.

**nephron** functional unit of the kidney that performs filtration, reabsorption, and excretion

**filtrate** material passing through a filter

**ion** an electrically charged particle

**inorganic** not bonded to carbon

**glucose** simple sugar that provides energy to animal cells and is the building block of cellulose in plants

**amino acid** a building block of protein

**distal** away from

**pH** measure of acidity or alkalinity; numbers below 7 are acid, above are basic

**osmosis** passage of water through a membrane in response to concentration differences

**gradient** difference in concentration between two places

**metabolism** chemical reactions within a cell

**protein** complex molecule made from amino acids; used in cells for structure, signaling, and controlling reactions

time about one-fifth of the body's blood is flowing through the kidneys. The blood enters each kidney from the body's major artery, the aorta, by means of the renal artery. (The word "renal" refers to kidney.) Blood leaving the kidney enters the major vein, the vena cava, via the renal vein. Also connecting to the kidney is a third tube, the ureter, which conducts urine to the urinary bladder for temporary storage.

From this "plumbing diagram" one can get an overview of renal function: blood enters the kidney, wastes and excess molecules are removed with the urine, and the blood is returned to the circulatory system. To appreciate how the kidneys function, however, one must take a microscopic view of one of the million or so structures called **nephrons** within each kidney. Each nephron begins its work by producing a **filtrate** of blood. Filtration occurs in a tuft of capillaries called the glomerulus. The lining of the glomerulus is leaky enough to allow blood pressure to force water, **ions**, and small molecules out while retaining cells and very large molecules in the blood. The filtrate, which is very much like the fluid portion of blood (plasma), enters Bowman's capsule, which encloses the glomerulus like a helmet. Bowman's capsule conducts the filtrate into the first part of the nephron tubule, called the proximal convoluted tubule. In humans approximately 180 liters of filtrate (almost enough to fill a 50-gallon drum) make it this far each day. Fortunately, not all of it goes into urine. In the proximal tubule, many of the **inorganic** ions and almost all of the **glucose** and **amino acids** get pumped out of the filtrate and go back into the blood. Most of the water in the filtrate is also drawn back into the blood.

The tubular fluid next passes through a hairpin turn called the loop of Henle, which helps the nephron return more water to the bloodstream rather than allowing it to be lost in the urine. How this works will be explained later. Tubular fluid then enters the **distal** convoluted tubule of the nephron. Here further transport of particular ions may occur, depending on whether the concentration of that ion in the blood is too high or too low. For example, if the **pH** of the blood is too low, hydrogen ions ( $H^+$ ) are transported out of the blood and into the tubular fluid. If the pH is too high,  $H^+$  ions are transported from the fluid into the blood.

By the time the fluid has completed its journey through the distal convoluted tubule, it is essentially dilute urine, called preurine. Preurine from several nephrons enters a tube called the collecting duct. As preurine passes through the collecting duct, more water can be removed and returned to the blood.

Water is drawn out of the collecting duct by **osmosis** due to an increasing concentration of ions surrounding the collecting duct. The loops of Henle produce this concentration **gradient** by a combination of transport and diffusion of ions and urea. Urea is a molecule that temporarily stores the nitrogen produced by the **metabolism** of **proteins**. After helping to create the concentration gradient, urea is eventually eliminated with the urine. SEE ALSO BLOOD; DRUG TESTING; EXCRETORY SYSTEMS; HEART AND CIRCULATION; OSMOREGULATION; PITUITARY GLAND

C. Leon Harris

### Bibliography

*The Kidney*. <<http://www.ultranet.com/~jkimball/biologyPages/K/Kidney.html>>.

Saladin, Kenneth S. "The Urinary System." In *Anatomy and Physiology*, 2nd ed. Dubuque, IA: McGraw-Hill Higher Education, 2001.

*Supplemental Image Database, The Kidney.* <[http://www.kumc.edu/instruction/medicine/pathology/ed/ch\\_16/mainframe.html](http://www.kumc.edu/instruction/medicine/pathology/ed/ch_16/mainframe.html)>.

## Kingdom

Kingdom is the highest category in the hierarchical classification of organisms created by Carolus Linnaeus around 1750. Linnaeus recognized two kingdoms, plants and animals, a scheme that worked reasonably well for large multicellular organisms but failed as microscopes revealed diverse unicellular organisms. In 1959 Robert Whittaker devised a five-kingdom system that maintained kingdoms Plantae and Animalia but added kingdoms Monera, Protista, and Fungi (see Table).

**A COMPARISON OF THE FIVE KINGDOMS**

Characteristic	Monera	Protista	Plantae	Fungi	Animalia
Internal cell membranes	Absent (Prokaryotes)	Present (Eukaryotes)	Present (Eukaryotes)	Present (Eukaryotes)	Present (Eukaryotes)
Cell wall	Present	Present or Absent	Present	Present	Absent
Organization	Unicellular	Unicellular or Multicellular	Multicellular	Mainly multicellular	Multicellular
Mode of nutrition	Autotrophs or Heterotrophs	Autotrophs or Heterotrophs	Autotrophs	Heterotrophs	Heterotrophs
Representative groups	Archaea, eubacteria	Protozoa, algae, slime molds	Mosses, ferns, seed plants	Molds, yeasts, mushrooms	Animals with and without backbones

Note: An autotroph is an organism that uses solar energy or energy from inorganic chemicals to make organic molecules. A heterotroph obtains organic molecules by consuming other organisms or their products.

Whittaker placed bacteria in their own kingdom, Monera, because of fundamental organizational differences between **prokaryotic** bacterial cells, which lack membrane-enclosed nuclei and **organelles**, and the **eukaryotic cells** of other organisms that possess internal membranes. Plantae, Fungi, and Animalia consist of complex, multicellular eukaryotic organisms that differ from each other in details of cell structure and in how they secure and process energy. Protista is a collection of single-celled eukaryotic organisms and simple multicellular forms, some animal-like, some plantlike.

Molecular evidence, particularly from ribosomal ribonucleic acid (RNA), suggests that the five-kingdom scheme is also too simple. Some biologists believe that Protista should be partitioned into three or more kingdoms. Similarly, kingdom Monera contains two very biochemically distinct groups of prokaryotes: archaeobacteria, and eubacteria. A proposed system acknowledges this ancient evolutionary split by creating a higher level of classification, domain, above kingdom. This system distinguishes three domains: Archaea, Eubacteria, and Eukarya (containing protists, plants, fungi,

**prokaryotic** without a nucleus

**organelle** membrane-bound cell compartment

**eukaryotic cell** a cell with a nucleus

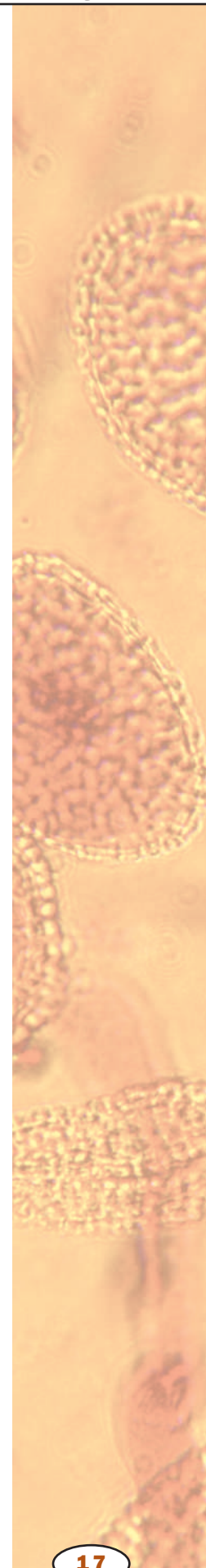

and animals). SEE ALSO ANIMALIA; ARCHAEA; EUBACTERIA; FUNGI; LINNAEUS, CAROLUS; PLANT; PROTISTA

Cynthia A. Paszkowski

### Bibliography

Margulis, Lynn, and Karlene V. Schwartz. *Five Kingdoms: An Illustrated Guide to the Phyla of Life on Earth*. New York: W. H. Freeman and Company, 1998.

## Krebs Cycle

When **glucose** is converted to **pyruvate** during **glycolysis**, two adenosine triphosphates (ATPs) are formed, but most of the energy in the original glucose remains in pyruvate. In most **aerobic** cells, the pyruvate formed by glycolysis is further degraded in a pathway called the Krebs cycle (also called the tricarboxylic acid cycle or citric acid cycle). In the Krebs cycle, the carbon of pyruvate is fully oxidized to carbon dioxide in a series of **oxidation-reduction** reactions. During these reactions, much of the energy in the original pyruvate is carried as high-energy electrons by the electron shuttles NADH and FADH<sub>2</sub>. These electrons will ultimately be passed to the electron transport chain, where their energy will be used to synthesize ATP by **oxidative phosphorylation**. Much more ATP is made by the Krebs cycle and oxidative phosphorylation than by glycolysis alone.

In **eukaryotic cells**, pyruvate is transported to the **mitochondrial matrix**, where the Krebs cycle takes place. Before entering the Krebs cycle, the three-carbon pyruvate is oxidized to a two-carbon acetate molecule and carbon dioxide, producing one molecule of NADH. The acetate joins to a molecule of coenzyme A to form acetyl coenzyme A, which carries the acetyl group to the Krebs cycle. The acetate enters the cycle by combining with OAA (oxaloacetic acid) to form citric acid. At this point, two of the original three carbon atoms in pyruvate have been incorporated into citric acid and one has been oxidized to carbon dioxide, and one molecule of NADH has been produced.

As the reactions of the Krebs cycle continue, the two acetyl carbons are successively oxidized to carbon dioxide, forming two molecules of NADH and one of FADH<sub>2</sub>, which will provide electrons to the electron transport chain to form ATP. In addition, one guanosine triphosphate (GTP) is formed directly by substrate-level **phosphorylation**, or transfer of a phosphate directly from the reacting molecules. (The GTP eventually transfers its phosphate to form ATP.) The final unoxidized product of the entire cycle is OAA, which can accept another acetyl group to start the cycle again.

The Krebs cycle occupies a central position in cellular **metabolism**. It can break down the pyruvate produced in glycolysis, but these two pathways do not form an isolated system in cells. Both are linked to other processes in many ways. Acetyl coenzyme A is produced by other means, notably by fatty-acid oxidation, and the Krebs cycle will oxidize this acetyl coenzyme A as readily as that produced from pyruvate.

Similarly, other substances are fed into the Krebs cycle at this and other points, either to be consumed as fuel or to be transformed for other cellu-

**glucose** simple sugar that provides energy to animal cells and is the building block of cellulose in plants

**pyruvate** the ionized form of pyruvic acid, a key intermediate in cell metabolism

**glycolysis** initial stages of sugar breakdown in a cell

**ATP** adenosine triphosphate, a high-energy nucleotide used by cells to power most energy-requiring reactions

**aerobic** with oxygen, or requiring it

**oxidation-reduction** oxidation is loss of electrons, and reduction is gain of electrons

**oxidative phosphorylation** use of oxygen to make ATP

**eukaryotic cell** a cell with a nucleus

**mitochondria** subcellular organelle that creates ATP used for energy-requiring processes in a cell

**matrix** innermost space within a mitochondrion

**phosphorylation** addition of the phosphate group PO<sub>4</sub><sup>3-</sup>

**metabolism** chemical reactions within a cell



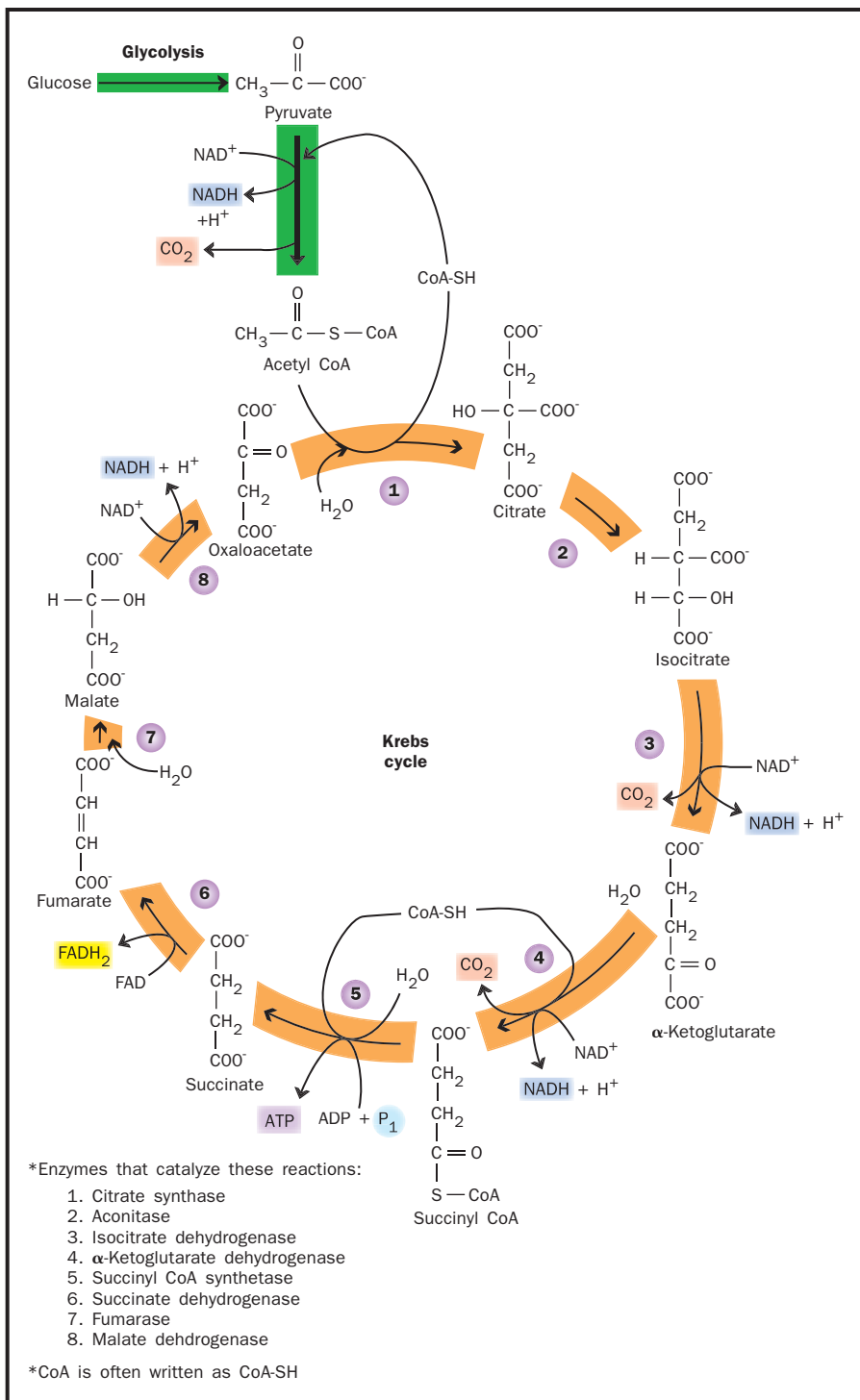

The series of reactions that make up the Krebs cycle.

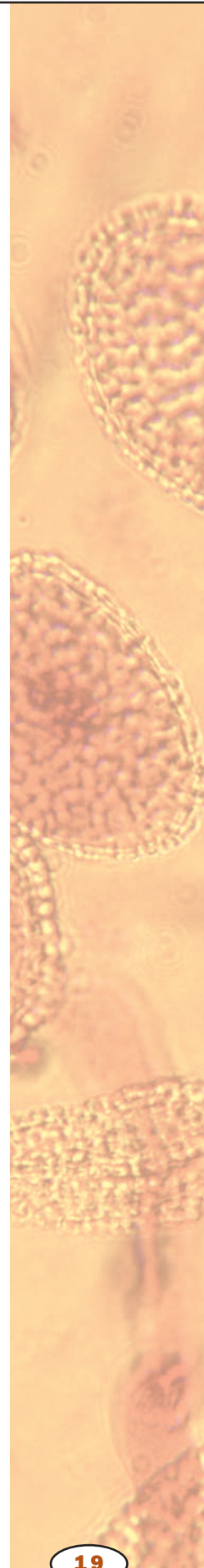

lar needs. For example, **amino acids** can be consumed by entering the Krebs cycle at several points. Conversely, several amino acids can be synthesized from intermediates of the Krebs cycle. Thus the Krebs cycle can serve either to degrade amino acids, releasing energy in the process, or to supply precursor molecules for amino acid synthesis. Which of these activities prevails depends on the needs of the cell at any particular time. SEE ALSO

**amino acid** a building block of protein

GLYCOLYSIS AND FERMENTATION; METABOLISM, CELLULAR; MITOCHONDRION;  
OXIDATIVE PHOSPHORYLATION

David W. Tapley

**Bibliography**

Bodner, G. M. "The Tricarboxylic Acid (TCA), Citric Acid or Krebs Cycle." *Journal of Chemical Education* 63 (1986): 673–677.

Hinkle, P. C., and R. E. McCarty. "How Cells Make ATP." *Scientific American* 238 (March 1978).

Racker, E. "The Membrane of the Mitochondrion." *Scientific American* 218 (February 1968).

**Laboratory Technician**

Laboratory technicians do almost all of the hands-on work in scientific research, development, and analysis. One of the benefits of being a laboratory technician is being the first to see experimental outcomes, whether they are prize-winning projects or more routine medical exams.

The different types of jobs that laboratory technicians have and the skills and training required for those jobs can vary tremendously. For example, a laboratory technician working on a research project might operate an electron microscope, isolate DNA (deoxyribonucleic acid), make behavioral observations of animals, monitor pharmaceutical effects in test subjects, or monitor environmental quality. In a clinical laboratory, a laboratory technician may examine blood samples for cell counts, examine tissue samples for **parasites**, or test fluids for chemical contaminants or drugs. In industrial production environments, laboratory technicians may conduct product quality tests and monitor product quality control. In all settings, laboratory technicians work with the most modern and sophisticated laboratory and computer equipment available. Potential employers include government and private research laboratories, universities, hospitals, and private industries. These employers may have research, development, clinical, **forensic**, or production-oriented objectives. With growth in technology, the job market for laboratory technicians is expected to expand.

Education and training for a laboratory technician is based in science and technology. Preparation in high school should include college preparatory courses that will support extensive college requirements for mathematics and science. Entry-level positions for laboratory technicians almost always require a two-year associate's or a four-year bachelor's degree in a scientific area (commonly biology, chemistry, physics, biotechnology, or natural resources). In some cases, a master's of science degree or professional certification program and exam must be completed. Almost all beginning laboratory technicians receive additional on-the-job training, and laboratory technicians should expect to continue updating their education and training as technology advances. SEE ALSO MEDICAL ASSISTANT; MICROSCOPIST

Michael G. Scott

**Bibliography**

U.S. Department of Labor. Bureau of Labor Statistics. *Occupational Outlook Handbook*. <<http://stats.bls.gov/ocohome.htm>>.

**parasite** organism living in close association with another from which it derives most of its nutrition

**forensic** related to legal proceedings

## Lakes and Ponds

Lakes and ponds are inland bodies of standing or slowly moving water. Although lakes and ponds cover only 2 percent of the world's land surface, they contain most of the world's fresh water. Individual lakes and ponds range in area from a few square meters to thousands of square kilometers. In general, ponds are smaller than lakes, though regional idiosyncrasies of naming abound—Henry David Thoreau's famous Walden Pond in Massachusetts has a surface area of 64 acres. Lakes and ponds are an important source of fresh water for human consumption and are inhabited by a diverse suite of organisms.

### Formation

Lakes and ponds are formed through a variety of events, including glacial, tectonic, and volcanic activity. Most lakes and ponds form as a result of glacial processes. As a glacier retreats, it may leave behind an uneven surface containing hollows that fill with water. Glacial activity at the end of the Pleistocene epoch (ten thousand to twenty thousand years ago) resulted in the formation of most of the lakes and ponds in the Northern Hemisphere, including the Great Lakes of North America. Some of the oldest lakes and ponds (more than three hundred thousand years old) were formed by tectonic activity related to movement of Earth's crust. For example, Lake Baikal in Siberia formed from the movement of **tectonic plates** and is the largest freshwater lake by volume in the world. Volcanic activity can also lead to lake and pond formation. For example, the collapse of a volcanic cone of Mount Mazama in Oregon led to the formation of Crater Lake, the seventh deepest lake in the world.

### Physical and Chemical Features

Light and temperature are two key physical features of lakes and ponds. Light from the sun is absorbed, scattered, and reflected as it passes through Earth's atmosphere, the water's surface, and the water. The quantity and quality of light reaching the surface of a lake or pond depends on a variety of factors, including time of day, season, latitude, and weather. The quality and quantity of light passing through lake or pond water is affected by properties of the water, including the amount of particulates (such as algae) and the concentration of dissolved compounds. (For example, dissolved **organic** carbon controls how far ultraviolet wavelengths of light penetrate into the water.)

Light and wind combine to affect water temperature in lakes and ponds. Most lakes undergo a process called thermal stratification, which creates three distinct zones of water temperature. In summer, the water in the shallowest layer (called the epilimnion) is warm, whereas the water in the deepest layer (called the hypolimnion) is cold. The middle layer, the metalimnion, is a region of rapid temperature change. In winter, the pattern of thermal stratification is reversed such that the epilimnion is colder than the hypolimnion. In many lakes, thermal stratification breaks down each fall and spring when rapidly changing air temperatures and wind cause mixing. However, not all lakes follow this general pattern. Some lakes mix only once a year and others mix continuously.

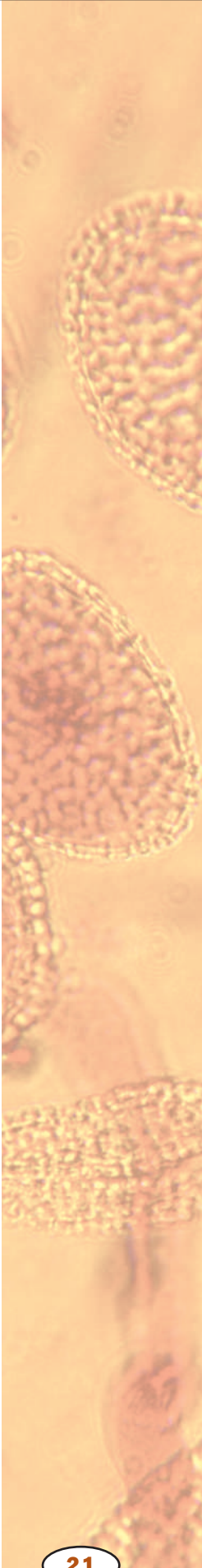

**tectonic plate** large segment of Earth's crust that moves in relation to other similar plates

**organic** composed of carbon, or derived from living organisms



A mountain lake in the Canadian Rockies. Although lakes and ponds cover only 2 percent of the world's land surface, they contain most of the world's fresh water.

**pH** measure of acidity or alkalinity; numbers below 7 are acid, above are basic

**ion** an electrically charged particle

The chemistry of lakes and ponds is controlled by a combination of physical, geological, and biological processes. The key chemical characteristics of lakes and ponds are dissolved oxygen concentration, nutrient concentration, and **pH**. In lakes and ponds, sources of oxygen include diffusion at the water surface, mixing of oxygen-rich surface waters to deeper depths, and photosynthesis. Oxygen is lost from lakes and ponds during respiration by living organisms and because of chemical processes that bind oxygen. The two most important nutrients in lakes and ponds are nitrogen and phosphorus. The abundance of algae in most lakes and ponds is limited by phosphorus availability, whereas nitrogen and iron are the limiting nutrients in the ocean. The acidity of water, measured as pH, reflects the concentration of hydrogen **ions**. The pH value of most lakes and ponds falls between 4 and 9 (the pH value of distilled water is 7). Some aquatic organisms are adversely affected by low pH conditions caused by volcanic action, acid-releasing vegetation surrounding bog lakes, and acid rain.

### Habitats and Diversity

Lakes and ponds are characterized by three main habitats: the pelagic zone, the littoral zone, and the benthic zone. The pelagic zone is the open water

area of lakes and ponds. In large lakes, the pelagic zone makes up most of the lake's volume. The littoral zone is the inshore area where light penetrates to the bottom. This zone often contains large, rooted plants called macrophytes. The areas of the lake or pond bottom that are not part of the littoral zone are referred to as the benthic zone. This zone contains fine sediment that is free of plant life because light levels are too low to support plant growth.

Lakes and ponds typically contain a diversity of organisms that perform different ecological functions. Many of the organisms in lakes and ponds are quite small and can only be seen with a microscope. Plankton are microscopic aquatic organisms, including bacteria, algae, and zooplankton, that have little or no means of locomotion. In addition, there are many larger vertebrate animals that inhabit lakes and ponds, including fish and amphibians. Other organisms that use lakes and ponds for some activities include birds such as ducks, mammals such as beavers, and reptiles such as snakes.

Larger lakes can support as many as four or five different **trophic** levels, or groups of organisms that get energy in the same way. For instance, the major trophic levels in the pelagic zone, or open water areas, are **phytoplankton**, zooplankton, planktivorous (plankton-eating) fish, and piscivorous (fish-eating) fish. Microbes such as bacteria and protists are also important in lakes and ponds due to their role in decomposition and nutrient recycling. The **food web** in the pelagic zone is connected to the inshore food web because many mobile organisms from the pelagic zone (especially fish) use the inshore areas for shelter and food. SEE ALSO ALGAE; ECOSYSTEM; ESTUARIES; LIMNOLOGIST; RIVERS AND STREAMS; WETLANDS

*Janet M. Fischer and Katharine E. Yoder*

### Bibliography

Lampert, Winfried, and Ulrich Sommer. *Limnoecology: The Ecology of Lakes and Streams*. New York: Oxford University Press, 1997.

Moss, Brian. *Ecology of Fresh Waters: Man and Medium*. Oxford: Blackwell Scientific Publications, 1988.

Wetzel, Robert G. *Limnology*. Philadelphia, PA: W. B. Saunders Co., 1983.

## Lamarck, Jean-Baptiste

**French naturalist**  
**1744–1829**

Jean-Baptiste Lamarck is best remembered for the incorrect hypothesis that evolutionary change occurs due to the inheritance of acquired characteristics. However, Lamarck's contributions to biological thought are much more important than being the champion of a failed idea. He was the first really important thinker about evolution, and he established the central role of the environment in determining the adaptations of all types of organisms.

Born into a military family, Lamarck had a brief career as a soldier before turning his attention to medicine and science. His *Flore Française* (1778) on the plants of France brought him to the attention of French naturalist Comte de Buffon (Count Buffon), who became his sponsor in scientific circles. He was appointed professor at the National Museum of

**trophic** related to feeding

**phytoplankton** microscopic floating creatures that photosynthesize

**food web** set of feeding relations in an ecosystem

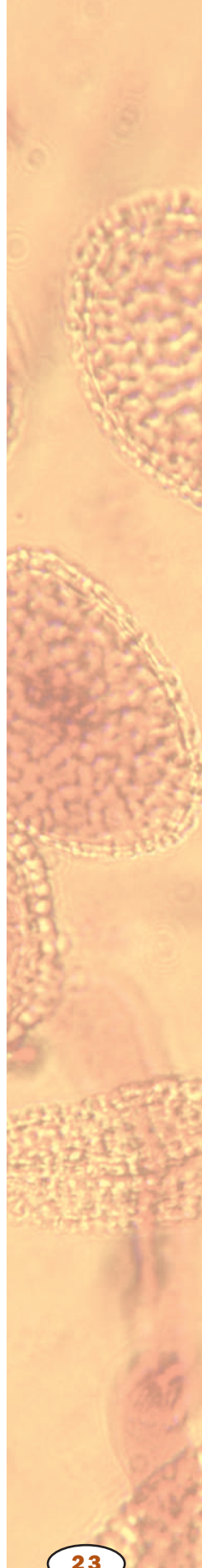

Natural History, in charge of insects and “worms,” meaning all invertebrates. Lamarck was the first to propose separating the arachnids (spiders), mollusks, and crustaceans from the insects, placing them in separate classes.

Lamarck’s appreciation of the enormous diversity of the invertebrates (a term he invented) strengthened his belief that species evolve over time. Lamarck proposed that environmental changes cause a change in an organism’s needs, which leads to a change in behavior. For instance, scarce prey might lead to the need for a hawk to search the ground more carefully from a greater height. The increased use of its eyes would, according to Lamarck, improve the hawk’s eyesight. Furthermore, this acquired improvement would be inherited by the hawk’s offspring over time. Alternatively, the disuse of an organ would cause it to shrink or weaken. Lamarck published his hypothesis in his book *Philosophie Zoologique* (1809).

Lamarck also believed that all animals were becoming progressively more complex and “perfect” over time, leading him to propose that **spontaneous generation** accounted for the appearance of the simplest of organisms.

We now know that heritable change cannot be induced by use or disuse, but can only arise through changes in an organism’s deoxyribonucleic acid (DNA); nor does spontaneous generation occur. Despite his incorrect mechanism for evolution, Lamarck focused evolutionary thought on the idea of adaptation to the environment, an idea that was to be central to English naturalist Charles Darwin’s concept of **natural selection** fifty years later. SEE ALSO ADAPTATION; BUFFON, COUNT (GEORGES-LOUIS LECLERC); DARWIN, CHARLES; EVOLUTION; NATURAL SELECTION

*Richard Robinson*

### Bibliography

- Magner, Lois E. *History of the Life Sciences*, 2nd ed. New York: Marcel Dekker, 1994.
- Mayr, E. *The Growth of Biological Thought*. Cambridge, MA: Harvard University Press, 1982.

## Landscape Ecology

Landscape ecology is the study of the causes and ecological consequences of spatial pattern in landscapes. While there is no specific spatial extent that defines a landscape, most landscape ecologists are interested in large areas ranging from a few square kilometers to entire continents. Within landscapes it is usually possible to define a series of different **ecosystem** types occurring as patches within the greater landscape. For example, in an agricultural landscape the patches might be different fields, woodlots, hedgerows, buildings, and ponds. The goal of a landscape ecologist is to understand and describe landscape structure; how this structure influences the movement of organisms, material, or energy across the landscape; and how and why landscape structure changes over time.

A landscape’s structure can be quantified by describing characteristics of patches, such as their number, size, shape, position, and composition. Landscape ecologists have defined measures to quantify each of these at-

**spontaneous generation**  
the theory that life began from nonliving matter

**natural selection**  
process by which organisms best suited to their environments achieve greater reproductive success, thus creating more “fit” future generations

**ecosystem** an ecological community and its environment

tributes. For example, a shape index has been defined as the ratio of the patch's perimeter to the perimeter of a circle the same area as the patch. A circular patch would have the value of 1, and as the patch became more convoluted in shape, its shape index would increase in value.

A landscape's structure has an important influence on various ecological processes occurring in the landscape. For example, consider two landscapes having equal areas of forest and agricultural land. In one landscape the forest is divided into many small patches, whereas in the other landscape the forested area occurs as one large patch. The more fragmented landscape will provide more habitat to those organisms that thrive at boundaries between two ecosystem types, whereas the less fragmented landscape will be better for those species that require larger areas of undisturbed forest. So, just knowing what percentage of the landscape is forest versus cropland is not sufficient to predict what species may occur; it is also important to know how the patches are distributed across the landscape.

Another example of how landscape structure can be important comes from studies of lakes within a forested landscape. The position of a lake within the landscape can be an important determinant of the lake's physical, chemical, and biological characteristics. Because water flows downhill, lakes that are lower in the landscape receive more water from streams and groundwater than lakes higher in the flow system, which receive most of their water from precipitation. Lakes higher in the landscape tend to be smaller, more dilute chemically, and have fewer species of fish than lakes lower in the landscape, even though all of the lakes in the landscape experience the same weather and are situated in the same geological **substrate**.

Landscape structure can change through natural geological or biological processes. Earthquakes, volcanoes, and landslides are examples of geological processes. The work of beavers building a dam to flood an area is an example of a biological activity that can change landscape structure. Human activity, such as the clearing of forest land for agriculture or the expansion of urban areas, has also caused significant changes in landscape structure. These changes in structure, whether caused by natural forces or by humans, can have significant impacts on the ecology of landscapes.

Although landscape ecology is a relatively new scientific discipline, since the 1980s landscape ecologists have begun to understand how to characterize landscape structure, how landscape structure influences ecological processes, and how landscape structure changes. SEE ALSO COMMUNITY; ECOSYSTEM; FOREST, TEMPERATE; LAKES AND PONDS

*Timothy K. Kratz*

### **Bibliography**

- Forman, Richard T. T. *Land Mosaics: The Ecology of Landscapes and Regions*. New York: Cambridge University Press, 1995.
- International Association for Landscape Ecology, United States Regional Association. <<http://www.edc.uri.edu/iale/>>.
- Sanderson, James, and Larry D. Harris, eds. *Landscape Ecology: A Top-Down Approach*. Boca Raton, FL: Lewis Publishers, 2001.
- Turner, Monica Goigel. *Landscape Ecology in Theory and Practice: Pattern and Process*. New York: Springer, 2001.

**substrate** underlying surface

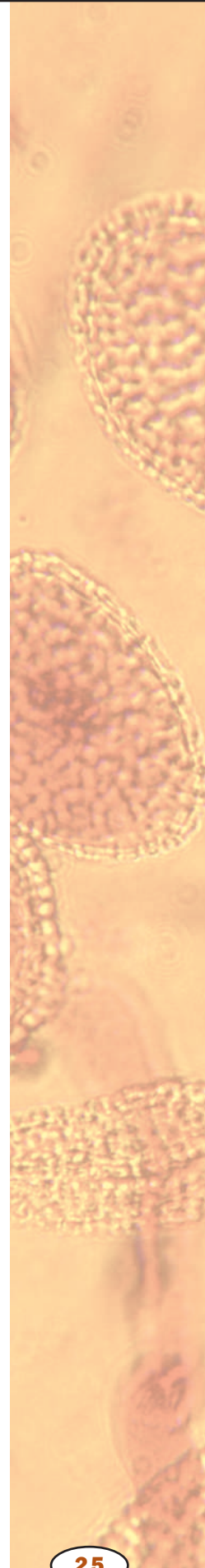



Mary and Louis Leakey.

### FOSSEY, DIAN (1932–1985)

American zoologist and authority on the behavior of mountain gorillas. Fossey established the Karisoke Research Center in the mountains of Rwanda. The wild gorillas accepted her presence, and she was able to record every detail of their behavior. In 1985, however, her efforts to protect the gorillas from poachers resulted in her own murder.

## Leakey Family

The Leakey family has been the most famous and one of the world's most productive groups of paleoanthropologists, scientists who study human origins. Over the span of more than seventy years, they have made major discoveries proving that humans originated in Africa, and that human ancestors were much older than previously believed.

Louis Leakey (1903–1972) was born and raised in Kenya, Africa, as the son of missionaries. He began research there in 1924, convinced that humans originated in Africa rather than Asia, as many scholars thought at the time. In 1931, he began work at Olduvai Gorge in Tanzania, which became the site of many of the most important discoveries of human fossils. In 1936, Leakey married Mary Nicol (1913–1996), who joined him in his work and eventually became the principal scientist after Louis Leakey began to devote more time to fundraising and lecturing to support their research. They were later joined by their sons Jonathan and Richard, Richard's wife Maeve, and Richard and Maeve's daughter Louise.

The Leakeys continue to research human origins throughout East Africa. For many years, they have been assisted by Kamoya Kimeu, a Tanzanian who has actually made many of the greatest fossil discoveries under the direction of the Leakeys. Among the major discoveries by the Leakeys are the prehuman *Zinjanthropus* (now called *Australopithecus boisei*) and *Homo habilis*, or “handy man,” which, at approximately two million years old, is the oldest known primate with human characteristics.

In addition to their paleoanthropological work, the Leakeys have been central figures in promotion of conservation of Africa's biodiversity. Louis Leakey was also the mentor for three great field primatologists: Jane Goodall, who continues to study chimpanzees in Africa; Dian Fossey, who died studying gorillas; and Birute Galdikas, who studies orangutans in Borneo. SEE ALSO HUMAN EVOLUTION; PALEONTOLOGY; PRIMATE

*Richard Robinson*

### Bibliography

Morell, Virginia. *Ancestral Passions: The Leakey Family and the Quest for Humankind's Beginnings*. New York: Simon & Schuster, 1995.

## Learning

Learning produces a relatively long-lasting change in behavior as a result of experience. The ability to learn, to gain from experience, allows animals to adapt to and cope with variable environments and therefore contributes to reproductive fitness.

### Habituation and Sensitization

Habituation, the most rudimentary learning process, can occur in single-celled animals as well as all higher animals. Habituation is the reduction of a response to a stimulus as a result of repeated low-level stimulation. For example, protozoans contract when touched. However, repeated touching causes a gradual decrease in this response and is not the result of fatigue or



sensory adaptation but rather true learning. In fact, habituation in planaria survives regeneration; when a planarian is split in two, both new planaria exhibit the response learned by the original one. Increased response magnitude, or sensitization, can also occur to a repeated stimulus if it is of high intensity or aversive (unpleasant). Sensitization has only been observed in multicellular organisms with at least a rudimentary nerve network.

Animals with **central nervous systems** can learn through more complex processes that allow them to adapt to a larger variety of environmental circumstances. The main types are classical conditioning, operant conditioning, imitation, and imprinting.

### Classical Conditioning

Classical conditioning (also called Pavlovian conditioning after its discoverer Ivan Pavlov) involves the creation of a conditioned reflex. In a classic experiment, a bell (neutral stimulus) is rung just before meat powder (unconditioned stimulus) is squirted into a dog's mouth. The meat powder produces the reflexive response of salivation (unconditioned response). If the bell is rung and followed by a squirt of meat powder into the mouth many times in succession (with a rest period between presentations), eventually salivation will occur to the sound of the bell *before* the meat powder is squirted into the mouth. The bell is now a conditioned stimulus, and the salivation to the bell is now called a conditioned response; they comprise a new conditioned reflex. The conditioned response will be sustained as long as the ringing of the bell continues to be correlated with the presentation of the meat powder. As in this example, conditioned responses are probably adaptive because they prepare the organism for the forthcoming unconditioned stimulus.

### Operant Conditioning

A second type of conditioning, operant conditioning, does not involve reflexes at all. Rather, certain kinds of voluntary behavior, usually skilled motor behavior, are affected by the consequences that follow. Stimuli associated with particular contingencies do not force a response as in the case of reflexes. Rather, such stimuli alter the likelihood that a behavior will occur. For example, the “open” sign on the door of a restaurant makes it likely someone who is ready for a meal will open the door because of past experience.

In general, pleasant events increase the likelihood of, or reinforce, voluntary (operant) behavior, and unpleasant events weaken or punish operant behavior. New behavior can be created through operant conditioning using a procedure called shaping, or the reinforcement of successive approximations of a target behavior. For example, a dog can learn to roll over if a skillful trainer provides it with food and praise (the reinforcement) for closer and closer approximations of rolling over during a training session.

### Imitation

Many species also learn through imitation. In general, it is a fast and efficient way of learning functional new behaviors. For example, in England some birds had learned to get milk by piercing the caps of milk bottles on doorsteps. Over a period of years, this behavior spread to several species of birds and other parts of the British Isles. There is disagreement about



The ability to learn, to gain from experience, allows one to adapt to and cope with variable environments.

**central nervous system**  
brain and spinal cord

whether imitation is a special case of operant conditioning or an additional type of learning.

### Imprinting

Imprinting is the development of an attachment to the mother or, if the mother is absent, any moving object close by during a certain brief period in the life of a young animal. For example, a newly hatched goose or duck will become attached to a shoe box, a human being, or any object if the goose or duck is removed from its nest shortly after hatching. Comparable behavior can be observed in many mammal species such as sheep, deer, and dogs. The adaptive value of following a mother is obvious. Again, there is disagreement over whether imprinting is a special case of operant conditioning or a unique type of learning. SEE ALSO BEHAVIOR, GENETIC BASIS OF; NATURAL SELECTION; NERVOUS SYSTEMS

*Lynda Paulson LaBounty*

### Bibliography

- Abramson, Charles I. *Invertebrate Learning: A Laboratory Manual and Source Book*. Washington, DC: American Psychological Association, 1990.
- Chance, Paul. *Learning and Behavior*, 4th ed. Pacific Grove, CA: Brooks Cole, 1999.
- Mazur, James E. *Learning and Behavior*, 5th ed. Upper Saddle River, NJ: Prentice Hall, 2001.

## Leaves

Leaves are plant organs primarily adapted for photosynthesis, although many species have modified leaves that serve a variety of functions besides photosynthesis. Imagine walking through a forest on a summer day surrounded by the green leaves attached to the branches of trees, shrubs, and herbs. The grain in a nearby farmer's field is a sea of narrow green grass leaves, and the pond behind his barn has green water lily leaves floating on the surface and the green leaves of cattails protruding from the water.

At first glance one might come to the erroneous conclusions that all leaves are green, and that which is green in nature is a leaf. While often this is the case, there are numerous exceptions. Plant organs are green because of the presence of chloroplasts in the cells near the surface, which reflect green light and absorb other wavelengths as a source of energy for photosynthesis. Certain cells in many leaves contain these **organelles**, but chloroplasts are also found elsewhere in other organs, such as the stems of cacti of the desert and twigs of sassafras trees in the deciduous forest. In addition, flowers such as the head of broccoli, and fruits such as watermelons also contain chloroplasts.

Conversely, many leaves are not green. The winter holiday season brings potted poinsettia plants into many homes. The bright red or pink organs on these plants are not the flowers; they are specialized leaves called bracts, with cells that contain so much pigment that the limited amount of chlorophyll in the chloroplasts is obscured from view. Some poinsettias are white; usually a close look reveals that they have a green tinge due to the presence of a few chloroplasts. Poinsettias do, however, produce flowers. They are

**organelle** membrane-bound cell compartment

less conspicuous small, round yellow and green organs nestled at the apex of the stem, surrounded by the colorful modified leaves.

Similarly colored pigments are present in virtually all leaves, but there is often an abundance of chlorophyll, which predominates during the summer months. However, the green chlorophyll pigment often degenerates as summer transitions to fall, yielding leaves with vibrant red, yellow, brown, and orange pigments that were hidden during much of the growing season.

## Leaf Anatomy

What defines a leaf? An organ is a leaf, and not some other organ, if there is a **lateral** bud in the angle above where the leaf stalk attaches to the stem (called the axil of the leaf). Under the proper circumstances, lateral buds can grow into a branch, a shoot with flowers, or a modified branch such as a thorn. Most true leaves in vascular plants are attached by petioles (leaf stalks) to stems at specific locations, called nodes. In many plants, near the base of the petiole there is a layer called the **abscission** zone, which has cells that degenerate during senescence, the aging of the leaf, and ultimately form the weakest point. This allows the leaf to drop from the tree in autumn in deciduous forests. If only one leaf is attached at each node, the plant has an alternate leaf arrangement; if the leaves occur in pairs at the node, the arrangement is opposite; and more than two leaves can even be attached in a whorl similar to the ribs of an umbrella.

Typical leaves are flat, multicellular organs with a single layer of cells on both the upper and lower surface forming the epidermis, a sheet of cells without chloroplasts. Scattered throughout the epidermis (primarily the lower epidermis) are pairs of specialized cells with chloroplasts called **guard cells**. A pore, the stoma, lies between these cells, and allows gases to pass into and out of the leaf. This includes the carbon dioxide needed for photosynthesis, the oxygen it produces in the light-dependent reactions, and escaping water vapor resulting from transpiration. The outermost side of the epidermis is generally coated with the cuticle, a waxy layer produced by the underlying cells. This layer is impervious to water and restricts or prevents evaporation from tissues within the leaf except through the **stomata**, the structure formed by the guard cells. When the guard cells swell, the stoma opens, and this prevents the leaf from drying out.

Between these protective epidermal layers, the leaf is filled with thin-walled parenchyma cells containing chloroplasts. Photosynthesis occurs within these cells, and evolution has produced modifications to aid this process. For instance, the cells in the layer just beneath the upper epidermis (closest to the incoming sunlight) are lined up like the logs driven into the ground to construct the stockade of a frontier fort. The cells in this palisade parenchyma are extremely efficient in capturing light, thereby enhancing photosynthesis.

Parenchyma cells below the palisade layer form the spongy mesophyll, so called because they are often loosely packed allowing for air circulation between them. A network of veins is found within this layer, composed of both **xylem** to conduct water in the transpiration stream, and **phloem** to transport water containing sugar produced by photosynthesis in the leaves to other parts of the plant (translocation). Larger veins can be seen in thin leaves when they are held in front of a light, with many small veins nested

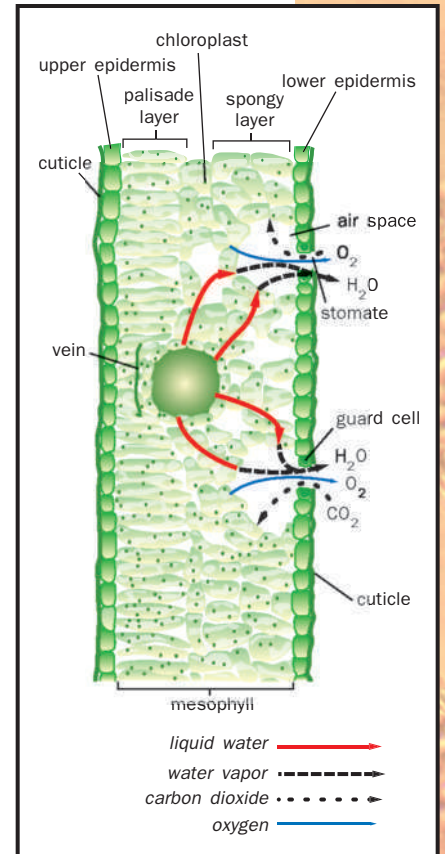

**lateral** side-to-side

**abscission** shedding of leaves; falling off

**guard cells** paired cells on leaves that control gas exchange and water loss

**stomata** openings in leaves for gas exchange, surrounded and regulated by guard cells

**xylem** water-transporting system in plants

**phloem** plant tissue that conducts sugars from leaves to roots and other tissues



Many leaves, like the spines of this cactus, take different shapes and may have special functions.

between them. Finally, a major vein, the midrib, often runs from the tip of the blade to where it joins the petiole. However, some species have more than one major vein, resulting in a fan-shaped (palmate) pattern of venation.

### Modifications

The shapes, sizes, and fine details of leaves are highly variable, and many leaves do not fit this typical pattern. Evolutionary selection pressures favor modifications that result in the leaves being adapted to many different environments. Leaves of plants living in dry habitats have a number of adaptations to reduce water loss. Stomates may be sunken into the leaf tissue within a moist depression or chamber, causing a reduction in the rate of evaporation; fine hairs may protrude from the epidermal cells, giving the leaf a “white” appearance that reflects sunlight and helps cool the leaf; or the cuticle may be very thick to prevent virtually all water loss. Leaves on aquatic plants have big intercellular air spaces that facilitate flotation, and the stomates are generally on the upper surface of the leaves allowing gas exchange with the air. Even leaves on the same plant can differ, with those exposed to bright sunlight being thicker and smaller while those in the shade being larger and thinner. Finally, many leaves take different shapes and may have special functions, such as the flasklike structure that captures insects on a pitcher plant; the tendrils of climbing pea plants; the spines on a cactus; the needles on a pine; or the expanded leaf petiole forming a stalk of celery. SEE ALSO ANATOMY OF PLANTS; CHLOROPLAST; PLANT; PLANT DEVELOPMENT; PHOTOSYNTHESIS; SENESCENCE; TRANSLOCATION; WATER MOVEMENT IN PLANTS

*Dean Cocking*

### Bibliography

- De Graff, K. M., S. R. Rushforth, and J. L. Cawley. *A Photographic Atlas for the Botany Laboratory*, 3rd ed. Englewood, CO: Morton Publishing Company, 1998.
- Perry, J. W., and D. Morton. *Photo Atlas for Botany*. Belmont, CA: Wadsworth Publishing Company, 1998.
- Raven, Peter H., Ray F. Evert, and Susan E. Eichhorn. *Biology of Plants*, 6th ed. New York: W. H. Freeman and Company, 1999.

## Leeuwenhoek, Antony van

**Dutch naturalist**  
**1632–1723**

Antony van Leeuwenhoek is often credited with inventing the microscope. In actuality, Galileo, Robert Hooke, and Jan Swammerdam had built microscopes before him; compound (double-lens) microscopes were invented nearly forty years before Leeuwenhoek was born. Those early microscopes, however, were relatively crude and could magnify only twenty to thirty times. This was enough for Galileo to recoil at how ugly he thought a flea was at such a scale, but it was Leeuwenhoek who first produced microscopes capable of seeing single cells, achieving useful magnifications up to two hundred times.

This important step forward was due to Leeuwenhoek’s extreme patience and skill in grinding lenses, and to his insatiable curiosity, acute eyesight, and keen observational skills. These personal qualities were more

important than higher education or scientific expertise, for Leeuwenhoek was not a scientist and, indeed, had no university education. He nevertheless became one of the most important figures in the history of biology.

Leeuwenhoek was a textile merchant and minor city official in his native city of Delft, Holland. His original motive for designing a microscope was to examine the weave of fabrics more closely so he could judge their quality and set a fair price. His simple (single-lens) microscope consisted of a ground glass bead mounted over a hole in a rectangular brass plate, with a tiny clip for holding a specimen near the lens. The plate had to be held close to the eye, with good backlighting and great patience.

Intent on studying more than fabric, Leeuwenhoek examined pond water, tooth scrapings, animal tissues, and almost anything else he could lay hands on. He was the first to see protozoans, bacteria, sperm and blood cells, muscle striations, and blood capillaries. Leeuwenhoek was hesitant at first to communicate with scientists, who were more highly educated and somewhat intimidating to him, but in 1673 he began corresponding with the Royal Society of London, describing his observations in such vivid prose that even twenty-first-century biologists can instantly recognize the organisms he had seen. To Leeuwenhoek, they were an esthetic delight; “little animals, very prettily a-swimming” was how he described bacteria from the mouths of men who had gone all their lives without cleaning their teeth.

Leeuwenhoek became famous for his reports and was elected to the Royal Academy in 1680. The cell theory—the idea, among other principles, that all living things are composed of cells—is probably the single most important principle in biology and medicine, and it all began with a modest Dutch cloth-seller. SEE ALSO CELL; HISTORY OF BIOLOGY: CELL THEORY AND CELL STRUCTURE; LIGHT MICROSCOPY

*Kenneth S. Saladin*

### Bibliography

Dobell, Clifford. *Antony van Leeuwenhoek and His “Little Animals.”* New York: Dover, 1960.

*University of California at Berkeley.* <[www.ucmp.berkeley.edu/history/leeuwenhoek.html](http://www.ucmp.berkeley.edu/history/leeuwenhoek.html)>.

## Lichen

A lichen is a compound organism built of a fungus intimately entwined about cyanobacteria or cells of an alga. From a distance, a lichen is a brightly colored coat on a tree, a low, bushlike structure, or greenish growths hanging from branches. Lichens are found in diverse places, from tropical rain forests to dry grasslands, shrinking where water is scarce and growing lushly where water is plentiful. They are particularly plentiful in the tundra, where they feed reindeer and are known as “reindeer moss.” Some lichens even grow in association with a third organism, such as on the cuticle of an insect.

Each partner of a lichen contributes different synthetic capabilities. The cyanobacterium or algal cell, which comprises less than 10 percent of the mass of the dual organism, is vital to its survival because it can photosynthesize, capturing solar energy. The fungus secretes acids that release **minerals** and water from rocks. The fungus seems to benefit more from this

**minerals** iron, calcium, sodium, and other elements needed by living organisms

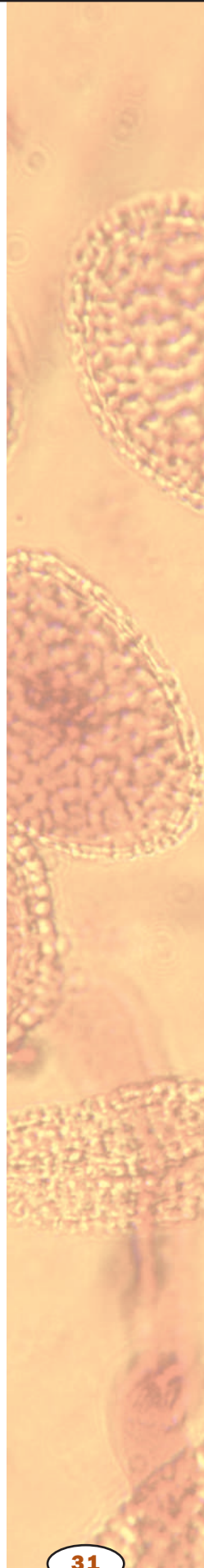



Lichens take the appearance of a brightly colored coat on a tree, greenish growths hanging from branches, or a low, bushlike structure, such as this golden-hair lichen (*Teloschistes flavicans*).

**ecosystem** an ecological community and its environment

**excrete** deposit outside of

**zygote** fertilized egg

living partnership, for it grows more slowly alone than when part of a lichen, but the situation is the opposite for the alga or cyanobacterium. Lichens may reproduce with knoblike structures that house sex cells from both components. These reach new sites carried by rain, wind, or animals.

Lichens play key roles in **ecosystems**. They can survive extremes of altitude and temperature that either component alone cannot. By growing within rock crevices, they contribute to soil formation, the first event as life comes to an area. Despite their hardiness, lichens are exquisitely sensitive to pollution because they cannot detoxify and **excrete** harmful chemicals.

Humans have used lichens in various ways. As a food, it might have been the biblical “manna from heaven.” Various cultures have used lichens to create and dye fabrics, to tan leather, to poison arrows, and to treat infections. About 13,500 types of lichen are recognized. **SEE ALSO** ALGAE; FOREST, BOREAL; FUNGI; PLANT

*Ricki Lewis*

### Bibliography

Milius, Susan. “Yikes! The Lichens Went Flying.” *Science News* 158, no. 9 (26 August 2000): 140.

Purvis, William. *Lichens*. Washington, DC: Smithsonian Institution Press, 2000.

## Life Cycle, Human

The human life cycle begins at fertilization, when an egg cell inside a woman and a sperm cell from a man fuse to form a one-celled **zygote**. Over the next few days, the single, large cell divides many times to form a hollow ball of smaller cells. On the sixth day after fertilization, this hollow ball burrows into the wall of the mother’s uterus, or womb. The cells then form three layers that fold and bend into the more complex shape of an early embryo. Gradually, the cells begin to become different from one another, forming, for example, the nervous system and the circulatory system.

On the twenty-second day after fertilization, a simple tubelike heart begins to beat. The embryo has no other working organs: the first brain activity will not begin for five more months. But in just one more month, all the major organs will have formed in miniature, including tiny eyes and ears, liver, and kidneys. These organs do not work, but they are there. Once all the organs have formed, the individual is called a fetus. During the fetal period, all the organs begin to mature. Cells from the embryo and its mother also combine to form a placenta, an organ in the uterus that connects the embryo to the mother’s blood supply.

Biologists count the days of development starting from fertilization, but medical doctors count from the first day from the last menstrual period, which is about two weeks before fertilization. So, where a biologist would say the embryo’s heart begins beating at three weeks, a medical doctor would say the heart begins beating at five weeks. The total time from fertilization to birth is about thirty-eight weeks. At the end of the embryonic period (eight weeks), the embryo is about 30 millimeters (just over 1 inch) long. Between three months and nine months the fetus grows until it is about twenty times as long.

At birth, the muscles of the mother's uterus begin to contract and push the baby out through the vagina. This process is called "labor," because it is hard work and can take a long time. In the first stage, called **dilation**, the lower end of the uterus, called the cervix, opens to about the same diameter as the baby's head. Dilation takes from eight to twenty-four hours in a woman who has never given birth before. In the second stage, called expulsion, the baby is pushed out of the uterus, into the vagina, and out of the body. Expulsion takes about half an hour the first time a woman gives birth. In the third stage, the mother expels the placenta. A few hours later, her uterus begins to contract to a smaller size, and her breasts begin to synthesize milk.

Within a few minutes after the baby is born, it may begin to nurse. The mother and baby can nurse as many months as they like. Women in traditional cultures may nurse for several years, but most American women nurse for about six months. Human milk is better for babies than bottled formula or other alternatives. For example, human milk contains antibodies and immune cells that protect the infant from infections. Babies who eat solid foods too early seem to be more subject to allergies later in life.

During infancy, between birth and one year, the brain continues to develop and grow. In this respect, human infants differ from other primate infants, whose brains stop growing at birth. Indeed, the human brain continues to grow new **neurons** until the child is two years old.

Infants' bodies also grow and develop rapidly, though not as fast as the brain. A one-year-old human typically weighs three times what he or she did at birth, has several teeth, and has begun to walk. At about two years, most humans begin to speak in sentences. During childhood (one to thirteen years), humans develop their first set of teeth, lose them, and begin to develop a second, or adult, set of teeth.

Between eleven and thirteen, children enter puberty. After puberty, adolescent humans can produce viable eggs and sperm, and many girls can carry a baby to term. Girls and boys develop secondary sexual characteristics, including body hair, deeper voices (especially in boys), breasts (in girls), and larger external **genitalia** (in both girls and boys). Boys begin to produce fertile sperm for the first time. Girls begin a monthly cycle of ovulation (releasing eggs) and menstruation (shedding the uterine lining) that will continue until they are in their fifties.

The changes that adolescents go through are so dramatic that many biologists compare puberty to the **metamorphosis** that tadpoles go through when they become frogs. For example, before puberty, boys and girls have the same amount of muscle mass, bone mass, and body fat. After puberty, men have 1.5 times as much bone and muscle mass as women, and women have twice as much body fat as men. Changes in the brain and in behavior also occur. By their early to mid-twenties, humans have reached their adult size. The bones stop growing and the brain is fully mature.

Humans in their twenties are in their peak reproductive years. Women who reproduce at this time have the least-complicated pregnancies. For males, the late teens and twenties are a time of peak death rates from accidents and other misfortunes, most likely due to the behavioral effects of high testosterone levels.



Infants' bodies grow and develop rapidly, though not as fast as the brain. After age thirty, human beings begin to age noticeably.

**dilation** expansion or swelling

**neuron** nerve cell

**genitalia** reproductive organs

**metamorphosis** development process that includes a larval stage with a different form from the adult

**hormone** molecule released by one cell to influence another

**protein** complex molecule made from amino acids; used in cells for structure, signaling, and controlling reactions

**lipid** fat or waxlike molecule, insoluble in water

**metabolism** chemical reactions within a cell

After age thirty, human beings begin to age noticeably. **Hormone** levels decline, skin becomes thinner and less flexible, gray hair and wrinkles appear, muscle mass decreases, bones lose calcium, blood vessels stiffen, and brain cells begin to die. Starting around age thirty-five, humans may lose one hundred thousand brain cells per day. The ears, the eyes, and other sensory organs also become less sensitive. Women gradually stop ovulating and menstruating in their fifties, and men experience a slow decline in testosterone levels that is most often noticed in the fifties.

Why people age is not completely understood. But some aspects of aging result when cells can no longer divide and replace themselves as they die. Some cells also begin to lose their ability to repair mistakes in the DNA (deoxyribonucleic acid), which leads to abnormalities, including, sometimes, cancer. Another cause of aging may be destructive molecular fragments known as free radicals, which damage DNA, **proteins**, and **lipids**. The average American woman lives seventy-nine years, and the average man lives seventy-two years. But despite advances in health care and healthier lifestyles, few people live beyond age one hundred. SEE ALSO AGING, BIOLOGY OF; DEVELOPMENT; FETAL DEVELOPMENT, HUMAN; SEXUAL REPRODUCTION

*Jennie Dusbeck*

#### Bibliography

Browder, Leon W., Carol A. Erickson, and William R. Jeffery. *Developmental Biology*, 3rd ed. Philadelphia, PA: Harcourt College Publishing, 1991.

Moore, Keith L. *The Developing Human*, 3rd ed. Philadelphia, PA: W. B. Saunders, Co., 1982.

Saladin, Kenneth S. *Anatomy and Physiology*, 2nd ed. New York: McGraw-Hill, 2001.

## Life Cycles

A life cycle describes the series of stages that an individual organism passes through between the time it is conceived until the time it produces offspring of its own. This series of stages is referred to as a life cycle because offspring pass through the same series before they produce their own offspring. Hence, the life cycle is repeated each generation. The basic stages of a life cycle for all organisms include a prereproductive (or juvenile) stage in which individuals grow and mature and a reproductive (or adult) stage in which individuals produce offspring. However, species vary tremendously in the particular aspects of their own unique life cycles.

Differences among species in the basic life cycle often reflect adaptations for surviving and producing offspring under different ecological conditions. For example, some plant species live in habitats in which they are able to grow, mature, and reproduce in a single growing season. In less fertile habitats, however, plants may not grow enough to successfully complete their life cycle in one year. Consequently, plant species in these habitats may have life cycles with longer prereproductive stages. In addition to being affected by environmental conditions, life cycles are also influenced by patterns of energy allocation. Energy that is used for growth or **metabolism** cannot also be used to produce offspring. Therefore, adaptations that increase survival or reproductive success in one life cycle stage may reduce



survival or reproductive success in other stages. This situation is referred to as a trade-off.

One example of such a trade-off is related to the length of the reproductive stage. Some organisms, including humans and perennial plants, have long reproductive stages and may reproduce many times during that stage. These types of organisms are said to have iteroparous (repeated births) life cycles. In contrast, salmon and annual plants are examples of species with semelparous (single-birth) life cycles. In this type of life cycle, individuals reproduce only once and then die. Intuitively, iteroparous organisms might be expected to produce more offspring than semelparous species. Due to the tradeoff in energy allocation, however, semelparous species can, in some cases, be more successful in producing offspring than iteroparous species despite the fact that they only reproduce once. Because semelparous species do not survive after reproducing, they can allocate all available energy to producing offspring. Under certain environmental conditions, this extra energy allocation can result in a larger number of offspring than an iteroparous species that must reserve enough energy to survive.

### Asexual versus Sexual Reproduction

The life cycles of different species may also vary in the type of reproduction used. Many species are capable of reproducing asexually. In this type of reproduction, a single parent produces offspring that are genetically identical to themselves (and to each other). In some cases, offspring are produced by budding, where an individual grows directly out of the parent and is eventually separated to become an independent organism. This form of reproduction is common in plants and cnidarians (for example, sea anemones). Other species reproduce asexually with eggs or seeds that do not require **fertilization**. Several species of crustaceans and some lizards can reproduce asexually by producing these types of eggs.

Organisms that reproduce through the fusion of **gametes** (eggs and sperm) from two parents are said to reproduce sexually. In this mode of reproduction, offspring differ genetically from their parents because they represent the combination of genes from each parent. Offspring also vary from one another because of differences in the particular genes inherited from each parent. Sexual reproduction is the only form of reproduction for most vertebrates and many plant species as well.

Although asexual and sexual reproduction are presented as contrasting modes of reproduction, many organisms are capable of reproducing both ways. These organisms often reproduce asexually when environmental conditions are favorable for growth and reproduction. As conditions deteriorate, however, these species can switch to sexual reproduction and produce more genetically variable offspring. In many plant species, a single individual is capable of producing both eggs and sperm. Furthermore, these plant species can often fertilize their eggs with their own sperm, a process known as self-fertilization. This form of reproduction is still classified as sexual, but does not produce as much genetic variation among offspring as when eggs and sperm come from different parents.

**fertilization** union of sperm and egg

**gamete** reproductive cell, such as sperm or egg

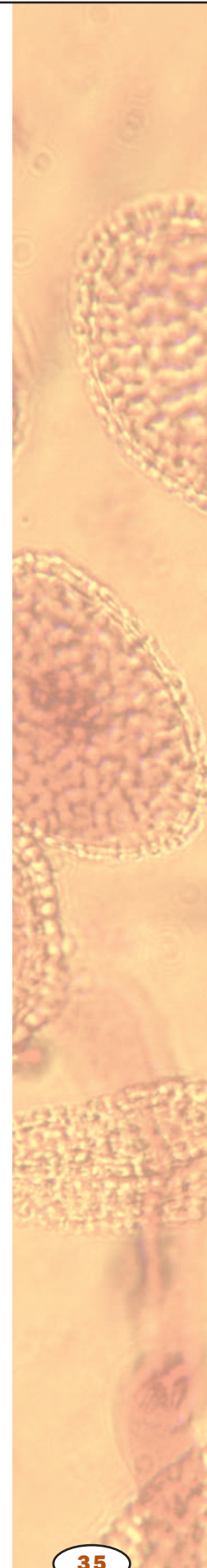

Spawning sockeye salmon run the Fraser River in British Columbia. When salmon mature, they migrate back up the same river in which they were born to reproduce and complete their life cycle.



### Simple versus Complex Life Cycles

For some organisms, including humans, individuals in prereproductive and reproductive stages are morphologically very similar to one another. Although they may differ in body size, the two stages have similar appearances, live in similar habitats, and consume similar types of food. This type of life cycle is referred to as a simple life cycle to emphasize the similarity of individuals in different stages. In clear contrast to organisms with simple life cycles are organisms that change **morphology**, habitat, and diet as they move from one stage to the next. These organisms have a complex life cycle.

**morphology** related to shape and form

One example of a complex life cycle is that of the monarch butterfly (*Danaus plexippus*). Like all butterflies, prereproductive monarchs are worm-like caterpillars. After growing and molting four times, monarch caterpillars build a cocoon and enter a new stage of their life cycle, the pupae. In the pupal stage, monarchs undergo tremendous morphological change (metamorphosis) and eventually emerge as adults. Adults are morphologically distinct from caterpillars, with long legs, antennae, and wings. As adults, monarchs are capable of traveling long distances in search of food or mates.

Complex life cycles occur in a wide range of plant and animal species. Aquatic insects found in lakes, streams, and ponds have juvenile and adult stages that are both morphologically distinct and occupy different habitats. Whereas juveniles are typically found in the water, adults are often terrestrial flying insects. As these adults mate, they deposit fertilized eggs at the surface of water bodies, where juveniles will hatch and grow.

Some organisms are considered to have complex life cycles, not because of morphological changes, but because of changes in habitat. For example, many birds migrate long distances between their summer breeding grounds and their more southern wintering grounds. **Anadromous** fish, such as salmon, also migrate between rivers and streams where they are born downstream to the ocean. Once in the ocean, salmon will continue to grow and eventually reach reproductive maturity. When salmon mature, they migrate

**anadromous** returning to the rivers where they were born in order to breed

back up the same river in which they were born to reproduce, thus completing their life cycle. SEE ALSO ADAPTATION; ALTERNATION OF GENERATIONS; BONY FISH; INSECT

Mark H. Olson

### Bibliography

Ebenman, B., and L. Persson, eds. *Size-Structured Populations: Ecology and Evolution*. Berlin: Springer-Verlag, 1988.

Roff, D. A. *The Evolution of Life Histories: Theory and Analysis*. New York: Chapman and Hall, 1992.

Stearns, S. C. *The Evolution of Life Histories*. Oxford: Oxford University Press, 1992.

## Life, What Is

“Is it alive?” Children ask that question when they see a bug or perhaps a mouse that is very quiet. Then they poke it, and if it moves they say, “It’s alive!” But single-celled organisms such as yeast cannot move. How does one know if yeast is alive? If one puts a few yeast cells into a clear solution of sugar and comes back the next day, the solution is cloudy and full of yeast cells. Maybe a better definition of life is that living things reproduce themselves. But what about an old pet cat? She is too old to reproduce, yet there is no doubt that she is alive. There is more to a definition of life than just reproduction.

Instead of starting with a complex organism like a bug or a cat, or even a yeast cell, think about an even simpler system. Scientists know that all living things are composed of molecules such as **proteins**, nucleic acids, **carbohydrates**, and **lipids**. Could a scientist (or a student in his high-school biology class) put together a mixture of molecules in the laboratory that is alive?

Using this approach, a definition of life can be created. A “thought experiment” with the yeast cells might garner such a definition. First, use a soapy detergent to dissolve the yeast cell membranes so that all the cell components fall out into the detergent solution. No matter how one recombines the parts, one cannot regenerate the living yeast cell even though all the components that were in the yeast are present in the mixture. Why not? Because the components became disorganized when they were dumped out of the original yeast cells. To prove this, add a single yeast cell that has all the same components but organized within its cell membrane. When one returns the next day, that single yeast has used the nutrients and energy available in the growth **medium** to produce millions of new yeast cells. It is definitely alive.

Living things are complex, and the definition of life must also be complicated. In fact, the definition used here has three parts. The first is that something is alive if it is an organized system of molecules that can use energy and nutrients (a process called **metabolism**) to grow by linking smaller molecules to make larger molecules. This energy-dependent process is called polymerization, and all life grows by making polymers from smaller molecules.

The second part of the definition is that a living organism also has the potential to reproduce itself at some point in its life cycle. The reason that

**protein** complex molecule made from amino acids; used in cells for structure, signaling, and controlling reactions

**carbohydrates** sugars, starches, and other molecules combining carbon, hydrogen, and oxygen and serving as fuel or structural components

**lipid** fat or waxlike molecule, insoluble in water

**medium** nutrient source

**metabolism** chemical reactions within a cell

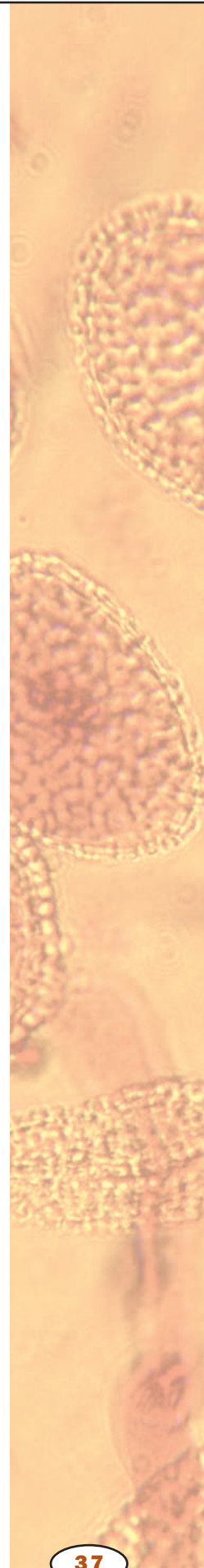

A chicken embryo. Something is considered alive if it is an organized system of molecules that captures energy and nutrients to grow, has the ability to reproduce at some point, and has the potential to evolve.



an old cat is considered to be alive is that she can use energy and nutrients (cat food) to grow. And, of course, when she was younger she could reproduce by giving birth to kittens, so during her life cycle the cat had the potential to reproduce, even though it may no longer be possible.

The third part of the definition of life takes into account the fact that populations of living organisms can change over time from generation to generation and thereby respond to changes in their environment. This process is called evolution. Living organisms do not need to evolve to be alive, but as populations they must have the potential to evolve, and this potential is part of the definition of life.

In summary, life can be defined as an organized system of molecules that captures energy and nutrients to grow by polymerization reactions, has the ability to reproduce at some point in its life cycle, and has the potential to evolve in response to changes in the environment. **SEE ALSO** EVOLUTION; FUNGI; ORIGIN OF LIFE

*David W. Deamer*

### **Bibliography**

- Hazen, Robert. "Life's Rocky Start." *Scientific American* (April 2001): 77–85.
- Holland, John H. *Emergence: From Chaos to Order*. Reading, MA: Helix Books, 1998.
- Morowitz, Harold J. *Beginnings of Cellular Life*. New Haven, CT: Yale University Press, 1992.

## **Light Microscopy**

A light microscope (LM) is an instrument that uses visible light and magnifying lenses to examine small objects not visible to the naked eye, or in finer detail than the naked eye allows. Magnification, however, is not the

most important issue in microscopy. Mere magnification without added detail is scientifically useless, just as endlessly enlarging a small photograph may not reveal any more detail, but only larger blurs. The usefulness of any microscope is that it produces better resolution than the eye. Resolution is the ability to distinguish two objects as separate entities, rather than seeing them blurred together as a single smudge. The history of microscopy has revolved largely around technological advances that have produced better resolution.

## History of the Light Microscope

Light microscopes date at least to 1595, when Zacharias Jansen (1580–1638) of Holland invented a compound light microscope, one that used two lenses, with the second lens further magnifying the image produced by the first. His microscopes were collapsing tubes used like a telescope in reverse, and produced magnifications up to nine times (9x).

Antony van Leeuwenhoek (1632–1723) invented a simple (one-lens) microscope around 1670 that magnified up to 200x and achieved twice the resolution of the best compound microscopes of his day, mainly because he crafted better lenses. While others were making lenses by such methods as squashing molten glass between pieces of wood, Leeuwenhoek made them by carefully grinding and polishing solid glass. He thus became the first to see individual cells, including bacteria, protozoans, muscle cells, and sperm.

Englishman Robert Hooke (1635–1703) further refined the compound microscope, adding such features as a stage to hold the specimen, an illuminator, and coarse and fine focus controls. Until 1800, compound microscopes designed by Hooke and others were limited to magnifications of 30x to 50x, and their images exhibited blurry edges (spherical aberration) and rainbowlike distortions (chromatic aberration). The most significant improvement in microscope optics was achieved in the nineteenth century, when business partners Carl Zeiss (1816–1888) and Ernst Abbe (1840–1905) added the substage condenser and developed superior lenses that greatly reduced chromatic and spherical aberration, while permitting vastly improved resolution and higher magnification.

## Tissue Preparation

The advancement of light microscopy also required methods for preserving plant and animal tissues and making their cellular details more visible, methods collectively called histotechnology (from *histo*, meaning “tissue”). In brief, classical histotechnology involves preserving a specimen in a fixative, such as formalin, to prevent decay; embedding it in a block of paraffin and slicing it very thinly with an instrument called a microtome; removing the paraffin with a solvent; and then staining the tissue, usually with two or more dyes. The slices of tissue, called histological sections, are typically thinner than a single cell. The colors of a prepared tissue are not natural colors, but they make the tissue’s structural details more visible. A widely used stain combination called hematoxylin and eosin, for example, typically colors cell nuclei violet and the **cytoplasm** pink.

Other methods of histotechnology have been developed for special purposes. One variation is to embed the tissue in special plastics (resins),

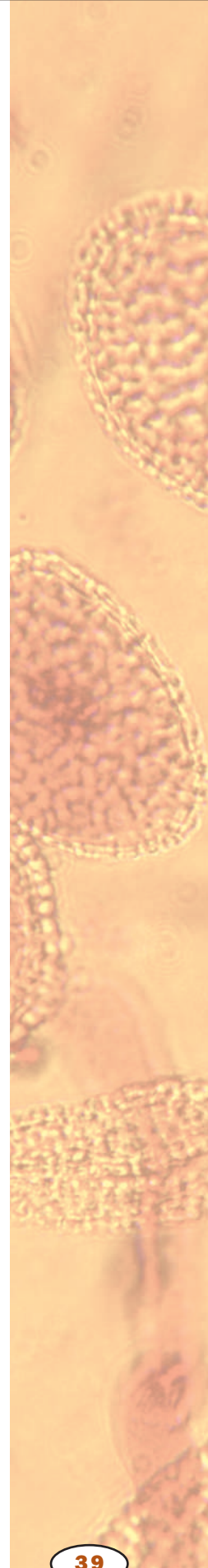

**cytoplasm** material in a cell, excluding the nucleus

A compound light microscope.

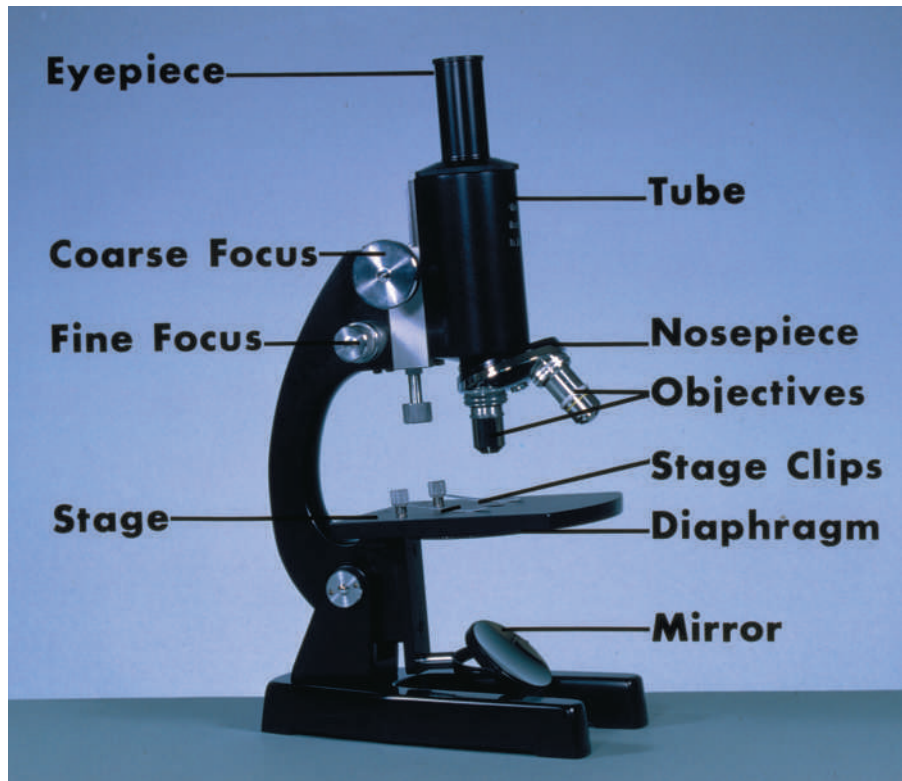

allowing for thinner sectioning. Another is the frozen section method, in which a tissue is frozen with compressed carbon dioxide and sectioned with a special cold microtome, eliminating the time-consuming process of paraffin embedding. Some prefer this method for its relative simplicity, and its speed is an asset in hospitals, where a biopsied tissue may need to be examined rapidly and the diagnosis reported to the surgeon while the patient is in the operating room.

### Varieties of Light Microscopes

Most compound microscopes today have an illuminator built into the base. A condenser located below the stage has lenses that focus the light on the specimen and a diaphragm that regulates contrast. After passing through the specimen on the stage, the light enters an objective lens. Most light microscopes have three or four objective lenses on a rotating turret. These lenses magnify the image by 4x to 100x. The light then passes up the body tube to an ocular lens that magnifies the image another 10x to 15x. Research-grade microscopes and the better student microscopes have a pair of ocular lenses so that one can view the specimen with both eyes at once.

There are many varieties of compound light microscopes for special purposes. For viewing tissue cultures covered with liquid media, biologists can use an inverted light microscope in which the culture is illuminated from above and the objective lenses are positioned below the specimen. The phase contrast microscope can be used to enhance contrast in living specimens,

thus avoiding the use of lethal fixatives and stains. The polarizing light microscope is used for analyzing crystals and **minerals**, among other things. The fluorescence microscope is used to examine structures that bind special fluorescent dyes. It can be used, for example, to identify where a dye-tagged **hormone** binds to its target cell.

Compound light microscopes achieve useful magnifications up to 1200x and resolutions down to about 0.25 micrometers. That is, two objects in a cell can be as close as 0.25 micrometers and still detected as separate entities. Such resolution is good enough to see most bacteria and some **mitochondria** and microvilli.

These microscopes generally require thin, transparent, relatively small specimens. They also require that the user adjust to the phenomenon of optical inversion; if a specimen is moved to the left, it appears under the microscope to move right; when moved up, it appears to move down; and vice versa. The stereomicroscope works at much lower magnification and resolution, but has several advantages: (1) it has two lens systems that view the specimen from slightly different angles, thus giving the specimen a stereoscopic (three-dimensional) appearance; (2) it can use either transmitted or reflected light; and with reflected light, it can be used to view opaque specimens such as rocks, fossils, insects, electronic circuit boards, and so forth; (3) it has a much greater working distance between the specimen and objective lens, allowing for the examination of relatively large objects and for easier manipulation of objects under the microscope; (4) the working distance enables relatively easy dissection of specimens such as insects, allowing hands and instruments to reach the working space while one looks through the microscope; and (5) it does not produce optical inversion; that is, movements to the right appear to go to the right, making dissection and other manipulations much easier.

The utility of light microscopy is governed by its use of visible light, which limits resolution. The shorter the wavelength of the illumination, the better the resolution. Electron beams have shorter wavelengths than photons. The invention of the electron microscope in the late 1930s and its refinement over the next half century permitted vastly improved visualization of cell and tissue fine structure. SEE ALSO CELL CULTURE; ELECTRON MICROSCOPY; HISTORY OF BIOLOGY: CELL THEORY AND CELL STRUCTURE; LEEUWENHOEK, ANTONY VAN; MICROSCOPIST

*Kenneth S. Saladin and Sara E. Miller*

### Bibliography

- Bradbury, Savile, and Brian Bracegirdle. *Introduction to Light Microscopy*. New York: Springer-Verlag, 1998.
- Jones, Thomas E. *History of the Light Microscope*. <[http://www.utmem.edu/~thjones/hist/hist\\_mic.htm](http://www.utmem.edu/~thjones/hist/hist_mic.htm)>.
- Levine, S., and L. Johnstone. *The Microscope Book*. New York: Sterling Publishing Co., 1996.
- Nachtigall, Werner. *Exploring with the Microscope: A Book of Discovery and Learning*. London: Sterling Publications, 1997.
- Rogers, K. *The Usborne Complete Book of the Microscope*. Tulsa, OK: EDC Publishing, 1999.
- WWW Virtual Library: Microscopy*. <<http://www.ou.edu/research/electron/mirror/>>.

**minerals** iron, calcium, sodium, and other elements needed by living organisms

**hormone** molecule released by one cell to influence another

**mitochondria** subcellular organelle that creates ATP used for energy-requiring processes in a cell

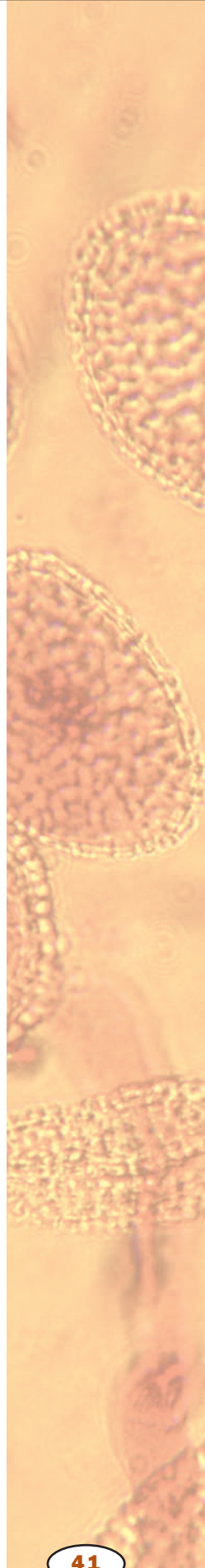

## Limnologist

In an era when most of the world's population lacks access to clean drinking water, the science of limnology (the study of bodies of fresh water) is making a resurgence in both the scientific and political communities. Earth's water supply is limited, with no new sources in sight. This is important to public policy-making given that growing populations are placing increased demands on the water supply and that pollution is posing a greater threat to the health of that supply.

Limnologists study rivers, streams, lakes, and wetlands. The field of limnology has become an interdisciplinary one, filled with creative scientists from several disciplines. This group of scientists participates in areas that range from field studies to serving as White House fellows who assist in policy-making.

To become a limnologist, a broad education is necessary. In middle and high school, it is imperative that one master science and mathematics classes. In college, most limnologists choose a major in biology, chemistry, physics, geology, or mathematics.

Many seek additional formal training in graduate school programs. It can be equally important to gain some hands-on experience and perhaps to even participate in a research project before applying to graduate school. Classes and volunteer programs are available at aquariums, nature groups, and science museums.

A career in limnology can be challenging and exciting. There are many varied opportunities. One of the biggest challenges facing the science is protecting and improving the quality of fisheries and fresh drinking water supplies. One other benefit, as stated by Mia Tegner, a research biologist at Scripps Institute of Oceanography, is the opportunity to "do science outdoors rather than in an indoor laboratory." SEE ALSO LAKES AND PONDS; MARINE BIOLOGIST; RIVERS AND STREAMS

Leslie Carlson

### Bibliography

- Committee on Inland Aquatic Ecosystems, Water Science, and Technology. *Freshwater Ecosystems: Revitalizing Educational Programs in Limnology*. Washington, DC: National Academy Press, 1996.
- Kowalski, Kathiann M. "Dive In!" *Odyssey* 7, no. 9 (December 1998): 32–35.
- Margalef, R. *Limnology Now: A Paradigm of Planetary Problems*. New York: Elsevier Science, 1996.
- Wetzel, Robert G. *Limnology: Lake and River Ecosystems*. San Diego, CA: Academic Press, 2001.

## Linkage and Gene Mapping

Linkage refers to the presence of two different genes on the same **chromosome**. Two genes that occur on the same chromosome are said to be linked, and those that occur very close together are tightly linked. Study of linkage provides information about the relative position of genes on chromosomes, allowing the construction of chromosome maps.

**chromosome** "colored body" in the cell nucleus; made of DNA and protein, and divided functionally into genes and nongene regions



## Basic Concepts

Different forms of the same gene, called **alleles**, are present on matching, or homologous, chromosomes in similar positions, or loci. For instance, in Gregor Mendel's experiments with peas, green and yellow are two alleles for pod color. In a heterozygote, which has both alleles, the two alleles occupy the same loci on homologous chromosomes. Similarly, round and wrinkled are alleles for seed texture. In the pea, these two genes—pod color and seed texture—are on different pairs of homologs and are therefore not linked. When **gametes** form in double heterozygotes (for example, a green/yellow-round/wrinkled plant), these genes assort independently, because the two chromosomes that bear them assort independently. Therefore, **meiosis** will create equal numbers of green-round, green-wrinkled, yellow-round, and yellow-wrinkled gametes. Mating between double heterozygotes (called a dihybrid cross) will give a characteristic ratio of the different possible plant types.

However, if the two traits were located close to one another on the same chromosome—in other words, if they were linked—the observed ratio will be quite different from that seen for unlinked traits. Allele combinations that began together (for instance, round-green) will tend to stay together, and the offspring will show a skewed ratio reflecting the original combinations.

Despite being on the same chromosome, the round and green alleles could become separated during meiosis by crossing over, a form of genetic recombination. During crossing over, homologous chromosomes exchange segments. This could allow the yellow allele to switch places with the green allele and lead to a round-yellow gamete. If the loci for the two genes are very close, crossing over is unlikely to separate alleles, whereas if they are far apart, crossing over is much more likely to separate them. Therefore, the frequency of crossing over is related to the physical distance between the loci for the two genes.

The particular combination of alleles on the homologous chromosomes in the dihybrid parent (for example, round-green) is known as linkage phase. Separation of this combination by crossing over is said to be a change in phase. The two alleles of a particular gene are said to be markers for that site of the chromosome.

## Linkage in Fruit Flies

An example of using linkage to explore gene position is provided by inheritance of eye color and body color in fruit flies, both of which are located on the X chromosome. This example begins with purebred (homozygous) parents, one yellow-bodied and red-eyed, the other grey-bodied and white-eyed. They mate to produce all **heterozygous** daughters, who carry the yellow-red combination on one **homologous** chromosome and the grey-white combination on the other. When the heterozygotes create gametes, the eye-color alleles cannot assort independently from the body-color alleles because they are linked. Some crossing over can occur, though. As in humans, male fruit flies carry only one X chromosome, and so will show exactly what alleles are present on their X. When one counts the male offspring, approximately 49.5 percent are yellow-bodied and red-eyed, 49.5

**allele** a particular form of a gene

**gamete** reproductive cell, such as sperm or egg

**meiosis** cell division that forms eggs or sperm

**heterozygous** characterized by possession of two different forms (alleles) of a particular gene

**homologous** similar in structure

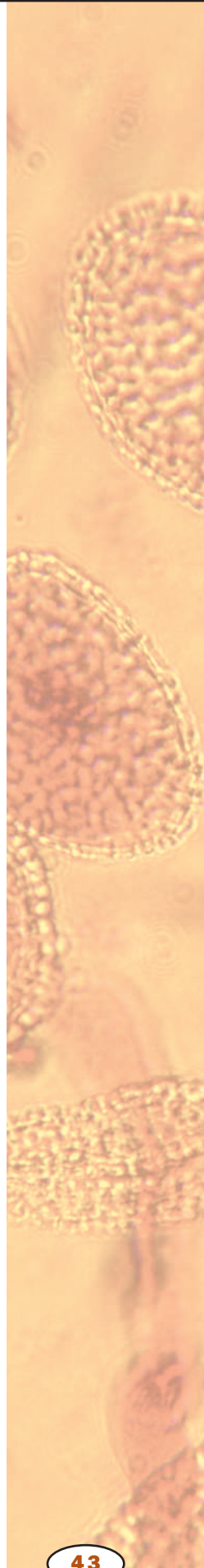

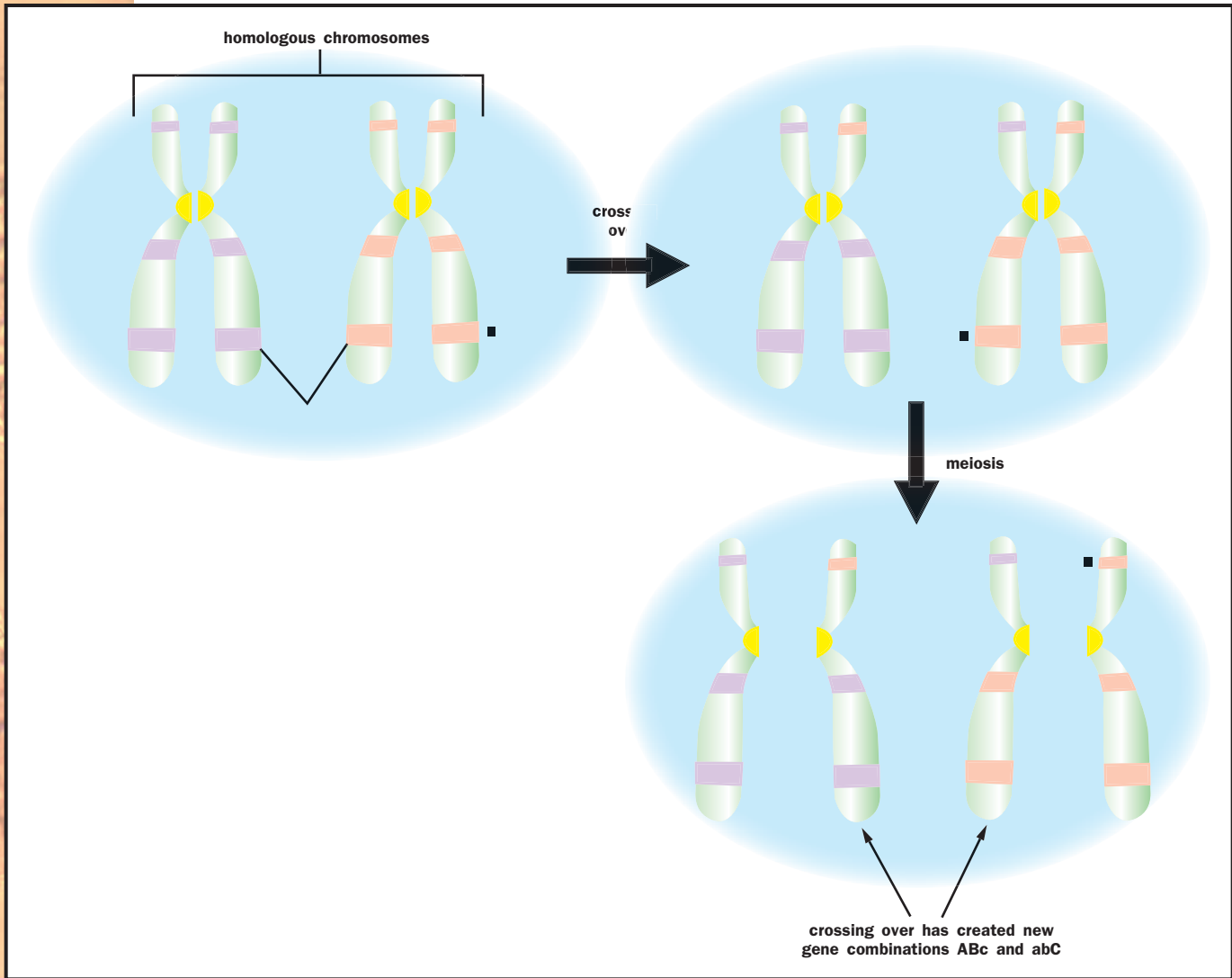

Crossing over between homologous chromosomes creates new combinations of alleles.

percent are grey-bodied and white-eyed, 0.5 percent are yellow-bodied and white-eyed, and 0.5 percent are grey-bodied and red-eyed. This indicates very tight linkage—close proximity—of the two genes.

In this example, the yellow-body allele and the white-eye allele are said to be “out of phase” in the parental strains. The most frequent pair of gamete types are described as “parental types” because they retain the alleles for the two genes as transmitted by the original parent strains. The two gamete types that are less frequent are the “recombinant types,” which results only from an exchange or crossover of homologous chromosomes in the interval between the genes.

### Gene Mapping

As an undergraduate in 1913, A. H. Sturtevant wrote a brilliant paper that extended linkage analysis into gene mapping. Sturtevant analyzed numerous linkage experiments in the fruit fly, each using two genes. For instance, a similar experiment with body color and wing shape shows many more out-of-phase offspring, indicating the wing-shape gene is further from the body-

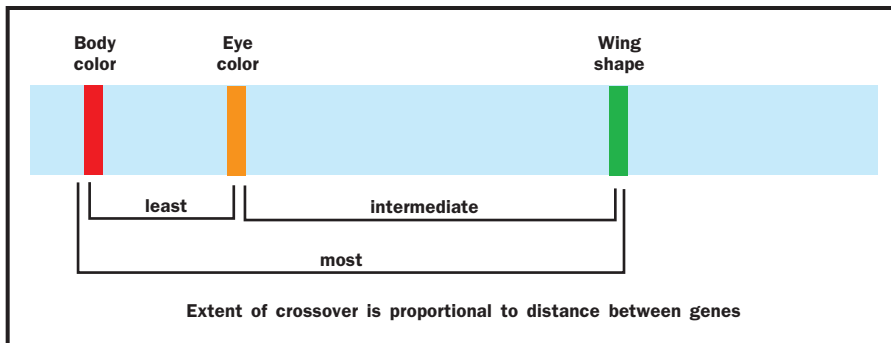

Three fruit fly genes on the same chromosome show different levels of separation during crossover, proportional to the distance between them.

color gene than the eye-color gene is. Another experiment showed an intermediate number of out-of-phase offspring for eye color and wing shape. This allowed Sturtevant to reason that the body-color gene and wing shape gene are furthest apart, with eye color in between them.

Extension of this technique allowed the distance between genes to be expressed as map units. One map unit is defined as the effective distance needed to obtain a 1 percent recombination between linked alleles. The map unit is also called the centiMorgan (cM), to honor T. H. Morgan, Sturtevant's teacher and one of the founders of chromosomal genetics. Because crossing over is not equally likely between any two points, map units do not correspond directly to number of **nucleotides** along the DNA double helix.

Sturtevant's work helped show that the chromosome is a linear sequence of genes. Gene mapping determines the position and order of genes relative to other genes along the chromosome. A well-marked linkage group extends from markers located at one end of the chromosome to those in the middle, and on to markers located at the other end. The number of linkage groups for an organism is equal to its number of homologous chromosome pairs.

## Modern Applications

Sturtevant's discovery led to the golden age of chromosome transmission genetics, with an emphasis on identifying genes through alleles with visible **phenotypes**, and using them as markers for determining their position on the linkage map. Since then the emphasis in genetics has shifted to understanding the functions of genes. Linkage and gene mapping studies have progressed to being a critical tool in cloning genes and providing more description of their roles in the organism. These approaches include:

- Using map locations to distinguish different genes with similar sequences, mutant phenotypes, or functions. Examples are the cell division cycle mutants of the yeast *Saccharomyces cerevisiae* or the uncoordinated mutants of the roundworm *C. elegans*. In some cases mutants with different phenotypes have been shown to be done to different mutations in the same gene, as is the case with the *Drosophila* **circadian** rhythm period mutants termed short, long, and none (per[S], per[L] and per[0]).
- Using map locations to track down genes to clone their deoxyribonucleic acid (DNA) by chromosome position. Examples are the

**nucleotide** the building block of RNA or DNA

**phenotype** observable characteristics of an organism

**circadian** related to a day or daylength

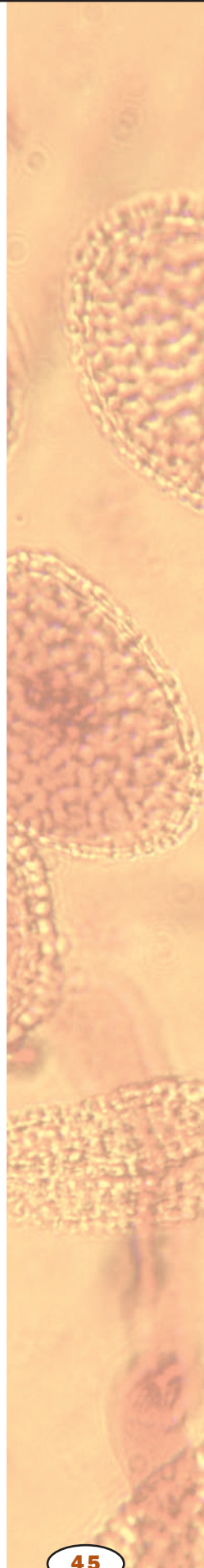

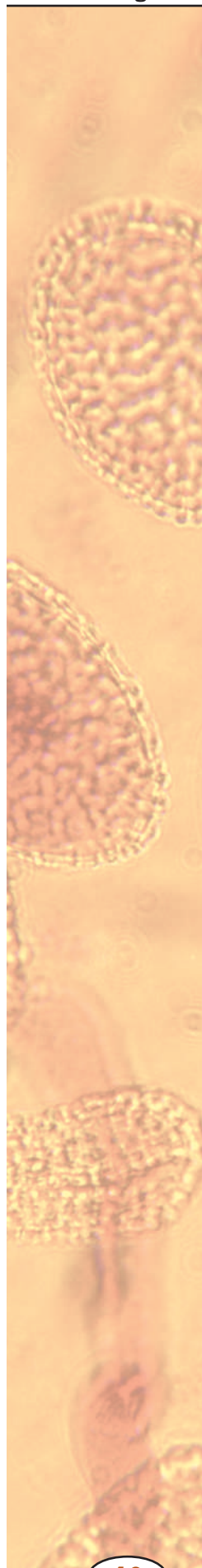

**genome** total genetic material in a cell or organism

**restriction enzyme** enzyme that cuts DNA at a particular sequence

**electrophoresis** technique that uses electricity to separate molecules based on size and electric charge

human cystic fibrosis transmembrane regulator gene mutated in cystic fibrosis, or the polyglutamine repeat gene that is mutated in Huntington's disease. With genome sequences available on databases, mapping mutant phenotypes points to candidate loci for the gene at the chromosome position.

New classes of markers in linkage analysis are based on naturally occurring DNA variation in the **genome**, and have many advantages. These variations are usually harmless and don't interrupt a gene, so there is no selection against them, meaning they persist over many generations. They are quite numerous and are distinguished throughout in the genome. Individuals are likely to be heterozygous from many of them and therefore the markers are informative for linkage. If the DNA variant is present heterozygously, can be detected, and shows Mendelian segregation, it is as good a linkage marker as yellow bodies or white eyes. The disadvantage is that analysis to detect the variant is sometimes more laborious and requires the techniques of molecular biology.

The common types of DNA markers and the molecular techniques used to follow their inheritance are:

- Restriction fragment length polymorphisms (RFLPs) are derived from sequence variation that results in the loss of a **restriction enzyme** digestion site. The result is a longer fragment of the DNA from that location following digestion with that enzyme. A heterozygous parent will transmit either the allele specifying the long fragment or the allele specifying the short fragment to each child. After size separation of DNA fragments by gel **electrophoresis** and transfer to a Southern blot, these DNA fragments of interest can be identified with a specific DNA or ribonucleic acid (RNA) probe that also comes from that location. If the long fragment, for example, is linked to a disease gene, the child's DNA can reveal if he or she is likely to develop the disease.
- Randomly amplified polymorphic DNAs (RAPDs) are derived from sequence variation that results in the loss of the complementary site to a primer necessary to initiate chain amplification by polymerase chain reaction (PCR). If the DNA used as template contains complementary sites for both primers, a PCR product is obtained that can be detected by gel electrophoresis. If either site is absent or changed in the template no product will be obtained from the reaction.

### Human Disease Genes

Human families pose some of the greatest challenges to linkage analysis. Human families are small, and matings are not designed by the needs of genetic analysis. Mapping a mutation that causes a disease usually requires assembling enough families that transmit the mutation in hopes that some of them will be heterozygous, or informative, at some RFLP, RAPD, or other markers that are near enough to the disease gene to show linkage. Instead of determining linkage by counting crossover numbers as Sturtevant did, human genetics uses an alternative means to estimate whether linkage is present between marker and disease gene. This approach is called LOD score analysis, after Log of the Odds for or against linkage. Each child from informative parents is scored as recombinant (R) or parental (P). The total

number of R and P results for each family is used to calculate “scores” for the odds that the results are due to linkage at a table of recombination frequencies from 1 cM, 10 cM, 20 cM, etc., relative to the chance that the results came from independent assortment.

The logs of the odds scores for each family are added to the log scores of other families to increase the number of independent observations. A LOD score value of 3, representing no more than a 5 percent chance of mistakenly declaring linkage, is the minimum acceptable score for assumption of true linkage between marker and disease gene. The recombination value that gives the highest LOD score over all the families is the presumptive linkage distance of the disease gene mutation from the adjacent markers. The first human disease gene mapped this way was Huntington’s disease, which had a LOD score of over 6 for a recombination distance from its marker of between 5 and 10 cM. Once a marker has been found, it can be used to predict whether any particular family member has inherited the marker and therefore is likely to have inherited the disease gene. **SEE ALSO** GENETIC ANALYSIS; GENETIC DISEASES; MENDEL, GREGOR; PATTERNS OF INHERITANCE; POLYMERASE CHAIN REACTION

*John Merriam*

#### **Bibliography**

Alberts, Bruce, et al. *Molecular Biology of the Cell*, 4th ed. New York: Garland Publishing, 2000.

Creighton, Thomas E. *Proteins: Structures and Molecular Properties*, 2nd ed. New York: W. H. Freeman and Company, 1993.

Freifelder, David. *Molecular Biology*, 2nd ed. Boston: Jones & Bartlett, 1987.

Lehninger, Albert L. *Principles of Biochemistry*, New York: Worth Publishers, 1982.

## **Linnaeus, Carolus**

**Swedish botanist and taxonomist**

**1707–1778**

Carolus Linnaeus developed the binomial system for naming organisms. Born Carl von Linné in Sweden, Linnaeus developed an early interest in botany and classification and later developed a new classification scheme for the growing numbers of plants and animals being discovered throughout the world. Linnaeus proposed using the number and arrangement of stamens and **pistils** in flowers as a simple set of characters to classify plants. This system was used widely for a time but later was replaced by more natural systems based on larger numbers of characters.

Linnaeus’s most important contribution was the naming system he devised to accompany his classification system. In contrast to the complex and at times chaotic rules used by other botanists, Linnaeus proposed that each type of organism be called by a simple, two-part (binomial) name. Each plant in his system was given a genus name, which grouped the plant with other similar plants, and a species name, often a descriptive term, to make a combination unique for that organism. Each name was given in Latin. For instance, the white oak is *Quercus alba* (*alba* means white), while the red oak is *Quercus rubra* (*rubra* means red). This nomenclatural system was first

**pistil** female reproductive organ of a flower

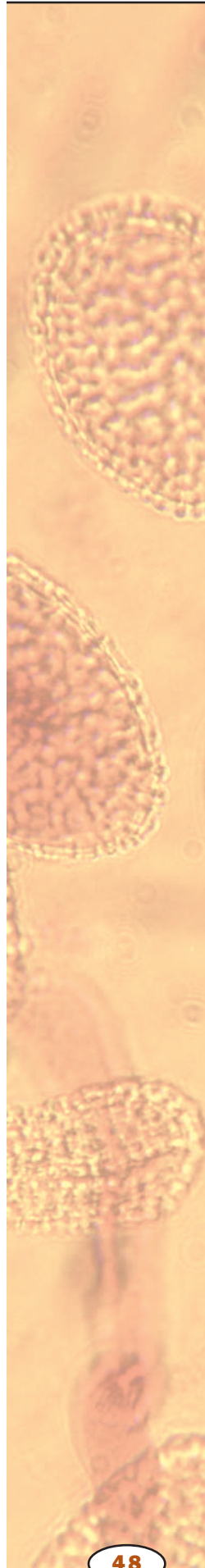

**protein** complex molecule made from amino acids; used in cells for structure, signaling, and controlling reactions

**polysaccharide** carbohydrate composed of many individual units of sugar

**organelle** membrane-bound cell compartment

**endoplasmic reticulum** network of membranes within the cell

**hydrocarbon** molecule or group composed only of C and H

**organic** composed of carbon

**acidic** having an excess of  $H^+$  ions, and a low pH

**amino acid** a building block of protein

**amphipathic** having both polar and nonpolar regions

**hydrophobic** “water hating,” such as oils

**hydrophilic** “water loving”

**aqueous** watery or water-based

published in *Species Plantarum* in 1753 and was widely and quickly accepted. While naming systems have grown more complex since his time, Linnaeus’s binomial system for the genus and species is used today by all biologists. SEE ALSO BUFFON, COUNT (GEORGES-LOUIS LECLERC); TAXONOMY, HISTORY OF

*Richard Robinson*

### Bibliography

Iseley, Duane. *One Hundred and One Botanists*. Ames: Iowa State University Press, 1994.

Reed, H. S. *A Short History of the Plant Sciences*. New York: Ronald Press, 1942.

## Lipids

Lipids are uniquely biological molecules, and they are synthesized and used by organisms in a variety of important ways. Unlike **proteins**, **polysaccharides**, and nucleic acids, lipids are much smaller, water-insoluble molecules. They are synthesized in association with a cellular **organelle** called the smooth **endoplasmic reticulum**. In a word, they are, as their etymology suggests, fats.

Several types of fats are made from fatty acids. Fatty acids are long, unbranched chains of **hydrocarbons** (typically made up of fourteen to twenty carbons) with a terminal **organic** acid group. In cartoon figures, fatty acids are often drawn as lollypops, consisting of long hydrocarbon “tails” and circular, polar “heads.” When free in cells, the **acidic** heads give the fatty acids a negative charge, which is lost when the molecules are linked chemically with glycerol to form glycerides.

Possibly the most common fat is a glyceride, which consists of fatty acids linked to glycerol (a three-carbon alcohol). Triglycerides are the most prevalent glyceride; they each contain three fatty acids, and because they are used almost exclusively for the storage of biological energy, they are the most common component of body fat. To understand their storage function it is useful to appreciate that the fatty acids commonly found in triglycerides each contain more than twice the energy present in octane, the primary component of gasoline.

Diglycerides are also common lipids; they are especially abundant in biological membranes (unlike triglycerides, which are never found in membranes). As its name suggests, a diglyceride contains two fatty acids linked to a glycerol backbone; the third carbon of glycerol is usually linked to a much more polar substance. The most common diglycerides found in membranes are phospholipids, compounds whose polar groups consist of negatively charged phosphate groups linked to other polar compounds (such as the organic base choline, or the **amino acid** serine, or the simple sugar inositol).

Unlike triglycerides, most diglycerides are distinctly “schizophrenic” (or more technically, **amphipathic**) with respect to their solubility properties. The fatty acid residues are distinctly **hydrophobic**, whereas the polar residue is very **hydrophilic**. Thus, the polar part of a phospholipid wants to dis-

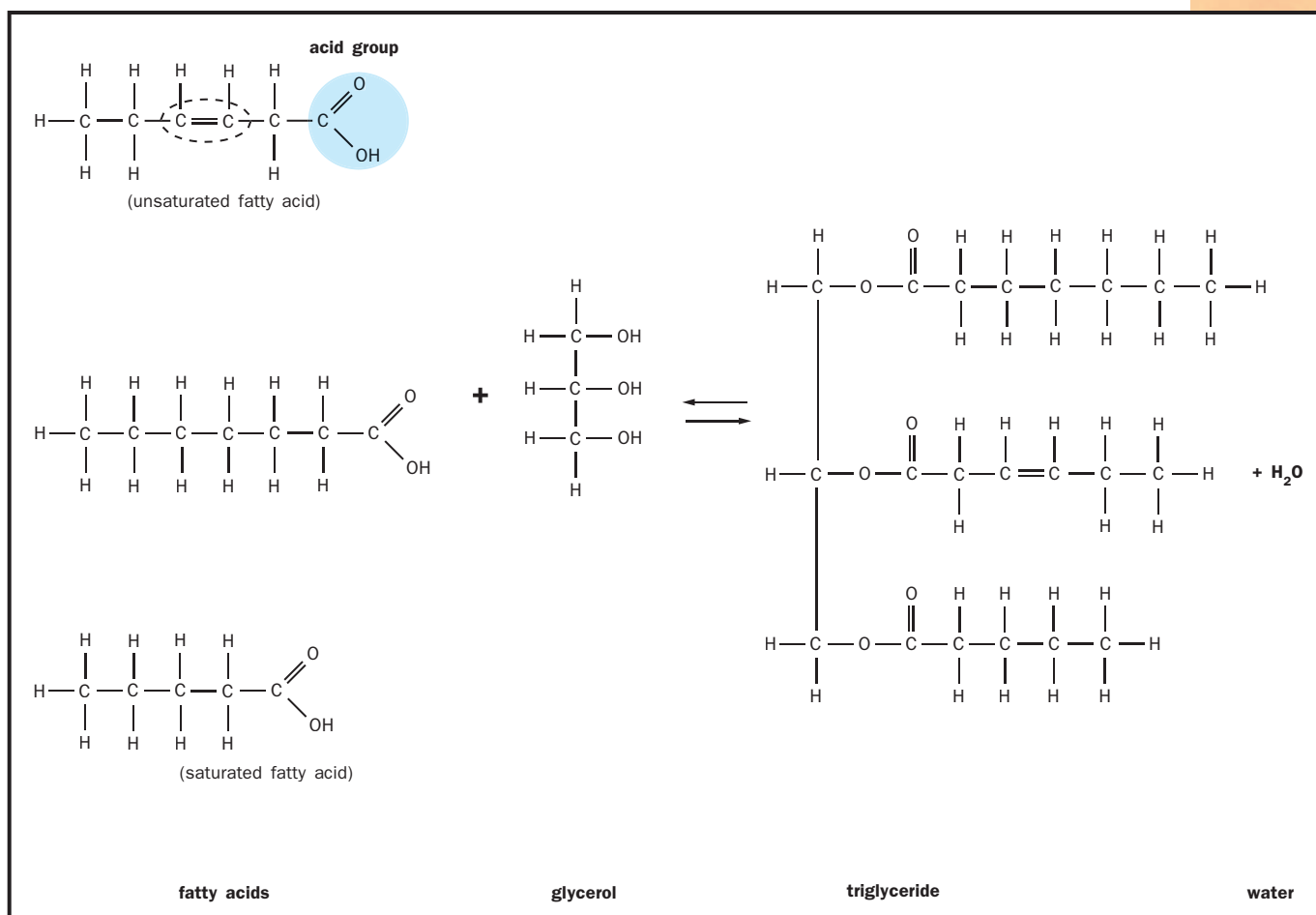

solve in **aqueous** solutions, while the nonpolar parts prefer their own company, so to speak. This amphipathic property is the basis for the spontaneous assembly of phospholipids into **bilayer** membranes and for the dynamic stability these important cellular components exhibit. For this reason phospholipid and other amphipathic membrane lipids are often called “structural lipids.”

Other structural, amphipathic lipids include glycolipids with polar residues consisting of one or more **carbohydrates** and hydrophobic regions containing both hydrocarbon and fatty acid residues, and cholesterol, a complex cyclical hydrocarbon with a very small polar residue. Cholesterol is also the parent compound of a group of very important **hormones** called **steroids** (including cortisol, estrogen, progesterone, and androgen) and of bile salts that facilitate the digestion of dietary fats.

In some organisms, fatty acids may also be linked to long-chain hydrocarbon alcohols, producing compounds called waxes; the spermaceti of sperm whales and the substances used by bees to form the walls of their honeycomb are good examples. Also uncommon, but very important in some plants, are hydrocarbons called terpenes, of which turpentine and camphor are the most well-known examples, and carotenoids, a yellow plant pigment. SEE ALSO HORMONES; MEMBRANE STRUCTURE

Fatty acids link to glycerol, by removal of water molecules, to make a triglyceride. If a phosphate group ( $\text{PO}_4^{3-}$ ) is used instead of one of the fatty acids, a phospholipid is formed. The phosphate end dissolves in water, while the fatty acid end does not.

**bilayer** composed of two layers

**carbohydrates** sugars, starches, and other molecules combining carbon, hydrogen, and oxygen and serving as fuel or structural components

**hormone** molecule released by one cell to influence another

**steroids** hormones such as testosterone or estrogens that control many aspects of physiology

*Chris Watters*

**Bibliography**

Karp, G. *Cell and Molecular Biology*, 3rd ed. New York: John Wiley & Sons, 2001.

**Liver**

The liver is the largest organ in the abdominal cavity and is located under the right and central portions of the diaphragm. It performs over two hundred functions including digestive, metabolic, storage, and other functions. This reddish-brown organ consists of two major lobes, the right lobe and the left lobe, and two smaller lobes, the **caudate** lobe and the quadrate lobe.

Lying under the right lobe is the gallbladder, a muscular sac that is anatomically and physiologically associated with the liver. Emerging from the gallbladder is the cystic duct.

The lobes contain liver cells (hepatocytes), which secrete bile, an **alkaline**, yellow-green liquid that is composed of water, bile salts, and several other substances. Bile is delivered to the duodenum, the first portion of the small intestine, where the bile salts **emulsify lipids**; that is, break down large lipid globules into small droplets, in order to increase the efficiency of lipid digestion and absorption by the small intestine.

The hepatocytes secrete bile into numerous tiny ducts, which merge to form progressively wider ducts. These ducts ultimately merge to form the common hepatic duct, which descends from the liver. This duct merges with the gallbladder's cystic duct to form the bile duct, which opens into the duodenum. The opening is guarded by a **sphincter**, a circular muscle that is usually closed. Since the sphincter is usually closed, bile flowing down from the liver is prevented from entering the duodenum and, consequently, backs up via the cystic duct into the gallbladder.

Within the gallbladder, bile is stored and concentrated until it is expelled, when needed, via the cystic and bile ducts into the duodenum. Expulsion of bile occurs due to the simultaneous contraction of the gallbladder walls and relaxation of the sphincter guarding the entrance to the duodenum.

In addition to producing bile for the emulsification of dietary lipids, the liver also plays an important role in the maintenance of normal blood **glucose** concentration, inactivation of toxins, synthesis of plasma **proteins**, and the **metabolism** of **carbohydrates**, fats, and proteins. SEE ALSO BLOOD SUGAR REGULATION; DIGESTION; DIGESTIVE SYSTEM; POISONS

*Izak Paul*

**Bibliography**

Saladin, Kenneth S. *Anatomy & Physiology: The Unity of Form and Function*, 2nd ed. New York: McGraw-Hill, 2001.

**Locomotion**

Locomotion is the active movement from one place to another. It does not include passive movements such as falling or drifting in currents of air or water. Many bacteria and protozoa are capable of locomotion, but animals move over much greater distances by a much larger variety of means, such as burrowing, running, hopping, flying, and swimming. The mode of loco-

**caudate** toward the tail

**alkaline** chemically basic, with an excess of OH<sup>-</sup> ions

**emulsify** suspend in solution through interaction with soap or similar molecules

**lipid** fat or waxlike molecule, insoluble in water

**sphincter** ring of muscle regulating passage of material through a tube such as the gastrointestinal tract

**glucose** simple sugar that provides energy to animal cells and is the building block of cellulose in plants

**protein** complex molecule made from amino acids; used in cells for structure, signaling, and controlling reactions

**metabolism** chemical reactions within a cell

**carbohydrates** sugars, starches, and other molecules combining carbon, hydrogen, and oxygen and serving as fuel or structural components



motion used by an animal depends on the size of the animal and the medium in which it moves—whether water, air, or land.

It is convenient to divide the modes of locomotion into four categories: (1) those used by very small organisms in water; (2) those used by larger animals in water; (3) those used by larger animals in air; and (4) those used by animals in or on land.

## Swimming

Very small animals, as well as protozoa, that locomote through water are commonly said to swim, but this is not actually what they do. For humans, the momentum of our bodies is very large compared with the resistance from the viscosity (stickiness) of water. For a microscopic crustacean or an **amoeba**, however, movement through water is like crawling through molasses. There are three types of locomotion commonly employed by tiny aquatic organisms. One is amoeboid motion, which is used by its namesake *Amoeba* and some other protozoans, as well as by white blood cells. Amoeboid motion is performed by protruding a portion of the cell to form a **pseudopodium**, then essentially flowing into the pseudopodium.

Some protozoans, as well as the sperm of many animals, have one or a few long, hairlike structures called flagella that are responsible for locomotion in liquid. The wavelike beating of a flagellum pulls or pushes the cell through water. Many other protozoans, as well as many small animal larvae, locomote through water by means of numerous **cilia**. Cilia are identical to flagella except that they are shorter and more numerous. As each cilium beats back and forth, it extends out on the backstroke and folds on the return stroke. Ciliary locomotion can be quite fast: up to 10,000 body lengths per hour for *Paramecium*.

Cilia are also responsible for locomotion in some much larger organisms, such as flatworms (Platyhelminthes). These animals secrete a film of mucus, then creep through it on numerous cilia. This is called mucociliary locomotion.

Larger aquatic animals are capable of true swimming, which means that their momentum carries them forward between swimming strokes. The change in momentum that propels them forward is matched by the momentum of water that is propelled backward as a vortex. Most aquatic animals have fins that are adapted for propelling a vortex backward. In addition, fast swimmers generally have streamlined bodies that reduce the friction of water. A few aquatic animals have unusual mechanisms for swimming. Octopus and squid, for example, often escape predators by means of jet propulsion. Contraction of the body forces out a jet of water that propels the animal in the opposite direction.

## Flying

Flying is more complicated than swimming since it must generate not only forward thrust but also upward lift. Wings must therefore produce vortices of air that move downward and rearward with a force equal and opposite to the gravitational force on the body. These vortices are produced by the flapping of wings during active flight or by the passive movement of air past the wings during gliding and soaring. Gliding by birds is the easiest to

**amoeba** a single-celled protist that moves by crawling and can cause diarrhea

**pseudopodium** “false foot”; extension of cell membrane used in amoeboid locomotion

**cilia** short, hairlike cell extensions of the cell membrane formed by the cytoskeleton

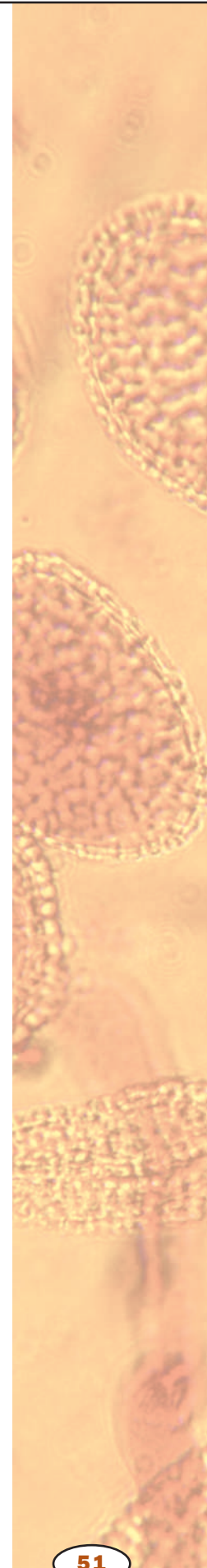

A photomicrograph of protozoans, *Ceratium tripos*, that use flagella to locomote through water.

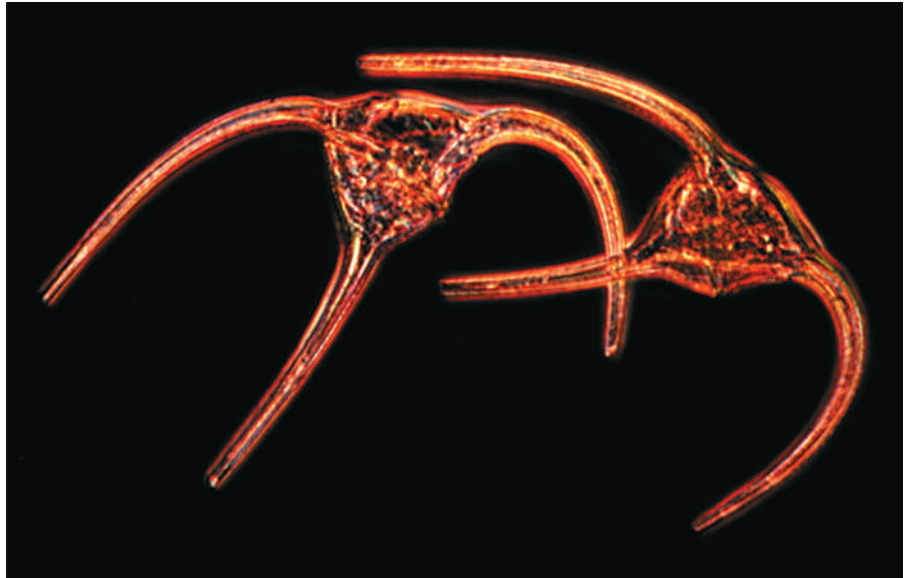

understand. Their wings have a cross section like those of an airplane, and they work similarly. In contrast to the wings of birds and bats, those of insects are flat and rough, and they, therefore, do not generate lift and thrust from the smooth flow of air past them. Instead they have a variety of other movements that produce downward and rearward vortices.

Locomotion by terrestrial animals takes a variety of forms, such as burrowing, creeping, walking, hopping, leaping, and running. In all these modes, the propulsive force is generated as a reaction to forces applied to Earth. When people walk, for instance, they propel themselves forward by pushing the balls of the feet against the stationary Earth. SEE ALSO BONY FISH; CARTILAGINOUS FISH; INSECT; MUSCULOSKELETAL SYSTEM; PROTOZOAN DISEASES

*C. Leon Harris*

### Bibliography

Chong, L., et al. "On the Move." *Science* 288 (7 April 2000): 79–106.

Hickman, Cleveland P., Jr., Larry S. Roberts, and Allan Larson. "Animal Movement." In *Integrated Principles of Zoology*, 11th ed. Boston: McGraw-Hill Higher Education, 2001.

## Lymphatic System

The lymphatic system plays a vital role as one of the organ systems of the body. This system functions with the digestive system to absorb dietary **lipids**, which enter lymphatic vessels rather than blood vessels for transport. It also acts with the cardiovascular system to control the body's fluid balance. This is accomplished by a series of interconnected thin-walled lymphatic vessels that permeate the body's tissues that collect substances lost through the walls of capillaries. These lymphatic vessels drain into lymphatic trunks and then into veins.

If lymphatic drainage is temporarily or permanently blocked, the buildup of **interstitial** fluid creates a condition called lymphedema. In tropical areas

**lipid** fat or waxlike molecule, insoluble in water

**interstitial** space between cells in a tissue

of the world, a mosquito-borne roundworm can infect lymph nodes, blocking lymphatic drainage and thereby creating a condition called elephantiasis.

The lymphatic system also plays a vital role in immunity by providing a defensive network against **pathogens**. Multiple lymphatic organs, all with specialized functions, work together for this purpose. Lymph flowing along the lymphatic vessels passes periodically through lymph nodes, primarily in the neck, armpit, and groin regions. The nodes contain lymphocytes and macrophages that mount an immune response to any pathogen borne within this fluid. Lymphatic vessels also lead to lymph nodes near internal organs such as the heart, lungs, and alimentary canal (gut).

**pathogen** disease-causing organism

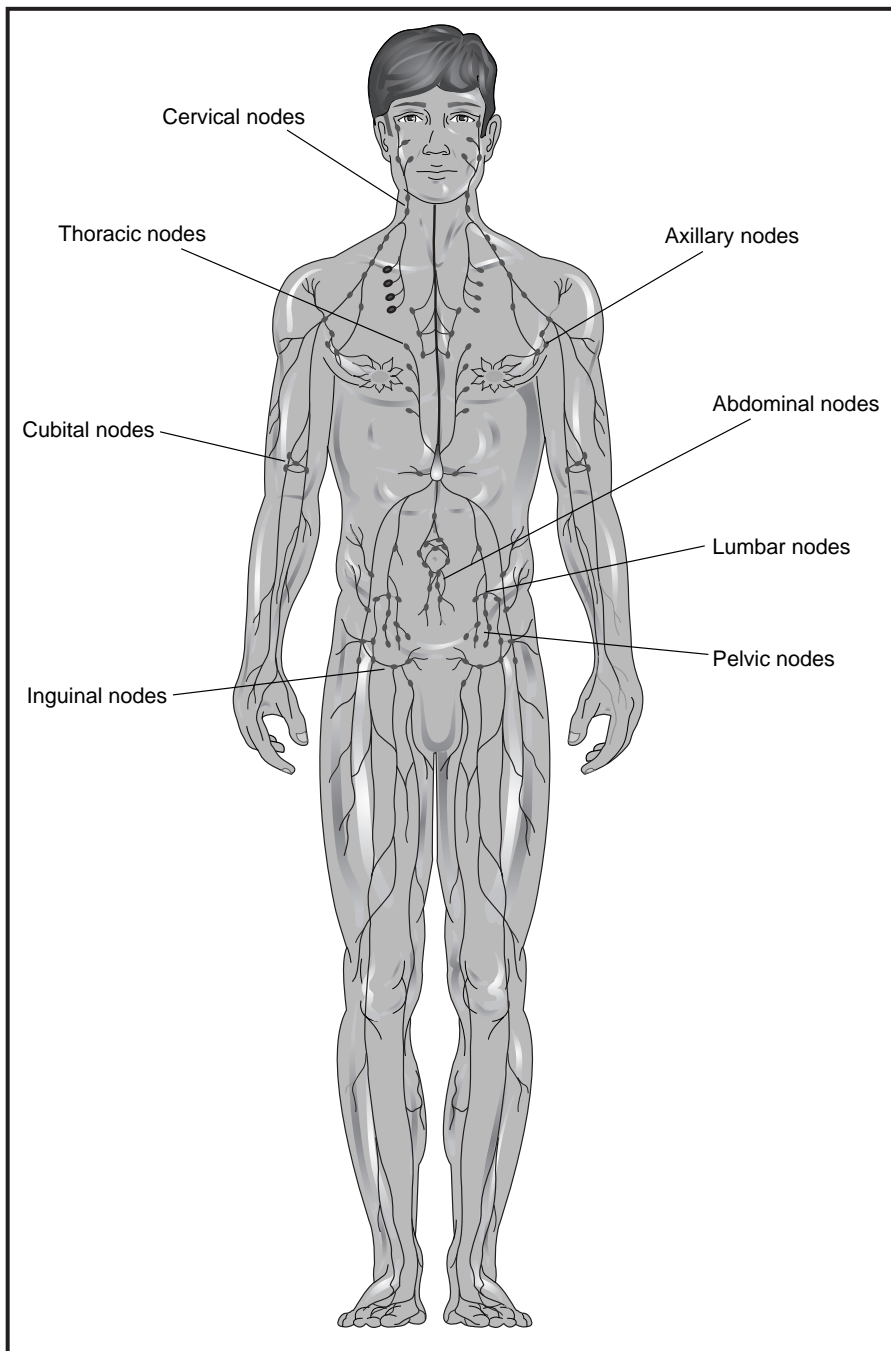

A lymphangiograph of a man, showing cervical, thoracic, cubital, inguinal, axillary, abdominal, lumbar, and pelvic nodes of the lymphatic system.

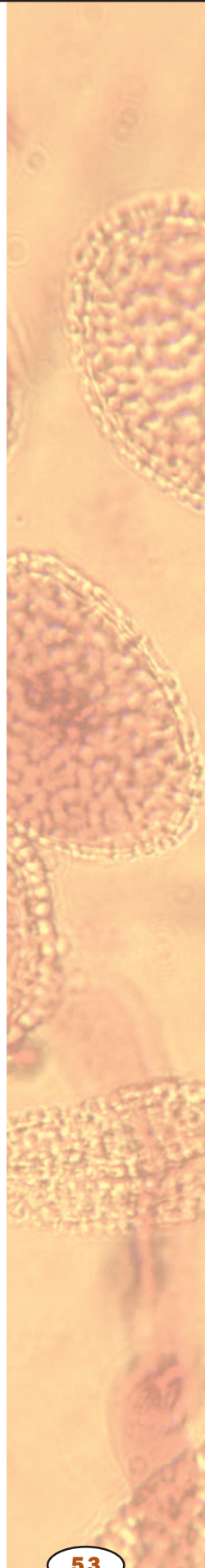

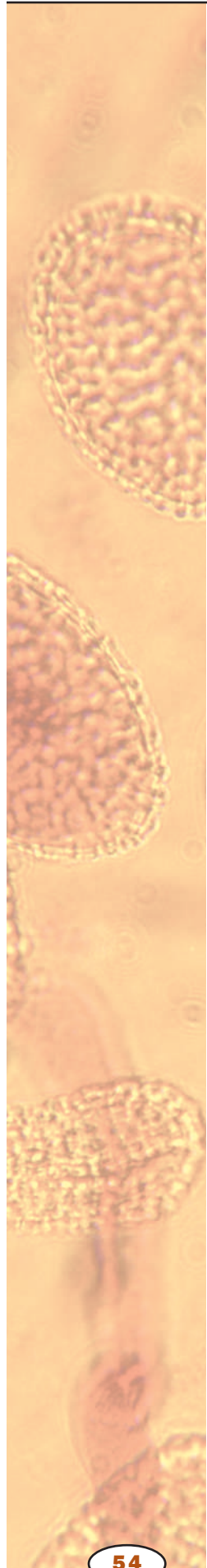

**superficial** on the surface; not deep

**T cell** white blood cell that controls the immune response

**organelle** membrane-bound cell compartment

**eukaryotic cell** a cell with a nucleus

**enzyme** protein that controls a reaction in a cell

**protein** complex molecule made from amino acids; used in cells for structure, signaling, and controlling reactions

**lipid** fat or waxlike molecule, insoluble in water

**carbohydrates** sugars, starches, and other molecules combining carbon, hydrogen, and oxygen and serving as fuel or structural components

**cytosol** fluid portion of a cell, not including the organelles

**intracellular** within a cell

**acidic** having an excess of  $H^+$  ions, and a low pH

Lining the alimentary canal are collections of mucosa-associated lymphatic tissues (MALT) that form lymphatic nodules. Clusters of lymphatic nodules are also deep to the lining of the alimentary canal. These include Peyer patches of the ileum (lower small intestine) and appendix that guard the entry of pathogens into the internal environment. When the appendix becomes inflamed, appendicitis results.

Other lymphatic organs—the tonsils, thymus, and spleen—also play a critical role in immunity. The tonsils include the pharyngeal tonsil located in the rear of the nasopharynx, the palatine tonsils to the side of the tongue, and the lingual tonsils at the base of the tongue. Together, the tonsils form patches of lymphatic tissue that encircle the back of the oral and nasal cavities as a defense mechanism to detect pathogens before they enter the alimentary canal. If the tonsils become infected, a tonsillectomy may be necessary.

The thymus is found deep to the sternum (breastbone) and **superficial** to the pericardial sac surrounding the heart. The thymus contains lymphocytes that differentiate into **T cells**. These cells are vital to the proper function of the immune system.

Finally, the spleen is located in the left upper quadrant of the abdomen. It has several functions. Its red pulp stores erythrocytes (red blood cells) for use in cases of sudden blood loss, whereas the white pulp contains macrophages and other leukocytes (white blood cells) that break down old erythrocytes as they squeeze through splenic sinuses. Additionally, these leukocytes can mount an immune response and fight infections that enter this organ. As the spleen contains many vessels, it bleeds easily when ruptured. In such cases, removal of the spleen (splenectomy) may be required to prevent fatal hemorrhage. SEE ALSO ANTIBODY; DIGESTIVE SYSTEM; IMMUNE RESPONSE; T CELLS

A. K. Huxley

### Bibliography

Moore, Keith L., and Arthur F. Dalley. *Clinically Oriented Anatomy*, 4th ed. Baltimore, MD: Lippincott Williams and Wilkins, 1999.

Saladin, Kenneth S. *Anatomy and Physiology: The Unity of Form and Function*. Dubuque, IA: McGraw-Hill, 2001.

## Lysosomes

Lysosomes are membrane-bound **organelles** that function as the “stomachs” of **eukaryotic cells**. They contain about fifty different **enzymes** that break down all types of biological molecules including **proteins**, nucleic acids, **lipids**, and **carbohydrates**. Cells transport material into lysosomes, the material is digested by the enzymes, and the digested molecules are moved back into the **cytosol** for use by the cell. Both extracellular materials brought into the cell by endocytosis and obsolete **intracellular** materials are degraded in the lysosome.

Lysosomes vary in size and shape, but have several common features. They are surrounded by a single membrane, have an **acidic** interior pH level of about 5, and carry a high content of digestive enzymes. All of the diges-

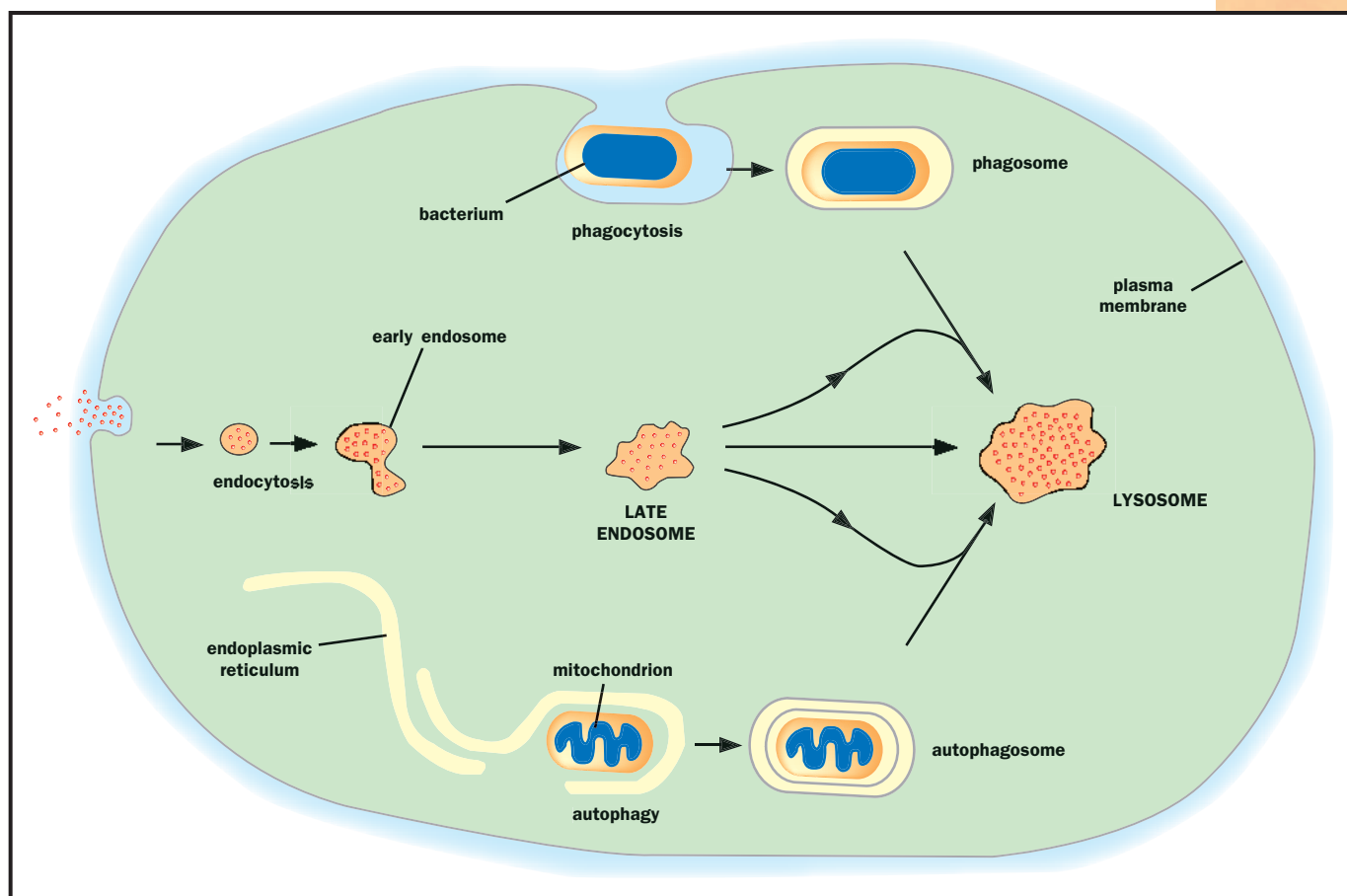

tive enzymes found in the lysosome require an acidic environment to function properly and are called acid hydrolases. The low pH of the lysosome is maintained by membrane proteins that pump protons ( $H^+$  ions) from the cytosol into the lysosome.

In addition to the proton pumps, the lysosomal membrane contains many other proteins that transport the digested molecules out of the lysosome and into the cytosol. Although it may seem dangerous for cells to contain enzymes that can digest most biological molecules, the contents of the cell are doubly protected from the digestive enzymes of the lysosome. First, the enzymes are enclosed in the lysosomal membrane and second, even if the enzymes were to leak out of the lysosome, they would not be active at the neutral pH of the cytosol.

Extracellular materials to be degraded in the lysosome are brought into the cell by either pinocytosis or phagocytosis. Pinocytosis, which occurs in all eukaryotic cells, is the internalization of extracellular fluid and small **macromolecules** by means of small **vesicles** that pinch off the inside of the plasma membrane. These small vesicles carrying endocytosed molecules are initially delivered to membranous organelles called endosomes. It is not precisely clear how molecules to be degraded progress from endosomes to lysosomes. Endosomes may actually mature into lysosomes when newly made acid hydrolases are delivered to the endosome.

Phagocytosis, which occurs in only specialized cell types, is the ingestion of large particles such as cell debris or whole microorganisms. Phagocytic

Three routes to degradation in lysosomes.

**ion** an electrically charged particle

**macromolecules** large molecules such as proteins, carbohydrates, and nucleic acids

**vesicle** membrane-bound sac

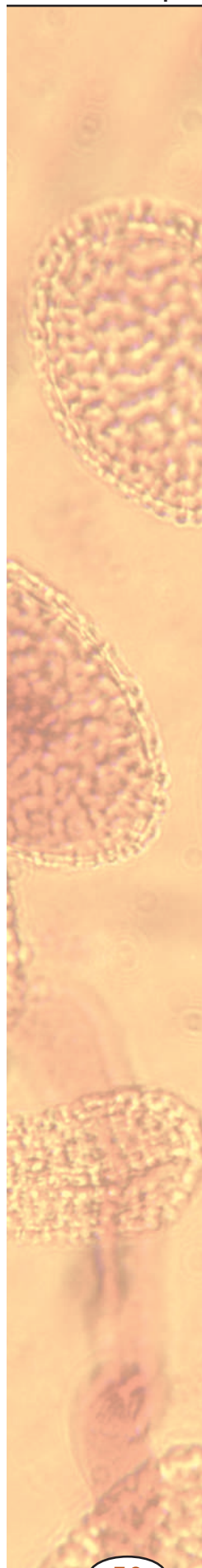

**endoplasmic reticulum**  
network of membranes  
within the cell



**gamete** reproductive  
cell, such as sperm or  
egg

**vas deferens** tube  
through which sperm  
travel from testes to  
urethra

**connective tissue** one  
of four types of body  
tissue, characterized by  
few cells and extensive  
extracellular material

**endocrine** related to  
the system of hormones  
and glands that regulate  
body function

**steroids** hormones  
such as testosterone or  
estrogens that control  
many aspects of physi-  
ology

cells engulf large particles by forming a large intracellular vesicle containing the engulfed particle. The large vesicle then fuses with a lysosome, resulting in a single membranous organelle in which the digestive enzymes break down the ingested particle.

Intracellular materials, such as old organelles, are brought into a lysosome by a process called autophagy. For example, when a mitochondrion comes to the end of its ten-day life, it is engulfed by membrane derived from the **endoplasmic reticulum**. The newly enclosed mitochondrion then fuses with a lysosome, resulting in its degradation by the acid hydrolases.

A group of genetic disorders caused by defective lysosomal enzymes demonstrates the importance of lysosomes. Called lysosomal storage diseases, these disorders are characterized by the harmful accumulation of undigested substances. The accumulated materials impair or kill the affected cells, resulting in skeletal or muscular defects, mental retardation, or even death. SEE ALSO ENDOCYTOSIS; ENDOPLASMIC RETICULUM; ENZYMES; MITOCHONDRION

*Cynthia K. Damer and Scott N. Daigle*

### Bibliography

Hunziker, Walter, and Hans J. Geuze. "Intracellular Trafficking of Lysosomal Membrane Proteins." *Bioessays* 18 (1996): 379–389.

Kornfeld, Stuart, and Ira Mellman. "The Biogenesis of Lysosomes." *Annual Review of Cell Biology* 5 (1989): 483–525.

Mellman, Ira. "Endocytosis and Molecular Sorting." *Annual Review of Cellular and Developmental Biology* 12 (1996): 575–625.

## Male Reproductive System

Reproduction is essential for any species to sustain its population. In the simplest sense, the most important function of every living organism is reproduction. Organs of the male and female reproductive systems play a central role in sexual reproduction by creating, nourishing, and housing sex cells called **gametes**.

The human male reproductive system consists of gonads called testes, a series of ducts (epididymis, **vas deferens**, ejaculatory duct, urethra) that serve to transport spermatozoa to the female reproductive tract, and accessory sex glands (seminal vesicles, prostate, and bulbourethral glands).

### Testes

The testes (singular, testis) are paired structures that originally develop in the abdomen and descend into the scrotum, a sac of skin and **connective tissue** positioned outside the pelvic cavity. This scrotal location is important for maintaining a testicular temperature, approximately 1.5 to 2.5 degrees Celsius (34.7 to 36.5 degrees Fahrenheit) below body temperature, required for spermatogenesis (sperm production). Testes also serve important **endocrine** functions as the source of male sex **steroids** called androgens. The most abundant androgen is testosterone.

Inside each testis is a network of fine-diameter tubes called seminiferous tubules. Sertoli cells form the walls of a seminiferous tubule. Sertoli cells

nourish, support, and protect developing germ cells, which undergo cell division by **meiosis** to form spermatozoa (immature sperm). During spermatogenesis, germ cells begin near the wall of a seminiferous tubule, and after division they are shed into the tubule. **Proteins** produced by Sertoli cells are required for spermatogenesis, as is testosterone.

## Hormonal Control

Surrounding the tubules are clusters of interstitial cells, which synthesize testosterone and secrete it into the bloodstream. Testosterone is present in infant boys, although synthesis increases dramatically at puberty around age thirteen. This increase stimulates the onset of spermatogenesis and development of accessory sex glands. All male reproductive organs require testosterone for functions such as protein synthesis, fluid **secretion**, cell growth, and cell division. Androgens also play important roles in the male sexual response and stimulate secondary sex characteristics such as skeletal development, facial hair growth, deepening of the voice, increased **metabolism**, and enlargement of the testes, scrotum, and penis.

Sperm production and androgen synthesis are controlled by a complex **feedback** loop involving the testes, hypothalamus, and pituitary gland. The pituitary controls testis function by producing follicle-stimulating **hormone** (FSH) and luteinizing hormone (LH). FSH stimulates spermatogenesis, in part by affecting Sertoli cells, while LH stimulates androgen production by interstitial cells. Pituitary production of these hormones depends on secretion of gonadotropin-releasing hormone (GnRH) by the hypothalamus. Elevated levels of GnRH initiate puberty.

How does this feedback loop prevent testosterone levels from getting too high or too low? While some may joke that the testis controls the brain in boys, there is some truth to this statement: the testis can control brain function. The production of LH is controlled by the actions of testosterone on the hypothalamus and pituitary. If testosterone concentration is elevated, testosterone inhibits production of GnRH by the hypothalamus; subsequently, LH and FSH production decreases.

## Sperm Maturation

Spermatozoa leave each testis through small tubes called efferent ductules. Fluid pressure from secretions in the testis and **ciliated** cells in the efferent ductules help move spermatozoa into the epididymis. Testicular spermatozoa are immature because they cannot swim and lack the ability to penetrate an egg.

Sperm maturation occurs in the epididymis. Located adjacent to the testis, the epididymis contains a single, highly coiled tubule nearly 6 meters (19.6 feet) long. Sperm transport through the epididymis takes approximately twenty days. As sperm transit the epididymis, they are bathed in a specialized fluid rich in proteins, **ions**, and a number of other molecules. Complex interactions between spermatozoa and epididymal fluid contribute to sperm maturation. The epididymis is also a site for sperm storage and for the protection of sperm against chemical injury.

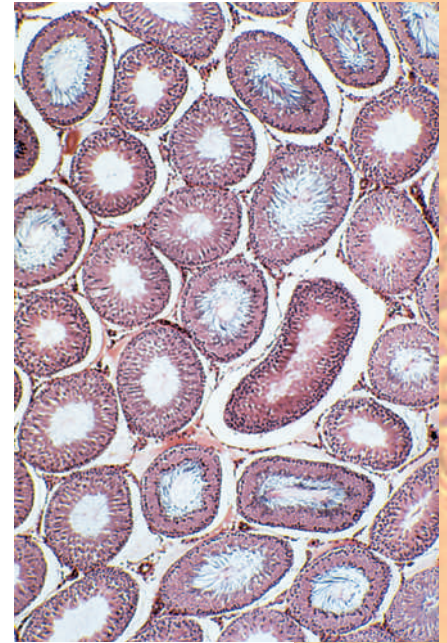

A photomicrograph of human testis showing spermatogenesis.

**meiosis** cell division that forms eggs or sperm

**protein** complex molecule made from amino acids; used in cells for structure, signaling, and controlling reactions

**secretion** material released from the cell

**metabolism** chemical reactions within a cell

**feedback** process in which the output or result influences the rate of the process

**hormone** molecule released by one cell to influence another

**ciliated** possessing cilia, short hairlike extensions of the cell membrane

**ion** an electrically charged particle

The male reproductive system provides for the formation, maturation, storage, and ejaculation of sperm. Both sperm and urine exit through the urethra.

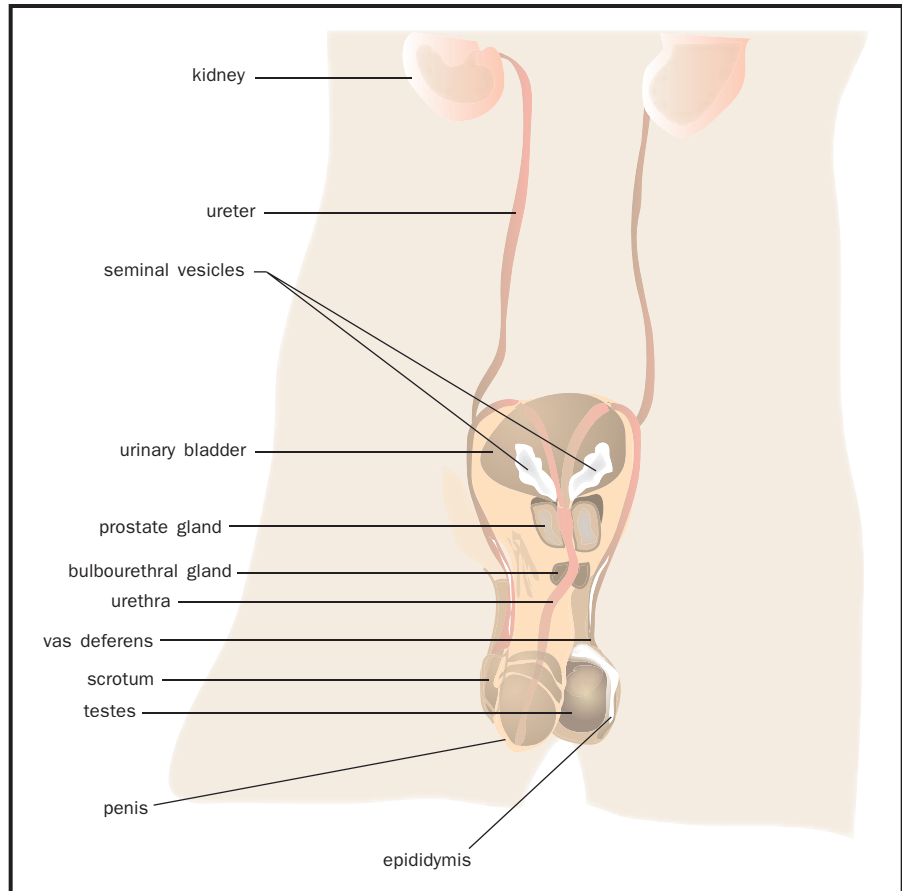

### Sperm Formation and Ejaculation

From the epididymis, spermatozoa enter a muscular tube called the vas deferens (approximately 45 centimeters [17.7 inches] long). The vas deferens contracts during the release of sperm—a process called ejaculation—to move spermatozoa out of the epididymis and into the ejaculatory duct, where sperm are mixed with secretions from the seminal vesicles. The ejaculatory duct enters the urethra as it passes through the prostate gland. In males, the urethra serves a dual purpose transporting sperm to the penis and urine from the urinary bladder.

The accessory sex glands consist of a single prostate gland and paired seminal vesicles and bulbourethral glands. The prostate and seminal vesicles secrete seminal fluid, or semen, a **viscous** mixture of spermatozoa and fluid from accessory sex glands. Spermatozoa constitute 10 percent of semen volume and number approximately 50 to 150 million sperm per milliliter. Combined secretions from the seminal vesicles and prostate account for roughly 90 percent of semen volume. The seminal vesicle secretions are rich in fructose (which serves as an energy source for spermatozoa), **prostaglandins**, and proteins that facilitate clotting of ejaculated semen in the female.

**viscous** thick

**prostaglandins** hormonelike molecules released by one cell that affect nearby cells, including smooth muscle



Prostate secretions are rich in zinc, citric acid, antibioticlike molecules, and **enzymes** important for sperm function. A protein called prostate-specific **antigen** can show elevated levels in the blood under conditions such as prostate growth. During sexual excitation, the bulbourethral glands produce a droplet of **alkaline** fluid that neutralizes residual urine in the urethra, protecting the sperm from its acidity.

The penis contains two bodies of tissue (corpora cavernosa) above the urethra and a lower cylinder of tissue (corpus spongiosum) surrounding the urethra. The enlarged tip of the penis is called the glans penis. Mechanisms responsible for penile erection are complex. During sexual arousal, penile arteries dilate and a large volume of blood fills the penis, resulting in erection. The nervous system plays an important role in controlling erection and ejaculation.

The parasympathetic division of the **autonomic** nervous system regulates erection, whereas ejaculation is triggered by sympathetic impulses. Medical and emotional conditions can cause clinical disorders of erectile dysfunction. Drugs such as Viagra increase erectile function by improving blood flow into penile tissue. Many factors result in poor fertility or infertility in males including hormone imbalances, reproductive tract blockages, decreased sperm concentration, and abnormal sperm.

The journey of spermatozoa from formation to release is complicated. Reproduction of any individual is never guaranteed, yet through combined functions of male and female reproductive organs, nature has provided a sophisticated sequence of biological events designed to maximize the likelihood that we pass our **genes** to future generations. SEE ALSO ENDOCRINE SYSTEM; FEMALE REPRODUCTIVE SYSTEM; HORMONES; HYPOTHALAMUS; PITUITARY GLAND; SEXUAL REPRODUCTION

Michael A. Palladino

### Bibliography

- Goldstein, Irwin. "Male Sexual Circuitry." *Scientific American* (2000): 70–75.
- Marieb, Elaine N. *Human Anatomy and Physiology*, 5th ed. Menlo Park, CA: Benjamin Cummings, 2000.
- Robaire, Bernard, John L. Pryor, and Jacquetta M. Trasler, eds. *Handbook of Andrology*. San Francisco, CA: American Society of Andrology, 1998. Also available at <<http://www.andrologysociety.com/resources.book.cfm>>.

## Mammal

Mammals are taxonomically separated from other animals at the class level (kingdom Animalia, **phylum** Chordata, subphylum Vertebrata, class Mammalia). Modern mammals are readily differentiated from other animals by the following characteristics: hair; a four-chambered heart with the aorta descending on the left; red blood cells that lack a **nucleus** (allowing for increased surface area for oxygen transport); a muscular diaphragm separating the abdominal and thoracic cavities that aids in breathing; descent of the testes into a scrotum to achieve a temperature environment amenable to sperm development; a variety of skin glands including sebaceous, sweat, and milk or mammary (the characteristic giving mammals

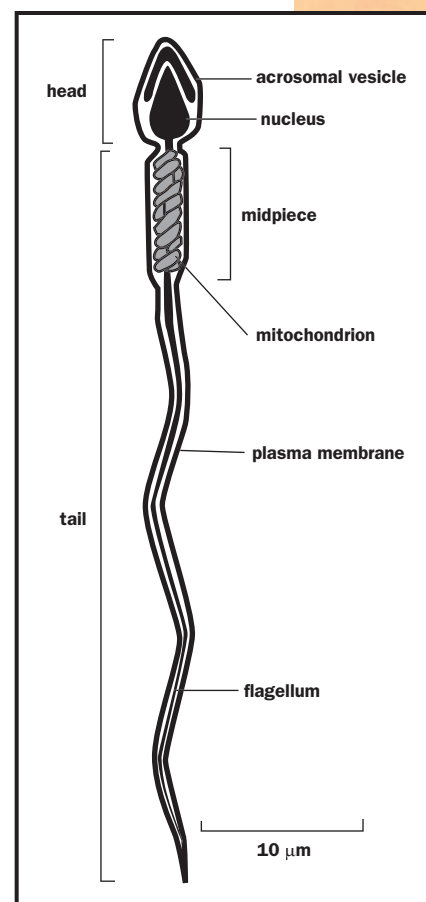

Anatomy of the human sperm.

**enzyme** protein that controls a reaction in a cell

**antigen** foreign substance that provokes an immune response

**alkaline** chemically basic, with an excess of OH<sup>-</sup> ions

**autonomic** independent; regulating involuntary actions

**gene** portion of DNA that codes for a protein or RNA molecule

**phylum** taxonomic level below kingdom, e.g., arthropod or chordate

**nucleus** membrane-bound portion of cell containing the chromosomes

their name); and elaborate dermal musculature (controlling the skin), particularly in the face (associated with suckling in young). All of these characters relate to the high metabolic rate of mammals. Mammals and birds are the only vertebrates that maintain a consistent body temperature through physiological (endothermy) rather than behavioral means (ectothermy).

None of these characters are readily apparent in fossils. There are, however, a number of skeletal and dental traits that are unique to mammals. The characters most useful in tracing the origin of mammals are: a bony secondary palate in the skull; a jaw joint between the dentary (jaw bone) and the squamosal bone of the skull (other terrestrial vertebrates have a quadrate-articular jaw joint); three bony ossicles (malleus, incus, and stapes) in the middle ear for sound transport rather than just one (stapes); teeth that are specialized for a variety of functions, including stabbing, nipping, shearing, and grinding; and a limb skeleton that can passively support the body off the ground (versus the reptilian posture of legs to the side). Most of these traits also relate to the high metabolic demands of endotherms. The reptile-to-mammal transition is one of the best documented in the fossil record. The first mammals appeared over 200 million years ago, about the same time as the first dinosaurs. SEE ALSO BODY CAVITIES; EVOLUTION, EVIDENCE FOR; REPTILE; SKIN

*William P. Wall*

#### Bibliography

- Martin, R. E., R. H. Pine, and A. F. DeBlase. *A Manual of Mammalogy with Keys to Families of the World*. New York: McGraw-Hill, 2001.
- Nowak, R. M. *Walker's Mammals of the World*. Baltimore, MD: Johns Hopkins University Press, 1999.
- Vaughan, T. A., J. M. Ryan, and N. J. Czaplewski. *Mammalogy*. Fort Worth, TX: Saunders College Publishing, 2001.
- Wilson, D. E., and F. R. Cole. *Common Names of Mammals of the World*. Washington, DC: Smithsonian Institution Press, 2000.
- Wilson, D. E., and D. Reeder. *Mammal Species of the World: A Taxonomic and Geographic Reference*. Washington, DC: Smithsonian Institution Press, 1993.

## Marine Biologist

A marine biologist is someone who studies plants, animals, and other organisms of the oceans, ranging from large marine mammals to microscopic **plankton**. Marine biologists study such subjects as animal behavior and ecology, biomedical uses of the sea, the commercial importance of the ocean's natural resources, and methods for preservation of species and habitats.

The need for marine biologists has increased because of growing interest in conservation of the oceans, and many are employed by private and government environmental protection and resource management agencies. For example, marine biologists are needed to determine catch quotas for species of fish in order to prevent a decline in population. In addition to performing basic research, they present information to governments and in-

**plankton** microscopic floating organisms

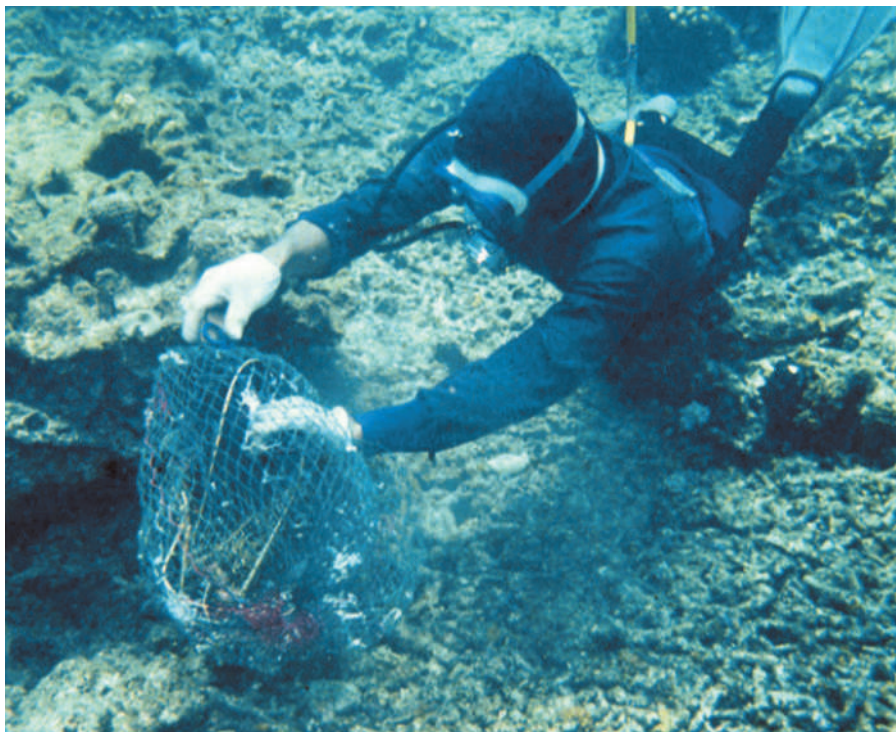

A marine biologist inspecting a coral reef in Indonesia that has been damaged by illegal fishing practices.

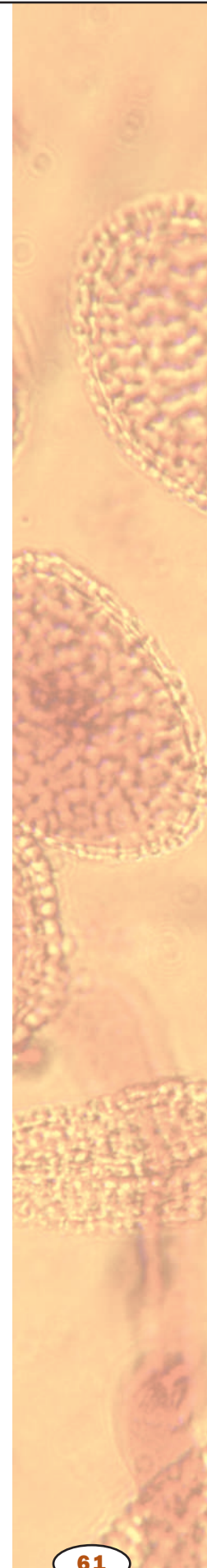

dustries to aid in resource conservation decisions. As land development increases, marine biologists are needed to determine its effects on surrounding habitats and whether an **ecosystem** can withstand human invasion. Marine biologists also find work worldwide teaching in colleges, universities, and even some high schools. Many work on oceanographic research vessels and in laboratories from polar to tropical settings.

**ecosystem** an ecological community and its environment

To be well prepared for a career in marine biology, a strong background in mathematics is crucial. One should also take a wide range of science courses in high school and college, such as biology, chemistry, physics, zoology, geology, marine science, oceanography, and atmospheric science. A working knowledge of computers is increasingly necessary for data collection and analysis. Satellite imaging and global information systems (GIS) are common uses of computers in the field.

Summer courses and internships are available worldwide to provide hands-on experience with marine life, the use of field and laboratory equipment, and other aspects of marine research. Employment opportunities are available from the bachelor to the doctorate level, with greater independence, decision-making responsibility, and income at the higher levels. SEE ALSO BONY FISH; CARTILAGINOUS FISH; CORAL REEF; CRUSTACEAN; ESTUARIES; OCEAN ECOSYSTEMS; PLANKTON

*Lisa Nicole Saladin and Kenneth S. Saladin*

### **Bibliography**

- American Fisheries Society Jobs Center Online.* <<http://www.fisheries.org/jobs.html>>.  
 Castro, Peter, and Michael E. Huber. *Marine Biology*, 3rd ed. Boston: McGraw-Hill, 2000.  
*Scripps Institution of Oceanography.* <<http://www.sio.ucsd.edu/>>.  
*Woods Hole Oceanographic Institution.* <<http://www.whoi.edu/>>.

**cranial** related to the cranium, or brain cavity

**gestation** period of fetal development within the mother

**lineage** ancestral line

**placental** related to mammals that nourish the fetus with a placenta, an exchange organ in the uterus

**niche** the habitat supplying the right environment for a particular species

## Marsupial

Marsupials, also known as metatherian mammals, are an ancient and diverse mammal group. They are distinguished from other mammals by a number of **cranial** and skeletal characteristics, including larger numbers of teeth. Marsupials also share a unique pattern of reproduction and development of the young. Marsupial young are born at an early stage of development after a **gestation** period that can be as short as twelve days. After birth, they crawl over the mother's fur and skin and attach themselves to a nipple. Many, but not all, marsupials develop a pouch that protects the nursing young, and most development occurs within the pouch.

The marsupial **lineage** is thought to be the sister group to the lineage of **placental** mammals. The two groups are believed to have diverged 140 million years ago by the mid-Cretaceous, but are first known from the late Cretaceous fossil record. Marsupials have never evolved flying or marine forms, but they are morphologically diverse and occupy every other ecological **niche**.

Most marsupial diversity occurs in the Australasian region (about two hundred species) and in the tropical regions of Central and South America (about seventy species). Examples of marsupials are the red kangaroo (*Macropus rufus*), the koala (*Phascolarctos cinereus*), and the Virginia opossum (*Didelphis virginiana*), the only native marsupial found in the United States and Canada. SEE ALSO MAMMAL

Tanya Dewey

### Bibliography

Nowak, Ronald M., ed. *Walker's Mammals of the World*. Baltimore, MD: Johns Hopkins University Press, 1991.

Vaughan, Terry A. *Mammalogy*. Philadelphia, PA: Saunders College Publishing, 1986.

## Mating Systems

Mating systems are descriptions of who mates with whom in the animal world. In simplest terms, definitions of mating systems are based on how many mates an individual acquires during the breeding season. In monogamy, both males and females have only one mate at a time. This type of mating system often occurs in species in which both the male and female are required to successfully raise young or in which males have little chance of monopolizing more than one female. Monogamy is common in birds whose males can help incubate eggs and feed young.

In a polygamous mating system, individuals of one or the other sex have more than one mate during the breeding season. When males in the population mate with more than one female, it is called polygyny (*poly* means "many," and *gyne* means "female"). Males compete for females, and this leads to strong selection for traits that either attract females (for example, elaborate songs or calls, bright coloration, and courtship displays) or allow males to compete effectively with other males (for example, aggressiveness, large size, and fighting aids such as antlers). Polygyny is common in species where males are less likely to provide parental care (and thus may increase their



A male frigate bird with its throat pouch inflated to attract females.

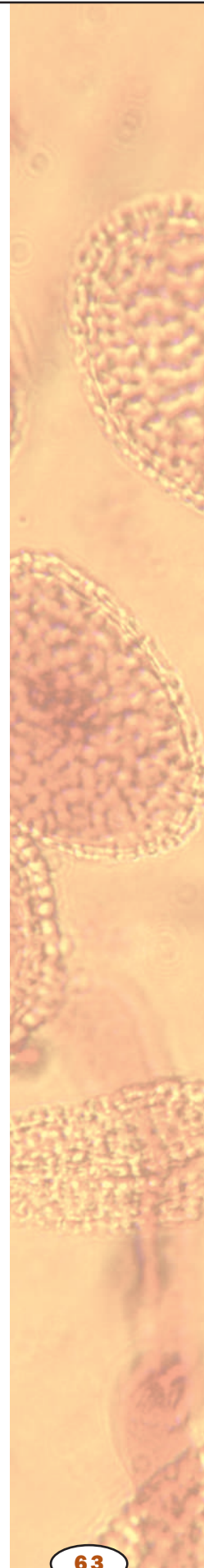

reproductive success by inseminating more females) or where males are able to monopolize more than one female (if females or the resources they require are spatially clumped). Mammalian mating systems are predominantly polygynous, in part because young develop within and are then nursed by the female.

In polyandry (*andros* means “male”), some females mate with more than one male during the breeding season. This is the rarest type of mating system. Females compete for males and may be larger and more colorful than males. In the spotted sandpiper, for example, females compete for territories in order to attract males. Once a male mates with a female, she lays a clutch of eggs that the male incubates. The female will then attempt to attract additional males for whom she will also lay eggs.

In addition to the number of mates an individual acquires during the breeding season, mating systems have also been described in terms of whether a pair bond is formed, how long the pair bond lasts, and how much each member of the pair contributes to care of the young, resulting in more complex definitions. Mating systems are also complicated by the fact that individuals of some species perform extra-pair copulations, which are copulations with individuals other than the mate. Evidence from deoxyribonucleic acid (DNA) studies of birds, mammals, and other species has shown that extra-pair copulations can result in fertilized eggs so that a presumably “monogamous” male or female may in fact have more than one mate.

Which mating system evolves is influenced by the relative parental investment of each sex and the ability of one sex to monopolize members of the opposite sex, which in turn may be driven by the abundance and distribution of resources such as food or nesting sites. Because resources vary among and within habitats, this leads to variation in mating systems, even within species. An excellent example of this is the mating system of the dunnock, a European songbird. The amount of food available affects the size of the area over which a female must forage, and this in turn affects how many females can be monopolized by one male and how many males can

**gamete** reproductive cell, such as sperm or egg

be attracted by a female. Within a single population of dunnocks, there may be monogamous pairs as well as birds in polygynous and polyandrous relationships.

Because of differences in the amount of energy invested in producing **gametes** (eggs are costly, sperm are not), finding a mate, and rearing offspring, the costs and benefits of a particular mating system may be different for males and females. In addition, not all individuals of the same sex in a population experience the same costs and benefits of a particular mating system (for example, some males in a polygynous mating system may have several mates whereas other males may have none). SEE ALSO BEHAVIOR PATTERNS; EVOLUTION; SEXUAL REPRODUCTION; SEXUAL REPRODUCTION, EVOLUTION OF; SEXUAL SELECTION; SOCIAL BEHAVIOR; SOCIOBIOLOGY

Susan Evarts

**Bibliography**

- Davies, Nicholas B. *Dunnock Behaviour and Social Evolution*. Oxford: Oxford University Press, 1992.
- Emlen, Stephen T., and Lewis W. Oring. "Ecology, Sexual Selection, and the Evolution of Mating Systems." *Science* 197 (1977): 215–223.
- Westneat, David F., Paul W. Sherman, and Martin L. Morton. "The Ecology and Evolution of Extra-Pair Copulations in Birds." *Current Ornithology* 7 (1990): 330–369.

**McClintock, Barbara**

**American geneticist**  
1902–1992



Barbara McClintock.

In the words of James Watson, codiscoverer of the structure of deoxyribonucleic acid (DNA), Barbara McClintock was one of the most important geneticists of the twentieth century. McClintock made major discoveries about **chromosome** structure and showed for the first time that movable elements within the chromosome (transposons) could control **gene expression**. In 1931, with her graduate student, Harriet Creighton, she showed that meiotic crossing over in corn separated formerly linked observable traits, thus proving that genes were located on chromosomes.

McClintock went on to study the genetic control of coloration in Indian corn. She discovered a genetic element whose presence would cause the chromosome to break where it occurred. McClintock termed this element *Ds*, for "dissociation." The breakage caused by *Ds* interrupted the normal expression of nearby genes, causing the color variegation. McClintock also discovered that after breakage, the chromosomal fragment containing *Ds* can reinsert itself elsewhere, interrupting other genes and causing different effects. She coined the term "transposition" to describe this new type of genetic mutation.

McClintock's discovery of the breakage and transposition of a genetic element conflicted with the then prevalent view of chromosomes as static blueprints, and her work was largely ignored throughout the 1950s. Her discoveries, however, laid the foundation for the dynamic view of the **genome**, and she was finally honored with the Nobel Prize in physiology

**chromosome** "colored body" in the cell nucleus; made of DNA and protein, and divided functionally into genes and nongene regions

**gene expression** use of a gene to create the corresponding protein

or medicine in 1983. SEE ALSO LINKAGE AND GENE MAPPING; MEIOSIS; TRANSPOSON

*Richard Robinson*

### Bibliography

Keller, Evelyn Fox. *A Feeling for the Organism: The Life and Work of Barbara McClintock*. San Francisco, CA: W. H. Freeman and Company, 1983.

**genome** total genetic material in a cell or organism

## Medical Assistant

A medical assistant is a health care professional who provides administrative or clinical assistance to a doctor. Duties of the administrative medical assistant include general office responsibilities, such as answering the phone and making appointments, as well as more specialized skills, such as keeping medical records and processing insurance reimbursements. The clinical medical assistant may be responsible for obtaining a medical history from the patient, taking vital signs (temperature, blood pressure, and pulse), performing visual exams, obtaining specimens such as blood samples or throat swabs, or other medical procedures that assist in the diagnosis of a patient. All of these are done at the request of the physician, but are usually performed without direct supervision. In smaller clinics or private doctor's offices, the medical assistant may perform both types of duties.

To become a medical assistant, one should take high school courses in science, mathematics, computer skills, and business. Medical assistant training programs are available at junior colleges, community colleges, and private vocational schools. Programs may last from seven months to two years, depending on the breadth of skills involved. Personal and professional skills essential to the medical assistant include attention to detail, desire to work with people, and a professional and friendly manner. SEE ALSO DOCTOR, FAMILY PRACTICE; NURSE; NURSE PRACTITIONERS

*Richard Robinson*

### Bibliography

*American Association of Medical Assistants*. <<http://www.aama-ntl.org/>>.

## Medical/Science Illustrator

Science and medical illustrators provide art for books, newspapers, magazines, advertisements, articles in scientific journals, online Web sites and other electronic references, and museum, zoo, and legal exhibits. Illustrators may draw an illustration of an arrowhead dug from an archaeological site, a diagram showing how **neurons** in the brain transmit signals, or an animation of a chemical reaction. Illustrations may be artistic (such as an artist's conception of the surface of a faraway planet), realistic, or diagrammatic.

Everything that science and medical illustrators draw is meant to communicate scientific or medical ideas or facts. Some science illustrators specialize in natural history, drawing a new species of fish or a coral habitat, for example. Medical illustrators specialize in human anatomy,

**neuron** nerve cell

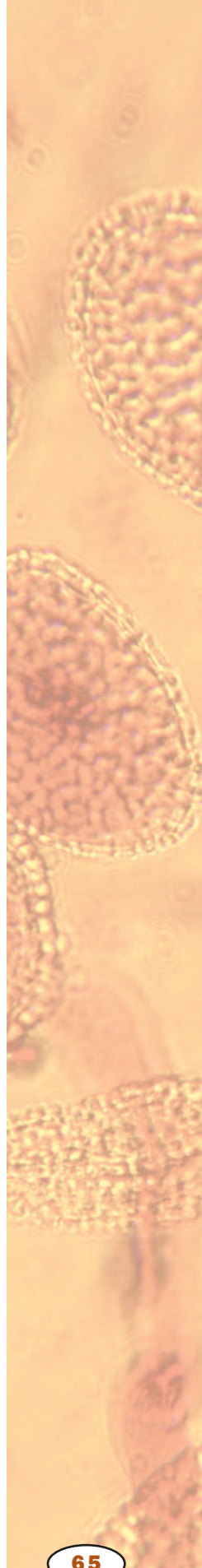

diseases, and surgical procedures. They may do anatomical drawings that help students and health professionals learn the structure of the human body, or they may make detailed drawings of how to perform a heart bypass operation.

The audience for an illustrator's work can be laypeople who know little science, the kind of people who wander into a museum on their lunch break; students; or highly specialized professionals. Illustration can be simple pen-and-ink line drawings, airbrush paintings, computer-generated graphics, cartoons, or even three-dimensional models.

Many science and medical illustrators begin by getting a bachelor's degree in biology or some other science. They may then spend one to two years studying medical illustration or science illustration in a graduate program at a university. Such students can launch their career by taking an internship or job at a magazine or art studio, for example. Others get a degree in art and teach themselves science as they work. Still others are self-taught. If art has always been a hobby, they may start out working with a researcher they know, then gradually find more work. High school students interested in science illustration should take as much math as possible, in an effort to prepare for science classes in college.

*Jennie Dusbeck*

#### Bibliography

*Association of Medical Illustrators.* <<http://medical-illustrators.org/state.html>>.

*Guild of Natural Science Illustrators.* <<http://www.gnsi.org/>>.

*Medical Illustration Source Book.* <<http://www.medillsb.com/>>.

## Meiosis

Meiosis is the two-step series of specialized cell divisions that makes sexual reproduction possible. Meiosis produces **haploid** cells, which contain just one member of every **chromosome** pair characteristic of an organism. In all animals, specialized cells in the reproductive organs, called germ cells, undergo meiosis to produce haploid **gametes** (sperm and egg), which then fuse during sexual reproduction to create new **diploid** embryos. For example, human gametes are haploid and contain twenty-three different chromosomes. All other cells in the human body are diploid, containing two versions of each chromosome for a total of forty-six. Fusion of gametes to form a new embryo restores the diploid number characteristic of the organism, and it mixes maternal and paternal **genes** to give new combinations of traits. Meiosis itself also yields great genetic diversity in the resultant gametes through two mechanisms: (1) independent assortment of chromosomes at both of the meiotic divisions; and (2) physical exchange of chromosomal regions through a process called crossing over. Both processes create new chromosomal combinations, resulting in an array of genetically diverse gametes from a single individual.

Plants, fungi, and some protists also perform meiosis. In plants, meiosis creates a multicellular haploid organism, called a **gametophyte**, which in some groups is independent of the diploid plant. Gametes are produced by **mitosis** of the gametophyte, which then fuse to form the embryo. This cycle is called alternation of generations.

**haploid** having single, nonpaired chromosomes in the nucleus

**chromosome** "colored body" in the cell nucleus; made of DNA and protein, and divided functionally into genes and nongene regions

**gamete** reproductive cell, such as sperm or egg

**diploid** having pairs of chromosomes in the nucleus

**gene** portion of DNA that codes for a protein or RNA molecule

**gametophyte** a haploid plant that makes gametes by mitosis

**mitosis** separation of replicated chromosomes



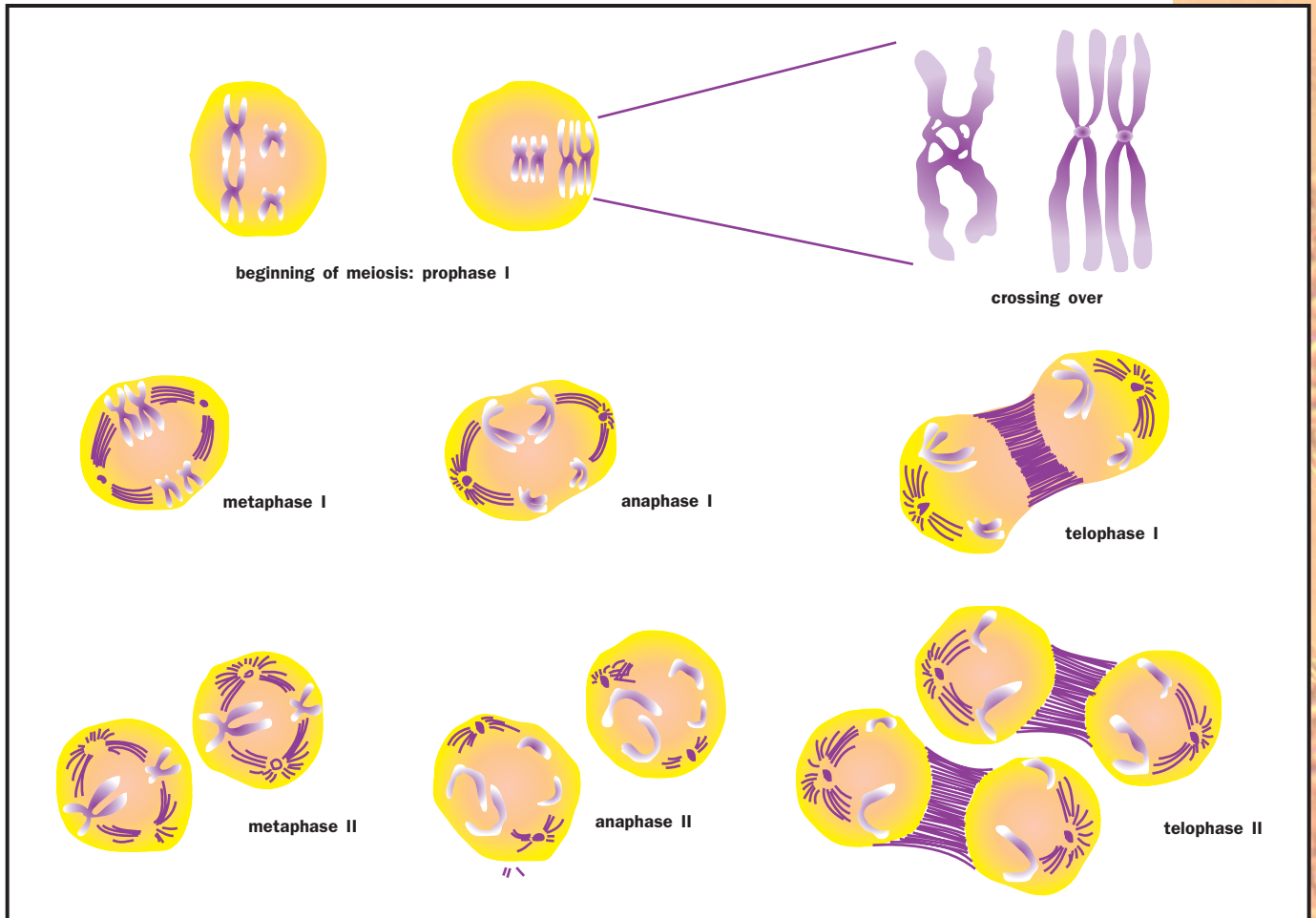

## Chromosome Basics and Meiosis Overview

As noted, diploid cells contain pairs of chromosomes, each member of which carries the same set of genes. One member of each pair is inherited from the mother, and one from the father. The two pair members are called **homologous chromosomes**, or homologs.

Prior to meiosis, the diploid cell replicates its deoxyribonucleic acid (DNA). During replication, each chromosome duplicates itself to form two identical copies, which remain attached at a region known as the **centromere**. Each copy is known as a **chromatid**; thus, each chromosome is composed of two identical sister chromatids.

During meiosis, homologous chromosomes line up and exchange segments, a process called crossing over. Following this, homologs are separated from each other in the first meiotic division. Next, in the second meiotic division, chromatids are separated from each other, in a process which is mechanically identical to mitosis. The result is four haploid cells. The coordination of the two meiotic chromosomal divisions gives meiosis its distinctive characteristics: a reduction in the number of chromosomes by half, accompanied by mixing of parental chromosomes, and swapping of regions between homologous chromosomes.

Meiosis involves two divisions. During meiosis I, homologous chromosomes cross over, exchanging segments. By the end of telophase I the members of homologous pairs have separated from each other. During meiosis II, sister chromatids are separated, just as they are during mitosis.

**homologous chromosomes** chromosomes carrying similar genetic information

**centromere** region of the chromosome linking chromatids

**chromatid** a replicated chromosome before separation from its copy

## Meiosis I

Consider a spermatocyte or oocyte about to embark on meiosis. This diploid cell contains one set of chromosomes contributed by its mother and one set of chromosomes contributed by its father. Following DNA replication, the unique aspects of the first division of meiosis (meiosis I) begin. Because meiosis reduces chromosome content, a mechanism must ensure that every final haploid gamete has both the correct number and the correct set of chromosomes, with one member of each homologous pair. Meiosis I guarantees this by keeping each chromatid pair together and aligning homologous pairs of duplicated sister chromosomes prior to the first chromosomal division. The alignment and subsequent separation of pairs of homologous chromosomes during meiosis I thus sets up the mechanism that ensures that all four haploid gametes will contain the correct complement of chromosomes. Interestingly, the mechanism whereby meiosis aligns homologs also results in reciprocal exchanges of DNA between aligned chromosomes.

Alignment of homologous chromosome pairs begins before meiosis I, when each duplicated set of chromosomes seeks its homologous partner pair within the oocyte or spermatocyte. The underlying DNA sequence homology of the similar maternal and paternal chromosome pairs guides this search and eventual alignment along the entire length of each chromosome. The alignment is further mediated and cemented by a three-dimensional zipperlike structure surrounding each set of paired homologous chromosomes, the synaptonemal complex. In the process of these alignment steps, specific **enzymes** nick and then rejoin DNA at different places along the paired chromosomes. This process of genetic exchange is called meiotic recombination, or crossing over. Crossing over provides an attachment that holds homologous chromosomes temporarily in place and, at the same time, produces **progeny** chromosomes consisting of a patchwork of material from each of the originals. Thus, the two central characteristics of meiosis, reduction in chromosome number and genetic rearrangements, are intimately intertwined.

Once all sets of chromosome pairs have established at least one such crossing over, correct assortment of chromosomes at meiosis I is ensured. The synaptonemal complexes dissolve and the newly rearranged chromosomes proceed through the second mechanism that generates genetic diversity at meiosis I: They assort independently of one another to opposite poles of the cell pulled by spindle fibers. Whereas one chromosome pair might divide so that its predominantly maternal chromosome moves to the cell's "north" pole, another pair of chromosomes will move its predominantly paternal chromosome to that same north pole. These chromosomal movements are randomly determined, yielding great genetic diversity of gametes in an organism with multiple chromosomes. In an organism with three homologous pairs, there are four different possible chromosome arrangements at the end of meiosis I. In humans there are more than 4 million possible arrangements.

Thus, overall, the first division of meiosis provides two major mechanisms for new genetic combinations: (1) cutting apart and pasting together various segments of homologous chromosomes to yield unique **hybrid** chromosomes; and (2) independent assortment of maternal and paternal chromosomes.

**enzyme** protein that controls a reaction in a cell

**progeny** offspring

**hybrid** combination of two different types

## Meiosis II and Cytokinesis

As meiosis II begins, each daughter **nucleus** contains the haploid number of chromosomes (for humans, twenty-three). Each chromosome is composed of two chromatids attached at the centromere. The second division of meiosis separates the chromatids. Once again, spindle fibers provide the pulling power. Once chromatids are separated, they are called chromosomes, and so at the end of meiosis II, each of the four new cells has the haploid number of chromosomes. Following this, cytokinesis occurs, in which the **cytoplasm** of the original cell is divided and membranes form to separate the new cells. Cytoplasm is divided evenly in sperm, but unevenly in eggs. During egg formation, most of the cytoplasm is allotted to one of the cell products, leaving one functional egg and several “polar bodies” that contain DNA and membrane, but little else. This unequal division gives the single egg a larger store of food to supply the developing embryo after **fertilization**.

**nucleus** membrane-bound portion of cell containing the chromosomes

**cytoplasm** material in a cell, excluding the nucleus

**fertilization** union of sperm and egg

## Meiosis versus Mitosis

The alignment of homologous chromosome pairs in meiosis I and the accompanying physical exchanges between aligned chromosomes is unique to meiosis. In mitosis, by contrast, homologous chromosome pairs never or very rarely interact. Each mitotic chromosome duplicates, forming two sister chromatids, and then these two identical sister chromatids separate to opposite poles. While mitosis is specialized to produce entirely identical progeny, meiosis is specialized to produce a wide range of distinctive haploid progeny.

## Mistakes in Meiosis

Among the many potential causes of infertility are problems with meiosis. If a person’s spermatocytes or oocytes consistently produce sperm or eggs that contain an incorrect number or complement of chromosomes, then there will be great difficulty in producing a viable embryo.

A much more common situation arises from the rare, sporadic occurrence in a normally fertile person of an improper chromosome separation. When two chromosomes fail to separate as they should, a “nondisjunction” event has occurred. Such **nondisjunctions** are almost always lethal to the egg or sperm, or to the resultant embryo. There are exceptions, however. For example, approximately one out of one hundred men is the result of such a nondisjunction, which gave him an extra X chromosome. Such XXY individuals have Klinefelter’s syndrome, a sex chromosome trisomy (three sex chromosomes instead of the normal two) with minor outward manifestations. Down syndrome individuals possess three copies of chromosome twenty-one instead of the normal two; their extra copy resulted from a nondisjunction of those chromosomes during one of the meiotic divisions of one of the parents. SEE ALSO ALTERNATION OF GENERATIONS; CHROMOSOME, EUKARYOTIC; CYTOKINESIS; MITOSIS; SEX CHROMOSOMES; SEXUAL REPRODUCTION

**nondisjunction** failure of separation of homologous chromosomes during meiosis

*Wendy E. Raymond*

### Bibliography

Griffiths, Anthony J. F., et al. *Modern Genetic Analysis*. New York: W. H. Freeman and Company, 1999.

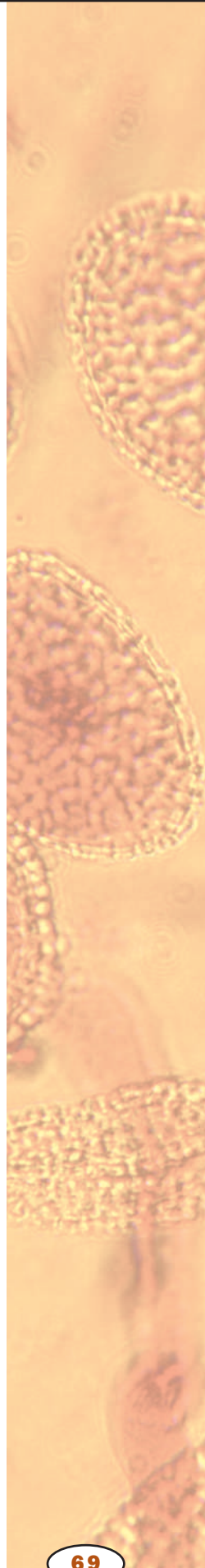

“Meiosis and Genetic Recombination.” *MIT's Biology Hypertextbook*. <<http://esg-www.mit.edu:8001/esgbio/mg/meiosis.html>>.

“Meiosis Tutorial.” *The Biology Project*. <[http://www.biology.arizona.edu/cell\\_bio/tutorials/meiosis/main.html](http://www.biology.arizona.edu/cell_bio/tutorials/meiosis/main.html)>.

**organelle** membrane-bound cell compartment

**aqueous** watery or water-based

**lipid** fat or waxlike molecule, insoluble in water

**bilayer** composed of two layers

A transmission electron micrograph of a Golgi apparatus, a membranous subcellular structure.

## Membrane Proteins

Cells and their **organelles** are **aqueous** compartments bounded by thin membranes. The core of these membranes is a film of specialized **lipids**, two molecules thick. Attached to and embedded in this lipid **bilayer** are numerous proteins, each specialized to carry out a different function. Thus, each membrane has its own team of proteins. A typical membrane might be composed half of lipid and half of protein. However, this varies widely. For example, the envelopes of some viruses employ only a few protein species to gain entry into cells and later mediate the exit of new virus particles. In contrast, busy membranes are crowded with hundreds of different proteins; each type is present in a specified number—hundreds, thousands, or even



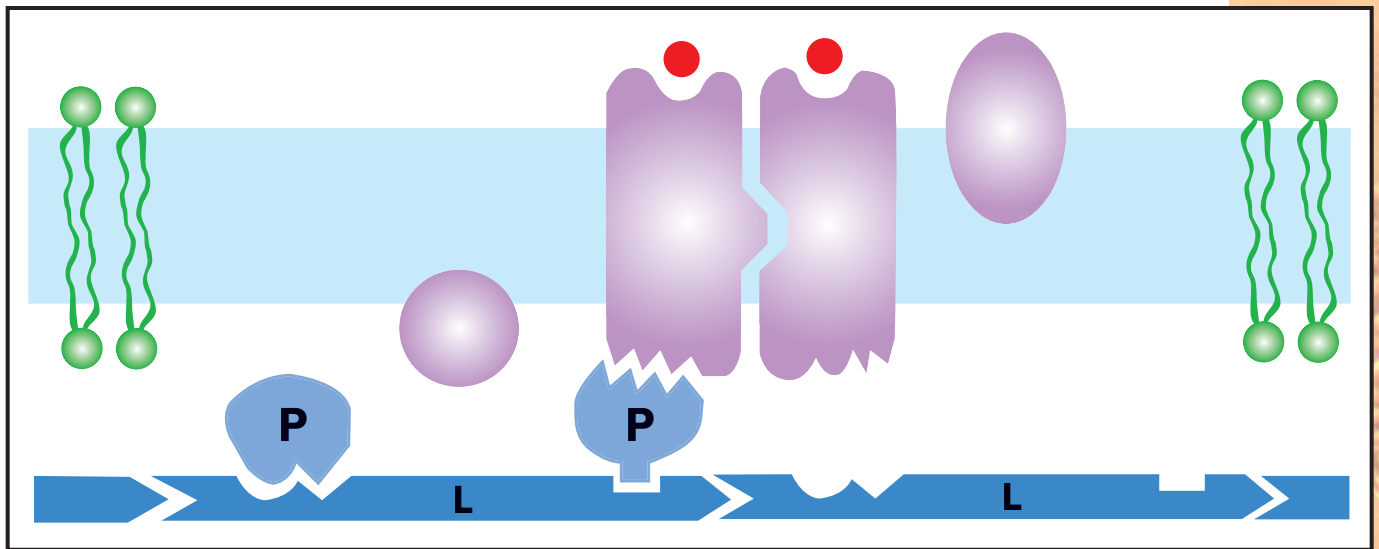

millions of copies per cell. Built into the structure of each of these proteins is molecular information directing the way it sits in its membrane and an address tag targeting it to its home.

### What Membrane Proteins Do

Membranes do not simply serve as walls between cellular compartments but are also participants in their **metabolism**. Many membrane proteins are transporters, moving **solutes** between the aqueous compartments. Other membrane proteins serve as **enzymes** that **catalyze** vital processes; for example, the harvest of energy from food.

A variety of membrane proteins are receptors, signal **transducers** that transmit stimuli received outside the cell (for example, **hormone** or odor molecules) to functional proteins inside. The signals conveyed to the **cytoplasm** typically turn on complex circuits of response, adapting the metabolism of the cell to a perception of the outside world. Thus, receptors transport information rather than cargo across membranes.

There are two general ways this transfer of information occurs. First, in many cases, the binding of the external stimulus molecule to the receptor brings about a specific change in the shape of this protein. The altered form of the receptor is then recognized by a relay protein inside the cell because its new shape precisely matches a site on the relay protein, enabling them to fit together like a key in a lock. This association turns on the response. The second class of receptors uses a somewhat different strategy: the binding of extracellular signal molecules to these membrane molecules causes them to change shape, but, in this case, their altered contour allows them to associate with one another (once again, through lock-and-key recognition). These conglomerates are then recognized as a stimulus by the appropriate relay proteins at the cytoplasmic side of the membrane.

Most cells have **cytoskeletons**: protein scaffolds that lend mechanical support to both the watery interior of the cell and to their fragile and deformable membranes. Membranes are bound to the underlying cytoskeleton through linker proteins. Cytoskeletal proteins can tap adenosine

Membrane proteins can be integral (I) or peripheral (P), determined by their amino acid structure. Peripheral proteins bind to integral proteins and to cytoskeletal proteins (L).

**metabolism** chemical reactions within a cell

**solute** dissolved substance

**enzyme** protein that controls a reaction in a cell

**catalyze** aid in the reaction of

**transduce** proteins that convert a signal of one type into another type

**hormone** molecule released by one cell to influence another

**cytoplasm** material in a cell, excluding the nucleus

**cytoskeleton** internal scaffolding in a cell, composed of protein

**ATP** adenosine triphosphate, a high-energy nucleotide used by cells to power most energy-requiring reactions

**pseudopod** “false foot”; an extension of the plasma membrane during locomotion by an amoeba or similar crawling cell

**polar** partially charged

**amino acid** a building block of protein

**hydrophobic** “water hating,” such as oils

**hydrocarbon** molecule or group composed only of C and H

triphosphate (**ATP**) or some other high-energy molecule to push and pull on the membrane so as to change its contour. Amebae and white blood cells, for example, are made to crawl as their plasma membranes are deformed into **pseudopods** by a dense mass of filaments in the underlying cytoskeletal array. In addition, some membrane-spanning proteins link the cytoskeleton inside the cell to filaments in the extracellular space and thereby manage the intricate relationships of the cells in human tissues.

### Associations of Proteins with Their Membranes

Lipid bilayers are like oily liquid films. Their molecules diffuse about randomly within the membrane but avoid the aqueous environment, just as oil shuns water. This is because the chemical nature of lipids is mostly nonpolar, whereas that of water is **polar**. Some proteins destined for the membrane are designed so that groups of nonpolar **amino acid** side chains create a water-shunning (hydrophobic) region on their surface. This lodges the protein in the interior of the bilayer. Proteins that are anchored by dissolving in the bilayer core are said to be integral to the membrane. At the same time, the tops and/or bottoms of these integral membrane proteins make contact with the water space. Predictably, these exposed regions are covered with polar amino acid side chains, attracted to water, which help to orient and stabilize the protein in the membrane. Every copy of an integral membrane protein that spans the bilayer is oriented identically; for example, with the same end pointed inside or outside, as befits its function.

Other membrane proteins are entirely covered with polar amino acid side chains. Although these proteins are water soluble, they nevertheless associate with membranes. This they do by making specific lock-and-key attachments to the projecting portions of integral proteins. These docked water-soluble molecules are called peripheral membrane proteins because they reside outside the lipid bilayer. Their anchorage can be permanent or they may get on and off the membrane, randomly in some cases or else in response to a biological signal.

A third mode of membrane association is for the cell to attach **hydrophobic** tails to peripheral proteins. The tails then dissolve in the hydrophobic (nonpolar) core of the bilayer, thereby anchoring the protein. Typically, these tails are long **hydrocarbon** chains; frequently, they are the very same fatty acids that hold the lipid molecules in the bilayer.

Scientists can disassemble biological membranes in the laboratory, separate the component molecules from one another, and then recombine them. With any luck, the molecules will reassemble into a membrane that is reminiscent of the original and, to some degree, functional. This self-assembly demonstrates that membrane molecules carry information about their intended destination within their structures.

### Constraining the Movement of Membrane Proteins

Membrane lipids and proteins can, in principal, diffuse freely by random (Brownian) motion, circumnavigating a cell within a few minutes. But some membranes have mechanisms to suppress this kind of freedom so as to segregate specified molecules into different domains, or regions of the membrane surface. For example, the epithelial cells that line the intestine,

separating the inside from the outside of the body, are polarized to perform distinctly different tasks at their two surfaces. To help maintain their two-faced existence, each cell surface has a belt of protein filaments around its waist called a tight junction that fences off the other membrane molecules into their proper compartments. SEE ALSO CELL JUNCTIONS; CELL MOTILITY; ENZYMES; HORMONES; ION CHANNELS; MEMBRANE STRUCTURE; MEMBRANE TRANSPORT; NUCLEAR TRANSPORT; PROTEIN TARGETING; SIGNALING AND SIGNAL TRANSDUCTION

Theodore L. Steck

### Bibliography

Alberts, Bruce, et al. *Molecular Biology of the Cell*, 4th ed. New York: Garland Publishing, 2000.

Lodish, Harvey, et al. *Molecular Cell Biology*, 4th ed. New York: W. H. Freeman and Company, 2000.

## Membrane Structure

A membrane separates a cell from its environment or subdivides a cell into specialized regions or compartments. The structure of a membrane is best understood in light of its component parts and in the context of the specialized functions performed by the cell or by its various, membrane-bound compartments.

### Molecular Structure

Cellular membranes consist mainly of phospholipid assembled into a stable, sheetlike structure called a **bilayer**. The process of assembly occurs spontaneously under normal cellular conditions once phospholipid has been synthesized. To understand this process and the important properties of all membranes, it is necessary to appreciate the **amphipathic** nature of phospholipid structure. An amphipathic **lipid** is structurally polarized into a molecular region that is **hydrophilic** and one that is **hydrophobic**. When the phospholipids in an **aqueous** environment like **cytoplasm** reach a critical concentration, they associate into **aggregates** that are more stable in an aqueous environment than are the individual lipids. These aggregates, or micelles, can assume several forms, but they all have two features in common: The polar “heads” of the phospholipids project into the aqueous environment, and the hydrophobic regions or “tails” are oriented away from water. At low lipid concentrations the micelles are spherical; at higher concentrations, the micelles aggregate to form an extended, two-dimensional sheet called a bilayer.

To understand the structure of a bilayer, imagine two single layers of phospholipid, each consisting of polar heads and nonpolar tails, aligned head with head and tail with tail. Then imagine these monolayers coming together in a symmetrical fashion, such that the tails of one monolayer touch those of the other, and the heads project outward away from the tails. The resulting structure is a stable bilayer, with a hydrophobic core and hydrophilic surfaces.

Such bilayers can be made in the laboratory. Moreover, compositional studies carried out in the early 1900s by Dutch scientists E. Gorter and F.

**bilayer** composed of two layers

**amphipathic** having both polar and nonpolar regions

**lipid** fat or waxlike molecule, insoluble in water

**hydrophilic** “water loving”

**hydrophobic** “water hating,” such as oils

**aqueous** watery or water-based

**cytoplasm** material in a cell, excluding the nucleus

**aggregate** clump together

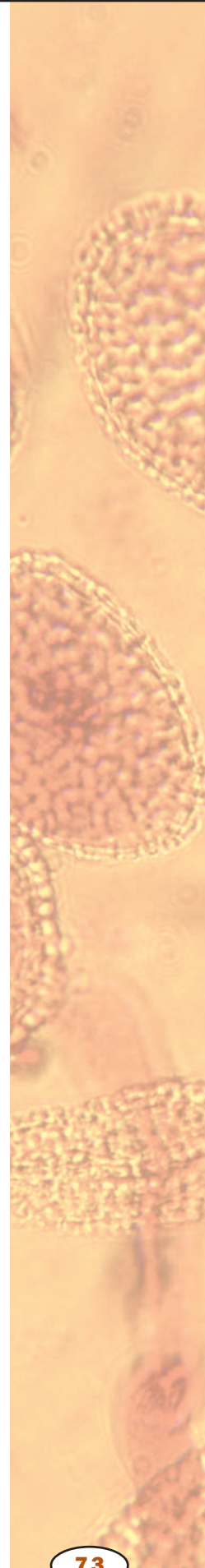

Three-dimensional view of a cell membrane.

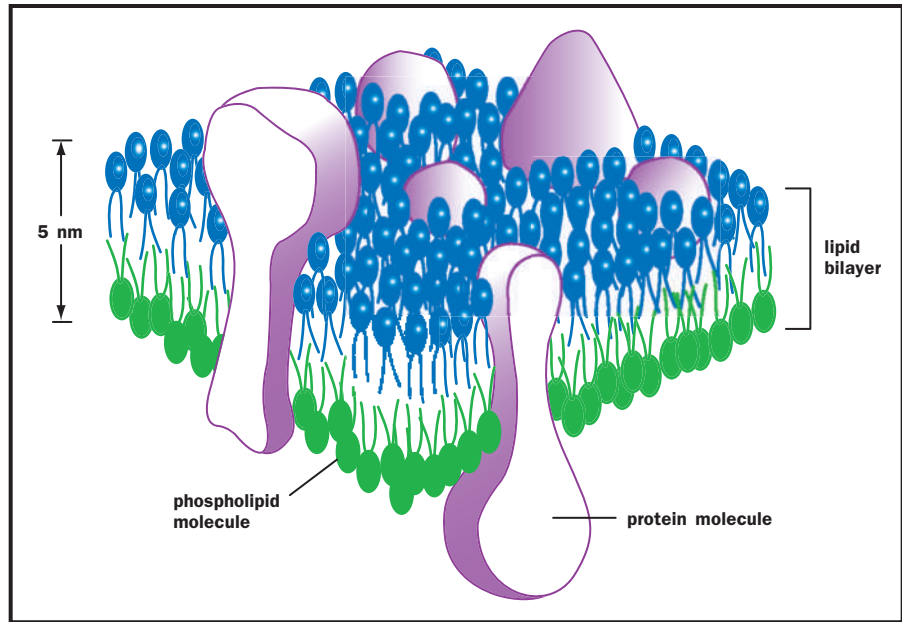

Grendel strongly suggested plasma membranes actually consist of lipid bilayers. When they extracted the lipid from plasma membranes of different mammals, they found just enough to make a monolayer with approximately twice the surface area of the cells from which the lipid was obtained. Thus, they concluded the cells were covered with a membrane consisting of a symmetrical lipid bilayer.

More recent studies indicate the lipid composition of one monolayer or leaflet of a membrane may differ somewhat from that of the other, introducing a degree of asymmetry into what is essentially a symmetrical structure. For example, phospholipid containing the sugar inositol as its polar head is found predominantly in that half of the bilayer facing the cytoplasm, whereas lipid containing longer, more complex saccharides (called glycolipids) are found exclusively in the extracellular half of the bilayer.

### Membrane Properties

The amphipathic nature of the phospholipid components generates the bilayer organization of a cellular membrane and also provides its three basic properties. First, a bilayer lipid membrane is stable: that is, once formed it stays formed and is unlikely to disintegrate. Such stability results from the weak interactions among the nonpolar tail regions and from the tendency of highly dipolar water molecules to exclude nonpolar molecules from their midst. Thus, bilayers can be thought of as being formed, in part, by the self-adhesiveness of water and its tendency to compact and segregate any substance that is not equally polar.

Second, a lipid membrane tends to prevent passage of polar substances; thus, a membrane forms a boundary and compartmentalizes regions of cytoplasm containing relatively water-soluble and nonamphipathic **solutes**, such as **ions**, sugars, **amino acids**, and **nucleotides**, and much larger molecules, such as **proteins**, that are unable to pass easily across it. The third and perhaps most important property of membranes is their dynamic

**solute** dissolved substance

**ion** an electrically charged particle

**amino acid** a building block of protein

**nucleotide** the building block of RNA or DNA

**protein** complex molecule made from amino acids; used in cells for structure, signaling, and controlling reactions



nature. A membrane will bend and fold; it can be deformed without breaking. Under special circumstances, such as occurs in **vesicle** fusion or budding, a bilayer can be broken. When this happens, it very quickly reseals. Moreover, and most important, at room temperature a membrane's constituents are in constant, random motion. In brief, the amphipathic nature of its lipid constituents makes a membrane both a stable and a fluid boundary.

Clearly, advantages are conferred on cells and **organelles** by their being compartmentalized and by the boundary nature of their membranes. Separated from each other, these compartments can differentiate to carry out specialized functions, precisely because the reactants, products, **enzymes**, and other factors appropriate for these functions are compartmentalized. Moreover, compartmentalized functions are more easily regulated and controlled.

No benefit comes without a price, however, and although compartmentalization is a fundamentally important feature of cells, the boundary nature of membranes poses problems as well. For one, a completely impenetrable boundary would stifle cells and their organelles. Thus, lipid membranes are modified to allow various water soluble substances, such as nutrients and waste products, to move from one side to the other. For another, cells and their organelles receive signals across their membranes, and these signaling functions modify the basic phospholipid bilayer structure. Also, cells are anchored to their environments—to other cells or to the extracellular **matrix** (ECM)—and organelles are attached to various cytoskeletal elements. Directed movement of both cells and organelles are possible when these anchorages and attachments are transient rather than permanent. For the most part, the protein components of membranes serve these additional functions of transport, signal conduction, and anchorage and attachment.

## Membrane Proteins

Proteins are very important components of membranes, although molecule for molecule they may be relatively minor constituents compared to the vastly greater numbers of membrane lipids. There are three types of basic membrane proteins. Integral membrane proteins (IMP) completely span the bilayer and have regions exposed to both the cytoplasm and to the extracellular environment (or in the case of organelles, to the interior or lumen environment). IMPs may span the membrane once or multiple times, and typically they carry out transport, signaling, and anchoring/attachment functions. Peripheral membrane proteins (PMP) are attached to the membrane, usually to integral membrane proteins, by electrostatic or **hydrogen bonds** at either their cytoplasmic or extracellular (or luminal) surfaces; these surfaces are often referred to, respectively, as the C- or the E-face of the membrane. Peripheral membrane proteins are involved primarily in anchoring or attachment.

Finally, lipid-anchored proteins (LAP), as their name implies, are covalently bound to membrane lipids and are found associated with either the C- or the E-face of the membrane. **Enzymatic** and signaling functions are performed by LAPs. In addition to facilitating specific functions, these modes of associations modulate the basic lipid bilayer structure of the membrane.

**vesicle** membrane-bound sac

**organelle** membrane-bound cell compartment

**enzyme** protein that controls a reaction in a cell

**matrix** a network, usually of threadlike fibers

**hydrogen bond** weak bond between the H of one molecule or group and a nitrogen or oxygen of another

**enzymatic** related to function of an enzyme

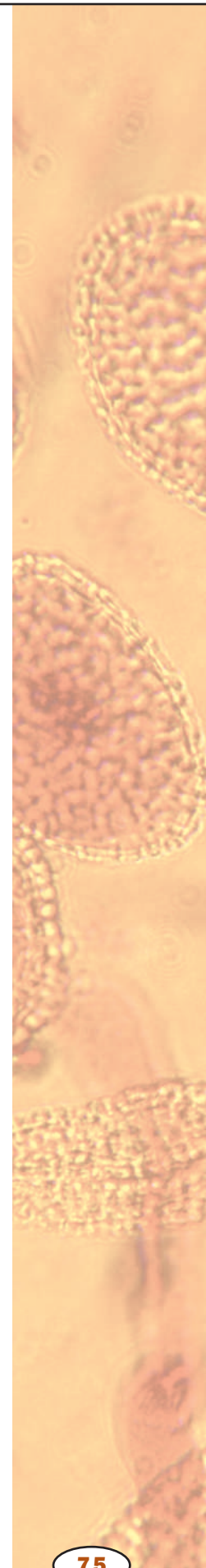

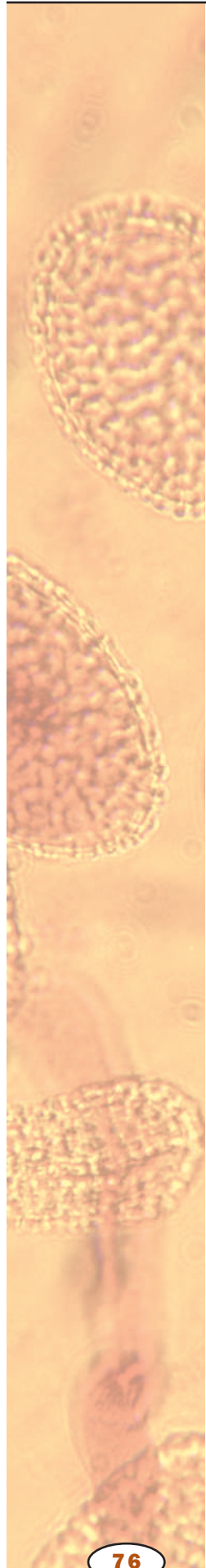

**lateral** side-to-side

**hormone** molecule released by one cell to influence another

**conformation** three-dimensional shape

**affinity** attraction

**polysaccharide** carbohydrate composed of many individual units of sugar

**aqueous** watery or water-based

**organelle** membrane-bound cell compartment

**solute** dissolved substance

**vesicle** membrane-bound sac

## Fluid Mosaic Model

The modern view of membrane structure, known as the fluid mosaic model, was developed in 1972 by S. J. Singer and G. L. Nicholson and reflects three basic features of membrane structure. Integral membrane proteins, when viewed from above one surface or the other, contribute a mosaic or “pebbled” pattern to a membrane, and these proteins and the membrane lipids are capable of **lateral** movement in the plane of the membrane, due to the fluid nature of lipid association. Lipid-anchored proteins are also potentially mobile as well, moving by virtue of their association with mobile lipids.

Any lateral movement of IMPs or LAPs may be constrained, however, by their associations with peripheral membrane proteins in the form of cytoskeletal elements or, outside the cell, in the form of the ECM. Moreover, certain IMPs may be constrained by association with IMPs of adjacent cells in a tissue. These associations reflect the anchoring or attachment functions served by membrane proteins.

A third important feature of membrane structure is its asymmetry. Thus, different peripheral membrane proteins are found associated with the extracellular or cytoplasmic faces of membranes and, in turn, are attached to regions of IMP exposed, respectively, at the extracellular and the cytoplasmic membrane surfaces.

Membrane asymmetry is also evident in the orientation of IMPs responsible for transmembrane signaling. For example, a **hormone** binding to the portion of an IMP exposed on the E-face of the plasma membrane can cause the transmembrane portion of the IMP to undergo a **conformational** change that results in a change in binding **affinity** in the portion exposed at the C-face. The cytoplasmic region of the IMP might then exhibit enzymatic activity, change the enzymatic activity of another protein with which it associates, or attach or detach from a cytoskeletal element as a result of extracellular hormone binding.

Bacteria and plant cells are surrounded by a relatively static and inflexible layer of **polysaccharides** called a cell wall, which is exterior to the plasma membrane and should not be confused with it. SEE ALSO BACTERIAL CELL; CELL WALL; CYTOSKELETON; LIPIDS; MEMBRANE PROTEINS; MEMBRANE TRANSPORT; PLASMA MEMBRANE; SIGNALING AND SIGNAL TRANSDUCTION

*Chris Watters*

### Bibliography

Karp, Gerald. *Cell and Molecular Biology*, 3rd ed. New York: John Wiley & Sons, 2001.

## Membrane Transport

Biological membranes are the structures that divide biological space into functional **aqueous** compartments: cells and their **organelles**. To allocate hundreds of different **solutes** to their proper locations, cells equip their various membranes with multiple transport mechanisms, some simple and some complex. (Use of membrane **vesicles** for endocytosis and exocytosis is covered elsewhere.)

## Membrane Diffusion

The simplest kind of transport is the unassisted diffusion of solutes across membranes (see Figure 1a). The kinds of molecules that transit in this fashion are more soluble in oil than water and so readily dissolve in and then spontaneously traverse the nonpolar **lipid** core of the membrane **bilayer**. Among these diffusible lipid-soluble molecules are **steroid hormones**, many kinds of drugs, the oxygen that cells **respire**, and the carbon dioxide they expire.

Motion of all kinds must be impelled by some form of energy. In the case of simple membrane diffusion, movement across the bilayer is a random walk driven by the kinetic (heat) energy provided by the collisions of the solute with surrounding molecules. This is the Brownian motion that agitates all molecules. Random diffusion causes the solute molecules to end up at equal concentrations on the two sides of the membrane no matter how great the initial difference (gradient) was. Solute transport by these means is thus said to be downhill.

## Membrane Channels

Most cellular solutes have a **polar** chemical structure and are therefore strongly attracted to water. Consequently, these water-soluble molecules tend not to enter the lipid core of the membrane readily; indeed, the bilayer is designed keep them from doing so. To transport these solutes across the barrier, membranes are equipped with a variety of special **protein** structures.

The simplest way to convey water-soluble solutes across membranes is through channels: membrane-spanning proteins with central pores. By these means, selected solutes diffuse downhill across membranes, passing single file along a narrow column of water molecules in these pores. Driven by random Brownian diffusion, a solute will ultimately reach an equal concentration in the two aqueous compartments.

Channels can discriminate among solutes. They use the diameter of their pores as a sieve and place critical **amino acid** side chains along the pore to give it the proper shape and chemical profile. As a result, different channels strongly prefer  $\text{Na}^+$  or  $\text{K}^+$  or  $\text{Ca}^{++}$  or  $\text{H}^+$  and pass cations much better than anions; another channel is specialized for  $\text{Cl}^-$ . Some channel families conduct larger solutes into cells; for example, nutrients like amino acids or sugars. There are also elaborate channels that enable newly synthesized

**lipid** fat or waxlike molecule, insoluble in water

**bilayer** composed of two layers

**steroid hormone** group of hormones that includes estrogen, testosterone, and progesterone

**respire** use oxygen to burn cellular fuel

**polar** partially charged, and usually soluble in water

**protein** complex molecule made from amino acids; used in cells for structure, signaling, and controlling reactions

**amino acid** a building block of protein

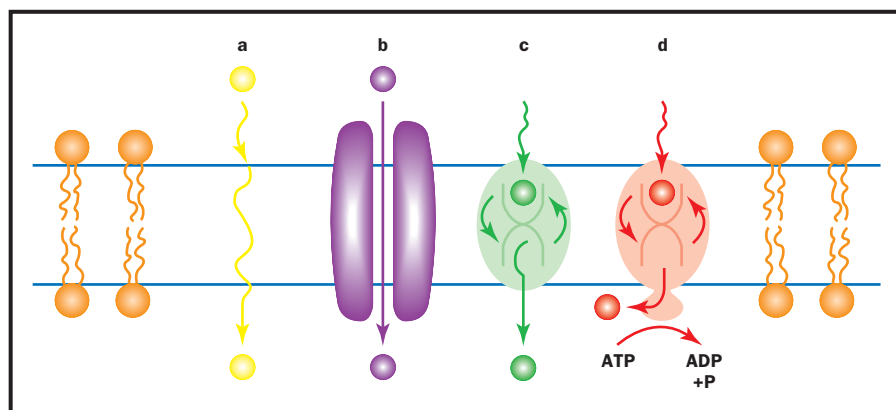

Figure 1. Modes of membrane transport. a) Some solute molecules can diffuse unassisted through the lipid bilayer. b) Certain solute molecules can diffuse through the aqueous pore of a specific channel protein. c) Reciprocating transporters can convey selected solute molecules across the bilayer by means of a fluctuating change in their shape. d) The energy released by the breakdown of ATP molecules can be coupled by a transport protein to pumping specific solute molecules against their concentration gradient.

**polypeptide** chain of amino acids

**conformation** three-dimensional shape

**secretion** material released from the cell

**axon** long extension of a nerve cell down which information flows

**ion** an electrically charged particle

**gradient** difference in concentration between two places

**enzyme** protein that controls a reaction in a cell

**substrate** the molecule acted on by an enzyme

**cytoplasm** material in a cell, excluding the nucleus

**metabolite** molecule involved in a metabolic pathway

**glucose** simple sugar that provides energy to animal cells and is the building block of cellulose in plants

**polypeptide** chains to slither across the membrane in an extended **conformation**; they then fold up into mature proteins on the other side. This is the basis for protein **secretion**.

Among the most interesting kinds of channels are those along the **axon** or at the synapses of nerve cells. When turned on for a few milliseconds by a stimulus, these proteins allow small numbers of  $\text{Na}^+$  or  $\text{K}^+$  to diffuse across the membrane. These pores open as the result of a change in the structure of the channel protein, typically brought about by one of two mechanisms: (1) the association of a specific neurotransmitter molecule to a binding site on the channel protein (at the synapse); or (2) a change in the electrical field across the membrane (along the axon). In both cases, the consequent movement of **ions** through these activated channels alters the electrical charge across the membrane, causing channels nearby to open. This electrical cascade is what propagates excitation along a nerve.

### Reciprocating Transporters

Animal cells have membrane transporters that “carry” specific nutrients down their concentration **gradients**. These transport proteins work like an engine with a four-step cycle. The first step is for the membrane-bound transporter to bind a solute molecule outside of the cell. Each kind of transporter is selective for a specific solute family, just as an **enzyme** acts only upon certain **substrates**. Discrimination comes from the close-fitting association of the solute with a pocket in the protein, like a key in a lock or a hand in a glove. The shape of the transporter molecule fluctuates constantly; driven, once again, by Brownian (thermal) motion within the fluid membrane. In the second step, the right twists and turns cause the protein to “swallow” the solute, reorienting it from the outside to the interior of the cell. Third, the solute diffuses away from the transporter into the **cytoplasm**. Finally, the empty transporter reorients to its initial shape, so that its solute binding site again addresses the cell exterior. The protein is then ready for the next cycle.

Such transporters convey **metabolites** such as **glucose** and amino acids in the bloodstream (where they are at high concentration) to the cell’s cytoplasm (where they are being consumed). Their activity can be regulated according to need, often through the action of hormones. For example, when excess glucose is available, the hormone insulin is released from the pancreas into the bloodstream. This hormone signals muscle cells to bring their glucose transporters into play; these convey the sugar into the cells, returning the blood glucose level to normal.

This mode of transport utilizes the energy of Brownian motion in two ways: molecular collisions not only propel solute molecules up to and away from the transporter but also drive the protein to change its shape, back and forth, between its two functional orientations. No matter how well designed, these reciprocating transporters can only equalize the concentration of a solute between the two compartments the membrane separates. That is, random motion cannot gather up every molecule of a nutrient outside a cell or expel every molecule of waste from the interior of a cell. If the cell needs to take up or pump out a solute beyond its equal distribution, it must apply energy. The methods of transport just described are therefore referred

to as “passive transport.” Mechanisms requiring applied energy are often called “active transport.”

## Active Transport

Cells draw upon metabolic energy to drive solutes across membranes against their concentration gradients. For example,  $K^+$  is continuously pumped into human cells as  $Na^+$  is pumped out. One source of energy used by these active transporters is the universal cellular currency, adenosine triphosphate (ATP). To tap its energy, plasma membrane–spanning proteins split the ATP to a simpler form (adenosine diphosphate plus phosphate). Instead of allowing the released energy to dissipate as heat, the cleavage step is coupled to the movement of the solute. To accomplish this, the breakdown of the ATP is performed in a pocket of the transporter such that the release of its energy forces the protein into an altered shape. This strain in the protein drives the solute to move “uphill” against its concentration gradient across the membrane, opposite the direction it would spontaneously diffuse. Indeed, the ATP molecules will not be split by the protein unless the solute is being transported simultaneously; the two processes are inextricably coupled through the transporter. A significant fraction of cellular energy is expended in this way.

## Membrane Energetics

The conversion of sunlight to electricity by solar panels is a new, “green” alternative to fossil fuels, but nature got there first. Billions of years ago, a membrane transport system evolved that converts solar energy into cellular energy. In this device, photons of sunlight are captured by chlorophyll and other pigments in the membrane. The energy trapped thereby is then used by membrane proteins to force negatively charged electrons away from positively charged protons, separating them across the bilayer. This charge separation turns the membrane into an electrical battery. The potential energy stored in these membranes can then be harvested by proteins that couple it to energy-consuming cellular processes, just as batteries can be used to power a flashlight.

One major use of the potential energy created by separating protons from electrons across membranes is to drive the synthesis of ATP. ATP then powers other metabolic processes, such as the formation of glucose (the major product of photosynthesis), or the transport of solutes discussed in the preceding section. In addition, the **membrane potential** can itself be directly coupled to pumping certain solutes against their concentration gradient (active transport). In those cases, the downhill diffusion of protons across the membrane provides the energy to pump other solutes uphill. (Picture a paddle wheel that taps a mountain stream for energy to grind grain.) Such membrane potentials also propel bacterial swimming by powering the rotation of their propellerlike flagella. Membrane potential energy is thus a currency as universal as ATP or glucose.

Finally, consider how the body’s cells extract energy from glucose. On a gross level, glucose reacts with the oxygen the lungs breathe, yielding energy as well as the carbon dioxide and water the body respires. But this “burning” of glucose is tightly coupled by membrane transport proteins to the pumping of protons and electrons across membranes. Then, just as in

**ATP** adenosine triphosphate, a high-energy nucleotide used by cells to power most energy-requiring reactions

**membrane potential** electrical and chemical differences across a membrane leading to storage of energy and excitability

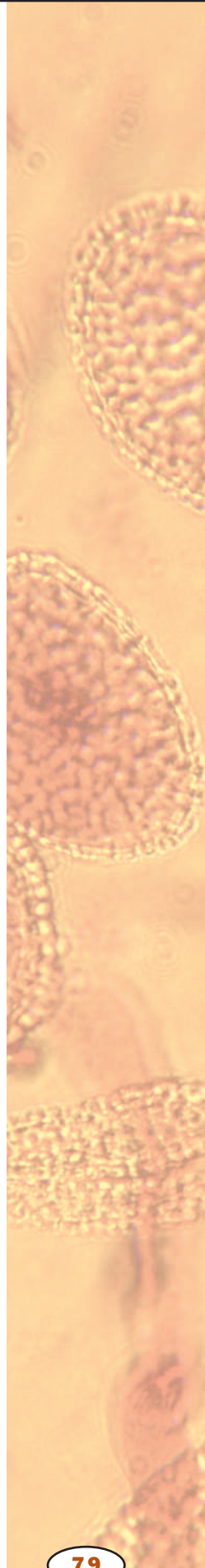

photosynthesis, the membrane potential is tapped by other membrane proteins to make ATP or to drive active transport or to enable bacteria to swim. SEE ALSO BLOOD SUGAR REGULATION; ENDOCYTOSIS; ENZYMES; EXOCYTOSIS; ION CHANNELS; MEMBRANE STRUCTURE; METABOLISM, CELLULAR; NEURON; NUCLEAR TRANSPORT; ORGANELLE; PHOTOSYNTHESIS; SYNAPTIC TRANSMISSION

Theodore L. Steck

### Bibliography

Alberts, Bruce, et al. *Molecular Biology of the Cell*, 4th ed. New York: Garland Publishing, 2000.

Lodish, Harvey, et al. *Molecular Cell Biology*, 4th ed. New York: W. H. Freeman and Company, 2000.

## Mendel, Gregor

**Czech geneticist**  
**1822–1884**



Gregor Mendel.

**true breeding** giving only offspring identical to the parents

**progeny** offspring

Gregor Johann Mendel was born on July 22, 1822, in what is now Hynčice, Czech Republic. He entered a monastery in what is now Brno, Czech Republic, and performed a famous and important series of breeding experiments while at the monastery. Mendel died on January 6, 1884, in Brno.

Mendel is often referred to as the father of genetics because his work set the foundation upon which modern biology, and especially genetics, is based. Numerous scientists during Mendel's time were studying the heritability of various traits. However, much of this science was descriptive and qualitative. Mendel's work, as reported in 1866, differed from that of others in four major ways: (1) his choice of material, (2) his careful observations, (3) his mathematical approach to the analysis of the data, and (4) his inductive leap used to explain his results.

In his genetic experiments, Mendel chose garden peas because they had many traits that appeared in two forms, because they grew quickly, and because he could perform both out-crosses (fertilization between two different plants) and self-crosses. He always began his crosses with plants that were **true breeding**, thus ensuring that all parents were uniform in their genetic contribution. Mendel usually followed the inheritance of only one trait in a given cross, and he was careful to distinguish parents and **progeny** in his analysis.

In all, Mendel examined seven different traits that each had two different forms, such as green versus yellow seeds. One form of each trait disappeared in the progeny of a cross; this form he referred to as recessive. The form that remained in the first generation of progeny was called dominant. However, when these progeny, all of whom expressed the dominant form, were allowed to self-pollinate, the recessive trait reappeared in about one-fourth of the progeny in the next generation. To explain these results, Mendel hypothesized that each individual had two bits of information for a trait, and that these bits of information separated from each other in the formation of the reproductive cells. This hypothesis has now become known as the Law of Segregation.

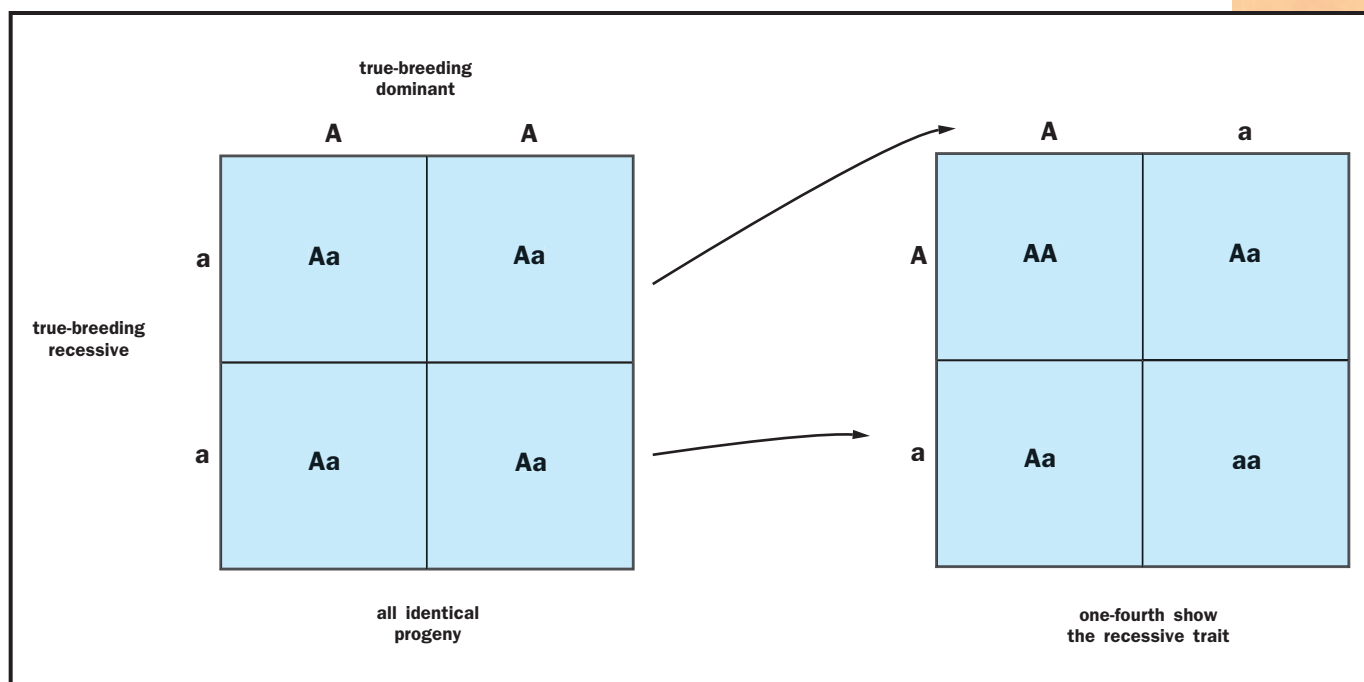

When Mendel crossed plants that differed in two traits, such as seed color and seed texture, he observed that each trait behaved independently of the other trait. This observation has become known as the Law of Independent Assortment. Scientists now know that not all traits assort independently. Some traits tend to stay associated because they are located on the same **chromosome**.

Mendel's theories went almost unread and uncited for thirty-five years, possibly because his mathematical explanations were foreign and confusing to many of the scientists of his time. In the early 1900s, three scientists independently rediscovered his work. Mendel's work now serves as the prototype and cornerstone for modern genetic analysis and much of modern biology. His work has allowed investigators to explain evolution in terms of changes in the frequencies of **alleles** and genes. SEE ALSO GENE; HISTORY OF BIOLOGY; INHERITANCE; MODEL ORGANISMS; CELL BIOLOGY AND GENETICS

*William R. Wellnitz*

### Bibliography

Campbell, Neil A., Jane B. Reece, and Lawrence G. Mitchell. *Biology*, 5th ed. Menlo Park, CA: Benjamin Cummings, 1999.

Mendel, Gregor. "Experiments in Plant Hybridization," trans. Royal Horticultural Society of London. In *Genetics*, ed. Cedric I. Davern. San Francisco, CA: W. H. Freeman and Company, 1981.

Cross between true-breeding dominant and true-breeding recessive.

**chromosome** "colored body" in the cell nucleus; made of DNA and protein, and divided functionally into genes and nongene regions

**allele** a particular form of a gene

## Meristems

Plants have the impressive abilities to reproduce asexually and regenerate damaged parts. The secret to these abilities lies within a tissue type called meristem. Meristematic cells are fully developed and functional at maturity,

but unlike other cells in the plant, they remain totipotent. This means that when induced, they can develop into any specific plant tissue at any point during the life of the plant. Other cells in the plant are fully differentiated (meaning that they are specialized in both form and function) and do not divide. Cells in the meristem, however, divide and produce all of the new cells in a plant.

While meristem tissue is the source of the regenerative potential of a plant, meristems also play a pivotal role in normal plant growth. Plants have the unique ability to continue to grow and develop new organs while functioning as a mature, reproducing organism. Plants grow larger via cell division and cell elongation. Simple plant growth is facilitated by meristem tissue because it is the primary site of cell division (mitosis) in the plant. Plants develop new organs (stems, leaves, flowers, roots) via cell division and cell differentiation. Because the source of all new cells in a plant is the meristem, this tissue plays an important role in organ development as well. While some of the cells of the **apical meristem** divide to generate new meristematic cells, most of the offspring cells differentiate into specialized cell types that stop dividing and function as a part of the organ in which they were generated.

### Meristems and Simple Plant Growth

Plants have meristematic tissue in several locations. Both roots and shoots have meristematic tissue at their tips called apical meristems that are responsible for the lengthening of roots and shoots. The shoot apical meristem is formed during embryonic development, but after germination gives rise to the stem, leaves, and flowers. The root apical meristem is also formed during development, but during germination gives rise to the root system. Cell division and cell elongation in the apical meristem is called primary growth and results in an increase in plant height and root length. Increasing root length enables the plant to tap into the water and mineral resources of a new region or layer of soil. Increasing shoot length makes the plant taller, thus allowing it better access to sunlight for photosynthesis.

Many types of plants also increase the diameter of their roots and stems throughout their lifetime. This type of growth is called secondary growth and is the product of **lateral** meristem. Lateral meristem is called the vascular cambium in many of the plants in which it is found. Secondary growth gives a plant added stability that allows for the plant to grow taller. Lastly, some plants have intercalary meristem. These are areas of plants that help in the regeneration of parts of the plant that have been damaged by predators or the environment. Intercalary meristems produce growth at the base of grass blades, for instance.

Meristem tissue is not autonomous. Throughout the life of the plant, the rate of cell division and cell elongation in the meristems is regulated by plant **hormones**. For example, gibberellins stimulate cell division in shoot apical meristem, causing the plant to grow taller. These hormones also cause cell elongation in intercalary meristem of grasses. Cytokinin and auxin are also important growth regulators. Auxin stimulates growth by inducing cell elongation, while cytokinins are thought to stimulate both cell division and cell elongation.

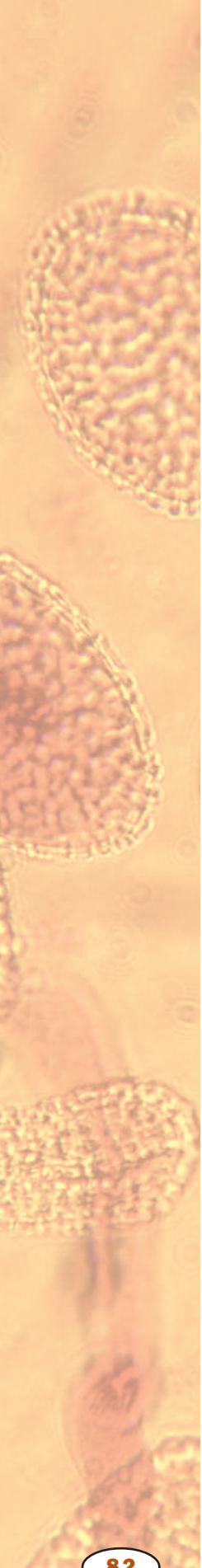

**apical meristem** growing tip from which all plant tissues arise

**lateral** side-to-side

**hormone** molecule released by one cell to influence another



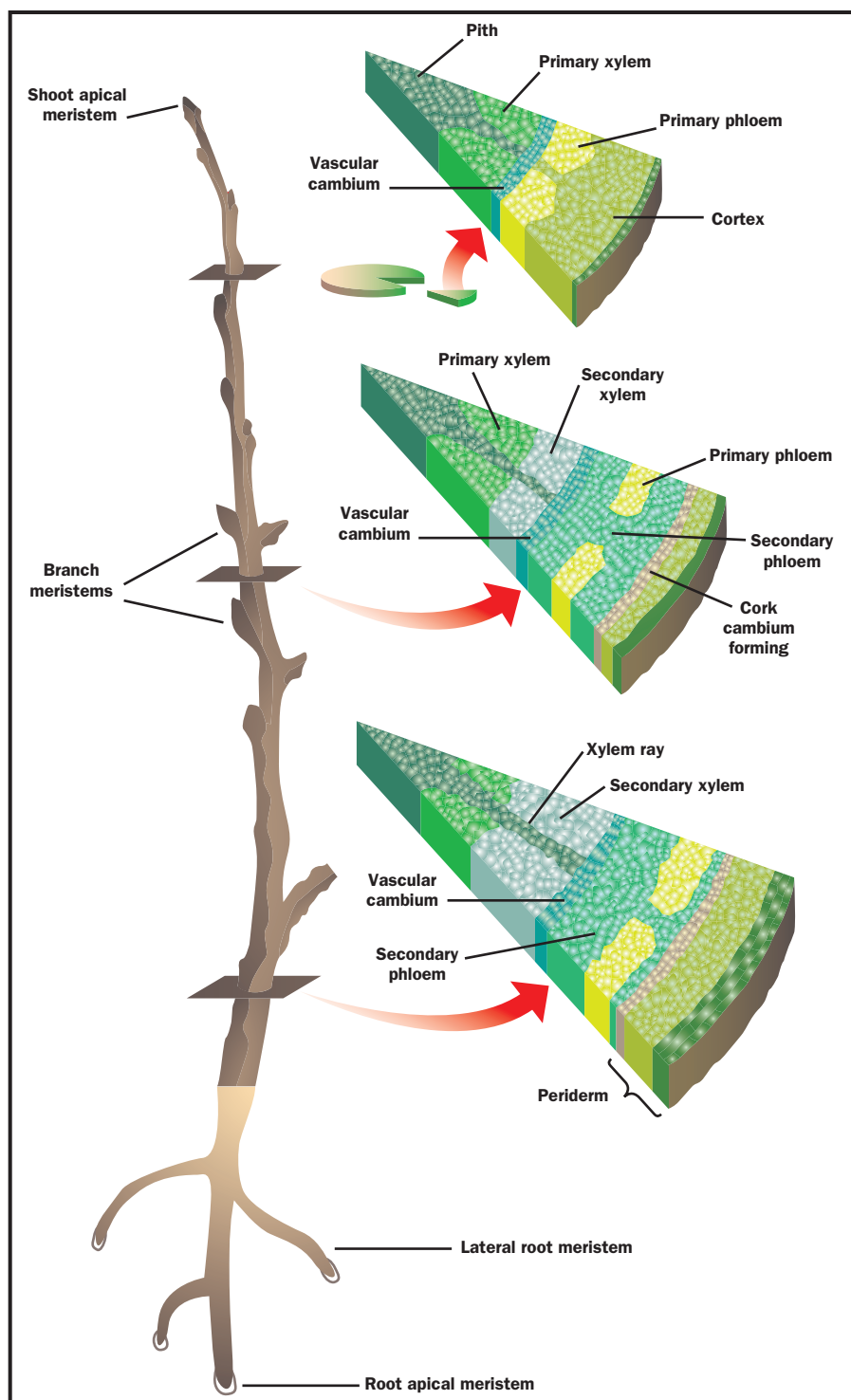

Meristem locations, with cross-sections of vascular tissues.

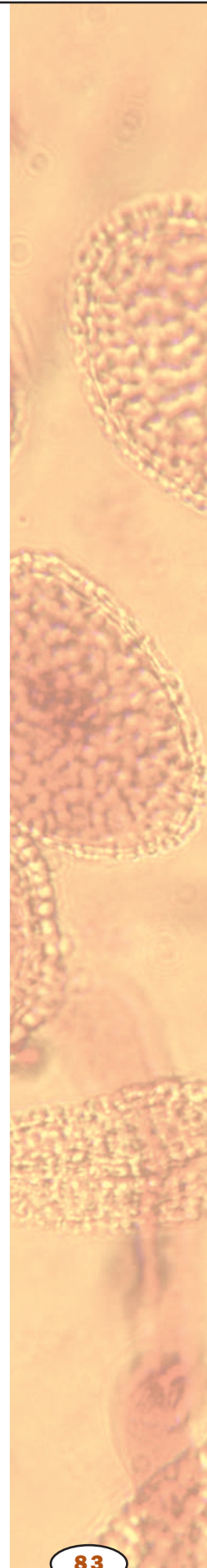

## Apical Meristems and Pattern Formation

As the source for all new cells of the growing plant, the meristem plays an important role in the formation of new organs and in the correct placement of those organs within the plant body. The process by which this organization happens is called pattern formation and, in plants, is directed by the meristem. To accomplish this task, meristematic cells must be able to interpret their position in the plant and establish a certain fate.

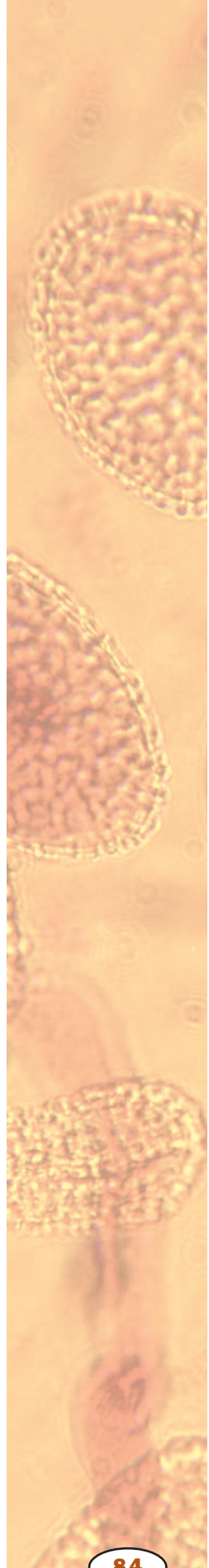

**transcription factor** protein that increases the rate of transcription of a gene

**gene expression** use of a gene to create the corresponding protein

**transcription** messenger RNA formation from a DNA sequence

**translation** synthesis of protein using mRNA code

**macromolecules** large molecules such as proteins, carbohydrates, and nucleic acids

**amino acid** a building block of protein

For example, during the development of a new leaf, the dividing cells of the meristem must differentiate into several different functional types of epidermal cells and parenchyma cells. However, they do not need to differentiate into reproductive cells like those found in a flower. How is it that meristematic cells “know” what to become? The actively dividing cells of the apical meristem use positional cues such as hormones and cell-cell interactions as guides during differentiation. Moreover, these positional cues result in the activation of certain genes and the inactivation of other genes in a set of cells, thus initiating their specific differentiation pattern based on their spatial location in the plant. The specific genes that are initially activated in meristem cells during this process are called homeotic genes. These genes encode a family of **transcription factors** that, once activated, will determine the fate of a cell by activating and inactivating a whole host of other genes.

One mechanism of differential **gene expression** (the activation and inactivation of genes during differentiation and organ development) is binding of plant hormones to the developing cell’s surface. Hormones such as cytokinins have been shown to affect ribonucleic acid (RNA) **transcription** and **translation**. It is thought that the presence of both cytokinins and another class of hormones, called auxins, are important for proper root and shoot development. In the laboratory, if a set of undifferentiated meristem cells are grown in culture, they will not develop into a plant embryo unless they are stimulated with auxin and cytokinin. A high cytokinin/auxin ratio will stimulate the meristematic cells to develop stems, leaves, and flower buds. On the other hand, a high auxin/cytokinin ratio will stimulate the meristematic cells to develop roots. SEE ALSO ANATOMY OF PLANTS; DIFFERENTIATION IN PLANTS; GENETIC CONTROL OF DEVELOPMENT; HORMONES, PLANT; ROOTS; SHOOTS; WATER MOVEMENT IN PLANTS

Susan T. Rouse

### Bibliography

- Fletcher J. C., and Elliott M. Meyerowitz. “Cell Signaling Within the Shoot Meristem.” *Current Opinions in Plant Biology* 3 (2000): 23–30.
- Meyerowitz, Elliott M. “The Genetics of Flower Development.” *Scientific American* (November 1994): 56–65.
- Moore, Randy, W. Dennis Clark, and Kingley R. Stern. *Botany*. Boston: William C. Brown Publishers, 1995.
- Salisbury, Frank B., and Cleon Ross. *Plant Physiology*, 4th ed. Belmont, CA: Wadsworth, Inc., 1992.
- Van Overbeek, J. “The Control of Plant Growth.” *Scientific American* 219 (1968): 75–81.

## Metabolism, Cellular

Cellular metabolism is the sum total of all the biochemical reactions taking place within a cell. It includes all the reactions involved in degrading food molecules, in synthesizing **macromolecules** needed by the cell, and in generating small precursor molecules, such as some **amino acids**, for cellular needs. It also includes all reactions involving electron transfers (oxidation-reduction, or redox, reactions). Metabolism takes place in sequences of biochemical reactions called pathways.

## Metabolic Pathways

Metabolic pathways can be simple linear sequences of a few reactions, or they can be extensively branched with reactions converging on or diverging from a central main pathway. They can be cyclic, with a precursor of an early reaction regenerated at the end of a pathway (for example, the **Krebs cycle** of **aerobic** respiration, or the Calvin cycle of photosynthesis). Some pathways serve multiple purposes. For example, the Krebs cycle is best known for its role in oxidizing sugars and other **organic** molecules to provide adenosine triphosphate (**ATP**) for the cell, but it is also used as a source of precursor molecules for cellular biosynthesis. Clearly, evolution has repeatedly used existing metabolic pathways to provide novel functions.

All biochemical reactions are **catalyzed** by **proteins** called **enzymes**; for most reactions, there is one enzyme that catalyzes only that reaction. Enzymes can be exquisitely regulated by the cell, providing a high degree of control of cellular metabolism. The activity of enzymes is often sensitive to the amount of specific molecules in the cell. For example, enzymes involved in producing ATP are often inhibited by ATP; when the cell has sufficient amounts of this **metabolite**, therefore, the pathways that produce it are turned off, thereby preventing wasteful reactions. Alternatively, these same enzymes may be strongly activated by ATP's precursor, adenosine diphosphate (**ADP**), levels of which become elevated when the cell is doing work and needs rapid generation of ATP. This pattern of regulation by molecules that are either precursors of or products of a pathway is common in cellular metabolism.

## Anabolism and Catabolism

Metabolism is divided into two broad categories. Catabolism, or the degradation of molecules, usually involves removing electrons from molecules (oxidation) and is generally accompanied by the release of energy. Anabolism, or the synthesis of complex molecules, usually involves enriching molecules in electrons (reduction) and generally requires the cell to expend energy in the form of ATP. Reactions that yield energy, such as most catabolic reactions, are called **exergonic**, whereas those that require an input of energy, such as most **anabolic** reactions, are called **endergonic**.

The main function of the anabolic pathways is to synthesize the four classes of macromolecules needed by the cell: **polysaccharides**, **lipids**, nucleic acids, and proteins. Although these four categories are chemically distinct, they are all synthesized by the same general type of reaction, condensation synthesis of individual small subunits (monomers) into the macromolecules (polymers). In a condensation reaction, a hydrogen atom is removed from one **monomer**, and a **hydroxyl** group from the other, forming water. A new bond is formed between the two monomers where the water was removed:

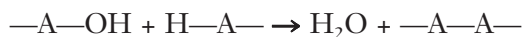

For example, nucleic acids such as DNA and RNA are synthesized from their monomers, **nucleotides**, by condensation synthesis. Polysaccharides and proteins are produced in a similar fashion from their monomers, sugars and amino acids, respectively. Lipids, the fourth class of macromolecule, are somewhat different. Unlike the other macromolecules, which are

**Krebs cycle** central metabolic pathway in mitochondria

**aerobic** with oxygen, or requiring it

**organic** composed of carbon, or derived from living organisms

**ATP** adenosine triphosphate, a high-energy nucleotide used by cells to power most energy-requiring reactions

**catalyze** aid in the reaction of

**protein** complex molecule made from amino acids; used in cells for structure, signaling, and controlling reactions

**enzyme** protein that controls a reaction in a cell

**metabolite** molecule involved in a metabolic pathway

**ADP** adenosine diphosphate, the low-energy form of ATP

**anabolic** characteristic of a reaction that builds complex molecules from simpler ones, and requires energy

**polysaccharide** carbohydrate composed of many individual units of sugar

**lipid** fat or waxlike molecule, insoluble in water

**monomer** "single part"; monomers are joined to form a polymer

**hydroxyl** chemical group consisting of -OH

**nucleotide** the building block of RNA or DNA

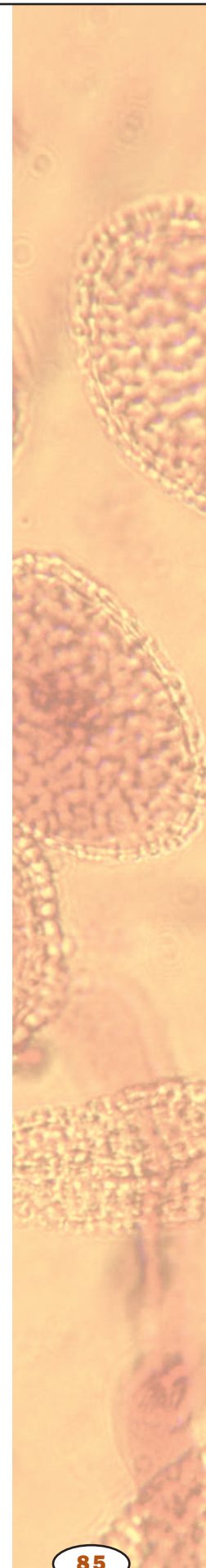

A scanning electron micrograph of an intestinal epithelial cell showing two lysosomes that contain digestive enzymes that destroy damaged molecules. One category of metabolism is catabolism, the degradation of molecules.

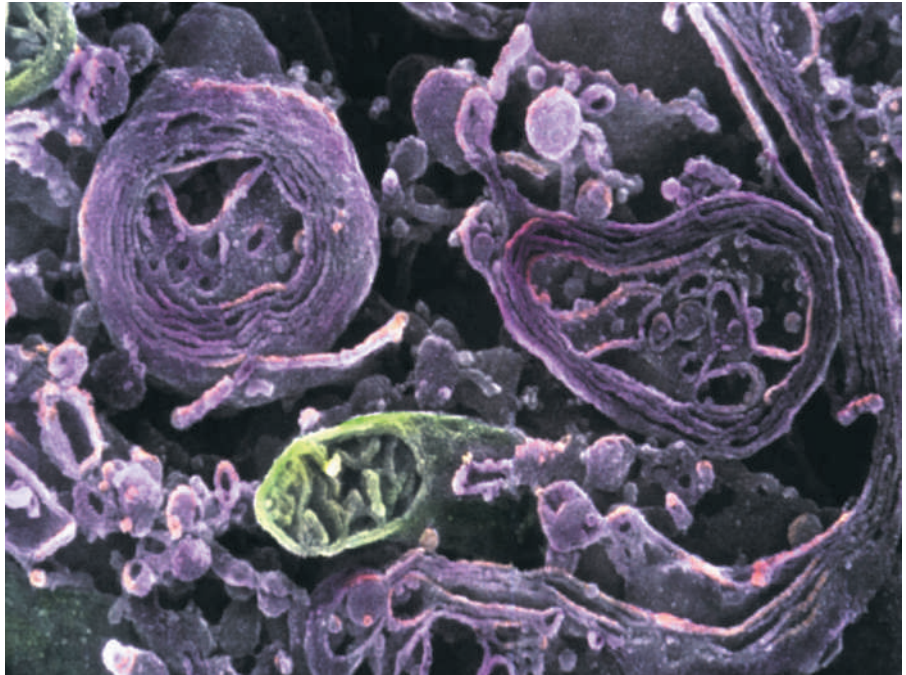

composed of long chains of monomers, most lipids have only three or four different molecular subunits, most important of which are the fatty acids. The fatty acids are not directly joined to each other, but are joined to another molecule such as glycerol (for fats and oils). However, the fatty acids are joined to glycerol by the same kind of dehydration reaction as in the other groups of macromolecules.

The reverse of condensation synthesis is **hydrolysis**, in which a water molecule is added to a bond between two monomers, breaking it and separating the monomers. One of the hydrogens from water becomes attached to one of the monomers, and the hydroxyl that remains is attached to the other:

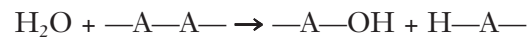

For example, nucleic acids are degraded to their monomers when water is inserted between the individual nucleotide monomers, breaking the bond that joins them. Hydrolysis reactions are a type of catabolic reaction, although they do not usually directly produce ATP; they do, however, produce monomers that often are further catabolized to generate ATP.

### Turnover

Metabolism is a dynamic process. The cell is continuously degrading and synthesizing molecules. In general, the catabolic pathways are providing energy in the form of ATP that is used to drive the anabolic processes. This is necessary since endergonic reactions, in order to proceed, require an input of energy, which they obtain from ATP. This is accomplished by coupling the endergonic reaction to the hydrolysis of ATP to ADP and **inorganic** phosphate, an exergonic reaction. As long as the amount of energy required is less than the amount released by ATP hydrolysis, the coupled reactions will proceed.

**hydrolysis** splitting with water

**inorganic** not bonded to carbon

The dynamic nature of metabolism results in constant degrading and rebuilding of most cellular materials. For example, proteins exist in a cell for relatively brief times, ranging from minutes to weeks, with most proteins having average life spans of a few days. Structural proteins generally last longer than enzymes, but they too are eventually degraded and synthesized anew. Likewise, other cellular materials are turned over in a similar fashion. This constant turnover of cellular materials keeps the cell in good condition. Molecules that may have been damaged by, for example, being partially oxidized, will sooner or later be degraded and replaced.

Cellular metabolism is the most fundamental level where the dynamic properties of life begin to appear. The complex interactions of diverse pathways, their regulation, and their organization demonstrate the exquisite refinement of the biochemistry of life. All processes that occur within individual organisms can be traced to the pathways of cellular metabolism. SEE ALSO CARBOHYDRATES; CONTROL MECHANISMS; ENZYMES; GLYCOLYSIS AND FERMENTATION; KREBS CYCLE; LIPIDS; NUCLEOTIDES; PROTEIN STRUCTURE

David W. Tapley

### Bibliography

Hinckle, P. C., and R. E. McCarthy. "How Cells Make ATP." *Scientific American* 238 (March 1978): 104–123.

Stryer, Lubert. *Biochemistry*. New York: W. H. Freeman and Company, 1995.

## Metabolism, Human

Metabolism means the sum of all chemical changes in a cell or the body of an organism. It has two subdivisions: catabolism and anabolism.

Catabolism (from the Greek *cata*, meaning "down") consists of all those reactions in which large molecules are broken down into smaller ones, with a release of energy from their chemical bonds. Examples include the digestion of a **protein** into **amino acids** that the body can absorb from the diet and use in its own metabolism, and the breakdown of stored **glycogen** in the liver to supply energy between meals. These breakdown processes are known chemically as **oxidation** reactions.

Anabolism (from the Greek *ana*, meaning "up") consists of all those reactions that assemble small molecules into larger ones and store energy in the newly formed chemical bonds. Examples include the assembly of amino acids into muscle proteins and the synthesis of glycogen and fat for energy storage. These synthetic processes are known chemically as reduction reactions.

### Metabolic Rate

Metabolic rate means the amount of chemical energy liberated in the body per unit time. Chemical energy is measured in calories (the amount of energy that will heat 1 gram [0.035 ounce] of water by 1 degree Celsius [1.8 degrees Fahrenheit]), although a calorie is such a small unit that it is more practical to think in terms of kilocalories (kcal). One kilocalorie is 1,000 calories, or what dietitians (and food labels) call a Calorie with a capital C. Metabolic rate is generally expressed in kcal/hour or kcal/day. A person's

**protein** complex molecule made from amino acids; used in cells for structure, signaling, and controlling reactions

**amino acid** a building block of protein

**glycogen** complex carbohydrate used as storage in animals and some other organisms

**oxidation** reaction characterized by loss of electrons, or reaction with oxygen

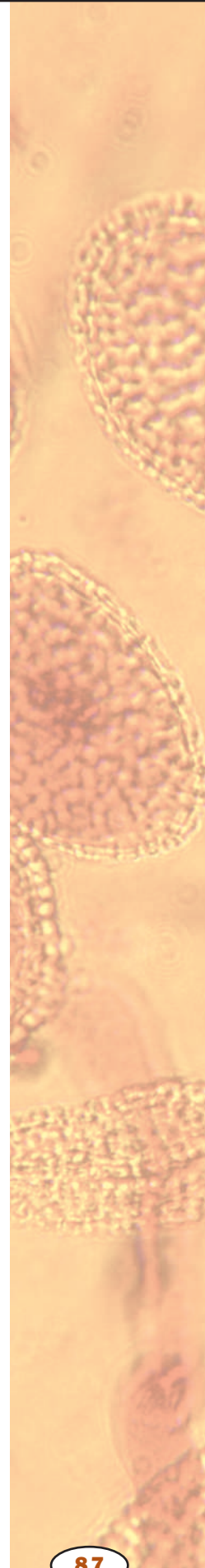

**organic** composed of carbon, or derived from living organisms

**hormone** molecule released by one cell to influence another

**basal** lowest level

**muscle tone** low-level, constant muscle contraction

**central nervous system** brain and spinal cord

metabolic rate can be estimated by having him or her breathe from a spirometer, a device that measures the person's rate of oxygen consumption. Every liter of oxygen consumed represents the release of approximately 4.82 kcal of energy from **organic** compounds such as fat and glycogen. This ratio varies, however, depending on what type of energy-storage molecules the person is oxidizing at the time of measurement.

Metabolic rate depends on such variables as physical activity, mental state, fed or fasting status, and **hormone** levels, especially thyroid hormone. The **basal** metabolic rate (BMR) is a standard of comparison that minimizes such variables. It is measured when a person has not eaten for twelve to fourteen hours and is awake, relaxed, and at a comfortable temperature. It is not the minimum rate needed to keep a person alive; the metabolic rate is lower than the BMR when one is asleep. Total metabolic rate (TMR) is the BMR plus the added energy expenditure for movement and other activities. Metabolic rate is elevated not only by physical activity but also by eating, anxiety, fever, pregnancy, and other factors. Factors that reduce the TMR below normal include depression, apathy, and prolonged starvation.

The TMR is higher in children than in adults. Consequently, as people approach middle age, they often gain weight even with no change in food intake. Weight-loss diets tend to be frustrating not only because most of the initial weight loss is water, which is quickly regained, but also because the TMR declines with time; as the diet progresses, fewer calories are burned and one begins to synthesize more fat even with a stable caloric intake.

The average young adult male has a BMR of 2,000 to 2,500 kcal/day, and the average female slightly lower. Thus, one must consume this many calories per day just to sustain such essential processes as the heartbeat, respiration, brain activity, **muscle tone**, renal function, and active transport through cell membranes. The **central nervous system** accounts for about 40 percent of the BMR and the muscular system for 20 to 30 percent. Even a relatively sedentary lifestyle requires another 500 kcal/day, and hard physical labor, as in farming or manufacturing, may require up to 5,000 kcal/day.

## Metabolic States

Two metabolic states, absorptive and postabsorptive, are defined by the time elapsed since food intake and by corresponding changes in the body's energy processing.

The absorptive (fed) state lasts for about four hours during and after a meal. It is a time when the body is absorbing digested nutrients, using some of them to meet immediate energy needs, and converting the excess to energy storage products. This state is regulated mainly by the hormone insulin, which promotes cellular uptake of glucose (blood sugar) and amino acids; glucose oxidation; and the synthesis of glycogen (glycogenesis) and fat (lipogenesis). Because of the rapid cellular uptake of glucose, the blood glucose level falls under the influence of insulin. Insulin is thus called a hypoglycemic hormone (from *hypo*, meaning "low"; *glyc*, meaning "sugar"; and *em*, meaning "blood").

The postabsorptive (fasting) state prevails in the late morning, late afternoon, and overnight; that is, when one has not eaten for four hours or longer. During this time, the stomach and small intestine are empty, and the body's metabolic needs must be met from stored fuel. The postabsorp-

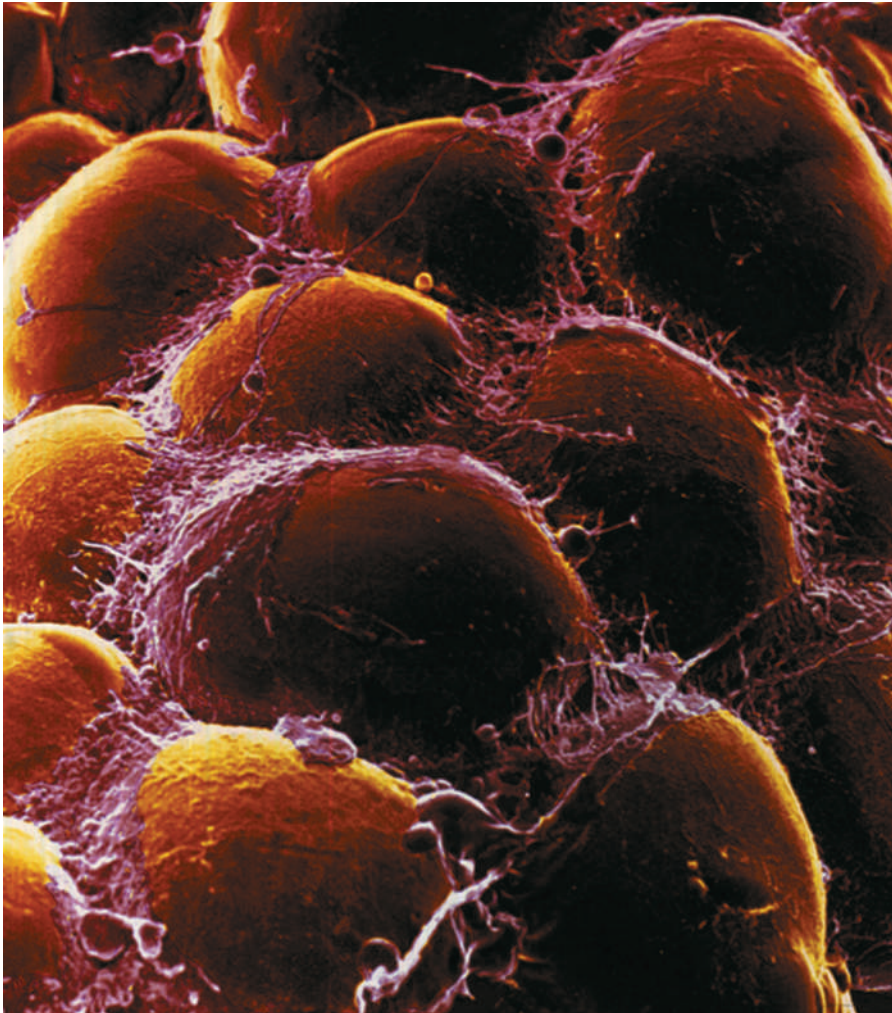

A scanning electron micrograph of fat cells that make up adipose connective tissue. The sympathetic nervous system issues commands to adipose tissue that mobilizes fuels such as glucose and fatty acids.

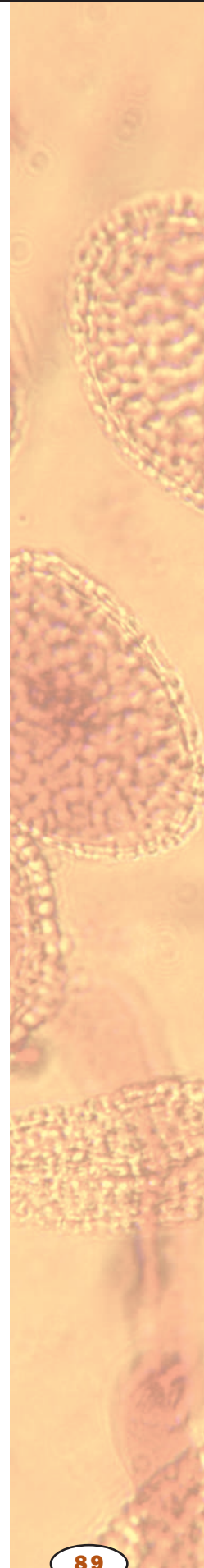

tive state is dominated by hyperglycemic hormones, which raise the blood glucose level and thus make glucose available to the brain and other organs that require it. Hyperglycemic hormones include glucagon, cortisol, growth hormone, epinephrine, and norepinephrine. Collectively, these hormones promote glycogen breakdown (glycogenolysis), fat breakdown (lipolysis), and the synthesis of glucose from amino acids and fats (gluconeogenesis).

The **sympathetic nervous system** also plays a major hyperglycemic role, issuing nerve fibers to liver, adipose tissue, and muscular tissue that directly stimulate glycogenolysis and lipolysis. The sympathetic nervous system is involved especially in conditions of fear, anger, injury, and other forms of stress. Thus, it mobilizes fuels such as glucose and fatty acids to meet the demands of the “fight or flight” state and tissue repair and recovery. SEE ALSO BLOOD SUGAR REGULATION; CARBOHYDRATES; DIGESTION; GLYCOLYSIS AND FERMENTATION; HORMONES; KREBS CYCLE; LIPIDS; METABOLISM, CELLULAR; OXIDATIVE PHOSPHORYLATION

*Kenneth S. Saladin*

#### **Bibliography**

- Berne, Robert M., and Matthew N. Levy. *Physiology*, 4th ed. St. Louis, MO: Mosby, 1998.
- Ganong, William F. *Review of Medical Physiology*, 19th ed. Stamford, CT: Appleton and Lange, 1999.

**sympathetic nervous system** branch of the nervous system that promotes heightened awareness, increased nutrient consumption, and other changes associated with “fight or flight”

## Microbiologist

Microbiologists are scientists who investigate the world of microscopic organisms including all bacteria, protozoa, and viruses, along with some algae and fungi. The microbes studied can be found everywhere from thermal hot springs (more than 100 degrees Celsius) to Antarctic ice shelves (less than 0 degrees Celsius). Therefore, microbiologists can be found everywhere.

Microbiologists are often associated with determining the microbes involved with causing disease, but their work extends into every other facet of life. Working variously as immunologists, epidemiologists, etiologists, chemotherapists, and microbial taxonomists, microbiologists identify, control, and prevent organisms from causing disease. Microbiologists can study transfer of genetic information from one organism to another (genetics) or the control of chemical **metabolism** inside organisms (physiology). Industrial applications using microbes can vary greatly. Microbiologists can use microscopic organisms for bioremediation (cleaning the environment), pharmaceutical uses (discovery and production of antibiotics), food microbiology (using microbes to produce/protect food and beverages), and fermentation technology (production/manufacture of products like vitamins and **enzymes**).

Microbiologists can work for a wide range of employers in either the public or private sector. Public sector employers include many federal governmental branches, along with state and county health departments. The private sector includes pharmaceuticals (e.g., Eli Lilly), genetic engineering companies (e.g., Monsanto), biotechnology firms (e.g., Promega), food and beverage industries (e.g., Budweiser), and chemical supply/manufacture companies (e.g., Sigma).

Degrees held by microbiologists can vary greatly from a high school diploma to a doctorate degree. The majority of microbiologists have at least an undergraduate degree in biology. More specific degrees are available in fields such as epidemiology, microbiology, virology, mycology, biochemistry, and food microbiology. Associate degrees or training programs may

**metabolism** chemical reactions within a cell

**enzyme** protein that controls a reaction in a cell

A quality control microbiologist inspects a bacteria culture from ground meat processed at a slaughterhouse.





help train microbiologists to work in hospital departments such as microbiology (identifying organisms), chemistry (profiles of patient physiology), cytology (identifying abnormal cells), and blood banks.

In order to prepare, students in high school could take classes in the following subjects: microbiology, health sciences/terminology, basic and advanced biology and/or chemistry, and biochemistry. SEE ALSO BACTERIAL DISEASES; BIOTECHNOLOGY; EPIDEMIOLOGIST; PLANT PATHOLOGIST; PLANT PATHOGENS AND PESTS; PROTOZOAN DISEASES; VIRAL DISEASES

*Mark S. Davis*

### Bibliography

Madigan, Michael T., John M. Martinko, and Jack Parker, eds. *Brock Biology of Microorganisms*, 9th ed. Upper Saddle River, NJ: Prentice Hall, 2000.

## Microscopist

A microscopist is any scientist or technician who routinely uses a microscope in his or her work. While beginning students usually have some experience with simple light microscopes, there are many types of more sophisticated microscopes for special purposes, such as phase contrast and fluorescence light microscopes, scanning and transmission electron microscopes, and tunneling electron microscopes that can see even down to the level of individual molecules. These types of microscopes require specialized training to be able to prepare specimens properly, use the microscope, and record the images.

Many scientists who work in anatomy, **cytology**, and other fields employ technicians to maintain and operate specialized microscopes, and employment opportunities for microscopists are abundant. Positions for technicians typically require a bachelor of science degree, although some are available with only a high school diploma and on-the-job training, an associate's degree, or certification from a training program in areas such as electron microscopy. Independent research in microscopy usually requires a master's degree or doctorate.

Microscopists are employed by universities, medical schools, hospitals, museums, industries, and government agencies. Microscopists work not only in biology but also in medicine, chemistry, geology, materials science, electronics, **forensic** science, food science, and other fields.

To prepare for a career in microscopy, one should take four years of high school science and mathematics; biology, chemistry, physics, and geology are all related to microscopy. Further training on the job or in college may involve physics (especially optics and electromagnetism), electronics, photography (for photomicrography and microcinematography), and histotechnology (slicing and staining tissues for microscopic examination). Biology, geology, chemistry, and physics are among the appropriate choices of a college major; a minor in photography or astronomy would also enhance one's qualifications. One's hobbies can also provide a good grounding for a career in microscopy; for example, photography (especially close-up nature photography), photoprocessing, and astronomy (which employs

**cytology** study of cells

**forensic** related to legal proceedings

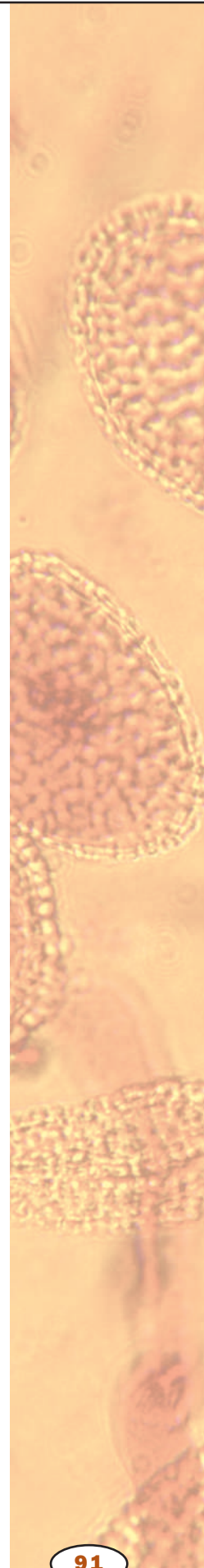

similar principles of optics). SEE ALSO ELECTRON MICROSCOPY; LEEUWENHOEK, ANTONY VAN; LIGHT MICROSCOPY

*Kenneth S. Saladin and Sara E. Miller*

### **Bibliography**

Dalley, John G. *Photography Through the Microscope*. Rochester, NY: Eastman Kodak Co., 1988.

*Microscopy—UK*. <<http://www.microscopy-uk.org.uk/forms/directly.html>>.

*Microworld Internet Guide to Microscopy*. <<http://www.mwrn.com/feature/joblinks.htm>>.

Smith, Roger F. *Microscopy and Photomicrography: A Working Manual*. Boca Raton, FL: CRC Press, 1994.

## **Migration**

Many animals move from one place to another at certain times of the year or during a particular period of their life cycle. These movements are often referred to as migration. Some animals, such as many species of insects, migrate only once during their lifetime, often just before they reproduce. Other animals, including many species of birds and many marine animals, such as sea turtles and whales, migrate long distances to their breeding grounds many times during their lives.

Animals migrate for several reasons. In some cases, animals can only reproduce in a particular habitat, such as sea turtles and sea birds that must return to land in order to lay their eggs. In other instances, animals are forced to leave an area when conditions in the environment deteriorate. Many bird species that nest in Canada and the northern regions of the United States migrate south as winter approaches. The ultimate reason these birds migrate south is because their food supply (including insects and fish) will not be available during the cold months. However, these birds normally begin migrating south before their food supply has disappeared, and often even before it has begun to decline.

In actuality, it is the changing length of the days (photoperiod) that stimulates hormonal and behavioral changes that result in migration. Such an environmental cue is often referred to as the proximate (or immediate) cause of migration, whereas the inevitable decline in food supply is referred to as the ultimate cause. A bird that waited until its food actually disappeared would not have sufficient body fat reserves to migrate a long distance. Thus, scientists believe that natural selection favored birds that used predictable environmental cues, such as the seasonal change in day length, to initiate migration before their food source disappeared.

Seasonal migrators exhibit obligatory migration, meaning they must migrate every year. For other animals, the decline in the conditions of their environment is not so predictable. For example, owls that live in the tundra and Canadian forests feed on small rodents that are abundant some winters and scarce during others. During winters when rodent populations are high, these owls remain in Canada and do not migrate. However, if rodent populations are low, these owls will migrate down into the northern regions of the United States. Animals such as these owls exhibit facultative migration, meaning migration is optional for them.



A spring tide of surfbirds surge from the mud flats of Alaska's Copper River delta. The strong-flying migrants winter as far south as the Strait of Magellan.

Scientists have been fascinated by how animals are able to navigate during their migration. Studies have shown that migrating species are able to use a wide variety of mechanisms to navigate, including the stars, the sun, olfactory (chemical) cues, and Earth's magnetic field. Some species learn their migration routes by first traveling with experienced individuals, but other species are able to migrate and navigate successfully without prior experience, an ability that still perplexes scientists. Migration requires a lot of energy and many individuals die during migration. Despite these heavy costs, the potential benefits of migration are great, which is why migration behavior has evolved in so many species. SEE ALSO BEHAVIOR PATTERNS; BIRD; FIELD STUDIES IN ANIMAL BEHAVIOR; TUNDRA; TURTLE

*Mark A. Davis*

#### **Bibliography**

Alcock, John. *Animal Behavior: An Evolutionary Approach*, 6th ed. Sunderland, MA: Sinauer Associates, Inc., 1997.

Berthold, Peter. *Bird Migration: A General Survey*. Oxford: Oxford University Press, 1993.

## **Mimicry, Camouflage, and Warning Coloration**

Many predators search for their prey with their eyes. As a result, many prey species have evolved special body coloration to reduce their chance of being eaten. For example, many prey species blend in with their environment, making it difficult for the predators to find them. These species use camouflage as their first line of defense. Another word for this type of defense is "crypsis" or "cryptic coloration." Cryptic coloration is especially common in small animals such as insects, lizards, snakes, and frogs. These animals are often the same color as the leaves or twigs on which they rest. Some insects even look like the twigs or leaves themselves. It is important to remember that crypsis is not just a morphological adaptation, but that behavior

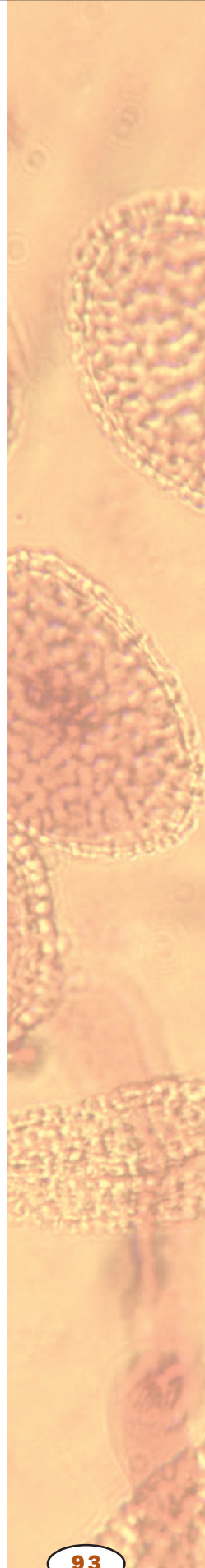



An Indian leaf butterfly exemplifying cryptic coloration.

plays a very important part as well. Crypsis works only if the animal is resting on the appropriate background and usually only when the animal isn't moving.

Many small animals have evolved toxic chemicals that make the creature poisonous to eat. Interestingly, many of these species are brightly colored, making it easy for the predators to see them. Scientists believe that the bright coloration has evolved to help the predator, often birds, remember that the species is poisonous. For example, if a bird eats a poisonous butterfly or frog, it will get very sick. In some cases, the poison is released so quickly that the bird will spit the prey out and avoid swallowing it. In either case, it is probably easier for the bird to remember to avoid this species in the future if the prey is distinctively colored. Experiments have shown that it often takes only a single encounter with a toxic prey species for a predator to learn to avoid it. Warning coloration, sometimes referred to as aposematic coloration, is found in a wide variety of animals, including insects, mites, spiders, and frogs.

One problem with being defended by toxic chemicals is that the animal has to use energy to make the chemicals, energy that could otherwise be used for such things as growth and reproduction. Some animals have evolved a way to enjoy the benefits of warning coloration without the costs. These animals mimic the coloration of the poisonous animals. This type of mimicry is referred to as Batesian mimicry, named after the nineteenth-century British naturalist who first described it. The best-known example of Batesian mimicry in the United States and Canada is probably the Viceroy butterfly that looks remarkably like the poisonous Monarch butterfly. The two species are unrelated and the caterpillars feed on different plants and do not look anything like one another. However the adults of both species look so similar that most people, and more importantly, most birds, cannot tell them apart. It is important that the Batesian mimic be less common than the toxic model species. For example, if the Viceroy were more common than the Monarch, birds would end up eating a lot of Viceroy before eating a Monarch and would not "learn the lesson" the coloration acts to teach. SEE ALSO ADAPTATION; NATURAL SELECTION; POISONS; PREDATION AND DEFENSE

*Mark A. Davis*

#### **Bibliography**

Alcock, J. *Animal Behavior: An Evolutionary Approach*, 6th ed. Sunderland, MA: Sinauer Associates, Inc., 1998.

## **Mitochondrion**

Mitochondria (singular mitochondrion) are abundant **organelles** present in nearly all **eukaryotic cells**. The main function of mitochondria is to produce adenosine triphosphate (ATP), the cellular energy source. Mitochondria are believed to be the evolutionary result of early anaerobic (nonoxygen-using) eukaryotic cells engulfing aerobic (oxygen-utilizing) bacteria, resulting in a symbiotic relationship between the two organisms. The eukaryotic cells received ATP in exchange for supplying nutrients to the engulfed bacteria, and the bacteria provided ATP and allowed the eukaryotic

**organelle** membrane-bound cell compartment

**eukaryotic cell** a cell with a nucleus

cell to survive in the increasing oxygen atmosphere present early in Earth's history.

## Evidence for Bacterial Origin

The bacterial origin of these organelles is evident in the structure of the mitochondrion, its method of reproduction, and its genetics. Mitochondria are generally oval to elongated in shape, like bacteria, and are approximately 0.5 to 1 **micron** in diameter. Two membranes like those present in many types of bacteria surround the mitochondrion.

Animal mitochondria possess an amazingly simple genetic system. The human mitochondrial **genome** is a circular deoxyribonucleic acid (DNA) molecule (like a bacterial **chromosome**) made up of only 16,569 **base pairs** of DNA encoding thirty-seven genes. The mitochondrial genome is too small to encode all of the genes necessary for the mitochondrion to function. Instead, most of the genes necessary for mitochondrial functions are contained in the nuclear genome. At some point in evolution, these genes were moved from the mitochondrion to the **nucleus** and integrated into the nuclear chromosomes. The mechanism by which this transfer occurred is unknown.

Mitochondria have their own **ribosomes** and transfer ribonucleic acid (tRNA) to make mitochondrial-encoded **proteins** within the mitochondrial matrix (the fluid enclosed by the membrane). The bacterial origins of the ribosome are most evident in the unique sequences of the ribonucleic acid (RNA) and proteins that comprise it. Mitochondrial ribosomes are more like bacterial ribosomes than they are like the **cytoplasmic** ribosomes made in the nucleus. The mitochondrial machineries that make proteins in the mitochondrial matrix and replicate the mitochondrial DNA are also sensitive to several antibiotics that inhibit bacterial growth. The other cellular systems for protein synthesis and DNA replication in the nucleus are not sensitive to these antibiotics, supporting the notion that the mitochondria have their origin in a bacterial ancestor.

Because many of the mitochondrial components are not encoded by the organelle's DNA, but by the nuclear DNA, mitochondria must have mechanisms to take up their components from the surrounding cytoplasm. The mitochondrial proteins encoded by nuclear genes and synthesized on ribosomes in the cytoplasm are transported into the mitochondria by specific machinery found in the mitochondrial membranes. The transport machinery recognizes unique sequences of **amino acids** found only in mitochondrial proteins.

## Reproduction

During cell growth, the contents of the cell approximately double to ensure that both daughter cells receive a full set of organelles and cytoplasm in addition to the correct number of chromosomes at cell division. The growth and division of mitochondria is not linked to the **cell cycle**; instead, mitochondria replicate their DNA and divide mainly in response to the energy needs of the cell. When the energy use by a cell is high, the mitochondria grow and divide. When the energy use is low, mitochondria are destroyed or become inactive. At cell division, mitochondria are distributed to the daughter cells more or less randomly by partitioning of the cytoplasm when the cell divides. Mitochondria divide by binary fission similar to bacterial

**micron** one-millionth of a meter; also called a micrometer

**genome** total genetic material in a cell or organism

**chromosome** "colored body" in the cell nucleus; made of DNA and protein, and divided functionally into genes and nongene regions

**base pair** two nucleotides (either DNA or RNA) linked by weak bonds

**nucleus** membrane-bound portion of cell containing the chromosomes

**ribosome** protein-RNA complex in cells that synthesizes protein

**protein** complex molecule made from amino acids; used in cells for structure, signaling, and controlling reactions

**cytoplasm** material in a cell, excluding the nucleus

**amino acid** a building block of protein

**cell cycle** sequence of growth, replication, and division that produces new cells

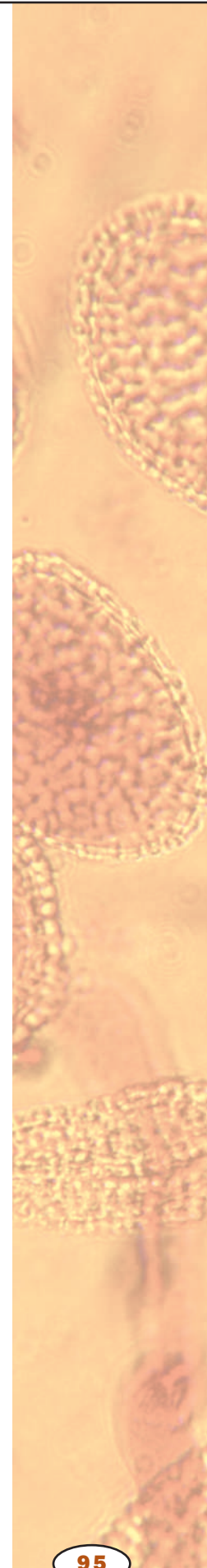

Three-dimensional drawing of the mitochondrion.

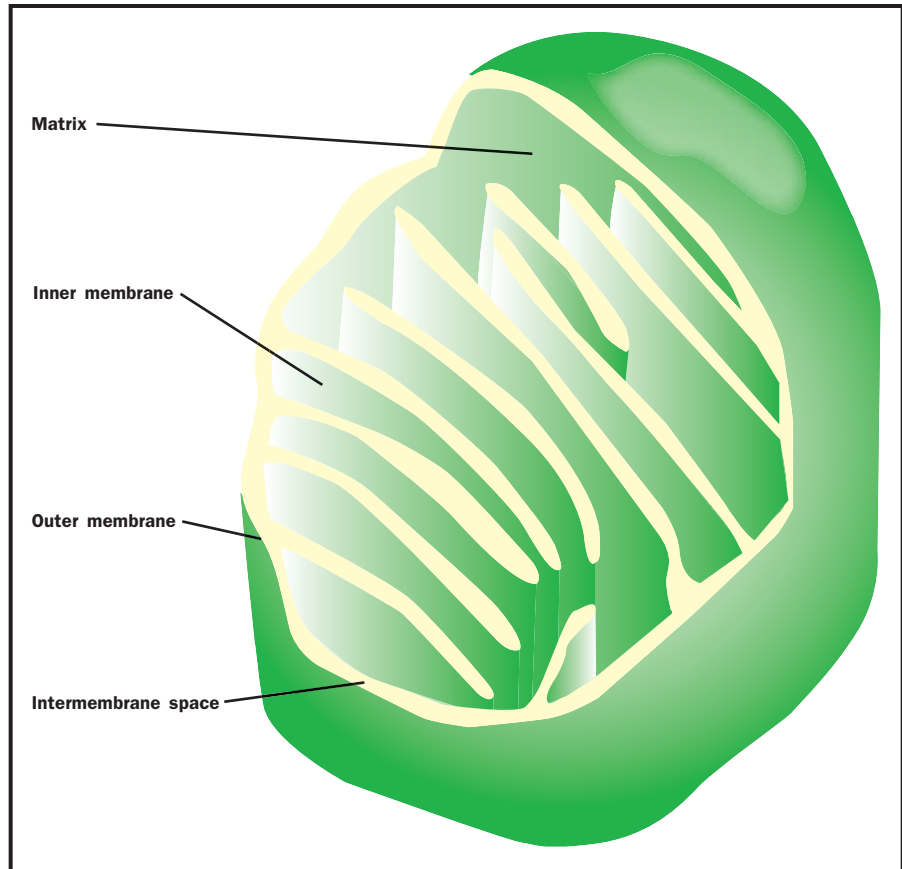

cell division. Unlike bacteria, however, mitochondria can also fuse with other mitochondria.

### Membranes and Matrix

The mitochondria are unique **organelles** in that they are surrounded by two membranes, rather than the single membrane that surrounds other non-nuclear organelles in the cell. The outer mitochondrial membrane completely encloses a large internal space called the matrix. The inner mitochondrial membrane is highly folded into structures called cristae, which significantly increase the surface area of the inner membrane. The narrow space between the inner membrane and the outer membranes is known as the intermembrane space. The outer membrane contains a large number of proteins that form pores or channels through the membrane allowing small molecules to pass freely between the intermembrane space and the cytoplasm. These pores make the outer membrane permeable to most **ions** and small molecules; therefore, the intermembrane space has the same ionic composition as the cytoplasm surrounding the mitochondrion.

The inner membrane, on the other hand, is relatively impermeable and blocks the movement of ions and other small molecules. Both the inner and outer mitochondrial membranes contain specific transport proteins that can move large molecules or ions across each by both passive active transport. Only those large molecules that have specific membrane transporters are able to enter mitochondria. This allows the mitochondria to create a unique

**organelle** membrane-bound cell compartment

**ion** an electrically charged particle

biochemical environment within the matrix to carry out the energy production reactions.

## Mitochondrial Metabolism

ATP is the main source of energy for most processes in the cell, and large quantities must be made for a cell to function. Most cells use simple sugars, such as **glucose**, as their primary energy source. The **metabolism** of glucose begins in the cytoplasm with a process called **glycolysis**. During glycolysis, glucose is processed from a 6-carbon sugar to two molecules of a 3-carbon compound called **pyruvate**. However, glycolysis is an inefficient process, yielding only two ATP molecules for each molecule of glucose metabolized. The pyruvate formed in glycolysis can be further metabolized in mitochondria to gain another thirty molecules of ATP from a single original glucose molecule. In addition to the metabolism of pyruvate, fatty acids derived from dietary fat can also be used by mitochondria to make ATP.

**Krebs Cycle.** The metabolic functions of the mitochondrion occur within the matrix and the inner mitochondrial membrane. The matrix contains a highly concentrated mixture of the **enzymes** of the Krebs, or citric acid, cycle and enzymes for the degradation of fatty acids. Pyruvate and fatty acids from the cytoplasm are actively transported into the mitochondrial matrix by specific membrane transporters that span both the outer and the inner membranes. Inside the matrix, both pyruvate and the fatty acids are first converted to an activated 2-carbon compound called acetyl-Coenzyme A that is the starting point of the **Krebs cycle**. The enzymes of the Krebs cycle process the acetyl CoA, removing high-energy electrons that will be used as an energy source to produce ATP. The high-energy electrons from the Krebs cycle are stored on the specialized carrier molecules that carry the electrons from the matrix to the inner mitochondrial membrane.

**Electron Transport Chain.** The high-energy electrons from the Krebs cycle are passed to a series of three large protein complexes located in the inner mitochondrial membrane, known as the electron transport chain. Each complex is made up of several proteins organized to form a pathway that moves electrons through the complex. The electrons from the Krebs cycle enter the chain at a very high energy and gradually give up part of their energy as they move through the electron transport chain. The energy from the electrons is used to pump hydrogen ions across the inner mitochondrial membrane from the matrix to the intermembrane space by active transport. This creates a chemical and electrical **gradient** across the inner membrane, storing energy in much the same way a battery does.

Low-energy electrons that emerge from the end of the electron transport chain are combined with an oxygen atom forming one molecule of water for every two electrons that pass through the chain. Because of the similarity to respiration by the body (inhaling oxygen and exhaling carbon dioxide), the Krebs cycle and the electron transport chain together are sometimes referred to as cellular respiration. The CO<sub>2</sub> that humans exhale is a product of the Krebs cycle, and the oxygen humans breathe in is used as the final electron acceptor in the electron transport chain.

**ATP Synthesis.** The electrochemical gradient is harnessed to produce ATP by an enzyme in the inner membrane called ATP synthase. As the

**glucose** simple sugar that provides energy to animal cells and is the building block of cellulose in plants

**metabolism** chemical reactions within a cell

**glycolysis** initial stages of sugar breakdown in a cell

**pyruvate** the ionized form of pyruvic acid, a key intermediate in cell metabolism

**enzyme** protein that controls a reaction in a cell

**Krebs cycle** central metabolic pathway in mitochondria

**gradient** difference in concentration between two places

Defects in mitochondrial genes are responsible for numerous maternally inherited diseases, including a number of muscle diseases (myopathies).

The maternal inheritance of mitochondria is being used to trace human evolutionary groups back to their African origins.

**ADP** adenosine diphosphate, the low-energy form of ATP

**cytoskeleton** internal scaffolding in a cell, composed of protein

**fertilization** union of sperm and egg

**zygote** fertilized egg

**lineage** ancestral line

**chromosome** “colored body” in the cell nucleus; made of DNA and protein, and divided functionally into genes and nongene regions

**eukaryotic cell** a cell with a nucleus

**cytoplasm** material in a cell, excluding the nucleus

hydrogen ions flow back down their concentration gradient into the matrix through the ATP synthase complex, the energy released is used to add a phosphate group to adenosine diphosphate (**ADP**) to make adenosine triphosphate. Because the actions of the electron transport chain and ATPase are tightly linked, the combination of the two is referred to as oxidative phosphorylation. In fact, some types of mitochondria uncouple the movement of electrons through the electron transport chain from ATP syntheses by shuttling electrons back across the inner membrane. Since the energy is not used to make ATP it can be released as heat energy. Such mitochondria are found in “brown fat” in babies and hibernating animals, and are an important source of heat.

Within a cell, mitochondria are typically positioned near areas of high ATP use such as near the contractile apparatus of muscle cells or wrapped around the whiplike tail of the sperm. The positioning of mitochondria within a cell is at least partially due to attachment to the microtubule **cytoskeleton**. The cytoskeleton is a very dynamic scaffold within the cytoplasm, constantly growing and retracting. As it grows and retracts, it drags along attached organelles such as mitochondria. Destruction of the microtubules with specific drugs leads to a disorganized arrangement of the mitochondria that is restored when the cytoskeleton is allowed to reform.

## Inheritance

Mitochondrial genes are not inherited by the same mechanism as nuclear genes. At **fertilization** of an egg by a sperm, the egg nucleus and sperm nucleus each contribute equally to the genetic makeup of the **zygote** nucleus. However, all of the mitochondria, and therefore all the mitochondrial genes, are contributed to the zygote by the egg. At fertilization of an egg, a single sperm enters the egg along with the mitochondria that it uses to provide the energy needed for its swimming behavior. However, the mitochondria provided by the sperm are targeted for destruction very soon after entry into the egg. The egg itself contains relatively few mitochondria, but it is these mitochondria that survive and divide to populate the cells of the adult organism. This type of inheritance is called maternal inheritance and is common to the mitochondria of all animals. Because mitochondria are inherited from the mother only, the sequence of mitochondrial DNA is sometimes used to trace the **lineage** of families. SEE ALSO CELL EVOLUTION; CYTOSKELETON; GLYCOLYSIS AND FERMENTATION; HISTORY OF BIOLOGY: BIOCHEMISTRY; HUMAN EVOLUTION; KREBS CYCLE; METABOLISM, CELLULAR; OXIDATIVE PHOSPHORYLATION; PRIMATE

Stephen A. Adam

## Bibliography

Raven, Peter H., Ray F. Evert, and Susan E. Eichhorn. *Biology of Plants*, 6th ed. New York: W. H. Freeman and Company, 1999.

## Mitosis

Mitosis is the process of dividing **chromosomes** during cell division in **eukaryotic cells**. Mitosis is followed by cytokinesis, the splitting of the **cytoplasm**. In cell division, a parent cell splits, producing two daughter cells that



are identical to the parent. Eukaryotic unicellular organisms like the protist *Amoeba* use cell division in the production of new individuals, propagating their species. Multicellular eukaryotic organisms, including plants, animals, and fungi, rely on cell division to grow larger by adding new cells. They also use cell division to repair injured or worn-out tissues by replacing damaged cells with new cells.

The function of mitosis is to divide a cell's **nucleus** with its chromosomes into two daughter cell nuclei, each of which inherits the same number of chromosomes as the parent cell. Consider mitosis in human cells, each of which contains forty-six chromosomes.

How does a parent cell with forty-six chromosomes divide to yield two daughter cells each with forty-six chromosomes identical to those of the parent? The eukaryotic parent cell first copies, or replicates, its chromosomes prior to mitosis. Rather than ninety-two chromosomes, however, this replication process yields forty-six chromosomes, each composed of two parts, called sister **chromatids**, that are genetically identical to each other. The sister chromatids are connected to each other at a point called the **centromere**.

During mitosis, the **nuclear envelope** dissolves, and sister chromatids separate at the centromere, becoming two individual daughter chromosomes, each now with only one chromatid. By the end of mitosis, these daughter chromosomes are segregated from each other to opposite poles of the cell and become enclosed within two separate daughter nuclei. Following mitosis, cytokinesis divides the cell into two, with two sets of **organelles** and two daughter nuclei, forming two separate but identical cells.

## Specifics of Mitosis

Mitosis is a continuous process that is often divided into four sequential phases known as prophase, metaphase, anaphase, and telophase. These phases can be distinguished through microscopic analysis. Several critical steps in mitosis are controlled by **phosphorylation** or dephosphorylation of proteins.

**Prophase.** Prior to mitosis, chromosomes appear in the nucleus as a tangled mass of thin strands (chromatin) and are not distinguishable from each other as separate entities. During prophase, the chromosomes condense into shorter and thicker rodlike structures that can be easily seen to consist of two sister chromatids connected by a centromere. This is thought to be driven by addition of phosphate groups to the **histone** proteins of the chromosome.

Another major event in prophase is the organization of what is known as the mitotic spindle. This too is thought to be driven by phosphorylation. Prior to mitosis, a special area of the cytoplasm near the nucleus, known as the centrosome, contains a pair of small cylindrical bodies called centrioles. The centriole pairs replicate and then the two pairs of centrioles begin to move with their centrosomes to opposite poles of the cell. During prophase, they continue their migration to the cell's poles and organize parts of the cell's cytoskeleton (the scaffold that maintains the cell's shape) into the mitotic spindle. The spindle consists of microtubules that reach from each centriole pair across the cell toward the other pair.

### FLEMMING, WALTHER (1843–1905)

German physician and cell biologist who first described the process by which cells divide and separate their chromosomes. He named this process "mitosis." At the time of his work, 1882, no one knew that the chromosomes carried the units of heredity, genes.

**nucleus** membrane-bound portion of cell containing the chromosomes

**chromatid** a replicated chromosome before separation from its copy

**centromere** region of the chromosome linking chromatids

**nuclear envelope** double membrane surrounding the cell nucleus

**organelle** membrane-bound cell compartment

**phosphorylation** addition of the phosphate group  $\text{PO}_4^{3-}$

**histone** protein around which DNA wraps to form chromosomes

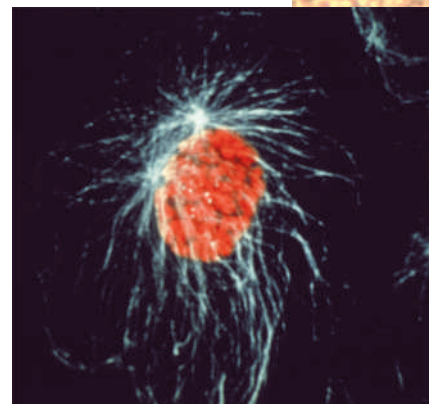

Prophase.

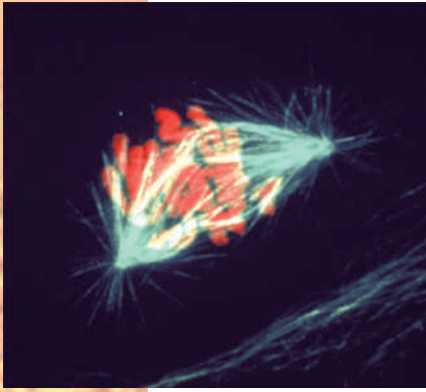

Metaphase.

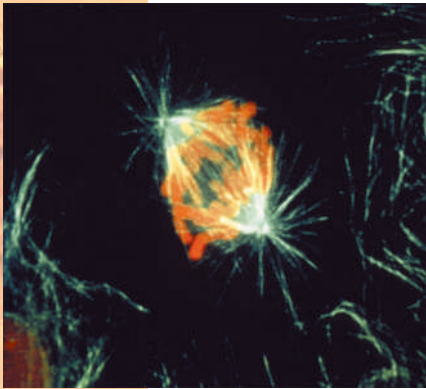

Anaphase.

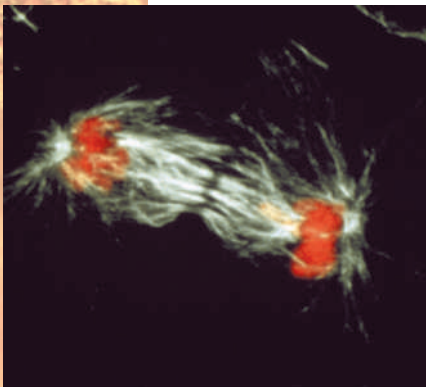

Telophase.

## Prometaphase

On either side of the centromere that connects the two sister chromatids of each chromosome, specialized complexes of proteins known as kinetochores form. These act as attachment points between chromosomes and the spindle fibers that are part of the mitotic spindle. Through these attachments, the spindle is able to physically move the chromosomes to opposite poles of the spindle. By the end of prometaphase, the nuclear membrane surrounding the chromosomes begins to break down (triggered by phosphorylation of membrane proteins) and the spindle fibers pull the chromosomes by their kinetochore attachments so that the chromosomes align at the midpoint between the spindle poles.

**Metaphase.** During metaphase the chromosomes are fully aligned end to end at the cell's midline at what is known as the metaphase plate. Each kinetochore is attached to spindle fibers emanating from centrioles at opposite poles.

**Anaphase.** The attachments between sister chromatids to each other split during anaphase, producing single-chromatid chromosomes. This is triggered by destruction of the phosphorylating proteins discussed earlier. For each pair of single chromatid chromosomes, one of the pair is pulled toward each of the two spindle poles. Meanwhile, the distance between the spindle poles also increases.

**Telophase.** During telophase, the nuclear membranes are dephosphorylated and begin to reform around the two sets of chromosomes at either pole, enclosing and separating them from the rest of the cytoplasm. The mitotic spindle disappears. The chromosomes decondense and become thinner and more difficult to distinguish from each other. Cytokinesis begins the process of separating the two daughter cells and is nearly complete by the end of telophase. The end result is the production of two new cells that are genetically identical to each other and to the parent cell.

## Differences Between Plants and Animals

Plants use a similar process with a few differences. For example, although a plant cell creates a mitotic spindle and has a centrosome, it lacks centrioles. The other major difference in plants is the way in which cytokinesis occurs. In animal cells, the plasma membrane pinches in along the midline of the cell, creating a cleavage furrow that will separate the cytoplasm in two. Plant cells have rigid cell walls that prevent this. Instead, they use two different approaches for cytokinesis. The plasma membrane and cell wall grow inward together, eventually separating the parent cell into two. Alternatively, the cell wall that will separate the two daughter cells starts growing in the middle of the cell between the two nuclei and continues toward the periphery. This is known as the cell plate. It continues growing until its edges reach the cell's outer surface, separating the parent cell into two daughter cells. SEE ALSO CELL CYCLE; CHROMOSOME, EUKARYOTIC; CYTOKINESIS; CYTOSKELETON; MEIOSIS; NUCLEUS; REPLICATION; SEXUAL REPRODUCTION

*Michele D. Blum*

## Bibliography

Mader, Sylvia S. *Biology*, 6th ed. Boston: WCB McGraw-Hill, 1998.

McFadden, Carol H., and William T. Keeton. *Biology: An Exploration of Life*. New York: W. W. Norton and Company, Inc., 1995.

## Model Organisms: Cell Biology and Genetics

Model organisms are used to study basic mechanisms common to many forms of life and to experiment with biological processes that may be difficult or unethical to study in humans. Model organisms are usually chosen for some combination of ease of study (for example, the transparent bodies of the **nematode** *Caenorhabditis elegans* or the zebrafish *Brachydanio rerio*), ability to grow and reproduce quickly in a small space (*Arabidopsis thaliana*, a four-inch plant with a life cycle of four to six weeks), prominent cell struc-

**nematode** worm of the Nematoda phylum, many of which are parasitic

Scanning electron micrograph of the head of a fruit fly (*Drosophila melanogaster*).



**NUSSLEIN-VOLHARD,  
CHRISTIANE (1942–)**

German biologist who won the Nobel Prize in medicine in 1995 with Edward Lewis and Eric Wieschaus. In her lab, she and Wieschaus studied how genes affect the way a fly egg turns into an adult fly. They found that specific gene mutations cause specific defects in the number of wings, antennae, or legs of fruit flies. Many of these mutations turned out to be mutations in “regulatory genes,” genes that control other genes.

**chromosome** “colored body” in the cell nucleus; made of DNA and protein, and divided functionally into genes and nongene regions

**genome** total genetic material in a cell or organism

**cell cycle** sequence of growth, replication, and division that produces new cells

**transduction** conversion of a signal of one type into another type

**gene expression** use of a gene to create the corresponding protein

**hormone** molecule released by one cell to influence another

ture of interest (the giant **chromosomes** of the fruit fly *Drosophila melanogaster*), or ability to closely model some aspect of human biology (the mammalian **genome** and complex brain of the mouse). Most model organisms combine many if not all of these characteristics.

*Escherichia coli* bacteria provide an especially important model for studies of gene regulation. Yeast (*Saccharomyces cerevisiae*) are used for a wide variety of studies in eukaryotic chromosome structure and gene regulation, as well as virtually every aspect of cell function, including the control of the **cell cycle** and signal **transduction**. The slime mold *Dictyostelium discoideum* is used to study cell motility and other aspects of cell function, especially those with applications to cancer. *C. elegans* has provided a window on the fate of individual cells during development, as each cell can be followed as it is formed, takes its place, and begins to function. *Drosophila* is central in the study of chromosomes and molecular aspects of development, especially development of the nervous system. Zebrafish and the frog *Xenopus laevis* are used most often to study vertebrate development. *Arabidopsis* is the major model of plant cell biology and genetics. Finally, cultures of human cells are often used to examine response to drugs, effects of genetic mutations, and other aspects of health and disease.

The genomes of each of these organisms are either fully sequenced or soon will be, allowing further investigation of the links between **gene expression** and cell function. This will make these models even more valuable, and also allow investigation of fundamental questions about the similarities and differences among all types of organisms. SEE ALSO MODEL ORGANISMS: PHYSIOLOGY AND MEDICINE

Richard Robinson

**Bibliography**

*The WWW Virtual Library: Model Organisms.* <<http://ceolas.org/VL/mo/>>.

**Model Organisms: Physiology and Medicine**

A model organism is a member of an easy-to-study species that is used in experiments to learn how a more complex organism functions. Biomedical research relies heavily on model organisms as stand-ins for humans, but other types of research use these organisms too. For example, the small mustard relative *Arabidopsis thaliana* is a favorite model organism of biologists who work with plants. Most models of the human are vertebrates, such as rodents and primates, but even an organism as simple as a yeast can provide valuable insights and information about life at the molecular and cellular levels.

Model organisms typically have very short life cycles, enabling researchers to observe them over many generations. *Arabidopsis*, for example, has a life cycle of just six weeks or less, giving plant scientists peeks at such activities as flowering, reproduction, defense against pests, and **hormone** signaling. In addition, model organisms can be bred for genetic uniformity and the environmental conditions manipulated, so that researchers can pinpoint the sources of particular responses. Model organisms have been sta-

ples of biomedical research for decades, but they are even more valuable in the twenty-first century because they can be engineered to harbor human genes in each of their cells. An organism that has genes of a different species is termed **transgenic**.

## A Rich History

The story of the discovery of the cause of Type I diabetes mellitus illustrates the role of model organisms in human health care. In this condition, the pancreas does not secrete the hormone insulin, leading to **glucose** buildup in the bloodstream, which causes weight loss, weakness, and many other signs, symptoms, and complications. It was once swiftly lethal.

In October 1921, a young surgeon at the University of Toronto named Frederick Banting was pondering earlier work that had shown that removing a dog's pancreas leads to symptoms identical to those of diabetes in humans. Would giving such a dog an extract from a pancreas reverse the symptoms? If the dog's predicament was similar to people with diabetes, might an extract help them, too? Banting and an assistant, Charles Best, addressed these questions in a small lab, with ten dogs. They removed the pancreas from one dog, and it soon developed symptoms. From a second dog, they tied off the pancreas, then removed it and obtained an extract, which they injected into the first dog. It recovered, although only for a day (diabetes requires daily insulin injections). A friend of Banting's became the first person to receive insulin, derived from fetal calves, and within two years insulin replacement therapy was in widespread use. Today, people with Type I diabetes mellitus obtain insulin not from cows or dogs, but from *Escherichia coli* bacteria given genetic instructions to produce human insulin.

Experiments on dogs led to other advances in medical technology, including open heart surgery, cardiac pacemakers, heart transplants, and coronary bypass surgery. Dogs haven't been alone. Diphtheria vaccine was tested on horses, polio vaccine on rabbits, and AIDS (acquired immunodeficiency syndrome) vaccines on chimps, macaques, cats, and mice. Using nonhuman animal models of human genetic diseases is commonplace (dogs for muscular dystrophy, and mice for sickle cell disease, for example).

## Choosing an Appropriate Model

Researchers must choose model organisms carefully, or their use can lead to misinterpretations. For many years, microbiologists extrapolated from the widely studied *E. coli* to other microorganisms, missing a great deal of natural microbial variation. Similarly, some vertebrates given human disease-causing genes nevertheless do not develop similar symptoms, due to differences in physiology or **metabolism** between the species. For example, Lesch-Nyhan syndrome in humans causes self-mutilation, yet the same metabolic defect in mice has no apparent effect.

An organism's development must be considered too in selecting a model. Mice, for example, are three thousand times smaller than humans, grow about one hundred times as fast, and age thirty times faster. These differences may explain why cancer treatments that work in mice do not necessarily help people.

**transgenic** characterized by the presence of one or more genes from a different organism

**glucose** simple sugar that provides energy to animal cells and is the building block of cellulose in plants

**metabolism** chemical reactions within a cell

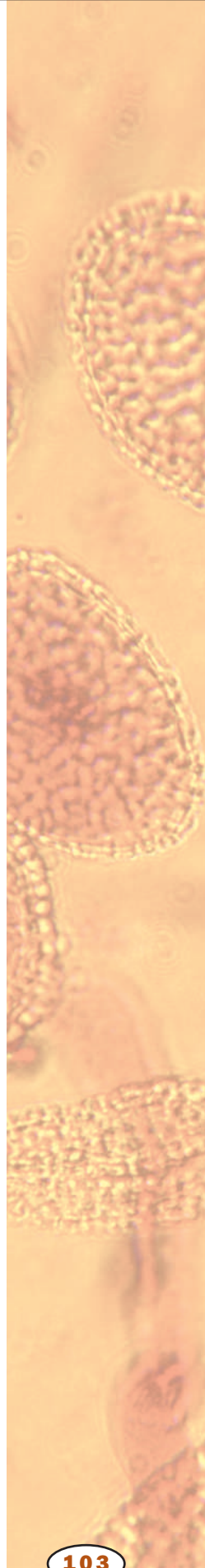

Mice have helped in developing treatments for seizures, multiple sclerosis, AIDS, and rejection of organ transplants.



Mice also do not live long enough to develop degenerative conditions associated with aging in humans. Still, mice are routinely used in preclinical investigations. They have helped in developing treatments for seizures, multiple sclerosis, AIDS, and rejection of organ transplants.

Different species provide different types of information, depending upon how closely they approximate the corresponding human condition. For example, pigs were used to pioneer heart surgery because their cardiovascular systems are remarkably like that of humans, and their organs are similar in size to those of humans. Mice are models for various forms of hereditary deafness, because their inner ears are structurally very similar to those of humans. A varied list of organisms has revealed the earliest stages in building an animal body, including sea urchins, frogs, worms, and fruit flies.

In pharmaceutical research, rats have modeled human reproduction, **endocrine** function, nutrition, and cancer. The rat's larger size compared to a mouse enables researchers to sample blood from the same animal over time, and to maintain the animal's body temperature and anesthesia level during surgery, which is much more difficult to do in mice. Rats are also more intelligent, making them useful in behavioral studies, and they tend to have more consistent litter sizes than mice.

### Clues in Genomes

Model organisms have proven so integral to research that in the late 1980s, the planners of the human **genome** project insisted that several nonhuman genomes be sequenced first. This enabled researchers to perfect deoxyribonucleic acid (DNA) sequencing technologies, and also provided a treasure trove of genes to which human genes can now be compared. Understanding how a gene functions in one species can provide clues to what it does in the human body, information that can be valuable in developing new ways to diagnose and treat disease.

**endocrine** related to the system of hormones and glands that regulate body function

**genome** total genetic material in a cell or organism

Since 1995, several dozen genomes have been sequenced, including those of many model organisms. The first step in investigating the function of a human gene is to seek matches in databases of gene sequences from other species. Consider long QT syndrome, an inherited cardiac arrhythmia that causes sudden death in otherwise healthy young adults, usually athletes. Investigation of the nearly identical gene in the fruit fly revealed the cause of the defect—abnormal channels for potassium **ions** in the cell membranes of heart cells. As genomes continue to be sequenced, researchers will be able to ask more questions, and to seek the answers using model organisms. SEE ALSO BLOOD SUGAR REGULATION; DISEASE; HEART AND CIRCULATION; HISTORY OF MEDICINE; HUMAN GENOME PROJECT; ION CHANNELS; MODEL ORGANISMS: CELL BIOLOGY AND GENETICS; PANCREAS; PHARMACOLOGIST; TRANSPLANT MEDICINE; ZOOLOGY RESEARCHER

*Ricki Lewis*

### Bibliography

- Lewis, Ricki. "Flies Invade Human Genetics." *The Scientist* 12, no. 13 (June 22, 1998): 1.
- . "How Well Do Mice Model Humans?" *The Scientist* 12, no. 21 (October 16, 1998): 1.
- Palevitz, Barry. "Arabidopsis Genome: Completed Project Opens New Doors for Plant Biologists." *The Scientist* 15, no. 1 (January 8, 2001): 1.

## Mollusk

The Mollusca (mollusks) are a large **phylum** of animals that includes the snails, slugs, clams, squids, and octopi, among others. Most are marine, many are freshwater, and some snails and slugs are terrestrial. The phylum name refers to their soft, pulpy bodies (*mollis* means "soft"). In many cases, the body is protected by a hard shell of calcium carbonate—the seashells familiar to beachcombers and "half shells" familiar to oyster lovers.

The shell is secreted by a membrane called the mantle that envelops the body like a cloak. In species without an external shell, such as octopi, the mantle forms an outermost skinlike body covering. The mantle encloses a space, the mantle cavity, which usually contains comblike gills for respiration. In some seemingly shell-less species—squids and cuttlefish—the shell is embedded in the mantle and can be found only by dissection. Most mollusks also have a radula. In snails, this is a tonguelike belt equipped with a few hundred to thousands of chitinous teeth, used to scrape food from surfaces such as rocks.

The most behaviorally sophisticated of all invertebrate animals are the cephalopod mollusks: the octopi, squids, cuttlefish, and nautilus. Cephalopods have long, flexible arms, equipped in most cases with suckers for prey capture. They are active swimmers; some have eyes remarkably similar to human eyes; they have more complex brains than any other invertebrate; and, correspondingly, they exhibit remarkably subtle social behaviors and learning capabilities. SEE ALSO ANIMALIA; OCEAN ECOSYSTEMS: HARD BOTTOMS; OCEAN ECOSYSTEMS: OPEN OCEAN; OCEAN ECOSYSTEMS: SOFT BOTTOMS; VISION

*Kenneth S. Saladin*

**ion** an electrically charged particle

**phylum** taxonomic level below kingdom, e.g., arthropod or chordate

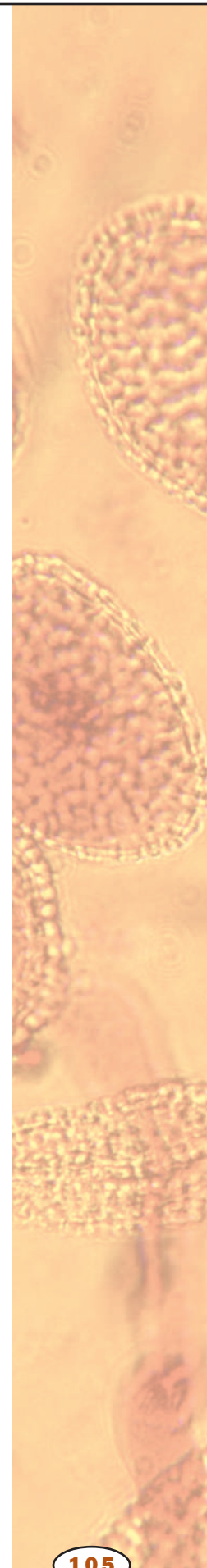

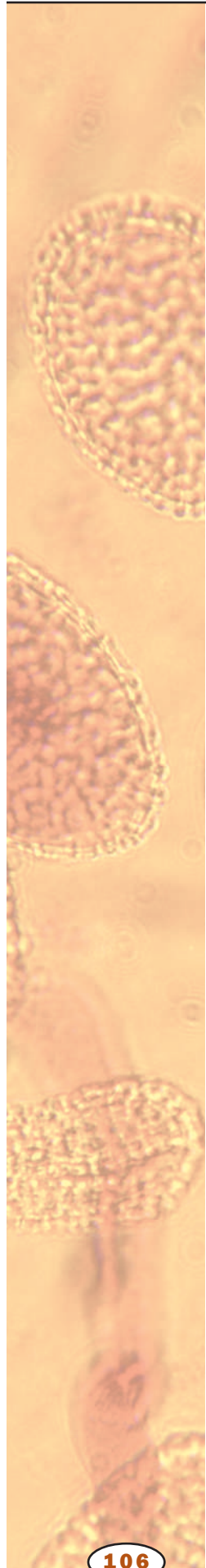

**cotyledon** seed leaf, which stores food and performs photosynthesis after germination

**dicot** plant having two cotyledons, or seed leaves

**eudicot** “true dicot”; plants with two seed leaves that originated from the earliest of flowering plants

**xylem** water-transporting system in plants

**phloem** plant tissue that conducts sugars from leaves to roots and other tissues

**adventitious** growing from a nonstandard location

**fertilization** union of sperm and egg

**Bibliography**

Pechenik, Jan A. *Biology of the Invertebrates*, 4th ed. Boston: McGraw-Hill, 2000.  
 Rupert, E. E., and R. D. Barnes. *Invertebrate Zoology*, 6th ed. Philadelphia, PA: W. B. Saunders, Co., 1994.

**Monocots**

Monocots, or monocotyledons, are a class of the flowering plants, or angiosperms. Monocots are named for and recognized by the single **cotyledon**, or seed leaf, within the seed. The first green blade emerging from the seed upon germination is the cotyledon, which contains sugars and other nutrients for growth until the leaf is able to photosynthesize.

Monocots comprise about 67,000 species, or one-quarter of all flowering plants. They include not only the very large grass family (Poaceae, 9,000 species), but also the orchid family (Orchidaceae, 20,000 species), and the sedge family (Cyperaceae, 5,000 species), as well as palms, lilies, bromeliads (including pineapple), and the Araceae, which includes skunk cabbage and philodendron. The angiosperms have traditionally been divided into monocots and **dicots** alone, but recent work has shown that while monocots form a natural evolutionary group, dicots do not, and so the angiosperms are now grouped into monocots, **eudicots**, and basal angiosperms.

In addition to the single cotyledon in the seed, monocots can be recognized by the arrangement of vascular tissue in the stem. Vascular tissue includes **xylem**, used for water transport from the roots, and **phloem**, which carries sugars and other nutrients from the leaves to other tissues throughout the plant. Unlike other angiosperms, whose vascular tissue is arranged in rings around the periphery, the vascular bundles of monocots are scattered throughout the stem. One consequence of this is that monocots cannot form annual rings of hardened tissue—wood—and so are limited in the strength of their stems. Nonetheless, some monocots, notably the palms, do attain significant height. Leaves of monocots have parallel veins, as seen in grass.

The roots of monocots also differ from other flowering plants. In monocots, the first root to emerge from the seed dies off, and so no strong, central tap root forms. Instead, monocots sprout roots from shoot tissue near the base, called **adventitious** roots. The familiar fibrous root system of grasses is an example of this rooting pattern. Many monocots form bulbs, such as onion, gladiolus, and tulips. These are not root structures, but rather modified stems, made of compact leaves. This can be easily seen in the layers of the onion.

Most monocot flowers have flower parts in sets of three, so that there may be three or six petals, for instance, along with three egg-bearing carpels and pollen-bearing stamens in some multiple of three. The pollen grains of monocots have a single slit, or aperture, which splits open to allow the pollen tube to grow during **fertilization**. In contrast, the pollen grain of eudicots has three apertures.

Orchid flowers are among the most beautiful and complex of all flowers, due in part to their long and specialized relationship with specific pollinators. Some orchid flowers have evolved to resemble the female of the





An Eastern prairie fringed orchid (*Plantanthera leucophaea*), a type of monocot.

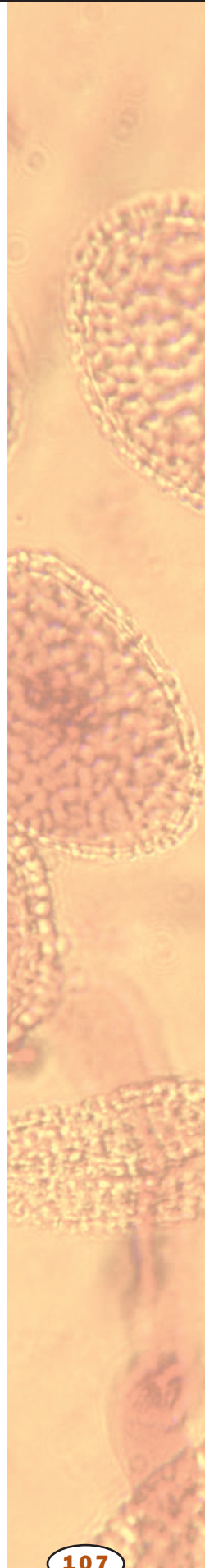

bee species that pollinates them, luring the male in to attempt copulation. During this process, the pollen, all of which is retained in a single, sticky mass, is transferred to the male bee, who will carry it to the next flower in another fruitless attempt to find a mate.

In contrast to the showy orchids, grass flowers are rather simple and dull, in keeping with the absence of any need to attract insects. Grass flowers are suspended at the tip of the plant, where wind can carry the pollen away to land on the female flower of a neighboring plant. Three grasses—corn, wheat, and rice—provide the vast majority of calories consumed by humans throughout the world. Their seeds, called grain, are rich in **carbohydrates** and contain some **protein** and vitamins as well. SEE ALSO ANGIOSPERMS; EUDICOTS; EVOLUTION OF PLANTS; FLOWERS; GRAIN; GRASSES; LEAVES; ROOTS; SEEDS; SHOOTS

*Richard Robinson*

#### **Bibliography**

Raven, Peter H., Ray F. Evert, and Susan E. Eichhorn. *Biology of Plants*, 6th ed. New York: W. H. Freeman and Company, 1999.

**carbohydrates** sugars, starches, and other molecules combining carbon, hydrogen, and oxygen and serving as fuel or structural components

**protein** complex molecule made from amino acids; used in cells for structure, signaling, and controlling reactions

**lineage** ancestral line

**marsupial** kangaroos and other mammals that gestate young in an external pouch

**placental** related to mammals that nourish the fetus with a placenta, an exchange organ in the uterus

**cloaca** common exit cavity for intestinal, genital, and urinary tracts

**cranial** related to the cranium, or brain cavity

## Monotreme

Monotremes are an ancient group of mammals in the order Monotremata, which probably split from the **lineage** leading to **marsupials** (those with no placenta and having a pouch in the abdomen) and **placental** mammals early in mammalian evolution. The earliest fossil occurrence of monotremes is in the lower Cretaceous, approximately 110 million years ago.

Monotremes retain some of the primitive characteristics of mammalian ancestors, the therapsids. Monotremes lay eggs, have a somewhat reptilian posture, and retain a **cloaca**, a body cavity into which the reproductive, urinary, and excretory systems empty. Monotremes lack teeth as adults and have an unusual **cranial** shape. However, monotremes possess several critical mammalian features. They have fur, four-chambered hearts, single dentary (lower jaw) bones, and mammalian ear structure, and they lactate, or produce milk. Females lay one to three small, leathery eggs and incubate them outside of the body. Upon hatching, the young lap milk from the mother's mammary glands, which lack a nipple.

There are two families and three species of monotremes. The family Tachyglossidae includes two species: the spiny anteater, found in Australia, Tasmania, and southern New Guinea; and the long-nosed anteater, found only in New Guinea. The family Ornithorhynchidae includes a single species, the duck-billed platypus, an aquatic species that is found in eastern Australia and Tasmania. All three species eat primarily invertebrates and are prodigious burrowers. Populations of the long-nosed anteater are currently threatened by overhunting. Platypus is a protected species, and both the spiny anteater and platypus populations seem stable as of 2001. SEE ALSO MAMMAL; MARSUPIAL

*Tanya Dewey*

### Bibliography

Anderson, Sydney, and J. Knox Jones, Jr., eds. *Orders and Families of Recent Mammals of the World*. New York: John Wiley & Sons, Inc., 1984.

Nowak, Ronald M., ed. *Walker's Mammals of the World*. Baltimore, MD: Johns Hopkins University Press, 1991.

Vaughan, Terry A. *Mammalogy*. Philadelphia, PA: Saunders College Publishing, 1986.

## Muscle

Muscle can be categorized into three types based on structure, function, and location in the body. The specific details of muscle, including structure, physiology of contraction, energy requirements, muscle conditioning, and disease, can be illustrated using skeletal muscle.

### Three Types of Muscle

The three types of muscle are skeletal, cardiac, and smooth muscle. Skeletal muscle is attached to the skeleton and moves the body and its components. It appears striated (striped) under the microscope and is under voluntary control. The biceps of the arm is an example of skeletal muscle. Cardiac muscle is only located in the heart. Cardiac muscle is also striated, but is not normally under voluntary control. Smooth muscle surrounds blood

vessels and other passageways and alters the size of openings or passageways and propels material through body tubes. Smooth muscle is distributed throughout the body. It lacks striations and is involuntary. The respiratory and digestive tracts have layers of smooth muscle in their walls.

## Muscle Ultrastructure

A skeletal muscle fiber is formed from the fusion of many embryonic cells during development to form slender cells that extend from one end of the muscle to the other. Each muscle fiber normally has one nerve fiber that extends to the cell membrane, forming the neuromuscular junction. There is a 100-nanometer space, the synaptic cleft, between the nerve fiber and the muscle fiber.

The muscle cell membrane forms inward projections, the **transverse** tubules, associated with the cell's smooth **endoplasmic reticulum** (here called sarcoplasmic reticulum). The sarcoplasmic reticulum stores calcium and surrounds bundles of contractile **proteins**. The contractile proteins, which do the work of contraction, are parallel and arranged in an overlapping pattern that gives rise to the muscle striations. The pattern of striations is repeated many times down the length of the muscle fiber in segments called sarcomeres.

The proteins of the sarcomere are grouped in thick filaments and thin filaments. Contraction occurs when thick and thin filaments slide past each other, pulling the muscle ends closer together. A thick filament is a bundle of approximately two hundred myosin proteins. A portion of each myosin protein projects outward to form myosin heads.

**transverse** situated or lying across

**endoplasmic reticulum** network of membranes within the cell

**protein** complex molecule made from amino acids; used in cells for structure, signaling, and controlling reactions

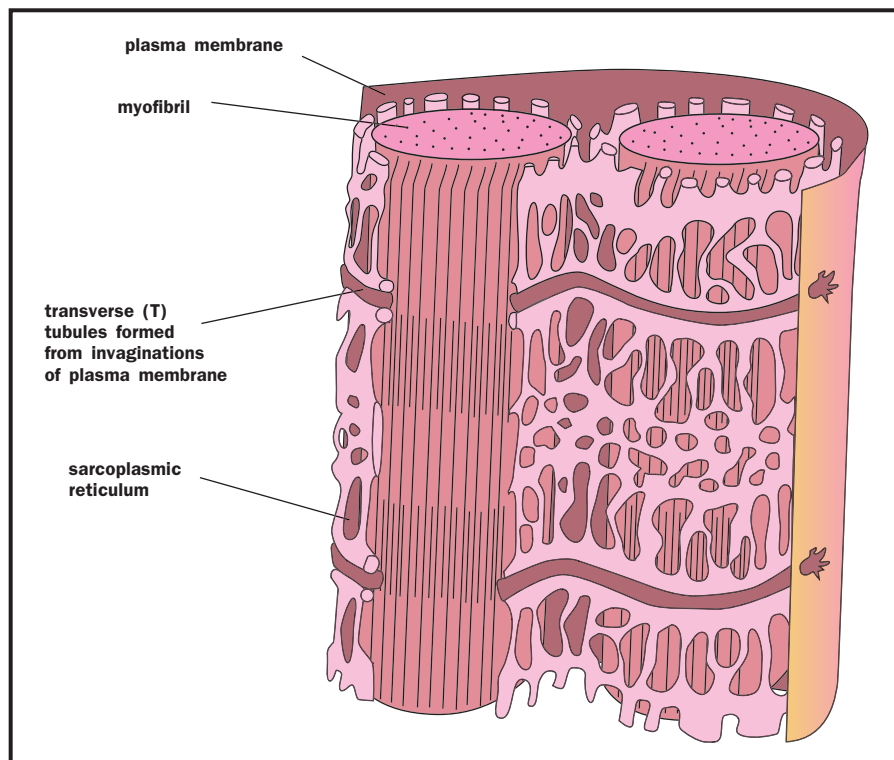

Microstructure of a muscle cell showing the close association of the sarcoplasmic reticulum and the myofibrils.

**active site** surface region of an enzyme where it catalyzes its reaction

**polypeptide** chain of amino acids

**action potential** wave of ionic movement down the length of a nerve cell

**neuron** nerve cell

Thin filaments overlap the thick filaments and are composed of three types of protein molecules. The main protein is actin. Three hundred to four hundred molecules of globular actin (G actin) link like beads in a necklace to form a strand called fibrous actin (F actin). Two such “necklaces” are then intertwined into a loose double helix. In the groove between the two F actins, much like a string, is the protein tropomyosin. Each G actin contains an **active site** to bind the myosin head. When the muscle is at rest, tropomyosin covers the active sites of actin. Attached to tropomyosin is troponin, a small complex of three **polypeptides**. This structural arrangement allows muscle to contract.

## Muscle Contraction

Muscle contraction begins when the nerve fiber releases the neurotransmitter acetylcholine into the synaptic cleft. Acetylcholine moves across the synaptic cleft and binds to receptors on the muscle fiber. This indirectly initiates an **action potential**, a change of electrical charge at the membrane that is similar to events in a **neuron**. The action potential spreads across and into the muscle fiber via the transverse tubules and triggers the release of calcium from the sarcoplasmic reticulum. Next, calcium binds to troponin, causing the troponin to change shape. Since troponin is attached to tropomyosin, as troponin changes shape the tropomyosin is pulled away from the active sites of actin, which become exposed. The myosin head, which was previously blocked by tropomyosin, now binds to the active site of actin, forming a cross-bridge between the thick and thin filament.

In a ratchetlike movement, myosin pulls the thin filament past the myosin as the myosin head repeatedly flexes, lets go of the actin, extends and attaches to a new active site, and flexes again. As the many myosin heads continue to repeat this process, thin filaments slide past the thick filaments and the sarcomere is shortened. Shortening of all sarcomeres within the muscle fiber results in contraction of the whole fiber.

Muscle relaxes and returns to its original form when tropomyosin covers up the active sites of actin, preventing the formation of cross-bridges. Relaxation also involves the destruction of acetylcholine by acetylcholinesterase in the synaptic cleft, ending muscle stimulation, and the reuptake of calcium into the sarcoplasmic reticulum. Without calcium, troponin returns to its original shape, pulling tropomyosin back over the active sites of actin. Myosin no longer forms cross-bridges, so the muscle re-

Depolarization of the T-tubule membrane causes a release of calcium ions from the sarcoplasmic reticulum, triggering muscle contraction.

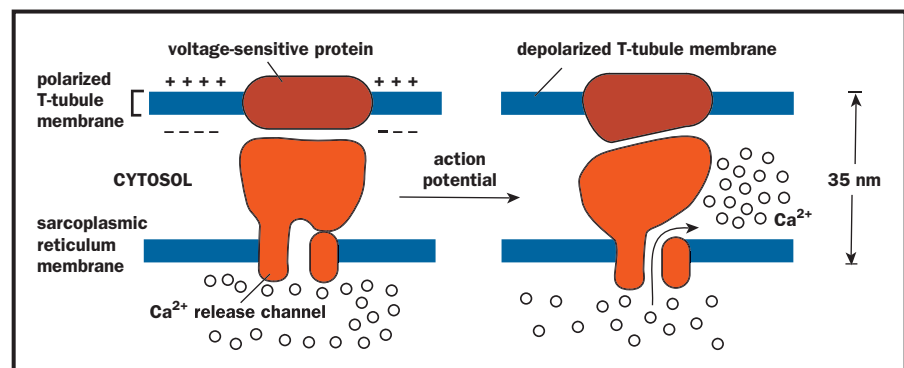

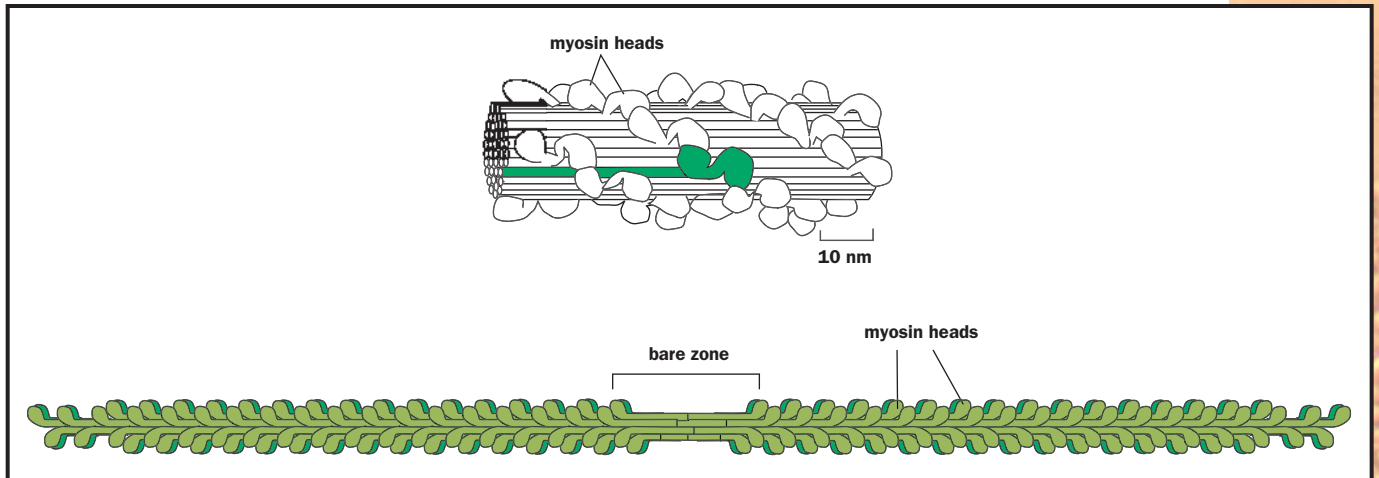

laxes. Note that a muscle can actively contract but cannot actively extend itself. For the releasing, muscles are usually present in pairs, each working against each other.

### Energy (ATP) Requirements

The contraction of muscle fibers requires a large amount of energy in the form of adenosine triphosphate (ATP). ATP is made available through various mechanisms. A limited amount of ATP is stored in the muscle cell. ATP is also produced by a phosphate transfer from creatine phosphate to **ADP**; muscles do store larger amounts of creatine phosphate. The stored ATP and the ATP created from creatine phosphate are available for immediate use and provide approximately enough ATP for about six seconds of exercise.

Additional ATP can be produced through **anaerobic** and **aerobic metabolism**. Aerobic respiration provides a larger production of ATP but depends on sufficient oxygen delivery. Myoglobin, a protein in muscle cells that binds oxygen, contributes some of the oxygen for aerobic respiration. Aerobic ATP production also requires **mitochondria**. Muscles packed with mitochondria give meat a darker color (“dark meat”) than muscles with fewer mitochondria (“white meat”). Anaerobic fermentation provides less energy but can produce ATP in the absence of oxygen. A serious drawback of anaerobic fermentation is the production of lactic acid, a product that can alter cell **pH**. Both processes can use **glucose** released from glycogen, which is stored in muscles as a reserve fuel.

### Muscle Fatigue

A decrease in the ability of muscle to contract is muscle fatigue. Muscle fatigue can result from short burst of maximum effort, such as a 50-meter swim, or sustained long-term activities such as marathon running. The cause of fatigue depends on the activity. Fatigue from short, extensive burst of activity can result from depletion of ATP or buildup of lactic acid. Muscle fatigue from sustained activities can result from depletion of fuel molecules or depletion of acetylcholine at the neuromuscular junction.

Myosin heads in a myosin thick filament cluster to the outside, with the tails lining up inside. The heads on either end point in opposite directions. During muscle contraction, the heads pull actin filaments together toward the center bare zone, contracting the muscle fiber.

**ADP** adenosine diphosphate, the low-energy form of ATP

**anaerobic** without oxygen, or not requiring oxygen

**aerobic** with oxygen, or requiring it

**metabolism** chemical reactions within a cell

**mitochondria** subcellular organelle that creates ATP used for energy-requiring processes in a cell

**pH** measure of acidity or alkalinity; numbers below 7 are acid, above are basic

**glucose** simple sugar that provides energy to animal cells and is the building block of cellulose in plants

**autoimmune disease**  
disease in which the immune system attacks the body's own tissues

### ARTHRITIS AND GROWTH OF CARTILAGE

Arthritis is a breakdown of articular hyaline cartilage, often increased by enzymes of inflammation. Rheumatoid arthritis is an autoimmune disease, in which one's own immune system attacks healthy tissue. Osteoarthritis may be caused or accelerated by obesity, joint injuries, defective cartilage, lack of exercise, or biomechanical defects. Defects of only 1 square centimeter will alter the functioning of the articular cartilage.

Osteoarthritis is a major cause of joint replacements. A process to harvest and grow articular cartilage outside the body, called autologous chondrocyte implantation, is under investigation as of 2001. It is expensive and not exactly like real cartilage. However, in the future, replacement may employ stimulating growth factors, cartilage cells taken from an accessible place in the patient's body, and a synthetic matrix (scaffolding).

## Hypertrophy and Conditioning

Through training, a muscle can become larger (hypertrophy) and have greater endurance. A muscle grows mainly by increasing the number of thin and thick filaments within the fibers. Growth results from repeated contractions of muscle, as in weight lifting. Muscle conditioning is the increased ability of the muscle to perform a task, either because of greater strength or better fatigue-resistance. Many changes in muscle performance, however, result from changes in the cardiovascular and respiratory systems, enabling them to deliver fuel and oxygen to muscle fibers more efficiently. Many changes specific to muscle fibers involve enhancing energy production, including an increase in number of mitochondria and myoglobin and greater storage of glycogen.

## Muscle Disease

Diseases affecting muscle can result from loss of neurons that stimulate the muscle, such as polio; changes in the neuromuscular junction that result in loss of ability to stimulate the muscle, such as myasthenia gravis (an **autoimmune disease**); or loss of structural integrity of the muscle fiber, such as muscular dystrophy. All result in decreased ability of the muscle to contract and sometimes the complete loss of the muscle's function. SEE ALSO AUTOIMMUNE DISEASE; GENETIC DISEASES; METABOLISM, CELLULAR; MITOCHONDRION; MUSCULOSKELETAL SYSTEM; NEURON; NUCLEOTIDES; SYNAPTIC TRANSMISSION

*Theresa Stouter Bidle*

### Bibliography

- Andersen, Jesper L. "Muscle, Genes and Athletic Performance." *Scientific American* 283, no. 3 (2000): 48–55.
- Bevan, James, and Richard Bayliss. *A Pictorial Handbook of Anatomy and Physiology*. Barnes and Noble Publishers, 1996.
- LeVay, David. *Teach Yourself Human Anatomy and Physiology*. NTC Publishing Group, 1993.
- Van Baak, Marleen A. "Relationships with Physical Activity." *Nutrition Reviews* 58, no.3 (2000): 52–53.

## Musculoskeletal System

The musculoskeletal system includes bones, joints, skeletal muscles, tendons, and ligaments. Muscles generate force; tendons transfer it to bones; and the bones move if enough force is transmitted. The force must be enough to overcome the weight of the moving body part, gravity, and other external resistance. Motion occurs at joints associated with one or both ends of the bone.

The force is produced in the muscle belly, which consists of muscle tissue. Tendons are basically connected bundles of collagen. They are classified as dense regular connective tissue and arise partially from the connective tissue coverings of muscle fibers and fiber groups. Tendons attach to the external membrane of a bone, the periosteum, which covers the bone except at joint surfaces. A few muscles bypass tendons and attach directly to the periosteum. Other muscles attach to skin (muscles of facial expression),

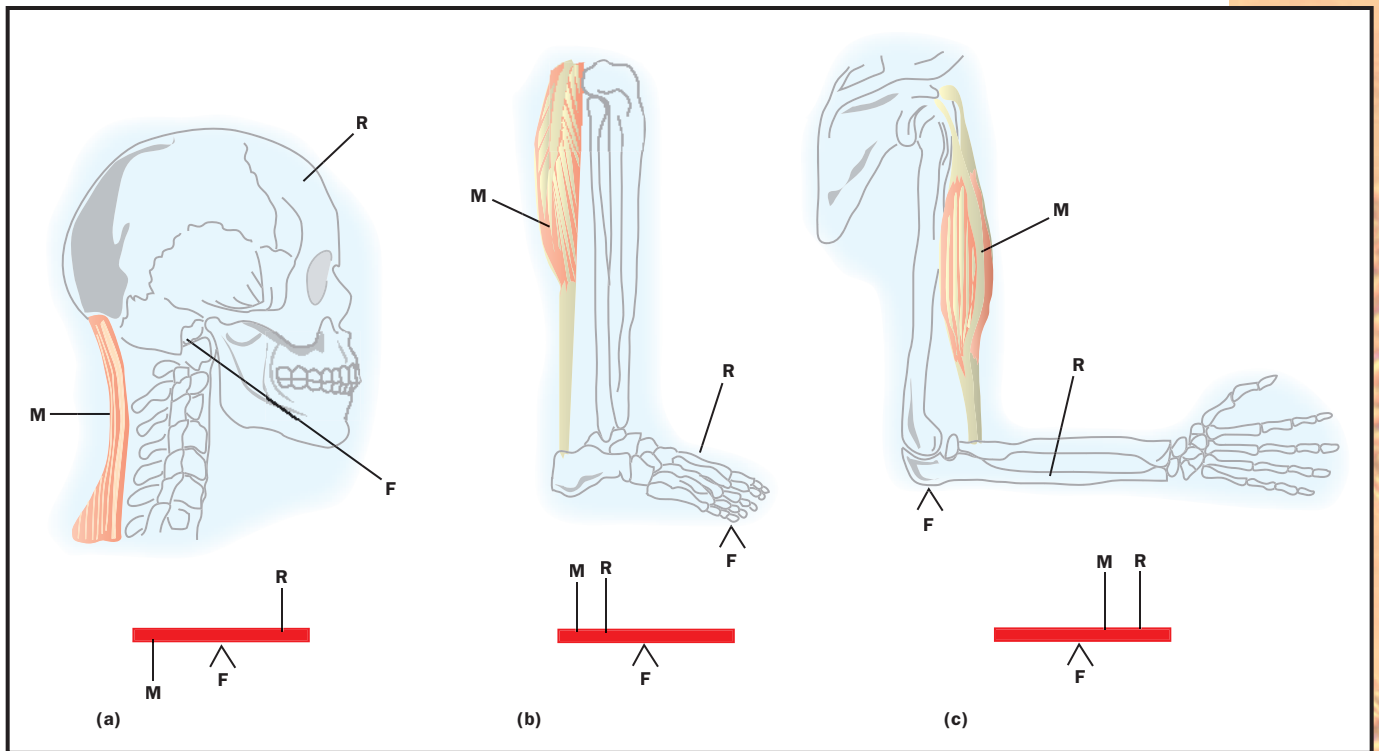

to other muscles, or to fascia, which are connective tissue sheets between muscles.

The surfaces of the bone making up the joint have a layer of hyaline cartilage, the articular cartilage, which forms a smooth surface for easy movement. Bone ends may be surrounded by a joint capsule, which secretes fluid for lubrication and nutrition. Joint motion is usually pain free, but age, injury, and some diseases damage the articular cartilage, resulting in arthritis.

Biomechanics applies the principles of physics to human movement. Some joints work like levers, others like pulleys, and still others like a wheel-axle mechanism. Most motion uses the principle of levers. A lever consists of a rigid “bar” that pivots around a stationary **fulcrum**. In the human body, the fulcrum is the joint axis, bones are the levers, skeletal muscles usually create the motion, and resistance can be the weight of a body part, the weight of an object one is acting upon, the tension of an antagonistic muscle, and so forth.

Levers are classified by first, second, and third class, depending upon the relations among the fulcrum, the effort, and the resistance. First-class levers have the fulcrum in the middle, like a seesaw. Nodding the head employs a first-class lever, with the top of the spinal column as the fulcrum. Second-class levers have a resistance in the middle, like a load in a wheelbarrow. The body acts as second-class lever when one engages in a full-body push-up. The foot is the fulcrum, the body weight is the resistance, and the effort is applied by the hands against the ground.

Third-class levers have the effort (the muscle) in the middle. Most of the human body’s musculoskeletal levers are third class. These levers are built for speed and range of motion. Muscle attachments are usually close

Classes of levers. (a) In a first-class lever, the fulcrum (F) is set up between the resistance (R) and the effort (M). (b) In a second-class lever, the resistance is between the fulcrum and the effort. (c) In a third-class lever, the effort is between the fulcrum and the resistance.

**fulcrum** pivot point of a lever

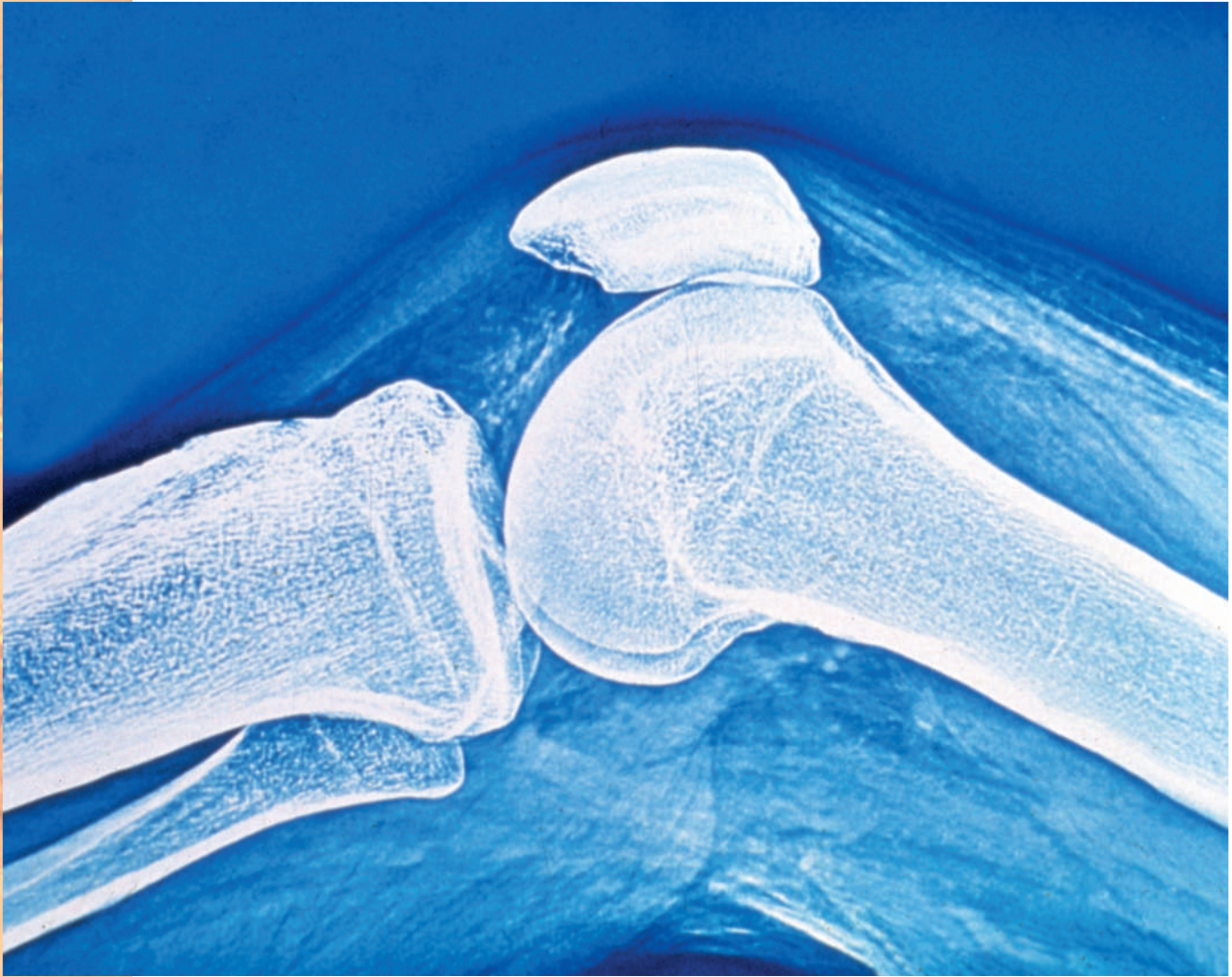

An X ray of the human knee joint with the patella, the bone located within the quadriceps tendon, which wraps over the front of the knee, forming the kneecap.

to the joint. As the length of the lever increases, the possible speed increases, but so does the force required to produce it. For instance, the forearm is a third-class lever, controlled by the biceps muscle. A longer forearm can produce faster motion of the hand, but requires more effort to move than a shorter forearm.

A few muscle-bone connections work on the principle of a pulley, which changes the direction of an applied force. A classic example is the patella (kneecap), which alters the direction in which the quadriceps (patellar) tendon pulls on the tibia.

Muscles play four roles in producing joint movements: agonist (prime mover), antagonist, synergist, and fixator. A given muscle can play any of these roles, often moving from one to the next in a series during an action. Agonists and antagonists are opposing muscles. This means that when an agonist creates tension, the antagonist produces an opposing tension, thereby contributing to control at the joint. When one lifts a glass of water from the table to one's mouth, for example, the biceps brachii muscle acts as an agonist to flex the elbow, while the triceps brachii acts as an an-



tagonist to keep the elbow from flexing too fast or too far. Synergists aid the motion of an agonist.

Although every musculotendinous unit (muscle belly and tendons attaching it to the bone) has a specific name, it is common to group muscles according to the motion they create. Flexors create motion that would bring the **distal** segment closer to the torso, while abductors cause a limb to move **laterally**, away from the body. SEE ALSO BONE; MUSCLE; SKELETONS

*Karen Jensen*

### Bibliography

*Arthritis Answers*. <[www.arthritis.org/Answers/disease\\_center.asp](http://www.arthritis.org/Answers/disease_center.asp)>.

Kreighbaum, Ellen, and Katharine Barthels. *Biomechanics: A Qualitative Approach for Studying Human Movement*. New York: Allyn and Bacon, 1996.

Marieb, Elaine. *Essentials of Human Anatomy and Physiology*. San Francisco, CA: Benjamin/Cummings, 2000.

## Mutation

Mutations are physical changes in **genes** and **chromosomes**. They may be confined to a single cell or may be transmitted from one cell to another within a multicellular organism (somatic cell mutation), or may be transmitted from one generation to another through mutation in the **gametes** (germ-line mutation). Mutations may be caused by natural events within the environment, by action or inaction of deoxyribonucleic acid (DNA) repair **enzymes**, and by human production of chemicals or high-energy radiation (mutagens). Mutation rates vary from organism to organism, from gene to gene, from time to time, and from place to place. They can have a significant effect not only on the individual, but on the evolution of species.

### Causes of Mutations

Since genes are composed of DNA, nearly anything that can change the structural composition, sequence, physical integrity, or length of a DNA molecule can cause mutations. Breakages may be caused by physical damage such as being severed by ice crystals in a frozen cell or violent agitation from high temperature. Exposure to high-energy radiation (bombardment by alpha, beta, or gamma particles) or ultraviolet light can have a similar effect. A variety of chemicals act as mutagens. Some chemicals, such as bromouracil, are structurally similar to DNA bases, and are inserted in place of normal bases. Ethidium bromide has a structure that allows it to wedge within the DNA double helix (intercalation), and is used as a stain for DNA. Many other chemicals, such as peroxides and mustard gas, chemically modify DNA.

Mutagens, which affect DNA, are distinct from **teratogens**, which influence the embryological development of an individual without necessarily affecting DNA structure. For example, thalidomide, a tranquilizer, causes nongenetic birth defects such as shortened limbs. Sensitive tests for identifying mutagens, like the Ames test, frequently also identify teratogens.

Spontaneous mutations can appear in DNA for many reasons, including faulty proofreading during replication. The fidelity of replication is

**distal** away from

**laterally** side-to-side

**gene** portion of DNA that codes for a protein or RNA molecule

**chromosome** “colored body” in the cell nucleus; made of DNA and protein, and divided functionally into genes and nongene regions

**gamete** reproductive cell, such as sperm or egg

**enzyme** protein that controls a reaction in a cell

**teratogens** substances that cause birth defects

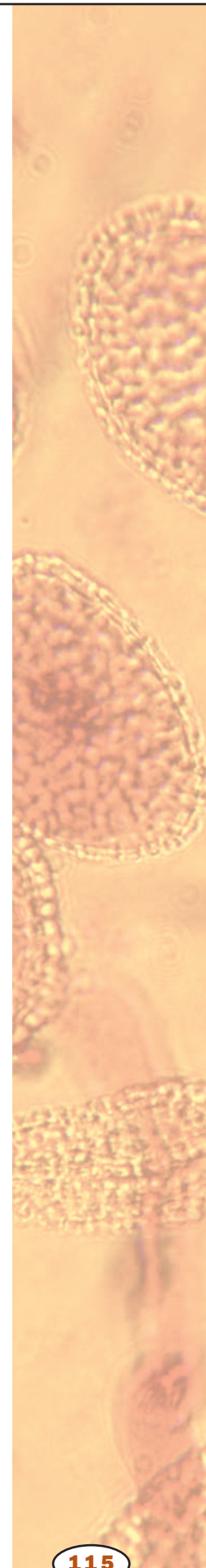

A white American alligator shows a genetic mutation known as leucism. This allele controls migration of pigment cells during development; absence in cells leads to white patches on the skin.



**nucleotide** the building block of RNA or DNA

greatly influenced by the cutting activities of DNA polymerases, which usually cut out incorrectly added **nucleotides**. Study of bacteria with high mutation rates (mutator strains) has shown they often have DNA polymerases with limited 3' to 5' (three-prime to five-prime) exonuclease activity. An exonuclease removes nucleotides at the end of the DNA chain. Low exonuclease activity means they are less able to remove incorrect nucleotides once added. On the other hand, antimutator strains often have DNA polymerases with very efficient 3' to 5' exonuclease activity. Due to these and other enzymes, a large number of different rates of mutation occur in different systems. Normally, the rate of change is about one in ten billion nucleotides per cell division, but the variance is wide and can be as high as one in ten thousand per generation. Human cells have approximately nine billion nucleotides, and so on average, about one mutation should occur in each round of DNA replication.

### Types of Mutations: Structure and Information

Mutations can be classified in terms of the structural changes they cause, and in terms of the changes in the genetic information they produce. Point mutations are those affecting a single nucleotide. Point mutations may be deletions or insertions of nucleotides, or changes from one nucleotide to another (substitutions).

To understand the types of changes, it is useful to remember that the DNA nucleotides are adenine, thymine, cytosine, and guanine (abbreviated A, T, C, G). Canonically, A pairs with T, C pairs with G. Because of their chemical structures, A and G are referred to as purines, while C and T are pyrimidines. Substitutions, then, may be from purine to purine or from pyrimidine to pyrimidine (transitions), or purine to pyrimidine or vice versa (transversions).

**amino acid** a building block of protein

**protein** complex molecule made from amino acids; used in cells for structure, signaling, and controlling reactions

The DNA within a gene codes for the **amino acid** sequence in a **protein**, and so DNA mutations can lead to protein changes. The code is read in triplets, sequences of three nucleotides. From this, it is readily seen that any insertion or deletion will change the triplet groups, and so may have

major effects on the amino acids coded for. This is called a frame-shift mutation. Frame-shift mutations almost always result in nonfunctional proteins.

Transitions and transversions often have less drastic effects. In some cases, there is no effect at all. This occurs when the change is from one “synonym” to another in the **genetic code**; that is, when the new triplet codes for the same amino acid as the old one. A “nonsense” mutation is much more serious, since this converts a triplet coding for an amino acid (sense) into one with no corresponding amino acid (nonsense). This causes protein synthesis to stop (such triplets are called stop **codons**). A **missense mutation** is also potentially serious, since this changes one amino acid to another. When the new amino acid is chemically similar to the old one, there may be little effect on the protein structure and function. When they differ in size, polarity, or charge the effect may be profound.

Such is the case with the sickling variant of the **hemoglobin** gene. In the 1940s, Nobel laureate Linus Pauling suggested, and, in the 1950s, Verne Ingram demonstrated, that the first well-described “molecular disease” namely sickle cell disease, was due to a mutation that affected just one position in the amino acid sequence of the hemoglobin (Hb) molecule that carries iron in human blood. The underlying mutation was later shown to be a transversion from thymine to adenine. This converts an amino acid near one end of the beta chain of human hemoglobin from a glutamic acid side to a valine. This change, from a negatively charged **hydrophilic** side chain to a **hydrophobic** side chain, converts HbA to HbS. This alters the way hemoglobin molecules **aggregate** at low oxygen concentrations; HbS molecules cause the red blood cells that contain them to bend into a sickle shape. When these misshapen cells obstruct blood flow, an affected individual experiences great pain.

## Mutation in Evolution

Mutation is one of the four forces of evolution; the others are selection, migration, and genetic drift. For a century after the publication of *The Origin of Species* by English naturalist Charles Darwin in 1859, mutation was often discussed as a source of new variation, but it was seldom considered to be highly important except in rare instances. However, in the 1960s, mutation became a major focus of evolutionary research.

The central question regarding mutation in evolution is to what extent mutations are harmful, harmless, or useful. In two experimental papers in 1966, Richard Lewontin and John Hubby demonstrated that many more individual fruit flies are **heterozygous** (meaning they have two different **alleles** at a genetic **locus**) and their populations had many more polymorphisms (the number of genes with more than one allele present) than could be accounted for by classical population genetic theory. R. K. Selander and others then extended this work for a broad **phylogenetic** spectrum of organisms. This gave strong support to the ideas of two population geneticists from Japan, Motoo Kimura and Tomoka Ohta, who hypothesized that most mutations were selectively neutral instead of being deleterious, as the standard view was at the time. In their view, mutations increase genetic diversity by giving rise to harmless differences in a gene that can be maintained in a population over long periods. These changes are reflected in the number of alleles (gene forms) within the population.

### SUGIMURA, TAKASHI (1926–)

Japanese biologist who demonstrated that chemicals, X rays, and other agents that cause cancer often do so by causing mutations in the deoxyribonucleic acid (DNA) of cells. Sugimura, along with American Bruce Ames, won the prestigious Japan Prize in 1997.

**genetic code** relationship between triples of RNA nucleotides and the amino acids they code for during protein synthesis

**codon** sequence of three mRNA nucleotides coding for one amino acid

**missense mutation** nucleotide change that causes a change in the amino acid normally added to the protein

**hemoglobin** oxygen-carrying protein complex in red blood cells

**hydrophilic** “water loving”

**hydrophobic** “water hating,” such as oils

**aggregate** clump together

**heterozygous** characterized by possession of two different forms (alleles) of a particular gene

**allele** a particular form of a gene

**locus** site on a chromosome (plural, loci)

**phylogenetic** related to phylogeny, the evolutionary development of a species



An African clawed frog (*Xenopus laevis*), mutated, with three hind legs.

Neutralists (such as Kimura and Ohta) argued that most alleles at a genetic locus were either neutral or likely to have nonsignificant deleterious consequences. If alleles are principally neutral, then changes in allele frequencies will be driven fundamentally by random forces (principally genetic drift). On the other hand, selectionists thought that alleles are predominantly harmful (with a view that only rare alleles have beneficial contributions), and, hence, natural selection would act to change allele frequencies in a predictable fashion, eliminating most new ones.

Kimura and Ohta's recognition of the neutral value of most mutations allowed the estimation of divergence times between related species by analyzing accumulated gene changes; the so-called molecular clock. Parts of proteins that were indispensable to function would be very well preserved and hence have few preserved mutational changes in their related gene sequences. Dispensable portions would have many more mutations. Changes in noncoding DNA regions, such as **introns** and "junk DNA," can accumulate even more mutations without effect.

**intron** untranslated portion of a gene that interrupts coding regions

In the last two decades of the twentieth century, two other major advances were made in the understanding of mutation. First, site-specific mutagenesis allowed molecular biologists to mutate genes almost letter by letter. With this approach, they can look at the impact of changing single amino acids on the structure and function of proteins.

Second, a debate on the role of mutation rate and the direction of mutations has been rekindled. In the 1940s, Salvador Luria and Max Delbrück showed definitively that mutations did not arise that specifically addressed some biochemical inability of the organism, such as an ability to metabolize a new food source or to resist **pathogenic** infection. Instead, random mutations are produced, and those populations with beneficial adaptations survived better than other populations.

However, in the 1980s, John Cairns and others challenged the orthodoxy of this view with a variety of new experiments, which they thought indicated that mutations with adaptive value preferentially arose in some bacterial populations.

The response from the majority scientific community was rapid. In 1999, Croatian scientist Miroslav Radman, working in Paris, provided the most widely accepted resolution to this conflict. Namely, he and others believe that some selective agents (in many experiments stress was induced by starvation) led to an increase in the overall rate of mutation rather than to an increased production of adaptive mutations. This increases the rate of all types of mutations, including adaptive ones. SEE ALSO BLOOD; CHROMOSOME, EUKARYOTIC; CHROMOSOME ABERRATIONS; DNA; GENE; GENETIC CODE; GENETIC DISEASES; NUCLEOTIDES; REPLICATION

*John R. Jungck*

### Bibliography

- Alberts, Bruce, et al. *Molecular Biology of the Cell*, 4th ed. New York: Garland Publishing, 2000.
- Atherly, Alan G., Jack R. Girton, and John F. McDonald. *The Science of Genetics*. Philadelphia, PA: Saunders College Publishing, 1998.
- Cooper, D. N. *Human Gene Mutation*. Bios Scientific Publishers Ltd., 1997.
- Kimura, Motoo. *Population Genetics, Molecular Evolution, and the Neutral Allele Theory: Selected Papers*. Chicago: University of Chicago Press, 1994.
- Lewontin, Richard C. *The Genetic Basis of Evolutionary Change*. New York: Columbia University Press, 1974.
- Ohta, T. "The Nearly Neutral Theory of Molecular Evolution." *Annual Review of Ecology and Systematics* 23 (1992): 263–286.
- Radman, Miroslav. "Mutation: Enzymes of Evolutionary Change." *Nature* 401 (1999): 866–868.
- Woodruff, R. C., and John N. Thompson, eds. *Contemporary Issues in Genetics and Evolution, Vol. 7: Mutation and Evolution*. Dordrecht, The Netherlands: Kluwer Academic Publishing, 1998.

## Mycorrhizae

Symbioses are intimate associations between two unrelated organisms. Mycorrhizae are very common but largely unseen symbioses between plant roots and fungi that are important in plant nutrition, community structure, and nutrient cycling. Throughout the course of their evolution, plants and fungi have formed many different types of mycorrhizal partnerships involving most plant families and thousands of fungal species.

These diverse symbioses have been grouped into general types: arbuscular mycorrhizae, ectomycorrhizae, orchid mycorrhizae, and mycorrhizae

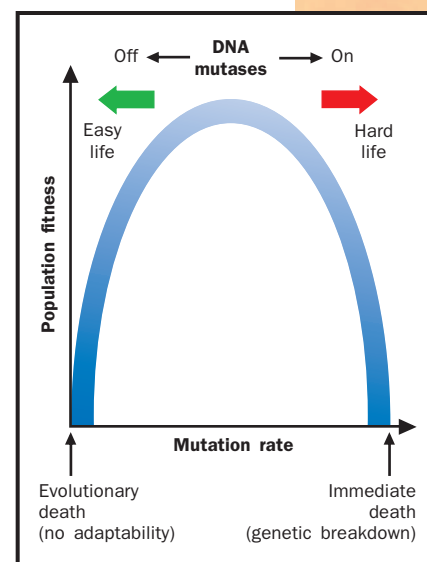

Mutation rates and genetic adaptability (fitness). Redrawn from Radman, 1999.

**pathogen** disease-causing organism

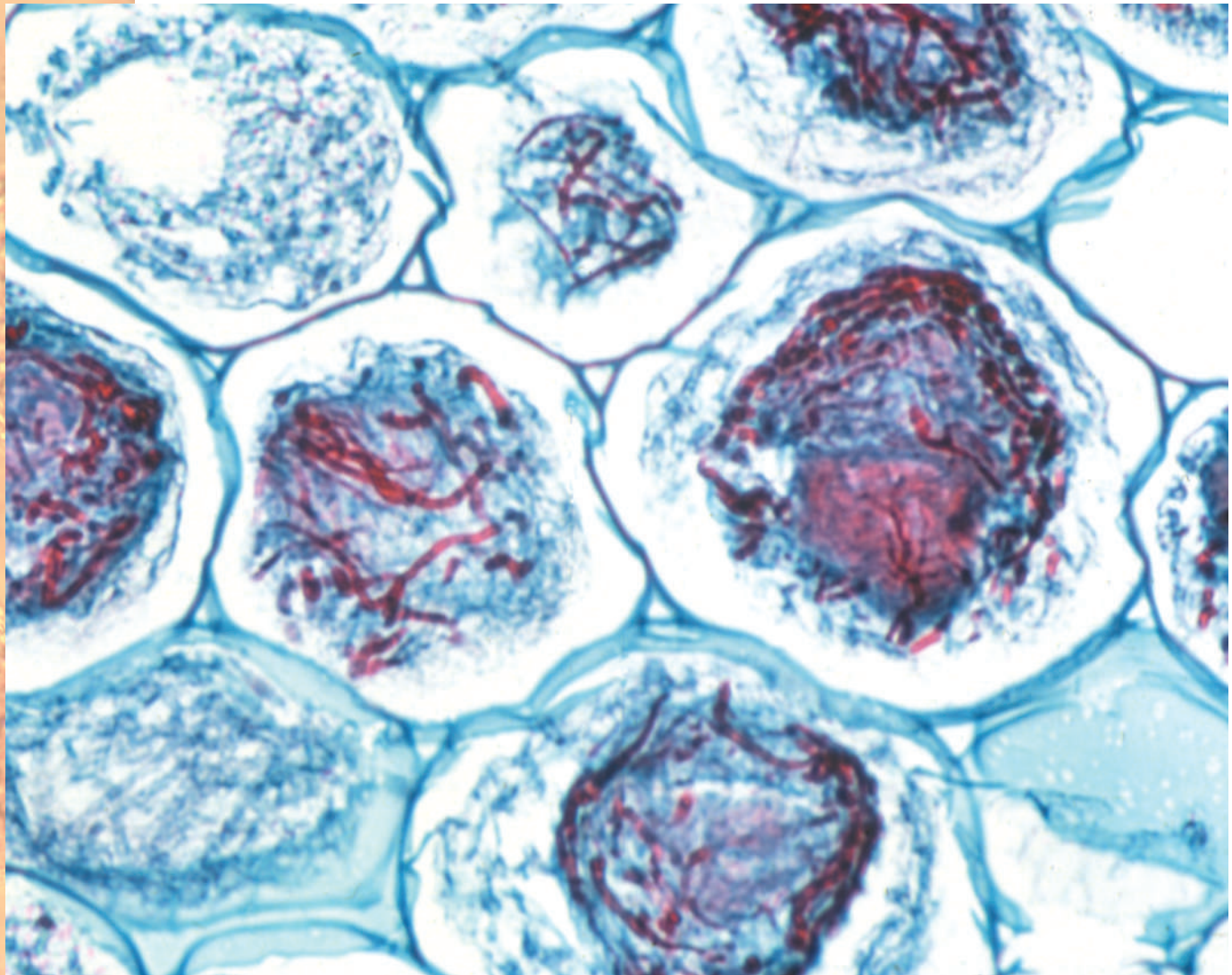

Endotrophic mycorrhizae in an orchid root. Mycorrhizae are very common but largely unseen symbioses between plant roots and fungi.

**minerals** iron, calcium, sodium, and other elements needed by living organisms

**carbohydrates** sugars, starches, and other molecules combining carbon, hydrogen, and oxygen and serving as fuel or structural components

**forb** broad-leaved herbaceous plant

in plants in the order Ericales including ericoid, arbutoid, and monotropoid mycorrhizae.

Mycorrhizae are critical for the mineral nutrition of many plants because threadlike fungal hyphae can exploit soil much more extensively than plant roots, and thus mycorrhizal associations greatly increase the absorption of **minerals** and water. Usually, mycorrhizal fungi supply minerals to their host plants, which reciprocate by supplying **carbohydrates** to their fungal associates, but there are a few exceptions. In orchids, and some chlorophyll-free plants in the order Ericales, the flow of carbon is reversed, and mycorrhizal fungi supply the plant with organic carbon derived from dead plant matter or from neighboring living plants.

Arbuscular mycorrhizae, the most common type, are associations between most crop plants, grasses, **forbs**, and many trees and fungi in the division Zygomycota, order Glomales. Both fossil and molecular evidence indicate that the earliest land plants had arbuscular mycorrhizal partnerships 450 million years ago. Ectomycorrhizae are commonly formed by woody shrubs and trees and a diverse array of fungi in the divisions Basidiomycota

and Ascomycota. Pines and other forest trees often grow poorly or cannot survive in the absence of ectomycorrhizae.

Taxa of mycorrhizal fungi differ greatly in their effects on plant fitness. Consequently, interactions between communities of mycorrhizal fungi and plants may have strong impacts on the structure and function of communities and **ecosystems**. SEE ALSO COMMUNITY; CONIFERS; FUNGI; SYMBIOSIS

*Nancy Collins Johnson*

**ecosystem** an ecological community and its environment

### Bibliography

Smith, Sally E., and David J. Read. *Mycorrhizal Symbiosis*, 2nd ed. San Diego, CA: Academic Press, 1997.

## Natural Selection

Natural selection is the process by which individuals with characteristics that are advantageous for reproduction in a specific environment leave more offspring in the next generation, thereby increasing the proportion of their genes in the population gene pool over time. Natural selection is the principal mechanism of evolutionary change, and is the most important idea in all biology. Natural selection, the unifying concept of life, was first proposed by Charles Darwin, and represents his single greatest contribution to science.

Natural selection occurs in any reproducing population faced with a changing or variable environment. The environment includes not only physical factors such as climate or terrain, but also living factors such as predators, prey, and other members of a population.

### Mechanism of Natural Selection

The mechanism of natural selection depends on several phenomena:

- **Heredity:** Offspring inherit their traits from their parents, in the form of genes.
- **Heritable individual variation:** Members of a population have slight differences among them, whether in height, eyesight acuity, beak shape, rate of egg production, or other traits that may affect survival and reproduction. If a trait has a genetic basis, it can be passed on to offspring.
- **Overproduction of offspring:** In any given generation, populations tend to create more progeny than can survive to reproductive age.
- **Competition for resources:** Because of excess population, individuals must compete for food, nesting sites, mates, or other resources that affect their ability to successfully reproduce.

Given all these factors, natural selection unavoidably occurs. Those members of a population that reproduce the most will, by definition, leave more offspring for the next generation. These offspring inherit their parents' traits, and are therefore also likely to succeed in competition for resources (assuming the environment continues to pose the same challenges as those faced by parents). Over several generations, the proportion of offspring in a population that are descended from the successful ancestor

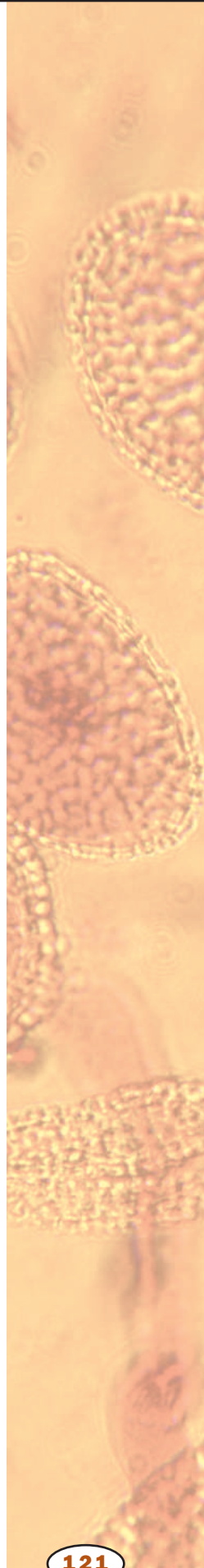

Uloborid spider eggs and spiderlings. In any given generation, populations tend to create more offspring than can survive to reproductive age.



increases, and traits that made the ancestor successful therefore also increase in frequency. Natural selection leads to adaptation, in which an organism's traits conform to the environment's conditions for existence.

### Consequences of Natural Selection

Natural selection is truly the ultimate inventor. A short list of some of its many "inventions" includes flight, celestial navigation, echolocation, insulation, infrared sensors, hypodermic needles, plus all sorts of useful biologically active chemicals such as antibiotics, analgesics, emetics, diuretics, laxatives, tranquilizers, contraceptives, hallucinogens, pain killers, and many, many more. Each of these has been fashioned by natural selection to meet the needs of particular organisms in specific environments.

Pesticide-resistant insects and antibiotic-resistant bacteria are well-documented examples of natural selection in action. In each case, humans have provided the environmental challenge in the form of poisons acting on the population. Preexisting variations in susceptibility to the poison



mean that some organisms survive while others die without reproducing. Offspring of survivors have the same variation, and the most resistant of those survive best to reproduce. Over time, populations of resistant insects or bacteria are formed. (This is why taking the full prescription of an antibiotic is important; it kills the entire microbe population, preventing any from reproducing.)

### Misconceptions About Natural Selection

Natural selection is easy to understand, but it is misunderstood much too often. Natural selection is not synonymous with evolution. Evolution refers to any genetic change in a population, whereas natural selection specifies one particular way in which such changes are brought about. Natural selection is the most important agent of evolutionary change simply because it results in adaptation of an organism to its environment. Other possible mechanisms of evolution besides natural selection include gene flow, meiotic drive, and genetic drift.

A persistent misconception is that natural selection occurs mainly through differences between organisms in death rates, or differential mortality. Differential mortality can be selective but only to the degree that it creates differences between individuals in the number of reproductive offspring they produce. Reproductive rate, rather than death rate, drives natural selection. A cautious tomcat that seldom crosses busy streets might live to a ripe old age without leaving behind as many descendent kittens as another less staid tomcat killed on a highway at a much younger age. If the short-lived cat leaves more descendants, its genes will spread faster than those of the long-lived cat, and natural selection will favor a short life span. Unless living longer allows or results in higher reproductive success, long life is not favored by natural selection.

Adaptations fashioned by natural selection suit an organism to its particular environment. For instance, a maple tree's broad leaves are well adapted to temperate climates, but unsuited to arctic cold. Similarly, a human's ability to store fat is an adaptation to environments in which fat is scarce, but is poorly suited to the modern fast-food environment. In this respect, natural selection is somewhat shortsighted, since it cannot "see" beyond the next generation.

Natural selection cannot preferentially create favorable variations, but instead must work with what is at hand. For instance, treatment with antibiotics does not create antibiotic-resistant mutants. Instead, it favors microbes that, by chance, already have genes for resistance.

Phrases such as "the struggle for existence" and "survival of the fittest" have had an unfortunate consequence. They tend to emphasize predation and fighting for food as the prevalent means of selection. This reinforces erroneous emphasis on differential death rates, with the strongest and fastest individuals being considered as having a selective advantage over weaker and slower individuals. But if this were true, every species would continually gain in strength and speed.

Because this is not happening, selection against increased strength and speed (countersélection) must be occurring and must limit the process. Animals can sometimes be too aggressive for their own good; an extremely

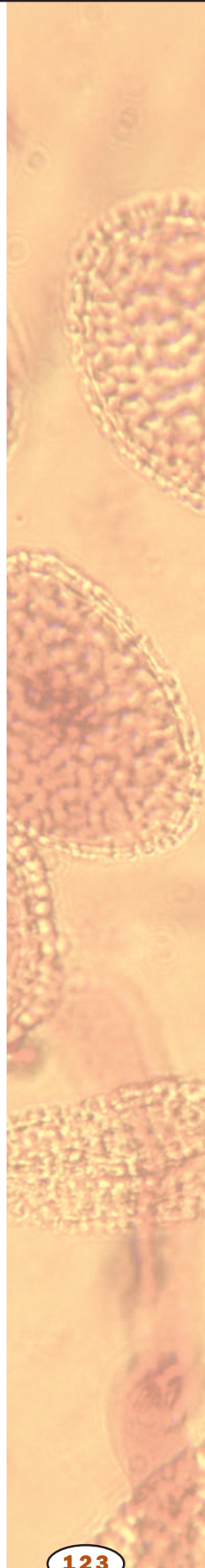

aggressive individual may spend so much time and energy chasing its prey that it spends less than average time and energy on mating and reproduction, and as a result, leaves fewer offspring than average. Likewise, an individual could be too submissive and spend too much time and energy running away from others. Usually, intermediate levels of aggressiveness result in the highest fitness.

Natural selection does not operate “for the benefit of the species.” Birds lay fewer eggs during drought years. Is this because competition for limited food supplies would be detrimental to the species, and do birds hold back “for the good of their species”? Such arguments have a fatal flaw: “cheaters” that laid as many eggs as possible would reap a higher reproductive success than individuals that voluntarily decreased their clutch size. Over time, cheater genes would spread through a population, and genes for holding-back would become rare.

However, the same phenomenon can be interpreted more plausibly in terms of natural selection at the level of individuals. During droughts, parental birds cannot bring as many insects to their nest and therefore cannot feed and fledge as many chicks as they can when food supplies are more ample. Laying extra eggs means most chicks would die of starvation. Birds can actually leave more surviving offspring to breed in the next generation by laying fewer eggs.

Any individual that sacrifices its own reproductive success for the benefit of a group is at a selective disadvantage within that group to any other individual not making such a sacrifice. Classical selection will always favor individuals that maximize their own selfish reproductive success. Natural selection recognizes only one currency: babies. Although we might wish otherwise, beauty, brains, or brawn need not be favored unless such traits are translated into more offspring than average. If ugly, dumb, weak individuals pass on more genes, those traits will prevail in future generations.

Whenever one organism leaves more successful offspring than others, in time its genes will come to dominate the population gene pool. Ultimately, natural selection operates only by differential reproductive success. An individual’s ability to perpetuate itself as measured by its reproductive success is known as its Darwinian fitness. SEE ALSO ADAPTATION; CONVERGENT EVOLUTION; EVOLUTION; POPULATION GENETICS; SEXUAL SELECTION

*Eric R. Pianka*

### Bibliography

Pianka, Eric R. *Evolutionary Ecology*, 6th ed. San Francisco, CA: Addison-Wesley-Longman, 2000.

## Nematode

**phylum** taxonomic level below kingdom, e.g., arthropod or chordate

Nematodes, also called roundworms, are members of the animal **phylum** Nematoda. These worms have a complete digestive system and are more complex than the flatworms (phylum Platyhelminthes) but lack a circulatory system and other advanced features found in the annelids (segmented worms). The Nematoda is one of the largest animal phyla, with over 15,000

described species. Many more species remain to be discovered because most nematodes are microscopic in size and not easily observed.

Nematodes are an extremely diverse group and are common in most habitats. These aquatic worms are abundant in freshwater and marine **ecosystems** but also inhabit the moisture film around soil particles. A small handful of soil may contain several thousand individuals. Nematodes even occur in desert soils and in Antarctica.

Many kinds of nematodes are **parasites**, inhabiting vertebrates (including humans) or invertebrates. Others are parasites of plants and feed on or live within roots, tubers, bulbs, and other below-ground plant parts. A few unusual species live inside leaves, stems, or seeds. Some of the nonparasitic, free-living nematodes are predators of other minute organisms. Most free-living nematodes feed on bacteria or fungi. Their activities are important in the decomposition of **organic** matter and recycling of nutrients. **SEE ALSO** ANIMALIA; PARASITIC DISEASES; PLATYHELMINTHES; SYMBIOSIS

*Robert McSorley*

### Bibliography

Poinar, George O., Jr. *The Natural History of Nematodes*. Englewood Cliffs, NJ: Prentice Hall, 1983.

Ruppert, Edward E., and Robert D. Barnes. *Invertebrate Zoology*, 6th ed. Philadelphia, PA: Saunders College Publishing, 1994.

## Nervous Systems

The nervous system is a network of nerve cells and, in most animals, a brain. In vertebrates, it also includes a spinal cord. The primary cell type found in the nervous system is the **neuron**, which has a cell body, containing the **nucleus**, and long extensions to carry information from one part of the body to another.

The nervous system has two primary functions that are critical in maintaining the life of the organism. First, sensory receptors allow the organism to monitor its external environment and detect changes that occur (for example, an increase in temperature). The nervous system then activates structures such as muscles and glands, which permit the organism to respond appropriately to the environmental changes (moving out of the sun or activating sweat glands). Second, the nervous system also monitors the organism's internal environment, controlling heart rate so that enough blood is delivered to organs, or measuring nutrient levels to signal when an organism needs to obtain food.

While all nervous systems carry out these basic functions, the structure and complexity of the nervous system varies tremendously in different organisms. In vertebrates, it is divided into the **central nervous system** (CNS), which contains the brain and spinal cord, and the **peripheral** nervous system (PNS), which is composed of the nerves that carry information to and from the CNS. Invertebrate nervous systems may or may not have distinct peripheral and central regions, but communication with and response to the environment still occurs. Overall, invertebrate systems are much less complex. A vertebrate nervous system may contain a trillion neurons, whereas an invertebrate may have as few as 305.

**ecosystem** an ecological community and its environment

**parasite** organism living in close association with another from which it derives most of its nutrition

**organic** composed of carbon, or derived from living organisms

**neuron** nerve cell

**nucleus** membrane-bound portion of cell containing the chromosomes

**central nervous system** brain and spinal cord

**peripheral** outside the central nervous system (brain and spinal cord)

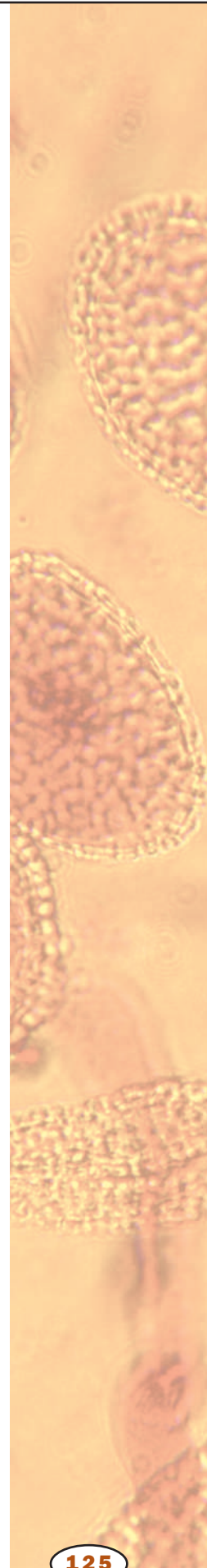

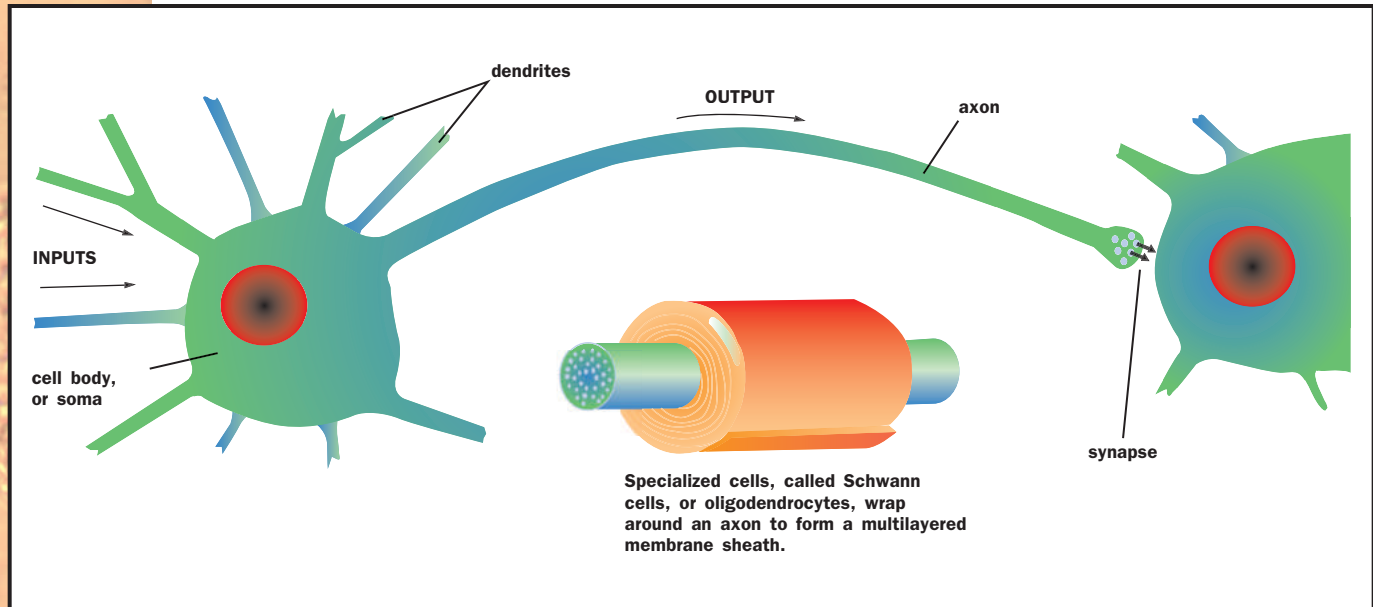

Neurons relay messages by accepting inputs at the dendrite and cell body, passing waves of electrochemical activity down the axon, and releasing chemical neurotransmitters from the axon to the next neuron at the synapse.

## Invertebrate Nervous Systems

Although the invertebrate nervous system is usually much simpler than the nervous systems found in vertebrates, there is still a broad range in complexity depending on the type of invertebrate.

The simplest type of nervous system is found in hydras and jellyfish (cnidarians) and is referred to as a “nerve net.” Nerve nets do not have distinct central or peripheral regions, and lack anything that resembles a brain. Instead, the scattered nerve cells form loose networks in each cell layer of the body wall. Some of these neurons carry information from sensory organs that detect touch, light, or other changes in the environment. These neurons in turn contact neurons that control movement of the organism, such as swimming.

Unlike the hydras and jellyfish, invertebrates such as sea stars (echinoderms) display some centralized organization of the nervous system. A ring of neurons is located in the center of the sea star, and simple bundles of neurons called radial nerves extend from the ring to the tip of each arm. In each arm, extensions of the radial nerves form nerve nets as in the jellyfish. This arrangement permits coordinated movement of each arm and the tube feet located on the surface of the arm.

A distinct separation of peripheral and central nervous systems is found in invertebrates such as worms, insects, and mollusks, like the squid. Neuron cell bodies are grouped into clusters called **ganglia**, which are usually located along the animal’s midline. The peripheral component of the nervous system is formed by the extensions of the cells in these ganglia; some carry sensory information from the environment to the ganglia, while others carry signals from the ganglia to produce a response (such as movement). This type of organization permits segmentation, in which each ganglion responds to and controls an individual segment of the body. To coordinate the segments, these ganglia are connected to each other in a chainlike fashion by a nerve cord, which is a bundle of neurons that runs the length of

**ganglia** cluster of nerve cell bodies

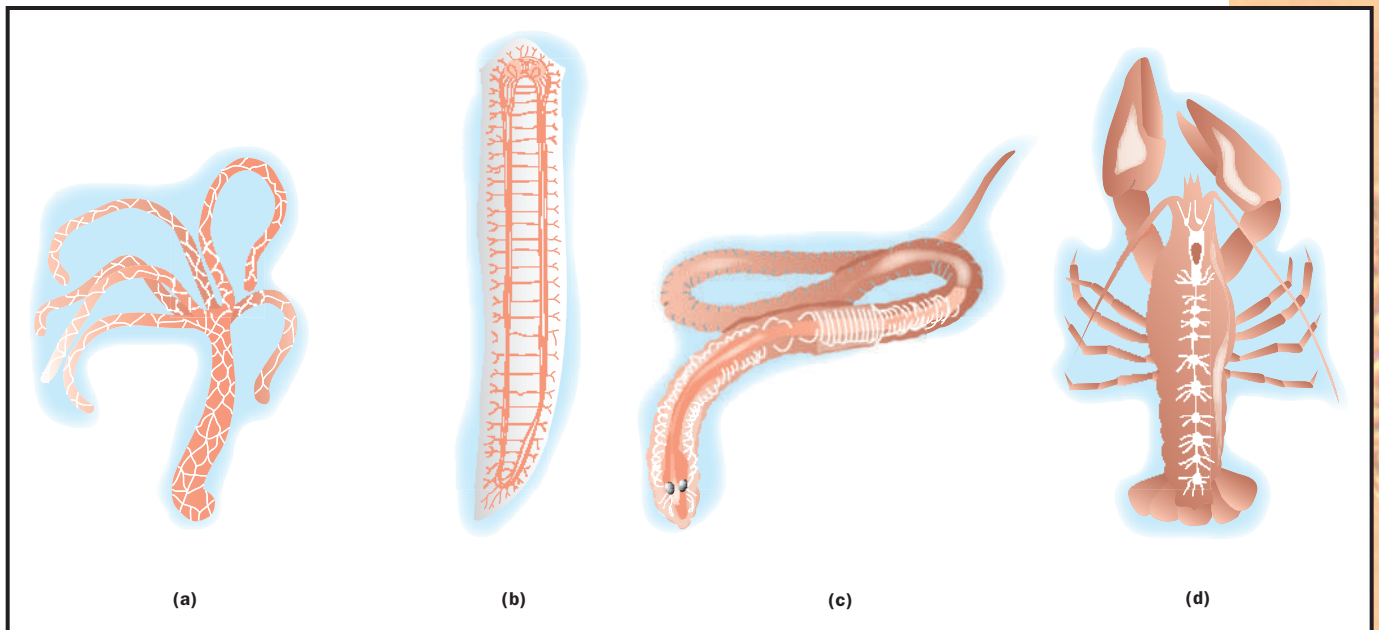

the animal. Some organisms have more than one nerve cord connected by **transverse** nerves, resembling a ladder.

In many invertebrates, the nerve cord is enlarged at the **anterior** (or head) end of the organism. This enlargement can be considered a primitive brain, and together with the nerve cord comprises the central nervous system. Without any type of brain, the coordination between different segments of the organism is limited at best, and the nervous system primarily produces simple reflexive movements. The presence of a brain allows the organism to receive a wide array of information from the environment, analyze it, and generate a coordinated and complex response. For example, the large brain of a squid enables it to process visual information and rapidly generate coordinated responses to capture prey. In fact, this invertebrate nervous system is so specialized, it closely resembles some vertebrate nervous systems.

### Vertebrate Nervous Systems

Many of the features observed in more complex invertebrate nervous systems are also present in vertebrates. All vertebrates have a distinct central component that consists of a brain and spinal cord, as well as peripheral structures such as ganglia and nerves. The primary difference from invertebrates is in the number of neurons and the size of nervous system structures. However, just as variety exists among the nervous systems of the invertebrates, there are also diverse levels of complexity from one type of vertebrate nervous system to another.

Regardless of complexity, vertebrate brains all contain three regions: the hindbrain, midbrain, and forebrain. The hindbrain is located at the junction of the brain and spinal cord, and is dedicated to coordination of motor (movement) reflexes and regulation of **autonomic** processes such as blood pressure and heart rate. An extension of the hindbrain called the cerebellum assists in coordinating motor movement in response to sensory

The nerve signal can travel in both directions in the hydra (a), a cnidarian. A planarian (b) has two nerve cords and two clusters of nerve cell bodies at its anterior end. In annelids, such as the earthworm (c), two cords are fused and run down the ventral surface of the body. Arthropods such as the crayfish (d) also have a double ventral nerve, in addition to clusters of nerve cells in the area of the head.

**transverse** situated or lying across

**anterior** toward the front

**autonomic** independent; involuntary actions

input. The midbrain is concerned with visual processing and some motor control. The forebrain (the region closest to the anterior end of the organism) shows the most variability among vertebrates. It can be divided into two distinct regions. The telencephalon is concerned with associative activity, that is, combining or integrating all incoming sensory information and directing an appropriate response. The diencephalon contains the thalamus and hypothalamus, regions important in processing sensory input and autonomic responses, respectively. The size of these regions varies depending on the vertebrate class.

The spinal cord is similar to the invertebrate nerve cord, but is usually enclosed in a protective column of vertebrae (with the exception of the most primitive vertebrates, the lampreys and hagfishes). Information is carried to and from the brain and spinal cord by the peripheral nervous system, which contains ganglia located adjacent to the spinal cord. Spinal nerves enter and exit the spinal cord to carry information to and from the body; **cranial** nerves carry similar information about the head directly into the brain.

### Variety in Vertebrate Brains

In primitive vertebrates such as fish, the hindbrain is the largest of the three regions. The cerebellum is relatively well developed for swimming and balance, although not in the lampreys and hagfishes. Fish have a small midbrain (just above the hindbrain) for the processing of visual information, and a small forebrain primarily concerned with the sense of smell (olfaction).

The hindbrain is more enlarged in amphibians compared to fish, but the cerebellum is often reduced in size, which reflects the relatively simple locomotion of amphibians. The forebrain is still small and functions primarily in olfaction.

In reptiles and birds, the size of the cerebellum is increased over amphibians, reaching massive proportions in birds where it regulates the complex muscle activity and spatial coordination needed for flying. The midbrain is enlarged as well, which permits interpretation of more complex visual images. This is particularly true of birds, which also have relatively large eyes. In addition, the sense of hearing becomes more developed, and, beginning with reptiles, the midbrain shows a distinct region dedicated to auditory processing. Reptiles and birds also possess forebrain regions that are much larger than those of more primitive vertebrates; the more complex motor skills and sensory input require a larger telencephalon to process input and coordinate responses. The regions devoted to the sense of smell diminish in size, especially in most birds, which have a very poor sense of smell.

In mammals, including humans, the most striking change is in the size of the cerebellum (again for more complex movements) and the telencephalon, which may be so large that it covers the diencephalon, midbrain, and part of the cerebellum. As specialization of the telencephalon increases, the increased size is correlated with the appearance of convolutions or folds in the surface. This specialization reaches its highest level in humans; the highly wrinkled **cerebral cortex** completely covers all but the cerebellum in humans. In addition to integrating all types of sensory information and coordinating voluntary movement, all **cognitive** functions (speech, math, learning, memory) are located here as well. SEE ALSO BRAIN; CENTRAL

**cranial** related to the cranium, or brain cavity

Birds possess a component of the forebrain called the hyperstriatum, which scientists believe could be the source of bird intelligence.

**cerebral cortex** outermost wrinkled portion of the brain

**cognitive** related to thought or awareness

NERVOUS SYSTEM; CNIDARIAN; ECHINODERM; NEUROLOGIC DISEASES; NEURON; PERIPHERAL NERVOUS SYSTEM; SYNAPTIC TRANSMISSION

Sheri L. Boyce

### Bibliography

Campbell, Neil A., Jane B. Reece, and Lawrence G. Mitchell. *Biology*, 5th ed. New York: Benjamin Cummings, 1999.

Kent, George C., and Robert K. Carr. *Comparative Anatomy of the Vertebrates*, 9th ed. New York: McGraw-Hill, 2001.

Linzey, Donald. *Vertebrate Biology*. Boston: McGraw-Hill, 2001.

## Neurologic Diseases

Neurological disease is a structural disturbance or a malfunction of the **central nervous system**. Common neurological disorders include stroke, Alzheimer Disease, migraine headaches, epilepsy, Parkinson's disease, sleep disorders, multiple sclerosis, pain, brain and spinal cord injuries, brain tumors, and **peripheral** nerve disorders. According to the National Institute of Neurological Disease and Stroke (NINDS), neurological disease is "a burden borne by every age group, by every segment of society, by people all over the world" ([www. http://ninds.nih.gov](http://ninds.nih.gov)).

**central nervous system**  
brain and spinal cord

**peripheral** outside the  
central nervous system  
(brain and spinal cord)

### Causes and Costs

The most common causes of neurological disorders include genetic, developmental, or **congenital** abnormalities; various peripheral diseases such as diabetes, high blood pressure, or a variety of infectious diseases; problems of the immune system (such as multiple sclerosis); brain or spinal cord injury; and environmental toxins. Neurodegenerative diseases affect brain cells, usually later in life, often for unknown reasons. Alzheimer Disease and Parkinson's disease are examples. Huntington's disease is a neurodegenerative disease known to be caused by inheritance of a mutant gene. Mental disorders have traditionally been distinguished from neurological diseases by their lack of evidence for an apparent mechanism as well as their principal symptom, maladaptive behavior.

**congenital** present at  
birth; inherited

However, this distinction is misleading because it suggests that mental disorders lack an underlying physical cause, which is increasingly being contradicted by research. Furthermore, many neurological diseases produce maladaptive behaviors, making this division less meaningful.

Taken together, neurological diseases are among the most destructive and costly public health problems for any society. Cerebrovascular accidents, more commonly called strokes, account for approximately half of all neurological problems in adults. Traumatic brain and spinal injuries constitute one of the leading causes of disability and death in the United States, particularly for young males. Epilepsy, chronic pain, and migraine headaches are widely diagnosed, and there is an increased incidence of Alzheimer Disease and Parkinson's disease due to the aging of society and greater exposure to environmental toxins.

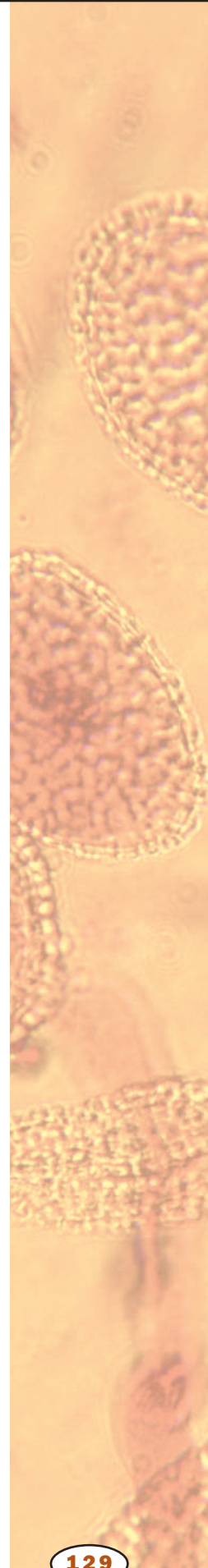

A computerized axial tomography (CAT) scan of a human brain with Parkinson's disease, showing atrophy. Neurodegenerative diseases such as Parkinson's affect brain cells, usually later in life.

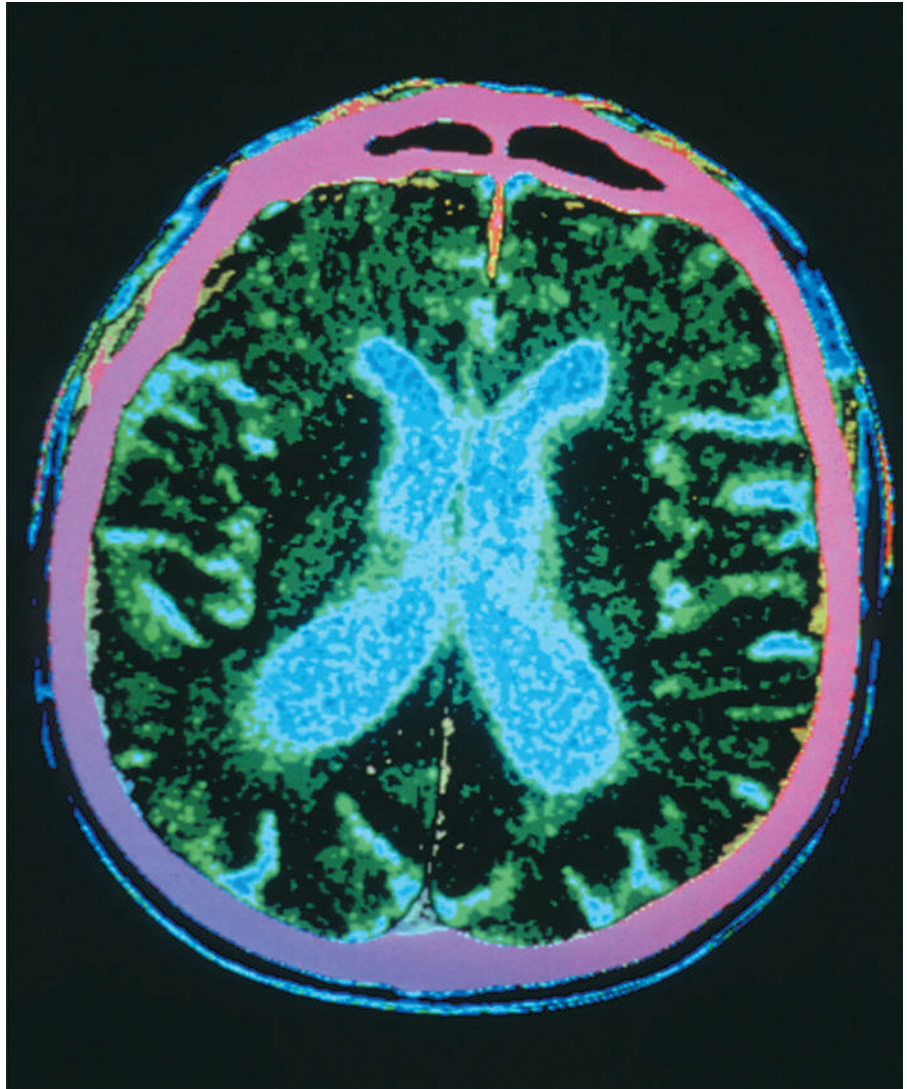

**agnosia** “not knowing”; loss of ability to recognize familiar objects

**aphasia** loss of the ability to form ideas into words

**dementia** neurological illness characterized by impaired thought or awareness

**lethargy** lack of excitability; torpor

**neurologist** doctor who treats brain disorders

**cranial** related to the cranium, or brain cavity

**autonomic** independent; regulating involuntary actions

## Symptoms and Diagnosis

The diagnosis and treatment of neurological diseases is the medical specialty of neurology. Neurosurgery is a medical specialty related to neurology. A variety of tools is available for the diagnosis and treatment of neurological diseases. Typically, the practitioner performs an initial evaluation, and tests for a variety of conditions that could be indicative of the underlying pathology.

Neurological symptoms can be quite variable. Common symptoms include chronic pain, impaired reflexes, tremors, motor coordination problems, localized muscle weakness, paralysis, numbness, tingling, loss of vision, **agnosia**, and **aphasia**, as well as confusion, mental retardation, **dementia**, delirium, **lethargy**, seizure, tremor, stupor, and coma. The **neurologist** uses both the symptoms and the patient's history to begin to determine a diagnosis. Neurological examinations include tests for mental status, **cranial** nerve performance, and motor systems functioning; assessment of muscle strength and coordination; and examination of reflexes and sensory systems as well as **autonomic** nervous system responses.



Other noninvasive diagnostic tools include the electroencephalograph (EEG), which records electrical brain activity; computerized axial tomography (CAT) or computerized tomography (CT) scan, which is often used to locate lesions and tumors; magnetic resonance imaging (MRI) scans, which provide a more detailed map of brain functioning; and, finally, cerebral angiography, which allows for the visualization of blood flow to and from the brain. Spinal taps (lumbar punctures) permit the withdrawal of cerebrospinal fluid for chemical and microbiological analysis. Despite the advances in diagnostic procedures, dramatically improved treatments with **psychotropic** drugs, neurosurgery, and various rehabilitative measures, many of the neurological diseases cannot be effectively treated or reversed. SEE ALSO BRAIN; CARDIOVASCULAR DISEASES; CENTRAL NERVOUS SYSTEM; DOCTOR, SPECIALIST; NEURON; PSYCHIATRIC DISORDERS, BIOLOGY OF; SYNAPTIC TRANSMISSION

*Arne Dietrich*

### Bibliography

- Beers, Mark H., et al., eds. *Merck Manual Diagnostics & Therapeutics*, 17th ed., Rahway, NJ: Merck & Co, 2000.
- Ross, R. T. *How to Examine the Nervous System*, 2nd ed. Stamford, CT: Appleton & Lange, 1999.
- Victor, Maurice, and Allan H. Ropper. *Adams and Victor's Principles of Neurology*, 7th ed., Elmsford, NY: McGraw-Hill, 2000.

## Neuron

The neuron (nerve cell) is the fundamental unit of the nervous system. The basic purpose of a neuron is to receive incoming information and, based upon that information, send a signal to other neurons, muscles, or glands. Neurons are designed to rapidly send signals across physiologically long distances. They do this using electrical signals called nerve impulses or **action potentials**. When a nerve impulse reaches the end of a neuron, it triggers the release of a chemical, or neurotransmitter. The neurotransmitter travels rapidly across the short gap between cells (the synapse) and acts to signal the adjacent cell.

### Functions and Classification

Communication by neurons can be divided into four major steps. First, a neuron receives information from the external environment or from other neurons. For example, one neuron in the human brain may receive input from as many as one hundred thousand other neurons. Second, the neuron integrates, or processes, the information from all of its inputs and determines whether or not to send an output signal. This integration takes place both in time (the duration of the input and the time between inputs) and in space (across the surface of the neuron). Third, the neuron propagates the signal along its length at high speed. The distance may be up to several meters (in a giraffe or whale), with rates up to 100 meters (328 feet) per second. Finally, the neuron converts this electrical signal to a chemical one and transmits it to another neuron or to an **effector** such as a muscle or gland.

**psychotropic** affecting consciousness, thought, or emotion

**action potential** wave of ionic movement down the length of a nerve cell

**effector** organ at the end of a nerve, such as a muscle or gland

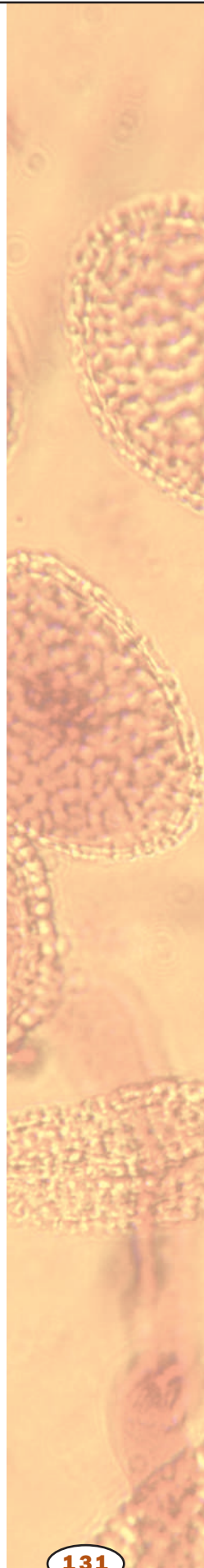

Parts of a neuron.

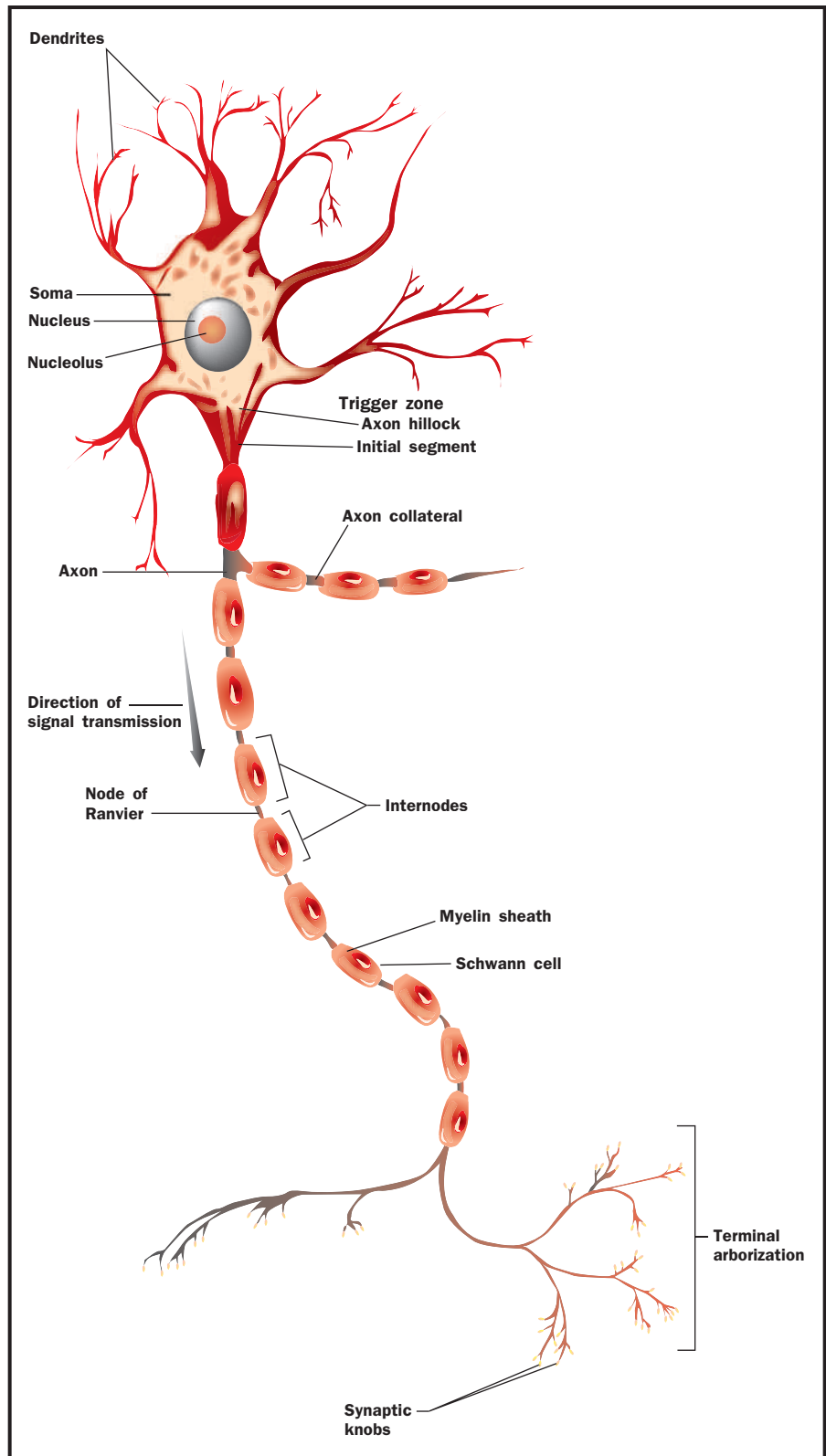

When combined into networks, neurons allow the human body memory, emotion, and abstract thought as well as basic reflexes. The human brain contains an estimated one hundred billion neurons which relay, process, and store information. Neurons that lie entirely within the brain

or spinal cord are referred to as interneurons and make up the **central nervous system**. Other neurons, receptors, and afferent (sensory) neurons are specialized to receive signals from within the body or from the external environment and to transmit that information to the central nervous system. Efferent neurons carry signals from the central nervous system to the effector organs (muscles and glands) of the body. If an efferent neuron is connected to a muscle, it is also called a motor neuron.

The ability of a neuron to carry out its function of integration and propagation depends both upon its structure and its ability to generate electrical and chemical signals. While different neurons have different shapes, all neurons share the same signaling abilities.

## The Structure of a Typical Neuron

Neurons have many different shapes and sizes. However, a typical neuron in a vertebrate (such as a human) consists of four major regions: a cell body, dendrites, an **axon**, and synaptic terminals. Like all cells, the entire neuron is surrounded by a cell membrane. The cell body (soma) is the enlarged portion of a neuron that most closely resembles other cells. It contains the **nucleus** and other **organelles** (for example, the **mitochondria** and **endoplasmic reticulum**) and it coordinates the metabolic activity of the neuron. The dendrites and axon are thin **cytoplasmic** extensions of the neuron. The dendrites, which branch out in treelike fashion from the cell body, are specialized to receive signals and transmit them toward the cell body. The single long axon carries signals away from the cell body.

In humans, a single axon may be as long as 1 meter (about 3 feet). Some neurons that have cell bodies in the spinal cord have axons that extend all the way down to the toes. Axons generally divide and redivide near their ends and each branch gives rise to a specialized ending called a synaptic knob (synaptic terminal). It is the synaptic terminals of a neuron that form connections either with the dendrites or cell body of another neuron or with effector cells in muscles or glands. Once an electrical signal has arrived at the end of an axon, the synaptic terminals release a chemical messenger called a neurotransmitter, which relays the signal across the synapse to the next neuron or to the effector cell.

## Classifying Neurons by Shape

Neurons can be classified according to the number of processes that extend from the cell body. Multipolar neurons are the most common type. They have several dendrites and one axon extending from the cell body. Bipolar neurons have two processes extending from the cell body, an axon and a single dendrite. This type of neuron can be found in the retina. Unipolar neurons are generally sensory (afferent) neurons that have a single process, which then divides into two. One of the two processes extends outward to receive sensory information from various areas of the body, while the other process relays sensory information towards the spinal cord or brain.

## Electrical Signals in Neurons

All living cells have a separation of charges across the cell membrane. This separation of charges gives rise to the resting **membrane potential**.

**central nervous system**  
brain and spinal cord

**axon** long extension of a nerve cell down which information flows

**nucleus** membrane-bound portion of cell containing the chromosomes

**organelle** membrane-bound cell compartment

**mitochondria** subcellular organelle that creates ATP used for energy-requiring processes in a cell

**endoplasmic reticulum** network of membranes within the cell

**cytoplasm** material in a cell, excluding the nucleus

**membrane potential** electrical and chemical differences across a membrane leading to storage of energy and excitability

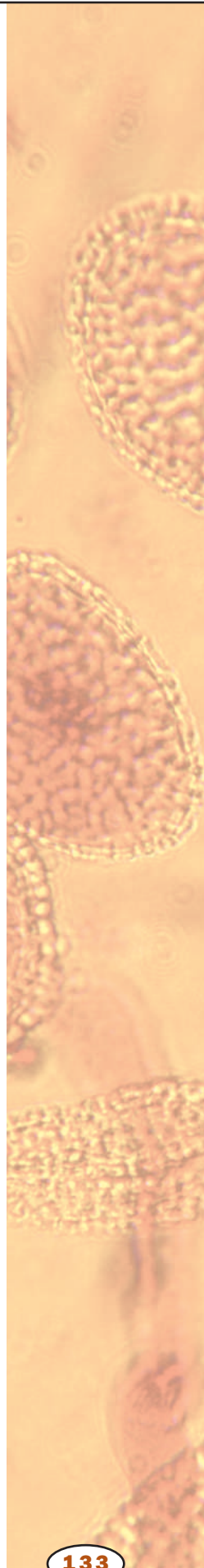

Scanning electron micrograph of two types of neurons: a bipolar neuron (top) and a developing neuron (bottom).

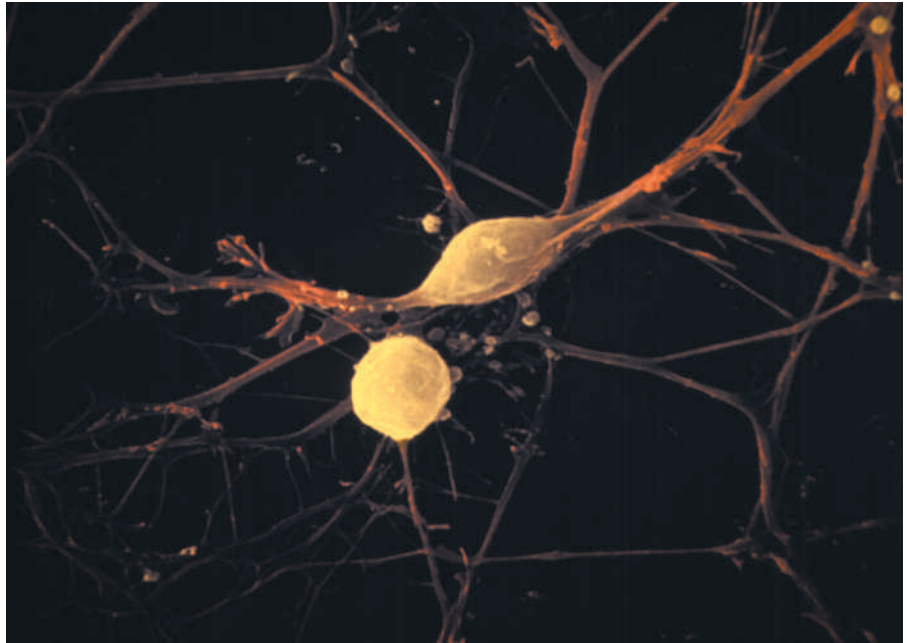

**glial** supporting tissue of the elements of nervous tissue, including the brain, spinal cord, and ganglia

**glucose** simple sugar that provides energy to animal cells and is the building block of cellulose in plants

**mitosis** separation of replicated chromosomes

**HYDE, IDA HENRIETTA  
(1857–1945)**

American physiologist who invented the microelectrode, a tiny needle used to measure electrical activity in living cells. The microelectrode was fundamental to studies of nerve and muscle cells. Hyde was the first woman elected to the American Physiological Society and the first woman to conduct research at Harvard Medical School.

Neurons and muscle cells both use brief changes in this resting membrane potential to quickly send signals from one end of the cell to the other. In neurons, electrical signals called action potentials propagate from the cell body down the axon to the synaptic terminals, where stored neurotransmitter is released. Action potentials are transient, all-or-none changes in resting membrane potential that travel along the axon at rates of 1 to 100 meters per second.

Myelin, a fatty insulating material derived from the cell membranes of **glial** cells, covers the axons of many vertebrate neurons and speeds the conduction of action potentials. The importance of this myelin covering to normal nervous system function is made painfully obvious in individuals with demyelinating diseases in which the myelin covering of the axons is destroyed. Among these diseases is multiple sclerosis, a demyelinating disease of the central nervous system that can have devastating consequences, including visual, sensory, and motor disturbances.

Although neurons share many of the features found in other cell types, they have some special characteristics. For example, neurons have a very high metabolic rate and must have a constant supply of oxygen and **glucose** to survive. Also, mature neurons lose the ability to divide by **mitosis**. Until the late twentieth century it was thought that no new neurons were produced in the adult human brain. However, there is evidence that, at least in some brain areas, new neurons are produced in adulthood. This finding suggests an exciting avenue for possible approaches to treating such common neurological diseases as Parkinson's disease and Alzheimer Disease, which are characterized by the loss of neurons in certain brain areas. SEE ALSO AUTOIMMUNE DISEASE; BRAIN; CENTRAL NERVOUS SYSTEM; CHEMORECEPTION; EYE; HEARING; MUSCLE; NERVOUS SYSTEMS; NEUROLOGIC DISEASES; PERIPHERAL NERVOUS SYSTEM; PSYCHOACTIVE DRUGS; SPINAL CORD; SYNAPTIC TRANSMISSION; TOUCH

*Katja Hoehn*

### Bibliography

Kandel, Eric R., James H. Schwartz, and Thomas M. Jessell. *Principles of Neural Science*, 4th ed. New York: McGraw-Hill, 2000.

Kemperman, Gerd, and Fred H. Gage. "New Nerve Cells for the Adult Brain." *Scientific American* 280, no. 5 (1999): 48–53.

Purves, Dale, et al. *Neuroscience*, 2nd ed. Sunderland, MA: Sinauer Associates, 2001.

## Nitrogen Cycle

The nitrogen cycle is the series of biogeochemical transformations in which the element nitrogen is transferred among organisms and nonliving reservoirs such as the soil, the oceans, and the atmosphere. Nitrogen is an essential element for all living things because it is a principal component of **proteins** and nucleic acids. Whereas animals generally have access to abundant nitrogen, it is often in short supply for plants.

### Ammonification

Most of the world's nitrogen is in the atmosphere, in the form of nitrogen gas ( $N_2$ ), which is extremely unreactive. Atmospheric nitrogen is ammonified, or converted to ammonia ( $NH_3$ ) or ammonium **ion** ( $NH_4^+$ ), in several ways. It occurs through **enzymatic** nitrogen fixation, which is carried out by either free-living or symbiotic bacteria; through lightning, volcanic eruptions, and other high-energy events in the atmosphere; and finally by industrial processes. Industrial ammonification, which requires large amounts of energy, is used to create ammonia and nitrate for use as agricultural fertilizer. Industrial processes convert approximately 80 million metric tons of nitrogen per year, whereas bacterial nitrogen fixation converts slightly more, with about half of that carried out by crop plants. Ammonia is also produced through the action of fungus and bacteria breaking down **organic** compounds in the soil.

### Nitrification, Denitrification, and Assimilation

Aerobic soil bacteria convert ammonia and ammonium to nitrate ( $NO_3^-$ ), which can be absorbed by plants. This process, called nitrification, is counterbalanced by denitrification, which forms  $N_2$  and  $N_2O$ , carried out by **anaerobic** bacteria. Nitrate is assimilated, or absorbed by plants, through their roots. Within the plant, nitrate is reconverted to ammonium for use in building organic compounds. Nitrogen moves through the food chain in these compounds and is eventually returned to the environment through urine, feces, or the decomposition of the organism.

Human nitrogen use has had a major impact on the nitrogen cycle. The agricultural use and overuse of nitrogen fertilizer has caused pollution of water bodies both near farms and more distantly. Nitrate in the soil is easily washed out and can become a pollutant of both groundwater and surface water. Nitrogen is usually a limiting nutrient in aquatic **ecosystems**, and therefore its runoff often produces overgrowth, or "eutrophication." Chronic eutrophication can change species composition of lakes, streams, and rivers. SEE ALSO BIOGEOCHEMICAL CYCLES; CYANOBACTERIA; ECOLOGY; EUBACTERIA; NITROGEN FIXATION; POLLUTION AND BIOREMEDIATION

Richard Robinson

**protein** complex molecule made from amino acids; used in cells for structure, signaling, and controlling reactions

**ion** an electrically charged particle

**enzymatic** related to function of an enzyme

**organic** composed of carbon, or derived from living organisms

**anaerobic** without oxygen, or not requiring oxygen

**ecosystem** an ecological community and its environment

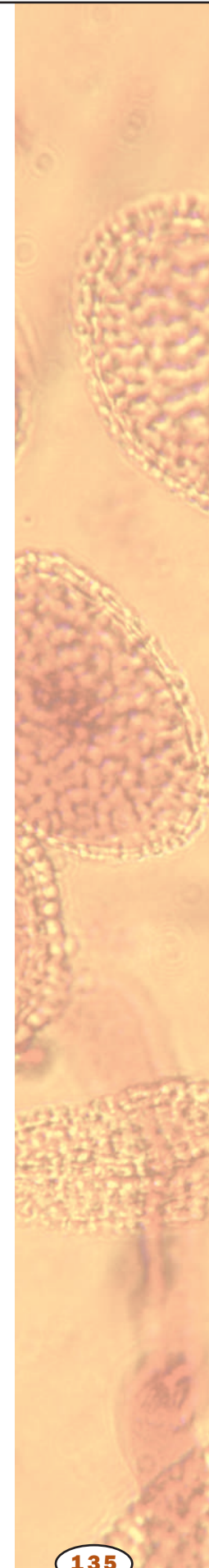

**Bibliography**

Berner, Elizabeth Kay, and Robert A. Berner. *Global Environment: Water, Air, and Geochemical Cycles*. Upper Saddle River, NJ: Prentice Hall, 1996.

*Human Alterations of the Global Nitrogen Cycle*. <<http://esa.sdsc.edu/tilman.htm>>.

## Nitrogen Fixation

Nitrogen fixation refers to the conversion of atmospheric nitrogen gas ( $N_2$ ) into a form usable by plants and other organisms. Nitrogen fixation is conducted by a variety of bacteria, both as free-living organisms and in **symbiotic** association with plants. Because it is the principal source of the nitrogen in the soil, nitrogen that plants need to grow, nitrogen fixation is one of the most important biochemical processes on Earth. Even modern agricultural systems depend on nitrogen fixation by alfalfa, clover, and other legumes to supplement chemical nitrogen fertilizers.

Living organisms need nitrogen because it is a part of the **amino acids** that make up **proteins**, and the nucleic acids that make up DNA (deoxyribonucleic acid) and RNA (ribonucleic acid). Nitrogen within living organisms is eventually decomposed and converted to atmospheric nitrogen ( $N_2$ ). This form, however, is highly stable and unreactive chemically, and is therefore not available for use by most organisms. Some species of bacteria, though, can convert  $N_2$  into  $NH_3$  (ammonia) or other usable forms of nitrogen. These nitrogen-fixing bacteria include species of the genera *Rhizobium*, *Anabaena*, *Azotobacter*, and *Clostridium*, as well as others.

Each of the nitrogen-fixing bacteria employs the same **enzyme**, nitrogenase. The nitrogenase enzyme is shaped something like a butterfly, and contains an atom of molybdenum at its core that is crucial for the reaction. Soils deficient in molybdenum cannot sustain effective nitrogen fixation, and monitoring soil for this element is important to ensure maximum fixation in managed fields or pastures.

Nitrogenase requires a large amount of energy to convert  $N_2$  to  $NH_3$ . Free-living bacteria must obtain the nutrients for supplying this energy themselves. Other bacteria have developed symbiotic associations with plants to provide them with sugars, supplying both a source of energy and a source of carbon for the bacterium's own synthetic reactions. The bacteria, in turn, supply the plant with some of the fixed nitrogen. For instance, the nitrogen-fixing *Anabaena* lives symbiotically with a water fern, *Azolla*. *Azolla* is grown in rice paddies early in the season. As the rice grows above the water surface, it shades out the fern, which dies, releasing the stored nitrogen. In this way, the paddy is fertilized without application of chemical fertilizers.

The bacterial genera *Rhizobium* and *Bradyrhizobium* have developed a large number of symbioses with members of the Fabaceae (legume) family. Fabaceae includes alfalfa, clover, beans and peas of all kinds, mesquites, acacias, and dozens of other species both domesticated and wild. The roots of the host plant become infected with the bacteria as seedlings, and respond by surrounding the bacteria with root hairs. The relationship between a particular host species and a particular bacterium is highly specific,

**symbiotic** cooperative; mutually beneficial

**amino acid** a building block of protein

**protein** complex molecule made from amino acids; used in cells for structure, signaling, and controlling reactions

**enzyme** protein that controls a reaction in a cell



Nitrogen-fixing bacteria *Rhizobium* on the roots of the broad bean plant *Vicia faba*.

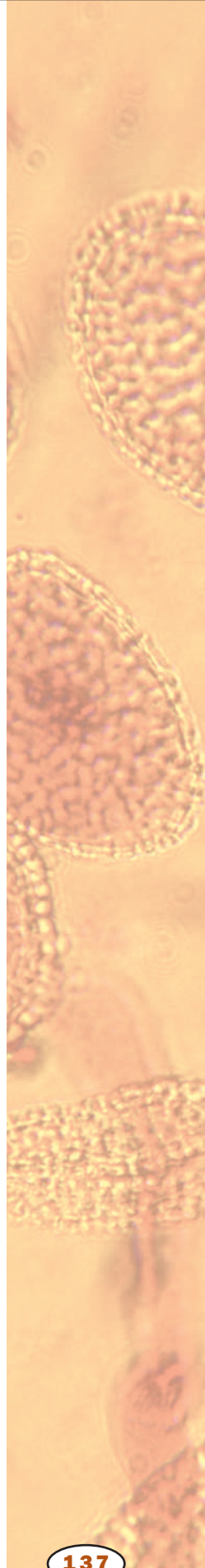

**hemoglobin** oxygen-carrying protein complex in red blood cells

and is regulated by a series of recognition events that prevent the wrong species of bacterium from taking up residence in the wrong plant.

The plant eventually develops a specialized structure known as a nodule, while the bacteria inside grow into enlarged forms known as bacteroids. The oxygen concentration inside the nodule must be closely regulated, since oxygen inhibits nitrogenase. This regulation is aided by the presence of leghemoglobin, an oxygen-binding protein similar to **hemoglobin**. The heme (oxygen-binding) portion is produced by the bacterium, while the globin (protein) portion is produced by the host plant, again illustrating the closeness of the symbiotic relationship.

*Richard Robinson*

#### **Bibliography**

Raven, Peter H., Ray F. Evert, and Susan E. Eichhorn. *Biology of Plants*, 6th ed. New York: W. H. Freeman and Company, 1999.

## Nonspecific Defense

In animals, there are two types of defenses against foreign invaders: specific and nonspecific. Specific immune responses can distinguish among different invaders. The response is different for each invader. With nonspecific defenses, the protection is always the same, no matter what the invader may be. Whereas only vertebrates have specific immune responses, all animals have some type of nonspecific defense. Examples of nonspecific defenses include physical barriers, **protein** defenses, cellular defenses, inflammation, and fever.

### Barriers

One way for an organism to defend itself against invasion is through barriers that separate the organism from its environment. Physical barriers such as the skin and **mucous membranes** mechanically regulate what enters the body. **Secretions** provide protection at the barrier as well. Mucus, for example, can trap potential invaders. Also, skin secretions are slightly **acidic**, inhibiting bacterial growth. Many body secretions (such as mucus, tears, and saliva) contain an **enzyme** called lysozyme that destroys bacteria.

### Proteins

There are proteins that protect the body nonspecifically. Complement proteins are found in the blood. When they bind to an invader, they stimulate inflammation, **phagocytosis**, and destruction of the invader's membrane. Although complement proteins may bind to an invader directly, they are most effective when they bind to antibodies that are attached to an invader. Antibodies are part of the body's specific immune response.

Some immune cells and cells that are infected with viruses produce another set of proteins called **interferons**. Interferons send a warning to nearby cells. They help prevent infection by stimulating the production of antiviral proteins. Interferons also stimulate natural killer cells and macrophages.

### Cellular Defenses

Natural killer cells and macrophages are examples of nonspecific cellular defenses. Natural killer cells are a class of lymphocytes that recognize abnormal cells (such as cancerous cells or virus-infected cells), attach to them, and release chemicals that destroy them.

Macrophages, neutrophils, and eosinophils are examples of phagocytes. In their attempt to defend the body, some phagocytes stay within a tissue and others travel freely throughout the body. However, all phagocytes are attracted to sites of tissue damage. In a process called phagocytosis, these cells surround debris or a foreign invader, bringing it inside the cell. The phagocyte then uses special enzymes to digest the material.

All animals have phagocytes that recognize and eliminate foreign invaders. For example, if a piece of one sponge is transplanted to a sponge from another colony, phagocytes in the sponges will attack and destroy each other. The same response can be observed in earthworms, **arthropods**, starfish, and all vertebrates. Scientist Elie Metchnikoff observed this process in starfish.

**protein** complex molecule made from amino acids; used in cells for structure, signaling, and controlling reactions

**mucous membrane** outer covering designed to secrete mucus, often found lining cavities and internal surfaces

**secretion** material released from the cell

**acidic** having an excess of  $H^+$  ions, and a low pH

**enzyme** protein that controls a reaction in a cell

**phagocytosis** engulfing of cells or large fragments by another cell, including immune system cells

**interferons** signaling molecules of the immune system

**arthropods** organisms with jointed appendages and exoskeletons, including insects, spiders, and crustaceans

In 1882 a scientist named Elie Metchnikoff stuck a thorn into a starfish larva. He observed starfish cells trying to destroy the thorn. His discovery was an important step in understanding nonspecific defenses in animals.





A colored scanning electron micrograph of a macrophage engulfing a parasite of the *Leishmania* genus. To defend the body, macrophages will surround a foreign invader, bring it inside the cell, then use enzymes to digest the material.

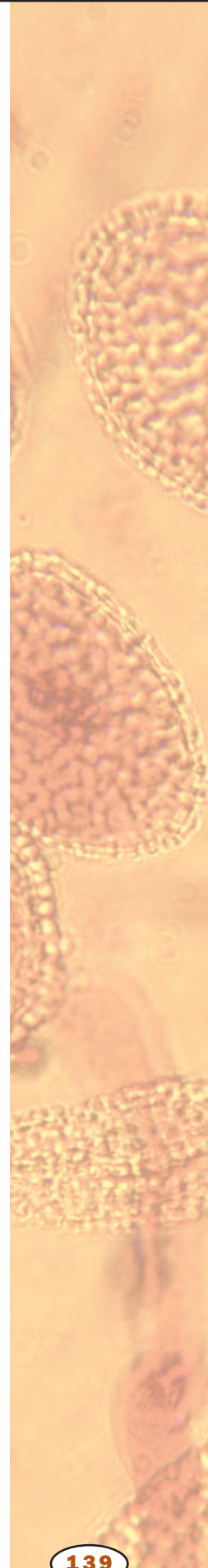

In vertebrates, some phagocytes are also important in stimulating specific immune responses. Additionally, phagocytosis is stimulated when the invaders are coated with antibodies. Consequently, phagocytes (like complement proteins) represent an important link between nonspecific and specific immunity.

### Inflammation

Infection, mechanical force, chemicals, and extreme heat or cold can damage tissues, causing the nonspecific process of inflammation. The goal of inflammation is to clean up the damage and start the repair process. Inflammation begins when damaged tissues release chemical messengers such as histamine, **prostaglandins**, and leukotrienes. These chemicals cause nearby blood vessels to expand and become more leaky, allowing more blood flow to the damaged area. These chemicals also attract white blood cells (such as phagocytes) to the site to remove debris and foreign invaders. The results of these activities are easily observed when the skin is inflamed: swelling, redness, heat, and pain.

**prostaglandins** hormone-like molecules released by one cell that affect nearby cells, including smooth muscle

### Fever

Another nonspecific protection against infection is the development of a fever. Either the invader or the response to an invader causes a part of the

**metabolism** chemical reactions within a cell

brain called the hypothalamus to increase the body temperature. Fevers may increase body **metabolism**, speeding up the repair process. Fevers may also slow down the reproduction of some bacteria and viruses.

Whether the mechanism is as complex as fever and inflammation or as simple as physical barriers and phagocytosis, all nonspecific defenses provide the body with general protection against foreign invaders. SEE ALSO ANTIBODY; BLOOD; ENDOCYTOSIS; IMMUNE RESPONSE

John M. Ripper

### Bibliography

Beck, Gregory, and Gail S. Habicht. "Immunity and the Invertebrates." *Scientific American* 275, no. 5 (1996): 60–65.

Friedlander, Mark P., Jr., and Terry M. Phillips. *The Immune System: Your Body's Disease-Fighting Army*. Minneapolis, MN: Lerner Publications Company, 1998.

National Institutes of Health. *Understanding the Immune System*. Washington, DC: National Institutes of Health, 1993.

Nossel, Gustav J. "Life, Death, and the Immune System." *Scientific American* 269, no. 3 (1993): 53–62.

Paul, William E. "Infectious Diseases and the Immune System." *Scientific American* 269, no. 3 (1993): 90–97.

## Nuclear Transport

**eukaryotic cell** a cell with a nucleus

**nucleus** membrane-bound portion of cell containing the chromosomes

**cytoplasm** material in a cell, excluding the nucleus

**protein** complex molecule made from amino acids; used in cells for structure, signaling, and controlling reactions

**macromolecules** large molecules such as proteins, carbohydrates, and nucleic acids

**aqueous** watery or water-based

**nuclear envelope** double membrane surrounding the cell nucleus

**amino acid** a building block of protein

The distinguishing feature of **eukaryotic cells** is the segregation of ribonucleic acid (RNA) synthesis and deoxyribonucleic acid (DNA) replication in the **nucleus**, keeping it separate from the **cytoplasmic** machinery for **protein** synthesis. As a consequence, messenger RNAs, ribosomal RNAs, transfer RNAs, and all cytoplasmic RNAs of nuclear origin must be transported from their site of synthesis in the nucleus to their final cytoplasmic destinations. Conversely, all nuclear proteins must be imported from the cytoplasm into the nucleus.

Traffic of **macromolecules** between the nucleus and cytoplasm occurs through nuclear pore complexes (NPCs). NPCs are large proteinaceous structures that form **aqueous** channels across the **nuclear envelope** or membrane. NPCs are composed of multiple copies of up to about fifty proteins termed nucleoporins and consist of three structural units. A ringlike central framework surrounding the central channel of the pore is sandwiched between two peripheral structures: the cytoplasmic ring from which eight cytoplasmic fibrils emanate, and the nuclear rim that anchors the nuclear basket.

Nuclear transport depends on signals for import or export that form part of the transported molecules. These signals are referred to as nuclear localization signals (NLSs) or nuclear export signals (NES), respectively. In proteins, they are specific **amino acid** sequences. NLSs or NESs are recognized and bound by soluble import or export receptors that shuttle between nucleus and cytoplasm. The interaction of the receptors with their cargoes (or substrates) can be direct or mediated by an additional adapter protein. Upon binding, the transport receptors dock their cargoes to the NPC and facilitate their translocation across the central channel of the pore. After delivering their cargoes, the receptors are recycled to initiate addi-

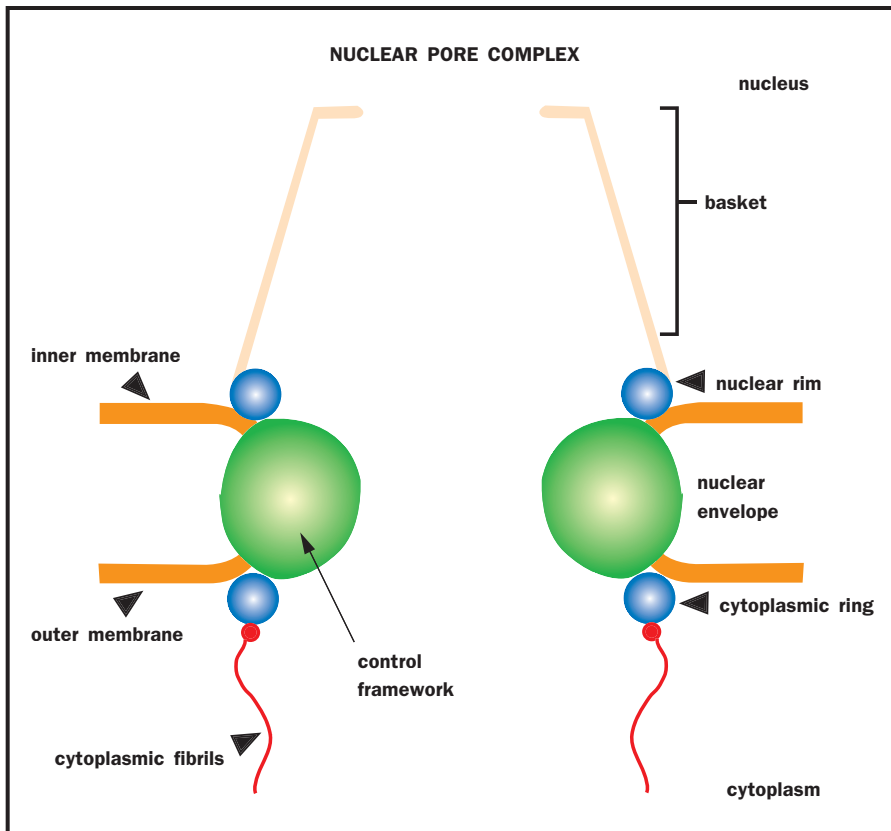

The structure of the nuclear pore complex.

tional rounds of transport. According to this model, an export receptor (R) binds its substrate (S) in the nucleus and carries it through the NPC into the cytoplasm. On the cytoplasmic side, the exported cargo is released and the receptor returns to the nucleus without the cargo. Conversely, an import receptor binds its import cargo in the cytoplasm and releases it in the nucleus.

The vast majority of nuclear transport receptors are members of a large family of proteins that exhibit a high **affinity** for a small GTPase, called Ran, in the GTP bound form. GTP (guanosine triphosphate) is an energy-carrying molecule used in cell signaling. A GTPase like Ran can cause GTP to become GDP (guanosine diphosphate), which will change the properties of the GTPase. The GTPase Ran regulates the interaction of the receptors with their cargoes.

The GTPase acts in concert with several cofactors. The striking property of Ran cofactors is that they are asymmetrically localized in the cell, with some predominantly cytoplasmic while others are predominantly found in the nucleus. This asymmetry helps to control the two-way transport between nucleus and cytoplasm. SEE ALSO MEMBRANE TRANSPORT; NUCLEOTIDES; NUCLEUS; PROTEIN TARGETING; RNA

*Elisa Izaurralde*

### Bibliography

- Mattaj, I. W., and L. Englmeier. "Nucleocytoplasmic Transport: The Soluble Phase." *Annual Review of Biochemistry* (1998) 67: 265-306.
- Nakielnny, S., and G. Dreyfuss. "Transport of Proteins and RNAs in and Out of the Nucleus." *Cell* (1999) 99: 677-690.

**affinity** attraction

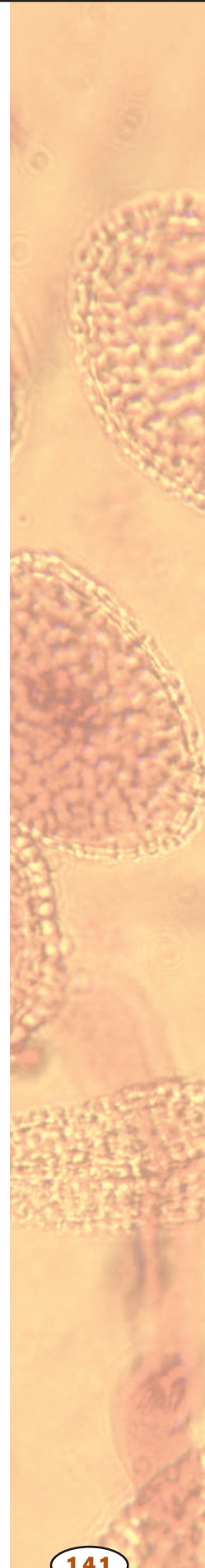

**nucleus** membrane-bound portion of cell containing the chromosomes

**ribosome** protein-RNA complex in cells that synthesizes protein

**protein** complex molecule made from amino acids; used in cells for structure, signaling, and controlling reactions

**transcribe** creation of an RNA copy of a DNA gene

**cytoplasm** material in a cell, excluding the nucleus

**translation** synthesis of protein using mRNA code

**mitosis** separation of replicated chromosomes

**gene** portion of DNA that codes for a protein or RNA molecule

**transcription** messenger RNA formation from a DNA sequence

## Nucleolus

The nucleolus is by far the most easily recognized substructure in the eukaryotic **nucleus**, and can be seen by using a variety of dyes as well as by phase contrast microscopy. Indeed, in budding yeast, the single nucleolus takes up nearly half of the nucleus. Cells from other species often have multiple nucleoli. The nucleolus is a **ribosome** factory, composed of deoxyribonucleic acid (DNA), ribonucleic acid (RNA), and **protein**. At the nucleolus, a long ribosomal RNA (rRNA) precursor molecule is **transcribed** from DNA, processed into three mature RNAs, and packaged together with specific proteins to make the large and small ribosomal subunits. Once the subunits have been assembled, they are transported out of the nucleolus to the **cytoplasm** for use in **translation** (protein synthesis).

Nucleoli are not static structures. They disassemble during **mitosis** and reform in early G1 phase. Nucleolar formation does not *cause* expression of rRNA **genes**. Rather, nucleoli are the *result* of rRNA **transcription** and processing.

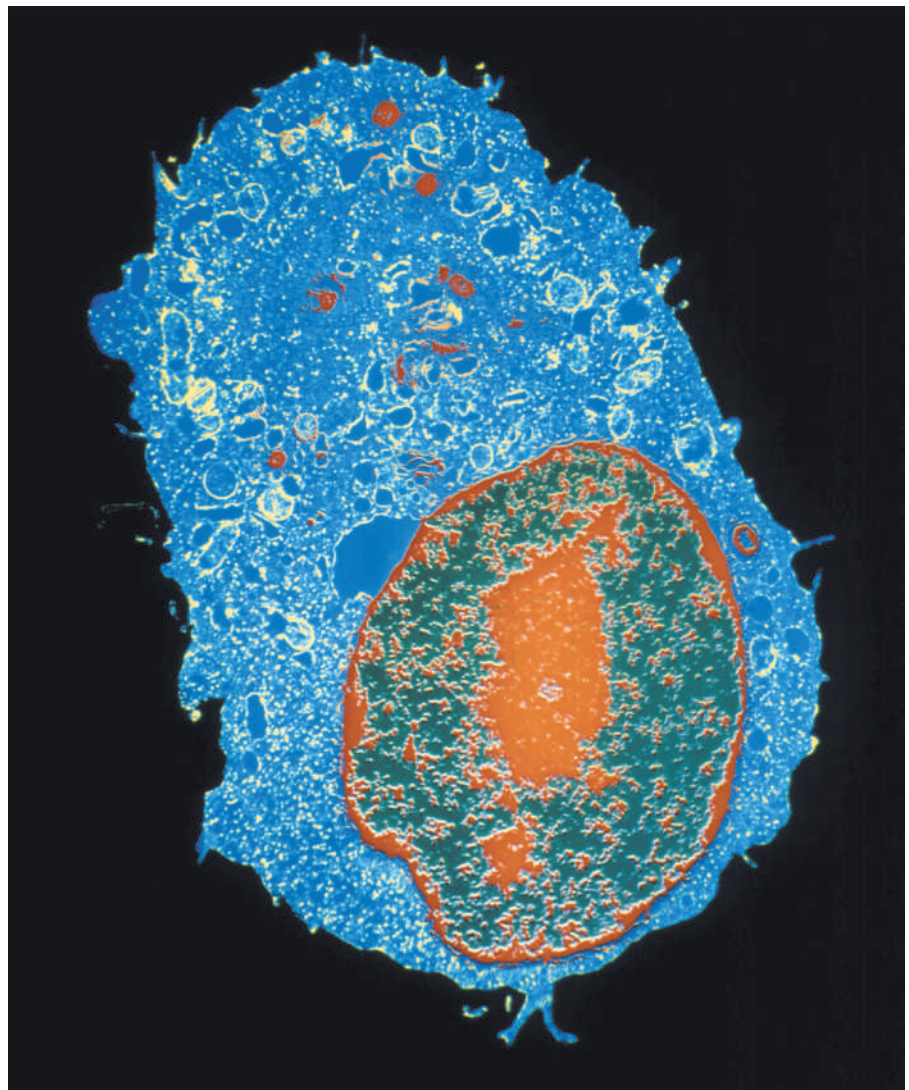

A colored transmission electron micrograph of a mammalian tissue culture cell, showing the nucleus (red), nucleolus (orange), and cytoplasm (blue),

Viewed in the electron microscope, a nucleolus has two distinct parts: the fibrillar component and the granular component. The fibrillar component can be subdivided into two compartments: the dense fibrillar component and the fibrillar center. Fibrillar centers contain large amounts of RNA polymerase I, which transcribes rRNA. Transcription of rRNA genes is thought to occur at the interface between the dense fibrillar component and the fibrillar center. Later stages of ribosome assembly take place in the granular component.

Human **chromosomes** contain five nucleolar organizer regions (called NORs), located on the short arms of the chromosomes 13, 14, 15, 21, and 22. In humans, each NOR contains approximately one hundred tandemly repeated rRNA gene copies. The NORs of different chromosomes typically come together in interphase. Thus, a single nucleolus is often made up of rRNA genes from two or more different NORs. Some species have only a single NOR-bearing chromosome and thus a single nucleolus.

In addition to the well-established function of nucleoli in ribosome assembly, recent evidence suggests that nucleoli are also involved in several other cellular processes, including assembly and modification of various small **ribonucleoproteins** (RNPs), sequestration of important cell-cycle regulatory proteins, export of other nonribosomal RNAs, and control of cellular senescence or aging. **SEE ALSO** CHROMOSOME, EUKARYOTIC; NUCLEAR TRANSPORT; NUCLEUS; RIBOSOME; RNA; TRANSCRIPTION

*A. Gregory Matera*

### Bibliography

Olson, M.O., M. Dundr, and A. Szebeni. "The Nucleolus: An Old Factory with Unexpected Capabilities." *Trends in Cell Biology* (2000) 10: 189-196.

Visintin, R., and A. Amon. "The Nucleolus: The Magician's Hat for Cell Cycle Tricks." *Current Opinions in Cell Biology* (2000) 12: 372-377.

## Nucleotides

Nucleotides are the subunits that are linked to form the nucleic acids ribonucleic acid (RNA) and deoxyribonucleic acid (DNA), which serve as the cell's storehouse of genetic information. Free nucleotides play important roles in cell signaling and **metabolism**, serving as convenient and universal carriers of metabolic energy and high-energy electrons.

All nucleotides are composed of three parts: a five-carbon sugar, a phosphate, and a nitrogen-rich structure called a nitrogenous base. The sugar can be ribose, which is found in ribonucleotides and RNA, or deoxyribose, which is found in deoxyribonucleotides and DNA. The only difference between these two sugars is that deoxyribose has one fewer oxygen atom than ribose. The five carbon atoms in the sugar are numbered sequentially. To distinguish these carbon atoms from those of the nitrogenous base, which are also numbered, they are designated as 1' (prime), 2', and so on.

There are five nitrogenous bases. The so-called pyrimidines (cytosine, thymine, and uracil) are smaller, having only one ring structure. The larger purines (adenine and guanine) have two rings. Adenine, guanine, and cytosine are found in both ribonucleotides and deoxyribonucleotides, while

**chromosome** "colored body" in the cell nucleus; made of DNA and protein, and divided functionally into genes and nongene regions

**ribonucleoprotein** combination of RNA and protein

**metabolism** chemical reactions within a cell

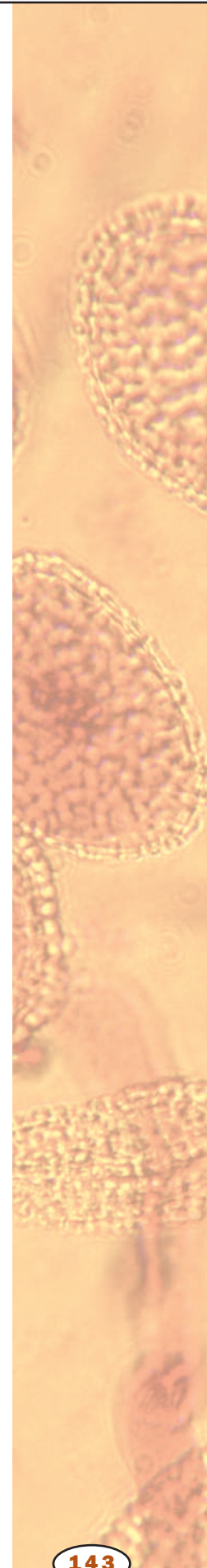

**biosynthetic** forming a complex molecule from simpler ones

**hydrolyze** to split apart using water

**AMP** adenosine monophosphate, form of ATP after removal of two phosphate groups

**enzyme** protein that controls a reaction in a cell

**mitochondria** subcellular organelle that creates ATP used for energy-requiring processes in a cell

**electron transport system** membrane-bound system of proteins that extracts energy from high-energy electrons, found in mitochondria and chloroplasts

**inorganic** not bonded to carbon

**hormone** molecule released by one cell to influence another

The molecular structures of the five nitrogenous bases.

thymine occurs only in deoxyribonucleotides and uracil only in ribonucleotides.

The phosphate group is bonded to the 5' carbon of the sugar (see Figure 2), and when nucleotides are joined to form RNA or DNA, the phosphate of one nucleotide is joined to the sugar of the next nucleotide at its 3' carbon, to form the sugar-phosphate backbone of the nucleic acid. In a free nucleotide, there may be one, two, or three phosphate groups attached to the sugar, as a chain of phosphates attached to the 5' carbon.

Three nucleotides merit special consideration because of their specialized roles in cellular function. These are adenosine triphosphate (ATP), flavin adenine dinucleotide (FAD), and nicotinamide adenine dinucleotide (NAD<sup>+</sup>). Most **biosynthetic** reactions require energy, which is usually supplied by ATP. When ATP is **hydrolyzed** to ADP (adenosine diphosphate) or **AMP** (adenosine monophosphate), energy is released. By coupling this energy release to a reaction requiring energy, that reaction can be made to occur. Since ATP is so frequently used this way, it is commonly called the "energy currency of the cell."

Adenine-containing molecules are also important coenzymes, serving to carry chemical functional groups that are needed for **enzyme** activity. Three important adenosine-containing coenzymes are coenzyme A (CoA), FAD, and NAD<sup>+</sup>. CoA carries acetyl groups into the Krebs cycle (the central metabolic pathway in **mitochondria**), and FAD and NAD<sup>+</sup> carry high-energy electrons from the Krebs cycle to the **electron transport system**, where their energy is used to synthesize ATP from ADP and **inorganic** phosphate.

Another adenine-based molecule is important in cellular signaling. When a **hormone** binds at a cell-surface receptor, it often promotes the production of cyclic AMP (cAMP) inside the cell. In cAMP, the phosphate group is joined to the 3' and 5' carbons of the ribose, forming a small ring struc-

**BASES**

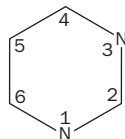

**PYRIMIDINE**

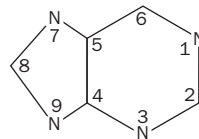

**PURINE**

The bases are nitrogen-containing ring compounds, either purines or pyrimidines.

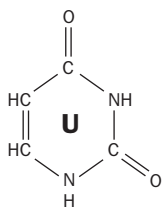

**uracil**

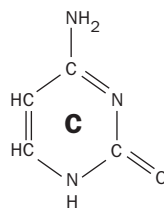

**cytosine**

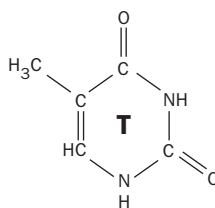

**thymine**

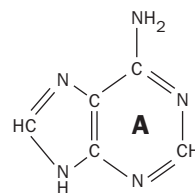

**adenine**

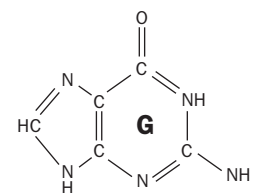

**guanine**

## NUCLEOTIDES

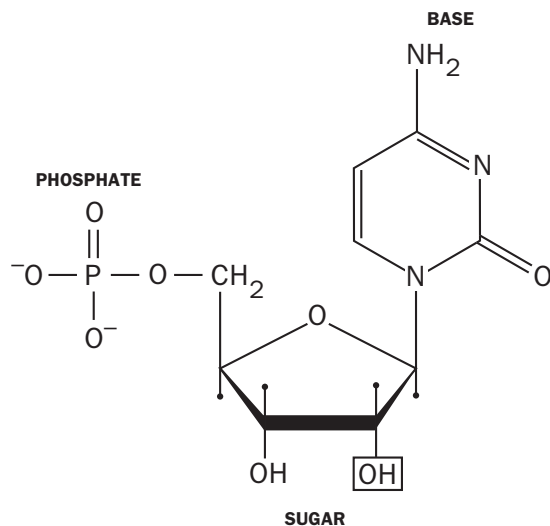

A nucleotide consists of a nitrogen-containing base, a 5-carbon sugar, and one or more phosphate groups. The sugar depicted is ribose. Deoxyribose has an H instead of an OH in the boxed position.

ture. cAMP can activate or suppress various cell processes, thereby serving as an **intracellular** signal and messenger that responds to hormone binding. SEE ALSO DNA; METABOLISM, CELLULAR; RNA; VITAMINS AND COENZYMES

David W. Tapley

## Bibliography

Nelson, David L., and Michael M. Cox. "Nucleotides and Nucleic Acids." In *Lehninger Principles of Biochemistry*, 3rd ed. New York: Worth Publishers, 2000.

## Nucleus

In eukaryotic cells, **chromosomes** are found in a special compartment called the nucleus. The nucleus is a defining feature of eukaryotic cells, which range from single-celled yeasts to plants and humans. In contrast, bacteria and other prokaryotes are more ancient in evolution and lack a nucleus. The development of the nucleus contributed to the evolution of complex life forms by separating **transcription** (reading of **genes**, occurring inside the nucleus) from **translation** (protein synthesis, occurring in the **cytoplasm**) and by providing a structural framework for organizing and regulating larger **genomes**. In multicellular organisms, individual cells can express different subsets of genes and thereby form specialized tissues such as muscle or skin.

### The Nuclear Envelope

The nuclear envelope surrounds the nucleus and creates and maintains a special environment inside it. The envelope consists of two nuclear mem-

**intracellular** within a cell

**chromosome** "colored body" in the cell nucleus; made of DNA and protein, and divided functionally into genes and nongene regions

**transcription** messenger RNA formation from a DNA sequence

**gene** portion of DNA that codes for a protein or RNA molecule

**translation** synthesis of protein using mRNA code

**cytoplasm** material in a cell, excluding the nucleus

**genome** total genetic material in a cell or organism

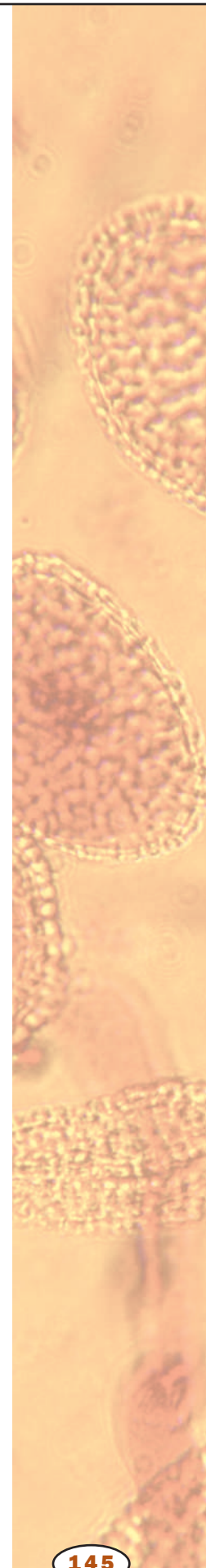

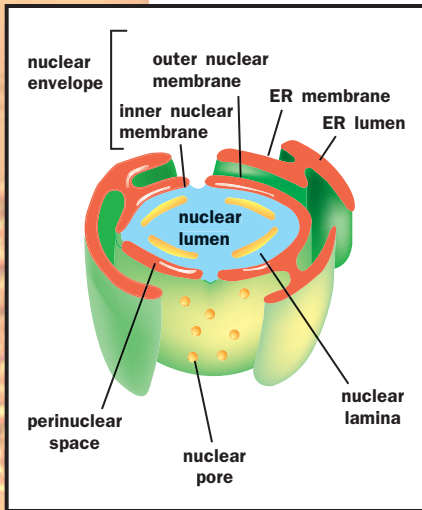

Illustration of the nuclear envelope.

**endoplasmic reticulum** network of membranes within the cell

**protein** complex molecule made from amino acids; used in cells for structure, signaling, and controlling reactions

**intermediate filament protein** one type of cytoskeleton protein

**neuron** nerve cell

**enzyme** protein that controls a reaction in a cell

**gene expression** use of a gene to create the corresponding protein

**chromatin** complex of DNA, histones, and other proteins making up chromosomes

**aqueous** watery or water-based

**ribosome** protein-RNA complex in cells that synthesizes protein

branes (inner and outer), nuclear pore complexes, and the lamina, a fibrous network. The nuclear membranes form an impermeable barrier. The outer membrane faces the cytoplasm and is part of the **endoplasmic reticulum** (ER). The inner membrane faces the chromosomes. Movement into and out of the nucleus occurs through pores (holes) where the inner and outer membranes are fused together. However, the pores are not empty; nuclear transport is controlled by nuclear pore complexes, each consisting of about a thousand **proteins** (“nucleoporins”). Each pore complex is large enough to accommodate the passage of ribosomal subunits, large protein-RNA (ribonucleic acid) complexes, which exit the nucleus after being assembled in the nucleolus.

The third major component of the envelope, the nuclear lamina, is found in multicellular eukaryotes (including humans), but not in single-celled eukaryotes or plants. (The plant nucleus evolved independently; less is known about its structure.) The lamina is a meshwork of fibers, formed by the head-to-tail polymerization of proteins named lamins. These fibers are concentrated near the inner membrane and also extend throughout the nuclear interior. Lamins are a type of **intermediate filament protein** and are strong yet flexible. Humans have three lamin genes, which through alternative messenger RNA (mRNA) splicing can produce seven “flavors” of A- and B-type lamin proteins. Different cell types, such as muscles and **neurons**, express different combinations of lamins.

Lamin filaments are key architectural elements in the nucleus. Beside providing structural stability, lamins also provide attachment sites for other proteins inside the nucleus. Biologists are discovering a growing number of proteins that bind to lamins. Lamin-binding proteins such as LAP2, emerin, and LBR are anchored at the inner nuclear membrane and also bind to chromosomes. This results in two-way and three-way attachments between the inner membrane, lamina, and chromosomes.

### Three-Dimensional Organization inside the Nucleus

When purified nuclei are treated with salts and **enzymes** to remove most proteins and DNA, what remains is a three-dimensional filamentous structure named the nuclear matrix. The composition of the matrix, and whether it includes lamins, has been controversial. However, deoxyribonucleic acid (DNA) replication machinery is stably attached to the matrix. Thus, the matrix may provide a scaffold that allows the orderly replication of chromosomal DNA, and possibly other activities inside the nucleus.

Chromosomes fill much of the nuclear interior, with each chromosome occupying its own neighborhood. In differentiated human cells, sectors of each chromosome are structurally compressed to prevent **gene expression**. This repressed **chromatin**, termed heterochromatin, is often located near the nuclear envelope. Other sections of chromosomes are loosely extended (“euchromatin”), making these genes available for transcription and mRNA processing at the surface of compact chromatin. Proteins responsible for transcription and mRNA processing are highly mobile and move rapidly within the **aqueous** spaces between and surrounding the chromatin fibers. There are also two specialized structures inside the nucleus, which are factories for making multiprotein “machines.” The nucleolus is the factory where **ribosomes** (the translational machines) are assembled. Nucleoli form



around the genes that encode ribosomal structural RNAs. Cajal bodies (coiled bodies) are smaller round structures that are proposed to be factories for assembling “transcription machines” responsible for transcribing genes into mRNA.

### In Multicellular Eukaryotes, the Nucleus Disassembles During Mitosis

In mammalian cells, the nucleus organizes about 0.7 meters (2.3 feet) of DNA inside a sphere approximately 5 **microns** in diameter. Remarkably, this structure is completely disassembled when mammalian cells undergo **mitosis**. Nuclear disassembly is triggered by mitotic **phosphorylation** of key structural proteins, including lamins, lamin-binding proteins, and nucleoporins. Phosphorylation causes these proteins to change **conformation** and release each other. Released nuclear membranes merge into the ER network, whereas released lamins and nucleoporins disperse throughout the cytoplasm. These components are then recycled to form two nuclear envelopes, soon after the two sets of daughter chromosomes are segregated.

During nuclear assembly, membranes reattach to chromosomes and fuse to enclose the chromosomes within one unified envelope. Pore complexes assemble and begin importing nuclear proteins that were released during mitosis, including lamins. The lamins reassemble into filaments, and the condensed chromosomes expand as the envelope expands to its full size. Few of these steps are understood at the molecular level.

### Defects in Nuclear Envelope Proteins Cause Human Disease

In the **nematode** worm, *C. elegans*, which has only one lamin gene, lamins are essential for life. Lamins are also important, either directly or indirectly, for nuclear shape, nuclear stability, chromatin attachment to the envelope, spacing of nuclear pore complexes, chromosome segregation, completion of mitosis, nuclear assembly, and the elongation phase of DNA replication.

In organisms with multiple lamin genes, the “extra” lamins appear to have specialized functions. For example, the lamin A/C gene is expressed mostly in differentiated cells. People who inherit one mutated copy of the lamin A/C gene develop one of three different diseases: the **autosomal dominant** form of Emery-Dreifuss muscular dystrophy; dilated **cardiomyopathy** with conduction system disease; or Dunnigan-type familial partial lipodystrophy (loss of fat tissue). Cardiomyopathy and lipodystrophy are correlated with **missense mutations** that change one **amino acid** in different regions of lamin A. Missense mutations might prevent lamin A/C from assembling properly, or might prevent its recognition by one or more binding partners. The loss of emerin, a membrane protein that binds lamins A/C, causes the X-linked recessive form of Emery-Dreifuss muscular dystrophy.

These diseases are not yet well understood. However, lamins and lamin-binding proteins may provide attachment sites needed by other nuclear proteins. For example, retinoblastoma, a transcriptional repressor critical for cell growth control, associates with the nuclear lamina. Insight into the functions of the nucleus may help to alleviate some diseases. SEE ALSO

#### BOVERI, THEODOR (1862–1915)

German biologist whose experiments with sea urchin eggs and embryos showed that the cell nucleus contains some substance that can, by itself, determine what kind of animal an egg will develop into. Boveri rightly predicted that humans inherit traits on the chromosomes.

**micron** one-millionth of a meter; also called a micrometer

**mitosis** separation of replicated chromosomes

**phosphorylation** addition of the phosphate group  $\text{PO}_4^{3-}$

**conformation** three-dimensional shape

**nematode** worm of the Nematoda phylum, many of which are parasitic

**autosomal dominant** pattern of inheritance in which inheritance of a single allele from either parent results in expression of the trait

**cardiomyopathy** heart muscle disease

**missense mutation** nucleotide change that causes a change in the amino acid normally added to the protein

**amino acid** a building block of protein

CHROMOSOME, EUKARYOTIC; DNA; NUCLEAR TRANSPORT; NUCLEOLUS; REPLICATION

Katherine L. Wilson

#### Bibliography

- Cohen, Merav, Kenneth K. Lee, Katherine L. Wilson, and Yosef Gruenbaum. "Transcriptional Repression, Apoptosis, Human Disease and the Functional Evolution of the Nuclear Lamina." *Trends In Biochemical Sciences* 26 (2001): 41–47.
- Gerace, Larry, and Roland Foisner. "Integral Membrane Proteins and Dynamic Organization of the Nuclear Envelope." *Trends in Cell Biology* 4 (1994): 127–131.
- Lamond, Angus I., and William C. Earnshaw. "Structure and Function in the Nucleus." *Science* 280 (1998): 547–553.
- Wilson, Katherine L. "The Nuclear Envelope, Muscular Dystrophy, and Gene Expression." *Trends in Cell Biology* 10 (2000): 125–129.

## Nurse

Nurses are health care professionals with direct responsibility for patient care. Nurses work in hospitals, clinics, long-term care facilities, schools, corporations, and many other settings. In hospitals, nurses provide care under a treatment plan prescribed by doctors, but often have considerable responsibility for managing the details of the patient's daily care. In other settings, nurses may be the first health care professional seen by a patient, and may be responsible for recommending treatment in conjunction with the doctor. Nurses combine medical expertise with strong interpersonal skills and a desire to help people.

To become a nurse, high school courses in math and science are required. Nurse training programs are offered at hospitals, junior colleges, community colleges, and four-year colleges. The degree of training offered by each differs, as does the advancement possible as a result. Following graduation from the training program, the student must pass a state licensure exam to become a registered nurse (RN), and is then able to work as a nurse. Further education allows the RN to obtain a master's degree in nursing. This is required to become a nurse practitioner (a nurse who performs many of the same functions as a family-practice doctor), a nurse-midwife (provides care to maternity patients), or several other nursing specialties. **SEE ALSO DOCTOR, FAMILY PRACTICE; MEDICAL ASSISTANT; NURSE PRACTITIONER**

Richard Robinson

#### Bibliography

- National Student Nurses' Association. <<http://www.nсна.org/>>.

## Nurse Practitioners

Nurse practitioners are registered professional nurses who have completed a graduate education program in advanced practice nursing. They provide many of the same services as physicians. A major focus for the nurse practitioner is the promotion of healthy lifestyles to prevent illness. Nurse practitioners can also diagnose and treat common minor health problems as well as chronic conditions, such as high blood pressure or diabetes. They order laboratory tests, prescribe medications, and prescribe various treatments. Studies have

### NIGHTINGALE, FLORENCE (1820–1910)

English nurse, founder of the profession of nursing and one of the first scientists to use statistical analysis. Nightingale used sophisticated data analysis, presented in diagrams, to persuade English authorities to make reforms necessary to save the lives of wounded soldiers in military hospitals in Turkey.

shown that they provide cost-effective and high quality care. Although some nurse practitioners practice in hospitals, most work in clinics. Many provide health care to those who may not otherwise have access to care, such as in rural areas, community clinics, shelters, schools, and other settings.

Nurse practitioners must complete a four-year bachelor's degree in nursing and must have experience working as a registered nurse. The graduate nurse practitioner education program takes approximately two years to complete. Graduate study includes nursing coursework as well as advanced study in performing physical examinations, diagnosis, and treatment. The student also has hands-on education with a nurse practitioner and/or a physician preceptor in a clinic or other health care facility.

Students can choose from several specialty areas of study. Some of these specialties include family nurse practitioner (FNP), adult nurse practitioner (ANP), geriatric nurse practitioner (GNP), pediatric nurse practitioner (PNP), and women's health care nurse practitioner (WHCNP).

Students interested in becoming a nurse practitioner would benefit by taking high school sciences and the required college level prerequisites for nursing school. Spending time with a nurse practitioner and working or volunteering in any type of health care service organization is also suggested.

In 1990 nurse practitioners numbered 28,600. In 2000 nearly 70,000 existed, and it was predicted that there would be 116,000 by 2005. SEE ALSO DOCTOR, FAMILY PRACTICE; NURSE; PHYSICIAN ASSISTANT

*Kevin Smith*

### Bibliography

*American Academy of Nurse Practitioners.* <<http://www.aanp.org/>>.

## Nutritionist

Nutrition is the study of food, essential nutrients, and other substances in food and their effects on the body in relation to health and disease. It concerns how we eat, digest, absorb, use, and **excrete** the many components of food. The study of nutrition encompasses psychological and social perspectives as well as biochemical and physiological approaches.

Nutritionists work in many different settings. Public health nutritionists may focus on developing programs to improve the nutritional status of specific populations, such as expectant mothers or the elderly. Community nutritionists may counsel individuals how to improve their diets, or develop educational materials on nutrition. These types of nutritionists often work for governmental agencies. They usually have obtained a bachelor's degree in nutrition, and often have advanced degrees, such as a master's degree in public health or science. There are also many opportunities in nutrition research, usually in a university or research institute. Nutritional epidemiologists, for example, study associations between nutrient intake and disease incidence in populations. Nutritional biochemists investigate how too little or too much of specific nutrients, both essential and nonessential, affect metabolic pathways and the development of various diseases. These positions require a B.S. in a biological science, with a doctoral degree (Ph.D.) in nutrition or closely related field.

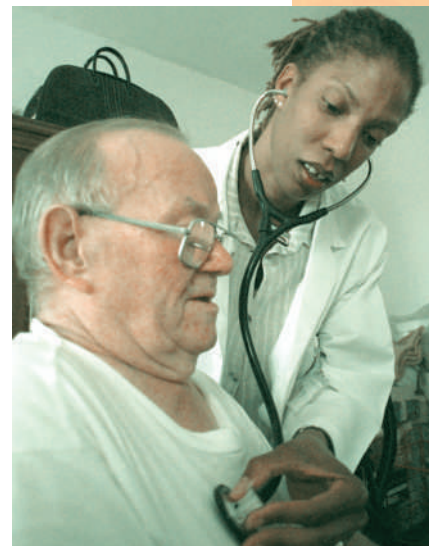

A registered nurse listens with a stethoscope to a patient's heart.

**excrete** deposit outside of

Dietitians have completed a B.S. in nutrition from an accredited program and completed an approved internship, as certified by the American Dietetics Association. Dietitians often work in hospitals or clinics providing nutritional services to patients. They also manage food service operations in hospitals, long-term care facilities, and universities.

Since nutrition is a biological science, high school courses in math and the sciences are necessary. Strong communication and computer skills are also extremely important. In college, nutrition degrees include courses in chemistry, physiology, and biochemistry, similar to other biological majors.

*Daniel D. Gallaber*

## Ocean Ecosystems: Hard Bottoms

The term “hard bottom” refers to the ocean region close to shore, where wave action prevents the accumulation of muddy sediment that will create a soft bottom. Plants and animals living on or in the seafloor are called benthos. Benthic epifauna reside on or attach to a rocky substrate (surface). Benthic infauna bury themselves in soft sediments or bore into the rocky bottom or shells of other animals.

Seaweeds, a kind of algae, anchor to the bottom with holdfasts. Unlike the roots of higher plants, holdfasts do not extract nutrients. Many seaweeds have pneumatocysts, gas-filled bladders that keep the photosynthetic parts of the seaweed in the photic zone, the near-surface layer of the ocean that light penetrates. All benthic animals are invertebrates. Although they inhabit all water depths, most are in the photic zone where light and nutrients are more abundant. Many benthic animals are **sessile**. Some are suspension feeders; they strain the fresh seawater brought in by waves, tides, or currents for **plankton** and other nutrients. Others wait for food to arrive.

When a small fish swims against a sea anemone’s tentacles, it is stunned by poisonous nematocysts and then dragged into the anemone’s central mouth. Some benthic animals can move to pursue their prey, scavenge over the bottom, or graze on seaweed-covered rocks. Starfish crawl on tube feet over a shellfish or sea urchin; they pry apart the shell with their arms, extrude their stomach into the prey’s shell, and begin digestion. Many benthic animals exist for part of their life cycle as tiny planktonic larvae, drifting with the water to colonize new areas.

Benthic epifauna have enormous species diversity, reflecting the diversity in the benthic environment. In the intertidal—between the highest high and the lowest low tides—small distances bring large variations in substrate, temperature, salinity, moisture, **pH** level, wave action, dissolved oxygen, and food supply. Organisms at the top must contend with weather, predators from land, crashing waves, and an occasional influx of fresh water from storms. Organisms at the bottom face ocean predators and sometimes land predators, waves, weather, and drying out. For protection against predators and **desiccation**, the animals of the intertidal have shells (clams and barnacles) or **exoskeletons** (crabs and lobsters), or they appear as crusts on rocks (lichens and algae). Sea anemones huddle together to conserve moisture, and segmented worms and crabs retreat into mussel beds or rocks.



**sessile** attached and remaining in one place

**plankton** microscopic floating organisms

**pH** measure of acidity or alkalinity; numbers below 7 are acid, above are basic

**desiccation** drying out

**exoskeleton** external skeleton



The anemone, tunicate, oyster, and sponge are examples of benthic fauna at the bottom of a lagoon in the Truk Islands.

For protection against waves and tides, intertidal organisms attach to rocks with holdfasts (seaweed), cement (barnacles), threads (mussels), or arms (starfish). Snails squeeze a muscular foot tightly into a rock and retreat into their shells.

The rocky intertidal has been the site of important ecological studies. In the rocky intertidal of Washington state, the top carnivore is the starfish *Pisaster ochraceus*. Removal of the starfish caused a decline in the number of species from fifteen to eight, including an enormous increase in the population of the mussel *Mytilus edulis*, the starfish's favorite prey. *Pisaster ochraceus* is therefore a keystone predator in its community; by limiting the size of mussel's population, it clears out space for other species. Keystone predators are often at a high risk for extinction since they are often high in the food chain and sparsely distributed. SEE ALSO ALGAE; COMMUNITY; ECHINODERM; ECOSYSTEM; MOLLUSK; OCEAN ECOSYSTEMS: OPEN OCEAN; OCEAN ECOSYSTEMS: SOFT BOTTOMS

*Dana Desonie*

### Bibliography

Paine, Robert T. *Marine Rocky Shores and Community Ecology: An Experimentalist's Perspective*, Excellence in Ecology Series, Book 4. Ecology Institute, 1994. <<http://www.int-res.com/ebooks/index.html>>.

Ricketts, Edward Flanders, et al. *Between Pacific Tides*, 5th ed. Stanford, CA: Stanford University Press, 1986.

## Ocean Ecosystems: Open Ocean

The realm of open water, called the pelagic zone, has the greatest volume and vertical range of any life zone. It includes the region above the **continental shelf**, called the **neritic** province, and the region beyond, called the oceanic province. Gradations in light, temperature, water chemistry, nutrient content, and pressure result in a diversity of environments that are filled by a large number of species.

**continental shelf** submerged offshore area demarcated by land on one side and deep sea on the other

**neritic** zone near the shore

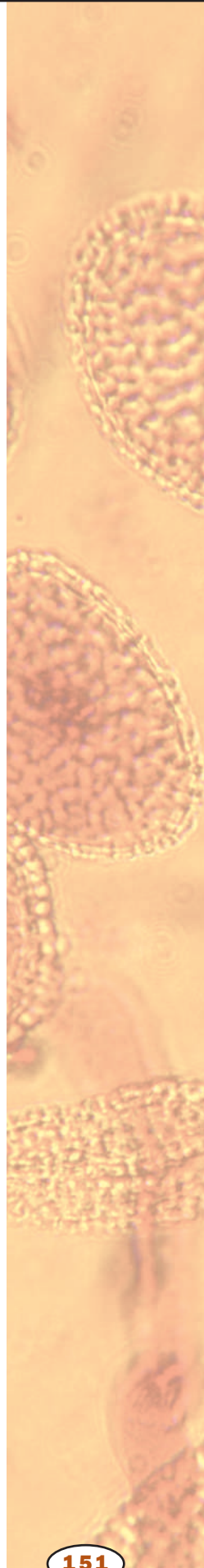

**photosynthesis** the process by which plants use the energy of light to produce carbohydrates and molecular oxygen from carbon dioxide and water

**plankton** microscopic floating organisms

**phytoplankton** microscopic floating creatures that photosynthesize

Life is found throughout the water column (that is, top to bottom), but mostly in the photic zone, the region where sunlight makes **photosynthesis** possible. Organisms are also more abundant where there are more nutrients: in the neritic, where nutrients wash off the land, and in upwelling zones, where relatively cold nutrient-rich waters from the deep ocean rise to the surface. Pelagic life is dominated by **plankton**, mostly tiny organisms that move with water currents. Photosynthesis by **phytoplankton** is directly or indirectly the primary food source for all marine life. The animals, or zooplankton, that eat them may also be tiny, like krill, or they may be larger, like jellyfish, and able to make small, directed motions.

The active swimmers that inhabit the open ocean are called nekton. While the vast majority of nekton are fish and mammals, they include invertebrates, such as mollusks and crustaceans. The most productive waters in the world are upwelling zones, such as those of the west coast of South America. Here, the abundance of nutrients supports a large population of phytoplankton, which in turn is the foundation of rich fishing grounds. If upwelling stops, as happens off Peru during an El Niño event, the fish population declines; if the fishery has already been weakened by overfishing, it may collapse, as did the Peruvian anchovy fishery in the early 1970s.

The ocean has a moderating effect on world climate because water has a high ability to absorb and store heat. When prevailing winds come off an ocean the climate is milder than in locations with no oceanic influence. This is why annual temperature fluctuations are much smaller in western than in eastern coastal North America. The surface layer of the ocean is a heat reservoir that may maintain temperature anomalies for years, and alter rainfall patterns. For example, increased sea surface temperature results in increased evaporation. This increases rainfall and therefore condensation, which provides the energy to drive an El Niño event.

The enormous productivity of phytoplankton has a large effect on the atmosphere, since these organisms use carbon dioxide ( $\text{CO}_2$ ) and release oxygen. Also,  $\text{CO}_2$  is highly soluble in seawater and the ocean is a carbon

A bottlenosed dolphin in the Bahamas. Gradations in light, temperature, water chemistry, nutrient content, and pressure result in a diversity of open ocean environments that are filled by a large number of species.



dioxide sink. Manipulations of oceanic chemistry have been proposed to control atmospheric levels of CO<sub>2</sub>, and possibly reduce greenhouse warming. In large regions of the ocean, phytoplankton growth is limited by lack of the trace element iron. In two experiments, small patches of the sea surface were fertilized with minute amounts of dissolved iron. This triggered a massive phytoplankton bloom: the phytoplankton growth rate doubled, its biomass increased by nearly thirty times, and its nitrate uptake increased by fourteen times. If phytoplankton populations were increased on a wide scale, phytoplankton might use more CO<sub>2</sub>. When these organisms died, some would fall to the seafloor, taking with them the carbon they had harvested from atmospheric CO<sub>2</sub>. SEE ALSO BIOGEOCHEMICAL CYCLES; BONY FISH; CARTILAGINOUS FISH; CRUSTACEAN; GLOBAL CLIMATE CHANGE; MOLLUSK; OCEAN ECOSYSTEMS: HARD BOTTOMS; OCEAN ECOSYSTEMS: SOFT BOTTOMS; PLANKTON

Dana Desonie

### Bibliography

- Carson, Rachel L. *The Sea Around Us*. New York: Oxford University Press, 1955.
- Kunzig, Robert. *The Restless Sea: Exploring the World Beneath the Waves*. New York: W. W. Norton and Company, 1999.
- Safina, Carl. *Song for the Blue Ocean: Encounters Along the World's Coasts and Beneath the Seas*. Toronto, ON: Owl Books, 1999.

## Ocean Ecosystems: Soft Bottoms

Where water movements are not strong enough to wash them away, sediments coat much of the benthic environment. Soft bottoms are common along coasts, along continental margins, and in the deep sea. Plants and animals that attach to sandy or rocky surfaces are called benthic epifauna; those that bury themselves in soft sediments or bore into the rocky bottom or shells of other animals are called benthic infauna. Few benthic organisms can live in shifting sediments, as on a beach exposed to wave action, and many more are found in sediments in protected bays or estuaries.

The plants of soft bottoms are marine angiosperms, seed-bearing vascular plants with true roots. So that they can photosynthesize, benthic plants live only in the photic zone. Grasses are the only marine plants that live on soft bottoms. They catch sediments and **organic** matter in their roots, protecting the shoreline from erosion and providing shelter, substrate, and food for a diverse group of animals. Much organic material from these wetland **ecosystems** is carried offshore, where it provides nutrients for organisms living beneath the photic zone.

The animals found on the shore or in near-shore sediments live primarily on **plankton** and organic debris from land. Suspension feeders attach themselves to hard or sandy bottoms and strain water for food. Filter feeders are similarly attached but actively pump large amounts of water through their bodies to get food. Many benthic infauna are deposit feeders who eat sediments, extracting the organic matter trapped between the grains. Predators and scavengers on soft bottoms include starfish, snails, cephalopods, and crustaceans. Bacteria are an important **protein** source and play a major role in decomposition.

**organic** composed of carbon, or derived from living organisms

**ecosystem** an ecological community and its environment

**plankton** microscopic floating organisms

**protein** complex molecule made from amino acids; used in cells for structure, signaling, and controlling reactions

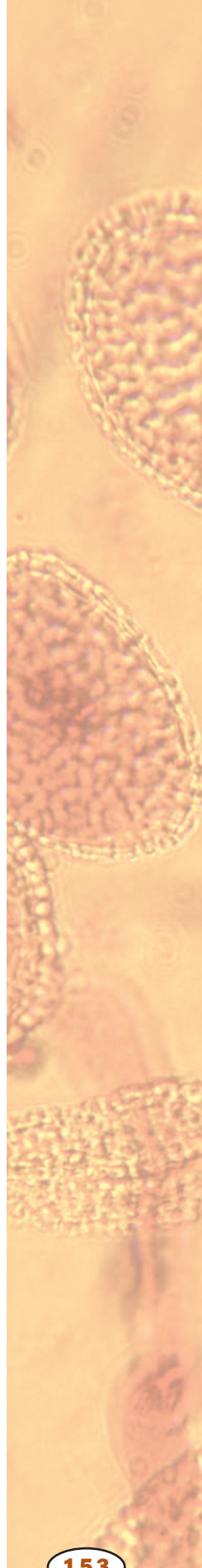

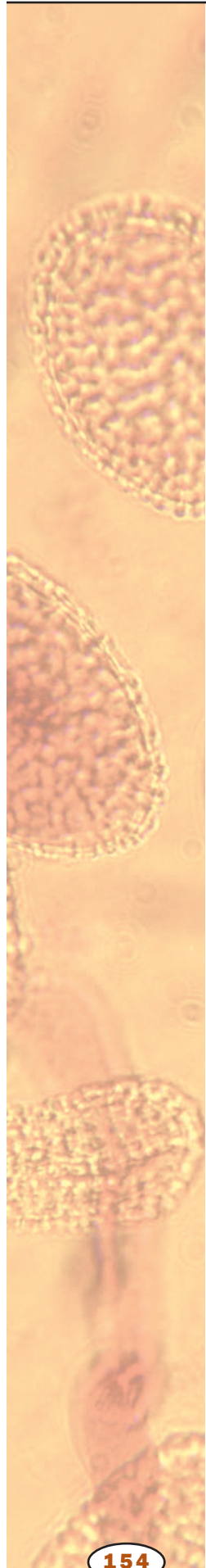

**aerobic** with oxygen, or requiring it

**anaerobic** without oxygen, or not requiring oxygen

**cell cycle** sequence of growth, replication, and division that produces new cells

**protein** complex molecule made from amino acids; used in cells for structure, signaling, and controlling reactions

**gene** portion of DNA that codes for a protein or RNA molecule

**somatic** nonreproductive; not an egg or sperm

The benthic environment is extremely diverse in water depth, temperature, salinity, substrate type, and predation and competition. The most important factor determining the distribution of near-shore benthic infauna is grain size. Large-grained particles, such as sands, are fairly porous. They gain and lose water, gases, and organic material quickly. Filter feeders attach to sands, since smaller sediments are easily swept up by water and can clog the animals' mucus-lined filtration systems. Deposit feeders prefer to live in the top 1 to 2 centimeters of organic-rich, fine-grained mud. This is the **aerobic** zone, where dissolved oxygen permeates. Below the oxygenated layer is the black, oxygen-depleted, or **anaerobic**, zone, where only anaerobic bacteria can live fully. Anaerobic bacteria produce hydrogen sulfide, the rotten egg smell of black mud. Some animals, like clams, live in the anaerobic zone to avoid predators but extend siphons into the aerobic zone to obtain food and oxygen.

The deep sea is uniformly cold and dense, and sediment particles are small and relatively uniform in size. The number of benthic species increases from the near shore to the deep ocean but the number of individuals and total biomass decreases. All major groups of shallow water benthos have deep ocean counterparts. But shortage of food causes the deep-sea organisms to be smaller, live longer, and reproduce less frequently. Most deep-sea organisms are deposit feeders with a few conspicuous filter feeders and predators. SEE ALSO CRUSTACEAN; CORAL REEF; ESTUARIES; OCEAN ECOSYSTEMS: HARD BOTTOMS; OCEAN ECOSYSTEMS: OPEN OCEAN

Dana Desonie

**Bibliography**

Kunzig, Robert. *The Restless Sea: Exploring the World Beneath the Waves*. New York: W. W. Norton and Company, 1999.

Ricketts, Edward Flanders, et al. *Between Pacific Tides*, 5th ed. Stanford, CA: Stanford University Press, 1986.

**Oncogenes and Cancer Cells**

Cancers are a collection of diseases that result from loss of control over cell division (mitosis). Because the **cell cycle** is controlled by **proteins**, and proteins are encoded by **genes**, cancers are genetic diseases.

Despite being genetic in origin, cancer is not usually inherited in as predictable a way as a Mendelian (single-gene) disorder, such as color blindness. Instead, cancer arises as a consequence of accumulated mutations in **somatic** (body) cells of an individual. This can happen in two ways. In the first method, a person inherits a cancer susceptibility allele (gene variant) from a parent, and therefore has that mutation present in one copy in each cell of the body. If a mutation then occurs in the second copy of the susceptibility gene in one somatic cell, that cell begins to divide uncontrollably. As the cell divides, the offspring cells inherit these mutations and perpetuate the cancerous characteristics. Alternatively, two somatic mutations may occur spontaneously in the same cell. For example, exposure to ultraviolet wavelengths in sunlight, or to cancer-causing chemicals, can cause somatic mutations. The somatic nature of the mutations that underlie cancer is the



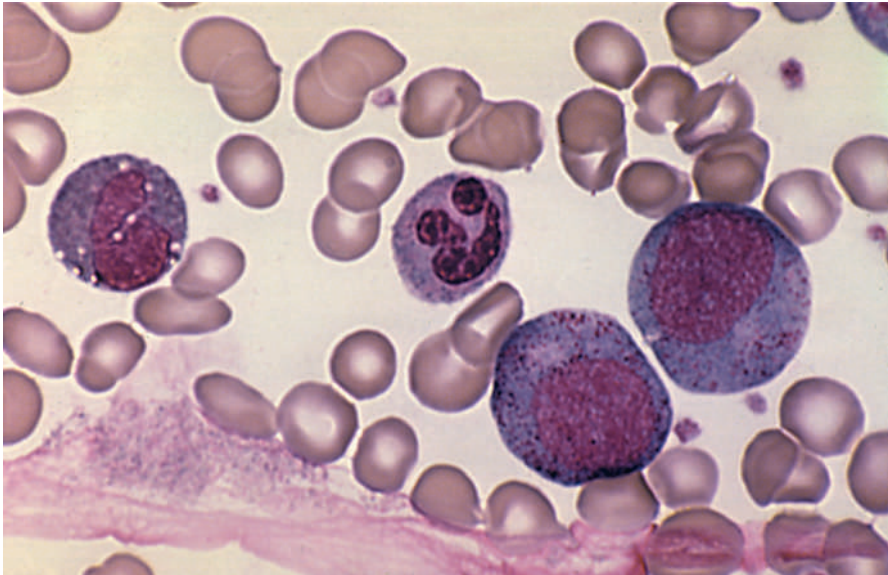

Photomicrograph of a blood smear showing leukemia cells. Until 1958, cancer was not considered to be a genetic disorder.

mechanism by which environmental factors can contribute to the disease. The nature and location of the cell type determines the type of cancer.

### Types of Cancer Genes

Mutations of two major types of genes cause cancer. An oncogene increases cell division rate in an inappropriate place in the body or at an inappropriate time in development. The oncogene is a mutated form of a so-called proto-oncogene, which is a gene that normally causes high cell division rates where it is needed, such as in the fetus or in a wound where cells must be replaced. The abnormal activation of such a gene in time or place causes cancer. Some oncogenes encode **transcription factors**, whose overexpression then activates other genes that cause the specific characteristics of cancer cells. An oncogene mutation is usually a single deoxyribonucleic acid (DNA) base substitution.

The second type of cancer-causing gene is a tumor suppressor, whose normal function is to halt cell division. Just as a proto-oncogene has a normal function, so too does the unaltered version of a tumor suppressor gene and its encoded protein; it shuts down cell division when it is no longer necessary. Tumor suppressors are critical to development and to the maintenance of organs because they keep cells from dividing uncontrollably. A tumor suppressor mutation is often a deletion. This makes sense, for removal of the gene lifts its normal control of cell division, and a cancer forms.

Many cancers are the culmination of several genetic steps, which may include the actions of both oncogenes and mutant tumor suppressor genes. For example, a type of colon cancer called familial adenomatous polyposis includes deletions of tumor suppressor genes on **chromosomes** 17 and 18, and activation of an oncogene called ras on chromosome 12.

### Activating Oncogenes

Oncogenes arise when proto-oncogenes mutate or are moved to a part of the **genome** where their expression is greatly heightened. For example, a virus might insert its DNA into a human chromosome next to a proto-oncogene,

**transcription factor**  
protein that increases the rate of transcription of a gene

**chromosome** “colored body” in the cell nucleus; made of DNA and protein, and divided functionally into genes and nongene regions

**genome** total genetic material in a cell or organism

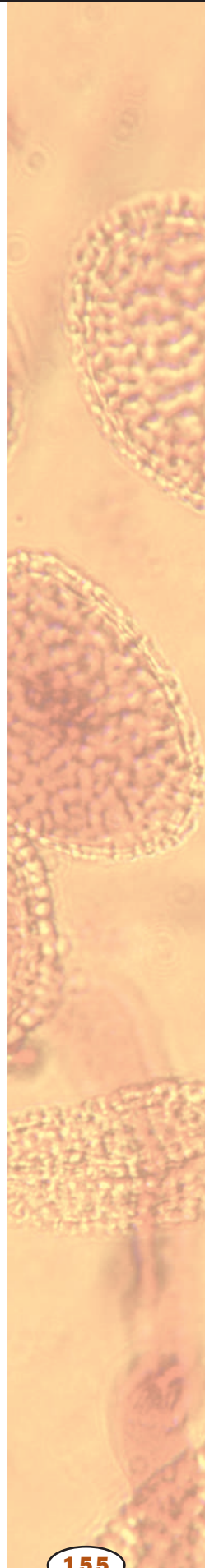

The BCR-ABL fusion gene causes chronic myelogenous leukemia. The experimental drug STI 571 competes with ATP to block the action of the fusion protein, thus stopping the cancer.

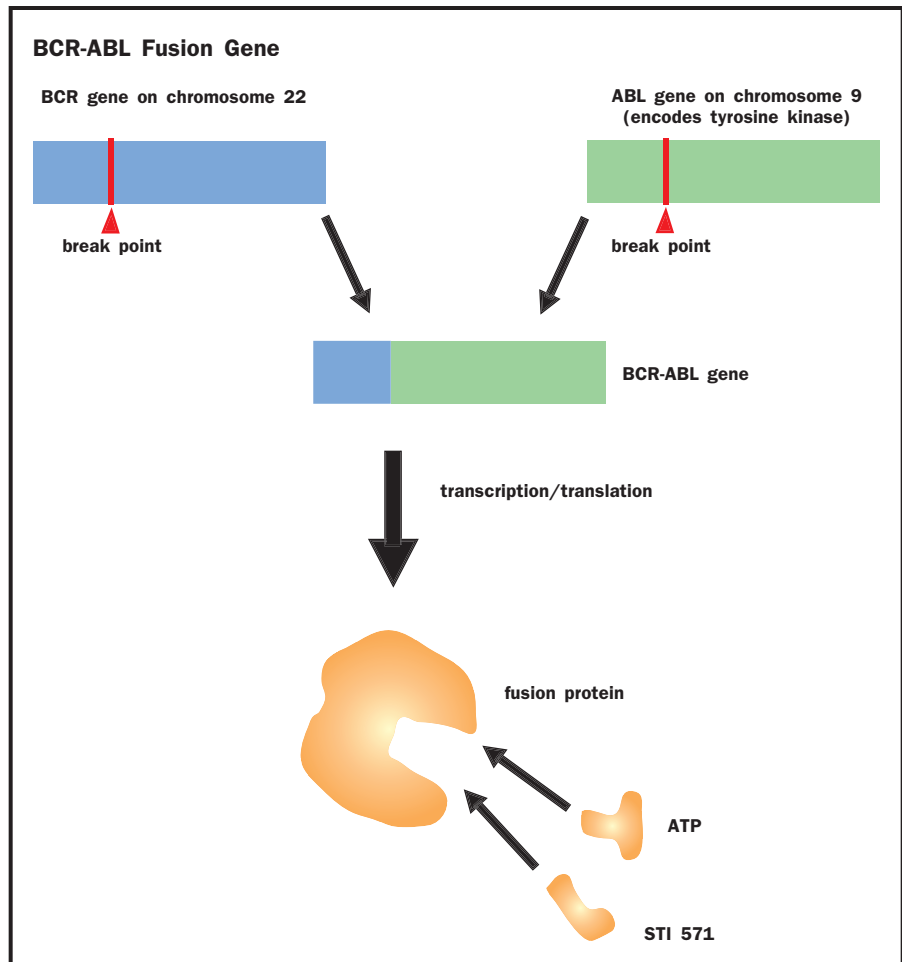

**transcribe** creation of an RNA copy of a DNA gene

**hormone** molecule released by one cell to influence another

**antibody** immune system protein that binds to foreign molecules

and as the viral genes are **transcribed** at their characteristically high rate, the adjacent proto-oncogene sequence is rapidly transcribed too. The result is a loss of control over cell division. Another way that a proto-oncogene can be overactivated and thereby turned into an oncogene is if a chromosome is inverted or translocated (two different chromosomes exchange parts or combine). Either action may relocate a proto-oncogene next to a highly expressed gene. This happens, for example, in a cancer of the parathyroid glands in the neck. An inversion of chromosome 11 places a proto-oncogene next to the gene that encodes parathyroid **hormone**. When the gland synthesizes the hormone, it also synthesizes too much of the encoded protein (called an oncoprotein) and cancer begins.

Oncogenic cancers can also start when proto-oncogenes are placed near **antibody** genes, which are highly expressed during infection. In Burkitt's lymphoma, which causes a large tumor to form in the lymph glands near the jaw, infection with Epstein-Barr virus in B cells places a proto-oncogene on chromosome 8 next to an antibody gene on chromosome 14. The cancer cells of these patients have the telltale chromosomal exchange.

### Chronic Myeloid Leukemia and the BCR-ABL Fusion Gene

Sometimes a proto-oncogene that has been moved next to a highly expressed gene is transcribed and translated with the second gene. The result is called

a fusion protein, which then causes cancer. Discovery of the first cancer-causing fusion protein was a milestone in medical history, and has recently received renewed attention because of development of a highly effective drug treatment. This fusion protein forms in people with a tiny, unusual chromosome, named the Philadelphia chromosome, who also have chronic myeloid leukemia (CML). The errant chromosome forms from a translocation of the tip of chromosome 9 to the minuscule chromosome 22, and transfer of a bit of chromosome 22 material to chromosome 9.

Researchers discovered the Philadelphia chromosome in 1958, when two men were hospitalized in that city complaining of chronic fatigue. Each man's blood had far too many white blood cells, which led to the diagnosis of leukemia. Their blood samples were sent to two young investigators at the University of Pennsylvania, assistant professor Peter Nowell and graduate student David Hungerford, who detected the small, unusual chromosome. At that time, cancer was not considered to be a genetic disorder, and so the apparent association of leukemia with a chromosomal abnormality was a surprise. With time, cases accumulated, and the link strengthened.

By 1972, chromosome banding technology made it possible to describe the nature of the material that makes up the Philadelphia chromosome, and to infer its origin. Janet Rowley at the University of Chicago identified the translocation between chromosomes 9 and 22 that produces the tiny Philadelphia chromosome. By 1984, other researchers discovered the genes that are juxtaposed in the translocation. One gene from chromosome 9 is called the Abelson oncogene (ABL), and the other gene, from chromosome 22, is called the breakpoint cluster region (BCR).

Because the translocation is reciprocal, swapping parts of two chromosomes, two different fusion genes form called BCR-ABL and ABL-BCR. The BCR-ABL fusion gene is part of the Philadelphia chromosome, and this is the one that causes CML. The encoded fusion protein, called the BCR-ABL oncoprotein, is a form of the **enzyme** tyrosine **kinase**, which is the normal product of the ABL gene. The cancer-causing form of tyrosine kinase is active for too long, which somehow turns on a cascade of signals that ultimately results in deregulated cell division and cancer. Further evidence that implicates the BCR-ABL oncoprotein in causing CML is that mice genetically modified to harbor the fusion gene develop leukemia. (The other translocated chromosome, which is mostly chromosome 9 material, includes the ABL-BCR fusion gene, which is not known by itself to affect health.)

The discovery that a fusion oncoprotein sets into motion the cellular changes that cause CML has led directly to a new and very promising treatment. The new drug is called signal **transduction** inhibitor 571, or STI571. (Existing treatment is the immune system biochemical interferon alfa, but it does not help most patients.) In 1990, Brian J. Druker, now at the Oregon Health Sciences University in Portland, proposed to a major pharmaceutical company that he design a small molecule that would lock onto the aberrant tyrosine kinase and squelch its overactivity. He knew that the tyrosine kinase must bind **ATP** to begin the signal cascade that causes cancer. So he synthesized the small molecule in a shape that enabled it to nestle into the pocket where ATP binds. This, he hoped, would block the signal cascade and stop the cancer.

**enzyme** protein that controls a reaction in a cell

**kinase** enzyme that adds a phosphate group to another molecule, usually a protein

**transduction** conversion of a signal of one type into another type

**ATP** adenosine triphosphate, a high-energy nucleotide used by cells to power most energy-requiring reactions

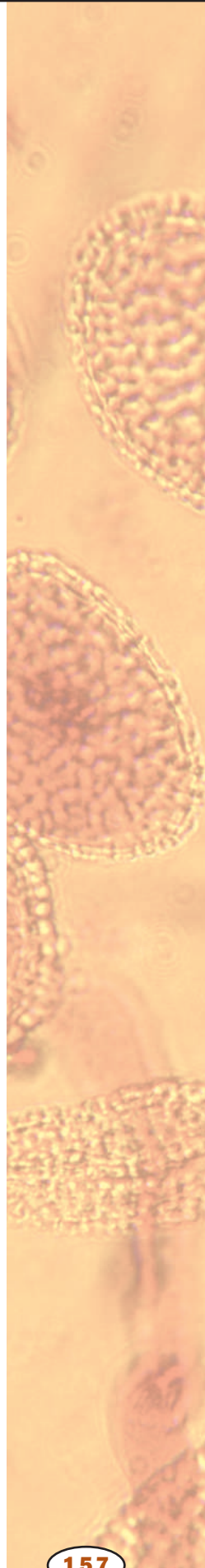

As of early 2001, clinical trials of STI571 had reached more than 2,800 patients in some 30 countries.

Following the usual drug discovery trajectory, Druker and his coworkers demonstrated that the molecule indeed halts the cancer in cell culture, and in mice. By 1998, STI571 was ready for phase I clinical trials, which are set up to determine safety at different dosages. In the study, 83 patients for whom interferon had not worked received doses ranging from 25 to 1000 milligrams per day (each participant received the same dose each day). Of the 54 participants who received 300 milligrams or more daily, 53 had their blood counts return to normal, and 29 of them had significantly fewer cells that had the telltale Philadelphia chromosome. In 7 participants, the unusual chromosome disappeared completely.

The new drug appears to have many benefits. Side effects are minimal; the drug is taken by mouth, unlike interferon, which must be injected; response is evident by four weeks; and perhaps most important, it helps people who did not respond to the conventional treatment.

Chronic myeloid leukemia is in many ways a landmark in cancer biology. It was the first type of leukemia to be recognized, in the 1840s, and was the subject of the first chromosome-cancer link. CML was also the type of cancer that led to identification of the first oncogene fusion protein. Finally, a highly effective new treatment is in development, based on understanding the molecular events that underlie the disease. SEE ALSO CANCER; CELL CYCLE; CHROMOSOME ABERRATIONS; CHROMOSOME, EUKARYOTIC; CLINICAL TRIALS; GENETIC DISEASES; MITOSIS; MUTATION

*Ricki Lewis*

#### Bibliography

- Druker Brian J., et al. "Efficacy and Safety of a Specific Inhibitor of the BCR-ABL Tyrosine Kinase in Chronic Myeloid Leukemia." *The New England Journal of Medicine* 344, no. 14 (2001): 1031–1037.
- Goldman, John M., and Junia V. Melo. "Targeting the BCR-ABL Tyrosine Kinase in Chronic Myeloid Leukemia." *The New England Journal of Medicine* 344, no. 14 (2001): 1084–1086.
- Nowell, P., J. Rowley, and A. Knudson. "Cancer Genetics, Cytogenetics —Defining the Enemy Within." *Nature Medicine* 4 (October 1998): 1107–1114.

## Organ

An organ is a structure composed of two to four types of tissues working to perform functions that are beyond the scope of an individual tissue type. A set of related organs working cooperatively toward the performance of even more complex functions constitutes an organ system.

Organs come in many different forms. The stomach, with its composition of **epithelium**, **connective tissue**, nervous tissue, and smooth muscle tissue, is a familiar example. Bones are organs; although they consist primarily of **osseous** tissue, bones have a vast supply of nervous tissue in their nerves, fibrous tissue lining their cavities, and muscle and epithelial tissue in their blood vessels. The skin (integument) is an organ consisting of an epithelium (epidermis) overlying a thick layer of connective tissue (dermis) rich with blood vessels and accessory structures such as secretory glands.

Even the glands within the integument can be considered organs; any gland is primarily secretory epithelium surrounded by connective tissue for

**epithelium** one of four tissue types found in the body, characterized by thin sheets and usually serving a protective or secretory function

**connective tissue** one of four types of body tissue, characterized by few cells and extensive extracellular material

**osseous** related to bone

support and protection. Likewise, the blood vessels and nerves in these organs are organs unto themselves.

This “organ within an organ” motif is also exhibited in the sense organs. For example, within the eyeball is an organ called the retina, an association of **neural** and epithelial tissue that detects light entering the eyeball. SEE ALSO BONE; CONNECTIVE TISSUE; DIGESTIVE SYSTEM; EPITHELIUM; KIDNEY; LIVER; MUSCLE; NEURON; PANCREAS; SKIN; TISSUE

*James A. Crowder*

### Bibliography

Saladin, Kenneth S. *Anatomy and Physiology: The Unity of Form and Function*. New York: WCB McGraw-Hill, 1998.

## Organelle

An organelle is a specialized cellular structure in **eukaryotic cells** analogous to an organ in the body. Organelles are discrete structures within the cell that perform a specialized function. Most are surrounded by internal membranes and can be seen in the light or the electron microscope. Organelles increase the efficiency of cellular processes by concentrating the factors necessary to carry out specific biochemical reactions separate from the rest of the cell. Bacterial cells do not contain organelles or **intracellular** membrane-bound structures. Examples of organelles are lysosomes, **nucleus**, **mitochondria**, and the **endoplasmic reticulum**. SEE ALSO CELL; CHLOROPLAST; ENDOPLASMIC RETICULUM; GOLGI; LYSOSOMES; MITOCHONDRION; NUCLEUS; RIBOSOME; VACUOLE

*Stephen A. Adam*

**neural** related to nerve cells or the nervous system

**eukaryotic cell** a cell with a nucleus

**intracellular** within a cell

**nucleus** membrane-bound portion of cell containing the chromosomes

**mitochondria** subcellular organelle that creates ATP used for energy-requiring processes in a cell

**endoplasmic reticulum** network of membranes within the cell

## Organic Agriculture

Organic agriculture uses the principles of diversity and nutrient cycling found in nature to raise crops and livestock. All kinds of food are grown using organic practices, from fruits and vegetables to grains and dairy products. Organic agriculture is popularly understood to mean farming without the chemical herbicides and pesticides used in conventional agriculture. Just as important are the techniques used by organic growers that make chemical use unnecessary. These include intelligently managing the **agroecosystem** by using crop rotation, cover crops, and tillage.

### Principles of Organic Agriculture

Crop rotation means growing a different crop in a field each year. When the same crop is grown year after year in an artificial **monoculture**, a habitat is created for weeds, pests, and diseases that attack that crop. Organic growers imitate the complexity found in nature by changing the crops grown in a field from year to year. Rotation continually disrupts pest habitat and reduces weeds and diseases.

Crop yields also increase because of the “rotation effect.” A basic two-year rotation involves alternating a grass family crop such as wheat or corn

**agroecosystem** agricultural ecosystem

**monoculture** cultivation of a single type of crop in a large area

Worm composting (vermicomposting) turns food scraps into a rich mixture of decayed organic matter used as fertilizer. Organic growers strive to make chemical use unnecessary.



with a broadleaf crop such as tomatoes or soybeans. Any pests that become established in the wheat will no longer have a habitat the following year when tomatoes are planted. Similarly, most corn pests do not find what they need to survive in a soybean field.

Many organic growers use more sophisticated four- to eight-year rotations carefully designed to optimize yield and the ecological function of each crop. Often, the complexity of such an organic system is similar to the complexity found in nature, and weeds, insects, and diseases are almost eliminated from the system.

Using cultural control of pests rather than chemical control makes organic farming better for the environment and for wildlife.

Organic farmers will often plant a cover crop in the fall that protects the soil from wind and rain erosion during the winter. Usually the cover crop will provide other benefits as well. If the cover crop is a member of the bean plant family (a legume), it will bring nitrogen into the soil that will be available for the next crop to use. If the cover crop has allelopathic, or toxic, properties, as does rye, it can help control weeds.

From handheld hoes to tractor-pulled cultivators, organic farmers use a wide range of cultivation equipment to control weeds during the growing season. All of these implements operate on the same principle: drag weeds out of the soil onto the surface to dry out and die.

## Commercial Organic Farming

A national law provides a set of standards that farmers in the United States must follow in order to sell what they grow as “organic.” Organic growers must be certified, or have their farming practices verified by an application and inspection process, every year in order to sell into the organic market.

Increasing awareness of the pesticides used in conventional farming has made many people decide to buy organic food. Because of increased labor costs in organic farming, organic produce may be priced higher than conventional produce. Farmers’ markets and roadside stands are places where consumers can purchase organic produce directly from the growers and eliminate retail mark-up costs.

Since the mid-1990s, sales of organic products have increased by at least 20 percent every year. Between 1995 and 1997, certified organic acres in the United States increased by 47 percent, making organic agriculture the largest growing segment of U.S. agriculture. SEE ALSO AGRICULTURE; AGRONOMIST; HISTORY OF AGRICULTURE; NITROGEN FIXATION

*Jane Sooby*

### Bibliography

Howard, Albert. *An Agricultural Testament*. New York: Oxford University Press, 1943. Reprint, Kutztown, PA: Rodale Press, 1979.

Magdoff, Fred, and Harold van Es. *Building Soils for Better Crops*, 2nd ed. Beltsville, MD: Sustainable Agriculture Network, 2000.

National Research Council. *Alternative Agriculture*. Washington, DC: National Academy Press, 1989.

## Origin of Life

How did life begin on Earth? The fact is that no one knows the answer yet, and it remains one of the primary unsolved questions of biology. We may never know with certainty because life began on Earth nearly four billion years ago. The events that initiated life no longer occur, and even the conditions of that the early Earth are not known with any certainty.

We do know one thing with reasonable certainty: Even bacteria, the simplest forms of life today, are so complex that they could not have appeared spontaneously on the early earth. More likely there were even simpler forms of life that required several hundred million years to evolve into bacterial life, complete with deoxyribonucleic acid (DNA) **genes**, metabolic pathways, ribonucleic acid (RNA) machinery, and **protein catalysts**.

The first life probably appeared several hundred million years after Earth was formed as a planet in the early solar system 4.5 billion years ago. There are many lines of evidence that support this statement, but the simplest to understand is the fossil record. Even bacteria leave fossils, and such microfossils were discovered in Australian rocks that are about 3.5 billion years old.

**gene** portion of DNA that codes for a protein or RNA molecule

**protein** complex molecule made from amino acids; used in cells for structure, signaling, and controlling reactions

**catalyst** substance that aids in a reaction without being used up

Something else scientists know with certainty is that Earth was very different when life first began. For example, the large number of craters on the moon's surface were produced by giant impacts of comets and asteroid-sized objects that were part of the accretion process by which the moon formed. The collisions continued until about 3.9 billion years ago. During that time Earth was also being hit by objects many kilometers in diameter, and the first life could not have begun until the violent bombardment ceased. Therefore, scientists estimate that the simplest form of life probably was present about 3.8 billion years ago, and over a few hundred million years evolved into the bacteria that left the Australian microfossils.

What sorts of chemical and physical processes might have produced the first forms of life? A brief summary of the properties of life today can tell scientists a lot about how life began. All life is cellular, from single-celled bacteria to multicellular human beings. Cells have anywhere from a thousand or so genes (bacteria) to thirty thousand genes (human beings) and each gene carries the information to synthesize a specific protein. The synthesis of proteins requires energy and occurs on **ribosomes**. RNA carries genetic information **transcribed** from DNA to the ribosomes where it is used to direct the synthesis of proteins.

## Properties of Life

The most basic activity of life is a process called polymerization. During this process organized systems of molecules use energy and nutrients to grow by linking smaller molecules into larger molecules. The chemical reactions involving energy and nutrients are collectively called **metabolism**, and the individual reactions of metabolism are catalyzed, meaning their rates are increased in a controlled way by specific molecules (proteins, in the case of all living organisms). Second, a living organism has the potential to reproduce itself at some point in its life cycle. Third, because mutations can lead to variations among individuals, populations of living organisms can evolve over time from generation to generation, responding to changes in their environment through natural selection. When one talks about the origin of life, one therefore must think about how organized systems of **organic** molecules could have appeared on the early Earth, and how they could take on the basic properties of the living state defined above.

## Early Proposals

Louis Pasteur was the first scientist to think about how life can begin. In 1865, Pasteur showed that bacteria do not occur spontaneously in sterile culture media, and concluded that life can only appear from preexisting microorganisms. This view was accepted by the scientific community for more than fifty years, until a young Russian scientist named Alexander Oparin realized that preexisting organisms could not have been present on the early earth, which must have been sterilized by the heat of its formation. And yet, somehow life began. Oparin suggested that organic molecules could spontaneously **aggregate** into larger structures he called coacervates, one of which could have happened to have the basic properties of life. In general, Oparin's proposal about aggregation remains a viable hypothesis for the origin of life, but his coacervates are no longer considered to be plausible models of the first forms of life.

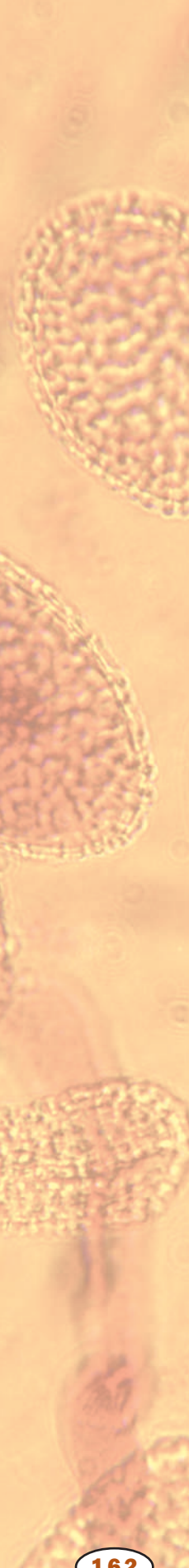

**ribosome** protein-RNA complex in cells that synthesizes protein

**transcribe** creation of an RNA copy of a DNA gene

**metabolism** chemical reactions within a cell

**organic** composed of carbon, or derived from living organisms

**aggregate** clump together



The next advance came with a better understanding of chemistry and biochemistry. Life as it is known in the twenty-first century requires organic compounds containing carbon, hydrogen, oxygen, nitrogen, phosphorus, and sulfur, and these are present in four kinds of biochemical compounds and their polymers: **amino acids** and proteins, **nucleotides** and nucleic acids, simple sugars and **polysaccharides** like starch and **cellulose**, and **lipids**, which self-assemble into cell membranes. Were such compounds available for the origin of life? The answer seems to be yes. Even today, certain meteorites fall to Earth that contain thousands of different organic compounds, including amino acids, synthesized by nonbiological processes. Scientists also know from the early experiments of Stanley Miller and Harold Urey that organic compounds can be synthesized under simulated **prebiotic** conditions, so it seems reasonable to assume that simple organic compounds were present on the early Earth.

### Self-Assembly

Now one can think about the actual process by which a living organism could appear on the early Earth. An important point to understand is that some organic molecules have properties that allow them to spontaneously organize into larger structures. A common example is the self-assembly of soap molecules into soap bubbles. A living cell resembles a microscopic bubble, and the same forces that produce a soap bubble also stabilize the membrane that surrounds all living cells like a skin and separates the **cytoplasm** from the outside world. It is easy to imagine that such microscopic bubbles were present on the early Earth, and it has been shown that some of the organic compounds in meteorites can in fact produce bubblelike structures.

Although the assembly of microscopic membranes from soaplike molecules is interesting, two other self-assembly processes are equally important. The first is that the long strings of polymerized amino acids called proteins can fold up into tightly packed balls that represent the functional proteins, such as **enzymes**. This folding process occurs in all cells as proteins are synthesized from amino acids on ribosomes. If proteinlike molecules were somehow produced on the early Earth, they would also have the capacity to fold into a variety of structures, some of which might act as catalysts.

The second self-assembly process is that long strings of polymerized nucleotides called nucleic acids can wind together into double stranded structures. The famous DNA double helix is an example, and this is the only way that scientists know that a molecule can reproduce itself. That is, one strand of DNA acts as a **template**, and a second strand is produced on the template when nucleotides bind to it and are then linked together. All life today depends on this process, which is called replication, and the earliest forms of life must have had a primitive version incorporated into their system of molecules.

### Defining How Life Began

Given all this, scientists can hypothesize how life began on Earth. There is little doubt that mixtures of organic compounds became organized into complex systems by self-assembly processes, because the same thing happens in the organic compounds of meteorites, which are as old as the

**amino acid** a building block of protein

**nucleotide** the building block of RNA or DNA

**polysaccharide** carbohydrate composed of many individual units of sugar

**cellulose** carbohydrate made by plants and some other organisms; part of the cell wall

**lipid** fat or waxlike molecule, insoluble in water

**prebiotic** before the origin of life

**cytoplasm** material in a cell, excluding the nucleus

**enzyme** protein that controls a reaction in a cell

**template** master copy

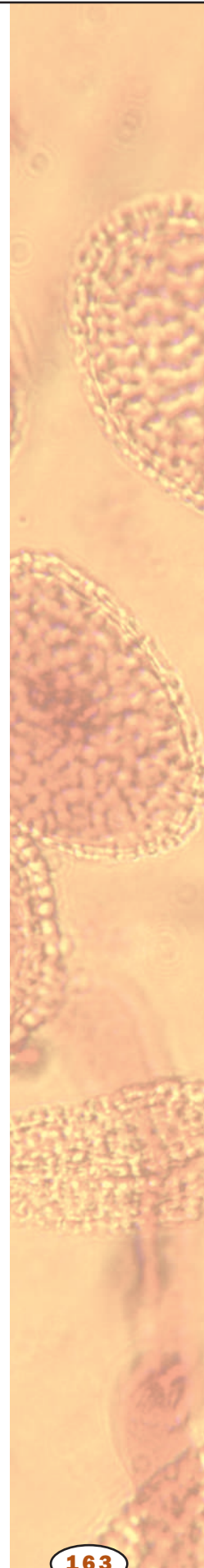

A meteorite from Mars, thought to be about 4.5 billion years old. There is a possibility that life similar to bacteria, the simplest form on Earth today, could be present on Mars.



solar system. These self-assembled systems can be thought of as countless natural experiments that occurred all over Earth for hundreds of millions of years.

The next step occurred when a few of the microscopic systems had the particular set of molecules and properties that allowed them to capture energy and nutrients from the environment, and use them to produce larger polymeric molecules. In the next step toward life, one of the growing systems contained molecules that could be used as templates to direct further growth, so that a second polymeric molecule was in a sense a replica of the first molecule. DNA synthesis in cells is a primary example of molecular growth by polymerization, and also demonstrates how the information in one molecule can be reproduced in a second molecule. Because these processes can be reproduced under laboratory conditions, one can be reasonably certain that they are plausible reactions on the early Earth, even though scientists don't know yet how the first long polymers were produced.

The last step in the origin of life is that one or more of the growing, replicating systems happened to find a way to use the sequence of **monomers** in one molecule, such as a nucleic acid, to direct the sequence of monomers in another kind of molecule such as a protein. This was the origin of the **genetic code** and the beginning of life. It also marked the beginning of evolution, because molecular systems composed of two different interacting molecules like nucleic acids and proteins have the potential to undergo mutational change followed by selection.

It is amazing to think that this complex set of events occurred spontaneously on the early Earth, and that life was up and running only a few hundred million years after Earth had cooled sufficiently for liquid water to exist. And yet, this seems to be what happened, and if it happened on Earth it could also happen elsewhere, since the laws of chemistry and physics are believed to be universal. This larger understanding of life has led to a new scientific discipline called astrobiology, which is defined as the study of life in the universe.

**monomer** "single part"; monomers are joined to form a polymer

**genetic code** relationship between triples of RNA nucleotides and the amino acids they code for during protein synthesis

## Could Life Have Begun Elsewhere?

Could life have begun elsewhere? The simplest place to look is in the solar system and compare other planets with Earth. Scientists now have a better understanding of where life exists on Earth, and it is much more widely distributed than we might have guessed. Bacterial life exists over a remarkable temperature range, from near 0°C (32°F) on melting snow to over 115°C (239°F) in submarine hydrothermal vents. It exists in **acidic** environments as strong as battery acid or as **alkaline** as household ammonia. Bacterial life exists in the dark, in the absence of oxygen, and has even been found growing in the radioactive water of nuclear reactors. In fact, the only constant is that microbial life requires liquid water, and if liquid water exists elsewhere we might expect that life could have started as it did on Earth, and may even still be flourishing.

Where in the solar system might one find liquid water? There are only two places that scientists know of: Mars and Europa. Mars certainly has water, but in the form of ice. Liquid water cannot exist for long on the surface of Mars, due to the cold temperature and low atmospheric pressure, but it could be locked up in ice beneath the surface, just as water is present in the permafrost of Arctic tundras. Recent images from the Mars Global Surveyor clearly show that liquid water occasionally breaks through the ice and pours down steep slopes on the edges of craters. Europa, a moon of Jupiter about the size of Earth's moon, also has water in the form of a thick sheet of ice, and beneath the ice is a global ocean of liquid water. On both Mars and Europa there is a distinct possibility that life similar to bacteria could be present, and future space missions may finally answer the age-old question: Does life exist elsewhere? SEE ALSO CELL EVOLUTION; EVOLUTION; EVOLUTION, EVIDENCE FOR; LIFE, WHAT IS

*David W. Deamer*

### Bibliography

Malin, M. C., and K. S. Edgett. "Evidence for Recent Groundwater Seepage and Surface Runoff on Mars." *Science* 288 (2000): 2330–2335.

Miller, S. L. "Production of Amino Acids Under Possible Primitive Earth Conditions." *Science* 117 (1953): 528–529.

Miller, S. L., and Urey, H. C. "Organic Compound Synthesis on the Primitive Earth." *Science* 130 (1959): 245–251.

## Osmoregulation

Osmoregulation means the physiological processes that an organism uses to maintain water balance; that is, to compensate for water loss, avoid excess water gain, and maintain the proper osmotic concentration (osmolarity) of the body fluids. Most humans are about 55 to 60 percent water by weight (45 percent in elderly and obese people and up to 75 percent in newborn infants). Many jellyfish are 95 percent or more water.

### Osmoconformers and Osmoregulators

Not all organisms osmoregulate. Some marine animals such as the sea stars are osmoconformers; their body fluids are similar to seawater in osmolarity, so they gain and lose water at equal rates and have no need to expend

**acidic** having an excess of H<sup>+</sup> ions, and a low pH

**alkaline** chemically basic, with an excess of OH<sup>-</sup> ions

Europa was discovered by Galileo Galilei in 1610. This moon of Jupiter is the sixth largest moon in our solar system.

**organelle** membrane-bound cell compartment

**protein** complex molecule made from amino acids; used in cells for structure, signaling, and controlling reactions

**ion** an electrically charged particle

**gradient** difference in concentration between two places

**osmosis** passage of water through a membrane in response to concentration differences

**excrete** deposit outside of

**hormone** molecule released by one cell to influence another

**cytoplasm** material in a cell, excluding the nucleus

**superficial** on the surface; not deep

**cilia** short, hairlike cell extensions of the cell membrane formed by the cytoskeleton

**glucose** simple sugar that provides energy to animal cells and is the building block of cellulose in plants

**amino acid** a building block of protein

energy expelling water or salt from the body. However, if they are placed in water more or less concentrated than seawater, their tissues shrink or swell, their **organelles** and cell membranes are damaged, and they die. This is why echinoderms are not found in estuaries, or river mouths where fresh and salt water meet and the salinity fluctuates greatly. Osmoconformers are stenohaline (*steno* means “narrow range,” and *hal* means “salt”), unable to tolerate much variation in environmental salinity.

Osmoregulators, on the other hand, maintain a more or less stable internal osmolarity by physiological means. Terrestrial animals must osmoregulate because they unavoidably lose water by evaporation and excretion, and replacement water is not always immediately available. Marine osmoregulators maintain an internal salinity lower than that of seawater, and freshwater osmoregulators maintain an internal salinity higher than that of fresh water. Euryhaline (*eury* means “broad”) animals, those able to tolerate a broad range of environmental salinity, must be good osmoregulators. The blue crab, *Callinectes sapidus*, for example, thrives in estuaries and requires efficient osmoregulation to survive there.

## Osmoregulatory Mechanisms

Water cannot be actively transported across cell membranes because there are no carrier **proteins** capable of binding and transporting it. Water can, however, pass directly through membranes in response to changes in **ion** concentration. Water movement is therefore controlled indirectly, by pumping ions such as sodium and potassium across cell membranes, creating a concentration **gradient** that causes water to follow by **osmosis**. If sodium is **excreted** from the body, for example, water tends to follow it. The rate of water loss can thus be regulated by **hormones** that control the rate of sodium excretion or the water permeability of the excretory ducts.

Osmoregulation is usually achieved by excretory organs that serve also for the disposal of metabolic wastes. Thus, urination is a mechanism of both waste excretion and osmoregulation. Organelles and organs that carry out osmoregulation include contractile vacuoles, nephridia, antennal glands, and malpighian tubules of invertebrates, and salt glands and kidneys of vertebrates.

Contractile vacuoles are organelles in the cells of sponges and freshwater protozoans. In the freshwater *Amoeba proteus*, for example, the bubble-like contractile vacuole swells with excess fluid from the **cytoplasm**. Its membrane then pumps valuable ions back into the cytoplasm, leaving mainly water in the vacuole. Contractile proteins surrounding the vacuole then abruptly compress it, squirting the water out of the cell through a pore in the cell membrane. The vacuole then slowly begins to refill, repeating the process with a rhythm **superficially** resembling a heartbeat.

Nephridia are tubular structures that filter body fluids other than blood, found in flatworms, annelids, and many other invertebrates. Beating **cilia** or flagella draw fluid into the tubular system, leaving cells and proteins behind in the tissues. The tubules then reabsorb useful substances such as **glucose** and **amino acids** from the fluid and return them to the tissues, while secreting excess ions into the fluid. Finally, the excess water, ions, and meta-

bolic wastes are expelled from the body by way of nephridiopores in the body wall. Nephridia are called protonephridia if the inner end of the tubule is closed, like a porous bulb, and extracts liquid from the tissue fluid. These occur in flatworms such as planarians and tapeworms. Metanephridia have a funnellike opening at the internal end, through which they draw in fluid from the body cavity. Earthworms have metanephridia.

Antennal glands occur in crustaceans such as crayfish. They receive a blood **filtrate**, modify it by the reabsorption of some substances and **secretion** of others into the fluid, and then expel the modified fluid (urine) from a pore at the base of the antenna.

Malpighian tubules are found in spiders and insects. Numbering from two to several hundred, they are attached in clusters to the digestive tract between the midgut and hindgut and hang freely in the abdominal cavity. They absorb water and ions from the coelomic fluid and pass the fluid to the gut. The hindgut reabsorbs most of the water, leaving excess ions and metabolic wastes to be excreted with the feces, which are often dry.

Salt glands are associated with the eyes, nostrils, or tongue of marine reptiles (sea snakes, sea turtles, marine iguanas, saltwater crocodiles) and birds (gulls, albatrosses). These animals ingest excess salt with their food and water and excrete it by way of these glands.

Kidneys are vertebrate osmoregulatory organs in which blood pressure forces fluid to filter through the walls of blood capillaries into tubules that process the filtrate into urine. Each human kidney has about 1.2 million tiny balls of capillaries called glomeruli, where the blood pressure is very high. A filtrate of the blood plasma, free of cells and protein, seeps from these capillaries into a hollow ball called a glomerular (Bowman) capsule. From there, it flows into a series of tubules that remove most of the salt and water along with useful material such as glucose and vitamins, while secreting hydrogen and potassium ions, urea, and drugs (for example, penicillin and aspirin) into the tubular fluid. A final tube in the pathway, called the collecting duct, adjusts the salinity of the urine by reabsorbing variable amounts of water, before the urine leaves the kidney for storage in the urinary bladder and eventual elimination from the body.

Two hormones, aldosterone and antidiuretic hormone, regulate the amounts of salt and water reabsorbed, enabling the human kidney to adjust water loss or retention to the body's state of hydration. Human blood plasma and tissue fluid normally has an osmolarity of 300 milliosmoles per liter (mOsm/L); that is, 0.3 mole of dissolved particles per liter of solution. Human urine can be as dilute (hypoosmotic) as 50 mOsm/L when the body is voiding excess water, or as concentrated (hyperosmotic) as 1,200 mOsm/L when conserving water.

Freshwater fish, by contrast, cannot produce hyperosmotic urine, but they have no need to. Surrounded by water, they can afford to produce abundant, dilute urine to flush away their metabolic wastes. Among mammals, the ability to concentrate the urine is also little developed in aquatic forms such as beavers and muskrats. Kangaroo rats, by contrast, are desert rodents that need never drink water (they obtain it from food), and can concentrate their urine to as much as fourteen times the osmolarity of their blood plasma (compared to four times for humans). SEE ALSO ARACHNID; BLOOD; CRUS-

**filtrate** material passing through a filter

**secretion** material released from the cell

Human kidneys are about the size of a fist. They are located in the back, just below the rib cage. Every day, the kidneys filter about 200 quarts of fluid. Approximately 2 quarts leave the body in the form of urine, while the rest is retained in the body.

**glycolysis** initial stages of sugar breakdown in a cell

**Krebs cycle** central metabolic pathway in mitochondria

**ATP** adenosine triphosphate, a high-energy nucleotide used by cells to power most energy-requiring reactions

**substrate** the molecule acted on by an enzyme

**glucose** simple sugar that provides energy to animal cells and is the building block of cellulose in plants

**aerobic** with oxygen, or requiring it

**electron transport system** membrane-bound system of proteins that extracts energy from high-energy electrons, found in mitochondria and chloroplasts

**inorganic** not bonded to carbon

**chemiosmosis** use of proton gradients to make ATP

**eukaryotic cell** a cell with a nucleus

**mitochondria** subcellular organelle that creates ATP used for energy-requiring processes in a cell

**prokaryotic** without a nucleus

**ion** an electrically charged particle

**matrix** a network, usually of threadlike fibers

**gradient** difference in concentration between two places

**protein** complex molecule made from amino acids; used in cells for structure, signaling, and controlling reactions

TACEAN; ECHINODERM; ESTUARIES; EXCRETORY SYSTEMS; HOMEOSTASIS; INSECT; KIDNEY; PHYSIOLOGICAL ECOLOGY; PASTEUR, LOUIS; PROTISTA

Kenneth S. Saladin

### Bibliography

Harris, C. L. *Concepts in Zoology*, 2nd ed. New York: HarperCollins, 1996.

Willmer, P., G. Stone, and I. Johnson. *Environmental Physiology of Animals*. Oxford: Blackwell Science, 2000.

## Oxidative Phosphorylation

**Glycolysis** and the **Krebs cycle** both generate the high-energy compound adenosine triphosphate (ATP) directly, by **substrate**-level phosphorylation, but this represents only a small fraction of the energy in each **glucose** that passes through these pathways. Much more of the energy in glucose is conserved in the form of high-energy electrons carried in pairs by the electron “shuttles” NADH and FADH<sub>2</sub>, which are generated in glycolysis and the Krebs cycle. In **aerobic** cells, these high-energy electrons are used to produce more ATP by oxidative phosphorylation, a process during which the electrons are passed to molecular oxygen via an **electron transport system** (ETS), giving up their energy along the way. This energy is used to phosphorylate adenosine diphosphate (ADP) and **inorganic** phosphate to ATP in a process called **chemiosmosis**. In **eukaryotic cells**, oxidative phosphorylation takes place on the inner **mitochondrial** membrane; in **prokaryotic** cells, it is associated with the plasma membrane. The remainder of this discussion will refer only to mitochondrial oxidative phosphorylation, but the process is similar in prokaryotes.

The ETS consists of a chain of electron carriers, associated with the inner mitochondrial membrane, that bind electrons at successively lower energy levels. The energy released as the electrons are passed from carrier to carrier moves hydrogen **ions** (protons) across the membrane, from the mitochondrial **matrix** to the intermembrane space, creating a concentration **gradient** of protons. Since the protons carry a charge, an electrical potential (voltage) also develops across the membrane, so the gradient is often called an electrochemical gradient. This electrochemical gradient is a form of stored energy, some of which is used to phosphorylate ADP to ATP, a process carried out by a complex of **proteins** called ATP synthase. As protons move down their concentration gradient, from the intermembrane space back to the matrix, the energy they release is used by the ATP synthase complex to phosphorylate ADP.

The electron transport chain consists of a series of carriers, including integral membrane proteins, peripheral proteins, and smaller, nonprotein carriers. Most of these carriers are arranged into four distinct aggregations embedded in the inner mitochondrial membrane, called electron-carrier complexes I through IV. Complex I receives electrons from NADH, whereas complex II receives them from FADH<sub>2</sub>. Complexes III and IV are further down the chain, and ultimately transfer the electrons to molecular oxygen to form water. In addition to these integral complexes, two smaller carriers play critical roles. Ubiquinone, a low-molecular-weight compound within the membrane, receives electrons from complexes I and II, and transfers

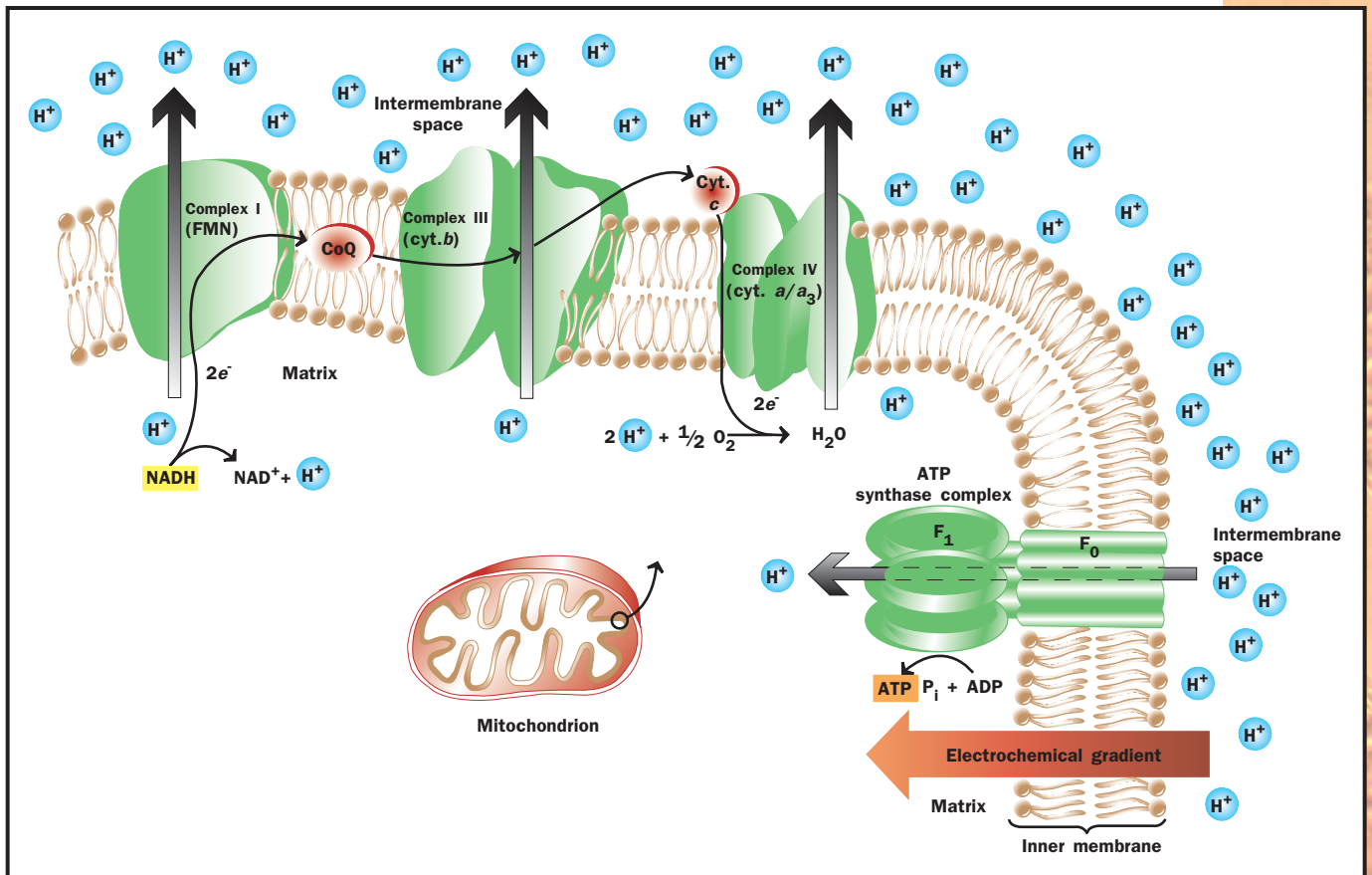

them to complex III. Cytochrome *c*, a small peripheral protein, receives electrons from complex III and transfers them to complex IV. Several other cytochromes are included as members of the four electron-carrier complexes. Cytochromes are a class of small proteins containing **heme** that are important in transferring electrons in cellular processes.

There are three sites along the ETS where protons are pumped across the membrane: complexes I, III, and IV. At each site, one proton is pumped across the membrane for each pair of electrons that passes through. Since each proton that returns through ATP synthase phosphorylates one ADP to ATP, each pair of electrons passing through the ETS can produce at most three ATP molecules. Electron shuttles such as NADH or FADH<sub>2</sub> carry pairs of electrons at specific energy levels, as do the carriers in the ETS. Electrons cannot be passed to a carrier at a higher energy level, so these shuttles pass electrons to different points in the ETS. NADH donates electrons to the highest energy carrier, complex I, whereas FADH<sub>2</sub> donates electrons to complex II, which can accept the lower-energy electrons it carries. Because one of the three sites that pump protons across the membrane, complex I, is bypassed by the electrons from FADH<sub>2</sub>, these electrons can ultimately produce only two molecules of ATP whereas those donated by NADH can produce three. This is consistent with the idea that FADH<sub>2</sub> carries electrons possessing less energy than those carried by NADH.

ATP synthase is a large complex of proteins that is imbedded in the inner mitochondrial membrane. It consists of two parts: an integral protein

Illustration of the chemiosmotic synthesis of ATP in the mitochondrion.

**heme** the deep-red iron containing, nonprotein portion of hemoglobin and myoglobin

**MITCHELL, PETER  
(1920–1992)**

English chemist who won the 1978 Nobel Prize in chemistry for discovering how the mitochondria (organelles of most eukaryotes) in cells make energy. According to Mitchell's "chemiosmotic theory," cells form the energy-rich molecule adenosine triphosphate (ATP) by means of chemical and electrical gradients.

**carbohydrates** sugars, starches, and other molecules combining carbon, hydrogen, and oxygen and serving as fuel or structural components

**amino acid** a building block of protein

**ubiquitous** found everywhere

**anaerobic** without oxygen, or not requiring oxygen



complex that serves as a channel through which the protons cross the membrane, and a peripheral complex that phosphorylates the ADP to ATP. As the protons pass through the integral complex, they cause the peripheral complex to rotate. In a manner that is not completely understood, this mechanical action provides the energy needed to phosphorylate ADP. However, it seems that the rotation of the peripheral complex is necessary. This complex is made of six subunits, arranged in three identical pairs, each of which can bind ADP or ATP. At any given time, one of the pairs will be empty, one will bind ADP and phosphate, and one will bind ATP. As the complex rotates, the site binding ADP and phosphate passes a stationary extension of the integral complex, which causes that pair of subunits to change shape. The result is that the ADP is phosphorylated to ATP. At the same time, the ATP that was bound by the other pair of subunits is released, and the empty pair of subunits picks up ADP and phosphate, rendering ATP synthase ready for the next step. Altogether, for each complete rotation of the peripheral complex, three ATPs are generated.

The pathways for oxidizing all food molecules—**carbohydrates**, fats, and **amino acids**—unite at oxidative phosphorylation. All these pathways produce NADH, which donates electrons to the ETS. The ETS and oxidative phosphorylation are thus versatile and **ubiquitous** pathways in all aerobic cells, and even in some **anaerobic** bacteria. Many such microbes use a similar mechanism to generate ATP, but in the absence of free oxygen they pass electrons to other acceptor molecules, such as sulfate or a variety of metal ions, thereby generating significant ATP in the absence of oxygen. SEE ALSO GLYCOLYSIS AND FERMENTATION; KREBS CYCLE; MEMBRANE PROTEINS; MEMBRANE TRANSPORT; METABOLISM, CELLULAR; METABOLISM, HUMAN; NUCLEOTIDES

David W. Tapley

**Bibliography**

- Hinkle, P. C., and R. E. McCarthy. "How Cells Make ATP." *Scientific American* 238 (1978): 104–123.
- Stryer, Lubert. *Biochemistry*. New York: Freeman Publishers, 1995.

**Pain**

Pain is experienced by humans and animals in response to excessive pressure, heat, or chemicals. Although humans often view pain as undesirable, pain helps protect them from injury by alerting them to its presence. The need for pain is revealed by diseases in which pain is absent or suppressed, as in leprosy. People with such disorders, unaware of injuries or infections, often die prematurely or require limb amputations because unfelt injuries may be neglected until they lead to massive infection and tissue death.

Although skin and other tissues contain cells that are activated by heat and pressure, pain arises from specialized cells that only respond to excessive stimuli that have the potential to cause damage. Light pressure or warming has no effect on these cells. Once activated, these cells transmit pain signals to the spinal cord and brain where pain sensations occur.

Unlike other senses such as sight, pain is highly variable. For example, pain sensitivity decreases in animals pursued or caught by predators, in



women giving birth, and in patients taking pain-killing drugs like morphine. Although the ability of morphine to decrease pain sensation has been known for thousands of years, it was not until the 1970s that specific receptors were found in the brain that mediate the effect of the drug. Shortly thereafter, it was discovered that the human body manufactures its own morphinelike chemicals, known as endorphins, that provide the body with its own built-in pain-regulatory system. This internal pain-suppression system is activated during stress such as fleeing lions or delivering babies.

Injury to skin or nerves can also cause a long-lasting increase in pain sensitivity, known as hyperalgesia, that can persist for days or even years. Sunburn is a common example; the skin burn causes normally nonpainful touch to become painful for days. Changes in both the skin and the **central nervous system** appear responsible for hyperalgesia. In the skin, chemicals released by inflammation, the process that also causes redness and swelling, sensitize the pain nerve endings to touch. In the central nervous system, **neural** circuits are permanently altered in much the same way that memories are stored.

Pain arises not only from skin and muscle, but also from internal organs such as the heart and kidney. Interestingly, pain from internal organs is often not perceived as arising from the internal organ, but instead from nearby areas of skin or muscle. This is known as referred pain. For example, heart attacks commonly produce pain perceived to arise from the left shoulder and not the heart.

Neurological injury following trauma or caused by diseases such as diabetes sometimes leads to severe, unrelenting pain. Following amputation, the cut nerve in the limb continues to send pain signals to the brain even though the limb has been severed. Consequently, the brain perceives the pain as arising from the amputated limb. This is known as phantom pain.

Given how commonly humans experience pain, it is not surprising that many medical treatments have been developed to suppress it. For example, aspirin blocks the inflammation in skin that leads to hyperalgesia. Acupuncture, an ancient treatment in which the skin is punctured by a pattern of fine needles, activates the internal morphine system and reduces pain in much the same way as taking morphine. **SEE ALSO** HORMONES; IMMUNE RESPONSE; NEURON; PITUITARY GLAND

Corey L. Cleland

### Bibliography

Silverthorn, Dee. *Human Physiology: An Integrated Approach*, 2nd ed. Upper Saddle River, NJ: Prentice Hall, 2001.

Wall, Patrick. *Pain: The Science of Suffering*. London: Weidenfeld & Nicolson, 1999.

Wall, Patrick, and Ronald Melzack. *Textbook of Pain*. Edinburgh: Churchill Livingstone, 2000.

## Paleontology

Paleontology is a broad field of study that focuses on the history of life on Earth. Fossils, which are the material remains (bones, teeth, shells) or traces (physical or chemical) of ancient organisms, are what paleontologists study.

**central nervous system**  
brain and spinal cord

**neural** related to nerve cells or the nervous system

### CUVIER, BARON GEORGES (1769–1832)

A gifted French paleontologist and anatomist who, in 1812, proposed the theory of “catastrophism” to explain the appearance and disappearance of dinosaurs and other species in the layers of the fossil record. Cuvier said that Noah’s flood was just one of dozens of catastrophes in Earth’s history, each one succeeded by a new Judeo-Christian creation.



Peter Larson, president of the Black Hills Institute of Geological Research, studies the skeleton of a *Tyrannosaurus rex*.

**isotopes** forms of an atom that differ by the number of neutrons in the nucleus

**prokaryote** single-celled organism without a nucleus

**eukaryote** a cell with a nucleus

Fossils of single-celled organisms are known from rocks approximately 3.5 billion years old, and chemical traces of life (carbon **isotopes** of presumed biological origin) may extend even further back in time. It is an undeniable fact that the fossil record is an incomplete archive of the history of life, and this is especially true for organisms with poor preservation potential, such as soft-bodied worms and jellyfish. However, the quality of the fossil record is surprisingly good for those animals with durable skeletons, such as brachiopods, trilobites, mollusks, and vertebrates.

Many subfields fall under the broad heading of paleontology. The majority of modern paleontologists focus their efforts on describing fossils and deciphering evolutionary history, or phylogeny. These “paleobiologists” tend to specialize on particular groups of fossil organisms, such as single-celled **prokaryotes** or **eukaryotes**, plants, invertebrates, or vertebrates. Through their efforts scientists gain a deeper understanding of life’s evolution and diversification through time. Scientists also gain a better appreciation of the evolutionary process, because the fossil record provides the long-term record of evolution in action. Indeed, proposed modes of evolu-

tionary change, such as **phyletic gradualism** and **punctuated equilibrium**, are based on patterns derived directly from the fossil record.

Another active branch of paleontological research is paleoecology, which is the study of the relationships and interactions between fossil organisms and their paleoenvironments. Paleontologists engaged in paleoecological research might focus their efforts on a single **taxon**. For example, a paleontologist may choose to study the predatory activities of a particular fossil snail by tracking distinctive traces of its predation (borings) in associated fossil bivalve shells. Another paleontologist may examine the fossilized leaves and woody tissues of ancient trees in order to identify diagnostic traces of a fossil insect that made its living within the tissues of the extinct plant. Still another may study the contents of fossilized feces (called coprolites) in order to decipher the dietary preferences and digestive capabilities of an extinct species of dinosaur. On a larger scale, paleontologists may choose to track ecological changes in entire communities through time. A prime example of this type of paleoecological research would be the analysis of ancient plant communities in response to long-term climate change.

Yet another contemporary field within the realm of paleontological research is taphonomy, which is the study of how **organic** remains are incorporated into the rock record. Taphonomic analyses focus on the post-mortem history of biological remains, such as decay, disarticulation (separation of body parts), transport (perhaps out of life habitat), and burial. Taphonomic studies can reveal important trends and biases in the fossil record, which must be recognized in order to produce accurate paleoecological and evolutionary reconstructions. At the most basic level, taphonomy points out that the scarcity of soft-bodied creatures in the fossil record is not due to scarcity of the original organisms, but to the poor preservation of soft body parts.

Finally, many paleontologists today are engaged in research directly related to the phenomenon of mass extinction, which unfortunately is also a contemporary environmental issue. By tracking the record of extinction through time, paleontologists can provide unique insights into the potential agents that cause the decimation of entire **ecosystems** on a global scale, such as extraterrestrial impacts. They can also gain an appreciation for the timing and nature of **biotic** recovery after major extinction events. SEE ALSO CAMBRIAN EXPLOSION; EVOLUTION, EVIDENCE FOR; EXTINCTION; HISTORY OF EVOLUTIONARY THOUGHT; MOLLUSK

*Raymond R. Rogers*

### Bibliography

Briggs, D. E. G., and P. R. Crowther, eds. *Paleobiology: A Synthesis*. Oxford, England: Blackwell Scientific Publications, 1990.

## Pancreas

The pancreas is a soft oblong organ located in the upper central region of the abdominal cavity, just behind the lower surface of the stomach. It has three portions: an expanded medial portion called the head, a central portion called the body, and a tapering **lateral** portion called the tail. The head is partially encircled by the C-shaped duodenum, the first portion of

**phyletic gradualism** the belief that evolutionary change is slow and steady

**punctuated equilibrium** pattern of evolution in which long periods of relatively little change are punctuated by rapid change

**taxon** a level of classification, such as kingdom or phylum

**organic** composed of carbon, or derived from living organisms

**ecosystem** an ecological community and its environment

**biotic** living

### ANNING, MARY (1799–1847)

English paleontologist who supported her family by finding and selling fossils. For example, she dug up the first complete skeletons of swimming dinosaurs, the ichthyosaur and plesiosaur. Although a woman of low birth, Anning was recognized as the most knowledgeable paleontologist in Great Britain in the early nineteenth century. In her old age, the British Association for the Advancement of Science helped support her.

**lateral** side-to-side

**exocrine gland** gland that secretes substances to an external or internal surface rather than into the bloodstream

**endocrine** related to the system of hormones and glands that regulate body function

**electrolytes** ions in body fluids

**enzyme** protein that controls a reaction in a cell

**protein** complex molecule made from amino acids; used in cells for structure, signaling, and controlling reactions

**lipid** fat or waxlike molecule, insoluble in water

**pH** measure of acidity or alkalinity; numbers below 7 are acid, above are basic

**hormone** molecule released by one cell to influence another

**glucose** simple sugar that provides energy to animal cells and is the building block of cellulose in plants

**metabolism** chemical reactions within a cell

**hyposecretion** lack of secretion

**arthropods** organisms with jointed appendages and exoskeletons, including insects, spiders, and crustaceans

the small intestine. The pancreas is both an **exocrine gland** and an **endocrine gland**.

The exocrine portion of the pancreas consists of acinar cells (which account for about 99 percent of all secretory cells in the pancreas) that are organized into numerous small clusters called acini. The acinar cells secrete a clear fluid called pancreatic juice, which plays a critically important role in the digestion of food within the small intestine. The pancreatic juice is usually delivered to the duodenum by way of two ducts, the main pancreatic duct and the accessory pancreatic duct. (In some people, the accessory duct disappears during development.) Pancreatic juice consists of water, **electrolytes**, sodium bicarbonate, and several digestive **enzymes** capable of digesting virtually all the nutrient molecules in food.

Among these enzymes are several **protein**-digesting enzymes (trypsin, chymotrypsin, carboxypeptidase, and elastase), a carbohydrate-digesting enzyme (pancreatic amylase), and a **lipid**-digesting enzyme (pancreatic lipase). These enzymes do not digest the pancreas itself because they are not activated or provided with optimal ionic conditions until pancreatic juice enters the duodenum. The sodium bicarbonate establishes the optimal **pH** for the actions of pancreatic and intestinal enzymes within the small intestine.

The remaining 1 percent of the secretory cells form the endocrine portion of the pancreas. These cells are organized into clusters called pancreatic islets (islets of Langerhans) that are scattered among the acini. These cells secrete several **hormones**, including glucagon (secreted by alpha cells) and insulin (secreted by beta cells), which play important roles in blood **glucose** regulation and carbohydrate **metabolism**. Diabetes mellitus is an endocrine disorder that arises from **hyposecretion** of insulin or a decreased sensitivity of body cells to insulin. SEE ALSO BLOOD SUGAR REGULATION; DIGESTIVE SYSTEM; ENDOCRINE SYSTEM; ENZYMES; HORMONES

Izak Paul

### Bibliography

Saladin, Kenneth S. *Anatomy & Physiology: The Unity of Form and Function*, 2nd ed. New York: McGraw-Hill, 2001.

## Parasitic Diseases

A parasite is typically an organism that lives in or on the body of another living organism, the host, and harms it by feeding on its tissues or stealing nutrients. In the broad sense, parasites include certain bacteria, fungi, protozoans, worms, **arthropods**, and a few vertebrates. Bacterial, fungal, and protozoan diseases are discussed elsewhere in this encyclopedia. This article focuses on a few human diseases caused by parasitic worms and arthropods.

The worms that infect humans include trematodes (flukes), cestodes (tapeworms), and nematodes (roundworms). One of the most serious trematode diseases is schistosomiasis, caused by three species in the genus *Schistosoma*. Schistosomes, or blood flukes, live in blood vessels of the urinary bladder and intestines. They lay eggs that digest their way through the blood

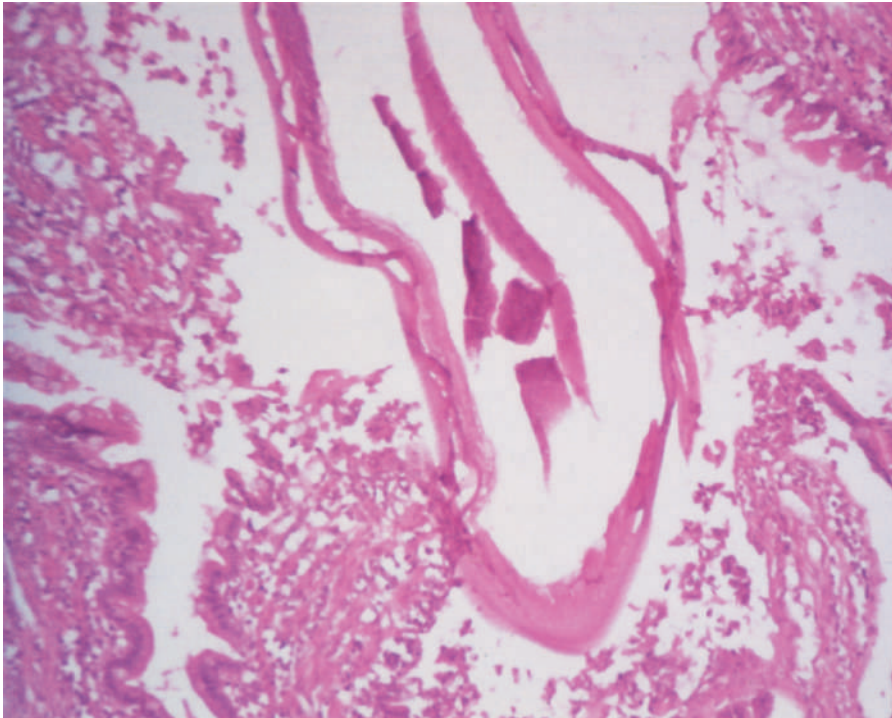

Hookworms (fuschia stain) in a dog's small intestine. Thousands of hookworms may attach to the wall of the small intestine, sucking so much blood that they make the victim severely anemic.

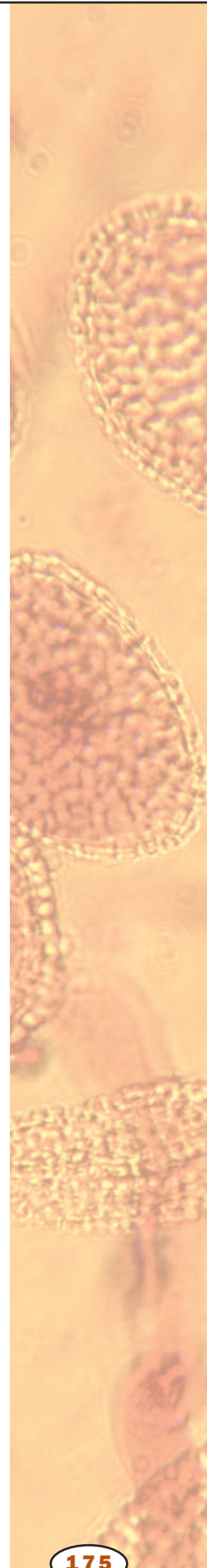

vessel and the bladder or intestinal wall, and thus find their way into the urine or feces.

When discharged into fresh water, they hatch and produce a swimming larva, the miracidium, which infects a snail. Later, another larva called the cercaria emerges from the snail and penetrates the skin of people who come in contact with the water. Eggs lodged in the human intestine or bladder, or washed by the bloodstream into the liver, cause an intense allergic reaction that leads to degeneration of these organs and often death of the victim.

Cestodes in general are less **pathogenic** (disease-producing) than trematodes. However, the fish tapeworm, *Diphyllobothrium latum*, can cause severe **anemia** by robbing the human host of vitamin B<sub>12</sub>. The pork tapeworm, *Taenia solium*, can cause intestinal obstruction and produces eggs that sometimes hatch in the human body, leading to larval invasion of the muscles, brain, lungs, heart, and other organs. *Echinococcus granulosus*, a tapeworm of dogs and wolves, sometimes infects humans when a dog licks a person in the face. It does not mature in humans, but its larvae can produce hydatid cysts, ranging from grape-sized to grapefruit-sized, in the liver, brain, and lungs, with fatal results.

Among the most widespread nematode infections of humans is hookworm disease, caused by *Necator americanus* and *Ancylostoma duodenale*. Hookworms are only 1 centimeter (0.4 inch) long, but thousands of them may attach to the wall of the small intestine, collectively sucking so much blood that they make a person severely anemic and stunt the victim's growth and mental development.

*Onchocerca volvulus*, a nematode transmitted by the bites of blackflies, produces larvae that migrate through the cornea of the human eye. In parts

**pathogen** disease-causing organism

**anemia** lack of oxygen-carrying capacity in the blood

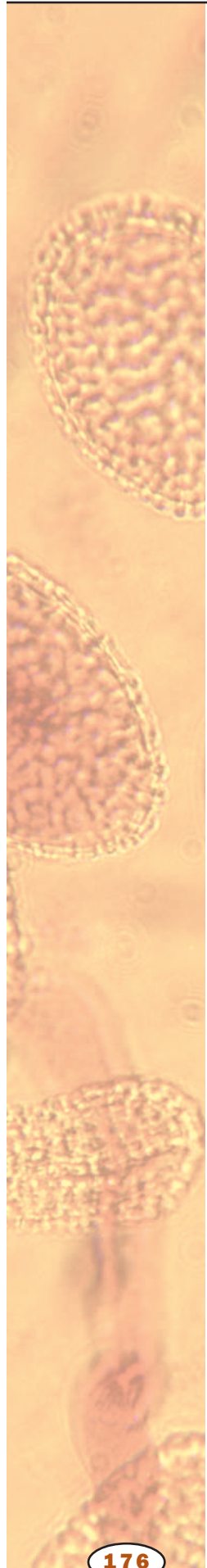

**vector** carrier

**epidemic** rapid spread of disease through a population, or a disease that spreads in this manner

**parasitology** study of parasites

**amino acid** a building block of protein

**protein** complex molecule made from amino acids; used in cells for structure, signaling, and controlling reactions

of Latin America and Africa, it blinds many people before middle age. Blackflies breed in flowing waters, and this disease is therefore called river blindness.

The major parasitic arthropods of humans are mites, ticks, fleas, lice, mosquitoes, and blood-sucking flies. In themselves, these parasites usually cause little more than irritation, although it can be intense. More seriously, however, they act as **vectors**—agents that transmit pathogenic viruses, bacteria, and protozoans. Millions of people have died in great **epidemics** of plague, transmitted by fleas, and typhus, transmitted by body lice. Malaria, transmitted by mosquitoes, remains one of the world’s greatest killers and most stubborn public health problems today.

Any **parasitology** textbook can provide further details on these and related parasites, how they infect humans, mechanisms of disease, and how to control or avoid them. Parasitic arthropods are also covered by books on medical entomology. **SEE ALSO** ARTHROPOD; NEMATODE; PROTOZOAN DISEASES; SYMBIOSIS

*Kenneth S. Saladin*

**Bibliography**

Cheng, Thomas C. *General Parasitology*, 2nd ed. Orlando, FL: Academic Press, 1986.  
 Harwood, Robert F., and Maurice T. James. *Entomology in Human and Animal Health*, 7th ed. New York: Macmillan, 1979.  
 Schmidt, Gerald D., and Larry S. Roberts. *Foundations of Parasitology*, 6th ed. Dubuque, IA: McGraw-Hill Higher Education, 2000.  
 Zinsser, Hans. *Rats, Lice, and History*. Boston: Little, Brown, 1963.

**Pasteur, Louis**

**French microbiologist  
1822–1895**

Louis Pasteur was a French microbiologist who made major discoveries about the biology of bacteria; invented techniques to prevent the spoilage of milk, wine, and beer by microorganisms; and pioneered the prevention of infectious disease through vaccination.

Pasteur was born in 1822 in Dôle, France. He studied physical sciences at a prominent teachers’ college in Paris and, at the age of twenty-six, presented his first significant research results to the Paris Academy of Sciences. Pasteur had discovered that a certain chemical could form two different crystals, whose shapes were mirror images of each other. Pasteur proposed, correctly, that this difference reflected a molecular difference, and that the two forms of the molecule had the same relationship as the left and right hands, being similar in form but opposite in orientation of parts. Pasteur showed that many molecules display this property, and that often only one form can be used by living organisms for food. This mirror-image property (called chirality) was later shown to be possessed by virtually every molecule of biological importance, including the **amino acids** that make up **proteins**.

In 1854, Pasteur was appointed dean of the Science Faculty at the University of Lille, where he offered evening classes to local workmen and introduced his day students to the foreign world of the industrial factories of

Lille, demonstrating to both groups the connection between scholarship and industry he believed would profit them both. Pasteur became deeply involved in the study of fermentation, the process by which grape juice becomes wine, grain mash becomes beer, and milk sours. Back in Paris several years later, Pasteur showed that microorganisms (yeasts and bacteria) were responsible for the fermentation process, and that fermentation could be accelerated or retarded by changing the conditions of the liquid in which it occurred. He invented the process of preserving milk and other drinks by heating, which killed the microorganisms within, a process called pasteurization in his honor. In the following years, he discovered a bacterium threatening the French silk industry and devised procedures to identify and destroy infected silkworms.

Pasteur also played a critical role in a theoretical debate of the time, that of spontaneous generation. Proponents argued that the rank growth produced in standing water was due to creation of new organisms from inanimate matter. By first boiling the water and then excluding any airborne sources of contamination, Pasteur showed the water remained clear. Thus the most likely source of growth was preexisting microorganisms, not the spontaneous generations of new ones.

At age fifty-two, Pasteur was given financial security by the French parliament, allowing him to continue his researches without worry about income. At age fifty-nine, he devoted himself to vaccination, the process of disease prevention invented by Englishman Edward Jenner in 1796. Jenner had prevented smallpox infection by inoculation with cowpox, a related but less harmful organism. Not all virulent organisms have such relatives, though, and so the problem faced by Pasteur was how to weaken the infectious organism so it could be used as the vaccine. Pasteur discovered that storing cultures under various conditions for weeks to months accomplished this, and he used this technique to develop vaccines for anthrax in sheep and rabies in humans. He first used the rabies vaccine on July 6, 1885, to cure a young boy bitten by a rabid dog. Pasteur saved the boy's life, and earned international fame in the process. Pasteur became the head of the Pasteur Institute in 1888, where he remained until his death in 1895. SEE ALSO GLYCOLYSIS AND FERMENTATION; HISTORY OF BIOLOGY: BIOCHEMISTRY; MICROBIOLOGIST; VACCINES

*Richard Robinson*

### **Bibliography**

Magner, L. N. *History of the Life Sciences*. New York: Marcel Dekker, 1994.

The Pasteur Institute has led the fight against infectious diseases for more than a century. The worldwide biomedical research organization was the first to isolate the AIDS virus in 1983.

## **Patterns of Inheritance**

Whether an organism is a worm or a human, virtually all its characteristics are influenced by its genetic makeup. Since Gregor Mendel's pioneering studies of inheritance in the mid-nineteenth century, enormous strides have been made in understanding the molecular basis of inheritance. With the blossoming of the biotechnology industry in the 1980s and the birth of the field of genomics in the 1990s, which seeks to sequence and study the entire genetic content of organisms, countless genes have been identified and their contributions to specific characteristics elucidated. Such understand-



A young native of the Solomon Islands. A slight variation in the activity of an enzyme for pigment synthesis may result in phenotypic variation.

**phenotype** observable characteristics of an organism

**protein** complex molecule made from amino acids; used in cells for structure, signaling, and controlling reactions

**enzyme** protein that controls a reaction in a cell

**genome** total genetic material in a cell or organism

**amino acid** a building block of protein

ing will amplify in the decades to come, undoubtedly leading to advances in many fields, but particularly in agriculture and medicine. With the draft of the human genome DNA sequence completed in 2001, scientists can anticipate a vast increase in their understanding of the molecular genetics of human disease.

### Phenotype and Genotype

The **phenotype** includes all observable characteristics of an individual. Although Mendel's studies were restricted to the outward traits of pea plants, such as flower color and plant height, phenotype can include characteristics observable only under certain circumstances or with specialized tools and technology. For example, a human phenotype certainly includes eye and skin color, but it also includes characteristics such as blood type and bone density.

A genotype is the complete genetic makeup of an individual. Nonetheless, as it has been impractical to consider the entire genetic makeup of an individual, the reference to genotype is usually restricted to those genes influencing the aspect of phenotype being studied at the time. In other words, if scientists are interested in studying the coat color trait in Labrador retrievers, they focus their attention on the gene(s) identified with influencing coat color.

### Proteins Dictate Phenotype

Genotype controls phenotype because genes direct the production of **proteins**. Proteins, in turn, dictate virtually every reaction in the cell and thus are directly responsible for observable characteristics.

How do the proteins work to direct phenotype? Some proteins serve structural functions (for example, in the maintenance of cell and/or tissue shape and rigidity) while others are involved in the transport of molecules and communication between cells. A substantial proportion of proteins are **enzymes**, catalyzing chemical reactions for the synthesis and transformation of virtually all biological molecules. The varying types and quantities of all biological molecules in the cells and tissues of an individual is what ultimately leads to phenotypic variation. For example, slight variation in the activity of an enzyme for pigment synthesis in a plant may result in white flowers rather than red. Likewise, a slight difference in a protein responsible for cell communication during the development of leaf tissue might result in variation of leaf shape. Understanding the path from genotype to phenotype is a major concern of modern molecular biology and one of the ultimate goals of the human **genome** project.

### Mutation and Genetic Variation

If a particular gene is mutated (the deoxyribonucleic acid [DNA] sequence is somehow altered), the result can be a change in the **amino acid** sequence of a protein or the quantity of a protein produced. Such a change may affect phenotype for the organism in a detrimental manner (for example, a mutation that causes muscle deterioration in humans), a seemingly neutral manner (a change from purple to green stems in cultivated tomato plants), or sometimes even a beneficial manner (a mutation that allows a soil bacterium to survive freezing).



Mutation is an essential and ongoing component of evolution. All living organisms are “mutants” in some sense, having arisen by virtue of genetic change from an ancestor. Within a population, there may be many versions of a given gene, called **alleles**. The term “mutant” allele is used somewhat arbitrarily to describe a version of a gene that is found very rarely in the population, whereas any version of a gene is considered “wild-type” or “normal” if it is relatively common. Each human being contains a handful of mutated alleles because of errors in replication early in development, as well as a number of rare, harmful alleles each has inherited from his or her parents.

### Mutation Affects Protein Function

In order to understand how mutations cause changes in phenotype, it is essential to study how mutations affect protein function. If one amino acid in the protein sequence is changed to another with very similar properties, the **conformation** of the folded protein may not be functionally altered. However, if the amino acid change is substantial (for instance, from small to large or from nonpolar to **polar**), the protein architecture may be altered in such a way as to cause a decline or abolition of function. It is likely that such a loss of function will ensue from mutation, since protein function has been fine-tuned during evolution and depends on the precise architecture of the protein. (If a person whacks a computer with a sledgehammer, it is unlikely that the computer’s performance will actually increase.) In some rare situations, however, instead of causing an ineffective protein, a mutation may result in a hyperactive protein. An enzyme may work at its job overtime, for example, by synthesizing excessive quantities of a product. Although a hard-working protein may sound like a benefit to the organism, this is rarely the case. Such gain-of-function mutations are usually toxic, disrupting the delicate balance of biomolecules needed for life.

### Dominance Between Alleles

The path from allele to phenotype is complex in most organisms, since more than one allele of a given gene is usually present. In **diploid** organisms such as humans, an individual carries two alleles of each gene. If the individual carries two identical alleles (a homozygote), then the phenotype necessarily will reflect the only version present. However, if an individual carries two different alleles (a heterozygote), each encoding a slightly different characteristic, what will the phenotype show? For example, if a diploid plant carries one allele encoding red flowers and one allele encoding white flowers, will the flowers be red or white? The answer depends on the molecular behavior of the encoded proteins.

Imagine that the red flower allele encodes a functional enzyme essential for the synthesis of the chemical compound leading to red pigmentation. If the white flower allele is a loss-of-function mutation, the enzyme encoded by this allele will not be functional and consequently will not contribute toward the synthesis of red pigment; the absence of red pigment leads to white flowers. In the heterozygote, however, enough functional enzyme may be produced by one allele to result in pigmented flowers.

In this case, geneticists would describe the red allele as dominant and the white allele as recessive. If the allele encoding red flowers is dominant,

**allele** a particular form of a gene

**conformation** three-dimensional shape

**polar** partially charged, and usually soluble in water

**diploid** having pairs of chromosomes in the nucleus

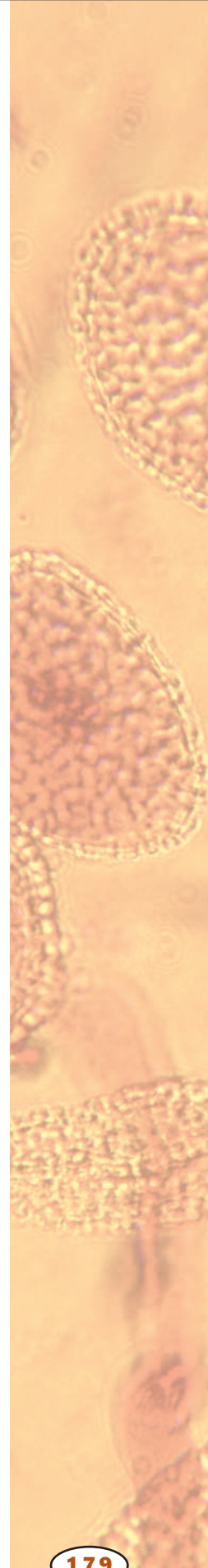

then this allele will phenotypically mask expression of the recessive allele (in this case encoding white flowers), resulting in the expression of red flowers. Thus, in order for a recessive allele to be expressed in the phenotype, only the recessive alleles can be present.

### Alternatives to Dominance

Two dissimilar alleles in a pair need not have a completely dominant/recessive relationship. In fact, it is often the case that neither allele is fully dominant, causing the heterozygote to appear different from either homozygote. In one type of allelic relationship, termed incomplete or partial dominance, the heterozygote produces a phenotype that is intermediate between both homozygotes. Snapdragons provide a good example of partial dominance. In this organism, the two homozygotes produce either red or white flowers, but the heterozygote produces pink flowers. In this case, the single functional allele in the heterozygote does not produce enough enzyme to synthesize large quantities of red pigment; the result is just enough pigment to make the flowers appear pink.

In another type of allelic relationship, termed codominance, the heterozygote produces a phenotype that incorporates both phenotypes of the homozygotes. A codominant relationship between alleles is often more apparent at the cellular or molecular level. A good example of codominance is seen in human blood type. People who are **homozygous** for the A blood type allele produce an enzyme that adds a particular type of sugar onto the exterior of red blood cells, thereby producing the “A **antigen**.” Similarly, homozygotes for the B blood type allele produce a different type of sugar on red blood cells, leading to the presence of “B antigen.” Heterozygotes with one A and one B allele produce enzymes that deposit both different types of sugars, resulting in red blood cells displaying both the A and B antigens.

### When Does Mutation Affect Phenotype in Diploids?

If a mutant allele is dominant, a **heterozygous** individual will display the mutant phenotype; if the mutant allele is recessive, heterozygotes will have a normal phenotype (although they will be “carriers” of the mutant allele). What determines whether a mutant allele is recessive or dominant?

Loss-of-function mutations are usually recessive because the single functional allele can often create adequate levels of protein. Such is the case with the recessive cystic fibrosis disease in humans. Most homozygous children with this lethal disorder do not live to adulthood, although advances in treatment have prolonged life significantly. The normal allele of the cystic fibrosis gene encodes a cell membrane protein that provides an essential function of transporting chloride **ions** across the cell membrane. Mutant alleles of the gene encode a defective protein, and consequently chloride transport is blocked in people who are homozygous for the defective allele. There are many downstream consequences to this defect that ultimately lead to the cystic fibrosis disease. The most serious effects are in the lungs and the pancreas. In heterozygous carriers of mutant alleles, however, the single normal allele produces enough functional protein to transport chloride effectively and these individuals lead healthy lives.

**homozygous** containing two identical copies of a particular gene

**antigen** foreign substance that provokes an immune response

**heterozygous** characterized by possession of two different forms (alleles) of a particular gene

**ion** an electrically charged particle

The most common mechanism by which a mutant allele is dominant is through a gain-of-function mutation. In one type of gain-of-function mutation, termed hypermorphic, the protein is produced in excessive quantities or is somehow hyperactive. The presence of a single normal allele can do nothing to tone down the activity resulting from the mutant allele. This situation is observed, for example, in an extreme type of dwarfism called achondroplasia and in many human cancers. In these cases, specific molecular switch proteins are continually in the “on” mode, causing a number of processes to occur when they otherwise would not.

In a second type of gain-of-function mutation, termed neomorphic, the mutant protein takes on a new, inappropriate role. Although the normal protein may function adequately in its usual role, it cannot stop the mutant protein from wreaking havoc in the cell. Such is the case with Huntington’s disease and some other human neurodegenerative disorders in which **neurons** in the brain slowly die off. The normal function of the protein responsible for Huntington’s disease has yet to be determined, but it is known that the mutant protein forms abnormal aggregates in neurons. Whether this, or some other less visible, function is the toxic event is not yet clear.

### Living with a Single Allele

It is often the case that a loss-of-function mutation is fully recessive, allowing heterozygous human carriers of mutant alleles to lead completely healthy lives. But suppose a person has only a single allele of a gene. This is the normal situation for all human males, who carry only a single X **chromosome** along with a single Y chromosome (the sex determination chromosomes). The X is a large chromosome with many essential genes having functions outside of sex determination. Women have two X chromosomes and therefore have two alleles for all the genes that lie on the X.

Traits carried on the X or Y chromosome are known as “sex-linked traits.” Those on any of the other chromosomes are called “autosomal traits.”

While women can carry recessive alleles of X-linked genes without disease manifestation, males with a single recessive allele are forced to express it, as they lack the possibility to mask the effect with a dominant, normal allele. Affected males necessarily pass the mutant allele onto their daughters and cannot pass it onto their sons (because they give their sons a Y, not an X, chromosome).

Hemophilia is an example of a human disorder caused by a mutation of a gene on the X chromosome. Hemophilia is caused by a loss-of-function mutation in a gene encoding a blood-clotting protein. Before treatment was available, males often bled to death in childhood from a small cut.

### Many Factors Influence Phenotype

Genetic studies clearly are facilitated by phenotypes readily identified as resulting from a single gene, inherited in a simple so-called Mendelian fashion (a one gene–one phenotype relationship). It is important to keep in mind, however, that genes do not work in isolation. The expression of a single gene is dependent on many other genes in the genome (the genetic background) and many external, or environmental, factors such as nutrition, climate, or exposure to infectious agents. Although the complete DNA



**neuron** nerve cell

**chromosome** “colored body” in the cell nucleus; made of DNA and protein, and divided functionally into genes and nongene regions

Other X-linked disorders include Duchenne muscular dystrophy and some forms of color blindness.

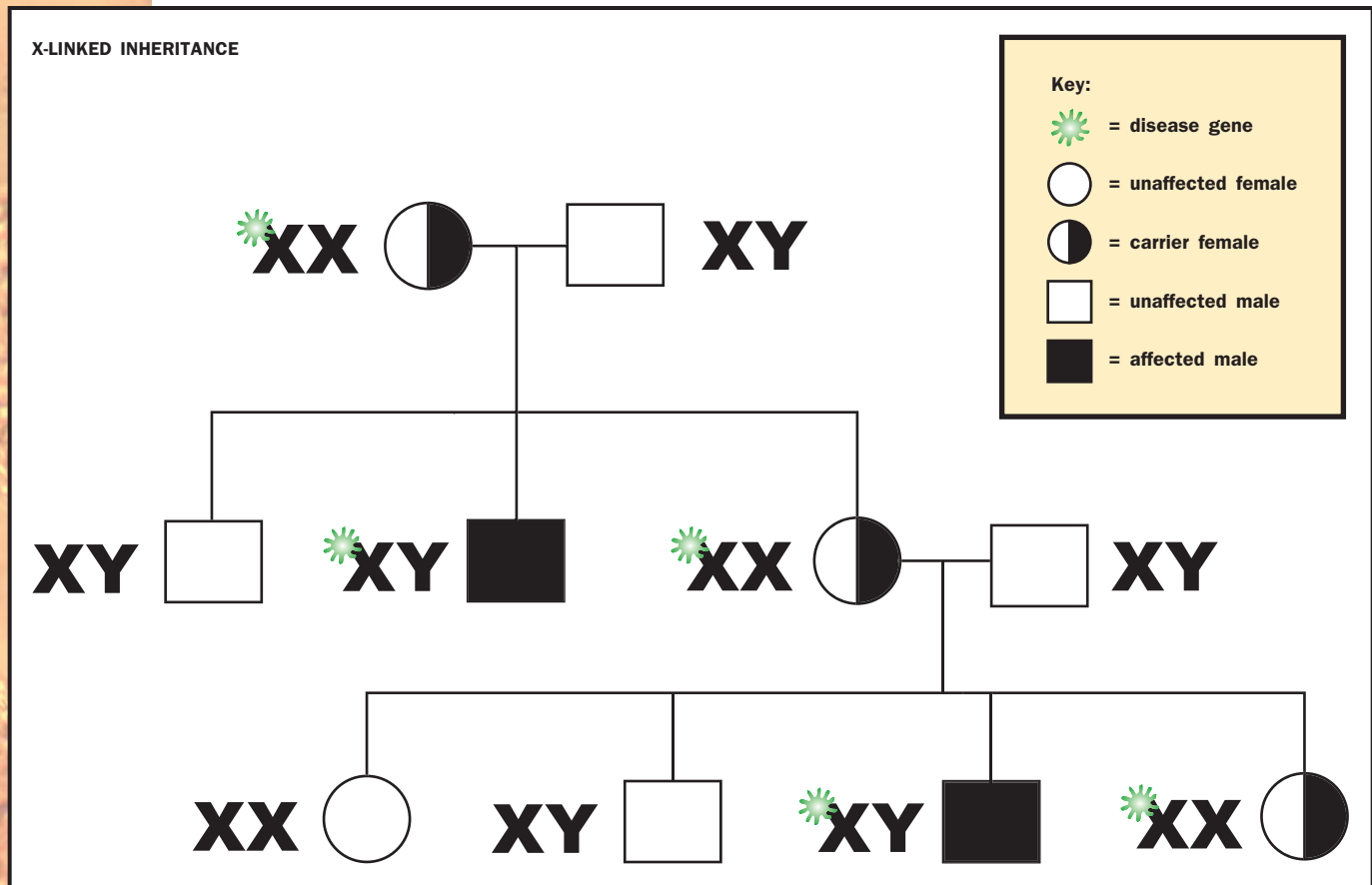

sequence analysis of a genome will hasten one's understanding of the many genes responsible for a trait, the identification of environmental factors will undoubtedly be slower because understanding these factors requires careful and controlled experimentation and observation. Such conditions are difficult to study, particularly in humans.

The effect of environment is evident in many experimental organisms, such as fungi, where "conditional" mutants are artificially constructed and utilized in genetic studies. For instance, temperature-sensitive mutants grow well at certain temperatures but die at a slightly elevated temperature that normal cells can easily tolerate. Even in humans, some environmental contributions to the manifestation of disease have been identified. Until the molecular mechanism for the phenylketonuria disease (PKU) was elucidated, it was not known that the mental retardation normally associated with this disease could be prevented by diet. Homozygotes with this recessive condition are unable to metabolize the amino acid phenylalanine (also found in some artificial sweeteners). The resulting excessive buildup of phenylalanine leads to impairment of mental abilities. By placing homozygous-recessive babies on a diet restrictive of phenylalanine, normal brain function occurs during development.

### Epistasis: Many Genes, One Effect

The contributions of more than one gene on phenotypic expression have been well documented in genetic studies. In many instances, one gene has

been found to mask the expression of a second gene; the former gene is said to be epistatic to the latter. Epistasis relationships are often observed in biochemical pathways, which employ numerous proteins in an assembly-line fashion. If enzyme A normally converts compound X into compound Y, and then enzyme B converts compound Y into red flower pigment, B can only affect the phenotype if a functional allele for enzyme A is first expressed. If enzyme A loses function and is unable to produce compound Y, the red pigment will not be produced irrespective of whichever gene B alleles might be present. This situation differs from dominance, as it involves two separate genes (and two separate proteins).

### Nonpenetrance

The influence of other, unidentified factors can be seen when some individuals in a study do not display the phenotype normally associated with their defined genotype, a situation termed nonpenetrance. For example, polydactyly is a dominant human disorder resulting in the development of more than five digits on hands and feet. Since the mutant allele is dominant, all individuals carrying the allele should display the phenotype. Nonetheless, some individuals have normal numbers of fingers and toes in spite of the presence of the dominant allele. Thus, there must be other factors that influence the penetrance of the mutant allele; these factors might be other genes in the individual's genome, or certain unknown factors in the individual's environment.

### Pleiotropy: One Gene, Many Effects

Sickle cell disease is a very common genetically inherited disorder that is often fatal in childhood; although some treatment is available, there is no cure to date. The disease is characterized by **anemia**, extreme pain and fatigue, heart failure, spleen enlargement, severe microbial infection, and impaired mental abilities. Early genetic studies demonstrated that the disease is inherited in an autosomal (not linked to the sex chromosomes), recessive manner.

The responsible allele of sickle cell disease expresses a mutated version of a protein subunit of **hemoglobin**. Normal hemoglobin is found in red blood cells and is essential for the transport of oxygen to all tissues of the body. In sickle cell disease, the conformation of the mutant hemoglobin subunit is altered, by virtue of a single amino acid change from the wild-type subunit, causing the proteins to associate with each other into abnormal fibers. This association inhibits the binding of oxygen and causes the red blood cells to appear stretched out in a characteristic "sickle" shape. The sickle cells clog capillaries, seriously compounding the effect by reducing all blood flow to various tissues.

Sickle cell disease provides a useful example of how a highly complex phenotype can result from a single, well-defined genotype (in this case a single **nucleotide** mutation). Such a situation, termed pleiotropy, arises due to a cascade of consequences from the single mutated protein. In this case, the abnormal hemoglobin causes poor oxygen transport and sickling of red blood cells, which in turn causes anemia, poor blood circulation, and accumulation of sickle cells in the spleen. The poor blood circulation in turn causes heart failure, lung damage (often followed by pneumonia), and brain dam-



A scanning electron micrograph showing healthy, round red blood cells and a diseased sickle-shaped cell.

**anemia** lack of oxygen-carrying capacity in the blood

**hemoglobin** oxygen-carrying protein complex in red blood cells

**nucleotide** the building block of RNA or DNA

age. Overloading the spleen with sickle cells causes extreme pain and an increased frequency of infectious disease. SEE ALSO BLOOD CLOTTING; DISEASE; GENE; GENETIC ANALYSIS; HUMAN GENOME PROJECT; MENDEL, GREGOR

Karen E. Kirk

### Bibliography

- Cavenee, Webster K., and Raymond L. White. "The Genetic Basis of Cancer." *Scientific American* 272, no. 3 (1995): 72–79.
- Edwards, D. D. "Sudden Death Tied to Sickle-Cell Trait." *Science News* 132 (1987): 197.
- Fairbanks, Daniel J., and W. Ralph Andersen. *Genetics: The Continuity of Life*. Pacific Grove, CA: Brooks/Cole Publishing Company, 1999.
- Griffiths, Anthony J. F., et al. *Modern Genetic Analysis*. New York: W. H. Freeman and Company, 1999.
- Keefe, Richard S. E., and Philip D. Harvey. *Understanding Schizophrenia: A Guide to the New Research on Causes and Treatment*. New York: Free Press, 1994.
- Lunkes, A., Y. Trottier, and J. L. Mandel. "Pathological Mechanisms in Huntington's Disease and Other Polyglutamine Expansion Diseases." *Essays in Biochemistry* 33 (1998): 149–163.
- Nowak, Rachel. "Look Lively (Busy Lifestyle Could Delay Genetic Illness)." *New Scientist* 165, no. 2225 (2000): 10.
- Online Mendelian Inheritance in Man, OMIM™*. McKusick-Nathans Institute for Genetic Medicine, Johns Hopkins University and National Center for Biotechnology Information, National Library of Medicine, 2000. <<http://www.ncbi.nlm.nih.gov/omim/>>.
- Strachan, Tom, and Andrew P. Read. *Human Molecular Genetics*, 2nd ed. New York: Wiley-Liss, 1999.
- Welsh, Michael J., and Alan E. Smith. "Cystic Fibrosis." *Scientific American* 273, no. 6 (1995): 52–61.

## Pauling, Linus

### American chemist 1901–1994

Linus Carl Pauling, American chemist, is the only person to have won two undivided Nobel prizes (in chemistry in 1954 and the Nobel Peace Prize in 1962). He is best known for his work on molecular structure, the nature of the chemical bond, and the effects of various chemical agents on the human body.

Pauling was born on February 28, 1901, in Portland, Oregon, the son of a pharmacist. In 1922, he received his bachelor's degree from Oregon State College. He then became a doctoral student at California Institute of Technology (CIT), from which he received his doctoral degree in 1925. For the next two years, Pauling received fellowships that allowed him to study abroad with Niels Bohr in Denmark, Erwin Schrodinger in Switzerland, and Arnold Sommerfeld in Germany.

In 1927, Pauling was appointed assistant professor at CIT, and four years thereafter became chairman of the Department of Chemistry and Chemical Engineering, a position he held until 1964. Meanwhile, between 1963 and 1967, he was a professor at the Center for the Study of Democratic Institutions at Santa Barbara. From 1969 until his death he was affiliated with Stanford University.

Pauling made significant contributions to molecular biology and **organic** chemistry. His work focused on the spatial architecture of molecules, and the relationship between molecular structure and molecular behavior. The theory of resonance, which Pauling first formulated, has since explained certain properties of the carbon compounds, particularly the subgroup known as the **aromatics**.

Pauling successfully applied the theories of physics to biological problems. He helped make strides in the field of immunology, for example, by looking at the basic molecular structure of **antitoxins**. His substantial research on the structure of **amino acids** helped determine the **conformation** of **proteins**. For this work, Pauling was awarded the 1954 Nobel Prize in chemistry.

During World War II, Pauling worked as a part of the National Defense Research Committee and the Research Board for National Security, helping design substitutes for human serum and blood plasma, rocket propellants, and an oxygen efficiency indicator.

As a result of the dropping of the atomic bomb at the end of the war, Pauling became concerned about the negative effects that nuclear fallout has on the molecules of the human body. After the war, Pauling became a member of Albert Einstein's Emergency Committee of Atomic Scientists, as well as of many other pro-peace organizations that formed in the 1950s. Among other things, he protested the development of the hydrogen bomb and vigorously promoted the adoption of a nuclear test ban treaty.

Finally, in the 1960s and 1970s, Pauling became an outspoken advocate of the value of vitamin C to human nutrition. He proposed the theory that colds could be prevented by improving nutrition, and particularly by increasing intake of ascorbic acid (vitamin C).

In 1962, Pauling won the Nobel Peace Prize for his work toward the nuclear test ban treaty. In addition, he was one of seven individuals awarded the International Lenin Peace Prize in 1968–1969. The U.S. government gave him the National Medal of Science in 1975.

Among his most significant publications are *The Nature of the Chemical Bond and the Structure of Molecules and Crystals* (1939); *No More War* (1951), a cry for world peace; and *Vitamin C and the Common Cold* (1970). SEE ALSO HISTORY OF BIOLOGY: BIOCHEMISTRY

Hanna Rose Shell

### Bibliography

- Brock, William H. *The Norton History of Chemistry*. New York: Norton Press, 1993.
- Goertzel, Ted, and Ben Goertzel. *Linus Pauling: A Life in Science and Politics*. New York: Basic Books, 1995.
- Gilpin, Robert. *American Scientists and Nuclear Weapons Policy*. Princeton, NJ: Princeton University Press, 1962.
- Pauling, Linus, with Roger Hayward. *The Architecture of Molecules*. San Francisco, CA: Freeman, 1964.
- Serafini, Anthony. *Linus Pauling: A Man and His Science*. New York: Paragon House, 1989.

**organic** composed of carbon, or derived from living organisms

**aromatic** compound including a double-bonded carbon ring

**antitoxin** molecule used to inactivate a toxin

**amino acid** a building block of protein

**conformation** three-dimensional shape

**protein** complex molecule made from amino acids; used in cells for structure, signaling, and controlling reactions

Linus Pauling took 18,000 milligrams of vitamin C each day, which is 300 times the recommended daily allowance.

**PCR** See *Polymerase Chain Reaction*

## Pedigrees and Modes of Inheritance

A pedigree is a diagram that depicts the blood relationships of family members, as well as which individuals express the trait or disorder under study. Construction of a pedigree is often the first step in the identification of a **gene** variant that causes a particular disease or trait. Several terms are encountered in pedigree analyses.

### Phenotype, Genotype, and Alleles

A **phenotype** is an observable trait that is the expression of a gene combination, or genotype. Eye color, blood group, and the symptoms of inherited diseases are examples of phenotypes. **Chromosomes**, and therefore genes, occur in pairs in a **diploid** organism, such as a human. An individual inherits one copy of each gene from his or her mother and another copy from the father. A gene can exist in alternate forms, called **alleles**. A gene may have many alleles, but a person can only have two copies of the same allele, or two different alleles, for a particular gene. An individual who inherits two copies of the same allele is **homozygous**; inheriting two different alleles is termed **heterozygous**.

### Pedigree Symbols

The figures in this article show symbols commonly used in pedigrees. Squares represent males, circles represent females, and diamonds depict individuals of unknown or, for reasons of confidentiality, disguised gender. A double line between parents indicates consanguineous marriages (between blood relatives) (see Figure 3). Filled symbols represent individuals who display a certain trait, such as an inherited disease. Bars next to the symbols represent genetic loci, and different alleles are color-coded. Disease-causing mutations are shown as stars or crosses. Symbols that are half filled indicate heterozygous individuals, but often this information isn't known.

**gene** portion of DNA that codes for a protein or RNA molecule

**phenotype** observable characteristics of an organism

**chromosome** "colored body" in the cell nucleus; made of DNA and protein, and divided functionally into genes and nongene regions

**diploid** having pairs of chromosomes in the nucleus

**allele** a particular form of a gene

**homozygous** containing two identical copies of a particular gene

**heterozygous** characterized by possession of two different forms (alleles) of a particular gene

Figure 1. In autosomal dominant inheritance, one copy of the disease gene (shown as a star on one homologous chromosome) is enough to cause the disease. Affected individuals are shown in black.

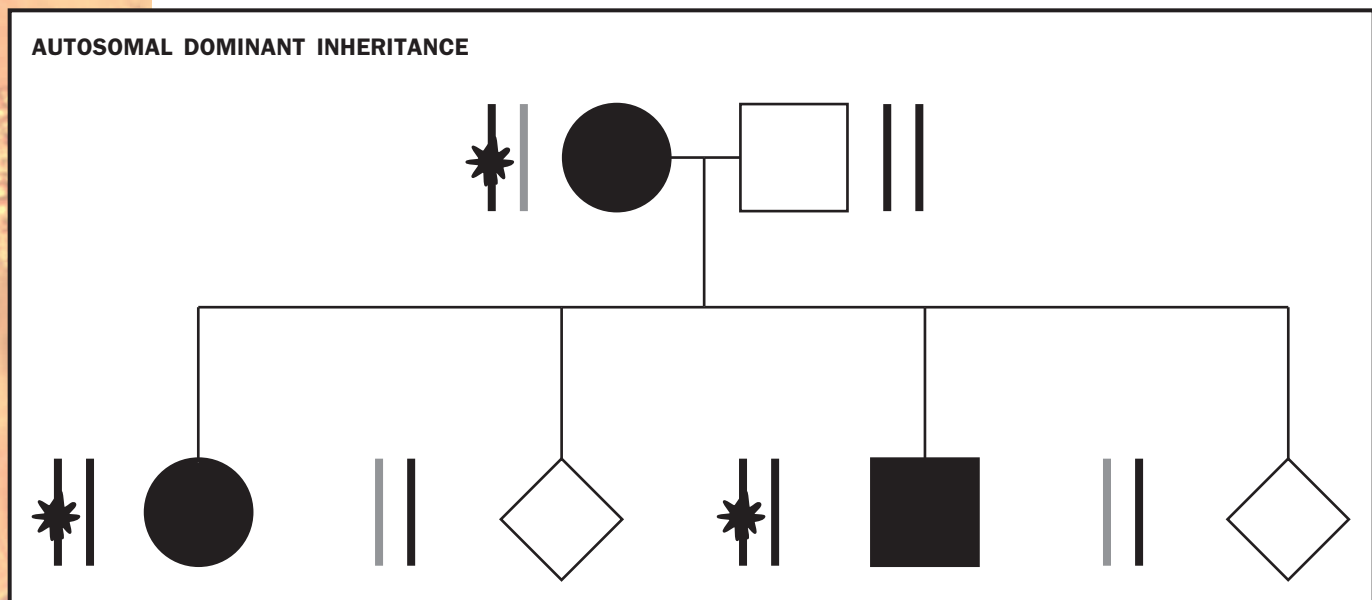



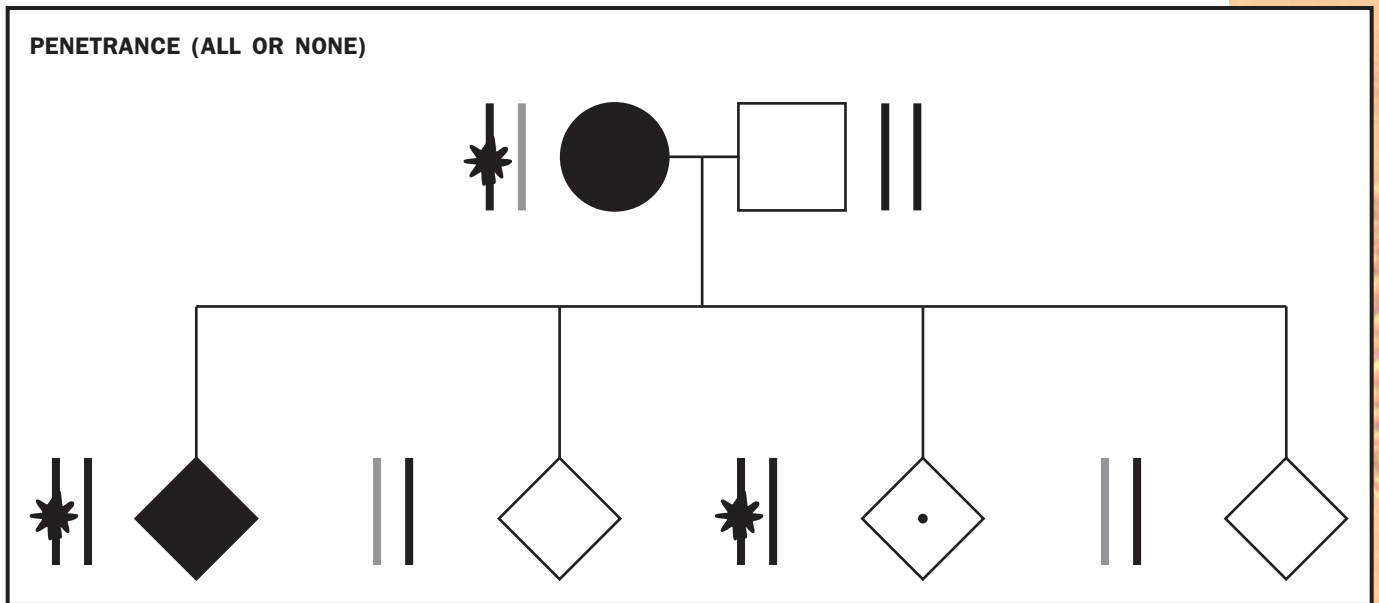

## Modes of Inheritance

A pair of alleles can show one of three modes of inheritance. Augustinian monk and botanist Gregor Mendel (1822–1884) demonstrated these patterns of inheritance using pea plant crosses. The modes of inheritance are **autosomal dominant**, autosomal recessive, and X-linked. To simplify the discussion of these different forms, the trait used in the following text will be a hereditary disease.

### Autosomal Dominant

In individuals with an autosomal dominantly inherited condition (Figure 1), one mutation is sufficient to cause disease. Statistically, an affected individual is therefore expected to have 50 percent affected and 50 percent unaffected offspring. However, each child has the same chance (50 percent) of inheriting the mutated gene. That is, if the first two children are affected, the next two are not necessarily going to be unaffected. “Autosomal” indicates genes on the chromosomes that do not carry genes that determine sex, and so both males and females are affected in successive generations. Usually, the disease does not occur in the offspring of unaffected individuals. Rarely, an autosomal-dominant mutation does not cause disease, perhaps because of the effects from other genes. Such a mutation is said to be incompletely penetrant (Figure 2). Penetrance is an all-or-none phenomenon: the disease is either present or absent. In contrast, expressivity refers to the degree of phenotypic expression. For example, the trait of extra fingers or toes, called polydactyly, is incompletely penetrant, because some individuals with affected parents and children have the normal numbers of fingers or toes. Polydactyly is also variably expressive, because affected individuals vary in the numbers of extra digits.

### Autosomal Recessive

In individuals with an autosomal recessively inherited disease (see Figure 3), both alleles are mutant. Usually, the parents of the affected individual are

Figure 2. Penetrance refers to “all or none” inheritance; the disease is either present or absent. The first is affected (darkened diamond), but the third child is not (diamond with dot).

**autosomal dominant** pattern of inheritance in which inheritance of a single allele from either parent results in expression of the trait

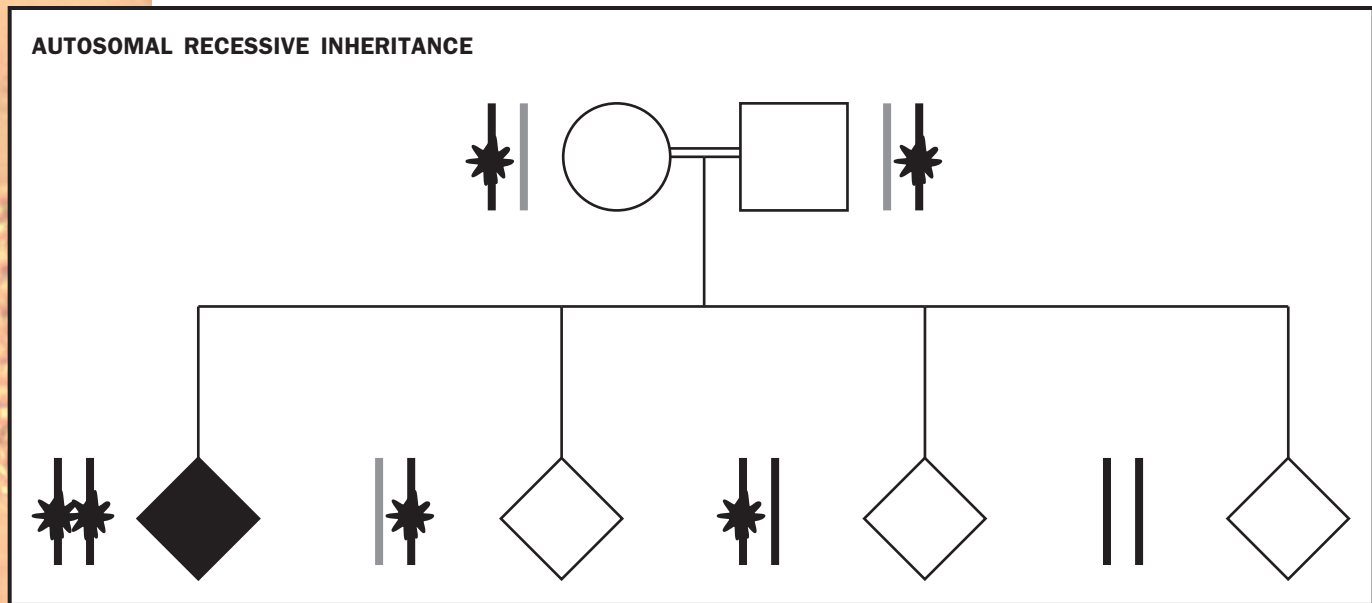

Figure 3. In autosomal recessive inheritance, both alleles are mutant. Parents of affected individuals are unaffected carriers.

**consanguineous**  
descended from the same ancestor

heterozygous for this mutation and thus unaffected carriers. Each of the parent's offspring has a 25 percent chance of inheriting the illness and a 75 percent chance of being unaffected. However, of the latter, two-thirds will be heterozygous like their parents, and one-third will be homozygous for the normal gene and thus cannot pass on the trait. An autosomal recessive trait or disease may occur in individuals of both sexes. People with homozygous mutations are frequently the product of a **consanguineous** marriage (Figure 3). A recessive disease can, however, also be caused by two *different* mutations in the same gene (more frequent in nonconsanguineous marriages), which are then called *compound heterozygous* mutations.

### X-linked

An X-linked trait is carried on the X chromosome. In pedigrees depicting X-linked inheritance, usually only males are affected and, although affected males may occur in consecutive generations, transmission is always through females. This is based on the fact that males have a single X chromosome (in addition to their Y chromosome), which they always inherit from their mother and will always pass on to their daughters but never to their sons. Females, on the other hand, have two X chromosomes. Therefore, they can be carriers of an X-linked mutation, but in most cases are phenotypically unaffected because they have a second (nonmutated) X chromosome, compensating for whatever loss of function is caused by the mutated gene.

### Mitochondrial

Some additional genetic material in humans is contained in the **mitochondrial** genome, and some diseases result from mutations in mitochondrial genes. Only females can transmit mitochondrial diseases because sperm cells rarely contribute mitochondria to the **oocyte** at **fertilization**. Therefore, a mitochondrial disease is typically passed from an affected mother to all her children, but not from an affected man to any of his children. Many mitochondrial disorders cause muscle fatigue, because muscle cells contain thou-

**mitochondria** subcellular organelle that creates ATP used for energy-requiring processes in a cell

**oocyte** unfertilized egg

**fertilization** union of sperm and egg

sands of mitochondria that provide energy for contraction. SEE ALSO GENETIC ANALYSIS; GENETIC DISEASES; MENDEL, GREGOR; PATTERNS OF INHERITANCE

*Christine Klein*

### Bibliography

Goss, S. J., and H. Harris. "New Method for Mapping Genes in Human Chromosomes." *Nature* 255 (1975): 680–684.

Passarge, Eberhard. *Color Atlas of Genetics*. New York: Thieme, 1995.

Watson, James D., Michael Gilman, Jan Witkowski, and M. Zoller. *Recombinant DNA*, 2nd ed. New York: W. H. Freeman and Company, 1993.

## Peripheral Nervous System

The peripheral nervous system (PNS) refers to all the **neurons** (and their supporting cells, or glia) of the body outside the brain and spinal cord (central nervous system [CNS]). The brain is the organ that decides how a person responds to what happens in the surrounding world. While this is an extremely important function, the brain relies upon the peripheral nervous system, and its information gathering capabilities, to receive information about the world and to send appropriate responses to various body parts, such as muscles and glands. The neurons of the peripheral nervous system do not make complex decisions about the information they carry. The appropriate decisions are made instead in the brain and spinal cord. However, without the peripheral nervous system's ability to bring in sensory information and send out motor information, it would be impossible for a person to walk, talk, ride a bike, or even watch television. Without the ability to take in information and send out responses, the brain would be useless.

Peripheral neurons are of two types, sensory and motor. Sensory (afferent) neurons bring information about the world within and around the body from sense organs to the brain and spinal cord, while **motor** (efferent) **neurons** carry messages from the brain and spinal cord out to the muscles and glands. For example, if a mosquito lands on a person's arm, sensory neurons in the skin send a message to the spinal cord and then the brain, where the message is understood, and a reaction formulated. The brain's response may be to use motor neurons to cause muscle contractions resulting in a slap on the skin where the mosquito landed.

### Sensory Division

The sensory division of the PNS carries all types of sensory information to the CNS, including that from the "special senses" of touch, smell, taste, hearing, and sight, as well pain, body position (proprioception), and a variety of **visceral** sensory information. The information from the viscera (internal organs) includes some of which the body is aware (bladder fullness and stomach aches, for example), as well as much of which the body is not aware, including blood pressure, concentration of substances in the blood, and many other bits of sensory information used to regulate the internal environment.

**neuron** nerve cell

**motor neuron** nerve cell that controls a muscle or gland

**visceral** related to the viscera, or internal organs

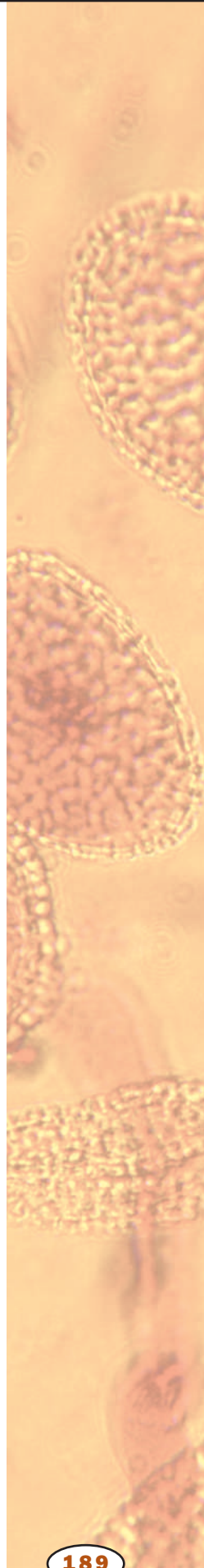

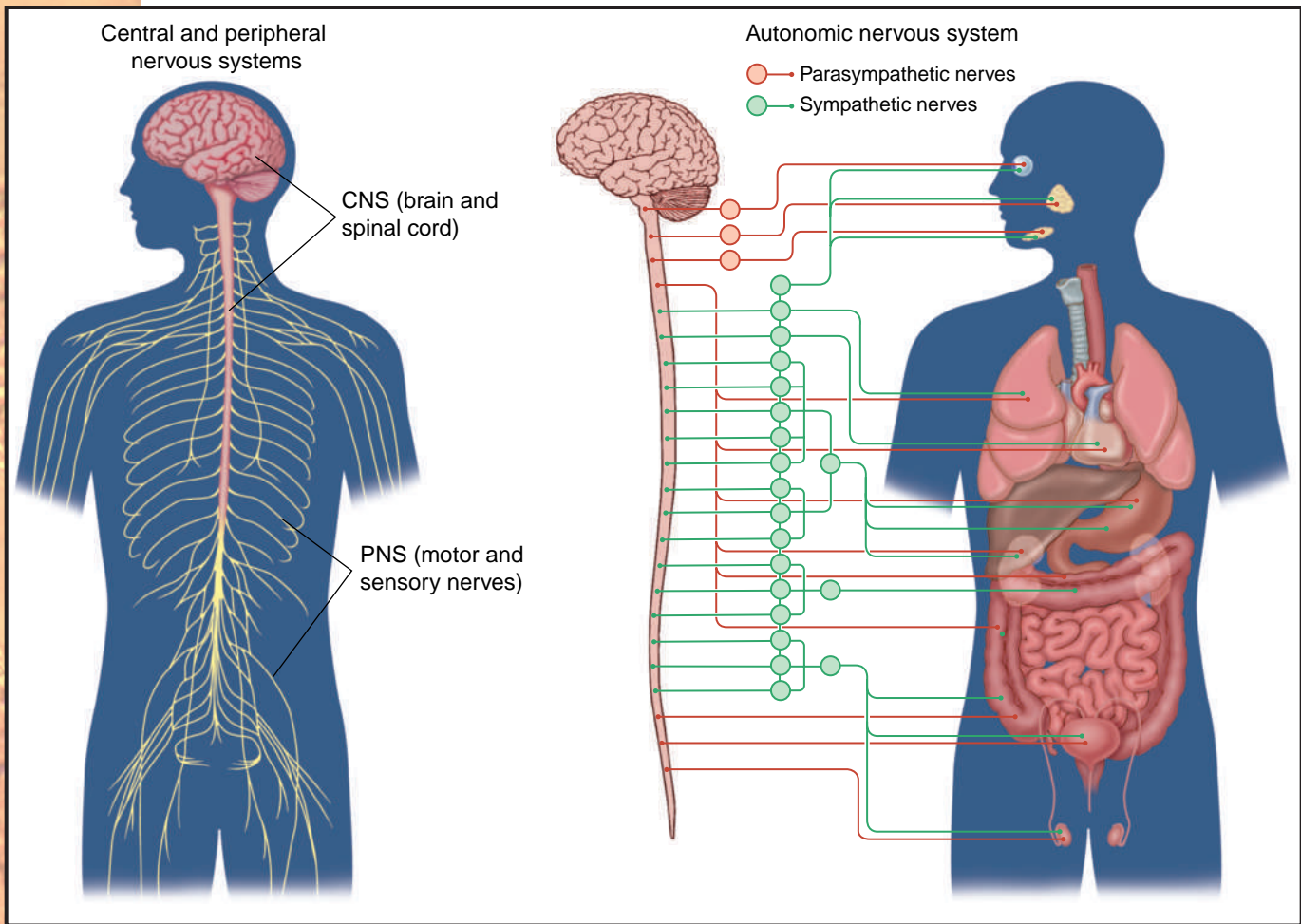

The central and peripheral nervous systems (left) and the autonomic nervous system (right).

**hormone** molecule released by one cell to influence another

### Motor Division

The motor division of the PNS is subdivided into several branches. The somatic motor branch carries voluntary (willed) commands to the skeletal muscles, allowing a person to perform such action as swatting a mosquito or sticking out the tongue. The autonomic motor branch carries autonomic (automatic, or unwilled) commands to a variety of muscles and glands throughout the body, allowing the brain to control heart rate, blood pressure, breathing rate, sweat production, and **hormone** release, among other functions.

Much like a car, which has both a gas pedal and a brake to give the driver very precise speed control, the autonomic nervous system can be subdivided into two parts, the sympathetic and the parasympathetic. The sympathetic part of the autonomic nervous system generally acts in opposition to the parasympathetic part. So while the sympathetic motor neurons speed up the heart, the parasympathetic motor neurons will slow it down, and while the sympathetic motor neurons slow down digestion, parasympathetic motor neurons speed digestion.

When a person is frightened, for example, sympathetic motor neurons trigger adrenaline release, increase the heartbeat and blood pressure, close off blood vessels to the gut and open them to the skeletal muscles, dilate

the pupils, and open the airways. Combined, these are known as the “fight or flight” response, since they prepare the body for rapid action. Afterward, parasympathetic neurons reverse these actions, bringing the body back to a more peaceful resting state.

### Anatomical Considerations

Some of the somatic sensory neurons are very long, stretching from the sensory receptors all over the body all the way into the spinal cord, or even directly into the brain. Likewise, a single somatic motor neuron spans the distance from the spinal cord or brain to whichever muscle it operates, even if that is the muscle controlling the big toe. Autonomic motor neurons are not as long, and usually two neurons are needed to stretch from the spinal cord to the muscle or gland being turned on or off.

Many of the connections among neurons in the peripheral nervous system are made in special structures called **ganglia** (singular, ganglion). Most ganglia are large collections of connecting neurons located in specific regions of the body, and are part of the autonomic nervous system. In some cases, the ganglia are located close to the spinal cord, and thus close to the target organ. **SEE ALSO** ADRENAL GLAND; CENTRAL NERVOUS SYSTEM; EYE; HEARING; MUSCLE; NERVOUS SYSTEMS; NEURON; PAIN; SPINAL CORD; TOUCH

*Curt Walker*

#### Bibliography

Greenfield, Susan A. *The Human Mind Explained*. New York: Holt and Company, 1996.

Martini, F. H., and E. F. Bartholomew. *Structure and Function of the Human Body*. Upper Saddle River, NJ: Prentice Hall, 1999.

Scott, A. S., and E. Fong. *Body Structures and Functions*, 9th ed. New York: Delmar Publishing, 1998.

## Peroxisomes

Peroxisomes (microbodies) are **cytoplasmic organelles** involved in **metabolism** of hydrogen peroxide,  $H_2O_2$ . The peroxisome is about 0.5 **microns** in diameter, and is surrounded by a membrane. They are widely distributed in most animal and plant cells. Although peroxisomes possess more than sixty **proteins**, their function requires at least one  $H_2O_2$ -generating **enzyme**, flavinoxidase, and an  $H_2O_2$ -degrading enzyme, catalase, a peroxisome. Peroxisomal proteins are synthesized on free polyribosomes and a peroxisomal targeting signal position enables them to be targeted to peroxisomes post-translationally.

Peroxisomes are major sites of oxygen consumption in the cell and participate in several metabolic functions that use oxygen. Oxygen consumption in the peroxisome leads to  $H_2O_2$  production, which is then used to oxidize a variety of molecules. Important reactions in the peroxisome include **oxidation** of long-chain and very long-chain fatty acids, metabolism of glyoxalate, degradation of uric acid, and synthesis of ether **lipids** and cholesterol, among others. Alcohol is detoxified to acetaldehyde in part by action of peroxisomes. In plants, peroxisomes perform photorespiration.

**ganglia** cluster of nerve cell bodies

**cytoplasm** material in a cell, excluding the nucleus

**organelle** membrane-bound cell compartment

**metabolism** chemical reactions within a cell

**micron** one-millionth of a meter; also called a micrometer

**protein** complex molecule made from amino acids; used in cells for structure, signaling, and controlling reactions

**enzyme** protein that controls a reaction in a cell

**oxidation** reaction characterized by loss of electrons, or reaction with oxygen

**lipid** fat or waxlike molecule, insoluble in water

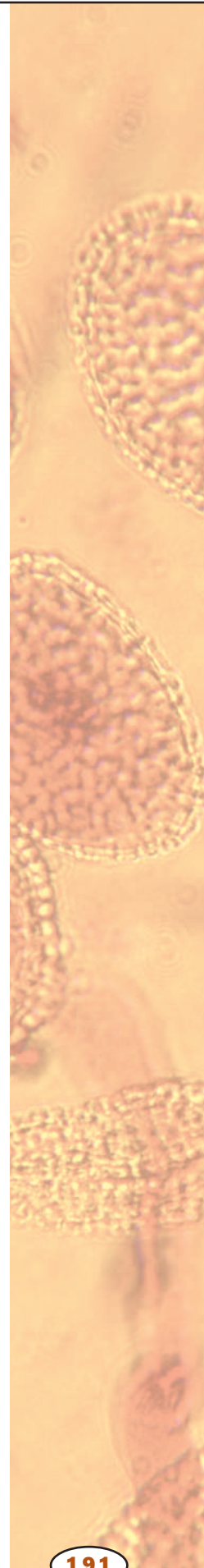

In humans, defects in peroxisome biogenesis lead to at least twelve peroxisomal disorders, most of them lethal during childhood. In liver cells peroxisomes are few in number, but several drugs that lower serum lipids, and many other chemicals designated as peroxisome proliferators, induce a profound increase in peroxisome number by activating a nuclear receptor called peroxisome proliferator-activated receptor (PPAR). Sustained activation of PPAR and induction of peroxisome proliferation in liver leads to the development of liver cancer in rats and mice. SEE ALSO ALCOHOL AND HEALTH; C4 AND CAM PLANTS; LIPIDS; METABOLISM, CELLULAR; ORGANELLE

*Janardan Reddy*

#### Bibliography

Masters, Colin, and Denis Crane. *The Peroxisome: A Vital Organelle*. Cambridge: Cambridge University Press, 1995.

## Pharmaceutical Sales Representative

The people who tell others about new medicinal preparations usually work for pharmaceutical manufacturing companies as pharmaceutical sales representatives. To keep informed about new products, pharmaceutical sales representatives are continuously learning as part of their jobs.

Pharmaceutical sales representatives talk to those who influence the prescription and sale of medicines. Such people include: those who write prescriptions (doctors, nurse practitioners, and dentists), the pharmacists who legally sell the preparations, and the policymakers who determine which drugs are covered by health management organizations and health insurance plans. Some are involved in advertisement of specific drug preparations directly to consumers.

A four-year bachelor's degree (B.S. or B.A.) with a major in chemistry, microbiology, animal biology, or pharmacology is the usual minimum preparation for this career. A better general understanding of the actions of drug preparations is obtained through an entry-level pharmacy degree (which is now in most states a Doctor of Pharmacy [Pharm.D.] degree), requiring six years after high school to complete. People with nonscience baccalaureate majors such as business or marketing will have the most "catching up" to do. In high school a person interested in a pharmaceutical sales career should take college preparatory courses with a science and mathematics emphasis. SEE ALSO CLINICAL TRIALS; PHARMACOLOGIST

*Margaret A. Weck*

#### Bibliography

Clayton, Anne. *Insight into a Career in Pharmaceutical Sales*, 3rd ed. Northbrook, IL: Marketing Essentials, Inc., 2001.

## Pharmacologist

A pharmacologist practices the science of pharmacology, which is the study of drug, **hormone**, and chemical actions on biological systems. A pharmacologist must have knowledge in the sources, chemical properties, biologi-



A scientist performing pharmacological research.

**hormone** molecule released by one cell to influence another

cal effects, and therapeutic uses of drugs. The pharmacologist must be multidisciplinary with experience and/or knowledge in experimental techniques such as analytical chemistry, biochemistry, cellular and molecular biology, genetics, immunology, medicinal chemistry, microbiology, pathology, and physiology. Pharmacologists can be subcategorized as doing biologic, industrial, human, or regulatory research.

Pharmacologists perform studies to examine drug interactions and define the mechanism involved in producing these interactions. In order to determine the mechanism of action of a particular drug, the pharmacologist may perform experiments on cellular *in vitro* systems. However, in order to identify the physiological, biochemical, or immunological response, it is often necessary to perform the experiments in *in vivo* experimental animal systems such as rats and mice (preclinical). Many pharmacologists consider toxicology to be an important part of pharmacologic research. Pharmacologists may perform this type of research in an academic (university) or industrial (drug company) environment.

Pharmacology training usually requires graduate degrees (M.Sc. and Ph.D.). Pharmacologists who study the therapeutic and toxic actions of drugs in humans are referred to as clinical pharmacologists. The clinical pharmacologist often has medical training (M.D.) with specialized training in the use of drugs in the treatment of disease. Clinical pharmacologists determine the correct routes of drug administration (e.g., oral or intravenous), assess their adverse effects, monitor drug levels, and establish therapies which prevent or treat overdoses as well as the consequences of interactions with other drugs. Some pharmacologists are involved with the administration of the rules and regulations relating to the development of new drugs. The pharmacologist unlocks the mysteries of drug actions, discovers new therapies, and develops new medicinal products, which inevitably touch upon all human lives. SEE ALSO BIOCHEMIST; POISONS; PHARMACEUTICAL SALES REPRESENTATIVE

David S. Lester

### Bibliography

Lewis, P. "The Clinical Pharmacologist in Drug Discovery and Development." *British Journal of Clinical Pharmacology* 42 (1996): 133–136.

Raskova, H. "How I Became a Pharmacologist." *Pharmacology and Toxicology* 80 (1997): 255–261.

University of Western Ontario, Faculty of Medicine. <<http://www.pharmtox.med.uwo.ca>>.

## Pheromone

Pheromones are chemical signals released by an organism that influence the behavior of another. Communication between living cells is often ultimately chemical in nature. Chemical substances produced by one cell travel to another cell where they bind to **protein** receptors in the cell membrane or within the interior of the cell and initiate a series of signal **transduction** mechanisms that elicit a response. Chemicals that travel within an organism between cells of its own body are variously termed paracrines, **neurotransmitters**, neuromodulators, or **hormones**. Pheromones are chemicals that are carried between individual organisms of the same species.

### ELION, GERTRUDE BELLE (1918–)

American pharmacologist who received, along with George Hitchings and James Black, the 1988 Nobel Prize in medicine for developing drugs to treat autoimmune disorders, leukemia, malaria, urinary tract infections, herpes, and gout. Elion's name appears on forty-five patents.

**protein** complex molecule made from amino acids; used in cells for structure, signaling, and controlling reactions

**transduction** conversion of a signal of one type into another type

**neurotransmitters** molecules released by one neuron to stimulate or inhibit another neuron or cell

**hormone** molecule released by one cell to influence another

Female *Cecropia* moths broadcast a pheromone that serves as an attractant for flying males.



The response of the receiving organism is usually a change in its physiology or behavior.

Pheromones are often involved in the mating behavior between males and females in which the chemical serves as an attractant for one of the sexes. Following emergence from the cocoon, female *Cecropia* moths crawl a short distance away and broadcast a pheromone early in the morning that serves as an attractant for flying males. Males have olfactory (“smell”) receptors on their antennae and they fly upwind and orient themselves to equalize the signals received by the two antennae. In this way, they can locate a virgin female from several miles away. Females of closely related species may use the same or a similar chemical but broadcast it at different times of the day. Males are genetically programmed to respond only at the appropriate time.

The female nearly always produces pheromones that serve as sex attractants, but males may produce pheromones that serve as aphrodisiacs. Mantispids are small predaceous insects that resemble miniature praying mantids. Courtship behavior is elaborate because the male must convince the female that he is a potential mate rather than an easy meal. The male produces a sweet musklike substance from his abdomen that helps to appease the female and reduce her predatory instincts.

Pheromones may be involved in mating even when the organisms do not actually meet. Many marine creatures such as sea urchins and oysters release eggs and sperm in the water in a process called spawning. Pheromones in these **secretions** will induce other members of the same species to simultaneously release their eggs or sperm, thereby increasing the likelihood that external **fertilization** will occur.

The preceding examples have involved pheromones carried in the air or water, but direct contact between the receiving organism and the pheromone must sometimes occur. Ants finding a source of food will lay

**secretion** material released from the cell

**fertilization** union of sperm and egg



down a trail with a secretion from their Dufour's gland by touching their abdomen to the ground as they return to the colony. Foragers leaving the colony can follow the pheromone trail back to the food source.

Sometime a pheromone can be “decoded” by another species and used against the animal that normally responds to it. The bolas spider twirls a silken thread tipped with a glob of sticky silk that it throws at insect prey to entrap them. The strand is coated with the same pheromone produced by certain female moths to attract males of their own species. When the amorous moths fly to the spider expecting to mate, they are instead captured and eaten. SEE ALSO CHEMORECEPTION; HORMONES; INSECT; SEXUAL REPRODUCTION; SYNAPTIC TRANSMISSION

*Kurt Redborg*

### Bibliography

Chapman, Reginald F. *The Insects: Structure and Function*, 4th ed. Cambridge: Cambridge University Press, 1998.

Sumich, James L. *An Introduction to the Biology of Marine Life*. Dubuque, IA: William C. Brown, 1996.

Wilson, E. O. *The Insect Societies*. Cambridge, MA: Belknap Press, 1971.

## Photoperiodism

The term “photoperiodism” was coined to describe a plant’s ability to flower in response to changes in the photoperiod: the relative lengths of day and night. Because flowers produce seeds, flowering is crucially important for the plant to complete its life cycle. Although people had long known that plants such as tulips flower in the spring and chrysanthemums flower in the fall, until the early 1900s little was known about what actually caused flowering.

Beginning in 1910, Wightman Garner and Henry Allard conducted experiments to test the effect of day length on flowering. They discovered that plants such as barley flowered when the day length was longer than a certain critical length. These plants, which they named long-day plants (LDPs), flower mainly in the summer as the days are getting longer. Others, such as soybeans, flower when the day length is shorter than a certain critical length. These short-day plants (SDPs) flower in the fall as the days are getting shorter. Still others are not sensitive to the photoperiod and are called day-neutral plants.

Photoperiodism is responsible for the distribution of many plants worldwide. For example, ragweed (a SDP) is not found in northern Maine because the plant flowers only when the day length is shorter than 14.5 hours. In northern Maine, days do not shorten to this length until August. This is so late in the growing season that the first frost arrives before the resulting seeds are mature enough to resist the low temperatures, and so the species cannot survive there. By contrast, spinach (a LDP) is not found in the tropics because there the days are never long enough to stimulate the flowering process.

To investigate photoperiodism, plants can be grown in growth chambers, in which timers are used to control the length of the light and dark

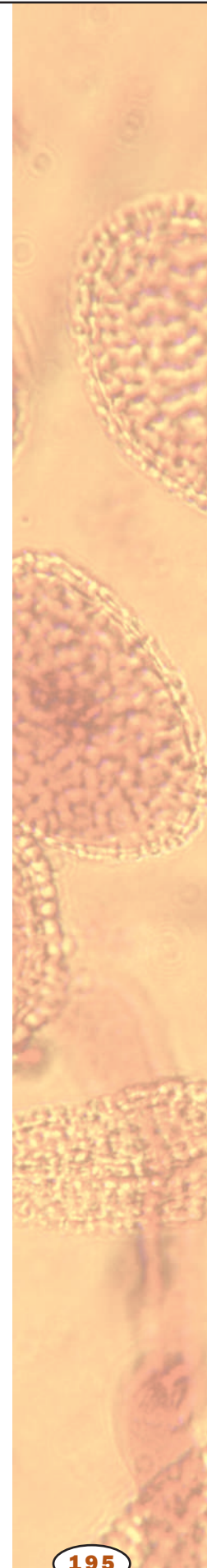

**nanometer**  $10^{-9}$  meters; one-billionth of a meter

**gene** portion of DNA that codes for a protein or RNA molecule

**carbohydrates** sugars, starches, and other molecules combining carbon, hydrogen, and oxygen and serving as fuel or structural components

**ecosystem** an ecological community and its environment

periods. Such research has shown that the dark period is more important than the light period. For example, if SDPs are grown under short-day conditions but the dark period is interrupted by a flash of light, the SDPs will not flower. The long night that normally accompanies a short day is interrupted by the flash. An interruption of the light period with dark has no effect. Thus, SDPs should more accurately be called long-night plants; and LDPs should be called short-night plants to emphasize the key role played by darkness in photoperiodism. Most plants require several weeks of the appropriate long-night or short-night cycle before they will flower.

Red light having a wavelength of 660 **nanometers** was found to be the most effective for interrupting the dark period, and this effect can be reversed by a subsequent exposure to far-red light (730 nanometers). These observations led to the discovery of phytochrome, the pigment responsible for absorbing those wavelengths and apparently the light sensor in photoperiodism. It has been suggested that photoperiodism results from an interaction between phytochrome and the plant's biological clock, which measures the time between successive dawns (rich in red light) and successive dusks (rich in far-red light). Under the appropriate conditions, these interactions are thought to activate the **genes** for flowering.

Many other processes in plants and animals are now known to be affected by the photoperiod. **SEE ALSO** FLOWERS; PLANT DEVELOPMENT

*Robert C. Evans*

### Bibliography

- Curtis, Helen, and N. Sue Barnes. *Invitation to Biology*, 5th ed. New York: Worth Publishers, 1994.
- Raven, Peter H., Ray F. Evert, and Susan E. Eichhorn. *Biology of Plants*, 6th ed. New York: W. H. Freeman and Company, 1999.
- Salisbury, Frank B., and Cleon Ross. *Plant Physiology*, 4th ed. Belmont, CA: Wadsworth, Inc., 1992.
- Taiz, Lincoln, and Eduardo Zeiger. *Plant Physiology*, 2nd ed. Sunderland, MA: Sinauer Associates, 1998.

## Photosynthesis

Photosynthesis is the process by which plants use the energy of light to produce **carbohydrates** and molecular oxygen ( $O_2$ ) from carbon dioxide ( $CO_2$ ) and water:



Virtually all **ecosystems** on Earth depend on photosynthesis as their source of energy, and all free oxygen on the planet, including that in the atmosphere, originates from photosynthesis. The overall reaction is the reverse of respiration, which releases energy by oxidizing carbohydrates to produce  $CO_2$  and water. Photosynthesis and respiration are linked ecologically, being the cellular metabolic processes that drive the carbon and oxygen cycles.

Photosynthesis occurs in plants, photosynthetic protist (algae), and some bacteria. In plants and algae, it takes place within chloroplasts, whereas in

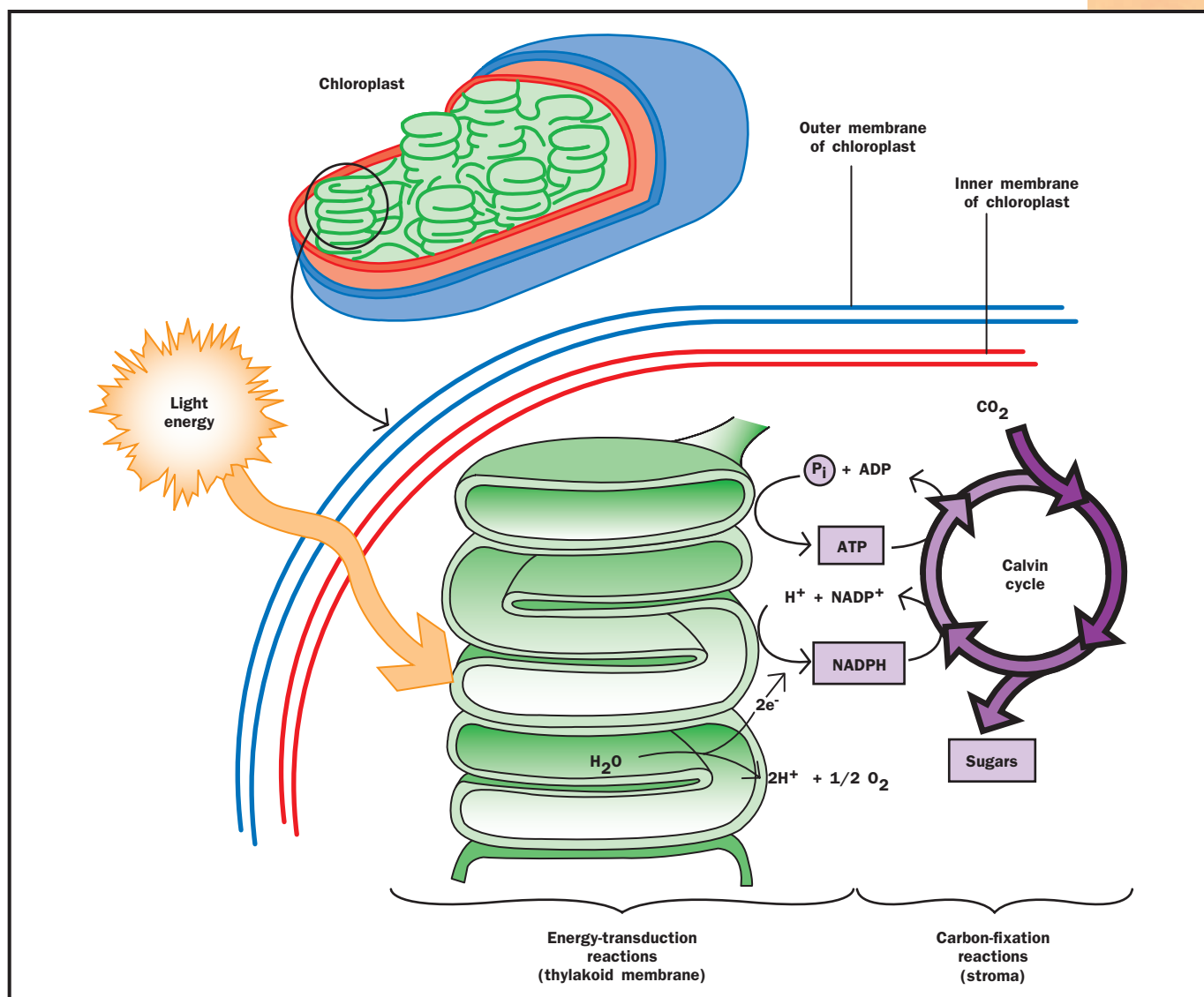

bacteria it occurs on the plasma membrane and in the **cytosol**. The remainder of this discussion will refer to photosynthesis in chloroplasts of plants.

## Overview

Photosynthesis is divided into two sets of reactions: the light-dependent (light) reactions and the light-independent (dark) reactions. As their names imply, the first set depends directly on light, whereas the second set does not. Nevertheless, even the dark reactions will cease if the plants are deprived of light for too long because they rely on the products of the light reactions.

The light reactions, which convert the energy in light into chemical energy, take place within the thylakoid membranes of the chloroplasts, whereas the dark reactions, which use that chemical energy to fix  $CO_2$  into **organic** molecules, take place in the stroma of the chloroplast. In the light reactions, the energy of light is used to “split water,” stripping a pair of electrons from it (and causing the two hydrogens to be lost), thus generating molecular

An overview of the photosynthetic process.

**cytosol** fluid portion of a cell, not including the organelles

**organic** composed of carbon, or derived from living organisms

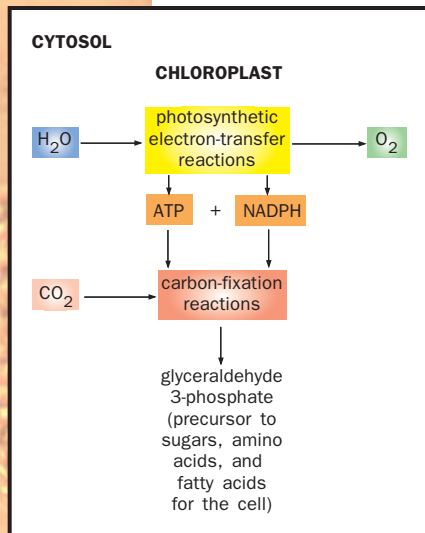

Photosynthesis in a chloroplast.

**ATP** adenosine triphosphate, a high-energy nucleotide used by cells to power most energy-requiring reactions

**protein** complex molecule made from amino acids; used in cells for structure, signaling, and controlling reactions

**ion** an electrically charged particle

**oxidative phosphorylation** use of oxygen to make ATP

oxygen. The energy in light is transferred to these electrons, and is then used to generate adenosine triphosphate (**ATP**) and the electron carrier NADPH. These two products carry the energy and electrons generated in the light reactions to the stroma, where they are used by the dark reactions to synthesize sugars from CO<sub>2</sub>.

### The Light Reaction

The light reactions rely on colored molecules called pigments to capture the energy of light. The most important pigments are the green chlorophylls, but accessory pigments called carotenoids are also present, which are yellow or orange. The accessory pigments capture wavelengths of light that chlorophylls cannot, and then transfer the energy to chlorophyll, which uses this energy to carry out the light reactions. These pigments are arranged in the thylakoid membranes in clusters, along with **proteins** and electron carriers, to form light-harvesting complexes referred to as photosystems. Each photosystem has about two hundred chlorophyll molecules and a variable number of accessory pigments.

In most plants there are two photosystems, which differ slightly in how they absorb light. At the center of each photosystem is a special chlorophyll molecule called the reaction center, to which all the other pigment molecules pass the energy they harvest from sunlight. When the reaction-center chlorophyll absorbs light or receives energy from its accessory molecules, a pair of electrons on it becomes excited. These electrons now carry the energy from light, and are passed to an electron acceptor molecule.

The fate of these electrons depends on which photosystem they arose from. Electrons from photosystem I are passed down a short electron transport chain to reduce NADP<sup>+</sup> to NADPH (which also gains an H<sup>+</sup> ion). Electrons from photosystem II are passed down a longer electron transport chain, eventually arriving at photosystem I, where they replace the electrons given up by photosystem I's reaction center. Along the way, the energy released by the electrons is used to make ATP in a process called photophosphorylation. Many of the molecular details of this ATP-generating system are similar to those used by the mitochondrion in **oxidative phosphorylation**. (Phosphorylation refers to the addition of a phosphate group to adenosine diphosphate [ADP] to form ATP.) Like the mitochondrion, the chloroplast uses an electron transport chain, and ATP synthetase to create ATP.

The end result of excitation of both photosystems is that electrons have been transferred from chlorophyll to NADP<sup>+</sup>, forming NADPH, and some of their energy has been used to generate ATP. While photosystem I gains electrons from photosystem II, the electrons lost by photosystem II have not been replaced yet. Its reaction center acquires these electrons by splitting water. During this process, the electrons in water are removed and passed to the reaction center chlorophyll. The associated hydrogen ions are released from the water molecule, and after two water molecules are thus split, the oxygen atoms join to form molecular oxygen (O<sub>2</sub>), a waste product of photosynthesis. The reaction is:



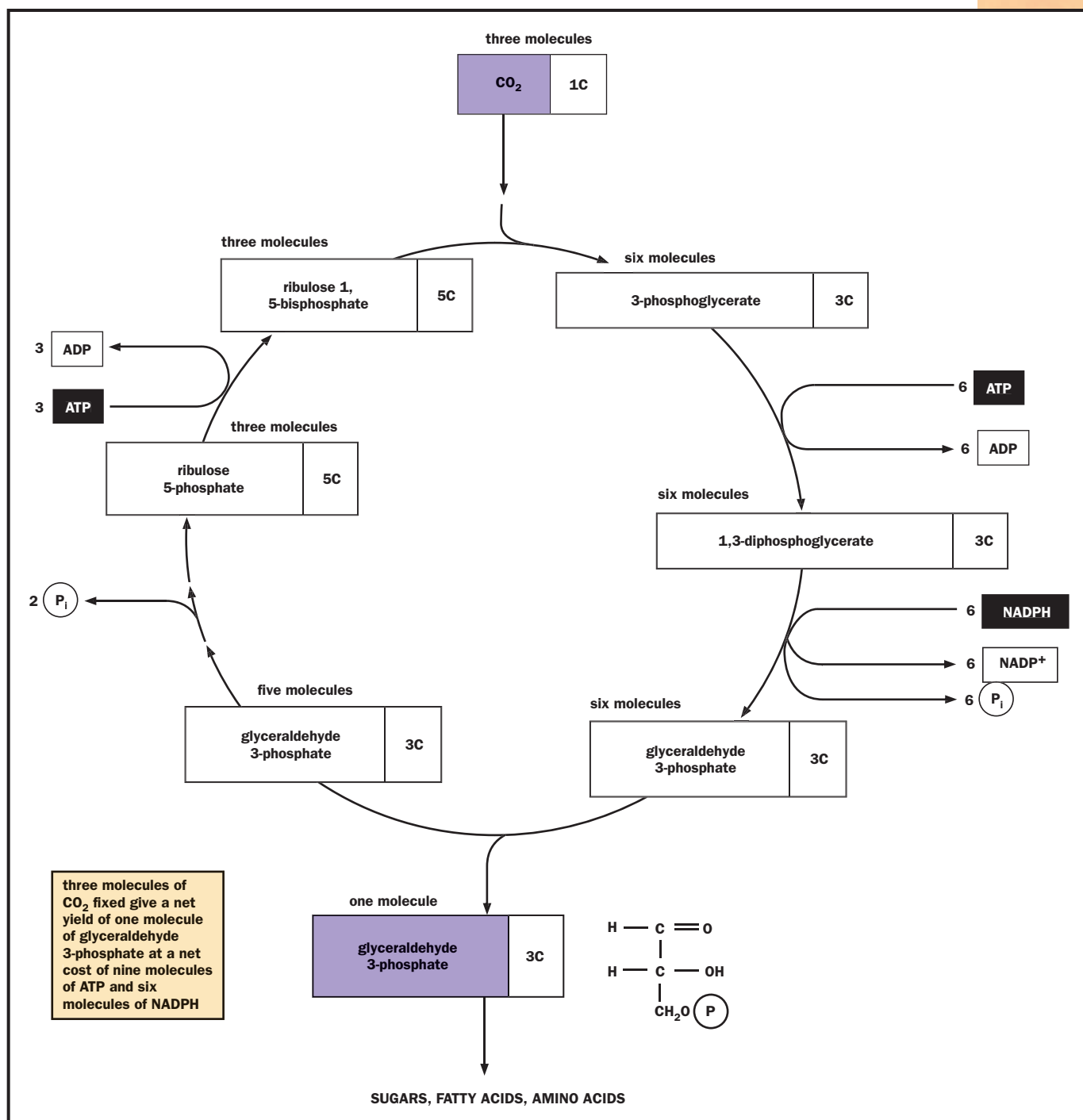

## The Dark Reactions

The NADPH and ATP generated in the light reactions enter the stroma, where they participate in the dark reactions. Energy and electrons provided by ATP and NADPH, respectively, are used to incorporate  $\text{CO}_2$  into carbohydrate via a cyclic pathway called the Calvin-Benson cycle. In this complex pathway, the  $\text{CO}_2$  is added to the five-carbon sugar ribulose bisphosphate to form a six-carbon unstable intermediate, which immediately breaks down to two three-carbon molecules. These then go through the rest

The carbon fixation cycle transforms simple, inorganic compounds of carbon into more complex forms of organic matter.

**glucose** simple sugar that provides energy to animal cells and is the building block of cellulose in plants

of the cycle, regenerating ribulose biphosphate as well as the three-carbon sugar glyceraldehyde phosphate. It takes three turns of the cycle to produce one glyceraldehyde phosphate, which leaves the cycle to form **glucose** or other sugars.

Some plants bind CO<sub>2</sub> into a four-carbon compound before performing the Calvin-Benson cycle. Such plants are known as C<sub>4</sub> plants or CAM plants, depending on the details of the CO<sub>2</sub> capture process. SEE ALSO BIOGEOCHEMICAL CYCLES; C<sub>4</sub> AND CAM PLANTS; CHLOROPLAST; OXIDATIVE PHOSPHORYLATION

David W. Tapley

#### Bibliography

- Bishop, M. B., and C. B. Bishop. "Photosynthesis and Carbon Dioxide Fixation." *Journal of Chemical Education* 64 (1987): 302-305.
- Govindjee, and W. J. Coleman. "How Plants Make O<sub>2</sub>." *Scientific American* 262 (February 1990): 50-58.
- Youvan, D. C., and B. L. Marrs. "Molecular Mechanisms of Photosynthesis." *Scientific American* 256 (June 1987): 42-48.

## Physical Therapist and Occupational Therapist

Physical therapists and occupational therapists are health care professionals who help people with a wide range of diseases, injuries, or disabilities maintain or improve their health and ability to carry out everyday tasks. They assess a patient's overall condition, develop a treatment plan, help the patient carry out the plan, and determine if the plan is working.

Physical and occupational therapists work in hospitals, clinics, schools, long-term care homes, research institutions, and in private practice. Both professions can be physically demanding and require strong interpersonal skills and a solid background in biology, chemistry, physics, psychology, and mathematics. Although some schools still offer four-year baccalaureate degrees, by 2002 (for new physical therapists) and 2007 (for new occupational therapists) all students will have to complete at least a master's degree in their field. After graduation, students must pass a licensing exam in order to treat patients. Students interested in these fields can do volunteer work to learn more about the work and gain experience before committing to a full training program.

Physical therapists work with patients to relieve pain and improve joint mobility, balance, coordination, movement, and overall health. For example, they may help a person recovering from shoulder surgery regain normal range of motion, a stroke patient learn to walk again, or a spinal cord injury patient to become as independent as possible.

Physical therapists use many techniques and tools to accomplish their goals, including exercises, massage, hot and cold packs, ultrasound, electrical stimulation, and assistive devices (crutches, prostheses, and wheelchairs).

Occupational therapists work with patients to improve their ability to carry out activities associated with daily living or employment. For ex-

ample, they may help a person who recently lost his vision learn to navigate his home, a developmentally disabled student participate in school, or a patient with head trauma learn to eat, dress, and bathe again. Occupational therapists use many tools to accomplish their goals, including assistive devices, computers, and a variety of everyday objects. SEE ALSO DOCTOR, FAMILY PRACTICE; MEDICAL ASSISTANT; NURSE; NURSE PRACTITIONER

*John M. Ripper*

### **Bibliography**

- American Occupational Therapy Association. "A Career in Occupational Therapy: A Rewarding Choice in Health Care." *AOTA Student Area*. <<http://www.aota.org/>>.
- American Physical Therapy Association. "A Future in Physical Therapy," *APTA Education*. <<https://www.apta.org/>>.
- Krumhansl, Bernice. *Opportunities in Physical Therapy Careers*. Lincolnwood, IL: VGM Career Horizons, 1990.

## **Physician Assistant**

A physician assistant (PA) career has been rated by *U.S. News and World Report* as one of the fastest growing and most desirable careers for the future. Job opportunities include work in clinics, care for patients in hospitals, and care for patients in nursing homes. Many of the PA job duties are very much like the job of a doctor. Physician assistants see patients, take a history, do a physical exam, make a diagnosis, and decide on the treatment needed. The difference between a physician and a physician assistant is the amount of education required, the physician supervision, and the level of responsibility. Every PA needs to have a supervising physician, someone who oversees his or her work. The PA and physician work together as a team.

Most physician assistant programs require an undergraduate degree in one of sciences, such as biology or chemistry. Many PA programs require certain courses to get into a PA school, such as general biology, microbiology, general and organic chemistry, biochemistry, anatomy, physiology, psychology, and statistics. The PA education is anywhere from two to three years in length after a minimum of three years of college. All PA programs award a certificate of completion at the end of the program. Some programs also award a degree along with the certificate.

Getting into PA school is quite challenging. As of 2000, there were 125 programs in the United States. The class size for each PA program averages thirty-one. In order to be considered, one needs to get good grades in college, at least consistent Bs. Volunteering and working in the health care field, such as in a nursing home, increase one's chances of acceptance into a program. Many prospective students talk with PAs before starting a program so that they get a better idea of what PAs do on the job. SEE ALSO DOCTOR, FAMILY PRACTICE; NURSE; NURSE PRACTITIONER

*Dawn B. Ludwig*

### **Bibliography**

- American Academy of Physician Assistants*. <<http://www.aapa.org/>>.

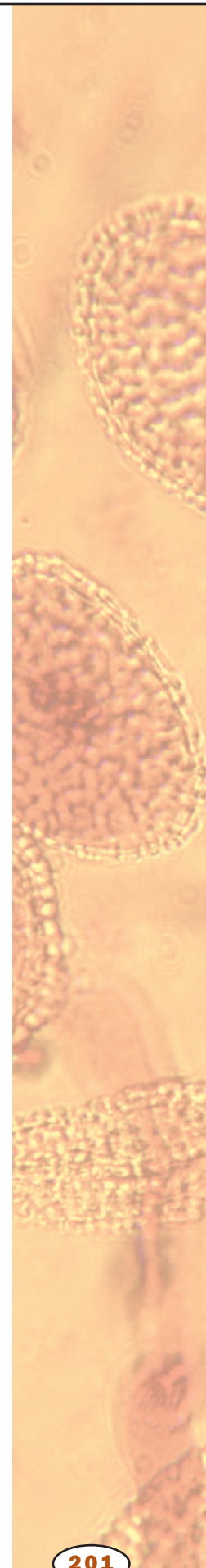

## Physiological Ecology

The earth offers a huge variety of possible environments to inhabit: the hot arid environments of the desert, the salty environment of the oceans, the darkness of the deep sea, low oxygen environments of mountain peaks, and the frigid environments of the Arctic and Antarctic poles. This diversity of living conditions is reflected in the intriguing physiological adaptations developed by animals that live in these environments.

### Adaptions to Cold

Temperature has a widespread impact on design. Two basic approaches to dealing with the challenge of temperature are to either maintain a constant and relatively high body temperature independent of ambient temperature (endothermy) or to let body temperature fluctuate with environmental temperature (ectothermy).

**Endothermy.** Endotherms maintain a high internal temperature through metabolic heat generation. Most of this heat comes from **metabolism** in the gut and brain. In cold weather, increased muscular activity through shivering or simply exercising provides a mechanism to increase metabolic heat production.

Some endotherms, like the arctic fox, are cold-weather specialists. Their most obvious strategy against the cold is insulation provided by a thick layer of fur. Aquatic animals rely predominantly on blubber for insulation as fur loses much of its insulation value upon immersion in water.

Another cold weather strategy is to temporarily decrease metabolic rate and body temperature. This regulated decrease in body temperature decreases the temperature difference between the animal and the air and therefore minimizes heat loss. Furthermore, having a lower metabolic rate is less energetically expensive. Many animals survive cold frosty nights through torpor, a short-term temporary drop in body temperature. Other animals such as marmots take a much more drastic approach: They hibernate through the cold months, letting their body temperature fall to a few degrees above ambient temperature. Contrary to popular belief, bears are not true hibernators as they undergo only a slight drop in body temperature and this activity can only be considered a deep sleep.

**Ectothermy.** Ectotherms, which rely mostly on external sources of heat, adopt much different strategies to the cold. Ectotherms have little or no insulation. This is helpful to gain heat from the environment but ectotherms have difficulty coping with cold temperatures. Without the ability to prevent heat loss, cold-weather ectotherms either must be able to tolerate freezing or to be able to live in sub-freezing environments without ice formation in their bodies. Freeze-tolerant animals like the wood frog can survive the freezing (crystallization) of up to 65 percent of their body water. Freeze-intolerant animals, including many antarctic fish, avoid freezing by having antifreeze compounds in their plasma to lower the freezing and supercooling point of their tissues.

### Adaptations to Heat and Dryness

A major challenge in hot and dry environments is the balance of water and temperature regulation. For endotherms, the main cooling mechanism is

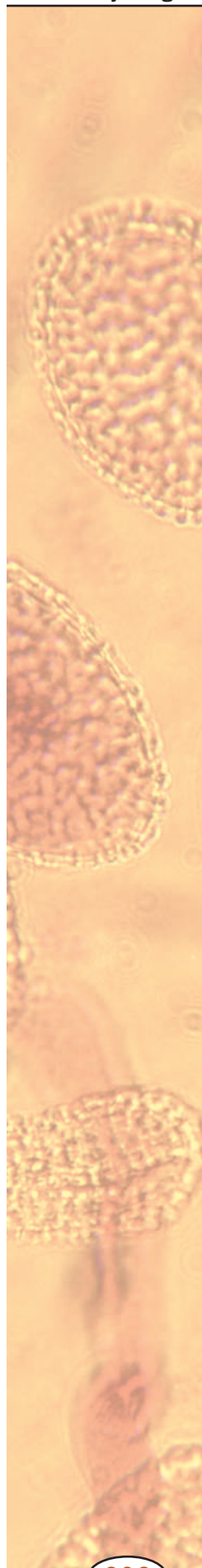

**metabolism** chemical reactions within a cell





An African dromedary. Animals adapted to hot and dry environments have mechanisms for minimizing water loss while surviving the heat.

evaporation of water, either across respiratory surfaces or across the skin in those animals possessing sweat glands (mammals). Animals with a body covered by fur have limited ability to sweat, and rely heavily on panting to increase evaporation of water across the moist surface of the tongue and mouth. Birds have no sweat glands and therefore all birds pant. Animals adapted to hot and dry environments have mechanisms for minimizing water loss while surviving the heat. Interestingly, dense fur on desert inhabitants may also help to insulate the animal from heat gain.

Long loops of Henle of the kidney are another adaptation to arid environments. These long tubes are capable of super-concentrating urine, and enabling desert dwellers such as the kangaroo rat to conserve water. Big noses also help in the heat. A camel's elongated nose is an adaptation to minimize water loss across the respiratory surface of the nasal passages and even to keep the brain cool. Camels also are known to let their body temperature rise during the day and dissipate the extra heat load during the cool night through conduction (contact with a cool surface), which does not require water.

Small animals, with their high surface area-to-volume ratio, are in great danger of heat overload in hot environments. Most small animals therefore remain in burrows during the day and come out at night when the temperature is lower. (The **nocturnal** lifestyle of desert-adapted rodents explains why gerbils keep their owners up at night.)

### Adaptations to Marine Environments

Marine environments pose a similar problem to an arid environment, the lack of fresh water. Bony fish osmoregulate (control salt regulations) in this high-salt environment by drinking seawater and eliminating salt through pumps in the gills. Similarly, marine birds drink seawater and eliminate salt

**nocturnal** characterized by activity at night, or related to the night

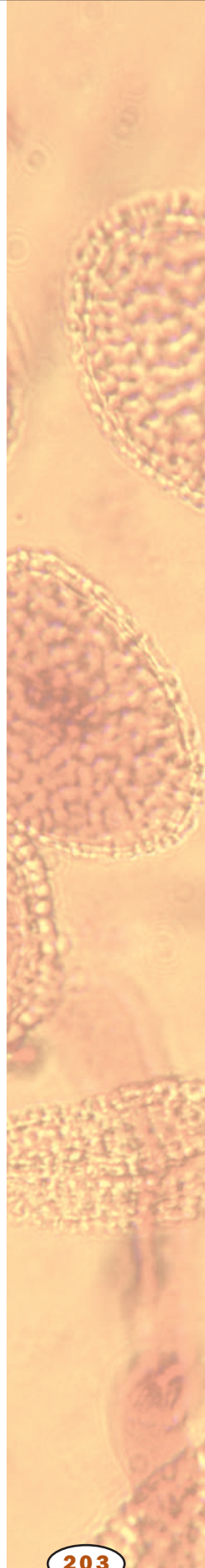

through glands located in their eye orbit. Sharks have the curious arrangement of salt glands in the rectum.

The ocean floor provides the strange environment of high ambient pressure and little or no light. One adaptation to lack of light has been the loss of eyes and pigmentation in some deep-sea fish. Other organisms have adapted to low light levels by possessing bioluminescent systems, either by having luminous organs or carrying bioluminescent bacteria. Such a system is useful for species recognition, luring prey, startling predators and mating. Deep-sea life also requires an adaptation to the extremely high pressure found at depths. Barophilic, or pressure-loving, organisms have adapted ways to avoid problems caused by high pressure. One adaptation is the modification of the set of **lipids** in cell membranes, designed to maintain fluidity despite the high pressure. Relatively pressure-insensitive **enzymes** are also found in organisms that live at great depths.

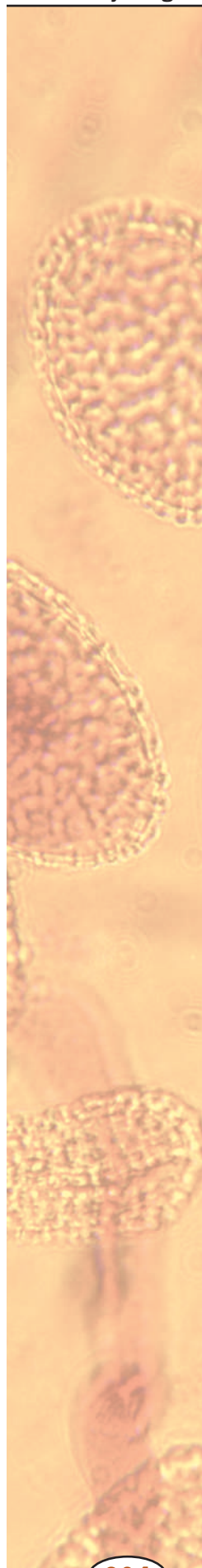

**lipid** fat or waxlike molecule, insoluble in water

**enzyme** protein that controls a reaction in a cell

**hemoglobin** oxygen-carrying protein complex in red blood cells

### Adaptations to Low Oxygen Concentration

Just as high pressure influences organismal design, the low barometric pressure (and thus low oxygen availability) of the skies also presents an evolutionary force on physiology. A dramatic example of high altitude adaptation is seen in the bar-headed goose, a bird whose migration path between India and Tibet requires flight over Mount Everest. Research suggests that these birds maintain a phenomenal blood supply to flight muscles, and their blood has a unique **hemoglobin** structure, which optimizes oxygen transport in high-altitude conditions. Warm, stagnant bodies of water also present a low-oxygen environment and fish inhabiting these waters survive by managing to breathe both air and water. Lungfish, as the name suggests, possess both gills to breathe water and lungs to breathe air. It is likely that an organism similar to this air-breathing fish gave rise to terrestrial vertebrates millions of years ago.

Every organism on Earth represents a successful path to adapting to a specific environment, which helps to explain the impressive biodiversity of life present today. SEE ALSO ADAPTATION; BONY FISH; CARTILAGINOUS FISH; KIDNEY; OSMOREGULATION; TEMPERATURE REGULATION

*Maureen E. Basha*

#### Bibliography

- Fedde, M. R. "High-Altitude Bird Flight: Exercise in a Hostile Environment." *NIPS* 5 (1990): 191–193.
- Hollister, C. D., A. R. M. Nowell, and P. A. Jumars. "The Dynamic Abyss." *Scientific American* (March 1984): 42–53.
- Lee, R. E., Jr. "Insect Cold-Hardiness: To Freeze or Not to Freeze." *Bioscience* 39, no. 5 (1989): 308–313.
- Robinson, M. D. "Beating the Heat." *Natural History* 8 (1993): 27–67.
- Schmidt-Nielsen, K. *Animal Physiology: Adaptation and Environment*, 5th ed. New York: Cambridge University Press, 1990.
- Storey, K. B., and J. M. Storey. "Frozen and Alive." *Scientific American* (December 1990): 92–97.
- Walsberg, G. E. "Small Mammals in Hot Deserts: Some Generalizations Revisited." *BioScience* 50, no. 2 (2000): 109–120.

## Pituitary Gland

The pituitary gland is one of the principal glands of the **endocrine** system. It releases at least nine **hormones** affecting a wide variety of body functions, including growth, reproduction, and levels of **electrolytes** and water in the body fluids. The pituitary sits near the center of the head, behind the nose and beneath the brain, just below the hypothalamus. The hypothalamus is a brain structure from which the pituitary receives chemical signals that control its action. Nerve endings from the hypothalamus stimulate the posterior portion of the pituitary to secrete oxytocin and antidiuretic hormone (ADH). Capillaries from the hypothalamus carry releasing factors and inhibiting factors to the **anterior** portion of the pituitary, stimulating or inhibiting release of eight other hormones (see Table 1). All the hormones of the pituitary gland are peptides, small chains of **amino acids**.

**endocrine** related to the system of hormones and glands that regulate body function

**hormone** molecule released by one cell to influence another

**electrolytes** ions in body fluids

**anterior** toward the front

**amino acid** a building block of protein

### Hormones Released by the Pituitary Gland

Hormone	Site of Action	Effects
<b>Posterior Pituitary</b>		
Oxytocin	uterus breast	stimulates contraction during labor stimulates contraction to express milk
Antidiuretic hormone (ADH)	kidney	stimulates retention of water
<b>Anterior Pituitary</b>		
Corticotrophin (adrenocorticotropic hormone, ACTH)	adrenal cortex	stimulates release of cortisol
Thyroid-stimulating hormone (TSH)	thyroid	stimulates release of thyroxine
Growth hormone (GH)	bone	stimulates growth
Follicle-stimulating hormone (FSH)	female ovaries male testes	stimulates follicle to mature an egg, estrogen production stimulates sperm production
Luteinizing hormone (LH)	female ovaries male testes	stimulates ovulation, progesterone production stimulates testosterone production
beta-Endorphin	brain	reduces pain

Both the hypothalamus and the pituitary are involved in complex **feedback** loops with other glands in the body, sending and receiving hormonal signals to maintain homeostasis. Because of its central role in so many systems, pituitary abnormalities can lead to a variety of disorders. Disorders may lead to either **hyposecretion** or **hypersecretion**. Deficient growth hormone, for instance, leads to dwarfism, while excess causes gigantism. SEE ALSO ENDOCRINE SYSTEM; GROWTH; HOMEOSTASIS; HORMONES; HYPOTHALAMUS

**feedback** process in which the output or result influences the rate of the process

**hyposecretion** lack of secretion

**hypersecretion** excess secretion

*Richard Robinson*

## Plankton

Plankton are small aquatic organisms that live in both freshwater and marine environments. The word “plankton” is derived from the Greek word

Marine plankton. Plankton are a critical food resource for other aquatic organisms that live in freshwater and marine environments.

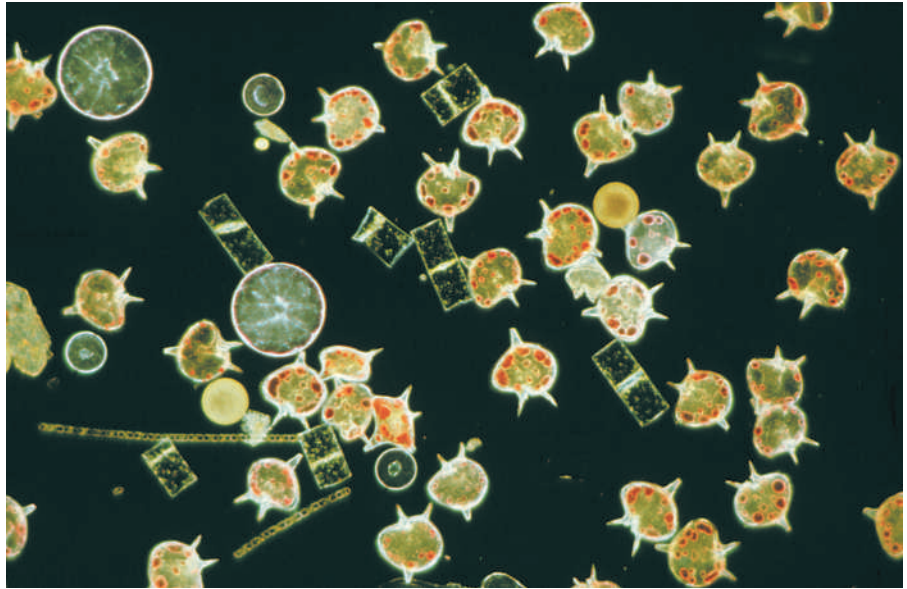

**appendage** attached organ or structure

**phytoplankton** microscopic floating creatures that photosynthesize

**organic** composed of carbon, or derived from living organisms

**food web** set of feeding relations in an ecosystem

**protein** complex molecule made from amino acids; used in cells for structure, signaling, and controlling reactions

**fertilization** union of sperm and egg

*planktos*, which means “drifting.” In general, plankton have little or no means of locomotion and their distribution is determined largely by water currents and mixing. However, some plankton can swim through less turbulent waters using flagella and other **appendages**.

There are several broad categories of plankton. **Phytoplankton** are small plantlike plankton and are commonly referred to as algae. Phytoplankton are primary producers (they use energy from the sun to make **organic** food molecules). Bacterioplankton are very small (only seen through a microscope) and include bacteria, fungi, and viruses. Some bacterioplankton play important roles as primary producers and others as decomposers. Zooplankton are planktonic invertebrate animals (for example, the water-flea *Daphnia*). Some zooplankton consume phytoplankton, whereas others are predatory and consume smaller zooplankton. Ichthyoplankton are planktonic fish eggs and larvae. The ichthyoplankton are highly vulnerable to predation by invertebrate and vertebrate predators.

Plankton are important because they form the base of aquatic **food webs**. That is, plankton are a critical food resource for other aquatic organisms (such as fish) that live in freshwater and marine environments. Plankton are important to humans because they support recreational and commercial fisheries. Some humans consume plankton directly in the form of dietary supplements. For example, the phytoplankton species *Spirulina* has been marketed as a source of vitamins and **protein**.

Plankton are also important in processes that control the distribution and movement of energy and essential nutrients such as carbon, nitrogen, and phosphorus. A significant amount of the total global carbon is stored in the ocean. Some researchers have proposed that it is possible to increase the uptake of carbon dioxide generated by human combustion of fossil fuels by increasing production of ocean plankton through **fertilization**. Researchers debate whether this proposal is practical at a large scale. SEE ALSO ALGAE; BIOGEOCHEMICAL CYCLES; ECOSYSTEM; ESTUARIES; OCEAN ECOSYS-

TEMS: HARD BOTTOMS; OCEAN ECOSYSTEMS: OPEN OCEAN; OCEAN ECOSYSTEMS: SOFT BOTTOMS

Janet M. Fischer

### Bibliography

Hutchinson, G. Evelyn. *A Treatise on Limnology*, vol. 2. New York: John Wiley & Sons, Inc., 1967.

Smith, DeBoyd L. *A Guide to Marine Coastal Plankton and Marine Invertebrate Larvae*. Dubuque, IA: Kendall/Hunt Publishing Company, 1996.

## Plant

Plants (of the kingdom Plantae) are multicellular, eukaryotic organisms that develop from an embryo and that have cell walls and chloroplasts. Plants are distinguished from algae (from which they are descended) by a higher degree of multicellular complexity and from fungi by the ability to photosynthesize (those few plants that have lost this ability evolved from others that could).

### Characteristics of Plants

Almost all plants live on land and have adapted to the conditions on land through the development of a waxy cuticle to prevent drying out, structures to absorb and transport water throughout their bodies (the bryophytes are an exception), and rigid internal support to remain erect without the buoyancy available in water. This rigidity is provided in large part by the cell wall, which is composed of **cellulose**, a **complex carbohydrate**, and **lignin**, a phenolic compound that stiffens the cellulose fibers.

The plant life cycle has two distinct multicellular phases: a **haploid** phase (in which **chromosomes** are present only as single copies) and a **diploid** phase (in which chromosomes are present in pairs). The haploid organism produces **gametes** that fuse to form an embryo, which develops into the diploid organism. The diploid organism produces haploid spores that germinate to form the haploid organism. This “alternation of generations” is found only in plants and some algae.

Almost all plants photosynthesize, using the sun’s energy to power the production of sugar from carbon dioxide and water. Photosynthesis occurs in chloroplasts, membrane-bound **organelles** that contain the green pigment chlorophyll. Chloroplasts are descended from free-living photosynthetic bacteria that became symbiotic partners of ancient single-celled plant ancestors. Evidence of the chloroplast’s bacterial origin is found in the presence of deoxyribonucleic acid (DNA) within it, as well as its size and structure.

The photosynthetic production of sugars by plants is the basis for all terrestrial food chains. Photosynthesis also produces oxygen, needed by animals, fungi, and other organisms (including plants themselves) to release the stored energy in those sugars.

### Diversity

Plants are classified into twelve phyla (sometimes called divisions) in two major groups. The bryophytes are the most primitive group, lacking vascular

**cellulose** carbohydrate made by plants and some other organisms; part of the cell wall

**complex carbohydrate** molecule formed by linking simpler carbohydrates such as sugars

**lignin** organic molecule used in plant cell walls to add stiffness to cellulose

**haploid** having single, nonpaired chromosomes in the nucleus

**chromosome** “colored body” in the cell nucleus; made of DNA and protein, and divided functionally into genes and nongene regions

**diploid** having pairs of chromosomes in the nucleus

**gamete** reproductive cell, such as sperm or egg

**organelle** membrane-bound cell compartment

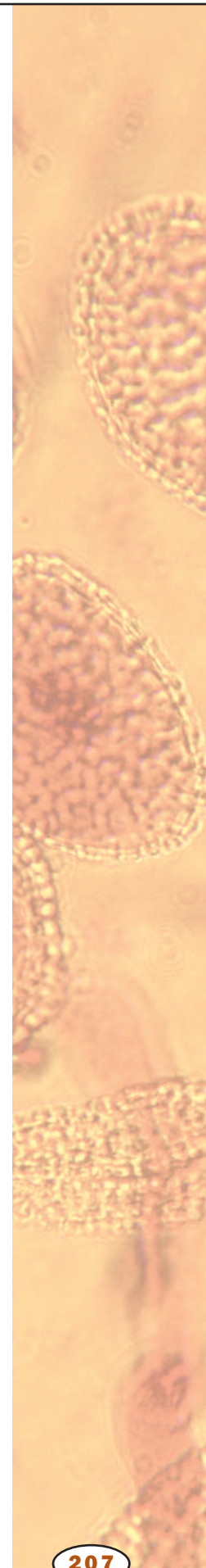

tissues for the transport of water. There are three phyla of bryophytes—the mosses, liverworts, and hornworts—that together comprise about 24,000 species. In contrast, plants in the second group, the tracheophytes, have well-developed vascular systems. The tracheophytes contain nine phyla and are divided into two groups: those without seeds and those with them. Ferns, which reproduce without seeds, contain approximately 13,000 species. Three other phyla of seedless vascular plants (Psilophyta, Lycopodophyta, and Equisetophyta) together include just over 1,000 species.

Seeds are structures that contain an embryo and food reserves wrapped in a protective seed coat. In the **gymnosperms**, the seed develops on structures exposed to the environment. Gymnosperms include Ginkophyta, which contains only one species, *Ginkgo biloba*; Cycadophyta (220 species); Gnetophyta (68 species); and Coniferophyta (588 species). Conifers bear seeds in cones and include many familiar needle-bearing evergreens, such as pine, spruce, and fir. Anthophyta, or angiosperms, enclose their seeds within ovaries. The angiosperms are the flowering plants and are the most diverse of all plant phyla, with about 235,000 species. SEE ALSO ALGAE; ALTERNATION OF GENERATIONS; ANGIOSPERMS; BIODIVERSITY; BRYOPHYTES; FUNGI; GYMNOSPERMS; PTERIDOPHYTES; SEEDLESS VASCULAR PLANTS

*Richard Robinson*

### Bibliography

Raven, Peter, Ray F. Evert, and Susan E. Eichhorn. *Biology of Plants*, 6th ed. New York: W. H. Freeman and Company, 1999.

## Plant Development

Plant development is an umbrella term for a broad spectrum of processes that include: the formation of a complete embryo from a **zygote**; seed germination; the elaboration of a mature vegetative plant from the embryo; the formation of flowers, fruits, and seeds; and many of the plant's responses to its environment. Plant development encompasses the growth and differentiation of cells, tissues, organs, and organ systems. Plant development shares many similarities with developmental processes in animals, but the fact that plants are nonmotile, photosynthetic organisms requires certain novel developmental processes in addition to the common ones.

### Embryo and Seed Development

Embryogenesis, the formation of a multicellular embryo from a single-celled zygote, is one of the most dramatic and best-characterized aspects of plant development. Four key developmental processes take place during embryogenesis. First, the zygote expresses **apical**-basal polarity, meaning that the apical and **basal** ends of the zygote cell differ structurally and biochemically. When the zygote divides, it typically divides asymmetrically, giving rise to a small apical cell with dense **cytoplasm** and a large basal cell with watery cytoplasm. Although these two cells have identical nuclei, their fates differ dramatically. The apical cell gives rise to the embryo itself, while the basal cell gives rise to a short-lived structure called a suspensor and the tip of the root system. The **progeny** of the apical cell grow and divide to form a

**gymnosperms** “naked seed” plants, including conifers

**zygote** fertilized egg

**apical** at the tip

**basal** lowest level

**cytoplasm** material in a cell, excluding the nucleus

**progeny** offspring

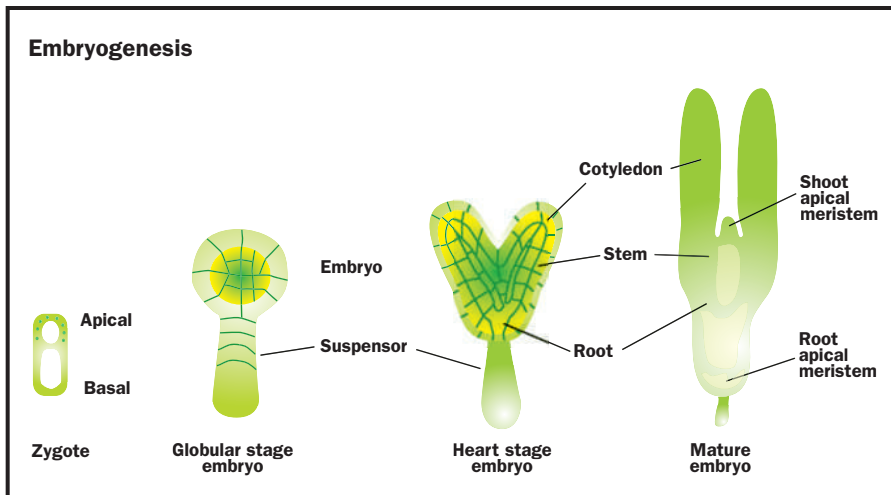

Embryo formation begins with cell division that establishes the apical-basal (top-bottom) axis. Further divisions elaborate on this basic plan, finally forming the cotyledons (seed leaves), as well as the apical meristems of root and shoot.

spherical mass of cells, the globular-stage embryo. Second, differential growth within the globular embryo gives rise to the “heart” stage embryo, the earliest stage when the precursors of **cotyledons**, root, and stem can be recognized. This key embryogenic process is called **organogenesis**. Third, distinctive planes of cell divisions bring about **histogenesis**, the process by which cells within embryonic cotyledons, root, and stem acquire different shapes, forming the precursors of the plant tissue systems. Last, the **apical meristems** of the shoot and root systems are formed at the apical and basal ends of the embryo.

After an embryo has reached full size, developmental changes continue to occur at the cellular level. Embryonic cells, particularly those of the cotyledons, begin to synthesize and store the **proteins**, **lipids**, and starch that will provide the energy and basic building blocks for germination and seedling growth. Next, the embryo begins to desiccate, sometimes losing up to 80 percent of its previous water content, and enters a phase of dormancy. Development and **metabolism** are arrested in dormant embryos, and seeds containing dormant embryos can survive for many years (sometimes centuries) and withstand extreme temperatures and drought.

Plant **hormones** are important regulators of embryogenesis and seed dormancy. The hormones auxin, gibberellic acid, and cytokinin all stimulate growth and are present in the embryo during the stages of embryogenesis. As the embryo matures, these hormones are degraded and abscisic acid is synthesized by the embryo. Abscisic acid provides a developmental signal for the embryo to initiate the synthesis of storage compounds and to undergo **desiccation**. Abscisic acid is present in dormant seeds and is thought to play an important role in maintaining seed dormancy.

## Germination and Seedling Development

Embryo development and metabolism resume upon seed germination. Given the right combination of water availability, temperatures, and light, the desiccated seed begins to take up water and the embryo begins to grow and metabolize again. Some species have specific requirements for germination; for instance, many temperate zone tree species require several weeks of temperatures of 4 degrees Celsius (39.2 degrees Fahrenheit) or less in

**cotyledon** seed leaf, which stores food and performs photosynthesis after germination

**histogenesis** origin or production of tissues

**apical meristem** growing tip from which all plant tissues arise

**protein** complex molecule made from amino acids; used in cells for structure, signaling, and controlling reactions

**lipid** fat or waxlike molecule, insoluble in water

**metabolism** chemical reactions within a cell

**hormone** molecule released by one cell to influence another

**desiccation** drying out

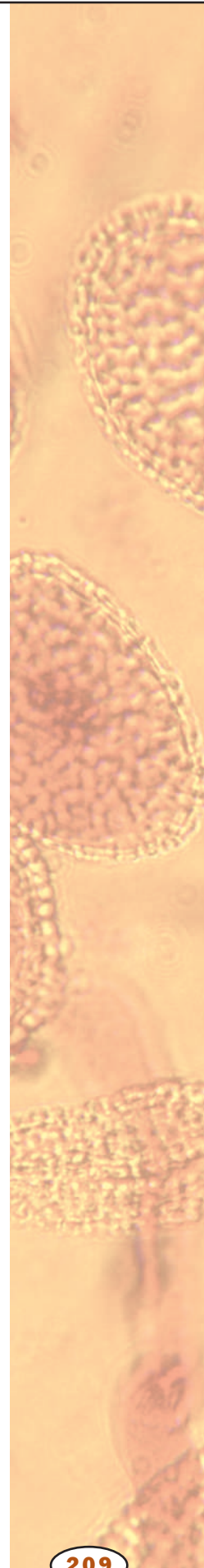

The root is the first portion of the plant to emerge during germination. Growth of the stem behind the cotyledons forms a “hook” that emerges from the soil, followed by emergence of the cotyledons, which begin to photosynthesize to feed further growth.

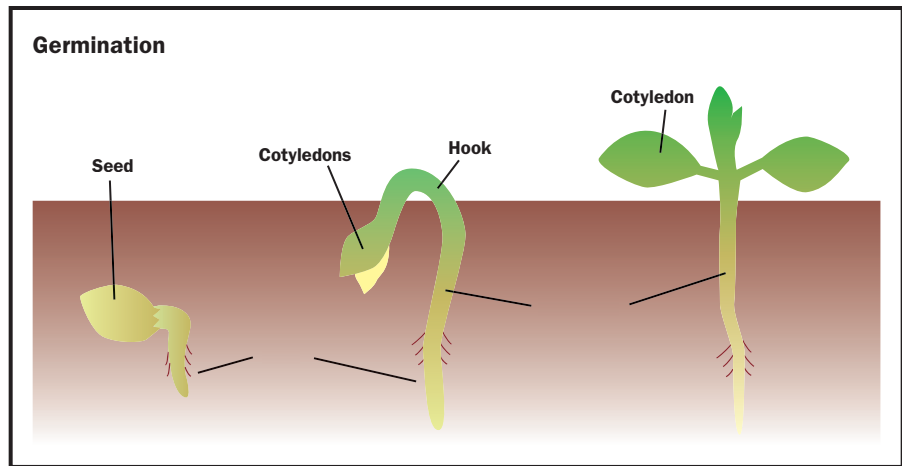

order to germinate. Other species require low levels of light in order to germinate. Once germination is initiated, the embryo follows a typical pattern of development. In many plants, the preformed embryonic root elongates first, forcing its way out of the seed coat and into the soil. Next, the embryonic stem, usually the part below the attachment of the cotyledons (the hypocotyl), elongates. Once the hypocotyl has carried the cotyledons into the light, they expand, providing a broad surface for photosynthesis.

**translation** synthesis of protein using mRNA code

Environmental factors and their **translation** into hormonal signals are important for seedling development. For instance, germination in the dark results in developmental events that help the seedling push its way through the soil into the light. The hypocotyl elongates quickly and maintains a “hook” near its tip that protects the cotyledons and shoot apical meristem region. Cotyledon expansion is suppressed so that they are not damaged as they are pulled through the soil. In contrast, if the same seeds germinate in the light, the hypocotyl hardly elongates at all and does not form a hook, while the cotyledons quickly expand. The hormone gibberellic acid plays an important role in seed germination and early seedling growth. Gibberellic acid induces the synthesis of **enzymes** required for the metabolism of stored foods, thus providing energy for seedling growth. Gibberellic acid also induces cell division and cell expansion in dark-grown hypocotyls, maintaining their rapid growth through the soil.

**enzyme** protein that controls a reaction in a cell

### Apical Meristems and Development

The early stages of germination simply involve the enlargement of the root, hypocotyl, and cotyledons that were preformed in the embryo. Post-embryonic development, however, is focused on the apical meristems. The shoot apical meristem is the source of all the leaves, stems, and their component cells formed during the lifetime of the plant. The meristem itself is composed of a small population of perpetually embryonic (meristematic) cells. These cells grow and divide, giving rise to new cells, but never mature themselves. Thus there is always a source of new cells at the tip of the shoot. The root tip has a similar population of meristematic cells that gives rise to all root tissues. Both of these meristems are characterized by an indeterminate growth pattern: one that is not finite, but, in theory at least, could continue throughout the lifetime of the plant.



Apical meristems are involved in several distinct developmental processes. The meristems are the location of cell proliferation and thus the source of all new cells in the shoot and root systems. The regions below the meristems are the sites of active growth, as new shoot and root tissue rapidly expands. The shoot apical meristem plays a role in organogenesis, the formation of new leaves and axillary buds in a precise spatial pattern. In contrast, the root apical meristem is not involved in organogenesis; **lateral** roots are initiated by pericycle cells, which are themselves derived from the meristem, usually several centimeters away from the meristem. The apical meristems also play a role in histogenesis by giving rise to cells that undergo distinct patterns of differentiation to form the specialized tissue types of the shoot and root. While the embryo initially gives rise to the precursors of dermal, ground, and vascular tissues (protoderm, ground meristem, and procambium, respectively), these tissue precursors continue to be formed by the apical meristems and represent the first stages of cell and tissue differentiation.

### Cell Growth and Cell Division

Growth is defined as an irreversible increase in mass that is typically associated with an increase in volume. Plant cell growth is associated with meristems and must be carefully regulated in order for organogenesis and histogenesis to occur in the appropriate patterns. The plant regulates growth by regulating the **extensibility** of its cell walls. A cell that has nonextensible cell walls can take up some water, but eventually the physical pressure of the water inside the cell pressing out on the cell wall (the **turgor** pressure) prevents the entry of additional water and any further change in volume. In contrast, a cell that has extensible cell walls can take up a substantial volume of water and thus increase in size. Turgor pressure that would otherwise prevent water entry momentarily decreases because the walls keep stretching.

Typically cell growth occurs in small increments: (1) wall extensibility increases, reducing turgor pressure; (2) reduced turgor pressure allows water to enter the cell, increasing cell volume; (3) wall extensibility decreases, allowing the cell to build up turgor and preventing further water entry; and (4) the cell undergoes a cycle of synthesis of cytoplasmic and wall components, adding to the cell's mass. This cycle of incremental growth is repeated many times until the cell reaches its final size.

The plant hormones auxin and gibberellin are produced in the vicinity of the apical meristems and usually act in concert to induce cell growth. Both hormones regulate wall extensibility, but carry out this function in different ways. Auxin induces the activity of cell membrane H<sup>+</sup> adenosine triphosphatase (ATPase) molecules. Proton (H<sup>+</sup>) extrusion lowers the pH of the cell wall, thus activating the cell wall enzyme expansin. Expansin cleaves the **hydrogen bonds** between two cell wall components: The **cellulose** microfibrils and the **hemicellulose** molecules that link adjacent cellulose microfibrils. Breakage of these bonds allows these structural wall components to reposition themselves farther apart, increasing wall extensibility. Gibberellic acid, on the other hand, stimulates the activity of another cell wall enzyme called xyloglucan endotransglycosylase (XET). Xyloglucans are a type of hemicellulose that is cleaved by the XET enzyme. Breakage of the

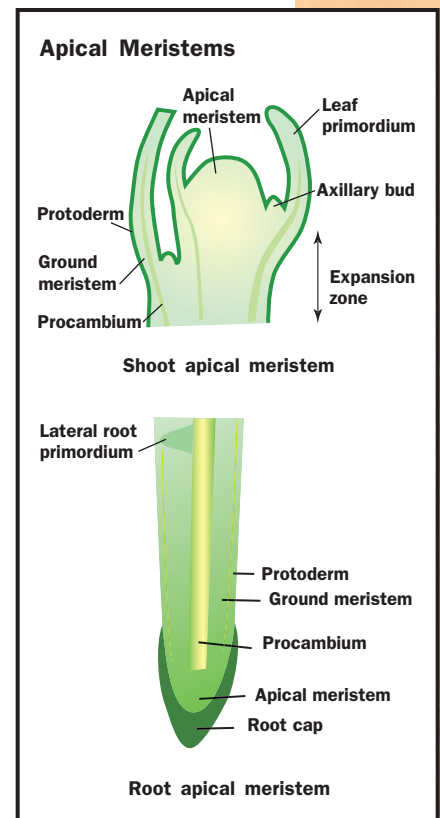

Structure of root and shoot apical meristems.

**lateral** side-to-side

**extensibility** ability to expand or grow larger

**turgor** internal pressure

**hydrogen bond** weak bond between the H of one molecule or group and a nitrogen or oxygen of another

**cellulose** carbohydrate made by plants and some other organisms; part of the cell wall

**hemicellulose** complex carbohydrate related to cellulose and found in cell walls of plants and some other organisms

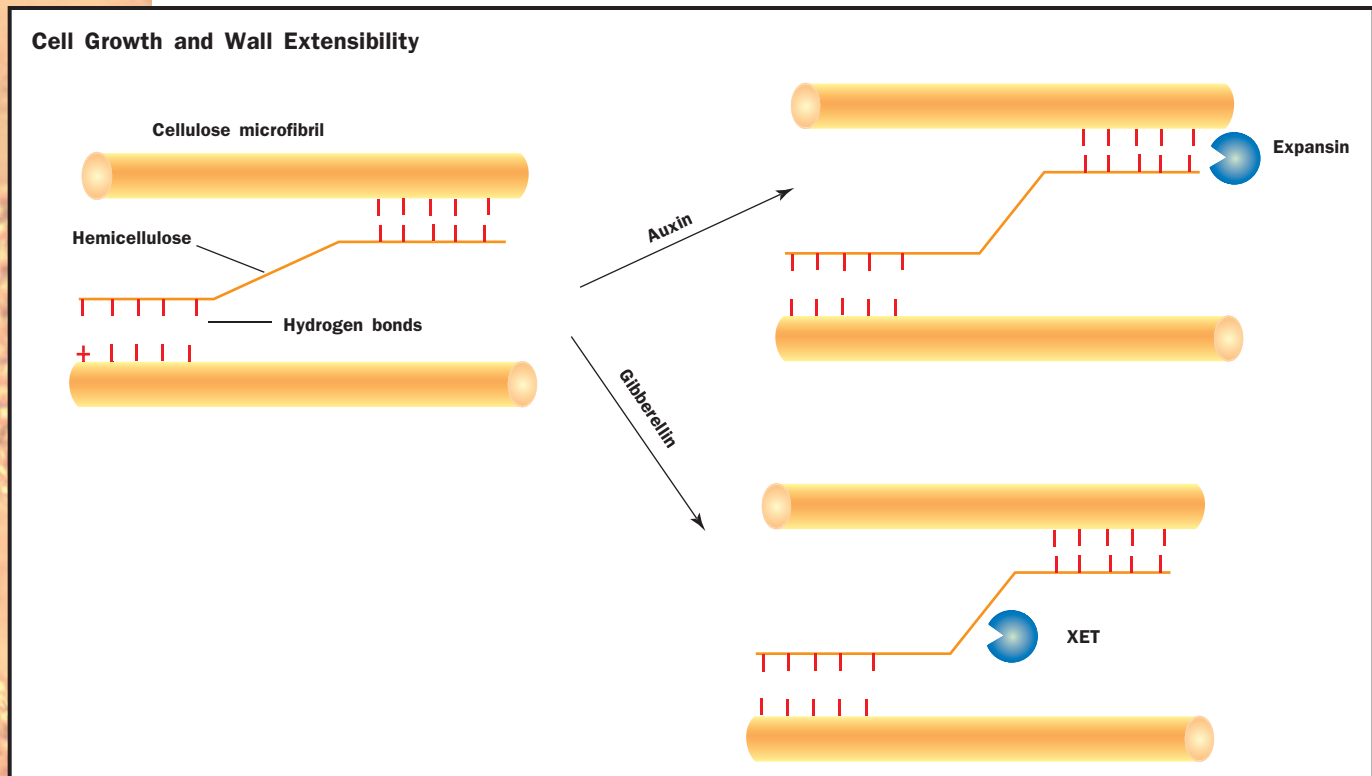

The hormones auxin and gibberellin each promote cell expansion by loosening the bonds between adjacent cell wall molecules. Each hormone acts on a different molecular target.

hemicellulose molecules also allows the cellulose microfibrils to move farther apart, increasing wall extensibility.

Cell division and cell growth are often tightly linked. When the rate of cell division is balanced by cell growth, as in the apical meristems, average cell size does not increase. As the meristem grows away from earlier formed cells, the ratio of growth to division increases, resulting in overall cell enlargement. As the tissues mature further, cell division ceases completely, giving rise to zones of pure cell enlargement where most of the visible growth of the plant occurs. This relationship between division and growth, coupled with observations of the predictable planes of cell division during histogenesis, indicates that cell division is carefully regulated during plant development.

Molecules called cyclin-dependent **kinases** (CDKs) are key regulators of cell cycling (including cell division) in plants. CDKs are activated by association with a regulatory subunit called a cyclin and by **phosphorylation** and dephosphorylation events. The plant hormone cytokinin appears to regulate the **cell cycle** by interacting with the CDKs. Cytokinins enhance the synthesis of the cyclin subunits that are required for the cell to enter the deoxyribonucleic acid (DNA) synthesis phase of the cell cycle. Cytokinins also enhance the CDK dephosphorylation step that is required for the cell to progress into **mitosis**. Both of these processes are inhibited by the hormone abscisic acid; thus a “developmental tug-of-war” occurs between a division-enhancing hormone and a division-suppressing hormone. The delicate balance between them determines the rate of cell division and this type of interaction is probably typical of the hormonal regulation of many aspects of plant development.

**kinase** enzyme that adds a phosphate group to another molecule, usually a protein

**phosphorylation** addition of the phosphate group  $\text{PO}_4^{3-}$

**cell cycle** sequence of growth, replication, and division that produces new cells

**mitosis** separation of replicated chromosomes

## Differentiation

Differentiation is the process whereby cells, tissues, and organs become different from each other and from their precursors. The concept can be applied to organogenesis since cotyledons, foliage leaves, **sepals**, and petals may all develop from similar appearing precursors, the leaf primordia. As these organs mature, they become different from each other in size, shape, and the development of distinctive cell types. For instance, the epidermis tissue of petals is sharply differentiated from that of cotyledons, foliage leaves and sepals that are photosynthetic organs. Correlated with a photosynthetic function, the epidermis of these organs is made up of flat, transparent cells that allow the penetration of light into internal tissues. Specialized **guard cells** that allow CO<sub>2</sub> to enter the leaf are also present. In contrast, the epidermal cells of petals contain brightly colored carotenoid or anthocyanin pigments. These cells also have a **papillate** shape that imparts a velvetlike sheen to the petal surface. Since petals carry on minimal photosynthesis, they often lack guard cells.

The process of differentiation is best understood on a cellular level. For instance, guard cells are highly specialized epidermal cells. Early in the development of a leaf, protodermal precursor cells undergo a distinctive pattern of cell divisions. At first the cell divisions are asymmetric, producing one large and one small derivative. The large derivative stops dividing and differentiates as an unspecialized epidermal cell, while the small derivative undergoes another asymmetric division. At an unknown stop signal, the small derivative undergoes a symmetric division, giving rise to two equal sized cells that become the guard cells. Unlike their plain neighbors, these cells develop a distinctive kidney shape, unevenly thickened cell walls, large, conspicuous chloroplasts, and finally form a pore (the **stomatal** aperture) between them.

## Uniqueness of Plant Development

Although plants share many features of development with animals such as apical-basal polarity, regulation of the balance between cell growth and cell division, formation of distinctive patterns of organs, cells and tissues, and differentiation, some aspects of development are unique to plants. Among these are:

- The formation and maintenance of the perpetually embryonic regions, the apical meristems. The meristems have an indeterminate growth pattern that result in the occurrence of growth, organogenesis, and histogenesis throughout the life of the plant.
- Plant cells have rigid cell walls that prevent cell movement. Thus organogenesis and histogenesis must occur through differential growth and regulation of the planes of cell division. Cell-cell communication is important in plant development, but cell recognition is likely less important than it is in animals since plant cells keep the same neighbors throughout their life.
- Plant cells are totipotent; that is, able to differentiate as a different cell type if given the appropriate stimulus. Totipotency is likely a reflection of the plant's sedentary lifestyle. Plants can't escape predators and other kinds of damage, but they can readily repair wounds

**sepal** whorl of flower organs outside of the petals, usually green and serving to protect the flower before it opens

**guard cells** paired cells on leaves that control gas exchange and water loss

**papillate** small, nipple-like projection

**stomata** openings in leaves for gas exchange, surrounded and regulated by guard cells

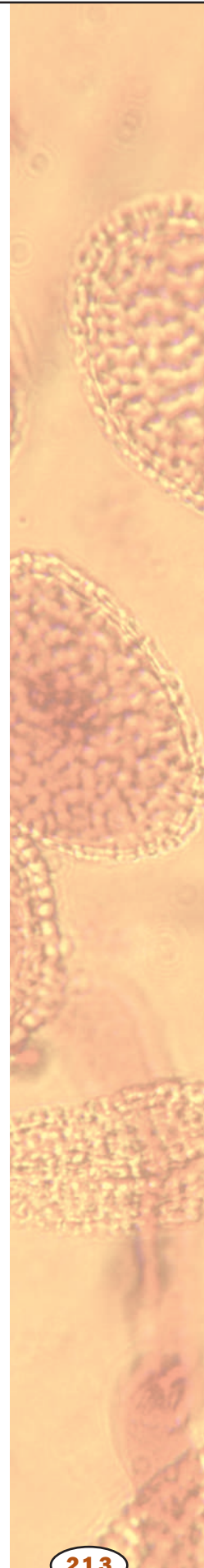

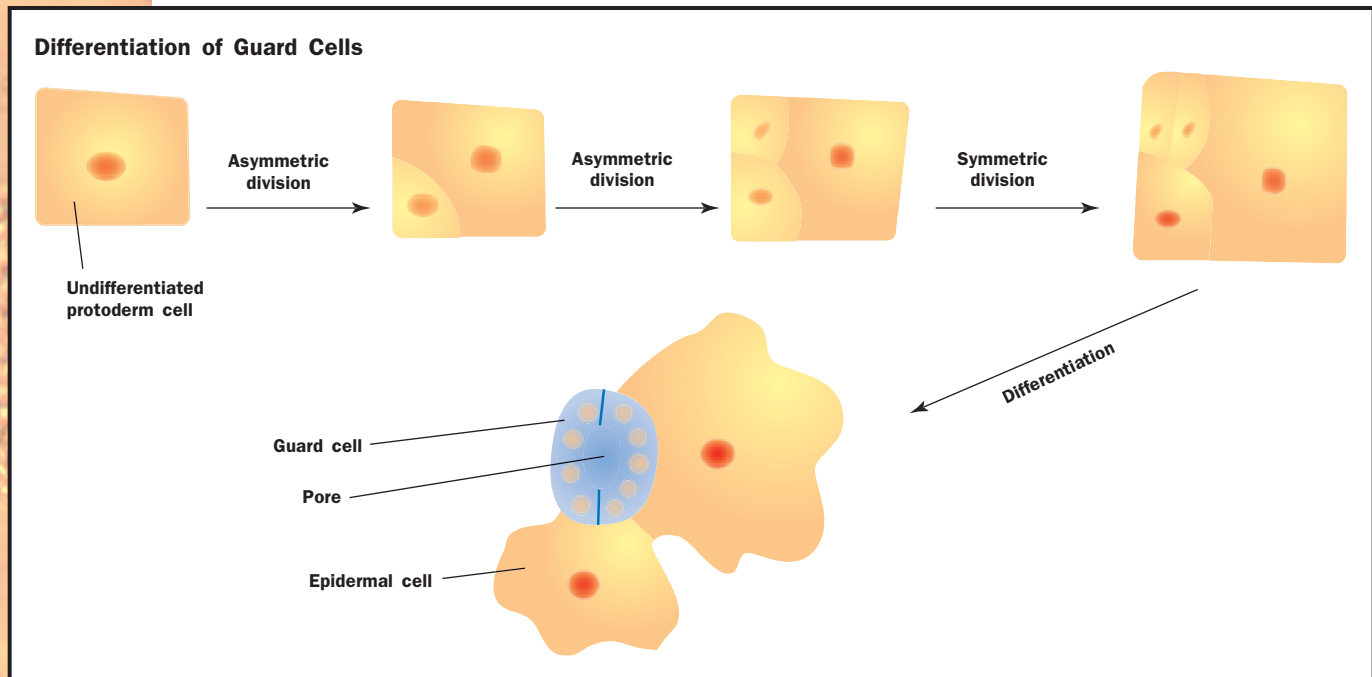

Guard cells regulate passage of gasses into and out of the leaf through pores in the surface. Guard cells form by a series of cell divisions from undifferentiated protoderm, including a final symmetric division that forms the two identical cells.

and reconnect vascular strands by differentiating the appropriate cell types. SEE ALSO CELL CYCLE; CELL WALL; FLOWERS; HORMONES, PLANT; LEAVES; PHOTOPERIODISM; REPRODUCTION IN PLANTS; ROOTS; SEEDS; SHOOTS

Nancy G. Dengler

#### Bibliography

Raven, Peter H., Ray F. Evert, and Susan E. Eichhorn. *Biology of Plants*, 6th ed. New York: W. H. Freeman and Company, 1999.

Steeves, Taylor A., and Ian M. Sussex. *Patterns in Plant Development*. New York: Cambridge University Press, 1989.

Wolpert, Lewis. *Principles of Development*. New York: Oxford University Press, 1998.

## Plant Nutrition

**organic** composed of carbon, or derived from living organisms

**inorganic** not bonded to carbon

**C4 and CAM plants** plants that employ accessory systems for trapping carbon for photosynthesis

Green plants, unlike animals, are able to manufacture their major **organic** constituents entirely from **inorganic** raw materials that are obtained from soil, water, or atmosphere using energy provided by photosynthesis. Of over fifty elements found in plant tissues, only sixteen are considered essential nutrients for all plants. Of these sixteen, nine are macronutrients, and seven are micronutrients. Macronutrients are required in high amounts and each is present at levels of greater than 0.2 percent of plant dry weight. Most macronutrients are important constituents of organic molecules, and most have more than one role. Micronutrients are required in small amounts often have special purposes. The seven known micronutrients each make up less than 0.1 percent of plant dry weight. A few other elements (nickel, silicon, and sodium) are considered essential only for some plants. Soybeans require nickel; horsetails require silicon; **C4 and CAM plants** require sodium.

## Essential Elements for Proper Plant Nutrition: Roles, Available Forms, and Deficiency Symptoms

Essential Element*	Role	Symbol	Form absorbed	Deficiency symptoms	Leaves affected
<b>Macronutrients</b>					
<b>Hydrogen</b>	Component of organic compounds and water; chemiosmotic synthesis of ATP in mitochondria and chloroplasts	H	H <sub>2</sub> O		
<b>Carbon</b>	Component of organic compounds	C	CO <sub>2</sub>		
<b>Oxygen</b>	Component of organic compounds and water; electron acceptor in respiration	O	O <sub>2</sub> , CO <sub>2</sub> , H <sub>2</sub> O		
<b>Nitrogen</b>	Component of proteins, phospholipids, nucleic acids, some hormones, and chlorophyll	N	NO <sub>3</sub> <sup>-</sup> , NH <sub>4</sub> <sup>+</sup>	Plants stunted; foliage light green, roots long and slender	Old
<b>Potassium</b>	Enzyme activator, involved in starch formation; regulates osmotic balance and movement of guard cells	K	K <sup>+</sup>	Stems slender, numerous small necrotic spots form near the margins of leaves	Old
<b>Calcium</b>	Component of middle lamella (Capectate); controls activity of many enzymes; maintains membrane integrity; 2nd messenger	Ca	Ca <sup>2+</sup>	Plants stunted; terminal bud dies; young leaves hooked; root tips die	Young
<b>Magnesium</b>	Component of chlorophyll; component of middle lamella (Mg-pectate); activates many enzymes	Mg	Mg <sup>2+</sup>	Leaves with chlorotic spots; tips and margins of leaves turned upward	Old
<b>Phosphorus</b>	Component of nucleic acids, phospholipids, coenzymes; involved in sugar metabolism	P	H <sub>2</sub> PO <sub>4</sub> <sup>-</sup> HPO <sub>4</sub> <sup>2-</sup>	Plants stunted, foliage purple/dark green	Whole plant affected
<b>Sulphur</b>	Components of the amino acids cysteine and methionine; component of coenzyme A	S	SO <sub>4</sub> <sup>2-</sup>	Young leaves light green, no necrosis	Young
<b>Micronutrients</b>					
<b>Chlorine</b>	Involved in water balance; possibly involved in photosynthetic reactions in which O <sub>2</sub> is released	Cl	Cl <sup>-</sup>	Leaves wilted, chlorotic, ultimately necrotic; roots thickened	Whole plant affected
<b>Iron</b>	Component of cytochromes ferredoxin and nitrogenase; cofactor of peroxidase; involved in chlorophyll synthesis	Fe	Fe <sup>2+</sup> , Fe <sup>3+</sup>	Stunted growth; interveinal chlorosis of young leaves	Young
<b>Boron</b>	May be involved in sugar transport; regulates enzyme function	B	H <sub>2</sub> BO <sub>4</sub>	Terminal bud dies; leaves may be twisted, base of young leaves chlorotic; root tips discolored	Young
<b>Manganese</b>	Activator of enzymes; involved in electron transfer, chlorophyll synthesis, and the photosynthetic evolution of O <sub>2</sub>	Mn	Mn <sup>2+</sup>	Interveinal necrosis of young leaves	Young
<b>Zinc</b>	Activates many enzymes; involved in the formation of pollen	Zn	Zn <sup>2+</sup>	Stems with short internodes; leaves thick; leaf margins distorted	Old
<b>Copper</b>	Component of plastocyanin; present in lignin of xylem elements; activates enzymes	Cu	Cu <sup>+</sup> , Cu <sup>2+</sup>	Young leaves permanently wilted; foliage dark green; terminal branches unable to stand erect	Young
<b>Molybdenum</b>	Involved in nitrogen reduction	Mo	MoO <sub>4</sub> <sup>2-</sup>	Young leaves twisted, chlorotic	Young

\*Elements are listed in order of decreasing number of atoms relative to molybdenum.

For an element to be considered an essential nutrient, it must meet the following three criteria: (1) The element must be necessary for normal plant development through a complete life cycle; (2) no other element can substitute for that element; and (3) the element must play a role in **metabolism** within the plant. Studies to demonstrate whether an element is essential

**metabolism** chemical reactions within a cell

**electron transport system** membrane-bound system of proteins that extracts energy from high-energy electrons, found in mitochondria and chloroplasts

**mitochondria** subcellular organelle that creates ATP used for energy-requiring processes in a cell

**middle lamella** layer of material between two plant cells that holds them together

**minerals** iron, calcium, sodium, and other elements needed by living organisms

**enzyme** protein that controls a reaction in a cell

**protein** complex molecule made from amino acids; used in cells for structure, signaling, and controlling reactions

**guard cells** paired cells on leaves that control gas exchange and water loss

**stomata** openings in leaves for gas exchange, surrounded and regulated by guard cells

**ion** an electrically charged particle

**gradient** difference in concentration between two places

**anthocyanins** colored compounds made by plants

**phloem** plant tissue that conducts sugars from leaves to roots and other tissues

are often very difficult to conduct. Special hydroponic culture in growth chambers that eliminate contamination from the air allows scientists to eliminate a particular element and determine plant response to the deficiency.

## Roles of Nutrients

**Structural and Metabolic Components.** Carbon, hydrogen, and oxygen comprise a major portion of organic compounds that make up plant cells. Nitrogen and phosphorus are found in phospholipids and nucleic acids. Copper and iron are components of **electron transport systems** in **mitochondria** and chloroplasts. The **middle lamella** that cements adjacent plant cells together is rich in calcium and magnesium pectate. Magnesium is also a component of chlorophyll.

**Enzymatic Role.** Many **minerals** serve as **enzyme** activators. Potassium, for example, is involved in the activation of many enzymes. Calcium binding **protein** (calmodulin) regulates many cellular activities. Manganese is essential in the photosynthetic release of O<sub>2</sub> in photosystem II.

**Osmotic Role.** Potassium plays a major role in opening and closing movements of **guard cells** of the **stomatal** apparatus. Hydrogen **ion gradients** are important in the generation of adenosine triphosphate (ATP) in mitochondria and chloroplasts.

## Deficiency Symptoms

Chlorosis, a yellowing of leaf and stem tissue, is a common symptom of mineral deficiencies. In nitrogen deficiency a general chlorosis is exhibited, but in iron-deficient plants, chlorosis is confined to areas between leaf veins. Occasionally, plants will develop a purple coloration due to the production of large amounts of **anthocyanins**, when certain elements, such as phosphorus, are deficient. Necrosis (death of tissue) may follow chlorosis as deficiencies become more acute. In potassium-deficient plants necrosis occurs along leaf margins, but in manganese-deficient plants necrosis occurs between veins.

For several essential nutrients, young leaves show symptoms first, which means that the element is not easily translocated from old to young leaves, as is the case with iron deficiency. Nitrogen, potassium, and magnesium are easily loaded into sieve tube members of the **phloem** and translocated from old leaves to younger developing leaves. In those cases the older leaves exhibit the symptoms. SEE ALSO C4 AND CAM PLANTS; CHLOROPLAST; PHOTOSYNTHESIS; TRANSLOCATION

*George H. Wittler*

### Bibliography

Raven, Peter H., Ray F. Evert, and Susan E. Eichhorn. *Biology of Plants*, 6th ed. New York: W. H. Freeman and Company, 1999.

## Plant Pathogens and Pests

Plants, being immobile, are unable to escape pests (herbivores) that eat them, or microorganisms (pathogens) that cause plant diseases. On a global basis, it is estimated that plant diseases annually cause an 11 to 16 percent reduc-

tion in the value of rice, wheat, corn, and potato harvests. Additional losses to these major food crops as a result of pests (primarily insects and mites) are estimated at 9 to 21 percent. The magnitude of these losses, despite people's best efforts at prevention, are of major concern.

## Diseases

Diseases of plants are caused by fungi, bacteria, viruses, mollicutes, and **nematodes**. Fungi are eukaryotic, spore-bearing, heterotrophic organisms that produce extracellular **enzymes** to break down plant or animal products to small molecules (for example, sugars and **amino acids**), which they absorb as nutrients. Fungi may grow as unicellular yeasts, but more commonly they grow as multicellular chains of elongated cells that form threadlike structures collectively called mycelium. Important diseases caused by fungi include Dutch elm disease, apple scab, and wheat stem rust. Fungilike protists (primitive eukaryotic microorganisms) also cause many serious diseases, of which the best known is the late blight of potato, which caused the Irish potato famine in the 1840s. Since the 1980s, late blight (caused by *Phytophthora infestans*) has become the single most important biological constraint to global food production and the cause of one of the biggest uses of pesticides.

Bacteria, although differing from fungi in being unicellular **prokaryotic** organisms, also cause disease by extracellular digestion of plant tissues. These bacteria are highly infectious and are easily spread on seed and by wind-blown rain, irrigation water, and insects. Fire blight of apple and pear, caused by *Erwinia amylovora*, is a serious problem because the bacterium is so easily spread by rain and insects. Most bacterial plant pathogens survive as **saprophytes** living on crop debris and in soil. Mollicutes, which can be described as prokaryotes lacking cell walls, cause diseases of plants by living within the **phloem** cells from which they obtain their nutrients. Mollicutes are very effectively carried from plant to plant by insects in which they can also reproduce.

The viruses that cause plant diseases are also often carried by insects and other pests, as well as by **grafting** and on cutting tools, machinery, or in seed. Most such viruses consist of ribonucleic acid (RNA), surrounded by a **protein** coat (the capsid). A few plant pathogenic viruses contain deoxyribonucleic acid (DNA) rather than RNA. All viruses are **intracellular** and are **obligate parasites** as they are dependent on the plant cell for their reproduction.

Plant pathogenic nematodes are small (approximately 1-millimeter long) wormlike animals that live in soil and feed on plant roots by piercing the cells with a needlelike structure called a stylet through which they suck up the cell contents. Nematodes, which may feed from outside or inside the root, cause enormous damage to roots, thus reducing nutrient and water uptake. Root knot nematodes, one of the most damaging pathogens, stimulate division and expansion of root cells to create "galls" in which the female nematodes remain to feed and produce eggs.

**nematode** worm of the Nematoda phylum, many of which are parasitic

**enzyme** protein that controls a reaction in a cell

**amino acid** a building block of protein

**prokaryotic** without a nucleus

**saprophyte** plant that feeds on decaying parts of other plants

**phloem** plant tissue that conducts sugars from leaves to roots and other tissues

**grafting** attachment and fusing of parts from different plants

**protein** complex molecule made from amino acids; used in cells for structure, signaling, and controlling reactions

**intracellular** within a cell

**obligate** required or necessary, especially referring to a metabolic process or mode of nutrition

**parasite** organism living in close association with another from which it derives most of its nutrition

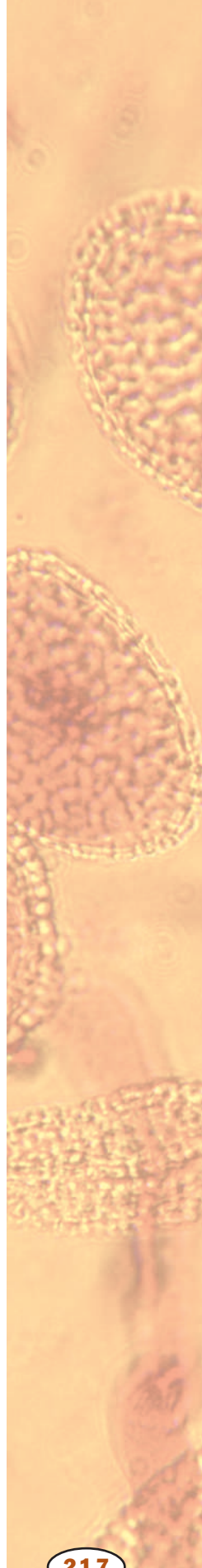

**arthropods** organisms with jointed appendages and exoskeletons, including insects, spiders, and crustaceans

Stink bugs have the ability to emit a foul-smelling substance from a pore on each side of their thorax. They often have symbiotic relationships with bacteria, which aids the insect in the production of nutrients.

## Pests

Plant pests include the **arthropods** (such as insects and mites), slugs, snails, sowbugs, and pillbugs. Only a small proportion of insects are plant pests with the most conspicuous being the butterflies and moths. The larvae (caterpillars) of butterflies and moths cause severe damage by feeding on foliage until they pupate. The adults rarely feed on foliage. The most common butterfly pest in North America is the cabbage white, which is seen in great numbers in the summer. Beetles also damage plants as both larvae and adults chew on plant tissue. The Colorado potato beetle is the most notorious of these pests. Juvenile (nymphs) and adult grasshoppers are also foliage-eating insect pests. Larvae of flies feed and burrow into roots, bulbs, and stems of plants and thus cause considerable damage.

The least conspicuous insect pests are those that pierce the stem or leaf and suck nutrients from the plant. Nymphs and adults of aphids, leaf hoppers, stink bugs, and plant bugs cause extensive damage in this manner and, as well, they carry plant pathogens, especially viruses, from plant to plant. Insects called thrips also pierce plant parts and are important in transmitting viruses.

Mites differ from insects, as the adults have four pairs of legs (versus six for insects) and lack an antennae. Larvae of mites feed and molt to form six-legged nymphs before becoming adults. The mites that feed on plants have rasping and sucking mouth parts that damage plants and they also transmit plant pathogens as they feed. Both thrips and mites are very small and, as a result, often avoid detection until the plant growth is visibly affected.

Damage to plants caused by slugs and snails is very obvious, but is generally limited to crops growing in very damp situations and those, such as strawberries, in contact with the soil. Slugs and snails glide on an obvious slime trail of secreted mucus and feed at night, or on very cloudy days, to avoid drying out. Also at home in damp environments are the sowbugs and pillbugs. These oval (pill-sized) bugs have a small head, two pairs of antennae, and seven pairs of legs. These species are more important as decomposers of rotting vegetation than as plant pests.

## Control

Crop management to reduce damage by diseases and pests is based on integrated control strategies involving exclusion, eradication, and protection. Whenever possible, growers attempt to exclude the pathogen or pests from their land by purchasing pathogen- and pest-free planting material (seeds, seedlings, grafting material, tubers, and bulbs). When a pathogen or pest is present in fields or orchards, every effort is made to eradicate it by cultivation practices designed to “starve” the organism, for example, by planting a crop on which it can not obtain nutrients. When such methods fail, pesticides may be required to reduce pathogen populations; for example, nematocides to kill root-knot nematodes. Many pests and pathogens (for example, apple scab and wheat stem rust fungi, fire blight bacterium) are, however, so widespread and so readily distributed from field to field that exclusion and eradication are impossible. Ideally, for these problems, plant varieties that are genetically resistant to the pathogen or pest are available.



Alternatively, growers may be able to reduce crop losses by cultural practices that make the environment unfavorable for the agent; for example, spacing plants to prevent the high humidity conducive to plant disease. If such methods are unsuccessful, the grower may be required to use biological control (for example, the bacterium *Bacillus thuringiensis* for moth and beetle control) or chemical pesticides (fungicides to control late blight of potato, or insecticides to control grasshoppers). Bioengineering techniques are enhancing researchers' ability to produce genetically resistant crop plants, and this technology will eventually decrease reliance on chemical pesticides. SEE ALSO DNA VIRUSES; EUBACTERIA; FUNGI; INSECT; NEMATODE; SECONDARY METABOLITES IN PLANTS; VIRUS

Verna J. Higgins

### Bibliography

Borror, Donald Joyce, and Richard E. White. *Peterson Field Guide to Insects*. Boston: Houghton Mifflin, 1998.

*Insect Biology and Ecology: A Primer*. <<http://www.nysaes.cornell.edu/ent/biocontrol/info/primer.html>>.

*Plant Disease Lessons*. <[http://www.apsnet.org/education/phi\\_index.html](http://www.apsnet.org/education/phi_index.html)>.

Schumann, Gail L. *Plant Diseases: Their Biology and Social Impact*. St. Paul, MN: The American Phytopathological Society, 1991.

## Plant Pathologist

Plant pathologists specialize in the study of the nature, cause, and control of the diseases of plants. Plant pathologists are employed by colleges and universities, agricultural businesses, research organizations, government agencies, private enterprises, and as self-employed practitioners. They teach and conduct research; provide advice on the diagnosis and control of plant diseases; manage greenhouses, parks, golf courses, and farms; and serve as sales representatives and administrators.

A career as a plant pathologist typically begins with a Bachelor's degree in one of the chemical, biological, or physical sciences. Coursework or a major in plant pathology will result in greater employment opportunities. High school preparation should include four years of science and math. Preparation for most professional positions will include specialized graduate work leading to a master of science and/or doctor of philosophy degrees (Ph.D.). Graduate plant pathology specialties include virology, bacteriology, mycology, molecular plant pathology, epidemiology, biological control, and diagnosis. Individuals interested in a career in plant pathology should contact the plant pathology department at a university. SEE ALSO BOTANIST; MICROBIOLOGIST; PLANT PATHOGENS AND PESTS

John R. Steele

### Bibliography

*Dr. Nelson's Page*. University of Arizona—Department of Plant Pathology. <<http://ag.arizona.edu:80/PLP/feculty/nelson.html>>

*Plant Pathology/Disease Online*. The American Phytopathological Society (APSnet). <<http://www.apsnet.org>>.

*Plant Pathology Specialities*. University of Florida. <<http://128.227.207.24/Specialities/plpSpecialities.htm>>.

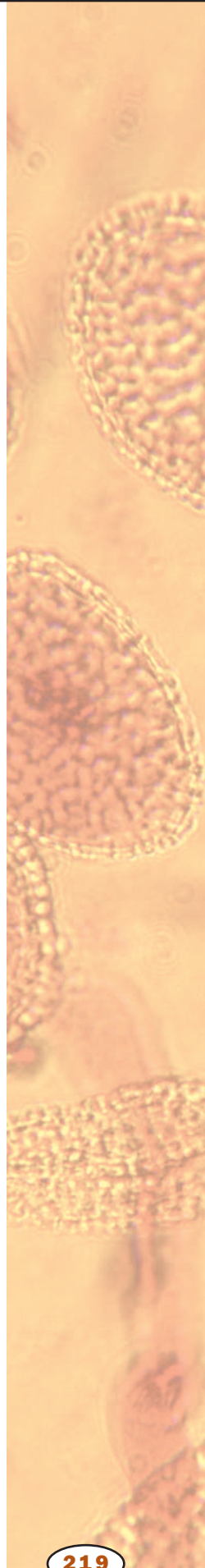

**prokaryote** single-celled organism without a nucleus

**lipid** fat or waxlike molecule, insoluble in water

**intracellular** within a cell

**solute** dissolved substance

**bilayer** composed of two layers

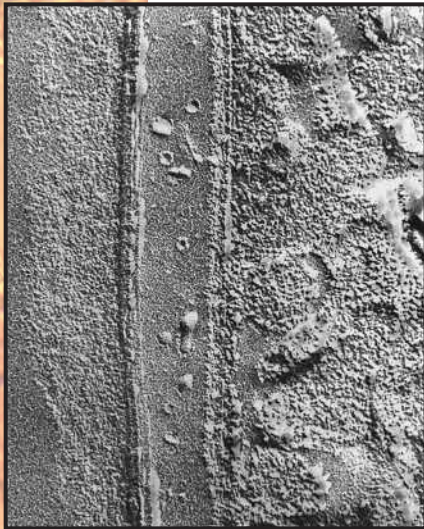

Freeze fracture image across the cell wall and membrane of a blue-green alga.

**glucose** simple sugar that provides energy to animal cells and is the building block of cellulose in plants

**amino acid** a building block of protein

**ion** an electrically charged particle

**gradient** difference in concentration between two places

**metabolism** chemical reactions within a cell

**neuron** nerve cell

**action potential** wave of ionic movement down the length of a nerve cell

## Plasma Membrane

Plasma membranes envelop all plant and animal cells and all single-celled eukaryotes and **prokaryotes**, separating them from their environments. Structurally, they resemble other cellular membranes, but differ slightly in their **lipid** composition and more drastically in their protein content from one cell to another and from **intracellular** membranes. These compositional similarities and differences, in turn, are reflected in the ways in which plasma membranes carry out their functions, facilitating **solute** transport, conducting signals, and anchoring cells to their environments.

### The Roles of Membrane Proteins

Like other membranes, plasma membranes are essentially lipid **bilayers** and exhibit a dynamic organization and fluidity characteristic of such “liquid crystalline” structures. The predominant lipids found in most plasma membranes include phospholipid and glycolipid; those in animal cells also contain significant amounts of cholesterol. Since cholesterol is a stiff, planar molecule and is thought to have a stabilizing influence on plasma membranes, scientists speculate its presence represents an adaptation by animal cells to the absence of the external cell wall that surrounds bacterial and plant cells. Plasma membranes also contain protein and glycoprotein in addition to lipid, of both the integral and peripheral varieties. These proteins perform the major functions associated with plasma membrane and they account for the major differences in plasma membranes among different cells of an organism.

Plasma membranes transport nutrients into (and out of) cells and are responsible for facilitating the removal of carbon dioxide, the waste product of respiration. To perform these functions, they contain integral membrane proteins (IMP) that serve as carriers for **glucose** and a variety of **amino acids** and for  $\text{HCO}_3^-$  (bicarbonate, the soluble form of carbon dioxide). All cells typically maintain cytoplasmic concentrations of  $\text{Na}^+$  (sodium) and  $\text{K}^+$  (potassium) at very different levels than found in their immediate environment: higher in the case of  $\text{K}^+$  and lower in the case of  $\text{Na}^+$ . These **ion gradients** are maintained by another group of IMP called pumps, which actively transport these ions up their gradients, using energy supplied by **metabolism**.

Membranes are also leaky to these ions, which diffuse across the plasma membrane and down their respective gradients through another class of IMPs called channels. Differences in the rates of ion diffusion produce differences in electrical charge across most membranes; these are measured as small differences in voltage and are called resting potentials. In so-called excitable cells, such as muscle fibers and **neurons**, channels may be opened by changes in resting potentials (or by signaling molecules binding to them). When this happens a wave of change in electrical potential may pass along the plasma membrane over the entire surface of the cell; these are called **action potentials** and represent the major way our nerves and sense organs communicate.

Proteins integral to plasma membranes are involved in other forms of signaling as well. In these instances, an external signaling molecule, such as a hormone, binds very selectively to that portion of the IMP extending into

the external environment (often involving the **carbohydrates** attached to the IMP). Such IMPs are more commonly called receptors, which differ in their binding specificity for various signaling molecules. When binding occurs, the receptor changes its overall structure (its **conformation**) and that portion projecting into the cytoplasm becomes reactive in some manner. The cytoplasmic region might become an activated **enzyme** or it might, in turn, become “sticky” for a soluble cytoplasmic enzyme. In any event, the presence of an external signal is conveyed across the plasma membrane and is amplified by the activation of cytoplasmic enzymes, which continue the signaling process by producing second messengers.

Under certain circumstances, the cytoplasmic “tails” of receptors are anchored to peripheral membrane protein components of the **cytoskeleton**, and the binding of a molecule to the extracellular surface releases the receptor from its anchorage. The IMP is then free to diffuse in the plane of the membrane and may become associated with other peripheral membrane proteins in the cytoplasm and **aggregated** into a specialized region of the plasma membrane called a coated pit. The coated pit then invaginates and forms a **vesicle**, by a process called endocytosis that removes the receptor (and its attached signal) from the cell surface.

## Cell Junctions

Integral membrane proteins of the plasma membranes also anchor cells to their environment: that is, to neighboring cells and to the proteins and glycoproteins of the extracellular environment (the extracellular **matrix** or ECM). The cytoplasmic portions of these IMP in turn are usually attached to peripheral membrane components of the cytoskeleton (such as microfilaments and intermediate filaments). Although these IMPs are not usually called receptors, their binding with the IMP of an adjacent cell or with the peripheral membrane proteins of the ECM is very selective, and a complex terminology has developed to characterize the very specific nature of these cell-cell and cell-matrix interactions and the IMP involved.

Anchoring IMPs also resemble receptors insofar as changes in cell-cell and cell-ECM interactions mediated by these IMPs are often associated with changes in the cytoplasmic regions of the IMP, in this case to their attachments with the cytoskeleton. In this manner, some cells move from place to place (by changing their anchorage points), either normally in the case of circulating leukocytes and abnormally in the case of metastasizing cancer cells.

Clusters of anchoring IMPs and their cytoskeletal elements are often referred to as desmosomes when the associations involve other cells and hemidesmosomes when the clusters attach to the ECM. Certain intercellular IMP associations are so tight they effectively seal adjacent cells to each other (without causing fusion of their membranes), forming so-called tight junctions. Tight junctions are especially common in epithelial tissue where their presence in bands around all the epithelia cells produces a very effective barrier against leakage of materials across the tissue through the extracellular space.

Finally, certain IMPs may self-associate to form large, nonselective channels in the plasma membrane; such channels arise in close association with identical channels in neighboring cells, establishing cytoplasmic continuity among the cells so connected. These junctions are called gap junctions and

**carbohydrates** sugars, starches, and other molecules combining carbon, hydrogen, and oxygen and serving as fuel or structural components

**conformation** three-dimensional shape

**enzyme** protein that controls a reaction in a cell

**cytoskeleton** internal scaffolding in a cell, composed of protein

**aggregate** clump together

**vesicle** membrane-bound sac

**matrix** a network, usually of threadlike fibers

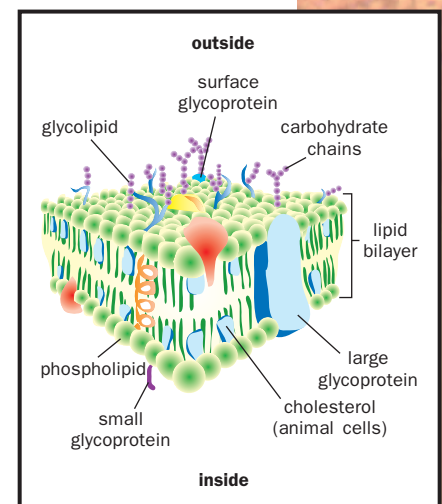

The plasma membrane is composed of a bilayer of phospholipid molecules, plus large numbers of embedded proteins, many of which have attached sugar molecules (glycoproteins). Animal cells also contain cholesterol, which increases rigidity.

they are thought to represent a major means of communications among neighboring cells making up a specialized tissue.

Receptors and anchoring IMPs, and the plasma membranes containing them, differ respectively in the signals they can receive, in the second messengers they produce and in the selective nature of their anchorages. To a lesser extent, this is true of transport IMPs as well. These IMPs are the products of differential gene activation and they thus represent a major way in which specialized cells differ from each other. SEE ALSO CELL JUNCTIONS; MEMBRANE STRUCTURE; MEMBRANE TRANSPORT

Chris Watters

### Bibliography

Raven, Peter H., Ray F. Evert, and Susan E. Eichhorn. *Biology of Plants*, 6th ed. New York: W. H. Freeman and Company, 1999.

## Platyhelminthes

**phylum** taxonomic level below kingdom, e.g., arthropod or chordate

**bilaterally symmetric** symmetric, or similar, across a central line

**parasite** organism living in close association with another from which it derives most of its nutrition

**cilia** short, hairlike cell extensions of the cell membrane formed by the cytoskeleton

The **phylum** name Platyhelminthes literally means “flatworms.” Members of this phylum are soft, thin-bodied, leaf or ribbonlike worms, including the familiar planaria of ponds and streams, as well as the flukes and tapeworms parasitic in human and other animal bodies. Some defining characteristics of the phylum are that flatworms are acoelomate (they have no body cavity), triploblastic (the body has three tissue layers), and **bilaterally symmetric** (they have symmetric right and left sides and usually a definite head), and they have organ systems, including an excretory, digestive, reproductive, and nervous system, but no respiratory system.

The class Turbellaria includes all free-living members of the phylum, as well as a few **parasites**. It includes many marine forms, whose beautiful colors serve as a warning of their toxicity to would-be predators, as well as the more drab freshwater planarians (*Dugesia*). Some Turbellaria can swim by undulations of the body margins, but most of them glide gracefully over surfaces along a trail of mucus, pushed by **cilia** on their ventral surface.

The class Trematoda, commonly called flukes, are unsegmented parasitic flatworms that usually parasitize a snail as an intermediate host (in which they reproduce asexually) and a human or other vertebrate as a definitive host (in which the worms mate and lay eggs). Many species have other hosts between these two, such as fish or frogs. Trematodes usually have a pair of suckers for crawling and clinging to the host’s tissues. Many humans are infected with blood flukes, liver flukes, lung flukes, and other trematode parasites of great medical importance.

The Cestoda, commonly called tapeworms, are segmented, ribbonlike parasites usually found as adults in the small intestines of vertebrate animals. Unlike the other classes, they have no digestive tract, for they can absorb predigested nutrients from the host’s intestine. The body consists of a long chain of segments, each with its own reproductive system. The anterior end is a knoblike holdfast called a scolex, equipped with suckers and often hooks for attachment to the host’s intestine. In general, tapeworm infections are not as medically serious as trematode infections, but some tapeworms can be lethal. SEE ALSO ANIMALIA; BODY CAVITIES; NEMATODE; PARASITIC DISEASES; SYMBIOSIS

Kenneth S. Saladin

### HYMAN, LIBBIE HENRIETTA (1888–1969)

U.S. zoologist famous for her authoritative six-volume treatise on invertebrates, whose own specialty was hydras and flatworms. Hyman went to college despite her family’s objections. In her last years, she lived off the royalties from her textbooks and worked at the American Museum of Natural History.

**Bibliography**

- Pechenik, Jan A. *Biology of the Invertebrates*, 4th ed. Boston: McGraw-Hill, 2000.
- Schmidt, Gerald D., and Larry S. Roberts. *Foundations of Parasitology*, 6th ed. Dubuque, IA: McGraw-Hill Higher Education, 2000.

**Poisonous Plants**

Poisonous plants contain substances that can cause sickness or death if those substances are ingested or come into contact with the body of an animal. These substances are often referred to as “secondary compounds.” Primary

**Some Plants Poisonous to Humans and Animals**

Plant name and occurrence	Poisonous plant parts and toxins	Comments
Alfalfa ( <i>Medicago sativa</i> ) - forage and silage	leaves and stems - phytoestrogenic compounds, saponins, bloat-causing proteins	livestock, poultry: bloat, photosensitization (sickness after ingesting plant and subsequent exposure to sunlight), phytoestrogens cause infertility, reduced egg-laying in poultry
Astragalus ( <i>Astragalus lentiginosus</i> ) - rangeland plant	above-ground plant parts - alkaloid: swainsonine	livestock: locoism (erratic behavior), birth deformities, abortion, and (above 2120 m) contributes to congestive heart failure in cattle
Castor bean ( <i>Ricinus communis</i> ) - garden plant	seeds and to a lesser extent the leaves - toxalbumin: ricin	humans, livestock, pets: illness and death; chewing a single seed may sicken a child
Crown-of-thorns ( <i>Euphorbia milii</i> ) - house plant	plant juices or sap - toxic diterpenes including 5-deoxyingenol	humans and pets: irritant in the sap causes irritation of the skin, eyes, mouth
Johnson grass ( <i>Sorghum halepense</i> ) - outdoor weedy grass	leaves and stems - cyanogenic glycoside: dhurrin; nitrate accumulation	livestock: in the animal body dhurrin is converted to cyanide (which may be lethal); can accumulate excessive amounts of nitrates causing death, abortion
Kochia ( <i>Kochia scoparia</i> ) - outdoor and garden plant	leaves, flowers, and seeds - alkaloids, oxalates, and saponins	livestock: photosensitization
Oleander ( <i>Nerium oleander</i> ) - house and garden plant	leaves and stems - glycosides: oleandrin, nerioside	livestock and humans: nausea, vomiting, dizziness, death (e.g. poisoning of humans after eating hot dogs roasted on oleander sticks)
Poison ivy ( <i>Rhus radicans</i> ), Poison sumac ( <i>Rhus vernix</i> ), Western poison oak ( <i>Rhus diversiloba</i> ), - outdoor plants	plant sap - allergin: urushiol containing catechols	humans: allergic reaction causing dermatitis, blisters (many humans develop symptoms after only one exposure); sap contaminates clothing, tools, etc.
Rhubarb ( <i>Rheum raponticum</i> ): - food plant	leaf blade, not the leaf stems - oxalic acid	livestock and humans: leaf stems (petioles) are edible; leaf blades contain oxalic acid crystals causing nausea, vomiting, abdominal pain
Spotted water-hemlock ( <i>Cicuta maculata</i> ) - outdoor plant	all parts, especially roots - alkaloids: cicutoxin, cicutol	animals and humans: most violently toxic plant in North America; symptoms can appear suddenly causing spasms, coma, and death

**metabolism** chemical reactions within a cell

compounds are chemicals involved in basic **metabolism**, whereas secondary compounds are chemicals that are generally waste products of metabolism. Secondary plant compounds, the toxic substances, have coevolved in higher plants in response to attack by herbivorous insects for over one hundred million years. Animals are poisoned when the animals' protection mechanisms (detoxification) are inadequate.

Secondary compounds include chemicals such as alkaloids, glycosides, oxalates, saponins, tannins, and toxalbumins. These chemicals are toxic in various ways to vertebrates. Some responses are dramatic (violent spasms, death) or subtle (reduced weight gain, birth defects). Other chemicals are only toxic after being altered inside the animal body (for example, cyanogenic glycosides, which produce cyanide) or if the animal is exposed to the sun (photosensitization). Researchers continue to discover new toxins from plants.

In 1986 it was estimated that poisoning of cattle, sheep, and horses grazing western U.S. rangelands cost ranchers \$190 million per year. Most cases of human poisoning involve house and garden plants. In 1998 there were 122,578 plant-related calls to poison control centers in the United States, according to information from the American Association of Poison Control Centers. Only 109 of those cases were serious (but included four fatalities).

Some cases of plant poisoning are remarkable. During the nineteenth century tragic loss of human life occurred from a mysterious milk sickness in which cattle ingested white snakeroot and a toxin was passed on to humans through the milk. In 1971 near Garrison, Utah, more than twelve hundred sheep died after ingesting the rangeland plant halogeton. Although these toxic compounds are harmful to most species that ingest them, some insects are not harmed by some of the toxins and actually sequester the poison in their own body as a defense against their own predators.

*Derek Bishop Munro*

When white snakeroot is eaten by livestock, it can cause a sickness known as trembles. Symptoms in animals include depression, inactivity, labored breathing, loss of weight, and trembling.

### Bibliography

Keeler, Richard F., Kent R. Van Kampen, and Lynn F. James, eds. *Effects of Poisonous Plants on Livestock*. New York: Academic Press, 1978.

Munro, Derek B. *Canadian Poisonous Plants Information System*. <<http://sis.agr.gc.ca/poison/>>. Agriculture and Agri-Food Canada, 1993.

Spoerke, David G., and Susan C. Smolinske. *Toxicity of Houseplants*. Boca Raton, FL: CRC Press, 1990.

## Poisons

Poisons are substances that are harmful to living organisms. It is said that "the dose makes the poison" because almost any substance can be poisonous at high enough concentrations, especially many substances used as medicines.

Poisons include compounds of biological origin and chemicals manufactured by humans. Biological poisons, also known as toxins, are produced by some members of every living kingdom, including bacteria, fungi, protists, plants, and animals. The chemical industries produce thousands of chemicals, many of which are poisonous. Regulation of workplace exposure to these is the responsibility of the Occupational Safety and Health Agency,

or OSHA. The Environmental Protection Agency (EPA) oversees cleanup of toxic wastes and spills.

## Exposure

There are three major routes of exposure for poisons: absorption through the skin, inhalation into the lungs, and ingestion in the gut. Skin forms a barrier against many poisons, but its large surface area provides a route of entry for liquids especially. Inhalation provides a rapid route of entry directly into the bloodstream for small, **volatile** molecules. The **enzymes** and acids of the gastrointestinal tract inactivate some ingested poisons, but the long transit time and high surface area of the gut mean that an ingested poison is likely to enter the bloodstream if not inactivated.

Most poisons act acutely, meaning their toxic effects come on very quickly after exposure. In contrast, heavy metals such as lead and mercury accumulate slowly in the fatty tissue of the body, and chronic exposure to low doses can cause poisoning.

## Mechanisms

Poisons disrupt metabolic processes or destroy tissue through chemical reactions with cells. While the number of specific mechanisms of action is large, there are several broad means by which many poisons exert their effects. The list below is not comprehensive.

**Oxygen Deprivation.** The brain consumes large amounts of oxygen and cannot survive if deprived of it for more than ten minutes. Oxygen deprivation may occur if the respiratory muscles cannot deliver adequate air to the lungs, if the lungs cannot absorb adequate oxygen from the air, or if the blood cannot carry the oxygen to the brain.

Barbiturates and benzodiazepines, drugs prescribed as sedatives, depress activity in the brain center that controls the respiratory muscles, thus preventing those muscles from working sufficiently. Respiratory muscle paralysis may be caused by ingestion of botulinum toxin, one of the most poisonous substances known. It is formed by the bacterium *Clostridium botulinum*, a contaminant of improperly canned food. Botulinum toxin prevents release of acetylcholine by **neurons** at the neuromuscular junction. Without this neurotransmitter, the respiratory muscles cannot contract.

Absorption of adequate oxygen can be interrupted when otherwise harmless gases, such as nitrogen or carbon dioxide, are present in high concentration. In 1986, a massive release of dissolved carbon dioxide from Lake Nyos in Cameroon, Africa, asphyxiated eighteen hundred people in the surrounding villages. **Hemoglobin** carries oxygen in the bloodstream. Carbon monoxide binds to hemoglobin, displacing oxygen and preventing its transport. Carbon monoxide is produced by combustion and is found in car exhaust and furnace smoke.

**Cardiac Toxicity.** The heart muscle relies on chemical signals to control the rate and force of its contractions. Digitalis, derived from the foxglove plant, is prescribed for congestive heart failure to increase heart output. In slightly larger doses, it is deadly. Related compounds are produced by

**volatile** easily vaporized

**enzyme** protein that controls a reaction in a cell

**neuron** nerve cell

**hemoglobin** oxygen-carrying protein complex in red blood cells

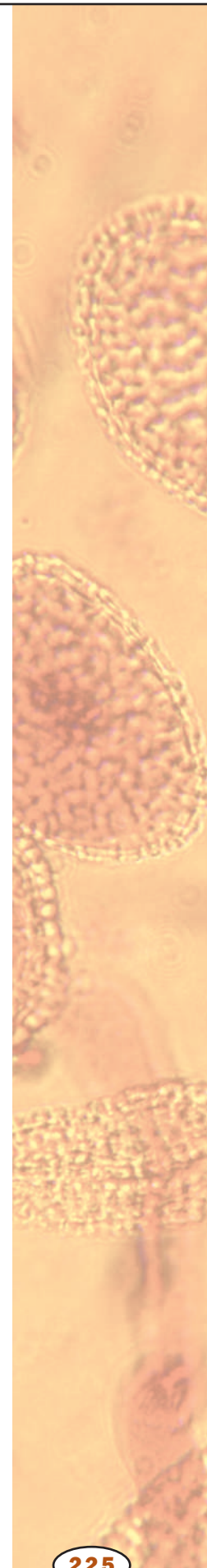

Digitalis, derived from the foxglove plant, is prescribed for congestive heart failure to increase heart output. In slightly larger doses, it is deadly.



**mitochondria** subcellular organelle that creates ATP used for energy-requiring processes in a cell

**oxidative phosphorylation** use of oxygen to make ATP

**protein** complex molecule made from amino acids; used in cells for structure, signaling, and controlling reactions

**ion** an electrically charged particle

various South American frogs of the genus *Dendrobates*, and are used on arrow tips for hunting.

**Mitochondrial Poisons.** Most cells in the body are supplied with fuel by subcellular structures called **mitochondria**. One step of the energy-producing reactions, **oxidative phosphorylation**, relies on electron-carrying **proteins** called cytochromes. Cyanide binds permanently to these cytochromes, preventing them from carrying electrons and thus inactivating them. Another step in these reactions requires a buildup of **H<sup>+</sup> ions** across the mitochondrial membrane. Dinitrophenol, a chemical used in dye manufacture, is a membrane-soluble H<sup>+</sup> carrier. By carrying H<sup>+</sup> ions across the mitochondrial membrane, dinitrophenol interrupts this step. Impaired energy production affects all cells, especially brain and heart cells.

**Liver and Kidney Poisons.** The liver is the principal site of poison detoxification. It has many different types of enzymes that attack and degrade the wide variety of molecules to which the body may be exposed. Inhalants such as glues, gasoline, or other solvents cause direct tissue damage to the liver, leading to liver failure. The kidneys excrete most poisons or their breakdown products. Kidneys may be damaged from exposure to poisons, or by accumulation of compounds that cannot be excreted.

**Mutagens and Carcinogens.** Chemicals that cause changes in deoxyribonucleic acid (DNA) sequence, or mutations, are called mutagens. If these changes prompt the cell to begin dividing, the cell may become cancerous. Substances that cause cancer are called carcinogens. Inhaled asbestos fibers can cause lung cancer, as can chemicals in cigarette smoke.

## Treatment

Antidotes are available for very few poisons. Snakebite, for instance, may be treated with antivenin, which provides antibodies that inactivate the poisonous venom. However, in most cases of poisoning, medical treatment focuses



on removing the poison from the body when possible, and maintaining respiration and circulation until the toxic effects are reduced as the compound is metabolized and **excreted** over time. Poison control centers in every state maintain telephone hotlines to deal with poisoning emergencies. If a victim is in medical distress, 911 should be called immediately. SEE ALSO ALCOHOL AND HEALTH; ANTIBODY; CANCER; HEALTH AND SAFETY OFFICER; LIVER; MUTATION; MITOCHONDRION; NEURON; OXIDATIVE PHOSPHORYLATION; PEROXISOMES; SYNAPTIC TRANSMISSION

*Richard Robinson*

### Bibliography

*American Association of Poison Control Centers.* <<http://www.aapcc.org/>>.

*Medical Toxicology On-Line.* <<http://toxikon.er.uic.edu/>>.

Turkington, Carol. *The Poisons and Antidotes Sourcebook*, 2nd ed. New York: Checkmark Books, 1999.

## Pollination and Fertilization

Pollination is the transfer of pollen to the female organs of seed plants. In flowering plants (angiosperms, or “covered seeds”), immature seeds (ovules) are located within carpels. In contrast, nonflowering seed plants have uncovered **ovules** to which the pollen is transferred, making these “naked seeds” (gymnosperms).

Gymnosperms have simpler pollination as all transmit their pollen by wind. In contrast, angiosperm have a wealth of pollination methods involving many different agents to transfer pollen, including insects (entomophily), birds (ornithophily), bats (chirophily), wind (anemophily), and water (hydrophily). Attraction of animals usually occurs through a conspicuous floral display, with color and scent playing important roles. Yellow and blue flowers tend to attract bees, red flowers attract hummingbirds, pink flowers attract butterflies, and white flowers that stand out at night often attract moths and bats. Animal-based pollination is efficient and usually associated with a food reward to assure a continuing relationship. Frequently, this is a simple symbiotic relationship; however, other plants seem to practice deceit. For example, trap pollinators may hold insects hostage until a flower is pollinated successfully, when they are released. A most unusual mechanism are orchids that seemingly imitate the form and scent of female wasps, attracting amorous male wasps to mount the flower, inadvertently pollinating it. Aquatic plants frequently have filamentous pollen, which is more easily captured in water, and may release male flowers that float freely to their attached female counterparts.

When pollen is deposited on the stigma (in angiosperms) or the ovule (in **gymnosperms**), it germinates, forming a slender pollen tube through a weakened area of the pollen wall. The pollen tube elongates through “tip extension,” penetrating between cells of the host parent. Within the pollen tube, two nonmotile sperm cells are ultimately formed and are conveyed through the tube, keeping pace with tip growth. The pollen tube uses chemotropic signals to determine the final pathway to the egg cell, deep within the ovule. In angiosperms, pollen tubes penetrate the stigma, style, and ovary until they are amid the ovules. In gymnosperms, pollen germinates

**excrete** deposit outside of

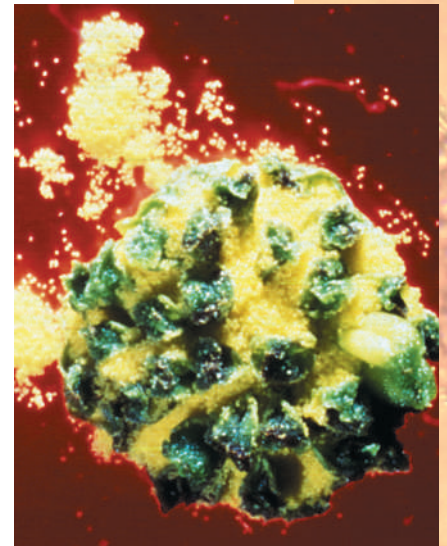

Pollen being released from the anther of a black walnut.

**ovule** multicellular structure that develops into a seed after fertilization

**gymnosperms** “naked seed” plants, including conifers

**gametophyte** a haploid plant that makes gametes by mitosis

**zygote** fertilized egg

**endosperm** nutritive tissue within a seed

**fertilization** union of sperm and egg

**gamete** reproductive cell, such as sperm or egg

**bioaccumulate** buildup within organisms

**inorganic** not bonded to carbon

**organic** composed of carbon, or derived from living organisms

**acidic** having an excess of  $H^+$  ions, and a low pH

**hydrolysis** splitting with water

**enzyme** protein that controls a reaction in a cell

directly on the ovule. Pollen tubes enter ovules through a tiny pore called the micropyle and then elongate into the female **gametophyte** (called the embryo sac in angiosperms). In gymnosperms, the pollen tube directly penetrates the egg cell, but in angiosperms, there are sterile cells in the embryo sac, called synergids, that initially receive the sperm.

At this point, one sperm cell is discharged from the pollen tube and fuses, with the egg cell to form the **zygote** (the immediate fusion product) and subsequent embryo, which will become the offspring plant. In angiosperms, the second sperm fuses with the central cell to form a nutritive **endosperm** during double **fertilization**. The endosperm is needed for successful embryo development.

During fertilization the male and female **gametes**: (1) contact one another, (2) adhere, (3) cells fuse, and finally (4) nuclei fuse. The act of fertilization triggers embryo development in all plants and endosperm development in angiosperms. SEE ALSO FLOWERS; PLANT DEVELOPMENT; REPRODUCTION IN PLANTS; SEEDS

Scott D. Russell

### Bibliography

Cresti, M., S. Blackmore, and J. L. Van Went. *Atlas of Sexual Reproduction in Flowering Plants*. Heidelberg: Springer-Verlag, 1992.

Meeuse, B. J. D., and S. Morris. *The Sex Life of Flowers*. New York: Oxford Scientific Films, 1984.

## Pollution and Bioremediation

When a substance is released to the environment at a rate in excess of what can be safely assimilated, that substance becomes an environmental pollutant.

### Properties of Pollutants

Three properties make environmental pollutants especially hazardous: resistance to decomposition (persistence); ability to **bioaccumulate**, which is related to insolubility in water (hydrophobicity) and solubility in oil (lipophilicity); and the concentration or quantity at which toxic effects occur (potency). Elements like **inorganic** mercury cannot be further broken down but can only be changed in form, so once a source is reduced or eliminated pollutants' concentrations decrease over time only as a result of dilution or burial in accumulating soil or sediments.

Synthetic **organic** substances (SOCs), like the pesticide DDT, can persist in the environment because they are only very slowly decomposed by natural physical, chemical, and microbiological processes. Sunlight can break down some SOC, while others react with water molecules under **acidic** or basic conditions in a process called **hydrolysis**. The **enzymes** of some microbes that decompose wood can also decompose SOC. The products of these reactions tend to be more water-soluble and less fat-soluble than the parent compounds, reducing their tendencies to bioaccumulate. In general, the breakdown products are also less toxic, although there are exceptions to this rule.

Some air pollutants, like sulfur trioxide and nitrogen dioxide, react with the water vapor in the air to produce acid rain. The high acidity (low pH)

caused by acid rain in poorly buffered lakes has decimated fish populations. Acid rain also leaches metals from the soils in the watershed more efficiently than does normal rain, and some of these metals like copper are especially toxic to aquatic organisms.

The metal mercury presents an example of a pollutant that is persistent, bioaccumulates, *and* is extremely toxic. Mercury is released into the air in small quantities from burning coal and municipal, medical, and industrial waste, and into water as pollution from a variety of industrial chemical processes. Like other air pollutants, mercury can eventually deposit on watershed surfaces and be carried by storm runoff into the stream, wetland, or lake, or deposit on them directly. Once present in the lake, the inorganic mercury attaches to living (biotic) or nonliving (abiotic) particles and eventually settles into the sediments. There, oxygen-avoiding (anaerobic) bacteria synthesize methylmercury from inorganic mercury as a byproduct of their life processes. The methylmercury then moves out of the sediment and into the overlying water and is absorbed by microscopic plants and animals.

Methylmercury is rapidly taken up but only slowly eliminated from the bodies of aquatic animals, and elimination efficiency decreases with increasing size. Thus, at the top of the aquatic food chain, prized sport fish like the largemouth bass can bioaccumulate as much as ten million times the concentration of methylmercury in the water in which it lives. The birds that feed on top-predator fish, like the eagle and the osprey, can further biomagnify the methylmercury in their bodies. When eggs are laid, the methylmercury is deposited in the egg's albumin, or white.

Mercury is not only a threat to birds, but to all animals, including humans. Methylmercury crosses into the developing brain, disrupting brain (neural) development and thought processing. At low doses, methylmercury can slow the development of movement (motor) and learning (cognitive) skills. At high doses in humans, it can cause the severe retardation and twisted limbs now referred to as Minamata disease, after the small city (Minamata Bay) in Japan where the severest toxic effects of methylmercury poisoning were first observed.

### **Synthetic Organic Substances: Targets for Bioremediation**

Typically, decomposition of SOCs occurs more rapidly by oxygen-loving (aerobic) bacteria and fungi than by the more primitive, oxygen-avoiding (anaerobic) bacteria. Unfortunately, many SOCs like the benzene in gasoline leach into the aquifers underlying leaking storage tanks or spills where there is little oxygen. This means that decomposition occurs only slowly, if at all. To speed up this process, engineers have developed ingenious systems to pump water supersaturated with oxygen (and sometimes with added bacteria) into the groundwater. Other systems rely on pumping the groundwater with substitute hydrogen peroxide for oxygen, which releases oxygen as it breaks down. Scientists are also working with the bacteria and fungi that decompose wood to develop a taste for SOCs. While weaning the organisms onto SOCs used to be a time-consuming process in the past, a new generation of genetically engineered organisms are being tested for their efficiency and safety.

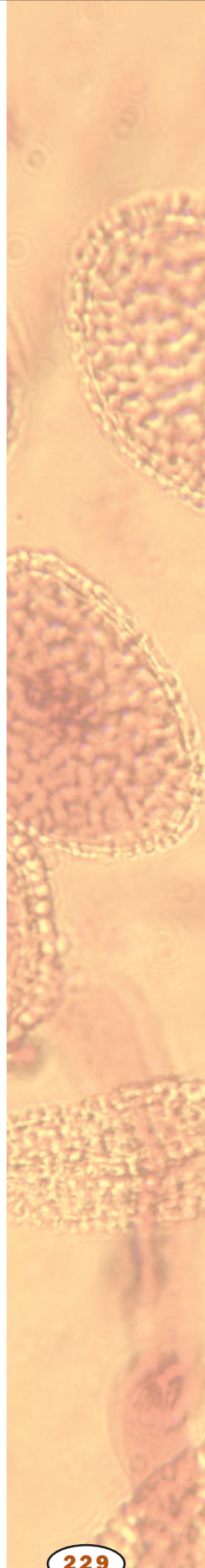

This General Electric plant in Pittsfield, Massachusetts, lay dormant from the 1970s, when the use of PCBs was banned, until the mid-1990s, when GE and civic leaders agreed to clean the site on the Housatonic River on which it sits.



**volatile** easily vaporized

Finally, some plants are capable of transporting **volatile** organic compounds (VOCs) like benzene through their roots and out their leaves, while others take up toxic metals through their roots and store them in their stems and leaves. The process of using plants to clean up (remediate) a contaminated site is called phytoremediation. These bioremediation alternatives are often preferable to such techniques as burying hazardous waste in clay-lined pits, stabilizing the contaminant in place using soil-cement mixtures, or turning the soil into glass one section at a time using a powerful electric current.

### DDT: An Environmental Success Story

By the late 1930s the pesticide SOC named dichlorodiphenyltrichloroethane (DDT) had been shown to be an effective pesticide against a wide variety of insects, including the mosquitoes, lice, and fleas that carried human diseases, and a wide variety of agricultural insect pests. By the mid-1950s, it was readily available to farmers, who hailed DDT as the beginning of a new era in agriculture, allowing them to plant more crops in greater densities with less pest damage, and the use of DDT expanded dramatically. It was also broadcast on lakes, ponds, and swamps for mosquito control. Soon thereafter, when environmental samples were analyzed from across the United States and then the world, scientists were shocked to learn that DDT was not only building up in the soils and soil organisms where it was being applied, but in the birds feeding on those soil organisms in the sediment and water in nearby lakes, in the fish in those lakes, and in the birds eating those fish.

This intrigued an unknown biologist named Rachel Carson, who in the late 1950s began to review the scientific literature and compile lay unpublished reports and anecdotal information on the toxic effects of DDT, ultimately resulting in her book *Silent Spring* (1962). In it she predicted that

the indiscriminate use of DDT and related pesticides threatened nontarget species like worm- and fish-eating birds with local extinction.

Studies showed that DDT mimicked the **hormone** that controlled calcium deposition in egg shell formation. DDT was not directly toxic to adult birds or their offspring, but it caused eggshell thinning, so that the shells broke under the weight of the nesting mother. At the same time, field scientists were able to document the serious declines in populations of fish-eating birds, even along the shores of the seemingly pristine Great Lakes.

Goaded by these revelations, within five years of the publication of *Silent Spring*, the state of Wisconsin was the first to ban all uses of DDT. By 1972, the then two-year-old U.S. Environmental Protection Agency (EPA) banned DDT across the United States, although manufacture and export are still lawful. One by one, DDT's chemical cousins—aldrin, endrin, heptachlor, chlordane, lindane, and toxaphene—were also banned. Clearly, *Silent Spring* was one of the most influential books of the twentieth century, giving birth to both the environmental movement and the environmental science that would guide the implementation of laws to restore and protect clean air, water, and soil and the proper disposal of hazardous waste.

### Endocrine Disrupters: A New Challenge

In the 1990s Theo Colborn has refocused attention on chemicals that mimic, suppress, or amplify the action of animal hormones, so-called **endocrine** disrupters. When an organism is exposed to these endocrine signal scramblers in the egg or uterus, normal sexual development can be disrupted, resulting in increased incidences of infertility, underdeveloped sex organs, possession of both sets of sex organs (hermaphroditism), masculinization of females, and feminization of males.

In 1996, Colborn and her co-authors released *Our Stolen Future*, which summarized the scientific literature on the effects of endocrine disrupters to animals in the laboratory and in the wild and linked the occurrence of similar effects in humans to exposure to endocrine disrupters. While the controversy surrounding *Our Stolen Future* can only be compared to that of *Silent Spring*, so too its almost immediate impact on national policy. Because of the potentially serious consequences of human exposure to endocrine disrupting chemicals, Congress included specific language on endocrine disruption in the Food Quality Protection Act and amended Safe Drinking Water Act in 1996. The former mandated that EPA develop an endocrine disrupter screening program, whereas the latter authorizes EPA to screen endocrine disrupters found in drinking water sources. As of 2000, scientists are still in the process of developing the standardized tests required to screen for endocrine disrupter effects in the more than seventy thousand chemicals produced commercially each year. SEE ALSO CARSON, RACHEL; ENDANGERED SPECIES; ENDOCRINE SYSTEM; HORMONES; LIMNOLOGIST

Larry Fink

#### Bibliography

- Carson, Rachel. *Silent Spring*. New York: Houghton Mifflin, 1962.
- Colborn, Theo, Dianne Dumanowski, and John P. Myers. *Our Stolen Future*. New York: Dutton, Penguin Books, 1996.
- Ehrlich, P. R., A. Ehrlich, and J. P. Holdren. *Ecoscience*. New York: W. H. Freeman and Company, 1977.

**hormone** molecule released by one cell to influence another

**endocrine** related to the system of hormones and glands that regulate body function

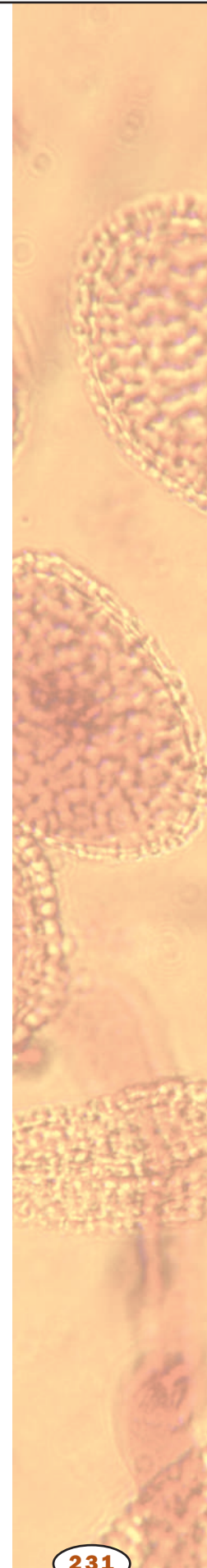

Kruger, Ellen L., Todd A. Anderson, and Joel R. Coates, eds. *Phytoremediation of Soil and Water Contaminants*. American Chemical Society, Symposium Series 664. Washington, DC: American Chemical Society, 1997.

*Mercury Report to Congress*. Washington, DC: U.S. Environmental Protection Agency, 1997.

## Polymerase Chain Reaction

The polymerase chain reaction (PCR) is a process that allows one to make in a short amount of time many copies of a particular deoxyribonucleic acid (DNA) sequence. It was developed in 1985 by Kary Mullis and has provided scientists in diverse fields with a powerful tool for DNA amplification, analysis, and manipulation.

The technique involves repeated heating and cooling cycles and requires the DNA polymerase (known as *Taq*) from the organism *Thermus aquaticus*; these cycles are usually controlled by a machine known as a thermal cycler. Since high temperatures usually inactivate most **enzymes**, the DNA polymerase used in this procedure is isolated from a heat-tolerant bacterium.

The high temperature (90 to 92 degrees Celsius [194 to 197 degrees Fahrenheit]) disrupts the **hydrogen bonds** between the bases of DNA and results in the separation of the two DNA strands. Since all enzymes that duplicate DNA require short sequences known as **primers**, the priming sequences for the desired region are added and the temperature is then lowered. The primers anneal with sequences on each strand of the DNA, and *Taq* then uses added **nucleotides** to synthesize a new strand of DNA that is attached to the primers and **complementary** to each of the original strands.

The sample is then heated again to separate the strands and liberate the primer, and the sample is again cooled to allow another round of DNA duplication. Each round takes only a few minutes, and double the number of DNA strands each time. The process is repeated many more times with the

**enzyme** protein that controls a reaction in a cell

**hydrogen bond** weak bond between the H of one molecule or group and a nitrogen or oxygen of another

**primer** short nucleotide sequence that helps begin DNA replication

**nucleotide** the building block of RNA or DNA

**complementary** matching opposite

The polymerase chain reaction is a process that allows one to make many copies of a DNA sequence in a short amount of time.

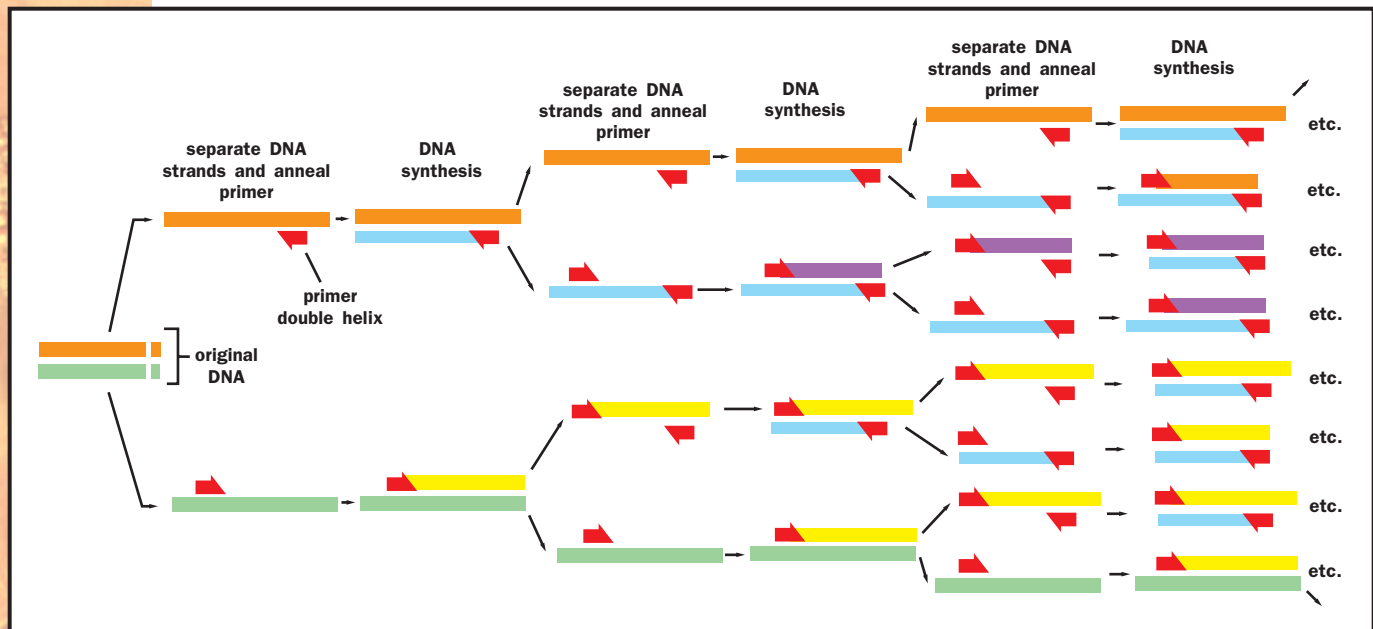

result that thousands, and even millions, of copies of a particular DNA sequence are produced within a few hours. The first two or three rounds of duplication produce DNA molecules of various lengths, but the final rounds produce identically sized molecules.

While early PCR techniques were limited to copying up to 1,000 **base pairs**, methods developed in the late 1990s have extended the limit up to 10,000 base pairs or more. The procedure will copy any DNA molecule and, consequently, the scientist must make certain that no extraneous DNA is present in the reaction tube.

PCR has allowed people to produce large amounts of DNA from a variety of sources: blood or semen from a crime scene; single embryonic cells for prenatal diagnosis; frozen ancient mammals; cells infected with viruses such as HIV (human immunodeficiency virus). **SEE ALSO** ARCHAEA; CLONE; DNA SEQUENCING; FORENSIC DNA ANALYSIS; REPLICATION

*William R. Wellnitz*

### **Bibliography**

Campbell, Neil A., Jane B. Reece, and Lawrence G. Mitchell. *Biology*, 5th ed. Menlo Park, CA: Benjamin Cummings, 1999.

**base pair** two nucleotides (either DNA or RNA) linked by weak bonds

## **Population Dynamics**

A population is a collection of individual organisms of the same species that occupy some specific area. The term “population dynamics” refers to how the number of individuals in a population changes over time. Biologists study the factors that affect population dynamics because they are interested in topics such as conservation of endangered species (for example, the Florida panther) and management of fish and wildlife. In addition, basic knowledge about the processes that affect population dynamics can be used to predict future patterns of human population growth.

### **How Do Biologists Characterize Populations?**

Biologists distinguish between two main types of populations: unstructured and structured. In an unstructured population, all individuals are subject to the same general ecological pressures. That is, the rates of growth, reproduction, and mortality are roughly the same for all individuals in the population. A bacterial colony is a good example of an unstructured population. Conversely, in structured populations, individuals can differ from one another in ways that make some individuals more susceptible to mortality or more likely to reproduce than others. Examples of structured populations include many insects, sea turtles, trees, and fish. In these cases, mortality is often much higher for younger (and/or smaller) individuals. In addition, reproduction is often delayed until individuals are older (and/or larger).

### **How Does Resource Abundance Affect Population Dynamics?**

The abundance of environmental resources such as food, water, and space determines how population abundance changes over time. In the presence of unlimited resources, populations grow exponentially. If one plots the number of individuals in an exponentially growing population over time,

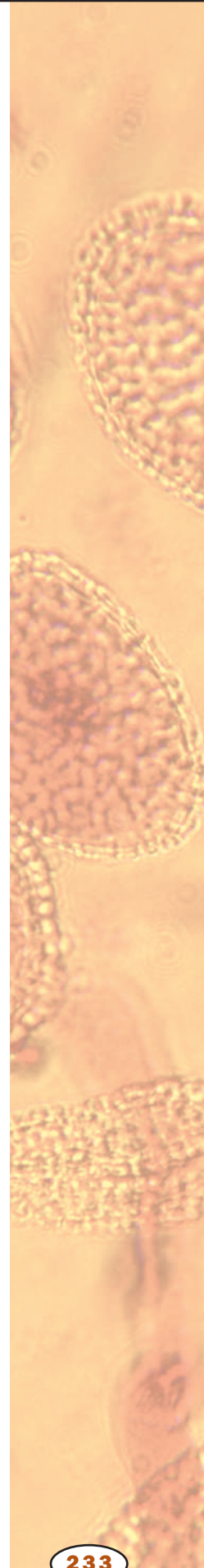

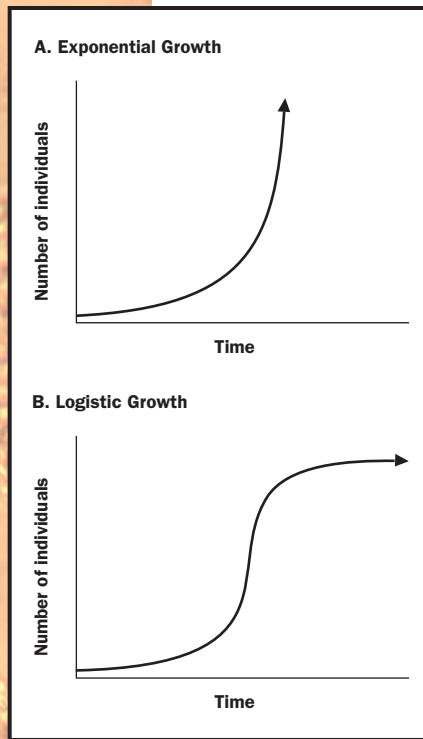

The abundance of environmental resources determines the rate of population growth over time.

one finds a J-shaped curve where the slope gets ever steeper. This curve is described by the following equation:

$$N_t = N_0 e^{rt}$$

Where  $N_0$  is the initial number of individuals,  $N_t$  is the number of individuals at a future time,  $r$  is the rate of increase,  $t$  is time, and  $e$  is the base of the natural logarithm (roughly 2.718). The rate of increase ( $r$ ) is determined by the difference between birth and death rates of the population. In 1999 the U.S. Bureau of the Census estimated the rate of population increase ( $r$ ) for the world human population to be 0.0129 (or 1.29 percent) per year. Few natural populations grow at exponential rates for extended periods of time because resources typically become limiting when population abundance is very high.

In an environment where resources become limited, populations exhibit a pattern of growth called logistic growth. In this case, if one plots the number of individuals in the population over time, one finds a sigmoidal, or S-shaped curve. When population abundance is low, the population grows exponentially. However, as population size increases, resources become limited, the population growth rate slows, and the population abundance curve flattens. The number of individuals present in the population when the growth rate slows to zero is referred to as  $K$ , the carrying capacity. The carrying capacity is the theoretical maximum number of individuals that the environment can support. Although estimates of  $K$  for humans are controversial, most are around 12 billion.

Using concepts from basic population biology, biologists have distinguished two strategies for population growth. Some species have characteristics that allow them to grow rapidly when an environment with abundant resources is newly created (for example, a new clearing in a forest). These species are referred to as  $r$ -selected species and typically reproduce at a young age and produce many offspring. Other species, called  $K$ -selected species, have characteristics that make them well suited for life in environments where there is intense competition for limited resources. These species are often strong competitors, reproduce later in life, and produce fewer offspring than  $r$ -selected species.

### How Does Variability in Environmental Conditions Affect Population Dynamics?

A key assumption of the logistic population growth model for environments where resources are limiting is that environmental conditions are constant. In nature, environmental conditions may vary substantially over time. In such variable environments, the abundance of individuals in a population may also fluctuate over time. Some populations cycle in a predictable manner. Populations that fluctuate widely or have low abundance are especially vulnerable to extinction, an event in which population abundance declines to zero. Extinctions may be local (a population in a particular area is lost) or global (all populations of a species decline to zero and there are no living individuals of the species left on the planet). For example, the passenger pigeon, which was once one of the most numerous birds on Earth, went globally extinct in 1914 due to overhunting and habitat loss.



## How Do Physical and Biological Factors Regulate Population Dynamics?

Patterns of population abundance are affected by a variety of biological and physical factors. For example, the abundance of a given species (for example, snails) might be controlled by the abundance of organisms that have a negative effect on the species of interest, such as competitors, predators, and diseases. Similarly, population abundance could be limited by the abundance of organisms that benefit the species of interest (for example, algae consumed by the snails).

In fact, some organisms require the presence of other species called **symbionts** with whom they live in direct contact. For example, corals use food molecules synthesized by symbiotic zooxanthellae (a type of algae), and zooxanthellae receive nutrients and protection from corals. However, not all populations are regulated by biological factors involving interactions with other species. Physical factors like water availability and temperature can control population abundance of some species.

Which type of factor (biological or physical) has a stronger effect on population dynamics? As one might suspect, the answer depends largely on the population that is studied. Some populations are regulated mostly by biological factors, others are controlled by physical factors, and most populations are affected by both biological and physical factors. **SEE ALSO** ALGAE; CORAL REEF; EXTINCTION; HUMAN POPULATION; THEORETICAL ECOLOGY

*Janet M. Fischer*

### Bibliography

- Cohen, Joel E. "Population Growth and Earth's Human Carrying Capacity." *Science* 269, no. 5222 (1995): 341–346.
- Ehrlich, Paul R. *The Population Bomb*. San Francisco, CA: Sierra Club, 1969.
- Molles, Manuel C. *Ecology: Concepts and Applications*. Boston: McGraw-Hill, 1999.
- U.S. Bureau of the Census, *International Data Base*. <<http://www.census.gov/pub/ipc/www/worldpop.html>>.

## Population Genetics

The field of population genetics examines the amount of genetic variation within populations and the processes that influence this variation. A population is defined as a group of interbreeding individuals that exist together at the same time. Genetic variation refers to the degree of difference found among individuals, for instance in height, coat color, or other less observable traits. The particular set of genes carried by an individual is known as his or her genotype, while all the genes in a population together comprise the "gene pool."

### Foundations

The foundation for population genetics was laid in 1908, when Godfrey Hardy and Wilhelm Weinberg independently published what is now known as the Hardy-Weinberg equilibrium. The "equilibrium" is a simple prediction of genotype frequencies in any given generation, and the observation that the genotype frequencies are expected to remain constant from

**symbionts** organisms living in close association with another organism

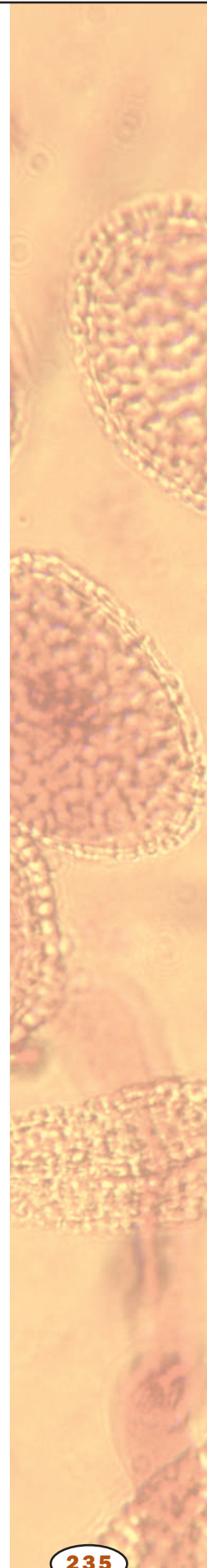

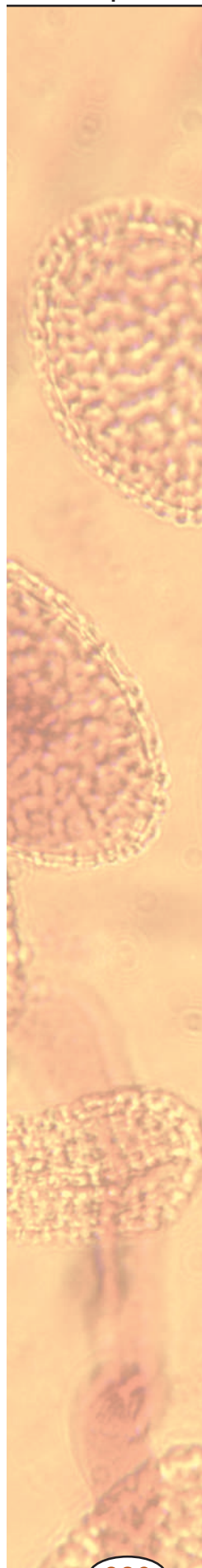
A vertical strip on the left side of the page shows a microscopic view of plant cells, likely from a leaf or stem, stained to show their internal structure. The cells are roughly rectangular and arranged in a grid-like pattern.

**allele** a particular form of a gene

generation to generation as long as several simple assumptions are met. This description of stasis provides a counterpoint to studies of how populations change over time.

The 1920s and 1930s witnessed the real development of population genetics, with important contributions by Ronald Fisher, Sewall Wright, and John B. S. Haldane. They, with many others, clearly established the basic processes which caused populations to change over time: selection, genetic drift, migration, and mutation. The change in the genetic makeup of a population over time, usually measured in terms of **allele** frequencies, is equivalent to evolutionary change. For this reason, population genetics provides the groundwork for scientists' understanding of evolution, in particular microevolution, or changes within one or several populations over a limited time span.

The questions addressed by population genetics are quite varied, but many fall within several broad categories. How much genetic variation is found in populations, and what processes govern this? How will a population change over time, and can a stable endpoint be determined? How much and why do populations of the same species differ? The answer is always cast in terms of selection, drift, mutation, migration, and the complex interplay among them. Of the four, selection and genetic drift are usually given credit as the major forces.

### Selection

Simply put, selection occurs when some genotypes in the population are on average more successful in reproduction. These genotypes may survive better, produce more offspring, or be more successful in attracting mates; the alleles responsible for these traits are then passed on to offspring. There is broad theoretical consensus and abundant empirical data to suggest that selection can change populations radically and quickly. If one genetic variant, or allele, increases survivorship or fertility, selection will increase the frequency of the favored allele, and concurrently eliminate other alleles. This type of selection, called directional selection, decreases the amount of genetic variation in populations.

Alternatively, an individual carrying two different alleles for the same gene (a heterozygote) may have advantages, as exemplified by the well-known example of the sickle-cell allele in Africa, in which heterozygotes are more resistant to malaria. In this case, called overdominant selection, genetic variation is preserved in the population. Although a number of similar examples are known, directional selection is much more common than overdominant selection; this implies that the common action of selection is to decrease genetic variation within populations. It is equally clear that if different (initially similar) populations occupy different habitats, selection can create differences among populations by favoring different alleles in different areas.

### Genetic Drift

Often overlooked by the layperson, genetic drift is given a place of importance in population genetics. While some analyses of genetic drift quickly become complicated, the basic process of drift is simple and involves random



Cheetahs, which have very little genetic variation, are presumed to have gone through several genetic bottlenecks.

changes in allele frequency. In sexual species, the frequency of alleles contained in the **progeny** may not perfectly match the frequency of the alleles contained in the parents. As an analogy, consider flipping a coin twenty times. Although one might expect ten heads and ten tails, the actual outcome may be slightly different; in this example, the outcome (progeny) does not perfectly represent the relative frequency of heads and tails (the parents).

**progeny** offspring

What does this mean for populations? Start by considering neutral alleles, which have no impact on survival or reproduction. (An example is the presence or absence of a widow's peak hairline.) The frequency of a neutral allele may shift slightly between generations, sometimes increasing and sometimes decreasing. What outcomes are expected from this process? Suppose that a particular allele shifts frequency at random for a number of generations, eventually becoming very rare, with perhaps only one copy in the population. If the individual carrying this allele does not pass it on to any offspring or fails to have any offspring, the allele will be lost to the population. Once lost, the allele is gone from the population forever. In this light, drift causes the loss of genetic variation over time. All populations are subject to this process, with smaller populations more strongly affected than larger ones.

Perhaps better known than the pervasive, general effects of genetic drift are special examples of drift associated with unusually small populations. Genetic bottlenecks occur when a small number of individuals from a much larger population are the sole contributors to future generations; this

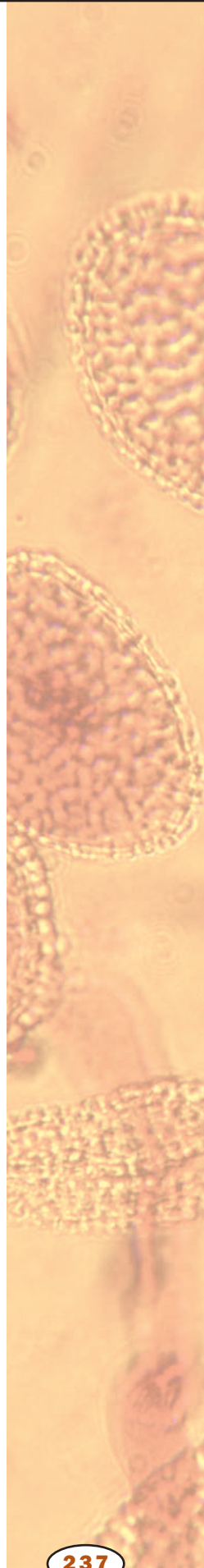

**HALDANE, J. B. S.  
(1862–1964)**

British biologist and author who immigrated to India. Haldane was famous for both his flamboyant personality and his influence on genetics and evolutionary biology. Haldane, along with Ronald Fisher, showed that evolution is the change in frequency of individual genes over time.

**chromosome** “colored body” in the cell nucleus; made of DNA and protein, and divided functionally into genes and nongene regions

occurs when a catastrophe kills most of the population, or when a few individuals start a new population in different area. Genetic bottlenecks reduce the genetic variation in the new or subsequent population relative to the old. Cheetahs, which have very little genetic variation, are presumed to have gone through several genetic bottlenecks. Occasionally, these new populations may have particular alleles that are much more common than in the original population, by chance alone. This is usually called the founder effect.

**Migration and Mutation**

Migration may also be important in shaping the genetic variation within populations and the differences among them. To geneticists, the word “migration” is synonymous with the term “gene flow.” Immigration may change allele frequencies within a population if the immigrants differ genetically. The general effect of gene flow among populations is to make all of the populations of a species more similar. It can also restore alleles lost through genetic drift, or introduce new alleles formed by mutation in another population. Migration is often seen as the “glue” that binds the subpopulation of a species together. Emigration is not expected to change populations unless the migrants are genetically different from those that remain; this is rarely observed, so emigration is often ignored.

The last important process is mutation. Mutation is now understood in great detail at the molecular level, and consists of any change in the deoxyribonucleic acid (DNA) sequence of an organism. These mutations range from single base substitutions to the deletion or addition of tens or hundreds of bases to the duplication or reorganization of entire **chromosomes**. Mutation is most important as the sole source of all new genetic variation, which can then be spread from the population of origin by migration. This importance should not be undervalued, although the impact of mutation on most populations is negligible at any given time. This is because mutation rates are typically very low.

**Questions and Contributions**

The real challenge of population genetics has been in understanding how the four processes work together to produce the observable patterns. For instance, genetic drift eliminates variation from populations, as do the most common modes of natural selection. How then can the abundance of genetic variation in the world be explained?

This question has many complicated answers, but some cases, such as the observation of deleterious alleles in humans (for example, alleles for phenylketonuria, a genetic disease), might be explained in terms of mutation and selection. Mutation adds these alleles to a population, and selection removes them; although the rate of mutation is likely to be nearly constant, the rate at which selection removes them increases as the abundance of the allele increases. This is certainly true for recessive alleles, which are only expressed when an individual has two copies. With only one, the allele remains unexpressed and therefore not selected. At some point, predictable from the mutation rate and physical consequences of the disease, the two opposing forces balance, producing the stable persistence of the disease allele at low frequency.

As a discipline, population genetics has contributed greatly to scientists' understanding of many disparate topics, including the development of resistance of insects to insecticides and of **pathogenic** bacteria to antibiotics, an explanation of human genetic variation like the alleles for sickle-cell **anemia** and blood groups, the evolutionary relationships among species, and many others. Of particular interest is the use of genetic data in conservation biology.

By definition, endangered and threatened species have reduced population sizes, making them subject to the vagaries of genetic drift and also to inbreeding. Inbreeding is mating between genetically related individuals, and often leads to inbreeding depression, a reduction of health, vigor, and fertility. Genetic drift leads to a loss of genetic variation, which limits what selection can do to produce adaptations if the environment changes. Keeping these two issues in mind, greatly reduced populations may be at increasingly greater risk for genetic reasons, leading to further declines. *SEE ALSO* CONSERVATION; ENDANGERED SPECIES; EVOLUTION; EXTINCTION; HARDY-WEINBERG EQUILIBRIUM; NATURAL SELECTION; SEXUAL REPRODUCTION

*Paul R. Cabe*

### Bibliography

- Gillespie, John H. *Population Genetics: A Concise Guide*. Baltimore, MD: Johns Hopkins University Press, 1998.
- Hardy, Godfrey. "Mendelian Proportions in Mixed Populations." *Science* 28 (1908): 49–50.
- Hartl, Daniel. *A Primer of Population Genetics*. Sunderland, MA: Sinauer Associates, 1999.
- Hedrick, Philip W. *Genetics of Populations*. Boston, MA: Jones and Bartlett, 2000.
- Smith, John Maynard. *Evolutionary Genetics*, 2nd ed. Oxford, England: Oxford University Press, 1998.

## Porifera

Porifera, or sponges, are the simplest and oldest of the multicelled animals, with fossils dating back to **Precambrian** times. They are aquatic and **sessile**, living permanently attached to submerged objects. More than 5,000 species are known, most of which occur in shallow coastal waters and in the deep sea. About 150 species live in fresh water. Sponges are found at all latitudes, even in polar regions.

Sponges are unique among animals because they lack a brain, nerves, muscles, organs, and specialized tissues. They rely upon highly specialized, but poorly coordinated cells. As the name Porifera ("pore bearers") suggests, the body is perforated. Numerous small pores (ostia) convey water into an internal canal system lined with flagellated collar cells (choanocytes). The flagella of these cells beat **synchronously** to produce currents that pump water through the sponge. Choanocytes filter water through their sievelike collars to remove suspended food particles (bacteria, protozoans, microscopic algae, **organic** particles). The particles are digested by wandering **amoeboid** cells (amoebocytes), which carry nutrients to various parts of the sponge. Filtered water and waste products are expelled through large vents (oscula).

**pathogen** disease-causing organism

**anemia** lack of oxygen-carrying capacity in the blood

**Precambrian** before the Cambrian era; before 600 million years ago

**sessile** attached and remaining in one place

**synchronously** at the same time

**organic** composed of carbon, or derived from living organisms

**amoeboid** like an amoeba, especially in movement via extension of portions of the membrane

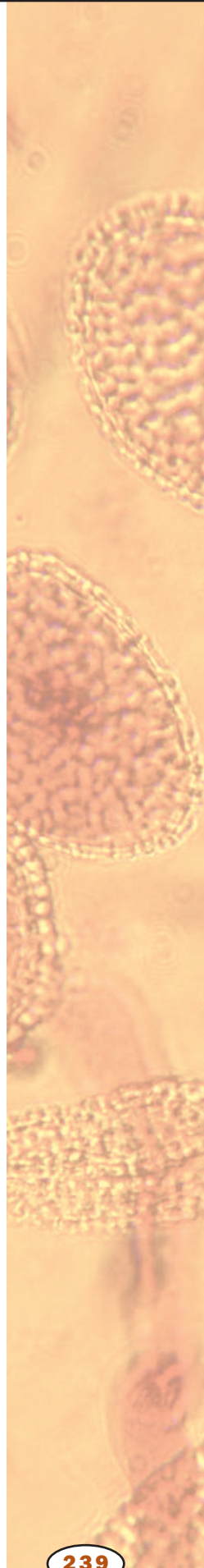

**protein** complex molecule made from amino acids; used in cells for structure, signaling, and controlling reactions

**zygote** fertilized egg

**ciliated** possessing cilia, short, hairlike extensions of the cell membrane

**substrate** the molecule acted on by an enzyme

The skeleton supporting these canals and chambers is composed of needlelike spicules and/or elastic **protein** fibers (spongin). The spicules are made of silica or calcium carbonate and occur in various shapes and sizes characteristic of each species.

Sponges can reproduce both sexually and asexually. Clouds of sperm expelled into the water by one sponge are drawn into other sponges with water currents. Specialized cells (modified choanocytes) carry sperm to the eggs. **Zygotes** develop into **ciliated** larvae that are released into the water, where they are planktonic for a short period before settling onto a suitable **substrate** to become adult sponges. Asexual reproduction occurs by fragmentation and/or budding; for example, freshwater sponges use resistant buds (gemmules) for surviving winter or periods of drought. **SEE ALSO ANIMALIA; CORAL REEF**

*Anthony Ricciardi*

### Bibliography

Barnes, Robert D. *Invertebrate Zoology*, 5th ed. Philadelphia, PA: Saunders College Publishing, 1987.

Margulis, Lynn, and Karlene V. Schwartz. *Five Kingdoms: An Illustrated Guide to the Phyla of Life on Earth*, 3rd ed. New York: W. H. Freeman, 1998.

## Porter, Keith

**Canadian cytologist**  
**1912–1997**

In 1945 Keith Porter, with Albert Claude and Ernest F. Fullam, published the first electron micrograph of a complete cell in the *Journal of Experimental Medicine*. The photograph gave a new vigor to the study of cells that had been “becalmed in the doldrums” (Willmer 1965, p. 8). Biologists began to study subcellular components using centrifugation, tissue culture, and electron microscopy techniques devised by Porter, Claude, and George Palade. These techniques led to the integration of cell structure and function and the modern science of cell biology.

Porter was born in Yarmouth, Nova Scotia, in 1912. In 1939 he joined the laboratory of cancer researcher James B. Murphy at The Rockefeller Institute (now University) to study cultured cells. However, conventional light microscopy was inadequate, and he began his mastery of the newly available electron microscope to examine fine cell structure. This demanded radical changes in specimen preparation. The cells had to be ultra thin and dry.

Porter was the first to identify the cell’s **endoplasmic reticulum**, **cilia**, microtubules, and the microtrabecular lattice. To produce superior electron micrographs he devised methods of tissue culture and standards for cell preparation, founded the Tissue Culture Association, and designed the Porter-Blum microtome. He died in 1997. **SEE ALSO CELL; ELECTRON MICROSCOPY**

*Carol L. Moberg*

### Bibliography

Moberg, Carol L. “The Electron Microscope Enters the Realm of the Intact Cell.” *Journal of Experimental Medicine* 181 (1995): 829–837.

———. “Keith Porter and the Founding of the Tissue Culture Association.” *In Vitro Cellular and Developmental Biology* 32 (1996): 663–669.

Porter, Keith R., Albert Claude, and Ernest F. Fullam. “A Study of Tissue Culture Cells by Electron Microscopy.” *Journal of Experimental Medicine* 81 (1945): 233–246.

Willmer, E. N., ed. *Cells and Tissues in Culture*. New York: Academic Press, 1965.

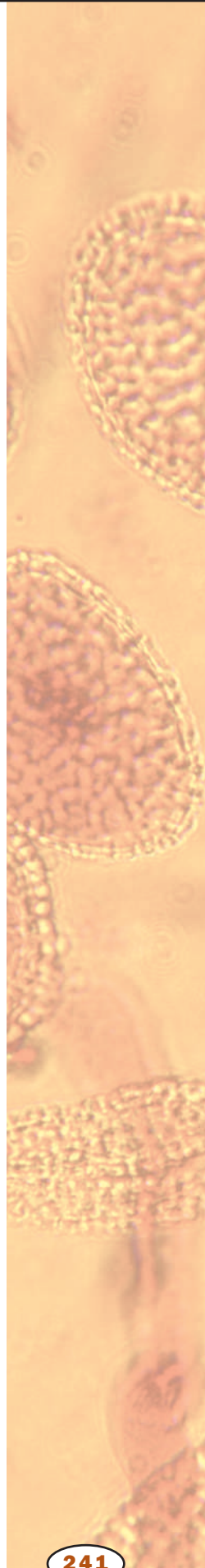

# Photo and Illustration Credits

*Unless noted below, the illustrations and tables featured in Biology were created by GGS Information Services. The photographs appearing in the text were reproduced by permission of the following sources:*

## Volume 1

**p. 4** Willow ptarmigan in summer color, photograph. © JLM Visuals; **p. 5** Willow ptarmigan in winter color, photograph. © Marypat Zitzer/JLM Visuals; **p. 6** Cross section of human adrenal gland, triangular shape, photograph by Martin M. Rotker. Phototake NYC; **p. 8** Elderly married couple, photograph. © Kevin R. Morris/Corbis; **p. 11** Wild rice plant grows in Ocala, Florida, photograph. © Jonathan Blair/Corbis; **p. 12** Herd of Holsteins eat silage from troughs on a Minnesota farm, photograph. © Richard Hamilton Smith/Corbis; **p. 15** AIDS virus attacking T4 lymphocytes, scanning electron micrograph image. ©Wagner/Seifert, Inc./Phototake; **p. 18** Santa Monica police officer, administering Breathalyzer test, photograph. © Shelley Gazin/Corbis; **p. 21** Algae on Pond, photograph. © Charles Mauzy/Corbis; **p. 27** Strawberry poison arrow frog, photograph. © Alex Kerstitch/JLM Visuals; **p. 28** Weightlifting with a dumbbell, photograph. © Duomo/Corbis; **p. 31** Maidenhair fern with fan-shaped leaves, photograph by Robert J. Huffman/Field Mark Publications; **p. 32** Light blue iris against black background, photograph. JLM Visuals; **p. 35** Transparent jellyfish with short tentacles, photograph by Mark A. Johnson/Stock Market; **p. 38** Enzyme-lined immunoabsorbent assay, ELISA plate, photograph. © Lester V. Bergman/Corbis; **p. 43** Newly hatched Green Lynx spiders, photograph. © J. C. Cokendolpher/JLM Visuals;

**p. 44** Ten million year old Archeobacteria, scanning electron micrograph by Eurelios. © Eurelios/Phototake; **p. 47** Digitally enhanced X ray of left hand showing rheumatoid arthritis, photograph. © 1994 Michael English, M.D. Custom Medical Stock Photo; **p. 49** Streptococcus bacteria attached to a human tonsil cell, colored transmission electron micrograph by Dr. Immo Rantala. © Dr. Immo Rantala/SPL/Photo Researchers, Inc; **p. 51** Streptococcus pyogenes bacteria, colored transmission electron micrograph by Alfred Pasiaka. © Alfred Pasiaka/Science Photo Library, Photo Researchers, Inc.; **p. 54** Laboratory technician performing Analytical Profile Index (API), photograph by Geoff Tompkinson. © Geoff Tompkinson/Science Photo Library, Photo Researchers, Inc; **p. 57** DNA circles of bacterial plasmid, scanning electron micrograph. © Gopal Murti/Phototake; **p. 59** Electron micrograph of T4 Cells, or bacteriophage, photograph. © Dr. Dennis Kunkel/Phototake; **p. 61** Honey bees around Queen in hive, photograph. © J. C. Cokendolpher/JLM Visuals. Reproduced by permission; **p. 64** Elk fighting, Wyoming, photograph. © Breck P. Kent/JLM Visuals; **p. 69** Soil erosion on the trail, Adirondack, photograph by Yoav Levy/Phototake; **p. 71** Continental Drift, illustration by Accurate Art, Inc., Gale Group; **p. 72** Mary Pat Reeves-Daly, mapping human Y chromosome, as part of Human Genome Mapping Project, photograph. © Roger Ressmeyer/Corbis; **p. 75** Immunization technician Sgt. Louis Rios giving 2nd Lieutenant Clayton Bland a vaccination for anthrax, photograph. AP/Wide World Photos; **p. 78** Smiling school girls,

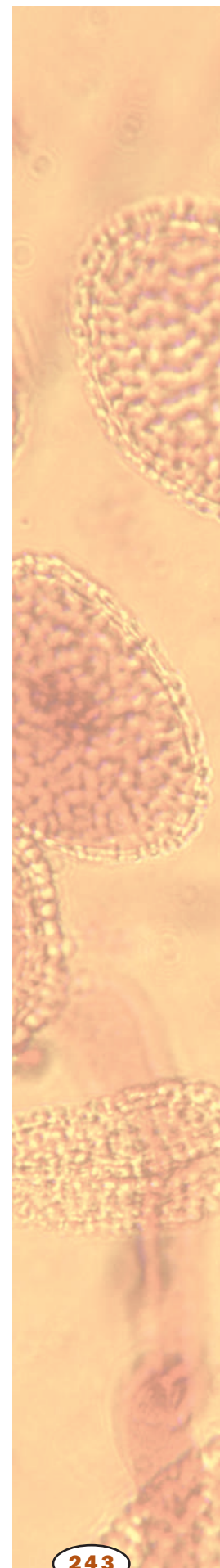



photograph. © The Purcell Team/Corbis; **p. 81** Red-tailed hawk perched on stump, photograph by Robert J. Huffman/Field Mark Publications; **p. 83** Beaulieu, Emile-Etienne, holding handful of the RU-486 abortion drug/pills, which he invented, photograph. AP/Wide World Photos; **p. 90** Red and white blood cells flowing through saphenous vein, scanning electron micrograph. © Image Shop/Phototake; **p. 94** Cancellous bone tissue affected by osteoporosis, false-color scanning electron micrograph. © Professor P. Motta/Dept. of Anatomy/University of La Sapienza, Rome/Science Photo Library, Photo Researchers, Inc.; **p. 97** Axial section of human brain showing metastatic tumor, MRI by Simon Fraser. © Simon Fraser/Science Photo Library, Photo Researchers, Inc.; **p. 101** Human brain with hypothalamus highlighted, green dot, MRI scan by Scott Camazine & Sue Trainor; © Scott Camazine & Sue Trainor/Photo Researchers, Inc.; **p. 105** Liverwort, plant with leaf-like structures covered with tiny capsules, photograph. JLM Visuals; **p. 109** Marine life from Cambrian Period, photograph by Robert J. Huffman/Field Mark Publications; **p. 110** Human breast cancer cells growing in culture, photograph by Cecil Fox. © Cecil Fox/Photo Researchers, Inc; **p. 111** Human abdomen showing cancer of the ascending colon, colored barium enema X ray. © Science Photo Library/Photo Researchers, Inc.; **p. 116** Electronic image of human heart undergoing angiography; indicates massive aneurism of aortal arch, photograph. © CNRI/Phototake; **p. 119** *Listeria monocytogenes*, scanning electron micrograph image. © CNRI/Phototake; **p. 137** Tobacco leaf chloroplast, micrograph, photograph. © Dr. Jeremy Burgess/Science Photo Library, National Audubon Society Collection/ Photo Researchers, Inc. Reproduced with permission; **p. 141** Human chromosomes showing male mutation on gene 7, which determines cystic fibrosis, photomicrograph by Jean Claude Revy. © Jean Claude Revy/Phototake; **p. 142** Digital image of multipolar and bipolar spindles from T84 colonic cancer cell cultures, photograph. © Albert Tousson/Phototake; **p. 144** Mitosis metaphase of an animal cell, immunofluorescence photomicrograph. © CNRI/Phototake; **p. 146** Human male chromosomes, XY karyotype, with G banding, karotype. © CNRI/Phototake; **p. 153** Micro injection introducing foreign genes into animal cells, photograph by M. Baret. © M. Baret/Rapho, Photo Researchers, Inc; **p. 158** Second growth birch forest, photograph. © Richard P. Jacobs/JLM Visuals; **p. 161** Ground finch with dark feathers and bill, photograph by Tim Davis. Photo Researchers, Inc; **p. 163** Pine cones, photograph. JLM Visuals; **p. 167** People along polluted Swazambhunath River, in Kathmandu, Nepal, photograph. © Charlie Crangle/JLM Visuals; **p. 182** Sand skink on top of shiny dark green leaf, 1985, Florida, photograph by Joseph T. Collins/Photo Researchers, Inc.; **p. 184** Stretch of the great coral reef, between Cairns and Townsville, photograph. © Yann Arthus-Bertrand/Corbis; **p. 187** Crick, Francis, photograph. The Library of Congress; **p. 189** Horseshoe crab, photograph. © John M. Burnley/The National Audubon Society Collection/Photo Researchers, Inc; **p. 192** Breast cancer cell dividing, colored scanning electron micrograph. © Quest/Science Photo Library, Photo Researchers, Inc.; **p. 198** Darwin, Charles, photograph. Popperfoto/Archive Photos. © Archive Photos, Inc.; **p. 202** Shadows form on the El Oued dunes, The Algerian Sahara Desert, Algeria, photograph. © Adam Woolfitt/Corbis; **p. 203** High desert oasis, photograph. © Richard P. Jacobs/JLM Visuals; **p. 205** Human embryo, 8-cell stage, day 3, scanning electron micrograph, SEM, scan by Dr. Yorgos Nikas. © Dr. Yorgos Nikas/Phototake; **p. 209** Frog embryos complete their metamorphoses inside their eggs, photograph. Michael & Patricia Fogden/Corbis; **p. 224** Human DNA fingerprint taken from blood to match donor and patient in organ transplantation, photograph. © Index Stock/Phototake; **p. 227** Herpes simplex virus, HSV6, scanning electronic micrograph. © Dr. Dennis Kunkel/Phototake; **p. 230** Surgeon looking at CAT scans, photograph. © Steve Chenn/Corbis; **p. 233** Lab technician Li Zhang performing a density test from urine samples at the Australian Sports Drug Testing Laboratory, photograph. AP/Wide World Photos.

## Volume 2

**p. 6** Professor Ernst Haeckel, the German naturalist and philosopher, poses as if in a jungle scene, photograph. © Hulton-Deutsch Collection/Corbis; **p. 9** Lush growth, mossy tree, temperate rain forest, photograph by Robert J. Huffman/Field Mark Publications; **p. 12** Scientist sitting at scanning transmission electron microscope, STEM, photograph by Sinclair Stammers/Science Photo Library/Photo Researchers, Inc.; **p. 14** Gloved hands holding a sheet/culture, electrophoresis gel, photograph. © Eurelios/Phototake; **p. 17** White tiger in the zoo, photograph. © Shawn Gerrits/JLM Visuals; **p. 21** Scintigram of normal human thyroid, front view, photograph. © CNRI/Phototake; **p. 23** Phagocytosis, color enhanced transmission electron micrograph. © Biophoto Associates/Science Source/Photo Researchers, Inc; **p. 27** Entomologist Elidia Fernandez sorts an insect collection for the Institute for Biodiversity, photograph. © Gary Braasch/Corbis; **p. 39** Ravenglass Estuary curving to the sea, Cumbria, England, photograph. Corbis/Genevieve Leaper; **p. 41** Chlamydia pneumonia, photograph by Dr. Kari Lounatmaa. Custom Medical Stock Photo; **p. 42** Escherichia Coli, photograph by Kari Lounatmaa. Photo Researchers; **p. 44** Bumble bee, photograph. © Lloyd R. Brockus III/JLM Visuals; **p. 46** Darwin's Large Cactus Finch, © Breck P. Kent/ JLM Visuals; **p. 50** Antibiotic Staphylococcus aureus, photograph by Hank Morgan. © Hank Morgan/Science Photo Library, Photo Researchers, Inc.; **p. 53** Fossil fish, photograph. © Richard P. Jacobs/JLM Visuals; **p. 58** Ginkgo tree, photograph. JLM Visuals; **p. 60** X ray, color enhanced normal intravenous pyelogram. © Biophoto Associates/Science Source/Photo Researchers, Inc; **p. 65** Dinosaur skeleton on display at the Royal Terrell Museum, photograph. © Paul A. Souders/Corbis; **p. 67** Carolina parakeets lie in bags with tags, photograph. © Jonathan Blair/Corbis; **p. 73** Rod cells in the retina of the human eye, colored scanning electron micrograph. © Quest/Science Photo Library, Photo Researchers, Inc.; **p. 77** Normal human uterus and fallopian tubes, hysterosalpinograph. © GCA/CNRI/Phototake; **p. 83** Human fetus, 10 weeks old, inside amniotic sac, photograph. © CNRI/Phototake; **p. 86** Gray wolves exhibiting submissive behaviors, photograph. © Mary Ann McDonald/Corbis; **p. 88** Agronomists place a plastic greenhouse over crops, photograph. © Ted Spiegel/Corbis; **p. 90** Despain, Don, measures Lodgepole Pine Seedlings, photograph. © Raymond Gehman/Corbis; **p. 94** Snapdragons in flower, photograph by Eric Kamp. © Eric Kamp/Phototake; **p. 95** Lab Agent Kathy Dressel works on DNA evidence in the murder of JonBenet Ramsey at the Colorado Bureau of Investigation, Boulder, Colorado, photograph. AP/Wide World Photos; **p. 98** Boreal forest, evergreen trees, Michigan, photograph. JLM Visuals; **p. 100** Oak/hickory trees in autumn, photograph by Robert J. Huffman/Field Mark Publications; **p. 102** Moss-covered lianas in the Daintree National Park, Queensland, Australia, photograph. © Paul A. Souders/Corbis; **p. 103** Agile gibbon hanging from tree branch with baby at waist, photograph. © Breck P. Kent/JLM Visuals; **p. 105** Strawberry plants with fruit and blossoms, photograph. © Ed Young/Corbis; **p. 111** Dark yellow Witches' Butter jelly fungus, photograph. © Richard P. Jacobs/JLM Visuals; **p. 113** Detail that shows the gills of a mushroom, photograph. © Laura Sivell; Papilio/Corbis; **p. 114** Salmon gills showing the filaments of the gills, photograph. © Ron Boardman; Frank Lane Picture Agency/Corbis; **p. 124** Cancer cells infected with bioengineered adenovirus, photograph by Jean Claude Revy. © Jean Claude Revy/Phototake; **p. 132** Chicken embryo, 96-hours old, photograph. © Richard P. Jacobs/JLM Visuals; **p. 142** Man using computer to design complex proteins, photograph by Richard Nowitz. © Richard Nowitz/Phototake; **p. 147** Mexico City, photograph. Reuters/Archive Photos; **p. 154** Piles of wheat during harvest, Polouse Valley, Washington, photograph. © Vince Streano/Corbis; **p. 157** Grassland, photograph. © Richard P. Jacobs/JLM Visuals; **p. 159** Baby smiling, photograph. © Simon Dearden/Corbis; **p. 160** Hand development of a 2, 6, and 19 year old male, computer color enhanced X ray by Scott Camazine. © Scott Camazine, Photo Researchers, Inc.; **p. 162** Cycad, photograph. JLM Visuals;

**p. 166** Harvey, William, photograph. U.S. National Library of Science; **p. 167** Bicyclist sitting under a shade tree, photograph by Robert J. Huffman/Field Mark Publications; **p. 170** Hearing, human system, diagram by Hans & Cassidy. Gale Group; **p. 173** Heart, diagram by Hans & Cassidy. Gale Group. **p. 178** Close-up of branch with very long thorns, photograph. © Richard P. Jacobs/JLM Visuals; **p. 181** Close-up of genetically manipulated corn, photograph. © Carolina Biological Supply Company/Phototake; **p. 183** Buchner, Eduard, photograph. Hulton-Deutsch Collection/Corbis; **p. 186** Microscope used by Robert Hooke, 17th century, photograph. © Bettmann/Corbis; **p. 189** Young girl on her father's shoulders, photograph. © Raoul Minsart/Corbis; **p. 193** Cuvier, Georges Leopold, photograph. The Library of Congress; **p. 199** Hales, Stephen, engraving. The Library of Congress; **p. 209** Beginnings of Civilization, map by XNR Productions Inc. Gale Research; **p. 213** Female researcher loading an automated DNA sequencer at the Joint Genome Institute, photograph. Photo Researchers; **p. 215** Computer print-out of sequence of DNA, placed below multi-well sample tray, upper left, and automated pipettes, lower right, illustration by © James King-Holmes/Science Photo Library. Photo Researchers; **p. 217** Ingredients that should make up the bulk of a healthy diet, including fruits, vegetables, whole grains, photograph. © Nathan Benn/Corbis; **p. 221** Tomatoes ripen on vine for market, photograph. © Ed Young/Corbis.

### Volume 3

**p. 2** Human brain, cervical spine, and spinal marrow, magnetic resonance imaging (MRI). © GCA/CNRI/Phototake; **p. 6** Cancer cell attacked by tumor infiltrating lymphocytes, scanning electron micrograph by Jean Claude Revy. © Jean Claude Revy/Phototake; **p. 8** Katydid on human hand, photograph. JLM Visuals; **p. 11** House and hill overgrown with kudzu, photograph. JLM Visuals; **p. 22** Canadian Rockies, Ben My Chreem, Yukon, photograph. © Lowell R. Laudon/JLM Visuals; **p. 26** Leakey, Dr. L.S.B and Mary, photograph. AP/Wide World Photos, Inc; **p. 27**

Young girl fits blocks of different shapes through similarly shaped holes in a red box, photograph. © Robert Kozma/Corbis; **p. 30** Spine of Cleistocactus, close-up, photograph. © Peggy Morsch/JLM Visuals; **p. 32** Golden lichen, photograph. © Don Blegen/JLM Visuals; **p. 33** Grandmother holding her grandson, Philadelphia, PA, photograph. © Ed Eckstein/Corbis; **p. 36** Spawning sockeye salmon run the Fraser River from Shushwap Lake to Adams River, photograph. © Stuart Westmorland/Corbis; **p. 38** Chicken embryo, 56-hours old, photograph. © Richard P. Jacobs/JLM Visuals; **p. 40** Microscope, parts labeled, photograph. Carolina Biological Supply Company/Phototake; **p. 52** Two Ceratium tripos, photomicrograph by Eric Grave. © Eric Grave/Phototake; **p. 53** Lymphangiography, diagram of man's body, illustration. Electronic Illustrators Group; **p. 57** Human testis showing spermatogenesis, photomicrograph by Ken Wagner. © Ken Wagner/Phototake; **p. 61** Marine biologist in diving suit inspecting coral reef damaged by illegal fishing practices, photograph. AP/Wide World Photos; **p. 63** Male frigatebird with its red throat pouch inflated, photograph. © Wolfgang Kaehler/Corbis; **p. 64** McClintock, Barbara, photograph. UPI/Corbis-Bettmann; **p. 70** Transmission Electron Micrograph, TEM, image of Golgi apparatus, photograph. © Dr. Dennis Kunkel/Phototake; **p. 80** Mendel, Gregor, photograph. Archive Photos, Inc; **p. 86** Two lysosomes that contain digestive enzymes which destroy damaged molecules; in an intestinal epithelial cell, colored high resolution scanning electron micrograph. P. Motta & T. Naguro/Science Photo Library/Photo Researchers, Inc; **p. 89** Fat cells that make up adipose connective tissue, colored scanning electron micrograph. © Quest/Science Photo Library, Photo Researchers, Inc; **p. 90** Quality control microbiologist Kim Egger inspects a bacteria culture from ground meat processed at Excel Corporation's slaughterhouse, photograph. AP/Wide World Photos; **p. 93** Spring tide of surfbirds surge from the mud flats of Alaska's Copper River delta, photograph. © Jonathan Blair/Corbis; **p. 94** Indian leaf butterfly, photograph. © Richard P. Jacobs/JLM Visuals; **p.**

**99** Mitosis of an animal cell, early prophase, photograph. © CNRI/Phototake; **p. 100** Mitosis of an animal cell, early metaphase, photograph. © CNRI/Phototake; mitosis of an animal cell, immunofluorescence photomicrograph. © CNRI/Phototake; mitosis telophase of an animal cell, photograph. © CNRI/Phototake; **p. 101** Fruit fly head, magnified 200 times, scanning electron micrograph. © Dr. Dennis Kunkel, Phototake; **p. 104** Hands holding lab mouse, photograph. © Mario Beauregard/Corbis; **p. 107** Eastern prairie fringed orchid, photograph. U.S. Fish and Wildlife Service; **p. 114** Human knee joint with patella, X ray. © CNRI/Phototake; **p. 116** White American alligator shows a genetic mutation known as ieucism, Miami Zoo, photograph. © W. Perry Conway/Corbis; **p. 118** African clawed frog, *Xenopus laevis*, mutated, with three hind legs, photograph by Mark Smith. © Mark Smith/Science Source/Photo Researchers, Inc.; **p. 120** Endotrophic mycorrhizae in orchid root, magnified 100x, photograph. © Carolina Biological Supply Company/Phototake; **p. 122** Eggs and spiderlings of Uloborid Spider, photograph. © J. C. Cokendolpher/JLM Visuals; **p. 130** Human brain with Parkinson's Disease showing atrophy, Computerized Axial Tomography, CAT, scan. © GJLP/CNRI/Phototake; **p. 134** Two types of neurons; top of image shows a bipolar neuron, bottom of image is a developing neuron, scanning electron micrograph. © Dr. Dennis Kunkel/Phototake; **p. 137** Nitrogen fixation, bacteria, plants, photograph. © Adam Hart-Davis, National Audubon Society Collection/Photo Researchers, Inc.; **p. 139** Macrophage engulfing a *Leishmania* sp. parasite, colored scanning electron micrograph. © Juergen Berger, Max-Planck Institute/Science Photo Library, Photo Researchers, Inc.; **p. 142** Single mammalian tissue culture cell, color transmission electron micrograph. Dr. Gopal Murti/Science Photo Library/Photo Researchers, Inc.; **p. 149** Loh, Dan, photograph. AP/Wide World Photos; **p. 151** Anemone, Tunicate, Oyster, and Sponge, photograph. © Stephen Frink/Corbis; **p. 152** Bottlenosed dolphin playing, photograph. © Stephen Frink/Corbis; **p. 155** Blood smear showing leukemia cells, photomicrograph. ©

Margaret Cubberly/Phototake; **p. 160** Hand wearing glove, holding worms, compost sits below, photograph by Robert J. Huffman/Field Mark Publications; **p. 164** Meteorite ALH84001, from Mars, 4.5 billion years old, photograph. National Aeronautics and Space Administration (NASA); **p. 172** Larson, Peter, running fingers over teeth of a *Tyrannosaurus rex* skeleton, photograph. AP/Wide World Photos; **p. 175** Dog hookworms in small intestines, photograph. © Michael L. Wolmack/JLM Visuals; **p. 178** Young native boy with blonde hair trait, Lubarria Island, Solomon Islands, photograph. © Wolfgang Kaehler/Corbis; **p. 183** Micrograph comparing healthy red blood cells with a sickle cell, photograph by Dr. Gopal Murti. National Audubon Society Collection/Photo Researchers, Inc.; **p. 190** Diagram showing the central and peripheral nervous systems, left, and the autonomic nervous system, right, illustration by Frank Forney; **p. 192** Scientist performing pharmacological research, photograph. © Bob Krist/Corbis; **p. 194** Cecropia moth, photograph. Robert J. Huffman/Field Mark Publications; **p. 203** Dromedary camel, photograph. © Leonard Lee Rue, III/The National Audubon Society Collection/Photo Researchers, Inc.; **p. 206** Marine Plankton, green organisms with orange spots, 1960-1995, photograph by Douglas P. Wilson. Corbis/Dougals P. Wilson; Frank Lane Picture Agency; **p. 226** Digitalis, photograph. © Ken Wagner/Phototake; **p. 227** Release of pollen from anther of a black walnut, photograph. © Yoav Levy/Phototake; **p. 230** Closed General Electric plant in Pittsfield, Massachusetts, on the Housatonic River, photograph. AP/Wide World Photos; **p. 237** Cheetah, photograph. Robert J. Huffman/Field Mark Publications.

## Volume 4

**p. 2** Peregrine falcon with wings outstretched, photograph by Tim Davis. Photo Researchers, Inc.; **p. 3** School of fish swimming above blue and green coral reef, Indian Ocean, off Pemba Island, 1991, photograph by Stephen Frink. Corbis/Stephen Frink; **p. 21** Dinoflagellate *gambierdiscus toxicus*, scanning electron micrograph by Dr. Dennis

- Kunkel. © Dr. Dennis Kunkel/Phototake; **p. 22** Diatoms, photograph. © Richard P. Jacobs/JLM Visuals; **p. 24** Euglena protozoa, photomicrograph by Eric Grave. © Eric Grave/Phototake; **p. 27** Plasmodium flaciparum, malaria parasite, electron micrograph. © Institut Pasteur/Phototake; **p. 28** Brain scans of a schizophrenic patient, bottom, versus a normal patient, top, colored positron emission tomography. © Wellcome Dept. of Cognitive Neurology/Science Photo Library, Photo Researchers, Inc.; **p. 32** Man shows the milky juice of unripe seedpods used to make opium from the opium poppy plant, photograph. © Michael S. Yamashita/Corbis; **p. 33** Sensitive fern, close-up of single leaf, photograph by Robert J. Huffman/Field Mark Publications; **p. 39** Slade, Dennis, photograph. AP/Wide World Photos; **p. 53** Structure of Hibiscus flower, photograph by Ken Wagner. © Ken Wagner/Phototake; **p. 57** Bumblebee pollinating flower, photograph by Robert J. Huffman/Field Mark Publications; **p. 61** *In vitro* fertilization, photograph. © CC Studio/Science Photo Library, Photo Researchers, Inc.; **p. 64** Respiratory system, diaphragm, photograph by Hans & Cassidy. Gale Group; **p. 67** Model of HIV virus, photograph. Corbis-Bettmann; **p. 70** Old-growth forest with understory of wood sorrel in Mt. Hood National Forest in Oregon, photograph by William H. Mullins. Photo Researchers, Inc.; **p. 71** Color-coded cryo-EM map of the *E. coli* ribosome, photograph. Courtesy of Joachim Frank/Health Research, Inc.; **p. 74** Farmland on the banks of the Nile, Egypt, photograph. © Yann Arthus-Bertrand/Corbis; **p. 79** Cross-section of plant in soil, photograph. © Premium Stock/Corbis; **p. 86** Kidney bean sprouting into a seedling, photograph. Photo Researchers, Inc.; **p. 90** Arabidopsis sp. seed pods, scanning electron micrograph, SEM. © Dr. Dennis Kunkel/Phototake; **p. 92** Autumn scene with man, photograph by Robert J. Huffman/Field Mark Publications; **p. 93** Purified adenovirus, photograph by Jean Claude Revy. © Jean Claude Revy/Phototake; **p. 95** Barr body in a female squamous epithelium cell, photograph. © Lester V. Bergman/Corbis; **p. 97** Normal human female chromosomes (XX) in karyotype. © Leonard Lessin, FBPA/Photo Researchers, Inc.; **p. 99** Common frogs in amplexus, photograph. © John Tinning; Frank Lane Picture Agency/Corbis; **p. 102** Rainbow trout eggs hatching, photograph. JLM Visuals; **p. 105** Male and female black widow spiders, photograph. © J. C. Cockendolpher/JLM Visuals; **p. 107** Gonorrhea cells, photograph. Custom Medical Stock Photo; **p. 108** Syphilitic infection, sexually transmitted disease, photograph. © CNRI/Phototake; **p. 111** Fiddlehead ferns, close-up, photograph by Robert J. Huffman/Field Mark Publications; **p. 113** Lymphocytes, T-cells, and 3 red cells, scanning electron micrograph. © NYU Franklin Research Fund/Phototake; **p. 118** Snake skeleton, photograph. © Richard P. Jacobs/JLM Visuals; **p. 125** Pillows of coral colored Myxomycetes grow on damp wood, photograph. © Steve Austin; Papilio/Corbis; **p. 128** Two gannets greeting each other on Bonaventure Island, Quebec, photograph. © Breck P. Kent/JLM Visuals; **p. 130** Olive baboon grooming papio cynocephalus, photograph. © Joe McDonald/Corbis; **p. 131** Wilson, Edward O., 1991, photograph. AP/Wide World Photos; **p. 143** Cleaner shrimp, cleaner moray, photograph. JLM Visuals; **p. 149** Three T-lymphocytes, scanning electron micrograph, SEM, image. © Microworks/Phototake; **p. 152** Linnaeus, Carolus, engraving. The Library of Congress; **p. 153** Archeobacteria, scanning electron micrograph by Eurelios. © Eurelios/Phototake; **p. 155** Pit Bull Panting, photograph. © Lawrence Manning/Corbis; **p. 159** Thyroid Nuclear Medicine Scan, enhanced Scintigram, photograph by Oliver Meckes. Photo Researchers, Inc.; **p. 161** Close-up of a human fingerprint, macrophotograph by Martin Dohrn. © Martin Dohrn/Science Photo Library, Photo Researchers, Inc.; **p. 173** Surgeons clean a human kidney in preparation for transport into a patient at the University of Pittsburgh Medical Center, photograph. © Nathan Benn/Corbis; **p. 177** Cook Strait Tutuata, photograph by Tom McHugh. Photo Researchers, Inc.; **p. 178** Sea-peach tunicate, photograph. JLM Visuals; **p. 181** Vaccination process, illustration. Electronic Illustrators Group. **p. 185** Veterinarian technicians check the blood pressure of a dog, photograph.

AP/Wide World Photos; **p. 188** T4 bacteriophage virus, colored transmission electron micrograph. © Department of Microbiology, Biozentrum/Science Photo Library/Photo Researchers, Inc.; **p. 189** Compound eye of a fruit fly, scanning electron micrograph, SEM. © Dr. Dennis Kunkel; **p. 194** Drop of guttation, water extruded by a plant's root pressure, on a blade of grass. Alpine Lakes Wilderness Area, Washington, photograph. © Pat O'Hara/Corbis; **p. 196** Watson, Dr. James Dewey, with DNA model, 1962, photograph. UPI/Corbis-Bettmann; **p. 198** Dead

tree trunks, stumps in deep blue water, golden leaves, photograph by Robert J. Huffinan/Field Mark Publications; **p. 199** Biologists take samples from drugged polar bears for data about pesticides, photograph. © Galen Rowell/Corbis; **p. 201** Man walks across giant rollers used to crush wood pulp at the Ketchikan Pulp Company, photograph. © Kevin Fleming/Corbis; **p. 205** Zoo veterinarian Don Janssen examining the San Diego Zoo's 2-week old giant panda cub, photograph. AP/Wide World Photos.

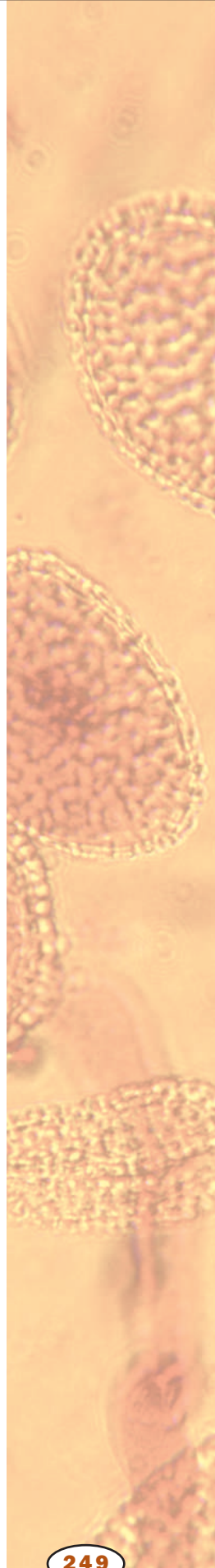

# Glossary

- abiotic** nonliving
- abscission** shedding of leaves; falling off
- acetylation** addition of an acetyl group,  $\text{CH}_3\text{-CHOO-}$
- acidic** having an excess of  $\text{H}^+$  ions and a low pH
- acinus** one of the small divisions of a fruit such as a raspberry
- action potential** wave of ionic movement down the length of a nerve cell
- active site** surface region of an enzyme where it catalyzes its reaction
- adaptive radiation** diversification of a group of organisms into several different forms that adapt to different environments
- adhesion** attachment; sticking to the surface of
- ADP** adenosine diphosphate, the low-energy form of ATP
- adventitious** growing from a nonstandard location
- aerobe** organism that needs oxygen
- aerobic** with oxygen, or requiring it
- aestivating** remaining dormant for the summer
- affinity** attraction
- aflatoxin** toxic compound produced by a mold fungus
- agar** gel derived from algae
- agnosia** “not knowing”; loss of ability to recognize familiar objects
- agroecosystem** agricultural ecosystem
- alkaline** chemically basic, with an excess of  $\text{OH}^-$  ions
- allele** a particular form of a gene
- allelopathy** inhibition of one plant’s growth by another plant
- amino acid** a building block of protein
- amoeba** a single-celled protist that moves by crawling

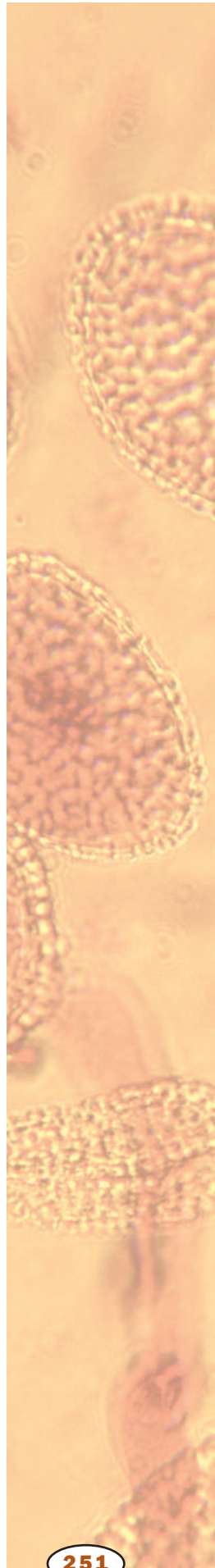

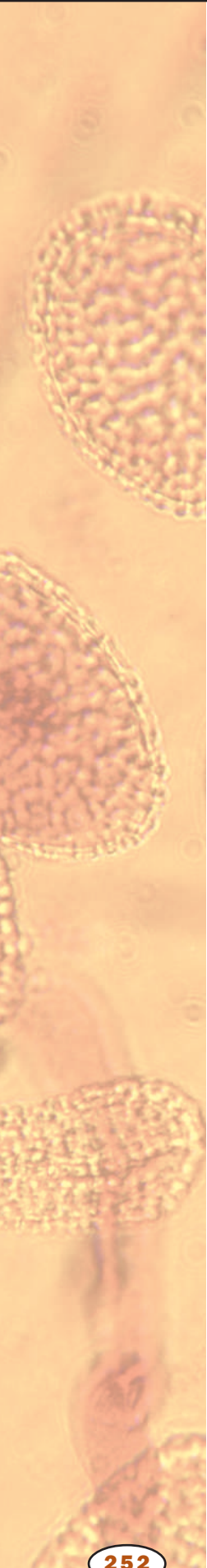

**amoeboid** like an amoeba, especially in movement via extension of portions of the membrane

**AMP** adenosine monophosphate, form of ATP after removal of two phosphate groups

**amphipathic** having both polar and nonpolar regions

**anabolic** characteristic of a reaction that builds complex molecules from simpler ones, and requires energy

**anadromous** describes fish that return to the rivers where they were born in order to breed

**anaerobe** organism not needing oxygen

**anaerobic** without oxygen, or not requiring oxygen

**anemia** lack of oxygen-carrying capacity in the blood

**aneurysm** bulging of the wall of a blood vessel

**antagonism** working against

**antagonist muscle** muscle that works against the action undertaken

**anterior** toward the front

**anterograde** forward

**anthocyanins** colored compounds made by plants

**anthropogenic** of, or relating to, the influence of human beings or nature

**antibody** immune system protein that binds to foreign molecules

**antigen** foreign substance that provokes an immune response

**antioxidant** substance that prevents damage from oxidation

**antitoxin** molecule used to inactivate a toxin

**aphasia** loss of the ability to form ideas into words

**apical** at the tip

**apical meristem** growing tip from which all plant tissues arise

**appendage** attached organ or structure

**aqueous** watery or water-based

**areolar** related to a small space within a tissue

**aromatic** compound including a double-bonded carbon ring

**arterioles** any of the small, terminal twigs of an artery that ends in capillaries

**arthropods** organisms with jointed appendages and exoskeletons, including insects, spiders, and crustaceans

**asymptomatic** without symptoms

**ATP** adenosine triphosphate, a high-energy nucleotide used by cells to power most energy-requiring reactions



- atria** two upper chambers of the heart (singular, atrium)
- attenuation** lessening over time
- autoimmune disease** disease in which the immune system attacks the body's own tissues
- autonomic** independent; regulating involuntary actions
- autonomic nervous system** one of the branches of the motor system, controlling involuntary muscles and glands
- autosomal dominant** pattern of inheritance in which inheritance of a single allele from either parent results in expression of the trait
- avian** concerning birds
- axon** long extension of a nerve cell down which information flows
- B lymphocyte** white blood cell that makes antibodies
- B.C.E.** before the Common Era, equivalent to B.C.
- basal** lowest level
- base pair** two nucleotides (either DNA or RNA) linked by weak bonds
- basic** having an excess of  $\text{OH}^-$  ions and a high pH
- bilaterally symmetric** symmetric, or similar, across a central line
- bilayer** composed of two layers
- bioaccumulate** build up within organisms
- bioluminescence** production of light by biochemical reactions
- biopharmaceuticals** drugs produced by and harvested from living organisms
- biosynthetic** forming a complex molecule from simpler ones
- biotic** living
- bolting** sudden spurt of growth
- boreal** of, relating to, or located in northern regions
- brood parasite** organism of one species that lays its eggs in the nest of another species
- C4 and CAM plants** plants that employ accessory systems for trapping carbon for photosynthesis
- cadherins** family of calcium-dependent adhesion proteins
- carbohydrates** sugars, starches, and other molecules combining carbon, hydrogen, and oxygen and serving as fuel or structural components
- cardiomyopathy** heart muscle disease
- catalysis** aiding in the reaction of
- catalyst** substance that aids in a reaction without being used up

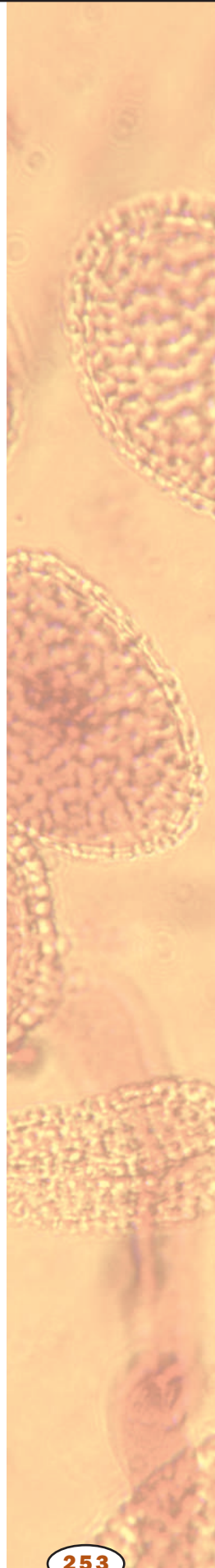

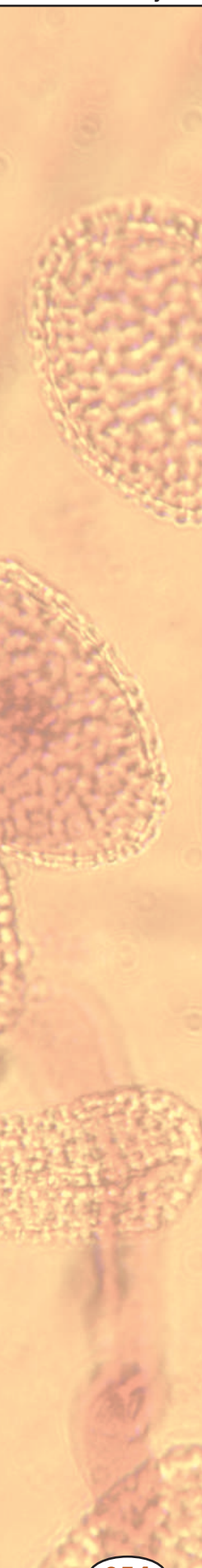
- 
- catalyze** aid in the reaction of
- caudate** toward the tail
- C.E.** Common Era; equivalent to AD
- cell cycle** sequence of growth, replication, and division that produces new cells
- cellulose** carbohydrate made by plants and some other organisms; part of the cell wall
- central nervous system** brain and spinal cord
- centromere** region of the chromosome linking chromatids
- cerebral cortex** outermost wrinkled portion of the brain
- chemiosmosis** use of proton gradients to make ATP
- chitin** nitrogen-containing carbohydrate found in arthropod exoskeletons and fungus cell walls
- chromatid** a replicated chromosome before separation from its copy
- chromatin** complex of DNA, histones, and other proteins making up chromosomes
- chromosomal analysis** staining, banding, and other techniques for detection of chromosomal abnormalities
- chromosome** “colored body” in the cell nucleus; made of DNA and protein, and divided functionally into genes and non-gene regions
- cilia** short, hairlike cell extensions of the cell membrane formed by the cytoskeleton
- ciliated** possessing cilia, which are short, hairlike extensions of the cell membrane
- circadian** related to a day or daylength
- clavicle** collar bone
- cloaca** common exit cavity for intestinal, genital, and urinary tracts
- codon** sequence of three mRNA nucleotides coding for one amino acid
- cognition** mental processes of thought and awareness
- cognitive** related to thought or awareness
- communicable** transmissible from person to person
- complementary** matching opposite
- complex carbohydrate** molecules formed by linking simpler carbohydrates such as sugars
- condensation** compaction of chromosome strands into a tight structure
- conformation** three-dimensional shape
- congenital** present at birth; inherited

- conjunctiva** eye membrane that helps seal the eye socket
- connective tissue** one of four types of body tissue, characterized by few cells and extensive extracellular material
- consanguineous** descended from the same ancestor
- constitutive** at a constant rate or continually
- contiguous** adjacent to or touching
- continental shelf** submerged offshore area demarcated by land on one side and deep sea on the other
- coralloid** resembling coral
- coronary artery** artery supplying blood to the heart
- cortical** related to the cortex, or outer portion
- cotyledon** seed leaf, which stores food and performs photosynthesis after germination
- cranial** related to the cranium, or brain cavity
- cryptobiosis** when a plant or animal becomes so inactive that its life processes nearly come to a stop
- cutaneous** related to the skin
- cutaneous respiration** gas exchange through the skin
- cytology** study of cells
- cytoplasm** material in a cell, excluding the nucleus
- cytoskeleton** internal scaffolding in a cell, composed of protein
- cytosol** fluid portion of a cell, not including the organelles
- Darwinian fitness** capacity to survive and reproduce
- deciduous** trees that shed their leaves in the fall
- deciliter** one-tenth of a liter; a unit of volume
- dementia** neurological illness characterized by impaired thought or awareness
- desiccation** drying out
- desynchronized** not happening at the same time
- deuterostome** “mouth second”; referring to the early development of the anal pore during gut tube formation
- dialysis** cleansing by partial filtration
- dicot** plant having two cotyledons, or seed leaves
- dikaryotic cell** cell with a pair of nuclei
- dilation** expansion or swelling
- dimer** polymer formed from two molecules of a simple compound

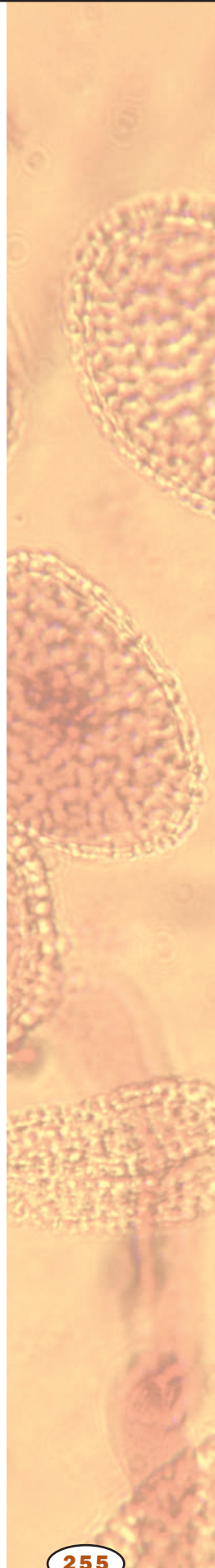

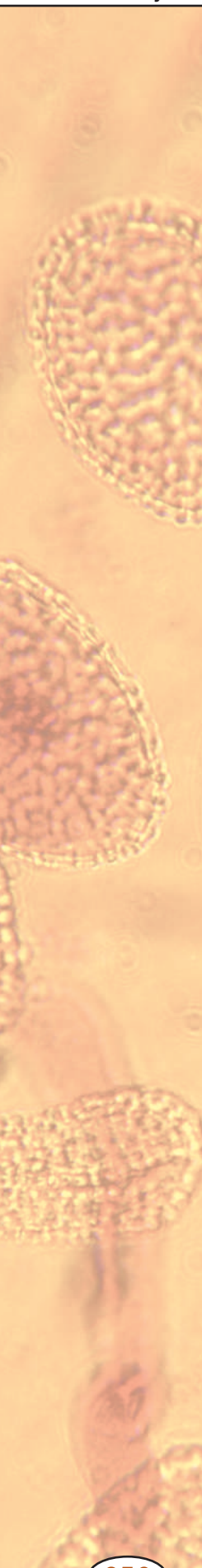
- 
- dimerizes** forms a pair
- diploid** having pairs of chromosomes in the nucleus
- dissociate** break apart
- distal** away from
- diurnal** active during the daytime
- dorsal** to the back of
- ecosystem** an ecological community and its environment
- effector** organ at the end of a nerve, such as a muscle or gland
- efferent** conducting outward or directing away from
- electrolytes** ions in body fluids
- electromagnetic radiation** light, X rays, and other forms of radiant energy
- electron transport system** membrane-bound system of proteins that extracts energy from high-energy electrons, found in mitochondria and chloroplasts
- electrophoresis** technique that uses electricity to separate molecules based on size and electric charge
- electrophoresis gel** porous medium through which molecules can be separated using an electric current
- embalming** treating a dead body to protect it from decay
- embryology** development of the embryo
- emulsify** suspend in solution through interaction with soap or similar molecules
- endocrine** related to the system of hormones and glands that regulate body function
- endogenous** caused by factors inside the organism
- endometriosis** disorder of the endometrium, the lining of the uterus
- endoplasmic reticulum** network of membranes within the cell
- endosperm** nutritive tissue within a seed
- endosymbiosis** symbiosis in which one partner lives within the other
- endothermic** characterized by regulation of body temperature through metabolic activity
- Enlightenment** eighteenth-century philosophical movement stressing rational critique of previously accepted doctrines in all areas of thought
- enzymatic** related to the function of an enzyme
- enzyme** protein that controls a reaction in a cell
- epidemic** rapid spread of disease through a population, or a disease that spreads in this manner

- epistasis** suppression of a characteristic of one gene by the action of another gene
- epithelium** one of four tissue types found in the body, characterized by thin sheets and usually serving a protective or secretory function
- esophagus** tube connecting the throat to the stomach
- eudicot** “true dicot”; plants with two seed leaves that originated from the earliest of flowering plants
- eukaryotic cell** a cell with a nucleus
- eutrophication** process by which waters become enriched in dissolved nutrients that promote plant growth which results in depletion of dissolved oxygen
- evapotranspiration** loss of water from a plant by evaporation within the leaf
- evidentiary DNA profile** analyzed DNA from a sample used as evidence
- excrete** deposit outside of
- exocrine gland** gland that secretes substances to an external or internal surface rather than into the bloodstream
- exoskeleton** external skeleton
- extensibility** ability to expand or grow larger
- fallopian tubes** tubes through which eggs pass to the uterus
- fecundity** ability to reproduce
- feedback** process in which the output or result influences the rate of the process
- fertilization** union of sperm and egg
- fibroblast** undifferentiated cell normally giving rise to connective tissue cells
- filtrate** material passing through a filter
- focal** at a point
- follicle** a vesicle that contains a developing egg surrounded by a covering of cells
- food web** set of feeding relations in an ecosystem
- forb** broad-leaved herbaceous plant
- forensic** related to legal proceedings
- fulcrum** pivot point of a lever
- fungi** major group of parasitic, lower plants that obtain their food from the products of organic decay (e.g. molds, smuts, etc.)
- gamete** reproductive cell, such as sperm or egg
- gametophyte** a haploid plant that makes gametes by mitosis
- ganglia** cluster of nerve cell bodies

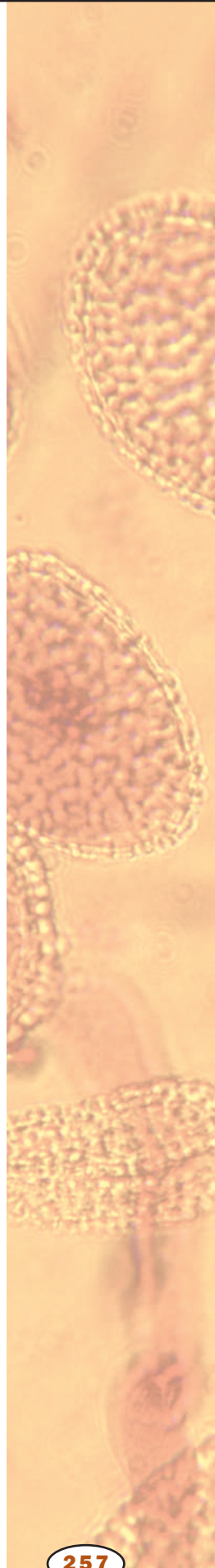

**gastroenteritis** inflammation of the gastrointestinal tract, often from infection

**gene** portion of DNA that codes for a protein or RNA molecule

**gene expression** use of a gene to create the corresponding protein

**genetic code** relationship between triples of RNA nucleotides and the amino acids they code for during protein synthesis

**genitalia** reproductive organs

**genome** total genetic material in a cell or organism

**germ line** cells creating eggs or sperm

**gestation** period of fetal development within the mother

**glial** supporting tissue of the elements of nervous tissue, including the brain, spinal cord, and ganglia

**glucose** simple sugar that provides energy to animal cells; it is the building block of cellulose in plants

**glycogen** complex carbohydrate used as storage in animals and some other organisms

**glycolysis** initial stages of sugar breakdown in a cell

**gradient** difference in concentration between two places

**grafting** attachment and fusing of parts from different plants

**guard cells** paired cells on leaves that control gas exchange and water loss

**gymnosperms** “naked seed” plants, including conifers

**hallucination** altered sensory experience resulting in the perception of objects that are not real

**haploid** having single, nonpaired chromosomes in the nucleus

**hectare** 10,000 square meters (2.47 acres)

**heme** the deep red, iron containing, nonprotein portion of hemoglobin and myoglobin

**hemicellulose** complex carbohydrate related to cellulose and found in cell walls of plants and some other organisms

**hemoglobin** oxygen-carrying protein complex in red blood cells

**herbarium** a collection of dried plant specimens systematically arranged for reference

**hermaphrodite** organism possessing both male and female reproductive structures

**heterodimer** complex molecule composed of two different parts

**heterogeneous** composed of, or containing, different parts or types

**heterozygous** characterized by possession of two different forms (alleles) of a particular gene

- hexamer** a structure composed of six parts
- histogenesis** origin or production of tissues
- histology** study of tissues
- histone** protein around which DNA wraps to form chromosomes
- homologous** similar in structure
- homologous chromosomes** chromosomes carrying similar genetic information
- homologous recombination** exchange of DNA segments between chromosomes
- homozygous** containing two identical copies of a particular gene
- hormone** molecule released by one cell to influence another
- hybrid** combination of two different types
- hydrocarbon** molecule or group composed only of C and H
- hydrogen bond** weak bond between the H of one molecule or group and a nitrogen or oxygen of another
- hydrolyze** to split apart using water
- hydrophilic** “water loving”
- hydrophobic** “water hating,” such as oils
- hydroponics** growing of plants without soil
- hydroxyl** chemical group consisting of -OH
- hypersalinity** very high level of salt
- hypersecretion** excess secretion
- hypersensitivity reaction** immune reaction characterized by rapid and severe response, often with swelling of airways
- hyphae** threadlike part of the vegetative portion of the fungus
- hyposcretion** lack of secretion
- hypothermia** subnormal temperature of the body
- ice-out** a thawing of ice covering a lake or other body of water
- immunoglobulin** an immune protein, also called an antibody
- immunosuppressant** inhibition of the immune response
- in utero** inside the uterus
- in vitro** “in glass”; in lab apparatus, rather than within a living organism
- inbred** repeatedly bred with close relatives, creating organisms with very little genetic variation

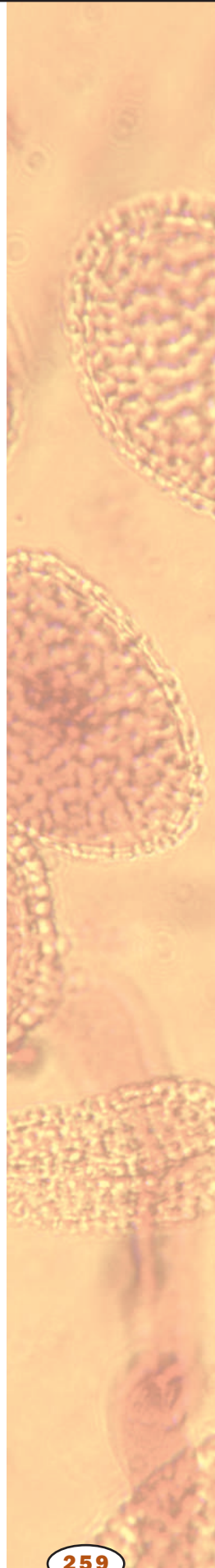

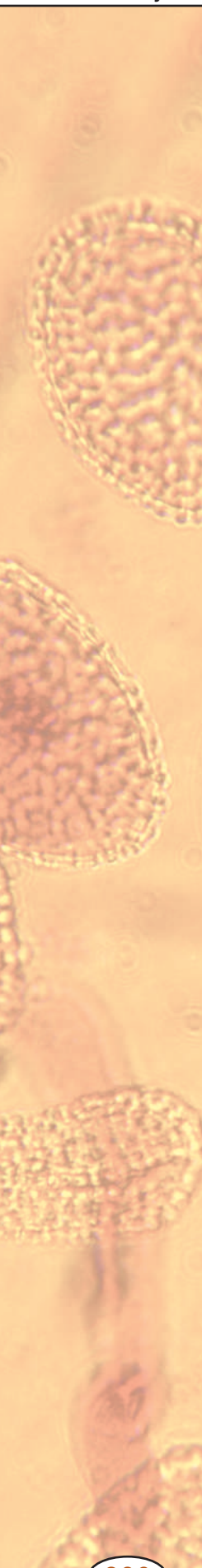
- 
- inducible** able to be switched on
- inflorescence** characteristic arrangement of flowers on a stalk
- infrastructure** roads, phone lines, and other utilities that allow commerce
- inorganic** not bonded to carbon
- insectivorous** insect-eating
- integrins** a family of transmembrane linking proteins
- interferons** signaling molecules of the immune system
- intermediate filament protein** one type of cytoskeleton protein
- interspecific** between different species
- interstitial space** space between cells in a tissue
- intracellular** within a cell
- intraocular** within the eyeball
- intrinsic to** intimate part of; within
- intron** untranslated portion of a gene that interrupts coding regions
- ion** an electrically charged particle
- ionic** based on or functioning by means of ions
- ionizing radiation** high-energy radiation that destroys chemical bonds
- isometric** relating to contraction without movement
- isotopes** forms of an atom that differ by the number of neutrons in the nucleus
- keratin** a major structural protein
- kilobase** one thousand DNA bases; a measure of size of a piece of DNA
- kilobasepair** one thousand DNA base pairs; a measure of size of a piece of DNA
- kinase** enzyme that adds a phosphate group to another molecule, usually a protein
- Krebs cycle** central metabolic pathway in mitochondria
- lactation** production of milk by the mammary glands
- laparoscopic surgery** surgery in which an instrument is inserted through a very small incision, usually guided by some type of imaging technique
- larynx** “voice box”; muscles at the top of the trachea that control pitch and loudness
- lateral** side-to-side
- lethargy** lack of excitability; torpor
- lignified** hardened by impregnation with lignin, a compound formed in plants



**lignin** organic molecule used in plant cell walls to add stiffness to cellulose

**lineage** ancestral line

**lipid** fat or waxlike molecule, insoluble in water

**lipoprotein** combination of protein and lipid, or fatlike molecule

**locus** site on a chromosome (plural, loci)

**lotic** of, relating to, or living in actively moving water

**lymph** pale fluid that circulates in the lymphatic system, principally composed of blood plasma and cell fluid

**lymphatic system** network of tubes that permeates the body for transport of lymph and combat of infection

**lymphocyte** white blood cell found in lymph nodes

**lyse** break apart

**lysine** an amino acid

**lysing** disintegration or dissolution of cells

**macromolecules** large molecules such as proteins, carbohydrates, and nucleic acids

**marsupials** kangaroos and other mammals that gestate young in an external pouch

**materialism** the belief that life is due entirely to biochemical interactions, without the intervention of supernatural forces

**matrix** a network, usually of threadlike fibers

**medium** nutrient source

**meiosis** cell division that forms eggs or sperm

**membrane potential** electrical and chemical differences across a membrane leading to storage of energy and excitability

**metabolism** chemical reactions within a cell

**metabolite** molecule involved in a metabolic pathway

**metamorphosis** development process that includes a larval stage with a different form from the adult

**metaphase** intermediate stage in cell division, in which chromosomes line up before separating

**metastasis** breaking away of cancer cells from a solid tumor to travel elsewhere in the body

**metazoans** animals other than sponges

**methylation** addition of the methyl group  $\text{CH}_3$

**micron** one-millionth of a meter; also called a micrometer

**mid-dorsal** middle of the back

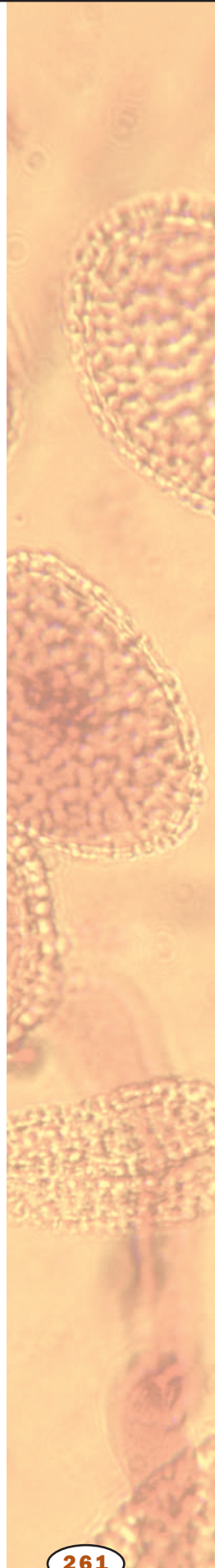

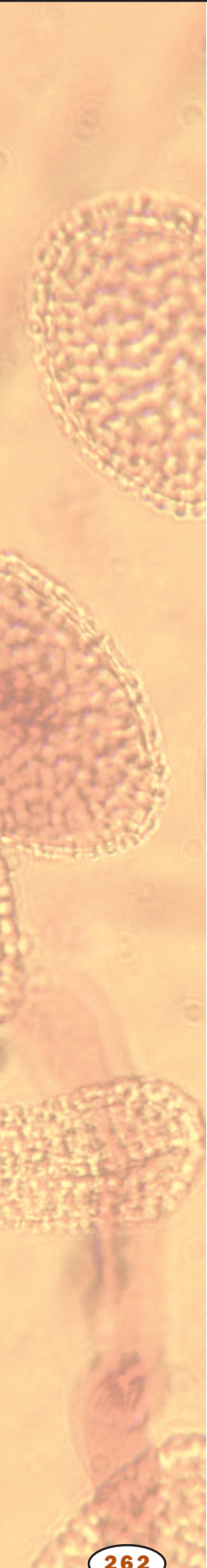

**middle lamella** layer of material between two plant cells that holds them together

**minerals** iron, calcium, sodium, and other elements needed by living organisms

**missense mutation** nucleotide change that causes a change in the amino acid normally added to the protein

**mitochondria** subcellular organelle that creates ATP used for energy-requiring processes in a cell

**mitogen** substance that stimulates mitosis

**mitosis** separation of replicated chromosomes

**molecular hybridization** base-pairing among DNAs or RNAs of different origins

**monocot** any of various flowering plants, such as grasses and orchids, that have a single cotyledon in the seed

**monoculture** cultivation of a single type of crop in a large area

**monomer** “single part”; monomers are joined to form a polymer

**monophyletic** a group that includes an ancestral species and all its descendants

**montane** mountainous region

**morphology** related to shape and form

**motile** able to move

**motor neuron** nerve cell that controls a muscle or gland

**mucous membrane** outer covering designed to secrete mucus, often found lining cavities and internal surfaces

**multimer** composed of many similar parts

**multinucleate** having many nuclei within a single cell membrane

**muscle tone** low level, constant muscle contraction

**mutualism** symbiosis between two organisms in which both benefit

**mycorrhizae** symbiosis between soil fungus and plant root to maximize absorption

**myxedema** thyroid disorder characterized by dry skin, swelling in the face, and mental deterioration

**nanometer**  $10^{-9}$  meters; one-billionth of a meter

**natural selection** process by which organisms best suited to their environments achieve greater reproductive success thus creating more “fit” future generations

**nematode** worm of the Nematoda phylum, many of which are parasitic

**nephron** functional unit of the kidney that performs filtration, reabsorption, and excretion

- neritic** zone near the shore
- neural** related to nerve cells or the nervous system
- neurologist** doctor who treats brain disorders
- neuron** nerve cell
- neurotransmitters** molecules released by one neuron to stimulate or inhibit another neuron or cell
- niche** the habitat supplying the right environment for a particular species
- nm** nanometer; one-billionth of a meter
- nocturnal** characterized by activity at night, or related to the night
- nondisjunction** failure of separation of homologous chromosomes during meiosis
- nuclear envelope** double membrane surrounding the cell nucleus
- nucleated** having a nucleus
- nucleotide** the building block of RNA or DNA
- nucleus** membrane-bound portion of cell containing the chromosomes
- obligate** required or necessary, especially referring to a metabolic process or mode of nutrition
- octomer** composed of eight parts
- oligosaccharide** chain of several sugar molecules
- oncogene** gene that causes cancer
- oocyte** unfertilized egg
- opportunistic** caused by a microorganism that is usually harmless but which causes infection in an immunosuppressed person
- organelle** membrane-bound cell compartment
- organic** composed of carbon, or derived from living organisms; also, a type of agriculture stressing soil fertility and avoidance of synthetic pesticides and fertilizers
- osmosis** passage of water through a membrane in response to concentration differences
- osseous** related to bone
- outcross** fertilization between two different plants
- ovipary** production of eggs that hatch outside the body
- ovovivipary** production of eggs that hatch within the female's body
- ovule** multicellular structure that develops into a seed after fertilization
- oxidation** reaction characterized by loss of electrons, or reaction with oxygen

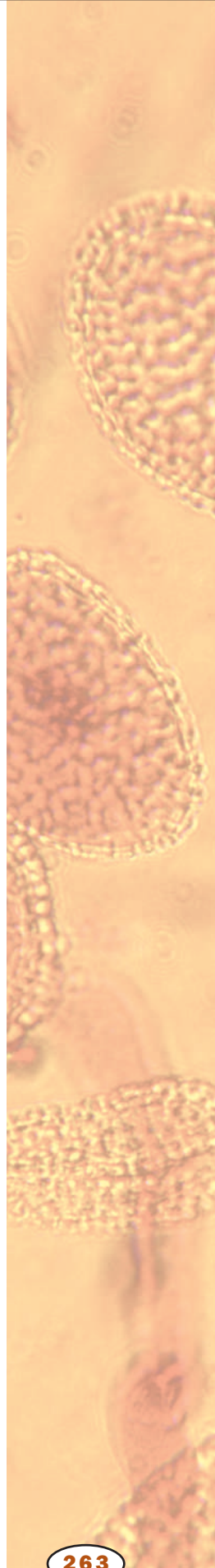

**oxidation-reduction** oxidation is loss of electrons, and reduction is gain of electrons

**oxidative** characterized by oxidation, or loss of electrons

**oxidative phosphorylation** use of oxygen to make ATP

**oxidize** to react or make react with oxygen

**palatine bone** bone of the hard palate at the roof of the mouth

**paleoanthropology** study of ancient humans

**palindromic** reading the same forward and backward

**pandemic** disease spread throughout an entire population

**papillate** small, nipplelike projection

**parasite** organism living in close association with another from which it derives most of its nutrition

**parasitology** study of parasites

**parasympathetic nervous system** branch of the nervous system promoting nutrient absorption and other maintenance activities

**pathogen** disease-causing organism

**pathogenesis** pathway leading to disease

**pathologic** related to disease

**pectin** carbohydrate in plants that forms crosslinks to stabilize cell walls

**peptide bond** bond between two amino acids

**peptidoglycans** polymer that is composed of polysaccharides and peptic chains

**perianth** combined sepals and petals

**peripheral** outside the central nervous system (brain and spinal cord)

**pH** measure of acidity or alkalinity; numbers below 7 are acid, above are basic

**phage** short for bacteriophage

**phagocytosis** engulfing of cells or large fragments by another cell, including immune system cells

**pharynx** throat

**phase-contrast microscopy** technique that manipulates passage of light through transparent specimens to reveal internal features

**phenotype** observable characteristics of an organism

**pheromone** molecule released by one organism to influence another organism's behavior

**phloem** plant tissue that conducts sugars from leaves to roots and other tissues

- phosphodiester** the link between two nucleotides in DNA or RNA
- phosphorylate** add a phosphate group to
- phosphorylation** addition of the phosphate group  $\text{PO}_4^{3-}$
- phyletic gradualism** the belief that evolutionary change is slow and steady
- phylogenetic** related to phylogeny, the evolutionary development of a species
- phylum** taxonomic level below kingdom, e.g., arthropod or chordate
- physiology** branch of biology that deals with the functions and activities of living matter
- phytoplankton** microscopic floating creatures that photosynthesize
- pinnate** featherlike
- pinocytosis** introduction of fluids into a cell by enclosing it and pinching off the plasma membrane
- pipette** lab instrument for precise measurement and transfer of small volumes of liquids
- pistil** female reproductive organ of a flower
- placental** related to mammals that nourish the fetus with a placenta, an exchange organ in the uterus
- plankton** microscopic floating organisms
- plant hybridization** creation of offspring by union of two different types of plants, such as wheat and rye
- plasmid** small ring of DNA found in many bacteria
- plasticity** change form
- plate tectonics** the movement of large plates of Earth's crust
- polar** partially charged, and usually soluble in water
- polar covalent** bond in which electrons are unevenly shared
- polymer** molecule composed of many similar parts
- polymerase** enzyme complex that synthesizes DNA or RNA from individual nucleotides
- polymerization** linking together of similar parts to form a polymer
- polypeptide** chain of amino acids
- polysaccharide** carbohydrate composed of many individual units of sugar
- posterior** toward the back
- postmortem** after death
- prebiotic** before the origin of life
- Precambrian** before the Cambrian era; before 600 million years ago

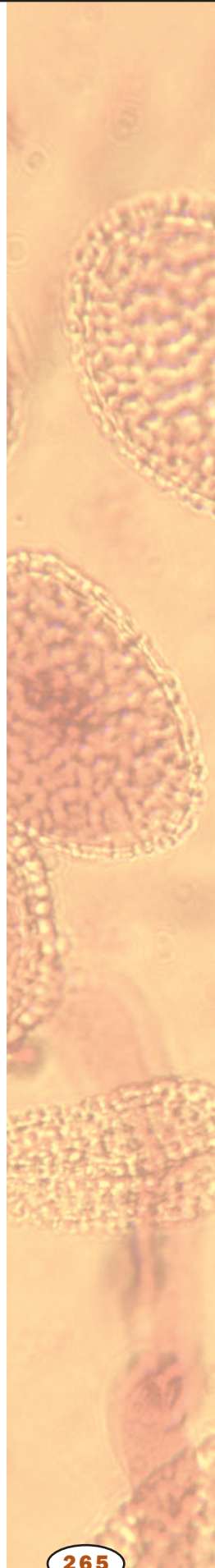

**primer** short nucleotide sequence that helps begin DNA replication

**progeny** offspring

**prokaryote** single-celled organism without a nucleus

**promoter** DNA sequence to which RNA polymerase binds to begin transcription

**prostaglandins** hormonelike molecules released by one cell that affect nearby cells, including smooth muscle

**prostrate** face downward

**protein** complex molecule made from amino acids; used in cells for structure, signaling, and controlling reactions

**proteolysis** breakdown of proteins

**protoecology** early ecology

**protoplasm** fluid portion of a plant cell within the cell wall

**protostome** “mouth first”; referring to the early development of the oral pore during gut tube formation

**protozoa** any of a phylum of minute protoplasmic animals present in almost every kind of habitat, some of which pose serious threats to humans and animals

**pseudopod** “false foot”; an extension of the plasma membrane during locomotion by an amoeba or similar crawling cell

**psychosis** severe mental disorder characterized by diminished connection with reality

**psychotropic** affecting consciousness, thought, or emotion

**punctuated equilibrium** pattern of evolution in which long periods of relatively little change are punctuated by rapid change

**pyruvate** the ionized form of pyruvic acid, a key intermediate in cell metabolism

**quaternary** fourth level

**radially symmetric** symmetric, or similar, about a central point (a wheel is radially symmetric)

**reproductive isolation** isolation of a population from other populations of the same species due to inability to successfully reproduce; an early stage in species formation

**respire** use oxygen to burn cellular fuel

**restriction enzyme** enzyme that cuts DNA at a particular sequence

**restriction fragments** fragments of DNA created by restriction enzymes

**reticular** netlike

**retrograde** backward

- reverse transcriptase** enzyme that copies RNA into DNA
- reverse transcription** creation of DNA from an RNA template
- ribonucleoprotein** combination of RNA and protein
- ribosome** protein-RNA complex in cells that synthesizes protein
- rickettsia** (pl. -sias or siae) any of a family of polymorphic microorganisms that cause various diseases
- RNA polymerase** enzyme complex that creates RNA from DNA template
- saline** of, or relating to, salt
- saprophyte** plant that feeds on decaying parts of other plants
- savanna** open grassland with sparse trees
- sclerophyll** small, tough evergreen leaves
- secretion** material released from the cell
- secretory pathway** series of events within a cell by which molecules are brought to the plasma membrane for release from the cell
- sepals** whorls of flower organs outside of the petals, usually green and serving to protect the flower before it opens
- serotinous** developing late in the season
- serotype** identity of an organism or virus based on reaction to an antibody
- sessile** attached and remaining in one place
- silviculture** cultivation of forest trees
- sleep apnea** difficulty breathing while asleep
- solenoid** cylindrical coiled structure
- solute** dissolved substance
- solvation** the process of dissolving
- somatic** nonreproductive; not an egg or sperm
- somatostatin** hormone produced by the hypothalamus that influences growth
- spasticity** of, or relating to, spasms
- spectroscopy** process using light or other emitted radiation to determine properties of a sample
- sphincter** ring of muscle regulating passage of material through a tube such as the gastrointestinal tract
- spontaneous generation** the theory that life began from nonliving matter
- stasis** state of no change
- steroid hormone** group of hormones that includes estrogen, testosterone, and progesterone

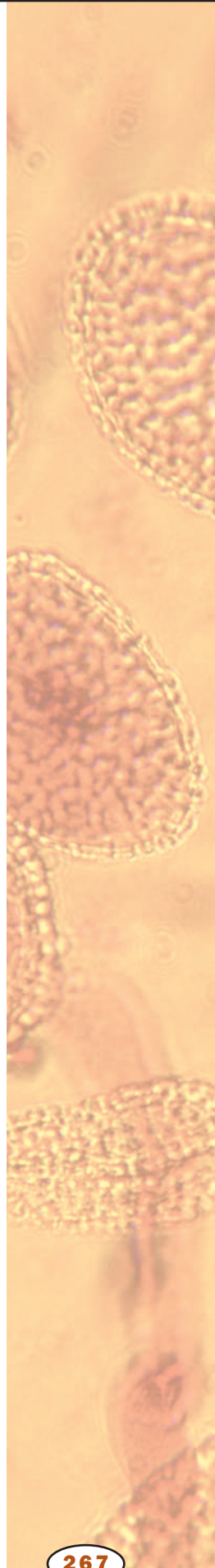

**steroids** hormones such as testosterone or estrogens that control many aspects of physiology

**stomata** openings in leaves for gas exchange, surrounded and regulated by guard cells

**strong bond** high-energy arrangement between two atoms involving electron-sharing; strong bonds require more energy to break than weak bonds

**subcutaneous** below the skin

**substrate** the molecule acted on by an enzyme; also a surface for attachment

**succession** series of changes seen in some plant communities over time, in which low-growing, rapidly reproducing species are replaced by taller and more slowly reproducing ones

**superficial** on the surface; not deep

**symbiont** organism living in close association with another organism

**symbiosis** close relationship between two species in which at least one benefits

**sympathetic nervous system** branch of the nervous system that promotes heightened awareness, increased nutrient consumption, and other changes associated with “fight or flight”

**synaptic transmission** passage of chemicals between nerve cells to send messages or alter neuron firing

**synchronously** at the same time

**synergism** working together to create a larger product rather than a simple sum

**systemic** throughout the body

**T cell** white blood cell that controls the immune response

**taxon** a level of classification, such as kingdom or phylum

**tectonic plate** large segment of Earth’s crust that moves in relation to other similar plates

**template** master copy

**teratogens** substances that cause birth defects

**tertiary** third level

**thermoregulation** temperature regulation

**transcribe** creation of an RNA copy of a DNA gene

**transcription** messenger RNA formation from a DNA sequence

**transcription factor** protein that increases the rate of transcription of a gene

**transduction** conversion of a signal of one type into another type



**transgenic** characterized by presence of one or more genes from a different organism

**translation** synthesis of protein using mRNA code

**translocation** movement of sugars and other nutrients throughout a plant

**transverse** situated or lying across

**trimer** a structure composed of three parts

**triploid** possessing three sets of chromosomes

**trophic** related to feeding

**trophic level** feeding level in an ecosystem

**true breeding** giving only offspring identical to the parents

**turgor** internal pressure

**ubiquitous** found everywhere

**ultrasonography** use of sound waves to produce an image

**ungulate** hoofed mammals such as cattle

**uninucleate** possessing one nucleus

**vas deferens** tube through which sperm travel from testes to urethra

**vector** carrier

**ventral to** toward the belly side

**ventricle** fluid-filled chamber

**venule** any of the minute veins connecting the capillaries with the larger systemic veins

**vesicle** membrane-bound sac

**vestigial** no longer functional

**visceral** related to the viscera, or internal organs

**viscous** thick

**vivipary** production of live young

**volatile** easily vaporized

**vulva** external female genitalia

**weak bond** low-energy arrangement between two atoms involving electron-sharing; weak bonds require less energy to break than strong bonds

**X-ray crystallography** use of X rays to determine the structure of a molecule

**xylem** water-transporting system in plants

**zygote** fertilized egg

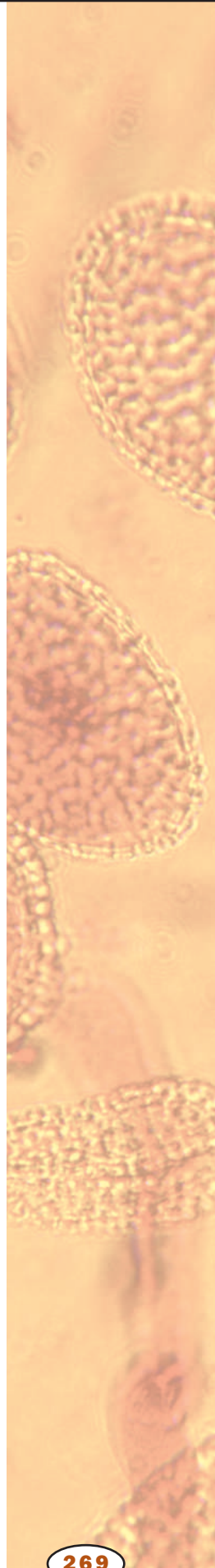

# Topic Outline

## **AGRICULTURE AND ECONOMIC BOTANY**

---

Agriculture  
Agronomist  
Beer-making, Botany of  
Coffee, Botany of  
Desertification  
Ethnobotany  
Forester  
Grain  
Grasses  
History of Agriculture  
Horticulturist  
Hybridization-Plant  
Landscape Ecology  
Nitrogen Cycle  
Nitrogen Fixation  
Organic Agriculture  
Plant Pathogens and Pests  
Pollution and Bioremediation  
Soil  
Vavilov, Nikolay  
Wine-making, Botany of

## **ANIMAL ANATOMY AND PHYSIOLOGY**

---

Amniote egg  
Animalia  
Circulatory Systems  
Connective Tissue  
Digestion  
Epithelium  
Excretory Systems  
Gas Exchange  
Growth  
Life Cycles  
Locomotion  
Model Organisms in Physiology and Medicine  
Muscle  
Nervous Systems  
Neuron  
Organ

Osmoregulation  
Physiological Ecology  
Respiration  
Scaling  
Sex Determination  
Skeletons  
Social Behavior  
Temperature Regulation  
Vision  
Zoology

## **ANIMAL BEHAVIOR**

---

Behavior, Genetic Basis of  
Behavior Patterns  
Feeding Strategies  
Field Studies in Animal Behavior  
Migration and Animal Navigation  
Mimicry, Camouflage, and Warning Coloration  
Pheromone  
Physiological Ecology  
Population Dynamics  
Predation and Defense  
Sexual Selection  
Symbiosis  
Temperature Regulation  
Wildlife Biologist

## **ANIMAL DIVERSITY**

---

Amphibian  
Animalia  
Annelid  
Arachnid  
Arthropod  
Biodiversity  
Bird  
Bony Fish  
Cambrian Explosion  
Cartilaginous Fish  
Chordata  
Cnidarian

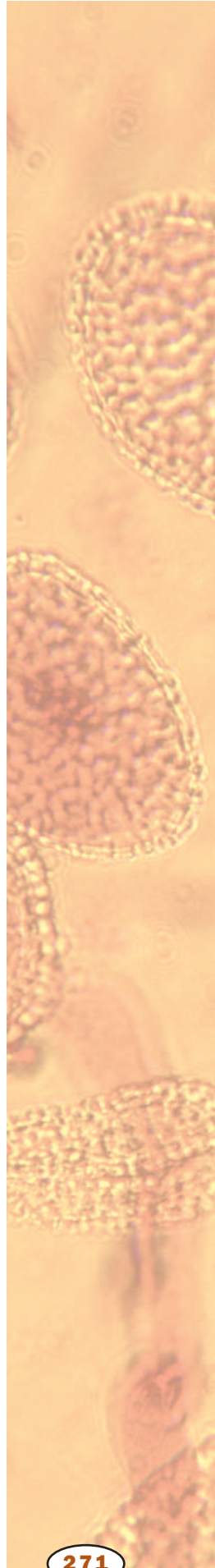

Coral Reef  
Crocodilian  
Crustacean  
Echinoderm  
Endangered Species  
Entomologist  
Extinction, Mammals  
Human Evolution  
Insect  
Mammal  
Marsupial  
Mollusk  
Monotreme  
Nematode  
Parasitic Diseases  
Platyhelminthes  
Porifera  
Primate  
Reptile  
Tuatara  
Tunicate  
Turtle  
Zoology  
Zoology Researcher

**AQUATIC BIOLOGY**

---

Algae  
Amphibian  
Bony Fish  
Cartilaginous Fish  
Cnidarian  
Coral Reef  
Crustacean  
Echinoderm  
Estuaries  
Extreme Communities  
Lakes and Ponds  
Limnologist  
Marine Biologist  
Mollusk  
Ocean Ecosystems: Hard Bottoms  
Ocean Ecosystems: Open Ocean  
Ocean Ecosystems: Soft Bottoms  
Platyhelminthes  
Porifera  
Rivers and Streams  
Water

**BACTERIA AND ARCHAEA**

---

Archaea  
Bacterial Cell  
Bacterial Diseases  
Bacterial Genetics  
Bacterial Viruses

Biotechnology  
Cell Evolution  
Cell Wall  
Chloroplast  
Clone  
Control of Gene Expression  
Cyanobacteria  
Dubos, René  
Ecosystem  
Eubacteria  
Microbiologist  
Mitochondrion  
Model Organisms: Cell Biology and Genetics  
Plant Pathogens and Pests  
Poisons  
Recombinant DNA  
Sexually Transmitted Diseases  
Transgenic Techniques

**BEHAVIOR**

---

Behavior, Genetic Basis of  
Behavior Patterns  
Brain  
Competition  
Feeding Strategies  
Field Studies in Animal Behavior  
Flight  
Learning  
Locomotion  
Migration and Animal Navigation  
Mimicry, Camouflage, and Warning Coloration  
Pheromone  
Predation and Defense  
Sexual Reproduction  
Sexual Selection  
Sleep  
Social Behavior  
Sociobiology

**BIOCHEMISTRY**

---

Amino Acid  
Antibodies in Research  
Biochemist  
Biogeochemical Cycles  
Carbohydrates  
Carbon Cycle  
DNA  
DNA Sequencing  
Drug Testing  
Electrophoresis  
Enzymes  
Glycolysis and Fermentation  
History of Biology: Biochemistry  
Krebs Cycle

Lipids  
 Lysosomes  
 Membrane Proteins  
 Metabolism  
 Mitochondrion  
 Nitrogen Cycle  
 Nitrogen Fixation  
 Nucleotides  
 Origin of Life  
 Oxidative Phosphorylation  
 Pauling, Linus  
 Peroxisomes  
 Pharmacologist  
 Poisons  
 Polymerase Chain Reaction  
 Prion  
 Protein Structure  
 Protein Synthesis  
 Radionuclides  
 RNA  
 Secondary Metabolites in Plants  
 Separation and Purification  
 Structure Determination  
 Vitamins and Coenzymes  
 Water

### **BIOLOGY AND SOCIETY**

---

Alcohol and Health  
 Anabolic Steroids  
 Behavior, Genetic Basis of  
 Biological Weapons  
 Biology of Race  
 Carson, Rachel  
 Creationism  
 Desertification  
 Doctor, Specialist  
 Dubos, René  
 Endangered Species  
 Ethnobotany  
 Evolution, Evidence for  
 Extinction, Mammals  
 Fire Ecology  
 Gene Therapy  
 Global Climate Change  
 Human Genome Project  
 Human Population  
 Invasive Species  
 Organic Agriculture  
 Pauling, Linus  
 Pollution and Bioremediation  
 Psychiatric Disorders, Biology of  
 Psychoactive Drugs  
 Recombinant DNA  
 Reproductive Technology  
 Sexually Transmitted Diseases

Smoking and Health  
 Sociobiology  
 Transgenic Techniques

### **BIOMES**

---

Biogeography  
 Biome  
 Coral Reef  
 Desert  
 Field Studies in Plant Ecology  
 Forest, Boreal  
 Forest, Temperate  
 Forest, Tropical  
 Global Climate Change  
 Grassland  
 Remote Sensing  
 Tundra

### **BIOTECHNOLOGY**

---

Antibodies in Research  
 Antisense Nucleotides  
 Bacterial Genetics  
 Bioinformatics  
 Biological Weapons  
 Biotechnology  
 Clone  
 Electrophoresis  
 Forensic DNA Analysis  
 Genomics  
 Human Genome Project  
 Hybridization  
 Polymerase Chain Reaction  
 Recombinant DNA  
 Reproductive Technology  
 Reverse Transcriptase  
 Separation and Purification  
 Structure Determination  
 Transgenic Techniques

### **CAREERS**

---

Agronomist  
 Biochemist  
 Botanist  
 College Professor  
 Dentist  
 Doctor, Family Practice  
 Doctor, Specialist  
 Emergency Medical Technician  
 Entomologist  
 Epidemiologist  
 Forester  
 Health and Safety Officer  
 High School Biology Teacher  
 Horticulturist

Laboratory Technician  
Marine Biologist  
Medical Assistant  
Microbiologist  
Microscopist  
Nurse  
Nurse Practitioner  
Nutritionist  
Pharmaceutical Sales Representative  
Pharmacologist  
Physician Assistant  
Plant Pathologist  
Psychiatrist  
Public Health Careers  
Science Writer  
Veterinarian  
Wildlife Biologist  
Zoology Researcher

### CELL FUNCTION

---

Active Transport  
Cancers  
Cell Cycle  
Cell Motility  
Control Mechanisms  
Control of Gene Expression  
Cytokinesis  
Endocytosis  
Enzymes  
Exocytosis  
Glycolysis and Fermentation  
History of Plant Physiology  
Hormones  
Ion Channels  
Krebs Cycle  
Lysosomes  
Meiosis  
Membrane Proteins  
Membrane Transport  
Metabolism  
Mitochondrion  
Model Organisms: Cell Biology and Genetics  
Nuclear Transport  
Oxidative Phosphorylation  
Peroxisomes  
Protein Synthesis  
Protein Targeting  
Replication  
Ribosome  
RNA Processing  
Signaling and Signal Transduction  
Synaptic Transmission  
Transcription

### CELL STRUCTURE

---

Archaea  
Bacterial Cell  
Cell  
Cell Evolution  
Cell Junctions  
Cell Motility  
Cell Wall  
Chloroplast  
Connective Tissue  
Cyanobacteria  
Cytoskeleton  
Electron Microscopy  
Endoplasmic Reticulum  
Epithelium  
Eubacteria  
Extracellular Matrix  
Golgi  
History of Biology: Cell Theory and Cell Structure  
Ion Channels  
Life, What Is  
Light Microscopy  
Lysosomes  
Membrane Proteins  
Membrane Structure  
Membrane Transport  
Microscopist  
Mitochondrion  
Model Organisms: Cell Biology and Genetics  
Muscle  
Neuron  
Nuclear Transport  
Nucleolus  
Nucleus  
Organelle  
Origin of Life  
Peroxisomes  
Plasma Membrane  
Porter, Keith  
Ribosome  
T Cells  
Tissue  
Vacuole

### CIRCULATION AND RESPIRATION

---

Blood  
Blood Clotting  
Blood Sugar Regulation  
Blood Vessels  
Cardiovascular Diseases  
Circulatory Systems  
Gas Exchange  
Harvey, William  
Heart and Circulation

Lymphatic System  
 Physiological Ecology  
 Respiration  
 Smoking and Health  
 Temperature Regulation

### **DIGESTION AND EXCRETION**

---

Digestion  
 Digestive System  
 Excretory Systems  
 Human Nutrition  
 Kidney  
 Liver  
 Metabolism  
 Osmoregulation  
 Physiological Ecology

### **DISEASE AND HEALTH**

---

AIDS  
 Alcohol and Health  
 Anabolic Steroids  
 Autoimmune Disease  
 Bacterial Diseases  
 Birth Control  
 Blood Sugar Regulation  
 Cancers  
 Cardiovascular Diseases  
 Clinical Trials  
 Disease  
 Environmental Health  
 Female Reproductive System  
 Fungal Diseases  
 Gene Therapy  
 Health  
 Health and Safety Officer  
 Herbal Medicine  
 History of Medicine  
 Human Nutrition  
 Imaging in Medicine  
 Immune Response  
 Male Reproductive System  
 Model Organisms in Physiology and Medicine  
 Neurologic Diseases  
 Oncogenes and Cancer Cells  
 Pain  
 Parasitic Diseases  
 Poisonous Plants  
 Prion  
 Protozoan Diseases  
 Psychiatric Disorders, Biology of  
 Psychoactive Drugs  
 Sex Determination  
 Sexual Reproduction  
 Sexually Transmitted Diseases

Sleep  
 Smoking and Health  
 Stress Response  
 Transplant Medicine  
 Vaccines  
 Viral Diseases  
 Vitamins and Coenzymes

### **DNA, RNA, CHROMOSOMES**

---

Antisense Nucleotides  
 Chromosome Aberrations  
 Chromosome, Eukaryotic  
 Crick, Francis  
 DNA  
 DNA Sequencing  
 Gene  
 Genome  
 Medical/Science Illustrator  
 Meiosis  
 Mitosis  
 Mutation  
 Nucleotides  
 Polymerase Chain Reaction  
 Recombinant DNA  
 Replication  
 Sex Chromosomes  
 Transfer RNA  
 Watson, James

### **ECOLOGY**

---

Biogeochemical Cycles  
 Biogeography  
 Biome  
 Carbon Cycle  
 Community  
 Competition  
 Conservation  
 Coral Reef  
 Desert  
 Desertification  
 Ecological Research, Long-term  
 Ecology  
 Ecology, History of  
 Ecosystem  
 Endangered Species  
 Estuaries  
 Extinction, Mammals  
 Feeding Strategies  
 Field Studies in Plant Ecology  
 Fire Ecology  
 Forest, Boreal  
 Forest, Temperate  
 Forest, Tropical  
 Global Climate Change

Grassland  
 Habitat  
 Invasive Species  
 Lakes and Ponds  
 Landscape Ecology  
 Limnologist  
 Marine Biologist  
 Mimicry, Camouflage, and Warning Coloration  
 Nitrogen Cycle  
 Ocean Ecosystems: Hard Bottoms  
 Ocean Ecosystems: Open Ocean  
 Ocean Ecosystems: Soft Bottoms  
 Physiological Ecology  
 Pollution and Bioremediation  
 Population Dynamics  
 Predation and Defense  
 Remote Sensing  
 Rivers and Streams  
 Symbiosis  
 Theoretical Ecology  
 Tundra  
 Water Cycle  
 Wetlands

**ENDOCRINE SYSTEM**

Adrenal Gland  
 Anabolic Steroids  
 Birth Control  
 Blood Sugar Regulation  
 Endocrine System  
 Female Reproductive System  
 Hormones  
 Hypothalamus  
 Pancreas  
 Pituitary Gland  
 Sex Determination  
 Stress Response  
 Thyroid Gland

**EVOLUTION AND ADAPTATION**

Adaptation  
 Amniote Egg  
 Angiosperms  
 Biodiversity  
 Biogeography  
 Buffon, Count (Georges-Louis Leclerc)  
 Cambrian Explosion  
 Cell Evolution  
 C4 and CAM Plants  
 Convergent Evolution  
 Creationism  
 Darwin, Charles  
 Evolution  
 Evolution, Evidence for

Evolution of Plants  
 Extinction, Mammals  
 Extreme Communities  
 Hardy-Weinberg Equilibrium  
 Herbivory and Plant Defenses  
 History of Evolutionary Thought  
 Human Evolution  
 Lamarck, Jean-Baptiste  
 Leakey Family  
 Mimicry, Camouflage, and Warning Coloration  
 Natural Selection  
 Origin of Life  
 Osmoregulation  
 Paleontology  
 Physiological Ecology  
 Population Genetics  
 Predation and Defense  
 Scaling  
 Secondary Metabolites in Plants  
 Sociobiology  
 Speciation  
 Species

**EXPERIMENTAL TECHNIQUES**

Antibodies in Research  
 Antisense Nucleotides  
 Biochemist  
 Bioinformatics  
 Biotechnology  
 Cell Culture  
 Clinical Trials  
 Clone  
 Crick, Francis  
 DNA Sequencing  
 Drug Testing  
 Ecological Research, Long-term  
 Electron Microscopy  
 Electrophoresis  
 Field Studies in Animal Behavior  
 Field Studies in Plant Ecology  
 Forensic DNA Analysis  
 Gene Therapy  
 Genetic Analysis  
 Genomics  
 Hardy-Weinberg Equilibrium  
 History of Biology: Biochemistry  
 History of Plant Physiology  
 Human Genome Project  
 Hybridization  
 Imaging in Medicine  
 Ingenhousz, Jan  
 Laboratory Technician  
 Leeuwenhoek, Anton  
 Light Microscopy  
 Linkage and Gene Mapping

Microbiologist  
 Microscopist  
 Model Organisms: Cell Biology and Genetics  
 Model Organisms: Physiology and Medicine  
 Pasteur, Louis  
 Pauling, Linus  
 Pharmacologist  
 Polymerase Chain Reaction  
 Porter, Keith  
 Radiation Hybrid Mapping  
 Radionuclides  
 Recombinant DNA  
 Reproductive Technology  
 Reverse Transcriptase  
 Scaling  
 Separation and Purification  
 Structure Determination  
 Theoretical Ecology  
 Transgenic Techniques  
 Transplant Medicine  
 Van Helmont, J. B.  
 Watson, James  
 Zoology Researcher

## **FUNGI**

---

Biodiversity  
 Cell  
 Cell Wall  
 Fungal Diseases  
 Fungi  
 Lichen  
 Mycorrhizae  
 Plant Pathogens and Pests  
 Symbiosis  
 Taxonomy, History of

## **GENE—PROTEIN**

---

Antisense Nucleotides  
 Chromosome, Eukaryotic  
 Control Mechanisms  
 Control of Gene Expression  
 DNA  
 Endoplasmic Reticulum  
 Gene  
 Genetic Code  
 Genetic Control of Development  
 Genetic Diseases  
 Hormones  
 McClintock, Barbara  
 Mutation  
 Nuclear Transport  
 Nucleolus  
 Nucleotides  
 Nucleus

Prion  
 Protein Structure  
 Protein Synthesis  
 Protein Targeting  
 Recombinant DNA  
 Retrovirus  
 Reverse Transcriptase  
 Ribosome  
 RNA  
 RNA Processing  
 Transcription  
 Transfer RNA  
 Transposon  
 Virus

## **GENETICS**

---

Bacterial Genetics  
 Bacterial Viruses  
 Behavior, Genetic Basis of  
 Biology of Race  
 Chromosome Aberrations  
 Chromosome, Eukaryotic  
 Clone  
 Control of Gene Expression  
 Crick, Francis  
 DNA  
 DNA Sequencing  
 DNA Viruses  
 Forensic DNA Analysis  
 Gene  
 Gene Therapy  
 Genetic Analysis  
 Genetic Code  
 Genetic Control of Development  
 Genetic Counselor  
 Genetic Diseases  
 Genome  
 Genomics  
 Hardy-Weinberg Equilibrium  
 History of Biology: Inheritance  
 Human Genome Project  
 Hybrid  
 Hybridization  
 Hybridization, Plant  
 Linkage and Gene Mapping  
 McClintock, Barbara  
 Meiosis  
 Model Organisms: Cell Biology and Genetics  
 Nucleotides  
 Patterns of Inheritance  
 Pedigrees and Modes of Inheritance  
 Population Genetics  
 Prion  
 Radiation Hybrid Mapping  
 Recombinant DNA



Replication  
 Retrovirus  
 Reverse Transcriptase  
 Transgenic Techniques  
 Transposon  
 Virus  
 Watson, James

### **HISTORY OF BIOLOGY**

---

Buffon, Count (Georges-Louis Leclerc)  
 Carson, Rachel  
 Crick, Francis  
 Darwin, Charles  
 De Saussure, Nicolas  
 Dubos, René  
 Ecology, History of  
 Gray, Asa  
 Harvey, William  
 History of Agriculture  
 History of Biology: Biochemistry  
 History of Biology: Cell Theory and Cell Structure  
 History of Biology: Inheritance  
 History of Evolutionary Thought  
 History of Medicine  
 History of Plant Physiology  
 Ingenhousz, Jan  
 Lamarck, Jean-Baptiste  
 Leakey Family  
 Leeuwenhoek, Anton  
 Linnaeus, Carolus  
 McClintock, Barbara  
 Mendel, Gregor  
 Pasteur, Louis  
 Pauling, Linus  
 Porter, Keith  
 Taxonomy, History of  
 Torrey, John  
 Van Helmont, J. B.  
 Vavilov, Nikolay  
 Vesalius, Andreas  
 Von Humboldt, Alexander  
 Watson, James

### **IMMUNE SYSTEM**

---

AIDS  
 Antibodies in Research  
 Antibody  
 Autoimmune Disease  
 Immune Response  
 Lymphatic System  
 Nonspecific Defense  
 Stress Response  
 T Cells

Transplant Medicine  
 Vaccines

### **INHERITANCE**

---

Bacterial Genetics  
 Behavior, Genetic Basis of  
 Biology of Race  
 Cell Cycle  
 Chromosome Aberrations  
 Clone  
 DNA  
 Feeding Strategies  
 Genetic Counselor  
 Genetic Diseases  
 History of Biology: Inheritance  
 Hybridization-Plant  
 Life Cycles  
 Linkage and Gene Mapping  
 Meiosis  
 Mendel, Gregor  
 Mitosis  
 Model Organisms: Cell Biology and Genetics  
 Mutation  
 Patterns of Inheritance  
 Pedigrees and Modes of Inheritance  
 Radiation Hybrid Mapping  
 Replication  
 Transgenic Techniques

### **INTERACTIONS, POPULATIONS, AND COMMUNITIES**

---

Behavior Patterns  
 Biogeography  
 Community  
 Competition  
 Ecological Research, Long-term  
 Ecology, History of  
 Ecosystem  
 Feeding Strategies  
 Field Studies in Animal Behavior  
 Field Studies in Plant Ecology  
 Fire Ecology  
 Habitat  
 Herbivory and Plant Defenses  
 Human Population  
 Invasive Species  
 Landscape Ecology  
 Lichen  
 Mimicry, Camouflage, and Warning Coloration  
 Mycorrhizae  
 Pheromone  
 Population Dynamics  
 Population Genetics  
 Predation and Defense

Symbiosis  
Theoretical Ecology  
Von Humboldt, Alexander

### **LIFE CYCLES**

---

Aging, Biology of  
Alternation of Generations  
Amniote Egg  
Cell Cycle  
Cnidarian  
Development  
DNA Sequencing  
Female Reproductive System  
Ferns  
Fetal Development, Human  
Growth  
Life Cycle, Human  
Life Cycles  
Male Reproductive System  
Reproduction in Plants  
Seedless Vascular Plants  
Seeds  
Sexual Reproduction  
Slime Molds

### **NERVOUS SYSTEM**

---

Biological Weapons  
Brain  
Central Nervous System  
Chemoreception  
Eye  
Hearing  
Hypothalamus  
Ion Channels  
Nervous Systems  
Neurologic Diseases  
Neuron  
Pain  
Peripheral Nervous System  
Psychiatric Disorders, Biology of  
Psychiatrist  
Psychoactive Drugs  
Spinal Cord  
Stress Response  
Synaptic Transmission  
Touch  
Vision

### **PLANT ANATOMY AND PHYSIOLOGY**

---

Alternation of Generations  
Anatomy of Plants  
Beer-making, Botany of  
C4 and CAM Plants  
Cell Wall

Chloroplast  
De Saussure, Nicolas  
Differentiation in Plants  
Flowers  
Fruits  
Grain  
History of Plant Physiology  
Hormones, Plant  
Hybridization-Plant  
Ingenhousz, Jan  
Leaves  
Meristems  
Mycorrhizae  
Nitrogen Fixation  
Photoperiodism  
Photosynthesis  
Plant Development  
Plant Nutrition  
Plant Pathogens and Pests  
Poisonous Plants  
Pollination and Fertilization  
Propagation  
Reproduction in Plants  
Rhythms of Plant Life  
Roots  
Secondary Metabolites in Plants  
Seed Germination & Dormancy  
Seeds  
Senescence  
Shoots  
Soil  
Translocation  
Tropisms and Nastic Movements  
Van Helmont, J. B.  
Water Cycle  
Water Movement in Plants  
Wine-making, Botany of  
Wood and Wood Products

### **PLANT DIVERSITY**

---

Angiosperms  
Biodiversity  
Biogeography  
Bryophytes  
C4 and CAM Plants  
Conifers  
Eudicots  
Evolution of Plants  
Ferns  
Grasses  
Gray, Asa  
Gymnosperms  
Hybridization-Plant  
Monocots

Plant  
Seedless Vascular Plants  
Torrey, John  
Vavilov, Nikolay  
Von Humboldt, Alexander

---

**PROTISTS**

Algae  
Beer-making, Botany of  
Cell  
Coral Reef  
Evolution of Plants  
History of Biology: Cell Theory and Cell Structure  
Leeuwenhoek, Anton  
Lichen  
Model Organisms: Cell Biology and Genetics  
Plankton  
Protista  
Protozoa  
Protozoan Diseases  
Slime Molds

---

**REPRODUCTION AND DEVELOPMENT**

Aging, Biology of  
Birth Control  
Cell Cycle  
Cytokinesis  
Development  
Female Reproductive System  
Fetal Development, Human  
Genetic Diseases  
Life Cycle, Human  
Life Cycles  
Male Reproductive System  
Meiosis  
Mitosis  
Reproductive Technology  
Sexual Reproduction  
Sexually Transmitted Diseases

---

**SKIN, MUSCLE, AND BONE**

Body Cavities  
Bone  
Connective Tissue  
Epithelium  
Growth  
Locomotion  
Muscle  
Musculoskeletal System  
Skeletons  
Skin

---

**TAXONOMY AND BIODIVERSITY (SEE ALSO ANIMAL DIVERSITY AND PLANT DIVERSITY)**

Animalia  
Archaea  
Biodiversity  
Eubacteria  
Evolution of Plants  
Fungi  
Kingdom  
Lamarck, Jean-Baptiste  
Leeuwenhoek, Anton  
Linnaeus, Carolus  
Plant  
Protista  
Speciation  
Species  
Taxonomy, History of

---

**VIRUSES AND PRIONS**

AIDS  
Bacterial Viruses  
Plant Pathogens and Pests  
Prion  
Retrovirus  
Reverse Transcriptase  
Sexually Transmitted Diseases  
Viral Diseases  
Virus

# biology

VOLUME 4  
Plants and Careers in Biology

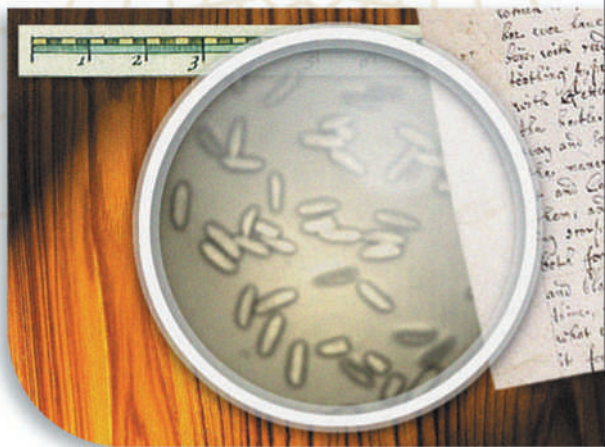

The Macmillan Science Library

**biology**



## **EDITORIAL BOARD**

### **Editor in Chief**

Richard Robinson  
rrobinson@nasw.org  
*Tucson, Arizona*

### **Advisory Editors**

Peter Bruns, *Howard Hughes Medical Institute*  
Rex Chisholm, *Northwestern University Medical School*  
Mark A. Davis, *Department of Biology, Macalester College*  
Thomas A. Frost, *Trout Lake Station, University of Wisconsin*  
Kenneth S. Saladin, *Department of Biology, Georgia College and State University*

### **Editorial Reviewer**

Ricki Lewis, *State University of New York at Albany*

### **Students from the following schools participated as consultants:**

Pocatello High School, Pocatello, Idaho  
Eric Rude, *Teacher*  
Swiftwater High School, Swiftwater, Pennsylvania  
Howard Piltz, *Teacher*  
Douglas Middle School, Box Elder, South Dakota  
Kelly Lane, *Teacher*  
Medford Area Middle School, Medford, Wisconsin  
Jeanine Staab, *Teacher*

## **EDITORIAL AND PRODUCTION STAFF**

Linda Hubbard, *Editorial Director*  
Diane Sawinski, Christine Slovey, *Senior Editors*  
Shawn Beall, Bernard Grunow, Michelle Harper, Kate Millson, Carol Nagel, *Contributing Editors*  
Kristin May, Nicole Watkins, *Editorial Interns*  
Michelle DiMercurio, *Senior Art Director*  
Rhonda Williams, *Buyer*  
Robyn V. Young, *Senior Image Editor*  
Julie Juengling, Lori Hines, *Permissions Assistants*  
Deanna Raso, *Photo Researcher*

### **Macmillan Reference USA**

Elly Dickason, *Publisher*  
Hélène G. Potter, *Editor in Chief*  
Ray Abruzzi, *Editor*

# biology

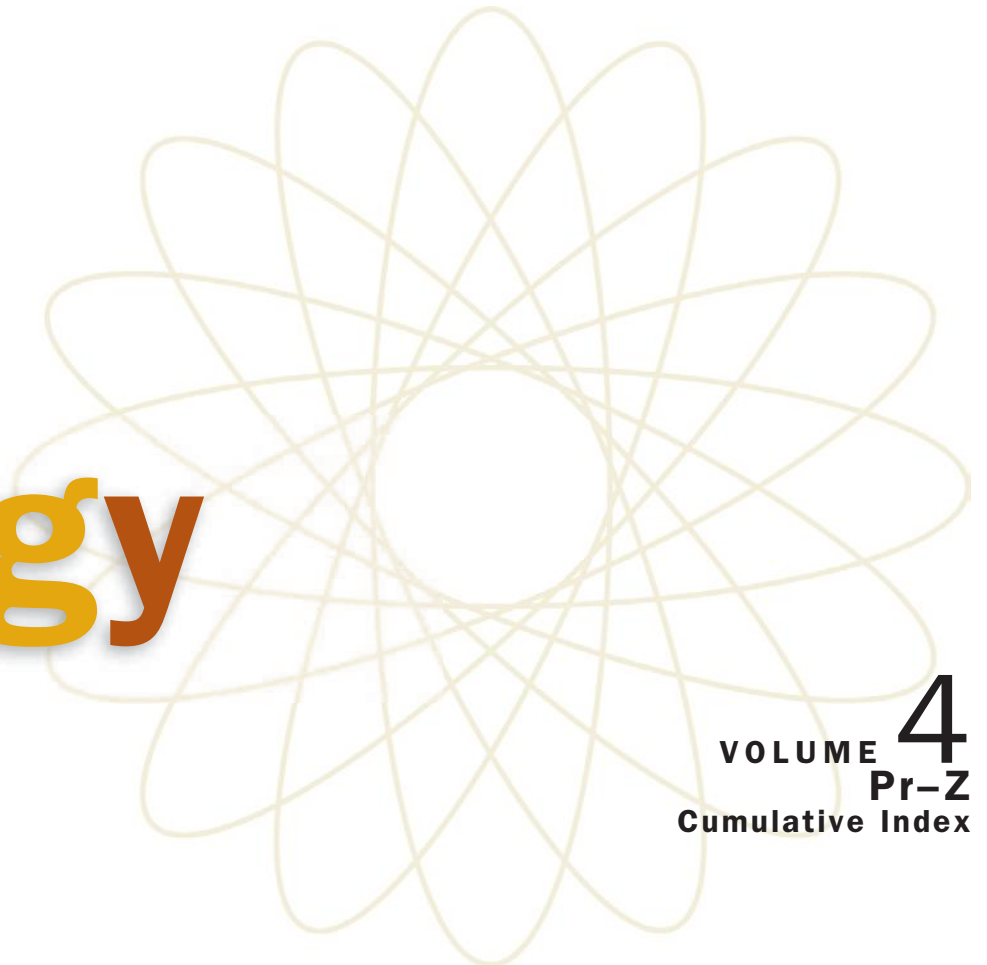

VOLUME **4**  
Pr-Z  
Cumulative Index

Richard Robinson, Editor in Chief

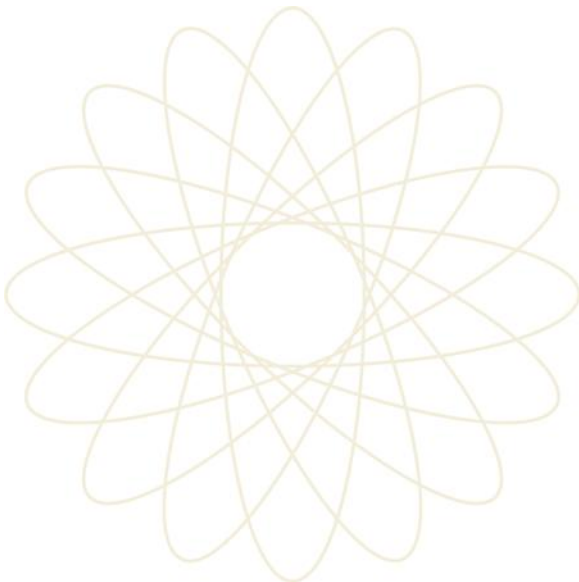

MACMILLAN  
REFERENCE  
USA™

THOMSON  
★  
GALE™

**Copyright © 2002 by Macmillan Reference USA**

All rights reserved. No part of this book may be reproduced or transmitted in any form or by any means, electronic or mechanical, including photocopying, recording, or by any information storage and retrieval system, without permission in writing from the Publisher.

Macmillan Reference USA  
300 Park Avenue South  
New York, NY 10010

Gale Group  
27500 Drake Rd.  
Farmington Hills, 48331-3535

Printed in the United States of America

1 2 3 4 5 6 7 8 9 10

**Library of Congress Catalog-in-Publication Data**

Biology / Richard Robinson, editor in chief.

p. cm.

Includes bibliographical references and index.

ISBN 0-02-86551-6 (set: hardcover) — ISBN 0-02-86-5552-4 (vol. 1) — ISBN 0-02-865556-7 (vol. 2) — ISBN 0-02-865554-0 (vol. 3) — ISBN 0-02-865555-9 (vol. 4)

1. Biology. I. Robinson, Richard, 1956–  
QH07.2.B556 2001

570-dc21  
2001040211



# For Your Reference

The following section provides information that is applicable to a number of articles in this reference work. Included are a metric measurement and conversion table, geologic timescale, diagrams of an animal cell and a plant cell, illustration of the structure of DNA nucleotides, detail of DNA nucleotides pairing up across the double helix, and a comparison of the molecular structure of DNA and RNA.

## METRIC MEASUREMENT

### Definitions

Kilo = 1000  
 Hecto = 100  
 Deka = 10  
 Deci = 0.10 (1/10)  
 Centi = 0.01 (1/100)  
 Milli = 0.001 (1/1000)  
 Micro = 0.000001 (1/1,000,000)  
 Nano = 0.000000001 (1/1,000,000,000)

### Conversions

To convert	Into	Multiply by
Acres	Hectares	0.4047
Centimeters	Inches	0.3937
Feet	Meters	0.3048
Gallons	Liters	3.7853
Grams	Ounces	0.0353
Grams	Pounds	0.0022
Hectares	Acres	2.4710
Inches	Centimeters	2.5400
Kilograms	Pounds	2.2046
Kilometers	Miles	0.6214
Liters	Gallons]	0.2642
Meters	Feet	3.2808
Miles	Kilometers	1.6093
Ounces	Grams	28.3495
Pounds	Kilograms	0.4536
Pounds	Grams	453.59

### Temperature Conversion

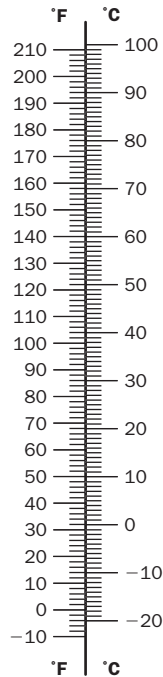

100°C = water boils  
 0°C = water freezes

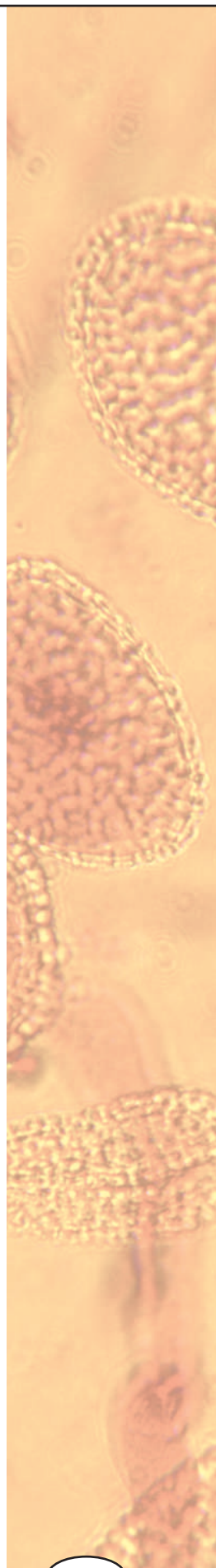

## GEOLOGIC TIMESCALE

ERA	PERIOD	EPOCH	STARTED (millions of years ago)	
<b>Cenozoic:</b> 66.4 millions of years ago–present time	<b>Quaternary</b>	Holocene	0.01	
		Pleistocene	1.6	
	<b>Tertiary</b>	<b>Neogene</b>	Pliocene	5.3
			Miocene	23.7
		<b>Paleogene</b>	Oligocene	36.6
			Eocene	57.8
			Paleocene	66.4
<b>Mesozoic:</b> 245–66.4 millions of years ago	<b>Cretaceous</b>	Late	97.5	
		Early	144	
	<b>Jurassic</b>	Late	163	
		Middle	187	
		Early	208	
	<b>Triassic</b>	Late	230	
		Middle	240	
		Early	245	
	<b>Paleozoic:</b> 570–245 millions of years ago	<b>Permian</b>	Late	258
Early			286	
<b>Carboniferous</b>		<b>Pennsylvanian</b>	Late	320
		<b>Mississippian</b>	Early	360
<b>Devonian</b>		Late	374	
		Middle	387	
		Early	408	
<b>Silurian</b>		Late	421	
		Early	438	
<b>Ordovician</b>		Late	458	
		Middle	478	
		Early	505	
<b>Cambrian</b>		Late	523	
		Middle	540	
		Early	570	
<b>Precambrian time:</b> 4500–570 millions of years ago			4500	

**A TYPICAL ANIMAL CELL**

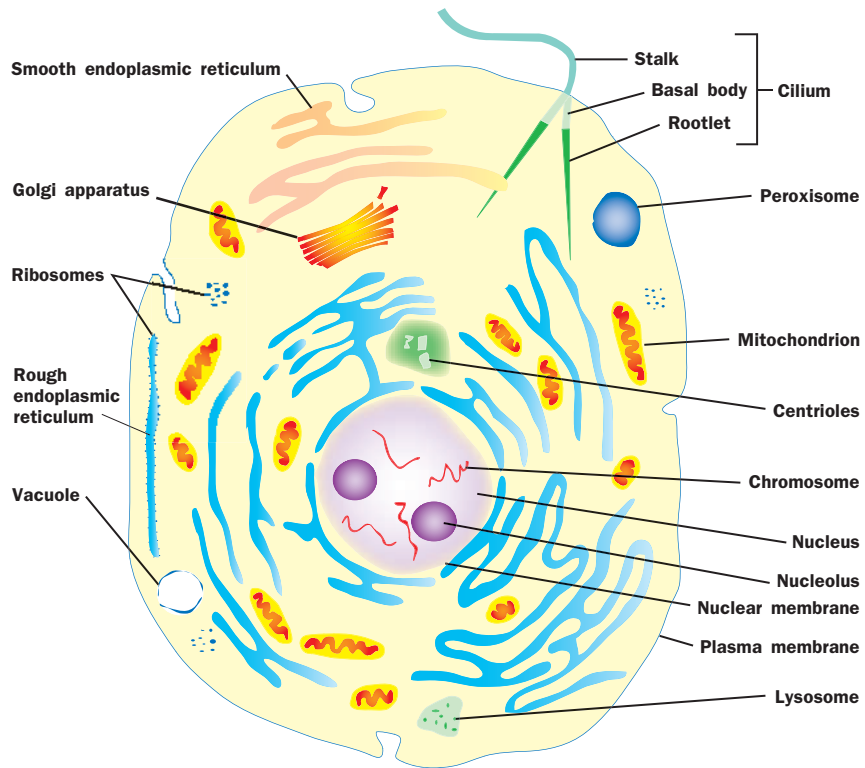

**A TYPICAL PLANT CELL**

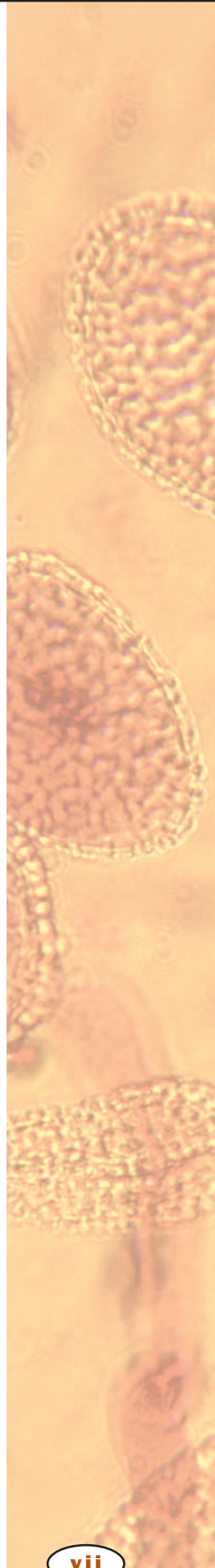
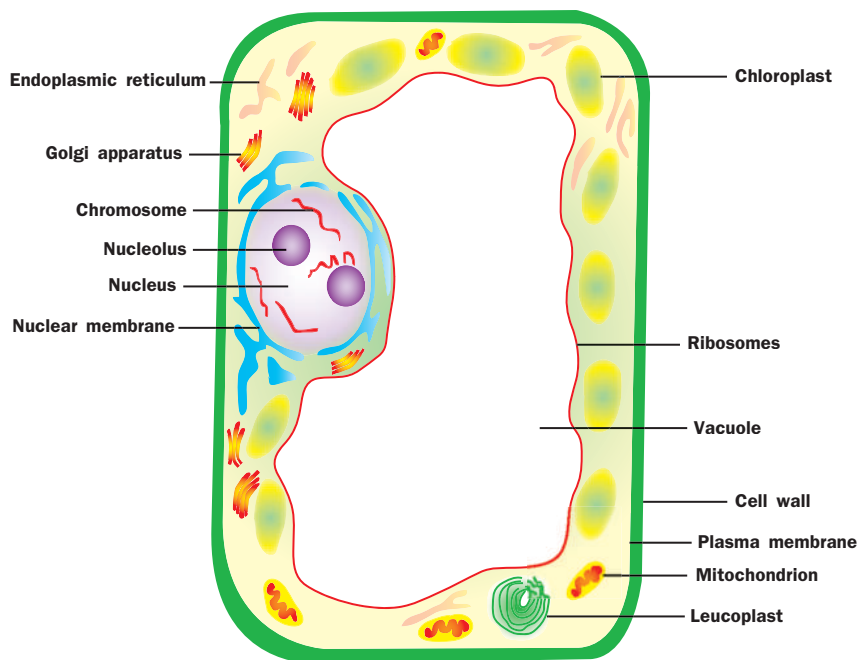

## STRUCTURE OF DNA NUCLEOTIDES

### Components of a nucleotide

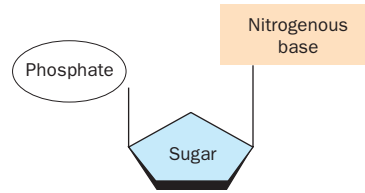

### Purine-containing nucleotides

Adenine

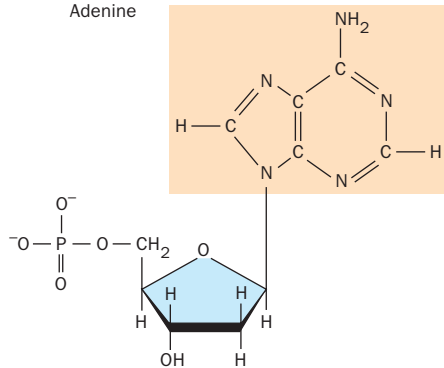

### Pyrimidine-containing nucleotides

Thymine

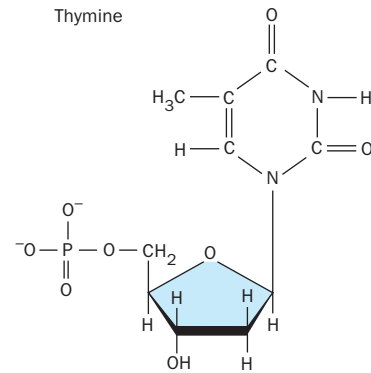

Guanine

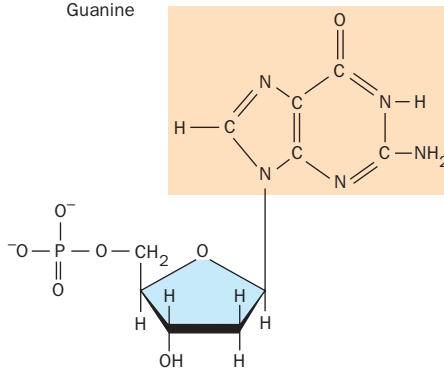

Cytosine

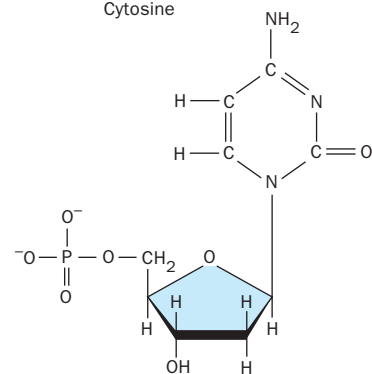

# DNA NUCLEOTIDES PAIR UP ACROSS THE DOUBLE HELIX

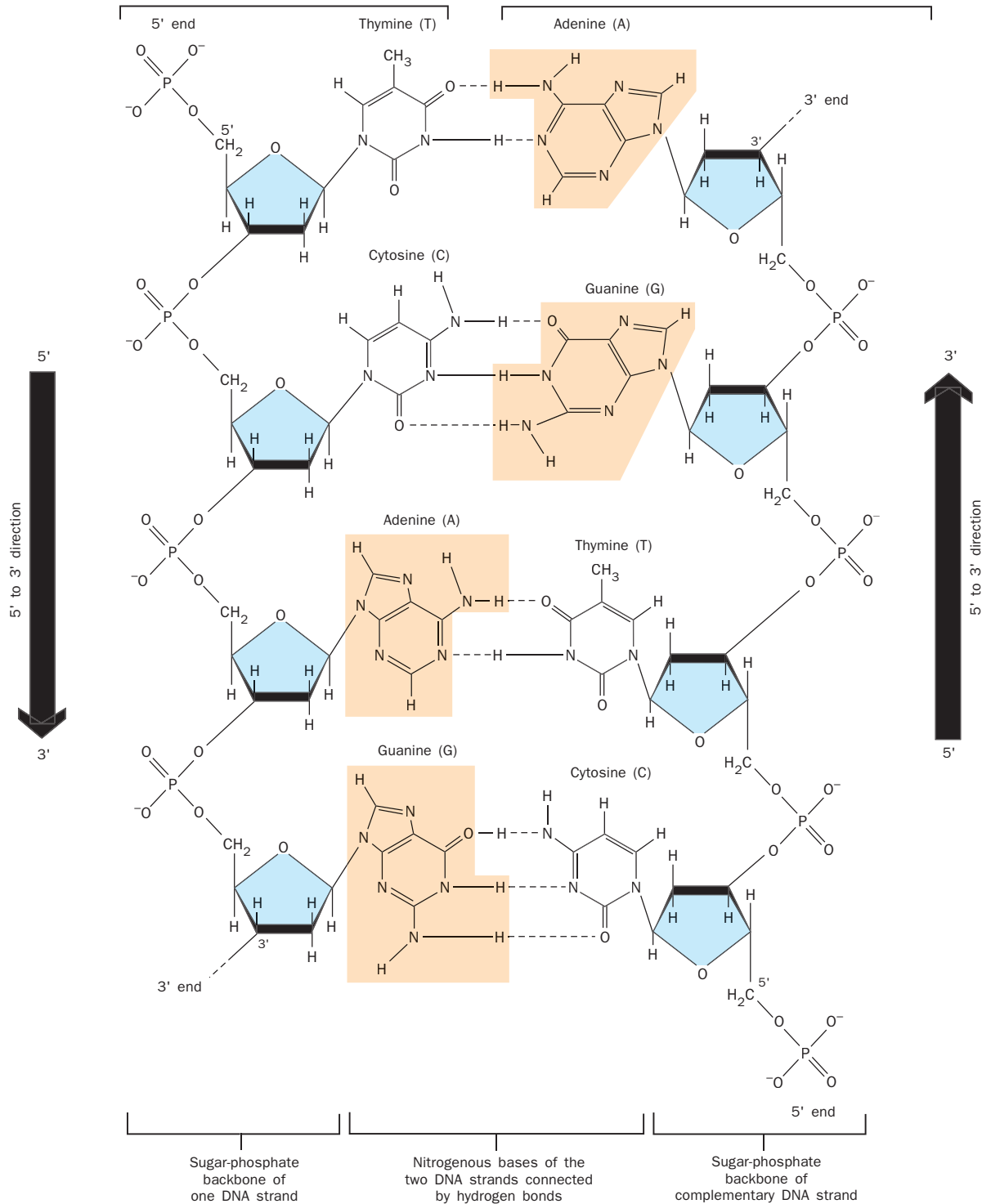

# COMPARISON OF DNA AND RNA

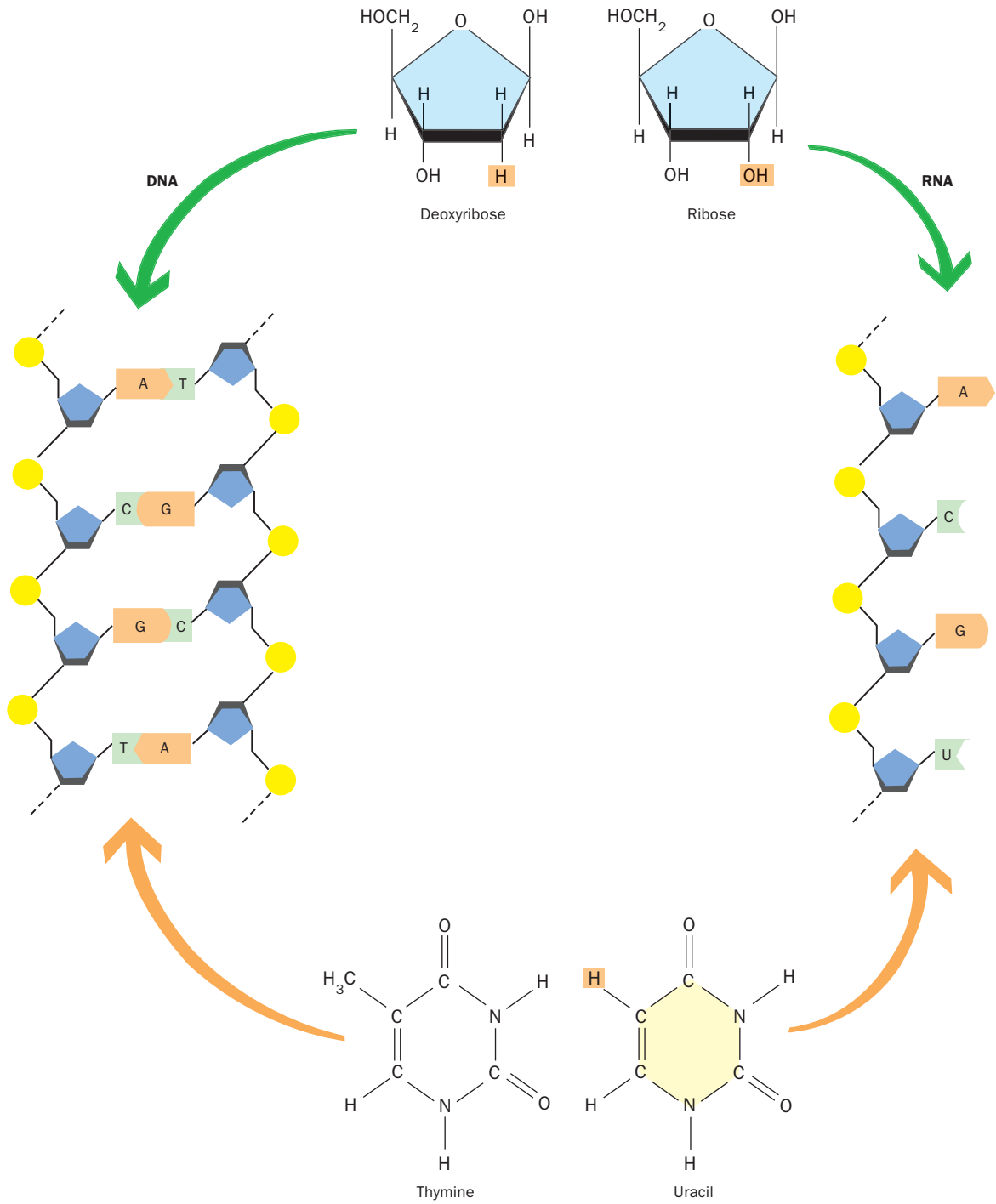

# Table of Contents

## VOLUME 1

PREFACE .....	v
FOR YOUR REFERENCE .....	vii
LIST OF CONTRIBUTORS .....	xiii

## A

Active Transport .....	1
Adaptation .....	3
Adrenal Gland .....	5
Aging, Biology of .....	7
Agriculture .....	10
Agronomist .....	13
AIDS .....	14
Alcohol and Health .....	17
Algae .....	20
Alternation of Generations .....	22
Amino Acid .....	24
Amniote Egg .....	25
Amphibian .....	26
Anabolic Steroids .....	27
Anatomy of Plants .....	29
Angiosperms .....	31
Animalia .....	34
Annelid .....	36
Antibodies in Research .....	37
Antibody .....	39
Antisense Nucleotides .....	41
Arachnid .....	42
Archaea .....	43
Arthropod .....	46
Autoimmune Disease .....	47

## B

Bacterial Cell .....	48
Bacterial Diseases .....	52
Bacterial Genetics .....	53
Bacterial Viruses .....	58
Beer-making, Biology of .....	59

Behavior, Genetic Basis of .....	60
Behavior Patterns .....	63
Biochemist .....	65
Biodiversity .....	66
Biogeochemical Cycles .....	68
Biogeography .....	70
Bioinformatics .....	71
Biological Weapons .....	74
Biology .....	76
Biology of Race .....	77
Biome .....	79
Biotechnology .....	80
Bird .....	80
Birth Control .....	82
Blood .....	84
Blood Clotting .....	86
Blood Sugar Regulation .....	87
Blood Vessels .....	89
Body Cavities .....	91
Bone .....	93
Bony Fish .....	95
Botanist .....	96
Brain .....	97
Bryophytes .....	104
Buffon, Count (Georges-Louis Leclerc) .....	106

## C

C4 and CAM Plants .....	107
Cambrian Explosion .....	108
Cancer .....	110
Carbohydrates .....	112
Carbon Cycle .....	114
Cardiovascular Diseases .....	115
Carson, Rachel .....	117
Cartilaginous Fish .....	118
Cell .....	119
Cell Culture .....	122

Cell Cycle .....	124	DNA Sequencing .....	224
Cell Division .....	127	DNA Viruses .....	227
Cell Evolution .....	127	Doctor, Family Practice .....	228
Cell Junctions .....	129	Doctor, Specialist .....	229
Cell Motility .....	130	Drug Testing .....	232
Cell Wall .....	132	Dubos, René .....	233
Central Nervous System .....	134	PHOTO AND ILLUSTRATION	
Chemoreception .....	135	CREDITS .....	235
Chloroplast .....	137	GLOSSARY .....	243
Chordata .....	138	TOPIC OUTLINE .....	263
Chromosome Aberrations .....	139	INDEX .....	273
Chromosome, Eukaryotic .....	143		
Circulatory Systems .....	149	<b>VOLUME 2</b>	
Clinical Trials .....	151	FOR YOUR REFERENCE .....	v
Clone .....	152	<b>E</b>	
Cnidarian .....	155	Echinoderm .....	1
Coffee, Botany of .....	155	Ecological Research, Long-Term .....	3
College Professor .....	156	Ecology .....	4
Community .....	157	Ecology, History of .....	5
Competition .....	159	Ecosystem .....	7
Conifers .....	162	Electron Microscopy .....	10
Connective Tissue .....	164	Electrophoresis .....	13
Conservation .....	165	Emergency Medical Technician .....	15
Control of Gene Expression .....	170	Endangered Species .....	16
Control Mechanisms .....	177	Endocrine System .....	18
Convergent Evolution .....	181	Endocytosis .....	22
Coral Reef .....	183	Endoplasmic Reticulum .....	25
Creationism .....	185	Entomologist .....	27
Crick, Francis .....	187	Environmental Health .....	28
Crocodylians .....	188	Enzymes .....	29
Crustacean .....	189	Epidemiologist .....	36
Cyanobacteria .....	190	Epithelium .....	37
Cytokinesis .....	191	Estuaries .....	38
Cytoskeleton .....	193	Ethnobotany .....	40
<b>D</b>		Eubacteria .....	41
Darwin, Charles .....	197	Eudicots .....	43
De Saussure, Nicolas-Théodore .....	199	Evolution .....	44
Dentist .....	200	Evolution, Evidence for .....	52
Desert .....	201	Evolution of Plants .....	55
Desertification .....	204	Excretory Systems .....	60
Development .....	205	Exocytosis .....	62
Differentiation in Plants .....	212	Extinction .....	64
Digestion .....	217	Extracellular Matrix .....	68
Digestive System .....	219	Extreme Communities .....	69
Disease .....	221	Eye .....	72
DNA .....	222		



<b>F</b>	
Feeding Strategies	74
Female Reproductive System	77
Fetal Development, Human	81
Field Studies in Animal Behavior	85
Field Studies in Plant Ecology	87
Fire Ecology	89
Flight	91
Flowers	93
Forensic DNA Analysis	94
Forest, Boreal	97
Forest, Temperate	99
Forest, Tropical	101
Forester	105
Fruits	105
Fungal Diseases	108
Fungi	109
<b>G</b>	
Gas Exchange	114
Gene	117
Gene Therapy	124
Genetic Analysis	125
Genetic Code	129
Genetic Control of Development	131
Genetic Counselor	135
Genetic Diseases	136
Genome	140
Genomics	141
Global Climate Change	145
Glycolysis and Fermentation	148
Golgi	150
Grain	153
Grasses	155
Grassland	156
Gray, Asa	158
Growth	158
Gymnosperms	161
<b>H</b>	
Habitat	163
Hardy-Weinberg Equilibrium	164
Harvey, William	166
Health	167
Health and Safety Officer	169
Hearing	169
Heart and Circulation	172
Herbal Medicine	176
Herbivory and Plant Defenses	178
High School Biology Teacher	180
History of Agriculture	180
History of Biology: Biochemistry	182
History of Biology: Cell Theory and Cell Structure	186
History of Biology: Inheritance	189
History of Evolutionary Thought	192
History of Medicine	196
History of Plant Physiology	198
Homeostasis	201
Hormones	203
Hormones, Plant	206
Horticulturist	208
Human Evolution	208
Human Genome Project	212
Human Nutrition	217
Human Population	219
Hybridization	220
Hybridization, Plant	221
Hypothalamus	222
PHOTO AND ILLUSTRATION CREDITS	
CREDITS	227
GLOSSARY	235
TOPIC OUTLINE	255
INDEX	265
<b>VOLUME 3</b>	
FOR YOUR REFERENCE	
	v
<b>I</b>	
Imaging in Medicine	1
Immune Response	4
Ingenhousz, Jan	7
Insect	7
Invasive Species	10
Ion Channels	12
<b>K</b>	
Kidney	15
Kingdom	17
Krebs Cycle	18
<b>L</b>	
Laboratory Technician	20
Lakes and Ponds	21

Lamarck, Jean-Baptiste	23	Mollusk	105
Landscape Ecology	24	Monocots	106
Leakey Family	26	Monotreme	108
Learning	26	Muscle	108
Leaves	28	Musculoskeletal System	112
Leeuwenhoek, Antony von	30	Mutation	115
Lichen	31	Mycorrhizae	119
Life Cycle, Human	32		
Life Cycles	34	<b>N</b>	
Life, What Is	37	Natural Selection	121
Light Microscopy	38	Nematode	124
Limnologist	42	Nervous Systems	125
Linkage and Gene Mapping	42	Neurologic Diseases	129
Linnaeus, Carolus	47	Neuron	131
Lipids	48	Nitrogen Cycle	135
Liver	50	Nitrogen Fixation	136
Locomotion	50	Nonspecific Defense	138
Lymphatic System	52	Nuclear Transport	140
Lysosomes	54	Nucleolus	142
		Nucleotides	144
<b>M</b>		Nucleus	145
Male Reproductive System	56	Nurse	148
Mammal	59	Nurse Practitioners	148
Marine Biologist	60	Nutritionist	149
Marsupial	62		
Mating Systems	62	<b>O</b>	
McClintock, Barbara	64	Ocean Ecosystems: Hard Bottoms	150
Medical Assistant	65	Ocean Ecosystems: Open Ocean	151
Medical/Science Illustrator	65	Ocean Ecosystems: Soft Bottoms	153
Meiosis	66	Oncogenes and Cancer Cells	154
Membrane Proteins	70	Organ	158
Membrane Structure	73	Organelle	159
Membrane Transport	76	Organic Agriculture	159
Mendel, Gregor	80	Origin of Life	161
Meristems	81	Osmoregulation	165
Metabolism, Cellular	84	Oxidative Phosphorylation	168
Metabolism, Human	87		
Microbiologist	90	<b>P</b>	
Microscopist	91	Pain	170
Migration	92	Paleontology	171
Mimicry, Camouflage, and Warning		Pancreas	173
Coloration	93	Parasitic Diseases	174
Mitochondrion	94	Pasteur, Louis	176
Mitosis	98	Patterns of Inheritance	177
Model Organisms: Cell Biology and		Pauling, Linus	184
Genetics	101	Pedigrees and Modes of Inheritance	186
Model Organisms: Physiology and		Peripheral Nervous System	189
Medicine	102	Peroxisomes	191

Pharmaceutical Sales Representative . . .	192	Protozoan Diseases . . . . .	26
Pharmacologist . . . . .	192	Psychiatric Disorders, Biology of . . . . .	27
Pheromone . . . . .	193	Psychiatrist . . . . .	30
Photoperiodism . . . . .	195	Psychoactive Drugs . . . . .	31
Photosynthesis . . . . .	196	Pteridophytes . . . . .	33
Physical Therapist and Occupational Therapist . . . . .	200	Public Health Careers . . . . .	35
Physician Assistant . . . . .	201	<b>R</b>	
Physiological Ecology . . . . .	202	Radiation Hybrid Mapping . . . . .	36
Pituitary Gland . . . . .	205	Radionuclides . . . . .	38
Plankton . . . . .	205	Recombinant DNA . . . . .	38
Plant . . . . .	207	Remote Sensing . . . . .	46
Plant Development . . . . .	208	Replication . . . . .	47
Plant Nutrition . . . . .	214	Reproduction in Plants . . . . .	52
Plant Pathogens and Pests . . . . .	216	Reproductive Technology . . . . .	60
Plant Pathologist . . . . .	219	Reptile . . . . .	62
Plasma Membrane . . . . .	220	Respiration . . . . .	63
Platyhelminthes . . . . .	222	Retrovirus . . . . .	66
Poisonous Plants . . . . .	223	Reverse Transcriptase . . . . .	68
Poisons . . . . .	224	Rhythms of Plant Life . . . . .	69
Pollination and Fertilization . . . . .	227	Ribosome . . . . .	71
Pollution and Bioremediation . . . . .	228	Rivers and Streams . . . . .	73
Polymerase Chain Reaction . . . . .	232	RNA . . . . .	75
Population Dynamics . . . . .	233	RNA Processing . . . . .	77
Population Genetics . . . . .	235	Roots . . . . .	78
Porifera . . . . .	239	<b>S</b>	
Porter, Keith . . . . .	240	Scaling . . . . .	81
<b>PHOTO AND ILLUSTRATION</b>		Science Writer . . . . .	83
CREDITS . . . . .	243	Secondary Metabolites in Plants . . . . .	84
<b>GLOSSARY</b> . . . . .	251	Seed Germination and Dormancy . . . . .	86
<b>TOPIC OUTLINE</b> . . . . .	271	Seedless Vascular Plants . . . . .	88
<b>INDEX</b> . . . . .	281	Seeds . . . . .	89
		Senescence . . . . .	91
		Separation and Purification of Biomolecules . . . . .	93
<b>VOLUME 4</b>		Sex Chromosomes . . . . .	94
<b>FOR YOUR REFERENCE</b> . . . . .	v	Sex Determination . . . . .	96
		Sexual Reproduction . . . . .	98
<b>P</b>		Sexual Reproduction, Evolution of . . . . .	101
Predation and Defense . . . . .	1	Sexual Selection . . . . .	104
Primate . . . . .	4	Sexually Transmitted Diseases . . . . .	106
Prion . . . . .	5	Shoots . . . . .	110
Propagation . . . . .	6	Signaling and Signal Transduction . . . . .	112
Protein Structure . . . . .	7	Skeletons . . . . .	118
Protein Synthesis . . . . .	13	Skin . . . . .	120
Protein Targeting . . . . .	19	Sleep . . . . .	121
Protista . . . . .	21	Slime Molds . . . . .	124
Protozoa . . . . .	23		

Smoking and Health ..... 126  
 Social Behavior ..... 127  
 Sociobiology ..... 131  
 Soil ..... 132  
 Speciation ..... 134  
 Species ..... 136  
 Spinal Cord ..... 137  
 Stress Response ..... 139  
 Structure Determination ..... 141  
 Symbiosis ..... 142  
 Synaptic Transmission ..... 145

**T**

T Cells ..... 148  
 Taxonomy, History of ..... 151  
 Temperature Regulation ..... 154  
 Theoretical Ecology ..... 157  
 Thyroid Gland ..... 158  
 Tissue ..... 159  
 Torrey, John ..... 160  
 Touch ..... 161  
 Transcription ..... 162  
 Transfer RNA ..... 166  
 Transgenic Techniques ..... 167  
 Translocation ..... 168  
 Transplant Medicine ..... 172  
 Transposon ..... 174  
 Tropisms and Nastic Movements ..... 175  
 Tuatara ..... 176  
 Tundra ..... 177  
 Tunicate ..... 178  
 Turtle ..... 179

**V**

Vaccines ..... 180  
 Vacuole ..... 182  
 van Helmont, Jan ..... 183  
 Vavilov, Nikolay ..... 183  
 Vesalius, Andreas ..... 184  
 Veterinarian ..... 185  
 Viral Diseases ..... 186  
 Virus ..... 187  
 Vision ..... 188  
 Vitamins and Coenzymes ..... 190  
 von Humboldt, Alexander ..... 192

**W**

Water ..... 192  
 Water Cycle ..... 193  
 Water Movement in Plants ..... 193  
 Watson, James ..... 196  
 Wetlands ..... 197  
 Wildlife Biologist ..... 199  
 Wine-making, Botany of ..... 200  
 Wood and Wood Products ..... 201

**Z**

Zoology ..... 204  
 Zoology Researcher ..... 204

PHOTO AND ILLUSTRATION

CREDITS ..... 207  
 GLOSSARY ..... 215  
 TOPIC OUTLINE ..... 235  
 CUMULATIVE INDEX ..... 245

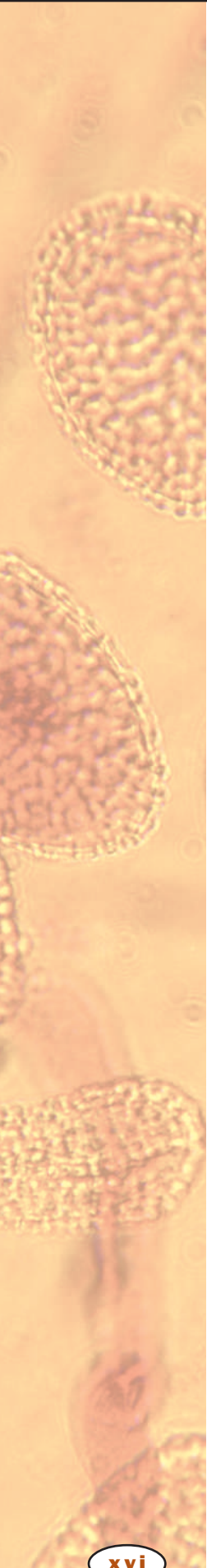

**biology**



## Predation and Defense

---

Predatory behavior is that which results in the killing of another animal for food. Some predators, such as lions and tigers, are large and ferocious, while others can be small and benign in appearance, such as lady bugs. (Lady bugs, however, might seem ferocious to their prey, which are tiny insects called aphids.) Some predators, such as bears and crows, eat a mixed diet that includes a lot of plant material as well as other animals. Other animals, such as frogs, lizards, and most species of wild cats, are more strictly carnivorous, and their diet consists almost entirely of animals.

### Characteristics of Predators

Predators usually possess excellent senses to find their prey and special abilities to capture the prey. Predatory birds, for example, possess outstanding eyesight and often hearing, as in the case of owls. Other predators, such as many species of mammals, have a very keen sense of smell that helps them locate prey. Many predators are very fast, and use their speed to help capture their prey. Cheetahs, predators of the African **savannas**, are the world's fastest runners; falcons, predators of other bird species, are the world's fastest fliers; and dolphins and barracudas are very fast swimmers.

### Prey Defenses

Most species are potential prey for another animal at least sometime during their lives. Even lions and wolves can fall victim to other predators when they are very young. Most species possess several lines of defense against predators. Often the first line of defense is to avoid being detected by the predator. One way to do this is to minimize noise production and any visual cues that the predator might use to locate the prey. Frogs and crickets usually stop singing as another creature approaches. The resulting silence makes it more difficult for the predator to find them. Other prey have evolved camouflage coloration that blends into the background making it difficult for visual predators to find them. Many moths, common prey for birds, look like the bark of trees on which they rest during the day, and snowshoe hares, the primary prey for lynx, have brown fur in the summer but white fur in the winter when their northern environment is covered with snow. Because predators often use prey movements to detect them, many prey remain as still as possible when a predator approaches.



**savanna** open grassland with sparse trees

Predatory birds, such as this peregrine falcon (*Falco peregrinus anatum*), possess outstanding eyesight.



The prey usually has other lines of defense it can utilize if spotted. Many prey species are very fast runners, swimmers, or fliers, and they often can use their speed to escape. Even if a prey is spotted and caught, or cornered, the result is often not a foregone conclusion. Many prey successfully deter a predatory attempt by fighting back. An adult moose is usually successful at warding off an attack by a pack of wolves, even if the moose has been surrounded by the wolves. The moose is able to use its hooves as lethal weapons against the much smaller wolves, and the wolves generally give up once they realize the moose is healthy and a formidable adversary.

Some animals have morphological and behavioral adaptations that make it difficult for the predator to get the prey into their mouth. Many fish and insects have spines that prevent a predatory fish or bird from being able to eat them. Some prey, like the puffer fish, make themselves larger if threatened, again making it more difficult, often impossible, for the predator to ingest the prey.

Many prey have evolved to use social behavior as a predatory defense. For example, many species of fish and birds travel in groups, such as schools of fish and flocks of birds. These schools and flocks often move very quickly in a highly synchronized fashion. Scientists believe that these groups provide protection for individuals in the group. Most predators have to single out and focus on a single individual in order to successfully capture a prey. However, the fast-moving and synchronized flocks and schools are believed to make it difficult for the predators to accomplish this. In some cases, a group of prey is able to successfully fight off a predatory attack, whereas an individual prey probably would not be able to do this. For example, although a baboon on its own would probably succumb to a predatory attack from a leopard, a group of males in a baboon troop can usually ward off such an attack.

Some prey are easy for predators to find, easy for predators to capture, and easy for predators to ingest. Yet they seldom fall prey to predators because they employ a final line of defense: toxicity. They are poisonous. The poison dart frogs of the rain forests of Central and South America are an



Some species of fish swim in a highly synchronized fashion to defend themselves against their predators.

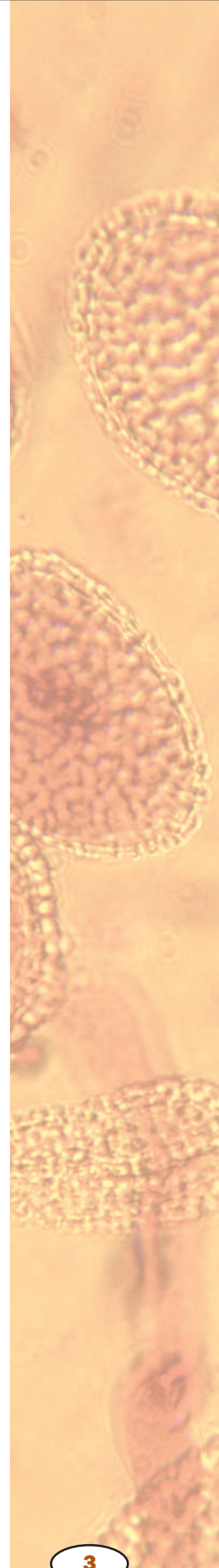

excellent example. These are small, brightly colored frogs that are easy to find, catch, and eat. However, they are very poisonous, and most birds quickly learn to avoid them. The indigenous people of these rainforests discovered that these frogs contain a potent toxin and learned to extract the toxin from the frogs. They then dipped the tips of their arrows in the toxin before going out on a hunting expedition. Ironically, by using the toxin that had evolved as an antipredatory defense, the people became more effective predators.

### Evolution of Predator-Prey Relationships

Because the cost of being caught and eaten by a predator is so great, the intensity of natural selection on prey species has been very high throughout evolution. The selection pressure on the prey is probably higher than that on the predator. If a fox fails in its attempt to catch a rabbit, it just misses lunch. However, if a rabbit fails in its attempt to escape from a fox, it loses its life. Because of the intensity of selection on prey species, the variety and effectiveness of antipredatory defenses is especially impressive.



It is believed that predators and their prey have coevolved. This means that as the predators developed adaptations that enabled them to capture the prey more successfully, the selection pressure on prey intensified, resulting in the selection of more effective antipredator adaptations. In turn, these more effective antipredator adaptations are believed to have promoted the selection of more effective predatory adaptations. This reciprocal on-going evolutionary cycle among predators and prey is sometimes referred to as an evolutionary arms race. SEE ALSO ECOSYSTEM; FEEDING STRATEGIES; MIMICRY, CAMOUFLAGE, AND WARNING COLORATION; POISONS

Mark. A. Davis

#### Bibliography

Alcock, J. *Animal Behavior: An Evolutionary Approach*, 6th ed. Sunderland, MA: Sinauer Associates, Inc., 1998.

## Primate

The order Primates includes prosimians, monkeys, and apes. Primates are well studied, to a large extent because people are primates. (Humans are apes, within the superfamily Hominoidea.) There are some 240 species of primates alive today, ranging across South America, Africa, and Asia. Since nearly all primates are primarily arboreal (they live in trees), their geographic distribution is largely confined to forest or woodland and to warm regions where all of the trees do not lose their leaves and fruits at the same time.

Traditionally primates are divided into two groups: the Prosimians (lemurs of Madagascar and Africa, lorises of Asia, and tarsiers of Asia) and the Anthropoidea (monkeys and apes). Many primatologists prefer to classify them in two main groups: the Strepsirrhini (lemurs and lorises) and Haplorrhini (tarsiers, monkeys, and apes). The difference between the two classificatory systems is the placement of tarsiers, which demonstrate many evolved features relative to the prosimians.

Primates are a generalized group of mammals defined by a series of characters variously present in each species. Tendencies in the primates include:

- An emphasis on the sense of sight and a relative deemphasis on the sense of smell; forward-facing eyes that allow good depth perception; and, in the monkeys and apes, there is color vision.
- Grasping hands, with retention of all five digits; nails (not claws) on the ends of digits; sensitive tactile pads on grasping hands, opposable thumbs; and usually grasping feet.
- Large brains for body size; efficient nourishment of the fetus *in utero*, with usually one infant born at a time, and a prolonged childhood, allowing for more time to learn; longer lives and a great deal of sociality.
- Generalized diets, eating some combination of insects, fruit, and leaves (there are some specialists in each of those categories); baboons and chimpanzees also hunt vertebrates to a small degree, while humans hunt relatively more.

- Varying social and mating habitats. There are multi-male, multi-female groups (baboons); single male multi-female groups (some gorillas, some baboons); and monogamous (gibbons), polyandrous (tamarins and marmosets), polygynous, and promiscuous mating species (chimpanzees). Some are relatively solitary (for example, orangutans). In some cases males immigrate from their natal group and in others, females do.

The relationship between the primates and other orders is not resolved, despite attempts using **morphology** and comparisons of molecular biology. Molecular and anatomical comparisons have indicated sister groups, which include Chiroptera (bats), Rodentia (rodents), and Lagamopha (rabbits), among others.

The earliest fossils that are undisputed primates are from a warm epoch called the Eocene, found in North America, North Africa, and Asia, but not in South America or Antarctica.

There is special urgency to preserve primates because they inform scientists about humans and human evolution. About one-third of primate species are in danger of extinction because of rampant destruction of their forest habitats via logging and the bush-meat trade. SEE ALSO CHORDATA; HUMAN EVOLUTION

*Martha Tappen*

### Bibliography

- Fleagle, John. *Primate Adaptations and Evolution*, 2nd ed. New York: Academic Press, 1999.
- Strier, Karen. *Primate Behavioral Ecology*. Needham Heights, MA: Allyn & Bacon, 1999.

## Prion

Unlike all other infectious agents, prions contain no deoxyribonucleic acid (DNA) or ribonucleic acid (RNA). This radical difference has slowed the understanding and acceptance of the infectious properties of prions since their discovery. Prions are infectious agents composed of **protein** that cause fatal brain diseases. Prion diseases include scrapie in sheep, “mad cow disease” (bovine spongiform encephalopathy, or BSE) in cattle, and Creutzfeldt-Jakob disease (CJD) in humans. Prion diseases can be transmitted when an organism consumes infected brain material from another organism. This occurred in England (and elsewhere) when cows were fed processed remains of infected livestock. While the cause of most cases of CJD is unknown, a small number of European cases have been correlated with the consumption of contaminated beef.

First called “slow viruses,” the unusual nature of these infectious agents became clear from experiments performed in the 1960s. For example, the agents were particularly resistant to sterilization procedures that inactivated bacteria and viruses.

In the early 1980s American **neurologist** Stanley Prusiner published biochemical purification studies suggesting that these **pathogens** were composed mainly of one type of protein and were thus fundamentally different—and by

### GOODALL, JANE (1934–)

British biologist whose long-term study of the behavior and social organization of chimpanzees in Tanzania has transformed scientific understanding of primate behavior. She showed, for example, that chimpanzees make and use tools and engage in highly complex social behaviors.

**morphology** related to shape and form

**protein** complex molecule made from amino acids; used in cells for structure, signaling, and controlling reactions

**neurologist** doctor who treats brain disorders

**pathogen** disease-causing organism

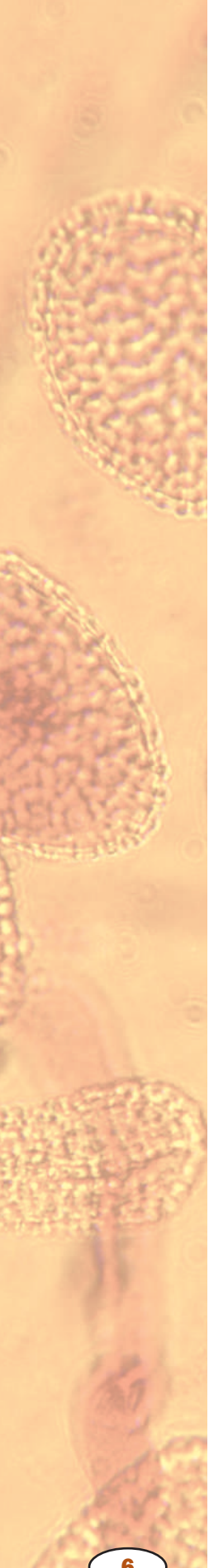

**amino acid** a building block of protein

**conformation** three-dimensional shape

$\alpha$  the Greek letter alpha

**template** master copy

**hybrid** combination of two different types

**protein** complex molecule made from amino acids; used in cells for structure, signaling, and controlling reactions

implication, far simpler chemically—than conventional infectious pathogens of animals and plants. Prusiner coined the term prion (derived from *proteinaceous infectious pathogen*) to highlight this distinction. The single protein implicated as the causative agent was named the prion protein, PrP for short. Although the theory was first greeted with skepticism, Prusiner was vindicated by receiving the 1997 Nobel Prize in Biology or Medicine.

Generally, and as first suggested by Norwegian-American chemist Christian Anfinsen, the linear sequence of **amino acids** in a protein determines its unique three-dimensional structure, or “conformation.” This **conformation** arises from folding of the peptide chain driven by thermodynamic considerations. A normal form of PrP made in healthy animals is called PrP<sup>C</sup> and follows a predetermined pattern of folding. The folding results in three corkscrew (“ $\alpha$ -helical”) segments that compact down upon each other to form a globular core region. Surprisingly, analysis of the infectious form of the PrP referred to as PrP<sup>Sc</sup> reveals a different shape. Compared to PrP<sup>C</sup>, PrP<sup>Sc</sup> has a diminished amount of  $\alpha$ -helix and an increased amount of another folding pattern called  $\alpha$ -sheet, despite the fact that they have the same amino acid sequence.

These findings defined a new mechanism of disease resulting from proteins adopting alternative, inappropriate conformations. The exact means whereby PrP<sup>Sc</sup> molecules are formed from PrP<sup>C</sup> molecules is not fully understood. Nonetheless, it appears to involve a templating reaction where PrP<sup>C</sup> molecules are first unfolded and then refolded into the shape characteristic of PrP<sup>Sc</sup> using preexisting PrP<sup>Sc</sup> molecules as **templates**. Since the generation of new PrP<sup>Sc</sup> molecules is equated with (and perhaps the same as) the generation of new infectious particles, it can be seen that prions “replicate” in a strange and novel manner, namely by subverting the folding of a normal cell-surface protein. SEE ALSO NEUROLOGIC DISEASES; PROTEIN STRUCTURE

*David Westaway*

**Bibliography**

Prusiner, S. B. *Scientific American* 272, no. 1 (January 1995): 48–57.

**Propagation**

Plant propagation is the art and science of increasing numbers of plants utilizing both sexual and asexual methods. It is not an exaggeration to say that the continued existence of modern civilization depends upon plant propagation.

Sexual plant propagation is accomplished using seeds or spores. Many crops grown this way are essential for environmental quality, food, fiber, fuel, medicines, shelter, and myriad other plant-derived substances essential for quality of human life.

Seeds may be harvested from wild plants or from those subject to carefully controlled cross-pollination, which produces plants known as **hybrids**. These hybrid plants may have characteristics superior to their parents such as increased **protein**, better flavor, and pest resistance. Sexual plant propa-

gation begins with seed harvesting and is separate from the creation of the cross-pollination process.

Seeds of most grains and vegetables require specific environmental conditions to germinate and grow. For these plants, proper seed harvest and storage to maintain **viability** and vigor are essential. Once a seed is sown, it can be expected to germinate in a period of time ranging from a few days to a few weeks.

**viability** ability to live

Many seeds require special events or processes to occur before they can germinate. These may include cycles of warm and/or cool, moist treatments (stratification), cracking or wearing away of seed coats (scarification), smoke, intense heat from fire, or even passing through the digestive tract of an animal. Seeds of many perennial flowers as well as most trees and shrubs originating in temperate climates require physical and/or chemical treatment to overcome dormancy.

Some natural and human-made plant hybrids will not retain their desirable traits if allowed to reproduce sexually, so they must be propagated by asexual means to produce clones. A common technique in asexual plant propagation is stimulating root growth on plant parts such as stems that have been cut off. This is known as cutting propagation and is the most common form of propagation used in ornamental nursery production.

An ancient yet common asexual propagation technique involves joining the top of one plant (the “scion”) with the root system of another. This is called **grafting**. Grafting allows combinations of desirable root characteristics of a plant (such as pest resistance) with desirable shoot characteristics of another (such as flavorful fruit). Often grafting is the only economical means to produce plants with those desirable characteristics. Grafting is a skill commonly employed in the production of fruit and nut-producing plants.

**grafting** attachment and fusing of parts from different plants

Another asexual plant propagation method is micropropagation, or tissue culture. In micropropagation, a very small piece of plant tissue is placed on an artificial growth **medium** under conditions similar to a hospital laboratory. Once sufficient tissue increase has occurred, plants are hormonally stimulated into differentiating to create a plant that can be grown outside the laboratory. SEE ALSO CLONE; HORMONES, PLANT; HORTICULTURIST

**medium** nutrient source

*Richard E. Bir*

### Bibliography

Bir, Richard E. *Growing and Propagating Showy Native Woody Plants*. Chapel Hill, NC: University of North Carolina Press, 1992.

Cullina, William. *The New England Wildflower Society Guide to Growing and Propagating Wildflowers of the United States and Canada*. New York: Houghton Mifflin, 2000.

Hartman H., et al. *Plant Propagation Principles and Practices*, 6th ed. Englewood Cliffs, NJ: Prentice Hall, 1997.

## Protein Structure

Proteins are chains of **amino acids** that fold into a three-dimensional shape. Proteins come in a wide variety of amino acid sequences, sizes, and three-dimensional structures, which reflect their diverse roles in nearly all cellular

**amino acid** a building block of protein

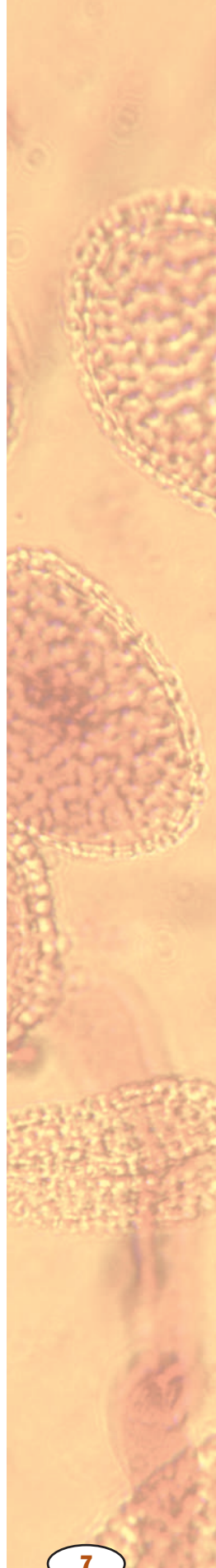

**macromolecules** large molecules such as proteins, carbohydrates, and nucleic acids

**lipoprotein** combination of protein and lipid, or fatlike molecule

**multimer** composed of many similar parts

**hydrophobic** “water-hating,” such as oils

**polar** partially charged, and usually soluble in water

**peptide bond** bond between two amino acids

functions. Each protein has a particular structure necessary to bind with a high degree of specificity to one or a few molecules and to carry out its function; thus, function is directly correlated to structure of the protein. Proteins make up about 50 percent of the dry weight of cells and are the most abundant of the **macromolecules** inside the cell and of the cellular membranes. Proteins (including their **lipoprotein** and glycoprotein forms) also constitute 10 percent of the weight of the blood plasma of living organisms, carrying various nutrients throughout the body and acting as signals to coordinate bodily functions between the different organs.

The sizes of proteins vary greatly. The size is described by the molecular weight given in the units of a dalton. One dalton is the molecular mass of one hydrogen atom. The molecular weight of a protein is equal to the addition of the molecular weights of the amino acids constituting the protein. Some proteins are of relatively small molecular size, such as insulin, with a molecular weight of about 5,700 daltons. Others, like titin (a protein found in muscle), are very large. Some proteins consist of a single amino acid sequence (polypeptide chain), while others are **multimers** of the same or different subunits.

## Organization of Protein Structure

There are four levels of protein structure: primary, secondary, tertiary, and quaternary. These levels also reflect their temporal sequence. Proteins are synthesized as a primary sequence and then fold into secondary → tertiary → and quaternary structures. The figures show these various types of structure, which are described as follows.

Amino acids (see Figure 1) are the building blocks (units) of proteins. Each amino acid has several common features: an amino and a carboxyl chemical group both bonded to the alpha carbon ( $C\alpha$ ) and an R group that defines a particular amino acid. Some R groups are **hydrophobic** and tend to project to, and be buried in, the inside of a protein structure. Four amino acid R groups contain either a positive or negative charge and thus project to the water environment to the exterior of proteins. Other R groups are **polar** in nature and also tend to project to the outside.

The amino acids of a protein are connected to each other by **peptide bonds**. During protein synthesis the amino group of the amino acid being added is coupled to the carboxyl group of the prior amino acid, and two hydrogen atoms and one oxygen atom are removed as a water molecule ( $H_2O$ ) and the peptide bond is formed (see Figure 2).

**Primary Structure of Proteins.** The linear sequence of amino acids constitutes a protein’s primary structure. The sequence is written from the amino-terminal end (the first amino acid) to the carboxyl-terminal end (the same sequence in which the protein is synthesized). All properties of a protein are derived from the primary structure, the linear sequence. Encoded in the sequence is the ability of the protein to fold into its secondary, tertiary, and quaternary structures, and thus to be able to carry out a function. The function of a protein is only expressed when the protein has achieved its three-dimensional shape.

**Secondary Structures of Proteins.** Secondary structures arise from non-covalent interactions between amino acids across the chain. There are only

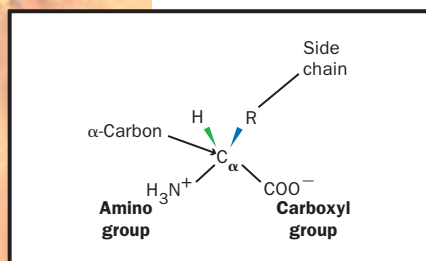

Figure 1. Structure of an amino acid.

two bonds that can rotate in space between each amino acid in the backbone of the primary sequence. These restricted movements, when repeated through several amino acids in a chain, yield the two main types of protein secondary structure: the alpha ( $\alpha$ ) helix and the beta ( $\beta$ ) strand.

The  $\alpha$  helix is shaped like a spiral staircase, with each step representing a single amino acid. Each 3.6 amino acids complete a 360-degree turn in the helix. If a helical portion of a protein contained 36 amino acids, there would be 10 complete turns in the helix. Each amino acid projects an R group to the outside of the staircase. **A** helices of proteins vary in length from 5 to 40 amino acids with an average of about 10. Certain proteins are made up entirely of  $\alpha$  helices (and the loops connecting the helices) such as the subunits of **hemoglobin**, which contain 8  $\alpha$  helices.

As the name “strand” implies, the amino acids of the  $\beta$  strand form a linear structure. However, the bond angles along the peptide backbone produce a regular zigzag pattern within this linear structure. Adjacent R groups project in opposite directions. When amino acid sequences fold into a three-dimensional structure of  $\beta$  strands, one amino acid R group will then project to the interior of the protein and the adjacent R group will project to the outside (to the water environment).

$\beta$  strands of proteins may be arranged adjacent to each other like strings on an instrument to form what is termed a  $\beta$  sheet. The  $\beta$  strands of a  $\beta$  sheet may be parallel in orientation (all the sequences running from amino-to carboxyl-terminal) or antiparallel (that is, the strands alternate in orientation).

To form a complete protein, the  $\alpha$  helices or  $\beta$  strands must be joined together through the amino acid sequence. The amino acids that make up these joining regions are called “loops.” For example, two adjacent antiparallel  $\beta$  strands of a  $\beta$  sheet are often connected by a loop consisting of two or three amino acids. Loops also connect segments of  $\alpha$  helices and connect  $\beta$  strands that are adjacent to  $\alpha$  helices in a protein sequence. Some loop regions can be very long, consisting of up to twenty-one amino acids; but, most commonly, they are between two and ten amino acids.

**Tertiary Structures of Proteins.** The three-dimensional structure of a single **polypeptide** chain is termed its tertiary structure. Tertiary structures are different combinations of the secondary structures ( $\alpha$  helices,  $\beta$  strands, and loops). Tertiary structure is subdivided into certain portions that are termed motifs and domains.

Motifs are simple combinations of secondary structure that occur in many different proteins and which carry out a similar function. An example is the helix-loop helix. It consists of two antiparallel  $\alpha$  helices at about a 60-degree angle to each other connected by a loop. This motif, which binds the calcium **ion**, is found in several proteins that regulate cellular activity via changes in calcium ion concentrations. Many proteins that bind to deoxyribonucleic acid (DNA) and regulate **gene expression** incorporate a zinc finger motif. As the name implies, this motif binds the zinc ion using combinations of the amino acids cysteine and histidine. One type of zinc finger motif consists of a single  $\alpha$  helix opposite two  $\beta$  strands in an antiparallel arrangement. The zinc ion is held between the  $\alpha$  helix and the two  $\beta$  strands using two histidine R groups from the  $\alpha$  helix and two cysteine R groups

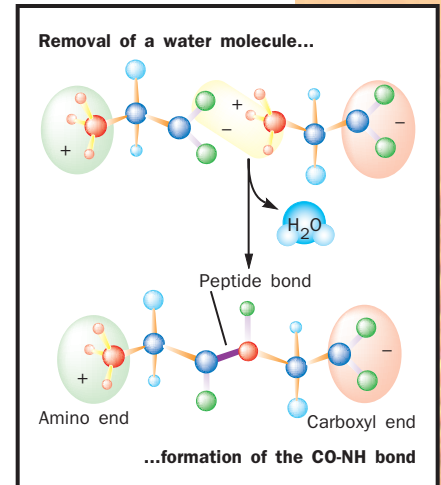

Figure 2. Formation of a peptide bond.

**A** the greek letter alpha  
**hemoglobin** oxygen-carrying protein complex in red blood cells

**polypeptide** chain of amino acids

**ion** an electrically charged particle

**gene expression** use of a gene to create the corresponding protein

Levels of protein structure. Alpha helices and beta sheets are linked by less-structured loop regions to form domains, which combine to form larger subunits and ultimately functional proteins.

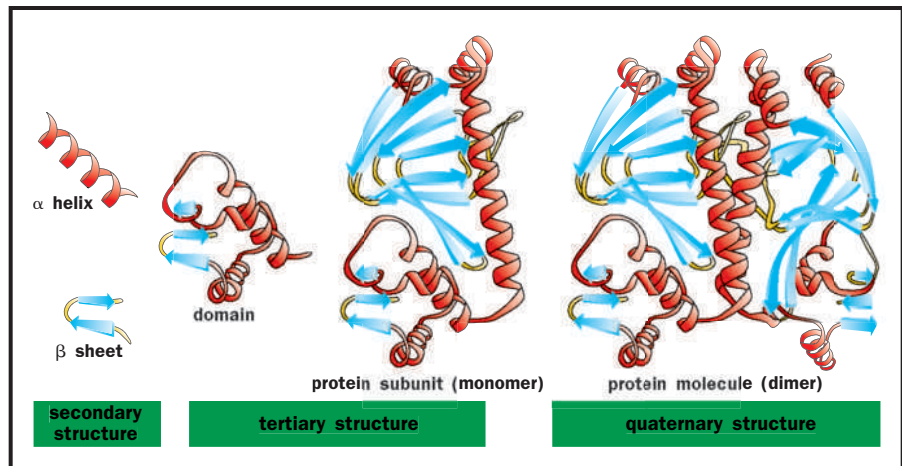

from the  $\beta$  strands. Another motif common to DNA binding proteins is the leucine zipper, in which two parallel  $\alpha$  helices are adjacent to each other with the leucine side chains projecting from each helix binding together and thus binding the two helices together.

A single polypeptide chain may fold into one or more domains to yield the tertiary structure of a protein. The eight  $\alpha$  helices of a subunit of hemoglobin connected by seven loop regions constitute the globin domain. Two  $\beta$  sheets (each of four antiparallel  $\beta$  strands) form a “ $\beta$  barrel” structure domain that is repeated in the **immunoglobulin** proteins. Each domain can express a distinct function and is sometimes arranged in a single protein to efficiently carry out an overall function that has several parts. For example, there are seven different chemical reactions that act in sequence to synthesize a fatty acid. In mammals, the fatty acid synthetase **enzyme** is a single polypeptide chain folded into seven domains, each domain carrying out one of the seven chemical reactions.

**Quaternary Structures of Proteins.** Two or more polypeptide chains may bind to each other to form a quaternary structure. The quaternary structure of hemoglobin, for example, consists of four polypeptide chains, two  $\alpha$ , and two  $\beta$  subunits arranged in space in a defined manner.

**How Does Protein Structure Determine Function?** For almost all biological functions to be expressed, two molecules must bind to each other. An **antibody** protein must bind to an **antigen** to provoke an immune response, a **hormone** protein (for example, a growth factor) must bind to a cell surface receptor to trigger a cell reaction, an enzyme protein must bind to a **substrate** to **catalyze** a reaction, and a protein containing the leucine zipper motif must bind to DNA to regulate gene expression. In order for two molecules to bind, they must recognize each other and form a series of noncovalent bonds. Recognition of two molecules for each other is termed “structural complementarity”; that is, the three-dimensional structures must complement each other in the shapes of the interacting surfaces. Analogies that have been used are a key fitting into a lock or the wooden square of a simple child’s game that fits into the square-shaped cutout of a puzzle board.

**immunoglobulin** an immune protein, also called an antibody

**enzyme** protein that controls a reaction in a cell

**antibody** immune system protein that binds to foreign molecules

**antigen** foreign substance that provokes an immune response

**hormone** molecule released by one cell to influence another

**substrate** the molecule acted on by an enzyme

**catalyze** aid in the reaction of

“Ligand” is the general term used to denote the molecule bound by the protein. When a protein binds to a ligand, many noncovalent bonds are formed. These may be ionic bonds between the charged **acidic** or **basic** groups of side chains of amino acids, or **hydrogen bonds** whereby a hydrogen proton is shared between two atoms, or a weak force of binding termed van der Waals bonding that can occur between any two atoms that are very close in space. Water may also be excluded from the surfaces of two molecules binding to each other, contributing what is called the hydrophobic effect. The number of such noncovalent bonds formed between two molecules directly relates to the strength (the **affinity**) of binding. Thus strength of binding can be strong, as in the case of a protein hormone binding to a cell surface receptor, or weak, as with binding to their substrate enzymes.

Binding of ligands occurs on certain portions of the protein surface. All three types of secondary structure (or combinations of secondary structure) can be involved in binding a particular ligand. The immunoglobulin molecule uses a total of six loop structures, three each from the variable domains of the heavy and light chains to bind to an antigen. By a very large number of variations of the spatial relationships of these loop regions and differences in amino acid residues of the loops, immunoglobulins exhibit binding activities to a very large number of antigens that are encountered in the environment.

For instance, DNA-binding proteins often use  $\alpha$  helices to recognize and bind to the nucleic acids of DNA sequences. Different sequences of amino acids along the  $\alpha$  helices allow such gene regulatory proteins to recognize specific nucleic acid sequences of the DNA and thus to alter expression of a single or only a few genes. The hexokinase protein binds both **glucose** and **ATP** to form glucose-phosphate, the first step in the **metabolism** of glucose through the glycolytic pathway. The hexokinase protein has two domains, and the glucose spatially complements within a groove between the two domains and thus is bound by the enzyme. Galactose is another sugar very similar to glucose except for the spatial orientation of one of five **hydroxyl** groups common to glucose and galactose. This single hydroxyl orientation difference does not allow galactose to bind to hexokinase and thus hexokinase exhibits specificity of binding. Galactose is **phosphorylated** by another enzyme protein, galactokinase, which exhibits specificity for the galactose sugar; that is, galactokinase structurally complements and binds galactose, but not glucose.

## Protein Modifications

Proteins can be glycosylated (glycoproteins) or associated with **lipids** (lipoproteins).

**Glycoproteins.** Glycoproteins have attached carbohydrate molecules (residues). Carbohydrate residues are added to the protein structure and modified during and following protein synthesis. There are many different carbohydrate sequences found in glycoproteins, many of which have functional consequences. In general, most proteins that are secreted from cells are glycosylated. Most of the proteins in serum are glycosylated as are the proteins found in saliva and the digestive juices of the gastrointestinal tract. **Carbohydrates** have many hydroxyl (-OH) groups that bind to water molecules, and thus increase stability. Thus the glycoproteins of saliva tend to

**acidic** having an excess of  $H^+$  ions and a low pH

**basic** having an excess of  $OH^-$  ions and a high pH

**hydrogen bond** weak bond between the H of one molecule or group and a nitrogen or oxygen of another

**affinity** attraction

**glucose** simple sugar that provides energy to animal cells and is the building block of cellulose in plants

**ATP** adenosine triphosphate, a high-energy nucleotide used by cells to power most energy-requiring reactions

**metabolism** chemical reactions within a cell

**hydroxyl** chemical group consisting of -OH

**phosphorylate** add a phosphate group to

**lipid** fat or waxlike molecule, insoluble in water

**carbohydrates** sugars, starches, and other molecules combining carbon, hydrogen, and oxygen and serving as fuel or structural components

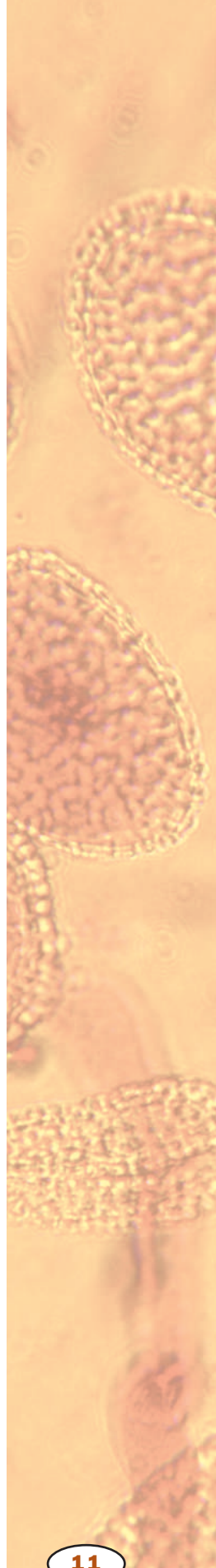



**esophagus** tube connecting throat to stomach

lubricate the food chewed, in part to allow easier swallowing of food and its passage through the **esophagus**. The glycoproteins secreted in the stomach protect the lining of that organ from its acidic environment. This protective role of carbohydrates is also apparent for the serum glycoproteins. The carbohydrates on the surface of the protein protect the protein from the actions of proteases that degrade protein structures.

Certain types of carbohydrate residues on glycoproteins also serve as signal mechanisms. If a tissue is injured or becomes infected, certain glycoproteins are recruited to the surfaces of endothelial cells (the cells that line all blood vessels), where they are recognized by white blood cells, as a signal that this is a site of injury requiring attention. Particularly in the last ten years, about three hundred functions of the carbohydrate portions of glycoproteins have been described.

**Lipoproteins.** Lipoproteins are complexes between a particular set of proteins (termed apoproteins) and lipids (phospholipids, triglycerides, cholesterol, and cholesterol esters). These lipids are transported throughout the body as the complex lipoproteins. Humans have nine different apoproteins of various molecular sizes and concentrations in the blood. Portions of the surfaces of apoproteins exhibit specificity and bind the various lipids, providing the scaffold upon which the lipoprotein particles are constructed. Their densities—high-density (HDL), low-density (LDL), and very-low-density lipoproteins (VLDL)—are used to characterize the protein. The apoproteins are synthesized in the cell (mainly in the liver) and acquire lipids to become HDL, LDL, or VLDL.

## Proteins and Evolution

The presence of similar domain structures in different proteins, the duplication of domain structures in a single protein, and similarities in amino acid sequences (sequence homologies) indicate an evolutionary relationship of many proteins in a single species and between species. There are many examples of these relationships, of which a few will be described here.

The globin fold, as described above, consists of eight  $\alpha$  helices (connected by loops) that form a pocket as an **active site**. A heme structure is bound in many globin fold proteins that binds and carries oxygen in an organism. The globin fold structure has been preserved in mammals, insects, and plants although the amino acid sequence similarities may be very low between such disparate species. Thus, natural selection has maintained similar structures to carry out similar functions even as the gene sequences have diverged to such a great extent between the different species.

The helix-turn-helix motif is common to many gene repressor proteins that bind to DNA sequences. Rigorous statistical analyses of the amino acid sequences of these motifs suggest that these repressor proteins all evolved from a common ancestral gene and that certain amino acid residues in the motif structure are crucial to maintain the helix-turn-helix structure of the motif.

Serine proteases (for example, chymotrypsin, a digestive enzyme in mammals) consist of two  $\beta$  barrel domains, the ends of which come together to form an active site. Within the active site is a catalytic triad, which consists of three amino acids (histidine, serine, and cysteine) arranged in space to catalyze the **hydrolysis** of a peptide bond. The two  $\beta$  barrels probably

**active site** surface region of an enzyme where it catalyzes its reaction

**hydrolysis** splitting with water

evolved from duplication of a common gene. In humans, there are many serine proteases that cleave peptide bonds of different proteins. All have the same two  $\beta$  barrel domain structure with the same spatial catalytic triad. Specificity of binding and cleaving different proteins is achieved by altering the sequences around the catalytic triad such that different proteins complement the different binding sites.

## Protein Structures and Disease

Some differences of amino acid sequences of proteins are directly related to disease. A well-defined example is that of sickle-cell disease. A single difference at position number 6 in the amino acid sequence of the  $\beta$  chain of hemoglobin (a valine amino acid is found in the person with sickle-cell disease instead of glutamic acid) results in aggregation of the hemoglobin molecules with consequent elongation (the sickle shape) and fragility of the red blood cells. The disease cystic fibrosis has now been defined as mutations in a particular gene that codes for a cell membrane protein that functions to pump chloride ions out of the cell. This protein in cystic fibrosis is defective in this function because the amino acid sequence is different from normal. SEE ALSO AMINO ACID; ENZYMES; GENETIC DISEASES; MEMBRANE TRANSPORT; NUCLEAR TRANSPORT; PROTEIN SYNTHESIS; PROTEIN TARGETING

*Byron Anderson*

### Bibliography

Alberts, Bruce, et al. *Molecular Biology of the Cell*, 4th ed. New York: Garland Publishing, 2000.

Branden, Carl, and John Tooze. *Introduction to Protein Structure*. New York and London: Garland Publishing, Inc., 1997.

Stryer, Lubert. *Biochemistry*, 4th ed. New York: W. H. Freeman and Company, 1995.

## Protein Synthesis

Proteins are the workhorses of the cell, controlling virtually every reaction within as well as providing structure and serving as signals to other cells. Proteins are long chains of **amino acids**, and the exact sequence of the amino acids determines the final structure and function of the protein. Instructions for that sequence are encoded in **genes**. To make a particular protein, a messenger ribonucleic acid (mRNA) copy is made from the gene (in the process called **transcription**), and the mRNA is transported to the **ribosome**. Protein synthesis, also called **translation**, begins when the two ribosomal subunits link onto the mRNA. This step, called initiation, is followed by elongation, in which successive amino acids are added to the growing chain, brought in by transfer RNAs (tRNAs). In this step, the ribosome reads the **nucleotides** of mRNA three by three, in units called **codons**, and matches each to three nucleotides on the tRNA, called the anticodon. Finally, during termination, the ribosome unbinds from the mRNA, and the amino acid chain goes on to be processed and folded to make the final, functional protein.

**amino acid** a building block of protein

**gene** portion of DNA that codes for a protein or RNA molecule

**transcription** messenger RNA formation from a DNA sequence

**ribosome** protein-RNA complex in cells that synthesizes protein

**translation** synthesis of protein using mRNA code

**nucleotide** the building block of RNA or DNA

**codon** sequence of three mRNA nucleotides coding for one amino acid

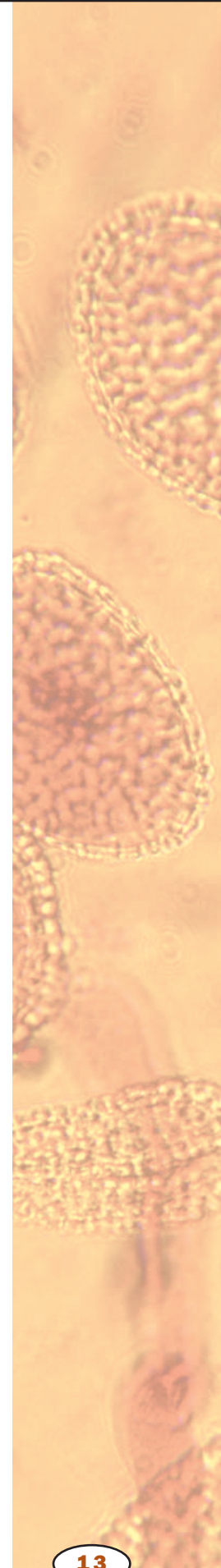
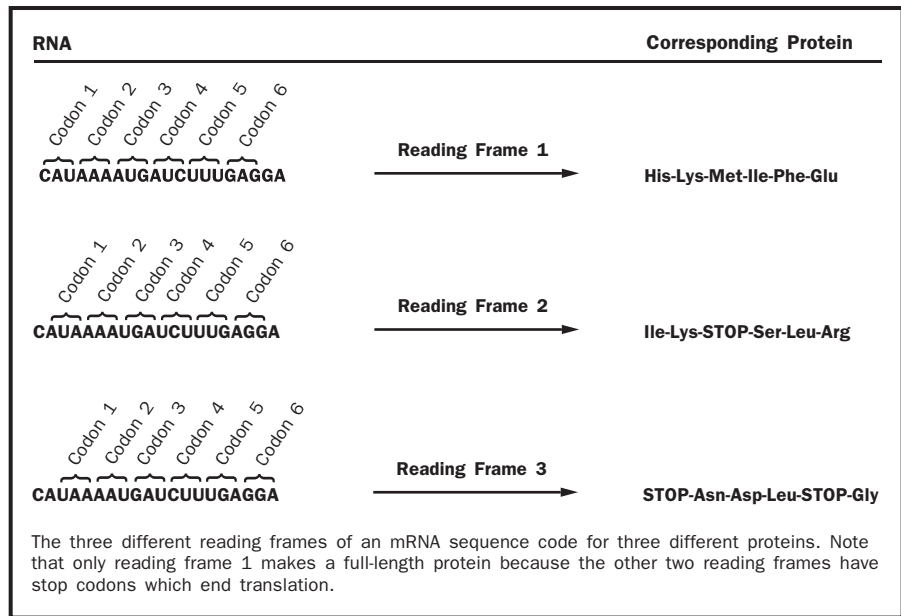

Figure 1.



**genetic code** relationship between triples of RNA nucleotides and the amino acids they code for during protein synthesis

### Initiation

In the first step, initiation, the ribosome must bind the mRNA and find the appropriate place to start translating it to make the protein. If the ribosome starts translating the mRNA in the wrong place, the wrong protein will be synthesized. This is a particularly tricky problem because there are three different reading frames in which an mRNA can be read. Each unit of the **genetic code**, called a codon, is made up of three bases and codes for one amino acid. Completely different protein sequences will be read out by the ribosome if it starts translating with the start of the first codon at base 0, base 1, or base 2 (Figure 1). Thus, it is easy to see why the ribosome must have a way to find the correct starting point for translating each different mRNA.

In almost every known case, translation begins at the three-base codon that codes for the amino acid methionine. This codon has the sequence AUG. Ribosomes are made up of two parts, called subunits, that contain both protein and RNA components. It is the job of the smaller ribosomal subunit to locate the AUG codon that will be used as the starting point for translation (called the initiation codon). Although always starting at AUG helps solve the reading frame problem, finding the right AUG is not an entirely straightforward task. There is often more than one AUG codon in an mRNA, and the small ribosomal subunit must find the correct one if the right protein is to be made.

**Initiation in Prokaryotes.** In prokaryotes (bacteria) there is a nucleotide sequence on the upstream (5-prime, or 5') side of the initiation codon that tells the ribosome that the next AUG sequence is the correct place to start translating the mRNA. This sequence is called the Shine-Delgarno sequence, after its discoverers. The Shine-Delgarno sequence forms base pairs with RNA in the small ribosomal subunit, thus binding the ribosomal subunit to the mRNA near the initiation codon.

Next, a special tRNA forms **base pairs** with the AUG sequence of the initiation codon. The tRNA contains the **complementary** sequence to AUG

**base pair** two nucleotides (either DNA or RNA) linked by weak bonds

**complementary** matching opposite

as its anticodon. This tRNA carries a modified version of the amino acid methionine (fMet-tRNA<sub>i</sub> or formylmethionyl initiator tRNA) and is already bound to the small ribosomal subunit. The interaction of codon and anticodon triggers a series of events that is not entirely understood but that results in the joining of the large ribosomal subunit to the small ribosomal subunit. The resulting complex is called an initiation complex; it is a whole ribosome bound to an mRNA and an initiator tRNA, positioned so as to make the correct protein from the mRNA.

**Initiation in Eukaryotes.** In eukaryotes (animals, plants, fungi, and protists), the Shine-Delgarno sequence is missing from the small ribosomal subunit's RNA, and thus a different mechanism is used for locating the initiation codon. The strategy employed by eukaryotes is more complex and less well understood than that used by prokaryotes. In eukaryotes, the small ribosomal subunit is thought to bind to the 5' end of the mRNA. This binding is mediated by a special structure on the 5' end of eukaryotic mRNAs called a 7-methylguanosine cap and is also aided by a special tail of adenosine bases (the poly-A tail) on the 3' end, both of which are added during RNA processing. A group of proteins called initiation factors binds to the 7-methylguanosine cap and poly(A) tail and appears to direct the binding of the small ribosomal subunit to the mRNA near the cap structure.

Once this has happened, the small ribosomal subunit can read along the mRNA and look for an AUG codon, a process called scanning. Recognition of the initiation codon is largely mediated by base-pairing interactions between the AUG codon and the anticodon sequence in a methionyl initiator tRNA (Met-tRNA<sub>i</sub>; the methionine is not modified with a formyl group in eukaryotes as it is in **prokaryotes**). As in prokaryotes, this Met-tRNA is already bound to the small ribosomal subunit.

In most cases, the first AUG codon in a eukaryotic mRNA is used as the initiation codon, thus the small subunit locates the correct initiation codon simply by scanning along the mRNA starting at the 5' end until it reaches the first AUG codon. However, the initiation AUG codon may be flanked by certain base sequences not found around other AUG codons not used for initiation. This preferred set of bases around the initiation codon is called the Kozak sequence, named after its discoverer, Marilyn Kozak. How the Kozak sequence helps direct the small ribosomal subunit to use one AUG codon instead of another is not known. As is the case in prokaryotes, once the correct AUG codon has been found, a complex series of steps takes place that results in the joining of the large ribosomal subunit to the small ribosomal subunit to produce an initiation complex: a complete ribosome assembled at the correct place on an mRNA with an initiator tRNA bound to it.

In both prokaryotes and eukaryotes there are proteins called initiation factors that are required for the correct assembly of an initiation complex. In prokaryotes there are three initiation factors, logically enough called IF1, IF2, and IF3. IF2 helps the fMet-tRNA<sub>i</sub> bind to the small ribosomal subunit. IF3's main role appears to be to ensure that an AUG, and not another codon, is used as the starting site of translation. That is, IF3 monitors the fidelity of the selection of the initiation codon. IF1 appears to prevent the initiator tRNA from binding to the wrong place in the small ribosomal subunit.

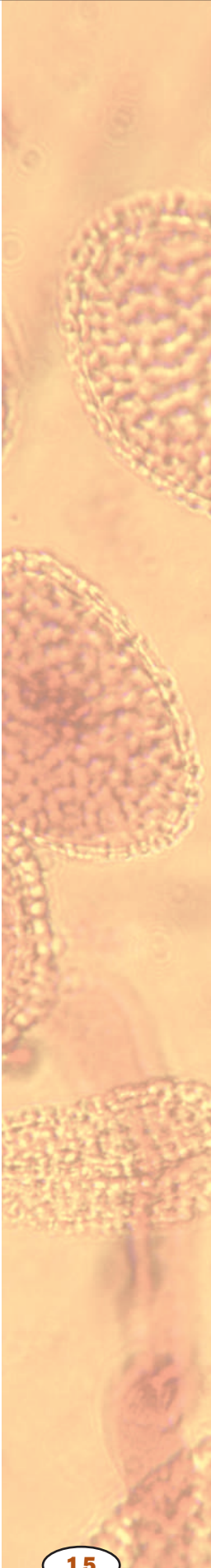
A vertical micrograph on the right side of the page shows several prokaryotic cells, likely bacteria, stained with a pinkish-orange dye. The cells are roughly spherical and have a textured, granular appearance. One cell in the upper right is particularly prominent, showing internal structures. The background is a uniform light orange color.

**prokaryote** single-celled organism without a nucleus

The antibiotic tetracycline prevents tRNA from binding to the A sites.

In eukaryotes, the situation is considerably more complex, with at least twenty-four protein components required for the initiation process.

### Elongation

In the next phase of protein synthesis, elongation, the ribosome joins amino acids together in the sequence determined by the mRNA to make the corresponding protein. Amino acids are brought onto the ribosome attached to tRNAs. tRNAs are the adapter molecules that allow the ribosome to translate the information contained in the codon sequence of the mRNA into the amino acid sequence of a protein. This decoding happens by base pairing between the anticodon bases of the tRNA and the codon bases of the mRNA. When all three anticodon bases of the tRNA form base pairs with the next codon of the mRNA, the ribosome, with the aid of an elongation factor protein, recognizes that this tRNA has the correct amino acid attached to it and adds this amino acid to the growing protein chain. The process can then be repeated until the entire protein has been synthesized.

As just mentioned, elongation requires the help of elongation factor proteins. The tRNAs with attached amino acids (called aminoacyl tRNAs) are brought onto the ribosome by one such elongation factor. This factor is called EF-Tu in prokaryotes and EF1 in eukaryotes. Its job is to bring aminoacyl tRNAs onto the ribosome and then to help the ribosome make sure that this tRNA has the correct amino acid attached to it. The ribosome has three aminoacyl tRNA binding sites: the acceptor site (A), the peptidyl site (P), and the exit site (E). The tRNA that has the growing protein attached to it binds in the P site (hence the name peptidyl, for peptide). The incoming aminoacyl tRNA, containing the next amino acid to be added, binds in the A site. The A site is where decoding of the genetic code takes place; the correct aminoacyl tRNA is selected to match the next codon of the mRNA. Spent tRNAs that no longer have an amino acid or the growing peptide chain attached to them end up in the E site, from

Figure 2. Peptide bond formation by the ribosome. The three lines between the mRNAs and the tRNA indicate base pairing between the codon of the mRNA and the anticodon of the tRNA.

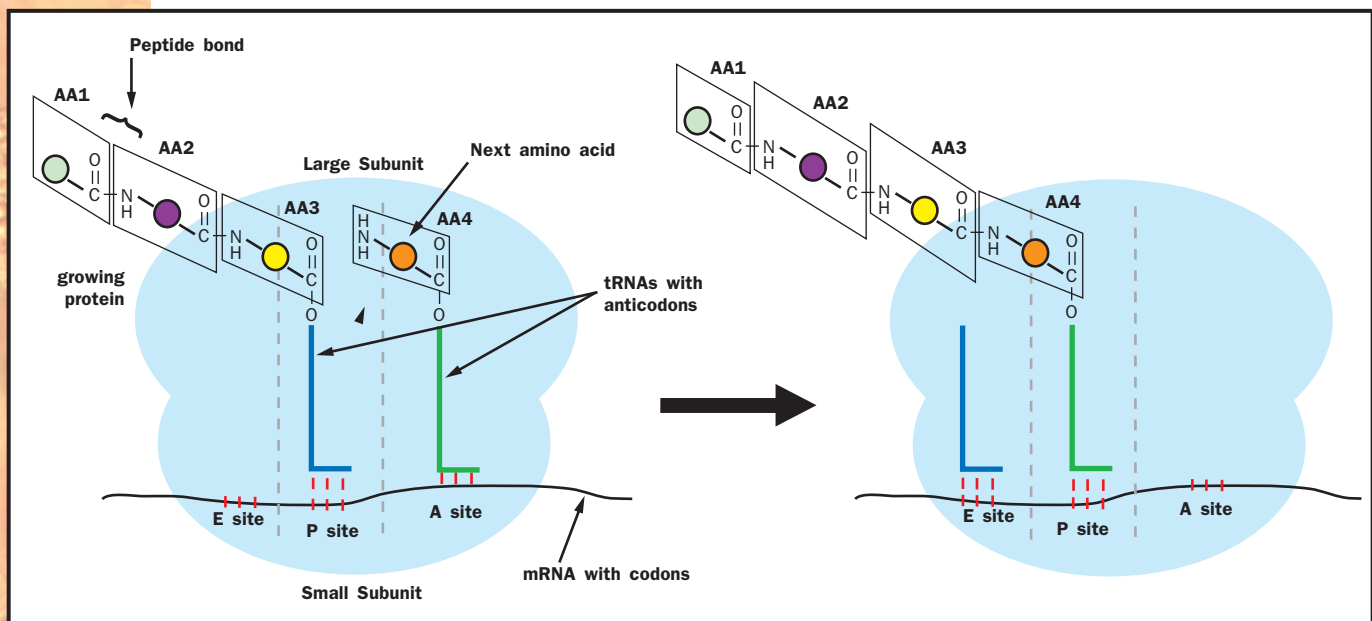

Special Proteins Involved in Protein Synthesis		
	Prokaryotes	Eukaryotes
<b>Initiation</b>	IF1 IF2 IF3	at least 24 protein components
<b>Elongation</b>	EF-Tu EF-G	EF1 EF2
<b>Termination</b>	RF1 RF2 RF3	eRF1 eRF3
<b>Recycling</b>	RRF	

which they fall off the ribosome back into the **cytoplasm**, where they can pick up new amino acids.

Once the A site is occupied by the correct tRNA, the ribosome links the new amino acid to the growing peptide chain. It does this by catalyzing the formation of a peptide (amide) bond between the amino ( $\text{NH}_2$ ) group of the new amino acid in the A site and the carbonyl (CO) group that attaches the growing protein chain to the tRNA in the P site (Figure 2). This results in an intermediate state of the ribosome, called a **hybrid** state, in which the tRNA in the P site has lost the growing protein chain and moved partially into the E site, and the tRNA in the A site now has the growing protein chain attached to it and has moved partially into the P site.

To complete the round of elongation, a second elongation factor, called EF-G in prokaryotes and EF2 in eukaryotes, is needed. This elongation factor moves the tRNAs such that the spent tRNA that has lost the protein chain moves fully into the E site, and the tRNA with the growing protein chain moves fully into the P site. The mRNA is also shifted over one codon by EF-G, so that the next codon is in the A site. The A site is now empty of tRNAs and the next aminoacyl tRNA can be brought into it.

Many antibiotics (drugs that kill bacteria) affect the elongation phase of **prokaryotic** translation. Some decrease the fidelity (accuracy) with which the ribosome decodes the mRNA and the wrong amino acids get put into the proteins. This decrease in fidelity leads to an accumulation of proteins that do not work, which eventually kills the bacterium. Other antibiotics prevent the formation of the **peptide bond** or the movement of the tRNAs by EF-G after the peptide bond has been formed. The reason these drugs are effective on bacteria without killing the patient is that prokaryotic ribosomes have some different structural features than eukaryotic ribosomes, and thus these drugs can bind to the prokaryotic (bacterial) ribosomes but not the eukaryotic (that is, human) ribosomes. Since viruses use human ribosomes to reproduce, these antibiotics are not effective against them.

## Termination

The end of the code for the protein in the mRNA is signaled by one of three special codons called stop codons. These stop codons have the sequences

**cytoplasm** material in a cell, excluding the nucleus

**hybrid** combination of two different types

**prokaryotic** without a nucleus

**peptide bond** bond between two amino acids

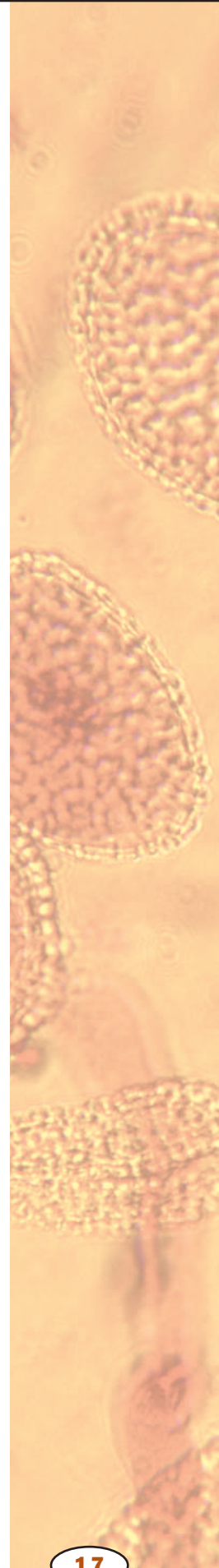

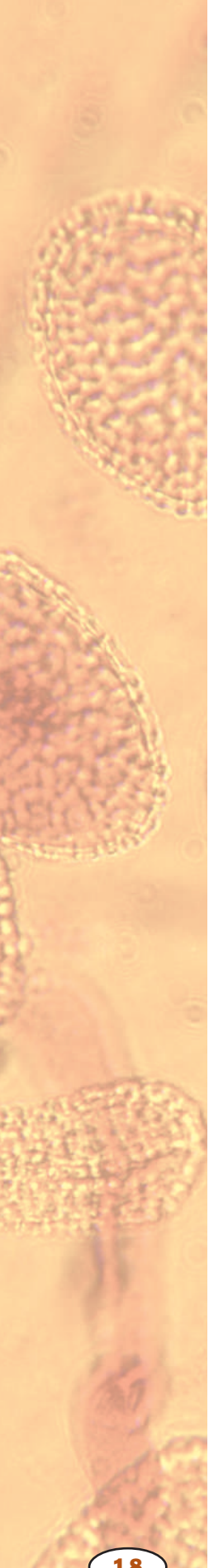

**dissociate** break apart

**conformation** three-dimensional shape

**aggregate** clump together

UAA, UAG, and UGA. In prokaryotes, the stop codons are bound by one of two release factor proteins (RFs) in prokaryotes: RF1 or RF2. These release factors cause the ribosome to cleave the finished protein off the tRNA in the P site. A third release factor, RF3, is responsible for releasing RF1 and RF2 from the ribosome after they have recognized the stop codon and caused the protein to be cleaved off the tRNA. Eukaryotes appear to have one protein, eRF1, that performs the functions of RF1 and RF2, and a second protein, eRF3, that performs the function of RF3. Once released, the protein can then go on to perform its function in the cell.

After the protein has been cleaved off the tRNA, the two ribosomal subunits must be **dissociated** from one another so that the ribosome can start translating another mRNA. This process is called recycling. In prokaryotes, recycling requires three proteins: one initiation factor (IF3), one elongation factor (EF-G), and a ribosome recycling factor called RRF. Once the subunits are dissociated from each other the whole process of translation can begin again.

### Protein Folding

A functional protein is not a long, stretched-out chain of amino acids but rather a complex, three-dimensional structure. That is, each protein must fold up into a particular shape, or **conformation**, in order to perform its function in the cell. The evidence strongly suggests that all of the information required for the protein to fold into its correct three-dimensional structure is contained in the amino acid sequence of the protein (rather than, say, being determined by some other factor in the cell). However, as the protein is being synthesized on the ribosome there is a danger that the unfinished protein will begin to fold up incorrectly because the rest of the protein has not yet been made. It is also possible that the unfinished protein will interact with other unfinished proteins being made on other ribosomes and form what is called an **aggregate**: a network of partially folded proteins that have interacted with each other rather than with themselves, thus producing a mess inside the cell. Such protein aggregates can be fatal for the cell. It is the job of a class of proteins called chaperones to bind to the growing protein chains as they are synthesized by ribosomes and prevent aggregates from forming or the proteins from folding incorrectly before they have been fully synthesized. Chaperones may also help proteins efficiently fold up into the correct three-dimensional structure once translation is complete.

### Protein Modification

While the mRNA encodes the complete amino acid sequence of the corresponding protein, some proteins are altered after they are translated. This process is called post-translational modification. For example, some proteases (proteins that digest other proteins) are synthesized by the ribosome as precursor proteins (pro-proteins) that contain an extra sequence of amino acids at one end that prevents them from digesting any proteins until they get to the right place (usually outside of the cell). Once the proteases reach their destination, the amino acid sequences that prevent them from being active (called pro-sequences) are removed (by another protein), and the proteases can begin digesting other proteins. If these pro-sequences did not ex-

ist, the proteases would digest all of the useful proteins inside the cells that made them—which would not be a good thing.

Many proteins made by **eukaryotic cells** are modified by having sugars attached to various amino acids, a process called glycosylation. Proteins that are destined to be exported from the cell or are going to be inserted into the cell's membrane enter the **endoplasmic reticulum** (ER) as they are synthesized by ribosomes that bind to the surface of the ER and feed the new proteins into the ER through small pores. Inside the ER, sugars are added to the protein, which is then sent to the Golgi apparatus where some of the sugars are removed and additional sugars are added. The role of protein glycosylation is not well understood, but because many eukaryotic proteins are glycosylated, it is clearly important.

There are a number of additional ways that proteins can be modified after they are made. For example, many proteins can have one or more phosphate groups added to them by **enzymes** called **kinases**. These **phosphorylations** are often used by the cell to regulate the activity of specific proteins; the phosphorylated form of the protein often has different properties than the unphosphorylated form.

## Protein Degradation

When a protein has outlived its usefulness or become damaged, it is degraded by the cell. In eukaryotes, a protein that is to be degraded has a number of copies of the small protein ubiquitin attached to it by a series of ubiquitin-adding enzymes. Ubiquitin serves as a tag that marks the protein for degradation. A tagged protein is then sucked into a large cellular machine called the proteasome, which itself is made up of a number of protein components and looks something like a trash can. Inside the proteasome, the tagged protein is digested into small peptide fragments that are released into the cytoplasm where they can be further digested into free amino acids by other proteases. The life of a protein begins in one cellular machine called the ribosome and ends in another called the proteasome. SEE ALSO ENDOPLASMIC RETICULUM; GENETIC CODE; GOLGI; PROTEIN STRUCTURE; RIBOSOME; RNA; RNA PROCESSING

*Jon Lorsch*

### Bibliography

Lewin, Benjamin. *Genes VI*. Oxford: Oxford University Press, 1997.

Merrick, William C., and John W. B. Hershey. "The Pathway and Mechanism of Eukaryotic Protein Synthesis." In *Translational Control*. Plainview, NY: Cold Spring Harbor Laboratory Press, 1996.

Stryer, Lubert. *Biochemistry*, 4th ed. New York: W. H. Freeman and Company, 1995.

## Protein Targeting

Protein targeting refers to the methods cells use to get proteins to the proper location after synthesis. Proteins play a major role in most cellular processes but must be located properly to serve their functions. Knowing how newly synthesized proteins target within cells is essential for understanding protein function.

**eukaryotic cell** a cell with a nucleus

**endoplasmic reticulum** network of membranes within the cell

**enzyme** protein that controls a reaction in a cell

**kinase** enzyme that adds a phosphate group to another molecule, usually a protein

**phosphorylation** addition of the phosphate group  $\text{PO}_4^{3-}$

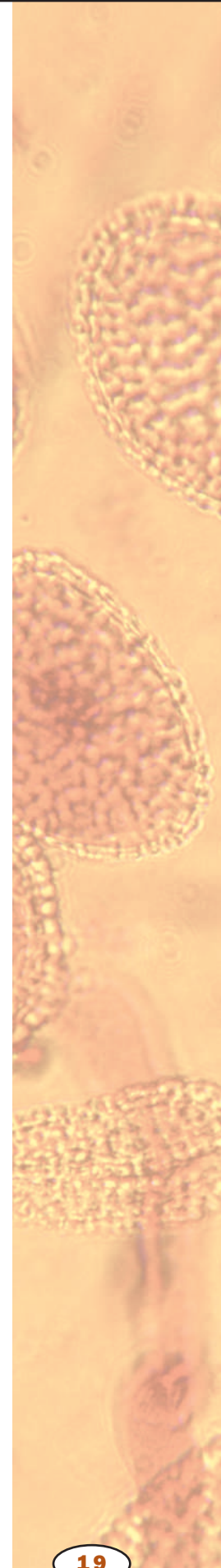



**cytosol** fluid portion of a cell, not including the organelles

**endoplasmic reticulum** network of membranes within the cell

**ribosome** protein-RNA complex in cells that synthesizes protein

**substrate** attachment site

**monomer** “single part”; monomers are joined to form a polymer

**cytoplasm** material in a cell, excluding the nucleus

**polymer** molecule composed of many similar parts

**complementary** matching opposite

**cytoskeleton** internal scaffolding in a cell, composed of protein

**affinity** attraction

**Ophosphorylation** addition of the phosphate group  $\text{PO}_4^{3-}$

**amino acid** a building block of protein

**basic** having an excess of  $\text{OH}^-$  ions and a high pH

**nucleus** membrane-bound portion of cell containing the chromosomes

**eukaryotic cell** a cell with a nucleus

**mitochondria** subcellular organelle that creates ATP used for energy-requiring processes in a cell

**lipid** fat or waxlike molecule, insoluble in water

**polypeptide** chain of amino acids

Proteins are synthesized either in the **cytosol** or on the **endoplasmic reticulum**. When synthesized in the cytosol on free **ribosomes**, most proteins diffuse freely until they are bound to a particular **substrate** or assemble into a larger complex. Protein diffusion in the cytosol is usually rapid, so an unbound protein is capable of diffusing across the cell in only a few seconds.

One way cytosolic proteins are targeted within cells is by forming large macromolecular assemblies. Many proteins can exist either as **monomers**, which freely diffuse through the **cytoplasm**, or as **polymers**, which form large-scale structures that dynamically distribute to distinct locations in the cell. The cytoskeletal proteins actin and tubulin, for example, have a pair of **complementary** self-binding sites on their surfaces that allow them to polymerize into long helical filaments that stretch across the cell. These filaments form the **cytoskeleton** of the cell, which reorganizes continuously as the cell changes shape, divides, and responds to its environment.

Conformational changes in a protein often lead to changes in the protein’s **affinity** toward a particular substrate. This process can play a crucial role in regulating the intracellular localization of a protein. An example of this type of regulation is protein **phosphorylation**, or addition of a phosphate group. This can dramatically change a protein’s affinity for a substrate and can thereby lead to rapid changes in the protein’s location. This type of regulation of protein localization is crucial for enabling cells to coordinate their activities under different growth conditions and during cell division.

Some cytoplasmic proteins are targeted to a particular site in the cell because they contain a specific **amino acid** sequence that causes them to bind to receptors located at that site. An example of such a targeting sequence is the so-called nuclear localization signal (NLS), which consists of two short stretches of **basic** amino acids divided by a 10–11 amino acid spacer region. This sequence of amino acids allows a protein possessing it to bind to nuclear localization receptors found in the **nucleus**. Once a protein containing an NLS signal binds to a nuclear receptor it is no longer able to freely diffuse and becomes “localized” to the nucleus.

Many proteins are embedded within or associated with membranes. In **eukaryotic cells**, membranes form the boundaries of a variety of distinct compartments, including the nucleus, **mitochondria**, endoplasmic reticulum (ER), and Golgi complex. Some proteins are synthesized in the cytosol and are then modified with a **lipid** “anchor,” and association with membranes is simply a matter of embedding in the membrane’s outer lipid layer. Signaling molecules, such as the GTP-binding protein Ras, localize to membranes in this manner.

All other proteins that target to intracellular membranes require sorting signals that direct their transport from the cytosol. For example, proteins targeted to mitochondria contain a specific peptide sequence of 20–80 amino acids that mediates their import. This sequence is found at the amino terminus of the protein and after import is rapidly removed by a protease.

Proteins localized within those membranes involved in endocytosis and exocytosis are first targeted to the ER, and then use membrane transport pathways to reach other compartments. Targeting of proteins to the ER begins before the **polypeptide** chain is completely synthesized. This is in contrast to import of proteins to mitochondria, chloroplasts, and peroxisomes,

Gunther Blobel won the 1999 Nobel Prize for his work on protein targeting.

which occurs after synthesis is completed. An ER signal peptide, localized at the amino terminus of these proteins, directs the ribosome to attach to the ER membrane before the protein has been completely translated. The ER signal peptide is guided to the ER membrane by a signal-recognition particle (SRP), which binds to the signal peptide, and an SRP receptor in ER membranes.

From the ER proteins use a variety of mechanisms to reach different final destinations in the cell. Proteins destined for the **nuclear envelope** simply diffuse there and stick, since the nuclear envelope is in direct continuity with the ER. To reach the Golgi complex, plasma membrane, endosomes, and lysosomes, however, proteins must enter the **secretory pathway** and use membrane trafficking pathways. For membrane proteins, entry into the secretory pathway is thought to require their concentration and sorting at ER exit sites. In contrast, proteins that are soluble in the ER lumen (inner space) move out by a bulk flow process. After leaving the ER, most soluble proteins are eventually secreted by the cell. Many membrane proteins are directed to specific **organelles** within the secretory and endocytic pathways because they contain specific sorting signals in their cytoplasmic tails, which function much like zip codes. Alternatively, sorting may be due to properties of a protein's transmembrane domain, a region of the protein that gives its affinity for different lipid environments characteristic of different organelles. SEE ALSO CELL CYCLE; CYTOSKELETON; ENDOCYTOSIS; EXOCYTOSIS; MEMBRANE PROTEINS; PROTEIN SYNTHESIS

Jennifer Lippincott-Schwartz

### Bibliography

Alberts, Bruce, et al. *Molecular Biology of the Cell*, 4th ed. New York: Garland Publishing, 2000.

## Protista

The Protista, or Protoctista, are a kingdom of simple eukaryotic organisms, usually composed of a single cell or a colony of similar cells. Protists live in water, in moist terrestrial habitats, and as **parasites** and other **symbionts** in the bodies of multicellular eukaryotes.

Other eukaryotic kingdoms—the Plantae, Fungi, and Animalia—are each believed to be **monophyletic**. That is, all plants evolved from one ancestral plant, all animals from one ancestral animal, and all fungi from one ancestral fungus. The Protista, however, are not; they are almost certainly polyphyletic and did not arise from a single ancestral protist. Rather, the Protista are a category of miscellaneous eukaryotes, not closely related to each other and not sharing many characteristics, but not fitting any other kingdom of life. Some authorities divide the Protista into as many as twenty-seven phyla, and some feel the Protista should be discarded as a kingdom name, and these organisms divided into as many as twelve kingdoms.

Historically, the Protista were divided into three main categories: the plantlike algae, animal-like protozoans, and funguslike slime molds. This classification persists in many elementary textbooks; however, current molecular evidence indicates that these are not natural groups related by common descent, but groups with merely **superficial**, deceptive similarities.

### nuclear envelope

double membrane surrounding the cell nucleus

### secretory pathway

series of events within a cell by which molecules are brought to the plasma membrane for release from the cell

**organelle** membrane-bound cell compartment

**parasite** organism living in close association with another from which it derives most of its nutrition

**symbionts** organisms living in close association with another organism

**monophyletic** a group that includes an ancestral species and all its descendants

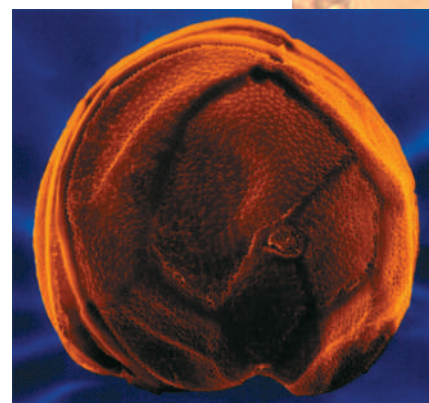

A scanning electron micrograph of the dinoflagellate *Gambierdiscus toxicus*.

**superficial** on the surface; not deep

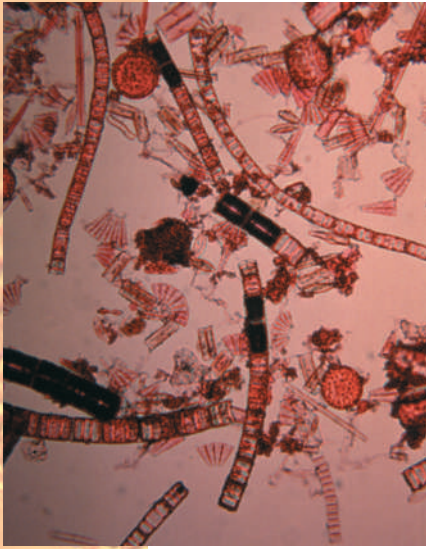

Diatoms, unicellular algae encased in siliceous walls, often display delicate lacy designs.

**mitochondria** subcellular organelle that creates ATP used for energy-requiring processes in a cell

**basal** lowest level

**cellulose** carbohydrate made by plants and some other organisms; part of the cell wall

**intracellular** within a cell

Classifying them together is probably no more scientific than it would be to classify bees, birds, and bats in one group simply because they all have wings and fly. The two flagellated protozoan groups called trypanosomes and dinoflagellates, for example, are probably less related to each other than a human is to a fish. Genetic evidence (base sequences in their **mitochondrial** deoxyribonucleic acid [mtDNA] and ribosomal ribonucleic acid [rRNA]) now indicates that the following are more natural (evolutionarily related) groups of Protista.

## Basal Protista

These are the most primitive protists. Some lack mitochondria and suggest what the first eukaryotes may have been like, while others have primitive mitochondria that closely resemble bacteria. Some **basal** Protista without mitochondria are *Trichomonas*, a vaginal parasite of humans; *Giardia*, an intestinal parasite; and *Entamoeba*, the cause of amoebic dysentery. The lack of mitochondria is not necessarily the primitive (original) condition of all these protists, however. Although *Giardia* lacks mitochondria, it does have mitochondrial genes. Apparently it once had mitochondria, and these genes transferred to its nuclear DNA before the mitochondria were lost.

Basal Protista with mitochondria include *Trypanosoma*, a genus of blood parasites that cause African sleeping sickness and other diseases; *Euglena*, a green freshwater flagellated protozoan with chloroplasts; and *Physarum*, a common terrestrial slime mold.

## Alveolates

Alveolates are named for flattened sacs called alveoli just beneath their plasma membranes. They have mitochondria with tubular cristae rather than the flattened cristae typical of most mitochondria. Alveolates include dinoflagellates, aquatic forms with two flagella and a cell wall made of armorlike **cellulose** plates; *Paramecium* and other familiar ciliates; and the Apicomplexa, a group of **intracellular** parasites that includes *Plasmodium*, the cause of malaria, and *Toxoplasma*, the cause of toxoplasmosis.

## Stramenopiles

Stramenopiles include water molds, golden and brown algae, and diatoms. The funguslike water molds (oomycetes) live in fresh water and soil, feeding on living or decaying organisms. Despite their name, some of them are important pests of row crops, including potato blight, downy mildew, and white rust. The golden algae (*Chrysophyta*) and brown algae (*Phaeophyta*) include many familiar seaweeds easily found on rocky coasts. Kelp is a gigantic marine brown alga (*Macrocystus*) that grows up to 30 meters (100 feet) long and forms dense “forests” in some coastal waters. Diatoms are microscopic unicellular algae encased in siliceous (glasslike) walls, often with delicate lacy designs like tiny jewel boxes or Christmas ornaments.

## Red Algae

The red algae (*Rhodophyta*) include most seaweeds and are most abundant in tropical seas. Coral reefs are made not only by corals but also by coralline

red algae that deposit calcium carbonate in the reef. Some red algae produce **viscous polysaccharides** such as **agar** and carrageenan, used to thicken ice cream, desserts, salad dressings, toothpaste, cosmetics, paints, and bacterial culture media.

## Green Algae

The green algae (*Chlorophyta*) include the single-celled *Chlamydomonas*, the spherical colonies of *Volvox*, and large seaweeds such as *Codium magnum*. Some unicellular green algae, notably *Chlorella*, live within the cells of animals, imparting a green color to some sponges, hydras, and flatworms. The plant kingdom probably evolved from a green alga.

## The Study of Protista

Biologists in several subdisciplines of biology specialize in the Protista or have interests that overlap with this kingdom. Microbiologists study bacteria and some unicellular protists. Phycologists specialize in algae. Protozoologists study protozoans. Mycologists specialize in fungi but also often study water molds and slime molds, formerly classified as fungi. Parasitologists study disease-producing protists. SEE ALSO ALGAE; CORAL REEF; FUNGI; MITOCHONDRION; PLANT PATHOGENS AND PESTS; PROTOZOA; PROTOZOAN DISEASES; SLIME MOLDS

*Kenneth S. Saladin*

### Bibliography

Margulis, L., J. O. Corlis, M. Melkonian, and D. J. Chapman. *Handbook of Protocista*. Boston: Jones & Bartlett, 1990.

Margulis, L., and K. Schwartz. *The Five Kingdoms*, 3rd ed. New York: W. H. Freeman and Company, 1998.

Patterson, D. J. "The Diversity of Eukaryotes." *American Naturalist* 154 (1999): S96–S124.

## Protozoa

Protozoa (meaning "first animals") are heterotrophic, single-celled or colonial eukaryotes. Individuals are microscopic and range in size from a few to hundreds of micrometers, depending on the species. Most protozoa are animal-like (heterotrophic) because their carbon and energy must be obtained by eating or absorbing **organic** compounds originating from other living organisms. As eukaryotes they have several **organelles**, including at least one **nucleus** that contains most of the cell's deoxyribonucleic acid (DNA).

Beyond this broad description, it is difficult to define protozoa because they are so diverse and only distantly related to each other. While the term "protozoa" is commonly used, it has little basis in evolutionary history, or phylogeny, of these organisms. Taxonomic systems try to assign organisms to a **monophyletic** group, that is, one that includes an ancestor and all of its descendants. Plants, animals, and fungi are monophyletic groups; protozoans are not. (The understanding of evolutionary relationships of unicellular eukaryotes is in a state of flux.) Further complicating a precise definition of protozoa is the close relationship between some protozoa and

**viscous** thick

**polysaccharide** carbohydrate composed of many individual units of sugar

**agar** gel derived from algae

**organic** composed of carbon, or derived from living organisms

**organelle** membrane-bound cell compartment

**nucleus** membrane-bound portion of cell containing the chromosomes

**monophyletic** a group that includes an ancestral species and all its descendants

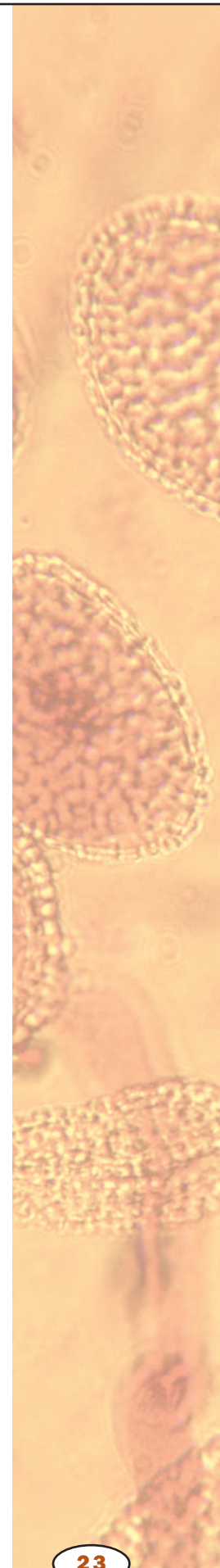

A photomicrograph of the protozoa *Euglena*.

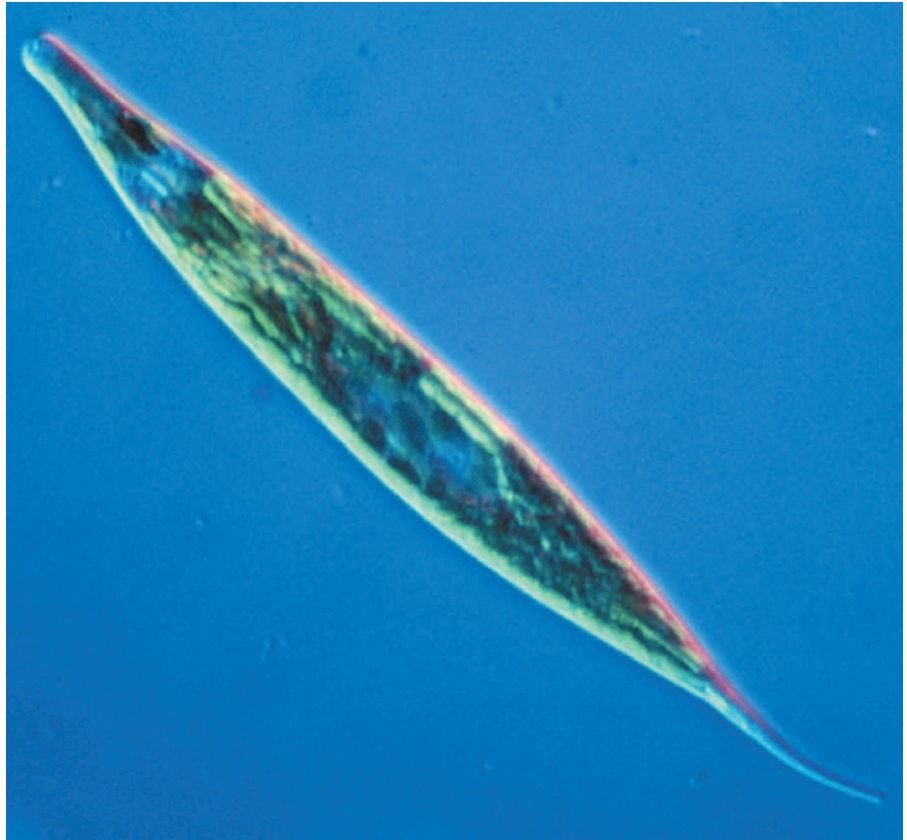

## EUGLENA

Species in the genus *Euglena* are photosynthetic members of a diverse group of pigmented and colorless flagellates in the order Euglenida. Both protozoologists and botanists traditionally have studied them. The cylindrical shape of the body is maintained by a flexible pellicle composed of the cell membrane and a layer of protein strips.

*Euglena* have large, bright green chloroplasts and two flagella that arise from within a pocket on the anterior end. Usually only one flagellum is long enough to emerge from the reservoir. Beside the reservoir is a small, red-pigmented spot, the stigma, which is associated with a light-sensing region. Many euglenids have visible rods or rings made of paramylum, which, like starch, is a glucose storage molecule.

*Euglena* swim with a gyrating motion using their emergent flagellum, which pull the organism forward like a propeller. When not swimming, *Euglena* often alternately contract and elongate the pellicle, causing a bulge to move from one end of the cell to the other in a characteristic "euglenoid motion."

*Euglena* are most common in organically rich freshwater environments.

unicellular algae. Modern taxonomic treatments recognize these similarities and group protozoa, photosynthetic unicellular algae, and slime molds together as protists or protocists. Whichever term one prefers, the classification is not monophyletic. Despite the fact that protozoa is not a proper taxonomic name, it is a useful, functional term. Ecologists differentiate between autotrophic and heterotrophic components of an ecosystem, and it is natural to separate the animal-like protozoa from the photosynthetic algae based on their nutritional mode. (However, *Euglena*, which can be induced to lose their chloroplast, illustrate why unicellular algae are included with protozoa.)

As is appropriate for heterotrophic organisms that capture food, most protozoa are motile (able to move). The way they move is one of the important characteristics historically used to divide them into major groups: amoebae, flagellates, and ciliates. Apicomplexa, formerly called Sporozoa, is a fourth group of generally **obligate** parasitic protozoa. Amoebae crawl along surfaces by extending a **cytoplasm**-filled pseudopod (false-foot) that bulges outward from any edge of the cell. Flagellates and ciliates use specialized organelles, flagella and cilia, that differ primarily in length and number, to propel the cells through water. Flagella are whiplike structures that usually occur one to a few per cell and have an undulating motion. Cilia are shorter and move in concert, like oars, with alternating power and recovery strokes. Sporozoa are either nonmotile or very slow.

Other organelles that are widely distributed among protozoa include food vacuoles, in which ingested particles are digested, and lysosomes that

fuse with food vacuoles and supply digestive enzymes. Contractile vacuoles, common in freshwater protozoa, eliminate water that moves into the cells by **osmosis**. Extrusomes are associated with the membrane of many protozoa and contain material that can be ejected from the cell. Some extrusomes secrete an amorphous material that is involved in formation of a capsule or cyst, and others discharge a pointed projectile that may serve for protection or predation. The thousands of “trichocysts” distributed over the surface of the ciliate *Paramecium* are extrusomes that discharge rapidly in response to physical stimulation and are probably effective deterrents to some predators. Ciliates are unique among protozoa in having two kinds of nuclei: the micronucleus, which is involved only in sexual reproduction; and the macronucleus, which is involved only in the production of messenger ribonucleic acid (RNA) for cell function.

Most protozoa reproduce most of the time by equal binary fission, in which a cell divides into two daughter cells after the chromosomes have been duplicated and distributed between them. This asexual mode of reproduction leads to rapid population growth of a clone of genetically identical cells. However, sex is widespread in protozoa and complicated life histories do exist. Sexuality is associated with environmental change and interrupts asexual reproduction; sex in protozoa usually marks the end of the existence of a genetically unique individual, when it becomes the gamete (reproductive cell) or gametes.

Protozoa are ubiquitous (found everywhere); they are present in all aquatic or moist environments, and their cysts can be found in even the most inhospitable parts of the biosphere. Most are free-living and eat bacteria, algae, or other protozoa. Protozoa are important components of aquatic and soil ecosystems, where they eat bacteria that are too small to be efficiently captured by most animals and are in turn eaten by other organisms. Bacterivorous protozoa also are abundant in activated sludge sewage treatment plants and, in fact, are necessary for their proper functioning. There are several protozoa of medical and economic importance. Examples include the flagellate *Trypanosoma*, which causes African sleeping sickness; the amoeba *Entamoeba histolytica*, which can attack the intestinal wall and cause amoebic dysentery, and the sporozoans of the *Plasmodium* species, which cause malaria.

Protozoa have many features linking them to the other kingdoms of life. Scientists widely believe that animals evolved from protozoan ancestors, probably colonial choanoflagellates. New tools and methods from molecular biology are leading to a better understanding of the evolutionary relationships to multicellular organisms and among protozoa. **SEE ALSO** ALGAE; CELL MOTILITY; CYTOSKELETON; LYSOSOMES; OSMOREGULATION; PLANKTON; PROTISTA; PROTOZOAN DISEASES

Robert W. Sanders

### Bibliography

- Anderson, O. Roger, and Marvin Druger, eds. *Explore the World Using Protozoa*. Arlington, VA: National Science Teachers Association and the Society of Protozoologists, 1997.
- Lee, John J., Seymour H. Hutner, and Eugene C. Bovee, eds. *An Illustrated Guide to the Protozoa*, 2nd ed. Lawrence, KS: Society of Protozoologists, 2001.
- Patterson, David J. *Free-Living Freshwater Protozoa: A Color Guide*. New York: John Wiley & Sons, 1996.

### AMOEBA

Most amoebae live on surfaces in moist soil or aquatic sediment. They are easily overlooked because they are small, predominantly transparent, and slow moving. Amoebae are characterized by the flow of granular cytoplasm into lobes of cell membrane (pseudopodia) that serve the dual functions of motility and food capture. These protozoa typically lack a fixed external anatomy and are flexible but can be categorized by the shape and number of the pseudopodia. Pseudopodia can occur as multiple rounded or needlelike projections or as a single advancing front. When a food particle is encountered, pseudopodia surround it with a membrane-enclosed sac that pinches off internally to form a food vacuole. In addition to food vacuoles, a contractile vacuole and a single large nucleus or many small nuclei can be distinguished. Some amoebae excrete tests, or shells. The marine foraminiferans harden their shells with calcium carbonate, and fossilized foram shells make up a large proportion of some marine sediments and terrestrial deposits (like the White Cliffs of Dover, England).

**obligate** required or necessary, especially referring to a metabolic process or mode of nutrition

**cytoplasm** material in a cell, excluding the nucleus

**osmosis** passage of water through a membrane in response to concentration differences

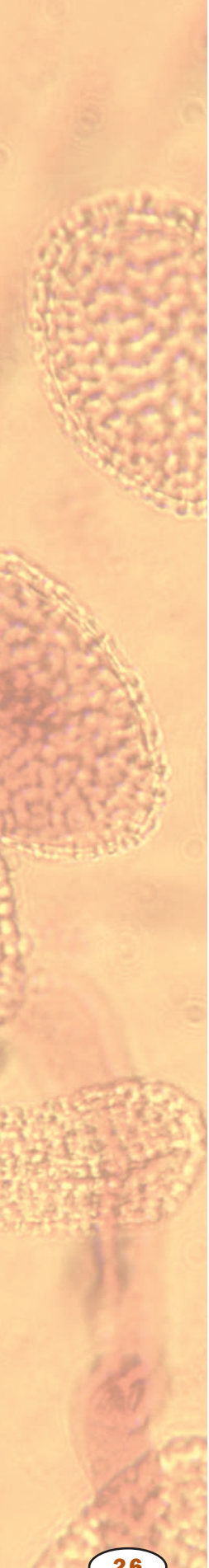

**parasite** organism living in close association with another from which it derives most of its nutrition

**mucous membrane** outer covering designed to secrete mucus, often found lining cavities and internal surfaces

**anemia** lack of oxygen-carrying capacity in the blood

## Protozoan Diseases

Protozoans are a group of eukaryotic single-celled organisms. Several species of protozoans infect humans and inhabit the body as commensals or **parasites**. The parasitic protozoans of major medical importance include certain species of amoebae, flagellates, and sporozoans.

### Amoebae

The most notorious amoeba of humans is *Entamoeba histolytica*, an inhabitant of the large intestine. Although often harmless, it can become invasive, penetrating into the **mucous membrane** of the intestine, multiplying and eroding the tissue. The result is a disease called amebiasis, characterized by intense abdominal pain, blood and mucus in the stool, diarrhea, and dehydration (a syndrome called amebic dysentery). Amebiasis can be fatal, especially to infants and children.

In addition to the intestinal infection, the amoebae sometimes get into the bloodstream and establish secondary sites of infection in the liver, brain, or elsewhere. *Entamoeba histolytica* is acquired from food or water contaminated with sewage. Several other amoebae, such as *Entamoeba coli*, inhabit the human intestine with little or no harm to the host, but their presence indicates that the person has ingested food or water contaminated with human feces and may be at risk of more serious infections.

### Flagellates

The world's most common cause of water-borne diarrhea is the flagellate *Giardia lamblia*. Outbreaks of giardiasis are common in schools, mental hospitals, prisons, and other crowded institutions, but occur in circumstances as diverse as luxury resorts, backcountry camping, and impoverished villages. *Giardia* attaches to the surface of the small intestine, often in numbers great enough to seriously interfere with nutrient absorption. Unabsorbed nutrients then pass to the large intestine and cause gas production, painful abdominal cramps, and diarrhea.

In Africa, tsetse flies transmit another parasitic flagellate, *Trypanosoma*, which causes African sleeping sickness. Victims become fatigued, emaciated, and eventually lapse into a coma and die. Even though it does not occur in the United States, trypanosomiasis is one of the world's leading public health problems.

### Sporozoans

Malaria is another leading cause of death in tropical countries. It is caused by four species of the protozoan genus *Plasmodium*. Transmitted by mosquitoes, *Plasmodium* multiplies in the liver and then invades the red blood cells, destroying them so extensively as to cause severe **anemia**. The victim experiences alternating fever and chills as the parasites emerge together from infected red cells, invade new ones, multiply, and repeat the cycle until finally the victim is overcome by exhaustion.

Another sporozoan disease is toxoplasmosis, caused by *Toxoplasma gondii*. *Toxoplasma* can be contracted from unpasteurized milk, undercooked meat, or house cats. It causes little pathology in adults, but when a pregnant woman



An electron micrograph of *Plasmodium falciparum*, one of the parasites that causes malaria.

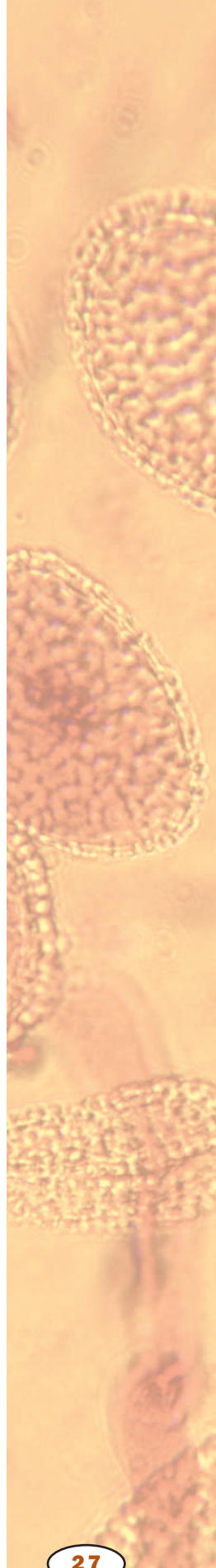

is infected, it can cause serious fetal deformities resulting in infant blindness, hydrocephalus, and physical and mental retardation.

Any **parasitology** textbook can provide further details on these and related parasitic protozoans, how they infect humans, mechanisms of disease, and how to control or avoid them. SEE ALSO DIGESTIVE SYSTEM; PARASITIC DISEASES; VACCINES

*Kenneth S. Saladin*

#### **Bibliography**

Cheng, Thomas C. *General Parasitology*, 2nd ed. Orlando, FL: Academic Press, 1986.  
Schmidt, Gerald D., and Larry S. Roberts. *Foundations of Parasitology*. 6th ed. Dubuque, IA: McGraw-Hill Higher Education, 2000.

**parasitology** study of parasites

## **Psychiatric Disorders, Biology of**

Mental illnesses affect millions of people each year, and billions of dollars are spent on their treatment and legal fees in the United States alone. Even



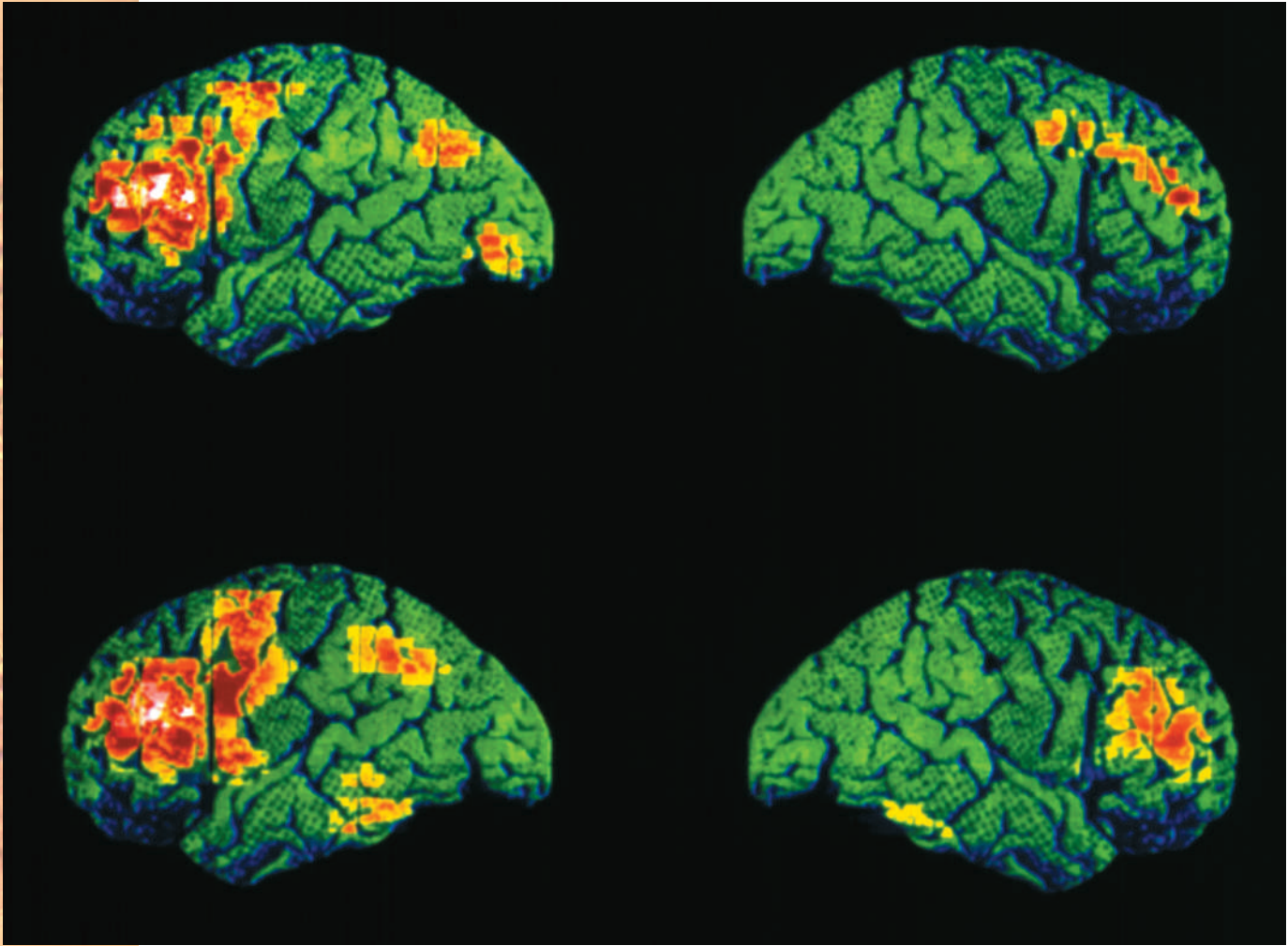

Colored positron emission tomography (PET) brain scans of a healthy person (top of image) and a person with schizophrenia (bottom).

more devastating is the impact these illnesses have on people, both those who are ill and those with whom they interact. Much ground has been gained in the areas of psychiatric research, diagnosis, and treatment options, but medical professionals still have a great deal more to learn. Current research shows that there is a strong biological component to many psychiatric disorders. Yet, it would be irresponsible to assume that biology, in either the form of physiology or genetics, can completely explain the basis for mental illnesses.

Humans and the human brain are complex entities. Humans are affected not only by their internal environment (biology) but by the external environment as well. There is no ethical method of separating one from the other when studying humans. Most researchers agree that in the “nature versus nurture” debate, both heredity and environment play a significant role in the development of human personality, whether “normal” or “abnormal.”

Mental health disorders are classified into groups with some overlap. The major groups of disorders as they are classified are: anxiety, bipolar, borderline personality, depression, obsessive-compulsive, phobic, narcissistic, schizophrenic, substance abuse, and eating disorders. This article focuses on three of the more common and devastating ones.

## Schizophrenia

Schizophrenia is a group of disorders characterized by some form of **psychosis** or disconnected thought processes. The symptoms associated with schizophrenia vary, and can affect thinking, behavior, and emotions. Schizophrenics suffer from delusions, **hallucinations**, and/or emotional unresponsiveness. Many people have the misconception that people suffering from schizophrenia have “split personalities,” which is not the case. This misconception probably arose because some patients may hear voices that seem to arise from inside the head.

It is estimated that about 1 percent of the world population suffers from schizophrenia. The disease usually first becomes evident in men between the ages of fifteen and twenty-five, and in women between twenty-five to thirty-five. It usually starts slowly and progresses over time to a severely disabling state. While no single factor has been identified as causing schizophrenia, research has shown that there may be a strong genetic predisposition for the disease. Additionally, there may be structural differences in the schizophrenic brain. This group of disorders is now recognized officially as a brain disorder instead of a psychological problem. Current treatments include medications, community support services, and electroshock therapy.

## Bipolar Disorder

The defining characteristic of bipolar disorder (formerly called “manic-depressive” disorder) is intense mood swings. During the manic phase of the disease, the person experiences a state of extreme euphoria (feeling good). He or she has bursts of energy or may become highly irritable. During the depressive phase, the person becomes increasingly despondent and insoluble.

It is estimated that between 15 and 20 percent of those with untreated bipolar disorder commit suicide, usually during a depressive cycle. Research has demonstrated a genetic link between this disorder and genes on **chromosomes** 18 and 21, though the significance of this is not fully understood. Treatment for bipolar disorder includes behavioral therapy, medications, and close supervision or support, especially during depressive phases.

## Substance Abuse

Substance abuse is defined as the maladaptive negative pattern of substance use that leads to impairment or distress. Estimates for the costs of substance abuse disorders on society are staggering and range from \$117 billion to \$235 billion per year. The personal costs to those afflicted are numerous as well. These disorders often cause severe impairments and complications. Those afflicted may have a deterioration of their general health because of malnutrition and poor hygiene. They are more likely to suffer from trauma and sudden death, to contract transmittable or **communicable** diseases, and to suffer from toxic or allergic reactions to ingested substances. Substance abusers are more likely than nonabusers to exhibit increased levels of aggression and violence, which lead to legal involvement.

The biological research on substance abuse includes studies on genetics and the physiology of the brain. Results are inconclusive, but there may

**psychosis** severe mental disorder characterized by diminished connection with reality

**hallucination** altered sensory experience resulting in the perception of objects that are not real

**chromosome** “colored body” in the cell nucleus; made of DNA and protein, and divided functionally into genes and non-gene regions

**communicable** transmissible from person to person

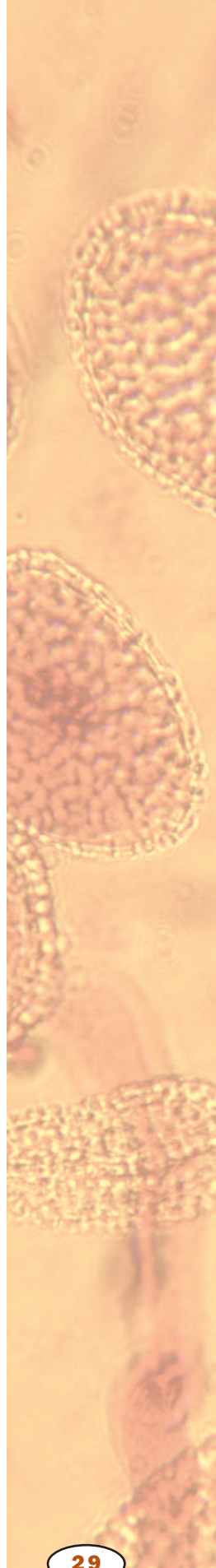

**neurotransmitters** molecules released by one neuron to stimulate or inhibit another neuron or cell

be a genetic component in some forms of alcoholism. Current studies are looking at the functioning of the brains of addicts in comparison to nonaddicts. Initial reports show that there are some structural differences as well as some differences in the ways the brain uses certain **neurotransmitters**, such as dopamine and serotonin.

Substance abuse is often a comorbidity (simultaneous occurrence of two or more disorders) associated with many other mental illnesses. In such cases, both the underlying psychiatric disorder and the substance abuse must be treated in order to achieve remission. There are many treatment methods, some controversial, for substance abuse. All claim therapeutic success, but many lack objective substantiation. Treatments can include therapy and/or medications and are most successful when used in combination. **SEE ALSO** ALCOHOL AND HEALTH; BRAIN; NEUROLOGIC DISEASES

*Leslie R. Carlson*

#### **Bibliography**

Collins, R. Lorraine. *Alcohol and the Family: Research and Clinical Perspectives*. New York: The Guilford Press, 1990.

Reid, William H., George U. Balis, and Beverly Sutton. *The Treatment of Psychiatric Disorders*. Levittown, PA: Brunner/Mazel Publishers, 1997.

## **Psychiatrist**

A psychiatrist is a physician who treats mental illness. The types of illnesses treated by psychiatrists include clinical depression, bipolar disorder (manic depression), obsessive-compulsive disorder (OCD), attention deficit disorder (ADD), drug and alcohol abuse, and many more. Mental illnesses that are categorized as psychoses involve chemical imbalances in the brain that require medication in addition to behavioral therapy. The psychiatrist is trained as a physician and is therefore qualified to prescribe the appropriate medication, but is also trained to administer behavioral therapies. In addition, psychiatrists often work cooperatively with psychologists (specialists who do not have an M.D. [Doctor of Medicine] degree).

Psychiatrists work in a variety of settings. Most hospitals employ psychiatrists to service the psychiatric ward and the emergency room. In addition, psychiatric hospitals (specializing in the care of the mentally ill) and detoxification facilities (specializing in the care of recovering addicts) rely on psychiatrists to administer treatment to their patients. Many psychiatrists also work in private practices, and some are employed by state governments to administer psychiatric treatment to prison inmates.

A psychiatrist must complete four years of medical school and a four-year residency in the field of psychiatry. A strong background in the sciences and math is an absolute requirement for medical school, and additional background in psychology is useful preparation for a career in psychiatry. High school and undergraduate courses in biology and psychology (specifically neuropsychology classes that discuss the link between brain function and behavior) allow one to explore one's interest level in this field. Strong interpersonal skills and compassion are essential qualities of a good psychiatrist. **SEE ALSO** DOCTOR, SPECIALIST; PSYCHIATRIC DISORDERS, BIOLOGY OF

*Susan T. Rouse*

**Bibliography**

*American Psychiatric Association.* <[http://www.psych.org/med\\_ed/careers.cfm](http://www.psych.org/med_ed/careers.cfm)> and <[http://www.psych.org/public\\_info/talk\\_facts.cfm](http://www.psych.org/public_info/talk_facts.cfm)>.

*Health Communities.* <<http://www.MentalHealthChannel.net/>>.

*Psychiatry.com.* <<http://www.psychiatry.com/student.html>>.

## Psychoactive Drugs

Psychoactive drugs are a class of chemical substances that act on the **central nervous system** and can alter behavior and **cognition**. All psychoactive drugs are highly fat-soluble and thus cross the blood-brain barrier readily. Psychoactive drugs alter **synaptic transmission** by altering neurotransmitter amounts and availability or by affecting receptor activity. In addition to the drug's primary effects on behaviors such as arousal, thought processes, mood, perception, and consciousness, psychoactive drugs can produce a variety of nonbehavioral effects that may more directly affect health and, in some instances, can lead to death.

Although there are several different classification schemes for psychoactive drugs (pharmacological, legal, medical), the most common organization is based on their effect on behavior and cognition. According to this scheme, psychoactive drugs can be classified into four broad categories: (1) sedatives and hypnotics, (2) stimulants, (3) opiates, and (4) hallucinogens and psychedelics.

### Sedatives and Hypnotics

Sedatives and hypnotics depress or inhibit brain activity and produce drowsiness, sedation, or sleep; relieve anxiety; and lower inhibition. Although the depressant compounds do not share a common **neural** mechanism of action, most of them either decrease the metabolic activity in the brain or increase the transmission of the principal inhibitory neurotransmitter of the brain, gamma-aminobutyric acid (GABA).

All sedatives have the potential for addiction and dependency. Common depressants include barbiturates, such as Seconal; benzodiazepines, such as Xanax and Valium (commonly called minor tranquilizers); nonbarbiturate sedatives, such as methaqualone; newer nonbenzodiazepines, such as buspirone, antihistamines, and anesthetics; and alcohol. In low doses, alcohol can act as a stimulant; however, with increased dosage alcohol's main effect is depressive.

### Stimulants

Stimulants produce behavioral arousal. As with the sedatives and hypnotics, there are a variety of substances, each with a different neural mechanism of action. Examples of stimulants are amphetamine, cocaine, antidepressants, caffeine (the most widely used psychoactive drug in the world), nicotine or tobacco, appetite suppressants, and a variety of exotic plant products. Stimulants vary in strength, legal status, and the manner in which they are taken; however, all stimulants have addictive potential.

**central nervous system**  
brain and spinal cord

**cognition** mental  
processes of thought  
and awareness

**synaptic transmission**  
passage of chemicals  
between nerve cells to  
send messages or alter  
neuron firing

**neural** related to nerve  
cells or the nervous  
system

The milky juice of unripe seed pods is used to make opium from the opium poppy plant.



### Opiates

All drugs in the opiate class act on opiate receptors in the brain. They mediate relief from pain and produce feelings of euphoria. Opiates, which are referred to as narcotics by scientists and medical practitioners, are highly addictive and can either be natural, semisynthetic, or synthetic. Natural opiates such as opium are derived from the opium poppy. The active ingredients of opium are morphine and codeine. The most common semisynthetic opiate is heroin, which is five to ten times more potent than morphine. Examples of synthetic opiates include methadone and the prescription pain medication Demerol.

### Hallucinogens and Psychedelics

Hallucinogens and psychedelics do not share a common mechanism of action, but all induce **hallucinations**. These drugs can either be natural such as mescaline, which is derived from the peyote cactus, or synthetic such as lysergic acid diethylamide (LSD), but they are typically classified pharmacologically according to the affected neurotransmitter system.

Cholinergic psychedelics (drugs altering acetylcholine transmission) include physostigmine, scopolamine, and atropine. Drugs that alter norepinephrine transmission include mescaline and **ecstasy**. Drugs that alter serotonin transmission include LSD and psilocin. Other drugs in this category include the psychedelic anesthetics phencyclidine (PCP) and ketamine.

Marijuana, which is derived from the hemp plant *Cannabis sativa*, is often classified as a psychedelic substance, although only in very high doses does it produce sensory distortions. Marijuana's most common behavioral symptom is sedation. Unlike other drug classes, and with the exception of the cholinergic psychedelics, hallucinogenic and psychedelic drugs are generally nonlethal even when taken in large doses.

### Other Drugs that Affect the Central Nervous System

Additionally, there are a number of other drugs that affect central nervous system functioning. These compounds are used to treat a variety of psy-

**hallucination** altered sensory experience resulting in the perception of objects that are not real

**ecstasy** Methylene-dioxymeth amphetamine (MDMA) is a synthetic, psychoactive drug possessing stimulant and hallucinogenic properties

chological and neurological disorders and include antidepressants, antipsychotic medication, and drugs for epilepsy, Parkinson's disease, the **dementias** (such as Alzheimer Disease), and **spasticity**.

## Categorizing Drugs into Five Schedules

A different approach to the classification of psychoactive drugs is taken by the legal system, which considers all illegal drugs or controlled substances "narcotics." According to the Comprehensive Drug Abuse Prevention and Control Act of 1970, drugs are categorized into five schedules according to the perceived risk of dependency.

Schedule I drugs, such as heroin, marijuana, and most psychedelics, have a high risk of dependency and no widely accepted medical use. These drugs are forbidden and cannot be obtained even by prescription (although marijuana is available in some states). Schedule II drugs, such as morphine, codeine, amphetamines, and certain barbiturates, have a high risk of dependency but are accepted by the medical community for treatment. Schedule III drugs have a risk of moderate physical dependency or high risk of psychological dependency and include preparations with limited opiates (morphine) and barbiturates not in Schedule II.

Schedule IV drugs, which include the benzodiazepines, have a slight risk of mild physical or psychological dependency. Schedule V drugs have less risk of mild physical or psychological dependency. Finally, alcohol and tobacco are not classified under this law. They fall under the jurisdiction of the Bureau of Alcohol, Tobacco and Firearms (ATF), which is a division of the U.S. Department of the Treasury. SEE ALSO ALCOHOL AND HEALTH; DRUG TESTING; NERVOUS SYSTEMS; NEURON; SYNAPTIC TRANSMISSION

*Arne Dietrich*

### Bibliography

- Goodman, Louis S., et al., eds. *Goodman & Gilman's The Pharmacological Basis of Therapeutics*, 9th ed. Elmsford, NY: McGraw-Hill, 2000.
- Ross, R. T. *How to Examine the Nervous System*, 2nd ed. Stamford, CT: Appleton & Lange, 1999.
- Schatzberg, Alan F., and Charles B. Nemeroff, eds. *Textbook of Pharmacology*, 2nd ed. Washington, DC: American Psychiatric Press, 1995.

## Pteridophytes

Pteridophytes are a **phylum** of plants. They are the vascular plants (those having **xylem** and **phloem** tissues) that reproduce by releasing spores rather than seeds, and they include the highly diverse true ferns and other graceful, primarily forest-dwelling plants. There are about eleven thousand different species of pteridophytes, making them the most diverse land plants after the flowering plants (angiosperms). Pteridophytes may represent the closest living relatives (sister group) to the seed plants. (Seed plants include the angiosperms, the conifers, and a smaller assortment of other plants.)

As in seed plants, the greatest diversity of pteridophytes is found in the tropics, with only about six hundred species adapted for life in temperate climates. Species living today are relics of ancient **lineages** that once dominated

**dementia** neurological illness characterized by impaired thought or awareness

**spasticity** of, or relating to spasms

**phylum** taxonomic level below kingdom, e.g., arthropod or chordate

**xylem** water-transporting system in plants

**phloem** plant tissue that conducts sugars from leaves to roots and other tissues

**lineage** ancestral line



Ferns reproduce by releasing spores rather than seeds.

## CLASSIFICATION OF THE PTERIDOPHYTES

### Phylum Pteridophyta

#### Class Lycopodiopsida

Order Lycopodiales, the club mosses\* and ground pines, approximately 400 species

Order Selaginellales, the spike mosses\*, approximately 450 species

Order Isoetales, the quillworts, approximately 130 species

Class Equisetopsida, the horse-tails or scouring rushes\*, 15 species

Class Psilotopsida, the whisk ferns, approximately 12 species

Class Filicopsida, the true ferns, approximately 10,000 species

\* The common names “mosses” and “rushes” applied to these species do not mean that these groups are related to the mosses and rushes, any more than a pineapple is related to pines or a breadfruit has some affinity to wheat. True mosses are nonvascular plants whose most commonly recognized life form is a gametophyte, and true rushes are grasslike flowering plants. Instead, these common names indicate that the club “mosses” and spike “mosses” are often small plants that hug the ground, and scouring “rushes” have long, grasslike stems.

**meiosis** cell division that forms eggs or sperm

**gametophyte** a haploid plant that makes gametes by mitosis

**gamete** reproductive cell, such as sperm or egg

the land surface. There is a rich fossil record showing that pteridophytes have ancestors dating back nearly four hundred million years. Before there were seed plants, there were pteridophytes such as large, treelike (up to 36.5 meters [120 feet] tall) *Lepidodendron*, an ancestor of modern club mosses (which are no more than .30 meter [1 foot] tall), and shrubby *Sphenophyllum*, a forebear of today’s horsetails. Some of the ancient predecessors of modern ferns were also preserved, but there are comparatively few fossils for interpreting relationships among the approximately eleven thousand species of true ferns. These relatively young species probably arose along with the other most recent lineages of vascular plants, the angiosperms or flowering plants, another group lacking an extensive fossil record.

Pteridophytes range greatly in size. There are tiny floating ferns used as “green fertilizer” in rice paddies because they partner with bacteria that pull nitrogen from the air and “fix” it in chemical compounds that other plants can use. In some tropical forests, the largest plants are tree ferns that can be up to 30 meters (100 feet) tall and have huge spreading leaves up to 4.5 meters (15 feet) in length. Pteridophytes also show a transition from simple to complex leaves. Some pteridophyte groups, including the club mosses and horsetails (classes Lycopodiopsida and Equisetopsida), have simple microphyllous leaves, featuring a single, unbranched vein and modest vascular supplies that do not cause breaks or gaps in the stem vasculature. The true ferns (class Filicopsida), however, have larger, more complex macrophyllous leaves whose veins are usually extensively branched, placing such large demands on the plant’s vasculature that distinctive gaps form in the xylem and phloem of the stem.

All pteridophytes have a true alternation of generations, in which a dominant sporophyte generation produces spores through **meiosis**, and a free-living **gametophyte** generation forms **gametes** (egg and sperm) by **mitosis**. Ferns can be used to illustrate the life cycle stages common to all pteridophytes. **Diploid** (2n) fern sporophytes are familiar to most people and are often found as quiet accompaniments in floral arrangements. When mature, the undersides of fern leaves produce clusters of capsular structures called sporangia, within which meiosis forms the **haploid** (n) spores. These spores are released from the sporangia, often when dry wind currents cause the active snapping of the capsules, lofting the spores into the air.

Spores that are wind-borne to shady, moist habitats germinate and yield multicellular, but microscopic, gametophytes, the sexual stage of the life cycle. These short-lived, delicate plants mature and produce egg-forming archegonia and sperm-producing antheridia. When water is present, multi-flagellated sperm swim from mature antheridia, are chemically attracted to the necks of the archegonia, and fertilize the eggs. Although frequently bisexual (hermaphroditic), in most cases the sperm produced by a gametophyte cannot successfully fertilize its own eggs and must swim to archegonia on neighboring, genetically different gametophytes. The diploid **zygotes**, produced by the fusion of haploid egg and sperm, divide mitotically and differentiate into mature sporophytes, completing the life cycle.

Although most pteridophytes are homosporous (produce spores that are all the same size), a few groups are heterosporous with large megaspores and small microspores. The megaspores produce megagametophytes that

only form eggs, and microspores only produce microgametophytes and sperm. Heterospory evolved independently in several groups of vascular plants, including all members of the orders Selaginellales and Isoëtales and those in a few fern groups (the families Marsileaceae and Salviniaceae of the class Filicopsida). The most successful origin of heterospory ultimately resulted in the great diversity of seed plants.

No pteridophytes are cultivated as crop plants, but the leaf buds (“fiddleheads”) of some ferns are commercially harvested and canned or frozen. Fern leaves used in floral arrangements are a major industry in Florida, and in some cultures tree fern stems are used to make elegant, naturally sculpted bowls. The contrasting colors of the vascular tissue in the stems and leaf bases of these plants create complex and pleasing designs. In the past, club moss spores provided the powder used to coat rubber gloves and prophylactics, and photographers used masses of these same spores as flash powder, since they could be easily and quickly ignited. SEE ALSO ALTERNATION OF GENERATIONS; ANGIOSPERMS; BRYOPHYTES; NITROGEN FIXATION; PLANT; REPRODUCTION IN PLANTS; SEEDLESS VASCULAR PLANTS

*Christopher Haufler*

### Bibliography

- Jones, David. *Encyclopaedia of Ferns*. Melbourne, Australia: Lothian Publishing Co., 1987.
- Raven, Peter H., Ray F. Evert, and Susan E. Eichhorn. *Biology of Plants*, 6th ed. New York: W. H. Freeman and Company, 1999.
- Tyron, Rolla, and Alice Tyron. *Ferns and Allied Plants*. New York: Springer-Verlag, 1982.

## Public Health Careers

Public health takes a population-based approach to address the physical, mental, and environmental health concerns of communities. With such information the appropriate health promotion and disease prevention is applied to improve and enhance quality of life. This can take place at the local public health clinic, at regional or national agencies, international organizations, or in the private sector. Each presents unique challenges to understand the health issues and health hazards, to provide access to quality health care at affordable cost, and to educate and promote sound health behaviors.

What do people involved in public health do? It depends on the specific career choice. You could give vaccinations at an inner city clinic, develop educational programs, investigate environmental problems, help determine how to get people to adopt healthier lifestyles, administer health service programs, or create health policies.

What education is needed to become part of public health? At the present time, registered nurses need an associate’s degree in nursing, a bachelor of science degree in nursing, or a diploma from a hospital program. Other medical personnel, social workers, and therapists need a bachelor’s degree in a specialized field or postgraduate education in an appropriate program.

**mitosis** separation of replicated chromosomes

**diploid** having pairs of chromosomes in the nucleus

**haploid** having single, nonpaired chromosomes in the nucleus

**zygote** fertilized egg

### AMERICAN PUBLIC HEALTH ASSOCIATION

As the oldest and largest public health professional association in the world, American Public Health Association (APHA) has more than 50,000 members representing more than 50 occupations. It provides a forum for the exchange of ideas, study, and action on a variety of issues that affect personal and environmental health. Researchers, health providers, administrators, teachers, and others work together on items as diverse as funding possibilities, pollution control, disease, and smoke-free societies.



Programs leading to a master's in public health degree allow the student to specialize in areas such as epidemiology, biostatistics, environmental health, health education, health policy/administration, occupational medicine, nutrition (as a registered dietitian), or maternal and child health.

What can help prepare a person for a career within public health?

1. Visit, interview, and/or volunteer with people or sites involved in the areas of interest. Find out education and experience requirements from them and plan high school classes accordingly.
2. Develop strong communication skills with individuals and in front of groups.
3. Learn a second language.
4. Learn to work with diverse populations.
5. Learn to handle stressful situations.
6. Develop a strong concern for others.

Karen E. Jensen

#### Bibliography

American Public Health Association. <<http://www.apha.org/about/>>.

U.S. Department of Labor, Bureau of Labor Statistics. *Occupational Outlook Handbook 2000–2001*. <<http://stats.bls.gov/ocohome.htm>>.



**chromosome** “colored body” in the cell nucleus; made of DNA and protein, and divided functionally into genes and non-gene regions

**genome** total genetic material in a cell or organism

## Radiation Hybrid Mapping

Radiation hybrid mapping is a genetic technique that was originally developed for constructing long-range maps of mammalian **chromosomes**. It is based on a statistical method to determine not only the distances between deoxyribonucleic acid (DNA) markers but also their order on the chromosomes. DNA markers are short, repetitive DNA sequences, most often located in noncoding regions of the **genome**, that have proven extremely valuable for localizing human disease genes in the genome.

### Theory and Application

In radiation hybrid mapping, human chromosomes are separated from one another and broken into several fragments using high doses of X rays. Similar to the underlying principle of mapping genes by linkage analysis based on recombination events, the farther apart two DNA markers are on a chromosome, the more likely a given dose of X rays will break the chromosome between them and thus place the two markers on two different chromosomal fragments. The order of markers on a chromosome can be determined by estimating the frequency of breakage that, in turn, depends on the distance between the markers. This technique has been used to construct whole-genome radiation hybrid maps.

### Technique

A rodent-human somatic cell hybrid (“artificial” cells with both rodent and human genetic material), which contains a single copy of the human chro-

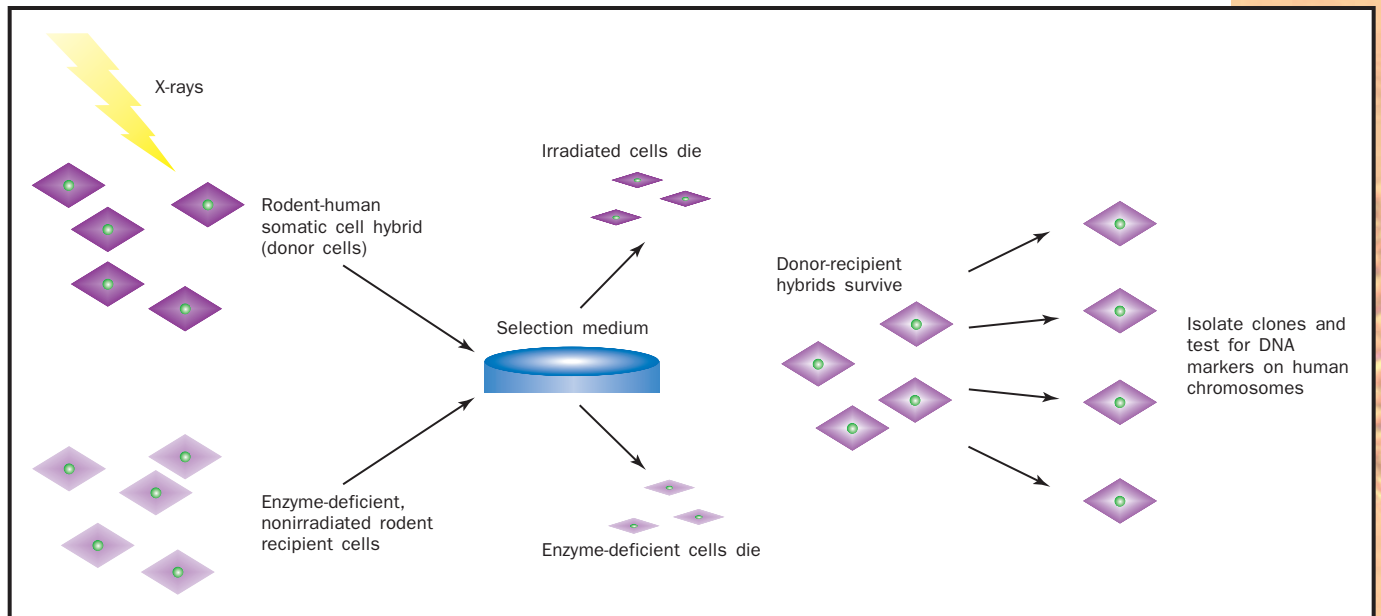

mosome of interest, is X-irradiated. This breaks the chromosome into several pieces, which are subsequently integrated into the rodent chromosomes. In addition, the dosage of radiation is sufficient to kill the **somatic** cell hybrid or donor cells, which are then rescued by fusing them with nonirradiated rodent recipient cells. The latter, however, lack an important **enzyme** and are also killed when grown in a specific medium. Therefore, the only cells that can survive the procedure are donor-recipient hybrids that have acquired a rodent gene for the essential enzyme from the irradiated rodent-human cell line (see Figure above).

From these donor-recipient hybrids, clones can be isolated and tested for the presence or absence of DNA markers on the human chromosome of interest, and the frequencies with which markers were retained in each clone can be calculated. This process is complicated by the fact that hybrids may contain more than one DNA fragment. For example, two markers retained in one hybrid may result from retention of the two markers on separate fragments or from no break between the markers. However, the frequency of breakage,  $\theta$ , can be estimated using statistical methods, and a lod score (logarithm of the likelihood ratio for linkage) can be calculated to identify significantly linked marker pairs. SEE ALSO LINKAGE AND GENE MAPPING

*Christine Klein*

### Bibliography

Cox, David R., Margit Burmeister, Price E. Roydon, Suwon Kim, and Richard M. Myers. "Radiation Hybrid Mapping: A Somatic Cell Genetic Method for Constructing High-Resolution Maps of Mammalian Chromosomes." *Science* 250 (1990): 245–250.

Goss S. J., and H. Harris. "New Method for Mapping Genes in Human Chromosomes." *Nature* 255 (1975): 680–684.

*Rutgers University*. <<http://compgen.rutgers.edu/rhmap/>>.

Watson, James D., Michael Gilman, Jan Witkowski, and M. Zoller. *Recombinant DNA*, 2nd ed. New York: W. H. Freeman and Company, 1993.

Radiation hybrid mapping process.

**somatic** nonreproductive; not an egg or sperm

**enzyme** protein that controls a reaction in a cell

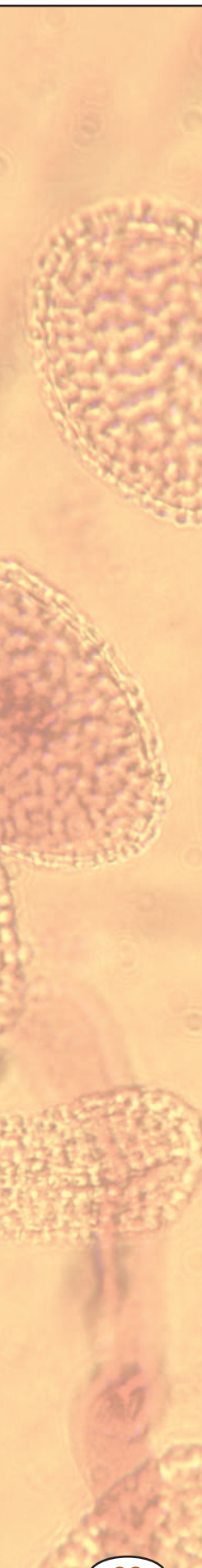

**isotopes** forms of an atom that differ by the number of neutrons in the nucleus

**protein** complex molecule made from amino acids; used in cells for structure, signaling, and controlling reactions

**amino acid** a building block of protein

**nucleotide** the building block of RNA or DNA

**glucose** simple sugar that provides energy to animal cells and is the building block of cellulose in plants

## Radionuclides

Radionuclides or radioisotopes are radioactive **isotopes** of elements that are extremely important tools in biochemistry and cell biology. Radionuclides allow scientists to tag specific molecules without altering the structure or function of the studied compounds. Radioactive isotopes of elements normally found in biological systems include carbon 14, hydrogen 3 (tritium), sulfur 35, and phosphorous 32. These unstable atoms decay over time (from seconds to centuries), emitting radioactive particles that can be detected by laboratory instruments.

Because radioactive elements can be detected, the tagged molecule, such as a **protein**, nucleic acid, or sugar, can then be detected with great accuracy and sensitivity, especially if only a small amount of the molecule is present.

In a type of experiment called a pulse-chase, a radionuclide-tagged **amino acid** or **nucleotide** is incorporated into a protein or nucleic acid, and the fate of the protein or nucleic acid is monitored over time. For instance, cells are fed a nutrient mixture (the “pulse”) containing a radioactively tagged amino acid such as methionine, containing sulfur 35. After a few minutes, the cells have incorporated the tagged amino acid into most of the proteins synthesized during exposure to the tagged amino acid. The tagged amino acid mixture is then removed and replaced with untagged amino acids (“the chase”) that are then incorporated into all newly synthesized proteins from that point on. As time passes, the radioactivity incorporated into each protein will disappear due to degradation of the protein by the cell. This is a measure of protein longevity and will vary from protein to protein.

Radionuclides can also be used to monitor the metabolic fate of a nutrient. For instance, radionuclide-tagged sugars can be fed to cells or to a live animal and samples of the cells or waste products from the animal analyzed over time. The radionuclide tag will appear in new compounds as time passes. The first products to appear are the initial metabolic breakdown products of the sugar. Later, other radioactive compounds will appear representing intermediates in the complete breakdown of the sugar. This procedure can be used to identify the metabolic pathway used to break down the sugar and derive energy. For instance, the carbon in C-14-tagged **glucose** will eventually be found in carbon dioxide, the final breakdown product. **SEE ALSO** KREBS CYCLE; METABOLISM, CELLULAR; PHOTOSYNTHESIS; PROTEIN SYNTHESIS; REPLICATION

*Stephen A. Adam*

## Recombinant DNA

Recombinant deoxyribonucleic acid (DNA) technology allows the creation and manipulation of DNA sequences that come from different sources, even different species. The development of recombinant DNA technology in the 1970s was hailed as the most exciting invention since the development of transistors some twenty to thirty years earlier. The transistor changed people’s lives forever by creating the microelectronics revolution and enabling

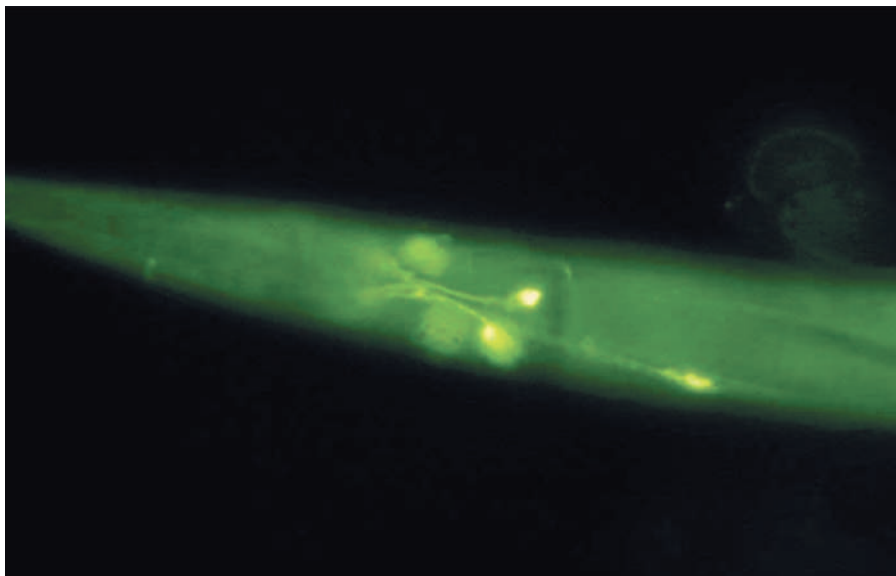

Recombinant DNA technology helps highlight the brain of *C. elegans*. To photograph its brain, a fluorescent protein was linked to the fax-1 protein in the brain; the glowing neurons reveal the cells in which fax-1 functions.

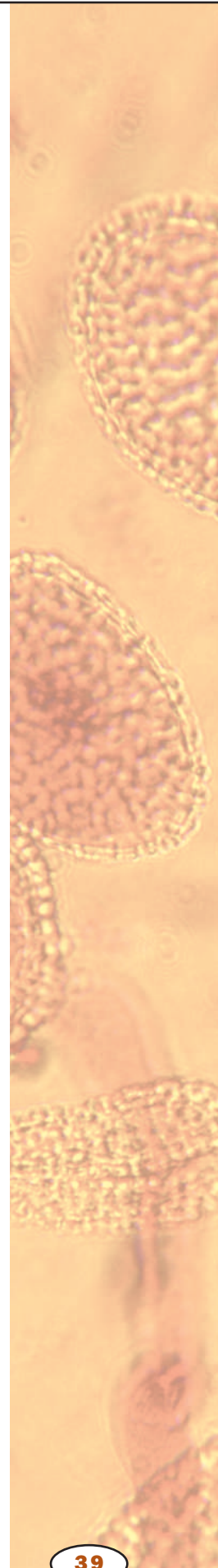

the development of portable radios, tape and compact disc players, cellular phones, and computers, all leading to fabulous wealth in the developed world. Recombinant DNA technology is likely to also have profound effects on society, including better health through improved disease diagnosis, much better understanding of human **gene** variation, improved drug and pharmaceutical production, vastly more sensitive and specific crime scene **forensics**, and production of genetically modified organisms that significantly improve yields and nutritional value of crops while decreasing reliance on pesticides and artificial fertilizers. Recombinant DNA and the **transgenic** technology that it spawned have already entered everyday lives to a degree, as evidenced by the completion of a draft of the human **genome** sequence, criminal trials relying on DNA evidence, and controversy over the use of genetically modified corn and other organisms.

Recombinant DNA technology has had to create its place instead of entering an existing market. As a result, recombinant DNA technology has probably consumed more finances than it has yet generated, although this discounts the long-term value of increasing knowledge. Where recombinant DNA technology has made the biggest economic impact is in the pharmaceutical industry, allowing the production of single human **proteins** for therapeutic use or to generate specific antibodies. Harvesting human insulin created in bacterial cells is far easier than isolating it from pig or human cadaver pituitary glands, for instance. The financial base for recombinant DNA technology should continue to improve as genetically modified organisms are becoming widely used in agriculture; more than half the U.S. soybean crop now consists of a strain genetically modified to reduce the amount of herbicides necessary to bring in a good yield.

## Gene Cloning

A clone is a collection of organisms that are genetically identical, and a recombinant DNA clone is a collection of genetically identical organisms (most often bacteria) that each carry a specific foreign (from another source) DNA molecule. “Clone” also refers to the foreign DNA itself after being

**gene** portion of DNA that codes for a protein or RNA molecule

**forensic** related to legal proceedings

**transgenic** characterized by presence of one or more genes from a different organism

**genome** total genetic material in a cell or organism

**protein** complex molecule made from amino acids; used in cells for structure, signaling, and controlling reactions

The process of DNA cloning has two components: one is the use of restriction enzymes *in vitro* to cut DNA into a unique set of fragments; the other is the use of vectors to ensure that the host organism carries and replicates the foreign DNA.

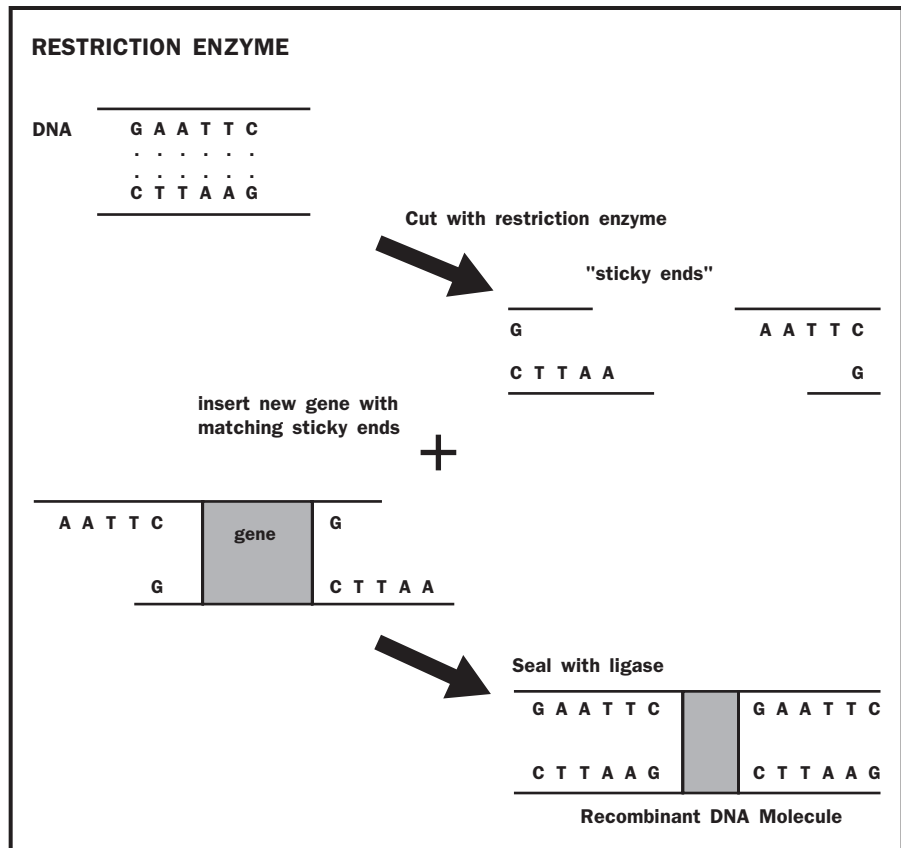

**vector** carrier

**restriction enzyme** enzyme that cuts DNA at a particular sequence

**enzyme** protein that controls a reaction in a cell

**nucleotide** the building block of RNA or DNA

placed in the target organism. Thus, scientists would speak of the “cloned DNA.” Typically, a specific DNA molecule is inserted into a **vector** DNA molecule that can carry foreign DNA, and the resulting recombinant DNA is introduced into a host organism (often the common bacterium *Escherichia coli* or the yeast *Saccharomyces cerevisiae*). Large numbers of genetically identical host organisms, each carrying the same specific foreign DNA molecule, can be produced, allowing the DNA or its protein product to be produced in large quantities.

The process of DNA cloning has two components. One is the use of **restriction enzymes** *in vitro* to cut DNA into a unique set of fragments. Restriction enzymes are endonucleases that bacteria naturally use to defend against DNA viruses by cleaving DNA at specific sites. The **enzyme** EcoRI, for example, from *E. coli*, cleaves every site with the six-nucleotide sequence of GAATTC, found on average every 4,100 **nucleotides** in DNA. (A companion methylase enzyme modifies the bacterium’s own GAATTC sites so they are not targets of EcoRI.) Researchers have isolated many different restriction enzymes from bacterial species. The enzymes differ in the sequences of the target sites that they cut, in the locations of the cleavage sites, and by whether modified target sites are cleaved (in some cases modification is required for cleavage). The collection of restriction enzymes with these different properties provides an invaluable toolbox for cutting and joining DNA molecules from different sources.

The other component of DNA cloning technology is the use of vectors to ensure that the host organism carries and replicates the foreign DNA.

PLASMID VECTORS ARE USED TO INSERT DNA INTO BACTERIA

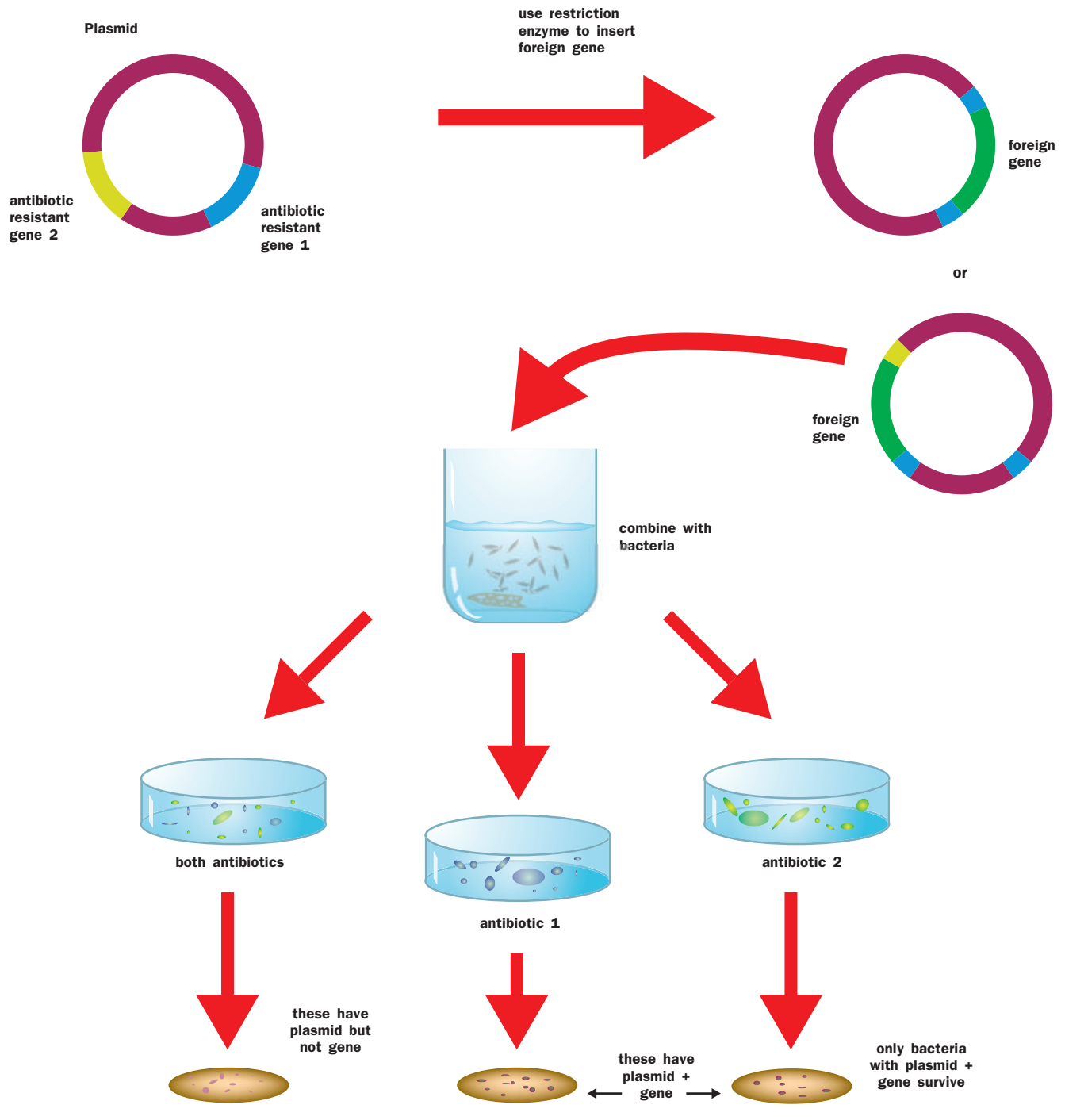

Most often bacteria are used as the host organism, because of their fast growth and the ready availability of techniques for manipulating and growing bacteria in small- and large-scale cultures. Vectors are DNA molecules that contain an origin of replication that functions in the host organism (to allow the vector to be copied), and a gene that confers some survival advantage on host

A plasmid carrying antibiotic resistant genes provides both a vector for introducing a foreign gene into a bacterium, and a method for testing the success of the introduction.

**chromosome** “colored body” in the cell nucleus; made of DNA and protein, and divided functionally into genes and non-gene regions

**plasmid** small ring of DNA found in many bacteria

**inducible** able to be switched on

**promoter** DNA sequence to which RNA polymerase binds to begin transcription

**transcribe** creation of an RNA copy of a DNA gene

**reverse transcriptase** enzyme that copies RNA into DNA

**gene expression** use of a gene to create the corresponding protein

cells that contain the vector DNA. Typically the vector carries a gene that confers resistance to a particular drug, such as an antibiotic.

The original vectors used were based on naturally occurring small, circular DNA molecules distinct from the bacterial **chromosome**, called **plasmids**. The most widely used vector of the late 1970s to early 1980s was the plasmid pBR322, which contained an origin of replication, a gene that confers resistance to the antibiotic ampicillin, and a second gene that confers resistance to the antibiotic tetracycline. Each of these antibiotic resistance genes contains the recognition sequence for a restriction endonuclease. Opening the vector at one of those sites by restriction digestion *in vitro* and ligating (splicing) the foreign DNA into that site destroys the resistance encoded by that gene but leaves the other resistance factor intact. Plasmid DNA can then be put back into bacterial host cells (by transfection) where it can replicate up to several hundred copies per bacterium. The bacteria are then grown in media containing one or the other antibiotic. This facilitates selection and identification of bacteria receiving the ligation product. The cloned DNA then replicates along with the rest of the plasmid DNA to which it is joined.

Later improved editions of plasmid vectors incorporated such features as polylinker sequences that consist of several unique restriction sites close together to form a specific cloning site and **inducible promoter** sequences adjacent to the polylinker used to **transcribe** into RNA, or “express,” the cloned DNA as desired.

### cDNAs and Gene Analysis

Plasmid vectors are limited in the size of the cloned DNA that can be incorporated and successfully reintroduced into the bacterium, typically holding a maximum of about 15 kb (kilobases [1 kb equals 1,000 bases]) of foreign DNA. One common use for plasmid vectors is to make cDNA (complementary DNA) libraries; cDNA molecules are DNA copies of messenger ribonucleic acid (mRNA) molecules, produced *in vitro* by action of the enzyme **reverse transcriptase**. Because cDNAs represent only the portions of eukaryotic genes that are transcribed into the mRNA, cDNA clones are particularly useful for analysis of **gene expression** and cell specialization. The existence of a cDNA is also evidence that the gene is active, or transcribed, in the cells or tissues from which the mRNA was isolated. Such information can be used to compare gene activities in healthy versus diseased cells, for instance.

Frequently the simpler sequence of a cDNA is easier to analyze than the corresponding genomic sequence since it will not contain noncoding, or intervening, sequences (introns). Another advantage of cDNA is that generally the sequence does not include enhancers or regulatory sequences to direct their transcription. As a result, they can be combined with other regulatory systems in the clone to direct their expression.

Genome sequencing projects typically generate sequence information from many different cDNA clones. The cDNA cloned sequence is termed an “expressed sequence tag” (EST), and, when correlated with the whole genomic DNA sequence, EST information can help determine the locations and sizes of genes.

In order to obtain the cDNA for a specific gene, it is first necessary to construct a cDNA “library.” This is a collection of bacteria that contain all the cDNAs from the cell or tissue type of interest. To make a library, the thousands of different mRNAs are first harvested from the cell of interest, and cDNA is made using reverse transcriptase. The cDNA is then cloned into plasmids, and introduced into bacteria. Under the right conditions, each bacterium will take up only one cDNA. The bacteria are then grown in Petri dishes on a solid medium. A library therefore consists of a mixed population of bacteria, each carrying one type of cDNA. To find the bacterium containing a particular type of cDNA, one can either search for the gene itself with a nucleotide probe or for its protein product with an **antibody**.

Screening a library depends either on having a probe bearing part of the nucleotide sequence or an antibody or other way of recognizing the protein coded by the gene. Screening by nucleotide probes (labeled with radioactive or chemical tags for detection) depends on **base pair** complementarity between the single-stranded target DNA and the probe DNA; this allows the label to mark the cell with the desired cDNA. Screening by labeled antibody depends on binding of the antibody to the protein encoded by the gene. Literally thousands of cloned genes have been isolated this way from libraries of many different species. One of the most powerful observations in biology is that the same or similar gene sequences can be isolated from different species, ranging from bacteria to humans.

Human insulin was the first medicine to be created through recombinant DNA technology. Insulin is a protein **hormone** produced by the pancreas that is vital for regulation of blood sugar. In the disease insulin-dependent diabetes mellitus (IDDM), the immune system attacks and destroys the insulin-producing cells. A person with IDDM requires daily injections of insulin to control blood sugar. Before 1980, insulin was isolated from pigs or other animals. Animal insulin has a slightly different **amino acid** sequence from the human form. In the early 1980s, recombinant DNA technology was used to splice the human insulin gene into bacteria, which were grown in vats to make large amounts of the human protein. Recombinant human insulin was the first recombinant drug approved for human use. Since then more than two dozen other drugs have been created in this way, including growth hormone, blood clotting factors, and tissue plasminogen activator, used to break up blood clots following a stroke. Gene sequence similarities indicate that all living organisms have descended from shared common ancestors, back to the beginning of life.

## Transgenic Organisms

Cloned DNA can also be incorporated into the genomes of multicellular organisms to create a transgenic organism. This makes possible a new approach to designing genotypes by adding genes (gene-coded functions) to species where those genes (functions) do not exist. Genetically modified organisms (GMOs) created by modifying a gene or adding one from another species frequently offer the most direct way to improve the way people use organisms for food or chemistry.

One example of a GMO is the development of “golden rice,” designed to reduce blindness caused by vitamin A deficiency in rice-consuming areas

**antibody** immune system protein that binds to foreign molecules

**base pair** two nucleotides (either DNA or RNA) linked by weak bonds

**hormone** molecule released by one cell to influence another

**amino acid** a building block of protein

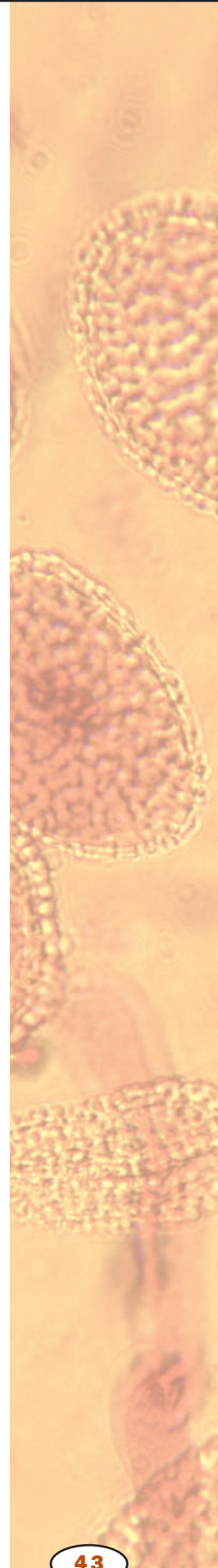



**endosperm** nutritive tissue within a seed

**intron** untranslated portion of a gene that interrupts coding regions

**hybrid** combination of two different types

**centromere** region of the chromosome linking chromatids

of the world. A polished rice grain, which is the portion of the seed that provides nourishment (the **endosperm**) does not contain beta-carotene, the substance the human body converts into vitamin A, yet many plants with yellow/orange colored leaves or flowers produce it in abundance. To convert rice endosperm into a beta-carotene-rich food, a transgene was constructed with the genes required for beta-carotene production and inserted into rice cells. The transgene consists of a cDNA for phytoene synthase, from a daffodil flower library, plus other sequences. Rice with these extra genes show a rich “golden” color from the beta-carotene that accumulates in the rice grain. If golden rice can be bred into commercial strains and enough can be provided into the diet to reduce the incidence of vitamin A-related blindness, current agitation against GMO crops may evolve into enthusiasm for their application.

### Genome Libraries: Sequencing Genomes

Recall that cDNAs do not contain **introns**. Comparing a cDNA sequence with its corresponding DNA sequence on a chromosome (the genomic sequence) reveals the locations of introns in the genomic sequences. Genomic DNA libraries, in which the cloned DNA originates from fragments of the chromosomal DNA, carry intronic sequences, as well as the DNA between genes. In the more complex eukaryotes the same genomic region may correspond to several different cDNAs. This reveals the existence of alternative splicing, in which different sets of exons are used to make separate mRNA transcripts from one gene region. This expands the diversity of the protein, encoded by a single gene to include slightly different protein forms, called isoforms. Tissue-specific regulation of splicing indicates that these isoforms contribute important nuances to creating developmental differences between tissues.

Genomic DNA libraries have also proved invaluable for isolating genes that are poorly expressed (that is, make little mRNA) and for mapping disease-causing genes to specific chromosomal sites. The vectors used in genomic libraries are designed to incorporate greater lengths of cloned DNA than plasmids can carry. The first of these vectors was the lambda bacterial virus, which could hold an insert of 15 kb, followed by the cosmid, a **hybrid** between a plasmid and a phage (a virus that infects bacteria) with a DNA insert size of 45 kb. Development of linear yeast artificial chromosomes (YACs), which include a yeast **centromere**, origin of replication, and ends (telomeres), which successfully grow in the yeast *Saccharomyces cerevisiae*, carry clones of 200 kb to more than 2,000 kb. Subsequent development of bacterial artificial chromosomes (BACs) that contain 100 kb of insert DNA and are relatively easy to culture has put genomic cloning within reach of almost every molecular biology laboratory. (Clones are harder to work with as they get larger.)

BACs provided one route to sequencing the human genome, where their large capacity was critical. All the different genome sequencing projects start with a large number of BAC clones for that species, subclone 1 kb fragments of the DNA from each BAC into plasmids, and determine their sequence using high-speed machines. Computer-based comparisons of the results then assemble the nucleotide sequences into a coherent order by aligning the regions where they overlap.

A library of genomic DNA contains many clones with inserts that partially overlap each other because random breakage of chromosomal DNA is used to produce fragments for cloning. The order of fragments in the original chromosome can be determined by “chromosome walking.” In this technique, a portion (subclone) from one clone is used as a probe to identify another clone that also carries that sequence. The two clones are then compared, and the nonoverlapping end of the second clone is subcloned for use as the next probe. In this way, a “walk” is carried out over many steps to identify adjacent DNA on the same chromosome, allowing the fragments to be placed in sequence. A series of sequential, partially overlapping clones is termed a “contig” (for **contiguous** sequence); the goal of genome mapping is to make a separate contig for all the DNA clones from one chromosome (a continuous covalent molecule). Contigs made large genome sequencing feasible since a minimum number of BACs could be chosen from their order in the map.

### Finding Disease Genes

Locating a human disease gene on a chromosome map is now equivalent to locating the gene (approximately) on a contig and the DNA sequence map. This speeds gene identification through cloning the gene and determining what protein the gene encodes. The positional approach is important for single-gene (Mendelian) disease traits that are well known clinically but not at a biochemical level.

Cystic fibrosis (CF) was one such disease. It is the most common severe autosomal recessive disorder among European populations and their descendants in the New World. Patients suffer from mucus accumulation and frequent bacterial infections in their lungs. In the United States, CF patients are the single largest group receiving transplants to replace damaged lungs. However, the clinical studies failed to determine which gene product is defective in the patients. Extensive studies on families with CF led to identification of the causative gene on chromosome 7.

Initially recombination studies placed the gene within a small region of the chromosome of approximately one million base pairs. Starting at DNA clones from both ends of this region, the researchers used chromosome walking to clone all of the interval; several candidate genes were identified within the region but rejected as the cause of CF. Finally, one gene was identified within these clones that had the right properties: It was normally expressed in the lungs but not the brain, and it encoded a protein that made sense for the cause of the disease. In addition, patients with CF had specific mutations in this gene. The functional CF gene encodes a chloride channel transmembrane regulatory protein (CFTR) that controls transport of certain **ions** in and out of epithelial (surface) cells. The most common mutation encodes a CFTR protein that is missing one amino acid and cannot reach its site of function in the cell membrane. As a result, ions become too concentrated inside the cell, and water moves in. The result is dried **secretions**, such as very sticky mucus.

Gene therapy to add a functional copy of the CFTR to lung cells has not been successful, in part because the patients develop an immune response to reject the vector, and, in some cases, the normal protein. Mild improvements have been short-lived, or affect only small patches of cells in

**contiguous** adjacent to or touching

**ion** an electrically charged particle

**secretion** material released from the cell

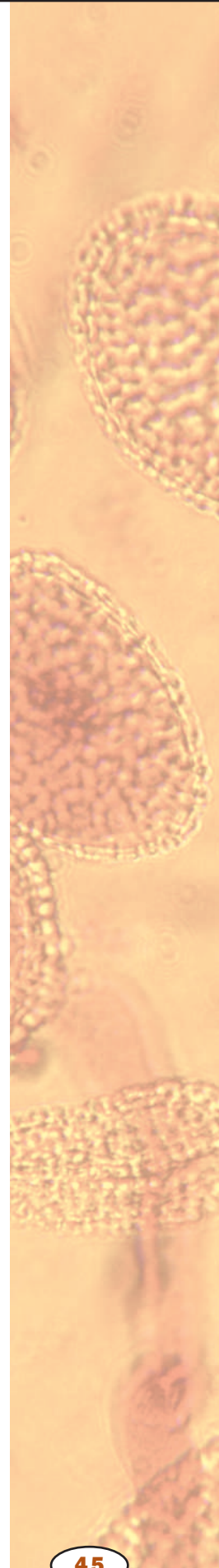

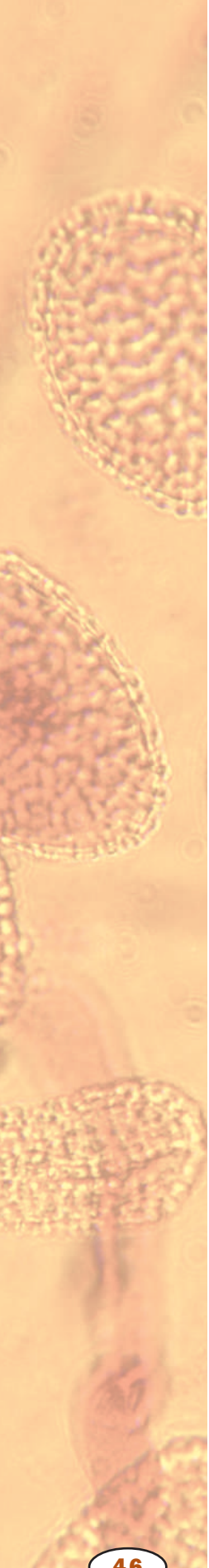

**electromagnetic radiation** light, X rays, and other forms of radiant energy

**evapotranspiration** loss of water from a plant by evaporation within the leaf

**heterogeneous** composed of or containing different parts or types

**ecosystem** an ecological community and its environment

the respiratory tract. Alternative approaches to better understanding the physiology of the disease to direct drug design seem more viable. To this end, a mouse model with an inactivated CFTR gene is used to test potential drugs. SEE ALSO BACTERIAL GENETICS; BIOINFORMATICS; CLONE; DNA SEQUENCING; FORENSIC DNA ANALYSIS; GENE THERAPY; GENETIC DISEASES; GENOME; GENOMICS; HUMAN GENOME PROJECT; RADIATION HYBRID MAPPING; REVERSE TRANSCRIPTASE; TRANSGENIC TECHNIQUES

*John Merriam*

### Bibliography

Alberts, Bruce, et al. *Molecular Biology of the Cell*, 4th ed. New York: Garland Publishing, 2000.

Felsenfeld, Gary. "DNA." *Scientific American* 253 (1985): 58–67.

Levin, Benjamin. *Genes VII*. New York: Oxford University Press, 1999.

Watson, James D., and Francis H. Crick. "A Structure for Deoxyribose Nucleic Acid." *Nature* 171 (1953): 737.

Watson, James D., Michael Gilman, Jan Witkowski, and Mark Zoller. *Recombinant DNA*, 2nd ed. New York: Scientific American Books, 1992.

## Remote Sensing

At its simplest definition, remote sensing is obtaining information about an object by a device that is not in contact with the object. In ecology remote sensing usually involves sensors on satellite platforms or airplanes. Most devices have a series of sensors that record the intensity of **electromagnetic radiation** in particular segments of the spectrum for each point, or pixel, in an image. These sensors are designed to collect data in the visible wavelength as well as in other portions of the electromagnetic spectrum (such as the infrared region) that are needed to examine specific aspects of the physical world.

In addition to collecting data from a large part of the electromagnetic spectrum, remote sensing systems collect data over large areas. For instance, the U.S. *Landsat* satellites record continuous data over an area 71.4 square miles (185 square kilometers) wide. Since some satellites have been in orbit since the mid-1970s scientists can effectively "collect data" from this time period. Therefore, remote sensing offers scientists a wide spectral, spatial, and temporal data range.

For remote sensing to be of use to ecologists the spectral data must be related to some ground-based measurement such as land cover type or vegetation characteristics (biomass or net primary production, **evapotranspiration** rates, water stress, vegetation structure). Most work in ecology is done at the scale of a small plot, or piece of a field or forest. It can be difficult to extrapolate these small-scale measurements to larger, **heterogeneous** areas. Because sensors record continuous data over large areas, remote sensing can be used to "scale-up" plot-based measurements to examine landscape or even regional patterns. For example, ecologists have used remote sensing data to determine the rate at which rainforest in Brazil is being converted to agricultural land. In North America, scientists using satellite data have determined that one of the most endangered **ecosystems**, the tallgrass prairie, is being replaced by woody vegetation at an alarming rate.

Another set of questions that can be addressed with remote sensing data involves landscape heterogeneity. In these analyses, any of a number of spatial statistics can be applied to the original spectral data. Also, the original bands can be recombined to create indices. The most common of these is the Normalized Difference Vegetation Index, a ratio of red to near infrared bands, which has been useful in quantifying vegetation in numerous locations around the world.

Spectral data can be analyzed directly (total infrared reflected) or a classification can be performed on the data. With this method, the spectral data are analyzed and each pixel is assigned to a land cover type: forest, grassland, or urban. For instance, forests reflect less infrared than grasslands. These land cover data can then be incorporated into a Geographical Information System (GIS) for further analysis. A GIS is a computer-based system that can deal with virtually any type of information that can be referenced by geographical location.

Once the land cover types are identified and GIS coverage is generated, additional data such as soil type, elevation, and land use history can be entered into the GIS. Ecologists can then ask questions about landscape-level patterns such as the average patch size of a certain land cover type or its dispersion across the landscape. This information can then be related to some ecological process such as the movement or dispersal of animals. SEE ALSO ECOLOGY; ECOSYSTEM; GRASSLAND; LANDSCAPE ECOLOGY

*Greg A. Hoch and John M. Briggs*

### Bibliography

Lillesand, Thomas M., and Ralph W. Kiefer. *Remote Sensing and Image Interpretation*, 4th ed. New York: John Wiley & Sons, 1999.

Schott, John R. *Remote Sensing: The Image Chain Approach*. Oxford: Oxford University Press, 1996.

Schowengerdt, Robert A. *Remote Sensing: Models and Methods for Image Processing*. San Diego, CA: Academic Press, 1997.

## Replication

There is no more critical issue in the origin of life than a method for the faithful and timely replication of genetic information. Genes are encoded in deoxyribonucleic acid (DNA), which is made of four types of **nucleotides**, distinguished by the bases adenine (A), guanine (G), cytosine (C), and thymine (T). When James Watson and Francis Crick discovered the double helical structure of deoxyribonucleic acid (DNA), they also recognized that DNA replication could occur by opening the double helix into single strands, and from those **templates** creating new **complementary** strands by the principle of **base pairing**. As an overview, their proposal was correct. The details of the chemistry, of the **enzymes** involved, and of the structure on which replication occurs tell a fascinating story that is far more complex than Watson and Crick anticipated.

### Semiconservative Replication

Chromosomes are the extended molecules of DNA that carry genes in both bacteria and eukaryotes. Bacterial **chromosomes** are usually circular, with

**nucleotide** the building block of RNA or DNA

**template** master copy

**complementary** matching opposite

**base pair** two nucleotides (either DNA or RNA) linked by weak bonds

**enzyme** protein that controls a reaction in a cell

**chromosome** “colored body” in the cell nucleus; made of DNA and protein, and divided functionally into genes and non-gene regions

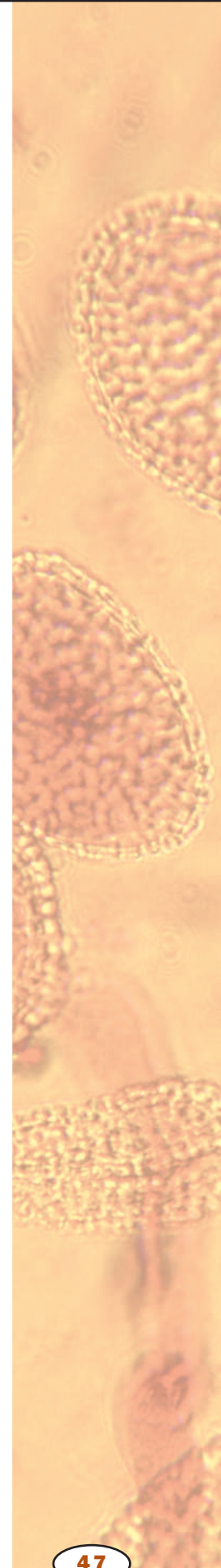

the double helix looping around to make a complete circle. Eukaryotic chromosomes are linear, with the double helix sealing up at the two distant ends. In both cases, the result of replication is that one double helix with its two complementary strands of nucleotides becomes two identical double helices with the same sequence of nucleotides. In this way, the genetic material of a cell is passed along unchanged through all the descendants of the original cell (except for replication errors or other mutations).

Each new helix includes one original side and one new side, and so the replication process is said to be “semiconservative.” Semiconservative replication was discovered by Matthew Meselson and Frank Stahl, who grew bacteria with radioactive nucleotides. Fully radioactive chromosomes became half as radioactive after one round of replication, indicating that half the original chromosome was preserved in each new copy.

### Replication Forks and Accessory Enzymes

Replication is a huge task, whether in bacteria or in eukaryotes. There are several physical and biochemical challenges the cell must overcome. First, the site or sites at which to begin replication must be located and the proper enzymes collected there. Second, the double helix must be unwound to expose the two strands. This imposes twisting strain on the portions of the helix farther away from the unwinding site, much like untangling a twisted phone cord does, and those forces must be relieved to prevent breakage of the DNA strands. Complementary nucleotides must be put in place and linked to form a new strand, and errors must be checked and corrected.

The orientation of the two strands poses an additional challenge. Because of the way the deoxyribose sugar is structured, the sugar, and hence the whole DNA strand, has a direction, an up versus down, so to speak. The two sides are oriented with up and down directions opposite, in a so-called antiparallel fashion. In biochemical terms, one direction is 5'-3' (“five-prime to three-prime”), while the other side is oriented 3'-5'. The consequence of this arises because the enzymes that perform replication only function in one direction. The solution to this problem is discussed below.

Much of the understanding of DNA replication has come from studying the bacterium *Escherichia coli*. In bacterial chromosomes one site, called the origin of replication, has a sequence of base pairs to which an initiator **protein** binds. The initiator protein attracts enzymes called helicases that interrupt base pairing in a way that separates the double helix into a short region of two single strands. Other binding proteins then attach to maintain the single strand separation on the double-stranded region. Adjacent to the single-stranded region, an enzyme called gyrase cleaves and reforms the sugar-phosphate backbones in the double strand helix, which relieves the strain that the single strand separation causes. Separating the double-stranded helix into a region of two single strands creates a “replication bubble” initially of a few hundred nucleotides. Within the replication bubble, each strand serves as the template for a new chain; these chains grow in opposite directions because the templates have opposite 5' to 3' polarity. As the chains elongate, the replication bubble expands in both directions, and the ends become known as replication forks. As replication occurs, the helicase molecules are pushed toward the fork where the double strand separates into

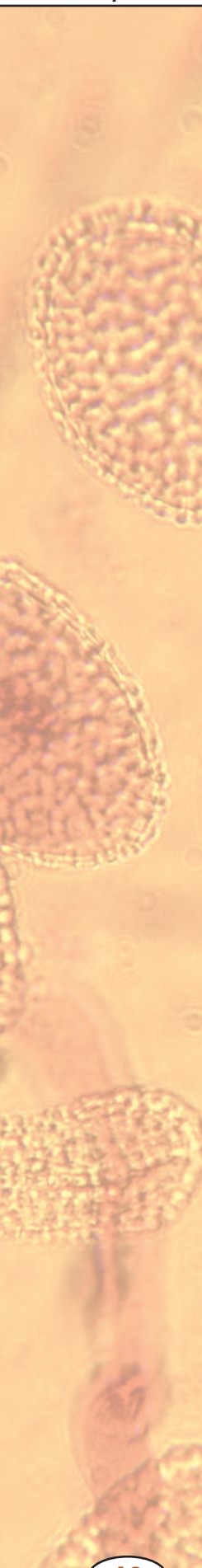

**protein** complex molecule made from amino acids; used in cells for structure, signaling, and controlling reactions

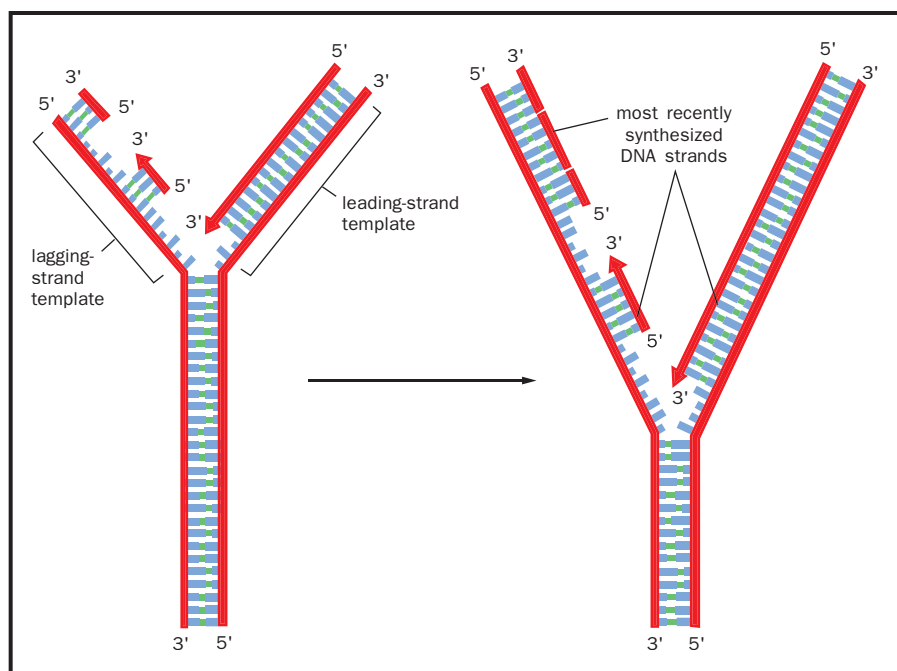

Figure 1. Replication adds a free nucleotide to the 3' OH group of the last nucleotide in the growing chain of DNA.

single strands, thus moving the fork and extending the region of single strands.

### Priming and Elongation

*E. coli* use three enzymes for replications, called *pol I*, *pol II*, and *pol III*. Early work with *pol I* showed that replication adds a free nucleotide to the 3'OH group of the last nucleotide in the growing chain (see Figure 1). Each nucleotide-added hydrogen bonds to the complementary nucleotide in the template single strand. The 3'OH of the last nucleotide attacks the high-energy triphosphate group at the 5' position of the free nucleotide, splitting off two phosphates and forming a covalent bond to the innermost phosphate. This binds the new nucleotide to the existing chain.

Some anticancer and antiviral drugs are nucleotides missing the 3' OH. Such “dideoxy” nucleotides shut down replication after being incorporated into the strand. Fast-replicating DNA in cancer cells or viruses is inactivated by these drugs.

To begin elongation, DNA **polymerases** require an existing chain with a 3' OH end. This posed the problem of how replication could ever begin, since the needed 3' OH is on the newly replicated strand. The key to understanding the initiation of replication came with the discovery of ribonucleic acid (RNA) priming, which does not require an existing 3' OH to start the process. In priming, an enzyme called primase places a short sequence of RNA nucleotides into position at the origin of replication. This sequence is complementary to the 3' end of the single-stranded portion of the template at that point. DNA polymerase then adds nucleotides to the RNA's 3'OH, continuing replication, until they reach the end of the complementary template.

Since polymerase only elongates in a 5' to 3' direction, at each replication fork only one chain is elongating in a smooth, unbroken fashion. The

**polymerase** enzyme complex that synthesizes DNA or RNA from individual nucleotides

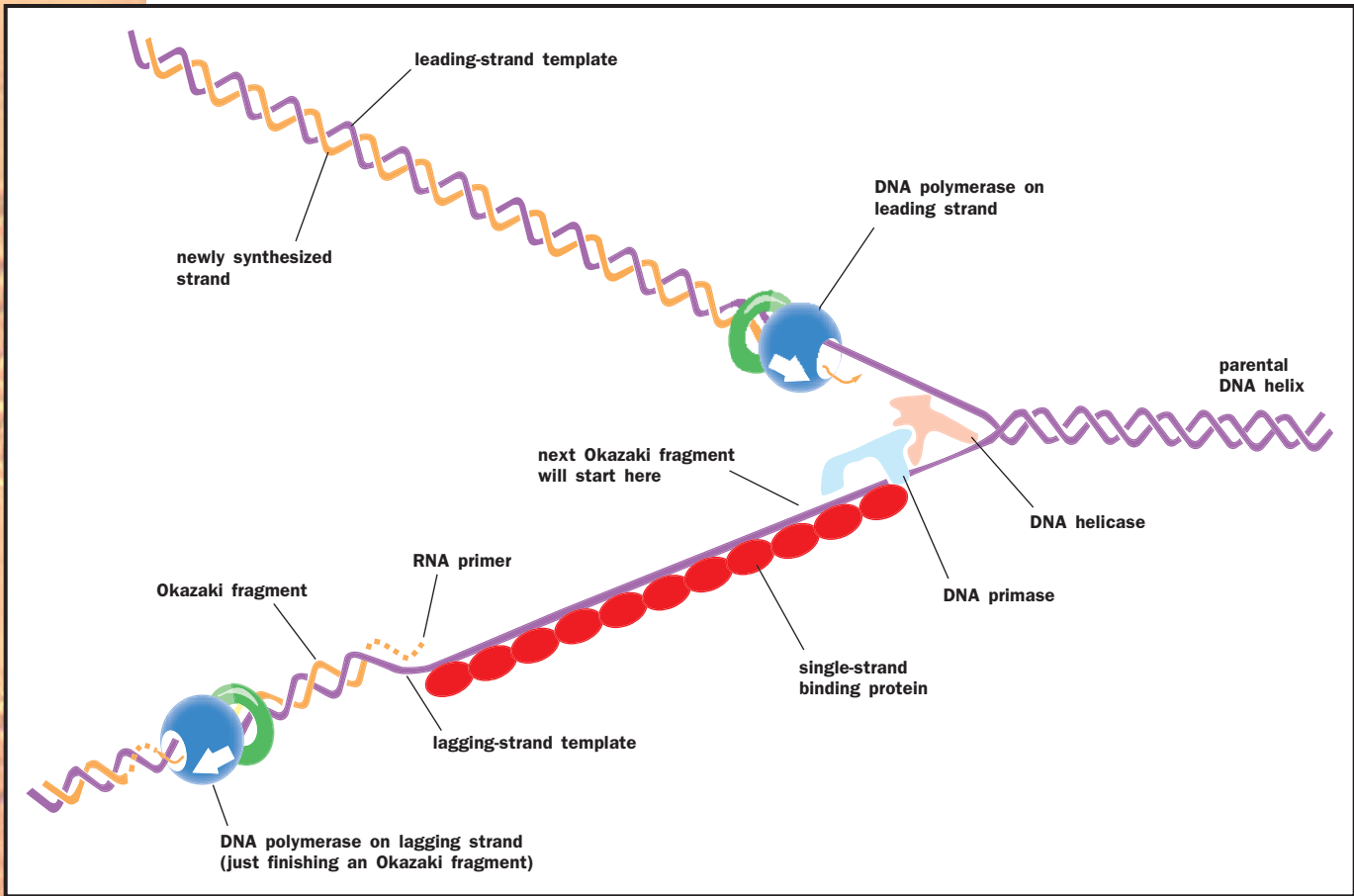

Figure 2. The proteins at a DNA replication fork.

**primer** short nucleotide sequence that helps begin DNA replication

**catalyze** aid in the reaction of

**cell cycle** sequence of growth, replication, and division that produces new cells

continuous elongation product is termed the “leading strand,” while the discontinuous product is the “lagging strand.” For every new section on the lagging strand, primase creates a new RNA **primer** and 3’OH end to start DNA chain elongation. Called Okazaki fragments after their discoverer, each short fragment lasts only a brief period before the primer ribonucleotides are digested and replaced with DNA nucleotides, which are then ligated (“tied”) to the adjacent nucleotides by DNA ligase. Ligation of the Okazaki fragments into long chains completes synthesis of the lagging strand (see Figure 2). The *pol III* enzyme is a large complex of subunits that **catalyzes** both leading-strand and lagging-strand elongation and has roles in proofreading and replacing mismatched nucleotides. The *pol I* enzyme digests the RNA nucleotides and replaces them with DNA nucleotides; it also proofreads and replaces incorrect with correct nucleotides. It is thought that *pol II* mostly repairs replication errors.

Replication in the *E. coli* chromosome is bidirectional and continues in opposite directions until the two replication forks meet about halfway around the circular chromosome. Replication is then complete.

### Special Features of Eukaryotic Replication

Replication of eukaryotic chromosomes is more complex inasmuch as they are linear (versus circular) and usually much larger than bacterial chromosomes. DNA replication is restricted to the S, or synthesis, phase during the **cell cycle**, between mitotic divisions. As a result of replication, each chro-

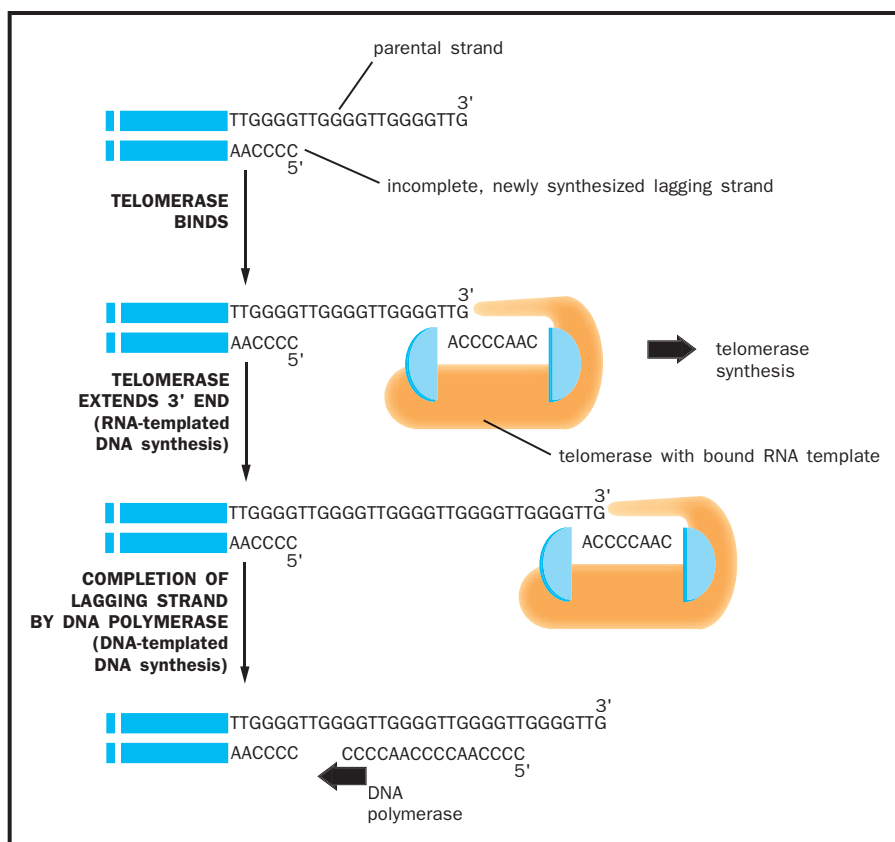

Figure 3. Telomerase is a hybrid protein-RNA molecule; the RNA sequence is complementary to several repeat lengths of the telomeric DNA. The telomerase uses the RNA sequence to bind to the template end of telomeric DNA, and uses the overhang protein portion to add DNA nucleotides to the template, extending it beyond its normal length.

mosome consists of two identical **chromatids** joined together, which are then separated into daughter cells by mitotic division.

Instead of a single origin of replication, as in bacteria, eukaryotic chromosomes have many origins for each chromosome in keeping with their much larger size. Replication proceeds bidirectionally from each origin until it meets the replication fork from the adjacent origin. A replicon refers to the interval replicated from one origin. This concept is shaky, however, since there is evidence that origins of replication are somewhat specific to the stage and tissue the cells are in, rather than being a permanent physical property. For example, nuclei in the *Drosophila* embryo divide every nine minutes initially. This requires the fastest replication of chromosomes known and utilizes many origins. Later stages use fewer origins.

Eukaryotes have five polymerases, termed alpha, beta, gamma, delta, and epsilon. Replication of nuclear DNA utilizes the alpha and delta polymerases. Alpha polymerase is a complex of several subunits, one of which has primase activity when it is in the complex. The alpha polymerase is thought to carry out synthesis of the lagging strand, whereas the delta polymerase, also a complex of subunits but lacking primase activity, carries out synthesis of the leading strand. As in the **prokaryotes**, helicase and gyrase are required to unwind the double helix ahead of the replication fork. The alpha and delta polymerases function in proofreading and correction as well. The beta and epsilon polymerases are thought to carry out nuclear DNA repair. The gamma polymerase replicates the **mitochondrial genome**. It lacks the error correction mechanism of the other polymerases, with the re-

**chromatid** a replicated chromosome before separation from its copy

**prokaryote** single-celled organism without a nucleus

**mitochondria** subcellular organelle that creates ATP used for energy-requiring processes in a cell

**genome** total genetic material in a cell or organism



sult that the mutation rate in mitochondrial replication is substantially higher than it is in replication of nuclear DNA.

### Telomeres and Telomerase

Because eukaryotic chromosomes are linear and have ends, another enzyme, called telomerase, is necessary but is not found in the prokaryotes. The problem with chromosome ends, called telomeres, is that the 3' template for the lagging strand cannot be primed at the last nucleotides because there is no further DNA on which to build. By itself, this would reduce the length of the lagging strand and the chromosome would get shorter at each replication. Telomeric DNAs, which are repeats of a specific sequence of six nucleotides, are normally present at the ends of chromosomal DNA and avoid this problem. Telomerase is a **hybrid** protein-RNA molecule; the RNA sequence is complementary to several repeat lengths of the telomeric DNA. The telomerase uses the RNA sequence to bind to the template end of telomeric DNA and uses the overhang protein portion to add DNA nucleotides to the template, extending it beyond its normal length. With several movements of the enzyme outward and reiterations of this process, the template 3' end is extended sufficiently to allow DNA polymerase to complete synthesis of a normal length lagging strand. In multicellular organisms, **somatic** cells usually cease mitotic division during development and lack telomerase activity thereafter. Cancer cells abnormally turn their telomerase back on, which enables the cell to divide continually. Telomerase is a target of drug research for the combat of cancer. SEE ALSO BACTERIAL CELL; CELL CYCLE; CHROMOSOME, EUKARYOTIC; DNA; NUCLEOTIDES; RNA; TRANSCRIPTION

*John Merriam*

#### Bibliography

Cotterill, Sue, ed. *Eukaryotic DNA Replication: A Practical Approach*. Oxford: Oxford University Press, 1999.

Kornberg, Arthur, and Tania Baker. *DNA Replication*. New York: W. H. Freeman and Company, 1991.

## Reproduction in Plants

Plant reproduction is the process by which plants generate new individuals, or offspring. Reproduction is either sexual or asexual. Sexual reproduction is the formation of offspring by the fusion of **gametes**. Asexual reproduction is the formation of offspring without the fusion of gametes. Sexual reproduction results in offspring genetically different from the parents. Asexual offspring are genetically identical except for mutation. In higher plants, offspring are packaged in a protective seed, which can be long lived and can disperse the offspring some distance from the parents. In flowering plants (angiosperms), the seed itself is contained inside a fruit, which may protect the developing seeds and aid in their dispersal.

### Sexual Reproduction in Angiosperms: Ovule Formation

All plants have a life cycle that consists of two distinct forms that differ in size and the number of **chromosomes** per cell. In flowering plants, the

**hybrid** combination of two different types

**somatic** nonreproductive; not an egg or sperm

**gamete** reproductive cell, such as sperm or egg

**chromosome** "colored body" in the cell nucleus; made of DNA and protein, and divided functionally into genes and non-gene regions

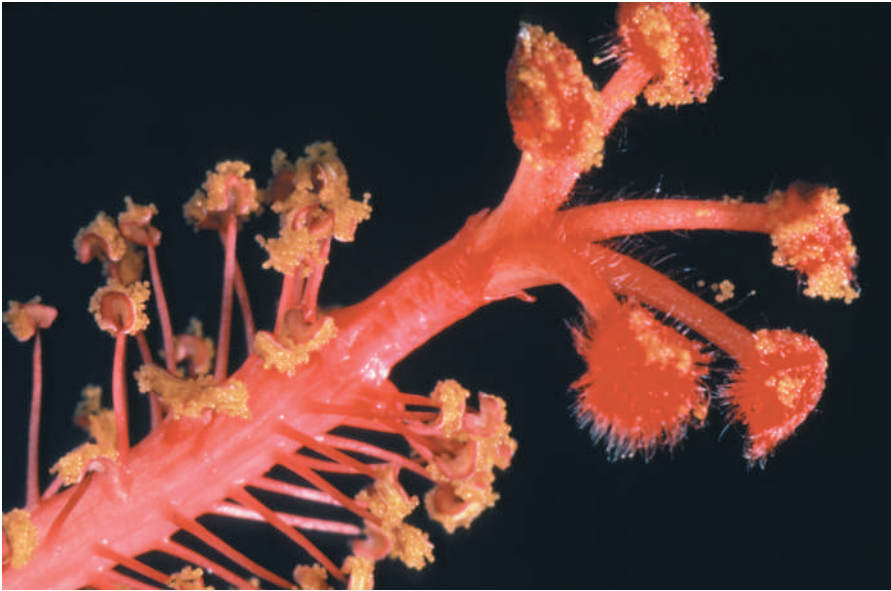

A hibiscus flower, showing anthers, five stigmas, and pollen.

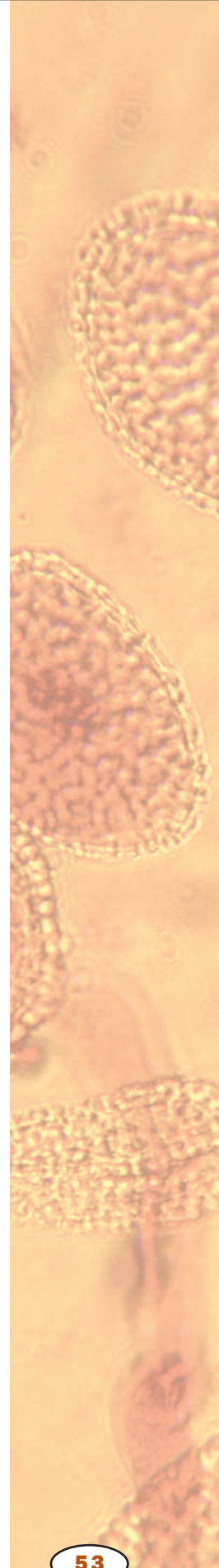

large, familiar form that consists of roots, shoots, leaves, and reproductive structures (flowers and fruit) is **diploid** and is called the sporophyte. The sporophyte produces **haploid** microscopic **gametophytes** that are dependent on tissues produced by the flower. The reproductive cycle of a flowering plant is the regular, usually seasonal, cycling back and forth from sporophyte to gametophyte.

The flower produces two kinds of gametophytes, male and female. The female gametophyte arises from a cell within the **ovule**, a small structure within the ovary of the flower. The ovary is a larger structure within the flower that contains and protects usually many ovules. Flowering plants are unique in that their ovules are entirely enclosed in the ovary. The ovary itself is part of a larger structure called the carpel, which consists of the stigma, style, and ovary. Each ovule is attached to ovary tissue by a stalk called the funicle. The point of attachment of the funicle to the ovary is called the placenta.

As the flower develops from a bud, a cell within an ovule called the archesporium enlarges to form an embryo-sac mother cell (EMC). The EMC divides by **meiosis** to produce four megaspores. In this process the number of chromosomes is reduced from two sets in the EMC to one set in the megaspores, making the megaspores haploid. Three of the four megaspores degenerate and disappear, while the fourth divides mitotically three times to produce eight haploid cells. These cells together constitute the female gametophyte, called the embryo sac.

The eight embryo sac cells differentiate into two synergids, three antipodal cells, two fused **endosperm** nuclei, and an egg cell. The mature embryo sac is situated at the outer opening (micropyle) of the ovule, ready to receive the sperm cells delivered by the male gametophyte.

## Pollen

The male gametophyte is the mature pollen grain. Pollen is produced in the anthers, which are attached at the **distal** end of filaments. The filament and

**diploid** having pairs of chromosomes in the nucleus

**haploid** having single, nonpaired chromosomes in the nucleus

**gametophyte** a haploid plant that makes gametes by mitosis

**ovule** multicellular structure that develops into a seed after fertilization

**meiosis** cell division that forms eggs or sperm

**endosperm** nutritive tissue within a seed

**distal** away from

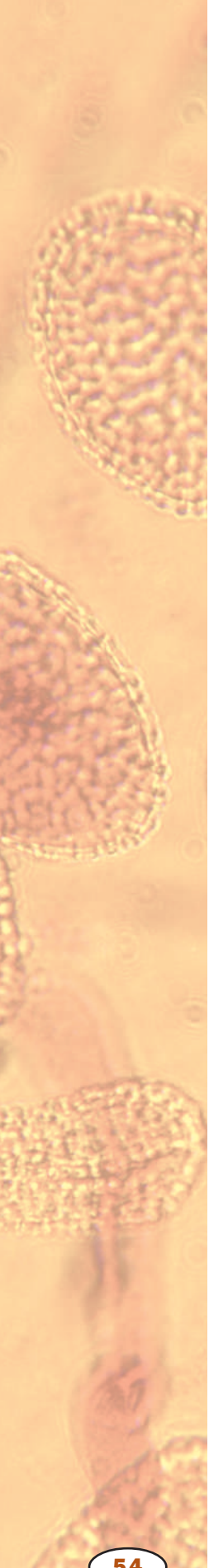

**lipoprotein** combination of protein and lipid, or fatlike molecule

**pectin** carbohydrate in plants that forms crosslinks to stabilize cell walls

**solute** dissolved substance

**aqueous** watery or water-based

**endoplasmic reticulum** network of membranes within the cell

**organelle** membrane-bound cell compartment

**protein** complex molecule made from amino acids; used in cells for structure, signaling, and controlling reactions

**enzyme** protein that controls a reaction in a cell

**carbohydrates** sugars, starches, and other molecules combining carbon, hydrogen, and oxygen and serving as fuel or structural components

**nucleus** membrane-bound portion of cell containing the chromosomes

**zygote** fertilized egg

**triploid** possessing three sets of chromosomes

anther together constitute the stamen, the male sex organ. Flowers usually produce many stamens just inside of the petals. As the flower matures, cells in the anther divide mitotically to produce pollen mother cells (PMC). The PMCs divide by meiosis to produce haploid microspores in groups of four called tetrads. The microspores are housed within a single layer of cells called the tapetum, which provides nutrition to the developing pollen grains.

Each microspore develops a hard, opaque outer layer called the exine, which is constructed from a **lipoprotein** called sporopollenin. The exine has characteristic pores, ridges, or projections that can often be used to identify a species, even in fossil pollen. The microspore divides mitotically once or twice to produce two or three haploid nuclei inside the mature pollen grain. Two of the nuclei function as sperm nuclei that can eventually fuse with the egg and endosperm nuclei of the embryo sac, producing an embryo and endosperm, respectively.

For sexual fusion to take place, however, the pollen grain must be transported to the stigma, which is a receptive platform on the top of the style, an elongated extension on top of the carpel(s). Here the moist surface or chemicals cause the pollen grain to germinate. Germination is the growth of a tube from the surface of a pollen grain. The tube is a sheath of **pectin**, inside of which is a solution of water, **solutes**, and the two or three nuclei, which lack any cell walls. Proper growth of the pollen tube requires an **aqueous** solution of appropriate solute concentration, as well as nutrients such as boron, which may aid in its synthesis of pectin.

At the apex of the tube are active ribosomes and **endoplasmic reticulum** (types of cell **organelles**) involved in **protein** synthesis. Pectinase and a glucanase (both **enzymes** that break down **carbohydrates**) probably maintain flexibility of the growing tube and aid in penetration. The pollen tube apex also releases ribonucleic acid (RNA) and ribosomes into the tissues of the style. The tube grows to eventually reach the ovary, where it may travel along intercellular spaces until it reaches a placenta. Through chemical recognition, the pollen tube changes its direction of growth and penetrates through the placenta to the ovule. Here the tube reaches the embryo sac lying close to the micropyle, and sexual fertilization takes place.

## Double Fertilization

Fertilization in flowering plants is unique among all known organisms, in that not one but two cells are fertilized, in a process called double fertilization. One sperm **nucleus** in the pollen tube fuses with the egg cell in the embryo sac, and the other sperm nucleus fuses with the diploid endosperm nucleus. The fertilized egg cell is a **zygote** that develops into the diploid embryo of the sporophyte. The fertilized endosperm nucleus develops into the **triploid** endosperm, a nutritive tissue that sustains the embryo and seedling. The only other known plant group exhibiting double fertilization is the Gnetales in the genus *Ephedra*, a nonflowering seed plant. However, in this case the second fertilization product degenerates and does not develop into endosperm.

Double fertilization begins when the pollen tube grows into one of the two synergid cells in the embryo sac, possibly as a result of chemical attraction to calcium. After penetrating the synergid, the apex of the pollen tube breaks open, releasing the two sperm nuclei and other contents into

the synergid. As the synergid degenerates, it envelops the egg and endosperm cells, holding the two sperm nuclei close and the other expelled contents of the pollen tube. The egg cell then opens and engulfs the sperm cell, whose membrane breaks apart and allows the nucleus to move near the egg nucleus. The **nuclear envelopes** then disintegrate, and the two nuclei combine to form the single diploid nucleus of the zygote. The other sperm cell fuses with the two endosperm nuclei, forming a single triploid cell, the primary endosperm cell, which divides mitotically into the endosperm tissue.

Double fertilization and the production of endosperm may have contributed to the great ecological success of flowering plants by accelerating the growth of seedlings and improving survival at this vulnerable stage. Faster seedling development may have given flowering plants the upper hand in competition with gymnosperm seedlings in some habitats, leading to the abundance of flowering plants in most temperate and tropical regions. **Gymnosperms** nevertheless are still dominant at higher elevations and latitudes, and at low elevations in the Pacific Northwest coniferous forests, such as the coastal redwoods. The reasons for these patterns are still controversial.

## The Seed

The seed is the mature, fertilized ovule. After fertilization, the haploid cells of the embryo sac disintegrate. The maternally derived diploid cells of the ovule develop into the hard, water-resistant outer covering of the seed, called the testa, or seed coat. The diploid zygote develops into the embryo, and the triploid endosperm cells multiply and provide nutrition. The testa usually shows a scar called the hilum where the ovule was originally attached to the funicle. In some seeds a ridge along the testa called the raphe shows where the funicle originally was pressed against the ovule. The micropyle of the ovule usually survives as a small pore in the seed coat that allows passage of water during germination of the seed.

In some species, the funicle develops into a larger structure on the seed called an aril, which is often brightly colored, juicy, and contains sugars that are consumed by animals that may also disperse the seed (as in nutmeg, arrowroot, oxalis, and castor bean). This is distinct from the fruit, which forms from the ovary itself.

The embryo consists of the **cotyledon(s)**, epicotyl, and hypocotyl. The cotyledons resemble small leaves, and are usually the first photosynthetic organs of the plant. The portion of the embryo above the cotyledons is the epicotyl, and the portion below is the hypocotyl. The epicotyl is an **apical meristem** that produces the shoot of the growing plant and the first true leaves after germination. The hypocotyl develops into the root. Often the tip of the hypocotyl, the radicle, is the first indication of germination as it breaks out of the seed. Flowering plants are classified as monocotyledons or dicotyledons (most are now called **eudicots**) based on the number of cotyledons produced in the embryo. Common monocotyledons include grasses, sedges, lilies, irises, and orchids; common dicotyledons include sunflowers, roses, legumes, snapdragons, and all nonconiferous trees.

The endosperm may be consumed by the embryo, as in many legumes, which use the cotyledons as a food source during germination. In other species the endosperm persists until germination, when it is used as a food

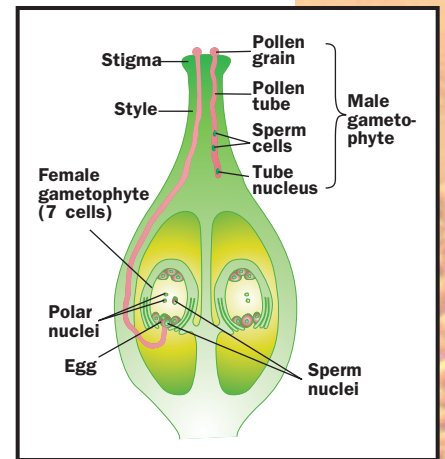

Anatomy of the reproductive organs in angiosperms.

### nuclear envelope

double membrane surrounding the cell nucleus

**gymnosperms** “naked seed” plants, including conifers

**cotyledon** seed leaf, which stores food and performs photosynthesis after germination

**apical meristem** growing tip from which all plant tissues arise

**eudicot** “true dicot”; plants with two seed leaves that originated from the earliest of flowering plants

reserve. In grains such as corn and wheat, the outer layer of the endosperm consists of thick-walled cells called aleurone, which are high in protein.

## The Fruit

The fruit of a flowering plant is the mature ovary. As seeds mature, the surrounding ovary wall forms a protective structure that may aid in dispersal. The surrounding ovary tissue is called the pericarp and consists of three layers. From the outside to inside, these layers are the exocarp, mesocarp, and endocarp. The exocarp is usually tough and skinlike. The mesocarp is often thick, succulent, and sweet. The endocarp, which surrounds the seeds, may be hard and stony, as in most species with fleshy fruit, such as apricots.

A fruit is termed simple if it is produced by a single ripened ovary in a single flower (apples, oranges, apricots). An **aggregated** fruit is a cluster of mature ovaries produced by a single flower (blackberries, raspberries, strawberries). A multiple fruit is a cluster of many ripened ovaries on separate flowers growing together in the same **inflorescence** (pineapple, mulberry, fig). A simple fruit may be fleshy or dry. A fleshy simple fruit is classified as a berry (grape, tomato, papaya), pepo (cucumber, watermelon, pumpkin), hesperidium (orange), drupe (apricot), or pome (apple).

Dry simple fruits have a dry pericarp at maturity. They may or may not dehisce, or split, along a seam to release the seeds. A dehiscent dry fruit is classified as legume or pod (pea, bean), silique or silicle (mustard), capsule (poppy, lily), or follicle (milkweed, larkspur, columbine). An indehiscent dry fruit that does not split to release seeds is classified as an achene (sunflower, buttercup, sycamore), grain or caryopsis (grasses such as corn, wheat, rice, barley), schizocarp (carrot, celery, fennel), winged samara (maple, ash, elm), nut (acorn, chestnut, hazelnut), or utricle (duckweed family). Some fruiting bodies contain non-ovary tissue and are sometimes called pseudocarps. The sweet flesh of apples and pears, for example, is composed not of the pericarp but the receptacle, or upper portion, of the flowering shoot to which petals and other floral organs are attached.

Fruiting bodies of all kinds function to protect and disperse the seeds they contain. Protection can be physical (hard coverings) or chemical (repellents of seed predators). Sweet, fleshy fruits are attractive food for birds and mammals that consume seeds along with the fruit and pass the seeds intact in their fecal matter, which can act as a fertilizer. Dry fruits are usually adapted for wind dispersal of seeds, as for example with the assistance of winglike structures or a fluffy pappus that provides buoyancy. The diversity of fruiting bodies reflects in part the diversity of dispersal agents in the environment, which select for different fruit size, shape, and chemistry.

## Pollination and Pollinators

Pollination is the movement of pollen from the stamens to the stigma, where germination and growth of the pollen tube occur. Most (approximately 96 percent) of all flowering plant species are hermaphroditic (possess both sexual functions within a plant, usually within every flower), and thus an individual can be pollinated by its own pollen or by pollen from another individual. Seed produced through self-pollination (“selfed” seed) is often inferior in growth, survival, and **fecundity** to seed produced through **outcross** pollination (“outcrossed” seed). As a result, in most species there is

**aggregate** clump together

**inflorescence** characteristic arrangement of flowers on a stalk

**fecundity** ability to reproduce

**outcross** fertilization between two different plants

strong natural selection to maximize the proportion of outcrossed seed (the “outcrossing rate”).

Flowering plants are unusual among seed plants in their superlative exploitation of animals (primarily insects) as agents of outcross pollination. The outcross pollination efficiency of insects, birds, and mammals (primarily bats) may have contributed to both the abundance and diversity of flowering plants. Abundance may have increased because of less wastage of energy and resources on unsuccessful pollen and ovules. Diversity may have increased for two reasons. First, insects undoubtedly have selected for a wide variety of floral forms that provide different rewards (pollen and nectar) and are attractive in appearance (color juxtaposition, size, shape) and scent (sweet, skunky) in different ways to different pollinators. Second, faithfulness of pollinators to particular familiar flowers may have reduced hybridization and speeded evolutionary divergence and the production of new species.

Although flowering plants first appeared after most of the major groups of insects had already evolved, flowering plants probably caused the evolution of many new species within these groups. Some new insect groups, such as bees and butterflies, originated after flowering plants, their members developing mouthpart structures and behavior specialized for pollination. In extreme cases, a plant is completely dependent on one insect species for pollination, and the insect is completely dependent on one plant species for food. Such tight interdependency occurs rarely but is well documented in yuccas/yucca moths, senita cacti/senita moths, and fig trees/some fig wasps. In all three insects, females lay eggs in the flowers, and their young hatch later to feed on the mature fruit and its contents. Females ensure that the fruit develops by gathering pollen from another plant and transporting it to the stigma of the flower holding their eggs. Plants benefit greatly in outcrossed seed produced, at the small cost of some consumed fruit and seeds, and the insects benefit greatly from the food supply for developing larvae at the small cost of transporting pollen the short distances between plants.

Pollinating agents, whether **biotic** or **abiotic**, have exerted strong selection on all aspects of the flower, resulting in the evolution of tremendous floral diversity. This diversity has been distilled into a small number of characteristic pollination syndromes.

Pollination by beetles selects usually for white color, a strong fruity scent, and a shallow, bowl-shaped flower. Bees select for yellow or blue/purple colorings, a landing platform with color patterns that guide the bee to nectar (often reflecting in the ultraviolet range of the spectrum), bilateral symmetry, and a sweet scent. Butterflies select for many colors other than yellow, a corolla (petal) tube with nectar at the base, and the absence of any scent. Moths in contrast select for **nocturnally** opening flowers with a strong scent and drab or white color, and also a tube with nectar at the base. Bats select also for nocturnally opening flowers, but with a strong musky scent and copious nectar, positioned well outside the foliage for easy access, and drab or white color. Hummingbirds select for red or orange flowers with no scent, copious nectar production, and a corolla tube with nectar at the base. Other pollinating birds that do not hover while feeding select for strong perches and flowers capable of containing copious nectar (tubes, funnels, cup shapes).

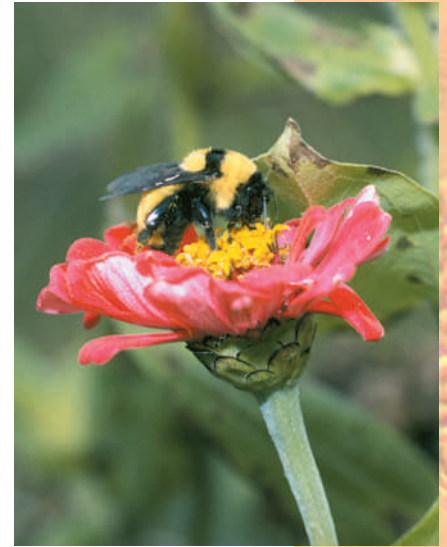

Some insect groups, such as bees, originated after flowering plants, their members developing mouthpart structures and behavior specialized for pollination.

**biotic** living

**abiotic** nonliving

**nocturnally** at night

Wind as a pollinating agent selects for lack of color, scent, and nectar; small corolla; a large stigmatic surface area (usually feathery); abundantly produced, buoyant pollen; and usually erect styles and limp, hanging stamens. In addition there is great floral diversity within any of these syndromes, arising from the diverse evolutionary histories of the member plant species.

### Selfing and Outcrossing

Most flowering plant species reproduce primarily by outcrossing, including the great majority of trees, shrubs, and perennial herbs. Adaptations that prevent self-fertilization include self-incompatibility (genetic recognition and blocking of self-pollen) and dioecy (separate male and female individuals). Adaptations that reduce the chances of self-pollination in **hermaphrodites** include separation of the anthers and stigma in space (herkogamy) or time (dichogamy). In many species, both self-incompatibility and spatiotemporal separation of the sex organs occur.

The ability to produce seeds by selfing, however, is advantageous in situations where outcrossing pollination is difficult or impossible. These include harsh environments where pollinators are rare or unpredictable, and regularly disturbed ground where survivors often end up isolated from each other. Selfing is also cheaper than outcrossing, because selfers can become pollinated without assistance from animals and therefore need not produce large, attractive flowers with abundant nectar and pollen rewards.

Most primarily selfing species are small annuals in variable or disturbed habitats, with small, drab flowers. Most desert annuals and roadside weeds, for example, are selfers. The evolutionary transition from outcrossing to near-complete selfing has occurred many times in flowering plants.

Outcrossing and selfing species differ in their evolutionary potential. Outcrossers are generally more genetically diverse and produce **lineages** that persist over long periods of evolutionary time, during which many new species are formed. Selfers, however, are less genetically diverse and tend to accumulate harmful mutations. They typically go extinct before they have an opportunity to evolve new species.

### Asexual Reproduction

The ability to produce new individuals asexually is common in plants. Under appropriate experimental conditions, nearly every cell of a flowering plant is capable of regenerating the entire plant. In nature, new plants may be regenerated from leaves, stems, or roots that receive an appropriate stimulus and become separated from the parent plant. In most cases, these new plants arise from undifferentiated parenchyma cells, which develop into buds that produce roots and shoots before or after separating from the parent.

New plants can be produced from aboveground or belowground horizontal runners (stolons of strawberries, rhizomes of many grasses), tubers (potato, Jerusalem artichoke, dahlia), bulbs (onion, garlic), corms (crocus, gladiola), bulbils on the shoot (lily, many grasses), parenchyma cells in the leaves (Kalanchoe, African violet, jade plant) and inflorescence (arrowhead). Vegetative propagation is an economically important means of replicating valuable agricultural plants, through cuttings, layering, and **grafting**. Veg-

**hermaphrodite** organism possessing both male and female reproductive structures

**lineage** ancestral line

**grafting** attachment and fusing of parts from different plants

etative reproduction is especially common in aquatic vascular plants (for example, surfgrass and eelgrass), from which fragments can break off, disperse in the current, and develop into new whole plants.

A minority of flowering plants can produce seeds without the fusion of egg and sperm (known as parthenocarpy or agamospermy). This occurs when meiosis in the ovule is interrupted, and a diploid egg cell is produced, which functions as a zygote without fertilization. Familiar examples include citrus, dandelion, hawkweed, buttercup, blackberry/raspberry, and sorbus. Agamospermous species are more common at high elevations and at high latitudes, and nearly all have experienced a doubling of their chromosome number (tetraploidy) in their recent evolutionary history. These species experience evolutionary advantages and disadvantages similar to those of selfers.

### Evolutionary Significance of Plant Reproduction Strategies

The attractive, colorful, and unique features of the most abundant and diverse group of land plants—the flowering plants—are believed to have evolved primarily to maximize the efficiency and speed of outcross reproduction. Each major burst of angiosperm evolution was a coevolutionary episode with associated animals, primarily insects, which were exploited to disperse pollen and seeds in ever more efficient and diverse ways.

The first major burst of flowering plant evolution was the appearance of the closed carpel together with showy flowers that were **radially symmetrical**. The closed carpel prevented self-fertilization through recognition and blocking of self pollen within the specialized conducting tissue of the style. Insects attracted to the showy flowers carried pollen between plants less wastefully than wind, and the radial symmetry accommodated insects of many sizes and shapes.

The second major burst was the appearance of **bilaterally symmetrical** flowers, which happened independently in many groups of plants at the same time that bees evolved. Bilateral symmetry forced bees to enter and exit flowers more precisely, promoting even more efficient outcross pollen transfer.

The third major burst of flowering plant evolution was the appearance of nutritious, fleshy fruits and seeds, coincident with a diversification of birds and rodents. The exploitation of vertebrates for fruit and seed dispersal resulted in less haphazard transport of offspring to neighboring populations of the same species (also visited as a food source), thereby reducing the chances that **progeny** inbreed with their siblings and parents and providing more assurance than wind currents that they find good habitat and unrelated mating partners of the same species. SEE ALSO ALTERNATION OF GENERATIONS; FLOWERS; FRUITS; PLANT NUTRITION; SEEDS

Stewart T. Schultz

#### Bibliography

- Ayala, F. J., W. M. Fitch, and M. T. Clegg, eds. *Variation and Evolution in Plants and Microorganisms*. Washington, DC: National Academy Press, 2000.
- Barth, F. G. *Insects and Flowers*. Princeton, NJ: Princeton University Press, 1991.
- Baskin, C. C., and J. M. Baskin. *Seeds: Ecology, Biogeography, and Evolution of Dormancy and Germination*. San Diego, CA: Academic Press, 1998.

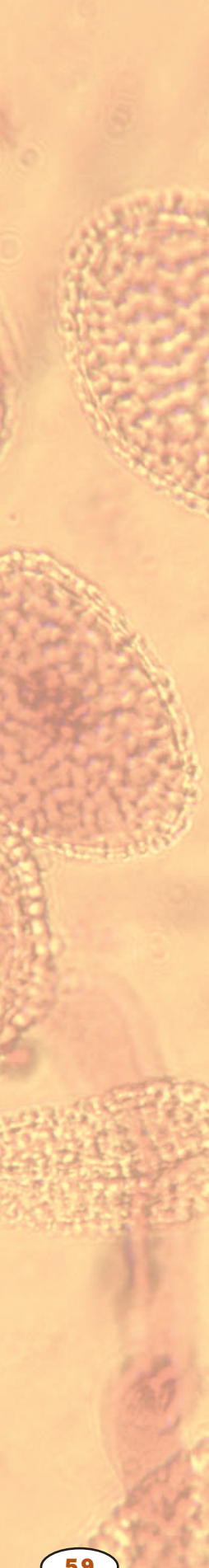

**radially symmetric** symmetric, or similar, about a central point (a wheel is radially symmetric)

**bilaterally symmetric** symmetric, or similar, across a central line

**progeny** offspring



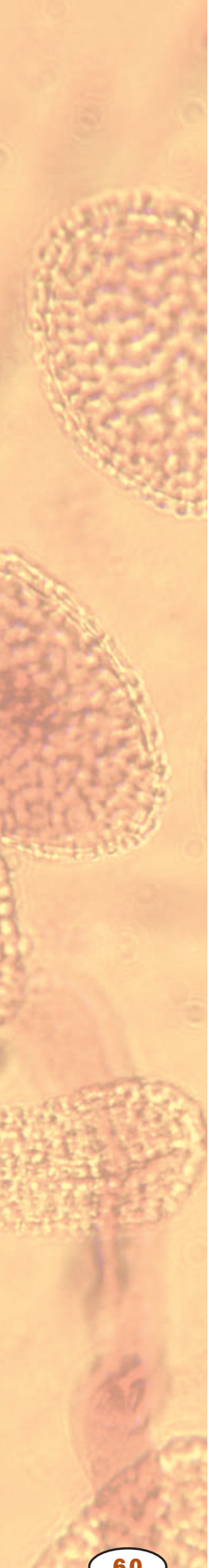

Briggs, D., and S. M. Walters. *Plant Variation and Evolution*, 3rd ed. New York: Cambridge University Press, 1997.

Chittka, L., and J. D. Thomson, eds. *Cognitive Ecology of Pollination: Animal Behavior and Floral Evolution*. New York: Cambridge University Press, 2001.

Dickison, W. C. *Integrative Plant Anatomy*. San Diego, CA: Harcourt/Academic Press, 2000.

Heywood, V. H., ed. *Flowering Plants of the World*. Oxford: Oxford University Press, 1993.

Marshall, C., and J. Grace. *Fruit and Seed Production: Aspects of Development, Environmental Physiology and Ecology* (Society for Experimental Biology Seminar, No. 47). New York: Cambridge University Press, 1992.

Proctor, M., P. Yeo, and A. Lack. *The Natural History of Pollination*. Portland, OR: Timber Press, 1996.

Richards, A. J. *Plant Breeding Systems*, 2nd ed. Cheltenham, England: Stanley Thornes Publishers Ltd., 1997.

Simpson, B. B., and M. Conner-Orgorzaly. *Economic Botany: Plants in Our World*, 2nd ed. New York: McGraw-Hill, 1995.

**fertilization** union of sperm and egg

**fallopian tubes** tubes through which eggs pass to the uterus

**endometriosis** disorder of the endometrium, the lining of the uterus

**hormone** molecule released by one cell to influence another

## Reproductive Technology

Reproductive technologies are medical procedures designed to help infertile people have children. These procedures include artificial insemination, *in vitro* fertilization, embryo adoption, and surrogate mothers.

### Artificial Insemination

In artificial insemination (AI), sperm are collected from a man and placed into the female’s uterus by a reproductive specialist. AI is often used for men with low sperm counts, men with genetic disorders, and women who wish to become pregnant without a male partner. Sperm used in AI may come from a known donor or an anonymous sperm bank.

### In Vitro Fertilization

The first “test tube” baby, Louise Brown, was born in England in 1978. Since then, hundreds of thousands of babies have been born using *in vitro* fertilization and related techniques. *In vitro* (which means “in glass”) fertilization (IVF) is often used for women with blocked or malfunctioning **fallopian tubes**, severe **endometriosis**, or unexplained infertility. Prior to IVF, a woman is given synthetic **hormones** that stimulate the maturation and release of a large number of eggs. The eggs are removed from the ovaries using an ultrasound-guided needle and combined with sperm in a laboratory dish. To increase the chances of pregnancy, four to six embryos are typically implanted into the woman’s uterus when they are about three days old. Extra embryos may be frozen for later use.

Since multiple embryos are implanted, there is an increased chance of multiple births and the associated risks to both mother and children. “Selective reduction,” or abortion of one or more fetuses, may be used to reduce the number of multiples. IVF is expensive (\$8,000 to \$10,000 per trial) and the likelihood of producing a child using IVF decreases with increased maternal age. In addition, the success rate is typically less than 20 percent, although it varies by clinic and is improving as the procedure becomes more common.



*In vitro* fertilization: a needle injecting sperm DNA into a human egg.

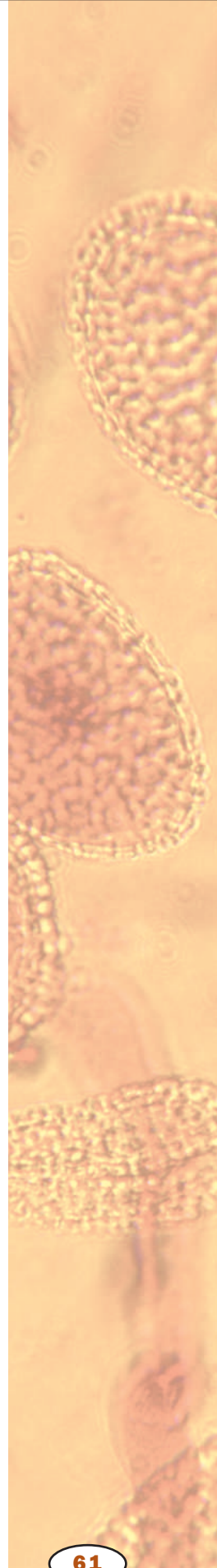

**Gamete Intrafallopian Transfer.** Gamete intrafallopian transfer (GIFT) is similar to IVF except that eggs and sperm are mixed and placed immediately into the woman's fallopian tubes using **laparoscopic surgery**. In **zygote** intrafallopian transfer (ZIFT), eggs and sperm are fertilized in the laboratory, but the resulting zygotes are not incubated and are placed in the woman's fallopian tubes rather than her uterus. Although more complicated, GIFT and ZIFT are thought to more closely simulate natural events and have a higher (5 to 10 percent higher) success rate than IVF. Unfortunately, women with severely diseased fallopian tubes cannot use them.

**Intracytoplasmic Sperm Injection.** In intracytoplasmic sperm injection (ICSI), a single sperm is injected directly into an egg using a tiny glass needle to create an embryo prior to *in vitro* fertilization. ICSI therapy can be used when sperm are scarce, have poor motility, or are otherwise unable to fertilize an egg. Because the procedure has only been in effect since the early 1990s, the side effects of ICSI are not well known but may include genetic or chromosomal abnormalities, major birth defects, and infertility (particularly in males).

**gamete** reproductive cell, such as sperm or egg

**laparoscopic surgery** surgery in which an instrument is inserted through a very small incision, usually guided by some type of imaging technique

**zygote** fertilized egg

## Embryo Adoption

Embryo adoption is a procedure in which an embryo created from the egg of a woman and the sperm of a man is transferred into the uterus of another woman to be raised by her and her partner. Embryos for “pre-birth adoption” may be surplus frozen embryos from IVF donated by the genetic parents or embryos created specifically from egg and sperm donors. In both cases, the embryo has no genetic relationship to its parents.

## Surrogate Mothers

A surrogate mother is a woman who signs a contract with a man to be artificially inseminated with his sperm, give birth to the child, then turn the child over to the man and his partner at birth. The man and his partner usually legally adopt the child. Alternately, embryos created through IVF can be implanted into a surrogate mother if the female partner is unable or unwilling to go through a pregnancy herself. Surrogate mothers are paid for their expenses and receive an additional fee. Agencies and/or lawyers are often involved in the process.

The use of reproductive technologies by single people, postmenopausal women, homosexual couples, and others is increasing since the technologies give people more choices about when and how to become a parent as well as some control over the genetic quality and even the sex of the offspring. However, reproductive technologies also bring with them complex social, psychological, and ethical considerations, and the multi-billion-dollar industry has little regulation. Egg, sperm, and embryo donors may worry about anonymity or being sued for child support. Children may want the right to know their medical history and perhaps their biological parents and siblings. Genetic or surrogate parents may want to claim the children they have helped produce. Couples may argue about custody of frozen embryos or disposal of extra or inferior embryos. Others may question the ethics of selling eggs, sperm, and “womb space.” SEE ALSO BIRTH CONTROL; CHROMOSOME ABERRATIONS; CLONE; FEMALE REPRODUCTIVE SYSTEM; SEXUAL REPRODUCTION

Lynnette Danzl-Tauer

### Bibliography

- Bach, Julie S., ed. “Should Limits Be Placed on Reproductive Technology?” In *Bio-medical Ethics: Opposing Viewpoints*. San Francisco, CA: Greenhaven Press, 1998.
- Lasker, Judith N., and Susan Borg. *In Search of Parenthood*. Philadelphia, PA: Temple University Press, 1994.
- Nordenberg, Tamara. “Overcoming Infertility.” *FDA Consumer* 31, no. 1 (1997): 18.
- Sesson, Donna R., Diane G. Hammit, Mark A. Domario, and Daniel A. Dumesic. “Recent Advances in Infertility Treatment.” *Minnesota Medicine* 81 (1998): 27–32.
- Wright, Karen. “Human in the Age of Mechanical Reproduction.” *Discover* 19, no. 5 (1998): 74–81.

## Reptile

The class Reptilia is composed of about 5,100 species, organized in three very closely interrelated groups: the lizards (order Lacertilia), composed of about 3,165 species; the amphisbaenians (order Amphisbaenia), which con-

sist of about 135 species; and the snakes (order Serpentes), which contain about 1,800 species. According to most experts, lizards appeared in the fossil record in the middle Jurassic, about 165 million years ago (although some authorities place the earliest known fossil lizards in the late Permian, about 250 million years ago). Fossil amphisbaenians have been recorded as early as the late Cretaceous, over 65 million years ago. Snakes are known from the early Cretaceous, about 135 million years ago.

Research has shown that the separation of lizards and snakes into distinct orders is an unnatural artifact of outmoded scientific methodologies and does not reflect the evolutionary history of these animals; significant changes in the classification of the class Reptilia can be expected in the future. Members of the class Reptilia all share numerous characteristics (called synapomorphies) of physiology, behavior, and functional **morphology** that readily set them apart from amphibians, mammals, turtles, tuataras, and birds. One of the most striking of these is the presence in males of well-developed, paired copulatory organs called hemipenes (all other classes of terrestrial vertebrates have a single penis).

Two of the orders exhibit a combination of characteristics that generally permit ready identification: Lizards generally possess four limbs, ear openings, and eyelids, and snakes lack functional limbs, ear openings, and eyelids. Amphisbaenians differ substantially from lizards and snakes in many ways, most notably by their very short tails, distinctly annulated (ringed) bodies, and the reduction of the right lung (instead of the left lung, as in snakes and limbless lizards).

From small lizards such as geckos, with a snout-vent length sometimes as small as 1.5 centimeters (.59 inches), to the reticulated python of southeastern Asia that reaches 10 meters (32.8 feet) in total length, reptiles display an amazing diversity of size, shape, color, and pattern. Their beauty and comparative ease to maintain as pets has created an entirely new venture, distinct and separate from the science of herpetology, known as herpetoculture. Herpetoculturists worldwide are devoted to the husbandry of many reptiles (mostly snakes), breeding, trading, and selling captive reptiles for fun and profit. SEE ALSO AMPHIBIAN; CROCODYLIANS; TUATARA; TURTLE;

*Joseph T. Collins*

### Bibliography

- Gans, Carl, ed. *Biology of the Reptilia*. Chicago: University of Chicago Press, 1992.
- Halliday, Tim R., and Kraig Adler. *The Encyclopedia of Reptiles and Amphibians*. New York: Facts on File, 1986.
- Pough, F. Harvey, R. M. Andrews, J. E. Cadle, M. L. Crump, A. H. Savitzky, and K. D. Wells. *Herpetology*. Upper Saddle River, NJ: Prentice Hall, 1998.

## Respiration

Respiration refers to the mechanisms for obtaining oxygen from the air and delivering it to the tissues, while eliminating carbon dioxide from the body. It is related to cellular respiration, the biochemical processes that consume this oxygen and generate the carbon dioxide in the course of making adenosine triphosphate (ATP). Respiration in the former sense involves four processes: (1) breathing, or ventilation of the lungs; (2) gas exchange be-

**morphology** related to shape and form

**ATP** adenosine triphosphate, a high-energy nucleotide used by cells to power most energy-requiring reactions

The human respiratory system.

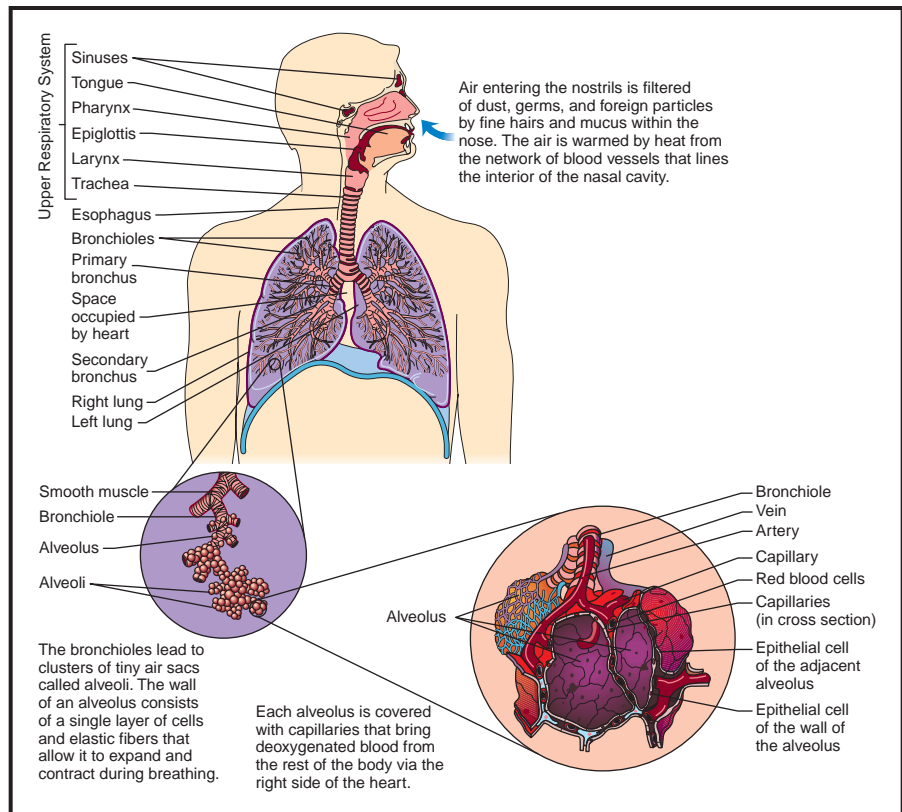

tween air and blood in the lungs; (3) gas transport in the blood; and (4) gas exchange between the blood and target tissues.

### Respiratory Anatomy

The respiratory system consists of: (1) the nasal cavity, which warms, cleans, and humidifies inhaled air; (2) the **pharynx**, where the respiratory and digestive systems meet and then diverge again; (3) the **larynx**, or voice box, which contains the vocal cords; (4) the trachea, or windpipe, a tube about 12 centimeters (4.7 inches) long and 2.5 centimeters (just less than an inch) wide that passes behind the heart and branches like a Y at its lower end; (5) bronchi and bronchioles, air tubes that begin at the fork of the trachea and divide into smaller and smaller divisions within each lung; and (6) alveoli, millions of tiny air sacs in the lung.

Except in the walls of the bronchi and bronchioles, the lungs have no muscle; they do not pump air in and out of themselves like the heart pumping blood, but are passively ventilated as the chest expands and contracts. The muscles that drive pulmonary ventilation are the diaphragm, a sheet of muscle between the thoracic and abdominal cavities; the intercostal muscles between the ribs; and other muscles of the abdomen and thorax that aid the primary respiratory muscles.

### Pulmonary Ventilation

Ventilation is a rhythmic process, like the heartbeat, but its pacemakers are in the brainstem rather than in the chest. The medulla oblongata of the brainstem contains an inspiratory center composed of **neurons** that send

**pharynx** throat

**larynx** “voice box”; muscles at the top of the trachea that control pitch and loudness

**neuron** nerve cell

signals to the diaphragm and external intercostal muscles. When these muscles are stimulated, they contract and enlarge the thoracic cavity. This creates a partial vacuum in the lungs. With the atmospheric pressure outside the body now greater than the pressure in the lungs, air flows “downstream” into the lungs and inflates them.

Usually no muscular effort is needed to exhale. When these muscles stop contracting, the elasticity of the thoracic cage (ribs, cartilages, diaphragm, and ligaments) causes it to spring back by itself, squeezing air out of the lungs. When one needs to exhale more deeply, however, the expiratory center of the medulla sends signals to the internal intercostal muscles, which pull the ribs downward and produce an extra degree of chest compression. The abdominal muscles also aid by increasing pressure in the abdominal cavity, pushing up on the diaphragm. These muscles are important in public speaking, singing, shouting, playing wind instruments, and blowing out candles, for example.

In normal, relaxed breathing, most adults inhale a tidal volume averaging 500 milliliters (16.9 fluid ounces) of air in each respiratory cycle. With maximum effort, however, one can inhale a greater amount called the vital capacity, averaging about 4,700 milliliters (almost 159 fluid ounces) in adults.

## Pulmonary Gas Exchange

About 70 percent of the air a person inhales fills the millions of alveoli in the lungs. Each alveolus is surrounded by a basketlike mesh of blood capillaries. The wall separating the inhaled air from the blood is only 0.5 micrometer thick—only one-fifteenth the diameter of a single red blood cell—so it presents very little barrier to gas diffusion between the air and blood.

Oxygen has a concentration (partial pressure) of 104 mmHg in the alveolar air and 40 mmHg in the arriving capillary blood. Thus, it diffuses down its concentration **gradient** from the air, through the alveolar wall, into the blood. About 98.5 percent of this oxygen binds to the pigment **hemoglobin** in the red blood cells, and the other 1.5 percent dissolves in the blood plasma.

Carbon dioxide (CO<sub>2</sub>), has a partial pressure of 46 mmHg in the arriving blood and 40 mmHg in the alveolar air, so its concentration gradient dictates that it diffuses the other way, from blood to air, and is then exhaled. About 70 percent of this CO<sub>2</sub> comes from the breakdown of carbonic acid in the blood; 23 percent from CO<sub>2</sub> bound to hemoglobin, albumin, and other blood **proteins**; and 7 percent from gas dissolved in the blood plasma.

## Gas Transport

Blood leaving the lungs is therefore relatively high in O<sub>2</sub> (oxygen in its diatomic form) and low in CO<sub>2</sub>. It travels via the pulmonary veins to the left side of the heart, which pumps it out into the **systemic** circulation. This division of the circulatory system delivers it to every organ of the body.

**gradient** difference in concentration between two places

**hemoglobin** oxygen-carrying protein complex in red blood cells

**protein** complex molecule made from amino acids; used in cells for structure, signaling, and controlling reactions

**systemic** throughout the body

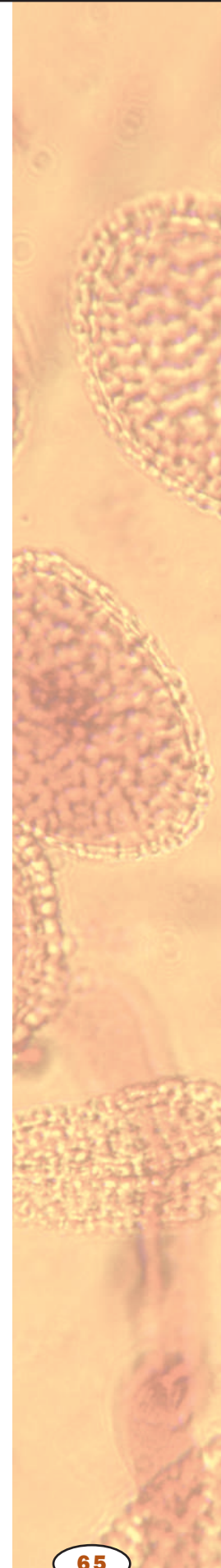

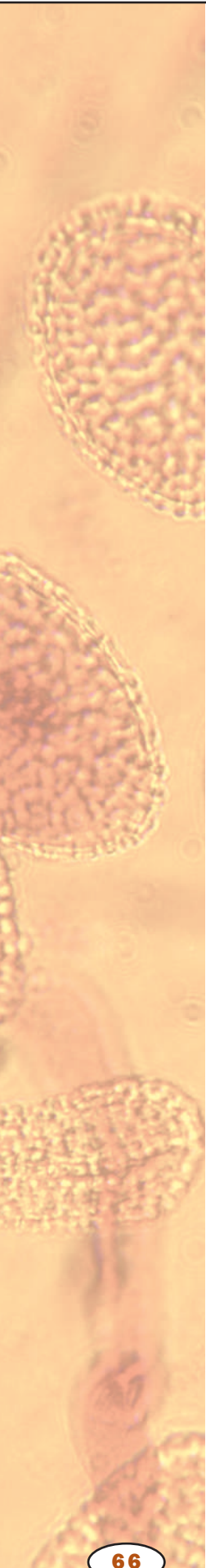

**metabolism** chemical reactions within a cell

**pH** measure of acidity or alkalinity; numbers below 7 are acid, above are basic

**genome** total genetic material in a cell or organism

**nucleus** membrane-bound portion of cell containing the chromosomes

**cytoplasm** material in a cell, excluding the nucleus

**kilobase** one thousand DNA bases; a measure of size of a piece of DNA

**protein** complex molecule made from amino acids; used in cells for structure, signaling, and controlling reactions

**enzyme** protein that controls a reaction in a cell

**reverse transcriptase** enzyme that copies RNA into DNA

**catalyze** aid in the reaction of

## Systemic Gas Exchange

When the blood reaches the systemic blood capillaries, gases undergo processes that are essentially the reverse of what occurs in the pulmonary alveoli. The blood unloads  $O_2$ , which diffuses into the tissue fluid and thus reaches the cells around the blood capillaries. At the same time, the  $CO_2$  generated by the **metabolism** of those cells diffuses into the blood to be carried away to the lungs for disposal.

Blood typically contains 95 mmHg  $O_2$  upon arrival at the systemic capillaries and 40 mmHg  $O_2$  upon leaving. Conversely, the blood has 40 mmHg of  $CO_2$  on arrival at the systemic capillaries and typically 46 mmHg  $CO_2$  when it leaves. The blood does not, however, unload the same amount of  $O_2$  to all tissues or pick up the same amount of  $CO_2$ . The more active a tissue is, the warmer it is, the lower its  $O_2$  level is, and the lower its **pH** is (because it generates more  $CO_2$  and  $CO_2$  reduces the pH of body fluids). Heat, low  $O_2$ , low pH, and other factors enhance  $O_2$  unloading and  $CO_2$  loading, so tissues that need the most oxygen and waste removal get more than less active tissues do. The biochemistry of hemoglobin is mainly responsible for this elegant adjustment of gas exchange to the individual needs of different tissues. SEE ALSO BLOOD; BLOOD VESSELS; BRAIN; GAS EXCHANGE; HEART AND CIRCULATION; OXIDATIVE PHOSPHORYLATION

*Kenneth S. Saladin*

### Bibliography

Ganong, William F. *Review of Medical Physiology*, 19th ed. Stamford, CT: Appleton and Lange, 1999.

Saladin, Kenneth S. *Anatomy and Physiology—The Unity of Form and Function*, 2nd ed. Dubuque, IA: McGraw-Hill, 2001.

## Retrovirus

Retroviruses are a unique class of single-stranded ribonucleic acid (RNA) containing viruses, which replicate their **genome** through a double-stranded viral deoxyribonucleic acid (DNA) intermediate in the **nucleus** of the host cell. This is in contrast to all other RNA-containing viruses that replicate their genomes through double-stranded RNA intermediates almost always in the **cytoplasm** of host cells. Most retroviruses contain an RNA genome of 9 to 10 **kilobases** in length, which encodes a minimum of three genes required for replication. These are referred to as *gag* (structural **proteins** of the virus), *pol* (enzymes involved in replication), and *env* (envelope glycoproteins required for the virus to attach to a receptor of a new host cell). Human immunodeficiency virus (HIV), which causes acquired immunodeficiency syndrome (AIDS), belongs to a subclass of retroviruses, the lentiviruses, which encode additional viral genes that permit the virus to grow in nondividing cells, such as white blood cells.

The remarkable replication pathway of retroviruses requires that once the virus enters the host cell, a viral *pol* gene-encoded **enzyme** called **reverse transcriptase** (RT), which is packaged in virus particles, reverse transcribes the single-stranded RNA genome into a double-stranded DNA. This DNA intermediate migrates to the nucleus of the cell where it is integrated into the host cell genome. This process is **catalyzed** by another viral en-

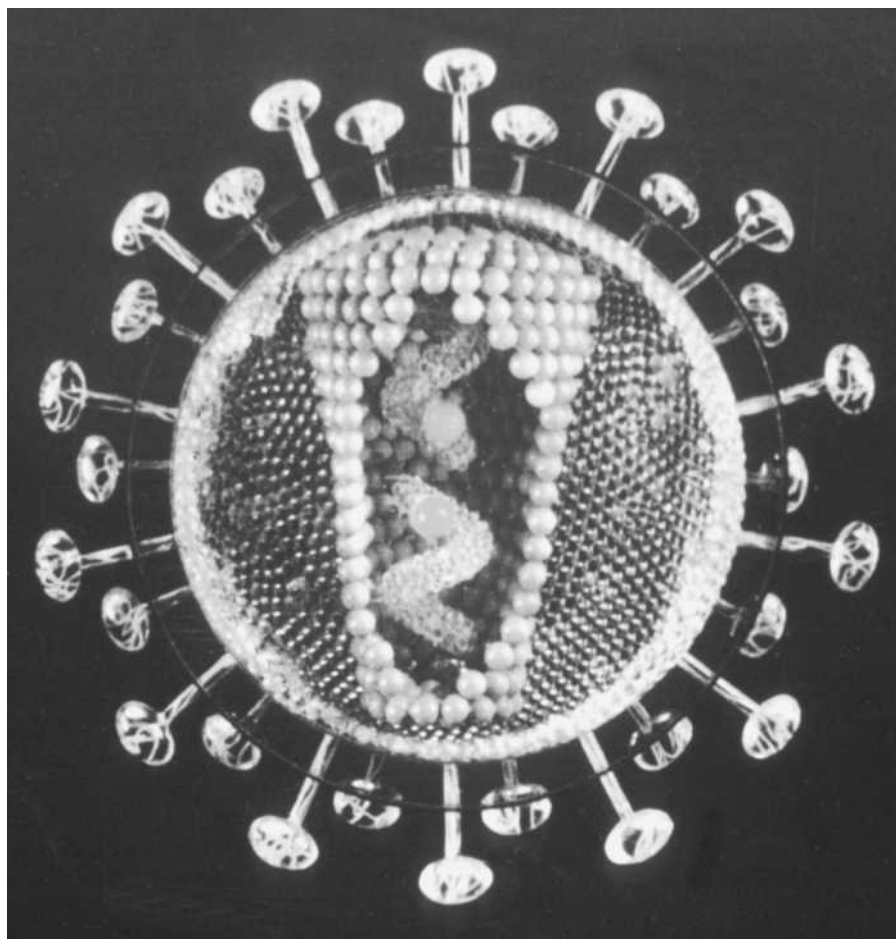

Model of the human immunodeficiency virus (HIV). RNA is enclosed within proteins, surrounded by membrane and glycoproteins.

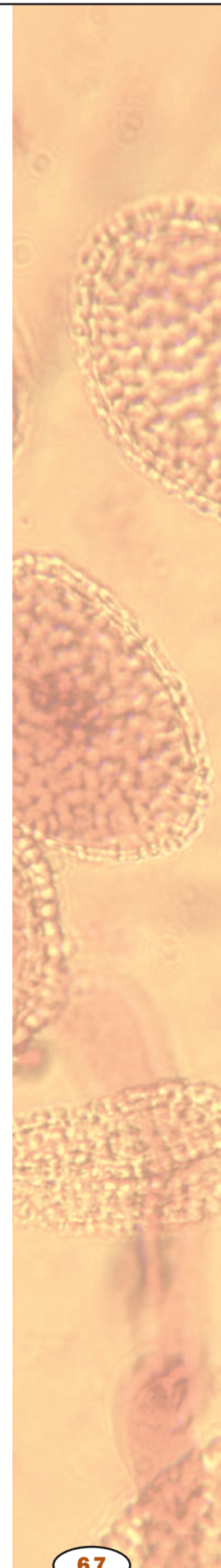

zyme called integrase (IN). Since there is no matching sequence between the viral DNA and the host genomic DNA, sites of insertion are mostly randomly distributed. Because the viral DNA is now part of the cellular **chromosome**, it is duplicated whenever the cell's own DNA is replicated.

Transcription of the viral sequence from the integrated DNA to make messenger RNA (mRNA) requires cellular enzymes. Full-length viral mRNA is transported to the cytoplasm where it is either packaged into **progeny** virus or translated on non-membrane-bound (free) **ribosomes** to yield viral Gag and Gag-Pol polyproteins (assemblies of many similar proteins). These polyproteins in turn migrate to the cell membrane where they assemble into virus particles, containing RNA, which bud from the cell surface. Concomitantly, viral glycoproteins are translated as polyproteins from a smaller-sized, spliced viral mRNA on membrane-bound ribosomes. These polyproteins are processed in the **endoplasmic reticulum**, where they also go through an additional modification known as glycosylation, in which sugar groups are added to the protein. When virus particles bud from the cell, they pinch off a portion of the cell membrane, containing the viral glycoproteins. This membrane becomes an outer coating of the virus particle.

The Gag and Gag-Pol polyproteins are cleaved into the mature-sized proteins during or immediately after the budding process by a third viral-encoded enzyme called protease (PR). Once the protein-cleaving proteolytic processing is complete, an infectious virus results, which can infect new cells.

**chromosome** "colored body" in the cell nucleus; made of DNA and protein, and divided functionally into genes and non-gene regions

**progeny** offspring

**ribosome** protein-RNA complex in cells that synthesizes protein

**endoplasmic reticulum** network of membranes within the cell



**opportunistic** caused by a microorganism that is usually harmless but which causes infection in an immunosuppressed person

**catalyze** aid in the reaction of

**genome** total genetic material in a cell or organism

**enzyme** protein that controls a reaction in a cell

**transcription** messenger RNA formation from a DNA sequence

**template** master copy

**enzymatic** related to function of an enzyme

During an active infection process, approximately 1 percent of a cell's resources are diverted to synthesis of virus genomes and proteins. Infected cells are therefore not killed. Most retroviruses activate expression of a cancer-causing gene, called an "oncogene," which transforms host cells so that they become immortalized, providing a long-term home for the retrovirus. Lentiviruses, including HIV, do not transform cells. Instead they cause cell death in some of the cell types in which they replicate. When these cells are important components of the immune system, an infected person loses the ability to mount an effective immune response, resulting in AIDS. This leaves the person susceptible to almost any **opportunistic** infection. Patients with HIV infection are treated with drugs that inhibit either RT or PR to slow the spread of virus. As of May 2001, the treatment of choice for HIV patients included two RT inhibitors and one PR inhibitor, and is known therefore as "triple therapy." These drugs do not cure AIDS because the viral genome is integrated into the host chromosome. Also, virus-containing drug-resistant enzymes can be rapidly selected in a treated patient, necessitating the need for multidrug clinical strategies. Thus the only sure defense against AIDS is not to become infected by the virus. **SEE ALSO AIDS; ONCOGENES AND CANCER CELLS; PROTEIN SYNTHESIS; REPLICATION; REVERSE TRANSCRIPTASE; TRANSCRIPTION; TRANSPOSON; VIRUS**

*Jonathan Leis*

#### **Bibliography**

Alberts, Bruce, et al. *Molecular Biology of the Cell*, 4th ed. New York: Garland Publishing, 2000.

Gallo, Robert. *Virus Hunting: AIDS, Cancer, and the Human Retrovirus*. Vancouver, WA: Vintage Books, 1991.

———, and Gilbert Jay. *The Human Retrovirus*. San Diego, CA: Academic Press, 1991.

## **Reverse Transcriptase**

Reverse transcriptase **catalyzes** the formation of double-stranded deoxyribonucleic acid (DNA) from a single-stranded ribonucleic acid (RNA) **genome**. It is called "reverse" transcriptase because it reverses the usual direction of information flow, from DNA to RNA. Reverse transcriptase is characteristic of retroviruses, including HIV (human immunodeficiency virus), the virus responsible for AIDS (acquired immunodeficiency syndrome).

All retroviruses encode a polymerase **enzyme** in their *pol* gene that is both necessary and sufficient for the replication of their RNA genomes. The enzyme was first detected in virus particles in 1970 by Howard Temin and David Baltimore. These investigators permeabilized the virus membrane with non-ionic detergents, which allowed them to introduce deoxynucleotides. They detected the synthesis of DNA that was dependent upon the RNA genome. This was a novel reaction because, at this time, polymerases were only known to use DNA for the synthesis of RNA in a process known as **transcription**. Thus this new process of using RNA as a **template**/primer for the synthesis of DNA was named reverse transcription. For their discovery, Temin and Baltimore shared the Nobel Prize.

Reverse transcriptase (RT) has several **enzymatic** activities, including an RNA-dependent DNA polymerase, DNA-dependent DNA poly-

merase, RNase H (a ribonuclease that degrades RNA in RNA-DNA **hybrid** structure), and the ability to unwind DNA-DNA and RNA-DNA duplexes. Each of these activities is required during the process of reverse transcription to convert the single-stranded RNA genome into a double DNA copy, which in turn becomes integrated into the host **chromosome** of the infected cell catalyzed by a second *pol* gene-encoded enzyme, called integrase.

Purified RT has become a very useful as a tool for modern molecular biology, especially coupled to polymerase chain reaction (PCR) techniques. It provides the ability to reverse transcribe any RNA with the appropriate **complementary primer** into a DNA copy that can then be amplified many times by a thermal stable DNA polymerase during the PCR reaction. The combination of the two techniques has allowed scientists to clone actively expressed genes in cells from their mRNAs (messenger RNAs). SEE ALSO AIDS; CLONE; RETROVIRUS

*Jonathan Leis*

### Bibliography

Coffin, John M., Stephen H. Hughes, and Harold E. Varmus, eds. *Retroviruses*. Plainview, NY: Cold Spring Harbor Laboratory Press, 1997.

## Rhythms of Plant Life

Plants exhibit regular, cyclic physiological changes of many sorts. For example, leaflets of wood sorrel, *Oxalis*, fold downward to a vertical position at night and return to their normal horizontal orientation during the day. Because this rhythm takes place over a period of approximately twenty-four hours, it is called a **circadian** rhythm.

Forces within the plant control the movements of wood sorrel and many other circadian rhythms. This is easily demonstrated by placing wood sorrel in total darkness for several days. In the absence of external light stimuli, the movements continue in an approximate circadian rhythm, but the period tends to lengthen slightly to approximately twenty-six hours. A rhythm that is controlled by an internal timing mechanism, the so-called “biological clock,” is an **endogenous** rhythm.

Environment can affect endogenous rhythms. By changing the photoperiod scientists can alter the period of a circadian rhythm as long as the imposed photoperiod does not differ significantly from the normal circadian rhythm. Altering circadian rhythms by varying one or more environmental parameters is called entrainment. Phytochrome, an important plant pigment, and blue light receptors regulate entrainment.

Why should a plant like wood sorrel fold its leaves at night? German botanist Erwin Bünning suggests that the folding of leaves at night hides them from moonlight, which could disrupt the plant’s ability to measure night length accurately. Thus, wood sorrel can use its internal biological clock to anticipate the middle of the night, when a moon might be full.

Circadian rhythms are advantageous to *Gnetum gnemon*, a plant found in tropical rainforests, which secretes nectar in the evening, the most active time for the moths that carry its pollen. Other endogenous circadian

**hybrid** combination of two different types

**chromosome** “colored body” in the cell nucleus; made of DNA and protein, and divided functionally into genes and non-gene regions

**complementary** matching opposite

**primer** short nucleotide sequence that helps begin DNA replication

**circadian** related to a day or daylength

**endogenous** caused by factors inside the organism

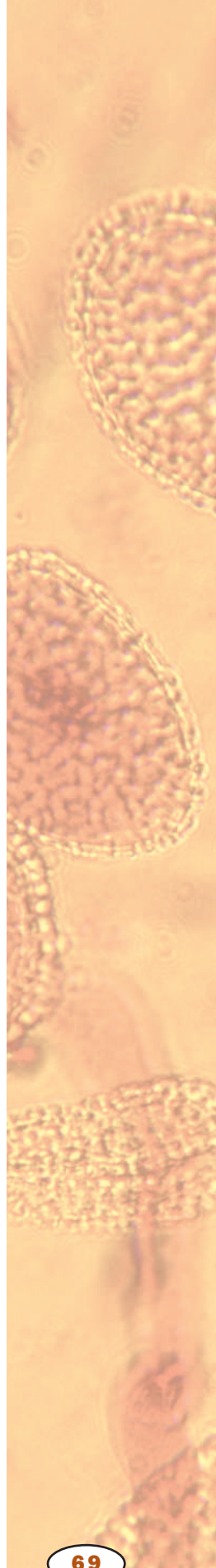

An old-growth forest with an understory of wood sorrel in Mt. Hood National Forest in Oregon. Plants exhibit regular, cyclic physiological changes of many sorts.



**stomata** openings in leaves for gas exchange, surrounded and regulated by guard cells

rhythms of plants include opening and closing of **stomata**, growth rate of stems and roots, opening and closing of flowers, production of floral scent, and carbon dioxide uptake. SEE ALSO HORMONES, PLANT; PHOTOPERIODISM

*George H. Wittler*

**Bibliography**

- Sweeney, Beatrice. *Rhythmic Phenomena in Plants*. San Diego, CA: Academic Press, 1987.
- Thomas, Brian, and Daphne Vince-Prue. *Photoperiodism in Plants*. San Diego, CA: Academic Press, 1996.

## Ribosome

The ribosome is the molecular machine inside the cell that makes **proteins** from **amino acids** in the process called **translation**. It binds to a messenger ribonucleic acid (mRNA) and reads the information contained in the **nucleotide** sequence of the mRNA. Transfer RNAs (tRNAs) containing amino acids enter the ribosome in a special pocket, or binding site, called the acceptor site (A site). Once correctly bound, the ribosome can add the amino acid on the tRNA to the growing protein chain.

### Structure

The ribosome is made up of two parts, called subunits. The larger of the two subunits is where the amino acids get added to the growing protein chain. The small subunit is where the mRNA binds and is decoded. Each of the subunits is made up of both protein and ribonucleic acid (RNA) components.

The small ribosomal subunit is made up of one ribosomal RNA (rRNA) and approximately twenty-one proteins in **prokaryotes** (bacteria) and approximately thirty-three proteins in **eukaryotes** (mammals). In prokaryotes, the large ribosomal subunit contains two rRNAs—one large one and one small one—and approximately thirty-one proteins. In eukaryotes, the large subunit is composed of three rRNAs—one large one and two different small ones—and approximately forty-nine proteins. In eukaryotic cells, ribosomal subunits are synthesized in the nucleolus and then exported to the **cytoplasm** before use.

The rRNAs have many regions of self-complementarity, that is, regions within the rRNA that can form **base pairs** with other regions of the same rRNA, linking them together. This self-complementarity produces highly

**protein** complex molecule made from amino acids; used in cells for structure, signaling, and controlling reactions

**amino acid** a building block of protein

**translation** synthesis of protein using mRNA code

**nucleotide** the building block of RNA or DNA

**prokaryote** single-celled organism without a nucleus

**eukaryote** an organism whose cells have nuclei

**cytoplasm** material in a cell, excluding the nucleus

**base pair** two nucleotides (either DNA or RNA) linked by weak bonds

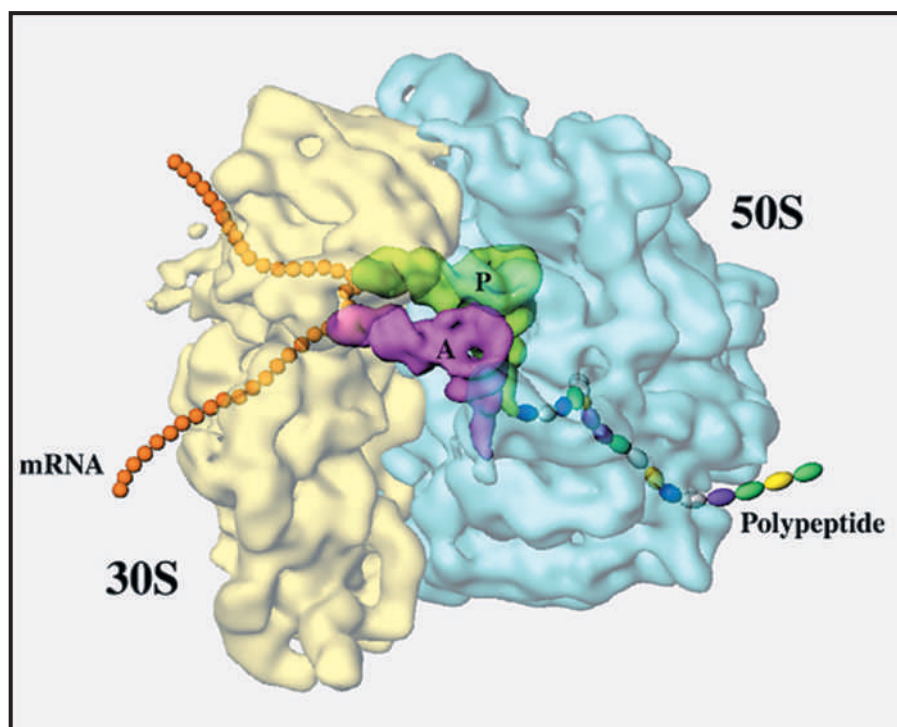

A color-coded cryo-EM map of an *E. coli* ribosome showing the interface between the small (30S) and large (50S) ribosomal subunits.

structured RNA molecules that serve as the core of the ribosome. In fact, rRNAs make up most of the mass of the ribosome. The proteins bind to various parts of the rRNAs to fill in the ribosome's structure.

Researchers have worked for many years to try to determine what the ribosome's structure is at the atomic level. How are all the atoms that make up the ribosome arranged in three-dimensional space? On a gross level, the ribosome looks something like an oyster with one of its shells somewhat smaller than the other. The two subunits are joined to each other by interactions between the rRNAs in one subunit and proteins in the other subunit. There may also be interactions between an RNA on one subunit and an RNA on the other subunit and between proteins on the two subunits.

### RNA Movements

tRNAs move through the ribosome during the course of protein synthesis. A tunnel runs through the ribosome, right at the interface between the two subunits, and the tRNAs enter one side of this tunnel and are propelled along it during each step of protein synthesis. The three tRNA binding sites of the ribosome—A (acceptor), P (peptidyl), and E (exit)—appear to be intermediate spots in this tunnel. The mRNA binds to a groove at the bottom of the tRNA tunnel. After each amino acid is added to the growing protein, the tRNAs must be moved from one site to the next, and the mRNA must also be moved over one **codon** (three bases) so that the next amino acid coded for by the mRNA can be added to the protein.

These movements of the tRNAs and mRNA are made possible by a protein factor, called EF-G in prokaryotes or EF-2 in eukaryotes, which binds to the ribosome and uses the energy stored in the triphosphate group of guanosine triphosphate (GTP) to help propel the tRNAs and mRNA along. It also appears that parts of the ribosome move as the tRNAs and mRNA move. In fact, it is possible that EF-G produces movement of these parts of the ribosome and that these movements in turn produce movement of the tRNAs and mRNAs. Certain antibiotics (drugs that kill bacteria) are known to work by preventing some of the movements of bacterial ribosomes, thus stopping protein synthesis.

Intriguingly, there are certain mutations of the ribosome (changes to the structure of the rRNA or proteins) that affect its movements during translation and appear to cause a decrease in the accuracy of protein synthesis (for example, the wrong amino acids get put into the protein with increased frequency). Thus, the movements themselves may be directly tied to the mechanism by which the ribosome makes sure that the correct amino acid is being added to the protein at each point along the mRNA.

The growing protein chain exits the ribosome through a second tunnel, this one at the top of the large subunit. When protein synthesis ends, the binding of proteins called release factors is thought to induce the ribosome to release the finished protein into the cytoplasm. Exactly how the ribosome does this is unclear.

For many years it was thought that the rRNAs in the ribosome served merely as a scaffold on which to hang the ribosomal proteins. It was proposed that the proteins did all of the important work in the ribosome, such as catalyzing the formation of **peptide bonds** and moving the tRNAs and

**codon** sequence of three mRNA nucleotides coding for one amino acid

The poison ricin, from castor bean seeds, cleaves part of the RNA in the large subunit.

**peptide bond** bond between two amino acids

mRNA along during protein synthesis. However, it is now clear that the rRNAs play an active role in protein synthesis and are not merely the frame on which the ribosome is built. As more detailed information about the three-dimensional structure of the ribosome becomes available and as researchers do more experiments to probe the inner workings of this fascinating machine, we will have a better understanding of what the rRNAs do and how they do it. SEE ALSO NUCLEOLUS; PROTEIN SYNTHESIS; RNA; TRANSFER RNA

*Jon Lorsch*

### Bibliography

- Cate, Jamie H., et al. "X-ray Crystal Structures of 70S Ribosome Functional Complexes." *Science* 285 (1999): 2095–2104.
- Frank, Joachim. "How the Ribosome Works." *American Scientist* 86, no. 5 (1998): 428–439.
- Hill, Walter E., et al., eds. *The Ribosome: Structure, Function & Evolution*. Washington, DC: American Society for Microbiology Press, 1990.
- Lewin, Benjamin. *Genes VI*. Oxford: Oxford University Press, 1997.
- Puglisi J. D., S. C. Blanchard, and R. Green. "Reviews—Approaching Translation at Atomic Resolution." *Nature Structural Biology* 7, no. 10 (2000): 855–861.

## Rivers and Streams

On the continents, aquatic **ecosystems** are of two kinds: lotic ecosystems, in which the water is free-flowing (streams and rivers), and lentic ecosystems, in which the water is relatively stationary. The scientists who specialize in aquatic ecosystems are limnologists.

### Physical Features

The limiting factors that govern what organisms can live in lotic ecosystems include current, light intensity, temperature, **pH**, dissolved oxygen, salinity, and nutrient availability—variables routinely measured by limnologists to develop a profile of the environment. These conditions differ greatly between small headwater streams and the mouths of such great rivers such as the Mississippi and the Amazon. Living occupants of streams and rivers show corresponding differences along the way.

Small headwater streams, where water first collects by runoff from the land or emerges from springs, are called first-order streams. When two first-order streams meet, they form a second-order stream; two of these converge to form a third-order stream, and so on, until the water may flow into bodies as large as twelfth-order rivers (for example, the Columbia and the Mississippi). Bodies of the first to third order are usually considered streams, and those of the fourth order and larger are considered rivers.

Streams provide diverse habitats including relatively swift rapids and quiet pools. They often have hard **substrates** of stones, rubble, or bedrock to which animals can cling. Flat rocks and rubble typically harbor the greatest species diversity of stream animals. Stream animals often have flat, streamlined bodies that are not easily swept away by currents, and hooks, suckers, or sticky undersides for clinging to substrates. They tend to face into a current and swim against it, behavior called rheotaxis. Lake animals,

**ecosystem** an ecological community and its environment

**pH** measure of acidity or alkalinity; numbers below 7 are acid, above are basic

**substrate** the molecule acted on by an enzyme

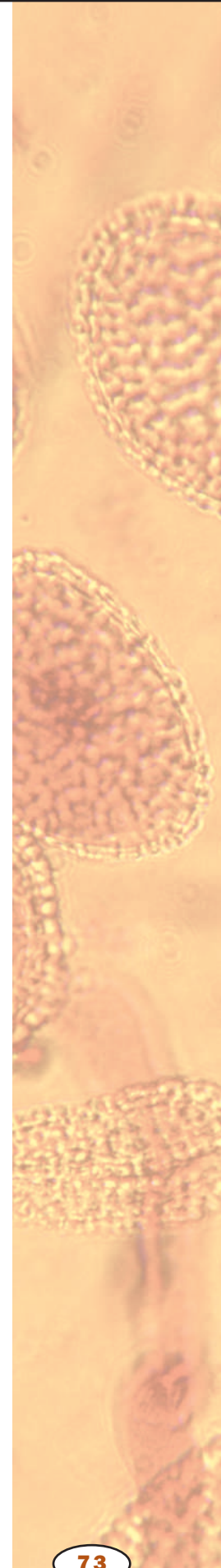

Farmland on the banks of the Nile River near Luxor, Egypt.



by contrast, are unaccustomed to resisting currents and allow themselves to be passively washed away if placed in flowing water.

### Food Chains and Ecosystem Structure

The bank of a stream or river is called the riparian zone, a place where overhanging foliage provides shade and the tree roots of undercut banks provide shelter. The deep shade produced by riparian foliage limits photosynthesis and primary production of **organic** nutrients. Much or most of the organic matter that nourishes the stream habitat originates as foliage that falls into the water, ranging from leaves, twigs, and seeds to fallen trees. Aquatic food chains in first-order streams thus begin with coarse particulate organic matter. This matter enters the food chain by way of aquatic bacteria and fungi that decompose it, and animals classified as shredders that tear it into finer particles. Shredders produce nutrient-rich feces that, in turn, are eaten by collectors. Farther downstream where there is more light, algae grow on rocks and other submerged surfaces and support a small community of animal grazers. Most shredders, collectors, and grazers are aquatic insects, but snails, bivalves, and crustaceans also play a part. The total pop-

**organic** composed of carbon, or derived from living organisms

ulation of these invertebrates is relatively small, however, so there are few predators in headwater streams; there is not enough for them to eat.

Rivers, being wider, have more surface exposed to sunlight, so their primary productivity (photosynthesis) is greater. This is aided by **inorganic** nutrients such as nitrogen and phosphorus flowing down from the smaller-order streams. Fourth- to sixth-order rivers provide ideal conditions for algae and rooted aquatic plants because of their softer substrates and ample light. Shredders become less abundant, grazers increase, and the relative populations of collectors and predators remain about the same. Species diversity increases in these mid-order rivers, with fish and burrowing animals such as clams and worms becoming more common. High-altitude, cold, oxygen-rich midsized rivers are an ideal haven for trout, which feed on the insect community. The organisms in midsized rivers, where there is more photosynthesis, produce more organic matter than they consume, and the excess nourishes the larger rivers downstream.

Large rivers (seventh to twelfth order) are relatively deep and wide. They are rich in organic matter but also contain a lot of inorganic sediment produced by erosion and runoff into the upland waters. Thus, the water is more turbid (muddy), and there is insufficient light to support as much photosynthesis as in smaller rivers. Collectors and predators dominate the consumer community, and consumption exceeds primary production. Fish species such as sturgeon and catfish, which feed on sediments, are more common here than predatory fish.

All **lotic** organisms must adapt to drift, the incessant flow of water toward the sea, carrying nutrients and the organisms themselves downstream. Drift is particularly significant when spring snowmelts and heavy summer rains increase the current. River valleys offer especially rich farmland because of the great quantities of nutrients deposited by periodic flooding. Nutrient loss by drift is compensated for by the continual addition of riparian organic matter to the lower-order upland streams, while animals compensate for drift by their rheotaxis and other means. Many aquatic insects fly upstream to lay their eggs, and fish such as trout and salmon are well known for their upstream spawning runs. The immature animals drift downstream as they grow and typically reach maturity at lower altitudes, only to repeat the process and deposit their offspring back in the headwaters. SEE ALSO ECOSYSTEM; LAKES AND PONDS; LIMNOLOGIST

*Kenneth S. Saladin*

### Bibliography

- Cole, Gerald A. *Textbook of Limnology*, 4th ed. Prospect Heights, IL: Waveland Press, 1994.
- Giller, Paul S., and Bjorn Malmqvist. *The Biology of Streams and Rivers*. New York: Oxford University Press, 1999.
- Wetzel, Robert G. *Limnology: Lake and River Ecosystems*, 3rd ed. Burlington, MA: Academic Press, 2001.

## RNA

Ribonucleic acid (RNA), like deoxyribonucleic acid (DNA), is a polymer made up of **nucleotides**. A nucleotide is composed of a pentose (5-carbon)

**inorganic** not bonded to carbon

**lotic** of, relating to, or living in actively moving water

**nucleotide** the building block of RNA or DNA

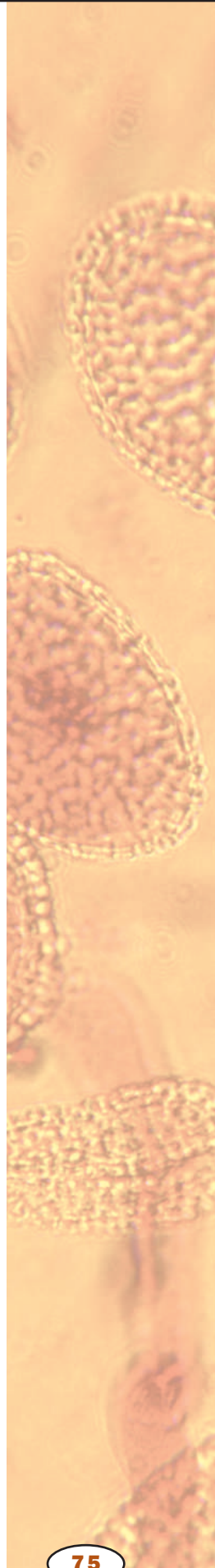



RNA chains are composed of simpler units called nucleotides. Four different bases are used in RNA; adenine is shown.

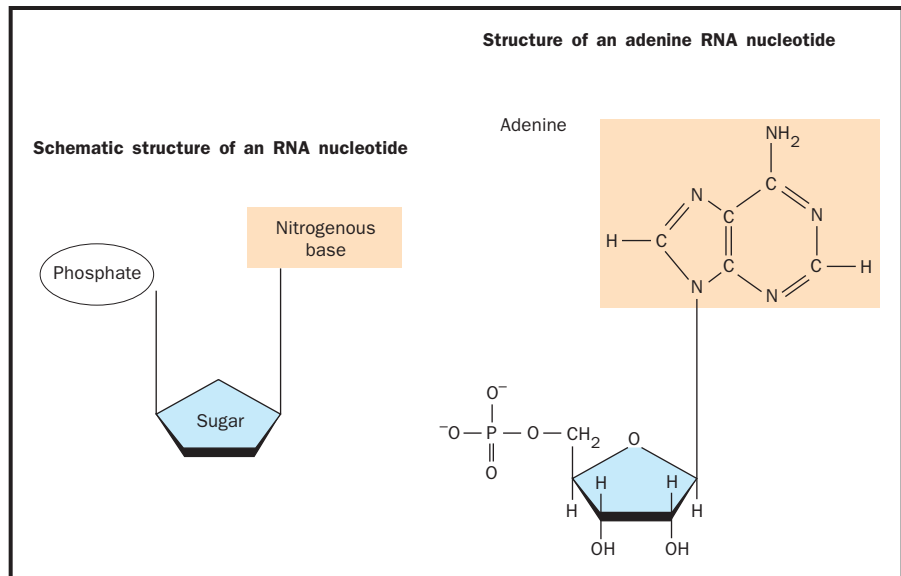

sugar, a nitrogen-containing base, and phosphate. The pentose sugar found in RNA nucleotides is ribose, whereas that in DNA is 2' (2-prime) deoxyribose. The bases commonly found in RNA nucleotides are adenine (A), guanine (G), cytosine (C), and uracil (U). Bases found in DNA are A, G, C, and thymine (T instead of U). As in DNA, the individual nucleotides in the polymer are joined together by **phosphodiester** bonds. Unlike DNA, RNA is single-stranded; however, many RNA molecules fold into complex three-dimensional structures.

During **transcription** the DNA code is read and copied into RNA. The sequence of nucleotides in an RNA is therefore determined by the sequence of nucleotides in the **gene** from which it was transcribed. Following transcription, RNA may be processed before it becomes functional.

There are three main classes of RNA: messenger RNA (mRNA), transfer RNA (tRNA), and ribosomal RNA (rRNA). Each of the classes is important in some aspect of **protein** synthesis. The nucleotide sequence of a messenger RNA specifies the order of **amino acids** in the protein which it encodes. A cell contains many different mRNA molecules, each being the blueprint for a different protein. Although mRNAs are the least abundant class of RNA, they are the most **heterogeneous**. **Ribosomes** play an important role in protein synthesis, and ribosomal RNA (rRNA), is an important structural component of ribosomes. rRNA is the most abundant type of RNA. tRNAs act as adaptors in protein synthesis, in that they read the sequence of nucleotides in the mRNA and deliver the correct amino acid to the growing **polypeptide** chain.

Most scientists believe that life has evolved from what was essentially an “RNA world.” In today’s world, most organisms store their genetic information in DNA and use proteins (encoded by DNA) to **catalyze** biologically important chemical reactions. RNA molecules, however, are believed to have been the first biological catalysts. Through evolution, some of these RNA molecules gained the ability to replicate themselves, and through many rounds of replication, the RNA molecules gained new capa-

**phosphodiester** the link between two nucleotides in DNA or RNA

**transcription** messenger RNA formation from a DNA sequence

**gene** portion of DNA that codes for a protein or RNA molecule

**protein** complex molecule made from amino acids; used in cells for structure, signaling, and controlling reactions

**amino acid** a building block of protein

**heterogeneous** composed of or containing different parts or types

**ribosome** protein-RNA complex in cells that synthesizes protein

**polypeptide** chain of amino acids

**catalyze** aid in the reaction of

bilities, such as the ability to code for and synthesize proteins. Eventually, the RNA **genome** was replaced with DNA.

Scientists have uncovered a number of **enzymatic** RNA molecules, called ribozymes, believed to be typical of those in the RNA world. RNA **enzymes** can make phosphodiester bonds, suggesting that early RNA molecules could reproduce their genetic material. In fact, it is now known that RNA in the ribosome catalyzes the formation of **peptide bonds** during protein synthesis, supporting the idea that RNA molecules were able to synthesize proteins. Even in the twenty-first century, not all genomes are composed of DNA: some very important viruses, such as the one that causes AIDS (acquired immunodeficiency syndrome), has RNA as its genetic material. However, the so-called RNA viruses express their genome only after they have turned it into DNA. SEE ALSO RIBOSOME; RNA PROCESSING; TRANSFER RNA

*James E. Blankenship*

### Bibliography

Alberts, Bruce, et al. *Molecular Biology of the Cell*, 4th ed. New York: Garland Publishing, 2000.

Stryer, Lubert. *Biochemistry*, 4th ed. New York: W. H. Freeman and Company, 1995.

## RNA Processing

In the appropriate cell type and at the correct developmental stage, ribonucleic acid (RNA) polymerase **transcribes** an RNA copy of a gene, the primary transcript. However, the primary transcript may contain many more **nucleotides** than are needed to create the intended protein. In addition, the primary transcript is vulnerable to breakdown by RNA-degrading enzymes.

Before the primary transcript can be used to guide protein synthesis, it must be processed into a mature transcript, called messenger RNA (mRNA). This is especially true in **eukaryotic cells**. Processing events include protection of both ends of the transcript and removal of intervening nonprotein-coding regions.

On an RNA molecule, the end formed earliest is known as the 5' (5-prime) end, whereas the trailing end is the 3' end. The ends of the primary transcript are particularly susceptible to a class of degradative enzymes called exonucleases. During processing, the 5' end of the primary transcript is protected against the effects of these enzymes by the addition of a CAP. The CAP uses an unusual linkage between nucleotides. Exonucleases do not recognize this unusual structure and therefore cannot remove the CAP. Since exonucleases work only from an end, if the CAP nucleotide cannot be removed, the entire 5' end of the mRNA is protected. The 5' CAP also aids in transport out of the **nucleus** and helps bind the mRNA to the **ribosome**.

To protect the 3' end against degradative exonucleases, a poly-A tail is added by poly-A polymerase. Poly-A is a chain of adenine nucleotides, one hundred to two hundred units long. The poly-A tail has typical bonds that are susceptible to degradation by exonucleases, but it does not have any protein coding function so it does not particularly matter if some of the A

**genome** total genetic material in a cell or organism

**enzymatic** related to function of an enzyme

**enzyme** protein that controls a reaction in a cell

**peptide bond** bond between two amino acids

**transcribe** create an RNA copy of a DNA gene

**nucleotide** the building block of RNA or DNA

**eukaryotic cell** a cell with a nucleus

$\beta$ -thalassemia, a hemoglobin disease, can be caused by an intron mutation that prevents recognition of a splice site.

**nucleus** membrane-bound portion of cell containing the chromosomes

**ribosome** protein-RNA complex in cells that synthesizes protein

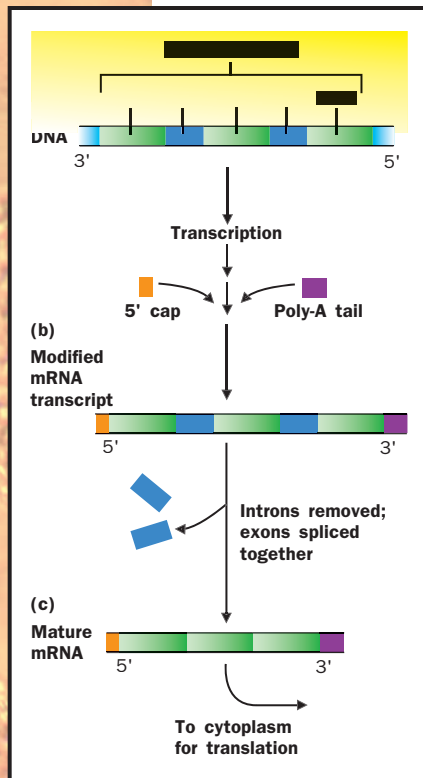

Stages in the processing of an mRNA transcribed from a gene of a eukaryote. (a) Genetic data are transcribed into an RNA copy. (b) The copy is modified with a cap at the 5' end and a poly-A tail at the 3' end. (c) The exons are spliced together. The mature mRNA then passes to the cytoplasm, where it is translated into protein.

**catalyze** aid in the reaction of

**ribonucleoprotein** combination of RNA and protein

**cytoplasm** material in a cell, excluding the nucleus

**minerals** iron, calcium, sodium, and other elements needed by living organisms

residues are degraded. It actually takes quite some time for the poly-A tail to be completely lost, and during this time the protein coding portion of the mRNA remains intact. Without the poly-A tail, however, the exonucleases would rapidly degrade into the protein coding portion of the mRNA. An exception to the poly-A strategy is seen in the mRNA for histones, proteins that wrap deoxyribonucleic acid (DNA) into chromosomes. Instead of poly-A, histone mRNA uses a much smaller structure that is regulated by factors present during DNA synthesis.

The most striking event in RNA processing occurs because the protein coding region in eukaryotic genes is not continuous. A typical eukaryotic gene is composed of a number of protein coding regions, called exons, that are separated by noncoding regions called introns. In fact, the number of nucleotides in the introns can be much larger than the number of nucleotides in the combined exons. The DNA gene contains the code for both the exons and the introns, as does the primary RNA transcript, but the noncoding intron sequences must be removed to form the mRNA before protein synthesis.

The process by which introns are removed and exons are joined to one another is called RNA splicing, and it is **catalyzed** by complexes of proteins and RNA called SNuRPs (small nuclear **ribonucleoprotein** particles). These complexes locate special RNA sequences that flank the exon/intron junctions, bind to them, and catalyze the splicing reactions. Some primary transcripts can be spliced in a few different ways. Such “alternate splicing” yields a range of related proteins.

After addition of the CAP to the 5' end, the poly-A tail to the 3' end, and splicing of the introns, the processing is complete and the mRNA is transported through nuclear pores to the **cytoplasm** of the eukaryotic cell where translation (protein synthesis) will occur. SEE ALSO GENE; NUCLEAR TRANSPORT; PROTEIN SYNTHESIS; RNA; TRANSFER RNA; TRANSCRIPTION

*James E. Blankenship*

### Bibliography

Alberts, Bruce, et al. *Molecular Biology of the Cell*, 4th ed. New York: Garland Publishing, 2000.

Stryer, Lubert. *Biochemistry*, 4th ed. New York: W. H. Freeman and Company, 1995.

## RNA Virus *See Retrovirus*

## Roots

Plants are autotrophic and make their own food via photosynthesis. However, they must acquire the molecular building blocks for the production of food from the environment. Carbon dioxide (CO<sub>2</sub>), water, and a variety of **minerals** are needed for photosynthesis to occur. While CO<sub>2</sub> comes from the air, all plants get the majority of their water and minerals from the soil via their roots. In addition, roots provide structural support for the plant. Moreover, roots can serve as storage houses for the food produced by the plant. Roots also act as the gatekeepers for the plant by actively regulating the entry of substances into the plant body.



The root system of a plant.

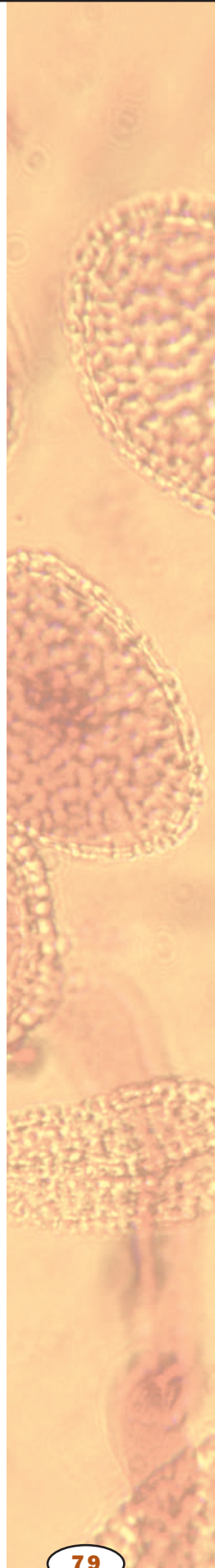

## Root Anatomy

Examining the anatomy of a root reveals a highly organized set of cell types that reflect the main functions of roots previously mentioned. The exterior of the root is called the epidermis and is composed of dermal tissue, made up of epidermal cells. Some of these epidermal cells have long membranous extensions called root hairs. Root hairs increase the surface area of the root, maximizing water and mineral absorption. Immediately interior to the epidermis lies the root cortex. The parenchyma cells store nutrients and are also involved in mineral uptake. In roots that are designed for storage, these cells are numerous and are filled with the carbohydrate products of photosynthesis (starch).

The innermost layer of the cortex, surrounding the vascular tissue (stele), is the endodermis. A waxy material called the Casparian strip surrounds each individual endodermal cell. This structure acts as a gasket, creating a seal to limit diffusion of water and minerals into the vascular tissue of the root. Due to the presence of the Casparian strip, all water and minerals must pass through endodermal cells, not around them, before entering the vascular

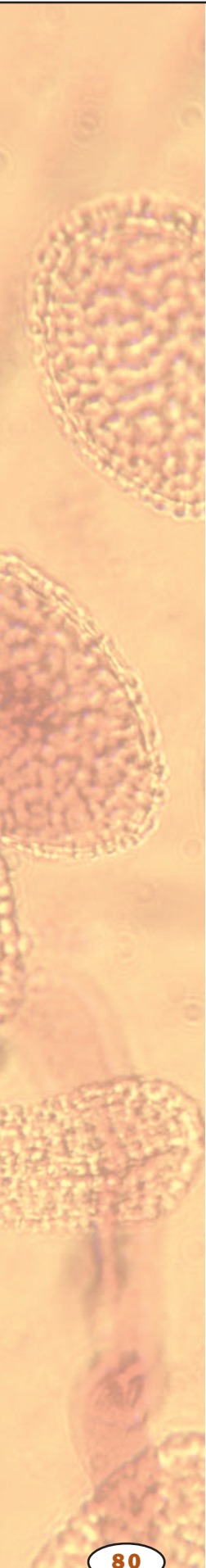

**xylem** water-transporting system in plants

**phloem** plant tissue that conducts sugars from leaves to roots and other tissues

**symbiosis** close relationship between two species in which at least one benefits

**protein** complex molecule made from amino acids; used in cells for structure, signaling, and controlling reactions

**enzyme** protein that controls a reaction in a cell

**eudicot** “true dicot”; plants with two seed leaves that originated from the earliest of flowering plants

tissue of the plant. This allows the endodermal cells to regulate the entry of nutrients and other substances into the plant.

Finally, **xylem** and **phloem** occupy the central region of the root. The xylem transports the water and minerals absorbed by the root up to the stems, leaves, and flowers. The phloem transports the sugars and other nutrients made by the leaves down to the root for immediate use or for storage during periods of dormancy.

### Root Symbioses

Most root systems have microorganisms that are living in or near them in **symbiosis**. These microorganisms help the root absorb and process nutrients that are needed by the plant, while the root delivers food made by the plant to the microorganism.

**Nitrogen-Fixing Bacteria.** Many of the minerals needed by the plant are readily available in the soil in forms that the plant can use (including calcium, sulfur, sodium, chloride, and potassium). However, nitrogen in the environment is in the form of nitrogen gas. Plants cannot convert nitrogen gas into ammonia or nitrate (nitrogen forms they can use to build **proteins**). However, many microorganisms that live in the soil (and some that live in the root cells of some plants) have the proper **enzymes** to convert nitrogen into ammonia or nitrate. These bacteria are called “nitrogen-fixing” because they capture atmospheric nitrogen and convert it into a usable form. Some plants, notably the legumes such as soybeans, house specific nitrogen-fixing bacteria with their roots in specialized structures called nodules.

**Mycorrhizae.** In addition to their symbiotic relationships with bacteria in the soil, roots have symbiotic relationships with fungi. Particular types of fungi can infect the root epidermis and provide the plant with phosphate that it cannot acquire on its own. Roots that have these beneficial fungal infections are called mycorrhizae.

### Types of Roots

As there are many different types of plants, there are many different types of root systems. Each system is structured to serve the needs of the plant body, based on the metabolic demands of the plant and the environment in which it lives.

**Taproots.** Taproots are roots that are specialized for reaching water deep in the ground or for storing the nutrients produced by the plant. Many **eudicots** such as sugar beets and carrots have taproot systems that are specialized for storage. In fact, the most familiar part of the carrot (the orange, edible portion) is a taproot. In addition, conifers (evergreens) that live in climates with harsh winters have taproot systems. During the winter months the water in the upper layers of the soil is frozen and inaccessible to the plant. The taproot system in these plants can grow to access available water sources in deep layers of the soil.

**Fibrous Roots.** Fibrous root systems consist of an elaborate network of small roots that spread throughout the upper layers of soil. Most monocots, such as grasses, have fibrous root systems. These roots allow the plant to access a large area of soil water and minerals. The mat-like formation of fi-

brous roots provides a strong anchor for the plant and also preserves the integrity of the top layer of soil by preventing erosion.

**Adventitious Roots.** Both taproots and fibrous roots are root systems that arise at the base of the plant shoot during germination. However, it is not uncommon for roots to develop from plant structures such as stems or leaves that are aboveground. These roots are called **adventitious** roots and mainly serve both support and conductive roles. SEE ALSO MYCORRHIZAE; NITROGEN FIXATION; PLANT DEVELOPMENT; PLANT NUTRITION; SOIL; WATER MOVEMENT IN PLANTS

**adventitious** growing from a nonstandard location

Susan T. Rouse

### Bibliography

*Atlas of Plant Anatomy.* <<http://atlasveg.ib.usp.br/English/>>.

Moore, R., W. D. Clark, and D. Vodopich. *Botany*, 2nd ed. New York: McGraw-Hill.

## Scaling

Scaling can be defined as the structural and functional consequences of a change in size and scale among similarly organized animals. To examine what “consequences of a change in size” means, consider what would happen if one scaled up a cockroach simply by expanding it by a factor of 100 in each of its three dimensions. Its mass, which depends on volume, would increase by a factor of 1 million ( $100 \times 100 \times 100$ ). The ability of its legs to support that mass, however, depends on the cross-sectional area of the leg, which has only increased by a factor of ten thousand ( $100 \times 100$ ). Similarly, its ability to take in oxygen through its outer surface will also grow only by ten thousand, since this too is a function of surface area. This disparity between the rapid growth in volume and the slower growth in surface area means the super-sized cockroach would be completely unable to support its weight or acquire enough oxygen for its greater body mass.

The consequences of body size on the physiology, ecology, and even behavior of animals, can be appreciated if one examines in more detail differences in function between organisms of widely different sizes. For example, consider that a 4-ton elephant weighs about 1 million times more than a 4-gram shrew, and further consider that the shrew consumes enough food daily to equal about 50 percent of its body weight. Imagine then what the daily food consumption of 1 million shrews would be (2 tons of food), and realize that the elephant is probably consuming instead only about 100 pounds of food. From this example it is obvious that daily food requirements do *not* scale directly with body mass. In fact, most body processes scale to some proportion of body mass, rarely exactly 1.0.

### Allometric Analysis

How can one determine the relationship of body processes to body mass? The best technique for uncovering the relationship is to plot one variable (for example, food requirements or metabolic rate) against body mass for groups of similar animals (for example, all mammals, or even more specifically, carnivorous mammals). Such a plot is called an X-Y regression. Using a statistical technique called least-squares regression gives an equation

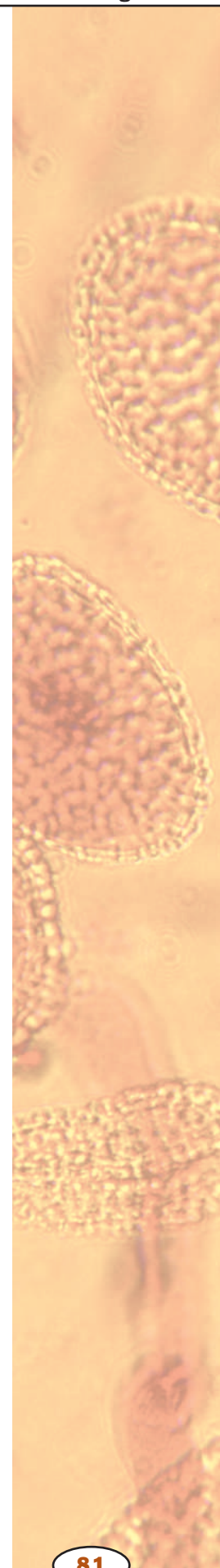

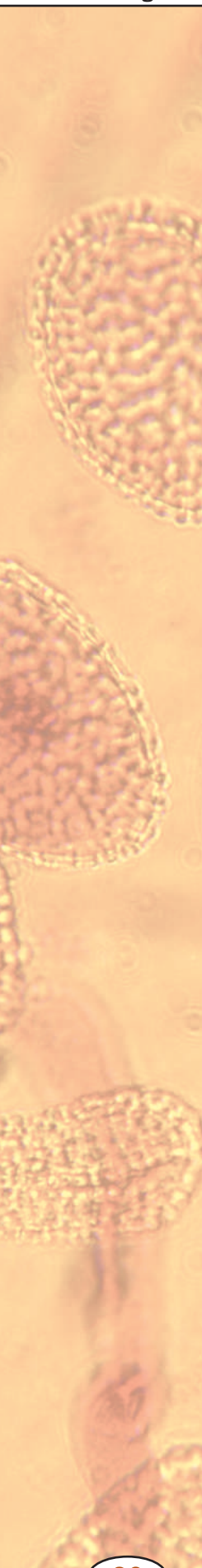

**metabolism** chemical reactions within a cell

that best fits the data. The equation for scaling of any variable to body mass is  $Y = aW^b$ , where  $Y$  is the variable to be determined,  $W$  is the animal body mass (or weight), and  $a$  and  $b$  are empirically derived constants from the regression. The exponent  $b$  is of particular interest, since it gives the scaling relationship one is looking for in nonlinear relations, such as that of **metabolism** and body mass. This mathematical technique is called allometric analysis. Allometric analysis can be used to predict the capacity or requirements of an unstudied animal, one that might be too rare to collect or too difficult to maintain in captivity for study.

## Metabolism

Using this technique, several interesting relationships between animal structure and function have been uncovered. Among the most well studied is the relationship between animal metabolism and body mass, introduced above, in which  $M$  (metabolism) scales to the 0.75 power of body weight ( $M = aW^{0.75}$ ). This means that while the total energy needs per day of a large animal are greater than that of a small animal, the energy requirement *per gram* of animal (mass-specific metabolism) is much greater for a small animal than for a large animal. Why should this be the case? For birds and mammals that maintain a constant body temperature by producing heat, the increased mass-specific metabolism of smaller animals was once thought to be a product of their greater heat loss from their proportionately larger surface area-to-volume ratio. However, the same mathematical relationship between metabolism and body mass has been found to hold for all animals studied, and even unicellular organisms as well. Therefore, the relationship of metabolism to body size seems to represent a general biological rule, whose basis eludes scientific explanation at this time.

Allometric analysis has shown that different body processes, involving different organs, scale with different exponents of body mass. For example, blood volume, heart weight, and lung volume all scale almost directly with body mass (exponent = 0.99–1.02). Thus, the oxygen delivery system (heart and lungs) is directly proportional to body mass, even though the metabolism, and thus oxygen requirements, of the body scale with body mass to the 0.75 power. If the hearts are proportionately the same size for large and small animals, but mass-specific oxygen requirements are higher for small animals, then this implies that hearts in small animals must pump faster to deliver the greater quantity of oxygenated blood. Similarly, lung ventilation rates of smaller animals must be higher than those of larger animals. Both predictions have been borne out by measurements that support this conclusion from the allometric analysis.

## Locomotion

The energy requirement for locomotion also scales with body size, in much the same way that metabolism does. But here another factor comes into play: the type of locomotion. It is obvious that locomotion is much more energetically expensive than sitting still, but are some types of locomotion more expensive than others? Let's compare running, swimming, and flying. In plotting the cost of running versus body mass, one notes that metabolic cost increases directly as a function of mass. What about swimming and flying?

Again, cost increases with mass, but the regression lines for these allometric analyses exhibit different slopes than the one for runners. As might be expected the cost (per kilometer per gram of animal) is lowest for swimmers, where the body mass is supported by buoyancy; next highest for flyers, where body mass is partially supported by air mass; and highest for runners, who lose energy to friction with the ground. While water is more **viscous** to move through than air, swimmers (especially fish) have streamlined bodies that reduce frictional drag and reduce cost.

**viscous** thick

Allometric analysis helps explain why animals can only get so large or so small. Limits placed on structural support, amount of gut surface area required to process the required energy per day, and cost of locomotion become limiting factors for large animals. High surface area-to-volume ratios, high metabolic costs of existence, and limits on the speed of diffusion and cell surface area become limiting factors for small animals. Thus, animal structural design has functional implications that determine physiological processes and ultimately the ability to exist under specific ecological constraints. SEE ALSO CIRCULATORY SYSTEMS; FLIGHT; GAS EXCHANGE; PHYSIOLOGICAL ECOLOGY; TEMPERATURE REGULATION

*Susan Chaplin*

### **Bibliography**

Peters, Robert H. *The Ecological Implications of Body Size*. Cambridge: Cambridge University Press, 1983.

Schmidt-Nielsen, Knut. *How Animals Work*. Cambridge: Cambridge University Press, 1972.

## **Science Writer**

In 1999, gene therapy researchers accidentally killed a healthy nineteen-year-old boy and then covered up the evidence. Only the work of two newspaper reporters—one a science writer—brought the story to light. The science writer's work showed that the scientists had continued risky experiments on humans for months.

A science writer is a person who writes about science for newspapers, magazines, television shows, or university public information offices. Anyone with a talent for writing can become a science writer. Most science writers have at least a college degree. Some have no training in science and learn what they need to know on the job by talking to scientists. Others have at least a B.A. in a science such as biology or chemistry.

To become a science writer, you can just start writing articles and try to get them published, perhaps in a college newspaper. Once you have "clips" from your volunteer work, you can show them to an editor and find paying work. Many students enter a graduate program in science writing, then launch their careers by taking an internship or job at a newspaper, radio station, or magazine.

*Jennie Dusbeck*

### **Bibliography**

National Association of Science Writers. <<http://www.nasw.org>>.

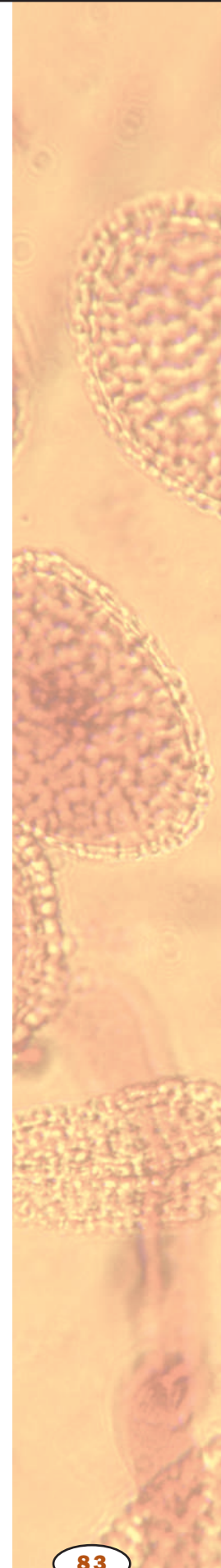



## Secondary Metabolites in Plants

Secondary metabolites are chemicals produced by plants for which no role has yet been found in growth, photosynthesis, reproduction, or other “primary” functions. These chemicals are extremely diverse; many thousands have been identified in several major classes. Each plant family, genus, and species produces a characteristic mix of these chemicals, and they can sometimes be used as taxonomic characters in classifying plants. Humans use some of these compounds as medicines, flavorings, or recreational drugs.

Secondary metabolites can be classified on the basis of chemical structure (for example, having rings, containing a sugar), composition (containing nitrogen or not), their solubility in various solvents, or the pathway by which they are synthesized (e.g., phenylpropanoid, which produces tannins). A simple classification includes three main groups: the terpenes (made from mevalonic acid, composed almost entirely of carbon and hydrogen), phenolics (made from simple sugars, containing benzene rings, hydrogen, and oxygen), and nitrogen-containing compounds (extremely diverse, may also contain sulfur).

The apparent lack of primary function in the plant, combined with the observation that many secondary metabolites have specific negative impacts on other organisms such as herbivores and **pathogens**, leads to the hypothesis that they have evolved because of their protective value. Many secondary metabolites are toxic or repellant to herbivores and microbes and help defend plants producing them. Production increases when a plant is attacked by herbivores or pathogens. Some compounds are released into the air when plants are attacked by insects; these compounds attract **parasites** and predators that kill the herbivores. Recent research is identifying more and more primary roles for these chemicals in plants as signals, **antioxidants**, and other functions, so “secondary” may not be an accurate description in the future.

Consuming some secondary metabolites can have severe consequences. Alkaloids can block **ion** channels, inhibit **enzymes**, or interfere with neurotransmission, producing **hallucinations**, loss of coordination, convulsions, vomiting, and death. Some phenolics interfere with digestion, slow growth, block enzyme activity and cell division, or just taste awful.

Most herbivores and plant pathogens possess mechanisms that ameliorate the impacts of plant metabolites, leading to evolutionary associations between particular groups of pests and plants. Some herbivores (for example, the monarch butterfly) can store (sequester) plant toxins and gain protection against their enemies. Secondary metabolites may also inhibit the growth of competitor plants (allelopathy). Pigments (such as terpenoid carotenes, phenolics, and flavonoids) color flowers and, together with terpene and phenolic odors, attract pollinators.

Secondary chemicals are important in plant use by humans. Most pharmaceuticals are based on plant chemical structures, and secondary metabolites are widely used for recreation and stimulation (the alkaloids nicotine and cocaine; the terpene cannabinol). The study of such plant use is called ethnopharmacology. Psychoactive plant chemicals are central to some religions, and flavors of secondary compounds shape our food preferences. The characteristic flavors and aroma of cabbage and relatives are caused by

**pathogen** disease-causing organism

**parasite** organism living in close association with another from which it derives most of its nutrition

**antioxidant** substance that prevents damage from oxidation

**ion** an electrically charged particle

**enzyme** protein that controls a reaction in a cell

**hallucination** altered sensory experience

Class	Example Compounds	Example Sources	Some Effects and Uses
<b>NITROGEN-CONTAINING</b>			
<b>Alkaloids</b>	nicotine cocaine theobromine	tobacco coca plant chocolate (cocoa)	interfere with neurotransmission, block enzyme action
<b>NITROGEN- AND SULFUR-CONTAINING</b>			
<b>Glucosinolates</b>	sinigrin	cabbage, relatives	
<b>TERPENOIDS</b>			
<b>Monoterpenes</b>	menthol linalool	mint and relatives, many plants	interfere with neurotransmission, block ion transport, anesthetic
<b>Sesquiterpenes</b>	parthenolid	Parthenium and relatives ( <i>Asteraceae</i> )	contact dermatitis
<b>Diterpenes</b>	gossypol	cotton	block phosphorylation; toxic
<b>Triterpenes, cardiac glycosides</b>	digitogenin	Digitalis (foxglove)	stimulate heart muscle, alter ion transport
<b>Tetraterpenoids</b>	carotene	many plants	antioxidant; orange coloring
<b>Terpene polymers</b>	rubber	Hevea (rubber) trees, dandelion	gum up insects; airplane tires
<b>Sterols</b>	spinasterol	spinach	interfere with animal hormone action
<b>PHENOLICS</b>			
<b>Phenolic acids</b>	caffeic, chlorogenic	all plants	cause oxidative damage, browning in fruits and wine
<b>Coumarins</b>	umbelliferone	carrots, parsnip	cross-link DNA, block cell division
<b>Lignans</b>	podophyllin urushiol	mayapple poison ivy	cathartic, vomiting, allergic dermatitis
<b>Flavonoids</b>	anthocyanin, catechin	almost all plants	flower, leaf color; inhibit enzymes, anti- and pro-oxidants, estrogenic
<b>Tannins</b>	gallotannin, condensed tannin	oak, hemlock trees, birdsfoot trefoil, legumes	bind to proteins, enzymes, block digestion, antioxidants
<b>Lignin</b>	lignin	all land plants	structure, toughness, fiber

nitrogen- and sulfur-containing chemicals, glucosinolates, which protect these plants from many enemies. The astringency of wine and chocolate derives from tannins. The use of spices and other seasonings developed from their combined uses as preservatives (since they are antibiotic) and flavorings. SEE ALSO FLOWERS; HERBIVORY AND PLANT DEFENSES; METABOLISM, CELLULAR; POISONS

*Jack Schultz*

### **Bibliography**

Agosta, William. *Bombardier Beetles and Fever Trees: A Close-up Look at Chemical Warfare and Signals in Animals and Plants*. Reading, MA: Addison-Wesley, 1996.

Bidlack, Wayne R. *Phytochemicals as Bioactive Agents*. Lancaster, PA: Technomic Publishers, 2000.

Karban, Richard, and Ian T. Baldwin. *Induced Responses to Herbivory*. Chicago: University of Chicago Press, 1997.

Rosenthal, Gerald A., and May R. Berenbaum. *Herbivores, Their Interactions with Secondary Plant Metabolites*. San Diego, CA: Academic Press, 1991.



A kidney bean sprouting into a seedling.

**metabolism** chemical reactions within a cell

**enzyme** protein that controls a reaction in a cell

**mitochondria** subcellular organelle that creates ATP used for energy-requiring processes in a cell

**organelle** membrane-bound cell compartment

**protein** complex molecule made from amino acids; used in cells for structure, signaling, and controlling reactions

**template** master copy

**transcribe** create an RNA copy of a DNA gene

**turgor** internal pressure

## Seed Germination and Dormancy

The embryo, contained within the seed, is the next generation of plant. Thus successful seed germination is vital for a species to perpetuate itself. By definition, germination commences when the dry seed, shed from its parent plant, takes up water (imbibition), and is completed when the embryonic root visibly emerges through the outer structures of the seed (usually the seed or fruit coat). Thereafter, there is seedling establishment, utilizing reserves stored within the seed, followed by vegetative and reproductive growth of the plant, supported by photosynthesis.

### Quiescence and Germination

The seed is metabolically inactive (quiescent) in the mature, dry state and can withstand extremes of drought and cold. For example, dry seeds can be stored over liquid nitrogen at -150 degrees Celsius (-238 degrees Fahrenheit) for many years without harm. Upon hydration of a seed, **metabolism** commences as water enters its cells, using **enzymes** and structural components present when the seed was dry. Respiration to provide energy has been observed within minutes of water uptake. **Mitochondria** that were stored in the dry seed are involved, although initially they are somewhat inefficient because of damage sustained during drying and rehydration. During germination they are repaired and also new **organelles** are synthesized. **Protein** synthesis also commences rapidly in the imbibing seed.

Early during germination, stored messenger ribonucleic acids (mRNAs) are used as **templates** for protein synthesis, but later in germination these are replaced with newly **transcribed** messages, some of which code for a different set of proteins. Although the pattern of seed protein synthesis changes during germination, no proteins have been identified as being essential for this event to be completed.

Elongation of cells of the radicle (embryonic root) is responsible for its emergence from the seed. This is a **turgor**-driven process and is achieved through increased elasticity of the radicle cell walls, by a process which is not known. Cell division and deoxyribonucleic acid (DNA) replication occur after germination, as the radicle grows, and reserves of protein, carbohydrate, and oil, stored in the dry seed, are used to support seedling growth.

### Dormancy

Mature seeds of some species are incapable of germinating, even under ideal conditions of temperature and hydration, unless they receive certain environmental stimuli; such seeds are dormant. Breaking of this dormancy may be achieved in several ways, depending upon the species. Frequently, dormancy is lost from seeds as they are stored in the dry state for several weeks

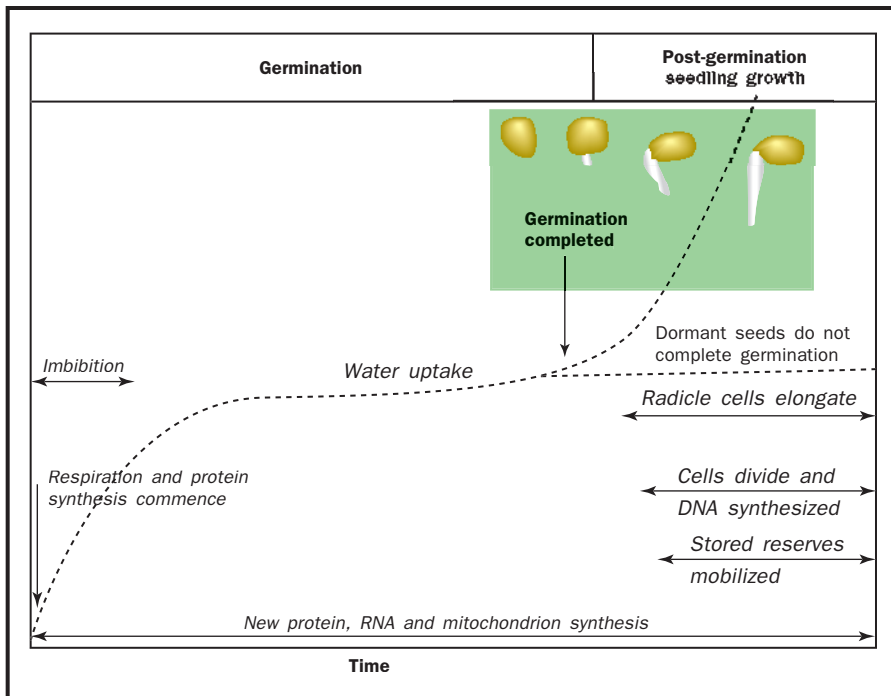

The stages of germination and early growth.

to years, a phenomenon called dry after-ripening. But many seeds remain dormant in a fully imbibed state; they are as metabolically active as non-dormant seeds, but yet fail to complete germination. Dormancy of these seeds may be broken by one or more of the following: (1) light, sunlight being the most effective; (2) low temperatures (1 to 5 degrees Celsius [33.8 to 41 degrees Fahrenheit]) for several weeks; (3) day/night fluctuating temperatures of 1 to 10 degrees Celsius (41 to 50 degrees Fahrenheit); (4) chemicals, such as nitrate in the soil, or applied **hormones** (gibberellins) in the laboratory; and (5) fire.

Dormancy mechanism operate to control the germination of seeds in their natural environment and to optimize the conditions under which the resultant seedling can become established. Dormant seeds that require light will not germinate unless they are close to the soil surface; hence germinated seeds will not expend their stored reserves before they can reach the surface and become photosynthetically independent seedlings. This is particularly important for small, wind-dispersed weed seeds. The light-perception mechanism in light-requiring seeds involves a receptor protein, phytochrome, which is activated by red wavelengths of light and inactivated by far-red (near-infrared). Far-red light from sunlight penetrates farther into soil than does red, but also light penetrating through a leaf canopy is richer in far-red than red, since the latter is absorbed by photosynthetic pigments in the leaf. Hence, germination of light-sensitive seeds is advantageously inhibited under a leaf canopy and helps explain why germination and subsequent plant growth is so profuse in forest clearings.

Seeds that need a period of low temperature cannot germinate immediately after dispersal in the summer or early autumn but will do so after being subjected to the cold of winter, conditions that may cause the parent plant to die, and thus remove competition for space in the spring. The requirement for alternating temperatures will prevent germination of seeds

**hormone** molecule released by one cell to influence another

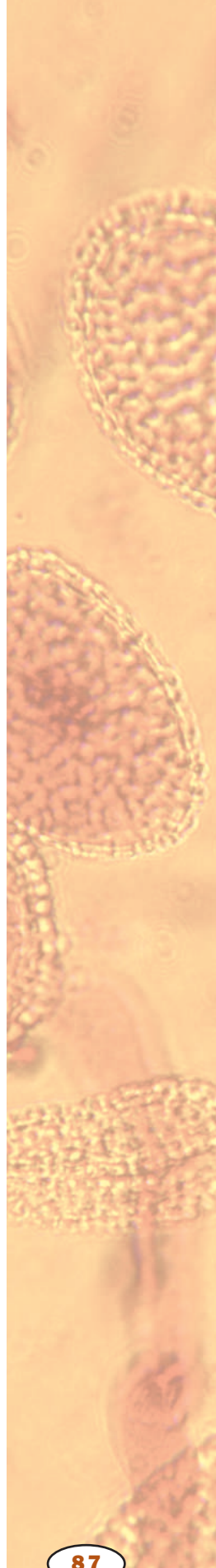

beneath dense vegetation because the latter dampens the day/night temperature fluctuations; these seeds will germinate only when there is little vegetation cover, again reducing competition with established plants.

Seed dormancy is also important in relation to agricultural and horticultural crops. Its presence causes delayed and sporadic germination, which is undesirable. On the other hand, the absence of dormancy from cereals, for example, can result in germination of the seed on the ear, causing spoilage of the crop. Thus having mild dormancy to prevent this, which is lost during storage of the seed (dry after-ripening), is desirable. SEE ALSO FIRE ECOLOGY; REPRODUCTION IN PLANTS; SEEDS

J. Derek Bewley

### Bibliography

- Bewley, J. Derek. "Seed Germination and Dormancy." *Plant Cell* 9 (1997): 1055–1066.  
 ———, and Michael Black. *Seeds: Physiology of Development and Germination*, 2nd ed. New York: Plenum Press, 1994.

## Seedless Vascular Plants

When one walks through a contemporary forest, all of the surrounding trees are vascular plants. Wood, which is made up primarily of **xylem**, and bark, which contains **phloem**, are the major structural elements of the trunks and stems. These trees produce seeds, whether they be formed within the cones of the pines or within fruits, such as the winged samaras of maples or the fleshy cherries of the cherry tree. In the Carboniferous period a similar hike would also place one in a forest of woody trees, many as large as 98 feet (30 meters) tall, but there would be no seeds produced. These plants were seedless vascular plants, which were propagated by spores. Ultimately they became extinct, leaving behind expansive fossil fuel deposits.

The differences between spores and seeds are extensive. Seeds are multicellular structures that provide a protected place where the egg (n) was to be fertilized by male **gamete** nuclei (n) in pollen. The resulting cell, called a **zygote**, is **diploid** (2n), the same as the original plant that produced it. It repeatedly divides mitotically, while still within the protection of the seed coat, to form an embryo. The embryo may remain dormant for a significant time period but ultimately emerges from the seed when it germinates.

The seedless vascular plants do not have this protection. Their gametes are produced mitotically by a **gametophyte** (n) that lives independently. There are often many vase-shaped archegonia on these small plants, and the unfertilized egg is inside the base of this structure. The embryo formed following **fertilization** is not as well protected as one located within a seed. It grows and emerges from the archegonium, where it is exposed to the environment.

These embryos survive best to develop into young sporophyte individuals when they are in moist habitats, whereas seeds can endure more severe conditions and therefore can have wide habitat type distributions. The sporophyte eventually develops rhizomes, underground stems, roots, or rhizoids that serve to absorb water and nutrients and allow independent survival. In the case of the plants of the Carboniferous forests, this development was extensive.

**xylem** water-transporting system in plants

**phloem** plant tissue that conducts sugars from leaves to roots and other tissues

**gamete** reproductive cell, such as sperm or egg

**zygote** fertilized egg

**diploid** having pairs of chromosomes in the nucleus

**gametophyte** a haploid plant that makes gametes by mitosis

**fertilization** union of sperm and egg

The simplest type of spore production in living seedless vascular plants is found in the leafless whisk fern, *Psilotum*, a member of the **phylum** Psilotophyta. This sporophyte (2n) plant, really little more than a branching twig, has many sets of three-fused sporangia, which produce spores through **meiosis**. These **haploid** (n) spores grow into minute plants about the size of a small piece of macaroni. These plants have archegonia and small gametangia (which produce the male gametes) to complete sexual reproduction and make new sporophytes.

Many variations on this basic spore-producing alternation of generations life cycle are found in the seedless vascular plants. The carboniferous trees, which are now recognized only through the study of their fossils, most likely had common ancestors with a variety of present-day organisms including the ferns, horsetails, and lycopods.

The modern ferns, phylum Pterophyta, have leaves of varying sizes and shapes and still occur as trees in tropical areas. The descendants in the other groups do not presently attain treelike stature. Horsetails or scouring rushes, phylum Sphenophyta, have ancestors stretching as far back as the Devonian era. A ribbed, silicon-impregnated stem has branches in many species that are whorled and give the plant the appearance of a bottle brush or animal tail.

The phylum Lycophyta includes club mosses, sometimes called ground pines, which in some cases have stems with reduced leaves (microphylls) fused together to look like the foot of an animal. The name lycopodium means “wolf foot,” and most likely originated because of this morphological analogy. The selaginellas, which often **superficially** resemble mosses, are in fact very different from mosses. Their small, leafy green stems are sporophytes (2n) and have vascular tissue. In contrast, the small leaves of mosses are gametophytes (n) and no vascular tissue is present. Shifts like this, from a predominant gametophyte generation to a predominant sporophyte generation represent one of the major trends of evolutionary advance in the plant kingdom. SEE ALSO ALTERNATION OF GENERATIONS; BRYOPHYTES; EVOLUTION OF PLANTS; PLANT; PTERIDOPHYTES

Dean Cocking

### Bibliography

- Perry, James W., and David Morton. *Photo Atlas for Botany*. Belmont, CA: Wadsworth Publishing Company, 1998.
- Raven, Peter H., Ray F. Evert, and Susan E. Eichhorn. *Biology of Plants*, 6th ed. New York: W. H. Freeman and Company, 1999.
- Van De Graff, Kent M., Samuel R. Rushforth, and John L. Cawley. *A Photographic Atlas for the Botany Laboratory*, 3rd ed. Englewood, CO: Morton Publishing Company, 1998.

## Seeds

In seed-bearing plants, a seed is the end product of sexual reproduction. It is a mature **ovule**, comprising an embryo or miniature plant along with food reserves, all within a protective seed coat. Seed plants first appeared during the Devonian period some 400 million years ago and rapidly became the dominant vegetation. Up to that point, plants relied on spores for dispersal and were heavily dependent on water for reproduction.

**phylum** taxonomic level below kingdom, e.g., arthropod or chordate

**meiosis** cell division that forms eggs or sperm

**haploid** having single, nonpaired chromosomes in the nucleus

**superficial** on the surface; not deep

**ovule** multicellular structure that develops into a seed after fertilization

A scanning electron micrograph image of Arabidopsis seed pods.

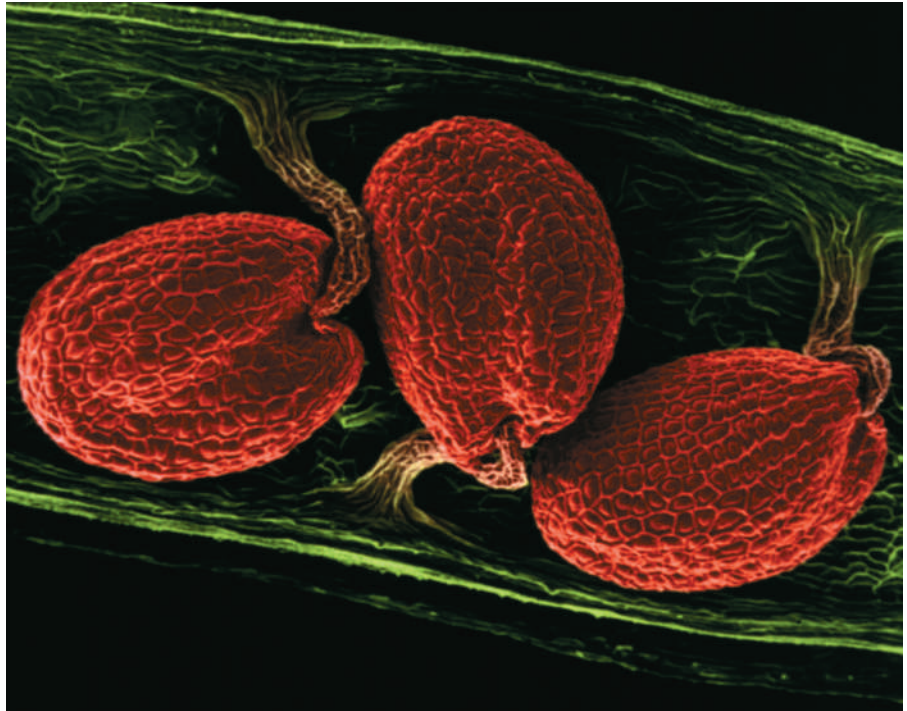

**fertilization** union of sperm and egg

**gymnosperms** “naked seed” plants, including conifers

**nucleus** membrane-bound portion of cell containing the chromosomes

**gamete** reproductive cell, such as sperm or egg

**diploid** having pairs of chromosomes in the nucleus

**zygote** fertilized egg

**triploid** possessing three sets of chromosomes

**endosperm** nutritive tissue within a seed

**intracellular** within a cell

**protein** complex molecule made from amino acids; used in cells for structure, signaling, and controlling reactions

**polysaccharide** carbohydrate composed of many individual units of sugar

**hydrolyze** to split apart using water

Seeds develop by **fertilization** of ovules, both the exposed ovules of **gymnosperms** like the conifers and the enclosed ovules of the angiosperms (flowering plants). The seeds of gymnosperms are virtually naked and exposed to the elements, whereas those of the flowering plant develop within a protective structure: the fruit. In both groups, the egg within the ovule is fertilized by a male **nucleus** arriving via a pollen grain. From this, a miniature plant or embryo develops that will later resume development in a process termed “germination,” utilizing energy stores laid down in the seed.

Flowering plants differ from gymnosperms in that seed development in angiosperms starts with double fertilization. Male and female **gametes** fuse to form the **diploid zygote**, which develops into the embryo, while a second male nucleus fuses with two other nuclei of the ovule to give rise to a **triploid endosperm**. The endosperm is a nutritive tissue that provides food material for the developing embryo. In some flowering plant seeds it remains throughout seed development, storing the reserves that the embryo will require for germination. Such endospermic seeds are produced by cereals like wheat, as well as dicotyledonous plants like castor bean.

In nonendospermic seeds the endosperm virtually disappears, all the food reserves being transferred during seed development to the embryo itself. In such seeds, the cotyledons or first seed leaves become quite large and accumulate the reserves that will be mobilized later in germination. Reserves may take the form of **intracellular** oil droplets (for example, the sunflower), **protein** bodies (beans), and starch grains (cereals), or combinations of these. Some seeds also store **polysaccharide** reserves as massively thickened cell walls (some leguminous plants and date palm) that will later be **hydrolyzed**. The exception to this general pattern is the family of flowering plants known as orchids. They produce the smallest seeds known. These dustlike seeds contain just a few cells, often not even organized into a rec-

ognizable embryo, and contain absolutely no food reserves. Their germination relies on symbiotic associations with fungi to provide the fuel for germination.

Seeds often exhibit dormancy, meaning they fail to germinate even when provided with adequate water and suitable temperature conditions. Dormancy acts to prevent germination until conditions are right. This dormancy may be broken by proper exposure to light or darkness. Alternatively, a hard seed coat may physically prevent water uptake and embryo expansion or even gas exchange, with germination only proceeding following physical damage to the seed coat. Last, chemical inhibitors present in the seed may cause dormancy, and these must first leach out into the soil before germination can take place. Seeds of crop plants can often be stored for years under cold, dry conditions, and some plants show extreme seed longevity under natural conditions (for example, the sacred lotus germinates after hundreds of years buried in lake mud). SEE ALSO ANGIOSPERMS; FLOWERS; FRUITS; GRAIN; GYMNOSPERMS; POLLINATION AND FERTILIZATION

C. M. Sean Carrington

### Bibliography

Kaufman, Peter B., et al. *Plants: Their Biology and Importance*. New York: Harper & Row Publishers, 1989.

## Senescence

Senescence refers to all of the changes that take place in a plant that will finally lead to the death of cells, tissues, and, eventually, the whole plant body. These changes can be seen to occur in some cells even in very young, vigorously growing plants. For example the contents of those cells that make up the **xylem** tissue must senesce and die very early in development. The hollow cells, their cell walls arranged in a pipeline, can then allow water to flow up the plant in a process called transpiration.

Apart from the very precisely controlled death of specific cells during early development, senescence can also be seen in large, multicellular plant organs including leaves and fruits. Golden fields of ripening grain and the reds and yellows of the fall landscape in forests are both due to the pigment changes occurring during the early stages of senescence in millions and millions of leaves. The green chlorophyll pigments are removed, some yellow carotenes remain, and some species synthesize the red anthocyanin pigments at this time. Similar pigment changes occur in many fruits. These symptoms of organ senescence are often accompanied by changes in the levels of plant **hormones** in the cells, with shifts in the absolute amount and sensitivity towards the gaseous hormone, ethylene, playing a pivotal role.

Annual herbaceous plants live only a single growing season, with senescence occurring in all of the structures as the next generation, represented by the seeds, is shed. In perennial plants like trees, the leaves may be shed every year in a process called **abscission**, but the main part of the plant will continue to survive. Abscission in these deciduous plants is often considered as a part of their senescence, although the process of leaf abscission and the formation of a leaf scar is an active process. Some perennials are evergreen,

**xylem** water-transporting system in plants

**hormone** molecule released by one cell to influence another

**abscission** shedding of leaves; falling off

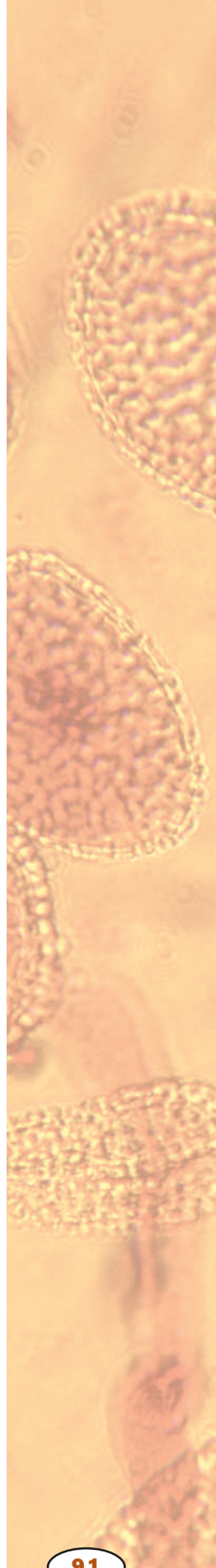



The reds and yellows of the fall landscape are due to the pigment changes occurring during the early stages of senescence in millions and millions of leaves.



and their leaves may be retained and function in the processes of photosynthesis for several years.

Although some individual trees and some seeds can survive for many decades or even centuries, eventually disease and other environmental challenges will lead them to their death. At that time the plant body, along with those thousands of tons of plant material returned to the soil every year, will be recycled by microbes and other soil organisms and feed a new generation of living plants.

In a world increasingly dominated by global markets for fruits, vegetables, and horticultural products, including cut flowers, people's ability to

control the rate of senescence in plant tissues has become one of the most important technologies. Harvesting, transport, storage, and distribution facilities are now focused on attempts to delay the natural senescence of a huge range of living commodities. Scientists will continue to develop their understanding of the biochemistry and molecular biology of plant senescence and refine the environmental controls in storage and transport facilities so that the world's harvest can feed everyone. SEE ALSO HORMONES, PLANT; WATER MOVEMENT IN PLANTS

Roger F. Horton

### Bibliography

Buckner B., D. Janick-Buckner, J. Gray, and G. S. Johal. "Cell-Death Mechanisms in Maize." *Trends in Plant Science* 3 (1998): 218–223.

Nooden L. D., and A. C. Leopold, eds. *Senescence and Aging in Plants*. London: Academic Press, 1988.

## Separation and Purification of Biomolecules

Cell biologists research the intricate relationship between structure and function at the molecular, subcellular, and cellular levels. However, a complex biological system such as a biochemical pathway can only be understood after each one of its components has been analyzed separately. Only if a biomolecule or cellular component is pure and biologically still active can it be characterized and its biological functions elucidated.

Fractionation procedures purify **proteins** and other cell constituents. In a series of independent steps, the various properties of the protein of interest—solubility, charge, size, polarity, and specific binding **affinity**—are utilized to fractionate it, or separate it progressively from other substances. Three key analytical and purification methods are chromatography, electrophoresis, and ultracentrifugation. Each one relies on certain physicochemical properties of biomolecules.

### Chromatography

Chromatography is the separation of sample components based on differential affinity for a mobile versus a stationary phase. The mobile phase is a liquid or a gas that flows over or through the stationary phase, which consists of spherical particles packed into a column. When a mixture of proteins is introduced into the mobile phase and allowed to migrate through the column, separation occurs because proteins that have a greater attraction for the solid phase migrate more slowly than do proteins that are more attracted to the mobile phase.

Several different types of interactions between the stationary phase and the substances being separated are possible. If the retarding force is **ionic** in character, the separation technique is called ion exchange. Proteins of different ionic charges can be separated in this way. If substances adsorb onto the stationary phase, this technique is called absorption chromatography. In gel filtration or molecular sieve chromatography, molecules are separated because of their differences in size and shape. Affinity chromatography exploits a protein's unique biochemical properties rather than the small dif-



Test tube showing the opalescent line of purified adenovirus after centrifugation.

**protein** complex molecule made from amino acids; used in cells for structure, signaling, and controlling reactions

**affinity** attraction

**ionic** based on or functioning by means of ions

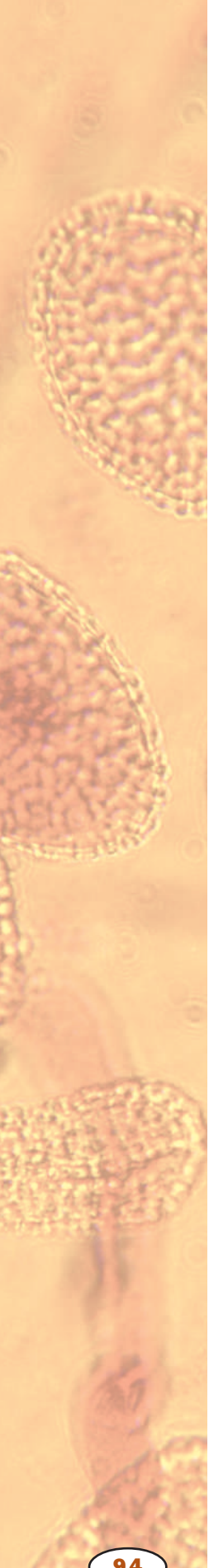

**matrix** a network, usually of threadlike fibers

**organelle** membrane-bound cell compartment

**macromolecules** large molecules such as proteins, carbohydrates, and nucleic acids

ferences in physicochemical properties between different proteins. It takes advantage of the ability of proteins to bind specific molecules tightly but noncovalently and depends on some knowledge of a particular protein's properties in the design of the affinity column.

## Electrophoresis

Many important biological molecules such as proteins, deoxyribonucleic acid (DNA), and ribonucleic acid (RNA) exist in solution as cations (+) or anions (-). Under the influence of an electric field, these molecules migrate at a rate that depends on their net charge, size and shape, the field strength, and the nature of the medium in which the molecules are moving.

Electrophoresis in biology uses porous gels as the media. The sample mixture is loaded into a gel, the electric field is applied, and the molecules migrate through the gel **matrix**. Thus, separation is based on both the molecular sieve effect and on the electrophoretic mobility of the molecules. This method determines the size of biomolecules. It is used to separate proteins, and especially to separate DNA for identification, sequencing, or further manipulation.

## Ultracentrifugation

Cells, **organelles**, or **macromolecules** in solution exposed to a centrifugal force will separate because they differ in mass, shape, or a combination of those factors. The instrument used for this process is a centrifuge. An ultracentrifuge generates centrifugal forces of 600,000 g and more. (G is the force of gravity on Earth.) It is an indispensable tool for the isolation of proteins, DNA, and subcellular particles. **SEE ALSO** ELECTROPHORESIS

*Gabriele K. Wienhausen*

### Bibliography

Alexander, Renee R., and Joan M. Griffiths. *Basic Biochemical Methods*, 2nd ed. New York: Wiley-Liss, 1993.

Bollag, Daniel M., and Stuart J. Edelman. *Protein Methods*. New York: Wiley-Liss, 1991.

Scopes, Robert K. *Protein Purification: Principles and Practice*, 3rd ed. New York: Springer Verlag, 1994.

## Sex Chromosomes

Sex chromosomes are particular chromosomes that are involved in determining the sex of an organism. In the cells of humans and many other organisms the sex chromosomes consist of a pair of chromosomes called the X and Y chromosomes. The X and Y chromosomes were first discovered in beetles by Nettie Stevens in 1906. She noticed that cells of female beetles had identical looking pairs of each of their several chromosomes, but that male beetles had one pair in which the chromosomes were very different in appearance from each other. She called these two chromosomes the X and the Y, and found that female beetles differed from males in containing two X chromosomes. The same situation is also found in humans where females are XX and males are XY.

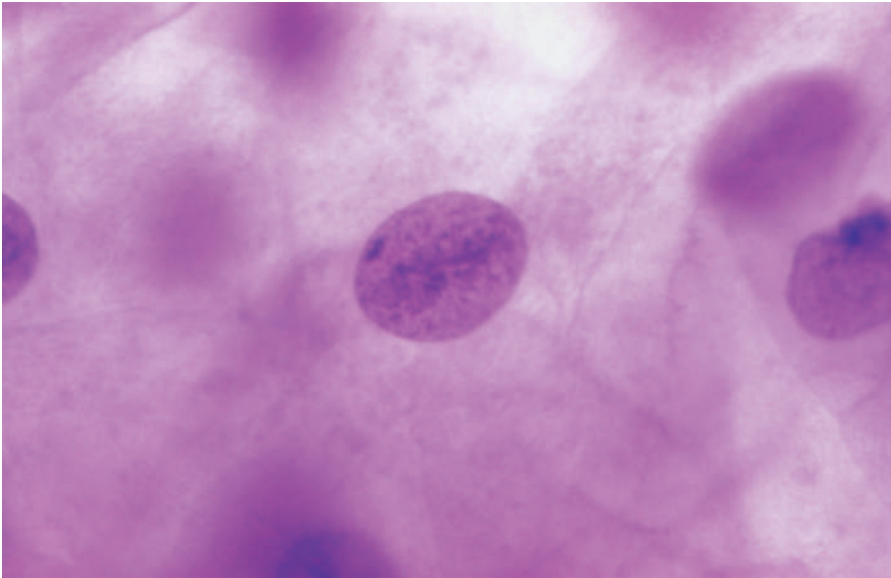

A Barr body—a condensed X chromosome—in a female squamous epithelium cell at interphase.

The X and Y chromosomes in humans are also very different in appearance, with the X chromosome being considerably larger than the Y. With the exception of only about nine shared **genes**, the X and Y chromosomes do not contain the same genes, unlike the other twenty-two pairs of human chromosomes in which members of a pair share all the same genes. The Y chromosome contains the genes for determining a male pattern of development, and in the absence of a Y chromosome an embryo will follow a female pattern of development.

The sex of an individual is determined by which paternal sex chromosome (X or Y) is inherited at **fertilization**. Eggs and sperm, as reproductive cells, each contain only one of the two sex chromosomes as a result of having undergone **meiosis**, a form of cell division that produces daughter cells containing only one member of each chromosome pair. All eggs therefore contain an X chromosome, but half of sperm will contain an X chromosome and the other half a Y chromosome. If an egg is fertilized by a sperm carrying an X chromosome an XX or female embryo will result, while fertilization of the egg by a Y-bearing sperm will produce an XY or male embryo. In some organisms, including birds, the female contains the unlike pair of sex chromosomes. Thus, in these cases the mother determines the sex of the offspring.

Since cells in a male contain a single X chromosome and cells in a female contain two X chromosomes, females contain twice as many copies of the genes on the X chromosome per cell as do males. To equalize the dosage of X chromosome genes between the two sexes, one of the two X chromosomes in each cell of all female mammals is inactivated early in embryonic development by becoming very tightly wound up or condensed. Most of the genes on the condensed X chromosome cannot be expressed. Since males carry only one copy of each X-linked gene, they are much more likely to suffer from disease if they inherit a defective gene. X-linked disorders include some forms of color blindness, Duchenne's muscular dystrophy, and some types of hemophilia.

The inactivation of an X chromosome in the cells of a developing female embryo occurs randomly, so that about half of the cells express the

**gene** portion of DNA that codes for a protein or RNA molecule

**fertilization** union of sperm and egg

**meiosis** cell division that forms eggs or sperm

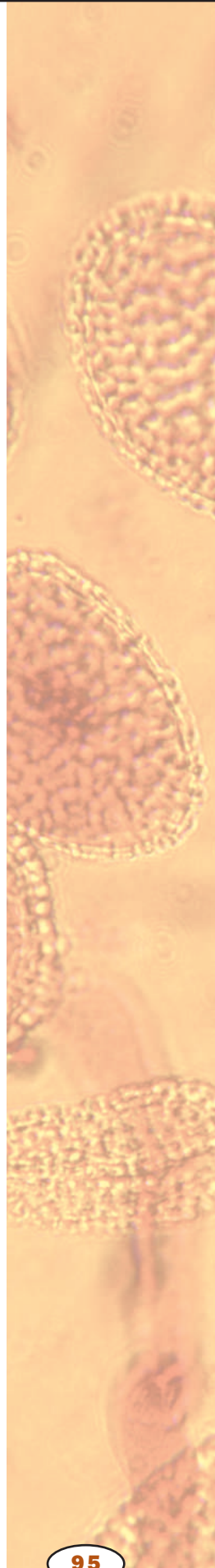

**allele** a particular form of a gene

**condensation** compaction of chromosome strands into a tight structure

**forensic** related to legal proceedings

genes in one X chromosome and half express the genes in the other X chromosome. Once a particular X chromosome has been inactivated in a cell, it will remain inactivated in all of the descendants of that cell. If a female mammal has different forms or **alleles** of a particular gene on each of her two X chromosomes, then about half of her cells will express one of the alleles and about half the other allele. An example of such a genetic mosaic is a calico cat, carrying an allele for orange fur color on one X chromosome and an allele for black fur color on the other X chromosome. The result is a characteristic coat of mottled orange and black patches of fur. Since this type of genetic mosaicism requires the presence of two X chromosomes, calico cats are normally always female.

Chromosomes are ordinarily visible under a microscope only when the cell is dividing. However, when nondividing cells are treated with stains that bind to chromosomes, a darkly staining body is visible in the nuclei of cells from females but not in cells from normal males. This body is actually the condensed X chromosome, and it is called a “Barr body” after its discoverer, Murray Barr. In 1961 Mary Lyon proposed that the **condensation** of the X chromosome into a Barr body was a mechanism for inactivating the genes on the chromosome. This is called “The Lyon Hypothesis,” in her honor. The presence or absence of a Barr body in cells is used in medical and criminal **forensics** to determine and legally define the sex of an individual. **SEE ALSO** CHROMOSOME, EUKARYOTIC; CONTROL OF GENE EXPRESSION; GENE; SEX DETERMINATION

*Anthony R. Kaney*

#### **Bibliography**

Audesirk, Teresa, and Gerald Audesirk. *Biology: Life on Earth*. Upper Saddle River, NJ: Prentice Hall, 1996.

## **Sex Determination**

Sex determination refers to the hormonal, environmental, and especially genetic mechanisms that make an organism male or female.

### **Chromosomal Sex Determination**

It is widely known that people who inherit sex chromosome X from the mother and Y from the father are genetically male, while people who inherit X from both parents are genetically female. Thus, the sex of an offspring is determined entirely by which of the male’s sperm (one carrying X or Y) fertilizes the egg (which always carries X). This fact was not realized until the twentieth century, however. Before that, women were often held accountable for not producing a male heir, and in some cases even murdered for it (as in the case of Anne Boleyn, second wife of King Henry VIII).

In actuality, it is merely the presence of a Y chromosome that makes a person male and its absence that makes a person female. Through accidents of chromosomal sorting (meiosis) during sperm and egg production, some people inherit an XXY combination, but are still male (with Klinefelter syndrome). Others inherit only one X, and are thus denoted XO; they are genetically female (with Turner syndrome). Such people are often, but not

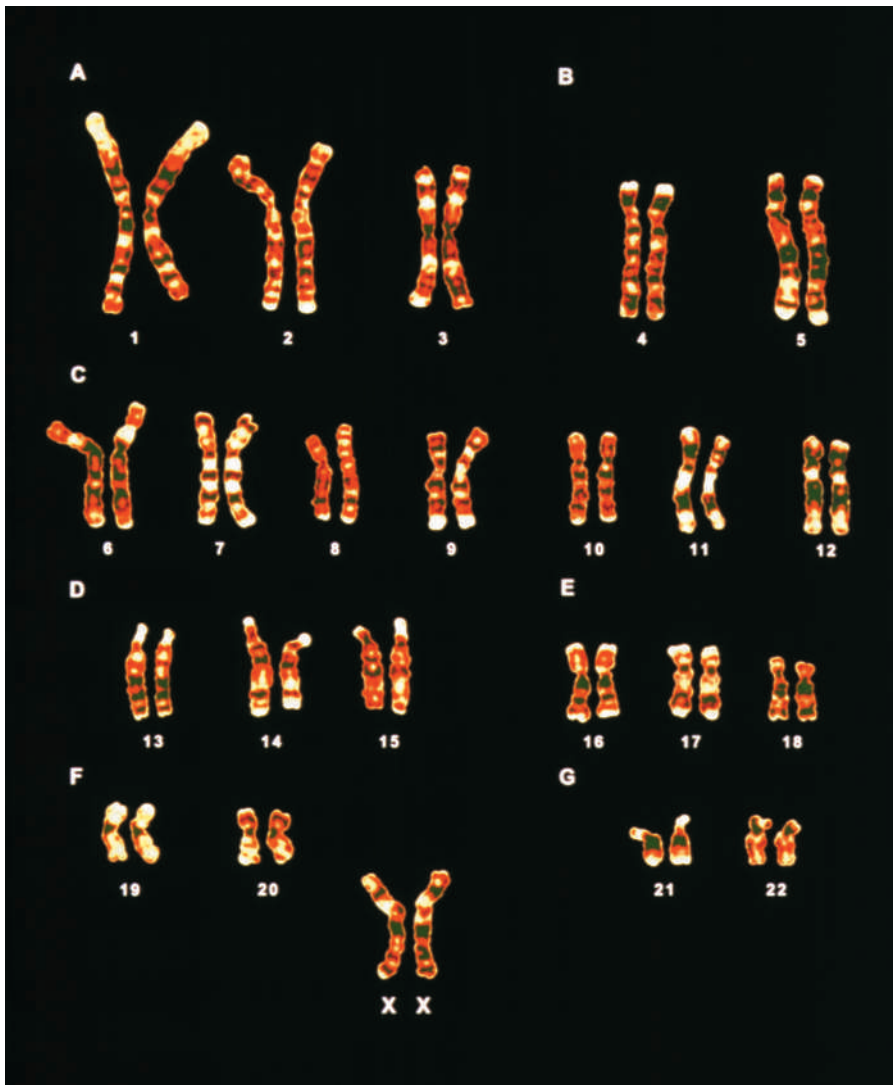

Normal human female chromosomes (XX) in karyotype (their ordered set). The stained banding reveals variations in the DNA sequence composition.

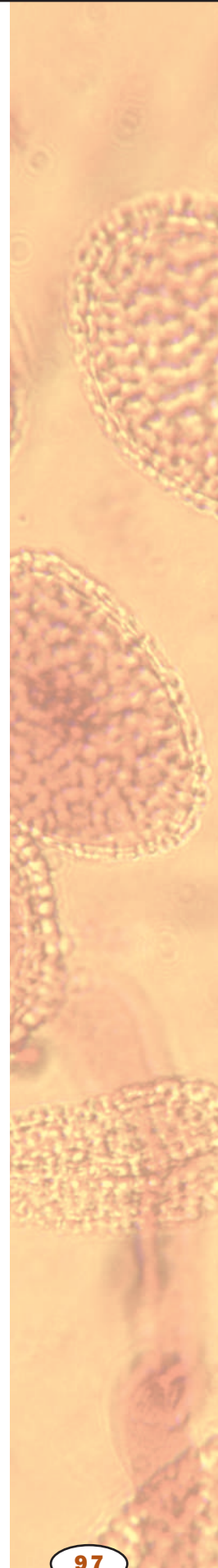

always, sterile. (The YO condition is fatal, because the X carries many genes that are indispensable for survival.)

The biological law that XX results in a female and XY results in a male is true not only in humans, but in all mammals. In birds and most reptiles, however, it is the opposite: XX individuals are male and XY individuals are female. In fruit flies (*Drosophila*), XX is female and XY is male, but the Y is inert and the sex is determined by whether there are two X chromosomes or only one. (Thus, XO is female in humans but male in *Drosophila*.)

Not all animals have sex chromosomes. In ants, wasps, and bees (insect order Hymenoptera), sex is determined by whether or not the egg is fertilized. If it is not, it remains **haploid** ( $n$ ) and produces a male; if fertilized, it becomes **diploid** ( $2n$ ) and produces a female. This is true in some other invertebrates as well, such as rotifers. In whip-tailed lizards of northern Mexico and the southwestern United States, males are nonexistent. Every egg remains unfertilized and produces a female, yet females have to simulate copulation with each other to induce the eggs to develop.

**haploid** having single, nonpaired chromosomes in the nucleus

**diploid** having pairs of chromosomes in the nucleus

**STEVENS, NETTIE MARIA  
(1861–1912)**

American biologist who first showed, in 1906, that sex is determined by the presence or absence of X and Y chromosomes, thus confirming the new theory that chromosomes carry the genes and are the instruments of heredity.

**genitalia** reproductive organs

**gene** portion of DNA that codes for a protein or RNA molecule

**fertilization** union of sperm and egg

**genome** total genetic material in a cell or organism

**zygote** fertilized egg

**Hormonal Sex Determination**

Genes are not enough to make a male or female. To produce a human male requires not only the XY chromosome pair but also an adequate level of testosterone exposure during fetal development. If testosterone or the cellular receptors for it are lacking, as in androgen-insensitivity syndrome (AIS), an XY human may be born with female **genitalia** and misidentified as a baby girl. Conversely, if an XX fetus is exposed to a testosterone excess (from the adrenal glands), the labia may fuse into a scrotumlike sac, the clitoris may grow to resemble a penis, and the baby may be misidentified as a boy; this is called adrenogenital syndrome (AGS). The mistaken identity often comes to light only at puberty, when the individual fails to develop as he or she normally would for the mistakenly assumed sex. Such belated discovery of the child's genetic sex creates some difficult issues of gender identity.

**Environmental Sex Determination**

In some fish and reptiles, sex is determined by the temperature at which the eggs are incubated. In lizards and alligators, warm incubation temperatures cause all eggs to produce males, while temperatures only 1 or 2 degrees Celsius (34 or 35 degrees Fahrenheit) cooler produce females. The opposite is true of most turtles. Thus, a sea turtle might have all daughters if she lays her eggs on a beach site with full sun, but all sons if she lays them in the shade of vegetation in the dunes. Conservationists who rescue sea turtle eggs from predators and hatch them in the laboratory quickly learned that they had to vary the incubation temperature if they were to produce a mixture of sexes.

The sex of an animal is not always fixed for life. Many fish change sex at some point. In some coral reef fish, a male controls a harem of females, and the females have a dominance hierarchy among themselves. If the male dies or disappears, the top-ranking female changes into a male within a few days. Her ovaries regress, testes develop, and she/he soon produces sperm and takes over control of the harem. SEE ALSO CROCODILIANS; FEMALE REPRODUCTIVE SYSTEM; MALE REPRODUCTIVE SYSTEM; REPTILE; SEX CHROMOSOMES; SEXUAL REPRODUCTION; TURTLE

*Kenneth S. Saladin*

**Bibliography**

Crews, David, ed. *Psychobiology of Reproductive Behavior*. Englewood Cliffs, NJ: Prentice Hall, 1987.

Daly, Martin, and Margo Wilson. *Sex, Evolution, and Behavior*, 2nd ed. Belmont, CA: Wadsworth, 1983.

Forsyth, Adrian. *A Natural History of Sex*. Shelburne, VT: Chapters Publishing, Ltd., 1993.

**Sexual Reproduction**

Sexual reproduction is a method for producing a new individual organism while combining **genes** from two parents. A single sperm and egg fuse during **fertilization**, and their **genomes** combine in the new **zygote**. Sperm are small and contain little more than the father's genes. Eggs are large and contain the mother's genes and all cellular components necessary for the



Common frogs in amplexus. Sexually reproducing individuals spend a considerable amount of time and energy locating mates, exchanging genetic material, and often caring for young.

early development and nutrition of the embryo. The sexual dimorphism in **gamete** size is echoed in many other traits of adults and has resulted in the evolution of different male and female reproductive strategies. Sexual reproduction is widespread in almost all groups of multicellular organisms, but the reasons for its evolution and prevalence are not well known.

## Fertilization

Much scientific knowledge about the steps of fertilization comes from observations on sea urchins and other marine invertebrates. In these animals, sperm cells that contact the jelly coat surrounding the egg react with large **carbohydrates** in the jelly. These carbohydrates cause the sperm to release **protein-digesting enzymes** that erode a path through the jelly coat and stimulate the sperm to burrow into the egg. Once the sperm reaches the egg surface, a protein called bindin on the sperm membrane attaches to a receptor molecule on the egg membrane. Following this attachment, the egg and sperm membranes fuse and fertilization is complete.

Fertilization usually must involve only one egg and one sperm. Fusion of additional sperm is prevented by a change in the electrical voltage of the egg cell membrane within a second or two of the first sperm fusing with it. The change in voltage results from sodium **ions** moving into the egg **cytoplasm**, but how it prevents additional sperm from fusing is not well known. Multiple fertilizations are further prevented by chemical reactions that change the receptivity of the egg's outer layers.

Successful fertilization must involve gametes (sperm and egg) from the same species. In many animals with internal fertilization, courtship behaviors and reproductive anatomy prevent fertilization between species. In some animals with external fertilization (like marine invertebrates that release their gametes into the water around them), fertilization involves species-specific chemical interactions. For example, in many sea urchins the

**gamete** reproductive cell, such as sperm or egg

**carbohydrates** sugars, starches, and other molecules combining carbon, hydrogen, and oxygen and serving as fuel or structural components

**protein** complex molecule made from amino acids; used in cells for structure, signaling, and controlling reactions

**enzyme** protein that controls a reaction in a cell

**ion** an electrically charged particle

**cytoplasm** material in a cell, excluding the nucleus

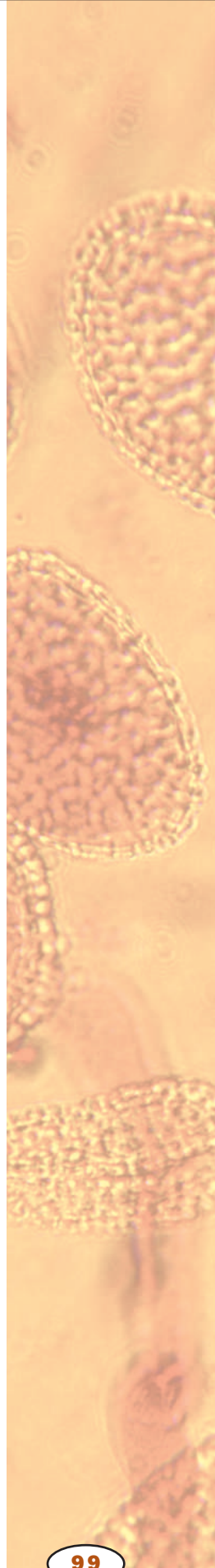



**JUST, ERNEST E.  
(1883–1941)**

American biologist who first described how fertilization sets the stage for development. Just found that the place on an egg where a sperm enters determines which side of the embryo will be the dorsal (back) side and which the ventral (belly) side.

**prostaglandins**  
hormone-like molecules released by one cell that affect nearby cells, including smooth muscle

sperm-activating carbohydrates in the jelly and the bindin and bindin-receptor proteins are very species-specific, thereby ensuring conspecific fertilizations.

### Male and Female Sexual Strategies

Because their gametes are rare and energetically costly to produce, females suffer a greater consequence of mating with the wrong species or with a low-quality mate than do males. This disparity between the sexes imposes different selective pressures on males and females. Females usually increase their evolutionary fitness (number of surviving offspring) by mating with high-quality males. Males usually increase their fitness by mating frequently to increase the chances that their sperm will encounter a rare egg. Consequently, females have often evolved mechanisms for choosing the fathers of their children, while males have often evolved mechanisms for gaining access to females and their eggs.

Males may gain access to females by competing with other males. The enormous size of bull elephant seals and the head-slamming contests of mountain goat rams are familiar examples of attributes that increase an individual male's access to females. More cryptically, competition for access to eggs rather than to females can occur among sperm even after mating has occurred. For example, boars and some promiscuous monkeys produce copious amounts of semen to displace the sperm left in the female's vagina by other males. A male damselfly will remove a previous male's sperm from a female before depositing his own. Male snakes insert a plug into the female's reproductive tract after mating to prevent insemination by subsequent males. Many rodents have evolved penises with hooks and spines to dislodge the plug left by a previous male. And mammalian semen contains **prostaglandins** that stimulate the uterus to contract, thereby pumping the semen toward the egg and hastening fertilization.

Females can choose mates on the basis of material offerings or particular male traits. Female hangingflies mate with males that present them with large prey items, while peahens choose peacocks with showy tails, and female frogs choose males with energetic calls. As with sperm competition in males, females may also exercise cryptic choice in deciding which males will fertilize their eggs even after mating with them. Examples include beetles in which the female contracts muscles in her reproductive tract to prevent males from inserting their sexual organs completely, lionesses that delay ovulation after their pride is taken over by new males, zebras that eject semen from their vaginas, and female spiders that transport more or less sperm from a given male down their reproductive tracts depending on the vigor of his courtship.

### Evolution of Sexual Reproduction

Many organisms reproduce asexually; that is, they produce genetically identical clones. All of an asexual individual's offspring can also produce offspring, but for a sexual female that produces both daughters and sons, only the daughters can bear young. If an asexual individual and a sexual female each produce the same total number of offspring in an unchanging environment, then the asexual individual will have twice as many grandchildren as will the sexual female (since only half of the sexual female's children will

bear young), four times as many great-grandchildren, and so on. In this sense, sex is evolutionarily very costly; that is, it appears to have a lower fitness than a strictly asexual strategy. Sex also carries other costs such as energy expenditures associated with finding and competing for mates and the risk of exposure to sexually transmitted diseases. So why has sex evolved and why does it persist?

Most explanations for sex are based on the fact that sexual reproduction results in genetically variable offspring, whereas asexual reproduction does not. Genetic variation among offspring is valuable, particularly when environments change over time. If the environment changes for the worse, an asexual mother may lose all of her offspring, while a sexual mother is likely to have at least some of her offspring survive the new conditions. Environments usually do change, particularly in terms of the adaptations of other organisms with which a species interacts. In such uncertain environments sexual reproduction should be favored by natural selection. But as in much of biology, there is no single widely accepted answer for the evolution and persistence of sex in all organisms. SEE ALSO EVOLUTION; FEMALE REPRODUCTIVE SYSTEM; FETAL DEVELOPMENT, HUMAN; MALE REPRODUCTIVE SYSTEM; MATING SYSTEMS; MEIOSIS; SEX DETERMINATION; SEXUAL REPRODUCTION, EVOLUTION OF; SEXUAL SELECTION

*Tim Watkins*

### **Bibliography**

- Alcock, John. *Animal Behavior: An Evolutionary Approach*, 6th ed. Sunderland, MA: Sinauer Associates, Inc., 1998.
- Catton, Chris, and James Gray. *Sex in Nature*. New York: Facts on File Publications, 1985.
- Eberhard, William. *Female Control: Sexual Selection by Cryptic Female Choice*. Princeton, NJ: Princeton University Press, 1996.
- Forsyth, Adrian. *A Natural History of Sex*. Shelburne, VT: Chapters Publishing, 1986.
- Gilbert, Scott. *Developmental Biology*, 5th ed. Sunderland, MA: Sinauer Associates, Inc., 1997.

## **Sexual Reproduction, Evolution of**

The most basic way to reproduce is to make more copies of one's self, a process called asexual reproduction. In contrast, sexual reproduction involves the union of specialized sex cells (eggs and sperm) from two parents to produce genetically unique offspring.

### **Asexual Reproduction**

A variety of ways exist by which organisms can reproduce asexually. Many protozoans, such as Euglena or Amoeba, undergo binary fission, whereby a single-celled organism divides evenly into two identical cells. Others, such as Trypanosoma (which causes African sleeping sickness), undergo multiple fission, involving repeated nuclear division before splitting into many daughter cells. Some organisms divide in a different way, with a single parent forming an outgrowth, or bud. Many yeasts, hydroids, and freshwater sponges reproduce by budding, typically in combination with sexual reproduction. A wide variety of organisms are capable of regenerating whole individuals from a fragment. Flatworms, sea anemones, green algae, and some

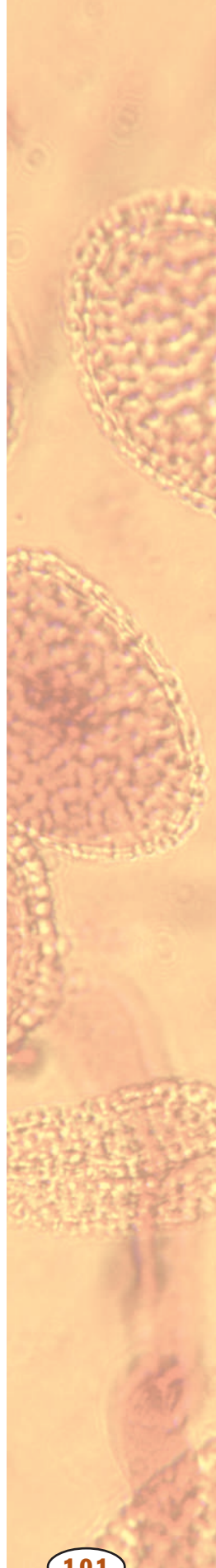

Rainbow trout hatchlings emerging from their eggs. Organisms producing many unique individuals in an unpredictable environment have a greater chance that at least some their offspring will survive.



**nematode** worm of the Nematoda phylum, many of which are parasitic

**meiosis** cell division that forms eggs or sperm

plants can reproduce asexually by fragmentation if injured, and some sea stars can actually split their own body into pieces to form multiple individuals.

Parthenogenesis is another unique form of asexual reproduction in which female organisms are able to produce offspring from unfertilized eggs. Several species of **nematodes**, crustaceans, insects, and desert lizards are able to reproduce parthenogenetically. Many plants are capable of reproducing both asexually and sexually. Asexual reproduction occurs in a variety of ways, including production of rhizomes (horizontal underground stems), runners (aboveground stems that run along the ground), and suckers (vertical stems that arise from the base of stumps or existing stems).

Because asexually reproducing organisms produce identical copies of themselves, they pass on the maximum quantity of their own genetic material to each offspring: 100 percent. This kind of reproduction is typically very rapid.

### Sexual Reproduction

In contrast, sexually reproducing individuals spend a considerable amount of time and energy locating mates, exchanging genetic material, and often caring for young. Sexual reproduction begins with production of sex cells via **meiosis**, a process that halves the genetic material of each parent in preparation for combination with another sex cell. Consequently, a sexually reproducing parent transfers only 50 percent of its genetic material to each offspring. This loss in genetic contribution to each offspring is known as the cost of meiosis. In addition to this cost, males produce enough sperm to fertilize the eggs of many females, yet many males in some species never even fertilize one egg, resulting in many wasted sperm. In light of all of these disadvantages, why did sexual reproduction evolve?

For some plants, spore-forming protozoans, and invertebrates, sexual reproduction may yield seeds or eggs that are resistant to harsh environments and are capable of being dispersed. However, scientists agree that

the most important advantage of sexual reproduction is the variation produced by the continual recombination of sex cells to create unique individuals. In 1930, Ronald A. Fisher noted in *The Genetical Theory of Natural Selection* that this variation allowed evolution to occur at a faster rate. This idea led to two theories explaining how increased genetic variation might benefit individuals.

### Importance of Genetic Variation

George Williams compared reproduction to a raffle in which one can either have many tickets with different numbers (sexual reproduction) or many tickets with the same number (asexual reproduction). If one doesn't know which number will be drawn in a raffle, it is better to have many different tickets. Similarly, organisms producing many unique individuals in an unpredictable environment have a greater chance that at least some their offspring will survive. Thus, Williams proposed that sexual reproduction evolved because of the benefits gained by organisms in fluctuating physical environments. This is often called the “bet-hedging” or “tangled bank” hypothesis.

Others argue that sexual reproduction evolved because of advantages gained in the face of changes in other organisms. Predators, prey, and **parasites** constantly improve their efficiency at capturing prey, evading predators, and extracting nutrients from hosts. Genetically variable offspring offer more opportunities for each to increase its efficiency. This is called the “Red Queen” hypothesis after the popular book, *Alice in Wonderland*, in which the queen tells Alice, “Now *here*, you see, it takes all the running you can do, to keep in the same place.”

Scientists have collected data in support of each of these hypotheses. The bet-hedging or tangled bank hypothesis predicts that sexual reproduction should predominate in unpredictable environments, while asexual reproduction should be found more frequently in stable environments. In support of this prediction, scientists have found that when species alternate between sexual and asexual reproduction, they often reproduce asexually in the spring and summer but sexually in the fall and winter when the environment is harsher.

The Red Queen hypothesis, on the other hand, predicts that sexual reproduction should increase in frequency as rates of parasitism or predation increase. Curt Lively studied a species of snail that lives in lakes and streams in New Zealand. He found more parasites infecting the snails living in the lakes than the snails living in the streams. As predicted by the Red Queen hypothesis, the snails in the lakes were more likely to reproduce sexually than those living in the streams. Furthermore, the number of males in a population (an indicator of the frequency of sexual reproduction) increased as rates of parasitism increased. Scientists continue to seek support for each of these hypotheses, and it appears likely that each applies to at least some situations; both environmental and **biotic** fluctuations make sexual reproduction advantageous.

Michelle J. Solensky

#### Bibliography

Bell, Graham. *The Masterpiece of Nature: The Evolution and Genetics of Sexuality*. Berkeley, CA: University of California Press, 1982.

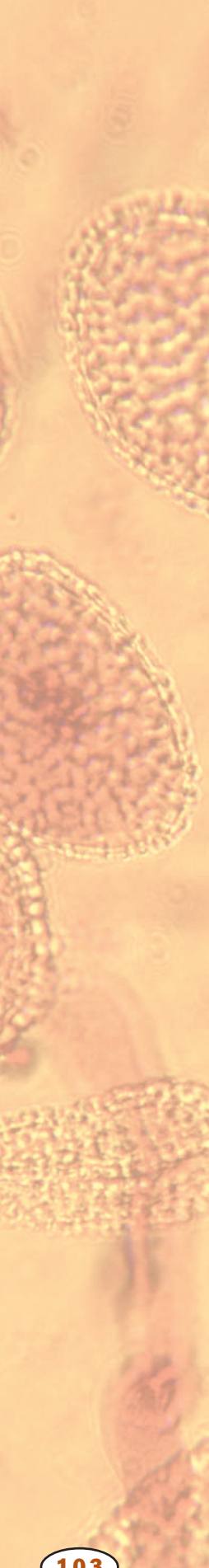

**parasite** organism living in close association with another from which it derives most of its nutrition

**biotic** living

- Fisher, Ronald A. *The Genetical Theory of Natural Selection*. Oxford: Clarendon Press, 1930.
- Hamilton, William D., R. Axelrod, and R. Tanese. "Sexual Reproduction as an Adaptation to Resist Parasites." *Proceedings of the National Academy of Science USA* 87 (1990): 3566–3573.
- Hurst, L. D., and William D. Hamilton. "Cytoplasmic Fusion and the Nature of Sexes." *Proceedings of the Royal Society of London, Series B: Biological Sciences* 247 (1992): 189–194.
- Lively, Curt M. "Evidence from a New Zealand Snail for the Maintenance of Sex by Parasitism." *Nature* 328 (1987): 519–521.
- Williams, George C. *Sex and Evolution*. Princeton, NJ: Princeton University Press, 1975.

## Sexual Selection

English naturalist Charles Darwin revolutionized scientific thinking when he proposed that species evolve over time to become adapted to their environments by means of natural selection in his *On the Origin of Species* (1859). He was initially puzzled, though, by the seemingly useless exaggerated characters often found in animals, particularly males. The long and colorful tail of the peacock, for example, seemed to hinder rather than help its bearer survive. In his later work, *The Descent of Man, and Selection in Relation to Sex* (1871), Darwin proposed that some characters do not increase survival, but instead increase reproductive success. He called this sexual selection, which refers to the process that produces traits that affect an individual's reproductive success as a result of competition over mates.

While both sexual selection and natural selection are evolutionary processes that increase an organism's fitness, they differ in several important ways. Environmental, physical, or biological factors often drive natural selection, whereas sexual rivals and mates are the exclusive agents of sexual selection. Furthermore, the evolutionary effects of sexual selection differ markedly from those of natural selection. Sexual selection frequently produces sexual dimorphism and exaggerated male traits, often in opposition to the forces of natural selection.

For example, male widowbirds have extraordinarily long tails (more than twice their body length) that make flight more difficult. When researchers manipulated the tail length of several males, they found that female widowbirds preferred males with longer tails to males with short or normal length tails. Thus, while the long tails of widowbirds may be selected against by natural selection, they are favored by sexual selection.

There are two broad categories of sexual selection: intrasexual selection (members of one sex compete among themselves for reproductive opportunities with individuals of the other sex) and intersexual selection (members of one sex choose among members of the other sex).

### Intrasexual Selection

Many examples of intrasexual selection are readily observable. Males of many species fight, display, vocalize, and otherwise compete for the opportunity to mate with available females. Male deer fight with their antlers and enormous male elephant seals fight with their bulk to establish dominance and

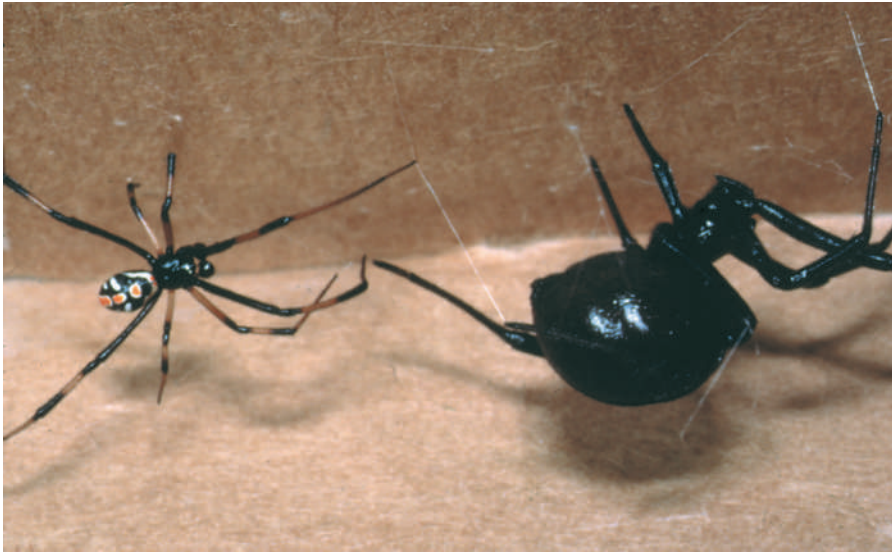

Male (left) and female black widow spiders. Mate choice is a widely popular topic of study.

consequently the right to mate with females. Male red-winged blackbirds display and sing to establish their territories, the quality of which determines the number of mates they will attract.

Post-mating competition also occurs. Male dragonflies often guard their mates after copulation to ensure that the female lays her clutch of eggs before remating. Male fruit flies sometimes transfer a substance to their mate that inhibits courtship by subsequent males. Male dunnocks (a small European bird) often peck the **cloaca** of their mate until she everts it, sometimes ejecting sperm.

Once the male has successfully rid the female of the sperm from a previous mate he will proceed to reseed her. Some male parasitic worms cement the **genitalia** of their mates after copulation to form a copulatory plug. These male worms take intraspecific competition one step further by occasionally “mating” with rival males and cementing the genitalia of their rivals to prevent subsequent sperm transfer.

## Intersexual Selection

For several decades after Darwin presented his theory of sexual selection, most naturalists discounted the importance of intersexual selection, or mate choice. However, in the 1950s a few scientists began to revisit this subject, and by the 1980s mate choice had gained wide popularity as a topic of study.

Many exaggerated male traits are now thought to have evolved as a result of female mate choice, although several competing hypotheses exist to explain the origin and maintenance of these female preferences. Ronald A. Fisher proposed an explanation called “runaway sexual selection” in *The Genetical Theory of Natural Selection* (1930). Fisher suggested that as females began to evolve a preference for a particular male trait, such as tail feather length, these females would be more likely to mate with males who displayed the preferred trait. The offspring of these matings would inherit the genes for both the male trait and the female preference, resulting in a genetic correlation between the preference and the trait. Consequently, as the male trait spreads because females prefer it, the female preference itself also

**cloaca** common exit cavity for intestinal, genital, and urinary tracts

**genitalia** reproductive organs

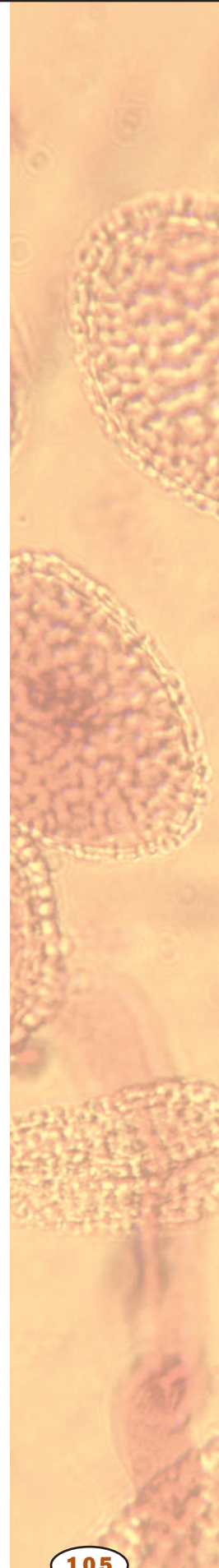

spreads because it is linked with the male trait. This is called a self-reinforcing choice, and is one way that exaggerated male traits can evolve without conferring any direct benefits on the females who prefer them.

Another explanation for the evolution of female choice is called the handicap hypothesis. In his study “Mate Selection—A Selection for a Handicap” (1975), Amotz Zahavi suggested that exaggerated male traits indicate to females that the male is healthy enough to survive despite his substantial handicap. The exaggerated trait is a signal through which females can assess a male’s genetic quality, and therefore is often called a good genes hypothesis. This is another way that exaggerated male traits can evolve without directly benefiting the females who prefer them.

Other explanations of the evolution of female mate choice include sensory bias (for example, female frogs prefer males who call loudly or in a low pitch because they can hear them better) and direct benefits (for example, females might prefer males who provide superior resources, defense, or parental care).

### Experimental Techniques

The refinement of several genetic analyses in the late 1980s and the 1990s have contributed greatly to the study of sexual selection. Using deoxyribonucleic acid (DNA) fingerprinting, microsatellite DNA typing, and related techniques, researchers can confidently assign paternity to offspring using genetic markers, whereas in the past they had to rely on behavioral cues. These techniques are particularly well used in **avian** studies, where scientists are learning that many birds thought to be monogamous actually have a high frequency (30 to 95 percent) of promiscuity. Using molecular techniques to definitively assign paternity has and will continue to further the study of sexual selection, particularly mate choice and sperm competition. SEE ALSO BEHAVIOR, GENETIC BASIS OF; DARWIN, CHARLES; EVOLUTION; MATING SYSTEMS; NATURAL SELECTION; SEXUAL REPRODUCTION

Michelle J. Solensky

### Bibliography

- Andersson, Malte. *Sexual Selection*. Princeton, NJ: Princeton University Press, 1994.
- . “Female Choice Selects for Extreme Tail Length in a Widowbird.” *Nature* 299 (1982): 818–820.
- Darwin, Charles. *On the Origin of Species by Means of Natural Selection, or the Preservation of Favoured Races in the Struggle for Life*. London: John Murray, 1859.
- . *The Descent of Man, and Selection in Relation to Sex*. London: John Murray, 1871.
- Fisher, Ronald A. *The Genetical Theory of Natural Selection*. Oxford: Clarendon Press, 1930.
- Zahavi, Amotz, and Avishag Zahavi. *The Handicap Principle: A Missing Piece of Darwin’s Puzzle*. New York: Oxford University Press, 1997.

## Sexually Transmitted Diseases

A sexually transmitted disease (STD) is any disease whose primary (though not necessarily only) mode of transmission is some form of sexual contact. STDs may be viral, bacterial, protistan (protozoan), or fungal. Certain

**avian** concerning birds

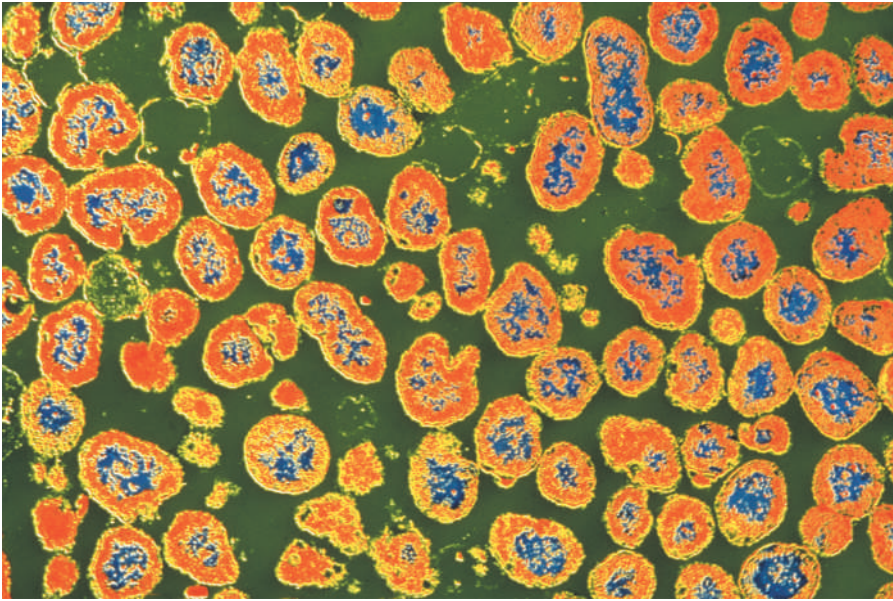

Colorized micrograph of gonorrhea cells. Because of the permanent reproductive tract damage gonorrhea can cause, it is often called the “great sterilizer.”

STDs, such as gonorrhea and syphilis, are classified as “reportable” because when diagnosed they must be reported to a proper health or government agency to prevent their spread.

## Bacteria

**Gonorrhea.** Gonorrhea, one of the most widespread of the STDs, is caused by the bacterium *Neisseria gonorrhoeae*, some strains of which are resistant to treatment by penicillin as well as the other drugs of choice. The organism itself is quite fragile and cannot survive long enough outside the body to be transmitted from one person to another via infected toilet seats, clothing, or household utensils. It is readily killed by sunlight, drying, or ultraviolet light.

Although any **mucous membrane** may be affected, the usual gonorrheal infection is found in the genitourinary tract. In the female, the symptoms of gonorrhea are usually mild and may resemble a simple vaginal infection, or they may go completely unnoticed. If left untreated in females, the infection can cause a blockage of the **fallopian tubes** as well as other pelvic inflammatory diseases. Because of the permanent reproductive tract damage gonorrhea can cause it is often called the “great sterilizer.”

In males, the organism often causes a painful infection of the urethra and if left untreated, a complete blockage of the urethra can occur. Other complications of gonorrhea may include damage to the kidneys, heart valves, and joints. The rectal area, **conjunctiva**, and oral mucosa may also be affected. Because infants can acquire gonorrhea of the conjunctiva while passing through the birth canal of an infected mother, the eyes of newborns are routinely treated with silver nitrate or a penicillin ointment.

**Syphilis.** Syphilis begins when the spirochete bacterium *Treponema pallidum* enters the body through a tiny break in the skin. The primary lesion, forming at the site of entry between ten and ninety days after infection, is called a chancre and it is teeming with the spirochetes. This chancre is also normally painless and thus may go undetected, particularly in females if it

**mucous membrane** outer covering designed to secrete mucus, often found lining cavities and internal surfaces

**fallopian tubes** tubes through which eggs pass to the uterus

**conjunctiva** eye membrane that helps seal the eye socket

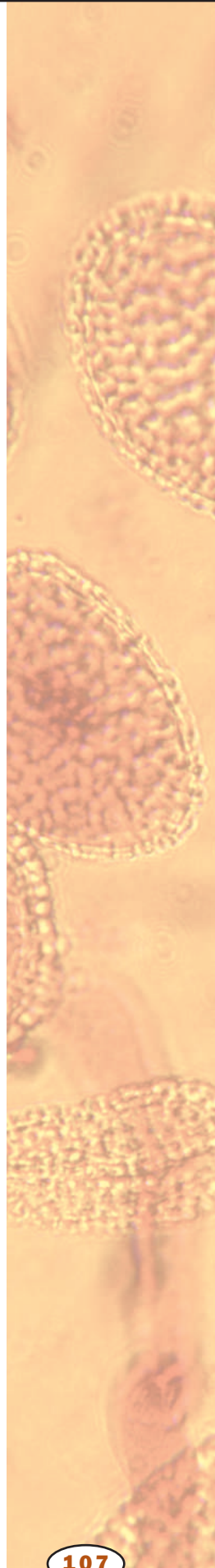



Syphilitic infection on a man's back. Syphilis is classified as a "reportable" disease: when a case of syphilis is diagnosed, it must be reported to a proper health or government agency to prevent its spread.



**hypersensitivity reaction** immune reaction characterized by rapid and severe response, often with swelling of airways

**tertiary** third level

**aneurysm** bulging of the wall of a blood vessel

**central nervous system** brain and spinal cord

**congenital** present at birth; inherited

**coronary artery** artery supplying blood to the heart

is high in the vagina. The chancre usually disappears, but the organisms disperse to various parts of the body. About six weeks later, secondary syphilis appears as a **hypersensitivity reaction** to the bacteria. Secondary syphilis is usually characterized by a generalized skin rash (including on the palms of the hands and the soles of the feet) and often by such flu-like symptoms as headache, fever, and general malaise.

In about half the cases, anywhere from several months to twenty or more years after the initial infection, syphilis progresses to the **tertiary** stage. (Of the remaining cases, about half appear to be cured, and the rest, while not cured, do not seem to progress to the tertiary stage.) Tertiary syphilis may be relatively mild, affecting only the bones or skin; or it may be serious or even fatal, affecting the cardiovascular system (causing such conditions as aortic **aneurysms**) or the **central nervous system** (causing paralysis or syphilitic insanity). In **congenital** syphilis, the fetus acquires the disease prenatally; the chancre of primary syphilis is bypassed.

Syphilis is usually treated with penicillin, which is especially effective in primary and secondary cases. Other drugs can be used. Treating a pregnant woman also treats her child. As with the gonorrhea organism, *Treponema pallidum* is quite fragile and cannot survive long enough outside the body to be transmitted from one person to another via infected toilet seats, clothing, or household utensils.

**Nongonococcal Urethritis (NGU).** Nongonococcal urethritis is a categorical term for any of a number of inflammatory diseases of the sexual organs. By far the most frequently observed of the STDs is chlamydial NGU. Other chlamydial infections include trachoma, an eye disease, and possibly certain arterial plaques and other **coronary artery** diseases.

**Chlamydial NGU.** Chlamydial NGU, caused by the **obligate intracellular** bacterium *Chlamydia trachomatis*, is also a reportable STD. Chlamydial NGU is often a secondary infection following a gonorrheal infection. Although asymptomatic infections are common in both sexes, in males chlamydial NGU causes urethritis, and in females it causes urethritis, cervicitis, and pelvic inflammatory disease (PID). In serious cases, acute complications such

**EHRlich, PAUL  
(1854–1915)**

German physician who discovered an effective drug treatment for the sexually transmitted disease syphilis. Ehrlich's drug was the first example of a modern antibiotic, a substance that specifically kills disease-causing organisms without significantly hurting the patient. He won many awards and prizes, including the 1908 Nobel Prize in medicine.

as testicular or prostate swelling in males or the **lysing** of fallopian tube cells in females can occur.

**Pelvic Inflammatory Disease.** Pelvic inflammatory disease is a categorical term for any of several inflammations of the pelvic organs. The most common causative agents of PID are *Chlamydia trachomatis* and *Neisseria gonorrhoeae*. The specific drug of choice for treatment depends on the cause of the PID. PID is more commonly associated with females than with males. Untreated PIDs can be extremely serious. PID is a leading cause of sterility, particularly among females.

**Lymphogranuloma Venereum (LGV).** Lymphogranuloma venereum is caused by a specific strain of *Chlamydia trachomatis* and is one of the most serious of the chlamydial infections. This disease occurs more frequently in males and is characterized by swelling in the groin and in the lymph nodes. The bacteria may also cause proctitis (inflammation of the rectal tissues). Doxycycline is the drug of choice.

## Viruses

**Herpes.** Herpes is a virus or family of viruses (the herpes viruses) causing cold sores, fever blisters, and genital infections. Herpes virus type I (HV1) was formerly thought of as causing problems “above the belt,” while Herpes virus type 2 (HV2) has been credited with problems “below the belt.” Today it is known that either HV1 or HV2 (including their many **serotypes**) can infect any area of the body.

Genital (or anogenital) herpes results in painful blisters of the anus, penis (in males), and cervix, **vulva**, or vagina (in females). The disease, which can recur at sporadic intervals, is most contagious during the blister stage. Although the disease is incurable, it can be treated. Acyclovir is the drug of choice. Because genital herpes can be passed on through the birth canal, babies of pregnant women with this infection are often delivered by caesarian section. A significant correlation exists in females between genital herpes and cervical cancer.

**Genital Warts.** Genital warts are caused by a group of papilloma viruses. The presence of these warts in women has been associated with an increased risk of cervical cancer. Warts can be removed surgically, chemically, or by cryotherapy (freezing).

**The Hepatitis Viruses.** The hepatitis viruses, often identified today as A, B, C, D, and E, are not strictly STDs. However, hepatitis B and hepatitis C can be spread by sexual contact and hepatitis B can be spread in utero.

## Protozoans and Yeast

**Trichomoniasis.** Trichomoniasis is an NGU caused by the protozoan *Trichomonas vaginalis*. Although usually sexually transmitted, this disease is occasionally acquired from infected toilet or sauna seats, paper towels, or clothing. The organism infects the vagina and urethra of females and affected women experience vaginitis, vaginal discharge, and painful urination. In males the organism can infect the prostate, seminal **vesicles**, and urethra. The disease seems to be more prevalent among females than males, although males are more likely than females to be **asymptomatic**.

**obligate** required or necessary, especially referring to a metabolic process or mode of nutrition

**intracellular** within a cell

**lysing** disintegration or dissolution of cells

**serotype** identity of an organism or virus based on reaction to an antibody

**vulva** external female genitalia

**vesicle** membrane-bound sac

**asymptomatic** without symptoms

### HAZEN, ELIZABETH LEE (1885–1975)

U.S. biologist who, with Rachel Brown (1898–1980), developed the first fungicide. Nystatin is still used to treat dangerous oral and intestinal yeast infections. Hazen was orphaned at age two, attended the first state-supported college for women in the United States, and succeeded against great odds to become a biologist. Hazen and Brown donated all royalties from nystatin—worth more than \$13 million—to academic science.

**opportunistic** infectious in an immunosuppressed person but not a healthy person

**systemic** throughout the body

**minerals** iron, calcium, sodium, and other elements needed by living organisms

**xylem** water-transporting system in plants

**phloem** plant tissue that conducts sugars from leaves to roots and other tissues

**Candidiasis.** Candidiasis, caused by the fungus (yeast) *Candida albicans*, is an **opportunistic** disease that often infects the vaginal tract, oral cavity, or respiratory system. The organism can also cause **systemic** tissue damage. SEE ALSO AIDS; BACTERIAL CELL; BACTERIAL DISEASES; BIRTH CONTROL; FEMALE REPRODUCTIVE SYSTEM; FUNGAL DISEASES; MALE REPRODUCTIVE SYSTEM; PARASITIC DISEASES; PROTOZOAN DISEASES; VIRAL DISEASES

Roberta M. Meehan

### Bibliography

Berkow, R. *The Merck Manual of Diagnosis and Therapy*, 16th ed. Rahway, NJ: Merck Research Laboratories, 1992.

Carlson, K. J., S. A. Eisenstat, and T. Ziparyn. *The Harvard Guide to Women's Health*. Cambridge, MA: Harvard University Press, 1996.

Center for Disease Control, Division of Sexually Transmitted Diseases. <[www.cdc.gov/nchstp/dstd/disease\\_info.htm](http://www.cdc.gov/nchstp/dstd/disease_info.htm)>.

Madigan, Michael T., John M. Martinko, and Jack Parker. *Brock Biology of Microorganisms*, 9th ed. Upper Saddle River, NJ: Prentice Hall, 2000.

## Shoots

The shoot is the production center for a plant. It is the organ system that gives rise to stems, leaves, and flowers. Therefore, the shoot system is functionally responsible for food production (photosynthesis) and reproduction. Shoots can be classified as vegetative or floral. Vegetative shoots are described in this article.

### Anatomy

Vegetative shoots consist of stems and leaves. The stem is the major structural support for the plant, but also contains vascular tissues that transport water, **minerals**, and food throughout the plant. Examining the organization of plant tissues within a stem highlights these functional characteristics. The outer regions of the stem are covered with dermal tissue made up of epidermal cells. These cells protect the stem and help to prevent water loss. Internal to the epidermis lies the ground tissue and vascular bundles. The organization of these tissue types within a stem varies with the type of plant. For example, monocotyledons have vascular bundles of **xylem** and **phloem** scattered throughout the diameter of the stem with ground tissue surrounding them. In contrast, dicotyledons have vascular bundles that are arranged in a ring surrounded by ground tissue. The ground tissue that lies to the exterior of the vascular bundle ring is called cortex, and the ground tissue that lies interior to the vascular bundles is called pith.

### Vascular Functions

Regardless of the organization within the stem, the function of the vascular components is essentially the same in all higher plants. The xylem transports the water and minerals absorbed by the root up through the stems to the leaves and flowers. On the other hand, the phloem transports the sugars and other nutrients, made by the leaves throughout the plant, to the root for immediate use or for storage during periods of dormancy and to flow-



Young shoots of fiddlehead ferns.

ers for growth or fruit production. The ground tissue, which constitutes the bulk of the stem, is mainly composed of parenchyma cells that produce **carbohydrates** (via photosynthesis) and store nutrients. However, the ground tissue also contains collenchyma and sclerenchyma cells that provide support with their rigid cell walls.

### Branching

On a larger anatomical scale, stems contain nodes, where leaves are attached, and internodes, the stem segments between nodes. There is usually a main shoot and side shoots, called branches. The side shoots grow from axillary buds that form at the nodes. In a young plant, most of the growth in the shoot system occurs in the main shoot and the developing leaves. During this stage, the growth is concentrated in the terminal bud at the shoot tip. The plant invests its energy into growing taller in order to maximize the plant's exposure to light. In fact, certain cells in the shoot tip produce a **hormone**, called auxin, that is transported down the shoot and functions to inhibit the growth of axillary buds. As the plant ages, the stimulatory effects of a group of hormones called cytokinins overcome the inhibitory control of auxin and the axillary buds begin to develop into **lateral** branches. This results in a bushier plant that allows for more leaf growth and greater exposure to the plant's environment. These hormonal effects are often taken advantage of in agriculture and gardening to manipulate the shape of a plant. Removing the shoot tip ("cutting back") will remove the source of auxin and will stimulate the growth of axillary buds, and make the plant thicker and bushier.

### Modified Shoots

Some plants have modified stems that serve a variety of different functions. Strawberries have modified stems called stolons that grow on the surface of the ground and allow the plant to spread and occupy a large section of

**carbohydrates** sugars, starches, and other molecules combining carbon, hydrogen, and oxygen and serving as fuel or structural components

**hormone** molecule released by one cell to influence another

**lateral** side-to-side

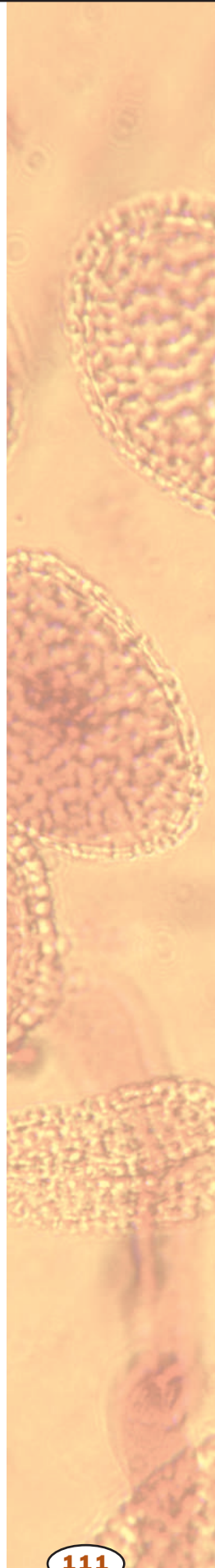

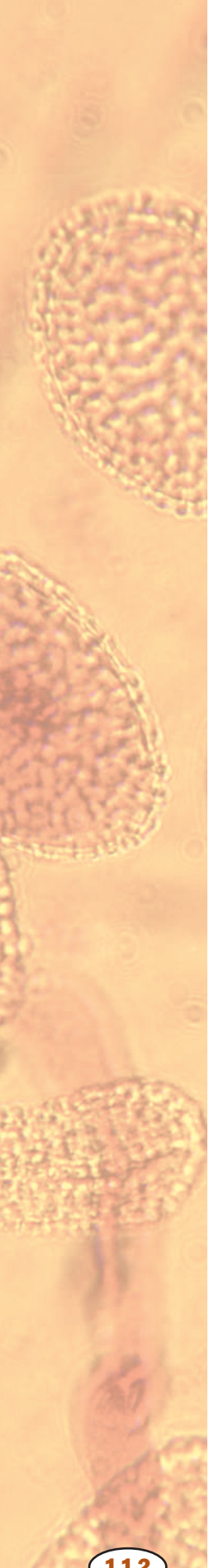

**guard cells** paired cells on leaves that control gas exchange and water loss

**stomata** openings in leaves for gas exchange, surrounded and regulated by guard cells

**motile** able to move

**protein** complex molecule made from amino acids; used in cells for structure, signaling, and controlling reactions

**neurotransmitters** molecules released by one neuron to stimulate or inhibit another neuron or cell

**hormone** molecule released by one cell to influence another

nutrient-rich soil. Tubers, such as the modified stems of white potatoes, are specialized for food storage. Bulbs are also modified stems that are specialized for storage, and rhizomes are stems that grow laterally underground and are often mistaken for roots.

## Leaves

Leaves are the major sites of photosynthesis in most plants. They are joined to the stem via a petiole and extend from the stem at nodes. While leaves of different plants vary greatly in size and shape, they have several similar cellular features that optimize photosynthesis. Like stems, leaves are covered with epidermal cells that protect the leaf from excessive water loss. Leaves, however, have specialized epidermal cells called **guard cells**, which surround pores called **stomata**. Stomata facilitate the exchange of gases in the leaf. CO<sub>2</sub> diffuses into the leaf through the stomata for use in photosynthesis, and O<sub>2</sub>, the waste product of photosynthesis, diffuses out of the leaf through stomata. The vascular tissue within a leaf is organized into veins. The remaining tissue in the leaf is ground tissue. This ground tissue is composed mostly of parenchyma cells that have numerous chloroplasts in which photosynthesis takes place. SEE ALSO DIFFERENTIATION IN PLANTS; FLOWERS; LEAVES; MERISTEMS; ROOTS

Susan T. Rouse

## Bibliography

*Atlas of Plant Anatomy*. <<http://atlasveg.ib.usp.br/English/>>.

Moore, Randy, W. Dennis Clark, and Kingley R. Stern. *Botany*. Boston: William C. Brown Publishers, 1995.

## Signaling and Signal Transduction

All cells are able to sense and respond to substances present in their external environments. For example, **motile** bacteria will move toward a source of sugar but away from a toxic chemical such as phenol. Cells are not only able to sense chemical substances in their environments, but also such things as heat and cold. Sudden exposure to elevated temperatures results in the synthesis of a set of **proteins** that protect the cell from heat damage.

The ability to respond to external stimuli enhances a cell's chance of survival, but in addition, especially in multicellular organisms, responding to external stimuli can be part of a cell's moment-to-moment function. For example, nerve impulses are transmitted through the body by the action of extracellular signaling molecules called **neurotransmitters**. Insulin, a **hormone** circulating in the bloodstream, promotes the absorption of sugar into a variety of cell types. Neurotransmitters and hormones are two important examples of extracellular signaling molecules released by one cell to influence another.

Extracellular signaling molecules exert their effects on a cell by binding to cellular receptors. In some cases these are inside the cell, and the signaling molecule must pass through the membrane to bind with the receptor. In most cases, however, the receptor spans the plasma membrane and the signal remains outside the cell. A membrane receptor is ideally positioned to sense signals on the outside and transmit them to the cell's interior. The

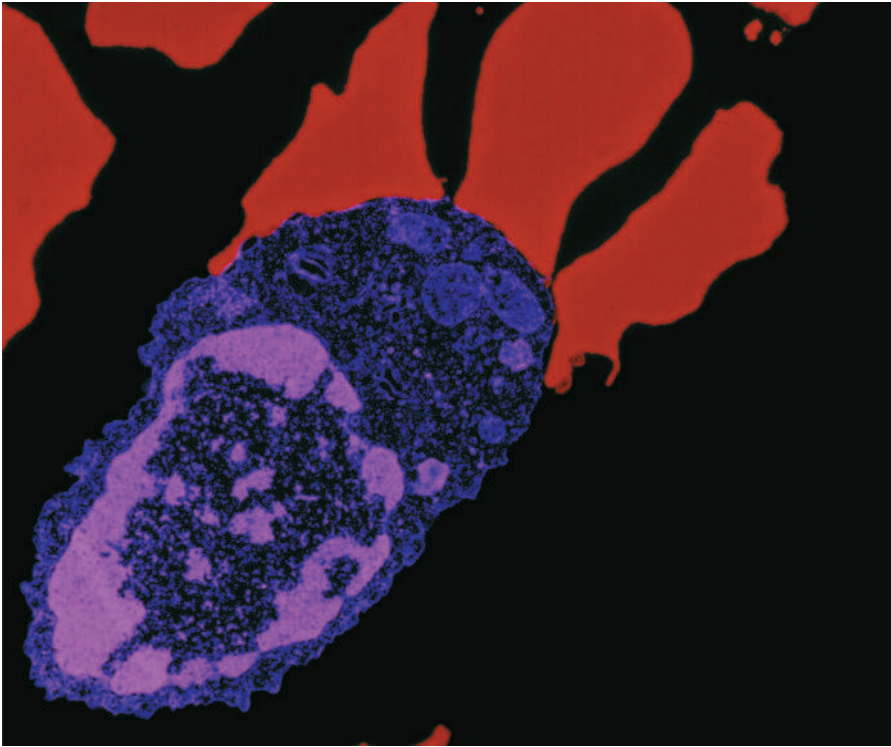

A scanning electron micrograph of lymphocytes (T cells) and three red blood cells. Responding to external stimuli (in the case of lymphocytes, to infectious agents) can be part of a cell's moment-to-moment function.

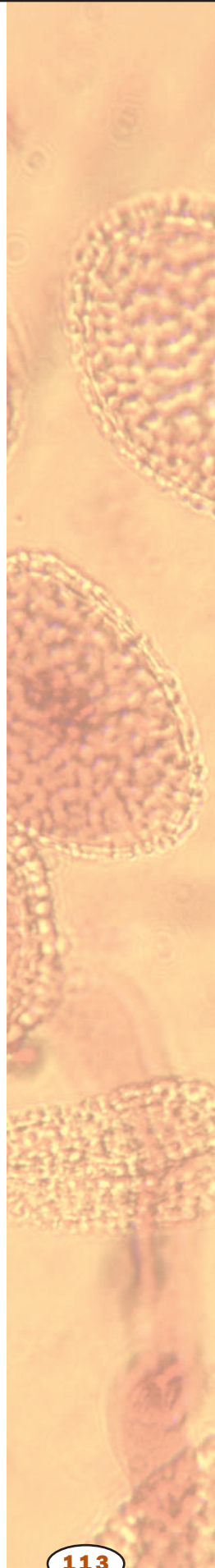

binding of a signaling molecule to its receptor activates the receptor, setting off a chain of events, much like a row of falling dominoes, called a signal transduction cascade. Activation of the receptor transmits the signal (but not the signaling molecule) to the first in a series of **enzymes** inside the cell, which in turn activates others, until the ultimate enzyme (or enzymes) is reached that causes the final response.

The different kinds of signal transduction pathways that exist are discussed below, followed by a more detailed description of a few of those that are the best understood, and that are **ubiquitous** throughout the animal kingdom.

### Modes of Signaling

The different signaling pathways in multicellular organisms are often divided into three categories: **endocrine**, paracrine, and autocrine signaling. In endocrine signaling, a signaling molecule, called a hormone, acts on a cell located at a distance from where it was synthesized. An example of this is stimulation of **glucose** uptake by insulin. Insulin is a hormone produced by the  $\beta$  cells in the pancreas and is secreted into the bloodstream, from where it can act on many different cells, even those located far from the pancreas.

Paracrine signaling refers to signaling between neighboring cells. Paracrine signaling is common during development, where a cell's fate is determined by interactions with its neighbors. In addition, the passing of nerve impulses between nerve cells is an example of paracrine signaling: neurotransmitters secreted by a nerve cell into a synapse (the space between two nerve cells) bind receptors located on the neighboring nerve cell, thus transmitting an impulse.

**enzyme** protein that controls a reaction in a cell

**ubiquitous** found everywhere

**endocrine** related to the system of hormones and glands that regulate body function

**glucose** simple sugar that provides energy to animal cells and is the building block of cellulose in plants

$\beta$  the Greek letter beta

**T cell** white blood cell that controls the immune response

**steroid hormone** group of hormones that includes estrogen, testosterone, and progesterone

**enzymatic** related to function of an enzyme

**effector** organ at the end of a nerve, such as a muscle or gland

**transcription factor** protein that increases the rate of transcription of a gene

**kinase** enzyme that adds a phosphate group to another molecule, usually a protein

**intracellular** within a cell

In autocrine signaling, a cell responds to stimulants it produces. An example of this occurs during the immune response. The **T cells** of the immune system help destroy harmful invaders, and upon detecting their presence they produce and secrete growth factors to which they themselves respond. The result is an increase in their numbers, and an ensuing increase in the magnitude of the defensive response. Whether a cell responds to a signal, and how it responds, is determined by the set of receptors it has and the transduction pathways it has in place when it receives the signal. Much of the development is based on using these differences in receptors and pathways.

The kinds of signaling molecules that exist are almost as varied as the types of proteins that exist in an organism. As would be expected, many are proteins, but many, such as neurotransmitters and **steroid hormones**, are nonprotein molecules, and still others, such as nitrous oxide and carbon monoxide, are gaseous. The types of receptors to which they bind are varied in structure and possess a variety of **enzymatic** activities, however, they are all protein in nature.

### The Logic of Complex Pathways

The three signaling pathways described below may seem overly complex. Why not have much simpler relay systems, say, involving just a cell surface receptor spanning the plasma membrane and a direct **effector**, such as a metabolic enzyme or a **transcription factor**? The answer may lie in the flexibility that such complex pathways afford. Having many different components in a pathway gives the cell many points at which to stimulate or inhibit the pathway, or the opportunity to use the components in different ways (see the mating pathway in yeast, for example). In addition, the relay system allows for amplification of the signal at each step. Thus, for example, the binding of a single molecule to a cell surface receptor may activate one hundred G-proteins, each of which may then activate one hundred **kinase** molecules and so on. Thanks to this type of amplification the cell can be made sensitive to even very low concentrations of extracellular stimulants.

Also, each of these pathways has been shaped over millions, or perhaps billions, of years of evolution. The features and functions of each pathway have been modified many times during evolution, with new levels of control added on top of older systems. The result is not necessarily the most efficient (although it may be in some cases), but it was what worked and was chosen by natural selection.

### Stimulation of Glucose Production by Epinephrine: A Cyclic AMP-Dependent Pathway

Upon anticipation of muscular activity, such as when a fearsome predator appears in one's vicinity, the hormone epinephrine (also called adrenaline), is released into the bloodstream by the adrenal medulla. At the surface of its target cells (muscle cells, and to a lesser extent, liver cells) it binds to a receptor called the  $\beta$ -adrenergic receptor. The  $\beta$ -adrenergic receptor spans the plasma membrane. The **intracellular** portion of the receptor is bound to a member of the G-protein class of proteins. In the absence of epinephrine, the G-protein is bound by GDP and is inactive, but binding of the hormone to its receptor induces the exchange of GDP for GTP.

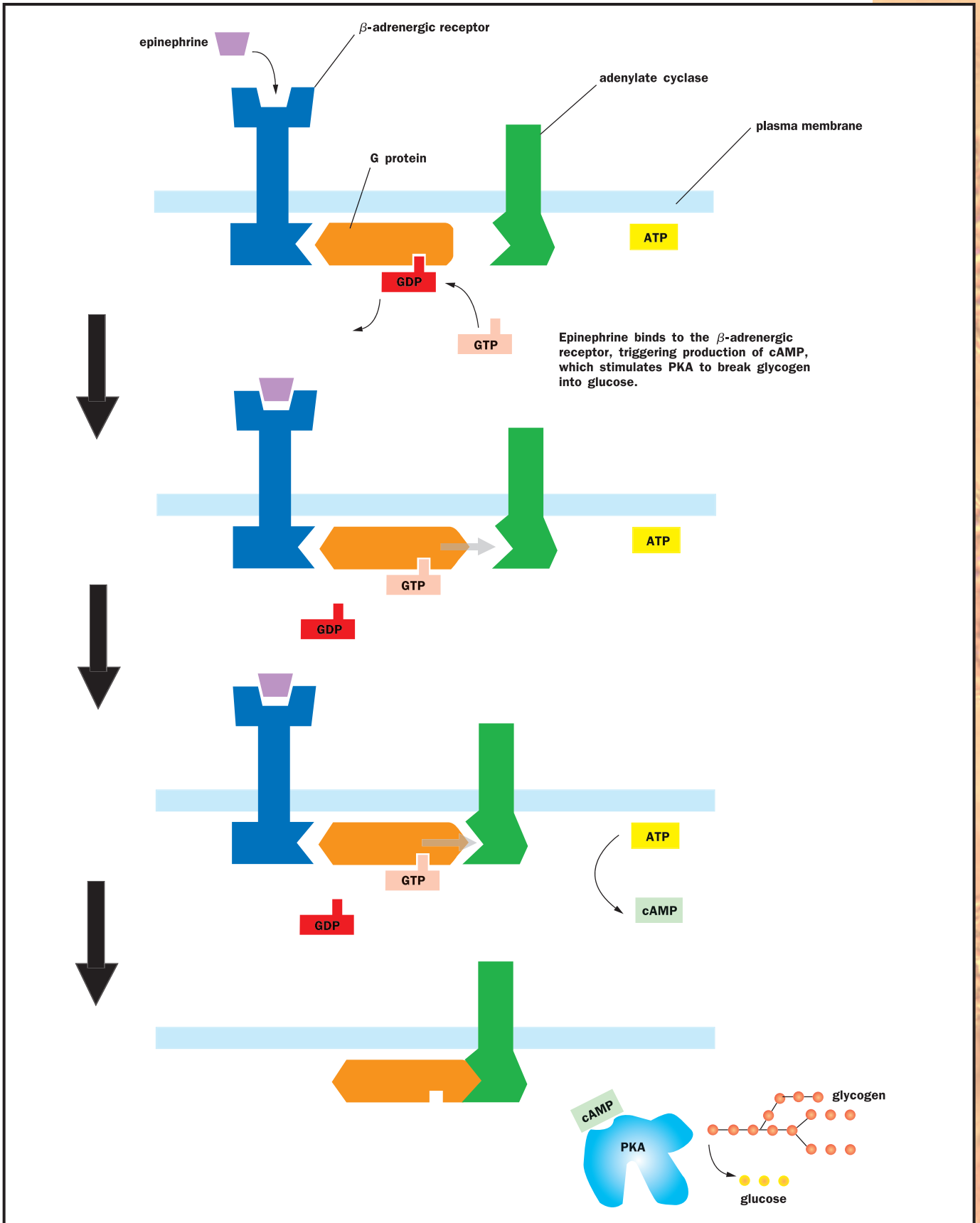

Stimulation of glucose production by epinephrine.



Epinephrine release is part of the “fight or flight” response.

**ATP** adenosine triphosphate, a high-energy nucleotide used by cells to power most energy-requiring reactions

**AMP** adenosine monophosphate, form of ATP after removal of two phosphate groups

**glycogen** complex carbohydrate used as storage in animals and some other organisms

**α** the Greek letter alpha

**pheromone** molecule released by one organism to influence another organism’s behavior

**trimeric** of a structure composed of three parts

**phosphorylate** add a phosphate group to

**gene** portion of DNA that codes for a protein or RNA molecule

Through a series of steps, this activates an enzyme located in the plasma membrane called adenylate cyclase. Adenylate cyclase converts adenosine triphosphate (**ATP**), a ubiquitous molecule in the cell, into cyclic **AMP** (cAMP). cAMP is called a *second messenger* because it mediates the effects of the *first messenger*, the original inducer, which in this case is epinephrine. cAMP then activates an enzyme called protein kinase A (PKA), which activates another enzyme that stimulates the breakdown of **glycogen** into glucose, the cell’s primary energy source.

Stimulated by a different enzyme, PKA acts to inhibit the incorporation of glucose into glycogen, which is the cell’s energy storage molecule. Thus, by this two-pronged approach, PKA keeps the cell’s usable pool of energy at a maximum during epinephrine stimulation.

### The Yeast Mating Pathway: A Map Kinase-Dependent Pathway

The yeast *S. cerevisiae* can be one of two mating types, called *a* and **α**, and when the two mating types encounter one another they can mate (or fuse), and subsequently give rise to offspring. Each mating type secretes its own mating factor (or mating **pheromone**), a small molecule that can be detected by receptors on the surface of cells of the opposite mating type. When an *a* cell detects α-factor in its vicinity, a variety of physiological changes occur (such as growth toward the α cell) that prepare it to undergo mating.

The α-factor receptor, like the β-adrenergic receptor described previously, is coupled to a **trimeric** G-protein. In this case, however, the next member of the pathway is a kinase called Ste20 (for *sterile 20*). Ste20 then stimulates a Map kinase (*mitogen activated protein kinase*) cascade, which is a group of three kinases that are activated sequentially.

Each of the three kinases in the cascade of the mating pathway **phosphorylates** the next. Finally, the last one phosphorylates and thereby activates a transcription factor called Ste12, which activates a set of **genes** whose products prepare the cell for mating.

A fourth protein, called Ste5, plays a critical role in the activation of the Map kinase pathway, yet it possesses no known enzymatic activity. It is thought to serve as a scaffold, binding all three kinases and keeping them in close proximity, thus maximizing the efficiency of the chain reaction. This kind of scaffolding molecule has been found in other pathways as well, and may turn out to be a common mechanism for keeping signaling pathways rapid and specific.

An interesting aside to the mating pathway is that a second pathway, called the filamentous growth pathway, uses some of the same components as the mating pathway. The filamentous growth pathway is stimulated by nitrogen starvation and is characterized by morphologic changes very different from those observed during mating. Two of the same three kinases (plus Ste5) are required for filamentous growth; however, a different Map kinase called Kss1 substitutes for the last member of the pathway. Both pathways converge on Ste12, which is the ultimate recipient of the signal in both cases.

If the last domino is the same in both cases, how do the different responses come about? The answer is complex and is still being deciphered;

Map kinase cascades are extremely common in animal cells and are involved in many different processes, including cell proliferation in mammalian cells (hence their name), development in fruit flies and nematodes, and programmed cell death in fruit flies and mammalian cells.

however, part of the solution appears to lie in the ability of Ste12 to associate with different partners. Ste12 functions as a **dimer** and, depending on the identity of its partner, will activate a different set of genes. Thus, low nitrogen levels promote the association of Ste12 with one partner (and activation of a specific set of genes), while mating factor promotes association with another partner (and activation of another set of genes). Further experimentation is needed for a more complete understanding of this enigma.

## The Phosphoinositide Pathway

A third ubiquitous eukaryotic pathway is the phosphoinositide pathway. Its activation signals many different processes including cell proliferation, hormone **secretion**, smooth muscle contraction, and transduction of visual information. A key enzyme in the pathway is called phospholipase C (PLC), which cleaves PIP<sub>2</sub> (phosphatidyl inositol 4,5 bisphosphate), a minor phospholipid component of the plasma membrane, into IP<sub>3</sub> (inositol 1,4,5 trisphosphate) and DAG (diacylglycerol), as represented by PIP<sub>2</sub> PLC → IP<sub>3</sub> + DAG. Receptor stimulation results in the release of both IP<sub>3</sub> and DAG, each of which then goes on to elicit a separate cellular response.

IP<sub>3</sub> is a small **hydrophilic** molecule that diffuses into the **cytoplasm** and binds its receptor, located in the membrane of the **endoplasmic reticulum** (ER). This stimulates the release of calcium from the ER into the cytoplasm, increasing the cytoplasmic concentration approximately tenfold. Calcium binds a small molecule called calmodulin, through which it exerts most of its effects. One of these is stimulation of a kinase called calcium/calmodulin kinase II (CaM kinase II), which phosphorylates many different target proteins, such as **ion** channels, metabolic enzymes, and transcription factors.

Meanwhile, DAG, which remains bound to the cytoplasmic side of the plasma membrane, binds and activates a kinase called protein kinase C (PKC), which exists in many different forms in the cell. Interestingly, calcium also stimulates the activity of some forms of PKC, and thus these forms of the enzyme integrate signals from both arms of the phosphoinositide pathway. PKC activates many different pathways in the cell including a Map kinase pathway (see above) that leads to cell proliferation. In addition, it activates the transcription factor NF-κB by phosphorylating its inhibitor, IκB, thus targeting it for degradation. SEE ALSO BLOOD SUGAR REGULATION; CONTROL MECHANISMS; ENDOPLASMIC RETICULUM; ENZYMES; HORMONES; MEMBRANE PROTEINS

*Kirstie Saltsman*

### Bibliography

- Changeux, J. P. "Chemical Signaling in the Brain." *Scientific American* 269, no. 3 (1993): 58–62.
- Cooper, Geoffrey. "Cell Signaling." In *The Cell: A Molecular Approach*. Sunderland, MA: Sinauer Associates, Inc., 1997.
- Gibbs, W. W., S. Nemecek, and G. Stix. "The 1998 Nobel Prizes in Science." *Scientific American* 280, no. 1. (1999): 16–19.
- Stryer, Lubert. *Biochemistry*, 4th ed. New York: W. H. Freeman and Company, 1995.

**dimer** a polymer formed from two molecules of a simpler compound.

**secretion** material released from the cell

**hydrophilic** "water-loving"

**cytoplasm** material in a cell, excluding the nucleus

**endoplasmic reticulum** network of membranes within the cell

**ion** an electrically charged particle

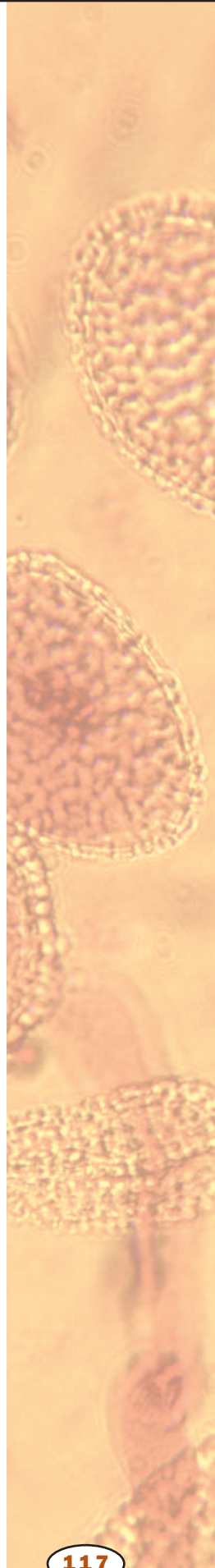

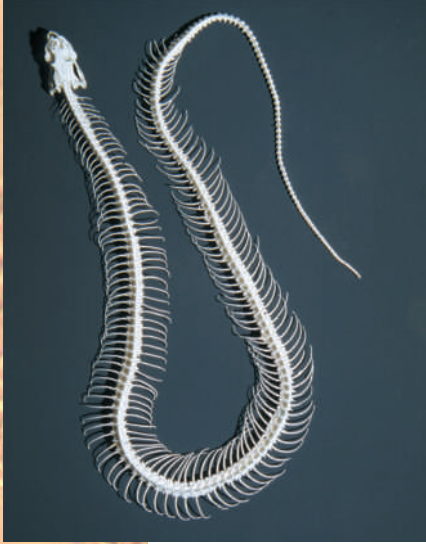

A snake skeleton.

**arthropods** organisms with jointed appendages and exoskeletons, including insects, spiders, and crustaceans

## Skeletons

Everyone is familiar with the human skeleton and its role in supporting the body. Less familiar is the variety of skeletons in other animals and the additional functions they provide. Zoologists generally recognize three types of skeletons: a hydroskeleton, an exoskeleton, and an endoskeleton.

A hydroskeleton, also called hydrostatic skeleton, occurs in many soft-bodied animals, such as earthworms. A hydroskeleton is not bony, but rather is a cavity filled by pressurized fluid. Like air in a truck's tires, the pressurized fluid keeps the body from collapsing from the forces of gravity or movement. By manipulating the pressure in different parts of the cavity, many soft-bodied animals can change shape and produce considerable force. Earthworms (annelids), for example, can burrow through soil using pressure in the hydroskeleton.

An exoskeleton is a hard, nonliving structure that encloses the rest of the body. The exoskeleton may consist of a single hard piece, like the shell of a snail, or it may have two or more hard pieces linked together by flexible tissue, as in a clam. In crustaceans, insects, spiders and other **arthropods** (Arthropoda), and also in some other groups of animals, the exoskeleton is called a cuticle. Animals with exoskeletons of two or more pieces can generally move the parts by means of muscles that attach to the inner surface. Exoskeletons have the advantage of providing protection from predators. (Consider the work it takes to eat a lobster.) One disadvantage, however, is that it restricts the growth of the animal inside it. Snails and many other mollusks solve that problem by continually enlarging their shells as they grow. An arthropod sheds (molts) the old cuticle as it grows, then it secretes a new and larger one.

Endoskeletons are enclosed in other tissues. The human endoskeleton does not offer much protection from predators, but it does a good job of keeping the body from collapsing into a helpless pile. It also provides sites for attachment of muscles. Most muscles connect two different bones, and almost all movements result when muscle contraction moves some bones relative to others.

The skeletons of humans and other vertebrates consist of differing proportions of cartilage and bone. Cartilage, being flexible yet resilient, is well suited to cushioning joints and changing size and shape easily. Cartilage serves as a temporary skeleton in the embryos of vertebrates. In sharks and a few other vertebrates, cartilage persists as the skeleton throughout life. In humans and most other vertebrates, most cartilage is gradually replaced by bone, but some remains as cushions for joints and flexible supports in the nose, ears, and trachea. Bone is, of course, harder and more rigid than cartilage, but it is still living tissue that can slowly adapt to strains imposed upon it.

The 206 bones of the adult human skeleton occur in several distinctive parts of the skeleton. The skull, vertebrae, and ribs belong to the axial skeleton. The bones of the arms and legs and the pectoral and pelvic girdles are parts of the appendicular skeleton, which attaches to the axial skeleton.

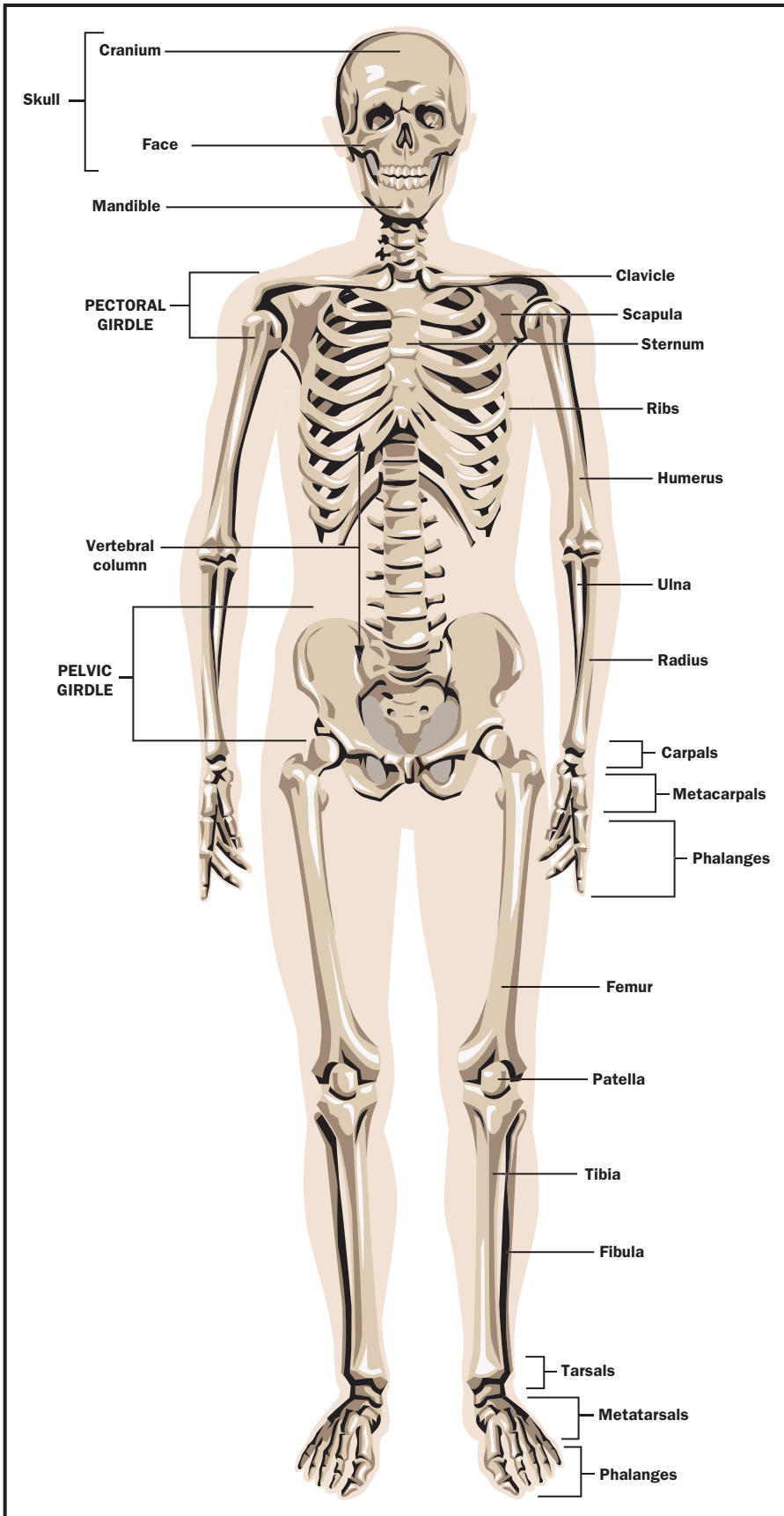

Some of the major bones of the human skeleton.

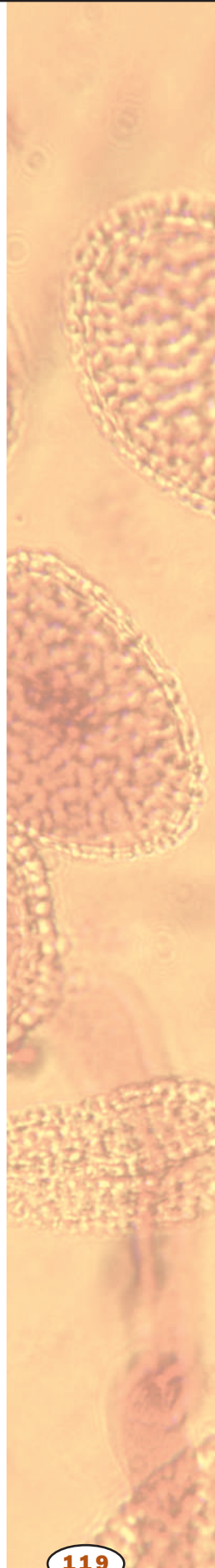

SEE ALSO ANNELID; ARTHROPOD; BONE; CONNECTIVE TISSUE; INSECT; MUSCULOSKELETAL SYSTEM

C. Leon Harris

### Bibliography

Hickman, Cleveland P., Jr., Larry S. Roberts, and Allan Larson. *Integrated Principles of Zoology*, 11th ed. Boston: McGraw-Hill Higher Education, 2001.

Saladin, Kenneth S. *Anatomy and Physiology*, 2nd ed. Dubuque, IA: McGraw-Hill Higher Education, 2001.

## Skin

How is the skin, the largest organ in the body, constructed? The skin has two layers: the upper layer is the epidermis, and the lower layer is the dermis. Below the dermis is the hypodermis, or **subcutaneous** layer, composed of fat or other **connective tissue**.

The epidermis itself is an **epithelium** made up of sublayers. The outermost portion consists of many layers of flat, dead, dry epithelial cells called keratinocytes. Clearly this barrier of dead cells needs no blood supply. The waxy surface coating of these cells allows the skin to be waterproof and dry. In effect, the body surrounds itself with a hostile desert where few germs can live.

Living keratinocytes in the deepest layer of the epidermis undergo rapid cell division and push the overlying cells toward the surface. Melanocytes are also deep and produce the dark pigment in the skin, melanin. Upon exposure to ultraviolet light, melanin production is increased, a process called tanning. The melanin helps protect other cells from the damaging effects of ultraviolet light. Ultraviolet light from any source can harm the skin by causing skin cancer and wrinkling.

The dermis is composed of fibrous connective tissue. The upper part of the dermis exhibits many hills, called the dermal papillae, which prevent slippage between the dermis and the epidermis and increase surface area. There are blood capillaries and small organs of fine touch inside the papillae. In the fingertips, the papillae occur in ridges and help to form the fingerprints. The lower parts of the dermis are home to larger blood vessels, nerves, hair follicles, oil glands, sweat glands, and fibrous connective tissues.

Hair follicles contain the root of a hair and have a bulb at the deep end. A small muscle, the arrector pili, attaches to the hair and raises it when the body is cold or frightened. In hairier mammals, the raised hair creates an insulating layer of air to preserve the animal's warmth, but in humans this reaction merely causes goose bumps. There is a sebaceous (oil) gland associated with the follicle. **Parasites** called follicle mites are found in the hair follicles of many people, especially on the face.

Other organs related to the skin are the finger- and toenails. These are made of plates of hardened keratin and are dead and dry, like the upper layer of the epidermis. The nails begin as new cells added in the nail **matrix**, under the skin.

Two types of glands also start out in the dermis: merocrine sweat glands and apocrine sweat glands. Merocrine sweat glands are those that increase

**subcutaneous** below the skin

**connective tissue** one of four types of body tissue, characterized by few cells and extensive extracellular material

**epithelium** one of four tissue types found in the body, characterized by thin sheets and usually serving a protective or secretory function

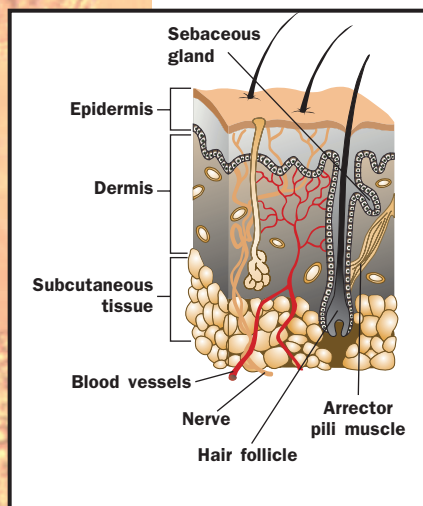

**parasite** organism living in close association with another from which it derives most of its nutrition

**matrix** a network, usually of threadlike fibers

their watery **secretions** when the body starts to overheat. The evaporation of the secretions off the skin cools the body off. Sweat is only responsible for about one-fifth of the cooling in a resting person; most is due to radiation, in which heat is given off as infrared rays. Apocrine sweat glands are found around the breasts, armpits, and **genitalia** and produce sex-attracting chemicals called **pheromones**. Other glands include the ceruminous (earwax) glands, sebaceous glands, and mammary glands. SEE ALSO CONNECTIVE TISSUE; EPITHELIUM; ORGAN; TEMPERATURE REGULATION

David L. Evans

**secretion** material released from the cell

**genitalia** reproductive organs

**pheromone** molecule released by one organism to influence another organism's behavior

### Bibliography

Diamond, J. "Pearl Harbor and the Emperor's Physiologists." *Natural History* 91, no. 12 (1991): 2, 4, 6-7.

Jarrett, A. *Science and the Skin*. London: English Universities Press, 1964.

Saladin, Kenneth S. *Anatomy and Physiology: The Unity of Form and Function*, 2nd ed. Dubuque, IA: McGraw-Hill, 2000.

Zinsser, H. *Rats, Lice and History*. Boston: Little Brown and Co., 1963.

## Sleep

Sleep is a very important process and is characterized by a stereotypical posture, little movement, and a decrease in response to stimuli. These characteristics might also describe coma, but in sleep, unlike in coma, the characteristics are reversed each morning. Because creatures are not eating or mating and are also very vulnerable to attack by predators during sleep, sleep must have a very important function to make it worthwhile.

Sleep is also a very insistent drive. Whereas a person can voluntarily stop eating until he or she dies, the human body cannot force itself to stay awake indefinitely. In fact, there are situations when falling asleep might mean death (while driving a car, for example), yet the desire to sleep is so insistent that body will still succumb to it.

### Stages of Sleep

Sleep is divided into two main stages: REM sleep (which stands for "rapid eye movement"), and non-REM (NREM) sleep. These stages are characterized by changes measured on instruments such as the electroencephalograph (EEG), which measures changes in electrical signals in the brain; electrooculogram (EOG), which measures eye movements; and the electromyogram (EMG), which measures muscle movements. In humans, REM and NREM sleep alternate in ninety-minute cycles approximately three to six times per night. During the first part of the sleep cycle, REM sleep takes approximately ten minutes of each cycle, but REM sleep periods become longer and closer together as the course of sleep progresses (see figure 1).

Non-REM sleep is divided into four stages. As one progresses from stage one to stage four, sleep gets deeper and EEG waves become taller and slower; stages three and four are often grouped together and called slow wave sleep (SWS). During SWS, muscle movements and eye movements are diminished in comparison to wakefulness, and the EEG is more synchronized, indicating that large portions of brain tissue are firing together.

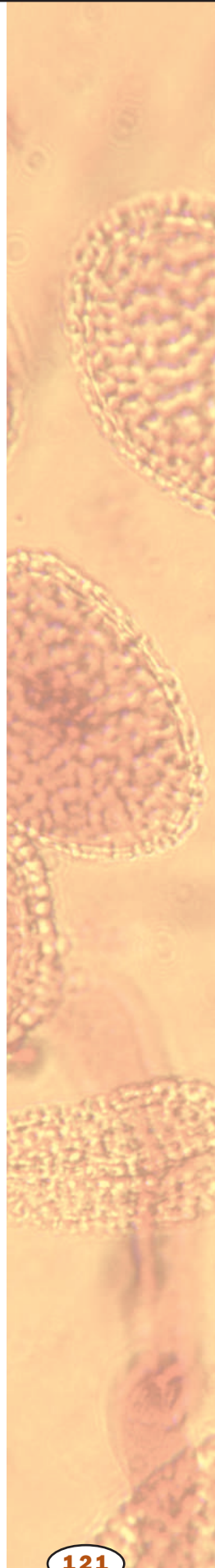

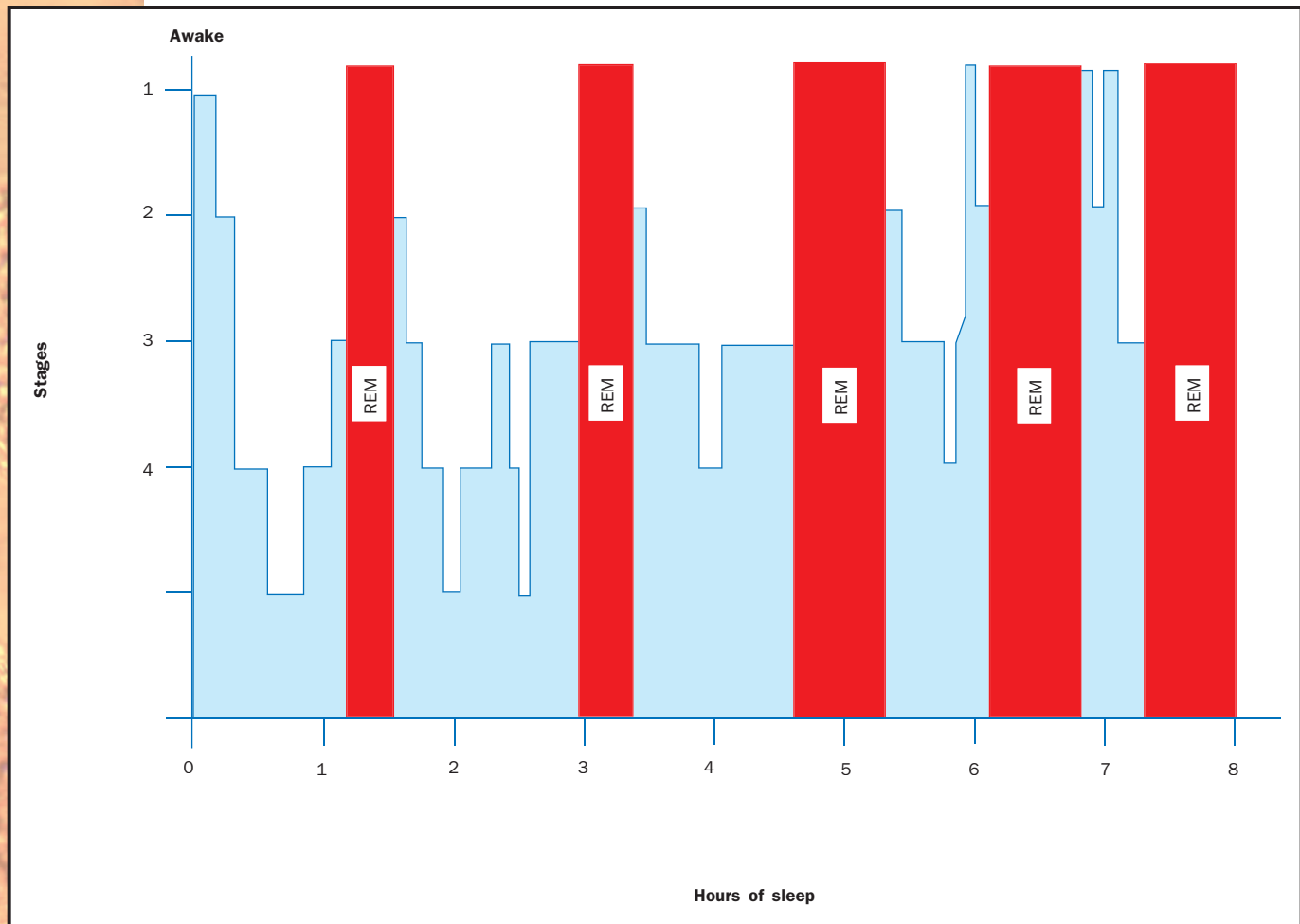

Figure 1. Stages of sleep.

**desynchronized** not happening at the same time

**thermoregulation** temperature regulation

**muscle tone** low level constant muscle contraction

REM sleep is characterized by a **desynchronized** EEG, a lack of **thermoregulation**, loss of tone in the skeletal muscle, erections of the penis or clitoris, rapid eye movements, and dreams. As seen by the desynchronized EEG, which is similar to the brain patterns seen during wakefulness, the brain is very active during REM sleep. However, one part of the brain that does shut off during REM sleep is the part of the hypothalamus that is responsible for temperature regulation. During REM sleep, the body does not thermoregulate and therefore does not shiver or sweat.

Skeletal muscles are also less active during REM sleep and thus lose **muscle tone**. This loss enables the muscles to relax during REM sleep. It also prevents people from acting out their dreams (sleep walking occurs during NREM sleep, when muscle tone is maintained but diminished). Not all muscles lose their tone during REM sleep. The diaphragm, necessary for breathing, continues to contract. Muscles are also active in the eyes: although the lids are closed, the eyes dart back and forth during REM sleep, which gives REM its name.

During REM sleep the penis and clitoris often become erect, but this is not necessarily related to dream content. Although REM sleep is associated with dreams, dreams actually occur during all stages of sleep. The dreams that occur during REM sleep have characteristics different from those dreams in NREM sleep. REM dreams are longer, more emotional,

and more visual than NREM dreams, and they usually do not follow the events of the day as closely as NREM dreams.

### Neurological Control

A common misconception is that the brain shuts down during sleep. In truth, parts of the brain may be even more active during NREM or REM sleep than during wakefulness. The level of consciousness depends upon the activity of the **reticular** activating system, a network of **neurons** in the brainstem that send projections throughout the thalamus, hypothalamus, and **cerebral cortex**. Certain areas of the brain have been found to be responsible for causing different sleep stages. Whereas NREM sleep is controlled by the **basal** forebrain (the **anterior** hypothalamus and adjacent forebrain areas), REM sleep is mostly controlled by an area in the brainstem called the pons.

### Functions of Sleep

Although humans spend approximately one-third of their lives asleep, no one knows for sure what the function of sleep is. It is known that sleep is necessary for life. Constant sleep deprivation in rats leads to death. Studies suggest that constant deprivation of REM sleep alone causes metabolic changes in rats that can also lead to death.

There are a number of theories on the function of sleep. Sleep may help the body recover from an active day and give it the chance to restore substances that are lost during the day. However, since simply resting the body without sleep does not fulfill the same function as sleep, it is thought that there is more to sleep than resting.

- reticular** netlike
- neuron** nerve cell
- cerebral cortex** outer-most wrinkled portion of the brain
- basal** lowest level
- anterior** toward the front

Figure 2. Electroencephalogram (EEG), electromyogram (EMG), and electrooculogram (EOG) show activity of the brain, muscles, and eyes during three different states: wakefulness, REM sleep, and slow-wave sleep (SWS).

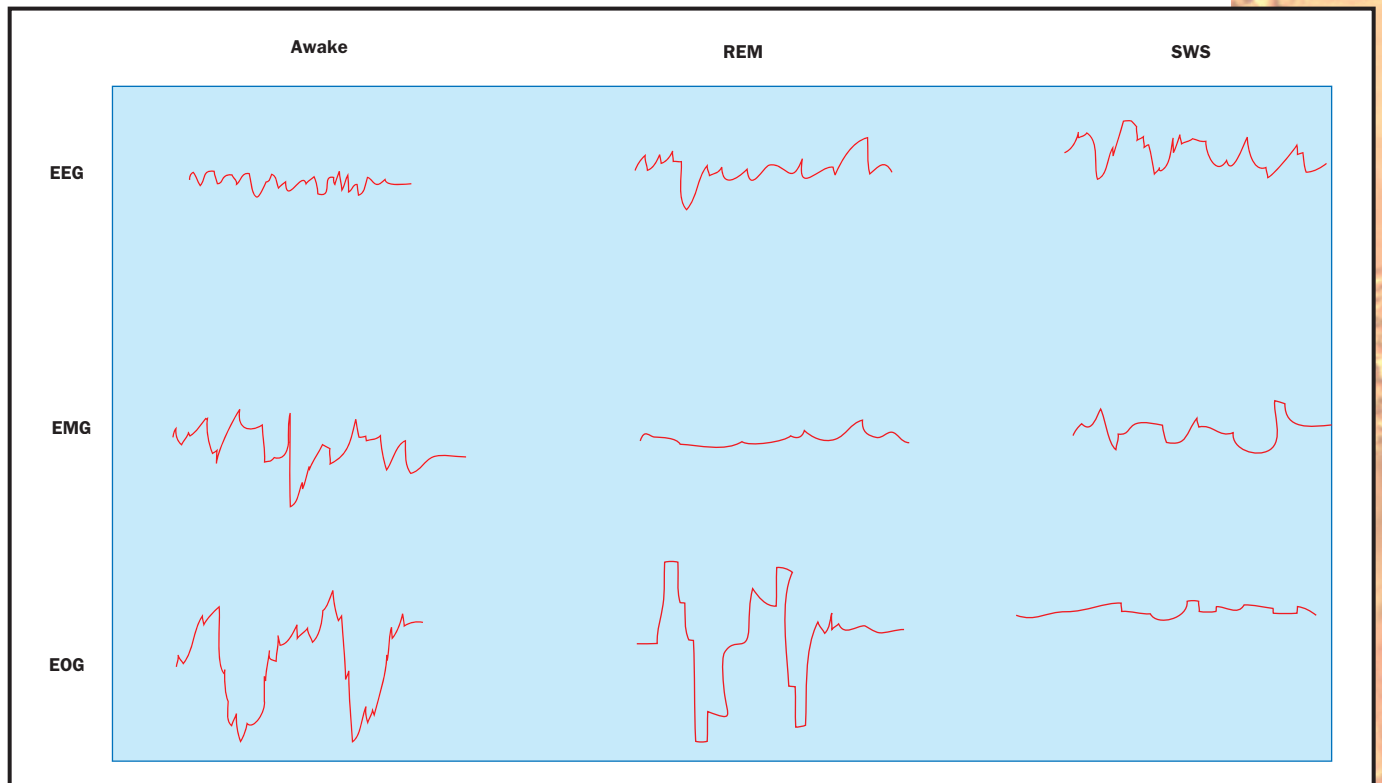



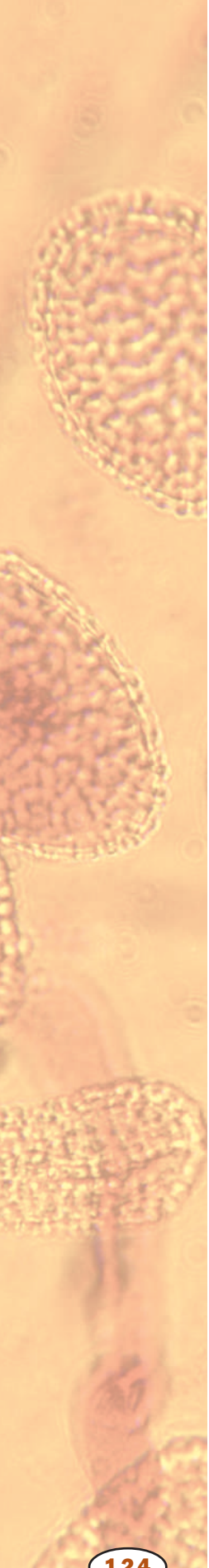

**multinucleate** having many nuclei within a single cell membrane

**protoplasm** fluid portion of a plant cell within the cell wall

**amoeba** a single-celled protist that moves by crawling and can cause diarrhea

**pseudopod** “false foot”; an extension of the plasma membrane during locomotion by an amoeba or similar crawling cell

**phagocytosis** engulfing of cells or large fragments by another cell, including immune system cells

Sleep may have developed evolutionarily as an adaptive mechanism to keep animals out of harm’s way, preventing them from wandering around in the dark, vulnerable to accidents and attack by predators, during a time when food foraging may be less efficient. It is interesting to note that small animals with safe hiding places and large predators sleep a lot, whereas large prey sleep less often, suggesting sleep may be related to an animal’s relative safety, although the evidence for this is far from clear. The question remains, however, why the complex process of sleep would have evolved to merely keep animals out of danger.

It is known that REM sleep is a necessary stage of sleep; however, the function of REM sleep is also unclear. Temporary REM sleep deprivation can lead people to become bad-tempered and uneasy. If REM deprivation continues, and the subject is then allowed to sleep undisturbed, he or she experiences “REM rebound,” which means that REM sleep occurs more frequently and lasts longer than normal. There is evidence that REM sleep is necessary for learning and memory. Furthermore, theorists are proposing that REM sleep may be important in the development of the brain. SEE ALSO BRAIN; HYPOTHALAMUS; TEMPERATURE REGULATION

*Martha S. Rosenthal*

#### Bibliography

Carlson, Neil R. “Sleep and Biological Rhythms.” In *Physiology of Behavior*, 7th ed. Boston: Allyn & Bacon Publishers, 2001.

Myers, David G. “States of Consciousness.” In *Exploring Psychology*, 4th ed. New York: Worth Publishers, 1999.

Rechtschaffen, A., et al. “Sleep Deprivation in the Rat. X: Integration and Discussion of the Findings.” *Sleep* 12 (1989): 68–87.

*Sleep Research Society*. “Basics of Sleep Behavior Syllabus.” WebSciences International and Sleep Research Society, 1997. <<http://www.sleephomepages.org/sleepsyllabus/>>.

## Slime Molds

There are two major unrelated phyla of slime molds. The Myxomycota are the true (plasmodial) slime molds, and the Dictyosteliomycota are the cellular slime molds. Both were formerly classified as fungi but are now considered protists. Slime molds are often found on old, well-rotted logs because there they can find the moisture and bacteria required for survival. Their small, delicate fruiting bodies tend to be fungal in appearance. Most of the fruiting bodies are only a millimeter or two in height, and therefore often difficult to notice.

### Myxomycota

A myxomycete exists in nature as a plasmodium, a **multinucleate** blob of **protoplasm** up to several centimeters in diameter, without cell walls and only a cell membrane to keep everything in. It resembles a large **amoeba** and feeds much the same way, by engulfing its food (mostly bacteria) with **pseudopodia** (“false feet”), in a process called **phagocytosis**. Thus the slime mold ingests its food and then digests it. (In contrast, true fungi have cell walls and digest their food externally before ingesting it.) When the plasmodium runs out of food, or environmental conditions become harsh, fruit-



Pillows of the coral-colored slime mold *Myxomycetes* grow on damp wood.

ing bodies form. These fruiting bodies produce dormant, resistive spores. These later germinate to form **uninucleate** myxamoebae or flagellated swarm cells. These later fuse and then divide mitotically to form a plasmodium, completing the life cycle. Myxomycetes are important scavengers in dark, damp parts of the **ecosystem**. Occasionally, during rainy periods, large plasmodia (up to a few meters in diameter) crawl out of the woods and into people's lawns and gardens. These plasmodia were the inspiration for the science fiction movie *The Blob* and are eaten in parts of Mexico.

### Dictyosteliomycota

The Dictyosteliomycota are also known as the social amoebae. Their life cycle is considered among the most bizarre among microorganisms. It begins with free-living **amoeboid** cells (not to be confused with the Amoebae); there is no true plasmodium. As long as there is enough food (usually bacteria) the amoebae thrive. However, when food runs out, the amoebae send out chemical signals to surrounding amoebae. Next, they stream toward a central point and form a sluglike multicellular pseudoplasmodium, which can then migrate like a single organism. When conditions are right, the pseudoplasmodium stops migrating and forms a multicellular fruiting body. Some of the cells become spores that disseminate, while the rest form stalk cells whose only function is to raise the spores up into the air to be more easily caught in air currents.

The Dictyosteliomycota pose an interesting challenge for evolutionary theory, since some of the cells (in the stalk) actually seem to sacrifice their own reproductive potential so that others (the spores) can be transported to a new location where there is more food and they can grow again. This altruistic sacrifice would seem to be counter to the reproductive interests of the cells that became the stalk (because they never reproduce) and **genes** for stalk-forming behavior would therefore be selected against. It may be

**uninucleate** possessing one nucleus

**ecosystem** an ecological community and its environment

**amoeboid** like an amoeba, especially in movement via extension of portions of the membrane

**gene** portion of DNA that codes for a protein or RNA molecule

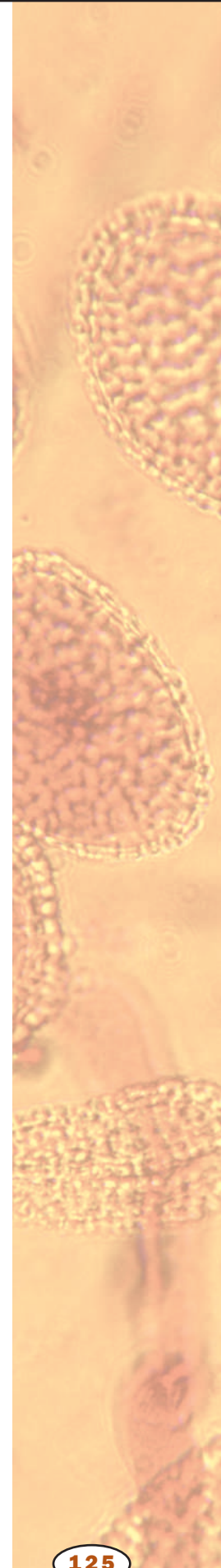

maintained if the spore cells are closely related to the stalk cells (and thus both have the stalk-forming genes) or if the allocation of cells to spore versus stalk is random, so that genes for stalk formation are preserved over time. However, evidence suggests that the position of the cells in the slug and thus in the fruiting body is determined by the timing of their coming into the aggregation stream, rather than by genetics. SEE ALSO ENDOCYTOSIS; FUNGI; PROTISTA; SOCIOBIOLOGY

Tom Volk

### Bibliography

- Farr, M. L. *How to Know the True Slime Molds*. Dubuque, IA: William C. Brown Publishers, 1981.
- Keller, Harold W., and Karl L. Braun. *Myxomycetes of Ohio: Their Systematics, Biology and Use in Teaching*. Columbus, OH: Ohio Biological Survey, 1999.
- Raper, Kenneth B. *The Dictyostelids*. Princeton, NJ: Princeton University Press, 1984.
- Stephenson, Steven, and Henry Stempen. *Myxomycetes: A Handbook of Slime Molds*. Portland, OR: Timber Press, 1994.
- Volk, Thomas J. *Tom Volk's Fungi*. <<http://www.wisc.edu/botany/fungi/volkmyco.html>>.

**Smell** See *Chemoreception*

## Smoking and Health

Smoking cigarettes sets into motion a chain reaction of changes that set the stage for infection, degenerative diseases, cardiovascular disease, and cancer. Smoke contains thousands of chemicals, but it is nicotine that causes the powerful addiction that compels a person to continually deliver the other harmful chemicals to the respiratory system. Nicotine binds to receptors on certain nerve cells in the brain, causing the cells to release dopamine, which produces the associated pleasurable sensations. Addiction happens when a person seeks the good feelings and wants to avoid withdrawal symptoms.

Many of the health problems associated with cigarette smoking stem from impairment of the ability of the respiratory tract to cleanse itself. Each inhalation slows the beating of the **cilia** that line the tract, so that they cannot move mucus and particles out of the respiratory system. Eventually, the cilia are lost. Accumulating mucus causes smoker's cough, which can develop into chronic bronchitis. In addition, the mucus entraps **pathogens**, increasing the likelihood of respiratory infections. Meanwhile, the bronchiole linings thicken, and breathing becomes strained. As the bronchioles lose elasticity, the respiratory tract cannot resist the pressure changes that coughing produces, and the microscopic alveoli (air sacs) may burst. This leads to emphysema. Symptoms include difficulty taking a deep breath, worsening cough, wheezing, and fatigue that results from impaired oxygen delivery to tissues. Smokers face a fifteen times greater likelihood of developing emphysema than nonsmokers. Chronic bronchitis and emphysema are the two most common forms of chronic obstructive pulmonary disease (COPD), which is a general term for conditions that block the airways.

Smoking cigarettes accounts for 85 percent of lung cancer cases. The process begins years before a person notices symptoms. First, cells of the bronchial linings begin to divide more often than normal, which displaces

**cilia** short, hairlike cell extensions of the cell membrane formed by the cytoskeleton

**pathogen** disease-causing organism

The Centers for Disease Control and Prevention report that there were approximately 47 million smokers in the United States in the late 1990s.

the ciliated cells. If smoking continues, these errant cells break through to lung tissue, where they grow into a tumor. Lung cancer can also begin within a single alveolus. Smoking also increases the risk of cancers of the mouth and throat. In one case, a man who repeatedly placed chewing tobacco on his ear developed a skin cancer in that location. Smoking raises serum cholesterol, and can contribute to diseases of the blood vessels. About 21 percent of cases of coronary heart disease and 18 percent of strokes are directly related to smoking.

If a pregnant woman smokes cigarettes, the fetus is at greater risk of premature delivery or low birth weight. Spontaneous abortions and stillbirth are also more likely. Fetal growth becomes stunted because carbon monoxide in cigarette smoke crosses the placenta and binds to fetal **hemoglobin** molecules, blocking oxygen delivery. Other chemicals in cigarette smoke prevent nutrients from reaching a fetus.

A person can regain health if smoking ceases before too much damage has occurred. Although emphysema cannot be reversed and cancer or cardiovascular disease must be treated, the ciliated cells that are the guideposts of the respiratory system can regrow, and the cough and susceptibility to infection abate. SEE ALSO CANCER; CARDIOVASCULAR DISEASES; HEART AND CIRCULATION; ONCOGENES AND CANCER CELLS; PSYCHOACTIVE DRUGS; RESPIRATION

*Ricki Lewis*

### Bibliography

Fisher, Edwin B., Jr., and C. Everett Koop. *American Lung Association's Seven Steps to a Smoke-Free Life*. New York: John Wiley, 1998.

Kleinman, Lowell, et al. *Complete Idiot's Guide to Quitting Smoking*. Indianapolis, IN: Macmillan, 2000.

## Social Behavior

Social behavior is defined as interactions among individuals, normally within the same species, that are usually beneficial to one or more of the individuals. It is believed that social behavior evolved because it was beneficial to those who engaged in it, which means that these individuals were more likely to survive and reproduce. Social behavior serves many purposes and is exhibited by an extraordinary wide variety of animals, including invertebrates, fish, birds, and mammals. Thus, social behavior is not only displayed by animals possessing well-developed brains and nervous systems.

### Benefits of Social Behavior

Social behavior seems to provide many benefits to those who practice it. Studies have shown that many animals are more successful in finding food if they search as a group. This is especially true if food resources are clumped together only in certain places. If more individuals are cooperating in the search, there is a greater chance one of them will find the clump of food. In some cases, foraging in a group makes it easier to capture a prey. Dolphins are known to surround a school of fish and to take turns darting into the center to eat the fish that are trapped in the middle. Many carnivores will band together when they try to capture large prey. For examples, wolves

**hemoglobin** oxygen-carrying protein complex in red blood cells

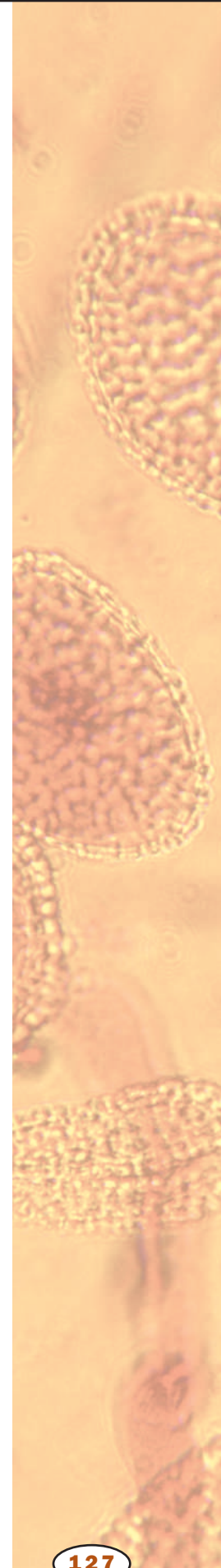

Two gannets greeting each other on Bonaventure Island, Quebec.



will hunt together when hunting moose, and lions will hunt together when hunting large prey such as wildebeests. When these animals are hunting much smaller prey, they will often hunt singly.

Many animals live in social groups partly for protection. Although one baboon might not be able to fight off a leopard, a troop of baboons often is able to do so. In addition, with more individuals cooperating together, some can serve as sentries looking for danger while the other group members are eating or sleeping. Prairie dogs and large flocks of crows normally have some individuals acting as sentries, which makes it nearly impossible to sneak up on a prairie dog town or a flock of crows.

Many prey species, such as schools of fish and flocks of shorebirds, travel in groups in which their movements are highly coordinated. The entire group moves quickly, darting one way and then another as an entire group, as if they were all somehow physically connected with one another. It is believed this behavior creates confusion for the predator. Predators generally need to pick out a single individual in a group that they will focus on and try to capture. A rapidly moving and turning school of fish, flock of birds,

or herd of antelope is believed to make it very difficult for the predator to remain focused on a single individual. However, if one individual is unable to keep up with the group, the predator will then be able to focus on it and usually will succeed in catching it.

Some animals form social groups to make travel easier. Canada geese and other bird species typically fly in a V formation. Just like bicyclists who ride behind one another in order to reduce wind resistance, the geese fly in formation to reduce the wind they must encounter. In this situation, the lead bird has the most tiring job, which is why several birds usually take turns leading the V. Some animals congregate in close proximity to one another in cold weather in an effort to stay warm. Small birds are sometimes known to huddle so closely they form a single large ball of birds.

### Breeding Behavior

Sometimes social behavior is exhibited by groups of males or females during the breeding season. In some cases, males may band together and try to chase the dominant male away so they have a better chance of mating success. In other instances, males are known to cooperate in making their courtship displays. Turkeys often perform their courtship display in pairs, even though only one of the turkeys ends up doing most of the mating. Why would the unsuccessful male agree to help? The two male turkeys are usually brothers. Since brothers share about 50 percent of the same genes, even if only one brother mates, many of the genes of the unsuccessful brother are passed on too.

In some species, the females form social groups during the breeding season. In certain circumstances, females will look after one another's offspring while the other mother goes out to find food. In other species, such as lemurs, females may form social groups as a kind of defense. Males of some lemur species will try to kill the offspring of females that mated with another male. By banding together, the females are sometimes able to ward off the attacking male.

Many animals form social groups only during certain times of the year. Many bird species flock together in foraging groups in the winter. However, these same birds that sought one another out in the winter set up breeding territories in the spring and will go to great lengths to keep the same birds out of their territory. Thus, for many species, social behavior is a flexible form of animal behavior, one that can be adopted or abandoned depending on the conditions of the environment and the time of year.

### Insect Societies

Some of the most well-developed social behavior is exhibited by insects such as ants, termites, bees, and wasps. Many of these species live in colonies with thousands or even millions of individuals. One benefit of social behavior for these insects is that different individuals specialize in certain activities. For example, some are the workers who build the colony and go out looking for food that they bring back. Other individuals are the soldiers of the colony. Their job is to continually patrol the colony perimeter and to protect the colony from possible attacks from other colonies. In many ant and bee colonies, all worker and soldier ants are females. Males are usually present in the colony, but do not contribute much. Finally, there is the queen ant

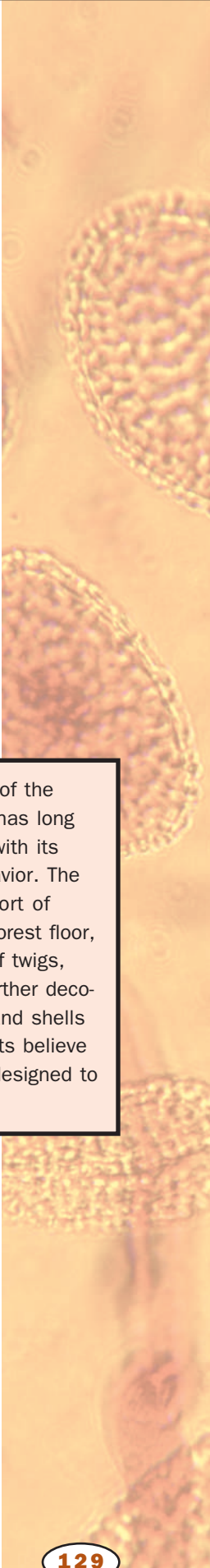

The male bowerbird, of the Australian rainforest, has long interested scientists with its unusual courting behavior. The bower constructs a sort of bachelor pad on the forest floor, a complex structure of twigs, leaves, and moss. Further decorating it with berries and shells and feathers, scientists believe that it is specifically designed to attract mates.

An olive baboon grooming another in Nairobi National Park, Kenya. Individuals who engage in social behavior are more likely to survive and reproduce.



or bee. The queen's only job for her entire life is to lay eggs that the workers will care for.

There are substantial benefits to forming social groups and there are also some definite costs to living closely with others of the same species. First, one competes most with others that are most like oneself, and thus a member of a social group always has to share or compete with others for resources. Second, because of the numbers and close proximity of individuals in many social groups, disease may spread through social groups relatively rapidly. SEE ALSO BEHAVIOR, GENETIC BASIS OF; BEHAVIOR PATTERNS; FIELD STUDIES IN ANIMAL BEHAVIOR; MATING SYSTEMS; NATURAL SELECTION; SOCIOBIOLOGY; SYMBIOSIS; WILDLIFE BIOLOGIST

*Mark A. Davis*

#### **Bibliography**

- Alcock, John. *Animal Behavior*, 3rd ed. Sunderland, MA: Sinauer Associates, 2001.
- Wilson, E. O. *Sociobiology*, abridged ed. Cambridge, MA: Belknap Press of Harvard University Press, 1980.

## Sociobiology

Sociobiology is the study of the biological basis of social behavior using evolutionary principles. The term was coined by a prominent entomologist E. O. Wilson in his book *Sociobiology: The New Synthesis* (1975). Wilson pointed out that just as physical characteristics such as beak length and fur color could be subject to natural selection, so too could aspects of social behavior.

The field of sociobiology was part of a broad conceptual shift during the late 1960s and throughout the 1970s. Sociobiology looked closely at the nature of interactions between individuals, replacing a cooperative view of social behavior with the idea that more often, from an evolutionary perspective, individuals should behave in their own self-interest. It was one of several fields that emphasized the genetic basis of behavior in all animals, including humans. In doing so, sociobiology shed light on a number of important aspects of animal behavior, including the evolution of altruism, the occurrence of infanticide and sibling rivalry, parental care, and social and mating systems. The extension of some aspects of sociobiology to humans initiated a controversy, which continues today.

### Altruism

Wilson's original focus was on the insects, such as ants, bees, and wasps, a group that commonly contains species that are eusocial. Eusocial species typically live in large highly cooperative groups or colonies, with reproduction limited to a very few members. Why would individual worker bees defend a colony from intruders, feed offspring that belonged to others, and forgo their own reproduction?

Such altruistic or helping behavior puzzled biologists. If natural selection works on behavior just as it works on other traits, why should individuals expend energy or time helping others survive or reproduce when that effort may reduce their own chances of reproduction? In 1964, William Hamilton developed the idea that individuals help their relatives because relatives share genes. Just as genes may be passed on by direct reproduction (producing offspring yourself), "your" genes can be passed on by increasing the reproduction of close relatives. In the social insects, cooperative behaviors associated with eusociality make evolutionary sense because these species have an unusual system of genetic relatedness, making colony members very closely related.

### Competition and Cooperation

An evolutionary approach has shed light on other puzzling aspects of behavior. Infanticide or infant killing by males in social monkeys is now believed to be a strategy used by males to speed up female receptivity and prevent females from spending energy on offspring fathered by competing males. Using an evolutionary approach, even close relatives can have conflicts of interest. Natural selection is expected to favor offspring that compete with each other for food (sibling rivalry). Parents should care for offspring, but offspring may demand more attention and energy than parents are willing to give. Parents, after all, must balance the amount of time and energy they devote to any single offspring with demands of other offspring and potential future offspring.



E. O. Wilson, founder of sociobiology.



Sociobiology has addressed broad questions concerning the social systems or kinds of groups in which species are found. For example, if groups of certain sizes have a greater likelihood of detecting predators, then they should be favored by natural selection. This may explain herding and flocking. An evolutionary approach to the study of mating systems has highlighted potential conflict of interest between males and females. Females produce few eggs, while males make many sperm. Because of this, females may be more selective in their choice of mates. In each of these cases, the field of sociobiology and an evolutionary approach to behavior led to insights that otherwise would have been missed.

### Human Applications

The last chapters of Wilson's book extended the study of sociobiology to humans. Although not the core of his text, this final chapter generated heated controversy over the nature of human social behavior and, in particular, the role of genes versus environment in determining human behavior. Some scientists considered Wilson's ideas dangerous. Genetically determined behavior seems to leave little room for free will, and downplayed the importance of the social and physical environment within which individuals grow and develop.

Since the publication of Wilson's book, more evidence has emerged that aspects of behavior have a genetic basis. With the increasing evidence from genetic and inheritance studies, however, comes an appreciation of the critically important role of the environment. Biologists now appreciate that the environment works together with genes in complex ways to affect behavior. SEE ALSO BEHAVIOR, GENETIC BASIS OF; EVOLUTION; FIELD STUDIES IN ANIMAL BEHAVIOR; MATING SYSTEMS; SEXUAL SELECTION; SOCIAL BEHAVIOR

*Diane K. Angell*

### Bibliography

Hamilton, W. D. "The Genetical Theory of Social Behavior: I and II." *Journal of Theoretical Biology* 7 (1964): 1-52.

Wilson, E. O. *Sociobiology: The New Synthesis*. Cambridge, MA: Belknap Press, 1975.

## Soil

One of the first distinctions made by a soil scientist is that "soil" and "dirt" are not the same. Dirt is what collects on the car or in the corner of the bedroom when it has been months since the last time it was vacuumed. Soil, on the other hand, is a highly structured matrix of **inorganic** and **organic** particles that form the substrate for terrestrial **ecosystems**. The substrate is the foundation where plants, ranging in size from minute ferns to tall trees, are rooted. The inorganic particles are formed from **minerals** in rock through weathering; a process that produces them by physical means (for example, erosion, freezing and thawing, and wind abrasion) or chemical means (for example, **oxidation**, dissolving crystals, or the action of acids). The organic particles originate from plant and animal tissues through fragmentation, decomposition, and chemical transformation.

The climate, rainfall, and temperature determine the pattern of soil weathering in a particular area. The weathering process often produces hor-

**inorganic** not bonded to carbon

**organic** composed of carbon, or derived from living organisms

**ecosystem** an ecological community and its environment

**minerals** iron, calcium, sodium, and other elements needed by living organisms

**oxidation** reaction characterized by loss of electrons, or reaction with oxygen

horizontal layers of soil of varying thickness called soil horizons because each layer is roughly parallel to Earth's horizon. The uppermost horizon often contains the most organic matter and others have differing nutrient contents and physical properties.

Soil provides physical support for plants, and the pores between particles provide spaces that contain water used by the plants and animals living within the soil. Oxygen from air diffuses into the pores when the water drains through the soil. This allows plant roots, **aerobic** microorganisms, and invertebrates to survive. Root systems may be located just below the surface, or may penetrate many meters deep. Too much water prevents air from reaching roots. Because of this, too much continuous water can kill many species of plants just as effectively as the absence of water during an extended drought. Only certain specially adapted plants are successful in water-saturated soils.

The particles that make up the soil may occasionally be all of the same size, as in the case of river sand deposits, or a silt layer that settled out on the bottom of ancient lakes. Sand particles are fairly large, only slightly smaller than gravel used in a fish tank, while silt particles are smaller than sand grains and clay particles are even smaller, approaching the fineness of talcum powder or baker's flour. Soils that are composed predominately of one of these particle sizes are known respectively as sands, silts, and clays. However, very often there is a mixture of particle sizes and the soil is referred to as a loam (a sandy loam has a mixture of particle sizes, but is mostly composed of sand). Loams are generally the best soils for plants to grow in. The larger sand particles facilitate drainage and oxygen penetration, while the small clay or organic humus particles provide a large amount of surface area where nutrient **ions** can become attached. Examples of these nutrients include nitrate, potassium, calcium, phosphate, and iron. They can be provided by commercial fertilizers, but are present naturally in nutrient-rich soils. The ions are attracted to electrically charged sites on clay or fine humus particles and gradually released into the water as they are exchanged with other ions. This nutrient-rich soil solution provides nutrition to plants through the roots.

Finally, the soil is a habitat for millions of small organisms per cubic meter such as bacteria, algae, **nematodes**, insects, and mites. These organisms make nutrients available through metabolic activity or the production of feces. They also die and add to organic matter and in general contribute to good soil quality. Larger organisms also inhabit the soil. Earthworms are particularly important because they mix the soil and process organic matter, which passes through their intestinal tracts and is released as feces. This helps produce loose textured soils with a high organic content and nutrient-holding capacity. In addition, their burrowing increases oxygen penetration. Larger animals such as moles, rabbits, foxes, and groundhogs create burrows that provide them with amenities such as shelter and food storage areas. This allows them to survive and thrive within the subterranean part of the ecosystem. **SEE ALSO** BIOGEOCHEMICAL CYCLES; MYCORRHIZAE; NEMATODE; NITROGEN FIXATION; PLANT NUTRITION; ROOTS

*Dean Cocking*

### **Bibliography**

Killham, Ken. *Soil Ecology*. New York: Cambridge University Press, 1994.

**aerobic** with oxygen, or requiring it

**ion** an electrically charged particle

**nematode** worm of the Nematoda phylum, many of which are parasitic

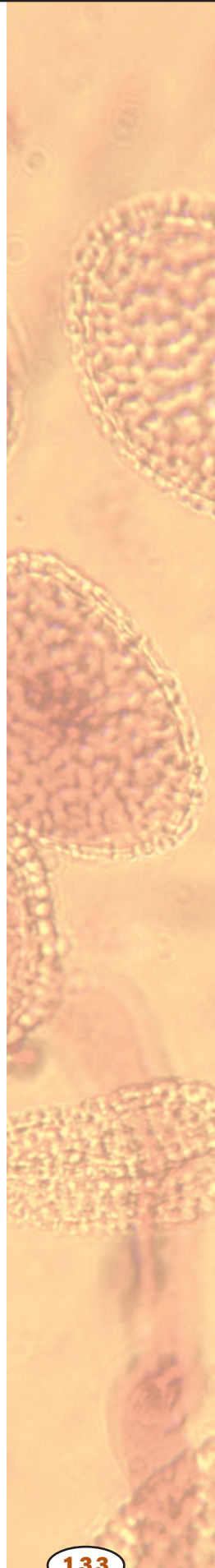

Miller, Raymond W., and Duane T. Gardiner. *Soils in Our Environment*, 9th ed. Upper Saddle River, NJ: Prentice Hall, 2001.

Paton, T. R., G. S. Humphreys, and P. B. Mitchell. *Soils: A New Global View*. New Haven, CT: Yale University Press, 1995.

## Speciation

Speciation refers to the genesis of a new species from an ancestral species. There are two basic ways this can happen. Anagenesis involves one species evolving into a different species. Cladogenesis occurs when one species splits into two or more species. Cladogenesis is of greater interest in terms of biodiversity and is the type of speciation discussed here. Speciation has two primary components: diversification and genetic isolation. The two principal types of cladogenesis are allopatric speciation and sympatric speciation.

### Allopatric Speciation

Allopatric speciation is the better understood of the two types of cladogenesis. It occurs when one species is separated into two groups by some physical barrier, resulting from, for example, climate change, a geological event, or a human-induced change in the environment. For example, the uplift of a new mountain range might divide an ancestral species into two isolated groups. Once the species is separated into these groups, each group may accumulate genetic changes that serve to differentiate it from the other. This accumulation of changes may result from natural selection or from random events.

If the environment on either side of the barrier is different, natural selection may favor genes that produce different traits on either side of the barrier. Even if the environment on either side of the barrier is similar, it may be that when the two groups were separated, by chance one of the groups had a different subset of the total genetic diversity present in the species, and so that group has different “raw materials” for selection to act upon. It may also happen that a neutral mutation occurs in one of the groups, meaning it is neither favorable to the organism nor unfavorable to it. Selection will not act upon such a mutation, and it may persist in the population purely by chance. Also by chance, some versions of genes may become common in a small population while others disappear. This is called genetic drift.

So by a variety of processes, involving either selection or chance, two physically separated groups may accumulate differences between them. This is the first part of the process of speciation. The second part involves the lack of gene flow between the two groups. That is, individuals from one group do not cross the barrier to mate with individuals in the other group, resulting in the genetic isolation of each group from the other. This genetic isolation permits the development of differences in the two groups.

If these differences are to persist, there must be a persistent impediment to gene flow between them. If the two groups never come into contact again, they will almost certainly accumulate enough differences over time to become separate species. If they expand their ranges and come back into contact, some other mechanism must act to “preserve” the differences they

evolved in isolation (allopatry). Traditionally, this mechanism is known as **reproductive isolation**, and it is a byproduct of the diversification that has already taken place.

## Reproductive Isolation

Reproductive isolation can operate prezygotically (premating) or postzygotically (postmating). Prezygotic reproductive isolation prevents **fertilization** from taking place. It may be that members of the two groups breed at different times of the day or different times of the year or in different habitats. They may have developed mechanical differences that prevent copulation, or perhaps copulation takes place, but the two groups have become chemically incompatible so that fertilization does not occur. Postzygotic reproductive isolation acts after fertilization. The embryo may not develop normally, or the offspring may be unhealthy or infertile as adults. In all these ways, reproductive isolation may prevent the gene pools of the two groups from mixing, allowing them to continue on independent evolutionary trajectories.

There is some disagreement among scientists regarding the importance of reproductive isolation in the speciation process. If, as noted above, the two groups that have accumulated differences between them remain separated by a physical barrier preventing their members from ever meeting, it may not matter whether they develop reproductive isolating mechanisms. Proponents of the **phylogenetic** species concept, for instance, would say that the fact that the groups have accumulated diagnostic differences and are evolving independently is sufficient evidence to say that speciation has taken place.

## Sympatric Speciation

The other principal type of cladogenesis is sympatric speciation. In this type of speciation, a species splits into two groups that diversify and become genetically isolated while remaining in the same place. “Same place” typically means that individuals from both groups meet in the same habitat during the breeding season. Most of the mechanisms by which sympatric speciation may occur are poorly understood. There must be some impediment to gene flow if differentiation into two groups is going to take place.

Sympatric speciation can happen if a mutation results in an immediate reproductive barrier in a segment of the species. The most common example of this is polyploidy in plants. In this case, errors in cell division may cause a doubling of the normal number of chromosomes, which instantaneously produces a reproductive barrier.

Another possible mechanism for sympatric speciation is disruptive selection, which takes place when a species has a trait that is manifested in two very different ways, such as two different coat colors. In this case, natural selection operating in a highly partitioned environment (dark versus light background, for instance) may favor one expression of the trait in one particular portion of the habitat and the other expression of the trait in a different portion of the habitat. Selection may thus compound the differences in the trait’s expression and in this way result in differentiation.

Polyploidy in plants is also an example of how quickly speciation can take place, even in a single generation. Usually, however, speciation takes

**reproductive isolation** isolation of a population from other populations of the same species due to inability to successfully reproduce; an early stage in species formation

**fertilization** union of sperm and egg

**phylogenetic** related to phylogeny, the evolutionary development of a species

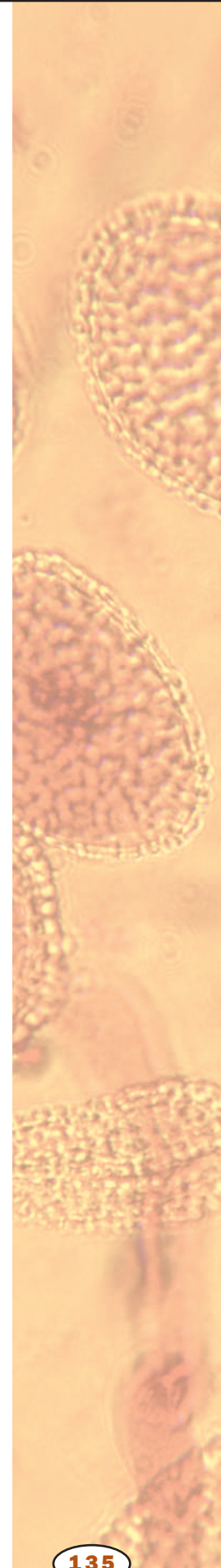

longer. Just how long is dependent on many variables, such as the generation time of the organisms involved, as well as factors of chance. There are two predominant schools of thought regarding the speed of speciation. “Gradualists,” on the one hand, believe groups accumulate differences slowly over hundreds of thousands or millions of years. “Punctationalists,” on the other hand, believe that speciation takes place comparatively rapidly, over thousands of years, and little change occurs between these rapid bursts of differentiation. SEE ALSO BIODIVERSITY; EVOLUTION; EVOLUTION, EVIDENCE FOR; NATURAL SELECTION; POPULATION GENETICS; SPECIES

*Ann E. Kessen and Robert M. Zink*

### Bibliography

Darwin, Charles. *The Origin of Species: By Means of Natural Selection or the Preservation of Favoured Races in the Struggle for Life*. Edited with an introduction by Gillian Beer. Oxford, England: Oxford University Press, 1996.

Gould, Stephen Jay. *The Panda's Thumb*. New York: W. W. Norton, 1980.

Otte, Daniel, and John A. Endler, eds. *Speciation and Its Consequences*. Sunderland, MA: Sinauer Associates, 1989.

Quammen, David. *The Song of the Dodo: Island Biogeography in an Age of Extinctions*. New York: Simon & Schuster, 1996.

## Species

There is little agreement among scientists about the definition of the word “species.” However, most biologists would agree that a species is a detectable, naturally occurring group of individuals or populations that is on an evolutionary path independent from other such groups. Several more detailed definitions have been articulated over the years; two that have gained prominence are the biological species concept (BSC) and the **phylogenetic species concept (PSC)**.

In 1942 biologist Ernst Mayr defined the biological species concept as follows: “Species are groups of actually or potentially interbreeding natural populations, which are reproductively isolated from other such groups.” This definition places emphasis on restriction of **gene flow** among groups. **Reproductive isolation** means that individuals from two groups are unable to interbreed successfully, that is, produce healthy, fertile offspring. So according to this definition, an individual is a member of a particular species if it can breed successfully with members of that species but not with members of other species.

Interbreeding between two different groups is called hybridization and is viewed differently by different scientists. In animals, hybrid offspring of two different species are thought to be unhealthy or infertile as adults, but in plants hybrid offspring are often thought to be more vigorous than their parents. As a result, plant biologists and animal biologists differ regarding the significance of interbreeding in answering species questions, and most plant biologists are not proponents of the BSC.

Objections to the BSC include the fact that the extent of hybridization can range from very little to extensive, making its interpretation subjective. Also, it requires guesswork regarding the species status of groups that do not occur in the same place and thus have no opportunity to interbreed, and

**phylogenetic** related to phylogeny, the evolutionary development of a species

**gene** portion of DNA that codes for a protein or RNA molecule

**reproductive isolation** isolation of a population from other populations of the same species due to inability to successfully reproduce; an early stage in species formation

it cannot easily be applied to organisms in the fossil record or to those that lack sexual reproduction. Furthermore, it is now known that hybridization can occur between two independent groups that are not each other's nearest relatives. Thus, putting two hybridizing groups into one species could misrepresent evolutionary history by excluding other more closely related (and often reproductively isolated) groups.

A phylogenetic species concept was articulated by Joel Cracraft in 1987 as follows: "a species can be defined as an irreducible cluster of organisms, within which there is a parental pattern of ancestry and descent, and which is diagnosably distinct from other such clusters." This definition views a species as being the smallest possible grouping of organisms in time and space that can be differentiated from other groupings, with the basis for the differentiation being inherited. So an individual is a member of a species if it shares the inherited characteristics of the species, irrespective of whether it can hybridize with a member of another species. The primary objection to this definition is that it is too vague.

These are but two examples of the numerous definitions from a century of ongoing debate about the definition and meaning of species. Scientists often approach the species question differently depending on what organisms they are studying and the way in which they are studying them. Traditionally, organisms have been grouped into species based on aspects of their appearance or particular behaviors. More recently, analysis of deoxyribonucleic acid (DNA) has joined the list of techniques for differentiating or grouping organisms. Additionally, there are specific criteria used for different groups. In plants, for instance, plant chemistry, insect associations, and number of **chromosomes** may be important indicators of species status. As another example, scientists studying bacteria may use such characteristics as shape, biochemistry, and conditions favoring growth to help them answer species questions. Thus, there is no simple, universally agreed-upon definition of species. SEE ALSO BIODIVERSITY; BUFFON, COUNT; EVOLUTION; SPECIATION; TAXONOMY, HISTORY OF

*Ann E. Kessen and Robert M. Zink*

### Bibliography

Keller, Evelyn Fox, and Elisabeth A. Lloyd, eds. *Keywords on Evolutionary Biology*. Cambridge, MA: Harvard University Press, 1992.

Otte, Daniel, and John A. Endler. *Speciation and Its Consequences*. Sunderland, MA: Sinauer Associates, 1989.

## Spinal Cord

The spinal cord is a bundle of nerve fibers, no thicker than the human thumb, that links the brain with the rest of the body. The spinal cord is protected by the vertebral column, and together with the brain it comprises the central nervous system. The nerves that enter and exit the spinal cord form the peripheral nervous system.

Some nerves enter the spinal cord on its dorsal surface (which is closest to the back). These nerves carry sensory information to the spinal cord and are called afferent nerves. For example, they allow a person to determine if the pan on the stove is hot or cold, or if one's hand is touching

### MAYR, ERNST (1904–)

German-born U.S. evolutionary biologist who helped found the "modern synthesis," the melding of evolutionary theory with genetics. Mayr's greatest contribution was to explain how new species can arise. When a population is isolated, on an island, for example, it can evolve separately from the rest of the species. Mayr's views have defined evolutionary biology for nearly three-quarters of a century, and he has won two prestigious prizes, the Balzan Prize and the Japan Prize.

**chromosome** "colored body" in the cell nucleus; made of DNA and protein, and divided functionally into genes and non-gene regions

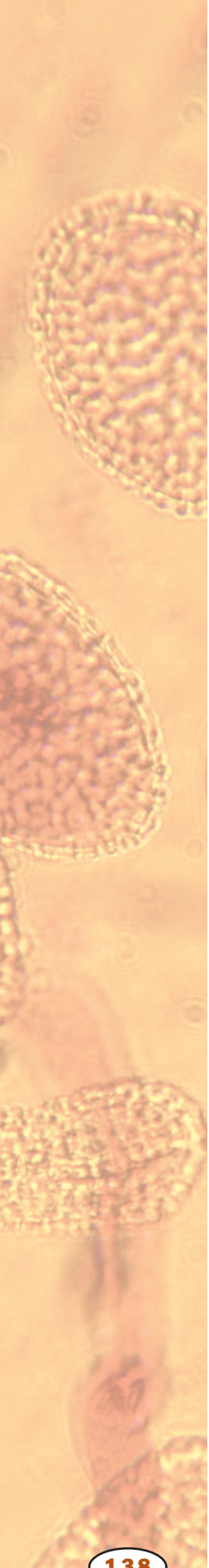

**neuron** nerve cell

**axon** long extension of a nerve cell down which information flows

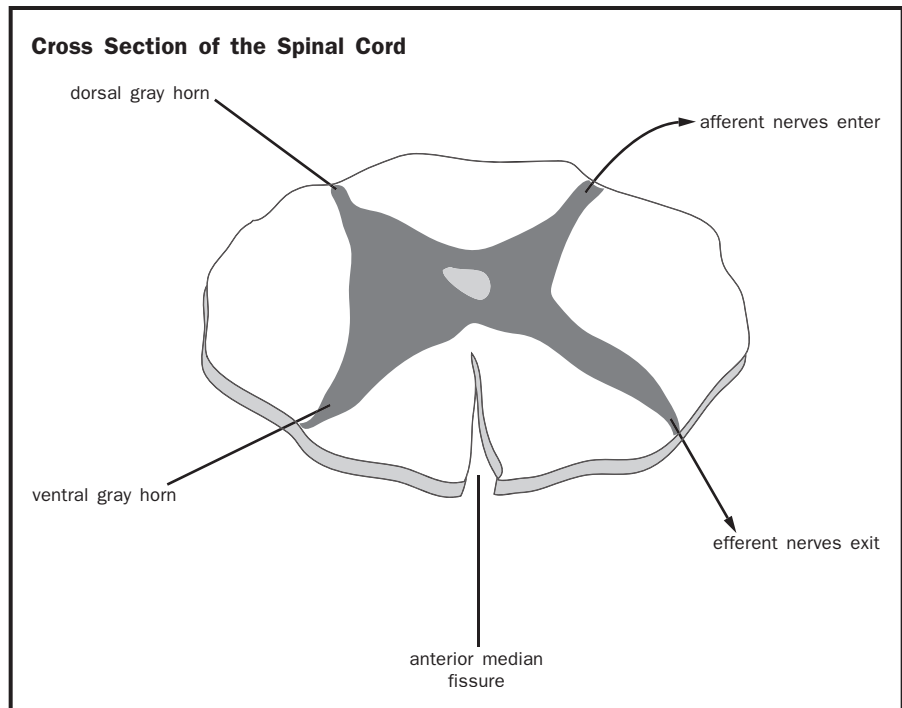

rough sandpaper or smooth silk. In contrast, the nerves that exit the ventral surface (closest to the stomach) of the spinal cord carry information from the spinal cord to the rest of the body. These nerves enable a person to jerk his or her hand away from a hot pan or throw a dog a ball. The term for nerves that conduct commands from the spinal cord to muscles and organs is efferent.

The afferent and efferent nerves are associated with an H-shaped area of gray matter in the center of the spinal cord. The gray matter is separated into dorsal and ventral horns. The ventral horn contains the cell bodies of efferent **neurons** that control muscles and organs. The sensory nerves enter the dorsal horn where they make connections with nerve cells that travel to the brain.

The gray matter is surrounded by white matter, which contains the long projections of nerve cells (called **axons**) that carry information to other parts of the nervous system. Axons that carry similar information are grouped into bundles or tracts. Many tracts start in the dorsal horn and carry sensory information from the cord to the brain (for example, the message that the hand is touching silk instead of sandpaper). Since these neurons are traveling “up” the cord, they are often referred to as ascending tracts. In addition to ascending tracts, the white matter also contains descending tracts. As the name implies, these tracts begin in the brain and travel down the spinal cord to make connections with neurons in the ventral horn. They provide a person with voluntary control of his or her muscles, as well as the involuntary control over internal organs.

In short, the spinal cord carries all of the information that enters and exits the brain. Therefore, it is not surprising that when this flow of information is blocked by injury, the consequences are devastating. Patients suffer paralysis and loss of sensation in their legs (paraplegia) if the lower part

of the cord is damaged, or in their arms and legs (quadriplegia) if the injury is in the upper regions of the cord. In addition, control over urination, defecation, and sometimes respiration is lost depending on the level and extent of the damage. Once the spinal cord has been injured, the damage is usually permanent. Physical therapy can enable a patient to regain a small amount of movement over time, but the medical field has yet to discover a way to reconnect the severed nerve cells to produce normal function. SEE ALSO BRAIN; CENTRAL NERVOUS SYSTEM; NEURON; PERIPHERAL NERVOUS SYSTEM

Sheri L. Boyce

### Bibliography

- Martini, Frederic H., and Edwin F. Bartholomew. *Essentials of Anatomy and Physiology*, 2nd ed. Upper Saddle River, NJ: Prentice Hall, 2000.
- Martini, Frederic H., Edwin F. Bartholomew, and Kathleen Welch. *The Human Body in Health and Disease*. Upper Saddle River, NJ: Prentice Hall, 2000.
- McDonald, John. "Repairing the Damaged Spinal Cord." *Scientific American* 280 (1999): 65–73.

## Stress Response

The stress response is the human body's reaction to anything that throws off the balance inside it—injury, infection, fear, exercise, or pain. The body reacts with an alarm phase, then a resistance phase, during which it tries to fix the imbalance, and then, if that fails, an exhaustion phase.

The response starts when a part of the brain called the hypothalamus detects stress. The hypothalamus starts the alarm phase by turning on the sympathetic division of the nervous system. The sympathetic nerves release adrenaline. The "adrenaline rush" makes the heart beat harder and faster, raising blood pressure. A person's skin turns pale as blood vessels to the skin constrict and direct the blood to the muscles. Blood vessels to the intestines and kidneys also constrict. The liver releases stored sugar into the blood, hair stands up, and the body begins to sweat. The body's natural response is to run away or fight back; that's why the sympathetic system is called the "fight or flight" system.

Next, the body must enter the resistance phase and fix whatever is causing this stress. If the body has lost blood from an injury, the kidneys can help minimize the loss. The hypothalamus makes the kidneys take water from the urine and put it back into the blood by releasing a **protein** called antidiuretic (which means "against urination") **hormone** (ADH).

The adrenal glands (sitting right on top of the kidneys) can also make the kidneys move fluid from the urine back into the blood. But what makes them do it? It's the kidneys, located just below them. When the kidneys' blood supply is reduced during the alarm phase, they release a protein called renin (which means "kidney substance") into the blood. Renin reacts with other proteins in the blood to form angiotensin (which means "blood vessel constricting"). When angiotensin reaches the adrenal glands, their outer layer, the adrenal cortex, releases the hormone aldosterone. Aldosterone makes the kidneys secrete potassium into the urine and reabsorb sodium and water into the blood. This helps maintain blood volume.

**protein** complex molecule made from amino acids; used in cells for structure, signaling, and controlling reactions

**hormone** molecule released by one cell to influence another



The hypothalamus and adrenal cortex work together in the resistance phase to replace lost blood volume and send food to damaged cells.

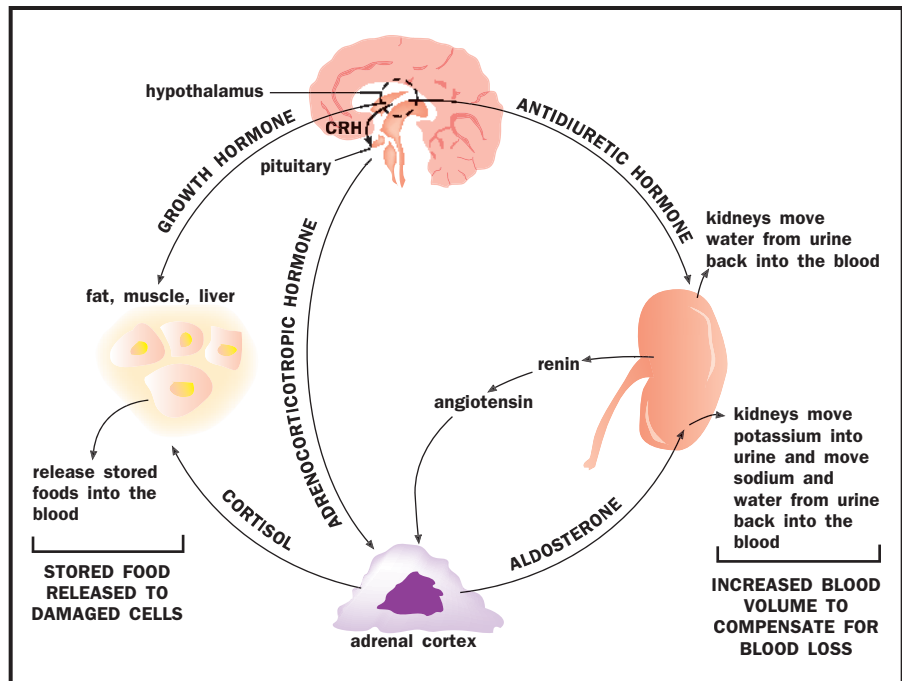

**glucose** simple sugar that provides energy to animal cells and is the building block of cellulose in plants

**carbohydrates** sugars, starches, and other molecules combining carbon, hydrogen, and oxygen and serving as fuel or structural components

As the stress continues, the body uses up its stored **glucose**. It will need to use its stored **carbohydrates**, fat, and proteins for energy and to heal damaged cells. Once again, the hypothalamus and adrenal glands tell the body what to do. The hypothalamus releases growth hormone and the adrenal cortex releases cortisol. Both of these hormones tell the body to release stored compounds from body fat, muscles, and the liver. In this case, the adrenals get their orders to release cortisol from the hypothalamus when it releases a protein called corticotropin (meaning “cortex stimulating”) releasing hormone (CRH).

The hypothalamus does not affect the adrenals directly. Instead, the CRH goes to the pituitary gland, just below the brain. The pituitary sends the message on to the adrenals by releasing adrenocorticotropic (meaning “adrenal cortex stimulating”) hormone (ACTH). This chain of command, in which the hypothalamus tells the pituitary what to do, and then the pituitary tells the adrenals, is called the hypothalamic-pituitary-adrenal axis. When ACTH reaches the adrenals, the adrenal cortex releases cortisol into the blood. Cortisol makes the body release stored chemicals into the blood.

With ADH and aldosterone helping the body preserve blood volume, and cortisol and growth hormone providing food for the cells, the body should recover. But if this isn’t enough help, the body could become exhausted and suffer organ damage.

Long-term or chronic stress can keep the body’s stress response too active. That can cause high blood pressure by increasing blood volume. It can make the body lose too much potassium in the urine or develop high blood sugar levels. Also, cortisol suppresses the immune and inflammatory systems (that is why the similar compound cortisone is used to treat rashes). With high cortisol levels, the body has trouble fighting off infections. Stress even makes some animals more prone to cancer. The stress response helps save the body from life-threatening injury, but it may need to be controlled with

medications, biofeedback, or meditation to keep it from causing new illnesses or complications. SEE ALSO ADRENAL GLAND; BLOOD SUGAR REGULATION; HORMONES; HYPOTHALAMUS; IMMUNE RESPONSE; LIVER; NERVOUS SYSTEMS; PITUITARY GLAND

Patricia S. Bowne

### Bibliography

Martini, Frederic H. *Fundamentals of Anatomy and Physiology*. Upper Saddle River, NJ: Prentice Hall, 1998.

Porth, Carol M. *Pathophysiology: Concepts of Altered Health States*. Philadelphia, PA: Lippincott Press, 1998.

## Structure Determination

Determining the structure of a molecule, especially a protein, is an important step in determining its function. In many diseases, changes in molecular structure are involved in the **pathologic** process, and understanding these changes can help in the design of therapy. The three-dimensional arrangement of atoms in a molecule can be determined using a variety of physical techniques. For large biological **macromolecules** the most common experimental techniques for structure determination include X-ray crystallography, electron microscopy, and nuclear magnetic resonance (NMR). Finally, approximate models depicting the three-dimensional arrangement of atoms can be built using computer modeling.

The principles behind the use of X rays for the determination of the structures of biological macromolecules are quite different from the use of “X rays” in the practice of medicine. A medical X-ray film shows a shadow revealing internal body parts depending on how easily the X rays penetrated them. In contrast, **X-ray crystallography** looks at how X rays are diffracted, or scattered, by the atoms in a sample and determines what the three-dimensional arrangement of the atoms must be to give rise to the observed pattern of scattering. (This is somewhat akin to determining the structure of a jungle gym by bouncing a tennis ball off it and recording the pattern of bounces.)

The distances between atoms in a molecule are very small, on the order of  $10^{-10}$  meters, and the wavelength of the radiation used to determine their relative positions must be correspondingly small. X rays have the necessary small wavelength. The amount of radiation scattered by one molecule is too small to measure; therefore, it is necessary to combine the diffraction from a large number of molecules. Crystals are used because they contain an ordered arrangement of many molecules. Computers are used to reconstruct an image of the molecules in the crystal. The technique of X-ray crystallography provides the most detailed and accurate information on the structure of biological macromolecules.

Electron microscopy uses an electron beam to study the structure of biological materials. By using a magnet to focus electrons scattered from a sample, an electron microscope can form an image in a manner similar to a conventional microscope. One problem is that the electron beam used in such a microscope has a very high energy and can destroy sensitive biological samples. To aid in its preservation, the sample is often maintained at a

**pathologic** related to disease

**macromolecules** large molecules such as proteins, carbohydrates, and nucleic acids

**X-ray crystallography** use of X rays to determine the structure of a molecule

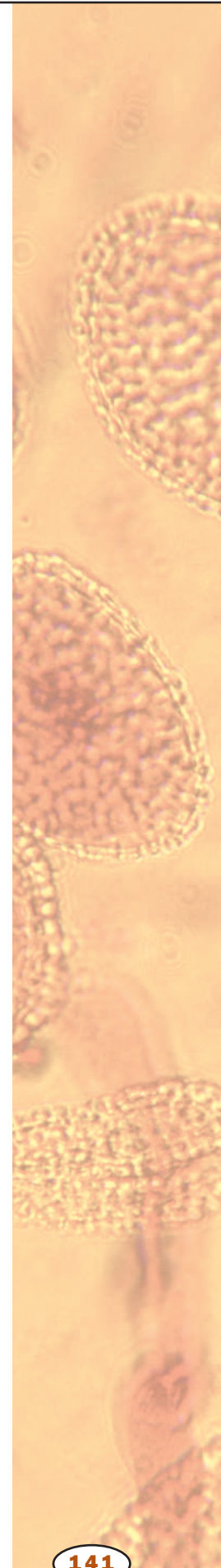

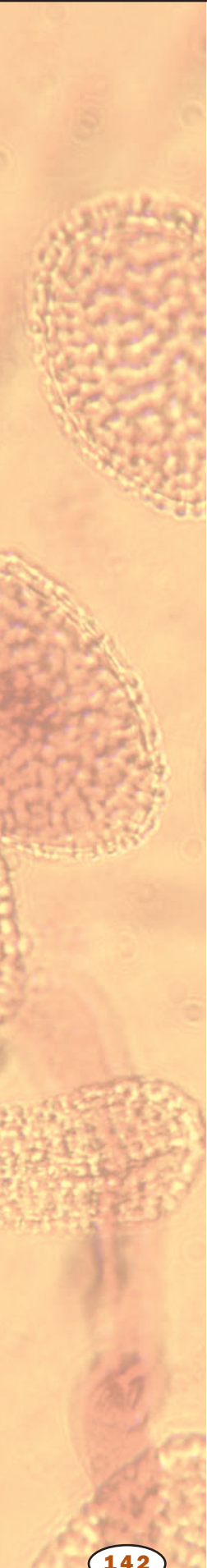

**amino acid** a building block of protein

**mutualism** symbiosis between two organisms in which both benefit

very low temperature (this is called cryo-electron microscopy). As in the case of X-ray diffraction, it is an advantage to combine the electrons scattered from many molecules to get an average image. This can be done using ordered samples such as two-dimensional crystals or by orienting and averaging many images. Electron microscopy is especially useful for large complexes of macromolecules.

Nuclear magnetic resonance is not a scattering technique, but a spectroscopic technique that depends on the interaction of atomic nuclei with radio-frequency radiation and a magnetic field. This interaction is very sensitive to the environment surrounding an atom, and therefore can be used to determine what other atoms are nearby a given atom. Once the features in an NMR spectrum have been associated with specific atoms it is possible to combine this experimental information of the local arrangement of atoms with knowledge of the chemical structure of a molecule to derive a three-dimensional structure. An advantage of NMR is that it examines molecules in solution and can also provide information about their dynamic properties, or motion.

In addition to the experimental techniques for determining the three-dimensional structures of molecules, it is possible to use computational techniques to predict structures. The most successful approach to structure prediction utilizes the observation that proteins with similar **amino acid** sequences have similar three-dimensional structures. This allows one to predict an approximate structure if a structure of a related protein is already known. This starting point can then be combined with knowledge of the chemical structure and physical principles to improve the model. SEE ALSO ELECTRON MICROSCOPY; PROTEIN STRUCTURE

Wayne F. Anderson

### Bibliography

- Alberts, Bruce, et al. *Molecular Biology of the Cell*, 4th ed. New York: Garland Publishing, 2000.
- Branden, Carl, and John Tooze. *Introduction to Protein Structure*, 2nd ed. New York: Garland Publishing, 1999.
- Stryer, Lubert. *Biochemistry*, 4th ed. New York: W. H. Freeman and Company, 1995.

## Symbiosis

A wide array of interactions among plants, animals, and microorganisms occurs in nature. Some of these relationships are characterized by a close physical association among species that persists for a significant period of the life cycle. In 1879 German botanist Heinrich Anton de Bary coined the term “symbiosis” to describe these relationships, meaning the living together of different species of organisms.

An interaction is considered a symbiosis based on the closeness of the physical association among the organisms rather than on the effect or outcome of the interaction. Symbiotic relationships span a spectrum from beneficial to detrimental effects. Many people associate symbiosis with **mutualism**, interactions that are beneficial to the growth, survival, and/or reproduction of *both* interacting species. But symbiotic interactions also include commensalism (one species receives benefit from the association and



the other is unaffected), amensalism (one species is harmed, with no effect on the other), and parasitism. An example of commensalism is found in the anemone fish, which gains protection from living among the poisonous tentacles of the sea anemone, but offers no known benefit to its host.

In parasitic interactions, one species lives on or within a host organism and receives nourishment from the host, whereas the host is harmed by the interaction. In **obligate** interactions, the relationship is essential to at least one of the interacting species. Facultative interactions are those that are beneficial to at least one of the interacting species, but not essential.

### Mutualisms in Plants

A common and widespread symbiosis occurs between terrestrial plants and fungi that colonize their roots. These associations are called “mycorrhizae,” a word meaning “fungus-root.” Unlike **pathogenic** fungi that cause disease, mycorrhizal fungi benefit the plant in several ways. These fungi germinate from spores in the soil to form thin threadlike structures called hyphae, which grow into the roots of plants. Once the roots are colonized,

Cleaner shrimp cleaning a zebra moray eel. Mutualistic relationships such as these promote the well-being of the host fishes and provide food for those that do the cleaning.

**obligate** required or necessary, especially referring to a metabolic process or mode of nutrition

**pathogen** disease-causing organism

**carbohydrates** sugars, starches, and other molecules combining carbon, hydrogen, and oxygen and serving as fuel or structural components

**minerals** iron, calcium, sodium, and other elements needed by living organisms

**ecosystem** an ecological community and its environment

**ungulate** hoofed mammals such as cattle

**cellulose** carbohydrate made by plants and some other organisms; part of the cell wall

**enzyme** protein that controls a reaction in a cell

**parasite** organism living in close association with another from which it derives most of its nutrition

the fungal hyphae grow out from the root in an extensive network to explore the soil beyond the reach of the roots, gathering essential mineral nutrients and transporting them into the plant, increasing its growth. In return, the plant provides **carbohydrates** as a food source for the fungus.

Mycorrhizal symbiosis occurs in about 80 percent of all plant species. It is essential to many plants in low-nutrient environments because their roots alone are incapable of absorbing adequate amounts of some essential **minerals** such as phosphorus. The symbiosis is essential to the fungus because, unlike plants, fungi cannot make their own food via photosynthesis.

Mycorrhizal fungi provide other benefits to plants including improved resistance to drought and disease. The additional mineral nutrients acquired by these fungi have been shown to aid plants in coping with competitors and herbivores. This symbiosis plays a large role in the growth and functioning of plants in both natural and agricultural **ecosystems**.

Legumes and certain other plants are colonized by *Rhizobium* bacteria that form small swellings or nodules on their roots. These symbiotic bacteria carry out the process of nitrogen fixation, the conversion of nitrogen gas into ammonia. Nitrogen is an essential element required by all organisms. Although nitrogen gas is abundant in the air, plants are unable to use nitrogen in this form, but they can readily use the ammonia formed by these bacteria and thus benefit from this symbiosis. As with mycorrhizal associations, the host plant benefits its symbiont by providing a carbohydrate energy source.

## Mutualisms in Animals

In animals, a common mutualistic symbiosis occurs between many herbivores and microorganisms of their digestive tracts. **Ungulates** (hoofed animals) and some other animals eat plant material that is high in **cellulose**, even though they lack **enzymes** capable of breaking down cellulose molecules. They obtain energy from cellulose with the help of symbiotic bacteria and protozoa living within their digestive tracts. These microbes produce enzymes called cellulase that break down cellulose into smaller molecules that the host animal can then utilize. Similarly, wood-consuming termites depend upon symbiotic protozoans living within their intestines to digest cellulose. These are obligate symbioses. The termites cannot survive without their intestinal inhabitants, and the microorganisms cannot live without the host. In each of these symbioses, the host animal benefits from the food provided by the microorganism and the microorganism benefits from the suitable environment and nourishment provided by the host.

A variety of animals engage in a mutualistic relationship referred to as cleaning symbioses. Birds such as oxpeckers benefit their large ungulate hosts by removing their external **parasites**, benefiting in return from the food source the host provides. In the marine environment, certain species of fish and shrimp similarly specialize in cleaning parasites from the outside of fishes. This mutualistic relationship promotes the well-being of the host fishes and provides food for those that do the cleaning. Unlike herbivores and their gut microorganisms, these interactions do not involve a close association of one organism living exclusively within another. These and other mutualistic but not clearly symbiotic relationships, such as those between plants and their pollinators, are sometimes referred to as proto-cooperation.

## Parasitism

Perhaps the most common type of symbiotic interaction in nature is parasitism. Many kinds of worms, protozoa, bacteria, and viruses are important animal parasites. Some, such as fleas or ticks, are ectoparasites, living on the outside of their host. Others, such as tapeworms or hookworms, are endoparasites that live inside their host.

A variety of parasitic **symbionts** also occur in plants. In some plants, insects deposit their eggs within the growing shoot tips or other plant part, at the same time producing chemicals that cause the development of a large swelling or tumorlike growth called a gall. The insect larvae then develop within the gall, feeding on the plant tissue as they grow. When its development is completed, the adult insect emerges from the gall to mate and then initiate the gall-forming cycle again. This is an obligate symbiosis because the insect larvae lives inside the plant and cannot complete its life cycle without its host plant. It is also a parasitic association because the insect living within the plant consumes plant tissue and causes harm to its host plant, while benefiting from the food resources and shelter provided by the plant. In addition to insects, other gall-forming symbionts include viruses, bacteria, and fungi.

Symbioses are widespread and important in the life of many organisms and ecologically important in the functioning of natural ecosystems. The patterns of adaptations of mutualists, parasites, and hosts suggest that these interactions are the product of coevolution, leading to increasingly specialized, and often increasingly beneficial, associations. In many mutualistic symbioses such as lichens (symbioses of algae and fungi) and corals (cnidarians and endosymbiotic algae), the adaptive value of the association is that one organism acquires from its partner some new metabolic capability (for example, photosynthesis) that it does not itself possess. SEE ALSO CNIDARIAN; CORAL REEF; MYCORRHIZAE; POPULATION DYNAMICS

David C. Hartnett

### Bibliography

- Abrahamson, Warren G. *Plant-Animal Interactions*. New York: McGraw-Hill, 1989.
- Begon, Michael, John L. Harper, and Colin R. Townsend. "Symbiosis and Mutualism." In *Ecology*, 3rd ed. Oxford: Blackwell Sciences Ltd., 1996.
- Douglas, Angela E. *Symbiotic Interactions*. New York: Oxford University Press, 1994.

## Synaptic Transmission

Synaptic transmission is the process whereby one neuron (nerve cell) communicates with other neurons or **effectors**, such as a muscle cell, at a synapse. A typical neuron has a cell body (soma), branching processes specialized to receive incoming signals (dendrites), and a single process (axon) that carries electrical signals away from the neuron toward other neurons or effectors. Electrical signals carried by **axons** are **action potentials**. Axons often have thousands of terminal branches, each ending as a bulbous enlargement, the synaptic knob or synaptic terminal. At the synaptic knob, the action potential is converted into a chemical message which, in turn, interacts with the recipient neuron or effector. This process is synaptic transmission.

**symbionts** organisms living in close association with another organism

**effector** organ at the end of a nerve, such as a muscle or gland

**axon** long extension of a nerve cell down which information flows

**action potential** wave of ionic movement down the length of a nerve cell

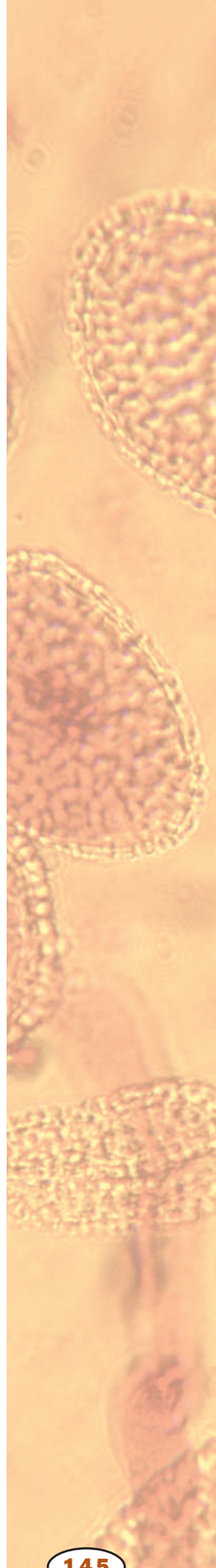

## Synapses

Synapses are junctional complexes between presynaptic membranes (synaptic knobs) and postsynaptic membranes (receptor surfaces of recipient neurons or effectors). The prefixes “pre-” and “post-” reflect the direction of synaptic transmission: presynaptic is the transmitting side (synaptic knob) and postsynaptic is the receiving side (dendrite, soma, or effector). Synaptic knobs contain many membrane-bounded synaptic **vesicles**, 40 to 100 **nanometers** in diameter. Synaptic vesicles contain the neurotransmitter. Synaptic knobs also contain **mitochondria**, microtubules, and other **organelles**.

Synapses are named according to their location on the postsynaptic neuron: Axospinous synapses are synapses on dendritic spines (tiny projections on the dendrites), axodendritic synapses are on shafts of dendrites, axosomatic synapses are on the soma of neurons, and axoaxonal synapses are synapses on other synaptic knobs. Synapses on skeletal muscle cells are neuromuscular junctions.

## Neurotransmitter Release

Action potentials arriving at synaptic knobs trigger the release of neurotransmitter into the synaptic cleft. The molecular mechanism is not completely understood. A “synaptic delay” of one to two milliseconds occurs between the arrival of the action potential and the neurotransmitter release. Action potentials open calcium channels in the membrane of the synaptic knob, which causes an inward movement of calcium **ions**. Calcium ions trigger the release of neurotransmitter from synaptic vesicles into the synaptic cleft. The synaptic vesicles fuse with the presynaptic membrane during this process of exocytosis. The membranes of old vesicles become part of the presynaptic membrane and new vesicles pinch off from an adjacent area of membrane. These new vesicles are subsequently refilled with newly synthesized or “recycled” **neurotransmitters**.

Released neurotransmitters diffuse across the narrow synaptic cleft. At the postsynaptic membrane, neurotransmitter molecules bind to membrane-bound receptor molecules with recognition sites specific for that neurotransmitter. Binding of the neurotransmitter to the receptor triggers a postsynaptic response specific for that receptor. These responses can be either excitatory or inhibitory, depending on the properties of the receptor. If receptor stimulation results in the postsynaptic membrane becoming more electrically positive (depolarized), it is an excitatory postsynaptic potential (EPSP). If more negative (hyperpolarized), it is an inhibitory postsynaptic potential (IPSP). Excitation and inhibition depend on the properties of the receptor and not the neurotransmitter. Receptors coupled to sodium or calcium channels are excitatory and produce a depolarization of the postsynaptic membrane, whereas receptors coupled to chloride or potassium channels are inhibitory and produce a hyperpolarization of the postsynaptic membrane. Such receptors coupled to ion channels are called ionotropic receptors.

Other receptors are coupled to “second-messenger” systems that initiate a series of biochemical reactions in the postsynaptic cell. These are metabotropic receptors. Metabotropic receptors can produce many different

**vesicle** membrane-bound sac

**nanometer**  $10^{-9}$  meters; one-billionth of a meter

**mitochondria** subcellular organelle that creates ATP used for energy-requiring processes in a cell

**organelle** membrane-bound cell compartment

**ion** an electrically charged particle

**neurotransmitters** molecules released by one neuron to stimulate or inhibit another neuron or cell

### LOEWI, OTTO (1873–1961)

German-born American physician who received, with Henry Dale, the 1936 Nobel Prize in physiology for the discovery of a substance that stimulates nerve cells. In the 1920s, Loewi provided the first evidence that chemicals transmit impulses between nerves and organs, such as the heart.

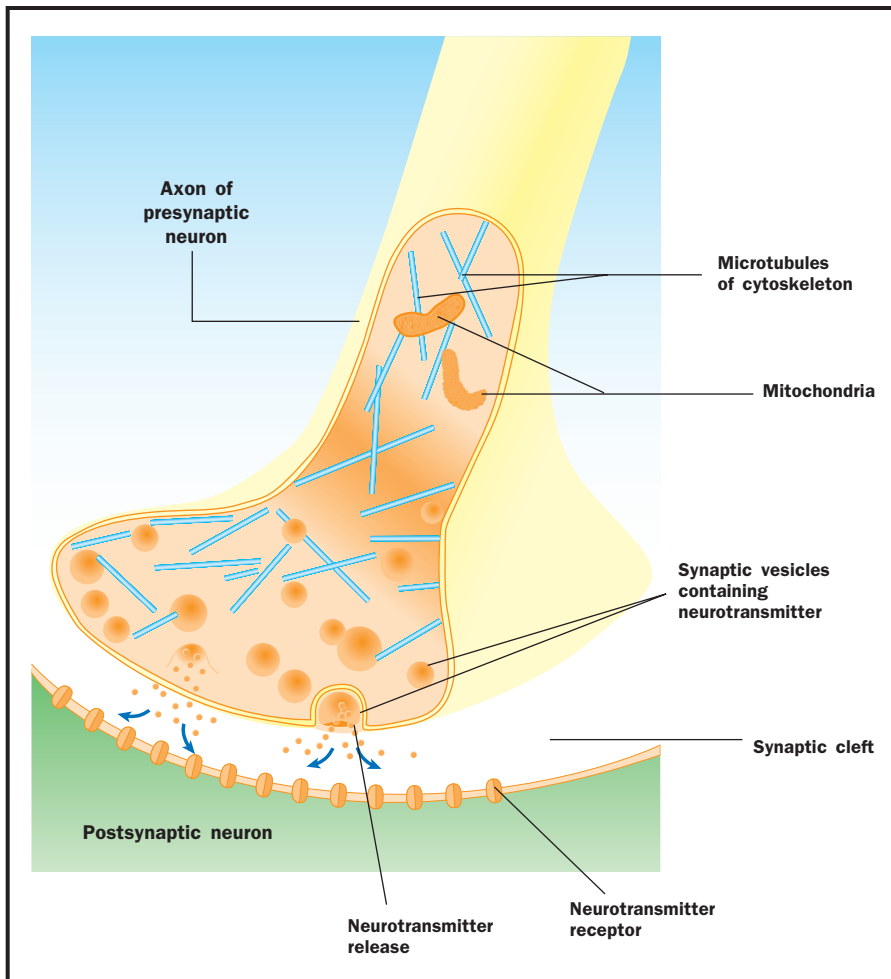

Synapses are junctional complexes between the presynaptic neuron and the postsynaptic neuron. Presynaptic is the transmitting side of the nerve impulse and postsynaptic is the receiving side.

postsynaptic events. These range from the direct activation of adjacent ion channels, to alteration of receptor sensitivity, to **transcription** of specific messenger ribonucleic acids (RNAs), or even the activation of specific **genes**. Chemical synapses are part of a very adaptable and flexible communications system. These are not static anatomical structures with fixed properties but are dynamic structures, able to change their molecular properties with changing circumstances.

There are literally hundreds of neurotransmitters. Some are fairly simple compounds such as acetylcholine, serotonin, the catecholamines (dopamine, norepinephrine, and epinephrine) and a number of the **amino acids**. Many are more complex and belong to the vast array of neuropeptide transmitters. Once released into the synaptic cleft, neurotransmitters remain active until they are either altered chemically or taken back into the synaptic knob by special carrier systems and recycled. At cholinergic synapses, acetylcholinesterase is present in the synaptic cleft. This **enzyme** cleaves the neurotransmitter into acetate and choline, neither of which is active. Serotonin and epinephrine, on the other hand, are taken up into the presynaptic terminal and recycled.

**transcription** messenger RNA formation from a DNA sequence

**gene** portion of DNA that codes for a protein or RNA molecule

**amino acid** a building block of protein

**enzyme** protein that controls a reaction in a cell

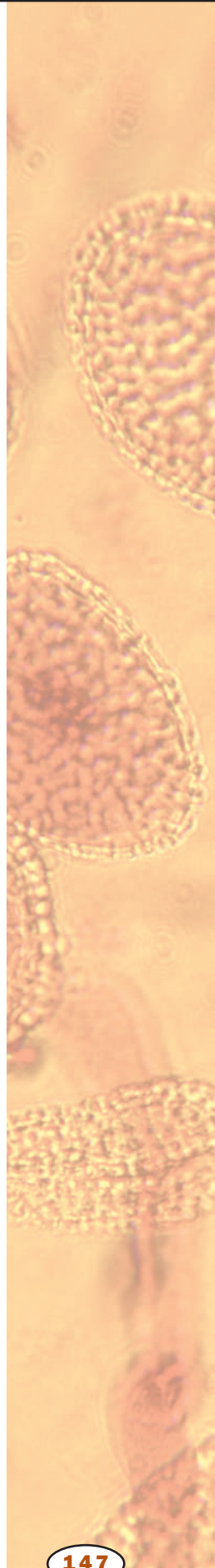



## Electrical Synapses

Electrical synapses, although rare in vertebrate nervous systems, do exist. In an electrical synapse, or gap junction, the presynaptic and postsynaptic membranes are partially fused. This allows the action potential to cross from the membrane of one neuron to the next without the intervention of a neurotransmitter. Electrical synapses often lack the directional specificity of chemical synapses and may transmit a signal in either direction. During biological activity, electrical synapses do not have the potential for as much variation as do chemical synapses. SEE ALSO AMINO ACID; EXOCYTOSIS; HORMONES; ION CHANNELS; MUSCLE

Alvin M. Burt

### Bibliography

Burt, Alvin M. "Histology and Fine Structure of Nervous Tissue," "Neuronal Communication," and "Chemical Transmission." In *Textbook of Neuroanatomy*. Philadelphia, PA: W. B. Saunders, Co., 1993.

Saladin, Kenneth S. "Nervous Tissue." In *Anatomy and Physiology: The Unity of Form and Function*. New York: McGraw-Hill, 2001.



**protein** complex molecule made from amino acids; used in cells for structure, signaling, and controlling reactions

**antigen** foreign substance that provokes an immune response

**gene** portion of DNA that codes for a protein or RNA molecule

## T Cells

Vertebrate animals have two immune system mechanisms to specifically identify and remove infectious agents from the body. In humoral immunity, **proteins** called antibodies bind to the foreign invader, targeting it for destruction by nonspecific defenses. In cell-mediated immunity, immune cells directly attach to and destroy the invader. Both mechanisms require the actions of T cells.

T cells belong to a category of white blood cells called lymphocytes. Lymphocytes are slightly larger than red blood cells and are found in the blood, lymphatic organs, and many other structures in the body. The spleen, lymph nodes, and tonsils are examples of lymphatic organs. Lymphocytes have large, round nuclei that take up almost all of the space inside the cell. Other examples of lymphocytes include B cells and natural killer cells.

Like all blood cells, T cells are made in the bone marrow. The *T* is an abbreviation for the word "thymus," an organ found on the front of the trachea, near the lungs and heart. After T cells are made, they go to the thymus to become mature. Three important events occur in the thymus.

First, each T cell begins to produce a protein called a receptor on its cell surface. T cell receptors recognize **antigens**, which are molecules that can start an immune response. Foreign invaders are made of many antigens. An antigen can fit inside the T cell receptor much like a key fitting into a lock. Each T cell receptor recognizes only one type of antigen. This explains how the immune system specifically identifies foreign invaders.

As a T cell matures, the **genes** that contain the information on how to build the T cell receptor are rearranged. Millions of possible T cell receptors can be produced by this rearrangement. However, once the genes are rearranged, a given T cell is committed to making only one type of receptor.

Unfortunately, some T cells express receptors that can recognize and damage the body's own antigens. Consequently, the second event that oc-

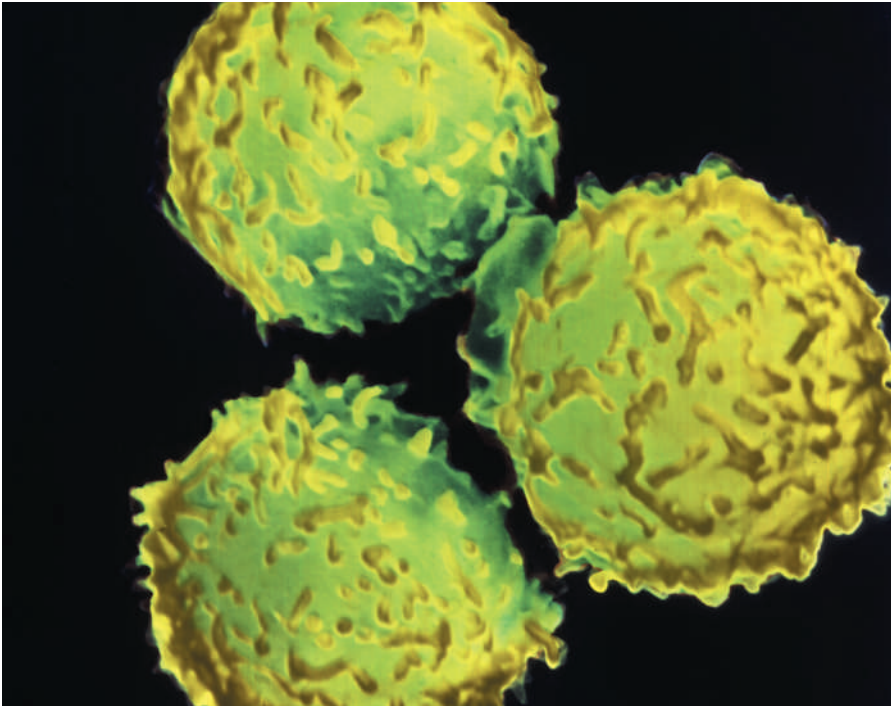

Scanning electron micrograph of three T cells.

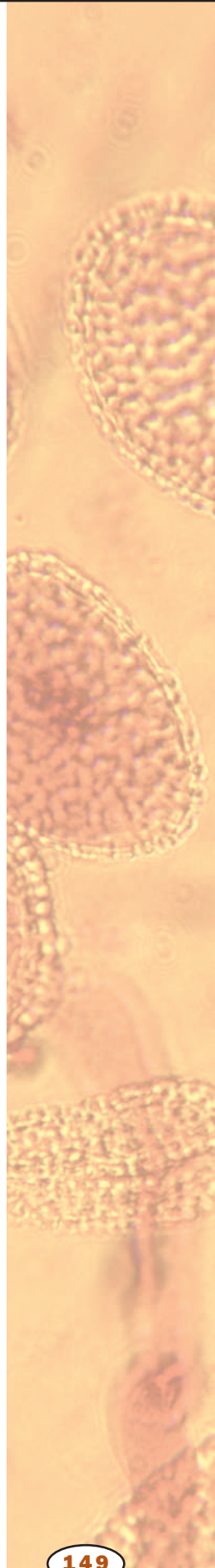

curs in the thymus is the destruction of these T cells. This process is called clonal deletion. The surviving T cells can roam through the body's organs, searching only for invaders.

The third event that occurs before the T cells leave the thymus results in the production of T cells with different functions. Some of the T cells will produce a surface protein called CD4. These T cells are called helper T cells ( $T_H$  cells), T4 cells, or CD4 cells. As their name implies,  $T_H$  cells assist other immune cells. Other T cells in the thymus produce a surface protein called CD8. These T cells are called cytotoxic T cells ( $T_C$  cells), T8 cells, or CD8 cells. As their name implies,  $T_C$  cells destroy foreign invaders. Some CD8 cells seem to be able to control the immune system and are consequently called suppressor T cells.

$T_H$  cells function in both humoral immunity and cell-mediated immunity. If foreign antigens enter the body, cells called antigen-presenting cells (APCs) engulf the antigen and attach it to a molecule called a class II major histocompatibility complex (MHC) protein. The antigen and class II MHC protein are then moved to the surface of the APC. The APC presents these molecules to a series of  $T_H$  cells with different receptors. If there is a match between a  $T_H$  cell receptor and the antigen, the  $T_H$  cell is stimulated to divide rapidly and produce chemicals called cytokines. The CD4 molecule on the  $T_H$  cell connects with the class II MHC protein on the APC to stabilize the cell-to-cell connection and provide additional signals. There are many other molecules on the surfaces of these cells that must interact, showing the complexity of the process.

In humoral immunity, stimulated  $T_H$  cells activate B cells. Like APCs, B cells bring foreign antigens inside and then display them with class II MHC proteins on the surface. The stimulated  $T_H$  cells then attach to the B cells just as they did with the APCs. This contact, along with the cytokines,

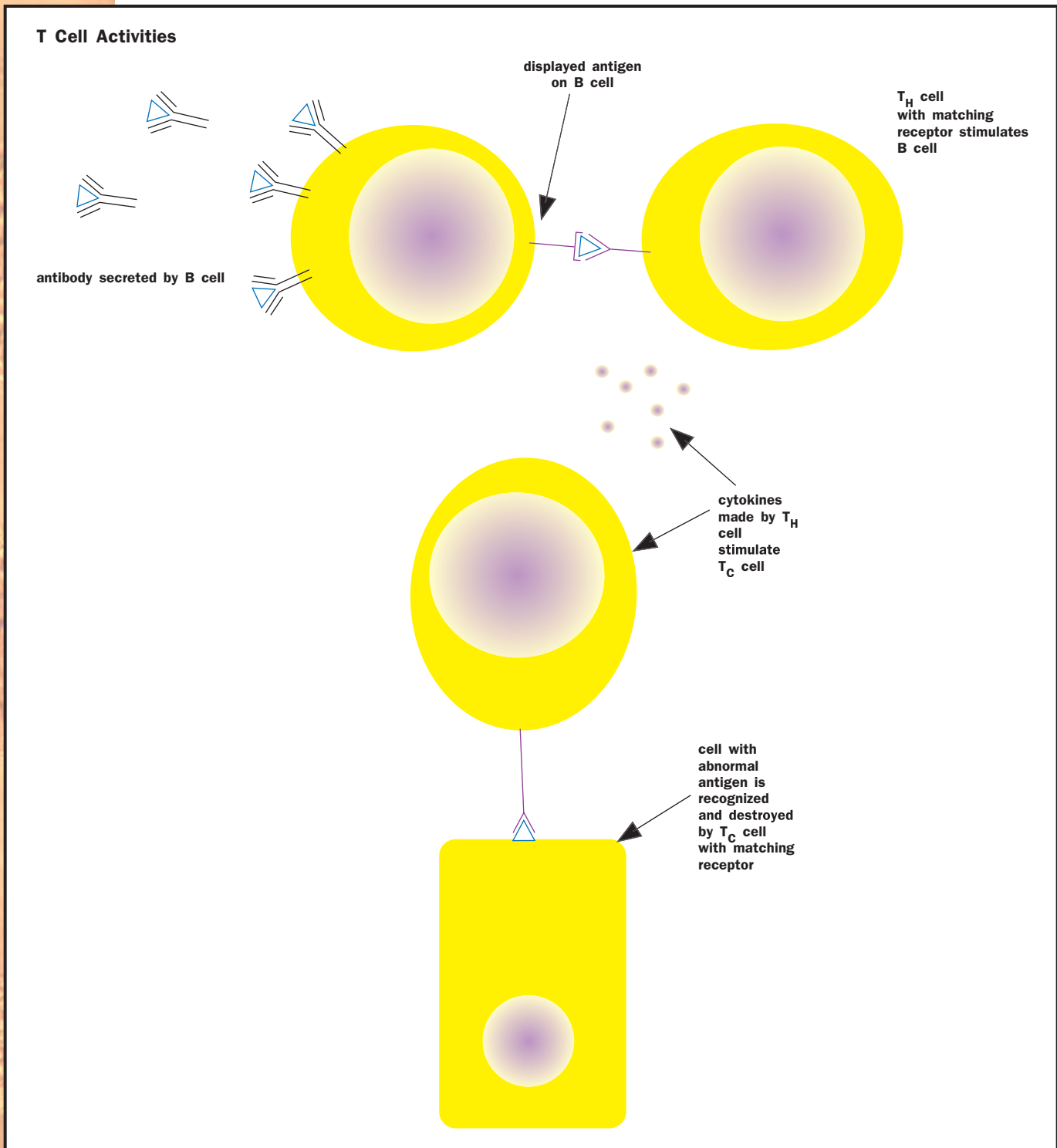

$T_H$  cells interact with B cells and  $T_C$  cells to protect the body from infection.

stimulates the B cell to divide rapidly, and it produces antibodies. Antibodies can clear other copies of the foreign invader from the body.

In cell-mediated immunity, stimulated  $T_H$  cells activate  $T_C$  cells. All cells of the body produce surface proteins called class I MHC proteins. If the cell is abnormal (cancerous or infected with a virus), the abnormal antigen is displayed with the class I MHC protein. A  $T_C$  cell with the match-

ing receptor will recognize the abnormal cell. The  $T_C$  cell receptor binds to the abnormal antigen and the CD8 molecule binds to the class I MHC molecule. The  $T_C$  cell receives other signals from cytokines made by  $T_H$  cells. Now the  $T_C$  cell divides rapidly and searches for other abnormal cells. When the  $T_C$  cells find abnormal cells, they bind to them and release chemicals that destroy the target cell. Perforin, lymphotoxin, and tumor necrosis factor are examples of these chemicals. Both B cells and  $T_C$  cells can become memory cells. Memory cells eliminate an invader more quickly if it appears again.

$T_H$  cells also aid nonspecific immunity by producing cytokines that cause inflammation and attract and activate white blood cells such as neutrophils, natural killer cells, and macrophages to the site of infection.

T cells may function abnormally, causing a variety of medical problems. For example, human immunodeficiency virus infects and destroys  $T_H$  cells. Consequently, many  $T_C$  cells and B cells are not activated. The invader gets the upper hand, and the body cannot easily rid itself of the infection or abnormal cell.

Sometimes  $T_C$  cells overreact to a harmless antigen and damage healthy tissue. This is what happens in individuals with allergies to poison ivy, latex, cosmetics, and metals.  $T_C$  cells are also responsible for the rejection of a transplanted organ. SEE ALSO AIDS; ANTIBODY; AUTOIMMUNE DISEASE; IMMUNE RESPONSE; NONSPECIFIC DEFENSE

*John M. Ripper*

### Bibliography

- Beck, Gregory, and Gail S. Habicht. "Immunity and the Invertebrates." *Scientific American* 275, no. 5 (1996): 60–65.
- Friedlander, Mark P., Jr., and Terry M. Phillips. *The Immune System: Your Body's Disease-Fighting Army*. Minneapolis, MN: Lerner Publications Company, 1998.
- National Institutes of Health. *Understanding the Immune System*. Washington, DC: National Institutes of Health, 1993.
- Nossal, Gustav J. "Life, Death, and the Immune System." *Scientific American* 269, no. 3 (1993): 53–62.
- Paul, William E. "Infectious Diseases and the Immune System." *Scientific American* 269, no. 3 (1993): 90–97.

**Taste** See *Chemoreception*

## Taxonomy, History of

Taxonomy, the field of biological classification, attempts to group types of organisms in meaningful ways. Modern taxonomy is based on similarities among organisms that reflect descent from recent shared ancestors, rather than similar solutions to environmental challenges. For example, a bird's wing and a human's arm reflect common descent from a vertebrate ancestor, whereas a bird's wing and an insect's wing are derived from different structures and therefore not characteristics on which modern classification might be based.

Taxonomic designations increasingly rely on deoxyribonucleic acid (DNA) sequence similarities. Because DNA mutates at a known rate, the

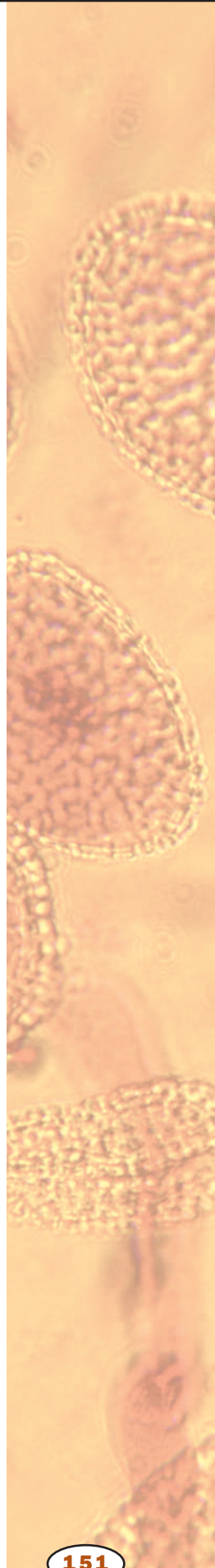



Carolus Linnaeus, the great eighteenth-century taxonomist, distinguished plants by their sexual parts.

**superficial** on the surface; not deep

**phylum** taxonomic level below kingdom, e.g., arthropod or chordate

more alike the DNA sequences are for two types of organisms, the more recently they diverged from a shared ancestor. By considering such data on pairs of species, biologists can construct evolutionary tree diagrams that depict how existing organisms are related to one another. In this way, taxonomy in the modern sense reflects evolution.

### Early Classification Schemes

Humans have probably always classified life. Thousands of years ago, people designated plants, animals, and fungi by whether they were tasty and safe to eat, of medicinal value, or were foul-tasting or even poisonous. An early taxonomist was Greek philosopher Aristotle (384–322 B.C.), who organized five hundred types of animals according to habitat and body form. His designations were rather subjective: he considered animals that gave birth to live young and had lungs as the pinnacle of living perfection.

By the sixteenth century, explorers had discovered so many new species that Aristotle's plan could no longer suffice. Newer schemes continued to be based on what people could see, but the characteristics considered were often more mystical than scientific. For example, an early-sixteenth-century botanical classification assigns a high ranking to the plantain, because "more than any other plant, it bears witness to God's omnipotence." John Ray (1627–1705) was an English naturalist who classified more than twenty thousand types of plants and animals. His highly descriptive method distinguished animals by their hoofs, nails, claws, teeth, and toes. Yet the inability to see microscopic distinctions and reliance on **superficial** similarities led him to group together algae, lichens, fungi, and corals. A lichen is a compound organism that consists of an alga and a fungus, but a coral is an animal.

Carolus Linnaeus (1707–1778) is the best-known taxonomist. Heavily influenced by John Ray, Linnaeus compared, contrasted, and meticulously listed types of organisms from his earliest childhood. He started his first botanical listing at age eight, which evolved into a series of publications called *Systema Naturae*, reaching twenty-five hundred pages by its tenth edition. Linnaeus distinguished plants by their sexual parts. He is most noted for introducing the binomial name for a species, which includes an organism's genus and "specific epithet," an adjective that describes the species in some way. The human animal, according to Linnaeus's scheme, is *Homo sapiens*, *sapiens* meaning "wise." French anatomist Georges Cuvier (1769–1832) and others contributed broader levels of taxonomic classification: family, order, class, **phylum** or division, and kingdom. The full taxonomic classification of humans is: Animalia (kingdom), Chordata (phylum), Mammalia (class), Primates (order), Hominidae (family), *Homo* (genus), *sapiens* (specific epithet).

### Beyond Plants and Animals

As biologists catalogued more of life's diversity, classification as plant or animal was no longer sufficient. For a while, biologists assigned to the plant kingdom anything that couldn't move, such as the fungi. These organisms are not plants because they do not photosynthesize, among other distinctions. Then the invention of the microscope revealed an entirely hidden, but vastly populated, world. In 1866, German naturalist Ernst Haeckel

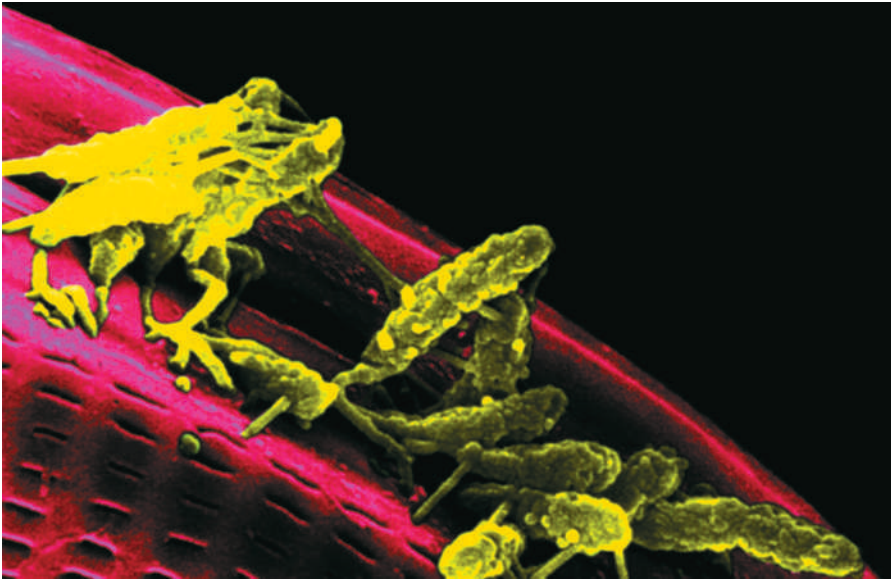

The discovery of archaea in the 1970s led scientists to add a taxonomic level, called domain, above kingdom.

(1834–1919) proposed a third kingdom, Protista, to include one-celled organisms. But Protista according to this early definition lumped together some very different types of organisms. In 1937, French marine biologist Edouard Chatton made an enormous contribution to biology by introducing the terms prokaryote and eukaryote. The prokaryotes lack nuclei; eukaryotes have nuclei as well as other **organelles**, and include unicellular and multicellular life. The prokaryotes include bacteria, cyanobacteria, and the fairly recently recognized archaea.

By 1959, it became clear that three kingdoms weren't enough. For a decade, several four-kingdom schemes reigned. One approach split single-celled life into prokaryotes and eukaryotes; another separated fungi from plants. Both changes were included in Cornell University ecologist Robert Whittaker's five-kingdom system. He introduced it in 1969 and it prevailed for many years. Whittaker's scheme recognized the Monera (prokaryotes), Protista (unicellular eukaryotes), Fungi, Plantae, and Animalia.

## Enter the Archaea

Classification of life reflects the tools that scientists have to observe organisms and to compare their characteristics. With the ability to distinguish nucleic acid sequences in the 1970s came a new way to deduce evolutionary relationships and classify organisms on this basis. Carl Woese, a microbiologist at the University of Illinois, analyzed the ribosomal ribonucleic acid (rRNA) **genes** of various microbes, reasoning that these genes are so vital that they would be similar in sequence among different types of organisms. (That is, any major deviation would be lethal.) Comparing the differences in sequence, therefore, might be useful in establishing evolutionary relationships. He quickly learned that prokaryotes and eukaryotes have very distinctive rRNA gene sequences.

After examining the rRNA genes of all of the microbes in his colleagues' labs, Woese turned to an organism in a more natural habitat, *Methanobacter thermoautotrophica*, a methane-emitting microbe found in a nearby lake. Its rRNA genes were markedly different in sequence from the prokaryotic

**organelle** membrane-bound cell compartment

**gene** portion of DNA that codes for a protein or RNA molecule

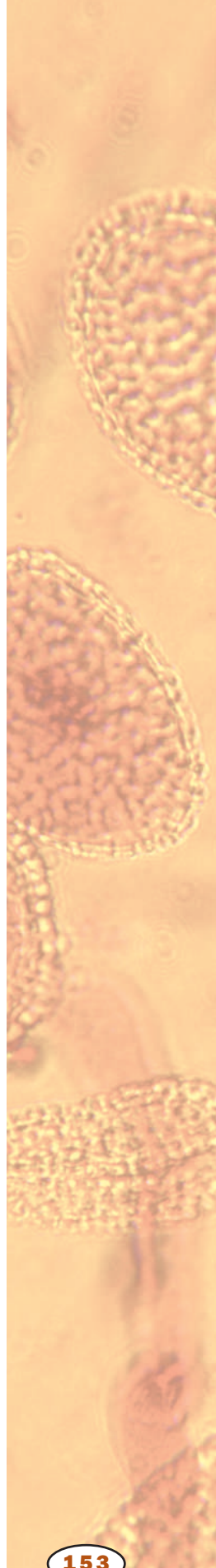

**lipid** fat or waxlike molecule, insoluble in water

**protein** complex molecule made from amino acids; used in cells for structure, signaling, and controlling reactions

**genome** total genetic material in a cell or organism

“signature.” Woese found others like it. This new class of microbes also had different **lipid** molecules in their membranes than other bacteria. Eventually, when the list had grown, Woese published his work. In 1977 he introduced the archaeobacteria and suggested that a new and broader taxonomic level, called the domain, embrace them.

Early use of the term “archaebacteria” led to much initial confusion, because these organisms are quite different from bacteria, although they are also small and lack nuclei. Because the first archaea that Woese worked with were found in what are termed extreme environments—high heat, salt, or pressure—the idea arose that this was one of their key characteristics. Since then, however, biologists have found archaea in many habitats, including rice paddies, swamps, and throughout the oceans. To identify them, biologists just had to know what to look for.

The three domains of life are the Archaea, the Prokarya, and the Eukarya. Both the Archaea and the Prokarya consist of unicellular organisms that are prokaryotic cells. The Eukarya includes the eukaryotes (protista, plants, fungi, and animals). This invention of domains to supercede kingdoms solved a problem that the identification of archaea brought to Whittaker’s five-kingdom scheme. At first, the archaea were considered a sixth kingdom. The dilemma was that the differences between archaea and any of the other five kingdoms were greater than the differences among those other kingdoms. The three-domain organization has gained acceptance as distinctions among the groups have accumulated. Today scientists know that archaea lack nuclei and organelles like the bacteria, their cell walls are distinctive, and their mechanisms of DNA replication and **protein** synthesis are more like those of eukaryotes than other prokaryotes. The **genome** sequences of a few archaea have confirmed what Woese proposed a quarter century ago: that they share some characteristics with bacteria and eukaryotes, but are very much a distinct type of organism. On a more philosophical note, the addition of domains to biological classification indicates that taxonomy is very much a dynamic discipline. SEE ALSO ANIMALIA; ARCHAEA; EUBACTERIA; EXTREME COMMUNITIES; FUNGI; LINNAEUS, CAROLUS; PLANT

*Ricki Lewis*

### Bibliography

- Mayr, Ernst. “Two Empires or Three?” *Proceedings of the National Academy of Science* 95 (1998): 9720–9723.
- Wade, Nicholas. “Rethinking the Universal Ancestor: A New ‘Tree of Life.’” *New York Times* (June 4, 2000): F1.
- Woese, Carl R., and George E. Fox. “Phylogenetic Structure of the Prokaryotic Domain: The Primary Kingdoms.” *Proceedings of the National Academy of Science* 74 (1977): 5088–5090.

## Temperature Regulation

Humans and other mammals are homeothermic, able to maintain a relatively constant body temperature despite widely ranging environmental temperatures. Although the average human body temperature is 36.7 degrees Celsius (98.2 degrees Fahrenheit), this temperature varies depending on individual differences, time of day, the stage of sleep, and the ovulatory cycle in women. Temperature regulation, or thermoregulation, is the balance be-



A pit bull panting. Thermoregulation is the balance between heat production mechanisms and heat loss mechanisms that occur to maintain a constant body temperature.

tween heat production mechanisms and heat loss mechanisms that occur to maintain a constant body temperature.

Heat flows from higher temperature to lower temperature. Conduction is the transfer of heat between objects that are in direct contact with each other. For instance, if a person sits on the cold ground, heat moves from the body to the cold ground. Convection is the transfer of heat by the movement of air or liquid moving past the body. This explains why a breeze across the skin may cool one down, whereas trapping air inside clothing keeps the body warm.

A lizard sunning itself on a rock on a warm summer day illustrates radiation: the transfer of heat energy via electromagnetic waves. Whereas conduction, convection, and radiation can cause both heat loss and heat gain to the body, evaporation is a mechanism of heat loss only, in which a liquid is converted to a gas. Perspiration evaporating off the skin is an example of this heat loss mechanism.

When the body is too hot, it decreases heat production and increases heat loss. One way of increasing heat loss is through peripheral vasodilation, the **dilation** of blood vessels in the skin. When these vessels dilate, large quantities of warmed blood from the core of the body are carried to the skin, where heat loss may occur via radiation, convection, and conduction. Evaporation of fluids from the body also causes heat loss. Humans constantly lose fluids from the skin and in exhaled air. The unconscious loss of fluid is called insensible perspiration.

Although the body has no active control over insensible perspiration, the **sympathetic nervous system** controls the process of sweating and can stimulate secretion up to 4 liters (4.22 liquid quarts) of sweat per hour. In order for the sweat to evaporate and cool the body, the environmental air must have a relatively low humidity.

When the body is too cold, it increases heat production and decreases heat loss. Vasoconstriction, the constriction of the vessels of the skin, helps prevent heat loss. Shivering, which is a rhythmic contraction of skeletal

**dilation** expansion or swelling

**sympathetic nervous system** branch of the nervous system that promotes heightened awareness, increased nutrient consumption, and other changes associated with “fight or flight”

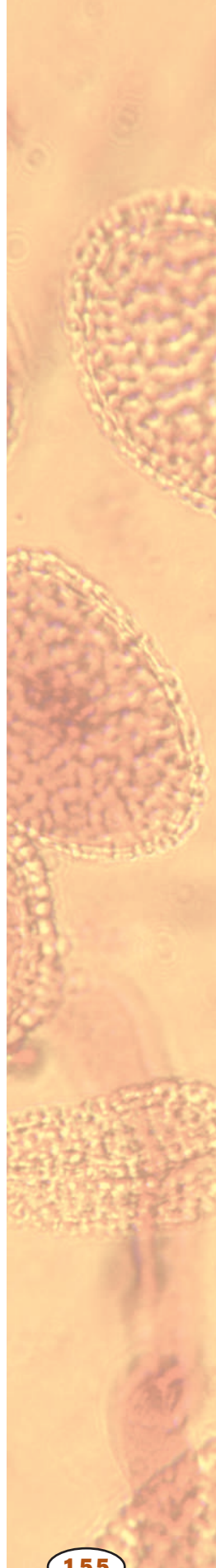



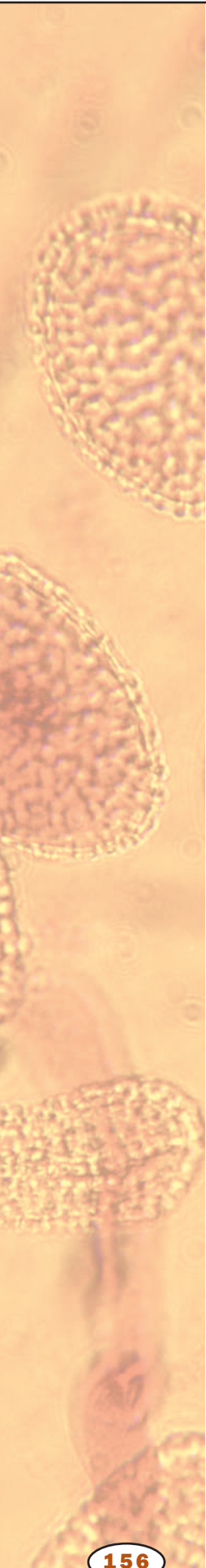

**hormone** molecule released by one cell to influence another

**metabolism** chemical reactions within a cell

**anterior** toward the front

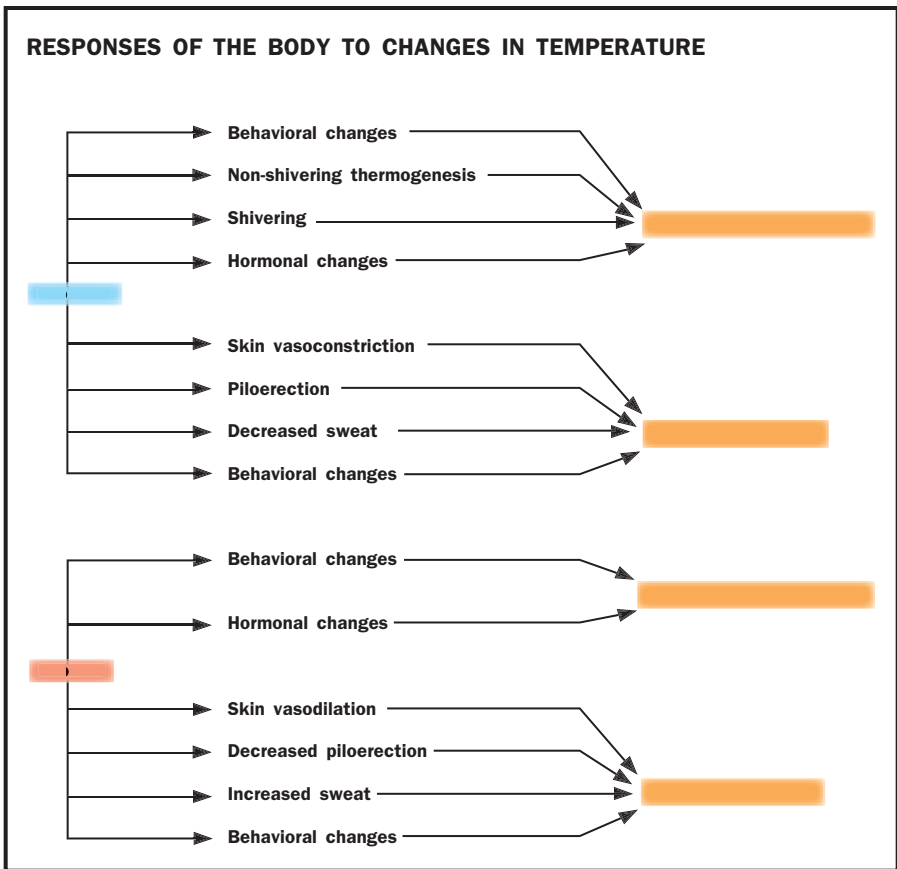

muscles, produces heat. Heat can also be produced by nonshivering thermogenesis, an increase in metabolic heat production.

**Hormones** such as epinephrine, norepinephrine, and thyroid hormone increase the metabolic rate by stimulating the breakdown of fat. Humans also change posture, activity, clothing, or shelter to adjust for fluctuations in temperature. The goose bumps that arise on the skin in the cold are another sign the body is trying to prevent heat loss. They are due to piloerection, the erection of the hair follicles on the skin. This is a vestige of the time when humans were covered in hair: piloerection would trap air and retain heat.

Body temperature is regulated by a system of sensors and controllers across the body. The brain receives signals regarding body temperature from the nerves in the skin and the blood. These signals go to the hypothalamus, which coordinates thermoregulation in the body. Signals from the hypothalamus control the sympathetic nervous system, which affects vasoconstriction, **metabolism**, shivering, sweating, and hormonal controls over temperature. In general, the posterior hypothalamus controls responses to cold, and the **anterior** hypothalamus controls responses to heat.

Hypothermia, or low body temperature, is a result of prolonged exposure to cold. With a decrease in body temperature, all metabolic processes begin to slow. Hypothermia can be life-threatening.

Hyperthermia describes a body temperature that is higher than normal. One example of hyperthermia is fever. A fever is generally considered to be

a body temperature over 38 degrees Celsius (100.4 degrees Fahrenheit). A fever is the body's natural defense to an infection by a bacterium or virus. Fevers are one of the body's mechanisms for eliminating an invading organism. Fevers may even make the immune system work more effectively. Heat exhaustion and heatstroke are other examples of hyperthermia. These occur when heat production exceeds the evaporative capabilities of the environment. Heatstroke may be fatal if untreated. *SEE ALSO* HORMONES; HYPOTHALAMUS; METABOLISM, HUMAN; NERVOUS SYSTEMS; SKIN; THYROID GLAND

*Martha S. Rosenthal*

### **Bibliography**

Marieb, Elaine. "Nutrition, Metabolism, and Body Temperature Regulation." In *Human Anatomy and Physiology*, 5th ed. New York: Benjamin Cummings, 2001.

Sherwood, Laurelee. "Energy Balance and Temperature Regulation." In *Fundamentals of Physiology: A Human Perspective*, 2nd ed. New York: West Publishing Company, 1995.

## **Theoretical Ecology**

The study of ecology involves investigations of specific organisms and environments and the development of general conclusions about how the natural world works. These generalizations are called theories. The goal of ecology, like all sciences, is to develop theories that aptly describe what human beings know about the natural world. For example, the statement "islands have fewer species than similar sized environments on the mainland because islands have higher extinction rates and lower immigration rates" is a theory. It does not describe the situation of a particular island but proposes a generalization regarding patterns and mechanisms for all islands.

Theoretical ecology is a branch of ecology that particularly focuses on the development of theory. To accomplish this, theoretical ecologists usually develop models of the patterns and processes about which they are interested in generalizing. These models usually consist of a series of mathematical equations intended to quantify the phenomenon under study. Ecologists do not pretend that their models include everything involved in the study system. In fact, the models are intentionally simplified representations of what they are studying. This simplification enables the ecologist to analyze in detail certain aspects of their system.

Virtually all aspects of ecology are of interest to theoretical ecologists. In the 1920s and 1930s ecologists Alfred Lotka and Vito Volterra developed some of the first theoretical models of ecology. These simple models consisted of equations intended to describe the growth of two interacting populations over time. The two populations could be competitors or predator and prey. These famous equations are referred to as the Lotka-Volterra model. These equations predicted the conditions in which one species would drive the other to extinction and also what conditions permitted coexistence of the two species. Although very simple models, the results prompted ecologists to think more deeply about species interactions and eventually to develop more complex, but realistic, models and theories.

A number of theoretical models have been developed to describe how animals make foraging choices. For example, optimal foraging theory predicts

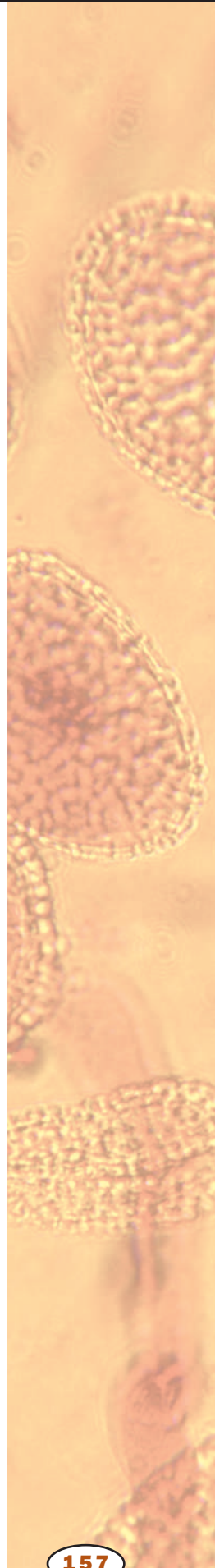

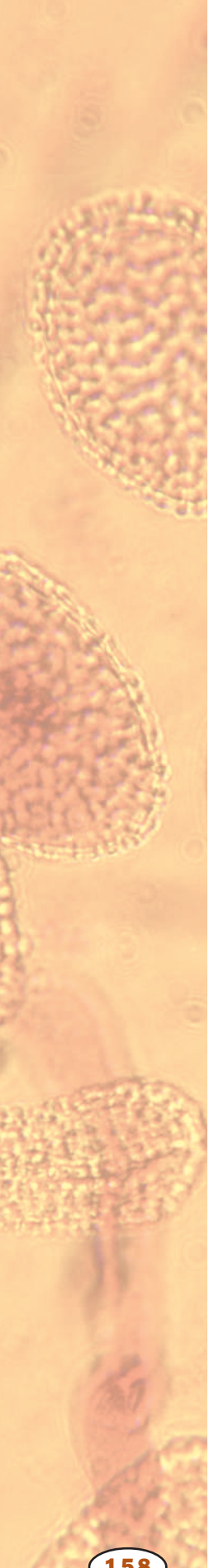

**endocrine** related to the system of hormones and glands that regulate body function

**larynx** “voice box”; muscles at the top of the trachea that control pitch and loudness

**amino acid** a building block of protein

**hormone** molecule released by one cell to influence another

**enzyme** protein that controls a reaction in a cell

**oxidation** reaction characterized by loss of electrons, or reaction with oxygen

**glucose** simple sugar that provides energy to animal cells and is the building block of cellulose in plants

**autoimmune disease** disease in which the immune system attacks the body’s own tissues

**myxedema** thyroid disorder characterized by dry skin, swelling in the face, and mental deterioration

that animals should forage in a way that maximizes the net intake of energy in the shortest period of time. Other theoretical models have been developed to explain how plants compete for resources, why animals sometimes behave altruistically toward kin but not unrelated individuals, why some species of plants reproduce many times in their lifetime while other species reproduce only once, how disease spreads through a population, and why sexual reproduction evolved.

One important value of developing models is that the formal process of modeling requires the ecologist to be very thorough and precise in defining the assumptions of the model. Thus, modeling helps ecologists think more clearly about the issues they are studying in the natural world. Another value of these theoretical models is that they often suggest field experiments that can be conducted to test certain predictions made by the model. Data collected from the field often then prompt the theoretical ecologists to revise their models or theories. Thus data collection and theory building work together to advance the ecological understanding of the world. SEE ALSO BIODIVERSITY; ECOLOGICAL RESEARCH, FIELD STUDIES IN PLANT ECOLOGY; ECOLOGY; ECOLOGY, HISTORY OF; ECOSYSTEM; POPULATION DYNAMICS

*Mark A. Davis*

#### Bibliography

Gotelli, N. J. *A Primer of Ecology*, 2nd ed. Sunderland, MA: Sinauer and Associates Inc., 1998.

## Thyroid Gland

The thyroid gland, the largest of the **endocrine** glands, is located in the neck just below the thyroid cartilage of the **larynx**. It consists of two lobes, one on either side of the trachea, joined by a narrow band or isthmus. It is composed of numerous hollow ball-shaped follicles with small, interspersed clusters of parafollicular cells.

Follicle cells concentrate and attach iodine to the **amino acid** tyrosine, producing two forms of thyroid **hormone** (TH): thyroxine or tetraiodothyronine ( $T_4$ ), and smaller amounts of triiodothyronine ( $T_3$ ). Manufacture and release of these hormones into the blood is regulated by thyroid stimulating hormone, TSH, from the pituitary gland. The major effect of TH is to stimulate activity of **enzymes** involved in energy production through the **oxidation** (burning) of **glucose**, thus increasing basal metabolic rate. A side effect of this increased activity is the production of body heat.

Overactivity of the thyroid gland, called hyperthyroidism, causes elevated metabolic rate, nervousness, and weight loss. The most common form of hyperthyroidism, Graves’ disease, is an **autoimmune disease**; it is accompanied by swelling of the thyroid (goiter) and bulging of the eyes (exophthalmos). Adult hypothyroidism, or underactive thyroid, causes **myxedema**, characterized by lowered metabolic rate, sluggishness, and weight gain. Additional consequences of low TH levels in infants are stunted growth and irreversible brain damage. Hypothyroidism resulting from low iodine intake, with consequent low TH manufacture, produces an enlarge-

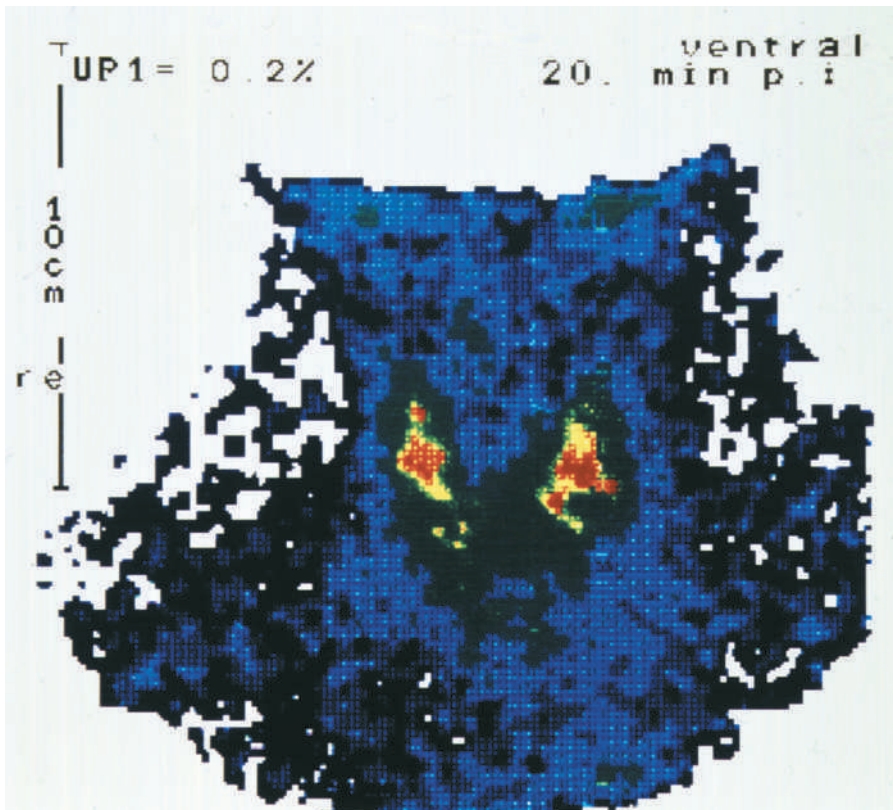

A color-enhanced scintigram (gamma scan) of a human thyroid gland.

ment of the thyroid gland called endemic goiter. TSH is responsible for this enlargement.

Parafollicular cells produce the hormone calcitonin, which lowers blood calcium levels by suppressing the activity of bone-destroying cells called osteoclasts, and stimulating calcium uptake by bones. Calcitonin is important in children, where growing bones are being constantly remodeled. It has little effect on the normal adult skeleton, but may be prescribed in nasal spray form to help reduce bone destruction in osteoporosis. Parathormone, produced by the parathyroid gland, has opposing effects on blood calcium levels. SEE ALSO AUTOIMMUNE DISEASE; BONE; ENDOCRINE SYSTEM; HORMONES; METABOLISM, HUMAN

*Patricia L. Dementi*

### **Bibliography**

Marieb, Elaine Nicpon. *Human Anatomy and Physiology*, 5th ed. Boston: Addison-Wesley-Longman, 2001.

Saladin, Kenneth S. *Anatomy and Physiology: The Unity of Form and Function*, 2nd ed. Boston: McGraw-Hill, 2001.

## **Tissue**

A tissue is made up of a group of cells that usually look similar to one another and come from the same region in a developing embryo. The group of cells that make up a tissue have physiological functions that work together in a coordinated way to support special functions. The special function of

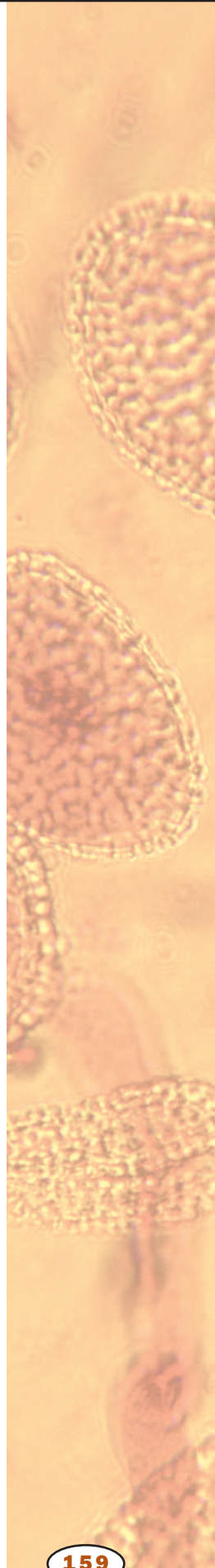

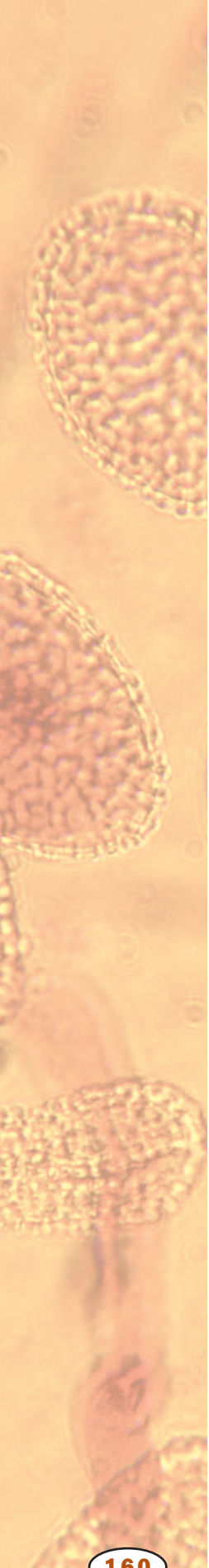

**neuron** nerve cell

**action potential** wave of ionic movement down the length of a nerve cell

a tissue is also influenced by the kind of material that surrounds the tissue and by communication among the cells of the tissue. Different kinds of tissue have different physical properties. Tissues may be hard (bone), soft (muscle), or even liquid (blood).

In the structural organization of the body, tissues are located between the cell and organ levels of organization. Individual cells are a lower level of organization. Tissues are made up of many individual cells. Groups of different kinds of tissues are organized together to form organs, which have special functions with characteristic shapes and functional properties.

There are four kinds of tissues based on differences in their anatomy and function: epithelial tissue, connective tissue, muscle tissue, and nervous tissue. Epithelial tissue is made of layers of cells that are joined together and may cover the surface of the body (epidermis of the skin), line spaces in the body (lining of the abdominal cavity) and hollow structures (lining of blood vessels), or form glands (sweat glands). Connective tissue is usually made of cells and extracellular fibers that hold structures together (tendons), protect them (cartilage), store energy (fat), or produce blood.

Muscular tissue is made of cells that are organized to shorten and produce force when they contract (smooth skeletal and cordine muscle). Nervous tissue is made of **neurons** and accessory cells. Neurons are the cells that carry information in the form of electric **action potentials**. Accessory cells protect and support the function of neurons. **SEE ALSO** BLOOD; CONNECTIVE TISSUE; EPITHELIUM; MUSCLE; NERVOUS SYSTEMS; NEURON; ORGAN; SKIN

*Michael G. Scott*

#### **Bibliography**

Tortora, Gerard J., and Sandra R. Grabowski. *Principles of Anatomy and Physiology*. New York: John Wiley & Sons, Inc., 2000.

## **Torrey, John**

**American botanist and chemist  
1796–1873**

John Torrey was the preeminent botanist in the United States during the nineteenth century. Born in New York City and trained as a physician, chemist, and mineralogist, he taught at West Point, the College of Physicians and Surgeons in New York City, and Princeton University. Torrey became the central figure in classifying the thousands of new plants discovered by explorers during the period of westward expansion, and he wrote numerous scientific monographs on the flora of the American West.

Torrey introduced to the United States the natural system of classification developed by his European contemporaries Antoine-Laurent de Jussieu and Augustin de Candolle, overthrowing the sexual system of classification of Swedish botanist Carolus Linnaeus. In 1833 Torrey began his work with American botanist Asa Gray, first as teacher and later as partner, and by 1843 Torrey and Gray had published two volumes of the *Flora of North America*.

Throughout his life, Torrey developed a large and significant herbarium, housing thousands of plant specimens. His collection is the heart of the herbarium of the New York Botanical Garden. Torrey's name is found in a genus of evergreen trees, *Torreya*, as well as numerous plant species names. The Torrey Botanical Society is a national scientific organization promoting interest in and understanding of botany. SEE ALSO GRAY, ASA; LINNAEUS, CAROLUS

*Richard Robinson*

### Bibliography

Isely, Duane. *One Hundred and One Botanists*. Ames, IA: Iowa State University Press, 1994.

## Touch

Touch is one of the five major sensory channels by which humans sample and experience their environment. The word “touch” describes the sensory experience resulting from gentle contact of the skin with the environment, including air moving over the skin and hairs. The sense of touch is so exquisitely sensitive that the brain can consciously experience the activity of a single **neuron** supplying the skin. Touch sensation not only informs one about the near environment but plays an essential role in guiding fine movements basic to such skills as playing musical instruments, reading Braille, typing on a computer keyboard, or performing surgery.

Touch (mechanoreception) is distinguished from pain (nociception) and temperature perception (thermoreception). Pain is sensed by free nerve endings, mostly located in the skin, bones, and joint capsules, and around blood vessels. Two broad categories of painful sensations, fast pricking pain versus slow aching or burning pain, are carried to the spine by two different types of sensory neurons. Thermoreceptors are located immediately below the skin, with warmth receptors more numerous than cool receptors. They are most sensitive not to absolute level of temperature, but to rapid change in temperature, and quickly become quieter once the temperature has stabilized at a new level.

Detection of touch stimuli begins with mechanical deformation of several types of specialized touch receptors, distributed unevenly over the body surface. Nerve fiber endings in the skin may be free, “naked” endings (for light touch) or more commonly are associated with other, cooperating cells. Thus nerve endings that wrap around hair follicles are activated by hair movement; other nerve endings adhere closely to specialized accessory cells or have tiny cellular capsules. The latter include pacinian corpuscles for vibration, and Meissner corpuscles (abundant in sensitive, hairless skin of the fingertips) for light touch. Ruffini corpuscles and Merkel disks respond to pressure or to stretch of the skin with signals that continue as long as a stimulus is applied.

When any of these touch-sensitive nerve endings are mechanically deformed, electrical signals (action potentials) are transmitted along the **axons** of sensory nerve cells. These signals pass rapidly to the spinal cord and brainstem to activate a second set of neurons. As these secondary touch cells relay information up the brainstem, their axons cross the body's midline, so that the touch information they carry activates neurons in the thalamus on

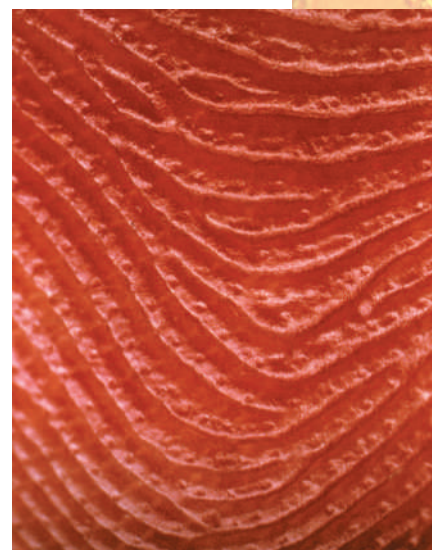

The fingertips are richly endowed with nerve endings and are very sensitive.

**neuron** nerve cell

**axon** long extension of a nerve cell down which information flows

**cerebral cortex** outer-most wrinkled portion of the brain

the side opposite the stimulation. Thalamic neurons transmit the signal to the primary sensory cortex in the brain's postcentral gyrus, where touch is actually experienced.

All of the touch information transmitted from the various receptor types in a given body area is combined in the **cerebral cortex**. It provides sophisticated analysis of the total pattern of nerve signals so that one can instantly (and consciously) judge the texture, force, location, and movement of the skin stimulus with great precision.

Touch sensitivity varies in different body regions because of differential density of distribution of the specific nerve endings. Areas such as the fingertips and lips (glabrous skin) are richly endowed with nerve endings and are very sensitive. Hairy skin has fewer endings and different kinds, and so produces a different sensory experience; skin of the trunk and back, with a low density of touch receptors, is less sensitive to touch than skin elsewhere.

Touch receptors branch out at their ends, and a single neuron may receive input from a region of the skin several centimeters in diameter, called its receptor field. Receptor fields in the lips may be as small as 2 to 3 millimeters (.78 to .118 inches), while in much of the rest of the body they are 4 to 7 centimeters (1.5 to 2.7 inches). SEE ALSO CENTRAL NERVOUS SYSTEM; NEURON; PERIPHERAL NERVOUS SYSTEM; SKIN

*James L. Culbertson*

#### Bibliography

Delcomyn, Fred. *Foundations of Neurobiology*. New York: W. H. Freeman and Company, 1998.

Kandel, Eric. R., James H. Schwartz, and Thomas M. Jessell, eds. *Essentials of Neural Science and Behavior*. Norwalk, CT: Appleton and Lange, 1995.

## Transcription

**gene** portion of DNA that codes for a protein or RNA molecule

**chromosome** "colored body" in the cell nucleus; made of DNA and protein, and divided functionally into genes and non-gene regions

**protein** complex molecule made from amino acids; used in cells for structure, signaling, and controlling reactions

**ribosome** protein-RNA complex in cells that synthesizes protein

**template** master copy

**prokaryote** single-celled organism without a nucleus

Each **gene** on a **chromosome** can be thought of as the instructions for making a particular **protein** in a cell. However, the genes themselves cannot direct the synthesis of the proteins they encode but must first be converted into a form that can be recognized by the cellular protein-making machine, the **ribosome**. This conversion process is called transcription. During transcription the instructions held in the genes (in the form of deoxyribonucleic acid [DNA]) are transcribed into a chemical form called ribonucleic acid (RNA). Because this RNA carries the message, or instructions, from the genes to the ribosomes, where it is ultimately converted into a protein molecule, it is called messenger RNA (mRNA).

Most genes in a cell code for protein and hence are transcribed into mRNA. However, a few genes code for different types of RNA that are not used as **templates** for protein synthesis but instead are ends in themselves and carry out a variety of functions in the cell. Examples of these other kinds of RNA are transfer RNA (tRNA) and ribosomal RNA (rRNA), which are both critical to the process of protein synthesis.

### Transcription in Prokaryotes

Much of the pioneering work on transcription was carried out in **prokaryotes**, most notably in the bacterium *E. coli*. These studies laid the founda-

tion for work that was later carried out in the more complex eukaryotes. The **enzyme** that carries out transcription is called RNA polymerase, and it consists of four kinds of **polypeptides**, designated  $\alpha$ ,  $\beta$ ,  $\beta'$  and  $\sigma$ , which are bound together into a complex called a holoenzyme.

Transcription can be divided into three phases: initiation, elongation, and termination. Initiation occurs when the polymerase, sliding along the chromosome, encounters a **promoter**, a sequence of DNA that identifies the beginning of a gene. The promoter contains two sequence elements, six **base pairs** apiece, called the -10 and -35 elements, which are located ten and thirty-five base pairs respectively upstream of the transcription start site. DNA is double-stranded, but only one side serves as a template from which RNA is made. With the two strands bound to one another, the template strand must be made accessible if it is to serve as a template for RNA synthesis. To begin, the polymerase unwinds a region of approximately seventeen base pairs, setting the stage for the formation of the first **phosphodiester** bond. Unlike DNA, the synthesis of RNA can be initiated without the need for a **primer**.

RNA is made by linking together ribonucleotides in an order dictated by the DNA template strand. The essence of transcription is to use the sequence of **nucleotides** already on the DNA strand to dictate the sequence of RNA nucleotides that will be formed into the new RNA strand. The four DNA nucleotides are adenine, guanine, cytosine, and thymine (A, G, C, and T). RNA nucleotides are A, G, C, and uracil (U). RNA polymerase pairs up an RNA nucleotide with each DNA nucleotide. However, rather than matching the DNA sequence, the polymerase pairs up **complementary** base pairs. G is always paired with C, so that if the DNA sequence is GGCC, the resulting RNA sequence is CCGG. The A of DNA is paired with the U of RNA, and the T of DNA is paired with the A of RNA, so that if the DNA sequence is AATT, the RNA sequence is UUAA. Thus, like DNA replication, the rules of Watson-Crick base pairing apply during transcription.

The nucleotides used in RNA synthesis are triphosphates, meaning they have three phosphate groups attached. This energizes them, and **hydrolysis** of these phosphates powers the transcription process. Once the chain has reached a length of approximately ten ribonucleotides the  $\sigma$  subunit **dissociates**, leaving the core enzyme ( $\alpha_2\beta\beta'$ ) to continue transcribing until the signal for termination is reached. Termination signals on DNA vary but the most common is a GC-rich region followed by an AT-rich region.

## Transcription in Eukaryotes

The basic features of RNA synthesis are shared between prokaryotes and eukaryotes; however, transcription in eukaryotes differs in that it is significantly more complex. First, rather than having a single RNA polymerase, eukaryotes have three different RNA polymerases, each of which transcribes a different set of genes. RNA polymerase I transcribes three types of rRNA (the 18S, 5.8S, and 28S species), RNA polymerase II transcribes mRNA, and RNA polymerase III transcribes tRNA and the smallest rRNA (the 5S species). The eukaryotic RNA polymerases consist of between eight and fourteen subunits, with two of them corresponding to the  $\beta$  and  $\beta'$  subunits of prokaryotic RNA polymerases.

**enzyme** protein that controls a reaction in a cell

**polypeptide** chain of amino acids

$\alpha$  the Greek letter alpha

$\beta$  the Greek letter beta

$\sigma$  the Greek letter sigma

**promoter** DNA sequence to which RNA polymerase binds to begin transcription

**base pair** two nucleotides (either DNA or RNA) linked by weak bonds

**phosphodiester** the link between two nucleotides in DNA or RNA

**primer** short nucleotide sequence that helps begin DNA replication

**nucleotide** the building block of RNA or DNA

**complementary** matching opposite

**hydrolysis** splitting with water

**dissociate** break apart

### OCHOA, SEVERO (1905–)

Spanish molecular biologist who received, with Arthur Kornberg, the 1959 Nobel Prize in physiology for discovering an enzyme that can be used to make ribonucleic acid (RNA). His work was fundamental to modern biotechnology.



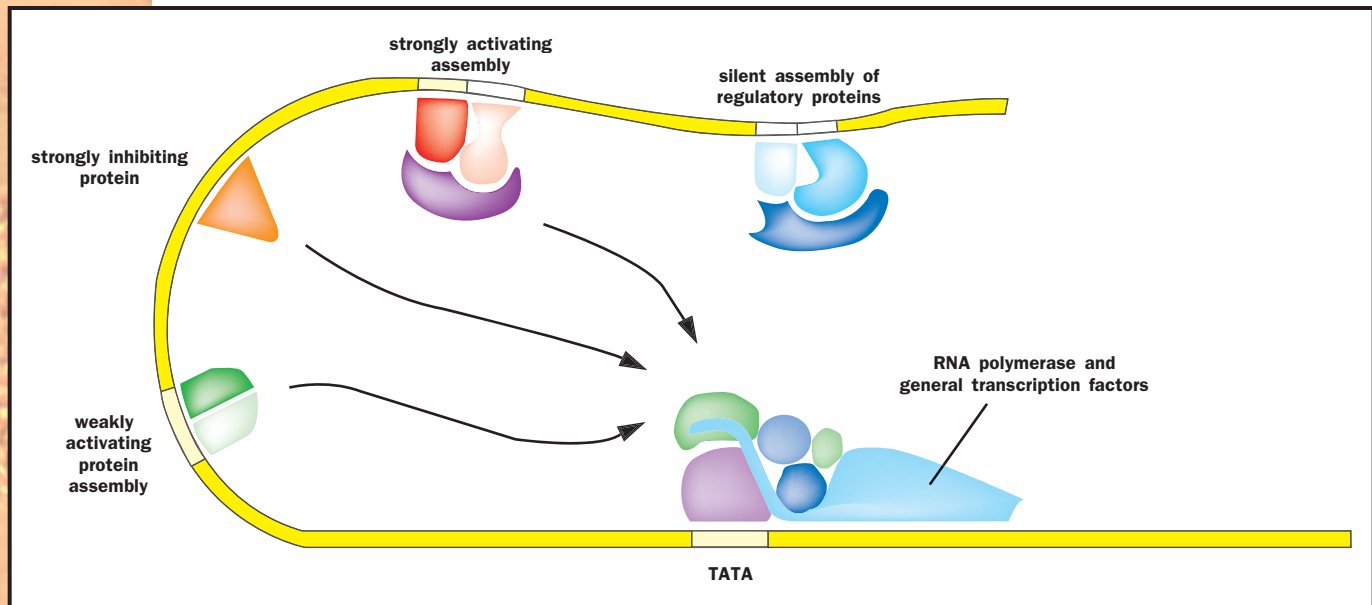

Integration at a promoter.

Unlike the bacterial RNA polymerase, eukaryotic RNA polymerases cannot initiate transcription by themselves but need the help of a set of proteins called the basic transcription factors. The basic transcription factors perform a number of functions, including binding to gene promoter regions and attracting the appropriate RNA polymerase to the initiation site, as well as unwinding the DNA double helix to allow access of the incoming ribonucleotides of the growing RNA chain.

**RNA Polymerase II Transcription.** The promoters of eukaryotic genes have been intensely studied, especially those transcribed by RNA polymerase II. Most genes transcribed by RNA polymerase II contain a sequence called a TATA-box located twenty-five to thirty-five nucleotides upstream of the transcription start site. The TATA-box contains the sequence TATAA, which is recognized by a multicomponent transcription factor called TFIID. One of the components of the transcription factor is the TATA-binding protein (TBP), which directly links to the TATAA sequence. RNA polymerase II genes contain additional binding sites in their promoters for transcriptional regulators and can even be affected by elements located at large distances called enhancers.

In contrast to prokaryotes, transcription termination by RNA polymerase II does not occur simply by release of the RNA molecule. Rather, transcription continues well beyond the termination point, and the transcript is later cleaved to the appropriate length. Following cleavage an enzyme called poly-A polymerase adds approximately 250 adenine residues to the tail end of the transcript.

**RNA Polymerase I and III Transcription.** RNA polymerase I is exclusively devoted to transcribing the ribosomal RNA genes, which are present in many copies as tandem arrays (multiple copies, existing side by side). RNA polymerase I synthesizes one long RNA molecule containing the 28S, 18S, and 5.8S rRNAs, which is subsequently cleaved into separate parts. In contrast to the promoters for RNA polymerases I and II, the promoters of RNA polymerase III genes typically lie downstream of the

Each polymerase has its own set of basic transcription factors, designated by a number and a letter. For example, TFIIA is transcription factor A, which functions with RNA polymerase II.

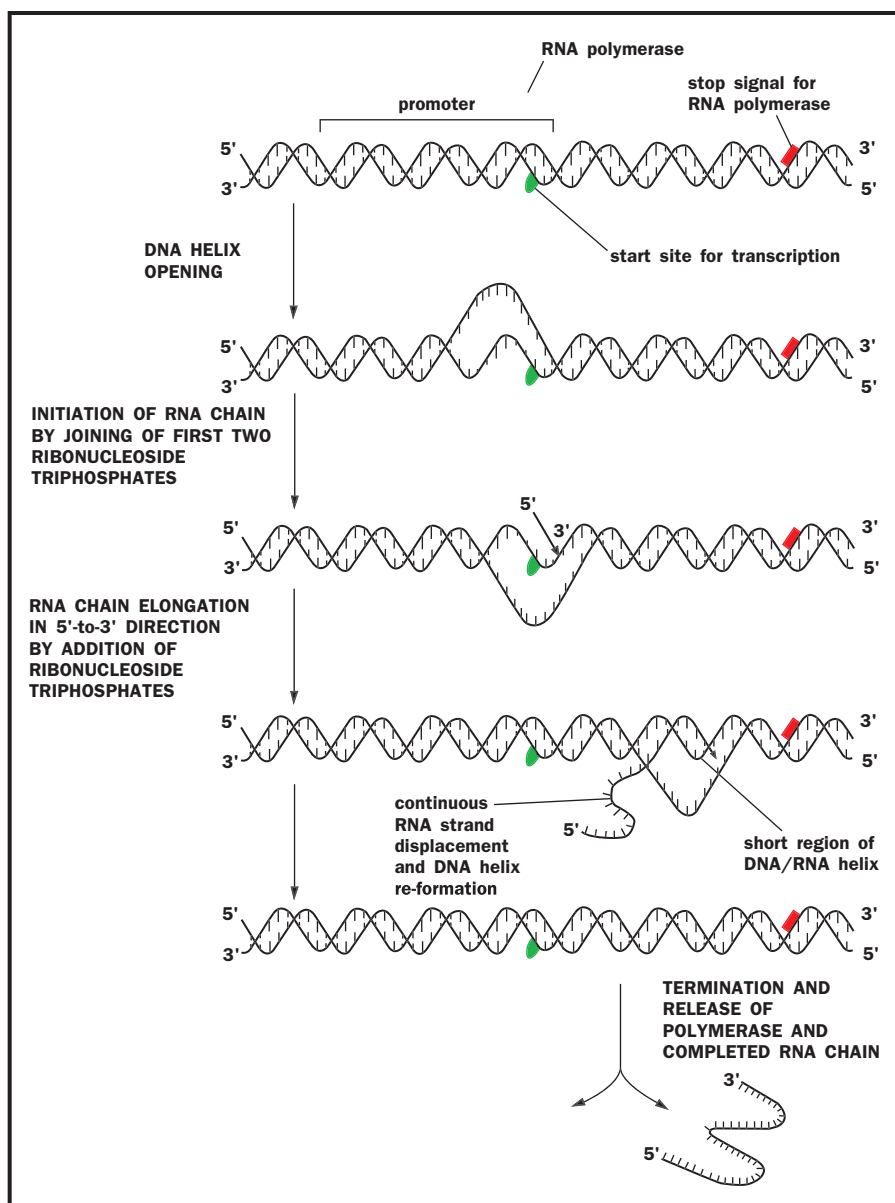

Synthesis of an RNA molecule by RNA polymerase.

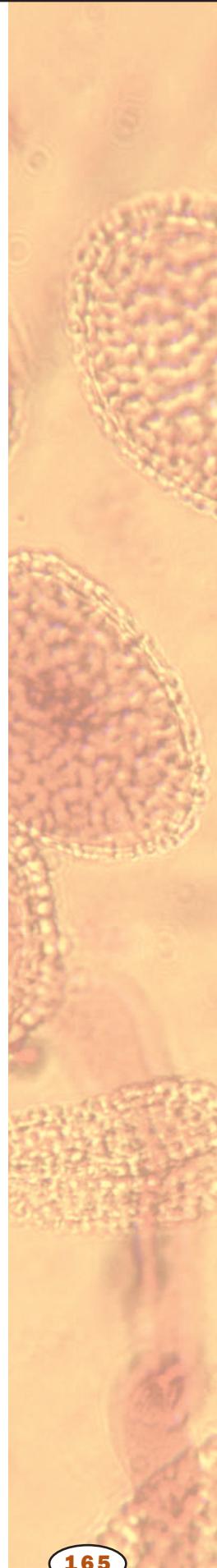

transcription start site. Interestingly, although most of the basic transcription factors are not shared between the three polymerases, TBP, which was first discovered as a protein involved in RNA polymerase II transcription, has now been found to be required for transcription by all three polymerases. Thus, despite the differences between the polymerases, they have all incorporated TBP into their mechanism of transcription initiation. SEE ALSO CONTROL OF GENE EXPRESSION; GENETIC CODE; RNA; RNA PROCESSING; TRANSFER RNA

*Kirstie Saltsman*

### Bibliography

Stryer, Lubert. *Biochemistry*, 4th ed. New York: W. H. Freeman and Company, 1995.  
Tijian, Robert. "Molecular Machines that Control Genes." *Scientific American* 272 (1995): 54-61.

**protein** complex molecule made from amino acids; used in cells for structure, signaling, and controlling reactions

**ribosome** protein-RNA complex in cells that synthesizes protein

**amino acid** a building block of protein

**polypeptide** chain of amino acids

**transcribe** creation of an RNA copy of a DNA gene

**gene** portion of DNA that codes for a protein or RNA molecule

**genome** total genetic material in a cell or organism

**enzymatic** related to function of an enzyme

**nucleotide** the building block of RNA or DNA

**codon** sequence of three mRNA nucleotides coding for one amino acid

**base pair** two nucleotides (either DNA or RNA) linked by weak bonds

Unfolded transfer RNA (left) has a clover-leaf shape. In the cell, it folds into a more compact L shape (right). The sequence of each tRNA molecule differs, but includes an invariant amino acid binding end. The anticodon is unique for each type of amino acid. Asterisks indicate modified RNA nucleotides unique to tRNA.

## Transfer RNA

During **protein** synthesis at the **ribosome**, the nucleic acid sequence of deoxyribonucleic acid (DNA) and ribonucleic acid (RNA) is translated into the **amino acid** sequence of a protein. Transfer RNA (tRNA) is an important adapter that “reads” the nucleic acid code in the messenger RNA (mRNA) and “writes” an amino acid sequence. Transfer RNAs transfer individual amino acids onto the growing **polypeptide** chain.

There is at least one tRNA for each of the twenty naturally occurring amino acids. Each tRNA is **transcribed** from a different **gene** but the tRNA genes are clustered in the **genome** of some organisms. These clusters of genes are transcribed as a single unit, which results in the production of one large precursor RNA molecule. Individual tRNAs are then **enzymatically** separated from one another. Each tRNA is distinguished by a particular three-nucleotide sequence (the “anticodon”) in one region, and by its ability to link up with a particular amino acid.

The **nucleotide** sequence of the first tRNA was determined in 1965. As of 2000, there are more than one hundred tRNA sequences known, and they are all quite similar. All tRNA molecules are relatively short, composed of less than one hundred nucleotides. Unlike those found in DNA and mRNA, many of the nucleotides found in tRNA are modified to enhance their interactions. Although the three-dimensional shape of tRNA molecules has traditionally been depicted as a cloverleaf, X-ray crystallographic methods have revealed that the actual shape of a tRNA is an upside down letter L.

During protein synthesis, the anticodon at one end of the L interacts with a triplet nucleotide in the mRNA called a **codon**. The correct tRNA will form “Watson-Crick”-type **base pairs** between the triplet anticodon

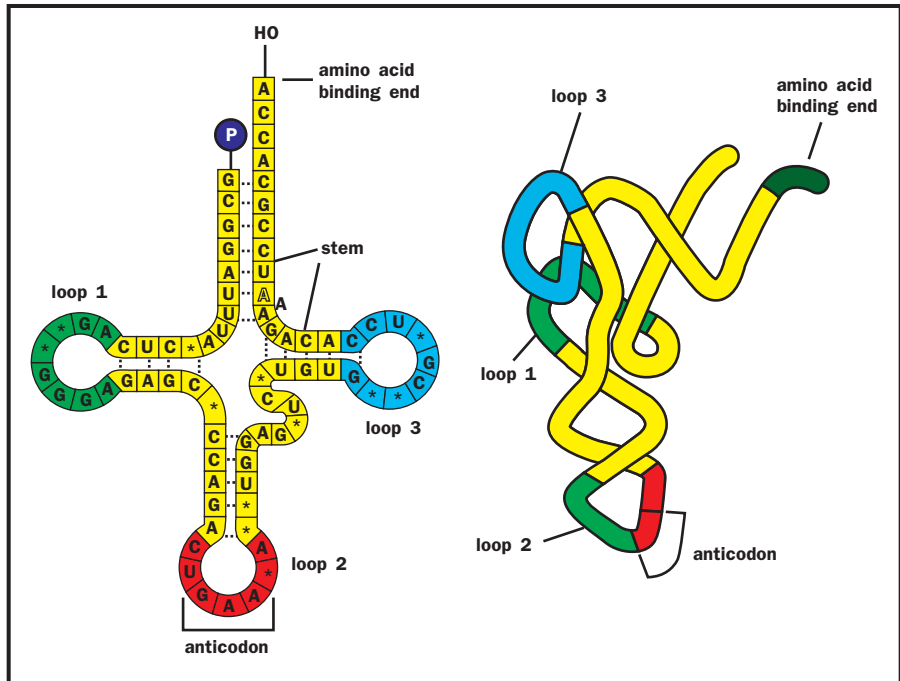

on the tRNA and the triplet codon on the mRNA. The tRNAs must be exactly **complementary** at the first two codon positions (for example, A pairs with U, C pairs with G), but can vary in the third codon position. This flexibility in the third position is called “wobble,” and it ultimately enables a single tRNA to bind to more than one triplet codon sequence. If the tRNA is not complementary as described above, it will be rejected from the ribosome, and its amino acid will not be incorporated into the polypeptide chain.

At the other end of the L is the amino acid binding site. **Enzymes** (called aminoacyl tRNA synthetases) join the proper amino acid to its corresponding tRNA. This reaction requires **ATP** and the bond generated is a “high-energy” (that is, weak) bond. During the addition of the amino acid to the growing polypeptide, this bond is easily **hydrolyzed**, releasing the energy needed to power the process. SEE ALSO PROTEIN SYNTHESIS; RIBOSOME; RNA

*James E. Blankenship*

### Bibliography

Alberts, Bruce, et al. *Molecular Biology of the Cell*, 4th ed. New York: Garland Publishing, 2000.

Stryer, Lubert. *Biochemistry*, 4th ed. New York: W. H. Freeman and Company, 1995.

## Transgenic Techniques

Transgenics describes the process of introducing foreign deoxyribonucleic acid (DNA) into a host organism’s **genome**. The foreign DNA, or “transgene,” that is transferred to the recipient can be from other individuals of the same species or even from unrelated species. In multicellular organisms, this is often done through experimental manipulation of **gametes** or early embryos. Usually the transgene is incorporated at a very early stage in embryonic development so that cells of the entire organism contain the transgene. A wide range of species can be made transgenic including plants, insects, worms, and vertebrates. The most commonly genetically manipulated vertebrate animal is the mouse because a variety of techniques exist to produce transgenic mice.

Transgenic techniques have been used for a number of goals: to determine an unknown gene’s function; to analyze the malfunction of a mutated gene; to model human disease; and to provide better agricultural and pharmaceutical products by making transgenic plants and animals. For example, insect-resistant transgenic plants have been engineered. While the benefits of modified plants and animals are far-reaching, there is debate about the ethics of genetically altering plants and animals, and the impact these alterations may have on the environment.

There are several ways to introduce a transgene into the organism. Microinjection is one of these techniques. As its name suggests, microinjection is the process of injecting the transgene into the **nucleus** of a cell where it is randomly inserted into the host genome. This technique, initiated in 1981, is most commonly used to generate transgenic mice. DNA is injected into the nucleus of a fertilized egg, which is then transferred

**complementary** matching opposite

**enzyme** protein that controls a reaction in a cell

**ATP** adenosine triphosphate, a high-energy nucleotide used by cells to power most energy-requiring reactions

**hydrolyze** to split apart using water

**genome** total genetic material in a cell or organism

**gamete** reproductive cell, such as sperm or egg

**nucleus** membrane-bound portion of cell containing the chromosomes

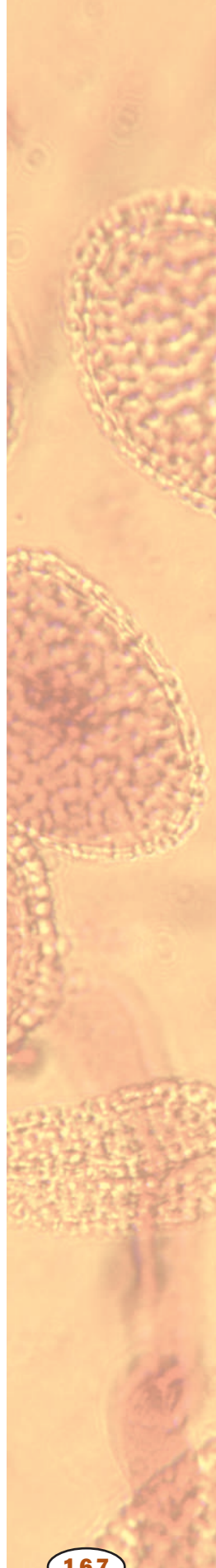

**protein** complex molecule made from amino acids; used in cells for structure, signaling, and controlling reactions

**chromosome** “colored body” in the cell nucleus; made of DNA and protein, and divided functionally into genes and non-gene regions

**homologous recombination** exchange of DNA segments between chromosomes

**progeny** offspring

**homozygous** containing two identical copies of a particular gene

to a foster mother. If the introduced DNA becomes integrated into the developing embryo’s genome, the offspring will carry the transgene. Two other techniques for random insertion are retroviral and transposable element insertion.

An important application of transgenic technology, introduced in the 1990s, is gene targeting, or the production of “knock-out” organisms. The term “knock out” refers to the ability to disrupt a specific gene, so that it no longer encodes a complete **protein**. Genes are knocked out by being replaced by a transgene that has been disrupted *in vitro*, either by the addition of some sequence into the gene itself or by the deletion of part of the gene. Gene replacement occurs when the disrupted transgene is introduced into a cell. Here, it recombines with the recipient’s copy of that gene, inserting itself into the **chromosome** by **homologous recombination**.

In mice, transgenes can also be introduced with cultured embryonic stem (ES) cells, using selection techniques to recover the transformed cells. The altered ES cells are then injected into early mouse embryos, and result in a mosaic embryo with normal and transgenic cells. If the altered cells contribute to the germ cells of the mouse, **progeny** in a subsequent mating will inherit the knocked out gene. These mice can then be mated to produce mice that are **homozygous** for both copies of the altered gene (both copies of the gene are knocked out). These mice can then be carefully examined to determine what happens when the specific gene is absent. The knock-out technique is most commonly applied to mice, insects, and yeast.

Extensions of gene targeting are the “knock-in” approach and conditional mutation. The knock-in approach involves inserting a mutated gene or a similar gene in place of the gene of interest. The newly added gene is expressed at the same time and location as the replaced gene. This method allows scientists to study the effects of mutations in genes as well as discover if certain genes have redundant functions. Conditional mutation is a way of either turning on or turning off the gene of interest, and can be done either in specific tissues or at specific time points. **SEE ALSO** CLONE; RECOMBINANT DNA

*Michelle Tallquist*

#### **Bibliography**

Alberts, Bruce, et al. *Molecular Biology of the Cell*, 4th ed. New York: Garland Publishing, 2000.

Drlica, Karl. *Understanding DNA: A Guide for the Curious*. New York: John Wiley & Sons, 1997.

Strachan, Tom, and Andrew Read. *Human Molecular Genetics*, 2nd ed. New York: Wiley-Liss, 1999.

**Translation** *See Protein Synthesis*

## **Translocation**

Translocation is the movement of materials from leaves to other tissues throughout the plant. Plants produce carbohydrates (sugars) in their leaves by photosynthesis, but nonphotosynthetic parts of the plant also require

carbohydrates and other **organic** and nonorganic materials. For this reason, nutrients are translocated from sources (regions of excess carbohydrates, primarily mature leaves) to sinks (regions where the carbohydrate is needed). Some important sinks are roots, flowers, fruits, stems, and developing leaves. Leaves are particularly interesting in this regard because they are sinks when they are young and become sources later, when they are about half grown.

## Phloem Structure and Function

The tissue in which nutrients move is the **phloem**. The phloem is arranged in long, continuous strands called vascular bundles that extend through the roots and stem and reach into the leaves as veins. Vascular bundles also contain the **xylem**, the tissue that carries water and dissolved minerals from the roots to the shoots. When plants increase in diameter (secondary growth) they do so by divisions of a layer of cells just under the bark; this cell layer makes new xylem to the inside (forming the wood of the tree trunk) and a thin, continuous cylinder of new phloem to the outside.

The contents of the phloem can be analyzed by cutting off the stylets (mouth parts) of phloem-feeding insects such as aphids and collecting the drops of sap that exude. Phloem sap is composed largely of sugar dissolved in water. All plants translocate sucrose (table sugar) and some also transport other sugars such as stachyose, or sugar alcohols such as sorbitol. Many other organic compounds are found, including **amino acids**, **proteins**, and **hormones**. **Glucose**, the sugar found in the circulatory system of animals, is not translocated.

In order to accommodate the flow of sap, the internal structure of the conducting cells of the phloem, the sieve elements, is drastically altered. As the sieve elements mature, they lose many of the **organelles** commonly found in living cells and they modify others. The **nucleus** disappears, as do the vacuoles, microfilaments, microtubules, **ribosomes**, and Golgi bodies. Therefore, the inside (lumen) of the cell is left essentially open. The sieve elements are greatly elongated in the direction of transport and are connected to one another to form long sieve tubes. Large pores perforate the end walls of the sieve elements to facilitate flow through the tube. The connecting walls thus look like a sieve, giving the cell type its name.

Some sieve elements can live for a long time, as many as one hundred years in palm trees, even though they have no nucleus or any of the machinery needed for protein synthesis. Cells closely associated with them, called companion cells, apparently keep them alive. The association of sieve elements and companion cells is one of the most intimate and complex in nature, and one of the least understood. It now appears that both small and large molecules can move from companion cells to sieve elements through the plasmodesmata that connect them. Plasmodesmata are minute pores that traverse the common walls between plant cells. They have an intricate internal structure. Interest in plasmodesmata is high because viruses move through them to cause infections. If a virus enters the phloem this way it will travel with the sap, spread widely around the plant, and infect sink organs. Since viruses are much larger than plasmodesmata, they must be disassembled in one cell and reassembled when they get to their destination.

**organic** composed of carbon, or derived from living organisms

**phloem** plant tissue that conducts sugars from leaves to roots and other tissues

**xylem** water-transporting system in plants

**amino acid** a building block of protein

**protein** complex molecule made from amino acids; used in cells for structure, signaling, and controlling reactions

**hormone** molecule released by one cell to influence another

**glucose** simple sugar that provides energy to animal cells and is the building block of cellulose in plants

**organelle** membrane-bound cell compartment

**nucleus** membrane-bound portion of cell containing the chromosomes

**ribosome** protein-RNA complex in cells that synthesizes protein

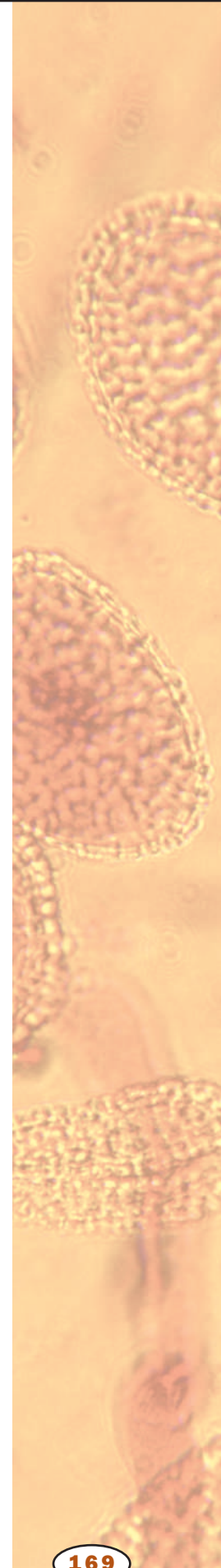

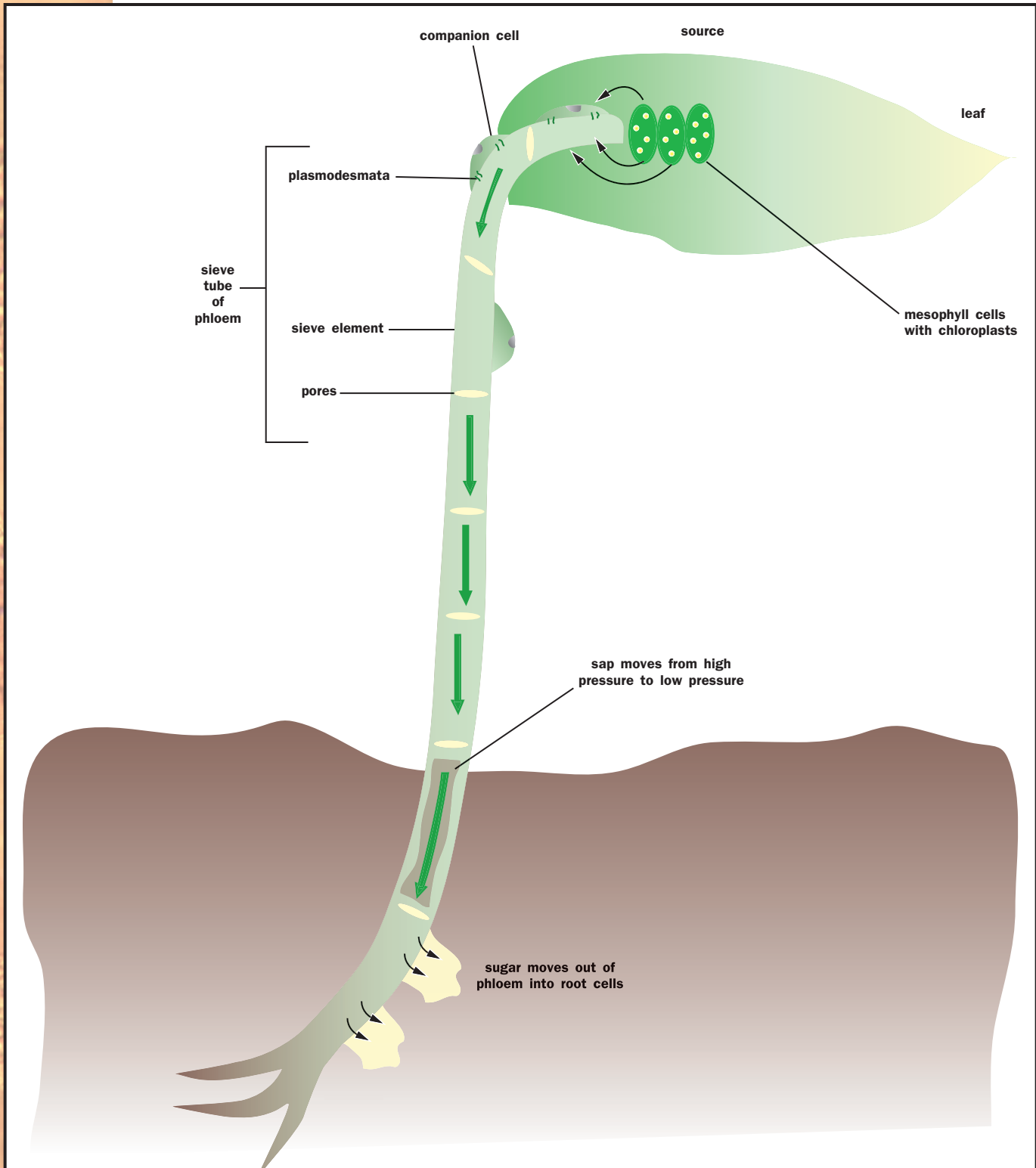

Sugars synthesized in the chloroplasts are actively pumped into the sieve tubes. Water follows by osmosis, creating high pressure. Sugar is then removed by active transport, and water again by osmosis, lowering the pressure in the sieve tube.

### The Pressure-Flow Mechanism

The rate of translocation in angiosperms (flowering plants) is approximately 1 meter per hour. In conifers it is generally much slower, but even so this is far too fast to be accounted for by diffusion. Instead, the sap flows, like a

river of dilute syrup water. What is the force that drives the flow of material in the phloem? It is pressure, generated in the sieve elements and companion cells in source tissues. In leaves, sugar is synthesized in mesophyll cells (the middle layer of the leaf), and is then actively pumped into the phloem, using metabolic energy. By using energy, the sugar is not only transferred to the phloem but is also concentrated. When a **solute** such as sugar is concentrated inside cells, water enters the cells by **osmosis**. Since the plant cells have a rigid cell wall, this influx of water creates a great deal of internal pressure, over ten times the pressure in an automobile tire. The pressure causes sap to move out through the pores of the sieve element, down the tube.

At the other end of the transport stream, in the sinks, sugar is constantly leaving the phloem and being used by surrounding cells. Some is consumed as an energy source, some is stored as sugar or starch, and some is used to make new cells if the sink tissue is growing. Since sugar leaves the phloem in the sink, water exits too (again by osmosis) and the pressure goes down. Therefore, there is a difference in pressure between source and sink phloem. This causes the solution to flow, just as water flows along a pressure **gradient** in a garden hose. This process is known as the pressure-flow mechanism.

### Sugar Loading and Unloading

How is sugar actively pumped (loaded) into the phloem? There are two known mechanisms, operating in different species. In one, sucrose enters the cell walls near the phloem in the smallest (minor) veins of the leaf. It then enters the phloem by attaching to sucrose transporter proteins embedded in the plasma membranes of the sieve elements and companion cells. In the second mechanism, sucrose enters the companion cells of the minor vein through small plasmodesmata, and is converted to larger sugars, raffinose, and stachyose. These larger sugars are unable to diffuse back through these plasmodesmata due to their size. Therefore they are trapped in the phloem of the leaf and build up to high concentration. They enter the sieve elements through larger plasmodesmata and are carried away toward the sinks.

When sugars and other nutrients arrive in sink tissues they unload from the phloem and enter surrounding cells, either through plasmodesmata or by crossing from one cell to another across the cell walls. The size and metabolic activity of the different sinks determines the amount of material that is delivered to them. Thus, the use of sugar in the sinks determines how much sugar flows to them. SEE ALSO ANATOMY OF PLANTS; CARBOHYDRATES; LEAVES; MEMBRANE TRANSPORT; PHOTOSYNTHESIS; ROOTS; WATER MOVEMENT IN PLANTS

*Robert Turgeon*

#### Bibliography

- Oparka, K. J., and Richard Turgeon. "Sieve Elements and Companion Cells: Traffic Control Centers of the Phloem." *Plant Cell* 11 (1999): 739–750.
- Raven, Peter H., Ray F. Evert, and Susan E. Eichhorn. *Biology of Plants*, 6th ed. New York: W. H. Freeman and Company, 1999.
- Taiz, Lincoln, and Eduardo Zeiger. *Plant Physiology*, 2nd ed. Sunderland, MA: Sinauer Associates, 1998.

**solute** dissolved substance

**osmosis** passage of water through a membrane in response to concentration differences

**gradient** difference in concentration between two places

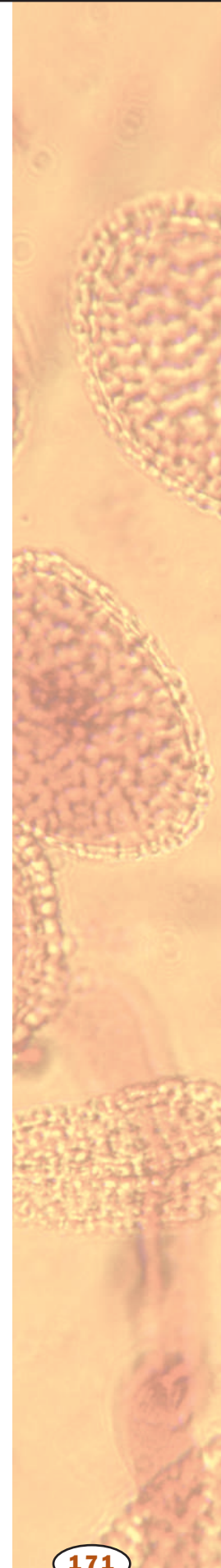



## Transplant Medicine

### TRANSPLANTS PERFORMED IN THE U.S. IN 1999

Type of Transplant	Number
kidney alone (4,153 were living donors)	12,518
liver	4,696
pancreas alone	383
kidney-pancreas	944
intestine	70
heart alone	2,184
heart-lung	49
lung alone	877

**gene** portion of DNA that codes for a protein or RNA molecule

**antigen** foreign substance that provokes an immune response

**inbred** repeatedly bred with close relatives, creating organisms with very little genetic variation

When conventional medical and surgical procedures are insufficient to help a patient, organ and tissue transplants are sometimes the only solutions. From a blood transfusion to multiple organ transplants, the procedures and mechanisms associated with these diverse medical interventions all fall under the common area of medical practice known as transplant medicine.

The beginnings of successful tissue and organ transplant can be attributed to Karl Landsteiner, an immunologist and pathologist who received the 1930 Nobel Prize in physiology and medicine. In 1901, Landsteiner discovered that there were four different blood types. He called these the A, B, AB, and O types and established that transfusion was possible between individuals having the same type, while mixing of incompatible blood could lead to death due to immune system actions. Because the goal of histocompatibility and immunosuppression transplantation is to insure that the recipient does not reject the transplant but lives with it for the rest of his or her life, histocompatibility and immunosuppression are critical aspects of transplant medicine.

A tightly linked cluster of **genes** known as the major histocompatibility complex (MHC) governs tissue and organ compatibility between individuals. This complex is located on chromosome 6 in humans. These genes regulate the expression of the human leukocyte **antigens** (HLA) on the cell surface that, in turn, regulate the immunologic reactions associated with organ and tissue transplantation. Because the donor tissue is seen as foreign, it is necessary to suppress the body's natural defense systems to prevent rejection. The drugs cyclosporine, prednisone, and azathioprine are used to accomplish this goal.

Organ and tissue transplants are also called grafts. Homografts (allografts) are obtained from individuals of the same species. Homografts are usually rejected unless immunosuppressive methods are used to prevent the recipient from immunologically attacking the donor tissue. If a tissue is removed from one part of an individual's body and grafted onto another part of the body, it is termed an autograft. This is a common procedure in the treatment of burn victims. Isografts involve transplants between identical twins or between members of a very **inbred** species. In these situations there is no tissue rejection due to the similarity in the HLAs expressed on both the donor's and the recipient's cells. Heterografts (xenografts) involve tissue transfer between individuals of different species, such as transplanting a heart valve from a pig to a human.

While tissue compatibility is the principal determinant in the success of a transplant, some grafts, such as the skin allografts, are intended for short-term use, to prevent the loss of fluids and infection in severely burned individuals. Even though the graft will be rejected relatively soon, it allows the victim time to recover.

### Organ Transplants

Transplantation procedures range in complexity from simple tissue replacement procedures, such as a cornea or tendon transplant, to single-organ



Surgeons at the University of Pittsburgh Medical Center prepare a human kidney for transplanting.

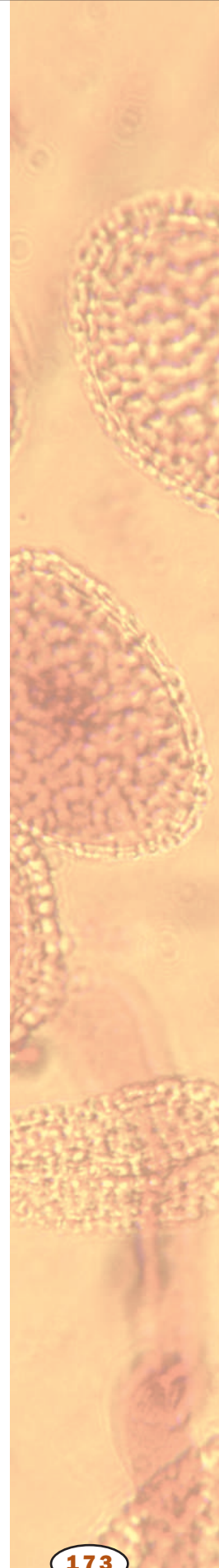

transplants such as the heart, liver, and kidney, to multiple-organ transplants involving the heart and lungs or the kidney and pancreas.

Corneal transplant is considered in cases of deformity in the shape of the cornea or corneal disease preventing the proper transmission of light to the retina. Corneal transplants were first performed in 1920. Due to a lack of extensive blood supply to this tissue, it was thought that histocompatibility issues would not be significant. While this was generally true, it has been shown that corneal graft rejection is an issue in approximately 10 percent of the surgeries.

If a person's kidneys fail to remove metabolic wastes from the blood, the only available options are usually hemodialysis or a kidney transplant. A kidney obtained from a living relative or an unrelated histocompatible donor, or from a cadaver, is used to replace the diseased organ.

The liver is responsible for filtering the blood and also for producing blood-clotting factors. Conditions such as cirrhosis and cancers involving the hepatocytes (liver cells) or the bile ducts (which convey the bile juice to the duodenum) are treatable by liver transplant. This is a complex procedure that needs to be done rapidly due to critical functions of the liver that cannot be duplicated artificially.

In 1967 in Cape Town, South Africa, a surgical team led by Dr. Christian Barnard performed the first heart transplant. His patient survived for a few weeks after the operation, but died of pneumonia soon after. His second patient, however, survived for a year and a half after the operation. Heart transplants were not a very successful procedure until the discovery of cyclosporine in 1980. Since then, heart transplant operations have become much more common with the average postoperative survival period being close to five years.

Heart transplants may be the only solution if a patient experiences **coronary artery** disease (blockage of the arteries supplying blood to the heart itself), **cardiomyopathy** (thickening of the heart walls), heart valve disease with congestive heart failure (weakening of the heart muscle and an

**coronary artery** artery supplying blood to the heart

**cardiomyopathy** heart muscle disease

**congenital** present at birth; inherited

**polymer** molecule composed of many similar parts

**gene** portion of DNA that codes for a protein or RNA molecule

**chromosome** “colored body” in the cell nucleus; made of DNA and protein, and divided functionally into genes and non-gene regions

**eukaryote** a single-celled or multicellular organism in which the cell or cells have a nucleus

**prokaryote** single-celled organism without a nucleus

**enzyme** protein that controls a reaction in a cell

**nucleotide** the building block of RNA or DNA

associated failure of the heart valves to regulate the passage of blood), or severe **congenital** heart disease.

Individuals who have conditions such as emphysema, pulmonary fibrosis, or cystic fibrosis and accompanying heart failure, or who have pulmonary hypertension with associated heart failure, are potential heart-lung transplant candidates.

Strategies involving the development of artificial tissues and organs are also being developed. In May 1998, the U.S. Food and Drug Administration approved Apligraf, an artificial skin manufactured by Organogenesis, Inc., as a biomedical device. It is made up of the same two layers, the dermis and epidermis, that make up human skin. This was the first living, tissue-engineered product to become commercially available. It has demonstrated effectiveness in the repair of skin lesions, and its use in patients with burns and diabetic ulcers is being investigated. Additionally, cartilage obtained from damaged knees has been used to engineer tissues for knee repair. Complete structural recovery is possible in about a year. Research is occurring in the development of “neo-organs,” which involves injecting cells into a three-dimensional matrix made of biodegradable **polymers**. These cells gradually replace the matrix, leaving behind a new organ. SEE ALSO ANTI-BODY; BLOOD; IMMUNE RESPONSE; SKIN; T CELLS

David A. Woodman

**Bibliography**

1999 *Annual Report of the U.S. Scientific Registry of Transplant Recipients and the Organ Procurement and Transplantation Network: Transplant Data 1989–1998*. Rockville, MD, and Richmond, VA: HHS/HRSA/OSP/DOT and UNOS, 2000. Available at <[http://www.unos.org/Data/anrpt\\_main.htm](http://www.unos.org/Data/anrpt_main.htm)>.

Finn, Robert. *Organ Transplants: Making the Most of Your Gift of Life*. Cambridge, MA: O’Reilly & Associates, 2000.

Guyton, Arthur C., and John E. Hall. *Textbook of Medical Physiology*, 10th ed. Philadelphia, PA: W. B. Saunders, 2000.

Mooney, David J., and Antonios G. Mikos. “Growing New Organs.” *Scientific American* 280, no. 4 (1999):60–65.

*Transplant Patient DataSource*. Richmond, VA: United Network for Organ Sharing, 2000. Available at <<http://www.patients.unos.org/data.htm>>.

**Transposon**

Transposons, also called transposable elements or jumping **genes**, are stretches of deoxyribonucleic acid (DNA) that can move around an organism’s **chromosome**. These “transpositions” occur at a very low frequency. A transposon can contain one gene or a set of genes, and transposons are found in both **eukaryotes** and **prokaryotes**. The transposon encodes **enzymes** that cut the transposon from the DNA sequence and reinsert it elsewhere. This cutting and pasting requires short DNA segments at either end that are inverted repeats of each other called insertion sequences. These insertion sequences are duplicated by the transposon enzymes at the insertion site, also called the target site. No particular DNA sequence serves as the target site for transposons. However, during insertion each transposon duplicates a set number of **nucleotides** at the chromosomal target site.

Prokaryote transposons may replicate DNA as well as cut and paste it. Transposons in eukaryotes do not replicate DNA. They move either by cutting and pasting, or by creating a ribonucleic acid (RNA) intermediate. These so-called retroposons are thought to be related to retroviruses whose genetic material is RNA. Retroposons are also thought to have created the repetitive *Alu* sequences that make up a very large fraction of human chromosomes.

Although transposition occurs at a low frequency, evolution has provided ample time in which to transpose elements. In addition to the *Alu* sequences in humans, about 3 percent of the fruit fly *Drosophila melanogaster* **genome** is made up of transposable element DNA.

In the 1940s, Barbara McClintock first discovered mobile genetic elements in corn that caused differences in **gene expression**, resulting in kernels containing dots of different colors against a background predominant color. Because transposons can be inserted anywhere in a chromosome, they can cause genetic mutations by disrupting whole genes, which they do in pigment genes in corn. They can also disrupt expression of genes downstream of the target site by inserting between the regulatory and the expressed parts of a gene. If two transposons end up flanking a gene, the ends can work together as one large transposon, duplicating that gene within the genome. Gene duplication is a mechanism of evolution. One copy of the gene can mutate further, perhaps resulting in a new function, while the other is retained. **SEE ALSO** CHROMOSOME, EUKARYOTIC; DNA; GENE; MCCLINTOCK, BARBARA; RETROVIRUS

Mary Beckman

### Bibliography

Alberts, Bruce, et al. *Molecular Biology of the Cell*, 4th ed. New York: Garland Publishing, 2000.

**genome** total genetic material in a cell or organism

**gene expression** use of a gene to create the corresponding protein

## Tropisms and Nastic Movements

Tropisms are growth responses of plants that result in curvatures of plant organs toward or away from certain stimuli. Tropisms can be positive, in which case the plant will bend toward a stimulus, or negative, in which case the plant will bend away from a stimulus. Important tropisms in plants include phototropism, gravitropism, and thigmotropism.

Phototropism is the tendency for plant organs to bend in response to a directional light source. For example, light streaming in a window from one direction will often cause the stems of plants placed nearby to bend toward the window, a positive phototropism. Gravitropism is the tendency for plant organs to bend in response to gravity. In most plants, roots grow downward with gravity while shoots grow upward against gravity. Within hours, the shoot of a plant placed on its side will usually bend upward and the roots will bend downward as the plant reorients its direction of growth in response to gravity. Thigmotropism is the tendency for a plant organ to bend in response to touch. For example, the specialized touch-sensitive tendrils of many vining plants, such as pea, will bend toward the side receiving a touch stimulus. Continual stimulation can lead to the coiling of the tendril around an object, which enables vining plants to grasp objects on which they can climb.

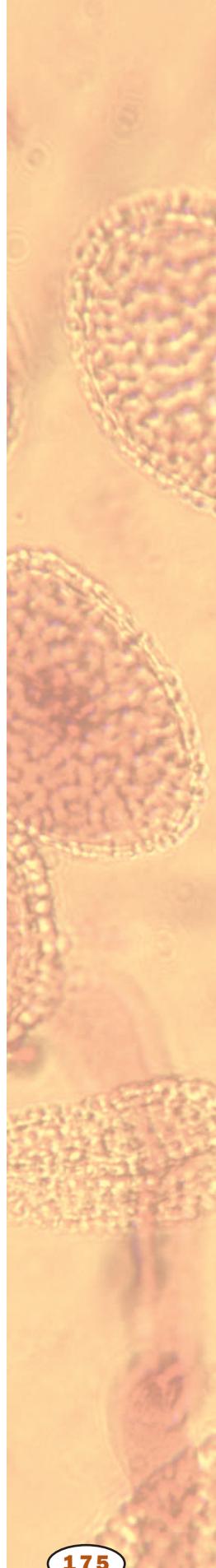

**hormone** molecule released by one cell to influence another

**superficial** on the surface; not deep

**lineage** ancestral line

**palatine bone** bone of the hard palate at the roof of the mouth

For a plant organ to bend in response to a stimulus, differential growth of cells on either side of the organ is required. For example, for the stem of a plant to bend toward a light source, cells on the shaded side of the stem near the shoot tip must elongate faster than cells on the lighted side. Differential cell growth results from either the accumulation of growth-promoting substances on the shaded side, accumulation of growth inhibitors on the lighted side, or both. One substance that appears to mediate many tropisms is auxin, a plant **hormone** that promotes cell elongation. When the tip of a plant is lighted from one side only, auxin appears to accumulate on the shaded side of the tip, where it promotes more rapid cell elongation than occurs on the lighted side, resulting in the bending of the stem toward the light source.

Nastic movements are rapid movements of plant organs in response to a stimulus that results from alterations in cell volume in a specialized motor organ called a pulvinus. For example, handling of the touch-sensitive leaves of *Mimosa pudica* results in the folding of its leaflets within a few seconds and is an example of a thigmonastic movement. Leaf folding is due to the rapid uptake of water and increase in volume of some cells in the pulvinus located at the base of each leaflet, coupled with the rapid water loss and collapse of adjacent cells. Because nastic movements occur so rapidly, the movement of plant hormones (which can be slow) does not appear to be involved. Instead, rapidly propagated bioelectrical signals appear to mediate many nastic movements. SEE ALSO HORMONES, PLANT; RHYTHMS OF PLANT LIFE

Donald F. Cipollini

### Bibliography

Campbell, Neil A., Jane B. Reece, and Lawrence G. Mitchell. *Biology*, 5th ed. Menlo Park, CA: Benjamin Cummings, 1999.

Hopkins, William J. *Introduction to Plant Physiology*, 2nd ed. New York: John Wiley & Sons, 1999.

## Tuatara

Tuataras (class Rhynchocephalia) **superficially** resemble lizards (class Reptilia), but the two known species are actually members of the smallest terrestrial vertebrate class on Earth, the Rhynchocephalia, a unique and ancient evolutionary **lineage** whose fossils (from Asia, Europe, North and South America, and Africa) first appeared in the early Triassic more than 220 million years ago. Today, Tuataras are found only on about thirty islands off the coast of New Zealand; their ancestors on other continents became extinct around 65 million years ago.

Male Tuataras lack a penis or other copulatory organ (unlike mammals, turtles, reptiles, crocodylians, and birds), possess a skull with two pairs of arches (like crocodylians), exhibit teeth on the **palatine bones** of the jaw (unlike lizards), and have teeth that are set squarely on the jawbone (with limited ability for replacement when lost, unlike the class Reptilia); old individuals may have teeth worn entirely away. Tuataras lay shelled eggs on land (unlike the class Amphibia), and the eggs may take as long as fifteen months to hatch. Tuataras live in burrows, emerging mostly at night but sometimes during the day to bask in the sun.



A Cook Strait Tuatara. *Tuatara* is a Maori word meaning “peaks or spines on the back.”

Tuataras are long-lived, apparently reaching over one hundred years of age. Males are larger (up to 61 centimeters [2 feet] in length and 1 kilogram [2.2 pounds] in weight) than females (45 centimeters [1.4 feet], .15 kilograms [.33 pounds]). They are **insectivorous** (depending on insects for food), but will opportunistically prey on small vertebrates. *Tuatara* is a Maori word meaning “peaks or spines on the back,” in reference to the conspicuous middorsal crest on the back and tail of males and, to a lesser extent, females. Access to much of the remote island habitat of this animal is difficult, providing it with protection from human disturbance; historically, on those islands where access was less daunting, humans arrived, and the tuataras became extinct. SEE ALSO AMPHIBIAN; CROCODYLIANS; EXTINCTION; REPTILE

*Joseph T. Collins*

#### **Bibliography**

Pough, F. Harvey, et al. *Herpetology*. Upper Saddle River, NJ: Prentice Hall, 1998.  
Robb, Joan. *New Zealand Amphibians and Reptiles*. Auckland, Australia: Collins, 1986.

**insectivorous** insect-eating

## **Tundra**

Tundra is the global biome that consists of the treeless regions in the north (Arctic tundra) and high mountains (alpine tundra). The vegetation of tundra is low growing, and consists mainly of sedges, grasses, dwarf shrubs, wildflowers, mosses, and lichens. The word “tundra” is derived from the Finnish word “tunturi,” which refers to the upland treeless parts of hills and low mountains free of woodlands.

Tundra climates are extremely cold and snowy in winter. Summers are cool. The southern or lower limit of trees corresponds roughly to a mean July temperature between 10 and 12 degrees Celsius (50 and 53.6 degrees Fahrenheit), but in maritime areas the limiting summer temperature can be lower. Low shrubs, less than about 1 meter (3.2 feet) tall, and peaty

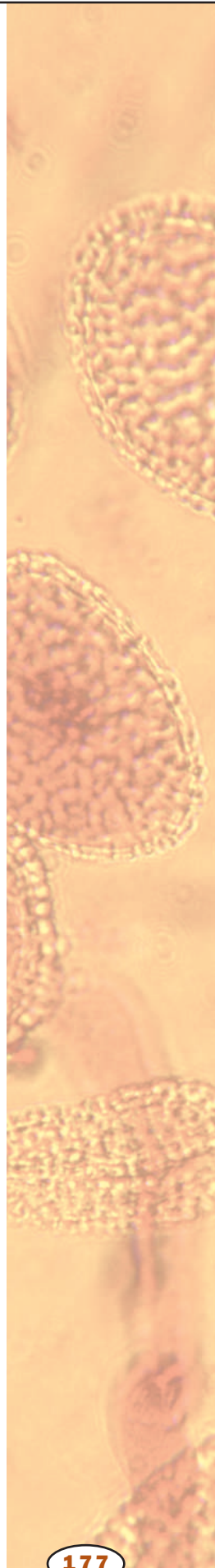

**ecosystem** an ecological community and its environment

soils are common near treeline. In the northern extremes and at higher elevations, the landscapes are predominantly barren with scattered wildflowers, such as purple mountain saxifrage and Arctic poppies, mosses, and lichens. Most of the Arctic tundra regions are underlain by permafrost, ground that is permanently frozen beneath a shallow layer of soil that thaws annually.

Tundra **ecosystems** have a variety of animal species that do not exist in other regions, including the Arctic hare, musk oxen, lemmings, Arctic ground squirrels, and ptarmigan. Other animals migrate annually to the Arctic including caribou and many species of birds.

The Arctic tundra is the least exploited of Earth's biomes. It is a unique biological laboratory for scientists to study unaltered ecosystems. The chief ecological concerns in the Arctic tundra are cumulative impacts of oil and mineral exploitation, roads, tourism, and long-range transport of air pollution from industrial centers to the south. Global warming is likely to have its greatest effect on tundra. Major concerns are the fate of permafrost and the carbon contained in Arctic peat. Decomposition of this carbon could increase the concentration of carbon dioxide in the atmosphere. **SEE ALSO** GRASSES; GRASSLAND

*Skip Walker*

#### **Bibliography**

Wielgolaski, F. E. *Polar and Alpine Tundra*. The Netherlands: Elsevier, 1997.

## **Tunicate**

On such surfaces as marine dock pilings, rocks, ships, offshore oil rigs, and coral reefs, one can often find humble blobs of jelly among the sponges and hydroids. Some are as small as sesame seeds and some as big as potatoes. Some are solitary and others live in dense clusters. Some are transparent

A sea peach tunicate. Tunicates are named for the cloaklike tunics that support their saclike bodies.

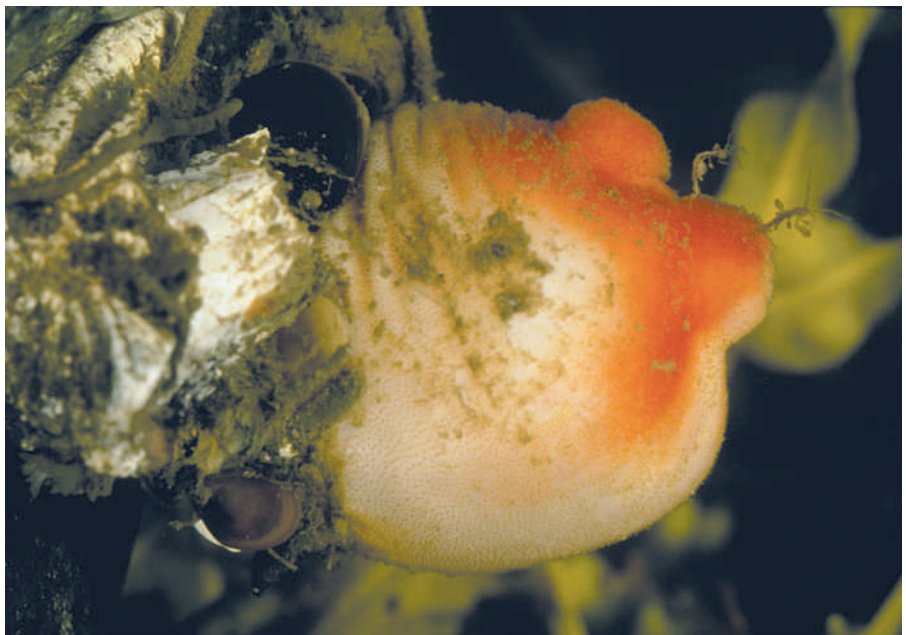

and nearly invisible, while others are as brilliantly colored as a flower garden. These are tunicates, named for the cloaklike tunic that supports their saclike bodies. The tunic ranges from gelatinous to stiff. It often contains **cellulose**, a product normally associated with plants.

Tunicates, like humans, are in the animal **phylum** Chordata. Their swimming, tadpolelike larvae have a notochord and dorsal nerve cord as humans and other vertebrates do, but these are absent from the adults. Tunicates are classified in the subphylum Urochordata, signifying that the notochord is present only in the tail of the larva (*uro* means “tail”).

Adult tunicates are filter-feeders, meaning they feed by pumping water through their bodies and straining **plankton** from it. Most of them are also **sessile**, or fixed in one place. Some, however, are swimming members of the marine plankton community. Adult tunicates have two body openings called siphons. They suck water into one opening, strain plankton from it with a filter called the branchial sac, and expel the water through the other siphon. When taken from the water, tunicates may expel a jet of water from this exit siphon, earning them the alternative name sea squirts. **SEE ALSO** ANIMALIA; CHORDATA; CORAL REEF; PLANKTON

*Kenneth S. Saladin*

### Bibliography

Pechenik, Jan A. *Biology of the Invertebrates*, 4th ed. Boston: McGraw-Hill, 2000.

Rupert E. E., and R. D. Barnes. *Invertebrate Zoology*, 6th ed. Philadelphia, PA: W. B. Saunders, 1994.

## Turtle

There are about 260 species of turtles, tortoises, and terrapins. They range in size from the leatherback, a marine species reaching an upper shell length of about 190 centimeters (6.2 feet) and a weight of over 900 kilograms (1,984 pounds), to small freshwater species that average around 10 centimeters (3.9 inches) in length and weigh less than 100 grams (a few ounces). Turtles are no longer classified as reptiles but are considered a distinct and unique evolutionary **lineage** of terrestrial vertebrates, the class Chelonia. Possession of an upper (carapace) and lower (plastron) shell in combination with a skull that lacks temporal (“the temple”) openings behind the eye socket sets turtles distinctly apart from amphibians, reptiles, tuataras, crocodilians, and birds. Over their 210-million-year history since the late Triassic, turtles have remained conservative in retaining a shell, their distinctive skeletal feature, but at the same time demonstrating an amazing diversity during their evolution, from sleek, flexible water-loving softshell turtles to high-domed, land-dwelling galapagos tortoises.

All turtles are egg-layers; females dig nests in which to lay their eggs but like amphibians provide no maternal care after hatching (as in crocodilians and birds). Some turtles, such as softshells, snapping turtles, and diamondback terrapins, have commercial value and have been regularly consumed as food by people. Turtles are popular in the pet trade, and many species have been adversely impacted by overcollecting. In addition, the natural habitats of turtles are disappearing at an alarming rate, due to human

**cellulose** carbohydrate made by plants and some other organisms; part of the cell wall

**phylum** taxonomic level below kingdom, e.g., arthropod or chordate

**plankton** microscopic floating organisms

**sessile** attached and remaining in one place

**lineage** ancestral line

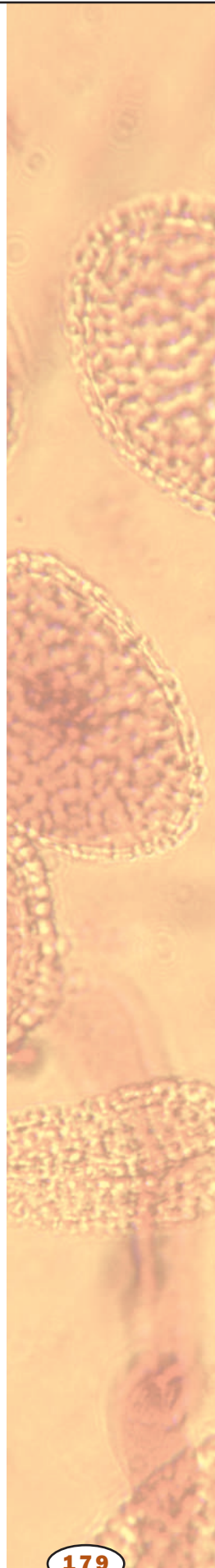



overpopulation worldwide. SEE ALSO AMPHIBIAN; CROCODYLIANS; EXTINCTION; REPTILE

*Joseph T. Collins*

#### **Bibliography**

Halliday, Tim R., and Kraig Adler. *The Encyclopedia of Reptiles and Amphibians*. New York: Facts on File, 1986.

Pough, F. Harvey, et al. *Herpetology*. Upper Saddle River, NJ: Prentice Hall, 1998.



## **Vaccines**

Vaccines are drugs used to increase the body's ability to combat disease organisms. Most vaccines are designed to help the body fight off a specific type of bacterium, protozoan, or virus. Some vaccines have been developed to stop the growth of cancer cells and to protect military troops from biological warfare. The administration of vaccines to animals and humans is called vaccination or immunization. Vaccination is one medical strategy for preventing the spread of infectious diseases. Vaccines encourage the body to build up immunity against disease organisms.

### **Vaccination**

In 1796, an English physician named Edward Jenner developed the first vaccine to protect people from smallpox. Smallpox is caused by a potentially fatal virus that severely blemishes the skin and internal organs. Jenner noticed that cattle handlers infected with a related disease called cowpox did not contract smallpox. Jenner used this observation to test whether exposure to cowpox prevented people from getting smallpox. He introduced the fluids from a cowpox sore into the arm of a young boy. The boy developed cowpox, a mild disease in humans, but did not get smallpox after Jenner exposed the boy to the smallpox virus. (This highly unethical experiment could not be performed today!) The word "vaccine" comes from the Latin *vaccus*, meaning "cow." Today, smallpox has been effectively eliminated from the human population through vaccination.

Vaccines for vaccination are made from the disease organism. They are composed of either a weakened ("attenuated") form of the live disease organism, the killed disease organism, or chemical components of the disease organism. The cowpox fluids collected by Jenner contained live viruses that he scratched into the boy's body. Vaccination works by stimulating the immune system to produce antibodies against the disease organism. It takes a few days before the vaccine can protect the body, but the **antibody**-producing cells impart an immunity that can last several years to a lifetime. Booster shots are sometimes given years after immunization with an active vaccine to extend the body's immunity. Many vaccines must be given as several small doses over a six-month or one-year period. This prevents the person from being ill from a large dose given at once. Vaccination is used against a variety of common diseases including diphtheria, polio, rabies, and tetanus. Development of vaccines against HIV (human immunodeficiency virus) and malaria are two of the most active areas of research in twenty-first-century medicine.

**antibody** immune system protein that binds to foreign molecules

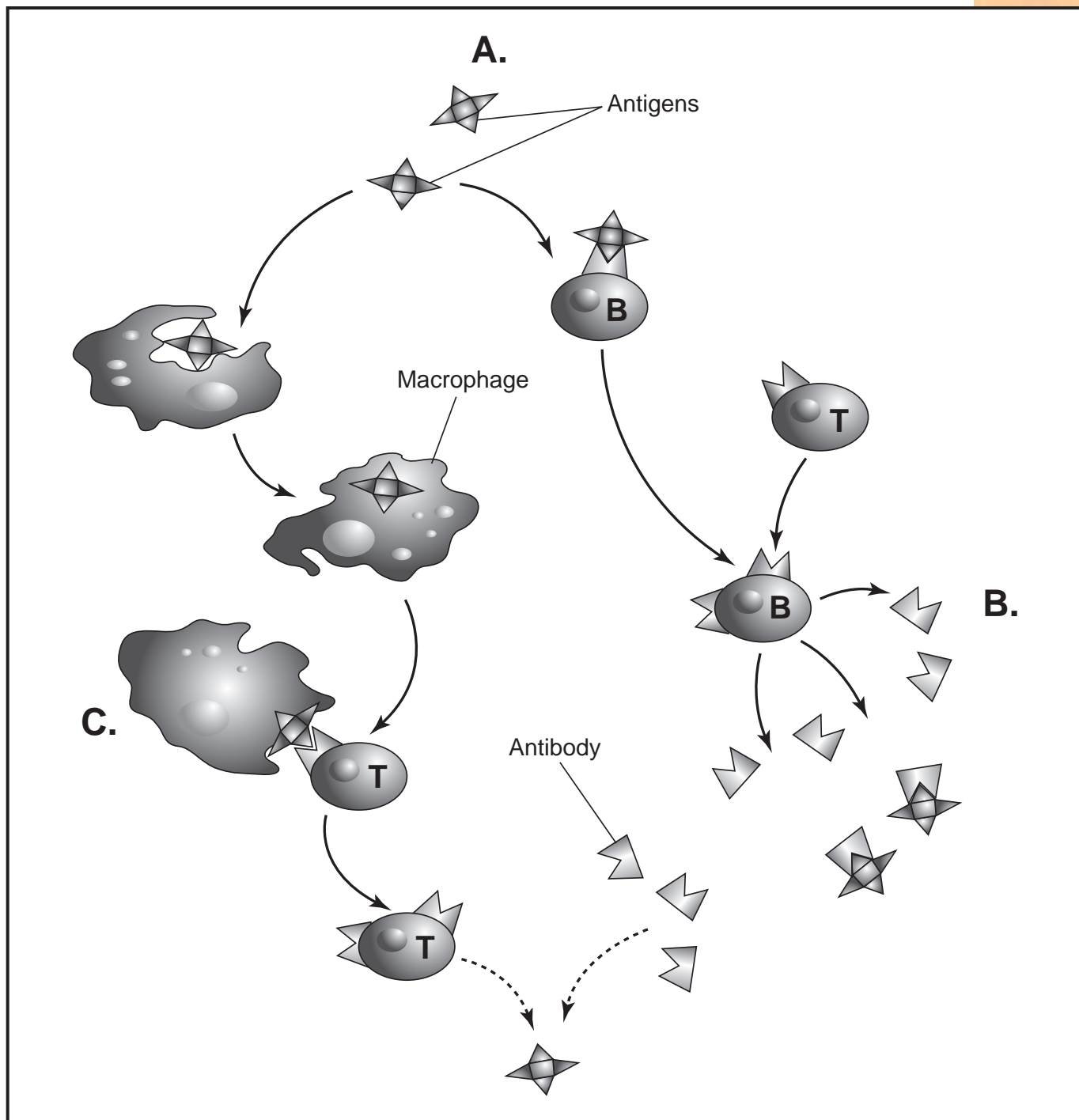

How vaccines work: A. Vaccines containing antigens are introduced into the body, stimulating the immune system response by instructing B cells, with assistance from T cells, to produce antibodies. B. Antibodies are produced to fight the weakened or dead viruses in the vaccine. The immune system prepares to destroy real and stronger viruses in the future. C. When new antigens enter the body, white blood cells called macrophages engulf them, process the information contained in the antigens, and send it to the T cells so that an immune system response can be mobilized.

French scientist Louis Pasteur was the first to develop a way to produce effective vaccines. Pasteur's first vaccine was derived from attenuated cultures of the disease organisms. Developed in 1879, it was for fowl cholera found in chickens. The first vaccine he used on humans was for the deadly viral disease rabies.

## Adverse Effects of Vaccines

Many people are concerned that vaccines can have side effects in certain individuals. Several children have fallen ill from the DPT, or diphtheria-pertussis-tetanus, vaccination. Most illnesses from vaccinations are found in individuals who are allergic to the vaccine. Vaccines made from living organisms may cause the same illness physicians are trying to prevent. The oral polio vaccine, containing weakened virus, is designed to remain in the environment after defecation by the person ingesting it. This exposes other people to it, immunizing them. However, a few people exposed this way have contracted polio. The injected form of the vaccine does not carry this risk, but neither does it help immunize other people.

## Passive Immunity

Another form of protection against disease, termed passive immunity, relies on injection of antibodies into the blood. These antibodies perform the same function as a person's own antibodies, attaching to the disease organism and acting as a label that tells immune cells to kill and remove the organism. These antibodies may be collected from laboratory animals immunized against the disease, or may be produced in cell cultures from special cells called monoclonal antibody cells. Passive immunization permits a person to have the protective antibodies already in the body before getting ill from the disease. Passive immunization works immediately after being administered, but gives only temporary immunity; the protective value may disappear after several weeks. Passive immunization is commonly given during influenza or "flu" outbreaks (but is not the same as a "flu shot," which is a true vaccine, given before exposure to the virus). Antivenoms used to treat the bites or stings of venomous insects and snakes are antibodies, and therefore are a form of passive immunization. SEE ALSO AIDS; ANTIBODY; BACTERIAL DISEASES; DISEASE; IMMUNE RESPONSE; IMMUNIZATION; PASTEUR, LOUIS; T CELL; VIRAL DISEASES

Brian R. Shmaefsky

### Bibliography

Nester, Eugene W., et al. *Microbiology, A Human Perspective*, 2nd ed. Dubuque, IA: WCB/McGraw-Hill. 1996.

## Vacuole

A vacuole is a characteristic type of **organelle** found in plant and fungi cells and many single-cell organisms. The single large vacuole of the cell is surrounded by a membrane, called the tonoplast, and filled with a solution of water, dissolved **ions**, sugars, **amino acids**, and other materials.

In plants, nicotine and other toxins are stored in vacuoles, since these are as toxic to the plant as they are to the herbivores they are meant to repel. The tart juice of the orange and other citrus fruits is stored in vacuoles, as are the bright pigments that give autumn leaves their color. The vacuole also serves as waste disposal and recycling center for worn-out organelles, such as **mitochondria** and chloroplasts, and in this function they are similar to lysosomes in animal cells. Expansion of the vacuole by water intake is the major driving force in plant cell growth, and is also the means for

**organelle** membrane-bound cell compartment

**ion** an electrically charged particle

**amino acid** a building block of protein

**mitochondria** subcellular organelle that creates ATP used for energy-requiring processes in a cell

maintaining cell rigidity, or **turgor**. To increase turgor, the tonoplast will pump ions or other material into the vacuole, causing water to infiltrate by **osmosis**. In a mature cell, the vacuole may occupy as much as 90 percent of the cell volume, such that the rest of the cell contents are flattened against the cell membrane. SEE ALSO ANATOMY OF PLANTS; CELL WALL; FUNGI; PROTISTA; SECONDARY METABOLITES IN PLANTS; WATER MOVEMENT IN PLANTS

**turgor** internal pressure

**osmosis** passage of water through a membrane in response to concentration differences

*Richard Robinson*

#### **Bibliography**

Raven, Peter, Ray F. Evert, and Susan E. Eichhorn. *Biology of Plants*, 6th ed. New York: W. H. Freeman and Company, 1999.

## **van Helmont, Jan**

***Flemish physician and chemist***  
**1579–1644**

Jan van Helmont was an early pioneer in the study of gases, and performed numerous chemical experiments, including an analysis of smoke, distinguishing it from ordinary air by the particles it contained. However, van Helmont is best known for a single experiment demonstrating that the weight a plant gains during growth is not due to absorption of an equal amount of soil, but instead is due (at least in part) to water.

Van Helmont undertook his famous experiment in plant growth, in part, to learn more about water. In this experiment, he carefully weighed a young willow shoot, and then planted it in a large container whose soil he had also carefully dried and weighed. He watered the willow as needed for five years, and then reweighed both the willow and the soil. The willow had grown from 2.2 kilograms (5 pounds) to 77 kilograms (169 pounds), while the dry weight of the soil had lost only 57 grams (2 ounces). In this way, van Helmont demonstrated that plants do not simply take up soil as they grow, and concluded that water was the sole source of this increased weight. However, van Helmont did not suspect that gases in the air might contribute to plant growth, a fact demonstrated by Nicolas de Saussure more than one hundred years later. SEE ALSO SOIL; WATER

*Richard Robinson*

#### **Bibliography**

Isley, D. "Helmont." In *One Hundred and One Botanists*. Ames, IA: Iowa State University Press, 1994.

Pagel, W. "J. B. Van Helmont." In *Dictionary of Scientific Biography*, Vol. 6. New York: Scribner's, 1972.

## **Vavilov, Nikolay**

***Russian Plant Geneticist***  
**1887–1943**

Nikolay Vavilov is best known for attempting to apply the science of genetics to Russian agriculture, for his theories of the origin of crop plants, and for being persecuted during the Stalin Regime in the Soviet Union.

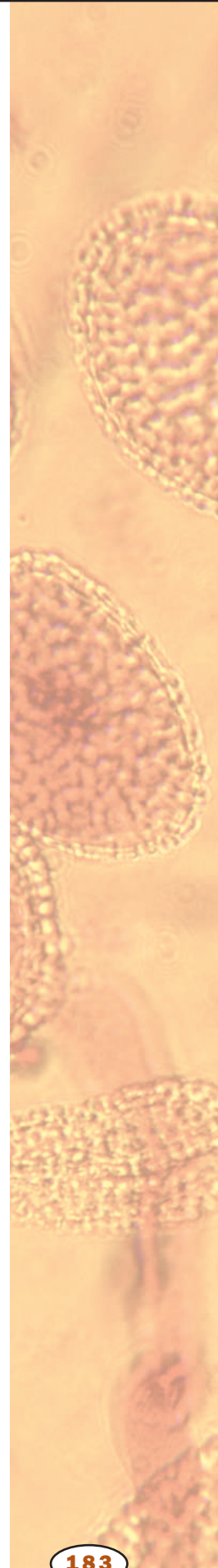

Vavilov studied genetics in Moscow and in England. Under Lenin, he became the head of the Bureau of Applied Botany in St. Petersburg, building it into one of the premier research institutions in the world. Vavilov traveled widely to collect and observe crop plants and their wild relatives. By analyzing the diversity of plants in different regions, and combining this information with archaeological and other evidence, Vavilov formulated his theory of crop plant origins. He believed that regions in which the domesticated varieties of a crop plant were most diverse were most likely the regions in which that crop had first been cultivated by humans. He postulated there were eight “centers of origin,” an idea that led to much further research and the eventual refinement and modification of Vavilov’s theory. Through the 1930s, however, under Stalin, genetic science became suspect because of its associations with the West, and Vavilov was attacked by Trofim Lysenko, who had Stalin’s trust. In 1940, Vavilov was arrested and imprisoned. He died in jail three years later.

*Richard Robinson*

## Vesalius, Andreas

**Belgian anatomist**  
**1514–1564**

Andreas Vesalius was the founder of modern human anatomy. Before his time, medical illustrations served more to decorate a page than to teach human structure. Humans were often shown in squatty froglike postures with only crude representations of the locations and relationships of the internal organs. Often the figures were surrounded by signs of the zodiac, as astrologers thought each constellation influenced a particular body organ. Medical professors taught from an elevated chair, the cathedra, reading dryly in Latin from such ancient authorities as Roman physician Galen, while a low-ranking barber-surgeon removed organs from a rotting corpse and held them up for the medical students to see. Neither **embalming** nor cadaver refrigeration were yet known to Western medicine, and the professors considered it beneath their dignity to touch the foul cadaver.

**embalming** treating a dead body to protect it from decay

Vesalius revolutionized the teaching of medicine. A native of Brussels, educated at Paris and Padua, he taught medicine at the University of Padua in Italy. Vesalius broke with tradition and personally dissected cadavers with his students. He soon learned that the anatomy described by Galen was highly inaccurate, and he commissioned artists from the studio of Italian painter Titian to render more accurate illustrations. When other anatomists began plagiarizing these illustrations, Vesalius had them published in a seven-volume work, *De Humani Corporis Fabrica (On the Structure of the Human Body)*, in 1543. This was the first accurate atlas of human structure, and ushered in the era of modern human anatomy.

After the publication of the *Fabrica*, Vesalius enjoyed an illustrious career as a physician to, among others, Charles V, emperor of the Holy Roman Empire, and his son, Philip II. In 1564, Vesalius died in a shipwreck on the way home from a voyage to the Holy Land.

Twenty-first-century anatomical atlases, such as Frank Netter’s *Atlas of Human Anatomy*, Carmine Clemente’s *Anatomy*, and Anne Agur’s *Grant’s*

*Atlas of Anatomy*, and even the standard college textbooks of human anatomy owe a great debt to the tradition begun by Vesalius. SEE ALSO HISTORY OF MEDICINE

*Kenneth S. Saladin*

### **Bibliography**

Moore, John A. *Science as a Way of Knowing*. Cambridge, MA: Harvard University Press, 1993.

Vesalius, Andreas. *The Illustrations from the Works of Andreas Vesalius of Brussels*. New York: Dover, 1973.

## **Veterinarian**

Becoming a veterinarian is a challenging yet rewarding process. A veterinarian is someone who has earned a Doctor of Veterinary Medicine (DVM) or a Veterinary Medical Doctor (VMD) degree from an accredited college or university. The veterinary program consists of four years of a combination of lecture classes, practical laboratory work, and clinical experience. Many veterinary programs allow students to choose an area of emphasis (usually small animals, equine, food animals, exotic animals, or mixed), although this varies among programs. While an undergraduate degree is not required to enter a veterinary program, the great majority of veterinary students have a degree, usually a Bachelor of Science in a biological science, and many may also have a Master of Science degree. Every veterinary program's entry requirements are different, but most include undergraduate courses in biology, chemistry, physics, mathematics, biochemistry, animal science, and animal nutrition. The high school student interested in pursuing a veterinary degree would be wise to take as many science and math courses as possible. Experience in handling animals is also a necessity for admission to a veterinary program, whether in a paid position or on a vol-



A veterinary technician checks a dog's blood pressure.

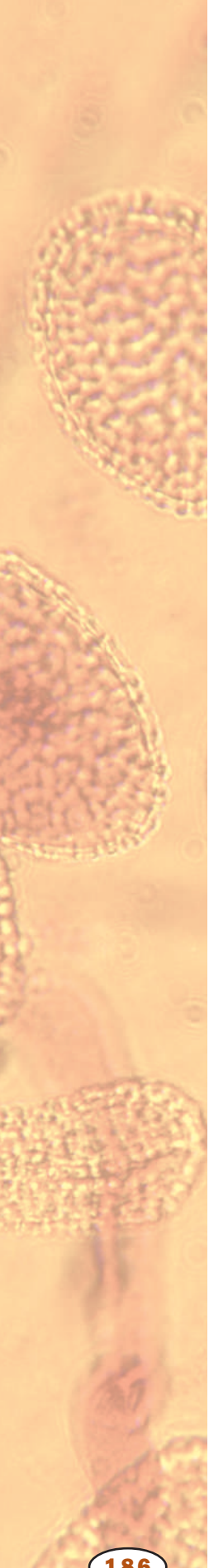

**obligate** required or necessary, especially referring to a metabolic process or mode of nutrition

**parasite** organism living in close association with another from which it derives most of its nutrition

**protein** complex molecule made from amino acids; used in cells for structure, signaling, and controlling reactions

**genetic code** relationship between triples of RNA nucleotides and the amino acids they code for during protein synthesis

**enzyme** protein that controls a reaction in a cell

**secretion** material released from the cell

**interferons** signaling molecules of the immune system

unteer basis. Excellent grades are necessary: entrance into a veterinary program is very competitive because of the small number of veterinary programs in the United States.

The great majority of veterinarians are employed in private practice, but this is not the only employment opportunity. Veterinarians are needed in government to serve on medical and agricultural committees, to inspect meat and meat products, and to work in laboratories. Colleges and universities hire veterinarians to teach undergraduate and graduate courses and to conduct research. Overseas veterinary mission and Peace Corps work is available. Large research and pharmaceutical companies often have veterinarians on their staffs. A veterinary degree is extremely versatile and useful, particularly when combined with an undergraduate degree in a biological science.

*Amy L. Massengill*

### Bibliography

Hurwitz, Jane. *Choosing a Career in Animal Care*. New York: The Rosen Publishing Group, Inc., 1999.

## Viral Diseases

In order to understand viral infections, one must understand a little about how a virus functions. All viruses are **obligate parasites**; that is, they depend on a “host” to survive and reproduce. In the case of a virus, the host is the cell of a living organism. Outside of a host cell, viruses are inert molecules, waiting to attach to a victim cell. Although viruses contain genetic material (either deoxyribonucleic acid [DNA] or ribonucleic acid [RNA]), they lack the internal machinery (organelles) to produce **proteins** from the information contained in their own **genetic code**. The simplest virus contains only three genes.

A viral infection begins when a virus inserts its genetic material into a host cell. First, the virus attaches to a specific structure on the cell’s surface via an attachment protein. Depending on the virus, either the genetic material diffuses into the host cell or the entire virus enters the cell. The poliomyelitis virus may have over one million copies of its basic genetic information (RNA) inside a single, infected human intestinal mucosal cell.

One or more of the genes on the viral genetic material code for **enzymes** that essentially “hijack” the host cell, causing it to produce only viral parts, which are then assembled into copies of the virus within the host cell. These viral copies are released, leaving the cell either by a process called “budding” (where just one or a few viruses leave the cell at a time) or by a process called lysis (where the cellular membrane ruptures and releases all of the virus particles at once). Both processes usually kill the host cell. The new viruses then infect surrounding cells, continuing the process. Examples of diseases that are viral in origin are influenza (swine flu), some types of pneumonia, poliomyelitis, cold sores and shingles, and AIDS (acquired immunodeficiency syndrome).

Of course, host cells have several defenses against the viral attacks. For example, in animals (including humans), viral infection leads to the synthesis and **secretion** of proteins called **interferons**, which “interfere” with vi-

ral replication by helping adjacent uninfected cells become resistant to infection. Often, this is not enough to stop the spread of infection, and the body's immune system can cause fever, achiness, tiredness, and other defenses, making the person feel "sick" but acting to help the body fight off the attack. Eventually, the virus is completely removed, and the symptoms subside.

HIV (human immunodeficiency virus) is an exception to this situation because HIV infects cells of the immune system that are necessary to kill the infected cells. So, although HIV does not itself directly cause the condition known as AIDS, the eventual death of immune cells allows other infections to spread (called secondary infections).

So far, no agents have been identified that are secreted by a cell that actually kills a virus. Although antibiotics are effective against bacteria, they do not kill viruses. Recently, there have been agents called antivirals designed in the laboratory and isolated from natural sources that are being used to fight certain viral infections. For example, protease inhibitors are used to inhibit the replication of HIV. **SEE ALSO AIDS; DISEASE; DNA VIRUSES; RETROVIRUS; SEXUALLY TRANSMITTED DISEASES; VIRUS**

*Carl J. Shuster*

### Bibliography

Crawford, Dorothy H. *The Invisible Enemy: A Natural History of Viruses*. New York: Oxford University Press, 2000.

Voyles, Bruce A. *The Biology of Viruses*. New York: McGraw-Hill, 1993.

## Virus

Viruses are not cells and are metabolically inert outside of living cells. They can infect organisms consisting of just one cell, such as a single bacterial cell, or the individual cells of multicellular organisms such as humans. They are small compared to the cells they infect and as such must live as **intracellular parasites**. They absolutely require cells to reproduce. Within the appropriate cell, viruses are able to program the cell to replicate themselves by hijacking the normal cellular systems. The extracellular form of a virus, also known as a virion, is stable enough to survive the conditions required for transmission from one cell to another. The virion is composed of a set of **genes** (encoded by ribonucleic acid [RNA] or deoxyribonucleic acid [DNA]), which is protected by a **protein**-containing coat. The coat is often characterized by regularity and symmetry in its structure and is capable of binding to and invading cells. On invasion of a susceptible cell the virion is disassembled to release the viral **genome**. Once the viral genome is released, viral genes are expressed to reprogram the **biosynthetic** activities of the cell so that large numbers of **progeny** virions may be produced by the cell. These virions are then released by the infected cell to invade other cells so that the process can be repeated. **SEE ALSO BACTERIAL VIRUSES; DNA VIRUSES; RETROVIRUS**

*Richard Longnecker*

### Bibliography

Flint, S. J., et. al. *Principles of Virology: Molecular Biology, Pathogenesis, and Control*. Washington, DC: ASM Press, 2000.

The first outbreaks of the paralyzing poliomyelitis (polio) virus in the United States occurred in the early nineteenth century. It reached its peak in 1952 when more than 21,000 people were infected. Due to the effective use of vaccines, the incidence of polio declined rapidly; the last documented transmission of the virus in the United States was 1979.

**intracellular** within a cell

**parasite** organism living in close association with another from which it derives most of its nutrition

**gene** portion of DNA that codes for a protein or RNA molecule

**protein** complex molecule made from amino acids; used in cells for structure, signaling, and controlling reactions

**genome** total genetic material in a cell or organism

**biosynthetic** forming a complex molecule from simpler ones

**progeny** offspring



A colored transmission electron micrograph of a T4 bacteriophage virus.

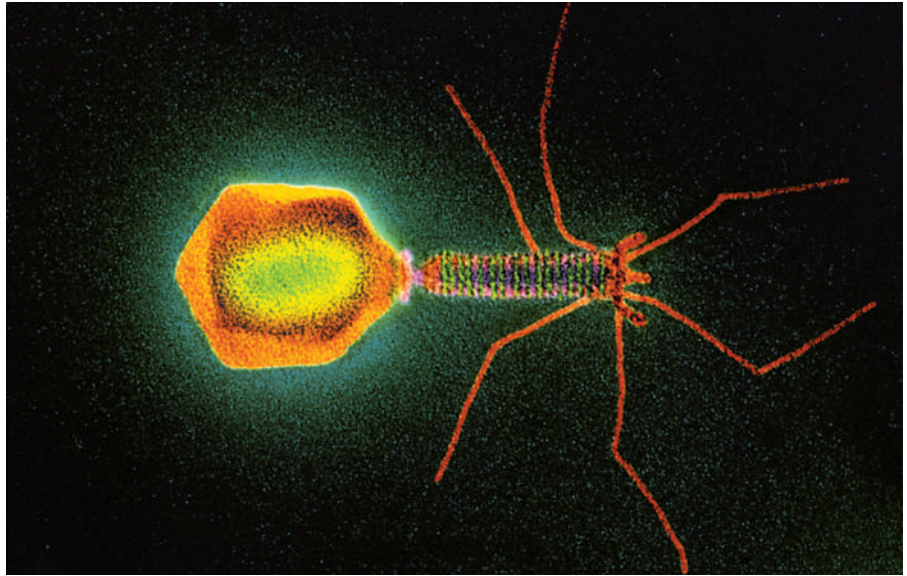

## Vision

The eyes are the windows on the world. Vision is found widely in many different classes of animals and may have evolved independently at different times. Vision, which involves perception of light and dark, is distinct from simple light sensitivity, such as that displayed by germinating plant sprouts that respond to the sun's direction.

### Eyecups

The complexity of eyes varies markedly in different groups of animals. Non-focusing eyecups are found in the planarians, the medusas (jellyfish) of cnidarians, some snails, and some other invertebrates. Light enters a depression lined with pigment-containing, light-sensitive cells. **Neurons** connected to these cells carry messages to the rest of the nervous system. Because there is no focusing system, the general direction and intensity of light can be detected, but there can be no perception of form or image.

### Compound Eyes

Most adult insects and crustaceans, as well as the horseshoe crab and the extinct trilobite, have compound eyes, constructed of as few as one (in some ants) to as many as thirty thousand (in some dragonflies) individual units called ommatidia. Each ommatidium is covered with a cornea, formed from the insect **exoskeleton**, and has its own crystalline cone within. Both structures focus light on the retinula (light-sensitive) cells at the base. The amount of light entering the ommatidium may be controlled by increasing or decreasing the amount of screening pigments within. The individual ommatidia do not usually cast clear images on the retinula cells, rather just a spot of color. The individual retinula cells then send this information into the brain, which puts all of the spots together to form a mental image.

Although the details of insect visual processing are unknown, there appear to be multiple levels of processing, as there are in vertebrate visual sys-

**neuron** nerve cell

**exoskeleton** external skeleton

tems. Finally, insects usually have three ocelli, non-image-forming simple eyes, on the tops of their heads. These seem to awaken insects for their daily activities.

## Camera Eyes

Vertebrates (including humans) and cephalopods (such as the octopus) have so-called camera eyes. Camera eyes have muscular rings called irises to control the amount of light that can hit the light-sensitive cells in the back of the eye. The ability to control the amount of light is called visual adaptation. Human eyes have a cornea on the outer surface that provides about 70 percent of the eye's focusing power, and they have an adjustable lens that provides the rest of the focusing power and allows accommodation, or change, of focus for near or far objects. Light entering the eye passes first through the cornea, then past the iris, through the lens, then the vitreous humor, which is a clear jellylike substance that gives the eye its shape. Light is absorbed by the retina, the layer of light-sensitive cells lining the back of the eye.

## Light Transduction

Despite the differences in structure, eyes generally use the same set of biochemical tools to **transduce** light into a **neural** signal. A carotenoid compound (such as the chemical relatives of vitamin A), linked to a **protein** in the retinal cell membrane, captures the light energy. The light alters a chemical bond in the carotenoid, which then changes its shape, causing the membrane to alter its electrical state. The change in electrical state then will cause the retinal cell to release a chemical (called a neurotransmitter) which will excite an adjacent nerve cell. The carotenoid plus an associated protein is referred to as the visual pigment. (Interestingly, carotenes are also used by plants to help them capture the energy of the sun in photosynthesis.)

## Image Processing

The visual image detected by the retina is not recorded whole and passed unchanged to the brain. Instead, the image is processed, with highlighting and integration of some features along the way. The degree of image processing varies among different types of animals. For example, toads have a “worm detector.” When the optic nerves send signals to the visual-processing area of the brains to form a linear pattern, the brain says “worm” and the toad aligns to the worm and snaps it up.

The eyes of some animals have fields of vision with little or no overlap between the two eyes, giving them a 360-degree view of the world. Such wide fields of view are seen often in prey animals, allowing higher vigilance against predators. Some ground birds, for example, have eyes that have absolutely no overlap. In contrast, other animals have eyes with highly overlapping fields of vision. This allows stereoscopic vision, in which an object is viewed from two different points. Integration of these images, along with information about the relative direction in which the two eyes are pointing, allows depth perception, a critical tool for predators. It is also important for monkeys and other tree-dwelling primates, for instance, in order to know how far that next branch is so that they do not fall out of their trees!

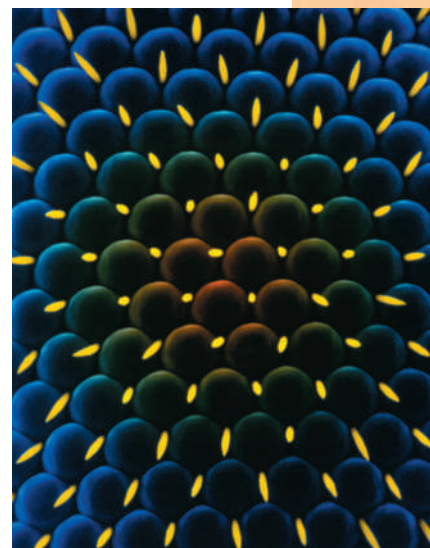

A scanning electron micrograph of the compound eye of a fruit fly (*Drosophilla melanogaster*).

**transduce** to convert a signal of one type into another type

**neural** related to nerve cells or the nervous system

**protein** complex molecule made from amino acids; used in cells for structure, signaling, and controlling reactions

**nanometer**  $10^{-9}$  meters; one-billionth of a meter

## Ultraviolet and Polarized Light

The visual spectrum of all animals goes from around 350 **nanometers** (ultraviolet) through all the colors most humans see to the infrared, around 800 nanometers (one nanometer equals one-billionth of a meter). In the vertebrates, elaborate color vision is found in the primates (including humans), birds, lizards, and fish. Most other mammals lack the ability to see red or other colors (including bulls).

Insects are less well able to see the red than humans can, but they do see colors, and some insects can detect ultraviolet light. Bees can see the hidden ultraviolet color patterns of black-eyed susans and other flowers, for instance, allowing them to hone in on these flowers more easily.

Another unusual light quality that insects can detect is the plane of light polarization. Light polarization means that all of the rays arriving at the retinal cells are vibrating in the same plane; light typically becomes polarized when it is reflected off surfaces. Insects' retinas are arranged so that they detect changes in polarization. This makes it possible for honeybees to determine the direction of the sun even on cloudy days. The sun's direction in the sky is a critical piece of information communicated in the bee dance that a scout bee will do to communicate the location of nectar or pollen sources to other bees in the hive. **SEE ALSO EYE**

David L. Evans

### Bibliography

- Drickamer, Lee C., Stephen H. Vessey, and Elizabeth M. Jakob. *Animal Behavior*, 5th ed. Dubuque, IA: McGraw-Hill, 1996.
- Romoser, William S., and J. G. Stoffolano, Jr. *The Science of Entomology*, 4th ed. Boston: McGraw-Hill, 1998.
- Saladin, Kenneth S. *Anatomy and Physiology: The Unity of Form and Function*, 2nd ed. Boston: McGraw-Hill, 2000.

## Vitamins and Coenzymes

Vitamins are chemical compounds that are vital to life and indispensable to body functions. They often exist as provitamins, inactive forms that must be converted into active vitamins before they can perform metabolic tasks in the body's cells. There are thirteen individual vitamins required by the human body for growth and maintenance of good health.

Vitamins are grouped on the basis of their ability to dissolve in water or fat. The fat-soluble Vitamins A, D, E, and K generally are found together in the fats and oils of foods. Once absorbed, they can be stored indefinitely in the liver and fatty tissues of the body. This capacity for storage can lead to unwanted toxic buildup of certain vitamins, A, D, and K in particular, that can cause great harm. Deficiencies of any vitamin can also be harmful. The National Academy of Sciences publishes recommended intake values for all thirteen vitamins.

Each of the fat-soluble vitamins performs unique functions in the body. The three active forms of Vitamin A are required for night and color vision, reproduction, and cell maturation and differentiation, the process by which precursor cells develop into a specific cell type. Vitamin A also plays

a role in fighting infections and in the development and maintenance of bone. Beta-carotene and other provitamin forms of vitamin A known as carotenoids are **antioxidants**, chemicals that block the harmful cancer-causing effects of oxidizing agents (oxygenlike molecules) on cells. This antioxidant property may also play a role in vitamin A's prevention of heart disease.

The provitamin form of vitamin D is made by skin cells using sunlight and a derivative of cholesterol. It is then converted to its active form in the kidneys and liver. Vitamin D plays a role in the differentiation of cells in the intestines, skin, immune system, and bones. It also regulates blood calcium levels, which are important in maintaining proper bone density.

Vitamin E's major function in the body is as an antioxidant. It inserts itself into cell membranes and protects substances inside the cells, such as deoxyribonucleic acid (DNA), from being chemically modified by oxygenlike molecules.

Vitamin K is involved in synthesizing **proteins** that help blood clot. It is also necessary for making a key protein important in bone formation. In addition to dietary sources of vitamin K, the body can use vitamin K manufactured by bacteria that live in the intestines.

The water-soluble vitamins include vitamin C and the group of eight vitamins known collectively as Vitamin B. They are not readily stored and are **excreted** in urine when consumed in excess of the body's needs. Vitamin C's roles include assisting in the production and maintenance of collagen, a protein found in bones, skin, teeth, and tendons. Vitamin C also plays roles in supporting the immune system and producing thyroxine, the **hormone** that regulates body temperature and **metabolism**.

The B vitamins act as part of coenzymes, small molecules that combine with an **enzyme** to make it active. Enzymes are proteins responsible for catalyzing most chemical reactions in the body, such as digesting food and synthesizing new compounds. The B vitamins riboflavin, thiamin, niacin, pantothenic acid, and biotin help the body use protein, fat, and carbohydrate to produce energy for the body's cells.

Vitamin B<sub>6</sub> assists in the synthesis of new proteins in the cell by assembling protein building blocks called **amino acids**. Folate and Vitamin B<sub>12</sub> are required for cell multiplication. In particular, folate is involved in synthesizing DNA for the dividing cells. Vitamin B<sub>12</sub> helps folate enter cells. B<sub>12</sub> also maintains the protective sheaths that surround nerve fibers. SEE ALSO ENZYMES; NUCLEOTIDES

Michele D. Blum

### Bibliography

Committee on Dietary Allowances. *Recommended Dietary Allowances*, 10th ed. Washington, DC: National Academy Press, 1989.

Committee on Dietary Reference Intakes. *Dietary Reference Intakes for Calcium, Phosphorus, Magnesium, Vitamin D and Fluoride*. Washington, DC: National Academy Press, 1997.

———. *Dietary Reference Intakes for Thiamin, Riboflavin, Niacin, Vitamin B<sub>6</sub>, Folate, Vitamin B<sub>12</sub>, Pantothenic Acid, Biotin and Choline*. Washington, DC: National Academy Press, 1998.

Sizer, Frances, and Eleanor Whitney. *Nutrition Concepts and Controversies*, 8th ed. Belmont, CA: Wadsworth, 2000.

**antioxidant** substance that prevents damage from oxidation

**protein** complex molecule made from amino acids; used in cells for structure, signaling, and controlling reactions

**excrete** deposit outside of

**hormone** molecule released by one cell to influence another

**metabolism** chemical reactions within a cell

**enzyme** protein that controls a reaction in a cell

**amino acid** a building block of protein

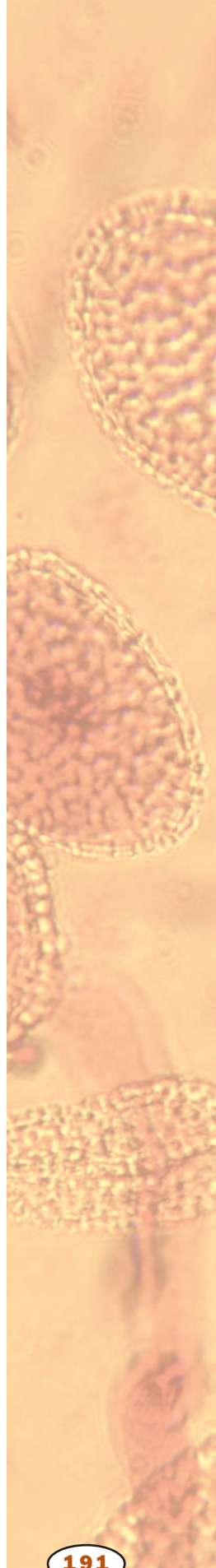

Smolin, Lori A., and Mary B. Grosvenor. *Nutrition Science and Applications*, 3rd ed. Fort Worth, TX: Saunders College Publishing, 2000.

Wardlaw, Gordon M. *Perspectives in Nutrition*, 4th ed. Boston: McGraw-Hill, 1999.

## von Humboldt, Alexander

**German explorer and scientist**  
1769–1859

Alexander von Humboldt was a scientist and explorer who founded the field of plant biogeography, the analysis of the distribution of plants throughout the world. Humboldt was born in Germany and apprenticed with several leading German botanists as a young man. He also became trained as a geologist and worked for a time at the German Ministry of Mines.

By 1797, however, Humboldt had developed a **wanderlust** and thirst for adventure, and in 1799 he set out for South America to find out, as he put it, “how the geographic environment influences plant and animal life.” While there, and despite many hardships, Humboldt made significant studies of the botany, zoology, geography, and climate of the region. He was probably the first European to recognize the rich diversity of the tropical flora.

Humboldt discovered that the distribution of plant groups could be correlated with changes in temperature and rainfall, laying the intellectual groundwork for developments in plant ecology that would come a century later. After leaving South America, Humboldt visited the United States and met with Thomas Jefferson, whose own thinking about scientific expeditions in America was probably influenced by these conversations. Humboldt’s memory is honored in the names of rivers, mountains, and counties in the western United States. SEE ALSO BIOGEOGRAPHY; BUFFON, COUNT

*Richard Robinson*

### Bibliography

von Humboldt, Alexander. *Personal Narrative of a Journey to the Equinoctial Regions of the New Continent*. New York: Penguin Books, 1995.

**wanderlust** strong desire to travel



**polar covalent** bond in which electrons are unevenly shared

**polar** partially charged, and usually soluble in water

**ion** an electrically charged particle

**solvation** the process of dissolving

**aqueous** watery or water-based

## Water

Water (H<sub>2</sub>O) is vital for all living organisms, and it is no exaggeration to say that life could not occur without it. The central feature of the water molecule is the bond between the strong electron attractor oxygen and the weak attractor hydrogen. This creates a **polar covalent** bond, with a weak positive charge on each hydrogen and a weak negative charge on the oxygen. The **polar** water molecule dissolves **ions** (such as sodium, essential for membrane transport) and polar molecules (including sugars) while excluding large nonpolar molecules such as fats. This selective **solvation** forms the basis of cell structure and function, in which large insoluble membranes enclose **aqueous** solutions of nutrients and other small molecules.

Water is liquid between 0 and 100 degrees Celsius (32 to 212 degrees Fahrenheit), a temperature range that is high enough to promote random mixing in aqueous solutions (necessary for biochemical reactions) but low

enough to prevent random breaking of most covalent bonds, which would make stable life forms impossible. Most organisms must live in the low end of this range. Finally, its high heat capacity moderates temperature changes, especially in organisms with large bodies. SEE ALSO LIPIDS; MEMBRANE STRUCTURE

*Richard Robinson*

## Water Cycle

The water, or hydrologic, cycle refers to the global scale continuous movement of water between the oceans, the atmosphere, and the continents. Water exists on Earth in three states: liquid water, solid (ice or snow), and gas (water vapor). Liquid water covers about 70 percent of Earth's surface, primarily in oceans that store 96 percent of Earth's total water volume ( $1460 \times 10^6 \text{ km}^3$ ). The remaining water is mostly contained in the polar ice caps, glaciers, and groundwater, while only small amounts occur in rivers, lakes, soils, and the atmosphere. Freshwater lakes, rivers, and groundwaters comprise only a tiny fraction of Earth's water.

Evaporation and precipitation are the major exchange processes for water between the atmosphere and Earth's surface. Water, evaporated from land, surface waters, and the oceans and transpired by vegetation, is returned to the atmosphere as water vapor. Water molecules cycle rapidly in the atmosphere, with an average residence time of only eleven days. Falling as precipitation on land, water can enter the groundwater, later emerging in lakes and rivers; run off as surface flow into rivers and lakes and, eventually, the ocean; or evaporate back to the atmosphere. The residence time of water in rivers and lakes is extremely variable (from a few weeks for rivers to over one hundred years for the deepest lakes), but is fast compared to 20,000 years in deep groundwater layers and 39,000 years in the ocean.

Although the amount of water stored is small and the residence times short, atmospheric water, rivers, and lakes are extremely important for maintenance of the world's **ecosystems**. Global patterns of precipitation and evaporation determine the distribution and character of biological habitats from deserts to rain forests. Water transports **minerals**, sediments, nutrients, and pollutants across the landscape, and over long distances in the atmosphere. Because of close links with global energy and carbon and nitrogen cycles, the water cycle is vitally important to Earth's ecology. SEE ALSO BIOGEOCHEMICAL CYCLES; ECOSYSTEM; LAKES AND PONDS; LIMNOLOGIST

*Katherine E. Webster*

### Bibliography

Berner, Elizabeth Kay, and Robert A. Berner. *Global Environment: Water, Air, and Geochemical Cycles*. Upper Saddle River, NJ: Prentice Hall, 1996.

Maidment, David R., ed. *Handbook of Hydrology*. New York: McGraw-Hill, 1993.

**ecosystem** an ecological community and its environment

**minerals** iron, calcium, sodium, and other elements needed by living organisms

## Water Movement in Plants

Long-distance water movement is crucial to the survival of land plants. Although plants vary considerably in their tolerance of water deficits, they all

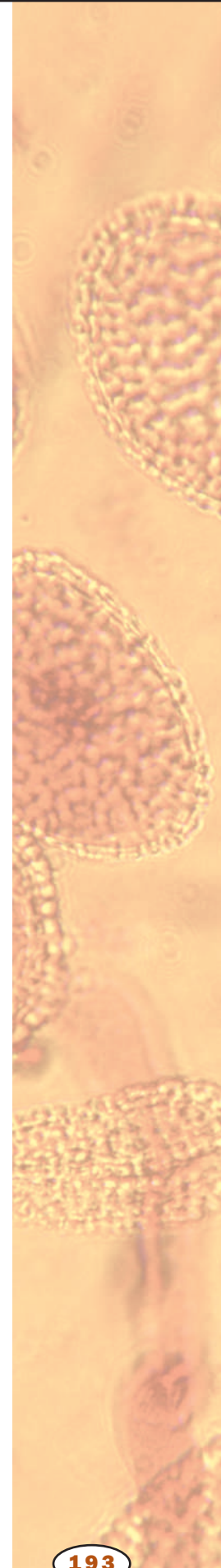



A drop of guttation, water extruded by a plant's root pressure, on a blade of grass.

**xylem** water-transporting system in plants

**mycorrhizae** symbiosis between soil fungus and plant root to maximize absorption

**minerals** iron, calcium, sodium, and other elements needed by living organisms

have their limits, beyond which survival is no longer possible. About 85 percent of the fresh weight of leaves can be water. On a dry, warm, sunny day, a leaf can evaporate 100 percent of its water weight in just an hour. Water loss from the leaves must be compensated for by the uptake of water from the soil. Water transport is also important for the uptake of essential mineral nutrients from the soil. Shortages of mineral nutrients such as nitrogen, potassium, and phosphorus are often limiting to plant growth, which is why fertilizers are often added to the soil to improve plant productivity and appearance.

### The Cohesion-Tension Theory

The major mechanism for long-distance water transport is described by the cohesion-tension theory, whereby the driving force of transport is transpiration, that is, the evaporation of water from the leaf surfaces. Water molecules cohere (stick together), and are pulled up the plant by the tension, or pulling force, exerted by evaporation at the leaf surface.

Water will always move toward a site with lower water potential, which is a measure of the chemical free energy of water. By definition, pure water has a water potential of 0 MegaPascals (MPa). In contrast, at 20 percent relative humidity, the water potential of the atmosphere is -500 MPa. This difference signifies that water will tend to evaporate into the atmosphere. The water within plants also has a negative potential, indicating water will tend to evaporate into the air from the leaf. The leaves of crop plants often function at -1 MPa, and some desert plants can tolerate leaf water potentials as low as -10 MPa. The water in plants can exist at such low water potentials due to the cohesive forces of water molecules. The chemical structure of water molecules is such that they cohere very strongly. By the cohesion-tension theory, when sunlight strikes a leaf, the resultant evaporation first causes a drop in leaf water potential. This causes water to move from stem to leaf, lowering the water potential in the stem, which in turn causes water to move from root to stem, and soil to root. This serves to pull water up through the **xylem** tissue of the plant.

### From Root to Leaf

Plants have root hairs and often mycorrhizal fungi at the root surface, both of which serve to filter the soil water as it enters the plant. **Mycorrhizae** are symbiotic associations between plant roots and fungi. The root cells and mycorrhizal fungi both actively uptake certain mineral nutrients. Mycorrhizae can be particularly important for the uptake of phosphate. The active uptake of **minerals** by living cells of the root and the subsequent transfer of minerals to the xylem can result in positive root pressures, with water potentials above 0 MPa. This occurs only under certain conditions, such as at night or during rainstorms, when water loss from the leaves is minimal. Such positive root pressures disappear with the onset of leaf transpiration.

Water molecules move from the soil into living cells of the root, and eventually into the transport cells of the xylem, known as tracheids and vessels. These xylem cells are dead and hollow, allowing rapid water transport. They also have hardened cell walls to help them resist the tendency to collapse as water is sucked through them. Both tracheids and vessels

have pits on the sides of their walls, which include porous areas for side-to-side transport. Unlike tracheids, a vessel is composed of many cells stacked end to end, with perforations between cells, allowing for more efficient transport.

The long-distance transport of the water molecule occurs first within the xylem cells of the root, then the xylem of the stem and branch, and then into the xylem of a leaf midrib and vein. Driven by transpiration, the water molecule is pulled from the nonliving tracheids and vessels of the xylem in the living cells of the leaf mesophyll (middle layer) and to the surface of mesophyll cell walls. The water molecule then evaporates into a leaf intercellular air space and finally out of a **stomatal** pore and into the atmosphere. Though photosynthetic action consumes some water, only a small fraction of the water that travels through the plant is used directly for the photosynthetic reaction, which occurs in leaf mesophyll cells. Instead, most water is lost by transpiration through the stomates.

### The Role of Stomates

Leaves of land plants are covered with a waxy cuticle that prevents water loss and gas exchange. The stomates at the leaf surface have **guard cells** that open and close the stomate to regulate the uptake of carbon dioxide and release of oxygen, as required for photosynthesis. They also serve to regulate water loss from transpiration. During the day, the stomates normally open up in response to sunlight, allowing for photosynthetic gas exchange, but also allowing for transpiration. At night, the stomates normally close, preventing unnecessary water loss. When excessive water loss occurs during the day, drops in leaf water potential can cause stomates to close. Were it not for stomate closure in response to water stress, the leaves would suffer excessive water loss, the leaf cell membranes and photosynthetic apparatus would be destroyed, and “cavitation” would occur in the xylem cells. Cavitation, which is a break in the water column, occurs when air is pulled into the xylem vessel or tracheid. This can make the xylem cell unable to conduct water. Plants vary considerably in their vulnerability to cavitation, but for most plants, stomate closure can prevent cavitation from occurring.

The transpirational water loss allows for uptake of mineral nutrients from the soil. However, much of the water loss that land plants exhibit can be viewed as a “necessary evil.” The stomates must open up to allow for photosynthesis to occur, and during the process of letting carbon dioxide into the leaf, water vapor is lost to the atmosphere. When the stomates close to prevent excess water loss, photosynthesis is compromised. SEE ALSO ANATOMY OF PLANTS; LEAVES; MYCORRHIZAE; ROOTS; SHOOTS; WATER

*Frank Ewers*

#### Bibliography

- Holbrook, N. M., M. J. Burns, and C. B. Field. “Negative Xylem Pressures in Plants: A Test of the Balancing Pressure Technique.” *Science* 270 (1995): 1183–1192.
- Raven, Peter H., Ray F. Evert, and Susan E. Eichhorn. *Biology of Plants*, 6th ed. New York: W. H. Freeman and Company, 1999.
- Taiz, Lincoln, and Eduardo Zeiger. *Plant Physiology*, 2nd ed. Sunderland, MA: Sinauer Associates, 1998.

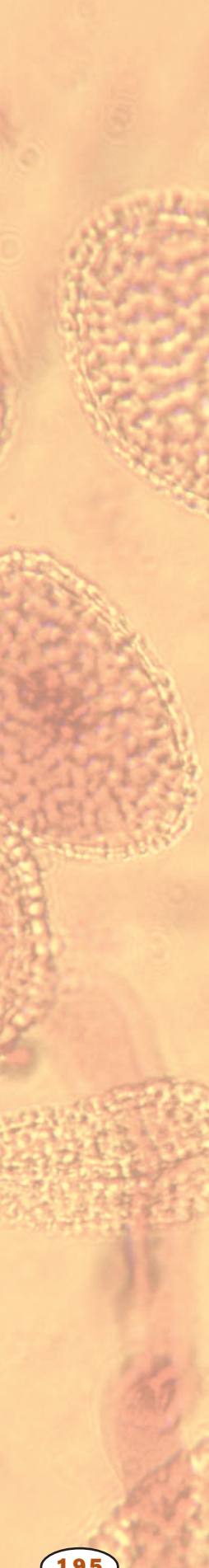

**stomata** openings in leaves for gas exchange, surrounded and regulated by guard cells

**guard cells** paired cells on leaves that control gas exchange and water loss





James Watson.

**X-ray crystallography** use of X rays to determine the structure of a molecule

**complementary** matching opposite

**nucleotide** the building block of RNA or DNA

## Watson, James

**American biologist**  
**1928–**

James Dewey Watson, American biologist, won the Nobel Prize in 1962 for the discoveries he made in molecular genetics, along with Francis Crick and Maurice Wilkins.

Watson was born on April 6, 1928, in Chicago, Illinois, and was declared a child prodigy at an early age. Indeed, in his youth, he appeared on a television program called “Chicago Quiz Show.”

Watson began his university studies at the age of fifteen at the University of Chicago, from which he graduated at nineteen. While in college, Watson was deeply affected by the writings of Erwin Schrodinger, who was among the first to articulate the concept of the gene. Watson received his doctoral degree in 1950 from Indiana University, after conducting research on bacterial viruses.

After receiving his Ph.D., Watson won a fellowship from the Merck Foundation and spent a year furthering his study of bacterial viruses in Copenhagen, Denmark. From Copenhagen, Watson moved on to Cambridge University, where he first met and collaborated with Frances Crick, a young British biophysicist.

In 1952, Watson and Crick began to investigate the molecular structure, and significance to genetics, of nucleic acids. The collaborators began by looking specifically at the earlier work done by Maurice Wilkins and Rosalind Franklin on **X-ray crystallography** analysis of deoxyribonucleic acid (DNA), a substance that was already considered to make genes, the fundamental units of heredity.

Watson and Crick used Wilkins’s and Franklin’s data to create a three-dimensional model of the DNA molecule. Watson and Crick hoped that their model would agree with the chemical facts previously established about DNA; for example, that DNA consisted of phosphates, nitrogenous bases, and sugars. In addition, Wilkins’s X-ray crystallography experiments had already determined many of the patterns by means of which such molecules were connected.

Watson and Crick tried out various ways of arranging model molecules in space, finally settling on the aptly named “double helix.” Their model, afterward referred to as the Watson-Crick model, showed DNA as a two-stranded twisted “helix.” The two strands consisted of **complementary** pairs of **nucleotide** units. This model both matched chemical facts previously known about DNA, and provided a viable explanation for how DNA could replicate, and thus for how genetic information could pass from one generation to the next generation of living organisms.

Between 1956 and 1976, Watson ran a laboratory at Harvard University, where he also taught courses in biology. Additionally, in 1969 he was named director of the Cold Spring Harbor Laboratory in New York State. In 1991, Watson became the first director of the Human Genome Project, established by a consortium of public agencies to sequence the entire human genome, but he later resigned over the issue of patenting human genes.

Among his notable publications are *Molecular Biology of the Gene* (1965) and *The Double Helix* (1968). SEE ALSO CRICK, FRANCIS

Hanna Rose Shell

### Bibliography

Crick, Francis. *What Mad Pursuit?* New York: Basic Books, 1988.

Sherborn, Victoria. *James Watson and Francis Crick: Decoding the Secrets of DNA*. Woodbridge, CT: Blackbirch Press, 1995.

Strathern, Paul. *The Big Idea: Crick, Watson and DNA*. New York: Anchor, 1997.

Watson, James. *The Double Helix*. New York: Norton Press, 1968.

## Wetlands

“Wetlands” is the collective term for habitats that are too wet to be upland and not wet enough to be fully aquatic. They occur in areas of transition between dry upland and open water or in low areas where drainage water collects or the water table is at the ground’s surface.

Wetlands are characterized by:

- the presence of surface water, at least part of the year
- unique soils that differ from adjacent uplands (due to the influence of waterlogging)
- plants adapted to wet soil conditions (hydrophytic vegetation)

There are many types of wetlands, differing in water chemistry, hydrology, soils, topography, climate, and vegetation. The broadest categories are coastal and inland wetlands. Coastal wetlands experience periodic flooding by saltwater or brackish water, and include estuaries (tidal marshes), mud flats, and mangrove swamps. They are nurseries for crustaceans, such as shrimp, and many fish species, and are also important habitat for birds and other wildlife. The presence of coastal wetlands can reduce inland erosion and other damage from hurricanes and winter storms.

Inland wetlands are freshwater wetlands and occur throughout the interior of a continent. These wetlands include: cattail marshes and wet meadows dominated by grasses, sedges, and herbs; swamps dominated by woody vegetation such as shrubs and trees; and peatlands (fens and bogs) that contain a buildup of peat, which forms as plants die and fall into the water and are not completely decomposed. The Florida Everglades are a vast inland wetland system.

A key factor determining what kind of soil and plant community develops in a wetland is the depth and duration of waterlogging and its effect on oxygen (O<sub>2</sub>) in the soil. Soils that are waterlogged for any length of time become depleted of O<sub>2</sub> because soil microbes and plant roots use it during cellular respiration. The oxygen is not quickly replaced by O<sub>2</sub> from the atmosphere because O<sub>2</sub> diffuses very slowly through water. The anoxic (low oxygen) conditions influence soil development. Decomposition of plant litter and other **organic** matter is slowed in absence of O<sub>2</sub> and the wetland soils become high in organic matter. If decomposition is much slower than the production of plant matter, peat will form. Peatlands typically occur in northern climates where low average temperatures further slow decomposition.

**organic** composed of carbon, or derived from living organisms

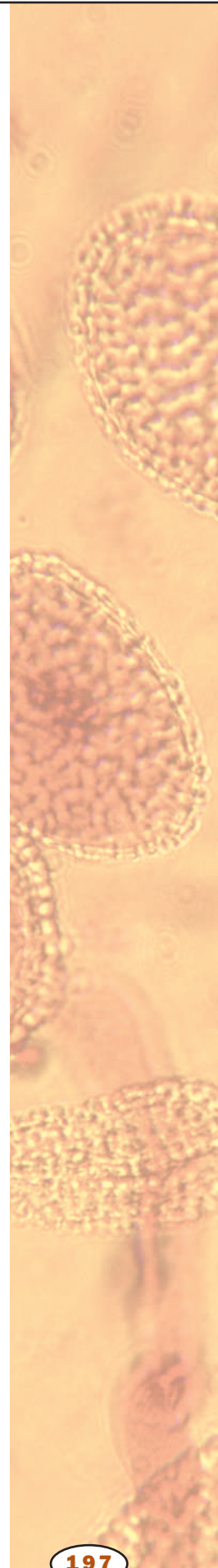

Wetlands are important and valuable natural resources.



**adventitious** growing from a nonstandard location

Since  $O_2$  availability is a limiting factor for plants growing in wetlands, most wetland plants have structural adaptations that increase gas exchange. Some have spongy tissues, called aerenchyma, in their stems and roots that conduct  $O_2$  within the plant from the aboveground shoot down to the roots. Others produce **adventitious** roots above the anoxic zone or have prop roots with pores that let in oxygen from the atmosphere.

In the past, many people viewed wetlands as mosquito-infested wastelands needing to be drained. More than one-half of the original wetlands of the United States have been drained or otherwise altered. Now there is a public consciousness that wetlands are important and valuable natural resources. Wetlands improve water quality by removing and retaining nutrients from surface waters and trapping sediments. They reduce flood and storm damage, and act to control erosion of shorelines. They provide important habitat for fish, crustaceans, and other wildlife and produce natural products such as blueberries, cranberries, rice, mink, and beaver. They support hunting and fishing activities and provide other recreational and educational opportunities.

SEE ALSO ESTUARIES; GLOBAL CLIMATE CHANGE; LIMNOLOGIST

*Martha Phillips*

**Bibliography**

Mitsch, William J., and James G. Gosselink. *Wetlands*. New York: Van Nostrand Reinhold, 1986.

Williams, Michael, ed. "Understanding Wetlands." In *Wetlands: A Threatened Landscape*. Cambridge, MA: Basil Blackwell, Inc., 1990.

U.S. Environmental Protection Agency. *America's Wetlands: Our Vital Link Between Land and Water*. Washington, DC: U.S. Environmental Protection Agency, 1988.

## Wildlife Biologist

Wildlife biologists are scientists who study wild animals to understand how they interact with other animals and their habitat. They may also manipulate wildlife populations and their habitats (for instance, by planting food sources) in an effort to conserve these valuable resources. The job of a wildlife biologist involves a variety of outdoor activities such as observing, capturing, and measuring animals, or measuring and manipulating their habitats. An equally important part of the job involves developing management plans; collecting and analyzing data; documenting activities; and

Biologists take samples from a drugged polar bear for data about pesticides in the Hudson Bay area of Manitoba.



communicating with other professionals and the public. Private landowners occasionally hire wildlife biologists, but most are employed by federal or state fish and game agencies (e.g. Fish and Wildlife Service, Forest Service). In addition to a solid foundation in biology, a wildlife biologist needs a good background in chemistry and mathematics (especially statistics), and must be able to communicate clearly both orally and in writing. Anyone interested in a career as a wildlife biologist should earn a bachelor's degree in Wildlife Management and should also gain experience through part-time or seasonal employment in the field. Opportunities for career advancement are significantly enhanced by earning a master's degree and those individuals interested in research should consider acquiring a doctoral degree (Ph.D.). SEE ALSO BIODIVERSITY; CONSERVATION; ZOOLOGY; ZOOLOGY RESEARCHER

*John H. Roese*

#### **Bibliography**

Anderson, Stanley H. *Managing Our Wildlife Resources*, 3rd ed. Upper Saddle River, NJ: Prentice Hall, 1999.

Leopold, Aldo. *A Sand County Almanac*. New York: Oxford University Press, 1949.

## **Wine-making, Biology of**

Wine is made by fermenting fleshy fruits, principally the cultivated grape *Vitis vinifera* (family Vitaceae). Grapes are grown on farms called vineyards. Grapevines are trellised to improve air circulation and access to sunlight. When they are ripe, wine grapes are usually harvested by hand and then mechanically destemmed and crushed. The juice is then inoculated with yeast (*Saccharomyces cerevisiae*), which ferments the sugars in the grape juice to form ethyl alcohol, at a final concentration of 12 to 14 percent. White wine is made without the grape skins, whereas red wine uses the skin to give color to the wine. After fermentation, the wine is usually transferred to oak casks for finishing, or flavor development. Sparkling wines, such as champagne, are bottled before fermentation is complete, thus trapping some carbon dioxide in the bottle.

The flavor of wine is influenced by many factors, beginning with the soil and climate. Although most varieties of grapes are frost-hardy, the best wines come from regions with more moderate climates. Grapes grow well on rocky hillsides, but more level and richer soils also produce fine wines, as long as the ground drains well. The deep roots of the grapevine minimize the need for irrigation, and fertilizer is kept to a minimum to prevent overproduction of lesser-quality grapes. Weather during the growing season is critical to fruit set, grape development, and wine quality. The best harvests occur in years with plentiful rainfall early in the season, followed by a warm but not excessively hot summer and a dry harvest season. SEE ALSO AGRICULTURE; BEER-MAKING, BIOLOGY OF; COFFEE, BOTANY OF; GLYCOLYSIS AND FERMENTATION

*Richard Robinson*

#### **Bibliography**

Johnson, Hugh. *World Atlas of Wine*, 4th ed. New York: Simon & Schuster, 1994.

## Wood and Wood Products

Wood and wood products have played a critical role in the evolution of humankind. From the most primitive of beginnings, humans have used wood for survival and to improve the quality of life. In the twenty-first century, people continue to use wood for many of the same purposes that their most ancient ancestors did. Fuel for heating and cooking is still the largest consumer of wood fiber. Construction of shelter and furniture is secondary as is pulp and paper production.

As a raw material, nothing else in history possesses the versatility of timber. On a volumetric basis, in the year 2000 worldwide annual consumption was between 3 and 4 billion cubic meters. To put this in perspective, if all of this wood was lashed together it could make a floating bridge 2 meters (6.54 feet) thick and 40 meters (131 feet) wide that stretches around the world at the equator. As evidence of wood's exceptional utility value, there are approximately 5,000 distinctly different types and applications of wood products in society.

As a raw material, wood has no equal peers. On a strength-to-weight ratio, wood is stronger than steel. Heavy timber has unique thermal insulating properties, which often allow it to retain structural integrity during building and warehouse fires that completely soften and deform structural steel members. While concrete has excellent structural properties, its density is so high that it is often ruled out as a building material. High shipping



A man walks across giant rollers used to crush wood pulp at the Ketchikan Pulp Company in Ketchikan, Alaska.

and handling costs associated with concrete limit its use to areas close in proximity to the raw mineral mines.

Petrochemical-based plastics offer new alternatives to wood use in construction but such plastics are not renewable. The energy requirements and pollution volumes associated with the production of each of these products is significantly higher than those levels associated with wood products conversion, often four to ten times greater. Additionally, of the materials concrete, plastic, steel, and wood, only wood is naturally renewable.

### Forest to Lumber Yard

In the United States, most round wood (in the form of stems or logs) comes from managed forest land (both public and private). The growing population's demand for land, renewable raw materials, and environmental protection has pushed forest management and wood products production to become highly efficient and ecologically healthy. Most management strategies are geared toward multiple use; that is, recreation, wildlife, sporting, ecology, and other uses are included with timber production.

Both natural regeneration and manual replanting are used to restock forest land after timber harvesting. North America is rich with productive land on which to grow trees and with intellectual capital to promote the wise, efficient, and sustainable use of wood fiber. Third-party certification or "green" labeling is emerging as a means to assure wise and efficient forest management and timber conversion.

Also, approval by the International Standards Organization (ISO) is a key tool for companies involved in worldwide wood products trading. Companies that are able to gain wood certification and/or ISO approval have a distinct market advantage because consumers have assurance that the products or materials they consume have conformed to stringent manufacturing and sound environmental principles.

The techniques of timber conversion (turning trees into wood products) have been evolving for thousands of years. During the latter half of the twentieth century, conversion technology advanced exponentially. Computer power has been a key ingredient for optimizing production of wood products. Sawmilling (turning trees into lumber) has been practiced for hundreds of years. Formerly, only the biggest and best trees were cut and brought to mills, and people made decisions regarding how to cut these into lumber.

During the early 1900s, sawmill timber conversion efficiency was approximately 35 to 40 percent, meaning more than half of each trunk was wasted. In the twenty-first century, computers and automated equipment often make most of the decisions regarding how tree stems will be converted to products. The scanning and automation technology used in the forest products industry is the same as that used by the military and the automobile and aerospace industries. Development and application of such technology has allowed smaller and less valuable trees to be used for products.

Historically, the wood fiber that did not become lumber was burned or landfilled. Today, conversion efficiency can reach 70 percent. (There is always some inherent loss associated with turning round stems into rectan-

gular boards.) The residual chips and sawdust from sawmilling are turned into pulp for paper and particles for pressed wood composites. Bark is mainly used as fuel or mulch. The close alliance of these different industries can raise conversion efficiency to 100 percent.

## Wood Products

In addition to solid lumber production, there are a variety of composite wood products that have been developed. Plywood and laminated veneer lumber use thin sheets of wood veneer as lamina (layers) for panel-type and lumber-type products, respectively. The conversion efficiency associated with wood veneer production is higher than that of lumber production. Oriented strand products use thin wafers of wood as a raw material. In this case, low-grade trees are reduced to thousands of small strands, and the strands are subsequently pressed together with adhesive into panel products. When trees are reduced to strands, conversion efficiency is 90 to 95 percent. The only fraction not used for strands is the bark, which is converted to fuel or mulch.

Structural panel products like plywood and oriented strand board have revolutionized the building construction industry in the Americas and worldwide. Panel products allow rapid housing construction and provide many superior properties compared to the materials used previously. Non-structural wood composites offer further utilization potential for wood fiber. Often using waste sawdust or shavings as raw materials, particleboard and medium-density fiber board are used extensively in the furniture and cabinet industry. These stable products are used as core materials for both low- and high-cost furniture. When used properly, each of these composite products offers advantages over traditional solid wood products. Dimensional stability, uniformity, long spans, and engineered strength enhancement are just a few such advantages.

The quest to develop stronger, straighter, and more efficient renewable products is ongoing. In an effort to better utilize agricultural byproducts, materials such as wheat straw, kenaf, cotton gin trash, and bagasse are being researched as supplemental fiber sources in wood-based composites. Advanced **hybrid** composites between wood and materials such as carbon fiber, plastics, and fiberglass have been investigated and are becoming more common in highly specialized structural materials. The level of information-sharing currently available through technology continues to foster the research and development of amazing products at a record pace. **SEE ALSO** CONIFERS; FORESTER

*Rubin Shmulsky*

### Bibliography

- Haygreen, John G., and Jim L. Bowyer. *Forest Products and Wood Science: An Introduction*, 3rd ed. Ames, IA: Iowa State University Press, 1996.
- Hoadley, R. Bruce. *Understanding Wood: A Craftsman's Guide to Wood Technology*. Newtown, CT: The Taunton Press, Inc, 1990.
- Walker, Aiden, ed. *The Encyclopedia of Wood*. London, England: Quarto Publishing, 1989.
- Wood Handbook: Wood as an Engineering Material*. Publication No. FPL-GTR-113. Madison, WI: U.S. Forest Service, 1999.

The United Nation's Food and Agriculture Organization has reported that the world's overall forest area declined by 1.6 percent (140 million acres) between 1990 and 1995. Because of this sharp decline, there is a growing trend toward harvesting from plantation forests versus natural forests.

**hybrid** combination of two different types





**embryology** develop-  
ment of the embryo

## Zoology

Zoology is a branch of biology that concentrates on the study of animals. The term comes from two Greek words: “zoon,” which means “animal,” and “logos,” which means “the word about.” Although the Greek philosopher Aristotle is sometimes called “the father of zoology,” humans have always been interested in learning about animals, so it is difficult to say when zoology originated.

Because the animal kingdom is by far the largest and most varied of all the kingdoms, zoology is an extremely broad discipline. It includes such topics as the anatomy, physiology, **embryology**, genetics, and ecology of animals. It was natural, therefore, that this topic became subdivided as human knowledge increased. An early partition distinguished vertebrate zoology from invertebrate zoology, but because about 97 percent of all animals are invertebrates (spineless), that was not an appropriate distinction. While classical zoologists of the 1800s and 1900s were concerned largely with discovering new kinds of animals and describing their structure and their evolutionary relationships, twenty-first-century zoology focuses on understanding how different animals solve the common problems of survival (such as obtaining energy, coping with temperature changes, and coordinating behavior), a field known as comparative animal physiology. SEE ALSO ANIMALIA; BIOLOGY.

*Margaret Simpson*

### Bibliography

- Hall, Thomas S. *A Source Book in Animal Biology*. New York: Hafner Publishing Company, 1964.
- Hays, Hoffman Reynolds. *Birds, Beasts, and Men: A Humanist History of Zoology*. Baltimore, MD: Penguin Books, 1973.

## Zoology Researcher

A zoologist is a scientist who studies animals, whether slugs or spiders, rattlesnakes or ravens. Most zoologists work at universities where often they also teach biology. Others work as government biologists for the Forest Service or the U. S. Fish and Wildlife Service, for example. Others work for nonprofit environmental organizations or private companies that do environmental impact reports. A few write about science for the public.

Zoologists may study animals in a laboratory or in the wild. For example, a zoologist might go to Africa several times a year to study the social behavior of hyenas. The zoologist catches individual hyenas and puts collars on them that carry radio transmitters. Each transmitter emits a different signal, so the zoologist always knows where each hyena is. This not only allows the researcher to map the movements of each animal, but to find the animal when necessary.

Zoologists also breed animals in captivity. In captivity, animals rarely behave the same way that they do in the wild, but it is easier to do experiments under controlled conditions. Whether in the lab or in the field, zoologists study the behavior, evolution, ecology, and physiology of animals. Many zoologists study how one species interacts with another or how plants and animals “coevolve.” Zoologists who study behavior or physiology often study animals mainly in a laboratory.



A zoo veterinarian examines the San Diego Zoo's female giant panda cub in October 1999.

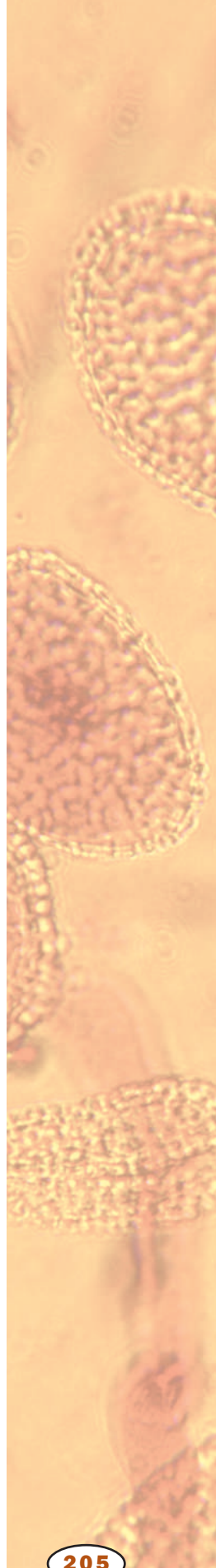

Almost all zoologists have at least a bachelor's degree in biology, zoology, ecology, or a similar field. Many zoologists have a master of arts (M.A.) or a master of science (M.S.) degree. University and college professors almost always have a doctor of philosophy (Ph.D.). Often, zoologists who work for the government must pass an exam in a field such as wildlife biology. High school students interested in a career in zoology should take math classes, through calculus, and explore nearby natural areas, learning the names of the plants and animals. SEE ALSO BEHAVIOR PATTERNS; ENDANGERED SPECIES; FIELD STUDIES IN ANIMAL BEHAVIOR

*Jennie Dusbeck*

#### **Bibliography**

- Crompton, John. *Ways of the Ant*. New York: Nick Lyons Books, 1988.
- Owens, Mark, and Delia Owens. *Cry of the Kalahari: Seven Years in Africa's Last Great Wilderness*. Boston: Houghton Mifflin Company, 1984.
- Steinhart, Peter. *The Company of Wolves*. New York: Knopf, 1995.

# Photo and Illustration Credits

*Unless noted below, the illustrations and tables featured in Biology were created by GGS Information Services. The photographs appearing in the text were reproduced by permission of the following sources:*

## Volume 1

**p. 4** Willow ptarmigan in summer color, photograph. © JLM Visuals; **p. 5** Willow ptarmigan in winter color, photograph. © Marypat Zitzer/JLM Visuals; **p. 6** Cross section of human adrenal gland, triangular shape, photograph by Martin M. Rotker. Phototake NYC; **p. 8** Elderly married couple, photograph. © Kevin R. Morris/Corbis; **p. 11** Wild rice plant grows in Ocala, Florida, photograph. © Jonathan Blair/Corbis; **p. 12** Herd of Holsteins eat silage from troughs on a Minnesota farm, photograph. © Richard Hamilton Smith/Corbis; **p. 15** AIDS virus attacking T4 lymphocytes, scanning electron micrograph image. ©Wagner/Seifert, Inc./Phototake; **p. 18** Santa Monica police officer, administering Breathalyzer test, photograph. © Shelley Gazin/Corbis; **p. 21** Algae on Pond, photograph. © Charles Mauzy/Corbis; **p. 27** Strawberry poison arrow frog, photograph. © Alex Kerstitch/JLM Visuals; **p. 28** Weightlifting with a dumbbell, photograph. © Duomo/Corbis; **p. 31** Maidenhair fern with fan-shaped leaves, photograph by Robert J. Huffman/Field Mark Publications; **p. 32** Light blue iris against black background, photograph. JLM Visuals; **p. 35** Transparent jellyfish with short tentacles, photograph by Mark A. Johnson/Stock Market; **p. 38** Enzyme-lined immunoabsorbent assay, ELISA plate, photograph. © Lester V. Bergman/Corbis; **p. 43** Newly hatched Green Lynx spiders, photograph. © J. C. Cokendolpher/JLM Visuals;

**p. 44** Ten million year old Archeobacteria, scanning electron micrograph by Eurelios. © Eurelios/Phototake; **p. 47** Digitally enhanced X ray of left hand showing rheumatoid arthritis, photograph. © 1994 Michael English, M.D. Custom Medical Stock Photo; **p. 49** Streptococcus bacteria attached to a human tonsil cell, colored transmission electron micrograph by Dr. Immo Rantala. © Dr. Immo Rantala/SPL/Photo Researchers, Inc; **p. 51** Streptococcus pyogenes bacteria, colored transmission electron micrograph by Alfred Pasiaka. © Alfred Pasiaka/Science Photo Library, Photo Researchers, Inc.; **p. 54** Laboratory technician performing Analytical Profile Index (API), photograph by Geoff Tompkinson. © Geoff Tompkinson/Science Photo Library, Photo Researchers, Inc; **p. 57** DNA circles of bacterial plasmid, scanning electron micrograph. © Gopal Murti/Phototake; **p. 59** Electron micrograph of T4 Cells, or bacteriophage, photograph. © Dr. Dennis Kunkel/Phototake; **p. 61** Honey bees around Queen in hive, photograph. © J. C. Cokendolpher/JLM Visuals. Reproduced by permission; **p. 64** Elk fighting, Wyoming, photograph. © Breck P. Kent/JLM Visuals; **p. 69** Soil erosion on the trail, Adirondack, photograph by Yoav Levy/Phototake; **p. 71** Continental Drift, illustration by Accurate Art, Inc., Gale Group; **p. 72** Mary Pat Reeves-Daly, mapping human Y chromosome, as part of Human Genome Mapping Project, photograph. © Roger Ressmeyer/Corbis; **p. 75** Immunization technician Sgt. Louis Rios giving 2nd Lieutenant Clayton Bland a vaccination for anthrax, photograph. AP/Wide World Photos; **p. 78** Smiling school girls,

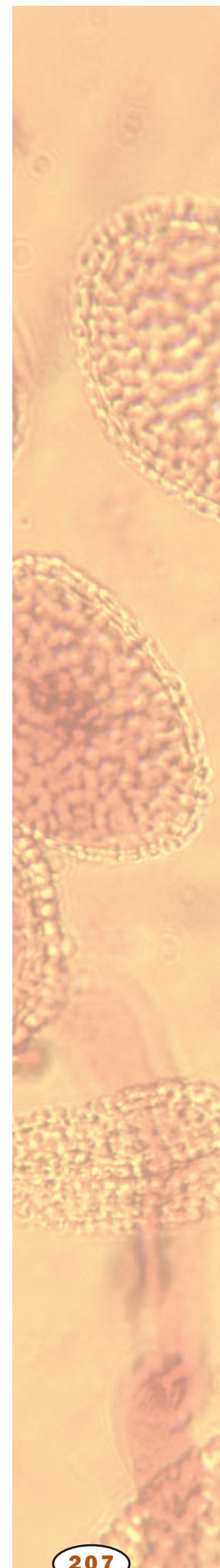

photograph. © The Purcell Team/Corbis; **p. 81** Red-tailed hawk perched on stump, photograph by Robert J. Huffman/Field Mark Publications; **p. 83** Beaulieu, Emile-Etienne, holding handful of the RU-486 abortion drug/pills, which he invented, photograph. AP/Wide World Photos; **p. 90** Red and white blood cells flowing through saphenous vein, scanning electron micrograph. © Image Shop/Phototake; **p. 94** Cancellous bone tissue affected by osteoporosis, false-color scanning electron micrograph. © Professor P. Motta/Dept. of Anatomy/University of La Sapienza, Rome/Science Photo Library, Photo Researchers, Inc.; **p. 97** Axial section of human brain showing metastatic tumor, MRI by Simon Fraser. © Simon Fraser/Science Photo Library, Photo Researchers, Inc.; **p. 101** Human brain with hypothalamus highlighted, green dot, MRI scan by Scott Camazine & Sue Trainor; © Scott Camazine & Sue Trainor/Photo Researchers, Inc.; **p. 105** Liverwort, plant with leaf-like structures covered with tiny capsules, photograph. JLM Visuals; **p. 109** Marine life from Cambrian Period, photograph by Robert J. Huffman/Field Mark Publications; **p. 110** Human breast cancer cells growing in culture, photograph by Cecil Fox. © Cecil Fox/Photo Researchers, Inc; **p. 111** Human abdomen showing cancer of the ascending colon, colored barium enema X ray. © Science Photo Library/Photo Researchers, Inc.; **p. 116** Electronic image of human heart undergoing angiography; indicates massive aneurism of aortal arch, photograph. © CNRI/Phototake; **p. 119** *Listeria monocytogenes*, scanning electron micrograph image. © CNRI/Phototake; **p. 137** Tobacco leaf chloroplast, micrograph, photograph. © Dr. Jeremy Burgess/Science Photo Library, National Audubon Society Collection/ Photo Researchers, Inc. Reproduced with permission; **p. 141** Human chromosomes showing male mutation on gene 7, which determines cystic fibrosis, photomicrograph by Jean Claude Revy. © Jean Claude Revy/Phototake; **p. 142** Digital image of multipolar and bipolar spindles from T84 colonic cancer cell cultures, photograph. © Albert Tousson/Phototake; **p. 144** Mitosis metaphase of an animal cell, immunofluorescence photomicrograph. © CNRI/Phototake; **p. 146** Human male chromosomes, XY karyotype, with G banding, karotype. © CNRI/Phototake; **p. 153** Micro injection introducing foreign genes into animal cells, photograph by M. Baret. © M. Baret/Rapho, Photo Researchers, Inc; **p. 158** Second growth birch forest, photograph. © Richard P. Jacobs/JLM Visuals; **p. 161** Ground finch with dark feathers and bill, photograph by Tim Davis. Photo Researchers, Inc; **p. 163** Pine cones, photograph. JLM Visuals; **p. 167** People along polluted Swazambhunath River, in Kathmandu, Nepal, photograph. © Charlie Crangle/JLM Visuals; **p. 182** Sand skink on top of shiny dark green leaf, 1985, Florida, photograph by Joseph T. Collins/Photo Researchers, Inc.; **p. 184** Stretch of the great coral reef, between Cairns and Townsville, photograph. © Yann Arthus-Bertrand/Corbis; **p. 187** Crick, Francis, photograph. The Library of Congress; **p. 189** Horseshoe crab, photograph. © John M. Burnley/The National Audubon Society Collection/Photo Researchers, Inc; **p. 192** Breast cancer cell dividing, colored scanning electron micrograph. © Quest/Science Photo Library, Photo Researchers, Inc.; **p. 198** Darwin, Charles, photograph. Popperfoto/Archive Photos. © Archive Photos, Inc.; **p. 202** Shadows form on the El Oued dunes, The Algerian Sahara Desert, Algeria, photograph. © Adam Woolfitt/Corbis; **p. 203** High desert oasis, photograph. © Richard P. Jacobs/JLM Visuals; **p. 205** Human embryo, 8-cell stage, day 3, scanning electron micrograph, SEM, scan by Dr. Yorgos Nikas. © Dr. Yorgos Nikas/Phototake; **p. 209** Frog embryos complete their metamorphoses inside their eggs, photograph. Michael & Patricia Fogden/Corbis; **p. 224** Human DNA fingerprint taken from blood to match donor and patient in organ transplantation, photograph. © Index Stock/Phototake; **p. 227** Herpes simplex virus, HSV6, scanning electronic micrograph. © Dr. Dennis Kunkel/Phototake; **p. 230** Surgeon looking at CAT scans, photograph. © Steve Chenn/Corbis; **p. 233** Lab technician Li Zhang performing a density test from urine samples at the Australian Sports Drug Testing Laboratory, photograph. AP/Wide World Photos.

## Volume 2

**p. 6** Professor Ernst Haeckel, the German naturalist and philosopher, poses as if in a jungle scene, photograph. © Hulton-Deutsch Collection/Corbis; **p. 9** Lush growth, mossy tree, temperate rain forest, photograph by Robert J. Huffman/Field Mark Publications; **p. 12** Scientist sitting at scanning transmission electron microscope, STEM, photograph by Sinclair Stammers/Science Photo Library/Photo Researchers, Inc.; **p. 14** Gloved hands holding a sheet/culture, electrophoresis gel, photograph. © Eurelios/Phototake; **p. 17** White tiger in the zoo, photograph. © Shawn Gerrits/JLM Visuals; **p. 21** Scintigram of normal human thyroid, front view, photograph. © CNRI/Phototake; **p. 23** Phagocytosis, color enhanced transmission electron micrograph. © Biophoto Associates/Science Source/Photo Researchers, Inc; **p. 27** Entomologist Elidia Fernandez sorts an insect collection for the Institute for Biodiversity, photograph. © Gary Braasch/Corbis; **p. 39** Ravenglass Estuary curving to the sea, Cumbria, England, photograph. Corbis/Genevieve Leaper; **p. 41** Chlamydia pneumonia, photograph by Dr. Kari Lounatmaa. Custom Medical Stock Photo; **p. 42** Escherichia Coli, photograph by Kari Lounatmaa. Photo Researchers; **p. 44** Bumble bee, photograph. © Lloyd R. Brockus III/JLM Visuals; **p. 46** Darwin's Large Cactus Finch, © Breck P. Kent/ JLM Visuals; **p. 50** Antibiotic Staphylococcus aureus, photograph by Hank Morgan. © Hank Morgan/Science Photo Library, Photo Researchers, Inc.; **p. 53** Fossil fish, photograph. © Richard P. Jacobs/JLM Visuals; **p. 58** Ginkgo tree, photograph. JLM Visuals; **p. 60** X ray, color enhanced normal intravenous pyelogram. © Biophoto Associates/Science Source/Photo Researchers, Inc; **p. 65** Dinosaur skeleton on display at the Royal Terrell Museum, photograph. © Paul A. Souders/Corbis; **p. 67** Carolina parakeets lie in bags with tags, photograph. © Jonathan Blair/Corbis; **p. 73** Rod cells in the retina of the human eye, colored scanning electron micrograph. © Quest/Science Photo Library, Photo Researchers, Inc.; **p. 77** Normal human uterus and fallopian tubes, hysterosalpinograph. © GCA/CNRI/Phototake; **p. 83** Human fetus, 10 weeks old, inside amniotic sac, photograph. © CNRI/Phototake; **p. 86** Gray wolves exhibiting submissive behaviors, photograph. © Mary Ann McDonald/Corbis; **p. 88** Agronomists place a plastic greenhouse over crops, photograph. © Ted Spiegel/Corbis; **p. 90** Despain, Don, measures Lodgepole Pine Seedlings, photograph. © Raymond Gehman/Corbis; **p. 94** Snapdragons in flower, photograph by Eric Kamp. © Eric Kamp/Phototake; **p. 95** Lab Agent Kathy Dressel works on DNA evidence in the murder of JonBenet Ramsey at the Colorado Bureau of Investigation, Boulder, Colorado, photograph. AP/Wide World Photos; **p. 98** Boreal forest, evergreen trees, Michigan, photograph. JLM Visuals; **p. 100** Oak/hickory trees in autumn, photograph by Robert J. Huffman/Field Mark Publications; **p. 102** Moss-covered lianas in the Daintree National Park, Queensland, Australia, photograph. © Paul A. Souders/Corbis; **p. 103** Agile gibbon hanging from tree branch with baby at waist, photograph. © Breck P. Kent/JLM Visuals; **p. 105** Strawberry plants with fruit and blossoms, photograph. © Ed Young/Corbis; **p. 111** Dark yellow Witches' Butter jelly fungus, photograph. © Richard P. Jacobs/JLM Visuals; **p. 113** Detail that shows the gills of a mushroom, photograph. © Laura Sivell; Papilio/Corbis; **p. 114** Salmon gills showing the filaments of the gills, photograph. © Ron Boardman; Frank Lane Picture Agency/Corbis; **p. 124** Cancer cells infected with bioengineered adenovirus, photograph by Jean Claude Revy. © Jean Claude Revy/Phototake; **p. 132** Chicken embryo, 96-hours old, photograph. © Richard P. Jacobs/JLM Visuals; **p. 142** Man using computer to design complex proteins, photograph by Richard Nowitz. © Richard Nowitz/Phototake; **p. 147** Mexico City, photograph. Reuters/Archive Photos; **p. 154** Piles of wheat during harvest, Polouse Valley, Washington, photograph. © Vince Streano/Corbis; **p. 157** Grassland, photograph. © Richard P. Jacobs/JLM Visuals; **p. 159** Baby smiling, photograph. © Simon Dearden/Corbis; **p. 160** Hand development of a 2, 6, and 19 year old male, computer color enhanced X ray by Scott Camazine. © Scott Camazine, Photo Researchers, Inc.; **p. 162** Cycad, photograph. JLM Visuals;

**p. 166** Harvey, William, photograph. U.S. National Library of Science; **p. 167** Bicyclist sitting under a shade tree, photograph by Robert J. Huffman/Field Mark Publications; **p. 170** Hearing, human system, diagram by Hans & Cassidy. Gale Group; **p. 173** Heart, diagram by Hans & Cassidy. Gale Group. **p. 178** Close-up of branch with very long thorns, photograph. © Richard P. Jacobs/JLM Visuals; **p. 181** Close-up of genetically manipulated corn, photograph. © Carolina Biological Supply Company/Phototake; **p. 183** Buchner, Eduard, photograph. Hulton-Deutsch Collection/Corbis; **p. 186** Microscope used by Robert Hooke, 17th century, photograph. © Bettmann/Corbis; **p. 189** Young girl on her father's shoulders, photograph. © Raoul Minsart/Corbis; **p. 193** Cuvier, Georges Leopold, photograph. The Library of Congress; **p. 199** Hales, Stephen, engraving. The Library of Congress; **p. 209** Beginnings of Civilization, map by XNR Productions Inc. Gale Research; **p. 213** Female researcher loading an automated DNA sequencer at the Joint Genome Institute, photograph. Photo Researchers; **p. 215** Computer print-out of sequence of DNA, placed below multi-well sample tray, upper left, and automated pipettes, lower right, illustration by © James King-Holmes/Science Photo Library. Photo Researchers; **p. 217** Ingredients that should make up the bulk of a healthy diet, including fruits, vegetables, whole grains, photograph. © Nathan Benn/Corbis; **p. 221** Tomatoes ripen on vine for market, photograph. © Ed Young/Corbis.

### Volume 3

**p. 2** Human brain, cervical spine, and spinal marrow, magnetic resonance imaging (MRI). © GCA/CNRI/Phototake; **p. 6** Cancer cell attacked by tumor infiltrating lymphocytes, scanning electron micrograph by Jean Claude Revy. © Jean Claude Revy/Phototake; **p. 8** Katydid on human hand, photograph. JLM Visuals; **p. 11** House and hill overgrown with kudzu, photograph. JLM Visuals; **p. 22** Canadian Rockies, Ben My Chreem, Yukon, photograph. © Lowell R. Laudon/JLM Visuals; **p. 26** Leakey, Dr. L.S.B and Mary, photograph. AP/Wide World Photos, Inc; **p. 27**

Young girl fits blocks of different shapes through similarly shaped holes in a red box, photograph. © Robert Kozma/Corbis; **p. 30** Spine of Cleistocactus, close-up, photograph. © Peggy Morsch/JLM Visuals; **p. 32** Golden lichen, photograph. © Don Blegen/JLM Visuals; **p. 33** Grandmother holding her grandson, Philadelphia, PA, photograph. © Ed Eckstein/Corbis; **p. 36** Spawning sockeye salmon run the Fraser River from Shushwap Lake to Adams River, photograph. © Stuart Westmorland/Corbis; **p. 38** Chicken embryo, 56-hours old, photograph. © Richard P. Jacobs/JLM Visuals; **p. 40** Microscope, parts labeled, photograph. Carolina Biological Supply Company/Phototake; **p. 52** Two Ceratium tripos, photomicrograph by Eric Grave. © Eric Grave/Phototake; **p. 53** Lymphangiography, diagram of man's body, illustration. Electronic Illustrators Group; **p. 57** Human testis showing spermatogenesis, photomicrograph by Ken Wagner. © Ken Wagner/Phototake; **p. 61** Marine biologist in diving suit inspecting coral reef damaged by illegal fishing practices, photograph. AP/Wide World Photos; **p. 63** Male frigatebird with its red throat pouch inflated, photograph. © Wolfgang Kaehler/Corbis; **p. 64** McClintock, Barbara, photograph. UPI/Corbis-Bettmann; **p. 70** Transmission Electron Micrograph, TEM, image of Golgi apparatus, photograph. © Dr. Dennis Kunkel/Phototake; **p. 80** Mendel, Gregor, photograph. Archive Photos, Inc; **p. 86** Two lysosomes that contain digestive enzymes which destroy damaged molecules; in an intestinal epithelial cell, colored high resolution scanning electron micrograph. P. Motta & T. Naguro/Science Photo Library/Photo Researchers, Inc; **p. 89** Fat cells that make up adipose connective tissue, colored scanning electron micrograph. © Quest/Science Photo Library, Photo Researchers, Inc; **p. 90** Quality control microbiologist Kim Egger inspects a bacteria culture from ground meat processed at Excel Corporation's slaughterhouse, photograph. AP/Wide World Photos; **p. 93** Spring tide of surfbirds surge from the mud flats of Alaska's Copper River delta, photograph. © Jonathan Blair/Corbis; **p. 94** Indian leaf butterfly, photograph. © Richard P. Jacobs/JLM Visuals; **p.**

**99** Mitosis of an animal cell, early prophase, photograph. © CNRI/Phototake; **p. 100** Mitosis of an animal cell, early metaphase, photograph. © CNRI/Phototake; mitosis of an animal cell, immunofluorescence photomicrograph. © CNRI/Phototake; mitosis telophase of an animal cell, photograph. © CNRI/Phototake; **p. 101** Fruit fly head, magnified 200 times, scanning electron micrograph. © Dr. Dennis Kunkel, Phototake; **p. 104** Hands holding lab mouse, photograph. © Mario Beaugard/Corbis; **p. 107** Eastern prairie fringed orchid, photograph. U.S. Fish and Wildlife Service; **p. 114** Human knee joint with patella, X ray. © CNRI/Phototake; **p. 116** White American alligator shows a genetic mutation known as ieucism, Miami Zoo, photograph. © W. Perry Conway/Corbis; **p. 118** African clawed frog, *Xenopus laevis*, mutated, with three hind legs, photograph by Mark Smith. © Mark Smith/Science Source/Photo Researchers, Inc.; **p. 120** Endotrophic mycorrhizae in orchid root, magnified 100x, photograph. © Carolina Biological Supply Company/Phototake; **p. 122** Eggs and spiderlings of Uloborid Spider, photograph. © J. C. Cokendolpher/JLM Visuals; **p. 130** Human brain with Parkinson's Disease showing atrophy, Computerized Axial Tomography, CAT, scan. © GJLP/CNRI/Phototake; **p. 134** Two types of neurons; top of image shows a bipolar neuron, bottom of image is a developing neuron, scanning electron micrograph. © Dr. Dennis Kunkel/Phototake; **p. 137** Nitrogen fixation, bacteria, plants, photograph. © Adam Hart-Davis, National Audubon Society Collection/Photo Researchers, Inc.; **p. 139** Macrophage engulfing a *Leishmania* sp. parasite, colored scanning electron micrograph. © Juergen Berger, Max-Planck Institute/Science Photo Library, Photo Researchers, Inc.; **p. 142** Single mammalian tissue culture cell, color transmission electron micrograph. Dr. Gopal Murti/Science Photo Library/Photo Researchers, Inc.; **p. 149** Loh, Dan, photograph. AP/Wide World Photos; **p. 151** Anemone, Tunicate, Oyster, and Sponge, photograph. © Stephen Frink/Corbis; **p. 152** Bottlenosed dolphin playing, photograph. © Stephen Frink/Corbis; **p. 155** Blood smear showing leukemia cells, photomicrograph. ©

Margaret Cubberly/Phototake; **p. 160** Hand wearing glove, holding worms, compost sits below, photograph by Robert J. Huffman/Field Mark Publications; **p. 164** Meteorite ALH84001, from Mars, 4.5 billion years old, photograph. National Aeronautics and Space Administration (NASA); **p. 172** Larson, Peter, running fingers over teeth of a *Tyrannosaurus rex* skeleton, photograph. AP/Wide World Photos; **p. 175** Dog hookworms in small intestines, photograph. © Michael L. Wolmack/JLM Visuals; **p. 178** Young native boy with blonde hair trait, Lubarria Island, Solomon Islands, photograph. © Wolfgang Kaehler/Corbis; **p. 183** Micrograph comparing healthy red blood cells with a sickle cell, photograph by Dr. Gopal Murti. National Audubon Society Collection/Photo Researchers, Inc.; **p. 190** Diagram showing the central and peripheral nervous systems, left, and the autonomic nervous system, right, illustration by Frank Forney; **p. 192** Scientist performing pharmacological research, photograph. © Bob Krist/Corbis; **p. 194** Cecropia moth, photograph. Robert J. Huffman/Field Mark Publications; **p. 203** Dromedary camel, photograph. © Leonard Lee Rue, III/The National Audubon Society Collection/Photo Researchers, Inc.; **p. 206** Marine Plankton, green organisms with orange spots, 1960-1995, photograph by Douglas P. Wilson. Corbis/Dougals P. Wilson; Frank Lane Picture Agency; **p. 226** Digitalis, photograph. © Ken Wagner/Phototake; **p. 227** Release of pollen from anther of a black walnut, photograph. © Yoav Levy/Phototake; **p. 230** Closed General Electric plant in Pittsfield, Massachusetts, on the Housatonic River, photograph. AP/Wide World Photos; **p. 237** Cheetah, photograph. Robert J. Huffman/Field Mark Publications.

## Volume 4

**p. 2** Peregrine falcon with wings outstretched, photograph by Tim Davis. Photo Researchers, Inc.; **p. 3** School of fish swimming above blue and green coral reef, Indian Ocean, off Pemba Island, 1991, photograph by Stephen Frink. Corbis/Stephen Frink; **p. 21** Dinoflagellate *gambierdiscus toxicus*, scanning electron micrograph by Dr. Dennis

Kunkel. © Dr. Dennis Kunkel/Phototake; **p. 22** Diatoms, photograph. © Richard P. Jacobs/JLM Visuals; **p. 24** Euglena protozoa, photomicrograph by Eric Grave. © Eric Grave/Phototake; **p. 27** Plasmodium flaciparum, malaria parasite, electron micrograph. © Institut Pasteur/Phototake; **p. 28** Brain scans of a schizophrenic patient, bottom, versus a normal patient, top, colored positron emission tomography. © Wellcome Dept. of Cognitive Neurology/Science Photo Library, Photo Researchers, Inc.; **p. 32** Man shows the milky juice of unripe seedpods used to make opium from the opium poppy plant, photograph. © Michael S. Yamashita/Corbis; **p. 33** Sensitive fern, close-up of single leaf, photograph by Robert J. Huffman/Field Mark Publications; **p. 39** Slade, Dennis, photograph. AP/Wide World Photos; **p. 53** Structure of Hibiscus flower, photograph by Ken Wagner. © Ken Wagner/Phototake; **p. 57** Bumblebee pollinating flower, photograph by Robert J. Huffman/Field Mark Publications; **p. 61** *In vitro* fertilization, photograph. © CC Studio/Science Photo Library, Photo Researchers, Inc.; **p. 64** Respiratory system, diaphragm, photograph by Hans & Cassidy. Gale Group; **p. 67** Model of HIV virus, photograph. Corbis-Bettmann; **p. 70** Old-growth forest with understory of wood sorrel in Mt. Hood National Forest in Oregon, photograph by William H. Mullins. Photo Researchers, Inc.; **p. 71** Color-coded cryo-EM map of the *E. coli* ribosome, photograph. Courtesy of Joachim Frank/Health Research, Inc.; **p. 74** Farmland on the banks of the Nile, Egypt, photograph. © Yann Arthus-Bertrand/Corbis; **p. 79** Cross-section of plant in soil, photograph. © Premium Stock/Corbis; **p. 86** Kidney bean sprouting into a seedling, photograph. Photo Researchers, Inc.; **p. 90** Arabidopsis sp. seed pods, scanning electron micrograph, SEM. © Dr. Dennis Kunkel/Phototake; **p. 92** Autumn scene with man, photograph by Robert J. Huffman/Field Mark Publications; **p. 93** Purified adenovirus, photograph by Jean Claude Revy. © Jean Claude Revy/Phototake; **p. 95** Barr body in a female squamous epithelium cell, photograph. © Lester V. Bergman/Corbis; **p. 97** Normal human female chromosomes (XX) in karyotype. © Leonard Lessin, FBPA/Photo Researchers, Inc.; **p. 99** Common frogs in amplexus, photograph. © John Tinning; Frank Lane Picture Agency/Corbis; **p. 102** Rainbow trout eggs hatching, photograph. JLM Visuals; **p. 105** Male and female black widow spiders, photograph. © J. C. Cockendolpher/JLM Visuals; **p. 107** Gonorrhea cells, photograph. Custom Medical Stock Photo; **p. 108** Syphilitic infection, sexually transmitted disease, photograph. © CNRI/Phototake; **p. 111** Fiddlehead ferns, close-up, photograph by Robert J. Huffman/Field Mark Publications; **p. 113** Lymphocytes, T-cells, and 3 red cells, scanning electron micrograph. © NYU Franklin Research Fund/Phototake; **p. 118** Snake skeleton, photograph. © Richard P. Jacobs/JLM Visuals; **p. 125** Pillows of coral colored Myxomycetes grow on damp wood, photograph. © Steve Austin; Papilio/Corbis; **p. 128** Two gannets greeting each other on Bonaventure Island, Quebec, photograph. © Breck P. Kent/JLM Visuals; **p. 130** Olive baboon grooming papio cynocephalus, photograph. © Joe McDonald/Corbis; **p. 131** Wilson, Edward O., 1991, photograph. AP/Wide World Photos; **p. 143** Cleaner shrimp, cleaner moray, photograph. JLM Visuals; **p. 149** Three T-lymphocytes, scanning electron micrograph, SEM, image. © Microworks/Phototake; **p. 152** Linnaeus, Carolus, engraving. The Library of Congress; **p. 153** Archeobacteria, scanning electron micrograph by Eurelios. © Eurelios/Phototake; **p. 155** Pit Bull Panting, photograph. © Lawrence Manning/Corbis; **p. 159** Thyroid Nuclear Medicine Scan, enhanced Scintigram, photograph by Oliver Meckes. Photo Researchers, Inc.; **p. 161** Close-up of a human fingerprint, macrophotograph by Martin Dohrn. © Martin Dohrn/Science Photo Library, Photo Researchers, Inc.; **p. 173** Surgeons clean a human kidney in preparation for transport into a patient at the University of Pittsburgh Medical Center, photograph. © Nathan Benn/Corbis; **p. 177** Cook Strait Tutuata, photograph by Tom McHugh. Photo Researchers, Inc.; **p. 178** Sea-peach tunicate, photograph. JLM Visuals; **p. 181** Vaccination process, illustration. Electronic Illustrators Group. **p. 185** Veterinarian technicians check the blood pressure of a dog, photograph.



AP/Wide World Photos; **p. 188** T4 bacteriophage virus, colored transmission electron micrograph. © Department of Microbiology, Biozentrum/Science Photo Library/Photo Researchers, Inc.; **p. 189** Compound eye of a fruit fly, scanning electron micrograph, SEM. © Dr. Dennis Kunkel; **p. 194** Drop of guttation, water extruded by a plant's root pressure, on a blade of grass. Alpine Lakes Wilderness Area, Washington, photograph. © Pat O'Hara/Corbis; **p. 196** Watson, Dr. James Dewey, with DNA model, 1962, photograph. UPI/Corbis-Bettmann; **p. 198** Dead

tree trunks, stumps in deep blue water, golden leaves, photograph by Robert J. Huffinan/Field Mark Publications; **p. 199** Biologists take samples from drugged polar bears for data about pesticides, photograph. © Galen Rowell/Corbis; **p. 201** Man walks across giant rollers used to crush wood pulp at the Ketchikan Pulp Company, photograph. © Kevin Fleming/Corbis; **p. 205** Zoo veterinarian Don Janssen examining the San Diego Zoo's 2-week old giant panda cub, photograph. AP/Wide World Photos.

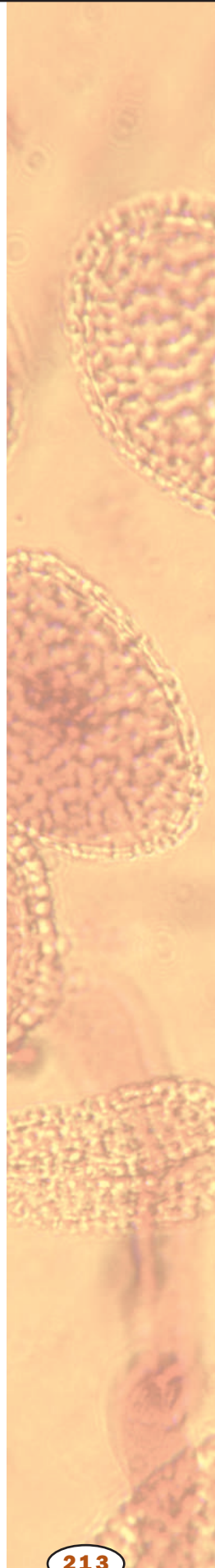

# Glossary

- abiotic** nonliving
- abscission** shedding of leaves; falling off
- acetylation** addition of an acetyl group,  $\text{CH}_3\text{-CHOO-}$
- acidic** having an excess of  $\text{H}^+$  ions and a low pH
- acinus** one of the small divisions of a fruit such as a raspberry
- action potential** wave of ionic movement down the length of a nerve cell
- active site** surface region of an enzyme where it catalyzes its reaction
- adaptive radiation** diversification of a group of organisms into several different forms that adapt to different environments
- adhesion** attachment; sticking to the surface of
- ADP** adenosine diphosphate, the low-energy form of ATP
- adventitious** growing from a nonstandard location
- aerobe** organism that needs oxygen
- aerobic** with oxygen, or requiring it
- aestivating** remaining dormant for the summer
- affinity** attraction
- aflatoxin** toxic compound produced by a mold fungus
- agar** gel derived from algae
- agnosia** “not knowing”; loss of ability to recognize familiar objects
- agroecosystem** agricultural ecosystem
- alkaline** chemically basic, with an excess of  $\text{OH}^-$  ions
- allele** a particular form of a gene
- allelopathy** inhibition of one plant’s growth by another plant
- amino acid** a building block of protein
- amoeba** a single-celled protist that moves by crawling

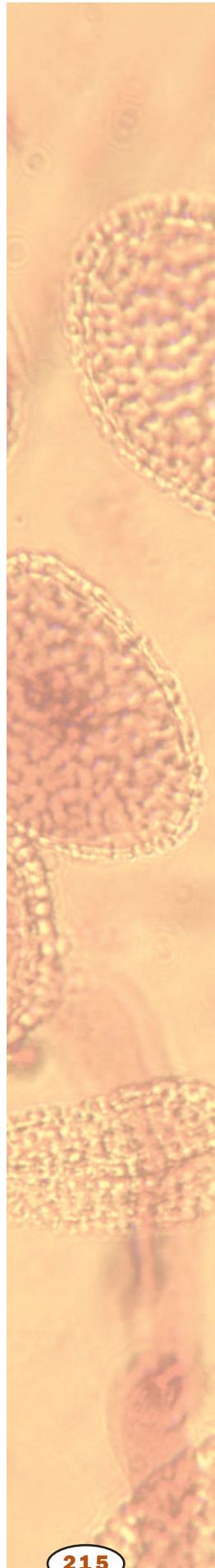

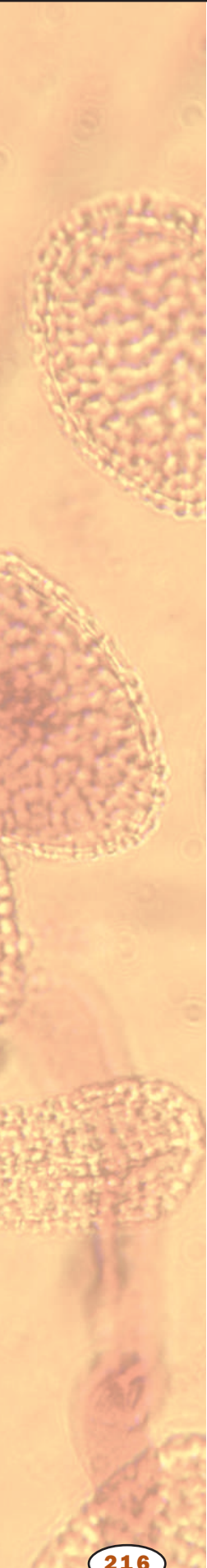

**amoeboid** like an amoeba, especially in movement via extension of portions of the membrane

**AMP** adenosine monophosphate, form of ATP after removal of two phosphate groups

**amphipathic** having both polar and nonpolar regions

**anabolic** characteristic of a reaction that builds complex molecules from simpler ones, and requires energy

**anadromous** describes fish that return to the rivers where they were born in order to breed

**anaerobe** organism not needing oxygen

**anaerobic** without oxygen, or not requiring oxygen

**anemia** lack of oxygen-carrying capacity in the blood

**aneurysm** bulging of the wall of a blood vessel

**antagonism** working against

**antagonist muscle** muscle that works against the action undertaken

**anterior** toward the front

**anterograde** forward

**anthocyanins** colored compounds made by plants

**anthropogenic** of, or relating to, the influence of human beings or nature

**antibody** immune system protein that binds to foreign molecules

**antigen** foreign substance that provokes an immune response

**antioxidant** substance that prevents damage from oxidation

**antitoxin** molecule used to inactivate a toxin

**aphasia** loss of the ability to form ideas into words

**apical** at the tip

**apical meristem** growing tip from which all plant tissues arise

**appendage** attached organ or structure

**aqueous** watery or water-based

**areolar** related to a small space within a tissue

**aromatic** compound including a double-bonded carbon ring

**arterioles** any of the small, terminal twigs of an artery that ends in capillaries

**arthropods** organisms with jointed appendages and exoskeletons, including insects, spiders, and crustaceans

**asymptomatic** without symptoms

**ATP** adenosine triphosphate, a high-energy nucleotide used by cells to power most energy-requiring reactions

- atria** two upper chambers of the heart (singular, atrium)
- attenuation** lessening over time
- autoimmune disease** disease in which the immune system attacks the body's own tissues
- autonomic** independent; regulating involuntary actions
- autonomic nervous system** one of the branches of the motor system, controlling involuntary muscles and glands
- autosomal dominant** pattern of inheritance in which inheritance of a single allele from either parent results in expression of the trait
- avian** concerning birds
- axon** long extension of a nerve cell down which information flows
- B lymphocyte** white blood cell that makes antibodies
- B.C.E.** before the Common Era, equivalent to B.C.
- basal** lowest level
- base pair** two nucleotides (either DNA or RNA) linked by weak bonds
- basic** having an excess of  $\text{OH}^-$  ions and a high pH
- bilaterally symmetric** symmetric, or similar, across a central line
- bilayer** composed of two layers
- bioaccumulate** build up within organisms
- bioluminescence** production of light by biochemical reactions
- biopharmaceuticals** drugs produced by and harvested from living organisms
- biosynthetic** forming a complex molecule from simpler ones
- biotic** living
- bolting** sudden spurt of growth
- boreal** of, relating to, or located in northern regions
- brood parasite** organism of one species that lays its eggs in the nest of another species
- C4 and CAM plants** plants that employ accessory systems for trapping carbon for photosynthesis
- cadherins** family of calcium-dependent adhesion proteins
- carbohydrates** sugars, starches, and other molecules combining carbon, hydrogen, and oxygen and serving as fuel or structural components
- cardiomyopathy** heart muscle disease
- catalysis** aiding in the reaction of
- catalyst** substance that aids in a reaction without being used up

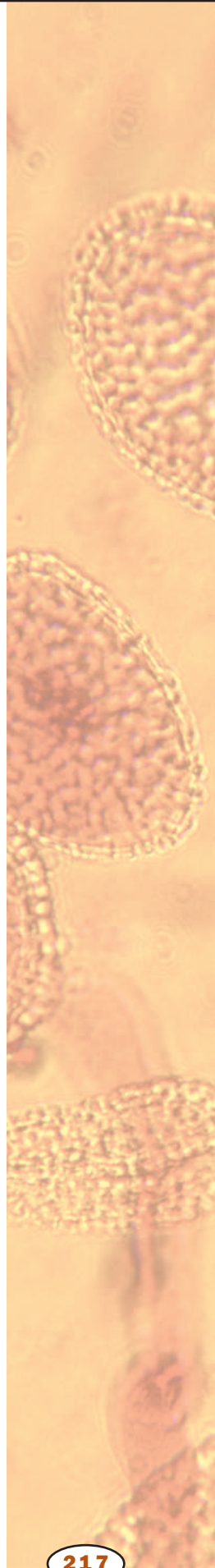

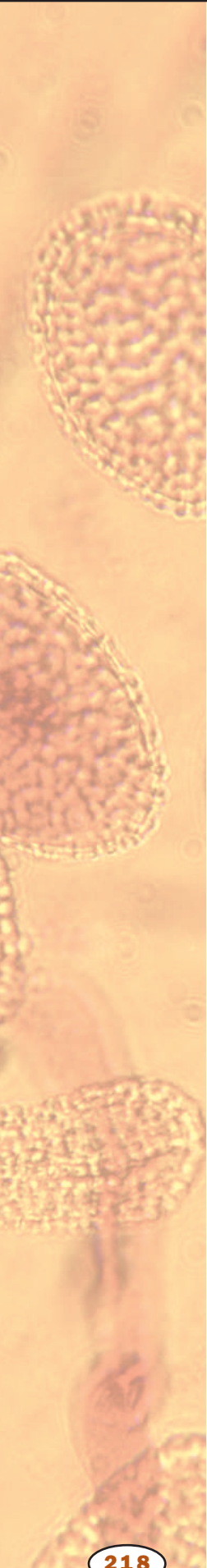

**catalyze** aid in the reaction of

**caudate** toward the tail

**C.E.** Common Era; equivalent to AD

**cell cycle** sequence of growth, replication, and division that produces new cells

**cellulose** carbohydrate made by plants and some other organisms; part of the cell wall

**central nervous system** brain and spinal cord

**centromere** region of the chromosome linking chromatids

**cerebral cortex** outermost wrinkled portion of the brain

**chemiosmosis** use of proton gradients to make ATP

**chitin** nitrogen-containing carbohydrate found in arthropod exoskeletons and fungus cell walls

**chromatid** a replicated chromosome before separation from its copy

**chromatin** complex of DNA, histones, and other proteins making up chromosomes

**chromosomal analysis** staining, banding, and other techniques for detection of chromosomal abnormalities

**chromosome** “colored body” in the cell nucleus; made of DNA and protein, and divided functionally into genes and non-gene regions

**cilia** short, hairlike cell extensions of the cell membrane formed by the cytoskeleton

**ciliated** possessing cilia, which are short, hairlike extensions of the cell membrane

**circadian** related to a day or daylength

**clavicle** collar bone

**cloaca** common exit cavity for intestinal, genital, and urinary tracts

**codon** sequence of three mRNA nucleotides coding for one amino acid

**cognition** mental processes of thought and awareness

**cognitive** related to thought or awareness

**communicable** transmissible from person to person

**complementary** matching opposite

**complex carbohydrate** molecules formed by linking simpler carbohydrates such as sugars

**condensation** compaction of chromosome strands into a tight structure

**conformation** three-dimensional shape

**congenital** present at birth; inherited

- conjunctiva** eye membrane that helps seal the eye socket
- connective tissue** one of four types of body tissue, characterized by few cells and extensive extracellular material
- consanguineous** descended from the same ancestor
- constitutive** at a constant rate or continually
- contiguous** adjacent to or touching
- continental shelf** submerged offshore area demarcated by land on one side and deep sea on the other
- coralloid** resembling coral
- coronary artery** artery supplying blood to the heart
- cortical** related to the cortex, or outer portion
- cotyledon** seed leaf, which stores food and performs photosynthesis after germination
- cranial** related to the cranium, or brain cavity
- cryptobiosis** when a plant or animal becomes so inactive that its life processes nearly come to a stop
- cutaneous** related to the skin
- cutaneous respiration** gas exchange through the skin
- cytology** study of cells
- cytoplasm** material in a cell, excluding the nucleus
- cytoskeleton** internal scaffolding in a cell, composed of protein
- cytosol** fluid portion of a cell, not including the organelles
- Darwinian fitness** capacity to survive and reproduce
- deciduous** trees that shed their leaves in the fall
- deciliter** one-tenth of a liter; a unit of volume
- dementia** neurological illness characterized by impaired thought or awareness
- desiccation** drying out
- desynchronized** not happening at the same time
- deuterostome** “mouth second”; referring to the early development of the anal pore during gut tube formation
- dialysis** cleansing by partial filtration
- dicot** plant having two cotyledons, or seed leaves
- dikaryotic cell** cell with a pair of nuclei
- dilation** expansion or swelling
- dimer** polymer formed from two molecules of a simple compound

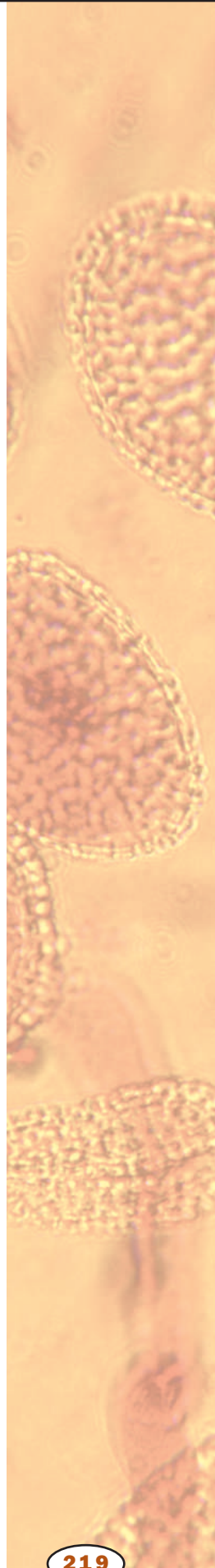

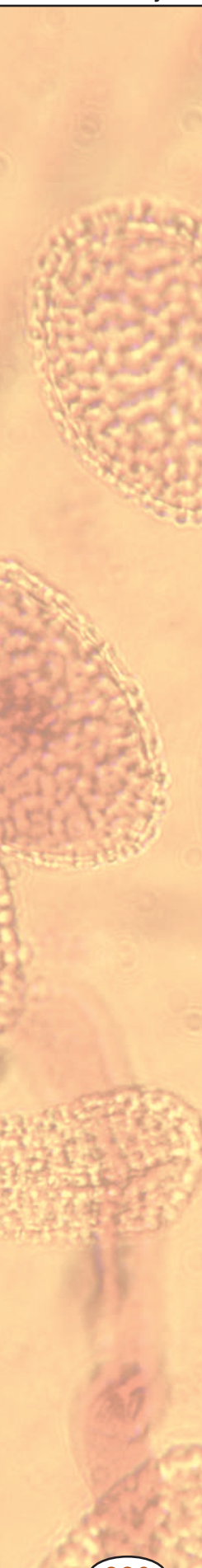
- 
- dimerizes** forms a pair
- diploid** having pairs of chromosomes in the nucleus
- dissociate** break apart
- distal** away from
- diurnal** active during the daytime
- dorsal** to the back of
- ecosystem** an ecological community and its environment
- effector** organ at the end of a nerve, such as a muscle or gland
- efferent** conducting outward or directing away from
- electrolytes** ions in body fluids
- electromagnetic radiation** light, X rays, and other forms of radiant energy
- electron transport system** membrane-bound system of proteins that extracts energy from high-energy electrons, found in mitochondria and chloroplasts
- electrophoresis** technique that uses electricity to separate molecules based on size and electric charge
- electrophoresis gel** porous medium through which molecules can be separated using an electric current
- embalming** treating a dead body to protect it from decay
- embryology** development of the embryo
- emulsify** suspend in solution through interaction with soap or similar molecules
- endocrine** related to the system of hormones and glands that regulate body function
- endogenous** caused by factors inside the organism
- endometriosis** disorder of the endometrium, the lining of the uterus
- endoplasmic reticulum** network of membranes within the cell
- endosperm** nutritive tissue within a seed
- endosymbiosis** symbiosis in which one partner lives within the other
- endothermic** characterized by regulation of body temperature through metabolic activity
- Enlightenment** eighteenth-century philosophical movement stressing rational critique of previously accepted doctrines in all areas of thought
- enzymatic** related to the function of an enzyme
- enzyme** protein that controls a reaction in a cell
- epidemic** rapid spread of disease through a population, or a disease that spreads in this manner

- epistasis** suppression of a characteristic of one gene by the action of another gene
- epithelium** one of four tissue types found in the body, characterized by thin sheets and usually serving a protective or secretory function
- esophagus** tube connecting the throat to the stomach
- eudicot** “true dicot”; plants with two seed leaves that originated from the earliest of flowering plants
- eukaryotic cell** a cell with a nucleus
- eutrophication** process by which waters become enriched in dissolved nutrients that promote plant growth which results in depletion of dissolved oxygen
- evapotranspiration** loss of water from a plant by evaporation within the leaf
- evidentiary DNA profile** analyzed DNA from a sample used as evidence
- excrete** deposit outside of
- exocrine gland** gland that secretes substances to an external or internal surface rather than into the bloodstream
- exoskeleton** external skeleton
- extensibility** ability to expand or grow larger
- fallopian tubes** tubes through which eggs pass to the uterus
- fecundity** ability to reproduce
- feedback** process in which the output or result influences the rate of the process
- fertilization** union of sperm and egg
- fibroblast** undifferentiated cell normally giving rise to connective tissue cells
- filtrate** material passing through a filter
- focal** at a point
- follicle** a vesicle that contains a developing egg surrounded by a covering of cells
- food web** set of feeding relations in an ecosystem
- forb** broad-leaved herbaceous plant
- forensic** related to legal proceedings
- fulcrum** pivot point of a lever
- fungi** major group of parasitic, lower plants that obtain their food from the products of organic decay (e.g. molds, smuts, etc.)
- gamete** reproductive cell, such as sperm or egg
- gametophyte** a haploid plant that makes gametes by mitosis
- ganglia** cluster of nerve cell bodies

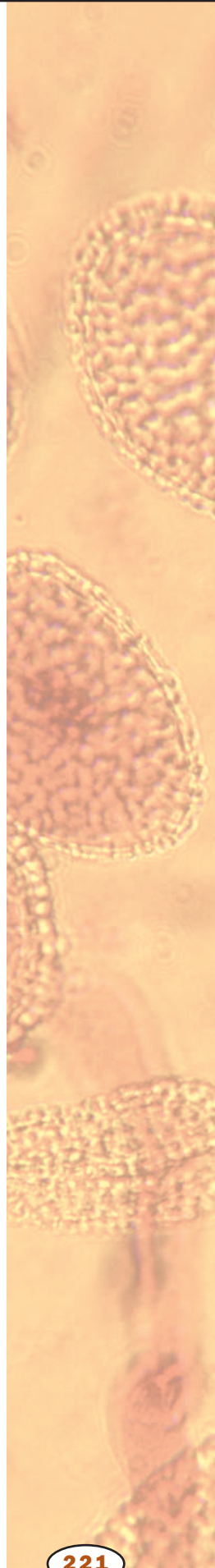



**gastroenteritis** inflammation of the gastrointestinal tract, often from infection

**gene** portion of DNA that codes for a protein or RNA molecule

**gene expression** use of a gene to create the corresponding protein

**genetic code** relationship between triples of RNA nucleotides and the amino acids they code for during protein synthesis

**genitalia** reproductive organs

**genome** total genetic material in a cell or organism

**germ line** cells creating eggs or sperm

**gestation** period of fetal development within the mother

**glial** supporting tissue of the elements of nervous tissue, including the brain, spinal cord, and ganglia

**glucose** simple sugar that provides energy to animal cells; it is the building block of cellulose in plants

**glycogen** complex carbohydrate used as storage in animals and some other organisms

**glycolysis** initial stages of sugar breakdown in a cell

**gradient** difference in concentration between two places

**grafting** attachment and fusing of parts from different plants

**guard cells** paired cells on leaves that control gas exchange and water loss

**gymnosperms** “naked seed” plants, including conifers

**hallucination** altered sensory experience resulting in the perception of objects that are not real

**haploid** having single, nonpaired chromosomes in the nucleus

**hectare** 10,000 square meters (2.47 acres)

**heme** the deep red, iron containing, nonprotein portion of hemoglobin and myoglobin

**hemicellulose** complex carbohydrate related to cellulose and found in cell walls of plants and some other organisms

**hemoglobin** oxygen-carrying protein complex in red blood cells

**herbarium** a collection of dried plant specimens systematically arranged for reference

**hermaphrodite** organism possessing both male and female reproductive structures

**heterodimer** complex molecule composed of two different parts

**heterogeneous** composed of, or containing, different parts or types

**heterozygous** characterized by possession of two different forms (alleles) of a particular gene

- hexamer** a structure composed of six parts
- histogenesis** origin or production of tissues
- histology** study of tissues
- histone** protein around which DNA wraps to form chromosomes
- homologous** similar in structure
- homologous chromosomes** chromosomes carrying similar genetic information
- homologous recombination** exchange of DNA segments between chromosomes
- homozygous** containing two identical copies of a particular gene
- hormone** molecule released by one cell to influence another
- hybrid** combination of two different types
- hydrocarbon** molecule or group composed only of C and H
- hydrogen bond** weak bond between the H of one molecule or group and a nitrogen or oxygen of another
- hydrolyze** to split apart using water
- hydrophilic** “water loving”
- hydrophobic** “water hating,” such as oils
- hydroponics** growing of plants without soil
- hydroxyl** chemical group consisting of -OH
- hypersalinity** very high level of salt
- hypersecretion** excess secretion
- hypersensitivity reaction** immune reaction characterized by rapid and severe response, often with swelling of airways
- hyphae** threadlike part of the vegetative portion of the fungus
- hyposcretion** lack of secretion
- hypothermia** subnormal temperature of the body
- ice-out** a thawing of ice covering a lake or other body of water
- immunoglobulin** an immune protein, also called an antibody
- immunosuppressant** inhibition of the immune response
- in utero** inside the uterus
- in vitro** “in glass”; in lab apparatus, rather than within a living organism
- inbred** repeatedly bred with close relatives, creating organisms with very little genetic variation

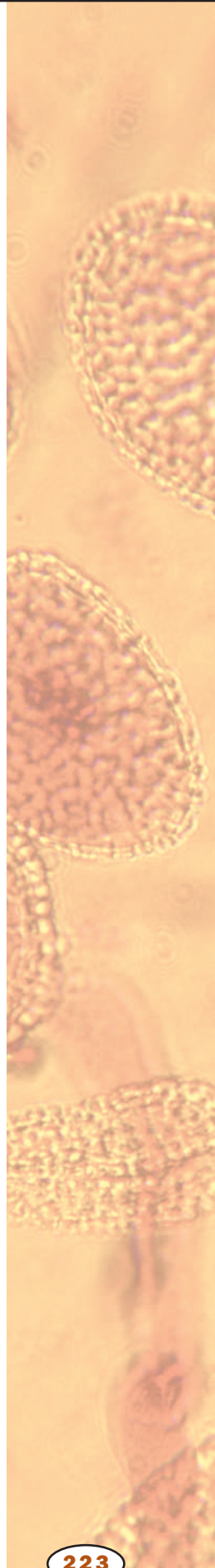

- inducible** able to be switched on
- inflorescence** characteristic arrangement of flowers on a stalk
- infrastructure** roads, phone lines, and other utilities that allow commerce
- inorganic** not bonded to carbon
- insectivorous** insect-eating
- integrins** a family of transmembrane linking proteins
- interferons** signaling molecules of the immune system
- intermediate filament protein** one type of cytoskeleton protein
- interspecific** between different species
- interstitial space** space between cells in a tissue
- intracellular** within a cell
- intraocular** within the eyeball
- intrinsic to** intimate part of; within
- intron** untranslated portion of a gene that interrupts coding regions
- ion** an electrically charged particle
- ionic** based on or functioning by means of ions
- ionizing radiation** high-energy radiation that destroys chemical bonds
- isometric** relating to contraction without movement
- isotopes** forms of an atom that differ by the number of neutrons in the nucleus
- keratin** a major structural protein
- kilobase** one thousand DNA bases; a measure of size of a piece of DNA
- kilobasepair** one thousand DNA base pairs; a measure of size of a piece of DNA
- kinase** enzyme that adds a phosphate group to another molecule, usually a protein
- Krebs cycle** central metabolic pathway in mitochondria
- lactation** production of milk by the mammary glands
- laparoscopic surgery** surgery in which an instrument is inserted through a very small incision, usually guided by some type of imaging technique
- larynx** “voice box”; muscles at the top of the trachea that control pitch and loudness
- lateral** side-to-side
- lethargy** lack of excitability; torpor
- lignified** hardened by impregnation with lignin, a compound formed in plants

**lignin** organic molecule used in plant cell walls to add stiffness to cellulose

**lineage** ancestral line

**lipid** fat or waxlike molecule, insoluble in water

**lipoprotein** combination of protein and lipid, or fatlike molecule

**locus** site on a chromosome (plural, loci)

**lotic** of, relating to, or living in actively moving water

**lymph** pale fluid that circulates in the lymphatic system, principally composed of blood plasma and cell fluid

**lymphatic system** network of tubes that permeates the body for transport of lymph and combat of infection

**lymphocyte** white blood cell found in lymph nodes

**lyse** break apart

**lysine** an amino acid

**lysing** disintegration or dissolution of cells

**macromolecules** large molecules such as proteins, carbohydrates, and nucleic acids

**marsupials** kangaroos and other mammals that gestate young in an external pouch

**materialism** the belief that life is due entirely to biochemical interactions, without the intervention of supernatural forces

**matrix** a network, usually of threadlike fibers

**medium** nutrient source

**meiosis** cell division that forms eggs or sperm

**membrane potential** electrical and chemical differences across a membrane leading to storage of energy and excitability

**metabolism** chemical reactions within a cell

**metabolite** molecule involved in a metabolic pathway

**metamorphosis** development process that includes a larval stage with a different form from the adult

**metaphase** intermediate stage in cell division, in which chromosomes line up before separating

**metastasis** breaking away of cancer cells from a solid tumor to travel elsewhere in the body

**metazoans** animals other than sponges

**methylation** addition of the methyl group  $\text{CH}_3$

**micron** one-millionth of a meter; also called a micrometer

**mid-dorsal** middle of the back

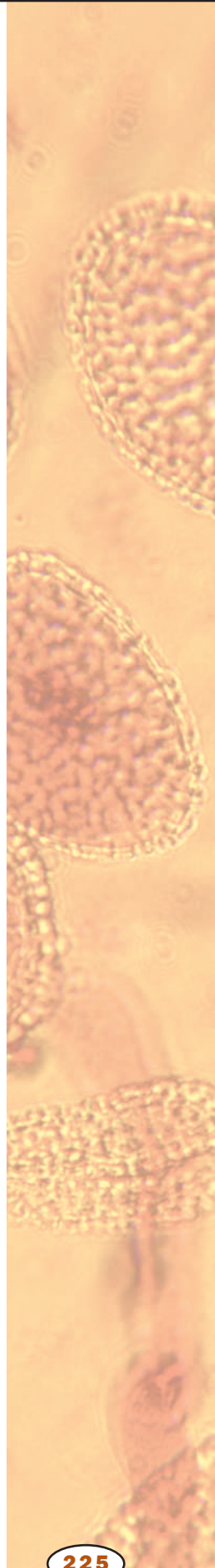

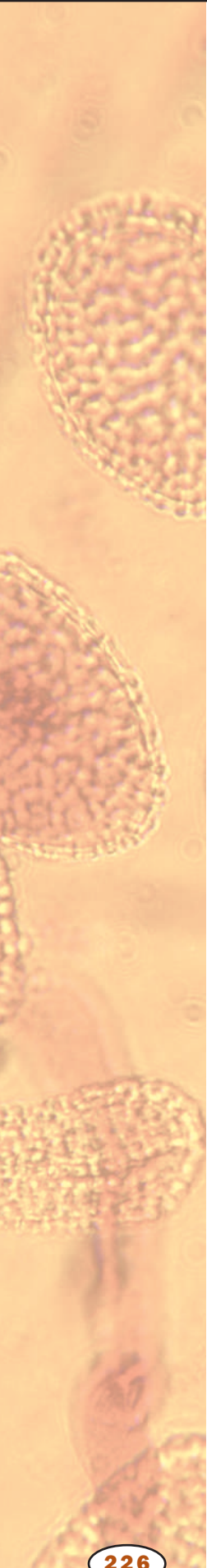

**middle lamella** layer of material between two plant cells that holds them together

**minerals** iron, calcium, sodium, and other elements needed by living organisms

**missense mutation** nucleotide change that causes a change in the amino acid normally added to the protein

**mitochondria** subcellular organelle that creates ATP used for energy-requiring processes in a cell

**mitogen** substance that stimulates mitosis

**mitosis** separation of replicated chromosomes

**molecular hybridization** base-pairing among DNAs or RNAs of different origins

**monocot** any of various flowering plants, such as grasses and orchids, that have a single cotyledon in the seed

**monoculture** cultivation of a single type of crop in a large area

**monomer** “single part”; monomers are joined to form a polymer

**monophyletic** a group that includes an ancestral species and all its descendants

**montane** mountainous region

**morphology** related to shape and form

**motile** able to move

**motor neuron** nerve cell that controls a muscle or gland

**mucous membrane** outer covering designed to secrete mucus, often found lining cavities and internal surfaces

**multimer** composed of many similar parts

**multinucleate** having many nuclei within a single cell membrane

**muscle tone** low level, constant muscle contraction

**mutualism** symbiosis between two organisms in which both benefit

**mycorrhizae** symbiosis between soil fungus and plant root to maximize absorption

**myxedema** thyroid disorder characterized by dry skin, swelling in the face, and mental deterioration

**nanometer**  $10^{-9}$  meters; one-billionth of a meter

**natural selection** process by which organisms best suited to their environments achieve greater reproductive success thus creating more “fit” future generations

**nematode** worm of the Nematoda phylum, many of which are parasitic

**nephron** functional unit of the kidney that performs filtration, reabsorption, and excretion

- neritic** zone near the shore
- neural** related to nerve cells or the nervous system
- neurologist** doctor who treats brain disorders
- neuron** nerve cell
- neurotransmitters** molecules released by one neuron to stimulate or inhibit another neuron or cell
- niche** the habitat supplying the right environment for a particular species
- nm** nanometer; one-billionth of a meter
- nocturnal** characterized by activity at night, or related to the night
- nondisjunction** failure of separation of homologous chromosomes during meiosis
- nuclear envelope** double membrane surrounding the cell nucleus
- nucleated** having a nucleus
- nucleotide** the building block of RNA or DNA
- nucleus** membrane-bound portion of cell containing the chromosomes
- obligate** required or necessary, especially referring to a metabolic process or mode of nutrition
- octomer** composed of eight parts
- oligosaccharide** chain of several sugar molecules
- oncogene** gene that causes cancer
- oocyte** unfertilized egg
- opportunistic** caused by a microorganism that is usually harmless but which causes infection in an immunosuppressed person
- organelle** membrane-bound cell compartment
- organic** composed of carbon, or derived from living organisms; also, a type of agriculture stressing soil fertility and avoidance of synthetic pesticides and fertilizers
- osmosis** passage of water through a membrane in response to concentration differences
- osseous** related to bone
- outcross** fertilization between two different plants
- ovipary** production of eggs that hatch outside the body
- ovovivipary** production of eggs that hatch within the female's body
- ovule** multicellular structure that develops into a seed after fertilization
- oxidation** reaction characterized by loss of electrons, or reaction with oxygen

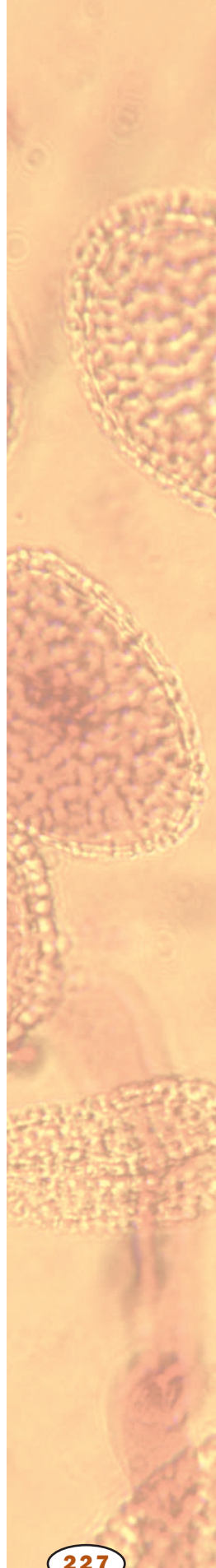

**oxidation-reduction** oxidation is loss of electrons, and reduction is gain of electrons

**oxidative** characterized by oxidation, or loss of electrons

**oxidative phosphorylation** use of oxygen to make ATP

**oxidize** to react or make react with oxygen

**palatine bone** bone of the hard palate at the roof of the mouth

**paleoanthropology** study of ancient humans

**palindromic** reading the same forward and backward

**pandemic** disease spread throughout an entire population

**papillate** small, nipplelike projection

**parasite** organism living in close association with another from which it derives most of its nutrition

**parasitology** study of parasites

**parasympathetic nervous system** branch of the nervous system promoting nutrient absorption and other maintenance activities

**pathogen** disease-causing organism

**pathogenesis** pathway leading to disease

**pathologic** related to disease

**pectin** carbohydrate in plants that forms crosslinks to stabilize cell walls

**peptide bond** bond between two amino acids

**peptidoglycans** polymer that is composed of polysaccharides and peptic chains

**perianth** combined sepals and petals

**peripheral** outside the central nervous system (brain and spinal cord)

**pH** measure of acidity or alkalinity; numbers below 7 are acid, above are basic

**phage** short for bacteriophage

**phagocytosis** engulfing of cells or large fragments by another cell, including immune system cells

**pharynx** throat

**phase-contrast microscopy** technique that manipulates passage of light through transparent specimens to reveal internal features

**phenotype** observable characteristics of an organism

**pheromone** molecule released by one organism to influence another organism's behavior

**phloem** plant tissue that conducts sugars from leaves to roots and other tissues

- phosphodiester** the link between two nucleotides in DNA or RNA
- phosphorylate** add a phosphate group to
- phosphorylation** addition of the phosphate group  $\text{PO}_4^{3-}$
- phyletic gradualism** the belief that evolutionary change is slow and steady
- phylogenetic** related to phylogeny, the evolutionary development of a species
- phylum** taxonomic level below kingdom, e.g., arthropod or chordate
- physiology** branch of biology that deals with the functions and activities of living matter
- phytoplankton** microscopic floating creatures that photosynthesize
- pinnate** featherlike
- pinocytosis** introduction of fluids into a cell by enclosing it and pinching off the plasma membrane
- pipette** lab instrument for precise measurement and transfer of small volumes of liquids
- pistil** female reproductive organ of a flower
- placental** related to mammals that nourish the fetus with a placenta, an exchange organ in the uterus
- plankton** microscopic floating organisms
- plant hybridization** creation of offspring by union of two different types of plants, such as wheat and rye
- plasmid** small ring of DNA found in many bacteria
- plasticity** change form
- plate tectonics** the movement of large plates of Earth's crust
- polar** partially charged, and usually soluble in water
- polar covalent** bond in which electrons are unevenly shared
- polymer** molecule composed of many similar parts
- polymerase** enzyme complex that synthesizes DNA or RNA from individual nucleotides
- polymerization** linking together of similar parts to form a polymer
- polypeptide** chain of amino acids
- polysaccharide** carbohydrate composed of many individual units of sugar
- posterior** toward the back
- postmortem** after death
- prebiotic** before the origin of life
- Precambrian** before the Cambrian era; before 600 million years ago

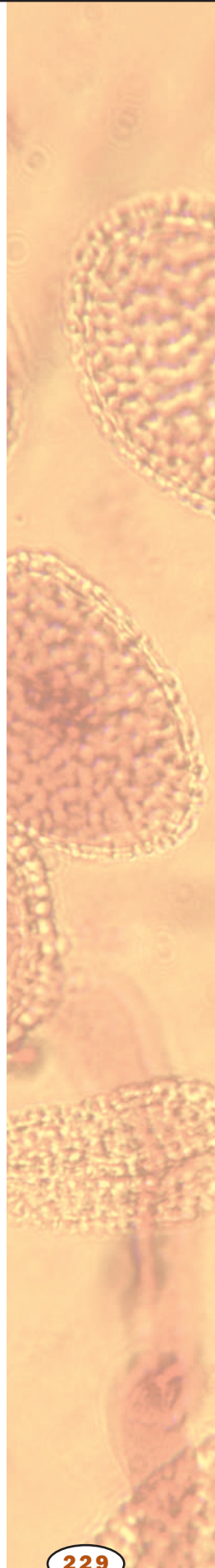



**primer** short nucleotide sequence that helps begin DNA replication

**progeny** offspring

**prokaryote** single-celled organism without a nucleus

**promoter** DNA sequence to which RNA polymerase binds to begin transcription

**prostaglandins** hormonelike molecules released by one cell that affect nearby cells, including smooth muscle

**prostrate** face downward

**protein** complex molecule made from amino acids; used in cells for structure, signaling, and controlling reactions

**proteolysis** breakdown of proteins

**protoecology** early ecology

**protoplasm** fluid portion of a plant cell within the cell wall

**protostome** “mouth first”; referring to the early development of the oral pore during gut tube formation

**protozoa** any of a phylum of minute protoplasmic animals present in almost every kind of habitat, some of which pose serious threats to humans and animals

**pseudopod** “false foot”; an extension of the plasma membrane during locomotion by an amoeba or similar crawling cell

**psychosis** severe mental disorder characterized by diminished connection with reality

**psychotropic** affecting consciousness, thought, or emotion

**punctuated equilibrium** pattern of evolution in which long periods of relatively little change are punctuated by rapid change

**pyruvate** the ionized form of pyruvic acid, a key intermediate in cell metabolism

**quaternary** fourth level

**radially symmetric** symmetric, or similar, about a central point (a wheel is radially symmetric)

**reproductive isolation** isolation of a population from other populations of the same species due to inability to successfully reproduce; an early stage in species formation

**respire** use oxygen to burn cellular fuel

**restriction enzyme** enzyme that cuts DNA at a particular sequence

**restriction fragments** fragments of DNA created by restriction enzymes

**reticular** netlike

**retrograde** backward

- reverse transcriptase** enzyme that copies RNA into DNA
- reverse transcription** creation of DNA from an RNA template
- ribonucleoprotein** combination of RNA and protein
- ribosome** protein-RNA complex in cells that synthesizes protein
- rickettsia** (pl. -sias or siae) any of a family of polymorphic microorganisms that cause various diseases
- RNA polymerase** enzyme complex that creates RNA from DNA template
- saline** of, or relating to, salt
- saprophyte** plant that feeds on decaying parts of other plants
- savanna** open grassland with sparse trees
- sclerophyll** small, tough evergreen leaves
- secretion** material released from the cell
- secretory pathway** series of events within a cell by which molecules are brought to the plasma membrane for release from the cell
- sepals** whorls of flower organs outside of the petals, usually green and serving to protect the flower before it opens
- serotinous** developing late in the season
- serotype** identity of an organism or virus based on reaction to an antibody
- sessile** attached and remaining in one place
- silviculture** cultivation of forest trees
- sleep apnea** difficulty breathing while asleep
- solenoid** cylindrical coiled structure
- solute** dissolved substance
- solvation** the process of dissolving
- somatic** nonreproductive; not an egg or sperm
- somatostatin** hormone produced by the hypothalamus that influences growth
- spasticity** of, or relating to, spasms
- spectroscopy** process using light or other emitted radiation to determine properties of a sample
- sphincter** ring of muscle regulating passage of material through a tube such as the gastrointestinal tract
- spontaneous generation** the theory that life began from nonliving matter
- stasis** state of no change
- steroid hormone** group of hormones that includes estrogen, testosterone, and progesterone

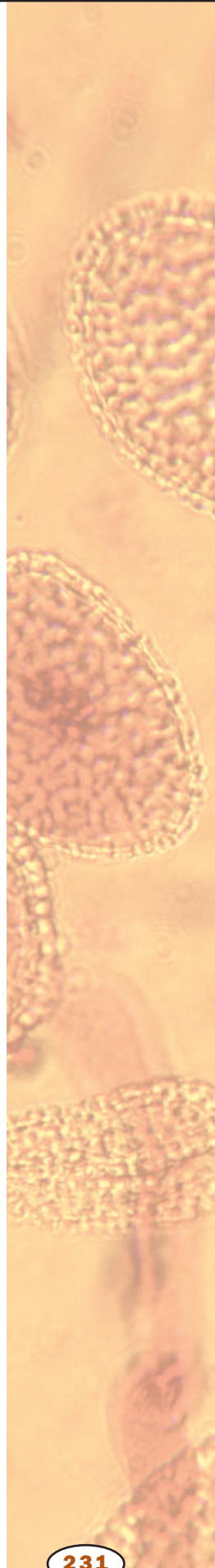

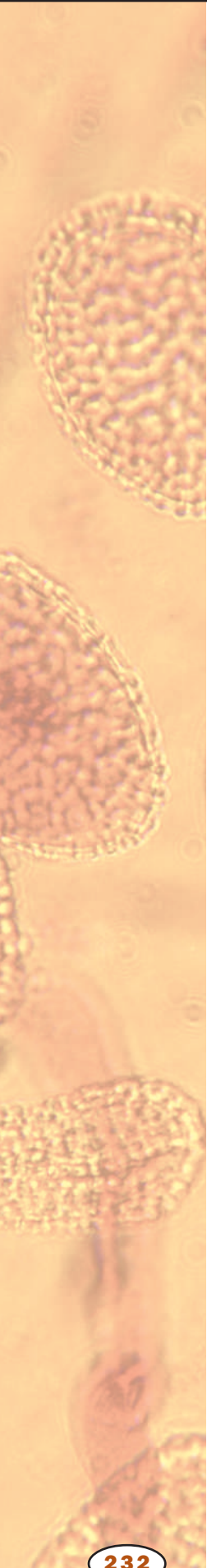

**steroids** hormones such as testosterone or estrogens that control many aspects of physiology

**stomata** openings in leaves for gas exchange, surrounded and regulated by guard cells

**strong bond** high-energy arrangement between two atoms involving electron-sharing; strong bonds require more energy to break than weak bonds

**subcutaneous** below the skin

**substrate** the molecule acted on by an enzyme; also a surface for attachment

**succession** series of changes seen in some plant communities over time, in which low-growing, rapidly reproducing species are replaced by taller and more slowly reproducing ones

**superficial** on the surface; not deep

**symbiont** organism living in close association with another organism

**symbiosis** close relationship between two species in which at least one benefits

**sympathetic nervous system** branch of the nervous system that promotes heightened awareness, increased nutrient consumption, and other changes associated with “fight or flight”

**synaptic transmission** passage of chemicals between nerve cells to send messages or alter neuron firing

**synchronously** at the same time

**synergism** working together to create a larger product rather than a simple sum

**systemic** throughout the body

**T cell** white blood cell that controls the immune response

**taxon** a level of classification, such as kingdom or phylum

**tectonic plate** large segment of Earth’s crust that moves in relation to other similar plates

**template** master copy

**teratogens** substances that cause birth defects

**tertiary** third level

**thermoregulation** temperature regulation

**transcribe** creation of an RNA copy of a DNA gene

**transcription** messenger RNA formation from a DNA sequence

**transcription factor** protein that increases the rate of transcription of a gene

**transduction** conversion of a signal of one type into another type

**transgenic** characterized by presence of one or more genes from a different organism

**translation** synthesis of protein using mRNA code

**translocation** movement of sugars and other nutrients throughout a plant

**transverse** situated or lying across

**trimer** a structure composed of three parts

**triploid** possessing three sets of chromosomes

**trophic** related to feeding

**trophic level** feeding level in an ecosystem

**true breeding** giving only offspring identical to the parents

**turgor** internal pressure

**ubiquitous** found everywhere

**ultrasonography** use of sound waves to produce an image

**ungulate** hoofed mammals such as cattle

**uninucleate** possessing one nucleus

**vas deferens** tube through which sperm travel from testes to urethra

**vector** carrier

**ventral to** toward the belly side

**ventricle** fluid-filled chamber

**venule** any of the minute veins connecting the capillaries with the larger systemic veins

**vesicle** membrane-bound sac

**vestigial** no longer functional

**visceral** related to the viscera, or internal organs

**viscous** thick

**vivipary** production of live young

**volatile** easily vaporized

**vulva** external female genitalia

**weak bond** low-energy arrangement between two atoms involving electron-sharing; weak bonds require less energy to break than strong bonds

**X-ray crystallography** use of X rays to determine the structure of a molecule

**xylem** water-transporting system in plants

**zygote** fertilized egg

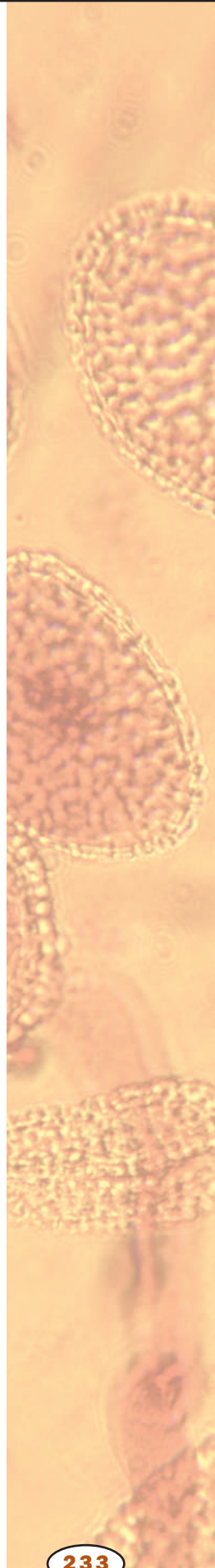

# Topic Outline

## **AGRICULTURE AND ECONOMIC BOTANY**

---

Agriculture  
Agronomist  
Beer-making, Botany of  
Coffee, Botany of  
Desertification  
Ethnobotany  
Forester  
Grain  
Grasses  
History of Agriculture  
Horticulturist  
Hybridization-Plant  
Landscape Ecology  
Nitrogen Cycle  
Nitrogen Fixation  
Organic Agriculture  
Plant Pathogens and Pests  
Pollution and Bioremediation  
Soil  
Vavilov, Nikolay  
Wine-making, Botany of

## **ANIMAL ANATOMY AND PHYSIOLOGY**

---

Amniote egg  
Animalia  
Circulatory Systems  
Connective Tissue  
Digestion  
Epithelium  
Excretory Systems  
Gas Exchange  
Growth  
Life Cycles  
Locomotion  
Model Organisms in Physiology and Medicine  
Muscle  
Nervous Systems  
Neuron  
Organ

Osmoregulation  
Physiological Ecology  
Respiration  
Scaling  
Sex Determination  
Skeletons  
Social Behavior  
Temperature Regulation  
Vision  
Zoology

## **ANIMAL BEHAVIOR**

---

Behavior, Genetic Basis of  
Behavior Patterns  
Feeding Strategies  
Field Studies in Animal Behavior  
Migration and Animal Navigation  
Mimicry, Camouflage, and Warning Coloration  
Pheromone  
Physiological Ecology  
Population Dynamics  
Predation and Defense  
Sexual Selection  
Symbiosis  
Temperature Regulation  
Wildlife Biologist

## **ANIMAL DIVERSITY**

---

Amphibian  
Animalia  
Annelid  
Arachnid  
Arthropod  
Biodiversity  
Bird  
Bony Fish  
Cambrian Explosion  
Cartilaginous Fish  
Chordata  
Cnidarian

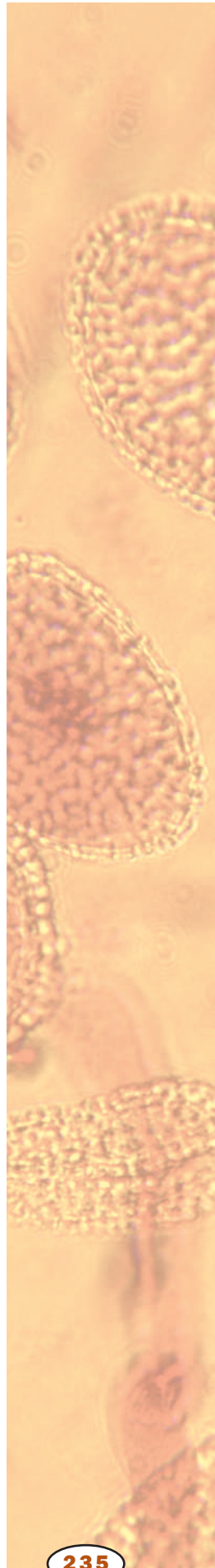

Coral Reef  
Crocodilian  
Crustacean  
Echinoderm  
Endangered Species  
Entomologist  
Extinction, Mammals  
Human Evolution  
Insect  
Mammal  
Marsupial  
Mollusk  
Monotreme  
Nematode  
Parasitic Diseases  
Platyhelminthes  
Porifera  
Primate  
Reptile  
Tuatara  
Tunicate  
Turtle  
Zoology  
Zoology Researcher

### **AQUATIC BIOLOGY**

---

Algae  
Amphibian  
Bony Fish  
Cartilaginous Fish  
Cnidarian  
Coral Reef  
Crustacean  
Echinoderm  
Estuaries  
Extreme Communities  
Lakes and Ponds  
Limnologist  
Marine Biologist  
Mollusk  
Ocean Ecosystems: Hard Bottoms  
Ocean Ecosystems: Open Ocean  
Ocean Ecosystems: Soft Bottoms  
Platyhelminthes  
Porifera  
Rivers and Streams  
Water

### **BACTERIA AND ARCHAEA**

---

Archaea  
Bacterial Cell  
Bacterial Diseases  
Bacterial Genetics  
Bacterial Viruses

Biotechnology  
Cell Evolution  
Cell Wall  
Chloroplast  
Clone  
Control of Gene Expression  
Cyanobacteria  
Dubos, René  
Ecosystem  
Eubacteria  
Microbiologist  
Mitochondrion  
Model Organisms: Cell Biology and Genetics  
Plant Pathogens and Pests  
Poisons  
Recombinant DNA  
Sexually Transmitted Diseases  
Transgenic Techniques

### **BEHAVIOR**

---

Behavior, Genetic Basis of  
Behavior Patterns  
Brain  
Competition  
Feeding Strategies  
Field Studies in Animal Behavior  
Flight  
Learning  
Locomotion  
Migration and Animal Navigation  
Mimicry, Camouflage, and Warning Coloration  
Pheromone  
Predation and Defense  
Sexual Reproduction  
Sexual Selection  
Sleep  
Social Behavior  
Sociobiology

### **BIOCHEMISTRY**

---

Amino Acid  
Antibodies in Research  
Biochemist  
Biogeochemical Cycles  
Carbohydrates  
Carbon Cycle  
DNA  
DNA Sequencing  
Drug Testing  
Electrophoresis  
Enzymes  
Glycolysis and Fermentation  
History of Biology: Biochemistry  
Krebs Cycle

Lipids  
 Lysosomes  
 Membrane Proteins  
 Metabolism  
 Mitochondrion  
 Nitrogen Cycle  
 Nitrogen Fixation  
 Nucleotides  
 Origin of Life  
 Oxidative Phosphorylation  
 Pauling, Linus  
 Peroxisomes  
 Pharmacologist  
 Poisons  
 Polymerase Chain Reaction  
 Prion  
 Protein Structure  
 Protein Synthesis  
 Radionuclides  
 RNA  
 Secondary Metabolites in Plants  
 Separation and Purification  
 Structure Determination  
 Vitamins and Coenzymes  
 Water

### **BIOLOGY AND SOCIETY**

---

Alcohol and Health  
 Anabolic Steroids  
 Behavior, Genetic Basis of  
 Biological Weapons  
 Biology of Race  
 Carson, Rachel  
 Creationism  
 Desertification  
 Doctor, Specialist  
 Dubos, René  
 Endangered Species  
 Ethnobotany  
 Evolution, Evidence for  
 Extinction, Mammals  
 Fire Ecology  
 Gene Therapy  
 Global Climate Change  
 Human Genome Project  
 Human Population  
 Invasive Species  
 Organic Agriculture  
 Pauling, Linus  
 Pollution and Bioremediation  
 Psychiatric Disorders, Biology of  
 Psychoactive Drugs  
 Recombinant DNA  
 Reproductive Technology  
 Sexually Transmitted Diseases

Smoking and Health  
 Sociobiology  
 Transgenic Techniques

### **BIOMES**

---

Biogeography  
 Biome  
 Coral Reef  
 Desert  
 Field Studies in Plant Ecology  
 Forest, Boreal  
 Forest, Temperate  
 Forest, Tropical  
 Global Climate Change  
 Grassland  
 Remote Sensing  
 Tundra

### **BIOTECHNOLOGY**

---

Antibodies in Research  
 Antisense Nucleotides  
 Bacterial Genetics  
 Bioinformatics  
 Biological Weapons  
 Biotechnology  
 Clone  
 Electrophoresis  
 Forensic DNA Analysis  
 Genomics  
 Human Genome Project  
 Hybridization  
 Polymerase Chain Reaction  
 Recombinant DNA  
 Reproductive Technology  
 Reverse Transcriptase  
 Separation and Purification  
 Structure Determination  
 Transgenic Techniques

### **CAREERS**

---

Agronomist  
 Biochemist  
 Botanist  
 College Professor  
 Dentist  
 Doctor, Family Practice  
 Doctor, Specialist  
 Emergency Medical Technician  
 Entomologist  
 Epidemiologist  
 Forester  
 Health and Safety Officer  
 High School Biology Teacher  
 Horticulturist

Laboratory Technician  
 Marine Biologist  
 Medical Assistant  
 Microbiologist  
 Microscopist  
 Nurse  
 Nurse Practitioner  
 Nutritionist  
 Pharmaceutical Sales Representative  
 Pharmacologist  
 Physician Assistant  
 Plant Pathologist  
 Psychiatrist  
 Public Health Careers  
 Science Writer  
 Veterinarian  
 Wildlife Biologist  
 Zoology Researcher

**CELL FUNCTION**

---

Active Transport  
 Cancers  
 Cell Cycle  
 Cell Motility  
 Control Mechanisms  
 Control of Gene Expression  
 Cytokinesis  
 Endocytosis  
 Enzymes  
 Exocytosis  
 Glycolysis and Fermentation  
 History of Plant Physiology  
 Hormones  
 Ion Channels  
 Krebs Cycle  
 Lysosomes  
 Meiosis  
 Membrane Proteins  
 Membrane Transport  
 Metabolism  
 Mitochondrion  
 Model Organisms: Cell Biology and Genetics  
 Nuclear Transport  
 Oxidative Phosphorylation  
 Peroxisomes  
 Protein Synthesis  
 Protein Targeting  
 Replication  
 Ribosome  
 RNA Processing  
 Signaling and Signal Transduction  
 Synaptic Transmission  
 Transcription

**CELL STRUCTURE**

---

Archaea  
 Bacterial Cell  
 Cell  
 Cell Evolution  
 Cell Junctions  
 Cell Motility  
 Cell Wall  
 Chloroplast  
 Connective Tissue  
 Cyanobacteria  
 Cytoskeleton  
 Electron Microscopy  
 Endoplasmic Reticulum  
 Epithelium  
 Eubacteria  
 Extracellular Matrix  
 Golgi  
 History of Biology: Cell Theory and Cell Structure  
 Ion Channels  
 Life, What Is  
 Light Microscopy  
 Lysosomes  
 Membrane Proteins  
 Membrane Structure  
 Membrane Transport  
 Microscopist  
 Mitochondrion  
 Model Organisms: Cell Biology and Genetics  
 Muscle  
 Neuron  
 Nuclear Transport  
 Nucleolus  
 Nucleus  
 Organelle  
 Origin of Life  
 Peroxisomes  
 Plasma Membrane  
 Porter, Keith  
 Ribosome  
 T Cells  
 Tissue  
 Vacuole

**CIRCULATION AND RESPIRATION**

---

Blood  
 Blood Clotting  
 Blood Sugar Regulation  
 Blood Vessels  
 Cardiovascular Diseases  
 Circulatory Systems  
 Gas Exchange  
 Harvey, William  
 Heart and Circulation



Lymphatic System  
 Physiological Ecology  
 Respiration  
 Smoking and Health  
 Temperature Regulation

### **DIGESTION AND EXCRETION**

---

Digestion  
 Digestive System  
 Excretory Systems  
 Human Nutrition  
 Kidney  
 Liver  
 Metabolism  
 Osmoregulation  
 Physiological Ecology

### **DISEASE AND HEALTH**

---

AIDS  
 Alcohol and Health  
 Anabolic Steroids  
 Autoimmune Disease  
 Bacterial Diseases  
 Birth Control  
 Blood Sugar Regulation  
 Cancers  
 Cardiovascular Diseases  
 Clinical Trials  
 Disease  
 Environmental Health  
 Female Reproductive System  
 Fungal Diseases  
 Gene Therapy  
 Health  
 Health and Safety Officer  
 Herbal Medicine  
 History of Medicine  
 Human Nutrition  
 Imaging in Medicine  
 Immune Response  
 Male Reproductive System  
 Model Organisms in Physiology and Medicine  
 Neurologic Diseases  
 Oncogenes and Cancer Cells  
 Pain  
 Parasitic Diseases  
 Poisonous Plants  
 Prion  
 Protozoan Diseases  
 Psychiatric Disorders, Biology of  
 Psychoactive Drugs  
 Sex Determination  
 Sexual Reproduction  
 Sexually Transmitted Diseases

Sleep  
 Smoking and Health  
 Stress Response  
 Transplant Medicine  
 Vaccines  
 Viral Diseases  
 Vitamins and Coenzymes

### **DNA, RNA, CHROMOSOMES**

---

Antisense Nucleotides  
 Chromosome Aberrations  
 Chromosome, Eukaryotic  
 Crick, Francis  
 DNA  
 DNA Sequencing  
 Gene  
 Genome  
 Medical/Science Illustrator  
 Meiosis  
 Mitosis  
 Mutation  
 Nucleotides  
 Polymerase Chain Reaction  
 Recombinant DNA  
 Replication  
 Sex Chromosomes  
 Transfer RNA  
 Watson, James

### **ECOLOGY**

---

Biogeochemical Cycles  
 Biogeography  
 Biome  
 Carbon Cycle  
 Community  
 Competition  
 Conservation  
 Coral Reef  
 Desert  
 Desertification  
 Ecological Research, Long-term  
 Ecology  
 Ecology, History of  
 Ecosystem  
 Endangered Species  
 Estuaries  
 Extinction, Mammals  
 Feeding Strategies  
 Field Studies in Plant Ecology  
 Fire Ecology  
 Forest, Boreal  
 Forest, Temperate  
 Forest, Tropical  
 Global Climate Change

Grassland  
Habitat  
Invasive Species  
Lakes and Ponds  
Landscape Ecology  
Limnologist  
Marine Biologist  
Mimicry, Camouflage, and Warning Coloration  
Nitrogen Cycle  
Ocean Ecosystems: Hard Bottoms  
Ocean Ecosystems: Open Ocean  
Ocean Ecosystems: Soft Bottoms  
Physiological Ecology  
Pollution and Bioremediation  
Population Dynamics  
Predation and Defense  
Remote Sensing  
Rivers and Streams  
Symbiosis  
Theoretical Ecology  
Tundra  
Water Cycle  
Wetlands

### **ENDOCRINE SYSTEM**

---

Adrenal Gland  
Anabolic Steroids  
Birth Control  
Blood Sugar Regulation  
Endocrine System  
Female Reproductive System  
Hormones  
Hypothalamus  
Pancreas  
Pituitary Gland  
Sex Determination  
Stress Response  
Thyroid Gland

### **EVOLUTION AND ADAPTATION**

---

Adaptation  
Amniote Egg  
Angiosperms  
Biodiversity  
Biogeography  
Buffon, Count (Georges-Louis Leclerc)  
Cambrian Explosion  
Cell Evolution  
C4 and CAM Plants  
Convergent Evolution  
Creationism  
Darwin, Charles  
Evolution  
Evolution, Evidence for

Evolution of Plants  
Extinction, Mammals  
Extreme Communities  
Hardy-Weinberg Equilibrium  
Herbivory and Plant Defenses  
History of Evolutionary Thought  
Human Evolution  
Lamarck, Jean-Baptiste  
Leakey Family  
Mimicry, Camouflage, and Warning Coloration  
Natural Selection  
Origin of Life  
Osmoregulation  
Paleontology  
Physiological Ecology  
Population Genetics  
Predation and Defense  
Scaling  
Secondary Metabolites in Plants  
Sociobiology  
Speciation  
Species

### **EXPERIMENTAL TECHNIQUES**

---

Antibodies in Research  
Antisense Nucleotides  
Biochemist  
Bioinformatics  
Biotechnology  
Cell Culture  
Clinical Trials  
Clone  
Crick, Francis  
DNA Sequencing  
Drug Testing  
Ecological Research, Long-term  
Electron Microscopy  
Electrophoresis  
Field Studies in Animal Behavior  
Field Studies in Plant Ecology  
Forensic DNA Analysis  
Gene Therapy  
Genetic Analysis  
Genomics  
Hardy-Weinberg Equilibrium  
History of Biology: Biochemistry  
History of Plant Physiology  
Human Genome Project  
Hybridization  
Imaging in Medicine  
Ingenhousz, Jan  
Laboratory Technician  
Leeuwenhoek, Anton  
Light Microscopy  
Linkage and Gene Mapping

Microbiologist  
 Microscopist  
 Model Organisms: Cell Biology and Genetics  
 Model Organisms: Physiology and Medicine  
 Pasteur, Louis  
 Pauling, Linus  
 Pharmacologist  
 Polymerase Chain Reaction  
 Porter, Keith  
 Radiation Hybrid Mapping  
 Radionuclides  
 Recombinant DNA  
 Reproductive Technology  
 Reverse Transcriptase  
 Scaling  
 Separation and Purification  
 Structure Determination  
 Theoretical Ecology  
 Transgenic Techniques  
 Transplant Medicine  
 Van Helmont, J. B.  
 Watson, James  
 Zoology Researcher

## **FUNGI**

---

Biodiversity  
 Cell  
 Cell Wall  
 Fungal Diseases  
 Fungi  
 Lichen  
 Mycorrhizae  
 Plant Pathogens and Pests  
 Symbiosis  
 Taxonomy, History of

## **GENE—PROTEIN**

---

Antisense Nucleotides  
 Chromosome, Eukaryotic  
 Control Mechanisms  
 Control of Gene Expression  
 DNA  
 Endoplasmic Reticulum  
 Gene  
 Genetic Code  
 Genetic Control of Development  
 Genetic Diseases  
 Hormones  
 McClintock, Barbara  
 Mutation  
 Nuclear Transport  
 Nucleolus  
 Nucleotides  
 Nucleus

Prion  
 Protein Structure  
 Protein Synthesis  
 Protein Targeting  
 Recombinant DNA  
 Retrovirus  
 Reverse Transcriptase  
 Ribosome  
 RNA  
 RNA Processing  
 Transcription  
 Transfer RNA  
 Transposon  
 Virus

## **GENETICS**

---

Bacterial Genetics  
 Bacterial Viruses  
 Behavior, Genetic Basis of  
 Biology of Race  
 Chromosome Aberrations  
 Chromosome, Eukaryotic  
 Clone  
 Control of Gene Expression  
 Crick, Francis  
 DNA  
 DNA Sequencing  
 DNA Viruses  
 Forensic DNA Analysis  
 Gene  
 Gene Therapy  
 Genetic Analysis  
 Genetic Code  
 Genetic Control of Development  
 Genetic Counselor  
 Genetic Diseases  
 Genome  
 Genomics  
 Hardy-Weinberg Equilibrium  
 History of Biology: Inheritance  
 Human Genome Project  
 Hybrid  
 Hybridization  
 Hybridization, Plant  
 Linkage and Gene Mapping  
 McClintock, Barbara  
 Meiosis  
 Model Organisms: Cell Biology and Genetics  
 Nucleotides  
 Patterns of Inheritance  
 Pedigrees and Modes of Inheritance  
 Population Genetics  
 Prion  
 Radiation Hybrid Mapping  
 Recombinant DNA

Replication  
 Retrovirus  
 Reverse Transcriptase  
 Transgenic Techniques  
 Transposon  
 Virus  
 Watson, James

### **HISTORY OF BIOLOGY**

---

Buffon, Count (Georges-Louis Leclerc)  
 Carson, Rachel  
 Crick, Francis  
 Darwin, Charles  
 De Saussure, Nicolas  
 Dubos, René  
 Ecology, History of  
 Gray, Asa  
 Harvey, William  
 History of Agriculture  
 History of Biology: Biochemistry  
 History of Biology: Cell Theory and Cell Structure  
 History of Biology: Inheritance  
 History of Evolutionary Thought  
 History of Medicine  
 History of Plant Physiology  
 Ingenhousz, Jan  
 Lamarck, Jean-Baptiste  
 Leakey Family  
 Leeuwenhoek, Anton  
 Linnaeus, Carolus  
 McClintock, Barbara  
 Mendel, Gregor  
 Pasteur, Louis  
 Pauling, Linus  
 Porter, Keith  
 Taxonomy, History of  
 Torrey, John  
 Van Helmont, J. B.  
 Vavilov, Nikolay  
 Vesalius, Andreas  
 Von Humboldt, Alexander  
 Watson, James

### **IMMUNE SYSTEM**

---

AIDS  
 Antibodies in Research  
 Antibody  
 Autoimmune Disease  
 Immune Response  
 Lymphatic System  
 Nonspecific Defense  
 Stress Response  
 T Cells

Transplant Medicine  
 Vaccines

### **INHERITANCE**

---

Bacterial Genetics  
 Behavior, Genetic Basis of  
 Biology of Race  
 Cell Cycle  
 Chromosome Aberrations  
 Clone  
 DNA  
 Feeding Strategies  
 Genetic Counselor  
 Genetic Diseases  
 History of Biology: Inheritance  
 Hybridization-Plant  
 Life Cycles  
 Linkage and Gene Mapping  
 Meiosis  
 Mendel, Gregor  
 Mitosis  
 Model Organisms: Cell Biology and Genetics  
 Mutation  
 Patterns of Inheritance  
 Pedigrees and Modes of Inheritance  
 Radiation Hybrid Mapping  
 Replication  
 Transgenic Techniques

### **INTERACTIONS, POPULATIONS, AND COMMUNITIES**

---

Behavior Patterns  
 Biogeography  
 Community  
 Competition  
 Ecological Research, Long-term  
 Ecology, History of  
 Ecosystem  
 Feeding Strategies  
 Field Studies in Animal Behavior  
 Field Studies in Plant Ecology  
 Fire Ecology  
 Habitat  
 Herbivory and Plant Defenses  
 Human Population  
 Invasive Species  
 Landscape Ecology  
 Lichen  
 Mimicry, Camouflage, and Warning Coloration  
 Mycorrhizae  
 Pheromone  
 Population Dynamics  
 Population Genetics  
 Predation and Defense

Symbiosis  
Theoretical Ecology  
Von Humboldt, Alexander

### **LIFE CYCLES**

---

Aging, Biology of  
Alternation of Generations  
Amniote Egg  
Cell Cycle  
Cnidarian  
Development  
DNA Sequencing  
Female Reproductive System  
Ferns  
Fetal Development, Human  
Growth  
Life Cycle, Human  
Life Cycles  
Male Reproductive System  
Reproduction in Plants  
Seedless Vascular Plants  
Seeds  
Sexual Reproduction  
Slime Molds

### **NERVOUS SYSTEM**

---

Biological Weapons  
Brain  
Central Nervous System  
Chemoreception  
Eye  
Hearing  
Hypothalamus  
Ion Channels  
Nervous Systems  
Neurologic Diseases  
Neuron  
Pain  
Peripheral Nervous System  
Psychiatric Disorders, Biology of  
Psychiatrist  
Psychoactive Drugs  
Spinal Cord  
Stress Response  
Synaptic Transmission  
Touch  
Vision

### **PLANT ANATOMY AND PHYSIOLOGY**

---

Alternation of Generations  
Anatomy of Plants  
Beer-making, Botany of  
C4 and CAM Plants  
Cell Wall

Chloroplast  
De Saussure, Nicolas  
Differentiation in Plants  
Flowers  
Fruits  
Grain  
History of Plant Physiology  
Hormones, Plant  
Hybridization-Plant  
Ingenhousz, Jan  
Leaves  
Meristems  
Mycorrhizae  
Nitrogen Fixation  
Photoperiodism  
Photosynthesis  
Plant Development  
Plant Nutrition  
Plant Pathogens and Pests  
Poisonous Plants  
Pollination and Fertilization  
Propagation  
Reproduction in Plants  
Rhythms of Plant Life  
Roots  
Secondary Metabolites in Plants  
Seed Germination & Dormancy  
Seeds  
Senescence  
Shoots  
Soil  
Translocation  
Tropisms and Nastic Movements  
Van Helmont, J. B.  
Water Cycle  
Water Movement in Plants  
Wine-making, Botany of  
Wood and Wood Products

### **PLANT DIVERSITY**

---

Angiosperms  
Biodiversity  
Biogeography  
Bryophytes  
C4 and CAM Plants  
Conifers  
Eudicots  
Evolution of Plants  
Ferns  
Grasses  
Gray, Asa  
Gymnosperms  
Hybridization-Plant  
Monocots

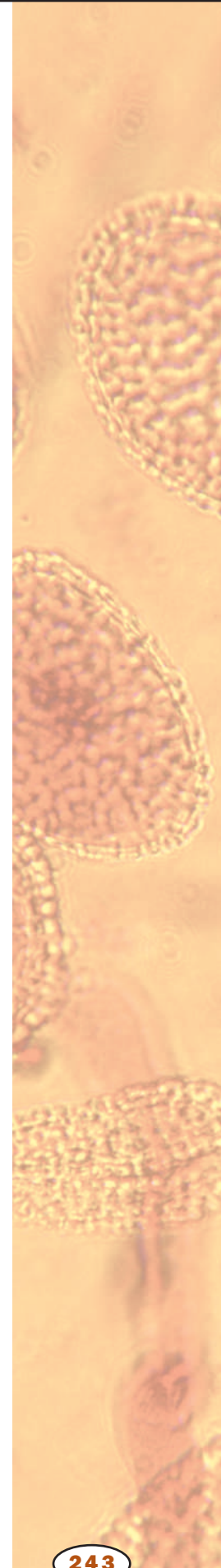

Plant  
Seedless Vascular Plants  
Torrey, John  
Vavilov, Nikolay  
Von Humboldt, Alexander

---

**PROTISTS**

Algae  
Beer-making, Botany of  
Cell  
Coral Reef  
Evolution of Plants  
History of Biology: Cell Theory and Cell Structure  
Leeuwenhoek, Anton  
Lichen  
Model Organisms: Cell Biology and Genetics  
Plankton  
Protista  
Protozoa  
Protozoan Diseases  
Slime Molds

---

**REPRODUCTION AND DEVELOPMENT**

Aging, Biology of  
Birth Control  
Cell Cycle  
Cytokinesis  
Development  
Female Reproductive System  
Fetal Development, Human  
Genetic Diseases  
Life Cycle, Human  
Life Cycles  
Male Reproductive System  
Meiosis  
Mitosis  
Reproductive Technology  
Sexual Reproduction  
Sexually Transmitted Diseases

---

**SKIN, MUSCLE, AND BONE**

Body Cavities  
Bone  
Connective Tissue  
Epithelium  
Growth  
Locomotion  
Muscle  
Musculoskeletal System  
Skeletons  
Skin

---

**TAXONOMY AND BIODIVERSITY (SEE ALSO ANIMAL DIVERSITY AND PLANT DIVERSITY)**

Animalia  
Archaea  
Biodiversity  
Eubacteria  
Evolution of Plants  
Fungi  
Kingdom  
Lamarck, Jean-Baptiste  
Leeuwenhoek, Anton  
Linnaeus, Carolus  
Plant  
Protista  
Speciation  
Species  
Taxonomy, History of

---

**VIRUSES AND PRIONS**

AIDS  
Bacterial Viruses  
Plant Pathogens and Pests  
Prion  
Retrovirus  
Reverse Transcriptase  
Sexually Transmitted Diseases  
Viral Diseases  
Virus

# Cumulative Index

*Boldface type indicates article titles; italics indicate illustrations; an italic f after a page number indicates figures; and an italic t after a page number indicates tables.*

## A

- α-amino acid side chains, **1:24**
- ABA. *See* Abscisic acid
- Abbe, Ernst, **3:39**
- Abdominal cavity, **1:92**
- Abdominal muscles, **4:64–65**
- Abducens nerve, **1:103**
- Abductors, **3:115**
- Abelson oncogene (ABL), **1:140**, **3:157**
- Abiotic environments, **1:3–4**, **2:7**
- ABL gene. *See* Abelson oncogene
- ABO blood types, **1:77**
- Abortion, **1:83**
- Abscisic acid (ABA), **2:207**, **3:209**, **212**
- Abscission, **4:91–92**
- Abscission zone, **3:29**
- Absorption
  - alcohol, **1:17**
  - nutrients in plants, **1:30**
- Absorption chromatography, **4:93**
- Absorptive metabolic state, **3:88**
- Acanthodellida, **1:36**, **37**
- Acanthodactylus*. *See* Lacertid lizards
- α-carbon atoms, **1:24**
- Acari. *See* Mites
- Accessory enzymes, **4:48–50**
- Accessory fruits. *See* False fruits
- Accessory sex glands, **3:58**
- Acetaldehyde dehydrogenase, **1:18**
- Acetate, alcohol and, **1:18**
- Acetyl coenzyme A, **3:18**, **97**
- Acetylation, of histones, **1:144**, **176–177**
- Acetylcholine, **4:147**
  - food poisoning, **3:225**
  - muscle contraction, **3:110–111**
- Acetylcholinesterase, **4:147**
- Acetyltransferases, **1:144**
- Achenes, **4:56**
- Achondroplasia, **3:181**
- Acid hydrolases, **3:55**, **56**
- Acid rain, **3:228–229**
- Acid-base relations, **2:32**
- Acidosis, **2:201**
- Acinar cells, **3:174**
- Acquired characteristics, inheritance
  - of, **2:189**, **194**, **3:23–24**
- Acquired diseases, **2:28**
- Acquired immunity. *See* Immune response
- Acquired immunodeficiency syndrome. *See* AIDS
- Acromegaly, **2:161**
- Acrylamide gel electrophoresis, **1:224f**, **225**
- ACTH. *See* Adrenocorticotrophic hormone
- Actin, **1:37–38**, **39**
  - cytoskeleton, **1:191**, **193–194**, **194**
  - muscles, **3:110**
- Actinopterygii. *See* Ray-fins
- Action potentials, **2:175**, **3:131**, **134**
  - muscle contraction, **3:110**
  - plasma membranes and, **3:220**
  - synaptic transmission and, **4:145–146**
  - touch, **4:161–162**
- Activation energy, **2:31**
- Activators, **1:171**, **173–175**
- Active site, **2:29–33**
- Active transport, **1:1–3**, **3:79**
- Acupuncture, for pain, **3:171**
- Acute diseases, **1:221**
- Acyclovir, **4:109**
- Adaptation, **1:3–5**
  - biogeographical, **1:70–71**
  - defense mechanism, **4:2**
  - evolutionary theory, **2:47–48**, **193–194**, **3:24**
  - extreme environments, **2:69–70**
  - fire survival, **2:89**
  - high altitudes, **3:204**
  - learning and, **3:27–28**
  - leaves, **3:30**
  - life cycles, **3:34**
  - marine environments, **3:203–204**
  - natural selection and, **3:122**, **123**
  - prey, **4:3–4**
  - temperature, **3:202–203**
- Adaptive immunity. *See* Immune response
- Adaptive radiation, **2:51**, **66**
- ADD. *See* Attention deficit disorder
- Addiction
  - nicotine, **4:126**
  - psychoactive drugs, **4:31–33**
- Addison's disease, **1:89**
- Adenine, **3:143–144**, **4:76**
- Adenosine deaminase deficiency, **2:124**, **125**
- Adenosine diphosphate (ADP), **2:148**, **3:144**
- Adenosine monophosphate (AMP), **3:144**
- Adenosine triphosphate (ATP), **1:2**, **2:148–149**, **184–185**, **3:144**
  - active transport, **3:79**
  - auxin and, **3:211**
  - glucose, **1:87**
  - Krebs cycle, **3:18–19**
  - metabolic pathways and, **3:85–86**
  - mitochondria and, **1:121**, **3:94**, **97–99**
  - muscle contraction, **3:111**
  - oxidative phosphorylation, **3:168–170**
  - photosynthesis, **3:198**, **199–200**
  - STI571, **3:157**

- Adenoviruses, 1:227, 2:124–125  
 Adenylate cyclase, 4:116  
 ADH. *See* Antidiuretic hormones  
 Adherens junctions, 1:130  
 Adipocytes. *See* Lipids  
 Administrative medical assistants, 3:65  
 Adolescent development, 3:33  
 Adoption, embryo, 4:62  
 ADP. *See* Adenosine diphosphate  
 Adrenal cortex, 1:5–7, 2:22  
 Adrenal glands, 1:5–7, 6, 2:22, 4:139–140  
 Adrenal medulla, 1:5–6, 2:22  
 Adrenaline. *See* Epinephrine  
 Adrenocorticotrophic hormone (ACTH), 1:6–7, 4:140  
 Adrenogenital syndrome (AGS), 4:98  
 Adrian, Edgar Douglas, 2:197  
 Adult nurse practitioners (ANPs), 3:149  
 Advanced practice nursing, 3:148  
 Adventitious roots, 3:106, 4:81, 198  
 AEC. *See* Atomic Energy Commission  
 Aerenchyma, 4:198  
 Aerobic bacteria cells, 1:127  
 Aerobic ocean zone, 3:154  
 Aerobic respiration, 3:111  
*Aeropyrum pernix* K1, 1:46  
 Afferent neurons. *See* Sensory neurons  
 Affinity chromatography, 4:93–94  
 Aflatoxins, 2:108  
 Africa  
   coffee, 1:155–156  
   deserts, 1:201  
   grasslands, 2:156  
   history of farming, 2:181  
   hominins, 2:210  
   human evolution, 2:210–212  
   human origins, 3:26  
   lacertid lizards, 1:183  
   *Onchocerca volvulus* in, 3:176  
   primates, 4:4, 5  
   savannas, 2:157  
   sickle-cell allele, 3:236  
 African pygmies, 2:161  
 African sleeping sickness, 4:26  
 Agamospermy. *See* Parthenocarpy  
 Agar, 1:21  
 Agarose, 2:13, 14  
 Aggregate fruits, 2:107, 4:56  
 Aggregation  
   integral membrane proteins, 3:221  
   origins of life, 3:162  
   protein, 4:18  
   coral reefs, 1:183–184  
   grazing, 2:74  
   intertidal, 3:150  
   lichens and, 3:31–32  
   photosynthesis, 3:196  
   plant evolution, 2:55  
   protist, 4:22  
   protozoans and, 4:23–24  
   rivers and streams, 4:74–75  
*Alice in Wonderland*, 4:103  
 Alien species. *See* Exotic species  
 Alkaloids, 2:178, 4:84  
 Alkalosis, 2:201  
 Allantois, 1:26  
 Allard, Henry, 3:195  
 Alleles, 2:127–128, 3:186  
   dominance, 3:179–180  
   frequencies, 2:164–165  
   genetic diseases and, 2:137  
   genetic diversity and, 3:236–239  
   linkage and, 3:43–44  
   mutations and, 3:117–118, 179, 180–181  
   *See also* Genetics  
 Allelopathy, 4:84  
 Allergies. *See* Hypersensitivity  
 Allografts. *See* Homografts  
 Allometric analysis, 4:81–83  
 Allopatric speciation, 4:134–135  
 Allosteric regulation, 1:177–178  
 Allosteric sites, 2:34, 35  
 Alpha helices in proteins, 4:9  
 Alpha polymerase, 4:51  
 Alpha-amino acids, 1:24  
 Alphoid satellite DNA, 1:147–148  
 Alpine tundra, 4:177–178  
 Alternation of generations, 1:22–24, 23, 3:66  
   plants, 3:207  
   pteridophytes, 4:34  
   spore-producing, 4:89  
   sporic meiosis, 1:22  
 Altruism, 4:125, 131  
 Alu gene sequence, 1:148, 4:175  
 Alveolates, 4:22  
 Alveoli, 4:64, 65  
*Alvin* (Submarine), 2:70  
 Alzheimer's disease, 3:129, 134  
 Amazon River, 4:73  
*Amborella trichopoda*, 1:32, 33  
 Amborellaceae, 1:32  
 Amebae. *See* Amoebae  
 Amebiasis, 4:26  
 Amensalism, 4:143  
 American Association of Poison Control Centers, 3:224



- American Board of Pediatrics, 1:231  
 American Board of Psychiatry and Neurology, 1:230  
 American Dietetics Association, 3:150  
 American Physiological Society, 3:134  
 American Public Health Association (APHA), 2:167, 4:35  
 Ames, Bruce, 3:117  
 Ames test, 3:115  
 Amino acids, 1:24–25  
   antibodies and, 1:39  
   genetic code and, 2:129–131  
   Krebs cycle and, 3:18–19  
   mutations, 3:115–117  
   origins of life, 3:163  
   protein structure, 4:7–13, 8f  
   protein synthesis, 4:13–19  
   ribosomes and, 4:71  
   *See also* Proteins  
 Aminoacyl tRNAs, 4:16  
 Ammonification, 3:135  
 Amniocentesis, 2:84  
 Amnion, 1:26, 2:82  
 Amniotes, 1:26  
 Amniotic egg, 1:25–26  
 Amoebae, 4:24, 25, 26  
 Amoebocytes, 3:239  
 Amoeboid motion, 3:51  
 Amoxicillin, 1:50  
 AMP. *See* Adenosine monophosphate  
 Amphetamines, 4:31, 33  
 Amphibians, 1:26–27, 36  
   brain in, 3:128  
   circulatory systems of, 1:150, 151  
   cloning of, 1:154  
   growth in, 2:159  
   lungs in, 2:116–117  
   *See also specific amphibians*  
 Amphipathic nature  
   diglycerides, 3:48–49  
   phospholipids, 3:73–75  
 Amphisbaenians, 4:62–63  
 Ampicillin, 1:50  
 Amygdala, 1:101–102  
 Amylase, 1:218, 3:174  
*Anabaena*, 3:136  
 Anabolic steroids, 1:27–28, 28  
   *See also* Steroids  
 Anabolism, 3:85–86, 87  
 Anadromous fish, 3:36–37  
 Anaerobic bacteria, 1:127  
 Anaerobic ocean zone, 3:154  
 Anaerobic respiration, 3:111  
 Anagenesis, 4:134  
 Analytical biochemists, 1:66  
 Analytical Profile Index test, 1:54  
 Anaphase, 3:100  
*Anatomical Studies on the Motion of the Heart and Blood in Animals* (Harvey), 2:166  
 Anatomy, 1:76  
   ear, 2:170–171, 170f  
   echinoderms, 2:1–2  
   eye, 2:72–73  
   female reproductive system, 2:77–78  
   heart, 2:173–174, 173f  
   hypothalamus, 2:223, 224f  
   illustrations of, 3:65–66  
   insects, 3:7–9  
   kidneys, 3:15–16, 15f  
   leaves, 3:29–30, 29f  
   liver, 3:50  
   lymphatic system, 3:52–54, 53f  
   male reproductive system, 3:56–57, 59f  
   mammals, 3:59–60  
   medicine and, 2:197  
   nervous systems, 3:125–128  
   neurons, 3:132f, 133  
   peripheral nervous system, 3:190f, 191  
   plant roots, 4:79–80  
   plants, 1:29, 29–31  
   respiratory system, 4:64  
   shoots, 4:110  
   Vesalius, Andreas and, 4:184  
*Anatomy* (Clemente), 4:184  
*Ancylostoma duodenale*, 3:175  
 Androecium, 2:93  
 Androgen-insensitivity syndrome (AIS), 4:98  
 Androgenic steroids. *See* Anabolic steroids  
 Androgens, 3:56–57  
 Anemia  
   anabolic steroids for, 1:28  
   from *Diphyllobothrium latum*, 3:175  
   iron and, 1:84  
 Anemones, 1:35, 155, 3:150  
 Anemophily, 3:227  
 Anesthesia, 2:197  
 Anesthetics, 4:31, 32  
 Aneuploids, 1:140  
 Aneurysms, 1:115–116, 3:2  
 Anfinsen, Christian, 4:6  
 Angina pectoris, 1:116  
 Angiogenesis, 1:91  
 Angiography, 3:1, 131  
 Angiosperms, 1:31–34, 32, 2:57–59, 3:208  
   cell walls of, 1:133  
   chromosome changes in, 1:141–142  
   divisions of, 3:106  
   fertilization in, 1:24, 4:54–55  
   flowers of, 2:93–94  
   fruits of, 2:105–108  
   marine, 3:153  
   pollination in, 3:227–228  
   seeds in, 4:90  
   sexual reproduction in, 4:52–53  
   translocation in, 4:169–170  
   *See also* Eudicots; Plants  
 Angiotensin, 4:139  
 Animal behavior. *See* Behavior  
 Animal starch. *See* Glycogen  
 Animalia. *See* Animals  
 Animals, 1:34–36  
   benthic, 3:150–151, 153–154  
   Cambrian period, 1:108–109  
   cell division in, 3:99  
   classification, 3:17  
   cloning of, 1:154  
   coral, 1:183  
   estuarine, 2:38–39  
   excretory systems in, 2:60–62  
   gas exchange in, 2:114, 115–117  
   grasslands, 2:157–158  
   growth in, 2:158–159  
   heterotrophs, 2:8  
   locomotion of, 3:50–52  
   mating systems of, 3:62–64  
   migration of, 3:92–93  
   mimicry in, 3:94  
   mitosis in, 3:98–100  
   model organisms, 3:101–105  
   mutualisms in, 4:143, 144  
   nonspecific defenses in, 3:138–140  
   protective coloration in, 3:93–94  
   rivers and streams, 4:73–75  
   scaling in, 4:81–83  
   skeletons in, 4:118  
   social behavior in, 4:127–130  
   tropical forests, 2:102–104  
   vision in, 4:188–190  
   zoology and, 4:204–205  
   *See also specific animals and animal species*  
 Annealing. *See* Hybridization  
 Annelids, 1:36–37  
   Cambrian period, 1:108  
   protostomes, 1:209  
   *See also* Segmented worms  
 Anning, Mary, 3:173

- Annual plants, 4:91  
 Anogenital herpes. *See* Genital herpes  
 ANPs. *See* Adult nurse practitioners  
 Antagonists, muscles as, 3:114–115  
 Antarctic Dry Valleys, 2:71  
 Anteaters, 3:108  
 Antelope, 2:157  
 Antennae, 3:7–8  
 Antennal glands, 3:167  
 Anther sacs, 2:93  
 Antheridia, 4:34  
 Anthers, 4:53–54  
 AnthoceroPHYta. *See* Hornworts  
 Anthocyanins, 3:216  
 Anthophyta. *See* Angiosperms  
 Anthrax as biological weapon, 1:75  
 Anthrax vaccines, 3:177  
 Anthropogeny, 1:69  
 Anthropoidea, 4:4  
 Anthropology, 2:40  
 Antiarrhythmia drugs, 3:14  
 Antibiotic resistance, 1:234, 2:50, 50–51, 3:122–123, 4:42  
 Antibiotics  
   bacteria and, 1:50, 52–53  
   bacterial ribosomes and, 4:72  
   cloning, 1:153–154  
   Dubos, René and, 1:233–234  
   elongation phase, 4:17  
   fungi, 2:112  
   syphilis, 4:108  
 Antibodies, 1:39–41, 40  
   B cells and, 4:150  
   cell research, 1:37–39  
   immune response, 3:5, 139  
   passive immunity, 4:182  
   proteins and, 3:138  
   Tonegawa, Susumu and, 2:120  
 Antibody genes, 3:156  
 Antibody-mediated immunity, 1:39, 3:5, 4:148–150  
 Anticancer drugs, 4:49  
 Anticodons, 2:130, 4:13, 15–16  
 Antidepressants, 4:31, 33  
 Antidiuretic hormones (ADH), 3:167, 205  
 Antidotes, 3:226  
 Anti-epileptic drugs, 3:14  
 Antievolution statutes, 1:186  
 Antifreeze, in ectotherms, 3:202  
 Antigen-presenting cells (APCs), 3:4–5, 5f, 4:149  
 Antigens  
   antibodies and, 1:37, 39–41  
   immune response and, 3:4  
   T cells and, 4:148  
 Antihistamines, 4:31  
 Anti-HIV agents, 1:16, 17  
 Antihypertensive drugs, 3:14  
 Antimicrobials. *See* Antibiotics  
 Antioxidants, 1:9, 2:70, 4:191  
 Antipredator behavior. *See* Defensive behavior  
 Antipsychotic drugs, 4:33  
 Antisense nucleotides, 1:41–42, 46  
 Antitoxins, 3:185  
 Antivenoms, 3:226, 4:182  
 Antivirals, 4:49, 187  
 Ants  
   colonies of, 4:129–130  
   pheromones in, 3:194–195  
 Anura. *See* Frogs  
 Aorta, 2:174  
 Aortic valve, 2:174  
 APCs. *See* Antigen-presenting cells (APCs)  
 Apes, 2:209–210, 4:4  
 APHA. *See* American Public Health Association  
 Aphanoneura, 1:36  
 Aphids, 3:9, 218  
 API test. *See* Analytical Profile Index test  
 Apiaceae. *See* Carrots  
 Apical-basal polarity, 3:208  
 Apical dominance, 2:206  
 Apical meristems, 3:82–84, 209, 210–211, 211f, 213  
   *See also* Meristems  
 Apicomplexa, 4:22, 24, 26–27  
 Apligraf, 4:174  
 Apocrine sweat glands, 4:120–121  
 Apoproteins, 4:12  
 Aposematic coloration. *See* Warning coloration  
 Appendicitis, 3:54  
 Appendicular skeleton, 4:118  
 Appetite suppressants, 4:31  
 Apple scab, 3:217  
 $\alpha$ -proteobacteria, 2:42  
 Apterygota, 2:92  
 Aquatic ecosystems, 1:167, 4:73  
 Aquatic insects, 3:36  
 Aquatic organisms, 3:51  
 Aquatic worms, 3:125  
 Aqueous humor, 2:72  
*Arabidopsis thaliana*, 3:101–102  
 Araceae, 3:106  
 Arachnids, 1:42–43  
 Araneae. *See* Spiders  
 Araucarias, 1:162  
 Arbuscular mycorrhizae, 3:119–120  
 Arbutoid mycorrhizae, 3:120  
 Archaea, 1:43–46, 44  
   *vs.* bacteria, 1:48  
   cell walls of, 1:134  
   classification of, 3:17, 4:153–154  
   *vs.* eubacteria, 2:41  
 Archaeobacteria, 1:127, 3:17, 4:154  
*Archaeofructus*, 2:59  
 Archaeocyatha, 1:109  
*Archaeoglobus fulgidus*, 1:46  
*Archaeopteryx*, 1:81  
 Archegonia, 4:34, 88  
 Archespore, 4:53  
 Arctic tundra, 2:90, 4:177  
*Ardipithecus ramidus*, 2:210  
 Arid environments, 3:202–203  
 Aridity in deserts, 1:201–202  
 Arils, 4:55  
 Aristotle, 2:166  
   classification and, 4:152  
   embryology, 1:205  
   evolution and, 2:193  
   inheritance, 2:189  
   medicine, 2:196  
   zoology and, 4:204  
 Arnon, Daniel, 2:184  
 Aromatic compounds, 3:185  
 Arrector pili, 4:120  
 Arrhythmias, 1:115  
 Arteries, 1:89–90, 151, 2:174  
 Arterioles, 1:90  
 Arthritis, 1:47, 3:112  
 Arthropods, 1:36  
   Cambrian period, 1:109  
   compound eyes in, 4:188  
   excretory system in, 2:61  
   eyes in, 2:73  
   intertidal, 3:150–151  
   parasitic, 3:176  
   plant pests, 3:218  
   protostomes, 1:209  
   *See also specific arthropods*  
 Articular cartilage, 3:112, 113  
 Artificial insemination (AI), 4:60  
 Artificial organs, 4:174  
 Artificial selection, 1:60–61  
 Artificial skin, 4:174  
 Artificial tissues, 4:174  
 Ascomycota, 2:113, 3:120–121  
 Asexual reproduction, 4:101–102  
   algae, 1:21  
   life cycles and, 3:35  
   meristems and, 3:81–82  
   plants, 4:7, 58–59, 102  
   *See also* Reproduction

- Asia  
 deserts in, 1:201  
 grasslands in, 2:156  
 human populations in, 2:219  
 primates in, 4:4, 5  
 rice in, 2:153
- Aspartate transcarbamoylase (AT-Case), 1:177
- Aspergillus flavus*, 2:108, 111
- Aspirin, for pain, 3:171
- Association cortex, 1:100
- Assyria, history of farming in, 2:181
- Asteraceae. *See* Composite family
- Asterids, 1:33
- Asterozoa. *See* Echinoderms
- Astral microtubules, 1:191
- Astrobiology, 3:164
- Asymmetry, of membrane structure, 3:76
- Atacama desert (Chile), 2:71
- Ataxia, 1:103
- AT-Case. *See* Aspartate transcarbamoylase
- ATF. *See* Bureau of Alcohol, Tobacco and Firearms
- Atherosclerosis, 1:116
- Athletes, anabolic steroid use, 1:27, 28
- Athlete's foot. *See* Tinea
- Atlas of Human Anatomy* (Netter), 4:184
- Atmosphere  
 extreme environment, 2:71  
 phytoplankton and, 3:152–153  
 water exchange with, 4:193
- Atmospheric nitrogen, 3:135, 136
- Atolls, 1:184
- Atomic Bomb Casualty Commission, 2:213
- Atomic bomb survivors, 2:213
- Atomic Energy Commission (AEC), 2:213
- Atomic force microscopes, 2:13
- ATP. *See* Adenosine triphosphate
- ATP-driven pumps, 1:2
- ATPase, 2:185, 3:97–98, 168, 169–170
- Atrium, 1:89–90, 2:173–174
- Atropine, 4:32
- Attention deficit disorder (ADD), 3:3, 4:30
- Auditory canal, 2:170
- Auditory cortex, 2:172
- Auditory ossicles, 2:171
- Auditory processing, 3:128
- Australia  
 coral reefs in, 1:184  
 desert lizards in, 1:182  
 deserts in, 1:201  
 fire ecology in, 2:89  
 population growth in, 2:219  
 savannas in, 2:157
- Australian Sports Drug Testing Laboratory, 1:233
- Australopithecus*, 2:210
- Australopithecus boisei*, 3:26
- Autoantigens, 1:47–48
- Autocrine signaling, 4:114
- Autografts, 4:172
- Autoimmune diseases, 1:47, 47–48
- Autologous chondrocyte implantation, 3:112
- Autolysis, 1:57
- Autonomic nervous system, 1:102, 3:190–191, 190f
- Autonomic processes, 3:127–128
- Autophagy, 3:56
- Autopsies, 2:197
- Autosomal disorders, 2:139
- Autosomal dominant inheritance, 3:186f, 187
- Autosomal recessive inheritance, 3:187–188, 188f
- Autosomal traits, 3:181
- Autotrophs, 2:8, 198, 3:206
- Auxins, 1:29, 217, 2:200, 206–207, 3:82, 84, 209  
 plant growth, 3:211  
 tropisms and, 4:176
- Avena sativa*. *See* Oats
- Avery, Oswald, 1:57, 233, 2:185, 191
- Avians. *See* Birds
- Avocados, 1:33
- Axial skeleton, 4:118
- Axoaxonal synapses, 4:146
- Axodendritic synapses, 4:146
- Axons, 1:98, 103, 3:133, 4:138, 145
- Axosomatic synapses, 4:146
- Axospinous synapses, 4:146
- Azolla*, 3:136
- B**
- B cells, 4:149–151  
 antibodies and, 1:37–40  
 autoimmunity, 1:47–48, 48  
 immune response, 3:4–6
- B lymphocytes. *See* B cells
- $\beta$  strands, of proteins, 4:9
- Baboons, 4:4–5
- Bacillus*, 2:41
- Bacillus anthracis*. *See* Anthrax
- Bacillus subtilis*, 1:57
- Backcrossing, 2:222
- BACs. *See* Bacterial artificial chromosomes
- Bacteria, 1:48  
 vs. archaea, 1:44–46  
 autotrophs/heterotrophs, 2:8  
 cell motility in, 1:131–132  
 cell walls of, 1:133–134  
 cells of, 1:48–52, 119–120, 127  
 chloroplasts and, 1:138  
 classification of, 3:17  
 DNA cloning, 1:152–154, 4:39–42, 39–43  
 lakes and ponds, 3:23  
 living conditions of, 3:165  
 mitochondria from, 3:95  
 nitrogen-fixing, 3:135, 136–137, 4:80  
 oceans, 3:153–154  
 origins of, 3:161  
 photosynthesis in, 3:196–197  
 symbiotic, 3:136–137, 137, 4:144  
*See also* Eubacteria; specific types of bacteria
- Bacterial artificial chromosomes (BACs), 1:154, 4:44–45
- Bacterial diseases, 1:52–53, 2:43  
 antibiotics for, 4:17  
 heart damage from, 1:117  
 in plants, 3:217  
 sexually transmitted, 4:107–109
- Bacterial genetics, 1:53–57, 54, 56, 57
- Bacterial viruses. *See* Bacteriophages
- Bacteriology, 3:219
- Bacteriophages, 1:58–59, 59  
 cloning, 1:154  
 Delbrück, Max and, 1:228  
 genome, 2:185  
 transduction of, 1:53, 55, 57
- Bacterioplankton, 3:206
- $\beta$ -adrenergic receptors, 4:114
- Bacteroids, 3:137
- Bailey, J. M., 1:62
- Baker, Kathleen Drew, 1:22
- Balanus*. *See* Barnacles
- Bald eagles, recovery of, 2:18
- Baltimore, David, 4:68
- Banting, Frederick, 3:103
- Barbiturates, 3:225, 4:31, 33
- Barley, 1:59–60, 2:154
- Barnacles  
 competition in, 1:161  
 intertidal, 3:151
- Barnard, Christian, 4:173
- Barophilic organisms, 3:204
- Barr, Murray, 4:96
- Barr bodies, 4:95, 96

- Barrier methods of birth control, **1:83**
- Barrier reefs, **1:184**
- Barriers, physical, **3:138**
- Basal ganglia. *See* Basal nuclei
- Basal lamina, **2:68**
- Basal metabolic rate (BMR), **3:88, 4:158**  
*See also* Metabolism
- Basal nuclei, **1:99, 101–102**
- Basal pons, **1:102**
- Basal protists, **4:22**
- Base pairing, **4:47**
- Basidiomycota, **2:113, 3:120–121**
- Basket stars, **2:1**
- Batesian mimicry, **3:94**
- Bats  
  flight in, **2:92**  
  pollination by, **3:227, 4:57**
- Bauer, Franz, **2:187**
- Bayliss, William, **2:197**
- BCG vaccination, **1:234**
- BCR-ABL oncoprotein, **3:157**
- BCR gene. *See* Breakpoint cluster region gene
- The Beak of the Finch* (Weiner), **2:53**
- Beaulieu, Emile-Etienne, **1:83**
- Beer-making, **1:59–60**
- Bees. *See* Hymenoptera
- Beetles. *See* Coleoptera
- Behavior  
  for birth control, **1:82**  
  field studies in, **2:85–87, 86**  
  genetic basis of, **1:60–63**  
  genetics and, **1:62–63**  
  learning and, **3:27–28**  
  nature *vs.* nurture in, **4:132**  
  patterns of, **1:63–65, 64**  
  social, **4:127–130, 128, 130**
- Behavioral research, field studies. *See* Field studies, in animal behavior
- Behavioral therapy, **4:30**
- Behring, Emil von, **1:39**
- Beneficial bacteria, **1:52**
- Benign tumors, **1:110**
- Bennettitales, **2:59**
- Benson, Andrew, **2:184, 200**
- Benthic epifauna, **3:150, 153**
- Benthic infauna, **3:150, 153**
- Benthic zone, **3:22–23, 150–151, 153–154**
- Benthos, **3:150**
- Benzodiazepines, **3:225, 4:31, 33**
- Berries, **4:56**
- Best, Charles, **3:103**
- Beta-adrenergic receptors, **4:114**
- Beta-carotene, **4:191**
- Beta-lactam antibiotics, **1:50**
- Bet-hedging hypothesis, **4:103**
- Bible, creationism and, **1:185–186**
- Bicarbonate, **1:85**
- Bilateral symmetry  
  angiosperms, **4:59**  
  animals, **1:35–36**  
  annelids, **1:36**
- Bilayers, in cell membranes, **3:73–74**
- Bile, **1:218, 221, 3:50**
- Bile duct, **3:50**
- Binary fission, **1:49, 2:41, 187, 188**  
  mitochondria, **3:95–96**  
  protozoans, **4:25, 101**
- Binaural hearing, **2:172**
- Binding antibodies to antigens, **1:39–41**
- Binomial classification system, **3:47–48**
- Bioaccumulation, **2:18, 3:228–229**
- Biochemists, **1:65–66**
- Biodiversity, **1:66–68**  
  conservation and, **1:165–169**  
  fires, **2:90**  
  global warming and, **2:148**  
  speciation and, **4:134–136**  
  *See also* Diversity
- “Biodiversity hotspots,” **1:67**
- Bioenergetics, **2:184**
- Bioengineering, **3:219**
- Biogenetic law, **1:210–212**
- Biogeochemical cycles, **1:67–68, 2:10, 42**
- Biogeography, **1:70–71, 71, 4:192**
- Bioinformatics, **1:71–74, 72, 2:145**
- Biological control, **3:219**
- Biological diversity. *See* Biodiversity
- Biological poisons. *See* Toxins
- Biological species concept (BSC), **4:136–137**
- Biological warfare  
  biotechnology for, **1:75, 80**  
  vaccines for, **4:180**
- Biological Weapons Convention, **1:74**
- Biology, **1:76–77**  
  biogeochemical cycles, **1:68–69**  
  history of biochemistry, **2:182–186, 183**  
  history of cell theory and structure, **2:186–188**  
  history of inheritance, **2:189–192**  
  impact on landscape structure, **3:25**  
  psychiatric disorders, **4:27–30, 28**  
  race, **1:77–79, 78**  
  wine-making, **4:200**  
  *See also specific types and fields of biology*
- Biology teachers, high school, **2:180**
- Bioluminescence, **1:21, 3:204**
- Biomagnification. *See* Bioaccumulation
- Biomass, **2:10**
- Biomechanics, **3:113–114**
- Biomedicine, **1:73–74**
- Biomes, **1:70, 79**
- Biomolecules, **4:93, 93–94**
- Biopharmaceuticals, **1:122**
- Bioremediation, **3:229–230**
- Biosphere, **2:8**
- Biostatistics, **4:36**
- Biotechnology, **1:76, 80**  
  agricultural, **1:11, 2:182**  
  biological weapons, **1:75**
- Biotic environments, **1:3–4**
- Biotin, **4:191**
- Bioturbation, **1:109**
- Bipedalism, **2:209–211**
- Bipolar disorder, **4:29, 30**
- Bipolar neurons, **3:133**
- Birch forests, **1:158**
- Birds, **1:80–82, 81**  
  amniotic eggs, **1:25–26**  
  brain, **3:128**  
  circulatory systems, **1:150, 151**  
  complex life cycle, **3:36**  
  deuterostomes, **1:36**  
  digestion, **1:218**  
  flight, **2:92**  
  gas exchange, **2:116**  
  growth, **2:159**  
  lakes and ponds, **3:23**  
  locomotion, **3:51–52**  
  migration, **1:4, 3:92**  
  monogamy, **3:62**  
  pollination, **3:227, 4:57**  
  predators, **4:1, 2**  
  sex determination, **4:97**
- Birge, Edward A., **2:5**
- Birth, **2:85, 202–203, 3:33**
- Birth control, **1:82–84**
- Birth control pills, **1:83**
- Birth defects, **1:139–140**
- Bison, **2:157**
- Black, James, **3:193**
- Black pepper, **1:32, 33**
- Blackflies, **3:175–176**
- Blastocysts, **2:81**
- Blastomeres, **1:206–207, 209–210**
- Blastopores, **1:207–209**
- Blastulas, **1:207**
- Blended inheritance, **2:189, 190**

- Blight, potato, 3:217  
 Blindness, 3:175–176  
 Blood, 1:84–86  
   flow of, 1:115  
   gas exchange in, 4:65–66  
   kidney function and, 3:15–16  
 Blood clotting, 1:85, 86–87  
   disorders of, 1:86  
   positive feedback systems in, 2:202  
 Blood coagulation. *See* Blood clotting  
 Blood plasma preservation, 1:85  
 Blood platelets. *See* Platelets  
 Blood pressure, 2:174–175  
   blood vessels and, 1:90–91  
   closed circulatory systems, 1:151  
   *See also* Hypertension  
 Blood-sucking fleas, 3:176  
 Blood sugar regulation, 1:87–89, 88  
 Blood transfusions, 1:16, 4:172  
 Blood typing, 3:180, 4:172  
 Blood vessels, 1:89–91, 90, 3:159  
   circulatory systems, 1:150–151  
   injuries to, 1:86  
   rupture of, 1:115–116  
 Blue-green algae, 1:20, 22  
 BMR. *See* Basal metabolic rate  
 Body cavities, 1:91–93, 92  
 Body height, 1:77–78  
 Body mass, 4:81–83  
 Body size, scaling and, 4:81–83  
 Body temperature  
   homeostasis, 2:201–202  
   hypothalamus and, 2:223, 225  
   mammals, 3:59  
   during ovulation, 2:80  
   regulation of, 4:122, 155, 156f,  
   154–157  
   spermatogenesis and, 3:56  
   water and, 4:193  
 Bogs, 4:197  
 Boldenone, 1:28  
 Bolus, 1:219  
 Bone marrow, 1:94  
 Bone matrix, 1:93  
 Bones, 1:93–95, 94  
   growth of, 2:159–160  
   length of, 1:94–95  
   musculoskeletal system,  
   3:112–113  
   as organs, 3:158  
   skeletons, 4:118  
 Bony fish, 1:95–96, 118  
 Book lungs, 2:116  
 Boreal forests, 1:162, 2:89–90, 98,  
   97–99  
 Botanical gardens, 1:169  
 Botanists, 1:96–97  
 Botany  
   ethnobotany, 2:40  
   Gray, Asa and, 2:158  
 Bottleneck, population, 2:49  
 Botulinum toxin, 3:225  
 Botulism, 3:225  
 Botulism, as biological weapon, 1:75  
 Boundaries, of ecosystems, 2:7–8  
 Boveri, Theodor, 2:188, 3:147  
 Bovine spongiform encephalopathy  
   (BSE), 4:5  
 Bowman's capsule, 3:16, 167  
 Boyer, Paul, 2:185  
 Boyle, Robert, 2:197  
 Brachiopoda, 1:109  
*Brachydanio rerio*. *See* Zebrafish  
 Bracts, 3:28–29  
 Bradycardia, 1:115  
*Bradyrhizobium*, 3:136  
 Brain, 1:97, 101, 97–104  
   embolisms in, 1:116  
   evolution of, 1:103  
   fMRI of, 3:3  
   *Homo ergaster*, 2:211  
   image processing, 4:189  
   infants, 3:33  
   injuries to, 3:129  
   invertebrate, 3:127  
   MRI of, 3:2, 3  
   neurons in, 3:132–133, 134  
   pain and, 3:170–171  
   as part of CNS, 1:134  
   peripheral nervous system and,  
   3:189  
   psychiatric disorders, 4:29–30  
   psychoactive drugs and, 4:31–33  
   during sleep, 4:121–123  
   spinal cord and, 4:137–139  
   vertebrate, 3:127–128  
   *See also* Central nervous system  
 Brain cancer, 1:111  
 Brain diseases, 4:5  
 Brainstem, 1:98, 102–103  
 Branchial circuit, 1:151  
 Branching (Plants), 4:111  
 Branchiobdellida, 1:36, 37  
*Brassica oleracea*, 2:44  
 Brassicaceae. *See* Mustard family  
 Brassinolides, 2:208  
 Brazil, coffee in, 1:156  
 Breakpoint cluster region (BCR)  
   gene, 3:157  
 Breast cancer, 1:110, 111  
   estrogen and, 1:126  
   gene, 1:111  
 Breathalyzers, for alcohol, 1:18  
 Breathing, 4:64–65  
 Breeding  
   behavior, 4:129  
   in captivity, 2:17–18, 4:204–205  
   gene-behavior links, 1:61  
   genetic analysis and, 2:126–127  
   rice, 2:153–154  
   selective, in agriculture,  
   2:181–182  
   *See also* Hybridization  
 Brine shrimp eggs, 1:4  
 Bristle leeches. *See* Acanthobdellida  
 Bristlecone pines, 1:162  
 British Museum of Natural History,  
   2:67  
 Brittlestars, 2:1, 2  
 Bromeliads, 3:106  
 Bromouracil, 3:115  
 Bronchi, 4:64  
 Bronchioles, 4:64, 126  
 Bronchitis, 4:126  
 Brown, Louise, 4:60  
 Brown, Michael, 2:25  
 Brown, Robert, 2:187  
 Brown algae, 4:22  
   *See also* Phaeophyceae  
 Brown rice, 2:153  
 Brown tree snake, 3:11  
 Brownian movement, 3:77–78  
 Browsing (Feeding), 2:74–75  
 Bryophytes, 1:104–106, 2:55, 56,  
   3:207–208  
 BSC. *See* Biological species concept  
 BSE. *See* Bovine spongiform  
   encephalopathy  
 $\beta$ -thalassemia, 4:77  
 Bubonic plague  
   bacteria, 2:43  
   as biological weapon, 1:74  
 Buccopharyngeal pump, 1:26  
 Buchner, Eduard, 2:183  
 Buffon, Count, 1:106–107, 2:193,  
   3:23  
 Building construction. *See* Construc-  
   tion industry  
 Bulbourethral glands, 3:58  
 Bulbs, of monocots, 3:106  
 Bundle sheath cells, 1:216–217, 217  
 Bünning, Erwin, 4:69  
 Bureau of Alcohol, Tobacco and  
   Firearms (ATF), 4:33  
 Burkitt's lymphoma, 3:156  
 Burns, skin grafts for, 4:172  
 Burrowing, for food, 2:75  
 Buspirone, 4:31  
 Butterflies. *See* Lepidoptera

**C**

- C3 pathway, 1:107
- C4 plants, 1:107–108, 216–217, 3:200
- Cabbage white butterflies, 3:218
- Caecilians. *See* Gymnophiona
- Caenorhabditis elegans*. *See* Nematodes
- Caffeine, 4:31
- Cairns, John, 3:119
- Cajal bodies, 3:147
- Calcineurin, 1:179, 180–181
- Calcitonin, 1:95, 2:22, 4:159
- Calcitriol, 1:95
- Calcium
- auxin and, 2:207
  - bone, 1:95
  - contraction, 2:175
  - endoplasmic reticulum and, 2:27
  - muscle contraction, 3:110
  - nutrient, 2:218
  - plants, 3:216
- Calcium carbonate
- bone matrix, 1:93
  - crustaceans, 1:190
  - echinoderms, 2:1
- Calcium phosphate, 1:93
- Calcium/calmodulin kinase II, 4:117
- California, 2:89, 90
- California condor, 2:18
- Calmodulin, 3:216
- Calories, 3:87–88, 107
- Calvin, Melvin, 2:184, 200
- Calvin-Benson cycle, 1:107–108, 2:184, 3:199–200
- Calyx, 2:93
- CaM kinase II. *See* Calcium/calmodulin kinase II
- CAM plants, 1:107–108, 3:200
- Cambrian period
- animal evolution in, 1:35
  - explosion, 1:108–110, 109
- Camera eyes, 4:189
- Camouflage, 3:93–94, 94, 4:1
- cAMP. *See* Cyclic-AMP
- Canada
- boreal forests in, 2:97
  - fire ecology in, 2:89
  - population growth in, 2:219
- Cancer, 1:110, 111, 112*t*, 110–112
- antisense nucleotides and, 1:41–42
  - causes of, 3:154–158
  - DNA mutations, 3:117
  - gene therapy for, 2:125
  - genomics and, 2:145, 216
  - oncologists for, 1:230
  - ras mutations and, 1:178
  - telomerase in, 1:146–147
  - vaccines for, 4:180
- See also specific types of cancer*
- Cancer cells, 3:154–158, 155
- Cancer research, 1:123
- Candida albicans*, 4:110
- Candidiasis, 2:109, 4:110
- Cane sugar. *See* Sucrose
- Cannabinol, 4:84
- Cannabis sativa*. *See* Marijuana
- Cannon, Walter, 2:201
- CAP. *See* Catabolite gene activator protein
- Capillaries, 1:89, 91, 151
- Capsid, 1:227
- Captive breeding programs, 2:17–18
- Captivity, breeding in, 4:204–205
- Carageenan, 1:21
- Carbohydrases, 1:218
- Carbohydrates, 1:112–114, 113
- biochemist specialty in, 1:66
  - digestion of, 3:174
  - glycoproteins and, 4:11–12
  - nutrients, 2:218
  - plants, 2:200–201
- Carbon
- biogeochemical cycles, 1:67–68
  - plants, 1:199, 3:216
- Carbon cycle, 1:114–115
- Carbon dioxide (CO<sub>2</sub>)
- blood, 1:85
  - carbon cycle, 1:114–115
  - climate changes, 2:145–146, 148
  - fermentation, 2:150
  - gas exchange, 2:114–116
  - oceans and, 3:152–153
  - photosynthesis, 1:199–200
  - plant water loss, 1:107–108
  - plants and, 2:87
  - plasma membranes and, 3:220
  - respiration, 4:63–66
- Carbon dioxide poisoning, 3:225
- Carbon 14, 4:38
- Carbon monoxide (CO), 1:85
- Carbon monoxide poisoning, 3:225
- Carboniferous period
- plants in, 2:56–57
  - seedless vascular plants in, 4:88
- Carboxypeptidase, 3:174
- Carcharodon carcharias*. *See* White sharks
- Carcinogens, 1:110, 3:226
- Cardiac arrest, 3:14
- Cardiac cycle, 2:174–175
- Cardiac muscle, 3:108
- Cardiac sphincter. *See* Esophageal sphincter
- Cardiac toxicity, 3:225–226
- Cardiologists, 1:229
- Cardiology, 3:3
- Cardiomyopathy, 1:115, 3:147
- Cardiovascular diseases, 1:115–117, 116, 4:127
- Cardiovascular system, 2:85, 197
- blood vessels in, 1:89–90
  - lymphatic system, 3:52
- Carnivores, 2:8, 10
- Carolina parakeets, 2:67
- Carotenoids, 3:49, 198, 4:189, 191
- Carotid arteries, 1:90
- Carpels, 1:31–32, 2:93, 4:53, 59
- Carrier protein, 1:2
- Carrots, 1:33
- Carrying capacity, 3:234
- Carson, Rachel, 1:117–118, 2:7, 18, 28, 3:230–231
- Cartilage, 4:118
- articular, 3:112, 113
  - synthetic, 4:174
- Cartilaginous fish, 1:118–119
- Caryopsis, 2:155, 4:56
- Casparian strip, 4:79
- CAT scans. *See* Computerized axial tomography scans
- Catabolism, 3:85–86, 87
- Catabolite gene activator protein (CAP), 1:171
- Catalysis, 2:29–36, 183
- Catastrophism, 2:51, 3:171
- Catecholamines, 1:7, 4:147
- Cattail marshes, 4:197
- Caudata, 1:26
- Caudate nucleus, 1:101–102
- Cavitation, 4:195
- CD4 cells. *See* Helper T cells
- CD8 cells. *See* Cytotoxic T cells
- CDC. *See* Centers for Disease Control
- CDKs. *See* Cyclin-dependent kinases
- cDNA, 4:42–43, 44
- Cecropia* moths, 3:194
- Cecum, 1:221
- Celera Genomics, 2:215–216
- Cell biology, 1:76, 3:101–102, 240
- Cell culture, 1:122–123
- Cell differentiation. *See* Differentiation
- Cell division, 2:187, 188
- aging and, 3:34
  - cancer cells and, 3:154–158
  - cytokinesis, 1:191–193
  - meristems and, 3:82

- mitochondria, 3:95–96  
plants, 3:212  
*See also specific methods of cell division*
- Cell junctions, 1:129–130, 130, 3:221–222
- Cell membranes, 1:119–121  
active transport through, 1:1  
channels of, 3:77–78  
ion channels and, 3:12–14  
lysosomal, 3:54–55  
mitochondrial, 3:96  
resting potential, 3:133–134  
*See also Membrane proteins*
- Cell research  
antibodies in, 1:37–39  
antisense nucleotides, 1:41–42
- Cell theory, 1:119  
history of, 2:186–188  
Leeuwenhoek, Antony von and, 3:31
- Cell walls, 1:132–134, 3:76, 207, 211, 213
- Cell-mediated immunity, 3:5, 4:150–151
- Cells, 1:119, 120, 121t, 119–122  
control mechanisms of, 1:177–181, 179, 180  
cycle of, 1:124–126, 125, 143  
evolution of, 1:127–129, 128  
metabolism of, 3:18–19  
motility of, 1:130–132, 132  
plant, 3:211–212, 212f  
Porter, Keith and, 3:240  
repair of, 2:70  
structure of, 2:186–188
- Cellular adaptations, 2:69–70
- Cellular defenses, 3:138–139
- Cellular Pathology* (Virchow), 2:197
- Cellular respiration, 3:97, 4:63
- Cellulose  
cell walls, 1:133  
plant cell walls, 3:207  
as polysaccharide, 1:113–114
- Centers for Disease Control (CDC)  
epidemiologists at, 2:36  
on HIV/AIDS, 2:197
- centiMorgan (cM), 3:45
- Central America  
coffee in, 1:156  
poison dart frogs in, 4:2–3
- Central nervous system (CNS), 1:134  
adrenal medulla and, 1:7  
alcohol and, 1:19  
brain in, 1:98  
invertebrates, 3:127  
learning and, 3:27  
neurologic diseases and, 3:129  
neurons in, 3:132–133  
pain sensitivity and, 3:171  
psychoactive drugs and, 4:31–33  
vertebrates, 3:127–128  
*See also Brain*
- Central United States, 2:99
- Centrioles, 1:122, 197, 3:99–100
- Centromeres, 3:67, 99
- Centrosomes, 1:197, 3:99
- Cephalopods. *See Mollusks*
- Cercaria, 3:175
- Cereal grains. *See Grains*
- Cerebellum, 1:98, 103, 3:127–128
- Cerebral angiography, 3:131
- Cerebral cortex, 1:99–100, 3:128, 4:162
- Cerebral hemispheres, 1:99, 101
- Cerebral hemorrhages, 3:2
- Cerebrospinal fluid (CSF), 1:98
- Cerebrovascular accidents. *See Strokes*
- Cerebrum, 1:98, 99–102
- Certified Safety Professional, 2:169
- Cerumen, 2:171
- Cervical cancer, 4:109
- Cervicitis, 4:108
- Cestodes, 3:175, 222
- CF. *See Cystic fibrosis*
- CFCs. *See Chlorofluorocarbons*
- CFTR. *See Channel transmembrane regulatory protein*
- Chaetae, 1:37
- Chain, Ernst, 1:234, 2:197
- Chambers, Robert, 2:194
- Champagne, 4:200
- Chancre, from syphilis, 4:107–108
- Channel transmembrane regulatory protein (CFTR), 1:73, 4:45–46
- Chaparral, 2:90
- Chaperones (Protein), 4:18
- Character displacement, 1:161
- Charales, 2:55
- Charophytes, 2:55
- Chase, Martha, 2:119, 191
- Chastetree, 2:177
- Chatton, Edouard, 4:153
- Cheetahs, 3:237, 238, 4:1
- Chelonia. *See Turtles*
- Chemical bonds, in protein structure, 4:11
- Chemical fertilizers, 2:199
- Chemical Research on Plant Matter* (De Saussure), 1:199
- Chemicals  
carcinogenic, 1:110  
mutagens, 3:115  
plant defenses, 2:178–179  
poisonous, 3:224–225  
pollution from, 1:117  
*See also specific chemicals*
- Chemiosmosis, 2:148, 3:168–170, 169f
- Chemoattraction, 1:131–132, 135
- Chemolithotrophic organisms, 2:42
- Chemoreception, 1:135–137, 136, 3:8
- Chemotaxis, 1:131, 135
- Chemotherapy, 1:112
- Chest X rays, 3:1
- Chewing. *See Mastication*
- Child health, 4:36
- Childbirth, 3:33
- Childhood development, 3:33
- Childhood diseases, 1:231
- Chimearas, 1:118
- Chimpanzees, 4:4–5
- China, ancient farming in, 2:181
- Chirality, 3:176
- Chirophily, 3:227
- Chitin  
cell walls, 1:133  
fungi, 2:110  
polysaccharide, 1:113–114
- Chlamydia trachomatis*, 4:108–109
- Chlamydial NGU, 4:108–109
- Chlamydomonas*, 4:23
- Chlorella*, 4:23
- Chlorofluorocarbons (CFCs), 2:146
- Chlorophyceae, 1:20, 133, 4:23
- Chlorophylls, 3:28–29, 198, 207
- Chloroplasts, 1:137, 137–138  
from bacteria, 2:43  
eukaryotic *vs.* prokaryotic, 1:48  
genome, 2:141  
leaves, 3:28–29  
photosynthesis, 3:196–198, 207  
plant cells, 1:121
- Chlorosis, 3:216
- Choanocytes, 3:239
- Cholesterol  
amphipathic property of, 3:49  
endocytosis of, 2:25  
plasma membranes, 3:220  
synthesis of, 3:191
- Cholinergic psychodelics, 4:32
- Chondrichthyes. *See Cartilaginous fish*
- Chondrocytes, 1:95, 165
- Chordates, 1:36, 209, 138–139
- Chorioallantoic membrane, 1:26

- Chorion, 1:25  
 Choroid, 2:72  
 Chromatids, 1:124, 143, 3:67–68, 69, 99–100  
 Chromatin, 1:172–173, 176–177  
 Chromatography, 4:93–94  
   gas, 1:233  
   liquid, 1:232–233  
 Chromosome transmission genetics, 3:45–46  
 Chromosomes  
   aberrations in, 1:139–143, 141, 142, 2:51, 137  
   bacterial, 1:53, 54, 55  
   cell cycles, 1:124–126  
   early research on, 2:188, 189–191  
   eukaryotic, 1:143–149, 144, 145*f*, 146  
   fetal, analysis of, 2:84  
   gene mapping and, 3:45–46  
   genes on, 2:119, 3:64  
   linkage and, 3:42–44  
   Mendel's laws and, 2:128  
   nuclei, 3:145–147  
   nucleoli and, 3:143  
   number of, 2:140–141  
   oncogenes and, 3:156  
   pedigrees and, 3:186  
   Philadelphia, 3:157  
   radiation hybrid mapping, 4:36–37  
   replication of, 4:47–48  
   sequencing of, 2:215  
   sex, 1:140, 4:94–96, 95  
   sex determination, 4:96–97, 97  
   *See also* DNA  
 Chronic bronchitis, 4:126  
 Chronic diseases, 1:221  
 Chronic myelogenous leukemia, 1:140  
 Chronic myeloid leukemia (CML), 3:156–158  
 Chronic obstructive pulmonary disease (COPD), 4:126  
 Chronic pain, 3:129  
*Chrysophyta. See* Golden algae  
*Chthamalus. See* Barnacles  
 Church and state, separation of, 1:186  
 Chyme, 1:218, 220  
 Chymotrypsin, 1:218, 3:174  
 Chytridiomycota, 2:112  
 Cigarettes. *See* Smoking, health and  
 Cilia, 1:197  
   locomotion, 3:51, 4:24  
   smoking and, 4:126–127  
   *See also* Flagella  
 Ciliary body, 2:72  
 Ciliates, 4:24, 25  
 Circadian rhythms, 2:200, 225, 4:69  
 Circulatory systems, 1:149–151, 150, 2:166  
   blood vessels in, 1:89  
   heart and, 2:172–176, 173*f*, 175*f*  
   insects, 3:9  
 Cisternal progression model, 2:151  
 Citric acid cycle. *See* Krebs cycle  
 CJD. *See* Creutzfeldt-Jakob disease  
 Cladogenesis, 4:134–136  
 Clams. *See* Mollusks  
 Classical conditioning, 3:27  
 Classical genetics, 2:191  
 Classification, 2:193, 4:152–154, 160  
   evolution and, 1:44, 2:51  
   fungi, 2:112–114  
   humans, 1:77  
   Linnaeus', 3:17–18, 47–48  
   microbes, 1:44  
   protists, 4:21–22  
   protozoans, 4:23–24  
   psychoactive drugs, 4:31  
   pteridophytes, 4:34  
   *See also* Taxonomy  
 Clathrin-coated pits, 2:24, 25  
 Claude, Albert, 3:240  
 Clays, 4:133  
 Cleaning symbiosis, 4:144  
 Clear-cutting, 2:100  
 Cleavage, 1:181, 206–207, 209–210, 2:34–35  
 Clemente, Carmine, 4:184  
 Clements, Frederick, 1:158, 2:5  
 Climacteric fruits, 2:108  
 Climate  
   coral reefs and, 1:184–185  
   desertification from, 1:204  
   effect of oceans on, 3:152  
   plants and, 2:89  
   tundra, 4:177–178  
   wine-making and, 4:200  
 Climax communities, 1:158  
 Clinical laboratory technicians, 3:20  
 Clinical medical assistants, 3:65  
 Clinical pharmacologists, 3:193  
 Clinical trials, 1:151–152, 2:177  
 Clitoris, 2:77  
 Clonal selection, 3:4–5  
 Clones, 1:152–155, 153, 2:143, 4:39–42, 40*f*  
   biological weapons, 1:75  
   gene mapping in, 3:45–46  
   plasmids, 1:57  
   positional, 2:144  
   reverse transcriptase and, 4:69  
 Closed circulatory systems, 1:150–151  
*Clostridium*, 2:41  
*Clostridium botulinum. See* Botulism  
 Clotting, blood. *See* Blood clotting  
 Club mosses, 2:57  
 cM. *See* centiMorgan  
 CML. *See* Chronic myeloid leukemia  
 Cnidarians, 1:35, 155  
   eyecups in, 4:188  
   nervous systems of, 3:126, 127*f*  
   reproduction in, 3:35  
   *See also* Coral polyps  
 CNS. *See* Central nervous system  
 CNS depressants, 1:19  
 CoA. *See* Coenzyme A  
 Coastal wetlands, 4:197  
 Coated pit, 3:221  
 Cocaine, 4:31, 84  
 Coccidioidomycosis, 2:109  
 Cochlea, 2:171  
 Cochlear duct, 2:171  
 Codeine, 4:32, 33  
 Codominance, 2:128, 3:180  
 Codons, 2:129–130, 4:13–16  
 Coelacanth, 1:96  
 Coelum, 1:92, 92–93  
 Coenzyme A (CoA), 3:144  
 Coenzymes, 2:34, 4:190–192  
 Coevolution, 2:179  
   angiosperms and insects, 4:59  
   predators and prey, 4:4  
 Cofactors, 2:34  
*Coffea arabica. See* Coffee  
*Coffea canephora. See* Coffee  
 Coffee, 1:33, 155–156  
 Cognitive functions, 3:128  
 Cohen, Stanley, 1:102  
 Cohesion-tension theory, 4:194  
 Colborn, Theo, 3:231  
 Cold, adaptation to, 3:202  
 Cold sores, 4:186  
 Coleochaetales, 2:55  
 Coleoptera, 3:9–10, 218, 4:57  
 Collagen  
   bone matrix, 1:93  
   connective tissue, 1:164  
   extracellular matrix, 2:68–69  
 Collecting duct, 3:167  
 Collectors, in rivers and streams, 4:74–75  
 College professors, 1:156–157  
 Collenchyma cells, 1:30, 213, 214  
 Collins, Francis, 2:214  
 Colon, 1:221



- Colon cancer, 1:111, 142  
 Color, of leaves, 3:28–29  
 Color vision, 4:190  
 Colorado Bureau of Investigation, 2:95  
 Colorado potato beetles, 3:218  
 Coloration  
   camouflage, 3:93–94, 4:1  
   warning, 3:94  
 Columbia River, 4:73  
 Columnar cells, 2:37  
 Comb jellies, 1:35  
 Commensalism, 2:76, 4:142–143  
 Committees of Correspondence, 1:186  
 Common hepatic duct, 3:50  
 Communicable diseases, 1:221, 2:28  
   *See also* Infections  
 Communication, 1:65  
   neurons, 3:131  
   pheromones in, 3:193–195  
   *See also* Signaling  
 Communities, 1:157–159, 158  
   conservation of, 1:167  
   ecology of, 2:4, 5–6  
   extreme, 2:69–71, 70  
 Community nutritionists, 3:149  
 Comorbidity, 4:30  
 Compact bone, 1:93  
 Companion cells, 1:31, 215  
 Comparative animal physiology, 4:204  
 Compartmentalization, of cells, 3:74–75  
 Compartmentation, 2:34  
 Competition, 1:159–162, 161, 4:131–132  
   communities, 1:157–158  
   natural selection, 2:46–47, 3:121  
   post-mating, 4:106  
   sexual selection, 4:100, 105–106  
 Competitive exclusion principle, 1:160–161  
 Complement proteins, 1:41, 3:138  
 Complementarity, in DNA, 1:222–223, 225, 2:220–221, 4:42–43, 44  
 Complex carbohydrates, 1:113  
 Complex life cycles, 3:36  
 Compos. *See* Temperate grasslands  
 Composite family, 1:33  
 Compound eyes, 4:188–189  
 Compound heterozygous mutations, 3:188  
 Compound light microscopes, 3:39–41, 40  
 Comprehensive Drug Abuse Prevention and Control Act of 1970, 4:33  
 Computational algorithms, 1:72–74  
 Computed tomography (CT), 3:1–2, 131  
 Computerized axial tomography (CAT) scans, 3:131  
 Computers, in timber industry, 4:202  
 Concentration gradients, 1:1–2, 2:114, 3:79  
   ions, 3:13–14  
   kidney function, 3:16  
   osmoregulation, 3:166  
   oxidative phosphorylation, 3:168  
 Conception, 2:81  
 Concrete *vs.* wood, 4:201–202  
 Condensation  
   anabolic pathways, 3:85  
   eukaryotic chromosomes, 1:147  
 Conditional mutation, 4:168  
 Conditioned response, 1:62, 3:27  
 Conditioning, muscle, 3:112  
 Condoms, 1:16, 83  
 Conduction, heat, 4:155  
 Conduction system disease, 3:147  
 Conformations, 2:26, 3:185  
   prion proteins, 4:6  
   protein structure, 4:9–10, 18  
 Congenital diseases, 2:28  
   *See also* Genetic diseases  
 Congenital hypothyroidism, 2:21  
 Congenital syphilis, 4:108  
 Conifers, 1:162–163, 163, 2:57, 162, 3:208  
 Conjugation, bacterial, 1:53–54, 56  
 Conjunctiva, 2:73, 4:107  
 Conjunctivitis, 2:73  
 Connective tissue, 1:164–165, 164f, 165t, 4:160  
   dermis, 4:120  
   extracellular matrix in, 2:68–69  
   osseous, 1:93  
   tendons as, 3:112  
 Connell, Joe, 1:161  
 Consanguineous marriages, 3:186, 188  
 Consciousness, 3:3  
 Conservation, 1:165–170, 167, 168  
   in Africa, 3:26  
   biodiversity, 1:67  
   Dubos, René and, 1:234  
   estuaries, 2:39–40  
   oceans, 3:60–61  
   plants, field studies in, 2:88–89  
   population genetics and, 3:239  
   timber industry and, 4:202  
   tropical forests, 2:101, 104  
   wildlife, 2:87  
   *See also* Ecology  
 Constant region, of antibodies, 1:40  
 Construction industry, 4:201, 203  
 Consumers. *See* Heterotrophs  
 Contagious diseases, 1:221, 2:66  
   *See also* Infections  
 Contigs, 4:45  
 Continental drift, 1:70, 71  
 Contraception. *See* Birth control  
 Contraceptive sponges, 1:83  
 Contractile proteins, 3:109  
 Contractile ring, 1:191, 194  
 Contractile vacuoles, 2:62, 3:166, 4:25  
 Contraction  
   cells, 1:131  
   heart muscle, 2:172, 174  
 Control mechanisms, 1:177–181, 179, 180  
 Convection, heat, 4:155  
 Convention on Biological Diversity, 1:67  
 Convergent evolution, 1:181–183, 182  
 Cooperation, 2:35, 4:127–128, 131–132  
 COPD. *See* Chronic obstructive pulmonary disease  
 Copper in plants, 3:216  
 Copper River (Alaska), 3:93  
 Coral polyps, 1:183  
 Coral reefs, 1:183–185, 184, 2:147  
 Corals, 1:35, 155  
 Corey, Robert, 2:184  
 Corn, 2:154, 155, 181  
 Corn meal, 2:154  
 Cornea, 2:72, 4:189  
 Corneal transplants, 4:173  
 Corolla, 2:93  
 Coronary arteries, 1:90, 2:174  
 Coronary artery bypass surgery, 1:91  
 Corpora cavernosa, 3:58  
 Corpus callosum, 1:99  
 Corpus luteum, 2:80, 81  
 Corpus spongiosum, 3:58  
 Correns, Carl, 2:190  
 Cortex, 1:98, 4:110  
 Cortical lesions, 1:100  
 Corticotropin releasing hormone (CRH), 4:140  
 Cortisol  
   blood glucose regulation, 1:89  
   postabsorptive metabolic state, 3:89  
   stress response, 4:140

- Cosmid vectors, **1:154**  
 Cotton, **1:114**  
 Cotyledons, **1:33, 3:209–210, 4:55**  
 Counseling, genetic, **2:135–136**  
 Counterselection, **3:123–124**  
 Coupled transporters, **1:2**  
 Covalent modification, **2:34–35**  
 Cover crops, **3:160**  
 Cowles, Henry C., **2:5**  
 CpG islands, **1:149**  
 Crabgrass, **2:156**  
 Crabs. *See* Arthropods  
 Cracraft, Joel, **4:137**  
 Cranberry extract, **2:177**  
 Cranial cavity, **1:92**  
 Cranial nerves, **1:98, 102–103, 3:128**  
 Crassulacean acid metabolism plants.  
   *See* CAM plants  
 Crater Lake, Oregon, **3:21**  
 Crayfish worms. *See* Branchiobdellida  
 Creatine phosphate, **3:111**  
 Creation Research Society, **1:186**  
 Creationism, **1:185–187**  
 Creighton, Harriet, **3:64**  
 Cretaceous period  
   angiosperms, **1:32**  
   gymnosperms, **2:57**  
   marsupials, **3:62**  
   monotremes, **3:108**  
   reptiles, **4:63**  
 Cretaceous-Tertiary period, **2:66**  
 Creutzfeldt-Jakob disease (CJD), **4:5**  
 CRH. *See* Corticotropin releasing  
   hormone  
 Crick, Francis, **1:187–188, 222,**  
   **2:128–129, 185, 191, 198, 4:47,**  
   **196**  
 Crinoidea. *See* Echinoderms  
 Criteria, for aging, **1:8**  
 Crocodilians, **1:188–189**  
 Crop management, **3:218–219**  
 Crop plants, **4:183–184**  
 Crop rotation, **3:159–160**  
 Crops, **2:182, 222**  
 Crossing over (Genetics), **2:119,**  
   **3:43–44, 44f, 66, 67**  
*Crucible of Creation* (Morris), **1:108**  
 Crustaceans, **1:36, 189–190**  
   compound eyes, **4:188**  
   gas exchange, **2:115–116**  
   reproduction, **3:35**  
   wetlands, **4:197**  
 Cryo-electron microscopy, **4:142**  
 Crypsis. *See* Camouflage  
 Cryptic behavior, **1:65**  
 Cryptic coloration. *See* Camouflage  
 Cryptobiosis, **1:202**  
 Cryptococcosis, **2:109**  
 CSF. *See* Cerebrospinal fluid  
 CT. *See* Computed tomography  
 Ctenophores. *See* Comb jellies  
 CTP. *See* Cytidine triphosphate  
 Cuboidal cells, **2:37**  
 Cultivation, **2:180–182**  
 Cultivation equipment, **3:161**  
 Curie, Marie, **3:1**  
 Cushing's syndrome, **1:89**  
 Cutaneous anthrax, **1:75**  
 Cutaneous respiration, **1:26**  
 Cuticle, of leaves, **3:29**  
 Cutin, **1:213**  
 Cutting propagation, **4:7**  
 Cuvier, Georges, **2:193, 3:171,**  
   **4:152**  
 Cyanide, **3:226**  
 Cyanobacteria, **1:20, 127, 190–191,**  
   **3:31–32**  
 Cycads, **2:57, 162, 162–163, 3:208**  
 Cyclic-AMP (cAMP), **1:171, 2:205,**  
   **3:144–145, 4:114, 116**  
 Cyclic-AMP-dependent protein  
   kinase, **1:180–181**  
 Cyclin-dependent kinases (CDKs),  
   **1:125, 125–126, 3:212**  
 Cyclosporine, **4:173**  
 Cyperaceae. *See* Sedge family  
 Cypresses, **1:162**  
 Cystic duct, **3:50**  
 Cystic fibrosis (CF), **1:78, 2:124,**  
   **125, 136, 3:180, 4:45**  
   ion channel defect and, **3:14**  
   protein structure and, **4:13**  
 Cytidine triphosphate (CTP), **1:177**  
 Cytochromes, **3:169, 226**  
 Cytokines  
   immune response, **3:4**  
   T cells, **4:149–151**  
 Cytokinesis, **1:124, 191–193, 192,**  
   **3:69, 99–100**  
 Cytokinins, **2:200, 206, 207, 3:82,**  
   **84, 209, 212**  
 Cytoplasm  
   cytoskeleton and, **1:194**  
   nuclear transport and, **3:140–141**  
 Cytoplasmic determinants, **2:133**  
 Cytoplasmic genes, **1:127–128**  
 Cytosine, **3:143–144, 4:76**  
 Cytosine methylation, **1:149, 224**  
 Cytoskeletal membrane proteins,  
   **3:71–72**  
 Cytoskeleton, **1:191, 194, 196,**  
   **193–197**  
   cell motility, **1:131**  
   cell organelles, **1:122**  
   mitochondria, **3:98**  
   proteins, **4:20**  
 Cytosol, **4:20**  
 Cytotoxic T cells, **3:5f, 4:149**
- D**  
 DAG. *See* Diacylglycerol  
 Daintree National Park (Australia),  
   **2:102**  
 Dakin, Henry, **2:183**  
 Daltons, for molecular weight, **4:8**  
 D-amino acids, **1:24**  
*Danaus plexippus*. *See* Monarch  
   butterflies  
 Dard reactions, **3:197, 199–200**  
 Darwin, Charles, **1:197–199, 198,**  
   **2:45–46, 52, 192, 194–195, 3:121**  
   angiosperm evolution, **1:32,**  
   **2:58–59**  
   field studies of, **2:85**  
   Gray, Asa and, **2:158**  
   particulate inheritance, **2:190**  
   protoecology, **2:5**  
   selective breeding, **2:181–182**  
   sexual selection, **4:104**  
 Darwin, Erasmus, **2:45, 194**  
 Darwinian fitness, **3:124**  
 Databases, on genetic structures,  
   **1:73**  
 Dawkins, Richard, **1:63**  
 Day-neutral plants, **3:195**  
 DDT, **3:228, 230–231**  
   bald eagles and, **2:18**  
   banning of, **1:117**  
   birds and, **1:82**  
 de Bary, Heinrich Anton, **4:142**  
 de Candolle, Augustin, **4:160**  
*De Humani Corporis Fabrica* (Vesalius),  
   **4:184**  
 de Jussieu, Antoine-Laurent, **4:160**  
*de Motu Cordis* (Harvey), **2:172**  
 De Saussure, Nicolas-Théodore,  
   **1:199–200, 2:198, 3:7, 4:183**  
 de Vries, Hugo, **2:190**  
 Deacetylases, **1:144, 176–177**  
 Decay. *See* Decomposition  
 Deciduous forests  
   beech-maple-hemlock, **2:99, 100**  
   oak-hickory, **2:99**  
 Decomposition, **2:8**  
   carbon cycle, **1:114**  
   fungi, **2:111**  
   plankton, **3:206**  
   pollutants and, **3:228, 229**  
   wetlands, **4:197–198**

- Decondensation, **1:147**
- Deep sea environment, **2:70–71**
- Deep sea organisms, **3:154, 204**
- Defenses  
  nonspecific, **3:138–140, 139**  
  predation and, **4:1–4, 3**  
  secondary metabolites as, **4:84**
- Defensive behavior, **1:64–65, 4:1–4**
- Deforestation  
  carbon cycle, **1:114**  
  tropical forests, **2:101, 104**
- Degradation, of proteins, **4:19**
- Dehiscent fruits, **2:106, 4:56**
- Deisenhofer, Johann, **2:184**
- Delbrück, Max, **1:228, 3:119**
- Deletions, genetic, **3:155**
- Delirium tremens, **1:19**
- Delisi, Charles, **1:71, 2:213**
- Delta polymerase, **4:51**
- Dementia, **4:33**
- Demerol, **4:32**
- Demyelinating diseases, **3:134**
- Denaturation, **2:143**
- Dendrites, **1:98, 3:133, 4:146**
- Dendrobates*, **3:226**
- Dengue fever, **2:147**
- Denitrification, **3:135**
- Dental X rays, **3:1**
- Denterostomes, **2:2**
- Dentists, **1:200**
- Deoxyribonucleic acid. *See* DNA
- Deoxyribonucleotides, **3:143–144**
- Deoxyribose in nucleotides, **3:143**
- Deoxyribozymes, **2:30**
- Department of Agriculture. *See* U.S. Department of Agriculture
- Department of Energy. *See* U.S. Department of Energy
- Department of Health and Human Services. *See* U.S. Department of Health and Human Services
- Dependency, drug. *See* Drug dependency
- Dephosphorylation, **1:178–179, 3:100, 212**
- Deposit feeders, **3:153–154**
- Deposit feeding, **2:75–76**
- Depressants, central nervous system, **4:31**
- Depression  
  fMRI for, **3:3**  
  psychiatrists and, **4:30**
- Depth recorders, **2:86**
- Dermal papillae, **4:120**
- Dermal tissue, **1:29–30, 212–213**
- Dermis, **4:120**
- The Descent of Man, and Selection in Relation to Sex* (Darwin), **1:199, 2:195, 4:104**
- Desert horned lizards, **1:182**
- Desertification, **1:204–205**
- Deserts, **1:201–203, 202, 203**  
  as extreme environments, **2:71**  
  fire regimes in, **2:90**  
  lizards in, **1:182–183**
- Desmin, **1:196**
- Desmosomes, **1:130, 3:221**
- Determinism, genetic, **1:63, 2:119, 133**
- Detritivores, **2:8**
- Detritus, **2:38**
- Deuterostomes, **1:36, 209–210**
- Development, **1:205–212, 207–211**  
  genes in, **2:122–123**  
  genetic control of, **2:131–135, 132**  
  Harvey, William on, **2:166**  
  human, **3:32–34**  
  plants, **3:208–214, 209f–212f, 214f**  
  *See also* Growth
- Developmental disorders, **3:129**
- Devonian period  
  bryophytes, **2:55**  
  seed plants, **4:89**  
  seedless vascular plants, **2:56**
- Diabetes mellitus, **1:47, 2:22**  
  as endocrine disorder, **3:174**  
  glucose levels, **1:89**  
  insulin-dependent, **4:43**  
  neurologic disease from, **3:129**
- Diacylglycerol (DAG), **4:117**
- Diagnostic imaging, **1:231–232, 3:1–3, 131**
- Diaphragm (Anatomy), **4:64–65**
- Diaphragms (Birth control), **1:83**
- Diarrhea, **4:26**
- Diastole, **2:174**
- Diatoms, **1:20, 21, 4:22**
- Dichlorodiphenyltrichloroethane. *See* DDT
- Dicots, **2:43, 93, 4:55, 110**
- Dicotyledons. *See* Dicots
- Dictionary of Fungi*, **2:112**
- Dictyosteliomycota, **4:125–126**
- Dictyostelium discoideum*. *See* Slime molds
- Didelphis virginiana*. *See* Virginia opossum
- Diencephalon, **1:98, 102, 3:128**
- Diet, alcoholism and, **1:20**
- Dietary supplements, **2:176**
- Dietary Supplements Health and Education Act of 1994, **2:176**
- Dietitians, **3:149–150**
- Diets, metabolic rate and, **3:88**
- Differential mortality, **3:123–124**
- Differentiation, **1:120–121**  
  genetic code and, **2:132–133**  
  integral membrane proteins and, **3:222**  
  plants, **1:212–217, 214, 216, 217, 2:206, 3:84, 213**
- Diffusion, **1:1, 2:114, 3:77**
- Digestion, **1:217–219**  
  insects, **3:8–9**  
  pancreatic juice, **3:174**  
  proteins, **2:203**
- Digestive enzymes, **1:218**  
  lysosome, **3:54–55**  
  pancreatic juice, **3:174**  
  protozoans, **4:25**
- Digestive system, **1:219–221, 220, 3:52**
- Digitalis, **3:225–226**
- Diglycerides, **3:48–49**
- Dihybrid cross, **3:43**
- Dilated cardiomyopathy, **3:147**
- Dilation, in childbirth, **3:33**
- Dimer, **1:40**
- Dinitrophenol, **3:226**
- Dinoflagellates, **1:20, 183–184, 4:22**
- Dinosaurs, **2:65**  
  extinction of, **2:66**  
  theropod, **1:81**
- Diphtheria  
  antibodies and, **1:39**  
  William, Anna Wessels, **1:52**
- Diphtheria-pertussis-tetanus (DPT) vaccination, **4:182**
- Diphyllotbrium latum*, **3:175**
- Diptera, **3:10, 218**
- Directional selection, **1:4, 3:236**
- Disaccharides, **1:113**
- Diseases  
  autoimmune, **1:47, 47–48**  
  cultured cells and, **1:123**  
  enzymes in, **2:30**  
  epidemiologists and, **2:36**  
  genes of, **4:45–46**  
  historical views of, **2:196–198**  
  positive feedback systems, **2:203**  
  protein structures and, **4:13**  
  protozoan, **4:22, 25**  
  *See also specific conditions*
- Dispersal, of plant seeds, **2:107–108**
- Dispersal behavior, **1:65**
- Dissection, **2:197, 4:184**

- Disseminated intravascular coagulation, **1:86**
- Dissociation, enzymic, **1:122**
- Distal convoluted tubule, **3:16**
- Disturbances, ecological, **1:158–159**
- Diurnal lizards, **1:182**
- Diversity
- angiosperms, **1:33, 4:57**
  - archaea, **1:44–46**
  - bacteria, **2:42**
  - benthic epifauna, **3:150**
  - insects, **3:9–10**
  - landscape, **2:91**
  - nematodes, **3:125**
  - plants, **3:207–208**
  - pteridophytes, **4:33–34**
  - stream habitats, **4:73**
  - tropical forests, **2:101–103**
- See also* Biodiversity; Genetic variation; Species, diversity in
- Dixen, Henry, **2:199**
- DNA, **1:222–224, 223, 224**
- as antisense nucleotides, **1:41, 42, 46**
  - bacterial replication, **1:50, 53–57**
  - binding proteins, **4:10, 11**
  - catalytic, **2:30**
  - classes of, **1:147–148**
  - cloning, **1:152–154, 4:39–42, 40f**
  - complementarity, **2:220–221**
  - duplication of, **3:232–233**
  - early research on, **2:185, 191–192, 198**
  - eukaryotic chromosomes, **1:143–149**
  - evolutionary evidence, **2:53–54**
  - forensic analysis of, **2:94–97, 95**
  - gene mapping and, **3:45–46**
  - genes and, **2:119**
  - genetic analysis and, **2:128–129**
  - genetic code and, **2:120–122, 129–131, 132–133**
  - genomes and, **2:140–141, 141–145**
  - human evolution, **2:209**
  - hybridization, **2:220–221**
  - mitochondria, **3:95**
  - nuclear matrix and, **3:146**
  - nucleotides and, **3:143–144**
  - origins of life, **3:163**
  - paternity tests, **4:106**
  - regulation of binding of, **1:175**
  - replication of, **1:124–126, 225, 4:47–52**
  - retroviruses, **4:66–67**
  - reverse transcriptase and, **4:68–69**
  - vs.* RNA, **4:75–77**
  - synthesis of, **3:164**
  - taxonomy, **4:151–152**
  - transgenic technique and, **4:167–168**
  - transposons and, **4:174–175**
  - Watson-Crick model of, **1:187, 4:196**
  - Weismann, August on, **2:117**
- See also* Mutations; Transcription
- DNA chips, **1:73**
- DNA markers. *See* Genetic markers
- DNA microarrays. *See* DNA chips
- DNA polymerase, **1:225**
- DNA sequencing, **1:71–74, 222, 225f, 226f, 224–227**
- electrophoresis, **2:13–15**
  - genomics, **2:142–145**
  - research on, **2:185**
- See also* Human Genome Project
- DNA viruses, **1:227–228, 3:217**
- Dobzhansky, Theodosius, **1:186, 2:51–52, 165, 195–196**
- Doctor of Veterinary Medicine (DVM), **4:185**
- Doctors
- family practice, **1:228**
  - specialists, **1:229–232, 230, 231t**
- DOE. *See* U.S. Department of Energy (DOE)
- Dogs, as model organisms, **3:103**
- “Dolly” (Sheep), **1:154**
- Dolphins, **1:181–182**
- Domains, **1:44, 4:10**
- Dominance, **2:127–128, 139, 164, 3:80**
- in alleles, **3:179–181**
  - apical, **2:206**
- Dopamine, **4:147**
- Dormancy, **4:7, 86–88, 87f, 91**
- as adaptation, **1:4**
  - in deserts, **1:202**
- Dorsal body cavity, **1:92**
- Double circulation, **1:151**
- Double fertilization, **2:57–58, 4:54–55, 90**
- Double helix, **1:187, 222, 2:191, 4:47–48, 196**
- The Double Helix* (Watson), **4:197**
- Doubling time, of bacterial cells, **1:49**
- Down syndrome, **2:137**
- from chromosome aberrations, **1:139, 140**
  - from nondisjunction, **3:69**
- Doxycycline, **4:109**
- DPT vaccination, **4:182**
- Drainage, lymphatic, **3:52–53**
- Dreams, **4:122–123**
- Drew, Charles, **1:85**
- Drift, in rivers and streams, **4:75**
- Drosophila*, **3:101**
- genetic behavior in, **1:61**
  - linkage in, **3:43–45**
  - model organisms, **3:102**
  - ras protein in, **1:178**
  - sex determination in, **4:97**
  - transposons in, **4:175**
- Drought
- desertification from, **1:204**
  - in grasslands, **2:157**
- Drude, Oscar, **2:5**
- Drug dependency, **4:31, 33**
- Drug testing, **1:17, 233, 232–233**
- Drugs
- pharmacologists and, **3:192–193**
  - psychoactive, **4:31–33, 32**
- See also specific drugs*
- Druker, Brian J., **3:157–158**
- Drunkness, **1:19**
- Drupes, **4:56**
- Dry after-ripening, **4:87**
- Dry fruits, **2:106, 4:56**
- DSHEA. *See* Dietary Supplements Health and Education Act of 1994
- DTs. *See* Delirium tremens
- Dubos, René, **1:233–234**
- Duchenne muscular dystrophy, **2:124, 125, 136, 139, 140**
- Duckweeds, **1:33, 2:94**
- Ductus arteriosus, **2:85**
- Dumortier, Barthélemy, **2:187**
- Dunnigan-type familial partial lipodystrophy, **3:147**
- Dunnock, **3:63–64**
- Duodenum, **1:220**
- bile and, **3:50**
  - pancreas and, **3:173–174**
- Dura mater, **1:98**
- Dutch elm disease, **3:217**
- Dutrochet, Henri, **2:187**
- DVM. *See* Doctor of Veterinary Medicine
- Dwarfism, **1:28, 2:21, 161**
- Dynamic equilibrium, **2:202**
- Dynein, **1:195–196, 197**
- Dystrophin genes, **2:121–122, 121f**
- E**
- Ear canal, **2:170–171**
- Ear wax. *See* Cerumen
- Eardrum, **2:170, 171**
- Ears, **2:170–172, 170f**
- Earth
- age of, **3:161–162**

- biogeographical history of, 1:70–71, 71  
 water sources on, 4:193
- Eating disorders, 1:62
- ECG. *See* Electrocardiography
- Echinococcus granulosus*, 3:175
- Echinoderms, 1:36, 2:1–3, 2  
 in Cambrian period, 1:108  
 as deuterostomes, 1:209  
 fertilization in, 4:98–99  
 intertidal, 3:150–151  
 nervous systems of, 3:126
- Echiura, 1:36
- ECM. *See* Extracellular matrix
- Ecological disturbances, 1:158–159
- Ecological importance of  
 angiosperms, 1:33–34  
 annelids, 1:37  
 conifers, 1:162  
 fungi, 2:111  
 gymnosperms, 2:162–163  
 nematodes, 3:125  
 plankton, 3:206  
 protozoans, 4:25  
 soil, 4:132–133  
 tundra, 4:178  
 water cycle, 4:193  
 wetlands, 4:198
- Ecological research, long-term, 2:3–4
- Ecology, 1:76, 2:4–5  
 of communities, 1:157–159  
 fire, 2:89–91, 90  
 history of, 2:5–7, 6  
 invasive species and, 3:10–12  
 landscape, 3:24–25  
 limitations, 1:70  
 physiological, 3:202–204, 203  
 plant, field studies in, 2:87–89, 88  
 remote sensing in, 4:46–47  
 theoretical, 4:157–158
- Economic development, rural. *See* Rural economic development
- Economic importance of  
 algae, 1:22  
 conifers, 1:162–163  
 eudicots, 2:44  
 fruits, 2:108  
 fungi, 2:111–112, 114  
 grains, 2:153–154  
 grasses, 2:155–156, 156t  
 lichens, 3:32  
 organic agriculture, 3:161  
 plankton, 3:206  
 plant diseases and pests, 3:216–217  
 plant secondary metabolites, 4:84–85  
 poisonous plants, 3:224  
 protozoans, 4:25  
 pteridophytes, 4:35  
 reptiles, 4:63  
 turtles, 4:179
- The Economy of Nature* (Linnaeus), 2:5
- Ecosystems, 2:7–10, 9  
 atmospheric water exchange and, 4:193  
 conservation of, 1:166  
 diversity in, 1:67  
 estuaries, 2:38–40  
 fire and, 2:89  
 lichens in, 3:32  
 photosynthesis and, 3:196  
 research on, 2:4, 6–7  
 rivers and streams, 4:74–75  
*See also specific types of ecosystems*
- Ecstasy (Drug), 4:32
- Ectoderm, 1:207, 2:82
- Ectomycorrhizae, 3:119–121
- Ectothermy, 3:202
- Edema, from alcohol, 1:19
- Education and training  
 agronomy, 1:13–14  
 AIDS, 1:16, 17  
 doctors, 1:228, 229–232  
 emergency medical technicians, 2:16  
 entomologists, 2:27–28  
 epidemiologists, 2:36–37  
 evolution, 1:185–186  
 foresters, 2:105  
 genetic counselors, 2:135  
 health and safety officers, 2:169  
 high school biology teachers, 2:180  
 horticulturalists, 2:208  
 laboratory technicians, 3:20  
 limnologists, 3:42  
 marine biologists, 3:61  
 medical assistants, 3:65  
 medical/science illustrators, 3:66  
 microbiologists, 3:90–91  
 microscopists, 3:91–92  
 nurse practitioners, 3:149  
 nurses, 3:148  
 nutritionists, 3:149–150  
 pharmaceutical sales representatives, 3:192  
 pharmacologists, 3:193  
 physical and occupational therapists, 3:200  
 physician assistants, 3:201  
 plant pathologists, 3:219  
 psychiatrists, 4:30  
 public health careers, 4:35–36  
 science writers, 4:83  
 veterinarians, 4:185–186  
 wildlife biologists, 4:200  
 zoology researchers, 4:205
- EEG. *See* Electroencephalograph
- Efferent ductules, 3:57
- Efferent neurons. *See* Motor neurons
- Eggs  
 amphibian, 1:26–27  
 fertilization of, 1:206  
*See also* Zygotes
- Egypt, history of farming in, 2:181
- Ehrlich, Paul, 1:39, 4:108
- Ejaculation, 3:58
- Ejaculatory duct, 3:58
- El Niño, 3:152
- El Oued dunes, 1:202
- Elastase, 3:174
- Eldredge, Niles, 2:51
- Electric rays, 1:118
- Electrical activity, of the heart, 2:175
- Electrical gradients, 1:3
- Electrical signals, in neurons, 3:133–134
- Electrical synapses, 4:148
- Electrocardiography, 1:115, 2:175
- Electrochemical gradients, 3:168
- Electroencephalograph (EEG), 3:131, 4:121–123, 123f
- Electromagnetic radiation, 4:46
- Electromyogram (EMG), 4:121, 123f
- Electron carrier complexes, 3:168–169
- Electron microscopy, 2:10–13, 12, 188, 3:41, 240, 4:141–142
- Electron transport system (ETS), 3:97  
 adenine molecules and, 3:144  
 oxidative phosphorylation, 3:168–170  
 photosynthesis, 3:198
- Electron-dense regions, 2:11
- Electron-lucent regions, 2:11
- Electro-oculogram (EOG), 4:121, 123f
- Electrons  
 Krebs cycle, 3:18  
 photosynthesis, 3:198
- Electrophoresis, 1:224f, 225, 2:13–15, 14, 142, 4:94
- Elements of Botany* (Gray), 2:158
- Elephantiasis, 3:53

- Elion, Gertrude Belle, 3:193  
 ELISA, 1:38, 38–39  
 Elongation  
   DNA replication, 4:49–50  
   protein synthesis, 4:13, 16–17  
   seed germination, 4:86  
 Elton, Charles, 2:5, 6  
 Embden, Gustav, 2:183  
 Embolisms, 1:116  
 Embolus, 1:86  
 Embryo adoption, 4:62  
 Embryo sac, in plants, 4:53, 54  
 Embryogenesis, 1:206–207, 2:82, 3:208–209, 209f  
 Embryology, 1:205–212  
   genetic code and, 2:132–135  
   Harvey, William on, 2:166  
 Embryos  
   amnion for, 1:25–26  
   human, 3:32  
   plant, 2:58, 4:54–56, 88  
 Embryo-sac mother cell (EMC), 4:53  
 EMC. *See* Embryo-sac mother cell  
 Emergency Committee of Atomic Scientists, 3:185  
 Emergency contraception, 1:83  
 Emergency medical technicians (EMTs), 2:15–16  
 Emergent properties, of plants, 1:29  
 Emerson, Ralph Waldo, 1:166  
 Emery-Dreifuss muscular dystrophy, 3:147  
 EMG. *See* Electromyogram (EMG)  
 Emigration, 2:49, 3:238  
 Empedocles, 2:192  
 Emphysema, 4:126  
 EMTs. *See* Emergency medical technicians  
 Encephalitis, 2:147  
 Encyclopedias, natural science, 1:106–107  
 Endangered species, 1:169, 2:16–18, 17, 3:239  
   amphibians, 1:27  
   field studies of, 2:87, 88–89  
 Endangered Species Act, 2:16  
 Endergonic reactions, 2:30, 3:85  
 Endocarp, 4:56  
 Endochondral ossification, 1:94  
 Endocrine disorders, 2:20, 21–22  
 Endocrine disrupters, 3:231  
 Endocrine glands  
   adrenal, 1:6, 4:139–140  
   pancreatic, 3:174  
   thyroid, 2:21, 21–22, 4:158–159, 159  
 Endocrine hormones, 2:78–80  
 Endocrine signaling, 4:113  
 Endocrine system, 2:18–22, 19, 21, 203  
 Endocytosis, 2:22–25, 23, 3:221  
 Endoderm, 1:207, 2:82  
 Endodermis, of plant roots, 4:79–80  
 Endodontics, 1:200  
 Endogenous plant rhythms, 4:69  
 Endometrium, 2:78, 82  
 Endoplasmic reticulum (ER), 1:121, 2:25–27, 26  
   Golgi apparatus and, 2:150–151  
   nuclear membrane in, 3:146  
   as organelle, 3:159  
   proteins and, 4:19, 20–21  
 Endorphins for pain regulation, 3:171  
 Endoskeletons, 4:118  
 Endosomes, 2:24, 3:55  
 Endosperm, 1:31–32, 2:58, 3:228, 4:53–56, 90  
 Endosymbiotic theory, 1:138  
 Endothelium, in arteries and veins, 1:90, 151  
 Endotherms, 2:116, 3:59  
 Endothermy, 3:202  
 Endotoxins, 1:51  
 Energy  
   activation, 2:31  
   life cycles and, 3:34–35  
   light, 3:197–198  
   metabolic rate and, 3:87–88  
   mitochondria, 3:97–98  
   muscle contraction, 3:111–112  
   nutrients, 2:218  
   *See also* Adenosine triphosphate; Potential energy  
 Engelhardt, Vladimir, 2:184  
 England, coral reefs in, 1:184  
 Enlightenment, 1:106, 2:193  
*Entamoeba histolytica*, 4:22, 25, 26  
 Enterocoelous development, 1:210  
 Enteropeptidase, 1:181  
 Entomologists, 2:27–28  
 Entomophily, 3:227  
*env* genes, 4:66  
 Environmental catastrophes, 2:51  
 Environmental cues, for migration, 3:92  
 Environmental health, 2:28–29, 4:36  
 Environmental impact of  
   agriculture, 1:12–13  
   algae, 1:22  
   bacteria, 1:52  
   coffee-growing, 1:156  
   cyanobacteria, 1:190–191  
   desert urbanization, 1:203  
   inheritance, 2:189  
   life cycles, 3:34–35  
   pesticides, 1:117  
   phenotypes, 3:181–182  
   pollutants, 3:228–231  
   racial variations, 1:77–78  
 Environmental pollution. *See* Pollution  
 Environmental protection. *See* Conservation  
 Environmental Protection Agency (EPA), 2:28, 29, 3:225  
   DDT, 3:231  
   endocrine disrupters, 3:231  
 Environmental resources. *See* Natural resources  
 Environmental toxins, 3:129  
 Environments  
   as cancer cause, 3:154–155  
   convergent evolution and, 1:181–182  
   coral reefs and, 1:184–185  
   deterioration of, 1:4, 5  
   endogenous plant rhythms and, 4:69  
   natural selection and, 3:123  
   nervous system responses to, 3:125  
   sex determination, 4:98  
   variability in, 1:70  
   variable, 3:234  
   *See also* Ecosystems; Pollution  
 Enzyme-linked immunosorbent assay. *See* ELISA  
 Enzymes, 2:29–36, 30f, 31f, 33f, 35f  
   activators for, 3:216  
   behavioral genetics, 1:63  
   cascading, in blood clotting, 1:86  
   cellular metabolism, 3:85  
   control mechanisms for, 1:177–181  
   digestive, 1:218  
   eukaryotic chromosomes, 1:144  
   gene encoding of, 2:119–120  
   proteins, 2:183  
   *See also specific enzymes and types of enzymes*  
 Enzymic dissociation, in cell cultures, 1:122  
 Enzymologists, 1:66  
 Enzymology, 2:185  
 Eocene period, 4:5  
 Eocene-Oligocene period, 2:66  
 EOG. *See* Electro-oculogram (EOG)  
 Eosinophils, 3:138  
 EPA. *See* Environmental Protection Agency

- Ephedra*, 2:59, 163, 177, 4:54  
 Epicotyl, 4:55  
 Epidemiological research, 2:29  
 Epidemiologists, 2:36–37  
 Epidemiology, 3:219, 4:36  
 Epidermal cells, 1:30, 213  
 Epidermis, 1:212–213, 3:29, 4:79, 120  
 Epididymis, 3:57  
 Epigenesis, 1:206  
 Epilepsy, 3:129, 4:33  
 Epilimnion, 3:21  
 Epinephrine, 2:204–205, 4:147  
   adrenal medulla and, 1:7, 2:22  
   blood glucose regulation, 1:89  
   glucose and, 4:114, 115*f*, 116  
   postabsorptive metabolic state, 3:89  
 Epiphyses, 2:159  
 Epiphytes, 2:101  
 Episomes, 1:53–54  
 Epistasis, 3:182–183  
 Epithalamus, 1:102  
 Epithelial tissue, 4:160  
 Epithelium, 2:37–38, 37*t*  
 Epperson, Susan, 1:185–186  
 EPSP. *See* Excitatory postsynaptic potential  
 Epstein-Barr virus, 1:228  
*Epulopiscium fishelsoni*, 1:50  
 Equisetopsida, 4:34  
*Equisetum*, 2:57  
 ER. *See* Endoplasmic reticulum  
 Eradication, of plant pests, 3:218  
 ErbB2 gene, 1:111  
 Erectile dysfunction, 3:58  
 Erection, 3:58  
 Ereky, Karl, 1:80  
 Ergonomics, 2:28  
 Ericales, 3:120  
 Ericoid mycorrhizae, 3:120  
 Erosion  
   desertification from, 1:201, 204  
   global warming and, 2:147  
   wetlands and, 4:198  
*Erwinia amylovora*, 3:217  
 Erythrocytes. *See* Red blood cells  
*Escherichia coli*  
   bacteriophages and, 1:58–59  
   beneficial, 1:52  
   DNA replication, 4:48–50  
   F factor in, 1:54  
   gram-negative bacteria, 1:134  
   lac operons and, 1:170–171, 173  
   model organisms, 3:102, 103  
   reproduction of, 1:49  
   transcription, 4:162–163  
 Esophageal cancer, 1:111  
 Esophageal sphincter, 1:219  
 Esophagus, in digestion, 1:219  
*An Essay on the Principle of Population*  
 (Malthus), 1:198, 2:46, 194  
 Essential plant nutrients, 3:214–216  
 EST. *See* Expressed sequence tag  
 Estrogen  
   cell cycles, 1:126  
   ovulation control, 2:22  
 Estuaries, 2:38–40, 39, 4:197  
 Ethanol. *See* Alcohol  
 Ethics  
   Human Genome Project, 2:216–217  
   reproductive technologies and, 4:62  
 Ethidium bromide, 3:115  
 Ethnicity, *vs.* race, 1:77  
 Ethnobotany, 2:40  
 Ethnopharmacology, 4:84–85  
 Ethology, 1:63, 2:85–86  
 Ethyl alcohol. *See* Alcohol  
 Ethylene, 2:108, 200, 207–208  
 ETS. *See* Electron transport system  
 Eubacteria, 2:41, 42  
   cell walls of, 1:133  
   classification of, 3:17  
 Euchromatin, 1:147, 3:146  
 Eudicots, 1:32–33, 2:43–44, 44, 59, 4:55  
   cell walls of, 1:133  
   taproots of, 4:80  
 Eugenics, 1:62  
*Euglena*, 4:22, 24  
 Euglenoid motion, 4:24  
 Eukarya. *See* Eukaryotes  
 Eukaryotes, 1:44, 120–122  
   algae, 1:21  
   *vs.* archaea, 1:44–46  
   cell evolution of, 1:127–128  
   cell motility in, 1:131–132  
   cell walls in, 1:133  
   chromosomes in, 1:143–149, 144, 145*f*, 146  
   classification of, 3:17–18, 4:153–154  
   DNA replication in, 4:50–52  
   endocytosis in, 2:22–25  
   gene transcription in, 1:144–145, 172–177, 174  
   genomes of, 2:140–141  
   Krebs cycle in, 3:18–19  
   lysosomes in, 3:54  
   mitochondria in, 3:94  
   mitosis in, 3:98–100  
   nuclear transport in, 3:140  
   nuclei in, 3:145  
   nucleoli in, 3:142  
   organelles in, 3:159  
   oxidative phosphorylation in, 3:168–170  
   protein initiation in, 4:15–16  
   protists as, 4:21  
   protozoans as, 4:23  
   ribosomes in, 4:71–72  
   RNA processing in, 4:77–78  
   symbioses with bacteria, 2:42–43  
   transcription in, 4:163–165  
   transposons in, 4:175  
   *See also specific organisms*  
 Eumycota, 2:109  
 Euphorbiaceae. *See* Spurge family  
 Europa, life on, 3:165  
 Europe  
   grasslands in, 2:156  
   history of farming in, 2:181  
   human evolution in, 2:211–212  
   population growth in, 2:219  
 European Jews, 2:140  
 Euryhaline organisms, 3:166  
 Euryphagous animals, 2:74  
 Eusociality, 4:131  
 Eustachian tubes, 2:171  
 Eutrophication, 1:191, 3:135  
 Evaporation, 4:193, 194  
   cooling mechanism, 3:202–203  
   deserts, 1:201  
   thermoregulation, 4:155  
 Evergreen pine forests, 2:99  
 Evergreen rain forests, temperate, 2:99  
 Evidentiary DNA profiles, 2:96  
 Evolution, 1:76, 2:44–52, 46, 50  
   angiosperms, 1:32–34, 4:59  
   animals, 1:35  
   biogenetic law and, 1:210–212  
   birds, 1:81  
   Buffon, Count on, 1:106–107  
   Cambrian period, 1:108–110  
   cells, 1:127–129, 128  
   change due to, 1:70  
   classification based on, 1:44  
   convergent, 1:181–183, 182  
   *vs.* creationism, 1:185–187  
   evidence for, 2:52–54, 53  
   fossils in, 3:172–173  
   fungi, 2:112  
   genetics and, 2:123, 130–131  
   Hardy-Weinberg equilibrium and, 2:165  
   history of research, 2:192–196, 193

- Evolution (continued)  
 human, 2:208–212, 209  
 insects, 4:57  
 Lamarck, Jean-Baptiste and, 3:23–24  
 life-defining, 3:38, 162  
 mutations in, 3:117–119, 179  
 natural selection and, 1:197–199, 3:121, 123  
 nuclei, 3:145  
 origins of, 3:164  
 plants, 2:55–60, 58, 179, 181  
 population genetics and, 3:236  
 predators-prey and, 4:3–4  
 proteins and, 4:12–13  
 RNA and, 4:76–77  
 sexual reproduction, 4:100, 102, 101–104  
 sociobiology and, 4:130–131  
 vertebrate brain, 1:103
- Evolutionary synthesis. *See* Neo-Darwinism
- Excitatory postsynaptic potential (EPSP), 4:146
- Exclusion, of plant pests and pathogens, 3:218
- Excretion, 3:8–9
- Excretory systems, 2:60–62, 61f, 62f, 3:166
- Exercise, heart attacks and, 1:116
- Exergonic reactions, 2:30, 3:85
- Exhalation, 4:65
- Exine, 4:54
- Exocarp, 4:56
- Exocrine glands, 3:174
- Exocytosis, 2:24, 62–64
- Exons, 4:78
- Exonucleases, 3:116, 4:77–78
- Exoskeletons, 4:118  
 chitin in, 1:114  
 of crustaceans, 1:189–190  
 of intertidal animals, 3:150
- Exotic species, 3:10
- Experimental physiology, 2:166
- Exploitative competition, 1:160
- Exports, coffee as, 1:156
- Exposure, to poisons, 3:225
- Expressed sequence tag (EST), 4:42
- Expulsion, in childbirth, 3:33
- External stimuli, 4:112
- Extinction, 2:64–67, 65, 67, 209, 3:234  
 biodiversity and, 1:67  
 paleontological study of, 3:173  
 primates, 4:5
- Extirpation of populations, 2:64
- Extra-pair copulations, 3:63
- Extracellular matrix (ECM), 2:68–69, 3:221–222
- Extreme communities, 2:69–71, 70
- Extremophiles, 2:69–70
- Extrinsic pathway, 1:86–87
- Extrusomes, 4:25
- Eyecups, 4:188
- Eyelashes, 2:73
- Eyelids, 2:73
- Eyes, 2:72–73, 72f, 73  
 animals, 4:188–190  
 insects, 3:7
- F**
- F actin. *See* Fibrous actin
- F factors, 1:54–55
- F pilus, 1:54–55
- Fabaceae. *See* Legumes
- Facial nerves, 1:103
- Factor VIII, 1:87
- Factor X, 1:86–87
- Factor XII, 1:86–87
- Facultative migration, 3:92
- Faculty members. *See* College professors
- FAD. *See* Flavin adenine dinucleotide
- FADH<sub>2</sub>  
 Krebs cycle, 3:18  
 oxidative phosphorylation and, 3:168–170
- Fallopian tubes, 2:77
- False fruits, 2:106
- Familial adenomatous polyposis, 3:155
- Familial hypercholesterolemia, 2:139
- Familial partial lipodystrophy, 3:147
- Family nurse practitioners (FNPs), 3:149
- Family practice doctors, 1:228
- Far East, human evolution in, 2:211
- Farming. *See* Agriculture
- Fat cells. *See* Lipids
- Fatigue, muscle, 3:111
- Fats. *See* Lipids
- Fat-soluble vitamins, 4:190
- Fatty acids, 3:48, 86  
 mitochondria, 3:97  
 oxidation of, 3:191
- Feather stars, 2:2
- Feathers, 1:81
- Feces, 1:221
- Feedback inhibition, 1:177, 2:35
- Feedback loops  
 hormone concentration, 2:20  
 male hormonal control, 3:57  
 pituitary glands and, 3:205
- Feeding  
 benthic animals, 3:150  
 ecosystems, 2:8–9  
 social behavior and, 4:127–128  
 strategies, 2:74–76
- Fell, Honor Briget, 1:123
- Female reproductive system, 2:77–81, 78f–80f
- Fens, 4:197
- Fermentation, 3:177  
 beer-making, 1:60  
 glycolysis and, 2:148–150, 149f, 150f  
 metabolic pathway, 2:183  
 wine-making, 4:200
- Ferns, 1:23, 31, 2:57, 4:33–35, 88–89
- Fertile Crescent, 2:181
- Fertilization, 1:206, 4:99–100  
 angiosperms, 1:24, 4:54–55  
 double, 2:57–58  
 humans, 2:82, 3:32  
 internal, 1:118  
 mitochondria, 3:98  
 pollination and, 3:227–228  
 seeds and, 4:90
- Fertilizers, agricultural. *See* Agricultural fertilizers
- Fetal development, 2:81–85, 83, 3:32
- Fetal period in humans, 2:83, 83–85, 3:32
- Fetal ultrasounds, 3:1
- Fetoscopy, 2:84
- Fevers, 3:139–140, 4:156–157
- Fibrillar components, 3:143
- Fibrils, 2:68
- Fibrin, 1:86–87
- Fibroblasts, 1:164
- Fibrous actin, 1:193–194, 3:110
- Fibrous roots, 4:80–81
- Field studies  
 animal behavior, 2:85–87, 86  
 plant ecology, 2:87–89, 88
- Fight or flight response, 1:7, 2:22, 3:89, 190–191, 4:139
- Filamentous growth pathway, 4:116
- Filamentous phages, 1:59
- Filicopsida, 4:34, 35
- Filter feeding, 2:75, 3:153–154, 4:179
- Filtrate, blood, 3:16
- Finches, 1:160–161, 161
- Fingernails, 4:120
- Fire blight, 3:217
- Fires  
 ecology of, 2:89–91, 90  
 grasslands, 2:157  
*See also* Forest fires



- First-order streams, 4:73  
 Fischer, Emil, 2:183  
 FISH, 1:148–149  
 Fish, 1:36  
   bony, 1:95–96  
   brain in, 3:128  
   cartilaginous, 1:118–119  
   circulatory systems of, 1:150, 151  
   estuaries, 2:38–39  
   gas exchange in, 2:114, 115–116  
   rivers and streams, 4:74–75  
   sex determination in, 4:98  
   urine concentration in, 3:167  
 Fish tapeworm. *See* *Diphyllbothrium latum*  
 Fish-eating fish. *See* Piscivorous fish  
 Fisher, Ronald, 2:49, 3:236, 239, 4:103, 105  
 Fisheries, 2:38–39, 3:206  
 Fitness, survival and. *See* Survival of the fittest  
 Fixators, muscles as, 3:114  
 Flagella, 1:122, 197, 3:51, 4:24  
 Flagellates, 4:24, 26  
 Flatworms, 1:36, 2:60–61  
 Flavin adenine dinucleotide (FAD), 3:144  
 Fleas, parasitic, 3:176  
 Fleming, Alexander, 1:234, 2:197  
 Flemming, Walther, 2:188, 3:99  
 Fleshy finned fish, 1:96  
 Fleshy fruits, 2:106–108, 4:56  
 Flexors, 3:115  
 Flies. *See* Diptera  
 Flight, 2:91–93  
 Flooding, from global warming, 2:147  
*Flora of North America* (Torrey and Gray), 2:158, 4:160  
*Flore Française* (Lamarck), 3:23  
 Florets, 2:155  
 Florey, Howard, 1:234, 2:197  
 Florida Everglades, 4:197  
 Flour, from wheat, 2:154  
 Flowering plants. *See* Angiosperms  
 Flowers, 1:29, 31–32, 2:93–94, 94  
   grasses, 2:155  
   monocots, 3:106–107  
   photoperiodism and, 3:195–196  
   sexual reproduction in, 4:53  
   *See also* Angiosperms  
 Fluid mosaic model, of membrane structure, 3:76  
 Fluids, body, 2:60  
 Flukes. *See* Trematodes  
 Fluorescence microscopes, 3:40  
 Fluorescent *in situ* hybridization. *See* FISH  
 Flying, 3:51–52  
   brain and, 3:128  
   effect on anatomy, 1:81  
 fMRI. *See* Functional MRI  
 FNPs. *See* Family nurse practitioners  
 Folate, 4:191  
 Folding (Proteins). *See* Conformations  
 Follicle mites, 4:120  
 Follicle-stimulating hormone (FSH), 2:21, 80, 3:57  
 Fontanelles, 2:85  
 Food  
   digestion of, 1:217–219  
   fruits as, 2:108  
   fungi as, 2:111  
   global warming and, 2:147  
   migration for, 3:92  
   *See also* Nutrition  
 Food and Drug Administration. *See* U.S. Food and Drug Administration  
 Food chains  
   algae, 1:22  
   ecology, 2:6  
   ecosystems, 2:8  
   rivers and streams, 4:74–75  
 Food contamination, 4:26  
 Food flavorings, 4:84–85  
 Food poisoning, 3:225  
 Food preservatives, 4:85  
 Food Quality Protection Act, 3:231  
 Food vacuoles, 4:24–25  
 Food web, 2:8  
   aquatic, 3:206  
   pelagic zone, 3:23  
   photosynthesis, 3:207  
 Foraging behavior, 1:64, 2:74–76  
 Foramen ovale, 2:85  
 Foraminiferans, 4:25  
 Forbes, Edward, 2:5  
 Forbes, S.A., 2:5  
 Forebrain, 3:128  
 Forensics  
   Barr body in, 4:96  
   DNA analysis in, 2:94–97, 95, 221  
   entomology in, 2:27  
 Forest fires, 2:89–91  
   boreal forests, 2:97  
   temperate forests, 2:99  
 Forest management, 4:202  
 Foresters, 2:105  
 Forestry, in biogeochemical cycles, 1:69  
 Forests  
   boreal, 2:97–99, 98  
   fire regimes in, 2:89–90  
   temperate, 2:99–101, 100  
   tropical, 2:101–104, 102, 103  
 Fossey, Dian, 3:26  
 Fossil fuels  
   biogeochemical cycles, 1:69  
   carbon cycle, 1:114  
 Fossils, 3:171–173  
   evolution research, 2:44–45, 53, 54  
   human evolution, 2:210  
   Leakey family and, 3:26  
   in origins of life, 3:161–162  
   primates, 4:5  
 Founder effect, 2:49, 3:238  
 Four-carbon plants. *See* C4 plants  
 Fractures, X rays of, 3:1  
 Fragile X syndrome, 2:139  
 Frame-shift mutations, 3:116–117  
 Franklin, Rosalind, 1:187, 222, 4:196  
 Free radicals  
   aging, 1:8–9, 3:34  
   antioxidants and, 1:9  
   mitochondria, 1:9  
 Freshwater  
   limnology and, 3:42  
   sources of, 3:21  
 Freshwater biomes, 1:79  
 Freshwater wetlands, 4:197  
 Fries, Elias, 2:112  
 Fringing reefs, 1:184  
 Frisch, Karl von, 1:63  
 Frog chytrids, 2:112  
 Frogs, 1:26, 27  
   embryos, 1:209  
   poison dart, 4:2–3  
 Frontal lobe, 1:99, 100  
 Fructose, 1:113  
 Fruit flies. *See* *Drosophila*  
 Fruits, 1:32, 2:75, 105, 105–108, 106t, 107f, 4:56  
 FSH. *See* Follicle-stimulating hormone  
 Fuel, wood for, 4:201  
 Fullam, Ernest F., 3:240  
 Functional MRI, 3:3  
 Fundamentalism, Protestant. *See* Protestant fundamentalism  
 Fungal diseases, 2:108–109, 111, 3:217  
 Fungi, 2:109–114, 111, 113  
   cell division in, 3:99  
   cell walls of, 1:133  
   chitin in, 1:114

- Fungi (continued)  
 as heterotrophs, 2:8  
 lichens and, 3:31–32  
*See also* Mycorrhizae
- Funicles, 4:53, 55
- Furniture, wood, 4:203
- Fusion proteins, 3:156–157
- G**
- G actin. *See* Globular actin
- GABA. *See* Gamma-aminobutyric acid
- gag* genes, 4:66
- Gain-of-function mutations, 3:179, 181
- Galapagos Islands, 1:198, 2:44–45, 46, 85
- Galdikas, Birute, 3:26
- Galen, 2:166, 196, 4:184
- Galileo Galilei, 2:197, 3:30
- Gallbladder, 3:50
- Gamete intrafallopian transfer (GIFT), 4:61
- Gametes  
 in female reproductive system, 2:77, 78  
 from meiosis, 3:66
- Gametic meiosis, 1:21
- Gametophytes  
 alternation of generations, 1:22–23  
 bryophytes and, 1:105–106  
 from meiosis, 3:66, 67  
 plant, 4:53–54
- Gamma-aminobutyric acid (GABA), 4:31
- Gamma globulins, 1:39  
*See also* Antibodies
- Gamma polymerase, 4:51–52
- Gamma rays, 1:110
- Ganglia, 3:127, 128, 191
- Gap junctions, 1:129–130, 130, 3:221–222
- Garner, Wightman, 3:195
- Gas chromatography (GC), 1:233
- Gas exchange, 2:114–117, 115f, 116f, 199  
 pulmonary, 4:65  
 systemic, 4:66  
 in wetland plants, 4:198
- Gas transport, in circulatory system, 4:65
- Gases  
 greenhouse, 2:145–146  
 leaves and, 3:29  
*See also specific gases*
- Gastric capillaries, 1:91
- Gastric juices, 1:220
- Gastroesophageal sphincter. *See* Esophageal sphincter
- Gastrointestinal tract, 3:225
- Gastrulation, 2:82
- Gause, G.F., 1:160
- Gazelles, 2:157
- GC. *See* Gas chromatography
- GDP. *See* Guanosine diphosphate
- GEF. *See* GTP exchange factor
- Gel electrophoresis. *See* Electrophoresis
- Gel filtration, 4:93
- GenBank, 1:73
- Gender identity, 4:98
- Gene expression, 2:129, 192  
 cell function and, 3:102  
 control of, 1:170–177, 172f, 174f  
 hybridization for, 2:143  
 morphogenesis and, 2:133–134  
 nucleoli and, 3:142–143  
 in plant defenses, 2:179  
 plant hormones and, 3:84  
 RNA electrophoresis for, 2:15
- Gene frequency  
 Dobzhansky, Theodosius and, 2:165  
 evolution and, 2:48–51
- Gene mapping, 3:44–47, 45f
- Gene repressor proteins, 4:12
- Gene targeting, 4:168
- Gene therapy, 2:124–125, 140, 4:45–46
- Genes, 1:224, 2:117–124, 118t, 120f–123f  
 defects in, 2:124, 136–137, 139–140, 144, 3:14  
 disease, 4:45–46  
 diversity in, 1:66–67  
 early research on, 2:190–192  
 lamin, 3:147  
 regulation of, 1:149  
 structure of, 2:120–121  
 susceptibility, 2:137  
*See also* Chromosomes; Clones; DNA; Human Genome Project; and *specific types of genes*
- Genetech, 1:80
- Genetic analysis, 2:125–129, 126f
- Genetic bottlenecks, 3:237, 237–238
- Genetic code, 1:223, 2:120, 129–131, 130f, 131f, 185, 3:164
- Genetic counselors, 2:135–136
- Genetic determinism, 1:63, 2:119
- Genetic diseases, 2:135–140, 137f, 138t  
 gene therapy for, 2:124–125
- neurological, 3:129  
 psychiatric, 4:29–30
- Genetic drift, 2:48–49, 3:118, 236–239, 4:134
- Genetic engineering  
 in agriculture, 1:11  
 in biological weapons, 1:75  
 in bioremediation, 3:229  
 of corn, 2:181  
 of rice, 2:154
- Genetic isolation, 4:134–135
- Genetic markers, 3:43–47  
 in DNA forensics, 2:96  
 mapping of, 4:36–37
- Genetic testing, 2:135, 140, 3:46–47
- Genetic transcription, 2:121–122, 129
- Genetic translation, 2:120–121
- Genetic variation, 3:121, 178–179, 235–239, 4:103  
 from crossing over, 3:68  
 in humans, 1:77–79  
 from mutations, 3:117  
 sexual reproduction and, 4:102–103  
*See also* Diversity
- The Genetical Theory of Natural Selection* (Fisher), 4:103, 105
- Genetically modified organisms (GMOs), 4:43–44
- Genetics, 1:76  
 agricultural, 4:183–184  
 altruism and, 4:131  
 bacterial, 1:53–57, 54, 56, 57  
 behavioral, 1:60–63  
 classical, 2:191  
 in development, 2:131–135, 132  
 linkage and mapping in, 3:42–47  
 McClintock, Barbara and, 3:64–65  
 Mendelian, 2:126–128, 3:80–81  
 model organisms in, 3:101–102  
 molecular, 2:200–201  
 population, 2:164–165, 3:235–239, 237
- Genital herpes, 4:109
- Genital warts, 4:109
- Genitourinary tract, 4:107
- Genomes, 1:223–226, 2:140–141  
 archaea, 1:45–46  
 bacteria, 1:50, 2:42  
 bacteriophage, 1:58  
 genetic code in, 2:120  
 genetic transfer of, 1:53  
 linking and gene mapping, 3:45–46  
 McClintock, Barbara, 3:64  
 of mitochondria, 3:95

- of model organisms, 3:102, 104–105  
 plant, 2:201  
 viral, 4:186, 187
- Genomic libraries, 4:44–45  
 of cDNAs, 4:42–43  
 in cloning, 1:154
- Genomics, 1:72–73, 2:141–145, 142, 144f
- Genotypes, 3:178, 186  
 frequencies in, 3:235–236  
 racial variations in, 1:77
- Genus, nomenclature for, 3:47–48
- Geoffroy Sainte Hilaire, Isidore, 2:194
- Geographical Information System (GIS), 4:46
- Geology  
 in biogeochemical cycles, 1:68  
 in evolutionary theory, 2:193  
 impact on landscape structure, 3:25
- Geospiza*. *See* Finches
- Geotropisms, 2:200
- Geriatric nurse practitioners (GNPs), 3:149
- Germ cells  
 meiosis of, 3:66  
 telomerase in, 1:146
- Germ-line mutations, 3:115
- Germ theory, 1:234
- Germination, 1:59–60, 3:209–210, 210f, 227–228, 4:7, 54, 86, 86–88, 87f, 90
- Gestation, 2:82
- GH. *See* Growth hormones
- GH-releasing hormone, 2:160
- Giardia lamblia*, 4:22, 26
- Giardiasis, 4:26
- Gibberellic acid, 3:209, 211–212
- Gibberellins, 2:207, 3:82
- Gibbons, 4:5
- GIFT. *See* Gamete intrafallopian transfer
- Gigantism, 2:21, 161
- Gilbert, Walter, 1:173, 2:213
- Gills  
 in chordates, 1:139  
 in gas exchange, 2:115–116, 115f
- Ginkgo biloba*, 2:57, 58, 163, 176–177, 3:208
- GIS. *See* Geographical Information System; Global information systems (GIS)
- Glaciers, 3:21
- Glands, 3:158–159  
*See also specific glands*
- Glans penis, 3:58
- Gleason, Henry A., 2:6
- Gliding, for locomotion, 3:51–52
- Global climate change, 2:145–148, 147
- Global cooling, 2:66
- Global information systems (GIS), 3:61
- Global warming, 1:69, 2:146–148  
 biodiversity and, 1:168  
 desertification from, 1:204–205  
 ecological research on, 2:3–4  
 effect on boreal forests, 2:98–99  
 mass extinctions from, 2:66  
 tundra and, 4:178
- Globin fold proteins, 4:12
- Globular actin, 1:193–194, 3:110
- Globular embryo, 3:208–209
- Globus pallidus, 1:101–102
- Glomerular capsule. *See* Bowman's capsule
- Glomeruli, 3:16, 167
- Glomerulonephritis, 1:47
- Glossopharyngeal nerve, 1:103
- Glucagon, 2:204  
 in blood glucose regulation, 1:88, 88–89, 2:22  
 from pancreatic islets, 3:174  
 in postabsorptive metabolic state, 3:89
- Glucanase, 4:54
- Glucocorticoids, 1:6, 9
- Gluconeogenesis, 3:89
- Glucose  
 epinephrine and, 4:114, 115f, 116  
 in human metabolism, 3:88–89  
 in mitochondria, 3:97  
 as monosaccharide, 1:113  
 NA<sup>+</sup> gradient and, 1:3  
 in PET scans, 3:3  
 in polysaccharides, 1:113–114  
 protein crosslinkage, 1:9  
 regulation of, 1:87–89, 88, 2:22, 63  
 repression, 1:171  
*See also* Glycolysis
- Glucose-6-phosphate, 2:149
- Glucose oxidation, 3:88
- Glucose reaction, 2:30–31, 31f
- Glucosinolates, 2:178, 4:85
- Gluten, in wheat, 2:154
- Glyceraldehyde-3-phosphate, 1:107
- Glyceraldehyde phosphate, 3:200
- Glycerides, 3:48
- Glycerol, 2:41
- Glycogen  
 in muscle contraction, 3:111–112  
 as polysaccharide, 1:113
- Glycogenesis, 3:88
- Glycogenolysis, 3:89
- Glycolipids, 1:113, 3:49, 220
- Glycolysis, 1:114, 2:183, 184  
 fermentation and, 2:148–150, 149f, 150f  
 in mitochondria, 3:97
- Glycoproteins, 1:113, 3:220, 4:11–12, 67
- Glycosylation, 2:26  
 aging and, 1:9  
 protein, 4:19  
 in retroviruses, 4:67
- Glyoxalate, 3:191
- GMOs. *See* Genetically modified organisms
- Gnetales, 4:54
- Gnetophytes, 2:57, 59, 163, 3:208
- Gnetum*, 2:59, 163
- Gnetum gnemon*, 4:69
- GNPs. *See* Geriatric nurse practitioners
- GnRH. *See* Gonadotropin releasing hormone
- Goiter, 2:21, 4:159
- Golden algae, 4:22
- Golden rice, 4:43–44
- Goldstein, Joseph, 2:25
- Golgi apparatus, 1:121, 2:150–153, 151f, 3:70
- Golgi, Camillo, 1:103, 2:150, 197
- Gonadotropin releasing hormone (GnRH), 2:79–80, 3:57
- Gonorrhea, 4:107
- Goodall, Jane, 2:87, 3:26, 4:5
- Gorillas, 4:5
- Gorter, E., 3:73–74
- Gould, Stephen Jay, 1:108, 2:51
- G-proteins, 1:178, 4:114, 116
- Gradualism, 2:54, 4:136
- Grafting  
 in plant propagation, 4:7, 58  
 of skin, 4:172
- Grain alcohol. *See* Alcohol
- Grains, 2:153–155, 154, 155, 4:56
- Gram-negative bacteria, 1:50–51, 134
- Gram-positive bacteria, 1:50–51, 134
- Gram stain, for bacteria, 1:50, 134
- Gramicidin, 1:233, 234
- Grant, Peter, 1:160
- Grant's Atlas of Anatomy* (Agur), 4:184–185

- Granular components, of nucleoli, 3:143
- Grapes, in wine-making, 4:200
- Grasses, 1:33, 2:155–156, 156*t*, 3:106, 107  
in desertification, 1:204  
evolution of, 2:59  
grazing for, 2:74  
marine, 3:153  
*Spartina*, 2:38
- Grasshoppers, 2:157, 3:218
- Grasslands, 2:89, 157, 156–158
- Graves' disease, 1:47, 2:22, 4:158
- Gravitropism, 4:175
- Gravity, 4:175
- Gray, Asa, 2:158, 4:160
- Gray matter, 1:98, 99, 4:138
- Gray wolves, 2:86
- Grazing, 2:74
- Great Barrier Reef, 1:184
- Great Lakes (North America), 3:21
- Great saphenous veins, 1:91
- Green algae. *See* Chlorophyceae
- Green revolution  
in biotechnology, 1:80  
labeling and, 4:202  
rice in, 2:154
- Greenhouse effect, 2:146, 3:153
- Greenhouse gases, 2:145–146
- Grendel, F., 3:73–74
- Grew, Nehemiah, 2:186
- Ground tissue, 1:30, 212, 213–215, 4:111
- Growth, 2:158–161, 159, 160  
fetal, 2:83–84  
plant, 2:198–199, 3:82, 4:182, 183  
*See also* Development
- Growth disorders, 2:161
- Growth factors  
for cell cultures, 1:122  
oncogenes and, 1:110–111
- Growth hormones (GH), 2:21, 159–161  
in aging, 1:9  
in blood glucose regulation, 1:89  
bone growth and, 1:94  
for cell cultures, 1:122  
in postabsorptive metabolic state, 3:89
- Growth inhibitors, plant, 2:207–208
- GTP. *See* Guanosine triphosphate
- GTP exchange factor (GEF), 1:178
- GTPase, 3:141
- Guam, brown tree snake in, 3:11
- Guanine, 3:143–144, 4:76
- Guanosine diphosphate (GDP), 1:178, 3:141
- Guanosine triphosphate (GTP), 1:178, 3:18, 141
- Guard cells, 1:213, 3:29, 213, 214*f*, 4:112
- Gurdon, John, 2:132
- Gustation, 1:136  
in insects, 3:8
- Gymnophiona, 1:26
- Gymnosperms, 1:31, 32, 2:57, 161–163, 162, 3:208  
pollination in, 3:227–228  
seeds in, 4:90  
translocation in, 4:169–170
- Gynecologists. *See* OB-GYNs
- Gynoecium, 2:93
- Gyrase, 4:48, 51
- Gyri, 1:99
- ## H
- Haartsoecker, Nicholas, 1:207
- Habitat destruction  
biodiversity and, 1:167  
birds and, 1:82  
endangered species from, 2:16  
mass extinctions from, 2:66–67
- Habitats, 2:163–164  
after fires, 2:91  
of bacteria, 2:42  
hybrid, 2:221–222  
in lakes and ponds, 3:22–23  
soil as, 4:133  
*See also specific habitats*
- Habituation, 3:26–27
- Haeckel, Ernst, 1:210–212, 2:5, 6, 4:152–153
- Haemophilus influenzae*, 1:57, 2:215
- Hair follicles, 4:120
- Haldane, J.B.S., 2:49, 165, 3:10, 236, 239
- Hales, Stephen, 2:199
- Hallucinogens, 4:32
- Halogeton, 3:224
- Hamilton, William, 4:131
- Handicap hypothesis, 4:106
- Haplodiploidy, 3:9
- Haploids. *See* Gametophytes
- Haplorrhini, 4:4
- Hard ocean bottoms, 3:150–151
- Hardy, Godfrey, 2:48, 164, 3:235
- Hardy-Weinberg equilibrium, 2:48, 164–165, 3:235–236
- Hartwell, Lee, 1:125
- Harvey, William, 1:206, 2:166–167, 172, 197
- Hawk, red-tailed, 1:81
- Hayflick limit, 1:9
- Hazardous wastes, 2:169
- Hazen, Elizabeth Lee, 4:109
- HCG. *See* Human chorionic gonadotropin
- HDL. *See* High-density lipoproteins
- Health, 2:167–168  
alcohol and, 1:17–20  
environmental, 2:28–29, 4:36  
smoking and, 4:126–127
- Health administration, 4:36
- Health and safety officers (HSO), 2:169
- Health care workers, 1:16
- Health education, 4:36
- Healthy People 2010*, 2:168
- Hearing, 2:169–172, 170*f*, 3:128
- Heart  
circulation and, 2:172–176, 173*f*, 175*f*  
poisons and, 3:225–226
- Heart attacks, 1:86, 116, 2:174, 203
- Heart diseases, 1:115–117  
cardiologists for, 1:229  
heart transplants for, 4:173–174  
from smoking, 4:127  
*See also specific conditions*
- Heart failure, 1:115
- Heart-lung transplants, 4:174
- Heart surgery, 2:197
- Heart transplants, 4:173–174
- Heat  
adaptations to, 3:202–203  
in blood, 1:85  
conduction of, 4:155  
loss of, 4:154–157
- Heat shock factor (HSF), 1:179–180
- Heitz, Emil, 1:147
- Helicases, 4:48, 51
- Helix-turn-helix motif, 4:12
- Helper T cells, 4:149  
in AIDS, 1:14–15  
in immune response, 3:4–5
- Hematemesis, 1:19
- Heme, 1:84–85
- Hemidesmosomes, 1:129–130, 2:68, 3:221
- Hemipenes, 4:63
- Hemlock forests, 2:90
- Hemocoel, 1:150
- Hemocyanin, 2:114
- Hemoglobin, 2:114  
genetic variants in, 1:78  
red blood cells and, 1:84–85

- Hemoglobin gene mutations, **3:117**, 183–184
- Hemolymph, **1:150**
- Hemophilia, **1:87**, **2:136**, **3:181**
- Hepatic arteries, **1:90**
- Hepatic duct, **3:50**
- Hepatic veins, **1:91**
- Hepatitis B, **1:227**
- Hepatitis B virus, **1:110**
- Hepatitis viruses, **4:109**
- Hepatocytes, **3:50**
- Heraclitus, **2:192**
- Herbal medicine, **2:40**, 177*t*, **176–178**
- Herbivores, **2:8**, 10, 178–179
- Herbivory, **1:157**, **2:178–179**
- Hereditary optic neuropathy, **2:139**
- Heredity. *See* Inheritance
- HERG gene, **3:14**
- Hermaphroditic plants, **4:56**, 58
- Heroin, **4:32**, 33
- Herpes, **1:227–228**, **4:109**
- Herpes simplex 2 virus, **1:110**
- Herpetoculture, **4:63**
- Hershey, Alfred, **1:228**, **2:119**, 191
- Hertwig, Oscar, **2:189**
- Hesperidium, **4:56**
- Heterochromatin, **1:147**, **3:146**
- Heterografts, **4:172**
- Heterospory, **4:34–35**
- Heterotrophs, **2:8**, **4:23–24**
- Hexokinase, **2:149**
- Hfr strains, **1:55**
- HGH. *See* Human growth hormone (HGH)
- HGP. *See* Human Genome Project
- HHS. *See* U.S. Department of Health and Human Services
- Hibernation, **3:202**
- High altitude adaptation, **3:204**
- High blood pressure. *See* Hypertension
- High-density lipoproteins (HDL), **4:12**
- High frequency of recombination. *See* Hfr strains
- High-risk populations, **1:15**
- High school biology teachers, **2:180**
- Hill, Robin, **2:184**
- Hindbrain, **3:127–128**
- Hippocampus, **1:99**
- Hippocrates, **1:110**, **2:196**
- Hirudinea. *See* Leeches
- Histocompatibility, **4:172**
- Histogenesis, **3:209**, 211
- Histoire Naturelle* (Buffron), **1:106–107**
- Histones, **1:143–144**, 223–224  
 acetylation of, **1:144**, 176–177  
 DNA sequences and, **1:147**  
 mRNA, **4:78**
- Histoplasmosis, **2:109**
- History  
 of agriculture, **2:180–182**, 181  
 of biochemistry, **2:182–186**, 183  
 of cell theory and structure, **2:186–188**  
 of evolutionary thought, **2:192–196**, 193  
 of inheritance research, **2:189–192**  
 of medicine, **2:196–198**  
 of plant physiology, **2:198–201**, 199
- Histotechnique, **3:39–40**
- Hitchings, George, **3:193**
- HIV. *See* Human immunodeficiency virus
- HIV-1  
 ELISA, **1:39**  
 pathogenesis of, **1:14–15**  
 prevention of, **1:16**  
 transmission of, **1:15–16**
- HLA. *See* Human leukocyte antigens
- HMS *Beagle*, **1:198**, **2:45**, 194
- Hodgkin, Dorothy, **1:89**
- Holdfasts, **3:150–151**
- Holothuroidea. *See* Sea cucumbers
- Home drug tests, **1:233**
- Homeostasis, **2:201–203**  
 excretory systems for, **2:60**  
 health and, **2:168**  
 hypothalamus and, **2:222–223**  
 negative feedback systems in, **1:87**, 88
- Homeotic genes. *See* *Hox* genes
- Hominins, **2:209**, 210
- Hominoidea. *See* Apes
- Homo erectus*, **2:211**
- Homo ergaster*, **2:211**
- Homo habilis*, **3:26**
- Homo neanderthalensis*, **2:211**
- Homo* species, **2:210–211**
- Homografts, **4:172**
- Homologous chromosomes, **2:128**, **3:43–45**, 67–69
- Homology, as evolutionary evidence, **2:52–53**
- Homomultimerization, **1:179–180**
- Homosexuality, heredity and, **1:62**
- Honeybees, **1:61**
- Hooke, Robert, **1:119**, **2:186**, **3:30**, 39
- Hookworm disease, **3:175**
- Hoppe-Seyler, Ernst, **2:183**
- Hops, in beer-making, **1:60**
- Hordeum vulgare*. *See* Barley
- Horizontal transmission, **1:53**
- Hormones, **2:203–205**, 204*f*, 205*t*  
 aging and, **1:9**  
 in birth control, **1:83**  
 in cell differentiation, **1:217**  
 early research on, **2:197–198**  
 endocrine system and, **1:5**, **2:18–20**  
 in female reproduction, **2:78–80**  
 hypothalamus and, **2:222–225**  
 from pituitary glands, **3:205**  
 plant, **2:200**, 205*t*, **206–208**, **3:82**, 209, 211–212  
 in sex determination, **4:98**  
 in signaling, **4:112**, 113  
*See also specific hormones*
- Hornworts, **1:104**, **2:56**, **3:208**
- Horseshoe crab, **4:188**
- Horsetails. *See* Equisetopsida
- Horticulturalists, **2:208**
- Hospitals, early, **2:197**
- Host cells, of viruses, **4:186**
- Hotchkiss, Rollin, **1:234**
- Howard Hughes Medical Institute, **2:214**
- Hox* genes, **2:134–135**, **3:84**
- HPV. *See* Human papillomavirus
- HSF. *See* Heat shock factor
- HSO. *See* Health and safety officers
- Hubby, John, **3:117**
- Human activities  
 agriculture and, **2:180–182**  
 coral reefs and, **1:184–185**  
 desertification from, **1:204**, 205  
 deserts and, **1:203**  
 ecosystems and, **2:6–7**  
 estuaries and, **2:39–40**  
 extinction from, **2:64**, 66–67  
 global warming and, **2:146**  
 invasive species and, **3:10**  
 landscape structure and, **3:25**  
 nitrogen cycle and, **3:135**  
 plant ecology and, **2:88–89**  
 plant senescence and, **4:92–93**  
 primates and, **4:5**  
 tropical forests and, **2:104**
- Human behavior. *See* Behavior
- Human Cancer Genome Anatomy Project, **2:216**
- Human chorionic gonadotropin (HCG), **1:38–39**, **2:81**
- Human evolution, **2:208–212**, 209  
*See also* Evolution

- Human genome, **1:223–224, 3:178**  
 behavioral genetics and, **1:62**  
 genetic counseling and, **2:135–136**
- Human Genome Diversity Project, **2:216**
- Human Genome Project (HGP), **1:71–74, 2:129, 141, 198, 212–217, 214, 215, 4:196**
- Human growth hormone (HGH), **1:80**
- Human immunodeficiency virus (HIV), **1:14–17, 2:197, 3:6, 4:187**  
 as lentivirus, **4:66**  
 T cells and, **4:151**  
 testing for, **1:38–39**  
 vaccine for, **4:180**  
*See also* AIDS
- Human leukocyte antigens (HLA), **4:172**
- Human milk, **3:33**
- Human nutrition, **2:217–219**
- Human papillomavirus (HPV), **1:227**
- Human population, biodiversity and, **1:166–169**
- Humans  
 biogeochemical cycles and, **1:69**  
 brain in, **3:128**  
 evolution of, **2:208–212**  
 hypothalamus in, **2:222–225**  
 lamins in, **3:146**  
 life cycles in, **3:32–34, 33**  
 as mammals, **4:4**  
 metabolism in, **3:87–89**  
 movement in, **3:113–114**  
 neurons in, **3:133**  
 nucleoli in, **3:143**  
 osmoregulation in, **3:167**  
 populations of, **2:219–220**  
 psychiatric disorders in, **4:27–30**  
 sex determination in, **4:96–98, 97f**  
 skeletons of, **4:118, 119f**  
 vision in, **4:189–190**  
 vitamins in, **4:190–191**
- Hummingbirds, **4:57**
- Humoral immunity. *See* Antibody-mediated immunity
- Humulus lupulus*. *See* Hops
- Hungerford, David, **3:157**
- Hunter, C. J., **1:28**
- Hunter School of Anatomy, **2:197**
- Hunting, endangered species from, **2:16–17**
- Huntington's disease, **2:136, 139, 3:129**  
 genetic mapping for, **3:47**  
 from neomorphic mutation, **3:181**
- Hutchinson, George Evelyn, **2:6, 164**
- Huxley, Julian, **2:195**
- Huxley, Thomas Henry, **1:199, 2:192**
- Hyaline membrane disease, **2:84**
- Hybrid habitats, **2:221–222**
- Hybridization, **2:220–221, 4:136–137**  
 electrophoresis and, **2:14, 15**  
 in genomics, **2:143–144**  
 molecular, **1:148–149**  
 plant, **2:221, 221–222**  
 of wheat, **1:142**  
*See also* FISH
- Hybrids, **4:6–7**  
 behaviors of, **1:61**  
 cell, mapping of, **4:36–37**  
 wood and, **4:203**
- Hyde, Ida Henrietta, **3:134**
- Hydras, **1:155, 3:126, 127f**
- Hydrogen 3. *See* Tritium
- Hydrogen bonds, **4:11**
- Hydrogen peroxide, **3:191–192**
- Hydrogen, in plants, **3:216**
- Hydrologic cycle. *See* Water cycle
- Hydrolysis, **3:86**
- Hydrophily, **3:227**
- Hydrophobia, **3:12, 228, 4:11**
- Hydrophytic vegetation, **4:197**
- Hydroskeletons, **4:118**
- Hydrostatic skeletons. *See* Hydro-skeletons
- Hydrothermal vents, **2:70**
- Hyman, Libbie Henrietta, **3:222**
- Hymenoptera, **3:10**  
 pollination by, **4:57**  
 sex determination in, **4:97**
- Hyperactive proteins, **3:181**
- Hyperalgesia, **3:171**
- Hypercholesterolemia, familial, **2:139**
- Hyperglycemic hormones, **3:89**
- Hyperinsulinism, **1:89**
- Hyperomorphic mutations, **3:181**
- Hyperosmotic urine, **3:167**
- Hyperpituitarism, **3:205**
- Hypersaline environments, **2:71**
- Hypersensitivity  
 to fungi, **2:108**  
 as immune response, **3:6**  
 syphilis and, **4:108**  
 T cells and, **4:151**
- Hypertension, **1:115–116, 3:129**
- Hyperthermia, **4:156–157**
- Hyperthermophiles, **2:71**
- Hyperthyroidism, **1:89, 2:21–22, 4:158**
- Hypertrophy, **3:112**
- Hyphae, **2:110**
- Hypnotics, **4:31**
- Hypocotyl, **3:210, 4:55**
- Hypoglossal nerve, **1:103**
- Hypoglycemia, **2:161**
- Hypoglycemic hormones, **3:88**
- Hypolimnion, **3:21**
- Hypoosmotic urine, **3:167**
- Hypopituitarism, **3:205**
- Hypothalamic-pituitary-adrenal axis, **4:140**
- Hypothalamus, **1:102, 2:222–225, 224f, 3:128**  
 dietary intake, **2:219**  
 fever and, **3:139–140**  
 GnRH production by, **3:57**  
 pituitary glands and, **2:20–21, 3:205**  
 in reproduction, **2:79–80**  
 stress response and, **4:139–140**  
 in temperature regulation, **2:202**
- Hypothermia, **4:156**
- Hypothyroidism, **1:89, 2:21, 4:158–159**
- I**
- IAA. *See* Indol-3-acetic acid
- Ice, **2:71, 4:193**
- I cell disease, **2:153**
- Ichthyoplankton, **3:206**
- ICSI. *See* Intracytoplasmic sperm injection
- Ig. *See* Immunoglobulins
- IgA, **1:40**
- IgD, **1:40**
- IgE, **1:40–41**
- IGF. *See* Insulin-like growth factors
- IgG, **1:40**
- IgM, **1:40**
- Ilanos. *See* Temperate grasslands
- Ileum, **1:220**
- Illegal drugs, **4:33**
- Illiciales. *See* Star anise
- Illness, *vs.* disease, **1:221**
- Illustrations, medical, **4:184**
- Illustrators, medical/science, **3:65–66**
- Image processing, **4:189**
- Imaging, medical, **1:231–232, 3:1–3, 2, 131**
- Imitation, **3:27–28**
- Immature infants, **2:83**
- Immigration, **2:49, 3:238**
- Immortalization, **1:146–147**
- Immune response, **3:4–6, 5f, 6, 4:114**  
 phagocytes in, **3:139**
- Immune system  
 in aging, **1:9–10**

- antibodies and, 1:37–41, 40  
 disorders, 3:6, 129  
 exocytosis and, 2:63  
 gene therapy and, 2:124–125  
 T cells and, 4:148–151  
 in vaccinations, 4:180  
 viral infections and, 4:187
- Immunity**  
 antibodies in, 1:39–41  
 lymphatic system and, 3:53  
*See also* Specific immunity
- Immunocompromised hosts**, 2:109
- Immunodeficiency diseases**, 3:6
- Immunoglobulins**, 1:39, 4:11  
*See also* Antibodies
- Immunologic memory**, 3:4, 5–6
- Immunology**, 3:185
- Immunosuppression**, 2:112, 4:140, 172
- Immunotherapy**, 1:112
- IMP**. *See* Integral membrane proteins
- Implantation**, 2:82
- Imprinting**, 3:28
- In vitro* fertilization (IVF)**, 4:60, 61
- Inbreeding**, 3:239
- Incomplete dominance**. *See* Partial dominance
- Incomplete penetrance**. *See* Non-penetrance
- Incus**, 2:171
- Indehiscent fruits**, 2:106, 4:56
- Independent Assortment, Law of**, 2:128, 3:66, 68, 81
- Indeterminate cleavage**, 1:210
- Indol-3-acetic acid (IAA)**, 2:206–207
- Induced enzymes**, 1:234
- Induction**, 1:207–209, 2:133
- Industrial ammonification**, 3:135
- Industrial chemicals**, 1:110
- Industrial waste**, 1:167
- Industrialization**, 2:146
- Infanticide**, 4:131
- Infants**, 2:83, 3:32–33
- Infections**, 1:221  
 in autoimmunity, 1:48  
 in cultured cells, 1:123  
 flatworm, 3:222  
 neurologic disease from, 3:129  
 opportunistic, 2:43  
 in plants, 3:217  
 from prions, 4:5–6  
 protozoan, 4:26–27  
 racial variations from, 1:78  
 viral, 4:186–187  
*See also* Bacterial diseases; Fungal diseases
- Infectious diseases**. *See* Infections
- Inferior vena cava**, 2:173
- Infertility**, 3:58  
 gonorrhea, 4:107  
 meiosis, 3:69  
 pelvic inflammatory disease, 4:109  
 reproductive technologies for, 4:60–62
- Inflammation**  
 as nonspecific defense, 3:138, 139  
 pain from, 3:171
- Inflorescences**, 2:93
- Influenza**, 4:186
- Informed consent**, 1:152
- Ingenhousz, Jan**, 1:199–200, 2:198, 3:7
- Ingestion**, 1:219  
 in insects, 3:8–9  
 of poisons, 3:225
- Ingram, Verne**, 3:117
- Inhalation**, 3:225, 4:65
- Inheritance**  
 early research, 2:189–192  
 in evolutionary theory, 1:199, 2:45, 195–196  
 genes in, 2:117–119, 123, 127–128  
 in genetic diseases, 2:136, 139  
 mitochondria and, 3:98  
 natural selection and, 3:121  
*See also* Genetics; Patterns of inheritance
- Inhibitory postsynaptic potential (IPSP)**, 4:146
- Initiation complex**, 4:15
- Initiation factors**, 4:15
- Initiation, in protein synthesis**, 4:13, 14–16
- Injuries**. *See* Wounds
- Inland wetlands**, 4:197
- Inner ear**, 2:171–172
- Inositol 1,4,5 trisphosphate (IP<sub>3</sub>)**, 4:117
- Insects**, 1:36, 3:7–10, 8  
 aquatic, 3:36  
 entomologists and, 2:27–28  
 eyes of, 2:73  
 flight in, 2:92  
 gas exchange in, 2:116  
 growth in, 2:159  
 locomotion of, 3:52  
 migration by, 3:92  
 nervous systems in, 3:126–127  
 pesticide-resistance, 3:122–123  
 pheromones in, 3:194  
 plant defenses and, 2:179  
 as plant pests, 3:218
- pollination by, 2:44, 59, 94, 3:227, 4:57–59  
 societies of, 4:129–130  
 symbiotic, 4:145  
 vision in, 4:188–189, 190  
*See also* Arthropods
- Insensible perspiration**, 4:155
- Insertion sequences, of DNA**, 4:174
- Institute for Creation Research**, 1:186
- The Institute for Genomic Research (TIGR)**, 1:45–46, 2:215
- Insulation**  
 in endotherms, 3:202  
 in wood, 4:201
- Insulin**, 2:204  
 in absorptive metabolic state, 3:88  
 in aging, 1:9  
 artificial production of, 1:80  
 in blood glucose regulation, 1:88, 88–89, 2:22  
 in cloning, 1:153–154  
 for diabetes, 3:103  
 from pancreatic islets, 3:174  
 from recombinant DNA technology, 4:43
- Insulin-dependent diabetes mellitus (IDDM)**, 1:47, 89, 3:103, 4:43
- Insulin-like growth factors (IGF)**, 2:161
- Integral membrane proteins (IMP)**, 3:71f, 72, 75–76, 220–222
- Integrase**, 4:67, 69
- Integrative Action of the Nervous System* (Sherrington)**, 2:197
- Interbreeding**. *See* Hybridization
- Intercalary meristems**, 3:82
- Intercellular junctions**, 1:129
- Intercostal muscles**, 4:64–65
- Interdependency**. *See* Obligate parasites
- Interference competition**, 1:160
- Interferons**, 4:186–187
- Intermediate filaments**, 1:196–197, 3:146
- Intermembrane space**, 3:96
- Internal medicine**, 1:229, 230
- International cooperation on global warming**, 2:148
- International Olympic Committee**, 1:28
- International Standards Organization (ISO)**, 4:202
- Interneurons**, 3:132–133
- Interphase**  
 in cell cycle, 1:143  
 condensation in, 1:147

- Intersexual selection, 4:105–106  
 Interspecific competition, 1:160–161  
 Interspecific hybridization, 2:221  
 Interspecific relationships, 1:4–5  
 Intertidal animals, 3:150–151  
 Intracellular motility, 1:130–131  
 Intracellular parasites, 4:187  
 Intracytoplasmic sperm injection (ICSI), 4:61  
 Intramembranous ossification, 1:93–94  
 Intrasexual selection, 4:104–105  
 Intraspecific competition, 1:160  
 Intraspecific hybridization, 2:221  
 Intrauterine devices (IUDs), 1:83  
 Intravenous drug abuse, 1:15, 16  
 Intrinsic pathway, 1:86–87  
 Introduced species, 1:168  
 Introgression, 2:222  
 Introns, 2:120–121, 4:44, 77, 78  
 Invagination, 1:207, 2:24  
 Invasive imaging techniques, 3:3  
 Invasive species, 3:10–12, 11  
 Invertebrate zoology, 4:204  
 Invertebrates  
   benthic animals as, 3:150  
   brain in, 1:97  
   in Cambrian period, 1:108–109  
   CNS in, 1:134  
   excretory systems in, 2:61  
   eyes in, 2:73  
   gas exchange in, 2:115–116  
   growth in, 2:159  
   Lamarck, Jean-Baptiste and, 3:24  
   nervous systems of, 3:125–127  
   neurons in, 3:133  
   osmoregulation in, 3:165–167  
   in rivers and streams, 4:74–75  
   sex determination in, 4:97  
   vision in, 4:188  
   *See also specific invertebrates and types of invertebrates*  
 Inverted light microscopes, 3:39  
 Iodine  
   as nutrient, 2:218  
   in thyroid hormone, 2:21  
 Ion channels, 3:12–15, 13f, 77–78, 220  
 Ion concentration, 3:166  
 Ion conduction pathway, 3:12  
 Ion exchange, 4:93  
 Ion gradients, 3:220  
 Ionic bonds, 4:11  
 Ionizing radiation, carcinogenic, 1:110  
 IP<sub>3</sub>. *See* Inositol 1,4,5 trisphosphate  
 IPSP. *See* Inhibitory postsynaptic potential  
 Irises (Eye), 2:72, 4:189  
 Irises (Plant), 1:32  
 Iron  
   in hemoglobin, 1:84–85  
   as nutrient, 2:218  
   phytoplankton and, 3:153  
   in plants, 3:216  
 Ischemia, 1:86, 115  
 Islets of Langerhans. *See* Pancreatic islets  
 ISO. *See* International Standards Organization  
 Isoetales, 4:34, 35  
 Isoforms, 2:121–122  
 Isografts, 4:172  
 Iteroparous life cycles, 3:35  
 IUDs. *See* Intrauterine devices  
 IVF. *See* *In vitro* fertilization
- J**  
 Jacob, François, 1:170, 2:185  
 Jansen, Zacharias, 2:197, 3:39  
 Japan  
   coral reefs in, 1:184  
   population growth in, 2:219  
 Jasmonic acid, 2:179  
 Jaundice, from alcoholism, 1:19  
 Jefferson, Thomas, 4:192  
 Jejunum, 1:220  
 Jellyfish. *See* Cnidarians  
 Jenner, Edward, 3:177, 4:180  
 Jericho, 2:181  
 Jet propulsion locomotion, 3:51  
 Jews, European, 2:140  
 Jock itch. *See* Tinea  
 Johannsen, Wilhelm, 2:190  
 Johnson, Ben, 1:28  
 Joint Genome Institute (California), 2:214  
 Joints, in musculoskeletal system, 3:112–114  
 Joly, John, 2:199  
*Journal of Experimental Medicine*, 3:240  
*Journal of the Linnaean Society*, 1:199  
 Jugular veins, 1:91  
 Jumping genes. *See* Transposons  
 Junipers, 1:162  
 “Junk” DNA. *See* Noncoding DNA  
 Jurassic period, lizards in, 4:63  
 Just, Ernest E., 4:100  
 Juvenile-onset diabetes. *See* Insulin-dependent diabetes mellitus
- K**  
 Karisoke Research Center (Rwanda), 3:26  
 Karyotypes, 1:148  
 Katydid, 3:8  
 Keilin, David, 2:184  
 Kelp, 1:21, 22, 4:22  
 Kendrew, John, 2:184  
 Kennedy, John F., 1:117  
*Kenyanthropus platyops*, 2:210  
 Keratinocytes, 4:120  
 Keratins, 1:196  
 Ketamine, 4:32  
 Ketchikan Pulp Company (Alaska), 4:201  
 Keystone predators, 3:151  
 Khorana, Gobind, 2:185  
 Kidney stones, 3:2  
 Kidney transplants, 4:173  
 Kidneys, 2:60, 61, 3:15–17, 15f  
   osmoregulation by, 3:167  
   poisons and, 3:226  
   in stress response, 4:139  
 Kilning, of grain, 1:60  
 Kimeu, Kamoya, 3:26  
 Kimura, Motoo, 3:117–118  
 Kinases, 1:178  
 Kinesin, 1:195–196  
 Kinetochores, 3:100  
 Kingdoms, 3:17–18, 17t  
 Kitasato, Shibasaburo, 1:39  
 Klinefelter’s syndrome, 3:69  
 Kneecap. *See* Patella  
 Knoop, Franz, 2:183  
 Koala, 3:62  
 Koch, Robert, 1:53, 2:197  
 Koch’s postulates, 1:53  
 Köhler, Josef, 2:221  
 Krebs cycle, 2:149, 183, 3:18–20, 19f, 85  
   adenine molecules and, 3:144  
   in mitochondria, 3:97  
 Krebs, Hans, 2:183  
 K-selected species, 3:234  
 Kudzu, 3:10, 11  
 Kyoto Protocol, 2:148
- L**  
 Labia majora, 2:77  
 Labia minora, 2:77  
 Labor (Birth). *See* Birth  
 Laboratory technicians, 3:20  
 Lac operon, 1:170–171, 173  
 Lacertid lizards, 1:183  
 Lacertilia. *See* Lizards



- Lacrimal caruncle, 2:73  
 Lacrimal glands. *See* Tear glands  
 Lactation, 2:81, 3:33  
 Lactic acid  
   from fermentation, 2:150  
   muscle contraction and, 3:111  
 Lactose, 1:113  
 Lagging strands, 4:50, 51  
 Lake Baikal (Siberia), 3:21  
 Lake Nyos (Cameroon, Africa), 3:225  
 Lakes, 3:21–23, 22, 25  
 Lamarck, Jean-Baptiste, 2:45, 189, 193–194, 3:23–24  
 Lamarckian evolution, 2:189, 194  
 Lambda bacterial virus, 4:44  
 Lamiaceae. *See* Mint family  
 Lamina, nuclear, 3:146, 147  
 Laminated veneer lumber, 4:203  
 L-amino acids, 1:24  
 Lamins, 3:146, 147  
 Lamp shells. *See* Brachiopoda  
 Lancelets, 1:36  
 Land degradation, 1:204  
 Land management, 1:167, 168  
 Landsat satellites, 4:46  
 Landscape design, 2:208  
 Landscape diversity, 2:91  
 Landscape ecology, 3:24–25  
 Landscapes, remote sensing of, 4:45–46  
 Landsteiner, Karl, 1:39, 4:172  
 Language-dominant hemisphere, 1:101  
 Lanugo hair, 2:84  
 LAP. *See* Lipid-anchored proteins  
 Large intestine, 1:218–219, 220–221  
 Larvaceans. *See* Urochordata  
 Larynx, 4:64  
 Late blight, 3:217  
 Lateral buds, 3:29  
 Lateral meristems, 3:82  
 Latin America, 3:176  
 Laurels, 1:32, 33  
 Lavoisier, Antoine, 2:198  
 Law of Independent Assortment, 2:128, 3:81  
 Law of Segregation, 2:127, 128, 3:66, 68, 80, 81f  
 LC. *See* Liquid chromatography  
 LDL. *See* Low-density lipoproteins  
 LDPs. *See* Long-day plants  
 Leading strands, 4:50, 51  
 Leaf hoppers, 3:218  
 Leafy spurge, 3:11  
 Leakey family, 3:26  
 Leakey, Louis, 3:26  
 Leakey, Mary, 3:26  
 Learning, 3:26–28, 27  
 Leaves, 1:29–30, 3:28–30, 29f, 30, 4:112  
   evaporation from, 4:194  
   of monocots, 3:106  
   night folding of, 4:69  
   of pteridophytes, 4:34  
 Leber's hereditary optic neuropathy, 2:139  
 Leclerc, Georges-Louis. *See* Buffon, Count  
 Lederberg, Joshua, 1:53–54, 55  
 Leeches, 1:36, 37  
 Leeuwenhoek, Antony van, 1:119, 205, 2:166, 186, 197, 3:30–31, 39  
 Left brain, 1:101  
 Leghemoglobin, 3:137  
 Legs, insect, 3:9  
 Legumes, 1:33, 34, 2:44, 3:136  
 Lemna. *See* Duckweeds  
 Lemurs, 4:4  
 Lenses, of microscopes, 3:39–40  
 Lentic ecosystems, 4:73  
 Lentiviruses, 4:66, 68  
 Leopold, Aldo, 1:166, 2:7  
 Lepidodendron, 4:34  
 Lepidoptera, 3:10, 218, 4:57  
 Lesch-Nyhan syndrome, 3:103  
 Lesions, cortical, 1:100  
 Leucine zipper, 4:10  
 Leukemia  
   chronic myelogenous, 1:140  
   chronic myeloid, 3:156–158  
   p53 gene, 1:111  
 Leukocytes. *See* White blood cells  
 Levers, in human movement, 3:113–114, 113f  
 Levi-Montalcini, Rita, 1:102  
 Lewis, Edward, 3:102  
 Lewontin, Richard, 3:117  
 LGV. *See* Lymphogranuloma venereum  
 LH. *See* Luteinizing hormone  
 Lice, parasitic, 3:176  
 Lichens, 2:110–111, 113, 3:31–32, 150  
 Liebig, Justus, 2:183  
 Life  
   defined, 3:37–38, 38  
   origin of, 3:161–165, 164  
   properties of, 3:162  
 Life cycles, 3:34–37, 36  
   algae, 1:21–22  
   human, 3:32–34, 33  
   model organisms, 3:102  
   myxomycota, 4:124–125  
   plants, 3:207  
   pteridophytes, 4:34  
   *See also* Alternation of generations  
 Life expectancy. *See* Mean longevity  
 Life span. *See* Longevity  
 Lift, 2:92  
 Ligamentum arteriosum, 2:85  
 Ligands, 4:11  
 Ligation, 4:50f  
 Light  
   deep sea environments, 3:204  
   lakes and ponds, 3:21  
   photosynthesis, 3:197–198  
   phototropism and, 4:175  
   polarization, 4:190  
   seed germination, 4:87  
   transduction of, 4:189  
 Light-driven pumps, 1:2  
 Light microscopy, 2:10–11, 3:38–41, 40  
 Lignin, 1:30  
   in cell walls, 1:133, 214, 215, 3:207  
   in vascular plants, 2:56  
 Lilies, 1:33, 3:106  
 Limbic system, 1:99  
 Limestone. *See* Calcium carbonate  
 Limnologists, 3:42, 4:73  
 Lindeman, Raymond, 2:6  
 Lingual tonsils, 3:54  
 Linkage (Genetics), 3:42–47, 44f  
 Linkage phase, 3:43  
 Linnaeus, Carolus, 2:5, 193, 3:17, 47–48, 4:152, 160  
 Lipase, 1:218, 3:174  
 Lipid-anchored proteins (LAP), 3:72, 75–76  
 Lipid bilayers, 3:73–74  
 Lipids, 3:48–50, 49f  
   anabolic pathways in, 3:85–86  
   biochemist specialty in, 1:66  
   in connective tissue, 1:164  
   digestion of, 3:174  
   emulsification by bile, 3:50  
   membrane, 3:70–75  
   as nutrients, 2:218  
   in origins of life, 3:163  
   in plasma membranes, 3:220  
   in smooth endoplasmic reticulum, 2:26–27  
   synthesis of, 3:191  
 Lipmann, Fritz, 2:184  
 Lipodystrophy, 3:147  
 Lipogenesis, 3:88  
 Lipolysis, 3:89  
 Lipophilicity, 3:228

- Lipopolysaccharide (LPS), 1:50–51  
 Lipoproteins, 4:12  
 Liquid chromatography (LC), 1:232–233  
 Liquid water, 4:193  
*Listeria*, 1:119  
 Liston, Robert, 2:197  
 Littoral zone, 3:22–23  
 Liver, 3:50, 226  
 Liver cancer, 1:111  
 Liver diseases, 1:89  
 Liver failure, 3:226  
 Liver transplants, 4:173  
 Liverworts, 1:104, 105, 2:56, 3:208  
 Lizards, 1:36, 4:62–63  
   convergent evolution in, 1:182, 182–183  
   reproduction in, 3:35  
 Lobsters. *See* Arthropods  
 Locomotion, 3:50–52, 52  
   body mass and, 4:82–83  
   in plankton, 3:206  
   in protozoans, 4:24  
 LOD score analysis, 3:46–47, 4:37  
 Loewi, Otto, 4:146  
 Log of the Odds. *See* LOD score analysis  
 Logging  
   in boreal forests, 2:98  
   in temperate forests, 2:100  
 Logistic growth, of populations, 3:234  
 Long, Crawford, 2:197  
 Long-day plants (LDPs), 3:195–196  
 Long Term Ecological Research program, 2:3  
 Longevity, biology of, 1:7  
 Loops of Henle, 3:16, 203  
 Lorenz, Konrad, 1:63, 2:85–86  
 Lorises, 4:4  
 Loss-of-function mutations, 3:179, 180  
 Lotic ecosystems, 4:73  
 Lotka, Alfred, 2:6, 4:157  
 Lotka-Volterra model, 4:157  
 Low-density lipoproteins (LDL), 2:25, 4:12  
 Low-oxygen environments, 3:204  
 LPS. *See* Lipopolysaccharide (LPS)  
 LSD. *See* Lysergic acid diethylamide  
 LTER program. *See* Long Term Ecological Research program  
 Lumbar punctures. *See* Spinal taps  
 Lumber, 4:201–202  
 Lung cancer, 1:111, 4:126–127  
 Lungs, 4:64–65  
   fetals, 2:84  
   in gas exchange, 2:116–117  
 Luria, Salvador, 1:228, 3:119  
 Luteinizing hormone (LH), 2:21, 79–80, 3:57  
 Lycophyta, 2:56–57, 4:89  
 Lycopodiaceae. *See* Club mosses  
 Lycopodiales, 4:34  
 Lycopodiopsida, 4:34  
 Lyell, Charles, 1:198, 2:45  
 Lyme disease, 2:27  
 Lymph nodes, 3:53  
 Lymphatic system, 3:52–54, 53f  
 Lymphatic vessels, 3:52–53  
 Lymphedema, 3:52  
 Lymphocytes  
   CD4, 1:14–15  
   in immunity, 3:53  
   *See also specific lymphocytes*  
 Lymphogranuloma venereum (LGV), 4:109  
 Lymphomas, Burkitt's, 3:156  
 The Lyon Hypotheses, 4:96  
 Lyon, Mary, 4:96  
 Lysenko, Trofim, 4:184  
 Lysergic acid diethylamide (LSD), 2:111, 4:32  
 Lysogenic conversion, 1:59  
 Lysogeny, 1:58  
 Lysosomal membranes, 3:54–55  
 Lysosomal storage diseases, 3:56  
 Lysosomes, 2:23, 24, 25, 3:54–56, 55f, 4:24–25  
   in cells, 1:122  
   Golgi apparatus and, 2:152–153  
   as organelles, 3:159  
 Lysozyme, 1:219, 3:138  
 Lytic cycle, 1:58  
 Lyubimova, Milita, 2:184
- M**  
 MacArthur, Robert, 2:6  
 MacLeod, Colin, 2:191  
*Macrocystus*. *See* Kelp  
 Macroevolution, 2:50–51  
 Macromolecules  
   anabolic pathways in, 3:85–86  
   nuclear transport of, 3:140–141  
   *See also* Chromosomes  
 Macronutrients, 2:217–218, 3:214  
 Macrophages  
   in connective tissue, 1:165  
   in immunity, 3:53  
   as nonspecific defenses, 3:138  
   phagocytosis and, 2:23  
 Macrophytes, 3:23  
*Macropus rufus*. *See* Red kangaroo  
 Mad cow disease. *See* Bovine spongiform encephalopathy  
 Magnesium, in plants, 3:216  
 Magnetic resonance imaging (MRI), 3:2, 2–3, 3, 131  
 Magnification, in microscopy, 3:38–41  
 Magnolias, 1:32, 33  
 Magnoliids, 1:32, 2:59  
 Major histocompatibility complex (MHC), 4:149, 150–151, 172  
 Malaria, 3:176, 4:26  
   global warming and, 2:147  
   sickle cell anemia and, 1:85  
   vaccine for, 4:180  
 Male reproductive system, 3:56–59, 58f, 59f  
 Malignant diseases, 1:221  
 Malignant tumors. *See* Cancer  
 Malleus, 2:171  
 Malpighi, Marcello, 1:205, 2:166, 186, 197  
 Malpighian tubules, 2:61, 3:167  
 MALT. *See* Mucosa-associated lymphatic tissues  
 Malt, in beer, 1:60  
 Malthus, Thomas, 1:198, 2:46, 194  
 Malthusian Principle, 2:46–47  
 Maltose, 1:113  
 Mammals, 3:58–59  
   amniotic eggs, 1:26  
   brain in, 3:128  
   circulatory systems of, 1:150, 151  
   as deuterostomes, 1:36  
   *vs.* dinosaurs, 2:66  
   growth in, 2:159  
   in lakes and ponds, 3:23  
   large, extinction of, 2:66  
   lungs in, 2:116  
   mating systems in, 3:63  
   nuclei in, 3:147  
   as predators, 4:1  
   sex determination in, 4:97  
   urine concentration in, 3:167  
   vision in, 4:190  
 Mammary glands, 2:78, 81  
 Mammography, 3:1  
 Manganese, in plants, 3:216  
 Mangold, Hilde, 1:208–209, 2:132, 133  
 Mangroves, 2:38, 101, 4:197  
 Manic-depressive disorder. *See* Bipolar disorder  
 Manta rays, 1:118  
 Mantispids, 3:194  
 Mantle membrane, in mollusks, 3:105

- Manual of Botany of the Northern United States* (Gray), 2:158
- Manure, 2:198, 199
- Many-bristled worms. *See* Polychaeta
- Map kinase cascade, 4:116–117
- Maple trees, 1:33
- MAPs. *See* Microtubule associated proteins
- Marchantiophyta Hepatophyta. *See* Liverworts
- Margulis, Lynn, 1:127–128
- Marijuana, 4:32, 33
- Marine angiosperms, 3:153
- Marine animals
  - filter-feeding by, 2:75
  - migration by, 3:92
  - osmolarity of, 3:165–166
  - osmoregulation in, 2:62
  - pheromones in, 3:194
- Marine biologists, 3:60–61, 61
- Marine biomes, 1:79
- Marine environments, 3:203–204
- Marine invertebrates, 3:152, 4:98–99
- Marine life, in Cambrian period, 1:108–110
- Marine reserves, 1:169
- Marine sediments, 1:109
- Mariposa, 2:221–222
- Marmosets, 4:5
- Mars Global Surveyor, 3:165
- Mars, life on, 3:165
- Marsh, George Perkins, 2:6–7
- Marshes, 4:197
- Marsileaceae, 4:35
- Marsupials, 3:62
- Mass extinctions, 2:66–67
- Mass spectrometry (MS), 1:233
- Mass spectroscopy, 1:73
- Mastication, 1:219
- “Mate Selection-A Selection for a Handicap” (Zahavi), 4:106
- Maternal health, 4:36
- Maternal inheritance, 2:139, 3:98, 188, 4:95
- Mating systems, 1:64, 3:62–64, 63, 4:104–106
  - in Hardy-Weinberg equilibrium, 2:164–165
  - male *vs.* female, 4:100
  - nonrandom, 2:49
  - pheromones in, 3:194
  - in primates, 4:5
  - social behavior in, 4:129
  - sociobiology and, 4:131
  - of yeasts, 4:116–117
- Matrix
  - extracellular, 2:68–69
  - nuclear, 3:146
- Matthew, Patrick, 2:47
- Maturity-onset diabetes. *See* Noninsulin-dependent diabetes
- Maximum longevity, 1:7
- Mayer, J.R., 2:198
- Mayr, Ernst, 2:195, 4:136, 137
- McCarty, Maclyn, 2:191
- McClintock, Barbara, 3:64–65, 4:175
- Meadows, wet, 4:197
- Mean longevity, 1:7
- Mean residence time (MRT), 1:67
- Mechanoreceptors, 3:8
- Median cubital veins, 1:91
- Medical abortion, 1:83
- Medical assistants, 3:65
- Medical illustrations, 4:184
- Medical illustrators, 3:65–66
- Medical imaging, 3:1–3, 2
- Medicine
  - enzymes in, 2:30
  - ethnobotany and, 2:40
  - genomics in, 2:145
  - herbal, 2:40, 177*t*, 176–178
  - history of, 2:196–198
  - model organisms in, 3:102–105, 104
  - preventive, 2:168*See also specific fields of Medicine*
- Medulla oblongata, 1:102–103
- Medullary pyramids, 1:102
- Medusa. *See* Cnidarians
- Megagametophytes, 4:34–35
- Megaspores, 4:53
- Meiosis, 3:66–69, 67*f*
  - in algae, 1:21–22
  - in angiosperms, 4:53, 54
  - chromosomes in, 2:128
  - crossing over in, 3:43
  - in flowers, 2:93
  - genes in, 2:119
  - inheritance and, 2:189–190
  - in ovaries, 2:78, 82
- Meiosis I, 3:68
- Meiosis II, 3:69
- Meiotic recombination. *See* Crossing over (Genetics)
- Melanin, 4:120
- Melanocytes, 4:120
- Melatonin, 2:204, 224–225
- Membrane budding model, 2:26–27
- Membrane lipids, 3:70–73
- Membrane proteins, 3:70–73, 71*f*, 75, 4:20, 21
- Membrane structure, 3:73–76, 74*f*
- Membrane transport, 3:76–80, 77*f*
- Membranes, cell. *See* Cell membranes
- Memory, 3:3
  - See also* Immunologic memory
- Memory cells, 4:151
- Menarche, 2:78
- Mendel, Gregor, 1:199, 2:117, 126–127, 190–191, 3:80, 81*f*, 80–81
  - evolution and, 2:47
  - linkage and, 3:43
  - patterns of inheritance, 3:187
  - on selective breeding, 2:181–182
- Mendelian genetics, 2:126–128, 164
- Mendelian inheritance, 2:119
- Mendel’s Law of Independent Assortment, 2:128
- Mendel’s Law of Segregation, 2:127, 128
- Meninges, 1:98
- Menopause, 2:78
- Menstrual cycle, 2:78
- Menstruation, 2:22
- Mental illness. *See* Psychiatric disorders
- Menten, Maud, 2:183
- Mercury, as pollutant, 3:229
- Merezhkovsky, Konstantin, 1:127
- Meristem cells, 1:212
- Meristems, 1:29, 3:81–84, 83*f*
  - See also* Apical meristems
- Merocrine sweat glands, 4:120–121
- Meroles anchietae*, 1:183
- Mescaline, 4:32
- Meselson, Matthew, 4:48
- Mesocarp, 4:56
- Mesoderm, 1:207, 2:82
- Mesonephros, 3:15
- Mesophyll, 1:216–217, 3:29
- Mesozoic period, mammals in, 2:66
- Messenger RNA. *See* mRNA
- Metabolic diversity, 2:42
- Metabolic pathways, 3:87, 4:38
  - See also* Glycolysis
- Metabolic rate, 3:87–88, 134
  - See also* Metabolism
- Metabolic water, 1:202
- Metabolism
  - alcohol, 1:18–19
  - biochemistry, 2:182, 183–184
  - body mass and, 4:82
  - carbon cycle, 1:114
  - cellular, 3:18–19, 86, 84–87
  - enzymes and, 2:34–35
  - heat generation, 3:202

- Metabolism (continued)  
 human, **3:87–89**  
 hydrogen peroxide, **3:191–192**  
 as life-defining, **3:37**  
 mitochondrial, **3:97–98**  
 origins of life, **3:162**  
 regulation of, **1:6**  
 thermoregulation, **4:156**  
 of tissues, **3:3**
- Metabolites, **1:232**  
*See also* Secondary metabolites
- Metabotropic receptors, **4:146–147**
- Metalimnion, **3:21**
- Metameric segmentation, **1:36–37**
- Metamorphosis  
 complex life cycles, **3:36**  
 insects, **3:9**  
*vs.* puberty, **3:33**
- Metanephridia, **3:167**
- Metanephridium, **2:61**
- Metanephros, **3:15**
- Metaphase, **1:143, 3:100**
- Metastasis, **1:110**
- Metatherian mammals. *See* Marsupials
- Metazoa. *See* Animals
- Metchnikoff, Elie, **3:138**
- Meteorites, **3:163–164, 164**
- Meteorology, **1:68, 2:148**
- Methadone, **4:32**
- Methanococcus jannaschii*, **1:45–46**
- Methanogens, **1:45**
- Methaqualone, **4:31**
- Methionine, **4:14–15**
- Methyl jasmonate, **2:179**
- Methylation, **1:149, 224**
- Methylmercury poisoning, **3:229**
- Meyerhof, Otto, **2:183**
- MHC. *See* Major histocompatibility complex
- Mice  
 cloning of, **1:154**  
 model organisms, **3:103–104, 104**
- Michaelis, Leonor, **2:183**
- Microbes in lakes and ponds, **3:23**
- Microbial diseases. *See* Infections
- Microbiologists, **3:90–91, 4:23**
- Microbiology, **1:76**
- Microbodies. *See* Peroxisomes
- Microelectrodes, **3:134**
- Microevolution, **2:50–51, 3:236**
- Microfibrils in cell walls, **1:133**
- Microfilaments, **1:193–194, 195**
- Microfossils, **3:161–162**
- Microgametophytes, **4:35**
- Microinjection, **4:167–168**
- Micronutrients, **2:217–219, 3:214**
- Micropropagation, **4:7**
- Micropyle, **3:228**
- Microscopic organisms, **3:23**  
*See also specific organisms*
- Microscopists, **3:91–92**
- Microscopy, **2:10–13, 12, 186**  
 Leeuwenhoek, Antony van and, **3:30–31**  
 light, **2:10–11, 3:38–41, 40**  
 medical history, **2:197**  
 training in, **3:91–92**
- Microspores, **4:54**
- Microtubule associated proteins (MAPs), **1:195**
- Microtubule organizing center (MTOC), **1:195**
- Microtubules, **1:127–128, 195–196, 196**
- Microvilli, **1:197**
- Midbrain, **1:102, 3:128**
- Middle arachnoid, **1:98**
- Middle ear, **2:171**
- Midrib veins in leaves, **3:30**
- Midwives, nurse, **3:148**
- Migraine headaches, **3:129**
- Migration, **3:92–93, 93**  
 bird adaptation, **1:4**  
 desert systems, **1:203**  
 genetic variation and, **3:238**  
 life cycles and, **3:36**  
 social behavior in, **4:129**
- Milk  
 human, **3:33**  
 pasteurization of, **3:177**
- Milk sugar. *See* Lactose
- Miller, Stanley, **3:163**
- Millet, **2:154**
- Milne-Edwards, Henri, **2:187**
- Mimicry, **3:94**
- Mimosa pudica*, **4:176**
- Minamata Bay, Japan, **3:229**
- Minamata disease, **3:229**
- Mineralocorticoids, **1:6**
- Minerals, plant, **3:216, 4:78–80**
- Minerals (Dietary), **2:218**
- Minnesota, boreal forests in, **2:97**
- Minor tranquilizers. *See* Benzodiazepines
- Mint family, **1:33**
- Miocene period, apes in, **2:209**
- Miracidium, **3:175**
- Missense mutations, **3:117, 147**
- Mississippi River, **4:73**
- Mitchell, Peter, **2:184, 3:170**
- Mites, **1:42, 3:176, 218**
- Mitochondria, **1:121, 3:94–98, 96f**  
 ATP production, **3:111–112, 168–170**  
 bacteria, **2:43**  
 DNA of, **2:96**  
 eukaryotic *vs.* prokaryotic, **1:48**  
 free radicals in, **1:9**  
 genetic code of, **2:131, 185**  
 genomes, **2:141**  
 maternal inheritance and, **2:139**  
 mutations in, **3:188–189**  
 as organelles, **3:159**  
 origins of, **1:127–129, 128**  
 protists, **4:22**  
 replication of, **4:51–52**  
 seeds, **4:86**
- Mitochondrial poisons, **3:226**
- Mitogen activated protein kinase cascade. *See* Map kinase cascade
- Mitosis, **3:98–101, 100**  
 angiosperms, **4:53, 54**  
 cell cycles, **1:124–126**  
 fertilized ovum, **2:81**  
 gametophytes, **3:66**  
 inheritance and, **2:189–190**  
*vs.* meiosis, **3:69**  
 microtubules in, **1:195**  
 nuclear disassembly in, **3:147**  
 sporic meiosis, **1:21**
- Mitotic spindle, **3:99–100**
- Mitral valve, **2:174**
- Mitral valve prolapse, **1:116–117**
- MMDB, **1:73**
- Model organisms  
 cell biology and genetics, **3:101, 101–102**  
 physiology and medicine, **3:102–105, 104**
- Modification, protein, **4:18–19**
- Modified shoots, **4:111–112**
- Mohl, Hugo von, **2:187**
- Molds  
 slime, **4:124–126, 125**  
 water, **4:22**
- Molecular biology  
 Crick, Francis and, **1:187–188**  
 Pauling, Linus and, **3:184–185**
- Molecular Biology of the Gene* (Watson), **4:197**
- Molecular genetics, **2:200–201**
- Molecular hybridization, **1:148–149**
- Molecular mimicry, **1:48**
- Molecular motors, **2:35–36**
- Molecular plant pathology, **3:219**
- Molecular research on Archaea, **1:44–46**

- Molecular sieve chromatography, **4:93**
- Molecular structure  
determination of, **4:141–142**  
proteins, **1:24–25**
- Molecules  
chirality of, **3:176**  
organized system of, **3:37**  
radionuclide imaging of, **4:38**  
small, regulation by, **1:177–178**  
weight of, **4:8**  
*See also* Proteins
- Mollicutes, **3:217**
- Mollusks, **1:36, 3:105–106**  
Cambrian period, **1:108**  
camera eyes in, **4:189**  
intertidal, **3:150–151**  
nervous systems in, **3:126–127**  
protostomes, **1:209**
- Moloch horridus*. *See* Thorny devil lizards
- Molting  
crustaceans, **1:190**  
insects, **3:9**
- Molybdenum, **3:136**
- Monarch butterflies, **3:36**
- Monera. *See* Bacteria
- Monkeys, **4:4**
- Monoclonal antibodies, **1:38**
- Monoclonal antibody cells, **4:182**
- Monocots, **1:32–33, 2:59, 93, 3:106–107, 107, 4:55**  
cell walls of, **1:133**  
fibrous root systems in, **4:80–81**  
shoots in, **4:110**
- Monocotyledons. *See* Monocots
- Monocultures, **2:182**
- Monod, Jacques, **1:170, 2:185**
- Monogamy, **3:62**
- Monophyletic classification, **4:21, 23**
- Monophyletics, **1:35**
- Monosaccharides, **1:113**
- Monosomies, **1:140**
- Monotremes, **3:108**
- Monotropoid mycorrhizae, **3:120**
- Montane forests  
evergreen, **2:99**  
tropical, **2:101**
- Mood swings, **4:29**
- Moore, Sanford, **2:183**
- Morgan, Thomas Hunt, **2:119, 191, 3:45**
- “Morning after” pill, **1:83**
- Morphine, **3:171, 4:32, 33**
- Morphogenesis, **2:133–134**
- Morphology, **2:53–54**
- Morris, Simon Conway, **1:108**
- Mortality, differential, **3:123–124**
- Morton, William, **2:197**
- Morulas, **1:207**
- Mosaicism, **1:139**
- Mosquitoes, parasitic, **3:176, 4:26**
- Mosses, **1:23–24, 104, 2:56, 3:208**
- Moths. *See* Lepidoptera
- Motifs in protein structure, **4:10**
- Motility of cells, **1:130–132, 132**
- Motor control, **3:3, 128**
- Motor neurons, **3:189, 190–191, 4:138**
- Motor system, **1:100**
- Mouths  
digestion, **1:219**  
insects, **3:8**
- Movement  
hindbrain and, **3:127–128**  
humans, **3:113–114**  
peripheral nervous system and, **3:190**  
*See also* Motility
- MRI. *See* Magnetic resonance imaging
- mRNA, **4:76, 77–78**  
antisense nucleotides and, **1:41–42**  
cDNAs and, **4:42–43**  
endoplasmic reticulum and, **2:26**  
gene expression regulators and, **1:171**  
genetic code and, **2:120–121, 129–130**  
nuclei and, **3:146**  
protein synthesis, **4:13–18**  
retrovirus, **4:67**  
ribosomes and, **4:71–73**  
seed germination, **4:86**  
sequencing of, **2:143–144**  
viral, **1:227**  
*See also* Transcription
- MRT. *See* Mean residence time
- MS. *See* Mass spectrometry
- MTOC. *See* Microtubule organizing center
- Mucociliary locomotion, **3:51**
- Mucosa-associated lymphatic tissues (MALT), **3:54**
- Mucous membranes as nonspecific defense, **3:138**
- Mud flats, **4:197**
- Muir, John, **1:166**
- Müller, H.J., **1:145, 2:213**
- Müller-Hill, Benno, **1:173**
- Mullis, Kary, **3:232**
- Multiple births, **4:60**
- Multiple fruits, **2:107, 4:56**
- Multiple sclerosis, **1:47, 3:134**
- Multipolar neurons, **3:133**
- Munch, E., **2:199**
- Murein wall, **1:133–134**
- Muscle diseases, **3:112**
- Muscles, **3:108–112, 109f, 110f, 111f**  
conditioning of, **3:112**  
contraction of, **3:109, 110–111**  
fatigue in, **3:111**  
fibers of, **3:109**  
during sleep, **4:122**  
tissue of, **4:160**
- Muscular atrophy, **1:28**
- Muscular dystrophy, **3:112, 147**
- Musculoskeletal system, **3:112–115, 113f, 114**
- Musculotendinous units, **3:115**
- Musical perception, **3:3**
- Mussels  
intertidal, **3:151**  
zebra, **3:10–11**
- Mustard family, **1:33**
- Mutagenesis, site-specific, **3:118**
- Mutagens, **1:110, 3:115, 226**
- Mutant phenotypes, **3:45–46**
- Mutations, **1:9, 3:115–119, 116, 118, 119f**  
behavioral changes from, **1:61**  
from carcinogens, **1:110**  
compound heterozygous, **3:188**  
conditional, **4:168**  
dominance and, **3:180–181**  
evolution, **2:47–48, 49–50**  
genetic diseases from, **2:136**  
genetic variations from, **3:178–179, 238**  
intermediate filaments, **1:196–197**  
lamin genes, **3:147**  
pedigrees, **3:186**  
proteins and, **3:179**  
radiation exposure, **2:213**  
random, **3:119**  
recessiveness from, **2:128**  
transposition, **3:64**  
transposons, **4:175**  
tumor suppressor genes, **3:155**  
*See also specific types of mutations*
- Mutualisms, **2:76**  
animals, **4:143, 144**  
communities, **1:157**  
fungi and, **2:110–111**  
plants, **4:143–144**  
tropical forests, **2:103–104**
- Myasthenia gravis, **1:47, 3:112**

- Mycologists, 4:23  
 Mycology, 2:109, 3:219  
*Mycoplasmas*, 1:50  
 Mycorrhizae, 1:30, 34, 2:110–111, 3:119–121, 120, 4:80, 143–144, 194  
 Mycoses. *See* Fungal diseases  
 Mycotoxins, 2:108, 111  
 Myelin, 1:98, 3:134  
 Myelogenous leukemia, chronic. *See* Chronic myelogenous leukemia  
 Myocardial infarction. *See* Heart attacks  
 Myoglobin in ATP production, 3:111–112  
 Myosins, 1:191, 194, 3:109–110  
*Mytilus edulis*, 3:151  
 Myxedema, 2:21, 4:158  
 Myxomycota, 4:124–125, 125
- N**
- N*-acetyl glucosamine, 1:114  
 Nad<sup>+</sup>. *See* Nicotinamide adenine dinucleotide  
 NADH  
   Krebs cycle, 3:18  
   oxidative phosphorylation and, 3:168–170  
 NADPH in photosynthesis, 3:198, 199–200  
 NAK pump. *See* Sodium-potassium pump  
 Nandrolone, 1:28  
 Naphthalene acetic acid, 2:207  
 Narcotics. *See* Opiates  
 Nasal cavity, 4:64  
 Nastic movements, 4:176  
 National Academy of Sciences, 2:214, 4:190  
 National Center for Biotechnology Information (NCBI), 1:73  
 National Center for Science Education, 1:186  
 National Collegiate Athletic Association, 1:28  
 National Defense Research Committee, 3:185  
 National Football League, 1:28  
 National Institute of Neurological Disease and Stroke (NINDS), 3:129  
 National Institutes of Health (NIH), 2:28  
   genome database, 2:141  
   Human Genome Project, 1:72, 2:214  
   medical research by, 2:168  
 National parks, 1:169  
 National Research Council, 2:214  
 National Science Foundation (NSF)  
   funding of long-term ecological research, 2:3  
   Human Genome Project, 2:214  
 National Wellness Association, 2:167  
 Native species, *vs.* introduced species, 3:10  
 Natural history, ecology and, 2:5  
 Natural killer cells, 3:138  
 Natural resources  
   conservation of, 1:166–169  
   destruction of, 1:67  
   population growth and, 3:233–234  
 Natural selection, 2:46–47, 49, 52, 194–196, 3:121–124, 122  
   behavior patterns in, 1:63–64  
   bird migration and, 1:4  
   convergent evolution and, 1:181–183  
   Darwin, Charles and, 1:197–199  
   humans, 2:208  
   migration and, 3:92  
   mutations and, 3:118  
   population genetics, 3:236, 238–239  
   predator–prey relations, 4:3–4  
   *vs.* sexual selection, 4:104  
   sociobiology and, 4:131–132  
   speciation, 4:134  
   Weismann, August on, 2:117  
   *See also* Evolution  
 Naturally competent bacteria, 1:57  
*The Nature of the Chemical Bond and the Structure of Molecules and Crystals* (Pauling), 3:185  
 Nature preserves, 1:169  
 Nature *vs.* nurture, 1:60, 4:28, 132  
 Navigation in migration, 3:93  
 Nazi Germany, 1:62  
 NCBI. *See* National Center for Biotechnology Information  
 Neanderthals. *See* *Homo neanderthalensis*  
 Near East, human evolution in, 2:211  
*Necator americanus*, 3:175  
 Necrosis in plants, 3:216  
 Nectar, 2:75  
 Negative feedback systems, 1:87, 2:168, 202  
 Negative gene expression control, 1:170–171  
 Negative reinforcement, 3:27  
*Neisseria gonorrhoeae*, 1:57, 4:107, 109  
 Nekton, 3:152  
 Nematocysts, 1:155  
 Nematodes, 1:36, 3:124–125  
   grasslands, 2:157–158  
   model organisms, 3:101–102  
   parasitic, 3:175–176  
   plant diseases from, 3:217  
 Neo-Darwinism, 2:48–49, 117–118, 195–196  
 Neomorphic mutations, 3:181  
 Neo-organs, 4:174  
 Neoplasms. *See* Tumors  
 Nephridia, 3:166–167  
 Nephrons, 2:61, 3:16  
 Neritic province, 3:151–152  
 Nerve cords, 1:138, 3:126–127  
 Nerve fibers, 3:109, 110  
 Nerve growth factor, 1:102  
 Nerve impulses. *See* Action potentials  
 Nerve nets, 3:126  
 Nervous systems, 3:125–129, 126*f*, 127*f*  
   development of, 2:84  
   early research on, 2:197  
   *vs.* endocrine system, 2:19  
 Nervous tissue, 4:160  
 NES. *See* Nuclear export signals  
 Net diffusion, 2:114  
 Netter, Frank, 4:184  
 Neurodegenerative diseases, 3:129  
 Neurofilament proteins, 1:196, 197  
 Neurologic diseases, 3:129–131, 130, 171  
 Neurological changes  
   aging, 1:7  
   alcohol and, 1:19  
 Neurological tests, 3:130–131  
 Neurologists, 1:229–230  
 Neurology, 3:130  
 Neuromuscular junctions, 3:109, 4:146  
 Neurons, 1:98, 103, 3:125–127, 132*f*, 134, 131–135  
   early research on, 2:197  
   exocytosis and, 2:63  
   fMRI of, 3:3  
   hypothalamus, 2:223  
   peripheral nervous system, 3:189–191  
   synaptic transmission of, 4:145–148  
   touch, 4:161–162  
 Neuroscience, 3:3  
 Neurosurgery, 3:130  
 Neurotransmitters, 2:19, 3:131, 133  
   behavioral effects of, 1:63  
   exocytosis and, 2:63  
   release of, 4:146–147  
   signaling, 4:112

- Neutrophils, **3:138**
- New York Botanical Garden, **4:160**
- New Zealand, coral reefs in, **1:184**
- NFAT. *See* Nuclear factor of activated T cells
- NGU. *See* Nongonococcal urethritis
- Niacin, **4:191**
- Nice, Margaret Morse, **2:86**
- Niches, **2:164**
- boreal forests, **2:98**
  - competition, **1:160–161**
  - ecology, **2:6**
- Nicholson, Garth, **2:184, 3:76**
- Nicotiana tabacum*, **2:44**
- Nicotinamide adenine dinucleotide (Nad<sup>+</sup>), **3:144**
- Nicotine, **4:31, 33, 84, 126**
- Nightingale, Florence, **3:148**
- NIH. *See* National Institutes of Health
- NINDS. *See* National Institute of Neurological Disease and Stroke
- Nirenberg, Marshall, **2:185**
- Nitrification, **3:135**
- Nitrites, carcinogenic, **1:110**
- Nitrogen
- biogeochemical cycles, **1:67–68**
  - lakes and ponds, **3:22**
  - plants, **3:216**
- Nitrogen-containing compounds, **4:84**
- Nitrogen cycle, **3:135–136**
- Nitrogen dioxide, **3:228–229**
- Nitrogen fixation, **1:52, 190, 3:136–137, 137, 4:80**
- Nitrogenase, **3:136, 137**
- Nitrogenous bases of nucleotides, **3:143–144**
- NLSs. *See* Nuclear localization signals
- NMR. *See* Nuclear magnetic resonance
- No More War* (Pauling), **3:185**
- Nociception. *See* Pain
- Nocturnal animals, **3:203**
- Nodules (Plant), **3:137**
- Nomenclature in Linnaeus' classification, **3:47–48**
- Nonbarbiturate sedatives, **4:31**
- Nonclimacteric fruits, **2:108**
- Noncoding DNA, **1:224, 2:140**
- Noncovalent bonds in proteins, **4:10–11**
- Nondisjunctions, **3:69**
- Noneudicots, **1:33**
- Nongonococcal urethritis (NGU), **4:108**
- Noninsulin-dependent diabetes, **1:89**
- Noninvasive imaging techniques, **3:3**
- Nonpenetrance, **2:139, 3:183, 187**
- Nonrandom mating, **2:49**
- Non-REM sleep, **4:121–123**
- Nonsense mutations, **3:117**
- Nonspecific defenses, **3:138–140, 139**
- Nonspecific immunity, **1:41, 4:151**
- Nonvascular plants. *See* Bryophytes
- Noradrenaline. *See* Norepinephrine
- Norepinephrine, **2:204–205, 4:147**
- from adrenal medulla, **2:22**
  - postabsorptive metabolic state, **3:89**
  - psychedelics and, **4:32**
- Nori, **1:22**
- Normal flora, **1:52**
- Normalized Difference Vegetation Index, **4:46**
- Norplant, **1:83**
- NORs. *See* Nucleolar organizer regions
- North America
- boreal forests in, **2:97–98**
  - deserts in, **1:201**
  - fire ecology in, **2:90**
  - forests in, **4:202**
  - grasslands in, **2:156**
  - history of farming in, **2:181**
  - lakes and ponds in, **3:21**
  - lizards in, **1:182, 183**
  - primates in, **4:5**
  - temperate forests in, **2:99–100**
- Northeastern United States, **2:99**
- Northern blot, **2:15**
- Northern boreal forests, **2:97**
- Northern pine forests, **2:99**
- Northern United States, **2:99**
- Norway, coral reefs in, **1:184**
- Notochord, **1:138**
- Nowell, Peter, **3:157**
- NPCs. *See* Nuclear pore complexes
- NREM sleep. *See* Non-REM sleep
- NSF. *See* National Science Foundation
- Nuclear envelope, **3:145–146, 147, 4:21**
- Nuclear export signals (NES), **3:140–141**
- Nuclear factor of activated T cells (NFAT), **1:178–179**
- Nuclear lamina, **3:146, 147**
- Nuclear localization, **1:174–175**
- Nuclear localization signals (NLSs), **3:140–141, 4:20**
- Nuclear magnetic resonance (NMR), **4:142**
- Nuclear matrix, **3:146**
- Nuclear medicine, **3:3**
- Nuclear membranes, **3:146**
- Nuclear pore complexes (NPCs), **3:140**
- Nuclear proteins, **3:140–141**
- Nuclear test ban treaty, **3:185**
- Nuclear transport, **3:140–141, 141f, 146**
- Nucleases, **1:218**
- Nuclei, **3:145–148, 146f**
- hypothalamic, **2:224–225**
  - organelles, **3:159**
  - polar, **2:58**
  - protozoans, **4:25**
- Nucleic acids
- anabolic pathways in, **3:85**
  - origins of life, **3:163**
- Nucleolar organizer regions (NORs), **3:143**
- Nucleoli, **3:142–143, 146–147**
- Nucleoporins, **3:140, 146, 147**
- Nucleosomes, **1:143–145**
- Nucleotides, **1:57, 222, 225–226, 3:143–145, 144f, 145f**
- antisense, **1:41–42**
  - mutations and, **3:115–117**
  - origins of life, **3:163**
  - RNA, **4:75–76**
- Nurse-midwives, **3:148**
- Nurse practitioners, **3:148–149, 149**
- Nurses, **3:148**
- Nursing of babies, **3:33**
- Nusslein-Volhard, Christiane, **3:102**
- Nutrients
- blood, **1:85**
  - lakes and ponds, **3:22**
  - metabolic rate of, **4:38**
  - plasma membranes and, **3:220**
- Nutrition
- fungal, **2:110–111**
  - human, **2:217, 217–219**
  - plant, **2:199, 3:214–216, 215t**
  - public health, **4:36**
- Nutritional biochemists, **3:149**
- Nutritional epidemiologists, **3:149**
- Nutritionists, **3:149–150**
- Nuts, **2:106, 4:56**
- Nymphaeales. *See* Water lilies

## O

- OAA. *See* Oxaloacetic acid (OAA)
- Oak forests, fire regimes in, **2:90**
- Oak trees, **1:33**

- Oats, 2:154  
 OB-GYNs, 1:230  
 Obligate parasites, 4:57, 143, 144, 186  
 Observational plant studies, 2:87–88  
 Obsessive-compulsive disorder (OCD), 4:30  
 Obstetricians. *See* OB-GYNs  
 Occipital lobe, 1:99  
 Occupational Safety and Health Agency (OSHA), 3:224–225  
 Occupational health, 2:28, 169  
 Occupational medicine, 4:36  
 Occupational therapists, 3:200–201  
 OCD. *See* Obsessive-compulsive disorder  
 Ocean ecosystems  
   Cambrian period, 1:109–110  
   hard bottoms, 3:150–151, 151  
   marine biologists and, 3:60  
   open ocean, 3:151–153, 152  
   soft bottoms, 3:153–154  
 Oceanic province, 3:151  
 Ocelli, 4:189  
 Ochoa, Severo, 2:185, 4:163  
 Octaploids, 1:142  
 Octopi, 1:36  
 Oculomotor nerve, 1:102  
 Odum, Eugene, 2:6  
 Ohta, Tomoka, 3:117–118  
 Okazaki fragments, 4:50  
 Olduvai Gorge (Tanzania), 3:26  
 Olfaction, 1:135–136, 136  
   brain and, 3:128  
   insects, 3:7–8  
 Oligochaeta, 1:36, 37  
 Oligonucleotides, 1:41–42  
 Oligosaccharides, 1:113, 2:26  
 Olympics, steroid use in, 1:28  
 OMIM, 1:73  
 Ommatidia, 2:73, 3:7, 4:188  
*On the Origin of Species, or the Preservation of Favored Races in the Struggle for Life*, 1:199, 2:47, 51, 52, 192, 194–195, 4:104  
*On the Structure of the Human Body* (Vesalius), 4:184  
*Onchocerca volvulus*, 3:175–176  
 Organogenesis, 1:110–111, 3:154–158, 156f  
   genomics, 2:143  
   retroviruses, 4:68  
   translocations, 1:140  
 Oncologists, 1:230  
 Oncology, 1:110  
 Oncoproteins, 3:156  
 Oomycota, 2:113–114  
 Oparin, Alexander, 3:162  
 Open circulatory systems, 1:150, 3:9  
 Operant conditioning, 3:27  
 Operons, lac, 1:170–171, 173  
 Ophiuroidea. *See* Brittlestars  
 Opiates, 4:32, 33  
 Opium, 4:32  
 Opportunistic infections, 2:43, 109, 4:68  
 Optic nerves, 1:102, 2:73, 4:189  
 Optic neuropathy, 2:139  
 Optical inversion, 3:41  
 Optimal foraging, 1:64  
 Oral contraceptives. *See* Birth control pills  
 Oral health, 1:200  
 Oral surgery, 1:200  
 Orangutans, 4:5  
 Orchid mycorrhizae, 3:119  
 Orchidaceae. *See* Orchids  
 Orchids, 1:33, 34, 2:59, 3:106–107, 107  
   pollination of, 3:227  
   seeds of, 4:90–91  
 Organ transplantation, 4:172–174  
 Organelles, 1:121, 3:159  
 Organic agriculture, 3:159–161, 160  
 Organic chemistry, 3:184–185  
 Organisms  
   deep-sea, 3:154  
   ecosystems, 2:7–8  
   lakes and ponds, 3:23  
   model, 3:101, 104, 101–105  
   *See also specific types of organisms*  
 Organogenesis, 1:206, 217, 3:209, 211  
 Organogenesis, Inc., 4:174  
 Organotrophic organisms, 2:42  
 Organs, 3:158–159  
   *See also specific organs*  
 Orientation effect, 2:32  
 Oriented strand board, 4:203  
 Origin of life, 1:76, 3:161–165, 164  
 Ornithophily, 3:227  
 Ornithorhynchidae. *See* Platypus  
*Orrorin tugenensis*, 2:210  
 Orthodontics, 1:200  
*Oryza sativa*. *See* Rice  
 Oscula, 3:239  
 OSHA. *See* Occupational Safety and Health Agency  
 Osmoconformers, 3:165–166  
 Osmoregulation, 2:60, 3:165–168, 203–204  
 Osmotica, 2:70  
 Osseous connective tissue, 1:93  
 Ossification, 1:93–94, 2:159  
 Osteichthyes. *See* Bony fish  
 Osteoarthritis, 3:112  
 Osteoblasts, 1:93–94, 95, 2:159  
 Osteoclasts, 1:94, 95  
 Osteocytes, 1:165  
 Osteomalacia, 1:95  
 Osteons, 1:93  
 Osteoporosis, 1:94, 95, 4:159  
 Otitis media, 2:171  
*Our Stolen Future* (Colborn), 3:231  
 Outcrossing, 4:56–58, 59  
 Outer ear, 2:170–171  
 Outer space, 2:71  
 Out-of-phase offspring, 3:44–45  
 Ova, 2:78, 80–81  
 Ovarian cancer, 1:111  
 Ovaries, 2:77, 82, 93, 106, 4:53–56  
 Overdominant selection, 3:236  
 Overpopulation, diseases from, 2:28  
 Overproduction of offspring, 3:121  
 Ovulation, 2:78, 80  
   estrogen and progesterone control of, 2:22  
   suppression of, 1:83  
 Ovules, plant, 4:53, 55  
 Ovum. *See* Eggs  
*Oxalis*. *See* Wood sorrel  
 Oxaloacetic acid (OAA), 1:108, 3:18  
 Oxandrolone, 1:28  
 Oxidation  
   catabolism, 3:87  
   fatty acids, 3:191  
 Oxidation-reduction reactions, 3:18  
 Oxidative phosphorylation, 3:18, 98, 169f, 168–170  
 Oxygen  
   bioremediation, 3:229  
   blood, 1:84–85  
   gas exchange, 2:114–117  
   high altitudes, 3:204  
   lakes and ponds, 3:22  
   nitrogenase and, 3:137  
   oceans, 1:109  
   photosynthesis, 3:7, 196, 198  
   plant use of, 1:200  
   plants, 3:216  
   respiration, 4:63–66  
   wetlands, 4:197–198  
 Oxygen deprivation, 3:225  
 Oxymetholone, 1:28  
 Oxytocin, 2:202–203, 3:205
- P**  
 p53 gene, 1:111  
 PA. *See* Physician assistants (PA)



- Pacemaker cells, 2:175  
 Pacifism, 3:185  
 Pain, 3:170–171  
   chronic, 3:129  
   *vs.* touch, 4:161  
 Palade, George, 3:240  
 Palatine tonsils, 3:54  
 Paleoanthropology, 3:26  
 Paleocology, 3:173  
 Paleontology, 3:171–173, 172  
 Palms, 1:33, 2:101, 3:106  
 Pampas. *See* Temperate grasslands  
 Pancreas, 2:22, 3:173–174  
 Pancreatic amylase, 1:218, 3:174  
 Pancreatic cancer, 1:112  
 Pancreatic ducts, 3:174  
 Pancreatic islets, 3:174  
 Pancreatic juice, 1:220–221, 3:174  
 Pancreatic lipase, 3:174  
 Panels, wood, 4:203  
 Panting for water evaporation, 3:203  
 Pantothenic acid, 4:191  
 Paper as cellulose, 1:114  
 Papilloma viruses, 4:109  
 Paracrine signaling, 4:113  
 Parakeets, Carolina, 2:67  
*Paramecium*, 4:22, 25  
 Paramylum, 4:24  
*Paranthropus*, 2:210  
 Paraplegia, 4:138–139  
 Parasites  
   crustaceans as, 1:190  
   nematodes as, 3:125  
   platyhelminthes as, 3:222  
   protist, 4:22  
   protozoan, 4:26–27  
   viral, 4:186, 187  
 Parasitic diseases, 3:174–176, 175, 4:26–27  
 Parasitism, 2:76, 4:145  
   in communities, 1:157  
   fungal, 2:110, 114  
 Parasympathetic nerves, 3:190–191  
 Parathyroid cancer, 3:156  
 Parathyroid hormones, 1:95  
 Paraventricular nucleus, 2:224  
 Parenchyma cells, 1:30, 213–217, 3:29, 4:58, 79  
 Parental care, 3:62–64  
 Parental type gametes, 3:44  
 Parietal lobe, 1:99  
 Parasitologists, 4:23  
 Parkinson's disease, 3:129, 130, 134, 4:33  
 Parks, national, 1:169  
 Parotid glands, 1:219  
 Parthenocarp, 2:107, 4:59  
 Parthenogenesis, 3:9, 4:102  
 Partial dominance, 2:128, 139, 3:180  
 Particulate inheritance, 2:190  
 Parturition. *See* Birth  
 Passive immunity, 4:182  
 Passive transport, 3:78–79  
 Pasteur, Louis, 2:197, 3:162, 176–177, 4:182  
 Pasteurization, 3:177  
 Patch clamp technique, 3:14  
 Patella, movement of, 3:114  
 Patent and Trademark Office. *See* U.S. Patent and Trademark Office  
 Patents for human genomes, 2:216  
 Paternity tests, 2:95, 4:106  
 Pathogens  
   fungal, 2:111, 114  
   plant, 3:216–219  
   prions as, 4:5–6  
 Pattern formation, 2:134–135, 3:82–83  
 Patterns of inheritance, 3:177–184, 178, 182*f*, 183, 187–189  
 Pauling, Linus, 1:187, 2:184, 3:117, 184–185  
 Pavlov, Ivan, 1:62, 3:27  
 Pavlovian conditioning. *See* Classical conditioning  
 PCP. *See* Phencyclidine  
 PCR. *See* Polymerase chain reaction  
 Peatlands, 4:197  
 Pectinase, 4:54  
 Pectins, 1:133, 4:54  
 Pediatric dentistry, 1:200  
 Pediatric nurse practitioners (PNPs), 3:149  
 Pediatricians, 1:231  
 Pedicels, 2:93  
 Pedigrees, 2:135, 3:186–189, 186*f*, 187*f*, 188*f*  
 Pelagic zone, 3:22–23, 151–153  
 Pelvic cavity, 1:92  
 Pelvic inflammatory disease (PID), 4:109  
   chlamydial NGU, 4:108  
   gonorrhea, 4:107  
 Penetrance (Genetics), 3:187  
 Penicillin, 1:234  
   bacteria and, 1:50  
   for syphilis, 4:108  
 Penis, 3:58  
 PEP. *See* Phosphoenolpyruvate  
 Pepos, 4:56  
 Pepsin, 1:220  
 Pepsinogen, 1:220  
 Peptidases, 1:218  
 Peptide bonds, 1:24, 25, 4:9, 10*f*, 16*f*, 17  
 Peptides, 2:20, 204–205, 3:205  
 Peptidoglycan, 1:50, 133, 2:41  
 Perennial plants, 4:91–92  
 Pericardium, 2:173  
 Pericarp, 4:56  
 Perinatology, 2:84  
 Periodontics, 1:200  
 Periosteum, 3:112  
 Peripheral diseases, 3:129  
 Peripheral membrane proteins (PMP), 3:71*f*, 72, 75–76  
 Peripheral nervous system (PNS), 3:189–191, 190*f*  
   invertebrates, 3:126–127  
   spinal cord and, 1:134  
   vertebrates, 3:128  
 Peripheral vasodilation, 4:155  
 Peristalsis in digestion, 1:219–221  
 Perkin Elmer Corporation, 2:215  
 Permafrost, 2:71, 4:178  
 Permeability of ions, 3:14  
 Permian period, lizards in, 4:63  
 Peroxidase in ELISA, 1:38–39  
 Peroxisome proliferator-activated receptor (PPAR), 3:192  
 Peroxisomes, 1:122, 3:191–192  
 Persistence, of pollutants, 3:228  
 Perspiration, 4:155  
 Peru, El Niño and, 3:152  
 Perutz, Max, 2:184  
 Pest control  
   organic agriculture, 3:159–161  
   plants, 3:218–219  
 Pesticide-resistance insects, 3:122–123  
 Pesticides, 3:218–219  
   birds and, 1:82  
   pollutants, 3:230–231  
   safety testing of, 1:117  
 Pests, plant, 3:218–219  
 PET. *See* Positron emission tomography; Potential evapotranspiration  
 Petals, 1:32  
 Peyer patches, 3:54  
*Pfiesteria*, 1:22  
 PFK. *See* Phosphofructokinase  
 pH  
   enzymes and, 2:33–34, 33*f*  
   homeostasis and, 2:201  
   lakes and ponds, 3:22  
 Phaeophyceae, 1:20, 21, 133  
*Phaeophyta*. *See* Brown algae  
 Phages. *See* Bacteriophages

- Phagocytes, 3:138
- Phagocytosis, 1:41, 2:23, 3:55–56  
 defense mechanism, 3:138–139  
 myxomycota, 4:124
- Phagosomes, 2:23
- Phantom pain, 3:171
- Pharmaceutical research, 3:104
- Pharmaceutical sales representatives, 3:192
- Pharmaceutics  
 recombinant DNA technology in, 4:39  
 sales of, 3:192
- Pharmacogenomics, 2:145
- Pharmacologists, 3:192, 192–193
- Pharmacology, 3:192
- Pharyngeal slits, 1:139
- Pharyngeal tonsils, 3:54
- Pharynx, 1:219, 4:64
- Phascolarctos cinereus*. See Koala
- Phase contrast microscopes, 3:39–40
- Phencyclidine (PCP), 4:32
- Phenolics, 2:178, 4:84
- Phenotypes, 3:178–183, 186  
*vs.* alleles, 2:164  
 genes and, 2:117–120  
 mutant, 3:45–46  
 racial variations in, 1:77
- Phenylalanine, 3:182
- Phenylketonuria disease (PKU), 2:140, 3:182
- Pheromones, 1:65, 3:7–8, 194, 193–195
- Philadelphia chromosome, 1:140, 3:157
- Philosophie Zoologique* (Lamarck), 3:24
- Phloem, 1:30–31, 213, 215  
 functions of, 4:110–111, 169–171  
 leaves, 3:29  
 plant roots, 4:80  
 tracheophytes, 2:55  
 translocation and, 4:169
- Phosphatases, 1:178
- Phosphates, 3:144
- Phosphodiester bonds, 4:76, 77
- Phosphoenolpyruvate (PEP), 1:108
- Phosphofructokinase (PFK), 2:149
- Phosphoinositide pathway, 4:117
- Phospholipase C (PLC), 4:117
- Phospholipid exchange model, 2:27
- Phospholipids, 3:48–49, 73–75, 220
- Phosphorus  
 biogeochemical cycles, 1:67  
 lakes and ponds, 3:22  
 nutrient, 2:218  
 plants, 3:216
- Phosphorus 32, 4:38
- Phosphorylation  
 of ADP, 2:148–149, 184  
 cell cycle, 1:126  
 cyclin-dependent kinases and, 3:212  
 of enzymes, 2:34  
 histone, 1:144  
 mitosis, 3:99–100  
 nuclear disassembly and, 3:147  
 of proteins, 4:19, 20  
 regulation by, 1:178–179, 179, 180  
 transcription activation, 1:174–175  
 See also Oxidative phosphorylation
- Photic zone, 3:150, 152, 153
- Photoperiodism, 2:200, 3:92, 195–196
- Photophosphorylation, 3:198
- Photorespiration, 1:107–108, 3:191
- Photosynthesis, 3:196–200, 197*f*, 198*f*, 199*f*, 207  
 algae, 1:22  
 carbon cycle, 1:114  
 carbon dioxide in, 1:199–200  
 chloroplasts in, 1:121, 137  
 cyanobacteria, 1:190  
 early research on, 2:184, 198–199, 200  
 leaves, 1:29–30, 3:28–29  
 ocean life and, 3:152, 153  
 oxygen in, 3:7  
 rivers and streams, 4:74–75  
 water regulation and, 4:195
- Photosynthetic protists. See Algae
- Photosystems, 3:198
- Phototrophic organisms, 2:42, 200
- Phototropism, 4:175
- Phrynosoma platyrhinos*. See Desert horned lizards
- Phycologists, 4:23
- Phycology, 1:22
- Phyletic gradualism, 3:173
- Phylogenetic species concept (PSC), 4:137
- Phylogeny, 1:210–212, 2:51, 3:172
- Physarium*, 4:22
- Physical barriers, as nonspecific defenses, 3:138
- Physical changes  
 aging, 1:8  
 alcohol and, 1:19–20
- Physical environment, in ecosystems, 2:7–8
- Physical therapists, 3:200
- Physician assistants (PA), 3:201
- Physicians. See Doctors
- Physiological ecology, 3:202–204, 203
- Physiology, 1:76  
 aging, 1:8  
 echinoderms, 2:2  
 experimental, 2:166  
 heart, 2:174–175  
 model organisms in, 3:102–105  
 plants, 1:199–200, 2:198–201, 199
- Physostigmine, 4:32
- Phytochrome, 2:200, 3:196, 4:87
- Phytophthora infestans*, 3:217
- Phytoplankton, 3:152  
 in pelagic zone, 3:23  
 See also Algae
- Phytoremediation, 3:230
- Pia mater, 1:98
- PID. See Pelvic inflammatory disease
- Piezophiles, 2:71
- Pigment, senescence, 4:91
- Pilin, 1:55
- Pillard, R.C., 1:62
- Pillbugs, 3:218
- Pinchot, Gifford, 1:166
- Pine forests, 2:90–91, 99
- Pine trees, 1:162
- Pinna, 2:170
- Pinocytosis, 2:23, 24, 3:55
- Pisaster ochraceus*, 3:151
- Piscivorous fish, 3:23
- Pistils, 1:32, 2:93, 106–107
- Pith, 4:110
- Pituitary glands, 2:20–21, 3:205, 4:140  
 regulation of adrenal cortex, 1:6–7  
 testes and, 3:57
- PKA. See Protein kinase A
- PKC. See Protein kinase C
- PKU. See Phenylketonuria disease
- Placenta, 1:26, 2:78, 81, 82  
 human, 3:32–33  
 plant, 4:53
- Plague, 2:43, 3:176
- Planaria, 3:222, 4:188
- Planktivorous fish, 3:23
- Plankton, 3:205–207, 206  
 in lakes and ponds, 3:23  
 in pelagic zone, 3:152
- Plankton-eating fish. See Planktivorous fish
- Plant biogeography, 4:192
- Plant bugs, 3:218
- Plant diseases, 3:216–219
- Plant nutrients, 1:30–31, 4:78–80

- Plant pathologists, 3:219
- Plants, 1:29, 3:207–208
- alternation of generations, 1:22–24
  - anatomy of, 1:29–31
  - as autotrophs, 2:8
  - benthic, 3:150, 153
  - bioremediation, 3:230
  - biotechnology and, 1:80
  - botanists and, 1:96–97
  - cell division in, 3:99
  - cell walls in, 1:114, 132–133
  - cells in, 1:120, 120–122
  - chromosome changes in, 1:141–142
  - cultivation of, 2:180–181
  - defenses of, 2:178, 178–179, 178–179
  - development in, 3:208–214, 209f–212f, 214f
  - differentiation in, 1:212–217, 214, 216, 217
  - estuarine, 2:38
  - evolution of, 2:55–60, 58
  - field studies in ecology of, 2:87–89, 88
  - food, 2:75
  - vs.* green algae, 1:20
  - hormones, 2:205t, 206–208
  - hybridization, 2:221, 221–222
  - kingdom, 3:17
  - life rhythms of, 4:69–70, 70
  - meiosis in, 3:66
  - meristems in, 3:81–84
  - mitosis in, 3:100
  - mutualisms in, 4:143–144
  - mycorrhizae and, 3:119–121
  - nitrogen cycle in, 3:135, 136–137
  - nutrition in, 3:214–216, 215t
  - pathogens and pests, 3:216–219
  - photoperiodism in, 3:195–196
  - physiology of, 1:199–200, 2:198–201, 199
  - poisonous, 3:223–224, 223t
  - pollination of, 3:227–228
  - propagation of, 4:6–7
  - reproduction in, 3:34–35, 4:52–60, 53, 55f, 57
  - roots of, 4:78–81, 79
  - secondary metabolites in, 4:84–86, 85t
  - senescence in, 4:91–93
  - translocation in, 4:168–171, 170f
  - tropical forests, 2:101, 102–104
  - tropisms in, 4:175–176
  - vacuoles in, 4:182–183
  - water movement in, 4:193–195, 194
  - wetlands, 4:198
- See also* Germination; Herbal medicine; specific plants and species of plants
- Plasma cells. *See* B cells
- “Plasma for Britain” program, 1:85
- Plasma membranes, 2:24, 62–63, 3:220–222, 220f, 222f
- Plasmid vectors, 4:42
- Plasmids
- cloning of, 1:57
  - genetic transfer of, 1:53–54, 55
  - genome, 2:141
- Plasmin, 1:87
- Plasmodesmata, 1:31, 4:169
- Plasmodia, 4:22, 25, 26, 27, 124–125
- Plastics, 2:28, 4:202
- Plastids
- in bacteria, 2:44
  - origins of, 1:127–129
- Platanaceae, 2:44
- Platelets, in blood clotting, 1:86
- Platyhelminthes, 1:36, 3:222–223
- Platypus, 3:108
- PLC. *See* Phospholipase C
- Pleiotropy, 2:118, 3:183–184
- Pleistocene period
- climate in, 2:146
  - Homo erectus* in, 2:211
  - lakes and ponds in, 3:21
- Plywood, 4:203
- PMCs. *See* Pollen mother cells
- PMP. *See* Peripheral membrane proteins
- Pneumatocysts, 3:150
- Pneumonia, 4:186
- PNPs. *See* Pediatric nurse practitioners
- PNS. *See* Peripheral nervous system (PNS)
- Poaceae. *See* Grasses
- Podocarps, 1:162
- Poinsettias, 3:28–29
- Point mutations, 3:116
- Poison control centers, 3:227
- Poison dart frogs, 4:2–3
- Poisonous plants, 3:223–224, 223t
- Poisonous prey, 3:94, 4:2–3
- Poisons, 3:223–227, 226
- See also* Mycotoxins
- pol* genes, 4:49–50, 66, 68
- Polar covalent bonds, 4:192–193
- Polar nuclei, 2:58
- Polarized light, 4:190
- Polarizing light microscopes, 3:40
- Polio, 3:112, 4:186
- Polio vaccine, 2:197
- Polio virus, 4:186
- Political philosophy, 1:62–63
- Pollen, 2:93, 4:53–54
- angiosperms and, 1:33
  - in eudicots, 2:43, 44
  - feeding on, 2:75
  - gymnosperm evolution, 2:57
  - hybridization from, 2:221
  - monocots, 3:106
  - See also* Pollination
- Pollen mother cells (PMCs), 4:54
- Pollination, 3:227–228, 4:56–58
- flowers in, 2:93–94
  - insect, 2:44, 59
- Pollution, 3:228–232, 229, 230
- biodiversity and, 1:167
  - Carson, Rachel on, 1:117
  - greenhouse gases, 2:147
  - health and, 2:28–29
  - lichens and, 3:32
  - plastics, 2:28
  - water, 3:135
- Poly-A polymerase, 4:77–78
- Polyacrylamide gel electrophoresis, 2:15
- Polyandry, 3:63–64
- Polychaeta, 1:36, 37
- Polydactyly, 3:183, 187
- Polygamy, 3:62–63, 64
- Polygenes, 1:77–78, 2:118–119
- Polygyny, 3:62–63, 64
- Polymerase chain reaction (PCR), 2:70, 142, 213, 221, 3:232–233, 232f
- in DNA cloning, 1:152
  - gene mapping and, 3:46
  - reverse transcriptase and, 4:69
- Polymerases, 4:51–52
- DNA, 1:225, 3:116
  - reverse transcriptase, 4:68–69
  - transcription, 4:163–165
- Polymerization, as life-defining, 3:37, 162, 164
- Polypeptides, 2:120
- Polyphyletic classification, 4:21, 23–24
- Polyploidy, 1:140, 141–142, 2:221, 4:135
- Polyproteins, 4:67
- Polyps, coral, 1:183
- Polysaccharides, 1:113–114
- anabolic pathways in, 3:85
  - cell walls, 1:133
  - origins of life, 3:163

- Pomes, 4:56
- Ponds, 3:21–23
- Pons, 1:102
- Population dynamics, 3:233–235, 234*f*
- Population genetics, 2:164–165, 3:235–239, 237
- Population growth, 1:160, 3:234
- Populations
- conservation, 1:166
  - ecology of, 2:4, 5–6
  - evolution and size of, 2:48–49
  - extirpation of, 2:64
  - fitness within, 1:4–5
  - human, 2:219–220
  - racial differences in, 1:77
  - types of, 3:233
- Porifera, 1:35, 3:239–240
- Pork tapeworm. *See Taenia solium*
- Porter, Keith, 2:188, 3:240–241
- Porter-Blum microtome, 3:240
- Positional cloning, 2:144
- Positive feedback systems, 2:202
- Positive gene expression control, 1:171–172
- Positive reinforcement, 3:27
- Positron emission tomography (PET), 1:99, 3:3
- Postabsorptive metabolic state, 3:88–89
- Post-mating competition, 4:106
- Postmortem examinations. *See* Autopsies
- Postsynaptic membranes, 4:146
- Post-translational modification, 4:18–19
- Potassium, in plants, 3:216
- Potassium ion channels, 3:12–13
- Potato blight, 3:217
- Potato family. *See* Solanaceae
- Potato plant. *See Solanum tuberosum*
- Potency of pollutants, 3:228
- Potential energy, membrane, 3:79
- Potential evapotranspiration (PET), 1:201
- Poxvirus, 1:227
- PPAR. *See* Peroxisome proliferator-activated receptor
- Prairies, 2:90, 4:46
- Pre-birth adoption, 4:62
- Precambrian period, porifera in, 3:239
- Precipitation, 1:201, 4:193
- Predation, 2:76, 4:1–4, 2
- benthic animals, 3:150
  - communities, 1:157–158
  - crustaceans, 1:190
  - effect on adaptation, 1:3–4, 5
  - image processing and, 4:189
  - keystone, 3:151
  - protection against, 3:93–94
  - skeletons and, 4:118
  - social behavior and, 4:127–129
- Preformation, 1:205
- Pregnancy, 2:81
- AIDS during, 1:15, 16
  - smoking and, 4:127
- Pregnancy tests, 1:38–39
- Premature infants, 2:83
- Prescribed fires, 2:90
- Pressure in deep sea environments, 3:204
- Pressure-flow mechanism, 4:170–171
- Presynaptic membranes, 4:146
- Preurine, 3:16
- Preventive medicine, 2:168
- Prey. *See* Predation
- Priestley, Joseph, 2:198, 3:7
- Primary auditory cortex, 1:100
- Primary motor cortex, 1:100
- Primary plant growth, 3:82
- Primary producers. *See* Autotrophs
- Primary somatosensory cortex, 1:100
- Primary structure of proteins, 4:9
- Primary tumors, 1:110
- Primary visual cortex, 1:100
- Primase, 4:49–50
- Primates, 4:4–5
- Priming in DNA replication, 4:49–50
- Principles of Geology* (Lyell), 2:45
- Prions, 4:5–6
- Proanthocyanidins, 2:177
- Probabilities
- DNA forensics, 2:96–97
  - genetic diseases, 2:139–140
- Procambium. *See* Vascular tissue
- Proctitis, 4:109
- Productivity of ecosystems, 2:9–10
- Proenzymes. *See* Zymogens
- Profilin, 1:194
- Progesterone
- ovulation control, 2:22
  - pregnancy, 2:81
- Progymnosperms, 2:57
- Prokaryotes, 1:119–120
- archaea, 1:44–46
  - blue-green algae, 1:20
  - cell evolution from, 1:127
  - cell motility in, 1:131–132
  - classification of, 3:17, 4:153–154
  - eubacteria as, 2:41
  - gene expression control in, 1:170–172, 172
  - gene transcription in, 1:170–172, 172
  - genomes of, 2:141
  - protein initiation in, 4:14–15
  - ribosomes in, 4:71–72
  - transcription in, 4:162–163
  - transposons in, 4:175
- See also* Bacteria
- Prolactin, 2:21, 81
- Prometaphase, 3:100
- Pronephros, 3:15
- Propagation, 4:6–7
- Propeptides, 2:68
- Prophase, 3:99
- Proprioception, 3:189
- Prosecutor's Fallacy, 2:96
- Prosimians, 4:4
- Prostaglandins, 4:100
- Prostate gland, 3:58
- Prostate-specific antigen, 3:58
- Prosthodontics, 1:200
- Proteas*, 2:44
- Protease inhibitors, 4:187
- Proteases, 4:18–19, 67–68
- Proteasomes, 4:19
- Protected areas for conservation, 1:169
- Protective equipment, 2:169
- Protein kinase A (PKA), 4:116
- Protein kinase C (PKC), 4:117
- Protein synthesis, 2:185, 3:142–143, 4:13–19, 14*f*, 16*f*, 17*t*
- mRNA and, 4:162
  - ribosomes in, 4:71–73
  - RNA in, 4:76, 77–78
  - seed germination, 4:86
- Proteins
- anabolic pathways in, 3:85
  - animal structure, 1:34
  - biochemist specialty in, 1:66
  - CDK, 1:125, 1:125–126
  - conformation of, 2:26, 3:185, 4:6, 9–10, 18
  - crosslinkage of, 1:9
  - digestion of, 2:203, 3:174
  - DNA and chromosomes, 1:143
  - early research on, 2:184–185
  - effects of mutation on, 1:9
  - electrophoresis of, 2:15
  - enzymes as, 2:30, 183
  - gene expression, 1:170–177
  - genetic code and, 2:119–120, 129–131
  - glycosylation, 1:9

- Golgi apparatus and, 2:151–153  
 hormones and, 2:203  
 hyperactive, 3:181  
 lamin-binding, 3:146  
 longevity of, 4:38  
 mass of, 1:73  
 as nonspecific defense, 3:138  
 nuclear transport, 3:140–141  
 as nutrients, 2:218  
 origins of life, 3:163  
 peroxisomal, 3:191–192  
 phenotypes and, 3:178  
 plasma membranes, 3:220–221  
 prion, 4:5–6  
 protein-protein interactions, 1:179–180  
 regulation of, 1:177–181  
 secretion, 1:57  
 structure of, 4:7–13, 8f, 9f, 10f, 141–142  
 targeting, 4:19–21  
*See also* Amino acids; Genes; specific proteins and types of proteins
- Proteobacteria, 2:42  
 Proteolytic cleavage, 1:181, 2:34–35  
 Proteomics, 1:72–73  
 Protestant fundamentalism, creationism and, 1:185  
 Prothrombin activator, 1:87  
 Protists, 4:21, 22, 21–23  
   cell division in, 3:99  
   classification of, 3:17, 4:153  
   as heterotrophs, 2:8  
   lakes and ponds, 3:23  
   *See also specific organisms*
- Proto-chordates, 1:36  
 Proto-cooperation, 4:144  
 Protoderm. *See* Dermal tissue  
 Protoecology, 2:5  
 Proton pumps, 3:55, 220  
 Protonephridia, 2:60–61, 62f, 3:167  
 Proto-oncogenes, 3:155–157  
 Protostomes, 1:36, 209  
 Prototracheophytes, 2:56  
 Protozoan diseases, 4:22, 25, 26–27, 27, 109–110  
 Protozoans, 4:23–25, 24  
   locomotion of, 3:51, 52  
   osmoregulation in, 3:166  
 Protozoologists, 4:23  
 Provitamins, 4:190  
 Proximal convoluted tubule, 3:16  
 Proximity effect, 2:32  
 Prusiner, Stanley, 4:5–6  
 PSC. *See* Phylogenetic species concept
- Pseudocarps, 4:56  
 Pseudocoelom, 1:92, 93  
 Pseudoextinction, 2:64  
 Pseudomurein wall, 1:134  
 Pseudoplasmodia, 4:125  
 Pseudopods, 1:131, 194, 3:51, 4:25  
 Pseudostratified columnar epithelium, 2:37  
 Psilocin, 4:32  
 Psilophyta, 2:56  
 Psilotopsida, 4:34  
*Psilotum*, 4:89  
 Psychedelics, 4:32, 33  
 Psychiatric disorders  
   biology of, 4:27–30, 28  
   environment and, 2:28–29  
   *vs.* neurologic diseases, 3:129  
 Psychiatrists, 4:30–31  
 Psychoactive drugs, 4:31–33, 32, 84  
 Psychologists, 4:30  
 Psychoses, 4:30  
 Psychosis, 4:29  
 Psychrophiles, 2:70–71  
 Pteridophytes, 4:33, 33–35  
 Pterophyta, 2:56–57  
 Pterosaurs, 2:92  
 Pterygota, 2:92  
 Puberty, 3:33  
   growth spurt in, 2:159–160  
   menstruation and, 2:78  
   testosterone in, 3:57  
 Public health, 4:35  
 Public health careers, 4:35–36  
 Public health nutritionists, 3:149  
 PubMed, 1:73  
 Pulmonary arteries, 1:89–90, 2:174  
 Pulmonary capillaries, 1:91  
 Pulmonary circuit, 1:151  
 Pulmonary circulation, 2:172–175  
 Pulmonary gas exchange, 4:65  
 Pulmonary valve, 2:174  
 Pulmonary veins, 1:89, 91, 2:174  
 Pulmonary ventilation, 4:64–65  
 Pulse-chase, 4:38  
 Pulvinus, 4:176  
 Punctuated equilibrium, 2:51, 54, 3:173  
 Punctationalism, 4:136  
 Pupils (Eye), 2:72  
 Purification of biomolecules, 4:93, 93–94  
 Purines, 3:143–144  
 Purkinje, Jan, 2:188  
 Putamen, 1:101–102  
 Pyloric sphincter, 1:218, 220  
 Pyramid of numbers, 2:6  
 Pyrimidines, 3:143–144  
 Pyrosomes. *See* Urochordata  
 Pyruvate  
   Krebs cycle and, 3:18  
   mitochondria, 3:97  
 Pyruvic acid, 2:148–149
- ## Q
- Quadriplegia, 4:139  
 Quantitative methods in ecology, 2:6  
 Quaternary structure of proteins, 4:10  
 Quickening (Fetal), 2:84  
 Quiescence, seed, 4:86  
 Quorum sensing, 1:57
- ## R
- R factors, 1:54  
 Rabies  
   vaccines, 3:177, 4:182  
   William, Anna Wessels, 1:52  
 Race, biology of, 1:77–79, 78  
 Radial cleavage, 1:209–210  
 Radial nerves, 3:126  
 Radial symmetry  
   angiosperms, 4:59  
   animals, 1:35  
 Radiation  
   Earth's balance of, 1:204  
   electromagnetic, 4:46  
   ionizing, 1:110  
   thermoregulation, 4:155  
   *See also* Ultraviolet radiation  
 Radiation exposure, 3:115  
 Radiation hybrid mapping, 4:36–37, 37f  
 Radiation therapy. *See* Radiotherapy  
 Radio telemetry, 2:86  
 Radioactive isotopes. *See* Radionuclides  
 Radiography. *See* X rays  
 Radioisotopes. *See* Radionuclides  
 Radiologists, 1:231–232  
 Radiology, 3:3  
 Radionuclides, 2:183–184, 4:38  
 Radiotherapy for cancer, 1:112  
 Radman, Miroslav, 3:119  
 Radula in mollusks, 3:105  
*Rafflesia*, 2:93  
 Rain forests, 2:101, 4:46  
 Rainshadow effect, 1:201  
 Ramon Y Cajal, Santiago, 1:103, 2:197  
 Ran (GTPase), 3:141  
 Random diffusion, 3:77

- Randomly amplified polymorphic DNAs (RAPDs), 3:46
- Ranunculales, 2:44
- RAPDs. *See* Randomly amplified polymorphic DNAs
- Rapid eye movement sleep. *See* REM sleep
- ras protein, 1:178
- Raspail, Francois, 2:187
- Ratfishes. *See* Chimearas
- Rats as model organisms, 3:104
- Ravenglass Estuary, 2:39
- Ray, John, 4:152
- Ray-fins, 1:96
- Rays (Fish), 1:118
- Reading, 3:3
- Receptor-mediated endocytosis, 2:24
- Receptors, 3:133
  - immune response, 3:4
  - nuclear transport, 3:140–141
  - plasma membranes, 3:221
  - signal transduction, 4:112–114
  - synaptic transmission, 4:145–146
  - T cell, 4:148–151
  - touch, 4:161–162
- Recessiveness, 2:127, 128, 139, 164, 3:80, 179–181
- Recherches chimiques sur la végétation* (De Saussure), 1:199
- Reciprocating transporters, 3:78–79
- Recombinant DNA, 1:80, 2:142–144, 4:38–46, 39, 40f, 41f
- Recombinant type gametes, 3:44
- Rectum in digestion, 1:221
- Red algae. *See* Rhodophyceae
- Red blood cells
  - connective tissue, 1:165
  - hemoglobin and, 1:84–85
- Red kangaroo, 3:62
- Red light in photoperiodism, 3:196
- Red Queen hypothesis, 4:103
- Red-tailed hawk, 1:81
- Red wines, 4:200
- Reduction reactions in anabolism, 3:87
- Redundant codons, 2:130
- Redwood trees, 1:162
- Referred pain, 3:171
- Reflexes
  - conditioned, 1:62
  - fetal, 2:84
- Registered nurses (RNs), 3:148
- Regulation
  - phosphorylation, 1:178–179, 179, 180
  - protein-protein interactions, 1:179–180
  - proteolytic cleavage, 1:181
  - small molecules, 1:177–178
  - transcriptional activators, 1:174–175
- Reinforcement in learning, 3:27
- Reintroductions
  - biodiversity, 1:169
  - endangered species, 2:18
- Relaxation, of muscles, 3:110–111
- Release factor proteins (RFs), 4:18
- Relocation. *See* Dispersal behavior
- REM rebound, 4:124
- REM sleep, 4:121–124
- Remak, Robert, 2:188
- Remote sensing, 4:46–47
- Renal function. *See* Kidneys
- Renaturation. *See* Hybridization
- Renewable resources, wood as, 4:202
- Renin, 4:139
- Repetitive DNA sequences, 1:147–148
- Replication, 4:47–52, 49f, 50f, 51f
  - of DNA, 1:222–223, 3:67–68
  - mutations in, 3:115–116
  - origins of life, 3:163
- Replication forks, 4:48–49, 50f, 51
- Repressors, transcriptional, 1:176
- Reproduction
  - after fires, 2:89
  - annelids, 1:37
  - bacterial cells, 1:49–50
  - bacteriophages, 1:58
  - as life-defining, 3:37–38
  - migration and, 3:92
  - mitochondria, 3:95–96
  - origins of life, 3:162
  - patterns in, 1:64
  - plants, 4:52–60, 53, 55f, 57
  - porifera, 3:240
  - protozoans, 4:25
  - rate of, natural selection and, 3:123–124
  - stages of, 3:35
  - viral, 4:187
  - See also* Asexual reproduction; Sexual reproduction
- Reproductive hormones in aging, 1:9
- Reproductive isolation, 4:134–135, 136
- Reproductive systems
  - female, 2:77, 78f–80f, 77–81
  - male, 3:56–59, 58f, 59f
- Reproductive technology, 4:60–62, 61
- Reptiles, 4:62–63
  - amniotic eggs, 1:25–26
  - vs.* birds, 1:80
  - brain in, 3:128
  - vs.* crocodylians, 1:188
  - heart of, 1:151
  - lakes and ponds, 3:23
  - lungs in, 2:116–117
  - sex determination in, 4:97, 98
- rER. *See* Rough endoplasmic reticulum (rER)
- Research
  - college professors, 1:156
  - environmental health, 2:29
  - long-term ecological, 2:3–4
  - pharmacologic, 3:192–193
  - See also* Field studies
- Research Board for National Security, 3:185
- Residency, medical, 1:228, 229, 231t
- Resistance, to antibiotics, 1:52–53, 54, 234
- Resolution, in microscopy, 3:39–41
- Resonance, 3:185
- Respiration, 4:63–66, 64f, 86
  - carbon cycle, 1:114
  - insects, 3:9
- Respiratory distress syndrome, 2:84
- Respiratory gases, 2:114–117
- Respiratory pigments, 2:114
- Respiratory system, 4:64, 126–127
- Resting membrane potential, 3:133–134
- Resting potentials, 3:220
- Restriction enzymes, 2:185
  - DNA cloning, 4:40
  - DNA electrophoresis, 2:13–14
- Restriction fragment length polymorphisms (RFLPs), 3:46
- Reticular activating system, 4:123
- Reticular formation, 1:102
- Retinas, 2:72–73, 3:159, 4:189
- Retinula cells, 4:188
- Retrograde transport, 2:152
- Retroposons, 4:175
- Retroviruses, 4:66–68, 67
  - AIDS, 1:14
  - reverse transcriptase and, 4:68
- Reverse transcriptase, 4:68–69
  - AIDS, 1:14
  - DNA cloning, 4:42–43
  - eukaryotic chromosomes, 1:146
  - retroviruses, 4:66
- RFLPs. *See* Restriction fragment length polymorphisms
- RFs. *See* Release factor proteins
- Rheotaxis, 4:73, 75
- Rheumatoid arthritis, 1:47, 3:112

- Rhincodon typhus*. See Whale sharks  
*Rhizobium*, 3:136  
 Rhizoids of bryophytes, 1:104  
 Rhizomes, 1:29  
 Rhodophyceae, 1:20, 21, 133, 4:22–23  
 Rhynchocephalia, 4:176  
 Rhythm method of birth control, 1:82  
 Rhythms of plant life, 4:69–70, 70  
 Riboflavin, 4:191  
 Ribonuclease, 2:183  
 Ribonucleic acid. See RNA  
 Ribonucleoproteins (RNPs), 3:143  
 Ribose  
   nucleotides, 3:143  
   RNA, 4:76  
 Ribosomal ribonucleic acid. See rRNA  
 Ribosomes, 4:71–73, 71f  
   eukaryotic, 1:121  
   of mitochondria, 3:95  
   nucleoli, 3:142–143  
   protein synthesis, 4:14–19, 76  
 Ribozymes, 2:30, 4:77  
 Ribulose 1,5-bisphosphate. See RuBP  
 Ribulose bisphosphate, 3:199–200  
 Rice, 1:80, 2:153–154, 155, 4:43–44  
 Rickets, 1:95  
 Right brain, 1:101  
 Ringworm. See Tinea  
 Rio de Janeiro Earth Summit, 1:67  
 Riparian zones, 4:74  
 Ripening, of fruits, 2:108, 200  
 River blindness, 3:175–176  
 Rivers, 4:73–75, 74  
 RNA, 4:75–77, 76  
   as antisense nucleotides, 1:41  
   catalytic, 2:30  
   electrophoresis of, 2:15  
   eukaryotic chromosome transcription, 1:144  
   genetic code and, 2:120–122  
   genomes, 2:141  
   hybridization, 2:220–221  
   nuclear transport of, 3:140–141  
   nucleotides and, 3:143–144  
   pollen tube, 4:54  
   processing, 4:77–78, 78f  
   reverse transcriptase and, 4:68–69  
   sequencing of, 1:188  
   transcription and, 4:162–165  
   transposons and, 4:175  
   See also DNA  
 RNA splicing, 4:78  
 RNA viruses, 3:217, 4:66, 77  
 RNPs. See Ribonucleoproteins  
 RNs. See Registered nurses  
 Robertsonian translocations, 1:140  
 Rockweed, 1:21  
 Rocky Mountains, fire regimes in, 2:90  
 Root cortex, 4:79  
 Root hairs, 4:79  
 Root knot nematodes, 3:217  
 Roots, 1:29, 30, 3:210–211, 4:78–81, 79  
   monocots, 3:106  
   pathogens of, 3:217  
   water uptake in, 4:194  
 Rose family, 1:33  
 Rosids, 1:33  
 Rotifers, 1:36  
 Rough endoplasmic reticulum (rER), 2:25–26, 26  
 Roundworms. See Nematodes  
 Roux, Wilhelm, 2:188  
 Rowley, Janet, 3:157  
 Royal Society of London, 3:31  
 Royal Terrell Museum (Alberta, Canada), 2:65  
 rRNA, 1:44–45, 4:76  
   classification systems, 4:153–154  
   DNA sequences and, 1:147  
   genetic code and, 2:120  
   nucleoli and, 3:142–143  
   in ribosomes, 4:71–73  
 r-selected species, 3:234  
 Ru486, 1:83  
 Rubiaceae. See Coffee  
 Rubisco, 1:107–108  
 RuBP in carbon fixation, 1:107  
 RuBP carboxylase. See Rubisco  
 Ruminants, digestion in, 1:218  
 Rural economic development, 1:169  
 Russia  
   agriculture in, 4:183–184  
   boreal forests in, 2:97, 98  
 Rusts (Fungi). See Teliomycetes  
 Rye, 2:154
- S**
- Sabin, Albert, 2:197  
*Saccharomyces cerevisiae*, 1:60, 4:44  
   genome of, 2:215  
   mating in, 4:116  
   wine-making, 4:200  
   See also Yeast  
*Saccharomyces uvarum*, 1:60  
 Sachs, Julius, 2:199  
 Saproterygii. See Fleshy finned fish  
 Safe Drinking Water Act, 3:231  
 Safety in the workplace, 2:169  
 Salamanders. See Caudata  
 Sales representatives, pharmaceutical, 3:192  
 Saliva, in digestion, 1:219  
 Salivary amylase, 1:219  
 Salivary glands, 1:219  
 Salmon life cycle, 3:36, 36–37  
 Salt glands, 3:167  
 Salt marshes, 2:38  
 Salviniaceae, 4:35  
*Sand County Almanac* (Leopold), 2:7  
 Sand dollars, 2:1  
 Sand dunes, 1:201  
 Sands, 4:133  
 Sandy deserts, 1:182  
 Sanger, Frederick, 2:15, 184, 185, 213  
 Sanger method, 2:15  
 Saprobes, 2:110  
 Saprophytes, 3:217  
 Sarcomeres, 3:109, 110  
 Sarcoplasmic reticulum. See Smooth endoplasmic reticulum  
 Sargassum, 1:21  
 Satellite imaging in marine biology, 3:61  
 Satellite telemetry, 2:86  
 Satellites, remote sensing and, 4:46  
 Savannas  
   fire regimes in, 2:89, 90  
   grasslands and, 2:157  
 Sawdust, 4:203  
 Sawmilling, 4:202–203  
 Scaling, 4:81–83  
 Scandinavia, boreal forests in, 2:97  
 Scanning electron microscopes (SEM), 2:11–12  
 Scanning tunneling microscopes, 2:13  
 Scavengers. See Decomposition  
 Scavenging, 2:76  
 Schedules of psychoactive drugs, 4:33  
 Schistosomiasis, 3:174–175  
 Schizocarp, 4:56  
 Schizocoelous development, 1:209  
 Schizophrenia, 3:3, 4:28, 29  
 Schleiden, Matthais, 2:187  
 Schrodinger, Erwin, 4:196  
 Schwann, Theodor, 2:187  
 Science illustrators, 3:65–66  
 Science professors, 1:156  
 Science writers, 4:83  
 Scientific creationism, 1:186  
*Scincus philbyi*. See Skinks  
 Sclera, 2:72

- Sclerenchyma tissue, 1:30, 213, 214–215
- Scopes, John T., 1:185
- Scopes trial (1925), 1:185
- Scopolamine, 4:32
- Scorpions, 1:42
- Scrapie, 4:5
- SDPs. *See* Short-day plants
- SDS-polyacrylamide gelelectrophoresis (SDS-PAGE), 2:15
- Sea anemones. *See* Anemones
- The Sea Around Us* (Carson), 1:117
- Sea cucumbers, 2:1, 2
- Sea level, global warming and, 2:147
- Sea lilies. *See* Echinoderms
- Sea squirts. *See* Urochordata
- Sea stars. *See* Echinoderms
- Sea urchins. *See* Echinoderms
- Seasonal migration, 3:92
- Seaweeds, 3:150–151, 4:22–23  
*See also* Algae
- Sebaceous glands, 4:120
- Secale cereale*. *See* Rye
- Seconal. *See* Barbiturates
- Second law of thermodynamics, 1:1
- Secondary metabolites, 4:84–86, 85*t*
- Secondary plant compounds, 3:223–224
- Secondary plant growth, 3:82
- Secondary structure, of proteins, 4:9
- Secondary syphilis, 4:108
- Secondary temperate forests, 2:100–101
- Secondary tumors, 1:110
- Secretions, as nonspecific defenses, 3:138
- Sedatives, 4:31
- Sedge family, 1:33, 3:106
- Sediment on ocean floors, 3:153–154
- Seed dormancy, 3:209
- Seedless vascular plants, 2:56, 4:88–89  
*See also* Tracheophytes
- Seedlings, 3:209–210, 4:54–55
- Seeds, 3:208, 4:55–56, 90, 89–91  
angiosperms, 1:31  
dispersal of, 2:107–108  
evolution of, 2:57  
feeding on, 2:75  
fires, 2:89  
fruits and, 2:105  
gymnosperms, 2:161–162  
plant propagation, 4:6–7  
*vs.* spores, 4:88  
*See also* Dormancy; Germination
- Segmented worms  
annelids, 1:36–37  
intertidal, 3:150
- Sego lilies, 2:221–222
- Segregation, Law of, 2:127, 128, 3:80, 81*f*
- Selaginellas, 4:34, 35, 89
- Selander, R.K., 3:117
- Selective reduction, 4:60
- Self-assembly, in origins of life, 3:163
- Self-complementarity, 4:71–72
- Self-fertilization, 3:35, 4:58
- Selving. *See* Self-fertilization
- Self-pollination, 4:56
- Self-tolerance in immune responses, 3:4
- SEM. *See* Scanning electron microscopes
- Semelparous life cycles, 3:35
- Semi-arid regions, 1:204
- Semiconservative replication, 4:47–48
- Seminal vesicles, 3:58
- Seminiferous tubules, 3:56–57
- Semmelweis, Ignaz Philipp, 2:197
- Senebier, Jean, 2:198
- Senescence, 1:146–147, 4:91–93, 92
- Sensitivity, to pain, 3:170–171
- Sensitization, 3:26–27
- Sensory neurons, 3:133, 189–191, 4:137–138
- Sensory system, 1:100, 3:7–8, 125, 126, 127–128
- Sepals, 1:32
- Separation of biomolecules, 4:93, 93–94
- Separation of church and state, 1:186
- Separation techniques, 1:232–233
- Sequoias, 1:162
- sER. *See* Smooth endoplasmic reticulum
- Serial endosymbiosis theory (SET), 1:127–129
- Serine proteases, 4:12–13
- Serotinous cones, 2:89
- Serotonin, 4:32, 147
- Serpentes. *See* Snakes
- Sertoli cells, 3:56–57
- Sessile animals, 3:150, 4:179
- SET. *See* Serial endosymbiosis theory (SET)
- Set point, in homeostasis, 2:202
- Sewage  
aquatic communities and, 1:167  
contamination of, 4:26
- Sex change in fish, 4:98
- Sex chromosomes, 1:140, 4:94–96, 95
- Sex determination, 4:95, 97, 96–98
- Sex glands, male, 3:57, 58
- Sex hormones, 2:22  
adrenal cortex and, 1:6  
bone growth and, 1:94
- Sex-linked traits, 3:181
- Sex pilus. *See* F pilus
- Sexual orientation, 1:62
- Sexual plant propagation, 4:6–7
- Sexual reproduction, 4:98–101, 99  
algae, 1:21–22  
alternation of generations, 1:22–24  
angiosperms, 2:57–58, 4:52–53  
animals, 1:34–35  
bryophytes, 2:56  
bryophytes, 1:105–106  
evolution of, 4:101–104, 102  
female reproductive system, 2:77–81  
flowers in, 2:93–94  
fungi, 2:112–114  
insects, 3:9  
life cycles and, 3:35  
male reproductive system, 3:56–59, 58*f*, 59*f*  
pollination and, 3:227–228  
pteridophytes, 4:34
- Sexual selection, 2:49, 4:104–106, 105
- Sexually transmitted diseases (STDs), 1:15–16, 4:106–110, 107, 108
- Shaker potassium ion channels, 3:12
- Sharks, 1:36, 118, 181–182
- Shells  
intertidal animals, 3:150  
mollusks, 3:105
- Sherrington, Charles Scott, 2:197
- Shine-Delgarno sequence, 4:14–15
- Shingles, 4:186
- Shivering, 4:155–156
- Shoots (Plants), 1:29, 31, 3:210–211, 4:110–112, 111
- Short-day plants (SDPs), 3:195–196
- Shredders (Animals), 4:74–75
- Shrimp-brine. *See* Brine shrimp
- Shull, George, 2:182
- Siberia, fire ecology in, 2:89
- Siberian larches, 1:162
- Sibling rivalry, 4:131
- Sickle cell anemia, 1:78, 85
- Sickle cell disease, 3:117, 183–184, 4:13
- Side chains  
amino acids, 1:24–25  
proteins, 1:25



- Sieve tubes, 1:31, 215
- Sight, brain and, 3:128
- Signal recognition particle (SRP), 2:26, 4:21
- Signal transduction, 3:193–194, 4:112–117, 113, 115f
- Signal transduction inhibitor 571 (STI571), 3:157–158
- Signaling, 4:112–117, 113, 115f
- Silent Spring* (Carson), 1:117, 2:28, 3:230–231
- Silk of spiders, 1:43
- Silkworms, 3:177
- Silts, 4:133
- Silurian period, tracheophytes in, 2:55, 56
- Simple epithelium, 2:37
- Simple fruits, 4:56
- Simple life cycles, 3:36
- Simple sugars in origins of life, 3:163
- Simpson, George Gaylord, 2:195
- Singer, Jonathon, 2:184
- Singer, S. J., 3:76
- Single circulation, 1:151
- Single nucleotide polymorphisms (SNPs), 1:62
- Sinsheimer, Robert, 2:213
- Siphons in tunicates, 4:179
- Sipunculida, 1:36
- Skeletal muscles, 3:108–112, 114–115
- Skeletons, 1:108, 109, 4:118, 119f, 118–120
- Skin, 4:120–121, 120f
  - absorption of poisons by, 3:225
  - artificial, 4:174
  - changes in, from aging, 1:8
  - nonspecific defense, 3:138
  - as organ, 3:158
- Skin allografts, 4:172
- Skin cancer, 1:112
- Skin color, 1:77–78
- Skinks, 1:182, 183
- Sleep, 2:160, 4:121–124, 122f, 123f
- Sleep deprivation, 4:123, 124
- Sleep stages, 4:121–123, 122f, 123f
- Slime molds, 3:102, 4:124–126, 125
- Slow wave sleep (SWS), 4:121
- Slugs as plant pests, 3:218
- Small intestine, 1:218, 220
- Small nuclear ribonucleoprotein particles. *See* SNuRPs
- Smallpox, 1:228
- Smallpox vaccines, 4:180
- Smell. *See* Olfaction
- Smoking, health and, 1:110, 4:126–127
- Smooth endoplasmic reticulum (sER), 2:26–27
  - lipids and, 3:48
  - muscles, 3:109, 110
- Smooth muscle, 3:108–109
- Smuts (Fungi). *See* Ustomycetes
- Snags, 2:91
- Snails as plant pests, 3:218
  - See also* Mollusks
- Snakes, 1:36, 4:63
- Snapdragons, 1:33, 2:94, 3:180
- Snow, 2:71, 4:193
- SNPs. *See* Single nucleotide polymorphisms (SNPs)
- SNuRPs (Small nuclear ribonucleoprotein particles), 4:78
- So Human an Animal* (Dubos), 1:234
- Social behavior, 1:65, 4:2, 3, 128, 130, 127–130
- Sociobiology, 1:67, 4:131, 131–132
- Sociobiology: The New Synthesis* (Wilson), 4:131–132
- SOCs. *See* Synthetic organic substances
- Sodium bicarbonate, 3:174
- Sodium ion channels, 3:13
- Sodium-potassium pump, 1:2
- Soft ocean bottoms, 3:153–154
- Soil water, 4:194
- Soils, 4:132–134, 197–198
- Solanaceae, 1:33
- Solanum tuberosum*, 2:44
- Solar system, origins of life and, 3:165
- Solenoids, in DNA compaction, 1:144–145
- Somatic cells
  - 30 nanometer fiber in, 1:144–145
  - telomerase in, 1:146–147
- Somatic mutations, 3:115, 154–155
- Somatic sensory neurons. *See* Sensory neurons
- Somatostatin, artificial production of, 1:80
- Sonography. *See* Ultrasonography
- Sounds, 2:169, 171–173
- South America
  - coffee in, 1:156
  - deserts in, 1:201
  - grasslands in, 2:156
  - history of farming in, 2:181
  - poison dart frogs in, 4:2–3
  - primates in, 4:4
  - savannas in, 2:157
  - upwelling zones in, 3:152
  - von Humboldt, Alexander in, 4:192
- Southeastern United States, 2:99
- Southern blot, 2:14
- Southern boreal forests, 2:97
- Sowbugs, 3:218
- Spallanzani, Lazzaro, 1:205
- Sparkling wines, 4:200
- Spartina* grasses, 2:38
- Spasticity, drugs for, 4:33
- Spawning, 3:194
- Specialists (Medical), 1:229–232, 230, 231t
- Specialized transduction, 1:55, 57
- Speciation, 4:134–136
- Species, 4:136–137
  - competition and, 1:160
  - diversity in, 1:67, 157, 159, 166–167
  - endangered, 2:16–18, 17
  - eusocial, 4:131
  - extinction of, 2:64–67
  - fitness between, 1:4–5
  - fixity of, 2:193
  - habitats of, 2:163–164
  - introduced, 1:168
  - invasive, 3:10–12, 11
  - nomenclature for, 3:47–48
  - See also* Evolution; specific species
  - Species Plantarum*, 3:47–48
- Specific immunity. *See* Immune response
- Speech, 3:3
- Speed, in predators, 4:1
- Spemann, Hans, 1:207–209, 2:132, 133
- Sperm, 3:57–58
  - conception, 2:81
  - fertilization, 1:206
  - testosterone regulation of, 2:22
- Sperm banks, 4:60
- Sperm nuclei, 4:54–55
- Spermatogenesis, 3:56, 57
- Spermatozoa, 3:57
- Spermicides, 1:83
- Sphenophyta, 2:56–57, 4:34, 89
- Spicules, 3:240
- Spiders, 1:36, 42, 43
- Spikelets, 2:155
- Spinal accessory nerve, 1:103
- Spinal cord, 3:128, 4:137–139, 138f
  - brain and, 1:98
  - medulla and, 1:102
  - MRI of, 3:2, 3
  - neurons in, 3:133
  - pain and, 3:170–171
  - part of CNS, 1:134

- Spinal cord (continued)  
 peripheral nervous system and, 3:189
- Spinal cord injuries, 3:129
- Spinal nerves, 3:128
- Spinal taps, 3:131
- Spiny dogfish sharks, 1:118
- Spiral cleavage, 1:209
- Spirulina*, 1:22, 3:206
- Spleen, 3:54
- Splenectomy, 3:54
- Sponges. *See* Porifera
- Spongins, 3:240
- Spongy bone, 1:93
- Spontaneous generation, 3:24, 177
- Sporozoa. *See* Apicomplexa
- Spores  
 bacterial, 2:41  
 bryophytes, 1:104  
 fungal, 2:110  
 pteridophytes and, 4:33–35  
*vs.* seeds, 4:88  
 slime molds, 4:125
- Sporic meiosis, in algae, 1:21–22
- Sporophytes, 4:52–53, 88–89  
 alternation of generations, 1:22–24  
 animals, 1:34  
 bryophytes, 1:105–106
- Sporopollenin, 4:54
- Sporotrichosis, 2:109
- Spot fires, 2:90
- Spurge family, 1:33
- Squalus acanthias*. *See* Spiny dogfish sharks
- Squamous cells, 2:37
- Squid brain, 3:127
- SRP. *See* Signal recognition particle
- St. John's wort, 2:176
- Stability, of communities, 1:159
- Stahl, Frank, 4:48
- Stains in microscopic tissue preparation, 3:39
- Stamens, 1:32, 2:93, 4:53–54
- Standards for organic farming, 3:161
- Stanozolol, 1:28
- Stapes, 2:171
- Staphylococcus aureus*, 2:50
- Star anise, 1:32, 33
- Starch as polysaccharide, 1:113
- Starfish. *See* Echinoderms
- Starling, Ernest, 2:197
- Station for Experimental Evolution (New York), 2:182
- Statistical analysis, 3:148
- STDs. *See* Sexually transmitted diseases
- Ste5, 4:116
- Ste12, 4:116
- Ste20 kinase, 4:116
- Stebbins, George Ledyard, 2:195
- Steel, *vs.* wood, 4:201
- Stein, William, 2:183
- Stems, plant, 1:29, 4:110–112
- Stenohaline organisms, 3:166
- Stenophagous animals, 2:74
- Steppes. *See* Temperate grasslands
- Stereocilia, 2:171
- Stereom, 2:1
- Stereomicroscopes, 3:41
- Sterility in medicine, 2:197
- Steroids, 2:20, 204–205  
 adrenal cortex, 1:6  
 plant, 2:208
- Stevens, Nettie Maria, 4:94, 98
- STI571. *See* Signal transduction inhibitor
- Stigma (Flowers), 2:93, 4:54
- Stimulants, 4:31
- Stimulating growth factors, 3:112
- Stingrays, 1:118
- Stink bugs, 3:218
- Stoma of leaves, 3:29
- Stomach, 1:220, 3:158
- Stomata, 1:29–30, 2:199, 4:112  
 abscisic acid and, 2:207  
 evolution of, 2:56  
 of leaves, 3:29  
 plant water regulation, 4:195
- Stop codons, 2:130, 3:117, 4:17–18
- Stramenopiles, 4:22
- Stranglers, in tropical forests, 2:101
- Stratified epithelium, 2:37–38
- Strawberries, 2:105, 106
- Streams, 4:73–75
- Strepsirrhini, 4:4
- Streptococcus*, 1:49, 117  
*Streptococcus pneumoniae*, 1:57  
*Streptococcus pyogenes*, 1:51
- Stress, adrenal medulla, 1:7
- Stress fibers, 1:194
- Stress management, 2:168
- Stress response, 4:139–141, 140*f*
- Striations in muscle, 3:108–109
- Strokes, 1:116, 3:129
- Stroma, 1:137, 3:197–198
- Structural complementarity, 4:10–11
- Structural lipids, 3:49
- Structure of landscape, 3:24–25
- Structure determination, 4:141–142
- Structured populations, 3:233
- Studies on the Generation of Animals* (Harvey), 2:166
- Sturtevant, Alfred H., 2:191, 3:44–45
- Sty (Eye), 2:73
- Style (Flowers), 2:93
- Subarachnoid space, 1:98
- Subcultivation, in cell cultures, 1:122–123
- Subcutaneous mycoses, 2:109
- Sublingual glands, 1:219
- Submandibular glands, 1:219
- Substance abuse, 4:29–30
- Subterranean lizards, 1:182
- Succession  
 ecology, 2:5  
 species, 1:159
- Sucrose, 1:113
- Suction-feeding worms. *See* Aphanoneura
- Sugar  
 cane (*See* Sucrose)  
 milk (*See* Lactose)
- Sugar maple forests, 2:90
- Sugarcane, 2:155
- Sugars  
 chloroplasts and, 1:137  
 nucleotides, 3:144  
 translocation of, 4:169–171
- Sugimura, Takashi, 3:117
- Sulci, 1:99
- Sulfur in biogeochemical cycles, 1:67
- Sulfur 35, 4:38
- Sulfur trioxide, 3:228–229
- Sumner, James, 2:183
- Sunlight energy, 2:10
- Superior vena cava, 2:173
- Superorganism, 2:5, 6
- Superstitions in medical history, 2:196
- Suppressor T cells, 4:149
- Supraoptic nucleus, 2:224
- Supraventricular bradycardia, 1:115
- Supraventricular tachycardia, 1:115
- Surfactant, fetal, 2:84
- Surfbirds, 3:93
- Surgery  
 anesthesia and, 2:197  
 birth control, 1:83  
 cancer, 1:112  
 illustrations of, 3:66
- Surrogate mothers, 4:62
- Survival of the fittest, 1:4–5, 2:47, 49  
 biogeography, 1:70  
 natural selection and, 3:123–124
- Suspension feeding, 2:75–76, 3:150, 153

- Sustainable development  
 agriculture, 1:10–11  
 conservation, 1:166  
 tropical forests, 2:104
- Sutherland, Earl, 2:197
- Sutton, Walter, 2:188
- Swammerdam, Jan, 3:30
- Swazambhunath River, 1:167
- Sweat glands, 3:203, 4:120–121
- Sweating, 4:155
- Swim bladders, 1:95
- Swimming, 3:51
- SWS. *See* Slow wave sleep
- Symbiosis, 3:235
- Symbiosis, 4:142–145, 143  
 angiosperms, 1:34  
 bacteria and eukaryotes, 2:42–43  
 bacteria and plants, 3:136–137, 137, 4:144  
 for feeding, 2:76  
 plant roots and, 4:80  
 pollination, 3:227  
*See also* Mycorrhizae; Parasitism
- Sympathetic nerves, 3:190–191, 4:139
- Sympathetic nervous system, 2:22  
 hyperglycemic role of, 3:89  
 thermoregulation, 4:155
- Sympatric speciation, 4:135–136
- Symptoms  
 neurologic diseases, 3:130  
 schizophrenia, 4:29  
 sexually transmitted diseases (STDs), 4:107–109
- Synapormorphies, 4:63
- Synapses, 1:98, 3:131, 133, 4:146, 147f, 148
- Synaptic cleft, 3:109, 110
- Synaptic transmission, 4:145–148, 147f
- Synaptonemal complex, 3:68
- Synergids, 3:228, 4:54–55
- Synergists, muscles as, 3:114
- Synoptical Flora of North America* (Gray), 2:158
- Synthetic evolutionary theory. *See* Neo-Darwinism
- Synthetic opiates, 4:32
- Synthetic organic substances (SOCs), 3:228, 229–230
- Syphilis, 4:107–108, 108
- Systema Naturae* (Linnaeus), 4:152
- Systematics, 1:76
- Systemic circuit, 1:151
- Systemic circulation, 2:172–175
- Systemic gas exchange, 4:66
- Systemic lupus erythematosus, 1:47
- Systemic mycoses, 2:109
- Systems ecology, 2:6
- Systole, 2:174
- T**
- T cells, 1:40, 4:148–151, 149, 150f  
 activated, nuclear factor of, 1:178–179  
 in autoimmunity, 1:47–48  
 exocytosis and, 2:63–64  
 in immune response, 3:4–6  
 in thymus, 3:54
- T lymphocytes. *See* T cells
- T phages, 1:59
- T4 cells. *See* Helper T cells
- T8 cells. *See* Cytotoxic T cells
- Tachycardia, 1:115
- Tachyglossidae. *See* Anteaters
- Taenia solium*, 3:175
- Taiga, 2:97
- Tamarins, 4:5
- Tangled bank hypothesis, 4:103
- Tanning (Skin), 4:120
- Tannins, 4:85
- Tansley, Arthur, 2:6
- Tapetum, 4:54
- Tapetum lucidum, 2:73
- Tapeworm infections, 3:222
- Tapeworms. *See* Cestodes
- Taphonomy, 3:173
- Taproots, 4:80
- Taq*, 3:232
- Tarsiers, 4:4
- Taste. *See* Gustation
- Tatum, Edward, 1:53–54
- Taxonomy  
 of bacteria, 2:42  
 fungi in, 2:109  
 history of, 4:151–154, 153  
 protists and, 4:21–22  
 protozoans and, 4:23–24  
*See also* Classification
- Tay-Sachs disease, 1:78, 2:140
- Teachers, college. *See* College professors
- Teachers, high school biology, 2:180
- Tear glands, 2:73
- Tectonic plates, lakes and ponds and, 3:21
- Teeth in digestion, 1:219
- Tegmentum, 1:102
- Tegner, Mia, 3:42
- Telencephalon, 3:128
- Teliomycetes, 2:113
- Telomerase, 1:123, 146–147, 4:51f, 52
- Telomeres, 1:123, 145–147, 4:52
- Telophase, 3:100
- TEM. *See* Transmission electron microscopes
- Temin, Howard, 4:68
- Temperate bacteriophages, 1:58
- Temperate estuaries, 2:38
- Temperate forests, 2:89–90, 100, 99–101
- Temperate grasslands, 2:156
- Temperature  
 adaptations to, 3:202–203  
 boreal forests, 2:97  
 enzymes and, 2:32–33, 33f  
 extreme communities, 2:69–70  
 global changes in, 2:145–148  
 perception of, 4:161  
 sex determination, 4:98  
 water, 3:21  
*See also* Body temperature
- Temporal lobe, 1:99, 100
- Ten percent law, 2:10
- Tendons, 3:112
- Teosinte, 2:181
- Teratogens, 3:115
- Terpenes, 3:49, 4:84
- Terpenoids, 2:178
- Terrapins, 4:179
- Terrestrial animals  
 locomotion by, 3:52  
 osmoregulation in, 3:166
- Terrestrial biomes, 1:79
- Terrestrial vertebrates  
 amphibians, 1:26–27  
 gas exchange in, 2:116–117, 116f  
 tuataras, 4:176  
 turtles, 4:179  
*See also specific vertebrates*
- Territorial behavior, 1:65
- Tertiary structure of proteins, 4:10
- Tertiary syphilis, 4:108
- Testa, 4:55
- Testes, 3:56–57
- Testosterone, 3:56–57  
 anabolic steroids, 1:27–28  
 behavioral effects of, 1:63  
 sex determination, 4:98  
 sperm regulation, 2:22
- Tetracycline, 4:16
- Tetrads, 4:54
- Tetraiodothyronine, 4:158
- Tetraploids, 1:141
- Tetrodotoxin, 3:14
- TGN. *See* Trans-Golgi network
- Thalamus, 1:102, 3:128
- Thalassemia, 1:78, 4:77

- Thecodonts, **1:81**
- Theistic evolution, **1:185**
- Theoretical ecology, **4:157–158**
- Theories of aging, **1:8–10**
- Theory of evolution. *See* Evolution
- Therapsids, **3:108**
- Thermal stratification, **3:21**
- Thermodynamics, second law of. *See* Second law of thermodynamics
- Thermogenesis, **4:155–156, 158**
- Thermoperception, **4:161**
- Thermus aquaticus*, **2:70, 3:232**
- Thermophiles, **2:42**
- Theropod dinosaurs, **1:81**
- Thiamin, **4:191**
- Thigmotropism, **4:175, 176**
- Thoracic cavity, **1:92, 4:64–65**
- Thoreau, Henry David, **1:166, 2:5, 3:21**
- Thorny devil lizards, **1:182**
- Thought, **3:3**
- Threat displays, **1:65**
- Threatened species, **2:16**
- Thrips, **3:218**
- Thrombin, **1:87**
- Thrombosis, **1:86**
- Thrust, **2:109**
- Thylakoid membranes, **3:197–198**
- Thylakoids, **1:137**
- Thymine, **3:143–144**
- Thymus, **3:54**
- Thyroid glands, **2:21, 21–22, 4:158–159, 159**
- Thyroid hormone, **2:21–22**
- Thyroxine, **2:21, 204–205, 4:158**
- Ticks, **1:42, 3:176**
- Tight junction, **2:37, 3:73**
- Tight junctions, **1:129, 3:221**
- TIGR. *See* The Institute for Genomic Research
- Timber, **4:201**
- Timber conversion, **4:202**
- Tinbergen, Nikolas, **1:63, 2:85–86**
- Tinea, **2:109**
- Tissue culture, plant. *See* Micropropagation
- Tissue Culture Association, **3:240**
- Tissue cultures, **3:39–40**
- Tissue factor, **1:86–87**
- Tissue plasminogen activator (t-PA), **1:87**
- Tissue thromboplastin. *See* Tissue factor
- Tissue transplantation, **4:172**
- Tissues, **4:159–160**  
*See also specific types of tissue*
- TMR. *See* Total metabolic rate
- Toads. *See* Frogs
- Tobacco. *See* Nicotine
- Tobacco plant. *See* *Nicotiana tabacum*
- Toenails, **4:120**
- Tonegawa, Susumu, **2:120**
- Tonoplast, **4:182–183**
- Tonsillectomy, **3:54**
- Tonsils, **3:54**
- Tools with *Homo ergaster*, **2:211**
- Torpor, **3:202**
- Torrey, John, **2:158, 4:160–161**
- Torrey Botanical Society, **4:160**
- Torreya*, **4:160**
- Tortoises, **4:179**
- Total metabolic rate (TMR), **3:88**
- Totipotency, **3:213–214**
- Touch, **4:161, 161–162**  
insects, **3:8**  
thigmotropism and, **4:175**
- Toxins, **3:224**  
environmental, **3:129**  
ion channels, **3:14**  
plant, **3:223–224, 4:84**
- Toxoplasma gondii*, **4:22, 26**
- Toxoplasmosis, **4:26–27**
- t-PA. *See* Tissue plasminogen activator (t-PA)
- Tracheae, **3:9, 4:64**
- Tracheids, **1:31, 4:194–195**
- Tracheophytes, **2:55, 3:208**
- Trachoma, **4:108**
- Trade-off in life cycles, **3:34–35**
- Traditional medicine, **2:40**
- Training. *See* Education and training
- Trans-Golgi network (TGN), **2:152–153**
- Transactivation. *See* Transcriptional activators
- Transcription, **1:223, 4:76, 77, 164f, 165f, 162–165**  
of cyclin genes, **1:126**  
eukaryotics, **1:144–145, 172–177, 174**  
nuclei, **3:146–147**  
nucleoli and, **3:142–143**  
oncogenes and, **3:156**  
prokaryotes, **1:170–172, 172**  
retroviruses, **4:67**
- Transcription, genetic. *See* Genetic transcription
- Transcription factors, **1:173, 178–179, 3:84**
- Transcriptional activators, **1:171, 173–175**
- Transcriptional attenuation, **1:171–172**
- Transcriptional repression, **1:176**
- Transdifferentiation, **1:217**
- Transduction  
in bacteria, **1:53, 55, 57**  
signal, **4:112–117**
- Transfer ribonucleic acid. *See* tRNA
- Transformation in bacteria, **1:53, 57**
- Transfusions. *See* Blood transfusions
- Transgenic organisms, **1:154, 2:182, 3:103, 4:43–44**
- Transgenic techniques, **4:167–168**
- Transition state, **2:31–32**
- Transitional epithelium, **2:38**
- Translocation, **1:140, 2:26, 199, 4:168–171, 170f**  
leaves, **3:29**  
Philadelphia chromosome and, **3:157**
- Transmission electron microscopes (TEM), **2:11**
- Transmutationism, **2:193–194**
- Transpiration, **2:199, 4:194–195**
- Transplant medicine, **2:197, 4:172–174, 172t, 173**
- Transportation, plant, **2:199**
- Transporters, membrane, **3:78–79, 96–97**
- Transposable elements. *See* Transposons
- Transposition, **3:64**
- Transposons, **4:174–175**
- Transverse nerves, **3:127**
- Treatment  
for AIDS, **1:16–17**  
for alcoholism, **1:20**
- Trees, **1:33**
- Trematode infections, **3:222**
- Trematodes, **3:222**
- Tremella*, **2:111**
- Treponema pallidum*, **4:107–108**
- Triassic period  
tuataras in, **4:176**  
turtles in, **4:179**
- Tricarboxylic acid cycle. *See* Krebs cycle
- Trichomes, **1:213, 215–216**
- Trichomonas*, **4:22**
- Trichomonas vaginalis*, **4:109**
- Trichomoniasis, **4:109**
- Trichomycetes, **2:113**
- Tricolpates. *See* Eudicots
- Tricuspid valve, **2:174**
- Trigeminal nerve, **1:102**
- Triglycerides, **3:48**
- Triiodothyronine, **2:21, 4:158**
- Trilobites. *See* Arthropods
- Trimerophytes, **2:57**
- Trimers, **2:68**

- Triple therapy for AIDS, 4:68  
 Triploid endosperm, 4:54  
 Triploids, 1:142  
 Trisomies, 1:139–140  
 Trisomy 13, 1:139–140  
 Trisomy 18, 1:139–140  
*Triticale*, 1:142  
*Triticum sativum*. *See* Wheat  
 Tritium, 4:38  
 tRNA, 1:45, 4:76, 166f, 166–167  
   genetic code and, 2:120, 129, 130  
   of mitochondria, 3:95  
   protein synthesis, 4:13, 14–18  
   ribosomes and, 4:71–72  
 Trochlear nerve, 1:102  
 Trophic levels, 2:8–9  
 Trophoblast, 2:82  
 Tropical diseases, 2:147  
 Tropical estuaries, 2:38  
 Tropical forests, 2:101–104, 102, 103  
 Tropical grasslands, 2:156  
 Tropisms, 2:207, 4:175–176  
 Tropomysin, 3:110  
 Troponin, 3:110  
 trp operon. *See* Tryptophan operon  
*Trypanosoma*, 4:22, 25, 26  
 Trypanosomiasis. *See* African sleeping sickness  
 Trypsin, 1:181, 218, 3:174  
 Trypsinogen, 1:181  
 Tryptophan operon, 1:171  
 Trysin, 1:181  
 TS genes. *See* Tumor suppressors  
 Tsetse flies, 4:26  
 Tuataras, 4:176–177, 177  
 Tubal ligation, 1:83  
 Tuberculosis vaccination, 1:234  
 Tubers, 1:29  
 “Tumble and run,” 1:131–132  
 Tumor suppressors, 1:111, 3:155  
 Tumors, 1:110, 3:2  
 Tundra, 4:177–178  
 Tunicates, 1:36, 4:178, 178–179  
 Turbellaria, 3:222  
 Turnover of cellular materials, 3:86–87  
 Turtles, 4:98, 179–180  
 Tympanic duct, 2:171  
 Tympanic membrane. *See* Eardrum  
 Type I diabetes. *See* Insulin-dependent diabetes  
 Type II diabetes. *See* Noninsulin-dependent diabetes  
 Typhus, 3:176  
 Tyrocidine, 1:234  
 Tyrosine, 4:158  
 Tyrosine kinase, 3:157  
 Tyrothricin, 1:234
- U**
- Ubiquinone, 3:168–169  
 Ubiquitin, 4:19  
 Ultracentrifugation, 4:94  
 Ultrasonography, 2:84, 3:1  
 Ultraviolet light, 4:120, 190  
 Ultraviolet radiation, 2:71  
*Uma* lizards, 1:183  
 Umbilical cord, 2:82  
 Uniformitarianism, 1:198  
 Unipolar neurons, 3:133  
 United States, 2:99  
   coral reefs in, 1:184  
   population growth in, 2:219  
   *See also* North America  
 University professors. *See* College professors  
 Unstructured populations, 3:233  
 Upwelling zones, 3:152  
 Uracil, 3:143–144, 4:76  
 Urbanization, 2:28  
 Urethra  
   female, 2:77  
   gonorrhoea and, 4:107  
   male, 3:58  
 Urethritis, 4:108  
 Urey, Harold, 3:163  
 Uric acid, 3:191  
 Urinalysis, 1:232, 233  
 Urine, 2:60, 61  
   kidneys and, 3:16  
   osmoregulation, 3:167  
 Urochordata, 1:138, 4:179  
 U.S. Bureau of the Census, 3:234  
 U.S. Department of Agriculture, 2:214  
 U.S. Department of Energy (DOE), 1:71–72, 2:213  
 U.S. Department of Health and Human Services (HHS), 2:168  
 U.S. Food and Drug Administration  
   artificial skin, 4:174  
   clinical trials, 1:151  
   herbal medicine, 2:176  
 U.S. Patent and Trademark Office, 2:216  
 USDA. *See* U.S. Department of Agriculture  
 Ustomycetes, 2:113  
 Uterine tubes. *See* Fallopian tubes  
 Uterus, 2:77  
 Utricles, 4:56
- V**
- Vaccinations, 4:180  
   immune response and, 3:6  
   Pasteur, Louis and, 3:177, 4:182  
 Vaccines, 2:197, 4:180–182, 181f  
 Vacuoles, 1:122, 4:182–183  
 Vagina, 2:77  
 Vagus nerve, 1:103  
 Valium. *See* Benzodiazepines  
 Valve disorders, 1:116–117  
 Valves in veins, 1:91  
 van der Waals bonds, 4:11  
 van Helmont, Jan, 2:198, 199, 4:183  
 van Neil, C.B., 2:200  
 Variable regions, of antibodies, 1:39–40  
 Variation, genetic. *See* Genetic variation  
 Varicella-zoster virus, 1:228  
 Varicose veins, 1:91  
 Vas deferens, 3:58  
 Vascular plants. *See* Tracheophytes  
 Vascular tissue, 1:30–31, 212, 213, 215, 3:106  
 Vasectomy, 1:83  
 Vasoconstriction in thermoregulation, 4:155  
 Vasodilators, alcohol as, 1:19  
 Vavilov, Nikolay, 4:183, 183–184  
 Vectors  
   DNA cloning, 4:40–42, 44  
   parasites as, 3:176  
*Vegetable Statics* (Hales), 2:199  
 Vegetative propagation, 4:6–7, 58–59  
 Vegetative shoots, 4:110–112  
 Veins, 1:89, 91  
   circulatory systems, 1:151  
   leaves, 3:29–30  
 Velds. *See* Temperate grasslands  
 Venter, J. Craig, 2:215  
 Ventilation, pulmonary, 4:64–65  
 Ventricles, 1:98, 99, 2:174  
 Ventricular bradycardia, 1:115  
 Ventricular tachycardia, 1:115  
 Ventromedial nucleus (VMN), 2:225  
 Vernix caseosa, 2:84  
 Vertebrate zoology, 4:204  
 Vertebrates, 1:36  
   brain in, 1:97  
   as chordates, 1:138  
   chromosome changes in, 1:141  
   circulatory systems of, 1:150, 151  
   CNS in, 1:134  
   common development in, 1:211–212, 2:52  
   echinoderms and, 2:2

- Vertebrates (continued)
- excretory system in, 2:61
  - eyes in, 2:73
  - flight in, 2:92
  - growth in, 2:159
  - hypothalamus in, 2:222–225
  - immune response in, 3:4
  - kidneys of, 3:15–16
  - lakes and ponds, 3:23
  - nervous systems of, 3:125, 127–128
  - oceans, 3:152
  - osmoregulation in, 3:165–167
  - phagocytes in, 3:138–139
  - poisonous plants and, 3:224
  - reproduction in, 3:35
  - skeletons of, 4:118
  - vision in, 4:189–190
  - See also specific vertebrates*
- Vertical transmission, 1:53
- Very-low-density lipoproteins (VLDL), 4:12
- Vesalius, Andreas, 4:184–185
- Vessel elements, 1:31, 216–217
- Vessels, plant, 4:194–195
- Vestibular duct, 2:171
- Vestibule, 2:171
- Vestibulocochlear nerve, 1:103, 2:172
- Vestiges of the Natural History of Creation* (Chambers), 2:194
- Vestigial organs, 2:53
- Veterinarians, 4:185, 185–186
- Veterinary Medical Doctor (VMD), 4:185
- Viceroy butterflies, 3:94
- Vimentin, 1:196
- Vineyards, 4:200
- Viral diseases, 4:186–187
- plants, 3:217, 218
  - sexually transmitted, 4:109
- Virchow, Rudolf, 2:188, 197
- Virginia opossum, 3:62
- Virions, 1:227, 4:187
- Viroids, 2:141
- Virology, 3:219
- Virulent bacteriophages, 1:58
- Viruses, 2:197, 4:186, 187
- carcinogenic, 1:110
  - DNA, 1:227–228
  - genomes of, 2:141
  - Immune system, 1:14–15
  - See also Bacteriophages; specific viruses*
- Visceral sensory information, 3:189
- Vision, 4:188, 189, 188–190
- Visual adaptation, 4:189
- Visual pigment, 4:189
- Visual processing, 3:128
- Vitamin A, 2:154, 4:43–44, 190–191
- Vitamin B complex, 4:191
- Vitamin B<sub>6</sub>, 4:191
- Vitamin B<sub>12</sub>, 4:191
- Vitamin C, 3:185, 4:191
- Vitamin C and the Common Cold* (Pauling), 3:185
- Vitamin D, 4:191
- Vitamin D deficiency, 1:95
- Vitamin deficiencies, 4:190
- Vitamin E, 4:191
- Vitamin K, 4:191
- Vitaminosis, 4:190
- Vitamins, 2:218, 4:190–192
- Vitis vinifera*, 4:200
- Vitreous humor, 2:73
- VLDL. *See* Very-low-density lipoproteins
- VMD. *See* Veterinary Medical Doctor
- VMN. *See* Ventromedial nucleus
- VOCs. *See* Volatile organic compounds
- Voice box. *See* Larynx
- Volatile organic compounds (VOCs), 3:230
- Volcanoes, lakes and ponds from, 3:21
- Voltage, ion channels and, 3:13–14
- Voltage-gated ion channels, 3:12–14
- Voltage gradients. *See* Electrical gradients
- Volterra, Vito, 2:6, 4:157
- Volvox*, 4:23
- von Baer, Karl, 1:206, 211, 211–212
- von Baer's law, 1:206
- von Humboldt, Alexander, 2:5, 4:192
- W**
- Waelsch, Salome, 2:134
- Waksman, Selman, 1:233
- Walden Pond, 3:21
- Walker, John, 2:185
- Wallace, Alfred Russel, 1:197, 198–199, 2:47, 52, 194
- Wallin, Ivan, 1:127
- Warburg, Otto, 2:183
- Warming, Eugene, 2:5
- Warning coloration, 3:94
- Wasps. *See* Hymenoptera
- Waste wood products, 4:203
- Water, 4:192–193
- acquisition of, in deserts, 1:201–202
  - balance in, 3:165–168
  - exclusion of, 2:32
  - fresh, 3:21, 42
  - frozen, environments of, 2:71
  - locomotion in, 3:51
  - as nutrient, 2:218
  - photosynthesis, 3:198
  - plant growth, 4:183
  - plant roots and, 4:78–80
  - pollination by, 3:227
  - retention of, 1:202
  - solar system, 3:165
  - transport in plants, 1:29–30, 31
- Water cycle, 4:193
- Water expulsion vesicles. *See* Contractile vacuoles
- Water lilies, 1:32, 33
- Water molds, 1:133, 4:22
- Water movement in plants, 4:193–195, 194
- Water pollution, 3:135
- Water potential, 4:194
- Water quality, 4:198
- Water-soluble vitamins, 4:191
- Water supply, 3:42
- Water temperature, 3:21
- Water vapor, 4:193
- Waterlogging, 4:197
- Watson, James, 1:187, 222, 2:128–129, 185, 191, 198, 4:196, 196–197
- DNA replication, 4:47
  - Human Genome Project, 2:214
  - McClintock, Barbara, 3:64
- Watson-Crick DNA model, 1:187, 4:196
- Waxes, from fatty acids, 3:49
- Weapons, biological. *See* Biological weapons
- Weather patterns. *See* Meteorology
- Weed control, 3:159–161
- Weeds, 2:156
- Weinberg, Wilhelm, 2:48, 164, 3:235
- Weiner, Jonathan, 2:53
- Weinert, Ted, 1:125
- Weismann, August, 2:117, 190
- Wellness, 2:167
- Welwitschia*, 1:32, 2:59, 163
- West coast (U.S.), 2:99
- West Nile virus, 2:27
- Western blot, 1:38, 2:15
- Western United States, 2:99
- Wet meadows, 4:197
- Wetlands, 4:197–199, 198
- Whale sharks, 1:118
- WHCNPs. *See* Women's health care nurse practitioners

- Wheat, 1:142, 2:154, 155  
 Wheat stem rust, 3:217  
 Whip-tailed lizards, 4:97  
 White blood cells  
   connective tissue, 1:164–165  
   immune responses, 3:4  
 White matter, 1:98, 4:138  
 “The White Plague” (Dubos), 1:234  
 White rice, 2:153  
 White sharks, 1:118  
 White wines, 4:200  
 Whitehead Institute (Cambridge, MA), 1:72  
 Whittaker, Robert, 2:109, 3:17, 4:153  
 WHO. *See* World Health Organization  
 Wieschhaus, Eris, 3:102  
 Wildebeest, 2:157  
 Wilderness area conservation, 1:67  
 Wildlife  
   boreal forests, 2:98  
   fire and, 2:91  
   temperate forests, 2:99–100  
 Wildlife biologists, 4:199, 199–200  
 Wildlife conservation, 2:87  
 Wildlife management, 4:200  
 Wildlife reserves, 2:17  
 Wilkins, Maurice, 1:187, 4:196  
 William, Anna Wessels, 1:52  
 Williams, George, 4:103  
 Willow ptarmigan, 1:4, 5  
 Wilmot, Ian, 1:154  
 Wilson, Edmund B., 2:188  
 Wilson, E.O., 1:67, 4:131, 131–132  
 Wind  
   pollination by, 3:227, 4:58  
   temperate forests, 2:99  
 Windpipe. *See* Tracheae  
 Wine-making, 4:200  
 Winged samara, 4:56  
 Wings  
   bird and bat, 2:92  
   insect, 2:92, 3:9  
   locomotion, 3:51–52  
 Wisk ferns. *See* Psilotopsida  
 Witches’ butter, 2:111  
 Woese, Carl, 1:44, 45–46, 4:153–154  
 Wolff, Kaspar Friedrich, 1:206  
*Wolffia*, 2:94  
 Wolpert, Lewis, 2:134  
 Women’s health care nurse practitioners (WHCNP), 3:149  
*Wonderful Life* (Gould), 1:108  
 Wood as cellulose, 1:114  
 Wood and wood products, 4:201, 201–203  
 Wood composites, 4:203  
 Wood panels, 4:203  
 Wood sorrel, 4:69, 70  
 Worksite Health Promotion, 2:167  
 World Health Organization (WHO), 2:28  
   epidemiologists at, 2:36  
   health definition, 2:167, 168  
 World population, 2:219–220  
 World War II, biological weapons in, 1:74  
 Worms  
   aquatic, 3:125  
   nervous systems in, 3:126–127, 127f  
   parasitic, 3:174–176, 175  
   *See also* Annelids  
 Wounds, blood clotting for, 1:86  
 Wright, Sewall, 2:49, 3:236  
 Writers, science, 4:83
- X**  
 X chromosomes, 1:146, 3:181, 4:94–98  
   aberrations in, 1:140  
   heterochromatinization of, 1:147  
   mammals, 1:141  
   mutations in, 3:188  
   repression of, 1:224  
 X ray crystallography, 1:143–144, 4:141  
 X rays, 1:110, 3:1  
 Xanax. *See* Benzodiazepines  
 Xenografts. *See* Heterografts  
*Xenopus laevis*, 3:102  
 XET. *See* Xyloglucan endotransglycosylase  
 X-linked disorders, 2:139, 3:188, 4:95, 96–97  
 X-Y regression, 4:81–82  
 Xylem, 1:29–31, 213, 215  
   functions of, 4:110  
   leaves, 3:29  
   plant roots, 4:80  
   plant water movement, 4:194–195  
   tracheophytes, 2:55  
   translocation and, 4:169
- Xyloglucan endotransglycosylase (XET), 3:211–212  
 Xyloglucans, 1:133
- Y**  
 Y chromosomes, 1:72, 140, 146, 3:181, 4:94–98  
 YACs. *See* Yeast artificial chromosomes  
 Yalow, Rosalyn Sussman, 1:39  
 Yeast artificial chromosomes (YACs), 1:154, 4:44  
 Yeast infections, 2:109, 4:110  
 Yeasts, 3:102, 4:116–117  
 Yellow fever, 2:147  
 Yellow River region (China), 2:181  
*Yersinia pestis*, 2:43  
 Yews, 1:162  
 Yolk sac, 1:26
- Z**  
 Zahavi, Amotz, 4:106  
*Zea mays*. *See* Corn  
 Zebra mussels, 3:10–11  
 Zebrafish, as model organisms, 3:101–102  
 Zebras, 2:157  
 Zeiss, Carl, 3:39  
 ZIFT. *See* Zygote intrafallopian transfer  
 Zinc finger motif, 4:10  
 Zinder, Norton, 1:55  
*Zinjantbropus*. *See* *Australopithecus boisei*  
 Zona fasciculata, 1:6  
 Zona glomerulosa, 1:6  
 Zona reticularis, 1:6  
 Zonula adherens. *See* Adherens junctions  
 Zonula occludens. *See* Tight junctions  
 Zoologists, 4:204–205  
 Zoology, 4:204  
 Zoology researchers, 4:204–205, 205  
 Zooplankton, 3:23, 206  
 Zoos, 1:169, 2:17  
 Zygomycota, 2:113, 3:120  
 Zygote intrafallopian transfer (ZIFT), 4:61  
 Zygotes, 1:206, 2:82  
   animal reproduction, 1:34  
   human, 3:32  
 Zygotic meiosis in algae, 1:21  
 Zymase, 2:183  
 Zymogens, 1:181