

**NUTRIENT DIGESTION AND
UTILIZATION IN FARM ANIMALS
MODELLING APPROACHES**

This book is dedicated to the memory of Dr A.B. Robson, Centre for Computing and Biometrics, Lincoln University, New Zealand, and co-organizer of the Third Workshop. Bruce died suddenly on 25 October 2000 aged only 55. He is very much missed by his many friends and colleagues.

NUTRIENT DIGESTION AND UTILIZATION IN FARM ANIMALS MODELLING APPROACHES

Edited by

E. Kebreab

*University of Guelph
Canada*

J. Dijkstra

*Wageningen University
The Netherlands*

A. Bannink

*Wageningen University
The Netherlands*

W.J.J. Gerrits

*Wageningen University
The Netherlands*

and

J. France

*University of Guelph
Canada*

CABI Publishing

CABI Publishing is a division of CAB International

CABI Publishing
CAB International
Wallingford
Oxfordshire OX10 8DE
UK

CABI Publishing
875 Massachusetts Avenue
7th Floor
Cambridge, MA 02139
USA

Tel: +44 (0)1491 832111
Fax: +44 (0)1491 833508
E-mail: cabi@cabi.org
Website: www.cabi-publishing.org

Tel: +1 617 395 4056
Fax: +1 617 354 6875
E-mail: cabi-nao@cabi.org

© CAB International 2006. All rights reserved. No part of this publication may be reproduced in any form or by any means, electronically, mechanically, by photocopying, recording or otherwise, without the prior permission of the copyright owners.

A catalogue record for this book is available from the British Library, London, UK.

Library of Congress Cataloging-in-Publication Data

International Workshop on Modelling Nutrient Utilization in Farm Animals
(6th: 2004: Wageningen, the Netherlands)
Nutrient digestion and utilization in farm animals: modeling approaches / edited
by E. Kebreab...[*et al.*].

p. cm.

Includes bibliographical references.

ISBN-13: 978-1-84593-005-9 (alk. paper)

ISBN-10: 1-84593-005-3 (alk. paper)

1. Ruminants--Feed utilization efficiency--Mathematical models--Congresses.

Animal nutrition--Mathematical models--Congresses. I. Kebreab, E. II. Title.

SF95.I688 2004

636.08'52'0151--dc22

2005009714

ISBN-13: 978 1 84593 005 9

ISBN-10: 1 84593 005 3

Typeset by SPI Publisher Services, Pondicherry, India

Printed and bound in the UK by Cromwell Press, Trowbridge

Contents

Contributors	ix
Preface	xv
Introduction: History, Appreciation and Future Focus	xvii
<i>J. France</i>	
Session 1: Fermentation, Absorption and Passage	
Session Chair: J.P. McNamara	
1. The Nordic Dairy Cow Model, Karoline – Development of Volatile Fatty Acid Sub-model	1
<i>J. Sveinbjörnsson, P. Huhtanen and P. Udén</i>	
2. A Three-compartment Model of Transmembrane Fluxes of Valine across the Tissues of the Hindquarters of Growing Lambs Infected with <i>Trichostrongylus colubriformis</i>	15
<i>N.C. Roy, E.N. Bermingham and W.C. McNabb</i>	
3. Using Rumen Degradation Model to Evaluate Microbial Protein Yield and Intestinal Digestion of Grains in Cattle	28
<i>P. Paengkoum</i>	
4. Simulation of Rumen Particle Dynamics using a Non-steady State Model of Rumen Digestion and Nutrient Availability in Dairy Cows Fed Sugarcane	33
<i>E.A. Collao-Saenz, A. Bannink, E. Kebreab, J. France and J. Dijkstra</i>	
5. Modelling Fluxes of Volatile Fatty Acids from Rumen to Portal Blood	40
<i>P. Nozière and T. Hoch</i>	

6. **The Role of Rumen Fill in Terminating Grazing Bouts of Dairy Cows under Continuous Stocking** 48
H.Z. Taweel, B.M. Tas, S. Tamminga and J. Dijkstra
7. **Functions for Microbial Growth** 54
S. López, M. Prieto, J. Dijkstra, E. Kebreab, M.S. Dhanoa and J. France
8. **Obtaining Information on Gastric Emptying Patterns in Horses from Appearance of an Oral Acetaminophen Dose in Blood Plasma** 69
J.P. Cant, V.N. Walsh and R.J. Geor

Session 2: Growth and Development

Session Chair: A. Danfær

9. **A Model to Evaluate Beef Cow Efficiency** 84
L.O. Tedeschi, D.G. Fox, M.J. Baker and K.L. Long
10. **Prediction of Energy Requirement for Growing Sheep with the Cornell Net Carbohydrate and Protein System** 99
A. Cannas, L.O. Tedeschi, A.S. Atzori and D.G. Fox
11. **Prediction of Body Weight and Composition from Body Dimension Measurements in Lactating Dairy Cows** 114
T. Yan, R.E. Agnew, C.S. Mayne and D.C. Patterson
12. **Relationships between Body Composition and Ultrasonic Measurements in Lactating Dairy Cows** 121
R.E. Agnew, T. Yan, D.C. Patterson and C.S. Mayne
13. **Empirical Model of Dairy Cow Body Composition** 127
O. Martin and D. Sauvant
14. **Simulating Chemical and Tissue Composition of Growing Beef Cattle: From the Model to the Tool** 135
T. Hoch, Ph. Pradel, P. Champciaux and J. Agabriel
15. **Representation of Fat and Protein Gain at Low Levels of Growth and Improved Prediction of Variable Maintenance Requirement in a Ruminant Growth and Composition Model** 144
J.W. Oltjen, R.D. Sainz, A.B. Pleasants, T.K. Soboleva and V.H. Oddy
16. **Growth Patterns of Nellore vs British Beef Cattle Breeds Assessed Using a Dynamic, Mechanistic Model of Cattle Growth and Composition** 160
R.D. Sainz, L.G. Barioni, P.V. Paulino, S.C. Valadares Filho and J.W. Oltjen

Session 3: Mineral Metabolism**Session Chair: E. Kebreab**

17. **A Kinetic Model of Phosphorus Metabolism in Growing Sheep** 171
R. Souza Dias, A.P. Roque, V.F. Nascimento Filho, D.M.S.S. Vitti and I.C.S. Bueno
18. **Dynamic Simulation of Phosphorus Utilization in Salmonid Fish** 180
K. Hua, J.P. Cant and D.P. Bureau
19. **Development of a Dynamic Model of Calcium and Phosphorus Flows in Layers** 192
J. Dijkstra, E. Kebreab, R.P. Kwakkel and J. France
20. **Estimating the Risk of Hypomagnesaemic Tetany in Dairy Herds** 211
S.T. Bell, A.E. McKinnon and A.R. Sykes

Session 4: Methodology**Session Chair: W.J.J. Gerrits**

21. **Modelling the Effects of Environmental Stressors on the Performance of Growing Pigs: from Individuals to Populations** 229
I.J. Wellock, G.C. Emmans and I. Kyriazakis
22. **Empirical Modelling through Meta-analysis vs Mechanistic Modelling** 242
D. Sauvant and O. Martin
23. **Iterative Development, Evaluation and Optimal Parameter Estimation of a Dynamic Simulation Model: a Case Study** 251
L.G. Barioni, J.W. Oltjen and R.D. Sainz
24. **Segmented, Constrained, Non-linear, Multi-objective, Dynamic Optimization Methodology Applied to the Dairy Cow Ration Formulation Problem** 257
R.C. Boston and M.D. Hanigan

Session 5: Environmental Impact**Session Chair: R.C. Boston**

25. **A Model to Simulate the Effects of Different Dietary Strategies on the Sustainability of a Dairy Farm System** 275
A. del Prado, D. Scholefield and L. Brown
26. **Advantages of a Dynamical Approach to Rumen Function to Help to Resolve Environmental Issues** 281
A. Bannink, J. Dijkstra, E. Kebreab and J. France

27. Evaluation of Models to Predict Methane Emissions from Enteric Fermentation in North American Dairy Cattle	299
<i>E. Kebreab, J. France, B.W. McBride, N. Odongo, A. Bannink, J.A.N. Mills and J. Dijkstra</i>	
Session 6: Production and Evaluation Models	
Session Chair: A. Bannink	
28. Investigating Daily Changes in Food Intake by Ruminants	314
<i>G.McL. Dryden</i>	
29. An Ingredient-based Input Scheme for Molly	328
<i>M.D. Hanigan, H.G. Bateman, J.G. Fadel, J.P. McNamara and N.E. Smith</i>	
30. Metabolic Control: Improvement of a Dynamic Model of Lactational Metabolism in Early Lactation	349
<i>J.P. McNamara</i>	
31. Rostock Feed Evaluation System – an Example of the Transformation of Energy and Nutrient Utilization Models to Practical Application	366
<i>A. Chudy</i>	
32. The Nordic Dairy Cow Model, Karoline – Description	383
<i>A. Danfær, P. Huhtanen, P. Udén, J. Sveinbjörnsson and H. Volden</i>	
33. The Nordic Dairy Cow Model, Karoline – Evaluation	407
<i>A. Danfær, P. Huhtanen, P. Udén, J. Sveinbjörnsson and H. Volden</i>	
34. A Composite Model of Growth, Pregnancy and Lactation	416
<i>I. Vetharaniam and S.R. Davis</i>	
Index	439

Contributors

- Jacques Agabriel**, INRA, Unité de Recherche sur les Herbivores, Centre de Clermont-Theix, F63122 Saint-Genès-Champanelle, France; *e-mail*: aga@clermont.inra.fr
- R.E. Agnew**, Agricultural Research Institute of Northern Ireland, Hillsborough, Co. Down BT26 6DR, UK
- Seppo Ahvenjärvi**, MTT Agrifood Research Finland, Virralantie 193, 14240 Janakkala, Finland; *e-mail*: Seppo.Ahvenjarvi@mtt.fi
- A.S. Atzori**, Dipartimento di Scienze Zootecniche, via De Nicola 9, Università di Sassari, 07100 Sassari, Italy
- M.J. Baker**, Department of Animal Science, Cornell University, Ithaca, NY 14850, USA
- André Bannink**, Animal Sciences Group, Division of Nutrition and Food, PO Box 65, 8200 AB Lelystad, The Netherlands; *e-mail*: Andre.Bannink@wur.nl
- Luís Barioni**, Embrapa Cerrados, Rodovia Brasília-Fortaleza BR 020 KM 18, Planaltina, DF 73301-970, Brazil; *e-mail*: LGBarioni@ucdavis.edu/Barioni@cpac.embrapa.br
- H.G. Bateman**, Department of Dairy Science, LSU Ag Center, Baton Rouge, LA 70803, USA
- S.T. Bell**, Animal and Veterinary Sciences Group, Lincoln University, Canterbury 8152, New Zealand
- E.N. Bermingham**, Livestock Industries, CSIRO, Perth, Australia
- L. Brown**, Institute of Grassland and Environment Research, North Wyke, Okehampton, Devon EX20 2SB, UK
- Ray Boston**, Clinical Studies, NBC, School of Veterinary Medicine, University of Pennsylvania, 382 West Street Road, Kennett Square, PA 19384, USA; *e-mail*: drrayboston@yahoo.com

- Anne Boudon**, UMR INRA Agrocampus, Rennes Production du Lait, Domaine de la Prise, 35590 Saint-Gilles, France; *e-mail*: Anne.Boudon@rennes.inra.fr
- I.C.S. Bueno**, Animal Nutrition Laboratory, Center for Nuclear Energy in Agriculture, PO Box 96, CEP 13400-970, Piracicaba, São Paulo, Brazil
- D.P. Bureau**, Department of Animal and Poultry Science, University of Guelph, Guelph, Ontario N1G 2W1, Canada
- Antonello Cannas**, Dipartimento di Scienze Zootecniche, via De Nicola 9, Università di Sassari, 07100 Sassari, Italy; *e-mail*: Cannas@uniss.it
- John Cant**, Department of Animal and Poultry Science, University of Guelph, Guelph, Ontario N1G 2W1, Canada; *e-mail*: JCant@uoguelph.ca
- P. Champciaux**, Unité de Recherche sur les Herbivores INRA-Centre de Clermont-Theix, F63122 Saint-Genès-Champanelle, France
- Arthur Chudy**, Forschungsinstitut für die Biologie landwirtschaftlicher Nutztiere, Dummerstorf, OT Warsow 11, D17154 Neukalen, Germany; *e-mail*: AChudy@aol.com/Chudy@fhn-dummerstorf.de
- Edgar Alain Collao-Saenz**, DZO/Animal Science Department, UNEMAT-Universidade do Estado de Mato Grosso, PO Box 181, CEP 78250-000 Pontes e Lacerda-MT, Brazil; *e-mail*: edgar@unemat.br
- Allan Danfær**, Danish Institute of Agricultural Sciences, Research Centre Foulum, PO Box 50, 8830 Tjele, Denmark; *e-mail*: Allan.Danfær@agrsci.dk
- S.R. Davis**, ViaLactia Biosciences (NZ) Ltd, PO Box 109-185, Newmarket, Auckland, New Zealand
- Agustin del Prado**, Institute of Grassland and Environmental Research, North Wyke, Okehampton, Devon EX20 2SB, UK; *e-mail*: Agustin.del_Prado@bbsrc.ac.uk
- Dan Dhanoa**, Institute of Grassland and Environmental Research, Plas Gogerddan, Aberystwyth, Dyfed SY23 3EB, UK; *e-mail*: Dan.Dhanoa@bbsrc.ac.uk
- Jan Dijkstra**, Animal Nutrition Group, Wageningen University, PO Box 338, 6700 AH Wageningen, The Netherlands; *e-mail*: Jan.Dijkstra@wur.nl
- Gordon Dryden**, School of Animal Studies, The University of Queensland, Gatton, Qld 4343, Australia; *e-mail*: G.Dryden@uq.edu.au
- G.C. Emmans**, Animal Nutrition and Health Department, Scottish Agricultural College, West Mains Road, Edinburgh EH9 3JG, UK
- James Fadel**, Department of Animal Science, University of California, Davis, CA 95616, USA; *e-mail*: JGFadel@ucdavis.edu
- D.G. Fox**, Department of Animal Science, Cornell University, Ithaca, NY 14850, USA
- Jim France**, Centre for Nutrition Modelling, Department of Animal and Poultry Science, University of Guelph, 50 Gordon Street, Guelph, Ontario N1G 2W1, Canada; *e-mail*: JFrance@uoguelph.ca
- Florence Garcia**, INRA, Research Unit on Milk Production, 35590 Saint-Gilles, France; *e-mail*: Garcia@st-gilles.rennes.inra.fr/FGarcia@clermont.inra.fr

- Walter Gerrits**, Animal Sciences Group, Wageningen University, Animal Nutrition Group, PO Box 338, 6700 AH Wageningen, The Netherlands; *e-mail*: Walter.Gerrits@wur.nl
- Frédéric Glasser**, INRA, Theix, 63122 Saint-Genès-Champanelle, France; *e-mail*: FGlasser@clermont.inra.fr
- R.J. Geor**, Department of Biomedical Sciences, University of Guelph, Guelph, Ontario N1G 2W1 Canada
- Jules Gosselink**, Animal Sciences Group, Wageningen University, Division of Nutrition and Food, PO Box 65, 8200 AB Lelystad, The Netherlands; *e-mail*: Jules.Gosselink@wur.nl
- Mark Hanigan**, Longview Nutrition Center, Land O' Lakes, 100 Danforth Dr., Gray Summit, MO 63039, USA; *e-mail*: MHanigan@landolakes.com
- T. Hoch**, Unité de Recherche sur les Herbivores, INRA-Centre de Clermont-Theix, F63122 Saint-Genès-Champanelle, France
- Katheline Hua**, Department of Animal and Poultry Science, University of Guelph, Guelph, Ontario N1G 2W1, Canada; *e-mail*: KHua@uoguelph.ca
- Pekka Huhtanen**, MTT Agrifood Research Finland, Animal Production Research FIN-31600 Jokioinen, Finland; *e-mail*: Pekka.Huhtanen@mtt.fi
- Ermias Kebreab**, Centre for Nutrition Modelling, Department of Animal and Poultry Science, University of Guelph, 50 Gordon Street, Guelph, Ontario N1G 2W1, Canada; *e-mail*: EKebreab@uoguelph.ca
- R.P. Kwakkel**, Animal Nutrition Group, Wageningen University, PO Box 338, 6700 AH Wageningen, The Netherlands
- I. Kyriazakis**, Animal Nutrition and Health Department, Scottish Agricultural College, West Mains Road, Edinburgh, EH9 3JG, UK
- Sophie Lemosquet-Simon**, UMR INRA Agrocampus, Rennes Production du Lait, Domaine de la Prise, 35590 Saint-Gilles, France; *e-mail*: Sophie.Lemosquet@rennes.inra.fr
- K.L. Long**, Bell Ranch, Solano, NM 87746, USA
- Secundino López**, Department of Animal Production, University of León, E-24071 León, Spain; *e-mail*: DP1SLP@unileon.es
- Peter Lund**, Danish Institute of Agricultural Sciences, Research Centre Foulum, PO Box 50, 8830 Tjele, Denmark; *e-mail*: Peter.Lund@agrsci.dk
- Olivier Martin**, UMR INRA INA P-G, Physiologie de la Nutrition et Alimentation, 16 rue Claude Bernard, 75231 Paris Cedex 05, France; *e-mail*: OMartin@inapg.inra.fr
- C.S. Mayne**, Agricultural Research Institute of Northern Ireland, Hillsborough, Co. Down BT26 6DR, UK
- B.W. McBride**, Centre for Nutrition Modelling, Department of Animal and Poultry Sciences, University of Guelph, Guelph, Ontario N1G 2W1, Canada
- Alan McKinnon**, Applied Computing Group, PO Box 84, Lincoln University, Canterbury 8152, New Zealand; *e-mail*: McKinnon@lincoln.ac.nz
- W.C. McNabb**, Metabolism and Microbial Genomics, Food and Health Group, AgResearch Limited, Grasslands Research Centre, Private Bag 11008, Palmerston North 5301, New Zealand

- John McNamara**, Department of Animal Sciences, Washington State University, Pullman, WA 99165, USA; *e-mail*: McNamara@wsu.edu
- J.A.N. Mills**, School of Agriculture, Policy and Development, The University of Reading, PO Box 237, Earley Gate, Reading RG6 6AT, UK
- V.F. Nascimento Filho**, Animal Nutrition Laboratory, Center for Nuclear Energy in Agriculture, PO Box 96, CEP 13400-970, Piracicaba, São Paulo, Brazil
- John Newbold**, Provimi Research and Technology Centre, Lenneke Marelaan 2, B-1932 St-Stevens-Woluwe, Belgium; *e-mail*: JNewbold@be.provimi.com
- Pierre Nozière**, Unité de Recherche sur les Herbivores, INRA, Theix, 63122 Saint-Genès-Champanelle, France; *e-mail*: Noziere@clermont.inra.fr
- Hutton Oddy**, Meat and Livestock Australia, 165 Walker Street, North Sydney, NSW 2060, Australia; *e-mail*: Hoddy@mlla.com.au
- N. Odongo**, Centre for Nutrition Modelling, Department of Animal and Poultry Science, University of Guelph, Guelph, Ontario N1G 2W1, Canada
- James Oltjen**, Department of Animal Science, University of California, Davis, CA 95616, USA; *e-mail*: JWoltjen@ucdavis.edu
- David Pacheco**, AgResearch Limited, Grasslands Research Centre, Private Bag 11008, Palmerston North 5320, New Zealand; *e-mail*: David.Pacheco@agresearch.co.nz
- Pramote Paengkoum**, School of Animal Production Technology, Institute of Agricultural, Suranaree University of Technology, Muang District, Nakhon Ratchasima 3000, Thailand; *e-mail*: Pramote@ccs.sut.ac.th/PPaengkhum@hotmail.com
- D.C. Patterson**, Agricultural Research Institute of Northern Ireland, Hillsborough, Co. Down BT26 6DR, UK
- P.V. Pauliao**, Departamento de Zootecnia, Universidade Federal de Viçosa, Av. P.H. Rolfs, s.n., Viçosa, MG 36571-000, Brazil
- Wilbert Pellikaan**, Animal Sciences Group, Wageningen University, Animal Nutrition Group, PO Box 338, 6700 AH Wageningen, The Netherlands; *e-mail*: Wilbert.Pellikaan@wur.nl
- A.B. Pleasants**, Ag Research, Ruakura Research Centre, Hamilton, New Zealand
- Candido Pomar**, Agriculture and Agri-Food Canada, PO Box 90, 2000 Route 108 East, Lennoxville, Québec J1M 1Z3, Canada; *e-mail*: Pomarc@agr.gc.ca
- Dennis Poppi**, University of Queensland, School of Animal Studies, St Lucia, Brisbane, Queensland 4072, Australia; *e-mail*: D.Poppi@uq.edu.au
- Ph. Pradel**, Domaine INRA de Marcenat, F 15190 Marcenat, France
- Gordon Rosen**, Pronutrient Services, 66 Bathgate Road, London SW19 5PH, UK; *e-mail*: G.D.Rosen@btinternet.com
- M. Prieto**, Department of Food Hygiene and Technology, University of León, E-24071 León, Spain
- A.P. Roque**, Animal Nutrition Laboratory, Center for Nuclear Energy in Agriculture, PO Box 96, CEP 13400-970, Piracicaba, São Paulo, Brazil
- Nicole Roy**, Metabolism and Microbial Genomics, Food and Health Group, AgResearch Limited, Grasslands Research Centre, Private Bag 11008,

- Palmerston North 5301, New Zealand; *e-mail*: Nicole.Roy@agresearch.co.nz
- Roberto Sainz**, Department of Animal Science, University of California, Davis, CA 95616, USA; *e-mail*: RDSainz@ucdavis.edu
- Daniel Sauvant**, UMR INRA INA P-G, Physiologie de la Nutrition et Alimentation, 16 rue Claude Bernard, 75231 Paris Cedex 05, France; *e-mail*: Sauvant@inapg.inra.fr
- D. Scholefield**, Institute of Grassland and Environmental Research, North Wyke, Okehampton, Devon, EX20 2SB, UK
- Raquel Souza Dias**, Animal Nutrition Laboratory, Center for Nuclear Energy in Agriculture, PO Box 96, CEP 13400-970, Piracicaba, São Paulo, Brazil, *e-mail*: raquelsd@cena.usp.br
- Anders Strathe**, The Royal Veterinary and Agricultural University, Grønnegaardsvej 2, 1870 Frederiksberg, Copenhagen, Denmark; *e-mail*: Strathe@dsr.kvl.dk
- Bernardo Suarez**, Animal Sciences Group, Wageningen University, Animal Nutrition Group, PO Box 338, 6700 AH Wageningen, The Netherlands; *e-mail*: Bernardo.Suarez@wur.nl
- Johannes Sveinbjörnsson**, Agricultural University of Iceland, Department of Natural Resources, Keldnaholt v/Vesturlandsveg, IS-112 Reykjavík, Iceland; *e-mail*: Jois@is
- A.R. Sykes**, Animal and Veterinary Sciences Group, Lincoln University, Canterbury 8152, New Zealand
- Hassan Taweel**, Animal Nutrition Group, Wageningen University, PO Box 338, 6700 AH Wageningen, The Netherlands; *e-mail*: Hassan.Taweel@wur.nl
- Luis Orlando Tedeschi**, Department of Animal Science, Cornell University, 124 Morrison Hall, Ithaca, NY 14853, USA; *e-mail*: Lot1@cornell.edu
- Thomas Tylutki**, Cornell University, 330 Morrison Hall, Ithaca, NY 14853, USA; *e-mail*: Tpt1@cornell.edu
- Peter Udén**, Department of Animal Nutrition and Management, Kungsängen Research Centre, S-753-23 Uppsala, Sweden; *e-mail*: Peter.Uden@huv.slu.se
- S.C. Valadares Filho**, Departamento de Zootecnia, Universidade Federal de Viçosa, Av. P.H. Rolfs, s.n., Viçosa, MG 36571-000 Brazil
- Marien Van den Brink**, CCL Research, PO Box 107, 5460 AC Veghel, The Netherlands; *e-mail*: Marien.van.den.brink@ccl.nl
- Kumar Vetharanim**, AgResearch Limited, Private Bag 3123, Hamilton, New Zealand; *e-mail*: Kumar.Vetharanim@agresearch.com.nz
- D.M.S.S. Vitti**, Animal Nutrition Laboratory, Center for Nuclear Energy in Agriculture, PO Box 96, CEP 13400-970, Piracicaba, São Paulo, Brazil
- Harald Volden**, Department of Animal and Aquacultural Sciences, Agricultural University of Norway, PO Box 5025, 1432 Ås, Norway; *e-mail*: Harald.Volden@iha.nlh.no
- Valentino Volpe**, Via G. Mazzini, 15, 33017 Tarcento (Ud), Italy; *e-mail*: VVolpe@iol.it
- V.N. Walsh**, Department of Animal and Poultry Science, University of Guelph, Guelph, Ontario N1G 2W1, Canada

Ian Wellock, Animal Nutrition and Health Department, Scottish Agricultural College, West Mains Road, Edinburgh EH9 3JG, UK; *e-mail*: I.Wellock@ed.sac.ac.uk

Tianhai Yan, Agricultural Research Institute of Northern Ireland, Hillsborough, Co. Down BT26 6DR, UK; *e-mail*: Tianhai.Yan@dardni.gov.uk

Preface

This book comprises articles given as papers or presented as posters at the Sixth International Workshop on Modelling Nutrient Utilization in Farm Animals, Wageningen, the Netherlands, 6–8 September 2004. This workshop, like the previous five, was held in conjunction with the International Ruminant Physiology Symposia. A description of the history and future of the Modelling Workshops is presented by Professor France in the Introduction.

Briefly, the purpose of this workshop was to present state-of-the-art scientific research in modelling nutrient digestion and utilization in farm animals. There is a strong interplay between modelling and experimental research, and I have often experienced the positive effect of the symbiosis between modelling and experimentation on the improvement of our understanding of animal nutrition. Thus, the workshop aimed to bring together active experimentalists and modellers interested in research into, and the application of, nutritional principles of cattle, pigs, poultry and fish.

Contributions covered a range of topics and modelling approaches and levels of generality. Presentations and discussions on research works in progress were central to the workshop. The format was as always informal and stimulatory. I remember well the very first modellers' workshop I attended (Lincoln, New Zealand, 1989) being a young, first-year PhD student. Many enthusiastic senior modellers showed a keen interest in my work and were willing to share new ideas and unpublished data. The atmosphere was that of collaboration, not competition. As an example, one evening we ended up in the pub drawing flow diagrams of biological processes on the rear of beer mats. Now, 15 years later, being more experienced in modelling, as the chair of the local organizing committee I have tried in particular to encourage young scientists to present (results of) models and to be involved in discussions.

About 60 participants (young and old) from many parts of the world made this workshop an exciting occasion. The workshop was organized in

six sessions with a wide range of topics: (i) fermentation, absorption and passage; (ii) growth and development; (iii) mineral metabolism; (iv) methodology; (v) environmental impact; and (vi) production and evaluation of models. As stated in the Introduction to this book, this suggests that biological research must be undertaken at several levels of generality, e.g. cell, organ or tissue, whole organism and population, and that there is much more to biology than just molecular science. In all these organizational levels, the role of mathematics is an integral part of the basic logic underlying the previewing and developmental imagination. Mathematics appeals to reason, enabling us to see the world more clearly, and allowing us to understand things that we previously failed to understand (quoted from the plenary paper of Dijkstra and France at the Fourth Modellers' Workshop).

At the present workshop, it was reiterated that the still active leading organizers of previous workshops form an international committee to advise and provide guidance to local organizers of future workshops. This committee comprises James France, Dennis Poppi, Allan Danfær, John McNamara and Jan Dijkstra.

I wish to thank all who have contributed to this workshop and to its publication, in particular the chairpersons of the sessions. Special thanks to the other members of the local organizing committee of this workshop, Andre Bannink and Walter Gerrits.

Jan Dijkstra
Chair of local organizing committee
Wageningen University
March 2005

Introduction: History, Appreciation and Future Focus

J. FRANCE

*Centre for Nutrition Modelling, Department of Animal and Poultry Science,
University of Guelph, Guelph, Ontario N1G 2W1, Canada*

This monograph records the sixth of our series of workshops on modelling nutrient utilization in farm animals, held in Wageningen, the Netherlands, during 6–8 September 2004, following the Tenth Ruminant Physiology Symposium in Copenhagen, Denmark (Nielsen *et al.*, 2004). The meetings were the brainchild of Dr Ransom Leland Baldwin III, Member of the US National Academy of Sciences, and formerly Sesnon Chair in Animal Science at the University of California, Davis – simply Lee to all of us who have the pleasure and honour of knowing him (Fig. I.1). Lee’s objectives in founding the workshops were to bring together research scientists from different countries working on ruminant nutrition physiology with an interest in applying mathematical modelling techniques, and to promote the role of dynamic simulation modelling in particular. Rather than rewrite history, I quote from Lee’s plenary paper (Baldwin, 2000) read at the fifth workshop held in Cape Town, South Africa (McNamara *et al.*, 2000), which followed the Ninth Ruminant Physiology Symposium in Pretoria (Cronje, 2000). My slight embellishments are indicated within square brackets.

The first workshop was held in Hurley, England, during the week between the Fifth Symposium on Digestive Physiology and Metabolism in Ruminants, held in Clermont-Ferrand, France (Ruckebusch and Thivend, 1980) and the Eighth Symposium on Energy Metabolism, held in Cambridge, England (Mount, 1980). As a contrast, the modelling workshop was sandwiched between these well-established venues for ruminant nutrition, which had been ongoing for 25 and 24 years respectively.

Our first meeting was truly a workshop and a beginning. There were no anointed leaders in the field to offer sage advice. We were simply a group of scientists gathered together to try to figure out how to integrate and utilize the ever-increasing knowledge of digestive physiology, rumen microbial metabolism, animal and tissue metabolism, metabolic regulation and animal energetics, as



Fig. I.1. Dr R.L. Baldwin III, founder of this series of workshops (photograph courtesy: Dr J.P. McNamara).

exemplified in the two symposia, in a quantitative fashion. This was to better explain and utilize the data and concepts presented to advance animal science and agriculture. We had all recognized that research thrusts at that time – learning more and more about less and less and documenting the many sources of variance in whole-animal energy expenditures – were interesting and rewarding in the sense that excellent, astute word descriptions of progress in the several specific areas of enquiry could be, and were, presented at the symposia, but that quantitative integration of our data and concepts was lacking. Organizers of both symposia realized that modelling was the means by which this goal could be achieved by incorporating several modelling papers. These papers depicted a field in its infancy. At the workshop, we were attempting to bring the field to its childhood. We discussed modelling philosophy, terminology and methods as best we could, and illustrated our diversity by dividing ourselves into work groups to address modelling approaches to specific problems, with variable and limited success. Deliberations of this workshop are unrecorded – who wants to record baby talk? – but we learnt.

Five years later, the workshop was reconvened at Davis, California [following the Sixth Ruminant Physiology Symposium in Banff, Canada (Milligan *et al.*, 1986)]. Development of the field is illustrated in the proceedings of that workshop (Baldwin and Bywater, 1984). Unifying philosophy, terminology and context, since adopted by most, were developed through the presentations of Thornley and France, Matis, and Ramberg, and the discussion edited by Bywater and

Pond. In subsequent sessions, specific models, modelling analyses, concepts, problems and challenges were addressed and discussed at length. The field had clearly advanced through its childhood and was moving towards puberty.

This process of maturation continued through the two subsequent workshops [at Lincoln, near Canterbury, New Zealand (Robson and Poppi, 1989), and at Foulum, Denmark (Danfær and Lescoat, 1995), following the Seventh and Eighth Ruminant Physiology Symposia in Sendai, Japan and Willingen, Germany, respectively (Tsuda *et al.*, 1991; Leonhard-Marek and von Engelhardt, 1995)]. Aspects of philosophy were reiterated, restated and discussed at each meeting, partly for the purpose of educating new participants entering the field. The breadth and depth of models presented and discussed continuously expanded as our knowledge of animal functions improved, along with improvements in our modelling skills and computer science and technology.

The results of this continuing development of the field are evident in this current workshop. One might even venture the opinion that modelling is now a mature discipline within the animal sciences. We can point to relatively sophisticated models of physiological and metabolic functions at the tissue and animal levels, to models currently in practical use in support of animal agriculture and to farming system models that incorporate mechanistic animal elements to an extent not previously realized; many of these models are represented in this workshop. There have been a number of books on modelling animal systems, including those authored or edited by participants in these workshops, such as France and Thornley (1984) [2nd edn, Thornley and France (2006)], Forbes and France (1993) [2nd edn, Dijkstra *et al.* (2005)] and Baldwin (1995), numerous chapters in symposia and other books addressing animal physiology, nutrition and production, and hundreds of original papers. However, this appearance of maturity should not be interpreted as indicating that the discipline has attained fruition.

Tremendous progress has been made. However, I suggest that we still have a long way to go. I am a firm believer in the defender vs. challenger concept in model evaluations. This view holds that, in order to replace a currently accepted (defender) model, new (challenger) models must be proved superior. When the challenged model fails in some regard, it behoves the investigator conducting the evaluation to identify specific elements within the defender model that led to the errors detected and to explain how deficiencies in the model were, could be or should be addressed in the challenged model. Similarly, the challenger model can be improved. It is not adequate to simply conclude that a given model fails to predict a specific output adequately. This does not advance animal science.

The present workshop is testament to Lee's original vision and the well-being of animal modelling. Contributions cover a range of topics and modelling approaches, animal species and levels of generality, with many of the contributions coming from younger scientists. The range of topics is exemplified by the workshop sessions: (i) fermentation, absorption and passage; (ii) growth and development; (iii) mineral metabolism; (iv) methodology; (v) environmental impact; and (vi) production and evaluation models. This suggests that biological research, if it is to remain truly relevant, must be undertaken at several levels of generality, e.g. cell, organ or tissue, whole organism, population, and that there is much more to biology than just molecular science. Hopefully the molecular chauvinism that seems to have dominated biological research thinking (and hence funding) for much of the last quarter century is finally at an end.

The chapters in this monograph also cover different modelling approaches, e.g. deterministic, stochastic, empirical and mechanistic, and therefore describe dynamic simulations, kinetic models, optimization routines and time-series analyses. The models are applied to dairy cows, beef cattle, sheep, pigs, poultry and fish. Our first two workshops were concerned exclusively with modelling digestion and metabolism in ruminants (e.g. Baldwin and Bywater, 1984). This was subsequently broadened to farm animals, and the first papers on pig modelling were presented at the third workshop (Robson and Poppi, 1989). It is noteworthy and pleasing that papers on poultry and fish modelling were read at the present workshop for the first time. It is, after all, a truism that those modelling ruminant nutrition have things to learn from their counterparts working, for example, in poultry nutrition, and vice versa. Thus scientific pluralism, not just across animal species but also across levels of generality and types of modelling, should be a pillar for future development of the activity of animal modelling.

One of the drivers that led Lee to found this series of workshops was his belief that more could be done with data that experimentalists were generating. This is certainly true today. Data are being generated at a rapidly increasing rate as a consequence of advances in technology, computing and engineering. Also the climate within which animal science operates has become increasingly turbulent, resulting in more academics taking early retirement, those in mid-career changing occupations, and a higher turnover amongst young postdoctoral workers. Consequently, each unit of data generated receives less attention from the experimentalist now than would have been the case in past years. Thus data mining and manipulation provide increasing opportunity for the modeller. It is perhaps an obligation that such opportunity be grasped in order to make more effective use of public money. Indeed, there may be a case for funding proportionately more dry (*in silico*) and proportionately less wet (*in vivo, in vitro*) biological research in the near future.

Peering into a crystal ball and attempting to foretell what lies ahead is usually a futile task. To quote Baldwin (2000): 'Previewing the future is an equivocal process'. I think it sufficient to conclude by saying that a future focus for animal modelling based on scientific pluralism and data mining, with emphasis on solving biological problems rather than applying mathematical techniques, offers a fruitful way ahead – a progression that would be very much in keeping with Lee's legacy.

References

- Baldwin, R.L. (1995) *Modelling Ruminant Digestion and Metabolism*. Chapman & Hall, London, 578 pp.
- Baldwin, R.L. (2000) Introduction: history and future of modelling nutrient utilization in farm animals. In: McNamara, J.P., France, J. and Beever, D.E. (eds) *Modelling Nutrient Utilization in Farm Animals*. CAB International, Wallingford, UK, pp. 1–9.

- Baldwin, R.L. and Bywater, A.C. (1984) *Modeling Ruminant Digestion and Metabolism: Proceedings of the 2nd International Workshop*. Department of Animal Science, University of California, Davis, California, 138 pp.
- Cronje, P. (2000) *Ruminant Physiology: Digestion, Metabolism, Growth and Reproduction*. CAB International, Wallingford, UK, 496 pp.
- Danfaer, A. and Lescoat, P. (1995) *Modeling Nutrient Utilisation in Farm Animals: Proceedings of 4th International Workshop*. National Institute of Animal Science, Foulum, Denmark, 195 pp.
- Dijkstra, J., Forbes, J.M. and France, J. (eds) (2005) *Quantitative Aspects of Ruminant Digestion and Metabolism*, 2nd edn. CAB International, Wallingford, UK, 752 pp.
- Forbes, J.M. and France, J. (1993) *Quantitative Aspects of Ruminant Digestion and Metabolism*. CAB International, Wallingford, UK, 515 pp.
- France, J. and Thornley, J.H.M. (1984) *Mathematical Models in Agriculture*. Butterworths, London, UK, 335 pp.
- Leonhard-Marek, S. and von Engelhardt, W. (1995) *Ruminant Physiology: Digestion, Metabolism, Growth and Reproduction*. Ferdinand Enke, Stuttgart, Germany.
- Milligan, L.P., Grovum, W.L. and Dobson, A. (1986) *Control of Digestion and Metabolism in Ruminants: Proceedings of the 6th International Symposium on Ruminant Physiology*. Prentice-Hall, Englewood Cliffs, New Jersey, xxi+567 pp.
- Mount, L.E. (1980) *Energy Metabolism: Proceedings of the 8th Symposium on Energy Metabolism*. Butterworths, London, UK, 484 pp.
- McNamara, J.P., France, J. and Beever, D.E. (2000) *Modelling Nutrient Utilization in Farm Animals*. CAB International, Wallingford, UK, xvi+418 pp.
- Nielsen, O.M., Sejrsen, K., Hvelplund, T., Norgard, P. and Madsen, J. (2004) The 10th International Symposium on Ruminant Physiology. *Journal of Animal and Feed Sciences* 13 (Suppl. 1).
- Robson, A.B. and Poppi, D.P. (1989) *Modelling Digestion and Metabolism in Farm Animals: Proceedings of the 3rd International Workshop*. Lincoln University, Canterbury, New Zealand, 360 pp.
- Ruckebusch, Y. and Thivend, P. (1980) *Digestive Physiology and Metabolism in Ruminants: Proceedings of the 5th International Symposium on Ruminant Physiology*. MTP Press, Lancaster, UK, 854 pp.
- Thornley, J.H.M. and France, J. (2006) *Mathematical Models in Agriculture*, 2nd edn. CAB International, Wallingford, UK, xviii+886 pp.
- Tsuda, T., Sasaki, Y. and Kawashima, R. (1991) *Physiological Aspects of Digestion and Metabolism in Ruminants: Proceedings of the 7th International Symposium on Ruminant Physiology*. Academic Press, San Diego, California, xxv+779 pp.

This page intentionally left blank

1

The Nordic Dairy Cow Model, Karoline – Development of Volatile Fatty Acid Sub-model

J. SVEINBJÖRNSSON,¹ P. HUHTANEN² AND P. UDÉN³

¹*Agricultural University of Iceland, Department of Natural Resources
Keldnaholt v/Vesturlandsveg, IS-112 Reykjavík, Iceland;* ²*MTT Agrifood
Research Finland, Animal Production Research, FIN-31600 Jokionen, Finland;*
³*Swedish University of Agricultural Sciences, Department of Animal Nutrition
and Management, Kungsängen Research Centre, 753 23 Uppsala, Sweden*

Abstract

The objective of our work was to develop a sub-model for rumen volatile fatty acid (VFA) production to be used in a Nordic dairy cow model, Karoline. An inter-Nordic database of 29 dairy cow experiments with 107 experimental treatments was formed, which included information on feed intake, feed composition and molar proportions (MPs) of individual VFAs observed in the rumen. Using a 33-treatments subset of our database, we made a limited evaluation of two sets of stoichiometrical equations, derived from the literature. For the whole database ($n = 107$), a multiple regression analysis was performed, where the effects of various dietary factors upon VFA proportions were analysed. Based on this analysis, the substrate classes that we found most relevant to use in our model were: neutral detergent fibre from forages (fNDF) and concentrates (cNDF), starch (St), crude protein (CP), lactic acid (LA) and rest fraction (Re), which is defined as total dry matter (DM) – ash – fNDF – cNDF – St – CP – LA – VFA. Further regression analysis demonstrated that in addition to these substrate classes, feeding level (FL) and concentrate ether extract (cEE) in the diet explained a significant part of the variation in VFA pattern. An iterative procedure was then used to derive coefficient values for a stoichiometrical model that describes the conversion of the six substrate classes (fNDF, cNDF, St, CP, LA, Re) to three types of VFAs, i.e. acetate (Ac), propionate (Pr) and butyrate (Bu). The fit of this model was considerably better for Ac and Pr than for Bu with $R^2 = 0.565, 0.558, 0.178$; and root mean squared prediction error (RMSPE) = 21.2, 15.4, 16.9 mmol/total mol VFA for Ac, Pr and Bu, respectively. Based on the results from multiple regression analysis, we used the iterative procedure to balance a combined model. This model included the above-mentioned stoichiometrical model with linear corrections for FL, and proportion of cEE in the feed. This improved the prediction of VFA proportions from feed information, compared to the original stoichiometrical model with $R^2 = 0.582, 0.618, 0.182$; and RMSPE = 20.8, 14.4 and 16.8 mmol/mol VFA for Ac, Pr and Bu, respectively. This combined model is presently used as the VFA sub-model in Karoline. An examination of prediction errors of this model showed that some of the unexplained variance can be related to different effects of individual substrates on VFA composition, depending on their

concentration in the diet. It can be argued, however, that adding new components to the model will always improve the fit, so possible extra components to the model have to be carefully selected.

Introduction

The objective of our work was to develop a sub-model for rumen VFA production for use in the Nordic dairy cow simulation model, Karoline (see Danfær *et al.*, Chapter 32, this volume). Recent rumen models divide the microbial population into two (Dijkstra *et al.*, 1992; Russell *et al.*, 1992) or three (Dijkstra, 1994) components. Our aim was to employ mechanistic principles to account for biological variation, using inputs that would not be too difficult to attain in practice. Based on this criterion, we decided during the development of Karoline, that the model should not attempt any division of the microbial population, but only apply reasonably simple stoichiometric principles to describe rumen fermentation. We considered it relevant to investigate whether some of the variations in VFA pattern, not accounted for by amounts of digested substrates, could be described by some other factors, which can easily be measured in practice.

Database

We formed a Nordic database of 29 dairy cow digestion studies including 107 treatment means with information on feed intake, feed composition and MPs of individual VFAs observed in the rumen. Of the treatments, 33 were from experiments carried out in Denmark, 51 in Finland, 12 in Norway and 11 in Sweden. The majority of these experiments were published in scientific journals, but some only in internal reports. Information on the contents of ash, fNDF, cNDF, St and CP was recorded for all the experimental diets. LA had also been measured in most silages, but in a few cases this had to be estimated from table values. Then an Re fraction was defined as: total DM – ash – fNDF – cNDF – St – CP – LA – VFA.

The proportions of individual substrates truly digested in the rumen were based on rumen digestion studies, when available. In other cases, rumen digestion coefficients were either obtained from *in situ* and *in vitro* measurements of rumen degradation or estimated from total tract digestibilities. It was assumed that LA and Re fractions were completely digested in the rumen.

Table 1.1 outlines the chemical composition, FL and rumen fermentation characteristics of the 107 diets. For only 20 of these diets, concentrate was more than 50% of DM, which reflects the relatively great emphasis on good quality forage in Nordic dairy cow diets.

Table 1.1. Mean and standard deviation (SD) for feed composition,^a cow live weight (LW) and feeding level^b and rumen fermentation characteristics^c for the 107 diets in the Nordic database used in our study.

	Mean	Standard deviation
DMI (kg/day)	17.23	3.64
LW (kg)	604.0	40.1
Concentrate (% of DMI)	38.63	15.01
fNDF (g/kg DM)	266.7	76.8
cNDF (g/kg DM)	119.4	64.8
St (g/kg DM)	166.2	78.7
CP (g/kg DM)	168.6	29.5
LA (g/kg DM)	34.5	22.0
Re (g/kg DM)	155.8	84.1
cEE (g/kg DM)	16.7	11.9
FL (kg DMI/kg LW)	2.855	0.565
Rumen pH	6.29	0.21
VFA concentration (mmol/l)	119.5	13.3
Ac (mmol/mol VFA)	668.5	32.2
Pr (mmol/mol VFA)	193.1	23.2
Bu (mmol/mol VFA)	138.4	18.7

^aCP = crude protein; LA = lactic acid; fNDF = forage NDF; cNDF = concentrate NDF; St = starch; Re = total DM – NDF – St – ash – CP – LA – VFA; cEE = concentrate ether extract (g/kg DM).

^bFeeding level (FL) = total dry matter intake (DMI) per kg live weight (LW).

^cAc = acetate; Pr = propionate; Bu = butyrate.

Evaluation of Published Coefficients

We evaluated the stoichiometrical model reported by Murphy *et al.* (1982) and the modified version of Bannink *et al.* (2000), which describe the stoichiometry of rumen conversion of soluble carbohydrates, St, hemicellulose, cellulose and protein to Ac, Pr, Bu and other VFAs. Only 33 experimental diets in our Nordic database included rumen digestibility values for hemicellulose and cellulose. This subset was used to evaluate the two sets of coefficients mentioned above, using the model structure presented by Bannink *et al.* (2000).

Murphy *et al.* (1982) reported different coefficients for roughage and concentrate diets; so we divided the 33-diet data-set into one containing 16 roughage diets (> 50% roughage) and the other containing 17 concentrate diets (> 50% concentrate) to evaluate these coefficients (C_{OR}). However, Bannink *et al.* (2000) did not report the roughage set of coefficients; so in that case we had to use only the concentrate set of coefficients (C_{TD}) for all the 33 diets. The results of the evaluation of the two sets of coefficients are reported in Table 1.2, which shows a poor prediction of VFA composition from substrate composition. Less than 4% of the variation in individual VFA composition was

Table 1.2. Predicted molar proportions (mmol/mol) of individual VFAs^a in the rumen of lactating dairy cows fed 33 different Nordic diets, using published 'C_{OR}' coefficients from Murphy *et al.* (1982) and 'C_{TD}' coefficients from Bannink *et al.* (2000).

	Ac	Pr	Bu	Bc
Observed values (mean)	634	195	137	26
Observed values (SD)	39	18	22	9
C_{OR} coefficients				
Predicted values (mean)	640	238	91	31
Predicted values (SD)	67	45	13	13
R ² (observed vs predicted)	0.004	0.001	0.246	0.006
RMSPE ^b	68	48	47	14
C_{TD} coefficients				
Predicted values (mean)	623	222	120	34
Predicted values (SD)	24	23	6	4
R ² (observed vs predicted)	0.01	0.006	0.332	0.037
RMSPE ^b	37	48	19	8

^aAc = acetate; Pr = propionate; Bu = butyrate; Bc = other VFAs.

^bRMSPE = root of mean squared prediction error = $\sqrt{[\sum(O_i - P_i)^2/n]}$, where $i = 1, 2, \dots, n$; n = number of experimental observations, and O_i and P_i are the observed and predicted values.

accounted for, except for Bu ($R^2 = 0.332$), where also the prediction error was smaller than for the other VFAs.

Using only the concentrate set increased the error for the C_{TD} coefficients, when applied to all the 33 diets. When the concentrate sets of the C_{OR} and C_{TD} coefficients were applied only to the 17 concentrate diets, the fit was somewhat better than what can be seen in Table 1.2. For the C_{OR} set, the R^2 was 0.16, 0.17 and 0.28 for Ac, Pr and Bu, respectively. For the C_{TD} set, the corresponding R^2 values were 0.05, 0.16 and 0.32.

As the number of diets in this evaluation is very small, for reasons described earlier, it probably does not give a very clear picture of the value of the coefficient sets tested for predicting VFAs from Nordic diets. There were, however, some other reasons for developing a new VFA sub-model for the Nordic dairy cow model, Karoline, rather than using these or other previously published coefficients. One thing is that we did not want to base the model structure on cellulose and hemicellulose as separate substrates, in order to keep down the feed analysis costs for the model that is supposed to be used in farming practice. Another reason that can be mentioned is that we wanted to account for the effect of lactate from silage on rumen VFA pattern.

Multiple Regression Models

To investigate relationships between dietary factors and MPs of the three major VFAs, we made a multiple linear regression analysis, using the whole database ($n = 107$), including both measured and estimated values for rumen digestion.

These regression equations (multiple regression model 1, see Table 1.3) explained more of the variation for Ac ($R^2 = 0.605$) and Pr ($R^2 = 0.580$) than for Bu ($R^2 = 0.409$). Increasing amounts of ruminally degraded CP increased the proportions of Ac and Pr at the expense of Bu. Ac proportion increased, but Bu decreased, with increasing levels of fNDF and cNDF. Ruminally digested St had a surprisingly small effect on VFA pattern, except for a negative effect on Bu proportion. This might at least partly be explained by the relatively low average St content (166.2 g/kg DM, see Table 1.1) of the 107 diets used in our study, of which only 40 had more than 200 g St/kg DM and only 12 more than 250 g St/kg DM. Also, the average rumen pH is high (Table 1.1); only for 9 of the 107 diets it was less than 6.0. LA increased Pr dramatically and also Bu, but to a lesser extent. The Re fraction also increased Pr, but decreased Ac.

The addition of two more variables recorded in the database – DM intake (DMI; g/kg of body weight (BW)) and cEE (g/kg diet DM) – explained some of the variation not accounted for by the six digested substrate classes (multiple regression model 2, see Table 1.4). An increase in both of these variables increased Pr at the expense of Ac, but the effects of the six substrate classes on VFA pattern was similar as before the inclusion of these variables. Adding these two variables also improved R^2 and RMSPE for Ac and Pr. Including pH measured in rumen digesta, concentrate proportion in the diet or other variables from the database did not add significantly to the explanation of the VFA pattern found by multiple regression model 2. This was to be expected because other strongly correlated factors were already included.

Table 1.3. Multiple regression equations^a of molar proportions of individual VFAs (mmol/mol VFA) upon rumen digested substrates^b (g/kg diet DM). Standard errors of parameter estimates are in parentheses. The regressions are based on 107 experimental treatments in 29 Nordic dairy cow experiments.

	Ac		Pr		Bu	
Constant	591.0	(34.8)	148.9	(25.9)	260.1	(24.7)
CP ^b	0.165	(0.076)	0.122	(0.057)	-0.287	(0.054)
LA	-0.585	(0.100)	0.439	(0.074)	0.145	(0.071)
fNDF	0.368	(0.100)	-0.096 ^{NS}	(0.075)	-0.272	(0.071)
cNDF	0.250	(0.057)	-0.038 ^{NS}	(0.042)	-0.211	(0.041)
St	0.064 ^{NS}	(0.055)	0.063 ^{NS}	(0.041)	-0.126	(0.039)
Re	-0.111	(0.052)	0.112	(0.039)	-0.002 ^{NS}	(0.037)
R^2	0.605		0.580		0.409	
RMSPE ^c	15.5		11.8		11.1	
RMSPE% ^d	2.3		6.1		8.0	

^aCoefficient values without superscripts are statistically significantly different from zero ($P < 0.05$); NS = not significant.

^bCP = crude protein; LA = lactic acid; fNDF = forage NDF; cNDF = concentrate NDF; St = starch; Re = total DM – NDF – St – ash – CP – LA – VFA.

^cRMSPE = root of mean squared prediction error = $\sqrt{[\sum(O_i - P_i)^2/n]}$; where $i = 1, 2, \dots, n$; n = number of experimental observations, and O_i and P_i are the observed and predicted values.

^dRMSPE% = (RMSPE/average observed value) \times 100.

Table 1.4. Multiple regression equations^a presenting relationships between molar proportions of individual VFAs (mmol/mol VFA) vs g/kg DM of six classes of digested substrates^b and additional correction for feeding level and level of concentrate ether extract. Standard errors of parameter estimates are in parentheses. The regressions are based on 107 experimental treatments in 29 dairy cow experiments carried out in the Nordic countries.

	Ac		Pr		Bu	
Constant	638.6	(35.7)	101.9	(24.9)	259.5	(27.4)
CP	0.302	(0.079)	-0.008 ^{NS}	(0.055)	-0.293	(0.060)
LA	-0.623	(0.095)	0.474	(0.067)	0.150	(0.073)
fNDF	0.294	(0.095)	-0.026 ^{NS}	(0.067)	-0.268	(0.073)
cNDF	0.176	(0.059)	0.035 ^{NS}	(0.041)	-0.211	(0.045)
St	0.027 ^{NS}	(0.053)	0.098	(0.037)	-0.125	(0.040)
Re	-0.171	(0.051)	0.170	(0.036)	0.000 ^{NS}	(0.039)
FL ^c	-9.69	(4.16)	9.78	(2.91)	-0.09 ^{NS}	(3.20)
cEE ^d	-0.565	(0.179)	0.526	(0.125)	0.039 ^{NS}	(0.137)
R ²	0.663		0.683		0.409	
RMSPE	13.6		9.3		11.2	
RMSPE%	2.0		4.8		8.1	

^aCoefficient values without superscripts are statistically significantly different from zero ($P < 0.05$); NS = not significant.

^bCP = crude protein; LA = lactic acid; fNDF = forage NDF; cNDF = concentrate NDF; St = starch; Re = total DM - NDF - St - ash - CP - LA - VFA.

^cFeeding level (FL) = total dry matter intake (DMI) per kg live weight (LW).

^dcEE = concentrate ether extract (g/kg DM).

Stoichiometrical Model

Based on the information gained by the multiple regression analysis, we constructed a stoichiometrical model that would at least account for the effects of the six substrate classes in the previous regression equations. We used the same model structure as Bannink *et al.* (2000), except that substrate classes were defined differently, as in the multiple regression analysis, and we only represented the three major VFAs, Ac, Pr and Bu. We assumed that per mol of amino acid equivalent, hexose and lactate, 1.1, 2.0 and 1.0 mol of pyruvate was formed, respectively; and that 1.0, 1.0 and 0.5 mol of Ac, Pr and Bu, respectively, was formed per mol of pyruvate used. Based on these assumptions, the following set of fermentation equations were derived:

$$P_{Ac} = U_{CP} \times C_{CP, Ac} \times 1.1 + U_{La} \times C_{La, Ac} + \left[U_{fNDF} \times C_{fNDF, Ac} + U_{cNDF} \times C_{cNDF, Ac} + U_{St} \times C_{St, Ac} + U_{Re} \times C_{Re, Ac} \right] \times 2$$

$$P_{Pr} = U_{CP} \times C_{CP, Pr} \times 1.1 + U_{La} \times C_{La, Pr} + \left[U_{fNDF} \times C_{fNDF, Pr} + U_{cNDF} \times C_{cNDF, Pr} + U_{St} \times C_{St, Pr} + U_{Re} \times C_{Re, Pr} \right] \times 2$$

$$P_{Bu} = U_{CP} \times C_{CP, Bu} \times 1.1/2 + U_{La} \times C_{La, Bu}/2 + U_{fNDF} \times C_{fNDF, Bu} + U_{cNDF} \times C_{cNDF, Bu} + U_{St} \times C_{St, Bu} + U_{Re} \times C_{Re, Bu}$$

$$MP_{Ac} = P_{Ac} / (P_{Ac} + P_{Pr} + P_{Bu})$$

$$MP_{Pr} = P_{Pr} / (P_{Ac} + P_{Pr} + P_{Bu})$$

$$MP_{Bu} = P_{Bu} / (P_{Ac} + P_{Pr} + P_{Bu})$$

where P_i = production rate of VFA_{*i*} (mol/day), MP_i = molar proportion of VFA_{*i*} (mol/mol), U_j = utilization rate of substrate *j* (mol/day) and $c_{j,i}$ = fraction of substrate *j* converted to VFA_{*i*} (mol/mol).

Microbial growth was not represented in the stoichiometrical model, assuming that partitioning between VFA production and microbial growth is equal for different substrate types. This assumption was supported by the study of Bannink *et al.* (2000), who found relatively small effects on coefficient estimates, except for CP, when they replaced rates of substrates truly digested with rates of substrate converted to VFA, obtained by running the rumen digestion model of Dijkstra *et al.* (1992).

We used the Solver tool (Fylstra *et al.*, 1998) in Microsoft® Excel, which employs the generalized reduced gradient (GRG2) non-linear optimization code (Lasdon *et al.*, 1978). This method was used to fit stoichiometrical coefficients ($c_{j,i}$) to the model described above, by minimizing RMSPE for VFA MPs in rumen fluid. All the 107 diets in the database were used for this analysis. Coefficient values (c_{iAc} , c_{iPr} , c_{iBu}) for all substrates except CP were constrained such that their sums were forced to unity and negative values were not allowed. We assumed that for CP, one-third was converted to branch-chained fatty acids.

Estimated coefficient values for this model (stoichiometrical model 1) are presented in Table 1.5. The variations in coefficients imply that the different substrates are fermented in a different pattern, as suggested by the multiple regression models presented in Tables 1.3 and 1.4. For example, more than half of the LA was estimated to convert into Pr, with the remaining nearly equally divided between Ac and Pr. These proportions were similar to those found by Jaakkola and Huhtanen (1992) from rumen infusion of lactate.

Stoichiometrical Model with Corrections

The inclusion of FL and cEE described additional variation, not accounted for by the six substrate classes in the multiple regression analysis shown earlier (Tables 1.3 and 1.4). These variables were therefore incorporated into the stoichiometrical model to estimate new MPs of VFA (*MP) in the following way:

$$*MP_{Ac} = MP_{Ac} + cEE \times a_{Ac} + FL \times b_{Ac}$$

$$*MP_{Pr} = MP_{Pr} + cEE \times a_{Pr} + FL \times b_{Pr}$$

$$*MP_{Bu} = MP_{Bu} + cEE \times a_{Bu} + FL \times b_{Bu}$$

Table 1.5. Estimated coefficients for stoichiometrical model with six classes of rumen digested substrates.^a

	Ac	Pr	Bu
CP	0.402	0.172	0.080
LA	0.257	0.520	0.223
fNDF	0.812	0.080	0.108
cNDF	0.788	0.132	0.080
St	0.656	0.199	0.145
Re	0.574	0.243	0.184
R^2	0.565	0.558	0.178
RMSPE	21.2	15.4	16.9
RMSPE%	3.2	8.0	12.2

^aCP = crude protein; LA = lactic acid; fNDF = forage NDF; cNDF = concentrate NDF; St = starch; Re = total DM – NDF – St – ash – CP – LA – VFA.

where cEE = concentrate ether extract (g/kg DM), FL = feeding level (kg DM/day/kg BW), a_i = factor correcting the MP of VFA_{*i*} for cEE, and b_i = factor correcting the MP of VFA_{*i*} for FL.

This model (stoichiometrical model 2) was fitted by the same method, as described earlier for stoichiometrical model 1. FL and cEE had again positive effects on Pr proportion, especially at the expense of Ac (Table 1.6). The stoichiometrical coefficients did not differ much from those found for stoi-

Table 1.6. Coefficients fitted to stoichiometrical model with six classes of digested substrates^a and with corrections for feeding level (FL) and concentrate ether extract (cEE).

	Ac	Pr	Bu
CP	0.402	0.172	0.080
LA	0.255	0.514	0.231
fNDF	0.815	0.080	0.105
cNDF	0.792	0.125	0.083
St	0.669	0.180	0.151
Re	0.585	0.227	0.188
FL	–0.508	0.665	–0.250
cEE	–0.333	0.442	–0.099
R^2	0.582	0.618	0.182
RMSPE	20.8	14.4	16.8
RMSPE%	3.1	7.5	12.1

^aCP = crude protein; LA = lactic acid; fNDF = forage NDF; cNDF = concentrate NDF; St = starch; Re = total DM – NDF – St – ash – CP – LA – VFA.

chiometrical model 1 (Table 1.5), but the fit of the model was improved (compare R^2 and RMSPE values in Tables 1.5 and 1.6). However, the improvements were smaller, compared to what was seen for the multiple regression analysis (compare R^2 and RMSPE values in Tables 1.3 and 1.4). Both stoichiometrical models also had somewhat poorer fits, especially for Bu, than for the corresponding multiple regression models (Table 1.5 vs Table 1.3 and Table 1.6 vs Table 1.4).

Model Evaluation

As all relevant Nordic VFA data were used to fit the models described earlier (see Tables 1.3–1.6 and text), a comparable data-set for a completely independent evaluation was not available. However, the two multiple regression models and the two stoichiometrical models were all tested on a subset with 33 diets, used earlier (Table 1.2) to test two sets of coefficients from literature. The results of this validation are shown in Table 1.7. Average predicted values from all the models were similar to observed values, but the range of values (standard deviations) were smaller for predicted than observed VFA proportions, especially for the two stoichiometrical models. This has also been found in previous attempts to predict VFA MPs (Murphy *et al.*, 1982; Pitt *et al.*, 1996; Bannink *et al.*, 2000), but is not found when simulated, or observed, and predicted VFA production rates are compared (Murphy *et al.*,

Table 1.7. Mean (and standard deviation; sd) of observed values and values of VFA molar proportions^a predicted by the different models presented in Tables 1.3–1.6 when applied to a sub-data-set of 33 Nordic diets fed to lactating dairy cows.

	Ac	Pr	Bu
Observed	656.2 (35.5)	201.6 (19.9)	142.2 (23.0)
Multiple regression model 1 (Table 1.3)	655.5 (27.0)	203.6 (15.7)	140.9 (15.0)
Multiple regression model 2 (Table 1.4)	657.8 (27.9)	201.3 (17.9)	140.9 (14.9)
Stoichiometrical model 1 (Table 1.5)	655.2 (23.4)	202.6 (15.1)	142.1 (8.7)
Stoichiometrical model 2 (Table 1.6)	656.1 (23.8)	201.1 (16.2)	142.7 (9.0)
R^2			
Multiple regression model 1 (Table 1.3)	0.482	0.368	0.432
Multiple regression model 2 (Table 1.4)	0.610	0.636	0.438
Stoichiometrical model 1 (Table 1.5)	0.484	0.349	0.285
Stoichiometrical model 2 (Table 1.6)	0.529	0.546	0.295
RMSPE (mmol/mol VFA) ⁽¹⁾			
Multiple regression model 1 (Table 1.3)	19.0 (2.9%)	13.2 (6.5%)	14.4 (10.1%)
Multiple regression model 2 (Table 1.4)	15.5 (2.4%)	9.8 (4.9%)	14.3 (10.1%)
Stoichiometrical model 1 (Table 1.5)	25.2 (3.8%)	16.1 (8.0%)	19.5 (13.7%)
Stoichiometrical model 2 (Table 1.6)	24.1 (3.7%)	13.3 (6.6%)	19.3 (13.6%)

^aValues in parentheses are RMSPE%, i.e. RMSPE as a percentage of average observed values.

1982; Bannink *et al.*, 2000). The lack of variation in predicted VFA MPs compared to observed VFA MPs seems to be caused by regressing MPs of VFAs that sum up to unity and are not independent (Bannink *et al.*, 2000). So, although VFA proportions predicted by these models reflect the major influences of various factors upon rumen fermentation, they cannot be expected to cover as broad a range as found *in vivo*.

As expected, the fit of equations was poorer when they were applied to the subset (Table 1.7), compared to the fit when they were applied to the whole data-set from which they had been derived (Tables 1.3–1.6). As before, the multiple regression equations fitted better than the corresponding stoichiometrical models, and stoichiometrical model 2 was superior to stoichiometrical model 1.

Choice of VFA Model for Use in the Nordic Dairy Cow Model, Karoline

We are presently using stoichiometrical model 2 as a rumen VFA model in the Nordic dairy cow model, Karoline (see Danfær *et al.*, Chapter 32, this volume). The reason for this choice is that in spite of a better fit for the multiple regression models, a stoichiometrical approach is in better accordance with other parts of the Karoline model, where all substrates entering the rumen are accounted for on the basis of carbon and nitrogen mols. Also, the intercept values that are fitted in the multiple regression models have relatively greater impact on their predictions, but result in coefficient values for individual substrates that do not make sense, stoichiometrically. What we learned from the multiple regression analysis, however, was that FL and cEE described some of the variation in VFA MPs, not accounted for by digested substrates. These variables were therefore incorporated into a corrected stoichiometrical model, which resulted in an improved performance. It must be emphasized that our purpose was to develop a model that would relate the proportions of VFA to the most important characteristics of feeds and feeding systems used in the Nordic countries, but not to come up with a model that would have general applicability to all feeding situations. Dairy cow diets in the Nordic countries are dominated by high levels of rapidly digested grass silage and moderate levels of concentrates, most often based on barley and rapeseed meal. Notable rumen lactate concentrations are rarely seen, and the main response to increased grain feeding is normally an elevated Bu proportion (Murphy, 1989; Jaakkola and Huhtanen, 1993). Therefore, we used all data available for the purpose of establishing our model, which means that a comparable data-set for a completely independent evaluation is not available. While tested on a sub-data-set ($n = 33$) of our whole database ($n = 107$), as presented in Table 1.7, the performance of the chosen model (stoichiometrical model 2) can be considered acceptable, at least for Ac and Pr.

It is noted that the model predicts St to have a much smaller effect on the Pr proportion, compared to the model of Murphy *et al.* (1982). The Re fraction, which does not consist only of sugars, yields somewhat more Pr than St.

Considerable amounts of lactate may be produced from St and sugars, but high numbers of lactate-fermenting bacteria compared to Pr and Ac have been seen as a response to high grain feeding (Murphy, 1989). Also, the practice in the Nordic countries to feed unwilted grass silage may ensure a daily supply of lactate that may maintain a large amount of lactate-fermenting bacteria in the rumen. Feeding barley-based supplements with grass silage increases rumen protozoa population (Chamberlain *et al.*, 1983; Jaakkola and Huhtanen, 1993). This may explain increased Bu but only small effects on Pr with increasing barley-based supplementation. Replacement of barley by unmolassed sugarbeet pulp (Huhtanen, 1988; Murphy *et al.*, 1993) or barley fibre (Huhtanen, 1992), or delaying harvest time of grass for silage (Rinne *et al.* 1996, 1997), has even resulted in an increase of Pr, mainly at the expense of Bu. These responses were, at least partly, associated with decreases in protozoa population when NDF concentration in the diet was increased. Increases in MPs of Pr are normally not found with increasing levels of barley-based concentrate, when diets are based on restrictively fermented grass silage (Huhtanen, 1998).

It is a great challenge to develop a model that would describe the major metabolic pathways and species interactions in the rumen so well that VFA proportions would be predicted with acceptable accuracy in all feeding situations. Until this has been achieved, however, it seems that VFA models used in practice must be developed with respect to the feeds and feeding systems where they will be used.

Areas for Improvements

The stoichiometrical approach to rumen fermentation assumes that an individual substrate always yields the same VFA pattern, irrespective of diet concentration. This might not be true, considering the complex interactions between different microbial species in the rumen. We therefore examined the prediction errors of each diet ($n = 107$) and VFA when stoichiometrical model 2 was used. Multiple linear regression of these prediction errors on concentrations of digested substrates showed that Ac became significantly underpredicted and Bu overpredicted with increasing concentration of digested CP in the diet. At the same time, increasing the concentration of digested fNDF and the Re fraction led to a significant overprediction of Ac and underprediction of Bu by this model.

Based on this analysis, we tried to improve the fit by adding corrections for the concentrations (g/kg DM) of each of the six substrates to the model presented in Table 1.6. This was done by the same model-fitting procedure as before, which resulted in higher R^2 than for the original stoichiometrical model 2 (Fig. 1.1). This exercise demonstrates that part of the variation in VFA pattern can be accounted for by differential substrate effects, depending on diet concentration. It is, however, not yet clear how this should be modelled as it can be argued that adding new components to the model will automatically improve fit. The complexity of the rumen ecosystem makes it a difficult but challenging task to decide which factors

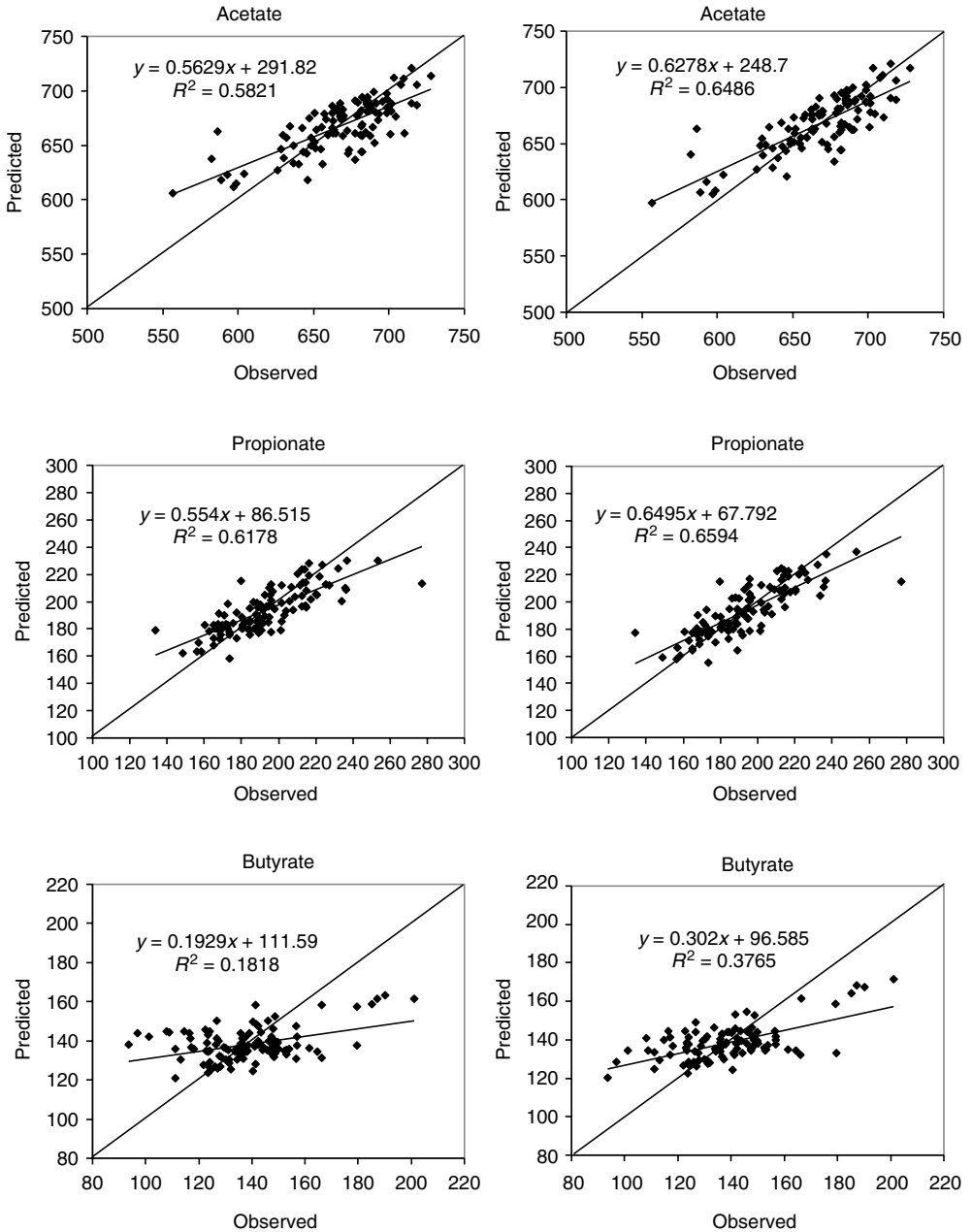

Fig. 1.1. Relationship between observed and predicted VFA molar proportions (mmol/mol). On the left: stoichiometrical model 2 (as recorded in Table 1.6). On the right: stoichiometrical model 2 with corrections for the concentrations (g/kg DM) of each of the six substrates.

should be added to improve the prediction of VFAs from rumen fermentation.

Even though the feeds used for model fitting are described in great detail, analytical improvements are necessary. The Re fraction requires a better description, as it does not contain sugars only. Also, in some cases ruminal NDF digestibility values were estimated from *in situ* degradation rates, which are far from being a precise measurement, as shown by Lund *et al.* (2004).

Conclusions

Our analysis of Nordic experimental data resulted in the definition of six classes of rumen digestible substrates that had different fermentation patterns. These were CP, lactate, fNDF, cNDF, St and an Re fraction. Silage is an important part of Nordic dairy cow diets, and lactate, contributed by this feed, was shown to have a substantial effect on the VFA pattern. Multiple regression analysis indicated that, in addition to the six substrate pools, FL and cEE in the diet explained a significant part of the variation in VFA pattern. This led to the development of a stoichiometrical model including the six substrate classes and the two additional factors. This model is presently used in the Nordic dairy cow simulation model, Karoline. An examination of prediction errors of this model also showed that some substrates contribute differently to the VFA pattern, depending on their dietary level.

References

- Bannink, A., Kogut, J., Dijkstra, J., France, J., Tamminga, S. and Van Vuuren, A.M. (2000) Modelling production and portal appearance of volatile fatty acids in dairy cows. In: McNamara, J.P., France, J. and Beever, D.E. (eds) *Modelling Nutrient Utilization in Farm Animals*. CAB International, Wallingford, UK, pp. 87–102.
- Chamberlain, D.G., Thomas, P.C. and Anderson, F.J. (1983) Volatile fatty acid proportions and lactic acid metabolism in the rumen of sheep and cattle receiving silage diets. *Journal of Agricultural Science, Cambridge* 101, 47–58.
- Dijkstra, J. (1994) Simulation of the dynamics of protozoa in the rumen. *British Journal of Nutrition* 72, 679–699.
- Dijkstra, J., Neal, H.D.St.C., Beever, D.E. and France, J. (1992) Simulation of nutrient digestion, absorption and outflow in the rumen: model description. *Journal of Nutrition* 122, 2239–2256.
- Fylstra, D., Lasdon, L., Watson, J. and Waren, A. (1998) Design and use of the Microsoft Excel Solver. *Interfaces* 28, 29–55.
- Huhtanen, P. (1988) The effects of supplementation of silage diet with barley, unmolassed sugar beet pulp and molasses on organic matter, nitrogen and fibre digestion in the rumen of cattle. *Animal Feed Science and Technology* 20, 259–278.
- Huhtanen, P. (1992) The effects of barley vs barley fibre with or without distillers solubles on site and extent of nutrient digestion in cattle fed grass silage based diets. *Animal Feed Science and Technology* 36, 319–337.

- Huhtanen, P. (1998) Supply of nutrients and productive responses in dairy cows given diets based on restrictively fermented silage. *Agricultural and Food Science in Finland* 7, 219–250.
- Jaakkola, S. and Huhtanen, P. (1992) Rumen fermentation and microbial protein synthesis in cattle given intraruminal infusions of lactic acid with a grass silage based diet. *Journal of Agricultural Science, Cambridge* 119, 411–418.
- Jaakkola, S. and Huhtanen, P. (1993) The effects of the forage preservation method and the proportion of concentrate on nitrogen digestion and rumen fermentation in cattle. *Grass and Forage Science* 48, 146–154.
- Lasdon, L., Waren, A., Jain, A. and Ratner, M. (1978) Design and testing of generalized reduced gradient code for non-linear programming. *ACM Transactions on Mathematical Software* 4, 34–49.
- Lund, P., Weisbjerg, M.R., Ahenjärvi, S., Huhtanen, P., Udén, P., Olafsson, B. and Volden, H. (2004) Nordic ring test on INDF and NDF degradation characteristics in three feeds. *Journal of Animal and Feed Sciences* 13, Suppl. 1, 139–142.
- Murphy, M. (1989) The influence of non-structural carbohydrates on rumen microbes and rumen metabolism in milk-producing cows. PhD thesis, Swedish University of Agricultural Sciences, Uppsala, Sweden.
- Murphy, M., Khalili, H. and Huhtanen, P. (1993) The substitution of barley by other carbohydrates in grass silage based diets to dairy cows. *Animal Feed Science and Technology* 41, 279–296.
- Murphy, M.R., Baldwin, R.L. and Koong, L.J. (1982) Estimation of stoichiometric parameters for rumen fermentation of roughage and concentrate diets. *Journal of Animal Science* 55, 411–421.
- Pitt, R.E., Van Kessel, J.S., Fox, D.G., Pell, A.N., Barry, M.C. and Van Soest, P.J. (1996) Prediction of ruminal volatile fatty acids and pH within the net carbohydrate and protein system. *Journal of Animal Science* 74, 226–244.
- Rinne, M., Jaakkola, S. and Huhtanen, P. (1996) Maturity effects of grass ensiled on diet digestion by dairy cows. *Proceedings of the 11th International Silage Conference*. Aberystwyth, Wales, pp. 196–197.
- Rinne, M., Jaakkola, S. and Huhtanen, P. (1997) Grass maturity effects on cattle fed silage-based diets: 1. Organic matter digestion, rumen fermentation and nitrogen utilization. *Animal Feed Science and Technology* 67, 1–17.
- Russell, J.B., O'Connor, J.D., Fox, D.G., Van Soest, P.J. and Sniffen, C.J. (1992) A net carbohydrate and protein system for evaluating cattle diets: I. Ruminant fermentation. *Journal of Animal Science* 70, 3551–3561.

2

A Three-compartment Model of Transmembrane Fluxes of Valine across the Tissues of the Hindquarters of Growing Lambs Infected with *Trichostrongylus colubriformis*

N.C. ROY,¹ E.N. BERMINGHAM^{1,2} AND W.C. McNABB¹

¹Metabolism and Microbial Genomics, Food and Health Group, AgResearch Limited, Grasslands Research Centre, Private Bag 11008, Palmerston North, 5301, New Zealand; ²Livestock Industries, CSIRO, Perth, Australia

Abstract

This review outlines the assumptions of a three-compartment model that describes amino acid (AA) kinetics in the tissues of the hindlimb or hindquarters. As well as determining the appearance and disappearance of AAs, this model predicts the transport of AAs into and out of the intracellular pool of this tissue bed. This model was used by Roy *et al.* to estimate the transmembrane kinetics of valine across the total hindquarter tissues of lambs with an established *Trichostrongylus colubriformis* infection. Briefly, six lambs were infected with *T. colubriformis* (6000/day for 6 days) while six lambs were kept as parasite-free controls (day 1 of infection). All lambs were offered Sulla (*Hedysarum coronarium*) at 800 g DM/day. On day 48 post infection, the lambs received a continuous infusion of [3,4-³H]-valine (5.8 MBq/h) into the jugular vein and indocyanin green (ICG; 14.6 mg/h) into the abdominal aorta for 8 h to measure total hindquarter blood flow. Blood was continually harvested every 2 h during the infusion period from the vena cava and mesenteric artery in order to determine the isotopic activity of valine, concentration of valine and ICG in plasma. The lambs were euthanized whilst these infusions were still running and a tissue sample was collected from a hindquarter muscle (*biceps femoris*) to determine the isotopic activity of valine in the muscle intracellular pool. Transmembrane valine kinetics in the tissues of the hindquarters were calculated using both a two- and three-compartment model. Intestinal worm burdens on day 48 post infection were significantly higher ($P < 0.10$) in the infected lambs. Valine inflow to (F_{ao}) and outflow from (F_{ov}) the intracellular free AA pool in the tissues of the hindquarters were similar between treatments, and consequently net balance (NB) of valine was not altered. Bypass of valine flow (F_{va}) from arterial to venous blood was unaffected ($P > 0.10$) by infection. However, valine transport kinetics (F_{ta} and F_{vt}) were reduced 48 days after parasitic infection. Estimates of valine used for protein synthesis and oxidation (F_{ot} ; $P = 0.10$) and released from protein degradation (F_{to} ; $P = 0.18$) were also lower in the infected lambs. These reductions could be responsible for the relative preservation of the skeletal muscle protein mass

that seems to be apparent at day 48 post infection. The three-compartment model of AA kinetics in the tissues of the hindquarters appears to provide more precise information on the effect of the parasitic infection on its AA metabolism and protein turnover, compared to that obtained with the two-compartment model.

Introduction

The discovery of the dynamic nature of protein in the body, now commonly known as protein turnover, has been a major turning point for understanding the central aspect of overall metabolic and physiological homeostasis (Wolfe, 1992). Application of radioactive and stable isotope tracer methodology to understand the dynamics between free AAs in the bloodstream and in the cytosol and tissue proteins has played an important role in advancement of this field in the last century. None the less, the enormously complex physiological system of AA and protein kinetics means that earlier estimates of protein turnover were based on a very simple model of this system, mainly at the whole body level (Waterlow *et al.*, 1978).

In the early 1960s, surgical techniques were developed to modify ruminant tissues in a way that allowed the NB of AAs across tissue beds to be measured. Briefly, indwelling catheters were inserted into the blood vessel(s) that irrigate and drain tissue bed(s) under general anaesthesia. Later on, this transorgan model was combined with the use of labelled AAs to follow their rate of disposal including their use for protein synthesis. Together these techniques have provided the tools for delineating the metabolic processes related to AA metabolism in tissue beds.

The cell membrane is the principal physical barrier limiting protein and AA movement between different metabolic compartments in an organism and is an important factor for overall control of whole-body protein metabolism (Taylor and Low, 1999). With the development of computer software the complexity of biological systems has been more thoroughly represented. Indeed, metabolic events occurring across the plasma membrane of cells can now be studied. The most quantitatively important sites of AA transport are the skeletal muscle, the kidneys, the splanchnic tissues (notably the small intestine and liver) and the mammary gland. This is either due to their importance in protein turnover or AA metabolism (Rennie *et al.*, 1996).

The Model

Most of the measurements of AA transport have been carried out *in vitro* using analogues of AAs (McGivan, 1996). *In vivo*, an alternative that takes into account transmembrane AA transport is to use a continuous infusion of a labelled AA into the bloodstream and to collect, at plasma steady state, samples of plasma and tissue (by either biopsy or a terminal procedure) in order to measure isotopic activity and/or concentration of the AA in these pools.

This three-compartment model described by Biolo *et al.* (1992, 1994, 1995) allows the quantification of intracellular AA kinetics, including transmembrane transport of AAs and the appearance (proteolysis/*de novo* AA synthesis) or removal (protein synthesis/AA oxidation) of tissue free AAs due to cell metabolism. The three-compartment model that is depicted in Fig. 2.1 allows assessment of various kinetic parameters.

The difference between the rate of AA inflow to (F_{ao} , equation (2.1)), and outflow from (F_{ov} , equation (2.2)), the hindlimb tissues enables the NB of an AA across these tissues to be determined as follows:

$$F_{ao} = AA_a \times \text{plasma flow} \tag{2.1}$$

$$F_{ov} = AA_v \times \text{plasma flow} \tag{2.2}$$

where AA_a and AA_v are the concentrations of an amino acid in the artery and vein, respectively.

The NB can also be calculated as the difference between the net movement (or transport) of an AA from arterial plasma to the tissues (F_{ta} , equation

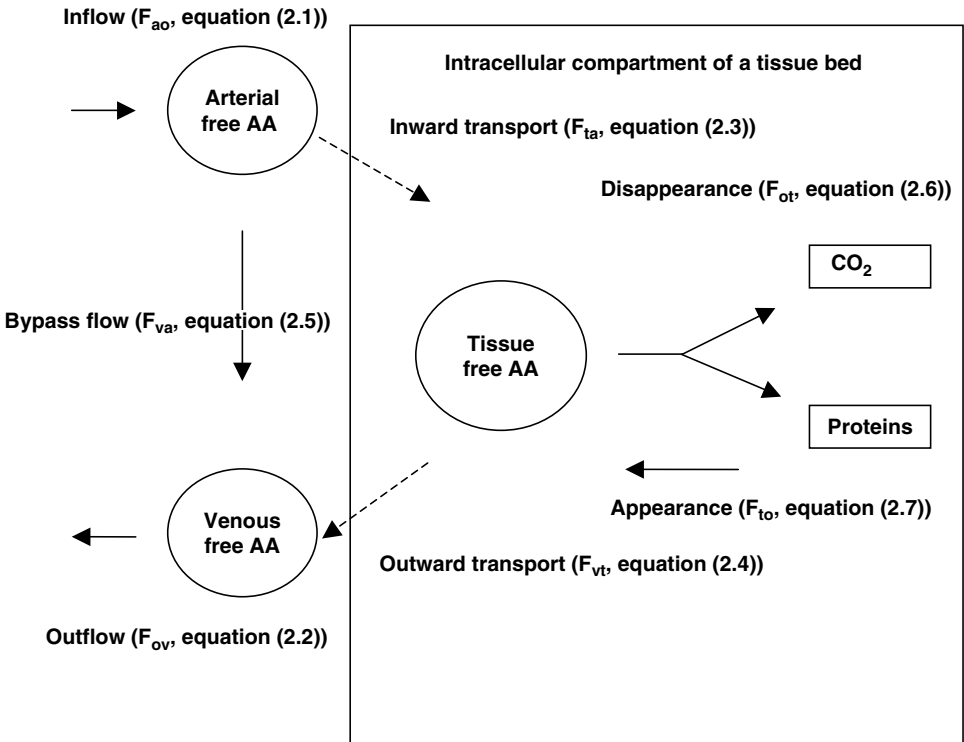

Fig. 2.1. Description of a three-compartment model of amino acid kinetics across a tissue bed based on the model described by Biolo *et al.* (1992). The arrows indicate the unidirectional amino acid flow between each compartment, where AA = concentration of amino acid.

(2.3)) and the transport of an AA from the tissue free pool to the venous drainage (F_{vt} , equation (2.4)). Bypass of an AA (F_{va} , equation (2.5)) from the arterial pool directly to the venous drainage (i.e. AA that does not enter into the cells) can also be calculated:

$$F_{ta} = \text{plasma flow} \times \left\{ \frac{[(AAIE_t - AAIE_v) / (AAIE_a - AAIE_t)] \times AA_v + AA_a \right\} \quad (2.3)$$

where AAIE is the isotopic enrichment of an amino acid.

$$F_{vt} = \text{plasma flow} \times \left\{ \frac{[(AAIE_t - AAIE_v) / (AAIE_a - AAIE_t)] \times AA_v + AA_v \right\} \quad (2.4)$$

$$F_{va} = F_{ao} - F_{ta} \quad (2.5)$$

The NB can also be calculated by the difference between the rates of disposal (F_{ot} , equation (2.6)) and appearance (F_{to} , equation (2.7)) of an AA:

$$F_{ot} = \frac{[AA_a \times AAIE_a] - [AA_v \times AAIE_v]}{AAIE_m} \times \text{plasma flow} \quad (2.6)$$

$$F_{to} = [(F_{ta} \times AAIE_a / AAIE_m) - 1] \quad (2.7)$$

The disposal rate is estimated by the transfer of an AA from the tissue free pool to the protein-bound pool and other pools, i.e. protein synthesis plus oxidation (F_{ot}). If lysine or phenylalanine is used as a tracer, F_{ot} will represent the rate of protein synthesis in the hindlimb only. Similarly, the transfer of an endogenous AA to the tissue free pool (F_{to}) represents the appearance of an AA, i.e. protein degradation and endogenous AA synthesis. If an essential AA (except branched-chained AAs unless the rate is corrected for transamination of the ketoacid to branched-chained AAs) is used as a tracer, F_{to} will equal the rate of protein degradation. The sum of inward transport of an AA (F_{ta}) and that appearing in the intracellular pool from endogenous sources (F_{to}) represents the total intracellular appearance of an AA (R_{at}). Overall, the physiological and isotopic steady state used for the three-compartment model means less biological samples (plasma and tissue) and simplified calculations are required.

Ideally the three-compartment model described above is best suited to a homogenous tissue bed and thus assumes, for the tissue arteriovenous preparation, that the isotopic activity and concentration of an AA in tissue is representative of the whole tissue preparation. This three-compartment model had been developed by Biolo *et al.* (1992) to study the AA kinetics across a hindlimb arteriovenous preparation where the deep femoral vein was used as the venous drainage site in an attempt to achieve the minimal contribution from non-muscular tissues (e.g. muscle, skin, bone and fat). The first three components are known to make a substantial and different contribution to protein turnover of the hindlimb (Biolo *et al.*, 1992; Loblely *et al.*, 1992). In practice, the similarity between intracellular AA enrichment in muscle and skin

(ratio of approximately 1.0 when valine, phenylalanine or alanine is used as a tracer; Biolo *et al.*, 1992) allows the hindlimb to be treated as a single homogeneous tissue. Moreover, it is reasonable to presume that blood flow is distributed in the hindlimb in proportion to the metabolic activity of the tissue. For example, the more active tissues such as muscle represent 68% of the blood flow through the hindlimb while the skin (9%) and bone (8%) together account for less than 20%. Biolo *et al.* (1992) have also shown that skin accounts for a negligible fraction of the total NB of AAs across the hindlimb. Furthermore, although the fractional rate of protein synthesis in skin is faster than in skeletal muscle, on an absolute basis, muscle mass accounts for 85–90% of the total hindlimb protein kinetics, while skin accounts for less than 10–15% of the hindlimb protein kinetics (Biolo *et al.*, 1994, 1995).

With the three-compartment model, the estimation of the inward and outward transport rates of an AA is not dependent on the assumption that the labelled AA needs to be essential, not oxidized in the tissue beds, not released from tissue protein during the measurement and not synthesized *de novo*. Therefore, non-essential AAs can be used as tracers to estimate their rates of transport, and multiple labelled AAs (including non-essential) can be simultaneously used to measure the rate of transport of many AAs (Hoskin *et al.*, 2003). In contrast, the rate of intracellular AA disappearance and appearance using a non-essential AA as a tracer cannot be estimated.

The use of the three-compartment model assumes that a steady state has been reached with isotopic activity of plasma, intra- and extracellular compartments as well as between plasma and red blood cells. The isotopic activity of an AA is measured in the free water of the whole muscle harvested. However, 14% of the tissue free water is the extracellular or interstitial space (Horber *et al.*, 1989). The extracellular isotopic activity of an AA is likely to be between plasma and the intracellular space. Biolo *et al.* (1992) have estimated that the error in calculated rates using the values from muscle free water would be less than 7%. Some AA tracers such as labelled leucine and phenylalanine would have a similar isotopic activity between plasma and red blood cells.

The model described above can also be adapted to the tissues of the hindquarters if the catheters for the arterial supply and venous drainage are placed caudal to the entry point of the renal arteries and renal veins, respectively. The assumptions described above are still valid although the contribution of the non-muscular tissues will be higher with the total hindquarter preparation.

Application

The tissues of the hindquarters are negatively affected during an intestinal parasitic infection in ruminants. Increased AA repartitioning from the skeletal muscle to other tissues could explain these well-documented negative impacts on growth performance (Sykes and Coop, 1976; van Houtert *et al.*, 1995), more specifically a decrease in muscle protein synthesis and an

increase in muscle protein degradation (Symons and Jones, 1971, 1972, 1975, 1978). This AA drain might be triggered by the increased demand for AAs to sustain the increased protein synthesis (Symons and Jones, 1983; Yu *et al.*, 2000) and AA oxidation (Yu *et al.*, 2000) observed in the gastrointestinal tract (GIT) during a *T. colubriformis* infection. Protein synthesis in the liver (Symons and Jones, 1971, 1978; Jones and Symons, 1982) and immune tissues (Breuillé *et al.*, 1998) has also been shown to increase during infection and could potentially increase the demand for AAs.

The increased AA requirements by the GIT, liver and immune tissues during infection can be further exacerbated as dietary intake may also be reduced (Sykes *et al.*, 1988), and the composition in AAs of these tissues differs. Therefore, to meet the increased requirements of these tissues, proportionally more muscle protein needs to be mobilized to supply these additional demands (MacRae and Loble, 1991; MacRae *et al.*, 1993). The AAs released from skeletal muscle protein, through increased protein degradation or reduced utilization for protein synthesis or oxidation, that are not required for GIT, hepatic and immune protein synthesis, are likely to be catabolized and therefore represent a further loss of AAs by the animal.

The hypothesis of our study was to test whether the outward transport of AAs from the muscle would be increased following an increase in skeletal muscle protein degradation in order to support the increased demands for AAs in the small intestine and tissues involved in mounting and maintaining the immune response during an intestinal parasitic infection. To achieve that, we measured AA kinetics in the tissues of the sheep hindquarters using the three-compartment model described in this review.

Twelve Romney cross-bred wether lambs (body weight (BW) 33.0 (SE 0.6) kg) offered Sulla (800 g DM/day) were prepared with catheters in the mesenteric artery, abdominal aorta and vena cava as well as in the mesenteric, portal and hepatic veins (Bermingham, 2004). Both abdominal aorta and vena cava catheter placements were caudal to the entry point of the renal arteries and veins, respectively. One week after surgery (day 1 of the experimental period) six sheep were given 6000 *T. colubriformis* L3 larvae/day orally for 6 consecutive days while the remaining six sheep were kept as controls. A completely randomized block design was used. Faecal egg counts from each sheep were determined every second day from day 20 to 45 and intestinal worm burdens were measured after euthanasia (Bermingham, 2004).

On day 48 post infection, the lambs were continuously infused with [3,4-³H]-valine (5.8 MBq/h; Amersham Life Science, Buckinghamshire, UK; containing 1.68 mg/l cold valine) into the jugular vein and ICG (14.6 mg/h) into the abdominal aorta for 8 h to measure blood flow through the hindquarters. Blood was continually harvested every 2 h during the infusion period from the vena cava and mesenteric artery in order to determine the isotopic activity of valine, concentration of valine and ICG in plasma. Upon completion of blood sampling but while [3,4-³H]-valine and ICG were still being administered, the sheep were euthanized. Tissue samples were rapidly collected from the sheep in the following order: skin, muscle (*biceps femoris*),

liver, duodenum and ileum, mesenteric lymph nodes, spleen and thymus, and prepared as described in Bermingham (2004).

The specific radioactivity of plasma valine was calculated by dividing its radioactivity by its concentration (Bermingham, 2004). Plasma flow across the total hindquarters was determined using ICG and the equation described by Wester *et al.* (2000). Transmembrane valine kinetics across the total hindquarters were calculated using a two-compartment model as shown by Harris *et al.* (1992). Transmembrane valine kinetics were calculated using the equations of a three-compartment model described by Biolo *et al.* (1992) and previously in this review. Statistical analysis was performed using a general linear model of SAS Version 8. Least squared means and associated pooled standard deviation are reported. Probabilities lower than 0.05 indicate a significant change, while values between 0.05 and 0.10 indicate a trend.

Intestinal worm burdens on day 48 post infection were significantly higher in the lambs infected with intestinal parasites (Bermingham, 2004). Valine inflow to (F_{ao}), and outflow from (F_{ov}), the intracellular free AA pool of the tissues of the hindquarters were similar ($P > 0.10$) between treatments, and consequently NB of valine was not altered ($P > 0.10$; Fig. 2.2).

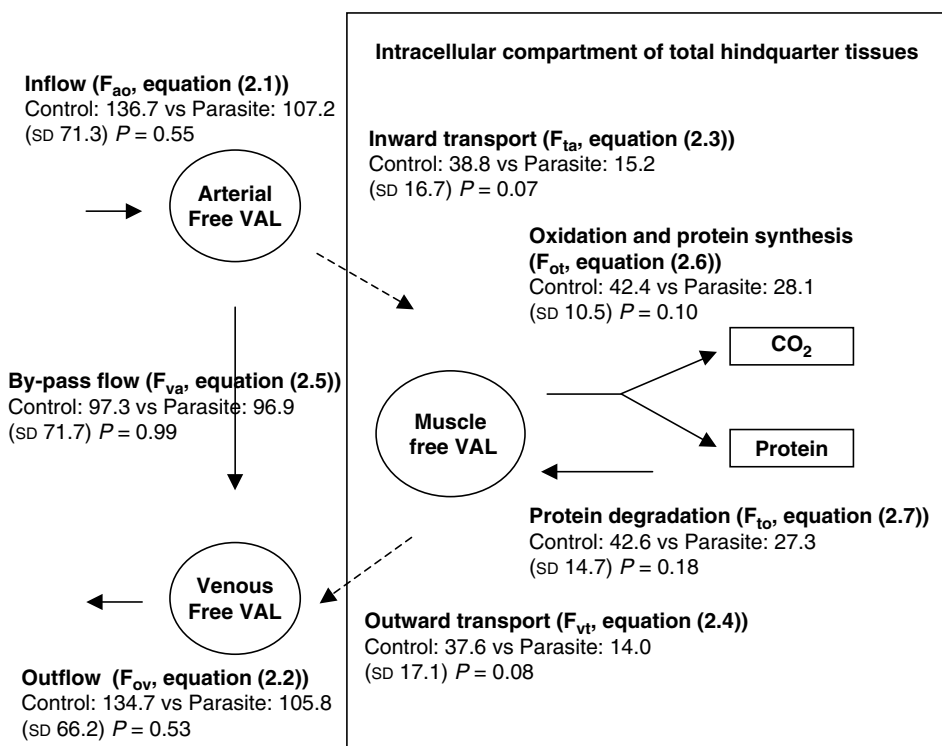

Fig. 2.2. Least squared means and standard deviation (SD) of valine kinetics (mmol/day) across the tissues of the hindquarters in lambs infected with *Trichostrongylus colubriformis* (parasite) or kept as parasite-free controls (control).

Valine irreversible loss rate (ILR) across the hindquarters calculated from arterial precursors using a two-compartment model was unaffected by parasitic infection (34 vs 23 (SD 21.4) mmol/day; $P > 0.10$). However, valine kinetics in the tissues of the hindquarters were altered by the presence of an intestinal parasite infection when calculated using a three-compartment model as indicated in Fig. 2.2. Lower ($P < 0.10$) transport rate of valine into (F_{ta}) and from (F_{vt}) the intracellular free AA pool of the tissues of the hindquarters was observed in infected lambs (Fig. 2.2). The bypass of valine flow (F_{va}) from arterial to venous blood was unaffected by infection ($P > 0.10$; Fig. 2.2). The decreased transport rate of valine was concomitant with a reduction of valine disappearance (F_{ot} , $P = 0.10$) and appearance (F_{to} , $P = 0.18$), suggesting that with the parasitic infection, there was a reduction in protein turnover (Fig. 2.2).

Discussion

Although there was a reduction in feed intake for the infected animals (Bermingham, 2004), this was unlikely to have been responsible for the reduced transport rate as there was no reduction in the arterial inflow of valine to the total hindquarters (F_{ao}) or the net flux of valine (Fig. 2.2). It could be possible that, at day 48 of parasitic infection, the transport rate of valine (and probably other AAs) had been reduced, maybe as a starting point for reducing protein turnover in the tissues of the hindquarters in order to preserve their protein mass. This explanation agrees with the lack of effect of parasitic infection observed on the nitrogen balance and fractional protein synthesis rate of the skeletal muscle and skin in the infected sheep but not with the reduced live weight (LW) gain (Bermingham, 2004).

The lack of increase in the outward transport of valine from the intracellular pool of the tissues of the hindquarters suggests that there was no repartitioning of valine from the total hindquarters to the intestinal tissues despite an increase in the fractional protein synthesis rate of the small intestine smooth muscles and mesenteric lymph nodes (Bermingham, 2004). There was also a reduction of apparent and net absorption of valine from the small intestine that can be attributed to the decreased feed intake observed with parasitic infection. A part of this effect on AA absorption could be explained by an increased utilization of AAs by the intestinal cells to sustain local repair of the damaged intestinal epithelium and for maintaining and controlling the local immune responses.

It would be important to determine if there were a mobilization of skeletal muscle protein at the peak of nematode establishment, i.e. on day 26 post initial infection (Bermingham, 2004). Additionally, how this coordination between tissues has evolved during the course of infection after the peak of establishment also needs to be determined.

The chosen labelled AA for our study (valine) does not meet all the assumptions required for measuring AA kinetics across the tissues of the hindquarters using the three-compartment model as described by Biolo *et al.* (1992). Valine

undergoes its first step of oxidation in the muscle (Rodwell, 2000). Thus, the estimates of intracellular disposal of valine from the free AA pool of the tissues of the hindquarters do not represent an estimate of valine used for protein synthesis but rather an estimate of valine ILR (protein synthesis and oxidation). However, the rate of intracellular production of valine from the free AA pool of the total hindquarters does more or less estimate protein degradation, as valine, an essential AA, does not undergo *de novo* synthesis.

This three-compartment model has also been applied to study the effects of fasting (Biolo *et al.*, 1992, 1994, 1995), undernutrition (Roy *et al.*, 1999) and level of intake (Hoskin *et al.*, 2003) on the AA kinetics in tissues of the hindlimb or hindquarters. Estimated parameter values of the control animals among these studies and the study described in this review using the three-compartment total hindquarter model are generally within a similar range (Table 2.1). The values from Biolo *et al.* (1992) are slightly higher and

Table 2.1. Comparison of amino acid kinetics (mmol/day) across the tissues of the hindquarters and hindlimb in the sheep and dog, respectively, among studies reported in the literature. Mean values and their associated error terms (SD = standard deviation; SEM = standard error of the mean) are reported.

	Bermingham (2004)		Hoskin <i>et al.</i> (2003) ^c	Roy <i>et al.</i> (1999) ^d	Biolo <i>et al.</i> (1992) ^e
	Mean ± SD ^a	Mean ± SD ^b	Mean ± SD	Mean ± SEM	Mean ± SD
F_{ao}^f	136.7 ± 71.3	111.2 ± 36.5	147.0 ± 75.2	40.4 ± 2.0	149.2 ± 7.4
F_{vo}^g	134.7 ± 66.2	106.1 ± 30.6	143.9 ± 74.2	42.6 ± 2.0	166.2 ± 5.4
NB ^h	2.0 ± 9.1	6.3 ± 8.1	Not calculated	2.2 ± 0.2	-15.9 ± 2.2
F_{ta}^i	38.8 ± 16.7	23.5 ± 15.3	34.3 ± 25.9	20.4 ± 2.5	77.5 ± 10.2
F_{vt}^j	37.6 ± 17.1	21.7 ± 16.8	31.1 ± 26.1	22.8 ± 2.4	93.4 ± 8.2
F_{va}^k	97.3 ± 71.7	88.9 ± 37.5	112.8 ± 67.0	20 ± 2.5	72.7 ± 5.1
F_{to}^l	42.6 ± 14.7	40.7 ± 26.3	24.0 ± 31.8	12.3 ± 1.2	53.3 ± 6.7
F_{ot}^m	42.4 ± 10.5	42.5 ± 26.4	20.7 ± 31.5	10.0 ± 1.1	69.2 ± 6.7
R_{at}^n	84.7 ± 19.4	64.2 ± 24.3	Not calculated	32.7 ± 3.1	Not calculated

^a Sheep fed sulla at 800 g DM/day; LW = 29–33 kg.

^b Sheep fed lucerne at 800 g DM/day; LW = 29–33 kg.

^c Sheep fed pelleted grass; LW = 30–35 kg.

^d Sheep fed pelleted rations at 0.6M; LW = 41.9 kg.

^e Dog under anaesthesia and post-absorptive period; LW = 18–26 kg; original hindlimb data multiplied by 2 for comparison with total hindquarter data from Roy *et al.* (1999), Hoskin *et al.* (2003) and Bermingham (2004).

^f F_{ao} : arterial valine inflow into the total hindquarters.

^g F_{vo} : venous valine outflow from the total hindquarters.

^h NB: net balance.

ⁱ F_{ta} : valine inward transport from artery to tissues of the hindquarters.

^j F_{vt} : valine outward transport from tissues of the hindquarters to vein.

^k F_{va} : valine bypass flow from artery to vein.

^l F_{to} : valine released from total hindquarter tissue protein degradation.

^m F_{ot} : valine used for total hindquarter tissue protein synthesis and oxidation.

ⁿ R_{at} : total appearance of valine in intracellular pool of the tissues of the hindquarters.

probably an indication of a post-absorptive state in the dogs used in this study compared to hourly continuous feeding used in the other studies. In contrast, the values of AA kinetics in Roy *et al.* (1999) are lower than in the studies of Hoskin *et al.* (2003) and Bermingham (2004) because the feeding regime in the former study was set at 0.6 maintenance compared to maintenance level for the latter studies.

The estimation of protein synthesis and oxidation (estimated from valine ILR) and protein degradation in the tissues of the hindquarters using the three-compartment model (Hoskin *et al.*, 2003; current study) are 2–4 times higher than those obtained from the traditional two-compartment arteriovenous approach for sheep of a similar age, LW and dry matter intake (DMI) (e.g. Harris *et al.*, 1992; Hoskin *et al.*, 2001). Estimates of protein turnover across the tissues of the hindquarters using the traditional two-compartment model range from 24–30 g protein/day (based on labelled phenylalanine and leucine, respectively; Harris *et al.*, 1992) to 46 g protein/day (based on valine; Hoskin *et al.*, 2001) to 80 g protein/day (current study). However, the traditional two-compartment arteriovenous approach does not take bypass of AAs into consideration and therefore will underestimate protein synthesis if there is a significant bypass of AAs directly from the arterial to venous blood without entry to the intracellular pool. This bypass flow ranged from 53–60 mmol/day (current study) to 110 mmol/day (Hoskin *et al.*, 2003).

Conclusions

A three-compartment model was used in order to calculate total hindquarter intracellular AA kinetics, including transmembrane AA transport, as well as the appearance or removal of tissue AAs due to cell metabolism (proteolysis/*de novo* AA synthesis or protein synthesis/AA oxidation) in sheep with an established parasite infection. Using a two-compartment model, there was no difference either in the net flux of valine or in intracellular valine appearance in, and disappearance from, the tissues of the hindquarters. In contrast, with the three-compartment model, there seems to be a down-regulation of the rate of transport of valine (and probably other AAs) into and from the intracellular free AA pool and a reduction of protein turnover in the tissues of the hindquarters. This could be responsible for the relative preservation of the skeletal muscle protein mass that seems to be apparent at day 48 post infection. Therefore, increased outward transport of valine in order to provide more AA to the affected intestinal tissue does not seem to be apparent on day 48 post infection. Knowledge as to whether there was a mobilization of total hindquarter proteins and increased outward transport of valine from the tissues of the hindquarters to the affected intestinal tissue at the peak of nematode establishment would be vital to fully understand the events at day 48 post infection. Overall, the three-compartment model of AA kinetics of the tissues of the hindquarters appears to provide more precise information on the effect of the parasitic infection on the AA metabolism and protein turnover compared to that obtained with the two-compartment model.

Acknowledgements

Many thanks to Gordon Reynolds, Brett Guthrie (Massey University, Palmerston North, New Zealand) for assistance with surgical procedures, Ian Sutherland (AgResearch Limited, now at CSIRO, Australia) for assistance with the parasitology, Garry Waghorn (AgResearch Limited, now at Dexcel Limited, New Zealand) for general assistance during the experiment, Dean Revell (Adelaide University, Australia) for guidance through Emma Bermingham's PhD, and Jason Peters and Mathew Deighton (AgResearch Limited) for skilled technical support. The analytical component of this review could not have been completed without the skill of Bruce Sinclair, Bryan Treloar, Anthony Kirk, Mike Tavendale, Clare Reynolds and Jennifer Lane (AgResearch Limited). This study was funded by the C. Alma Baker Trust, New Zealand Foundation of Research Science and Technology, and Meat and Wool New Zealand. Emma Bermingham thanks Meat and Wool New Zealand for funding her PhD studies. The authors would also like to acknowledge Hutton Oddy (MLA, Australia) for his valuable discussion with the lead author on the effect of parasitic infection on the total hindquarters AA transport and protein turnover.

References

- Bermingham, E.N. (2004) The metabolic cost of an intestinal parasite infection on amino acid kinetics in sheep fed fresh forages. PhD thesis. Massey University, Palmerston North, New Zealand.
- Biolo, G., Chinkes, D., Zhang, X.J. and Wolfe, R.R. (1992) A new model to determine *in vivo* the relationship between amino acid transmembrane transport and protein kinetics in muscle. *Journal of Parental and Enteral Nutrition* 16, 305–315.
- Biolo, G., Gastaldelli, A., Zhang, X.J. and Wolfe, R.R. (1994) Protein synthesis and breakdown in skin and muscle: a leg model of amino acids kinetics. *American Journal of Physiology* 267, E467–E474.
- Biolo, G., Declan-Flemming, R.Y., Maggi, S.P. and Wolfe, R.R. (1995) Transmembrane transport and intracellular kinetics of amino acids in human skeletal muscle. *American Journal of Physiology* 268, E75–E84.
- Breuillé, D., Arnal, M., Rambourdin, F., Bayle, G., Levieux, D. and Obled, C. (1998) Sustained modifications of protein metabolism in various tissues in a rat model of long-lasting sepsis. *Clinical Science* 94, 412–423.
- Harris, P.M., Skene, P.A., Buchan, V., Milne, E., Calder, A.G., Anderson, S.E., Connell, A. and Lobley, G.E. (1992) Effect of food intake on hindlimb and whole-body protein metabolism in young growing sheep: chronic studies based on arteriovenous techniques. *British Journal of Nutrition* 68, 389–407.
- Horber, F.F., Horber-Feyder, C.M., Krayer, S., Schwenk, W.F. and Haymond, M.W. (1989) Plasma reciprocal pool specific activity predicts that of intracellular free leucine for protein synthesis. *American Journal of Physiology* 257, E385–E389.
- Hoskin, S.O., Savary, I.C., Zuur, G. and Lobley, G.E. (2001) Effect of feed intake on ovine hindlimb protein metabolism based on thirteen amino acids and arteriovenous techniques. *British Journal of Nutrition* 89, 167–179.

- Hoskin, S.O., Savary-Auzeloux, I.C., Calder, A.G., Zuur, G. and Lobley, G.E. (2003) Effect of feed intake on amino acids transfers across the ovine hindquarters. *British Journal of Nutrition* 89, 167–179.
- Jones, W.O. and Symons, L.E.A. (1982) Protein synthesis in the whole body, liver, skeletal muscle and kidney cortex of lambs infected with *Trichostrongylus colubriformis*. *International Journal for Parasitology* 12, 295–301.
- Lobley, G.E., Harris, P.M., Skene, P.A., Brown, D., Milne, E., Calder, A.G., Anderson, S.E., Garlick, P.J., Nevison, I. and Connell, A. (1992) Response in tissue protein synthesis to sub- and supra-maintenance intake in young growing sheep: comparison of large-dose and continuous-infusion techniques. *British Journal of Nutrition* 68, 373–388.
- MacRae, J.C. and Lobley, G.E. (1991) Physiological and metabolic implications of conventional and novel methods for the manipulation of growth and production. *Livestock Production Science* 27, 43–59.
- MacRae, J.C., Walker, A., Brown, D. and Lobley, G.E. (1993) Accretion of total protein and individual amino acids by organs and tissues of growing lambs and the ability of nitrogen balance techniques to quantitate protein retention. *Animal Production* 57, 237–245.
- McGivan, J.D. (1996) Mammalian amino acid transporters and their regulation: introduction. *Biochemical Society Transactions* 24, 837–838.
- Rennie, M.J., Khogali, S.E.O., Low, S.Y., McDowell, H.E., Hundal, H.S., Ahmed, A. and Taylor, P.M. (1996) Amino acid transport in heart and skeletal muscle and the functional consequences. *Biochemical Society Transactions* 24, 869–873.
- Rodwell, V.W. (2000) Catabolism of proteins and of amino acid nitrogen. In: Murray, R.K., Granner, M.P.A. and Rodwell, V.W. (eds) *Harper's Biochemistry*. Appleton and Lange, New York, pp. 313–322.
- Roy, N.C., Zuur, G. and Lobley, G.E. (1999) Amino acid metabolism across the hindquarters of undernourished sheep supplemented with glutamine. In: Lobley, G.E., White, A. and MacRae, J.C. (eds) *Book of Abstracts of the VIIIth International Symposium on Protein Metabolism and Nutrition, Aberdeen, UK*. Wageningen Press, Wageningen, The Netherlands, p. 17.
- Sykes, A.R. and Coop, R.L. (1976) Intake and utilisation of food by growing lambs with parasitic damage to the small intestine caused by daily dosing with *Trichostrongylus colubriformis* larvae. *Journal of Agricultural Science, Cambridge* 86, 507–515.
- Sykes, A.R., Poppi, D.P. and Elliot, D.C. (1988) Effect of concurrent infection with *Ostertagia circumcincta* and *Trichostrongylus colubriformis* on the performance of growing lambs consuming fresh forages. *Journal of Agricultural Science, Cambridge* 110, 531–541.
- Symons, L.E.A. and Jones, W.O. (1971) Protein Metabolism. 1. Incorporation of ^{14}C -L-leucine into skeletal muscle and liver proteins of mice and guinea pigs infected with *Nematospiriodes dubis* and *Trichostrongylus colubriformis*. *Experimental Parasitology* 29, 230–241.
- Symons, L.E.A. and Jones, W.O. (1972) Protein metabolism: 2. Protein turnover, synthesis and muscle growth in suckling, young and adult mammals infected with *Nematospiriodes dubis* or *Trichostrongylus colubriformis*. *Experimental Parasitology* 32, 335–342.
- Symons, L.E.A. and Jones, W.O. (1975) Skeletal muscle, liver and wool protein synthesis by sheep infected by the nematode *Trichostrongylus colubriformis*. *Australian Journal of Agricultural Research* 26, 1063–1072.

- Symons, L.E.A. and Jones, W.O. (1978) Protein metabolism 5. *Trichostrongylus colubriformis*: changes of host body mass and protein synthesis in guinea pigs with light to heavy infections. *Experimental Parasitology* 44, 7–13.
- Symons, L.E.A. and Jones, W.O. (1983) Intestinal protein synthesis in guinea pigs infected with *Trichostrongylus colubriformis*. *International Journal for Parasitology* 13, 309–312.
- Taylor, P.M. and Low, S.Y. (1999) Investigation of amino acid transfer across tissue membranes. In: El-Khoury, E. (ed.) *Methods of Investigation of Amino Acid and Protein Metabolism*. CRC Press, London, pp. 1–21.
- van Houtert, M.F.J., Barger, I.A., Steel, J.W., Windon, R.G. and Emery, D.L. (1995) Effects of dietary protein intake on responses of young sheep to infection with *Trichostrongylus colubriformis*. *Veterinary Parasitology* 56, 163–180.
- Waterlow, J.C., Garlick, P.J. and Millward, D.J. (1978) *Protein Turnover in Mammalian Tissues and in the Whole Body*. North-Holland Biomedical Press, Amsterdam.
- Wester, T.J., Lobley, G.E., Birnie, L.M. and Lomax, M.A. (2000) Insulin stimulates phenylalanine uptake across the hind limb in fed lambs. *Journal of Nutrition* 130, 608–611.
- Wolfe, R.R. (1992) Basic characteristics of isotope tracers. In: Wolfe, R.R. (ed.) *Radioactive and Stable Isotope Tracers in Biomedicine: Principles and Practice of Kinetic Analysis*. Wiley-Liss, New York, pp. 1–18.
- Yu, F., Bruce, L.A., Calder, A.G., Milne, E., Coop, R.L., Jackson, F., Horgan, G.W. and MacRae, J.C. (2000) Subclinical infection with the nematode *Trichostrongylus colubriformis* increases gastrointestinal tract leucine metabolism and reduces availability of leucine for other tissues. *Journal of Animal Science* 78, 380–390.

3

Using Rumen Degradation Model to Evaluate Microbial Protein Yield and Intestinal Digestion of Grains in Cattle

P. PAENKOU

School of Animal Production Technology, Institute of Agricultural, Suranaree University of Technology, Muang District, Nakhon Ratchasima, 3000, Thailand

Abstract

Ruminal degradation and kinetic parameters are usually obtained using the polyester (nylon) bag technique. Rumen degradation data were used to estimate yields of rumen microbial protein (RMP) and total protein digestion in the intestines (PDI). The content of organic matter (OM) and crude protein (CP) disappearing from nylon bags were expressed as a proportion of the original sample content and the results fitted to the exponential model, $P = A + B(1 - e^{-k_d t})$, total yield (g/kg of dry matter (DM)) of RMP was estimated as: $RMP = (FOM/1000) \times 150$. The yield (g/kg DM) of RMP from fermentable CP (FCP) was estimated as: $RMPCP = (FCP/1000) \times 75$. The yield (g/kg DM) of RMP from fermentable carbohydrate (FCHO) was estimated as: $RMP-CHO = RMP - RMPCP$. The yield (g/kg DM) of RMP digested in the intestines was estimated as: $RMPI = RMP \times 0.85$, assuming that RMP is digested in the intestines with an efficiency of 85%.

The OM and CP degradability constants (A , B , k_d and $A + B$) of two grains treated with the highest temperature (140°C) were the lowest, while full-fat soybean (FFS) was higher ($P < 0.05$) than that of sunflower seeds (SS). The effective degradability of OM and CP increased with increasing temperature. The yields of RMP from FCHO, FCP and total RMP of FFS were significantly higher ($P < 0.05$) than those of SS. Nevertheless, yields of RMP from grains decreased with increasing temperature. Estimated rumen undegradable protein (RUP) increased with increasing temperature of grains. However, PDI declined at high temperatures. At 140°C total PDI was the lowest. The estimated values from this study could be used to improve ration formulation, efficiency utilization of feeds and nutritive value of grains. Available supplements should be evaluated using ruminal protein degradation information, estimates of support for microbial protein synthesis and intestinal digestibility.

Introduction

Models are an essential tool in the understanding of digestive systems. An appropriate model can be a useful tool to link the data obtained *in vitro* or *in situ*

with the processes occurring in organs and tissues *in vivo* (Lopez *et al.*, 2000). Disappearance curves are used to evaluate the kinetics of degradation of feed in the rumen by assuming that disappearance from the bag equals degradation of feed in the rumen. Moreover, ruminal degradation data have been used to estimate yields of RMP and total PDI (Muia *et al.*, 2001). To improve ration formulation and increase the utilization efficiency of feeds, nutritive values of grains or oil seed supplements should be evaluated for protein degradation in the rumen, microbial protein synthesis and intestinal digestion. Estimation of these parameters using rumen degradation data would be useful for comparing the nutritive value of local feed sources and for better reflecting feed nutritive values in diet formulation with the goal of improving animal production.

The objectives of this study were to assess degradation rate and estimate yields of RMP and PDI for SS and FFS treated with direct heat at 100°C, 120°C and 140°C, respectively.

Materials and Methods

Animals and description of test samples

Three Holstein cows aged 4–5 years with an average weight of 450 ± 15 kg, each fitted with permanent rumen cannulae, were used. SS and FFS were collected from Suranaree University feed mill, oven-dried at 60°C for 48 h, ground and passed through a 2 mm screen. Dried samples of SS and FFS were each sub-sampled to generate ten groups and subjected to various heat treatments. Treatments were: (i) control (untreated); (ii), (iii) and (iv) treated with 100°C for 30, 60 and 90 min; (v), (vi) and (vii) treated with 120°C for 30, 60 and 90 min; (viii), (ix) and (x) treated with 140°C for 30, 60 and 90 min, respectively. Treated samples were stored pending chemical analyses and *in sacco* evaluations.

Determination of rumen degradation

Rumen degradation was determined using the nylon bag (mesh size 45 μm ; bag size 6 \times 12 cm) technique. The contents of OM and CP disappearing from nylon bags were expressed as the proportion of the original sample incubated and the results fitted to the Ørskov and McDonald (1979) exponential model:

$$P = A + B(1 - e^{-k_d t})$$

where P is the nutrient disappearance at time t (g/kg OM or CP); A is the solubility in water (g/kg OM or CP), B the degradability of water-insoluble, but slowly degradable fraction (g/kg OM or CP), and k_d the rate of fraction B degradability (/h).

The effective degradability (g/kg OM or CP) was calculated as (Ørskov and McDonald, 1979):

$$ED = A + [B(k_d)/(k_d + k_p)]$$

where k_p is the outflow rate of digesta from rumen. An outflow rate of 0.05/h was assumed for grains or oil seeds.

The amounts (g/kg DM) of unfermentable CP and OM were calculated as:

$$UCP = [U \times (1/1000)] \times CP$$

$$UOM = [U \times (1/1000)] \times OM$$

where U is non-degradable proportion of feed at 72 h (undigested). The amounts (g/kg DM) of FCP and FOM were calculated as:

$$FCP = [ED \times (1/1000)] \times CP$$

$$FOM = [ED \times (1/1000)] \times OM$$

The amount of FCHO was calculated as:

$$FCHO = FOM - FCP$$

Estimation of rumen microbial protein yield

It was assumed that 150 g of RMP is synthesized per kg of FOM and that 1 kg of FCP will yield only half that amount (75 g RMP) (ARC, 1984; NRC, 1988; Tamminga *et al.*, 1994). Total yield (g/kg DM) of RMP was estimated as:

$$RMP = (FOM/1000) \times 150$$

The yield (g/kg DM) of RMP from FCP was estimated as:

$$RMPCP = (FCP/1000) \times 75$$

The yield (g/kg DM) of RMP from FCHO was estimated as:

$$RMPCHO = RMP - RMPCP$$

Estimation of intestinal protein digestion

The yield (g/kg DM) of RMP digested in the intestines was estimated as $RMPI = RMP \times 0.85$, assuming that RMP is digested in the intestines with an efficiency of 85% (Tamminga *et al.*, 1994).

The amount (g/kg DM) of rumen non-degradable protein was estimated as:

$$RUP = CP - FCP$$

The amount (g/kg DM) of RUP digested in the intestines was estimated as:

$$RUPDI = RUP - UCP$$

The amount (g/kg DM) of total protein digestion in the intestines was estimated as:

$$PDI = RMPI + RUPDI$$

Results and Discussion

The degradability constants for OM and CP of SS and FFS subjected to varying time and temperature are given in Table 3.1. The OM and CP degradability constants (A , B , k_d and $A + B$) of two grains treated with the highest temperature (140°C) were the lowest, while those of FFS were greater ($P < 0.05$) than those of SS. The effective degradability of OM and CP increased with increasing temperature.

The estimated yields of RMP and PDI for grains treated with high temperature are given in Table 3.1. The yields of RMP from FCHO, FCP and total RMP of FFS were significantly greater ($P < 0.05$) than those of SS. Nevertheless, yields of RMP and PDI of grains decreased with increasing temperature.

Table 3.1. Organic matter (OM) and crude protein (CP) degradability, estimated yields of rumen microbial protein (RMP) synthesis, and total protein digestion in the intestines (PDI) of grains treated with direct high temperatures.

	Sunflower seeds			Full-fat soybean			SEM
	100°C	120°C	140°C	100°C	120°C	140°C	
OM fractions (g/kg DM)							
A	228	157	113	195	224	114	17.21
B	474 ^{ab}	506 ^a	350 ^c	505 ^a	491 ^{ab}	447 ^b	16.76
K_d	0.086 ^a	0.068 ^{bc}	0.070 ^{bc}	0.075 ^{ab}	0.079 ^{ab}	0.057 ^c	0.03
A + B	702 ^a	662 ^a	462 ^c	705 ^a	715 ^a	511 ^b	28.68
ED	528 ^a	447 ^{ab}	317 ^c	497 ^a	525 ^a	353 ^{bc}	26.46
CP fractions (g/kg DM)							
A	119 ^c	89 ^d	44 ^e	202 ^a	153 ^b	109 ^c	14.97
B	532 ^a	538 ^a	374 ^c	532 ^a	542 ^a	390 ^b	21.98
K_d	0.069 ^{bc}	0.075 ^b	0.088 ^a	0.088 ^a	0.097 ^a	0.097 ^a	0.04
A + B	651 ^c	626 ^b	417 ^f	734 ^a	695 ^b	500 ^e	33.43
ED	426 ^c	411 ^d	283 ^f	539 ^a	510 ^b	330 ^e	27.32
Yields of RMP (g/kg DM)							
From FCHO	48.8 ^{bc}	47.2 ^c	31.9 ^d	53.3 ^a	50.8 ^b	31.5 ^d	2.67
From FCP	9.1 ^c	8.8 ^c	6.5 ^c	21.9 ^a	20.6 ^a	14.5 ^b	1.81
Total RMP	57.9 ^c	56.0 ^d	38.4 ^f	75.2 ^a	71.4 ^b	46.1 ^e	3.91
RUP	156.4 ^c	157.3 ^c	165.9 ^c	203.3 ^b	204.5 ^b	223.1 ^a	7.99
PDI (g/kg DM)							
From RMP	49.2 ^c	47.6 ^d	32.6 ^f	63.9 ^a	60.7 ^b	39.2 ^e	3.32
From RUP	57.1 ^a	50.5 ^b	41.1 ^c	59.5 ^a	40.1 ^c	32.0 ^d	2.98
Total PDI	106.3 ^b	98.1 ^c	73.7 ^d	123.4 ^a	100.8 ^c	71.2 ^d	5.52

^{a, b, c, d, e, f}Values on the same row under each main effect with different superscripts differ significantly ($P < 0.05$); ED = effective degradability, FCHO = fermentable carbohydrate, FCP = fermentable crude protein, RUP = rumen undegradable protein, SEM = standard error of the mean.

References

- ARC (1984) *The Nutrient Requirements of Ruminant Livestock*. Commonwealth Agricultural Bureaux, Farnham Royal, UK.
- Lopez, S., France, J., Dijkstra, J. and Dhanoa, M.S. (2000) Models to interpret degradation profiles obtained from in vitro and in situ incubation of ruminant feeds. In: McNamara, J.P., France, J. and Beever, D.E. (eds) *Modelling Nutrient Utilization in Farm Animals*. CAB International, Wallingford, UK, pp. 73–86.
- Muia, J.M.K., Tamminga, S., Mbugua, P.N. and Kariuki, J.N. (2001) Rumen degradation and estimation of microbial protein yield and intestinal digestion of napier grass (*Pennisetum purpureum*) and various concentrates. *Animal Feed Science and Technology* 93, 177–192.
- National Research Council (1988) *Nutrient Requirement of Dairy Cattle*, 6th edn. National Academy Press, Washington, DC.
- Ørskov, E.R. and McDonald, I. (1979) The estimation of protein degradability in the rumen from incubation measurements weighted to rate of passage. *Journal of Agriculture Science Cambridge* 92, 499–503.
- Tamminga, S., Van Straalen, W.M., Subnel, A.P.J, Maijer, R.G.M., Steg, A., Wever, C.J.G. and Blok, M.C. (1994) The Dutch protein evaluation system: the DVE/OEB system. *Livestock Production Science* 40, 139–155.

4

Simulation of Rumen Particle Dynamics Using a Non-steady State Model of Rumen Digestion and Nutrient Availability in Dairy Cows Fed Sugarcane

E.A. COLLAO-SAENZ,¹ A. BANNINK,² E. KEBREAB,³
J. FRANCE³ AND J. DIJKSTRA⁴

¹DZO/Animal Science Department, UNEMAT-Universidade do Estado de Mato Grosso, PO Box 181, CEP 78250-000 Pontes e Lacerda-MT, Brazil; ²Animal Sciences Group, Division of Nutrition and Food, PO Box 65, 8200 AB Lelystad, The Netherlands; ³Centre for Nutrition Modelling, Department of Animal and Poultry Science, University of Guelph, Guelph, Ontario N1G 2W1, Canada; ⁴Animal Nutrition Group, Wageningen University, PO Box 338, 6700 AH Wageningen, The Netherlands

Abstract

An extant dynamic model of digestion and absorption of nutrients in cattle fed sugarcane was adapted for non-steady state feeding conditions. This modified model includes mechanisms of particle size reduction and delay in availability of particles and intracellular contents for microbial fermentation after ingestion. Two trials (one with beef cattle and the other with dairy cattle) were used to evaluate the non-steady state model. In general, predicted values were close to observed values for duodenal neutral detergent fibre (NDF) and nitrogen flows (mean squared prediction error (MSPE) of 14% and 15% of observed mean, respectively). There was no indication of over- or underprediction of NDF and nitrogen flows. An overestimation of rumen volume observed in steers suggests that the equation to calculate rumen volume needs to be adapted for low feed intake. Overall mean of milk production was predicted accurately. Predictions under non-steady state conditions showed higher accuracy when real intake behaviour was simulated. The model can be used to select strategies of supplementation of dairy cows fed sugarcane-based diets.

Introduction

Among tropical forages, sugarcane has a high yield of dry matter (DM) and energy per unit area and productivity can reach more than 30 t DM/ha. High amounts of soluble sugars and fibre, and very low amounts of total nitrogen (N) and lipid are characteristics of sugarcane. Upon supplementation, good

animal production levels on sugarcane-based diets have been obtained. For example, in dairy cattle, Correa *et al.* (2003) observed around 30 kg of daily milk production on supplemented diets containing sugarcane as the only forage.

Dijkstra *et al.* (1996) developed a model of digestion and absorption of nutrients in cattle fed sugarcane-based diets to evaluate locally available supplements. However, this model assumed a continuous input of nutrients, whereas in meal-fed animals, dynamics of particle size reduction and rate of release of nutrients may affect rumen fermentation processes. The degradation rates of intracellular constituents (IC) of forages are generally considered to be high. However, recent research has shown that the IC are not immediately available for microorganisms in the rumen because they are locked up in plant cells that remain totally or partially intact after ingestion (Boudon and Peyraud, 2001). For that reason a representation of the release rate of IC might increase the accuracy of models of rumen function and help to understand the mechanisms involved.

The objective of the present study is to extend the model of Dijkstra *et al.* (1996) to non-steady state feeding conditions and to enable the model to simulate nutrient availability as a response to feed intake pattern, kinetics of particle size reduction and cell content release. The extended model may help in particular to explain the effects of variation in the physical and chemical characteristics of tropical feeds on observed milk yields.

Materials and Methods

The new traits and modifications were included in a SMART[®] version of the model developed by Dijkstra *et al.* (1996). A full description of the modifications is given by Collao-Saenz (2004).

Dry matter intake

The constant feed intake during the day assumed in the original model was changed into intake of two or more separate meals per day adapting the work of Miranda *et al.* (1999) with cross-bred Holstein × zebu heifers receiving sugarcane- plus urea-based diets. Because in non-steady state conditions, flows continuously vary with time, flows had to be integrated during the last 24 h for calculations of model outcomes after quasi-steady state was obtained. The integration step was reduced to 0.01 h to ensure that with pulses of feed intake accurate integration results will be obtained.

Particle size reduction

A new state variable for large particles (QL_p) was added to include the effect of particle size reduction. The concept of a single aggregate large particle (L_p) pool comprising all the insoluble components in the diet, except insoluble

starch (Si), corresponds to that proposed by Baldwin *et al.* (1987). A small particle (QSp) zero pool was introduced as the sum of insoluble nutrients in small particles from degradable fibre, undegradable fibre, insoluble degradable protein, undegradable protein and Si. The conversion of QLp to QSp was totally dependent upon rate of comminution and time spent ruminating. A comminution rate ($kLpSp$) of 2.2/day was used. This value is lower than that proposed by Bannink and De Visser (1997) (4.5/day) because of the high degradability of the fresh perennial ryegrass in the diets they evaluated. The proportion of time spent ruminating during the day is Rum and is set at 0.28. Lignification, DM intake (DMI), stage of maturity, protein content and many other features intrinsic to the plant may affect these figures.

Microbial death

A Michaelis–Menten equation was introduced to account for death of microorganisms in the absence of substrate and to reduce the nutrient utilization efficiency of microbial DM. Maximum fractional rate of death was assumed to be 0.4/day and death is inhibited by presence of soluble sugars (inhibition constant 0.001 g/l). Death of microorganisms resulting from this equation was distributed as a new input to the various substrate pools according to the composition of microbial matter used by Dijkstra *et al.* (1996).

Non-dietary nitrogen inflow

Non-dietary nitrogen inflow is simulated by quantification of ammonia production from urea transported across the rumen wall and of saliva production. The amount of dietary nitrogen used in the original equation to determine non-dietary nitrogen inflow was also adopted in the modified version, with the dietary nitrogen intake being the mean nitrogen intake per day.

Rumen volume

Volume of rumen fluid (V) changed from a constant parameter value in the original model into a variable dependent on the size of the meals and DM content of the diet according to the non-linear equation proposed by Chilibroste *et al.* (2001).

Cell content release

In order to account for the delay in IC release, two new state variables were introduced that represent the pools of soluble protein ($QPsu$) and soluble starch and sugars ($QScu$) not immediately available for microbial utilization.

Both pools received a fraction of the DMI, dependent on the fraction of small particles in the diet. Output of each pool was the release of nutrients to the two pools of nutrients directly available for microbial utilization. Release of the soluble nutrients was related to *Rum* and to fractional release rates of *Scu* and *Psu* (k_{ScuSca} and k_{PsuPsa} of 1.8/h and 1.2/h), following results reported by Boudon *et al.* (2002).

Results and Discussion

Sensitivity analyses revealed that absorption of nutrients was highly sensitive to a change in rate of utilization of soluble starch and sugars (*Sc*) for microbial maintenance (v_{ScMi}) and to changes in soluble sugar and starch release rate (k_{ScuSca}). A fast liberation of soluble carbohydrates from diets with fastening periods of 10 h leads to substantial periods of time without new substrates, which affects apparent bacterial yield by increased rate of death due to a lack of carbon skeletons and availability of energy (adenosine triphosphate; ATP) for microbial synthesis. In contrast, changes in the fractional release rate of soluble protein did not affect absorption of nutrients. This effect is probably due to the small quantity of soluble protein in sugarcane plus urea diets.

The model was evaluated with observations for growing cattle (Matos, 1991) and dairy cows (Assis *et al.*, 1999). For growing cattle, DMI and urea supplementation level were varied and a comparison was made between predicted and observed values of rumen outflow of NDF (Fig. 4.1) and of non-ammonia nitrogen (NAN) (Fig. 4.2). Predicted NDF and NAN outflows were quite close to observed values with a root MSPE (RMSPE) between 14.2% and 15.3% of observed mean. There was no indication of over- or

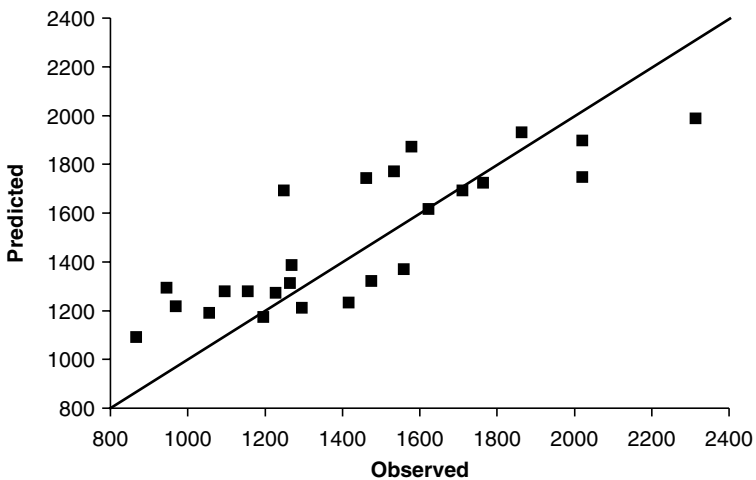

Fig. 4.1. Comparison of observed and predicted values of neutral detergent fibre (NDF) outflow (g/day) from the rumen.

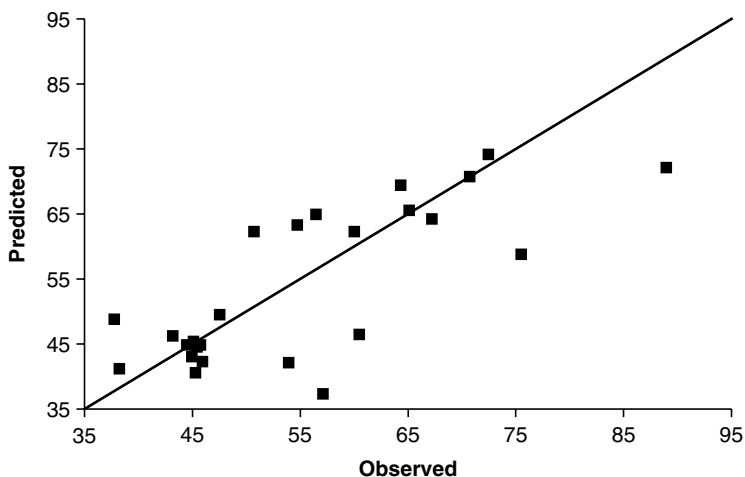

Fig. 4.2. Comparison of observed and predicted values of non-ammonia nitrogen (NAN) outflow (g/day) from the rumen.

underprediction of NDF and NAN flows. More than 90% of MSPE was attributed to the random disturbance proportion. Supplementation with urea slightly increased simulated rumen fibre degradation. The model simulated accurately the effect of increasing intake on rumen NAN outflow.

The model showed a consistent overestimation of V of some 25% and 10% for low and high intake, respectively. The equation used to predict V (Chilibroste *et al.*, 2001) was developed using cows with average live weights (LWs) of 574–618 kg. However, simulations using observed average values of V diminished the accuracy of the model because the rumen substrate concentrations did not follow the intake variations. The underestimation may be due to the low DMI of average 290 kg LW animals. Diets with low intake showed larger differences in V when compared with high intake treatments.

Evaluation of milk production using data of Assis *et al.* (1999) indicated good predictive behaviour (Fig. 4.3). Predictions of milk production (11.0 l/day) using energy, protein and glucose as predictors were quite close to observations (11.2 l/day). RMSPE was 16.5% of the observed mean and 76.5% of the MSPE was attributed to the random disturbance proportion. However, 22.7% of MSPE was related to deviation of the regression slope from one indicating some proportional bias due to inadequate representation of the relationships involved.

Conclusions

The model gives satisfactory predictions under non-steady state conditions and seems to be useful to select strategies for supplementation of sugarcane-based diets. Predicted outflow from the rumen generally corresponded with observed values. However, the equation that accounts for V as a function of

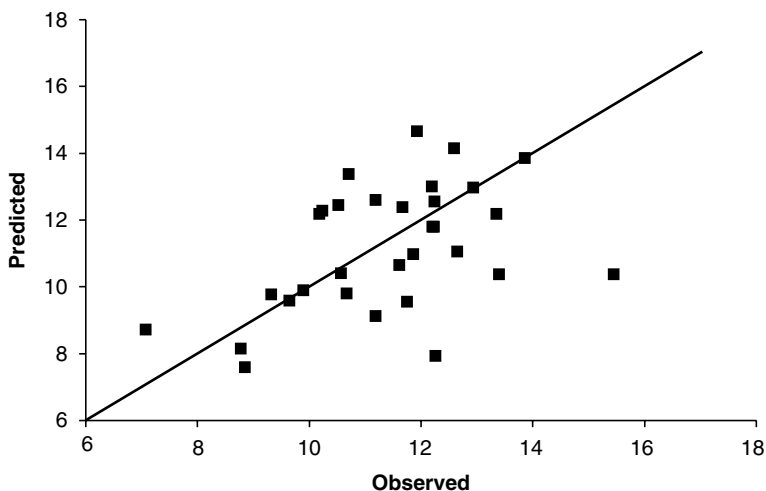

Fig. 4.3. Comparison of observed and predicted milk production (kg/day).

rumen DM content does not seem to be valid for low DMIs. Further evaluation of the prediction accuracy of the model in non-steady state conditions requires observations from experiments in which the effects of ingestive behaviour on rumen function are tested.

References

- Assis, A.G., Lopes, F.C.F., Durães, M.C., Simões, J.B., Andrade, R.S. and Verardo Junior, A.E. (1999) Validação de um modelo de simulação da cinética de nutrientes em vacas leiteiras. In: SBZ, Anais da 36ª Reunião anual da sociedade brasileira de zootecnia, 1999, Porto Alegre. CD-ROM. Arquivo NUR-008.
- Baldwin, R.L., Thornley, J.H.M. and Beever, D.E. (1987) Metabolism of the lactating cow: II. Digestive elements of a mechanistic model. *Journal of Dairy Research* 54, 107–131.
- Bannink, A. and De Visser, H. (1997) Comparison of mechanistic rumen models on mathematical formulation of extramicrobial and microbial processes. *Journal of Dairy Science* 80, 1296–1314.
- Boudon, A. and Peyraud, J.L. (2001) The release of intracellular constituents from fresh ryegrass (*Lolium perenne* L.) during ingestive mastication in dairy cows: effect of intracellular constituent, season and stage of maturity. *Animal Feed Science and Technology* 93, 229–245.
- Boudon, A., Peyraud, J.L. and Faverdin, P. (2002) The release of intracellular constituents from fresh ryegrass (*Lolium perenne* L.) during digestion in dairy cows: effect of intracellular constituent, season and stage of maturity. *Animal Feed Science and Technology* 97, 83–102.
- Chilibroste, P., Dijkstra, J. and Tamminga, S. (2001) Design and evaluation of a non-steady state rumen model. *Netherlands Journal of Agricultural Science* 49, 297–312.

- Collao-Saenz, E.A. (2004) Modeling of rumen particle dynamics in dairy cows fed sugarcane. PhD thesis, Universidade Federal de Lavras, Brazil.
- Correa, C.E.S., Pereira, M.N., de Oliveira, S.G. and Ramos, M.H. (2003) Performance of Holstein cows fed sugarcane or corn silages of different grain textures. *Scientia Agricola* 60, 621–629.
- Dijkstra, J., France, J., Neal, H.D.St.C., Assis, A.G., Aroeira, L.J.M. and Campos, O.F. (1996) Simulation of digestion in cattle fed sugarcane: model development. *Journal of Agricultural Science* 127, 231–246.
- Matos, J.M.N. (1991) Níveis de ingestão de alimentos e de uréia sobre alguns parâmetros ruminais e digestão total e parcial em bovinos, alimentados com dieta à base de cana-de-açúcar e uréia suplementada com farelo de arroz. DSc thesis. Universidade Federal de Viçosa, Viçosa–MG, Brazil.
- Miranda, L.F., Queiroz, A.C., Valadares Filho, S.C., Cecon, P.R., Pereira, E.S., Souza, J.M.C., Lanna, R.P. and Miranda, J.F. (1999) Comportamento ingestivo de novilhas leiteiras alimentadas com dietas à base de cana-de-açúcar. *Revista Brasileira de Zootecnia* 28, 614–620.

5

Modelling Fluxes of Volatile Fatty Acids from Rumen to Portal Blood

P. NOZIÈRE¹ AND T. HOCH^{1,2}

¹Unité de Recherche sur les Herbivores, INRA Theix, 63122 Saint-Genès-Champanelle, France; ²Unité de Recherche sur les Herbivores, INRA-Centre de Clermont-Theix, F63122 Saint-Genès-Champanelle, France

Abstract

A model was developed that describes the relationships between the production, the ruminal concentrations and the fluxes of volatile fatty acids (VFAs) across portal drained viscera (PDV). This study presents some preliminary results. Firstly, general steady state relationships between production and portal appearance of VFA were determined by fitting equations to published data coupling both intraruminal infusions and measurement of VFA portal fluxes. With a simple model consisting of one digestive and one blood compartment, saturation in uptake of arterial acetate (Ac) by PDV when arterial supply was high, linearity between production and portal net absorption for each VFA, and saturation in ketogenesis by PDV were evidenced. Secondly, a dynamic model was used to assess the effect of pH on the VFA fluxes in the rumen between two meals (12 h interval). The fractional absorption rate of each VFA by the rumen wall (%/h) was fitted to pH according to their dissociation constant, from data obtained with the emptied washed rumen method. With a diet inducing large postprandial variations of pH, the effects of fractional absorption rate – either constant (related to mean pH) or variable (related to postprandial variations of pH) – on ruminal VFA concentrations and kinetics of VFA absorbed by the rumen wall were quantified.

Introduction

Ruminal concentrations of VFAs do not reflect their production rate, particularly with highly fermentable diets, but the large amount of published data could be useful to assess quantitative fluxes of VFA available for animal production. For this purpose, a model was developed that represents the relationships between the production rates, the ruminal concentrations and the fluxes of VFA across PDV. Production and absorption have mainly been investigated at steady state, although they constitute dynamic processes resulting in large postprandial variations in ruminal concentrations. Thus, developing a full model in the future requires an investigation by both steady state and dynamic approaches. This study presents some preliminary results of these combined approaches.

Materials and Methods

Steady state approach

The first step was to determine steady state relationships between production and portal appearance of VFA by fitting equations to data from the literature. A simple model with one digestive and one blood compartment in equilibrium was chosen (Fig. 5.1). For the digestive compartment (lumen), one input (production) and two output fluxes (portal net absorption and metabolism by microbes or PDV) were considered. For the blood compartment, three inputs (arterial supply, portal net absorption and production of β -hydroxybutyrate (β -OH) by PDV) and two output fluxes (portal release and uptake by PDV) were considered.

Fluxes were standardized and divided by metabolic weight ($BW^{0.75}$) to account for data on sheep and cattle. The uptake of arterial Ac (C2) by PDV was assumed to depend on arterial flux, following a relationship calculated by fitting literature data ($N = 18$) from isotope experiments. For propionate (Pr) (C3) and butyrate (Bu) (C4) no data were available from literature and simulations were performed with uptake by PDV ranging from 0% to 30% of the arterial supply. β -OH taken up by PDV was assumed to be constant and fixed at 13% of arterial supply (Kristensen *et al.*, 2000). The net absorption of VFA and the production of β -OH by PDV were calculated by the equilibrium equation of the blood compartment with net absorption of β -OH and production of VFA by PDV equal to zero:

$$\begin{aligned} \text{net absorption} + \text{production by PDV} + \text{arterial supply} \\ = \text{portal release} + \text{uptake by PDV} \end{aligned}$$

In most trials the rates of VFA production were not known. Therefore, relationships between production and net absorption were assessed by fitting literature data from experiments in which changes in portal VFA fluxes were

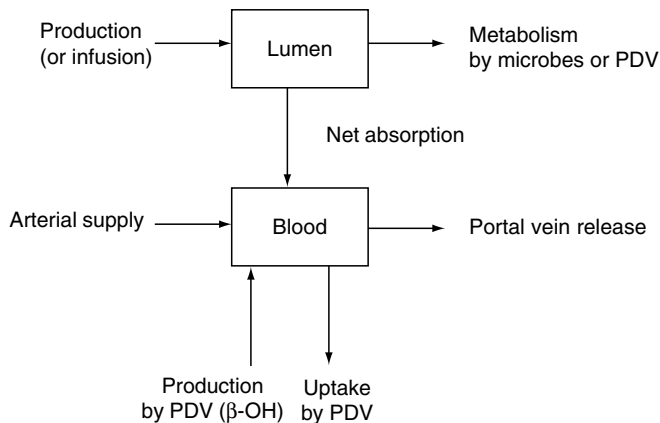

Fig. 5.1. Fluxes of volatile fatty acids (VFAs) and β -hydroxybutyrate (β -OH) across portal-drained viscera (PDV).

measured with intraruminal infusions of VFA (33, 35 and 33 data for C2, C3 and C4 respectively, 25% obtained from bovines and 75% from ovines).

Dynamic approach

The second step was to assess the effect of pH on the dynamics of VFA fluxes in the rumen between two meals (12 h interval). Evolution of fluxes with time was simulated using differential equations concerning C2, C3 and C4 in the rumen as state variables. A single input (production) and two output fluxes (absorption by rumen wall and outflow to omasum) were represented (Fig. 5.2).

Production rate was considered through a first-order kinetic:

$$\text{Prod}(t) = b(1 - e^{-ct})$$

where $\text{Prod}(t)$ was the cumulated amount (mmol) of VFA produced at time (t), t was the time after feeding (h), b was the asymptotic amount of VFA produced (mmol), c was the fractional production rate constant (/h). Rumen volume (litre) and outflow to the omasum (%/h) were considered constant with time. Fractional absorption rates for each VFA by the rumen wall (k_{abs} , %/h) were considered to depend on pH and on their dissociation constants, according to the following relationship:

$$k_{\text{abs}} = k_i + (k_{ni} - k_i) / (1 + 10^{\text{pH} - \text{pKa}})$$

where k_i and k_{ni} were the fractional absorption rates of the ionized (COO^-) and the non-ionized (COOH) forms, respectively, and $(1 + 10^{\text{pH} - \text{pKa}})$ was the proportion of the non-ionized form. k_i was the intercept and $(k_{ni} - k_i)$ was the slope of the linear relationship between k_{abs} and the proportion of the non-ionized form, determined by fitting data obtained with the emptied washed rumen method (107, 104 and 92 observations for C2, C3 and C4, respectively). Simulations with this simple model were compared to experimental data obtained on sheep fed a mixed diet (hay:barley is 40:60) twice a day to induce large postprandial variations in ruminal pH (from 6.52 to 5.20). The dynamics of ruminal pH and VFA concentrations were measured. The production of total VFA was estimated as 70% of metabolizable

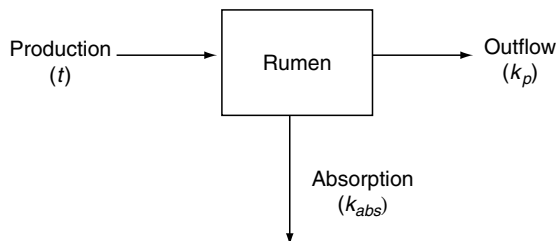

Fig. 5.2. Fluxes of volatile fatty acids (VFAs) in the rumen.

energy (ME) digested in the rumen, with a respective contribution of individual VFA proportional to their mean ruminal concentrations, so that the asymptotic amount of VFA produced (b) was 2800, 820 and 570 mmol for C2, C3 and C4, respectively. The fractional production rate constant (c) was arbitrarily fixed for each VFA. Ruminal volume and liquid turnover rate were measured and were 12.9 l and 4.8%/h, respectively. Changes in ruminal concentrations and flows of VFA absorbed by the rumen wall were compared with k_{abs} either constant (related to mean pH) or variable with time (related to postprandial variation in pH). The other parameters of the model (b , c , volume and turnover rate) were not modified between simulations.

Results and Discussion

Steady state approach

Fitting uptake of arterial C2 by PDV (y -axis) to arterial supply (x -axis) suggested an exponential relationship (Fig. 5.3). This reflected saturation when arterial supply was high. Although data were collected exclusively on sheep, it was assumed that this equation was applicable for both bovine and ovine, for the calculation of uptake of arterial C2 by PDV and for the subsequent estimation of portal net absorption of C2.

Comparing variations in portal net absorption (y -axis) with infusion rate (x -axis) suggested a linear relationship for each VFA (Fig. 5.4), with a slope

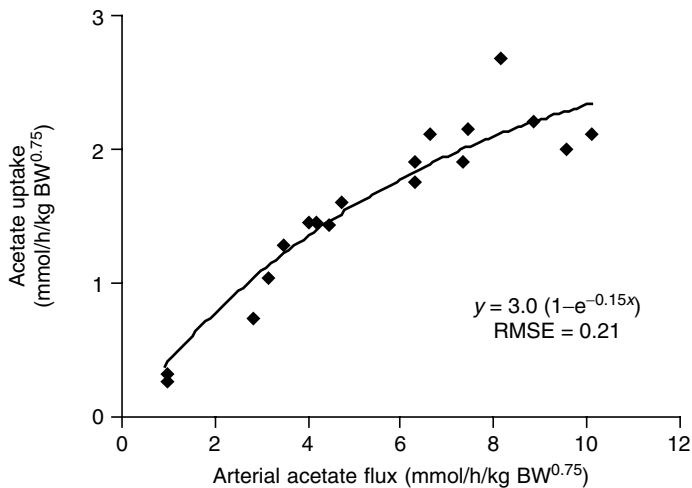

Fig. 5.3. Relationship between arterial Ac supply and uptake by portal-drained viscera (PDV; mmol/h/kg BW^{0.75}).

of 0.71, 0.69 and 0.26 for C2, C3 and C4, respectively. When uptakes of C3 and C4 by PDV were simulated to account for 30% of arterial supply, the slopes slightly increased, reaching 0.73 for C3 and 0.28 for C4. Residual differences between fitted and measured values were not significantly related to animal species ($P = 0.66, 0.76$ and 0.26 for C2, C3 and C4) or to ruminal pH ($P = 0.34, 0.39$ and 0.21 for C2, C3 and C4), although ruminal pH ranged from 5.70 to 7.18 among trials. Also, the residuals were not significantly related to the VFA composition of infusions. When the relationships were used to estimate VFA production from independent data of arterial and portal VFA fluxes measured in conventionally fed animals ($N = 66$), it appeared that production rates of C2 + C3 + C4 accounted for an average 64% of ME intake. This appears realistic, although these relationships were obtained from trials conducted on animals partially fed by intragastric infusions.

Since β -OH produced by PDV originates from C2 and C4 activated by acyl-coA-synthetase in PDV, the increase in β -OH production (y -axis) was fitted to the amount of 'C4 equivalent' infused as C2 or C4 and not recovered in the portal vein (x -axis). The relationship appeared to be exponential

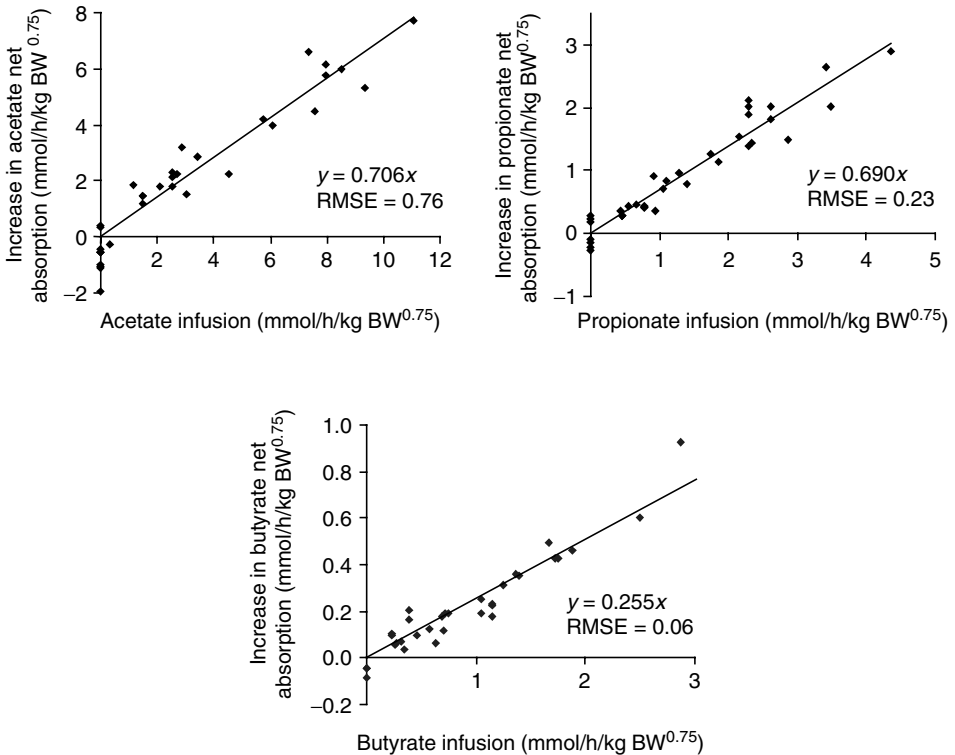

Fig. 5.4. Relationship between ruminally infused volatile fatty acids (VFAs) and increase in net absorption across portal-drained viscera (PDV; mmol/h/kg BW^{0.75}).

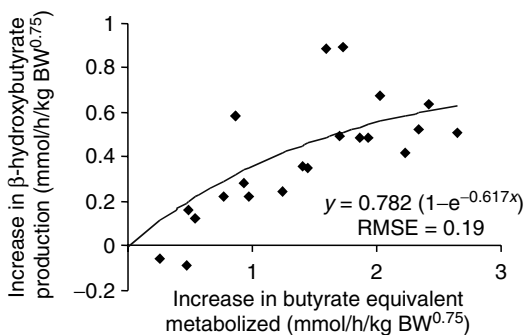

Fig. 5.5. Relationship between increase in metabolized acetate (Ac) and butyrate (Bu) (in Bu equivalent) and increase in production of β -hydroxybutyrate (β -OH) by portal-drained viscera (PDV; mmol/h/kg BW^{0.75}).

(Fig. 5.5) reflecting a saturation rate of ketogenesis by PDV, which has been reported before in both cattle (Krehbiel *et al.*, 1992) and sheep (Kristensen *et al.*, 1996).

Dynamic approach

The fractional ruminal VFA absorption rate increased with chain length and decreased with pH (Fig. 5.6), from 76%/h, 102%/h and 135%/h (non-ionized form) to 16%/h, 18%/h and 22%/h (ionized form) for C2, C3 and C4, respectively. This is consistent with what is generally reported (Dijkstra *et al.*, 1993). The root mean squared prediction error (RMSPE) of the linearized relationships was 13%/h, 16%/h and 15%/h for C2, C3 and C4, respectively. Residuals were not significantly related to ruminal concentrations of VFA or to ruminal osmolality, although these two factors were shown to influence the ruminal absorption rate of VFA (Bergman, 1990).

Simulated concentrations (Fig. 5.7) were higher when k_{abs} was assumed to be constant (related to mean pH) than to be variable (related to post-prandial variations in pH). The difference between simulations increased from 12% to 24% with chain length: 77 vs 69, 20 vs 16 and 12 vs 10 mM for C2, C3 and C4, respectively, on average over the simulation period. Although simulated concentrations were close to measured values, dynamic simulations may be improved by taking into account a variable time-dependent volume and turnover rate. Simulated kinetics of VFA absorbed by the rumen wall were very different between the two simulations (Fig. 5.7), as a result of the combination of the highest VFA concentrations and a higher k_{abs} in the first few hours after feeding. However, the mean flow was only slightly lower when k_{abs} was constant than when it was variable, and the differences between simulations were similar for both VFA (3%): 195 vs 200, 62 vs 63 and 46 vs 44 mmol/h for C2, C3 and C4,

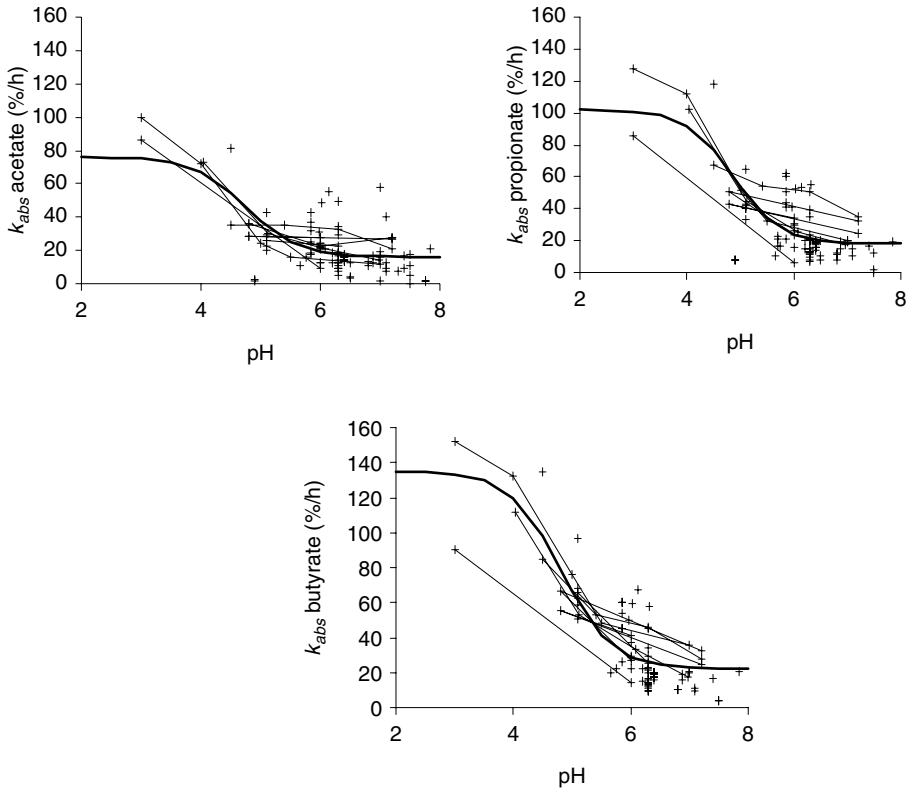

Fig. 5.6. Effect of ruminal pH on volatile fatty acids (VFAs) fractional absorption rate in the rumen (k_{abs} , %/h): measured values (+); relationships intra-experiment (thin lines); fitted relationships (bold lines).

respectively, on average over the simulation period. These preliminary results highlight the necessity of properly reflecting the effects of pH on VFA kinetics from rumen to portal blood.

Conclusions

The present work delivers relationships between production and portal appearance of VFA for a wide range of values during steady state. Furthermore, it quantifies the effect of ruminal pH on ruminal fractional absorption rate of VFA. The model used represents the impact of post-prandial variations in fractional absorption rate that was related to pH. Effects of pH on ruminal VFA concentrations and kinetics of VFA absorption by the rumen wall differ. The latter aspect is relevant with respect to quantification of the kinetics of the net appearance of VFA in the ruminal or portal vein.

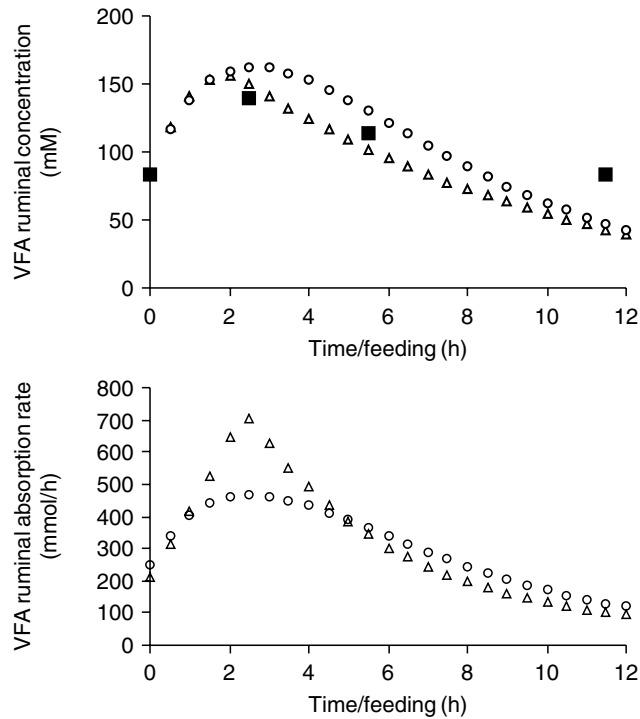

Fig. 5.7. Volatile fatty acids (VFAs = Ac + Pr + Bu) ruminal concentrations (mM) and absorption rate by the rumen wall (mmol/h): estimated values with a constant (related to mean pH) fractional absorption rate (○); estimated values with a variable (related to postprandial variations in pH) fractional absorption rate (△); measured values (■).

References

- Bergman, E.N. (1990) Energy contributions of volatile fatty acids from the gastrointestinal tract in various species. *Physiological Reviews* 70, 567–590.
- Dijkstra, J., Boer, H., Van Bruchem, J., Bruining, M. and Tamminga, S. (1993) Absorption of volatile fatty acids from the rumen of lactating dairy cows as influenced by volatile fatty acid concentration, pH and rumen liquid volume. *British Journal of Nutrition* 69, 385–396.
- Krehbiel, C.R., Harmon, D.L. and Schnieder, J.E. (1992) Effect of increasing ruminal butyrate on portal and hepatic nutrient flux in steers. *Journal of Animal Science* 70, 904–914.
- Kristensen, N.B., Danfaer, A., Tetens, V. and Agergaard, N. (1996) Portal recovery of intraruminally infused short-chain fatty acids in sheep. *Acta Agriculturae Scandinavica Section A Animal Science* 46, 26–38.
- Kristensen, N.B., Pierzynowski, S.G. and Danfaer, A. (2000) Portal-drained visceral metabolism of 3-hydroxybutyrate in sheep. *Journal of Animal Science* 78, 2223–2228.

6

The Role of Rumen Fill in Terminating Grazing Bouts of Dairy Cows under Continuous Stocking

H.Z. Taweel, B.M. Tas, S. Tamminga
and J. Dijkstra

*Animal Nutrition Group, Wageningen University, PO Box 338, 6700 AH
Wageningen, The Netherlands*

Abstract

This experiment was aimed at studying the role of rumen fill in signalling the termination of grazing bouts of dairy cows using a combination of experimental and modelling approaches. The day was divided into three main periods (06:00–12:00 h, 12:00–18:00 h and 18:00–24:00 h) during which the three main grazing bouts (dawn, afternoon and dusk) of dairy cows usually occur. Four rumen-cannulated dairy cows were used in a repeated measurements design, with time of day as the within subjects factor. The cows were rumen-evacuated at 6:00, 12:00, 18:00 and 23:30 h. Data on grazing behaviour of the cows were obtained using jaw recorders fitted to the cows. Fractional clearance rate (K_{cl}) was estimated from the difference in rumen fill between 23:30 and 8:00 h next morning, during which period cows were deprived of feed. Because rumen evacuations were performed at fixed times during the day and not immediately when grazing ceased, the fluctuation in rumen fill between the measured points had to be estimated in order to draw valid conclusions concerning its role in regulating the cessation of grazing. To estimate rumen fill fluctuation, a simple dynamic model was constructed. There is one state variable, the rumen neutral detergent fibre (NDF) pool. The model was based on the measured total eating time, the exact timing of each individual grazing event, bite rate, bite mass and K_{cl} . The diurnal fluctuation in rumen pool sizes of dairy cows was predicted satisfactorily. The mean squared prediction error (MSPE) was small (5.1% of observed mean), and the major part of the error was due to random variation. The simulated pool sizes indicated that cows stopped grazing during the morning and afternoon at a point where rumen pool size was much lower than what the rumen could hold at 23:30 h. This illustrated that dairy cows interrupted grazing bouts at dawn and in the afternoon long before reaching their maximum rumen fill capacity.

Introduction

Most of the research concerning the role of rumen fill in regulating dry matter intake (DMI) in dairy cows has been performed with animals kept indoors. Only a few studies addressed this issue with grazing animals, probably due to methodological limitations. In addition to animal factors, many plant and other environmental factors may influence DMI at grazing, including herbage allowance, sward surface height, tiller density, leaf strength, eating time and time allocated for rumination. Considerable research efforts are directed towards understanding and quantifying the effect of plant characteristics on grazing behaviour and DMI of dairy cattle (see Chilibroste *et al.*, 2005). However, when plant factors are not limiting, animal behavioural factors, metabolic and hormonal factors, and rumen factors (physical and physiological) may integrate in order to control DMI. Under such conditions rumen fill and/or fermentation end products may play a major role in signalling the termination of a grazing event. Dairy cows are known to have three main grazing events (bouts) during the day: at dawn, afternoon and dusk, among which the dusk grazing bout has been shown to be the longest (Rook *et al.*, 1994; Gibb *et al.*, 1998; Taweel *et al.*, 2004). Chilibroste *et al.* (1997) studied the role of rumen fill in signalling the termination of the morning grazing bout extensively and concluded that dairy cows stopped this bout long before their maximum rumen capacity was reached. However, this cannot be extrapolated to the other grazing bouts, especially the bout at dusk. Therefore, the aim of this experiment was to investigate the role of rumen fill in signalling the termination of a grazing bout using experimental and modelling approaches.

Materials and Methods

Experiment

Four multiparous rumen-cannulated Holstein \times Friesian dairy cows (600 ± 20 kg of body weight (BW)), in late lactation (310 ± 21 days in milk (DIM)), were used in the experiment. The cows were pregnant at the onset of the experiment and produced 18.0 ± 0.4 kg/day of milk. The cows were allowed access to a 1 ha *Lolium perenne* pasture under a continuous stocking system with *ad libitum* herbage allowance and no compound feed from the start (15 June) till the end (4 July) of the experiment. In this period, the sun rises at around 5:30 h and sets at around 22:30 h with total darkness falling at around 23:00 h.

The experiment lasted 3 weeks, of which the first two were for adaptation. In the third week, jaw recorders (Rutter *et al.*, 1997) were fitted to the cows at 5:30 h before the morning milking. The cows were rumen-evacuated simultaneously at 6:00, 12:00, 18:00, 23:30 and 8:00 h the next morning. After each rumen evacuation the cows were allowed to graze freely, except after the evacuation at 23:30 h when the jaw recorders were removed and the cows were tethered and deprived of food and water till 8:00 h the next morning.

This was done to estimate clearance rate (K_{cl} /h), which is required for further calculations. Details on the experimental design, rumen evacuation procedure, and the equations to calculate K_{cl} and intake from the changes in rumen pools are described by Taweel *et al.* (2004).

The model

As described earlier, it was important to estimate the fluctuation in rumen pools during the day. This was done by constructing a dynamic model, which was based on the measured eating time, the exact timing of each individual grazing event, bite rate and bite mass, K_{cl} and DM, organic matter (OM) and NDF content in rumen material. In the model all pools are expressed in kg and time is expressed in hours (h).

The model comprises one state variable, namely the pool of NDF in the rumen (Q_{NDF} ; kg). There is one input to the pool from the feed consumed (P_{NDF} ; kg/h), and clearance of NDF is the only output from the pool (U_{NDF} ; kg/h). The input is derived from the experimental data for each cow and includes bite rate (BR; bites/h), bite mass (BM; g NDF/bite) and eating duration and timing of each individual meal, calculated as:

$$P_{NDF} = EA \times BR \times BM$$

Eating activity (EA) is provided to the model as a tabular binary (0, 1) variable, which was obtained from the jaw recorders' analyses and defines eating activity (EA = 1) or non-eating activity (EA = 0) for each cow. BR was also obtained from the jaw recorders' analyses and was on average 3240, 3480 and 3660 bites/h for the dawn, afternoon and dusk bout, respectively. BM was estimated from the change in rumen pool size, taking into account clearance of NDF as described by Taweel *et al.* (2004) and was on average 0.179, 0.189 and 0.243 g NDF/bite for the dawn, afternoon and dusk bout, respectively. The outflow from the pool is calculated as:

$$U_{NDF} = k_{cl} \times Q_{NDF}$$

The clearance rate (k_{cl}) is the summation of both passage and degradation and is assumed to be constant during the day. The differential equation that describes the rate of change of rumen NDF is:

$$dQ_{NDF}/dt = P_{NDF} - U_{NDF}$$

The differential equation was solved using Euler's method of integration with a fixed integration step size of 0.1 h. The initial value of Q_{NDF} was set to the observed value at 23:30 h and the model was run starting at 24:00 h midnight. Rumen DM and OM pools were calculated from Q_{NDF} using the observed values of NDF and OM content of rumen matter (497 and 891 g/kg DM, respectively). The choice to base the model on NDF rumen pool and calculate the other pools from Q_{NDF} and chemical composition of rumen material was made to avoid any discrepancies that might arise from the contribution of microbial matter to the DM and OM pools.

Results and Discussion

The diurnal fluctuations in rumen DM and OM as influenced by grazing behaviour and activity of one animal are presented in Fig. 6.1. For all animals, rumen pool sizes were significantly ($P < 0.01$) larger at 23:30 h compared to the other times during the day. Rumen DM pool size fluctuated between 10.0 and 11.5 kg during the day but rose sharply at midnight to around 13.0 kg. A similar pattern was observed for rumen OM. This sharp rise in rumen pools at dusk is primarily related to the longer eating time, higher bite rate and higher bite mass at dusk compared with other times during the day.

From the simulated results in Fig. 6.1, it can be seen that when the cow stopped grazing during the morning or the afternoon, rumen pool sizes were much lower than what the rumen could hold at 23:30 h. This illustrates that dairy cows interrupted grazing bouts at dawn and in the afternoon long before reaching their maximum rumen fill capacity, indicating that rumen fill is less likely to play a significant role in signalling the termination of these grazing bouts. However, rumen pool sizes were always maximum when the dusk grazing bout ceased, indicating that rumen fill is more likely to play a major role in signalling the termination of the dusk grazing bout.

The relationship between observed and model-estimated rumen pools is shown in Fig. 6.2. The model estimations closely matched the observed (measured) values at all times of the day. The MSPE was 5.1% of the observed mean. The MSPE was decomposed into three components: overall bias of prediction (mean bias); deviation of the regression slope from one;

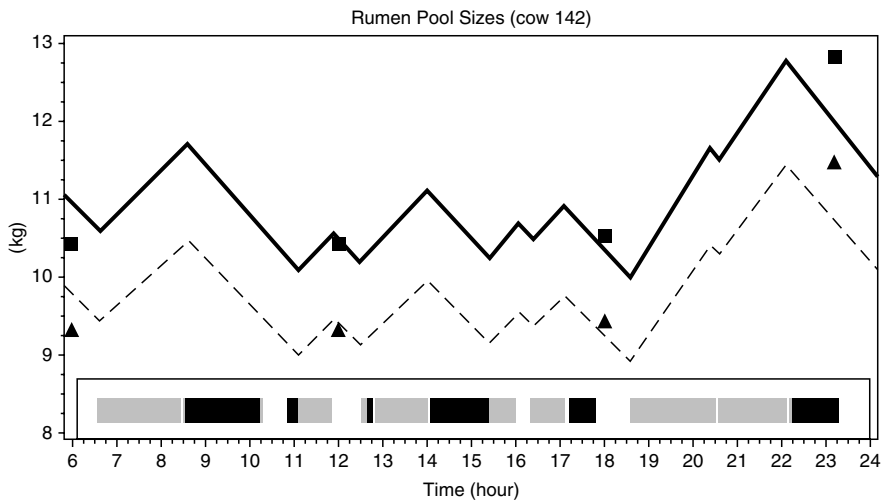

Fig. 6.1. The diurnal fluctuation in rumen DM and OM pool sizes of a dairy cow (cow 142): observed rumen DM (■) and OM (▲) pools; simulated rumen DM (solid line) and OM (dashed line) pool sizes; grazing behaviour of cow 142 on that day is presented on the horizontal axis (grey = eating, black = ruminating, white = idling).

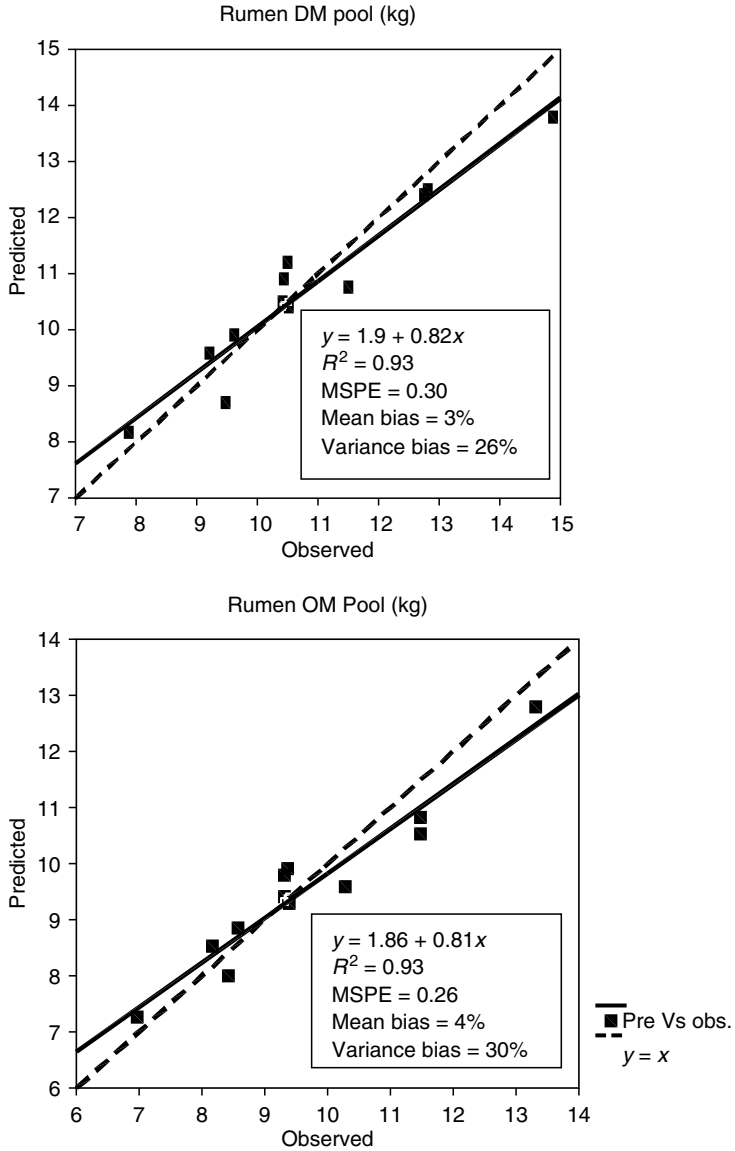

Fig. 6.2. Comparison of observed and predicted values of rumen DM and OM pool sizes: the best least squared error fit of predicted vs observed (solid line) and predicted = observed (dashed line).

and the disturbance or random error, using the equations presented by Bibby and Toutenburg (1977). The major contribution to the MSPE was from the random error component. The mean bias was small and contributed between 3% and 4% of the total MSPE. However, the contribution of the deviation of the regression slope from one (26–30% of total MSPE) indicates some inadequacy in the relationships assumed in the model. In particular,

the fixed fractional rate of clearance may add to this inadequacy. The potentially degradable part of NDF is subject to both degradation and passage, whilst clearance of the truly undegradable part is by passage only. Therefore, with lower rumen NDF contents observed in the morning and afternoon, the proportion of the undegradable part may have been higher and the true clearance rate lower than the constant value for K_{cl} assumed in the model. Modifications of the clearance rate might remove the inadequacy observed, but does require further data on fractional rate of degradation of the degradable part.

Conclusions

The model accurately predicted the rumen pool sizes of dairy cows based on their grazing behaviour pattern. From the simulated results and the grazing behaviour patterns it could be concluded that dairy cows stop grazing in the morning and afternoon long before reaching their maximum rumen capacity. However, rumen pool sizes were maximum when the dusk grazing bout ceased, indicating that rumen fill could be one of the main signals for terminating that bout.

References

- Bibby, J. and Toutenburg, H. (1977) *Prediction and Improved Estimation in Linear Models*. John Wiley & Sons, London, UK.
- Chilibroste, P., Tamminga, S. and Boer, H. (1997) Effects of length of grazing session, rumen fill and starvation time before grazing on dry matter intake, ingestive behaviour and dry matter rumen pool sizes of grazing lactating dairy cows. *Grass and Forage Science* 52, 249–257.
- Chilibroste, P., Gibb, M. and Tamminga, S. (2005) Pasture characteristics and animal performance. In: Dijkstra, J., Forbes, J.M. and France, J. (eds) *Quantitative Aspects of Ruminant Digestion and Metabolism*, 2nd edn. CAB International, Wallingford, UK, pp. 681–706.
- Gibb, M.J., Huckle, C.A. and Nuthall, R. (1998) Effect of time of day on grazing behaviour by lactating dairy cows. *Grass and Forage Science* 53, 41–46.
- Rook, A.J., Huckle, C.A. and Penning, P.D. (1994) Effects of sward height and concentrate supplementation on ingestive behaviour of spring-calving dairy cows grazing grass-clover swards. *Applied Animal Behaviour Science* 40, 101–112.
- Rutter, S.M., Champion, R.A. and Penning, P.D. (1997) An automatic system to record foraging behaviour in free-ranging ruminants. *Applied Animal Behaviour Science* 54, 185–195.
- Taweel, H.Z., Tas, B.M., Dijkstra, J. and Tamminga, S. (2004) Intake regulation and grazing behaviour of dairy cows under continuous stocking. *Journal of Dairy Science* 87, 3417–3427.

7

Functions for Microbial Growth

S. LÓPEZ,¹ M. PRIETO,² J. DIJKSTRA,³ E. KEBREAB,⁴
M.S. DHANOA⁵ AND J. FRANCE⁴

¹Department of Animal Production, University of León, E-24071 León, Spain; ²Department of Food Hygiene and Technology, University of León, E-24071 León, Spain; ³Animal Nutrition Group, Wageningen University, PO Box 338, 6700 AH Wageningen, The Netherlands; ⁴Centre for Nutrition Modelling, Department of Animal and Poultry Science, University of Guelph, Guelph, Ontario N1G 2W1, Canada; ⁵Institute of Grassland and Environmental Research, Plas Gogerddan, Aberystwyth, Dyfed SY23 3EB, UK

Abstract

The aim of this study was to evaluate the suitability of several mathematical functions for describing microbial growth curves. The functions considered were three-phase linear, logistic, Gompertz, Richards, Weibull and Baranyi. One data-set was used, comprising 34 curves stemming from viable count enumeration data of *Yersinia enterocolitica* grown on agar plates under different conditions of pH, temperature and carbon dioxide (time-constant conditions for each culture). Curves were selected to provide a wide variety of shapes with different growth rates and lag times. Statistical criteria used to evaluate model performance were based on goodness-of-fit: lowest residual mean square (RMS), extra residual variance *F*-test and Akaike's information criterion (AIC). The goodness-of-fit attained with all models was acceptable, with the Baranyi and three-phase linear functions showing best overall performance, followed by the Richards and Weibull, whilst the performances of the Gompertz and logistic were least satisfactory. Estimates of the maximum specific growth rate (μ_{\max}) and the lag time (*T*) were obtained with the six models, and then a multiple comparison was performed based on pairwise correlation analysis. Although Baranyi and three-phase linear gave lower estimates of μ_{\max} than the other four models, pairwise Pearson (*R*), Spearman rank-order (ρ) and Lin concordance (R_c) correlation coefficients were always greater than 0.998, 0.998 and 0.900, respectively, with a high level of statistical significance ($P < 0.001$). These results indicate that all six models gave comparable estimates of μ_{\max} , and that all the curves were ranked in almost the same order according to the estimates of this growth attribute. However, the estimates of *T* varied considerably among the models, and in this case the pairwise correlation coefficients were not so high ($R = 0.700\text{--}0.999$; $\rho = 0.486\text{--}0.995$ and $R_c = 0.222\text{--}0.983$). In general, the Baranyi and three-phase linear gave the shortest, and the logistic model the longest, lag times. The position of the point of inflection and the different approaches used to estimate *T* by each model may explain the discrepancies observed among models. Our results indicate that general application of the Gompertz to describe microbial growth should be reconsidered critically, as other models showed a significantly superior ability to fit experimental data.

Introduction

Fermentation is the process of decomposition and utilization of feedstuffs in the gastrointestinal tract (GIT) catalysed by enzymes produced by microorganisms. Microbial digestion of plant fibre is of crucial importance to herbivores, who have enlarged digestive structures in which an immensely complex microbial population is hosted. There is a mutual and reciprocal relationship between fermentation and microbial growth kinetics in the digestive tract of herbivores, as microbes obtain their nutrients from the fermentation of feeds, which, in turn, takes place by the action of microbial enzymes. In ruminants, the growth of the microbial population also determines the amount of microbial protein reaching the abomasum and duodenum, which is one of the main sources of amino acids for the animal (Van Soest, 1994). Therefore, microbial growth is an important process to be considered in models of microbial fermentation of feeds and of microbial synthesis in the rumen.

Mathematical modelling of microbial growth has been used to estimate parameters (specific growth rate and lag time) required to study growth under different physical and chemical conditions to enable the effects of antimicrobials to be investigated, or to build up prediction models for use in food and fermentation microbiology (McMeekin *et al.*, 1993; Whiting and Buchanan, 1997). A primary model is an equation or function that is used to describe the microbial response over time with a characteristic set of parameter values (Whiting, 1995; McMeekin and Ross, 2002). Microbial response has been mostly expressed in terms of microbial numbers (concentration of colony-forming units) or optical density as an indirect measurement (McMeekin *et al.*, 1993).

There are a number of sigmoidal functions that have been used for modelling somatic growth and population dynamics (Thornley and France, 2005), which could be applied to microbial growth. These functions have also been used to describe rumen degradation kinetics (López *et al.*, 1999), highlighting the close relationship between substrate degradation and microbial growth.

Despite the number of different non-linear equations used as growth functions, there is not one growth function that is essentially superior to all others. Mechanistic models are preferred because they are derived to represent the biochemical processes controlling microbial growth. This approach has been extensively used for somatic growth and population dynamics, and a large number of growth functions have been derived, such as the monomolecular, logistic and Gompertz (Turner *et al.*, 1976; Jason, 1983; Thornley and France, 2005). Strictly, models used to represent growth are not always wholly mechanistic, because regardless of the biological detail of their derivation, they are not derived exclusively from a set of differential equations in rate:state form constructed by direct application of scientific law. Nevertheless, as the equations seem to mimic reality, it is anticipated that the quantitative concepts and mechanisms underlying some of these expressions will be identified in the future as more understanding is gained

(Box and Draper, 1987; Baranyi and Roberts, 1995). Thus, model suitability can be evaluated from its ability to fit experimental data based on statistical criteria (López *et al.*, 2004).

The objectives of the present study were to investigate the statistical ability of six sigmoidal functions to fit an array of microbial growth curves recorded under different experimental conditions (resulting in pronounced differences in the shape of the curves) and to compare the estimates of important growth attributes (specific growth rate and lag time) derived by fitting the six functions to experimental data.

Materials and Methods

Mathematical considerations

Microbial growth is represented by the general equation:

$$dN/dt = \mu N \quad (7.1)$$

where N denotes microbial biomass (in units of mass, optical density, numbers, etc.), t is time (h) and μ is the specific growth rate (/h), which can be a function of time. The rate of change in the log microbial biomass [$\ln(N)$] is then:

$$\frac{d(\ln N)}{dt} = N^{-1} \frac{dN}{dt} = \mu(t) \quad (7.2)$$

If L_0 denotes the value of $\ln(N)$ at time zero, then integrating equation (7.2) yields:

$$\ln(N) = L_0 + \int_0^t \mu(t) dt = f(t) \quad (7.3)$$

giving $\ln(N)$ as a function of time.

The maximum value of μ (μ_{\max}) occurs at time t^* (h), which is found by solving:

$$d\mu/dt = 0 \quad (7.4)$$

The lag time, T (h), is the intercept of the tangent to the steepest part of the $f(t)$ vs time curve with the curve's lower bound. The equations of the tangent and the lower bound, respectively, are:

$$y - f(t^*) = \mu_{\max}(t - t^*) \quad (7.5)$$

and

$$y = L_0 \quad (7.6)$$

giving:

$$T = t^* - \frac{f(t^*) - L_0}{\mu_{\max}} \quad (7.7)$$

A number of candidates for $f(t)$, presented in Table 7.1, will be investigated as microbial growth functions; λ (/h) is a rate parameter, v (dimensionless) is a shape or curvature parameter and L_∞ is the maximum log microbial population size.

Model evaluation

Data

Thirty-four growth curves (Fig. 7.1) of *Y. enterocolitica* JBL 1307 grown under different environmental conditions were used. Stock cultures were maintained on Trypticase Soy Agar slants at 4°C. pH was adjusted to 5.0, 5.5, 6.0, 6.5 and 7.0 (± 0.01) using 5M HCl. Besides aerobic atmosphere, three combinations of carbon dioxide and oxygen (5:95, 15:85, and 25:75%) were used. Flasks were flushed for 10 min with gas mixtures sterilized through a 0.2 μm

Table 7.1. Candidate functions.

		$f(t)$
Linear	$L_0,$ $L_0 + \mu(t - T),$ $L_\infty,$	$t \leq T$ $T < t < tf$ $t \geq tf$
LIN		
Logistic	$\frac{L_\infty}{1 + e^{-\lambda(t-t^*)}}$	
LOG		
Gompertz	$L_\infty \exp \left[-e^{-\lambda(t-t^*)} \right]$	
GMP		
Richards	$\frac{L_\infty}{[1 + v e^{-\lambda(t-t^*)}]^{1/v}}$	
RCH		
Weibull	$L_\infty - (L_\infty - L_0) \exp \left[-(\lambda t)^v \right]$	
WBL		
	$L_0 + \mu_{\max} t + L_1 - L_2$	
Baranyi and Roberts	$L_1 = \ln \left[e^{-\mu_{\max} t} - e^{-\mu_{\max}(t+T)} + e^{-\mu_{\max} T} \right]$	
BAR	$L_2 = \ln \left[1 + \frac{e^{\mu_{\max}(t-T)} + e^{-\mu_{\max} T}}{e^{(L_2 - L_0)}} \right]$	

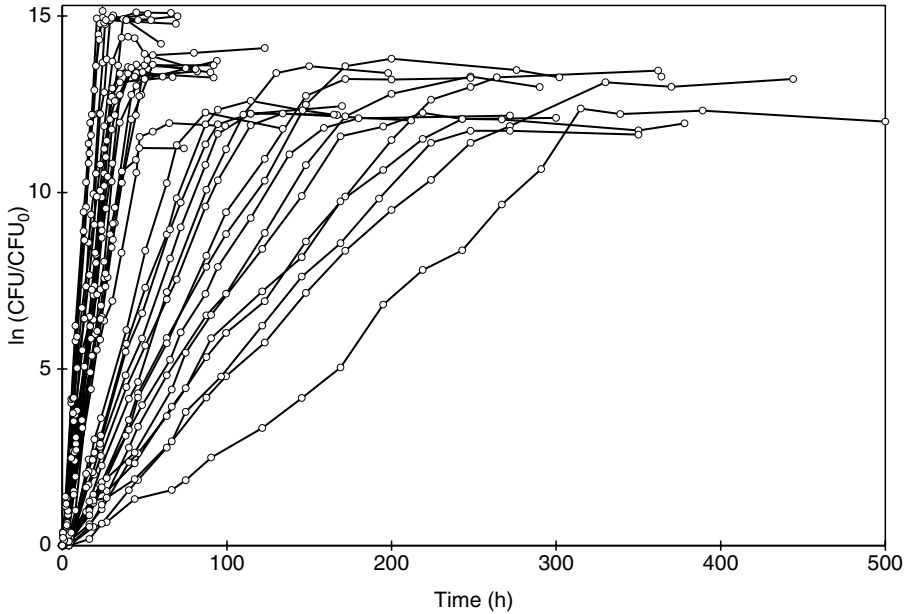

Fig. 7.1. Data-set (observed values) used for the study: plot of 34 viable count curves of *Yersinia enterocolitica* grown under different pH, temperature and gas atmosphere conditions [natural log of number of colony-forming units (CFU) vs time].

membrane (millipore). Cultures were grown in screw-capped flasks with rubber septum containing 250 ml of brain–heart infusion (BHI, Oxoid) inoculated with 0.1 ml of diluted microbial suspension (from cultures maintained for 18 h at 30°C in BHI) to give a concentration of ~ 1000 viable cells/ml. Flasks were placed in an incubator at 5°C, 10°C, 20°C and 30°C until stationary phase was reached. Each culture was maintained at constant conditions over the experimental period (no time-varying conditions). Samples taken aseptically from flasks at different incubation times were diluted in peptone water (1% peptone, 0.5% NaCl), plated in duplicate in BHI agar and incubated at 30°C for 48 h, and then the number of growing colonies were counted. The number of data points was between 10 and 20, with variable frequency of sampling. It is important to notice that the curves were selected to have a wide range of differences (Fig. 7.1) in order to study how each mathematical model fitted this high diversity of shapes.

Model fitting

All the models were fitted to the data by non-linear regression using the NLIN procedure of the SAS package (SAS, 1999). As for fitting behaviour, in general all the models were fitted without major problems, although the initial values supplied had to be different for each data-set in order to reach

convergence within a reasonable number of iterations. The selection of starting values was based on visual inspection of the plots. The uniqueness of the final solution achieved in each case was checked by changing the initial parameter estimates within a reasonable range for each data-set.

Statistical analyses

A number of statistics were used to evaluate the general goodness-of-fit of each model (López *et al.*, 2004). Proportion of variation accounted for (R^2) was calculated as $1 - \text{RMS}/s_y^2$, where s_y^2 is total variance of the y -variable. The statistical significance of the difference between models in terms of goodness-of-fit to the same data-set was assessed by using the F -tests described by Motulsky and Ransnas (1987) for comparing two models either with the same or different number of parameters. The residual sum of squares (RSS) and the number of parameters of each model are used to compute the F -ratio. An alternative method for comparing models is the AIC, based on information theory (Burnham and Anderson, 2002; Motulsky and Christopoulos, 2003). This method takes into account the change in goodness-of-fit and the difference in number of parameters between two models. Comparing the individual AIC values for each data-set, the model with the smallest AIC value is most likely to be correct (Motulsky and Christopoulos, 2003).

Growth attributes such as μ_{\max} and T were estimated for each growth curve after fitting each of the six models. Then the μ_{\max} and T estimates were compared from one model to another using pairwise correlation analysis. The similarity between μ_{\max} and T estimates derived from the different models was evaluated using the Pearson and the Spearman rank-order correlation coefficients (SAS, 1999) and, to measure the degree of reproducibility among models in the parameter estimates, the Lin concordance correlation coefficient (Lin, 1989) was used.

Results

Data fits obtained with all the models were evaluated taking into account statistics for goodness-of-fit. Proportion of variation explained was in general high for all the models, as the average values across the 34 growth curves were greater than 0.9896 (Table 7.2). The R^2 values were in most cases close to unity, but some differences were detected among models, indicating potential differences in goodness-of-fit. Models BAR and LIN showed the highest average R^2 values (Table 7.2), whereas model LOG was the worst using this criterion. Goodness-of-fit was also compared using the RMS (Table 7.2), which takes into account the number of parameters contained in each model. Average RMS across the 34 curves was smallest with models BAR and LIN, whereas the highest average RMS was observed with model LOG. The lowest mean rank of RMS corresponded to model BAR, with model LOG ranking the highest (Table 7.2). The smallest RMS was observed

Table 7.2. Goodness-of-fit: R^2 values and residual mean square (RMS) obtained when fitting the models to microbial growth data, mean rank of RMS (smallest RMS = rank 1, etc.) and number of curves (total = 34) for which the model showed the largest and the smallest RMS.

	LIN	LOG	GMP	RCH	WBL	BAR
Average R^2 values	99.73	98.96	99.15	99.27	99.35	99.74
RMS						
Average	0.0910	0.3230	0.2665	0.2497	0.2237	0.0888
Median	0.0694	0.2809	0.2257	0.2081	0.1883	0.0652
Minimum	0.0111	0.1436	0.0913	0.0642	0.0452	0.0189
Maximum	0.3798	0.7567	0.8568	0.8177	0.8019	0.3541
Ranking of models according to RMS						
Mean rank RMS	1.68	5.24	4.65	4.56	3.32	1.56
Number of curves with smallest RMS	14	0	0	0	2	18
Number of curves with largest RMS	0	24	10	0	0	0

in most curves with models BAR and LIN, whereas the greatest number of curves with the highest RMS was found with model LOG. In contrast to models LOG and GMP, fits to the BAR, LIN, WBL and RCH models never resulted in the largest RMS.

Pairwise comparisons between models are given in Tables 7.3 and 7.4, showing that in general models BAR and LIN were superior to the other models in terms of goodness-of-fit, whereas residual variance reached with models LOG and GMP were in general significantly ($P < 0.05$) larger than with other models. Models RCH and WBL were intermediate, and in many cases the pairwise difference in the RMS was not large enough to reach the level of statistical significance. The marginal column of Table 7.4 shows the total number of cases where each model was superior to others, showing clearly that BAR (103 cases) and LIN (100 cases) have a strong edge over the other models, mainly over LOG and GMP. The marginal row of Table 7.4 contains the column totals, lending support to the argument that BAR and LIN have claims for consideration, as overall they were outperformed by other models only in a small number of cases.

Parameter estimates (μ_{\max} , T) obtained by fitting the different models to data were compared using correlation analysis. Although BAR and LIN gave lower estimates of μ_{\max} than the other four models (Fig. 7.2), pairwise Pearson (R), Spearman rank-order (ρ) and Lin concordance (R_c) correlation coefficients were always greater than 0.998, 0.998 and 0.900, respectively (Table 7.5a), with a high level ($P < 0.001$) of statistical significance. These results indicate that the fit of the different models provided relatively close estimates of μ_{\max} and that all the curves were ranked in almost the same order according to the estimates of μ_{\max} obtained by any model. There were, however, rather important differences among the estimates of T obtained

Table 7.3. Pairwise comparisons between models based on the number of cases where the Akaike’s information criterion (AIC) value of the model specified in the row was smaller than that of the model specified in the column (total number of cases = 34), and ranking of models according to mean rank of AIC (smallest AIC = rank 1, etc.) and number of curves (total = 34) for which the model showed the largest and the smallest AIC.

	LIN	LOG	GMP	RCH	WBL	BAR
LIN		31	33	33	32	15
LOG	3		10	16	12	1
GMP	1	24		30	28	1
RCH	1	18	4		6	1
WBL	2	22	6	28		2
BAR	19	33	33	33	32	
Ranking of models according to AIC values						
Mean rank AIC	3.89	6.04	4.87	6.66	5.81	3.71
Number of curves with smallest AIC	14	1	0	0	2	17
Number of curves with largest AIC	0	18	2	10	4	0

Table 7.4. Pairwise comparisons between models: number of cases where the model specified in the row was significantly ($P < 0.05$) superior (using an F -test) to the model specified in the column (total number of cases = 34).

	LIN	LOG	GMP	RCH	WBL	BAR	Total
LIN		31	32	20	17	0	100
LOG	0		0	0	0	0	0
GMP	0	1		0	0	0	1
RCH	0	16	4		0	0	20
WBL	0	21	6	0		0	27
BAR	0	34	33	19	17		103
Total	0	103	75	39	34	0	

with the different models used to fit the data (Fig. 7.2) and, in this case, the pairwise correlation coefficients were not so high ($R = 0.700\text{--}0.999$, $\rho = 0.486\text{--}0.995$ and $R_c = 0.222\text{--}0.983$; Table 7.5b). The lower correlation coefficients were observed between the classical growth functions (LOG, GMP, RCH, WBL) and functions BAR or LIN. In general, BAR and LIN gave the shortest and LOG the longest estimates of T .

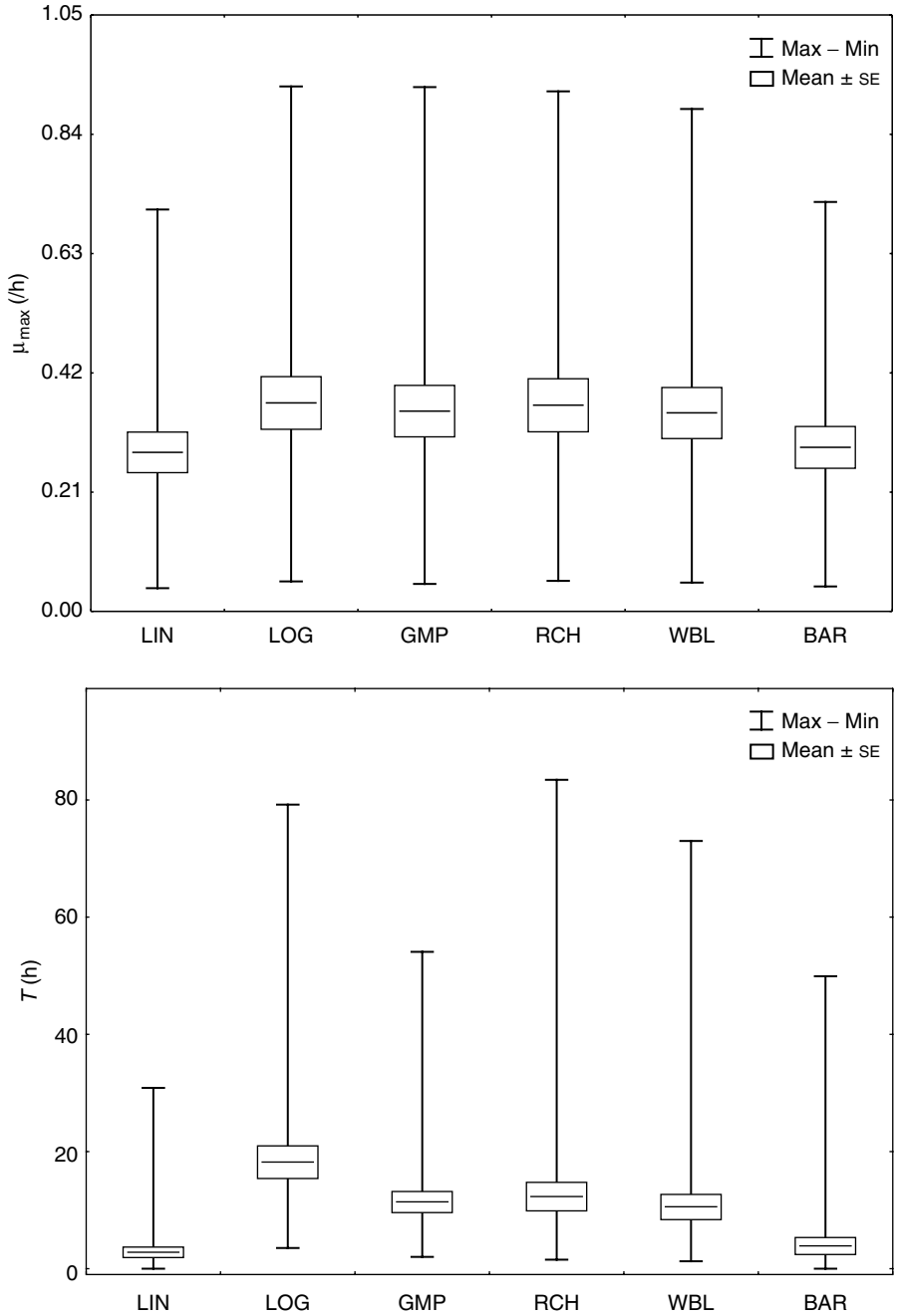

Fig. 7.2. Box plots of the estimates of maximum specific growth rate (μ_{\max}) and lag time (T) obtained by fitting the six models to 34 growth curves of *Yersinia enterocolitica*. Mean \pm standard error (SE), and range between minimum and maximum values across the 34 curves are shown.

Table 7.5. Concordance (upper diagonals) and Spearman rank-order (lower diagonals) correlation coefficients between estimates of maximum specific growth rate (matrix a) and of lag time (matrix b) obtained with each model.

(a) Maximum specific growth rate (μ_{\max})						
	LIN	LOG	GMP	RCH	WBL	BAR
LIN		0.998	0.999	0.999	1.000	0.998
LOG	0.906		0.999	0.999	0.999	0.999
GMP	0.928	0.997		0.999	1.000	0.998
RCH	0.909	0.999	0.997		0.999	0.998
WBL	0.933	0.996	0.999	0.997		0.998
BAR	0.998	0.924	0.943	0.926	0.948	

(b) Lag time (T)						
	LIN	LOG	GMP	RCH	WBL	BAR
LIN		0.486	0.516	0.526	0.550	0.748
LOG	0.222		0.995	0.949	0.965	0.502
GMP	0.389	0.808		0.954	0.972	0.523
RCH	0.409	0.838	0.895		0.990	0.518
WBL	0.470	0.773	0.924	0.983		0.539
BAR	0.836	0.368	0.576	0.643	0.715	

Discussion

The present study has compared the statistical performance of a number of models to describe microbial growth, including the three-phase linear model of Buchanan *et al.* (1997), the four-parameter model derived by Baranyi and Roberts (1995), and four other sigmoidal functions previously used to describe somatic growth (Turner *et al.*, 1976; Thornley and France, 2005). It is noteworthy that for microbial growth, modified functions are used, as the independent variable is log-transformed. Numbers (colony-forming units) or absorbance units are used to measure microbial growth, but data of this sort require logarithmic transformation because of their heteroscedasticity (i.e. they are not normally distributed and variance is not uniform). If data are not transformed, the regression analysis will be flawed (Schaffner, 1998). The relationship between $\ln(N)$ and time follows a sigmoidal pattern that can be described using available growth functions. The logistic and Gompertz are sigmoidal functions with a fixed point of inflection at $1/2$ and $1/e$ of the distance between the lower and the upper (L_∞) asymptotes, respectively. The Gompertz represents an asymmetrical sigmoidal shape and may offer greater flexibility than the logistic (Gibson *et al.*, 1987). The other models provide robust flexible growth functions, capable of describing both diminishing returns and sigmoidal behaviour, and with a variable point of inflection that can occur at any growth stage between L_0 and L_∞ . The flexible

functions encompass other growth equations as special or simpler cases; e.g. RCH encompasses LOG and GMP (Zwietering *et al.*, 1990; Dalgaard and Koutsoumanis, 2001; Thornley and France, 2005). Except for the LIN and BAR models, the point of inflection can be calculated using simple algebraic expressions.

The modified Gompertz (Gibson *et al.*, 1987) has been accepted commonly and used extensively, mainly on the grounds of the results reported by Zwietering *et al.* (1990), who concluded that this equation was statistically sufficient to describe microbial growth data and was easy to use. However, several studies have suggested that the modified Gompertz may show systematic lack of fit to microbial growth data, and other models should be used (Baranyi *et al.*, 1993; Dalgaard, 1995; Membré *et al.*, 1999; Schepers *et al.*, 2000).

Criteria for choosing a model are statistical goodness-of-fit and convenience (Draper and Smith, 1981; Motulsky and Ransnas, 1987; Motulsky and Christopoulos, 2003). Statistical performance led to some suggestions for the overall assessment of goodness-of-fit, as most of the statistical tests performed were consistent in rating the models. Generally, all the models studied proved valid for most growth curves, but it can be concluded that for many growth curves the fit with the BAR and LIN was significantly better than with the others, showing the highest R^2 values, and lowest residual variance and AIC values. The BAR and LIN models improved significantly ($P < 0.05$) the goodness-of-fit in comparison with the Gompertz for 94% and 97% of the growth curves, respectively. Buchanan *et al.* (1997) showed that goodness-of-fit attained with the three-phase linear model compared well with established models (Gompertz and Baranyi).

The extensively used Gompertz may be satisfactory to fit microbial growth curves, but in contrast with previous results (Gibson *et al.*, 1987; Zwietering *et al.*, 1990), other models are shown to be more accurate and appropriate to describe microbial growth (Baranyi *et al.*, 1993; Dalgaard, 1995; Membré *et al.*, 1999; Schepers *et al.*, 2000; Dalgaard and Koutsoumanis, 2001). The present study has shown that flexible growth functions with a variable point of inflection (BAR, RCH and WBL), and the LIN model improved significantly the goodness-of-fit achieved with the GMP when a wide range of microbial curves were analysed. Owing to the high diversity of curve shapes fitted, the results may be regarded widely applicable.

Statistical goodness-of-fit of each model is a useful unbiased criterion to establish which model is superior in describing the biological/experimental data, and in yielding more reliable and accurate estimates of growth indicators (Schepers *et al.*, 2000; López *et al.*, 2004). Model choice based on unbiased and objective criteria is essential, as precise estimates of μ_{\max} and T are required for evaluation of the effects of environmental factors (temperature, pH, anaerobiosis, nutrient availability) on microbial growth to assess optimal or non-favourable growth conditions. Estimates of these meaningful biological indicators were obtained for each growth curve using each of the models studied. Then pairwise comparisons between models were performed to examine discrepancies between models in the values of μ_{\max} and

T provided, and thus their capacity to give reliable estimates of the growth parameters. Estimates of μ_{\max} for each curve were similar regardless of the mathematical function used, with no significant differences in the values derived and high concordance and rank correlation coefficients. However, the different models yielded different values of parameter estimates for T , with LIN and BAR estimating on average lower T values compared with the other models (Baty *et al.*, 2002). Pronounced discrepancies among models in the estimation of T are stressed by the low concordance and rank correlation coefficients between the LIN/BAR models and the sigmoidal functions, indicating that the conclusions achieved in comparative studies of the growth conditions affecting duration of the lag phase may be driven by the model used to fit the data and to estimate this growth attribute (Baty *et al.*, 2002). Based on the model comparison, it seems that information on the value of μ_{\max} is reliable, whereas estimates for T do not seem to be so robust (McKellar, 1997).

Position of the point of inflection and the different approaches used to estimate T by each model may explain the discrepancies observed among models. The BAR and LIN models were developed on the basis of a clear differentiation between the lag, exponential and stationary phases of the growth curve, assuming that the relationship between $\ln(N)$ and T is, by definition, linear during the exponential growth phase (Buchanan *et al.*, 1997). The BAR model approaches a linear relation (Baranyi and Roberts, 1994), as specific growth rates close to μ_{\max} are maintained during an extended time interval that would correspond to the exponential growth phase. In contrast, the classical sigmoidal functions reach a higher μ_{\max} at the point of inflection, resulting in a longer T . Some authors have concluded that this characteristic behaviour may lead to overestimation of both growth attributes by the sigmoidal functions (Buchanan *et al.*, 1997; Membré *et al.*, 1999; Dalgaard and Koutsoumanis, 2001). Mathematical formulation of lag is also different in each model. In some models (LIN and BAR) T is estimated directly by non-linear regression as the parameter is contained explicitly in the function. However, with the sigmoidal functions, T is calculated numerically from other parameters of the predicted growth curve using equation (7.7). Lack of consistency in the T estimates has been emphasized on the basis of their wide confidence intervals, which have a given probability of containing the actual value of T . These confidence intervals are considerably large, to the point that differences among models in the T values estimated may be smaller than the lack of precision of each value considering the variation around every single estimate (Baty and Delignette-Muller, 2004). This precision can be improved by increasing the number of points in the data-set, but it will also reduce noticeably the differences among models in the parameter estimates (Baty and Delignette-Muller, 2004). Accurate predictions of T seem to be not always achievable (McKellar, 1997), probably due to the high variability of this parameter and to factors influencing the lag phase, such as environmental conditions, bacterial species, physiological stage of the cell and inoculum size (Swinnen *et al.*, 2004).

The particular difficulty in estimating T can be attributed to lack of biological understanding of the lag phenomenon and to the fact that the actual definition of T is purely mathematical or geometrical (Baranyi, 1998; Baty and Delignette-Muller, 2004). Actual values of T cannot be measured directly and thus it is not possible to evaluate how reliable the T estimates between models are and to elucidate which model provides a better approximation to the actual values.

In conclusion, probably all the functions evaluated can be used as primary-level microbial growth models with an acceptable degree of goodness-of-fit. However, a detailed statistical evaluation across a wide range of curve shapes and profiles has revealed some significant differences among models in their performance and accuracy. Models BAR and LIN showed the best fit for plate count data and, based on only statistical criteria, it would be appropriate to select them for general use in describing microbial growth curves. The comparison of the ability of the models to provide reliable estimates of growth indicators showed that all the models resulted in similar values of μ_{\max} , whereas there were significant differences in T estimates provided by the different models. Experimental measurement of T might contribute to establish which model results in a better approximation to the actual values and would be more appropriate for estimating this growth indicator.

Acknowledgements

The authors wish to acknowledge the financial support received from CICYT Project no. AGF98-0188. Support for J.F. from the Spanish Secretaría de Estado de Educación y Universidades del Ministerio de Educación, Cultura y Deporte and the European Social Fund (Ayuda para estancias de profesores, investigadores, doctores y tecnólogos extranjeros en España Ref. SAB2000-0112) is gratefully acknowledged.

References

- Baranyi, J. (1998) Comparison of stochastic and deterministic concepts of bacterial lag. *Journal of Theoretical Biology* 192, 403–408.
- Baranyi, J. and Roberts, T.A. (1994) A dynamic approach to predicting bacterial growth in food. *International Journal of Food Microbiology* 23, 277–294.
- Baranyi, J. and Roberts, T.A. (1995) Mathematics of predictive food microbiology. *International Journal of Food Microbiology* 26, 199–218.
- Baranyi, J., Roberts, T.A. and McClure, P. (1993) A nonautonomous differential equation to model bacterial growth. *Food Microbiology* 10, 43–59.
- Baty, F. and Delignette-Muller, M.L. (2004) Estimating the bacterial lag time: which model, which precision? *International Journal of Food Microbiology* 91, 261–277.
- Baty, F., Flandrois, J.P. and Delignette-Muller, M.L. (2002) Modeling the lag time of *Listeria monocytogenes* from viable count enumeration and optical density data. *Applied and Environmental Microbiology* 68, 5816–5825.

- Box, G.E.P. and Draper, N.R. (1987) *Empirical Model-building and Response Surfaces*. John Wiley & Sons, New York.
- Buchanan, R.L., Whiting, R.C. and Damert, W.C. (1997) When is simple good enough: a comparison of the Gompertz, Baranyi, and three-phase linear models for fitting bacterial growth curves. *Food Microbiology* 14, 313–326.
- Burnham, K.P. and Anderson, D.R. (2002) *Model Selection and Multimodel Inference: A Practical Information-Theoretic Approach*, 2nd edn. Springer-Verlag, New York.
- Dalgaard, P. (1995) Modelling of microbial activity and prediction of shelf-life for packed fresh fish. *International Journal of Food Microbiology* 26, 305–317.
- Dalgaard, P. and Koutsoumanis, K. (2001) Comparison of maximum specific growth rates and lag times estimated from absorbance and viable count data by different mathematical models. *Journal of Microbiological Methods* 43, 183–196.
- Draper, N.R. and Smith, H. (1981) *Applied Regression Analysis*. John Wiley & Sons, New York.
- Gibson, A.M., Bratchell, N. and Roberts, T.A. (1987) The effect of sodium chloride and temperature on the rate and extent of growth of *Clostridium botulinum* type A in pasteurized pork slurry. *Journal of Applied Bacteriology* 62, 479–490.
- Jason, A.C. (1983) A deterministic model for monophasic growth of batch cultures of bacteria. *Antonie Van Leeuwenhoek* 49, 513–536.
- Lin, L.I.K. (1989) A concordance correlation coefficient to evaluate reproducibility. *Biometrics* 45, 255–268.
- López, S., France, J., Dhanoa, M.S., Mould, F. and Dijkstra, J. (1999) Comparison of mathematical models to describe disappearance curves obtained using the polyester bag technique for incubating feeds in the rumen. *Journal of Animal Science* 77, 1875–1888.
- López, S., Prieto, M., Dijkstra, J., Dhanoa, M.S. and France, J. (2004) Statistical evaluation of mathematical models for microbial growth. *International Journal of Food Microbiology* 96, 289–300.
- McKellar, R.C. (1997) A heterogeneous population model for the analysis of bacterial growth kinetics. *International Journal of Food Microbiology* 36, 179–186.
- McMeekin, T.A. and Ross, T. (2002) Predictive microbiology: providing a knowledge-based framework for change management. *International Journal of Food Microbiology* 78, 133–153.
- McMeekin, T.A., Olley, J.N., Ross, T. and Ratkowsky, D.A. (1993) *Predictive Microbiology: Theory and Application*. John Wiley & Sons, New York.
- Membré, J.M., Ross, T. and McMeekin, T.A. (1999) Behaviour of *Listeria monocytogenes* under combined chilling processes. *Letters in Applied Microbiology* 28, 216–220.
- Motulsky, H.J. and Ransnas, L.A. (1987) Fitting curves to data using nonlinear regression: a practical and nonmathematical review. *FASEB Journal* 1, 365–374.
- Motulsky, H.J. and Christopoulos, A. (2003) *Fitting Models to Biological Data Using Linear and Nonlinear Regression: A Practical Guide to Curve Fitting*. GraphPad Software, San Diego, California.
- SAS (1999) *SAS/STAT® User's Guide (Version 8)*. SAS Publishing, Cary, North Carolina.
- Schaffner, D.W. (1998) Predictive food microbiology Gedanken experiment: why do microbial growth data require a transformation? *Food Microbiology* 15, 185–189.
- Schepers, A.W., Thibault, J. and Lacroix, C. (2000) Comparison of simple neural networks and nonlinear regression models for descriptive modeling of *Lactobacillus helveticus* growth in pH-controlled batch cultures. *Enzyme and Microbial Technology* 26, 431–445.
- Swinnen, I.A.M., Bernaerts, K., Dens, E.J.J., Geeraerd, A.H. and Van Impe, J.F. (2004) Predictive modelling of the microbial lag phase: a review. *International Journal of Food Microbiology* 94, 137–159.

- Thornley, J.H.M. and France, J. (2005) *Mathematical Models in Agriculture*, 2nd edn. CAB International, Wallingford, UK, 850 pp.
- Turner, M.E., Bradley, E.L., Kirk, K.A. and Pruitt, K.M. (1976) A theory of growth. *Mathematical Biosciences* 29, 367–373.
- Van Soest, P.J. (1994) *Nutritional Ecology of the Ruminant*, 2nd edn. Cornell University Press, Ithaca, New York.
- Whiting, R.C. (1995) Microbial modeling in foods. *Critical Reviews in Food Science and Nutrition* 35, 464–494.
- Whiting, R.C. and Buchanan, R.L.B. (1997) Predictive modelling. In: Doyle, M.P., Beuchat, L.R. and Montville, T.J. (eds) *Food Microbiology Fundamentals and Frontiers*. American Society for Microbiology Press, Washington, DC, pp. 728–739.
- Zwietering, M.H., Jongenburger, I., Rombouts, F.M. and van't Riet, K. (1990) Modeling of the bacterial growth curve. *Applied and Environmental Microbiology* 56, 1875–1881.

8

Obtaining Information on Gastric Emptying Patterns in Horses from Appearance of an Oral Acetaminophen Dose in Blood Plasma

J.P. CANT,¹ V.N. WALSH¹ AND R.J. GEOR²

¹*Department of Animal and Poultry Science, University of Guelph, Guelph, Ontario N1G 2W1, Canada;* ²*Department of Biomedical Sciences, University of Guelph, Guelph, Ontario N1G 2W1, Canada*

Abstract

The rate of passage of nutrients from the stomach to the small intestine is a regulated process that can influence metabolic responses to a meal. Acetaminophen has been used as an indicator of gastric emptying because of its negligible absorption in the stomach and high coefficient of absorption in the proximal small intestine. Seven horses were given an oral dose of 20 mg/kg acetaminophen simultaneously with a 5 ml/kg gastric gavage of water or a 20% glucose solution containing nothing else, triacetin, octanoic acid or maize oil. The five different liquid meals were administered on consecutive weeks in a randomized sequence. To identify the pattern of gastric emptying on different meals, several candidate models of gastric emptying and acetaminophen kinetics were evaluated from least squared fits to the 35 sets of acetaminophen concentrations in serial blood samples collected from a jugular catheter. In all models, absorption was assumed to be nil from the stomach and instantaneous from the small intestine. Elimination from the circulation followed first-order kinetics. Assuming continuous, zero-order outflow of acetaminophen from the stomach yielded R^2 for fits to the plasma appearance curves that ranged from 0.18 to 0.97 and AIC from 69 to 109. The average \pm standard deviation (SD) gastric emptying rate was 231 ± 176 mg/min from a dose of 8412 ± 819 mg. Assuming first-order kinetics of acetaminophen outflow relative to gastric contents did not improve the goodness-of-fit. The average \pm SD emptying rate constant was 0.046 ± 0.042 /min. An oscillation in residuals over time from both models was hypothesized to be due to the initial dose intermittently flowing out of the stomach. Two parameters (w and p) were added to the zero-order and first-order emptying models to simulate periodic gushing of gastric contents for w min every p min, where $w < p$. From the zero-order model, the duration of each gush (w) was estimated to be 52 min, on average, and the period between gushes (p) was 192 min. Representing intermittency of gastric outflow as a sequence of identically spaced pulses resulted, on average, in an 80% increase in the estimate of the rate constant for acetaminophen clearance from plasma. Periodicity parameters for variably intermittent

gastric emptying models were obtained from the sign of plasma acetaminophen appearance runs. The zero-order variably intermittent model performed better for meals of glucose plus octanoic acid, whereas the first-order model was superior for the other meals.

Introduction

One of the unique features of the horse as an athlete, compared to the human, is the relatively long period of time required for repletion of muscle glycogen stores following a bout of heavy exercise. Complete repletion may take up to 72 h (Hyypya *et al.*, 1997). The delay represents a problem for subsequent bouts of exercise because low muscle glycogen content can impair running performance (Lacombe *et al.*, 2001). One solution would be to exploit the effect of circulating metabolite profile on routes of disposition of absorbed glucose, e.g. into glycogen vs oxidation or lipogenesis. For example, it has been shown in the rat that fatty acyl CoA esters inhibit acetyl-CoA carboxylase to unlock carnitine-palmitoyl transferase I, allowing entry of the fatty acid into muscle mitochondria where their oxidation causes a slowing of pyruvate dehydrogenase activity and glycolytic flux (Jucker *et al.*, 1999), and diverts glucose and pyruvate into muscle glycogen (Fushimi *et al.*, 2001). The net effect of a mixed fat plus carbohydrate meal on glucose disposal is apparent in the postprandial change in glucose and insulin concentrations, but this glycaemic response is also affected by gastric emptying rates. The rate of passage of nutrients from the stomach to the small intestine is a regulated process that can be influenced by the contents of the meal (Malagelada and Azpiroz, 1989).

The so-called 'gold standard' for measuring gastric emptying is by nuclear scintigraphy in which a bolus of radioactively tagged foodstuff is dosed into the stomach and then non-invasively counted from outside the body wall. The plot of counts vs time is typically described by a first-order decay function containing a first-order delay (Bromer *et al.*, 2002):

$$\text{retention percentage} = 100[1 - (1 - e^{-kt})^\beta] \quad (8.1)$$

Gastric emptying rate is then characterized according to its half-time:

$$t_{1/2} = \frac{-\ln(1 - 0.5^{1/\beta})}{k} \quad (8.2)$$

and lag time:

$$t_{\text{lag}} = \frac{\ln\beta}{k} \quad (8.3)$$

An indirect method to assess gastric emptying involves monitoring the appearance of an oral acetaminophen dose in plasma. The technique is based on the observation that acetaminophen is very slowly absorbed from the stomach but rapidly absorbed in the proximal small intestine (Clements *et al.*, 1978). In order to assess the gastric emptying component of the

glycaemic response to mixed meals, seven horses were given an oral dose of 20 mg/kg acetaminophen simultaneously with a 5 ml/kg gastric gavage of water or a 20% glucose solution containing nothing else, triacetin, octanoic acid or maize oil. The five different liquid meals were administered on consecutive weeks in a randomized sequence.

Typically, although several models of acetaminophen absorption and elimination kinetics have been proposed (Clements *et al.*, 1978; Sanaka *et al.*, 1997, 1998), gastric emptying rate is not directly estimated from acetaminophen appearance curves. Rather, various model-independent indices of relative emptying rate such as area under the curve, peak concentration, time to peak concentration, and ratios thereof are calculated. Kinetic modelling has merely been used to justify the validity of one index vs another in reflecting the true emptying rate. The purpose of the following work was to use models of acetaminophen kinetics to identify, from plasma acetaminophen appearance curves, characteristics of gastric emptying of the five liquid meals given to horses. Of the 35 curves obtained and fitted by the candidate models, four were chosen to illustrate model behaviour and goodness-of-fit. These four (Fig. 8.1) represent the observed range of shapes.

Continuous Emptying Models 1 and 2

It was assumed in all models that there was no absorption of acetaminophen from the stomach and instantaneous absorption from the small intestine. This latter assumption meant that the stomach compartment (S) of acetaminophen emptied directly into blood (B; Fig. 8.2). Elimination from blood plasma was assumed to follow first-order kinetics.

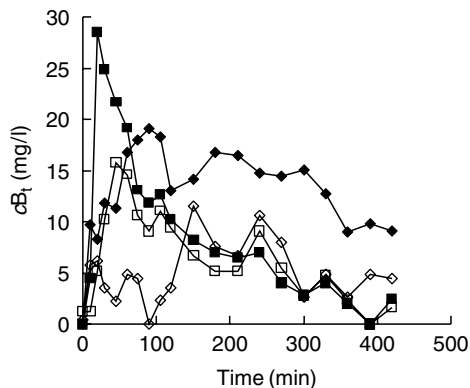

Fig. 8.1. Four curves of acetaminophen concentration in blood plasma (cB_t) of horses after an oral dose of 20 mg/kg body weight.

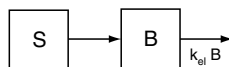

Fig. 8.2. Generic diagram of acetaminophen flows from stomach (S) and blood (B) compartments.

In model 1, gastric emptying rate from S to B was considered a zero-order process represented by the constant F . Acetaminophen from the initial dose flows out of the stomach until $t = \text{dose}/F$. The differential equations for acetaminophen mass in the two pools

$$\frac{dS}{dt} = F \text{ when } t < \text{dose}/F, \text{ else } \frac{dS}{dt} = 0 \quad (8.4)$$

$$\frac{dB}{dt} = F - k_{el} \times B \quad (8.5)$$

were solved analytically for estimation of best-fit F and k_{el} with the NLIN procedure of SAS:

when $t < \text{dose}/F$

$$S_t = \text{dose} - F \times t \quad (8.6)$$

$$B_t = \frac{F}{k_{el}} (1 - e^{-k_{el} \times t}) \quad (8.7)$$

else

$$S_t = 0 \quad (8.8)$$

$$B_t = \frac{F}{k_{el}} \left(1 - e^{-k_{el} \times \frac{\text{dose}}{F}} \right) e^{-k_{el} \left(t - \frac{\text{dose}}{F} \right)} \quad (8.9)$$

Calculation of the plasma acetaminophen concentration:

$$cB_t = \frac{B_t}{a \times BW} \quad (8.10)$$

where BW is body weight (kg), required fitting of a third parameter, a , representing the volume of distribution of acetaminophen and the fractional first-pass metabolism of acetaminophen between S and B.

In model 2, gastric outflow was considered first-order relative to stomach contents with the rate constant k_{SB} . Thus:

$$\frac{dS}{dt} = -k_{SB} \times S \quad (8.11)$$

$$\frac{dB}{dt} = k_{SB} \times S - k_{el} \times B \quad (8.12)$$

Analytical solutions of equations (8.11) and (8.12) parameterized in SAS were:

$$S_t = \text{dose} \times e^{-k_{SB} \times t} \quad (8.13)$$

$$B_t = \frac{\text{dose} \times k_{\text{SB}}}{k_{\text{SB}} - k_{\text{el}}} (e^{-k_{\text{el}} \times t} - e^{-k_{\text{SB}} \times t}) \quad (8.14)$$

Model fits were assessed and compared by coefficients of determination, residual sums of squares (RSS) and Akaike's information criterion (AIC), calculated as:

$$\text{AIC} = n \times \ln(\text{RSS}) + 2q \quad (8.15)$$

where n is the number of observations and q is the number of parameters. AIC may be a better statistic for comparison of models of different complexities because it adjusts the RSS for the number of parameters in the model.

Because of prolonged outflow from the stomach, fitted solutions of cB_t in model 2 displayed a less sharp peak than solutions in model 1. Accordingly, the rapid appearance of acetaminophen following water meals was better described by model 1 (Fig. 8.3). On the other hand, acetaminophen appearance curves from some of the caloric meals were more rounded and better fit by model 2. Meals containing octanoic acid were poorly fit by both models. According to the average rank, from 1 indicating best fit to 6 indicating worst, more of the 35 acetaminophen appearance curves were better fit by model 1 assuming zero-order than by model 2 with first-order gastric emptying (Table 8.1). Estimates of k_{el} were not significantly different between the two models but a was higher for model 1.

On average, 77% of the variation in plasma acetaminophen concentration was explained by model 1. Offsets of the observed acetaminophen concentrations from the predicted lines revealed a distinct temporal pattern of sizeable oscillations about the fitted lines, more pronounced on some meals than others (Fig. 8.3). In general, the observations described an erratic and not a smooth decay as would be expected from an acetaminophen injection into the jugular vein, as in Hirate *et al.* (1990). Lohmann *et al.* (2002) observed a similar degree of variation within a single curve of acetaminophen appearance following an oral dose to horses. We hypothesized for subsequent models that the oscillations in plasma acetaminophen were due to an intermittency of gastric emptying. It is well established that outflow of digesta from the stomach in many species is not continuous and is associated with frequent but periodic contractions in the antrum, pylorus and proximal duodenum (Girard and Sissons, 1992; Malbert *et al.*, 1997). Cumulative appearance of a radioactive dose from the stomach into the small intestine of cats after a meal followed a circuitous time course in which an intermediate plateau was maintained for approximately 60 min before ascending to a terminal plateau (Malagelada *et al.*, 1984). Similarly, by direct measurement of acetaminophen contents of gastric digesta samples, Clements *et al.* (1978) identified three patterns of gastric emptying from 17 human subjects given acetaminophen orally with various analgesics: type 1 outflow was a continuous first-order decline in acetaminophen mass; type 2 was an immediate loss of a fraction of the dose followed by first-order emptying; and type 3 was intermittent flow where first-order emptying was interrupted by

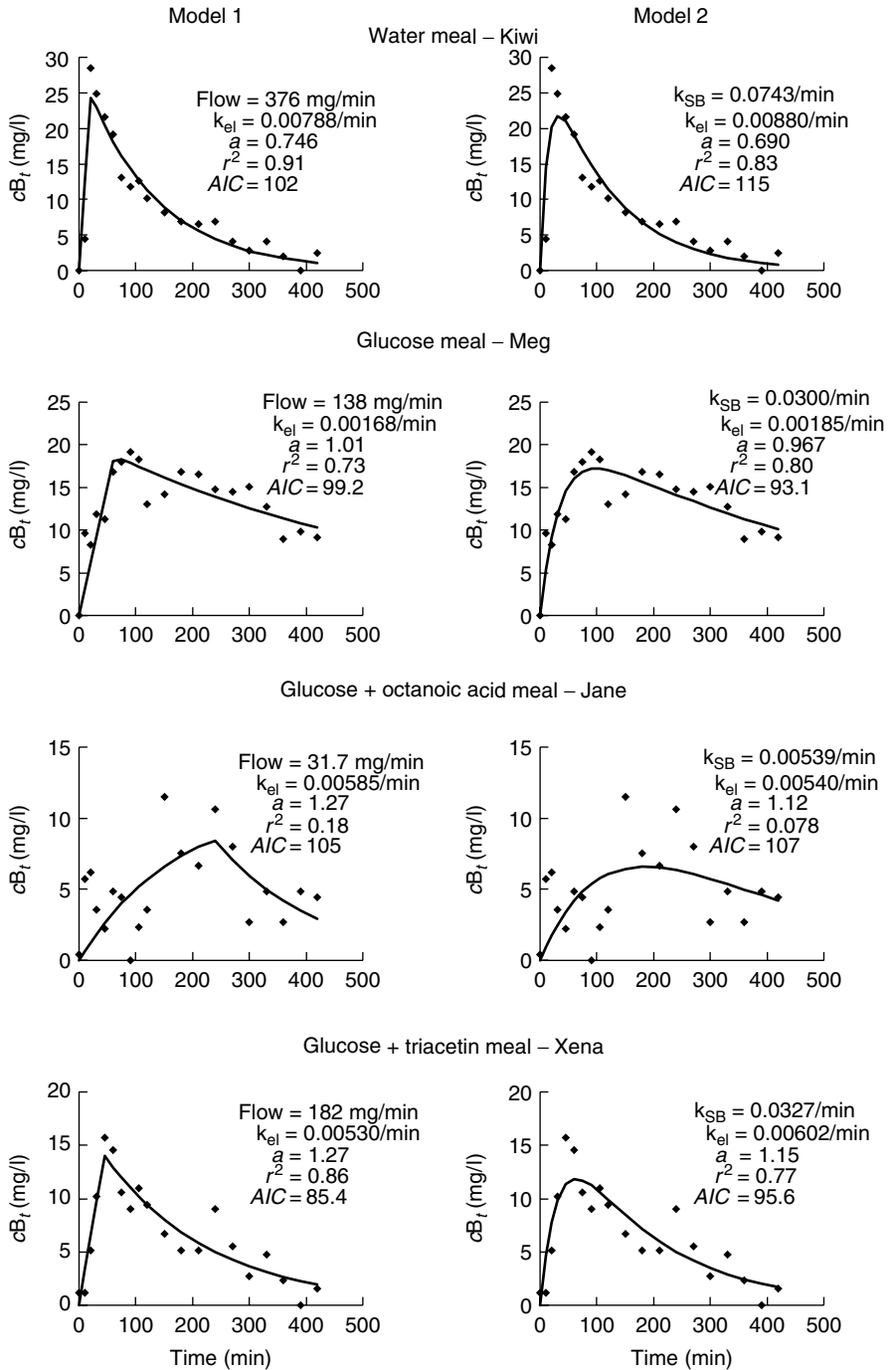

Fig. 8.3. Fits of models 1 and 2 (solid lines), assuming zero- and first-order gastric emptying, respectively, to four selected plasma acetaminophen appearance curves (◆).

Table 8.1. Average least-squared parameter estimates and statistics of fit to the 35 plasma acetaminophen curves by candidate models of acetaminophen flow. Variance was analysed with a statistical model containing horse, meal and period effects. Means were separated by orthogonal contrasts. For each of the 35 curves, models were ranked 1–6 from best to worst fit, according to R^2 , residual sums of squares (RSS) and Akaike's information criteria (AIC). Mean ranks are presented. Variance in ranks was analysed using the CATMOD procedure of SAS for categorical data.

	Model						<i>P</i>
	1	2	3	4	5	6	
F (mg/min)	231.5 ^a		198.3 ^a		97.0 ^b		0.000
k_{SB} (/min)		0.046 ^a		0.027 ^b		0.028 ^b	0.002
k_{el} (/min)	0.0045 ^a	0.0057 ^a	0.0081 ^b	0.0091 ^b	0.0147 ^c	0.0099 ^b	0.000
<i>a</i>	1.35 ^a	1.17 ^b	0.92 ^c	0.67 ^d	0.52 ^d	0.56 ^d	0.000
<i>w</i>			51.9	65.1			0.068
<i>p</i>			191.5 ^a	145.9 ^b			0.004
R^2	0.77 ^a	0.74 ^a	0.81 ^a	0.79 ^a	0.61 ^b	0.80 ^a	0.000
Rank	3.6 ^c	4.6 ^d	2.2 ^a	3.2 ^{bc}	4.7 ^d	2.8 ^{ab}	0.000
RSS	71.7 ^{ab}	89.6 ^b	60.1 ^a	70.9 ^{ab}	166.8 ^c	73.0 ^{ab}	0.000
Rank	3.6 ^c	4.7 ^d	2.2 ^a	3.1 ^{bc}	4.7 ^d	2.8 ^{ab}	0.000
AIC	88.9 ^a	92.2 ^a	89.4 ^a	91.8 ^a	104.3 ^b	90.5 ^a	0.000
Rank	2.6 ^a	3.9 ^c	2.8 ^a	3.7 ^{bc}	4.8 ^d	3.2 ^{ab}	0.000

a,b,c,d Means with different superscripts differ ($P < 0.05$).

a period of no change. By fitting equations to the gastric acetaminophen observations and simulating flow to the small intestine and body compartments, Clements *et al.* (1978) were able to account for oscillations in plasma acetaminophen decay.

Intermittent Emptying Models 3 and 4

Model 3 was a modification of model 1 in which the flow rate F in equations (8.4) and (8.5) was multiplied by a new variable z , which takes on a value of 0 or 1 according to a fixed rectangular pulsation (Fig. 8.4). The pulsation simulates periodic gushing of gastric contents for w min every p min, where $w < p$. Because of discontinuities between bouts of emptying and quiescence, analytical solutions of model 3 depend on how many times the emptying cycle has been repeated.

An iterative routine was written in SAS to solve cB_t for each observation time point t . At the outset, a counter n and a storage variable to keep track of B_t (*old*) were both set to 0. The integer number of required iterations (*num*) through the do loop and the time at which the stomach becomes empty (t_{empty}) were also calculated. The SAS routine was as follows:

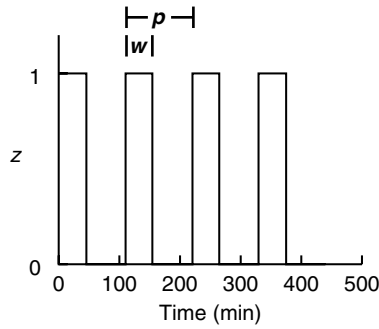

Fig. 8.4. Fixed pulsation of z between 0 and 1 according to periodicity parameters w and p .

$$n = 0 \quad (8.16)$$

$$old = 0$$

$$num = \min \left[\text{int} \left(\frac{\text{dose}}{F \times w} \right), \text{int} \left(\frac{t}{p} \right) \right]$$

$$t_{\text{empty}} = \frac{\text{dose}}{F} + \text{int} \left(\frac{\text{dose}}{F \times w} \right) (p - w)$$

$$t_{\text{dummy}} = \min(t, t_{\text{empty}})$$

do until $n > num$

if $n = num$ and $t_{\text{dummy}}/p - num \leq w/p$ then

/* middle of emptying phase */

$$B_t = \frac{F}{k_{\text{el}}} + \left(\text{old} - \frac{F}{k_{\text{el}}} \right) e^{-k_{\text{el}} \times p \left[t_{\text{dummy}}/p - num \right]}$$

else

/* end of emptying phase */

$$B_t = \frac{F}{k_{\text{el}}} + \left(\text{old} - \frac{F}{k_{\text{el}}} \right) e^{-k_{\text{el}} \times w}$$

$$\text{old} = B_t$$

if $t_{\text{dummy}}/p - n > w/p$ then

/* middle of quiescent phase */

$$\begin{aligned}
 B_t &= \text{old} \times e^{-k_{el}} \left\{ p \left[\left(\frac{t_{dumny}}{p} \right) \right] - \text{num} - w \right\} \\
 &\quad \text{else} \\
 &\quad /* \text{ end of quiescent phase} */ \\
 B_t &= \text{old} \times e^{-k_{el}(p-w)} \\
 \text{old} &= B_t \\
 &\quad n + 1 \\
 B_t &= \text{old} \times e^{-k_{el}(t-t_{dumny})} \\
 cB_t &= \frac{B_t}{a \times BW}
 \end{aligned}$$

Considering intermittency of flow had little impact on fits to curves from water meals but all other fits tended to be improved, particularly for the glucose plus octanoic acid meals (Fig. 8.5). The average RSS from all 35 fits was improved in model 3 vs model 1 but the AIC was not affected (Table 8.1). However, despite similar fits for many of the curves, a more reasonable profile of stomach acetaminophen contents was obtained from model 3 (Fig. 8.6) than from the presumption of continuous outflow in model 1. On average, it was estimated that emptying occurred less than half of the time: 52 out of 192 min (Table 8.1). Model 4, which assumed first-order emptying according to the periodic pulsation, similarly arrived at estimates of w and p of 65 and 146 min, respectively. Estimates of the elimination rate constant k_{el} were increased by 80% in the intermittent model because large increases in acetaminophen concentration on the tail of appearance curves (Fig. 8.5) were no longer considered exclusively as elimination but included gastric emptying.

Variably Intermittent Emptying Models 5 and 6

Typically, one additional bout of emptying beyond the initial bout was detected by the algorithm for iteration to least squares whereas more than four bouts were apparent in the observations (Figs 8.3 and 8.5). In order to be efficient, an iterative algorithm presumes a smooth descent to least squares, and the discontinuity of models 3 and 4 would have confounded that pursuit and served to hide the global best fit in a sea of local minima. Additionally, assuming a fixed w and p throughout the entire duration of acetaminophen appearance and elimination was a constraint that may have precluded detection of all emptying bouts. A model 5 of variably intermittent zero-order gastric emptying was parameterized by first assuming that a positive change in plasma acetaminophen concentrations within a sampling interval coincided with an emptying phase and a negative change indicated

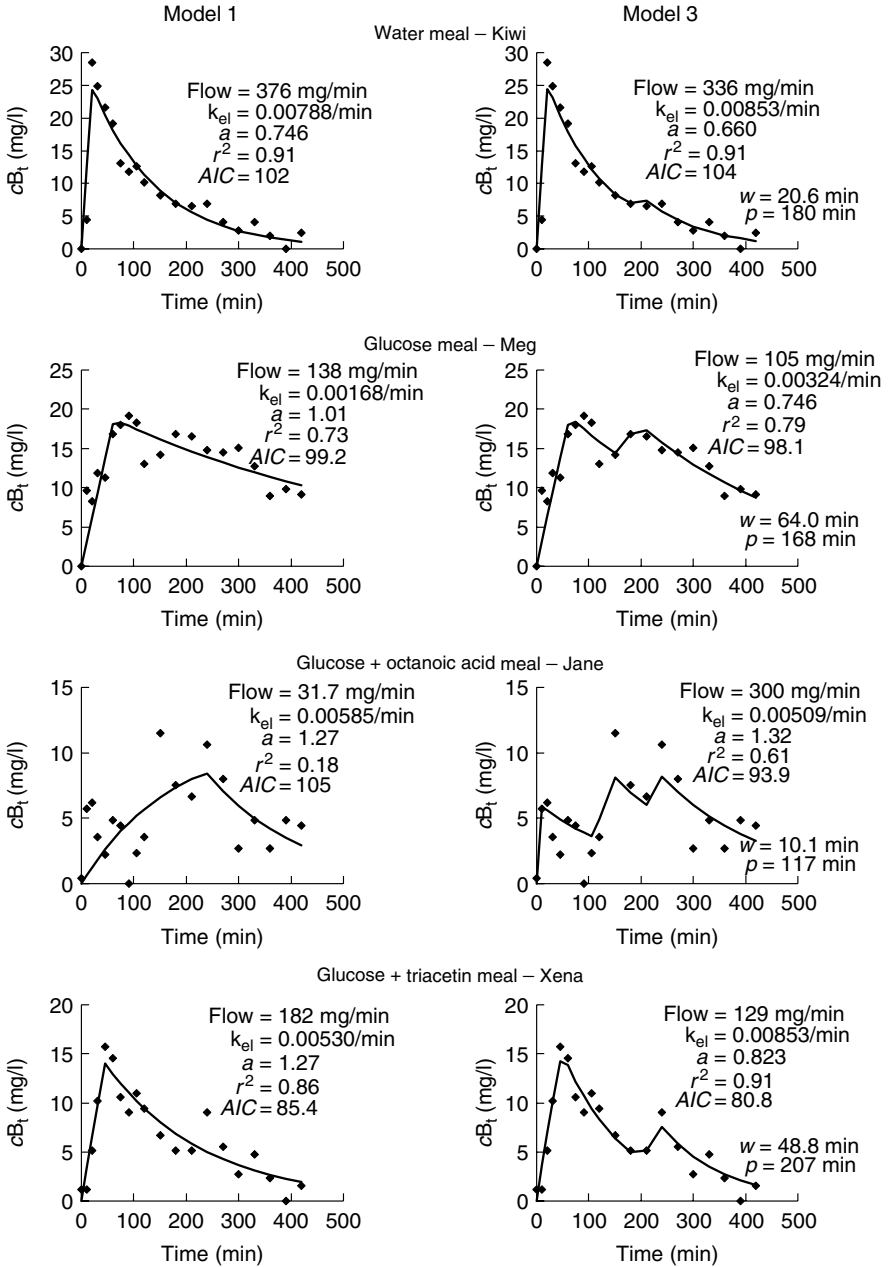

Fig. 8.5. Fits of models 1 and 3 (solid lines), assuming continuous and intermittent zero-order gastric emptying, respectively, to four selected plasma acetaminophen appearance curves (\blacklozenge).

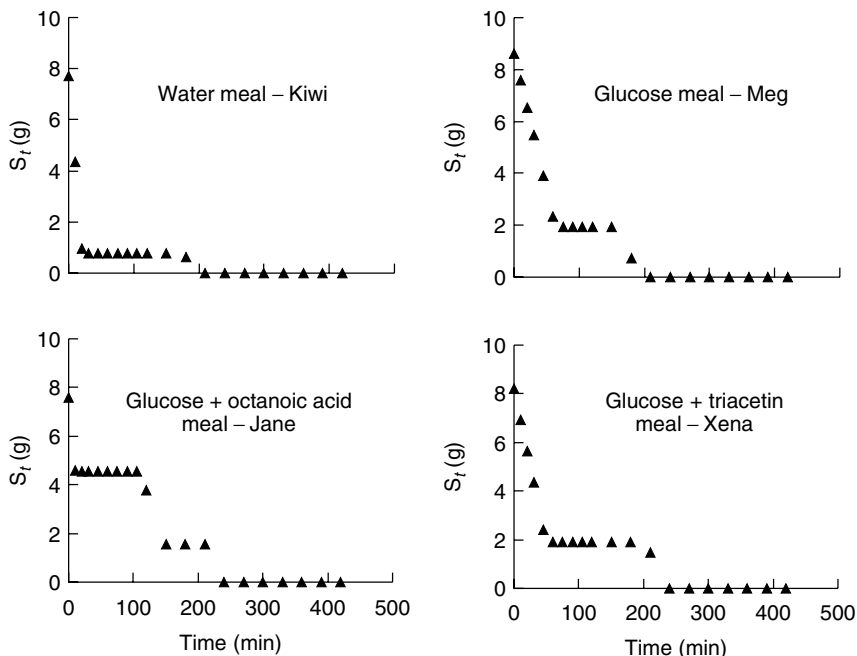

Fig. 8.6. Acetaminophen contents of the stomach of selected horses following an oral dose predicted from fits of model 3 to plasma acetaminophen appearance curves.

gastric quiescence. Thus, the value of z was calculated, and not estimated, directly from observations. The appropriate equations of the iteration to observation time point t (equation (8.16)) were solved in Microsoft Excel according to the now irregular pulsation of z . Least-squared estimates of the parameters F , k_{el} and a were obtained using the Excel Solver. For the glucose plus octanoic acid meal given to Jane, five bouts of gastric emptying of varying length were detected and the plasma acetaminophen appearance curve was fit with an R^2 of 0.50 (Fig. 8.7). For the glucose plus triacetin meal in Xena, three bouts were apparent and the R^2 was 0.90.

For the water meal and glucose meal curves presented in Fig. 8.8, the increases in plasma acetaminophen concentration during second and third emptying bouts predicted by model 5 were much larger than observed. One explanation is that the emptying bouts were actually shorter than assumed. A failing of the approach to parameterization of model 5 is that the estimated duration of emptying is never shorter than the interval between samples. The consequence is that, in contrast to standard practice, the frequency of blood sampling should not be reduced as the acetaminophen concentration declines because a new emptying bout could commence at any moment during the time course. In essence, the sampling interval determines the degree of resolution on the w and p parameters. A likely possibility for the overestimation of the amplitude of plasma acetaminophen spikes by model 5, given

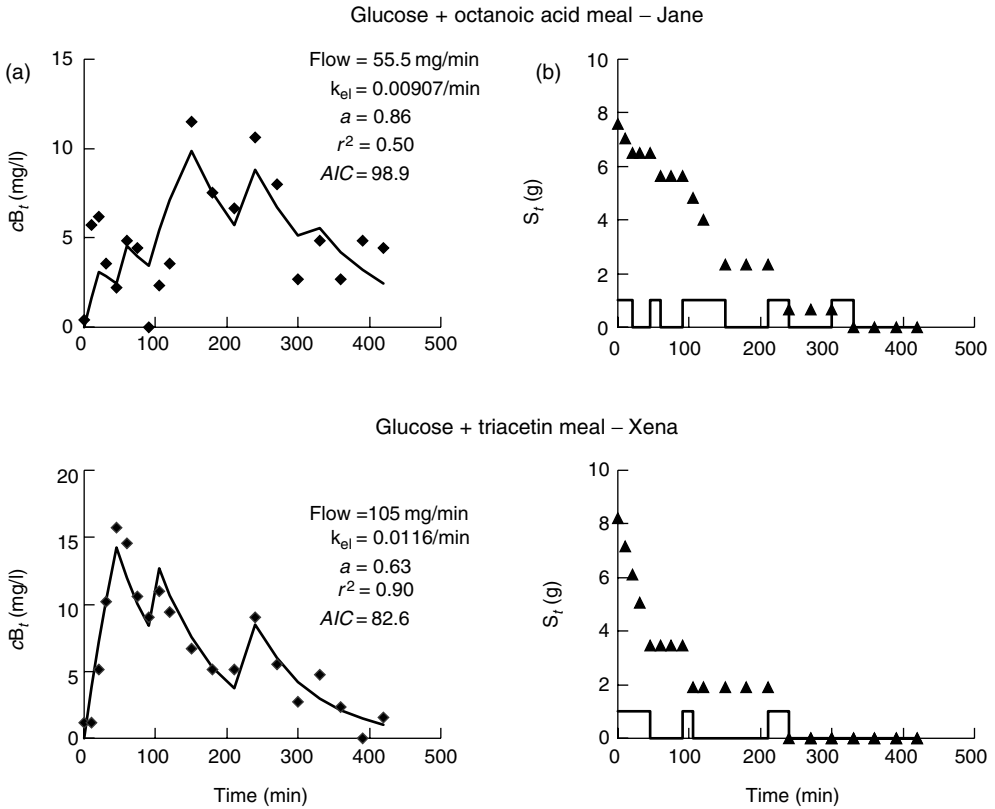

Fig. 8.7. (a) Fits of model 5 (solid lines), assuming variably intermittent zero-order gastric emptying, to two selected plasma acetaminophen appearance curves (\blacklozenge); and (b) predicted acetaminophen contents of the stomach (\blacktriangle) according to a variable pulsation between emptying and quiescence (solid line).

the long apparent duration of some emptying bouts, is that the quantity of acetaminophen released from the stomach in second and subsequent bouts of emptying was substantially reduced, as would occur with first-order kinetics, assuming first-order gastric emptying in the variably intermittent model dampened the fluctuations in plasma acetaminophen concentrations (Fig. 8.8). Overall, model 5 with zero-order emptying fitted acetaminophen curves from the glucose plus octanoic acid meals best, while model 6 with first-order variably intermittent emptying was better for all other meals. It is interesting to note that first-order emptying did not become apparent until a more realistic intermittency of gastric outflow was approximated.

Conclusions

It was apparent from the erratic nature of acetaminophen elimination from plasma that emptying of the indicator from the stomach was intermittent

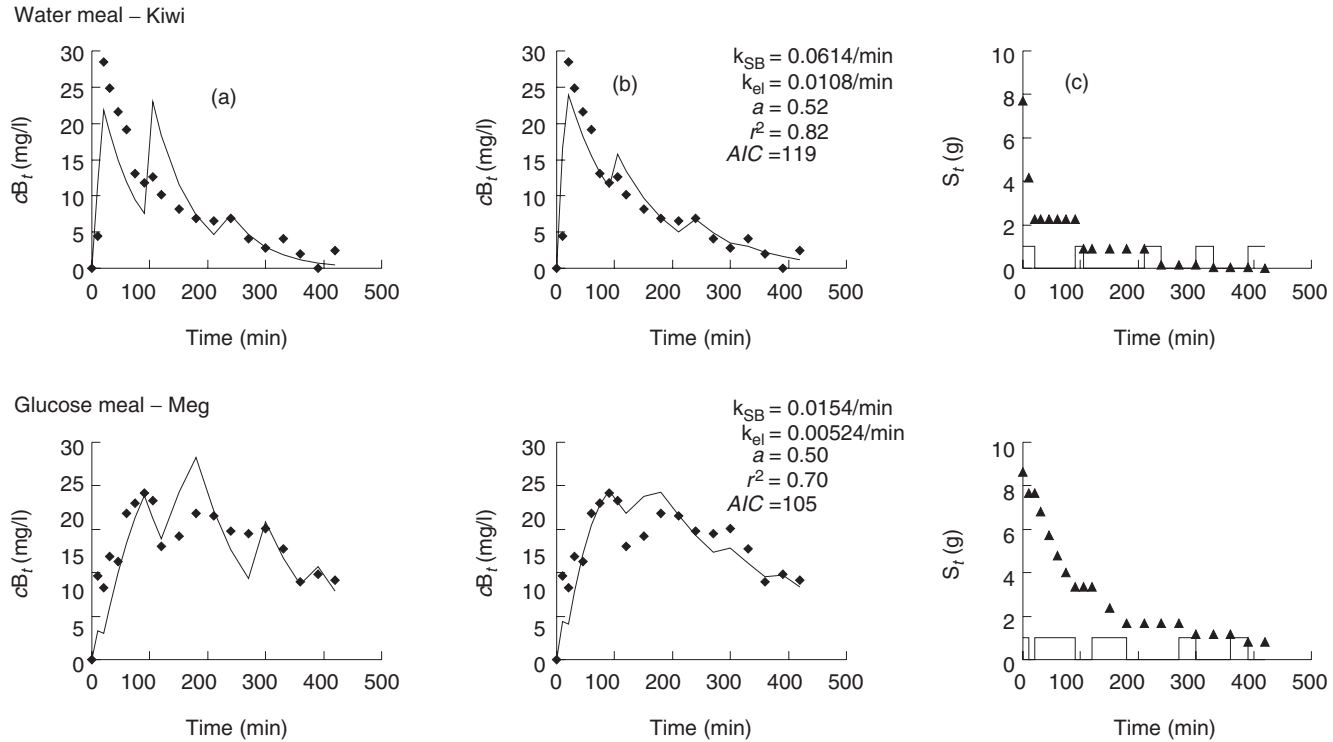

Fig. 8.8. (a) Fits of model 5 (solid lines), assuming variably intermittent zero-order gastric emptying, to two selected plasma acetaminophen appearance curves (\blacklozenge); (b) fits of model 6 (solid lines), assuming variably intermittent first-order gastric emptying; and (c) predicted acetaminophen contents of the stomach (\blacktriangle) according to model 6 variable pulsation between emptying and quiescence (solid line).

throughout the 420 min of observation. The recurrence of gastric emptying during elimination from plasma meant that the initial frequency of blood sampling to characterize emptying should be maintained throughout the time course. Although a second distinct bout of gastric emptying could be detected by least-squared parameter estimation algorithms, the irregularity of intervals between, and duration of, emptying bouts precluded any systematic characterization of outflow periodicity parameters. Instead, the pattern of gastric emptying was obtained from the sign of acetaminophen appearance runs.

The problem attacked herein was similar to one of deconvolution of the gastric acetaminophen profile from the plasma acetaminophen appearance curve. Yates and Fletcher (2000) used deconvolution to obtain a glucose appearance function from a blood glucose curve. Similarly to their findings, however, assuming first-order kinetics of gastric elimination from plasma and instantaneous absorption from the gastric outflow was not enough to yield a gastric acetaminophen profile; some assumptions of the gastric emptying kinetics were required. Emptying kinetics could not be distinguished from a single emptying bout but from successive bouts in the intermittent flow models. Meals differed in whether they were emptied from the stomach according to zero- or first-order kinetics.

References

- Bromer, O., Kantor, S.B., Wagner, D.A., Knight, L.C., Maurer, A.H. and Parkman, H.P. (2002) Simultaneous measurement of gastric emptying with a simple muffin meal using [^{13}C]octanoate breath test and scintigraphy in normal subjects and patients with dyspeptic symptoms. *Digestive Diseases and Sciences* 47, 1657–1663.
- Clements, J.A., Heading, R.C., Nimmo, W.S. and Prescott, L.F. (1978) Kinetics of acetaminophen absorption and gastric emptying in man. *Clinical Pharmacology and Therapeutics* 24, 420–431.
- Fushimi, T., Tayama, K., Fukaya, M., Kitakoshi, K., Nakai, N., Tsukamoto, Y. and Sato, Y. (2001) Acetic acid feeding enhances glycogen repletion in liver and skeletal muscle of rats. *Journal of Nutrition* 131, 1973–1977.
- Girard, C.L. and Sissons, J.W. (1992) The role of migrating myoelectric complexes in the regulation of digesta transport in the preruminant calf. *Canadian Journal of Physiology and Pharmacology* 70, 1142–1147.
- Hirate, J., Zhu, C.-Y., Horikoshi, I. and Bhargava, V.O. (1990) First-pass metabolism of acetaminophen in rats after low and high doses. *Biopharmaceutics and Drug Disposition* 11, 245–252.
- Hyypä, S., Rasanen, L.A. and Poso, A.R. (1997) Resynthesis of glycogen in skeletal muscle from standardbred trotters after repeated bouts of exercise. *American Journal of Veterinary Research* 58, 162–166.
- Jucker, B.M., Cline, G.W., Barucci, N. and Shulman, G.I. (1999) Differential effects of safflower oil versus fish oil feeding on insulin-stimulated glycogen synthesis, glycolysis, and pyruvate dehydrogenase flux in skeletal muscle. A ^{13}C nuclear magnetic resonance study. *Diabetes* 48, 134–140.
- Lacombe, V.A., Hinchcliff, K.W., Geor, R.J. and Baskin, C.R. (2001) Muscle glycogen depletion and subsequent replenishment affect anaerobic capacity of horses. *Journal of Applied Physiology* 91, 1782–1790.

- Lohmann, K.L., Bahr, A., Cohen, N.D., Boothe, D.M. and Roussel, A.J. (2002) Evaluation of acetaminophen absorption in horses with experimentally induced delayed gastric emptying. *American Journal of Veterinary Research* 63, 170–174.
- Malagelada, J.-R. and Azpiroz, F. (1989) Determinants of gastric emptying and transit in the small intestine. In: Schultz, S.G. and Wood, J.D. (eds) *The Gastrointestinal System*. American Physiological Society, Bethesda, Maryland, pp. 909–937.
- Malagelada, J.-R., Robertson, J.S., Brown, M.L., Remington, M., Duénes, J.A., Thorforde, G.M. and Carryer, P.W. (1984) Intestinal transit of solid and liquid components of a meal in health. *Gastroenterology* 87, 1255–1263.
- Malbert, C.H., Mathis, C., Guerin, S. and Laplace, J.P. (1997) Influence of jejunal nutrients on transpyloric flow and pyloric resistance in pigs. *Reproduction Nutrition et Développement* 37, 411–425.
- Sanaka, M., Koike, Y., Yamamoto, T., Mineshita, S., Yamaoka, S., Hirama, S., Tanaka, H., Kuyama, Y. and Yamanaka, M. (1997) A reliable and convenient parameter of the rate of paracetamol absorption to measure gastric emptying rate of liquids. *International Journal of Clinical Pharmacology and Therapeutics* 35, 509–513.
- Sanaka, M., Kuyama, Y. and Yamanaka, M. (1998) Guide for judicious use of the paracetamol absorption technique in a study of gastric emptying rate of liquids. *Journal of Gastroenterology* 33, 785–791.
- Yates, T.L. and Fletcher, L.R. (2000) Prediction of a glucose appearance function from foods using deconvolution. *IMA Journal of Mathematics Applied in Medicine and Biology* 17, 169–184.

9

A Model to Evaluate Beef Cow Efficiency

L.O. TEDESCHI,¹ D.G. FOX,¹ M.J. BAKER¹
AND K.L. LONG²

¹*Department of Animal Science, Cornell University, Ithaca, NY 14850, USA;* ²*Bell Ranch, Solano, NM 87746, USA*

Abstract

The beef cattle seed stock industry in the USA is searching for ways to select for improved beef cow efficiency. Most selection indexes for efficiency have a goal of using less resource while obtaining the same outcome in a sustainable environment. However, the inputs required to determine individual beef cow feed efficiency are not readily available in practical conditions. A mathematical model was developed to use inputs readily available in each production situation to estimate the ratio of cow metabolizable energy (ME) required to calf weaning weight (WW) for computing an energy efficiency index (EEI). This model ranks EEI estimates and compares individual cow EEI within the range of expected EEI using Monte Carlo methods to identify the upper and lower cut-off values. It uses the National Research Council recommendations as implemented in the Cornell Net Carbohydrate and Protein System (CNCPS) for energy requirements for maintenance, lactation and pregnancy. Data containing varying levels of milk and forage intake of individual calves during the first 200 days after birth were used to develop a submodel to estimate calf forage and peak milk intake (PKM) based on calf body weight (BW) and forage composition. A database collected at the Bell Ranch, New Mexico ($N = 182$), was used to evaluate the ranking from most to least efficient cows. The simulation indicated that as PKM increases, WW increases almost linearly, the difference in the calf WW between small and large cows tends to increase, and EEI estimates improve exponentially. As PKM increased, the EEI difference between small- and large-size cows decreased. The model-predicted least efficient cows corresponded with culling decisions made prior to evaluating the EEI ranking. The Monte Carlo simulation based on the distribution, mean and variability of cow BW, PKM and forage quality indicated that cows having EEI lower than 30.6 or higher than 38 Mcal/kg are within the 10% most efficient and least efficient cows, respectively. Our analysis suggested that this model could assist beef producers in identifying the most and least efficient cows for their resource, and can be used to simulate different production scenarios to identify the best match of cow type to alternative management systems.

Introduction

The beef cattle seed stock industry in the USA is searching for ways to select for improved beef cow efficiency to improve their competitiveness and prof-

itability. Increases in beef production have occurred due to enhancements in reproduction indexes (e.g. calving frequency, age at first calving, calving interval), nutrition concepts (e.g. strategic supplementation, type as well as quantity and quality of forage), genetic selection (e.g. bull selection, cross-breeding), and/or ranch management (e.g. matching breeding and calving seasons with availability of forage). None the less, beef production is still a relatively inefficient process from the standpoint of energy expenditure. Research has indicated that beef cows are responsible for 60–70% of the total energy expenditure (Johnson, 1984) in beef production (Ferrell and Jenkins, 1985). Ideally, efficient beef cows use less resource to obtain the same outcome in a sustainable environment. There are several indexes used to identify efficient beef cows. Most are based on retaining beef cows that routinely produce a weaned calf with fewer inputs, with a high ratio of kg of calf weaned per number of females exposed to a bull. Additionally, beef cow maturation rate has also been shown to be correlated with production efficiency and may be used to select for efficient cows (Parker *et al.*, 1972; Tedeschi *et al.*, 2000a,b).

Jenkins and Ferrell (2002) concluded that to evaluate biological efficiency, productivity must be expressed relative to some measure of input, and feed energy required per unit of output is logical. We have developed a beef cow model that uses this approach to identify differences in efficiency among beef cows. The principal objective of this study is to present our model that estimates the Mcal of ME required by a cow per kg of weaned calf, i.e. EEI. A second objective is to demonstrate how the model compares the EEI computed for each beef cow to the range of expected EEI using a Monte Carlo simulation to identify the upper and lower cut-off EEI. A third objective is to discuss the potential for identification and selection of mitochondrial DNA (mtDNA) mutants in beef cows that have higher energy efficiency.

Model Development

Several models have been developed to simulate cow/calf production systems (Long, 1972; Boyd, 1977; Notter *et al.*, 1979a,b,c; Miller *et al.*, 1980; Fox *et al.*, 1988; Naazie *et al.*, 1997). Fox *et al.* (1988) developed a nutritional model to evaluate the match of the energy requirements of a cow/calf herd with forage available each month to enhance profitability of the herd. Their model computes a balance between energy requirements for maintenance, pregnancy, lactation and tissue mobilization and energy available from the forage, thus allowing one to match availability of forage with periods of higher energy demand by the cow and calf. Reynoso-Campos *et al.* (2004) published an application of the CNCPS model for dual-purpose cattle that computes daily energy balances between the herd requirements and forage available. The model presented here is based on those developed at Cornell University for beef cows (Fox *et al.*, 1988) and for dual-purpose cows (Reynoso-Campos *et al.*, 2004), with modifications as described in this chapter.

Figure 9.1 summarizes the structure of our model developed to estimate daily energy requirements of the beef cow and the interactions between lactation and WW of the calf. The objectives of this model include: (i) computing the energy requirements of individual beef cows each day of the year and simulating the growth of the calf given the information available; (ii) computing energy balances for the herd each day of the year to evaluate the balance between herd numbers and requirements with the forage available; and (iii) identifying differences in efficiency among individual beef cows in a herd.

Maintenance requirement

Energy required for maintenance is based on BW adjusted for conceptus weight, environment (climate effects), physical activities and physiological stage (dry vs lactation), as recommended by the National Research Council (NRC, 2000). Smooth curve adjustments using the cubic spline technique are used during transition phases since this is a time-dependent model. DiConstanzo *et al.* (1990) found that among non-pregnant non-lactating Angus cows of similar fat masses, those with larger protein masses had

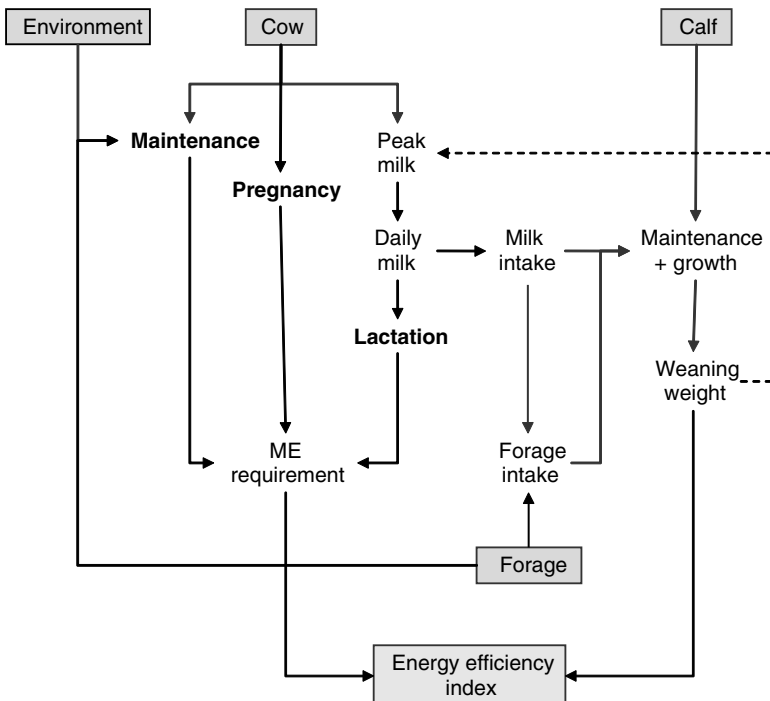

Fig. 9.1. Flowchart of the mathematical model to predict energy efficiency index.

higher energy requirements for maintenance because the ME required to maintain 1 kg of protein was 9.3 times higher than of fat (192.9 ± 24.8 vs 20.7 ± 21.5 kcal, respectively). We account for this effect in our growth model (Tedeschi *et al.*, 2004) and plan on incorporating a component for body composition effects on maintenance requirement into our beef cow model.

Pregnancy and lactation requirement

Energy for pregnancy is based on the NRC (2000) recommendations, which use number of days pregnant to derive energy concentration in the conceptus. The model assumes a fixed calving interval of 365 days. The model computes milk production by changing the PKM until WW predicted by the model matches observed WW. The energy requirement for lactation is computed based on data from NRC (2000) and Fox *et al.* (2004). Milk composition is used to compute net energy in milk, which drives the energy requirement for lactation. A fixed value of 5.29 Mcal of ME/kg of milk (dry matter (DM) basis) is assumed in computing intake of ME by the calf. The PKM is used to plot the lactation curve (George, 1984), which predicts the daily amount of milk available for the calf.

Forage and milk intake of the calf

The data of Abdelsamei (1989) were used to develop equations for estimating forage intake of the calf. In his experiment, the daily *ad libitum* intake of chopped lucerne of 40 Holstein calves fed five levels of milk (PKM at 59.5 DMI: 2.72, 5.44, 8.16, 10.88, and 13.6 kg) was measured for 200 days. We used this data to derive five multiple regression equations to estimate forage intake for the pre-PKM phase as shown in Table 9.1.

Table 9.1. Regression coefficients for estimating forage intake by calves for five milk levels before peak milk intake (PKM) is reached.

Variables	Peak milk intake (PKM; kg/day)				
	2.72	5.44	8.16	10.88	13.6
Calf BW (kg)	-0.008	0.025	0.004	-0.004	-0.001
DIM (day)	-0.019	0.221	0.108	-0.023	-0.002
Calf BW \times DIM	0.000	-0.005	-0.002	0.000	0.000
Cow milk (kg/day)	-1.272	0.496	-0.423	0.031	0.033
Calf BW \times cow milk	0.010	-0.008	0.007	0.001	0.000
DIM \times cow milk	0.027	-0.226	-0.066	0.006	-0.002
Calf BW \times DIM \times cow milk	0.000	0.005	0.001	0.000	0.000
Peak milk (kg/day)	0.595	-1.147	-0.196	0.183	0.025

BW = body weight; DIM = days in milk.

The intake of forage (kg/day) for the post-PKM phase (equation (9.1)) is computed using the surface response regression ($R^2 = 98.6\%$, $N = 394$, root mean squared prediction error (RMSPE) = 281.24):

$$\begin{aligned} \text{ForageIntake} = & (30.313 \times \text{CalfBW} - 753.76 \times \text{CowMilk} - 11.704 \times \text{CalfBW} \times \\ & \text{CowMilk} - 190.316 \times \text{PeakMilk} + 0.499 \times \text{CalfBW} \times \text{PeakMilk} + 112.106 \times \\ & \text{CowMilk} \times \text{PeakMilk} - 0.085 \times \text{CalfBW} \times \text{CowMilk} \times \text{PeakMilk}) / 1000 \end{aligned} \quad (9.1)$$

where *CalfBW* is the weight (kg) of the calf; *CowMilk* is the amount of milk (kg/day; DM basis, assumed to be milk production $\times 0.12$); and *PeakMilk* is the milk production at the peak (kg/day; as-fed basis).

Cow milk and peak milk have a negative correlation (-0.594 and -0.326 , respectively) whereas calf BW has a positive correlation (0.594) with forage intake. Figure 9.2 shows a three-dimensional plot of the forage intake based on calf BW and day post-PKM for a PKM of 3 kg/day. The amount of cow milk was estimated based on the equation proposed by George (1984). The higher the PKM is, the lower is the forage DMI at same calf BW and day post-PKM (Fig. 9.2), indicating that calves increase their forage intake as milk availability is reduced. It has been shown that forage intake per unit of BW prior to weaning is consistently greater for calves receiving low quantities of milk (Le Du *et al.*, 1976a,b; Broesder *et al.*, 1990), and the consumption of milk reduces herbage DMI (Baker *et al.*, 1976).

Body reserves

It is well documented that body condition score (BCS) has an important role in beef production and reproduction efficiency (Houghton *et al.*, 1990; Mortimer *et al.*, 1991). In our model, tissue mobilization and repletion is used to compute energy available/required for body reserves based on BCS changes, similar to that described by Reynoso-Campos *et al.* (2004).

The coefficients for energy interconversion were derived by Moe *et al.* (1970), using multiple regression analysis of 126 and 224 lactating dairy cows with negative and positive energy balances, respectively.

When intake of energy is lower than energy required for milk production (NE_l), it indicates a negative energy balance, and energy reserves (NE_r) are used for milk production. We used an efficiency of NE_r to NE_l of 82% (Moe, 1981; Fox *et al.*, 1999; NRC, 2001) in our current model to account for tissue mobilization. When intake of energy is greater than energy required for milk production plus maintenance, it indicates a positive energy balance, and energy intakes above requirements are deposited as energy reserves. We used an efficiency of diet ME to NE_r of 75% and diet ME to NE_l of 64.4% for lactating cows (Moe, 1981; Fox *et al.*, 1999; NRC, 2001).

We are developing a new approach to account for energy balance (EB) status (negative or positive) in assigning these efficiencies based on the work of Moe *et al.* (1970). For lactating cows in *negative EB*, average efficiencies of 66.1% and 84% were calculated for diet ME to NE_l and NE_r to

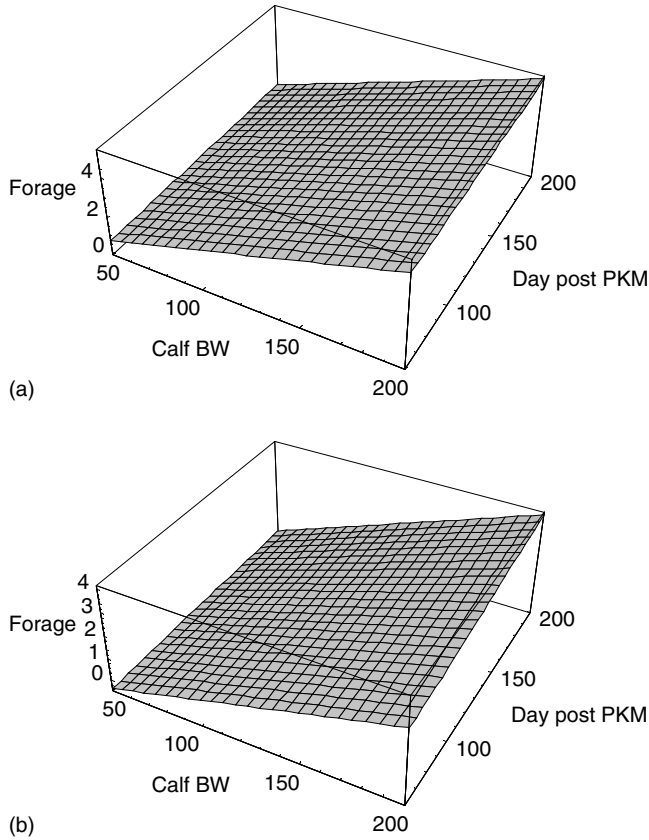

Fig. 9.2. Response curve of predicted forage dry matter intake (DMI; kg/day) based on calf body weight (BW; kg) and day post peak milk intake (day post PKM) assuming a PKM of (a) 3 kg/day and (b) 9 kg/day.

NE_l , respectively. An analysis of the variation indicated that the true efficiency values for cows in negative EB are between 63.3% and 69.2% for diet ME to NE_l and between 81.7% and 86% for diet NE_r to NE_l , assuming $\alpha = 5\%$ and a less rigid combination of the confidence interval. For lactating cows in *positive EB*, average efficiencies of 72.6% for diet ME to NE_r and 63.5% for diet ME to NE_l were estimated. The confidence intervals for cows in positive EB were between 67.4% to 78.6% for diet ME to NE_r and between 61.2% to 65.8% for diet ME to NE_l ($\alpha = 5\%$).

Model Evaluation

Figure 9.3 shows the comparison of WW and EEI of two cows (small, 450 kg, and large, 530 kg) with six PKM levels. Birth weight was assumed to be 6.5% of the mature weight of the cow. As PKM increases, WW increases almost

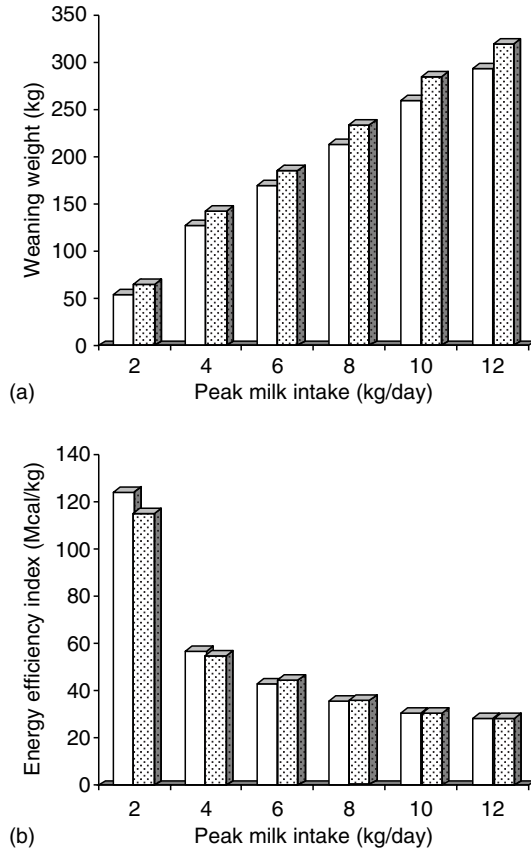

Fig. 9.3. Comparison of (a) weaning weight (WW) and (b) energy efficiency index (EEI) of two cows of 450 kg (open bars) and 530 kg (dotted bars) at six peak milk levels.

linearly (Fig. 9.3a) and the EEI decreases exponentially (Fig. 9.3b). Differences in EEI between the two cow sizes are due to differences in BW at the same milk production. Published data indicate that cow mature weight does not influence the efficiency of energy use (Klosterman and Parker, 1976; Morris and Wilton, 1976; Ferrell and Jenkins, 1984a,b). Their studies indicate that as mature size increases, milk production, WW and finished weight increase proportionally.

Figure 9.3b indicates that milk production is a determinant of calf WW and efficiency of the cow. Figure 9.3a shows that the higher the milk production is, the greater is the WW, in agreement with the studies of Abdelsamei (1989), Lewis *et al.* (1990), and Clutter and Nielsen (1987). As milk production increases, cow maintenance requirement becomes increasingly diluted by the additional WW produced. However, it is well known that high-milk production cows have higher energy requirements for maintenance because the

internal organs are larger and they have a faster metabolism compared to low-milk production cows (Ferrell and Jenkins, 1984a,b, 1985). This means that higher-milking cows require more feed for maintenance and energy per kg of BW than lower-milking cows (Montano-Bermudez and Nielsen, 1990). If feed available is adequate, this higher maintenance requirement will be offset by an increased WW of the calf. Compensatory growth may also play a role in the growth of calves from cows that produce less milk. In agreement with the study of Abdelsamei (1989), Lewis *et al.* (1990) found that post-weaning effects of increased WW on average daily gain (ADG) due to higher milk intake pre-weaning were small. They reported that only calves from the low-milking group (5.6 kg/day) showed compensatory growth. Miller *et al.* (1999) reported no effect of milk yield on biological efficiency of Hereford, Charolais \times Simmental \times Maine-Anjou, and Tarentaise \times Pinzgauer \times Gelbvieh \times Angus calves from calving to harvest.

Cows selected for improved efficiency in a certain environment may not express their potential efficiency in another environment (Ferrell and Jenkins, 1985). When forage availability is not limiting, cattle with higher milking and growth potential can utilize the extra feed to wean heavier calves, therefore increasing weight sold for the forage available. However, when forage is limited, those with lower milking and growth potential can wean more calves for the same forage because there is a higher proportion of the energy intake above maintenance available for maintaining reproductive efficiency.

We conclude that the cow mature size should be determined by the optimum weight for the calves at the target carcass composition, and that the milk production level should be based on the forage available.

Practical applications of the model

A database collected at the Bell Ranch, New Mexico ($N = 182$) was used to compute EEI for each cow and rank them for this measure of efficiency. Cows were in grazing conditions and were supplemented during January and April with a protein mix. Using the Monte Carlo simulation (Winston, 1993), one can predict the expected outcomes of the EEI given the distribution, mean and variability of the parameters used by the model. The results of a simulation of a beef cow herd averaging 530 kg BW ($\pm 5\%$), 8.35 kg/day PKM ($\pm 10\%$), with monthly variations in forage quality throughout the year are shown in Figs 9.4 and 9.5, assuming normal distributions. In Fig. 9.4, the model indicates that cows with EEI lower than 29.67 or higher than 39.27 Mcal ME/kg WW are within the 10% more and less efficient groups of cows, respectively. Therefore, one could use this model to assist in identifying the most efficient cows (those having approximately less than 30 Mcal ME/kg WW) to increase the efficiency of the herd, and conversely, one could cull those cows having EEI higher than 39 Mcal ME/kg WW. The model was able to identify accurately the cows that had been culled and to classify the ones that were judged to be efficient by the management team.

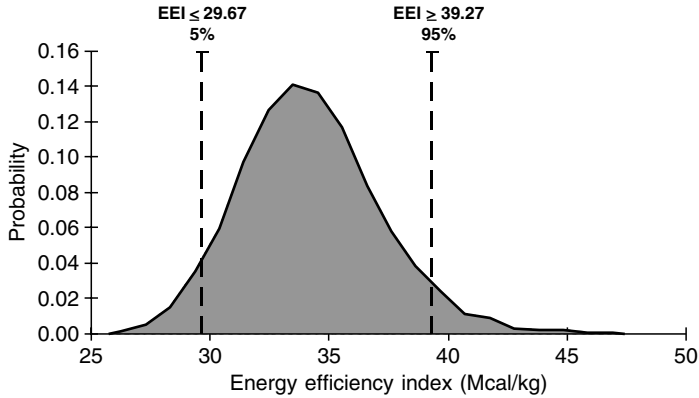

Fig. 9.4. Monte Carlo simulation of the energy efficiency index (EEI).

Further investigation has to be made regarding the relationship of frame size and/or age with EEI. We still have to address questions such as: (i) Will the model ranking of the same cow persist across years? (ii) Is there an effect of calf sex on EEI? and (iii) Does stocking rate or supplementation change the model ranking?

A second application of the model is to evaluate availability and quality of forage throughout the year relative to forage requirements for different cattle types. Figure 9.5a shows a potential range in forage ME for each month for a particular ranch and Fig. 9.5b shows the energy balance (requirement minus supply) across this range in forage ME for each month. The simulation indicates that improved forage quality, change in cattle type or numbers, or supplementation is needed during the months July through December.

A third application is to determine the highest level of milk production for the target cow size that can be supported by the forage available.

Identifying differences in beef cow efficiency in the future

The European Association on Animal Production published a report (Ostergaard *et al.*, 1990) that provides definitions of efficiency for primary and secondary traits for dairy cow efficiency, which also applies to beef cows. They summarized as follows:

The improvement in biological efficiency is important, and research has to be focused on the underlying processes such as rumen function, utilization of digested and metabolized energy, and the partitioning of feed energy between milk and body tissue. Knowledge about genetic variation between animals for these different biological processes is very limited, and should be studied in relation to the composition of feed ration, the feeding strategy and the physiological state of the animal.

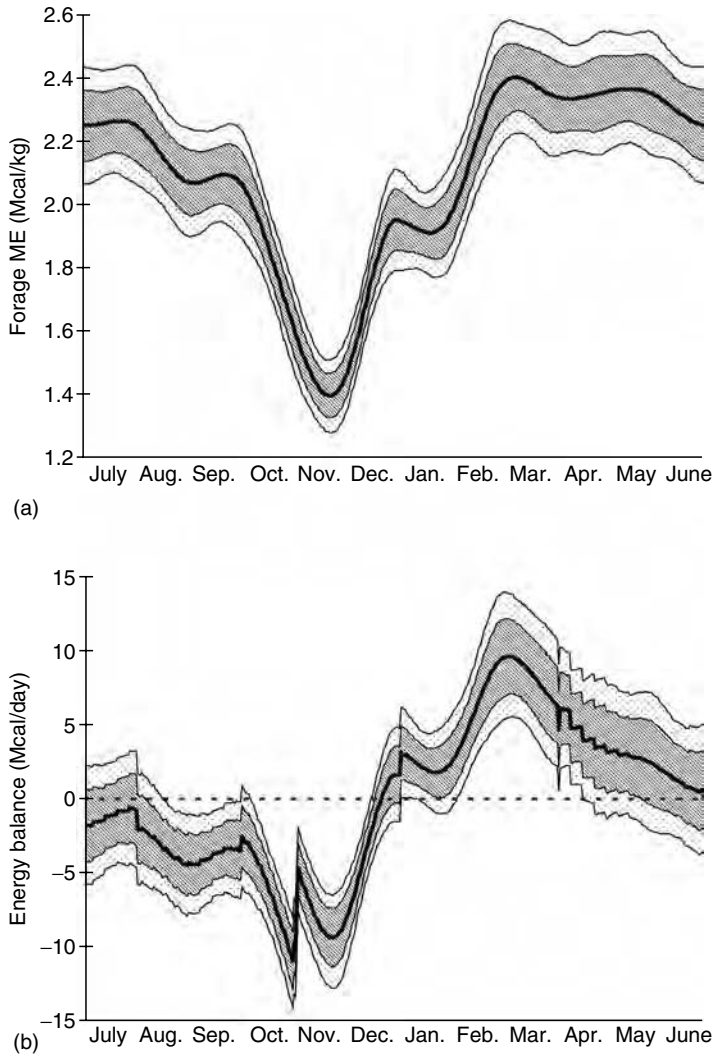

Fig. 9.5. Effect of variation on (a) forage energy content and (b) beef cow energy balance throughout the production cycle (hashed area indicates ± 1 SD and dotted area indicates ± 2 SD regions).

However, identification of differences among individual animals in these biological processes is difficult, particularly given the information typically available on farms and ranches. Australian scientists have used the residual feed intake (RFI) analysis of post-weaning growth of individually fed progeny to identify efficient bulls (Archer *et al.*, 1999; Archer and Bergh, 2000). The main problems with this technique are the need for measurement of individual intake and the tendency to select leaner animals as an undesirable consequence. We are currently evaluating our mathematical model, the Cornell

Value Discovery System (CVDS; Tedeschi *et al.*, 2004, 2005), for ranking individual animals fed in groups on the basis of feed required for the observed growth and BW. The CVDS estimates required intake given each animal's performance and adjusts gain and intake for body composition (degree of maturity). This model is currently available for growing/finishing animals and may be downloaded at <http://www.cvds.cals.cornell.edu>. The beef cow model described in this study is being incorporated into the CVDS. We are evaluating its potential for providing information that can be used to rank individual cows on the basis of their EEI. Our goal is to determine if the output of these biological models can be used to develop expected progeny differences (EPD) for feed efficiency for use in genetic selection programmes.

We are also working on a genomic modelling project, which involves mapping and identification of mtDNA mutants that are more energetically efficient. The presence of maternal genetic effects has long been hypothesized to have an effect on traits of economic importance in beef cattle. However, little support has been found in the common statistical analysis of genetic breeders (Gibson *et al.*, 1997). Mitochondria are a likely source of some of this 'unexplained' variation since they contain their own DNA and are only maternally inherited. It is well known that mtDNA variation may cause bias in the estimation of variance components (Boettcher *et al.*, 1996a). Therefore, a positive mitochondrial effect is desirable for dams of cows, but not for dams of sires, since they are not passed on to male progeny. mtDNA has been used extensively in phylogeny to identify cattle lineages using DNA displacement loop sequence variation (Loftus *et al.*, 1994; Bradley *et al.*, 1996). Additionally, mtDNA has also been used to characterize substitutions that could be responsible for several economically important traits, including meat quality (Mannen *et al.*, 2003), milk production and animal health (Schutz *et al.*, 1994; Boettcher *et al.*, 1996b,c). The basic hypothesis is that a lineage of cattle, which is more energetically efficient, might exist due to certain arrangements in the mtDNA that permit the mitochondria to be more efficient. This energetic efficiency of the mitochondria is reflected in the bioenergetics of the whole animal and is responsible for some variation found among progeny of the same sire but different dams. External effects that might regulate mitochondria efficiency have also been reported, such as acetyl-L-carnitine (Iossa *et al.*, 2002) and fatty acids (Schrijver and Privett, 1984; Jezek *et al.*, 1998; Clarke *et al.*, 2000).

In broilers, low feed efficiency is related to defects in electron leak in muscle mitochondria (Bottje *et al.*, 2002). In plants, adenosine triphosphate (ATP) synthase is a key enzyme in providing energy since it uses a transmembrane electrochemical proton gradient to drive synthesis of ATP. The enzyme complexes function as miniature rotary engines, ensuring energy coupling with very high efficiency (Bunney *et al.*, 2001). In rats, a low mitochondrial proton leak rate may partially explain the abnormally lower heat production and bioenergetics efficiencies of the obese Zucker rat (21% lower than leaner animals) as reported by Ramsey *et al.* (1996).

Mitochondrial proton leak may be responsible for at least 20% of the resting oxygen consumption in mammals (Ramsey *et al.*, 2001). It is also

documented that uncoupling protein 1 homologue, UCP3, is responsible for a decrease in efficiency of energy metabolism because of the dissipation of energy as heat due to an uncoupling of ATP production from mitochondrial respiration process (Schrauwen, 2002). Therefore, mutants that have a lower mitochondrial proton leak or have lower concentration of UCP3 will be more efficient energetically.

Conclusions

Mathematical models can be used to assist in the identification of efficient cows and simulation of different production scenarios to identify optimum management systems for beef cows to maximize profits on a given land base. In identifying the most efficient beef cow type, cow mature weight should be determined by the optimum weight for the calves at the target carcass composition, and milk production level should be based on the forage available. More work is needed to account for protein availability and quality in the current model. Once this is attained, this model can also be applied to select the best strategy for forage management and supplementation to minimize costs and environmental impacts of nitrogen.

References

- Abdelsamei, A.H. (1989) Forage intake, growth and final composition of suckling calves fed five levels of milk preweaning. PhD thesis, Cornell University, Ithaca, New York.
- Archer, J.A. and Bergh, L. (2000) Duration of performance tests for growth rate, feed intake and feed efficiency in four biological types of beef cattle. *Livestock Production Science* 65, 4755.
- Archer, J.A., Richardson, E.C., Herd, R.M. and Arthur, P.F. (1999) Potential for selection to improve efficiency of feed use in beef cattle: a review. *Australian Journal of Agricultural Research* 50, 147–161.
- Baker, R.D., Le Du, Y.L.P. and Barker, J.M. (1976) Milk-fed calves: 1. The effect of milk intake upon the herbage intake and performance and grazing calves. *Journal of Agricultural Science* 87, 187–196.
- Boettcher, P.J., Freeman, A.E., Johnston, S.D., Smith, R.K., Beitz, D.C. and McDaniel, B.T. (1996a) Relationships between polymorphism for mitochondrial deoxyribonucleic acid and yield traits of Holstein cows. *Journal of Dairy Science* 79, 647–654.
- Boettcher, P.J., Kuhn, M.T. and Freeman, A.E. (1996b) Impacts of cytoplasmic inheritance on genetic evaluations. *Journal of Dairy Science* 79, 663–675.
- Boettcher, P.J., Steverink, D.W.B., Beitz, D.C., Freeman, A.E. and McDaniel, B.T. (1996c) Multiple herd evaluation of the effects of maternal lineage in yield traits of Holstein cattle. *Journal of Dairy Science* 79, 655–662.
- Bottje, W., Tang, Z.X., Iqbal, M., Cawthon, D., Okimoto, R., Wing, T. and Cooper, M. (2002) Association of mitochondrial function with feed efficiency within a single genetic line of male broilers. *Poultry Science* 81, 546–555.
- Boyd, H.F. (1977) Beef cattle management systems for the Southeast: an application of computer modelling. *Dissertation Abstracts International*, B 38, 424.

- Bradley, D.G., Machugh, D.E., Cunningham, P. and Loftus, R.T. (1996) Mitochondrial diversity and the origins of African and European cattle. *Proceedings of the National Academy of Sciences USA* 93, 5131–5135.
- Broesder, J.T., Judkins, J.B., Krysl, L.J., Gunter, S.A. and Barton, R.K. (1990) Thirty or sixty percent milk replacer reduction for calves: effects on alfalfa hay intake and digestibility, digestive kinetics and ruminal fermentation. *Journal of Animal Science* 68, 2974–2985.
- Bunney, T.D., van Walraven, H.S. and de Boer, A.H. (2001) 14-3-3 Protein is a regulator of the mitochondrial and chloroplast ATP synthase. *Proceedings of the National Academy of Sciences USA* 98, 4249–4254.
- Clarke, S.D., Asp, N.G., Frayn, K. and Vessby, B. (2000) Polyunsaturated fatty acid regulation of gene transcription: a mechanism to improve energy balance and insulin resistance. *British Journal of Nutrition* 83, S59–S66.
- Clutter, A.C. and Nielsen, M.K. (1987) Effect of level of beef cow milk production on pre- and postweaning calf growth. *Journal of Animal Science* 64, 1313–1322.
- DiCostanzo, A., Meiske, J.C., Plegge, S.D., Peters, T.M. and Goodrich, R.D. (1990) Within-herd variation in energy utilization for maintenance and gain in beef cows. *Journal of Animal Science* 68, 2156–2165.
- Ferrell, C.L. and Jenkins, T.G. (1984a) Energy utilization by mature, nonpregnant, nonlactating cows of different types. *Journal of Animal Science* 58, 234–243.
- Ferrell, C.L. and Jenkins, T.G. (1984b) Relationships among various body components of mature cows. *Journal of Animal Science* 58, 222–233.
- Ferrell, C.L. and Jenkins, T.G. (1985) Cow type and the nutritional environment: nutritional aspects. *Journal of Animal Science* 61, 725–741.
- Fox, D.G., Sniffen, C.J. and O'Connor, J.D. (1988) Adjusting nutrient requirements of beef cattle for animal and environmental variations. *Journal of Animal Science* 66, 1475–1495.
- Fox, D.G., Van Amburgh, M.E. and Tylutki, T.P. (1999) Predicting requirements for growth, maturity, and body reserves in dairy cattle. *Journal of Dairy Science* 82, 1968–1977.
- Fox, D.G., Tedeschi, L.O., Tylutki, T.P., Russell, J.B., Van Amburgh, M.E., Chase, L.E., Pell, A.N. and Overton, T.R. (2004) The Cornell Net Carbohydrate and Protein System model for evaluating herd nutrition and nutrient excretion. *Animal Feed Science and Technology* 112, 29–78.
- George, P.D. (1984) A deterministic model of net nutrient requirements for the beef cow. PhD thesis, Cornell University, Ithaca, New York.
- Gibson, J.P., Freeman, A.E. and Boettcher, P.J. (1997) Cytoplasmic and mitochondrial inheritance of economic traits in cattle. *Livestock Production Science* 47, 115–124.
- Houghton, P.L., Lemenager, R.P., Hendrix, K.S., Moss, G.E. and Stewart, T.S. (1990) Effects of body composition, pre- and postpartum energy intake and stage of production on energy utilization by beef cows. *Journal of Animal Science* 68, 1447–1456.
- Iossa, S., Mollica, M.P., Lionetti, L., Crescenzo, R., Botta, M., Barletta, A. and Liverini, G. (2002) Acetyl-L-carnitine supplementation differently influences nutrient partitioning, serum leptin concentration and skeletal muscle mitochondrial respiration in young and old rats. *Journal of Nutrition* 132, 636–642.
- Jenkins, T.G. and Ferrell, C.L. (2002) Beef cow efficiency – revisited. In: *Beef Improvement Federation Annual Meeting*, 34, Omaha, Nebraska, pp. 32–43.
- Jezek, P., Engstova, H., Zackova, M., Vercesi, A.E., Costa, A.D.T., Arruda, P., Garlid, K.D., Dam, K.V. and Rydstrom, J. (1998) Fatty acid cycling mechanism and mitochondrial uncoupling proteins. *Biochimica et Biophysica Acta, Bioenergetics* 1365, 319–327.

- Johnson, D.E. (1984) Maintenance requirements for beef cattle: importance and physiological and environmental causes of variation. *Proceedings of Beef Cow Efficiency Forum*. Fort Collins, Colorado, p. 6.
- Klosterman, E.W. and Parker, C.F. (1976) *Effect of Size, Breed, and Sex upon Feed Efficiency in Beef Cattle*. Ohio Agricultural Research and Development Center, Wooster, Ohio.
- Le Du, Y.L.P., Baker, R.D. and Barker, J.M. (1976a) Milk-fed calves: 2. The effect of length of milk intake upon herbage intake and performance of grazing calves. *Journal of Agricultural Science* 87, 197–204.
- Le Du, Y.L.P., Baker, R.D. and Barker, J.M. (1976b) Milk-fed calves: 3. The milk intake, herbage intake and performance of suckled calves. *Journal of Agricultural Science* 87, 205–211.
- Lewis, J.M., Klopfenstein, T.J., Stock, R.A. and Nielsen, M.K. (1990) Evaluation of intensive vs extensive systems of beef production and the effect of level of beef cow milk production on postweaning performance. *Journal of Animal Science* 68, 2517–2524.
- Loftus, R.T., Machugh, D.E., Bradley, D.G., Sharp, P.M. and Cunningham, P. (1994) Evidence for two independent domestications of cattle. *Proceedings of the National Academy of Sciences USA* 91, 2757–2761.
- Long, C.R. (1972) Application of mathematical programming to evaluation of systems of beef cattle breeding. *Dissertation Abstracts International*, B 33, 972.
- Mannen, H., Morimoto, M., Oyama, K., Mukai, F. and Tsuji, S. (2003) Identification of mitochondrial DNA substitutions related to meat quality in Japanese Black cattle. *Journal of Animal Science* 81, 68–73.
- Miller, W.C., Ward, G.M., Yorks, T.P., Rossiter, D.L. and Combs, J.J. (1980) A mathematical model of the United States beef production system. *Agricultural Systems* 5, 295–307.
- Miller, S.P., Wilton, J.W. and Pfeiffer, W.C. (1999) Effects of milk yield on biological efficiency and profit of beef production from birth to slaughter. *Journal of Animal Science* 77, 344–352.
- Moe, P.W. (1981) Energy metabolism of dairy cattle. *Journal of Dairy Science* 64, 1120–1139.
- Moe, P.W., Tyrrell, H.F. and Flatt, W.P. (1970) Partial efficiency of energy use for maintenance, lactation, body gain and gestation in the dairy cow. In: Schürch, A. and Wenk, C. (eds) *Proceedings of Energy Metabolism of Farm Animals*, 5. EAAP, Vitznau, Switzerland, pp. 65–68.
- Montano-Bermudez, M. and Nielsen, M.K. (1990) Biological efficiency to weaning and to slaughter of crossbred beef cattle with different genetic potential for milk. *Journal of Animal Science* 68, 2297–2309.
- Morris, C.A. and Wilton, J.W. (1976) Influence of body size in the biological efficiency of cows: a review. *Canadian Journal of Animal Science* 56, 613–634.
- Mortimer, R.G., Boyd, G.W. and Morris, D.L. (1991) Evaluating the impact of body condition on production parameters in beef cows. *Veterinary Medicine* 86, 1030–1036.
- Naazie, A., Makarechian, M. and Hudson, R.J. (1997) Efficiency of beef production systems: description and preliminary evaluation of a model. *Agricultural Systems* 54, 357–380.
- Notter, D.R., Sanders, J.O., Dickerson, G.E., Smith, G.M. and Cartwright, T.C. (1979a) Simulated efficiency of beef production for a Midwestern cow-calf-feedlot management system: I. Milk production. *Journal of Animal Science* 49, 70–82.
- Notter, D.R., Sanders, J.O., Dickerson, G.E., Smith, G.M. and Cartwright, T.C. (1979b) Simulated efficiency of beef production for a Midwestern cow-calf-feedlot management system: II. Mature body size. *Journal of Animal Science* 49, 83–91.

- Notter, D.R., Sanders, J.O., Dickerson, G.E., Smith, G.M. and Cartwright, T.C. (1979c) Simulated efficiency of beef production for a Midwestern cow-calf-feedlot management system: III. Crossbreeding systems. *Journal of Animal Science* 49, 92–102.
- NRC (2000) *Nutrient Requirements of Beef Cattle*, updated 7th edn. National Academy Press, Washington, DC.
- NRC (2001) *Nutrient Requirements of Dairy Cattle*, 7th edn. National Academy Press, Washington, DC.
- Ostergaard, V., Korver, S., Solbu, H., Andersen, B.B., Oldham, J. and Wiktorsson, H. (1990) Main report – E.A.A.P. working group on: efficiency in the dairy cow. *Livestock Production Science* 24, 287–304.
- Parker, C.F., Klosterman, E.W. and Livesay, F.E. (1972) Rate of maturity as a measure of efficiency in beef cattle production. *Research Summary, Ohio Agricultural Research and Development Center*, 73–75.
- Ramsey, J.J., Johnson, D.E., Hossner, K.L. and Johnson, K.A. (1996) Metabolic rate, organ mass, and mitochondrial proton leak variations in lean and obese rats. *Comparative Biochemistry and Physiology. B, Biochemistry and Molecular Biology* 113, 461–466.
- Ramsey, J.J., Monemdjou, S., Lal, S., Weindruch, R., Harper, M.E., Chwalibog, A. and Jakobsen, K. (2001) Restriction of energy intake, mitochondrial proton leak and aging. In: Chwalibog, A. and Jakobsen, K. (eds) *Energy Metabolism in Animals. Proceedings, 15th International Symposium on Energy Metabolism*, Snekkersten, Denmark. Wageningen Press, Wageningen, The Netherlands, pp. 305–308.
- Reynoso-Campos, O., Fox, D.G., Blake, R.W., Barry, M.C., Tedeschi, L.O., Nicholson, C.F., Kaiser, H.M. and Oltenacu, P.A. (2004) Predicting nutritional requirements and lactation performance of dual-purpose cows using a dynamic model. *Agricultural Systems* 80, 67–83.
- Schrauwen, P. (2002) Skeletal muscle uncoupling protein 3 (UCP3): mitochondrial uncoupling protein in search of a function. *Current Opinion in Clinical Nutrition and Metabolic Care* 5, 265–270.
- Schrijver, R.D. and Privett, O.S. (1984) Energetic efficiency and mitochondrial function in rats fed trans fatty acids. *Journal of Nutrition* 114, 1183–1191.
- Schutz, M.M., Freeman, A.E., Lindberg, G.L., Koehler, C.M. and Beitz, D.C. (1994) The effect of mitochondrial DNA on milk production and health of dairy cattle. *Livestock Production Science* 37, 283–295.
- Tedeschi, L.O., Boin, C., Nardon, R.F. and Leme, P.R. (2000a) Growth curve analysis of Guzera and their crossbreeds fed under grazing with or without supplementation: 1. Analysis and selection of nonlinear functions. *Revista Brasileira de Zootecnia* 29, 630–637.
- Tedeschi, L.O., Boin, C., Nardon, R.F. and Leme, P.R. (2000b) Growth curve analysis of Guzera and their crossbreeds fed under grazing with or without supplementation: 2. Evaluation of growth curve parameters. *Revista Brasileira de Zootecnia* 29, 1578–1587.
- Tedeschi, L.O., Fox, D.G. and Guiry, P.J. (2004) A decision support system to improve individual cattle management: 1. A mechanistic, dynamic model for animal growth. *Agricultural Systems* 79, 171–204.
- Tedeschi, L.O., Fox, D.G., Baker, M.J. and Kirschten, D.P. (2005) Identifying differences in feed efficiency among group-fed cattle. *Journal of Animal Science*, in press.
- Winston, W.L. (1993) *Operations Research: Applications and Algorithms*, 3rd edn. Duxbury Press, Belmont, California.

10 Prediction of Energy Requirement for Growing Sheep with the Cornell Net Carbohydrate and Protein System

A. CANNAS,¹ L.O. TEDESCHI,² A.S. ATZORI¹
AND D.G. FOX²

¹*Dipartimento di Scienze Zootecniche, via De Nicola 9, Università di Sassari, 07100 Sassari, Italy;* ²*Department of Animal Science, Cornell University, 124 Morrison Hall, Ithaca, NY 14850, USA*

Abstract

This study evaluates the suitability of the Cornell Net Carbohydrate and Protein System for sheep (CNCPS-S) to predict average daily gain (ADG) of lambs. This model was also used to compare the efficiency of use of metabolizable energy (ME) to net energy (NE) for growth (k_g) from the Agricultural Research Council (ARC, 1980), the Australian system (CSIRO, 1990), the National Research Council (NRC, 2000) and a theoretical equation by Tedeschi *et al.* (2004), which uses a decay equation as a function of the composition of the gain. In addition, the equations used by ARC (1980), NRC (1985) and CSIRO (1990) to predict the energy content of empty body gain (EVG) were compared. Forty-two data points from nine published studies were used to investigate the adequacy of CNCPS-S and of the above equations to estimate ADG. Regardless of the k_g prediction equation used, the CNCPS-S markedly underpredicted ADG, due to an overprediction of ME requirements for maintenance (ME_m). When the factors causing overprediction of ME_m were corrected, the CNCPS-S underpredicted ADG when the NRC (1985) and CSIRO (1990) equations were used to estimate k_g , while good precision and accuracy were achieved when k_g was predicted with the Tedeschi *et al.* (2004) and ARC (1980) equations. With the ARC (1980) equation, the CNCPS-S model explained 82% of the variation in ADG, with small mean bias (-4 g/day) and root mean squared predicted error (RMSPE) (40 g/day); the simultaneous test of the intercept and slope did not reject ($P > 0.1$) the hypothesis that they were statistically similar from zero and unity, respectively. The model had an accuracy of 0.90 when evaluated with the concordance correlation coefficient test. The comparison of three different equations to predict EVG indicated that the best CNCPS-S prediction of ADG was obtained with the CSIRO (1990) approach. We concluded that a modified CNCPS-S model can be used to accurately predict ADG of growing lambs.

Introduction

The use of sheep to provide meat is an important activity in many parts of the world. Sheep meat is produced using specialized breeds, as well as with wool or dairy breeds. Thus, a variety of feeding systems, management techniques and breeds are used worldwide.

Several mathematical models have been developed to estimate weight gain and carcass composition of growing sheep (ARC, 1980; NRC, 1985; INRA, 1989; CSIRO, 1990; AFRC, 1995). These models rely mainly on empirical relationships, and the thorough evaluation of supply and requirement of energy and protein is lacking.

More recently, Cannas *et al.* (2004) developed a mechanistic model that is based on the CNCPS (Fox *et al.*, 2004) to estimate energy and protein supply. The CNCPS-S uses a mechanistic ruminal model that predicts feed biological values and bacterial yield, which is determined by the relationship between degradation rate of fibre and non-fibre carbohydrates, feed passage rate, and availability of amino-N and non-protein nitrogen (NPN) in the rumen. The model developed by Cannas *et al.* (2004) had a special emphasis on dairy sheep.

The primary objective of this study was to develop a mechanistic model to estimate energy requirements for growing sheep. The secondary objective was to evaluate the model's predictions and compare it with standard feeding models using published data that had enough information to describe animal feeds and the environment as required by the CNCPS-S.

Material and Methods

Model description and comparisons

Table 10.1 contains a list of abbreviations used throughout this chapter and in the CNCPS-S model.

The CNCPS-S computes ADG with equations based on the CSIRO (1990; equations (10.1)–(10.4)), with the modifications proposed by Freer *et al.* (1997). The NE_m is computed using ME_m times the partial efficiency of conversion of ME_m to NE_m (k_m) as described by Cannas *et al.* (2004). The standard reference weight (SRW) is based on the recommendation of CSIRO (1990).

$$ADG = \frac{RE}{EVG \times 0.92} \quad (10.1)$$

$$EVG = \left[\left(6.7 + 2 \times (L - 1) + \frac{Z_1 - 2 \times (L - 1)}{1 + e^{-6 \times (P - 0.4)}} \right) \right] \times 0.239 \quad (10.2)$$

$$L = \frac{MEI}{ME_m} - 1 \quad (10.3)$$

$$P = \frac{FBW}{SRW} \quad (10.4)$$

Table 10.1. Definitions for the abbreviations used in the equations.

a_1	Thermal neutral basal maintenance requirements (Mcal/kg of SBW ^{0.75})
a_2	Adjustment for previous temperature
ACT	Activity requirements for horizontal and slope walking (Mcal/day of NE _m)
ADG	Average daily gain (kg/day)
AGE	Adjustment for age effect on maintenance requirements (years)
EBG	Empty body gain = 0.92 ADG (kg/day)
EBW	Empty body weight = 0.851 SBW (kg)
E_{fat}	Fat energy content of the EBG (Mcal/kg)
E_{protein}	Protein energy content of the EBG (Mcal/kg)
EVG	Energy content of EBG (Mcal of NE _g /kg)
Fat	Fat in the EBG (g/kg)
FBW	Full body weight (kg)
FL	Level of feeding in multiples of ME _m (Mcal/Mcal)
k_m, k_g	Efficiency of conversion of ME to NE _m , NE _g , respectively
L	Level of feeding in multiples of ME _m minus one unit (Mcal/Mcal)
ME	Metabolizable energy (Mcal)
MEC	Feed or diet ME concentration (Mcal/kg of DM)
MEI	Metabolizable energy intake (Mcal/day)
ME _m	ME requirement for maintenance (Mcal/day)
NE _m	Net energy requirement for maintenance (Mcal/day)
NE _{mcs}	NE _m required for cold stress (Mcal/day)
P	Body maturity index (kg/kg)
Protein	Protein in the EBG (g/kg)
q_m	Metabolizability of the diet (Mcal/Mcal)
RE	NE available for gain (Mcal/day)
REp	Proportion of protein energy in RE (Mcal/Mcal)
SBW	Shrunk body weight, defined as 96% of full body weight (kg)
TE	Total body energy (Mcal of NE)
TF	Total body fat (kg)
TP	Total body protein (kg)
UREA	Cost of excreting excess nitrogen as urea (Mcal of NE _m /day)
Z_1	16.5
Z_2	490
Z_3	0.12

where EVG is the energy content of empty body gain (Mcal/kg); L is the level of feeding relative to ME_m minus one unit (Mcal/Mcal); MEI is ME intake (Mcal/day); Z_1 is equal to 16.5; P is a maturity index; FBW is full body weight (kg); SRW is the FBW that would be achieved by a specific animal of a certain breed, age, sex and rate of gain when skeletal development is complete and the empty body contains 250 g of fat/kg (corresponding to a body condition score (BCS) of 2.8–3.0 in ewes using a 0–5 scale system); ADG is FBW changes (kg/day); RE is retained energy, i.e. NE available for gain (Mcal/day).

CSIRO (1990) suggests two values for the parameter Z_1 (equation (10.2)): 20.3 for the set A growth parameters for sheep and most cattle breeds and

16.5 for the set B growth parameters for European cattle breeds. In this model the value of 16.5 (set B) was preferred to 20.3 (set A) because most sheep breeds are leaner than the Merino breed from which CSIRO (1990) based the parameters of the growth curves (Cannas and Susmel, 2002).

This approach to predict EVG was compared with those of the NRC (1985) model (equation (10.5)) and the ARC (1980) model, specific for non-Merino males, which is also adopted by the AFRC (1995) system (equation (10.6)):

$$\text{EVG} = (644 - 2.61 \times \text{YBW}) \times \text{EBW}^{0.75} \quad (10.5)$$

$$\text{EVG} = \frac{2.5 + 0.35 \times \text{SBW}}{0.92} \times 0.239 \quad (10.6)$$

where SBW is shrunk BW (0.96 FBW), kg; EBW is empty BW (kg); YBW is yearling BW of rams of the same breed (kg).

RE is computed using ME available for growth (MEI minus ME_m) times the efficiency of ME to NE_g (k_g) as described in equation (10.7):

$$\text{RE} = (\text{MEI} - \text{ME}_m) \times k_g \quad (10.7)$$

where MEI is ME intake predicted by the CNCPS-S (Mcal/day); ME_m is ME for maintenance (Mcal/day); and k_g is the partial efficiency of ME to NE_g .

In the CNCPS-S, the energy requirements for basal metabolism, expressed as ME_m , are adjusted for age, physiological state, environmental effects, activity, urea excretion, acclimatization and cold stress in order to estimate total NE_m and ME_m as shown in equation (10.8):

$$\text{ME}_m = \left\{ \left[(\text{SBW}^{0.75} \times a_1 \times a_2 \exp(-0.03 \times \text{AGE})) \right] + (0.09 \times \text{MEI} \times k_m) + \text{ACT} + \text{NE}_{mcs} + \text{UREA} \right\} / k_m \quad (10.8)$$

where ME_m is in Mcal/day and $\text{SBW}^{0.75}$ is metabolic shrunk body weight (kg). The factor a_1 in equation (10.8), the thermal neutral maintenance requirement per kg of metabolic weight for fasting metabolism (CSIRO, 1990), is assumed to be 0.062 Mcal of $\text{NE}_m/\text{kg}^{0.75}$. This value is corrected for the effect of age on maintenance requirements, using the CSIRO (1990) exponential equation $\exp(-0.03 \times \text{AGE})$, where AGE is in years, which decreases the maintenance requirements from 0.062 Mcal to 0.052 Mcal of NE_m per kg of $\text{SBW}^{0.75}$ as the animal ages from 0 to 6 years. The requirements of animals 6 years of age or older are similar to those of NRC (1985), INRA (1989) and AFRC (1995). The factor a_2 , an adjustment for the effects of previous temperature, is $(1 + 0.0091 \times C)$, where $C = (20 - T_p)$ and T_p is the average daily temperature of the previous month (NRC, 1981). The term $(0.09 \times \text{MEI} \times k_m)$ is based on the CSIRO (1990) adjustment to account for the increase in the size of the visceral organs as nutrient intake increases. The efficiency coefficient k_m is fixed at 0.64. The ACT factor (Mcal of NE_m/day) in equation (10.8) is the effect of activity on maintenance requirements and is fully described in Cannas *et al.* (2004). The

factor a_1 includes the minimum activity for eating, rumination and movements of animals kept in stalls, pens or yards (CSIRO, 1990). The NE_{mcs} factor in equation (10.8) is based on the CSIRO (1990) model to estimate the extra maintenance energy required to counterbalance the effect of cold stress (Cannas *et al.*, 2004). The factor UREA, which accounts for the energy cost of excreting excess nitrogen as urea, is fully described in Cannas *et al.* (2004).

The original equation used by the CNCPS-S to predict ME_m also included a multiplier for the effect of gender, with value 1.0 for females and castrates and 1.15 for intact males (Cannas *et al.*, 2004). This adjustment, from the ARC (1980) model, is also adopted by the CSIRO (1990) system, but it was excluded by an update of it (Freer *et al.*, 1997). The gender adjustment is not supported by experiments carried out on sheep (Bull *et al.*, 1976; Ferrell *et al.*, 1979). For this reason it was excluded in the version of the CNCPS-S used for this study.

Among the factors that modify basal maintenance requirements in the CNCPS-S, two have a major impact on equation (10.8): the age-correction factor and the MEI adjustment ($0.09 \times MEI \times k_m$). For this reason, maintenance energy requirements (equation 10.8), and subsequently RE (equation (10.7)), were predicted both with the complete form of equation (10.8) or by excluding alternatively the age factor, assuming that lamb basal metabolism was the same as that of 6-year-old sheep, or the MEI adjustment factor.

For the prediction of k_g in equation (10.7), the CNCPS-S (Cannas *et al.*, 2004) uses the NRC (2000) equation (equation (10.9)). Equation (10.9) was compared with the ARC (1980) model (equation (10.10)), with the CSIRO (1990) model (equations (10.10) and (10.11) combined) and the theoretical equation developed by Tedeschi *et al.* (2004) (equation (10.12)). The ARC (1980) model proposed equation (10.10) as valid for 'all diets' and was adopted by the AFRC (1995) system.

$$k_g = (1.42 \times MEC - 0.74 \times MEC^2 + 0.0122 \times MEC^3 - 1.65) / MEC \quad (10.9)$$

$$k_g = 0.78 \times q_m + 0.006 \quad (10.10)$$

$$k_g = 1.16 \times q_m - 0.308 \quad (10.11)$$

$$k_g = \frac{3}{4 + 11 \times REp} \quad (10.12)$$

where MEC is dietary ME concentration (Mcal/kg); q_m (also called metabolizability) is the ratio of ME to gross energy (GE) in the diet, where for GE the CSIRO (1990) system assumes a mean value of 4.398 Mcal/kg DM; and REp is the proportion of protein energy in RE (Mcal/Mcal). The CSIRO (1990) model uses two different equations, both originally proposed by ARC (1980), depending on the quality of the diet. CSIRO (1990) suggests that equation (10.10) should be used when $q_m > 0.52$ Mcal ME/Mcal GE, i.e. with diets based on spring growth of grass or legume pastures in a temperate climate or first growth of annual pastures in a Mediterranean climate. Equation (10.11) should be used when $q_m < 0.52$ Mcal ME/Mcal GE, i.e. with diets composed

of mature temperate and Mediterranean pastures and annual legumes and for all other pastures and forages at all stages of growth, including tropical and subtropical grasses and legumes and forage crops such as sorghum. Equation (10.11) was proposed by ARC (1980) as valid for 'aftermaths' of forage-based diets. In this evaluation the CSIRO (1990) approach to predict k_g was tested using both equation (10.10) (for diets for which the CNCPS-S predicted $q_m > 0.52$) and equation (10.11) (for diets with $q_m < 0.52$).

Equations (10.10) and (10.11) require the prediction of the ratio of ME to GE at maintenance feeding level (q_m). In this study the ME used is that predicted by the CNCPS-S. However, this system predicts ME at the actual feeding level, not at the maintenance feeding level. Thus, the ratio of ME to GE at actual feeding level (q_L), as predicted by the CNCPS-S, was adjusted assuming a maintenance feeding level by rearranging an equation (equation 3.3 of ARC, 1980) proposed by Blaxter (1969, cited by ARC, 1980):

$$q_m = \frac{q_L + 0.1246 \times L - 0.1246}{0.8 + 0.2 \times FL} \quad (10.13)$$

where q_m is the ratio between ME and GE for ME estimated at maintenance feeding level; FL is the feeding level, i.e. the ratio between total energy intake and maintenance energy requirements (Mcal/Mcal); and q_L is the ratio between ME and GE for ME estimated at any feeding level.

Equation (10.12) requires the calculation of the proportion of retained energy as protein (REp). The energy content of fat and protein in the gain can be calculated using the equations reported by CSIRO (1990) and modified by Freer *et al.* (1997). Then, REp is computed as $E_{\text{protein}} / (E_{\text{fat}} + E_{\text{protein}})$:

$$E_{\text{fat}} = \left[43 + 56 \times (L - 1) + \frac{Z_2 - 56 \times (L - 1)}{1 + e^{-6 \times (P - 0.4)}} \right] \times 0.0094 \quad (10.14)$$

$$E_{\text{protein}} = \left[0.212 - 0.004 \times 2 \times (L - 1) - \frac{Z_3 - 0.004 \times 2 \times (L - 1)}{1 + e^{-6 \times (P - 0.4)}} \right] \times 5.7 \quad (10.15)$$

where Z_2 and Z_3 are parameters equal to 490 and 0.12, respectively (set B of CSIRO, 1990); and E_{fat} and E_{protein} are respectively the fat and protein energy content of the EBG (Mcal/kg).

The supply of nutrients was predicted with the CNCPS-S (Cannas *et al.*, 2004) for all evaluations.

Model evaluation

The evaluation and comparison of the models were performed using nine published studies (Antongiovanni *et al.*, 1991; Costantini *et al.*, 1994; Franci *et al.*, 1997; Lanza *et al.*, 2003a,b; Ponnampalam *et al.*, 2003, 2004; Richardson *et al.*, 2003; Stanford *et al.*, 2003) with growing non-castrated male sheep, totalling 42 treatment means as described in Table 10.2.

The evaluations were carried out using the information in the publications on mean BW, feed intake and composition as inputs in the CNCPS-S.

Table 10.2. Description of the database ($n = 42$) used to evaluate the Cornell Net Carbohydrate and Protein System for sheep (CNCPS-S) prediction of lamb growth.^a

Item	SBW (kg)	<i>P</i>	ADG (g/day)	DMI (% of SBW)	CP (% of DM)	NDF (% of DM)	FL ^b	Forage (% of DM)	ME intake ^c (Mcal/day)	Ruminal nitrogen balance ^c (%)	Rumen pH ^c
Mean	25.5	0.30	199	4.2	13.7	42.8	1.99	46.9	2.42	15.0	6.34
SD	5.9	0.07	92	1.0	2.9	13.3	0.35	24.7	0.62	15.7	0.20
Minimum	17.5	0.21	13	2.3	7.6	23.1	1.29	0.0	1.48	-14.6	5.84
Maximum	37.3	0.49	378	5.9	19.0	73.8	2.49	100.0	3.91	80.1	6.46

^aAbbreviations are defined in Table 10.1.

^bFL = level of feeding, as estimated by the CNCPS-S (i.e. total ME intake/ME required for maintenance) excluding the age factor from equation (10.8).

^cEstimated with the CNCPS-S excluding the age factor from equation (10.8).

The feeds most similar to those cited in the publications were selected from the feed library of the CNCPS-S. Feed composition was then modified according to the chemical composition reported in each publication for each feed. Since most publications did not give complete information on the nitrogen fractions of the feeds, those in the CNCPS-S feed library were used for missing values. The same approach was used for the physically effective NDF concentration of feedstuffs and for the degradation rates for each fraction. The submodel of the CNCPS-S that corrects ruminal degradation in nitrogen-deficient diets (Tedeschi *et al.*, 2000) was used for the four diets for which the CNCPS-S predicted negative ruminal nitrogen balance. The SRW required by equation (10.4) was never reported in the publications. Thus, SRW values in the literature for each of the breeds used in the experiments were used. Since it was not possible to find appropriate values for YBW required by equation (10.5), YBW was assumed to be equal to SRW.

The assessment of the adequacy of the models is only possible through the combination of several statistical and empirical analyses and proper investigation regarding the purposes of the model initially conceptualized (Tedeschi, 2004), and in this study, several techniques were used. The coefficient of determination (R^2) (Neter *et al.*, 1996), the confidence intervals for the parameters (Mitchell, 1997) and the simultaneous test for the intercept and slope (Dent and Blackie, 1979; Mayer *et al.*, 1994) were compared.

Additional techniques were also used as discussed by Tedeschi (2004), including evaluation for accuracy with concordance correlation coefficient (CCC; Lin, 1989), mean bias (Cochran and Cox, 1957), and mean squared prediction error (MSPE; Bibby and Toutenburg, 1977). The MSPE values were expanded in three fractions to represent errors in central tendency, errors due to regression, and errors due to disturbances (or random errors), i.e. unexplained variance, which cannot be accounted for by the linear regression (Theil, 1961).

Results

The database used to evaluate the CNCPS-S prediction of ADG included a wide range of SBW, DMI, diet composition and production (Table 10.2). The level of intake varied from 2.3% to 5.9% of SBW, dietary CP concentration from 7.6% to 19.0% and dietary NDF from 23.1% to 73.8%. Rumen nitrogen balance, as predicted by the CNCPS-S (Cannas *et al.*, 2004), ranged from -14.6% to +80.1% of rumen bacteria requirements, while CNCPS-S predicted rumen pH varied from 5.84 to 6.46. The ADG across studies was nearly 199 g/day, ranging from 13 to 378 g/day.

Effect of k_g on ADG

Table 10.3 shows the comparison of observed and predicted ADG using the k_g equations of NRC (2000), ARC (1980), CSIRO (1990) and Tedeschi *et al.*

Table 10.3. Evaluation of the average daily gain (ADG) predicted by using different equations to estimate k_g and the energy value of gain (EVG) with the Cornell Net Carbohydrate and Protein System for sheep (CNCPS-S).

k_g or EVG (Reference)	CNCPS-S predicted (g/day)	Predicted - observed (g/day)	Mean bias (% of observed)	Components of MSPE ^a (%)			RMSPE ^b g/day	R^2 ^c	P ^d	C_b ^e	ρ_c ^f
				Mean bias	Res- sion bias	Unexpl. variation					
Maintenance estimated with equation (10.8)											
k_g equation (10.9) (NRC, 2000)	143	-56	28.3	64.6	0.3	35.1	70	0.79	<0.001	0.81	0.72
k_g equation (10.10) (ARC, 1980)	168	-31	15.6	37.3	0.9	61.8	51	0.81	<0.001	0.94	0.85
k_g equations (10.10) and (10.11) (CSIRO, 1990)	150	-48	24.3	50.9	4.9	44.2	68	0.75	<0.001	0.88	0.76
k_g equation (10.12) (Tedeschi <i>et al.</i> , 2004)	152	-47	23.6	59.5	10.3	30.2	61	0.83	<0.001	0.84	0.76
Maintenance estimated without age adjustment											
k_g equation (10.9) (NRC, 2000)	159	-39	19.7	47.5	0.3	52.2	57	0.79	<0.001	0.89	0.80
k_g equation (10.10) (ARC, 1980)	189	-10	5.0	6.1	1.2	92.7	40	0.81	NS	0.99	0.90
k_g equations (10.10) and (10.11) (CSIRO, 1990)	169	-30	15.0	27.3	9.8	62.9	57	0.75	<0.001	0.95	0.82
k_g equation (10.12) (Tedeschi <i>et al.</i> , 2004)	174	-25	12.6	30.0	7.5	62.5	46	0.84	<0.001	0.93	0.85
Maintenance estimated without MEI adjustment											
k_g equation (10.9) (NRC, 2000)	164	-34	17.3	41.5	0.1	58.4	53	0.80	<0.001	0.92	0.83
k_g equation (10.10) (ARC, 1980)	195	-4	1.9	0.9	5.8	93.3	40	0.82	NS	1.00	0.90
k_g equations (10.10) and (10.11) (CSIRO, 1990)	175	-24	12.0	18.5	16.5	65.0	56	0.76	<0.001	0.96	0.84
k_g equation (10.12) (Tedeschi <i>et al.</i> , 2004)	180	-18	9.2	19.7	2.4	77.9	41	0.84	<0.01	0.96	0.88

Continued

Table 10.3. (cont'd).

k_g or EVG (Reference)	CNCPS-S predicted (g/day)	Predicted - observed (g/day)	Mean bias (% of observed)	Components of MSPE ^a (%)			RMSPE ^b g/day	R^2 ^c	P ^d	C_b ^e	ρ_c ^f
				Mean bias	Regression bias	Unexpl. variation					
Maintenance estimated without MEI adjustment and k_g predicted with equation (10.10)											
EVG equation (10.2) (CSIRO, 1990)	195	-4	1.9	0.9	5.8	93.3	40	0.82	NS	1.00	0.90
EVG equation (10.5) (ARC, 1990)	204	5	2.6	1.0	11.8	87.2	52	0.72	<0.073	1.00	0.85
EVG equation (10.6) (NRC, 1985)	151	-48	24.0	53.0	0.6	46.4	65	0.71	<0.001	0.84	0.73

^aMSPE = mean squared prediction error.

^bRMSPE = root of mean squared prediction error.

^c R^2 = coefficient of determination of the best fit regression line not forced through the origin.

^d P = probability associated to an F-test to reject the simultaneous hypothesis that the slope = 1 and the intercept = 0; when NS ($P > 0.1$) in the hypothesis is not rejected (Dent and Blackie, 1979).

^eAccuracy of the model (Lin, 1989).

^fConcordance correlation coefficient (CCC) (Lin, 1989).

(2004). All except the ARC k_g with either no age adjustment or with no MEI adjustment to ME_m underpredicted ADG, with large mean biases and RMSPE.

The use of equation (10.8) without age adjustment improved precision and accuracy of the predictions (Table 10.3). The best prediction was obtained by predicting k_g with equation (10.10) (ARC, 1980). In this case the model explained 81% of the variation, with a small mean bias (-10 g/day) and RMSPE (40 g/day) (Table 10.3). The simultaneous test of the intercept and slope did not reject ($P > 0.1$) the hypothesis that they were statistically similar from zero and unity, respectively (Table 10.3). Based on the CCC analysis (Lin, 1989), the model had very high accuracy ($C_b = 0.99$) and an overall high CCC ($\rho_c = 0.90$).

The use of equation (10.8) without MEI adjustment further improved precision and accuracy with the ARC giving the best predictions (Table 10.3). Except for a further reduction of the mean bias (-4 g/day instead of -10 g/day), the other statistics were similar to those obtained with ME_m estimated by equation (10.8) without age adjustment.

Table 10.3 indicates that the best predictions of ADG were obtained when EVG was predicted using equation (10.2) (CSIRO, 1990).

Discussion

Previous work on mature sheep showed that the CNCPS-S predicts OM digestibility (used by this model to predict dietary TDN and ME) and MEI very accurately (Cannas *et al.*, 2004). In the present evaluation, only two publications (Costantini *et al.*, 1994; Ponnampalam *et al.*, 2004) reported digestibility measurements. The comparison of CNCPS-S predicted vs observed digestibility showed small mean bias (data not reported), suggesting good MEI prediction accuracy for lambs as well. Thus, it is unlikely that MEI prediction is an important source of error.

The simultaneous adjustment of ME_m for age and MEI results in underprediction of ADG. Decreasing fasting heat production and ME_m with increasing age has been reported in some experiments (Bouvier and Vermorel, 1975; Graham, 1980; Freetly *et al.*, 2002). In contrast, the sheep, beef and dairy NRC (NRC, 1985, 2000, and 2001) models, the CNCPS model for cattle (Fox *et al.*, 2004) and the Sahlu *et al.* (2004) model for goats do not include age-related ME_m adjustments. The CSIRO (1990) system includes the effect of $0.09 \times MEI$, which accounts for the effect of feeding level on visceral organ metabolism and then on maintenance requirements. Other feeding systems indirectly account for the effect of plane of nutrition on maintenance requirements, increasing the basal metabolism of the most productive breeds (NRC, 2000; Fox *et al.*, 2004).

The ARC (1980) equations for k_g consistently gave the best predictions (Table 10.3), followed by the equation proposed by Tedeschi *et al.* (2004). The equation of Tedeschi *et al.* (2004) is attractive from a biological point of view as it accounts for the change in the proportion of protein (decrease) and fat

(increase) in the gain as lambs mature, since the partial efficiency of protein energy deposition (k_{sp}) is lower than that of fat energy deposition (k_{sf}) (Graham, 1980). Nonetheless, the variable q_m in the ARC equation may account for some of the post-digestive dietary effects not considered by the equation of Tedeschi *et al.* (2004). In fact, a combination of body composition and energy content of the diet might be a better approach in computing the efficiency of utilization of energy for maintenance and growth. The equation developed by Tedeschi *et al.* (2004) used average efficiency values for k_{sp} and k_{sf} of 20% and 75%, respectively. The literature indicates very diverse values for these efficiencies (Tedeschi *et al.*, 2004). Graham (1980) reported an average k_{sp} of 0.27 and a k_{sf} of 0.68 for growing lambs. If these values are used in the development of equation (10.12) instead of those used by Tedeschi *et al.* (2004), the CNCPS-S predictions of ADG improve (Fig. 10.1). The higher accuracy obtained with the modified Tedeschi *et al.* (2004) equation suggests that if the CNCPS-S predictions of RE are accurate, the ADG prediction is precise and accurate. This implies that the CSIRO (1990) equation adopted by the CNCPS-S to predict EVG is also precise and accurate. The comparison of this equation to predict EVG with those proposed by NRC (1985) and ARC (1980) supports this conclusion (Table 10.3). The study of the relationship between the maturity index P (i.e. FBW/SRW) and the EVG estimated with equations (10.2), (10.5) and (10.6) showed that for all equations, the EVG increased as P increased (Fig. 10.2). In the case of equation (10.5) (NRC,

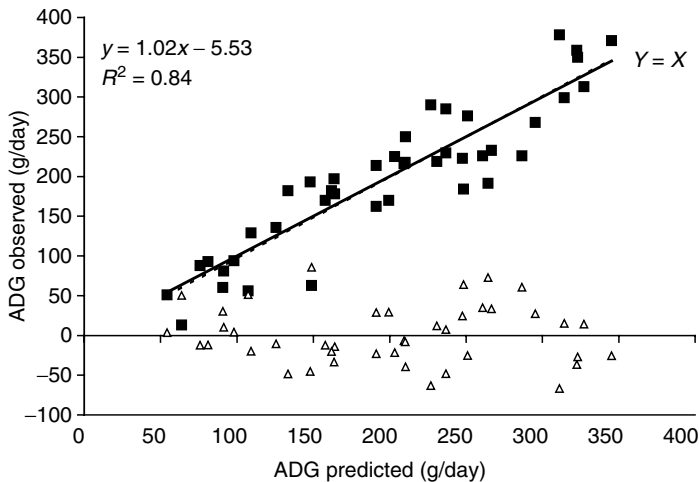

Fig. 10.1. Comparison between predicted and observed ADG using equation (10.8a) without MEI adjustment to predict ME_m and the k_g predicted by equation (10.12) (Tedeschi *et al.*, 2004) modified to consider an efficiency of protein energy deposition of 0.27 and of fat energy deposition of 0.68. The resulting prediction equation is $k_g = 18.36/(27 + 41 \times REp)$. The mean bias was 1 g/day, the RMSPE 37 g/day and the CCC overall coefficient 0.91. Triangles represent deviations between predicted and observed ADG.

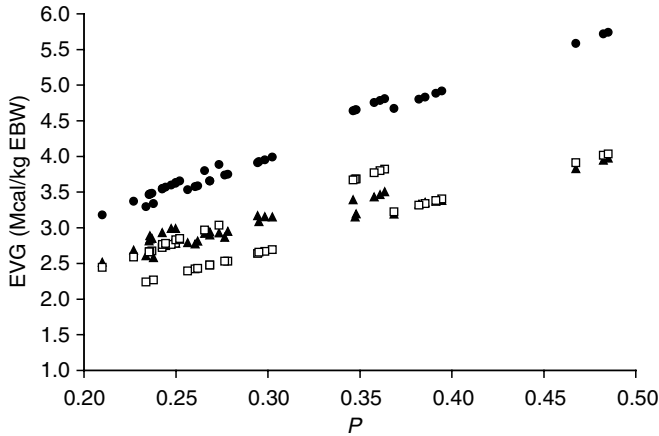

Fig. 10.2. Relationship between the maturity index P (i.e. FBW/SRW) and the energy value of gain (EVG) calculated following the methods of (●) NRC (1985) (equation (10.5)), (□) ARC (1980) (equation (10.6)) and (▲) CSIRO (1990) (equation (10.2)).

1985) and equation (10.6) (ARC, 1980), the data were separated into two distinct groups and the relationship between P and EVG was linear, while for equation (10.2) (CSIRO, 1990), there were no distinct groups and the relationship between P and EVG was curvilinear. This happened because only equation (10.2) accounts for the maturity index, while the other two systems do not explicitly consider it. Most of the feeding systems recently developed for cattle account for differences in mature size (NRC, 2000, 2001; Fox *et al.*, 2004).

Conclusions

The evaluation of the CNCPS-S model to predict ADG suggests that the adjustment to ME_m for MEI should be removed and the modified equation of Tedeschi *et al.* (2004) should be used for k_g . With these modifications, the CNCPS-S will accurately and precisely predict the ADG of growing lambs.

References

- AFRC (1995) *Energy and Protein Requirements of Ruminants*. CAB International, Wallingford, UK.
- Antongiovanni, M., Acciaioli, A., Grifoni, F., Martini, A. and Ponzetta, P. (1991) Effects of wheat straw treated with ammonia from urea hydrolysis in lamb diets. *Small Ruminant Research* 6, 39–47.

- ARC (1980) *The Nutrient Requirements of Ruminant Livestock*. Tech. Rev. Agric. Res. Council Working Party. Commonwealth Agricultural Bureaux, Farnham Royal, UK.
- Bibby, J. and Toutenburg, H. (1977) *Prediction and Improved Estimation in Linear Models*. John Wiley & Sons, Berlin, Germany.
- Bouvier, J.C. and Vermorel, M. (1975) Utilisation énergétique et azotée d'une même ration par le mouton adulte à l'engraissement et l'agneau en croissance. *Annales de Zootechnie* 24, 697–710.
- Bull, L.S., Tyrell, H.F. and Reid, J.T. (1976) Energy utilization by growing male and female sheep and rats, by comparative slaughter and respiration techniques. *Energy Metabolism Symposium Proceedings* 19, 137–140.
- Cannas, A. and Susmel P. (2002) Recent advances on the prediction of dairy sheep requirements (in Italian). *Proceedings XV Convegno Nazionale Società Italiana Patologia ed Allevamento Ovini e Caprini*. SIPAOC, Perugia, Italy, pp. 117–130.
- Cannas, A., Tedeschi, L.O., Fox, D.G., Pell, A.N. and Van Soest, P.J. (2004) A mechanistic model for predicting the nutrient requirements and feed biological values for sheep. *Journal of Animal Science* 82, 149–169.
- Cochran, W.G. and Cox, G.M. (1957) *Experimental Design*. John Wiley & Sons, New York.
- Costantini, F., Pollidori, P., Casoli, C. and De Vincenzi, S. (1994) Effect of the association of different fibrous feeds on digestibility of complete pelleted diets for lambs. *Zootecnica e Nutrizione Animale* 20, 293–303.
- CSIRO (1990) *Feeding Standards for Australian Livestock: Ruminants*. Commonwealth Scientific and Industrial Research Organization, Melbourne, Australia.
- Dent, J.B. and Blackie, M.J. (1979) *Systems Simulation in Agriculture*. Applied Science, London.
- Ferrell, C.L., Crouse, J.D., Field, R.A. and Chant, J.L. (1979) Effects of sex, diet and stage of growth upon energy utilization by lambs. *Journal of Animal Science* 49, 790–801.
- Fox, D.G., Tedeschi, L.O., Tylutki, T.P., Russell, J.B., Van Amburgh, M.E., Chase, L.E., Pell, A.N. and Overton, T.R. (2004) The Cornell Net Carbohydrate and Protein System model for evaluating herd nutrition and nutrient excretion. *Animal Feed Science and Technology* 112, 29–78.
- Franci, O., Antongiovanni, M., Acciaioli, A., Bruni, R. and Martini, A. (1997) Response surface analyses of the associative effects of lucerne hay, wheat straw and maize gluten feed on growing lambs. *Animal Feed Science and Technology* 67, 279–290.
- Freer, M., Moore, A.D. and Donnelly, J.R. (1997) GRAZPLAN: decision support system for Australian grazing enterprises: II. The animal biology model for feed intake, production and reproduction and the GrazeFeed DSS. *Agricultural Systems* 54, 77–126.
- Freetly, H.C., Nienaber, J.A. and Brown-Brandl, T. (2002) Relationships among heat production, body weight, and age in Finnsheep and Rambouillet ewes. *Journal of Animal Science* 80, 825–832.
- Graham, N.Mc. (1980) Variation in energy and nitrogen utilization by sheep between weaning and maturity. *Australian Journal of Agricultural Research* 31, 335–345.
- INRA (1989) *Ruminant Nutrition: Recommended Allowances and Feed Tables*, ed. R. Jarrige. INRA Publications, Paris.
- Lanza, M., Bella, M., Barbagallo, D., Fasone, V., Finocchiaro, L. and Priolo, A. (2003a) Effect of partially or totally replacing soybean meal and maize by chickpeas

- (*Cicer arietinum* L.) in lamb diets: growth performances, carcass and meat quality. *Animal Research* 52, 263–270.
- Lanza, M., Bella, M., Priolo, A. and Fasone, V. (2003b) Peas (*Pisum sativum* L.) as an alternative source in lamb diets: growing performances, and carcass and meat quality. *Small Ruminant Research* 47, 63–68.
- Lin, L.I.-K. (1989) A concordance correlation coefficient to evaluate reproducibility. *Biometrics* 45, 255–268.
- Mayer, D.G., Stuart, M.A. and Swain, A.J. (1994) Regression of real-world data on model output: an appropriate overall test of validity. *Agricultural Systems* 45, 93–104.
- Mitchell, P.L. (1997) Misuse of regression for empirical validation of models. *Agricultural Systems* 54, 313–326.
- Neter, J., Kutner, M.H., Nachtsheim, C.J. and Wasserman, W. (1996) *Applied Linear Statistical Models*, 4th edn. McGraw-Hill, Boston, Massachusetts.
- NRC (1981) *Effect of Environment on Nutrient Requirements of Domestic Animals*. National Academy Press, Washington, DC.
- NRC (1985) *Nutrient Requirements of Sheep*. National Academy Press, Washington, DC.
- NRC (2000) *Nutrient Requirements of Beef Cattle*, updated 7th edn. National Academy Press, Washington, DC.
- NRC (2001) *Nutrient Requirements of Dairy Cattle*, 7th edn. National Academy Press, Washington, DC.
- Ponnampalam, E.N., Hosking, B.J. and Egan, A.R. (2003) Rate of carcass components gain, carcass characteristics, and muscle longissimus tenderness in lambs fed dietary protein sources with low-quality roughage diet. *Meat Science* 63, 143–149.
- Ponnampalam, E.N., Dixon, R.M., Hosking, B.J. and Egan, A.R. (2004) Intake, growth and carcass characteristics of lambs consuming low digestible hay and cereal grains. *Animal Feed Science and Technology* 114, 31–41.
- Richardson, J.M., Wilkinson, R.G. and Sinclair, L.A. (2003) Synchrony of nutrients supply to the rumen and dietary energy source and their effects on the growth and metabolism of lambs. *Journal of Animal Science* 81, 1332–1347.
- Sahlu, T., Goetsch, A.L., Luo, J., Nsahlai, I.V., Moore, J.E., Galyean, M.L., Owens, F.N., Ferrell, C.L., and Johnson, Z.B. (2004) Nutrient requirements of goats: developed equations, other considerations and future research to improve them. *Small Ruminant Research* 53, 191–219.
- Stanford, K., Aalhus, J.L., Dugan, M.E.R., Wallins, G.L., Sharma, R. and McAllister, T.A. (2003) Effects of feeding transgenic canola on apparent digestibility, growth performance and carcass characteristics of lambs. *Canadian Journal of Animal Science* 83, 299–305.
- Tedeschi, L.O. (2004) The assessment of adequacy of mathematical models and the meta-analysis. In: Tedeschi L.O. (ed.) *Workshop on the Assessment of Adequacy of Mathematical Models*. University of Sassari, Sassari, Italy, 49 pp.
- Tedeschi, L.O., Fox, D.G. and Russell, J.B. (2000) Accounting for the effects of a ruminal nitrogen deficiency within the structure of the Cornell Net Carbohydrate and Protein System. *Journal of Animal Science* 78, 1648–1658.
- Tedeschi, L.O., Fox, D.G. and Guiroy, P.J. (2004) A decision support system to improve individual cattle management: 1. A mechanistic, dynamic model for animal growth. *Agricultural Systems* 79, 171–204.
- Theil, H. (1961) Economic forecasts and policy. In: Strotz, R., Tinbergen, J., Verdoorn, P.J. and Witteveen, H.J. (eds) *Contributions to Economic Analysis*, 2nd edn. North-Holland, Amsterdam, pp. 6–48.

11 Prediction of Body Weight and Composition from Body Dimension Measurements in Lactating Dairy Cows

T. YAN, R.E. AGNEW, C.S. MAYNE AND D.C. PATTERSON

*Agricultural Research Institute of Northern Ireland, Hillsborough,
Co. Down BT26 6DR, UK*

Abstract

Body composition data and live animal measurements were obtained from 146 Holstein × Friesian lactating cows. Live animal measurements were recorded 3 or 4 days prior to slaughter, including live weight (LW), body condition score (BCS), girth, belly girth, height and length. The objective was to develop prediction equations for body weight (BW) and body composition from live animal data. All dimension measurements were positively ($P < 0.001$) related to LW, empty body weight (EBW), carcass weight (CW) and EB contents (kg or MJ) of lipid, crude protein (CP), gross energy, ash and water. The correlation coefficients in these relationships were greatest with girth (0.62–0.88), followed by belly girth (0.52–0.88) and length (0.51–0.83), and lowest with height (0.35–0.69). Girth was then used as a primary predictor and multiple equations for prediction of BW and EB components (kg or MJ) were developed. All relationships were significant ($P < 0.001$) and each predictor had a significant effect on the relationship ($P < 0.001$). The R^2 values ranged from 0.65 for prediction of ash content to 0.91 for LW. These equations provide alternative approaches to estimate BW and composition of lactating dairy cows.

Introduction

LW and EBW are currently used across the world to calculate energy and protein requirements for maintenance for lactating dairy cows. The measurement of LW of large animals (e.g. dairy cows) requires weighbridges, which are not always available on commercial farms. However, BW is a function of body size (skeletal development), fatness and gut fill, which can be easily measured (e.g. body size) or estimated (e.g. fatness from BCS and gut fill from dry matter intake (DM), which relates to milk yield (MY)). However, there is little information available in the literature on the prediction of BW from body dimensions and other live animal variables.

A total of 146 lactating dairy cows were slaughtered and a wide range of parameters assessed including BW and body composition data, live animal variables and body dimension measurements (girth, belly girth, length and height). The objective of the study was to use these data to develop prediction equations for BW and body composition using dimension measurements and other live animal data.

Materials and Methods

In 1999, 146 Holstein × Friesian lactating cows were slaughtered that were selected to represent a parity range (PR), body condition, genetic merit, lactation stage (LS) and LW. Before slaughter, all cows were offered mixed diets of grass silages and concentrate supplements, with forage proportions in diets ranging from 0.30 to 0.60 (DM basis). There were 29 cows in the first LS, 32 in the second and the remaining in the third lactation or over. MY (kg/day) used in the present study was averaged from the week before slaughter. The LW, BCS and body dimension measurements were recorded 3 or 4 days prior to slaughter. The BCS of each cow fell into 1 of 5 categories from 1 (very thin) to 5 (very fat). Dimension measurements included girth (around cow behind the shoulder), belly girth (around cow just in front of the udder), height (from the floor to the top of the back in a line up the middle of the shoulder) and length (from front tip of shoulder to edge of pin bone).

Following assessment of dimensions, all cows were slaughtered and procedures for the determination of body composition were undertaken over a period of 2 weeks. The fetus and associated fluid and membranes were removed from pregnant cows. The exsanguinated bodies of the animals were then divided into eight components, namely, hide, feet, udder, head (including spinal cord and thymus), alimentary tract (excluding all contents except those of omasum), urogenital tract, pluck (trachea, lungs, heart, diaphragm, liver, kidneys and tail) and carcass. Perinephric and retroperitoneal fat were included with alimentary tract. The weight of each component was recorded at the time of collection and all components were stored at -20°C . Each component was subsequently shredded and minced while in the frozen state and representative samples taken for determination of DM, nitrogen, total lipid, ash and energy concentrations. The EBW was determined as LW minus weight of gut contents and fetus with associated fluid and membranes.

Linear and stepwise multiple regression techniques were used to examine relationships between BW and body composition. The statistical programme used in the present study was Genstat 6.1, sixth edition (Lawes Agricultural Trust, Rothamsted, UK).

Results and Discussion

The data on BW and body composition and live animal variables are presented in Table 11.1. The data-set represents a large range in BW and body

composition. For example, the differences between maximum and minimum data were 362 kg for LW, 313 kg for EBW, 196 kg for CW, 47.7 kg for CP and 117.1 kg for lipid. Girth ranged from 176 to 223 cm, height from 125 to 150 cm and length from 134 to 170 cm. Belly girth was larger than girth and ranged from 200 to 261 cm.

Correlation coefficients (R) in the linear relationships between dimension measurements and BW and body composition are presented in Table 11.2 and Figs 11.1–11.3 present the relationships between girth and LW, CP and lipid contents, respectively. All relationships are significant ($P < 0.001$). The R values in the relationships of LW, EBW and CW were higher with girth than length and height. This may be due to the effect of body fatness, which has a stronger relationship with girth than height and length. In terms of the relationships with different BWs, the R values with belly girth were reduced from 0.88 (LW) to 0.80 (EBW) to 0.78 (CW), while they remained similar with girth. This reduction in R values may reflect the effect of gut fill on belly girth.

Similarly, girth produced highest R values in the relationships with body components, followed by belly girth and length, whilst they were lowest with height. In terms of the relationships with dimension measurements, the R values were highest with CP and EB water contents, while they were lowest with lipid contents. This finding is in line with the results relating CP and lipid contents to LW as reported by Gibb and Iving (1993), who

Table 11.1. Data on body weight (BW) and body composition and live animal variables ($n = 146$).

	Mean	Standard deviation (sd)	Minimum	Maximum
Cow general data				
LW (kg)	574	74.4	419	781
MY (kg/day)	25.0	5.57	12.2	44.1
BCS	2.5	0.49	1.1	4.0
Pr	2.4	1.5	1	7
Empty body (kg)				
EBW	411	61.6	293	606
CW	230	37.4	155	351
CP	76.0	10.03	55.8	103.5
Lipid	43.1	21.34	16.6	133.7
Dimension measurements (cm)				
Girth	195	9.3	176	223
Belly girth	231	12.0	200	261
Height	138	4.9	125	150
Length	154	8.1	134	170

LW = live weight; MY = milk yield; BCS = body condition score; PR = parity range; EBW = empty body weight; CW = carcass weight; CP = crude protein.

Table 11.2. Correlation coefficients (*R*) in the linear relationships between dimension measurements (cm) and body weight (BW) and body composition of lactating dairy cows.

	Girth	Belly girth	Height	Length
LW (kg)	0.88	0.88	0.67	0.83
EBW (kg)	0.87	0.80	0.65	0.79
CW (kg)	0.87	0.78	0.65	0.77
Energy (MJ)	0.72	0.62	0.45	0.62
Lipid (kg)	0.62	0.52	0.35	0.51
CP (kg)	0.87	0.82	0.69	0.82
Ash (kg)	0.73	0.69	0.63	0.70
Oven dry matter (kg)	0.81	0.71	0.55	0.71
Empty body water (kg)	0.85	0.81	0.67	0.79

LW = live weight; EBW = empty body weight; CW = carcass weight; CP = crude protein.

found that CP content was linearly related to LW with an R^2 of 0.83, and a similar R^2 could only be achieved for lipid when using both LW and BCS as predictors.

Consequently, in the present study girth was used as a primary predictor to develop multiple prediction equations for BW and body composition. Other dimension measurements and live animal data were used as supporting predictors. These equations are presented in Table 11.3. All relationships are significant ($P < 0.001$) and each predictor has a significant effect on the relationships ($P < 0.05$ or less). The R^2 values are very high for

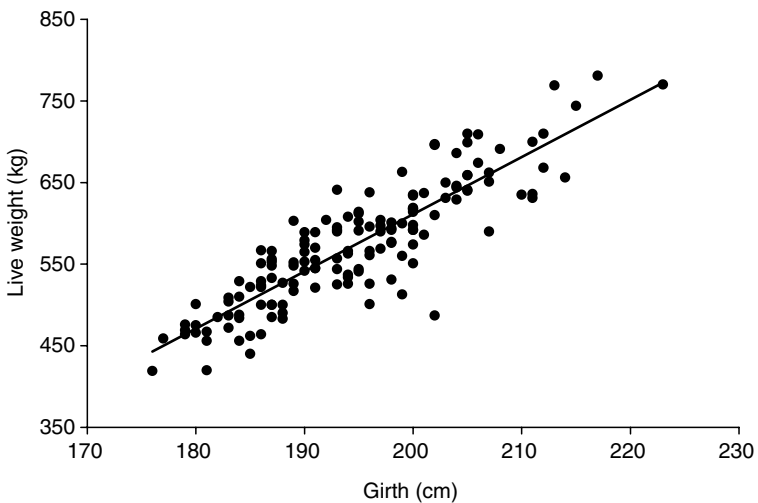

Fig. 11.1. Relationships between girth and live weight (LW) of lactating dairy cows ($n = 146$).

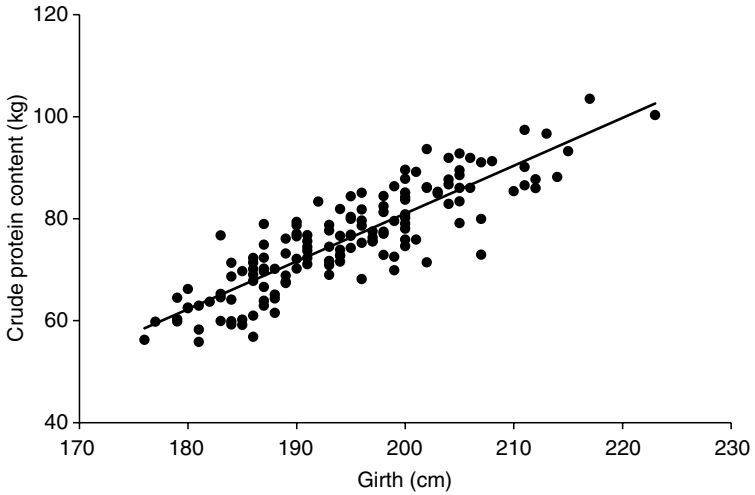

Fig. 11.2. Relationships between girth and crude protein (CP) content of lactating dairy cows ($n = 146$).

prediction of LW, EBW and CW (0.88–0.91), followed by CP, DM, EB water and energy contents (0.81–0.87). The R^2 value for prediction of lipid was relatively high (0.74) but relatively low (0.65) for ash. The high R^2 values in equations (11.1) and (11.2) indicate a high prediction accuracy for LW and EBW.

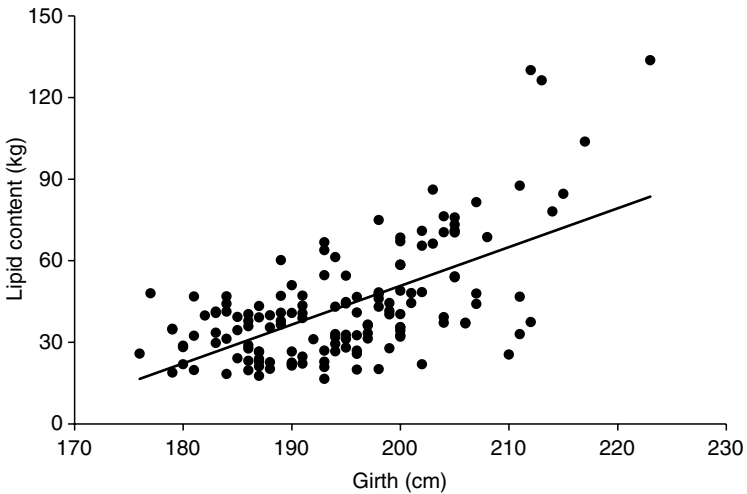

Fig. 11.3. Relationships between girth and lipid content of lactating dairy cows ($n = 146$).

Table 11.3. Multiple linear prediction equations for body weight (BW) and body composition using girth, length, belly girth and other variables.^{a,b}

Equations	R^2	No.
Live weight (LW; kg) = [2.730 _(0.415) + 0.056 _(0.022) BCS] girth + 3.263 _(0.345) length + 1.832 _(0.321) belly girth - 909.6 _(47.7)	0.906	(11.1)
Empty body weight (EBW; kg) = [3.242 _(0.284) + 0.143 _(0.021) BCS] girth + 2.585 _(0.297) length - 687.5 _(44.1)	0.882	(11.2)
Carcass weight (CW; kg) = [2.023 _(0.175) + 0.094 _(0.013) BCS - 0.0027 _(0.0010) MY] girth + 1.518 _(0.182) length - 430.5 _(27.4)	0.885	(11.3)
Lipid (kg) = [0.591 _(0.153) + 0.121 _(0.011) BCS - 0.0044 _(0.0009) MY] girth + 0.329 _(0.157) length - 162.3 _(24.7)	0.744	(11.4)
Crude protein (CP; kg) = [0.587 _(0.045) + 0.0068 _(0.0022) LS] girth + 0.547 _(0.050) length - 124.9 _(6.7)	0.873	(11.5)
Energy (MJ) = [37.46 _(6.44) + 5.025 _(0.476) BCS - 0.181 _(0.040) MY] girth + 26.53 _(6.61) length - 9496 ₍₁₀₃₁₎	0.809	(11.6)
Oven dry matter (kg) = [1.414 _(0.166) + 0.128 _(0.012) BCS - 0.0040 _(0.0010) MY] girth + 1.102 _(0.170) length - 341.7 _(26.1)	0.869	(11.7)
Ash (kg) = [0.164 _(0.039) + 0.0049 _(0.0017) LS + 0.0062 _(0.0020) PR] girth + 0.181 _(0.041) length - 39.4 _(6.9)	0.647	(11.8)
Empty body water (kg) = [1.486 _(0.246) + 0.024 _(0.008) LS] girth + 1.488 _(0.207) length + 0.468 _(0.195) belly girth - 370.7 _(26.0)	0.822	(11.9)

^aSubscripted data in parentheses are SE values.

^bBCS = body condition score; LS = lactation stage (1, 2 and 3 for lactation days of <101, 101–200 and >200); MY = milk yield (kg/day); PR = parity range (1, 2 and 3 for first, second and third LS or over

Conclusions

A range of multiple linear prediction equations for BW and body composition have been developed using body dimension measurements (girth, belly girth and length) and other live animal variables (BCS, MY, LS, PR). The high R^2 values (0.91 or 0.88) in equations (11.1) and (11.2) indicate a good accuracy for LW and EBW. These predictors are either recorded in every farm or easily measured on farms (dimension measurements). These equations can thus be used in practice for rationing or for other purposes where BW of lactating dairy cows cannot be recorded directly.

Acknowledgement

This study was funded by the Department of Agriculture and Rural Development for Northern Ireland.

Reference

- Gibb, M.J. and Ivings, W.E. (1993) A note on the estimation of the body fat, protein and energy content of lactating Holstein × Friesian cows by measurement of condition score and live weight. *Animal Production* 56, 281–283.

12 Relationships between Body Composition and Ultrasonic Measurements in Lactating Dairy Cows

R.E. AGNEW, T. YAN, D.C. PATTERSON AND C.S. MAYNE

*Agricultural Research Institute of Northern Ireland, Hillsborough,
Co. Down BT26 6DR, UK*

Abstract

The present study involves ultrasonic measurements and determination of body composition of 146 Holstein × Friesian lactating cows offered grass silage-based diets *ad libitum*. The ultrasonic measurements were recorded 3 or 4 days prior to slaughter, including back fat (BF) thickness and depth and area of eye muscle (EM), each being taken at three sites: between the 3rd and 4th lumbar vertebrae (L3), between the 10th and 11th ribs (R10) and between the 12th and 13th ribs (R13). The objective was to develop prediction equations for empty body (EB) composition of lipid, crude protein (CP) and energy from live animal data. Positive relationships were developed between EM area and depth measured at the three sites and EB concentrations of lipid, CP and energy ($P < 0.001$). The three BF thickness variables were also positively related to EB concentrations of lipid and gross energy (GE) ($P < 0.001$), while relationships with EB concentration of CP were not significant. As the relationships with BF thickness at lumbar 3 and EM area at rib 10 were stronger than those with their counterparts, they were used as primary predictors to develop prediction equations for EB concentrations of lipid, CP ($\text{g/kg}^{0.75}$) and GE ($\text{MJ/kg}^{0.75}$). The R^2 values in the multiple prediction equations for lipid and energy reached 0.68 and 0.69 respectively, compared with 0.33 for CP concentration. These findings indicate a relatively good accuracy for prediction of EB concentrations of lipid and GE for lactating dairy cows when using ultrasonic measurements and other live animal variables.

Introduction

The changes in body composition of lipid, CP and energy in lactating dairy cows reflect responses of animals to intakes of nutrients at different lactation stages (LS). Accurate measurement of body composition is important for developing appropriate nutritional and management regimes, given that there is increasing evidence to indicate that maintenance energy requirements of animals are mainly from body protein metabolism, and lipid metabolism requires much less energy (Agnew and Yan, 2000). A wide range

of techniques is available to predict body composition of live animals with one method being the ultrasonic technique for determination of body BF thickness and depth and area of EM. The objectives of the present study are to develop prediction equations for EB composition using ultrasonic measurements and other live animal data. The body composition and live animal data used in the present study were obtained from 146 Holstein × Friesian lactating cows selected from the herd of the Agricultural Institute of Northern Ireland.

Materials and Methods

In the present study Holstein × Friesian lactating cows ($n = 146$) were selected to achieve a large parity range (PR), body condition score (BCS), genetic merit, LS and live weight (LW). Ultrasonic measurements were recorded 3 or 4 days prior to slaughter, using an Aloka 500V ultrasonic scanner (Animal Ultrasound Services Inc., Ithaca, New York) equipped with a 17.2 cm long 3.5 MHz linear assay transducer. The measurements included BF thickness and EM depth and area, each being taken at three sites: between the 3rd and 4th lumbar vertebrae (L3), between the 10th and 11th ribs (R10) and between the 12th and 13th ribs (R13). Following assessment, all cows were slaughtered and procedures for the determination of body composition were undertaken over a period of 2 weeks. The fetus and associated fluid and membranes were removed from pregnant cows. The empty body weight (EBW) was determined as LW minus weight of gut contents and fetus with associated fluid and membranes. Linear and stepwise multiple regression techniques were used to examine the relationships between body composition and ultrasonic measurements plus other live animal data. These selected equations were fitted, as relevant, to the following equation to remove the effect of PR or LS on these relationships:

$$y = a_i + b_1 * x_1 + b_2 * x_2 + \dots + b_n * x_n$$

where a_i represents the effect of PR or LS i for $i = 1-3$, x_1, x_2, \dots, x_n are the x -variables and b_1, b_2, \dots, b_n are their regression coefficients. The LS were defined as 1, 2 and 3 for representing lactation days of <101, 101–200 and >200, respectively; and PR as 1, 2 and 3 for representing lactation number 1, 2 and 3 or over, respectively. The statistical programme used in the present study was GENSTAT 6.1, sixth edition (Lawes Agricultural Trust, Rothamsted, UK).

Results and Discussion

The mean, standard deviation (SD) and range for LW were 574, 74.4 and 419–781 kg; for EBW 411, 61.6 and 293–606 kg; for milk yield (MY) 25.0, 5.57, 12.2–44.1 kg/day; for BCS 2.5, 0.49 and 1.1–4.0; for parity 2.4, 1.5 and 1–7.

The corresponding data on EB composition and ultrasonic measurements are presented in Table 12.1. There was a large range in EB concentration of lipid (198–1146 g/kg^{0.75}) and energy (27.44–66.59 MJ/kg^{0.75}), while the range of CP concentration was relatively small (733–902 g/kg^{0.75}). All ultrasonic measurements also had a large range, e.g. BF thickness at L3 (BF_{L3}) ranged from 3.2 to 7.2 mm and EM area at R10 (EMA_{R10}) from 41.0 to 78.4 cm².

Correlation coefficients (*R*) in the linear relationships between ultrasonic measurements and EB concentrations of lipid, CP and energy are presented in Table 12.2. The relationships between BF_{L3} and lipid and energy concentration and between EMA_{R10} and CP concentration are presented in Fig. 12.1. There were positive relationships between EM area and depth measured at the three sites and EB concentrations of lipid, CP and energy (*P* < 0.001). The three BF thickness variables were also positively related to EB concentrations of lipid and GE (*P* < 0.001), while relationships with EB concentration of CP were not significant. The *R* values in the linear relationships between EB concentration of CP and ultrasonic measurements of EM depth and area at the three sites were all relatively smaller than those with EB concentrations of lipid and energy. There were no significant relationships between BF thickness variables and EB concentration of CP, while BF thickness data had higher *R*² than EM variables when relating to EB concentrations of lipid and energy. The poor relationship with EB concentration of CP may be attributed to the fact that this variable is relatively constant when compared with EB lipid concentration, especially in adult lactating cows. For example, the range of EB concentration of CP (733–902 g/kg^{0.75}) was much smaller than that of lipid (198–1146 g/kg^{0.75}) or energy (27.44–66.59 MJ/kg^{0.75}).

Table 12.1. Ultrasonic measurements of back fat (BF) thickness and eye muscle (EM) variables of lactating dairy cows.

	Mean	Standard deviation (SD)	Minimum	Maximum
EB composition				
Lipid (g/kg ^{0.75})	461	176.6	198	1146
CP (g/kg ^{0.75})	832	34.8	733	902
Energy (MJ/kg ^{0.75})	38.08	7.218	27.44	66.59
Ultrasonic measurements				
EM area at lumbar 3 (cm ²)	61.5	8.58	46.0	88.0
EM area at rib 10 (cm ²)	54.8	7.71	41.0	78.4
EM area at rib 13 (cm ²)	58.1	8.32	43.5	82.9
EM depth at lumbar 3 (cm)	5.6	0.84	4.0	8.9
EM depth at rib 10 (cm)	6.1	0.93	4.6	9.6
EM depth at rib 13 (cm)	6.6	0.94	4.9	10.0
BF thickness at lumbar 3 (mm)	5.0	0.74	3.2	7.5
BF thickness at rib 10 (mm)	6.4	0.77	4.8	9.1
BF thickness at rib 13 (mm)	4.7	0.70	2.9	7.2

EB = empty body; CP = crude protein.

Table 12.2. Correlation coefficients for linear relationships between ultrasonic measurements and empty body (EB) composition of lactating dairy cows.^a

		Lipid (g/kg ^{0.75})	Crude protein (g/kg ^{0.75})	Energy (MJ/kg ^{0.75})
EM depth (cm)	Lumbar 3	0.35	0.35	0.38
	Rib 10	0.36	0.29	0.38
	Rib 13	0.35	0.32	0.37
EM area (cm ²)	Lumbar 3	0.39	0.33	0.36
	Rib 10	0.40	0.34	0.43
	Rib 13	0.40	0.34	0.43
BF thickness (mm)	Lumbar 3	0.63		0.65
	Rib 10	0.62		0.64
	Rib 13	0.55		0.57

^aAll relationships with *R* values presented are significant (*P* < 0.001).
EM = eye muscle; BF = back fat; CP = crude protein.

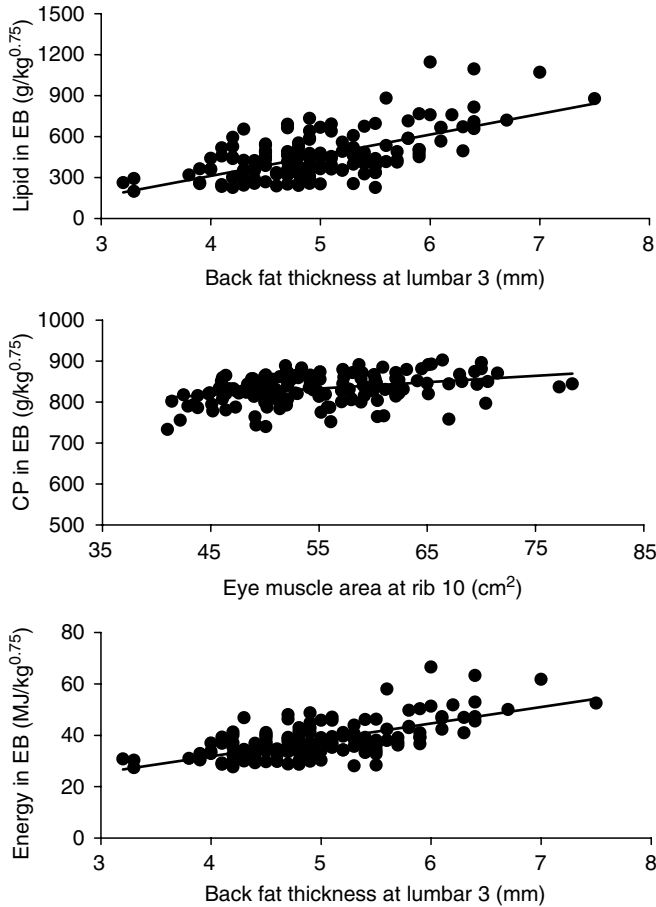

Fig. 12.1. Relationships between ultrasonic measurements and empty body (EB) composition of lactating dairy cows.

In terms of relationships with EB concentrations of CP, lipid and energy, BF_{L3} and EMA_{R10} produced relatively greater R values than their counterparts. These two variables were therefore used to develop linear and multiple (with other live animal data) regression equations for prediction of EB concentrations of CP, lipid and energy (Table 12.3). The effect of LS or PR on these relationships was removed, with the exception of equation (12.2b) for which effects of LS and PR were built in the relationship. The removal of the effect of LS and PR increased the R^2 values. For example, in linear relationships (equations (12.1a), (12.2a) and (12.3a)), the increases were from 0.397 to 0.432, 0.116 to 0.238 and 0.423 to 0.450, respectively. The R^2 values were further increased to 0.675 and 0.689 in the multiple regression equations for prediction of EB concentration of lipid and energy (equations (12.1b) and (12.3b)), but the increase (to 0.334) was relatively small for prediction of EB concentration of CP (equation (12.2b)). The lower increase in R^2 values in the multiple equation for prediction of EB concentration of CP (equation (12.2b)) may reflect the observation that the effects of MY, LS, BCS and PR on this variable are smaller than EB concentrations of lipid and energy.

Conclusions

The prediction of concentration of CP, lipid and GE in EB of lactating dairy cows using ultrasonic measurements was relatively poor. Adding other live animal data (BCS, MY, LS and PR) as supporting predictors considerably

Table 12.3. Prediction equations for lipid, crude protein (CP) and energy concentrations in empty body (EB) from ultrasonic measurements and other variables.^{a,b,c}

Equations	R^2	No.
Lipid (g/kg ^{0.75}) = 163.9 _(16.4) BF_{L3} - 364 ₍₇₈₎	0.432	(12.1a)
Lipid (g/kg ^{0.75}) = 62.9 _(17.0) BF_{L3} + 4.47 _(1.21) EMA_{R10} + 175.4 _(25.9) BCS - 8.04 _(1.70) MY - 349 ₍₈₅₎	0.675	(12.1b)
CP (g/kg ^{0.75}) = 0.905 _(0.397) EMA_{R10} + 787 ₍₂₀₎	0.238	(12.2a)
CP (g/kg ^{0.75}) = 1.226 _(0.387) EMA_{R10} - 20.66 _(5.45) BCS + 1.426 _(0.490) MY + 15.12 _(3.58) LS + 10.43 _(3.66) PR + 731 ₍₂₄₎	0.334	(12.2b)
Energy (MJ/kg ^{0.75}) = 6.292 _(0.637) BF_{L3} + 6.8 _(3.1)	0.450	(12.3a)
Energy (MJ/kg ^{0.75}) = 2.735 _(0.678) BF_{L3} + 0.213 _(0.048) EMA_{R10} + 6.81 _(1.04) BCS - 0.300 _(0.068) MY + 2.8 _(3.4)	0.689	(12.3b)

^aSubscripted data in parentheses are SE values.

^bThe effect of parity range (PR) or lactation stage (LS) on the relationships (equations (12.1a), (12.1b), (12.2a), (12.3a) and (12.3b)) was removed.

^c BF_{L3} = back fat thickness at lumbar 3 (mm); BCS = body condition score; EMA_{R10} = eye muscle area at rib 10 (cm²); LS = lactation stage (1, 2 and 3 representing lactation days of <101, 101–200 and >200); MY = milk yield (kg/day); PR = parity range (1, 2, and 3 representing lactation number 1, 2 and 3 or over).

improved the R^2 values for prediction of lipid and GE ($R^2 = 0.675$ and 0.689 respectively), although the improvement for prediction of EB concentration of CP was small ($R^2 = 0.334$). These findings indicate that ultrasonic measurements combined with other live animal data can be used to provide accurate prediction of EB concentrations of lipid and GE.

Acknowledgement

This study was funded by the Department of Agriculture and Rural Development for Northern Ireland.

Reference

Agnew, R.E. and Yan, T. (2000) The impact of recent research on energy feeding systems for dairy cattle. *Livestock Production Science* 66, 197–215.

13 Empirical Model of Dairy Cow Body Composition

O. MARTIN AND D. SAUVANT

*UMR INRA INA P-G, Physiologie de la Nutrition et Alimentation,
16 rue Claude Bernard, 75231 Paris Cedex 05, France*

Abstract

The knowledge of body condition and dynamic body reserve changes in dairy cows is of major importance in the understanding of lactation processes. An empirical model of dairy cow chemical body composition was developed and fitted to literature data. This model was aimed at predicting the concentrations of fat, protein, water, and minerals in empty body weight (EBW; kg) in relation to body condition score (BCS) on a 0–5 scale. Data were available for 239 groups of 1–36 animals. Body composition data were determined by direct analysis, anatomical dissection and organ weighing, or by indirect analysis. The relationship between body fat (F ; kg) and fat-free EBW (FFEBW; kg) was estimated with the sigmoidal model of Richards (1959), where the asymptote was assumed to be linearly dependent on BCS. This model, selected for its flexibility, was fitted to the data in two steps. First, the model was fitted to mean values of F by classes of FFEBW [<50 , 50–100), ..., (400–450), ≥ 450] assuming that these intraclass values were representative of a mean BCS (~ 2.5). Second, the asymptotic parameter of the Richards model was re-evaluated on each data-set for which BCS was available. The model finally obtained was $F = \{[117.4 + 39.8(\text{BCS} - 2.5)] \times [1 - \exp(-0.0068\text{FFEBW})]^{3.7235}\}$ with an estimated root mean squared prediction error (RMSPE) of 20 kg. This model was not usable as such (since $\text{FFEBW} = \text{EBW} - F$) but, given EBW and BCS, the EB fat was the numerical solution of this equation. The ratios of body water (W ; kg) to FFEBW, body protein (P ; kg) and body minerals (M ; kg) to dry FFEBW ($\text{DFEBW} = \text{FFEBW} - W$; kg) as well as their standard errors were estimated by bootstrap analysis on data limited to direct analysis: $100W/\text{FFEBW} = 72.6 \pm 0.1\%$ ($n = 169$), $100P/\text{DFEBW} = 78.9 \pm 0.1\%$ ($n = 164$) and $100M/\text{DFEBW} = 21.0 \pm 0.1\%$ ($n = 164$). The complete chemical body composition of a cow ($\text{EBW} = F + P + W + M$) could therefore be simulated. The proposed model predicted body composition data in dairy cows from a broad experimental context and provided a practical prediction tool to study body reserves, particularly from a dynamic viewpoint.

Introduction

The condition and dynamic changes of body reserves in dairy cows during lactation are of major importance in the processes of lactation. It is therefore essential to estimate the animal state of reserves, especially of fat and protein.

The chemical body composition of an animal corresponds to the distribution of its body mass into fat, protein, water and minerals. This distribution is established on an empty body weight (EBW) basis, i.e. without digestive tract contents (reticulo-rumen and intestine digesta) and urogenital tract contents (urine, fetus, fluids and fetal membranes). Studies on cattle body composition have traditionally been done by researchers working on growth and were aimed at determining energy requirements, especially in beef cattle. Therefore, investigations rather dealt with carcass composition than empty body (EB) composition. As far back as 1923, Moulton (1923) had formulated the concept of 'chemical maturity' defined as the age at which the fat-free body composition remains approximately constant. Thus, as mentioned by Reid *et al.* (1955), the effect of an increasing EB fat on EB protein, water and mineral content is rather a dilution effect. Various indirect determination methods of EB chemical composition have been proposed (De Campeneere *et al.*, 2000) to avoid the slaughter of animals for direct chemical analysis. In the field, to simply assess the level of body reserves the body condition score (BCS) is used as an indicator independent of the body weight (BW; Lowman *et al.*, 1976).

The objective of this study is to develop an empirical model aimed at predicting EB composition of fat, protein, water and minerals related to EBW (kg) and BCS (0–5 scale) in dairy cows. An empirical model to predict EBW from neutral detergent fibre (NDF) intake by estimating digestive tract fresh contents has been proposed elsewhere (Martin and Sauvant, 2003).

Compilation of the Literature

Records of EB composition of growing, pregnant, lactating or dry dairy-type cows (mainly Holstein × Friesian) published between 1920 and 1998 in Europe (8 articles) and North America (17 articles) were gathered in a database. Collected data concerned 239 groups of 1–36 animals (154 individual data-sets and 85 means of 13 ± 8 animals) and were obtained either by direct analysis (chemical analysis (170 groups), anatomical dissection and tissue weighing (10 groups)) or by indirect analysis (deuterium dilution (38 groups), densitometry (17 groups), estimate from adipocyte cell size (4 groups)). Direct and indirect analyses were assumed to furnish equivalent information. Moreover, no publication effect was taken into consideration, the database being considered only as a collection of body composition records rather than an experimental meta-design. Notations used for empty body fat, protein, water, minerals, FFEBW, and DFFEBW were F (kg), P (kg), W (kg), M (kg), FFEBW ($EBW - F$; kg) and DFFEBW ($FFEBW - W$; kg), respectively.

Modelling empty body fat

The relationship between F and FFEBW was modelled with the sigmoidal model of Richards (1959), where the asymptote was assumed to be linearly dependent on BCS:

$$F = [f_0 + \beta(BCS - 2.5)][1 - \exp(-f_1 FFEBW)]^{f_2} \tag{13.1}$$

Since FFEBW and BCS were reported in 25 ($n = 239$) and 7 articles ($n = 38$) respectively (Fig. 13.1), this model, selected for its flexibility, was fitted to data in two steps corresponding to the estimate of parameters f_0, f_1, f_2 and β . First, the model was fitted to mean values of F by classes of FFEBW [$<50, (50-100), \dots, (400-450), \geq 450$] assuming that these intraclass values were representative of a mean BCS (~ 2.5). Second, the asymptotic parameter f_0 was re-evaluated for each group of data for which BCS was available (Fig. 13.2):

$$f_0^* = F / [1 - \exp(-f_1 FFEBW)]^{f_2} \tag{13.2}$$

The parameter β was then estimated as the linear intratrial slope of f_0^* on BCS (Fig. 13.3) with a mixed model integrating the random effect of trial on intercept ($\beta = df_0^* / dBCS$)

Quantitative descriptors of fit accuracy associated with the first step (fit of the model $F = f_0[1 - \exp(-f_1 FFEBW)]^{f_2}$ on mean values of F by classes of FFEBW) and the second step (fit of the model $f_0^* = (\mu + \sigma_{\text{trial}}) + \beta BCS$) are respectively $n = 13$, RMSPE = 8.2 kg, $f_0 = 117.4 \pm 22.1$, $f_1 = 0.0068 \pm 0.0030$, $f_2 = 3.7235 \pm 2.1130$, and $n = 38$, RMSPE = 20.8 kg, $\beta = 39.8 \pm 3.7$, $\sigma_{\text{trial}} = 25.8$ kg.

The model finally obtained was:

$$F = [117.4 + 39.8(BCS - 2.5)][1 - \exp(-0.0068 FFEBW)]^{3.7235} \tag{13.3}$$

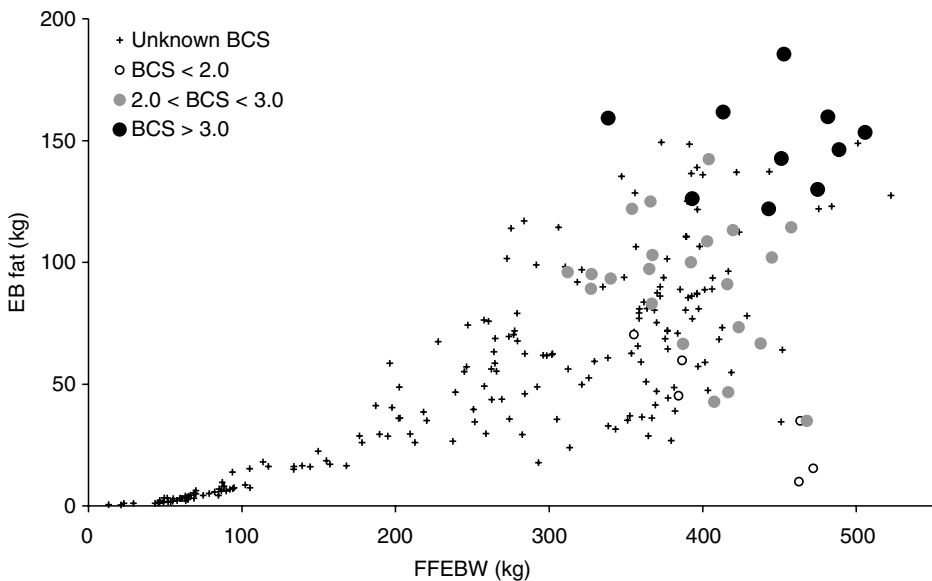

Fig. 13.1. Empty body (EB) fat data plotted against fat-free empty body weight (FFEBW); symbols encode for BCS).

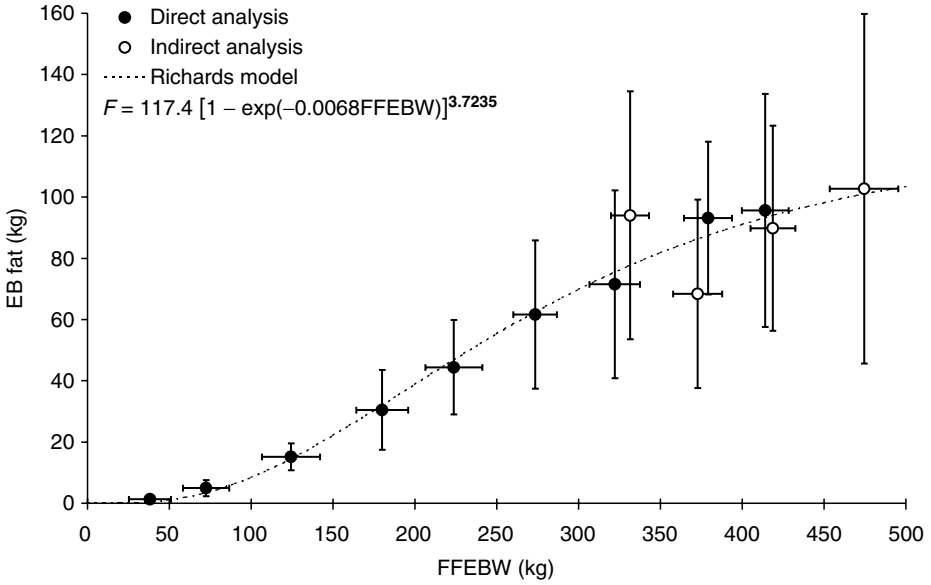

Fig. 13.2. Average empty body (EB) fat plotted against average fat-free empty body weight (FFE BW) by 50 kg classes (symbols encode for determination method).

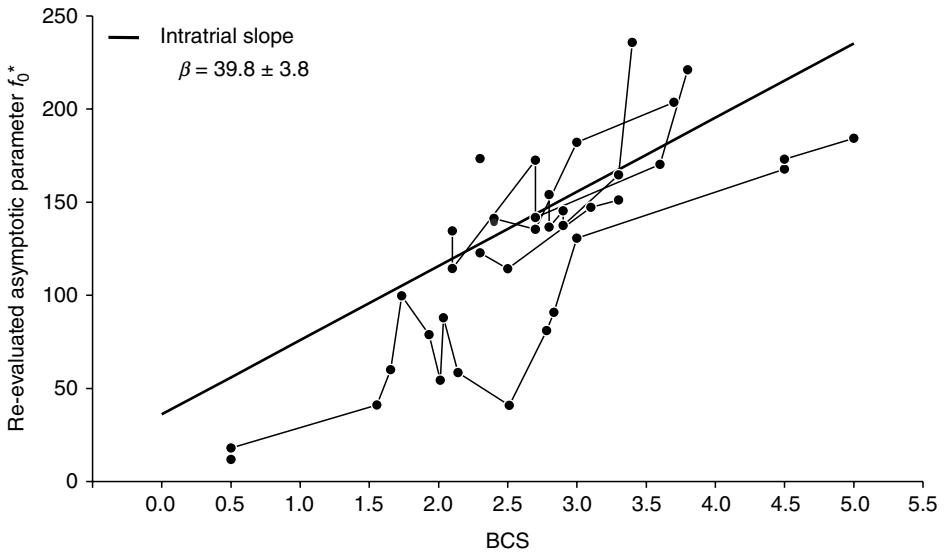

Fig. 13.3. Re-evaluated asymptotic parameter f_0^* plotted against body condition score (BCS; symbols linked by trial).

Since FFEBW is unknown in the field, this formula is not usable as such to estimate F . Given EBW and BCS, F is the numerical solution of the following equation (typically computed with the Newton–Raphson method):

$$F = [117.4 + 39.8(\text{BCS} - 2.5)] \left\{ 1 - \exp[-0.0068(\text{EBW} - F)] \right\}^{3.7235} \quad (13.4)$$

Fig. 13.4 shows simulated values of F plotted against EBW and BCS. The evaluated prediction error on F (unknown BCS assumed to be 2.5) is about ± 20 kg.

The following section was aimed at estimating body water content in FFEBW and body protein and minerals contents in DFFEBW. A first approach was performed using mixed model regression analysis taking into account the random effect of trial on intercept and slope of the regression $Y = f(X)$ where Y is the weight of the considered component into the total weight Y . Results showed that intercept was not significantly different from zero (and lower than residual error) and that random effects of trial on intercept and slope were not significant. It was therefore decided to quantify EB composition by the way of the ratio $Y:X$. The bootstrap analysis was then selected as the appropriate method to provide an unbiased estimate of the ratio and the estimated standard error of the estimated ratio.

Modelling fat-free empty body water content

The ratio W/FFEBW and its standard error were estimated by bootstrap analysis on data limited to direct analysis (Fig. 13.5):

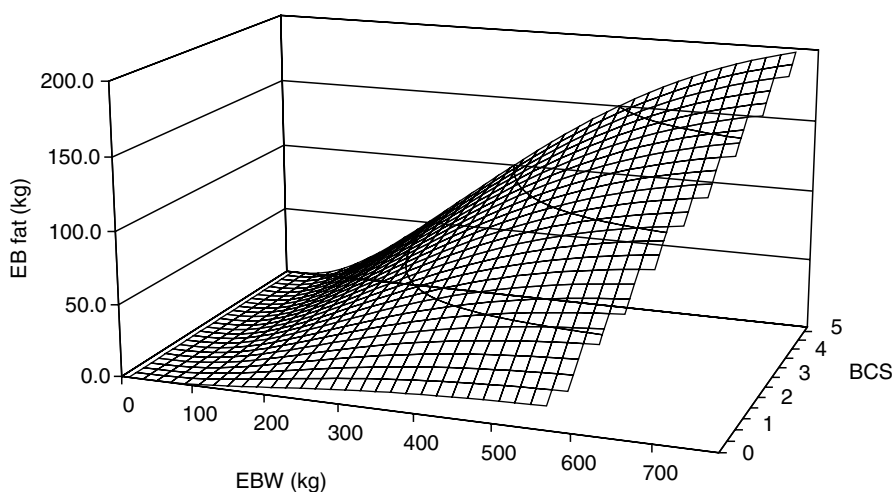

Fig. 13.4. Empty body (EB) fat (numerical solution of the model) plotted against empty body weight (EBW) and body condition score (BCS).

$$100W/FFEBW = 72.6 \pm 0.1\% \quad (n = 169) \quad (13.5)$$

Modelling dry fat-free empty body protein and minerals

The ratios P :DFFEBW and M :DFFEBW and their standard errors were estimated by bootstrap analysis on data limited to direct analysis (Fig. 13.6):

$$100P/DFFEBW = 78.9 \pm 0.1\% \quad (n = 164) \quad (13.6)$$

$$100M/DFFEBW = 21.0 \pm 0.1\% \quad (n = 164) \quad (13.7)$$

Discussion

The complete chemical body composition of a cow ($EBW = F + P + W + M$) at different BCS can be simulated stepwise with the proposed model. This modelling study synthesized body composition data in dairy cows from a broad experimental context and provided a practical prediction tool to study body reserves. Indeed, the model can be used to establish initial values of a mechanistic lactation model and to estimate the state of body reserves according to observed BCS changes during lactation. The proposed model gave predictions in average about 5% lower (10% for BCS 0 and 5) and 8% higher (regardless of BCS) values for EB fat and protein, respectively, of a

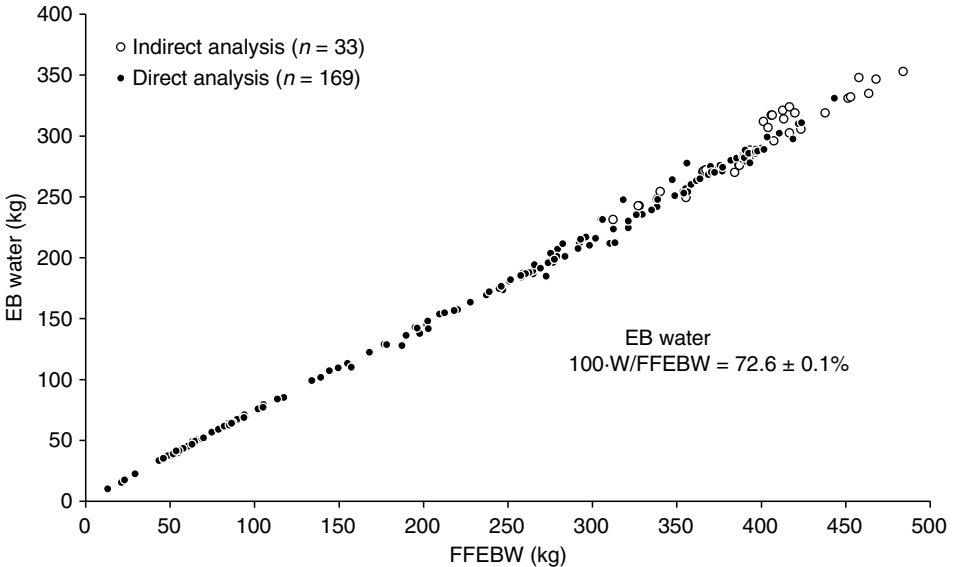

Fig. 13.5. Empty body (EB) water plotted against fat-free empty body weight (FFEBW; symbols encode for determination method).

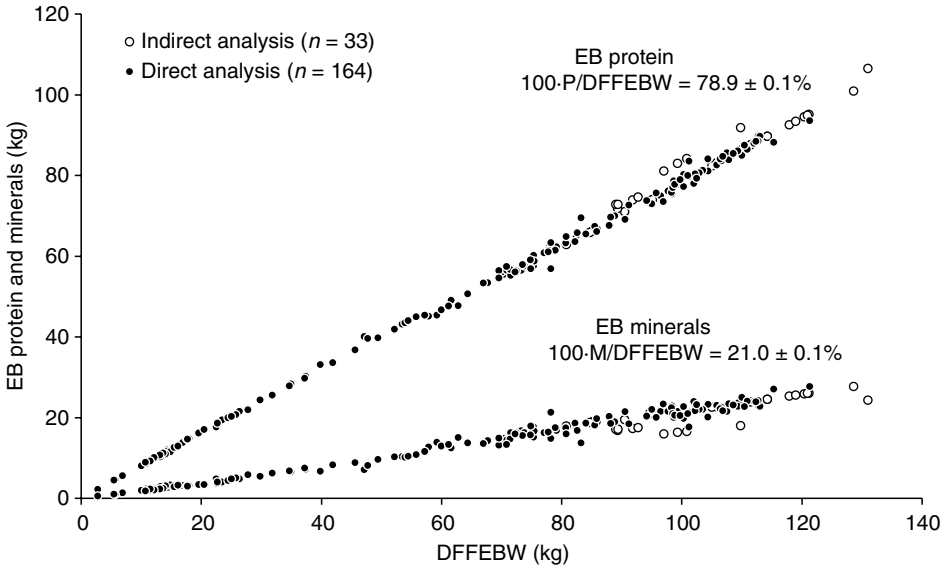

Fig. 13.6. Empty body (EB) protein and minerals plotted against dry fat-free empty body weight (DFFEBW; symbols encode for determination method).

400 kg EBW cow when compared to the model proposed by Fox *et al.* (1999). The estimated value of 39.8 kg fat per BCS unit used in the proposed model was in the range of the regression slopes of fat on BCS published in the literature (Wright and Russel, 1984; Rémond *et al.*, 1988; Chilliard *et al.*, 1991; Waltner *et al.*, 1994; Komaragiri and Erdman, 1997; Komaragiri *et al.*, 1998). Nevertheless, the present model has the advantage of integrating the effects of both BW and BCS. The model should be evaluated on a different data-set in order to verify its validity and to assess its associated prediction error.

Conclusion

The complete chemical body composition of a cow at different BCS was simulated with the proposed empirical model. The model can be used to establish initial values of a mechanistic lactation model and to estimate the state of body reserves according of observed BCS changes during lactation. The present model has the advantage of integrating the effects of both BW and BCS but requires further independent evaluation.

References

- Chilliard, Y., Cissé, M., Lefaiivre, R. and Rémond, B. (1991) Body composition of dairy cows according to lactation stage, somatotropin treatment, and concentrate supplementation. *Journal of Dairy Science* 74, 3103–3116.

- De Campeneere, S., Fiems, L. and Boucqué, C. (2000) *In vivo* estimation of body composition in cattle. *Nutrition Abstracts and Reviews Series B: Livestock Feeds and Feeding* 70, 495–508.
- Fox, D.G., Van Amburgh, M.E. and Tylutki, T.P. (1999) Predicting requirements for growth, maturity, and body reserves in dairy cattle. *Journal of Dairy Science* 85, 1968–1977.
- Komaragiri, M.V.S. and Erdman, R.A. (1997) Factors affecting body tissue mobilization in early lactation dairy cows: 1. Effect of dietary protein on mobilization of body fat and protein. *Journal of Dairy Science* 80, 929–937.
- Komaragiri, M.V.S., Casper, D.P. and Erdman, R.A. (1998) Factors affecting body tissue mobilization in early lactation dairy cows: 1. Effect of dietary fat on mobilization of body fat and protein. *Journal of Dairy Science* 81, 169–175.
- Lowman, B.G., Scott, N.A. and Somerville, S.H. (1976) *Condition Scoring of Cattle*. East of Scotland College of Agriculture Bulletin No 6.
- Martin, O. and Sauvant, D. (2003) Modélisation des contenus du tractus digestif bovin. *10ème Rencontres autour des Recherches sur les Ruminants, Paris, France, 2002/12/03–04*, 167–170.
- Moulton, C.R. (1923) Age and chemical development in mammals. *Journal of Biological Chemistry* 57, 7997.
- Reid, J.T., Wellington, G.H. and Dunn, H.O. (1955) Some relationships among the major chemical components of the bovine body and their application to nutritional investigations. *Journal of Dairy Science* 38, 1344–1359.
- Rémond, B., Robelin, J. and Chilliard, Y. (1988) Estimation de la teneur en lipides des vaches laitières Pie Noires par la méthode de notation de l'état d'engraissement. *Productions Animales, INRA* 1, 111–114.
- Richards, F.J. (1959) A flexible growth function for empirical use. *Journal of Experimental Botany* 10, 290–300.
- Waltner, S.S., McNamara, J.P., Hillers, J.K. and Brown, D.L. (1994) Validation of indirect measures of body fat in lactating cows. *Journal of Dairy Science* 77, 2570–2579.
- Wright, I.A. and Russel, A.J.F. (1984) Partition of fat, body composition and body condition score in mature cows. *Animal Production* 38, 23–32.

14

Simulating Chemical and Tissue Composition of Growing Beef Cattle: From the Model to the Tool

T. HOCH,¹ PH. PRADEL,² P. CHAMPCIAUX¹
AND J. AGABRIEL¹

¹Unité de Recherche sur les Herbivores, INRA-Centre de Clermont-Theix, F 63122 Saint-Genès-Champanelle, France; ²Domaine INRA de Marcenat, F 15190 Marcenat, France

Abstract

This study deals with an improvement of a previously published mechanistic and dynamic model of beef cattle growth, the fitting and validation processes, and the inclusion of this model in a decision support (DS) tool. The improvement of the model consists in the modelling of body tissue composition from simulated chemical composition, on account of allometry equations. These equations were determined thanks to a database gathering a large amount of slaughter data ($n = 124$) and concerning various breeds. Parameters of the allometry equations were fitted between muscle and total adipose tissue weights, and between carcass protein and total lipid contents.

A 2-year experiment with growing Salers heifers, whose feeding was continually controlled, was carried out in order to provide a better estimation of parameter values (especially protein synthesis rate constant). One group of animals ($n = 15$) underwent discontinuous growth whereas another group ($n = 9$) was continuously growing throughout the experiment. Serial slaughters were carried out to measure chemical and tissue compositions. Comparisons were performed between simulated and observed data. They showed a relatively good agreement, except for the simulation of adipose tissues weight that should be improved.

The validated model was translated into a computer program, and incorporated in an existing DS software package (INRAtion). Confronting outputs with expert knowledge underlines the interest of including a dynamic model of growth into a rationing tool. But it also shows the lack of the present approach, and the necessity for inclusion of a dynamic model of intake. The growth model could then be autonomous and simulate lots of practical cases, particularly when animals are fed *ad libitum*. A better estimation of protein synthesis rate constants for various types of animals is also needed.

Introduction

Our objective is to propose a tool to simulate French beef cattle growth and production in various conditions (diet, breed, sex, age, etc.). A mechanistic

and dynamic model describing the chemical composition of growing beef cattle was first built (Hoch and Agabriel, 2000). In this dynamic model, carcass and non-carcass protein and lipid contents (four compartments) evolve through synthesis, influenced by metabolizable energy (ME) supply, and degradation processes. Inputs are successive levels of daily ME supply. Outputs are chemical composition, carcass weight (CW), empty body weight (EBW) and live weight (LW) when adding gut fill estimation.

Since then we have improved the model in two directions: a better formalization of biological processes, not presented here (Hoch and Agabriel, 2004a); and the simulation of tissue composition from chemical composition. A 2-year experiment was also carried out in order to fit and validate the model with discontinuously growing heifers. The next step of the modelling process consisted of the inclusion of the model into an existing DS tool, namely 'INRATION' software. The purpose of the present study is to explain this 'from the model to the tool' process and to draw the line of the future steps to complete it.

Improving the Model by Simulating the Evolution of Tissue Composition

Tissue composition was considered in terms of muscle and total adipose tissue weights. It was related to the simulated chemical composition according to allometry equation:

$$Y = a(X^b) \quad (14.1)$$

Y represents muscle or adipose tissue weight and X the corresponding carcass protein or total lipid content. Parameters a and b are to be estimated. These parameters were determined from a database gathering a large amount of slaughter data ($n = 124$: 12 Charolais \times Friesian, 32 Friesians, 30 Charolais, 30 Limousins and 20 Salers) where chemical and tissue composition were measured. Data were obtained from animals slaughtered at various LW and age and after various growth rates during their life at the INRA experimental slaughterhouse, Theix, for 15 years. LW, EBW, protein and lipid content in fresh and dry matter (DM) of 19 body tissues and offals were retained.

Allometry equations were thus fitted, using the NLIN procedure of SAS (1988). The following were of particular interest: muscle weight = $f(\text{carcass protein, breed})$ and adipose tissue weight = $f(\text{lipid, breed})$.

To quantify breed effect, we fitted for each parameter (a and b) two models: a complete model with all parameters varying with breeds, and a second one without any variations. The comparison of residual sum of squares (RSS) between both models according to the extra sum of squares principle (Ratkowsky, 1983, cited in Van Milgen *et al.*, 1992) indicated that the breed did not have a significant effect on a and b values. From our data-set, it appeared that the value of coefficient b was never far from 1 (Table 14.1),

which indicated proportional development of muscle and adipose tissue weights with carcass protein and lipid contents, respectively.

To investigate further the breed influence on the estimation of parameter values, the simulated development of muscle weight was compared for Charolais and Friesian bulls, when taking or not taking into account the breed effect (Fig. 14.1). No large differences were observed, especially for the Charolais breed. From these statistical and visual analyses, the breed effect was not included in the allometry model.

Estimating Parameter Values and Validating the Model with Experimental Data

Implementation of the model requires fixed robust values for all 26 parameters. Available data used for the primary evaluation concerned mainly young bulls. A 2-year experiment was then carried out in order to fit and validate the model with independent data recorded on growing females (Hoch *et al.*, 2002). In this experiment, Salers heifers were divided into two separate groups, undergoing either continuous or discontinuous growth. The fitting process was performed on protein synthesis rate constants in carcass and non-carcass tissues, involved in a Gompertz-type equation (see Hoch and Agabriel, 2004a). Data from the discontinuously growing animals were used preferentially because these provided more information as they showed variation with time. Data from the discontinuous group appeared therefore more suitable for estimation of parameter values, whereas validation was carried out with data from the continuously growing group.

Experimental design

The growth trial took place on the INRA experimental farm at Marcenat (Cantal, France) where 23 Salers heifers 8–34 months old were managed in two groups: a discontinuous growth group, D ($n = 14$), and a continuous growth group, C ($n = 9$). All heifers were fed individually *ad libitum* with hay differing in quality. During winter, rough hay was fed to group D and a good quality hay to group C (organic matter digestibility (OMD) = 56.8% vs 65.1%; crude protein (CP) = 79 vs 142 g/kg DM; crude fibre (CF) = 341 vs 284 g/kg DM, respectively). In summer, animals were also housed and all received

Table 14.1. Allometry coefficients of the equation relating chemical and tissue composition $Y = a(X^b)$ (Y and X in kg, no unit for a and b) and associated root mean square predicted error (RMSPE).

	Coefficient a	Coefficient b	RMSPE
Muscle = f (carcass proteins)	3.532	1.014	8.54
Adipose tissue = f (carcass lipids)	0.956	0.992	3.01

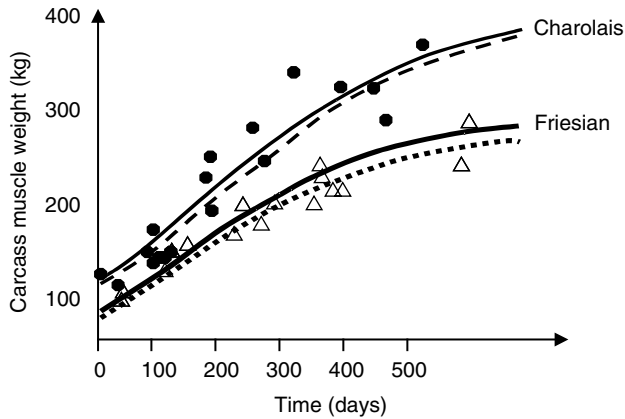

Fig. 14.1. Simulation of carcass muscle weight from initial model plus allometry equations including breed (continuous line) or without (dotted line). Case of continuous growth in Charolais or Friesian bulls.

good quality barn-dried hay (average OMD = 68%; CP = 147 g/kg DM; CF = 272 g/kg DM) to mimic pasture management. The differences in LW obtained during winter, as well as the compensation during summer, were expected to be due only to the hay quality. This *ad libitum* distribution of forage enabled the intake capacity (IC) of the animals to be monitored together with the daily ME intake (MEI). Due to the summer distribution of hay, we were able to quantify the effect of compensation either resulting from the increase in ingested quantities or associated with the change in accretion efficiency. To understand the influence of alternating restriction and refeeding phases on the animals' body composition, heifers from group D were slaughtered every 6 months. Representative animals, on an average weight basis, were slaughtered at the end of each reduced growth or compensation period (15, 21, 27 and 33 months old). To compare the body composition in the two groups, heifers from group C were slaughtered after each summer period (21 and 31 months old). The final slaughter was carried out at the same LW of animals from both groups, inducing a delay in the age for group D. Tissue and chemical compositions were estimated for each animal.

Fitting and validation processes

The number of parameters to be fitted has to be as low as possible to ensure goodness-of-fit and reduced confidence intervals of the estimations. From Hoch and Agabriel (2004a), parameters can be distinguished according to the following classification: (i) parameters that can be estimated from literature or from experts, mainly related to body composition, such as carcass protein at maturity; (ii) parameters in which value can be regarded as constant with animal type, such as synthesis and degradation rates of lipids;

(iii) parameters that should be estimated for each type of animal. This case concerns rate of protein synthesis in carcass or non-carcass tissues estimated from experimental chemical composition data. The model was very sensitive to these two parameters (Hoch and Agabriel 2004b). This fitting step was operated by means of SimuSolv software (1990).

MEI was considered as a driving variable and explained the observed differences in winter growth rates between the two groups. Estimation and visual validation phases showed quite good agreement between observed and simulated data, especially for proteins (Fig. 14.2). The simulated development of muscle and adipose tissue weight and its comparison with experimental observations are plotted in Fig. 14.3. Discrepancies are encountered for adipose tissue with overestimated quantities by the model. Differences are much smaller for carcass muscle weight.

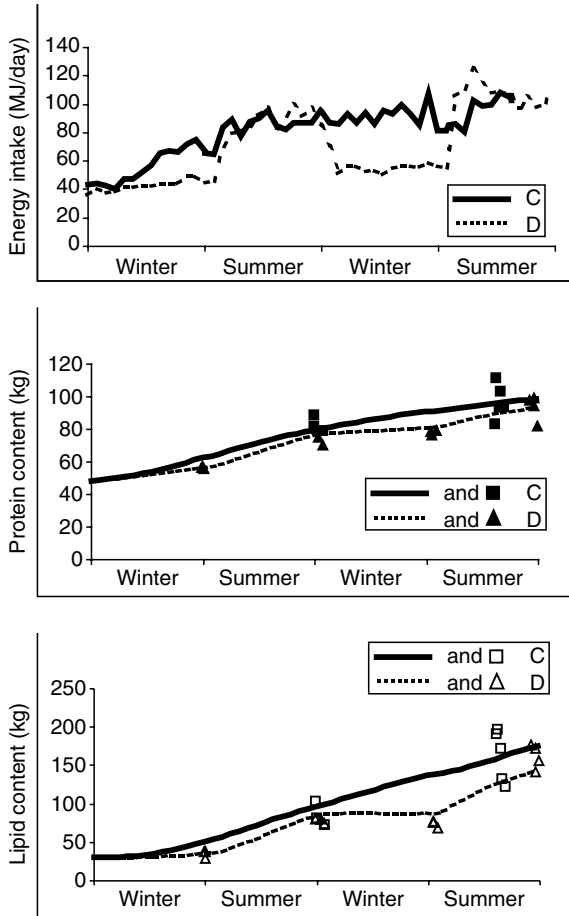

Fig. 14.2. Energy supply considered in the model and comparison between observations and simulated data for continuous (C) and discontinuous (D) growth for protein and lipid contents.

Towards Model Use as a Decision Support Tool

Finally, this validated model has been incorporated into a special version of INRATION software (1999). This software calculates recommended allowances for growing beef cattle as well as for other productions. In our case, INRATION furnishes daily diets based on available foods. These diets are equilibrated for the different nutrients (energy, protein and minerals). One diet is used as daily energy available for the model, which calculates the development of LW, EBW, CW, total lipids and proteins during a feeding sequence (Fig. 14.4). More data for carcass muscles and fat can be displayed. The user chooses the duration of the feeding sequence. The animal status at the end of a sequence is used as the initial status for the next one.

Future Improvements of the Model and the Tool

To improve the simulation of adipose tissue weight, it would be necessary, first, to improve the description and fitting of processes concerning lipid growth and, second, to choose a larger database to get more accuracy in our relation between adipose tissue weight and lipid content in the body. Includ-

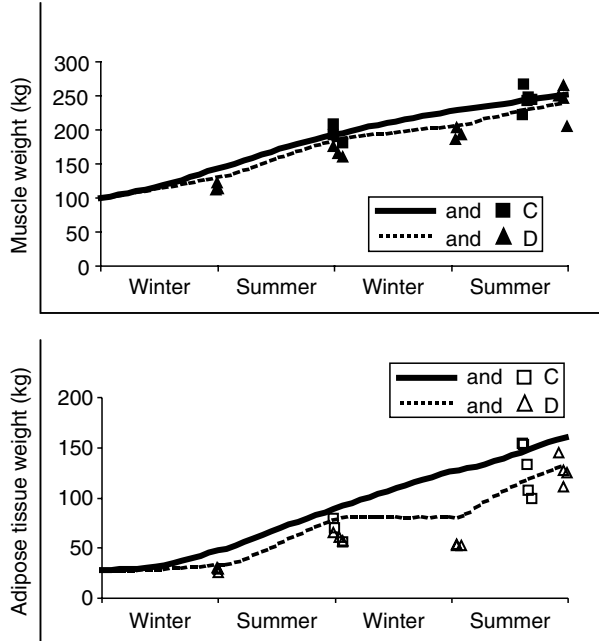

Fig. 14.3. Comparison between observations and simulated data for continuous (C) and discontinuous (D) growth for carcass muscle and total adipose tissue weight.

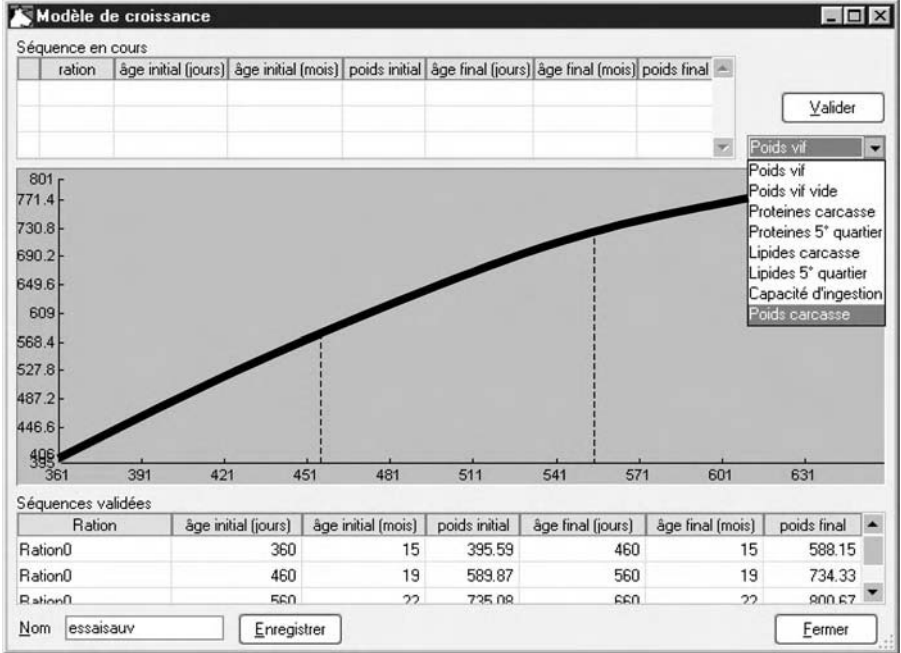

Fig. 14.4. Example of output from the decision support (DS) tool.

ing the influence of the protein content of the diet is also a way to improve the model.

In our model, estimation of variables is accurate with a fixed daily MEI for the whole feeding sequence. In order to develop an autonomous DS tool and simulate *ad libitum* feeding, the model should be able to predict intake, e.g. through simulation of the intake capacity (IC) measured in fill unit (FU; Jarrige *et al.*, 1986). On Salers heifers data, IC of the animals was calculated (DM × FU value of the hays). The IC was adjusted with a non-linear model involving LW (kg) and body condition score (BCS) on a scale of 0 (thin) to 5 (fat):

$$IC = (0.0463 \times LW^{0.88}) - (0.5361 \times BCS) \quad (14.2)$$

The exponent relating IC to LW (0.88) is close to the one proposed by INRA (1989), i.e. 0.9.

However, including this relation into the model did not lead to satisfactory results. Small errors made in the estimation of IC may generate errors in the simulation of LW, and further back on IC again. This possible accumulation of errors demonstrates the difficulty of including a static equation in a dynamic model. This stresses the need for the incorporation of a mechanistic dynamic model of intake, such as developed by Baumont *et al.* (2004).

Table 14.2. Values of adjusted protein synthesis rate constants (/day) for different animal types and breeds.

	Carcass	Non-carcass
Early maturing (e.g. Friesian)		
Bulls (growing and finishing)	0.0160	0.033
Heifers	–	–
Steers (finishing)	0.0150	0.035
Average maturity (e.g. Salers)		
Bulls (finishing)	0.0185	0.0385
Heifers	0.0180	0.04
Steers (finishing)	0.015	0.035
Late maturing (e.g. Charolais)		
Bulls (finishing)	0.0150	0.032
Bulls (growing)	0.0200	0.039
Heifers	–	–
Steers (finishing)	0.0200	0.039

Another problem arises from the application of the model to different types of animals, which differ in maturity. Ideally, each animal type should have a specific set of parameters. This appears unrealistic due to the lack of experimental data for all cases. From our data and from the literature, we propose different values of protein synthesis rate constants, to which the model is mostly sensitive (Hoch and Agabriel, 2004b; Table 14.2).

References

- Baumont, R., Cohen-Salmon, D., Prache, S. and Sauvant, D. (2004) A mechanistic model of intake and grazing behaviour in sheep integrating sward architecture and animal decisions. *Animal Feed Science and Technology* 112, 5–28.
- Hoch, T. and Agabriel, J. (2000) A mechanistic dynamic model of beef cattle growth. In: McNamara, J.P., France, J. and Beever, D. (eds) *Modelling Nutrient Utilization in Farm Animals*. CAB International, Wallingford, UK, pp. 227–240.
- Hoch, T. and Agabriel, J. (2004a) A mechanistic dynamic model to estimate beef cattle growth and body composition: 1. Model description. *Agricultural Systems* 81, 1–15.
- Hoch, T. and Agabriel, J. (2004b) A mechanistic dynamic model to estimate beef cattle growth and body composition: 2. Model evaluation. *Agricultural Systems* 81, 17–35.
- Hoch, T., Pradel, P., Begon, C., Jailler, R., Jurie, C., Picard, B., Listrat, A., Cluzel, S. and Agabriel, J. (2002) Influence de la croissance compensatrice sur la composition corporelle et les caractéristiques musculaires de génisses Salers. *9ème Rencontres autour des Recherches sur les Ruminants*, Paris, France, 4–5 Décembre 2002, 259–262.
- INRA (1989) *Ruminant Nutrition: Recommended Allowances and Feed Tables*, ed. R. Jarrige. John Libbey Eurotext, Montrouge, France.

- INRAtion (1999) INRAtion version 2.7. *Logiciel d'aide au rationnement des ruminants*. CNERTA Educagri Editions, Dijon, France, 205 pp.
- Jarrige, R., Demarquilly, C., Dulphy, J.P., Hoden, A., Robelin, J., Beranger, C., Geay, Y., Journet, M., Malterre, C., Micol, D. and Petit, M. (1986) The INRA 'Fill Unit' System for predicting the voluntary intake of forage-based diets in ruminants: a review. *Journal of Animal Science* 63, 1737–1758.
- Ratkowsky, D.A. (1983) *Nonlinear Regression Modelling. A Unified Practical Approach*. Marcel Dekker, New York.
- SAS (1988) *SAS/STAT User's guide, 6.03*. Statistical Analysis Systems Institute, Cary, North Carolina.
- SimuSolv (1990) *SimuSolv. Modelling and Simulation Software: Reference Guide*. The Dow Chemical Company, Midland, Michigan.
- Van Milgen, J., Berger, L.L. and Murphy, M.R. (1992) Fractionation of substrate as an intrinsic characteristic of feedstuffs fed to ruminants. *Journal of Dairy Science* 75, 124–131.

15 Representation of Fat and Protein Gain at Low Levels of Growth and Improved Prediction of Variable Maintenance Requirement in a Ruminant Growth and Composition Model

J.W. OLTJEN,¹ R.D. SAINZ,¹ A.B. PLEASANTS,²
T.K. SOBOLEVA² AND V.H. ODDY³

¹Department of Animal Science, University of California, Davis, CA 95616, USA; ²AgResearch, Ruakura Research Centre, Hamilton, New Zealand; ³Meat and Livestock Australia, 165 Walker Street, North Sydney, NSW 2060, Australia

Abstract

We have refined a prediction system for ruminant animal growth and composition developed previously. The model represents body protein in two pools: viscera and non-viscera (muscle). Using sheep data-sets, we have simplified the adjustments in the model for protein gain and loss of body fat at near maintenance feeding, and more precisely estimated variable maintenance parameters. In the model, muscle and viscera each have an upper bound (m^* and v^* , respectively). For muscle m^* is genetically fixed; however, v^* is affected by energy intake and muscle (protein) mass. Net energy intake above maintenance is used for muscle and viscera gain before its use for fat accretion. Our new work has allowed simplification of previous equations allowing gain of muscle or viscera at zero retained energy (RE) and for visceral growth. Maintenance energy includes a variable coefficient on body weight (BW) that results in a lag in change of maintenance requirements after intake changes. Alternatively, heat production may be represented by a regression equation with body protein components. Sheep growth and composition is more accurately predicted with the revised model, and the model predicts sheep empty BW (EBW) gain and fat content (± 25 g/day and 2.3% units respectively) more accurately than the current Australian feeding system. New additions refine predictions at levels of energy intake at or below maintenance.

Introduction

Most current feeding systems predict RE in order to estimate growth rate by using some empirical relationship between RE and BW gain. Composition of growth may be inferred in some of these by assuming protein content of the fat-free mass and energy value of protein and fat gain (e.g. 22.01% of fat-free mass is protein and the energy contents of fat and protein gain are 39.6 and 23.8 MJ/kg respectively; NRC, 2000). The prediction of RE is derived from the feed not used for maintenance or other productive functions. This may be arrived at in different ways. In net energy systems it is:

$$\text{NEG} = (\text{DMI} - \text{NEM}_{\text{req}} / \text{NEM}_{\text{c}}) \text{NEG}_{\text{c}}$$

where NEG is net energy for gain (i.e. RE; kJ/day), DMI is dry matter intake (kg), NEM_{req} is net energy required for maintenance (kJ/day), and NEM_{c} and NEG_{c} are net energy concentrations (kJ/kg) in ration DM for maintenance and gain, respectively. In metabolizable energy (ME) systems it is:

$$\text{NEG} = (\text{MEI} - \text{NEM}_{\text{req}} / k_{\text{m}}) k_{\text{g}}$$

where MEI is ME intake (kJ/day), and k_{m} and k_{g} are efficiency of ME use for maintenance and gain, respectively. Alternatively, it may be expressed as:

$$\text{NEG} = \text{MEI} - \text{HP}$$

where HP is heat production (kJ/day). In the model described in this study, based on a set of models (Soboleva *et al.*, 1999; Oltjen *et al.*, 2000), we have chosen to predict growth using an estimate of RE as the driver in contrast to our earlier model, which used empirical relationships with the ratio of MEI to a reference MEI (Oltjen *et al.*, 1986). Therefore, one of our objectives is to improve prediction of RE, essentially by estimating maintenance (which may be variable) or HP more accurately. This may require an estimate of visceral mass, since variation in maintenance and HP are greatly influenced by change in visceral organs such as gastrointestinal tract (GIT) and liver (Koong *et al.*, 1982). Hence, in predicting composition of gain we separate growth into three pools: visceral and non-visceral protein and EB fat. Thus variable maintenance can be dynamically related to the protein pools in the model. Further, the current version of the growth model contains improved representations of growth at low or near maintenance levels. Previous versions (Soboleva *et al.*, 1999; Oltjen *et al.*, 2000) had unidentified parameters for visceral protein growth. Our objective is to illustrate the hypothesis tested, the methods used, and subsequent equations and parameters accepted in achieving more accurate visceral mass and variable maintenance predictions.

Description of Original Model

In the original dynamic model (Oltjen *et al.*, 2000) viscera and non-viscera (muscle) each have an upper bound (v^* and m^* respectively). For muscle m^* is fixed, although the possibility of reaching this level depends on both the

current intake and nutritional history of the animal. However, v^* is affected by energy intake and depends on previous nutrition. As in previous models (Oltjen *et al.*, 1986) net energy intake above maintenance (NEG or RE) is used for viscera and muscle tissue gain before its use for fat accretion. Visceral tissues are more sensitive than muscle to changes in energy intake. Maintenance requirements and HP are related to MEI, but changes in maintenance requirements follow changes in intake with some time delay. This depends on both the magnitude and the duration of the change in energy intake. The model is expressed in terms of energy (kJ):

$$\begin{aligned} dm/dt &= k_m(\text{NEG} + c_m f_a)(1 - m/m^*) \\ dv/dt &= k_v(\text{NEG} + c_v f_a)(1 - v/v^*)^2 \\ df/dt &= \text{NEG} - dm/dt - dv/dt \end{aligned}$$

where

$$\begin{aligned} v^* &= cs_1 \text{MEI} / (1 + cs_2 \text{MEI})^2 \\ \text{and } f_a &= (1 - m/m^*)f / (f + f_0) \end{aligned}$$

so that if energy intake is near maintenance, body protein can be gained and fat lost in the immature animal. Constants are k_m , k_v , c_m , c_v , cs_1 , cs_2 and f_0 . Note that k_m and k_v separate the RE into m or v , and are not partial energetic efficiencies. The EBW of the animal (kg) is connected to our state variables (m , v and f) by the relationship:

$$d\text{EBW}/dt = [(dm/dt + dv/dt) / (23,800 \times 0.2201)] + [(df/dt) / 39,600]$$

where 0.2201 is the protein content of the fat-free EB. The energy driving the growth of muscle and viscera is given by the term NEG:

$$\text{NEG} = \text{MEI} - \text{HP}$$

where HP is total heat production, i.e. the sum of HP for maintenance (HP_{maint}) and HP for gain (HP_{gain}). HP_{maint} is estimated as:

$$\text{HP}_{\text{maint}} = \alpha_t \text{EBW}^{0.75} + 0.09 \text{MEI}$$

which is the form of Corbett *et al.* (1987) that partitions maintenance energy into that associated with metabolism and digestion of feed and

$$\alpha_t = \alpha_0 [1 + b(\text{MEI}_t / \text{MEI}_0 - 1)(1 - e^{-t/\tau})]$$

results in a lag in change of maintenance requirements after intake changes from MEI_0 to MEI_t . Here b and τ are constants; MEI_0 and α_0 are original values of intake and maintenance coefficient, respectively. The HP_{gain} is:

$$\text{HP}_{\text{gain}} = \text{MEI} - \text{HP}_{\text{maint}} - \text{NEG}$$

If one assumes a constant efficiency of feed energy use for gain (k_{gain}):

$$\begin{aligned} \text{NEG} &= k_{\text{gain}}(\text{MEI} - \text{HP}_{\text{maint}}) \\ \text{or } \text{HP} &= \text{MEI} - k_{\text{gain}}(\text{MEI} - \text{HP}_{\text{maint}}) \end{aligned}$$

Otherwise any general form for HP can be used.

Values for the coefficients in the original model that were chosen empirically to fit Ferrell *et al.* (1986) are given in Table 15.1. Most parameters were well fitted, with the exception that c_v (-0.5 ± 0.7) in the equation allowing visceral growth at low RE was not identified. Also, simple correlation coefficients of the relationship between parameters (Oltjen *et al.*, 2000) revealed strong relationships between c_m and f_0 ($R^2 = 0.72$), for example, and other parameters, suggesting that the equations allowing protein growth at near zero RE were overparameterized and should be simplified. The value of k_m was highly correlated ($R^2 = 0.86$) with fit of the model, suggesting great sensitivity to the partition of NEG to muscle. Also, Oltjen *et al.* (2000) suggested that systematic biases in model structure, more than parameter value estimation, needed further work.

Methods

Data obtained by Ferrell *et al.* (1986) studying compensatory growth of intact male Suffolk \times Rambouillet \times Finnish Landrace lambs were used to test model changes. Lambs were assigned to gain 16 (H), 5 (M) or -6 (L) kg during period one (42 days), followed by assignments of 27 (S), 16 (H), 5 (M) or -6 (L) kg gain during period two in an incomplete 3×4 factorial design with treatments HH, HM, HL, MH, MM, ML, LS, LH and LM (period one designated by first letter, period two by second). There were four lambs per treatment. Data for visceral protein alone were not available, so v has been defined as the sum of liver, heart, kidney, spleen and GIT protein, and m as the remaining EB protein for the example presented here. Measurements were made of the initial and final BW, average daily energy intake, and muscle, viscera and fat weight at slaughter. The dynamic system of three coupled

Table 15.1. Estimates of the parameters in the model of Soboleva *et al.* (1999) for sheep based on the data of Ferrell *et al.* (1986).

Parameter	Value	Standard deviation (sd)	Units
k_m	0.36	0.01	
k_v	0.56	0.02	
c_m	221	10	kJ/day
c_v	-0.5	0.7	kJ/day
m^*	351,200	1,086	kJ
cs_1	1.33	0.02	Day
cs_2	0.0000214	0.0000005	Day/kJ
f_0	12.3	2.5	kJ
b	0.117	0.006	
τ	48	5	Day
α_0	649	28	kJ/(day \cdot kg $^{0.75}$)
k_{gain}	0.522	0.009	

non-linear differential equations was solved numerically using initial conditions based on the BW of the animals at the beginning of the trial. We assumed that initial v (protein content) was 8.15% of BW, and that v was 16.58% of the sum of liver, heart, kidney, spleen and GIT weight. To account for the effect of the level of energy intake on maintenance requirements, the value of α_0 was adjusted relative to the HH treatment, and initial intake (MEI_0) was set to 19,000 kJ/day. The results from the simulation at day 84 were compared to the measurements made on the animals at this time.

Fitting the unknown parameters to the data is a simultaneous non-linear regression problem, given that the set of differential equations is solved numerically. The estimation involves simultaneous regression since the same parameters occur in each of the three equations. This means that the estimation must take account of both the different scales and variances between the three body components, and also the covariances between the residuals of these variables. For example, if fat had a greater variance than muscle or viscera, it would make the fat pool much more influential in determining the parameter values than muscle or viscera unless this greater variance were taken into account in the estimation.

The corollary of least squared parameter estimation for one equation is to minimize the determinant of the residuals for parameter estimation in simultaneous equations. This is also the maximum likelihood estimate when the residuals are multivariate normal. The derivation is given in Bates and Watts (1988).

Initially the parameter estimation was done by solving the set of differential equations numerically using a Runge–Kutta method with adaptive stepwise control (Press *et al.*, 1989) and a continuous parameter genetic algorithm (Haupt and Haupt, 1998) to minimize the determinant of the residual covariance matrix of muscle, viscera and fat. These estimates were used as the starting values for estimation using the Markov Chain Monte Carlo method (Metropolis–Hastings algorithm; Tanner, 1996). This method also provided estimates of the parameter distributions.

Results

The model parameters c_m , c_v and f_0 allow body composition changes to occur at zero or low NEG. If we plot the best fit line through the component gains of m and f (Fig. 15.1, v lines were not significantly different from zero and are not shown), and specifically look at the graph near NEG of zero, we find that both m and f gain approach zero as maturity increases, but from different directions. Thus, young animals gain more protein and lose more fat than older ones when feeding is restricted to maintenance levels.

Since c_m and f_0 are highly correlated ($R^2 = 0.72$), we replaced the $f/(f + f_0)$ term in the f_a equation with a simple exponent on the $(1 - m/m^*)$ term:

$$f_a = (1 - m/m^*)^{e_2}$$

New estimates for c_m and e_2 are 1,340 kJ/day and 3.4 respectively. If we plot dm/dt at $\text{NEG} = 0$ for different m for the original and revised equations,

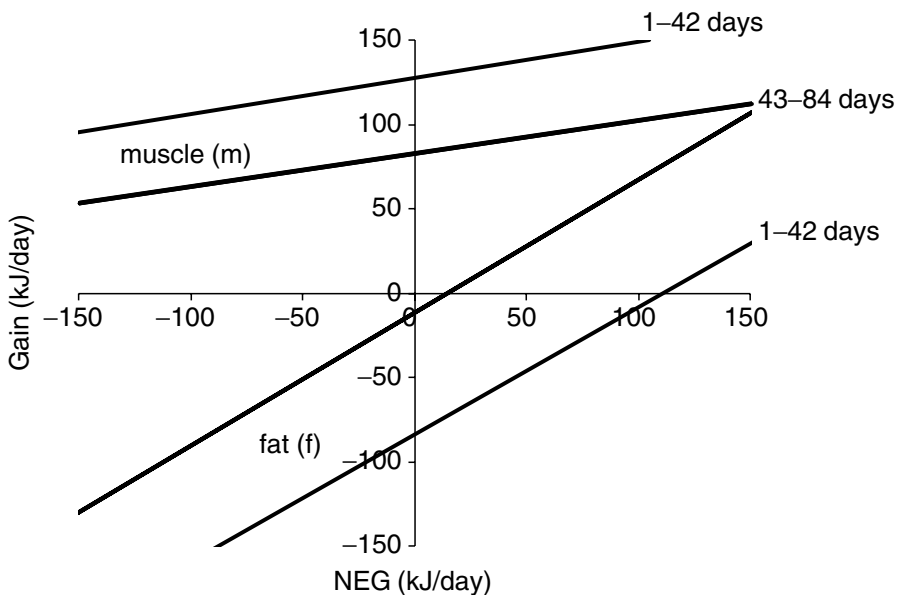

Fig. 15.1. Effects of age (period one, days 1–42; period two, days 43–84) on muscle or fat gain (loss) at near maintenance feeding levels (Ferrell *et al.*, 1986).

Fig. 15.2 shows that the original equation is not sensitive enough at younger ages, but the new form is more responsive. In fact, for animals of similar muscle mass, the previously assumed relationship that dm/dt increases more for relatively fatter animals was disproved in this data-set with a significant negative (not positive as expected) correlation (-0.69). Whether another equation form will be needed for long periods of maintenance feeding requires further data for analysis.

Turning next to viscera growth, if we assume that the calculation for v^* as a quadratic function of MEI is correct, f_a appears problematic. That is, when NEG is constrained to zero:

$$k_v c_v = (dv/dt)/(1 - v/v^*)^2$$

and using average visceral values for the first and second 42-day periods, $k_v c_v$ is -872 and $-3,803$ respectively, but both values should be the same. The problem is that there is a decrease in v growth with maturity at similar NEG (Fig. 15.3).

Further, sensitivity analysis for the function v^* showed a significant ($P < 0.001$) correlation ($R^2 = 0.42$) between m and the residual viscera (predicted v^* minus observed v at the end of each period; Fig. 15.4).

Therefore, we refined the prediction of v^* using a data-set including longitudinal observations for viscera for rams and ewes held for long periods of time on constant intakes after various prior nutritional manipulations (Ball, 1996). An equation including both m and MEI best fitted the ram data (Fig. 15.5):

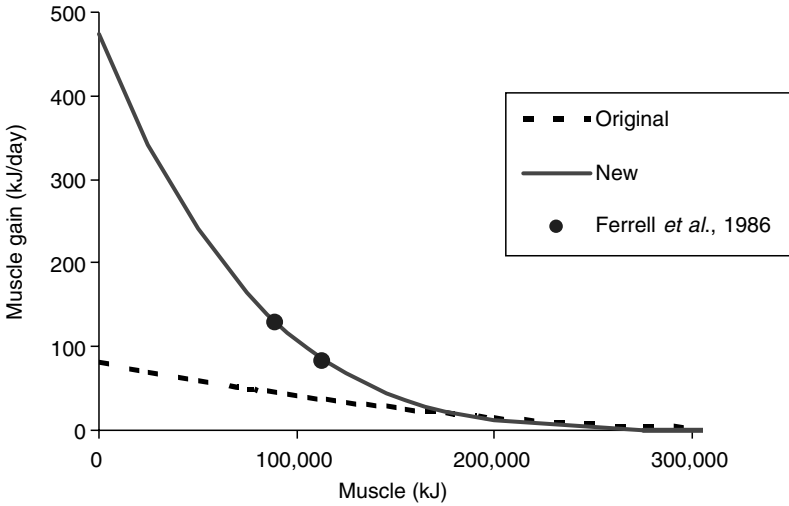

Fig. 15.2. Effects of age (increasing muscle, m) on rate of muscle gain at maintenance feeding; net energy for gain (NEG) = 0, for the original model with $f_a = [(1 - m/m^*)f/(f + f_0)]$ or a new model with an alternate equation form $f_a = (1 - m/m^*)^2$.

$$v^* = 0.31365MEI + 0.041573 m$$

without an intercept, since it was not significant ($P > 0.1$). When used with the Ferrell *et al.* (1986) data, similar good fit was observed (Fig. 15.6).

Simplifying the equation to predict visceral growth, we hypothesized that a simpler form might suffice, since fits of the previous equation were actually worse with NEG included:

$$dv/dt = k_v(v^* - v)^{0.5}$$

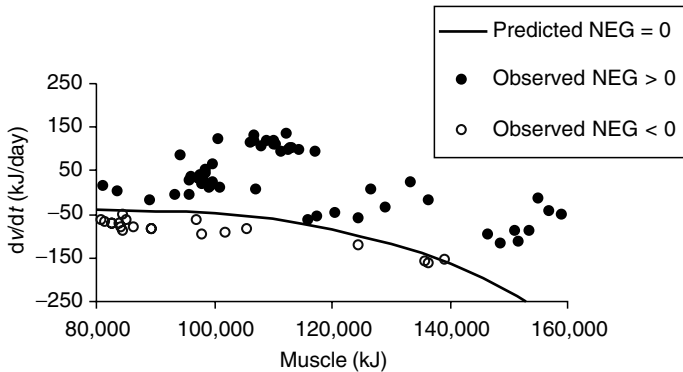

Fig. 15.3. Effects of age (increasing muscle, m) on rate of viscera gain around maintenance feeding; net energy for gain (NEG) = 0, for the original model.

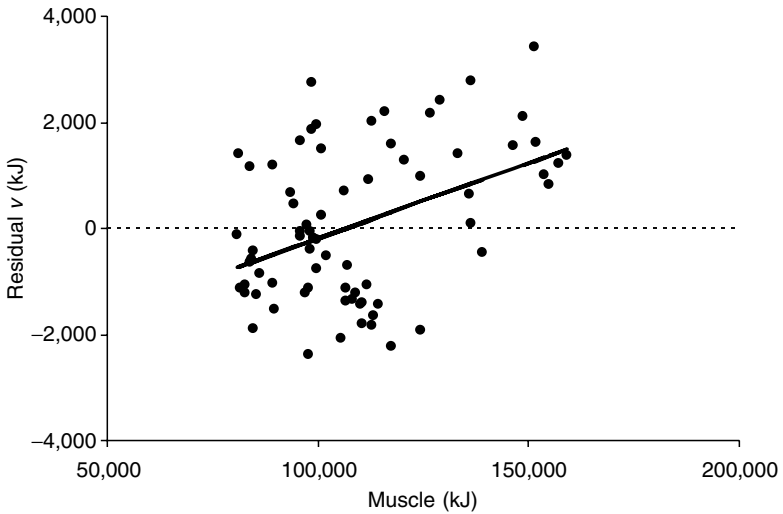

Fig. 15.4. The relationship of muscle (m) with residual viscera (predicted viscera, v^* , minus observed viscera, v) at the end of each period.

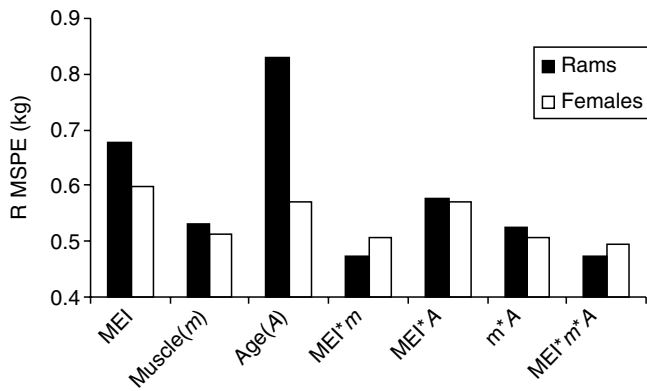

Fig. 15.5. Root mean square predicted error (RMSPE) of ending-period viscera mass for regressions with the terms metabolizable energy intake (MEI), muscle mass and age (Ball, 1996).

Fit of the Ball (1996) data-set for sheep both gaining or losing weight showed that e_3 was near unity and that k_v was 0.05 (Fig. 15.7).

Summarizing thus far, the new model gives:

$$dm/dt = k_m(NEG + c_m f_a)(1 - m/m^*)$$

$$dv/dt = k_v(v^* - v)$$

$$df/dt = NEG - dm/dt - dv/dt$$

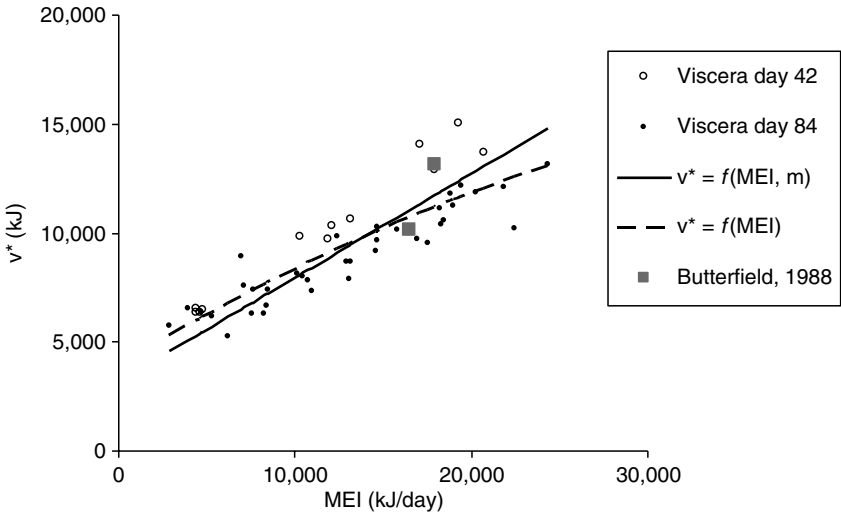

Fig. 15.6. Observed viscera at the end of each 42-day period (Ferrell *et al.*, 1986) and predicted v^* for the original equation based on metabolizable energy intake (MEI; Oltjen *et al.*, 2000) and a new equation based on MEI and muscle mass (m).

$$\text{with } f_a = (1 - m/m^*)^{e_2}$$

$$\text{and } v^* = cs_1 \text{MEI} + cs_2 m$$

where m is non-visceral EB protein (kJ), v is visceral EB protein (kJ), f is EB fat (kJ), NEG is RE (kJ/day), m^* is mature m , and k_m (0.353), c_m (1340 kJ/day), k_v (0.050/day), e_2 (3.4), cs_1 (0.314 day) and cs_2 (0.0416) are estimated parameters.

We also added the Standing Committee on Agriculture (SCA; 1990) energy terms for loss of body energy; for $\text{MEI} < \text{HP}_{\text{maint}}$ body energy is used at 0.8 efficiency, so:

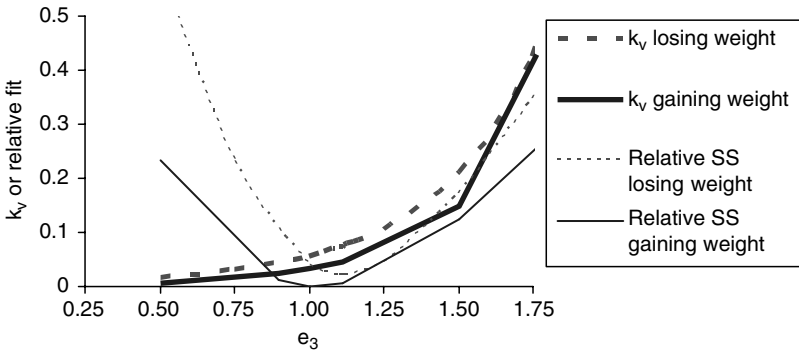

Fig. 15.7. Best fit for parameter k_v with different values of e_3 in the visceral growth equation and relative fit (sum of squared deviations, SS, between observed and predicted v) for the data of Ball (1996).

$$HP_{\text{maint}} = \alpha_i EBW^{0.75} + 0.09 * MEI$$

$$\text{and NEG} = (K_{\text{maint}}/0.8) * (MEI - HP_{\text{maint}})$$

where $K_{\text{maint}} = 0.02 * M/D + 0.5$ (SCA, 1990, p. 26, eq. 1.23); M/D is metabolizability of the feed.

Next we addressed a criticism that α_0 of $649 \pm 28 \text{ kJ}/(\text{day} \cdot \text{kg}^{0.75})$ was too large. If one again uses SCA (1990, p. 24, eq. 1.22) to estimate HP_{maint} :

$$HP_{\text{maint}} = KSM(260 W^{0.75} e^{-0.03A})/k_m + 0.09MEI$$

$$HP_{\text{maint}} = 1 * 1.15 * 1 * (260 * 22.76^{0.75} e^{-0.03 * 0.33}) / (0.02 * 10.6 + .5) + 0.09MEI$$

where K (species) is 1 for sheep, S (sex) is 1.15 for entire male, M (milk) is 1 for no milk feeding, W (weight, kg) is initial weight – 22.76 kg for Ferrell *et al.* (1986), A (age, max = 6 years) is initial age – 0.33 years for Ferrell *et al.* (1986), and k_m (kJ/kg) = $0.02M/D + 0.5$ with M/D = 10.6. If we use $W = 1.09(EBW + 2.9)$ as in SCA (1990, p. 40) or EBW of 17.98 kg:

$$HP_{\text{maint}} = 496EBW^{0.75} + 0.09MEI$$

for the initial conditions (Ferrell *et al.*, 1986). Subsequent fits with NEG over the average period data have shown that k_{gain} and α_0 are highly correlated ($r = 0.980$; Fig. 15.8). We chose to fix k_{gain} as the SCA value of 0.4558 ($k_{\text{gain}} = 0.043M/D$; SCA, 1990, p. 49, eq. 1.39) and α_0 as 500 (actually 499.8 from fit; Fig. 15.8). Compare this 500 with 496 for SCA above, suggesting that SCA (1990) provides excellent fit for the average ram in the fitted data.

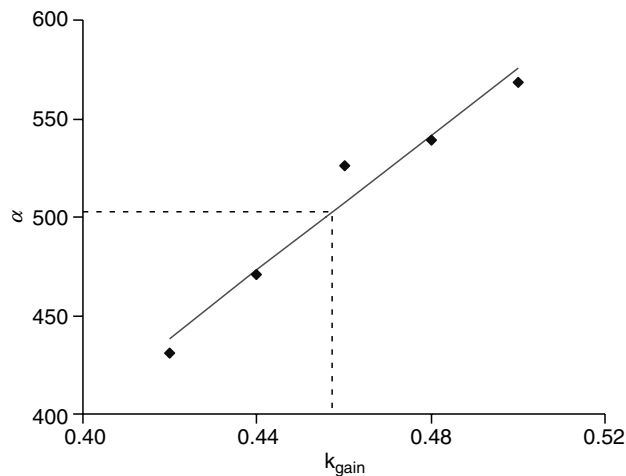

Fig. 15.8. Relationship between maintenance coefficient α at initial time and efficiency of metabolizable energy (ME) for gain (k_{gain}) for fits of retained energy (RE or NEG; Ferrell *et al.*, 1986); dotted lines are for k_{gain} corresponding to ration fed (SCA, 1990).

To this point we have used HP_{maint} as in the Australian feeding system (SCA, 1990) based on Corbett *et al.* (1987), but with a variable coefficient on BW:

$$HP_{\text{maint}} = \alpha_t EBW^{0.75} + 0.09 \text{MEI}$$

$$\alpha_t = \alpha_0 [1 + b(\text{MEI}_t / \text{MEI}_0 - 1)(1 - e^{-t/\tau})]$$

which results in a lag in change of maintenance requirements after intake changes from MEI_0 to MEI_t . Here EBW is empty body weight, t is time (days), b and τ are constants; MEI_0 and α_0 are original values of intake and the maintenance coefficient, respectively. Fit of the Nebraska data (Ferrell *et al.*, 1986) shows that the double correction for variable maintenance is not necessary; the previously used coefficient on MEI, 0.09, is not different than zero in a model where α varies (Fig. 15.9).

Thus:

$$HP_{\text{maint}} = \alpha_t EBW^{0.75}$$

The next task is to determine the best values for the trajectory of α by estimating b and τ . Again fitting Ferrell *et al.* (1986), b and τ are related ($r = 0.46$; Fig. 15.10), and finding a unique value is not possible. Exploring the relative fit of the data parametrically (Fig. 15.11), there is an apparent plateau above b of 0.113 or τ of 25 days; the bottom is not defined except by zero, which is similar to fixed α . However, Fig. 15.9 demonstrates the advantage of a variable α . Thus, further research and additional longitudinal data are needed to estimate these parameters with precision. If we fix b (0.116) and τ (20.0 day), Fig. 15.12 illustrates the dynamic nature of variable maintenance. Overall, these changes significantly improve the prediction (Fig. 15.13) of body fatness (bias, -0.22 , and standard deviation (SD), 2.29% units) and EBW gain (bias, 21, and SD, 25 g/day).

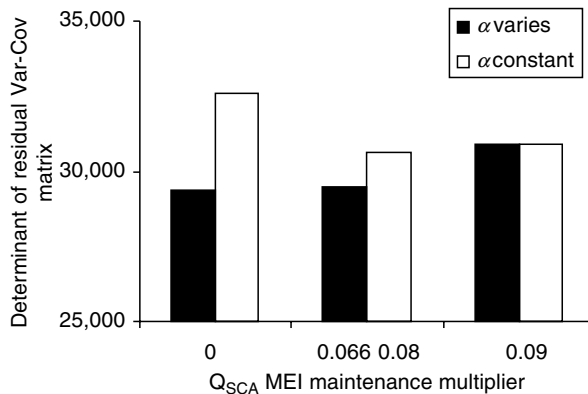

Fig. 15.9. Model fit of Ferrell *et al.* (1986) for $HP_{\text{maint}} = \alpha_t EBW^{0.75} + Q_{\text{SCA}} \text{MEI}$, where Q_{SCA} is the SCA (1990) coefficient.

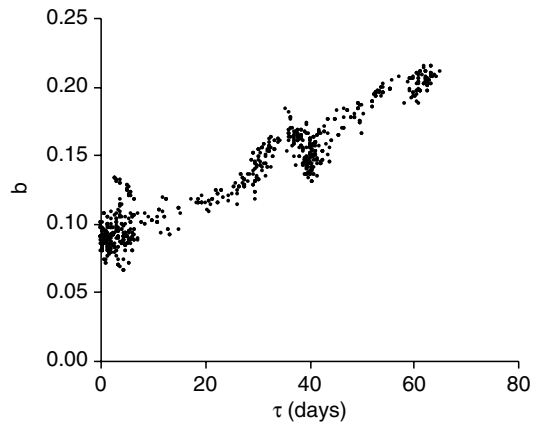

Fig. 15.10. Relationship between lag for maintenance, τ , and magnitude of maintenance adjustment, b , in fit of retained energy (RE or NEG; Ferrell *et al.*, 1986).

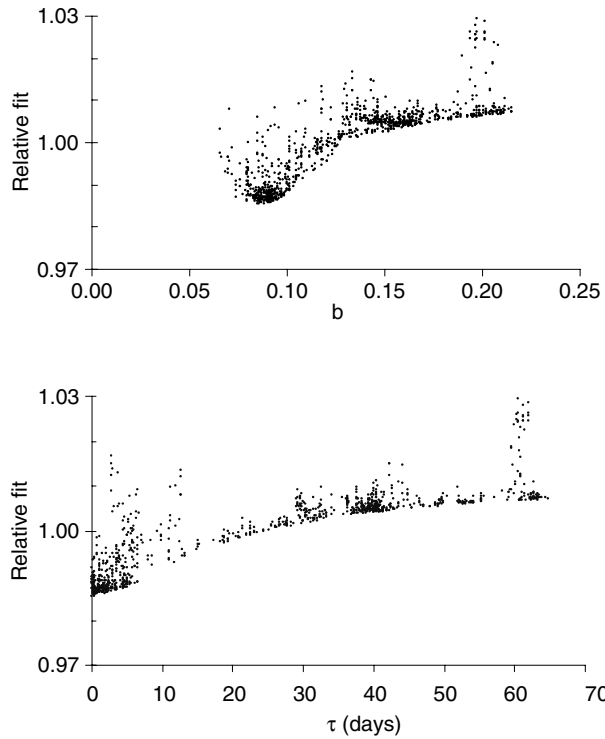

Fig. 15.11. Relative fit of retained energy (RE or NEG) for different values of maintenance adjustment, b , and lag for maintenance, τ (Ferrell *et al.*, 1986).

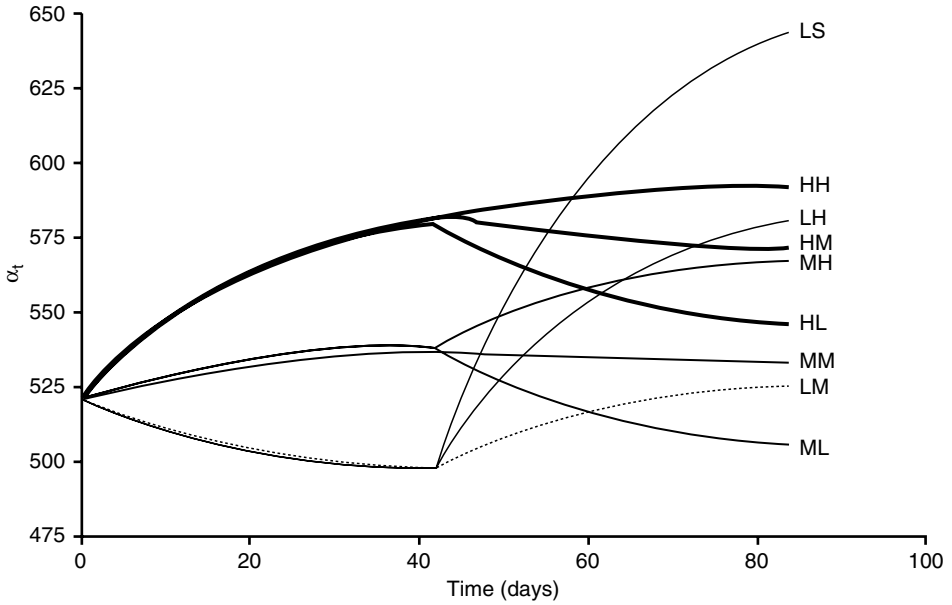

Fig. 15.12. Model-predicted maintenance coefficient (α) as a function of time (t) for nine treatment groups of Ferrell *et al.* (1986).

The maintenance function used is the traditional form adopted by nutritionists and may not be correct, especially in a dynamic situation. One of the advantages of the way the model is formulated is that the performance of different functions describing HP of the animal can be investigated. We tested different approaches to estimating HP and found that an alternative multiple regression equation including muscle protein, visceral protein, and the change in muscle and visceral protein could also be used (Fig. 15.14):

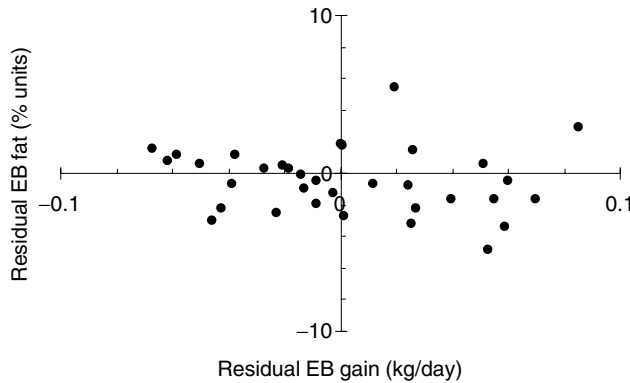

Fig. 15.13. Residual (predicted minus observed) empty body (EB) fat and gain for rams fed 84 days (Ferrell *et al.*, 1986).

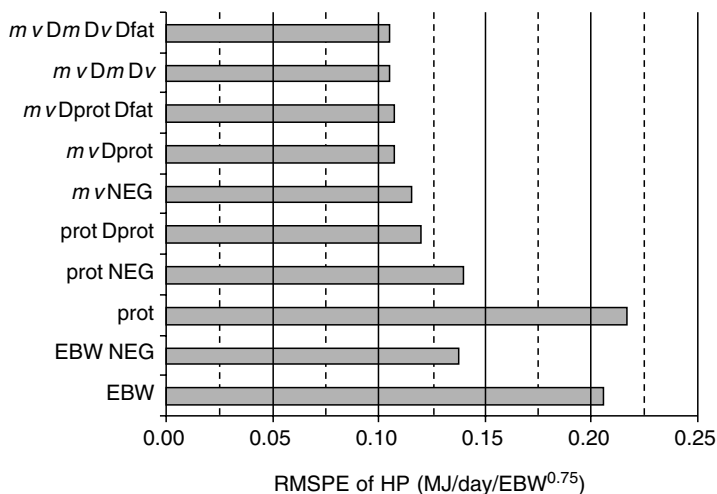

Fig. 15.14. Root mean square predicted error (RMSPE) of average daily heat production (HP) of rams (Ferrell *et al.*, 1986) using regression models with daily retained energy (RE or NEG), empty body weight (EBW) and EB and daily accretion (D) of muscle (*m*), viscera (*v*), fat and protein (prot).

$$HP = b_1 m + b_2 v + b_3 dm/dt + b_4 dv/dt$$

where b_1 and b_2 were 1.023 ± 0.333 and 10.54 ± 3.40 MJ/day/kg respectively, and b_3 and b_4 were 60.93 ± 13.80 and 282.7 ± 91.6 MJ/kg respectively (Oltjen and Sainz, 2001). The equation fitted the observed HP for rams (Ferrell *et al.*, 1986) in both periods (Fig. 15.15). HP per unit protein mass of viscera is

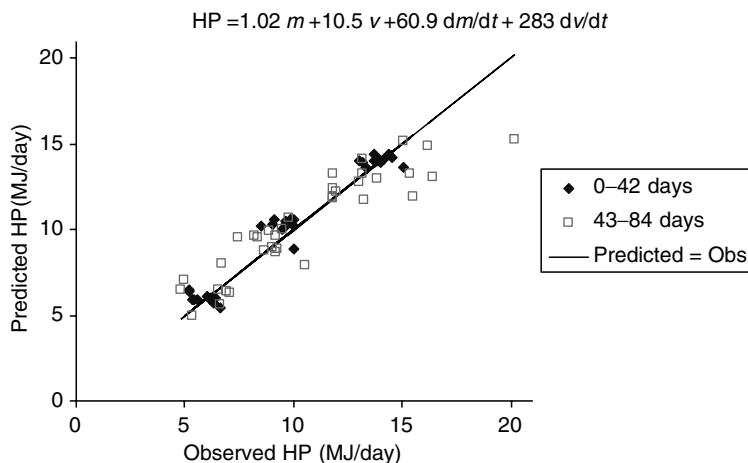

Fig. 15.15. Predicted and observed daily heat production (HP) for rams fed two 42-day periods (Ferrell *et al.*, 1986) using a regression model for muscle (*m*), viscera (*v*), and muscle and viscera daily gain.

about ten times that of muscle. Eisemann *et al.* (1996) found that oxygen consumption of liver plus portal-drained viscera of 450 kg steers was about 7.5 times that of hindquarter tissues on a per unit mass basis. Also, since viscera responds faster than muscle to changing energy intake by the animal, this equation results in more dynamic HP. In any case either traditional net energy concepts or more general functions for HP can be compared to choose the best functional description.

Conclusions

Sheep growth and composition is more accurately predicted with the revised model, and the model predicts EBW and fat content more accurately than the current feeding system (SCA, 1990). New additions refine predictions at levels of energy intake at or below maintenance. Limitations identified are imprecise parameter estimates due to lack of longitudinal data-sets. The model provides the structure for predicting composition of growing cattle as well, but has yet to be completely parameterized and tested.

References

- Ball, A.J. (1996) Changes in body composition and maintenance efficiency during periods of restricted and maintenance feeding in immature and mature sheep. PhD thesis, University of New England, Armidale, Australia.
- Bates, D.M. and Watts, D.G. (1988) *Nonlinear Regression Analysis*. John Wiley & Sons, New York.
- Corbett, J.L., Freer, M. and Graham, N.McC. (1987) A generalised equation to predict the varying maintenance metabolism of sheep and cattle. In: Moe, P.W., Tyrell, H.F. and Reynolds, P.J. (eds) *Energy Metabolism*. Rowman and Littlefield, New Jersey, pp. 62–65.
- Eisemann, J.H., Huntington, G.B. and Catherman, D.R. (1996) Patterns of nutrient interchange and oxygen use among portal-drained viscera, liver, and hindquarters of beef steers from 235 to 525 kg body weight. *Journal of Animal Science* 74, 1812–1831.
- Ferrell, C.L., Koong, L.J. and Nienaber, J.A. (1986) Effect of previous nutrition on body composition and maintenance energy costs of growing lambs. *British Journal of Nutrition* 56, 595–605.
- Haupt, R.L. and Haupt, S.E. (1998) *Practical Genetic Algorithms*. John Wiley & Sons, New York.
- Koong, L.J., Ferrell, C.L. and Nienaber, J.A. (1982) Effects of plane of nutrition on organ size and fasting heat production in swine and sheep. In *Energy Metabolism of Farm Animals*. European Association for Animal Production Publication 29. Agriculture University of Norway, Lillehammer, Norway, p. 245.
- NRC (2000) *Nutrient Requirements of Beef Cattle*, 7th rev. edn: Update 2000. National Academy Press, Washington, DC.
- Oltjen, J.W. and Sainz, R.D. (2001) Alternate forms for heat production in ruminant growth and composition models. In: Chwalibog, A. and Jakobsen, K. (eds)

- Energy Metabolism in Animals*. European Association for Animal Production Publication 103. Wageningen Press, Wageningen, The Netherlands, pp. 39–42.
- Oltjen, J.W., Bywater, A.C., Baldwin, R.L. and Garrett, W.N. (1986) Development of a dynamic model of beef cattle growth and composition. *Journal of Animal Science* 62, 86–97.
- Oltjen, J.W., Pleasants, A.B., Soboleva, T.K. and Oddy, V.H. (2000) Second-generation dynamic cattle growth and composition models. In: McNamara, J.P., France, J. and Beever, D.E. (eds) *Modelling Nutrient Utilization in Farm Animals*. CAB International, Wallingford, UK, pp. 197–209.
- Press, W.H., Flannery, B.P., Teukolsky, S.A. and Vetterling, W.T. (1989) *Numerical Recipes in Pascal*. Cambridge University Press, Cambridge, UK.
- SCA (Standing Committee on Agriculture) (1990) *Feeding Standards for Australian Livestock. Ruminants*. CSIRO, Melbourne, Australia.
- Soboleva, T.K., Oddy, V.H., Pleasants, A.B., Oltjen, J.W., Ball, A.J. and McCall, D.G. (1999) A dynamical model of body composition in sheep. *Proceedings of the New Zealand Society of Animal Production* 59, 275–278.
- Tanner, M.A. (1996) *Tools for Statistical Inference*, 3rd edn. Springer, New York.

16 Growth Patterns of Nellore vs British Beef Cattle Breeds Assessed Using a Dynamic, Mechanistic Model of Cattle Growth and Composition

R.D. SAINZ,¹ L.G. BARIONI,^{1,2} P.V. PAULINO,^{1,3}
S.C. VALADARES FILHO³ AND J.W. OLTJEN¹

¹Department of Animal Science, University of California, Davis, CA, 95616, USA; ²Embrapa Cerrados, Rodovia Brasília-Fortaleza BR 020 KM 18, Planaltina, DF 73301-970, Brazil; ³Departamento de Zootecnia, Universidade Federal de Viçosa, Av. P. H. Rolfs, s.n., Viçosa, MG 36571-000, Brazil

Abstract

The dynamic model of post-weaning growth and composition developed by Oltjen *et al.* (1986) was reparameterized using a data-set of seven experiments with a total of 119 Nellore bulls where dry matter intake (DMI), metabolizable energy (ME) concentrations of the diets, and initial and final empty body (EB) compositions were available. Running the model with the initial parameters (for British breed bulls) resulted in a slight underprediction of final EB protein mass but more serious errors (underpredictions) in body fat and energy, due to higher efficiency of energy utilization by the Nellore animals. An optimization routine was developed to enable parameter estimation, and the entire data-set was used to fit the model to the observed growth of body components. Fitting the protein deposition of the animals was possible either by: (i) decreased target DNA mass at maturity (DNAm_{max}) and simultaneously increased DNA accretion rate constant (k_1) and reduced protein degradation (DEG) rate constant (k_3); or (ii) fixing DNAm_{max} and fitting k_1 and k_3 . The maintenance energy coefficient (α) was fitted as well. The observed protein accretion curves could be due to higher rates of protein synthesis (SYN) or lower rates of protein DEG. The decreased maintenance requirement and data on post-mortem muscle metabolism in *Bos indicus* animals suggest that decreased DEG is the more likely hypothesis. Biologically, increased DNAm_{max} would imply a larger frame size in Nellore compared to British cattle, but this was not supported by the data or the literature, as Nellore animals reach maturity at a similar live weight (LW). Therefore, only k_1 , k_3 and α were allowed to change. Sensitivity analyses showed high non-linear correlations between these parameters, thus more detailed longitudinal data would be required to determine unique solutions. Best fit parameter estimates and insights from the model behaviour against field observations indicate that Nellore animals may have lower rates of DNA

accretion (k_1), confirming Nellore's reputation as a slower-maturing breed. This was accompanied by lower rates of protein DEG (k_3), and endogenous energy utilization (α). Therefore, these results indicate that an existing model of cattle growth, developed using data from *Bos taurus* breeds, is capable of simulating the growth and composition of Nellore cattle, as long as the parameters are adjusted accordingly. Parameter adjustments indicate that in comparison with their European counterparts, Nellore cattle are slower-maturing, have lower rates of protein turnover and lower endogenous energy expenditures.

Introduction

A recent study has concluded that human population growth, coupled with rising standards of living in developing countries, will result in a doubling in demand for animal products by 2020 (Delgado *et al.*, 1999). This will require greatly improved livestock productivity, particularly in the same developing countries. Among these, Brazil has the greatest potential to increase its production of beef and other animal products, due to available land, favourable climate and a large commercial cattle herd. In fact, the Brazilian cattle herd has been undergoing rapid expansion, increasing from 155 million in 1993 to 186 million in 2003 (FNP, 2004). At the same time, performance indices have also increased, with a turn-off of 17% in 1993 and 24% in 2003. These factors have helped Brazil to become the world's largest beef exporter in 2003.

Of the 191 million head of cattle in Brazil, about 80%, or over 150 million head, are zebu or *Bos indicus* breeds. The most important zebu breed is the Nellore, with over 100 million head. This breed has become the primary beef cattle breed in Brazil due to its adaptability to tropical conditions, including a hot and humid climate, endo- and ectoparasites, and periodic feed shortages. Despite its importance to the Brazilian livestock industry and global beef trade, there is a severe lack of quantitative nutritional data on the Nellore breed, especially in comparison with the abundance of information available regarding *Bos taurus* breeds in temperate countries. For example, the National Research Council (NRC, 2000) reviewed a wide range of data obtained with several zebu breeds and concluded that *Bos indicus* cattle have maintenance requirements 10% below those of *Bos taurus* beef breeds. Among the studies cited, however, none included animals of the Nellore breed. Recently, a collaborative study between Brazilian and US scientists (Tedeschi *et al.*, 2002) estimated maintenance energy requirements for Nellore bulls and steers that did not differ from those of *Bos taurus* cattle, or from each other.

This study was conducted with the following objectives: (i) to evaluate application of the Davis growth model (Oltjen *et al.*, 1986) for prediction of growth curves, body composition and energy retention of Nellore bulls; (ii) to compare energy requirements between *Bos indicus* and *Bos taurus*; and (iii) to develop a tool to aid in decision making for Nellore cattle management.

Materials and Methods

Individual animal data were obtained from seven experiments with a total of 119 growing Nellore bulls where DMI, ME concentrations of the diets, and initial and final EB compositions were available (Paulino, 1996, 2002; Véras, 2000; Martins, 2001; Silva, 2001; Backes, 2003; Freitas, 2004). These data were analysed using traditional regression techniques. For more detailed analyses, the dynamic, mechanistic model of cattle growth and body composition originally published by Oltjen *et al.* (1986) and updated by Oltjen and Sainz (1995) was used to simulate each individual animal in the data-set. The model's basic structure is repeated here for clarity. The model has three pools, corresponding to whole body DNA, protein and fat. The rates of accretion of DNA and protein are given as:

$$d\text{DNA}/dt(\text{g/day}) = k_1(\text{DNA}_{\text{max}} - \text{DNA})\text{NUT}_1$$

$$d\text{PROTEIN}/dt(\text{kg/day}) = \text{SYN} - \text{DEG}$$

$$\text{SYN} = k_2 \text{DNA}^{0.73} \text{NUT}_2$$

$$\text{DEG} = k_3 \text{PROTEIN}^{0.73}$$

where DNA_{max} is the target DNA mass at maturity, k_1 is the DNA accretion rate constant, k_2 is the protein SYN rate constant, k_3 is the protein DEG rate constant, and NUT_1 and NUT_2 are functions of ME intake (MEI). The deposition of fat is calculated from the net energy for gain (NEg) available after accounting for the energy costs for maintenance (MAINT) and protein deposition, using NRC (1984) equations to convert ME to NE, and for estimation of maintenance from EB weight (EBW):

$$\text{MAINT} = \alpha \text{EBW}^{0.75}$$

The Nellore data, including initial body and component weights, MEI and days on feed were simulated using the parameter set for *Bos taurus* bulls. Then, the model was fitted to the data using a commercial implementation of the Generalized Reduced Gradient method (Lasdon *et al.*, 1978; Frontline Systems, 1999). The optimization algorithm was set to minimize the error sum of squares of body protein plus the error sum of squares of body energy, weighted according to the respective experimental variances. Asymptotic standard deviations (SDs) were estimated for each parameter using the inverse of the Hessian matrix as described by France and Thornley (1984). The mean square prediction error (MSPE) was calculated for each model output (final body protein, fat and energy) as:

$$\text{MSPE} = \sum_i (Y - \hat{Y})^2 / n$$

where Y and \hat{Y} are the observed and predicted responses, respectively, i is the individual animal, and n is the number of observations. The root of MSPE (RMSPE) is presented to maintain consistency of units.

Results and Discussion

The aggregated data-set is summarized in Table 16.1. There was substantial variation in all the values, such as initial weights, intakes, diet qualities, and initial and final body compositions. The raw data were subjected to a traditional regression analysis (Fig. 16.1).

The regression equation relating retained energy (RE) to MEI was:

$$RE = -0.041 + 0.3827 \text{ MEI} \quad R^2 = 0.64$$

Rearranging and solving for $RE = 0$, ME requirement for maintenance (ME_{maint}) = 0.107 Mcal/kg^{0.75}/day. Assuming a net efficiency for maintenance (K_m or NE_m/ME) of 0.64 (expected value for the mean diet ME content of 2.43 Mcal/kg DM), a 10% reduction for *Bos indicus* cattle, and a 15% increase for intact bulls, the ME_{maint} requirement proposed by the NRC (2000) would be:

$$0.077 \text{ Mcal} NE_m / \text{kg}^{0.75} * 0.90 * 1.15 / 0.64 = 0.124 \text{ Mcal} ME / \text{kg}^{0.75} / \text{day}$$

Therefore, the data shown in Fig. 16.1 suggest that the NRC (2000) overestimates the maintenance energy requirements of Nellore bulls by about 15%. This is in agreement with the conclusions of Tedeschi *et al.* (2002), who found no differences in ME_{maint} between Nellore bulls and steers. On the other hand, these authors also found no difference between the maintenance energy requirements between Nellore and *Bos taurus* cattle, a result at odds with those here and elsewhere in the literature (i.e. NRC, 2000).

Table 16.1. Observed intakes, initial and final values and gains of weight, protein, fat and energy of Nellore bulls in seven feeding trials (total $n = 119$).

Observation ^a	Mean	Standard deviation (sd)	Minimum	Maximum
Initial LW (kg)	313	56.7	161	433
Final LW (kg)	409	66.9	234	518
Days on feed	105	43.8	33	215
Diet ME (Mcal/kg DM)	2.43	0.34	1.63	2.96
DMI (kg/day)	7.85	1.99	3.07	11.90
ADG (kg/day)	0.956	0.389	-0.030	1.725
Gain:feed	0.119	0.040	-0.007	0.203
Initial body protein (kg)	52.8	10.8	26.2	74.9
Initial body fat (kg)	36.1	13.9	10.3	66.2
Initial body energy (Mcal)	633	159	323	1026
Final body protein (kg)	66.3	10.7	36.7	90.3
Final body fat (kg)	72.8	25.0	21.6	133.8
Final body energy (Mcal)	1053	277	432	1698
MEI (kcal/kg ^{0.75} /day)	254	51.5	140	352
RE (kcal/kg ^{0.75} /day)	55.8	24.7	0.0	103.0

^aLW = live weight; DMI = dry matter intake; ADG = average daily gain; MEI = metabolizable energy intake; RE = retained energy.

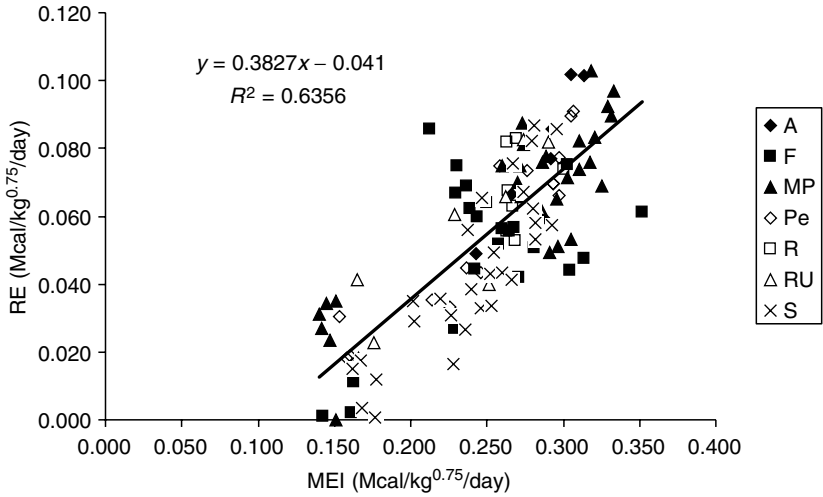

Fig. 16.1. Retained energy (RE) and metabolizable energy intake (MEI) by growing Nellore bulls. Data sources: A, Backes (2003); F, Silva (2001); MP, Paulino (1996); Pe, Paulino (2002); R, Martins (2001); RU, Freitas (2004); S, Vêras (2000).

Next, individual animal data were simulated using the Davis growth model, originally published by Oltjen *et al.* (1986). Model parameters were selected to represent the growth of intact reference (i.e. *Bos taurus*) males. The model reproduced the deposition of body protein quite well (Fig. 16.2), with a deviation of the slope from unity of -0.0235 and an R^2 of 0.57 . These values were strongly affected by a single outlier below the line. Deposition of body fat (Fig. 16.3) and body energy (Fig. 16.4), on the other hand, were significantly underpredicted by the model, with deviations of the slopes from unity of -0.1887 and -0.128 respectively. The model first predicts accretion of DNA, then protein (as the difference between SYN and DEG), and finally fat (as the storage of energy available after accounting for the requirements for maintenance and protein gain). Therefore, errors in accounting for energy utilization are accumulated in the estimate of energy retention, and consequently fat gain.

The data were then used to reparameterize the model. Specifically, the parameters for rates of k_1 , k_3 , DNAmx and α were studied. Because protein gain reflects the difference between SYN and DEG, either k_2 or k_3 could have been fitted, but due to the high correlation between them (Oltjen *et al.*, 1986) only one was selected. The reasons for selecting k_3 are given below. Table 16.2 contains the original parameters, as well as the fitted parameter values. Although DNAmx is a reflection of mature body weight, because of the form of the equations, actual mature body protein mass is determined by DNAmx, k_2 (SYN) and k_3 . Although the fitted value of DNAmx was lower than the reference bull, the lower value of k_3 maintained mature body

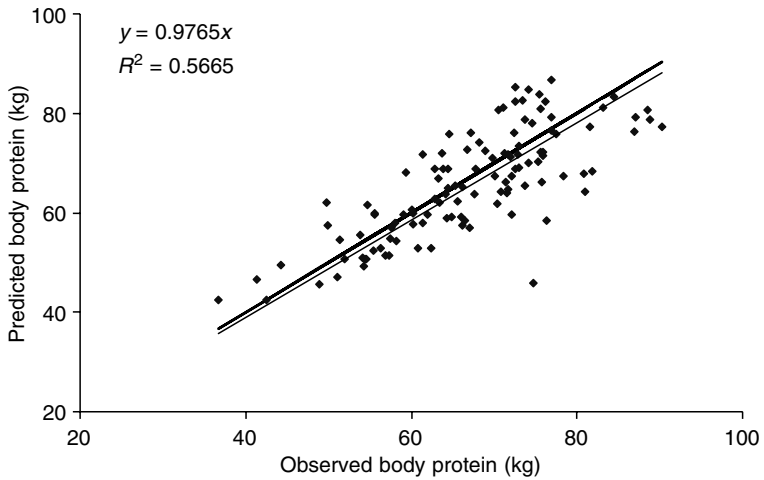

Fig. 16.2. Observed and predicted values for body protein – original model (*Bos taurus* reference bull). The thicker line is the line of unity ($y = x$).

protein mass at a similar level (103 kg). It should be noted that this is beyond the range of the data, so that estimates of mature size must be considered questionable. In the absence of evidence to the contrary, the authors believe the mature sizes of the genotypes to be similar. Therefore, the model was fitted to the data, maintaining a constant DNAm_{ax} in order to avoid problems of co-linearity between DNAm_{ax} and k_1 .

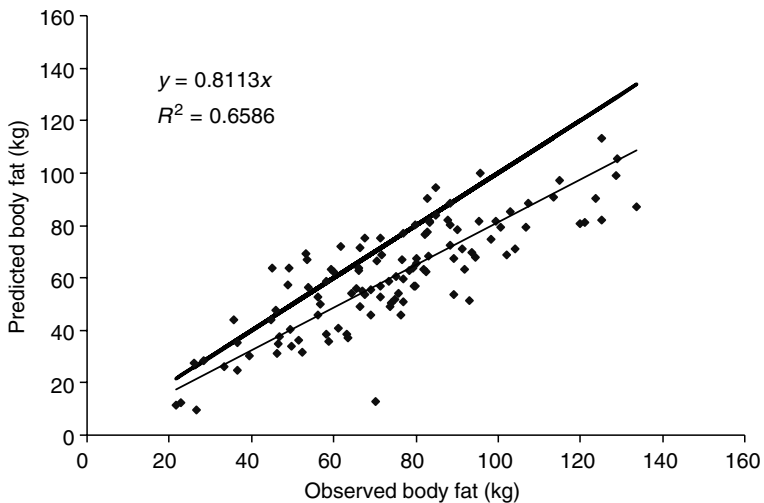

Fig. 16.3. Observed and predicted values for body fat – original model (*Bos taurus* reference bull). The thicker line is the line of unity ($y = x$).

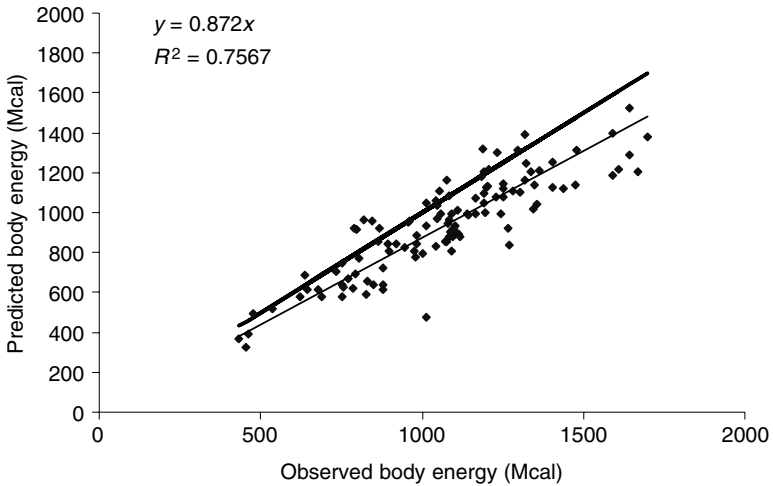

Fig. 16.4. Observed and predicted values for body energy – original model (*Bos taurus* reference bull).

The reparameterized model had improved predictions of body protein (Fig. 16.5; bias = + 0.0111), body fat (Fig. 16.6; bias = -0.0329) and body energy (Fig. 16.7; bias = -0.0212) relative to the reference model. The new parameters are also given in Table 16.2. This fit resulted in lower values for k_1 (-25.5%), k_3 (-9.1%) and α (-21.9%). Moreover, small asymptotic SDs of

Table 16.2. Results of least squared fitting of Nellore growth and composition data to the Davis growth model.

Parameters fitted	Parameters ^a					RMSPE ^b		
	k_1	k_2	k_3	DNAmax	α	Protein	Fat	RE ^c
Reference <i>Bos taurus</i> bull	0.00408	0.0479	0.143	462	0.0983	7.07	19.04	182.45
k_1, k_3, α	0.00416	0.0479	0.130	408	0.0769	5.69	14.16	135.51
DNAmax, α	(0.00009)		(0.0002)	(3.28)	(0.0133)			
Percentage of change	+2.0%		-9.1%	-11.7%	-21.8%			
k_1, k_3, α	0.00304	0.0479	0.130	462	0.0768	5.71	14.16	135.34
	(0.00004)		(0.0002)		(0.0119)			
Percentage of change	-25.5%		-9.1%		-21.9%			

^a k_1 = the rate constant for DNA accretion; k_2 = the rate constant for protein synthesis (SYN); k_3 = the rate constant for protein degradation (DEG); DNAmax = the maximum amount of whole body DNA; α = the maintenance energy coefficient; asymptotic standard errors in parentheses.

^bRMSPE = root mean squared prediction error; MSPE = Σ (predicted - observed)².

^cRE = retained energy.

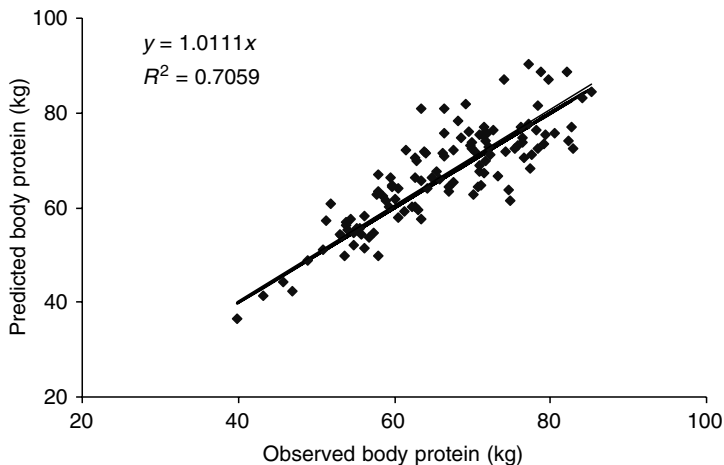

Fig. 16.5. Observed and predicted values for body protein – modified model (*Bos indicus* bull). The thicker line is the line of unity ($y = x$).

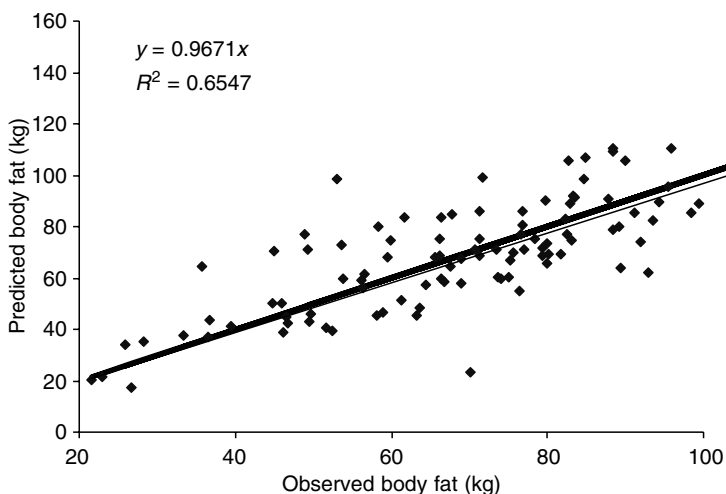

Fig. 16.6. Observed and predicted values for body fat – modified model (*Bos indicus* bull). The thicker line is the line of unity ($y = x$).

these parameters, coupled with sensitivity analyses (not shown), indicate that this data-set was capable of identifying several key parameters of the model, as long as others (i.e. DNAm_{max}) were fixed. Therefore, this fitted model was provisionally accepted for simulation of growth of Nellore bulls, pending further evaluations with an independent data-set.

The main value in mechanistic models such as this is their utility in extending the biological interpretation of data. The changes in the DNA

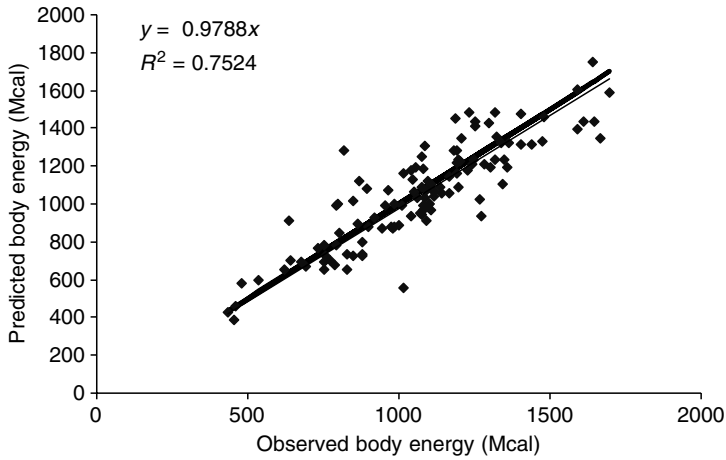

Fig. 16.7. Observed and predicted values for body energy – modified model (*Bos indicus* bull). The thicker line is the line of unity ($y = x$).

accretion curve indicate that Nellore cattle tend to be of similar mature size to medium-frame *Bos taurus* breeds, but the lower value of k_1 suggests that they are slower-maturing than their European counterparts. This is in agreement with the weight of evidence showing that zebu breeds mature more slowly. In Brazil, the average age at first calving is still above 36 months. The lower values of k_3 and α are also consistent with the literature. As stated above, the NRC (2000) proposes a 10% reduction in maintenance energy requirement for *Bos indicus* breeds, in agreement with the present results. Since protein accretion represents the difference between the rates of SYN and DEG, only one of these may be estimated from the data. In view of the reduced maintenance energy coefficient, and considering other data such as slower rates of post-mortem proteolysis (leading to tougher meat, incidentally), it seemed more realistic to fit k_3 rather than k_2 . Since protein turnover is known to be a major contributor to endogenous energy expenditures (Baldwin and Sainz, 1995), the simultaneous reduction in k_3 and α makes excellent biological sense.

Conclusions

The results indicate that an existing model of cattle growth, developed using data from *Bos taurus* breeds, is capable of simulating the growth and composition of Nellore cattle, as long as the parameters are adjusted accordingly. Parameter adjustments indicate that in comparison with their European counterparts, Nellore cattle are slower-maturing, have lower rates of protein turnover and lower endogenous energy expenditures. These conclusions must still be tested empirically, but this modelling exercise demonstrates

how the use of a mechanistic model, even a simple one, can yield insight into underlying biology.

Acknowledgement

Support for L.G. Barioni and P.V. Paulino from the Coordenação de Aperfeiçoamento de Pessoal de Nível Superior (CAPES) of the Brazilian government is gratefully acknowledged.

References

- Backes, A.A. (2003) Composição corporal e exigências de energia, proteína e macroelementos minerais, para bovinos mestiços leiteiros e Zebu, castrados, em fase de recria e engorda, em confinamento. PhD thesis, Universidade Federal de Viçosa, Brazil.
- Baldwin, R.L. and Sainz, R.D. (1995) Energy partitioning and modeling in animal nutrition. *Annual Reviews in Nutrition* 15, 191–211.
- Delgado, C., Rosegrant, M., Steinfeld, H., Ehui, S. and Courbois, C. (1999) *Livestock to 2020: The Next Food Revolution*. 2020 Vision Initiative Food, Agriculture, and the Environment Discussion Paper 28. IFPRI, FAO and ILRI. International Food Policy Research Institute, Washington, DC.
- France, J. and Thornley, J.H.M. (1984) *Mathematical Models in Agriculture*. Butterworths, London.
- Freitas, J.A.S. (2004) Exigências nutricionais de energia e proteína e eficiência líquida de utilização da energia metabolizável para bovinos de diferentes grupos genéticos, em confinamento. PhD thesis, Universidade Federal de Viçosa, Brazil.
- Frontline Systems (1999) *Solver User's Guide: Dynamic Link Library*. Frontline Systems, Incline Village, California.
- FNP (2004) *Anualpec 2004. Anuário da Pecuária Brasileira*. FNP Consultoria e Comércio, São Paulo, Brazil.
- Lasdon, L., Waremn, A., Jain, A. and Ratner, M. (1978) Design and testing of a generalized reduced gradient code for nonlinear programming. *ACM Transactions on Mathematical Software* 4, 34–50.
- Martins, R.G.R. (2001) Exigências de energia, proteína e macroelementos minerais (Ca, P, Na, K, Mg) de bovinos Nellore e mestiços, não-castrados, em confinamento. PhD thesis, Universidade Federal de Viçosa, Brazil.
- NRC (National Research Council) (1984) *Nutrient Requirements of Beef Cattle*, 6th edn. National Academy Press, Washington, DC.
- NRC (National Research Council) (2000) *Nutrient Requirements of Beef Cattle*, 7th rev. edn. National Academy Press, Washington, DC.
- Oltjen, J.W. and Sainz, R.D. (1995) Mechanistic, dynamic models of growth. In: Baldwin, R.L. (ed.) *Modelling Ruminant Digestion and Metabolism*. Chapman & Hall Scientific, London, pp. 441–468.
- Oltjen, J.W., Bywater, A.C., Baldwin, R.L. and Garrett, W.N. (1986) Development of a dynamic model of beef cattle growth and composition. *Journal of Animal Science* 62, 86–97.
- Paulino, M.F. (1996) Composição corporal e exigências de energia, proteína e macroelementos minerais (Ca, P, Mg, Na e K) de bovinos não-castrados de

- quatro raças zebuínas em confinamento. PhD thesis, Universidade Federal de Viçosa, Brazil.
- Paulino, P.V.R. (2002) Exigencias nutricionais e validação da seção HH para predição da composição corporal de zebrinos. MSc thesis, Universidade Federal de Viçosa, Brazil.
- Silva, F.F. (2001) Desempenho, características de carcaça, composição corporal e exigências nutricionais (energia, proteína, aminoácidos e macrominerais) de novilhos Nellore, nas fases de recria e engorda, recebendo diferentes níveis de concentrado e proteína. PhD thesis, Universidade Federal de Viçosa, Brazil.
- Tedeschi, L.O., Boin, C., Fox, D.G., Leme, P.R., Alleoni, G.F. and Lanna, D.P.D. (2002) Energy requirement for maintenance and growth of Nellore bulls and steers fed high-forage diets. *Journal of Animal Science* 80, 1671–1682.
- Véras, A.S.C. (2000) Consumo, digestibilidade, composição corporal e exigências nutricionais de bovinos Nellore alimentados com rações contendo diferentes níveis de concentrado. PhD thesis, Universidade Federal de Viçosa, Brazil.

17 A Kinetic Model of Phosphorus Metabolism in Growing Sheep

R. SOUZA DIAS, A.P. ROQUE, V.F. NASCIMENTO FILHO,
D.M.S.S.VITTI AND I.C.S. BUENO

*Animal Nutrition Laboratory, Center for Nuclear Energy in Agriculture,
PO Box 96, CEP 13400-970, Piracicaba, São Paulo, Brazil*

Abstract

Research in Brazil has been carried out to study phosphorus (P) metabolism in ruminants, by using the isotope dilution technique. The purpose of this study was to use data from balance and kinetic experiments to solve a kinetic model of P metabolism in growing sheep fed with different diets. During a 28-day period, 16 Brazilian-bred male sheep received rations containing different sources of calcium (Ca). The sources were limestone, lucerne hay, citrus pulp and oyster shell meal (L, LH, CP and OSM, respectively). After 3 weeks the animals were housed in metabolism cages and each animal was intravenously injected with 7.4 MBq of ^{32}P into the left jugular vein. Blood samples, faeces and urine were taken at 24 h intervals for analyses of P and detection of radioactivity. At the end of collection period tissue samples were collected (liver, heart, kidney, muscles and 12th rib) for analyses. Experimental measurements (model inputs) and model outputs were analysed as a completely randomized design. A comparison of means between treatments was carried out using the GLM procedure of SAS. The average P intake was 3.21, 4.16, 4.21 and 4.36 g/day for L, LH, CP and OSM, respectively ($P < 0.05$). Plasma P concentration had high values for all treatments: 10.23, 9.83, 8.41 and 9.45 mg/100 ml for L, LH, CP and OSM, respectively ($P > 0.05$). P excretion in faeces was similar for all treatments (3.57, 5.15, 4.65 and 3.71 g/day); however, P excretion in urine showed differences between treatments: 0.18, 0.02, 0.03 and 0.23 g/day for L, LH, CP and OSM, respectively ($P < 0.05$). P in blood, bone and soft tissue did not show differences between treatments. It was concluded that daily P supply was not adequate for growing lambs, resulting in negative balance of P in the majority of the animals.

Introduction

The understanding of how dietary P is controlled is an important step in determining adequate dietary P supply and to clarify the regulation of homeostasis in ruminants. It is not clear whether P homeostasis is achieved through control of P absorption, salivary P, excretion of P in urine or a combination of all factors (Challa *et al.*, 1989).

P excreted in faeces represents the most important factor controlling P homeostasis. Urinary loss of P in ruminants is generally very low but also plays a role in P homeostasis (Field *et al.*, 1983), mainly when the excretion of P through saliva is limited. The balance between the endogenous faecal and urinary routes for P excretion needs detailed investigation. Endogenous faecal P losses result almost completely from unabsorbed salivary P. Reabsorption of P from bone is also part of P homeostasis, and is related to Ca present in bone, the hormone 1,25 di-hydroxycholecalciferol, which is a metabolite of vitamin D₃, and the parathyroid hormone.

From all the essential minerals studied in animal nutrition, P represents an important potential risk when it is released to the environment in excessive amounts (Van Horn *et al.*, 1994; Tamminga, 1996). Therefore, the precise and efficient handling of the nutrient offered in the diet is crucial to optimize the performance of the animal and minimize the excretion of P.

The elimination of excess P in faeces occurs mainly due to intake of non-available P present in food, and great variations related to the requirement of P, which differ from country to country (Tamminga, 1992). As the metabolism of P and its excretion through faeces are regulated, especially by the ingestion of P (Morse *et al.*, 1992), the easiest way to reduce its losses is through the reduction of P in the concentrate part of the diet. The nutritional demands related to P must be re-evaluated (Van Horn *et al.*, 1994), because some studies have shown that the supply of P in lower levels than the ones recommended by certain institutions has not caused any harm to the performance of the animals, but substantially reduced the excretion of P.

The availability of information and knowledge generated in the wide range of science has allowed researchers to simulate and develop mathematical models that can be adjusted to the biological phenomena, physical or chemical, which occur in the natural systems, with results that can be transferred to the population group. Many researchers apply the mathematical models using results collected from experiments carried out with ³²P to study the kinetics of P in ruminants (Grace, 1981; Schneider *et al.*, 1985; Vitti *et al.*, 2000) and in non-ruminants (Moreira *et al.*, 2004). The model proposed by Vitti *et al.* (2000) separates bones and soft tissues into two distinct compartments (Fig. 17.1). In this model, the input of P to the system is accomplished through diet, and the output through faeces and urine. In this scheme it is assumed that there is no return of P marked from external sources.

Apart from the studies conducted to understand P metabolism in ruminants, little is known, for example, about the blood and soft tissue pools of the body and their rates of P inflow and outflow in ruminants. Research and development of models of nutrient metabolism is an important tool that will help to answer questions on utilization of a nutrient by the animal.

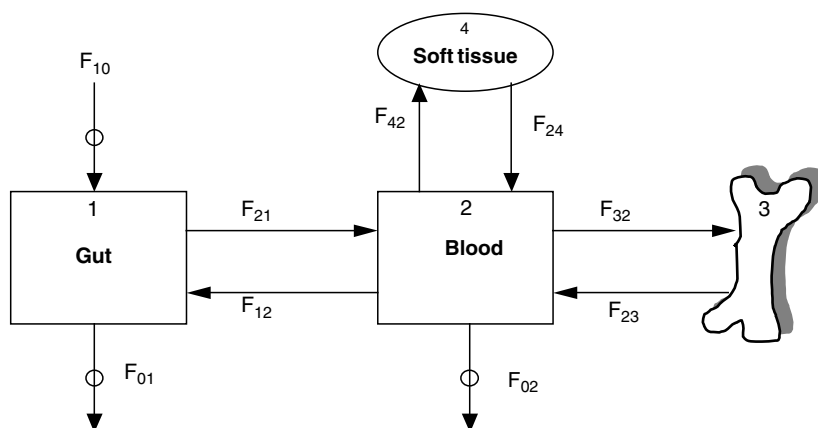

Fig. 17.1. Scheme of the model of distribution of phosphorus (P) in the animal body. (After Vitti *et al.*, 2000.)

Material and Methods

The Model

Kinetics of P was evaluated through the model proposed by Vitti *et al.* (2000) to explain P metabolism in growing goats. The model contains four P pools: (i) gut lumen; (ii) blood; (iii) bone; and (iv) soft tissue. The flow of P between pools and into and out of the system is shown in Fig. 17.1. Flows in the gut, bone and soft tissue pools are represented by F_{21} and F_{12} , F_{23} and F_{32} , and F_{24} and F_{42} , respectively (Fig. 17.1).

According to this model, the input of P to the blood pool is through absorption of fractions from dietary P and endogenous P, starting from the digestive tract (F_{21}), as well as from the P reabsorbed from the bone and soft tissues (F_{23} and F_{24}). The excretion involves the secretions of the digestive juice (F_{12}), P excreted in faeces (F_{01}) and in urine (F_{02}), and P incorporated in bones and soft tissues (F_{32} and F_{42}).

Experimental procedure

Animal and diets

Sixteen Brazilian-bred male sheep, 8 months old, averaging 31.6 kg were housed in metabolism cages, designed for isotope studies, located in the Centre of Nuclear Energy in Agriculture (CENA), University of São Paulo, Brazil. The animals received a diet based on hydrolysed sugarcane bagasse and supplemented with limestone (L), lucerne hay (LH), citrus pulp (CP)

Table 17.1. Ingredients of the diet fed to sheep containing different sources of calcium (Ca).

Ingredients (g/kg DM)	Treatments ^a			
	L	LH	CP	OSM
Soybean	150	–	150	140
Maize	400	400	140	395
Bagasse	420	138	394	433
Limestone	13	–	–	–
Lucerne hay	–	450	–	–
Citrus pulp	–	–	300	–
Oyster shell meal	–	–	–	12
Mineral mixture ^b	5	5	5	5
Urea	7	5	6	7

^aL = limestone; LH = lucerne hay; CP = citrus pulp; OSM = oyster shell meal.

^bComposition: Ca 0.03%, Mg 1.0%, S 7%, Na 14.5%, Cl 21.86%, Cu 300ppm, Mn 1100ppm, Zn 4600ppm, Fe 500ppm, I 80ppm, Co 40ppm, and Se 15ppm.

or oyster shell meal (OSM) (Table 17.1) for 21 days. Feed was given twice a day, at 8:00 and 17:00 h.

Radioactive P ($\text{Na}_2\text{H}^{32}\text{PO}_4$) was bought from Instituto de Pesquisas Energéticas e Nucleares (IPEN), São Paulo, Brazil. A dose of 7.4 MBq of ^{32}P was injected into the jugular vein in the morning before feeding the animals, and blood samples were withdrawn from the jugular at 24 h intervals for 7 days. During this period, P balance measurements were made. Urine was collected daily in a vessel containing 12 N HCl and the total volume was measured. Faeces were collected daily and total excretion was weighed.

Samples analyses

Samples of feed and feed refusal were analysed for dry matter (DM), crude protein (CD), P, Ca, neutral detergent fibre (NDF) and acid detergent fibre (ADF) following the recommendations of the Association of Official Analytical Chemists (1980; Table 17.2).

P content was determined by colorimetry (Sarruge and Haag, 1974) and Ca by spectrometry of atomic absorption (Zagatto *et al.*, 1979). Blood samples were centrifuged and plasma was separated. After protein precipitation (1 ml plasma and 9 ml TCA 100 g/l) inorganic P was determined by the method of Fiske and Subbarow (1925). Urine samples (30 ml) were collected every day and dissolved in 12 N HCl, dried (55°C) and ashed (500°C). Total P was determined using vanadate–molybdate reagents (Sarruge and Haag, 1974). Faecal samples were dried at 100°C, ashed at 500°C and the ash was dissolved in 5 ml of 2 N HCL.

Measurement of radioactivity

Radioactivity was measured in a liquid scintillation counting, and correction for quench (Horrocks and Peng, 1971) and decay were made by the external

Table 17.2. Proximal analysis of diets given to sheep fed with different sources of calcium.

Ingredients (g/kg DM)	Treatments ^a				
	P	Ca	ADF	NDF	CP
Soybean	0.73	0.28	12.19	19.11	51.16
Maize	0.25	0.03	4.55	47.67	8.96
Lucerne hay	0.39	1.15	29.47	40.92	23.08
Bagasse	0.05	0.09	54.35	58.85	1.95
Citrus pulp	0.12	1.55	28.86	23.78	7.46
Oyster shell meal	0.05	41.10	–	–	–
Limestone	0.01	38.60	–	–	–
Monoammonium phosphate	2.45	0.45	–	–	–
Mineral mixture ^b	0	0.13	–	–	–

^aP = phosphorus; Ca = calcium; ADF = acid detergent fibre; NDF = neutral detergent fibre; CP = crude protein.

^bComposition: Ca 0.03%, Mg 1.0%, S 7%, Na 14.5%, Cl 21.86%, Cu 300ppm, Mn 1100ppm, Zn 4600ppm, Fe 500ppm, I 80ppm, Co 40ppm, and Se 15ppm.

standard technique (external source channels ratio methods; Nascimento Filho, 1977). Samples of plasma (1 ml), urine (1 ml) and solution of ashed faeces in HCl (1 ml) were counted in 10 ml of a scintillation solution.

Statistical analyses

Experimental measurements (model inputs and outputs) were analysed as a completely randomized design. The GLM procedure (SAS, 1991) was used for comparison of means from each category with sources of variation being treatments (Ca source).

Results

The results of daily P intake and excretion, P in bone, blood and tissues are summarized in Table 17.3. The values are the means of the treatments according to the sources of Ca. All treatments supplied adequate amounts of P according to NRC (1985). P intake was 3.21, 4.16, 4.21 and 4.36 g/day for L, LH, CP and OSM, respectively ($P > 0.05$). Urinary loss of P presented significant differences between treatments. Animals from L excreted 0.32 g/day whereas animals from treatment LH and CP excreted 0.02 and 0.03 g/day respectively ($P < 0.05$). Animals from OSM excreted higher values of P in urine than animals from LH and CP ($P > 0.05$). The retention of P was negative for treatments L, LH and CP (−0.48, −0.95 and −1.00 g/day, respectively) and at the lower end of positive retention for treatment OSM, at 0.06 g/day ($P > 0.05$).

Total P excreted in faeces decreased with P retained, and there was a significant linear relationship between these flows (P faeces = 3.82 − 1.03 P

Table 17.3. Phosphorus (P) intake (g/day), in faeces (g/day), urine (g/day), blood (g), bone (g) and in soft tissue (g). The values shown are mean values for each treatment.

Item	Symbol ^b	Treatments ^a				SEM ^c
		L	LH	CP	OSM	
Intake	F ₁₀	2.82	4.15	4.09	4.02	0.50
Faeces	F ₀₁	3.57	5.15	4.65	3.71	1.03
Urine	F ₀₂	0.18 ^{xy}	0.02 ^x	0.03 ^{xy}	0.23 ^y	0.05
Blood P	Q ₂ ^d	0.11	0.14	0.11	0.12	0.019
Bone P	Q ₃	123	145	124	116	20.84
Soft tissue P	Q ₄	15.8 ^{xy}	19.9 ^x	16.3 ^{xy}	12.1 ^y	2.09

^aL = limestone; LH = lucerne hay; CP = citrus pulp; OSM = oyster shell meal.

^bSymbols are according to Fig. 17.1.

^cSEM = standard error of the mean.

^dQ = total quantity of P in pool (g).

^{x,y}Means within row and treatment category with different superscripts differ ($P < 0.05$).

retained; $n = 16$; $R^2 = 0.59$). Total endogenous losses were 1.69, 2.51, 2.34 and 1.46 g/day and represented 50.61, 45.54, 44.22 and 36.86% of total faecal P excreted for treatments L, LH, CP and OSM, respectively ($P > 0.05$). Truly absorbed P was 41.41, 36.48, 32.63 and 40.07% for L, LH, CP and OSM, respectively ($P > 0.05$). P contents in blood (10.23, 9.82, 8.41 and 9.45 mg/dl) and bone (123, 145, 124 and 116 g) for L, LH, CP and OSM, respectively, were not affected by treatments while P content in soft tissue was significantly different between treatments LH (15.8 g) and OSM (12.1 g) ($P < 0.05$) (Table 17.3).

According to the model output (Table 17.4) the P balances between the digestive tract and blood was negative for L (-0.75 g), LH (-1.00 g) and CP (-0.55 g), and positive for OSM (0.31 g). P balance in bone was negative for

Table 17.4. Comparison of kinetic outputs for the different sources of calcium (Ca). The values shown are mean values for each treatment.

Model outputs (g/day)	Symbol ^b	Treatments ^a				SEM ^c
		L	LH	CP	OSM	
P from blood to gut	F ₁₂	2.12	4.33	2.11	2.12	0.65
P from gut to blood	F ₂₁	1.37	3.33	1.56	2.43	0.74
P from blood to bone	F ₃₂	1.56	3.29	2.74	2.06	0.76
P from blood to soft tissue	F ₄₂	0.69	0.80	1.31	1.39	0.39
P from bone to blood	F ₂₃	2.82	4.51	4.09	3.05	0.94
P from soft tissue to blood	F ₂₄	0.36	0.61	0.56	0.32	0.12

^aL = limestone; LH = lucerne hay; CP = citrus pulp; OSM = oyster shell meal.

^bSymbols are according to Fig. 17.1.

^cSEM = standard error of the mean.

all treatments. The amount of P mobilized from blood to bone in relation to total P absorbed (F_{32}/F_{21}) was lower for OSM (1.14, 0.99, 1.79 and 0.85 g/day for L, LH, CP and OSM, respectively). P mobilized from tissue to blood related to P absorbed (F_{24}/F_{21}) was 0.26, 0.18, 0.36 and 0.13 g/day for L, LH, CP and OSM, respectively.

Discussion

P intake was lower for animals supplied with limestone, and this could be related to palatability. Urinary losses of P by ruminants are generally low, but considerable variation is found between animals (Manston and Vaag, 1970; Field *et al.*, 1984). The physical form of the diet can affect the pathway of P excretion (Scott *et al.*, 1984). In the present work, treatments that stimulate salivary secretion (LH and CP) resulted in higher values of endogenous faecal P and lower values of urinary P excretion. Scott and Buchan (1985) compared the effects of feeding either roughage or concentrate diets on salivary secretion and urinary P excretion in sheep, and observed that animals which ingested roughage secreted more saliva and excreted less P in urine. Differences in P excretion through urine may also be due to the saturation in the capacity of salivary glands to clear the P plasma, which was high.

Endogenous faecal P losses represented a mean value of 44% of total P excreted in faeces. This value is lower than 66% of total faecal P in cattle and sheep (Coates and Ternouth, 1992; Bortolussi *et al.*, 1996) and could be related to the low P availability in the different feeds. P true absorption was considered low for all treatments and this could be due to the form of P present in the diet, mainly as organic P (phytate). The negative values for P retention suggest that animals were not receiving adequate amounts of the element. Another factor that resulted in a negative retention of P was the low P absorption. The high P demand of the animals in the experiment, growing sheep in this case, could also have caused the negative values for P retention. Similar results are reported by Vitti *et al.* (2000) with growing goats.

Conclusions

Although all treatments have supplied adequate amounts of P, the low absorption led to negative balances and negative retention. The low P availability could be related to the presence of phytate, which was the main source of P. We suggest that further study should be carried out to investigate P availability from organic sources.

References

- Association of Official Analytical Chemists (1980) *Official Methods of the Analysis of the Association of Official Analytical Chemists*, 13th edn. Washington, DC.

- Bortolussi, G., Ternouth, J.H. and McMeniman, N.P. (1996) Dietary nitrogen and phosphorus depletion in cattle and their effects on live weight gain, blood metabolite concentrations and phosphorus kinetics. *Journal of Agricultural Science* 126, 493–501.
- Challa, J., Braithwaite, G.D. and Dhanoa, M.S. (1989) Phosphorus homeostasis in growing calves. *Journal of Agricultural Science* 112, 217–226.
- Coates, D.B. and Ternouth, J.H. (1992) Phosphorus kinetics of cattle grazing tropical pastures and implications for the estimation of their phosphorus requirements. *Journal of Agricultural Science* 119, 401–409.
- Field, A.C., Kamphues, J. and Woolliams, J.A. (1983) The effect of dietary intake of calcium and phosphorus on the absorption and excretion of phosphorus in chimaera-derived sheep. *Journal of Agricultural Science* 101, 597–602.
- Field, A.C., Woolliams, J.A., Dingwall, R.A. and Munro, C.S. (1984) Animal and dietary variation in the absorption and metabolism of phosphorus by sheep. *Journal of Agricultural Science* 103, 283–291.
- Fiske, C.H. and Subbarow, Y. (1925) The colorimetric determination of phosphorus. *Journal of Biological Chemistry* 66, 375–400.
- Grace, N.D. (1981) Phosphorus kinetics in sheep. *British Journal of Nutrition* 45, 367–374.
- Horrocks, B.F. and Peng, C.T. (1971) *Organic Scintillators and Liquid Scintillation Counting*. Academic Press, New York.
- Manston, R. and Vagg, M.G. (1970) Urinary phosphate excretion in dairy cows. *Journal of Agricultural Science* 74, 161–167.
- Moreira, J.A., Vitti, D.M.S.S., Lopes, J.B. and Trindade Neto, M.A. (2004) Cinética do fósforo em tecidos de suínos alimentados com dietas contendo enzima fitase. *Arquivo Brasileiro de Medicina Veterinária e Zootecnia* 56, 74–80.
- Morse, D., Head, H.H., Wilcox, C.J., Van Horn, H.H., Hissem, C.D. and Harris, B. Jr (1992) Effects of concentration of dietary phosphorus on amount and route of excretion. *Journal of Dairy Science* 75, 3039–3049.
- Nascimento Filho, V.F. (1977) *Métodos de determinação de eficiência de detecção em cintilação líquida e efeito Cerenkov*. Boletim Didático, CENA, Piracicaba, São Paulo, Brazil.
- NRC (National Research Council) (1985) *Nutrient Requirement of Sheep*, 6th edn. Academic Press, Washington, DC.
- Sarruge, J.R. and Haag, H.P. (1974) *Análises químicas em plantas*. ESALQ/USP. Piracicaba, São Paulo, Brazil.
- SAS (1991) *User's Application Guide 1*. SAS Institute, Cary, North Carolina.
- Schneider, K.M., Ternouth, J.H., Sevilla, C.C. and Boston, R.C. (1985) A short-term study of calcium and phosphorus absorption, in sheep fed on diets high and low in calcium and phosphorus. *Australian Journal of Agricultural Research* 36, 91–105.
- Scott, D. and Buchan, W. (1985) The effects of feeding either roughage or concentrate diets on salivary phosphorus secretion, net intestinal phosphorus absorption and urinary phosphorus excretion in the sheep. *Quarterly Journal of Experimental Physiology* 70, 365–375.
- Scott, D., McLean, A.F. and Buchan, W. (1984) The effect of variation in phosphorus intake on net intestinal phosphorus absorption, salivary phosphorus secretion and pathway of excretion in sheep fed roughage diets. *Quarterly Journal of Experimental Physiology* 69, 439–452.
- Tamminga, S. (1992) Nutritional management of dairy cows as a contribution to pollution control. *Journal of Dairy Science* 75, 345–357.

- Tamminga, S. (1996) A review on environmental impacts of nutritional strategies in ruminants. *Journal of Animal Science* 74, 3112–3124.
- Van Horn, H.H., Wilkie, A.C., Powers, W.J. and Nordstedt, R.A. (1994) Components of dairy manure management systems. *Journal of Dairy Science* 77, 2009–2030.
- Vitti, D.M.S.S., Kebreab, E., Lopes, J.B., Abdalla, A.L., Carvalho, F.F.R., Resende, K.T., Compton, L.A. and France, J. (2000) A kinetic model of phosphorus metabolism in growing goats. *Journal of Animal Science* 78, 2706–2712.
- Zagatto, E.A.G., Krug, F.J., Bergamim, F.H., Jorgensen, S.S. and Reis, B.F. (1979) Margin zones in flow injection analysis: Part 2. Determination of calcium, magnesium and potassium in plant material by flow injection atomic and flame emission spectrometry. *Analytica Chimica Acta* 104, 279–284.

18 Dynamic Simulation of Phosphorus Utilization in Salmonid Fish

K. HUA, J.P. CANT AND D.P. BUREAU

Department of Animal and Poultry Science, University of Guelph, Guelph, Ontario N1G 2W1, Canada

Abstract

Minimizing phosphorus (P) wastes is a key factor for environmental sustainability of freshwater aquaculture operations. A dynamic model was constructed to simulate P utilization in salmonid fish through digestion, body deposition and excretion into urine and faeces. Dietary P was classified into pools of bone P, phytate P, organic P, Ca monobasic/Na/K phosphate and Ca dibasic phosphate. Hydrolysis of P from Ca monobasic/Na/K phosphate and Ca dibasic phosphate pools was represented by linear equations, whereas hydrolysis of P from bone P, phytate P and organic P pools was simulated by Michaelis–Menten equations. The available P pool was the sink for these hydrolysed portions. Absorption from the available P pool was simulated by passive and active uptake of P into the blood pool. Indigestible and unabsorbed P was excreted through faeces. Clearance of blood P was simulated by deposition into bone and soft tissues, excretion through urine as well as endogenous secretion into faeces. Bone deposition and soft tissue deposition in relation to blood P concentration were represented by Michaelis–Menten equations. Urinary excretion was the difference between glomerular filtration and saturable tubular reabsorption and was regulated by blood P concentration. The model was made dynamic by incorporating a body weight (BW) growth function. Response analysis was performed for fish weighing between 50 and 500 g, and the model responded appropriately to dietary P sources and levels. Retention of P ranged from 25% to 28% of intake for a prototypical commercial feed containing 1.15% dietary P. The model was also tested for parameter sensitivity. The most sensitive parameters were those related to body deposition and urinary excretion. This model can be used to simulate the effects of different dietary P sources and levels on P digestibility, retention, solid waste output (faecal excretion) and soluble waste output (urinary excretion). It could be useful for formulating strategies to improve production efficiency and reduce waste output.

Introduction

P is the first limiting factor for algal growth in freshwater and excessive P stimulates eutrophication. P waste output by fish culture operations is an issue heavily scrutinized by environmental agencies around the world

and minimizing P waste is considered a key factor for the environmental sustainability of freshwater aquaculture operations. Nutritional management has been shown to be the most effective approach to reduce P waste output by fish culture operations. Further reduction of P waste output using this type of approach requires a better understanding of P utilization in fish.

Practical fish feeds are generally composed of fish meal and other animal products and a variety of plant ingredients. P is a component of different chemical compounds in these ingredients. In animal by-products, P exists primarily in bone as hydroxyapatite, which is fairly digestible to fish (Lall, 1991; Sugiura *et al.*, 2000). In plant ingredients, 60–80% of the total P is bound in phytate (Ravindran *et al.*, 1995). Since fish do not possess phytase in the digestive tract, digestibility of phytate is very poor (Ogino *et al.*, 1979; Lall, 1991). Organic P covalently linked to protein, lipid and sugar is easily hydrolysed and presumably highly digestible. The digestibility of inorganic phosphate supplements is believed to be affected by their solubility. Monobasic Ca phosphate is, for example, more digestible than dibasic Ca phosphate because of its higher solubility (Lall, 1991). Ingredient selection and quality determine the content and digestibility of P in finished feeds and this, in turn, affects P utilization, the forms of P waste released and the potential environmental impact or mitigation measures required. It is consequently important to take into consideration the relative contribution and fate of the different forms of dietary P when constructing frameworks aimed at better understanding of P utilization in fish.

Once digested and absorbed, P is deposited in the body to support biological functions, tissue growth and bone mineralization. Bone is the major storage site of P, whereas in soft tissues, P serves as a component of organic compounds for synthesis of cell structures and biological functions. Similarly to mammals, urinary phosphate excretion in fish is determined mostly by plasma phosphate concentration. A threshold exists below which P excretion is minimal and above which P excretion is proportional to the increase in plasma phosphate concentration (Bureau and Cho, 1999). Urinary P excretion and faecal P excretion make up total P waste output. However, urinary excreted P (soluble P waste) is more available to algae and can, consequently, have more immediate environmental impact than faecal excreted P (solid P waste), which can settle or be filtered out (Cho and Bureau, 2001).

A number of kinetic and dynamic models of P utilization have been developed for sheep (Grace, 1981; Schneider *et al.*, 1987), pigs (Fernández, 1995), goats (Vitti *et al.*, 2000) and dairy cows (Kebreab *et al.*, 2004), but there has been no attempt to model P utilization in a mechanistic and dynamic manner for fish. The objective of this model is, therefore, to dynamically simulate the partitioning of dietary P through digestion, body deposition, faecal excretion and urinary excretion in salmonid fish over growth stages, and to examine the effect of P chemical forms and their inclusion levels on P utilization and waste output.

Model Description

The model diagram is illustrated by Fig. 18.1. The modelling process comprises digestion of P (release of Pi, orthophosphates HPO_4^{2-} and H_2PO_4^- , from P chemical compound pools and absorption of Pi from available P pool), retention of blood P into soft tissue and bone, and excretion through urine and faeces.

Dietary P intake was the driving variable of the model. Amount of feed intake (g/day) was generated by the feed requirement model based on bioenergetics of salmonid fish (Cho and Bureau, 1998; Bureau *et al.*, 2002), which takes account of growth rate and diet composition (digestible energy (DE), digestible protein (DP)). Growth rate was represented by thermal-unit growth coefficient (TGC), which was a model input. Initial BW and water temperature were also model inputs. TGC allows comparison of growth at different temperatures and is defined as follows (Iwama and Tautz, 1981; Cho, 1992):

$$\text{TGC} = 100 * (\text{BW}^{1/3} - \text{IBW}^{1/3}) / \Sigma(\text{T} * \text{D})$$

where BW = final body weight (g), IBW = initial body weight (g), T = water temperature ($^{\circ}\text{C}$), and D = number of days. Therefore, BW (g, converted to kg in the modelling process) was calculated from TGC and initial BW as follows:

$$\text{BW} = (\text{TGC} * \Sigma(\text{T} * \text{D}) * 100 + \text{IBW}^{1/3})^3$$

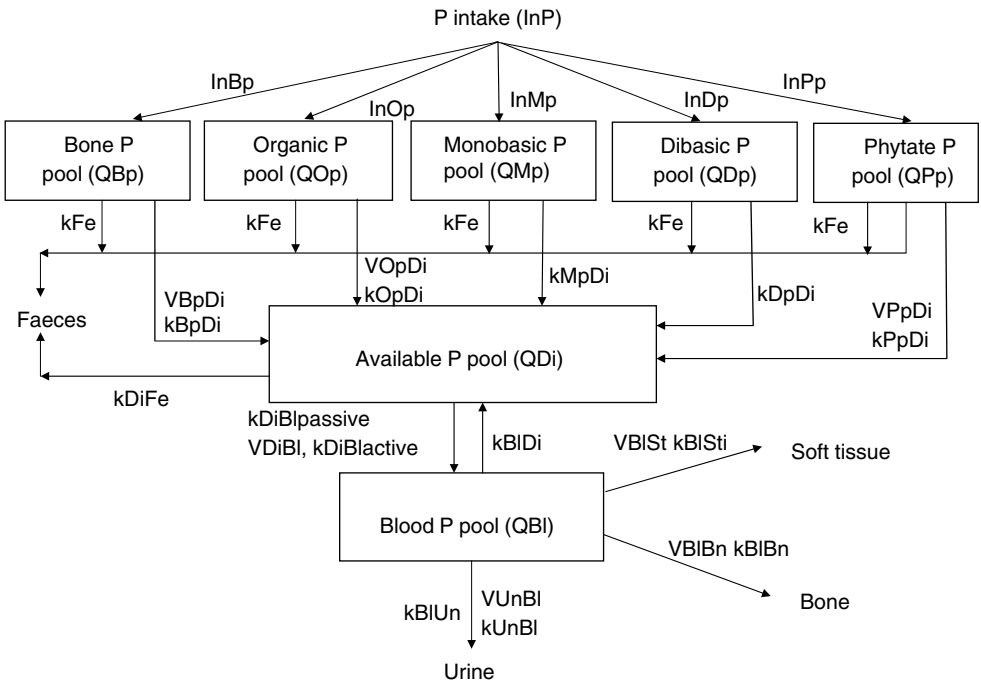

Fig. 18.1. Diagram of dynamic model of P utilization in salmonid fish. Boxes indicate pools and arrows indicate fluxes.

Phosphorus chemical compound pools, QBp, QOp, QMp, QDp, QPp (mg)

Dietary P chemical compounds were classified according to their chemical characteristics into bone P, phytate P, organic P, Ca monobasic/Na/K inorganic P supplement, and Ca dibasic inorganic P supplement. Amount of daily intakes of these P compounds (mg/day) was the product of feed intake and dietary concentration of these P chemical compounds, which were inputs to the P chemical compound pools, QBp, QOp, QMp, QDp and QPp. Orthophosphate Pi has to be released from these compounds in order to be rendered available for absorption; therefore, the first step in modeling of digestion was to simulate hydrolysis of P compounds in stomach. There is evidence that gastric acid output limits bone P digestibility. Agastric fish species such as carp are unable to utilize bone P due to lack of gastric acid secretion (Ogino *et al.*, 1979). In stomached fish species, such as salmonids, digestibility of bone P is dependent on the inclusion level and decreases significantly as inclusion increases (Sugiura *et al.*, 2000). Therefore, dissolution of bone P was simulated by a Michaelis–Menten equation. Similarly, Michaelis–Menten equations were also used to describe the hydrolysis of Pi from organic P and phytate P since enzymatic actions are involved. Maximum releases of Pi from bone P, organic P and phytate P were VBpDi (mg/kg/day), VOpDi (mg/kg/day) and VPPDi (mg/kg/day), whereas affinity constants were kBpDi (mg), kOpDi (mg) and kPpDi (mg), respectively. The release of Pi from Ca monobasic/Na/K and Ca dibasic inorganic phosphate supplement was assumed to be linearly related to dietary supply with fractional rates of kMpDi (/day) and kDpDi (/day). Derivation of these parameter values is presented in the section ‘Auxiliary equations’. The outputs of the chemical compound pools were the available fractions of these chemical compounds to the available P pool (QDi). The indigestible fractions were the flow (mg/day) from the chemical compound pools to faeces based on gastric empty rate, kFe = 0.9 (/day; Kristiansen, 1998).

Available P pool, QDi (mg)

Inputs to available P pool were the outputs from each chemical compound pool and P endogenous secretion. Absorption of P from QDi to blood was simulated by active and passive uptakes. Passive and active P uptake mechanism was identified in rainbow trout intestine (Avila *et al.*, 2000). The active uptake of P based on Pi concentration followed a Michaelis–Menten-type equation with maximum absorption of VDiBl (mg/day) and affinity of kDiBlactive (mg/l). Passive diffusion was linearly related to available P concentration cQDi (mg/l) with rate of kDiBlpassive (l/day). Values of VDiBl, kDiBlactive and kDiBlpassive were derived from Avila *et al.* (2000) and were 34.5 (mg/day), 37.2 (mg/l) and 0.067 (l/day), respectively. The portion of available P that was not absorbed into the blood pool was excreted through faeces at gut emptying rate of kDiFe = 2.36 (/day)

(Storebakken *et al.*, 1999). Total gut volume was exponentially related to BW based on the study of Burley and Vigg (1989) and was described as gut volume (L) = $1/1000 * e^{(2.854 + 1.2 * BW)}$.

Blood P pool, QBI (mg)

P absorbed from available P pool was the input to the blood P pool. From the blood P pool, there were four outputs: endogenous secretion, soft tissue deposition, bone deposition and urinary excretion. Endogenous secretion was derived from Riche and Brown (1996) and Rodehutschord *et al.* (2000), and was set at $kBIDi = 3.5$ (/day).

Depositions into soft tissues and bone at steady state were modelled at constant BW, being described by a Michaelis–Menten-type equation, with maximum deposition of $VB1St$ (mg/kg/day) into soft tissue and $VB1Bn$ (mg/kg/day) into bone, and affinity constants of $kB1St$ (mg/l) and $kB1Bn$ (mg/l) for soft tissue and bone deposition, respectively. These parameters were calculated separately with four different BWs at 5 g (Skonberg *et al.*, 1997), 90 g (Rodehutschord *et al.*, 2000), 125 g (Rodehutschord, 1996) and 210 g (Baeverfjord *et al.*, 1998). When only whole body deposition data were available, bone weight was assumed to be 10% of BW (Gingerich *et al.*, 1990), and partitioning between bone and soft tissue deposition was calculated from whole body deposition. Because there is no evidence in fish nutrition literature that plasma P_i concentration is affected by BW, the parameters were further adjusted by assuming similar $cQBI$ across these four BW values.

Relationship of the deposition parameters across BW was described by the following equations:

$$VB1St = 17.866 * BW^{-0.2170} (R^2 = 0.95)$$

$$kB1St = 0.142 * BW^{-0.1914} (R^2 = 0.97)$$

$$VB1Bn = 14.368 * BW^{-0.3605} (R^2 = 0.98)$$

$$kB1Bn = 0.085 * BW^{-0.3876} (R^2 = 0.98)$$

P urinary excretion was the difference between two processes regulated by plasma P_i concentration: linear glomerular filtration with rate $kBIUn$ (l/kg/day) and tubular reabsorption of the filtrates, which follows Michaelis–Menten mechanism with maximum reabsorption capacity $VUnBl$ (mg/kg/day) and affinity constant $kUnBl$ (mg/l). Fish have been known to show net tubular P_i secretion (Renfro and Gupta, 1990). However, recent development in molecular identification has suggested that tubular secretion may be limited to saltwater fish species. The location of active transporters indicates that renal handling of trout is the result of glomerular filtration and tubular reabsorption, which follows the mechanism rather similarly to monogastric mammals (Sugiura *et al.*, 2003). The equation

parameters were calculated based on the work of Bureau and Cho (1999). Glomerular filtration rate k_{BlUn} was calculated as 4.2 (l/kg/day), maximum tubular reabsorption capacity V_{UnBl} as 1250 (mg/kg/day), and affinity constant k_{UnBl} as 225 (mg/l). Plasma volume was assumed to be 3.5% of the BW (Gingerich *et al.*, 1990).

Auxiliary equations

Body deposition was calculated as the sum of deposition in soft tissue and bone. Body deposition coefficient was the percentage of dietary P intake deposited in body. Faecal P output (solid waste output) was the sum of indigestible P from each P chemical compound pool, Q_{Bp} , Q_{Op} , Q_{Mp} , Q_{Dp} , Q_{Pp} , and unabsorbed P from available P pool (Q_{Di}). Urinary excretion coefficient was the percentage of dietary P intake that was excreted through urine (soluble waste output). Apparent digestibility was the difference between dietary P and P faecal excretion expressed as a percentage of dietary P. True digestibility was the percentage of dietary P intake that was absorbed P from available P pool (Q_{Di}).

Apparent digestibility values of different P chemical compounds, estimated from P apparent digestibility of feed ingredients and inorganic phosphates to salmonids in the literature (Lall, 1991), were used to calculate the parameters in P chemical pools, Q_{Bp} , Q_{Op} , Q_{Pp} , Q_{Mp} , Q_{Dp} , after taking account of active and passive absorption from available P pool Q_{Di} into blood P pool Q_{Bl} as well as endogenous loss. Digestibility was set constant across BW modelled (from 50 g to 500 g). The maximum releases of P_i from bone P, organic P and phytate P (V_{BpDi} , V_{OpDi} and V_{PpDi}) were 77.5 (mg/kg/day), 223 (mg/kg/day) and 9.7 (mg/kg/day), and the affinity constants, k_{BpDi} , k_{OpDi} and k_{PpDi} , were 2.88 (mg), 0.45 (mg) and 0.06 (mg), respectively. For Ca monobasic/Na/K and Ca dibasic inorganic phosphate supplement, the fractional rates, k_{MpDi} and k_{DpDi} , were 1.5 (/day) and 1.1 (/day) respectively.

The model was written in Advanced Continuous Simulation Language (ACSL, MGA software, Concord, MA).

Model evaluation

A prototypical commercial feed for rainbow trout was used to evaluate the response of the model. The feed had 46% crude protein (CP), 23% crude fat and 7% ash. Dietary DE was 20 MJ/kg, and the ratio of DP to DE was 22 g/MJ. The dietary total P content was estimated to be 1.15%, including 0.61% of bone P, 0.12% of phytate P and 0.42% of organic P. No inorganic phosphate supplement was used. Optimal growth condition was assumed. TGC and temperature were assumed to be 0.2 and 15°C respectively. The modelled period was 50–500 g BW, a common market size for rainbow trout.

To test the model response to the effect of total dietary P and types of P on P utilization in fish, three sets of diets were theoretically formulated: (i) dietary bone P content was increased from 0.61% in the prototypical commercial feed to 1.01% by an increment of 0.1%, while organic P and phytate P contents were held the same as in the prototypical commercial feed (diets 1 to 4); (ii) dietary organic P content was increased from 0.42% in the prototypical feed to 0.82%, while bone P and phytate P contents were held constant (diets 5 to 8); and (iii) dietary phytate P content was increased from 0.12% in the prototypical feed to 0.52%, while bone P and organic P contents were held constant (diets 9 to 12). In these three sets of diets, the dietary total P contents increased from 1.15% to 1.55% in correspondence to increasing contents of different P types. In addition, a fourth set of diets (diets 13 to 16) was formulated by holding total P contents constant, while varying the contents of bone P, organic P and phytate P by 0.1% in pairs (Table 18.1).

All parameters were tested for sensitivity by examining model outputs when varying individual parameters from half to double the values.

Table 18.1. Contents (%) of total P and types of P in a prototypical commercial feed and four sets of diets used to simulate model response.

Diet	Total P	Bone P	Organic P	Phytate P
Prototypical feed	1.15	0.61	0.42	0.12
Set 1				
Diet 1	1.25	0.71	0.42	0.12
Diet 2	1.35	0.81	0.42	0.12
Diet 3	1.45	0.91	0.42	0.12
Diet 4	1.55	1.01	0.42	0.12
Set 2				
Diet 5	1.25	0.61	0.52	0.12
Diet 6	1.35	0.61	0.62	0.12
Diet 7	1.45	0.61	0.72	0.12
Diet 8	1.55	0.61	0.82	0.12
Set 3				
Diet 9	1.25	0.61	0.42	0.22
Diet 10	1.35	0.61	0.42	0.32
Diet 11	1.45	0.61	0.42	0.42
Diet 12	1.55	0.61	0.42	0.52
Set 4				
Diet 13	1.15	0.51	0.52	0.12
Diet 14	1.15	0.51	0.42	0.22
Diet 15	1.15	0.71	0.32	0.12
Diet 16	1.15	0.71	0.42	0.02
Diet 17	1.15	0.61	0.52	0.02
Diet 18	1.15	0.61	0.32	0.22

Results and Discussion

For the prototypical commercial feed, apparent digestibility coefficient (ADC) of P was approximately 60%, urinary excretion ranged from 29 to 36%, whereas body deposition coefficient was 25–28%. These values are comparable to reports for typical commercial diets (Heinen *et al.*, 1993; Ketola and Harland, 1993; Cho and Bureau, 1998). This indicates that the model responded appropriately over the growth period. The model could aid in the strategies of reduction of P waste output through feed formulation. For the commercial feed, the model simulated that about 40% of dietary P was excreted as solid waste, and soluble P waste exceeded retention in body. While solid waste can be reduced by selection of highly digestible ingredients, reduction in soluble waste can be achieved by decreasing digestible P level in feed. The level resulting in minimal soluble P waste is around 0.4% digestible P for rainbow trout (Rodehutsord *et al.*, 2000). There was about 0.7% digestible P in this feed according to model simulation, which can be reduced to the level where growth is maximized, acceptable deposition is achieved, and soluble waste is minimized through feed formulation (Cho and Bureau, 2001).

From model simulations of P flows on the four sets of diets, average values of P retention, urinary excretion and faecal excretion over the growth period are presented (Table 18.2). Increasing bone P contents in diet Set 1 resulted in a higher proportion of dietary P being excreted through faeces compared to the prototypical commercial feed, whereas P retention and urinary excretion, as a percentage of dietary P, were reduced. This illustrates the limited capability of fish to digest bone P. Increasing levels of organic P resulted in a proportion of faecal excretion similar to that in the prototypical commercial feed (diet Set 2). However, elevated proportions of dietary P were excreted through urine and less dietary P was retained in the fish body. This suggests that organic P is highly digestible, and as more digestible P is included in diets, P retention coefficient decreases, and more P is excreted as soluble metabolic waste in urine. Simulations of diet Set 3 indicated that increasing phytate P contents greatly depressed P digestibility of the diets. Consequently, faecal P excretion increased, and P body retention and urinary excretion decreased. This is in agreement with the poor digestibility of phytate P to fish and consistent with the physiology of fish that do not appear to possess phytase within the gastrointestinal tract (GIT; Ogino *et al.*, 1979; Lall, 1991).

Results from diet Set 4 further illustrate that the proportion of different types of P has great impact on P utilization even at a given dietary P level. This suggests that fish utilize different types of P to a varying degree. Accurate estimates of P utilization of the diets can only be achieved based on differentiation of P compounds rather than aggregates of total dietary P. Identical P retention coefficients were simulated across diets 15–18, but urinary and faecal P excretions varied and were negatively correlated. This illustrates that all six diets were sufficient in digestible P level, although their digestibility differed. Once requirement for maximum body saturation (maximum P retention) is met, surplus digestible P is excreted as soluble

Table 18.2. Model-simulated P utilization of a prototypical commercial feed and four sets of diets for rainbow trout growing from 50 to 500g.

Diet	% dietary P		
	P retention	P urinary excretion	P faecal excretion
Prototypical feed	27	33	40
Set 1			
Diet 1	25	31	43
Diet 2	23	30	46
Diet 3	22	29	49
Diet 4	20	27	52
Set 2			
Diet 5	25	36	39
Diet 6	23	38	39
Diet 7	22	40	38
Diet 8	20	41	38
Set 3			
Diet 9	25	30	44
Diet 10	23	28	48
Diet 11	22	26	52
Diet 12	20	24	55
Set 4			
Diet 13	27	37	36
Diet 14	27	31	42
Diet 15	27	28	44
Diet 16	27	32	40
Diet 17	27	37	36
Diet 18	27	27	46

P (urinary P) into the environment. Corresponding strategies could be constructed through feed formulation to reduce solid waste output or soluble waste output depending on objectives. The theoretical simulation illustrates that the model responds well to different levels and types of P compounds. This dynamic P model could be a useful tool for aquaculture operations to estimate P digestibility, retention and waste output.

Sensitivity tests suggested that k_{Fe} , k_{BlUn} , V_{UnBl} , V_{BlBn} and V_{BlSt} were sensitive parameters. Model outputs were affected by over 15% when varying these parameters from half to double the values. This suggests that gastric emptying rate could considerably affect digestibility. Sensitivity of body deposition and urinary excretion warrants optimization of these parameters using a large data-set. Estimates of body deposition and urinary excretion could be confounded by experimental conditions and physiological status of the fish. Plasma Pi concentration is important to the estimates of these parameters; however, measurements of plasma Pi concentration are variable among studies and affected by sampling protocols. Radioisotopes and compartment analysis have been used in ruminants and monogastric

mammals to study and model P metabolism (Grace, 1981; Schneider *et al.*, 1987; Fernández, 1995; Vitti *et al.*, 2000). This technique enables profiling of P distribution in different pools in the body and monitoring of kinetics of P flows between these pools, and can be applied to fish.

In this model, a simple growth equation was incorporated and growth was assumed to be independent of nutritional composition of the diet. The interaction between diet composition and growth performance could potentially affect the utilization of P, especially P deposition. Furthermore, P-deficient diets would depress feed intake and growth. Therefore, the P utilization model should eventually be integrated within a nutrient flow fish growth model in order to investigate the effect of digestion, metabolism and utilization of major nutrients on P utilization, and, conversely, the effect of digestible P supply on growth and utilization of other nutrients.

Future work should include optimization of parameters and validation of the model using independent experimental data. The effect of different combinations of P chemical forms on P utilization and waste output should be further evaluated with a wide range of diets fed to fish under controlled experimental conditions. The effect of microbial phytase should also be incorporated in the model.

Conclusions

This model simulates P utilization in salmonid fish through digestion, body deposition and excretion into urine and faeces. The model responded appropriately for a prototypical commercial feed containing 1.15% dietary P. This model could be a useful tool in diet formulation and nutrient management. It could aid in selection of highly digestible ingredients and help in formulating diets to just meet, but not exceed, P requirement of fish, and consequently improve production efficiency and reduce waste output.

Acknowledgements

Financial support of this study was provided by Aquaculture Collaborative Research and Development Program (ACRDP) of the Department of Fisheries and Oceans (Canada), AquaNet – the Network of Centres of Excellence in Aquaculture (Canada), the Ontario Ministry of Natural Resources (OMNR, Canada) and the Fats and Proteins Research Foundation (Bloomington, IL, USA).

References

- Avila, E.M., Tu, H., Basantes, S. and Ferraris, R.P. (2000) Dietary phosphorus regulates intestinal transport and plasma concentrations of phosphate in rainbow trout. *Journal of Comparative Physiology* 170B, 201–209.

- Baeverfjord, G., Asgard, T. and Shearer, K.D. (1998) Development and detection of phosphorus deficiency in Atlantic salmon, *Salmo salar* L., parr and post-smolts. *Aquaculture Nutrition* 4, 1–11.
- Bureau, D.P. and Cho, C.Y. (1999) Phosphorus utilization by rainbow trout (*Oncorhynchus mykiss*): estimation of dissolved phosphorus waste output. *Aquaculture* 179, 127–140.
- Bureau, D.P., Kaushik, S.J. and Cho, C.Y. (2002) Bioenergetics. In: Halver, J.E. and Hardy, R.W. (eds) *Fish Nutrition*, 3rd edn. Academic Press, San Diego, California, pp. 1–59.
- Burley, C.C. and Vigg, S. (1989) A method for direct measurement of the maximum volume of fish stomachs or digestive tracts. *Journal of Fish Biology* 34, 707–714.
- Cho, C.Y. (1992) Feeding systems for rainbow trout and other salmonids with reference to current estimates of energy and protein requirements. *Aquaculture* 100, 107–123.
- Cho, C.Y. and Bureau, D.P. (1998) Development of bioenergetic models and the fish-PrFEQ software to estimate production, feeding ration and waste output in aquaculture. *Aquatic Living Resources* 11, 199–210.
- Cho, C.Y. and Bureau, D.P. (2001) A review of diet formulation strategies and feeding systems to reduce excretory and feed wastes in aquaculture. *Aquaculture Research* 32, 349–360.
- Fernández, J.A. (1995) Calcium and phosphorus metabolism in growing pigs: III. A model resolution. *Livestock Production Science* 41, 255–261.
- Gingerich, W.H., Pityer, R.A. and Rach, J.J. (1990) Whole body and tissue blood volumes of two strains of rainbow trout (*Oncorhynchus mykiss*). *Comparative Biochemistry and Physiology* 97A, 615–620.
- Grace, N.D. (1981) Phosphorus kinetics in the sheep. *British Journal of Nutrition* 45, 367–374.
- Heinen, J.M., Hankins, J.A. and Subramanyam, M. (1993) Evaluation of four commercial diets for rainbow trout. *Progressive Fish-Culturist* 55, 265–269.
- Iwama, G.K. and Tautz, A.F. (1981) A simple growth model for salmonids in hatcheries. *Canadian Journal of Fisheries and Aquatic Sciences* 38, 649–656.
- Kebreab, E., Mills, J.A.N., Crompton, L.A., Bannink, A., Dijkstra, J., Gerrits, W.J.J. and France, J. (2004) An integrated mathematical model to evaluate nutrient partition in dairy cattle between the animal and its environment. *Animal Feed Science and Technology* 112, 131–154.
- Ketola, H.G. and Harland, B.F. (1993) Influence of phosphorus in rainbow trout diets on phosphorus discharges in effluent water. *Transactions of the American Fisheries Society* 122, 1120–1126.
- Kristiansen, H.R. (1998) Effects of handling, discrete meals and body weight on the individual variation of gastric emptying parameters. *Aquaculture Research* 29, 717–729.
- Lall, S.P. (1991) Digestibility, metabolism and excretion of dietary phosphorus in fish. In: Cowey, C.B. and Cho, C.Y. (eds) *Nutritional Strategies and Aquaculture Waste. Proceedings of the 1st International Symposium on Nutritional Strategies in Management of Aquaculture Waste*. Fish Nutrition Research Laboratory, University of Guelph, Canada, pp. 21–36.
- Ogino, C., Takeuchi, L., Takeda, H. and Watanabe, T. (1979) Availability of dietary phosphorus in carp and rainbow trout. *The Bulletin of the Japanese Society of Scientific Fisheries* 49, 1527–1532.
- Ravindran, V., Bryden, W.L. and Kornegay, E.T. (1995) Phytates: occurrence, bioavailability and implications in poultry nutrition. *Poultry and Avian Biology Reviews* 6, 125–143.

- Renfro, J.L. and Gupta, A. (1990) Comparative physiology of phosphate transport across renal plasma membranes. In: Kinne, R.K.H. (ed.) *Comparative Aspects of Sodium Cotransport Systems*. Karger, Basel, Switzerland, pp. 216–240.
- Riche, M. and Brown, P.B. (1996) Availability of phosphorus from feedstuffs fed to rainbow trout, *Oncorhynchus mykiss*. *Aquaculture* 142, 269–282.
- Rodehutsord, M. (1996) Response of rainbow trout (*Oncorhynchus mykiss*) growing from 50 to 200 g to supplements of dibasic sodium phosphate in a semipurified diet. *Journal of Nutrition* 126, 324–331.
- Rodehutsord, M., Gregus, Z. and Pfeffer, E. (2000) Effect of phosphorus intake on faecal and non-faecal phosphorus excretion in rainbow trout (*Oncorhynchus mykiss*) and the consequences for comparative phosphorus availability studies. *Aquaculture* 188, 383–398.
- Schneider, K.M., Boston, R.C. and Leaver, D.D. (1987) Quantitation of phosphorus excretion in sheep by compartmental analysis. *American Journal of Physiology* 252, R720–R731.
- Skonberg, D.L., Yogev, L., Hardy, R.W. and Dong, F.M. (1997) Metabolic response to dietary phosphorus intake in rainbow trout (*Oncorhynchus mykiss*). *Aquaculture* 157, 11–24.
- Storebakken, T., Kvien, I.S., Shearer, K.D., Grisdale-Helland, B. and Helland, S.J. (1999) Estimation of gastrointestinal evacuation rate in Atlantic salmon (*Salmo salar*) using inert markers and collection of faeces by sieving: evacuation of diets with fish meal, soybean meal or bacterial meal. *Aquaculture* 172, 291–299.
- Sugiura, S., Babbitt, J., Dong, F. and Hardy, R. (2000) Utilization of fish and animal by-product meals in low-pollution feeds for rainbow trout (*Oncorhynchus mykiss*) (Walbaum). *Aquaculture Research* 31, 585–593.
- Sugiura, S.H., McDaniel, N.K. and Ferraris, R.P. (2003) *In vivo* fractional Pi absorption and NaPi-II mRNA expression in rainbow trout are upregulated by dietary P restriction. *American Journal of Physiology* 285, R770–R781.
- Vitti, D.M., Kebreab, E., Lopes, J.B., Abdalla, A.L., De Carvalho, F.F., De Resende, K.T., Crompton, L.A. and France, J. (2000) A kinetic model of phosphorus metabolism in growing goats. *Journal of Animal Science* 78, 2706–2712.

19 Development of a Dynamic Model of Calcium and Phosphorus Flows in Layers

J. DIJKSTRA,¹ E. KEBREAB,² R.P. KWAKKEL¹ AND J. FRANCE²

¹*Animal Nutrition Group, Wageningen University, PO Box 338, 6700 AH Wageningen, The Netherlands;* ²*Centre for Nutrition Modelling, Department of Animal and Poultry Science, University of Guelph, Guelph, Ontario N1G 2W1, Canada*

Abstract

Phosphorus (P) is involved in most metabolic activities of the body as well as in bone formation. P and calcium (Ca) are closely related so that a deficiency in one can interfere with proper utilization of the other. In layers, requirement for dietary P is mainly due to the need to store Ca in bones prior to eggshell formation. Ca requirement for eggshell formation is high. If at any time during the day Ca requirement exceeds the amount of Ca absorbed from the gut, layers mobilize Ca, and consequently P, from medullary bones. P is then excreted in urine, potentially causing environmental pollution. A model of Ca and P dynamics in the layer was developed to describe and evaluate flows of Ca and P during the day.

The model comprises eight state variables representing Ca and P in the crop, stomachs (proventriculus and gizzard), plasma and bone. P is defined as P absorbable at the terminal ileum. Zero pools are assigned to Ca and P in the duodenum. Outflow of Ca and P from crop and stomachs is assumed to obey mass-action kinetics. A higher fractional Ca absorption rate from the duodenum is assumed during eggshell formation than at times when there is no such formation. Eggshell formation commences 20 h before oviposition and follows a sigmoidal pattern. Ca and P in plasma can be used for egg synthesis, accretion in bone and excretion in urine. Michaelis–Menten forms represent utilization and production of Ca and P for bone accretion and resorption. Rate of utilization of plasma Ca and P for accretion depends on the more limiting of the two minerals. Rate of bone resorption is inhibited by plasma Ca or P level when Ca or P requirement exceeds supply from the gut, and consequently is related to the lowest level of the two minerals. Ca and P excreted in urine is the sum of basal maintenance requirement for Ca and P and amount of Ca or P in plasma that cannot be utilized for bone accretion because the other mineral is lacking.

In the simulations, a light period of 16 h/day is assumed, and feed intake occurs continuously and only during the light period. Time of laying varies between 1 and 7 h after light is switched on. Simulated Ca and P absorption from the gut rises to a plateau until light is switched off, upon which absorption declines rapidly. However, depending on time of oviposition, simulated Ca requirement for eggshell formation is highest between

14 and 21 h after light is switched on. Because of the simulated imbalance between Ca absorption from the gut and Ca requirement for eggshell synthesis, Ca and consequently P are mobilized from bone. The model may be used to evaluate feeding strategies aimed at reducing P excretion to the environment in poultry manure.

Introduction

Surplus minerals in poultry manure, including P, present an environmental pollution problem for intensive poultry operations. Excess P from poultry manure contributes to build-up of P in the soil and may be washed from fertilized soil into surface waters causing eutrophication (Sharpley, 1999). High levels of P in surface waters increase the growth of bacteria and algae, reducing oxygen in the water and thus resulting in death of several aquatic species (Correll, 1999).

Reduction in P content of feed can mitigate pollution (Kebreab *et al.*, 2005). Such a reduction requires knowledge of mineral absorption and requirement for various purposes in the animal. In layers, P is required for replacement of tissue metabolites such as nucleotides and phospholipids, to maintain skeletal integrity and for production of the egg. There is a close relationship between P and Ca in the layer producing eggs. Ca is the major structural element in eggshell and large amounts of Ca are required to synthesize the shell. The shell gland is usually active during the dark hours, but Ca stores in the gut may be low at that time since hens show nocturnal fast (review Scanes *et al.*, 1987), and therefore the layer relies on other Ca sources, particularly from bone. The medullary bone is a special, highly mineralized bone and a very mobile source of Ca. Thus, the medullary bone acts as a temporary reserve, releasing Ca when needed at times when supply from feed is insufficient (Etches, 1987). Since Ca is stored almost entirely as calcium phosphate in bone, bone mobilization to fulfil Ca requirement results in elevated levels of plasma P and excretion of P, especially during times of shell formation (Hurwitz and Bar, 1965).

Nutritional deficiencies of Ca and P lead to production and health problems. Low P in diets may increase plasma Ca concentrations and urinary Ca excretion, and (as with low Ca diets) give rise to osteoporosis (cage layer fatigue) and mortality (Rao *et al.*, 1992). Modern high-producing hybrid strains of layers may be considered largely osteoporotic at the end of lay, while older lines with a lower rate of egg production showed no signs of osteoporosis (Rennie *et al.*, 1997). Depletion of bone and renal stress caused by low-P diets could predispose layers to other stressors like pathogens and high temperature (Rao *et al.*, 1992).

Nutritional requirements of the hen for P are uncertain and reviews of P requirement vary from 2.0 to 3.5 g available P per kg diet during peak lay (see Boorman and Gunaratne, 2001). Uncertainty regarding P requirement is related to, amongst others, the close relationship between P and Ca dynamics in layers and the wide range in oviposition times, and hence in P and Ca requirements within the day in a flock of layers. Several models have been developed to describe quantitatively mineral flows in hens. Etches (1987)

predicted on an hourly basis intestinal Ca content, Ca retention, Ca deposition in eggshell and flows of Ca into and out of bone reserves, but did not consider P in the model. Van Krieken (1996) and Tolboom and Kwakkel (1998) modelled Ca and P dynamics in layers partly based on the Etches (1987) model, also on an hourly basis, in which most transactions were linear. However, in describing nutrient dynamics based on the behaviour of the system and its underlying components (mechanistic models), differential equations are often used and the mathematically standard way of representing such models is the rate:state formalism (Thornley and France, 2005). The objective of this paper is the development of a dynamic, mechanistic model of Ca and P dynamics in layers applying the rate:state formalism using non-linear kinetics, in order to evaluate various dietary and management strategies for reducing P excretion.

Model Description

General structure

The scheme is given in Fig. 19.1. The model consists of eight state variables representing Ca and P pools in the crop (c), stomachs (proventriculus and gizzard) (s), plasma (p) and bone (b). P is defined as absorbable P at the terminal ileum. Zero pools are assigned to Ca and P in the duodenum (d), assuming that duodenal retention time for Ca and P is small. Also, there is little variation in ingesta content of the small intestine during the day or night, whereas large diurnal changes, especially in crop and gizzard contents, are observed (Scanes *et al.*, 1987). Pool sizes are expressed in mg and time in days. State variables (quantities) are denoted by Q_i and concentration (C_i) is calculated as pool size divided by liveweight (LW, W ; kg). Differential equations

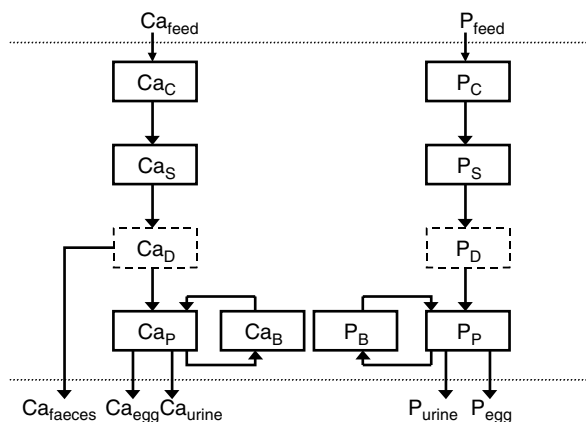

Fig. 19.1. Diagrammatic representation of the calcium (Ca) and phosphorus (P) model. Boxes enclosed by solid lines denote state variables; boxes enclosed by dashed lines depict zero pools; arrows depict flows.

(dQ_i/dt) describe the rate of change of state variable Q_i with time. Rate of utilization of i in the j to k transaction is denoted by U_{ijk} and rate of production of i in the j to k transaction by P_{ijk} . The variable t' (h) is used for diurnal time (time during the day, $0 \leq t' \leq 24$).

Calcium and phosphorus in the crop

There is one input to each of the two crop pools from the feed:

$$P_{\text{Cac,CafCac}} = I_f C_{\text{Caf}}$$

$$P_{\text{Pc,PfPc}} = I_f C_{\text{Pf}}$$

where I_f is feed intake (g/day) and C_{Caf} and C_{Pf} are the concentration (mg/g) of Ca and P, respectively, in the feed (Table 19.1). A layer is assumed to lay an egg at $L = 1, 2, \dots$, or 7 h after light is switched on; alternatively, on rest days, the layer will not produce an egg. Hens have been found to consume considerably less food on days when either an ovulation or oviposition is missed (review Scanes *et al.*, 1987). Assuming 95 eggs are laid every 100 days (Table 19.1) and the day before the rest day (assumed to occur when $L = 7$ h) occurs five times every 100 days, the driving variable I_f was set to 101% of averaged intake when $L = 1, 2, \dots, 6$ h but only 90% of averaged intake on the rest day and the day before rest day (Etches, 1987). Feed intake is assumed continuous during the photoperiod. The photoperiod is set at 16 h/day, light is switched on at $t' = 0$ h.

One output of Ca and one of P from the crop are represented, i.e. to the stomachs (proventriculus and gizzard). Fractional outflow rates are applied for Ca (k_{CacCas} ; /day) and P (k_{PcPs} ; /day) and based on data reported by Van der Klis *et al.* (1990; Table 19.1):

$$U_{\text{Cac,CacCas}} = k_{\text{CacCas}} Q_{\text{Cac}}$$

$$U_{\text{Pc,PcPs}} = k_{\text{PcPs}} Q_{\text{Pc}}$$

Rates of change of pool size in the crop are:

$$dQ_{\text{Cac}}/dt = P_{\text{Cac,CafCac}} - U_{\text{Cac,CacCas}}$$

$$dQ_{\text{Pc}}/dt = P_{\text{Pc,PfPc}} - U_{\text{Pc,PcPs}}$$

Calcium and phosphorus in the stomachs

There is one input to each stomach pool from the crop:

$$P_{\text{Cas,CacCas}} = U_{\text{Cac,CacCas}}$$

$$P_{\text{Ps,PcPs}} = U_{\text{Pc,PcPs}}$$

Table 19.1. Model parameter values and layer reference values

Egg and feed	Layer reference values
Feed	110 g/day
C_{Caf}	40 mg Ca/g feed
C_{Pf}	2.8 mg P/g feed
Live weight (LW)	1.7 kg
Eggs/100 days	95 eggs
Egg weight	59 g
Egg yolk	0.31 g yolk/g egg
P in yolk	5.70 mg P/g yolk
Ca in yolk	1.40 mg Ca/g yolk
Egg white	0.59 g white/g egg
P in white	0.14 mg P/g white
Ca in white	0.11 mg Ca/g white
Eggshell	0.10 g shell/g egg
P in shell	1.30 mg P/g shell
Ca in shell	372.88 mg Ca/g shell
Ca and P	Model parameter values
k_{CacCas}	10.6/day
k_{PcPs}	10.6/day
k_{CasCad}	21.6/day
k_{PsPd}	21.6/day
k_{CadCap}	0.7 if eggshell is being formed 0.4 if no eggshell is being formed
k_{PdPp}	1.0
R_{CapCam}	55 mg Ca/kg LW/day
R_{PpPm}	14 mg P/kg LW/day
$f_{Ca:P}$	2.2 mg Ca/mg P
V_{CapCab}	4500 mg Ca/kg LW/day
M_{CapCab}	5 mg Ca/kg LW
M_{PpPb}	5 mg P/kg LW
V_{CabCap}	4500 mg Ca/kg LW/day
J_{CabCap}	5 mg Ca/kg LW
J_{PbPp}	5 mg P/kg LW

Outflows to the duodenum are:

$$U_{Cas, CasCad} = k_{CasCad} Q_{Cas}$$

$$U_{Ps, PsPd} = k_{PsPd} Q_{Ps}$$

where k_{CasCad} (/day) and k_{PsPd} (/day) are fractional rates of outflow of Ca and P, respectively, to the duodenum (from Van der Klis *et al.*, 1990; Table 19.1). Rates of change of pool size in the stomachs are:

$$dQ_{Cas}/dt = P_{Cas, CacCas} - U_{Cas, CasCad}$$

$$dQ_{Ps}/dt = P_{Ps, PcPs} - U_{Ps, PsPd}$$

Calcium and phosphorus in the duodenum

Ca and P in the duodenum are represented as zero pools, where input equals output without quantification of pool size, based on the small residence time of duodenal digesta. Inflow to the duodenum (mg/day) equals outflow from the stomachs:

$$P_{\text{Cad, CasCad}} = U_{\text{Cas, CasCad}}$$

$$P_{\text{Pd, PsPd}} = U_{\text{Ps, PsPd}}$$

The upper part of the small intestine is the most active in absorbing Ca and P (Hurwitz and Bar, 1965). Absorption from the duodenum into blood plasma (mg/day) is represented as:

$$U_{\text{Cad, CadCap}} = k_{\text{CadCap}} P_{\text{Cad, CasCad}}$$

$$U_{\text{Pd, PdPp}} = k_{\text{PdPp}} P_{\text{Pd, PsPd}}$$

where k_{CadCap} and k_{PdPp} are fractional absorptions of Ca and P, respectively, from the duodenum. Ca retention on shell-forming days is higher than on days when no shell formation occurs (Clunies *et al.*, 1992), presumably because during times of high Ca demand, 1,25-dihydroxycholecalciferol levels are increased, stimulating Ca absorption from gut into blood. Parameter k_{CadCap} is taken as 0.7 during eggshell formation, when Ca requirement is high, and 0.4 when there is no eggshell formation (Hurwitz and Bar, 1969). Non-absorbed Ca is excreted in faeces. As P is defined in the model as absorbable P at the terminal ileum, k_{PdPp} is set at 1.

Calcium and phosphorus in the plasma

There are two inputs each to the Ca and P pools, absorption from the duodenum ($P_{\text{Cap, CadCap}}$ and $P_{\text{Pp, PdPp}}$) and mobilization from bone ($P_{\text{Cap, CabCap}}$ and $P_{\text{Pp, PbPp}}$) (all mg/day):

$$P_{\text{Cap, CadCap}} = U_{\text{Cad, CadCap}}$$

$$P_{\text{Pp, PdPp}} = U_{\text{Pd, PdPp}}$$

$$P_{\text{Cap, CabCap}} = U_{\text{Cab, CabCap}}$$

$$P_{\text{Pp, PbPp}} = U_{\text{Pb, PbPp}}$$

Three outputs each from the plasma Ca and P pools are represented, i.e. utilization for egg synthesis, deposition in bone and excretion in urine.

Ca and P for egg synthesis ($U_{\text{Cap, CapCae}}$ and $U_{\text{Pp, PpPe}}$; mg/day) is the sum of utilization for yolk, white (albumen) and shell formation:

$$U_{\text{Cap, CapCae}} = U_{\text{Cap, CapCayolk}} + U_{\text{Cap, CapCawhite}} + U_{\text{Cap, CapCashell}}$$

$$U_{\text{Pp, PpPe}} = U_{\text{Pp, PpPyolk}} + U_{\text{Pp, PpPwhite}} + U_{\text{Pp, PpPshell}}$$

The shell is assumed to be formed in the 20 h prior to oviposition (Etches, 1987) and to follow a logistic pattern (Thornley and France, 2005, ch. 5):

$$y = a/[1 + e^{-b(x-c)}] - d$$

where y (g/g) is fraction of shell formed, x (h) is time from start of shell formation, and parameters a , b , c and d have values of 1.11, 0.307692, 8.5 and 0.0757, respectively (Fig. 19.2a). The parameters of the curve were estimated by Van Krieken (1996) based on data collected from literature and reported by Etches (1987). Differentiating gives the fractional rate of eggshell formation (Fig. 19.2b):

$$dy/dx = abe^{-b(x-c)}/[1 + e^{-b(x-c)}]^2$$

As oviposition occurs at $x = 20$, i.e. when $t' = L$, instantaneous fractional rate of eggshell formation, k_E (/day), is expressed in the model as:

$$\begin{aligned} k_E &= 0, L < t' < L + 4 \\ &= abe^{-b(x-c)}/[1 + e^{-b(x-c)}]^2 \end{aligned}$$

There are two exceptions to this calculation of k_E . First, when $L = 7$ h, it is assumed that there is no ovulation on that day and, consequently, the next day will be a rest day; hence k_E is 0/day when $t' \geq 7$ h. Secondly, on a rest day, there is no oviposition but the layer is preparing for an egg at $L = 1$ h on the next day. Hence, on a rest day, k_E is 0/day if $t' < 5$ h. The above equation for k_E applies at all other times.

Egg white formation is taken to occur at the same time and rate as shell formation. Yolk formation is a continuous process (Moran, 1987). Utilization of Ca and P for yolk formation ($U_{\text{Cap,CapCayolk}}$ and $U_{\text{Pp,PpPyolk}}$) is calculated as requirement per unit of egg component formed multiplied by the fraction of that component in the egg and by egg weight, and multiplied by the fractional rate of laying in a 100-day period (all from Table 19.1). For egg white ($U_{\text{Cap,CapCawhite}}$ and $U_{\text{Pp,PpPwhite}}$) and shell ($U_{\text{Cap,CapCashell}}$ and $U_{\text{Pp,PpPshell}}$) formation, utilization is calculated as requirement per unit of egg component formed multiplied by the fraction of that component in the egg and by egg weight, and multiplied by k_E .

Depositions of Ca and P in bone are represented as saturable processes:

$$U_{\text{Cap,CapCab;Ca}} = V_{\text{CapCab}}W/(1 + M_{\text{CapCab}}/C_{\text{Cap}})$$

$$U_{\text{Pp,PpPb;P}} = V_{\text{CapCab}}W/[f_{\text{Ca:P}}(1 + M_{\text{PpPb}}/C_{\text{Pp}})]$$

$$U_{\text{Cap,CapCab;P}} = U_{\text{Pp,PpPb;P}}f_{\text{Ca:P}}$$

$$U_{\text{Pp,PpPb;Ca}} = U_{\text{Cap,CapCab;Ca}}/f_{\text{Ca:P}}$$

where $U_{\text{Cap,CapCab;Ca}}$ and $U_{\text{Cap,CapCab;P}}$ are utilization of plasma Ca for bone synthesis based on availability of plasma Ca and plasma P, respectively, and $U_{\text{Pp,PpPb;P}}$ and $U_{\text{Pp,PpPb;Ca}}$ are utilization of plasma P for bone synthesis based on availability of plasma P and plasma Ca, respectively (all in mg/day).

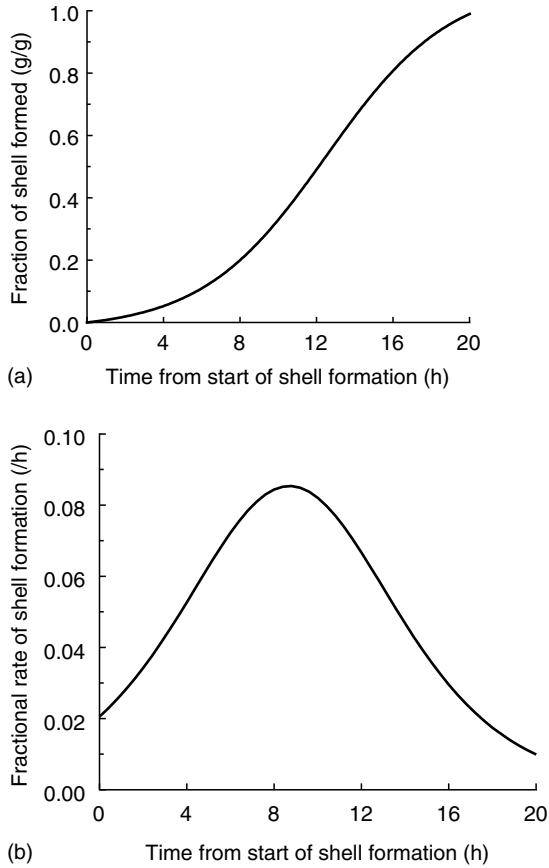

Fig. 19.2. Time course of eggshell formation (after Van Krieken, 1996): (a) cumulative eggshell formation; (b) fractional rate of eggshell formation.

V_{CapCab} [mg/(kg LW)/day] is maximal rate of Ca deposition in bone, M_{CapCab} and M_{PpPb} [mg/(kg LW)] are affinity constants, C_{Cap} and C_{Pp} [mg/(kg LW)] concentrations of Ca and P in plasma, and $f_{Ca:P}$ ratio of Ca to P in bone, assumed fixed (Table 19.1). The maximal rate of Ca deposition was assumed to be equal to that of Ca mobilization from bone. Actual deposition of Ca ($U_{Cap,CapCab}$; mg/day) and P ($U_{Pp,PpPb}$; mg/day) are therefore the minima:

$$U_{Cap,CapCab} = \text{MIN}(U_{Cap,CapCab;Ca}, U_{Cap,CapCab;P})$$

$$U_{Pp,PpPb} = \text{MIN}(U_{Pp,PpPb;P}, U_{Pp,PpPb;Ca})$$

Utilization of Ca and P for maintenance (mg/day) is:

$$U_{Cap,CapCam} = R_{CapCam} W$$

$$U_{Pp,PpPm} = R_{PpPm} W$$

where R_{CapCam} and R_{PpPm} [both mg/(kg LW)/day] are Ca and P maintenance requirements per unit LW (Table 19.1). The Ca and P maintenance requirements are based on recommendations of WPSA (1984) and CVB (1994).

Ca and P excreted in urine is the sum of: (i) basal requirements for Ca and P (maintenance requirements); (ii) amount of Ca or P in plasma that cannot be used for bone synthesis because the other mineral (P and Ca, respectively) is lacking; and (iii) amount of Ca or P released from bone because P or Ca is required for egg synthesis, respectively:

$$U_{\text{Cap, CapCau}} = U_{\text{Cap, CapCam}} + \text{MAX}(0, U_{\text{Cap, CapCab; Ca}} - U_{\text{Cap, CapCab; P}}) + \\ \text{MAX}(0, U_{\text{Cab, CabCap; P}} - U_{\text{Cab, CabCap; Ca}}) \\ U_{\text{Pp, PpPu}} = U_{\text{Pp, PpPm}} + \text{MAX}(0, U_{\text{Pp, PpPb; P}} - U_{\text{Pp, PpPb; Ca}}) + \\ \text{MAX}(0, U_{\text{Pb, PbPp; Ca}} - U_{\text{Pb, PbPp; P}})$$

where $U_{\text{Cab, CabCap; P}}$ and $U_{\text{Cab, CabCap; Ca}}$ are mobilization of bone Ca based on P and Ca needs, respectively, and $U_{\text{Pb, PbPp; Ca}}$ and $U_{\text{Pb, PbPp; P}}$ are mobilization of bone P based on Ca and P needs, respectively (all in mg/day). In these equations, it is assumed that any mineral not used for bone synthesis because availability of the other mineral is not enough to support that synthesis is excreted in urine. Equally, any mineral that has been mobilized because of necessary mobilization of the other mineral is excreted in urine. Thus, it is assumed that temporary storage of one of the minerals that is in excess does not occur.

Rates of change of pool size in the plasma are:

$$dQ_{\text{Cap}}/dt = P_{\text{Cap, CadCap}} + P_{\text{Cap, CabCap}} - U_{\text{Cap, CapCae}} - U_{\text{Cap, CapCab}} - U_{\text{Cap, CapCau}} \\ dQ_{\text{Pp}}/dt = P_{\text{Pp, PdPp}} + P_{\text{Pp, PbPp}} - U_{\text{Pp, PpPe}} - U_{\text{Pp, PpPb}} - U_{\text{Pp, PpPu}}$$

Calcium and phosphorus in the bone

Inputs to the Ca and P pools in bone are from plasma:

$$P_{\text{Cab, CapCab}} = U_{\text{Cap, CapCab}}$$

$$P_{\text{Pb, PpPb}} = U_{\text{Pp, PpPb}}$$

Outputs from bone are to plasma:

$$U_{\text{Cab, CabCap}} = \text{MAX}(U_{\text{Cab, CabCap; P}}, U_{\text{Cab, CabCap; Ca}})$$

$$U_{\text{Pb, PbPp}} = \text{MAX}(U_{\text{Pb, PbPp; Ca}}, U_{\text{Pb, PbPp; P}})$$

where $U_{\text{Cab, CabCap; P}}$ and $U_{\text{Cab, CabCap; Ca}}$ (mg/day) are rates of Ca mobilization from bone synthesis based on availability of P or Ca in plasma, respectively. Similarly, $U_{\text{Pb, PbPp; Ca}}$ and $U_{\text{Pb, PbPp; P}}$ (mg/day) are corresponding rates of P

mobilization. Mobilization of Ca and P from bone is assumed to be inhibited by plasma availability of these minerals (Boorman and Gunaratne, 2001):

$$U_{\text{Cab, CabCap; Ca}} = V_{\text{CabCap}} W / (1 + C_{\text{Cap}} / J_{\text{CabCap}})$$

$$U_{\text{Pb, PbPp; P}} = V_{\text{CabCap}} W / [f_{\text{Ca: P}} (1 + C_{\text{Pp}} / J_{\text{PbPp}})]$$

$$U_{\text{Cab, CabCap; P}} = U_{\text{Pb, PbPp; P}} f_{\text{Ca: P}}$$

$$U_{\text{Pb, PbPp; Ca}} = U_{\text{Cab, CabCap; Ca}} / f_{\text{Ca: P}}$$

where V_{CabCap} [mg/(kg LW)/day] is maximal rate of bone Ca mobilization and J_{CabCap} and J_{PbPp} [mg/(kg LW)] are inhibition constants (Table 19.1). Maximum rate of bone Ca mobilization was set so as to sustain maximum rates of Ca utilization for egg synthesis when other Ca sources were not available. Rates of change of pool size in bone are:

$$dQ_{\text{Cab}}/dt = P_{\text{Cab, CapCab}} - U_{\text{Cab, CabCap}}$$

$$dQ_{\text{Pb}}/dt = P_{\text{Pb, PpPb}} - U_{\text{Pb, PbPp}}$$

Model summary

The model was programmed in the dynamic simulation language SMART (©Wageningen University, Computer Science Group). Euler's method of integration, with a step size of 0.6 min, was used and the model was run for 5 days. Usually, within 3 days, quasi-steady state is achieved, and the results are taken for the last day of simulation (day 5).

Results and Discussion

Diurnal changes in Ca and P for a layer laying an egg when $L = 1$ h are presented in Fig. 19.3. An overview of hourly and daily P dynamics in such a layer is presented in Table 19.2.

From the moment light is switched on (at 0 h), feed intake commences and, consequently, Ca and P absorption increase. After 16 h, light is switched off and feed intake ceases. Therefore, Ca and P absorption decline, because the amounts of Ca and P present in crop and stomach quickly decrease and no new Ca or P enters the crop. The present simulations assume continuous intake. However, depending on the light scheme used, *ad libitum* feed intake may vary during the day. In a continuous lighting scheme, feed intake was reduced in the 2 h period before oviposition, whereas after oviposition feed intake was increased (Savory, 1978). Other authors observed a somewhat higher feed intake in the second half of the light period. Keshavarz (1998), for example, observed in a 16 h light scheme that hens consumed 40% of daily feed intake during the first 8 h after light

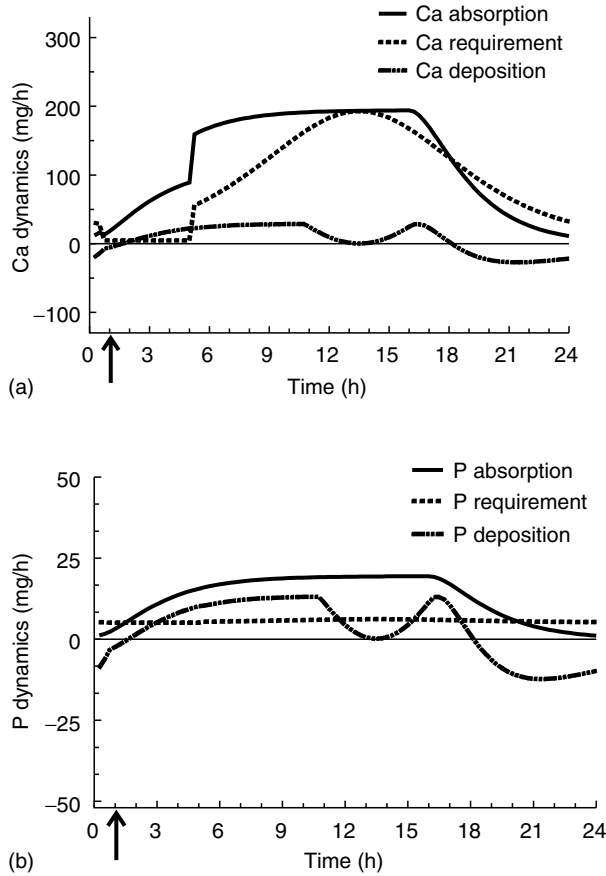

Fig. 19.3. Simulated diurnal dynamics of (a) calcium (Ca) and (b) phosphorus (P) in a layer at oviposition 1 h after light is switched on. The arrow denotes time of oviposition. Ca absorption is absorption from the duodenum, Ca requirement is requirement for maintenance and egg production (shell, yolk and white), and Ca deposition is bone synthesis (positive values) or bone mobilization (negative values).

was switched on, and 60% during the 8-h period before light was switched off. Considerable increases in feed intake in the second half of the photophase are also reported in the review of Scanes *et al.* (1987). Such patterns of feed intake can easily be incorporated in the model since feed intake is an independent driving variable. If the feed intake is higher during the second phase of the photoperiod, the simulated rate of Ca absorption from the gut will show a more gradual increase towards a maximum value around the start of the dark period, and a slower decrease in Ca absorption in the dark period than the absorption patterns shown in Fig. 19.3a. Obviously, when hens are fed several meals a day, the feed intake will also depend on the amount of feed offered per meal.

Table 19.2. Simulated phosphorus (P) flows in successive 1 h periods of the day following switching on of light at time zero for a layer producing an egg 1 h after light is switched on.

Hour	P flow (mg/h)					
	Absorbed	Into egg	Maintenance	Not utilized	Into bone	Into urine
1	3.18	4.13	0.99	0	-2.33	0.99
2	7.16	4.13	0.99	0	1.56	0.99
3	10.81	4.13	0.99	0	5.25	0.99
4	13.59	4.13	0.99	0	8.12	0.99
5	15.56	4.13	0.99	0	10.18	0.99
6	16.90	4.48	0.99	0	11.26	0.99
7	17.78	4.58	0.99	0	12.11	0.99
8	18.37	4.69	0.99	0	12.63	0.99
9	18.75	4.81	0.99	0	12.91	0.99
10	19.00	4.98	0.99	0	13.05	0.99
11	19.15	5.05	0.99	1.74	11.37	2.73
12	19.26	5.14	0.99	8.63	4.49	9.63
13	19.32	5.19	0.99	12.46	0.68	13.45
14	19.37	5.19	0.99	12.51	0.66	13.51
15	19.39	5.14	0.99	8.79	4.45	9.78
16	19.41	5.05	0.99	1.96	11.39	2.95
17	16.96	4.98	0.99	1.01	10.58	2.00
18	12.73	4.81	0.99	6.19	1.33	7.18
19	8.92	4.69	0.99	10.00	-6.33	10.99
20	6.04	4.58	0.99	11.35	-10.59	12.35
21	4.00	4.48	0.99	10.88	-12.16	11.88
22	2.63	4.40	0.99	9.41	-12.05	10.40
23	1.71	4.33	0.99	7.54	-11.08	8.53
24	1.11	4.28	0.99	5.65	-9.88	6.64
Total (mg/day)	311.1	111.6	23.8	107.9	67.8	131.7

Fractional rates of passage of Ca and P from the crop and stomachs are assumed not to vary within the day. Data on diurnal changes in transit times are scarce. Scanes *et al.* (1987) observed a gradual decrease in crop and gizzard contents during the dark period. However, crop and gizzard remained virtually empty during the first half of the photophase, when feed intake had already commenced. Such a pattern suggests much smaller retention times (higher fractional passage rates) in the first half of the photoperiod than at other times of the day. Fractional rate of passage from the stomachs (k_{CasCad}) will be greatly affected by source and particle size of Ca, with larger particles having a lower rate of solubilization and presumably a lower rate of passage from the stomachs, and limestone showing higher rates of solubilization than oyster shell (Rao and Roland, 1989). In the model, assuming a lower fractional rate of passage of Ca from the stomachs will result in a less rapid approach to maximum Ca absorption, and slower rate of decline of Ca absorption during the dark period.

From the moment of egg laying (hour 1), Ca requirement is small until hour 5, when formation of a new eggshell starts. P requirement is more or less equal during the day, since the majority of P is required for synthesis of egg yolk, assumed to be a continuous process. In hour 1, P requirement is higher than P absorption, and therefore P and Ca mobilization from bone occurs. In this hour, all mobilized P is utilized for maintenance and egg production, and P excretion in urine is merely related to maintenance. In contrast, mobilized Ca cannot be utilized or stored and is therefore excreted in urine.

After shell formation starts, Ca requirement increases and decreases in a pattern related to that of shell formation. Simulated Ca requirement is highest some 11–17 h after previous oviposition, which is qualitatively in line with the most rapid rates of shell secretion occurring during 12–18 h post oviposition observed by Clunies and Leeson (1995). The simulated Ca absorption is sufficient to meet Ca requirement until hour 18. P absorption is sufficient to meet requirement until hour 20. However, the surplus of P absorbed cannot always be utilized for bone synthesis, since Ca may be lacking to support this synthesis. That is the case during approximately hours 11–18. Hence, a part of absorbed P is not utilized in these hours, and excreted in urine. From hour 18 until the end of the dark period, Ca has to be mobilized to support requirement, and consequently P is mobilized as well. A large part of this mobilized P is not required for maintenance or egg synthesis and is thus excreted in urine. Note that there are two reasons why P is unutilized and excreted in the urine. During hours 11–18, P uptake in feed is too high relative to Ca availability to support high bone synthesis rates. During hour 18–24, P that is not utilized largely originates from bone mobilization because of Ca requirement. The simulated large amounts of P excreted during the process of shell formation are qualitatively in line with data of Hurwitz and Bar (1965).

The calculations indicate that only 44% of dietary available P is utilized for maintenance or deposited in the egg, and 22% is deposited in bone. Therefore, approximately one-third of available P intake (i.e. 107.9 out of 311.1 mg/day) is not utilized because of instantaneous deficits of Ca. Total net P deposition in bone is 67.8 mg/day. This would indicate that dietary absorbable P can be reduced by 22%. However, evaluation of feeding strategies requires simulations at all possible hours of oviposition and assumptions on the frequency distribution of those hours within a flock of layers, described later.

When oviposition occurs later after light is switched on, relatively more of the shell-forming process occurs during the night. Hence, Ca requirement occurs especially at hours when Ca supply from gut is small. This is illustrated in Fig. 19.4 for oviposition at $L = 5$ h. From hour 16 onwards, simulated Ca requirement is much higher than Ca absorption due to high shell synthesis rate and declining rate of Ca absorption, giving rise to bone mobilization. Consequently, large amounts of P are mobilized as well and excreted in urine. During hours 2–15, bone synthesis is limited because P is limiting and Ca surplus will be excreted. The amount of P not utilized (328.2 mg/day) is even higher

than the amount of available P from the feed (311.1 mg/day; see Table 19.3). Over a whole day, there is net P mobilization of bone (152.5 mg/day). In this case, dietary absorbable P cannot be reduced because of bone depletion that has already occurred.

Ca and P dynamics of a hen for oviposition at hour 7 and for a rest day are shown in Figs 19.5 and 19.6, respectively. On both days, feed intake is assumed to be 10% lower than average feed intake of a complete mixed diet. Etches (1987) presented an overview of data and concluded that when hens are presented with free-choice Ca, they consume some 70% of normal Ca intake on the day before a rest day but 95% on the rest day itself. This intake pattern reflects smaller Ca requirement on the day preceding the rest day, since no shell needs to be formed, whereas the Ca requirement on the rest day itself is high in order to synthesize the shell of the egg to be laid on the

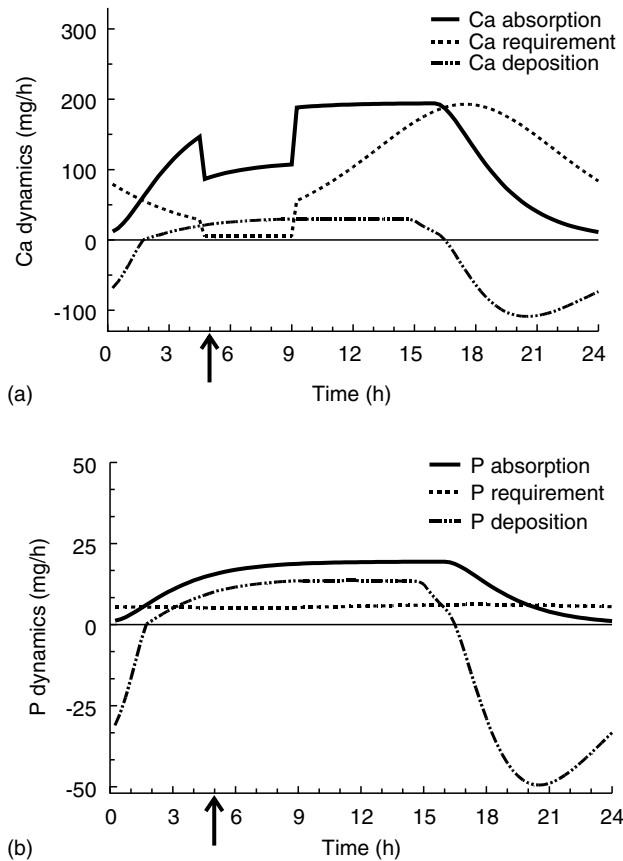

Fig. 19.4. Simulated diurnal dynamics of (a) calcium (Ca) and (b) phosphorus (P) in a layer at oviposition 5 h after light is switched on. The arrow denotes time of oviposition. Ca absorption is absorption from the duodenum, Ca requirement is requirement for maintenance and egg production (shell, yolk and white), and Ca deposition is bone synthesis (positive values) or bone mobilization (negative values).

Table 19.3. Simulated daily phosphorus (P) flows (mg/day) in layers at various laying times (LT) after light is switched on, and averaged P flow in a 100 day period.

LT (h)	Days/100 days	Absorbed	Into egg	Maintenance	Not utilized	Into bone	Into urine
1	15	311.1	111.6	23.8	107.9	67.8	131.7
2	16	311.1	111.6	23.8	167.3	8.4	191.1
3	20	311.1	111.6	23.8	224.2	-48.5	248.0
4	17	311.1	111.6	23.8	278.1	-102.4	301.9
5	12	311.1	111.6	23.8	328.2	-152.5	352.0
6	10	311.1	111.6	23.8	374.1	-198.4	397.9
7	5	277.2	101.4	23.8	62.9	89.1	86.7
Rest day	5	277.2	111.3	23.8	123.5	18.6	147.3
Weighted average		307.7	111.1	23.8	221.2	-48.3	245.0

next day. As before, such a Ca intake pattern can easily be incorporated into the model if desired. Even though feed intake is lower on the day when oviposition occurs at $L = 7$ h, the hen is in positive Ca and P balance during most of the day (Fig. 19.5). From hour 3 onwards until hour 20, bone accretion occurs and P is predicted to limit the rate of bone accretion. Therefore, P losses due to imbalance of Ca and P are small, and bone synthesis (P deposition in bone of 89.1 mg/day) helps to provide a store of Ca and P for the next clutch. On a rest day, there is no oviposition but Ca demands are high to form the shell for the next day. Given the lower Ca intake level on a rest day, there is bone mobilization during peak shell synthesis rates as well as during most of the dark hours (Fig. 19.6). The amount of P not utilized is therefore higher than on a day with oviposition at hour 1 (123.5 and 107.9 mg/day respectively).

To calculate total Ca and P flows during a longer period, assumptions about the frequency distribution of hours of oviposition within a flock of layers have to be made. Based on observations on frequency of laying times reported by Van Krieken (1996) and a high laying fraction of 95 eggs/100 days, average P flows in a layer are presented in Table 19.3. Such a frequency distribution of laying times may depend on the strain of laying hens, and calculations can easily be adapted to analyse different frequency distributions. Over a period of 100 days, the simulations indicate that on average 221.2 mg/day of P is not utilized because of Ca shortage and is excreted with urine. Also, P mobilization from bone is on average 48.3 mg/day, which corresponds to mobilization of Ca of 106.3 mg/day. Given such a level of bone mobilization, osteoporosis problems may occur. This negative Ca balance is more pronounced than the Ca balances reported by Clunies *et al.* (1992) of -107, -22 and 163 mg/day for dietary Ca levels of 25, 35 or 45 mg/kg feed, respectively. However, the hens in their study had a lower laying fraction (~ 90 eggs/100 days), therefore demanding less Ca

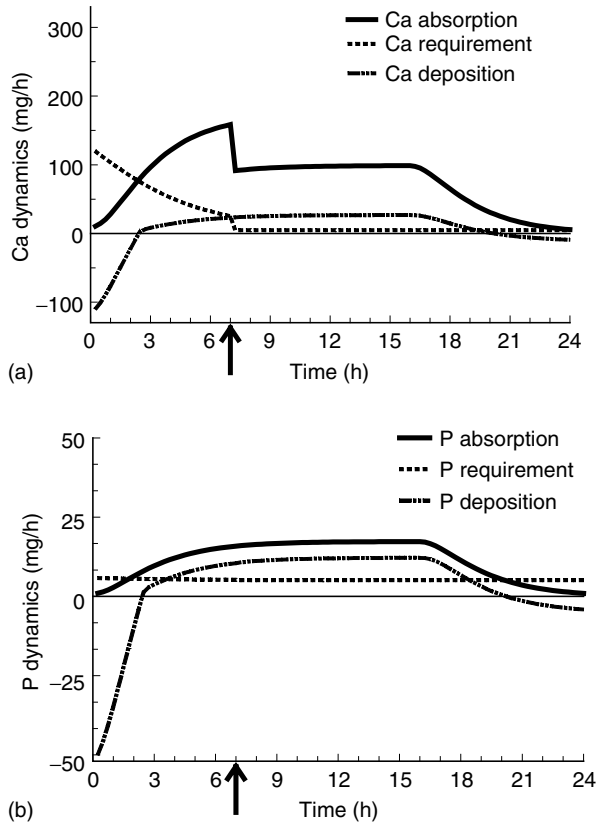

Fig. 19.5. Simulated diurnal dynamics of (a) calcium (Ca) and (b) phosphorus (P) in a layer at oviposition 7 h after light is switched on. The arrow denotes time of oviposition. Ca absorption is absorption from the duodenum, Ca requirement is requirement for maintenance and egg production (shell, yolk and white), and Ca deposition is bone synthesis (positive values) or bone mobilization (negative values).

and giving more opportunity for bone deposition. Also, available P level in their diet was 4.5 mg/g whereas in the present simulations a level of 2.8 mg/g was adopted. A higher supply of P will increase bone deposition rate at those hours when P, and not Ca, is limiting.

There are several options to reduce this level of bone depletion. Since there are hours during the day when Ca is in short supply and hence P cannot be utilized properly, supplying more Ca with the diet or ensuring a pattern of Ca absorption that better matches average instantaneous Ca requirement will reduce this mobilization and reduce P excretion to the environment. Equally, an increase in P supply may help to resynthesize bone at times when Ca supply is sufficient (normally during non-shell-forming hours), but this option will increase P excretion in urine as well. Increases in

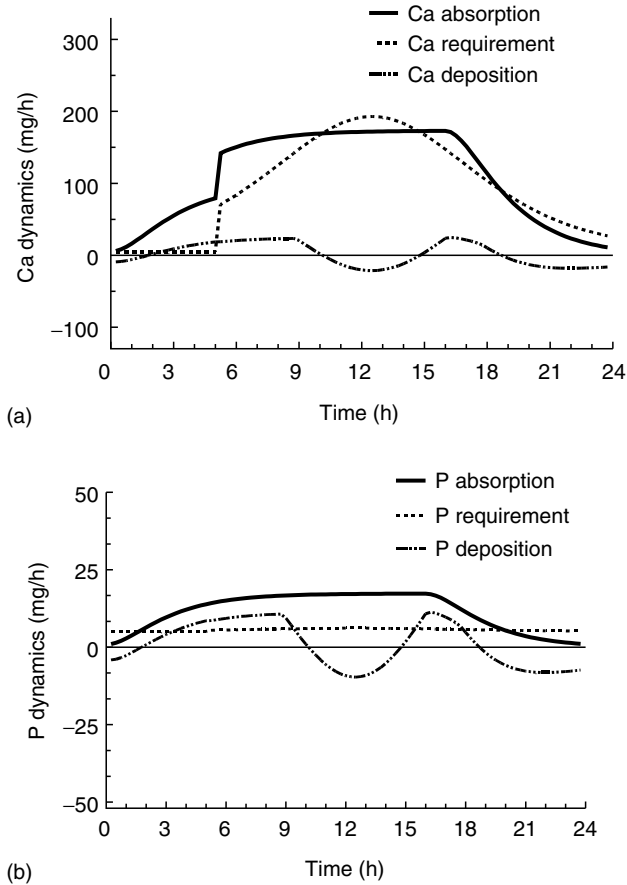

Fig. 19.6. Simulated diurnal dynamics of (a) calcium (Ca) and (b) phosphorus (P) in a layer on a rest day (no oviposition). Ca absorption is absorption from the duodenum, Ca requirement is requirement for maintenance and egg production (shell, yolk and white), and Ca deposition is bone synthesis (positive values) or bone mobilization (negative values).

dietary P and Ca levels may affect apparent digestion of these nutrients. Elevated dietary Ca levels increase pH in the gut and as a result P absorption is decreased. High plasma P levels decrease Ca absorption from gut (e.g. Keshavarz and Austic, 1990). The present model has available P as a driving variable and absorption of Ca is either 40% or 70%. Therefore, if such interactions between dietary Ca and P levels are expected to occur, these values should be changed. The model developed here is a promising tool in evaluating such alternative feeding strategies for effects on bone depletion or synthesis and P excretion in urine.

Conclusions

An inadequate supply of Ca or P may lead to excessive withdrawal of calcium phosphate from the medullary bones and make these bones weak. Recommendations on dietary P levels vary widely. The model developed is a tool to quantify Ca and P dynamics within a 24 h period based on understanding of the processes involved and to evaluate Ca and P dynamics for a wide range of oviposition times. This will help to evaluate feeding strategies aimed at reducing P excretion to the environment in poultry manure.

References

- Boorman, K.N. and Gunaratne, S.P. (2001) Dietary phosphorus supply, egg-shell deposition and plasma inorganic phosphorus in laying hens. *British Poultry Science* 42, 81–91.
- Clunies, M., Parks, D. and Leeson, S. (1992) Calcium and phosphorus metabolism and eggshell formation of hens fed different amounts of calcium. *Poultry Science* 71, 482–489.
- Clunies, M. and Leeson, S. (1995) Effect of dietary calcium level on plasma proteins and calcium flux occurring during a 24-h ovulatory cycle. *Canadian Journal of Animal Science* 75, 439–444.
- Correll, D.L. (1999) Phosphorus: a rate-limiting nutrient in surface waters. *Poultry Science* 78, 674–682.
- (CVB) Centraal VeevoederBureau (1994) *Preliminary System Available Phosphorus Poultry* (in Dutch). CVB, Lelystad, The Netherlands.
- Etches, R.J. (1987) Calcium logistics in the laying hen. *Journal of Nutrition* 117, 619–628.
- Hurwitz, S. and Bar, A. (1965) Absorption of calcium and phosphorus along the gastrointestinal tract of the laying fowl as influenced by dietary calcium and eggshell formation. *Journal of Nutrition* 86, 433–438.
- Hurwitz, S. and Bar, A. (1969) Intestinal calcium absorption in the laying hen and its importance in calcium homeostasis. *American Journal of Clinical Nutrition* 22, 391–395.
- Kebreab, E., France, J., Phipps, R.H. and Leeson, S. (2005) Potential cost and environmental impact of feeding high-oil corn to poultry in Brazil. *Journal of Applied Poultry Research* (in press).
- Keshavarz, K. (1998) Investigation on the possibility of reducing protein, phosphorus and calcium requirements of laying hens by manipulation of time of access to these nutrients. *Poultry Science* 77, 1320–1332.
- Keshavarz, K. and Austic, R.E. (1990) Effects of dietary minerals on acid–base balance and eggshell quality in chickens. *Journal of Nutrition* 120, 1360–1369.
- Moran, E.T. (1987) Protein requirement, egg formation and the hen's ovulatory cycle. *Journal of Nutrition* 117, 612–618.
- Rao, K.S. and Roland, D.A. (1989) Influence of dietary Ca level and particle size of Ca source on *in vivo* Ca solubilization by commercial leghorns. *Poultry Science* 68, 1499–1505.
- Rao, K.S., Roland, D.A. and Hoerr, F.J. (1992) Response of early- and late-maturing commercial leghorn pullets to low levels of dietary phosphorus. *Poultry Science* 71, 691–699.

- Rennie, J.S., Fleming, R.H., McCormack, H.A., McCorquodale, C.C. and Whitehead, C.C. (1997) Studies on effects of nutritional factors on bone structure and osteoporosis in laying hens. *British Poultry Science* 38, 417–424.
- Savory, C.J. (1978) The relationship between food and water intake and the effects of water restriction on brown leghorn hens. *British Poultry Science* 19, 631–641.
- Scanes, C.G., Campbell, R. and Griminger, P. (1987) Control of energy balance during egg production in the laying hen. *Journal of Nutrition* 117, 605–611.
- Sharpley, A. (1999) Agricultural phosphorus, water quality and poultry production: are they compatible? *Poultry Science* 78, 660–673.
- Thornley, J.H.M. and France, J. (2006) *Mathematical Models in Agriculture*, 2nd edn. CAB International, Wallingford, UK, 850 pp.
- Tolboom, J.G. and Kwakkel, R.P. (1998) Dynamic modelling of Ca and P flows in layers: prospects to reduce dietary digestible P levels. *British Poultry Science* 39 (Suppl.), S43–S44.
- Van der Klis, J.D., Verstegen, M.W.A. and De Wit, W. (1990) Absorption of minerals and retention time of dry matter in the gastro-intestinal tract of broilers. *Poultry Science* 69, 2185–2194.
- Van Krieken, M.A. (1996) Calcium and phosphorus in layers (in Dutch). MSc Thesis. Wageningen University, The Netherlands.
- (WPSA) World's Poultry Science Association (1984) Mineral requirements for poultry: mineral requirements and recommendations for adult birds. *World's Poultry Science Association Journal* 40, 183–187.

20 Estimating the Risk of Hypomagnesaemic Tetany in Dairy Herds

S.T. BELL,¹ A.E. MCKINNON² AND A.R. SYKES¹

¹*Animal and Veterinary Sciences Group, Lincoln University, Canterbury 8152, New Zealand;* ²*Applied Computing Group, PO Box 84, Lincoln University, Canterbury 8152, New Zealand*

Abstract

A model of magnesium dynamics in sheep has been adapted and improved as part of a programme to develop a tool that will assist dairy farmers to assess the risk of animals in a milking herd suffering from hypomagnesaemic tetany. The terms in the model for hindgut absorption have been altered to better represent the process of magnesium absorption and secretion in this region of the gastrointestinal tract, a term representing lactation has been introduced and the equation for urinary magnesium flux has been altered so that it no longer saturates at high plasma magnesium concentrations. Because the concentration of magnesium in cerebrospinal fluid (CSF) is strongly related to the onset of tetany, we have introduced a CSF compartment. We have also made allowance for diurnal feeding patterns. The improved model, scaled to represent dairy cattle, gives good agreement with a published experiment in which plasma and CSF magnesium concentrations were measured in animals on a magnesium-deficient diet.

To obtain an estimate of the risk of tetany, we included diurnal feeding patterns and information about animal variation in the model parameters and carried out Monte Carlo simulations. If at any time during a simulation run the value of the magnesium concentration in CSF were less than 0.6 mmol/l, the simulation was assumed to represent an animal at risk. With sufficient simulations we obtained an estimate of the risk of tetany for a herd as a whole. A sensitivity measure was used to determine which parameters significantly affected magnesium concentration in CSF and hence the importance of knowing their distributions. To make the risk estimate more specific to the herd under investigation, we calibrated the model using herd samples of milk and estimated urine magnesium flux. As the latter is a model output, a fitting procedure was required to use this information to improve the estimates of the sensitive model parameters. Although we have initially used a very simplistic fitting procedure, the calibrated model gave very reasonable estimates of risk.

Introduction

Hypomagnesaemic tetany is a significant problem for dairy farmers both economically and as an animal welfare issue, and for that reason has been the subject of extensive study during a lengthy period (Field *et al.*, 1958;

Martens and Schweigel, 2000; McCoy *et al.*, 2001). To aid our understanding of the factors that determine magnesium status in dairy cattle, we have adapted and improved a model of magnesium dynamics in sheep (Robson *et al.*, 1997). Although this model represents a single animal and was originally developed to create a platform for the experimental testing of various hypotheses, our intention is to explore the use of the model at the herd level to provide information to a farmer about the risk that animals in the herd will suffer from hypomagnesaemic tetany.

The concept of risk is based on variation. The variation in magnesium dynamics exhibited by a herd of dairy cows will be due to the genetic variation that exists within the herd variation, in the environment that each animal experiences and other more systematic variation due to factors such as diurnal feeding patterns. In addition to these is the unexplained variation due to measurement error and inadequacies in the model. It is important to minimize the latter so that, as much as possible, the risk estimate reflects the herd and its environment rather than lack of knowledge.

In this study, we first review the modifications that have been made to the model of Robson *et al.* (1997). We then describe our approach to using the model to estimate the risk that hypomagnesaemic tetany will occur in a dairy herd and finally present some preliminary results from our attempts to estimate the risk.

Model Modifications

A schematic diagram of the model adapted from Robson *et al.* (1997) is shown in Fig. 20.1. All model symbols used in this chapter are described in Table 20.1. The current version of the model has been implemented in the Python language. The differential equations are structured in the same way as in the original ACSL™ implementation (Robson *et al.*, 1997) and solved using a Euler method with an integration time step of 0.01 h.

In addition to the scaling required to convert the model from sheep to dairy cattle, the revised model includes:

- modifications to the equations representing urinary magnesium flux;
- modifications to the equations representing hindgut absorption;
- a term representing lactation;
- equations representing saliva flow into the rumen and the slow breakdown of dietary matter to incorporate effects of diurnal variation;
- a compartment representing magnesium in CSF.

The following sections briefly describe these modifications.

Urinary magnesium flux

The original model represented the relationship between plasma magnesium concentration (C_{pl}) and the rate of magnesium flow between the loop of Henle and urine (U_{HIUr} mmol/day) using the equation:

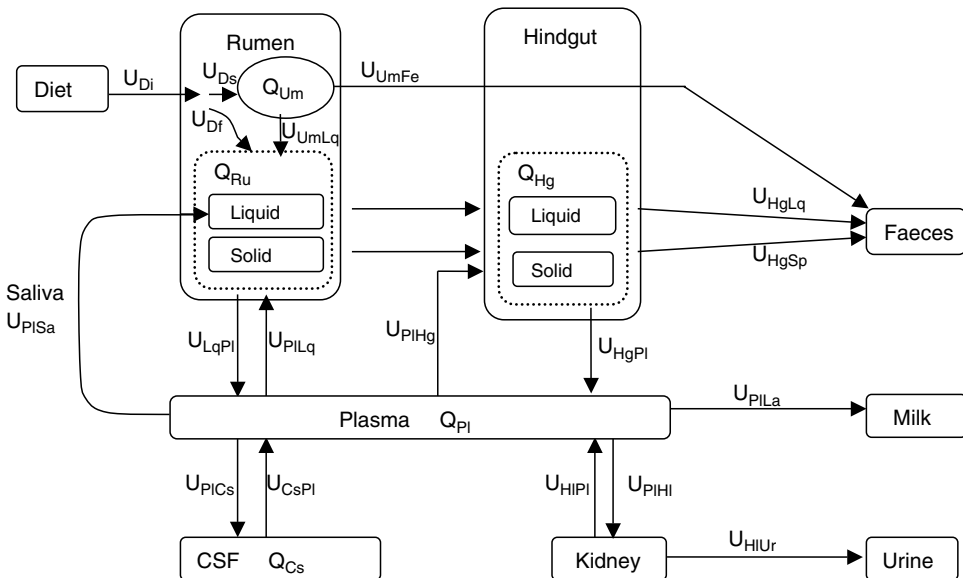

Fig. 20.1. Schematic diagram of the model of magnesium dynamics in dairy cows. The variables U_{ij} represent the flux of magnesium from compartment i to compartment j . The variables Q_i represent the quantity of magnesium in compartment i and are the state variables of the model. A description of all model symbols is given in Table 20.1.

$$U_{HIUr} = \frac{k_{HIUr} C_{Pl}}{v_{HIUr} - C_{Pl}} \tag{20.1}$$

where v_{HIUr} and k_{HIUr} are constants. Equation (20.1) represents an active transport process where U_{HIUr} increases rapidly with C_{Pl} as C_{Pl} approaches v_{HIUr} from below. This provides an important mechanism for the regulation of plasma magnesium. However, Robson and Vlieg (2000) reported that there is evidence for both passive (Shareghi and Agus, 1982) and active (di Stefano *et al.*, 1993) transport processes involved in the absorption of magnesium by the kidney. They added a linear term to the inverted form of equation (20.1) to give:

$$C_{Pl} = \frac{v_{HIUr} U_{HIUr}}{U_{HIUr} + k_{HIUr}} + d_{HIUr} U_{HIUr} \tag{20.2}$$

where d_{HIUr} is a constant with units of d/l . Equation (20.2) is a more realistic representation that fits the experimental data well, as shown in Fig. 20.2. The linear term $d_{HIUr} U_{HIUr}$ in equation (20.2) causes a sloping asymptote $v_{HIUr} + d_{HIUr} U_{HIUr}$ for C_{Pl} as U_{HIUr} increases, instead of the constant asymptotic value v_{HIUr} implied by equation (20.1). Following Robson and Vlieg (2000), the inverted form of equation (20.2), using the positive solution of the quadratic, has been incorporated into the model.

Table 20.1. Description of model symbols referred to in this chapter.

Parameter symbol	Description
C_{CSF}	Cerebrospinal fluid (CSF) magnesium concentration (mmol/l)
C_{Di}	Dietary magnesium concentration (g/kg dry matter (DM))
C_{HgLq}	Concentration of magnesium in the liquid phase in the hindgut (mmol/l)
C_{KRu}	Rumen potassium concentration (mmol/l)
C_{La}	Milk magnesium concentration (mmol/l)
C_{Pl}	Plasma magnesium concentration (mmol/l)
d_{HIUr}	Constant (day/l)
$k_{1\text{PIHg}}$	Constant (mmol/day)
$k_{2\text{PIHg}}$	Constant (l/day)
k_{HgPl}	Hindgut absorption constant (l/day)
k_{HIUr}	Constant (mmol/day)
k_{m}	Constant (mmol/l)
k_{UmLq}	Constant (/day)
Q_{Cs}	Amount of magnesium in cerebrospinal fluid (CSF; mmol)
Q_{Hg}	Total amount of magnesium in hindgut liquid and solid phases (mmol)
Q_{Pl}	Amount of magnesium in plasma (mmol)
Q_{Ru}	Total amount of digested magnesium in rumen solid and liquid phases (mmol)
Q_{Um}	Amount of magnesium in undigested form in the rumen (mmol)
r_{MgCsPl}	Cerebrospinal fluid (CSF) turnover rate (/day)
U_{CsPl}	Rate of flow of magnesium from cerebrospinal fluid (CSF) to plasma (mmol/day)
U_{Di}	Rate of intake of dietary magnesium (mmol/day)
U_{Df}	Rate of intake of dietary magnesium in soluble form (mmol/day)
U_{Ds}	Rate of intake of dietary magnesium in solid form (mmol/day)
U_{HgPl}	Rate of flow of magnesium from hindgut to plasma (mmol/day)
U_{HgLq}	Rate of flow of magnesium in the liquid phase from hindgut to faeces (mmol/day)
U_{HgSp}	Rate of flow of magnesium in the solid phase from hindgut to faeces (mmol/day)
U_{HIPl}	Rate of flow of magnesium from the loop of Henle to plasma (mmol/day)
U_{HIUr}	Rate of flow of magnesium from the loop of Henle to urine (mmol/day)
U_{LqPl}	Rate of flow of magnesium from rumen liquid phase to plasma (mmol/day)
U_{PlCs}	Rate of flow of magnesium from plasma to cerebrospinal fluid (CSF; mmol/day)
U_{PlHg}	Rate of flow of magnesium from plasma to hindgut (mmol/day)
U_{PlHI}	Rate of flow of magnesium from plasma to the loop of Henle (mmol/day)
U_{PlLa}	Rate of flow of magnesium from plasma to milk (mmol/day)
U_{PlLq}	Rate of flow of magnesium from plasma to rumen liquid phase (mmol/day)
U_{PlSa}	Rate of flow of magnesium from plasma to rumen as saliva (mmol/day)
U_{UmLq}	Rate of release of magnesium from ingested solid matter in the rumen (mmol/day)
U_{UmFe}	Rate at which magnesium in undegraded solid matter passes out of the rumen (mmol/day)
V_{Cs}	Volume of cerebrospinal fluid (CSF; l)
V_{La}	Daily milk production (l/day)
V_{Lq}	Rumen liquid volume (l)
v_{HIUr}	Constant (mmol/l)

Hindgut absorption

Robson *et al.* (1997) used a single ‘hindgut’ compartment to model magnesium secretion and absorption fluxes beyond the rumen. This accounted for the absorption of magnesium in the distal ileum and colon. A secretory flux at this site, U_{PIH_g} , was set at 3mg/kgBW/day, equivalent to experimental data for the net endogenous magnesium loss (ARC, 1980). The absorption from the hindgut was represented as:

$$U_{HgPI} = k_{HgPI}(C_{HgLq} - C_{PI}) \tag{20.3}$$

mmol/day where C_{HgLq} is the concentration of magnesium in the liquid phase in the hindgut and k_{HgPI} is a constant.

The current model uses a revised hindgut compartment, which is considered to be partitioned into two segments:

1. The proximal small intestine. The apparent secretory flux at this site is represented by U_{PIH_g} mmol/day.
2. The distal small intestine and colon. This corresponds to the model variable Q_{H_g} , which represents the amount of magnesium in the hindgut and is the site from where the absorption flux U_{HgPI} is considered to occur.

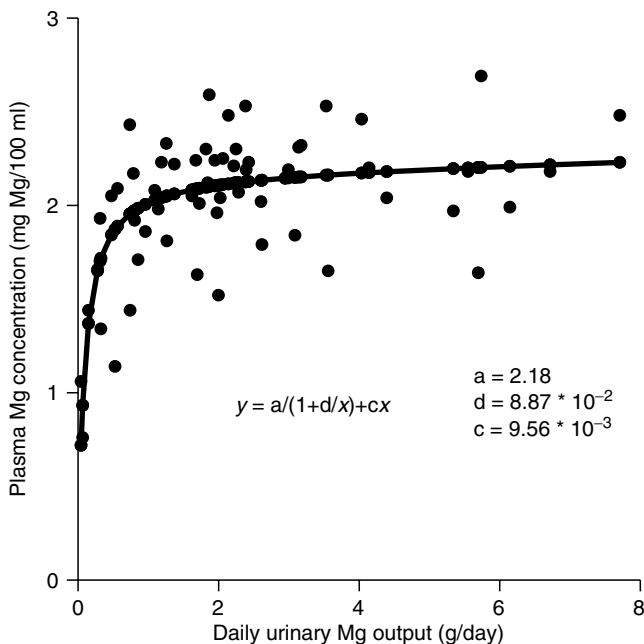

Fig. 20.2. A model of the form given by equation (20.2) fitted to measurements of plasma magnesium concentration (mg Mg/100 ml) versus daily urinary magnesium excretion (g/day). The measurements were taken from dairy cattle on 24 September 1998 at Lincoln University. (Reproduced from Robson and Vleig, 2000.)

The review by Laporté *et al.* (2001) showed that secretion of magnesium into the small intestine is substantial but that approximately 75% is subsequently reabsorbed. In addition, the analysis by Bell *et al.* (2001) and the review of Schweigel and Martens (2000) suggest that secretion of magnesium into the intestinal tract is dependent on plasma magnesium concentration. Accordingly, the model was modified to represent the secretion of magnesium into the small intestine as:

$$U_{\text{PIHg}} = (k_{1\text{PIHg}} + k_{2\text{PIHg}} C_{\text{PI}}) \quad (20.4)$$

where $k_{1\text{PIHg}}$ and $k_{2\text{PIHg}}$ are constants. Equation (20.3) was retained to describe absorption from the large intestine although the parameters were adjusted to better represent the available experimental information. When the model was being scaled from sheep to cattle, further adjustment of the parameters was necessary to account for differences in the species that were noted to be in the same ratio as the differences in hindgut water content (Hecker and Grovum, 1975).

With these modifications, the model predicts hindgut secretion and absorption that better agree with published data such as in Grace (1983) and Rogers and van't Klooster (1969).

Lactation

The magnesium flux in milk is given by:

$$U_{\text{PILa}} = C_{\text{La}} V_{\text{La}} \quad (20.5)$$

mmol/day where C_{La} is the concentration of magnesium in milk and V_{La} is the daily milk production in l/day. Although the concentration of magnesium in milk has been shown to vary significantly between animals in the herd, there appears to be no significant relationship between plasma magnesium concentration and milk magnesium concentration (Thielen *et al.*, 2001). C_{La} and V_{La} are therefore treated as model parameters that will vary both between animals and during the dairy season, but estimates of their values are readily obtained.

Magnesium in cerebrospinal fluid

Pauli and Allsop (1974) and Allsop and Pauli (1975) clearly demonstrated that the onset of hypomagnesaemic tetany is strongly related to the concentration of magnesium in the CSF. Accordingly, a compartment representing CSF was introduced into the model (Robson *et al.*, 2004) as:

$$\frac{dQ_{\text{Cs}}}{dt} = U_{\text{PICs}} - U_{\text{CsPI}} \quad (20.6)$$

where Q_{Cs} is the amount of magnesium in the CSF, U_{PlCs} (mmol/day) is the rate of transfer of magnesium from plasma to the CSF, and U_{CsPl} (mmol/day) is the rate of clearance of magnesium back to plasma.

The CSF is assumed to be a fixed volume V_{Cs} turned over at the rate of r_{MgCsPl} ($= 7.2/\text{day}$; Cserr, 1971). The rate of clearance of magnesium from the CSF U_{CsPl} is the product of the rate of clearance of fluid (l/day) and the concentration of magnesium in that secreted fluid which is equivalent to $r_{MgCsPl}Q_{Cs}$.

The uptake of magnesium from plasma by the CSF exhibits the hallmarks of a saturable process (Cserr, 1971; Meyer and Scholz, 1972) and was modelled (Robson *et al.*, 2004) using the Michaelis–Menten expression:

$$U_{PlCs} = \frac{v_{Max} V_{Cs}}{1 + \frac{k_m}{C_{Pl}}} \tag{20.7}$$

where v_{Max} and k_m are Michaelis–Menten constants (Martens, 1983).

Diurnal variation

One of the sources of variation that might affect the risk of tetany is diurnal feeding pattern. With the CSF turning over approximately every 7 h (Cserr, 1971), variation in magnesium concentration due to diurnal feeding patterns is potentially significant. Diurnal variation of magnesium concentration in the rumen is determined by water content and total magnesium. These are influenced by the following factors:

1. Ingestion and release of magnesium contained in the feed.
2. Involuntary water inflow into the rumen from feed.
3. Inflow of saliva which dilutes existing rumen magnesium but also contributes some magnesium to the rumen liquid phase pool.

Magnesium contained in the feed

Of the dietary magnesium entering the rumen, 60–80% is highly soluble (Grace and Davies, 1975) and very rapidly released into the rumen liquor. The remaining fraction is more closely bound to solid feed particles and release into the rumen liquid phase pool requires the action of digestive processes (Emanuele *et al.*, 1991). We have modelled this degradation process by adding a compartment to the model according to:

$$\frac{dQ_{Um}}{dt} = U_{Ds} - U_{UmLq} - U_{UmFe} \tag{20.8}$$

where Q_{Um} is the amount of magnesium in the undegraded solid matter in the rumen, U_{Ds} is the rate of ingestion of solid matter magnesium, U_{UmLq} ($= k_{UmLq}Q_{Um}$) is the rate of release of magnesium from ingested solid matter and U_{UmFe} is the rate at which undegraded solid matter containing magnesium passes out of the rumen.

Rumen liquid volume

To allow for diurnal feeding, the modified model incorporates a state variable, V_{Lq} , for rumen liquid volume. Changes in V_{Lq} are modelled by the equation:

$$\frac{dV_{Lq}}{dt} = \text{dietary water intake} + \text{saliva inflow} - \text{water clearance} \quad (20.9)$$

Dietary water intake

A significant supply of water to the rumen is from involuntary water intake ingested with feed (Warner and Stacy, 1968). The quantity ingested can be calculated from the dry matter (DM) content from feed analysis data and estimates of feed DM intake (DMI).

Saliva inflow

The volume of saliva flowing into the rumen (~ 120 l/day) is significant when compared with the rumen liquid volume (60–80 l) and daily water intake from feed (100 l). The rate of saliva flow into the rumen is variable, comprising a low basal rate between feeding periods with substantially increased flow during feeding (Bailey and Balch, 1961).

Water clearance

Water clearance occurs via rumen outflow and absorption across the rumen wall. These flows have been combined into a single fractional clearance rate using information from Warner and Stacy (1968).

Magnesium in saliva

Since the contribution from saliva to rumen liquid volume is significant, it is important to account for the magnesium content in saliva to enable correct calculation of rumen magnesium concentration. Magnesium concentration in saliva varies considerably and is inversely related to saliva production rate (Bailey and Balch, 1961; Grace *et al.*, 1985). Both saliva production and saliva magnesium concentration are currently implemented as user-defined parameters, which are set according to the feeding scenario being simulated.

Overall model performance

As an indication of the overall performance of the modified model scaled for dairy cattle, the experiment of Allsop and Pauli (1985) was simulated. In this experiment plasma and CSF magnesium concentrations were measured in cows on a magnesium-deficient diet. As all the model parameters had been estimated from independent sources, Fig. 20.3 shows that the model is capable of satisfactorily simulating this experimental situation. It is interesting to note that although the model predicts diurnal variation in rumen magne-

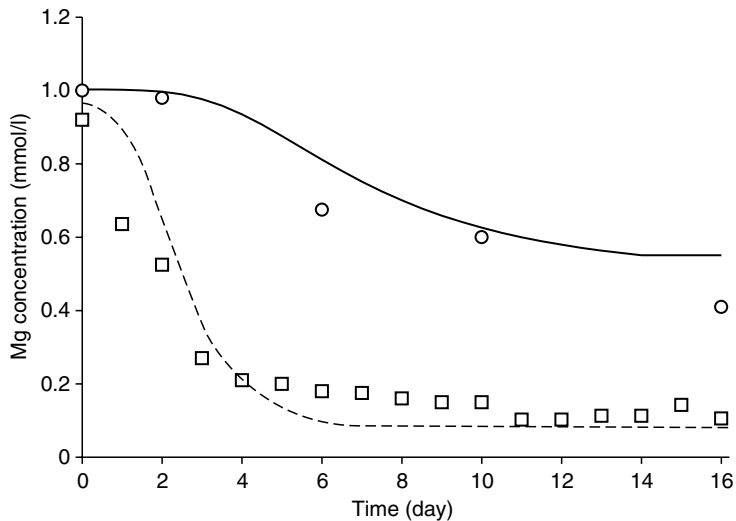

Fig. 20.3. Simulation of the experiment reported by Allsop and Pauli (1985) where animals were fed a magnesium-deficient diet. Measurements of cerebrospinal fluid (CSF) (O) and plasma magnesium concentrations (□) were as reported by Allsop and Pauli (1985). The lines indicate simulated CSF (solid line) and plasma magnesium concentrations (dashed line). The model parameters were for a 400 kg dairy cow with 11 l/day milk production. Dietary magnesium was as per Allsop and Pauli (1985).

sium concentration in accordance with experimental evidence (Dalley, 1994; Ferlay and Doreau, 1995), the effect on CSF magnesium concentrations, and therefore tetany risk, is minor.

Estimating the Risk of Hypomagnesaemic Tetany

A model such as that discussed in the previous section is often developed using experimental findings and observations reported in a range of publications involving more than one species. Validation is carried out on individual sections of the model and hopefully by assessing its overall performance against independent experiments such as that shown in Fig. 20.3. Developed in this way, the model can therefore represent the behaviour of only an ‘average’ animal. This is valuable in a research model designed to summarize the current state of knowledge and to assist in the design of new experiments (Robson *et al.*, 1997). However, we are interested in adapting the model as a tool that will assist farmers in assessing the extent to which animals in their dairy herds are at risk for hypomagnesaemic tetany.

Approach

Assuming that the structure of the model is correct, it should be possible to simulate any animal provided the values of all the parameters pertaining to that animal in its current environment are known. It is clearly not possible to obtain detailed knowledge of all the model parameters for a particular animal, but it is possible to estimate the statistical distribution for each model parameter using the information sources that were used to develop that model. We can use this information to carry out Monte Carlo simulations where we run the model repeatedly using different sets of parameter values for each run, selected randomly from their distributions.

By specifying a criterion which determines that an animal will fall victim to a particular disease, we obtain an assessment of the risk, R_d , that an animal will suffer from the disease using:

$$R_d = \frac{N_d}{N} \quad (20.10)$$

where N is the total number of simulation runs and N_d is the number of runs where the disease criterion was exceeded.

The estimate of risk obtained from this procedure would be for the species as a whole and would contribute little to the assessment of risk for a particular herd. To provide useful information, the parameter distributions used for the Monte Carlo simulations should reflect those for the particular herd under study as closely as possible. This calibration process requires data from measurements that are readily carried out on at least a sample of the animals in the herd. Some measurements, such as milk magnesium concentration, daily milk production and dietary magnesium concentration, can be used in the model directly as they are model parameters. Others, such as urinary magnesium flux, are model outputs and require a fitting process if they are to be used for calibration purposes. This is not a simple problem as we are trying to improve information about the distributions of model parameters using this calibration process.

Some model parameters affect the risk of disease more than others. It is therefore sensible to carry out a sensitivity analysis to determine those that have the most influence on risk. Those that have little influence need not be varied in subsequent simulations whereas those that have significant influence should receive most attention during the calibration process.

With the model parameter distributions determined as accurately as possible, the Monte Carlo simulations can be run to estimate the risk of disease for the herd. At this stage, the farmer might want to explore a number of 'what if' risk scenarios. An example would be to assess the risk if inclement weather caused the animals to miss a period of feeding.

In summary the approach is as follows:

- Determine the criterion that will be used to say whether a particular simulation run resulted in tetany (T) or not.
- Estimate the distributions of all model parameter values from information available in the literature.

- Carry out a sensitivity analysis to determine the parameters that need not be varied during subsequent Monte Carlo simulations and the parameters whose distributions, if possible, should be updated using data from the herd under study.
- Determine the measurements that can be readily obtained from the herd under study.
- Where the measurements relate directly to model parameters, assign the measured distributions to the relevant parameters.
- Where the measurements relate to model outputs, carry out a fitting process to update the estimates of the distributions of the sensitive model parameters.
- Use the calibrated model to estimate the risk of disease including any 'what if' scenarios that are relevant.

The following sections describe our initial attempts to apply these steps using the model of magnesium dynamics in dairy cattle described earlier.

Risk criterion

Allsop and Pauli (1975) and Meyer and Scholz (1972) have shown that tetany occurs when the concentration of magnesium in the CSF, C_{CSF} , falls below 0.6 mmol/l. Accordingly, a simulated animal was considered to have tetany if

$$C_{\text{CSF}} \leq 0.6 \text{ mmol/l} \quad (20.11)$$

at any time during a 10-day simulation.

Sensitivity analysis

The sensitivity of the i th parameter was determined by carrying out a large number of Monte Carlo simulations and classifying each as having resulted in tetany (T) or not according to equation (20.11). For each parameter the mean X_T^i and standard deviation ϵ_T^i of the values for which tetany occurred were calculated and compared with the mean X^i and standard deviation ϵ^i for all values for that parameter used in the Monte Carlo simulations. The comparison was done using a T-test. Parameters not showing a significant difference ($P < 0.05$) between the two categories after 1000 simulations were considered not to be sensitive and were not varied in subsequent analysis. The sensitive parameters determined from this exercise are listed in Table 20.2. (Note: this is not an exhaustive list.)

Herd measurements

Measurement of daily bulk milk production for a dairy herd is standard, providing a mean estimate for the herd. Milk production measurements for individual animals are available as part of a herd test conducted on two to five

Table 20.2. Sensitive parameters determined from sensitivity analysis.

Parameter symbol	Description
C_{Di}	Dietary magnesium concentration (g/kg dry matter (DM))
k_{HgPI}	Hindgut absorption constant (l/day)
C_{La}	Milk magnesium concentration (mmol/l)
V_{La}	Milk volume (l/day)

occasions during the season. By assuming that an individual animal's contribution to the total production on any particular day is in proportion to its contribution at the last herd test, estimates of the distribution of milk production for the herd can be readily obtained. The herd test also provides an opportunity to obtain milk magnesium concentration measurements for individual animals. Milk production and milk magnesium concentration are model parameters, so these distributions can be applied directly to the model. The repeatability of milk production measurements between successive herd tests gives the opportunity to separate the animal and random effects.

Under some circumstances it would be feasible to obtain measurements of pasture magnesium and potassium and use their distributions directly in the model, although in the test of the procedure reported below it was assumed that these measurements were not available.

Urinary magnesium flux, U_{HIUr} , can be estimated for individual animals using kits readily available to farmers (Merck Magnesium Test, E. Merck, Darmstadt, Germany). U_{HIUr} is a model output, so a fitting process is needed to use this information to improve estimates of the distributions of model parameters. As Fig. 20.4 shows, any set of distributions for the parameters $\{P_i, \text{where } 1 \leq i \leq N\}$ will produce a distribution for U_{HIUr} as a result of the Monte Carlo simulations. The problem then is to adjust the distribution of each parameter P_i until the simulated and measured distributions for U_{HIUr} match.

In the first instance, we have taken the following simple approach to this fitting problem:

1. Rank the parameters that we wish to fit (in this case the first three parameters in Table 20.2) in the order in which they are likely to be most strongly related to U_{HIUr} . The ranking was done by inspection of the model equations. This resulted in a ranked set of parameters $\{P_i, \text{where } 1 \leq i \leq 3\}$.
2. With the mean of each P_i initially at its standard value and the standard deviations (SDS) of P_i set to zero, iteratively adjust the mean of each parameter in turn to give the best fit between the means of the measured and simulated U_{HIUr} values. The iterative adjustments were constrained to prevent parameter means going outside predetermined physiologically reasonable ranges.

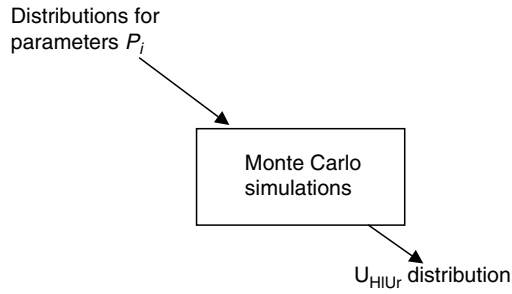

Fig. 20.4. The relationship between the distributions of model parameters P_i and the distribution of U_{HIUr} urinary magnesium flux.

3. Using the mean parameter values resulting from step 2, iteratively adjust the SD of each parameter in turn until the best fit between the measured and simulated SDs for U_{HIUr} is obtained. The iterative adjustments were constrained to prevent the SDs from being greater than 30% of their respective mean values.
4. Refine the mean values of the parameter distributions previously determined, as the mean value of the simulated U_{HIUr} may well be affected by the variability in the parameters.

With this simple approach to refining the parameter distributions, no real meaning can be assigned to the resultant parameter estimates because of the ranking of parameters carried out in step 1. Moreover, any covariation that might exist between model parameters is prevented from having an effect because the parameters were adjusted one at a time and in sequence. However, our objective was to calibrate the model to the measured U_{HIUr} data only so that we could calculate the risk of tetany in the herd. To assess whether our approach to finding the parameter distributions impacts the risk calculation, we changed the rank of the three parameters in step 1 and repeated the process.

A Test of the Procedure

To obtain an initial assessment of the approach outlined above, we have applied it to a fictitious herd. The details are given in Table 20.3.

The sensitivity analysis showed that milk volume and milk magnesium concentration are significant in determining the risk of suffering from tetany. In using the model to simulate experimental scenarios, it was necessary to match dietary magnesium, milk production and milk magnesium concentration within a single experiment, rather than using representative values across a range of experiments. Accordingly, for this test, the herd parameters were set at their normal values with dietary magnesium intake, milk production and milk magnesium concentration being representative of

McCoy *et al.* (2001). The urine magnesium flux values used were consistent with plasma magnesium concentration at the low end of the normal range (0.8 mmol/l) and the urinary excretion function adapted from Robson and Vlieg (2000).

Model calibration

The distributions of daily milk production and milk magnesium concentration were directly assigned to the relevant model parameters. The results of fitting the distributions of the three model parameters to the distribution of urine magnesium flux are given in Table 20.4.

Risk calculation

Having calibrated the model as described above, it was possible to carry out the Monte Carlo simulations and use equation (20.10) to estimate the risk that animals in this fictitious dairy herd would suffer from tetany. Figure 20.5 shows the result for various levels of dietary magnesium concentration relative to the value resulting from the calibration (Table 20.4). Figure 20.5 also shows that the parameter distributions obtained from the two different rankings (Table 20.4) gave similar risk.

Table 20.3. Herd parameter distributions for the fictitious herd used for an initial assessment of this approach to estimating risk. Standard deviations (SDs) are given in parentheses.

Distribution of milk production	Normal with mean 18.5 l/day (2 l/day)
Distribution of urine magnesium flux	Normal with mean 1.0 g/day (0.5 g/day)
Milk magnesium concentration	Normal with mean 85 mg/l (6 mg/l)

Table 20.4. Means and standard deviations (SDs) of the (normal) distributions for model parameters fitted to the distribution of urine magnesium flux. The results for two different rankings (A and B) of the parameters are shown.

Parameter	Rank A	Fitted distributions (μ , σ)	Rank B	Fitted distributions (μ , σ)
Dietary magnesium, C_{Di} (g/kg dry matter (DM))	1	1.97, 0.16	3	2.0, 0.25
Hindgut absorption constant, k_{HgPI} (l/day)	2	1.8, 0.1	2	1.55, 0.0
Rumen potassium, C_{KRu} (mmol/l)	3	15.0, 5.0	1	20.0, 0.0

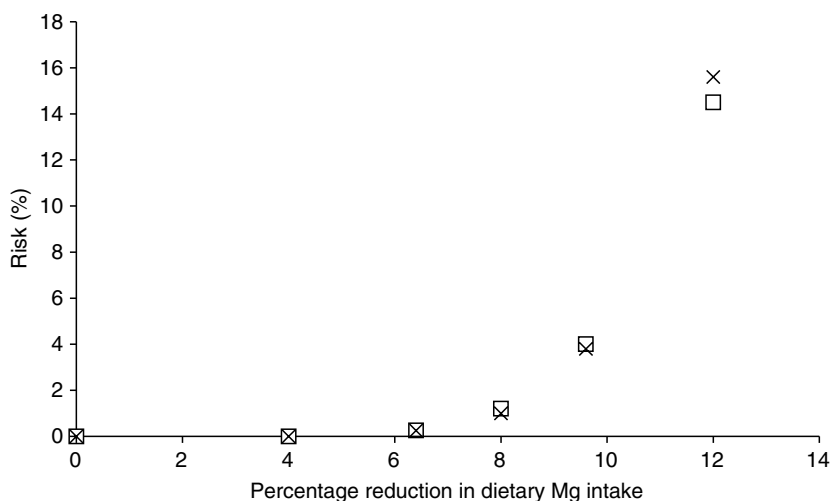

Fig. 20.5. The risk of tetany calculated using the calibrated model. The risk is shown for various values of mean dietary magnesium intake expressed as a percentage reduction applied to the value given in Table 20.4. Symbols represent parameter distributions obtained from rank A fitting (x; see Table 20.4) and parameter distributions obtained using rank B fitting (□).

Discussion and Conclusions

The original model of Robson *et al.* (1997) has been improved by making modifications to the urinary secretion of magnesium and the hindgut secretion and absorption of magnesium. Magnesium secretion through lactation has been included and provision has been made for diurnal feeding patterns with consequential variation in saliva flows and allowance for slow breakdown of solid matter containing magnesium in the rumen. Diurnal feeding patterns have been incorporated only to make it possible to simulate events such as missing a day's feeding. Under normal circumstances, we believe that it would be adequate to assume constant dietary intake rates. We have also introduced a compartment representing magnesium in the CSF, as the onset of tetany seems to be highly correlated with the magnesium concentration there.

With these improvements, the model appears to scale to dairy cows well and is able to satisfactorily simulate the experiments of Allsop and Pauli (1985) and McCoy *et al.* (2001). Nevertheless, the model requires further validation testing. In particular, further experimental work in relation to hindgut absorption and secretion would allow that aspect of the model to be tested and improved. Robson *et al.* (2004) reviewed information in the literature regarding the importance to magnesium homeostasis of magnesium resorption from bone. They concluded that the mobilization of

magnesium from bone is small compared to endogenous faecal loss, and because it seems to be inhibited when plasma magnesium concentration falls, there is no evidence to suggest that it should be included in the model.

Although the initial motivation for developing this model was as a research tool, subsequent modifications have allowed the model to be used as a predictive tool with Monte Carlo simulation in the assessment of the risk that animals in a dairy herd will suffer from hypomagnesaemic tetany. Results reported here seem to confirm the suitability of the model to be used for risk assessment. A major practical difficulty is the fitting process required to improve our estimates of the distributions of other model parameters such as the hindgut absorption constant using herd measurements of urinary magnesium flux. The initial approach to this fitting problem described here is very simplistic and current work is aimed at developing a more robust and efficient algorithm.

Nevertheless, the risk estimates shown in Fig. 20.5 are not unreasonable. To determine their reliability and usefulness requires further evaluation that would need to consider analysis of a number of field trials and case studies. Successful evaluation would increase the confidence of farmers in using this approach.

References

- Allsop, T.F. and Pauli, J.V. (1975) Responses to the lowering of magnesium and calcium concentrations in the cerebral spinal fluid of unanaesthetized sheep. *Australian Journal of Biological Science* 28, 475–481.
- Allsop, T.F. and Pauli, J.V. (1985) Magnesium concentrations in the ventricular and lumbar cerebrospinal fluid of hypomagnesaemic cows. *Research in Veterinary Science* 38, 61–64.
- ARC (Agricultural Research Council) (1980) *The Nutrient Requirements of Ruminant Livestock*. Commonwealth Agricultural Bureaux, Slough, UK.
- Bailey, C.B. and Balch, C.C. (1961) Saliva secretion and its relation to feeding in cattle: 2. The composition and rate of secretion of mixed saliva in the cow during rest. *British Journal of Nutrition* 15, 383–402.
- Bell, S.T., Laporté, J.A., Robson, A.B. and Sykes, A.R. (2001) Magnesium endogenous loss as a function of plasma magnesium concentration rather than a constant allows better development of magnesium models in ruminants. *Proceedings of the New Zealand Society of Animal Production* 61, 160–163.
- Cserr, H.F. (1971) Physiology of the choroids plexus. *Physiological Review* 51, 273–311.
- Dalley, D.E. (1994) Magnesium metabolism and hypomagnesaemia – what do we know? *Proceedings of the 11th Seminar for the Society of Dairy Cattle Veterinarians of the New Zealand Veterinary Association*. Queenstown, New Zealand.
- di Stefano, A., Roinel, M., Rouffignac, C. de and Wittner, M. (1993) Transepithelial Ca²⁺ and Mg²⁺ transport in the cortical thick ascending limb of Henle's loop of the mouse is a voltage-dependent process. *Renal Physiology and Biochemistry* 16, 157–166.
- Emanuele, S.M., Staples, C.R. and Wilcox, C.J. (1991) Extent and site of mineral release from six forage species incubated in mobile Dacron bags. *Journal of Animal Science* 69, 801–810.

- Ferlay, A. and Doreau, M. (1995) Influence of method of administration of rapeseed oil in dairy cows: 2. Status of divalent cations. *Journal of Dairy Science* 78, 2239–2246.
- Field, A.C., McCallum, J.W. and Butler, E.J. (1958) Balance experiments on sheep with herbage from fields associated with lactation tetany and from control pastures. *British Journal of Nutrition* 12, 433–446.
- Grace, N.D. (1983) The site of absorption of magnesium in ruminants. In: Bunce, G.E., Allan, V.G. and Webb, K.E. Jr (eds) *Proceedings of John Lee Pratt International Symposium on the Role of Magnesium in Animal Nutrition*. Blacksburg, Virginia, pp. 107–120.
- Grace, N.D. and Davies, E. (1975) The distribution of magnesium in the digesta of sheep fed fresh pasture. *Proceedings of the New Zealand Society of Animal Production* 35, 47–50.
- Grace, N.D., Carr, D.H. and Reid, C.S.W. (1985) Secretion of sodium, potassium, phosphorus, calcium, and magnesium via the parotid and mandibular saliva in sheep offered chaffed lucerne hay or fresh 'Grasslands Ruanui' perennial ryegrass. *New Zealand Journal of Agricultural Research* 28, 449–455.
- Hecker, J.F. and Grovum, W.L. (1975) Rates of passage of digesta and water absorption along the large intestines of sheep, cows and pigs. *Australian Journal of Biological Science* 28, 161–167.
- Laporté, J.A., Bell, S.T. and Sykes, A.R. (2001) The importance of an accurate estimate of net endogenous loss of magnesium in ruminants. *Proceedings of the New Zealand Society of Animal Production* 61, 156–159.
- Martens, H. (1983) Saturation kinetics of magnesium efflux across the rumen wall in heifers. *British Journal of Nutrition* 49, 153–158.
- Martens, H. and Schweigel, M. (2000) Pathophysiology of grass tetany and other hypomagnesemias: implications for clinical management. *The Veterinary Clinics of North America: Food Animal Practice* 16, 339–368.
- McCoy, M.A., Hutchinson, T., Davison, G., Fitzpatrick, D.A., Rice, D.A. and Kennedy, D.G. (2001) Postmortem biochemical markers of experimentally induced hypomagnesaemic tetany in cattle. *Veterinary Record* 148, 268–273.
- Meyer, H. and Scholz, H. (1972) Pathogenesis of hypomagnesaemic tetany: I. Relationship between Mg content of blood and cerebral spinal fluid in sheep. *Deutsch Tierarztl Wochenschr* 79, 55–61.
- Pauli, J.V. and Allsop, T.F. (1974) Plasma and cerebral spinal fluid magnesium, calcium and potassium concentrations in dairy cows with hypomagnesaemic tetany. *New Zealand Veterinary Journal* 22, 227–231.
- Robson, A.B. and Vlieg, M. (2000) Aspects of modelling kidney dynamics. In: McNamara, J.P., France, J. and Beever, D.E. (eds) *Modelling Nutrient Utilization in Farm Animals*. CAB International, Wallingford, UK, pp. 115–125.
- Robson, A.B., Field, A.C., Sykes, A.R. and McKinnon, A.E. (1997) A model of magnesium metabolism in young sheep: magnesium absorption and excretion. *British Journal of Nutrition* 78, 975–992.
- Robson, A.B., Sykes, A.R., McKinnon, A.E. and Bell, S.T. (2004) A model of magnesium metabolism in young sheep: transactions between plasma, cerebrospinal fluid and bone. *British Journal of Nutrition* 91, 1–8.
- Rogers, P.A.M. and van't Klooster A.Th. (1969) Observations on the digestion and absorption of food along the gastrointestinal tract of fistulated cows: 3. The fate of Na, K, Ca, Mg and P in the digesta. *Mededelingen Landbouwhogeschool Wageningen* 69, 26–39.
- Schweigel, M. and Martens, H. (2000) Magnesium transport in the gastrointestinal tract. *Frontiers in Bioscience* 5, 666–677.

- Shareghi, G.R. and Agus, Z.S. (1982) Magnesium transport in the cortical thick ascending limb of Henle's loop of the rabbit. *Journal of Clinical Investigation* 69, 759–769.
- Thielen, M., Sedcole, J.R. and Sykes, A.R. (2001) Changes in plasma, milk and urinary magnesium concentrations in pasture-fed dairy cows in early lactation. *Proceedings of the New Zealand Society of Animal Production* 61, 152–155.
- Warner, A.C.I. and Stacy, B.D. (1968) The fate of water in the rumen: 2. Water balances throughout the feeding cycle in sheep. *British Journal of Nutrition* 22, 389.

21

Modelling the Effects of Environmental Stressors on the Performance of Growing Pigs: from Individuals to Populations

I.J. WELLOCK, G.C. EMMANS AND I. KYRIAZAKIS

*Animal Nutrition and Health Department, Scottish Agricultural College,
West Mains Road, Edinburgh EH9 3JG, UK*

Abstract

A simulation model that predicts the performance of a population of growing pigs when raised under given dietary, physical and social environmental conditions has been constructed. The aim was to investigate through the model the impact of between-animal variation on the response of a population to environmental stressors. Variation was generated in initial state, growth potential and ability to cope when exposed to social 'stressors' (AB). Variation in initial state is described by initial body weight (BW_0), from which the chemical composition of the pig is calculated. Variation in potential is described by creating variation in the genetic growth descriptors. Variation in response to AB exists between genotypes, where it has been suggested that leaner, more modern genotype pigs tend to be less able to cope. It is expected that within a population or group the social environment (i.e. group composition and social hierarchy) also affects an individual's ability to cope. Consequently, it was assumed in the model that there is a negative correlation between BW_0 and AB, i.e. bigger pigs are better able to cope when socially stressed. Model predictions showed that whether or not the mean population response is the same as the 'average' individual response can be influenced by the way a given social stressor constrains performance. If all pigs are affected at the same stressor intensity, e.g. all pigs in a group are either mixed or not, then the predicted average individual and mean population responses will be the same. If, however, the intensity of stressor at which performance becomes limiting is able to differ between individuals, such as space allowance (SPA) or temperature, then differences between the individual and mean population responses will be predicted. Variation in the growth response of a population was determined to a greater extent by variation in AB and BW_0 than by variation in growth potential alone, when pigs were housed in simulated conditions likely to be encountered in commercial environments. Consequently, decreasing variation in BW_0 will lead to a more homogeneous population at slaughter, which may affect the economical efficiency of an enterprise, and improving pigs' ability to cope may be a better way of improving pig performance than selecting for increased potential per se.

Introduction

The performance of pigs reared commercially is often considerably below that seen under good experimental conditions (Campbell and Taverner, 1985). At least some of this decrease in performance can be attributed to factors in the physical, social and infectious environments. These factors are here termed environmental stressors. Quantifying the effects of environmental stressors and the aim of accurately predicting pig growth under a wide range of environmental conditions has led to the development and use of simulation models. These models may allow the identification and subsequent removal of those constraints that prevent pigs achieving their potential under farm conditions and substantially increase the profitability of commercial pig enterprises.

Models intended to simulate animal performance typically represent a single animal (e.g. Black *et al.*, 1986; Green and Whittemore, 2003; Wellock 2003a,b). The assumption necessarily made is that the mean response of the population, which is an average of all individuals, will be the same as that of the deterministically simulated response of the 'average' individual. However, this will be the case only if all animals in the population have an equal growth potential, all are at the same stage of growth and perhaps importantly all react in the same way to encountered stressors. Therefore, in order to attempt to predict adequately the response of a population in a given environment it is necessary to take account of between-animal variation (Fisher *et al.*, 1973). The stochastic pig growth models of Ferguson *et al.* (1997), Knap (2000) and Pomar *et al.* (2003) deal with variation in growth potential and are a good starting point. However, any variation that may exist between individuals in initial state and ability to cope when exposed to social stressors has largely been ignored.

The objective of this work was to construct a model that would be able to explore and, at least in principle, predict the impact of between-animal variation on the performance of a population of growing pigs when raised under given dietary, physical and social environmental conditions.

Model description

A simplified schematic representation of the model is shown in Fig. 21.1.

Individual pig growth and feed intake

The individual pig is described by four genetic characteristics. Three of these are used to predict its potential for growth: protein weight at maturity (P_m ; kg), the ratio of lipid to protein at maturity (L_m/P_m ; kg/kg) and a growth rate parameter (B ; /day) (see Wellock *et al.*, 2003b). The fourth parameter describes the ability to cope when exposed to social stressors (AB). The initial state of the pig is described by BW_0 (kg), from which the chemical composition of the

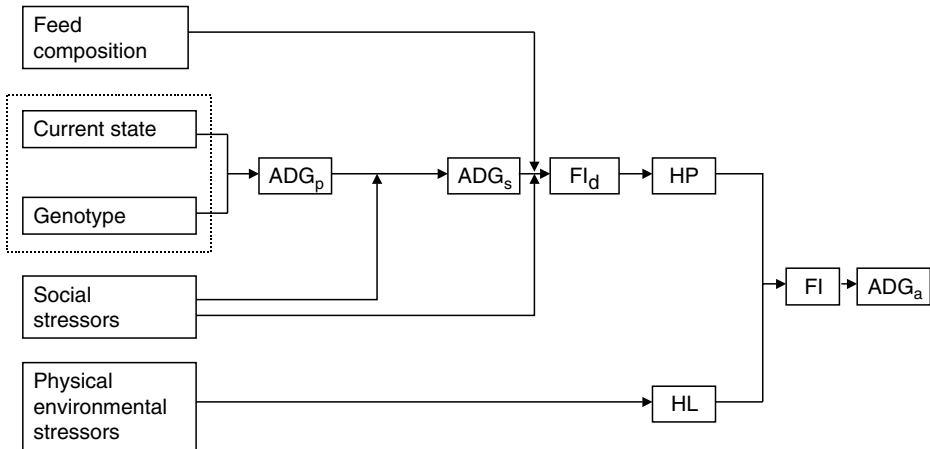

Fig. 21.1. A simplified schematic representation of the model described in this study: ADG = average daily gain; ADFI = average daily feed intake; HP = heat production; HL = and heat loss. The subscripts represent p = potential; s = stressed; d = desired; and a = actual. The five boxes to the left of the diagram represent the model inputs and FI_a and ADG_a are the main outputs. The dotted box represents parameters where between-animal variation is introduced.

pig is calculated assuming the pig has its ideal composition set by its genotype. The potential rate of protein retention is determined by pig genotype and current protein weight only. Its value is used to determine the potential gains of the other chemical components. Potential average daily gain (ADG_p ; kg/day) is the sum of the potential gains of the four chemical components; 5% of the gain is assumed to be gut fill.

It is assumed that all pigs attempt to consume an amount of feed that will satisfy their energy and protein requirements for ADG_p , maintenance and any compensatory lipid gain. The amount of feed that allows this to be achieved, termed the desired feed intake, is calculated from the composition of the given feed. Any costs of thermoregulation are calculated separately (see Wellock *et al.*, 2003b), and any increase in requirements from exposure to pathogens is ignored. The only feed resources considered are energy and protein; any of the essential amino acids may be limiting at first. Actual feed intake and the consequent actual gains in chemical component weights are predicted taking into account the capacity of the animal to consume feed bulk, its ability to maintain thermoneutrality and any consequences of the social environment.

Physical environmental stressors

The physical environment is described by the ambient temperature, air velocity, floor type and relative humidity, which set the maximum (HL_{max} ;

MJ/day) and minimum (HL_{\min} ; MJ/day) heat losses in the given environment. A comparison with the pig's calculated heat production (HP; MJ/day) determines whether the pig is hot ($HP > HL_{\max}$), cold ($HP < HL_{\min}$) or thermoneutral ($HL_{\min} < HP < HL_{\max}$). A constraint on intake will operate in hot environments due to an inability to lose the heat produced by maintenance and growth to the surrounding environment. In cold environments, there is an extra thermal demand placed upon the pig. If conditions are thermoneutral, no further action is taken.

Social stressors

While stressors in the physical environment, such as ambient temperature, humidity, air velocity and floor type, have been previously comprehensively modelled (e.g. Black *et al.*, 1986; Wellock *et al.*, 2003b), social stressors, including mixing, SPA, group size and feeder SPA, have been largely ignored. This is mainly due to a lack of quantitative data on which to build models and a lack of understanding of how such stressors affect performance.

The social environment is described by group size (N), pen area (A ; m^2), feeder SPA (FSA; feeder spaces/pig) and the occurrence or not of mixing. The SPA ($m^2/BW^{0.67}$) is calculated from N , A and BW (kg). All of these factors may act as social stressors and it is assumed in the model that they decrease performance by lowering the capacity of the animal to attain its potential for whole body growth following Chapple (1993). The exception is FSA that directly constrains intake when limiting. The descriptor AB adjusts both the intensity of the stressor at which the pig becomes stressed and the extent to which each stressor reduces performance at a given stressor intensity (Wellock *et al.*, 2003a). It is assumed in the model that these two factors are perfectly correlated; pigs that show signs of stress at a lower stressor intensity are also stressed to a greater degree at any given stressor intensity. Increasing the value of AB represents a decreasing ability to cope when stressed. The model was calibrated so that a unit change in AB produced deviations of approximately 1% from the mean performance and a value of ten represents the average pig type (Wellock *et al.*, 2003a).

From individual pigs to populations

Growth potential

The potential growth of individuals within a population can be described by generating variation around the population means of each of the genetic parameters, P_m , L_m/P_m and B (Ferguson *et al.*, 1997). Because there is likely to be a negative correlation between B and P_m (Knap, 2000) among animals of the same population, the scaled rate parameter, $B^* = B \times P_m^{0.27}$, described by Emmans and Fisher (1986) is used as an alternative to B . The values of B^* , P_m and L_m/P_m are assumed to be uncorrelated and normally distributed (Pomar *et al.*, 2003).

Initial state

Individual variation in BW_0 is generated from the assigned genotype mean (μBW_0 ; kg) and standard deviation (σBW_0 ; kg) using the simulated genetic parameters of the individual to correlate BW_0 with potential growth. By this means, individuals in the group with the greatest potential will tend to have the highest BW_0 as would be expected from non-limiting growth. The initial weight of pig i (BW_{0i} ; kg) is calculated as:

$$\begin{aligned} BW_{0i} = & \mu BW_0 + a \{ b_1 [1 - (\mu B^* / B_i^*)] \times [\sigma BW_0 (\mu B^* / \sigma B^*)] + \\ & b_2 [1 - (\mu L_m / P_m / L_m / P_{mi})] \times [\sigma BW_0 (\mu L_m / P_m / \sigma L_m / P_m)] + \\ & b_3 [1 - (\mu P_m / P_{mi})] \times [\sigma BW_0 (\mu P_m / \sigma P_m)] \} \pm \text{residual}_i \end{aligned} \quad (21.1)$$

The parameters B_i^* , P_{mi} and L_m / P_{mi} are the genetic parameter values for pig i . The parameters μB^* , μP_m and $\mu L_m / P_m$ are the mean values and σB^* , σP_m and $\sigma L_m / P_m$ are the standard deviations (SDs) of B^* , P_m and L_m / P_m , respectively. The parameter a is a general scaling factor; it is set at 0.6 to generate expected values. The parameters b_1 , b_2 and b_3 determine the degree of correlation between each of BW_{0i} and B_i^* , L_m / P_{mi} and P_{mi} , respectively. All three parameters were set at unity. The value of residual_i is drawn at random from a normal distribution with a mean value chosen to account for the expected variation in BW_0 . It adds a non-genetic component to BW_{0i} . The initial chemical composition of each pig is calculated from BW_{0i} assuming it has its ideal genetic composition at the start of the trial period. In this way, at the same BW_0 , genetically fatter pigs (higher values for L_m / P_m) will have a lower initial protein weight and a higher initial lipid weight than genetically thinner pigs.

Ability to cope

It has been shown in a number of studies that pigs classified as dominant tend to outperform their subordinates. This has been demonstrated when pigs are grouped (McBride *et al.*, 1964; Hansen *et al.*, 1982) or mixed (Hessing *et al.*, 1994; D'Eath, 2002), or when FSA is limiting (Giroux *et al.*, 2000). There is also evidence that social dominance is positively correlated to BW in pigs (Erhard and Mendl, 1997; Drickamer *et al.*, 1999; D'Eath, 2002). Taken together these results suggest that the larger pigs within a group tend to be dominant and better able to cope when conditions are suboptimal, i.e. when pigs are exposed to stressors. Consequently, it is assumed in the model that there is a negative correlation between BW_0 and AB. Individual values for AB (AB_i) are generated around the assigned genotype mean (μAB) and SD (σAB) of AB, whilst being negatively correlated to BW_0 :

$$AB_i = \mu AB + b_4 \left\{ \left[(1 - BW_{0i} / \mu BW_0) \right] \times \left[\sigma AB (\mu BW_0 / \sigma BW_0) \right] \right\} \pm \text{residual}_i \quad (21.2)$$

The parameter b_4 determines the degree of correlation between BW_0 and AB and is set equal to one. The residual_i is drawn at random taking account of σAB . Within a population, AB is not directly correlated to leanness. However, leaner animals will tend to have higher AB values due to the positive

correlation between L_m/P_m and BW_0 (equation (21.1)) and the negative correlation between BW_0 and AB (equation (21.2)). Between populations, it is expected that modern, 'leaner' genotypes will have higher values of AB than traditional, 'fatter' genotypes (Grandin, 1994; Schinckel *et al.*, 2003).

Generating individual pigs

For each simulated pig within a population, values for B_i^* , P_{mi} and L_m/P_{mi} are drawn at random from uncorrelated normal distributions. Values for BW_{0i} and AB_i are then generated from their respective means and SDS (model inputs) whilst taking into account the generated genetic parameter values of the individual (equations (21.1) and (21.2)). The values that characterize each animal are drawn before each simulation run and are maintained for multiple simulation runs.

Model Simulations: Consequences for Optimizing Production Systems and Genetic Selection Strategies

The model was used to simulate some relevant experimental conditions with environmental stressors as the experimental factors. In all simulations, 500 animals were drawn at random with estimated means and coefficients of variation (CV, shown in parentheses) for the genetic parameters B^* , P_m and L_m/P_m of 0.0408 (0.03), 32.0 (0.07) and 1.2 (0.15), respectively as characterized by Knap (2000). These values were kept constant throughout all model simulations. A group size of 20 was used, except where the effect of N was investigated. Using 500 pigs is thus equivalent to simulating 25 replicates of 20 pigs. Pigs were fed a standard grower diet throughout.

Firstly, the mean response of the population was compared with that of the average individual (i.e. zero variation) when exposed to environmental stressors at increasing intensities. Secondly, the effect of within-population variation in AB and BW_0 on pig performance to a given slaughter weight (BW_i ; kg) or over a given time period (t ; days) was investigated. Results of the simulations are discussed below with particular emphasis on the consequences for optimizing production systems and genetic selection strategies.

Comparison of the average pig response with the mean population response

Ferguson *et al.* (1997) stated that 'there is a marked difference in the response of the average individual in the population and the mean population'. Pomar *et al.* (2003) demonstrated clear differences between the average individual and the mean population response for the rate of protein retention in response to increasing dietary protein intake. However, from the model simulations presented here it is clear that differences between the average pig and mean population responses should not always be expected. It will depend partly upon the stressors to which the pigs are exposed. Where all individuals become adversely affected at the same stressor intensity, e.g.

being housed in a group as opposed to individually or being mixed or not, no differences between the average individual and mean population response are predicted (Fig. 21.2a). This is because all individuals are either affected or not, although this may be to varying extents. If, however, the intensity at which the stressor becomes limiting is able to differ between individuals, e.g. critical SPA (SPA_{crit} ; $m^2/BW^{0.67}$) and upper critical temperature, differences between the average individual and mean population response are expected (Fig. 21.2b).

The linear-plateau response of the average individual to decreasing SPA is a direct outcome of the assumption used in the model (see Wellock *et al.*, 2003a). The curvilinear-plateau response of the population, however, can be explained by individual differences in SPA_{crit} generated from between-animal variation in BW and AB. The plateau is predicted to occur when $SPA > SPA_{crit}$ for all pigs in the population and the curvilinear transition phase occurs when only a proportion of the population is constrained, i.e. $SPA < SPA_{crit}$ for only some individuals. As the intensity of the stressor increases, the proportion of the population that is constrained also increases until all individuals are affected. At a fixed SPA the proportion of pigs will increase with increasing population variance and this will result in a greater degree of curvature. This was demonstrated by Pomar *et al.* (2003) for average daily rate of protein retention in response to increasing protein intake. The mean population and individual responses to decreasing SPA are predicted to differ over only a small range of pen area. However, this quantitative finding may underestimate the position in commercial enterprises and could have important financial consequences when space is at a premium.

The type of stressor also influences the amount of variation around the mean population response to increasing stressor intensity. If the critical limit does not vary between individuals, an increase in variation is expected as the intensity of the stressor increases. This is a direct result of individual differences in the ability to cope with the stressor. Conversely, a decrease in variation is expected if the critical limit is able to vary between individuals. This is because some individuals will be limited at a lower stressor intensity than others, and consequently a narrower range of variation is expected as the intensity of the stressor increases. The experiment of Turner *et al.* (2000) with growing pigs supports this. They reported an increase in the variation of ADG with increasing N and a decrease in ADG variation with decreasing SPA.

Variation in initial state and ability to cope

Variation in initial state

Variation in BW_0 ($\mu BW_0 = 60$ kg) increased both the variation in time taken to reach a given BW_f (100 kg) and the variation in BW_f achieved over a given time period (50 days) when pigs were housed in conditions typical of a finisher system. This was as expected. Results from the set time simulations are given in Table 21.1. In these simulations, pigs were mixed at 75 kg and kept

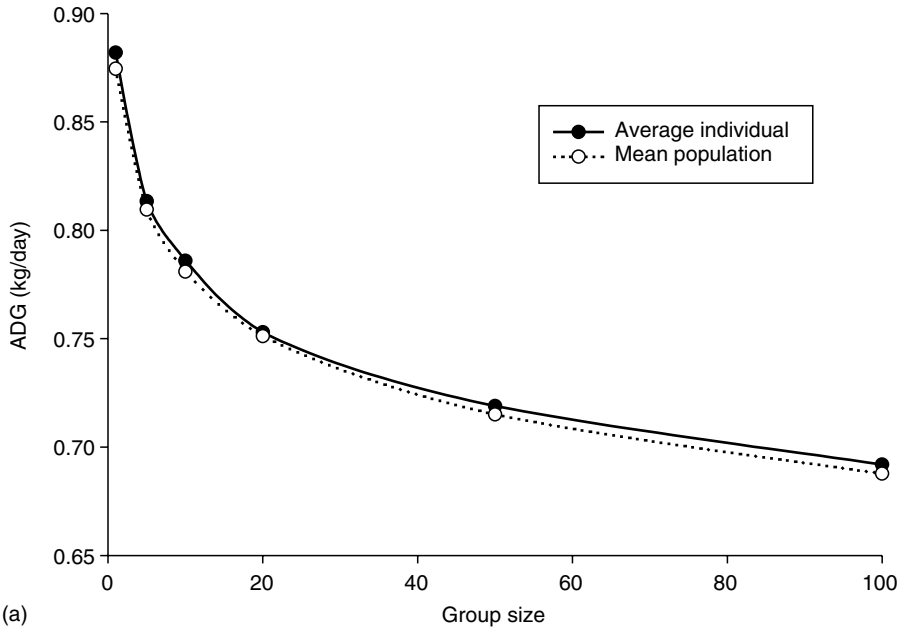

(a)

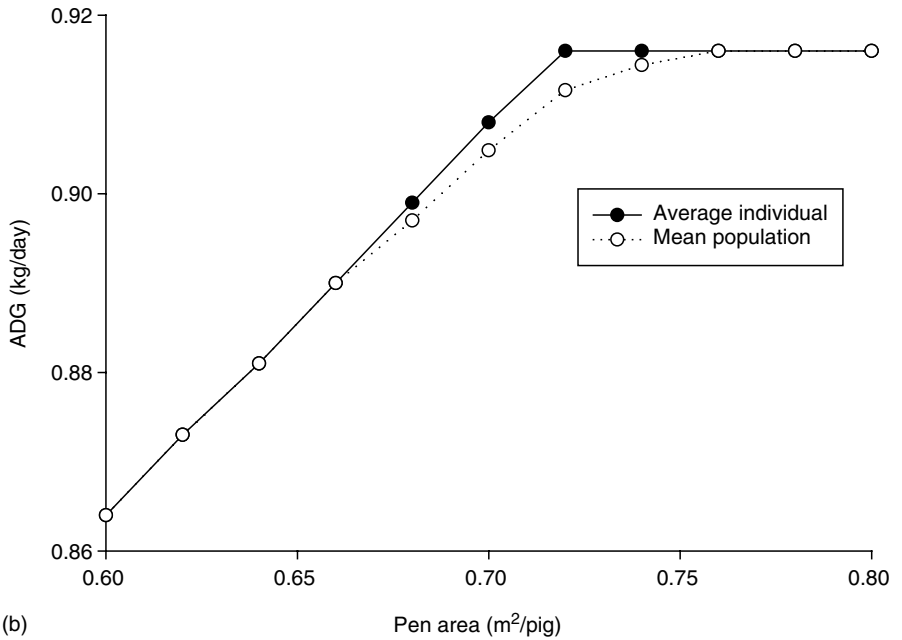

(b)

Fig. 21.2. Predicted effect of environmental stressors on the average daily gain (ADG) response of the average individual and mean population: (a) increasing group size on the ADG of pigs from 20 (\pm 2 kg) to 60 kg; (b) decreasing space allowance (SPA) on the ADG of 60 kg (\pm 6 kg) pigs over simulation period of 1 day.

Table 21.1. Effect of variation in initial body weight (σBW_0 ; kg) and ability to cope (σAB) on the mean population response and variation (standard deviation (sd) within parentheses) on the final BW (BW_f ; kg), P_2 backfat depth (P_2 ; mm) and carcass weight (CW; kg) achieved after a simulation period of 50 days. Mean BW_0 and mean AB were set at 60 kg and 10 respectively. Mixing occurred at 75 kg and pigs were given a space allowance (SPA) of 0.7 m²/pig throughout.

σBW_0 (kg) ^a	σAB ^a	BW_f (kg)	P_2 (mm)	CW ^c (kg)
0.00	0.00	100.2 (2.85) ^b	14.7 (1.12) ^b	76.9 (2.50) ^b
2.17	0.00	100.0 (4.23)	14.7 (1.42)	76.8 (3.75)
4.07	0.00	100.0 (5.56)	14.7 (1.69)	76.8 (4.93)
6.33	0.00	98.9 (7.57)	14.5 (1.95)	75.9 (6.66)
8.33	0.00	99.9 (9.31)	14.6 (2.27)	76.0 (8.20)
10.57	0.00	99.0 (11.02)	14.7 (2.39)	76.1 (9.67)
12.32	0.00	97.8 (12.77)	14.5 (2.66)	75.0 (11.08)
0.00	0.46	100.2 (2.92)	14.7 (1.20)	77.0 (2.57)
0.00	1.04	100.1 (3.15)	14.7 (1.18)	76.9 (2.76)
0.00	1.51	100.2 (3.38)	14.7 (1.19)	77.0 (2.96)
0.00	1.85	100.1 (3.57)	14.7 (1.19)	76.9 (3.13)
0.00	2.45	100.3 (4.13)	14.7 (1.34)	77.0 (3.65)
5.79	1.40	99.9 (8.48)	14.7 (2.14)	76.7 (7.73)
12.18	2.42	98.8 (14.80)	14.6 (3.01)	75.9 (12.90)

^aSimulated values.

^bResult of variation in growth potential only.

^cCW = $\{[66 + (0.09 \times BW_f) + (0.12 \times P_2)] \times (BW_f/100)\}$ (from Whitemore, 1998).

in an area of 0.7 m²/pig, which in the model becomes limiting at approximately 75 kg, coinciding with the occurrence of mixing. If there is no variation in BW_0 ($\sigma BW_0 = 0$), all pigs need to gain the same amount of weight in order to achieve a given BW_f , and any differences in the time taken to reach BW_f are due to individual differences in growth potential only. However, as σBW_0 is increased, the BW gain needed to achieve BW_f varies due to simulated differences in BW_0 . Similarly, over a specified time, individuals with greater BW_0 are generally able to achieve a greater BW_f than counterparts with lower BW_0 .

Many commercial pig enterprises employ all-in-all-out systems, with all pigs from a given pen (or building) taken to slaughter at the same time. The level of payment is usually dependent upon carcasses being within desired ranges of weight and fatness, as determined by a contract with the buyer. Therefore, as one of the main factors in determining the uniformity of a group at slaughter is the uniformity at the start of the growing period, σBW_0 is one of the major factors in determining enterprise profitability. This can be highlighted using the data from Table 21.1. Model predictions show that as σBW_0 increases from 0 to 6 kg, a variation in BW_0 of 10%, the population mean P_2 backfat depth (P_2 ; mm) and carcass weight (CW; kg) remain unchanged. Variation in the two parameters, however, increases by 4.72 kg

and 0.83 mm respectively. For example, if the target CW and P_2 range at slaughter were 65–85 kg and < 17 mm respectively, whereas only 11 individuals (2.2%) fell outside the desired range when $\sigma BW_0 = 0$, 91 (18.2%) do so when $\sigma BW_0 = 6$ kg (see Fig. 21.3).

Variation in ability to cope

Variation in AB was generated as a first step towards accounting for behavioural differences between individuals of a population and quantifying the resulting effects on population performance. It was predicted that variation in the growth response of a population was increased when variation in AB was included in addition to variation in growth potential, when pigs were exposed to social stressors (see Table 21.1).

There is literature suggesting that the ability to cope is negatively correlated with rapid growth rate and lean content. For example, Schinckel *et al.* (2003) noted that ‘pigs from populations with above average percent carcass lean have a greater percentage reduction in live weight and carcass lean growth than pigs of average percent carcass lean’ when exposed to

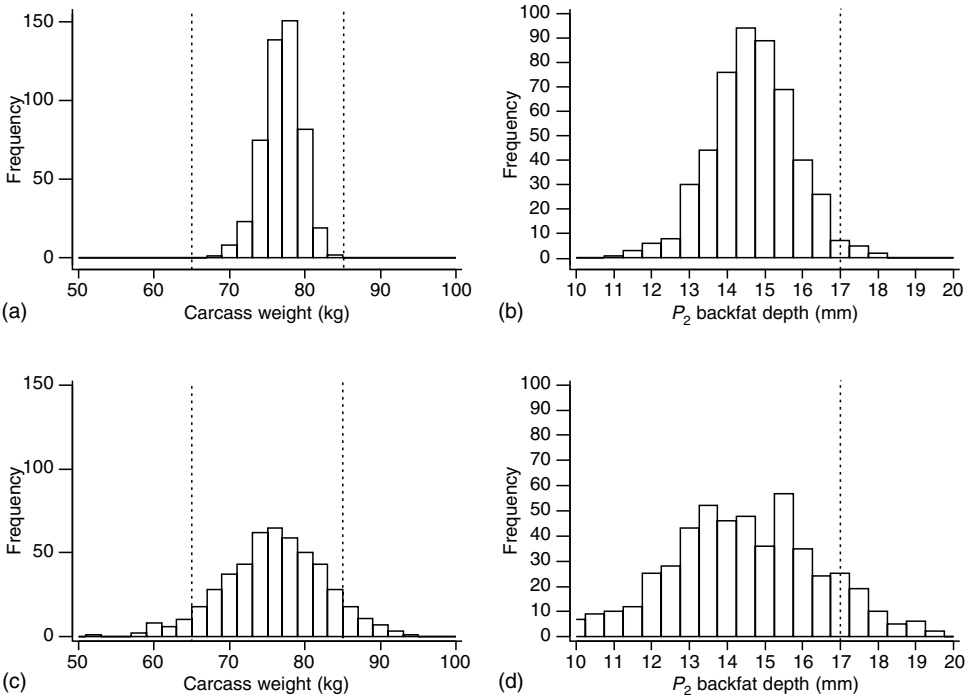

Fig. 21.3. The effect of variation in initial body weight (σBW_0) of the proportion of the population ($N = 500$) within the target slaughter range for carcass weight (CW; Fig. 21.3a,c) and P_2 backfat depth (Fig. 21.3c,d) when $\sigma BW_0 = 0$ kg (Fig. 21.3a,b) and 6 kg (Fig. 21.3c,d) respectively. The dashed lines represent the target ranges.

stressors. If AB and lean growth rate are adversely correlated, there may be negative implications regarding the welfare of pigs selected for lean growth, as selection for improved lean growth rate would then indirectly lead to selection for poorer ability to cope in the population (Rauw *et al.*, 1998). Since AB depends in part upon the structure of the group, group selection, whereby selection is based upon performance of the group opposed to the individual, may be necessary in order to improve the ability of animals to cope when exposed to social stressors. The experiment of Muir and Craig (1998) demonstrated that selection for desirable associate effects within a group may be a means to select animals that are better adapted to their rearing environment.

Currently there are no means of assigning estimates to the parameter AB and its variation. However, assuming that there is a measurable phenotypic difference between types of pigs and individuals within a population, it is thought that genetic characterization is possible. This is supported by Kanis *et al.* (2004), who described a conceptual framework for breeding for improved welfare in pigs and its use in practice. Comparing the variation in performance observed in experimental data with the variation predicted by the model will also allow an initial estimate of the variation in AB to be made. Such an inverted modelling technique was the method used by Ferguson *et al.* (1997) when predicting the variation in B^* , L_m/P_m and P_m from the variability in ADG, average daily feed intake (ADFI) and external estimates of the heritabilities of these traits.

It is also important to know if any correlations exist between AB and any of the other genetic parameters, particularly leanness described by L_m/P_m . If these exist, it will affect the nature and description of the variation of the correlated parameters and would need to be accounted for in the model by incorporating the covariation between the identified parameters and AB. This of course relies on the simplistic assumption that individuals react in the same way to all types of social stressors (i.e. an individual that copes well with one stressor will cope equally well with all stressors). If this is incorrect, the introduction of further parameters, in addition to AB, will be required for a sufficient descriptor of ability to cope when exposed to differing social stressors.

Quantifying the variation in AB may improve the rate of breeding for improved ability to cope, as the amount of variation determines the degree of selection pressure able to be applied. If a parameter such as AB were included into a selection index, individual pigs with both the greatest growth potential and best ability to cope could be selected for benefits to both welfare and production. Indeed, if increased growth rate and ability to cope are antagonistic as suggested by Schinckel *et al.* (2003), amongst others, then trying to increase pig performance achieved under excellent conditions, i.e. improving potential alone, may not prove to be the best selection strategy. Any improvement in pigs' response to stressors would allow a greater proportion of their potential to be attained under stressful conditions and may be a better way of improving pig performance and enterprise profitability than increasing potential per se.

Conclusions

Proper allowance for population variation is important when models are used to predict nutrient requirements, optimize pig production systems and devise animal-breeding strategies, as there may be differences between the response of the individual and the mean population due to between-animal variation. The variation in the growth response of a population was determined to a greater extent by variation in initial state and ability to cope than by variation in growth potential when pigs were simulated in conditions likely to be encountered in commercial environments. This is an important practical consideration in commercial pig production, especially for all-in-all-out systems, as the heterogeneity of a group at slaughter will largely determine enterprise profitability. Consequently, decreasing the variation in initial state and improving pigs' ability to cope may be a better way of improving pig performance and enterprise profitability than selecting only for increased growth potential.

References

- Black, J.L., Campbell, R.G., Williams, I.H., James, K.J. and Davies, G.T. (1986) Simulation of energy and amino acid utilisation in the pig. *Research and Developments in Agriculture* 3, 121–145.
- Campbell, R.G. and Taverner, M.R. (1985) Effect of strain and sex on protein and energy metabolism in growing pigs. In: *Energy Metabolism of Farm Animals*. EAAP Publication No. 32, pp. 78–81.
- Chapple, R.P. (1993) Effect of stocking arrangement on pig performance. In: Batterham, E.S. (ed.) *Manipulating Pig Production IV*. Australian Pig Science Association, Victoria, pp. 87–97.
- D'Eath, R.B. (2002) Individual aggressiveness measured in a resident–intruder test predicts the persistence of aggressive behaviour and weight gain of young pigs after mixing. *Applied Animal Behaviour Science* 77, 267–283.
- Drickamer, L.C., Arthur, R.D. and Rosenthal, T.L. (1999) Predictors of social dominance and aggression in gilts. *Applied Animal Behaviour Science* 63, 121–129.
- Emmans, G.C. and Fisher, C. (1986) Problems in nutritional theory. In: Fisher, C. and Boorman, K.N. (eds) *Nutrient Requirements of Poultry and Nutritional Research*. Butterworths, London, pp. 9–39.
- Erhard, H.W. and Mendl, M. (1997) Measuring aggressiveness in growing pigs in a resident–intruder situation. *Applied Animal Behaviour Science* 54, 123–136.
- Ferguson, N.S., Gous, R.M. and Emmans, G.C. (1997) Predicting the effects of animal variation on growth and feed intake in growing pigs using simulation modelling. *Animal Science* 64, 513–522.
- Fisher, C., Morris, T.R. and Jennings, R.G. (1973) A model for the description and prediction of the response of laying hens to amino acid intake. *British Journal of Poultry Science* 14, 469–484.
- Giroux, S., Martineau, G.P. and Robert, S. (2000) Relationships between individual behavioural traits and post-weaning growth in segregated early-weaned piglets. *Applied Animal Behaviour Science* 70, 41–48.
- Grandin, T. (1994) Solving livestock handling problems. *Veterinary Medicine* 89, 989–998.

- Green, D.M. and Whittemore, C.T. (2003) Architecture of a harmonised model of the growing pig for determination of dietary net energy and protein requirements and of excretions into the environment (IMS Pig). *Animal Science* 77, 113–130.
- Hansen, L.L., Hagelso, A.M. and Madsen, A. (1982) Behavioural results and performance of bacon pigs fed ad libitum from one or several self-feeders. *Applied Animal Ethology* 8, 307–333.
- Hessing, M.J.C., Schouten, W.G.P., Wiepkema, P.R. and Tielen, M.J.M. (1994) Implications of individual behavioural characteristics on performance in pigs. *Livestock Production Science* 40, 187–196.
- Kanis, E., van der Belt, H., Groen, A.F., Scakel J. and de Greef, K.H. (2004) Breeding for improved welfare of pigs: a conceptual framework and its use in practice. *Animal Science* 78, 315–329.
- Knap, P.W. (2000) Stochastic simulation of growth in pigs: relations between body composition and maintenance requirements as mediated through protein turnover and thermoregulation. *Animal Science* 71, 11–30.
- McBride, G., James, J.W. and Hodgens, N. (1964) Social behaviour of domestic animals: IV. Growing pigs. *Animal Production* 6, 129–139.
- Muir, W.M. and Craig, J.V. (1998) Improving animal well-being through genetic selection. *Poultry Science* 77, 1781–1788.
- Pomar, C., Kyriazakis, I., Emmans, G.C. and Knap, P.W. (2003) Modeling stochasticity: dealing with populations rather than individual pigs. *Journal of Animal Science* 81, E178–E186.
- Rauw, W.M., Kanis, E., Noordhuizen-Strassen, E.N. and Grommers, F.J. (1998) Undesirable effects of selection for high production efficiency in farm animals: a review. *Livestock Production Science* 56, 15–33.
- Schinckel, A.P., Spurlock, M.E., Richert, R.T. and Weber, T.E. (2003) Modelling health status: environmental effects on swine growth. *Book of Abstracts of the 54th Annual Meeting of the European Association for Animal Production*, Rome, Italy, p. 355.
- Turner, S.P., Ewen, M., Rooke, J.A. and Edwards, S.A. (2000) The effect of space allowance on performance, aggression and immune competence of growing pigs housed on straw deep litter at different group sizes. *Livestock Production Science* 66, 47–55.
- Wellock, I.J., Emmans, G.C. and Kyriazakis, I. (2003a) Predicting the consequences of social stressors on pig food intake and performance. *Journal of Animal Science* 81, 2995–3007.
- Wellock, I.J., Emmans, G.C. and Kyriazakis, I. (2003b) Modelling the effects of thermal environment and dietary composition on pig performance: model logic and concepts. *Animal Science* 77, 255–266.
- Whittemore, C.T. (1998) *The Science and Practice of Pig Production*. Blackwell Science, London.

22 Empirical Modelling through Meta-analysis vs Mechanistic Modelling

D. SAUVANT AND O. MARTIN

*UMR INRA INA P-G, Physiologie de la Nutrition et Alimentation, 16 rue
Claude Bernard, 75231 Paris Cedex 05, France*

Abstract

During the 1980s numerous papers had underlined that a mechanistic model would be more appropriate than an empirical one to understand and simulate animal responses to diets. The major criticism against empirical models was the strong limitation of their possibilities of application beyond the range of data used for the statistical treatment.

The trend in the last three decades has been an increase in the numbers of publications and data per publication. This evolution stressed the necessity to largely increase the process of extraction/integration of data into knowledge. Two aspects were necessary for each topic: the building of databases from the literature and thereafter the interpretation, through statistical meta-analysis, of these databases.

Meta-analysis of databases is faced with several difficulties. An important point is that there are missing values and it does not constitute a classic experimental design. Otherwise it is a necessary process to conduct a careful interpretation, associating closely both graphical studies and statistical treatments. The major challenge of this last aspect is to split the variations among and within the experiments.

Meta-analysis can be conducted on two levels between mechanistic and empirical models: (i) to provide valuable underlying parameters to build mechanistic models; and (ii) to use global and aggregated empirical models to perform the external evaluation of a mechanistic model. There are other ways to connect the two approaches. Meta-analysis of databases can be usefully applied to comparatively evaluate mechanistic models. Such a process was recently performed to compare three mechanistic models of rumen (Offner and Sauvant, 2004).

It appeared that mechanistic modelling and meta-analysis do not basically compete; they present, on the contrary, strong possibilities of synergy. Therefore, they will likely be more and more closely associated in a common process of data mining in the near future.

Introduction

A major change in the context of animal nutrition during the last decade was a new paradigm that consisted of replacing the classic concept of 'covering

the requirements' with the concept of 'predicting the multiple responses to diets' (Sauvant, 1992). Another aspect was the increasing number of publications per relevant topic and of data per publication. In contrast, the range of responses of animals to experimental factors tended to decrease. Users wanted to have more and more quantitative tools because modelling is now developed at various levels of organization (from molecule to farm and animal product chains). As a consequence, the current challenge was to improve the efficiency of transforming published data into quantitative and usable knowledge. In this context, classical reviews of the literature present strong limitations. Effectively, they are partly subjective, largely qualitative and generally lead to conclusions without sound statistical treatments.

Thus, performing meta-analysis on databases gathered from experiments published in the literature seems to be an efficient tool towards progress (Glass, 1976). Meta-analysis is a new scientific discipline that analyses critical reviews and statistical studies of previous researches to improve our quantitative knowledge on a given topic. Until now, most of the meta-analyses were performed in the medical and pharmaceutical area. However, they have recently demonstrated their ability to predict the most probable effective degradability of starch in sacco (Offner *et al.*, 2003) and the response of ruminants to defaunation (Eugène *et al.*, 2004), and to synthesize shape variations of lactation curves of cows (Martin and Sauvant, 2002).

In this study, attention is mainly focused on the complementarities between meta-analytical approaches and mechanistic modelling. The use of the latter approach in research has been largely developed lately. Mechanistic modelling presents two phases of data processing: first, building a mechanistic model and, second, performing the external validations of the built-up model (Fig. 22.1). The following sections explain these two phases.

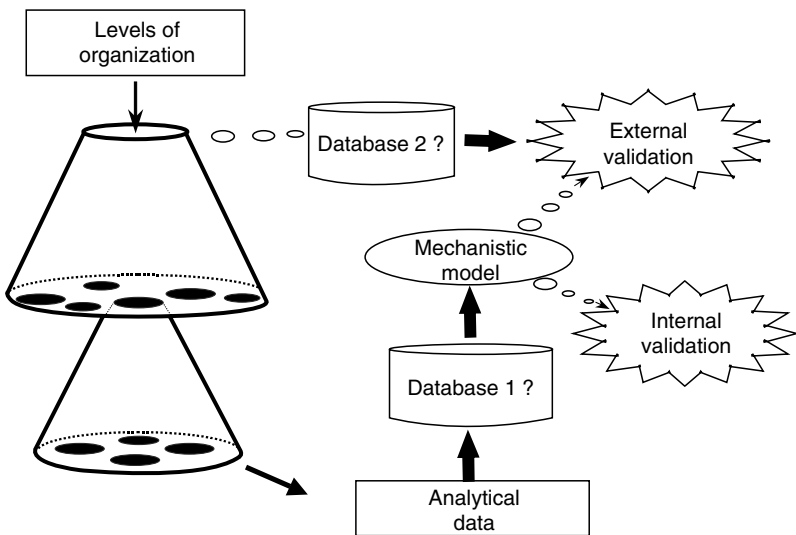

Fig. 22.1. Mechanistic modelling and data processing.

Meta-analysis in Building a Mechanistic Model

Objectives

In this context, meta-analysis can be applied to determine the most probable values of constants and of initial values of the state variables (compartment size). Moreover, meta-analysis can be particularly useful to determine the shape, choose the most relevant equations, and identify the most probable values of the parameters (i.e. fractional rates) that link the outflows with the size of the donor compartments. To calculate these relationships it is generally necessary to gather data from various experiments or publications.

Difficulties in database interpretation

Database interpretation through meta-analysis raises several difficulties. First, there are numerous missing values in the data-set. Consequently, it is impossible to apply multivariate analyses. Moreover, the 'meta design' constituted by the publications and experiments is not a classical one; nor is it either balanced or orthogonal. Second, variations across experiments are generally much more important than within them, although they frequently remain largely unexplained. One of the consequences is the recommendation to consider the variables two by two and to split and study the variations across and within the experiments.

The steps in meta-analysis

The process of meta-analysis comprises several major successive steps, which are summarized in Fig. 22.2:

- Definition of the objectives and specifications of the work: (i) choice of the logic and structure of the database (e.g. Excel); (ii) selection of experiments, which could be a priori consistent with the objectives of the work; (iii) evaluation of the experiment by an expert of the topic, which, if included in the database, has to be immediately compared to the already stored data; (iv) consistent encoding of treatments, experiments, experimental factors and targets, applied methodologies, etc. that is immensely important to the quality of a meta-analysis.
- Graphical examination of the data, with a systematic analysis of the variables two by two: today some logics are particularly suited to combine graphical and statistical approaches in a user-friendly manner, and numerous useful suggestions can be drawn from this phase.
- Study of the 'meta design', which comprises the gathered treatments, experiments, factors and publications – the process of interpretation of a database can be trapped if this phase has been neglected: (i) consideration of the possible and plausible ranges of variation for each explicative variable X_i ;

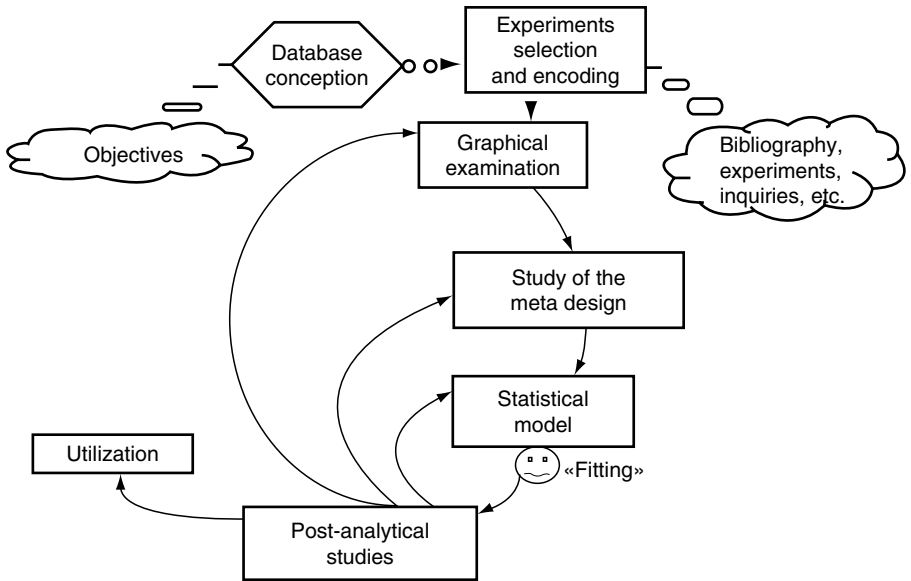

Fig. 22.2. Steps in developing a meta-analysis.

(ii) histogram of distribution of the treatments and experiments to know if there is a range of X_i values where researches have been mainly focusing; (iii) testing for any significant influence of the experiment on the variables X_i – if there is an effect, a confusing influence arises of among- and within-experiment variations of X_i on the parameter’s values; (iv) calculation of the leverage coefficients of the treatments, which allows detection of treatments that present excessive influence on the parameter’s value; (v) analysis of mutual relationship between two (or more) explicative variables X_i and X_j that are candidates to enter meta-analysis, not only globally but also across and within the experiments.

- Statistical treatment, which is frequently based on the application of the following general mixed model (St-Pierre, 2001):

$$Y_{ij} = B_0 + s_i + B_1 X_{ij} + b_i X_{ij} + e_{ij}$$

where Y_{ij} is explicative variable, B_0 is global intercept (fixed effect), s_i is random effect of experiments ($i = 1, n$), B_1 is global regression of Y on X (fixed effect), X_{ij} is explicative variable, b_i is random effect of experiment i on the coefficient of regression of Y on X and e_{ij} is residual variation (unexplained). This model can be more complicated, for instance by: (i) including possibilities of interactions between factors and also between covariates X_{ij} and factors; (ii) taking into account an effect of the year of publication (alternative methods have been proposed to avoid the arbitrary choice of the calibration and evaluation subsets such as cross-validation) (Geisser, 1975); (iii) considering the traditional debate ‘block

or covariable', which remains valuable to account for the experimental effect (if the experimental effect presents an obvious practical sense that can be summarized through one variable, e.g. live weight (LW) for a set of experiments dealing with growing animals, this variable can be preferred to a qualitative experimental factor).

- **Fittings:** as suggested by the statistical model, an important question dealing with the interpretation of the heterogeneity among experiments is choosing the nature of the factors of variation: fixed or random? (i) Fixed effects are those when the modalities can be considered as chosen by the researcher's community (in this case, the major target is to rank and interpret this variability among experiments, or groups of experiments); (ii) random effects are those when each experiment can be considered as a sample of a larger population (in this case, the target is to control heterogeneity). The space of inference is larger with a random effect; however, in this case, the intervals of confidences around fitted parameters are also larger.
- **Opportunity to apply weighting values to each experiment or treatment:** this aspect seems to be more important when the number of publications taken into account is low and when experimental conditions are particularly heterogeneous among experiments (type of design, number of animals, residual variations, etc.). The most intuitive choice is to give more weight to experiments leading to better accuracy in a given context (St Pierre, 2001); however, other rules of weighting could be applied.
- **Post-analytical studies:** (i) focusing on the study of the distribution and of the structure of the residual deviations (normality, non-linear trends, hidden interactions, etc.); (ii) calculating items such as the coefficients of leverage and the contributions of treatments to the variance, allowing detection of those treatments that could have an excessive influence on the value of the parameters; (iii) integrating these values per experiment to also evaluate the role of each in determining the parameter's values.

Meta-analysis and External Validation of a Mechanistic Model

External validation, or evaluation of a model, is performed to evaluate to what extent the predicted values agree with observations. This process generally consists of comparing model-simulated values to actually observed corresponding values. Obviously data used in this external evaluation must be different from those that were used to build the model (Fig. 22.1). Moreover, they are more aggregated. It is generally believed that three basic parameters have to be used to study the degree of agreement between the observed and predicted values (Fig. 22.3; Bibby and Toutenburg, 1977): mean deviation, slope of the relationship and the residual mean square error (RMSE).

An external validation performed through only one experiment obviously presents strong limitations. Therefore, it is recommended to carry out this step through several experiments covering all the contexts that are wanted for inference. To achieve this target, it is necessary to consider the

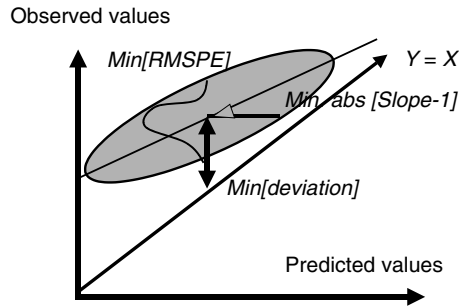

Fig. 22.3. External validation of a model: three basic parameters form root mean squared predicted error (RMSPE) analysis.

among- and within-experiment variations, which can be very different. In this context, it is believed that the general law is closer to the within-experiment one.

The quality of the external validation of a mechanistic model can be improved by meta-analysis. For example, a given mechanistic model of the whole organism can be successively evaluated through experiments corresponding to one, two or more dietary factors (i.e. dietary levels of concentrate and crude protein (CP), etc.). Each factor corresponds to a specific sub-database built from experiments focused on this topic. If two sub-databases can be pooled and if the new meta design allows modelling of the interactions between both factors, this can constitute a new topic of external evaluation. These basic principles can be extended to more than two factors.

Another challenge could be to build a mechanistic model that allows explanation of across-experiment variations, which are systematically larger than the within-experiment ones. Such an approach was performed by Offner and Sauvant (2004) to compare three mechanistic models of digestion in the rumen (Molly, 1999; CNCPS, 2000; Lescoat and Sauvant, 1995). The comparative evaluation needed an initial systematic simulation of the three models, with their specific parameters on a database of 194 treatments built from 47 publications of the literature. The selection of the publications was done on the basis of the indication of measurements of some specific parameters (microbial flow, starch digestibility, neutral detergent fibre (NDF) digestibility, volatile fatty acid (VFA) concentration, ratio of acetate (Ac) to propionate (Pr), and pH). A specific feed library of 73 ingredients had to be created to have a common and consistent base of comparison. For each of these parameters, the three items of external validation were calculated between observed and predicted data. Figure 22.4 shows the outcome of such a comparison for the microbial flow at duodenum. On this item the ranking order of the models is obvious. However, the order of ranking of the quality of these three models depends on the parameter (Table 22.1) showing that it is difficult, and partly subjective, to decide that a rumen model is definitely better than any other. Also, for some items such as VFA concentration and NDF digestibility, the three models failed to provide accurate predictions.

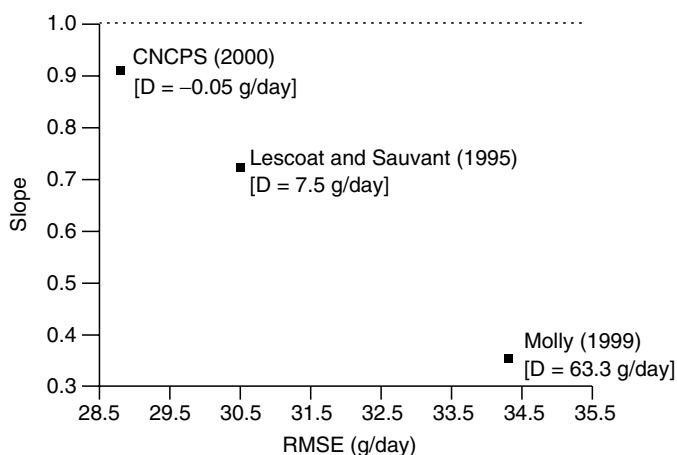

Fig. 22.4. Comparative evaluation of three mechanistic models of rumen to predict microbial nitrogen flow at duodenum. Source: Offner and Sauvant, 2004 (115 treatments, 32 references).

Table 22.1. Ranking of mechanistic models of the rumen in prediction of digestive items.

	CNCPS	Molly	Lescoat and Sauvant
Microbial nitrogen flow	1	3	2
Starch digestibility	3	2	1
NDF digestibility	2	1	3
pH	2	3	1
VFA concentration	n.s.	2	1
Acetate/propionate	n.s.	1	1

CNCPS = Cornell Net Carbohydrate and Protein System; NDF = neutral detergent fibre; VFA = volatile fatty acid.

Discussion

Other aspects dealing with the two approaches could be considered, particularly if there is any competition between them. Effectively, 10–15 years ago, the modelling community generally thought that mechanistic modelling was almost the only way to model the nutrition processes of farm animals (France and Thornley, 1984). Today, questions can be asked if empirical modelling through meta-analysis of databases would be more efficient than mechanistic modelling to integrate experimental data into models, which would be more useful. The answer to this issue is pending on various aspects, among which is the nature of the question and the type of response that is expected. Another important aspect is the diversity and structure of the available data; if the database is large, with a sufficient number of data

and a sufficiently balanced meta design (cf. possibility of testing interactions), meta-analysis can be more efficient to take into account this diversity through models of prediction. For instance, this seems to be particularly relevant for modelling some frequently studied animal responses to diets.

The choice between the two types of models can also depend on the length of time within which the response to the question is expected. On that aspect and for a given topic, meta-analysis seems to be more able to provide reliable predictions in a shorter term. Thus, when the target is to develop a model to have a fairly quick answer to a given question, the empirical way through meta-analysis is recommended. However, it must be kept in mind that this last approach cannot provide prediction beyond the range of data and practical situations that are taken into account. In contrast, as mechanistic modelling is closer to the scientific approach (explicative aim), the step of time is larger and even apparently infinite. For example, the first mechanistic model of the whole rumen was published almost 35 years ago (Baldwin *et al.*, 1970) and a fairly new model is published every 2 years. In spite of this, researchers on rumen agree that a satisfactory model of rumen does not yet exist!

Today, in a research team or department, it seems that the processes of experimentation have to be tightly and carefully associated with empirical and mechanistic modelling (Fig. 22.5). Empirical modelling allows, through meta-analysis, determination of underlying laws or item values to feed mechanistic models. Empirical modelling can also be used to calculate the global laws allowing external validation as previously described.

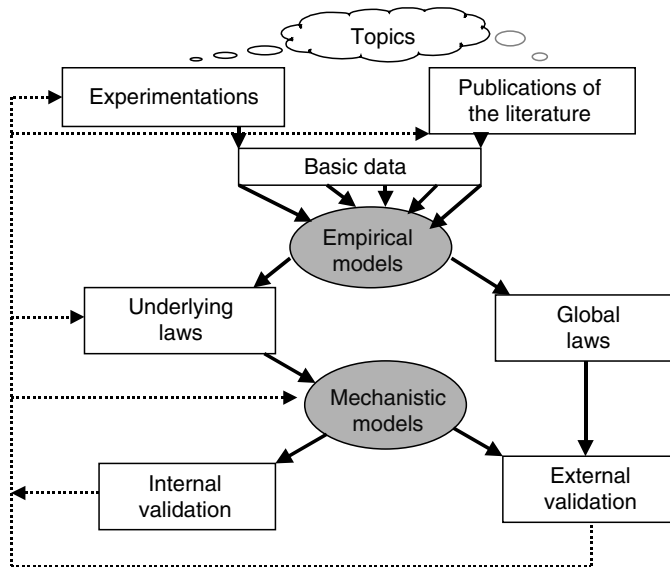

Fig. 22.5. Engineering of information and modelling in research.

Conclusions

This study suggests that empirical modelling has a renewed interest through meta-analysis of databases. However, it must be kept in mind that meta-analysis of databases is a powerful yet delicate method, which must be applied with great attention and respect to a code of good practice. Clearly, meta-analysis and mechanistic modelling have more reasons to be synergistic than to compete. This positive association boosts in a certain sense mechanistic modelling, and may mark the beginning of a new era.

References

- Baldwin, R.L., Lucas, H.L. and Cabrera, R. (1970) Energetic relationship in the formation and utilization of fermentation end products. In: Philipson, A.T. (ed.) *Physiology of Digestion and Metabolism in the Ruminant*. Oriel Press, Newcastle, UK, pp. 319–335.
- Bibby, J. and Toutenburg, H. (1977) *Prediction and Improved Estimation in Linear Models*. John Wiley & Sons, Chichester, UK.
- CNCPS (Cornell Net Carbohydrate and Protein System): Fox, D., Tylutki, T., van Amburgh, M., Chase, L., Pell, A., Overton, T., Tedeschi, L., Rasmussen, C., Durbal, V. (2000) The net carbohydrate and protein system for evaluating herd nutrition and nutrient excretion: MOL version 4.0.31. Model Documentation, Department of Animal Science, Cornell University Press, Ithaca, New York.
- Eugène, M., Archimède, H. and Sauvant, D. (2004) Quantitative meta-analysis on the effects of defaunation of the rumen on growth, intake and digestion in ruminants. *Livestock Production Science* 85(1), 81–97.
- France, J. and Thornley, J.H.M. (1984) *Mathematical Models in Agriculture*. Butterworths, London.
- Geisser, S. (1975) The predictive sample reuse method with applications. *Journal of the American Statistical Association* 70, 320–328.
- Glass, G.V. (1976) Primary, secondary and meta-analysis of research. *Educational Research* 5, 3–8.
- Lescoat, P. and Sauvant, D. (1995) Development of a mechanistic model for rumen digestion validated using the duodenal flux of amino acids. *Reproduction, Nutrition, Development* 35, 45–70.
- Martin, O. and Sauvant, D. (2002) Meta-analysis of input/output kinetics in lactating dairy cows. *Journal of Dairy Science* 85, 3363–3381.
- Molly (1999) Model developed by R.L. Baldwin: Version 2.0. University of California, Davis, California.
- Offner, A. and Sauvant, D. (2004) Comparative evaluation of the Molly, CNCPS, and LES rumen models. *Animal Feed Science and Technology* 112, 107–130.
- Offner, A., Bach, A. and Sauvant, D. (2003) Quantitative review of *in situ* starch degradation in the rumen. *Animal Feed Science and Technology* 106, 81–93.
- Sauvant, D. (1992) La modélisation systémique en nutrition. *Reproduction, Nutrition, Développement* 32, 217–230.
- St-Pierre, N.R. (2001) Invited review: integrating quantitative findings from multiple studies using mixed model methodology. *Journal of Dairy Science* 84, 741–755.

23

Iterative Development, Evaluation and Optimal Parameter Estimation of a Dynamic Simulation Model: a Case Study

L.G. BARIONI,¹ J.W. OLTJEN² AND R.D. SAINZ²

¹*Embrapa Cerrados, Rodovia Brasília-Fortaleza BR 020 KM 18, Planaltina, DF 73301-970, Brazil;* ²*Department of Animal Science, University of California, Davis, CA 95616, USA*

Abstract

Parameter estimation and model evaluation are crucial parts of the development of predictive simulation models. However, a lack of synchronization is often observed in the activities of modelling and experimentation in agriculture. One of the causes of the communication gap between modellers and experimental researchers is that the tools for parameter estimation in dynamic models, in contrast with those in empirical models, are not widely spread out among the scientific community. It is unlikely, therefore, that experimental data are readily used for model evaluation or parameterization. The result is poor model evaluation and difficulty in iterative refinement of parameter estimates and model structure. This chapter reports a case study of the iterative development, evaluation and parameterization of the Davis Growth Model (DGM). A new computer program, including different optimization and sensitivity routines, was developed and applied to the model. This program, in association with new experimental data, helped to highlight structure and parameter estimate deficiencies in particular situations, which is leading to actions for future model improvement.

Introduction

At a previous workshop in this series, Baldwin and Sainz (1995) remarked that one of the bottlenecks to progress in modelling animal function was the lack of a synergistic interaction between theory (or modelling) and experimentation. This synergy is extremely useful, and has resulted in most recent advances in physics. Animal biology has not typically functioned in this way. In most cases, researchers do not model and modellers do not conduct experiments. This would pose no problem except that there is seldom a close relationship between the two activities. Although modellers are avid users of experimental data, experimentalists rarely consult models or modellers in designing their experiments.

During the development and application of simulation models for predictive purposes, it is possible to identify four main processes in which the model interfaces with observed data. Two of these occur during model development: (i) parameter estimation and (ii) model evaluation; and the other two during model application: (iii) input data and (iv) output data from the system for calibration and/or filtering. The data used in these four processes have to be compatible to a predefined standard (measurement procedures, units, etc.) in order to allow the model to attain adequate predictions.

The lack of synchronization in the processes of modelling, experimentation and model application results in the development of models that would be hard to test experimentally, and in the design of experiments that are inadequate for the parameterization or evaluation of simulation models. One of the causes is that, in contrast with what happens with empirical models, the tools for parameter estimation for dynamic models are not widely spread out among the scientific community.

Our group has been modelling animal growth and body composition for a number of years. 'Normal' growth is easily simulated, but some situations present special challenges. Among these, specific genotype effects and the effects of previous nutrition deserve mention. In particular, the effect of growth path has been the focus of several research projects. We have reported on the impacts of previous nutrition on growth efficiency and final composition of beef cattle, in both experimental and modelling studies. These studies have pointed out the large impact that changing maintenance energy expenditures have on animal performance. In this study we present a more detailed examination of an experimental data-set, from a modelling perspective.

Materials and Methods

The model and data

The DGM was originally published by Oltjen *et al.* (1986), and is summarized in Chapter 16 (see Sainz *et al.*, Chapter 16, this volume). The model was originally parameterized using individual data from Garrett (1980) and Byers and Moffitt (1979) for medium-framed British steers, and did not account for variable maintenance energy requirements. In this study, the DGM was evaluated and refitted using data from an independent experiment (Sainz *et al.*, 1995). The data-set contains individual measurements of diet energy concentration, dry matter intake (DMI), and initial and final body composition for 110 animals. During the growing phase, steers were fed one of two diets (high or low concentrate). The low-concentrate diet (metabolizable energy (ME) = 1.87 Mcal/kg) was available *ad libitum* (FA) and the high-concentrate diet (ME = 3.06 Mcal/kg) was either available *ad libitum* (CA) or was limited (CL) to match the weight gains by the FA group. During the finishing phase, steers were fed the high-concentrate diet, either for *ad libitum* intake (CA) or

restricted to 70% *ad libitum* intake (CL). Thus the treatments are composed of either just a growing phase (CA, CL and FA) or both a growing and finishing phases (CA-CA, CL-CA, CL-CL, FA-CA and FA-CL).

Software

Software development based on object-oriented programming principles (Booch *et al.*, 1999) was implemented using the Borland Delphi™ 7.0 programming environment. The model is represented using a declarative approach (Muetzelfeldt, 2004), i.e. it is in a file, stored separately from the actual software. A mathematical compiler was used to parse the model formulas, so that the model can be modified and recompiled at run time. The software allows the inputs to be represented as time sequences for one individual record or multiple records (e.g. data with diet composition, intake and body composition). When used with multiple records, the program runs each of the records, changing the input values whenever specified, until the time the last measurement is taken for each record. Predicted and observed values are then stored for later computation. The software can use different parameter-fitting procedures. At this stage it uses a commercial implementation of an iterative optimization algorithm (Frontline Systems, 1999). For each iteration, all the records are run and the overall error (i.e. residual sum of squares (RSS)) is calculated and returned to the optimization algorithm as the objective function value. After convergence, the result is saved to ASCII and comma-separated values (csv) formatted files.

Parameter fitting

The model parameters for maintenance requirement (α) and protein synthesis (k_2) were fitted to the data using a commercial implementation of the Generalized Reduced Gradient method (Lasdon *et al.*, 1978; Frontline Systems, 1999). The optimization algorithm was set to minimize the error sum of squares of body protein plus the error sum of squares of body energy, weighed according to the respective experimental variances. Four different fits were performed: (i) a common value of α and a common value of k_2 for all the treatments ($C\alpha Ck_2$); (ii) different values of α but a common value of k_2 for all the treatments ($V\alpha Ck_2$); (iii) different values of k_2 but a common value of α for all the treatments ($C\alpha V k_2$); and (iv) different values of k_2 and α for each treatment ($V\alpha V k_2$). Error and bias in the estimates were used to point out the need for new parameter estimates or model modification.

Results and Discussion

Results of the parameter fittings are summarized in Table 23.1. Considering variable instead of fixed maintenance requirements for each experimental

group significantly improved the precision of the model for fat and retained energy (RE; Fig. 23.1). These results confirm the conclusions of Sainz *et al.* (1995), that previous nutrition had substantial impacts on maintenance energy expenditures, and they also indicate that variable maintenance can significantly improve model predictions. Sainz and Bentley (1996) showed that the observed changes in maintenance energy expenditures were closely related to changes in visceral protein mass. Oltjen *et al.* (Chapter 15, this volume) have shown that predictions of energy usage are improved by modelling visceral protein dynamics and predicting heat production (HP) from visceral and non-visceral protein pools.

A single value of k_2 for all experimental treatments resulted in a bias in final empty body weight (EBW) for some of the groups (Fig. 23.2). A bias in EBW also created a bias for the value of α in different groups, so simultaneous fits of α and k_2 were then carried out. It is important to note that the value of k_2 is not supposed to vary with nutritional level because the model explicitly represents nutritional effects on protein synthesis. This indicates, therefore, that the representation of the nutritional effects needs improvement. A modified version of the DGM (see Oltjen *et al.*, Chapter 15, this volume) already has an improved model structure to better estimate protein growth for sheep. However, that model still requires parameter estimates for cattle.

Table 23.1. Parameter values for the different parameter fitting procedures and treatments.

Parameter	Treatment	Fitted parameters				
		Original	$C\alpha Ck_2$	$C\alpha V k_2$	$V\alpha Ck_2$	$V\alpha V k_2$
k_2	All	0.0461	0.0503	—	0.0506	—
	CA	—	—	0.0494	—	0.0492
	CA-CA	—	—	0.0495	—	0.0491
	CL	—	—	0.0471	—	0.0471
	CL-CA	—	—	0.0522	—	0.0518
	CL-CL	—	—	0.0513	—	0.0509
	FA	—	—	0.0462	—	0.0461
	FA-CA	—	—	0.0469	—	0.0482
	FA-CL	—	—	0.0492	—	0.0494
α	All	0.0858	0.1152	0.1171	—	—
	CA	—	—	—	0.0852	0.0882
	CA-CA	—	—	—	0.1056	0.1063
	CL	—	—	—	0.1134	0.1112
	CL-CA	—	—	—	0.1027	0.1120
	CL-CL	—	—	—	0.1051	0.1107
	FA	—	—	—	0.1135	0.1085
	FA-CA	—	—	—	0.1399	0.1363
	FA-CL	—	—	—	0.1199	0.1210

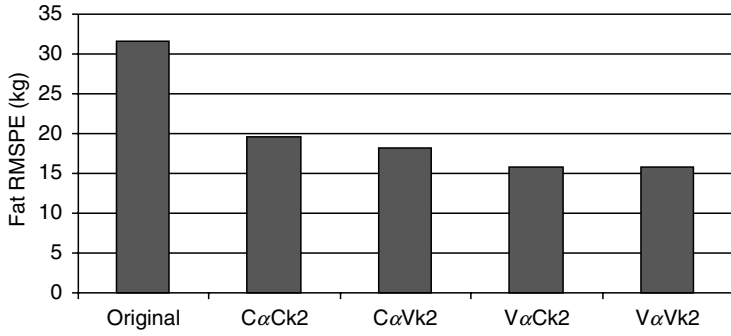

(a)

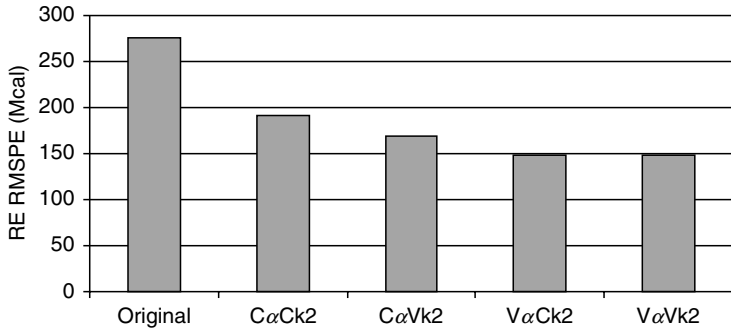

(b)

Fig. 23.1. Root mean square predicted error (RMSPE) of estimates for the different parameter fittings for (a) fat and (b) retained energy (RE).

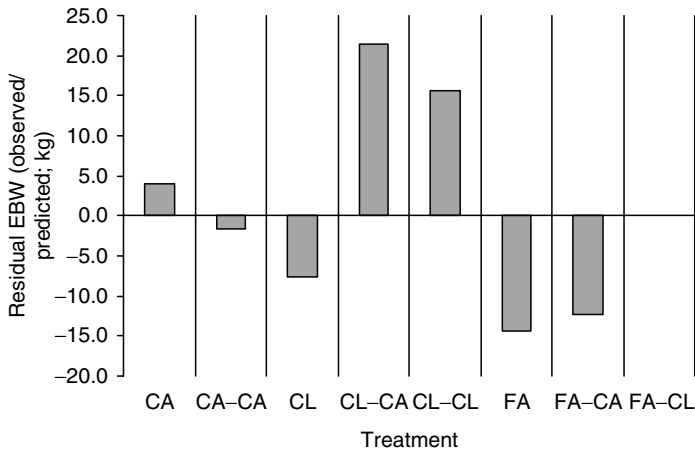

Fig. 23.2. Difference in the average empty body weight (EBW) predicted when using a common k_2 and a variable α in the predictions.

Conclusions

Questions arising from field and experimental observations led to the development of a dynamic model of animal growth. Deficiencies in model performance led to the design of experiments to address those issues. Software was also developed to aid in data analyses and model parameterization. This study has shed light on areas of model structure and parameter estimates that need improvement. With this ongoing cycle of modelling, experimentation and further model improvement, the DGM serves as a powerful research tool in addition to providing excellent predictions in the field.

Acknowledgements

Financial support for Luís Gustavo Barioni during the execution of this work at University of California was provided by Coordenação de Aperfeiçoamento de Pessoal de Nível Superior (CAPES) and Embrapa, Brazil.

References

- Baldwin, R.L. and Sainz, R.D. (1995) Bottlenecks for improvement of future models in animal nutrition science. In: Danfær, A. and Lescoat, P. (eds) *Proceedings of the IVth International Workshop on Modelling Nutrient Utilisation in Farm Animals*. National Institute of Animal Science, Foulum, Denmark, pp. 163–171.
- Booch, G., Rumbaugh, J. and Jacobson, I. (1999) *The Unified Modeling Language User Guide*. Addison-Wesley, Reading, Massachusetts, 482 pp.
- Byers, F.M. and Moffitt, P.E. (1979) Physiological and nutritional modification of growth patterns with DES, monensin, and wintering nutritional plane. Ohio Animal Research Development Center. Beef Research Report. *Animal Science Series* 79(1), 75–82.
- Frontline Systems (1999) *Solver User's Guide: Dynamic Link Library*. Frontline Systems, Incline Village, California.
- Garrett, W.N. (1980) Energy utilization by growing cattle as determined in 72 comparative slaughter experiments. In: Mount, L.E. (ed.) *Energy Metabolism*. European Association of Animal Production Publication 1. No. 26, pp. 3–7.
- Lasdon, L., Waren, A., Jain, A. and Ratner, M. (1978) Design and testing of a generalized reduced gradient code for nonlinear programming. *ACM Transactions on Mathematical Software* 4, 34–50.
- Muetzelfeldt, R. (2004) Position paper on declarative modeling in ecological and environmental research. European Commission Paper 20918.
- Oltjen, J.W., Bywater, A.C., Baldwin, R.L. and Garrett, W.N. (1986) Development of a dynamic model of beef cattle growth and composition. *Journal of Animal Science* 62, 86–97.
- Sainz, R.D. and Bentley, B.E. (1996) Visceral organ mass and cellularity in growth-restricted and refed beef steers. *Journal of Animal Science* 75, 1229–1236.
- Sainz, R.D., De La Torre, F. and Oltjen, J.W. (1995) Compensatory growth and carcass quality in growth-restricted and refed beef steers. *Journal of Animal Science* 73, 2971–2979.

24

Segmented, Constrained, Non-linear, Multi-objective, Dynamic Optimization Methodology Applied to the Dairy Cow Ration Formulation Problem

R.C. BOSTON¹ AND M.D. HANIGAN²

¹*Clinical Studies, NBC, School of Veterinary Medicine, University of Pennsylvania, 382 West Street Road, Kennett Square, PA 19384, USA;*

²*Longview Nutrition Center, Land O' Lakes, 100 Danforth Dr. Gray Summit, MO 63039, USA*

Abstract

In the last meeting of this series of modelling workshops we reported on the development of an optimization scheme for dealing with dairy cow ration formulation, in an optimal way, in the situation where constraints were both non-linear and discontinuous in their arguments. Indeed, we illustrated the implementation of this approach in the Cornell Pennsylvania Miner (CPM)-Dairy ration formulation system. The methodology underpinning CPM-Dairy, the Cornell Net Carbohydrate and Protein System (CNCPS) 'evaluator', projects dairy cow needs on a daily basis, and the solutions obtained by CPM-Dairy may be thought of as least-cost daily formulations. If we set ourselves the objective of, for example, balancing cost against production returns in an optimal way against the background of maintaining the health status of the animal over some period, e.g. the anoestrus period, we might want to examine a more dynamic approach in which the consequences of the time-varying pattern of dairy cow health indices are continuously monitored. In this presentation we report on an approach that addresses this problem, and we outline the issues that confronted us as we developed workable solutions.

Introduction

When the health and welfare of animals, and their environments, are totally controlled by agents (managers and producers) whose principal objective is conceivably to achieve maximum venture profit, a multitude of competing concerns arise. Many of these concerns derive from animal-based considerations, many from environmental considerations and, of course, many arise from financial considerations. For example, in regard to the animal at the tissue level, the maintenance and development of healthy tissue calls for tissue-specific (liver, muscle, etc.) amounts, and blends of feed-based nutrients.

Furthermore, as repeatedly emphasized by Baldwin (1995), feed combinations can interact synergistically and antagonistically in regard to their nutritional potential, and hence delivering nutrient combinations in the appropriate blend is not a simple factorial exercise.

Unfortunately for the dairy cow the tolerance of bacteria to nutrient blends and levels is quite bacteria-specific, and so care needs to be taken in formulating intakes that a whole-animal approach is adopted. If the intake mix is deleterious for the bacteria, then it is, of course, bad for the cow.

The states of a dairy cow are multidimensional and multilayered within the dimensions. For example, in regard to lactation and milk production per se, the cow transits from, let's say, dry to early lactation, to mid-lactation, to late lactation and, finally, back to the dry state. In regard to pregnancy, the cow transits from pregnant, to calving and acyclicity, to cycling, or open, and then to pregnant again. The energy and nutritional demands of all these states are state-dependent as is the requirement for smooth state-to-state transitions.

Changes to the intake formulation for dairy cows take some time (usually 10–14 days) for their consequences to be manifest, and failure to anticipate the consequences can seriously impair the production trajectory. It is critical that the impact of each dietary shift be based on balanced perspectives of the projected needs and changes of needs.

High-producing cows yield more than 45 kg of milk per day and the digestive implications of such burdens are immense. Indeed, legislators around the world have become so troubled by the massive potential for environmental consequences here that they have imposed stringent but fair requirements on dairymen to ensure that irresponsible or negligent damage to the environment from dairying does not take place. This reflects yet another critical concern for the producer to address.

So with production, animal health/welfare and environmental issues to juggle, and to keep profitability as a target of the venture, dairy producers must prevail on every possible means of decision assistance available. In this article we report on an entirely new approach to help in meeting the dairy cow needs while maximizing profitability.

Methods

Given the complexity of achieving profitable dairying, we have sought to explore the feasibility of implementing a dairy cow ration-balancing scheme that supports multiple (linear and non-linear) objectives, and multiple (linear and non-linear, equality and inequality) constraints. Furthermore, we have required that the scheme operates in a dynamic ration-balancing environment, and that it is designed with the eventual objective of being integrated into a field-deployable setting.

Optimization and ration balancing

Linear programming (LP) is a mathematical procedure developed by Dantzig (1951) to optimize (maximize/minimize) an objective, with respect

to a set of activities (denoted x in this article) subject to a series of linear constraints. In an effort to reinforce the utility of this methodology, Dantzig, in an early application of it, showed that the cost of food with required nutritional values could be minimized. Of course since that time the compelling advantages offered through the computer-based application of LP methodology in all sorts of areas have been demonstrated.

In dairy cow nutrition, computer programs using LP to maximize dairying profitability, subject typically to NRC nutrient criteria, have been applied since the mid-1970s. Good demonstrations of LP utility in this area come from VandeHar's SPARTAN software (VandeHar *et al.*, 1992).

As more extensive and more detailed information from experiments became available, it emerged during the late 1980s that linear models, or even linear descriptions of dairy cow systems, were inadequate. Nutritional yield from feeds, digestive processes and metabolic yields from feeds depend on feed levels in curvilinear, as opposed to linear, fashions. Boston *et al.* (2000) recognized this and described the first application of non-linear optimization technology to least-cost dairy ration formulation. The software system described, CPM-DAIRY, incorporated the CNCPS 4.0 dairy feed evaluator, a feed dictionary and both linear and non-linear optimizers permitting least-cost rations to be determined in computing times of around 1 s (Fig. 24.1).

CPM-DAIRY is now used in over 20 countries around the world, a minerals and vitamins balancer has been recently included, and it is about to be released in Version 3.0.

Spurred by the success of CPM-DAIRY, and the convincing verification of the feasibility of the application of constrained non-linear optimization methodology to dairy cow ration formulation, the next step was to explore whether this approach would be practical in a dynamic evaluator, as opposed to a static evaluator (CNCPS) setting. A dynamic setting would permit interacting mechanistic, as opposed to factorial, integration of digestive and metabolic processes. It would enable time-sensitive analysis and respond to health, production and maintenance signalments in the dairy cow. It would allow event-related, as opposed to day-by-day, nutritional planning, and would address the changing needs of the dairy cow in response to processes, as opposed to preset states and computed outputs.

The dynamic whole-animal dairy cow simulator selected for our system (eCow[®]) was MOLLY (Baldwin, 1995). MOLLY is a dynamic, mechanistic model of dairy cow digestion and metabolism. Based on laboratory and field data, differential equations (comprising MOLLY) describing the plausible fate of nutrients and metabolites in conjunction with patterns of utilization and production processes are solved to predict the changing levels of nutritional entities (nutrients and metabolites) over 'variously' long periods of time.

The MOLLY setting

The MOLLY simulator is written in a variant of Fortran 90 suitable for translation by the Advanced Continuous Simulation Language (ACSL) simulator (Mitchell and Gauthier, 1993). ACSL reads the simulation file (Computer

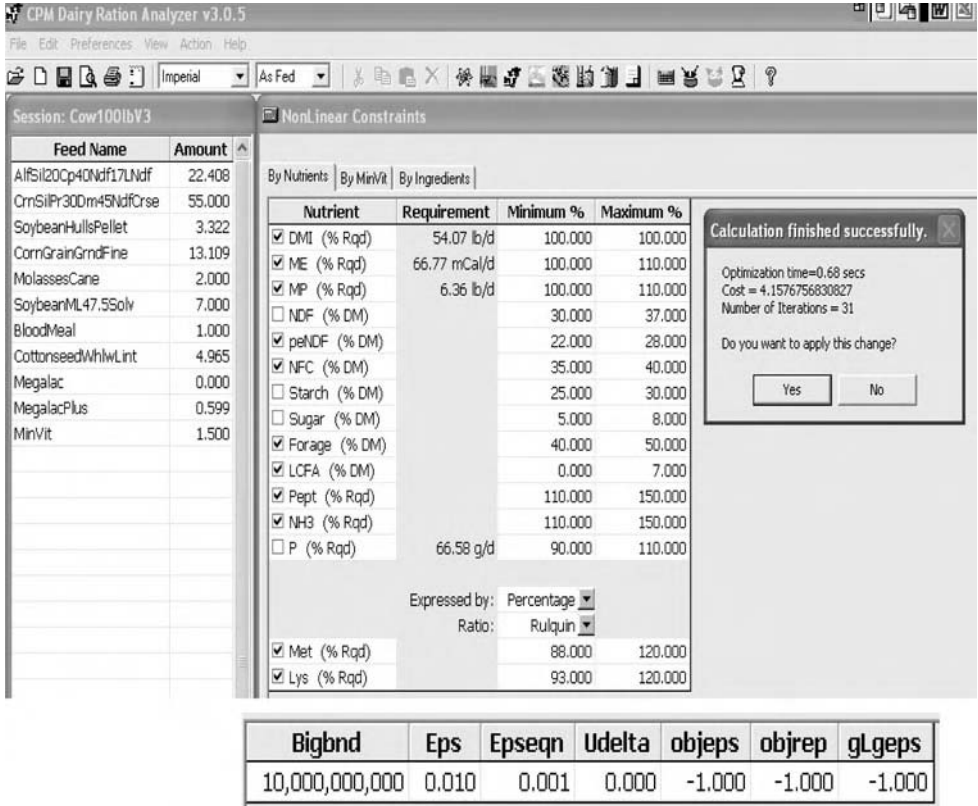

Fig. 24.1. Screen shot of dairy cow feed balancing. Note: (i) processing time and (ii) selected optimization objective criteria (especially 'Eps' and 'objrep').

Science Logic (CSL) constituting the model and builds two subroutines – simulator (SIML) and derivative (DERV) – and a common data block from it; these are then compiled and linked to the ACSL runtime library to create an executable version of the simulation model. It is by interaction with this executable version in the ACSL runtime environment that the simulation exploration of the model advances (Fig. 24.2).

A simulation session is initiated after the executable simulation module is created and the session takes the form of solving the simulation model for designated time intervals and displaying state variables of interest in conjunction with such solutions. Using a series of code substitutions (Fig. 24.2) it is possible to gain control over the ACSL simulator once simulation is under way, and by transferring that control to an optimizer it is possible to establish objectives and constraints needing to be met before the simulation terminates.

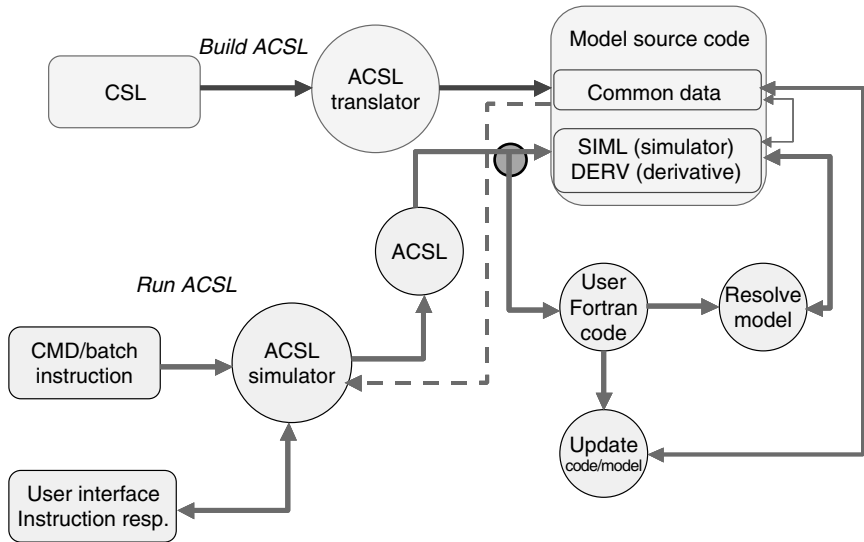

Fig. 24.2. Creating an executable ACSL and controlling the process flow.

Communicating with the optimizer

Clearly an important requirement of effective implementation of optimization into a simulation setting is to be able to alter system (MOLLY) parameters and optimizer settings while the session is under way. In Fig. 24.3 we show how using both common data and ACSL system services we are able to accomplish this.

The emphasis of our initial foray into dynamic optimization methodology was thus: establishing efficient intrasystem communication, verifying our understanding of the processing flow, confirming the robustness of our implementation, assuring widest access to key entities (system variables), and minimizing wastage of processing time.

Selection of optimization software

Our experience with CPM-DAIRY and its attendant optimization methodology gave us confidence to at least explore the same optimizer in the eCow[®] system. The optimizer, Fortran Feasible Sequential Quadratic Programming (FFSQP; Zhou and Tits, 1997), is maintained and developed by a Systems Research Group at the University of Maryland and uses the Mayne and Polak (1976) scheme for ‘feasible direction-based optimization of problems with equality and inequality constraints’. The approach is predicated on FFSQP to

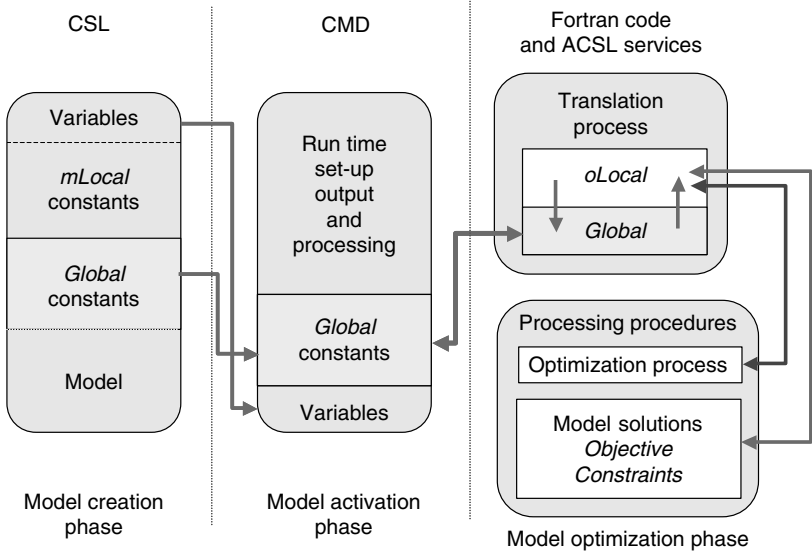

Fig. 24.3. Data exchange in association with phases of model interaction: *m* = model; *o* = optimizer.

$$\begin{aligned} &\text{minimize } \{ \max[f(x \mid \theta, T)] \} && \text{with respect to } x \\ &\text{subject to} && \\ &&& h(x \mid \theta, T) < 0 \end{aligned}$$

Some features of this optimization procedure are as follows:

- It automatically finds initial feasible solution.
- It automatically optimizes linear components.
- It automatically estimates partial derivatives using forward sequential differencing.
- It has four methods for stopping search – objective gradient, objective change, relative objective change and constraint gradient.

Exploring optimizer robustness and efficiency

The complexity of this project necessitated that we identify key areas of our implementation of the optimizer likely to limit its performance, and to implement a plan to explore their consequences. The list we isolated includes:

- stopping criteria;
- non-contributing ingredients;
- integration interval – time segment for analysis;
- solution retention;
- test setting.

Stopping criteria

Based on the magnitude of our objective(s), the precision required for the optimum values, and the relative confidence we have in aspects of our model's predictions, we can explore alternate 'acceptance', or stopping criteria for the final solution. In Table 24.1 we summarize criteria available in our optimizer along with their strengths and weaknesses.

Non-contributing ingredients

Most optimizers lack the capacity to drop optimization activities (e.g. x_i) from the 'contending' set when their contribution falls below some negligible (in regard to the domain) value. This is not surprising because the importance of activities at any level is relative to the investigation domain, and their nature per se. Our experience with CPM-DAIRY has shown us that inordinate time can be wasted in ration optimization in association with the fine-tuning of miniscule amounts of ingredients. Accordingly in this application we identified a critical ingredient amount, *amt_crit*, which, if it exceeds any ingredient amount during the optimization step, leads to that ingredient being dropped from the activity set.

Clearly, care needs to be exercised in regard to setting *amt_crit*, as excessively small values would waste time and lead to impractical ingredient amounts, and excessively large values would erode optimization continuity.

Table 24.1. Stopping criteria available in optimizer.

Criterion	Based on	Advantages	Disadvantages
1	Objective gradient (<i>opeps</i>)	Locates possible turning point; relates directly to algorithm	Stalls at inflexions; stalls at local minima
2	Objective change (<i>opobjeps</i>)	Applies user knowledge of response; easiest to achieve	Needs to be balanced against each objective; requires knowledge of objective values
3	Relative change in objective (<i>opobjrep</i>)	No knowledge of objective needed; automatically balances objectives	May lead to excessive, unwarranted effort
4	Constraint gradient change (<i>opglgeps</i>)	Leads to sensitivity of objectives to activities for each constraint; good step to confirm solution	Difficult to identify meaningful values

Integration/solution interval (segment size)

With only limited appreciation of the potential impact on optimization of the time domain over which the 'best' solution was sought, an important issue in regard to the feasibility of this project was: 'would the number of solution calls in conjunction with optimization be so large that integration duration would become a serious impediment to finding solutions in reasonable time?' Clearly short-duration (e.g. 10-day) solutions should present no problems, but what about 50-, 100- or 200-day solutions? These integration durations reflect likely size of lactation stages for which we might be seeking single optimum rations. Our investigation would need to address this concern.

Solution retention

Just as optimizers make no 'intelligent' judgement concerning dropping marginal activities, they also digress repeatedly into identical solution domains (i.e. same activity values) in their quest for the optimum. This may not be a serious problem for simple, explicit scalar objectives but when solving the objective involves evaluation of 70 or more state equations over thousands of integration steps, care needs to be exercised that unnecessary solving (objective evaluation) is not invoked. To address this we experimented with a scheme (Fig. 24.4) involving saving solutions, where it was our intention that new solutions would only be invoked if they could not be found amongst the history of already saved solutions. Questions regarding the size and structure of the solution 'library' needed to be explored.

Test setting

Two variations to testing software are white box and black box testing (Boston *et al.*, 1995), where the former exhaustively tests the software in very simple settings and the latter tests the software in its application domain. Whereas black box testing does not use precise answers for validation like white box, it does provide the experienced 'tester' with performance and feasibility indices that may achieve more by way of validation in a far shorter time than would be achieved by white box testing. With our experience with CPM-DAIRY and with the domain of application, we felt justified in moving to black box testing as soon as preliminary white box testing gave us confidence that our implementation was correct.

The feed selection available for each of three lactation periods used to test our simulation is presented in Table 24.2. These reflect an ingredient pattern/mix typically used in the dairy industry.

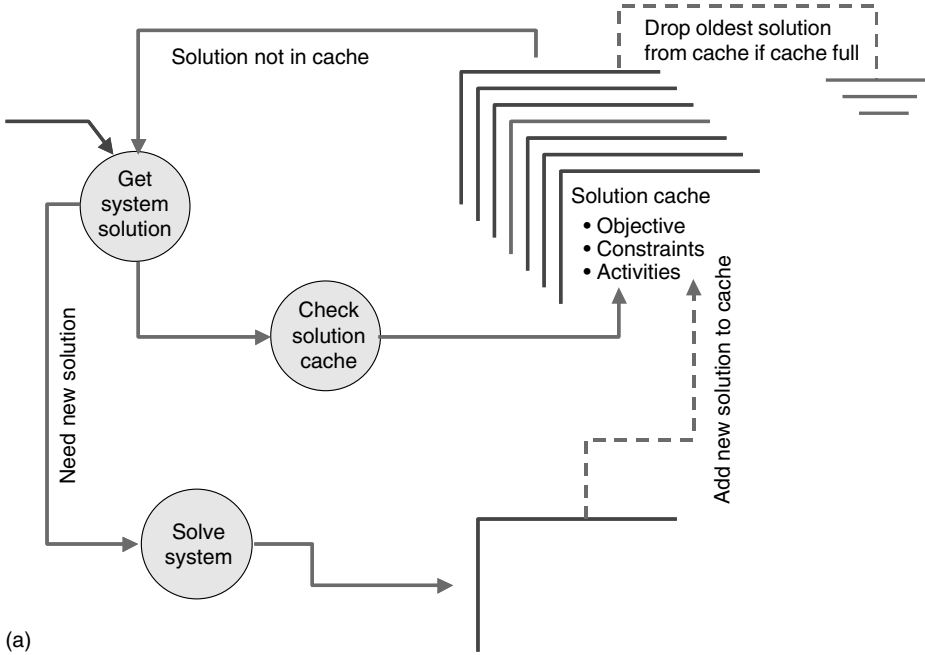

(a)

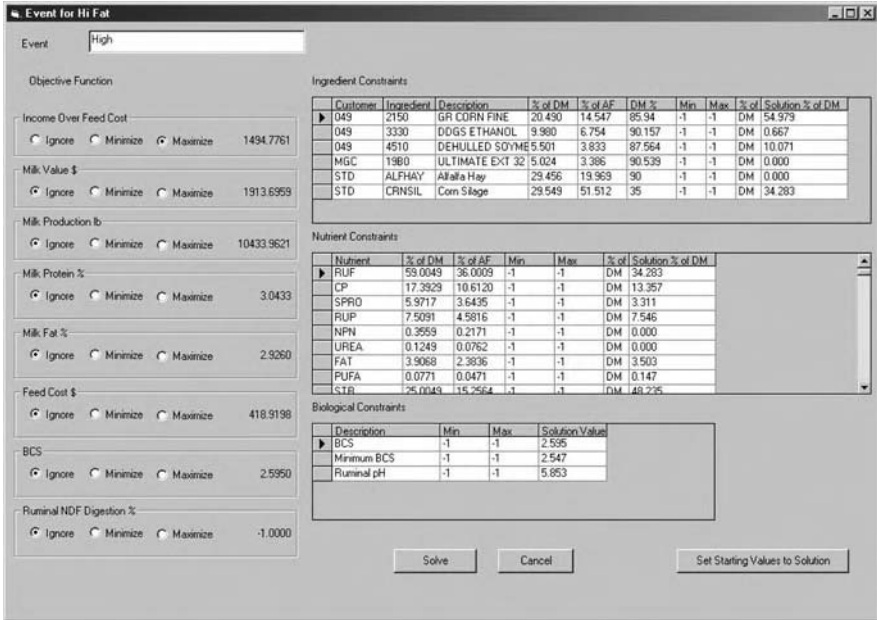

(b)

Fig. 24.4. (a) Organization of a ‘solution library’ enabling processing time to be reduced by avoiding (b) re-solving the dairy cow model (MOLLY) under identical conditions.

Table 24.2. Feeds offered during three lactation periods (DIM < 21; 21 < DIM < 220; DIM > 220).

Feed	Type ^a	Cost	DM	CP	SolCP	RUP	NPN	Fat	Combination
1	SBM	202	87	54	12	27	0	2	3/4/5
3	LucHay	110	90	18	8	3	0	3	3/4/5
5	GrdMaize	103	85	8	1	6	0	4	3/4/5
7	MEC	275	90	35	15	13	7	12	3//5
8	MaizeSlg	27	35	8	4	3	0	3	3/4/5
9	MinVit	253	98	0	0	0	0	0	3//5
10	DistGrn	222	90	29	4	21	0	3	/4/
11	UEC	297	90	35	18	9	7	17	/4/5

Feed	Type	Starch	ForNDF	NDF	ADF	Lignin	Forage	Ash	Seg. d
1	SBM	3	0	10	5	1	0	7	Entire
3	LucHay	3	42	42	36	7	10	9	Entire
5	GrdMaize	72	0	14	3	1	0	1	Entire
7	MEC	6	0	23	14	1	0	14	<21,>220
8	MaizeSlg	24	51	51	26	3	100	4	Entire
9	MinVit	0	0	0	0	0	0	86	<21,>220
10	DistGrn	7	0	40	19	4	0	4	21–220
11	UEC	26	0	16	6	1	0	12	>21

^aSBM = soybean meal; LucHay = lucerne hay; GrdMaize = ground maize; MEC = moderate energy commercial blend; MaizeSlg = Maize; MinVit = mineral–vitamin mix; DistGrn = dried distillers grain; UEC = high energy commercial blend.

The development and testing environments

The software was developed in Visual Compaq Fortran Version 6.4 (Etzel and Dickinson, 1999) using the MicroSoft Development Environment, and tested in the ACSL 10.4 runtime environment. Crucial to this project was access to the comprehensive debugging services offered in MSDEV, as was the ease of exploration of runtime changes to our system supported within ACSL. The computer used for this report was a Sony PCG-Z1VAP notebook, 1.6 GHz Pentium® M processor, 512 MB RAM, 60 G HD, MS Windows XP Professional OS.

Results

Our analysis of performance of the optimizer included the following objectives in various combinations: income over feed cost (IOFC; \$), milk protein (%) and total feed costs (\$). Constraints considered were: minimum body condition score (MinBCS) reached at any point during the simulation and rumen pH (biological constraints); dietary crude protein (CP; %) and roughage (%) (nutrient constraints); and ingredient level (%) (ingredient constraints).

The specific questions we wanted to explore in this investigation were:

- Could feasible optimum objectives be found in reasonable computing time for all likely integration durations (segment sizes)?
- Would altering acceptance criteria change the final solution and, if so, in a likely way?
- Would a dual objective setting expose competition between objectives?
- Would acceptance criteria setting play a predictable role in the dual objective setting?
- Would altering the direction of objective pairs (max/min) impact optimizer performance?
- Would the imposition of a biological (non-linear) constraint affect the final objective in a predictable way?
- Would the imposition of a biological constraint dramatically impact performance?
- Could dual biological constraints be met and how would the incremental application of biological constraints impact performance?
- Would a nutrient (linear) constraint be honoured and would its imposition affect the final objective predictably?
- Could dual nutrient constraints be met and would their imposition impact performance?

1. Single objective (maximum IOFC), no constraints

Tables 24.3a and 24.3b show the effect of different combinations of values of 'opeps' and 'opobjrep' (objective gradient and objective relative change,

Table 24.3a. Maximizing IOFC (\$), no constraints (opeps and opobjrep effect). In Tables 24.3–24.6 we use the notation $x-y = x(10/y)$, e.g. 4–2 = 0.04.

Duration (days)	Opeps	Opobjrep	Iterations	Time	IOFC
50	1	1–3	7	1.5	322
50	1–1	1–3	82	17.2	345
50	1–2	1	8	1.7	324
50	1–2	1–2	8	1.7	324
50	1–2	5–2	8	1.7	324
50	1–2	1–2	8	1.7	324
50	1–2	1–3	90	18.9	346
100	1–1	1	8	3.4	657
100	1–1	1–1	8	3.4	657
100	1–1	5–2	8	3.4	657
100	1–1	1–3	74	31.1	725
200	1–2	1–1	8	6.8	1276
200	1–3	1–1	8	6.8	1276
200	1–4	1–1	8	6.8	1276
200	1–1	5–2	8	6.8	1276
200	1–1	1–2	42	35.2	1436
200	1–1	1–3	42	35.2	1436
200	1–1	1–4	42	35.2	1436

Table 24.3b. Maximizing IOFC (\$), no constraints (opeps effect, opobjrep turned off).

Duration (days)	Opeps	Iterations	Time	IOFC
50	1–2	312	65.1	345
50	5–2	82	17.1	345
50	1–1	63	14.9	345
50	1	7	1.5	322
100	5–2	74	31.1	725
100	1–1	74	31.1	725
100	1	68	28.7	724
200	5–2	42	35.3	1436
200	1–1	42	35.3	1436
200	1	42	35.3	1436

respectively), and integration duration (segment size) on optimum IOFC and processing performance (processing time and number of iterations to acceptance). We see the following:

- Setting opeps or opobjrep too high results in premature solutions.
- Rapid approximate IOFC optima are located for all integration durations, where neither opeps nor opobjrep ‘aggressively force’ solutions.
- As either acceptance constraint is tightened, improved IOFC optima are found, with opobjrep needed to be quite small to cause changes. The newly located optima are quite stable.

- Initial estimates of IOFC optima are found in ~0.03 s (computing)/day (simulation); however, refined optima take around 30 s to locate.
- Best optima are around 10% improved over initial estimates.

2a. Dual objectives (maximum IOFC, maximum milk protein), no constraints

In an exercise to see if two objectives would become competitive as acceptance criteria were altered, we explored the joint maximization of IOFC and milk protein. The results are shown in Table 24.4a and summarized as follows:

- The same solution (approximate) for IOFC is found rapidly with the optimizer where opeps limits the solution.
- As opobjrep is reduced, milk protein eventually drives the solution and, indeed, a new optimum for milk protein is found when the fractional influence of milk protein surpasses the influence of IOFC on the solution.
- Solution times are around four times longer (~200 s) when two objectives are used and the smaller is exercised.

2b. Dual, reverse-directed objectives (maximum IOGC, minimum milk protein), no constraints

To confirm that the optimizer would behave sensibly when dual, reverse-directed (max, min) objectives are sought, we repeated the above analysis, but attempting to minimize milk protein. The results are shown in Tables 24.4b and 24.4c and summarized as follows:

Table 24.4a. Maximizing IOFC (\$) and milk protein (MilkP; %), no constraints 50–250 days.

Duration (days)	Opeps	Opobjrep	IOFC	MinBCS	TotFDcost	Iterations	Time	MilkP
50	1–2	1–2	323	2.40	112	8	1.78	3.20
50	1–2	1–4	323	2.40	112	8	1.78	3.20
50	1–2	1–6	301	2.35	104	162	33.96	3.84
50	1–2	1–8	301	2.35	104	162	33.96	3.84
50	1–4	1–4	323	2.40	112	8	1.76	3.20
50	1–6	1–6	323	2.40	112	8	1.76	3.20
100	1–2	1–2	649	2.12	245	8	3.42	2.86
100	1–2	1–4	586	1.91	209	198	112.19	3.92
150	1–2	1–2	953	2.04	378	8	5.10	2.72
150	1–2	1–4	772	2.20	511	96	60.81	3.49
200	1–2	1–2	1235	2.02	502	8	6.80	2.67
200	1–2	1–4	1154	2.14	449	290	244.14	3.84
250	1–2	1–2	1509	2.02	616	8	8.47	2.66
250	1–2	1–4	1284	2.30	883	183	192.40	3.53

Table 24.4b. Maximizing IOFC (\$), minimizing milk protein (MilkP; %), no constraints, 50–100 days.

Duration (days)	Opeps	Opobjrep	IOFC	MinBCS	TotFDcost	Iterations	Time	MilkP
50	1–2	1–5	330	2.35	108	71	14.93	2.99
50	1–2	1–6	330	2.35	108	71	14.93	3.06
50	1–2	1–7	330	2.35	108	71	14.93	3.06
50	1–3	1–5	329	2.37	112	150	31.44	2.99
50	1–4	1–4	323	2.40	112	8	1.71	3.20
50	1–4	1–5	329	2.37	112	150	31.44	2.99
50	1–5	1–4	323	2.40	112	8	1.71	3.20
50	1–5	1–5	329	2.37	112	150	31.44	2.99
100	1	1–6	648	2.12	249	7	2.99	2.87
100	1–1	1–6	648	2.12	249	7	2.99	2.87
100	1–2	1–4	658	1.95	235	64	27.18	2.61
100	1–2	1–5	658	1.95	235	71	30.10	2.61
100	1–2	1–6	658	1.95	235	71	30.10	2.61

Table 24.4c. Maximizing IOFC (\$), minimizing milk protein (MilkP; %), no constraints, 150–250 days.

Duration (days)	Opeps	Opobjrep	IOFC	MinBCS	TotFDcost	Iterations	Time	MilkP
150	1–2	1–2	953	2.04	378	8	5.12	2.72
150	1–2	1–3	953	2.04	378	8	5.12	2.72
150	1–2	1–4	646	1.54	493	173	109.97	2.13
150	1–2	1–5	646	1.54	493	173	109.97	2.13
150	1–3	1–2	953	2.04	378	8	5.12	2.72
150	1–5	1–2	953	2.04	378	8	5.12	2.72
150	1–7	1–2	953	2.04	378	8	5.12	2.72
200	1–2	1–3	1235	2.02	502	8	6.81	2.66
200	1–2	1–5	809	2.04	693	69	58.42	2.18
200	1–5	1–2	1235	2.02	502	8	6.81	2.66
200	1–10	1–2	1235	2.02	502	8	6.81	2.66
250	1–2	1–2	1509	2.02	616	8	8.50	2.66
250	1–2	1–5	967	1.53	772	120	126.54	2.00
250	1–5	1–2	1509	2.02	616	8	8.50	2.66

- In general, optimum solutions are reached within 2 min although simple optima, with relaxed acceptance criteria, initially seem to be reached in about 5 s for all integration durations.
- As before, tightening the relative objective change (opobjrep) ultimately focuses optimization effort on milk protein and, especially for long integration intervals, we see a dramatic influence here on final optimum values for both IOFC and milk protein.

3a. Single biological constraints

To explore the optimizer performance in regard to honouring biological (non-linear) constraints, we optimized IOFC while constraining BCS to remain within preset ranges ($BCS > 2.30$ and separately, $2.30 > BCS > 2.31$). The results are shown in Table 24.5a and we note the following:

- All biological constraints that were feasible were indeed honoured; however, maintaining BCS in the range (>2.30) beyond 200 days was not achievable and the constraint for a 250-day integration simulation needed to be lowered to 2.20 (or $2.20 < BCS < 2.21$).
- Processing times for such tight (non-linear) constraints were somewhat long, especially for the longer integration runs (~4 min).
- The pattern of IOFC optima predicted, subject to the BCS responses, were sensible based on likely feed costs.

3b. Dual constraints

In Table 24.5b we show how salient features of the optimizer performance altered as a rumen pH constraint ($6.0 < \text{rumen pH} < 6.1$) was added to the BCS constraint, and optimum IOFC levels were again sought. We see that:

Table 24.5a. Maximizing IOFC (\$), constraining BCS.

Duration (days)	IOFC	MinBCS	Iterations	Time	Constraints
50	324	2.40	8	1.76	$2.30 < BCS$
50	326	2.30	51	10.75	$2.30 < BCS < 2.31$
100	658	2.34	63	26.69	$2.30 < BCS$
100	657	2.30	80	33.99	$2.30 < BCS < 2.31$
200	1332	2.46	160	134.55	$2.30 < BCS$
200	1271	2.30	222	187.43	$2.30 < BCS < 2.31$
250	1589	2.20	215	226.40	$2.30 < BCS$
250	1589	2.20	215	226.40	$2.30 < BCS < 2.31$

Table 24.5b. Maximizing IOFC (\$), constraining BCS and rumen pH, 50–250 days.

2.20 < BCS < 2.21 and 6.0 < rumen pH < 6.1						
Duration (days)	Opeps	IOFC	MinBCS	Rumen pH	Iterations	Time
50	1–2	328	2.206	6.009	51	10.75
100	1–2	629	2.203	6.003	110	46.67
200	1–2	1189	2.206	6.004	141	119.47
2.20 < BCS < 2.21 and 5.9 < rumen pH < 6.1						
250	1–2	1586	2.204	5.987	167	176.04

- The constraint ranges imposed were all honoured.
- The IOFC optima were consistent with earlier results.
- Processing times here were not excessively longer than for the single constraint times (~2 min) for longer runs and, indeed, sometimes shorter for the short integration runs.

The purpose of feed formulation is at least in part to ensure that dairy cows receive nutrition to match their overall needs. Naturally then a major concern for optimization assessment is to explore its adequacy for this very task.

4a. Isolated nutrient constraint

In Table 24.6a we show the highlights of the optimizer performance when constraining dietary CP ($16\% < \text{CP} < 16.1\%$) range while maximizing IOFC for various integration ranges (days). For each test the CP constraints were met, the processing performance times quite acceptable (< 1 min) and final objective values sensible. The improved performance of the optimizer when constrained by nutrient versus biological values (e.g. BCS) is almost surely linked to the linear nature of nutrient constraints (i.e. they are linear functions of the activities).

4b. Dual nutrient constraints

By adding a roughage ($40.0\% < \text{roughage} < 40.2\%$) constraint along with the CP constraint and again optimizing IOFC, we were able to see how adding nutrient constraints might incrementally degrade optimizer performance. Table 24.6b shows that there is only very minor impact of the additional constraint on performance (still < 1 min for all cases).

Table 24.6a. Maximizing IOFC (\$), constraining crude protein (CP).

16.0% < CP < 16.1%							
Duration (days)	IOFC	MinBCS	TotFdCost	Roughage (%)	MilkP	Iterations	Time
50	294	2.42	99	61	3.88	8	1.71
100	675	2.25	203	32	3.00	49	20.64
150	1031	2.38	318	31	2.87	41	21.75
200	1369	2.51	432	26	2.72	64	52.68
250	1692	2.91	596	5	2.22	50	50.41
300	1998	2.71	731	0	2.51	47	58.75

Table 24.6b. Maximizing IOFC (\$), constraining crude protein (CP).

16.0% < CP < 16.1% and 40.0% < roughage < 40.2%

Duration (days)	IOFC	MinBCS	TotFdCost	MilkP	Iterations	Time
50	297	2.47	105	3.73	8	1.73
100	642	1.75	176	3.43	65	28.67
150	912	1.68	264	3.21	61	38.42
200	1151	1.67	344	3.11	56	47.06
250	1372	1.67	440	3.09	56	58.75
300	1603	1.68	556	3.18	48	60.31

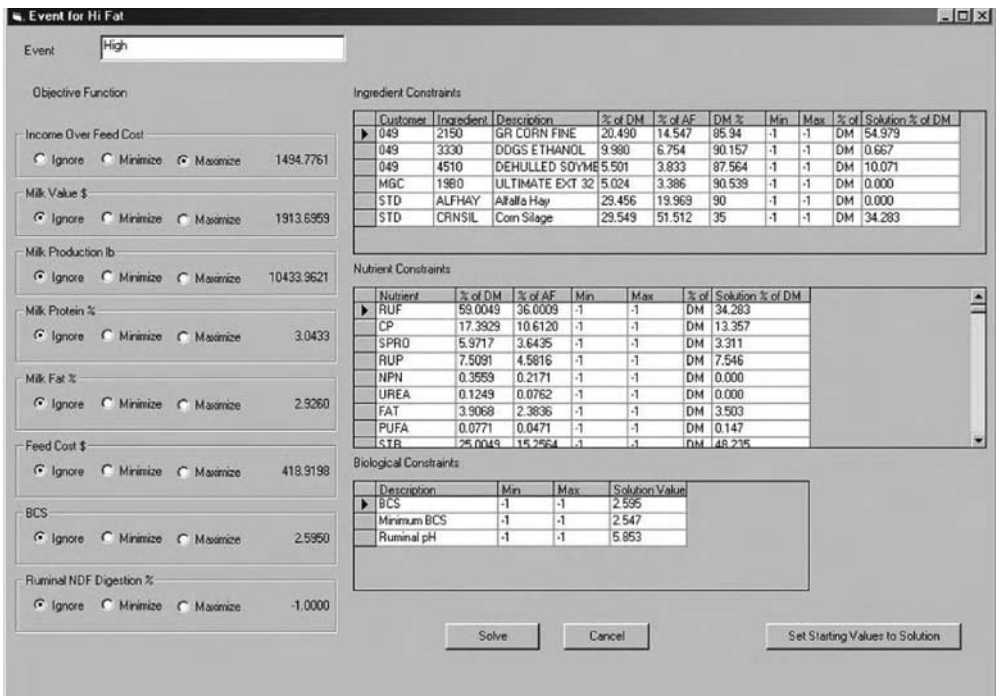

Fig. 24.5. The eCow® interface encapsulating the optimization methodology discussed in this article. We see eight pre-pre-programmed objectives (left panel), three pre-programmed biological constraints (bottom right panel) and, logically organized, ingredient (upper right panel) and nutrient (mid-right panel) constraint options.

Conclusions

We have made the case for incorporating optimization capability into the dynamic domain of dairy cow digestion and metabolism models. We have proposed a strategy for accomplishing this step and have indeed shown that: (i) it is possible to link optimization capabilities into a dynamic digestion and metabolism model for the dairy cow; and (ii) the performance of the tested system suggests that dynamic dairy cow ration optimization may be a realistic tool for dairymen as the 21st century unfolds. In Fig. 24.5 we show the eCow[®] optimization interface encapsulating the methodological approaches discussed in this article.

References

- Baldwin, R.L. (1995) *Modelling Digestion and Metabolism*. Chapman & Hall, New York.
- Boston, R.C., Ferguson, J.D., Kohn, R.A. and Black, J.L. (1995) Model testing and evaluation. In: Danfaer, A. and Lescoat, P. (eds) *Modelling Nutrient Utilization in Farm Animals: Proceedings of IVth International Workshop*. National Institute of Animal Science, Foulum, Denmark, pp. 25–34.
- Boston, R.C., Fox, D.G., Sniffen, C., Janczewski, E., Munson, R. and Chalupa, W. (2000) The conversion of a scientific model describing dairy cow nutrition and production to an industry tool: the CPM Dairy project. In: McNamara, J.P., France, J. and Beever, D.E. (eds) *Modelling Nutrient Utilization in Farm Animals*. CAB International, Wallingford, UK, pp. 361–378.
- Dantzig, G.B. (1951) *Activity Analysis of Production and Allocation*. John Wiley & Sons, New York.
- Etzel, M. and Dickinson, K. (1999) *Digital Visual Fortran*. Digital Press, Boston, Massachusetts.
- Mayne, D.Q. and Polak, E. (1976) Feasible directions algorithms for optimization problems with equality and inequality constraints. *Mathematical Programming* 11, 67–80.
- Mitchell, L. and Gauthier, J. (1993) *ACSL: Advanced Continuous Simulation Language*. Mitchell and Gauthier Associates (MGA), Concord, Massachusetts.
- VandeHar, M., Buckholz, R., Beverly, R., Emery, R., Allen, M., Sniffen, C. and Black, R. (1992) Spartan Ration Evaluator/Balancer for Dairy Cattle. Michigan State University, East Lansing, Michigan.
- Zhou, J.L. and Tits, L. (1997) *User's Guide for FFSQP Version 3.5*. Electrical Engineering Department and Institute for Systems Research, University of Maryland, College Park, Maryland.

25

A Model to Simulate the Effects of Different Dietary Strategies on the Sustainability of a Dairy Farm System

A. DEL PRADO, D. SCHOLEFIELD AND L. BROWN

Institute of Grassland and Environmental Research, North Wyke, Okehampton, Devon EX20 2SB, UK

Abstract

A new model is being developed to study the main elements that affect sustainability within a dairy farm by using multiple goal programming. In this work, we describe the main characteristics of this modelling approach and we evaluate, via optimization, the effect of different dietary strategies and some component attributes such as plant nitrogen (N) uptake and cow N intake on milk and N losses.

Introduction

European dairy farming has evolved mainly in response to economic drivers but additionally is now being given environmental goals. There is a need to reconcile these economic and environmental pressures in the form of more sustainable systems.

Farm management has been identified as the single most important factor determining the economic and environmental performance of farming systems. Cattle diet manipulation has been regarded as a very important means to improve the efficiency of N utilization.

A new model is being developed using an existing field-based grassland decision support system (DSS) for N fertilizer (NGAUGE) and a simpler model (NCYCLE). The new model is intended to be part of a more complex modelling framework comprising existing N and phosphorus (P) cycling models connected to 'score matrices' for measuring attributes of biodiversity, landscape, product quality and animal welfare.

As a first step, the grassland models are being modified and multiple goal programming methodology has been used to explore feasible combinations of component attribute values leading to improved sustainability of the farm (e.g. N efficiency, product quality, N pollution) and particularly a decrease in environmental impact.

Feed-based management scenarios at a field scale are simulated in this study (e.g. increasing silage ratio of maize land to grassland, using high energy concentrates) and performance at a field level is investigated in terms of sustainability. The sustainability criteria are based on the economic (e.g. animal milk yield) and environmental (nitrate leaching, nitrous oxide and ammonia emissions) results. The model is capable of maximizing the ratio of milk yield to environmental loss results subject to milk and/or environmental constraints by means of selecting optimum component attribute values.

Model Development

The model is an annual model based on the grassland field mass balance model NCYCLE (Scholefield *et al.*, 1991) and the NGAUGE DSS (Brown *et al.*, 2005). The feeding component of the model has been improved and different submodels have been included in order to introduce sensitivity to feeding management.

Model development consists of two main stages: (i) the coding of the main pathways of the N cycle of a grazed dairy grassland; and (ii) a goal-seeking procedure that enables the user to seek multiple solutions to meet specific environmental and economic goals.

For the simulation of annual N transformations, fluxes and losses, a mass balance empirical model, NCYCLE, has been used as a basis. NCYCLE simulates the fluxes of N in a grazed grassland field according to inputs specifying climatic zone, soil texture, drainage class, sward management and age, and fertilizer input. The feeding component of the model has been improved by incorporating supplements and concentrates to the existing 'only grass-grazing' cow. Metabolizable energy (ME) from the feed and energy requirements per grazing dairy cow and grazing year are also calculated in order to investigate targets of livestock density for different weight and/or milk-yield dairy cows according to the Agricultural Research Council (ARC, 1980). Four new pools have also been incorporated into the model in order to provide further insight into the animal-rumen-excreta flows, following the approach of Kebreab *et al.* (2002).

Modifications have been made to the N-leaching and denitrification submodels according to Rodda *et al.* (1995) and Brown *et al.* (2005) in order to calculate the proportion of leachable N that is actually leached below the root zone and the average concentration in the leachate, and to split denitrification into nitrous oxide (N₂O) and dinitrogen (N₂).

For the development of the goal-seeking tool, the main component attributes of the system were assigned a feasible range of values. Environmental loss and milk production values can be set as minimum goals (constraints) and different combinations of components can be selected and optimized to: (i) meet the goals and (ii) be maximized according to the ratio of animal milk yield to environmental losses (N₂O, NH₃ and N leached).

Component attributes are composed of N inputs (i.e. N input as fertilizer, input as grass, maize silage or concentrates, as protein degradability ratios in the diet) and efficiency factors (i.e. fraction of inorganic N in the soil taken up by the plant, fraction of the plant consumed by the animal, efficiency of the animal to capture N from the diet). Interpretation of these optimized values may well suggest the need for different plant, cow or microbial population genotypes to meet the predicted optimized component attributes' values.

In an optimized simulation, the model iterates for every selected optimized component a number of times (0–50) employing a range of feasible values. The results that comply with the selected constraints are recorded in a text file as a two-dimensional matrix, where the rows represent the number of runs that meet the minimum goals ($n = \text{variable number}$) and the columns the number of components of the N cycle system (46). Once this matrix is recorded, the model reads this file and seeks the best solution through the best compliance of the optimization basis (maximizing milk production over environmental losses).

The model is programmed in the object-oriented language Borland Delphi 5 and has two screens. The main screen (Fig. 25.1) is used: (i) to enter the typical NCYCLE inputs about N management on a grassland; (ii) to set the constraining minimum goals; (iii) to select the component attributes to be optimized; and (iv) to display the optimized and non-optimized N fluxes and results of the simulations. The second screen (Fig. 25.2) shows a graph that displays the target stocking rates for different yielding and different weight cows.

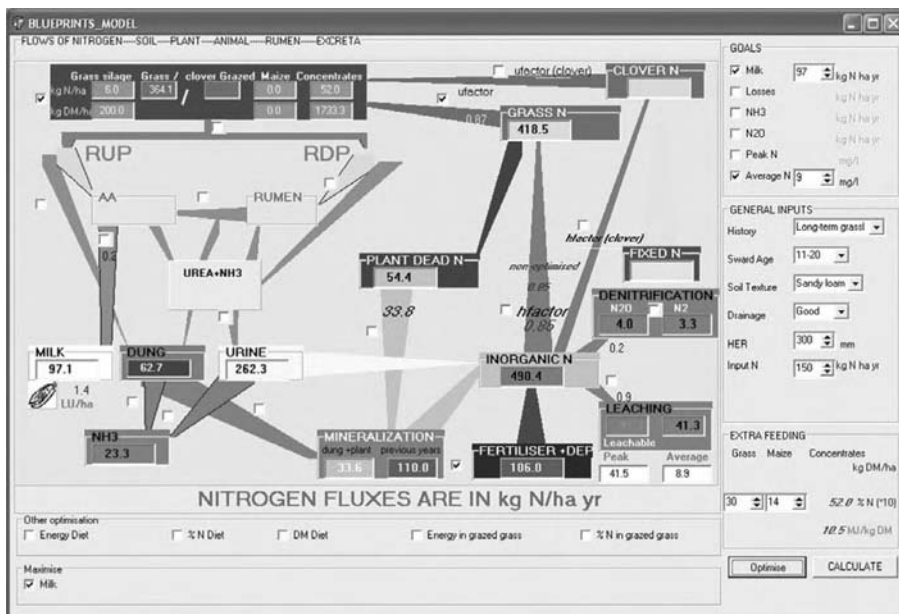

Fig. 25.1. Main screen of the model displaying an optimized run.

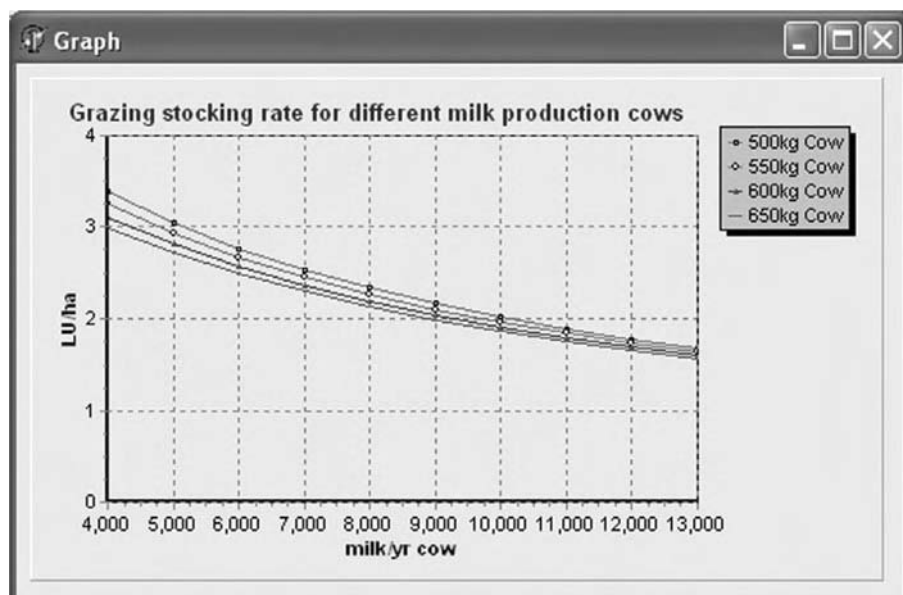

Fig. 25.2. Screen of the model displaying different target stocking rates for the simulation.

An example of the feeding optimization

Table 25.1 shows the results obtained after simulating a grazed grassland field whose main characteristics are: (i) history of a long-term grassland with a sward age of 11–20 years; (ii) well-drained sandy loam soil; and (iii) situated in a UK site with hydrological effective rainfall (HER) of 300 mm.

Three simulations were performed:

Table 25.1. Comparison of results from non-optimized (1) and optimized simulations (2 and 3).

Run	Factors		Fertilizer (kg N/ha)	Extra feeding			Milk (kg N/ha)	LU/ha	Leachate (average)	
	U	h		Dry matter (DM; t/ha)	%N	Energy (MJ/kg)			N (mg/l)	
1	0.62	0.87	150	0	—	—	53.4	1.6	8.9	
2	0.62	0.78	412	0	—	—	97.6	2.4	24.8	
3	0.87	0.85	106	1.7 (Con) ^a 0.2 (Sil) ^b	5.2 3.0	10.5	97.1	2.4	8.9	

^aCon = concentrates.

^bSil = grass silage.

1. Non-optimized simulation.
2. Optimizing the fertilizer N and plant uptake factor (hfactor) and complying with a minimum milk yield of 97 kg N/ha.
3. Optimizing the following component attributes: fertilizer N, herbage utilization factor by the cow (ufactor), total dry matter (DM)/ha in concentrates, maize silage and grass silage, ME/DM in concentrates and percentage of N in concentrates; and complying with a minimum milk yield of 97 kg N/ha and a maximum average N concentration in the leachate of 9 mg/l.

Type 1 simulation predicts that by using 150 kg N/ha of fertilizer N and with no supplements or concentrates fed to the animal, a stocking rate of 1.6 live-stock units (LU)/ha (cow weight = 600 kg and milk yield/cow = 6000 l/year) could be sustained, resulting in an N milk yield of 53.4 kg N/ha as average concentration in the leachate of 8.9 mg/l. This leaching result complies with the European Commission (EC) nitrate directive's level of 11.3 mg/l but it might not be the best result in milk yield.

With type 2 simulation (where N milk yield is more than 40% of the result of type 1) the needed fertilizer usage was about 400 kg N/ha and it resulted in an average concentration in the leachate of 24.8 mg/l. The high usage of fertilizer and resulting leaching losses suggest that it would only be possible to obtain the targeted milk yield by producing considerable increase in nitrate leaching.

By using type 3, the simulation met both environmental (8.9 mg/l in the leachate) and economic (97.1 kg N milk/ha) conditions by means of a low fertilizer use (106 kg N/ha), either by using cows with an improved N capture ability or a plant with an improved ratio of shoot N to root N (greater ufactor), and by supplementing the grazing cows with a combination of high energy and N content concentrates (1.7 t/ha) and grass silage (0.3 t/ha).

Conclusions

The model has proved to be a useful tool in order to investigate combinations of the efficiency controls for hypothetically economically and environmentally sustainable systems. Further work is required in order to incorporate this approach into the whole framework, which includes the whole set of models to investigate sustainability in farming systems.

References

- ARC (Agricultural Research Council) (1980) *The Nutrient Requirements of Ruminant Livestock*. Commonwealth Agricultural Bureaux, Farnham Royal, UK.
- Brown, L., Scholefield, D., Jewkes, E.C., Lockyer, D.R. and del Prado, A. (2005) NGAUGE: a decision support system to optimise N fertilisation of British grassland for economic and/or environmental goals. *Agriculture Ecosystems and Environment* 109, 20–39.

- Kebreab, E., France, J., Mills, J.A.N., Allison, R. and Dijkstra, J. (2002) A dynamic model of N metabolism in the lactating dairy cow and an assessment of impact of N excretion on the environment. *Journal of Animal Science* 80 (1), 248–259.
- Rodda, H.J.E., Scholefield, D., Webb, B.W. and Walling, D.E. (1995) Management model for predicting nitrate leaching from grassland catchments in the United Kingdom: 1. Model development. *Hydrological Sciences Journal – Journal Des Sciences Hydrologiques* 40 (4), 433–451.
- Scholefield, D., Lockyer, D.R., Whitehead, D.C. and Tyson, K.C. (1991) A model to predict transformations and losses of nitrogen in UK pastures grazed by beef-cattle. *Plant and Soil* 132, 165–177.

26

Advantages of a Dynamical Approach to Rumen Function to Help to Resolve Environmental Issues

A. BANNINK,¹ J. DIJKSTRA,² E. KEBREAB³ AND J. FRANCE³

¹*Animal Sciences Group, Division of Nutrition and Food, PO Box 65, 8200 AB Lelystad, The Netherlands;* ²*Animal Nutrition Group, Wageningen University, PO Box 338, 6700 AH Wageningen, The Netherlands;* ³*Centre for Nutrition Modelling, Department of Animal and Poultry Science, University of Guelph, Guelph, Ontario N1G 2W1, Canada*

Abstract

Simulation studies demonstrated the difference between current practice (static representation) and a dynamic representation of rumen function. Where current feed evaluation indicated absent or linear responses to changes in dry matter intake (DMI) and exchange of grass and maize silage, simulated responses were essentially non-constant and non-linear. Besides diet characteristics, rumen fermentation conditions also strongly affected simulated degradability of organic matter (apparent), neutral detergent fibre (NDF), starch (apparent) and feed protein; simulated outflow of feed starch and protein; quantity of fermented organic matter (apparent), efficiency of microbial yield and rumen nitrogen (N) balance. In addressing environmental issues, the argument was made that seemingly good empirical relationships between N excretion or ammonia emission and practical values of milk urea or rumen protein balance might be useful for the purpose of legislation, but are far less useful for individual farmers with the need to respond to (new) constraints put to them by legislation, economy and control of farm management. The error made with these empirical relationships is almost as large as the difference among individual farms and, therefore, a dynamic mechanistic approach seems more promising.

Introduction

In research, as well as in practical nutrition, modifications to the standard feed evaluation systems are often proposed. The purpose of these modifications may be an improved accuracy (e.g. empirical equations based on new data analyses) or a more pragmatic use of these systems (e.g. data availability in practice). Such modifications may be considered relatively small, however, and are mostly of a highly empirical nature. A rather different type of modification is involved when the possibility is created to let the evaluation system address new types of questions. These questions may be related to

constraints placed upon dairy production by their impact on the environment, or by new legislation. These constraints bring along questions concerning nutrition of dairy cows that appeared less relevant in the recent past.

It must be questioned, however, whether current feed evaluation systems can be modified to address the various, new types of questions in current dairy farming in an integrated manner. These systems have been developed with the purpose of comparing cost-effectiveness of feedstuffs in terms of animal productivity (Van der Honing and Alderman, 1988). As a result, the concept of constant feeding values is adopted, irrespective of type of diet and cow characteristics. The purpose of the present contribution is to demonstrate some limitations of these concepts, and to evaluate whether applying a dynamic, mechanistic approach offers specific advantages.

Dynamic Representation of Rumen Function

In current feed evaluation, the characteristics and feeding value of a specific feed ingredient are considered constant. These values are derived by standardized methods of feed evaluation. This standardization enables a comparison of characteristics and feeding value among different feed ingredients. However, the way these values are collected (standardized rumen conditions) and the level at which these values are described (faecal digestibility) do not allow for the inclusion of the impact of various specific factors influencing rumen function. Several attempts have been published to overcome these limitations by a more dynamic representation. Some principal differences with respect to representation of substrate degradability and microbial growth will be discussed below.

Rumen degradability

In current practice the degradation of feed substrates in the rumen is often calculated from the fractional rates of passage and the degradation characteristics. The fractional rate of passage (k_p) is mostly assumed constant (e.g. 4.5 and 6.0%/h for roughages and concentrates; Tamminga *et al.*, 1994). The washable part of organic matter (OM) fractions is considered to be fermented completely, with some corrections (e.g. Tamminga *et al.*, 1994) whereas the non-washable degradable fraction is assumed to degrade according to the ratio of the *in situ* fractional degradation rate (k_d) and the sum of k_d and k_p (Ørskov and McDonald, 1979). This type of calculation is applied to obtain degradation of OM, NDF, starch and crude protein (CP).

Several alternative models have been developed that adopt a more mechanistic representation of rumen degradation. These models may be distinguished into static (Russell *et al.*, 1992; Sniffen *et al.*, 1992) and dynamic models (France *et al.*, 1982; Baldwin *et al.*, 1987; Danfaer, 1990; Dijkstra *et al.*, 1992; Lescoat and Sauvant, 1995). Although the static models make use of

kinetic parameters, they remain static in nature and represent no interaction between the microbial population and substrate quantities present in the rumen. The models do not represent a microbial pool size, and hence a feedback between the microbes present and substrate degradation is lacking (Fig. 26.1). Furthermore, the double reciprocal Pirt equation has been applied to calculate microbial growth assuming that fractional rates of microbial growth and substrate degradation are equal, but this is not likely to be a good approximation under all circumstances (Dijkstra *et al.*, 1996, 1998).

Fully dynamic representations of microbial activity and substrate degradation in the rumen are those of Baldwin *et al.* (1987) and Dijkstra *et al.* (1992). In these models the rate of substrate degradation is not predetermined fully by the degradation characteristics given as an input to the model but also by the pool size of the microbial population in the rumen (Fig. 26.1). The main focus of these models was to describe the microbial ecosystem in the rumen by a chemostat representation (France *et al.*, 1982), and enzyme kinetics were applied to describe the dependency of substrate degradation and microbial activity on the concentration of both the substrate and microorganisms present in the rumen environment. Particle dynamics have

Static representation of substrate (*Sub*) degradation and microbial growth (*Y-Mi*)

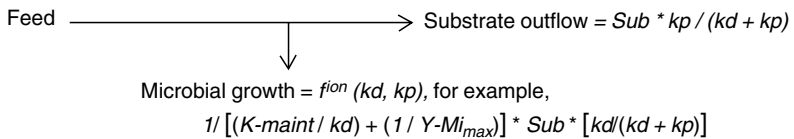

Dynamic representation of substrate degradation,
no interrelationship between substrate (*Sub*) and microorganisms

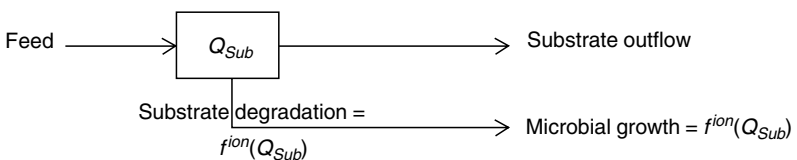

Dynamic representation of substrate degradation and microbial growth,
interrelationship between substrate (*Sub*) & microorganisms (*Mi*) quantified

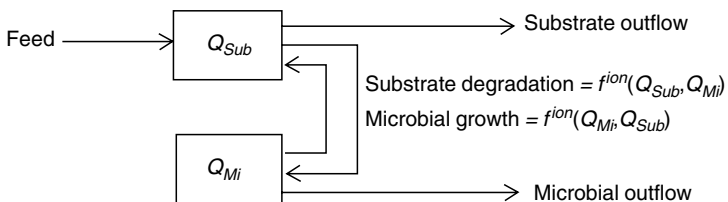

Fig. 26.1. Comparison of static and dynamic representations of substrate degradation and microbial growth (arrows indicate flows, boxes indicate state variables in a dynamic system).

received much less attention, with the exception of the efforts of Baldwin *et al.* (1987), even though it has been suggested that the dynamics of particle comminution and outflow, and of the microorganisms attached to it, may be of major importance to microbial metabolism and degradation kinetics in the rumen (Czerkawski, 1986). At present, most models represent particle dynamics and passage rates by mass action flow and make a distinction between particles and fluid.

Microbial protein synthesis

Most systems in current practice treat microbial yield (MY) per kg of fermented organic matter (FOM) and microbial composition as constant. Based on these assumptions, values of rumen protein balance (PB) are calculated by the difference between the quantity of substrate N degraded and the quantity of N needed to sustain MY of N (outflow of microbial N – degraded feed N). Values of FOM, PB and metabolizable protein (MP) are calculated per diet ingredient and are summed up to obtain the value for the total diet. In current practice a positive PB (or rather PB intake) is advised.

There are many indications, however, that MY is not a constant. Several factors affect the efficiency of microbial synthesis, such as energy requirements for maintenance of microorganisms, growth on ammonia or soluble protein as preformed monomers, composition of microbial mass, fractional growth rate and recycling of microbial matter in the rumen. The reservations made in the previous section regarding the interaction between microbial pool size and substrate degradation also apply to MY. For a more complete discussion of the matter the reader is referred to Dijkstra *et al.* (1996, 1998).

Dynamic Model Used for Simulation

An extant dynamic model (Dijkstra *et al.*, 1992) was used to represent the dynamics of rumen fermentation. The model is fully dynamic in the sense that degradation rate of feed substrates, as well as metabolism and substrate use by the microbial populations, are represented in a dynamic manner and are mutually dependent. The rumen model was extended with some empirical equations to represent the digestion in the small and large intestine, the use of nutrients for maintenance and milk production (Dijkstra *et al.*, 1996) and the excretion with urine and faeces. The model was used to test the impact of specific feeding conditions on simulated rumen function, and also the constancy of feed characteristics and feeding values as an outcome of simulated rumen function. Evaluated outcomes of simulated rumen function included degradation rate and apparent digestibility of distinct fractions of carbohydrates and protein, balance of rumen N flows and efficiency of microbial synthesis.

Simulation results were compared to the concepts of substrate degradability and feeding values adopted in current feed evaluation systems. The

Dutch feed evaluation systems of net energy (NE; Van Es, 1978) and MP (Tamminga *et al.*, 1994) were used as a reference, if applicable. The intention was not to specifically evaluate elements of these systems, but rather to challenge some general concepts of rumen function used in current practice in general. First, some general outcomes of the dynamic rumen model will be shown to demonstrate the principal difference in approach of a dynamic rumen model against the concept of constant feeding values. Next, results will be shown that address current questions related to environmental issues such as excretion per cow or herd, gaseous emissions (methane, ammonia) and manure composition.

Evaluation of Constancy of Substrate Degradability and Feeding Values

In the previous section it was argued that substrate degradabilities and feeding values in fact may be non-constant and non-additive, and may depend to a large extent on the precise conditions of rumen fermentation. These presumptions were investigated with the dynamic rumen model and the simulation results will be discussed in this section. The effect was simulated of either a varying level of DMI (fixed diet) or a change in composition of dietary DM (fixed intake). The simulation results will be discussed against the background of typical results that concepts applied in current practice would deliver.

Variable dry matter intake, constant feed composition

Rumen degradability of substrates and microbial yield

Rumen degradation of feed ingredients is treated in current practice as not being influenced by rumen conditions and animal characteristics. However, this is not necessarily true as DMI varies drastically through the lactation cycle of a dairy cow, causing in itself variation in rumen function. This effect was simulated with a fixed diet based on 50% DM of fresh ryegrass, 25% maize silage and 25% concentrates. Typical values were assumed for the chemical composition and degradation characteristics. First, DMI was varied while keeping all the other parameter inputs constant. Second, parameter inputs for the passage rate of solids and fluids, volume, pH-related parameters and the fraction of protozoa in the population of amylolytic microorganisms were varied together with variation in DMI, according to empirical equations (Van Straalen, 1995) or effects reported in literature or in previous studies (Dijkstra and Tamminga, 1995).

With the first approach, increasing intake from 16 to 24 kg DM/day without changing other parameters caused a change in the rumen digestibility of substrates. Rumen digestibility of OM (apparent) and feed protein increased by 6% and 5% respectively, and that of NDF and starch (apparent) by 5% and 18% respectively (Figs 26.2a and 26.2b). Simultaneously the outflow of undigested feed starch and feed protein decreased by 37% and 10%

respectively. The quantity of FOM in feed DM and rumen N balance (NB, calculated as the balance of N intake and N outflow to the duodenum) increased by 5% and 22–26 g N/day respectively (Fig. 26.2c), whereas MY (calculated as g microbial N outflow to intestine per kg of FOM) decreased by 4% (Fig. 26.2d). All the changes appeared to be related to DMI in a fairly linear manner, which is in contrast with the assumption of constant values in current practice. Typical estimates of current feed evaluation systems have been indicated in Figs. 26.2a–26.2d.

When other parameter inputs (not feed composition) were varied together with variation in DMI, the changes in simulated outcomes were larger, of a different direction and non-linearly related to DMI. Rumen digestibility of OM (apparent) and feed protein decreased by 31% and 28% respectively, and of NDF and starch (apparent) by 44% and 3% (Figs 26.2a and 26.2b). Simultaneously the outflow of undegraded feed starch decreased by 4% and that of feed protein increased by 60%. The quantity of FOM in feed DM decreased by 28%. Both NB and MY showed a quadratic response

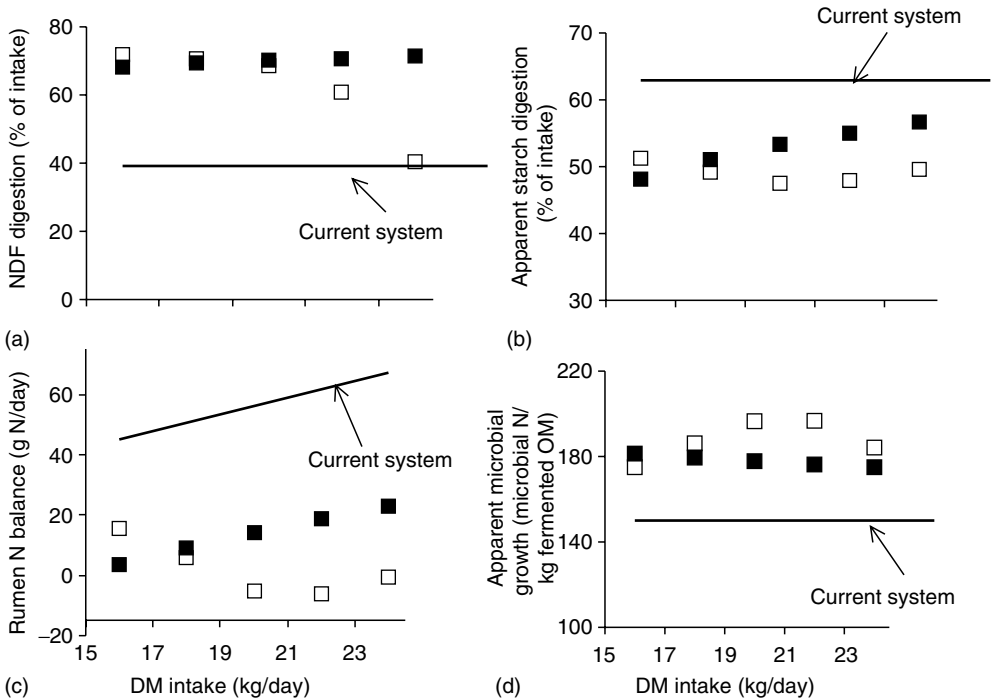

Fig. 26.2. Simulated response of (a) degradability of NDF (% of intake); (b) apparent degradability of starch (% of intake); (c) rumen N balance (g N/day); and (d) apparent efficiency of microbial growth (g microbial N/kg fermented OM) by the dynamic rumen model to change in dry matter intake (DMI; constant dietary composition), compared to results in current feed evaluation systems. Simulation results were obtained with (open boxes) and without (closed boxes) simultaneous alteration of the other parameter inputs to the model.

to variation in DMI with a minimum NB of -6 g N/day (decrease of 22) and a maximum increase in MY of 12% at 22 kg DMI/day (Figs 26.2c and 26.2d). The increase of fractional passage rate with DMI initially resulted in a higher MY, but at the highest intake of 24 kg DM/day, NDF degradation was strongly limited and MY declined.

These simulation results indicated that changes in DMI and in rumen fermentation conditions had a major impact on substrate degradability, outflow of feed substrates resistant to rumen degradation, FOM, NB and MY. Although DMI in itself stimulated substrate availability for microbial use, this effect was superseded by the effect of pH, fractional passage rates and rumen volume. This finding is generally confirmed in reviews of rumen function *in vivo* with respect to microbial activity, substrate degradability and outflow of resistant feed substrates (Clark *et al.*, 1992). Curvilinear responses to increased DMI have also been found *in vivo* (Robinson *et al.*, 1987a,b). A lower rumen digestibility of NDF and OM with increased feed intake was caused by the changed rumen conditions (pH in particular). Although such a lower digestibility in the rumen with higher feed intakes will be compensated partly by increased digestion in the intestine, faecal digestibility will still be low. In the calculation of NE requirements of ruminants in the Dutch system (Van Es, 1978), consideration was given to the depressing effect on the diet digestibility with increased feed intake. Nevertheless, for practical reasons constant NE values of feedstuffs were used that have been derived for average feeding conditions of dairy cows. Hence, variation in NE value or in rumen functioning (substrate degradation, microbial activity, rumen N balance, outflow of digestible protein and starch to the intestine) due to variation in level of feed intake is not taken into account in current practice. The assumptions of constant MP and PB clearly do not match the simulated variation in MP and PB obtained using the mechanistic rumen model.

End products of fermentation

Besides rumen degradability of feed substrates and MY, the production rate and type of volatile fatty acid (VFA) produced is of particular importance. Considering the importance of the contribution of VFA to ME for the ruminant, current estimates appear surprisingly inaccurate, and the best way to represent the stoichiometry of VFA formation is still under debate. Besides the type of fermented substrate (Bannink *et al.*, 2000), rumen fermentation conditions are also determinants for the type of VFA produced (Kohn and Boston, 2000). DMI, type of fermented substrate and rumen fermentation conditions together determine the availability of VFA as either glucogenic (propionate) or ketogenic (acetate and butyrate) nutrient to the ruminant. This latter aspect may prove to be of particular importance in nutritional conditions where glucose availability may become limiting for milk production. A complicating factor remains, however, that available *in vivo* VFA data are restricted to observations of concentrations of VFA in rumen fluid. Such concentrations are the outcome of a combination of rates of VFA production, VFA outflow with fluid and VFA absorption by rumen wall, and perhaps all

of these are interrelated with rumen pH (Murphy, 1984). This seriously complicates the analysis of published VFA concentrations because these processes have not been measured within the same experiment. In a preliminary analysis of the same data-set previously used by Bannink *et al.* (2000), it was attempted to include the effects of rumen pH on the type of VFA produced. The results thus obtained (Fig. 26.3) were qualitatively similar to those presented before by Argyle and Baldwin (1988), but in the present case have been derived fully from *in vivo* data.

Calculations of methane yield are largely complementary to those of VFA yields (Mills *et al.*, 2001). For this reason, reasonable estimates of methane yields by ruminants require at least a proper representation of three aspects of rumen function (Mills *et al.*, 2001): (i) the apparent digestibility of OM; (ii) the efficiency of microbial synthesis; and (iii) the type of VFA produced. In current practice, the first two aspects are treated as constants with the use of MP, PB and NE (feeding values, animal requirements). The third aspect is not represented at all. Current systems do not consider type of substrate fermented, impact of rumen fermentation conditions on substrate degradability, microbial activity in the rumen, or type of nutrient becoming available for the ruminant. For these reasons, current systems seem of limited value for the evaluation of ruminant diets and production systems on their potential for reduction of methane emission (see Kebreab *et al.*, Chapter 27, this volume). A detailed explanation of the effects of nutrition on

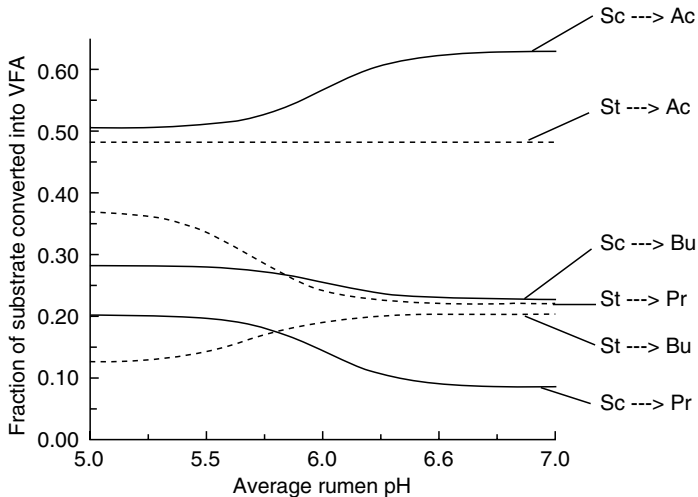

Fig. 26.3. Estimated *in vivo* relationship between the fraction of fermented soluble carbohydrates (Sc; defined by organic matter (OM) minus crude protein (CP), starch, NDF, crude fat and ash; solid lines) and starch (St; dashed lines) converted into acetate (Ac), propionate (Pr) or butyrate (Bu). Regression procedures were analogous to the method described by Bannink *et al.* (2000).

methane yield also requires a detailed representation of the dynamics of rumen function including the three aspects mentioned above.

Dietary changes at constant dry matter intake

In current practice, feeding values of dietary ingredients are assumed to be independent from each other and may be summed up to obtain the feeding value of the whole diet. This means that, regardless of the diet in which the ingredient is included, the feeding value of a specific ingredient remains exactly the same. Although this allows easy calculation and ration formulation, it is very likely that with strongly different diets also the conditions of the rumen environment can differ, which has consequences for the feeding value. The advantage of the dynamic rumen model is that it is capable of evaluating effects in an integrated manner on the level of the whole diet, with information on nutrient composition and degradation characteristics per individual dietary ingredient as an input instead of outcome. In the present study simulations were performed with the dynamic rumen model to evaluate the concept of additivity of feeding values of individual ingredients. The effect was simulated of a gradual increase in the degree at which fresh ryegrass was exchanged for maize silage, whereas concentrate remained unchanged at 25% of DM. The simulation results were compared with typical NE, MP and PB results, which current practice would deliver.

As a result of the relatively low degradability of the NDF fraction in maize silage (kd of 2.5%/h, 40% undegradable) compared to that of fresh ryegrass (kd of 5%/h, 10% undegradable), simulated values of the apparent rumen digestibility of NDF and OM decreased from 75% to 51% and 57% to 48% respectively when increasing amounts of maize silage were substituted for fresh ryegrass. Simulated NDF degradability changed in a similar manner, comparable to what would be calculated from kd and kp values adopted in current practice; however, simulated values were 20–30% higher (Fig. 26.4a).

Another important feeding value of a ruminant diet is the fraction of starch that is resistant against rumen degradation and may hence serve as a source of glucose for the ruminant. The simulated synthesis of microbial starch had a profound impact on simulated starch outflow and apparent starch digestion in the rumen (Fig. 26.4b). Changing from a minimum to a maximum fraction of maize silage in the diet almost doubled the simulated outflow of starch from the rumen. The simulated fate of feed starch was very different from that calculated from kd and assumed kp values in current practice. Changing the diet from maximum fresh ryegrass to maximum maize silage resulted in very distinct changes in the percentage of feed starch that was resistant to rumen degradation (an increase was simulated, whereas a decrease was calculated according to principles adopted in current practice). A significant part of simulated starch outflow was composed of microbial starch, a concept not represented in current feed evaluation systems. As a result, with low starch intake the simulated

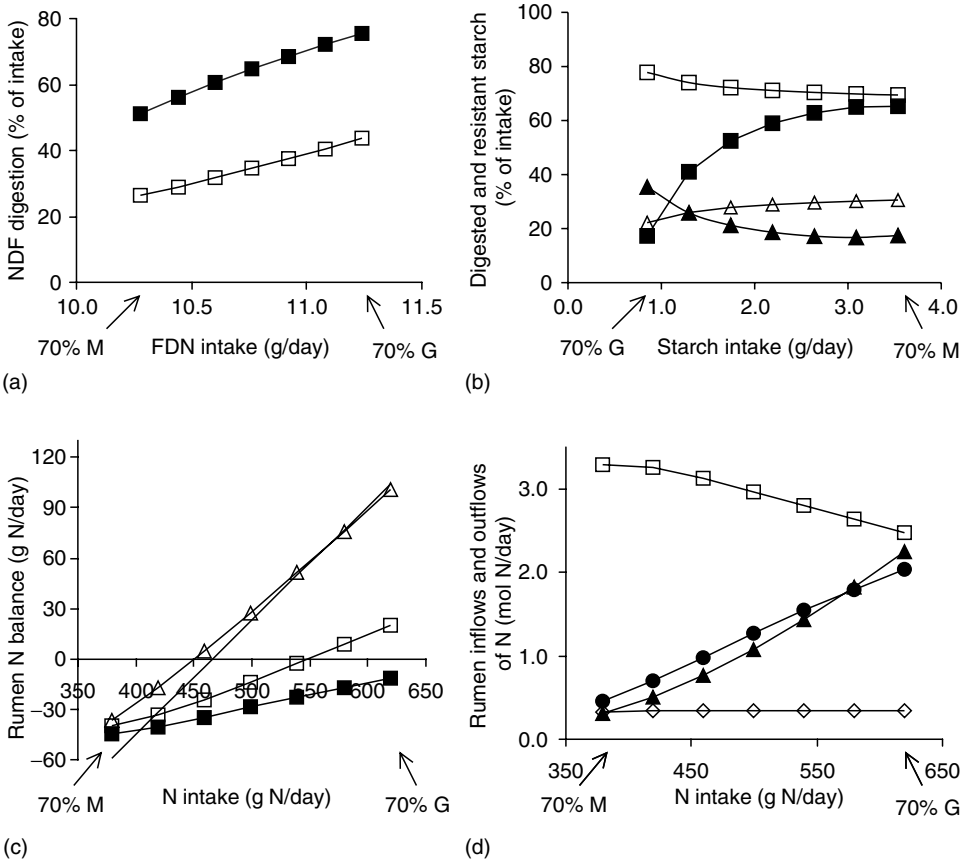

Fig. 26.4. Simulated response of (a) degradability of NDF (% of intake, ■) and (b) apparent degradability (■) or resistance to degradation (▲) of starch (% of intake) by the dynamic rumen model to changes in dietary composition (changed 10% maize silage, 70% grass silage and 20% concentrate to 70% maize silage, 10% grass silage and 20% concentrate in dry matter (DM); constant dry matter intake (DMI)), compared to results in current feed evaluation systems (open symbols). Other parameter inputs to the model remained unchanged. Simulated response of (c) rumen N balance (g N/day) as the true rumen N balance (■), N balance calculated analogous to the method in current protein evaluation (□), and N balance calculated analogous to the method in current protein evaluation under assumption of efficiency of microbial growth as in current protein evaluation (△), compared to values according to protein balance (PB) values that are typical in current protein evaluation (no markers). Simulated response of (d) the rate (mol N/day) of N recycling from blood to rumen (□), of protein inflow to rumen with saliva production (◇), and of ammonia outflow (▲) and absorption (●) from the rumen.

outflow of starch was much higher than assumed with current feed evaluation (701 vs 188 g starch/day). Finally, simulated outflow of starch increased curvilinearly with an increase in starch intake, which is in contrast to the linear increase according to current feed evaluation. Only at the highest levels of starch intake at around 3.5 kg starch/day the simulated

starch outflow came near to that of the current feed evaluation (1229 versus 1082 g starch/day) with very similar apparent rumen digestion of starch (65.2 vs 69.4%; Fig. 26.4b).

The exchange of roughages also had important consequences for the simulated N dynamics in the rumen and fate of feed N. The percentage of feed protein flowing out of the rumen increased from 27% to 35% of protein intake when maize silage was increasingly substituted for fresh ryegrass. This effect was caused by a lower degradability of protein in maize silage. Together with a more resistant protein, increasing levels of maize silage in the diet also caused a reduction in protein intake. The combined effect was a slight decrease in the outflow of feed protein (from 995 to 832 g of feed N/day). In current practice, fractions of feed protein and starch resistant to rumen degradation are calculated from kd and assumed kp values. This approach leads to similar changes in the percentage of feed protein resistant to rumen degradation, but values are almost 10% higher than the values simulated here. Because the simulated outflow of microbial protein, which contributes most to total protein outflow, reduced drastically, total protein outflow decreased accordingly. This reduction was much more than would be calculated in current practice.

The quantity of FOM decreased by 21% and of MY by 17% because the synthesis of microbial N became increasingly dependent on ammonia as a N source, which requires more energy than microbial growth on soluble protein from fresh ryegrass. Both results together led to a 35% reduction in outflow of microbial N. However, when a constant MY would be assumed, according to current practice, the reduction in outflow of microbial N and FOM would have been identical. The more the diet was composed of fresh ryegrass, the more the simulated MY exceeded the constant values used in current practice (150 g of microbial N/kg FOM) up to a maximum of 184 g microbial N/kg FOM.

Related to the differences discussed above, simulated NB and PB intake according to current practice differed accordingly. A change from maximum fresh ryegrass in the diet to maximum maize silage resulted in increasingly negative values for simulated NB, indicating a net inflow of N from the animal to the rumen (Fig. 26.4c). Upon a decrease in protein intake, ammonia absorption and ammonia outflow decreased substantially, whereas recycling of urea N from blood to the rumen increased (Fig. 26.4d). At the lowest levels of protein intake (maximum maize silage), all three flows were simulated to saturate, which also resulted in a saturation of the net N inflow (Fig. 26.4d). A comparison of these simulation results with the assumption of constant PB values in current practice illustrates two important differences. First, the absolute values are very different with highly positive values for PB when the diet contains maximum fresh ryegrass, whereas simulated NB is negative. Although most of this difference originated from differences in MY and the consequent microbial N outflow, it also becomes apparent that PB intake differs conceptually from the simulated NB, with only the latter representing a true balance in inflows of feed N and all outflows of N to the duodenum. Another difference is that the simulated decrease in NB with reduction of protein intake

saturates (starting around 14.5% of dietary CP), in contrast to a continuing linear decrease of PB intake according to current practice (Fig. 26.4c). The majority of *in vivo* observations in dairy cows seems to confirm the simulation results, with a less rapid increase of NB with rate of N intake than indicated by the linear response according to current practice (Bannink and Tamminga, 2005).

Conclusions

Current feed evaluation systems treat the feed characteristics typically as constants. The general outcome of the present study, however, challenges the applicability of this concept. For several aspects of rumen function, such as degradability of NDF, protein or starch, efficiency of microbial protein synthesis and rumen N balance, simulation results obtained with the dynamic model differed substantially from the static approach in current practice. The differences were not only large in terms of absolute value but, more importantly, the dietary alterations induced changes in simulated rumen function that do not support the concept of constant and additive feeding values.

Addressing Environmental Issues

Much research is directed to monitor and control the environmental impact of ruminant production, and because of its intensity, of dairy production in particular. On the one hand, this control refers to legislation to keep the environmental impact within acceptable limits, and on the other hand, it involves dairy farmers who face a complicated optimization problem of grassland management, fertilizing programme, roughage harvest, purchase of concentrates or other products, target levels of animal production, milk quota, animal housing, manure storage and application, land area available, soil properties, weather conditions, cost effectiveness and, of increasing importance, legislation.

The level of detail of the information needed to achieve control of the environmental impact of dairy farming very much depends on whether the argument is made from the viewpoint of law enforcement or from that of the farmer. First, the difference between these viewpoints will be illustrated by some recent discussions concerning milk urea as a useful indicator of N excretion and ammonia emission by dairy cows. It will then be argued that a dynamic representation of cow metabolism may have important advantages from the perspective of the farmer, but also in preparing new legislation. Finally, a case study will be discussed to demonstrate the additional value of a dynamic approach to represent dairy cow metabolism in order to exert more precise control in practice on both cow performance and environmentally related issues.

Milk urea and protein balance as monitoring tools

Milk urea has been investigated as an indicator of N utilization by dairy cows (Hof *et al.*, 1997; Schepers and Meijer, 1998) and appears to be closely related to PB intake in particular. Recently, it was investigated as to whether the rate of N excretion by dairy cows could be predicted from milk monitoring data only. Regression studies on data from balance trials with dairy cows demonstrated that N excretion could be described reasonably from milk data only (around 80% of variation explained with a residual standard deviation (SD) of more than 40 g N/day; Schröder *et al.*, 2006). With a drop in milk urea from 30 to 20 mg urea/100 ml milk, the quantity of N excreted would reduce by slightly more than 60 g to ~325 g of N excreted per cow per day. Additionally, close relationships have been established recently between ammonia emission and PB intake or milk urea (around 80% of variation explained with a residual SD of more than 2 kg of ammonia emission per cow per year; Van Duinkerken *et al.*, 2003). A similar reduction of milk urea from 30 to 20 is accompanied by a reduction of ammonia emission of 2.34–6.01 kg of ammonia emitted per cow per year. Very similar results were obtained for the relationship between ammonia emission and PB.

From the viewpoint of legislation, it seems tempting to use these relationships to evaluate the quantities of N excreted and ammonia emitted per cow on dairy farms in practice. One complication is that, although these relationships may have general applicability, an essential part of the variation remains unexplained. The inaccuracy is of a similar size as the predicted response to milk urea or PB intake, which means that still a large part of the variation among farms remains unexplained. At the lower range of milk urea and PB intake, the error in estimated rates of N excretion and ammonia emission easily reaches 20% or even 30%. From the viewpoint of legislation, this lack of accuracy may be taken for granted, but the implications are large for a farmer who faces legislation with respect to N excretion and ammonia emission. Also from the viewpoint of a farmer who aims at the control of cow performance and farm management, much higher accuracy seems necessary. Taking into consideration the difference between the simulation results and the outcomes of feed evaluation according to current practice, it is questionable whether simple indicators such as milk urea or PB intake (or other characteristics of current feed evaluation) are appropriate to achieve the level of accuracy needed.

A dynamic approach to represent substrate degradation and microbial activity seems much more promising than for two reasons: (i) it represents more realistically the mechanisms of microbial activity and is able to deliver useful details on rumen function; and (ii) it introduces the possibility of evaluating the impact of changes in rumen conditions on whole rumen function. The importance of this was demonstrated and discussed in the previous sections, where it became apparent that the simulated results differ substantially from values calculated according to the concepts adopted in current practice. For a farmer who wishes to explore the boundaries at

which nutritional management can be stretched, more and different details are needed to represent rumen function compared to those needed in the past. For example, answers are needed on the effect of changing the fertilizing and harvesting regime of grasslands, which has a profound impact on the composition and the degradation characteristics of the carbohydrate and protein fraction in the grass. Another example is the possibility to evaluate the potential of diets with a low protein content or negative PB value without a detrimental effect on cow performance and with a maximum N utilization by the cows, or to evaluate the extent to which N excretion may be shifted from urine to faeces in an attempt to diminish ammonia emission. For this purpose, an accurate representation of rumen function is needed first of all.

Perhaps only dynamic approaches will eventually prove to be able to deliver the level of detail needed to address the range of farming conditions met in practice. Percentages of observed variation explained by simple empirical equations are always to be expected to be around 70% or 80% if a very wide range of conditions is covered (such as N intake). This means that some broad relationship can be easily established between the dependent and independent explaining variables. With the relationships between milk urea and PB intake as independent variables and the rate of N excretion and ammonia emission as dependent variables, this was typically the case. For explanatory power within a small range of conditions, or for some nutritional situation at a specific farm, it is very unlikely that this type of empirical relationships will deliver accuracy. Furthermore, these relationships give hardly any indication of where and how to exert control on N excretion and ammonia emission.

A practical case as an illustration

The results of a case study are presented here to illustrate the potential of a more dynamic approach compared to current practice. Monitoring results (Smolders and Wagenaar, 2005) of four selected ecological dairy farms that differed in DML, diet composition and milk yield were used (Table 26.1). These values were compared to predictions with the dynamic model, and simulated milk yield compared well with monitored yields. In all cases, ME was simulated to limit milk yield, whereas in three of the four cases glucose (Gl) (farms 1 and 2) or MP availability (farm 4) was near to becoming limiting for milk production (Table 26.1). This means that with slightly different nutritional management or production conditions (e.g. with extra ME from mobilization of body reserves in early lactation, stimulating milk yield), these nutrients could easily become limiting. Hence, the conclusion seems justified that on three farms specific attention is needed for the glucose or MP availability. Under these conditions, it may pay off to have more details available on the fermentation conditions in the rumen (passage rates, volume, pH), on the fate of starch, and on the impact of microbial metabolism on the outflow of digestible protein from the rumen.

Table 26.1. Characterization of four ecological dairy farms and a comparison between monitoring and simulation results.

Farm	1	2	3	4
Diet				
Grass silage	0.66	0.65	0.85	0.37
Maize silage	0.07	0.08	—	0.16
Potatoes	—	—	—	0.17
Cereals	—	—	0.15	—
Concentrates	0.27	0.27	—	0.30
Animal				
Intake (kg DM/day)	20.7	19.6	19.5	22.7
Days in milk (DIM; day)	156	156	56	135
Results				
Milk (kg/day)				
<i>Monitored</i>	22.2	24.9	21.4	34.4
<i>Simulated</i>	23.7	25.1	23.4	32.8
Limiting milk yield				
<i>Simulated</i>	ME (&GI)	ME (&GI)	ME	ME (&MP)
Metabolizable protein (MP; g/day)				
<i>Monitored</i>	2039	2029	1765	2259
<i>Simulated</i>	1902	1847	1758	1991
Protein balance (PB) intake (g N/day)				
<i>Monitored</i>	113	25	84	44
<i>Simulated</i>	-41	-32	-40	-38
Net energy (NE) requirement (%)				
<i>Monitored</i>	116	106	110	102
MP requirement (%)				
<i>Monitored</i>	123	113	112	87
Milk urea (mg/dl milk)				
<i>Monitored</i>	27.5	23.5	25.6	—

Feeding values monitored on these farms differed substantially from simulated values. The simulated rumen N balance was negative and varied from -30 to -40 g of N/day, whereas monitored PB intake was strongly positive and varied by almost 90 g of N/day (Table 26.1). Compared to this variation of PB intake, the variation of milk urea appears very small (four units monitored, whereas more than double would be expected according to Schepers and Meijer, 1998). However, the variation in milk urea may be completely unrelated to PB, and simulated rumen N balance may be more realistic than the PB intake monitored. Also simulated MP values were 0–12% lower than monitored values of MP intake (corrected for endogenous protein losses). A case of particular interest is farm 4, in which MP requirement for observed milk yield was covered for only 87% by the MP intake monitored (Table 26.1). Despite the lower MP values simulated than monitored, the simulation model indicates that the milk yield monitored was possible on this particular diet because simulated efficiency of the milk protein production from MP was substantially higher (72%) than assumed for the monitoring results (~60%).

This case study demonstrates the potential of the dynamic approach in explaining observations collected in practice. Without accurate insight in the dynamics of rumen function, in the variability of the MP and PB values and in the limitation of milk yield by individual nutrients calculated as an outcome (instead of an input), the rather simple indicators such as PB or milk urea in current practice may prove to be of limited help to a dairy farmer in controlling cow performance and farm management. More dynamic approaches are more likely to deliver the level of accuracy needed. It needs to be mentioned, however, that this type of analysis of monitoring data is seriously hampered by the lack of details on the chemical composition and the degradation characteristics of the dietary components. Also in the present case study, no such data were available and best guesses had to be made.

Conclusions

It is concluded that a dynamic, mechanistic representation of rumen function is capable of a more detailed and a more realistic analysis of the effects of nutrition on rumen function. Thereby, the dynamic, mechanistic approach has a clear advantage over the static approaches that are adopted in current practice. In view of the increasing need for farmers to adapt to new and very specific constraints placed upon them by legislation and economy, this is thought to be an important advantage. The dynamic approach will allow the farmer to explore the boundaries to which manipulations of dietary composition can be stretched (e.g. aim to reduce dietary content of protein or to optimize supplementation of basal diets of roughages with energy/protein-rich ingredients). It also will deliver the farmer an improved insight into the specific indicators required to act in response to future legislation. The use of a combination of static approaches and meta-analysis is less likely to provide both accuracy and insight on all relevant aspects simultaneously and in an integrated manner.

Acknowledgements

This work is closely related to that of the development of a nutrient-based feed evaluation system for dairy cows. Funding of the latter by the Dutch Ministry of Agriculture, Nature and Food Quality and the Dutch Commodity Board of Feedstuffs is gratefully acknowledged.

References

- Argyle, J.L. and Baldwin, R.L. (1988) Modeling of rumen water kinetics and effects of rumen pH changes. *Journal of Dairy Science* 71, 1178–1188.
- Baldwin, R.L., Thornley J.H.M. and Beever, D.E. (1987) Metabolism of the lactating cow: II. Digestive elements of a mechanistic model. *Journal of Dairy Research* 54, 107–131.

- Bannink, A. and Tamminga, S. (2005) Rumen function. In: Dijkstra, J., Forbes J.M. and France J. (eds) *Quantitative Aspects of Ruminant Digestion and Metabolism*. CAB International, Wallingford, UK, pp. 236–288.
- Bannink, A., Kogut, J., Dijkstra, J., France, J., Tamminga, S. and van Vuuren, A.M. (2000) Modelling production and portal appearance of volatile fatty acids in cows. In: McNamara, J.P., France, J. and Beever, D.E. (eds) *Modelling Nutrient Utilization in Farm Animals*. CAB International, Wallingford, UK, pp. 87–102.
- Clark, J.H., Klusmeyer, T.H. and Cameron, M.R. (1992) Microbial protein synthesis and flows of nitrogen fractions to the duodenum of dairy cows. *Journal of Dairy Science* 75, 2304–2323.
- Czerkawski, J.W. (1986) *An Introduction to Rumen Studies*. Pergamon Press, Oxford, UK.
- Danfaer, A. (1990) *A Dynamic Model of Nutrition Digestion and Metabolism in Lactating Dairy Cows*. Beretning fra Statens Husdyrbrugforsog 671. National Institute of Animal Science, Foulum, Denmark.
- Dijkstra, J. and Tamminga, S. (1995) Simulation of the effects of diet on the contribution of rumen protozoa to degradation of fibre in the rumen. *British Journal of Nutrition* 74, 617–634.
- Dijkstra, J., Neal, H.D.St.C., Beever, D.E. and France, J. (1992) Simulation of nutrient digestion, absorption and outflow in the rumen: model description. *Journal of Nutrition* 122, 2239–2256.
- Dijkstra, J., France, J. and Sauvant, D. (1996) A comparative evaluation of models of whole rumen function. *Annales de Zootechnie* 45 (suppl. 1), 175–192.
- Dijkstra, J., France, J. and Davies, D.R. (1998) Different mathematical approaches to estimating microbial protein supply in ruminants. *Journal of Dairy Science* 81, 3370–3384.
- France, J., Thornley, J.H.M. and Beever, D.E. (1982) A mathematical model of the rumen. *Journal of Agricultural Science, Cambridge* 99, 343–353.
- Hof, G., Vervoorn, M.D., Lenaers, P.J. and Tamminga, S. (1997) Urea in milk as a tool to monitor protein nutrition of dairy cows. *Journal of Dairy Science* 80, 3333–3340.
- Kohn, R.A. and Boston, R.C. (2000) The role of thermodynamics in controlling rumen metabolism. In: McNamara, J.P., France, J. and Beever, D.E. (eds) *Modelling Nutrient Utilization in Farm Animals*. CAB International, Wallingford, UK, pp 11–24.
- Lescoat, P. and Sauvant, D. (1995) Development of a mechanistic model for rumen digestion validated using duodenal flux of amino acids. *Reproduction Nutrition & Development* 35, 45–70.
- Mills, J.A.N., Dijkstra, J., Bannink, A., Cammell, S.B., Kebreab, E. and France, J. (2001) A mechanistic model of whole-tract digestion and methanogenesis in the lactating cow: model development, evaluation, and application. *Journal of Animal Science* 79, 1584–1597.
- Murphy, M.R. (1984) Modeling production of volatile fatty acids in ruminants. In: Baldwin, R.L. and Bywater, A.C. (eds) *Modelling Ruminant Digestion and Metabolism, 2nd International Workshop*. University of California, Davis, California, pp. 59–62.
- Ørskov, E.R. and McDonald, I. (1979) The estimation of protein degradability in the rumen from incubation measurements weighed according to rate of passage. *Journal of Agricultural Science* 92, 499–504.
- Robinson, P.H., Tamminga, S. and Van Vuuren, A.M. (1987a) Influence of declining level of feed intake and varying the proportion of starch in the concentrate on rumen ingesta quantity, composition and kinetics of ingesta turnover in dairy cows. *Livestock Production Science* 17, 37–62.

- Robinson, P.H., Tamminga, S. and Van Vuuren, A.M. (1987b) Influence of declining level of feed intake and varying the proportion of starch in the concentrate on milk production and whole tract digestibility in dairy cows. *Livestock Production Science* 17, 19–35.
- Russell, J.B., O'Connor, J.D., Fox, D.G., van Soest, P.J. and Sniffen, C.J. (1992) A net carbohydrate and protein system for evaluating cattle diets: 1. Ruminal fermentation. *Journal of Animal Science* 70, 3551–3561.
- Schepers, A.J. and Meijer, R.G.M. (1998) Evaluation of the utilization of dietary nitrogen by dairy cows based on urea concentration in milk. *Journal of Dairy Science* 81, 579–584.
- Schröder, J.J., Bannink, A. and Kohn, R.A. (2006) Improving the efficiency of nutrient use in cattle operations. In: Pfeffer, E. and Hristov, A.N. (eds) *Nitrogen and Phosphorus Nutrition in Cattle*. CAB International, Wallingford, UK, pp. 255–280.
- Smolders, E.E.A. and Wagenaar, J.P. (2005) Rapportage monitoring Bioveem1-bedrijven. Praktijkrapport Rundvee. *Praktijkonderzoek Veehouderij*, Lelystad, The Netherlands (in press).
- Sniffen, C.J., O'Connor, J.D., Van Soest, P.J., Fox D.G. and Russell, J.B. (1992) A net carbohydrate and protein system for evaluating cattle diets: II. Carbohydrate and protein availability. *Journal of Animal Science* 70, 3562–3577.
- Tamminga, S., van Straalen, W.M., Subnel, A.P.J., Meijer, R.G.M., Steg, A., Wever, C.J.G. and Blok, M.C. (1994) The Dutch protein evaluation system: the DVB/OEB-system. *Livestock Production Science* 40, 139–155.
- Van der Honing, Y. and Alderman, G. (1988) Systems for energy evaluation of feeds and energy requirements for ruminants. *Livestock Production Science* 19, 217–278.
- Van Duinkerken, G., André, G., Smits, M.C.J., Monteny, G.J., Blanken, K., Wagemans, M.J.M. and Sebek, L.B.J. (2003) Relatie tussen voeding en ammoniakemissie vanuit de melkveestal. *Praktijkrapport Rundvee 25, Praktijkonderzoek Veehouderij*, Lelystad, The Netherlands.
- Van Es, A.J.H. (1978) Feed evaluation for ruminants: I. The system in use from May 1977 onwards in The Netherlands. *Livestock Production Science* 5, 331–345.
- Van Straalen, W.M. (1995) Modelling of nitrogen flow and excretion in dairy cows. PhD thesis. Wageningen Agricultural University, Wageningen, The Netherlands.

27

Evaluation of Models to Predict Methane Emissions from Enteric Fermentation in North American Dairy Cattle

E. KEBREAB,¹ J. FRANCE,¹ B.W. McBRIDE,¹ N. ODONGO,¹
A. BANNINK,² J.A.N. MILLS³ AND J. DIJKSTRA⁴

¹Centre for Nutrition Modelling, Department of Animal and Poultry Science, University of Guelph, Guelph, Ontario N1G 2W1, Canada; ²Animal Sciences Group, Division of Nutrition and Food, PO Box 65, 8200 AB Lelystad, The Netherlands; ³School of Agriculture, Policy and Development, The University of Reading, PO Box 237, Earley Gate, Reading RG6 6AT, UK; ⁴Animal Nutrition Group, Wageningen University, PO Box 338, 6700 AH Wageningen, The Netherlands

Abstract

The increasing focus on the environmental impact of agriculture means that there is a need for an accurate inventory of greenhouse gases (GHGs) to identify main sources of pollution and evaluate effects of potential mitigating options. A number of models have been developed to predict methane emissions from enteric fermentation applicable to North American cattle. The objectives of this work are to collate data on methane emissions from the literature and evaluate selected models using these independent data. Six models are considered: linear model of Moe and Tyrrell (1979b), linear and non-linear models of Mills *et al.* (2003), dynamic model of Kebreab *et al.* (2004) and Tier I and Tier II models recommended by the Intergovernmental Panel on Climate Change (IPCC, 1997).

A database consisting of 47 records, not used in the development of the models, was used. Analyses were done on lactating cows only and on both dry and lactating cows. Assessment of the error of prediction relative to observed values was made by calculation of mean squared prediction error (MSPE). In addition, concordance correlation coefficient (CCC) was also used to evaluate if predicted values were precise and accurate when compared to observations. When data from lactating cows only were used, the models tended to underpredict methane production, except for the linear model of Mills *et al.* (2003). The linear model of Mills *et al.* (2003) predicted methane production from lactating dairy cows better than from a mixture of dry and lactating cows, while the opposite was true for the other linear model. The non-linear model improved MSPE and random error considerably accounting for more than 98% of MSPE for both data-sets. The dynamic simulation model also gave accurate and precise prediction for both sets of data with bias correction factor close to unity. Tier I model underpredicted mean methane production by 4%. Tier II model performed as well as the other linear models for the mixed data-set but not for the lactating cows

data-set. The linear models are recommended for use if there is a lack of nutrient information and within the range in which they were developed. The non-linear model can be used for extrapolation but for assessment of mitigation options, more mechanistic models are recommended. Tier I model may be adequate for general inventory of methane emissions but Tier II model requires further refinement.

Introduction

Methane is one of the GHGs emitted from livestock and is four times more potent than CO₂ in its damaging potential to the ozone layer. Agriculture in North America contributes between 7% (Phetteplace *et al.*, 2001) and 10% (Environment Canada, 2004) of the total US and Canadian GHG emissions respectively. About 90% of methane emissions from Canadian agriculture (2.6% of total GHG emissions) comes from ruminants (Environment Canada, 2004), where methane is a by-product of enteric fermentation of feed in the rumen and to a lesser extent, the large intestine.

In recent years, focus on environmental impact of agriculture on GHG has been intensifying and there is need for an accurate inventory to identify sources that can be mitigated. Canada's commitment under the Kyoto Protocol is to reduce net GHG emissions to 6% below 1990 levels (608 Mt CO₂ equivalents) between 2008 and 2012 (Environment Canada, 2004). The IPCC publishes guidelines for national GHG inventories (IPCC, 1997) that are used for official estimates of methane emissions. With most of the countries that had signed up on the Kyoto protocol ratifying the agreement, accurate estimation of methane emissions has a profound effect on mitigation options available to each nation to meet its commitments under the protocol. There have been several attempts to formulate mathematical models of various complexity to predict methane emissions from cattle. We have selected the linear and non-linear models of Mills *et al.* (2003), the widely used model of Moe and Tyrrell (1979b) and the dynamic simulation model of Kebreab *et al.* (2004), based on their reported performance, to represent various types of models.

The objectives of the study were therefore: (i) to collate data related to methane emissions from North American dairy cattle; (ii) to evaluate models selected and IPCC (1997) recommendations against those data for an independent appraisal of the performance of the models in predicting methane emissions from enteric fermentation; and (iii) to assess the applicability of the models for use in inventory and/or identifying mitigation options.

Materials and Methods

Data sources

A database was constructed from the literature in which lactating and non-lactating dairy cows were fed North American diets based on maize silage

and lucerne hay. As much as possible, control diets in the experiments were used in the construction of the database to avoid bias. The database was similar to that used by Benchaar *et al.* (1998) and Mills *et al.* (2001), with the addition of recently published data making up more than one-third of the database (Table 27.1). Although the data were summarized by Benchaar *et al.* (1998), not all nutritional input required to run some of the models were reported. Thus, some of the nutritional characteristics needed were estimated from the diets described and are shown in Table 27.1.

The models

Several models have been proposed to predict methane production from dairy cows. We chose to evaluate the predictive ability of four models based on their ease of application and widespread usage for making inventories of methane emissions from enteric fermentation. The models chosen were the linear model of Moe and Tyrrell (1979b), the linear and non-linear models of Mills *et al.* (2003), the dynamic model of Kebreab *et al.* (2004) and Tier I and Tier II models recommended by IPCC (1997).

The model of Moe and Tyrrell (1979b) relating intake of carbohydrate fractions to methane production is:

$$\text{Methane (MJ/day)} = 3.41 + 0.51\text{NFC} + 1.74\text{HC} + 2.65\text{C} \quad (27.1)$$

where NFC is non-fibre carbohydrate (kg/day), HC is hemicellulose (kg/day), and C is cellulose (kg/day).

The linear and non-linear models of Mills *et al.* (2003) evaluated are:

$$\text{Methane (MJ/day)} = 5.93 + 0.92\text{DMI} \quad (27.2)$$

$$\text{Methane (MJ/day)} = a - (a + b)e^{-c(\text{ME})} \quad (27.3)$$

where a is theoretical maximum methane output, b is minimum methane output, c is a shape parameter, DMI is dry matter intake (kg/day) and ME is metabolizable energy (MJ/day). Mills *et al.* (2003) reported that c parameter is influenced by acid detergent fibre (ADF) and starch content of the diet, where an increase in the former tends to increase methane output while replacement by starch tends to reverse the effect such that:

$$c = -0.0011 \times \text{starch}(\text{kg/day}) / \text{ADF}(\text{kg/day}) + 0.0045 \quad (27.4)$$

Various dynamic, mechanistic models have been developed that estimate methane emissions (e.g. Baldwin *et al.*, 1987; Mills *et al.*, 2001). The model of Kebreab *et al.* (2004) was taken as representative of such models and was used to simulate methane output from enteric fermentation based on diets reported in the studies. The model uses the approach described by Mills *et al.* (2001). In the model, excess hydrogen produced during fermentation is

Table 27.1. Database used to evaluate models selected.

Reference and diet	Animal ^a	DMI (kg/day)	CP (g/kg DM)	NDF (g/kg DM)	Starch and WSC (g/kg DM)	Starch/ ADF (g/kg DM)	Milk (l/day)	GE (MJ/kg)	ME (MJ/kg)	CH ₄ (MJ/day)
<i>Belyea et al.</i> (1985)										
Long lucerne hay	DH	5.49	166.0	490.0	70.0	0.00	–	97.9	7.31	8.03
Chopped lucerne hay	DH	5.39	166.0	490.0	70.0	0.00	–	99.6	7.57	8.56
<i>Coppock et al.</i> (1964)										
Ration A	L	13.80	289.0	268.0	235.0	1.40	16.7	258.2	11.28	16.26
Ration B	L	15.50	226.0	354.0	153.0	0.61	17.7	287.4	10.06	17.25
Ration C	L	16.30	196.0	440.0	71.0	0.22	14.9	299.6	9.28	17.38
<i>Harlan et al.</i> (1991)										
Lucerne hay early	NL	12.60	220.0	424.0	98.0	0.00	–	246.0	9.37	12.30
Lucerne hay late	NL	9.40	151.0	534.0	91.0	0.00	–	167.4	7.99	8.87
Clover hay late	NL	8.60	141.0	617.0	58.0	0.00	–	154.8	6.36	5.73
Grass hay late	NL	8.20	163.0	714.0	52.0	0.00	–	154.4	8.24	7.57
<i>Holter et al.</i> (1986)										
Dry period = 1: low	NL	8.40	127.0	509.0	227.0	0.55	–	160.7	9.91	9.00
Dry period = 1: high	NL	9.70	127.0	509.0	227.0	0.55	–	190.8	10.58	10.11
Dry period > 1: low	NL	9.20	127.0	509.0	227.0	0.55	–	173.2	9.91	10.39
Dry period > 1: high	NL	10.30	127.0	509.0	227.0	0.55	–	188.3	10.87	10.92
<i>Holter et al.</i> (1992)										
Control diet	L	17.40	181.0	322.0	288.0	1.15	35.2	316.7	10.92	12.99
Whole cottonseed diet	L	16.60	168.0	363.0	266.0	0.94	29.6	310.5	10.75	11.18
<i>Holter et al.</i> (1990)										
6 weeks postpartum	L	18.00	172.0	285.0	438.0	2.16	39.3	312.1	10.96	10.61
10 weeks postpartum	L	18.90	165.0	319.0	411.0	1.79	37.0	328.4	10.75	13.47
14 weeks postpartum	L	18.40	155.0	383.0	359.0	1.24	31.1	322.2	10.38	16.43
<i>Moe and Tyrrell</i> (1972)										
Protein diet: high	L, NL	10.40	160.0	401.0	315.0	1.14	8.2	199.6	11.00	14.37
Protein diet: low	L, NL	12.20	114.0	420.0	369.0	1.32	11.2	232.2	10.33	15.09
<i>Moe and Tyrrell</i> (1977)										
All hay	NL	6.60	51.0	696.0	52.0	0.00	–	122.2	7.36	8.19

Maize meal diet	NL	7.20	102.0	350.0	432.0	1.95	–	131.8	10.04	9.09
Maize meal diet	L	17.00	136.0	344.0	374.0	1.67	18.1	310.9	9.56	18.03
Moe and Tyrrell (1979a)										
Basal	L	17.90	164.0	317.0	336.0	1.55	25.4	333.5	10.54	19.01
Basal	NL	6.50	164.0	317.0	336.0	1.59	–	113.4	10.00	8.84
Moe <i>et al.</i> (1973a)										
Maize diet	L	13.10	162.0	253.0	438.0	2.76	14.2	245.6	11.38	11.05
Oat diet	L	14.00	181.0	350.0	286.0	1.19	14.5	265.7	10.79	10.63
Moe <i>et al.</i> (1973b)										
Maize meal diet (Experiment 1)	L	14.20	156.0	262.0	438.0	2.63	16.0	265.7	10.99	11.96
Maize meal diet (Experiment 2)	L	13.40	132.0	276.0	432.0	1.57	15.2	245.2	10.34	13.24
Tyrrell and Moe (1972)										
Ration L	L	14.80	154.0	401.0	332.0	1.14	21.7	287.0	11.00	18.37
Ration M	L	12.80	139.0	288.0	482.0	2.39	19.5	243.5	11.29	12.42
Sauer <i>et al.</i> (1998)										
Control (Experiment 1: stage 1)	L	16.10	154.5	301.0	303.0	1.33	30.7	252.1	10.40	20.73
Control (Experiment 1: stage 4)	L	16.00	148.0	319.0	281.0	1.10	26.6	250.5	10.40	23.30
Control (Experiment 2: stage 1)	L	19.80	148.0	333.0	263.0	1.02	24.9	310.0	10.40	22.09
Control (Experiment 2: stage 4)	L	16.00	148.0	333.0	263.0	1.02	25.5	250.5	10.40	21.61
Control (Experiment 3: stage 1)	L	16.10	153.1	314.0	286.0	1.10	27.6	246.5	10.17	24.14
Control (Experiment 3: stage 4)	L	14.90	158.4	288.0	319.0	1.40	33.0	228.1	10.17	21.06
Control (Experiment 3: stage 5)	L	14.60	159.6	282.0	325.0	1.47	34.1	223.5	10.17	21.46
Control (Experiment 3: stage 6)	L	15.20	159.6	280.0	328.0	1.49	34.8	232.7	10.17	20.47
Control (Experiment 3: stage 7)	L	15.40	158.4	288.0	319.0	1.40	33.3	235.8	10.17	21.90
Control (Experiment 3: stage 8)	L	15.90	157.6	292.0	314.0	1.35	32.6	243.4	10.17	21.68
Control (Experiment 4: stage 1)	L	16.50	168.2	299.0	305.0	1.39	31.2	259.8	10.46	23.22
Control (Experiment 4: stage 4)	L	16.90	163.2	317.0	283.0	1.18	27.1	266.1	10.46	20.51
Control (Experiment 4: stage 5)	L	18.20	163.2	317.0	283.0	1.18	27.3	286.6	10.46	21.17
Control (Experiment 4: stage 6)	L	16.20	162.7	320.0	280.0	1.16	26.3	255.1	10.46	20.99
Control (Experiment 4: stage 7)	L	17.00	161.0	325.0	274.0	1.11	25.2	267.7	10.46	21.83
Control (Experiment 4: stage 8)	L	18.10	161.0	325.9	273.0	1.10	24.9	285.0	10.46	21.98

^aDH = dairy heifers, L = lactating, NL = non-lactating.

partitioned between use for microbial growth, biohydrogenation of unsaturated fatty acids and production of glucogenic volatile fatty acids (VFA). The assumption is made that the remaining hydrogen is used solely and completely for methanogenesis (Fig. 27.1).

IPCC in its revised reference manual (IPCC, 1997) outlines methods of estimating methane emissions from enteric fermentation at two levels of detail and complexity. In Tier I, the IPCC (1997) guideline assumes an average milk production of 6700 kg/head/year and the estimated enteric fermentation emission factor for North American dairy cows is 118 kg/head/year. For dry cows, the estimate is 47 kg/head/year.

IPCC (1997) recommends the Tier II approach for estimating methane emissions from enteric fermentation for cattle in countries with large cattle populations. Average daily feed intake (in terms of gross energy (GE) content, MJ/day) and methane conversion rates are used to estimate methane emissions. For North American dairy cattle, a 6% conversion rate is recommended except for those consuming diets with a large quantity of grain. Feed intake is estimated from body weight (BW), average weight gain per

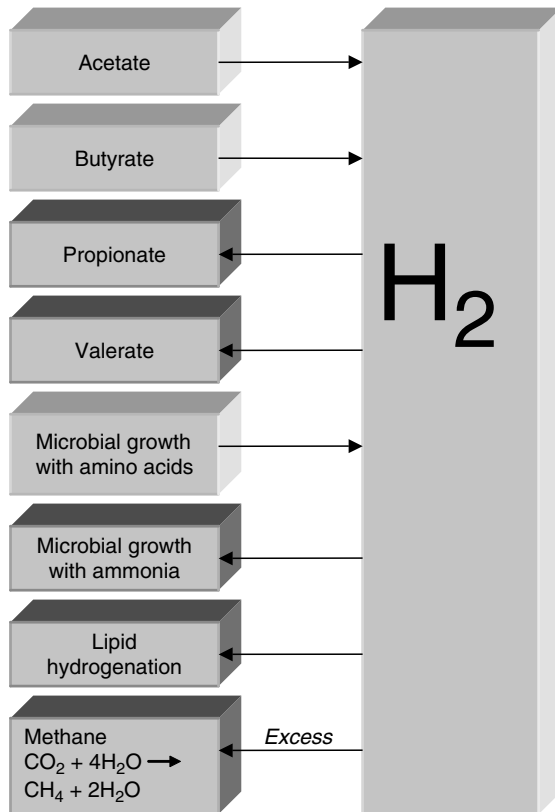

Fig. 27.1. Hydrogen sources and sinks used in the dynamic simulation model of Kebreab *et al.* (2004).

day, feeding situation, milk production per day, average amount of work performed per day, percentage of cows that give birth in a year and feed digestibility. However, in this study, GE intakes as reported in the database were used.

Statistical analysis

Observed values of methane output reported in the studies were compared with model predictions. An assessment of error of predicted relative to observed values was made by computing MSPE:

$$\text{MSPE} = \sum_{i=1}^n (O_i - P_i)^2 / n \quad (27.5)$$

where $i = 1, 2, \dots, n$, n is number of experimental observations, and O_i and P_i are observed and predicted values respectively. MSPE was decomposed into errors due to the overall bias of prediction, due to deviation of the regression slope from unity and due to the disturbance or random variation (Bibby and Toutenburg, 1977). Root MSPE (RMSPE) values expressed as a percentage of the observed mean were used as a measure of prediction error.

CCC (Lin, 1989) calculated using ModEval software (Version 1.0.33; Tedeschi, 2004) was also used to evaluate the precision and accuracy of predicted against observed values. CCC can be represented as a product of two components: (i) the correlation coefficient estimate that measures precision (r); and (ii) the bias correction factor that indicates how far the regression line deviates from the line of unity (C_b). Another estimate (μ) that measures location shift relative to the scale (squared difference of the means relative to the product of two standard deviations (SDs)) is also reported here.

Results

Comparison of model performance in predicting methane emissions from lactating cows

Table 27.2 gives summarized statistics for each model's performance in predicting methane emissions from lactating dairy cattle, based on literature data. In general, all models except the linear model of Mills *et al.* (2003) tended to underpredict methane production with varying degrees of magnitude. The mechanistic and Tier II models showed the smallest and highest levels of underprediction respectively (Table 27.2).

Mills *et al.* (2003) reported that DMI explained significant variation in daily methane production and that they were linearly related. The linear model of Mills *et al.* (2003) showed a good correlation between observed and predicted methane production ($R^2 = 0.46$; Table 27.2); however, the model overpredicted average methane production by about 9%. Statistical analysis showed that 17% of MSPE was due to overall bias of prediction with the

Table 27.2. Comparison of model performance using North American lactating dairy cattle data collated from the literature.

	Models				
	Mills <i>et al.</i> (2003): Linear	Moe and Tyrrell (1979b)	Mills <i>et al.</i> (2003): Non-linear	Kebreab <i>et al.</i> (2004)	IPCC (1997): Tier II
Mean squared prediction error (MSPE) ^a					
MSPE	13.75	20.71	11.70	13.60	26.42
RMSPE (MJ/day)	3.71	4.55	3.42	3.69	5.14
%RMSPE (%)	23.89	29.34	22.01	23.65	33.10
ECT (%)	17.34	22.23	0.006	0.006	23.71
ER (%)	1.03	2.10	1.77	2.91	6.10
ED (%)	81.63	75.67	98.23	97.08	70.19
R^2	0.46	0.26	0.45	0.40	0.10
Concordance correlation coefficient (CCC) ^b					
r	0.57	0.41	0.60	0.66	0.27
C_b	0.82	0.80	0.97	0.98	0.75
μ	-0.42	0.56	0.007	0.006	0.69

^aRMSPE = root MSPE; %RMSPE = RMPSE as a percentage of the observed mean; ECT = MSPE decomposed into error due to overall bias of prediction; ER = error due to deviation of the regression slope from unity; ED = error due to disturbance or random variation.

^b r = correlation coefficient estimate; C_b = bias correction factor; μ = location shift relative to the scale (squared difference of the means relative to the product of two standard deviations (SDs)).

largest component being random error. The bias correction factor of CCC was at the lower end compared to the other models (C_b varies from 0 to 1 for accurate prediction, which falls along the line of perfect agreement). The model of Moe and Tyrrell (1979b) had lower R^2 and higher RMSPE values compared to the linear model of Mills *et al.* (2003). Decomposition of MSPE showed only 76% of error was due to random variation compared to 82% obtained by the model of Mills *et al.* (2003). CCC analysis indicated that values predicted by the model of Moe and Tyrrell (1979b) had similar accuracy but lower precision than those predicted by the other linear model.

The non-linear model of Mills *et al.* (2003) gave significantly improved MSPE, which was reflected in a lower RMSPE value (3.7 vs 3.4 MJ/day for linear and non-linear models respectively; Table 27.2). Source of error also shifted from overall bias to random error (98%). CCC analysis confirmed that the non-linear model gave a much closer value to unity than the linear models (Table 27.2). Magnitude of the underprediction was also among the lowest of the models compared.

The dynamic simulation model of Kebreab *et al.* (2004) had the second lowest RMSPE value (4.5 MJ/day) with 97% of MSPE from random error. CCC analysis showed that this model predicted methane production more accurately and precisely than the linear and non-linear models. The model

of Kebreab *et al.* (2004) had the lowest magnitude of underprediction among the models compared.

Tier I model has only one prediction for all observed methane emissions. Therefore, the R^2 and CCC analyses gave a zero value. However, the observed mean was compared with the Tier I estimate and an RMSPE of 4.62 MJ/day was obtained. Although the same methane emission is predicted for a wide range of observed methane productions, the model underestimated average methane production by only 4%. Most of the error was attributed to random variation. Tier II model had the lowest R^2 and highest RMSPE values. CCC analysis also suggested that Tier II model had the lowest degree of accuracy and precision in predicting methane emissions for lactating dairy cows.

Comparison of model performance in predicting methane emissions from both dry and lactating dairy cows

When the models were run using data from both dry and lactating cows, the Moe and Tyrrell (1979b) and Tier II models underpredicted while the others overpredicted methane emissions from enteric fermentation (Table 27.3). Results of regression between observed values, reported from experiments in the literature, and predicted methane production are shown in Fig. 27.2.

Table 27.3. Comparison of model performance using North American dairy cattle data collated from the literature.

	Models				
	Mills <i>et al.</i> (2003): Linear	Moe and Tyrrell (1979b)	Mills <i>et al.</i> (2003): Non-linear	Kebreab <i>et al.</i> (2004)	IPCC (1997): Tier II
Mean squared prediction error (MSPE) ^a					
MSPE	26.77	21.61	13.61	20.34	21.73
RMSPE (MJ/day)	5.17	4.65	3.69	4.52	4.66
%RMSPE (%)	33.31	29.93	23.75	29.04	30.01
ECT (%)	36.93	0.35	5.74	8.45	7.34
ER (%)	2.42	0.50	0.10	2.61	2.03
ED (%)	60.65	99.15	94.16	88.94	90.63
R^2	0.45	0.26	0.57	0.50	0.32
Concordance correlation coefficient (CCC) ^b					
r	0.59	0.44	0.72	0.71	0.52
C_b	0.79	0.86	0.92	0.93	0.90
μ	-0.60	0.07	-0.21	-0.31	0.28

^aRMSPE = root MSPE; %RMSPE = RMPSE as a percentage of the observed mean; ECT = MSPE decomposed into error due to overall bias of prediction; ER = error due to deviation of the regression slope from unity; ED = error due to disturbance or random variation.

^b r = correlation coefficient estimate; C_b = bias correction factor; μ = location shift relative to the scale (squared difference of the means relative to the product of two standard deviations).

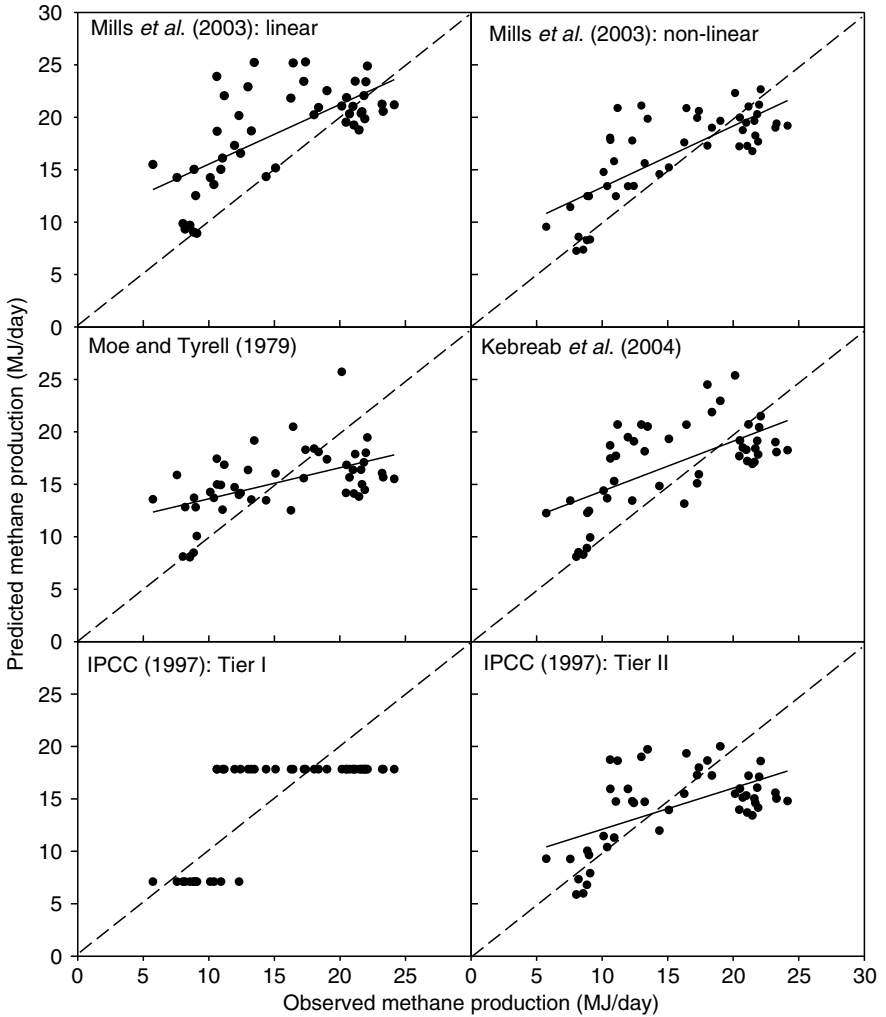

Fig. 27.2. Comparison of six models in predicting methane production (MJ/day) from North American dairy cattle obtained by pooling all data.

Statistical analysis showed that the linear model of Mills *et al.* (2003) was the poorest predictor of methane emissions with the highest MSPE value; a significant (37%) component of which was due to overall bias of prediction. CCC analysis revealed a high overprediction value for the linear model, and the bias correction factor was the lowest among the models tested. However, although the model of Moe and Tyrrell (1979b) had the lowest R^2 value, it had low RMSPE values and decomposition of MSPE showed that more than 99% of error was due to random variation. CCC analysis indicated that values predicted by the model of Moe and Tyrrell (1979b) were closer to the observed values compared to the other linear model and had a small magnitude of underprediction.

Once again, the non-linear model of Mills *et al.* (2003) improved the RMSPE value considerably when used with data from both dry and lactating dairy cows (Table 27.3). Most of the error (94%) was random. CCC analysis revealed that the non-linear model was both accurate and precise in predicting methane emissions from North American dairy cows. The non-linear model of Mills *et al.* (2003) tended to overpredict methane production but the magnitude was among the lowest.

The dynamic model of Kebreab *et al.* (2004) was among those with lower RMSPE values (4.5 MJ/day) with 89% of MSPE coming from random error and 8% due to overall bias of prediction. CCC analysis showed that this model had the highest degree of accuracy in predicting methane production compared to the other models.

Tier II model gave better RMSPE values than the Mills *et al.* (2003) linear model. Both MSPE and CCC analyses suggested that Tier II model had a similar degree of accuracy in predicting methane emissions as the Moe and Tyrrell (1979b) model.

Discussion

Predictive accuracy and precision of six models of methane emissions from dairy cows were compared using two data-sets from North America: one containing observations from lactating cows and the other containing observations from both lactating and dry cows. The two linear models showed different predictive performance depending on the data-set. The linear model of Mills *et al.* (2003) was superior in its methane prediction on data from lactating dairy cattle, while the model of Moe and Tyrrell (1979b) showed better performance on data from both dry and lactating cows. This can be explained in part by data used to develop these models. Mills *et al.* (2003) used data from high-yielding lactating cows with an average DMI of 19.6 kg/day, in contrast to Moe and Tyrrell (1979b), who used data on dry and lactating cows with an average DMI of 12.1 kg/day to develop their model. CCC analysis also showed that, although both linear models had similar accuracy of prediction, the Mills *et al.* (2003) model was more precise in predicting methane production in both data-sets. It is not surprising that the linear model of Mills *et al.* (2003) overpredicted while that of Moe and Tyrrell (1979b) underpredicted, given the sets of data used to develop those models. When predicting methane production from dry and lactating cows, the magnitude or prediction error was smaller in Moe and Tyrrell (1979b) mainly because the observed data had a mean methane production closer to that of the data used to develop the model.

The non-linear model of Mills *et al.* (2003) improved the accuracy and precision of predicting methane production considerably compared to the linear models. Improvement in prediction was more pronounced in the lactating than in the mixed dry and lactating cow group. Again this could be because the model was originally developed using high-yielding lactating dairy cows. Nevertheless, the model was also one of the best in predicting

methane emissions from dry and lactating cattle (Table 27.3). The non-linear equation had two components that helped to improve its prediction capability. The first, which is well established, is that the percentage of GE lost decreases as methane declines as DMI increases. This implies that any model of methane production based on feed intake (DMI, GEI, MEI) ought to be non-linear. The second component is based on previous research, which suggests that fibrous diets (high ADF) tend to increase methane production, whereas the reverse is true for diets high in starch (Mills *et al.*, 2001).

The dynamic simulation model of Kebreab *et al.* (2004) predicted methane emissions for both data-sets accurately and precisely (Tables 27.2 and 27.3). Compared to the non-linear model, prediction by the dynamic model did not show much improvement. This can be explained by the nature of the model, which is constructed such that many nutritional factors are considered during simulation. Therefore, application of the dynamic model to various diets represents more than just the effect of the ratio of starch to ADF. Accurate description of feed nutritional contents, therefore, predetermines performance of the model. In this study, a few of the feed nutritional contents had to be estimated using book values. Furthermore, given that methane production is closely related to VFA production, VFA stoichiometry of dietary substrates in rumen fermentation needs to be predicted accurately. The simulation model used coefficients developed by Bannink *et al.* (2000). Prediction of VFA molar proportions in rumen fluid can be inaccurate (Bannink *et al.*, 1997; Dijkstra and Bannink, 2000) and future developments in estimation of VFA stoichiometry are expected to improve model prediction.

The two-point estimate of Tier I model was in close agreement with the mean of observed methane production. However, Tier II model did not predict methane production as well as the other models. Part of the problem could be the assumption that a fixed proportion of GE is converted to methane regardless of DMI. As discussed earlier, it is now well established that as intake increases, the percentage of GE lost decreases as methane declines. Therefore the fixed value of 6% by the IPCC (1997) should be revised to vary with GE intake. Moreover, type of carbohydrate in the feed that constitutes the bulk of GE also affects methane production. Mills *et al.* (2001), for example, showed that starch inclusion leads to a much higher recovery of feed energy as net energy in contrast to water-soluble carbohydrates.

The usefulness of each model therefore depends on the objectives of the user in predicting methane production and availability of nutritional information. For a quick appraisal of national inventory of methane emission from enteric fermentation, the predicted mean methane production from Tier I model has proved closest to observed values for dairy cattle in North America. Although Tier II model did not predict methane production as well as the other models in this study, Lee and Lee (2003) reported that it improved the accuracy and reliability of national methane emission estimates from enteric fermentation in livestock in Korea. Linear models are important predictors of methane production where detailed nutritional information is lacking. However, as shown in this study, one should

remember that linear models are only applicable within the range of data used in their development. In contrast, non-linear models can be used for cautious extrapolation and have been shown to describe the relationship between intake and methane production more accurately. The strength of a more mechanistic model on the other hand arises where one considers mitigation options in relation to dietary manipulation, since the impact mitigation strategies might have on methane emissions has to be assessed holistically, in both the whole rumen and whole animal. Empirical models lack the biological basis necessary to evaluate mitigation strategies, so mechanistic models are important tools for assessing these options and for directing experimental research towards options most likely to result in significant reduction of methane emissions from enteric fermentation.

Conclusions

The linear models in this study are useful methane predictors but have to be used with caution and applied only within the range of data used in their development. The non-linear model gave accurate and precise estimate of methane production without the need for detailed nutrient profiling of the diet consumed. Tier I model might be enough for a general assessment of methane production in a country because predicted mean was closer to observed mean. Tier II models require further refinement, especially in relation to the fixed proportion of GE that is converted and emitted as methane energy. Although a few of the nutritional parameters were estimated from book values, the dynamic simulation model proved to be accurate in predicting methane emission from enteric fermentation in North American cattle. For full assessment of mitigation options, mechanistic models are required.

References

- Baldwin, R.L., Thornley, J.H.M. and Beever, D.E. (1987) Metabolism of the lactating cow: II. Digestive elements of a mechanistic model. *Journal of Dairy Science* 54, 107–131.
- Bannink, A., De Visser, H. and Van Vuuren, A.M. (1997) Comparison and evaluation of mechanistic rumen models. *British Journal of Nutrition* 78, 563–581.
- Bannink, A., Kogut, J., Dijkstra, J., France, J., Tamminga, S. and Van Vuuren, A.M. (2000) Modelling production and portal appearance of volatile fatty acids in dairy cows. In: McNamara, J.P., France, J. and Beever, D.E. (eds) *Modelling Nutrient Utilization in Farm Animals*. CAB International, Wallingford, UK, pp. 87–102.
- Belyea, R.L., Marin, P.J. and Sedgwick, H.T. (1985) Utilization of chopped and long alfalfa by dairy heifers. *Journal of Dairy Science* 68, 1297–1301.
- Benchaar, C., Rivest, J., Pomar, C. and Chiquette, J. (1998) Prediction of methane production from dairy cows using existing mechanistic models and regression equations. *Journal of Animal Science* 76, 617–627.
- Bibby, J. and Toutenburg, H. (1977) *Prediction and Improved Estimation in Linear Models*. John Wiley & Sons, Chichester, UK.

- Coppock, C.E., Flatt, W.P., Moore, L.A. and Stewart, W.E. (1964) Effect of hay-to-grain ratio on utilization of metabolizable energy for milk production by dairy cows. *Journal of Dairy Science* 47, 1330–1338.
- Dijkstra, J. and Bannink, A. (2000) Analyses of modelling whole-rumen function. In: Theodorou, M.K. and France, J. (eds) *Feeding Systems and Feed Evaluation Models*. CAB International, Wallingford, UK, pp. 299–322.
- Environment Canada (2004) Available at: <http://www.ec.gc.ca/international/multilat/fccc> (accessed on 24 May 2004).
- Harlan, D.W., Holter, J.B. and Hayes, H.H. (1991) Detergent fiber traits to predict productive energy of forages fed free choice to nonlactating dairy cattle. *Journal of Dairy Science* 74, 1337–1353.
- Holter, J.B., Bullis, J.A. and Hayes, H.H. (1986) Predicting maternal protein and fat balances of growing and mature dry cows. *Journal of Dairy Science* 69, 2622–2635.
- Holter, J.B., Slotnick, M.J., Hayes, H.H., Bozak, C.K., Urban Jr, W.E. and McGilliard, M.L. (1990) Effect of prepartum dietary energy on condition score, postpartum energy, nitrogen partitions, and lactation production responses. *Journal of Dairy Science* 73, 3502–3511.
- Holter, J.B., Hayes, H.H., Urban Jr, W.E. and Duthie, A.H. (1992) Energy balance and lactation response in Holstein cows supplemented with cottonseed with or without calcium soap. *Journal of Dairy Science* 75, 1480–1494.
- IPCC (Intergovernmental Panel on Climate Change) (1997) *Revised 1996 IPCC Guidelines for National Greenhouse Gas Inventories: Reference Manual*.
- Kebreab, E., Mills, J.A.N., Crompton, L.A., Bannink, A., Dijkstra, J., Gerrits, W.J.J. and France, J. (2004) An integrated mathematical model to evaluate nutrient partition in dairy cattle between animal and environment. *Animal Feed Science and Technology* 112, 131–154.
- Lee, H.J. and Lee, S.C. (2003) National methane inventory relevant to livestock enteric fermentation. *Journal of Animal Science and Technology* 45, 997–1006.
- Lin, L.I.K. (1989) A concordance correlation coefficient to evaluate reproducibility. *Biometrics* 45, 255–268.
- Phetteplace, H.W., Johnson, D.E. and Seidl, A.F. (2001) Greenhouse gas emissions from simulated beef and dairy livestock systems in the United States. *Nutrient Cycling in Agroecosystems* 60, 99–102.
- Mills, J.A.N., Dijkstra, J., Bannink, A., Cammell, S.B., Kebreab, E. and France, J. (2001) A mechanistic model of whole-tract digestion and methanogenesis in the lactating dairy cow: model development, evaluation, and application. *Journal of Animal Science* 79, 1584–1597.
- Mills, J.A.N., Kebreab, E., Yates, C., Crompton, L.A., Cammell, S.B., Dhanoa, M.S., Agnew, R.E. and France, J. (2003) Alternative approaches to predicting methane emissions from dairy cows. *Journal of Animal Science* 81, 3141–3150.
- Moe, P.W. and Tyrrell, H.F. (1972) Net energy value for lactation of high- and low-protein diets containing corn silage. *Journal of Dairy Science* 55, 318–324.
- Moe, P.W. and Tyrrell, H.F. (1977) Effects of feed intake and physical form on energy value of corn in timothy hay diets for lactating cows. *Journal of Dairy Science* 60, 752–758.
- Moe, P.W. and Tyrrell, H.F. (1979a) Effect of endosperm type on incremental energy value of corn grain for dairy cows. *Journal of Dairy Science* 62, 447–454.
- Moe, P.W. and Tyrrell, H.F. (1979b) Methane production in dairy cows. *Journal of Dairy Science* 62, 1583–1586.
- Moe, P.W., Tyrrell, H.F. and Hooven Jr, N.W. (1973a) Energy balance measurements with corn meal and ground oats for lactating cows. *Journal of Dairy Science* 56, 1149–1153.

- Moe, P.W., Tyrrell, H.F. and Hooven Jr, N.W. (1973b) Physical form and energy value of corn grain. *Journal of Dairy Science* 56, 1298–1304.
- Sauer, F.D., Fellner, V., Kinsman, R., Kramer, J.K.G., Jackson, H.A., Lee, A.J. and Chen, S. (1998) Methane output and lactation response in Holstein cattle with monensin or unsaturated fat added to the diet. *Journal of Animal Science* 76, 906–914.
- Tedeschi, L.O. (2004) ModEval: a computer program to assess mathematical model adequacy. Available at: <http://www.cncps.cornell.edu/modeval/> (accessed on 28 September 2004).
- Tyrrell, H.F. and Moe, P.W. (1972) Net energy value for lactation of a high and low concentrate ration containing corn silage. *Journal of Dairy Science* 55, 1106–1112.

28 Investigating Daily Changes in Food Intake by Ruminants

G.MCL. DRYDEN

School of Animal Studies, The University of Queensland, Gatton, Qld 4343, Australia

Abstract

Trajectories of food intake for 12 sets of animals (weekly average intakes of four individual growing sheep, mean daily intakes of four pens of three growing cattle, and the mean daily intakes of four groups of six pregnant fallow does) were examined. The raw data exhibited expected seasonal trends, including changes in the amount of food eaten with changing live weight (LW) and age. The data were detrended by fitting polynomial equations of time. The residuals between the predicted and actual values were examined to determine the nature of period-to-period variations in food intake. Although the data-sets were obtained in different ways, the detrended data all showed similar food intake behaviours. In all but one case the residuals distributions were skewed negatively. The residuals vs time plots showed that large deviations below the expected values were more likely than deviations above the expected intakes, and that similar types of deviation tended to be clustered. Autoregressive integrated moving average (ARIMA) modelling indicated that autoregressive (AR) and/or moving average (MA) models, usually with a seasonal component, best fitted these data. However, the models had limited ability to predict food intake trajectories in the long term. These results suggest that when models are used to predict day-to-day variations in food intake, they should be primed by measuring actual intakes over at least 7–10 days; that similar intake behaviours are likely to occur together but that intakes that are lower than predicted will occur more often than those that are greater than predicted; and that intakes will additionally fluctuate in an apparently random way.

Introduction

Many relationships are available to predict food intake by ruminants. These are generally deterministic models in which predictor variables are identified and the relationships between these and intake are quantified. Common predictor variables are LW, age or current LW in relation to mature weight, body fat content, stage of lactation, net energy (NE) requirements, feed chemical composition (including cell wall content), ambient temperature, etc. Almost all these models simply attempt to forecast the mean feed intake of groups or of individuals over time, and several have been described and evaluated by Pittroff and Kothmann (2001a,b,c). There have been few

attempts to use previous intake records to refine forecasts of feed intake in animals. Oltjen and Owens (1987) compared two methods – (i) a Bayes modification of the Kalman filter, and (ii) an adjustment factor derived from the ratio of actual to predicted intake in the previous period – of refining predictions of feed intake by lot-fed cattle obtained from a mechanistic intake model. Bermejo *et al.* (2003a,b) used an AR approach to forecast short-interval changes in intake in pigs but apparently this approach has not been applied to ruminants.

Average feed intake gives useful information, e.g. for planning feed supplies and storages, or in forecasting average animal performance, but adds very little to our understanding of the magnitudes of expected day-to-day variations and why they occur, or to our capacity to predict meal-eating behaviour. A detailed understanding of short-interval changes in feed intake may allow more accurate updating of dynamic models of animal performance and better estimation of feed intake variability in stochastic models, would reassure animal managers that day-to-day variation in feed intake is normal, would be helpful in forecasting short-term variations in animal performance such as the daily changes in feed intake in lot-fed cattle, and may help to identify breeding objectives as suggested by Bermejo *et al.* (2003a).

Better knowledge of the nature of short-term intake behaviour may help us to understand better the process of feed intake control in ruminants. The purpose of the work described here is to investigate the structure of short-interval changes in feed intake in three different ruminant species, and to investigate the possibility of using feed intake trajectory data to forecast feed intake in ruminants.

Methods

Trajectories of food intake for 12 sets of animals were examined. The datasets were:

1. Sheep: weekly average dry matter intakes (DMIs) of four growing weaned lambs – one Border Leicester and three Suffolk – held in individual indoor pens and fed *ad libitum* a pelleted diet of 50% lucerne meal plus cereal grains and protein meals. Intakes were measured from weaning (average age = 10.6 ± 2.50 weeks, mean \pm SD) for 88–97 weeks. The initial and final LW of these animals were 21.6 ± 2.06 and 124.5 ± 7.01 kg, respectively. DMIs were expressed as $\text{g}/\text{kg}^{0.75}$ daily.

2. Cattle: daily DMIs of four pens of three growing yearling Wagyu cattle, held in outdoor feedlot yards. The initial and final LW of these cattle were 259 ± 17.1 and 287 ± 16.5 kg, respectively. Cattle in two yards were fed a medium-quality lucerne hay unchopped, in amounts sufficient to allow refusals. The other two groups were fed the lucerne hay plus an amount of hydroponically grown barley sprouts equivalent to 5% of average LW/day, equivalent to 25% of the diet DM. The feed was given in troughs

that provided 2 m per animal of linear trough space per pen. Measurements were made over 41 days. DMIs were expressed as kg/day.

3. Deer: daily average metabolizable energy intakes (MEIs) of pregnant *Dama dama* and *D. dama* × *D. mesopotamica* fallow does. The experiment was conducted in 1997 when data from five does in each genotype group were recorded and in 1998 with six does per group. The deer were housed indoors in individual pens. Three deer in each group were given a pelleted lucerne chaff/oat grain ration that had 10.3 MJ ME/kg DM, and the other three were given a pelleted concentrate diet with 14 MJ ME/kg DM. The amount of feed offered to each doe was increased by ~100 g/day, and was sufficient to allow refusals. There was no statistically significant difference between diets in the amount of ME eaten. Measurements were made during the second and third trimesters of pregnancy, over periods of 131–152 days. MEIs were expressed as MJ/day.

The data were detrended by fitting polynomial equations of time. The equations were fitted by forward inclusion of successively higher-order terms using changes in the significance of the regression equation, the significance of t values for the included regressor variables, and the R^2 value to decide on a satisfactory equation. The residuals between the predicted and actual values were examined to determine the nature of period-to-period variations in food intake.

For each set of residuals the mean and variance were calculated, and tests made for randomness (runs test, and tests for clustering and mixing), normality (kurtosis and skew, and the Andersen–Darling test for normality) using the Minitab (2000) software. Evidence for periodicity was sought from the autocorrelation functions (ACFs; Minitab, 2000), and spectral density plots derived using the Spectra procedure of SAS (2000), which uses a finite Fourier transform, and the Tukey–Hanning window. Multiple regression analysis (the stepwise inclusion method of the Reg procedure of SAS, 2000) of X_t vs $X_{t-1...k}$ was carried out to further investigate the relationships between feed intake on day t (X_t) and on the preceding days, $k = 16$ (cattle) or $k = 20$ days. Variables entered the model at $P < 0.15$.

ARIMA (Box and Jenkins, 1970) modelling (Minitab, 2000) was used to generate prediction models.

Results

Characteristics of the raw data

The raw data exhibited the expected seasonal trends, including changes in the amount of food eaten with changing LW and age. Representative plots of DM and ME intakes vs time are shown in Fig. 28.1. The equations and their statistics are given in Table 28.1.

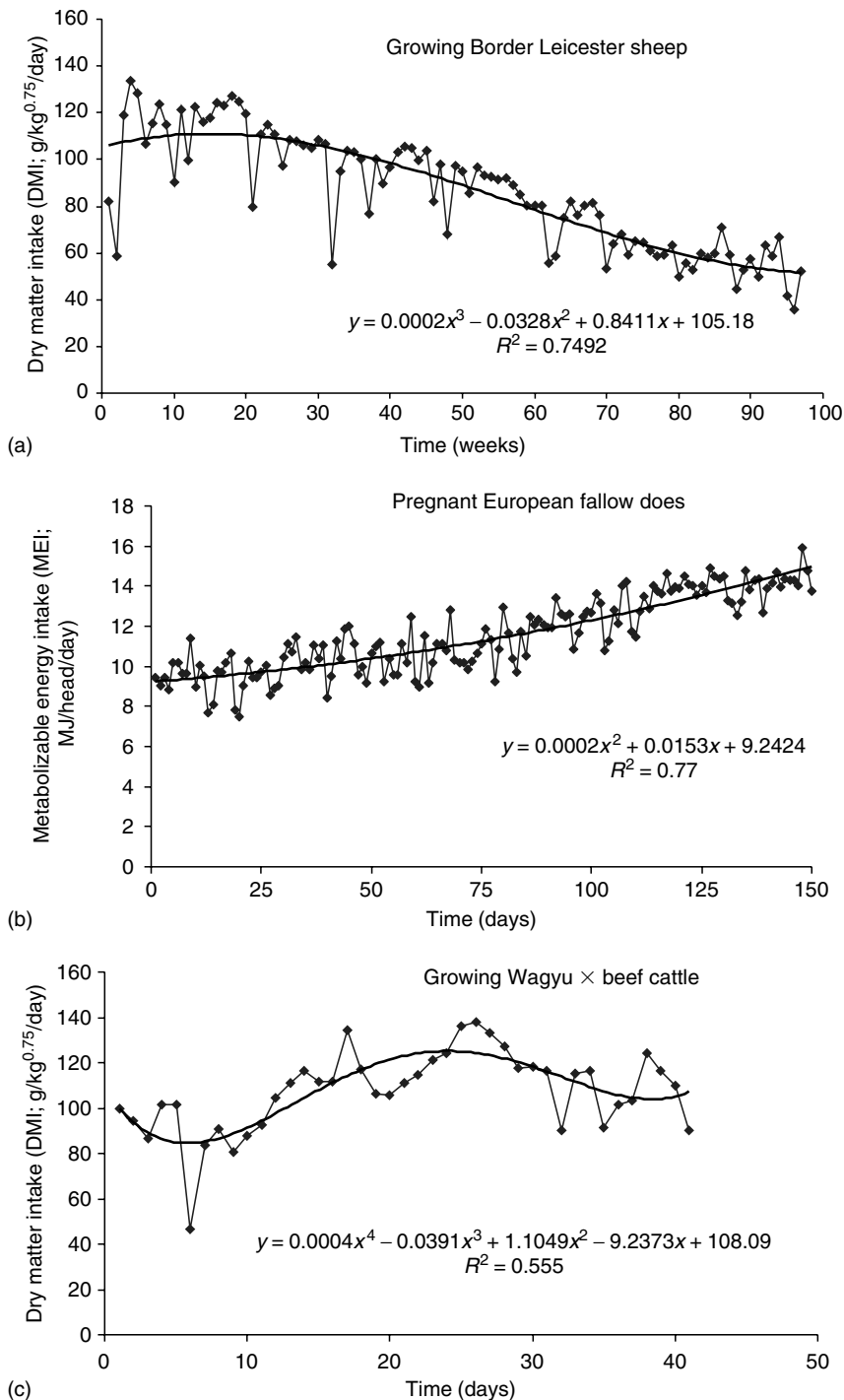

Fig. 28.1. Food intake trajectories, unadjusted for seasonal and other trends.

Table 28.1. Statistics for the residuals from the detrended data.

Data-set ^a	SD	Tests for normality			Tests for randomness		
		Distribution (<i>P</i> =) ^b	Skew	Kurtosis	Clustering ^c (<i>P</i> =)	Mixtures ^c (<i>P</i> =)	Runs (<i>P</i> =)
Pregnant deer (ME intake MJ/day)							
97–98E	0.923	0.086	–0.208	–0.530	0.025	0.975	0.013
97–98H	0.786	0.007	–0.514	0.645	0.000	1.000	0.000
98–99E	0.716	0.462	0.295	0.020	0.284	0.716	0.382
98–99H	0.644	0.740	–0.143	–0.395	0.022	0.978	0.286
Growing sheep (DM intake g/kg ^{0.75} /day)							
BL100	12.294	0.000	–1.591	4.142	0.002	0.999	0.478
SF4	13.769	0.000	–1.126	5.245	0.099	0.901	0.401
SF6	12.704	0.000	–1.381	8.079	0.092	0.908	0.264
SF62	14.008	0.000	–1.199	4.511	0.002	0.999	0.082
Growing cattle (DM intake g/kg ^{0.75} /day)							
L-C1	14.675	0.434	–0.037	1.144	0.041	0.949	0.082
L-C2	11.858	0.187	–0.815	1.525	0.078	0.922	0.162
L-5S7	15.349	0.513	–0.276	0.257	0.319	0.681	0.281
L-5S8	13.320	0.372	–0.434	–0.209	0.439	0.561	0.447

^aFor all data-sets, mean → 0.0000.

^bSignificance of the Anderson–Darling normality test.

^cOne-tailed tests.

The tests for randomness gave ambiguous results. According to the runs test, except for two cases (Table 28.1), the residuals were apparently randomly distributed about the mean. However, tests for clustering were significant in 6 of the 12 cases. In many cases the residuals were not distributed normally, and 11 of the 12 sets were negatively skewed, indicating that values less than the mean were more common than those greater than the mean (see also Fig. 28.1).

Evidence of periodicity

Multiple regression analysis (Table 28.2) was used to investigate possible relationships between residuals obtained at varying times along the intake trajectory. One or more significant relationships ($P \leq 0.05$) were discovered for each data-set. While all of the multiple regression equations were significant ($P < 0.05$), they generally explained very little of the variance in the dependent variable. The notable exceptions were L-C1 and 97–98H where the equations explained about 60% of the variance in the dependent variable. The characteristics of these equations are summarized in Table 28.3.

The spectral density plots generally did not have the classic pattern of a fundamental followed by a series of harmonics. Instead, in many cases, there

Table 28.2. Multiple regression analysis of residuals.

Data-set	Equation		
	R^2	$P =$	$X_t =$
Pregnant deer			
97–98E	0.196	0.0001	$0.03 + 0.14(X1) + 0.16(X6) + 0.15(X7) - 0.0003(X15) - 0.18(X18)$
97–98H	0.620	0.0001	$-0.01 + 0.99(X1) - 0.76(X2) + 0.58(X3) - 0.39(X4) + 0.34(X5) - 0.15(X10) - 0.09(X12)$
98–99E	0.217	0.0001	$-0.01 + 0.18(X2) + 0.19(X3) + 0.12(X10) - 0.18(X16) - 0.27(X18) + 0.18(X20)$
98–99H	0.212	0.0001	$0.01 + 0.32(X2) + 0.23(X3) - 0.15(X19)$
Growing sheep			
BL100	0.205	0.009	$-0.034 - 0.22(X6) + 0.29(X7) + 0.26(X11) - 0.21(X12) - 0.25(X18)$
SF4	0.113	0.044	$-0.53 + 0.17(X7) - 0.16(X13) - 0.14(X16)$
SF6	0.289	0.0002	$-0.61 - 0.15(X2) - 0.25(X4) - 0.19(X5) - 0.12(X17) + 0.25(X18)$
SF62	0.300	0.0001	$0.32 + 0.19(X1) + 0.17(X8) - 0.26(X14) - 0.11(X18)$
Growing cattle			
L-C1	0.587	0.003	$-1.86 - 0.32(X2) - 0.70(X4) - 0.94(X8) + 0.33(X9) + 0.21(X15)$
L-C2	0.394	0.004	$-0.79 + 0.31(X12) + 0.43(X13)$
L-5S7	0.630	0.004	$-6.79 - 0.38(X2) - 0.25(X3) + 0.32(X10) + 0.66(X13) + 0.80(X16)$
L-5S8	0.352	0.007	$-0.61 + 0.39(X9) - 0.42(X11)$

was a series of peaks of approximately similar size (Table 28.3; examples of spectral density plots are given in Fig. 28.2).

The locations (i.e. lags) of significant autocorrelations are indicated in Table 28.3. Two of the cattle data-sets exhibited no significant autocorrelation. In the other data, significant ACFs were located at lags of between 1 and 17 (more commonly 1 and 7) time periods.

ARIMA modelling

ARIMA models were chosen on the basis of: (i) the best fitting model (i.e. with the highest level of significance); (ii) the smallest residual mean square (RMS); (iii) parsimony; and (iv) the absence of correlated residuals. AR and/or MA models, usually with a seasonal component, best fitted these data (Table 28.4).

The models had limited ability to predict long-term feed intake trajectories. In particular, AR and MA models converged rapidly and while they accurately predicted the mean feed intake, they were of no use in modelling period-to-period variations (Fig. 28.3a). Seasonal models (Fig. 28.3b) gave

Table 28.3. Comparison of evidence for periodicity from three different approaches.

Data-set	Spectral analysis ^a	Multiple regression ^b	Autocorrelation analysis	
			ACF ^c	lag ^d
Growing cattle				
L-C1	2.5, 3.25, 6.75	2, 4, 8 , 9, 15	-0.34	4
L-C2	2.5, 3.25, 4.25 , 5.5, 7	12, 13	-	-
L-5S7	2.25, 3.5, 5, 7	2, 3, 10, 13, 16	-0.38	8
L-5S8	2.5, 3.25, 4.5, 8.5	9, 11	-	-
Pregnant deer				
97-98E	2.25, 3, 3.5, 7	1, 6, 7, 15, 18	0.24	1, 6, 7
97-98H	4.75, 7 , 8.5, 10.25	1, 2, 3, 4, 5, 10, 12	0.66	1, 2, 16
98-99E	2, 2.5, 3, 3.25 , 4, 5.25, 11	2, 3, 10, 16, 18, 20	0.21	2, 3
98-99H	2.25 , 2.5, 3.5, 4, 7, 10, 15.5	2, 3, 19	0.35	2, 3
Growing sheep				
BL100	2.25, 2.75, 3.75 , 8.25, 12.5	6, 7, 11 , 12, 18	-0.24	17
SF4	2.25, 3.25, 3.75, 4.75 , 6.5, 11	7, 13, 16	0.24	1
SF6	2.25, 3.25, 3.5, 3.75 , 4.75, 9.5, 12	2, 4, 5, 17, 18	0.24	1, 5, 6
SF62	4, 4.75, 7, 9.75	1, 8, 14, 18	0.24	1, 5, 6

^aLocations of peaks in the spectral density vs period plots; values in bold indicate the main peaks.

^bVariables (X_i) included in the final regression equations; values in bold indicate variables with significant ($P < 0.05$) regression coefficients.

^cThe value of first significant (i.e. Student's $t > 2$) autocorrelation function (ACF).

^dLocations (i.e. lags) of statistically significant ACF; values in bold indicate the lag of the largest ACF.

better simulations of day-to-day variations, but again their tendency to converge meant that the accuracy of predictions declined after some 7–10 time units. When the model was reinitialized every seven time periods (Fig. 28.4), the simulation accuracy improved, giving deviations between actual and simulated intakes of 3.1 ± 2.36 g DM/kg^{0.75} daily (mean \pm SE). However, this obscures the fact that the maximum and minimum deviations were 410.9% and 5.7% of the corresponding actual intake.

Discussion

The three data-sets allowed three types of feed intake data to be tested. ARIMA models obtained from relatively short data runs (41 days), compared with those from longer runs (131–152 days), suggest that relatively short runs can give acceptable models. Bermejo *et al.* (2003b) similarly obtained useful data from only 25-day observations. It is perhaps surprising

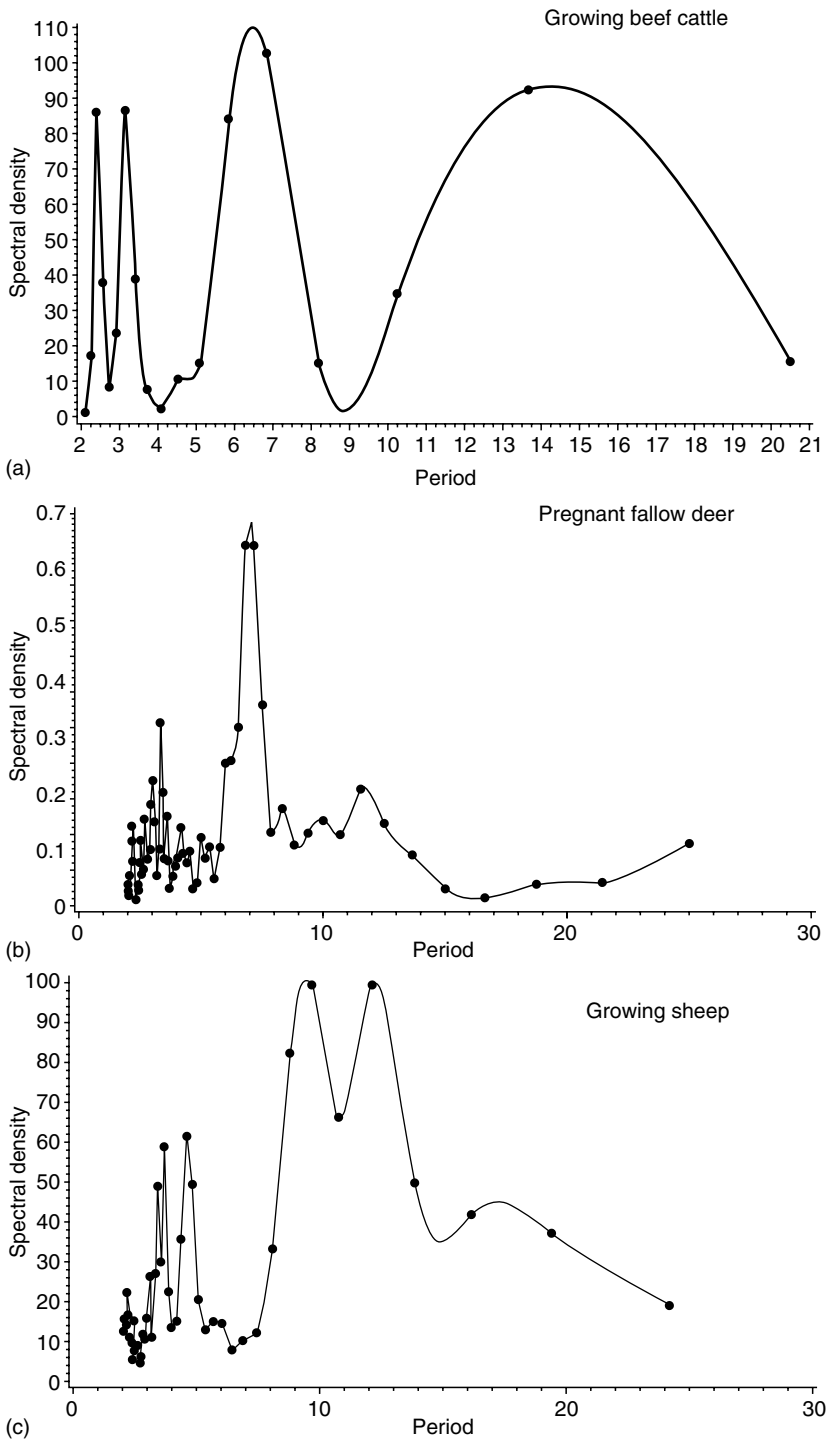

Fig. 28.2. Spectral density vs period plots of daily variations in feed intakes over time.

Table 28.4. Best ARIMA models for the estimation of food intake by growing sheep and cattle, and pregnant deer.

Data-set	Model type	Residual mean square (RMS)	Model			Autocorrelation of residuals to lag 24 ^a
			t	P =	R ²	
Pregnant deer						
97–98E	SAR(7)	0.8000	3.10	0.002	0.105	<i>P</i> > 0.05
97–98H	AR(1)		4.13	0.000		
		0.2247			0.641	<i>P</i> > 0.05
	MA(1)		–35.31	0.000		
98–99E	SMA(2)	0.4901	–2.57	0.011	0.056	<i>P</i> = 0.055
98–99H	SAR(2)	0.3642	4.27	0.000	0.136	<i>P</i> > 0.05
Growing sheep						
BL100	SAR(11)	133.9	3.68	0.000	0.216	<i>P</i> > 0.05
SF4	AR(1)	178.0	2.38	0.020	0.072	<i>P</i> > 0.05
SF6	SAR(6)	139.9	–3.95	0.000	0.187	<i>P</i> > 0.05
SF62	AR(1)	166.6	4.16	0.000	0.160	<i>P</i> > 0.05
Growing cattle						
L-C1	SAR(4)	168.05	–3.60	0.001	0.298	<i>P</i> > 0.05
L-C2	SAR(7)	96.44	–5.35	0.000	0.434	<i>P</i> > 0.05
L-5S7	SAR(8)	165.98	–4.63	0.000	0.436	<i>P</i> = 0.012
L-5S8	SAR(9)	154.87	2.52	0.016	0.324	<i>P</i> > 0.05

^aUsing the Box-Ljung χ^2 test.

that feed intake averaged over several animals (three cattle and five or six deer) gave very similar patterns of day-to-day variation in feed intake to those recorded for individual sheep. If endogenous factors (e.g. digestive tract fill, energy status) that regulate feed intake in animals do not become entrained when animals are kept in groups, they are likely to appear to act 'randomly' when the feed consumptions of individuals in a group of animals are compared. The similarity of feed intake patterns between the individuals and the groups of animals examined in this study suggests that exogenous factors may have important influences on feed intake. These factors could include changes in feed type, the effects of weather, social cues, etc. The management of housed animals may induce a weekly cycle; taking the weekly average of feed intakes, e.g. as in the sheep data, will remove this effect. However, comparison of the sheep data with those from deer and cattle does not offer any evidence that weekly cycles in feed intake occurred with the deer or cattle.

The probes of data structure reported in Table 28.1 suggest that between-time period variations in feed intake are: (i) often, but not always, normally distributed; (ii) generally negatively skewed; and (iii) often clustered so that there are runs of observations on the same side of the mean. Feed intake will

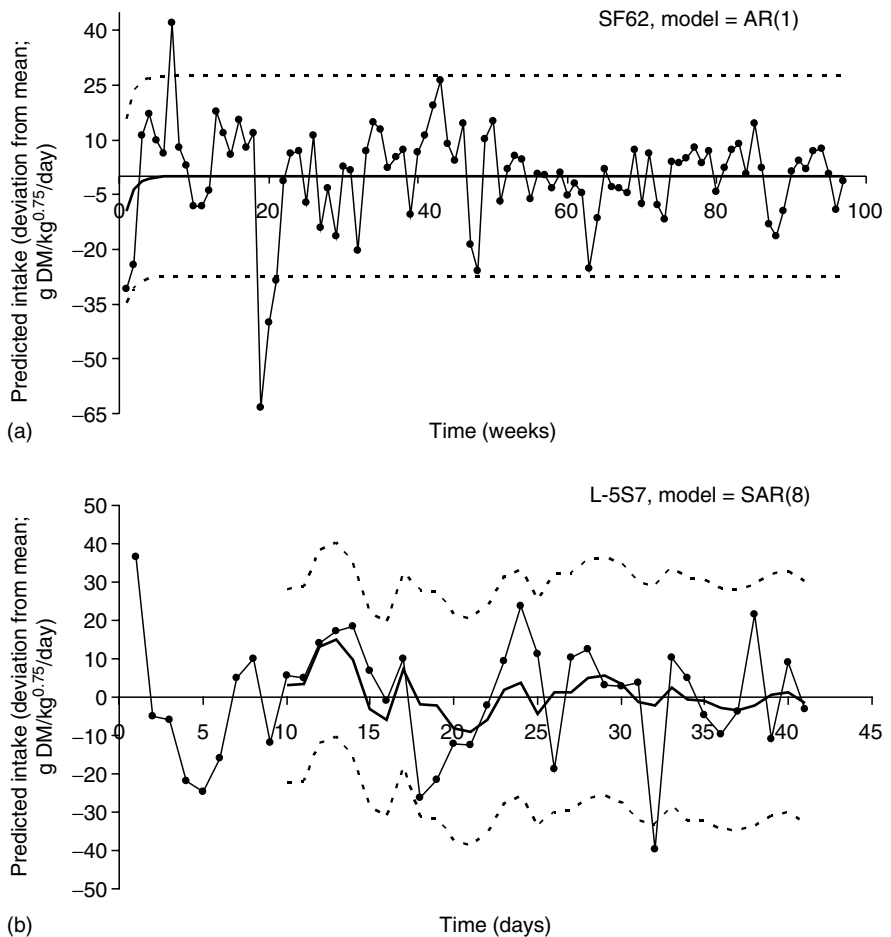

Fig. 28.3. Examples of the ability of ARIMA models to predict period-to-period variation in food intake (●—● original values; — forecast values; ---- upper and lower 95% confidence intervals for the forecasts).

be bounded by zero intake at the minimum and an upper value that is less easily quantified, but that will be a function of the animal's hormonal and neural responses to its energy status/demand, and possibly the capacity of its digestive tract for undigested feed. In practice, feed intakes will approach the upper bound from time to time, but quite large reductions below the mean are common. This suggests that it would be fruitful to identify and quantify the factors that commonly reduce feed intake below expected levels.

ARIMA modelling indicated that AR and/or MA models, usually with a seasonal component, best fitted these data. Similar results were reported by Bermejo *et al.* (2003a,b) for variations in daily feed intake by pigs. These workers found that ARMA(1,1) models adequately described the non-environmental fluctuations in daily feed intake. Taking the simplest general case,

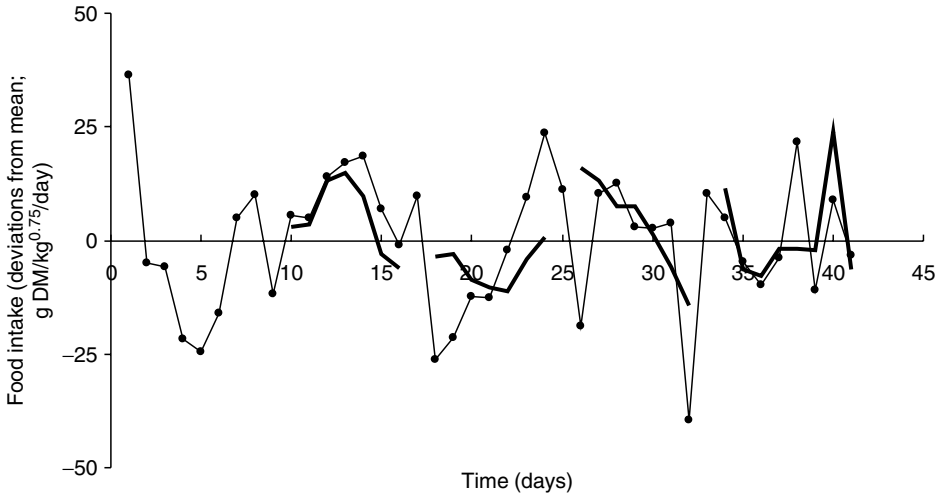

Fig. 28.4. Trajectory of food intake (for data-set L-5S7) simulated by an SAR(8) model, reinitialized every 7 days (●—● actual values; — predicted values).

an AR(1) model (Chatfield, 1996) of feed intake would be described by a relationship between today's intake (X_t), the overall mean intake (μ), a proportion (a) of yesterday's intake (X_{t-1}) and an error term (e_t):

$$X_t = \mu + a(X_{t-1} - \mu) + e_t \quad (28.1)$$

It is possible to expand the error term in equation (28.1) after the manner suggested by Turchin and Ellner (2000) to explicitly identify: (i) a component attributable to whatever relationship exists between intake today (X_t) and intakes in the few days before ($X_{t-1...k}$); (ii) the effects of other endogenous but unmeasured factors that may not be closely related to the effects of previous days' intakes but that also operate to regulate today's intake (U_t); and (iii) unidentified and unmeasured effects (e_t), so that

$$X_t = \mu + [a_1(X_{t-1} - \mu) + \dots + a_k(X_{t-k} - \mu)] + U_t + e_t \quad (28.2)$$

Significant relationships were obtained for most data-sets between previous days' intakes and present intake. Biological explanations for this may involve digestive tract-level factors that affect rumen fill (Faverdin *et al.*, 1995), such as rumen microbial metabolism, capacity of the reticulo-rumen, digestion kinetics and digesta flow kinetics; or behavioural responses to eating indigestible feeds such as more frequent meal-eating and rumination (Baumont *et al.*, 1990). All of these will influence the amount of free space in the digestive tract, and thus the amount of new feed that can be eaten. It might be expected that slower-digesting feeds, such as the lucerne hay fed to

the growing cattle, would give closer relationships between X_t and X_{t-k} than the concentrate-rich, pelleted diets used in the deer and sheep studies. However, there is no convincing evidence that AR models fitted the cattle data better than the deer or sheep data.

The highly significant AR terms in many of these models do not necessarily mean that previous days' intakes per se directly influence present intake. There may be rapid, but indirect, AR effects mediated via the neuroendocrine system. For example, fluctuations in neuropeptide Y concentration in the third ventricle preceded exactly by 24 min episodes of meal-eating by goats (Mogi *et al.*, 2003). Less direct effects, e.g. where leptin acts via the effect of feed intake on the size of adipose tissue (e.g. Vega *et al.*, 2004), will also be modelled as AR effects, although in these cases there may be long lags. This might explain why a succession of daily feed intake variations tends to cluster on the same side of the mean.

Statistical significance of the model components did not necessarily equate with good predictive ability, as is easily seen in Fig. 28.3a. A seasonal component in the model appeared to be necessary to prevent rapid convergence to the mean, and even the seasonal models converged after several time intervals. This convergence is a characteristic of stationary AR models (Cryer, 1986, p. 164). Reinitialization every few time intervals thus appears to be necessary to get a reasonably good simulation of actual day-to-day feed intake.

The U_t term in equation (28.2) may represent shocks or innovations that perturb the expected feed intake trajectory. The sharp changes in trajectory recorded in these data-sets suggest that such shocks occurred. Given the uniform nature of the feeds used in these experiments, they were probably from exogenous sources. It is noticeable that the ARIMA models did not adequately forecast these peaks and troughs of feed intake (Fig. 28.4). Shocks may include social interactions such as bullying or competition for feed, introduction of a new feed type, rapid changes in ambient conditions or method of feeding management. Seasonal ARIMA models can model regular exogenous shocks, but not erratic ones. Threshold models can model the effects of exogenous shocks (Chatfield, 1996), and the timing (r) of the shock can be set to suit the data. The relationships (a) between X_t and X_{t-k} , and the nature of U_t , change as a result of the shock. Such a model is defined as:

$$X_t = \begin{cases} \mu + a_1(X_{t-1} - \mu) + \dots + a_k(X_{t-k} - \mu) + U_t + e_t & \text{where } t < r \\ \mu + a_1^*(X_{t-1} - \mu) + \dots + a_k^*(X_{t-k} - \mu) + U_t^* + e_t & \text{where } t \geq r \end{cases} \quad (28.3)$$

The time periods between the apparent shocks in these data-sets are too short ($r \approx 7$) to be able to fit appropriate threshold models, and the data used in this analysis are not sufficiently rich to identify exogenous reasons for unexpected changes in the direction of the feed intake trajectories.

Although reasonable short forecasts of actual intakes were achieved with some models, the residuals between forecast and actual observations, and the

low estimated model R^2 , suggest that a substantial part of the variation in day-to-day changes in feed intake remains unexplained. The structure of this variation needs to be identified before we can expect to predict daily intake in ruminants with any accuracy. The ARIMA analyses indicated that the residuals were uncorrelated, and in all but the sheep data they were normally distributed. The e_t term in equation (28.2) thus appears to be random. This apparent randomness could be a result of the interaction of an unknown number of deterministic factors, as it seems counter-intuitive that animal metabolism should act in a random fashion.

The nature of the error in these models is crucial, as certain error structures would imply that it is impossible to model short-term food intake. Food intake is subject to deterministic control, but if it is non-linear, the process could be chaotic. This of course means that daily food intake could only be modelled broadly, within certain bounds, as the trajectory would be sensitively dependent on initial conditions. It would almost certainly be impossible to adequately describe these. There are many examples of chaotic systems in biology, e.g. ecological systems, kidney function, disease outbreaks and mammalian enzyme systems (Degn *et al.*, 1987; Perry *et al.*, 2000), but the possibility of a chaotic component to food intake in ruminants does not appear to have been tested.

Conclusions

These results suggest that when models are used to predict short-term variations in food intake, they should be primed by measuring actual intakes over at least 7–10 days so that periodicity can be adequately quantified; that similar intake behaviours are likely to occur together but that intakes that are lower than predicted will occur more often than those that are greater than predicted; and that intakes will additionally fluctuate in an apparently random way.

ARIMA modelling may offer a way of forecasting feed intake in ruminants. The main constraint to its use is a tendency for the model estimates to converge and ultimately to simply give an estimate of the mean intake. In practice, this constraint may be overcome by using ARIMA models for only short-term feed intake forecasts, and to reinitialize the model at short (e.g. 7-day) intervals.

Better understanding of the structure of unexplained error is needed before we can devise completely adequate models of day-to-day intake by ruminants.

Acknowledgements

I thank Alan Lisle for helpful discussions on statistical techniques, and Jason Flesch and John Thompson for providing the deer and sheep data.

References

- Baumont, R., Malbert, C.H. and Ruckebusch, Y. (1990) Mechanical stimulation of rumen fill and alimentary behaviour in sheep. *Animal Production* 50, 123–128.
- Bermejo, J.L., Roehe, R., Rave, G. and Kalm, E. (2003a) Comparison of linear and non-linear functions and covariance structures to estimate feed intake pattern in growing pigs. *Livestock Production Science* 82, 15–26.
- Bermejo, J.L., Roehe, R., Schulze, V., Rave, G., Looft, H. and Kalm, E. (2003b) Random regression to model genetically the longitudinal data of daily feed intake in growing pigs. *Livestock Production Science* 82, 189–199.
- Box, G.E.P. and Jenkins, G.M. (1970) *Time Series Analysis, Forecasting and Control*. Holden-Day, San Francisco, California.
- Chatfield, C. (1996) *The Analysis of Time Series*, 5th edn. Chapman & Hall, London, p. 53.
- Cryer, J.D. (1986) *Time Series Analysis*. Duxbury Press, Boston, Massachusetts.
- Degn, H., Holden, A.V. and Olsen, L.F. (1987) *Chaos in Biological Systems*. Proceedings of a NATO Advanced Research Workshop. Plenum, New York.
- Faverdin, P., Baumont, R. and Ingvartsen, K.L. (1995) Control and prediction of feed intake in ruminants. In: Journet, M., Grenet, E., Farce, M.H., Thériez, M. and Demarquilly, C. (eds) *Recent Developments in the Nutrition of Herbivores*. Proceedings of the IVth International Symposium on the Nutrition of Herbivores. INRA Editions, Paris, pp. 95–120.
- Miller, D.W., Findlay, P.A., Morrison, M.A., Raver, N. and Adam, C.L. (2002) Seasonal and dose-dependent effects of intracerebroventricular leptin on LH secretion and appetite in sheep. *Journal of Endocrinology* 175, 395–404.
- Minitab (2000) *Minitab Version 13.1*. Minitab, State College, Pennsylvania.
- Mogi, K., Yonezawa, T., Chen, D.-S., Li, J.-Y., Sawasaki, T. and Nishihara, M. (2003) Correlation between spontaneous feeding behavior and neuropeptide Y profile in the third ventricular cerebrospinal fluid of goats. *Domestic Animal Endocrinology* 25, 175–182.
- Oltjen, J.W. and Owens, F.N. (1987) Beef cattle feed intake and growth: empirical Bayes derivation of the Kalman filter applied to a nonlinear dynamic model. *Journal of Animal Science* 65, 1362–1370.
- Perry, J.N., Smith, R.H., Wolwod, I.P. and Morse, D.R. (2000) *Chaos in Real Data*. Kluwer Academic Publishers, Dordrecht, The Netherlands.
- Pittroff, W. and Kothmann, M.M. (2001a) Quantitative prediction of feed intake in ruminants: I. Conceptual and mathematical analysis of models for sheep. *Livestock Production Science* 71, 131–150.
- Pittroff, W. and Kothmann, M.M. (2001b) Quantitative prediction of feed intake in ruminants: II. Conceptual and mathematical analysis of models for cattle. *Livestock Production Science* 71, 151–169.
- Pittroff, W. and Kothmann, M.M. (2001c) Quantitative prediction of feed intake in ruminants: III. Comparative example calculations and discussion. *Livestock Production Science* 71, 171–181.
- SAS (2000) SAS/ETS Guide. *SAS OnlineDoc®*, Version 8. SAS Institute, Cary, North Carolina.
- Vega, R.A., Hidari, H., Matsunaga, N., Kuwayama, H., Manal, D.D., Lee, H.G. and Hata, H. (2004) Plasma leptin and performance of purebred and backcrossed Hereford throughout grazing and feedlot fattening. *Asian-Australasian Journal of Animal Science* 17, 954–959.

29 An Ingredient-based Input Scheme for Molly

M.D. HANIGAN,¹ H.G. BATEMAN,² J.G. FADEL,³
J.P. MCNAMARA⁴ AND N.E. SMITH¹

¹Longview Nutrition Center, Land O' Lakes, 100 Danforth Dr. Gray Summit, MO 63039, USA; ²Department of Dairy Science, LSU Ag Center, Baton Rouge, LA 70803, USA; ³Department of Animal Science, University of California, Davis, CA 95616, USA; ⁴Department of Animal Sciences, Washington State University, Pullman, WA 99165, USA

Abstract

The model described by Baldwin and co-workers (Baldwin *et al.*, 1987; Baldwin, 1995) known as Molly utilizes a nutrient-based input scheme, where each nutrient is generally treated as a homogeneous substrate regardless of the source of that nutrient. The exception is a limited, discrete accommodation for fibre derived from grass versus legume. There are several limitations to such an input scheme: (i) failure to consider unique aspects of the varying input ingredients may result in prediction errors to the extent that the sum of individual ingredients deviate in character from the homogeneous nutrient assumed in the model; (ii) ingredient inputs are not specified and thus cannot be optimized directly; and (iii) it is rare to find a full listing of nutrient profiles in the published literature. Therefore, evaluations of model accuracy require reconstruction of the dietary nutrients from ingredients using other sources such as the National Research Council (NRC, 2001) as an approximation of the original ingredients. At the same time, an automated scheme for switching diet and animal inputs was needed to ensure data integrity of inputs and to allow consideration of varying animal and diet inputs when simulating multiple animals within and across experiments. The latter is required for parameter estimation. To address these issues, an input scheme was devised and incorporated into Molly that allowed ingredient-based diet specifications by an experimental unit with the ability to change diets within a run and across runs based on pre-specified criteria. The scheme utilized NRC ingredient values to generate the needed nutrient inputs for the model. Subsequent to these changes a large data-set was assembled from the literature and used to test the model. Prediction errors for most digestive parameters were found to be greater than 20% of the observed mean values. In most cases, mean bias was the major contributing factor to the prediction errors suggesting that reparameterization of the model was needed. However, in some cases, significant slope bias was observed suggesting that there may be some underlying model structure problems.

Introduction

Current requirement models for dairy cattle generally utilize a static set of tabular inputs and presume that no input interactions occur. For the most part, input and requirement calculations are not complex. This lack of complexity is due in part to the need to use the models in a linear, least-cost formulation environment. Models such as that of Baldwin and co-workers (Baldwin *et al.*, 1987; Baldwin, 1995) and the latest NRC (2001) contain non-linear elements. Inclusion of such elements was based on biological observations and thus these models likely reflect the future of ration balancing. In particular, the post-absorptive elements of the Baldwin model represent much more biological detail than other models currently in use offering the possibility of predicting nutrient partitioning.

A limitation of the Baldwin model is that inputs are chemical specifications of the entire diet rather than ingredients. Such an input scheme limits the amount of ingredient-specific information that can be included in ration descriptions and passed to the model. Additionally, economic values must be assigned to each nutrient if an optimizer is to be used to solve for least-cost input formulations. Having derived the optimum nutrient profile, one must then derive a least-cost ingredient formula to deliver those nutrients utilizing another optimization. Such an approach can approximate the optimum solution, but would not guarantee such an outcome.

The Baldwin model makes limited accommodation for ingredient-specific information, e.g. varying fibre rates for grass versus legume. However, it does not currently have a mechanism for considering intrinsic rates of protein degradation specific to each ingredient of the diet. Rates of ruminal degradation have been determined for a wide range of ingredients. These have recently been summarized by NRC (2001). A scheme to relate the rate parameter for protein degradation in the Baldwin model to *in sacco* observations has not been described. The assumption implicit in this scheme is that *in sacco* measures of protein degradation are representative of *in vivo* rates. Other *in vitro* measures of protein degradation (e.g. enzymatic) could also be used provided they are representative of *in vivo* rates.

Another current limitation to the Baldwin model is the difficulty in simulating multiple rations within a run as well as multiple observations in a data-set. In order to conduct parameter estimation using multiple observations, the code must be able to automatically consider inputs unique to each observation and allow for input changes within a run.

Finally, Baldwin (1995) initialized the various body pools based on empty body weight (EBW), a required input. As this input is normally not known for lactating cows, an estimate based on live BW was required. When using such an approach, the summation of the estimated individual body components plus gut contents would often not equal the initial observed BW resulting in a prediction bias for all subsequent observations of BW for that animal or group of animals.

The objectives of this work are to modify the model of Baldwin (1995): (i) to allow ingredient-based inputs; (ii) to accommodate input changes

within a run; (iii) to allow preloading of data from multiple animals; and (iv) to alleviate problems in specifying initial body components.

Model Description

The base model used was that of Baldwin (1995) with the following modifications.

Initial body composition

As few studies measure EBW while measures of live BW are commonly made, the model was modified to allow calculation of initial EBW ($iEBW$; kg) based on initial BW (iBW ; kg) as specified by the user:

$$iEBW = iBW - iRumVol - iOthGutCont \quad (29.1)$$

where $iRumVol$ and $iOthGutCont$ represented initial rumen volume (kg) and initial lower gut contents (kg) respectively.

Examination of the relationship between BW and rumen contents using the data of Gibb *et al.* (1992; source data kindly provided by the authors) indicated that the relationship was non-significant with a trend for a negative correlation. Adding dry matter intake (DMI) to the regression slightly improved the prediction but did not result in a significant relationship ($Y = 98.8 - 0.13 BW + 2.18 DMI$, $P > 0.11$, where units for BW and DMI were kg and kg/day respectively). Consideration of additional data suggested a positive relationship between DMI and rumen volume (Shaver *et al.*, 1985; Woodford and Murphy, 1988; Johnson and Combs, 1991) although the relationship was still not significant. Offering other inputs as independent variables did not improve the relationship, and there were no indications of non-linearity within the range of available data. Given this uncertainty it was decided to calculate $iRumVol$ from initial DMI ($iDMI$; kg/day) maintaining the coefficient of 4.4 as derived from the relationship between DMI and $iRumVol$ in the original description of the model (Baldwin, 1995):

$$iRumVol = 4.4 \times iDMI \quad (29.2)$$

As $iRumVol$ represents approximately 10% of the initial BW, errors of prediction for $iRumVol$ could result in significant errors in predicting $iEBW$ underscoring the need for a better prediction equation for rumen volume.

From the literature, rumen DM content averaged 14.7% (Shaver *et al.* 1985; Woodford and Murphy 1988; Johnson and Combs 1991; Gibb *et al.*, 1992).

$$iRumDM = 0.147 \times iRumVol \quad (29.3)$$

Chilliard *et al.* (1991) and Gibb *et al.* (1992) observed that lower gut contents ($OthGutCont$; kg) were approximately equal to DMI and thus equated to such:

$$iOthGutCont = iDMI \quad (29.4)$$

These changes resolved the BW specification problem.

The final change undertaken is related to the calculation of the initial pool size for body fat. Again, depending on stage of lactation, body fat mass can vary dramatically. Waltner *et al.* (1994) described the relationship between body condition score (BCS), BW and body fat mass. As BCS is often collected, it was added as a required input and used to calculate initial fat mass ($iWtAdip$; kg) based on the equation of Waltner *et al.* (1994):

$$iWtAdip = (0.21 \times iBW) + (36 \times iBCS) - 122.1 \quad (29.5)$$

Equation (29.5) should allow for more accurate predictions of initial fat-free body mass, which is used for calculating visceral and carcass fat-free mass. Visceral and carcass fat-free mass are used in a number of other calculations throughout the model. As equation (29.5) could assume negative values at very low BCS and BW, the user must exercise caution with inputs. By definition, BCS can range to a low of 1. At a BCS of 1, $iWtAdip$ would assume a negative value at a BW of 410 kg. Normally BCS would not range below 2 for productive animals, which would result in negative $iWtAdip$ at a BW of 238 kg, a weight not likely to be observed for present dairy breeds.

Animal inputs, event control and nutrient inputs

The original nutrient-based input scheme was modified in the following manner. For purposes of discussion, animal will refer to the observational unit to be simulated, i.e. animal, treatment mean, etc. Similarly, rations will be referred to as an event. The latter allows an event to include not only ration information but also environmental or management information.

To achieve the objectives, four two-dimensional arrays were required (scheme depicted in Fig. 29.1):

1. The first array held the animal input data [$InitCond(c,a)$] including iBW , $iBCS$, the column position of the first event for that animal, and the number of events for that animal where dimensions c and a represented the number of input conditions (5) specific to each animal and the maximum number of animals (100) respectively.
2. The second array [$EventCriteria(cr,e)$] held the criteria for executing each event where dimensions cr and e represented the number of criteria statement components (5) and the maximum number of rations or events (1000) respectively.
3. The third array [$IngrInclusion(i,e)$] held the ingredient inclusion rates for each event where dimension i represented the maximum number of ingredients (150).
4. The fourth array [$IngrComp(n,i)$] held the ingredient composition data where the dimension n represented the maximum number of ingredient attributes (15). Ingredient attributes generally were proximate nutrients

although cost was also considered. Input nutrients included in the array are listed in Table 29.1.

Values for e , i and n were determined based on the size of available data-sets to be used for parameter estimation and model testing but were defined as type parameter and thus could easily be changed.

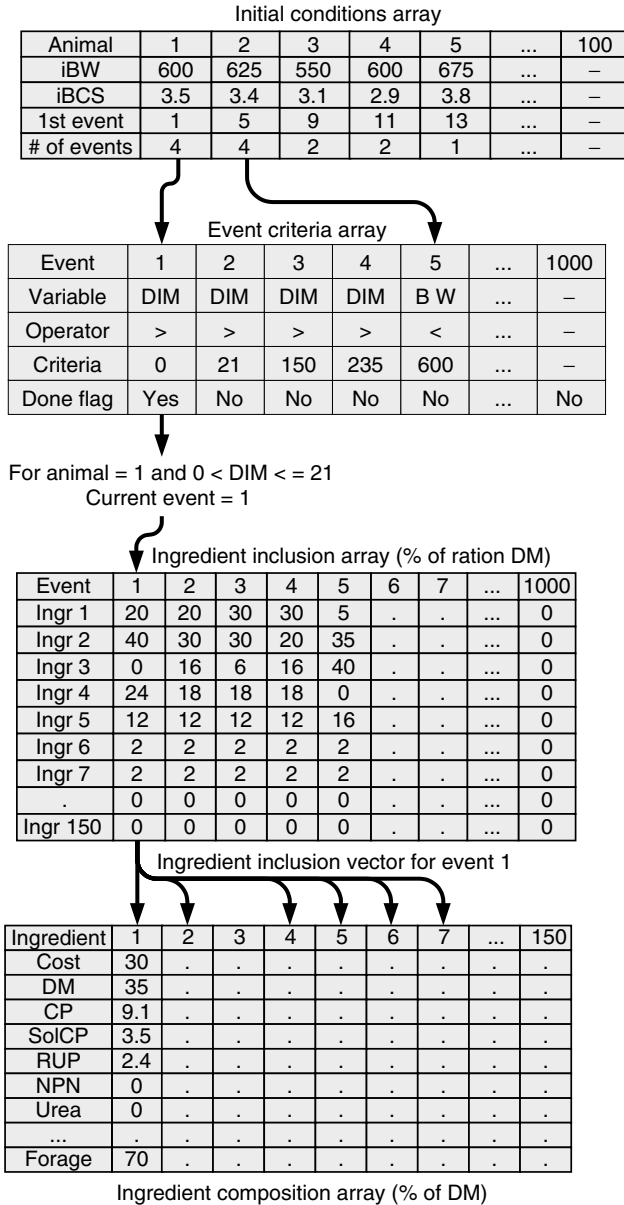

Fig. 29.1. Input scheme used to allow ingredient-based inputs and event switching within and between runs. Some example numbers are included.

Table 29.1. Ingredient attributes held in the IngrComp array and used as input to the model. Units were all expressed on a dry matter (DM) basis.

Description	Abbreviation	IngrComp position
Cost (\$/t)	Cost	1
DM (%)	$f_{DM,Fd}$	2
CP (%)	$f_{CP,Fd}$	3
Soluble protein (%)	$f_{SolCP,Fd}$	4
RUP (%)	$f_{RUP,Fd}$	5
NPN (%)	$f_{NPN,Fd}$	6
Urea (%)	$f_{Urea,Fd}$	7
Fat (%)	$f_{EE,Fd}$	8
Soluble starch (%)	$f_{SolSt,Fd}$	9
Starch (%)	$f_{St,Fd}$	10
ADF (%)	$f_{ADF,Fd}$	11
NDF (%)	$f_{NDF,Fd}$	12
Lignin (%)	$f_{Lg,Fd}$	13
Ash (%)	$f_{Ash,Fd}$	14
Forage (%)	$f_{For,Fd}$	15

CP = crude protein; RUP = ruminally undegraded protein; NPN = non-protein nitrogen; ADF = acid detergent fibre; NDF = neutral detergent fibre.

An input variable, *iAnimal*, was defined for use as a pointer for the InitCond array and the code related to cow inputs was modified to derive inputs from the array in the following manner:

$$iBW = \text{InitCond} (2, iAnimal) \tag{29.6}$$

$$iBCS = \text{InitCond} (3, iAnimal) \tag{29.7}$$

$$\text{FirstEvent} = \text{InitCond} (4, iAnimal) \tag{29.8}$$

$$\text{NumberEvents} = \text{InitCond} (5, iAnimal) \tag{29.9}$$

$$\text{LastEvent} = \text{FirstEvent} + \text{NumberEvents} - 1 \tag{29.10}$$

where FirstEvent represents the row position for the first event for *iAnimal* and NumberEvents represents the number of event rows for *iAnimal*. In this manner, specification of *iAnimal* by the user results in the appropriate loading of inputs specific to that animal.

The EventCriteria array was then used to determine the event for dietary inputs to the model at any given time during a model run. This was achieved by comparing the criteria from the EventCriteria array to current model variables during a run and changing an array pointer (CurrentEvent) when the criterion for the next event was met. CurrentEvent was initialized to FirstEvent and altered within a loop that compared the criteria for each event in the range CurrentEvent + 1 to LastEvent. When the criterion for any of those events was met, CurrentEvent was set to the row number for that event. Event flow was restricted to events with numbers greater than CurrentEvent using a flag to denote event status (already executed or not yet executed).

The value of CurrentEvent specified the current row vector in IngrInclusion, which was used for summation of IngrComp nutrients within a loop. The summed proximate nutrients expressed as kg/kg of DM were then used as a replacement for the static inputs originally defined by Baldwin (1995). As can be observed from Table 29.1, some conversion of proximate nutrients to inputs was required to maintain consistency with the original nutrient input scheme. Conversions were as follows.

Added dietary fat ($f_{\text{Fat,Fd}}$) was defined as:

$$f_{\text{Fat,Fd}} = f_{\text{EE,Fd}} - f_{\text{Li,Fd}} \quad (29.11)$$

where $f_{\text{EE,Fd}}$ represented ether extract and $f_{\text{Li,Fd}}$ represented the basal level of lipid found in plant material other than oilseeds and was assumed to be 0.0275 kg/kg DM. Soluble protein ($f_{\text{Ps,Fd}}$) was defined as:

$$f_{\text{Ps,Fd}} = f_{\text{SolCP,Fd}} - f_{\text{NPN,Fd}} \quad (29.12)$$

where $f_{\text{SolCP,Fd}}$ and $f_{\text{NPN,Fd}}$ represented soluble crude protein (CP) and non-protein nitrogen (NPN) respectively, both expressed in CP units. Nitrogen from urea ($f_{\text{Urea,Fd}}$) and other NPN ($f_{\text{Nn,Fd}}$) sources was handled separately in the model, and thus $f_{\text{Nn,Fd}}$ was defined as:

$$f_{\text{Nn,Fd}} = \frac{f_{\text{NPN,Fd}} - 2.92f_{\text{Urea,Fd}}}{6.25} \quad (29.13)$$

where the coefficient 2.92 represents the CP content of urea. Insoluble protein ($f_{\text{Pi,Fd}}$) was then defined as:

$$f_{\text{Pi,Fd}} = f_{\text{CP,Fd}} - f_{\text{SolCP,Fd}} \quad (29.14)$$

where $f_{\text{CP,Fd}}$ and $f_{\text{SolCP,Fd}}$ represented the CP and soluble CP contents respectively. Insoluble ash ($f_{\text{Ai,Fd}}$) was assumed to be a constant 0.012 kg/kg DM based on observations of acid detergent fibre (ADF) ash values for a variety of feedstuffs (data not presented). Soluble ash ($f_{\text{As,Fd}}$) was calculated by difference from total ash ($f_{\text{Ash,Fd}}$):

$$f_{\text{As,Fd}} = f_{\text{Ash,Fd}} - f_{\text{Ai,Fd}} \quad (29.15)$$

Hemicellulose ($f_{\text{Hc,Fd}}$) and cellulose ($f_{\text{Ce,Fd}}$) were calculated as:

$$f_{\text{Hc,Fd}} = f_{\text{NDF,Fd}} - f_{\text{ADF,Fd}} \quad (29.16)$$

$$f_{\text{Ce,Fd}} = f_{\text{ADF,Fd}} - f_{\text{Lg,Fd}} - f_{\text{Ai,Fd}} \quad (29.17)$$

where $f_{\text{Lg,Fd}}$ represented the fraction of lignin (kg/kg DM) and $f_{\text{NDF,Fd}}$ and $f_{\text{ADF,Fd}}$ represented the fractions of neutral detergent fibre (NDF) and ADF respectively.

In order to ensure unity of nutrient components, the following calculations were performed. The non-starch fraction ($f_{\text{NonSt,Fd}}$) was calculated as:

$$f_{\text{NonSt,Fd}} = f_{\text{Urea,Fd}} + f_{\text{Ps,Fd}} + f_{\text{Pi,Fd}} + f_{\text{Nn,Fd}} + f_{\text{Ac,Fd}} + f_{\text{La,Fd}} + f_{\text{Bu,Fd}} + f_{\text{Pe,Fd}} + f_{\text{Oa,Fd}} \\ + f_{\text{Hc,Fd}} + f_{\text{Ce,Fd}} + f_{\text{Lg,Fd}} + f_{\text{Li,Fd}} + f_{\text{Fat,Fd}} + f_{\text{As,Fd}} + f_{\text{Ai,Fd}} \quad (29.18)$$

where $f_{Ac,Fd}$, $f_{La,Fd}$, $f_{Bu,Fd}$, $f_{Pe,Fd}$ and $f_{Oa,Fd}$ were the fractions of feed DM represented by acetate, lactate, butyrate, pectin and other organic acids, respectively, as originally described by Baldwin *et al.* (1987). These are still required inputs for each feed although acetate, lactate and butyrate can be assumed to be zero for feeds not ensiled. As pectin and organic acids were not available, they were assumed to represent constant fixed proportions of 0.04 and 0.008 of feed DM. If desired, these nutrients could be added to IngrComp by simply expanding the array.

The sum $1 - f_{NonSt,Fd}$ should be equivalent to $f_{St,Fd}$ if all components are measured or assumed without error. As this is rarely the case, any difference between $f_{NonSt,Fd}$ and $f_{St,Fd}$ was used to adjust $f_{St,Fd}$ to ensure that feed nutrients always summed to 1.

Although degradation rates for individual diets can be treated as inputs to the model (Bannink and De Visser, 1997), such an approach requires a suitable evaluation of the total diet. For this formulation, it was desired to derive degradation rates for the total diet from individual ingredient values. Such a representation allows the use of ingredient information such as that summarized by NRC (2001). However, the NRC degradation rates were determined using a three-pool model, and they are not additive when applied to individual ingredients within a total ration. The Baldwin model uses a two-pool protein scheme with soluble and insoluble pools. Thus the NRC (2001) data must be converted. This was accomplished in the following manner. The A fraction (buffer-soluble nitrogen) of NRC was assumed equivalent to $f_{SolCP,Fd}$ and the B (buffer-insoluble but potentially degradable) and C fractions (buffer-insoluble and undegradable in the rumen) were assumed equivalent to $f_{Pi,Fd}$. A ruminal residence time (t ; h) was assumed and used to calculate a three-pool ruminally undegradable protein (RUP) value ($f_{RUP,Fd(3-pool)}$) from NRC values for each ingredient:

$$f_{RUP,Fd(3-pool)} = f_{CP,B} \times e^{(-k_d \times t)} + f_{CP,C} \quad (29.19)$$

where $f_{CP,B}$ and $f_{CP,C}$ refer to the B and C fractions (kg/kg DM) and k_d represents the rate of degradation (/h) for the B fraction. Equation (29.19) was applied to all ingredients using $t = 8$ h for non-forage ingredients and $t = 18$ h for forages. The resulting RUP values were then used as model input ($f_{RUP,Fd}$). In performing this transformation, the choice of a ruminal residence time (t) is not highly critical although it should approximate the average time for a class of ingredients (forages or concentrates). Where the C fraction is relatively large, use of an assumed residence time in the transformation that is much less than the expected *in vivo* state would not generate significant errors, but use of a residence time that was much greater than the *in vivo* state would result in significant errors of prediction. Where the C fraction is small, the choice of residence time has little bearing (Fig. 29.2).

Calculation of $f_{RUP,Fd}$ in the above manner linearizes the problem, allowing summation across ingredients within a diet. The resulting diet summation for $f_{RUP,Fd}$ was used to calculate a rate constant for application within the model:

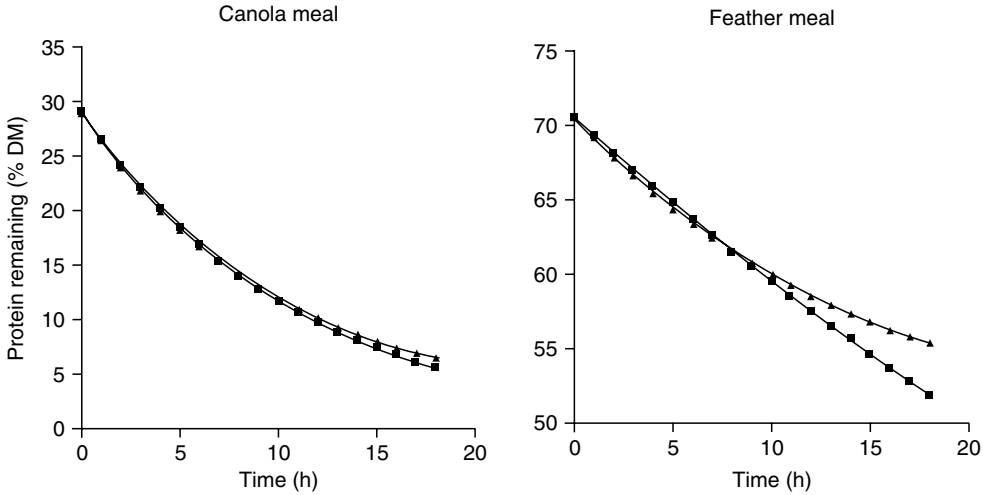

Fig. 29.2. Predicted protein degradation curves for canola and feather meal using a two-pool (■) or three-pool (▲) model.

$$k_{\text{PiAa}} = \frac{24}{8} \times -\ln \left(f_{\text{RUP, FD (3-pool)}} / f_{\text{Pi, FD}} \right) \quad (29.20)$$

where $f_{\text{RUP, FD (3-Pool)}}$ had units of kg/kg DM and k_{PiAa} (/day) represented the model variable for fractional degradation rate of insoluble protein. A constant ruminal residence time of 8 h was assumed. The rate estimate was multiplied by 24 h to maintain unit consistency with the model. Replacement of the static protein degradation rate in the original representation with that calculated from equation (29.20) accommodates degradation rate changes in association with diet changes. This approach circumvents the problem with attempting to sum non-linear rate constants. A similar scheme could be applied to fibre and starch degradation if ruminal degradation rates were known.

RUP estimates from three- or two-pool models are identical at time (t ; Fig. 29.2). Additionally, little deviation exists between model estimates within normal *in vivo* ruminal residence times (4–12 h) provided the value used for t approximates a value near the centre of the *in vivo* range.

Input code changes were validated using a standard reference ration containing ten ingredients with ingredient composition from NRC (2001). Inclusion rates were assumed and used to calculate diet composition in an Excel spreadsheet. The same ingredients and inclusion rates were then applied to the model and the calculated diet composition from the model was compared to that from the spreadsheet.

Model Evaluation

To test the model, a data-set was constructed from the literature. Studies were used if dietary ingredient inclusion rates, DMI and some digestive

measurements were reported. The 62 studies that were used for the analyses are listed in Table 29.2. A summary of the data from those studies is provided in Table 29.3. Where dietary ingredients could not be cross-referenced to NRC (2001) ingredients, treatments were excluded resulting in 233 treatment mean observations. Where BW was missing, an assumed weight of 600 kg was used; BCS was assumed to be 3.4 for all studies. Neither assumption had a significant effect on digestive parameters.

Ingredient composition was reported for some ingredients, but there were no cases where all the ingredients were analysed for the full array of nutrients required as input. Where nutrient information was missing, the data of NRC (2001) were used. Starch and soluble carbohydrate were not included in the NRC database and thus were estimated as 80% and 20% respectively of non-structural carbohydrate.

Table 29.2. Publications used to construct the test data-set.

Reference	Number of treatments	Reference	Number of treatments
Aldrich <i>et al.</i> (1993)	4	Merchen and Satter (1983)	4
Armentano <i>et al.</i> (1986)	3	Murphy <i>et al.</i> (1987)	3
Blauwiel <i>et al.</i> (1997)	4	Narasimhalu <i>et al.</i> (1989)	2
Calsamiglia <i>et al.</i> (1995)	2	Ohajuruka <i>et al.</i> (1991)	5
Cameron <i>et al.</i> (1991)	4	Oliveira <i>et al.</i> (1995)	4
Chan <i>et al.</i> (1997)	4	O'Mara <i>et al.</i> (1997)	1
Christensen <i>et al.</i> (1993)	4	Overton <i>et al.</i> (1995)	5
Christensen <i>et al.</i> (1996)	4	Pantoja <i>et al.</i> (1994)	6
Cunningham <i>et al.</i> (1994)	4	Pantoja <i>et al.</i> (1995)	4
Cunningham <i>et al.</i> (1996)	5	Pena <i>et al.</i> (1986)	1
Doreau <i>et al.</i> (1991)	4	Pires <i>et al.</i> (1997)	5
Erasmus <i>et al.</i> (1994)	4	Poore <i>et al.</i> (1993)	4
Espindola <i>et al.</i> (1997)	3	Prange <i>et al.</i> (1984)	2
Feng <i>et al.</i> (1993)	4	Price <i>et al.</i> (1988)	2
Gomez-Alarcon <i>et al.</i> (1990)	6	Putnam <i>et al.</i> (1997)	4
Herrera-Saldana <i>et al.</i> (1990)	4	Robinson and Sniffen (1985)	3
Holden <i>et al.</i> (1994)	4	Robinson <i>et al.</i> (1997)	2
Horner <i>et al.</i> (1988)	4	Santos <i>et al.</i> (1984)	4
Joy <i>et al.</i> (1997)	3	Sarwar <i>et al.</i> (1991)	5
Kalscheur <i>et al.</i> (1997a)	4	Schwab <i>et al.</i> (1992a)	4
Kalscheur <i>et al.</i> (1997b)	4	Schwab <i>et al.</i> (1992b)	4
King <i>et al.</i> (1990)	3	Seymour <i>et al.</i> (1992)	2
Klasmeyer <i>et al.</i> (1990)	4	Song and Kennelly (1989)	3
Klasmeyer <i>et al.</i> (1991)	8	Stokes <i>et al.</i> (1991)	3
Kung <i>et al.</i> (1983)	4	Tice <i>et al.</i> (1993)	5
Lu <i>et al.</i> (1988)	2	Waltz <i>et al.</i> (1989)	4
Lykos <i>et al.</i> (1997)	3	Windschitl and Stern (1988)	4
Lynch <i>et al.</i> (1991)	4	Yang <i>et al.</i> (1997)	3
Mabjeesh <i>et al.</i> (1997)	4	Yoon and Stern (1996)	4
Mansfield and Stern (1994)	4	Zerbini <i>et al.</i> (1988)	4
McCarthy <i>et al.</i> (1989)	4	Zhu <i>et al.</i> (1997)	4

Table 29.3. Statistical summary of the test data-set. There were 233 possible observations in the data-set.

Variable	N	Mean	SD	Minimum	Maximum
DMI (kg/day)	233	18.6	4.1	5.8	26.8
BW (kg)	187	590	51	480	731
DIM	131	103	57	16	213
Milk (kg/day)	188	26.6	7.6	0	43.2
Milk lactose (%)	30	4.80	0.12	4.54	4.98
Milk protein (%)	163	3.13	0.28	2.59	3.90
Milk fat (%)	163	3.37	0.43	2.19	4.63
Nutrient composition of the total diet (% of DM)					
DM	139	67.1	1.4	15.7	93.0
OM	204	92.5	1.7	85.4	96.9
CP	233	16.7	1.8	10.3	22.2
NDF	187	33.6	5.4	17.6	49.8
ADF	192	19.6	4.0	8.8	30.6
Starch	101	33.0	7.9	13.7	47.9
Fat	76	5.6	2.9	2.1	20.2
Ruminal pH and ammonia and VFA concentrations					
pH	181	6.1	0.3	5.5	6.7
Ammonia (mmol/l)	173	8.8	3.6	1.0	23.0
VFA (mmol/l)	180	106	21	11	148
Acetate (% of VFA)	177	61.6	4.3	52.1	74.9
Propionate (% of VFA)	177	23.0	3.9	15.3	33.0
Butyrate (% of VFA)	177	11.8	1.5	8.1	16.9
True ruminal digestion (% of intake)					
DM	32	47.3	8.2	27.0	59.0
OM	201	52.2	9.5	29.3	83.4
N	227	56.6	13.2	14.6	85.5
ADF	129	38.9	12.6	6.2	72.4
NDF	152	42.8	12.8	3.0	71.2
Starch	92	59.7	15.4	27.3	87.4
Fat	24	7.9	10.6	-17.0	25.0
Duodenal flow (kg/day)					
DM	57	11.9	3.7	3.5	21.3
OM	181	11.3	3.2	2.8	18.3
ADF	120	2.3	0.8	0.4	4.8
NDF	155	3.7	1.2	0.7	6.8
Starch	84	2.9	1.4	0.5	5.9
Fat	23	0.9	0.1	0.0	1.6
N (g/day)	214	501	139	154	930
Microbial N (g/day)	233	256	82	87	493
NANMN (g/day)	227	219	88	34	433

Table 29.3. (cont'd).

Variable	N	Mean	SD	Minimum	Maximum
Total tract digestibilities (% of intake)					
DM	101	66.3	4.3	48.2	77.9
OM	183	68.2	4.4	49.4	81.4
N	193	68.6	12.4	40.3	155.0
ADF	115	42.7	9.7	18.0	72.1
NDF	137	49.2	10.7	25.1	82.9
Starch	77	92.7	5.7	77.4	99.3
Fat	41	69.8	9.3	40.2	89.9

DMI = dry matter intake; BW = body weight; DIM = days in milk; OM = organic matter; CP = crude protein; NDF = neutral detergent fibre; ADF = acid detergent fibre; VFA = volatile fatty acid; N = nitrogen; NANMN = non-ammonia non-microbial nitrogen.

Simulations were run using ACSL Optimize (Version 2.5.4, Aegis Technologies Group, Huntsville, AL 35806, USA). Residual analyses were conducted as previously described (Roseler *et al.*, 1997) using the matrix scripting language available within ACSL Optimize. No statistical adjustments were made for laboratory effects or variable numbers of animals per treatment.

Results and discussion

As the composition of many ingredients was predicted from tabular NRC values, predictions of dietary nutrient content as calculated from individual ingredients were compared to those reported for the total diet (Table 29.4). Errors ranged from a low of 2.2% for organic matter (OM) to a high of 50% for fat with very little mean bias. Some slope bias was present, but the majority of prediction error was random as could be expected when using static tabular values to represent a population sample. Based on these results, model predictions resulting from the use of these dietary inputs can be expected to have no mean bias.

Prediction errors for ruminal and total tract measurements are summarized in Table 29.5. Prediction errors for ruminal pH and the molar proportion of acetate were relatively small, while errors for the proportion of butyrate were intermediate and errors for volatile fatty acid (VFA) concentration, ammonia concentration and the proportion of propionate were relatively large. Ruminal pH was predicted with insignificant mean and slope bias. A large proportion of the prediction errors for the VFA was associated with mean bias error while a major proportion of the prediction error for ruminal ammonia was associated with slope bias. The latter is a possible indication of a model structure problem. Others have previously reported similar errors for VFA predictions (Kohn *et al.*, 1994; Bannink *et al.*, 1997;

Table 29.4. Prediction errors for dietary inputs when missing nutrient data for ingredients was supplemented with NRC (2001) nutrient data. Root mean squared prediction errors (RMSPE) were expressed as a percentage of the mean observed values. Bias, slope and dispersion errors were expressed as a percentage of the mean squared prediction error (MSPE).

Variable (% of DM)	<i>N</i>	Mean observed	Mean predicted	RMSPE (%)	MSPE _{Bias} (%)	MSPE _{Slope} (%)	MSPE _{Dispersion} (%)
OM	204	92.5	92.8	2.3	3.1	36.5	60.4
CP	233	16.7	16.8	13.5	0.0	45.1	54.9
NDF	187	33.7	31.8	17.0	10.3	19.8	69.9
ADF	192	19.7	20.4	23.5	2.4	30.3	67.4
Starch	101	33.0	34.5	22.9	3.4	4.2	92.3
Fat	76	5.58	5.26	49.9	1.3	7.3	91.4

OM = organic matter; CP = crude protein; NDF = neutral detergent fibre; ADF = acid detergent fibre.

Hanigan *et al.*, 2002) using independent data-sets. Although VFA concentrations are predicted with poor accuracy and precision, it is not clear whether the problem stems from inaccurate prediction of production rates or absorption rates. If the problem is with VFA production, post-absorptive metabolism may be poorly predicted, as the VFAs represent a major part of the total energy supply to the animal. Given the mean bias in total VFA concentration predictions and the dependence of pH predictions on VFA concentration, it is surprising that pH was predicted without mean bias.

Kohn *et al.* (1994) also reported a mean bias for ruminal ammonia concentrations. However, they did not observe a significant linear bias as was observed herein. As ruminal nitrogen balance is partially dictated by influx across the rumen wall from blood, it is possible that a portion of the observed bias is due to inappropriate predictions of blood urea concentrations. Such measurements were not collected for the summarized studies, and thus such a hypothesis cannot be tested with these data.

Prediction errors for ruminal digestion coefficients (DCs) ranged from a low of 19% for OM to a high of 51% for ADF excepting lipid, which had an error of greater than 300%. OM errors exhibited insignificant mean and slope bias. The remainder of ruminal DCs were predicted with insignificant slope bias but relatively great mean bias.

Prediction errors for duodenal flows ranged from a low of 17% for DM to a high of 55% for lipid. Significant proportions of the prediction error were associated with mean bias for all flow predictions excepting that for DM and total nitrogen, suggesting that reparameterization is needed. The proportion of error associated with slope bias was greatest for non-ammonia non-microbial nitrogen (NANMN) at 15.5%.

Microbial flow was underpredicted on average and NANMN flow was overpredicted resulting in an offsetting bias as indicated by the lack of mean bias in total nitrogen flow. Kohn *et al.* (1994) previously reported a relatively large mean underprediction bias for total nitrogen flow to the duodenum

Table 29.5. Prediction errors for digestive measures when using the model of Baldwin (1995) to simulate studies summarized in Table 29.2. Inputs were individual ingredients. See Table 29.4 for an explanation of the statistics.

Variable	N	Mean observed	Mean predicted	RMSPE (%)	MSPE _{Bias} (%)	MSPE _{Slope} (%)	MSPE _{Dispersion} (%)
Ruminal pH, ammonia and VFA							
pH	181	6.11	6.11	4.2	0.1	3.8	96.1
Ammonia (mM)	173	8.81	6.59	69.6	13.0	53.6	33.4
Total VFA (mM)	180	106	73.0	37.5	70.0	1.5	28.6
Acetate (% of VFA)	177	61.6	57.1	10.6	47.3	9.0	43.7
Propionate (% of VFA)	177	23.0	29.4	32.5	71.9	2.2	25.9
Butyrate (% of VFA)	177	11.8	13.5	20.1	49.1	13.1	37.8
True ruminal digestibility (% of intake)							
OM	201	52.2	51.1	18.6	1.3	5.0	93.6
N	227	56.6	42.6	36.4	46.4	13.6	40.0
NDF	152	42.8	27.3	49.7	53.0	10.9	36.1
ADF	129	38.9	24.2	50.1	56.9	3.3	39.7
Starch	92	59.7	69.0	30.1	26.7	1.0	72.2
Lipid	24	7.9	30.5	333	72.6	13.8	13.6
Duodenal flow (kg/day)							
DM	57	11.9	12.0	16.7	0.5	14.1	85.3
OM	181	11.3	8.73	29.5	60.9	4.1	35.1
Total N (g/day)	214	501	500	20.5	0.0	11.3	88.7
Microbial N (g/day)	233	256	216	33.4	22.6	4.1	73.3
NANMN (g/day)	227	219	282	47.0	37.1	15.5	47.5
NDF	155	3.71	4.33	33.2	24.9	5.5	69.5
ADF	120	2.32	2.96	38.8	50.5	5.7	43.8
Starch	84	2.93	2.26	49.6	21.5	0.7	77.8
Lipid (g/day)	23	864	1068	55.4	18.1	10.8	71.0
Total tract digestibility (% of intake)							
DM	101	66.3	63.7	8.9	19.5	31.0	49.4
OM	183	68.2	64.4	9.4	35.2	18.3	46.4
N	193	68.6	49.7	33.7	67.1	4.3	28.6
NDF	137	49.2	33.5	39.3	65.7	5.1	29.2
ADF	115	42.7	29.9	37.9	63.1	3.7	33.2
Starch	77	92.7	90.7	6.5	10.3	1.1	88.6
Lipid	41	69.8	85.0	25.9	70.1	6.6	23.3

VFA = volatile fatty acid; OM = organic matter; N = nitrogen; NDF = neutral detergent fibre; ADF = acid detergent fibre; DM = dry matter; OM = organic matter; NANMN = non-ammonia non-microbial nitrogen.

when testing this model. Those errors resulted from an overprediction of microbial nitrogen and a relatively greater underprediction of undegraded feed nitrogen.

Overpredictions of NANMN flow to the duodenum suggest that the rate of ruminal degradation of feed protein was underpredicted or that the rate of escape from the rumen was too great. In the representation of Baldwin (1995), protein passage is driven by pool size where the small-particle portion of the pool is assumed to turn over a constant 1.33 times/day and the soluble portion 3.5 times/day. Measurements of ruminal nitrogen pool size and distribution would be required to resolve whether the prediction errors were a function of passage predictions. However, pool turnover of 1.33 times/day is considerably slower than 3 times/day, which would be inferred from the assumed 8 h residence time used in equation (29.20) to calculate the degradation rate. Increasing the passage rate of small particles from 1.33/day to 3/day ($24/8 = 3$) would result in even greater NANMN flows. Similarly, increasing the divisor in equation (29.20) from 8 to 18 ($24/1.33 = 18$) would result in slower rates of protein degradation and an increase in NANMN flow.

These observations suggest that either *in sacco* measures of protein degradation rates underpredict *in vivo* rates or the representation of ruminal protein degradation kinetics within the model is incorrect. The representation of very rapid degradation of soluble protein in the model is consistent with *in sacco* assumptions; however, the representation of a large particle pool in the model that is not subject to degradation may not be consistent with *in sacco* passage rate assumptions. If protein in the large-particle pool were subject to degradation, predictions of the rate of protein escape from the rumen would be reduced. Regardless of the cause, an additive scalar could be used to adjust the mean rate upward, thus maintaining the relative differences among ingredients while increasing the overall degradation rate. Such a scalar could easily be derived from the existing data.

A multiplicative scalar could also be used to adjust k_{PiAa} and may be warranted. Plotting residual errors against the predicted k_{PiAa} from equation (29.20) suggests that changes associated with diet may be slightly underpredicted as denoted by a slight positive slope to the residuals (Fig. 29.3).

Given the bias in predictions of carbohydrate degradation and fermentation, it is not surprising that there is bias in microbial nitrogen flow predictions. There may be other causes for the microbial flow bias, but these cannot easily be assessed until the carbohydrate biases have been addressed. Starch bias is not surprising given that starch inputs were estimated as a static proportion of non-forage carbohydrate. However, NDF and ADF biases are indicative of a parameterization problem given the segregation of those errors primarily into the mean bias fraction. For both fibre entities, the mean flow bias was -0.7 kg/day (overpredicted), suggesting that the problem was related to parameterization of cellulose hydrolysis (all the NDF overprediction was also present in ADF). Increasing the rate of cellulose hydrolysis would result in greater substrate for microbial fermentation and greater microbial growth, which would help address the microbial flow prediction bias.

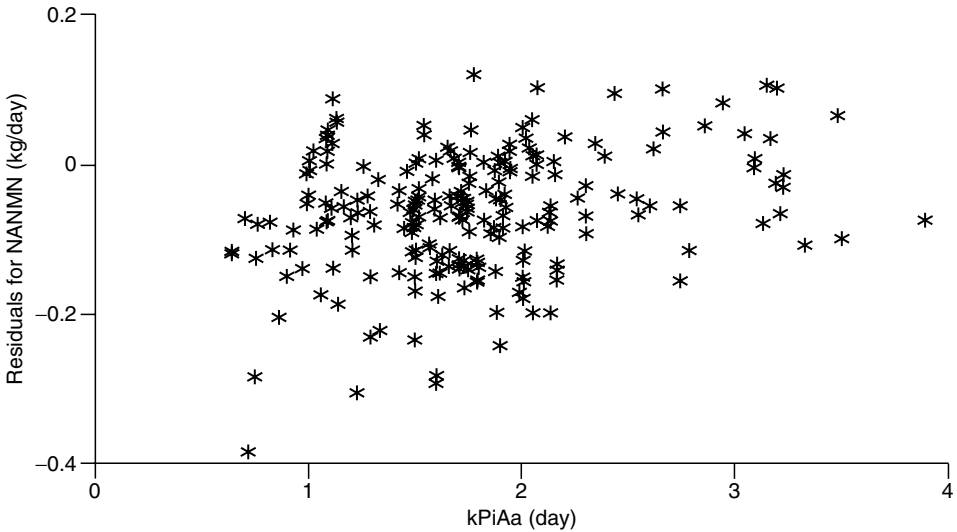

Fig. 29.3. Non-ammonia non-microbial nitrogen (NANMN) residual errors plotted against k_{PiAa} as predicted from equation (29.20).

Prediction errors for total tract DCs ranged from a low of 7% for starch to a high of 40% for NDF. The proportion of error associated with mean bias was the least for starch at 10%, moderate for DM at 19% and quite large for the remainder ranging up to 70% of the error for lipid. Slope bias was insignificant excepting for DM and OM at 31% and 18% respectively.

Total tract DCs would not be expected to be more accurate or precise than ruminal DCs given the dependency of the former on the latter. In the case of starch and lipid, this is not the case, indicating significant mean bias in predictions of lower gut digestion of those entities. In the case of starch, total tract digestibility is underpredicted and for lipid it is overpredicted. The latter is of particular concern given the energy density of lipid. Overpredictions of its absorption would result in overpredictions of post-absorptive energy supply. As the added energy must be utilized, it would probably result in overpredictions of milk yield (MY) or of BW gain. For these simulations, MY was overpredicted by an average of 12 kg/day (data not shown). However, given all the challenges in predicting gut metabolism, it seems premature to assess the adequacy of MY predictions.

To conduct such an evaluation given the current model state, one would have to utilize observed total tract digestibilities as inputs to the post-absorptive model, which is certainly possible but beyond the scope of this work. Even if such an exercise were conducted or the digestive elements were corrected, it seems unlikely that the model would predict the correct MY given the magnitude of the current error. Other challenges with the post-absorptive model likely exist, including the possibility of inappropriate

partitioning of energy or inappropriate estimates of energy expenditure for maintenance purposes.

Conclusions

An improved scheme for data input was devised and implemented, allowing assessment of model accuracy across a broad range of diets. Additionally, a scheme to consider protein degradation rates was incorporated. Using a large data-set, the model was found to be in error for a number of digestive predictions. It would appear that many of these deficiencies may be resolved by model reparameterization. There are likely some problems that are related to inappropriate representations within the model; however, until mean bias errors have been removed, such representations cannot be identified.

References

- Aldrich, J.M., Muller, L.D., Varga, G.A. and Griel, L.C. (1993) Nonstructural carbohydrate and protein effects on rumen fermentation, nutrient flow, and performance of dairy cows. *Journal of Dairy Science* 76, 1091–1105.
- Armentano, L.E., Herrington, T.A., Polan, C.E., Moe, A.J., Herbein, J.H. and Umstadt, P. (1986) Ruminal degradation of dried brewers grains, wet brewers grains, and soybean meal. *Journal of Dairy Science* 69, 2124–2133.
- Baldwin, R.L. (1995) *Modeling Ruminant Digestion and Metabolism*. Chapman & Hall, London.
- Baldwin, R.L., Thornley, J.H.M. and Beever, D.E. (1987) Metabolism of the lactating cow: II. Digestive elements of a mechanistic model. *Journal of Dairy Research* 54, 107–131.
- Bannink, A. and De Visser, H. (1997) Comparison of mechanistic rumen models on mathematical formulation of extramicrobial and microbial processes. *Journal of Dairy Science* 80, 1296–1314.
- Bannink, A., De Visser, H., Klop, A., Dijkstra, J. and France, J. (1997) Causes of inaccurate prediction of volatile fatty acids by simulation models of rumen function in lactating cows. *Journal of Theoretical Biology* 189, 353–366.
- Blauwiel, R., Xu, S., Harrison, J.H., Loney, K.A., Riley, R.E. and Calhoun, M.C. (1997) Effect of whole cottonseed, gossypol, and ruminally protected lysine supplementation on milk yield and composition. *Journal of Dairy Science* 80, 1358–1365.
- Calsamiglia, S., Caja, G., Stern, M.D. and Crooker, B.A. (1995) Effects of ruminal versus duodenal dosing of fish meal on ruminal fermentation and milk composition. *Journal of Dairy Science* 78, 1999–2007.
- Cameron, M.R., Klusmeyer, T.H., Lynch, G.L., Clark, J.H. and Nelson, D.R. (1991) Effects of urea and starch on rumen fermentation, nutrient passage to the duodenum, and performance of cows. *Journal of Dairy Science* 74, 1321–1337.
- Chan, S.C., Huber, J.T., Theurer, C.B., Wu, Z., Chen, K.H. and Simas, J.N. (1997) Effects of supplemental fat and protein source on ruminal fermentation and nutrient flow to the duodenum in dairy cows. *Journal of Dairy Science* 80, 152–159.

- Chilliard, Y., Cisse, M., Lefaivre, R. and Remond, B. (1991) Body composition of dairy cows according to lactation stage, somatotropin treatment, and concentrate supplementation. *Journal of Dairy Science* 74, 3103–3116.
- Christensen, R.A., Cameron, M.R., Klusmeyer, T.H., Elliott, J.P., Clark, J.H., Nelson, D.R. and Yu, Y. (1993) Influence of amount and degradability of dietary protein on nitrogen utilization by dairy cows. *Journal of Dairy Science* 76, 3497–3513.
- Christensen, R.A., Overton, T.R., Clark, J.H., Drackley, J.K., Nelson, D.R. and Blum, S.A. (1996) Effects of dietary fat with or without nicotinic acid on nutrient flow to the duodenum of dairy cows. *Journal of Dairy Science* 79, 1410–1424.
- Cunningham, K.D., Cecava, M.J. and Johnson, T.R. (1994) Flows of nitrogen and amino acids in dairy cows fed diets containing supplemental feather meal and blood meal. *Journal of Dairy Science* 77, 3666–3675.
- Cunningham, K.D., Cecava, M.J., Johnson, T.R. and Ludden, P.A. (1996) Influence of source and amount of dietary protein on milk yield by cows in early lactation. *Journal of Dairy Science* 79, 620–630.
- Doreau, M., Legay, F. and Bauchart, D. (1991) Effect of source and level of supplemental fat on total and ruminal organic matter and nitrogen digestion in dairy cows. *Journal of Dairy Science* 74, 2233–2242.
- Erasmus, L.J., Botha, P.M. and Meissner, H.H. (1994) Effect of protein source on ruminal fermentation and passage of amino acids to the small intestine of lactating cows. *Journal of Dairy Science* 77, 3655–3665.
- Espindola, M., DePeters, E., Fadel, J., Zinn, R. and Perez-Monti, H. (1997) Effects on nutrient digestion of wheat processing and method of tallow addition to the diets of lactating dairy cows. *Journal of Dairy Science* 80, 1160–1171.
- Feng, P., Hoover, W.H., Miller, T.K. and Blauwiel, R. (1993) Interactions of fiber and nonstructural carbohydrates on lactation and ruminal function. *Journal of Dairy Science* 76, 1324–1333.
- Gibb, M.J., Ivings, W.E., Dhanoa, M.S. and Sutton, J.D. (1992) Changes in body components of autumn-calving Holstein-Friesian cows over the first 29 weeks of lactation. *Animal Production* 55, 339–360.
- Gomez-Alarcon, R.A., Dudas, C. and Huber, J.T. (1990) Influence of cultures of *Aspergillus oryzae* on rumen and total tract digestibility of dietary components. *Journal of Dairy Science* 73, 703–710.
- Hanigan, M.D., Weakley, D.C., Standaert, F.E. and Reutzler, L.R. (2002) Evaluation and refinement of ruminal volatile fatty acid absorption equations in dynamic, metabolic model of the lactating dairy cow. *Journal of Dairy Science* 85, 402.
- Herrera-Saldana, R., Gomez-Alarcon, R., Torabi, M. and Huber, J.T. (1990) Influence of synchronizing protein and starch degradation in the rumen on nutrient utilization and microbial protein synthesis. *Journal of Dairy Science* 73, 142–148.
- Holden, L.A., Glenn, B.P., Erdman, R.A. and Potts, W.E. (1994) Effects of alfalfa and orchardgrass on digestion by dairy cows. *Journal of Dairy Science* 77, 2580–2594.
- Horner, J.L., Coppock, C.E., Moya, J.R., Labore, J.M. and Lanham, J.K. (1988) Effects of niacin and whole cottonseed on ruminal fermentation, protein degradability, and nutrient digestibility. *Journal of Dairy Science* 71, 1239–1247.
- Johnson, T.R. and Combs, D.K. (1991) Effects of prepartum diet, inert rumen bulk, and dietary polyethylene glycol on dry matter intake of lactating dairy cows. *Journal of Dairy Science* 74, 933–944.
- Joy, M.T., DePeters, E.J., Fadel, J.G. and Zinn, R.A. (1997) Effects of corn processing on the site and extent of digestion in lactating cows. *Journal of Dairy Science* 80, 2087–2097.

- Kalscheur, K.F., Teter, B.B., Piperova, L.S. and Erdman, R.A. (1997a) Effect of dietary forage concentration and buffer addition on duodenal flow of trans-C-18:1 fatty acids and milk fat production in dairy cows. *Journal of Dairy Science* 80, 2104–2114.
- Kalscheur, K.F., Teter, B.B., Piperova, L.S. and Erdman, R.A. (1997b) Effect of fat source on duodenal flow of trans-C-18:1 fatty acids and milk fat production in dairy cows. *Journal of Dairy Science* 80, 2115–2126.
- King, K.J., Huber, J.T., Sadik, M., Bergen, W.G., Grant, A.L. and King, V.L. (1990) Influence of dietary protein sources on the amino acid profiles available for digestion and metabolism in lactating cows. *Journal of Dairy Science* 73, 3208–3216.
- Klasmeyer, T.H., McCarthy, R.D.J., Clark, J.H. and Nelson, D.R. (1990) Effects of source and amount of protein on ruminal fermentation and passage of nutrients to the small intestine of lactating cows. *Journal of Dairy Science* 73, 3526–3537.
- Klasmeyer, T.H., Lynch, G.L., Clark, J.H. and Nelson, D.R. (1991) Effects of calcium salts of fatty acids and proportion of forage in diet on ruminal fermentation and nutrient flow to duodenum of cows. *Journal of Dairy Science* 74, 2220–2232.
- Kohn, R.A., Boston, R.C., Ferguson, J.D. and Chalupa, W. (1994) The integration and comparison of dairy cow models. In: Danfaer, A. and Lescoat, P. (eds) *Proceedings of IV International Workshop on Modelling Nutrient Utilisation in Farm Animals*. National Institute of Animal Science, Denmark, pp. 117–128.
- Kung, L.J., Huber, J.T. and Satter, L.D. (1983) Influence of nonprotein nitrogen and protein of low rumen degradability on nitrogen flow and utilization in lactating dairy cows. *Journal of Dairy Science* 66, 1863–1872.
- Lu, C.D., Jorgensen, N.A. and Satter, L.D. (1988) Site and extent of nutrient digestion in lactating dairy cows fed alfalfa protein concentrate or soybean meal. *Journal of Dairy Science* 71, 697–704.
- Lykos, T., Varga, G.A. and Casper, D. (1997) Varying degradation rates of total non-structural carbohydrates: effects on ruminal fermentation, blood metabolites, and milk production and composition in high producing Holstein cows. *Journal of Dairy Science* 80, 3341–3355.
- Lynch, G.L., Klasmeyer, T.H., Cameron, M.R., Clark, J.H. and Nelson, D.R. (1991) Effects of somatotropin and duodenal infusion of amino acids on nutrient passage to duodenum and performance of dairy cows. *Journal of Dairy Science* 74, 3117–3127.
- Mabjeesh, S.J., Arieli, A., Bruckental, I., Zamwell, S. and Tagari, H. (1997) Effect of ruminal degradability of crude protein and nonstructural carbohydrates on the efficiency of bacterial crude protein synthesis and amino acid flow to the abomasum of dairy cows. *Journal of Dairy Science* 80, 2939–2949.
- Mansfield, H.R. and Stern, M.D. (1994) Effects of soybean hulls and lignosulfonate-treated soybean meal on ruminal fermentation in lactating dairy cows. *Journal of Dairy Science* 771, 1070–1083.
- McCarthy, R.D., Klasmeyer, T.H., Vicini, J.L., Clark, J.H. and Nelson, D.R. (1989) Effects of source of protein and carbohydrate on ruminal fermentation and passage of nutrients to the small intestine of lactating cows. *Journal of Dairy Science* 72, 2002–2016.
- Merchen, N.R. and Satter, L.D. (1983) Changes in nitrogenous compounds and sites of digestion of alfalfa harvested at different moisture contents. *Journal of Dairy Science* 66, 789–801.
- Murphy, M., Uden, P., Palmquist, D.L. and Wiktorsson, H. (1987) Rumen and total diet digestibilities in lactating cows fed diets containing full-fat rapeseed. *Journal of Dairy Science* 70, 1572–1582.

- Narasimhalu, P., Teller, E., Vanbelle, M., Foulon, M. and Dasnoy, F. (1989) Apparent digestibility of nitrogen in rumen and whole tract of Friesian cattle fed direct-cut and wilted grass silages. *Journal of Dairy Science* 72, 2055–2061.
- NRC (National Research Council) (2001) *Nutrient Requirements of Dairy Cattle*, 7th edn. National Academy Press, Washington, DC.
- O'Mara, F.P., Stakelum, G.K., Dillon, P., Murphy, J.J. and Rath, M. (1997) Rumen fermentation and nutrient flows for cows fed grass and grass supplemented with molassed beet pulp pellets. *Journal of Dairy Science* 80, 2466–2474.
- Ohajuruka, O.A., Wu, Z.G. and Palmquist, D.L. (1991) Ruminal metabolism, fiber, and protein digestion by lactating cows fed calcium soap or animal-vegetable fat. *Journal of Dairy Science* 74, 2601–2609.
- Oliveira, J.S., Huber, J.T., Simas, J.M., Theurer, C.B. and Swingle, R.S. (1995) Effect of sorghum grain processing on site and extent of digestion of starch in lactating dairy cows. *Journal of Dairy Science* 78, 1318–1327.
- Overton, T.R., Cameron, M.R., Elliott, J.P., Clark, J.H. and Nelson, D.R. (1995) Ruminal fermentation and passage of nutrients to the duodenum of lactating cows fed mixtures of corn and barley. *Journal of Dairy Science* 78, 1981–1998.
- Pantoja, J., Firkins, J.L., Eastridge, M.L. and Hull, B.L. (1994) Effects of fat saturation and source of fiber on site of nutrient digestion and milk production by lactating dairy cows. *Journal of Dairy Science* 77, 2341–2356.
- Pantoja, J., Firkins, J.L. and Eastridge, M.L. (1995) Site of digestion and milk production by cows fed fats differing in saturation, esterification, and chain length. *Journal of Dairy Science* 78, 2247–2258.
- Pena, F., Tagari, H. and Satter, L.D. (1986) The effect of heat treatment of whole cottonseed on site and extent of protein digestion in dairy cows. *Journal of Animal Science* 62, 1423–1433.
- Pires, A.V., Eastridge, M.L., Firkins, J.L. and Lin, Y.C. (1997) Effects of heat treatment and physical processing of cottonseed on nutrient digestibility and production performance by lactating cows. *Journal of Dairy Science* 80, 1685–1694.
- Poore, M.H., Moore, J.A., Eck, T.P., Swingle, R.S. and Theurer, C.B. (1993) Effect of fiber source and ruminal starch degradability on site and extent of digestion in dairy cows. *Journal of Dairy Science* 76, 2244–2253.
- Prange, R.W., Stern, M.D., Jorgensen, N.A. and Satter, L.D. (1984) Site and extent of protein digestion in lactating cows fed alfalfa silage or baled alfalfa hay. *Journal of Dairy Science* 67, 2308–2314.
- Price, S.G., Satter, L.D. and Jorgensen, N.A. (1988) Dehydrated alfalfa in dairy cow diets. *Journal of Dairy Science* 71, 727–736.
- Putnam, D.E., Schwab, C.G., Socha, M.T., Whitehouse, N.L., Kierstead, N.A. and Garthwaite, B.D. (1997) Effect of yeast culture in the diets of early lactation dairy cows on ruminal fermentation and passage of nitrogen fractions and amino acids to the small intestine. *Journal of Dairy Science* 80, 374–384.
- Robinson, P.H. and Sniffen, C.J. (1985) Forestomach and whole tract digestibility for lactating dairy cows as influenced by feeding frequency. *Journal of Dairy Science* 68, 857–867.
- Robinson, P.H., Gill, M. and Kennelly, J.J. (1997) Influence of time and feeding a protein meal on ruminal fermentation and forestomach digestion in dairy cows. *Journal of Dairy Science* 80, 1366–1373.
- Roseler, D., Fox, D., Pell, A. and Chase, L. (1997) Evaluation of alternative equations for prediction of intake for Holstein dairy cows. *Journal of Dairy Science* 80, 864–877.

- Santos, K.A., Stern, M.D. and Satter, L.D. (1984) Protein degradation in the rumen and amino acid absorption in the small intestine of lactating dairy cattle fed various protein sources. *Journal of Animal Science* 58, 244–255.
- Sarwar, M., Firkins, J.L. and Eastridge, M.L. (1991) Effect of replacing neutral detergent fiber of forage with soyhulls and corn gluten feed for dairy heifers. *Journal of Dairy Science* 74, 1006–1017.
- Schwab, C.G., Bozak, C.K. and Whitehouse, N.L. (1992a) Amino acid limitation and flow to duodenum at four stages of lactation: 1. Sequence of lysine and methionine limitation. *Journal of Dairy Science* 75, 3486–3502.
- Schwab, C.G., Bozak, C.K., Whitehouse, N.L. and Olson, V.M. (1992b) Amino acid limitation and flow to the duodenum at four stages of lactation: 2. Extent of lysine limitation. *Journal of Dairy Science* 75, 3503–3518.
- Seymour, W.M., Polan, C.E. and Herbein, J.H. (1992) *In vivo* degradation of protein in diets formulated for two degradabilities. *Journal of Dairy Science* 75, 2447–2453.
- Shaver, R.D., Satter, L.D. and Jorgensen, N.A. (1985) Ruminal retention time and fill in dairy cows: effects of level of feed intake, forage physical form and forage fiber content. *Proceedings of the XVIII Conference on Rumen Function*, Chicago, Illinois, p. 45.
- Song, M.K. and Kennelly, J.J. (1989) Effect of ammoniated barley silage on ruminal fermentation, nitrogen supply to the small intestine, ruminal and whole tract digestion, and milk production of Holstein cows. *Journal of Dairy Science* 72, 2981–2990.
- Stokes, S.R., Hoover, W.H., Miller, T.K. and Blauweikel, R. (1991) Ruminal digestion and microbial utilization of diets varying in type of carbohydrate and protein. *Journal of Dairy Science* 74, 871–881.
- Tice, E.M., Eastridge, M.L. and Firkins, J.L. (1993) Raw soybeans and roasted soybeans of different particle sizes: 1. Digestibility and utilization by lactating cows. *Journal of Dairy Science* 76, 224–235.
- Waltner, S.S., McNamara, J.P. and Hillers, J.K. (1994) Validation of indirect measures of body fat in lactating cows. *Journal of Dairy Science* 77, 2570–2579.
- Waltz, D.M., Stern, M.D. and Illg, D.J. (1989) Effect of ruminal protein degradation of blood meal and feather meal on the intestinal amino acid supply to lactating cows. *Journal of Dairy Science* 72, 1509–1518.
- Windschitl, P.M. and Stern, M.D. (1988) Evaluation of calcium lignosulfonate-treated soybean meal as a source of rumen protected protein for dairy cattle. *Journal of Dairy Science* 71, 3310–3322.
- Woodford, S.T. and Murphy, M.R. (1988) Effect of forage physical form on chewing activity, dry matter intake, and rumen function of dairy cows in early lactation. *Journal of Dairy Science* 71, 674–686.
- Yang, W.Z., Beauchemin, K.A., Koenig, K.M. and Rode, L.M. (1997) Comparison of hull-less barley, barley, or corn for lactating cows: effects on extent of digestion and milk production. *Journal of Dairy Science* 80, 2475–2486.
- Yoon, I.K. and Stern, M.D. (1996) Effects of *Saccharomyces cerevisiae* and *Aspergillus oryzae* cultures on ruminal fermentation in dairy cows. *Journal of Dairy Science* 79, 411–417.
- Zerbini, E., Polan, C.E. and Herbein, J.H. (1988) Effect of dietary soybean meal and fish meal on protein digesta flow in Holstein cows during early and midlactation. *Journal of Dairy Science* 71, 1248–1258.
- Zhu, J.S., Stokes, S.R. and Murphy, M.R. (1997) Substitution of neutral detergent fiber from forage with neutral detergent fiber from by-products in the diets of lactating cows. *Journal of Dairy Science* 80, 2901–2906.

30 Metabolic Control: Improvement of a Dynamic Model of Lactational Metabolism in Early Lactation

J.P. McNAMARA

*Department of Animal Sciences, Washington State University,
Pullman, WA 99165, USA*

Abstract

A mechanistic, dynamic model of metabolism exists to allow testing of complex hypotheses on nutrient metabolism of the dairy cow. The model describes protein synthesis and degradation in the viscera and muscle, lipogenesis and lipolysis in the adipose tissue, and milk synthesis. It is dynamic, integrating rates over the course of a few hours or an entire lactation. The model performs very well at describing milk production given nutrient intakes. Errors still exist in descriptions of visceral, muscle and adipose metabolism, especially in early lactation. Over the last 15 years, we have had as an objective the task of improving the performance of this model for research into metabolic control in dairy cattle. Areas of emphasis have been lipogenesis and lipolysis in the adipose tissue, body protein use and basal energy use. A series of model challenges has determined that descriptions of basic processes (such as ion pumping, protein and fat turnover rates, increased metabolic costs associated with increased intake) in this model are inadequate. Errors in the descriptions of viscera and muscle tissue result in excess energy accumulation in the adipose tissue. A hypothesis based on experimental evidence is that simulated rates of energy use in the viscera, due to the hormonal and nutrient intake changes that take place in early lactation, are too low. A corollary hypothesis is that rates of energy use by the body, especially in protein turnover and associated metabolic costs is also too low in the model. Simulations increasing these energetic costs in the model resulted in realistic reductions in body fat compared to observed experimental data. These improvements become hypotheses for a framework of focused experimentation to improve our quantitative knowledge of metabolism in lactating cows.

Introduction

Models are representations of reality. A model is an ordered way of describing knowledge of a system. Models are used, for example, to order knowledge into practical systems to describe nutrient requirements for agricultural animals. Much research into nutrition of farm animals since the 1900s was used, directly or 'by default', to build, evaluate and improve models of nutrient

requirements. Billions of dollars, as conservation of resources and decreased costs of raising feed for livestock and of the labour for feeding of livestock, has been saved by application of these nutritional models.

Research and development of models of nutrient use are no less important today. Our ability to describe metabolic transactions, and their resultant effect on nutrient requirements, is critical to our ability to raise food-producing animals in efficient ways. Empirical systems have been adequate to date and will continue to have utility. However, as our knowledge of variation in genetic and environmental situations continues to increase, this author agrees with the philosophy that it is only through continuing to develop models of increasing complexity, ever grounded in validated research data, that we will continue to improve our knowledge, wisdom and their application to feeding the world.

A model that represents reality as closely as realistically possible allows the level of complexity to answer these questions in a way that respects the true complexity of the organisms. To define reality is to have an ordered approach that, in a planned iterative fashion, asks increasingly complex questions and increases our knowledge with the clear answers we receive. There is one basic ultimate cause: the genome of the animal existing. There is one basic factor affecting the expression of the genome and that is the environment in which the 'genome' finds itself. It is in defining the detail that we must excel, and research must continue to have the goal of defining the detail in the full context of the system under study.

The Example of Lactation

Late pregnancy and early lactation is a time of metabolic stress met with a coordinated response from hormonal and neural systems. To manage the changes in flux (nutrient flow through the animal) there is a complex and redundant system of control factors, better known as hormones and neurotransmitters (McNamara, 1994). These systems are inextricably linked, and although we use a reductionistic approach to identify key elements of each subsystem, knowledge gained is useless unless applied to the entire organism.

In late pregnancy, the cow has a 10–25% increase in demand for glucose, fatty acids, amino acids and minerals, increasing over the course of 4–12 weeks, or a rate of change from 0.1% to 1% units/day. At parturition, demand for all nutrients doubles within a few days and within a few weeks can be 3–5 times as high as in mid-gestation. For a cow reaching 40 kg of milk in 60 days after calving – pretty much an average cow in North America presently – this is a rate of change in nutrient requirements of about 8.6%/day! The changes in rates of metabolism to prepare for, initiate and maintain milk production over several months still provide a major challenge for dairy producers.

Our focus should be primarily on those organs about which we still understand the least: those of the digestive tract and metabolism (liver primarily) and

the body muscle. At present, our ability to predict more precisely is most limited by our inadequate knowledge of what happens in the gut tissues, liver and body muscle during lactation, especially of how changes in metabolism in these organs change maintenance requirements (Baldwin, 1995; McNamara and Baldwin, 2000; Reynolds *et al.*, 2003). Continued improvement in nutrition will occur as we recognize that the use of any one nutrient is intrinsically linked with nutrition and metabolism of all compounds.

As the mammary gland demands 20 times or more glucose than the brain uses in a day, there are homeostatic and homeorhetic endocrine and neural systems that are activated, de-activated, attenuated and/or enhanced to ensure that glucose supply to neural tissues remains adequate. The mechanisms are at the gene transcription or intracellular signal levels, and we see the effects of these signals in rates of voluntary feed intake, in rates of lipogenesis and lipolysis in the adipose tissues, in proteolysis, protein synthesis and amino acid interconversions in muscle and liver, and in the increase in supply of glucose to the mammary gland.

Brief Description of the Molly Model

In the 1960s, R.L. Baldwin, working with colleagues already well on the way to formulating the most successful nutritional model to date, the Net Energy System (Lofgreen and Garrett, 1968), began a programme, eventually lasting more than 35 years, to 'develop a dynamic, mechanistic model of digestion and metabolism in lactating dairy cows suitable for evaluation of hypotheses regarding underlying energetic relationships and patterns of nutrient use' (Baldwin, 1995). There have been hundreds of experiments on ruminal and tissue processes of dairy cattle. Experimental data and model development have come from that effort, and there are many dairy nutritionists in the world who have built directly on, or benefited from, it.

Another key characteristic of a model is how it describes change over time. A dynamic model *integrates* change over time. The requirements of an animal for a short time period are always partially a function of what has come before. Dynamic models can describe the constant turnover functions, which actually are maintenance, such as ion transport, protein turnover in the muscle and viscera, and triglyceride turnover in the adipose tissue. For example, a change in muscle protein turnover of 10%, which is at least a minimum increase in early lactation (Overton *et al.*, 1998; McNamara and Baldwin, 2000; McNamara *et al.*, 2001a,b; Drackley *et al.*, 2003), would increase energy for maintenance by about 2 mcals/day (see Baldwin, 1995 for calculations and stoichiometry). Over 100 days, that is an error of 200 mcals or about 28 kg of adipose tissue (assuming adipose tissue will grow relative to the energy 'left over' after other energetic costs).

The requirements in early lactation are clearly understood now to be a function in part of the situation the animal was in 60 (or 130, or 30, etc.) days prior to lactation. The same is true for any period in lactation – the state of the

animal is a function of the previous conditions, and the requirements for any animal are a function of its state. A cow producing 50 kg of milk at 200 days of lactation with a body condition score (BCS) of 1.5 (about 30 kg of body fat) has a different requirement *for the total body* than a cow producing 50 kg of the same quality milk but with a BCS of 3 (about 65 kg of body fat), although the requirement for the milk output may be the same. A cow producing 50 kg of milk at 15 days of lactation has a different set of requirements than a cow of the same weight giving the same amount of milk at 150 days of lactation, because of the differences in metabolic rates in non-mammary tissues. Static models can incorporate some of these effects of time by adding more equations relating to previous conditions, but they are still static – they cannot describe the process over time.

Baldwin's model has been described in numerous publications, so only a brief description is given here. Inputs include chemical components of the diet: soluble carbohydrate, organic acids, pectin, lactic acid, lipid, starch, hemicellulose, cellulose, soluble protein, insoluble protein, non-protein nitrogen, lignin, soluble ash, insoluble ash and added fat. The model inputs also include feed acetate and butyrate for high-silage diets, and urea. It also includes factors for starch solubility, particle size and to calculate organic matter (OM). All these data can be either obtained by analysis or readily calculated from tabular values. In the absence of information, the model can be run with various 'educated guesses' until performance is in the expected range. In Molly, soluble protein is 100% converted to amino acids in the rumen, so this would be similar to the Cornell Net Carbohydrate and Protein System (CNCPS) protein fraction A plus the CNCPS protein fraction B converted to amino acids. The insoluble protein would be similar to the total B fraction, with degradation occurring at a rate that can be changed by the user at the beginning of a simulation. The amount of actual insoluble protein passed out of the rumen in the model is thus an estimate of rumen undegradable protein (RUP).

Inputs include body weight (BW), fat and protein, expected or measured rates of milk protein and fat, and various rates of metabolic reactions in the body. The model describes, at the request of the user, most of the practical feeding strategies and intake estimates, based on either single or multiple meals per day, a specified feeding rate (usually used for simulating research trials where intake is measured), feed based on 1 kg of feed intake for each 3 kg of milk, two different equations used by earlier National Research Council (NRC) versions based on actual data from thousands of records (Ely or Mertens equations; see Baldwin, 1995), and several others. Basic accepted equations to describe intake can also be used. Any new equation developed can be included in the model text as well.

This model has been criticized by some as being too complex. but this author argues that it is far less complex than the system it represents, and that over the last 30 years we have had sufficient data to evaluate much of its complexity. In addition, nothing is learned (or not enough is learned) from constructing too simple a model. Practical dairy nutritionists today use far more complicated spreadsheets and programs than what is explicit in

Molly. Although there clearly are parameters and equations that are difficult to measure directly, they are embedded in the framework such that the inputs and outputs can be evaluate against real data. This can help us to identify upon which areas of the model (and our research programmes) to focus our efforts.

Model Descriptions of Body Processes

Emphasis will be given on the modelling of the chemical processes in the body, and a focus around glucose will be built. The major regulatory processes of the body have evolved around glucose. The brain and central nervous system require glucose. This change in glucose flux has demonstrable and significant effects on the major turnover pathways for protein and fat, and on other energetic costs of cell function (respiration, ion transport, protein synthesis), which in turn affect the amount of carbon and nitrogen available for body fat and protein synthesis.

The full set of model equations has been published previously and will not be reiterated here (Baldwin *et al.*, 1987a,b,c; Baldwin, 1995). A few key differential equations and their control will be summarized. Carbohydrate in the body that is metabolized for energy (or to make fat or lactose) is eventually converted to triose phosphates or glucose, or is used through the same metabolic pathways, so for simplicity we can aggregate a lot of this. So we have the following equation (all units are in moles/day unless otherwise stated):

$$G_I = \text{up}G_I + \text{Aa}G_I + \text{Pr}G_I + \text{La}G_I + \text{Gy}G_I - G_I\text{Lm} - G_I\text{HyF} - G_I\text{HyV} - G_I\text{TpF} - G_I\text{TpV} - G_I\text{LaB} - G_I\text{Cd}$$

where glucose (G_I) use in the body is the sum of glucose uptake (up); gluconeogenesis from amino acids (Aa), propionate (Pr), lactate (La), and glycerol (Gy); and glucose used for lactose (Lm), triose phosphates (Tp) – in the viscera (V), adipose (F) or body (B) – which is used to make pentose phosphates (NADPH_2 ; Hy) and lactate; and glucose that is oxidized to carbon dioxide (Cd).

Thus, as glucose is used, the concentration of glucose changes, and this elicits loss from the available glucose. If the loss from the pool exceeds the inputs to the pool, gluconeogenesis from amino acids can supply the deficit. This reduces the amount of amino acids circulating, and if uptake from the gut cannot maintain the pool, proteolysis of muscle protein will increase and muscle protein synthesis will decrease, allowing maintenance of amino acid supply. Carbohydrate nutrition cannot be described without invoking amino acid nutrition.

Deficits of energy and glucose are met by two major processes: lipolysis to release free fatty acids that the cow can use for energy and milkfat, and proteolysis of proteins to amino acids for gluconeogenesis. It must be stressed that lipolysis not only responds to the glucose lack but also to the

need by the mammary gland for milk fat. So some increase in lipolysis is inevitable. Also, fatty acid release can only spare a limited amount of actual glucose, as most organs require some glucose for energy in addition to the mammary demand.

Supply of glucose in the model directly affects body fat (Ts) and protein (Pb) synthesis. For body fat synthesis from acetate (rate is AcTs), we have the aggregate equation (all units in moles/day):

$$\text{AcTs} = V\text{AcTs} / [1.0 + K\text{AcTs}/c\text{Ac} + K\text{GI}\text{AcTs}/(\text{Ahor} * c\text{GI})]$$

Body fat synthesis is a function of genetics of the cow (maximal velocity (V) and sensitivity to substrate (K; McNamara, 1994)); nutrition (acetate availability (Ac), i.e. circulating acetate, primarily from absorbed acetate); and glucose, which is both a direct supplier of reducing equivalent (energy) for fat synthesis and a direct indicator of energy balance, represented in the model as 'Ahor' or anabolic hormone. Thus, as glucose availability drops dramatically in relation to demand, the rate of body fat synthesis drops as well (basically to zero; McNamara, 1994). The anabolic hormone of the model is equal to $c\text{GI}/rc\text{GI}$, i.e. glucose concentration (cGI) divided by reference glucose concentration at zero energy balance (rcGI). As glucose drops, so does anabolic hormone (just like insulin), and this further reduces the rate of body fat synthesis. The control of lipolysis, or body fat release, is in the opposite direction. This is probably an oversimplification, as there are now ample data to suggest that rates of lipolysis can be dramatically fast even when total body fat is low, suggesting that the fractional breakdown rate is not a constant (suggested by the scaling to amount of body fat; McNamara, 1994; McNamara and Baldwin, 2000). Animals with little body fat can still release amounts greater than cows with more body fat.

The principles and concepts outlined above for the interaction of carbohydrate and fat apply directly to the connection with glucose, amino acids and body protein synthesis and degradation. We have in the body the following summation for use of total amino acids (Aa; all units are in moles/day):

$$\text{DAa} = \text{absAa} + \text{PbAaB} + \text{PvAa} - \text{AaPb} - \text{AaPv} - \text{AaPm} - \text{AaGI} - \text{SAPsAa} - \text{AaPreg}$$

where amino acid use per day is the sum of absorbed amino acids (absAa), amino acids released from the body (PbAaB) and from the viscera (PvAa), and amino acids used for body protein synthesis (AaPb), visceral protein synthesis (AaPv), milk protein (AaPm), gluconeogenesis (AaGI), saliva (SAPsAa) and pregnancy (AaPreg). As glucose supply decreases in early lactation, the only major source besides propionate absorbed from the gut is amino acids residing in body proteins. As the body viscera (in the model, this includes the gastrointestinal organs, liver, udder) usually grow or at least stay the same size in early lactation, no net glucose can be derived from proteolysis there. That leaves body muscle protein as the major source of

amino acids for glucose, although uterine resorption may supply significant amounts of amino acids. Gluconeogenesis (AaGl) is represented in the published model as a summation of amino acid use:

$$\text{AaGl} = \text{VAaGl}(\text{EBW}^{0.75}) / (1.0 + \text{KAaGl}/\text{cAa})$$

such that as amino acid concentration (cAa) goes up, glucose synthesis increases as well. Amino acid concentration increases because body protein synthesis decreases more than proteolysis. These are a function of anabolic hormone, so as glucose decreases, anabolic hormone (insulin) and body protein synthesis decrease, leading to a net increase in release of amino acids, to supply glucose.

Challenging the Model for Improvement

In order to continue to improve this model, one must challenge the behaviour with data from experiments designed with the broad null hypotheses: 'Our knowledge is inadequate to describe the system adequately'. If a model fails to describe some aspect adequately, compared to what we already know, or at least have some serious basis to hypothesize how a system should act, we learn what we do not know. The next step is to design an experiment to determine the equation forms or parameter values of the model to improve it. Experiments designed over nearly the last 18 years in our laboratory have had one overriding goal of improving our models of metabolism of the cow or the sow (see McNamara and Baldwin, 2000; McNamara and Pettigrew, 2002a,b).

Many experiments point to the description of body fat and protein use as a major inadequacy in this model, as in many other models of dairy cattle nutrition (Komaragiri and Erdman, 1998; Overton *et al.*, 1998; Citron and McNamara, 2000; McNamara and Baldwin, 2000; Sage *et al.*, 2000; Drackley *et al.*, 2003; Phillips *et al.*, 2003). Milk production from nutrient inputs, or vice versa, is described well in the model. However, in Molly, challenge experiments that measured variations due to genetic merit, dietary starch, fibre and protein composition in dairy cattle over the majority of the lactation cycle all demonstrated that the model accumulated too much body fat and to some extent, body protein. This was after careful and repetitive analysis of feed and milk chemistry and model behaviour to allow us to say that the model was doing a very precise job of balancing the feed inputs and milk outputs. However, the model was 'balancing' these by accumulating error in the body pools.

Our conclusion, based on measurements done on muscle, adipose tissue, mammary gland and liver (in many labs, not only ours) was that the errors, or at least the majority of them, were not in the quantitative descriptions in the adipose tissue itself, but that the adipose tissue was receiving a greater quantity of nutrients than was actually observed. Rather, the model underestimates the true costs of maintenance-type functions in the lactating cow, resulting in accretion of more muscle and fat than would be expected or

measured. In this context, the true biochemical costs of maintenance include the increased energy use due to increased metabolic activity and turnover of protein and fat in the viscera and muscle. In the Net Energy scheme, these increased costs are not truly maintenance, but heat increment. These transactions are truly increased energy costs that are not accounted for by milk and 'basic maintenance functions', but must be described and accounted for. We are now accumulating enough data on protein turnover and other costs in the body and viscera to challenge our current estimates (Lobley *et al.*, 1980; Overton *et al.*, 1998; Phillips *et al.*, 2003; Reynolds *et al.*, 2003).

One example is a recent experiment conducted in early lactating cows (days -21 to 120 postpartum) to measure body fat and protein of the animals (McNamara *et al.*, 2003). After running simulations on individual cows, it was evident that the model did a very good job of describing milk production (predicted milk, kg/day = $2.93 + 0.903 * \text{observed milk, kg/day}$, $r^2 = 0.96$; Phillips *et al.*, 2003), however, it overaccumulated body fat and protein. For body fat at 180 days the equation was: predicted fat, kg = $180.1 + 0.58 * \text{observed fat, kg}$, $r^2 = 0.09$. The mean bias accounted for 97% of the mean squared prediction error (MSPE). For protein in the body the equation was: predicted protein, kg = $-5.1 + 0.90 * \text{observed protein, kg}$, $r^2 = 0.33$ for body protein overall, with mean bias making up 83% of the MSPE. However, by day 120, this equation was: predicted protein, kg = $-86.5 + 1.75 * \text{observed protein, kg}$, $r^2 = 0.45$. Thus, for body fat, the model has a large mean bias, suggesting that we do not understand the absolute amount of energy used, and for body protein, we do have an 'average' understanding of body protein use, but still cannot describe the time curve of protein use adequately in early lactation. Again, this is no surprise, as very few data were available on body protein use in early lactation when the model was constructed.

Although the descriptions of body protein use are simplistic in the model, the preponderance of evidence supports the idea that errors in maintenance costs are at fault. These would include the rates and energetic costs of body protein turnover, liver protein turnover, body fat turnover, and the increased costs of metabolism upon a large increase in feed intake. These are energetic costs, which increase during lactation. It is noted that no other model can readily identify these errors, as this is the only available model that describes these processes dynamically.

We have, in the last several years, accumulated new data on nutrient intake, milk output and body fat and protein (as well as other measures) on approximately 75 cows from 21 days prepartum until at least 90 days in milk (DIM; McNamara and Baldwin, 2000; Phillips *et al.*, 2003; McNamara and Valdez, 2005). These animals on average consumed over 25 kg/day dry matter (DM), ranging from 19 to 43 kg/day. Milk production ranged (days 1-90) from 29 to 56 kg/day with a mean of 43 kg/day. Diets were lucerne- and lucerne silage-based, with whole cottonseed, wheat millrun, maize and barley as the primary other ingredients.

Based on our findings from challenges, we tested what would happen if we increased the energetic costs of the increased food intake on metabolic rates in the viscera, as is justified by recent data (Reynolds *et al.*, 2003). We did find

that we could correct a large proportion of the error in body fat (Table 30.1; Figs 30.1–30.3). This then becomes a hypothesis to test with additional data from the literature or through continued study of these processes. We did the same process to test what would happen if we increased the rates of protein turnover in the body protein. As these costs are less than those in the viscera, the quantitative effect was less. Yet by increasing the estimate of protein turnover moderately, an action supported by recent, albeit indirect, data (Overton *et al.*, 1998; McNamara and Baldwin, 2000; Overton, 2001; Phillips *et al.*, 2003), we can further improve the description of body fat in the model.

An additional ability of the model is to describe different shapes of lactation curves based on udder synthetic capacity and degradation thereof during lactation. One problem with trying to describe observed data-sets during early lactation is the rapid and variable change in milk production, nutrient intake and resultant metabolic rates. The default

Table 30.1. Comparison of measured energy use in splanchnic tissues^a with Molly simulations.

Data are for total splanchnic flux	Day about parturition					
	-19	-9	11	21	33	83
DMI (kg/day)	9.6	9.6	14.7	17.1	19.5	22.1
ME intake (Mcal/day)	22.5	22.5	42.4	49.3	56.2	63.7
4% FCM (kg/day)			41.2	41.9	44.2	42.4
BW (kg)			676	662	660	647
Oxygen uptake (mmol/h)	3137	3161	5760	6323	6746	8101
Moles/day	75.3	75.9	138.2	151.8	161.9	194.4
Energy used (Mcal/day)	8.1	8.2	14.9	16.4	17.5	21.0
Percentage of change from -19 days	1	101	184	202	215	258
ATP produced (moles/day)	452	455	829	911	971	1167
Simulated (sim) data	-19	-9	11	21	33	83
DMI (kg/day), observed and sim			15.8	17.3	19.9	25.4
ME intake (Mcal/day)			41.1	45.8	53.3	68.1
4% FCM (kg/day), observed			25.4	29.3	33.2	35.5
4% FCM (kg/day), sim			25.1	28.6	30	30.1
BW (kg), sim			719	670	627	572
ATP requirement for splanchnic (moles/day)			733	742	793	952
ATP simulated at DMI = 24.3 kg/day			812	846	926	1039
ATP simulated at DMI = 33.7 kg/day			977	1033	1189	1472
Model simulation as percentage observed			88	81	82	82
4% FCM at greater UCELLS			29	33.6	35.3	35.2
ATP requirement at same intake, higher milk			808	815	871	1081

^aObserved data (Reynolds *et al.*, 2003).

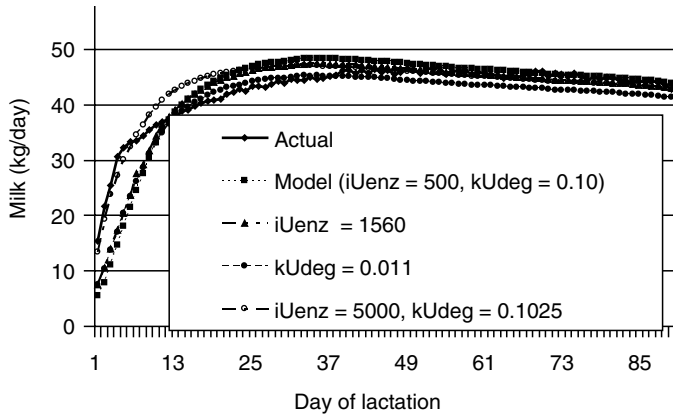

Fig. 30.1. Milk production simulated in a data-set of dairy cattle in early lactation. Kilograms of milk produced in approximately 75 dairy cattle at Washington State University (WSU) from 1998 to 2003. Simulations represent different shapes of the lactation curve at the same total capacity (UCCELLS). The parameter *iUenz* sets the amount of udder enzymes at the initiation of lactation; *kUdeg* sets the *k* value for rate of degradation of udder enzymes.

model assumes one lactation curve shape, but can be adjusted if desired and justified with data. The equations describing this have been published elsewhere (Baldwin, 1995). We did a simple comparison to change the initial value of udder enzymes and the rate of their degradation to demonstrate that the initial amount of milk production and the shape of the lactation curve can be altered in the model (Fig. 30.1). With some fur-

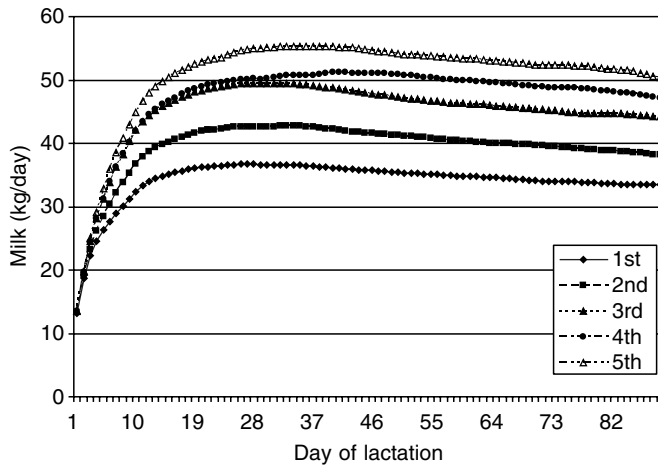

Fig. 30.2. Simulation of milk production in WSU cattle based on quintiles of DMI. Data are simulated milk production when the model is given inputs at five quintiles of DMI: 21.1, 24.3, 27.9, 33.7, 39.7 kg/day of a lucerne forage/maize/soybean meal dairy ration (Phillips *et al.*, 2003) from 1 to 90 DIM. This provides a base of comparison for body fat and visceral energy use in Figs 30.3 and 30.4.

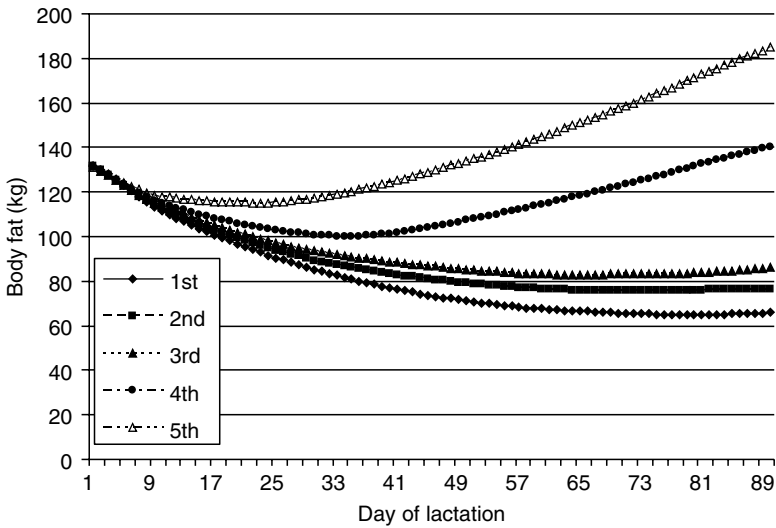

Fig. 30.3. Simulated body fat content in early lactation. Kilograms of body fat simulated by the model when the model is given inputs at five quintiles of DMI: 21.1, 24.3, 27.9, 33.7, 39.7 kg/day of a lucerne forage/maize/soybean meal dairy ration (Phillips *et al.*, 2003). At low to average intakes, body fat is close to observations, but the model accumulates too much fat at the higher intakes. However, the model behaves consistently with the general knowledge. The higher intakes demonstrate that the model must be updated to include varied and differential genetic effects on the mammary gland, liver and other tissues and the adipose tissue.

ther parameter estimation, several different types of lactation curves can be described. This is important if we desire to describe rapid changes in metabolic rates or pool sizes in the body over small time periods. For simulations only requiring cumulative changes over several weeks, the shape may not be relevant if the final change is correct, but for shorter-term studies this is critical.

A few other additions were made to have the model reflect reality more closely. In the published versions (Baldwin, 1995) all the absorbed butyrate is converted to carbon dioxide. Yet it is known that some can be used for milk fat synthesis. Based on older data (Moore and Christie, 1981), we assumed that 25% of the butyrate absorbed was used to make the C1 to C4 carbons of fatty acid synthesized *de novo* in the mammary gland.

The equations are (rates are in moles/day):

$$\text{BuTm} = \text{VBuTm} * \text{Uenz} * \text{KMinh} * \text{INS}^{**} \text{P1} / (1.0 + \text{KBuTm}/\text{cBu} + \text{K1BuTm}/\text{cGI})$$

where BuTm is the production of milk triacylglycerol from butyrate, V is the V_{\max} , KBUtm is the sensitivity constant and K1BUtm is the sensitivity constant for glucose supply on milk fat synthesis (Uenz, Kminh regulate mammary growth and involution, INS is insulin; see Baldwin, 1995 for complete description). Change in butyrate concentration (DBu; moles/day) becomes:

$$DBu = AbsBu - BuTm - BuCd$$

where AbsBu is absorbed butyrate and BuCd is butyrate oxidation to carbon dioxide. Constants used in these equations are: initial pool size and concentration: ivbu = 0.654; icbu = 0.000235; VBUtm = 0.00525; KBUtm = 0.000166; K1BUtm = 0.001; BuCor = 1 (see Baldwin, 1995, Ch. 17 for a full explanation of terminology) and are based primarily on the older work on milk fat synthesis (Moore and Christie, 1981; Thomas and Martin, 1988) and in keeping with the structure of the model. This addition is reasonable based on knowledge at hand and in keeping with the idea that every transaction is important to predict with close precision. Using these equations and data from our cows in early lactation, the model would suggest 1500–2700 g/day butyrate absorbed (minimal–maximal), 1300–2400 g/day to carbon dioxide and 210–330 g/day to milk fat. With these diets across the range of intake, the model suggests that about 13% of absorbed VFA is butyrate. This does not seem unreasonable, but even if the true value is 50% of that, 6% of total absorbed carbon cannot be assumed to be converted solely to carbon dioxide. Further refinements will simply require more stringent comparisons to observations.

A more useful addition has been the introduction of ketone body formation and lipid accumulation in the viscera (primarily liver) as a result of excess adipose tissue lipolysis. Based on measured (Grummer *et al.*, 1993; Rukkamsuwik *et al.*, 2000; Piepenbrink and Overton, 2003) amounts of liver triacylglycerols (Tg) accumulation and circulating beta-hydroxybutyrate concentrations, the following equations were added (data in moles/day):

$$FaTg = TsFa * KFaTg$$

$$DTg = TgFaTg - TgFa$$

$$Tg = INTEG(DTg, iTg)$$

in which the accumulation of fatty acids as Tg in the liver (FaTg) is a mass action effect of lipolysis from adipose tissue; KFaTg is a rate of liver hydrolysis, which for now is a mass action constant that could be changed if data warrant; and INTEG is the command that integrates the input and output equations. The accumulation of liver Tg (DTg) was set to be within the range reported by Piepenbrink and Overton (2003) in early lactation, with a maximum of about 20%. In keeping with what we understand about this process, it is the net rate of fatty acid release from the adipose tissue that dictates the

uptake and accumulation of liver Tg, and not the rate of removal by the liver. Rate of liver Tg removal was set at 5%/day. To the author's knowledge, this has not been directly measured in dairy cattle, but is in keeping with studies suggesting that the rate of liver Tg removal is low, and also consistent with the time frame of loss of liver Tg in whole-animal studies measuring liver Tg. The other equations and constants that support these major equations are: mass action constant of net fatty acid release from adipose Tg (K_{TsFa}) = 0.40; rate of liver Tg removal (K_{FaTg}) = 0.05. The mass action constant for the percentage of fatty acids released from adipose Tg is also a function of catabolic hormone:

$$K_{FaTg} = K_{FaTg1} * Chor1$$

such that as rate of lipolysis increases, the percentage of fatty acids accumulating in the liver increases. Catabolic hormones ($Chor1$, $Chor2$) are functions of glucose concentration, such that as glucose concentration decreases, catabolic hormone increases. The different designations (1, 2) indicate that different sensitivities of hormone to different reactions can be set. With this control, the practical maximum percentage of fatty acid going to liver Tg is about 20%, or about 600–1200 g/day at very negative fatty acid balances. These rates provide about a maximum of 12% of liver wet weight as lipid, consistent with published data (Grummer, 1993; Rukkwamsuk *et al.*, 2000; Piepenbrink and Overton, 2003;).

Production of beta-hydroxybutyrate from excess fatty acid release is represented as:

$$cBh = TsFaf * K_{FaBh}$$

where the concentration of beta-hydroxybutyrate (cBh) is a mass action function of lipolysis:

$$K_{FaBh} = K_{FaBh1} * Chor2$$

The mass action constant for K_{FaBh1} = 0.0001; such that the cBh increases from 2 to 40 mM as adipose tissue lipolysis increases 2.5-fold.

Returning to our hypothesis on the model underpredicting visceral energy use with the data-set described above, we conducted a set of simulations, using the new model, designed to determine whether we could describe the time course of milk production more exactly in early lactation, and to determine the effects on descriptions of body fat and protein. We divided our data from 75 cows into quintiles based on DM intake (DMI), and again based on milk. We applied the five sets of DMI measures to the model and determined the shape of the described milk curve and use of body fat and protein (Fig. 30.2). By adjusting the initial concentration of udder enzymes ($iUenz$) and the degradation rate of udder enzymes ($kUdeg$), we could more closely match the average curve of milk production in our cattle (Fig. 30.1). The total amount produced (days 1–90) agreed within 0.7% or

0.3 kg/day at UCELLS = 1350, and with additional refinement of this parameter one could describe milk production even more closely. The results demonstrate the range of body fat and body protein use predicted by the model at the given feed intakes and milk productions compared to actual amounts measured. Using the original parameters for basal energy use, body fat accumulation was overestimated in all situations. However, using more realistic estimates, the use of body fat was described in a manner more closely representing measured values (Fig. 30.3), although for the first quintile of intake, body fat accumulation was indeed rapid. These few animals were eating very large quantities of food (> 40 kg DMI/day) and producing close to 50 kg/day of milk. It is likely that in fact these animals, for obvious genetic reasons, probably have an even faster rate of visceral and body metabolism, and thus their energy use is probably greater than simulated.

Finally to test the hypothesis of the increase in energy expenditure in the gut, we compared simulations to data collected on oxygen uptake and metabolism in the liver of lactating cattle having similar intakes and milk productions to the lower quintiles of our data-set (Reynolds *et al.*, 2003). DMI (Table 30.1) was compared to cows in our data-set at similar intakes (fifth quintile). The rate of 4% fat-corrected milk (Table 30.1) production was simulated slightly lower than for the cows in Reynolds's data-set (Table 30.1). Moles of adenosine triphosphate (ATP)-equivalent energy used by the total splanchnic viscera in simulations (Fig. 30.4) were about 80–88% of the observed data-set of Reynolds *et al.* (2003). However, the model did not describe as much milk production with these settings. When we compared the observed data to simulations in which we increased milk production, energy use was about 90% of that observed. When we compared data from the third quintile of our animals that consumed about 10% more food, described visceral energy use was similar to that observed. Remember that these simulations were done with an increase in the parameters describing visceral energy use compared to original default values. Thus we can be fairly certain that in fact the original parameter values were too low, which is not surprising given data available 20–25 years ago. With more fine-tuning, it would be straightforward to match energy use more closely. Yet, these simulations demonstrate that in fact we have described energy use in the viscera fairly closely, and are certainly not overestimating it.

Recent information from the study of ATP generation has indicated that in fact our classic assumptions of 3 ATP generated per mole of NADH_2 and 2 from FADH_2 may be overestimates. Several biochemists would argue, with convincing proof, that the yield is 2.5 and 1.5 respectively. Obviously this would change the production of ATP from catabolized nutrients significantly (a reduction to 83% and 75% of that assumed in the model). Preliminary challenges with the model would then estimate that the required use of glucose, amino acids and fatty acids for maintenance functions in the model should be increased by a factor of close to 20%. This in itself would help to account for much of the errors described above, but does not change the basic findings of inadequacies in the description of visceral and body meta-

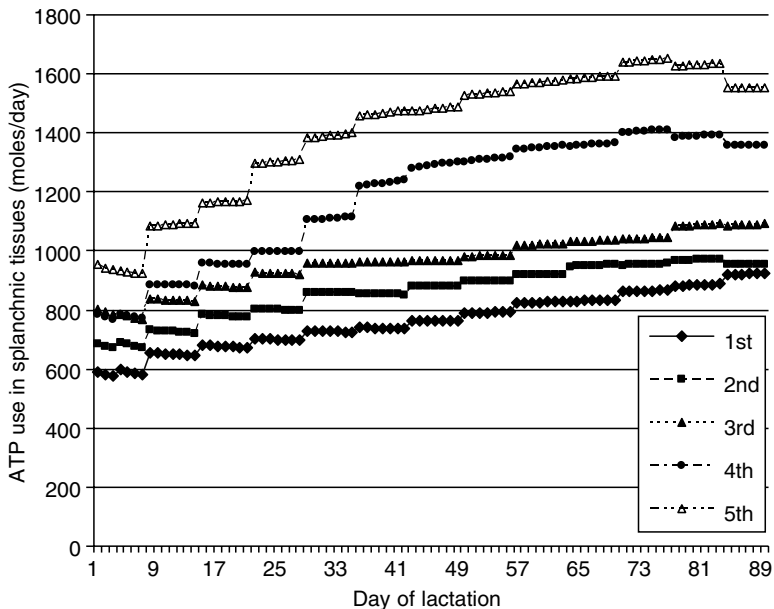

Fig. 30.4. Simulated energy use by the cow in early lactation. Simulation of total moles of ATP used by splanchnic tissue of the cow during early lactation. Data are in moles of ATP/day. Heat can be calculated using 0.0195 Mcal (0.0815 MJ) per mole ATP. These rates are simulated by the model when it is given inputs at five quintiles of DMI: 21.1, 24.3, 27.9, 33.7, 39.7 kg/day of a lucerne forage/maize/soybean meal dairy ration (Phillips *et al.*, 2003). This demonstrates the equation: $basalV = (kbasV + KNaAtV) * wtV^{0.75}$; $KNaAtV = 3.2 + KNaV * T3 * fdomin$; where *basalV* is the amount of energy, in ATP, needed for basal metabolism in the viscera; *kbasV* and *KNaAtV* are constants; *wtV* is the weight of the viscera (kg); *T3* is thyroxine; *fdomin* is feed organic matter intake (OMI) and *KNaV* is the function that increases visceral energy use with increasing intake. Basal use includes ion gradient maintenance and tissue turnover. Also included in the simulated data are visceral protein synthesis and the cost of intermediary reactions such as glucose to lactate to glucose.

bolic transactions. In fact, it strengthens the usefulness of the model because these transactions (ATP generation) were so meticulously described based on sound quantitative data that such new findings can easily be evaluated. The model proves its worth. Further work along these lines has recently been published (Hanigan *et al.*, 2006).

Conclusions

With the objective of eventually understanding everything that happens in an animal coming closer and closer to fruition, our true purpose of feeding the world efficiently is nearing achievement. A quantitative systems approach is

the only way to continue upon this path. Reductionistic research, especially into the functionality of the genome and physiological control of metabolism, will be essential to improvement. In addition, continued effort in simple, economical and effective chemical methodology for defining feedstuffs is a must. But overriding all is the integration of knowledge, data, and concepts into an organized representation of reality – a model that will achieve our goal. These simulations demonstrate the robust and useful nature of this model to study energy transactions in early lactation.

References

- Baldwin, R.L. (1995) *Modeling Ruminant Digestion and Metabolism*. Chapman & Hall, New York, 578 pp.
- Baldwin, R.L., France, J. and Gill, M. (1987a) Metabolism of the lactating cow: I. Animal elements of a mechanistic model. *Journal of Dairy Research* 54, 74–105.
- Baldwin, R.L., Thornley, J.H.M. and Beever, D.E. (1987b) Metabolism of the lactating cow: II. Digestive elements of a mechanistic model. *Journal of Dairy Research* 54, 106–132.
- Baldwin, R.L., France, J., Beever, D.E., Gill, M. and Thornley, J.H.M. (1987c) Metabolism of the lactating cow: III. Properties of mechanistic models suitable for evaluation of energetic relationships and factors involved in the partition of nutrients. *Journal of Dairy Research* 54, 133–145.
- Citron, T.L. and McNamara, J.P. (2000) Challenging behavior of a metabolic model simulation of muscle protein turnover by indirect means in lactating dairy cattle fed various amounts of protein. *Journal of Dairy Science* 83 (Suppl. 1), 13.
- Drackley, J.K., Dann, H.M., Litherland, N.B. and Underwood, J.P. (2003) Physiological adaptations in dairy cows during the transition period. In: *Proceedings of the California Animal Nutrition Conference*. Fresno, California, pp. 1–16.
- Grummer, R.R. (1993) Etiology of lipid-related metabolic disorders in periparturient dairy cows. *Journal of Dairy Science* 76, 3882–3986.
- Hanigan, M.D., Bateman, H.G., Fadel, J.G. and McNamara, J.P. (2006) Metabolic models of ruminant metabolism: recent improvements and current status. *Journal of Dairy Science* 89 E52–64E.
- Komaragiri, M.V.S. and Erdman, R.A. (1998) Factors affecting body tissue mobilization in early lactation dairy cows: 1. Effect of dietary protein on mobilization of body fat and protein. *Journal of Dairy Science* 80, 929–937.
- Lobley, G.E., Milne, V., Lovie, J.M., Reeds, P.J. and Pennie, K. (1980) Whole body and tissue protein synthesis in cattle. *British Journal of Nutrition* 43, 491–500.
- Lofgreen, G.P. and Garrett, W.N. (1968) A system for expressing net energy requirements and feed values for growing and finishing beef cattle. *Journal of Animal Science* 27, 793–802.
- McNamara, J.P. (1994) Lipid metabolism in adipose tissue during lactation: a model of a metabolic control system. *Journal of Nutrition* 124, 1383S–1391S.
- McNamara, J.P. and Baldwin, R.L. (2000) Estimation of parameters describing lipid metabolism in lactation: challenge of existing knowledge described in a model of metabolism. *Journal of Dairy Science* 83, 128–143.
- McNamara, J.P. and Pettigrew, J.E. (2002a) Protein and energy intake in lactating sows: 1. Effects on milk production and body composition. *Journal of Animal Science* 80, 2442–2451.

- McNamara, J.P. and Pettigrew, J.E. (2002b) Protein and energy intake in lactating sows: 2. Challenging parameters of a model of metabolism. *Journal of Animal Science* 80, 2452–2460.
- McNamara, J.P. and Valdez, F. (2005) Effects of dietary chromium propionate and calcium propionate on adipose tissue metabolism and milk production of dairy cattle in the transition period. *Journal of Dairy Science* 88, 2498–2507.
- McNamara, J.P., Sage, J.J., Citron, T.L. and Phillips, G.J. (2001a) Adaptations in amino acid concentrations, body fat and body protein in dairy cattle fed varying amounts of protein in the transition period. *Journal of Dairy Science* 84 (Suppl. 1), 294.
- McNamara, J.P., Sage, J.J., Citron, T.L. and Phillips, G.J. (2001b) Challenging performance of a mechanistic model of metabolism to describe nutrient flux and body pools in early lactation. *Journal of Dairy Science* 84 (Suppl. 1), 294.
- Moore, J.H. and Christie, W.W. (1981) Lipid metabolism in the mammary gland of ruminant animals. In: Christie, W.W. (ed.) *Lipid Metabolism in Ruminant Animals*. Pergamon Press, Oxford, UK, pp. 227–277.
- NRC (National Research Council) (2001) *Nutrient Requirements of Dairy Cattle*, 10th rev. edn. National Academy Press, Washington, DC.
- Overton, T.R. (2001) Managing metabolism of transition dairy cows through nutrition. In: *Proceedings of the Pacific Northwest Animal Nutrition Conference*. Washington State University, Puyallup, Washington, DC, pp. 171–188.
- Overton, T.R., Drackley, J.K., Douglas, G.N., Emmert, L.S. and Clark, J.H. (1998) Hepatic gluconeogenesis and whole-body protein metabolism of periparturient dairy cows as affected by source of energy and intake of the prepartum diet. *Journal of Dairy Science* 81 (Suppl. 1), 295.
- Phillips, G.J., Citron, T.L., Sage, J.S., Cummins, K.A., Cecava, M.J. and McNamara, J.P. (2003) Adaptations in body muscle and fat in transition dairy cattle fed differing amounts of protein and methionine hydroxy analog. *Journal of Dairy Science* 86, 3534–3647.
- Piepenbrink, M.S. and Overton, T.R. (2003) Liver metabolism and production of cows fed increasing amounts of rumen-protected choline during the periparturient period. *Journal of Dairy Science* 86, 1722–1733.
- Reynolds, C.K., Aikman, P.C., Lupoli, B., Humphries, D.J. and Beever, D.E. (2003) Splanchnic metabolism of dairy cows during the transition from late gestation through early lactation. *Journal of Dairy Science* 86, 1201–1217.
- Rukkamsuk, T., Geelen, M.J.H., Kruip, T.A.M. and Wensing, T. (2000) Interrelation of fatty acid composition in adipose tissue, serum and liver of dairy cows during the development of fatty liver postpartum. *Journal of Dairy Science* 83, 52–59.
- Sage, J.G., Phillips, J., Citron, T.L. and McNamara, J.P. (2000) Challenging a mechanistic model of dairy cattle metabolism to describe changes in body fat of high producing dairy cattle fed various diets during early lactation. *Journal of Dairy Science* 83 (Suppl. 1), 13.
- Thomas, P.C. and Martin, P.A. (1988) The influence of nutrient balance on milk yield and composition. In: Garnsworthy, P.C. (ed.) *Nutrition and Lactation in the Dairy Cow*. Butterworths, London, pp. 97–118.

31 Rostock Feed Evaluation System – an Example of the Transformation of Energy and Nutrient Utilization Models to Practical Application

A. CHUDY

*Forschungsinstitut für die Biologie landwirtschaftlicher Nutztiere,
Dummerstorf, OT Warsow 11, D-17154 Neukalen, Germany*

Abstract

The history of energetic feed evaluation is an excellent example of the transfer of models of scientific knowledge to practical application. In developmental steps spanning over 50 years the Rostock team investigated the energy metabolism and utilization of nutrients for fat synthesis (net energy fat (NEF)) in cattle, sheep, pigs, rabbits and poultry. The experiments, including 'pure nutrients' and different groups of feedstuffs and substrates, evaluated the relation between intake of a wide range of digestible nutrients and measured energy retention (ER) and maintenance energy requirement using a multiple regression model. A study based on a mathematical–biochemical model of intermediary nutrient utilization found that the relative utilization of the nutrients, protein and carbohydrates, for fat synthesis and for (non-thermic) maintenance and work (adenosine triphosphate (ATP) synthesis) are similar; verified the higher efficiency (22%) of utilization of dietary fat for fat synthesis compared with oxidation for maintenance (ATP synthesis) as a result of the direct incorporation of fatty acids into body fat; developed a model of whole intermediary metabolism (ATP concept), which demonstrates that: (i) except for chemical heat regulation, all energy metabolic processes consume or produce ATP-bound energy; (ii) energy metabolism (heat production (HP)) is determined both quantitatively and qualitatively only by the efficiency with which substrates are used for ATP synthesis; (iii) the gain or secretion of body nutrients is only a storage or exchange of ATP potentials, misleadingly expressed in gross energy; and (iv) the incorporation of fatty acids and amino acids is seen only as a transfer of substrates and of their ATP potential with consumption of ATP-bound energy and not as the result of metabolic substrate synthesis. Therefore it follows for practical application that the basis for energetic feed efficiency has to be the potential in catabolic processes but not in anabolic processes. The ATP-related NE is to be used as the scale to characterize the energetic potential of nutrients and feedstuffs in the ATP pool, available for all performances (activities). The use of the ATP pool is mostly determined by animal factors (physiological state), which consequently must be defined by standards for nutritional requirements.

As a final conclusion, the new revised Rostock Feed Evaluation System decided on 'net energy retention (NER)' as the measure of the relative utilization of the metabolizable energy (ME) of digestible nutrients for ATP synthesis (catabolic processes),

derived from measurements of fat synthesis and, based on metabolism modelling, with the reduction of fat utilization to 92% of the utilization of carbohydrates. Consequently the equations for estimation of energetic values of feedstuffs and rations for cattle (c), pigs (p) and poultry (fowl; f) for practical use are:

$$\text{NER}_c = (7.2 \text{ dCP} + 20 \text{ dCF} + 10.1 \text{ dSt} + 8.3 \text{ dSu} + 8.2 \text{ dNFR}) * \\ (-0.5574 + 0.0405 \text{ DE} - 0.0002633 \text{ DE}^2)$$

$$\text{NER}_p = 11.0 \text{ dCP} + 27 \text{ dCF} + 12.7 \text{ dSt} + 11.6 \text{ dSu} + [12 - 0.14(80 - \text{DE}) \text{ dNFR}]$$

$$\text{NER}_f = 10.8 \text{ dCP} + 29 \text{ dCF} + 13.5 \text{ dSt} + 12.4 \text{ dSu} + 10.5 \text{ dNFR}$$

where d = digestible, C = crude, P = protein, F = fat, St = starch, Su = sugar, NFR = nitrogen-free residue (fibre), DE = energy digestibility.

Introduction

The history of energetic feed evaluation is an excellent example of the transfer of models of scientific knowledge to practical application. Following Kellner's 'Starch Equivalent System', the Rostock team started systematic investigations into energy metabolism and feed evaluation for some 50 years following the foundation of the 'Oskar-Kellner Institut für Tierernährung' of the Academy of Agricultural Science by Professor K. Nehring. The buildings of the institute in Rostock were equipped with the highest capacity in the world for respiration experiments: four air-conditioned respiration chambers for cattle, four for pigs, two for sheep, six for rabbits (later for poultry (broilers and hens)) and eight for rats. The aims of these investigations were to research the fundamentals of energy metabolism and nutrient utilization in farm animals, to apply the results in feed evaluation and to develop a complete feed evaluation system. The following methodical steps characterized these investigations: theoretical foundation (modelling) of the problem; consideration of the experimental programme required; analysis for verification of the model; and generalization for practical use. The aim of this study is to demonstrate the methodical development of the Rostock Feed Evaluation System as an example of modelling, experimental verification and practical application.

Investigation Steps and Results

Scientific and methodical clarification

The first step, a complete evaluation of the scientific principles of Kellner and Fingerling (Leipzig Möckern), concluded that Kellner's NEF is a suitable measure for feed evaluation and that the difference experiment is a suitable method for its estimation (Schiemann, 1958), provided that ER above maintenance (ER (NEF)) is directly proportional to ME intake:

$$ER(NEF)(MJ) = a_1 * ME$$

where a_1 is a constant. This prerequisite was illustrated in a total of 669 respiration experiments (321 with rats, 129 with rabbits, 132 with pigs, 35 with sheep and 52 with cattle) (Schiemann *et al.*, 1971); later it also verified for milk production in experiments with dairy cows (Schiemann *et al.*, 1970).

Methods

Model difference experiments

Difference experiments use two measurements: (i) at a feed level slightly higher than maintenance (basal ration); and (ii) with the basal ration plus the supplement:

$$\text{Supplement (ER, ME)} = (\text{ER, ME (basal ration + supplement)} - (\text{ER, ME basal ration}))$$

$$\text{Efficiency of utilization ME supplement} = \frac{\text{difference supplement (ER)}}{\text{difference supplement (ME)}}$$

Preconditions for these experiments are the use of adult animals, meeting the heat requirement of the animal from the level of feed intake of the basal ration (environmental temperature) and, as discussed later, a very low fat content of the basal ration.

Based on this model, measurements were made of the energy utilization of 'pure nutrients' and single feedstuffs (concentrates) in terms of the energetic potential of digestible nutrients for fat synthesis in farm animals (Schiemann *et al.*, 1971).

The efficiency of ME utilization of pure nutrients by monogastric animals (pigs, rats and rabbits) at > 70% for carbohydrates, > 60% for protein and nearly 90% for fat is ~10% units higher than that for ruminants (cattle and sheep; Table 31.1). The utilization of fat, compared to protein and carbohydrates, is only 60% for ruminants, which is very low and not valid, because in these experiments the high fat supplementation reduced the digestion of the basal ration. But these absolute efficiency values together with the accompanying ER (kJ/g) are less important than the *relative efficiency* of ME utilization between the main nutrients. These relative efficiencies for carbohydrates:fat:protein are 100:115:85. They are equal for all animal species and are therefore not influenced by animal species. They are also in agreement with theoretical derivations. It may be concluded that the energetic utilization of feed depends on the source of nutrients, according to the different intermediary pathways of substrate utilization. These differences are an expression of biological laws of the uniformity of intermediary metabolism. The feed evaluation system for practical use should take account of this important factor and therefore NE should be the measure used for feed evaluation.

Table 31.1. Efficiency of metabolizable energy (ME) utilization of pure nutrients (E %) and efficiency relative to that of carbohydrates at 100 (relative efficiency, R %) in different species.

Nutrient	Cattle		Sheep		Rabbits		Pigs		Rats	
	E %	R %	E %	R %	E %	R %	E %	R %	E %	R %
Carbohydrates	63	100	59	100	71	100	74	100	74	100
Starch	64.1	100	64.1	100	67.0	100	75.7	100	75.5	100
Sucrose	55.7	87	58.8	92	70.1	105	74.6	99	73.3	97
Glucose					71.0	106			73.7	98
Lactose					71.3	106			74.2	98
Fructose					67.0	100			67.5	89
Galactose					(78.1)	117			78.2	104
Cellulose	69.0	108	53.2	83			70.6	93		
Alcohol							72.2	98		
Lactic acid							74.8	101		
Acetic acid							59.9	81		
Fat ^a	59	94	58	98	93	131	86	116	83	112
Groundnut oil	59.2	92	57.9	90	92.8	138	85.9	113	83.1	110
Protein	51	81	52	88	61	86	62	84	64	86
Wheat gluten	48.2	75	54.5	85			59.1	78		
Fish protein	52.8	82	49.5	77	60.8	91	65.5	87	63.6	84

^a Fowl – fat (sunflower oil) ME utilization = 84.1 ± 1.1%, similar to pig and rat.

The next research step was the estimation of the energy utilization of 14 concentrates (cereals, peas, expeller solvent-extracted oil meals, oilseeds) varying widely in their nutrient content in different experiments with cattle, sheep, rabbits, pigs and rats. The energetic reference value of single feed-stuffs was derived using a multiple regression model (Schiemann *et al.*, 1971). The multiple regression model is defined as equation without absolute member ($a_0 = 0$).

To estimate the energetic relationships (ER (a_i (kJ/g)) of the digestible nutrients), the following model was defined for the determination of ME and ER (NE, ER) based on the difference experimental method:

$$\text{ME (kJ)} = a_1\text{dCP} + a_2\text{dCF} + a_3\text{dCFi} + a_4\text{dNFE} \pm \text{SD (kJ, \%)}$$

$$\text{ER (kJ)} = a_1\text{dCP} + a_2\text{dCF} + a_3\text{dCFi} + a_4\text{dNFE} \pm \text{SD (kJ, \%)}$$

$$\text{Efficiency of ME utilization} = a_i \text{ (kJ ER/g)} * 100 / a_i \text{ (kJ ME/g)}$$

where d = digestible, C = crude, P = protein, F = fat, Fi = fibre, NFE = nitrogen-free extract. The standard deviations (\pm SDs; kJ, %) between estimated and calculated values are considered the criteria for accuracy. For complete rations, basal ration and rations with supplements, including maintenance requirement as function of body weight (BW; ration method), the following scheme was used:

ER = NE of the ration – NE of maintenance requirement

ME (kJ) = $a_1dCP + a_2dCF + a_3dCFi + a_4dNFE \pm SD$ (kJ, %)

ER (kJ) = $a_1dCP + a_2dCF + a_3dCFi + a_4dNFE) - a_5BW$ (kg, $kg^{0.75}) \pm SD$ (kJ, %)

Efficiency of ME utilization = a_i (kJ ER/g)*100/ a_i (kJ ME/g)

The results show good agreement with the results for pure nutrients as well as between the different methods of analysis (Table 31.2). The values for crude fibre are not valid, because the variation of the crude fibre content in concentrates was inadequate for regression analyses. In particular, the efficiency of ME utilization for the main nutrients, protein, fat and carbohydrates (NFE), and their relative efficiencies agree with the range of biological variation. These results verify the biological basis of the approach and the chosen methods for NEF estimation. The agreement in the relative values of ME utilization between the two different methods suggests a biological connection between maintenance and fat utilization.

Relationships between maintenance and fat deposition

The investigation of this problem was one of the next research tasks, because each NE feed evaluation needs the transference of the evaluation scales used in the study to the other forms of animal performances such as maintenance, secretion (milk, eggs), work, etc. for the definition of standards.

Therefore, after 1960, the Rostock team studied the biochemical interpretation and modelling of energy metabolism. A mathematical–biochemical model of the intermediary utilization of nutrients was created (Fig. 31.1; Chudy, 1967; Chudy and Schiemann, 1969a,b; Schiemann *et al.*, 1971).

Derivations

The mathematical derivation of energy utilization for maintenance (M) and fat synthesis (F) with acetyl CoA as a key metabolite based on the defined utilization coefficients (k_1, \dots, k_6) for two different nutrients (A, B) results in the relation of total utilization A:B = a constant. This implies that no interactions between these two aspects of metabolism are to be expected.

For the verification of this hypothesis, experiments with rats were carried out as follows. The energy utilization of carbohydrates (glucose), fat (isolated from rats) and protein (casein, egg protein) were measured in difference experiments below and above maintenance under thermo-neutral conditions (environmental temperature 32°C). As shown in Table 31.3, the efficiency of utilization of nutrients is higher for maintenance than for fat synthesis of carbohydrates and protein but not of fat (ratio of maintenance to fat synthesis: glucose 1.19, fat 0.97, protein 1.11). However, for the relative efficiencies, the ratios of fat synthesis to maintenance are 1.00:1.22:1.07, which is a satisfactory verification of the hypotheses for carbohydrates and protein. The conclusions were that the relative utilization of the nutrients, protein and carbohydrates,

Table 31.2. Comparison of difference method (Diff.) with ration method (Ration) for determining the metabolizable energy (ME) content and efficiency of ME utilization of concentrates ($n = 14$). Results of multiple regression analyses.

Animal species	Crude protein (a_1)		Crude fat (a_2)		Crude fibre (a_3)		Nitrogen-free extract (NFE; a_4)		Maintenance kJ NEF/kg LW ^{0.75}	± SD %	
	Diff.	Ration	Diff.	Ration	Diff.	Ration	Diff.	Ration		Diff.	Ration
	ME (kJ/g)										
Cattle	15.2	15.7	34.2	35.0	12.8	10.5	16.0	16.2		2.6	0.9
Sheep	17.1	17.3	39.0	42.2	12.9	11.6	16.0	15.6		1.5	1.0
Rabbit	18.0	18.2	39.2	39.5	18.6	18.8	17.5	17.1		2.1	0.6
Pig	18.8	19.6	36.1	34.0	16.7	14.7	17.5	17.5		1.8	0.5
Rat	19.3	18.4	40.2	39.4	17.5	15.2	17.9	17.5		2.1	0.7
Fowl	17.8	18.5	39.8	39.8			17.7	17.1		3.2	1.0
	NER (kJ/g)									Ration	
Cattle	7.5	7.1	29.5	28.5	9.9	1.7	8.9	8.8	193	3.7	3.2
Sheep	7.7	7.5	33.9	32.9	-0.4	0.0	10.0	8.8	122	4.4	4.4
Rabbit	9.7	10.1	33.2	33.7	13.2	10.5	11.0	10.5	230	2.7	1.3
Pig	10.0	9.4	32.3	31.4	0.0	2.1	13.7	13.1	260	5.8	3.1
Rat	10.6	11.8	36.9	38.9	7.9	3.7	13.6	13.0	288	3.3	1.5
Fowl	10.8	11.1	33.5	33.5			13.4	13.8	258	5.2	2.7
	Efficiency of ME utilization (%)										
Cattle	49	45	86	81	77	16	56	54			
Sheep	45	44	87	78	-3	0	63	56			
Rabbit	54	56	85	85	71	56	63	61			
Pig	53	48	89	92	0	14	78	75			
Rat	55	64	92	99	45	24	76	74			
Fowl	61	60	84	84			75	80			

Continued

Table 31.2. cont'd.

Animal species	Crude protein (a ₁)		Crude fat (a ₂)		Crude fibre (a ₃)		Nitrogen-free extract (NFE; a ₄)		Maintenance	± SD %	
	Diff.	Ration	Diff.	Ration	Diff.	Ration	Diff.	Ration	kJ NEF/kg LW ^{0.75}	Diff.	Ration
Relative efficiency of ME utilization (NFE = 100)											
Cattle	88	84	154	151	139	30	100	100			
Sheep	72	77	139	138	-5	0	100	100			
Rabbit	86	91	135	140	113	91	100	100			
Pig	68	64	114	123	0	19	100	100			
Rat	72	87	120	133	59	33	100	100			
Fowl	80	74	112	105	0	0	100	100			

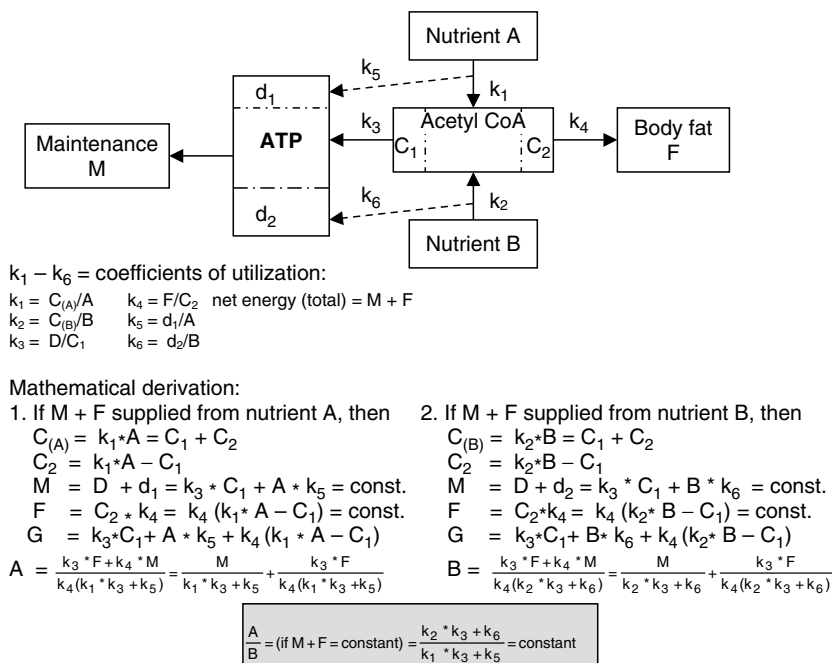

Fig. 31.1. Model of energetic utilization of nutrients for maintenance (adenosine triphosphate (ATP) synthesis) and fat synthesis.

for fat synthesis and for (non-thermic) maintenance and work (ATP synthesis) is constant. There are no interactions between these two nutrients. The exception is fat. Of relevance is the experimentally verified higher efficiency (22%) of fat utilization for fat synthesis compared with oxidation for maintenance (ATP synthesis). This result was an important fact for the use of NEF as a measure for energetic feed evaluation.

Table 31.3. Efficiency of utilization of the metabolizable energy (ME) of main nutrients for maintenance and for gain (fat synthesis; difference to basal rations) in experiments with rats under thermo-neutral conditions (32°C; Chudy and Schiemann, 1969). Also relative efficiency (relative to glucose; RE) and theoretical RE.

Nutrient	Maintenance			Fat synthesis		
	Efficiency ^a (%)	Relative efficiency (RE; %)	Theoretical RE (%)	Efficiency ^b (%)	Relative efficiency (RE; %)	Theoretical RE (%)
Glucose	87.6 ± 1.9	100	100	73.7 ± 4.1	100	100
Fat	81.0 ± 1.3	92.5	95	83.1 ± 1.5	113	112
Protein	70.5 ± 1.45	80.5	78	63.6 ± 1.7	86	81

^aBasal ration = protein–vitamin–mineral mixture.

^bBasal ration = ration at maintenance level.

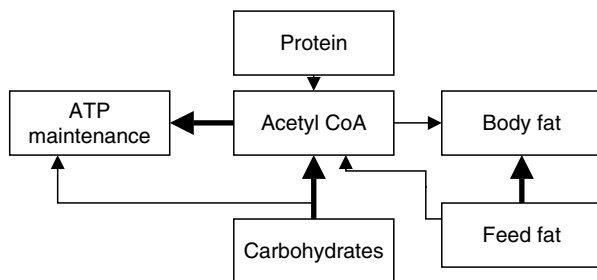

Fig. 31.2. Model of interaction of fat utilization for maintenance and fat synthesis.

To explain this, it was assumed that there was an interaction caused by the direct incorporation of fatty acids into body fat, thereby bypassing the acetyl CoA step. The model of this interaction is shown in Fig. 31.2.

Based on this model, this hypothesis was verified in an experiment with rats, where fat (groundnut and sunflower oil) and carbohydrates (maize meal) were isoenergetically exchanged between the basal ration and the supplement. The experimental conditions and results are shown in Table 31.4. In the case of carbohydrate basal ration and carbohydrate supplement, the efficiency of carbohydrate utilization was found to be $73.4 \pm 1.0\%$. When carbohydrate was supplemented to a basal ration with a high fat content, the efficiency of fat utilization was measured as $90.4 \pm 1.1\%$ because of priority of feed fat for fat deposition and of carbohydrates for maintenance (energy supply). When fat was supplemented to a carbohydrate basal ration without fat, the efficiency of fat utilization was $90.0 \pm 0.9\%$. These results demonstrate the priority of carbohydrates to meet energy requirement (maintenance) and the preference of feed fat over other nutrients for fat deposition, once the energy requirement for maintenance, synthesis and work through surplus carbohydrate and protein is met. This biological principle must be taken into account in the planning and interpretation of experiments with animals.

Volatile fatty acids – utilization in ruminants

Another important problem is the efficiency of energetic utilization of the volatile fatty acids (VFAs) as the end products of rumen fermentation in ruminants for ATP synthesis. Based on the 'ATP concept' of energy metabolism (Chudy, 2000), a model was developed for the indirect estimation of the relative efficiency of energy utilization for ATP synthesis between acetic acid, butyric acid, propionic acid and lactic acid in comparison to glucose in experiments with sheep (Fig. 31.3; Chudy *et al.*, 2001). As supplements to a basal feed ration, VFAs were infused into the rumen and glucose into the abomasum. The specific aspects of the model experiments were: feeding level below maintenance, thermo-neutral conditions (environmental temperature 26°C) and compensation of gluconeogenesis by abomasal infusion of glucose

Table 31.4. Influence of fat (oil) in the basal ration on the efficiency of utilization of metabolizable energy (ME) of a carbohydrate supplement (maize) in difference experiments in rats (Chudy, 1967; Chudy and Schiemann, 1969). Also relative efficiency (relative to carbohydrate).

Target utilization of	Basal ration	Supplement	Efficiency (%)	Relative efficiency (%)
Carbohydrate	Carbohydrate: maize – 76 % of ME	Carbohydrate: 52 % of ME of basal ration	73.4 ± 1.0	100
Carbohydrate	Fat: oil – 50 % of ME	Carbohydrate: 52 % of ME of basal ration	90.4 ± 1.1	123
Fat	Carbohydrate: maize – 76 % of ME	Fat: 50 % of ME of basal ration	90.0 ± 0.9	123

(50g/day) as part of the basal ration and as a supplement. Under these physiological conditions, the differences in energetic efficiency between the investigated substrates for ATP synthesis may be estimated without the effect of certain interactions. The summarized results (Table 31.5) show marked differences in energetic efficiency: glucose (117%) = lactic acid (117%) > propionic acid (100%) > butyric acid (87%) > acetic acid (80%). The estimated efficiency of utilization relative to glucose (glucose = 100%) is glucose:lactic acid:propionic acid:butyric acid:acetic acid = 100:100.6:85.6:74.1:68.5.

These results agree well with the biochemical calculations of utilization for ATP synthesis (100:97:87:95:85) and emphasize the necessity and importance of feed evaluation on the basis of ATP-related NE, which allows an estimate of the real energetic value of feedstuffs in terms of ruminal and metabolic processes, and therefore an objective evaluation (graduation) of feed quality.

Enlargement of database for feed evaluation and standards

Parallel to the fundamental experiments, the systematic investigations of energetic efficiency of different groups of feedstuffs (roughages, silages, tubers and roots, comparisons of fresh and dried feedstuffs) were continued by means of the ration and difference method. A large database from measurements of 65 rations with cattle, 59 rations with sheep, 67 rations with pigs and 29 rations with poultry, each founded on at least four parallel measurements, was available as the basis for the further development of feed evaluation (Schiemann *et al.*, 1971). The mathematical model was widened to consider the influence of rumen digestion products in cattle and sheep. The basal equations for the estimation of feed value, defined as NEF, used in the former (DDR) Rostock Feed Evaluation System were simplified, and for ruminants (cattle) were provided with an additional function for correction of NEF contents of whole rations. The digestibility of energy (DE) was used

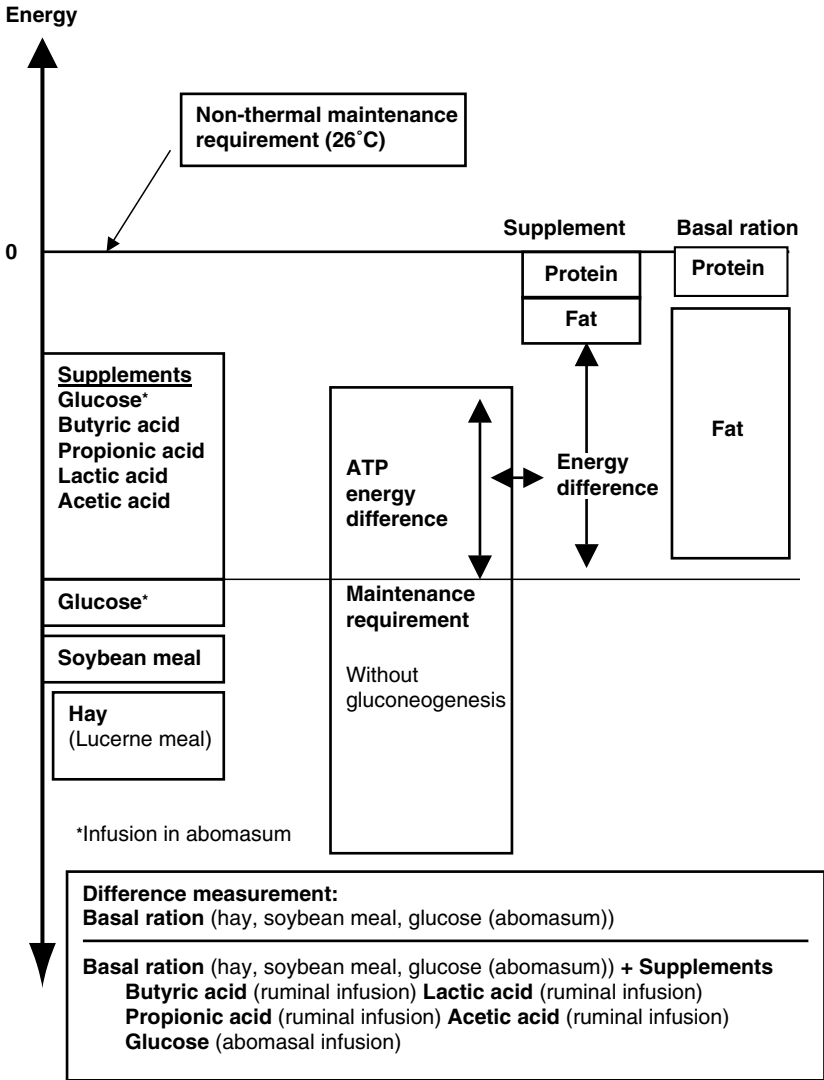

Fig. 31.3. Model for measurement of energetic utilization of ruminally infused volatile fatty acids (VFAs) for maintenance (adenosine triphosphate (ATP) synthesis) in relation to abomasally infused glucose.

in the correction function. The results are shown in Table 31.6. The reference values for ME, NEF, efficiency and relationship of ME agree well with the results described earlier.

The NEF equations for cattle (NEFc), sheep (NEFs), pigs (NEFp) and fowl (NEFf) were estimated as follows:

Table 31.5. Efficiency of utilization of ruminally infused volatile fatty acids (VFAs) for maintenance and efficiency relative to abomasally infused glucose measured at 26°C (Chudy *et al.*, 2000).

Substrate	Energy utilization		
	Efficiency (%)	Relative efficiency	
		Experimental (%)	Theoretical (%)
Glucose	116.8 ± 29	100	100
Butyric acid	86.6 ± 9.2	74	95
Propionic acid	100.0 ± 8.3	86	87
Lactic acid	117.5 ± 5.4	101	97
Acetic acid	79.9 ± 19	68.5	85

Table 31.6. Energetic utilization of digestible nutrients of feedstuffs – full ration measurements (ration method) and multiple regression analyses. Also maintenance requirement and equations for net energy fat (NEF) estimation.

Animal species	Rations (n)	Crude protein (CP)	Crude fat	Crude fibre	Nitrogen-free extract (NFE)	Maintenance (kJ NEF/kg LW ^{0.75})
		ME (kJ/g)				
Cattle	92	18.1	32.4	15.0	15.2	
Sheep	81	18.8	37.9	15.1	15.3	
Pig	67	21.0	37.4	14.4	17.1	
Fowl	29	17.8	39.8	17.7	17.7	
		NE (kJ/g digestible nutrient); correction: Σ NE ration (kJ)*f ^a				
Cattle	92	7.2	31.5		8.4	242
Sheep	81	7.6	35.1		8.0	171
Pig	67	10.7	35.8		12.4	279
Fowl	29	10.8	33.5		13.4	243
		Efficiency of ME utilization (%)				
Cattle		40	97		55	
Sheep		41	93		52	
Pig		51	96		73	
Fowl		61	84		76	
		Relative efficiency of ME utilization (NFE = 100)				
Cattle		72	176		100	
Sheep		78	177		100	
Pig		70	132		100	
Fowl		80	111		100	

^aCattle – f = $-0.549 + 0.04068 \text{ DE} - 0.0002670 \text{ DE}^2$ (ration, when DE > 70%).

Sheep – f = $-0.617 + 0.04419 \text{ DE} - 0.0003018 \text{ DE}^2$ (ration, when DE > 70%).

$$\text{NEFc (kJ)} = (7.2 \text{ dCP} + 31.5 \text{ dCF} + 8.4 (\text{dCFi} + \text{dNFE}) * (-0.549 + 0.04068 \text{ DE} - 0.000267 \text{ DE}^2))$$

$$\text{NEFs (kJ)} = (7.2 \text{ dCP} + 35.1 \text{ dCF} + 8.0 (\text{dCFi} + \text{dNFE}) * (-0.617 + 0.04419 \text{ DE} - 0.0003018 \text{ DE}^2))$$

$$\text{NEFp (kJ)} = (10.7 \text{ dCP} + 35.8 \text{ dCF} + 12.4 (\text{dCFi} + \text{dNFE}))$$

$$\text{NEFf (kJ)} = (10.8 \text{ dCP} + 33.5 \text{ dCF} + 13.4 (\text{dCFi} + \text{dNFE}))$$

where d = digestible, C = crude, P = protein, F = fat, Fi = fibre, NFE = nitrogen-free extract, DE = energy digestibility.

These equations, except for sheep (because a separate feed table for sheep was not deemed necessary), were the basis of feed evaluation in the former DDR. The energy measure, NEF, as well the equations, was converted into feed units and used as the foundation of feed evaluation in agricultural practice from 1971 until 1990. The practical application includes the results of the estimations of energy requirement for different levels of animal performance. The former Rostock Feed Evaluation System ('DDR-Futterbewertungssystem'), based on NEF, was published in seven editions (Autorenkollektiv, 1971, 1989). The system was totally used in feed production, feeding, economic evaluation and feed planning in farms with high success in the whole country.

Further development of feed evaluation

Later, the database was extended to 110 rations for cattle, 92 rations for pigs and 78 rations for fowl by further experiments. Meanwhile the methods of feed analysis were partially changed. As well as the traditional parameters, such as crude protein (CP) and crude fat, the contents of starch and sugar were analysed and by difference to organic matter (OM), the content of 'nitrogen-free residue (NFR)' was calculated (Hoffmann *et al.*, 1993). These new analytical parameters could be estimated subsequently, because the feed samples from the respiration experiments were stored. For the new revision of the NEF equations, the mathematical model was widened to include the new variables and also a factorial function for integration of the influence of rumen digestion products in cattle or of the colon digestion products (VFAs) in pigs on energy utilization dependent on DE (Jentsch *et al.*, 2000, 2001).

The equations for NEF estimation for cattle(c), pigs(p) or fowls(f), respectively, are:

$$\text{NEFc(kJ)} = (a_1 \text{dCP} + a_2 \text{dCF} + a_3 \text{dST} + a_4 \text{dSU} + a_5 \text{dNFR}) * f[= f(\text{DE})] - a_5 \text{BW}(\text{kg}, \text{kg}^{0.75}) \pm \text{SD} (\text{kJ}, \%)$$

$$\text{NEFc(kJ)} = a_1 \text{dCP} + a_2 \text{dCF} + a_3 \text{dST} + a_4 \text{dSU} + a_5 [= f(\text{DE})] \text{dNFR} - a_6 \text{BW}(\text{kg}, \text{kg}^{0.75}) \pm \text{SD} (\text{kJ}, \%)$$

$$\text{NEFc(kJ)} = a_1 \text{dCP} + a_2 \text{dCF} + a_3 \text{dST} + a_4 \text{dSU} + a_5 \text{dNFR} + a_6 \text{BW}(\text{kg}, \text{kg}^{0.75}) \pm \text{SD} (\text{kJ}, \%)$$

where d = digestible, C = crude, P = protein, F = fat, Fi = fibre, NFE = nitrogen-free extract, DE = energy digestibility.

The results are shown in Table 31.7. The NEF values, as well as the efficiency and relationships of utilization of ME from the digestible nutrients derived from the extended parameters, agree with the results described earlier.

The modelling of the complete intermediary substrate and energy metabolism system (Fig. 31.4) according to the ATP concept (Chudy, 2000) suggests that: (i) except for chemical heat regulation, all energy metabolism processes consume or produce ATP-bound energy; (ii) only the efficiency of the partially utilized substrates for ATP synthesis determines the energy metabolism (HP) quantitatively and qualitatively; (iii) the gain or secretion of body nutrients is only a storage or exchange of ATP potentials, misleadingly expressed in terms of gross energy; and (iv) the incorporation of fatty acids and amino acids may be viewed as a transfer of substrates and of their ATP potential with consumption of ATP-bound energy and not as the result of metabolic substrate utilization for synthesis. Therefore the basis for energetic feed efficiency has to be the potential in catabolic processes but not in

Table 31.7. Energetic utilization of digestible nutrients of feedstuffs – full ration (ration method) measurement and multiple regression analyses, maintenance requirement and new revision of equations for net energy fat (NEF) and net energy retention (NER) estimation.

Animal species	Rations	Crude protein (CP; a ₁)	Crude fat (a ₂)	Starch (a ₃)	Sugar (a ₄)	Nitrogen-free residue (NFR; a ₅)	Maintenance (kJ NE/kg ^{0.75})
Metabolizable energy (kJ/g)							
Cattle	110	17.3	34.0	15.9	15.1	15.4	
Pig	92	20.5	39.8	17.3	16.0	17.0	
Fowl	78	18.8	39.8	17.3	16.0	17.2	
NE (kJ/g digestible nutrient)							
			NEF	NER^b			
Cattle ^a	110	7.2	26.6	20	10.1	8.3	248
Pig	92	11	34.0	27	12.7	11.6	279
Fowl	78	10.8	33.5	29	13.5	12.4	243
Efficiency of ME utilization (%)							
Cattle		42	78	59	64	55	53
Pig		54	85	68	73	73	71
Fowl		57	84	73	78	78	61
Relative efficiency of ME utilization (starch = 100)							
Cattle		66	123	92	100	87	84
Pig		73	116	92	100	99	96
Fowl		74	108	92	100	99	78

Corrections:

^aCattle Σ NE (kJ) \cdot f (f = -0.55574 + 0.04050 DE - 0.0002633 DE²) (single feedstuff when DE < 70%).

^bNER – efficiency of fat utilization reduced to 92% of the efficiency of carbohydrate utilization (starch).

^cPig a₅ (NFE (kJ/g)) = 12 - (0.14(80 - DE) \cdot NFR(g)) (DE \leq 80%).

anabolic processes. The balance of ATP-bound energy is the only additive NE balance, because the feed energy, maintenance requirements, work and also, instead of gross energy, the retained body nutrients (gain, secretions) can be expressed in a uniform additive scale, the ATP-related energy. The ATP-related NE, as a measure, is the characterization of the energetic potential of nutrients and feedstuffs in the ATP pool, which is available for all performances (activities) in the animal. The use of this energetic potential (pool) is mostly determined by animal factors (physiological state), which consequently must be defined by standards for nutritional requirements. Therefore, the new revised Rostock Feed Evaluation System (Jentsch *et al.*, 2003) uses, with NER, the relative utilization of ME of the digestible nutrients for ATP synthesis (catabolic processes) as the measure (scale), derived for protein and carbohydrates from measurements of fat synthesis and reduction of fat utilization relatively to 92% of the utilization of carbohydrates, as found in experiments and theoretical derivations. The revised fat values also are shown in Table 31.7. In this way it was possible to exclude the energetic overevaluation of protein and fibre in the case of ME and of feed fat in the case of NEF as measures of energetic feed value.

NER was taken as a uniform relative measure for energetic feed evaluation and characterization of the energy requirement of farm animals. NER acts merely as an experimentally measurable and universal parameter for the biologically utilizable feed energy, and correlates closely with the ATP potential of nutrients and feedstuffs as well as with the energetic potential for all energy-consuming reactions of the animal body as the energy requirement for different performances (Schiemann *et al.*, 1971).

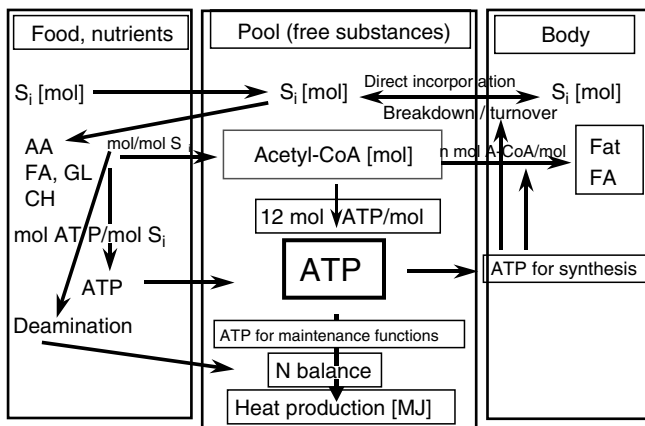

Fig. 31.4. Model of intermediary metabolism according to the adenosine triphosphate (ATP) concept. S = substrate, AA = amino acids, FA = fatty acids, GL = glycerine, CH = carbohydrates.

The equations for NER for cattle (c), pigs (p) and poultry (fowl) (f) are:

$$\text{NER}_c = (7.2 \text{ dCP} + 20 \text{ dCF} + 10.1 \text{ dSt} + 8.3 \text{ dSu} + 8.2 \text{ dNFR})^* \\ (-0.5574 + 0.0405 \text{ DE} - 0.0002633 \text{ DE}^2)$$

$$\text{NER}_p = 11.0 \text{ dCP} + 27 \text{ dCF} + 12.7 \text{ dSt} + 11.6 \text{ dSu} + [12 - \\ 0.14(80 - \text{DE})] \text{ dNFR}$$

$$\text{NER}_f = 10.8 \text{ dCP} + 29 \text{ dCF} + 13.5 \text{ dSt} + 12.4 \text{ dSu} + 10.5 \text{ dNFR}$$

where d = digestible, C = crude, P = protein, F = fat, Fi = fibre, NFE = nitrogen-free extract, DE = energy digestibility.

Conclusions

The genesis of the Rostock Feed Evaluation System is an example of a successful research approach, characterized by modelling, experimental verification and transformation to practical application. It emphasizes the importance of the modelling of physiological processes and, therefore, the theoretical clarification of processes before starting the experimental investigations.

The revised Rostock Feed Evaluation System represents the European tradition; it is based on over 50 years of systematic research, including results of other research teams and institutions, tested on farms and applied totally in the agricultural practice of a whole country. It represents the practical application of actual scientific knowledge.

The Rostock Feed Evaluation System is the only uniform feed evaluation system for all animal species and is recommended for practical application in European agriculture.

References

- Autorenkollektiv (1971) *Das DDR-Futterbewertungssystem – 1. Auflage*, VEB Dt. Landwirtschaftsverlag, Berlin, 205 pp.
- Autorenkollektiv (1989) *DDR-Futterbewertungssystem – 7. Auflage*, VEB Dt. Landwirtschaftsverlag, Berlin, 328 pp.
- Chudy, A. (1967) Zur energetischen Verwertung der Nähr- und Futterstoffe für Erhaltung und Fettbildung: Modellversuche an Ratten. Dissertation Deutsche Akademie der Landwirtschaftswissenschaften. Sektion Tierzucht, Tierernährung und Fischerei, Berlin, 166 pp.
- Chudy, A. (2000) Model for the interpretation of energy metabolism in farm animals. In: McNamara, J.P., France, J. and Beever, D.E. (eds) *Modelling Nutrient Utilization in Farm Animals*. CAB International, Wallingford, UK, pp. 329–364.
- Chudy, A. and Schiemann, R. (1969a) Utilization of dietary fat for maintenance and fat deposition in model studies with rats. In: Blaxter, K., Thorbek, G. and Kielanowski, J. (eds) *IVth Symposium on Energy Metabolism of Farm Animals*. EAAP publication No. 12. Oriel Press, Newcastle, UK, pp. 161–168.
- Chudy, A. and Schiemann, R. (1969b) Zur energetischen Verwertung der Nähr- und Futterstoffe für Erhaltung und Fettbildung. 1. Mitteilung: Die energetische Verwertung der Nährstoffe für Erhaltung oberhalb der kritischen Temperatur nach Versuchen an Ratten. *Archiv für Tierernährung Berlin* 19 (4), 31–247.

- Chudy, A., Shen, Z. and Bellmann, O. (2001) Relations of utilization by ATP-synthesis of rumen fermentations products (VFAs and lactic acid) in sheep. In: Chwalibog, A. and Jakobsen, K. (eds) *Proceedings of the 15th Symposium on Energy Metabolism in Farm Animals*. EAAP publication No. 103. Snekkersten, Denmark, pp. 221–224.
- Hoffmann, L., Jentsch, W. and Beyer, M. (1993) Abhängigkeit von Brutto-, verdaulicher und umsetzbarer Energie des Futters sowie des Energieansatzes vom Gehalt an verdaulichen Nährstoffen unter Berücksichtigung von Stärke und Zucker, ein Beitrag zur Weiterentwicklung der energetischen Futterbewertung. 2. Mitt.: Ergebnisse aus Untersuchungen mit Rindern. *Archive Animal Nutrition* 44, 235–250.
- Jentsch, W., Chudy, A. and Beyer, M. (2000) Die Rostocker Arbeiten zur energetischen Futterbewertung und zum Energiebedarf landwirtschaftlicher Nutztiere. 1. Mitt.: Historischer Rückblick und die Arbeiten in Rostock zur energetischen Futterbewertung. *Übersichten für Tierernährung* 28, 133–182.
- Jentsch, W., Beyer, M. and Chudy, A. (2001) Die Rostocker Arbeiten zur energetischen Futterbewertung und zum Energiebedarf landwirtschaftlicher Nutztiere. 2. Mitt.: Zur Weiterentwicklung des Rostocker Futterbewertungssystems. *Übersichten für Tierernährung* 29, 1–44.
- Jentsch, W., Chudy, A. and Beyer, M. (2003) *Rostock Feed Evaluation System: Reference Numbers of Feed Value and Requirement on the Base of Net Energy*. Plexus Verlag, Miltenberg, Frankfurt, Germany, 392 pp.
- Schiemann, R. (1958) *Kritische Betrachtungen über die Entwicklung der Stärkewertlehre Oskar Kellners*. *Wissenschaftliche Abhandlungen Nr. 31*. Deutsche Akademie der Landwirtschaftswissenschaften Berlin, Akademie Verlag, Berlin, 110 pp.
- Schiemann, R., Jentsch, W., Hoffmann, L. and Wittenburg, H. (1970) Die Verwertung der Futterenergie für die Milchproduktion: 1. Untersuchungen an Tieren mit verschiedenem Leistungspotential. *Archiv für Tierernährung* 20, 227–251.
- Schiemann, R., Nehring, K., Hoffmann, L., Jentsch, W. and Chudy, A. (1971) *Energetische Futterbewertung und Energienormen*. VEB Deutscher Landwirtschaftsverlag, Berlin, 344 pp.

32 The Nordic Dairy Cow Model, Karoline – Description

A. DANFÆR,¹ P. HUHTANEN,² P. UDÉN,³
J. SVEINBJÖRNSSON⁴ AND H. VOLDEN⁵

¹Danish Institute of Agricultural Sciences, Research Centre Foulum, PO Box 50, 8830 Tjele, Denmark; ²MTT Agrifood Research Finland, Animal Production Research, FIN-31600 Jokioinen, Finland; ³Swedish University of Agricultural Sciences, Department of Animal Nutrition and Management, Kungsängen Research Centre, 75323 Uppsala; ⁴Agricultural University of Iceland, Department of Natural Resources, Keldnaholt v/Vesturlandsveg, IS-112 Reykjavík, Iceland; ⁵Agricultural University of Norway, PO Box 5025, 1432 Ås, Norway

Abstract

The Karoline model described in this study is a whole-animal cow model intended to be used by the advisory services in the Nordic countries, i.e. Denmark, Finland, Iceland, Norway and Sweden. Karoline is a dynamic, deterministic and mechanistic simulation model of lactating dairy cows. It consists of two submodels: a digestion and a metabolism model. The first describes digestion in the forestomachs, the small intestine and the hindgut, while the second comprises portal-drained viscera (PDV), liver, extracellular fluid and mammary gland, as well as muscle, connective and adipose tissues. The model inputs are live weight (LW), week of lactation, rate of dry matter intake (DMI) and DM composition. Parameters describing the feed are crude protein (CP), crude fat, potentially degradable neutral detergent fibre (NDF), totally indigestible NDF, starch (St), fermentation products and a rest fraction (RF; sugars and other organic matter (OM) are not accounted for). The CP fraction is further divided into NH_3 , amino acids (AA), peptides (PEP), soluble protein (SP), insoluble protein (ISP) and totally indigestible protein. Rate constants for ruminal degradation of NDF, protein and St also have to be provided.

In the digestion submodel, ruminal degradation and passage of carbohydrates and protein is described by using two-compartment models. Rates of passage from the rumen are regulated by the NDF intake per kg LW. The rate of NDF degradation in the rumen is regulated by the ratio of non-structural carbohydrates to NDF. The fermentation pattern in the rumen is predicted by stoichiometric equations adjusted for feeding level and crude fat in concentrates. The efficiency of microbial protein synthesis (MPS) depends on the ruminal level of NH_3 .

In the metabolism submodel, nutrient partitioning between tissues as well as a number of intracellular transactions are regulated by the stage of lactation. The rates of nutrient oxidation are determined by the need of adenosine triphosphate (ATP) for tissue maintenance and product syntheses. The heat production (HP) in individual segments of the model is calculated according to the law of energy conservation.

Animal performance is calculated from relevant nutrient and energy flows when the model has reached steady state. To the extent that the output from Karoline is reliable, the simulated animal performance (e.g. milk yield (MY), body weight (BW) change, faecal, urinary and gaseous wastes, HP) expresses the real value of a given feed in a given situation. Thus, Karoline is a tool of great potential value to advisory services.

Introduction

Traditional feed evaluation systems determine the value of feedstuffs and feed rations on the basis of their chemical composition and apparent digestibility of the individual chemical fractions. One problem with these systems is that they are additive and ignore significant interactions in the digestion and metabolism of nutrients. This means that according to these systems, a given feedstuff and thereby a given feed ration has just one value, which we will call a *standard value*. However, the actual value of a feed is not necessarily what can be found in a feed table, but it is an expression of the animal performance resulting from the use of this feed, and it depends, besides the chemical composition, also on feeding level, physiological state of the animal as well as other factors of importance for nutrient digestion and utilization. We call this actual feed value a *real value* in contrast to the standard value, and it follows that a given feedstuff or feed ration can have many real values depending on the above-mentioned factors.

In fact, the real feed value cannot be determined until after the diet has been fed and animal performance has been recorded. However, the purpose of a feed evaluation system is to estimate feed values beforehand, which leads to the need for a tool to predict the performance of animals taking into consideration interactions between feed constituents, feeding level, animal physiology, etc. We believe that a dynamic, mechanistic whole-animal simulation model could be such a tool.

We have developed Karoline, a dairy cow simulation model intended for use as a diet evaluation tool by the advisory services in the Nordic countries, i.e. Denmark, Finland, Iceland, Norway and Sweden. The aim of this study is to present and describe Karoline – not in full detail, but to the extent that the reader may get an understanding of the model structure and how key processes in nutrient digestion and metabolism are modelled.

Overall Model Description

Karoline is a dynamic, mechanistic and deterministic whole-animal model of a lactating dairy cow. It consists of two submodels, one describing nutrient digestion and the other describing metabolism of absorbed nutrients. The first comprises the forestomachs, small intestine and hindgut, and the second includes the PDV, liver, extracellular fluid, and mammary gland as well as muscle, connective and adipose tissues.

The model is programmed in POWERSIM® 2.5, which is a graphical modelling software (Powersim, 1996). The POWERSIM program (340 kB) is connected to an Excel spreadsheet, the 'Feed mixer' (485 kB), for exchange of input and output data. The 'Feed mixer' consists of five sheets:

1. An 'Export-Import' sheet from which data are exchanged with the POWERSIM program and where a large number of parameters are calculated for use in the simulation model.
2. A 'Mixer' sheet where the diet is composed and where the cow's BW and stage of lactation are specified.
3. A 'Feeds' sheet, which is a library of available feedstuffs and their chemical composition.
4. A 'Results' sheet presenting outputs from the model in terms of animal performance and feed values of the ration.
5. A 'Log' sheet where simulation results from sequential runs can be saved and stored.

The model uses hour as the time unit, the iteration step is 0.1 h and the simulation time per run is 720 h to ensure that steady state is obtained. The method of integration is Runge-Kutta 4 (variable step).

Input parameters for Karoline are rate of feed intake, feed composition and description of the cow. The dietary inputs are entered as kg DM/day of individual feedstuffs chosen from the 'Feeds' sheet, and the cow is described in terms of LW and week of lactation. Feeds are classified as forage (f) or concentrates (c), and parameters describing feed composition are CP, crude fat (CF), potentially digestible forage (f) and concentrate (c) neutral detergent fibre (fDNDF, cDNDF), totally indigestible NDF (fINDF, cINDF), St, lactate (La), acetate (Ac), propionate (Pr), butyrate (Bu) and RF, i.e. sugars and other OM are not accounted for. The CP fraction is further divided into ammonium (NH₃), AA, PEP, SP, insoluble, degradable protein (fISP, cISP) and totally indigestible protein (fIDP, cIDP). Fermentation rate constants for DNDF, ISP and St also have to be provided.

The output from Karoline as presented in the 'Results' sheet includes parameters describing efficiencies of digestion and nutrient utilization (ruminal and faecal nutrient digestibilities, efficiency of rumen MPS, utilization of metabolizable energy (ME) for lactation), production (MY and milk composition, LW gain and composition) as well as protein and energy values of the ration in terms of metabolizable protein (MP), ME and net energy (NE).

The Digestion Submodel

The three segments in this submodel – the forestomachs, the small intestine and the hindgut – are briefly described. Emphasis is put on key processes of nutrient digestion and absorption. The units of state variables are g for carbohydrates and lipids, g N for protein and other nitrogenous compounds

and mol C for rumen and hindgut fermentation products. The nomenclature used is not consistent throughout the submodel.

Digestion in the forestomachs

Carbohydrates in the forestomachs are organized in a single array consisting of fDNDF, fINDF, cDNDF, cINDF, St, RF and La. The array for insoluble protein (ISP) consists of fISP, fIDP, cISP and cIDP. The degradation of carbohydrates and protein is modelled as a two-compartment system comprising a non-escapable (NE) and an escapable (E) pool. The NE pool represents large particles, which are not able to pass from the rumen, and the E pool represents particles sufficiently reduced in size to pass from the rumen. Dietary input enters the NE pool where the material is fermented or released to the E pool, but does not pass out of the forestomachs. The E pool is subjected to both fermentation and passage (see Figs 32.1 and 32.2). Rates of fermentation, release and passage are described by first order mass action kinetics.

Rates of release from the NE pools and passage from the E pools are regulated by the intake of NDF/kg LW. Release and passage rate factors for the individual carbohydrate and protein fractions are derived from a general passage rate factor for indigestible NDF in forages: $Kp'(fINDF) = 0.0083 + 0.001 \cdot TNDF/LW$, where TNDF is total NDF intake (g/day) and LW is live weight of the cow (kg). This relationship between passage rate and NDF intake is derived from unpublished rumen evacuation studies (P. Huhtanen, MTT Finland, 2004, personal communication).

The release rate factor (Kr) for NDF and protein in forages is calculated as: $Kr(fDNDF, fINDF, fISP, fIDP) = Kp'(fINDF)/fMRT_NE$, where $fMRT_NE = 0.3$ is the mean retention time (MRT) of forage NDF in the NE pool as a proportion of the total MRT. The value 0.3 represents the mean of a wide range of values estimated from duodenal marker profiles (Pond *et al.*, 1987; Huhtanen and Kukkonen, 1995; Lund, 2002). The release rate factor for NDF and protein in concentrates and for St, RE and La is calculated as: $Kr(cDNDF, cINDF, cISP, cIDP, St, RF, La) = 1.6 \cdot Kp'(fINDF)/cMRT_NE$, where $cMRT_NE = 0.2$ is the MRT of NDF in concentrates in the NE pool as a proportion of the combined MRT in both pools. Because the passage rate of concentrates is higher than that of forages (Owens and Goetsch, 1986; Cannas and Van Soest, 2000), a proportionality factor of 1.6 is used to calculate the release and passage rate constants for concentrates. The value 0.2 is based on the smaller particle size and lower proportional MRT of concentrates (Huhtanen *et al.*, 1993).

The passage rate factor (Kp) for NDF and protein in forages is calculated as: $Kp(fDNDF, fINDF, fISP, fIDP) = Kp'(fINDF)/(1 - fMRT_NE)$. The passage rate factor for NDF and protein in concentrates and for St, RF and La is calculated as: $Kp(cDNDF, cINDF, cISP, cIDP, St, RF, La) = 1.6 \cdot Kp'(fINDF)/(1 - cMRT_NE)$.

The degradation rate constants (Kd) for DNDF, ISP and St in individual feeds are given in the feed table of the 'Feed mixer'. Composite Kd values for the total diet are calculated according to the following formula for the NE pools: $Kd_NE = Kr_i / \{\sum Nu_{ij} / \sum [Nu_{ij} / (1 + Kr_i / Kd_{ij})] - 1\}$, where Nu_{ij} is the con-

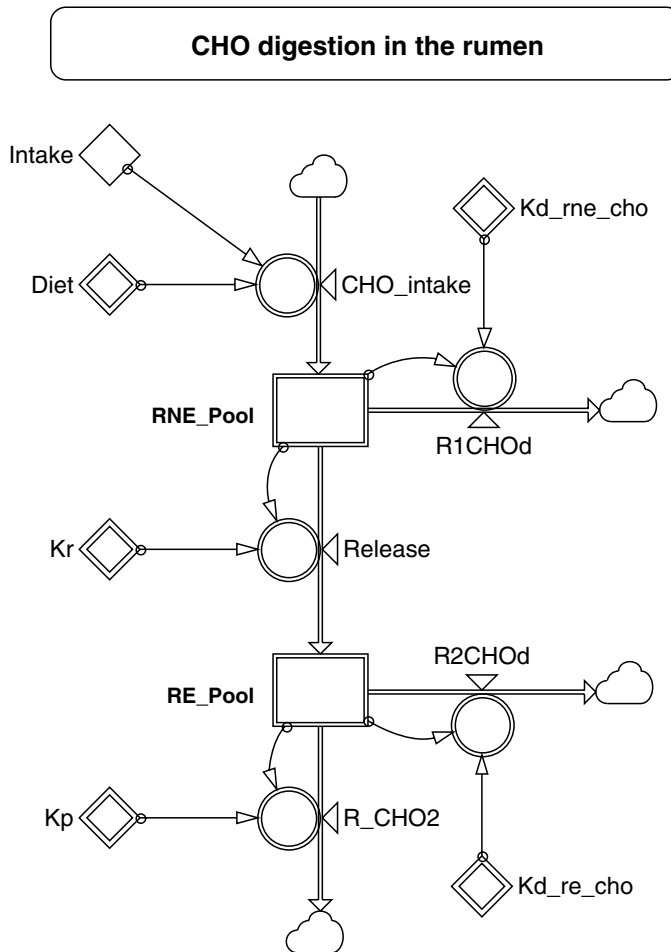

Fig. 32.1. POWERSIM diagram of carbohydrate digestion in the forestomachs. Square boxes are state variables (nutrient pools), circles attached to double-lined arrows are rate variables (nutrient flows), circles without arrows are auxiliary variables and diamond boxes are constants. Arrays are represented by double-lining of squares, circles and diamonds. Single-line arrows mean that the connected symbols are mathematically related.

tent of nutrient (i), i.e. fDNDF, cDNDF, fISP, cISP or St, in feedstuff (j), Kd_{ij} is the corresponding degradation rate constant and Kr_i is the release rate factor for nutrient (i). Composite Kd values for the E pool are calculated similarly: $Kd_E = Kp_i / \{\sum Nu_{ij} / \sum [Nu_{ij} / (1 + Kp_i / Kd_{ij})] - 1\}$, where Kp_i is the passage rate factor for nutrient (i). These formulas are derived under the assumption that Kr_i and Kp_i values do not differ between individual feedstuffs. The composite Kd values are calculated separately for concentrates and forages as the Kr and Kp values are different for these two categories of feed (due to different MRTs).

The long-chain fatty acid (LCFA) content (kg/kg DM) of concentrates and forages is calculated from empirical relations between crude fat and

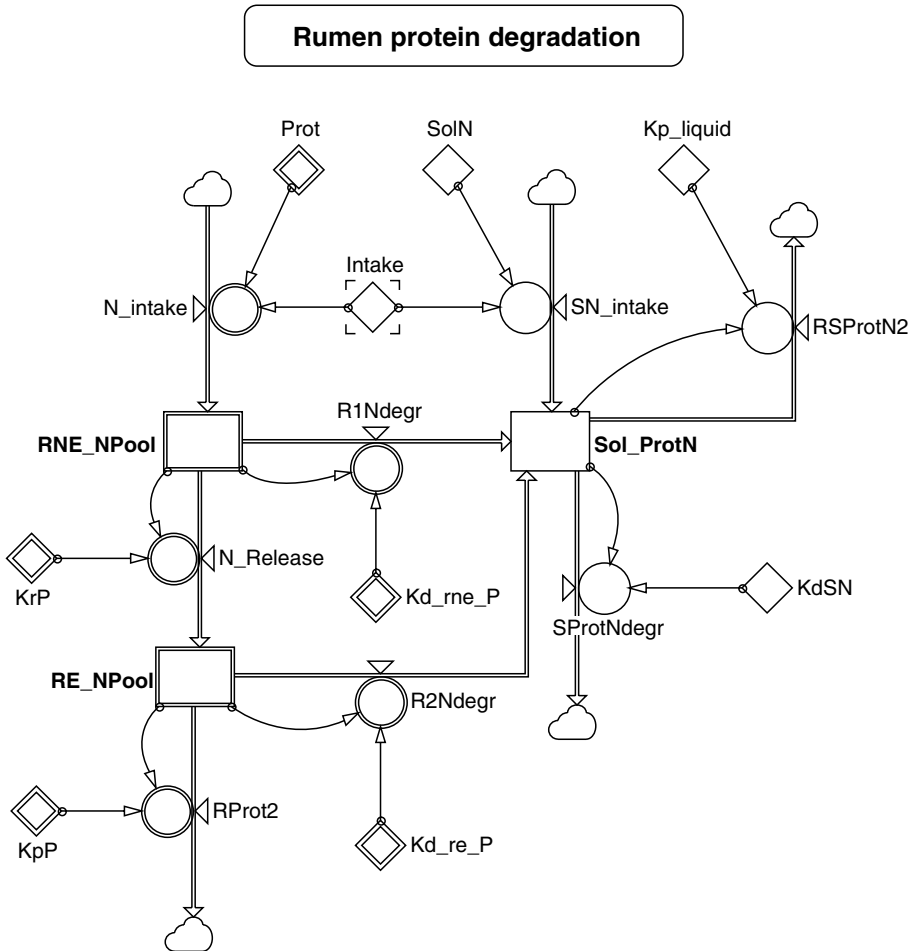

Fig. 32.2. POWERSIM diagram of protein degradation in the forestomachs. For explanation of symbols, see legend to Fig. 32.1.

LCFA (P. Udén, Uppsala, 2003, personal communication): $LCFA(c) = 0.904 * EE(c) - 0.00361$ and $LCFA(f) = 0.484 * EE(f) - 0.0013$, where EE is the crude fat content (kg/kg DM).

Feed carbohydrates

Pools of dietary carbohydrates in the forestomachs are represented by two state variables: NE carbohydrates (RNE_Pool) and E carbohydrates (RE_Pool) containing the previously described array of components (fDNDF, fINDF, cDNDF, cINDF, St, RF and La). The dietary input (CHO_intake) arrives at the RNE_Pool. Here it is degraded (R1CHOd) or released (Release) to the RE_Pool from where it is degraded (R2CHOd) or transported (R_CHO2) to the small intestine (Fig. 32.1).

The composite degradation rates of DNDF are regulated by the ratio of soluble 'carbohydrates' to total NDF in the diet (Sol/TNDF), where Sol (g/day) is the sum of St, RF, La, Ac, Pr and Bu. The degradation rate factors for DNDF fractions in concentrates and forages in the RNE_Pool and the RE_Pool are calculated as their respective composite Kd values times a Kd regulating factor = $\exp[-0.28 \cdot (\text{Sol}/\text{TNDF})^{2.4}]$. This means that rates of NDF fermentation in the forestomachs decrease with increasing dietary content of easily fermentable carbohydrates like sugar and St as well as fermentation products. The relationship is estimated from results of unpublished rumen evacuation studies on NDF digestion (P. Huhtanen, MTT Finland, 2004, personal communication).

Feed nitrogen

Six state variables represent dietary nitrogen in the forestomachs (Figs 32.2 and 32.3). Insoluble NE (RNE_Npool) and E protein (RE_Npool) contain the array described earlier (fISP, fIDP, cISP and cIDP). The soluble pools are SP (Sol_ProtN), PEP (Pept_N), AA (Amino_N) and ammonium (Ammonia_N). The origin of the last mentioned pool is partly dietary and partly endogenous. The dietary input (N_intake) of ISP and IDP enters the RNE_Npool, from which ISP is degraded (R1Ndegr) to SP or released (N_Release) to the RE_Npool together with IDP. In this pool, ISP degrades (R2Ndegr) to SP or passes (RProt2) to the small intestine together with IDP. The dietary intake (SN_intake) of SP and the degraded ISP enter the Sol_ProtN pool and are further degraded (SProtNdegr) to PEP or transported (RSProtN2) from the forestomachs to the small intestine (Fig. 32.2). The Pept_N pool receives PEP from dietary input (PeptN1) and from degradation of SP. Outflows from the pool are degradation (Pept_degrad) to AA and passage (PeptN2) to the small intestine. Entries to the Amino_N pool are dietary input (AAN1), degraded PEP and degraded microbial protein (RNitr_rec). Outflows are degradation to ammonium (AAN_deam), MPS (MPS_AAN) and passage to the small intestine (AAN_2). Throughout the model, AA refer to a common AA pool with no differentiation between individual AA. Inputs to the Ammonia_N pool are dietary ammonium (NH₃N1), degraded AA and degraded urea (Urea_recycle). Outflows are MPS (MPS_NH₃), absorption (NH₃abs) from the rumen and passage (NH₃N2) to the small intestine (Fig. 32.3). The absorption rate factor is dependent on the ruminal ammonium level: $K_{\text{NH}_3\text{abs}} = 0.25 \cdot \text{Ammonia_N}/6$. This equation is based on data from Sidons *et al.* (1985).

The rate of urea recycling into the rumen is a function of DMI: $\text{Urea_recycle} = 0.7 \cdot 3.3 \cdot \text{Intake}/1000$, where Intake is g DMI/h and the factor 3.3 g N/kg DMI is an assumed recycling of urea to the entire digestive tract. A further assumption is that 70% of this recycling enters the rumen. The rate factor (Kp_liquid) for passage of water-soluble substances, i.e. SP, PEP, AA and NH₃, is related to the total NDF intake (g/kg LW): $K_{\text{p_liquid}} = 0.08 + 0.004 \cdot \text{TNDF}/\text{LW}$. The equation is derived from results of digestibility studies carried out in the Nordic countries (P. Huhtanen, MTT Finland, 2004, personal communication).

Rumen nitrogen metabolism

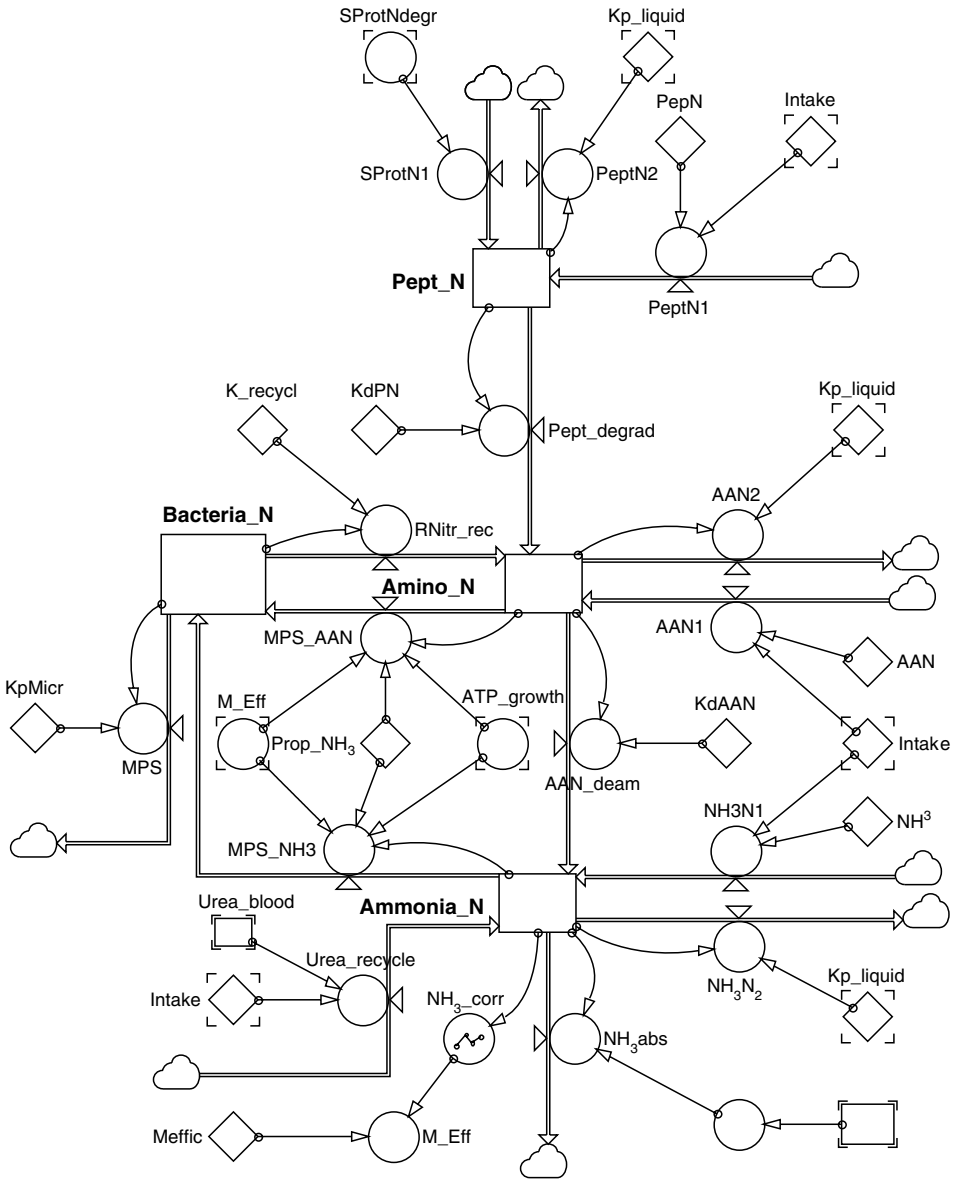

Fig. 32.3. POWERSIM diagram of peptide (PEP), amino acid (AA) and ammonium metabolism in the forestomachs. For explanation of symbols, see legend to Fig. 32.1.

Feed lipids

Pools of dietary lipids in the forestomachs are represented by three state variables as shown in Fig. 32.4: esterified LCFA (RuFat_Pool), non-esterified LCFA (Rumen_FAPool) and glycerol (Ru_Glycerol). The dietary triglyceride FA enter (FA_intake) the RuFat_Pool and pass (Lipolysis) as free FA to the Rumen_FAPool. Throughout the digestion submodel, LCFA refers to a common FA pool with no differentiation between individual FA. The released glycerol enters (Glycerol_release) the Ru_Glycerol pool from where it is fermented (Glyc_ferm) like the non-triglyceride fraction of the dietary crude fat. Outflows from the free FA pool are uptake (FA_uptake) into microbes and passage (RFA2) to the small intestine using the same passage rate factor as for INDF in concentrates. An absorption flow rate (RFA_d) is shown in Fig. 32.4, but the absorption of LCFA from the forestomachs is assumed to be zero.

Microbial transactions

Pools of fermentation products in the forestomachs are represented by six state variables: Ac (RAc), Pr (RPr), Bu (RBU), branched chain FA (R_BCFA), carbon dioxide (R_{CO₂}) and methane (R_{CH₄}). Pools of microbial constituents are: microbial protein (Bacteria_N), microbial cell wall carbohydrates (Microbial_CWCHO), microbial St (Micr_Starch), microbial fermentable carbohydrates (R_fmCHO) and microbial FA (Microbial_FA).

Entries to the pools of fermentation products (RAc, etc.) are rates of ruminal production and rates of dietary input from silage and other fermented feeds. Outflows are absorbed volatile fatty acids (VFAs) and released fermentation gases. The substrates of fermentation are the potentially degradable carbohydrates (including the non-FA fraction of crude fat) and protein. The fermentation pattern including ATP production is calculated from stoichiometric equations adjusted for effects of feeding level and content of crude fat in concentrates (see Sveinbjörnsson *et al.*, Chapter 1, this volume for details). Entry to the BCFA pool (R_BCFA) is derived from protein fermentation while outflows are absorption from the forestomachs and uptake by microbes for synthesis of branched chain AA.

Inflows to the Bacteria_N pool are protein syntheses from AA (MPS_AAN) and from ammonium (MPS_NH₃); outflows are degradation (RNitr_rec) into AA and passage (MPS) to the small intestine. Thus, the rate of MPS is the sum of syntheses from preformed AA and from ammonium: $MPS_{AAN} + MPS_{NH_3} = ATP_{growth} * M_{Eff}$ (Fig. 32.3). It is assumed that 70% of the synthesis is from ammonium ($Prop_{NH_3} = 0.7$). ATP available for microbial growth is calculated as: $ATP_{growth} = RuATP - Bacteria_N * BactMR$ (mol ATP/h), where RuATP is the total ATP production in the forestomachs, Bacteria_N is the microbial protein pool (g N), and BactMR is microbial maintenance requirement (mol ATP/(h* g N), which is calculated as: $(0.017 * DNDF + 0.051 * Sol) / (DNDF + Sol)$. This equation takes into account a higher maintenance requirement for amylolytic than for cellulolytic bacteria (Sniffen *et al.*, 1992). The efficiency of MPS, M_Eff, has a maximum value ($M_{effic} = 2.0$ g N/mol ATP; Hespell and Bryant, 1979), but is reduced when the Ammonia_N pool drops below 4 g N equivalent to 2.8 mM ammonium, assuming a rumen

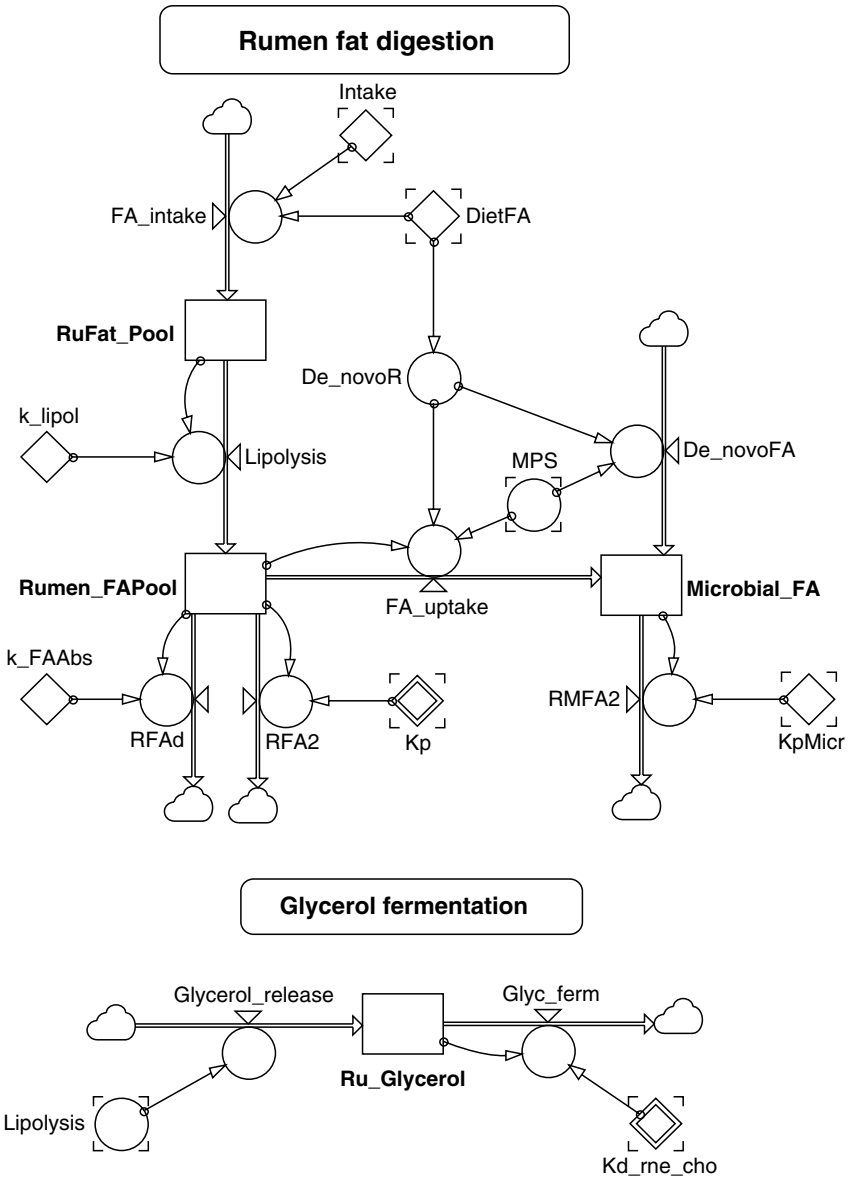

Fig. 32.4. POWERSIM diagram of lipid metabolism in the forestomachs. For explanation of symbols, see legend to Fig. 32.1.

liquid space of 80 l. This threshold value is a conservative estimate from data of Marini and Van Amburgh (2001). The synthesis of microbial carbohydrates and lipids is linked to the synthesis of protein via an assumed fixed chemical composition of microbial OM: 50.3% potentially digestible protein, 8.4% indigestible cell wall protein, 8.0% St, 9.9% potentially fermentable carbohydrate, 10.9% indigestible cell wall carbohydrate and 12.5% lipid.

Inflows to the microbial carbohydrate pools (Microbial_CWCHO, Micr_Starch and R_fmCHO) are the microbial syntheses, which are linked to the MPS at constant proportions as described above. Outflows are transports to the small intestine. Inputs to the microbial FA pool are dietary FA: $FA_{uptake} = 1.38 * MPS * (1 - De_novoR)$, and from *de novo* synthesis: $De_novoFA = 1.38 * MPS * De_novoR$. MPS is microbial net protein synthesis (g N/h), 1.38 is the ratio of microbial lipid to microbial nitrogen and De_novoR is the ratio of *de novo* to dietary FA in microbes: $De_novoR = \exp(-6.5 * DietFA^{0.55})$. This ratio is decreasing with increasing intake of fat (DietFA).

The rate factor (KpMicr) for passage of microbial matter is related to the proportion of liquid-associated microbes (Liq_Bact), which in turn is a function of the ratio of soluble 'carbohydrates' to total NDF in the diet: $Kp_Micr = Liq_Bact * Kp_liquid + (1 - Liq_Bact) * Kp'$ (fINDF), where $Liq_Bact = 0.142 * \ln(Sol/TNDF) + 0.564$ (Khalili and Huhtanen, 1991; Jaakkola and Huhtanen, 1993) and Kp' (fINDF) is the general passage rate factor for indigestible NDF in forages as defined previously.

Digestion in the small intestine

Carbohydrates

There are three pools of carbohydrates in the small intestine: SI_SCHO (St and water-soluble carbohydrates), SI_DNDF (potentially digestible NDF) and SI_INDF (indigestible NDF).

Unfermented dietary St, sugars and La as well as microbial St are inputs to the SI_SCHO pool from which there is absorption as glucose or passage to the hindgut. The rate of absorption to the blood is described by saturation kinetics. Unfermented and indigestible NDF fractions enter the two NDF pools and pass to the hindgut. There is a net loss of endogenous carbohydrate secretion, which is transferred to the hindgut (i.e. mucin, etc. assumed to be 20 g/kg duodenal OM flow). Microbial cell wall carbohydrates and microbial fermentable carbohydrates are transported through the small intestine from the forestomachs to the hindgut.

Nitrogen

The nitrogenous pools in the small intestine are represented by the following six state variables (their inputs given in parentheses): SI_IDP (indigestible protein), SI_dUDN (undegraded ISP), SI_SNAN (undegraded SP, PEP and AA), SI_MN (microbial protein), SI_endogIDN (indigestible endogenous protein) and SI_endogDN (digestible endogenous protein).

Inputs to the first four of these state variables come from the forestomachs, and input to the last two is endogenous protein secretion calculated as 10.8 g N/kg duodenal OM flow (Brandt *et al.*, 1980; Ørskov and McLeod, 1982; Hvelplund and Madsen, 1985; Van Bruchem *et al.*, 1997; Larsen *et al.*, 2000). The flow of endogenous protein is partitioned between the indigestible and digestible pools by an assumed digestibility of 90%. Outflows from the protein pools are absorption of AA and/or passage to the hindgut.

Rates of absorption are described by saturation kinetics. There is passage to the hindgut from all six pools and further passage to faeces from the indigestible pools, SI_IDP and SI_endogIDN. Indigestible microbial protein is transported through the small intestine from the forestomachs to the hindgut and further into faeces. Ammonium from the forestomachs is absorbed in the small intestine.

Lipids

There are two pools of FA (LCFA) in the small intestine: digestible (SI_digFA) and indigestible (SI_indigFA) FA.

Flows to the SI_digFA pool are digestible dietary, microbial and endogenous FA. Their digestibilities are assumed to be 100%, 95% and 85%, respectively. The secretion of endogenous FA is 3 g/kg DMI. Outflows from the SI_digFA pool are absorption and passage to the hindgut. The rate of absorption is described by saturation kinetics with a V_{\max} value = 55 g/h (Shingfield *et al.*, 2004). The indigestible dietary, microbial and endogenous FA are transported from the SI_indigFA pool to the hindgut and further into faeces.

Digestion in the hindgut

Carbohydrates

State variables in the hindgut are pools of dietary origin: HG_SCHO (St and water-soluble carbohydrates), HG_DNDF (digestible NDF), HG_INDF (indigestible NDF); pools of microbial origin: HG_Microbial_CHO (cell wall carbohydrates), HG_fmCHO (fermentable carbohydrates); and the fermentation product pools: HGAc, HGPr, HGBu, HGCO₂, HGCH₄.

Inputs to the dietary and microbial pools are outflows from the corresponding pools in the small intestine together with endogenous carbohydrates and *de novo* synthesis of microbial cell wall carbohydrates in the hindgut. The rate of this synthesis is related to the rate of MPS in the hindgut (HG_MPS) and is calculated as $3.88 \cdot \text{HG_MPS}$. The factor 3.88 is derived from an assumed chemical composition of hindgut microbes similar to, but with a lower lipid content than, that of rumen microbes. Non-fibre carbohydrates (HG_SCHO and HG_fmCHO), endogenous carbohydrates and digestible NDF (HG_DNDF) are subjected to fermentation together with degradable hindgut protein. The degradation rate factor for dietary non-fibre carbohydrates is the same as that for ruminal St, and the rate constant for degradation of microbial carbohydrates is of similar magnitude. The rate constant for degradation of hindgut NDF is a weighted mean of the composite ruminal Kd values for forage and concentrates with no adjustment for content of soluble 'carbohydrates' (Sol). Inputs to the fermentation product pools are rates of product formation from carbohydrate and protein fermentation, i.e. Ac, Pr, Bu, carbon dioxide and methane. The fermentation pattern and ATP production are calculated from a common fixed proportion of fermentation products, valid for all the substrates. Outflows from the hindgut are absorption of VFAs, release of fermentation gases and excretion into

faeces of indigestible (microbial cell wall CHO, indigestible NDF) and unfermented carbohydrates.

Nitrogen

State variables are HG_DN (degradable protein), HG_MN (hindgut microbial protein) and HG_NH₃ (ammonium).

Inflows to the HG_DN pool are undigested dietary, microbial and endogenous protein fractions from the small intestine. Input to the HG_MN pool is rate of MPS (HG_MPS), and entries into the ammonium pool are rate of protein degradation (HG_NDegr) and rate of urea hydrolysis (HG_Urea). One common degradation rate constant is used for the different protein fractions in the HG_DN pool. Urea recycling to the hindgut (HG_Urea) is calculated as 3/7 of the recycling to the rumen. The MPS is calculated as $1.6 \cdot \text{HG_ATP_gr}$, where HG_ATP_gr is ATP available for growth, i.e. total ATP production in the hindgut minus the microbial ATP maintenance requirement ($\text{HG_MN} \cdot 0.02$; mol ATP/h). Outflow rates from the hindgut are absorption of ammonium and faecal excretion of undigested nitrogen fractions. These are unfermented protein from the HG_DN pool, hindgut microbial protein, unabsorbed ammonium as well as indigestible dietary, microbial and endogenous protein transferred from the small intestine.

Lipids

There are two state variables in this segment of the model: HG_Dig_FA (digestible FA from the small intestine of dietary, microbial and endogenous origin) and HG_MFA (lipid in hindgut microbes).

Inputs to the HG_MFA pool are rate of FA uptake from the HG_Dig_FA pool and rate of *de novo* lipid synthesis. These rates are related to the rate of microbial synthesis in the hindgut, and both are calculated as $0.35 \cdot \text{HG_MPS}$. FA from the HG_Dig_FA pool that are not taken up in the microbial pool are excreted in faeces together with microbial lipid as well as indigestible dietary, microbial and endogenous FA transferred from the small intestine.

The Metabolism Submodel

This submodel simulates the partitioning of absorbed nutrients from the digestion submodel into body tissues and their subsequent intracellular metabolism and utilization. Limitations on the length of our study do not allow a thorough description of how the nutrient metabolism and its regulation is modelled in Karoline, but emphasis will be given to model structure, i.e. state variables and nutrient flows in the different tissues. Enzymatic processes and facilitated transports are mostly described by saturation kinetics while simple diffusions are described by first order mass action kinetics. HP in individual organs and tissues is calculated according to the first law of thermodynamics. Units of the state variables are mol C for carbohydrates and lipids, and mol N for nitrogenous compounds. The nomenclature used

here is different from that in the digestion submodel: state variables are named and rate variables are numbered.

In summary, the absorbed nutrients entering the metabolism submodel are VFAs from the forestomachs and the hindgut, glucose, AA, nucleotides and FA from the small intestine, and ammonium from all three segments of the gut.

The portal-drained viscera

The state variables are pools of Ac (Ace_PDV), glucose (Glu_PDV), AA (AA_PDV), protein (Prot_PDV) and FA (FA_PDV).

Input to the Ace_PDV pool is uptake from arterial blood and output is oxidation according to the need for ATP in PDV. As much as 80% of the absorbed Bu is metabolized to ketone bodies (Kristensen *et al.*, 1998) and the liver takes up the remaining 20%. The Glu_PDV pool takes up glucose from the gut and from arterial blood. Outputs are glucose oxidation, glycolysis into La, formation of glycerol for esterification of absorbed FA and endogenously secreted FA, secretion of endogenous carbohydrates, and transport to the peripheral blood. Flows of input to the AA_PDV pool are uptake of dietary, microbial and endogenous AA from the gut and uptake from the arterial blood. AA from AA_PDV are synthesized into endogenous protein (input to the Prot_PDV pool) or taken up by the liver. Output from Prot_PDV is secretion of endogenous protein. Input to, and output from, the FA_PDV pool is uptake from arterial blood and endogenous FA secretion, respectively.

The need for ATP in PDV is met by oxidation of Ac and glucose. The HP in PDV is assumed to be 80% of that in the liver (Danfaer, 1999).

The liver

State variables in the liver compartment are: Prop_liv (Pr), KA_liv (keto acids), Lac_liv (La), Gly_liv (glycerol), Glu_liv (glucose), FA_liv (FA), Ace_KB_liv (Ac + ketones), Lip_liv (lipoproteins), AA_liv (AA), NH₃_liv (ammonium) and Urea_liv (urea).

Inputs to the glucose pool are Pr (R136), keto acids (R142), La (R144a) and glycerol (R144b) as shown in Fig. 32.5. Glucose output (R139) is taken up in the peripheral blood. Inputs to the gluconeogenic pools are absorbed Pr (R133), deaminated AA (R140), La from PDV and muscle tissue, as well as glycerol from chylomicrons and from adipose tissue. Inputs to FA_liv are FA from chylomicrons and from adipose tissue, while outputs are synthesis of Ac + ketones, synthesis of lipoproteins, and FA oxidation. Glycerol for esterification of FA in lipoprotein is an output from Gly_liv. Outflow of Ac + ketones from Ace_KB_liv and outflow of lipoprotein FA from Lip_liv are taken up in the peripheral blood.

The modelled nitrogen transactions in the liver are depicted in Fig. 32.6. Entries to AA_liv are AA from PDV with the portal blood (R40), from the

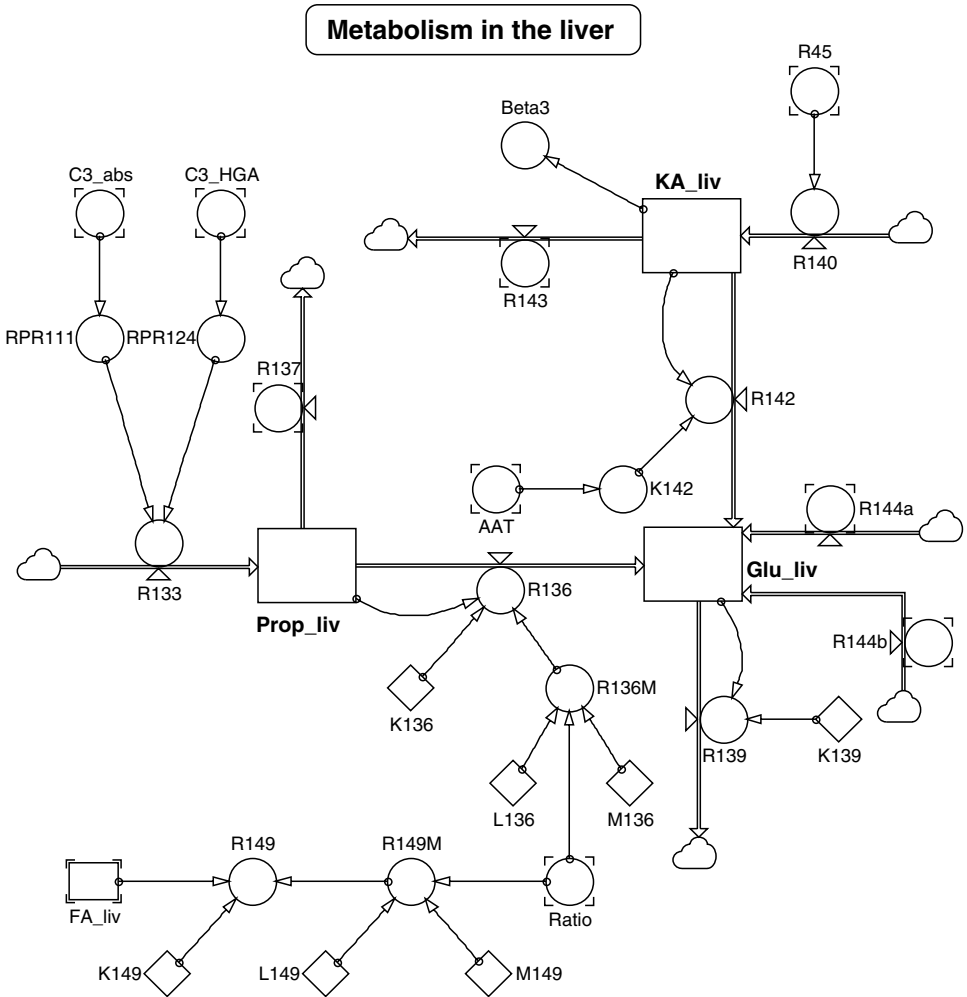

Fig. 32.5. POWERSIM diagram of gluconeogenesis in the liver. For explanation of symbols, see legend to Fig. 32.1.

body with arterial blood (R54), and from *de novo* synthesis (R42). Substrates for this AA synthesis in the liver are non_AA nitrogenous compounds absorbed from the small intestine (nucleotides etc.). AA from AA_liv are transported to the peripheral blood (R44) or deaminated (R45). The nitrogen from the latter process is input to NH₃_liv together with absorbed ammonium from the rumen (R16), the small intestine (R35) and the hindgut (R37). Input to Urea_liv is urea synthesis (R48) and its output (R49) is taken up into the peripheral blood. Protein turnover in the liver is not modelled explicitly as it is assumed that there is neither protein retention nor protein mobilization. However, an energy requirement for protein turnover is included in the ATP account.

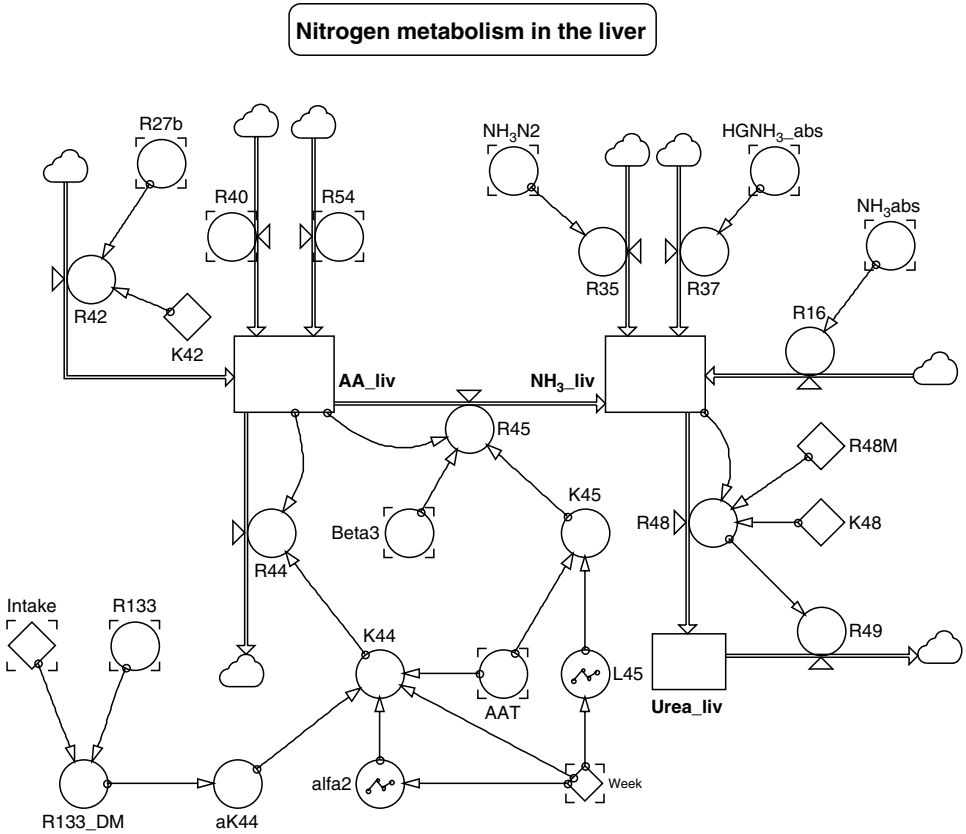

Fig. 32.6. POWERSIM diagram of nitrogen metabolism in the liver. For explanation of symbols, see legend to Fig. 32.1.

The energy requirement of the liver is calculated from an estimated ATP consumption in gluconeogenesis, ketogenesis, lipogenesis, urea synthesis, protein turnover and basal metabolism (maintenance) depending on feeding level, LW and stage of lactation. The ATP supply is provided by oxidation of Bu (taken up from PDV), Pr, keto acids (rates R137 and R143; Fig. 32.5) and FA.

The extracellular fluid

This compartment represents the peripheral blood and interstitial fluids. State variables are Ace_blood (Ac), KB_blood (ketone bodies), Glu_blood (glucose), Gly_Lac_blood (glycerol + La), FA_blood (FA), TG_blood (triglyceride in chylomicrons), Lip_blood (triglyceride in lipoproteins), AA_blood (AA) and Urea_blood (urea).

The metabolic hormones: growth hormone, insulin and glucagon are included as variables in the model. Their plasma concentrations (ng/ml) are calculated as functions of the lactational stage (Herbein *et al.*, 1985), but the

insulin concentration also depends on the simulated glucose flux rate. The effect of glucose flux on insulin concentration is related to a variable (Insulin_sens), which is increased with stage of lactation. These metabolic hormones in the model act as regulators of transactions concerning nutrient partitioning, gluconeogenesis and ketogenesis in the liver as well as FA synthesis in adipose tissue. In addition to this, FA oxidation and AA deamination in the liver, muscle protein synthesis and lipid turnover in adipose tissue are regulated directly by stage of lactation (by an input constant named Week). Descriptions of these regulations in the model are based on general views on nutrient partition and metabolism (Yang and Baldwin, 1973; Bassett, 1978; Bergman and Heitmann, 1978; Lomax *et al.*, 1979; Bauman and Currie, 1980; Buttery and Vernon, 1980; Danfær, 1994).

The mammary gland

The structure of this compartment of the model is shown in Fig. 32.7. Six metabolic and three product pools are included: Ac (Ace_ma), ketone bodies (KB_ma), glucose (Glu_ma), glycerol-P (Gly_ma), preformed FA (FA_ma), AA (AA_ma), lactose (Lactose_ma), milk fat (TG_ma) and milk protein (Prot_ma).

Uptakes from the blood of Ac (R156a) and ketone bodies (R156b) are inputs to Ace_ma and KB_ma, respectively. Outputs from these pools are FA synthesis (R174a, R174b) and oxidation (R175a, R175b). A fixed ratio (5:1) is assumed between carbon from Ac (two carbon units) and from ketone bodies (four carbon units) in the FA synthesized *de novo* (Bauman and Davis, 1974). Inputs to FA_ma are uptakes from the blood of free FA (R166a) and FA from chylomicrons and lipoproteins (R172a). Outputs are milk fat synthesis (R179) and FA oxidation (R180a, R180b). Uptake of blood glucose (R160) feeds Glu_ma, the substrate pool for glycerol-P (R176) and lactose (R177) syntheses as well as provision of NADPH via the PC pathway (R178a) and complete oxidation through the TCA cycle (R178b). The glycerol-P pool receives input also from glycerol (R172b) originating in chylomicrons and lipoproteins from which FA are taken up in the mammary gland (R172a). Inputs to the TG_ma pool are FA from the blood (R179, assumed chain length: C18) and synthesized *de novo* (R174a and R174b, assumed chain length: C12) esterified with glycerol-P (R181). AA taken up from the blood (R51) are synthesized into milk protein (R59). Lactose (R182), milk fat (R183) and milk protein (R60) are secreted into milk. The milk volume is derived directly from lactose production assuming a lactose content of 45.6 g/kg milk.

The energy requirement of the mammary gland is calculated from estimated ATP consumptions in FA synthesis, lipogenesis, lactose synthesis, protein synthesis and basal metabolism depending on feeding level, LW and stage of lactation. The need for ATP is met by oxidation of Ac (R175a), ketone bodies (R175b), glucose (R178b) and FA (R180a, R180b). The oxidation of Ac and glucose is regulated by the ratio of glucose to Ac mammary uptake (R160/R156a) so that an increase in this ratio will increase glucose and decrease Ac oxidation.

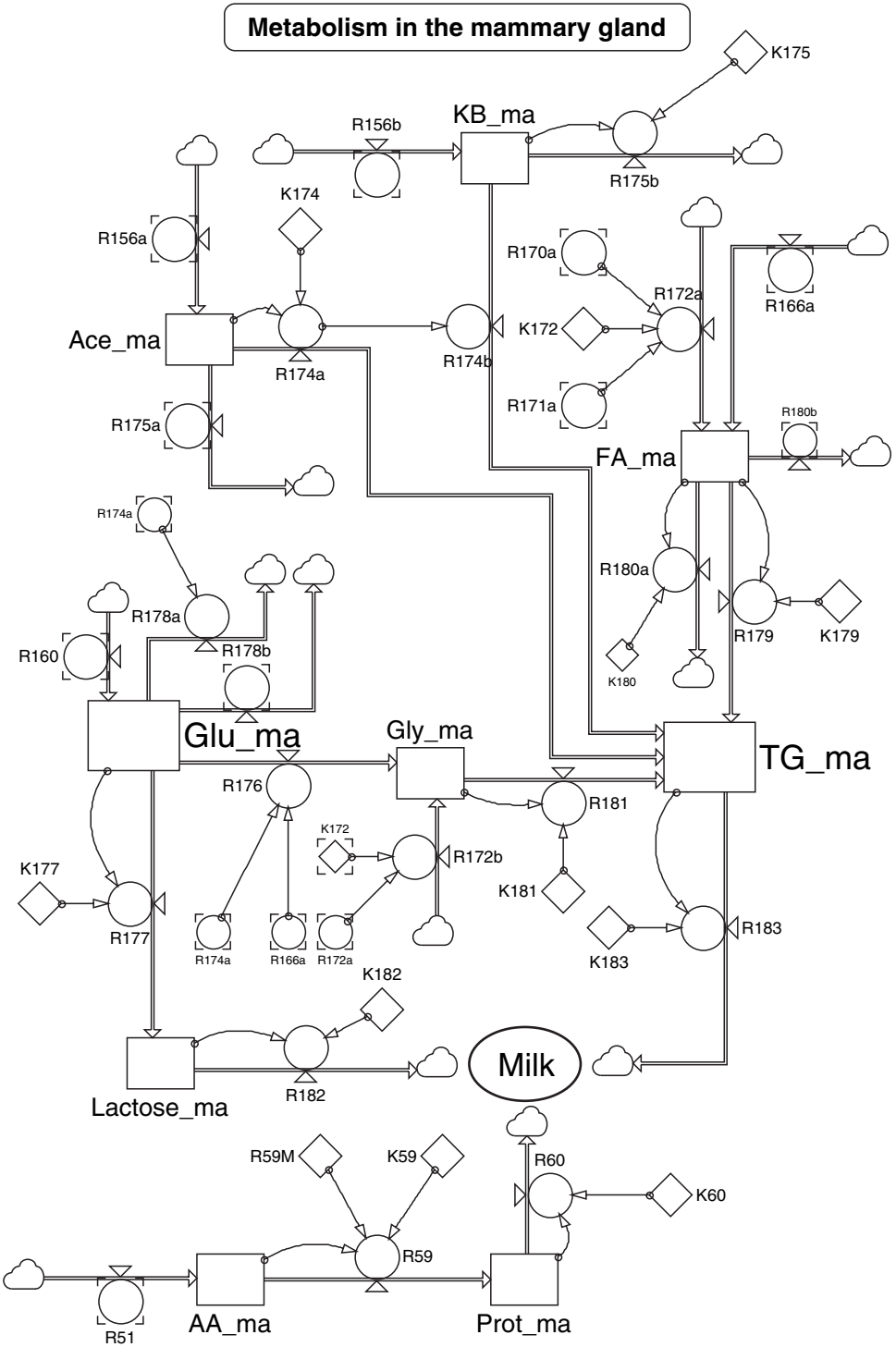

Fig. 32.7. POWERSIM diagram of metabolism in the mammary gland. For explanation of symbols, see legend to Fig. 32.1.

The muscle and connective tissues

The main metabolic event in this compartment of the model is protein turnover. The state variables are Ace_KB_mu (Ac + ketones), Glu_mu (glucose), Lac_mu (La), FA_mu (FA), AA_mu (AA in muscles), AA_con (AA in connective tissue), Prot_mu (protein in muscles) and Prot_con (protein in connective tissue). The protein turnover in muscles is modelled separately from the protein turnover in connective tissue because of different turnover times (Lobley *et al.*, 1980).

Inputs to Ace_mu, Glu_mu, FA_mu, AA_mu and AA_con are the respective nutrients taken up from the peripheral blood. Of these, Ac, ketone bodies and FA are oxidized completely, while glucose is partly metabolized via glycolysis to La and partly oxidized further to carbon dioxide. The produced La is output from Lac_mu and transported via the Gly_Lac_blood pool to the liver. The AA pools get inputs from the blood and from proteolysis of the protein pools. Outputs from the AA pools are protein syntheses and releases into the blood.

The estimated energy requirement in terms of ATP in this compartment is based on the simulated rates of protein synthesis, protein degradation and a basal metabolism depending on feeding level, LW and stage of lactation. Oxidation of Ac, ketone bodies, FA and glucose provides for the ATP supply.

The adipose tissue

The state variables are Ace_adi (Ac), KB_adi (ketone bodies), Glu_adi (glucose), GlyP_adi (glycerol-P), Gly_adi (glycerol), FA_adi (FA) and TG_adi (body fat).

Nutrient uptakes from the blood are the only inputs to the Ac, ketone body and glucose pools. Outputs from Ace_adi and KB_adi are FA synthesis and oxidation. Like in the mammary gland, there is a fixed proportion (7:1 on carbon basis) between FA synthesis from Ac and from ketone bodies. Outputs from Glu_adi are synthesis of glycerol-P, oxidation via the PC pathway for NADPH supply and oxidation via the TCA cycle. Inputs to FA_adi are FA uptake from blood triglycerides (TG_blood and Lip_blood) and *de novo* FA synthesized from Ac and ketone bodies. Output from the pool is esterification with glycerol-P to body fat. FA from lipolysis of body fat enter the FA_blood pool or are oxidized in cases with very low Ac supply. Input to the Gly_adi pool is glycerol from lipolysis of body fat and blood triglycerides taken up in the tissue. Output from the pool is transferred to the blood and used in the liver.

The need for ATP in the adipose tissue is calculated from requirements in FA synthesis, glycerol-P synthesis, FA activation to acyl-CoA and basal metabolism, which is a function of feeding level, LW and stage of lactation. The ATP supply is from oxidations of Ac, ketone bodies, glucose and FA (in case of too low supply of Ac).

The model runs for 720 h in order to obtain steady state, but the pools of body protein and body fat are not supposed to be in steady state during major

parts of the lactation period. Hence, the pool sizes of body protein in muscle and connective tissues as well as body fat in adipose tissue are reset to their initial values at simulation times = $n \times 24$, $n = \{1, 2, \dots, 30\}$. The initial pool sizes of protein in muscle and connective tissues are functions of LW, and the initial pool size of body fat is related to both LW and week of lactation.

Animal Performance and Feed Value

Simulated digestibility and efficiency parameters as well as animal performance are calculated from values of relevant rate variables at the end of each simulation run and shown in the 'Results' sheet of the 'Feed mixer'.

In the present version of Karoline, the 'Results' sheet displays simulated values of the following digestion parameters: (i) duodenal flows of OM, microbial as well as dietary CP, total carbohydrates, NDF and LCFA; (ii) faecal flows of OM, CP, total carbohydrates, NDF, crude fat and LCFA; (iii) ruminal digestibility (%) of OM (apparent as well as true) and NDF; (iv) ruminal VFA concentrations (mM) and individual VFA proportions (mmol/mol); (v) ruminal efficiency of MPS (g N/kg OM digested, apparent and true); and (vi) faecal digestibility (%) of OM, CP, NDF and LCFA. This list of parameters can easily be extended with other parameters of interest, e.g. urinary nitrogen and methane.

Milk production (kg/day) is calculated from the rate of anhydrous lactose production assuming a lactose molecular weight (mw) and content in milk of 342.3 and 45.6 g/kg, respectively. Calculation of milk fat yield (kg/day) presumes $mw = 200.3, 284.5$ and 92.1 for *de novo* FA (C_{12}), blood FA (C_{18}) and glycerol, respectively. Milk protein yield (kg/day) is calculated as $0.00638 \times \text{g N/day}$. The formula used for calculation of energy-corrected milk (ECM, kg/day) is: $[\text{lactose (g/day)} \times 16.5 + \text{milk protein (g/day)} \times 24.2 + \text{milk fat (g/day)} \times 38.3 + \text{MY (kg/day)} \times 20.7] / 3140$ (Sjaunja *et al.*, 1990). LW change (kg/day) is calculated as $\text{Lipid_bal} / 0.9 + \text{Protein_bal} / 0.2$ assuming that retained or mobilized fat and protein tissues contain 10% and 80% of other compounds (water and ash), respectively. Lipid_bal (kg/day) and Protein_bal (kg/day) are the differences between synthesized and mobilized body lipid and body protein, respectively.

The simulated digestibilities and animal performance are the basis for estimation of 'real' feed values. The simulated net energy value (MJ NE/day) of the diet is calculated as $\text{NE_prod} + \text{NE_maint}$, where $\text{NE_prod} = \text{Milk_E} + \text{Energy_bal}$, $\text{NE_maint} = 0.477 \times \text{LW}^{0.67}$ (ARC, 1980), $\text{Milk_E} = \text{ECM} \times 3.14$ and Energy_bal is energy balance in the pools of body protein and body fat using heat combustion values of 2.065 MJ/mol N, 10.03 MJ/mol FA (C_{16}) and 1.66 MJ/mol glycerol. The simulated ME (MJ ME/day) is total heat production plus net energy for production: $\text{ME} = \text{HE} + \text{NE_prod}$, where $\text{HE} = \text{Digestion_heat} + \text{Metabolic_heat}$. Heat of digestion is calculated as the combustion heat of nutrients entering minus the combustion heat of nutrients leaving the digestion submodel. Metabolic heat is the sum of heat produced in the body tissues of the metabolism submodel calculated in the same way according to

the first law of thermodynamics. The simulated protein value of the diet (MP) is the sum of dietary and microbial AA (g/day) absorbed from the small intestine compartment.

Model Behaviour

The principle of estimating 'real' feed values with Karoline is illustrated by a series of simulations where clover grass silage is gradually replaced by barley. The composition of the basal diet in the simulations is (kg DM/day): barley (2), soybean meal (1), rapeseed cake (1) and clover grass silage (16). Specifications of the model cow are 625 kg LW and week 16 of lactation. Simulation results are presented in Table 32.1. The level of concentrates in the diet is increased from 20% to 80% of DM by substitution of barley for silage. The simulated true digestibility of OM in the forestomachs increases from 72% to 75% at 50% concentrates and then decreases slightly, whereas the NDF digestibility in the forestomachs decreases from 57% to 21%. Simulated MY (kg ECM/day) and 'real' net energy value of the diet (MJ NE/kg DM) increase up to 80% concentrates, but the marginal effects are decreasing. Traditional feed evaluation systems would predict linear increases both in OM digestibility and in NE values. This is a principal difference between real feed values and standard feed values.

Test results from an evaluation of Karoline against experimental data are reported in an accompanying study (see Danfær *et al.*, Chapter 33, this volume).

Perspectives

It has been decided by farmer organizations and advisory services in Denmark, Iceland, Norway and Sweden that Karoline shall be included as a diet evaluator in a new feed evaluation system, NorFor-cattle, which is to be

Table 32.1. Simulated neutral detergent fibre (NDF) and true organic matter (OM) digestibility in the rumen, milk yield (MY) and 'real' feed value as affected by gradual replacement of clover grass silage with barley in diets^a fed at 20 kg DM/day.

Barley (kg DM/day)	Silage (kg DM/day)	NDF Concentrate (% of DM)	OM digestion (%)	OM digestion (%)	MY (kg ECM/day)	Diet NE (MJ/kg DM)
2	16	20	56.8	72.1	29.00	6.37
5	13	35	54.8	73.9	30.32	6.64
8	10	50	50.3	75.0	31.32	6.85
11	7	65	40.0	74.8	31.83	6.97
14	4	80	21.0	73.3	31.87	7.00

^aBasal composition (kg DM/day): barley (2), soybean meal + rapeseed cake (2), silage (16).

implemented in these countries during 2005–2006. Karoline will also be used as a diet evaluation tool by the advisory service in Finland. As described in this study, Karoline can predict consequences of using different diets in different stages of lactation, but it is not a handy tool for feed planning and economical optimization of feed rations. Therefore, another model with this purpose is also needed as part of the new system. This other model is developed by Volden (2001) and is a static, spreadsheet-based model of nutrient digestion and energy utilization in cattle. Its optimization procedure is built partly on non-linear functions. In the NorFor system, the feed-planning model will be named 'NorFor-plan' and Karoline will be named 'NorFor-evaluation'. It should also be mentioned here that an Internet version of Karoline's digestion submodel is available on the address: www.njfjord.dk.

Conclusions

The whole-animal model Karoline estimates 'real' feed values of input feed rations for lactating cows. This estimation is based on simulated animal performance and represents a new principle in feed evaluation. We conclude that Karoline will be a useful tool to the advisory service – at least as useful as the present feed evaluation systems and with much better perspectives for improvements.

To improve the model, it needs to be further developed by incorporation of new elements in the model. Issues of interest are: simulation of voluntary feed intake, fetus metabolism, digestion and metabolism of individual AA, FA and macro minerals.

References

- ARC (1980) *The Nutrient Requirements of Ruminant Livestock*. Commonwealth Agricultural Bureaux, Slough, UK.
- Bassett, J.M. (1978) Endocrine factors in the control of nutrient utilization: ruminants. *Proceedings of the Nutrition Society* 37, 273–280.
- Bauman, D.E. and Davis, C.L. (1974) Biosynthesis of milk fat. In: Larson, B.L. and Smith, V.R. (eds) *Lactation – A Comprehensive Treatise*. Academic Press, New York and London, pp. 31–75.
- Bauman, D.E. and Currie, W.B. (1980) Partitioning of nutrients during pregnancy and lactation: a review of mechanisms involving homeostasis and homeorhesis. *Journal of Dairy Science* 63, 1514–1529.
- Bergman, E.N. and Heitmann, R.N. (1978) Metabolism of amino acids by the gut, liver, kidneys, and peripheral tissues. *Federation Proceedings* 37, 1228–1232.
- Brandt, M., Rohr, K. and Lebzien, P. (1980) Bestimmung des endogenen Protein-N im Duodenalchymus von Milchkühen mit Hilfe von ¹⁵N. *Zeitschrift für Tierphysiologie, Tierernährung und Futtermittelkunde* 44, 26.
- Buttery, P.J. and Vernon, B.G. (1980) Aspects of protein metabolism and its control. *Livestock Production Science* 7, 111–120.
- Cannas, A. and Van Soest, P.J. (2000) Simple allometric models to predict rumen feed passage rate in domestic ruminants. In: McNamara, J.P., France, J. and Beaver,

- D.E. (eds) *Modelling Nutrient Utilization in Farm Animals*. CAB International, Wallingford, UK, pp. 49–62.
- Danfær, A. (1994) Nutrient metabolism and utilization in the liver. *Livestock Production Science* 39, 115–127.
- Danfær, A. (1999) Nutrient flow across the liver in dairy cows. *Proceedings of the Society of Nutrition Physiology* 8, 13–25.
- Herbein, J.H., Aiello, R.J., Eckler, L.I., Pearson, R.E. and Akers, R.M. (1985) Glucagon, insulin, growth hormone, and glucose concentrations in blood plasma of lactating dairy cows. *Journal of Dairy Science* 68, 320–325.
- Hespell, R.B. and Bryant, M.P. (1979) Efficiency of rumen microbial growth: influence of some theoretical and experimental factors on Y_{ATP} . *Journal of Animal Science* 49, 1640–1659.
- Huhtanen, P. and Kukkonen, U. (1995) Comparison of methods, markers, sampling sites and models for estimating digesta passage kinetics in cattle fed at two levels of intake. *Animal Feed Science and Technology* 52, 141–158.
- Huhtanen, P., Jaakkola, S., Kukkonen, U. and Nousianen, J. (1993) Influence of passage model in estimating ruminal protein degradability. *Journal of Animal Science* 71 (Suppl. 1), 263.
- Hvelplund, T. and Madsen, J. (1985) Amino acid passage to the small intestine in dairy cows compared with estimates of microbial protein and undegraded dietary protein from analysis on the feed. *Acta Agriculturae Scandinavica* Suppl. 25, 21–36.
- Jaakkola, S. and Huhtanen, P. (1993) The effects of forage preservation method and proportion of concentrate on nitrogen digestion and rumen fermentation in cattle. *Grass and Forage Science* 48, 146–154.
- Khalili, H. and Huhtanen, P. (1991) Sucrose supplements in cattle given grass silage-based diet: 1. Digestion of organic matter and nitrogen. *Animal Feed Science and Technology* 33, 247–261.
- Kristensen, N.B., Danfær, A. and Agergaard, N. (1998) Absorption and metabolism of short-chain fatty acids in ruminants. *Archives of Animal Nutrition* 51, 165–175.
- Larsen, M., Madsen, T.G., Weisbjerg, M.R., Hvelplund, T. and Madsen, J. (2000) Endogenous amino acid flow in the duodenum of dairy cows. *Acta Agriculturae Scandinavica, Section A, Animal Science* 50, 161–173.
- Lobley, G.E., Milne, V., Lovie, J.M., Reeds, P.J. and Pennie, K. (1980) Whole body and tissue protein synthesis in cattle. *British Journal of Nutrition* 43, 491–502.
- Lomax, M.A., Baird, G.D., Mallinson, C.B. and Symonds, H.W. (1979) Differences between lactating and non-lactating dairy cows in concentration and secretion rate of insulin. *Biochemical Journal* 180, 281–289.
- Lund, P. (2002) The effect of forage type on passage kinetics and digestibility of fibre in dairy cows. PhD thesis, The Royal Veterinary and Agricultural University, Copenhagen, Denmark.
- Marini, J.C. and Van Amburgh, M.E. (2001) Effect of different levels of dietary protein on nitrogen metabolism of heifers. *Journal of Dairy Science* 84 (Suppl. 1), 160–161.
- Ørskov, E.R. and MacLeod, N.A. (1982) The flow of N from the rumen of cows and steers maintained by intraruminal infusion of volatile fatty acids. *Proceedings of the Nutrition Society* 41, 76A.
- Owens, F.N. and Goetsch, A.L. (1986) Digesta passage and microbial protein synthesis. In: Milligan, L.P., Grovum, W.L. and Dobson, A. (eds) *Control of Digestion and Metabolism in Ruminants*. Prentice-Hall, Englewood Cliffs, New Jersey, pp. 196–223.
- Pond, K.R., Ellis, W.C., Matis, J.H., Ferreiro, H.M. and Sutton, J.D. (1988) Compartment models for estimating attributes of digesta flow in cattle. *British Journal of Nutrition* 60, 571–595.

- Powersim (1996) *Reference Manual*. Powersim Corporation, USA.
- Shingfield, K.J., Ahvenjärvi, S., Toivonen, V., Huhtanen, P. and Grinari, M.J. (2004) Synthesis of trans fatty acids and isomers of conjugated linoleic acid in the rumen of cows fed grass silage based diets supplemented with incremental levels of sunflower oil. *Journal of Dairy Science* 87 (Suppl. 1), 335–336.
- Siddons, R.C., Nolan, J.V., Beever, D.E. and MacRae, J.C. (1985) Nitrogen digestion and metabolism in sheep consuming diets containing contrasting forms and levels of N. *British Journal of Nutrition* 54, 175–187.
- Sjaunja, L.O., Bævre, L., Junkkarinen, L., Pedersen, J. and Setälä, J. (1991) A Nordic proposal for an energy corrected milk (ECM) formula. In: *EAAP Publication 50. Performance Recording of Animals: State of the Art*. PUDOC, Wageningen, the Netherlands, pp. 156–157.
- Sniffen, C.J., O'Connor, J.D., Van Soest, P.J., Fox, D.G. and Russell, J.B. (1992) A net carbohydrate and protein system for evaluating cattle diets: II. Carbohydrate and protein availability. *Journal of Animal Science* 70, 3562–3577.
- Van Bruchem, J., Voigt, J., Lammers-Wienhoven, T.S.C.W., Schönhusen, U., Ketelaars, J.J.M.H. and Tamminga, S. (1997) Secretion and reabsorption of endogenous protein along the small intestine of sheep: estimates derived from ¹⁵N dilution of plasma non-protein-N. *British Journal of Nutrition* 77, 273–286.
- Volden, H. (2001) Development of a semi-mechanistic feed evaluation system for ration formulation in ruminants: the AAT model. *Ruminant Symposium 18–19 September 2001* (in Norwegian), 30 pp.
- Yang, Y.T. and Baldwin, R.L. (1973) Lipolysis in isolated cow adipose cells. *Journal of Dairy Science* 56, 366–374.

33

The Nordic Dairy Cow Model, Karoline – Evaluation

A. DANFÆR,¹ P. HUHTANEN,² P. UDÉN,³
J. SVEINBJÖRNSSON⁴ AND H. VOLDEN⁵

¹Danish Institute of Agricultural Sciences, Research Centre Foulum, PO Box 50, 8830 Tjele, Denmark; ²MTT Agrifood Research Finland, Animal Production Research, FIN-31600 Jokioinen, Finland; ³Swedish University of Agricultural Sciences, Department of Animal Nutrition and Management, Kungsängen Research Centre, 75323 Uppsala; ⁴Agricultural University of Iceland, Department of Natural Resources, Keldnaholt v/Vesturlandsveg, IS-112 Reykjavík, Iceland; ⁵Agricultural University of Norway, PO Box 5025, 1432 Ås, Norway

Abstract

This study presents evaluation results of the model Karoline, which is described in another study (see Danfær *et al.*, Chapter 32, this volume). The validations comprise behavioural analyses, testing against experimental data and comparison of Karoline with the Cornell Net Carbohydrate and Protein System (CNCPS) model. The model behaviour is evaluated from simulated responses to stage of lactation, feed intake, dietary protein level, dietary fat level and ratio of concentrate to forage in the diet. The response parameters are milk yield (MY), milk composition and live weight (LW) gain. In most cases, Karoline behaves similarly to what is generally observed *in vivo*.

The digestion part of Karoline is tested against 61 treatment means from studies with cannulated dairy cows and growing cattle carried out in the Nordic countries. Simulated (X) and observed (Y) parameter values are compared in meta-analyses using both an unadjusted regression and a mixed model regression procedure with the individual experiment as a random factor. The parameters compared are duodenal flows of organic matter (OM), neutral detergent fibre (NDF), total crude protein (CP), dietary CP and microbial CP as well as faecal flows of OM, NDF and CP. In the mixed model analyses, the fixed regression coefficient is between 0.86 and 1.16, the fixed intercept is between -0.30 and 0.15 kg/day and the overall R^2 is between 0.95 and 1.00. The full Karoline model is tested against 142 treatment means from production studies with lactating cows carried out in the Nordic countries. Unadjusted as well as mixed model regression analyses compare simulated (X) and observed (Y) parameter values: MY, energy-corrected milk (ECM) yield, milk fat yield and milk protein yield. The fixed regression coefficient is between 0.74 and 0.83, the fixed intercept is between 0.20 kg/day (milk protein) and 6.1 kg/day (milk), and the overall R^2 is between 0.87 and 0.94.

Karoline is further validated by a comparison with the CNCPS model. Both models are tested against a Nordic data-set of 75 treatment means from dairy cow production

experiments. A deviation index based on mixed model regression analyses is calculated for both models. In this analysis, the deviation index is 0.19 and 0.07 for CNCPS and Karoline, respectively. For a perfect model, i.e. identical simulated and observed parameter values, the deviation index equals zero.

It is concluded that the Karoline model is a useful tool to evaluate feed rations for dairy cows by predictions of nutrient digestibility and MY. However, predictions of the milk composition, i.e. fat and protein contents, need to be improved. Possible reasons for problems in the model are discussed.

Introduction

Karoline is a whole-animal simulation model of lactating cows. It is developed by the authors and is intended for use as a feed evaluation tool by the advisory services in the Nordic countries. The model is described in some detail in another study (see Danfær *et al.*, Chapter 32, this volume). It has been decided recently that Karoline shall be included as a part of a new, official feed evaluation system for cattle, the NorFor system, implemented in Denmark, Iceland, Norway and Sweden during 2005–2006. In this new system, Karoline will be used to estimate effects of different feed rations on nutrient utilization, milk production and LW gain. Karoline will also be used as a diet evaluation tool by the advisory service in Finland. It is therefore important that the model is able to predict these effects with reasonable accuracy, and the purpose of this study is to present some test results obtained with the model. This evaluation of Karoline comprises analyses of overall model behaviour as well as comparisons of experimental data with corresponding simulated data.

Behavioural Analyses

Lactational responses predicted with Karoline are presented in Figs 33.1–33.3. Model inputs for the simulations are: week of lactation (1–44), weight of model cow (625 kg at week 0 and then using simulated LW at ensuing weeks), assumed feed intake (kg dry matter (DM)/day) during lactation, and diet composition (% of DM): barley (37.5), soybean meal (SBM; 7.5), rapeseed cake (5.0), clover grass silage (30.0) and maize silage (20.0). Figure 33.1 shows the presumed DM intake (DMI) together with simulated MY and ECM yield from week 1 to 44 after calving. The simulated peak yield is occurring at week 6 concurrently with the lowest concentration (g/kg) of fat and protein in the milk (Fig. 33.2). Simulated LW (kg) and LW changes (kg/day) during lactation are depicted in Fig. 33.3. The rate of LW gain is negative until approximately week 12 when the model cow has lost 62 kg from calving. From week 12 onwards, the model cow is gaining weight.

Responses of increasing feed intake are predicted by simulations with feed inputs from 10 to 30 kg DM/day. The feed composition (% of DM) is: barley (40), SBM (2.5), rapeseed cake (2.5) and clover grass silage (55).

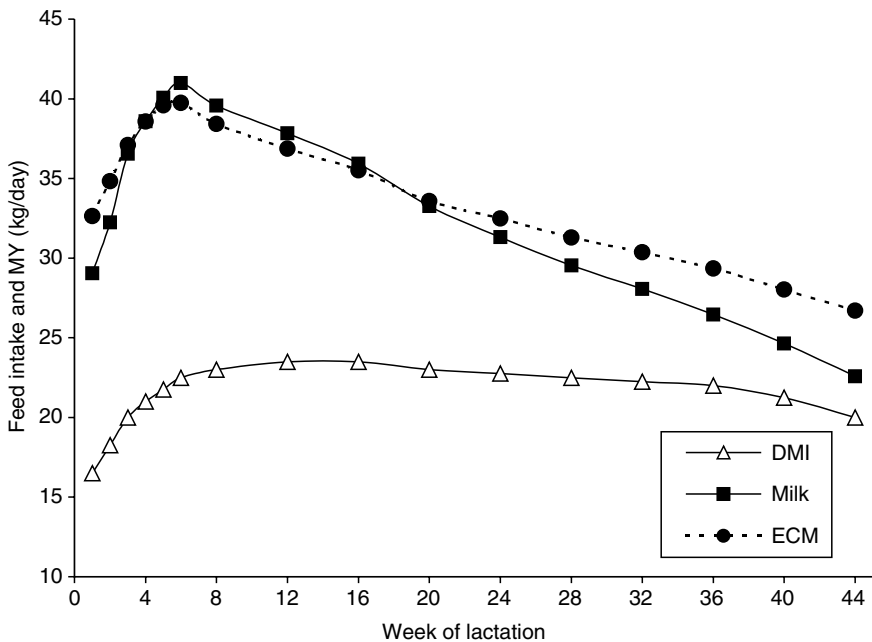

Fig. 33.1. Presumed dry matter intake (DMI) and simulated milk yield (MY) during lactation.

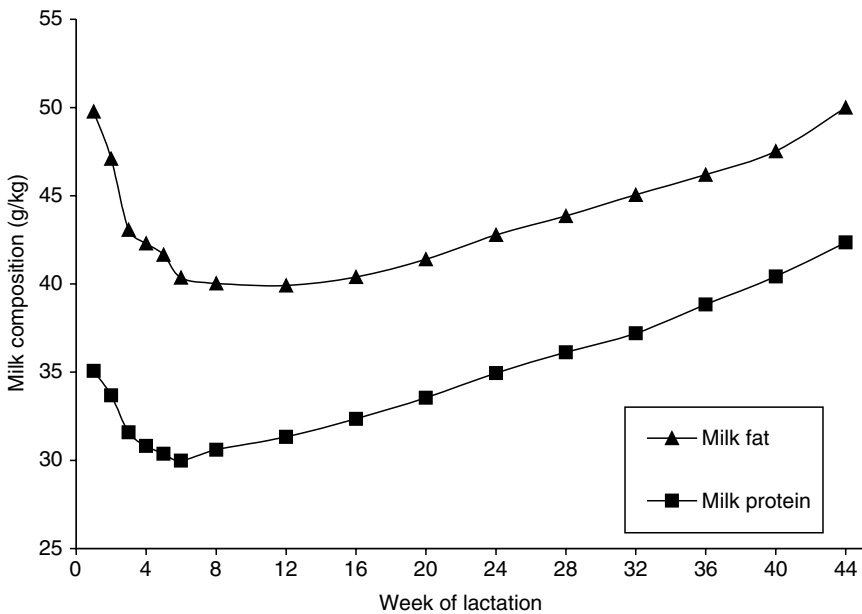

Fig. 33.2. Simulated fat and protein content in milk during lactation.

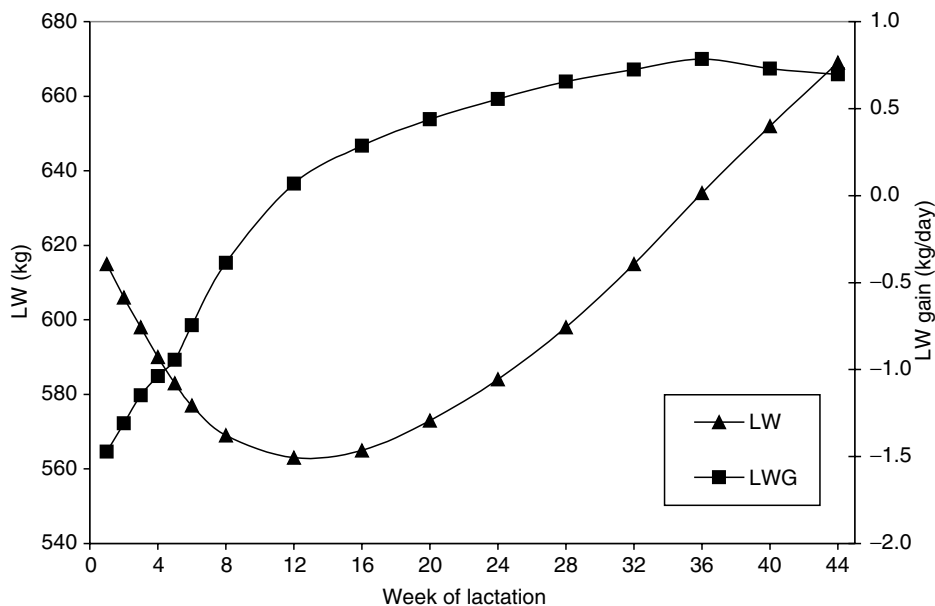

Fig. 33.3. Simulated live weight (LW) and LW gain during lactation.

Inputs regarding the model cow are 625 kg LW and lactation week 12. The simulated MY and ECM yield increase curvilinearly with declining marginal responses to increasing feed intake. At 10 kg DM/day, the ECM yield is 16.4 kg/day and the marginal increase from 10 to 11 kg DM/day is 2.0 kg ECM/kg DM. At 29 kg DM/day, the yield and marginal increase from 29 to 30 kg DM/day are 40.8 kg ECM/day and 0.7 kg ECM/kg DM, respectively. The marginal responses in MY are decreasing at a lower rate, i.e. 1.7 kg and 1.1 kg/kg DM at 10 and 29 kg DM/day, respectively. The explanation for this difference between milk and ECM marginal responses is that the simulated milk fat content is decreasing from 49 g/kg at 10 to 37 g/kg at 30 kg DM/day.

The predicted responses to increasing dietary CP are examined by simulations with gradual substitution of barley with SBM. The basal diet is (kg DM/day): barley (10.5), SBM (0.2), vegetable fat (0.3) and whole crop barley silage (9.0). The CP content of this diet is 111 g/kg DM and gradual replacements of 5 kg barley with SBM on DM basis increase the CP content to 217 g/kg DM. Model cow inputs are 625 kg LW and lactation week 12. The simulated MY increases curvilinearly from 30.2 kg/day at the lowest protein level to 34.0 kg/day at 196 g CP/kg DM and then decreases slightly. The marginal response from 111 to 132 g CP/kg DM is 0.26 kg/100 g CP and the marginal response from 196 to 217 g CP/kg DM is -0.04 kg/100 g CP. The simulated milk fat content is decreasing, the milk protein content is increasing and ECM yield is increasing almost linearly over the examined range of dietary CP levels.

The predicted responses to increasing dietary crude fat (Cfat) are examined by simulations with gradual substitution of barley with vegetable fat and SBM. The substitution ratio on DM basis is 1 kg barley with 0.79 kg fat and 0.21 kg SBM. The basal diet (kg DM/day) is: barley (9.0), SBM (2.0) and whole crop barley silage (9.0). The Cfat content of this diet is 25 g/kg DM and gradual replacements on DM basis of 1.5 kg barley with 1.18 kg fat and 0.32 kg SBM increase the Cfat content up to 82.5 g/kg DM. Model cow inputs are 625 kg LW and lactation week 12. The simulated ECM yield increases curvilinearly from 30.9 kg/day at the lowest fat level to 33.2 kg/day at 71 g Cfat/kg DM and then decreases. The marginal response from 25 to 36.5 g Cfat/kg DM is 0.40 kg/100 g Cfat and the marginal response from 71 to 82.5 g Cfat/kg DM is -0.33 kg/100 g Cfat. The simulated milk fat content is increasing up to 54 g Cfat/kg DM and then decreasing, while the milk protein content is declining continuously over the examined range of dietary Cfat levels.

The responses of increasing the ratio of concentrate to forage in the diet are also predicted. In these simulations, the concentrate mixture is 77.3% barley and 22.7% rapeseed cake on DM basis, and the forage is clover grass silage. Total feed intake is 20 kg DM/day, LW is 625 kg and lactation week is 12. The ratio of concentrate to forage is increased from 4:16 to 16:4. The simulated MY and ECM yield increase curvilinearly from 28.1 and 29.7 kg/day, respectively, at 20% concentrates, to 32.5 and 34.0 kg/day, respectively, at 80% concentrates. The predicted marginal responses from 20% to 25% concentrates are 0.68 kg milk/kg concentrate and 0.55 kg ECM/kg concentrate. From 75% to 80% concentrates, the marginal responses are 0.06 and 0.16 kg/kg concentrate for milk and ECM, respectively. The simulated milk fat content decreases and the milk protein content increases when the proportion of concentrates in the diet is increased from 20% to 80% on DM basis.

Evaluation against Experimental Data

The digestion part of Karoline is tested against 61 treatment means from studies with cannulated dairy cows and growing cattle carried out in the Nordic countries. Simulated (X) and observed (Y) parameter values are compared in meta-analyses using both an unadjusted regression (Table 33.1) and a mixed model regression procedure (PROC Mixed, SAS 8.02, 1999–2001) with the individual experiment as a random factor (Table 33.2). The use of mixed model regression analyses in this way allows for estimation of relationships between predicted and observed values within experiments adjusted for differences in analytical techniques, experimental animals, etc. (St-Pierre, 2001). The parameters compared are duodenal flows of OM (observed range 1.91–10.08 kg/day), total CP (observed range 0.60–3.32 kg/day), microbial protein (observed range 0.28–2.07 kg/day), dietary protein (observed range 0.21–1.45 kg/day), and NDF (observed range 0.46–4.93 kg/day), as well as faecal flows of OM (observed range 0.97–6.16 kg/day), CP (observed range 0.20–1.11 kg/day) and NDF (observed range 0.50–4.39

kg/day). In the unadjusted regression analyses, the regression coefficient is between 0.83 and 1.11, the intercept is between -0.24 and 0.22 kg/day, R^2 is between 0.73 and 0.98, and the root mean squared predicted error (RMSPE) is between 0.07 and 0.79 kg/day (Table 33.1). In the mixed model regression analyses, the fixed regression coefficient is between 0.86 and 1.16, the fixed intercept is between -0.30 and 0.15 kg/day, the overall R^2 is between 0.95 and 1.00, and RMSPE is between 0.03 and 0.20 kg/day (Table 33.2).

Table 33.1. Relationships between simulated (X) and observed (Y) values of nutrient flows in the digestive tract (g/day).

	Regression	R^2	RMSPE ^a	n^b	Range ^c
Flow at duodenum					
Organic matter (OM)	$Y = 1.069X + 223$	0.93	791	60	1910–10080
Crude protein (CP)	$Y = 0.960X + 80$	0.89	316	61	595–3315
Microbial CP	$Y = 1.037X - 98$	0.87	227	61	280–2065
Dietary CP	$Y = 0.834X + 169$	0.73	182	61	210–1445
Neutral detergent fibre (NDF)	$Y = 1.072X - 243$	0.95	278	61	460–4925
Faecal excretion					
OM	$Y = 1.040X - 11$	0.98	203	61	965–6160
CP	$Y = 1.114X + 3.6$	0.95	70	61	200–1105
NDF	$Y = 1.077X - 136$	0.97	199	61	495–4390

^aRoot mean squared prediction error.

^bNumber of observations.

^cRange of observations.

Table 33.2. Relationships between simulated (X) and observed (Y) values of nutrient flows in the digestive tract (g/day). Mixed model regressions with individual experiment as a random factor.

	Regression	R^2	RMSPE ^a	n^b	Range ^c
Flow at duodenum					
Organic matter (OM)	$Y = 1.118X + 65$	1.00	204	60	2080–11155
Crude protein (CP)	$Y = 1.034X - 47$	0.99	85	61	630–3440
Microbial CP	$Y = 1.147X - 213$	0.99	69	61	315–2235
Dietary CP	$Y = 0.857X + 149$	0.95	70	61	260–1340
Neutral detergent fibre (NDF)	$Y = 1.089X - 303$	0.99	126	61	380–4650
Faecal excretion					
OM	$Y = 0.991X + 135$	1.00	92	61	1090–6100
CP	$Y = 1.156X - 34$	0.99	29	61	165–1070
NDF	$Y = 0.989X + 20$	0.99	72	61	540–4060

^aRoot mean squared prediction error.

^bNumber of observations.

^cRange of adjusted observations.

The full Karoline model is tested against 142 treatment means from production trials with lactating cows carried out in the Nordic countries. Unadjusted regression and mixed model regression analyses compare simulated (X) and observed (Y) parameters of milk production and milk composition: MY (observed range 13.0–36.3 kg/day), ECM yield (observed range 12.5–38.1 kg/day), milk fat yield (observed range 0.49–1.65 kg/day) and milk protein yield (observed range 0.42–1.19 kg/day). In the unadjusted regression analyses (Table 33.3), the regression coefficient is between 0.80 and 0.97, the intercept is between 14 g/day (milk fat) and 2.11 kg/day (milk), R^2 is between 0.62 and 0.88, and RMSPE is between 77 g/day (milk protein) and 2.05 kg/day (ECM). In the mixed model regression analyses (Table 33.4), the fixed regression coefficient is between 0.74 and 0.83, the fixed intercept is between 202 g/day (milk protein) and 6.06 kg/day (milk), the overall R^2 is between 0.87 and 0.94, and RMSPE is between 41 g/day (milk protein) and 1.09 kg/day (milk).

Karoline is further validated by a comparison with the CNCPS model (Fox *et al.*, 2004). Both models are tested against a Nordic data-set of 75 treatment means from dairy cow production experiments. A deviation index based on mixed model regression analyses is calculated for both models. This index is defined as: $[\text{Abs}(\text{intercept}/\text{observed mean}) + \text{Abs}(1 - \text{slope}) +$

Table 33.3. Relationships between simulated (X) and observed (Y) milk yields (kg/day) and milk components (g/day).

	Regression	R^2	RMSPE ^a	n^b	Range ^c
Milk	$Y = 0.898X + 2.11$	0.88	1.94	142	13.0–36.3
Energy-corrected milk (ECM)	$Y = 0.969X + 0.10$	0.85	2.05	142	12.5–38.1
Milk fat	$Y = 0.929X + 14$	0.62	143	142	490–1650
Milk protein	$Y = 0.803X + 156$	0.80	77	142	415–1185

^aRoot mean squared prediction error.

^bNumber of observations.

^cRange of observations.

Table 33.4. Relationships between simulated (X) and observed (Y) milk yields (kg/day) and milk components (g/day). Mixed model regressions with individual experiment as a random factor.

	Regression	R^2	RMSPE ^a	n^b	Range ^c
Milk	$Y = 0.749X + 6.06$	0.94	1.09	142	13.7–34.5
Energy-corrected milk (ECM)	$Y = 0.827X + 3.93$	0.94	1.04	142	14.1–35.8
Milk fat	$Y = 0.763X + 207$	0.87	59	142	640–1510
Milk protein	$Y = 0.743X + 202$	0.92	41	142	430–1145

^aRoot mean squared prediction error.

^bNumber of observations.

^cRange of adjusted observations.

$\text{Abs}(1 - R^2) + \text{standard prediction error}] / 4$, i.e. a perfect model would have a deviation index = 0. In this analysis, the deviation index is 0.19 and 0.07 for CNCPS and Karoline, respectively.

Discussion

Simulated production responses to stage of lactation, feed intake, dietary CP, dietary Cfat and ratio of concentrate to forage are generally in agreement with *in vivo* observations. This shows that the overall model behaviour is acceptable. As an example, Figs 33.1–33.3 show simulated MY, milk composition and LW change during lactation.

Direct comparisons of simulated and experimental data show that nutrient flows at duodenum and nutrient digestibilities at the faecal level are well predicted by the model, especially the digestibility of OM and NDF. The regression coefficients in the mixed model analysis are 0.99 for the faecal excretion of OM and of NDF, and the corresponding R^2 values are 1.00 and 0.99, respectively (Table 33.2). We believe that this high accuracy of the model is related to the fact that the ruminal degradation of carbohydrates and protein is modelled as a two-compartment system, and further that dietary soluble carbohydrates downregulate the ruminal degradation of NDF (see Danfær *et al.*, Chapter 32, this volume). The model prediction of total protein flow at duodenum is quite accurate with a regression coefficient = 1.03 and $R^2 = 0.99$ in the mixed model analysis (Table 33.2). However, the simulated partition of this flow into microbial and dietary protein seems to be less precise, which can possibly be related to analytical problems in determining microbial protein *in vivo*.

Karoline is less accurate in prediction of milk production than in prediction of nutrient flows through the digestive tract. With the mixed model analysis, the regression equations for yields of milk, fat and protein show that the model is underpredicting at low yields and is overpredicting at high yields (Table 33.4). As the OM digestibility is predicted with high accuracy, the most likely reasons for the bias in predicted MY and milk composition are insufficient descriptions in the model of ruminal fermentation patterns, liver metabolism, nutrient partitioning and/or peripheral tissue metabolism.

Conclusions

It is concluded that Karoline is a useful tool for the advisory service in evaluation of dairy cow feed rations by predictions of nutrient digestibility and animal performance. However, in terms of milk production, Karoline seems to be too efficient at high feed intakes and/or in early lactation. On the other hand, the simulated biological efficiency seems to be too low at low feed intakes and/or in late lactation. The model especially needs to be improved in its prediction of fat and protein content of milk.

References

- Fox, D.G., Tedeschi, L.O., Tylutki, T.P., Russell, J.B., Van Amburgh, M.E., Chase, L.E., Pell, A.N. and Overton, T.R. (2004) The Cornell Net Carbohydrate and Protein System model for evaluating herd nutrition and nutrient excretion. *Animal Feed Science and Technology* 112, 29–78.
- SAS Version 8.02 (1999–2001) SAS Institute, Cary, North Carolina.
- St-Pierre, N.R. (2001) Invited review: integrating quantitative findings from multiple studies using mixed model methodology. *Journal of Dairy Science* 84, 741–755.

34 A Composite Model of Growth, Pregnancy and Lactation

I. VETHARANIAM¹ AND S.R. DAVIS²

¹AgResearch Limited, Private Bag 3123, Hamilton, New Zealand;

²ViaLactia Biosciences (NZ) Ltd, PO Box 109-185, Newmarket, Auckland, New Zealand

Abstract

Mathematical models of pre- and postnatal growth, pregnancy and lactation were combined and implemented using object-orientated computer code to form an energy-based model of a dairy cow. Each simulated cow 'grows', can have a computer pregnancy with multiple offspring, growing its fetuses to term, and 'lactates' at parturition. Each fetus is implemented as a separate entity and thus, after birth, is also capable of growth, pregnancy and lactation. Every cow (and fetus) can have different genetics, allowing the evolution of a herd over time to be modelled. The model uses dynamic energy partitioning between growth, pregnancy and lactation in a manner sensitive to intake. Additionally, milk production is sensitive to milking frequency (MF), and fetal growth is sensitive to number of siblings.

The model was fitted to milk yield (MY) and live weight (LW) data from 82 Holstein × Friesian cows on an individual cow basis, with up to 3 consecutive years of data for each cow. The model had R^2 values of 0.57 for LW and 0.88 for MY. The parameterized model proved useful for simulating the effects of management decisions either on a single animal or at a herd level. Results are presented from previous studies, which used the model to investigate the outcomes of different MFs under different nutritional scenarios, and as part of a decision-making tool for manipulating MF and feed to optimize profit in a pasture-based system. Additionally, simulations of singleton and twin fetal growth, and the response of the mammary gland to varying demand during suckling, are presented.

Introduction

An object-oriented (OO) programming approach allows the use of a model to be separated from the implementation of that model. Equations, rules and parameters are encapsulated in a computer module or 'class', and thus the user of the model does not have to deal with these complexities, but rather can communicate with the model in an intuitive way using prescribed commands. For a model of an animal such commands may be to eat, grow and lactate. OO construction techniques allow individual animals to be represented, each animal having its own 'object' containing the properties of that

animal. This allows simulations that range from a single animal to a herd scenario: the reusability of OO code allows a model to be rapidly applied to a number of different situations. OO programming is a natural approach to implementing models of animals.

This study describes a model of a cow that combines individual mathematical models of growth, pregnancy, fetal growth and lactation, and is implemented as an OO model. A huge variety of models of production in farm animals have been produced, addressing processes such as growth, pregnancy and fetal growth, and lactation either individually or in combination. They vary from the highly empirical to the highly mechanistic, and are pitched at different levels of complexity, from energy-based to biochemical. This range is bounded at one end by the empirical, energy-based model of Parks (1982) to the mechanistic, biochemical-based model of Baldwin (1995). The simpler models, having fewer parameters, are often more readily fitted to data, and are more robust across a range of data, whereas the more complex models may suffer from problems of parameter identification.

The constitutive models of the OO model described here are mechanistic, energy-based mathematical models that combine with each other in a natural way. The purpose of the model is to provide a flexible and robust model to investigate the interaction of feeding and milking strategies on production and performance of cows. While the model has been applied only to New Zealand Holstein \times Friesian dairy cows, with different parameterization it can be applied to other breeds of cow, and perhaps other ruminant species.

Model Description

The main component of the composite model is a model of energy partitioning and growth in mammals given by Vetharanim *et al.* (2001a), in which a mammal is represented as two interacting pools: (i) of 'free' energy, N (MJ); and (ii) of bound energy, M (kg), identified with the animal's empty body (EB). N is the energy available as a result of energy flux through the blood and liver, plus free cellular energy. N has two influxes of energy: absorbed energy (AE), I_I (MJ/day), derived from the animal's gross energy (GE) supply from its diet; and catabolized energy, I_K (MJ/day). For modelling the growth of the fetus, the energy supplied to the conceptus is identified as GE_c , and AE is identified as GE minus energy used for placental growth and maintenance. Effluxes from the energy pool supply energy used by the animal. Energy deposited as tissue is represented by an anabolic flow, I_A ; that contained in secreted milk by a lactation flow, I_L ; that consumed by the conceptus during pregnancy by a conceptual flow, I_C ; and that deposited in hair/wool/horn growth by a follicular flow, I_F . These four energy flows (all in MJ/day) represent the net energy of the processes, and the inefficiencies of these processes are included in a metabolic excreta current, I_E (MJ/day), which also includes energy associated with activity, thermal maintenance and excreted urine. These energy dynamics are represented in

Fig. 34.1, with I_p (production, MJ/day) representing collectively I_C , I_L and I_F ; additionally J represents the gross energy intake of the animal from consumed food (or, for a fetus, its dam's energy supply to the conceptus), and I_W represents energy not absorbed in the gut (or, for a fetus, the energy used by the placenta).

For each mode of energy utilization by the animal, a 'potential' or maximum rate of energy usage for that mode is specified and used to place a demand on N . Energy supplied towards that mode is generally less than the demand, varying with N as regulated by an 'elasticity' parameter specific to that mode. Differences between I_A , I_C , I_F and I_L in the values for their elasticity parameters result in differences in buffering during energy shortfalls, allowing a dynamically varying partitioning of energy.

Models of lactation (Vetharaniam *et al.*, 2003a) and pregnancy, both of which specify a potential energy consumption together with a performance determined by actual energy supply, were coupled to the animal model using the above scheme.

The lactation model (see Appendix) is based on the discovery that mammary secretory cells show heterogeneity of gene expression (Molenaar *et al.*, 1992), being either actively secreting or quiescent. Davis *et al.* (1999) postulated that the determination of gene expression between active and

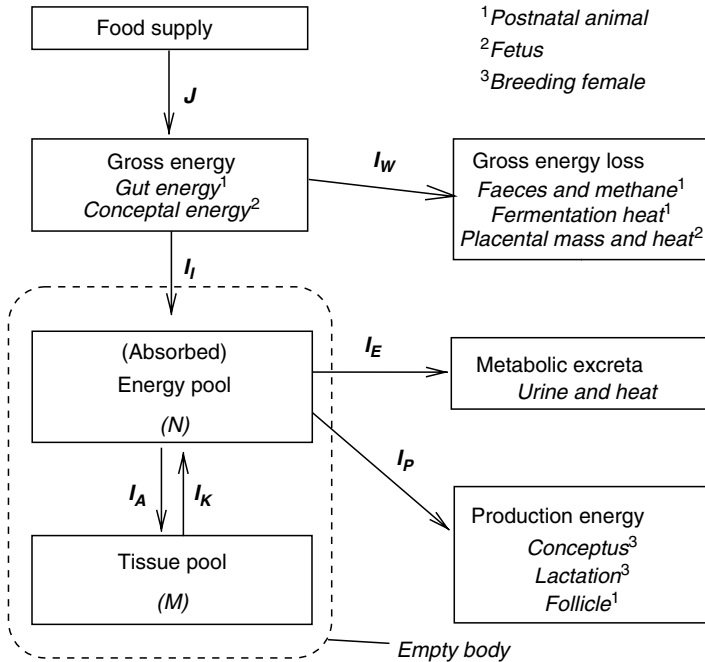

Fig. 34.1. Model representation of an animal's energetics with an absorbed energy (AE) pool supplying the needs of the animal, and being replenished by intake and catabolism. (Source: Vetharaniam *et al.*, 2001a.)

quiescent secretory cells occurs at the alveolar level (within a lobule), driven by alveolar engorgement through mechano-transduction. These ideas were incorporated into a lactation model (Vetharanim *et al.*, 2003a) that models numbers of active and quiescent alveoli, A_A and A_Q respectively (both dimensionless), and accumulated milk, v (litres), as driven by nutrition and MF (Fig. 34.2).

The pregnancy model (see Appendix) considers maternal energy supply to the conceptus in response to fetal energy demand and models competition between fetuses.

The composite model was implemented in C++ as an OO model, as one class, calling the Fortran 77 routine LSODA (Hindmarsh, 1983; Petzold, 1983) to solve the differential equations numerically. Because each animal represented in an OO simulation has a separate ‘instantiation’, an animal can have a separate set of parameter values, corresponding to different genetics.

The animal class provides the user with the usual options to set and retrieve the parameter and state values for each instance of an animal. The user can specify any desired time step, and can vary time steps within a simulation, and between different animals in the same simulation, as required. The commands to advance an animal forward over a given time step are:

1. Obtain the demand for energy from the animal.
2. Specify the feed consumption rate and feed quality for the next time step.
3. Instruct the animal to step forward a specified period of time.
4. Remove a user-specified amount of milk from the udder (for a lactating animal).

The food supplied should not exceed the animal’s demand. The instruction to step the animal forward calls for the models to predict changes in N and M , and for a lactating animal, to predict milk secretion and accumulation of milk in the udder, along with changes in the mammary gland due to mammary engorgement. If milk is not removed regularly, the udder regresses, mimicking what is observed in nature. Additionally the user can create a

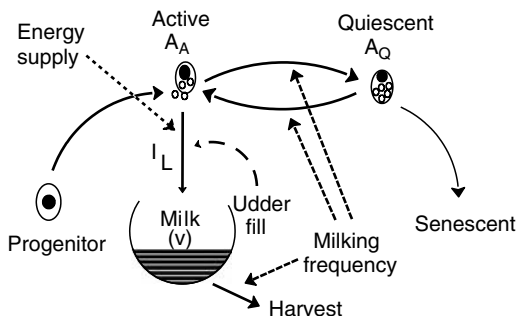

Fig. 34.2. Representation of the lactation submodel. Solid lines represent fluxes between pools and dashed lines represent influences of milking frequency (MF), energy availability and udder fill on these fluxes.

computer pregnancy, which makes a separate instance of the animal class for each of the required number of fetuses. When a pregnant animal advances a period, it carries out steps 1–3 for each fetus for the same period. At parturition, a pregnant animal starts lactating, and control of its offspring passes to the user, who must facilitate interactions between dam and offspring (such as suckling).

Fitting the Composite Model

The model was fitted individually to each of 82 cows using LW and MY data supplied by Dexcel Limited (Newstead, Hamilton, New Zealand). The cows were New Zealand Holstein × Friesians grazed on rye grass/white clover pasture at three different stocking rates (2.2, 3.2 and 4.3 cows/ha) and milked twice daily in a trial that ran for 3 consecutive years (MacDonald *et al.*, 2001). For cows present in the trial for multiple years, the model simulation ran continuously from the time of first recorded data to the time of the last, with all data fitted simultaneously. Intakes (Fig. 34.3) were estimated on a herd basis, which would increase the size of the residuals. The model fits had an average R^2 of 0.57 for LW and 0.88 for MY. Data for fetal growth were not available and so fetal growth was not fitted. Parameters controlling placental and fetal growth were set a priori, guided by data from Ferrell *et al.* (1976). Predicted birth weights (average 41.5 kg) were comparable to the data (average 38.3 kg), although the data had a larger range. Sample fits for a cow from each stocking rate are shown in Figs 34.4–34.6. Each spans three consecutive lactations.

Twelve of the model's parameters were fitted to the Dexcel data. Of those specified independently, many were obtained from the literature, and others needed to be estimated to give realistic results. These parameter values (Table 34.1) were used in the simulations below.

Simulations

Milking frequency

MF is a topical research area, with investigation for benefits of both reduced and increased MF in dairy cows (Davis *et al.*, 1999; Hale *et al.*, 2003). However, nutrition is also an important determinant of milk production, and the composite model was invaluable for simulating the interaction of intake and MF (Vetharanim *et al.*, 2003a). Results from the model suggested that the size of the pool of quiescent alveoli is small compared to the active pool, decreasing with increasing MF, and that small variations in the quiescent pool resulted in significant changes in secretory capacity over a lactation (Vetharanim *et al.*, 2003a). Simulations over a full lactation of cows fed either a high allowance (HA) or a low allowance (LA; Fig. 34.7) and being milked once, twice, three or four times daily (MF1, MF2, MF3 and MF4,

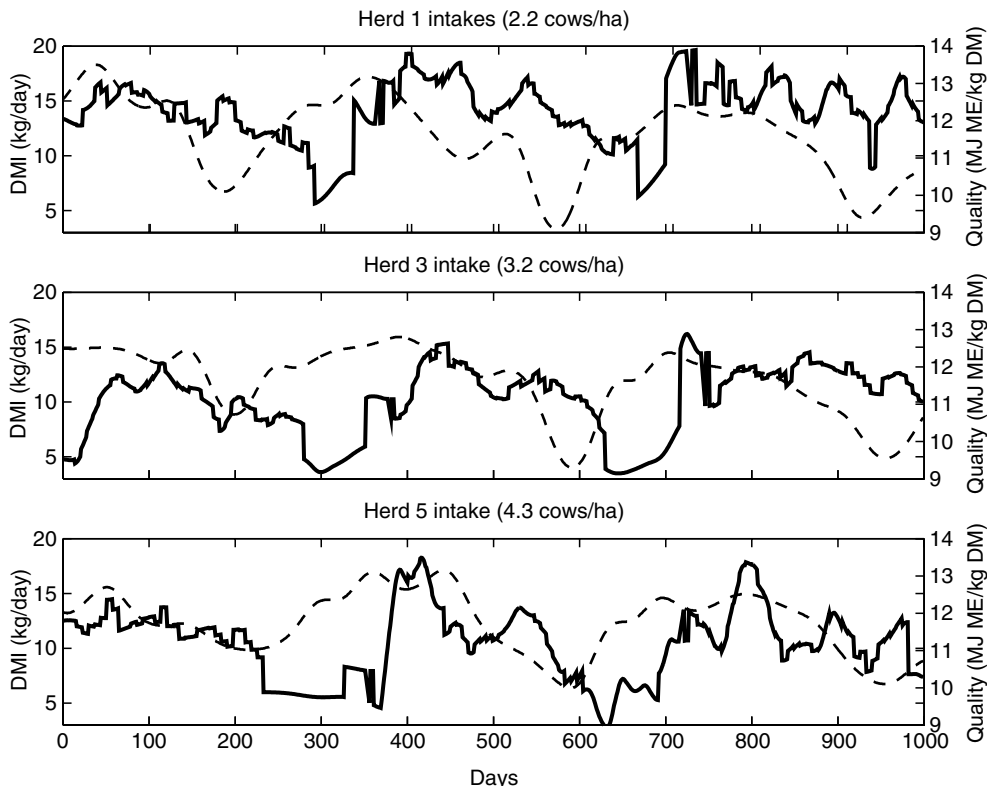

Fig. 34.3. The dry matter intakes (DMIs) and feed quality for three herds of cows grazed at different stocking rates (2.2, 3.2 and 4.3 cows/ha) that were used as inputs to the model during the fitting of the model to data from individual cows from those herds. Solid lines represent DMI and dashed lines represent feed quality.

respectively) showed that while the population of active alveoli increased with MF (Fig. 34.8), nutrition had a substantial impact on MY (Fig. 34.9). Compared with MF2, MF1, MF3 and MF4 had resulted in a 29% loss, and 8% and 12% gains, respectively, in production on LA compared with a 33% loss, and 22% and 40% gains, respectively, on HA (Vetharanim *et al.*, 2003a). The differences between MF1 and MF2 are similar to those found in the field (Davis *et al.*, 1999). Additionally udder capacity had an impact on yield during MF1. Increasing the solid content of milk by 20% reduced the yield loss associated with MF1 by 5% on HA and 4% on LA (Vetharanim *et al.*, 2003a). Pregnancy did not affect these results for HA cows, and was small for LA cows. LW decreased with increased MF (as a consequence of a larger, more active mammary gland). Additionally the model reproduced the acute and chronic effects of temporary MF1 found by Rémond *et al.* (1999) on a qualitative level (Vetharanim *et al.*, 2003a).

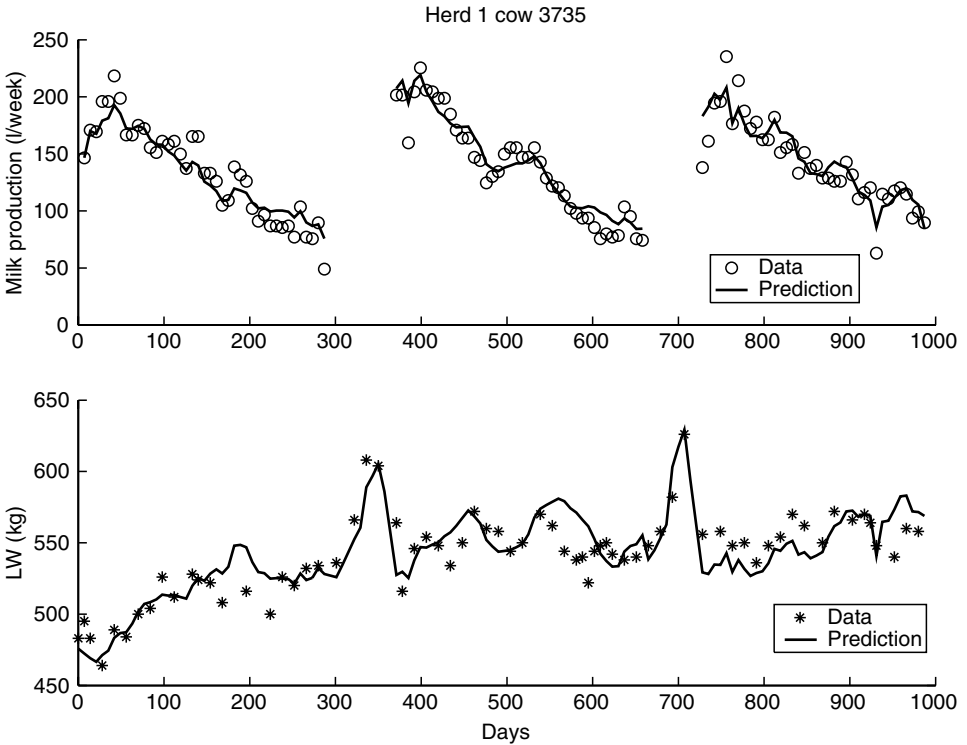

Fig. 34.4. An example fit of the model to a cow from the herd with stocking rate 2.2 cows/ha. The model was fitted simultaneously to weekly milk yield (MY) and irregularly measured live weight (LW) data over three consecutive lactations (1000 days).

New Zealand dairy farmers are increasingly considering MF1 over MF2 for lifestyle or financial reasons (Davis *et al.*, 1999), especially in conjunction with Jersey cows. Also, a switch from MF2 to MF1 during a lactation can ameliorate feed shortages and/or increase profits. Westbrooke *et al.* (2003) used the model (adjusted for a Jersey \times Friesian) to investigate the optimum day for such a switch under different conditions, specifying the cost of switching in terms of the break-even cost of labour per milking, to allow individual variation in valuing time (Fig. 34.10).

Pregnancy and calf rearing

In New Zealand, Friesian calves surplus to dairy farmers' requirements are often used (as cows) for calf rearing on beef farms and may suckle additional foster calves. The model was used to simulate this situation. Predictions of fetal and placental growth (singleton and twin) are shown in Fig. 34.11 along with singleton data for Herefords (Ferrell *et al.*, 1976). Qualitatively there was

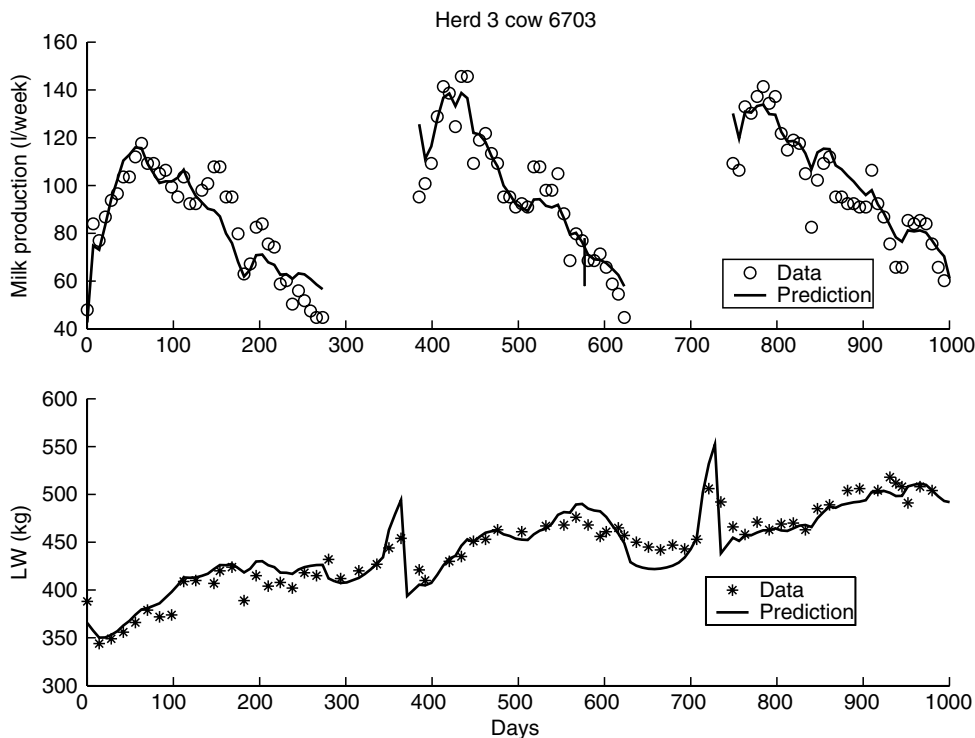

Fig. 34.5. An example fit of the model to a cow from the herd with stocking rate 3.2 cows/ha. The model was fitted simultaneously to weekly milk yield (MY) and irregularly measured live weight (LW) data over three consecutive lactations (1000 days).

agreement, although the model predicted faster fetal and placental growth in mid-pregnancy, and a slight plateau in the last trimester. The model slightly overpredicted the difference between twins and singleton (D. Smeaton, AgResearch, Ruakura, 2004, personal communication). Parameterization of the model to data would improve predictions.

The suckling simulations assumed that calves (including fosters) were of singleton birth weight. Suckling frequency (SF) was eight/day for the first week, with a unit reduction in SF each consecutive week until weaning. The simulated cow quickly adjusted her milk production to match demand. Milk production increased with number of calves suckled for the first three calves; a fourth calf did not increase production since the udder was fully emptied by three calves (Fig. 34.12). The cow with one or two calves initially reduced secretion, but later increased production to match increased demand (Fig. 34.12). Production was downregulated by a reduction in numbers of active alveoli, and an increase in quiescent alveoli, which provide a latent secretory capacity, later utilized by reactivation of quiescent alveoli (Figs 34.13 and 34.14). The steps in the curves are a result of changed SF. In the first

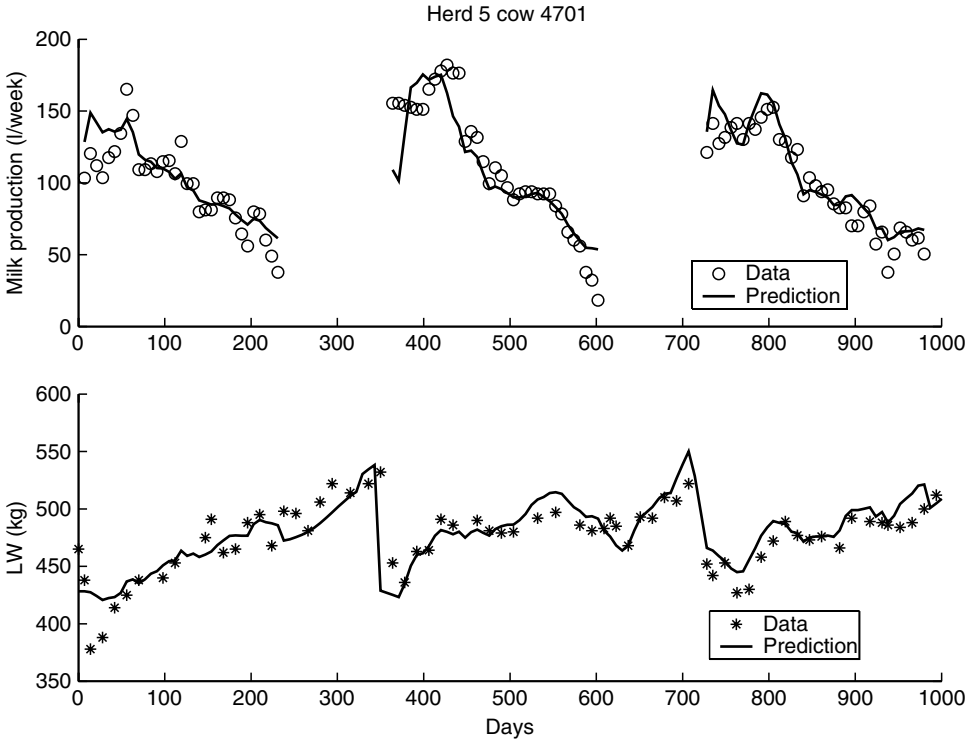

Fig. 34.6. An example fit of the model to a cow from the herd with stocking rate 4.3 cows/ha. The model was fitted simultaneously to weekly milk yield (MY) and irregularly measured live weight (LW) data over three consecutive lactations (1000 days).

week, the single calf averaged a milk consumption of 8.6 l/day compared with a value by Holmes *et al.* (2002) of 8 l/day. Milk consumption at 30 days was similar to data from weigh-suckle-weigh measurements involving Jersey and Hereford \times Friesian calves (D. Smeaton and D. Wells, 2004, unpublished report). Milk consumption and growth are shown in Figs 34.15 and 34.16.

Conclusions

The composite model provides a means to model the effects that management decisions have on the performance of individual cows in different contexts. It allows the manipulation of nutrition and MF for optimizing profits on a dairy farm and for investigating the performance of calf rearing and growth on a beef farm. The model implementation facilitates the inclusion of variance between animals and thus modelling of a herd. It can equally well be used for development of different model components (e.g. lactation and pregnancy).

Table 34.1. Parameters used in the model.

Parameter	Value	Parameter	Value	Parameter	Value
ρ_u^a	0.041 MJ/kg	ε_A^d	0.4	ε_K^d	0.15
ε_L^d	0.25	ε_U^a	0.35	r^d	0.078
η^a	0.042	C^d	0.1	L^b	0.754
χ_f^a	0.005	χ_2^a	0.91	χ_3^a	7e-3/day
κ_M^b	0.1351	κ_F^b	0.00440	K_N^b	0.0318
	MJ/kg/day		MJ/kg/day		MJ/kg/day
κ_A^b	0.4584	M_M^b	599 kg	w_i^d	1.227 MJ/kg/day
w_f^b	0.604 MJ/kg/day	w_c^d	0.05047/	σ_s^d	0.08472
			day		
ω^a	0.017224/day	t_s^b	199 days	P^d	10 MJ/day
β_1^d	13.40	β_2^d	9.97	β_3^d	0.1771
τ_b^d	285 days	θ^d	0.2533	s_{max}^c	3.0e-9 MJ/day
			MJ/kg/day		
c^c	8.5	v_a^c	4e-9 litre	v_c^c	7.6 l
ρ_{milk}^c	3.1 MJ/l	k_1^c	2.16e + 09/	k_2^c	0.355/day
			day		
k_5^c	0.0437/day	$p_{e,i}^b$	0.941	$p_{b,i}^b$	0.159/day
$t_{c,i}^c$	0.207 days	k^b	0.2410/day	$\bar{A}_{A,i}^b$	1.84e8 kg ^{-0.87}
ρ_R^d	0.13				

^aVetharaniem *et al.* (2001b).

^bFitted to Dexcel data.

^cVetharaniem *et al.* (2003a).

^dEstimated value.

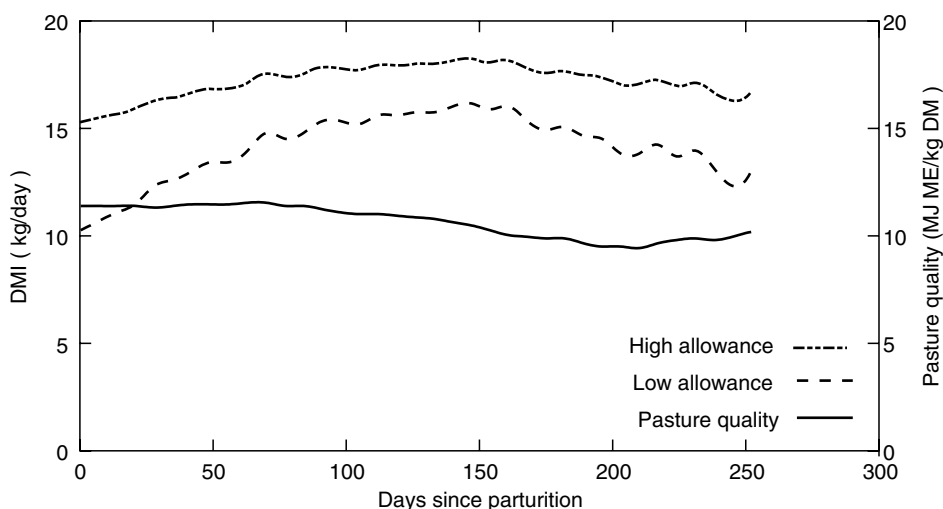

Fig. 34.7. Pasture quality and two different levels of dry matter intake (DMI) used as inputs to the model to investigate the interaction of milking frequency (MF) and nutrition. (Source: Vetharaniem *et al.*, 2003a.)

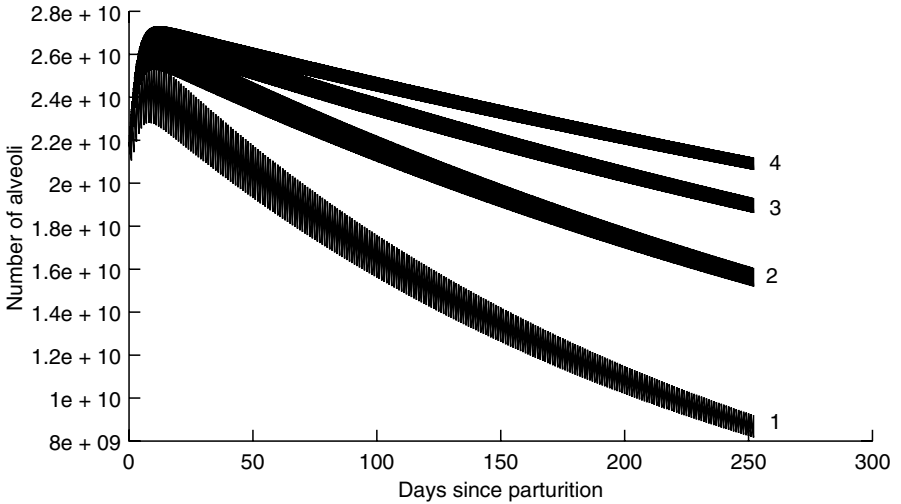

Fig. 34.8. Model predictions of numbers of active alveoli in the mammary gland over a 250-day lactation for one to four milkings/day, as labelled. (Source: Vetharanim *et al.*, 2003a.)

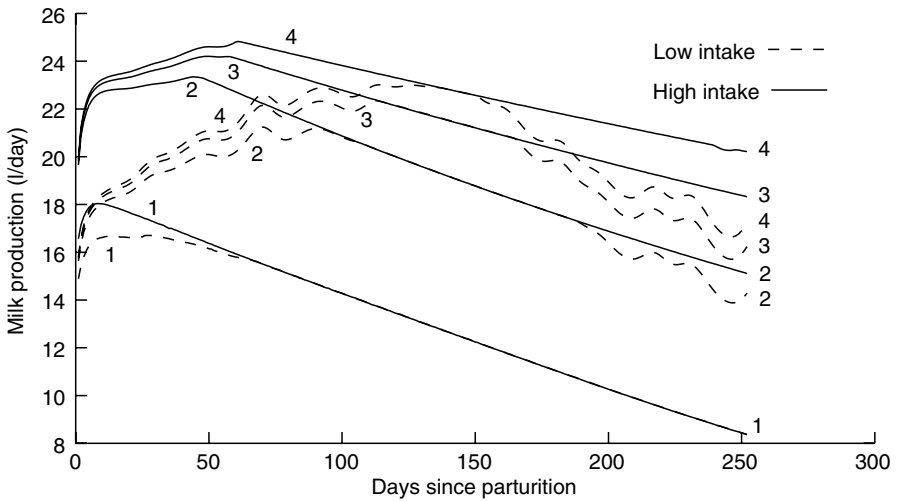

Fig. 34.9. Model prediction of milk yield (MY) for one to four milkings/day (as labelled), under high and low intakes. (Source: Vetharanim *et al.*, 2003a.)

Although the model was not parameterized to fetal growth data, it showed strong qualitative agreement with data in the literature. Similarly, the model was parameterized to MY data only from cows milked twice daily, but its predictions on MF are good on a qualitative level, and in many cases agree with field trials (Davis *et al.*, 1999). Fitting the model to MY under different MFs, simultaneously with growth and fetal growth data from one breed, is likely to improve the performance of the model.

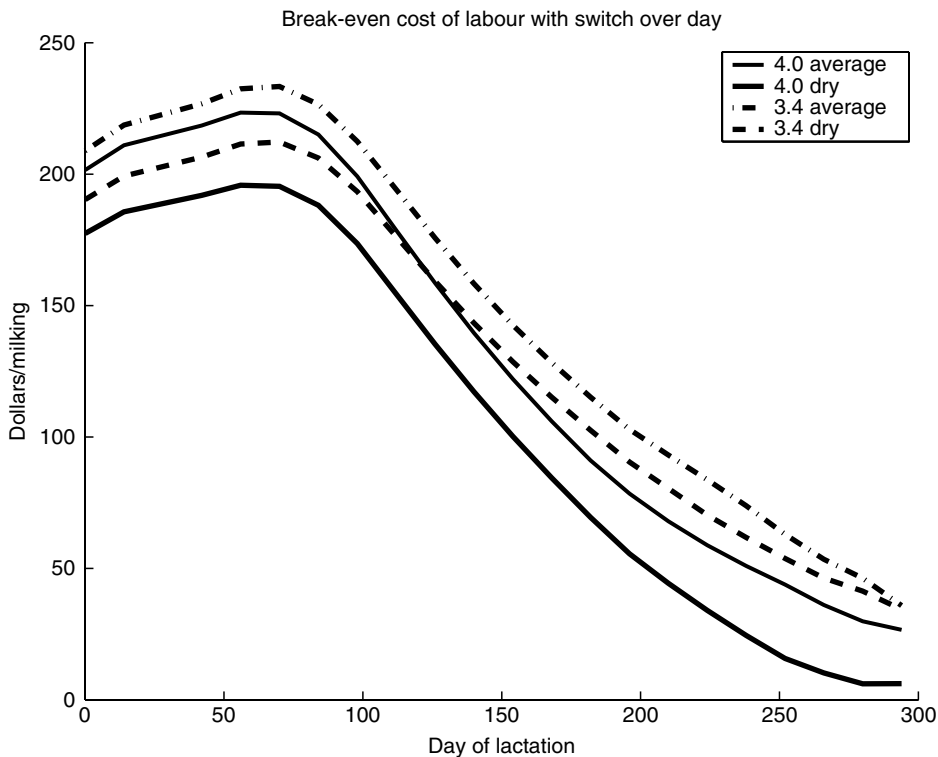

Fig. 34.10. Farms system predictions of the break-even cost of labour per milking for switching from twice- to once-daily milking, against day of lactation, on a pasture-based system, based on model predictions of milk yield (MY) and live weight (LW). Stocking rates of 4.0 and 3.4 cows/ha in dry and average years were used. (Source: adapted from Westbrooke *et al.*, 2003.)

The lactation model assumes that the parameters governing the quiescence, reactivation and senescence of alveoli are not affected by nutrition and considers only the chronic effect of nutrition on milk production. However, Vetharanim *et al.* (2003b) demonstrated a chronic effect of nutrition on some of these parameters, and the model would benefit from the inclusion of this. Additionally, the model does not have the capability to predict changes in body composition in a dynamic way. Extension of the model to explicitly include different fat and protein pools would further strengthen it.

Acknowledgements

We thank D. Smeaton for helpful discussions and advice. This work was performed in part with funding from the New Zealand Foundation for Research, Science and Technology. Data used for parameterizing the model were made available by Dexcel Limited (Newstead, Hamilton, New Zealand).

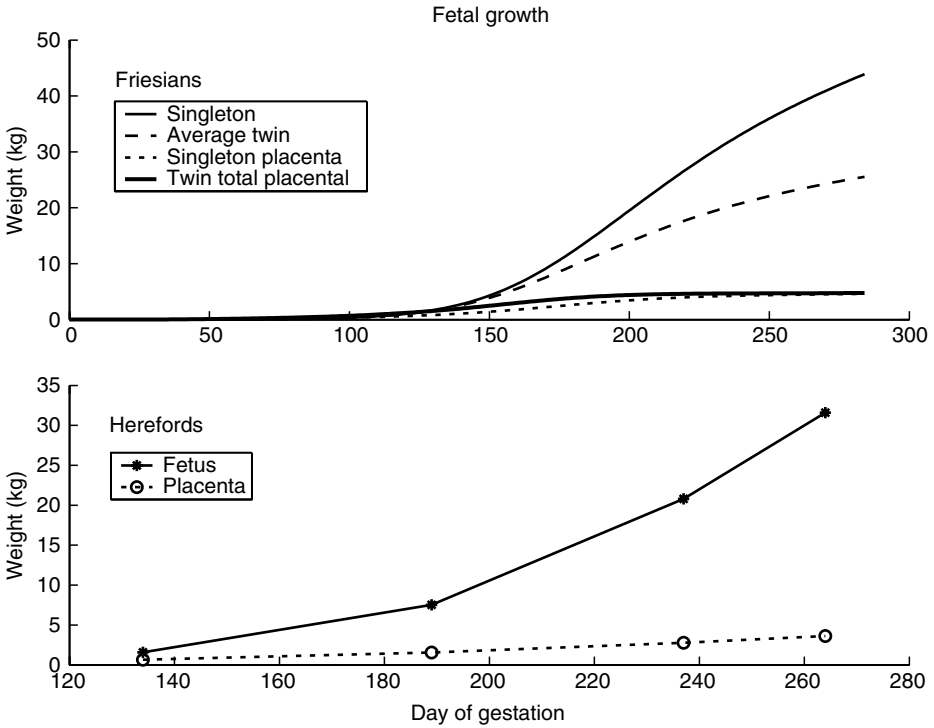

Fig. 34.11. Model predictions of singleton and twin Friesian fetal and placental growth in a Friesian heifer, compared with data for Herefords from Ferrell *et al.* (1976).

Appendix: Mathematical Formalism of the Model

Energy flows

It is assumed that the energy pool N has an upper limit, N_u (MJ), which is taken to be proportional to the empty body mass, M (Vetharanim *et al.*, 2001a):

$$N_u = \rho_u M \tag{34.1}$$

where ρ_u (MJ/kg) represents the carrying capacity of the blood and intracellular fluids and is assumed constant. The rate of change of N with time is given in (Fig. 34.1):

$$\frac{dN}{dt} = I_I + I_K - (I_A + I_C + I_E + I_F + I_L) \tag{34.2}$$

The energy flow, $I_{E'}$, includes heat from inefficiencies (I_{Σ} ; MJ/day), exercise energy (I_X ; MJ/day), thermal maintenance (I_T ; MJ/day) and energy in urine (I_U ; MJ/day):

$$I_E = I_{\Sigma} + I_T + I_X + I_U \tag{34.3}$$

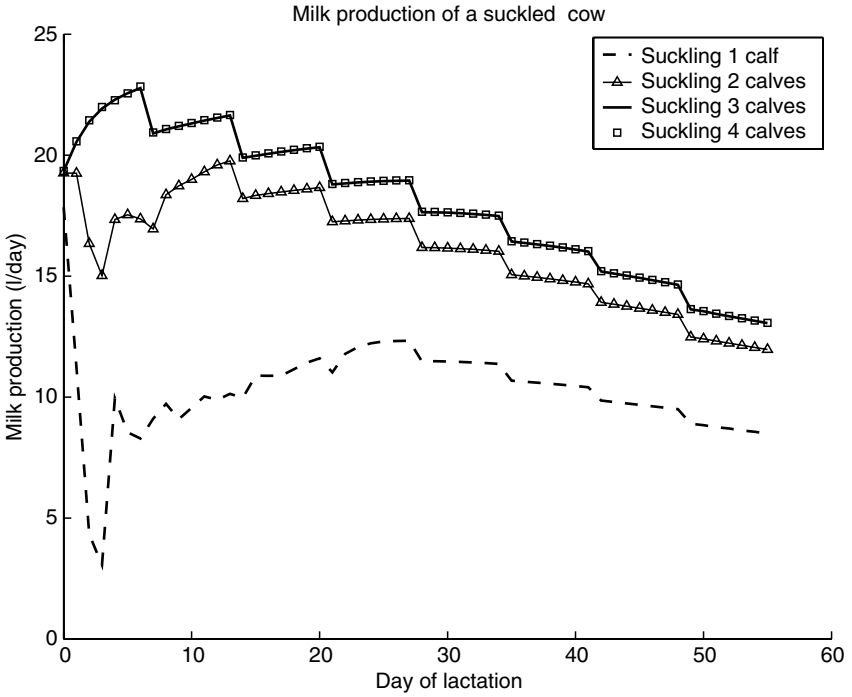

Fig. 34.12. Model predictions of the lactation curves of a Friesian cow suckling from one to four calves (as labelled), showing that three calves are sufficient to drive the mammary gland to maximum capability, and that with one or two calves production is downregulated in the first few days to match a lower demand, followed by an upregulation as demand increases with calf growth.

Inefficiencies in tissue and milk synthesis incur energy costs proportional to I_A and I_L by ϵ_A and ϵ_L respectively. The heat from catabolism is $\epsilon_K I_K$, that from urea synthesis is $\epsilon_U I_U$ and the extra cost of exercise is $\epsilon_X I_X$. All ϵ factors are dimensionless. Then:

$$I_\Sigma = \epsilon_A I_A + \epsilon_K I_K + \epsilon_L I_L + \epsilon_U I_U + \epsilon_X I_X \tag{34.4}$$

The model ignores the energy cost of nutrient absorption, and assumes I_C and I_F have no extra energy cost. Exogenous and endogenous urine are assumed proportional to I_I and I_K respectively, by respective factors r and η (both dimensionless):

$$I_U = r I_I + \eta I_K \tag{34.5}$$

Metabolic potentials and partitioning of energy

In the model, each of the flows I_A, I_C, I_L, I_F, I_X and I_T is associated with a ‘metabolic potential’ or maximum rate of energy use (in MJ/day) determined by

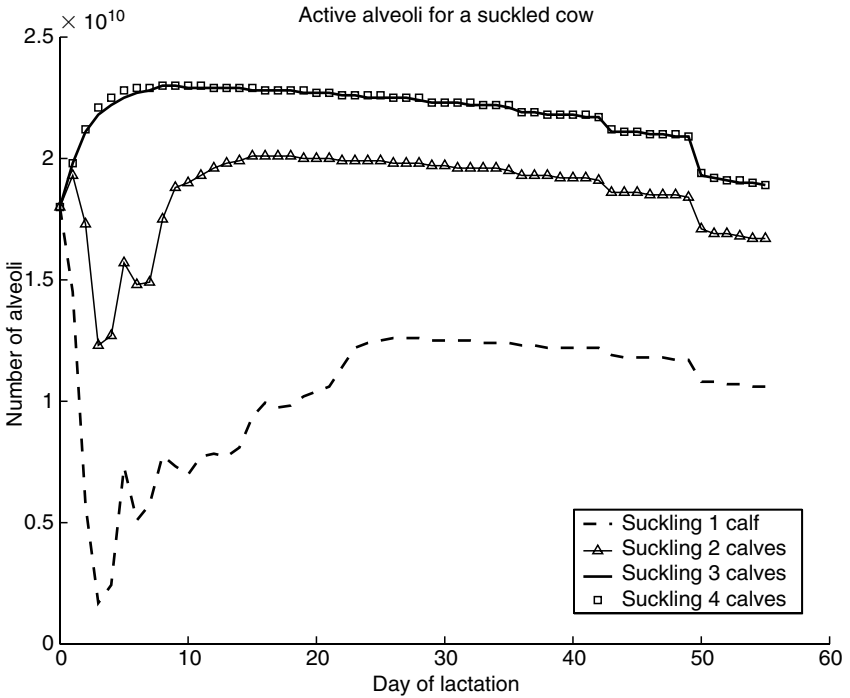

Fig. 34.13. Model predictions of the active alveoli population in a cow suckling from one to four calves. Numbers of active alveoli adjust to match demand on the udder.

degree of maturity and physiological state, and a dimensionless ‘elasticity of supply’ parameter, which, together with N , governs the actual energy flow. Energy supply to the conceptus and rate of milk synthesis have respective potentials Q_C and Q_L with respective elasticities C and L . Anabolism has a potential Q_A with elasticity = 1. All these potentials are met if $N = N_u$. Then the corresponding energy flows are:

$$I_L = \left(\frac{N}{N_u}\right)^L Q_L; \quad I_C = \left(\frac{N}{N_u}\right)^L Q_C; \quad I_A = \left(\frac{N}{N_u}\right)^L Q_A \quad (34.6)$$

Similarly, follicle growth has a potential Q_F with elasticity F . Maintenance of body temperature when the animal is not in thermal equilibrium has an energy expenditure rate Q_T , which must be met, and thus has elasticity zero. The analogous driver for activity Q_X is set by the actual activity of the animal and thus also has elasticity zero:

$$I_T = Q_T, \quad I_X = Q_X \quad (34.7)$$

Different elasticities between modes of energy use result in energy partitioning between modes varying dynamically with N and thus level of intake.

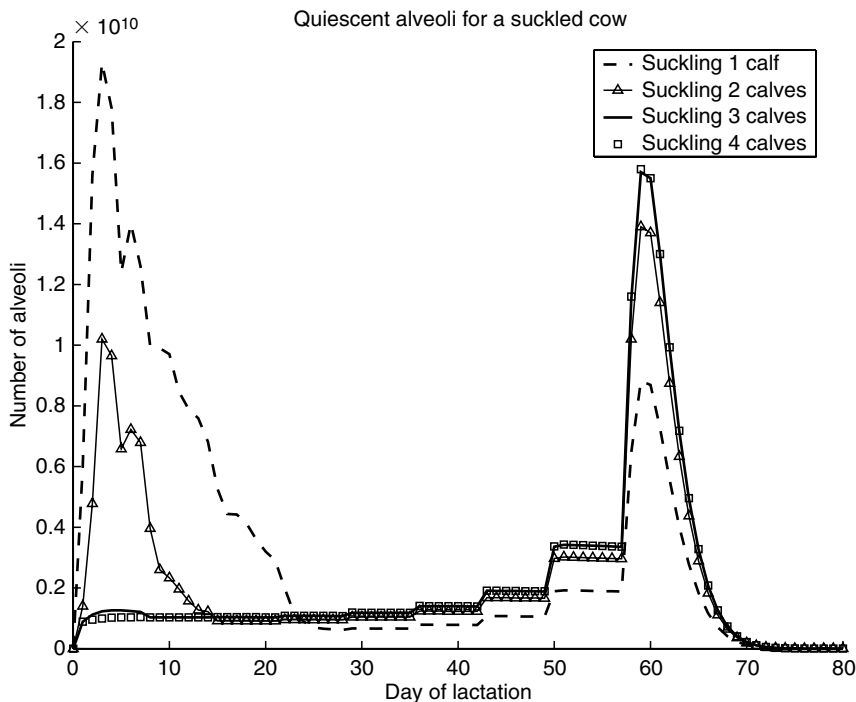

Fig. 34.14. Model predictions of the quiescent alveoli population in a cow, suckling from one to four calves. Quiescent alveoli increase in number with decreased demand on the udder, and provide a latent secretory capability that can later be reactivated.

Metabolic driver for intake demand

The functional forms for the metabolic potentials are given below. The model uses these potentials to evaluate a ‘metabolic demand’, Q (MJ/day), which is the maximum AE intake of the animal to achieve maximum rates for all its current flows:

$$Q = \frac{(1 + \epsilon_A)Q_A + Q_C + Q_F + (1 + \epsilon_L)Q_L + Q_T + (1 + \epsilon_X)Q_X - \kappa}{1 - r(1 + \epsilon_U)} \tag{34.8}$$

where the denominator in the above expression converts from metabolizable energy (ME) to AE, κ and accounts for energy from catabolism and prevents N from exceeding N_u :

$$\kappa = [1 - \epsilon_K - \eta(1 + \epsilon_U)I_K] \tag{34.9}$$

Q could be used as a driver for feed intake in an intake submodel. Such a model should also account for feed availability, quality and satiety (Weston, 1996).

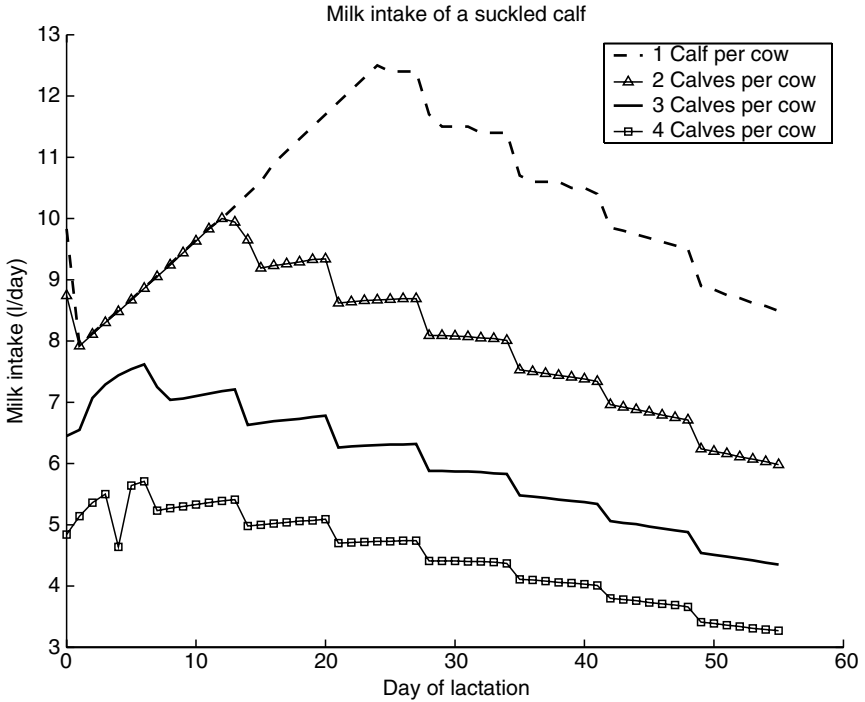

Fig. 34.15 Model predictions of milk intake per calf for one to four calves suckling the same cow. The cow produces sufficiently to meet the demand of two calves (but not three) in the first 2 weeks, but later her production is not adequate for this.

Growth

The difference, $I_A - I_K$, gives the rate of change of energy in the animal’s EB weight (EBW). However, the change in M also depends on its energy density, ρ_M (MJ/kg), (which varies as ratios of protein, fat, water and ash vary with time and maturity):

$$\frac{dM}{dt} = B \left(I_A - I_K - \frac{\partial \rho_M}{\partial t} \right), \quad \frac{1}{B} = \left(\rho_M + \frac{\partial \rho_M}{\partial M} M \right) \tag{34.10}$$

Body composition and energy density

Because the model treats the EB as one pool, M , body composition must be specified explicitly. Blaxter (1967) gives representative values for the energy content of fat (38.5 MJ/kg) and protein (23.1 MJ/kg), and estimates for the water, ash and protein content of fat-free mass (respectively 98%, 1% and 1% at conception, and respectively 71%, 6% and 23% at maturity). Then ρ_M is (Vetharanim *et al.*, 2001a):

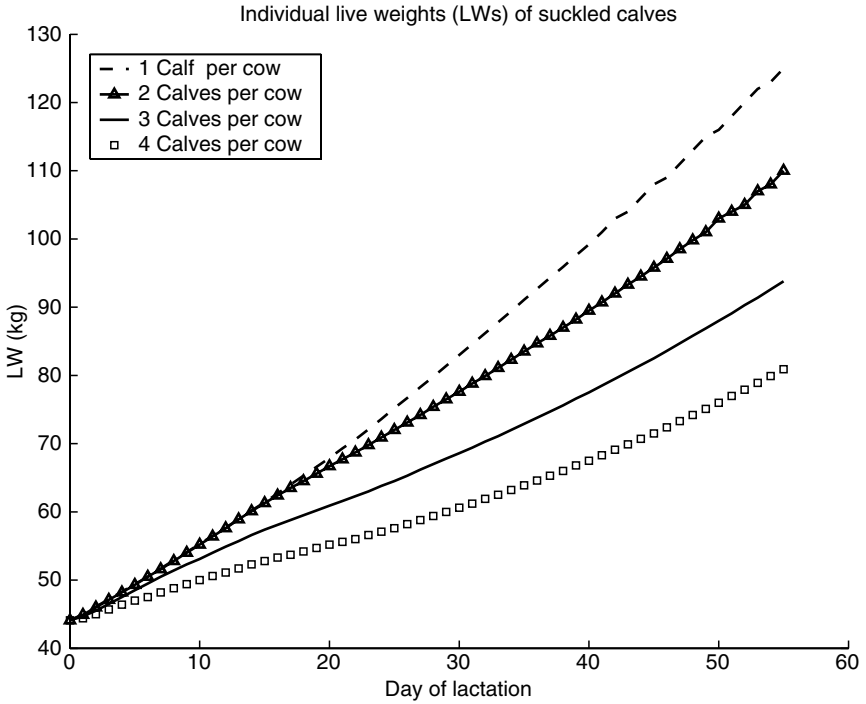

Fig. 34.16. Model predictions of individual calf weight for one to four calves suckling the same cow. In the first 2 weeks of lactation the cow can grow two calves (but not three) at the same rate as one calf, but not after this time.

$$\rho_M = \left[33.2 + 5.1 \exp(-\chi_3 \tau) \right] \left(\chi_1 + \frac{\chi_2 M}{2M_M} \right) + \left[5.3 - 5.1 \exp(-\chi_3 \tau) \right] \quad (34.11)$$

where χ_1 and χ_2 (both dimensionless) are respectively the minimum fat content of M and the rate of increase in fat with increased M , χ_3 (1/day) reflects the decline in water content of M with age, M_M (kg) is an upper bound of M , and τ (days) is the age of the animal from conception.

Catabolism

The rate of energy flow into N from catabolism is (Vetharanim *et al.*, 2001b):

$$I_K = \left(\kappa_M - \frac{\kappa_F M}{M_M} \right) M \left[1 - 0.97 \exp(-\chi_3 \tau) \right] + \kappa_A I_A + \kappa_N M \left(1 - \frac{N}{N_u} \right)^7 \quad (34.12)$$

where κ_M , κ_F and κ_N are all in MJ/kg/day, and κ_A is dimensionless. κ_M and κ_F reflect basal catabolism of protein and fat respectively. κ_N reflects catabolism to meet energy deficits (significant only when N is very low due to the

relatively high power of seven in the last term), and κ_A reflects catabolism associated with anabolism, which serves in the maintenance of tissues by balancing proliferation (Watson *et al.*, 2000).

Anabolic potential

The anabolic potential is given by the following equation:

$$Q_A = w_a M \left[1 - \frac{M}{\sigma M_M} \right] + \frac{\kappa_M - \kappa_F M/M_M}{1 - \kappa_A} M \left[1 - 0.97 \exp(-\chi_3 \tau) \right] \quad (34.13)$$

where

$$w_a = w_f + (w_i - w_f) \exp(w_c \tau); \sigma = 1 - \sigma_s \{1 + \cos[\omega(t + t_s)]\} \quad (34.14)$$

w_a (MJ/kg/day) reflects changes in growth potential with age through the parameters w_i , w_f (both MJ/kg/day) and w_c (/day); τ (days) is age from conception; σ (dimensionless) modulates M_M to provide seasonal effects through the parameters σ_s (dimensionless) and ω (/day); t_s (day) adjusts time, t (day), to match seasonal effects. The quantity σM_M provides a seasonally varying 'target' for growth, and the second term in equation (34.13) ensures that I_A and I_K are non-zero at maturity (Vetharanim *et al.*, 2001a).

Conceptual potential and fetal energy supply during pregnancy

The energy flow, I_C , supplied by a dam to its conceptus during pregnancy is a sink on the mother's energy pool, and is regarded as the GE supply to the fetus. The portion of I_C not used for placental growth and maintenance is identified as the fetus's AE supply. This allows the same model to be used for describing both pre- and postnatal growth. The model allows for multiple fetuses. Following Vetharanim *et al.* (2001b), each fetus will have an AE demand as discussed above. Let Q_i^{Fi} be the AE demand for fetus i , $i = 1, \dots, m$, where m is the number of fetuses. Total fetal demand on the dam, V (MJ/day), and her conceptual potential, Q_C , are then:

$$V = \sum_{i=1}^m Q_i^{Fi}; Q_C = (P/\alpha)[1 - \exp(V/P)] \quad (34.15)$$

where P (MJ/day) is the maximum energy the dam will supply to the conceptus and α (dimensionless) is the fetal 'absorbability of energy supplied to the conceptus', having the function:

$$\alpha = 1 / \left[1 + \beta_1 \exp(-\beta_2 \tau / \tau_b) + \beta_3 \right] \quad (34.16)$$

where β_1 , β_2 and β_3 (all dimensionless) govern energy supply to the conceptus over time, τ is the age of the fetus since conception, and τ_b is gestation length.

The form for equation (34.15) ensures that when V is small compared with P (in early pregnancy), each fetus receives its AE potential, but when V is large, fetal demand is only partially met. This mechanism introduces

competition between fetuses and reproduces growth differences between singletons, twins and triplets in sheep (Vetharaniam *et al.*, 2001b). The GE received by each fetus, $J^{F,i}$ (MJ/day), is proportional to its AE demand:

$$J^{F,i} = (Q_I^{F,i} / V) \times I_C \quad (34.17)$$

where I_C is the dam's energy supply to the conceptus. Each fetus's AE intake and the energy consumed by the placenta, I_{placenta} (MJ/day), are:

$$I_I^{F,i} = \alpha J^{F,i}; I_{\text{placenta}} = (1 - \alpha) \sum_{i=1}^m J^{F,i} \quad (34.18)$$

Change in placental weight, p (kg), was described by the following equation:

$$\frac{dp}{d\tau} = B_p(I_{\text{placenta}} - \theta p); B_p = 1/[3.3 - 3.26 \exp(-2 \times 10^{-6} \tau^3)] \quad (34.19)$$

where B_p (kg/MJ) converts energy retention to weight gain for the placenta, and θ (MJ/kg/day) is the energy consumption of the placenta for maintenance.

Lactation potential

The lactation model (Vetharaniam *et al.*, 2003a) links the lactation potential, Q_L , to the number of active alveoli in the mammary gland:

$$Q_L = S_{\text{max}} \left[1 - \left(\frac{v}{v_u} \right)^c \right] A_A \quad (34.20)$$

where c (dimensionless) governs the cessation of secretion due to udder fill, s_{max} (MJ/day) is the maximum milk secretion rate per alveolus, v (litres) is the volume of milk in the udder, and v_u (litres) is the capacity of the udder to hold milk, given by cistern capacity, v_c (litres), and number of alveoli:

$$v_u = v_a(A_A + A_Q) + v_c \quad (34.21)$$

where v_a (litres) is the average alveolar capacity. The evolution of v is given by:

$$\frac{dv}{dt} = I_L / \rho_{\text{milk}} - \sum_i (\delta t - T_i) \Delta v \quad (34.22)$$

where ρ_{milk} is the energy density (MJ/l) of milk, δ is the Dirac delta function, T_i is the time of milk removal for each milking i , and Δv (litres) is the amount of milk removed. For a dairy cow being emptied at each milking time, $\Delta v = v$ as assumed by Vetharaniam *et al.* (2003a), but in the case of a mother suckling her offspring, typically $\Delta v < v$. Note that equation (34.4) in Vetharaniam *et al.* (2003a) has a misprint: s_{max} should be multiplied by the number of active alveoli. The evolution in time of A_A and A_Q is:

$$\frac{dA_A}{dt} = k_1 \exp(-k_2 t) - k_3 A_A + \sum_{i=1}^m p_{e,i} \delta(t - T_i) A_Q \quad (34.23)$$

$$\frac{dA_Q}{dt} = k_3 A_A - \sum_{i=1}^m p_{e,i} \delta(t - T_i) A_Q - k_5 A_Q \quad (34.24)$$

where t (days) is the time since parturition; T_i (days) are the milking times for the milkings i ; $i = 1, \dots, m$, where m milkings have occurred since parturition up to time t ; k_1 (/day) is the specific rate of proliferation of new alveoli at parturition; k_2 (/day) governs the exponential decline in the rate of proliferation of new alveoli after parturition; k_5 (/day) is the relative rate of senescence of quiescent alveoli; k_3 (/day) is a function giving the relative rate of quiescence of active alveoli; and $p_{e,i}$ (dimensionless) is the fraction of quiescent alveoli disgorged and reactivated at milking i .

$$k_3 = \sum_{i=0}^m \left\{ [p_{b,i} + (t - T_i - t_{c,i})k] \times u(t - T_i - t_{c,i}) \right\} \times [u(t - T_i) - u(t - T_{i+1})] \quad (34.25)$$

where $p_{b,i}$ (/day) is the rate of quiescence immediately after milking, and depends on the residual milk; $T_0 = 0$ days is the start of lactation, the rest of the T_i being milking times as above; k (/day) reflects an increase in the rate of quiescence after a time, $t_{c,i}$ days, after milking time i ; and the function u is the unit step function. If $p_{e,i}$, $p_{b,i}$ and $t_{c,i}$ are constant during any milking interval, equations (34.23) and (34.24) have an analytical solution (Shorten *et al.*, 2003). Vetharaniam *et al.* (2003a) considered dairy cows whose udders were emptied at each milking, for which $p_{e,i}$, $p_{b,i}$ and $t_{c,i}$ are constant over a lactation. In this model these parameters varied with the amount of milk removed at each milking.

The large number of alveoli present at the start of lactation is specified as an initial condition (assuming alveoli are all in an active state at this time), using a 0.87 power relationship between mammary gland weight and LW. This relationship (Linzell, 1972) was adapted and used to specify the initial condition in terms of a parameter, \bar{A}_A ($\text{kg}^{-0.87}$), allowing mammary gland size to increase with maturity of the dam:

$$A_{A, \text{initial}} = \bar{A}_A M^{0.87} \quad (34.26)$$

Estimation of live weight

LW was estimated by adding estimates of rumen-fill weight G (kg) and conceptual weight to EBW. An empirical equation was found to give reasonable estimates for the time, T_R (h), for feed to pass through an animal, and thus G :

$$T_R = 0.25q^2 - 8.1q + 71.8; \quad G = (T_R/24) \times (J_D/\rho_R) \quad (34.27)$$

where q (MJ ME/kg DM) is feed quality, J_D (kg/day) is DMI, and ρ_R (dimensionless) is the DM content of rumen fill.

The weight of conceptual fluids plus uterus, W_F (kg), was calculated from placental weight (p). Exponential equations given by Ferrell *et al.* (1976) were

not sufficiently general, and so the following equation (which was found to relate fluid and uterus weight to placental weight in data by Ferrell *et al.*, 1976) was used:

$$W_F = 0.50p^4 - 2.55p^3 + 1.74p^2 + 8.88p \quad (34.28)$$

Then conceptual weight is calculated as the sum of W_F , p and fetal weight.

References

- Baldwin, R.L. (1995) *Modeling Ruminant Digestion and Metabolism*. Chapman & Hall, London.
- Blaxter, K.L. (1967) *The Energy Metabolism of Ruminants*, 2nd edn. Hutchinson, London.
- Davis, S.R., Farr, V.C. and Stelwagen, K. (1999) Regulation of yield loss and milk composition during once-daily milking: a review. *Livestock Production Science* 59, 77–94.
- Ferrell, C.L., Garrett, W.N. and Hinman, H. (1976) Growth, development and composition of the udder and gravid uterus of beef heifers during pregnancy. *Journal of Animal Science* 42, 1477–1489.
- Hale, S.A., Capuco, A.V. and Erdman, R.A. (2003) Milk yield and mammary growth effects due to increased milking frequency during early lactation. *Journal of Dairy Science* 86, 2061–2071.
- Hindmarsh, A.C. (1983) ODEPACK, a systematized collection of ODE solvers. In: Stepleman, R.S. (ed.) *Scientific Computing*. North-Holland, Amsterdam, pp. 55–64.
- Holmes, C.W., Brookes, I.M., Garrick, D.J., MacKenzie, D.D.S, Parkinson, T.J. and Wilson, G.F. (2002) *Milk Production from Pasture*. Massey University, Palmerston North, New Zealand.
- Linzell, J.L. (1972) Milk yield, energy loss in milk, and mammary gland weight in different species. *Dairy Science Abstracts* 34, 351–360.
- MacDonald, K.A., Penno, J.W., Nicholas, P.K., Lile, J.A., Coulter, M. and Lancaster, J.A.S. (2001) Farm systems: impact of stocking rate on dairy farm efficiency. *Proceedings of the New Zealand Grassland Association* 63, 223–227.
- Molenaar, A.J., Davis, S.R. and Wilkins, R.J. (1992) Expression of α -lactalbumin, α -S1-casein and lactoferrin genes is heterogeneous in sheep and cattle mammary tissue. *Journal of Histochemistry and Cytochemistry* 40, 611–618.
- Parks, J.R. (1982) *A Theory of Feeding and Growth of Animals*. Springer-Verlag, Berlin.
- Petzold, L.R. (1983) Automatic selection of methods for solving stiff and nonstiff systems of ordinary differential equations. *SIAM Journal of Scientific and Statistical Computing* 4, 137–148.
- Rémond, B., Coulon, J.-B., Nicloux, M. and Levieux, D. (1999) Effect of temporary once-daily milking in early lactation on milk production and nutritional status of dairy cows. *Annales de Zootechnie* 48, 341–352.
- Shorten, P.R., Vetharanim, I., Soboleva, T.K., Wake, G.C. and Davis, S.R. (2002) Influence of milking frequency on mammary gland dynamics. *Journal of Theoretical Biology* 218, 521–530.
- Vetharanim, I., McCall, D.G., Fennessy, P.F. and Garrick, D.J. (2001a) A model of mammalian energetics and growth: model development. *Agricultural Systems* 68, 65–68.
- Vetharanim I., McCall, D.G., Fennessy, P.F. and Garrick, D.J. (2001b) A model of mammalian energetics and growth: model testing (sheep). *Agricultural Systems* 68, 69–91.

- Vetharanim, I., Davis, S.R., Soboleva, T.K., Shorten, P.R. and Wake, G.C. (2003a) Modeling the interaction of milking frequency and nutrition on mammary gland growth and lactation. *Journal of Dairy Science* 86, 1987–1996.
- Vetharanim, I., Davis, S.R., Upsdell, M., Kolver, E.S. and Pleasants, A.B. (2003b) Modeling the effect of energy status on mammary gland growth and lactation. *Journal of Dairy Science* 86, 3148–3156.
- Watson, W.H., Cai, J. and Jones, D.P. (2000) Diet and apoptosis. *Annual Review of Nutrition* 20, 485–505.
- Westbrooke, V.C.F., Dooley, A.E. and Vetharanim, I. (2003) Modelling the optimum switch date from twice to once-daily milking in dairy herds. In: Peterson, S.W. (ed.) *Proceedings of the New Zealand Society of Animal Production*. Massey University, Palmerston North, New Zealand, 63, 133–137.
- Weston, R.H. (1996) Some aspects of constraint to forage consumption by ruminants. *Australian Journal of Agricultural Research* 47, 175–197.

Index

- Ability to cope 229–240
- Acetate 3, 335
 - fat synthesis 354
 - uptake 40
- Adipose tissue 349, 383
 - inputs 396, 401–402
 - lipid metabolism 351, 355, 360, 399
 - weight 135–140
- Amino acid
 - absorption 354
 - demand 350
 - essential 231
 - fermentation stoichiometry 6
 - gluconeogenesis 353, 355
 - incorporation 366, 379–380
 - metabolism model 15, 17
 - protein synthesis 354
 - sources 55
- Ammonia 35–37
 - absorption 291
 - concentration in rumen 338–341
 - emission 276, 281, 285, 292–294
 - model 389–391
- Anabolic hormone 354–355
- Anabolic potential 434
- Anabolic processes 366, 380
- Aquaculture 181, 188
- ATP
 - maintenance 395
 - model 390–391
 - pool 366, 380
 - potential 366, 379
 - requirement 357
 - simulated 357, 363
 - synthesis 94–95, 362, 366, 373–375
- ATP-bound energy 366, 379–380
- ATP equivalent 362
- Autoregressive integrated moving average (ARIMA) modelling 314, 316, 319
- Average daily gain (ADG) 91, 99
 - potential 231
- Backfat 237–238
- Bacteria
 - growth 193
 - model 390–391
 - yield 36, 100
- Baranyi model 54
- Basal metabolism 102–103, 109, 398–401
- Beef cattle
 - genetic effects 94

- Beef cattle (*continued*)
 - growth patterns 160
 - mechanistic model 135–136
- Behavioural analyses 408
- Beta-hydroxybutyrate 41, 360–361
- Biochemical process 55
- Biohydrogenation 304
- Blood plasma 69, 71, 197
- Body composition 87, 110, 148, 432
 - empirical model 127, 132
 - measurement 121–122
 - prediction 114–117, 127, 161, 330
- Body weight
 - calf 84
 - empty 128, 136, 154, 254, 329
 - gain 343
 - lambs 20
 - parameter 72
 - prediction 114, 122
- Bone formation 192
- Butyrate
 - absorption 359–360
 - feed fraction 335
 - model input 352
 - portal appearance 41
 - stoichiometric coefficient 1
- Calf
 - body weight 84, 88
 - feed intake 87
 - rearing 422, 424
 - weaning weight 84, 85
- Carbon dioxide 54, 57, 391
 - oxidation 353, 359–360, 401
- Carbohydrates
 - degradation 386, 391
 - feed 388
 - fermentation 3, 389
 - model 393–394
 - non-fibre 100, 383, 394
 - passage 383
 - utilization 367, 370, 380
 - water-soluble 310
- Carcass
 - composition 91, 100, 128
 - dynamic model 136
 - fat free 331
 - lipid 135–136
 - prediction 119
 - protein 135–136, 138
 - weight 237
- Casein 370
- Catabolism 429, 433–434
- Cattle
 - breeds 102
 - dual purpose 86
 - dynamic model 135
 - feed evaluation 375
 - feed intake 49, 161
 - growing 36, 158, 315, 325, 411
 - growth model 161
 - methane emissions 299, 305
 - non-steady state model 33
 - see also* Beef cattle; Dairy cattle
- Chaotic component 326
- Clustering 316, 318
- Composition *see* Body composition
- Concentrates
 - levels 253, 403
 - rumen passage 282, 386
 - stoichiometry 1–6, 383
 - supplement 115
- Conception 432–434
- Connective tissue 401–402
- Cornell Net Carbohydrate and Protein System (CNCPS)
 - comparative evaluation 247, 407
 - dual purpose cattle 85
 - evaluator 257
 - protein degradation 352
 - sheep 99–110
- Cornell Pennsylvania Miner (CPM) – Dairy
 - optimization 257, 261
 - software 259
- Crude protein
 - degradation 28
 - dietary 267
 - model 334, 378, 412
 - prediction 119, 125
- Cytosol 16

- Daily changes 315
- Dairy cattle
- dry matter intake 49
 - emissions 300
 - magnesium status 212
 - metabolic control 349, 355
 - requirement model 329
- Davis Growth Model 161, 164, 251
- Degradation
- disappearance rates 13, 50, 329
 - estimate in rumen 29, 37, 282, 342
 - kinetic parameters 28–29, 55, 386
 - model 217, 388
 - protein 18, 20, 28, 160, 343, 354
 - substrate 283–285
- Diet
- efficiency 88
 - energy density 103, 163, 252, 417
 - feed evaluation 335, 384, 408
 - magnesium-deficient 211
 - mixed 42, 205
 - phosphorus level 207
 - physical form 177
 - standard grower 234
- Diffusion 183, 396
- Digestion
- feed 146
 - intestinal 29, 284, 287
 - model 383–387, 411
 - phosphorus 181
 - rumen 2, 34, 325, 340, 375
- Disappearance curves 29
- Disease
- outbreak 326
 - risk 220
- DNA
- accretion 162–164
 - mass at maturity 160, 164
 - mitochondrial 85
- Dry matter intake 34, 285
- estimation 114
 - regulation 49
 - sheep 24, 315
- Duodenum 192, 197, 286, 342, 414
- Dynamic models 181, 252, 283, 351
- Efficiencies of digestion 385
- Empty body
- fat 128
 - gain 101
 - weight 114, 122, 128, 154, 254
- Energetic efficiency 94, 375
- Energetic feed evaluation *see* Feed evaluation
- Energy 417–418
- ATP-bound 366, 379
 - digestible 182, 367, 375
 - efficiency index 84
 - endogenous expenditure 169, 362
 - maintenance 86, 103, 160, 212, 282
 - metabolism 95, 366–367, 379
 - prediction 119, 123–125
 - requirement 85, 87, 100–102, 128, 161, 374, 398
 - retention 144, 161–163, 254, 366
 - utilization 160, 368–370, 404, 418
- Environment
- physical 230, 231
 - social 230, 232
 - temperature 28, 64, 182, 231–232, 368
- Environmental impact 95, 181, 275, 292
- Environmental pollution 172, 188, 192–193, 207
- Environmental stressors 229–231
- Enzymes
- kinetics 283
 - microbial 55
 - udder 361
- Essential amino acids *see* Amino acids
- Extracellular fluid 384, 398
- Faeces
- indigestible 394
 - phosphorus 171–177, 180, 187

- Fasting heat production 109
- Fat
 - back 121, 237
 - body 116
 - crude 383, 387, 411
 - energy content 104
 - gain 145
 - prediction 127
 - synthesis 384, 366, 370
 - utilization 370
- Fat-free mass 127–128, 145, 331, 432
 - modelling 131–132
- Fatty acids
 - absorption 391
 - concentration 247, 339
 - fluxes 40
 - lipolysis 353
 - long chain 387
 - synthesis 7, 359, 399
 - unsaturated 304
- Feed composition 1, 106, 285, 385, 408
- Feed efficiency 94, 379
- Feed energy
 - ATP 380
 - efficiency 85, 147
 - partitioning 92
- Feed evaluation
 - diet evaluator 403
 - energetic 367
 - net energy 370
 - Rostock system 366–381
 - systems 281–290, 384
- Feed intake 314–326, 356
- Feed value 375, 384
- Feeder space allowance 232
- Feeding level 1, 8, 104, 384
- Feeding systems 145
- Feedstuff
 - energetic value 367, 375, 384
 - NDF concentration 106
 - net energy value 287
 - utilization 55
- Fermentation gasses 394
- Fermentation pattern 13, 383, 414
- Fish
 - culture 180
 - growth model 189
 - nutrition 184
 - phosphorus utilization 181, 186
 - salmonid 182
- Forage
 - availability 85, 91
 - concentrate ratio 411
 - intake 84, 87–88
 - NDF 3, 385–386
 - tropical 33
- Forestomachs 384–403
- Free energy 417
- Functions 54–56, 272
- Gaseous emission 285
- Gastric emptying rate 70–82, 186, 188
- Gastric outflow 72–82
- Gastrointestinal tract 20, 145
 - fermentation 55
 - phytases 187
- Gluconeogenesis 353, 374, 398
- Glucose
 - absorption 70
 - availability 287, 353
 - blood level 82, 398–399
 - concentration 354, 361
 - demand 350
 - meal 79
 - pool 396, 401
 - prediction 37, 353
 - synthesis 355
- Glycerol 353, 391, 396–402
- Gompertz 55, 57, 63, 137
- Grass silage 10–11, 121, 279
- Group
 - mixing 232
 - size 232, 234
 - space allowance 229
- Growth 432
 - compensatory 91, 138, 147
 - curves 59, 64, 102
 - fetal 417, 420, 426
 - functions 55, 61
 - microbial 7, 55–65, 283, 342, 391
 - model 87, 145, 230, 417

- parameter 102
 - performance 19
 - potential 232
 - prediction 145, 230
- Hay 137, 171, 301
- Heat
- loss 95, 232
 - production 94, 109, 145–146, 254, 401
 - requirement 368
- Heat of digestion 402
- Hindgut 212, 215, 384–386
- Hindlimb tissues 17, 19
- protein synthesis 18
- Hindquarters 15, 19–22
- Housing
- feeder space allowance 232
- Hypomagnesaemia 211–213
- Ideal genetic composition 233
- Individual 230, 232–233
- Intermediary metabolism 16
- Intracellular metabolism 395
- Isotope dilution technique 171
- Isotope tracer methodology 16
- Kidney 16, 115, 147, 213, 326
- Lactate
- fermentation 11, 353
- Lactation
- curve 87, 243, 357
 - energy requirement 85–87, 351
 - mechanistic model 132–133
 - milk production 216, 258
 - model 416–437
 - prediction 408–411
 - protein turnover 351
- Lag time 55–56, 70
- Lamb 20–22, 103, 109–110, 147, 315
- Leucine 19, 24
- Lipid
- accretion 360
 - basal level 334
 - carcass 136
 - compensatory gain 231
 - concentration 123–125
 - dietary 391
 - energy density 343
 - metabolism 121
 - pool 391, 394
 - prediction 119
 - synthesis 395
 - total 33, 115, 136
- Lipogenesis 70, 351, 398
- Lipolysis 351–354, 360–361, 391
- Live weight gain 22, 385, 408
- see also* Body weight, gain
- Liver
- amino acid requirement 20
 - energy costs 356
 - oxygen consumption 158
 - pool 396
 - protein synthesis 351
 - synthesis 397
 - triacylglycerols 360, 362
- Logistic 54–57, 63, 198
- Long chain fatty acids *see* Fatty acids
- Lysine 18
- Magnesium
- dietary 217, 220
 - endogenous 215
 - milk 216
 - model 212, 221
 - plasma 213, 216
 - urine output 212
- Maintenance
- energy expenditure 254
 - energy requirement 86, 90, 102, 114, 163, 253, 370
 - estimation 145–146
 - feeding level 104, 149
 - microbial energy requirement 284

- Maintenance (*continued*)
 phosphorus requirement
 199–203
 requirement in beef cattle 161
- Maize silage 277, 285, 289
- Mammary gland
 amino acid transport 16
 energy requirement 399
 fatty acid synthesis 359
 glucose supply 351
 milk secretion 419
 pool 399
- Manure
 composition 285
 poultry 193
 storage 292
- Markov Chain Monte Carlo
 parameter estimation 148
- Mass action 284
 constant 360–361
 kinetics 192, 386, 395
- Mean square prediction error
 (MSPE) 1, 33, 45, 88, 106,
 162, 299, 412
- Meta-analysis 242–250, 296
- Metabolic heat 402
- Metabolic hormones 398–399
- Metabolism
 amino acid 16
 basal energy requirement 102
 energy efficiency 95, 367
 fasting 102
 lipid 121
 microbial 284, 294, 324
 model 355, 384, 395
 phosphorus 172–173
 post-absorptive 340
- Metabolizable energy
 availability 102
 dietary intake 88, 103, 276
 forage 91
 intake (MEI) 151, 162, 301, 367
 requirement 85–88, 163
 supply 136
 systems 145
 utilization 366, 368, 385
 VFA production 42
- Metabolizable protein 281, 385
- Methanogenesis 304
- Michaelis–Menten
 calcium and phosphorus
 accretion 192
 magnesium uptake 217
 microbial production 35
 phosphorus hydrolysis 183
- Microbes
 fermentation 55
 metabolism 41
 pool 283, 393
- Microbial mass 284
- Milk
 fat 354, 399
 synthesis 359–360, 399
 yield 407, 413
 production estimate 37
 protein 267, 269, 354
 pool 399
 synthesis 399
 yield 402, 413
 removal 435
- Milk yield
 biological efficiency 91
 minimum 279
 model 34, 276
 simulated 294, 409
- Mixed model regression *see*
 Regression
- Mixing *see* Group
- Model
 biological 94
 comparison 59, 73, 136, 305
 continuous emptying 71
 evaluation 104, 300, 336
 fitting 58
 multiple regression 4, 10
 non-linear 300–301
 phosphorus utilization 181, 275
 rumen 2, 34
 simulation 230, 252
 stoichiometry 9
- Modelling
 empirical 249
 energy metabolism 370
 fat 128, 131–132

- fetus growth 417
- kinetic 71
- mechanistic 242–243
- microbial 34, 276
- Muscle 19–20, 70, 136, 144–148, 351
- Muscle tissue 384, 396, 401

- Net energy
 - gain 162
 - prediction 145
 - requirement 87
 - retention 366
 - systems 285
 - value of diet 402–403
- Neutral detergent fibre (NDF)
 - duodenal flow 33
 - forage 1, 385
 - pool 334
- Nitrogen
 - balance 22, 106
 - environmental pollution 95
 - excretion of excess 103
 - feed 389
 - flow 35, 340
 - liver metabolism 398
 - microbial 342
 - pool 393, 395
 - urine 402
- Non-ammonia nitrogen (NAN) 36–37
- NorFor system 404, 408
- Nutrient
 - absorption 34, 36, 394, 395
 - demand 350
 - digestible 368–369
 - limiting 294
 - rate of passage 70
 - rate of release 34
 - supply 104
 - utilization 368–369
- Nutrient management 189
- Nutrient partitioning
 - prediction 329, 414
 - regulation 399
- Nutritional manipulation 149

- Oxygen consumption 57, 94
 - uptake by liver 158, 362

- P2 backfat depth 238
- Parameter estimation 82, 148, 251–252, 329, 359
- Parasitic infection 16, 19, 22
- Peptides 383
- Periodicity 69, 82, 316, 318
- pH, rumen 5, 42–45, 106, 267
- Phosphorus
 - dietary 189
 - fish 180
 - growing sheep 171
 - kinetic model 173
 - poultry 194
 - utilization 171
- Physical activity 86
- Pig
 - commercial enterprise 230, 237
 - genetic parameter 233
 - growth 230
 - growth models 230
 - performance 234, 239
- Population 229, 230–232
- Portal-drained viscera 41, 158, 396
 - see also* Visceral organs
- POWERSIM 385
- Production responses 414
- Propionate
 - absorption 354
 - prediction of proportion 41, 339
 - rumen fermentation 287
- Protein
 - accretion in beef 168
 - body reserve 127, 162, 355
 - carcass and non-carcass content 136–137
 - degradation 18, 29, 277, 329, 388
 - endogenous losses 295
 - forage 35, 294, 386
 - gain 144
 - kinetics 19, 342
 - microbial yield 30, 55, 284, 389
 - milk 269, 402, 408

- Protein (*continued*)
 muscle 156, 353–354, 401
 pool 145, 162, 389, 427
 requirements 114, 231
 retained energy 104
 retention 231, 235, 397
 stoichiometrical model 3
 synthesis 16, 139, 351
 systems 84, 99, 257, 352
 turnover 16, 168, 351, 397
 undegradable 28, 335, 352
 utilization 368, 370
 visceral pool 254
- Protozoa, rumen population 11, 285
- Rainfall 278
- Randomness 316, 318, 326
- Real feed value 384, 402–404
- Regression
 equations 5, 163, 316
 mixed model 131, 245, 411
 multiple linear 4–10, 115, 122, 318, 369
 non-linear 58, 65
 slope 37, 52, 133
- Respiration experiments 368, 378
- Richards 57, 128
- Rumen
 digestion 2, 33, 375
 microbes 395
 models 2, 247, 284–285
 stoichiometry of substrate 3–13, 287
- Rumen fermentation
 dynamics 284
 processes 34
 products 374
 stoichiometry of substrate 2, 310
- Rumen passage rate 285, 386
 large particles 342
 small particles 342
- Ruminants *see* Beef cattle; Dairy cattle; Lamb
- Runge–Kutta method 148, 385
- Salmonid *see* Fish
- Sigmoidal 55, 63, 128
- Small intestine
 absorption 71, 97
 amino acid demand 20
 model 385, 389
 protein synthesis 22
 rate of passage 70
 secretion, magnesium 216
- Social behaviour 229–239
- Standard feed value 403
- Starch 1, 35, 282–285, 301, 334, 352, 367, 391
- Stocking density 49, 92, 420
- Stoichiometry 3, 287, 310, 351
- Stressors *see* Environmental stressors
- Suckling
 frequency 423
 simulation 423
- Temperature *see* Environment
- Thermodynamics 395, 403
- Thermoneutral condition 370, 374
- Thermoneutrality 231
- Thermoregulation 231
- Three-compartment model 15–24
- Three-phase linear model 63, 64
- Triacylglycerol
 accumulation 360
 milk 360
- Triglycerides 401
- Two-compartment models 383
- Udder *see* Mammary gland
- Unadjusted regression 407, 411–413
- Undernutrition 23
- Unexplained error 326
- Urea
 blood 340
 diet 34
 excretion 102
 milk 281, 293
 model 334
 recycling 291, 389
 transport 35

- Urine
 - calcium excretion 197, 200
 - energy 428
 - magnesium excretion 211, 224
 - nitrogen excretion 294
 - nutrient excretion 284
 - phosphorus excretion 171–177, 182, 200
- Valerate 304
- Variable maintenance requirement 144
- Variance
 - estimation 94
 - residual 60, 316
- Visceral organs 102
 - energy use 361–362
 - growth 147
- mass 145, 331
- metabolism 109, 362
- pool 145
- protein 254, 354
- Volatile fatty acids (VFA)
 - absorption 42, 287, 360, 391
 - concentration 40, 247, 287, 340, 402
 - model 1–12
 - prediction 3, 9, 310, 339
 - production 41, 304, 310
 - stoichiometry 1, 257, 310
 - utilization 374
- Waste 180–181, 384
- Weibull 57
- Weight *see* Body weight