

SPACE EXPLORATION 2008



David M. Harland
Brian Harvey

*with contributions by leading authors
on space exploration*

 Springer

PRAXIS

David M. Harland *and* Brian Harvey

SPACE EXPLORATION 2008

 Springer

Published in association with
Praxis Publishing
Chichester, UK

PRAXIS 

Dr David M. Harland
Space Historian
Kelvinbridge
Glasgow
UK

Brian Harvey, M.A., H.D.E., F.B.I.S.
2 Rathdown Crescent
Terenure
Dublin 6W
Ireland

Front cover illustration: Landing on Mars. The Phoenix lander as it approaches the Martian surface at about 8 kilometres per hour using 12 thrusters to control its speed. Artist's impression courtesy NASA/JPL-Caltech/Corby Waste.

Back cover illustrations (Top): The International Space Station in August 2005, as viewed from the Space Shuttle *Discovery*. Image courtesy NASA. *(Middle):* An Ariane 5 launcher blasts off into the skies of Kourou, French Guyana, above Europe's spaceport. Image courtesy ESA/CNES/Arianespace – Service Optique CSG. *(Bottom):* NASA's Orion crew exploration vehicle orbits the Moon with disc-shaped solar arrays tracking the Sun to generate electricity. Artist's impression courtesy Lockheed Martin Space Systems.

SPRINGER-PRAXIS BOOKS IN SPACE EXPLORATION
SUBJECT ADVISORY EDITOR: John Mason B.Sc., M.Sc., Ph.D.

ISBN 978-0-387-71667-1 Springer Berlin Heidelberg New York

Springer is a part of Springer Science + Business Media (springeronline.com)

Library of Congress Control Number: 2007931637

Apart from any fair dealing for the purposes of research or private study, or criticism or review, as permitted under the Copyright, Designs and Patents Act 1988, this publication may only be reproduced, stored or transmitted, in any form or by any means, with the prior permission in writing of the publishers, or in the case of reprographic reproduction in accordance with the terms of licences issued by the Copyright Licensing Agency. Enquiries concerning reproduction outside those terms should be sent to the publishers.

© Copyright, 2008 Praxis Publishing Ltd.

The use of general descriptive names, registered names, trademarks, etc. in this publication does not imply, even in the absence of a specific statement, that such names are exempt from the relevant protective laws and regulations and therefore free for general use.

Cover design and cartoons: Jim Wilkie
Typesetting and design: BookEns Ltd, Royston, Herts., UK

Printed in Germany on acid-free paper

CONTENTS

Preface – Welcome to Space Exploration 2008	vii
1 The Epic Journey Continues..... The Annual Review <i>by Brian Harvey</i>	2
2 Prepare for Lift-off!..... The Future of Space Tourism <i>by Erik Seedhouse</i>	36
3 Stepping Out into the Solar System..... A Human Mission to an Asteroid <i>by Leonard David</i>	48
4 Long Duration Spaceflight..... The Work of the Institute of Bio-Medical Problems <i>by Dominic Phelan</i>	58
5 Another Giant Leap..... Human Missions to Mars <i>by Donald Rapp</i>	68
6 Beyond the Solar System..... Technologies for Ultra-Deep Space Probes <i>by Gregory Matloff</i>	80
7 Reviving the Old, Introducing the New..... Russia’s New Space Science Projects <i>by Igor Afanasiev</i>	92
RETURN TO THE MOON	
8 Paving the Way for Future Exploration..... The SMART-1 Mission to the Moon <i>by Peter Rathsmann</i>	104
9 NASA’s New Robotic Lunar Program..... Seeking Water on the Moon <i>by David M Harland</i>	116
10 And When We’re Back on the Moon, What Next?..... The Role of a Future Moonbase <i>by David Schrank</i>	128
SOLAR SYSTEM LOG	
11 Probing the Mysteries of Our Nearest Star..... Studying the Sun from Space <i>by Martin Mobberley</i>	140
12 Focusing on the Red Planet..... Mars Exploration Update <i>by James Graf</i>	150
13 Fire and Water..... The Phoenix Mission to Mars <i>by Peter Smith</i>	162
14 Report from the Ringed Planet..... Cassini at Saturn Update <i>by David M Harland</i>	170

■ NASA's Mariner 2 spacecraft which, a quarter of a century ago, became the first spacecraft to successfully encounter another planet. Mariner 2 was launched on 27 August 1962, sending it on a 109-day flight to Venus. On the way it measured for the first time the solar wind, a continuous stream of charged particles flowing outwards from the Sun. As it passed within 35,000 km of the surface of Venus on 14 December 1962, Mariner 2 scanned the planet with infrared and microwave radiometers, revealing that Venus has cool clouds and an extremely hot surface. Image courtesy NASA/JPL.



Preface

WELCOME TO SPACE EXPLORATION 2008

SPACE EXPLORATION 2008 is the second in a series of annuals by Springer–Praxis designed to report the latest news, views, information and ideas on the exploration of the Solar System.

As the series unfolds our team of writers will not only report on both the pathfinding voyages of robotic space probes and human missions, but will also review future activities and look back to the great events of the past.

In this volume:

- **Erik Seedhouse**, a research scientist in life sciences and physiology, and an astronaut training consultant for Bigelow Aerospace, assesses the prospects for space tourism.
- **Leonard David**, SPACE.com's senior space writer, looks at how a human flight to an asteroid might be undertaken.
- **Dominic Phelan**, a Dublin-based writer with a special interest in the Russian space programme, visits the Institute for Bio-Medical Problems in Moscow and describes how, through simulated missions on the ground, Russia is learning how humans can survive long-duration missions into deep space.
- **Donald Rapp**, once manager of the Mars Exploration Technology Program at the Jet Propulsion Laboratory, considers how we will follow our robots to Mars.
- **Gregory Matloff**, author and expert in possibilities for interstellar propulsion, reviews technologies for ultra-deep-space probes.
- **Igor Afanasiev**, a noted space journalist based in Moscow and editor of the magazine *Novosti Kosmonautiki*, explains how Russia is reviving its space science programme, and outlines some of the missions that are being developed.

In last year's volume we introduced a section called Return to the Moon, in which we reviewed plans by China and India to send spacecraft to investigate the Moon. Here, we continue this important theme:

- **Leading Swedish space engineer Peter Rathsman** reviews the European Space Agency's pioneering SMART-1 mission which spent 22 months in lunar orbit before being steered to a precision impact on the surface.
- **Space historian David Harland** looks forward to the mission of NASA's Lunar Reconnaissance Orbiter, and discusses why it is thought that there could be water ice in the polar regions.
- **The role that a future lunar base will serve is explained by author and specialist in quality laws and space development, David Schrunk.**



■ **Few sights in the Solar System are more strikingly beautiful than softly hued Saturn embraced by the shadows of its stately rings. Images taken with Cassini's wide-angle camera using blue, green and red spectral filters were used to create this colour view, which approximates the scene as it would appear to the human eye. The view was brightened to enhance detail visible in the rings and within their shadows. Image courtesy NASA/JPL/Space Science Institute.**

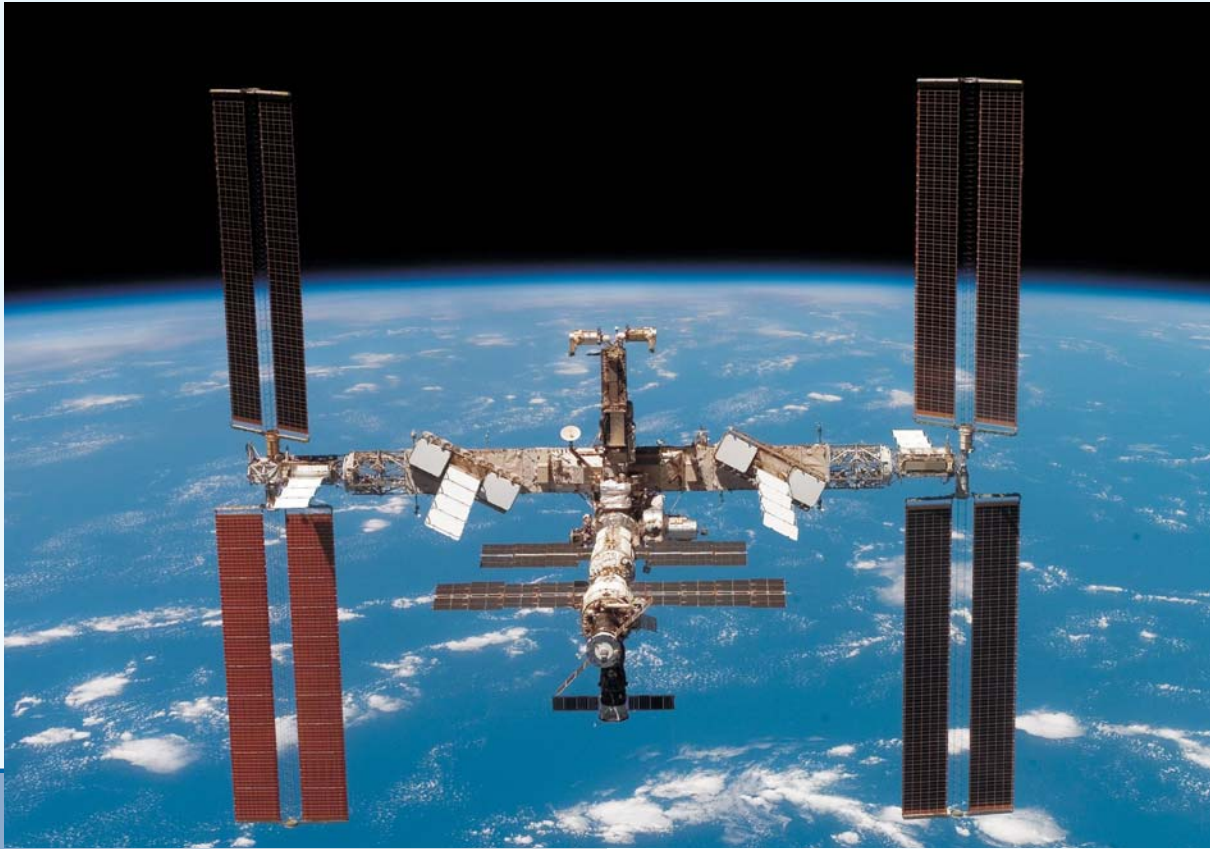

■ Backdropped by the blackness of space and Earth's horizon, the International Space Station is viewed from the Space Shuttle Atlantis. Earlier the STS-117 and Expedition 15 crews concluded about eight days of cooperative work on board the shuttle and station. Image courtesy NASA.

Solar System exploration will always be at the heart of any annual on space exploration. The Solar System Log section contains in this volume:

■ **Martin Mobberley**, former president of the British Astronomical Association and space author, looks at spacecraft observations of the Sun and considers whether the coming maximum in the 11-year sunspot cycle will be the most active yet.

■ The early results from Mars Reconnaissance Orbiter are presented by **James Graf**, the project manager at the Jet Propulsion Laboratory, together with an update on Mars Express, Mars Global Surveyor, Odyssey and the two Mars Exploration Rovers.

■ The mission of the Mars Phoenix lander is explained by the principal investigator, **Peter Smith** of the University of Arizona.

■ **David Harland** gives an update of the Cassini-Huygens mission which is exploring the Saturnian system.

But first, a review of all the key developments in 2006.



■ While sitting at a favourable location for winter-time solar energy, NASA's Mars Exploration Rover, Spirit, is taking exposures for a view called the 'McMurdo Panorama'. This portion of the work in progress looks toward the north. 'Husband Hill', which Spirit climbed, is on the horizon near the centre. 'Home Plate' is between that hill and the rover's current position. Wheel tracks imprinted when Spirit drove south from Home Plate can be seen crossing the middle distance of the image from the centre to the right. Image courtesy NASA/JPL/Cornell.



■ **Spot the Astronauts!**
This panoramic scene of the International Space Station could be used for a quick game of “find the two astronauts in this picture.” The combined crews of the Space Shuttle Atlantis and ISS resumed construction work on the station in September 2006. The two STS-115 crew members in this picture were participating in the second of three scheduled spacewalks. Astronaut Daniel C. Burbank can be recognized by the broken red stripe on each leg of his extravehicular mobility space suit. Not so readily visible is astronaut Steven G. MacLean, representing the Canadian Space Agency, just above and to the left of Burbank. Image courtesy NASA.

1

The Epic Journey CONTINUES...

They were stocking up the ship for the new mission:
Bunny made sure that no one economised on the AstroKat Snax!!

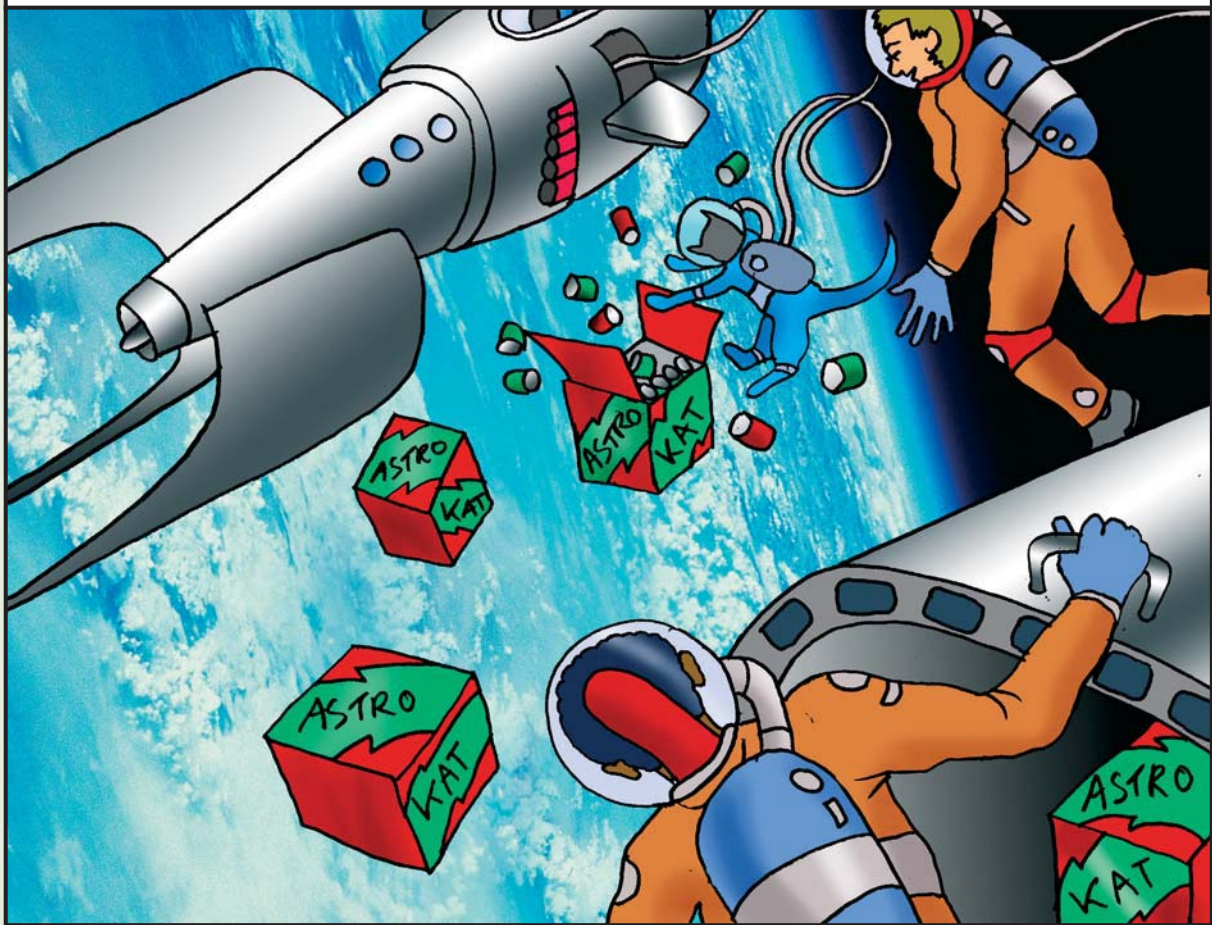

Fifty years ago, just a year after the launch of the first satellite, Sputnik 1, the race to the Moon began. Since that time, every year has brought its own crop of launches and recoveries, exciting developments and new records. Here *Brian Harvey* looks back at the historic events of 1958, and then reviews the highlights of 2006.

The Annual REVIEW

Anniversaries

1958, the year the Moon race began

If 1957 was the year of Sputnik, then the following year was the year the Moon race began. It started as the year the Americans caught up.

The United States were greatly shocked by the success of the Soviet Union in putting Sputnik into orbit and then, a month later, the first space dog, Laika on Sputnik 2. Many Americans went out into their backyards to watch the two Sputniks tracking across the

early winter skies of the United States, an ever-present visual reminder of Soviet superiority in space travel. Not until a month after Sputnik 2 were the United States ready for their first launch attempt. This was the Vanguard rocket, the launcher that had unexpectedly won the competition to build the first American satellite launcher. Unexpected, because the Vanguard bid won out over the US Army Huntsville Alabama-based team led by America's most experienced rocketeer, the German Wernher von Braun.

Things could not have gone worse. Broadcast on nationwide radio and television, Vanguard barely rose, thrust failed and it fell back on its back, blowing up in a giant fireball of flame and black smoke. Amazingly, the tiny satellite was thrown free, ending up on a nearby beach, still beeping. But that was not where it was supposed to be beeping and the press had a field day, calling it *Flopnik*, *Kaputnik* and even *Stayputnik*.

Von Braun was called in to save the day, which he did with typical energy and efficiency. He had the previous year built the Jupiter C rocket which he knew was well capable of orbiting a satellite and he had pleaded with the authorities, in vain, for permission to launch such a satellite. He was allowed to keep the rocket only for a 'long-term storage test', but he had secretly hoped to have the opportunity to take it out of storage. Now von Braun dusted it off, assembled a 14 kg satellite within weeks and persuaded the Head of the Physics Department at the University of Iowa, James Van Allen, to supply a radiation counter for the satellite, which would be called Explorer.



■ Left: William H. Pickering (left), James A. van Allen and Wernher von Braun hold up a full-scale model of America's first satellite, Explorer 1. Image courtesy NASA.

The Jupiter C took off on a pillar of flame from Cape Canaveral late on 31st January 1958. Von Braun calculated that if successful the first signals would be picked up in California 106 minutes later. With the press waiting, they wore smart suits in case of success, but had sunglasses in their pockets so they could make an unobtrusive getaway if it failed. And fail it did, or so they thought. Holding on a phone line to California, there were no signals. Suddenly, at the 114 minute point, when they had nearly given up, four tracking stations suddenly reported good strong signals. There was an hysterical 2 am press conference, von Braun and his colleagues holding a model of the satellite aloft and in Huntsville there was dancing outside the courthouse. Telegrams poured in, von Braun was declared a national hero and children sent in their savings for the next satellite.

As for Explorer 1, its radiation counter found that the Earth was surrounded by radiation belts, duly named after the physics professor from Iowa. By way of a footnote, James Van Allen died on 9th August 2006. Although best known for the radiation belts, he had a long and distinguished career in space science through the 1960s and 1970s.

For the Americans, Explorer meant that some honour was restored. The first Vanguard made it into orbit six weeks later on 17th March 1958

(it's still there). Now the score was Soviet Union, 2; United States, 2. Some of the shine was lost a couple of months later: whereas Vanguard weighed 1.48 kg, the next Soviet satellite, Sputnik 3, that May, weighed in at over 1.3 tonnes.

But now it was time for the next stage. The Soviet Union already had its sights on the Moon. Even as the Jupiter countdown was under way at Cape Canaveral, on 28th January 1958 in Moscow, chief designer Sergei Korolev and his leading engineer Mikhail Tikhonravov sent a memorandum to the government called *On the launches of rockets to the Moon*, asking for approval for spaceships to hit the Moon and photograph its far side. The government gave them a secret 'yes' on the 20th March. By coincidence, President Eisenhower announced publicly later that week that the United States would send a probe to the Moon that summer.

Using the Air Force's Thor Able rocket, America's first Moon probes were ambitious, aiming to put a 38 kg space probe, Pioneer, with a primitive camera into orbit around the Moon. The first of three was duly ready that summer.

Learning that the Thor Able was set for take-off on 17th August 1958, Korolev rushed his Moon rocket out to the pad the same day, fitted with a much larger probe, weighing around 350kg, to hit the lunar surface. The lunar trajectory mapped

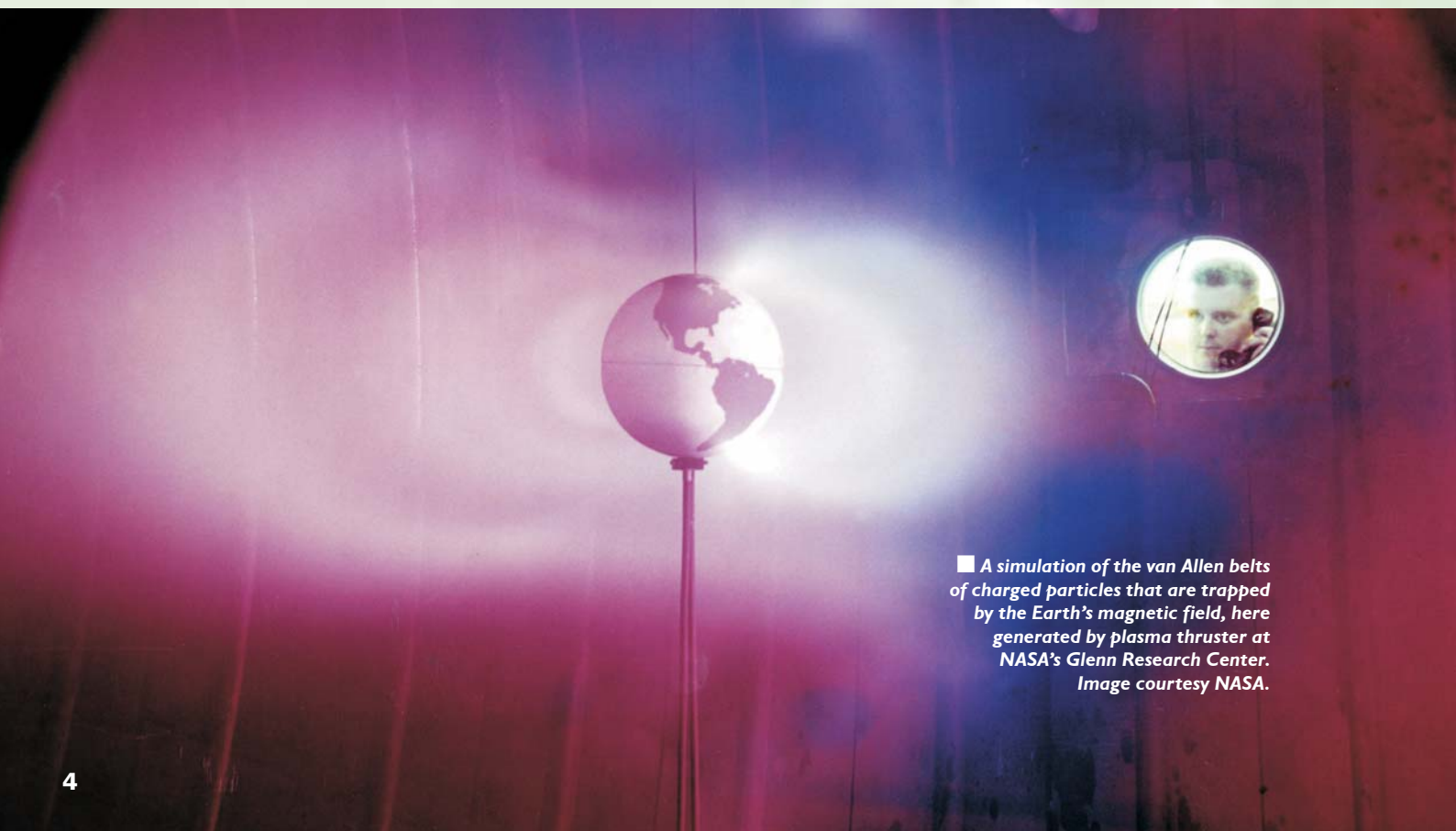

■ A simulation of the van Allen belts of charged particles that are trapped by the Earth's magnetic field, here generated by plasma thruster at NASA's Glenn Research Center. Image courtesy NASA.

out by Korolev and Tikhonravov was shorter than Pioneer. Korolev waited to see if Pioneer was successfully launched. If it was, then Korolev would launch and could still beat the Americans to the Moon. Fortunately for Korolev, though not for the Americans, Pioneer exploded at 77 seconds and a relieved Korolev was able to bring his rocket back to the shed for more careful testing.

A month later, all was eventually ready. The first Soviet Moon probe lifted off from Baikonour on 23rd September 1958. It did little better than the first American Moon probe, exploding after 93 seconds. The Kremlin was not pleased, but Korolev rounded on his political masters, yelling, "Do you think only American rockets explode?"

The frantic rivalry recurred the following month. At Cape Canaveral, the Americans counted down for a new probe, also given the name Pioneer, with launch set for 11th October, the events there broadcast minute-by-minute worldwide on radio. By contrast, not a word of what was going on in Baikonour reached the outside world. Again, Korolev planned to launch his spaceship on a faster, quicker trajectory after Pioneer. Taking advantage of the open press coverage at 'the Cape', news of the Pioneer launching was relayed immediately to Baikonour, Korolev passing it on in turn over the loudspeaker.

Not long afterwards, the news came through that the Pioneer's third stage had burned out too soon. But Pioneer was a true pioneer, for it reached the then-amazing altitude of 113,800 km, further than any human object had ever travelled, before crashing back, its signals ever clear and strong until it plunged into the Pacific. Korolev and his engineers now had the opportunity to eclipse the Americans. On 12th October, his second launching took place. Vibration tore the rocket apart at 104 seconds. Although Pioneer 1 was launched 13 hours before the Soviet Moon probe was due to go, the Russian ship had a shorter flight time and would have overtaken Pioneer and reached the Moon a mere six hours ahead of Pioneer. They were that close.



The Americans tried again on 6th November, Pioneer 2 reaching an altitude of 1,549 km. Now Korolev and his team tried again on 4th December, but the main stage cut out at 245 seconds and the rocket crashed, his third failure in a row. Next it was the Americans' turn again, except that von Braun's Army team had once again been called in to save America's pride. He developed what was called the Juno rocket, aiming to shoot a small 6 kg probe past the Moon. It was so small that it was brought to the Cape by the programme manager on

■ **Above:** Technicians wearing 'cleanroom' attire inspect the Pioneer 3 probe before shipping it to Cape Canaveral. It was launched on 6 December 1958 by a Juno II rocket to measure the radiation intensity of the Van Allen belts, but the rocket malfunctioned and the probe fell back into the atmosphere the next day. Image courtesy NASA.

■ **Left:** Preparing a Thor-Able launch vehicle with the Pioneer 1 spacecraft for launch at the Eastern Test Range at Cape Canaveral. When launched on 11 October 1958, it became the first spacecraft to be launched by the National Aeronautics and Space Administration. Image courtesy NASA.

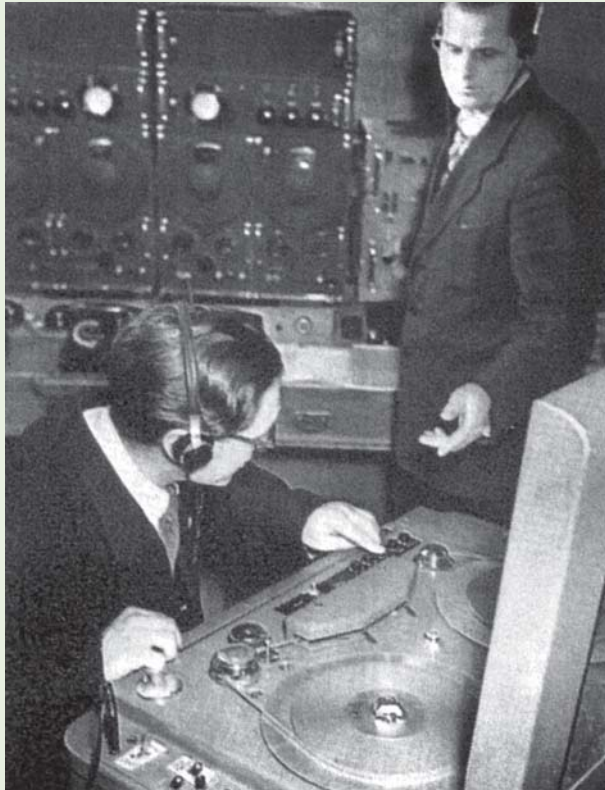

a passenger plane as his hand luggage! But the Juno's speed fell short by only 615km/hr and Pioneer 3 fell back to Earth.

So 1958 ended in disappointment for both countries. Their luck began to change early in the new year. Two days into 1959, the Soviet Union at last managed to send a probe to the Moon. Called 'The First Cosmic Ship', it narrowly missed the Moon by 5,965 km but it entered solar orbit and its instruments made the historic discovery of the solar wind. The American launch record improved too and in March the Americans also flew past the Moon, when von Braun's Pioneer 4 flew past at 60,000 km, ten times further out.

So 1958 set many important markers. The two countries began to draw even. The closeness of the events that year set a pattern that was to thread in and out of the Moon programmes of the two space superpowers for the next eleven years. The two countries raced one another to the first soft landing on the Moon, the first probe to orbit the Moon, the first to fly around the Moon and return and then the first landing. Just as in 1958, they were close right to the end. When Apollo

11 finally won the race for the Americans in July 1969, the Soviet Union made a desperate attempt to get Moon rock samples back to Earth first. The Russians almost pulled it off, and had they succeeded, Luna 15 would have returned to Earth only hours apart from the Americans.

1958 also set the pattern of secrecy and openness that characterized the Moon race. Although the Soviet Union had been quite open about its intentions before Sputnik, party chiefs decided in 1958 that only successful launches would be announced, information flow would be carefully controlled and the personalities of the space programme would be shielded from public view. By contrast, President Eisenhower took the opposite approach. The American launches in 1958 took place in the full glare of public view as thousands of journalists and reporters descended on Cape Canaveral. New words entered the vocabulary, like 'countdown', 'booster' and 'space shot'. Although Pioneer 1 fell back, the rest of the world regarded it as no failure and Eisenhower was flooded with gushing congratulatory telegrams from world leaders. Ordinary people were far from disheartened, the excitement instead building a groundswell of excited support for the space programme.

Highlights of 2006

January: Stardust returns

Utah, 15th January 2006. The recovery of Stardust was one of the most remarkable achievements in space exploration in 2006. Stardust was a small spacecraft, its capsule only 1 m across and weighing only 45kg, launched on a curving 3.5 billion km journey in 1999 in the course of which it intercepted Comet Wild 2. It was a relatively low-cost mission, coming in at €180m. Stardust's main instrument was a paddle, which it extended to collect interplanetary dust on one side and cometary debris on the other.

Stardust's return to Earth was made at enormous speed. Its tiny engine fired to adjust its course 60 days out from Earth, then ten days out and finally 29 hours away. The capsule was released four hours before entry into the Earth's atmosphere. Stardust came in at 35,000km/hr, with temperatures reaching over 3,000°C., and enduring forty times the force of gravity (40G). Next came the big test: would the parachute open? The last recovery from deep space, Genesis, had gone wrong, the parachute failing to open and

■ **Above:** Scientists following an early Soviet space mission. Image from Author's collection.



the spacecraft being badly damaged when it hit the ground.

But all went perfectly in the pre-dawn darkness. A drogue parachute came out high in the atmosphere 30 km up, followed by a 10 m diameter main parachute at 3,000 m. Drifting in the wind, it was quickly located by radar and then helicopters. The capsule bounced a couple of times on the desert floor and finished upside down - but intact. At daylight, the cabin, with its precious microscopic samples on board, was flown off to the American space agency, NASA and the 150 investigators involved in the mission. Stardust was a daring mission, with a rich scientific haul, accomplished with precision.

April: Yuval Neeman: the passing of a great designer

Israel, 26th April 2006. All the world's space programmes have been associated with a 'great designer' - an inspiring figure who conceived the idea of a national space programme and drove its early development, people like Wernher von Braun (Germany), Hideo Itokawa (Japan), Vikram Sarabhai (India), Tsien Hsue Shen (China) and Sergei Korolev (Russia). Israel's great designer was Yuval Neeman, born in Tel Aviv in 1925. He spent his youth in Egypt, joined the Israeli Defence Forces when the state was founded and went to London in the 1950s for postgraduate

studies where he became one of the discoverers of the quark and eventually authored more than 350 papers on physics. From 1983 he was chairman of the Israeli Space Agency which only five years led to Israel putting its first satellite into orbit. A leader of Israel's atomic industry, he was also a politician, defence and intelligence expert.



■ **Top:** NASA's Stardust sample return capsule containing cometary and interstellar samples successfully landed at the US Air Force Utah Test and Training Range on 15 January 2006 (left). Following the landing the recovery crew carefully retrieved the return capsule (inset). Images courtesy NASA.

■ **Above:** Portrait of Israel's great designer Yuval Neeman (1925-2006). Image courtesy Israel Hanukoglu, Israel Science and Technology.



July: Return to flight

Cape Canaveral, Florida, 4th July 2006. The American space agency, NASA, celebrated independence day in style with the return to flight of the space shuttle on mission STS-115. Following the *Columbia* disaster in 2003, the shuttle had originally returned to flight in July 2005, but post-flight analysis indicated that there was still a problem of debris falling off the external tank and putting the shuttle at risk. Making the necessary improvements took almost a year and even then, there were weather delays which aborted countdowns on 1st and 2nd July. The national holiday enabled millions of Americans to watch the shuttle return to flight, both at Cape Canaveral and on television. Mission commander Steven Lindsay and pilot Mark Kelly brought the shuttle up to the International Space Station two days later, where they steered it through what are called pitch-over manoeuvres to enable the station crew to make an exhaustive photographic examination of the shuttle's underside for damage. Then they flew it in to dock with the station, coming together over Pitcairn Island in the Pacific Ocean. There were some minor debris issues, but no further serious incidents and by the year's end, with three successful shuttle missions in 2006, NASA had put the debris problem behind.

July: 'This is mission control Las Vegas'

Dombarovska, Russia, 12th July 2006. The launching of Genesis 1 was remarkable for two reasons. First, it was the first launch into orbit from the Russian missile base of Dombarovska (see launch sites, on pages 12-13). Second, the

Dnepr launcher put into space an inflatable structure that would pave the way for large, manned space stations. The idea of large, inflatable structures to house people in orbit dates back to the 1960s (an inflatable wheel-shaped space station featured in the *Drift Marlo* cartoon strip). Genesis was an inflatable developed by the American Bigelow corporation and once Genesis was in orbit, the command was issued to inflate it. All went smoothly and pictures of the inside and out were soon beamed back to Bigelow's mission control centre in Las Vegas, Nevada. The pressure held and the concept was vindicated.

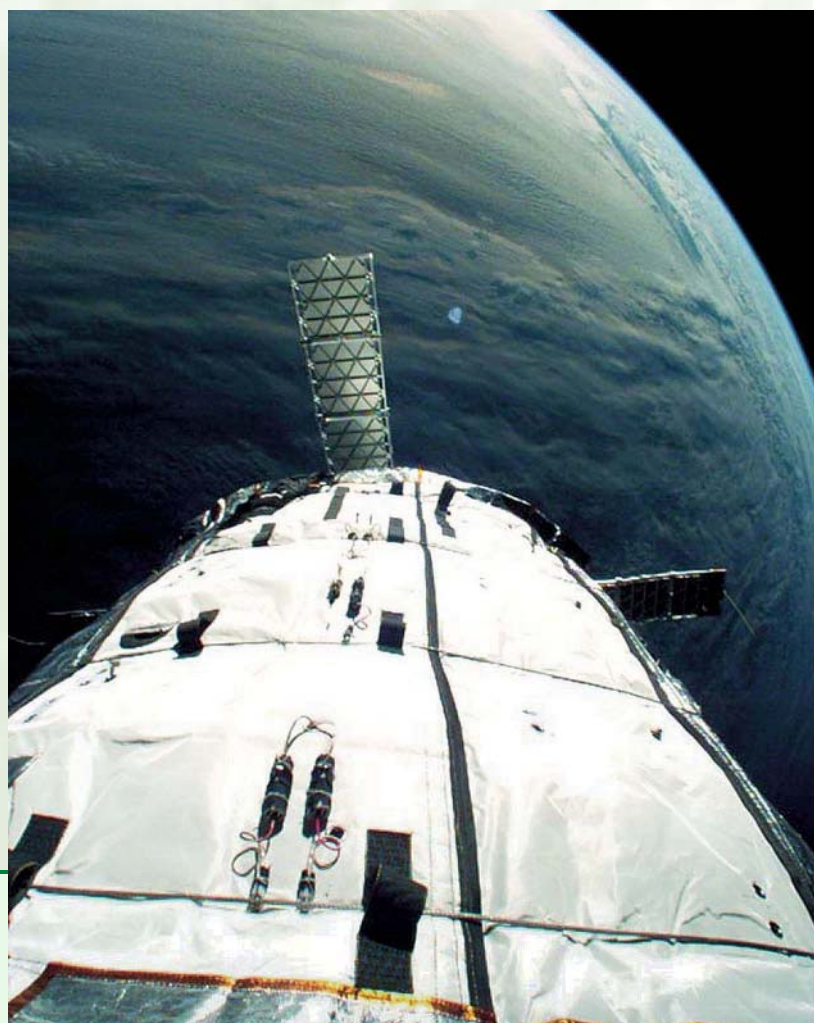

■ **Right:** An external view of the Genesis spacecraft, an inflatable structure developed by Bigelow Aerospace in the USA, and the forerunner of large, inflatable structures to house people in orbit. Image courtesy Bigelow Aerospace.

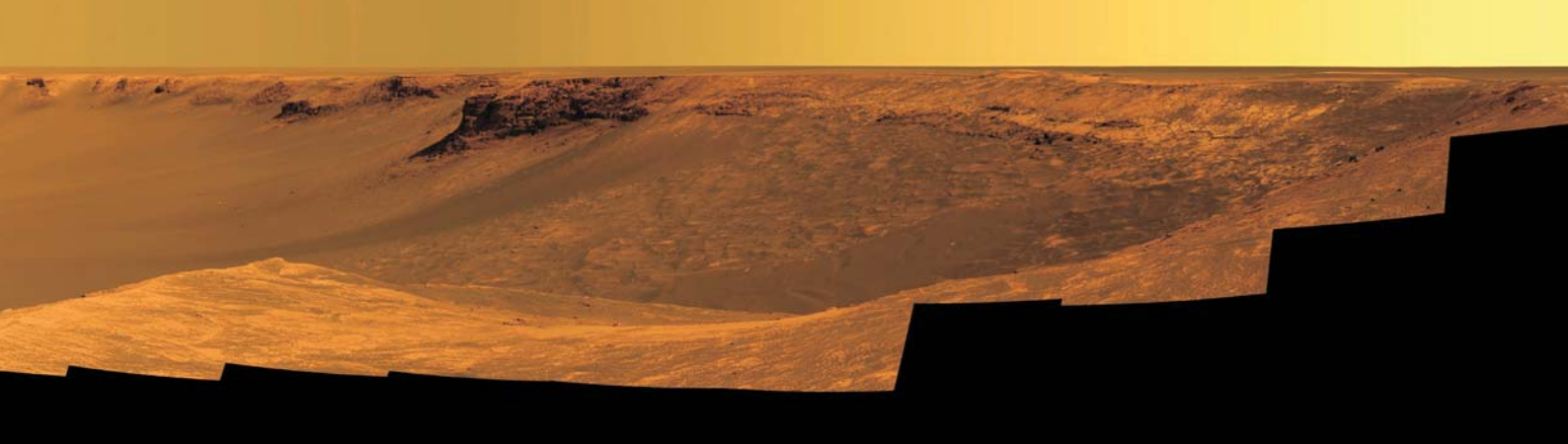

September: Seeds nursery in orbit

Sichuan, China, 24th September. China recovered, in mountainous Sichuan, its Shi Jian 8 space cabin. Launched on a Long March 2C rocket from Jiuquan cosmodrome, Shi Jian circled the Earth for 15 days with a cargo of 2,000 seeds, fungi, vegetables, fruit, grains and cotton. Cameras sent back to Xian mission control pictures of how they fared in weightlessness. After landing, the seeds were distributed to scientists, biologists and agriculturalists to see how they reacted to radiation and weightlessness.

October: Arrival at Victoria

Meridiani, Mars. The Mars rover *Opportunity* reached crater Victoria on Mars, one of the most important targets of its mission. *Opportunity* was one of two rovers landed on Mars by the United States in January 2004, *Opportunity* coming down in the Meridiani plain and *Spirit* in the crater Gusev. Designed to operate for only a year, the two rovers were still driving across Mars three years later and became the most long-lasting rovers ever built, surviving the extremes of the Martian climate, dust storms and enforced seasonal shut downs when the Sun was too distant to supply sufficient power. *Opportunity* reached Victoria after a 9 km drive from its landing site and was expected to spend a year there. Victoria is a 800 m wide, 70 m deep crater formed by a meteorite slamming into Mars a billion years ago. Most important, it has several layers of exposed bedrock which are expected to reveal much of the geological history of Mars. Meantime, its companion rover *Spirit* was hibernating south of the Martian equator, having descended from Husband Hill, whence it was able to image the wide flat crater floor where it landed.

Victoria was photographed from orbit by Mars Global Surveyor, which arrived in Mars orbit in 1997. Sadly, 2006 was the year to say goodbye to

Mars Global Surveyor. Early the following month, November, contact was lost with the spacecraft after nine years, another record.

November: Introducing the fourth spacefaring nation, India

Bangalore, India, 8th November 2006. Eighty leading Indian space scientists gathered in Bangalore, India to discuss plans for India to become the fourth country in the world able to



■ **Top:** A vista of Victoria crater taken by *Opportunity* from the viewpoint of Cape Verde, one of the promontories on the scalloped rim of the crater. The far rim is about 800m away. The panorama combines hundreds of exposures, the first taken on 16 October 2006 and the last on 7 November. Image courtesy NASA/JPL-Caltech/Cornell.

■ **Above:** A model of India's Geo-Synchronous Launch Vehicle GSLV Mk-III with its designer S. Ramakrishnan. Image courtesy Brian Harvey.

launch its own astronauts into orbit after Russia (1961), the United States (1962) and China (2003). The Indian Space Research Organization (ISRO) presented studies carried out over the past four years showing how this could be achieved. India's intention is to launch a two-person spaceship on an initial one-day mission in 2014, followed by a week-long mission, with splashdown in the Bay of Bengal. India already has a rocket powerful enough to launch a manned spaceship, the Geo Synchronous Launch Vehicle (GSLV). Two famous Indians have already flown in space - Rakesh Sharma on the Soviet Salyut 7 orbital station (1984) and Kalpana Chawla on the American space shuttle and, sadly, one of those lost on the *Columbia* in 2003. And one of India's most famous rocket scientists, Abdul Kalam, is now the President of India.

December: Finding planets

Baikonour, 27th December 2006. In a night-time launch, the Russian Soyuz 2.1.b rocket put into orbit the French-developed 605 kg COROT satellite. COROT is a planet-hunter, equipped with a 30 cm telescope. It is so sensitive that whenever a planet crosses the face of a distant star, it affects the amount of light coming from that star, albeit by a small amount. That difference can be detected by COROT, whose initials stand for CONvection, ROTation and planetary Transits. Locating planets around other stars is a field of astronomy that has developed only since 1995 - over 200 such planets have now been detected - and COROT will search 120,000 stars for planetary objects. Many are expected to be big gassy planets like Jupiter, but it is hoped that at least some will be rocky planets, like Earth.



■ An artist's depiction of the COROT satellite, the exoplanet hunter mission led by CNES with ESA participation, that incorporates a 30-cm telescope to monitor closely the changes in a star's brightness if an extrasolar planet passes in front of it. Image courtesy CNES/D. Ducros.

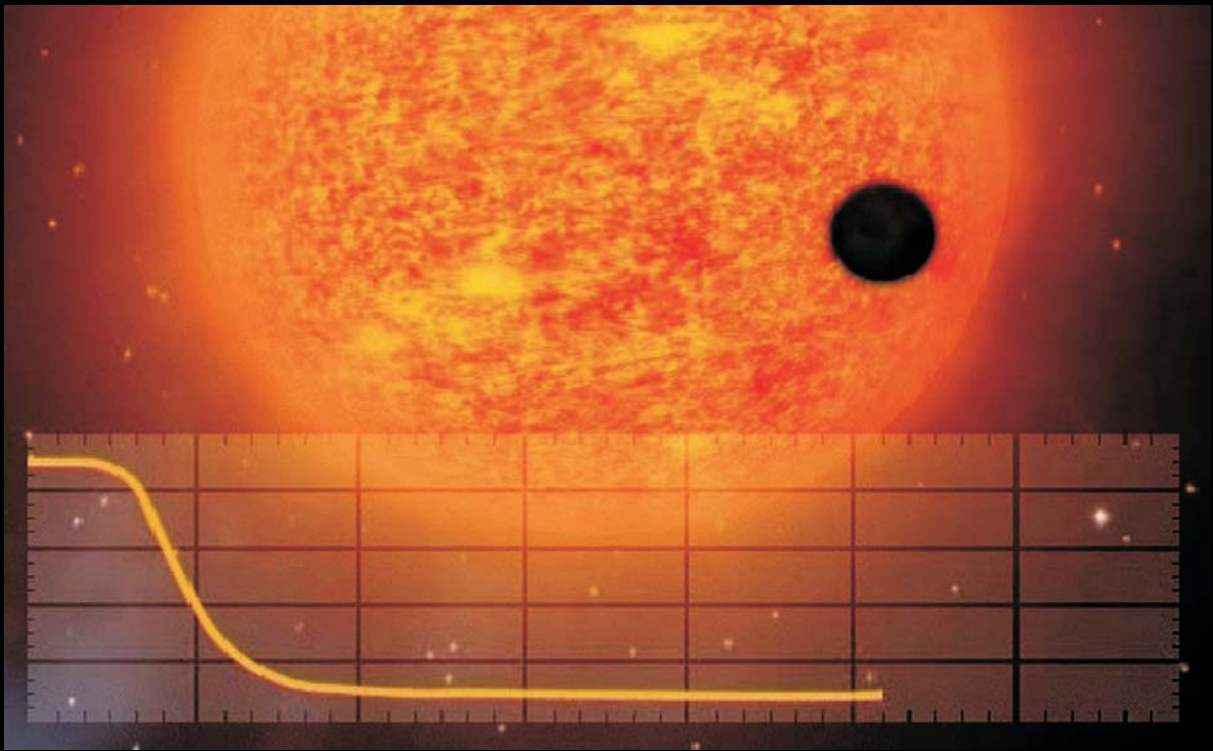

■ Above: An artist's depiction of a Jupiter-sized planet passing in front of its parent star, causing a small decrease in their combined brightness as depicted by the light curve below. Image courtesy CNES.

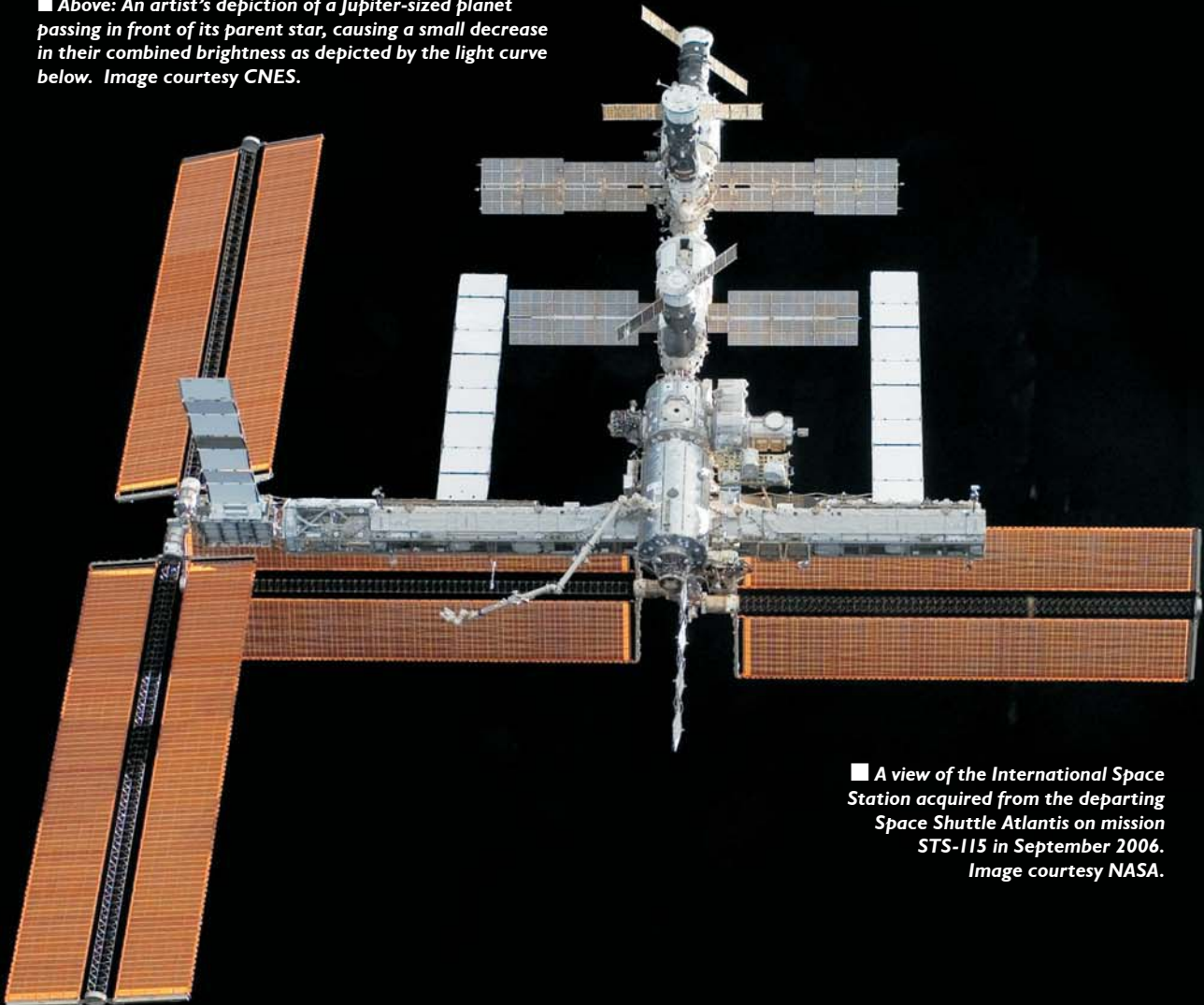

■ A view of the International Space Station acquired from the departing Space Shuttle Atlantis on mission STS-115 in September 2006. Image courtesy NASA.

LAUNCH LOG 2006

19 Jan	New Horizons	Atlas V	Cape Canaveral	USA
24 Jan	ALOS/Daichi	H-IIA	Tanegashima	Japan
15 Feb	Echostar 10	Zenit 3SL	Odyssey Platform	Russia/Ukraine
18 Feb	MTSAT 2	H-IIA	Tanegashima	Japan
21 Feb	Astro F/Akari CUTE 1.7	Mu-V	Kagoshima	Japan
1 Mar	Arabsat 4A	Proton M	Baikonour	Russia (fail)
11 Mar	Hotbird 7A Spainsat	Ariane V	Kourou	Europe
22 Mar	ST-5a,b,c	Pegasus	Vandenberg	USA
24 Mar	Falconsat 2	Falcon X	Omelek	USA (fail)
30 Mar	Soyuz TMA-8	Soyuz FG	Baikonour	Russia
12 Apr	JCSat 9	Zenit 3SL	Odyssey Platform	Russia/Ukraine
15 Apr	Formosat 3A-F	Minotaur	Vandenberg	USA
20 Apr	Astra 1KR	Atlas V	Cape Canaveral	USA
24 Apr	Progress M-56	Soyuz U	Baikonour	Russia
25 Apr	Eros B	START	Svobodny	Russia
26 Apr	Yaogan 1	CZ-4B	Taiyuan	China
28 Apr	Calipso Cloudsat	Delta II	Vandenberg	USA
3 May	Cosmos 2420	Soyuz U	Plesetsk	Russia
24 May	GOES N	Delta IV	Cape Canaveral	USA
26 May	KOMPASS 2	Shtil	Barents Sea	Russia
27 May	Satmex 6 Thaicom 5	Ariane 5	Kourou	Europe
15 June	Resurs DK	Soyuz U	Baikonour	Russia
18 June	Galaxy 16	Zenit 3SL	Odyssey Platform	Russia/Ukraine
18 June	Kazsat	Proton K block D	Baikonour	Russia
24 June	USA 187 USA 188 USA 189	Delta II	Cape Canaveral	USA
24 June	Progress M-57	Soyuz U	Baikonour	Russia
25 June	Cosmos 2421	Tsyklon 2	Baikonour	Russia
28 June	USA 184	Delta IV	Vandenberg	USA
4 July	Discovery	STS-121	Cape Canaveral	USA
10 July	Insat 4C	GSLV	Sriharikota	India (fail)
12 July	Genesis 1	Dnepr	Dombarovska	Russia
21 July	Cosmos 2422	Molniya M	Plesetsk	Russia
26 July	Belka 16 small satellites	Dnepr	Baikonour	Russia (fail)
28 July	Kompsat 2	Rockot	Plesetsk	Russia

4 Aug	Hot Bird 8	Proton M	Baikonour	<i>Russia</i>
11 Aug	JCSAT-10 Syracuse 3B	Ariane 5	Kourou	<i>Europe</i>
22 Aug	Koreasat 5	Zenit 3SL	Odyssey Platform	<i>Russia/Ukraine</i>
9 Sep	Shi Jian 8	CZ-2C	Jiuquan	<i>China</i>
9 Sep	Atlantis	STS-115	Cape Canaveral	<i>USA</i>
11 Sep	IGS-3	H-IIA	Tanegashima	<i>Japan</i>
12 Sep	Feng Huo 3	CZ-3A	Xi Chang	<i>China</i>
14 Sep	Cosmos 2423	Soyuz U	Baikonour	<i>Russia</i>
18 Sep	Soyuz TMA-9	Soyuz FG	Baikonour	<i>Russia</i>
21 Sep	Solar B/Hinode	Mu-V	Kagoshima	<i>Japan</i>
25 Sep	GPS-52	Delta II	Cape Canaveral	<i>USA</i>
13 Oct	DirecTV 8	Ariane V	Kourou	<i>Europe</i>
	Optus D1			
19 Oct	Metop A	Soyuz 2.1.a Fregat	Baikonour	<i>Russia</i>
23 Oct	Progress M-58	Soyuz U	Baikonour	<i>Russia</i>
23 Oct	Shi Jian 6 - 2A B	CZ-4B	Taiyuan	<i>China</i>
26 Oct	Stereo A Stereo B	Delta II	Cape Canaveral	<i>USA</i>
28 Oct	Xinnuo 2	CZ-3B	Xi Chang	<i>China</i>
30 Oct	XM-4 Blues	Zenit 3SL	Odyssey Platform	<i>Russia/Ukraine</i>
4 Nov	DMSP	Delta II	Cape Canaveral	<i>USA</i>
8 Nov	Arabsat 4B	Proton M	Baikonour	<i>Russia</i>
17 Nov	GPS 58	Delta II	Cape Canaveral	<i>USA</i>
8 Dec	Fengyun 2D	CZ-3A	Xi Chang	<i>China</i>
8 Dec	Wildblue I AMC 18	Ariane 5	Kourou	<i>Europe</i>
10 Dec	Discovery	STS-116	Cape Canaveral	<i>USA</i>
12 Dec	Measat 3	Proton M	Baikonour	<i>Russia</i>
14 Dec	USA 193	Delta 2	Vandenberg	<i>USA</i>
16 Dec	Tacsat Genesat	Minotaur	Wallops Island	<i>USA</i>
18 Dec	ETS-VIII	H-IIA	Tanegashima	<i>Japan</i>
19 Dec	SAR Lupe I	Cosmos 3M	Plesetsk	<i>Russia</i>
21 Dec	MEPSI 2 RAFT I N MARS ANDE FCAL	Shuttle	From orbit	<i>USA</i>
24 Dec	Meridian	Soyuz 2.1.a Fregat	Plesetsk	<i>Russia</i>
25 Dec	Cosmos 2424-6	Proton K	Baikonour	<i>Russia</i>
27 Dec	COROT	Soyuz 2.1.b	Baikonour	<i>Russia</i>

Here are some details for a few of the missions featured on the previous pages.

ALOS (*January*) stands for Advanced Land Observing Satellite and was the third in the series. In the Japanese tradition, it was renamed once it reached orbit and is now called Daichi, the Japanese word for 'Mother Earth'. This tells us about its mission, which is to observe the Earth with radar and optical instruments so as to identify natural resources, monitor disasters and compile maps. Daichi has a 22 m solar array able to generate 7 kw of power and at 4,200 kg was one of the heaviest payloads orbited by Japan, using the powerful H-IIA launcher. Data are transmitted back at the rate of 1.36 gigabytes per second.

ALOS began a year of space success for Japan, for it was followed in February by MTSAT 2 and Astro F. MTSAT 2, also using the H-IIA, stands for Multifunctional Transport Satellite, for it is dual use, being designed for weather forecasting and air traffic control. To provide power, the 4,650 kg MTSAT carries a 30 m wide solar panel. Astro F is much smaller, only 950 kg and used the much smaller Mu-V rocket. Astro

F is designed to work for nine years, searching for comets and examining galaxies and star formation. Astro F was given the name of Akari, the Japanese word for 'light'. Whilst arriving in orbit, it deployed a small, 3 kg nanosatellite. They were followed in September by the Solar B satellite, named Hinode once it reached orbit (Japanese for 'sunrise'). Hinode carried three telescopes - optical, X-ray and ultraviolet - developed with Britain and the United States to survey the Sun from its 630 km high orbit. ETS VIII or Kiku 8 (*December*) was the eighth in a series of Engineering Test Satellites (ETS), a huge 5.8 tonne satellite. With a 40m span for its solar panels, it looks like a hovering insect and is designed to test the development of satellite-based mobile telephone communications, leading to the eventual elimination of ground masts.

Yaogang (*April*) was a new Chinese satellite, weighing three tonnes and used for surveying, crop monitoring, disaster forecasting and remote sensing. Shi Jian 6-2 was a double Chinese launching, carrying two satellites into orbit to study the space environment, following an earlier double launching (Shi Jian 6-1, in September 2004), but little further information was given.



■ An artist's depiction of the Akari (ASTRO-F) spacecraft launched by Japan from the Kagoshima launch site on 21 February 2006. Image courtesy JAXA.

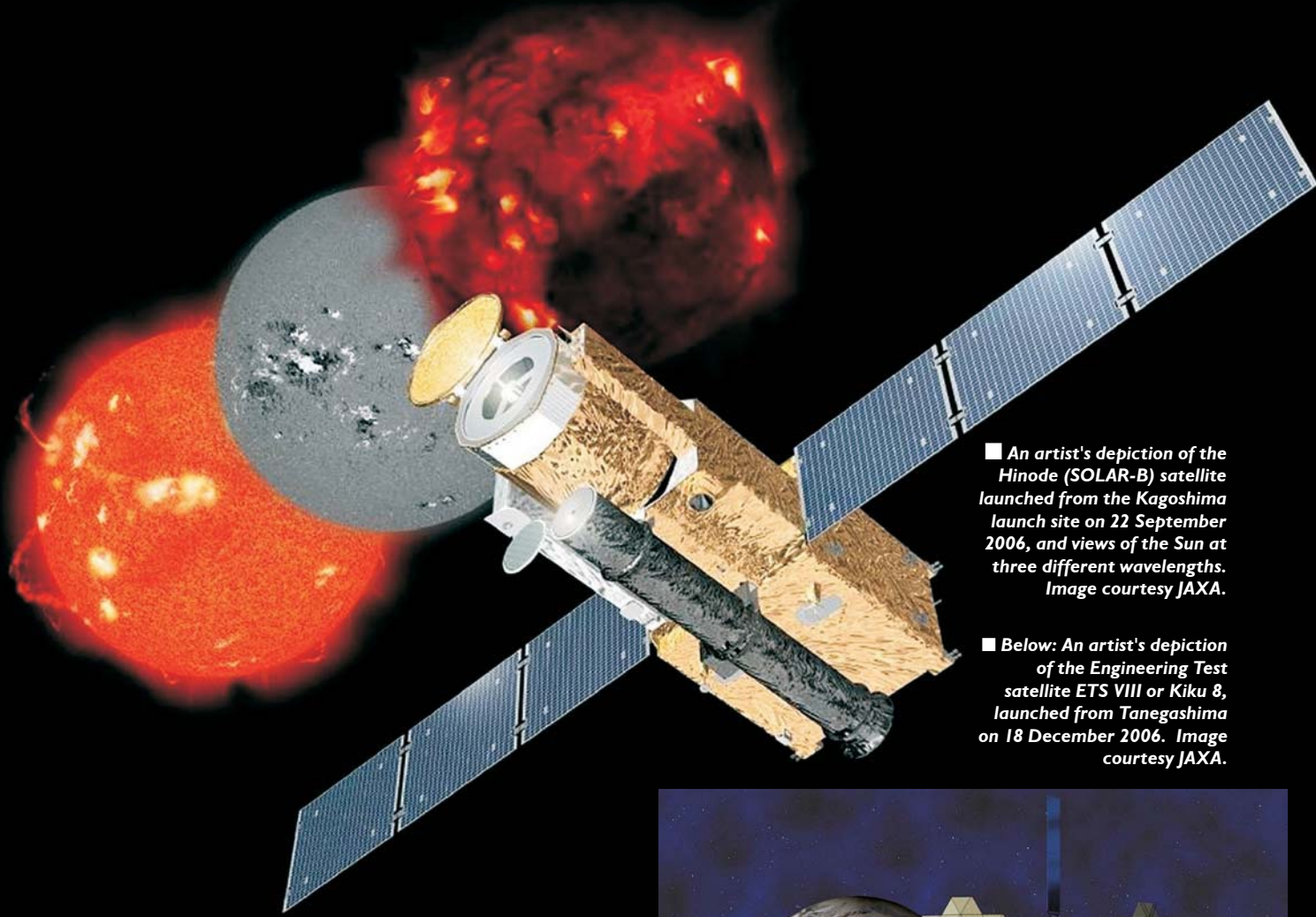

■ An artist's depiction of the *Hinode (SOLAR-B)* satellite launched from the Kagoshima launch site on 22 September 2006, and views of the Sun at three different wavelengths. Image courtesy JAXA.

■ Below: An artist's depiction of the Engineering Test satellite *ETS VIII* or *Kiku 8*, launched from Tanegashima on 18 December 2006. Image courtesy JAXA.

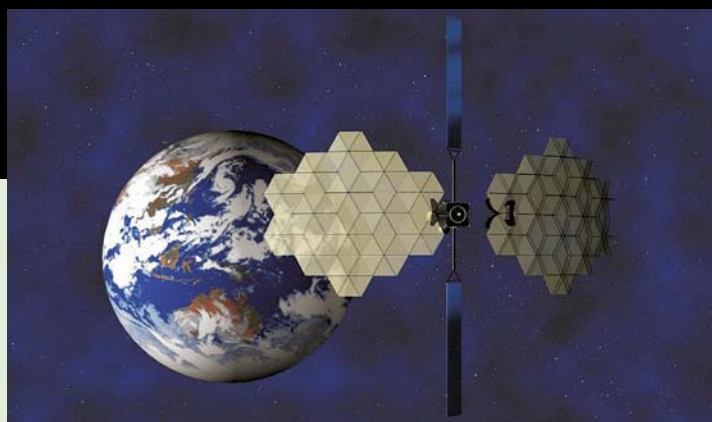

Cloudsat (*April*) was, as its name suggests, an American cloud observation satellite, put into orbit with a French satellite called Calypso. They are part of a constellation of remote sensing satellites orbiting in the same plane, called the A train, their companions so far being Aqua, Aura and Parosol.

KOMPASS (*May*) was a small 80 kg satellite with an electrical field analyzer and radio wave detectors to study electromagnetic radiation, orbital plasmas and the flow of particles, their interaction believed to give clues to impending earthquakes. KOMPASS stands for Complex Orbital Magneto Plasma Autonomous Small Satellite, developed by the IZMIRAN research institute. Launched by a missile from the submarine Ekaterinberg from under the Barents Sea, contact was lost after only a few days - but then miraculously recovered the following December.

Resurs DK (*June*) was the most advanced Russian Earth observation satellite launched to date. 'Resurs' means 'resources' in Russian, while the initials 'DK' stand for Dmitri Kozlov, named after the head of the bureau where it was designed. Weighing 6.5 tonnes, it was a

6 m long cone-shaped satellite with 15 m wide solar panels at its base, looking downward at the Earth. It was designed to circle the Earth for three years, taking panchromatic, multispectral and infrared pictures down to a resolution of 2.5 m (some claimed 1 m) in forty 350 km wide swathes each day, transmitting them back to Earth digitally to a number of ground stations. Kompsat was a remote-sensing satellite for South Korea launched by Russia. Staying with space applications, Meridian (*December*) was the first in a new series of Russian communications satellites, designed to replace the original Russian communications satellite, the Molniya, introduced in 1965.

GOES N (*May*) was an American meteorological satellite. Metop A (*October*) was Europe's



first polar weather satellite, a four-tonne satellite equipped with a range of French and American instruments. Reporting to mission control in Darmstadt, Germany, it is the first of three. Feng Yun 2D (*December*) was a Chinese weather satellite heading for 24 hour orbit.

Stereo (*October*) was a pair of American solar observation satellites. The first was named Stereo A, A for Ahead, the second Stereo B, B for Behind: A flew ahead of Earth's orbit around the Sun and B behind Earth's orbit around the Sun. The concept was a simple one: between them they would triangulate emissions from the Sun and build a three-dimensional picture of solar activity. ST 5a, b and c were three small satellites, each 25 kg, to study the magnetosphere.

There were three launchings of navigational satellites: GPS [Global Positioning System] 52 (*September*) and GPS 58 (*November*) were launched by the United States, while Russia orbited a trio of Cosmos 2424, 2425 and 2426 in its GLONASS series (GLONASS stands in Russian for global navigation satellite system). Formosat (*April*) was a series of six 62kg satellites to test the effect of atmospheric conditions on GPS signals.

The year saw its fair share of military missions. On the Russian side, these were

generally flown under the Cosmos title. Cosmos 2420 (*May*) and 2423 (*September*) were military photo-reconnaissance satellites (see section *They came back...*, below). Cosmos 2421 (*June*) was a US P electronic ocean surveillance satellite, while Cosmos 2422 (*July*) was an early-warning missile-alert satellite in the Oko series. EROS B (*April*) was an Israeli military observation satellite put into orbit by Russia. IGS-3 (*September*) was a Japanese military observation satellite designed to keep a close watch on missile and nuclear facilities in North Korea. SAR-Lupe (*December*) was a German radar surveillance satellite orbited by Russia.

A number of communications satellites were launched in 2006. Those launched by the Russian/Ukrainian Zenit 3SL were Echostar 10 (*February*), JCSAT (*April*) Galaxy 16 (*June*), Koreasat 5 (*August*) and XM-4 Blues (*October*). Those launched by the Russian Proton were Kazsat (*June*), Hotbird 8 (*August*) and Measat (*November*)

Most of Europe's Ariane launches were of communications satellites. These were Spainsat and Hotbird 7A (*February*); Satmex 6 and Thaicom 5 (*May*); JCSAT 10 and Syracuse 3a (*August*) (Syracuse was for military communications); DirecTV 9S and Optus D1 (*October*); and Wildblue 1 and AMC 18 (*December*).

The most prominent commercial satellite launched by the United States was Astra 1KR (*April*). China launched two communications satellites, Feng Huo 3 (*September*) and Xinnuo

■ **Above:** MetOp-A, Europe's first polar-orbiting satellite dedicated to operational meteorology, was launched on 19 October 2006 from the Baikonour Cosmodrome in Kazakhstan. Image courtesy EUMETSAT/ESA.

2 (October). Also called Sinosat 2, this was a powerful direct broadcast satellite with 32m wide solar panels, the first in the advanced Dong Fang Hong 4 series of communications satellites, but, unhappily, it broke down after less than ten days in orbit.

Few details are available of American military satellites and they were given 'USA' designators: USA 187, 188 and 189 (June); 184 (*June*) and 193 (*December*: this was a demonstrator satellite for the National Reconnaissance Office). DMSP (*November*) was a weather satellite for the military (Defence Meteorological Satellite Programme). Tacsat (*December*) was a telescope for the US Air Force, accompanied by a 3 kg microsatellite Genesat to study e-coli bacteria for Ames Research Centre.

Shortly before returning from orbit, the space shuttle Discovery deployed several microsatellites. MEPSI 1 and 2 were two cubes separated by a tether, while RAFT 1 and NMARS were 4 kg cubes for the US Air Force and ANDE was a small cannister.

Launches by country, 2006

There were 64 launches in 2006. In terms of number of launches, Russia continues to be the leading space-faring nation, a position it has held from the mid-1960s except for a brief phase in the late 1990s. China has overtaken Europe as the third space-faring nation. Japan had an exceptionally busy year in 2006 with six launches, following a difficult spell in which its main launcher, the H-IIA had been grounded.

	2006	2005	2004
Russia/Ukraine	29	27	26
USA	18	13	18
China	6	5	8
Europe	5	5	3
India	-	1	1
Japan	6	2	0

They went up: manned launches, 2006

There were five manned space launches in 2006: two by Russia and three by the United States. There were no manned Chinese space missions in 2006, the next not being scheduled until 2008.

30 Mar 2006	Soyuz TMA-8	Baikounour	Pavel Vinogradov (Russia) Marcos Pontes (Brazil) Jeffrey Williams (US)
17 July 2006	Discovery STS-121	Cape Canaveral	Steven Lindsay (US) Mark Kelly (US) Stephanie Wilson (US) Michael Fossum (US) Piers Sellers (US) Lisa Nowak (US) Thomas Reiter (Europe)
9 Sep 2006	Atlantis STS-115	Cape Canaveral	Brent Jett (US) Chris Ferguson (US) Joe Tanner (US) Dan Burbank (US) Heidi Stefanshyn Piper (US) Steven MacLean (Canada)
18 Sep 2006	Soyuz TMA-9	Baikounour	Mikhail Tyurin (Russia) Michael Lopez Alegria (US) Anousheh Ansari (adventurer)
9 Dec 2006	Discovery STS-116	Cape Canaveral	Mark Polansky (US) William Oefelein (US) Joan Higginbotham (US) Robert Curbeam (US) Sunita Williams (US) Nicholas Patrick (US) Christer Fuglesang (Europe)



All these missions were to the International Space Station. When the station was designed, it was intended that most of the construction would be undertaken by the American space shuttle. The shuttle duly made a series of missions to the station ever since the first, core module, *Zarya*, was launched by Russia in 1998. This role came to an abrupt halt with the loss of the shuttle *Columbia* in February 2003, forcing not only a reduction in crew size (*see below*), but suspending construction. With the three missions in 2006, construction could now resume. STS-115 in September carried a 17 tonne truss called the P3/P4 while STS-116 in December brought up the smaller P5 truss and wired the P3/P4 for operation (*see Neville Kidger: Building the International Space Station – A site still under construction, Space Exploration 2007 Annual, pp 26-37*).

First woman adventurer: Anousheh Ansari

The one individual who made the most space history in 2006 was Anousheh Ansari - and it was by accident. Anousheh Ansari was an American businesswoman of Iranian descent who enlisted in the space tourism programme run by Space Adventures. A Star Trek fan, she was one of the sponsors of the X-prize for the first private sub-orbital space flight. In early 2006 she began her training programme in Moscow for a week-long space mission on the Russian Soyuz rocket to the International Space Station, a mission scheduled for 2007-8.

■ **Above:** Two views of Arne Christer Fuglesang, the first Swedish astronaut, working at the International Space Station during the visit by the Space Shuttle *Discovery* on mission STS-116 in December 2006. With fellow astronaut Bob Curbeam, Christer Fuselang made three spacewalks during the mission. Images courtesy NASA/ESA.

■ **Right:** The fourth space adventurer, Anousheh Ansari, at the press conference held in the Cosmonaut Hotel in Baikonour, Kazakhstan, prior to her launch on Soyuz TMA-9 to the International Space Station. Image courtesy NASA/Victor Zelentsov.

Japanese Daisuke Enomoto had been scheduled to be the fourth space adventurer on the Soyuz TMA-9 flight in September. Just two weeks before his mission, his doctors disqualified him on account of a kidney problem. Anousheh Ansari suddenly received a surprise telephone call to tell her that she would be flying into orbit in less than two weeks! She lifted off from Baikonour cosmodrome on 18th September. Once in orbit, she watched the Earth go by from her window in the space station, carried out experiments on chromosomes, bacteria, blood cells and back pain for the European Space Agency and then returned to Earth on 29th September. She wrote a blog on her experience.



Crews on the International Space Station in 2006

The International Space Station was originally designed to have a three-person crew, brought up and down by the American space shuttle. The normal pattern was to alternate two Americans with one Russian and then one American and two Russians. With the loss of the space shuttle *Columbia* in February 2003, crews were brought up and down by the Russian Soyuz spacecraft, but because of the limited weight capacity of the Russian Soyuz and unmanned Progress freighter, the crew size was reduced from three to two. Although the space shuttle returned to flight in July 2005, there were still unresolved safety issues, with the consequence that it was not possible to return to the three-person crew until the *Discovery* STS-121 mission in July 2006. Here, a three-person crew was restored, though the European astronaut was actually a 'Russian' seat, paid for the European Space Agency to Roscosmos, the Russian space agency. After a six month mission, he came down on the shuttle in December and replaced by the American astronaut, Sunita Williams.

1 Jan 2006 to 30 March

Valeri Tokarev, William McArthur

30 Mar to 17 July

Pavel Vinogradov, Jeffrey Williams

17 July to 28 Sep

Pavel Vinogradov, Jeffrey Williams,
Thomas Reiter

28 Sep to 19 Dec

Mikhail Tyurin, Michael Lopez Alegria,
Thomas Reiter

From 19 Dec 2006

Mikhail Tyurin, Michael Lopez Alegria,
Sunita Williams

■ **Below:** Mikhail Tyurin (left), Thomas Reiter and Michael E. Lopez-Alegria at dinner in the Zvezda module of the International Space Station. Image courtesy NASA.



Supply missions to the International Space Station

During 2006, Russia launched three re-supply missions to the International Space Station. The Progress spacecraft is used and it is designed to carry fuel, water, equipment, experiments, food, laundry, supplies and personal items to orbiting space stations. Progress is derived from the manned Soyuz spaceship and flies entirely automatically. Progress has three series. The first, Progress, supplied the Salyut 6 and 7 space stations and concluded with Progress 42. Progress M was introduced in 1989 and was an improved version. A third variant, Progress M1 was introduced in 2000 and eleven have flown. Russia continues to operate both the M and M1 series. The older M series carries greater supplies of water and because of high water demands on

the International Space Station, the M version has continued in use. A new type of freighter, called the Parom, will be introduced in 2011.

24 Apr 2006 *Progress M-56*

28 June 2006 *Progress M-57*

23 Oct 2006 *Progress M-58*

All on Soyuz U launchers from Baikonour

Progress re-supply missions are generally routine. One which caused temporary worry was Progress M-58. One of the rendezvous antennae of the Kurs system called the 4AO VKO failed to close in properly during the final stages of docking, causing an obstruction and the risk that a hard docking could not be achieved. In the end, the station crew was able to retract the 4AO VKO and re-deploy the hooks on the ISS to obtain both a docking and a full airtight seal.

Spacewalks from the International Space Station

Date	Participants		Airlock used	Duration
3 Feb 2006	Valeri Tokarev	William McArthur	ISS Pirs	5hr 43min
1 June 2006	Pavel Vingradov	Jeffrey Williams	ISS Pirs	6hr 31min
3 Aug 2006	Thomas Reiter	Jeffrey Williams	Quest	6hr 0min
23 Nov 2006	Mikhail Tyurin	Michael Lopez Alegria	ISS Pirs	5hr 38min

Spacewalks from the shuttle while attached to the International Space Station

Either from the shuttle or from the ISS with the shuttle docked

STS-121 mission, Discovery

8 July 2006	Piers Sellers, Mike Fossum	7hr 31min
10 July 2006	Piers Sellers, Mike Fossum	6hr 39min
12 July 2006	Piers Sellers, Mike Fossum	7hr 11min

STS-115 mission, Atlantis

12 Sep 2006	Joe Tanner, Heidi Stefanshyn Piper	6hr 26min
13 Sep 2006	Dan Burbank, Steve MacLean	7hr 11min
15 Sep 2006	Joe Tanner, Heidi Stefanshyn Piper	6hr 42min

STS-116 mission, Discovery

12 Dec 2006	Christer Fuglesang and Bob Curbeam	6hr 36min
14 Dec 2006	Christer Fuglesang and Bob Curbeam	5hr 00min
16 Dec 2006	Bob Curbeam and Sunita Williams	7hr 31min
18 Dec 2006	Christer Fuglesang and Bob Curbeam	6hr 38min

Launches by launch site, 2006

There are over twenty launch sites in the world. Of these, the following were used in 2006:

	2006	2005	2004
Baikonour, Russia	16 (2)	19	17
Cape Canaveral, USA	11	8	14
Plesetsk, Russia	5	4	6
Xi Chang, China	3	1	4
Kourou, French Guyana	5	5	3
Vandenberg, USA	5	5	3
Jiuquan, China	1	4	2
Taiyuan, China	2	-	2
Odyssey Platform	5	4	3
Sriharikota, India	(1)	1	1
Tanegashima, Japan	4	1	0
Kagoshima, Japan	2	1	0
Barents Sea	1		
Svobodny	1		
Dombarovska	1		
Omelek, Kwajelein Atoll	(1)		
Wallops Island, Virginia	1		

2006 failures in brackets

Launch sites not used in 2006 were Kapustin Yar (Russia), Palmachim (Israel) and Woomera (Australia). A launch platform, called San Marco, was built off the Kenyan coast and was used by Italy with an American launcher in the 1970s. Brazil has a launch site at Alcantara, but has yet to successfully launch a satellite. Launch sites

are reported under construction in Iran, one at Shahrud, north east of Tehran and another at Dasht e Kavir, south east of Tehran. North Korea has a missile base at Musudan-ri, where a satellite launch attempt may have taken place in 1999, with a further possible attempt in summer 2006.

Russia/Ukraine

Russia has seven launch bases:

- *Kapustin Yar, on the Volga, used from the 1940s, but not in active use now;*
- *Its main spaceport, Baikonour, in Kazakhstan, used for manned spaceflight, civilian space missions and some military operations;*
- *Its military space base, Plesetsk, above the arctic circle in the far north, which is also used for some scientific missions;*
- *Two former missile bases, Svobody Blagoveschensk, in the far east; and Dombarovska (also called Yasny), which opened in 2006;*
- *The Barents Sea, where submarine-based launchings take place; and*
- *The Odyssey Platform, along the equator in the Pacific, which is used for the Russian - Ukrainian - American Sea Launch project. The Odyssey Platform is a converted oil rig operating in international waters in the Pacific Ocean and served by a logistics vessel whose home base is Long Beach California.*

■ Thomas Reiter during a spacewalk from the International Space Station on 3 August 2006. Image courtesy NASA/ESA.



An eighth is currently in construction, a launch pad for the Soyuz launcher at the European Space Agency launch site in Kourou, French Guyana in the European Union.

Russia's best known and premier launching base is Baikonour, which, under the terms of a treaty between the two governments, is Russian territory within Kazakhstan. This used to be operated by the Strategic Rocket Forces, but they pulled out in 2006, leaving Baikonour in the hands of Russian and western civilian agencies and commercial operators. Plesetsk used to be the busiest spaceport in the world, but declined as the Russian military space programme contracted. Both Plesetsk and Baikonour are largely rail-based facilities, with rockets brought to their pads by powerful diesel engines and then raised to the vertical. Dombrovskaya is at the southern tip of the Ural mountains, in southern Russia and only 15km from the border with Kazakhstan.

Russian launches in 2006

Baikonour	16
Plesetsk	5
Odyssey Platform, Pacific Ocean	5
Barents Sea	1
Svobodny Blagoveschensk	1
Dombrovskaya	1

United States

The United States has two original launch sites. The best known is Cape Canaveral, Florida, probably the most famous launch site in the world. This serves both NASA (its part is called the Kennedy Space Centre) and the United States Air Force (the Eastern Test Range). Vandenberg Air Force Base, along the hilly Pacific coast in California, is largely a military launch site and

is also known as the Western Test Range. Big changes may be expected at Cape Canaveral over the next number of years. Once the shuttle mission to renovate the Hubble space telescope is completed, work will begin on converting launch pad 39B, which dates back to the Apollo period, to take the new Ares rocket for the new manned spacecraft Orion, due to fly 2013.

Pegasus is a mobile launch system, for the launch site is an aircraft and the location depends on where the aircraft drops the rocket for its ascent into the atmosphere. The aircraft used was originally the B-52 bomber, but this role has been taken over by the Lockheed L-1011, normally operating out of California and here it was used in April from near the Vandenberg launch site to shoot three small 25kg satellites into orbit.

Newcomer to the launch site list in 2006 is Omelek in Kwajalein, an atoll site used for the Falcon launcher. An old launch site back in use is Wallops Island, Virginia. This was best known as the launch site for the famous light rocket, the Scout, a relatively inexpensive solid fuel rocket used from the 1960s to put small scientific satellites into orbit. This time it was used by the new Minotaur launcher.



American launches in 2006

Cape Canaveral	11
Vandenberg Air Force Base	5
Wallops Island, Virginia	1
(Omelek, Kwajalein Atoll	1 (fail))
Pegasus (Vandenberg)	1
(Shuttle from orbit	1)

Europe

Europe has one launch base, Kourou in French Guyana. It was originally a French launch base, built in 1965 when France was obliged to evacuate its first desert rocket base in Algeria, Hammaguir. The launch site was cut into the jungle and used for French launchings (Diamant rockets), the final launches of ESA's predecessor, ELDO and, from 1979, Europe's Ariane. French Guyana remains French territory and is part of the European Union. It is currently being expanded for the Soyuz launcher (see *Laurent de Angelis: Soyuz in the Jungle – Russia builds a launch base with Europe in South America in Space Exploration 2007 Annual*, pp 134-143).

European launches in 2006

Kourou, Guyana	5
----------------	---



This Page:

■ **Above:** Launch pads at Wallops Island, Virginia, an old launch site which is now back in use. Image courtesy NASA.

■ **Below:** The Pegasus air-dropped satellite launch vehicle used to place three small satellites into orbit for the US Department of Defense in April 2006. Image courtesy Orbital Sciences Corporation/NASA.

Opposite Page:

■ **Right:** An artist's depiction of the inflatable Genesis satellite in orbit. Image courtesy Bigelow Aerospace.

■ **Bottom:** Sequence of pictures showing (left to right) the first launch into orbit from the Russian missile base of Dombarovska by a Dnepr converted ballistic missile, carrying the Genesis satellite. Image courtesy Bigelow Aerospace/ISC Kosmotras.



China

China has three launch bases. Its original base is Jiuquan, in the high desert in north west China, used for the first Chinese satellite, Dong Fang Hong, in 1970. The site was extensively modernized in the 1990s in advance of the manned spaceflight programme, with the building of a large vehicle assembly building. The second launch site is Xi Chang in the hills of Sichuan south west China, used for sending communications satellites into 24hr orbit and was used three times in 2006. Taiyuan is the third site, a military rocket base near Beijing, used for applications satellites and was used in 2006 for Yaogang 1 and Shi Jian 6-2. Plans have been reported for a large new launch site on Hainan island, off the south-east coast, to take the new Long March 5 rocket.

Chinese launches in 2006

Jiuquan	1
Xi Chang	3
Taiyuan	2

Japan

Japan has two seaside launch sites, not far apart from one another, at the extreme rocky southern tip of the Japanese islands. Kagoshima was the original site used for the small rockets that put the first Japanese scientific satellites into orbit for the Institute of Space and Astronautical Sciences (ISAS). Tanegashima is a larger site, used by the Japanese National Space Development Agency (NASDA) for the larger N-I, H-I and H-II rockets, including the present H-IIA. The two sites continue to follow this pattern, even though ISAS and NASDA have now been joined as the Japanese space agency, JAXA.

Japanese launches in 2006

Tanegashima	4
Kagoshima	2



■ **Right:** Launch of The H-IIA Launch Vehicle No. 11 on 18 December 2006 from the Tanegashima Space Center carrying Engineering Test Satellite ETS VIII also known as Kiku 8. Image courtesy JAXA.

■ **Opposite:** As a Soyuz descent capsule lands, it fires retro-rockets to cushion the impact. Image courtesy ESA.

India

India has one satellite launching centre, Sriharikota, on the country's sandy south east coast, 100km north east of Chennai (Madras). It has two launch pads: one for the Polar Satellite Launch Vehicle (PSLV) and the other for the Geo Stationary Launch Vehicle (GSLV).

Indian launches in 2006

Sriharikota	1 (fail)
--------------------	-----------------

THEY CAME BACK: *satellites recovered*

Eight satellites returned to Earth for recovery in 2006, of which five were manned. The space faring countries use several different recovery zones.

The main recovery zone for Russian manned spacecraft is the desert around Arkalyk, Kazakhstan, north-east of the Baikonour launch site. Traditionally, returning unmanned military and civilian spacecraft used to be recovered there too, but when the Kazakhs began to charge the Russians for doing so, recoveries were moved a small distance north into Russian territory south of the Urals near the town of Orenburg. In the event of an emergency, the Soyuz spacecraft has a number of return sites, all flat areas with a terrain similar to Kazakhstan. These are Poltava (*Ukraine*), Manitoba and Saskatchewan (*Canada*), North Dakota, Forth Worth, Texas and Oklahoma (*United States*) and, in Europe, Flanders (*Belgium*) and Picardy (*France*).

For the space shuttle, NASA designated three landing sites: the desert Edwards Air Force Base in southern California; a purpose-built runway at the Kennedy Space Centre; and a military base in White Sands, New Mexico. A number of emergency sites have also been designated, Rioja, Spain being the preferred emergency landing site from a launch abort. The Kennedy

Space Centre is the preferred landing site, for the landed shuttle can then be towed straight to the Orbiter Processing Facility to be readied for its next launch. If obliged by bad weather to land elsewhere, the shuttle must be placed on top a Boeing 747 jetliner and flown back to Cape Canaveral, a slow and expensive process. In the event, all three shuttle missions in 2006 were able to return to Cape Canaveral.

Although shaped like Apollo, the new Crew Exploration Vehicle Orion is expected to return to Earth on land and for this a site is likely to be used in the high desert of the western United States. One possibility is Utah, used for Stardust.

China has two recovery sites. Its original landing site was mountainous Sichuan, south west China, where the recoverable cabins return to Earth (Shi Jian 8 in September). For the Shenzhou series, a landing site is used in the flat grasslands of inner Mongolia and to the north of Beijing.

Japan has recovered one satellite, the USERS technology demonstrator May 2003, the splashdown zone being in the Pacific near the Bonin islands. To recover Hayabusa, which touched down on asteroid Itokawa in November 2005, Japan will use a land site, the western Australian desert, where Hayabusa is expected in June 2010.



Landings of manned spacecraft, 2006

9 Apr 2006	Soyuz TMA-7	Kazakhstan	William McArthur (US) Valeri Tokarev (Russia) Marcos Pontes (Brazil)
17 July 2006	Discovery STS-121	Cape Canaveral	Steven Lindsay (US) Mark Kelly (US) Stefanie Wilson (US) Michael Fossum (US) Piers Sellers (US) Lisa Nowak (US)
21 Sep 2006	Atlantis STS 115	Cape Canaveral	Brent Jett (US) Chris Ferguson (US) Joe Tanner (US) Dan Burbank (US) Heidi Stefanshyn Piper (US) Steve MacLean (Canada)
29 Sep 2006	Soyuz TMA-8	Kazakhstan	Pavel Vinogradov (Russia) Jeffrey Williams (US) Anousheh Ansari (Adventurer)
21 Dec 2006	Discovery STS-116	Cape Canaveral	Mark Polansky (US) William Oefelein (US) Joan Higginbotham (US) Robert Curbeam (US) Nicholas Patrick (US) Christer Fuglesang (Europe) Thomas Reiter (Europe)

The only Russian unmanned recovery in 2006 was a photo-reconnaissance satellite, Cosmos 2420, which orbited for slightly more than two months in the summer. This was the 101st in a series of satellites dating to 1982, able to skim over the upper atmosphere, return to altitude, send down small recoverable capsules with film, descend to photograph new targets and then return to Earth. Cosmos 2420 was the first Kobalt M (M for 'modified') a new, improved version.

Unmanned recoveries, 2006

Recovery date	Mission	Location	Mission length
15 January 2006	Stardust	Utah, USA	7 years
19 July 2006	Cosmos 2420 Kobalt M	Orenburg, Russia	77 days
24 Sep 2006	Shi Jian 8	Sichuan, China	15 days

THEY WERE DE-ORBITED - satellites taken out of orbit in 2006

Three satellites were deliberately brought out of orbit in 2006, all Progress supply missions to the International Space Station. These spacecraft are not recoverable (though earlier on, some flew a recoverable capsule called Raduga). All are burned to destructive reentry. Normally, Progress undocks from the space station just before the arrival of a new Progress. It is then commanded to fire its engines two orbits later and crash into the Southern Ocean east of New Zealand and away from the shipping lanes. At year's end, Progress M-57 and M-58 were attached to the station. Arabsat 4A was a failure and when it was apparent that there was no chance of it completing its mission, it was brought out of orbit. It was replaced by Arabsat 4B, launched successfully in November.

De-orbited spacecraft, 2006

3 Mar 2006	Progress M-54	ISS
24 Mar 2006	Arabsat 4A	(Result of launch failure)
19 June 2006	Progress M-55	ISS
19 Sep 2006	Progress M-56	ISS

One particular class of Russian satellite ends its mission explosively - it is deliberately destroyed. This is called the Don class of photo-reconnaissance satellite, named after the river Don and dating to the Soviet period. Each carried eight small recoverable capsules and it was standard practice to activate an explosive charge

after the last capsule was sent down to Russian territory, presumably so that the cabin does not fall into the wrong hands. With a growing awareness of the level of débris in low Earth orbit, explosive end-of-mission detonation is considered an anti-social way to remove satellites from orbit. This has not stopped the Russians from blowing up their Dons, but Cosmos 2423 was the eighth and last in the series.

Explosive de-orbits

Recovery date	Mission	Type	Days on orbit
17 Nov 2006	Cosmos 2423	Don	65

And not coming down, quite yet...

A formerly manned space cabin remained in orbit throughout 2006, the Shenzhou 6 cabin. When Chinese yuhangyuan (Chinese word for 'astronaut' or 'cosmonaut') Fei Junlong and Nie Haisheng returned to Earth in their Shenzhou 6 landing module in October 2006, they left behind in orbit their spaceship's orbital module. Equipped with a range of scientific instruments, it carried on its own independent mission. Leaving the module behind in orbit in this way provides a significant scientific bonus, enabling the mission to go on long after the yuhangyuan return. Although previous Shenzhou orbital modules generally burned up after six months, the Shenzhou 6 cabin was still in orbit more than a year after it was left there, using small engines to raise its orbit on 12th September.

THEY FAILED - missions lost in 2006

There were four space failures in 2006 - two by Russia, one by the United States (a private venture) and one by India.

Arabsat 4A	1 Mar 2006	Baikonour	Proton M	Russia
Falconsat	24 Mar 2006	Kwajalein	Falcon X	USA
Insat 4C	10 July 2006	Sriharikota	GSLV	India
Belka	26 July 2006	Baikonour	Dnepr	Russia

The first failure was exceptionally disappointing for Russia. The upper stage of the most powerful Russian launcher, the Proton, had an upper stage called the block D, which suffered an unacceptable rate of failure. To address the problem, a new upper stage, the Briz M, made by a different company, was

introduced. Briz M worked perfectly at first, making ten successful missions until Arabsat 4, also called Badr, in March 2006. The Briz failed 27 minutes into its second of four planned burns (31 minutes), leaving Arabsat in a low and useless orbit. The Proton was grounded for the summer, while the cause was tracked down - a small piece of débris in the oxidizer supply. The Briz M eventually returned to service in August with the launch of the Hot Bird 8 communications satellite.



The Dnepr failure in July was a disappointment, but for other reasons. The Dnepr was an old cold war missile. It had performed perfectly on five previous occasions, but the sixth was a disaster, especially for Belarus, which had spent many years preparing Belka ('squirrel'), an Earth observation satellite based on the Victoria platform developed by Energiya with two cameras, of 2.5 m and 10 m resolution. Belarus president Alexander Lukashenko travelled to Baikonour to watch the take-off. Also on board was a 92 kg student satellite called Baumanetz, named after the Bauman institute where it was made to a University of Rome technology satellite with a camera, reentry experiment and global positioning system and fifteen small satellites, ranging in weight from 35 kg to very small satellites of about 1 kg, made in numerous countries.

Heading toward the old railway station of Baikonour, the Dnepr flipped about a minute

into its flight, its remains making two large craters, one 25 km downrange, the other 150 km distant from the pad, near the settlement of Zhanakala. Smaller impacts were found later. The fuel of the second stage never ignited, so it fell back to Earth with the rocket, dumping 24 tonnes of heptil and 62 tonnes of nitric acid. Lukashenko returned to Belarus a disappointed man and there was sadness worldwide in the universities that had cargoes on board, ranging from Montana to Arizona, Korea to Japan. Some of the satellites were later found by helicopter teams near the old town of Baikonour: they were hardy and although badly damaged, they had survived the crash back to Earth.

Kazakhstan made a big issue of the damage caused by the crash. Teams of ecologists were sent to fan out across the region and take soil samples, though high summer temperatures evaporated the deadly fuel and they had little to find. Zhanakala was cordoned off and all the citizens were given health checks. Very dramatically, the regional prosecutor opened criminal proceedings. Eventually, Russia provided €1m compensation.

Russia appointed a commission of investigation immediately and its members duly descended on the two companies that had made the first stage engines, Yuzhnoye's factory Yuzhmash (Pivdenmash) in Dnepropetrovsk and the Kharton company nearby. They found that there had been a sharp increase in the fuel flow at 73 seconds, which could be simulated if you took the insulation away from the fuel line. The commission of investigation reported in September, attributing the accident to an insulation failure on a line leading into the hydraulic engine drive on first stage engine #4. The faster flow caused an interruption in thrust for 0.27seconds some 73 seconds into the mission, and even such a short interruption was sufficient for control to be lost. Instructions were issued for all lines to be checked for manufacturing defects and faulty insulation. Alexander Lukashenko had taken the precaution of insuring the satellite and issued orders for a new Belka 2.

The Falcon was a private venture by the SpaceX company launching out of Omelek launch base in Kwajelejin atoll. Despite thorough preparations and ground testing, the engines of the first stage shut down 30 seconds into its first flight at an altitude of 1,500 m. Investiga-

■ **Above:** The Dnepr rocket carrying the Genesis satellite climbs away following its launch from the Russian missile base of Dombrovskaya. Image courtesy Bigelow Aerospace/ISC Kosmotras.

■ **Opposite:** Rolling out the Soyuz/ST Fregat rocket for the launch of MetOp-A at the Baikonour Cosmodrome in Kazakhstan. Image courtesy Starsem.

tions found that a nut had corroded, allowing fuel to leak into the engine, starting a fire. The fuel tank depressurized and the valve cut out the fuel supply, preventing a full airborne explosion. From now on, the company decided to use to replace aluminium nuts with stainless steel nuts.

India introduced the GSLV launcher in 2001, a powerful rocket designed to lift large communication satellites to 24 hour orbit. The GSLV upper stage was a powerful Russian rocket,

the KVD-1, originally built in the course of the Moon race in the 1960s, the Indians planning to eventually introduce a home-made upper stage. But it never got to fire. About a minute into the mission, one of the GSLV's side solid rocket motors lost thrust, causing it to go off course. The GSLV crashed into the Bay of Bengal. This was the first GSLV failure and the first Indian launch failure for thirteen years.

China continues to maintain its high reputation for reliability, with a clean sheet since 1996.

ROCKETS OF THE WORLD

Here we look at the rockets used in 2006.

Russia

	Stages	Length	Launch weight	Payload
Proton	4	48.6m	690,000kg	20,600kg
Proton M	4	44.9m	723,943kg	3,207kg (GTO)
Soyuz (U version)	3	49.5m	309,000kg	7,500kg
Molniya M	4	45.2m	305,000kg	1,600kg (GTO)
Rocket	3	29m	107,000kg	1,850kg
Tsyklon	2	40.5m	183,254kg	3,583kg
Dnepr	3	30.7m	210,800kg	4,000kg
Cosmos 3M	2	31.4m	109,000kg	1,780kg
START I	4	22.7m	46,900kg	700kg



The most used are the rockets in the R-7 series, which dates to 1953 and was the original rocket used for Sputnik in 1957. The series has been continuously modernized since then, the three main versions in use being the Soyuz U series (1960s), the Soyuz FG (2001) and the Molniya, a four-stage version originally introduced for interplanetary probes in 1960. 2006 marked the introduction into service of the Soyuz 2 launcher. The Soyuz 2 had improved pumps, piping and engine performance, giving it the ability to lift heavier payloads and comes in two versions, the 2.1.a model and the 2.1.b model, the latter having a new third stage engine, the RD-0110. The main change though is the introduction of digital controls, replacing the old-fashioned lock-and-key mechanical and electrical countdowns and large control room crews. Going digital presented a series of fresh problems, the Metop launch encountering a series of lengthy countdown delays arising from software problems. But all went well in the end.

Proton is the most powerful rocket in the Russian fleet. The rocket was introduced as a heavy-lift rocket in July 1965. Proton was used to lift Russia's space stations and space station modules into orbit and had a lifting capacity in the order of 20 tonnes. The four-stage version was used for lunar and interplanetary probes as well as for communications satellites. A more powerful version, the Proton M, was introduced in 2001 with an improved upper stage, the Briz.

Russia's two other rockets are the Cosmos 3M, a small rocket originally introduced as the Cosmos 3 in 1964 and the Tsyklon, derived from a missile introduced in the 1960s. Both are near the end of their production runs. In addition, Russia uses a number of missiles from the cold war converted to civilian use: the Rockot, Dnepr, START and one launched from a submarine, the Shtil. START, so called from an American acronym for the STrategic Arms Reduction Talks is a converted solid fuel military launcher derived from Pioneer and Topol silo-based missiles. It is the only solid-fuel rocket in the Russian fleet and when the cold war ended, a number were converted for civilian use by the Moscow Komplex Technical Centre to lift 700kg class satellites into orbit. It was introduced in 1993 and has been used for small test and Earth observation satellites for both domestic and foreign customers.



Russia/Ukraine

	Stages	Length	Launch weight	Payload
Zenit 3SL	3	48.2m	472,600kg	5,896kg (GTO)

The Zenit rocket goes back to 1976, when the Soviet Union committed itself to the construction of a space shuttle to take the place of the abandoned lunar programme. The system was called Energiya and comprised four powerful side rockets. These were built in the Yuzhnoye design bureau in Dnepropetrovsk, Ukraine and were used on the only two launches of the Energiya system in 1987 and 1988 as Zenit 1. These rockets were also used in their own right as the Zenit 2. From 1985, the Zenit 2 was used to put Soviet military satellites into orbit. A subsequent version, the Zenit 3SL, was developed as Sea Launch (hence 'SL') as a carrier for communications satellites. This is an international project developed by Yuzhnoye, the Russian Energiya corporation and the American Boeing company, firing the Zenit 3SL from a converted oil platform in international waters on the equator line in the Pacific near Kiribati island.

United States

	Stages	Length	Launch weight	Payload
Delta II (7925H)	3	33.2m	231,800kg	2,180kg
Delta IV (medium)	2	47.6m	256,300kg	4,210kg
Atlas V (400 version)	2	45.1m	333,300kg	5,620kg
Minotaur	4	16m	36,400kg	540kg
Shuttle	2	47m	2,041,000kg	25,400kg

Atlas was the United States original intercontinental ballistic missile and a version was used to put John Glenn into orbit in February 1962. Subsequent Atlases are so modernized and powerful that they have little in common with their predecessors apart from their name. From 1992, the Atlas was re-engineered with Russian engines, the RD-180, giving it unprecedented power. The first Russian-engined Atlas III flew in May 2000. The Atlas V was used in January 2006 for the New Horizons mission to Pluto.

The Delta rocket also had its origins in the cold war as an intermediate range ballistic missile, the first Delta flying in 1962. The Delta II later became the United States' most reliable medium lift launcher, being used for a wide variety of civilian and military missions to low Earth orbit. When the United States moved from launching large, heavy and costly interplanetary missions to 'faster, cheaper, better' projects, the Delta II was perfect. The Delta II comes in many versions, depending on the number of small solid rockets used on the side. The Delta IV was built in a number of versions (details of the medium version are given here).

The shuttle's proper name in the Space Transportation System (STS) and was originally approved by President Nixon in 1970. The shuttle first flew on 12th April 1981 and has since made over a hundred missions. The shuttle has probably the most unusual configuration of any rocket. The three engines of the orbiter are turned on first, burning liquid oxygen and hydrogen drawn from the huge external tank. After several seconds, while the engines build up their thrust, the two solid rocket



■ On 8 December 2006, the fifth Ariane 5 launch of 2006 took place. An Ariane 5 ECA launcher lifted off from Europe's spaceport in French Guyana on its mission to place two satellites into geostationary transfer orbits. The payload satellites were WildBlue-1 in the upper position in the payload 'stack' and AMC-1 in the lower position. Image courtesy ESA/CNES/ARIANESPACE-Service Optique CSG.

■ Opposite: A Rockot converted ballistic missile being prepared for launch. Image courtesy ESA.

motors on the side are ignited. The solid rockets provide enormous power for the first two minutes of the ascent and they are then dropped, falling back under parachutes into the Atlantic Ocean for recovery. The orbiter continues to fire on its three engines until it reaches orbit and the external tank is then discarded. The shuttle is the only manned spacecraft system to use solid fuel rockets and is also unique for being flown manned on its first ever flight.

The Minotaur is a recent addition to the American launch fleet, first flown in the space programme in 2000 and is an adaptation of the Minuteman missile (the Minotaur 4 is based on the subsequent Peacekeeper missile). It flew twice in 2006, putting Formosat into orbit in April and an Air Force payload and microsatellite into orbit in December.

Europe

	Stages	Length	Launch weight	Payload
Ariane 5	2	33.8	748,440	6,800kg

Europe's only operational launcher at present is the Ariane 5. From its formation in 1975, the main line of development for the European Space Agency was the Ariane series of rockets, derived from the L3S design. Four series were built to fly mainly commercial communications satellites into 24 hour orbit, each Ariane being an improvement on its predecessor and named simply in sequence Ariane 1, 2, 3 and 4. With its use of large solid rocket boosters on the side, Ariane 5 marked a significant design departure. Although the maiden launch of Ariane 5 was a spectacular failure and although there have been subsequent difficulties, Ariane 5 has gone on to become a reliable and successful launcher capable of putting large communications satellites into 24 hour orbit. Ariane 5's commercial success is partly due to the fact that it can put two large communications satellites into orbit at a time. It will also be used for the European Automated Transfer Vehicle, the *Jules Verne*, to be sent to the International Space Station. Later, Ariane 5 will be joined at its launch base in French Guyana by the small Vega rocket and the medium lift Soyuz (see Laurent de Angelis: *Soyuz in the Jungle – Russia builds a launch base with Europe in South America in Space Exploration 2007 Annual*, pp 134-143). French engineers are currently, in collaborative programmes with Russian rocket engineers, looking at how best to replace the Ariane 5 with a new generation of launchers - but not until 2020 at the earliest. Ariane 5 has a long flying career ahead.

Japan

	Stages	Length	Launch weight	Payload
Mu-V	3	24m	140,200kg	1,800kg
H-IIA	2	53m	285,000kg	4,000kg

Japan developed two lines of rockets. The first set was developed by father of the Japanese space programme, Hideo Itokawa and these were very small, solid-fuelled rockets. The original series was so small it was called the 'pencil' rocket, but his rockets were responsible for the first Japanese satellite in 1970 and subsequent small scientific, lunar and interplanetary missions of the Institute of Space and Astronautical Sciences. The Mu-V is the linear descendant of these solid fuel rockets and first flew in 1997. Mu-V flew twice in 2006, putting two scientific observatories into orbit, Astro F Akari (February) and Solar B Hinode (September), the latter being its last flight.



The H-IIA comes from the second line of Japanese rocket development. The Japanese National Space Development Agency required larger rockets for its applications satellites and, with American assistance, developed the N-1 rocket under licence based on the Thor system. Over time, these rockets used an increasing level of Japanese engineering, the present series being introduced with the H-II (1994) and its successor, the H-IIA which first flew in 2001.

China

	Stages	Length	Launch weight	Payload
CZ-2C	2	32.6m	192,150kg	2,800kg
CZ-3A	3	52.5m	241,000kg	2,300kg
CZ-3B	3	54.838m	425,000kg	4,800kg
CZ-4B	3	45.6m	248,500kg	3,800kg

China's rockets are called Long March, Chang Zheng (CZ) in Chinese (another type was used briefly, the Feng Bao, or Storm), starting with the CZ-1 used to launch China's first satellite, the Dong Fang Hong in 1970. The CZ-2 series was based on the Dong Feng 5 missile and was introduced for the launch of recoverable satellites in 1974 onward. The CZ-2 series uses nitric fuels and has two recent versions: the 2D, introduced for larger recoverable cabins in 1992 and the 2F, used for the manned programme in 1999. For the Shi Jian launch in September, China went back to an earlier model, the 2C.

The Long March 4 series (CZ-4) was derived from the CZ-2 series, stretching the first and second stages and adding a third stage. Generally, it has been used to launch satellites into polar orbit from Taiyuan launch base. It has two variants, the A version (introduced 1988) and the B version (1999, used here).

The CZ-3 series was introduced in 1984 for the launch of communications satellites from the Xi Chang base in Sichuan. The CZ-3 series was a radical break from the others, being much larger, having a hydrogen-fuelled upper stage and flying out of the Xi Chang base in south west China. There are several versions of the CZ-3: the original one (CZ-3, 1984), a stretched and modernized version (CZ-3A, 1994) and the most powerful version (CZ-3B, 1996). In 2006, the CZ-3B model was used once and the 3A model twice.

India

	Stages	Length	Launch weight	Payload
GSLV	4	40.4m	414,000kg	2,000kg (to GTO)

India's first rocket was the SLV, or Satellite Launch Vehicle and was a small solid-fuel rocket based on the American Scout launcher, giving way in time to a more powerful version, the Augmented Satellite Launch Vehicle, the ASLV. In the 1990s, India developed its first large rocket, the Polar Satellite Launch Vehicle, able to put applications payloads of over a tonne into polar orbit and this is the mainstay of the programme. The PSLV remains in service, although it was not used this year. In 2001, India introduced a much larger Geostationary Launch Vehicle (GSLV), using a Russian upper stage and this has been used to place satellites in 24hr orbit. It made its fourth mission, unsuccessfully in 2006 (see section *They failed – missions lost in 2006* above)

■ **Left:** A model of China's Long March 3B launcher at an aerospace exhibition. Image courtesy Brian Harvey

■ **Opposite:** A graphic showing the exterior of Japan's Mu-V launch vehicle and (left) an Mu-V-7 launcher carrying the Hinode (SOLAR-B) satellite lifting off from the pad at the Kagoshima Space Center on 22 September 2006. Images courtesy JAXA.

Where are they now? *Deep space missions in 2006*

The first space missions lasted only days or weeks. Now, some go on for a lifetime. In 2006, 14 spacecraft were flying in deep space. Some had long since accomplished their primary missions and were flying into interstellar space (the Voyagers), while others had only embarked on their long journeys (New Horizons, Rosetta). Ten are American, three European and one Japanese. The following were operational in 2006:

IN TRANSIT

Launch date	Spacecraft	Mission and status
9 May 2003	Hayabusa (Japan)	Returning from asteroid Itokawa in 2010
2 Mar 2004	Rosetta (ESA)	Comet Cheryumov Gerasimenko: due 2014
2 Aug 2004	MESSENGER	Mercury: due in 2011
19 Jan 2006	New Horizons	Pluto: due 14th July 2015

ORBITING VENUS

9 Nov 2005	Venus Express (ESA)	Arrived Venus orbit 10th April 2006
------------	---------------------	-------------------------------------

ORBITING MARS

7 Nov 1996	Mars Global Surveyor	Contact lost, November 2006
7 Apr 2001	Mars Odyssey	Operational
2 June 2003	Mars Express (ESA)	Operational
12 Aug 2005	MRO	Arrived 10th March 2006, operational

MARS SURFACE

10 June 2003	Spirit	Landed crater Gusev, Mars, January 2004
7 July 2003	Opportunity	Landed Meridiani, Mars, January 2004

ORBITING SATURN

15 Oct 1997	Cassini	Entered Saturn orbit, July 2004
-------------	---------	---------------------------------

HEADING TO INTERSTELLAR SPACE

20 Aug 1997	Voyager 2	11.9 billion km distant
5 Sep 1977	Voyager 1	15 billion km distant

■ Right: An artist's depiction of Europe's Rosetta spacecraft in interplanetary space en route to its rendezvous with Comet Churyimov Gerasimenko in 2014. Image courtesy ESA.

Opposite

■ The tiny Minerva probe which was dropped by the Hayabusa spacecraft prior to its descent to the surface of the asteroid Itokawa in an attempt to collect samples for later return to Earth. Image courtesy Brian Harvey.

■ Below: An artist's depiction of the Hayabusa (MUSES-C) spacecraft sampling the surface of the asteroid Itokawa. Image courtesy JAXA.

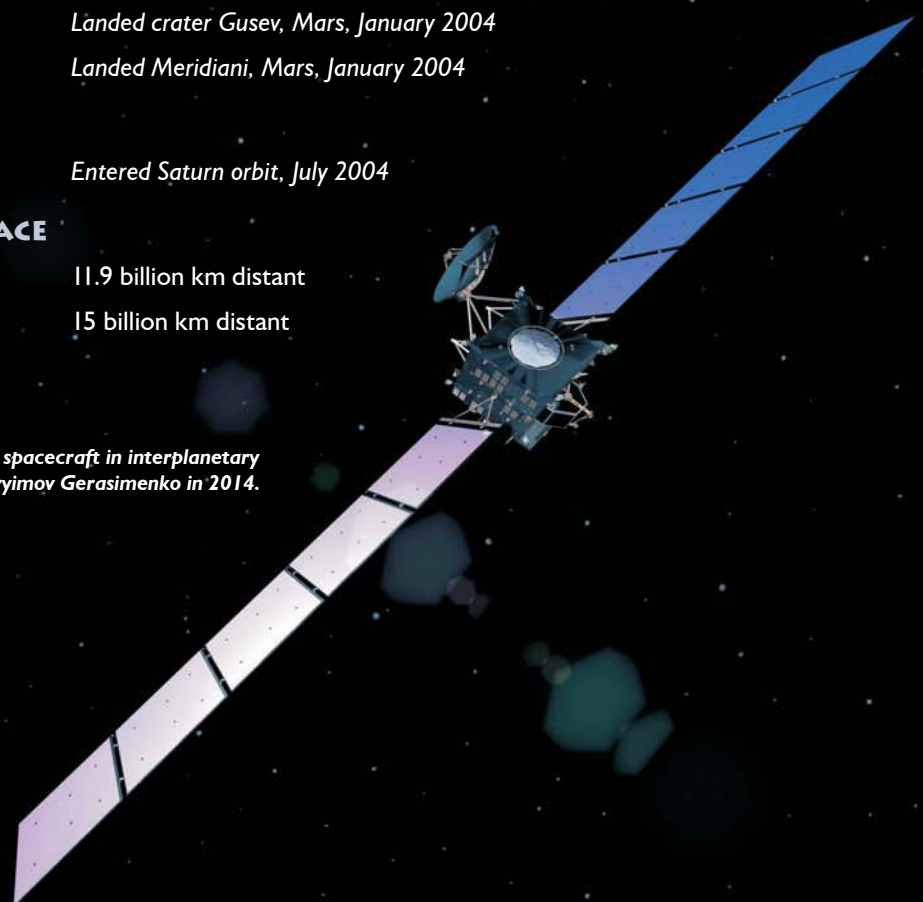

Hayabusa had been almost lost at the end of 2005 after its interception of the asteroid Itokawa. This small Japanese spacecraft, which used electric propulsion, had travelled across the solar system to intercept the asteroid, where it dropped target markers and a tiny probe, Minerva before descending to the surface to attempt to scoop up soil to be brought back to Earth. It was an adventurous and ambitious mission, but not everything went perfectly during the interception and contact with Hayabusa was lost. In March 2006, the Japanese Space Agency JAXA announced that contact had been restored with Hayabusa, some 330m km away from Earth, although power supplies on board were problematical. By June, the Japanese reported that the engine was in working order again and all was now set for recovery on Earth in 2010, when it is due to land in the Australian desert.

The two Voyagers are the great veterans. Launched to Jupiter and Saturn in 1977 (Voyager

2 was launched first), they have headed into deep space, following Pioneer 10 and 11 and 1972 and 1973. On 15th August 2006, Voyager 1 reached an extraordinary milestone: it went past 100 times the distance of the Earth to the Sun. Voyager 1 is travelling over one and a half million kilometres a day and has now in the heliosheath - the boundary between the solar system and interplanetary space. Ten people comprise the mission control team for the two Voyagers.

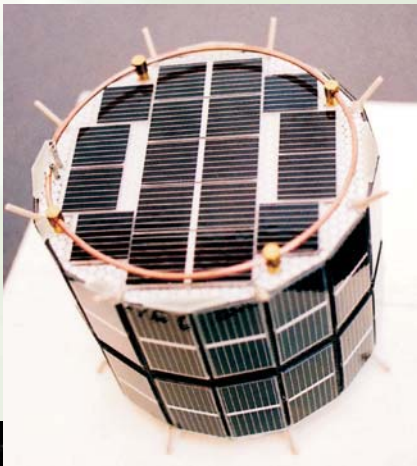

Brian Harvey is a writer and broadcaster on spaceflight, based in Dublin, Ireland. He has written several books with Praxis Publishing and his articles have appeared in 'Spaceflight', 'Orbit' and the 'Journal of the British Interplanetary Society.'



2

Prepare for **LIFT-OFF!...**

Bunny had found a smart place to go skating but it looked like someone had beaten her to it!!



The successful flights of Scaled Composites' SpaceShipOne (SS1) in 2004 generated significant media and industry interest in space tourism.

Here *Erik Seedhouse* considers the suborbital and orbital space tourism options open to space flight participants (SFPs) over the next 20 years. He also describes the different mission architectures, technology drivers, and applications being implemented by space tourism companies in order to send SFPs into space.

The Future of SPACE TOURISM

DEMAND FOR space tourism was determined by a study conducted by Zogby International for the Futron Corporation which published the *Space Tourism Market Study* report in 2006. The results of this study in respect of passenger interest and demand forecast for suborbital space tourism are shown in the graphs reproduced overleaf.

The Futron study provides a projection of demand based upon responses to a number of factors such as length of training, economics, and the public's willingness to pay. In reality, the

popularity of space tourism will also be driven by factors such as ticket prices, launch failures, space qualification requirements, infrastructure development, and the qualities of the companies offering suborbital access. The following section takes a look at some of the front runners in the suborbital space race.

■ **Below:** SpaceShipOne glides down for approach to the Mojave airport during an early test flight. Image courtesy Scaled Composites, LLC.





Survey Results: Interest in Suborbital Travel

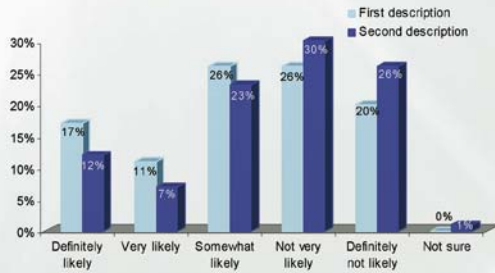

2006 Passenger and Revenue Forecast

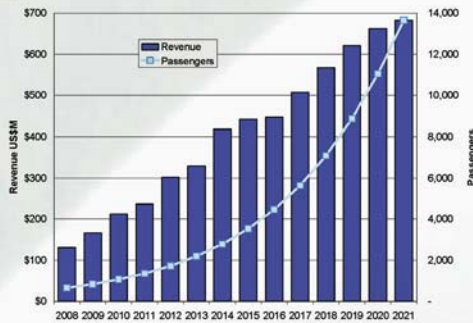

■ **Above:** Passenger Interest and Demand Forecast for Suborbital Space Tourism. Graphics courtesy Futron Corporation, see www.futron.com.

■ **Below:** On 4 October 2004 SpaceShipOne rocketed into history, becoming the first private manned spacecraft to exceed an altitude of 328,000 feet twice within a 14-day period, thus claiming the ten million dollar Ansari X-Prize. (The first of the two X-Prize flights had been completed successfully on 29 September 2004.) In addition to meeting the altitude requirement to win the X-Prize, pilot Brian Binnie also broke the 22 August 1963 record by Joseph A. Walker, who flew the X-15 to an unofficial world altitude record of 354,200 feet. Brian Binnie's SpaceShipOne flight carried him all the way to 367,442 feet or 69.6 miles above the Earth's surface. Here the White Knight turbojet climbs with SpaceShipOne under its belly. Image courtesy Scaled Composites, LLC.

Suborbital Companies

Virgin Galactic

Since SS1's epic flights, Richard Branson's Virgin group and Scaled Composites have signed an agreement to form The Spaceship Company, with the aim of constructing a fleet of commercial suborbital spaceships, including five SpaceShipTwo's (SS2) and two White Knight Two's (WK2).

The first Virgin Galactic SFPs will pay US\$190,000 for their suborbital ticket, a price that will include a pre-flight medical assessment and a three-day pre-flight training program, a component of which will be a parabolic flight. During take-off, SFPs will be in the spacecraft which will be attached to the mother ship until an altitude of 50,000 feet is reached at which point the countdown to release will commence. Shortly after the rocket motor ignites, passengers will be travelling in excess of three times the speed of sound as the vehicle heads towards space. As engine cut-off occurs passengers will experience microgravity and will be able to perform any number of aerobatic manoeuvres or simply look out of the windows and admire the view.

RocketPlane Kistler (RpK) Aerospace Corporation

Formed in 2001 to develop, build, and operate a vehicle capable of succeeding in the suborbital space tourism market, RocketPlane Kistler



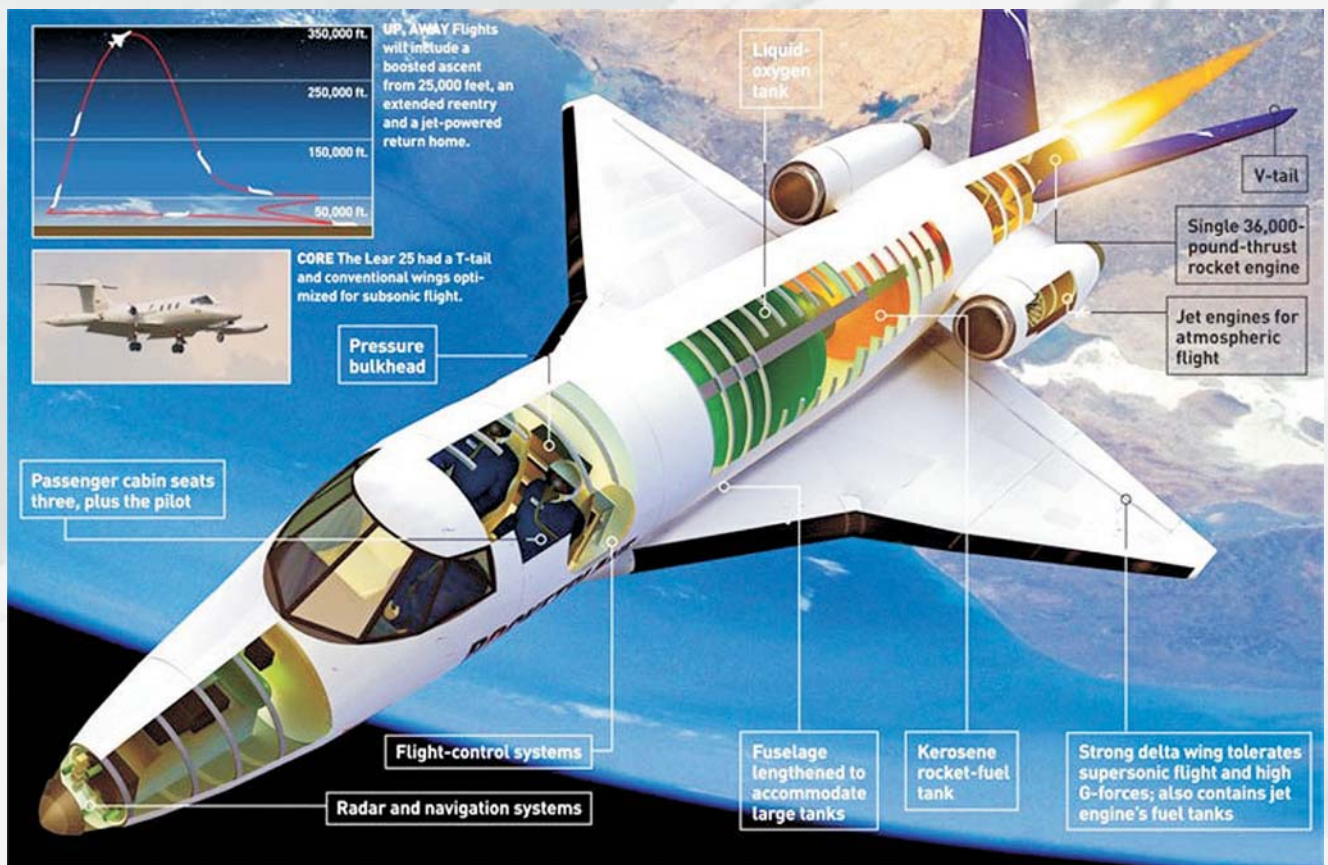

(RpK) has assembled a formidable team headed by Chief Executive Officer, George French, a previous winner of the NASA AMES Research Astrobiology Team Group Achievement Award and the National Space Society's Entrepreneur of the Year Award. President, retired Colonel Randy Brinkley, served as NASA Program Manager for the International Space Station (ISS), as well as Mission Director of the Hubble Space Telescope Repair Mission. RpK's resident astronaut is Commander (USN Ret.) John Herrington, RpK's Vice President of Flight Operations and Services. It will be Herrington who pilots the winner of a Microsoft Corp. sponsored competition (<http://vanishingpointgame.com>) on their trip to space. Before that happens though, RpK has to achieve its goal of bringing its Rocketplane XP to operational status.

The Rocketplane XP, due to enter service in late 2007, will carry four persons (one pilot and three passengers) to an altitude in excess of 330,000 ft (100 km) and provide them with at least three minutes of microgravity. The spacecraft, which utilizes the fuselage structural concept of the Lear Jet 25 series, will take off from a runway at the Oklahoma Spaceport and use jet engines to climb and accelerate to

a subsonic cruise altitude of 40,000 feet (12.2 km). At this altitude the pilot will switch to a liquid oxygen/kerosene rocket engine that will burn for 70 seconds. The rocket-propelled portion of the flight will result in a 3-G pull-up to suborbital altitude followed by a ballistic coast to mission altitude and a return to base in unpowered flight.

XCOR Aerospace

XCOR Aerospace, founded in 1999, is located at the Mojave Spaceport and Civilian Test Centre in Mojave, California. Though the company may not have the financial resources of other budding suborbital companies it certainly has an impressive team. President and co-founder, Jeff Greason, holds 18 patents and was cited by *Time* magazine in 2001 as one of the "Inventors of the Year" for his team's work on the EZ-Rocket.

■ **Above:** RocketPlane Kistler (RpK) Aerospace Corporation's conversion of a Lear Jet 25 series business jet into a passenger-carrying rocket ship – the RocketPlane XP – would be a spaceflight first. Graphic courtesy RocketPlane Kistler.



Dan DeLong, XCOR's Chief Engineer, served as lead engineer for Boeing's Life Support Systems Internal research development program, as Principal Engineer at Boeing Defense & Space, and as an engineering analyst in the Life Support group that developed the ISS air and water recycling systems. XCOR's test pilots, astronaut Colonel Rick Searfoss and Dick Rutan, are perhaps the most experienced employees of any suborbital company. Rick Searfoss's credentials include serving as pilot on STS-58 and STS-76, and Shuttle Commander for STS-90, while Dick Rutan is famous for flying the Voyager aircraft around the world non-stop with Jeana Yeager, in an aircraft designed by his brother, Burt Rutan, of Scaled Composites fame.

XCOR is currently developing its piloted rocket operations demonstrator aircraft, the EZ-Rocket, which serves as a manned technology demonstrator for its Xerus craft. The testing of



■ **Above:** In 2001, *Time Magazine* named the EZ-Rocket as a "Transportation Invention of the Year." In December 2005, on its 25th flight, the vehicle set the world record for distance without landing for any ground-launched rocket-powered aircraft. Image courtesy XCOR Aerospace.

■ **Right:** Three views of the Xerus spacecraft, a single stage suborbital vehicle capable of servicing three markets: microgravity research, space tourism, and microsatellite payloads. Images courtesy XCOR Aerospace.



Commercial Orbital Flight Operations

Though several companies have stated their intention of conducting orbital flight operations, only two are close to fulfilling this goal: Space Exploration Technologies (SpaceX) and Bigelow Aerospace (BA).

Space Exploration Technologies

Located in El Segundo, Southern California, near Los Angeles airport, SpaceX aims to offer light, medium and heavy lift capabilities to LEO using a suite of launch vehicles. SpaceX's founder, Elon Musk, an internet mogul turned spacecraft builder, created the company in 2002 with what he refers to as "non trivial assets". In September 2006, SpaceX was announced as a winner of the NASA Commercial Orbital Transportation Services (COTS) competition, and received an award of US\$278 million for three flight demonstrations of the Falcon 9 carrying the Dragon spaceship.

the EZ-Rocket has provided XCOR with valuable experience concerning rocket-powered flight and has allowed the company to push ahead with the design of the Xerus craft, a single stage suborbital spacecraft that will be capable of providing service to markets such as space tourism and microgravity payloads. The Xerus is being designed to take off and land from a conventional runway without the need for a carrier aircraft such as the SS1 configuration. XCOR plans a flight test program of approximately 20 flights, each flight incrementally extending the operational envelope.

If SpaceX is successful with its launch manifest it may win ISS resupply business worth between US\$300 and US\$500 million per year following the shuttle's retirement in 2010. In addition to potentially servicing NASA's needs, the Dragon may also be of service to BA with whom SpaceX has an ongoing dialogue to

ensure that Dragon meets the human transportation needs of Bigelow's planned space station as efficiently as possible.



■ **Top:** The Falcon 9 launch vehicle, and the cargo and crew versions of the Dragon spacecraft. Images courtesy SpaceX.

■ **Left:** The view from Bigelow Aerospace's Genesis I Pathfinder inflatable module in Earth orbit. Its successful launch on 12 July 2006 put the company as many as five years ahead in a schedule that will see fare-paying passengers embarking upon orbital travel as early as 2010. Image courtesy Bigelow Aerospace.

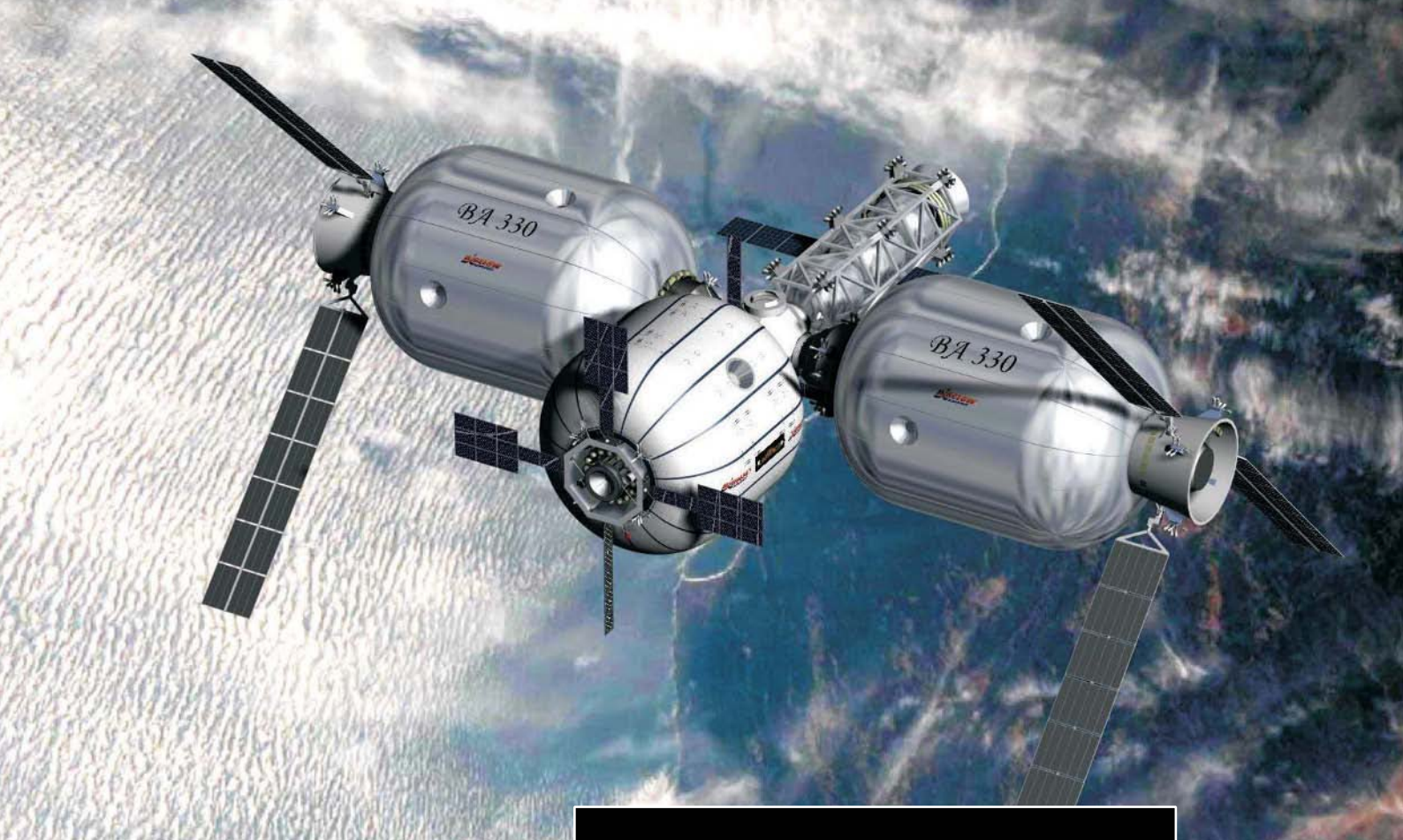

Bigelow Aerospace

In 1999 Robert T. Bigelow founded BA, a general contracting, investment and development company focused on realising economic breakthroughs in the costs associated with the design, development and construction of manned space habitats and launch facilities. Contrary to media reports Bigelow, who made his fortune as a general contractor and founder of Budget Suites of America, says he is not pursuing "space hotels" although he is interested in leasing his habitats, some of which may ultimately serve as a space hotel. To date he has spent more than \$75 million of his fortune and is prepared to invest up to \$500 million by 2015 with the goal of



■ **Above:** Artist's concept of the first planned commercial space complex by Bigelow Aerospace. The complex includes the Sundancer module, planned for launch in 2010, docked with a propulsion bus and node to be launched in 2011. Connected to that backbone are two BA 330 'Nautilus' modules, each of which are planned to have 330 cubic meters of workable space. BA is aiming to have the first complex completed by 2013. Image courtesy Bigelow Aerospace.

■ **Inset:** Artist's concept depicting possible future application of the BA330 'Nautilus' module, i.e. a 'corporate yacht'. Image courtesy Bigelow Aerospace.

full-scale deployment of a manned space habitat. To achieve this Bigelow has obtained exclusive licences on inflatable technologies and docking systems as well as multiple Space Act agreements with NASA.

Of all the private space companies, BA is clearly ahead of the pack when it comes to making good on its promise to deliver orbital access. The launch of the company's Genesis I Pathfinder module on 12 July 2006 represented a new chapter in the development and business of space, and signalled to the world that the space race is no longer the exclusive domain of government aerospace industry. How did Bigelow do it?

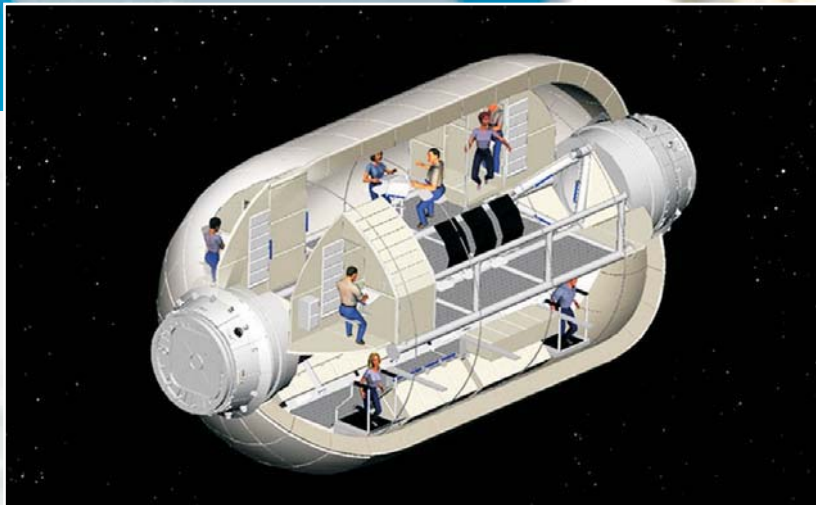
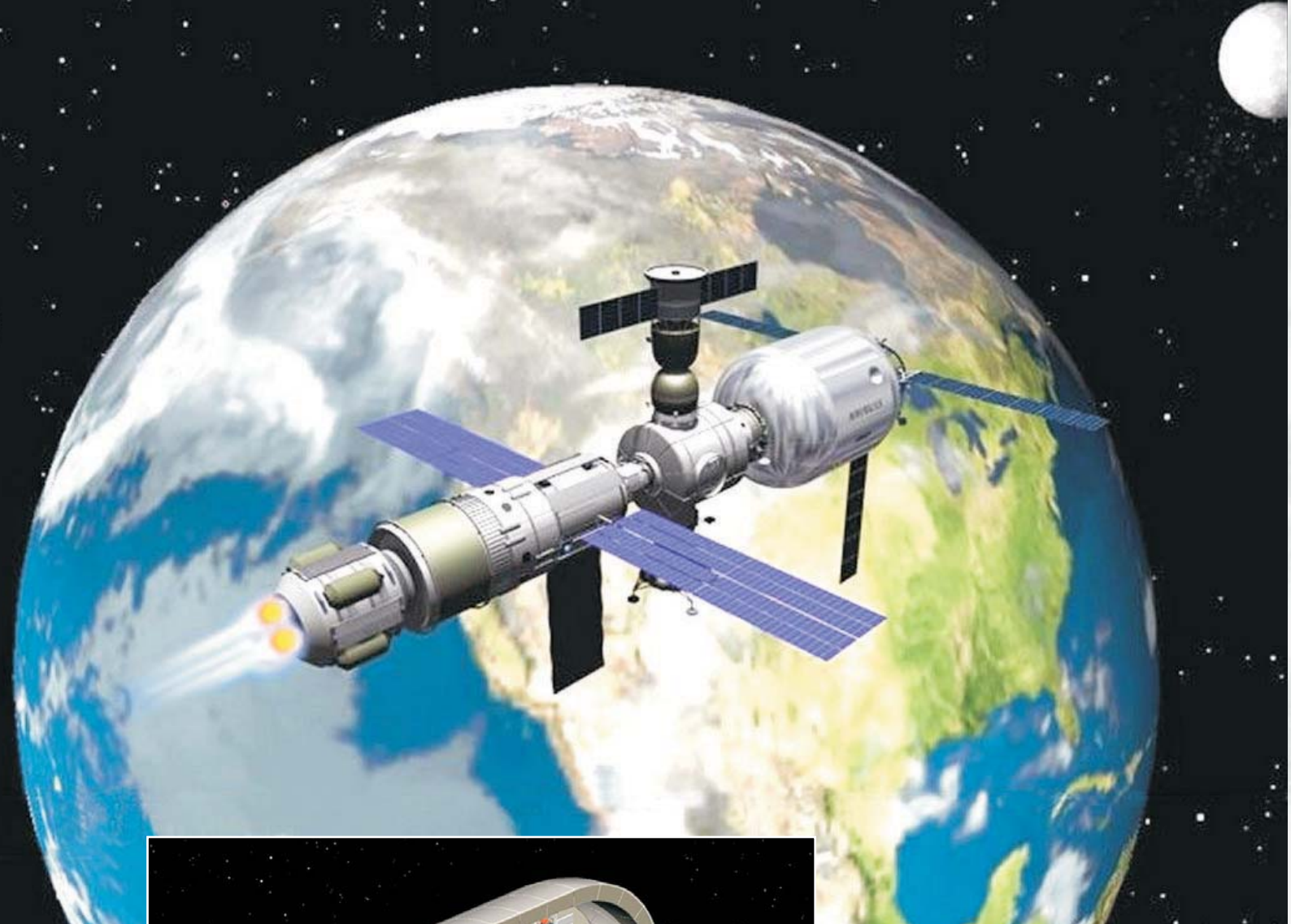

Inflatable Habitat Technology

The core of BA's operations is the use of inflatable habitat technology which forms the basis of each module. The sub-scale module, Genesis I, is the result of pioneering work by Bigelow, NASA and various subcontractors in the development of lightweight but extremely strong and long-lived inflatable modules made of proprietary advanced aerospace materials. The inflatable module technology, previously known

as the TransHab Project, was originally a concept proposed as a crew quarters for the ISS.

The technology was tested by NASA at the Johnson Space Center (JSC) but ultimately the project was cancelled in 2000, although testing continues at JSC. The BA 330 'Nautilus' module, which is planned to have 330 cubic meters of workspace, is a unique hybrid

structure that combines the mass efficiency of an inflatable structure with the advantages of a load bearing hard structure. It includes a bladder, a restraint layer and micrometeoroid/orbital debris (MMOD) shell layers that form a structure that is stronger than the ISS!

■ **Above:** Two artists' concepts depicting possible future applications of the BA 330 'Nautilus' module. (Top) A 'Moon cruiser'. (Left) A space station module. Images courtesy Bigelow Aerospace.

The almost two dozen layers of the Nautilus module provide insulation against space temperatures that can range from +121°C in the Sun to -128°C in the shade. These layers also provide protection against MMOD by the use of successive layers of Nextel (a material commonly used as insulation under the hoods of cars) and several-inches thick open cell foam. To test the shield, the University of Dayton Research Institute

and the University of Denver Research Institute conducted more than fifty ballistic tests that fired particles of 6.4 – 12.7 mm towards the shield at velocities of between 3.1 and 6.9 kilometres per second.

Other layers are composed of super strong woven Kevlar that holds the module's shape and Combitherm, a material used for the bladder (of which there are three) construction.

The BA 330 Nautilus Inflatable Module

Weight at launch (tonnes)	Length at launch (m)	Diameter at launch (m)	Diameter after inflation (m)	Inflated volume m ³
13.2	11	4.3	8.2	339.8

Below: A 2.24-metre diameter demonstration restraint layer being prepared for hydrostatic testing (top) at Johnson Space Center in November 2005. The fact that the restraint layer failed only at a pressure of 197 psi (13.85 kg/cm²) demonstrated a factor of safety exceeding 4.0 (bottom). Images courtesy NASA/Chris Johnson/Gary Spexarth.

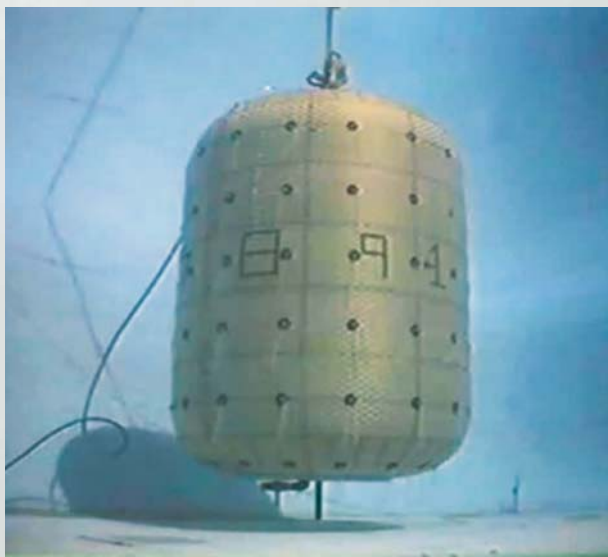
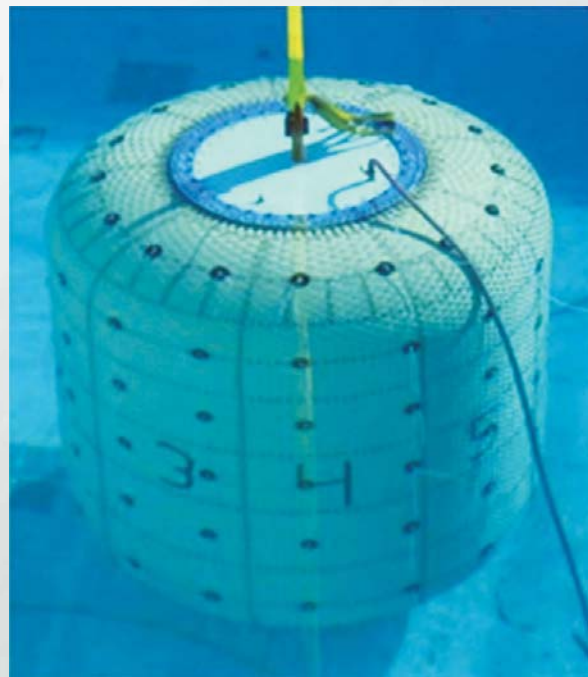
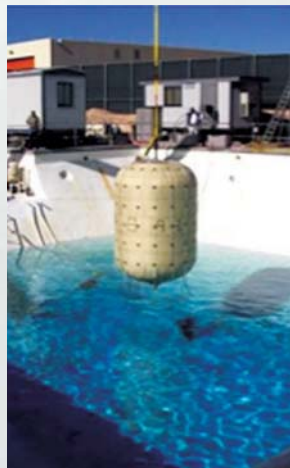

Upon deployment, the module's interior will be inflated to 10 psi (0.70 kg/m²), compared with 14.7 psi (1.03 kg/m²) for the ISS and 12 psi (0.84 kg/m²) for Skylab. To test the habitat's structural integrity, several test articles have been manufactured and tested by JSC engineers. One such test involved testing to failure of a 2.24-metre diameter restraint layer by increasing pressure to 197 psi (13.85 kg/cm²), a test that demonstrated the ability to build a 10.7-metre diameter inflatable with a factor of safety (FOS) of 4.0 at 10.2 psi (0.72 kg/cm²) using FAA Airship Requirements.

Another test investigated the structural integrity of a restraint layer when fitted with a window – an important feature for SFPs! Once again the restraint

layer was inflated to an ultimate pressure of 197 psi (13.85 kg/cm²) before failing, demonstrating that structural penetrations can be incorporated into the restraint layer without any reduction in strength.

Environmental Control and Life Support Systems are being provided in part by established aerospace companies such as EADS Astrium and Boeing. For example, EADS Astrium is supplying a thermal/humidity control system and a carbon-dioxide removal system that uses chemically coated beads instead of the molecular sieve technology on the ISS. A water handling system is being provided by Boeing. Several other subcontractors working for BA are small to medium-sized aerospace companies that, by being involved with Bigelow, are gaining valuable aerospace experience and establishing a trend that will prove increasingly important as private space travel becomes more common.

Bigelow's Launch Vehicle

BA passengers will most likely be launched into LEO aboard a man-rated Atlas V 401, an upgraded Atlas launcher designed by Lockheed Martin (LM) as a part of its Evolved Expendable Launch Vehicle (EELV) program.

The choice of the Atlas V is in keeping with Bigelow's vision, as he explained during Space 2006:

"We're a customer for whoever can produce an economical, reliable, safe transportation system that's user friendly. It's the other half of the coin. You have to have some place to go, but what good is an exotic island if there are no boats to get you there? One hand holds



■ **Above:** The Atlas V 401 configuration is the simplest, most robust, and most reliable version of this launch vehicle, and will probably be used to ferry Bigelow Aerospace's first orbital passengers. Image courtesy Lockheed Martin/United Launch Alliance.

the other. As we go forward over the next half-dozen years, we hope that if we are able to make improvements and evolve towards full scale, other people will be doing something similar in this country.”

Rate of Launch

At the Space Frontier Foundation’s NewSpace 2006 conference in Bigelow’s home town of Las Vegas, he outlined his transportation plans once his full-scale habitat becomes operational:

“In our third year of operation we estimate that we will need 20 launches. We need 16 launches for people and four launches for cargo. We’ve talked a lot about this over the last year and visited with a lot with one company in particular and a second company secondarily and we would be most happy if a crew return vehicle and a hab vehicle for transportation purpose could carry eight people. The artefact of eight people is really a function of cost. It helps to reduce the seat cost. If you can still have an affordable seat cost and fly five people, that’s fine. If you have a five-meter diameter on your crew return vehicle, you can accommodate eight folks in that architecture, and that can fly on a system like the Atlas V 401/402 series, or it could fly perhaps on the Falcon 9 if Elon [Musk - founder of SpaceX] is of a mind to do that.”

At 20 flights per year it is possible that LM will be able to offer flights as low as \$35-50 million, which would mean the costs per passenger will be as low as \$5 million.

The Business Plan

Although Bigelow plans to fly many passengers per year, he anticipates the major source of BA revenue will derive from building space stations for research, manufacturing, and providing low-cost space access to countries that do not have fully fledged space programs. For example, Bigelow is pursuing markets for a variety of users including biotech, pharmaceutical, university research, entertainment applications and government and military users.

Who Will Fly?

Potential SFPs able to afford \$5 million for an orbital flight belong to an elite demographic group that is mostly male, aged mid fifties and

has a net worth in excess of US\$200 million. Of the world’s estimated eight million millionaires, perhaps between 10,000 and 100,000 have the financial resources to consider an orbital space experience. This demographic sub-group understand risk but their time is valuable, a constraint that will need to be addressed when developing an orbital experience and the necessary training prior to flight.

Training For Suborbital and Orbital Flight

The space flight requirements for crew and SFPs are stated in the Federal Aviation Administration’s (FAA) Rules and Regulations, Vol. 71, (CFR Parts 410, 415, 431, 435, 440 and 460, published 15 December 2006). The training aspects are summarised in this section.

In accordance with FAA regulations crewmembers, which in most cases will be limited to one pilot, will be required to comply with the following:

- **Complete training on how to perform duties onboard and on the ground so that the spacecraft will not harm the public**
- **Hold a commercial pilot licence and at least a second category medical**
- **Be proficient in being able to perform necessary emergency egress duties and be familiar with all abort scenarios.**

Under the FAA regulations, SFPs will be required to:

- **sign an informed consent form acknowledging the hazards and risks that could result in serious injury, death, disability, or total or partial loss of physical and mental function**
- **be trained (under 460.15 of the FAA regulation) in how to respond to emergency situations such as fire, smoke and rapid and/or explosive decompression**
- **purchase their own space flight insurance.**

Of interest, the FAA does not provide the authority to protect SFPs which means that pressure suits will not be required.

Training, whether for suborbital or orbital flight, will consist of a theoretical and practical component as described in this section.

Theoretical Module. This will include a basic introduction into aerospace physiology, an overview of the flight trajectory/mission architecture, basic operation of the spacecraft's communications system, and an introduction to the physiological consequences of microgravity.

Practical Module. At a minimum this component will include an introduction to basic survival skills, a high altitude indoctrination test, indoctrination to simulators to expose

passengers to spatial disorientation, and a smoke chamber simulation. Additionally, companies may provide a parabolic flight experience to indoctrinate passengers to the experience of microgravity.

For suborbital SFPs training will vary in length between three and four days, whereas for orbital SFPs training will follow an abbreviated astronaut training format that may last between four and six weeks.

As Astronaut Training Consultant for Bigelow Aerospace **Erik Seedhouse** authored the Spaceflight Participants Flight Surgeon's Manual and designed training protocols for civilian astronauts. He is a member of the Aerospace Medical Association and a Fellow of the BIS. He is presently working on his first book on the subject of Space Tourism.



3

Stepping Out into the SOLAR SYSTEM...

They stopped by a likely looking asteroid: Bunny was sure there were AstroKat snacks buried down there somewhere!!



Scientists and engineers are stepping up research into how they might deal with an asteroid on a collision course with Earth. One idea that is gaining ground is human exploration of near-Earth asteroids. As *Leonard David* explains here, such missions would not only increase scientific knowledge of these objects, but help develop the technologies and skills needed to deflect or destroy a potentially hazardous asteroid.

A Human Mission TO AN ASTEROID

THERE IS no question that there are dangerous denizens of deep space – troublemaking asteroids that could have Earth in their crosshairs and smash into our planet. Once garnering a high-rating on the “giggle factor” listing of planetary worries, experts concur that the chance of a civilization-crippling impact by a large space rock is low ... but it is not zero.

For one, our globe has the scars to show that it has been on the receiving end of impactors – tagged as Near Earth Objects, or NEOs – in the past. Such a NEO strike has often been cited by scientists as the likely cause of the dinosaurs’ demise 65 million years ago. Buried under Chesapeake Bay is an ancient imprint from an impactor that slammed into that area about 35 million years ago – a ballistic blemish that measures 90 km across and is more than 3 km deep. This extraterrestrial blow instantly ejected water and debris tens of kilometres high into the atmosphere, as well as set off huge tsunamis.

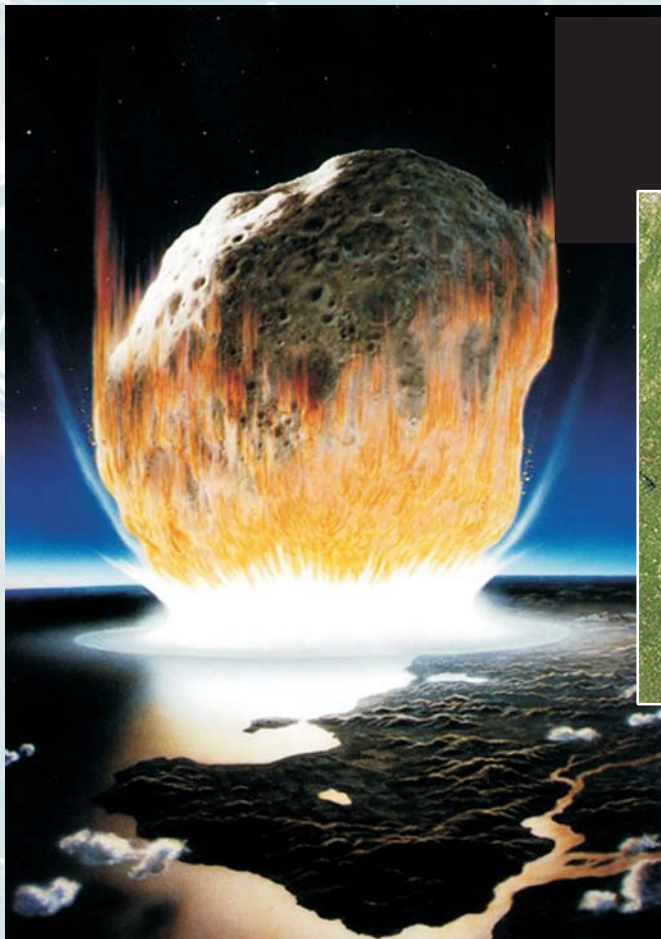

■ **Left:** A celestial grand slam: nature remodels a coastline. Human exploration of asteroids could well lead to a sharpening of the skills required to prevent a bad day here on Earth. Artist's impression courtesy NASA and Don Davis.

■ **Above:** Chesapeake Bay from the MODIS instrument on the Terra satellite. Buried under the Bay area is the imprint of an ancient cosmic impact dating from 35 million years ago. Image courtesy NASA and Jeff Schmaltz, MODIS Rapid Response.

Also viewed as a wake-up call from the heavens is the 15-megaton thump somewhere between 20,000 to 50,000 years ago that created a geological makeover of desert that is now called Arizona's Meteor Crater near Winslow. Then there's the more recent 1908 explosion of an extraterrestrial object over Tunguska, Siberia that flattened around 2,000 square kilometres of forest.

Now fast forward into the future – to 2029 when asteroid Apophis makes a flyby of Earth. That big space rock will be observable to sky watchers in Europe and North America, whisking by closer than where geosynchronous spacecraft are positioned and has a slight, but very real, prospect of striking our globe on a return pass in 2036.

Enough said. Just like the weather, everybody talks about troublesome NEOs. But can anybody do anything about intimidating asteroids that are on a crash course toward Earth?

Planetary Defense: Movie Making or Reality?

Over the past few years scientists and engineers have been stepping on the accelerator of research to concoct various ways to deal with the threat from these malicious cosmic interlopers – to help shape a “planetary defense” strategy. One idea that is gaining momentum in this regard is human exploration of near-Earth asteroids. Not only would such a mission foster scientific knowledge of these objects, it would hone the technology and procedural skills necessary to deflect or destroy a future asteroid that is deemed hazardous to Earth.

Indeed, if you think the idea of dispatching a crew of space travellers to an asteroid on an Earth-impacting trajectory sounds pure Hollywood moviemaking you would be correct. That was just the ticket behind the 1998 film hit, *Armageddon*, starring Bruce Willis. He portrayed a deep core oil driller leading a roughneck gang of drillers turned into astronauts on an intrepid journey to land upon an asteroid, deploy a nuclear device onto its surface and save everybody back on home planet Earth.

But there is a 21st century approach to this task – one that stems from U.S. President George W. Bush's “New Vision” for NASA's space exploration program that he blueprinted

in January 2004. The new plan announced was “to explore space and extend a human presence across our solar system. We will begin the effort quickly, using existing programs and personnel. We'll make steady progress - one mission, one voyage, one landing at a time,” Bush explained, focusing first on a human return to the Moon in preparation for human missions to Mars “and to worlds beyond.”

Regarding NASA's Vision for Exploration - back to the Moon, on to Mars and other destinations - a March 2007 report to Congress titled *Near-Earth Object Survey and Deflection Analysis of Alternatives* states that near Earth objects are one of those potential “other destinations.” Nevertheless, still to be fleshed out is how space travellers can first get to an asteroid, followed by what can be done by the expedition upon arrival.

NASA's Constellation Program

The tools at NASA's disposal for a human mission to an asteroid are emerging as the space agency flexes its technological muscle to respond to the Bush 2004 directive. To that end, the U.S. space agency's Constellation Program is now underway to extend human presence throughout the solar system.

A major piece of hardware required in the Constellation initiative is the Orion crew exploration vehicle, or CEV. That craft is being fabricated under NASA contract to the Lockheed Martin Corporation, picked as the prime contractor in August 2006 to design, develop, and build Orion, America's post-space shuttle spacecraft for a new generation of explorers. When delivered, Orion is to be capable of transporting four crewmembers for lunar missions and later supporting crew transfers for Mars missions. Orion is also being designed to carry up to six crew members to and from the International Space Station. Early intentions were to have the first Orion launch with humans onboard for no later than 2014, and for a human Moon landing no later than 2020. Orion is intended to form a key element of extending a sustained human presence beyond low-Earth orbit. But NASA budget realities, achieving technical milestones and dealing with probable setbacks will ultimately lead to true calendar dates.

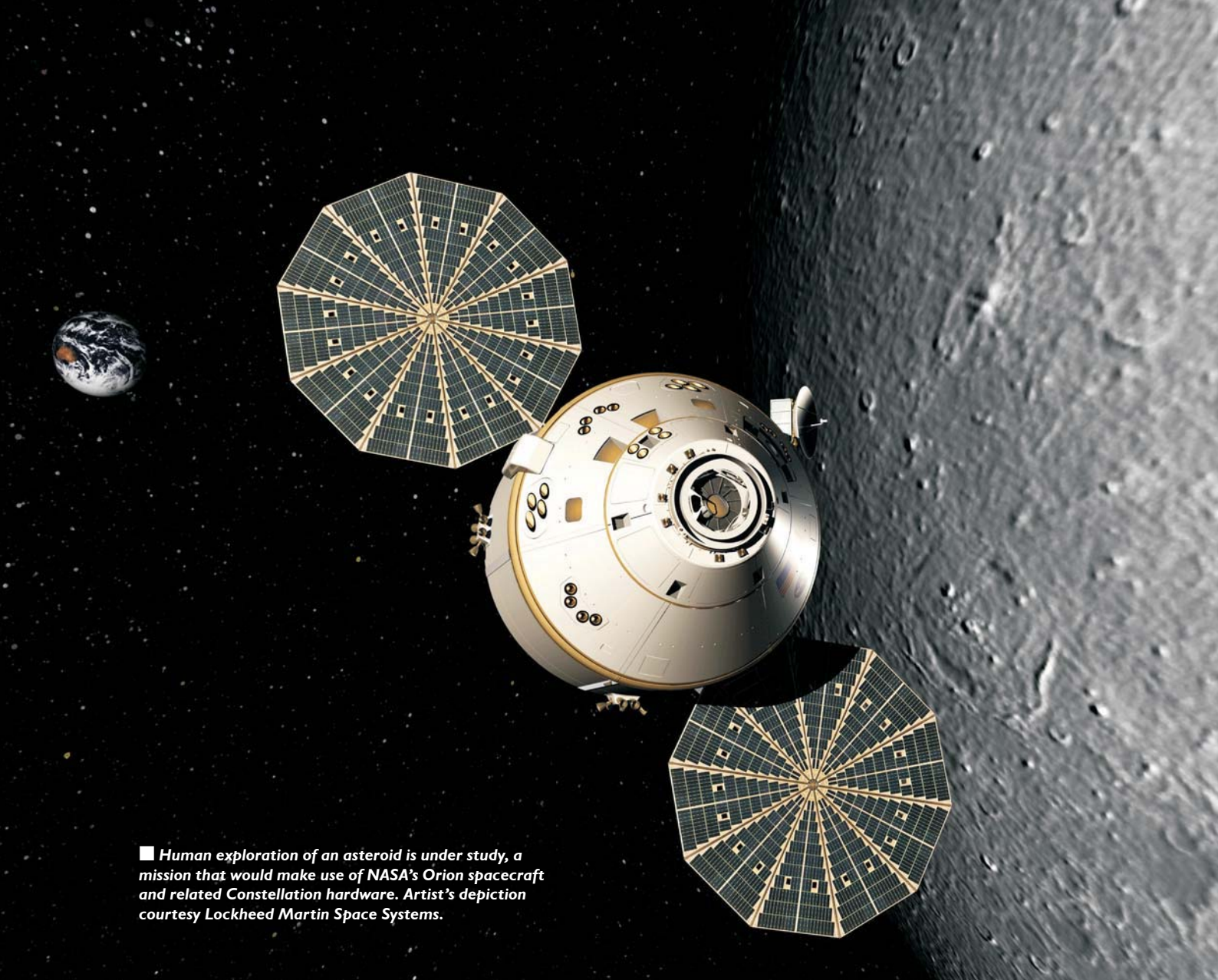

■ Human exploration of an asteroid is under study, a mission that would make use of NASA's Orion spacecraft and related Constellation hardware. Artist's depiction courtesy Lockheed Martin Space Systems.

The Orion crew-carrying spacecraft, topped by an escape tower, is to be boosted toward space via the now being built Ares I launcher - an in-line, two-stage rocket configuration. The Ares I first stage is a single, five-segment reusable solid rocket booster derived from the Space Shuttle programs reusable solid rocket motor. Ares I can use its 25-ton payload capacity to people, resources and supplies to the International Space Station, or to place payloads into orbit for retrieval by other spacecraft bound for the Moon or other destinations.

Not only is soon-to-be-retired space shuttle hardware to be utilized, but the Ares booster also dips back into decades old Apollo-era technology. The Ares I upper stage is propelled by a J-2X main engine fuelled with liquid oxygen and liquid hydrogen. The J-2X is an evolved variation

of two historic predecessors: the powerful J-2 engine that propelled the Apollo program's Saturn IB and Saturn V rockets, and the J-2S, a simplified version of the J-2. It was developed and tested in the early 1970s - but never flown.

NASA's Constellation program is geared also to produce the Ares V, a heavy lift launch vehicle, that makes use of five RS-68 liquid oxygen/liquid hydrogen engines mounted below a larger version of the space shuttle's external tank, along with two five-segment solid propellant rocket boosters for the first stage. The upper stage of the Ares V will use the same J-2X engine as the Ares I. The Ares V can lift some 130 tons to low Earth orbit, providing the needed oomph to propel cargo and components into Earth orbit that can, in turn, handle Moon, Mars and beyond operations.

Extending Human Reach

So given all that Constellation space hardware and launch power, expeditions to nearby asteroids, it would seem, fall naturally into the NASA plan for progression into deep space. That's just the view of former astronaut, Tom Jones, a veteran of four space shuttle missions. He points out that the proposed Constellation vehicles like the Orion crewed spacecraft and its Ares booster are probably capable of reaching favourable NEO targets, using an upper stage launched by an expendable rocket.

"Just building a lunar-capable spacecraft [like Orion] means that a completely different kind of science and exploration target – a near-Earth asteroid – comes within our grasp," Jones advises. Such missions might be a good fit for the time after NASA's return to the Moon, using proven hardware to extend U.S. reach beyond Earth-Moon space. Furthermore, he underscores a key fact that if - for budgetary or political reasons a

lunar return gets delayed – NASA would still have a destination beyond low Earth orbit to explore.

"NEOs would be ideal stepping stones into deep space," Jones adds, offering the nation an intermediate destination, in terms of difficulty and distance, between the Moon and Mars. NEOs might be the way to sustain exploration momentum, he continues, as NASA consolidates and expands a lunar outpost - a way to keep exciting exploration at the forefront of the U.S. space program.

"Imagine looking back from eight million kilometres away, seeing Earth the apparent size of a ball bearing held about 2 metres away," Jones says. "That dramatic perspective would be coupled with an important and common-sense mission: learning what it takes to operate around these ancient bodies, gaining the confidence and expertise to divert a NEO headed for a catastrophic collision with Earth. This is spaceflight-for-survival, probably the most basic and powerful rationale for getting ourselves out there."

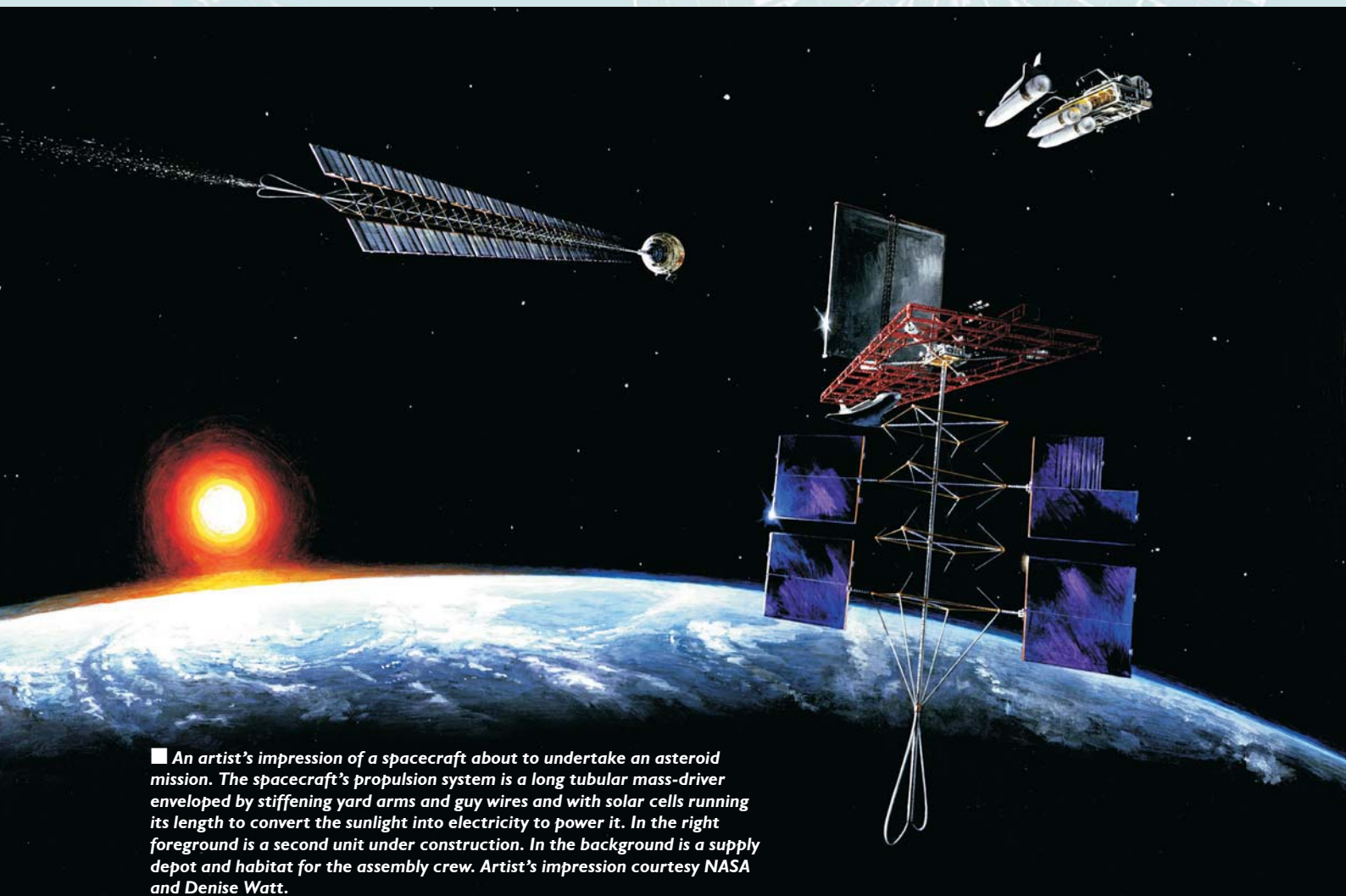

■ An artist's impression of a spacecraft about to undertake an asteroid mission. The spacecraft's propulsion system is a long tubular mass-driver enveloped by stiffening yard arms and guy wires and with solar cells running its length to convert the sunlight into electricity to power it. In the right foreground is a second unit under construction. In the background is a supply depot and habitat for the assembly crew. Artist's impression courtesy NASA and Denise Watt.

A Match Made in Heaven

Indeed, intensive looks into the feasibility of using the Constellation hardware for flight to a NEO has been done by several NASA-supported study teams, anchored both at the space agency's Ames Research Center near San Francisco, California and at the Johnson Space Center in Houston, Texas.

Thomas Meyer of the Boulder Center for Science and Policy in Boulder, Colorado is engaged in one appraisal done on behalf of the Science Architecture Office for the Constellation Program at NASA Johnson Space Center in support of the President's Vision for Space Exploration.

Meyer and his colleagues looked at 4,460 potential targets in the NASA asteroid catalogue, culling out 15 candidates greater than about 30 meters in size that make close approaches to Earth in the 2015-2025 time frame – a slice of time when the Constellation gear – boosters and spacecraft – would be available. Furthermore, identifying an ideal NEO for a human sojourn is one that's both slow moving and comes close to Earth – sort of a

match made in heaven that doesn't need a lot of rocket power to reach.

The goal of a piloted NEO mission, Meyer explains, can be seen as twofold: To carry out fundamental science as well as applied science devoted to understanding asteroids as potential hazards as well as identify possible methods for their mitigation. "This would be the first opportunity to use humans in the field on another body since Apollo," he says.

A human mission to a NEO, with the capability of carrying out space walks – or extravehicular activity (EVA) - at the targeted asteroid will have a significantly higher science return than will a robotic mission. That is, having a human in the field means having a pair of eyes, a pair of hands and a brain that far exceeds the capability of any robotic vehicle, Meyer continues. "Since most asteroids have very little gravity, an EVA will be much like ones carried out at the International Space Station where astronauts float on tethers rather than get out and walk on the surface. Given that asteroids may be quite varied as to

their type, from rocks to rubble piles to hollow shells, the science strategy could vary widely from one to the next," he adds.

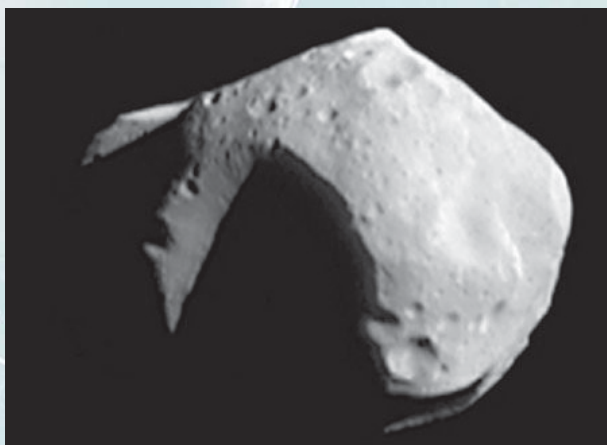

■ **Above:** A colour picture of the Main Belt asteroid 243 Ida made from images taken by the Galileo spacecraft from a range of 10,500 km on 28 August 1993. The images are from the sequence in which Ida's small companion moonlet, Dactyl, was discovered. Ida measures 56 x 24 x 21 km. Dactyl is spheroidal with a diameter of about 1.5 km. Both are S-type bodies. Image courtesy of NASA Jet Propulsion Laboratory.

■ **Top left:** A mosaic of two images of the Main Belt asteroid 951 Gaspra acquired by the Galileo spacecraft from a range of 5,300 km on 29 October 1991. This S-type (silicaceous or stony) asteroid measures about 20 x 12 x 11 km. More research is needed to better appreciate the nature of asteroids – be they solid objects or rubble piles. Image courtesy of NASA Jet Propulsion Laboratory.

■ **Bottom left:** An image mosaic of asteroid 253 Mathilde constructed from four images acquired by the NEAR/Shoemaker spacecraft from a range of 2,400 km on 27 June 1997. Mathilde measures about 59 km x 47 km. It is a C-type (carbonaceous) body. Its angular shape is believed to be the result of a violent history of impacts. Image courtesy of NASA and John Hopkins University Applied Physics Laboratory.

In the NEO science department, human surveying of asteroids can address several broad science themes. These include:

- **Measuring the physical characteristics of near-Earth objects**
- **Understanding the mineralogical and chemical compositions of asteroids**
- **Deciphering the relationships among asteroids, comets, and meteorites**
- **Understanding the formation and geologic histories of NEOs.**

In addition to addressing fundamental science questions, knowledge acquired during a human NEO mission would facilitate development of methods to mitigate the potential hazard of their impacting Earth. And in this arena, Meyer, along with study team mate, Malcolm LeCompte of the Center of Excellence in Remote Sensing Education and Research at Elizabeth City State University, Elizabeth City, North Carolina, suggest a suite of tasks, such as:

- **Understanding the NEO surface physical properties so as to allow the design of systems that impact, or attach to these surfaces.**
- **Understanding bulk properties of NEOs so as to allow modelling of their response to impacts, detonations or external forces.**
- **Determining the diversity of objects within the NEO population with respect to mechanical and bulk properties.**
- **Calibrating the ability of Earth observations to remotely determine the essential physical properties of NEOs.**

On Location

Paul Abell of the Planetary Astronomy Group at the NASA Johnson Space Center has also taken part in assessing the utility of sending a crew exploration vehicle to a NEO. The ideal mission profile would involve a crew of two or three astronauts on a 90 to 120 day flight, which would include a 7 to 14 day stay for proximity operations at the selected NEO. "Many proposed deflection schemes depend critically on asteroid characteristics such as density, internal structure, and material properties – precisely the parameters that a crewed mission to a NEO could measure," Abell reports.

But before a human NEO mission, Abell stresses that a robotic mission would be required in order to maximize crew safety and efficiency of mission operations at any candidate NEO. For instance, this robotic probe could chart the asteroid's gravitational field, shape, surface topography, and general composition – data highly useful in planning for later close-up operations by a human crew. An early robotic view of the object can also spot potential hazards to an Orion crew exploration vehicle, Abell suggests.

Once on location at a selected asteroid, Orion astronauts would make use of a high-resolution camera for detailed surface characterization and optical navigation purposes. A light detection and ranging (LIDAR) system would be ideal for close-up study of the asteroid, Abell adds, while an onboard radar transmitter could perform on-the-spot tomography of the space rock, a technique that enables a detailed look at the interior structure of the NEO. Such information not only has implications for the formation and impact history of the NEO, he continues, but also may have implications for future hazard mitigation techniques.

Abell and his study team members see other advantages of Orion astronauts in position at a NEO, such as having the capability to place precisely and re-deploy relatively small scientific packages on the surface of an asteroid. Such packages as remotely operated - or autonomous - rovers with one or two instruments could greatly enhance the amount of data obtained from the surface, and fine-tune the site selection for subsequent sample collection. Other packages that may be deployed at the asteroid might be experiments designed to test such technologies as surface anchors/tethers, drills/excavation equipment, or material extraction equipment. Additionally, Orion crewmembers could also deploy a transponder to the surface of the object for a long-term study of the NEO's orbital motion. This could be particularly helpful for monitoring the exact whereabouts of objects that have the potential to knock into Earth at some point in the future.

Over the past few years there have been a number of proposals to deal with a bothersome NEO that had Earth in its sights. From blasting the object with gas or detonating a nuclear warhead to nudging the object with a laser to modify its trajectory – all these ideas and many more have been proposed. Arguably, one

of the freshest approaches has been advocated by NASA space shuttle and space station astronaut, Edward Lu. He likens the idea to a “gravitational tractor beam” whereby the actual mass of a rendezvousing spacecraft with a target would attract that object in free space - enough so that the target’s trajectory is changed.

Still, there is a growing awareness by asteroid researchers concerned with planetary defense tactics that a “one NEO defense technology fits all” approach just won’t fit the bill. Among the asteroid experts that adopt this view is Donald Yeomans, Manager of the Near-Earth Object Program at Jet Propulsion Laboratory (JPL) in Pasadena, California. “The objects are so bizarre. You’ve got ex-cometary clumps, shattered rocks, slabs of solid iron...the deflection or dispersal mechanisms would have to be completely different for all of those,” he argues. “If you do find something with our name on it...you’d have to go out and investigate that particular object to find out what it’s like before you try and deal with it.”

Practice Makes Perfect

Why send humans to an asteroid in the first place? Obviously, NASA’s NEAR-Shoemaker voyage to and subsequent landing upon asteroid Eros in February 2001 and the Japan Aerospace Exploration Agency (JAXA) Hayabusa sample return mission to asteroid Itokawa in late 2005 both showcased robotic proficiency in examining and operating around asteroids.

You don’t have to have people there to do good near-Earth asteroid science, observes Dan Durda, a space scientist from the Southwest Research Institute in Boulder, Colorado. “But look at how having astronauts actually there on the Moon improved the both the quantity and quality of the science return from Apollo. People

■ **Below:** These colour images of the asteroid 433 Eros were acquired by the NEAR/Shoemaker spacecraft on 12 February 2000, from a range of 1,800 km during the final approach imaging sequence prior to orbit insertion. A five-and-a-half-hour long sequence of images was taken to provide a global overview of the asteroid. This S-type asteroid is roughly banana-shaped, measuring 33 x 13 x 13 km. Images courtesy of NASA and Johns Hopkins University Applied Physics Laboratory.)





have the judgment and creativity to select the best places to explore coupled with the dexterity to gather the best samples that no machine will have for quite a while."

A long-time advocate of human treks to the asteroids, Durda believes that the same technologies and techniques required to routinely explore the Moon and Mars, as well as extract resources from near-Earth asteroids, are the same ones that could be called to duty to fend off an impending asteroid impact. "I'm sure we'll be doing the former long before we'll ever need to do the latter, but it'll sure be nice to have had the practice first!"

■ **Above:** In late 2005 Japan's Hayabusa spacecraft (initially known as Muses-C) got up close and personal with the small S-type asteroid 25143 Itokawa. Hayabusa successfully demonstrated manoeuvres around the object as a preliminary to descending to the surface to collect samples. Artist's impression courtesy ISAS/JAXA, NASA NSSDC and James Garry.

■ **Right:** Images of asteroid 25143 Itokawa taken by Japan's Hayabusa spacecraft. The asteroid measures only 540 x 270 x 210 m, making it by far the smallest asteroid surveyed by spacecraft to date. Images courtesy ISAS/JAXA.

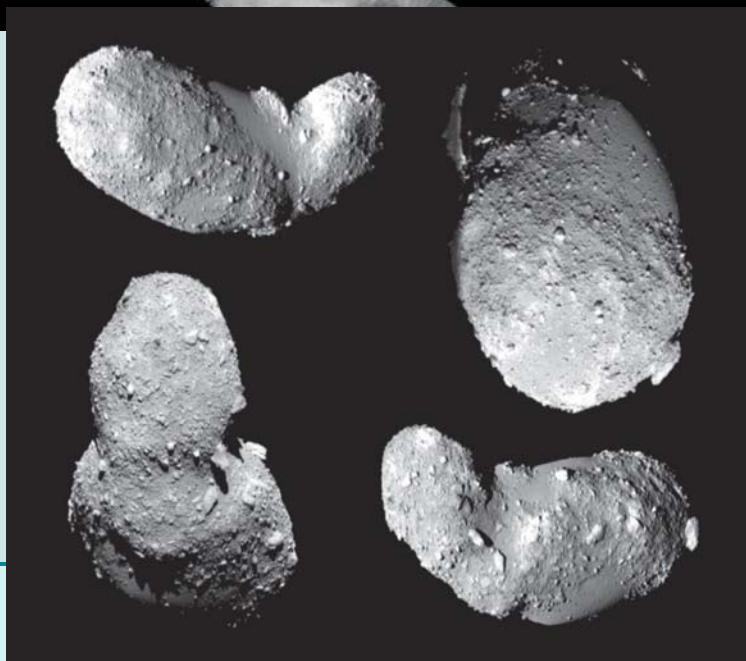

Similar in view is Chris McKay, deputy scientist in the Constellation science office at the NASA Johnson Space Center, but stationed at the space agency's Ames Research Center located in California's Silicon Valley. He feels, on one hand, that a human mission to a near Earth asteroid would be scientifically worthwhile. It could be

part of an overall program of understanding these objects. On the other hand, it would be useful, instrumentally, in terms of understanding the threat asteroids pose to the Earth.

Not only are asteroids relics from early solar system formation, ripe for scientific understanding, McKay explains, there is that Bruce Willis/*Armageddon* factor that resonates well with the general public. That is, the ability to send “significant assets” to an asteroid, and of mastering the problem of handling killer asteroids. While he emphasizes that more work is needed before any human outing to an asteroid can include taking on planetary defense duties, “Being able to have astronauts go out there and sort of poke one with a stick would be scientifically valuable as well as demonstrate human capabilities,” he concludes.

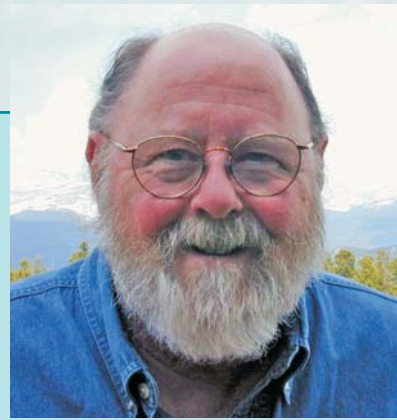

Leonard David is a special correspondent for SPACE.com and Space News newspaper, covering space exploration for some 45 years. He lives in Golden, Colorado where the night-time mountain sky fuels the imagination about space travel to other worlds.

■ *An artist's impression of an asteroid-mining operation on an asteroid stationed in the vicinity of Earth. In the left foreground is a mining system at work. Nearby platforms provide power and other facilities. Artist's impression courtesy NASA and Denise Watt.*



4

Long-Duration SPACEFLIGHT...

Bunny was sure that the Human Astronauts were keeping some AstroKat Snax to themselves!!



When a crewed mission to Mars finally gets the go-ahead, will the human body be up to the three-year round-trip? *Dominic Phelan* reports on the pioneering work of Russia's space doctors at the Institute of Bio-Medical Problems in Moscow, who aim to get us to the 'Red Planet' safely.

The Work of the INSTITUTE OF BIO-MEDICAL PROBLEMS

It is only when you notice the bronze bust of Russian space pioneer Konstantin Tsiolkovsky staring at you from the corner of the reception hall at the Institute of Bio-Medical Problems (IBMP) that you realise the staff there are aiming high. Although this large anonymous building situated in the suburbs of Moscow may literally be a world away from Mars, when cosmonauts finally reach its surface they will have done so because of decades of research carried out there.



Ever since its first cosmonauts were selected in 1960, Russia invested heavily in space medicine, with its team of 'space doctors' making sure that not only are the right people chosen but that they remain healthy before, during and after their spaceflight. This responsibility includes everything from the initial selection process, training, in-flight monitoring of cosmonauts, to helping them through life-threatening emergency situations.

For the last 25 years the Institute has been run by its energetic director Anatoly Grigoriev, a man now in his mid-60s but who still manages to impress visitors with his energy and passion. This probably stems from his own introduction to space medicine as he was personally hired by Boris Yegorov, the world's first doctor in space when he flew as part of the Voskhod 1 crew in 1964. Grigoriev himself had to undergo the same medical examinations as the cosmonauts to get his job but any hopes that he might be up-graded were dashed when the official 'doctor cosmonaut' team was disbanded shortly afterwards.



■ **Top left:** This large anonymous building situated in the suburbs of Moscow is home to the Institute of Bio-Medical Problems (IBMP), where Russia's leading space doctors have carried out decades of research into the problems of long-duration human spaceflight. Image courtesy IBMP.

■ **Above:** The Institute of Bio-Medical Problems in Moscow has been run for the last 25 years by its energetic director Anatoly Grigoriev. Image courtesy IBMP.

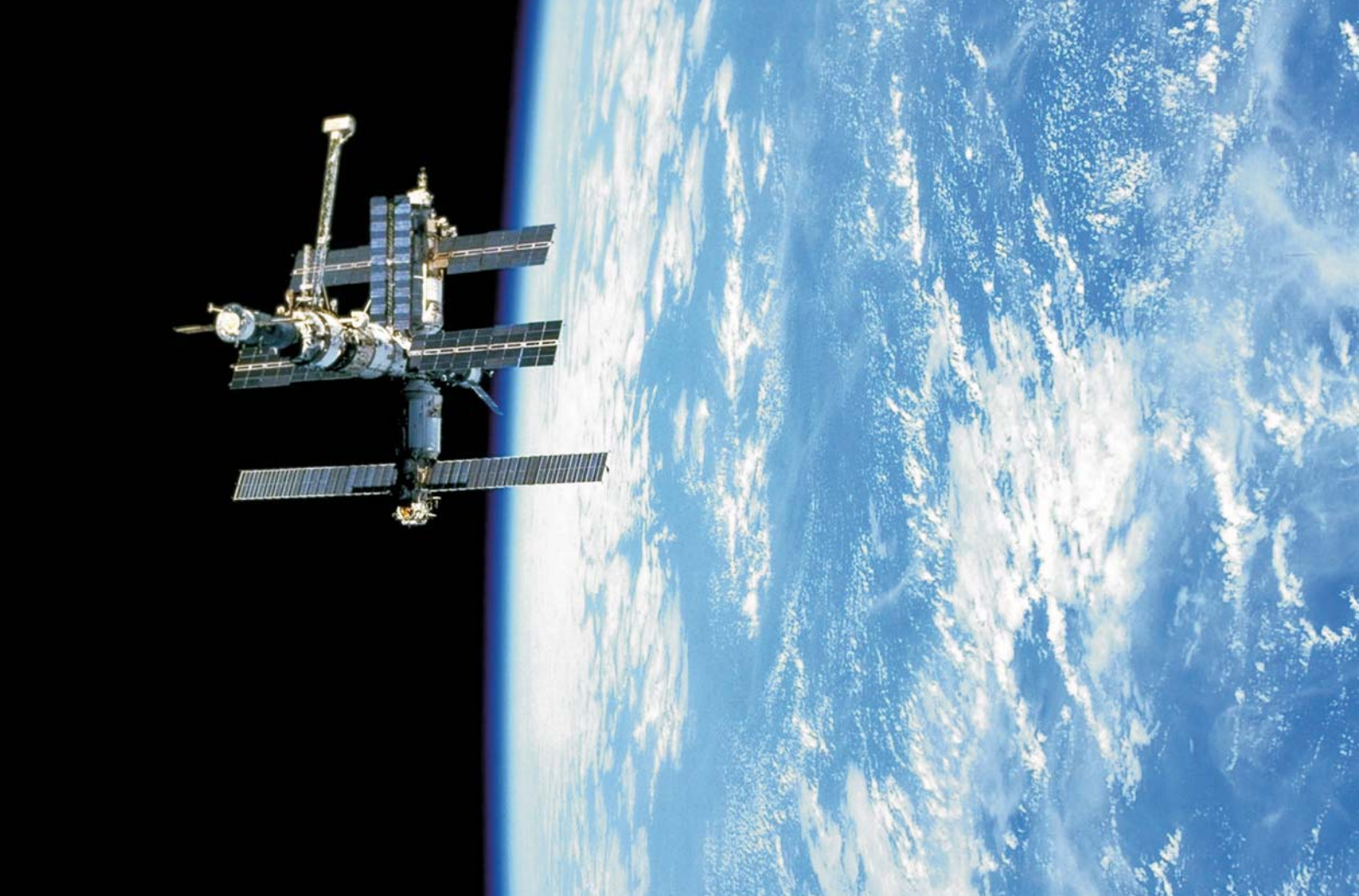

Mir Experience

Although IBMP staff have over the years been given a virtual veto on who has the 'right stuff', their own opportunities to fly have been small - so far only five dedicated Russian doctors have made it into orbit. The IBMP's staff are mainly Earth-based, relying on medical tests carried out on cosmonauts in orbit and test subjects on the ground.

The core of this data is based on the results of experiments carried out aboard the Mir space station in the 1980s and 1990s. In total over 1,500 dedicated medical experiments were carried out by the cosmonauts aboard Mir during nearly 5,000 days of permanent occupation. During that period (seen by many as the golden era of the Soviet/Russian space programme) the IBMP team grew to 700 staff in 17 departments.

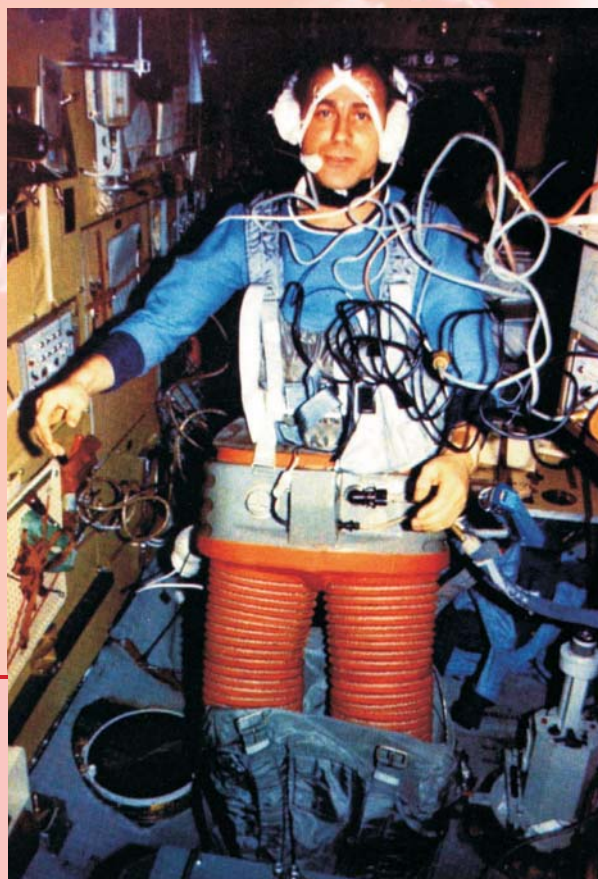

■ **Above:** Orbiting above the Earth, Russia's Mir space station is seen in its configuration at the time of Dr. Valeriy Polyakov's record-breaking 437-day stay aboard the station. Image courtesy NASA.

■ **Right:** By creating a vacuum around the wearer legs the Chibis gravity-simulation device helps to prevent the 'pooling' of blood in the upper-body. Image courtesy IBMP.

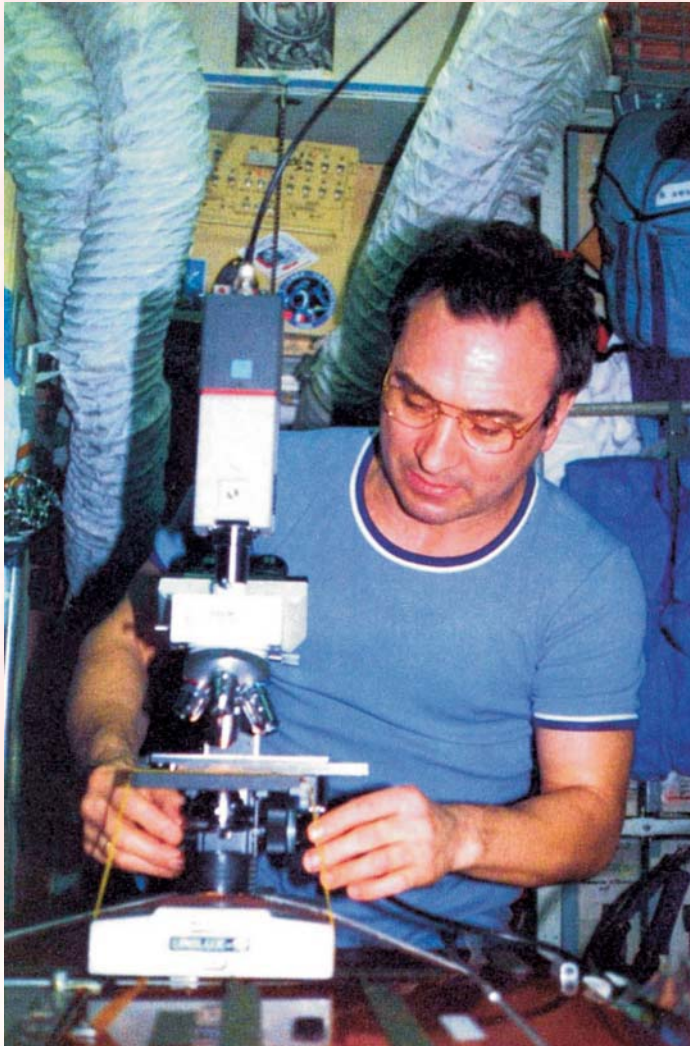

Now that present crews aboard the troubled International Space Station (ISS) are limited to six-month flights, due to its delayed construction period because of limited shuttle flights, these long-duration spaceflight experiments might not be matched for another decade or more.

Using this database Russia has developed a winning system for healthy spaceflight that includes: varied and interesting diets; the Chibis gravity-simulation suit, which created a vacuum around the wearer's legs to literally suck pooled blood away from their upper-body; an elasticated flightsuit which gives the cosmonaut a 'work-out' as they move around the space station; and conventional equipment such as a running treadmill and an exercise bicycle. Special medicines have also been developed to be taken before, during and after flights to help cosmonauts adapt to weightlessness and then back again to gravity when they return.

The ultimate aim is to make sure the human body keeps-up with the technology, so that it is medically possible for people to safely undertake a long-duration trip to Mars when such a mission is finally given the go-ahead.

Indeed one member of that IBMP team is uniquely qualified to study this data. Doctor Valeriy Polyakov holds the record for the longest duration space mission ever – having spent 437 continuous days aboard Mir in the mid-1990s. At the end of his flight he even made a conscious effort to walk away from his capsule to prove that cosmonauts who land on the surface of Mars would be able to do so too.

Although Polyakov is now too old to fly in space again there are also other IBMP staff 'on call' who have undergone cosmonaut training and can be included as part of an ISS crew. The latest of these is 34-year-old Sergey Ryazansky, who passed the cosmonaut training course at Star City in 2005 and is now an official candidate for a future mission to the ISS.

As well as being one of the most experienced of the younger IBMP researchers, his selection is fitting as his



■ **Top left:** Dr. Valeriy Polyakov still holds the record for the longest single space mission: 437 days aboard Mir in the mid-1990s. Image courtesy IBMP.

■ **Above:** IBMP researcher Sergey Ryazansky completed cosmonaut training at Star City in 2005.

grandfather was a space designer and one of the original ten signatories of the petition asking the Soviet government for permission to launch Yuri Gagarin on his historic mission.

"I wanted to join the cosmonaut team because of a family tradition – my grandfather was a rocket engineer and we were proud of that connection. It was a dream of mine to work with cosmonauts and I joined IBMP after graduating from the biological department of the Moscow State University," says Ryazansky.

Once construction of the ISS is finally complete and its crew numbers increase, Ryazansky would be ready to fly as soon as he was given the go-ahead.

Ground-Based Simulation

To complement its in-orbit data, the IBMP has also developed many innovative ways to simulate space conditions (both physical and psychological) on the ground. The facility boasts a 9-metre centrifuge, pressure chambers and an invention of its own design which can mimic the effects of weightlessness right here on the Earth.

Previously test subjects had been immersed in water baths to fool their bodies into thinking they were floating (as any unsupported state creates similar effects to weightlessness in the body) but they often complained of the harsh reactions of their skin to the water.

Although the longest of these 'wet tests' lasted an amazing 56-days, eventually a new 'dry immersion tank' was developed. This comprises a water-tight plastic membrane layer situated between the tester and the water, allowing them to 'float' on liquid but still remain dry – keeping skin problems and excuses to quit to a minimum.

For more dangerous experiments space doctors of all nations often use animals. At the start of their space

programme the Russians were fond of dogs (their mental reactions are similar to ours), but they decided to follow the American practice of using primates in the early 1980s because a monkey's physical reaction to spaceflight is nearly identical to that of a human.

The first such mission carried a monkey called 'Bion' on Cosmos 1514 in 1983. The series has been called Bion ever since and since then over a dozen multi-national bio-medical missions containing primates, rats and newts have flown successfully.

Importantly for humans these animal flights have proved conclusively that living organisms exposed to long-term microgravity won't suffer any type of permanent cell damage, hereditary gene mutations or chronic stress. Any changes in muscles, bones, cardiovascular and neurosensory systems are only short-term and reversible.

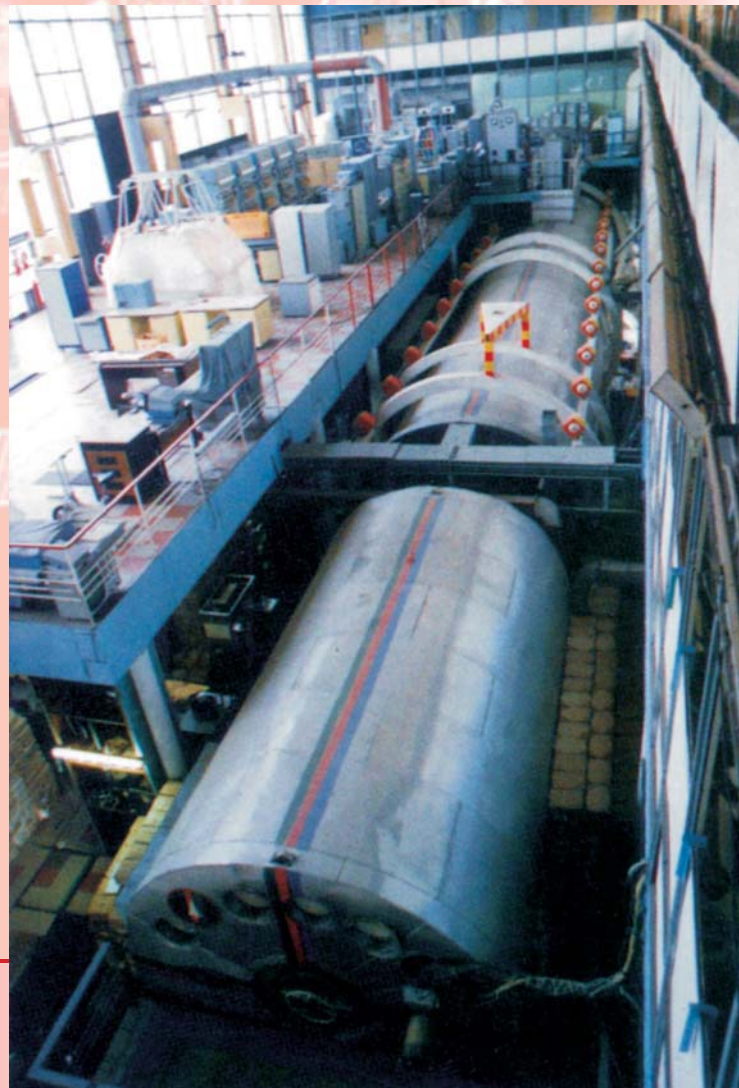

■ **Right:** The centrepiece of the Institute of Bio-Medical Problems (IBMP) facility is its space station mock-up, the site of the new international 'Mars-500' experiment. Image courtesy IBMP.

Mars-500

Originally constructed in 1970s the centrepiece of the IBMP facility is a large multi-module space station mock-up that we now know is based on a secret effort to design a manned Mars vehicle in the 1960s called the TMK . This programme had hoped to stage a manned fly-by of Mars by cosmonauts (but not a landing) in the 1970s. Incredible as it may now seem, if resources hadn't been diverted away from the project to try to catch up with the American Apollo challenge the Russians had hoped to attempt this mission by 1975!

After they spectacularly lost the 'Moon Race' the Russians reverted back to a more conservative approach, slowly developing new technology and more detailed medical data aboard a series of space stations. Unfortunately the dire economic situation caused by the collapse of the Soviet Union ruled out another shot at a manned Mars mission once again.

Consequently over the years this impressive simulator has been the site of over half-a-dozen long-duration Earth-based simulations. The longest so far was a 240-day isolation test in 1999, whilst the latest is called 'Mars-500.'

During this new experiment an international team of six researchers is being isolated inside for a total of 520-days - representing a 250-day 'journey' to Mars, a 30-day trip to the surface (during which time the researchers will live on a 'martian' surface) and a final 240-day 'return' to Earth.

To add to the realism all communication with the outside will be via email, as on a real Mars mission any meaningful voice communication would be impossible because of the time lag for radio messages to get from the ship to the Earth and back.

Psychology

Russian space doctors are also well-versed in the study of human psychology aboard space stations – something that is often more difficult to predict than a person's physical reactions. Bizarrely ground-based experiments have often provided the most interesting data.

In the mid-1980s scientists started to simulate the effect of upper-body blood pooling (a problem for space travellers as their hearts don't need to fight against gravity to circulate their blood to the 'lower' parts of their body) by tilting Earth-bound testers at six degrees to the horizontal.

During the longest test, a mammoth 370-day 'bed rest' study that began in 1986, things began

to go wrong from an early stage. Researchers soon began to realise that the interactions between the experimental subjects were their main worry. Although the test subjects had been grouped into 'crews' of five, three and two in separate rooms they all started to argue amongst themselves. It got so bad amongst the large five-man group that one of the most vocal was "expelled" to one of the smaller groups.

The experiment had long-term consequences too. One of the test subjects is reported to have fallen in love with the female nurse who looked after him during the year-long experiment and several others divorced their wives when it was all over.

Cultural Problems?

Another group interaction experiment at IBMP that didn't go according to plan was the first international "SFINCSS" isolation test carried out at IBMP during 1999-2000.

During that 240-day experiment a Canadian female participant accused a Russian male colleague of sexual harassment, whilst a Japanese researcher left early over issues of privacy. Although embarrassed about the circumstances, Russian researchers believe these situations only highlight the fact that cultural traits might be a greater problem to overcome on long-duration international missions than the medical issues.

So if an isolated all-male crew can inevitably turn on itself, would a mixed male-female crew make the situation better or worse?

Dr. Valeriy Polyakov has made his own views known and was even quoted as saying that women should be excluded from the first missions because they are an 'unnecessary emotional and hormonal disturbance.'

Women cosmonauts have been a rarity in the past - perhaps reflecting a long-standing Russian attitude to their place in society - but unfortunately this has resulted in so few of them having flown long-duration missions that the physical effects on the female body in orbit are less well understood.

"There are a lot of health problems for women in space," admits Anatoly Grigoriev. "Of course some of these are different from men, because women have different metabolisms and hormones, but they are enough for them to have serious problems adapting to the space environment."

The only mixed-sex international mission in orbit that seems to have worked well was astronaut Shannon Lucid's six-month stay aboard Mir in 1996. But this only seems to have worked



■ *Russia's Mir space station as seen from the approaching Space Shuttle Atlantis on 23 March 1996. The two spacecraft were in the process of making their third docking in Earth orbit. With the subsequent delivery of astronaut Shannon W. Lucid to Mir, the Mir-21 crew grew to three. As a cosmonaut guest researcher, Lucid would spend 179 days on Mir before returning to Earth. Image courtesy NASA.*

because of a maternal relationship that grew between herself and her younger crewmates.

"I should say she adapted very well - there were no problems psychologically or with her health. She called the two men in her team her 'sons' and they called her 'grandma'," revealed Grigoriev.

Years of research now shows that good morale is the most effective weapon against problems in orbit.

To keep in constant contact with cosmonauts aboard the ISS there is a small 'mini-mission

control' at IBMP which staff use to monitor the comfort of the crew. They also encourage relatives of the cosmonauts to visit and talk with their loved ones.

"The secret to keeping people healthy in orbit is threefold: preventing their muscles from wasting away because of a lack of gravity to work against; monitoring the heart and making sure it stays healthy; and making sure the crew's mental health doesn't suffer because of the isolation," says director Grigoriev.



In so-called “active zone” situations (i.e. during launch or a spacewalk) a cosmonaut’s health is monitored in real-time, with continuous measurements of heart rate, blood pressure and breathing, and there is a routine medical examination every ten days. As one of the doctors in the control centre quipped: “They can’t complain that they lack attention!”

A full medical kit is carried aboard the ISS for all possible emergency situations but the IBMP doctors have the authority to end a flight if they think there is a medical emergency in progress. This option has only been taken once in the past, when cosmonaut Vladimir Vasyutin was evacuated from the Salyut 7 space station after he suffered a potentially life-threatening infection.

Grigoriev reminds us that on a Mars mission the crew will have to fend for themselves if a serious medical problem arises: “The flight is going to be extremely long. On a flight around the Earth if there is something wrong with a cosmonaut we have an opportunity to bring them home. This situation is completely different on a flight to Mars.” For this reason there will almost certainly be a doctor on the first Mars crew.

Another major worry that could endanger the crew will be cosmic radiation - something which we shall have to try and protect the crew against. This is very important because they are leaving

the Earth’s own magnetosphere which protects us from the Sun’s rays and other dangerous particles.

Although much can be done to physically protect the crew from radiation - such as surrounding the living quarters of a Marship with the fuel tanks and other items to try and absorb some of the radiation - a more exotic solution might be the development of an artificial electromagnetic device that would create a ‘force field’ around the ship.

Probably the most effective tool will be a network of monitoring stations on Earth to detect any violent outburst from the Sun and give the Mars crew a few minutes warning so they can retreat to a safe zone of the ship as the radiation particles reach them.

IBMP researchers seem to be of the view that a crew can’t be protected 100 percent and thus believe the first cosmonauts to Mars should be mature people in their 50s, who have already had families and don’t need to worry about any possible long-term genetic damage to which they might be exposed.

■ **Above:** At the end of her record-breaking stay aboard Russia’s Mir space station, astronaut Shannon W. Lucid with flight engineer Aleksandr Y. Kaleri prepare to move Lucid’s cosmonaut spacesuit from Mir to the Space Shuttle Atlantis, following its docking with Mir on flight day 4 of the STS-79 mission in September 1996. Image courtesy NASA.

Multi-National Mission?

Russia (or any other nation for that matter) probably couldn't afford a solo manned mission to Mars now or in the immediate future. If it is to happen sooner rather than later, the Russians seem willing to take part in an international expedition. Despite the changing political climate, the relationship between the space medicine teams of the East and West has always been good - something which is obvious everyday aboard the ISS.

"We don't just have a professional interest in each other, there is a personal trust," reminds Grigoriev. "Perhaps that is why we have been co-operating in space medicine since 1971, even through the so-called 'Cold War' period. The only group that seemed to tie our two countries together during that time was the one working on biomedical space problems."

"Of course we have different education systems and different cultures. In spite of the fact that we have some differences in our medical approaches both sides manage to use all that we know to make our work better. That is why a new system was born that is a mix of the two systems. An example of this is the use of the treadmill - we believe that the main way to prevent problems though the flight is to use this, while our American colleagues often believe that the most important exercises in space are 'resistive exercises'. So onboard the ISS we have both measures, giving the cosmonaut the choice."

The institute is also beginning to forge links with China, the newest manned space power, and has co-operated on some satellite experiments.

Future cosmonaut Sergei Ryazansky is all in favour of bringing the strengths of each space nation together: "I think it must be a multi-national mission because it will be easier politically, financially and technologically. It is well-known that in some fields Russians are better, in some fields US engineering is better, and now in computer support Japanese companies

have much better technology. The best thing would be to combine them."

Conclusion

After they lost the Moon Race, Russian eyes focused back on Mars before their recent serious economic situation seemed to make that an impossible dream once again. But now with a revival in fortunes for the Russia space programme, brought about by its innovative embrace of commercialism using tried and tested space technology, a Mars mission might be on the cards again.

In 2005 it was formally adopted into the Federal Space programme when a report called 'Manned Mission to Mars' was commissioned. Although only a paper study looking at the technology issues such as the 'liquid fuels versus nuclear engine' debate its existence has signalled a new seriousness towards the topic.



■ **Right:** NASA ISS Science Officer and Expedition 7 crew member Ed Lu exercising on the treadmill aboard ISS: the entire treadmill below his feet is floating in a big pit in the floor. Image courtesy NASA.



■ **Above:** European Space Agency astronaut Ulf Merbold (on the left) looks on while Mir's resident physician Valeriy Polyakov withdraws blood from a vein in his arm during one of the numerous biomedical experiments carried out aboard the Russian space station Mir. Image courtesy ESA-RKA.

"I think it will be in the third decade of this century. I intend to see it!" proclaims Grigoriev confidently. He is firm in his belief that the only realistic option will be an international mission.

When describing such a flight, cosmonaut candidate Sergei Ryazansky says it all: "I just want to see this flight, not just to fly personally, but to finally see that human beings are able to go to Mars!"

One can't but be impressed by the passion and commitment of the IBMP staff. Many of them have dedicated their entire lives to the space programme - seeing both its high and low points - but they now sincerely believe that we are once again picking up the momentum for a manned mission to Mars sooner rather than later.

Acknowledgement

This chapter is based on interviews with IBMP director Anatoly Grigoriev and cosmonaut candidate Sergey Ryazansky.

Dominic Phelan (right) is a writer based in Dublin, Ireland, who has a special interest in the history of the Russian space programme.



5

Another GIANT LEAP...

Sometimes, when things did not go quite right, Bunny thought the Human Astronauts liked to make a bit of a fuss!!

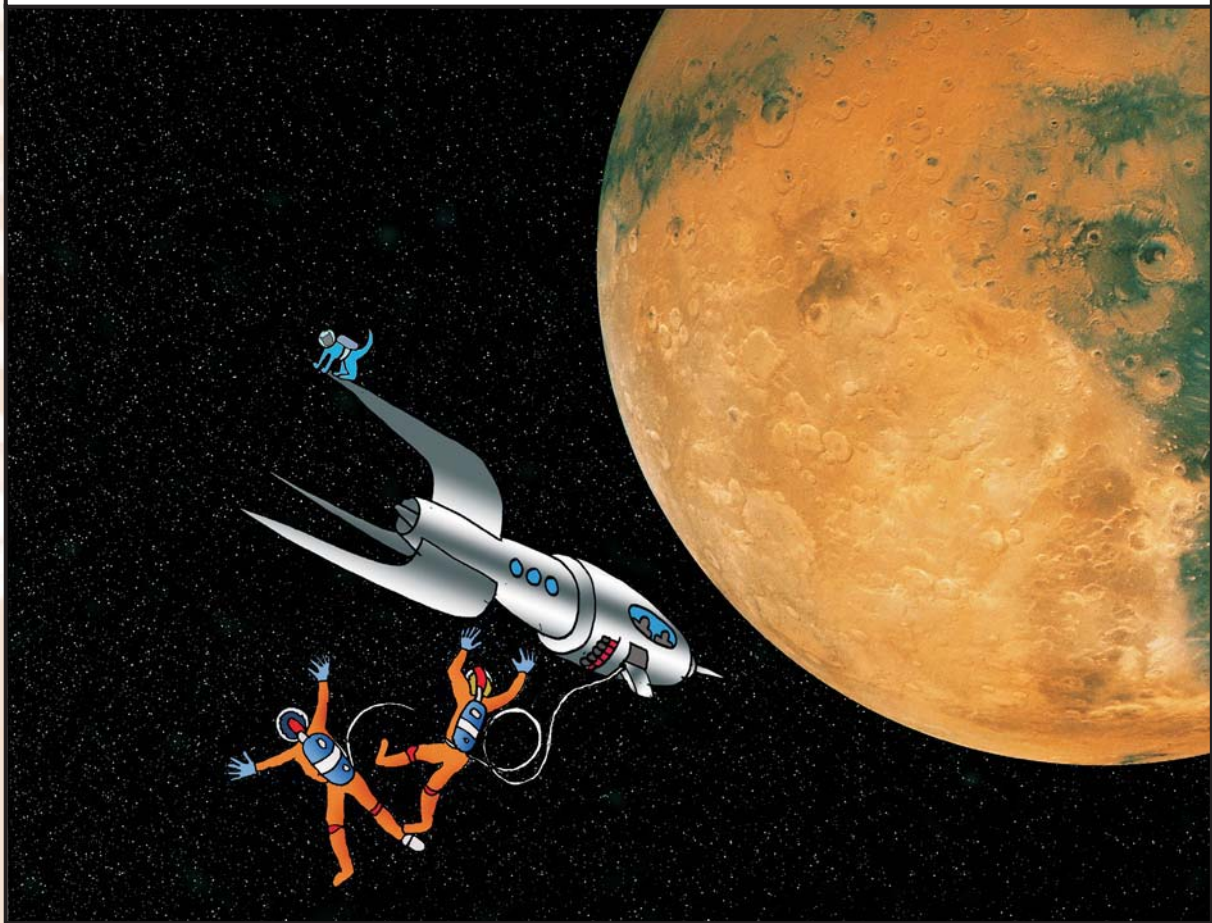

Several analyses by various groups have supported the feasibility of human missions to Mars ten to thirty years hence. But, as *Donald Rapp* explains here, a sober review of the requirements and challenges inherent in human missions to Mars suggests that the difficulties and impediments are considerably greater than has previously been reported. He outlines the steps needed to enable such missions to take place.

Human Missions to MARS

WHILE THE current lunar exploration initiative has been justified as a “stepping stone” toward Mars, human missions to Mars represent a major step up in complexity, scale, and rigour compared to lunar missions. Lacking a capability for rapid abort (such as exist for lunar missions), all systems for Mars missions **MUST** function for up to 2.7 years and there is no escape if a subsystem fails. Previous design

reference missions (DRMs) that outline future human missions to Mars have typically adopted optimistic assumptions regarding key technical capabilities: (1) nuclear thermal rocket (NTR)

■ **Below:** Artist's impression of impending docking manoeuvre between the Mars Ascent Vehicle (small vehicle at left) and Earth Return Vehicle (ERV) – the larger vehicle with solar arrays. The crew transfers to the ERV prior to leaving orbit and returning to Earth. Artwork produced for NASA by John Frassanito and Associates.

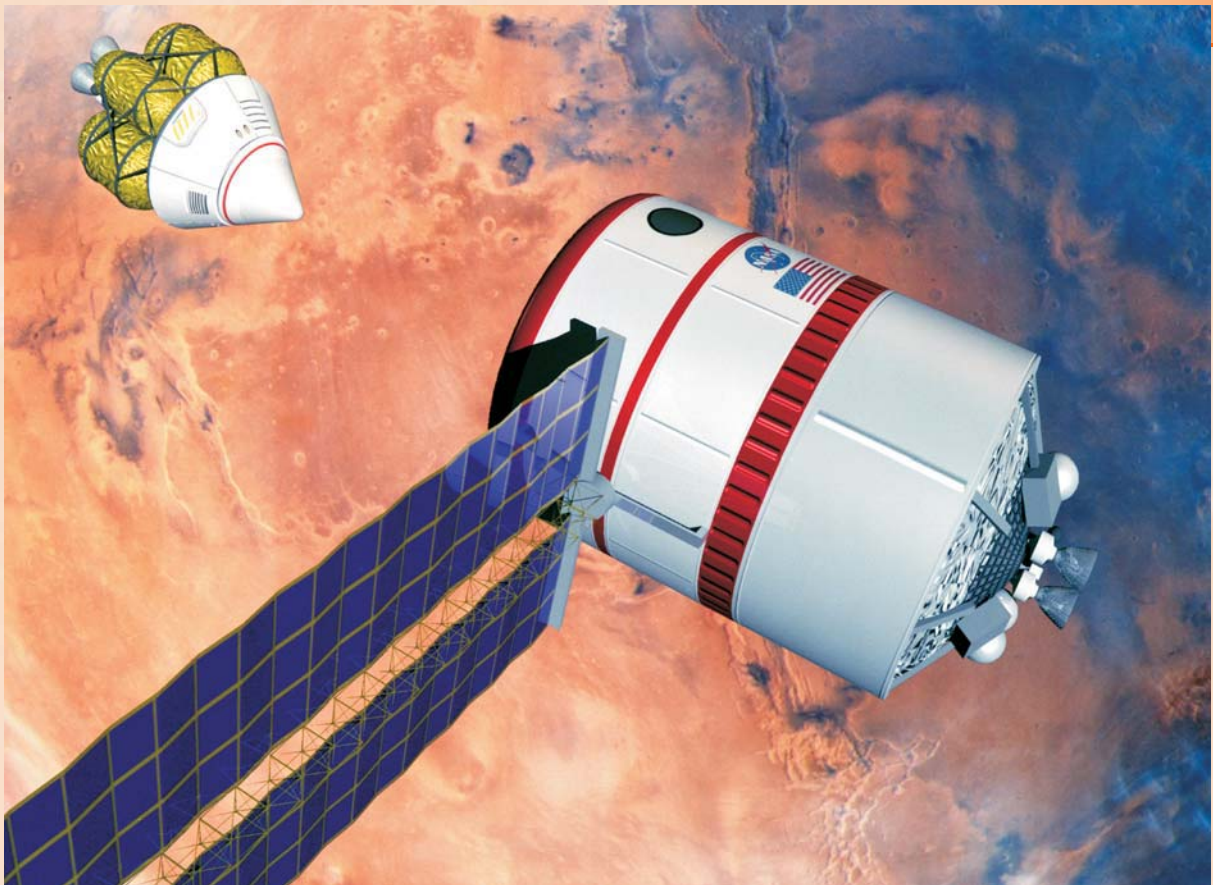

performance, (2) mass of aero-entry systems at Mars, (3) radiation shielding, (4) effects of zero-g, (5) efficiency and mass of life support systems, and (6) abort opportunities. With these assumptions, a case has been made that human missions to Mars could be feasible by perhaps 2040.

However, when a more realistic analysis is made of these factors, it seems likely that (1) the benefits of the NTR may be minimal, (2) entry systems may have more than twice the mass that was assumed in the past, (3) radiation poses a major threat and shielding does not provide full protection, (4) the effects of zero-g are debilitating and the requirements for artificial gravity systems will drive up mission complexity and cost, (5) life support systems must function for ~ 2.7 years without failure, and masses of these systems may be higher than suspected, and (6) there are no realistic abort possibilities for Mars missions. As a result, previous design reference missions for sending humans to Mars appear to be guilty of “irrational exuberance” and a costly multi-decade development programme will be needed to enable human missions to Mars. Since NASA seems to be bogged down with costs for its lunar initiative until ~ 2030, it seems unlikely that a human mission to Mars can be contemplated prior to ~ 2060, and maybe well beyond that date.

The Round Trip

The Earth circulates around the Sun in its orbit at the rate of 360° per Earth year, whereas Mars circulates at the rate of 191° per Earth year. Both planets move in the same direction around the Sun. The lowest energy trajectory from LEO to Mars is the so-called Hohmann trajectory that is tangent to the Earth’s path at departure, and tangent to the Mars path at arrival, since the thrust imparted to the spacecraft is always in the direction of spacecraft motion. Similarly, a Hohmann transfer trajectory can be defined for return from Mars to Earth.

Because of the requirement that the two planets, Earth and Mars, be positioned appropriately for a transfer between them, realistic opportunities for transfers to Mars occur for limited periods (several weeks) every 26 months. That means that sequential departures for Mars must be spaced by approximately 26-month periods. The elapsed time for a round trip at any opportunity is about 2.7 years, with 6-9 months for transit to Mars, 6-9 months for return to Earth, and 14-20 months spent at Mars.

If a more powerful propulsion system is used, generating a higher change in velocity (Δv) than the minimum (the Hohmann), the trip time can be reduced. However, one must still wait for the proper orientation of the two planets prior to return from Mars, and therefore the elapsed time from Earth departure to ultimate Earth return will not change much as Δv is increased. Hence, as Δv is increased, the trip times to and from Mars are decreased, but the length of stay on Mars is increased, so that the overall mission duration does not change much.

Abort Options and Safety

The word “abort” occurs 314 times in the 2005 NASA ESAS Report for lunar human missions. Evidently, NASA is keenly aware of the dangers involved in human missions into deep space and has made plans and allowances for “aborting” missions if serious problems arise. It should be emphasized that an escape route is always present from lunar orbit or the lunar surface in case there is a subsystem failure.

However, Mars provides a very different story. Although all of the abort modes during launch and LEO operations that were designed for lunar missions should be applicable to Mars missions as well, abort options downstream of LEO become problematic for Mars missions. If on arrival at Mars a problem develops, the propulsion requirements for immediate return are huge. Hence it becomes necessary to remain in the Mars vicinity for a considerable length of time (typically 500 - 600 days, depending on specific launch date and mission design) before attempting to return.

The present ESAS plan for Mars human missions involves the crew descending to the surface to conduct an exploratory short-term stay and after perhaps 30 days, they will make a “go/no go decision” for the surface stay mission. If surface systems and operations are functional and satisfactory, they will remain on the surface for the full 500-600 days. If not, they will return to orbit and transfer to the Earth Return Vehicle. However, if they return to orbit, the consequences are:

■ **Life support for an additional 500-600 days must be added to the Earth Return Vehicle to support the crew in orbit for that period, thus driving up the mission mass and cost**



■ The later stages of descent and landing are assisted by large parachutes. Minutes before landing, the spacecraft is slowed by the deployment of parachutes. Once these have been jettisoned, the actual touchdown will be achieved by propulsive braking. Artwork produced for NASA by Pat Rawlings, Eagle Engineering Incorporated.

- The crew will be exposed to zero-g for the additional 500-600 days in orbit unless artificial gravity is implemented in Mars orbit – which seems very unlikely
- The crew will be exposed to excessive radiation for the additional 500-600 days in orbit, having lost the benefits of (a) shielding by the planet from below, (b) shielding provided by the atmosphere, and (c) use of regolith piled on top of the habitat as shielding
- The psychological effects of sequestering the crew into a small habitat in space for this length of time are likely to be debilitating.

Although NASA continues to promulgate this approach, it is clearly not viable and furthermore it defeats the whole basis for going to Mars – which is to explore the surface in situ. The point is that NASA must do the preliminary work to assure that all systems are utterly reliable and fail-safe, which includes many un-crewed robotic demonstration missions – something that NASA does not seem disposed to do.

Initial Mass in Low Earth Orbit

Because of the difficulties in estimating the cost of a futuristic space mission, a widely accepted surrogate for mission cost for human missions to Mars is the initial mass in low Earth orbit (IMLEO). Therefore, a primary concern for mission designers is estimation of IMLEO.

All NASA plans for human missions to Mars involve transfer of some assets (mass = M_{MO}) to Mars orbit, and some assets (mass = M_{MS}) to the Mars surface. The resultant IMLEO can be calculated by multiplying each figure (M_{MO} or M_{MS}) by its appropriate “gear ratio:” the mass required in LEO to deliver one mass unit to Mars orbit or to the Mars surface. The gear ratios depend upon the propulsion systems or aero-entry systems used in each step along the trajectory. Previous estimates of IMLEO for human missions to Mars have been optimistic. Using LOX-LH2 propulsion for Earth departure, Methane-LOX propulsion at Mars, and recent Georgia Tech estimates for the masses of entry

Estimated IMLEO (metric tons) using a fast trip to Mars and full aero-assist at Mars for any combination of masses delivered to orbit and delivered to surface.

		M_{MO} = Mass sent to Mars orbit (mT)				
		20	40	60	80	100
M_{MS} = Mass sent to Mars surface (mT)	20	337	444	551	658	764
	40	568	674	781	888	995
	60	798	905	1012	1118	1225
	80	1028	1135	1242	1349	1456
	100	1259	1366	1472	1579	1686

systems, the values of IMLEO for arbitrary M_{MO} and M_{MS} are shown in the Table above. These estimates for IMLEO are considerably higher than those estimated previously by others.

Propulsion and Aero-Entry Systems

Three of the major steps in a Mars mission that determine IMLEO are (1) Earth departure, (2) Mars orbit insertion, and (3) Mars descent and landing (from orbit). The conventional approach

to Earth departure uses chemical propulsion with LOX-LH2 propellants. This requires ~3 mass units in LEO to send 1 mass unit on its way toward Mars (gear ratio for Earth departure step = 3). It has been proposed that a nuclear thermal rocket (NTR) could replace chemical propulsion for this step, resulting in a reduction in the gear ratio, thus reducing IMLEO. The performance of an NTR depends on two important parameters: (1) the ratio of propulsion system dry mass to hydrogen propellant mass (dry mass ratio), and (2) the minimum altitude allowable for igniting the NTR (due to safety and political concerns).

■ **Below:** The landing site for a human outpost on Mars will require multiple landings at the same site in order to link up the individually delivered surface modules to house greenhouse experiments, biological research, geochemical analysis of samples, and crew habitats. Two joined surface modules are shown in this artist's impression. Artwork produced for NASA by John Frassanito and Associates.

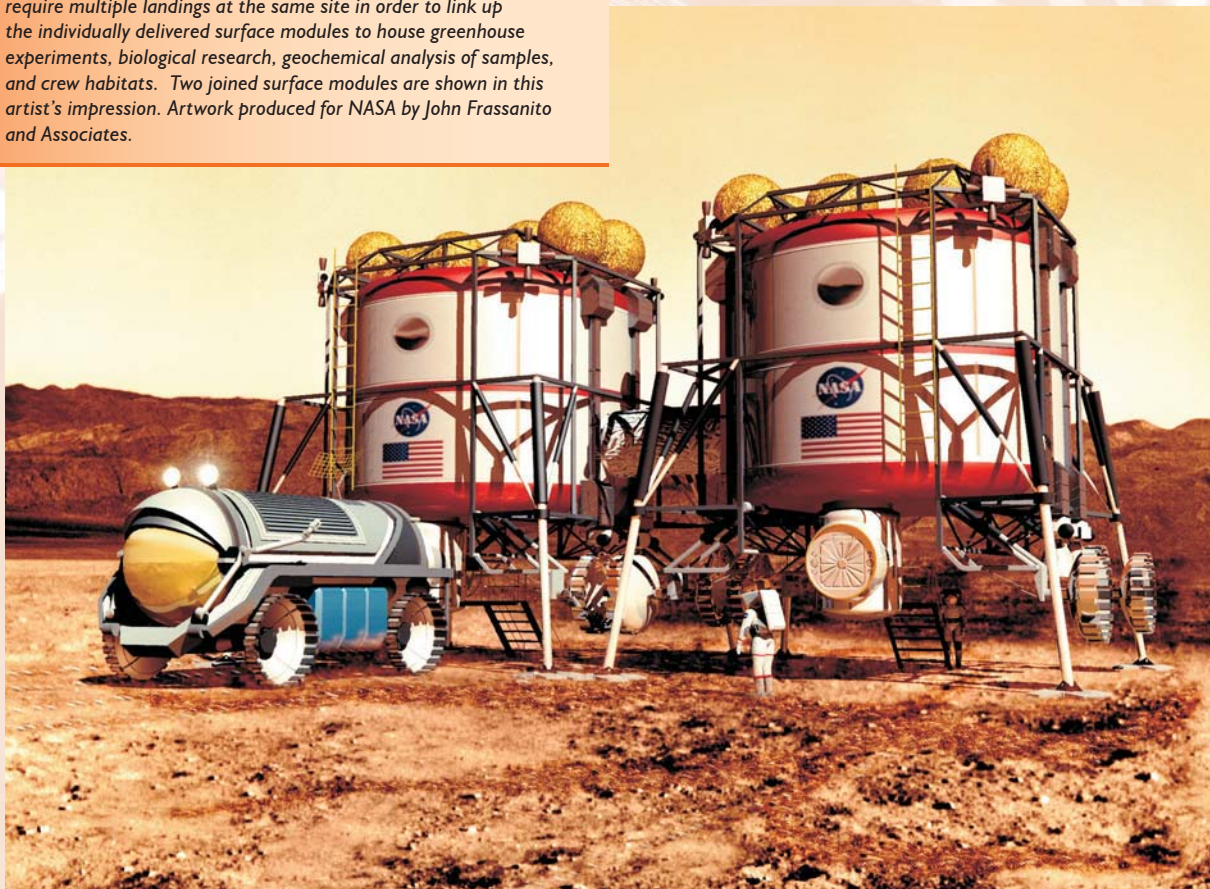

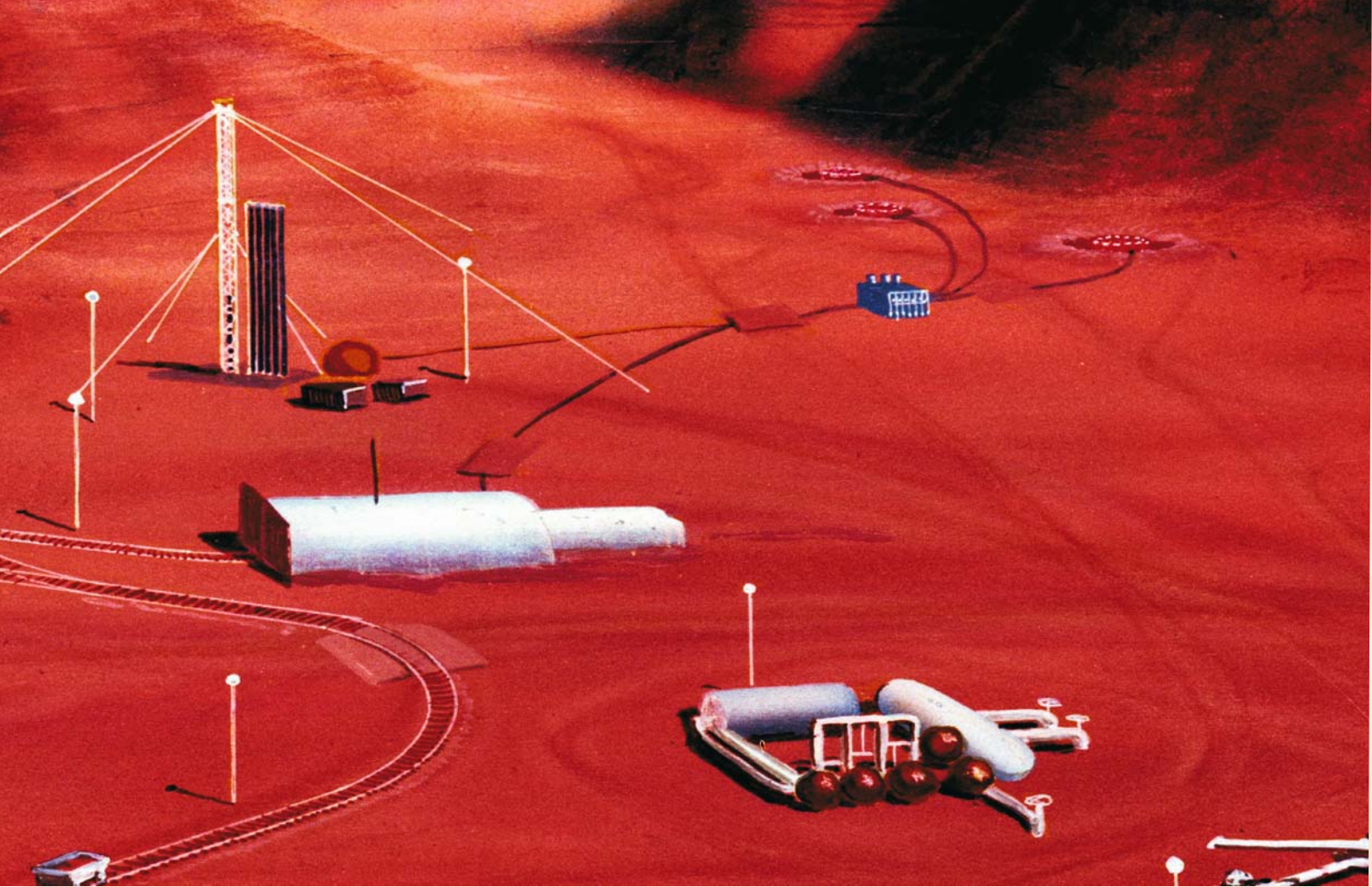

If the dry mass ratio is low, and if the NTR can be fired up in LEO, significant benefits may accrue from use of the NTR. However, for higher dry mass ratios and minimum altitudes > 1000 km, most (or all) of the benefit of using the NTR will disappear. For a dry mass ratio of 0.5 and a start-up altitude of 1250 km, the gear ratio using NTR is 2.8, as compared to 3.0 for chemical propulsion. The high cost and risk for NTR development would not be justified by this small improvement.

Most design reference missions utilize aerocapture for Mars orbit insertion and aero-assist for descent and landing because this leads to significant reductions in IMLEO compared to all-propulsive entry and descent. However, the masses assumed for the entry systems limit the magnitude of the gain from use of aero-assist. In the past, NASA DRM's utilized low estimates for the mass of entry systems, but the analyses leading to these low estimates were never published. Recently, a Georgia Tech. group has published a thorough and detailed study

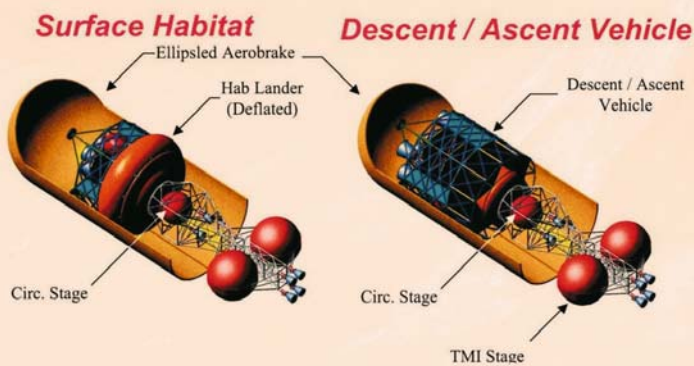

■ **Above:** Artist's concept of a substantive Mars outpost showing multiple assets deployed after multiple precision landings. Artwork produced for NASA by Pat Rawlings, Eagle Engineering Incorporated.

■ **Left:** In 1999 a mission study was conducted at NASA's Johnson Space Center to investigate the 'Dual-Landers' concept for packaging Mars landed assets into aeroshells for transport to Mars and aero-entry at Mars. Image courtesy NASA.

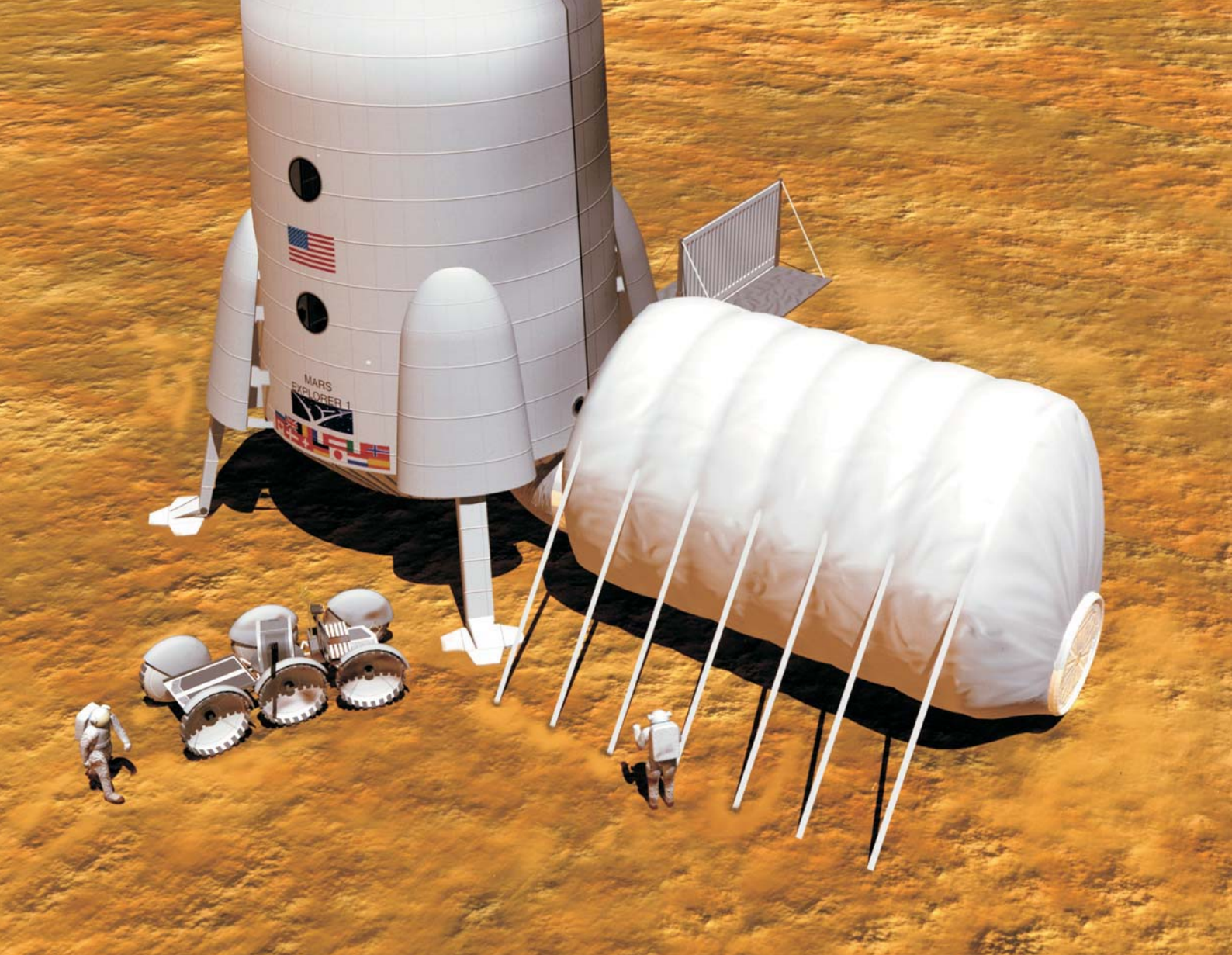

of aero-entry at Mars and derived much higher masses for entry systems. Thus, JSC assumed that 70% of the total mass approaching Mars can be landed as payload, whereas Georgia Tech. predicts that only 30% can be landed as payload. The later stages of descent and landing are assisted by large parachutes. Ultimate touchdown is achieved with propulsive retardation after jettisoning the parachutes.

Using full aero-assist at Mars, with LOX-LH2 propulsion used for Earth departure, the gear ratio for transfer from LEO to Mars circular orbit is estimated to be ~5, and the gear ratio for transfer from LEO to the Mars surface is ~11. These gear ratios are considerably higher

than has been assumed in the past by NASA in developing DRMs.

In addition to the mass requirements for aero-entry, it will also be necessary to perform pinpoint landing in order to combine the assets of multiple flights to a single landing site. Multiple assets will be needed, and it is unlikely that these can be landed by one vehicle.

Another important factor is the size of major elements of the exploration system, particularly habitats, and how these may be packaged into aeroshells that can be launched from Earth.

Radiation

Radiation in space poses a threat to humans embarked on missions to the Moon or Mars. There is considerable uncertainty as to the biological effects of various levels of radiation exposure, and how much exposure should be permitted in deep space. Preliminary estimates

■ **Above:** Current concepts for surface habitats on Mars are amenable to being protected from radiation by having regolith piled over them. Shown here is a two-storey lander/habitat, an inflatable laboratory and an unpressurized rover. Artwork produced for NASA by John Frassanito and Associates.

Estimated risks of exposure-induced death associated with round trip human missions to Mars

When?	Thickness of aluminum shielding (g/cm ²)	Indicated Dose Equivalent (Sv)	Indicated REID (%) (point estimate)	95% confidence risk of exposure-induced death (REID) (%)
Solar	5	1.07	5.1	16.4
Minimum	20	0.96	4.1	13.3
Solar	5	1.24	5.8	17.3
Maximum	20	0.60	2.9	9.5

indicate that radiation effects will be at least a serious problem for Mars missions, and may be a “show stopper.”

For a Mars surface mission involving ~400 days of transit in space plus ~600 days on the surface, the total exposure (dose equivalent) has been estimated assuming protection afforded by 5 (or 20 g/cm²) of aluminum wall (5 or 20 g/cm² corresponds to about 2 cm (or 8 cm) thickness of aluminum) at Solar Minimum and Solar Maximum. The estimated dose equivalents are due to a sum of GCR and SPE radiation sources. Recent analyses of radiation effects provide results in terms of the risk of exposure-induced death (REID) based on any computed dose equivalent,

but the uncertainties in REID are large. To assure 95% confidence for the estimate of REID the results are as shown in the Table above. A 10-17% risk of exposure-induced death would be unacceptable.

It has been suggested that regolith could be piled on top of the surface habitat to act as radiation shielding, but current concepts for habitats are not compatible with the use of regolith for shielding.

■ **Below:** Typical concepts for creating artificial gravity involve placing the crew in a habitat module at one end of a truss with a ‘counterweight’ (e.g. an empty propulsion module or a nuclear reactor) at the other end, and rotating the entire structure at a rate of several revolutions per minute. Image courtesy NASA.

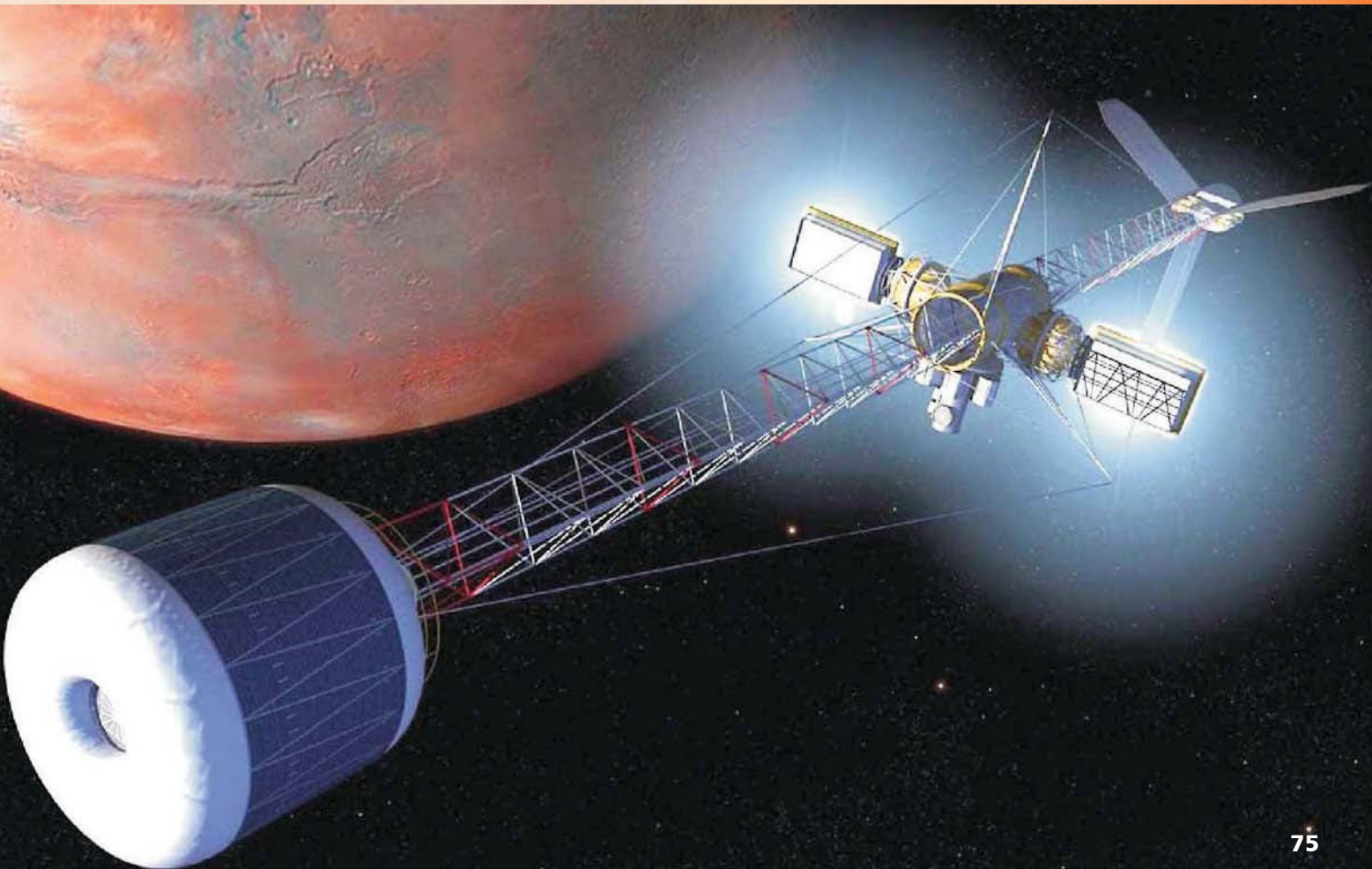

Zero-Gravity

According to Whedon and Rambaut (W&R): "One of the major effects of prolonged weightlessness seen in long-duration space flights has been an extended loss of bone from the skeleton." Metabolic studies carried out on the Skylab flights provide a wealth of data. It is noteworthy that there are close similarities in pattern and degree between space flight and bed rest in effects on calcium metabolism. W&R conclude that "The pattern of the rise in urinary calcium excretion in Skylab was strikingly similar in the two lack-of-weight-bearing conditions: bed rest and space flight in proportion to the extent of physical inactivity. W&R also discuss recovery upon return to Earth: "Of the three Skylab astronauts who lost bone in flight only one showed recovery, observed at 90 days post-flight; ... all three showed additional bone loss 5 years later, ranging from ~3.4% to ~5.6% from their 90 day post-flight values." W&R note that: "... assuming bone is lost at the same rate during 2-year flights as in 3-months flights,

the localized lower limb bone loss might be so great as to present an immediate threat of fracture to astronauts either at landing on Mars or on returning to Earth." Finally, W&R conclude that: "... studies of recovery of bone lost during space flight show that it is either slow, incomplete or not at all and highly variable from one astronaut to another." It is also stated that "current exercise countermeasures applied during exposure to microgravity have not been completely successful in maintaining or restoring impaired musculoskeletal and cardiovascular functions."

Artificial gravity for human missions has been discussed by a number of NASA engineers. Nevertheless, fundamental questions remain regarding the acceptable and/or optimal ranges for radius and angular velocity of a rotating space vehicle or centrifuge and the physiological thresholds for effective gravitational force. NASA-JSC reports describe several conceptual artificial gravity systems based on rotating trusses, while Mars Direct suggested a tether system for connecting the trans-habitat to a counterweight. However, none of these concepts provided artificial gravity for the return trip to Earth. It seems likely that technically, mitigation of zero-g health effects can be

Below: As this diagram suggests, Environmental Control and Life Support Systems (ECLSS) are complex interactive systems. Image courtesy NASA.

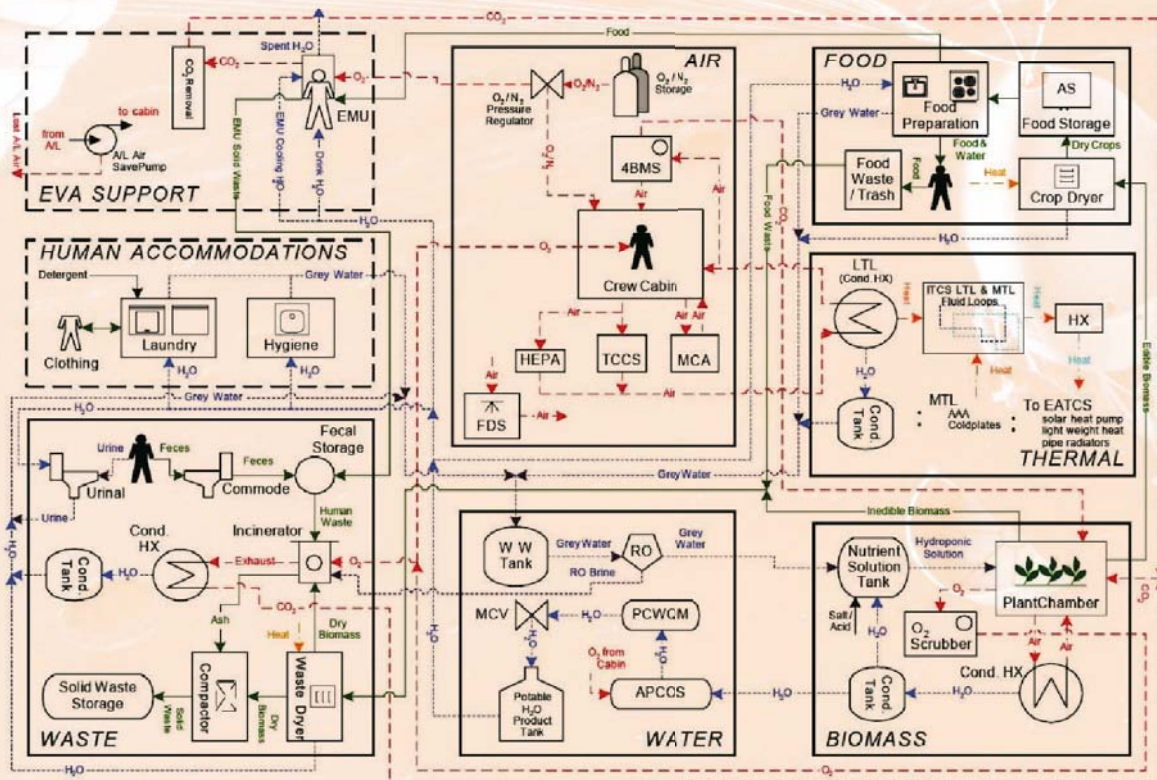

achieved to some degree with some form of artificial gravity – with a considerable increase in mission complexity (and cost). Some concepts of an artificial gravity system place the crew in a module at one end of a rotating truss to provide a centrifugal force. However, considerably more research needs to be done on physiological effects vs. design parameters (rotation speed, rotation radius, etc.), prospective designs for trusses and configurations of artificial gravity systems including packaging and deployment in space, methods and procedures for steering the structure, and realistic cost estimates for development, validation and implementation need to be made. A remaining unknown is the effect of ~550 to 600 days on the surface of Mars in a gravity field of about 0.38 of that on Earth.

Life Support

The total amount of life support consumables required for a putative crew of six on a 2.7-year round trip to Mars is shown in the Table below. Without recycling, the total required mass of consumables is about 200 metric tons – a clear show stopper. It is usually assumed that the consumables (other than food and waste disposal materials) can be recycled in an environmental control and life support system (ECLSS) that maximizes recycling of waste products.

The two critical parameters involved are the recycle efficiency and the mass of the recycling plant. The required mass of the ECLSS is the sum of the plant mass plus the mass of a backup cache needed for replacement of materials lost during recycling. Previous Mars design reference missions have blandly assumed recycle efficiencies in the 98-99% range and have typically assumed minimal plant masses. However, unlike life

support systems for the ISS (or even for the Moon) where immediate abort capabilities exist in case of malfunction, life support systems for Mars must function flawlessly for the 2.7-year round trip. It is likely that considerable redundancy will be required, driving up the required mass. The NASA Advanced Life Support (ALS) team has carried out preliminary analyses of Mars life support systems. The ALS estimate for the sum of plant mass and backup cache is shown in the lowermost row of the Table below. The ~ 200 tonne requirement is supplied by a ~ 38 tonne ECLSS. However these estimates do not include margins, redundancy or spares. Whether such performance can be achieved with the ultra-high reliability that is needed remains doubtful. Furthermore, design reference missions have typically allocated far less than 38 tonnes to life support. Assuring longevity of low-mass ECLSS remains a major challenge for human missions to Mars.

In Situ Resource Utilization

It requires less Δv to insert an incoming spacecraft into an elliptical orbit than it does into a circular orbit. Similarly, it is easier to depart an elliptical orbit to return to Earth. However, it requires a great deal more propellant to ascend from the Mars surface to an elliptical orbit than it does to ascend to a circular orbit and this is the transcendent factor. The mass of ascent propellants becomes problematic when an elliptical orbit is used if ISRU is not employed to produce propellants. Therefore, if ascent propellants are brought from Earth, the circular orbit is preferred. However, if the ascent propellants are manufactured on Mars, there are advantages in using an elliptical orbit.

Gross life support requirements for a human mission to Mars without the use of recycling or in situ resource utilization for a crew of six (metric tons)

Mission Phase →	Transit to Mars	Descent	Surface Stay	Ascent	Earth Return
Duration (days)	180	15	600	15	180
Water	29	2	100	2	29
Oxygen	1.1	0.3	4	0.3	1.1
Food	1.6	0.1	5.4	0.1	1.6
Waste Disposal Materials	0.6		1.8		0.6
Buffer Gas	3.3	0.9	12	0.9	3.3
Total Consumed	36	3	123	3	36
ALS Estimated ECLSS mass	5.0	3.1	21.8	3.1	5.0

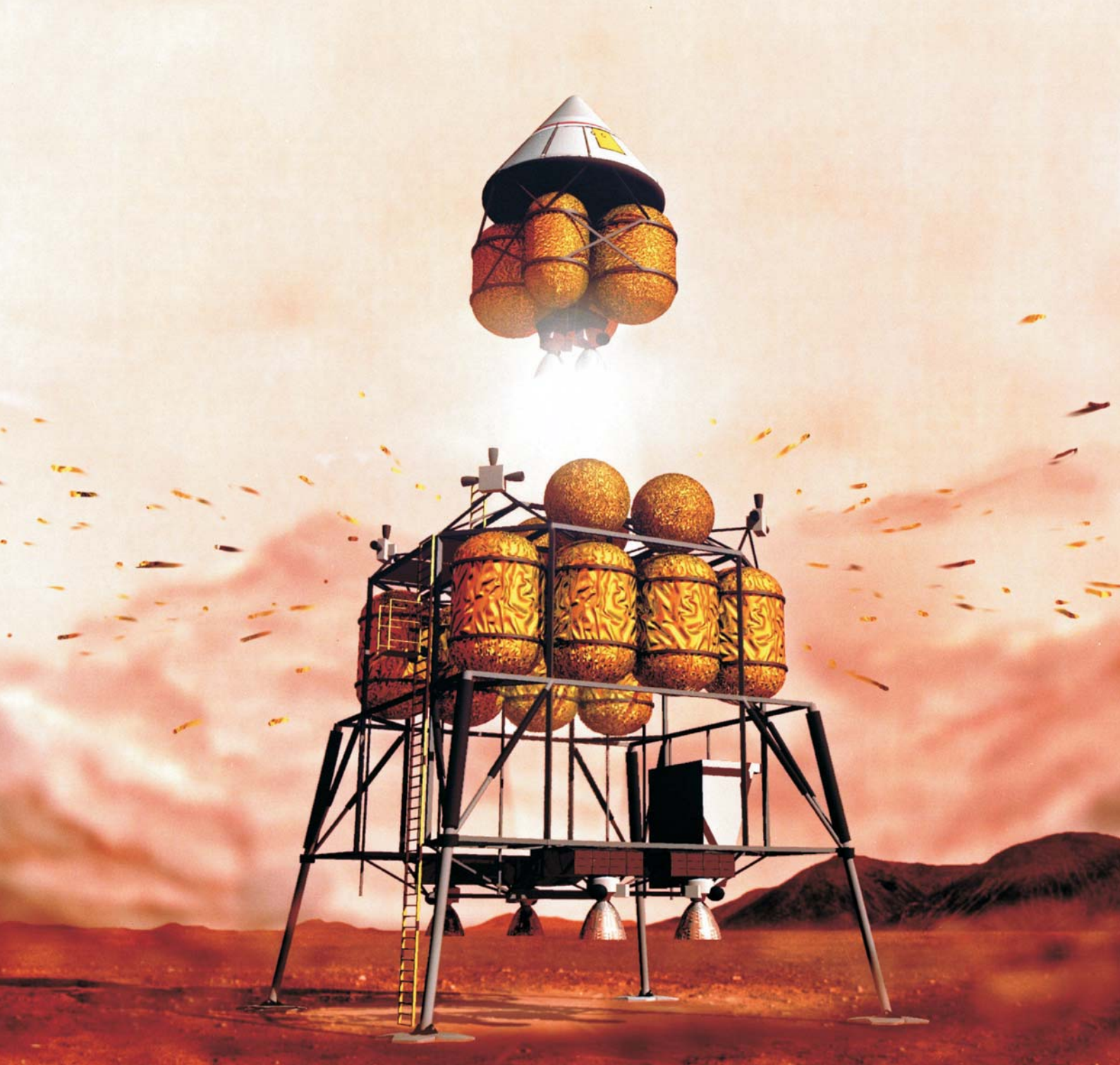

The most straightforward approach to Mars ISRU is to excavate regolith, extract water from the regolith, and react it with CO_2 from the Mars atmosphere, producing CH_4 and O_2 . Unfortunately, NASA has concentrated all of

■ **Above:** After a period on the Martian surface, the Mars Ascent Vehicle lifts off to rendezvous with the Earth Return Vehicle. Ascent from Mars to martian orbit requires a heavy load of propellants if rendezvous occurs in an elliptical orbit. Artwork produced for NASA by John Frassanito and Associates.

its ISRU funding on lunar ISRU that does not seem to have a useful benefit/cost ratio, and is investing nothing in Mars ISRU technology. It has been estimated that the reduction in IMLEO when ISRU is employed may be of the order of ~ 450 mT. This estimate is based on guesses for vehicle masses, and therefore is only suggestive of orders of magnitude. But this gain will only be achieved if it is built into the original mission design. If ISRU is tacked on as an afterthought, late in the campaign, the benefits will be reduced.

Summary and Conclusions

Previous “design reference missions” that outline future human missions to Mars have typically adopted optimistic assumptions regarding key technical capabilities: (1) nuclear thermal rocket (NTR) performance, (2) mass of aero-entry systems at Mars, (3) radiation shielding, (4) effects of zero-g, (5) efficiency and mass of life support systems, and (6) abort opportunities. When these issues are examined dispassionately it is found that the impediments to human missions to Mars are considerably greater than has heretofore been indicated.

A costly multi-decade technology development and demonstration programme must precede actual human missions to Mars. Some demonstrations will have to be made in space, and some will have to be done at Mars. Long-term performance of life support systems must be demonstrated, and long-term exposure to radiation and zero-g or low-g must be mitigated. Aero-entry of large systems at Mars must be demonstrated along with pinpoint landing. Storage of cryogenic propellants for multiple years must also be demonstrated.

Planning for human missions to Mars must use realistic estimates for IMLEO, and if, as seems likely, IMLEO is ten or more times the capability of the planned heavy lift launch vehicle (~ 125 tonnes to LEO), the capability to assemble systems in LEO prior to trans-Mars injection will need to be demonstrated.

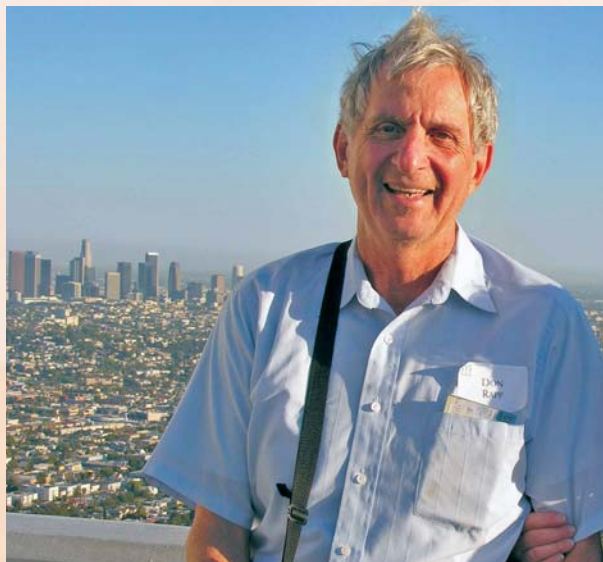

Spanning a 48-year career in science and engineering, **Dr. Donald Rapp** has published over 70 refereed articles and three textbooks, taught for 14 years in universities, managed programs for NASA for 25 years, and spent the last three years analyzing human missions to Mars. Noted for his independence of thought, he provides new insights that you won't find in the official documents.

■ This is an artist's impression of a possible future scene showing astronauts working on the surface of Mars. The area depicted is Noctis Labyrinthus in the Valles Marineris system of enormous canyons. The scene is just after sunrise, and on the canyon floor over six kilometres below, early morning clouds can be seen. The frost on the surface will melt very quickly as the Sun climbs higher in the Martian sky. Image courtesy NASA.



6

Beyond the **SOLAR SYSTEM...**

With her trusty deep space kats Bits and Gala on board, Bunny set the KatProbe's controls for deep space!!

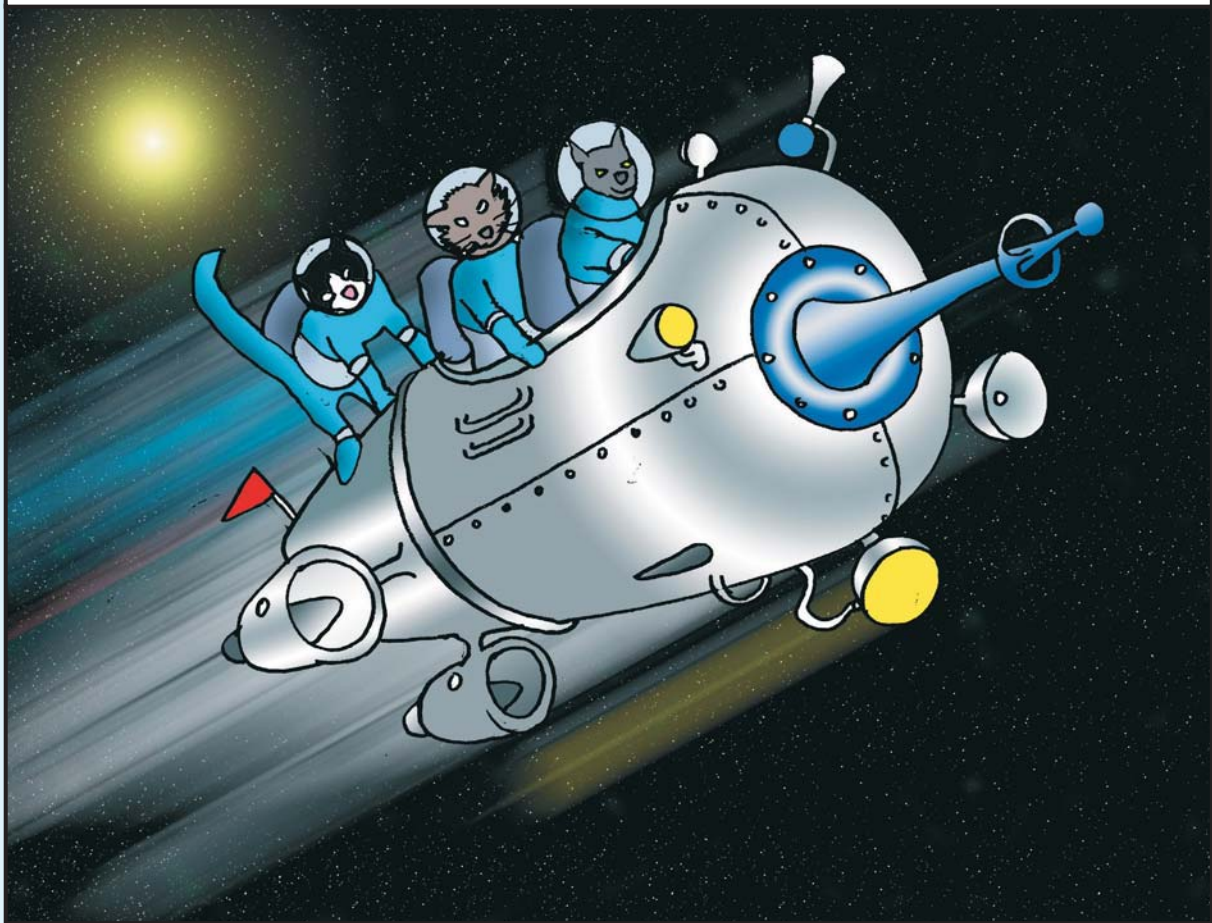

Space is a very big place. As *Gregory Matloff* explains, if we wish to probe the outer limits of our Sun's galactic influence, the heliopause, the flight will take decades even with the best feasible propulsion technology. Communication with probes at the edge of the galactic abyss will also be far from instantaneous, because of the limitation that nothing can exceed the speed of light. You'd better bring plenty of reading matter if you wish to explore the frigid, dark spaces beyond the orbit of Neptune!

Technologies for ULTRA-DEEP SPACE PROBES

WHEN YOU look at the night sky, it is not immediately apparent how big the solar system is compared with the ordinary scale of human events, and how tiny it is compared with the vaster universe beyond. A simple thought experiment can help you get a grip on these immensities.

Okay, so you're a bit jaded with terrestrial destinations and a visit to the International Space Station strikes you as a bit of a bore. So let's add another chemical stage to your rocket and you can leave Earth en route to the Moon at a velocity of about 11 kilometres per second. The Moon, our nearest celestial neighbour, is about 400,000 kilometres distant.

A roundtrip without stopping takes something like a week. Unfortunately, the Moon has little or no water, atmosphere, or native life. If you're in the mood to search out these commodities, slightly more energy will set your ship on course for Mars.

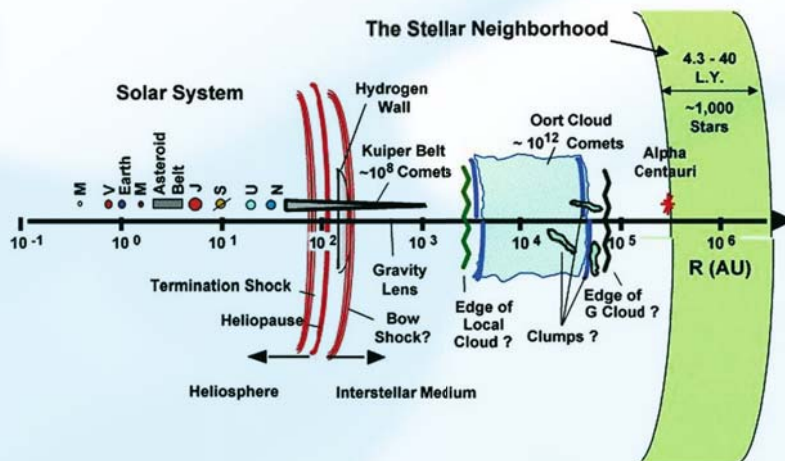

The Scale of Space

Suppose that you have at your disposal a large chemical rocket and you'd like to use it to perform a space voyage. If it is like the Ariane launcher or the Space Shuttle, you could use it to place a payload – perhaps yourself – in a low orbit around the Earth. Travelling at about 8 kilometres per second, you will circle the globe in 90 minutes or so. Not counting take off and landing, you could fly from London to Sydney, Australia in perhaps 45 minutes. Security, passport control and baggage retrieval will take a good deal longer!

At its closest, Mars is about 60 million kilometres from Earth. But today's spacecraft are not energetic enough to fly a straight-line trajectory between Earth and Mars. Instead, a Mars-bound craft travels along an elliptical solar orbit that intersects Earth and Mars. Even very energetic craft cannot make a one-way trip to Mars in much less than 6 months. And if we used the most energetic possible space propulsion methods to travel faster, we would still be faced with a small problem – how to stop!

■ **Above:** The Scale of Space. Here interstellar distances are placed in context with distances within the solar system. Distances are shown on a logarithmic scale. The Voyager spacecraft will take 80,000 years to reach a distance equivalent to that of Alpha Centauri, the nearest star system to the Sun. Image courtesy R.A. Mewaldt (Caltech) and P.C. Liewer (NASA Jet Propulsion Laboratory).

When measuring distances in the interplanetary realm, units such as kilometres become unwieldy. Instead, astronomers and astronauts utilize the Astronomical Unit (AU). One AU is the average distance between the Earth and the Sun, which is about 150 million kilometres. Mars, which is in a rather elliptical solar orbit, is on average 1.52 AU from the Sun.

Mars, the Red Planet, is a very interesting place. About one-tenth the mass of the Earth, Mars is the fourth rock from the Sun and is considerably colder than Earth. On this small world, you would weigh about 40% what you would on Earth, so it might be a nice place to visit if you are on a diet! But hold on, the atmosphere is very thin and most of the rare Martian water is frozen in the polar caps or beneath the surface soil. Mars may have had abundant life in the distant past, but any existing Martian life forms must be very rare and probably would be found beneath the planet's surface.

Realms of Rock, Gas and Ice

If you are bound for deeper space, you might set your sights beyond Mars. Moving further out from Mars, you first encounter the denizens of the Asteroid Belt. Asteroids are small worlds of various classes – some are rocky, others are stony, and a third class consists of objects rich in frozen water and other volatile substances. The smallest asteroids are planetesimals – mountain-sized objects like those that coalesced in the early days of the solar system to form the major planets. Some of the asteroids are a few hundred kilometres in diameter, large enough to be considered dwarf planets.

Not all of these objects remain in the main belt between Mars and Jupiter; some approach the Earth rather closely. In fact, during geological time, some of these Near Earth Objects (NEOs) have collided with our planet, causing vast damage to the ecosystem. Perhaps the largest impact is that of a 10-kilometre-sized object 65 million years ago. Striking what is now the Yucatan, this impact contributed to the demise of the dinosaurs and subsequent rise of the mammals.

One driving force behind human space flight beyond the Moon will be the desire to alter the orbits of threatening NEOs and prevent such planet-wide catastrophes in the future (see the chapter by Leonard David elsewhere in this volume). And while we are altering their orbits, perhaps we'll be wise enough to mine these objects for resources that could benefit humans

living off planet. But these dwarf worlds and planetesimals may not be your final destination. Perhaps you are interested in roaming farther out from the Sun – to the realm of the gas giants.

The giant worlds – Jupiter, Saturn, Uranus, and Neptune – are many times more massive than the Earth. All have ring systems, although only those of beautiful Saturn are easily visible from Earth. All are miniature solar systems, with many satellites. Jupiter's Io, Europa, Callisto, and Ganymede are distinct planetary environments in their own right – with varied terrain and frozen seas. And beneath Europa's icy outer shell, in a planet-wide, 60-km deep ocean, alien life may lurk. Saturn's giant satellite Titan, with surface features almost certainly shaped by liquid action, has an atmosphere with essentially Earth-normal pressure, although the surface temperature is close to minus 180°C.

Reaching these distant worlds and their satellites presents a challenge. Cruising along a minimum-energy ellipse, a ship from Earth can encounter Jupiter after a journey time of about three years, but you must patiently endure six years of travel to pass through Saturn's majestic rings. The outermost planets, Uranus and Neptune, are respectively 19 and 30 AU from the Sun. Flying a minimum-energy ellipse, a probe requires about 16 and 31 years respectively to reach these distant giants and their attendant satellites.

Even our best chemical rockets are clearly not up to the task of giant planet exploration, let alone the trek to the icy comet-like bodies (including dwarf-planet Pluto) further from the Sun. Planetary exploration would be confined to the inner solar system, if it were not for a major breakthrough in the art of astrodynamics.

Gravity Assists: One Route to the Outer Giants and Beyond

In the early 1970s, Pioneers 10 and 11 pioneered a new trajectory that would later be used by Voyagers 1 and 2 and other spacecraft. By swinging past a planet in just the right fashion, a spacecraft can utilize some of that planet's angular momentum to speed its heliocentric trajectory. The planet slows down a bit (relative to the Sun) in this game of celestial billiards due to momentum conservation, but the effect on the planet's solar orbit is infinitesimal since the planet is so much more massive than the spacecraft.

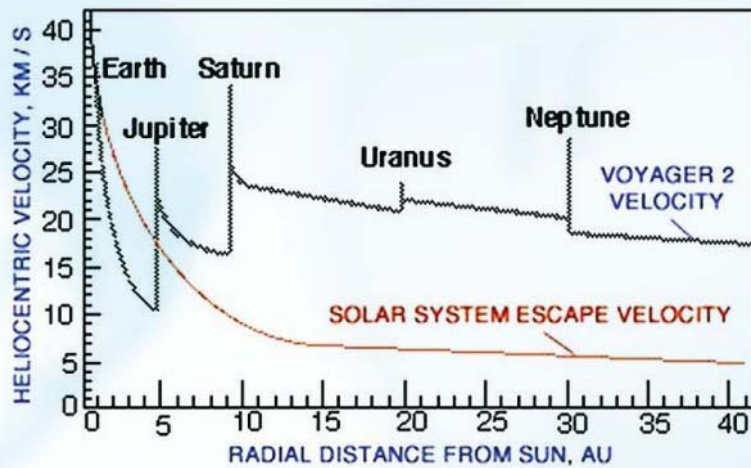

approached Jupiter with a heliocentric velocity of about 11 kilometres per second. After the planetary encounter, Voyager's heliocentric velocity was about 27 kilometres per second - sufficient to pursue the Grand Tour - but there was no net speed gain relative to Jupiter.

Using this approach, Pioneers 10 and 11 and Voyagers 1 and 2 were able to conduct the preliminary exploration of the

If a spacecraft passes close behind a planet in terms of the planet's motion around the Sun, then the spacecraft's heliocentric velocity will be increased and it will be deflected further from the Sun. If, on the other hand, it passes in front of the planet its heliocentric velocity will be decreased and will fall closer to the Sun. The closer the flyby, the greater the deflection of the spacecraft's trajectory. Voyager 2, for example,

■ **Above:** This diagram shows Voyager 2's changing heliocentric velocity with increasing distance from the Sun. Voyager leaves Earth at about 36 km/s relative to the Sun. Climbing out, it loses much of the initial velocity the launch vehicle provided. Nearing Jupiter, its speed is increased by the planet's gravity, and the spacecraft's velocity exceeds solar system escape velocity. Voyager departs Jupiter with more Sun-relative velocity than it had on arrival. The same is seen at Saturn and Uranus. The Neptune flyby design put Voyager close by Neptune's moon Triton rather than attain more speed. Diagram courtesy Steve Matousek, NASA Jet Propulsion Laboratory.

■ An artist's impression of the Orion spacecraft that would use nuclear pulse propulsion to achieve both high thrust and high specific impulse – the holy grail of space propulsion. The idea of nuclear pulse propulsion was first proposed by the Polish born American mathematician Stanislaw Ulam in 1947. Although its supporters felt that it had great potential for space travel, it lost political approval because of concerns about radioactive fallout as it lifted off! Image courtesy NASA.

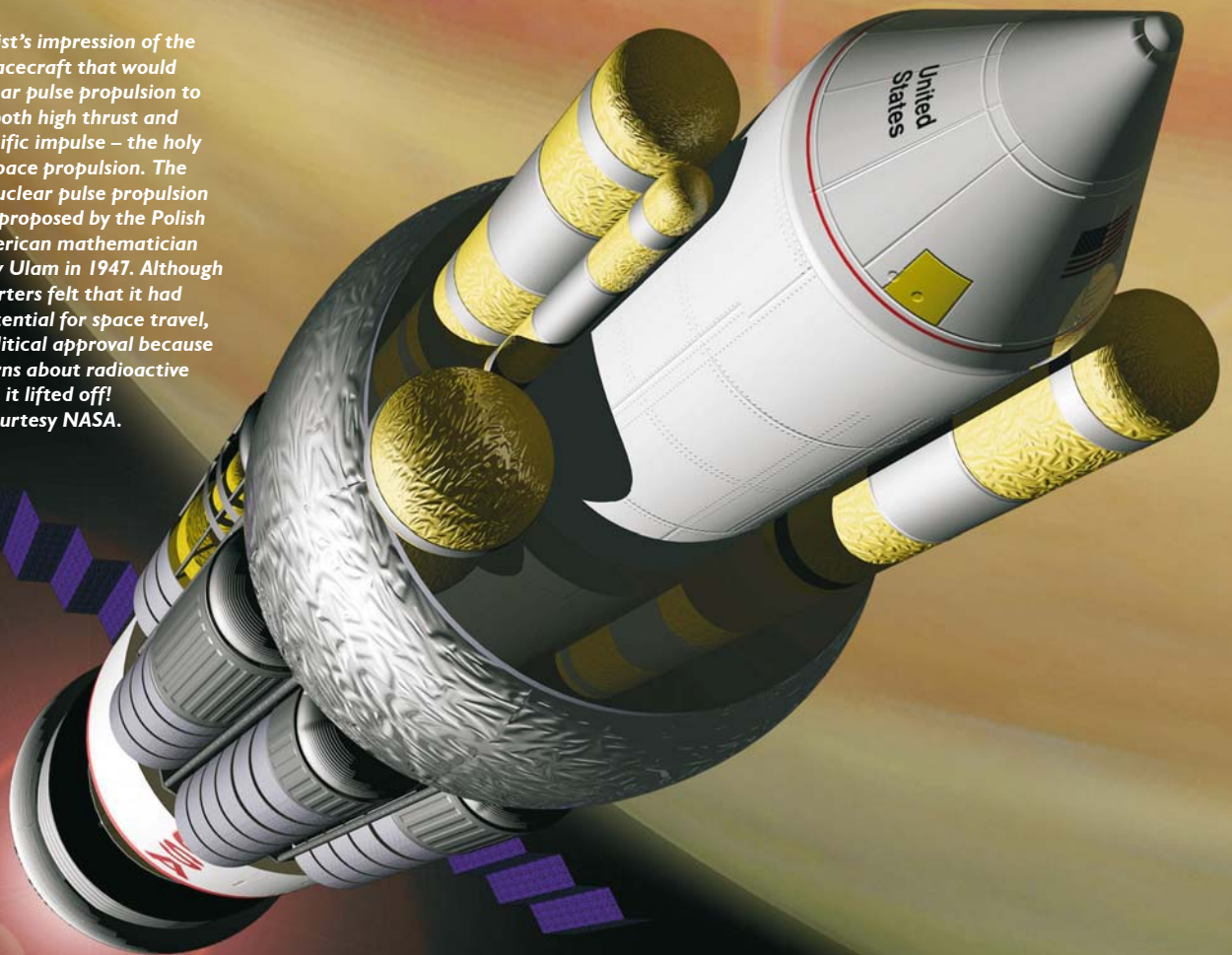

giant worlds within a reasonable time frame. Only about a dozen years separated Voyager 2's launch from its flyby of Neptune and its farewell to Sol's planetary system. Since then, other spacecraft have utilized planetary gravity assists. Ulysses used a Jupiter pass to alter its solar orbit; Galileo used multiple passes of Venus and Earth to reduce fuel requirements (with the trade of longer mission time) during its voyage to Jupiter.

The Voyagers are the current speed demons among humanity's deep space craft. Now approaching the heliopause – the boundary of the Sun's galactic influence at about 100 AU, they are speeding towards the stars at about 3.5 AU per year. Although this speed (about 17 kilometres per second) is enormous by terrestrial standards, Voyager would require more than 70,000 years to traverse the separation between the Sun and its nearest interstellar neighbours using Jupiter to fling our probes.

We can improve things a bit using powered planetary gravity assists and using Jupiter to fling our probes sunward to perform powered solar gravity-assist manoeuvres. But it is most unlikely that such gravitational billiard games will reduce interstellar transit times much below 10,000 years.

So if we desire to explore the icy Kuiper Belt dwarf planets beyond Pluto, or the more distant Oort Belt comets, or if we become ambitious enough to launch expeditions to the nearest stars, we'll need something better than gravity assists. Although many propulsion systems have been proposed, only a few have survived the engineers' scrutiny to become true candidates for ultra-deep space exploration.

Nuclear-Pulse: Don't Ban that Bomb!

Early in the Space Age, analysts funded by the US Department of Defense were issued a challenging assignment. Assuming that the USSR secretly placed nuclear bombs in arbitrary storage orbits, would it be possible to design a high-performance, manned space interceptor that could fly to the orbiting weapon and deactivate it? The concept

■ **Below:** A schematic of the Project Orion spacecraft. Project Orion was born in 1958 at General Atomics in San Diego with the objective of providing cheap interplanetary travel. The driving force behind Project Orion was Theodore Taylor, a veteran of the Los Alamos weapons programs, but he was assisted by the great physicist Freeman Dyson who went to San Diego from Princeton to work on the project. Image courtesy NASA.

**Nuclear Concepts
Project Orion**

1958-1965 Ted Taylor, et al.

10^2 - 10^3 T
payload
& crew

10^3 - 10^4 Isp
Accel \approx 1g

10^{-2} to 10^3 T
Fission
explosions
 \sim 5/sec

The diagram shows a schematic of the Project Orion spacecraft, a large cylindrical vessel with a conical nose and a tail section, set against a starry background. A bright, multi-pointed starburst representing a nuclear pulse is shown at the bottom, with a line indicating its trajectory towards the spacecraft's tail.

selected for further development – dubbed Orion – is the stuff of science fiction.

In its original form, Orion consists of a payload canister that rests on a fuel tank. Below the fuel tank are the world's largest shock absorbers. And below the shocks is a combustion chamber coated with an ablative material. When Orion is ready to roll, a fuel "pellet" is released down towards the combustion chamber. Unlike the benign pellets devoured by Little Miss PacMan in the old video game, Orion's fuel consists of nuclear "devices." As a bomb reaches the appropriate distance below Orion's combustion chamber, it ignites. Super-heated debris bounces off the ablative coating of the combustion chamber, which presses against the shocks and thrusts the entire vehicle forward.

A fully-fledged Orion never flew, although a sub-scale prototype powered by chemical explosions darted through the lower atmosphere, before returning to Earth by parachute to continue its career as an exhibit at the Smithsonian Air and Space Museum in Washington D.C. Before its demise in the mid-1960s, Orion was considered for interplanetary travel. As an upper stage to the Saturn V, this high-thrust, high (up to 100 kilometres per second) exhaust velocity rocket, could have opened up the solar

system to human exploration, development, and habitation. Nuclear-pulse voyage durations to Mars would be measured in months, not years and large crews with many creature comforts could be accommodated.

But Orion was a victim of US/USSR diplomacy. The signing of the 1963 Atmospheric Test Treaty signified the doom of this concept. Although Orion never flew, it has had great influence in the space-propulsion community. In 1968, the physicist Freeman Dyson pondered how to rescue the concept from bureaucratic oblivion. He decided to produce a paper on the super-secret concept that would reach the widest possible audience, and not land him in jail! Dyson selected *Physics Today* for his paper. And he cleverly used non-classified data to avoid legal hassles. In his October 1968 paper, Dyson extrapolated the fission-pulse Earth-launched Orion to a much larger craft propelled by one-megaton hydrogen (H) bombs, which would be constructed in Earth orbit. To estimate the yield-

■ **Below:** A schematic of the Daedalus spacecraft devised by the British Interplanetary Society in the 1970s. Based on the Orion propulsion concept, it used micro-fusion explosions to propel a probe to Barnard's star (about 6 light-years away) with a flight time of 50 years. Unlike the original Orion concept, Daedalus was to be assembled in orbit. Image courtesy NASA.

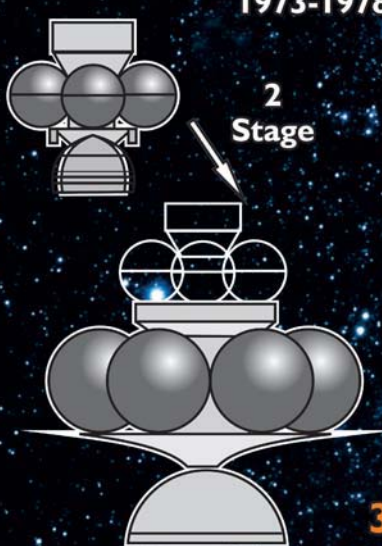

Nuclear Concepts Project Daedalus

1973-1978 British Interplanetary Society

2 Stage

10^2 T payload

10^6 Isp

12% Light speed

Micro-Fusion explosions
~ 250/sec

38 YEARS' Interstellar fly-by

to-mass ratio for an H-bomb, Dyson reasoned from the largest atmospheric H-bomb test of all time – a Soviet air-dropped 20-megaton H-bomb. Russian authorities did not reveal the drop-weight of the device, but they did reveal the aircraft that carried it. From published payload capabilities for that bomber, Dyson safely and accurately deduced the yield-to-mass ratio.

Of course, Dyson could not accurately calculate Super Orion’s performance using such strategies. But he could deduce a performance range. Dyson estimated that if the US and USSR thermonuclear arsenals were devoted to the project, a population in excess of 20,000 Earthlings could be transferred from the Earth to a hypothetical planet circling one of the Alpha Centauri suns, our solar system’s nearest stellar neighbours. But interstellar travel would be time consuming using this approach—the flight would take between 130 and 1,300 years, so you might want to pack plenty of reading material! Orion is huge and grandiose. Although it has not made it to flight readiness, it has done a stint in Hollywood. In the epic movie *Deep Impact*, where astronauts must rendezvous with a comet approaching on an Earth-impact trajectory, their deep space craft is a classic Orion.

Daedalus: An Orion Sequel

Propulsion scientists and engineers realized in the early 1970s that Orion, even though it opened the door to feasible deep space exploration, had several serious drawbacks. The principal one, of course, is the fuel source. It is difficult to imagine a political scenario in which a nuclear power would willingly use its bombs for anything constructive. It is also easy to imagine the world-wide uproar if a nuclear power began to build such a ship, storing its bombs in orbit,

A somewhat sanitized nuclear-pulse propulsion approach was investigated in the 1970s and 1980s by the British Interplanetary Society (BIS). Named after a mythological Minoan engineer who allegedly dabbled with hang gliding more than three millennia ago, the BIS Daedalus spacecraft would use electron-beam or laser induced fusion micro-explosions rather than fully-fledged one-megaton hydrogen bombs.

In principle, Daedalus would be fast – capable of projecting large robotic payloads towards nearby stars at speeds higher than 10% the speed of light (0.1c). Larger, human-occupied Daedalus-type craft could move at velocities of about 0.01c,

Interstellar Cruiser

(Illustrative Purposes Only)

Small Reactor
180 kWe, 335 Kg
32 cm x 35 cm core

30 AU in 6 yrs
25 AU in 15 yrs
500 AU in 26 years

123 km/s;
26 AU/yr;
0.4 milli-c

Mid-course
maneuvering

Delta 3 launch
to LEO
(17-yr Delta 2 option)

Radiation Shield Power Conversion Electric Thrusters (13,300 Isp) Thermal Radiators Payload (250 Kg)

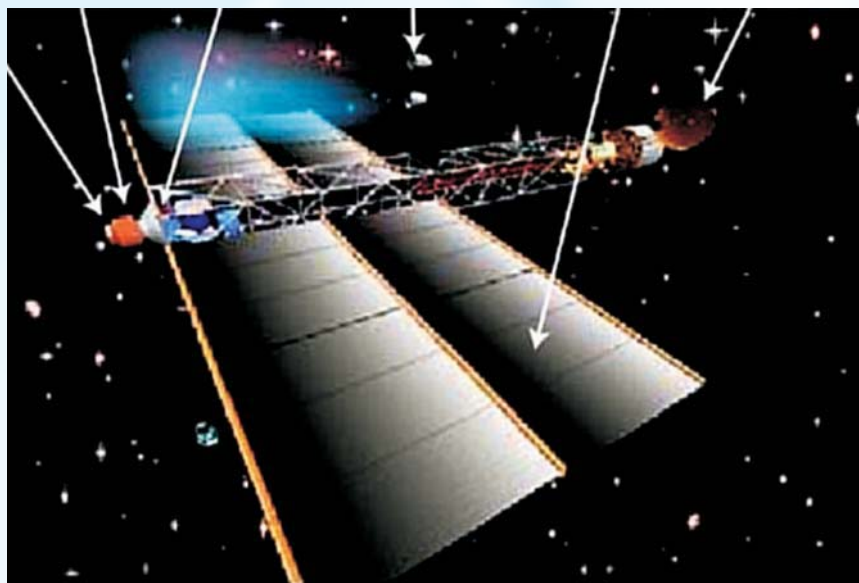

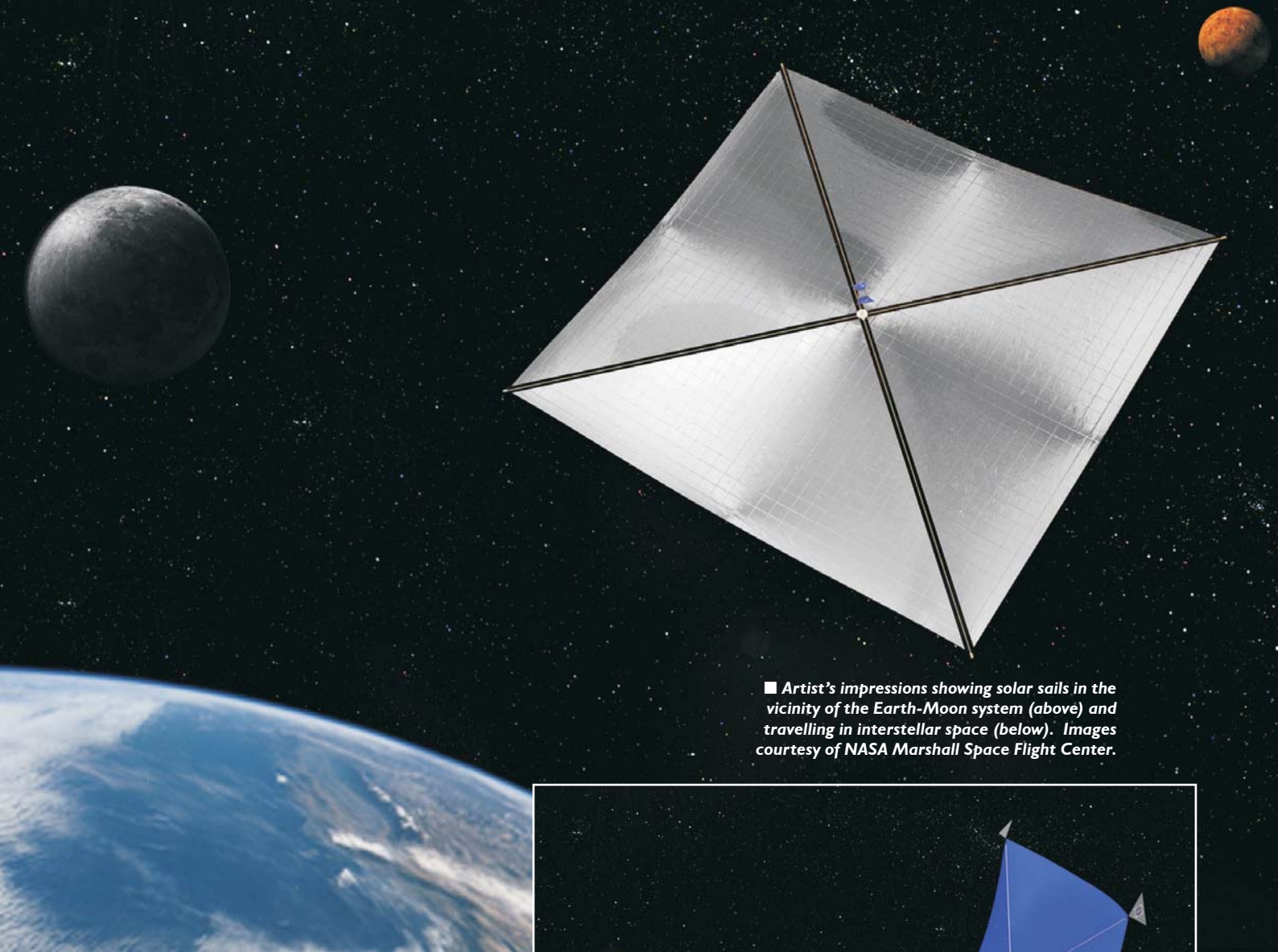

■ Artist's impressions showing solar sails in the vicinity of the Earth-Moon system (above) and travelling in interstellar space (below). Images courtesy of NASA Marshall Space Flight Center.

about the same performance as an Orion starship. To reduce radiation levels from the ship's inertial-fusion drive, contributors to Project Daedalus considered a number of thermonuclear fuel cycles. The winning fusion-pellet fuel mix was a combination of deuterium – a heavy form of hydrogen – and a low-mass helium isotope, helium-3. This reaction could be ignited with present-day or near-term technology and produces far less radioactivity than competing fuel mixes. But there is one small engineering detail. Although deuterium is very abundant in terrestrial oceans, helium-3 is vanishingly rare on our planet.

Unless we are to coat our world with nuclear reactors to breed the stuff – not a good scenario for those trying to reduce nuclear proliferation and terrorism – a cosmic source of helium-3 is the only way to preserve the Daedalus concept. Perhaps in the future we will be able to mine

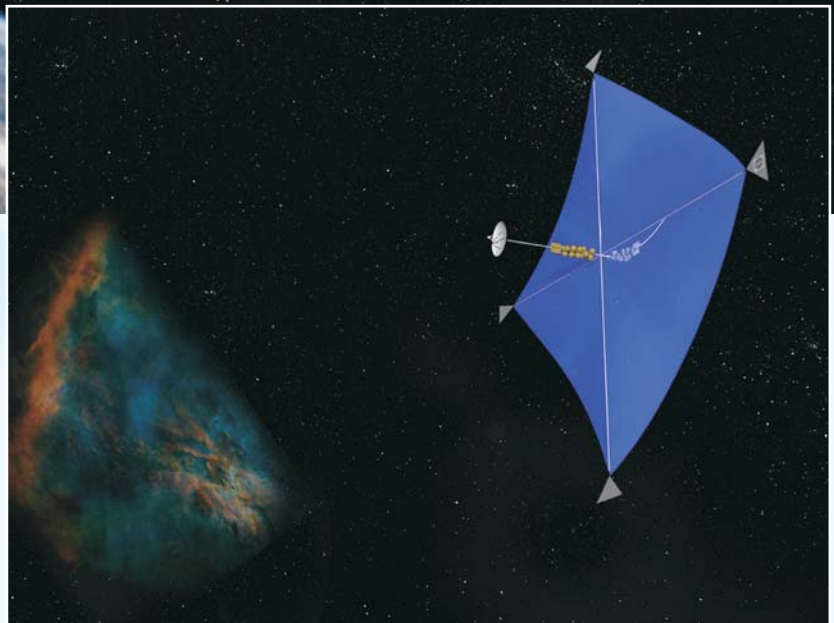

the lunar surface for this isotope, collect it from the solar wind, or even extract it from the atmospheres of giant planets. But sadly, no one will build a Daedalus in the near future.

■ **Opposite page:** This artist's depiction by Roger Lenard, a physicist at Sandia National Laboratories, shows what a nuclear-powered interstellar craft might look like, and some of its component parts. Artist's depiction courtesy Sandia National Laboratories.

Nuclear-Electric Propulsion (NEP): A Near-Term Possibility

In an electric rocket (or ion drive), solar or nuclear energy is first used to ionize a propellant – usually an inert gas such as xenon or krypton. Then electromagnetic techniques are used to transfer much of the solar or nuclear energy to an ion accelerator. Accelerated fuel ions are exhausted from the back of the craft. The reaction to this exhaust thrusts the spacecraft forward.

Solar-electric rockets have flown in space on robotic lunar and inner solar-system comet/asteroid rendezvous missions. At present, the operational electric-rocket exhaust velocity is in the neighbourhood of 30 kilometres per second (which, in the parlance of the rocket scientist, is equivalent to a specific impulse or Isp of 3,000). In the not too distant future, ion thrusters will achieve exhaust velocities of 100 kilometres per second (Isp=10,000) or higher.

Unlike nuclear-pulse craft, electric rockets are low-thrust devices. No ion rocket will ever lift from the Earth's surface, but given enough time they can build up a substantial velocity in the space environment. Safe nuclear-fission reactors have been designed that would only be turned on in space so as to prevent nuclear contamination in case of a launch catastrophe. But NEP still has the same political hurdles to clear as any other nuclear spacecraft.

Deep space probes launched using this technology would be large and expensive. Even if payloads were microminiaturized, there seems to be little hope of producing a micro-sized NEP engine. But if mission designers wish to stop in the dark realm between Neptune

and the nearest star – say to explore the surface of a Kuiper Belt Object or an Oort Cloud comet – NEP may present the best option.

Star Sailing

Suppose you wish to launch a probe into interstellar space and you don't care about stopping, or at least not until you reach the nearest extrasolar star? There is one more option – a non-nuclear approach – and one quite amenable to miniaturization.

The solar sail, more properly called the solar photon sail, derives its thrust from the momentum exchanged by reflected photons of sunlight. As demonstrated by Einstein in the early 20th century, each photon has a tiny bit of momentum, even though it lacks mass. Long understood as the physical basis for the fact that a comet's tail is always directed away from the Sun, solar photon radiation pressure was first

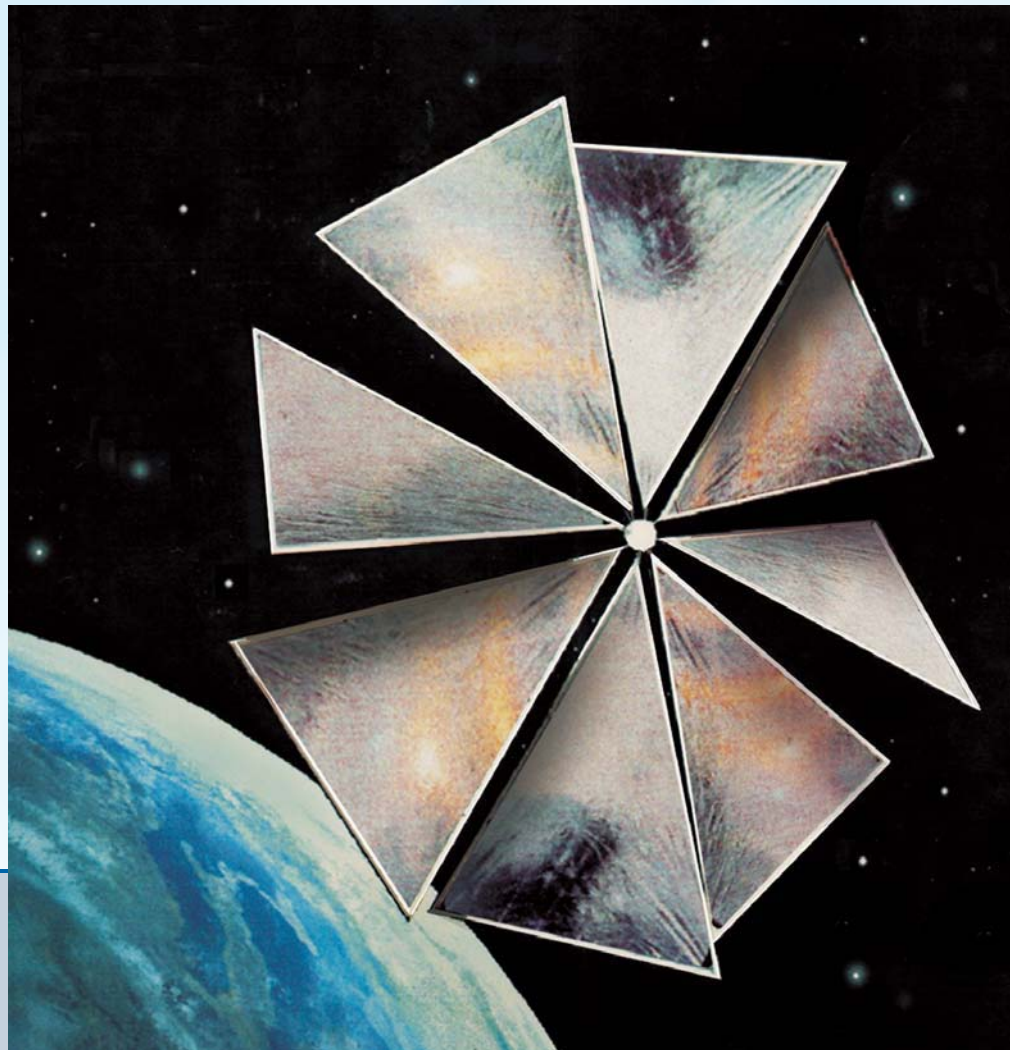

■ **Right:** An artist's depiction of The Planetary Society's *Cosmos 1* solar sail technology demonstrator. Image courtesy The Planetary Society.

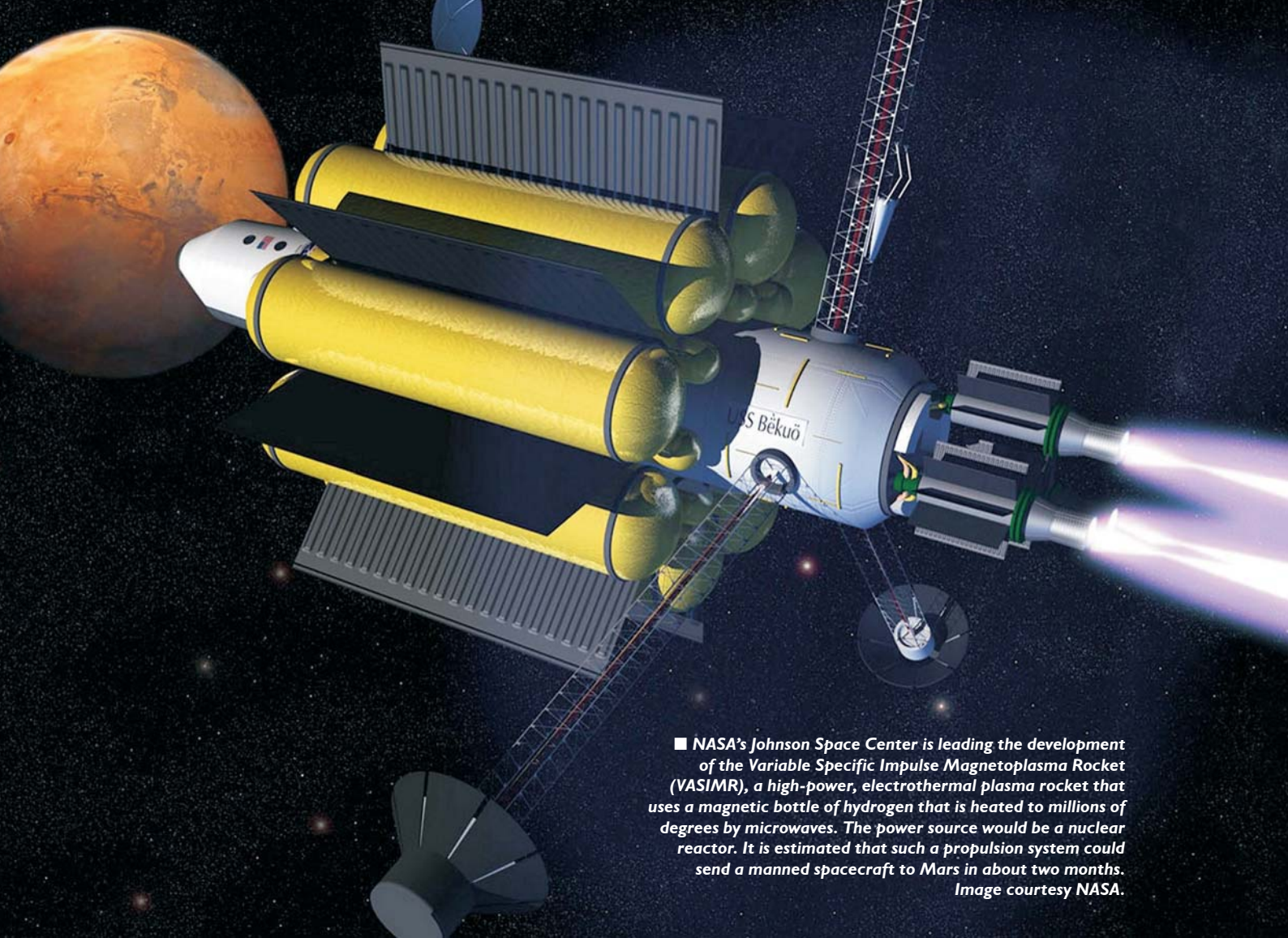

■ NASA's Johnson Space Center is leading the development of the Variable Specific Impulse Magnetoplasma Rocket (VASIMR), a high-power, electrothermal plasma rocket that uses a magnetic bottle of hydrogen that is heated to millions of degrees by microwaves. The power source would be a nuclear reactor. It is estimated that such a propulsion system could send a manned spacecraft to Mars in about two months. Image courtesy NASA.

applied in space travel during the early 1970s. Mariner 10, the first probe to visit Mercury, was on a trajectory allowing multiple flybys of that planet. To maximize scientific return and minimize consumption of on-board thruster fuel, mission controllers used solar photon radiation pressure on Mariner 10's solar panels to maintain the craft's attitude.

In the 1990s, the first experimental solar sails were tested in space with the unfurling of the Znamya experimental reflector from the Russian space station Mir and an inflatable antenna that was deployed from an American Space Shuttle. More recently, NASA and ESA have conducted ground tests of larger sail structures – some in the 20-metre class and a sub-orbital Japanese rocket successfully deployed two sub-scale sail prototypes in space. An orbital test of an operational sail constructed by The Planetary Society, dubbed Cosmos 1, was lost due to booster malfunction.

Today's sails typically consist of three layers. Facing the Sun is an aluminium reflective

layer mounted upon a plastic substrate. Behind this substrate is a thin film that radiates the small fraction of solar energy absorbed by the aluminium reflector. Typical sail thickness is in the micron range and the areal mass density is a few grammes per square metre. Ultimate space-manufactured sails may be a great deal thinner.

Before 2010, one or more of the space agencies may apply solar sailing in operational solar observatories positioned sunward of the Earth. Use of the sail for attitude control in this photon-rich environment will increase mission flexibility and lifetime while reducing costs. But the ultimate achievement for an Earth-launched first-generation sail may come around 2020, when NASA hopes to launch a sail on an interstellar trajectory. The first NASA interstellar sail might have dimensions equivalent to a few football fields, a thickness measured in microns and a science payload of about 30 kg. The craft would be injected into an elliptical solar orbit with an aphelion near the orbit of Mars and a perihelion near the orbit of Mercury.

At perihelion, the sail would be unfurled and blown out of the solar system at about 50 kilometres per second. At this speed (more than 3 times that of the Voyagers) the sail could reach the heliopause – the boundary of the Sun’s galactic influence – in about two decades. After another few decades, the craft would cruise by the inner focus of the solar gravitational lens. Beyond this point, light from objects occulted by the Sun is enormously amplified as a consequence of Einstein’s general theory of relativity.

Someday, we may develop the technology to manufacture the thinnest possible sails in space and we may develop the technologies capable of allowing very close solar passes. Then humans may venture to the nearest stars aboard interstellar clipper ships. After acceleration, sail and supporting structure might be wound around the crew habitat to provide extra cosmic ray shielding. The sail would be redeployed perhaps 1,000 years later for deceleration at the target star.

Far-Out Possibilities

All of the propulsion options discussed above seem to be feasible in terms of physics and economics, even if the engineering is a bit beyond us. But breakthroughs happen, even if they can’t be predicted. So it is worth considering some future options that might someday become possible.

What if we could learn to fuse hydrogen nuclei directly, as does the Sun and other main-sequence stars? Although proton-proton fusion is many orders of magnitude more difficult to master than the hydrogen- and helium-isotope thermonuclear reactions currently approaching feasibility, we can’t rule out the ultimate feasibility of proton-proton fusion. If we can master this technique, the universe will open up. Interstellar ramjets could ingest protons collected magnetically from the interstellar medium and fuse them to approach light speed.

What if we learn how to produce antimatter efficiently and economically and can store the stuff safely for decades? Combined with equal quantities of normal matter, antimatter is the most volatile stuff in the universe. During the reaction, all of the fuel mass is converted into energy. Perhaps someday the inner solar system will be graced by Sun-orbiting, solar-powered antimatter factories. Antimatter rockets may in that distant era venture far into the interstellar void.

What if we can solve vast engineering problems and learn how to construct solar-powered lasers in space that can very accurately maintain beam position for decades? Interstellar laser sails might allow human crews to explore and colonize many neighbouring planetary systems.

What if the laws of physics are altered by future theoretical breakthroughs? We might learn how to polarize vacuum fluctuations to reduce a spacecraft’s inertia or warp through singularities in the space-time fabric. Then, true interstellar commerce might become a reality.

It is impossible to predict when and if any of these eventualities may come to pass. But stay tuned—human ingenuity is an extraordinary tool and there may be surprises in our quest to develop deep space propulsion technologies!

Further Reading

G. L. Matloff: *Deep Space Probes*, 2nd ed., Springer-Praxis, Chichester, UK, 2005.

G. L. Matloff, L. Johnson, and C. Bangs: *Living off the Land in Space*, Copernicus-Praxis, Chichester, UK, 2007.

M. J. L. Turner: *Rocket and Spacecraft Propulsion*, 2nd ed., Springer-Praxis, Chichester, UK, 2005.

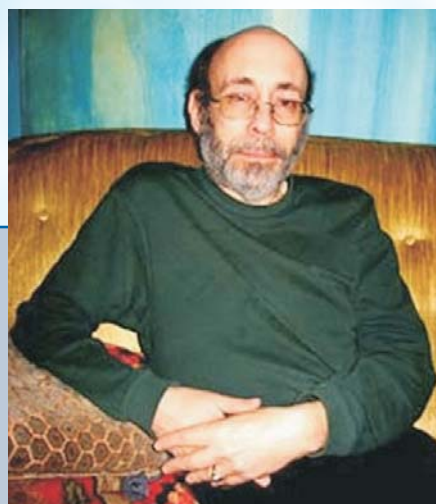

Gregory Matloff, a physics professor at New York City College of Technology and a Hayden Associate at the American Museum of Natural History, is a Fellow of the British Interplanetary Society and a Corresponding Member of the International Academy of Astronautics. He has consulted for NASA and has authored or co-authored seven books and over a hundred scientific or technical papers.

An artist's impression of the view looking back towards the Sun from the vicinity of a Kuiper Belt Object. The scene is set in the outer limits of our solar system, showing a vast field of stars and a bright star (the Sun) in the center. The foreground is a dark, rocky, and cratered surface, likely the Kuiper Belt Object, illuminated by the Sun. The background is a dense field of stars, with a prominent bright star in the center, representing the Sun. The overall atmosphere is dark and mysterious, with a sense of vastness and depth.

■ An artist's impression of the view looking back towards the Sun (the bright star centre frame) from the vicinity of a Kuiper Belt Object orbiting in the outer limits of our solar system. Such a vista might one day be obtained by a deep space probe heading out into interstellar space. Image courtesy NASA/ESA and A. Schaller.

7

Reviving the Old **INTRODUCING** the New . . .

The human crew was fed up with its rations, but Bunny could see that it was fast approaching the biggest potato ever!!

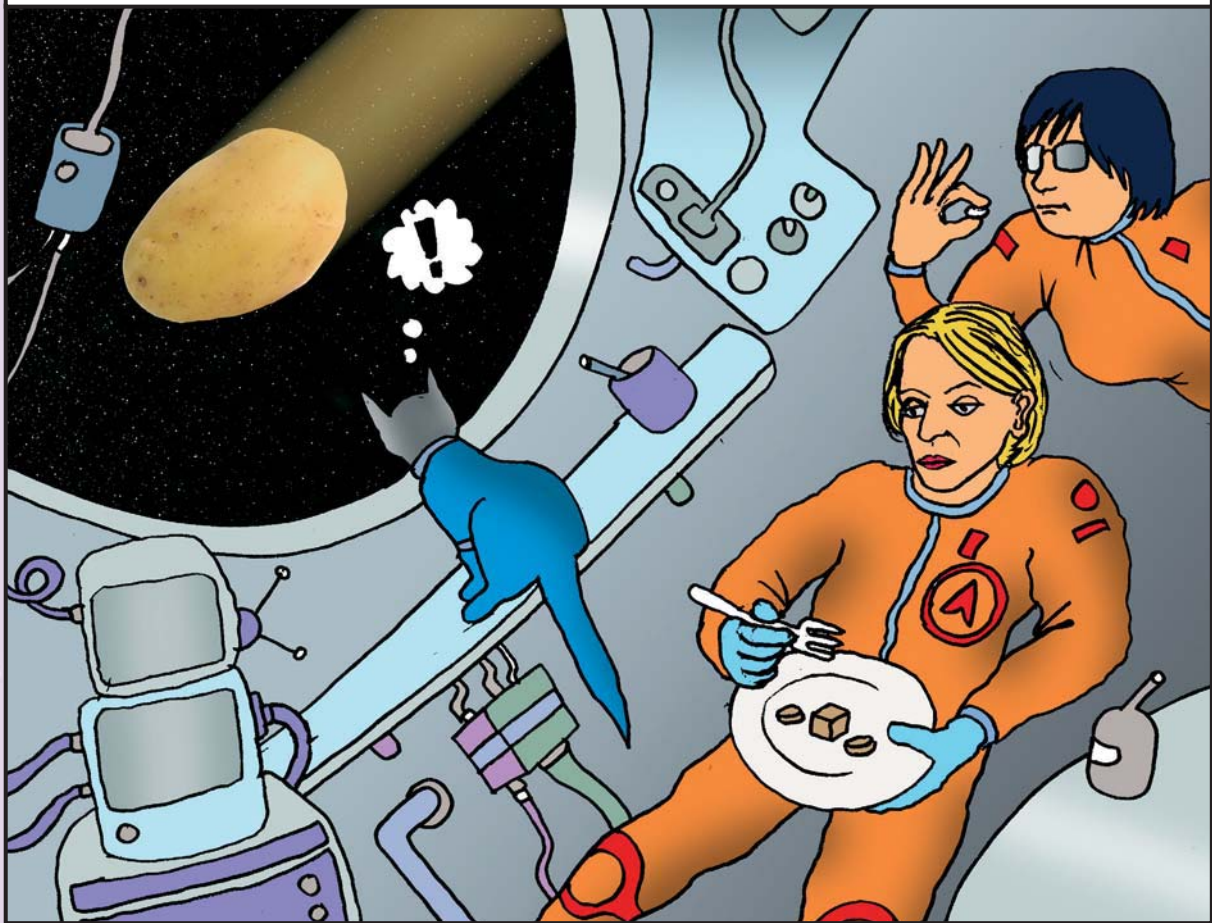

After years of funding problems, Russia is now about to embark on a wide range of innovative scientific missions in near-Earth space, to the Moon and elsewhere in the solar system. These missions herald a new age of Russian space science. Space Journalist *Igor Afanasiev* gives us the details from Moscow.

Russia's New Space SCIENCE PROJECTS

The Soviet Union carried out a comprehensive programme of exploration of the Moon, Venus and Mars. In the early days of the Russian Federation, there were extensive plans for missions to the Moon, Mars and the outer solar system, as well as for science missions in Earth orbit, notably the Koronas programme of solar observatories¹. Economic difficulties, though, meant that with the exception of Koronas, these missions could not be funded and few took place.

Now the economic situation has improved, permitting Russia to revive some old projects and introduce new ones. Russia's new space science projects have a number of important features. They are designed to be realistic, rather than over-ambitious. There is an emphasis on astrophysics and they use a standard type of spacecraft platform

and common scientific instruments. The size of spacecraft is much smaller, the reduction in weight meaning that medium-class launch vehicles may be used, instead of the larger but more expensive Proton rocket.

The following programme of missions has been drawn up by the Russian Space Agency, Roscosmos, in cooperation with the Russian Academy of Science (RAN in Russian). Sixteen missions are planned, and the first twelve of those discussed here have been grouped into four broad categories: astrophysical space observatories, spacecraft for studies of the Sun and solar-terrestrial interactions, probes to the Moon and planets, and space laboratories.



■ Above and left: Two views of the 10-m diameter main antenna of the Spektr R (Radioastron) space observatory being deployed during testing at the works of the Lavochkin Association during 2002. Images courtesy Lavochkin Association.

¹ Johnson, Nicholas L. and Rodvold, David R. *Europe and Asia in Space, 1991-1992*. Kaman Sciences Corporation and US Air Force Phillips Laboratory, pp.206, 208-209

SPACE OBSERVATORIES

The following four projects are listed in order of planned launch date.

Spektr R (Radioastron)

The Spektr R (Radioastron) astrophysical observatory will be used to carry out radio-interferometric observations in conjunction with a global ground-based radio telescope network to obtain images, coordinates, motions and evolution in the angular structure of radio emitting objects in the Universe at extremely high angular resolution. Radioastron's main antenna will have a diameter of 10 m, and it will carry out observations at wavelengths of 1.2-1.6 cm, 6 cm, 18 cm and 92 cm. It will also investigate the properties of near-Earth and interplanetary plasma.

Launch will hopefully take place before the end of 2007 from Baikonour cosmodrome on a Zenit 2 launch vehicle with Fregat SB upper stage, aiming for a highly elliptical orbit with perigee between 10,000 and 70,000 km and apogee between 310,000 and 390,000 km. (see below). Total mass will be 5,400 kg. The

mass of the scientific payload will be 2,500 kg, including the unfolding parabolic 10 m radio telescope (which has a mass of about 1,500 kg) and associated electronic equipment such as the receivers, power supplies, synthesizers, control units, frequency standards and radio system for data transmission.

This is a five to seven-year mission, the main contractor being the Lavochkin design bureau, with co-contractor the PN Lebedev Physical Institute Astrospace Centre.

Spektr UF

Spektr UF is a space observatory that will be able to conduct in-depth investigations into the physics of the early universe, the evolution of galaxies, the atmospheres of hot stars and the physics and chemistry of planetary atmospheres in the ultraviolet region of the electromagnetic spectrum. Spektr UF is part of the World Space Observatory (WSO) international programme. This project dates back to the early 1990s and was originally scheduled to be launched by a Proton rocket in 1997. The original platform for the spacecraft would have been three times

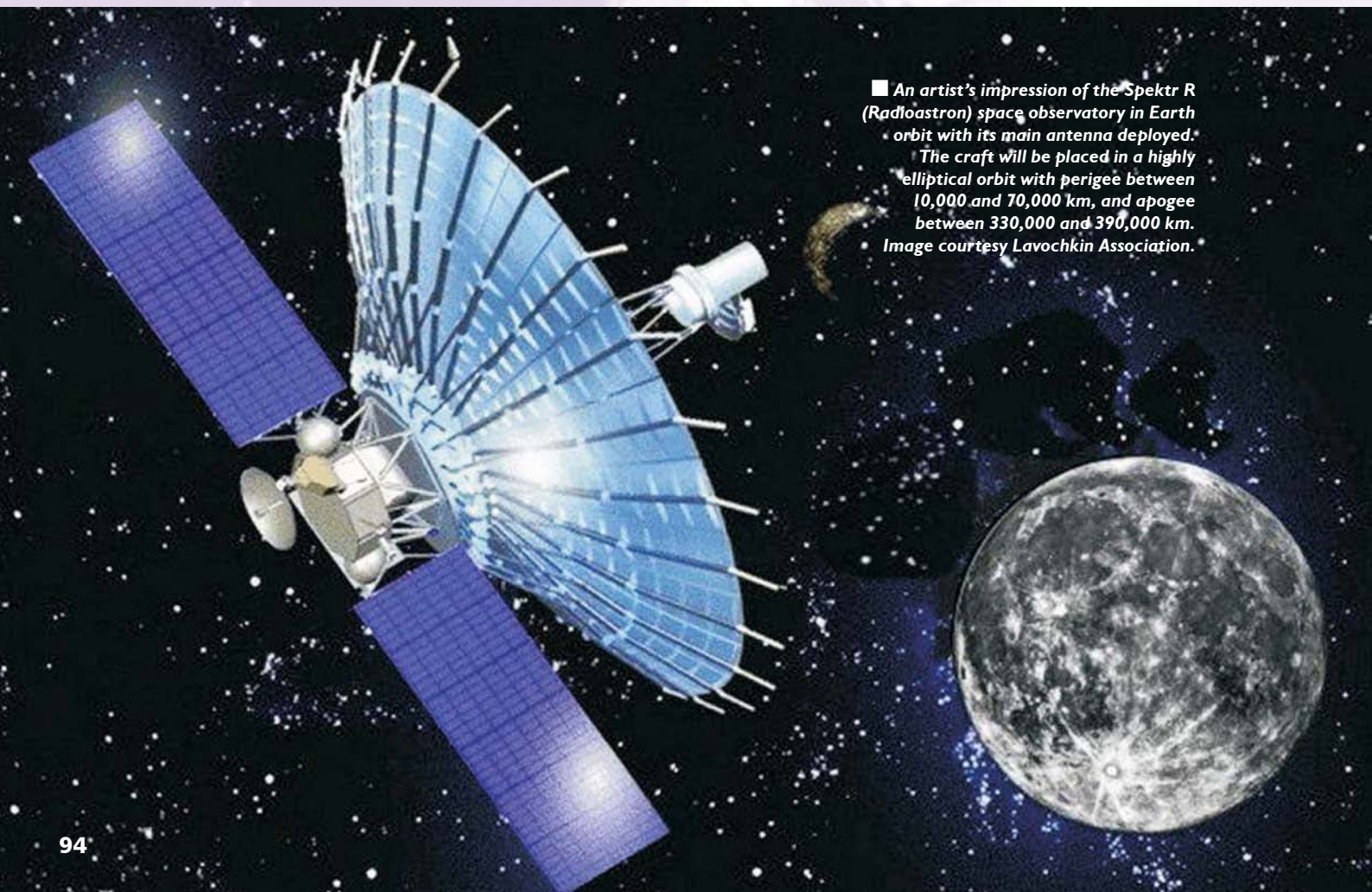

■ An artist's impression of the Spektr R (Radioastron) space observatory in Earth orbit with its main antenna deployed. The craft will be placed in a highly elliptical orbit with perigee between 10,000 and 70,000 km, and apogee between 330,000 and 390,000 km. Image courtesy Lavochkin Association.



heavier than the new Navigator platform which has now been developed for it by the Lavochkin design bureau, the science instruments coming from the Astronomical Institute of the Russian Academy of Sciences.

Spektr UF's main payload is the T-170M ultraviolet telescope, with a primary mirror diameter of 170 cm. The telescope's scientific equipment includes a High Resolution Double Echelle Spectrograph (HIRDES), a low resolution, long-slit, spectrograph, and two ultraviolet imagers - one for maximum spatial resolution; one for maximum sensitivity. Spektr also has a scientific data management block and a memory storage system. The Spektr UF project is assuming increased importance due to the expected increase in demand for ultraviolet observations and lack of suitable space platforms.

The Spektr UF spacecraft is scheduled to be launched in 2009 by a Soyuz 2 Fregat launch vehicle. Several different orbits have been considered: highly elliptical with apogee at 300,000 km, or the L2 Lagrangian point in the Sun-Earth system. The lifetime of the spacecraft

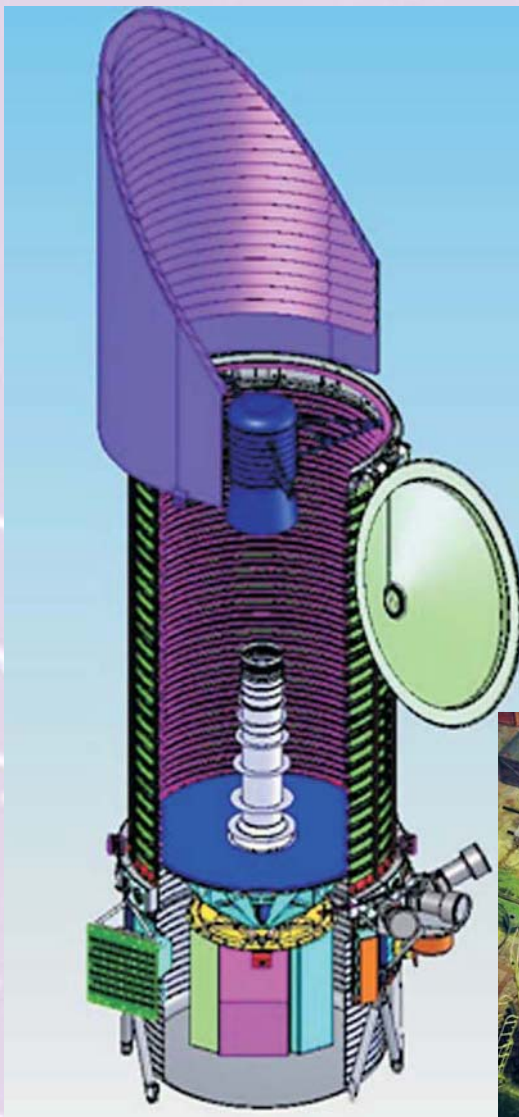

■ **Above:** The 1.7-m diameter primary mirror of the T-170M ultraviolet telescope which will be carried by the Spektr UF space observatory. It is anticipated that there will be increased demand for space-based observations in the ultraviolet region of the electromagnetic spectrum in the future. Image courtesy Lavochkin Association.

■ **Left:** An artist's schematic showing the main components of the Spektr UF space observatory (left), and a view from above of the spacecraft during assembly and testing at the works of the Lavochkin Association (right). Images courtesy Lavochkin Association.

■ An artist's impression of the Spektr UV ultraviolet space observatory in Earth orbit with solar panels deployed. Scheduled for launch in 2009, several different orbits are being considered: highly elliptical with apogee at 300,000 km, or the L2 Lagrangian point in the Sun-Earth system. Image courtesy Lavochkin Association.



is to be not less than five years. The cost of the project is €100m, half of which will come from the federal 2006-2015 space programme. The project will doubtless involve Germany which is developing the high resolution spectrograph and it is hoped that the European Space Agency will also participate. Ground communication and control stations will be provided by Spain and South Africa. China is also interested in contributing 20% of the cost with a view to obtaining a quota of observing time.

Spektr RG (Spektr Roentgen Gamma)

Spektr RG is an astrophysical observatory for the investigation of the universe in the X-ray and gamma-ray regions of the electromagnetic spectrum. It is intended that the spacecraft will make a survey of the whole sky in the X-ray energy range from 2 to 30 keV, with a view to tracing the hot gas in clusters of galaxies or from exploding stars and detecting X-rays from matter swirling around supermassive black holes.

This project dates back to the mid-1990s and was originally scheduled to be launched by 2008. Due to a lack of funding, it was repeatedly delayed and the planned instrumentation became out of date. In 2002, the space council of

the Academy of Sciences decided on a simplified version of the spacecraft, the assignment going to the Lavochkin design bureau in Khimki, Moscow region, with the scientific instruments developed by the Institute for Space Research (IKI) in Moscow and a number of international partners. The instruments include:

■ **eROSITA** (extended ROentgen Survey with an Imaging Telescope Array), developed by a European consortium led by the Max Planck Institute for Extraterrestrial Physics in Germany. eROSITA consists of seven Wolter-I telescope modules similar to the German mission ABRIXAS which failed in 1999 and ROSITA, a telescope which was planned to be installed on the International Space Station

■ **LOBSTER** wide-field X-ray monitor, developed by Leicester University, UK

■ **ART-XC**, an X-ray concentrator based on Kumakhov optics (systems composed of bundles of glass fibres that behave as waveguides to propagate X-rays by multiple internal reflections, and that can be bent or tapered to concentrate, collimate, or focus the radiation), for spectroscopy and time analysis of galactic and extragalactic radiation, developed by IKI, Russia

■ **Right:** Artist's schematics showing the main components of the Spektr RG astrophysical observatory, both in their launch configuration (left) and in Earth orbit with the spacecraft's solar panels deployed (right). Images courtesy IKI, Institute for Space Research, Moscow.



■ **GRBM** gamma-ray burst (GRB) detector

■ **SPIN-X** wide-field X-ray monitor, based on the principle of a coded-aperture telescope, which is designed to detect and localize gamma-ray burst (GRB) sources, to survey large areas of the sky in search of new transients, and to carry out long-term observations of bright galactic sources, including X-ray bursters

■ **BIUS** onboard computer.

Spektr RG will also use the Navigator platform. The total weight is 2,100 kg, including a 1,250 kg payload. The spacecraft is due for launch in 2011 and will either lift off from Baikonour cosmodrome on a Soyuz 2 Fregat launcher into a 600 km, 30° orbit, or alternatively use a Soyuz ST Fregat from the European space centre in French Guyana into a 600 km, 5° orbit. The planned mission duration is seven to ten years.

Spektr M (Millimetron)

Spektr M (Millimetron) is a space observatory operating in millimetre, sub-millimetre and infra-red wavelengths with an angular resolution up to 30 nanoarcseconds. The observatory will be equipped with a 12-m diameter cryogenically-cooled dish antenna, capable of operating on its own (in single-dish mode) for observations at very high sensitivity, or as an interferometer in conjunction with ground-based telescopes (or other space-based telescopes) for observations at very high resolution.

Spektr M will operate over a range of millimetre wavelengths from 0.01-20 mm. At wavelengths between 0.4-20 mm, the spectrum of the sky is dominated by the cosmic microwave background radiation, the left-over heat from the fireball of the Big Bang. Observations at millimetre and sub-millimetre wavelengths are very important for the understanding of a great diversity of problems in cosmology and extragalactic astronomy as well as for investigations of our own Galaxy and even objects in our own Solar System. Consequently, Spektr M is expected to make a unique and very important contribution in a wide range of disciplines.

Several possible orbits are under consideration for Spektr M:

■ **highly elliptical, 75,000 km by 300,000 km**

■ **halo-orbit near the L2 Lagrangian point in the Sun-Earth system**

■ **highly elliptical, with perigee around 75,000 km and apogee in the region of point L2.**

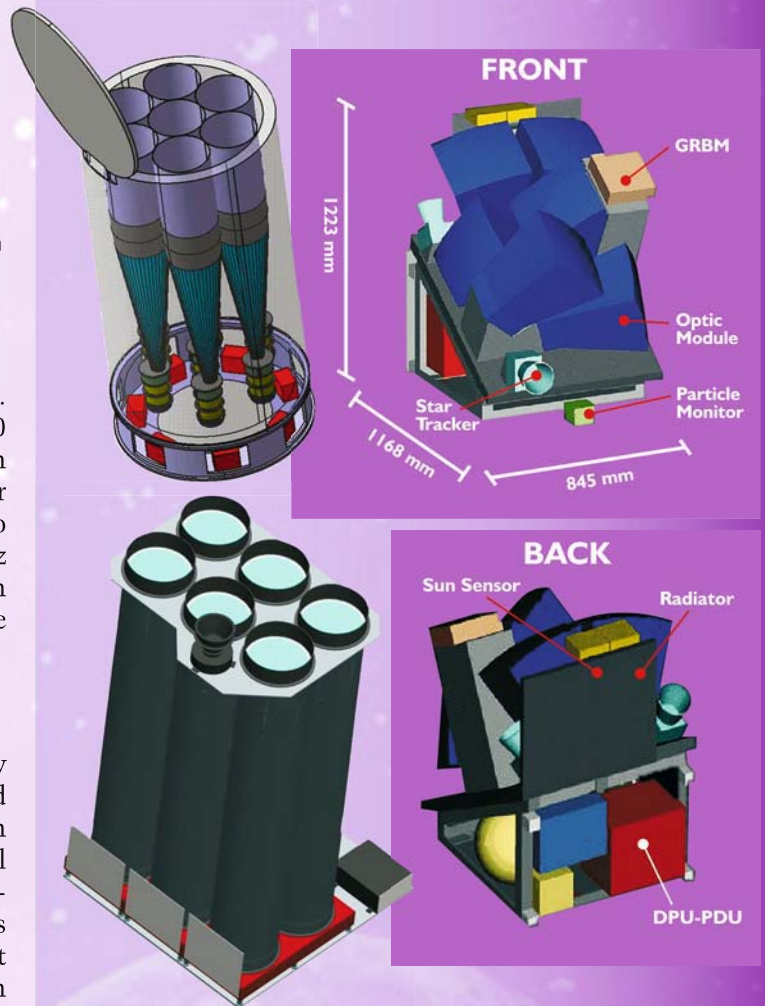

■ **Above:** Artist's schematics showing the three main instruments to be carried by the Spektr RG space observatory: eROSITA with its cluster of seven Wolter-I telescope modules (top left), LOBSTER, a wide-field X-ray monitor (right), and ART-XC, an X-ray concentrator based on Kumakhov optics (bottom left). Images courtesy IKI, Institute for Space Research, Moscow.

■ **Below:** Artist's schematic of the Navigator platform which has been used as a basis for the design of a range of new Russian space observatories, including the Spektr RG spacecraft. The Navigator platform is based on the Fobos Grunt platform designed for the mission to Mars' moon Phobos. Image courtesy IKI, Institute for Space Research, Moscow.



Launch is planned for 2018. The active lifetime of the mission will be three years with the highest sensitivity provided by both active and passive cooling of the entire dish antenna and science payload, and a subsequent period of 7-10 years operating with the passive cooling system alone. The main contractor is the Lavochkin design bureau, with the scientific instruments coming from the PN Lebedev Physical Institute of the Academy of Sciences Astrospace Centre.

STUDYING THE SUN AND SOLAR-TERRESTRIAL INTERACTIONS

The following three projects are listed in order of planned launch date.

Koronas Foton

Koronas Foton (Coronas-Photon) is a spacecraft to monitor the Sun from Earth orbit and is part of the international 'Living With A Star' programme in association with missions such as Yohkoh, SOHO, Ulysses and WIND. Koronas Foton is the third spacecraft of the series. Two previous missions of the programme were

Koronas-I, launched on 2 March 1994, and Koronas-F, launched on 31 July 2001, whose mission concluded at the end of 2005. The new Koronas Foton spacecraft is designed to investigate the processes of energy accumulation in solar flares and how this energy is transformed into very high energy particles such as electrons, protons and other ions; to study the acceleration mechanisms, propagation and interaction of high-energy particles in the solar atmosphere; to examine the relationship between solar activity and physical and chemical processes in the Earth's upper atmosphere and even their influence on terrestrial processes.

This spacecraft is based on the Meteor 3 weather satellite platform and weighs 1,900 kg, including a 540 kg payload. It is planned to launch Koronas Foton in late 2007 on a Tsyklon launch vehicle from Plesetsk into a 550 km, 82.5° circular orbit. It is intended that the satellite will operate for not less than three years. The main contractor is the Scientific Research Institute for Electromechanics in Istra, Moscow region, with co-contractors the Moscow Engineering Physical Institute of the State University and the National Space Agency of Ukraine.

■ **Above:** The main elements of 'space weather' – the conditions and processes occurring in space which have the potential to affect the near Earth environment. Space weather processes can include changes in the interplanetary magnetic field, coronal mass ejections from the Sun, and disturbances in Earth's magnetic field. The effects of space weather can range from damage to satellites to disruption of power grids on Earth. Image courtesy The SOHO Consortium. SOHO is an ESA/NASA project of international cooperation.

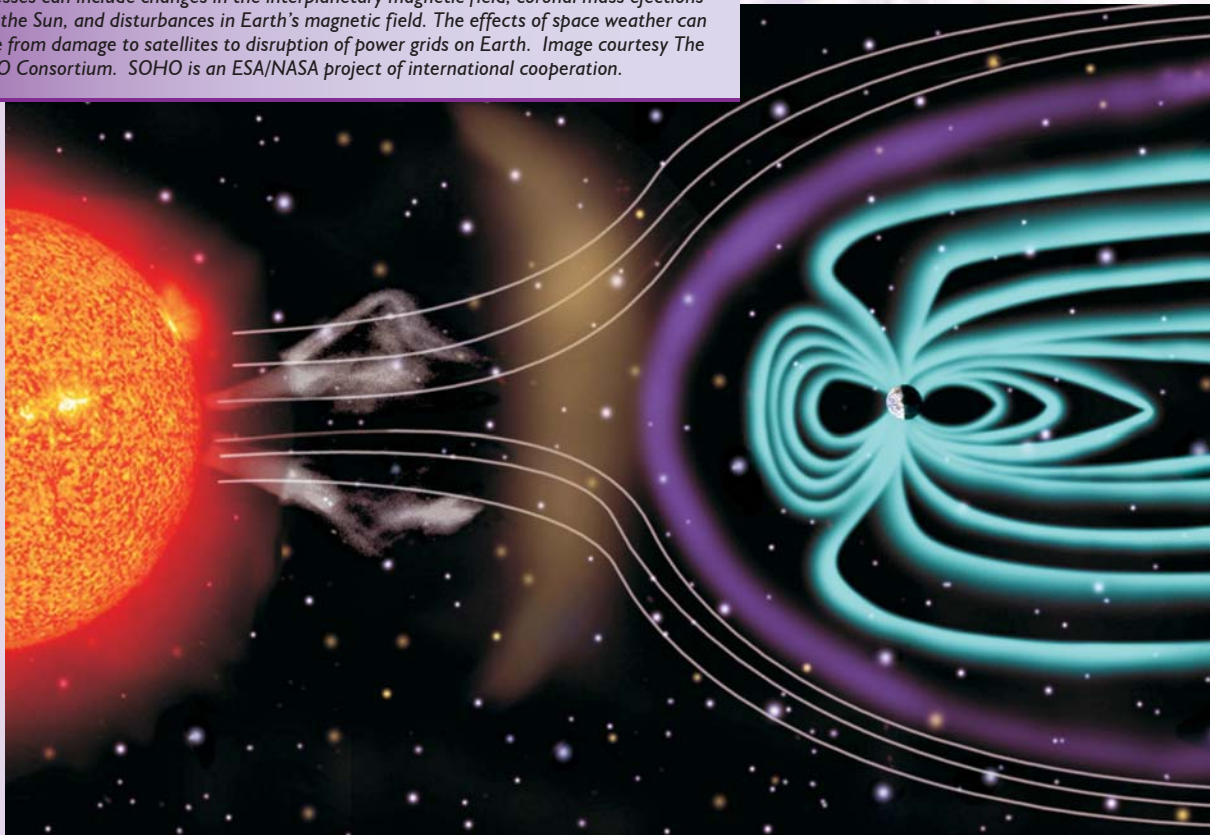

Resonance

The pair of Resonance spacecraft will monitor the inner magnetosphere and radiation belts of the Earth. For the first time ever, they will allow scientists to study a phenomenon known as 'magnetospheric cyclotron resonance masers', which arise as a consequence of the interactions between energetic particles and waves in the Earth's inner magnetosphere and the plasma environments of other planets possessing a magnetic field.

It is important to study magnetospheric masers because they regulate the composition of Earth's radiation belts. Measurements by the Resonance spacecraft will enable scientists to obtain information on the numbers of energetic particles in the radiation belts and their distribution, the formation of ring currents, the changes which take place in the magnetosphere during geomagnetic storms and the dynamics of perturbations in the plasma. Moreover, maser mechanisms are involved in a wide range of solar and stellar processes, but since the nearest example of the phenomenon is in Earth's magnetosphere (which is very close to us in cosmic terms), researchers may take detailed measurements there, and then extrapolate the results of their studies to more distant astrophysical objects.

The two Resonance spacecraft are to be launched in 2012 on a Soyuz 2 Fregat from Baikonour cosmodrome, each on a three year mission, with the following orbits:

■ **First spacecraft: 600 km by 32,507 km, inclination 63.4°**

■ **Second spacecraft: 1,800 km by 29,376 km, inclination 63.4°**

Each spacecraft weighs 500 kg, including a payload of 85 kg. The main contractor is the Lavochkin design bureau, with, as co-contractors the Institute of Space Research, the Institute of Applied Physics, the Institute of Terrestrial Magnetism, Ionosphere and Radio waves Distribution (IZMIRAN) and the Science Research Institute of Nuclear Physics and others. Scientific organizations in France, the United States, Finland, the Czech Republic, Ukraine and a number of other countries are expected to take part in the project.

Intergeliozond

Intergeliozond is an interplanetary spacecraft which will study the Sun and solar radiation from a close distance (30-40 solar radii), with high sensitivity and high resolution in the optical, ultra-violet and X-ray regions. The craft will carry a number of instruments for direct studies of the Sun as well as many for studying solar flares and coronal mass ejections and for analysing the energetic particles, plasma and dust of the solar corona and solar wind.

Intergeliozond will be launched into a heliocentric orbit and will benefit from gravity assist manoeuvres near the planet Venus; it will also observe Mercury. The spacecraft will carry out observations both in the Sun's equatorial plane and as the orbital inclination is increased up to 30-38° with respect to the Sun's equator. The spacecraft's perihelion distance (distance of closest approach to the Sun) will also be lowered as far as possible.

The spacecraft will be based on the Fobos Grunt spacecraft (see below) and will have an active lifetime of five years. Launch is not expected before 2014. The main contractor is the Lavochkin design bureau, working with IZMIRAN, the Institute of Space Research of the Russian Academy of Science, and other organizations.

PROBES TO THE MOON AND PLANETS

The following three projects are listed in order of planned launch date.



■ **Above:** Artist's schematics showing the Fobos Grunt spacecraft (comprising both the lander and the injection stage) prior to setting off for Mars (left), and the spacecraft during transit to Mars (right). Images courtesy Lavochkin Association.



■ **Above:** This image, taken by the High Resolution Stereo Camera (HRSC) on board ESA's Mars Express spacecraft, shows the Mars-facing side of the moon Phobos, taken from a distance of less than 200 km on 22 August 2004. Image courtesy ESA/DLR/FU Berlin (G. Neukum).



■ Artist's schematics showing the Fobos Grunt spacecraft in its landing configuration (above) and the ascent stage which will be used for returning samples of surface material from Phobos to Earth for analysis (right). Images courtesy Lavochkin Association.

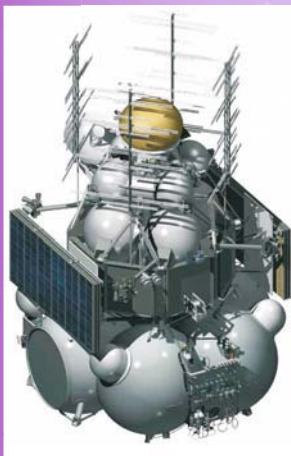
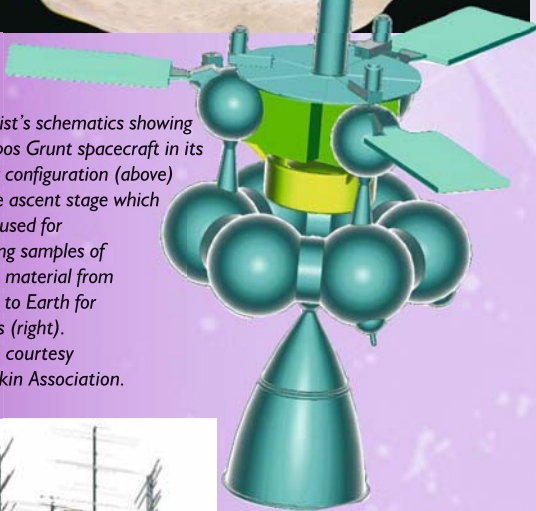

■ **Left:** Artist's schematic showing the Luna Glob spacecraft prior to setting off for the Moon. Image courtesy Lavochkin Association.

Fobos Grunt

Fobos Grunt is a project to return surface samples from the small Martian moon Phobos back to Earth. It will be the first Russian interplanetary mission since the failed Mars '96 project. The name of the craft is derived from the principal objective of the mission. 'Grunt' in this context literally means 'soil' (samples of which will hopefully be obtained) while 'Fobos' (Phobos) is the mission's destination.

In addition to its main objective of collecting surface samples from Phobos and returning them to Earth for study, the lander will also perform remote and in situ studies of Phobos. These will help to define its physical and chemical features, providing information on the origin of Mars' natural satellites, and on the interaction between small solar system bodies and the solar wind. Fobos Grunt will also study Mars and its radiation environment, including the planet's atmosphere and the dynamics of dust storms.

This is a project for the Russian Academy of Science and Roscosmos, the main contractors being the Lavochkin design bureau, with co-contractors the Institute of Space Researches and Russian Academy of Sciences VI Vernadski Institute of Geochemistry and Analytical Chemistry.

First funding of the project began in 2004 (40m rubles) and spacecraft construction began in 2007. Launch will be in October 2009 from the Baikonour cosmodrome on a Soyuz 2 Fregat launch vehicle.

Luna Glob

Luna Glob is a spacecraft designed to look for signs of water ice in a crater near the south pole of the Moon, to study the internal structure of the Moon, and to establish the size and mass of the Moon's core, which in turn will give important clues as to how the Moon was formed. Other objectives are the investigation of natural lunar resources, to study the influence of particles and electromagnetic radiation on the lunar surface, to carry out seismic experiments, and to define the characteristics of the lunar soil.

The spacecraft will be based on the Navigator platform and includes both a lunar orbiter and a surface probe which will land near the south pole. The seismic experiments will be carried out using a network of surface penetrators which will slam into the lunar surface. The mission will last three to five years with a 2012 launch by Soyuz 2 Fregat. The main contractor is the Lavochkin design bureau, assisted by the Institute of Geochemistry Research (GEOKhI)

Below: Artist's schematic showing the main part of the Luna Glob spacecraft that will remain in lunar orbit following deployment of the lander. Image courtesy Lavochkin Association.

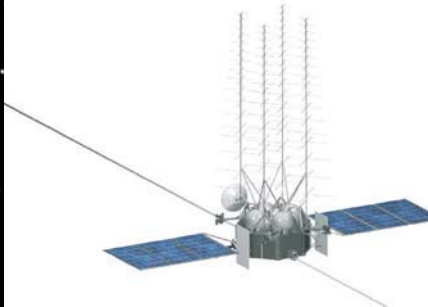

Artist's schematics showing a close-up of the Luna Glob lander (inside the airbag* at top) and its retrorocket system (left), a cutaway showing the Luna Glob lander inside the airbag (centre), and the Luna Glob lander as it will appear when deployed on the lunar surface (bottom). Images courtesy Lavochkin Association.

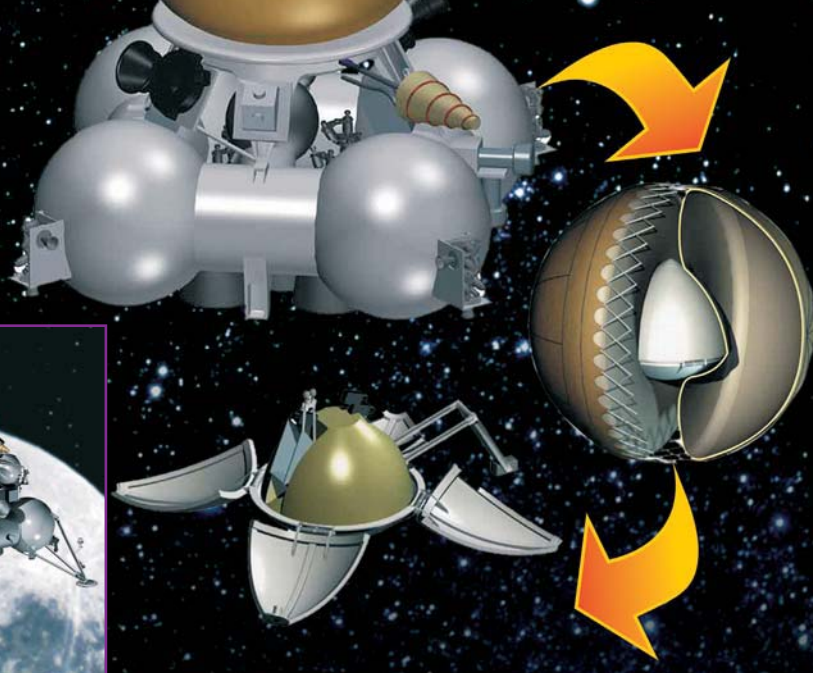

Far left: Artist's schematic showing the new Lunokhod lunar landing spacecraft, with the self-propelled rover visible at the top, prior to setting off for the Moon. Image courtesy Lavochkin Association.

Left: Artist's schematic showing the Lunar Grunt lunar landing spacecraft with the sample return stage in position on the top. Image courtesy Lavochkin Association.

in the Russian Academy of Science and some other organizations.

The Lavochkin design bureau has offered, as successors to Luna Glob, several follow-up projects over 2009-2015, but these have not yet been included in the federal space programme:

- **A new Lunokhod self-propelled lunar rover**
- **Luna Grunt project to deliver lunar soil samples back to Earth**
- **Luna Range, a number of different scientific instruments on the Moon.**

All projects also are based on Navigator platform and Fregat upper stage. These projects have been discussed in the space council of the Russian Academy of Sciences.

Venera-D

Venera D is a mission designed to carry out complex investigations of the planet Venus using an orbiter and a descent probe. The descent probe will carry a batch of 3-4 balloons and a lander. Together the orbiter, balloons and lander will study the nature, composition and optical properties of the clouds and chemical

composition of the atmosphere, investigate radiative balance and the greenhouse effect, measure the pressure, temperature and density in the atmosphere and at the surface, carry out imaging of the planetary surface during descent, examine the mineralogical characteristics of the surface, and research possible volcanic and seismic activity and lightning.

The balloons will be deployed at various locations and will float in the atmosphere at different latitudes and altitudes ranging from 60 km (in the clouds) to 10 km for more than one day, and some may land and carry out surface investigations for more than one hour. It is planned that the lander will transmit from the surface of Venus for thirty days. Such a long-duration lander was studied in the 1990s, but due to lack of funding no progress was made. The orbiter will circle Venus for up to three years. The planned launch date is 2016, but the company responsible for developing the spacecraft has yet to be selected.

SPACE LABORATORIES

Bion M

Bion M is a spacecraft designed to observe the behaviour of biological experimental subjects over the course of 45 days so as to address the biological and medical problems of long-duration human spaceflight. The main contractor is the TsSKB Progress company in Samara with, as co-contractor the Institute for Bio-Medical Problems in Moscow. The spacecraft weight is 6,300 kg, including 900 kg of scientific equipment, of which 700 kg is inside the landing vehicle. Launch, probably in 2010, will be by a Soyuz rocket into a 226 km by 394 km orbit, inclination 62.8°. The spacecraft was developed on the basis of the Foton/Zenit cabin.



OKA T and Vozvrat MKA

OKA T and Vozvrat MKA are long-term space laboratories for technological experiments in conditions of microgravity, in particular:

- **Processes of heat- and mass-transfer in liquids**
- **Technological processes for the improved manufacture of semiconductors, optical and other materials**
- **Semi-industrial manufacturing of materials.**

OKA T and Vozvrat MKA are designed to operate together with the International Space Station (ISS), dock with it and transfer to it the experimental results. Approved in 2006 as the main contractor is the TsSKB Progress company in Samara in cooperation with the Energiya rocket and space corporation in Moscow. The construction and launching of two OKA T laboratories is planned for 2012 and 2014. Each spacecraft weighs 7,800 kg, with launch on Soyuz 2 from Baikonour cosmodrome. Development costs are estimated at 2.82 bn rubles over 2006-2014.

The Vozvrat-MKA spacecraft will be smaller and lighter than OKA T, but will be equipped with its own landing vehicle. Vozvrat MKA will cost 860 m rubles, with allocations starting in 2009. It is planned to carry out the project in about 2016, which is the official end of ISS operations (NASA does not plan ISS financing after 2016).

■ **Above:** Preparing a Bion biological research satellite for launch at the Baikonour Cosmodrome. Image courtesy TsSKB-Progress.

OTHER SPACE PROJECTS

In addition to the twelve projects described in detail above, the federal space programme has a number of science projects whose exact status has not yet been decided. In all of these, the lead contractor has still to be selected. These are:

Astrometriya

Astrometriya is a space astrometry complex to measure optically the fundamental coordinates of celestial objects within a microarcsecond. Planned for launch in 2018, the mission duration is seven to ten years.

Gamma 400

Gamma 400 is a space observatory to investigate dark matter in the universe, with a view to developing a theory for the origin of high-energy cosmic rays and the physics of elementary particles. Launch date is 2013, with an active lifetime of seven to ten years.

Terion F2

Terion F2 is a space complex for the observation of the parameters and formative processes of the ionosphere and thermosphere from an Earth orbiting satellite at a height of 300 km. This will be a one-year mission, due for launch in 2018.

MKA FKI

MKA FKI is a programme of small spacecraft to study solar-terrestrial interactions and the relationships between the Sun and the small bodies of the solar system. Each spacecraft will have a lifetime of one year, with launches in 2007, 2009, 2011, 2013 and 2015.



Igor Afanasiev was born in Nizhny Novgorod, then called Gorky, in 1962 and graduated from the Bauman Technical University in Moscow in 1986 in metals and thermal processing, later becoming an engineer in the aviation and missile industries. In 1998, he became an editor with the magazine *Novosti Kosmonautiki*, where he has written over 500 articles, co-authoring many others in journals in related areas. He is author of *Unknown Spacecraft* (1991), *R-12 Sandal Tree* (1998) and co-author of *World Piloted Cosmonautics* (2005) and *The Great Space Club* (2006).

8

Paving the way for FUTURE EXPLORATION

Bunny had seen some cheeky mice in her time: but this one took the (AstroKat) biscuit!!

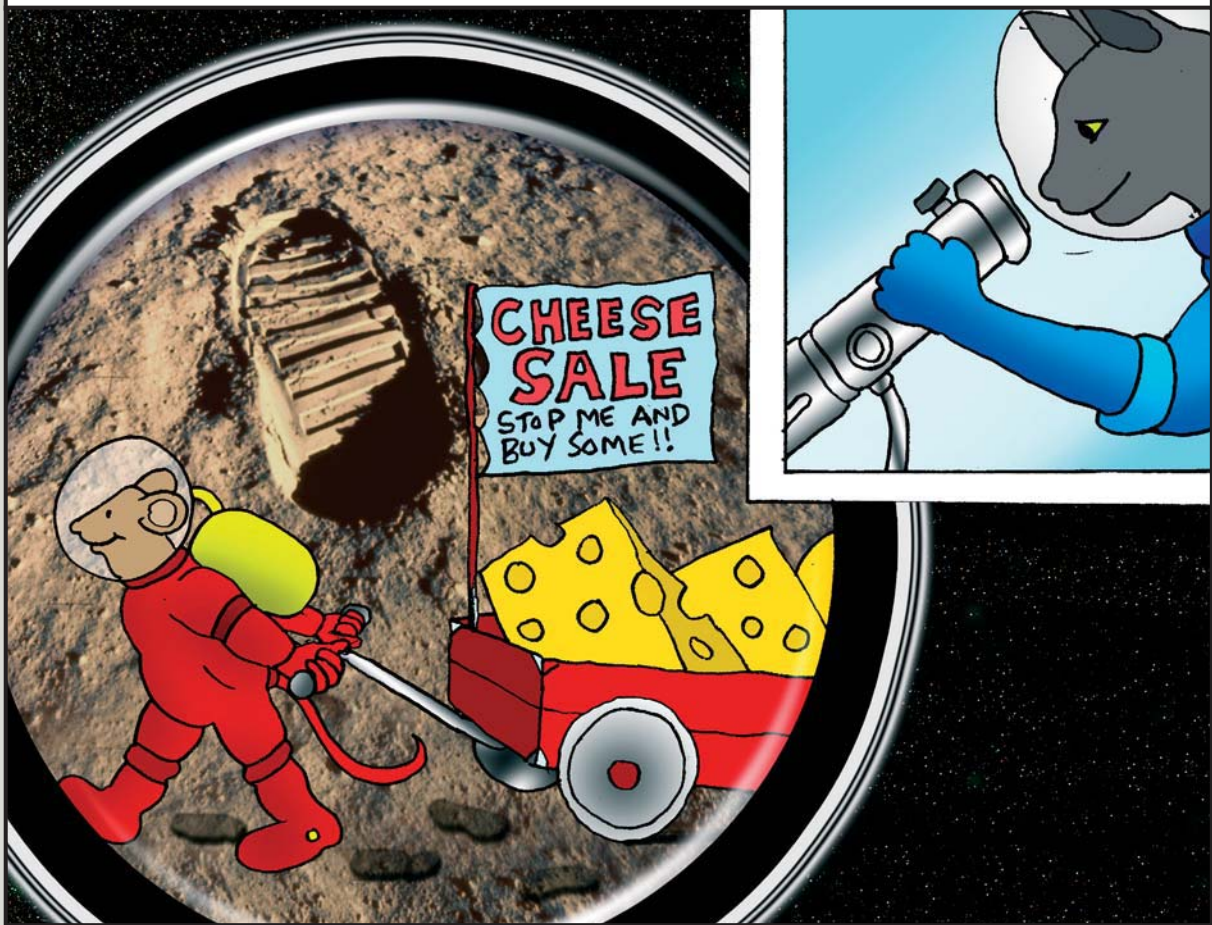

As the first lunar mission of the 21st century, the primary objective of SMART-1 was to demonstrate the use of solar-electric propulsion on a deep space trajectory, taking the spacecraft from the Earth to the Moon, but this innovative European mission achieved so much more, as the Project Manager, *Peter Rathsmann*, describes here.

The SMART-1 MISSION to the MOON

THE FIRST European lunar mission was SMART-1. The spacecraft was launched on 27 September 2003 from Kourou as an auxiliary payload on an Ariane V launcher. Using a single Xenon ion thruster providing 70 mN of thrust, SMART-1 travelled 82 million km in a spiral trajectory to the Moon. On 15 November 2005, after a journey taking 13½ months, SMART-1 was captured precisely into the

intended polar lunar orbit. The trajectory is arguably the most advanced ever performed by a Deep Space Mission.

After an extended lunar science phase, 22 months instead of the originally planned 6 months, SMART-1 had depleted its Xenon propellant and performed a controlled impact on the lunar surface. The time and location of the impact was predicted with a very high degree of

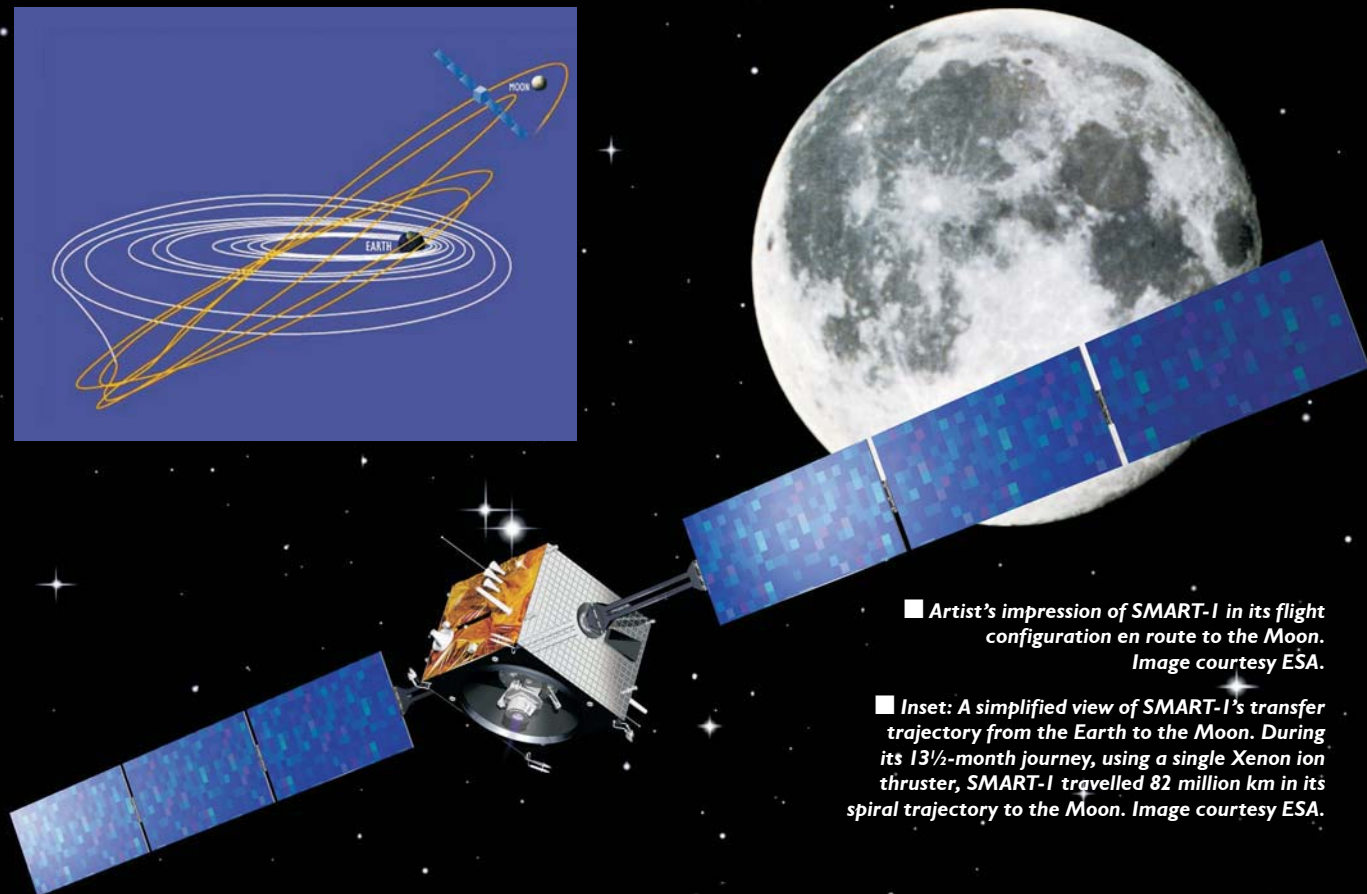
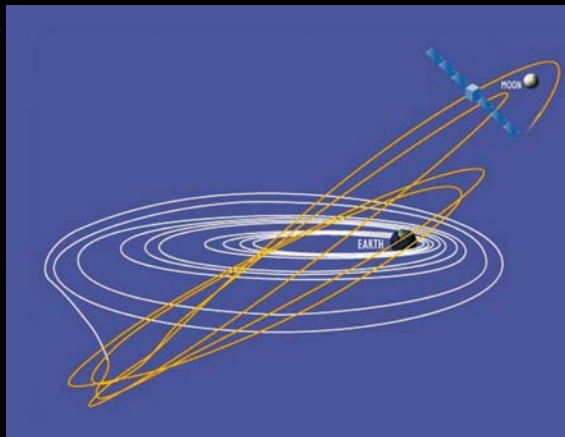

■ Artist's impression of SMART-1 in its flight configuration en route to the Moon. Image courtesy ESA.

■ Inset: A simplified view of SMART-1's transfer trajectory from the Earth to the Moon. During its 13½-month journey, using a single Xenon ion thruster, SMART-1 travelled 82 million km in its spiral trajectory to the Moon. Image courtesy ESA.

accuracy, and could be imaged in real-time by ground-based telescopes. The precision impact of SMART-1 on the Moon was voted one of the top 10 scientific achievements in 2006 by the Chinese Academy of Sciences and Chinese Academy of Engineering.

The Swedish Space Corporation (SSC) was the Prime Contractor for the SMART-1 spacecraft and was also responsible for the development of several of its subsystems including the attitude control system. The trajectory planning and spacecraft operations were performed by the European Space Operations Centre (ESOC) in Darmstadt, Germany. The overall management and funding of the project was provided by the European Space Agency (ESA).

SMART stands for “Small Missions for Advanced Research in Technology”. The objective

of this ESA-initiated SMART programme is to test critical technologies required for future Cornerstone missions. The primary mission objective of SMART-1 was to demonstrate the use of solar-electric propulsion in a relevant deep space trajectory, taking the spacecraft from one celestial body (Earth) to another (the Moon). The relevant Cornerstone mission is the ESA Mercury orbiter Bepi-Colombo, due for launch in 2013.

Spacecraft Overview

SMART-1 was a 3-axis controlled spacecraft with a launch mass of 367 kg. Of this, 82.5 kg was Xenon gas which was used as propellant for the Electric Propulsion (EP) system, and 8 kg was hydrazine used for momentum management when the EP system was not operating. The attitude control system was primarily based on autonomous star trackers and reaction wheels, but also used gimbaling of the EP thruster to achieve momentum management.

Below: The SMART-1 spacecraft mounted on its Ariane V launcher. Lift-off of Flight V162 with SMART-1 on board took place at 23:14 UT on 27 September 2003. As well as carrying SMART-1, the flight also launched two commercial satellites: INSAT-3E for India and Eutelsat's e-BIRD. Image courtesy ESA.



The data handling system was built around a single central processor and a serial CAN bus (Controller Area Network) that allowed communication with all on-board equipment. The 10 m² solar array used triple-junction GaAs cells to produce 1850 W of power, 1400 of which was used by the EP system. All platform functions were redundant and together provided single failure tolerance of the complete platform. The platform included extensive autonomy and Failure Detection, Isolation and Recovery (FDIR) implemented in software.

The main technological purpose of the mission was the flight testing of an Electric Propulsion (EP) system as the main propulsion system in a deep space mission. Whilst this had been partially achieved by the probe Deep Space 1 in 1998, the SMART-1 trajectory was significantly more complex in that it required an orbit transfer from one celestial body to another.

The components of the EP subsystem on SMART-1 are shown in the schematic diagram on this page. The EP thruster was the PPS-1350G, a modified European version of the Russian SPT-100 Hall Effect thruster currently flying on several Western and Russian telecommunication satellites. Xenon is used as propellant, and for reasons of volume efficiency, it is stored in supercritical state at high pressure (max 150 bars). The Xenon pressure is reduced by an electronic pressure regulator to a working pressure of 2 bars, followed by flow modulation to the thruster by the Xenon flow controller. The Power Processing Unit distributes the electrical power to the thruster at the proper voltages and the Electrical Filter Unit dampens out discharge current oscillations from the thruster. The thruster consumes 1220 Watt at the nominal operational point, providing approximately 68 mN of thrust. The dry mass of the EP subsystem was 29 kg. At launch, the tank contained 82.5 kg of Xenon, providing the spacecraft with a total of 4,000 m/s of delta-V. Of this, approximately 3,500 m/s was used for the 13.5 month transfer to the Moon.

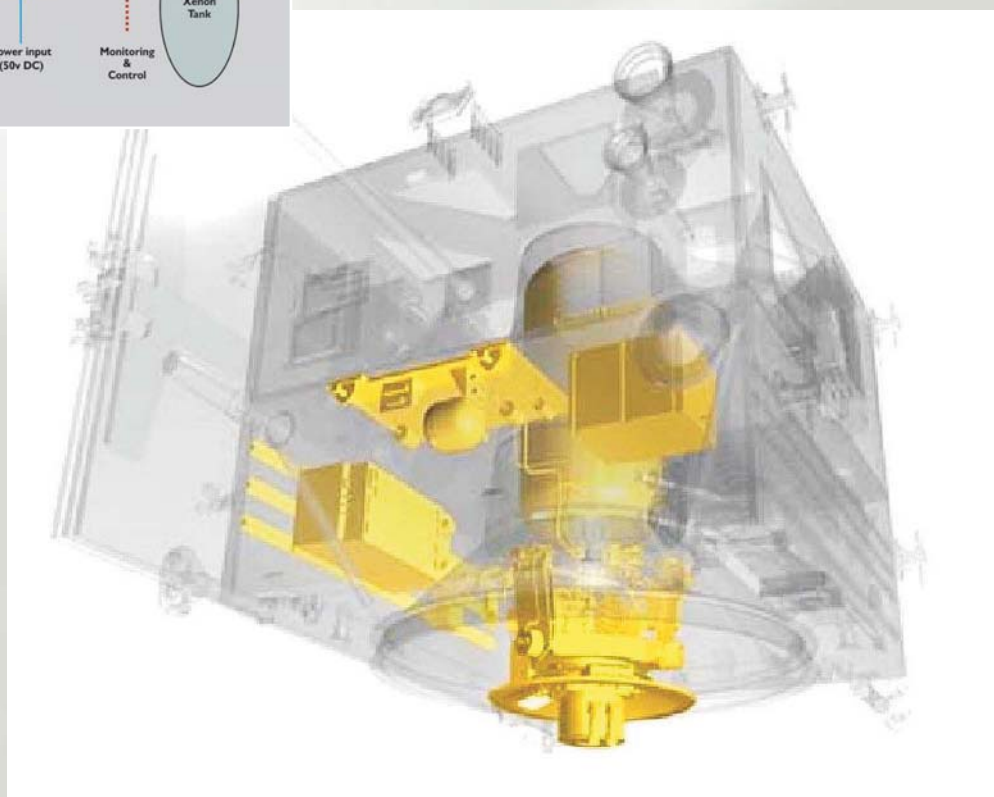
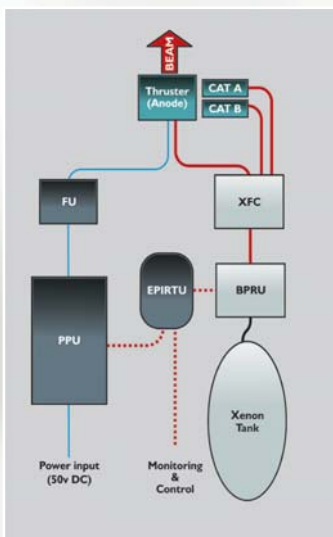

■ **Far left:** Block diagram showing the main components of SMART-1's Electric Propulsion (EP) subsystem, which consisted of the following units: Xenon tank, Bang-bang Pressure Regulation Unit (BPRU), Xenon Flow Controller (XFC), Power Processing Unit (PPU), Electrical Filter Unit (FU) and Pressure Regulation Electronics (PIRTU). Image courtesy ESA.

■ **Left:** SMART-1 spacecraft structure with EP components highlighted. Image courtesy ESA.

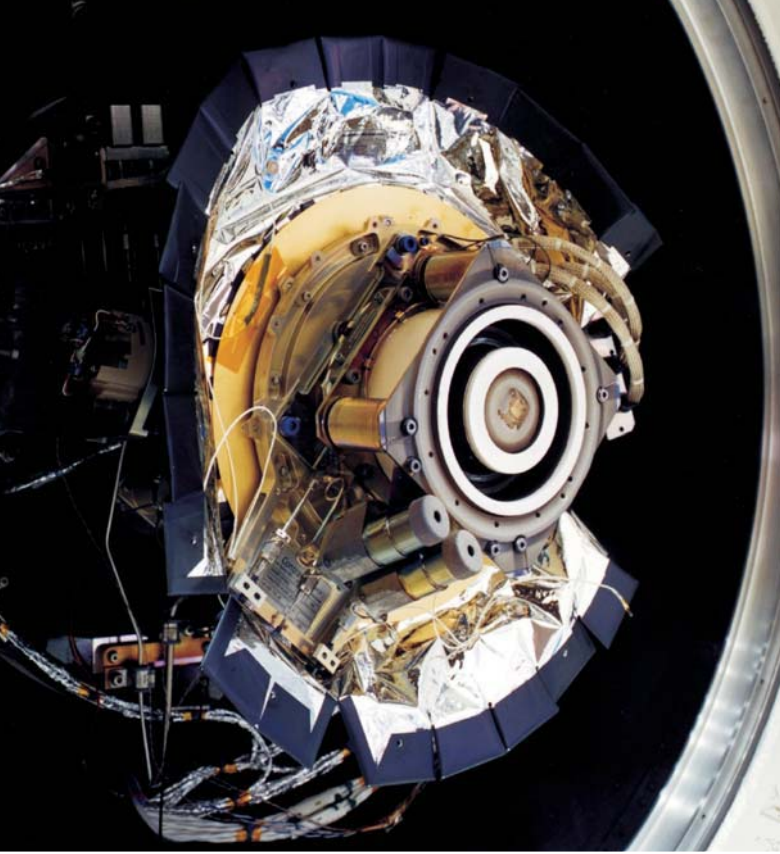

Although the primary goal of the mission was to test electric propulsion, SMART-1 also included a 19 kg scientific/technological payload with several miniaturized instruments. These included:

EPDP Electric Propulsion Diagnostic Package (2.3 kg, 18 W). A suite of sensors for thruster diagnostics with ion energy up to 400 eV and spacecraft contamination monitoring.

SPEDE Spacecraft Potential, Electron and Dust Experiment (0.8 kg 1.8 W) monitored the plasma oscillations during the EP operations.

KaTE X/Ka-band Telemetry and Telecommand (TT&C) Experiment (6.2 kg, 28 W). An X-up/X-down and Ka-down Deep-Space Transponder running turbo-codes, allowing up to 500 Kbps data rate from lunar orbit.

■ Two views of the SMART-1 PPS 1350G electric propulsion engine made by SNECMA. This was a modified European version of the Russian SPT-100 Hall Effect thruster, currently flying on several Western and Russian telecommunications satellites. Images courtesy SNECMA and ESA.

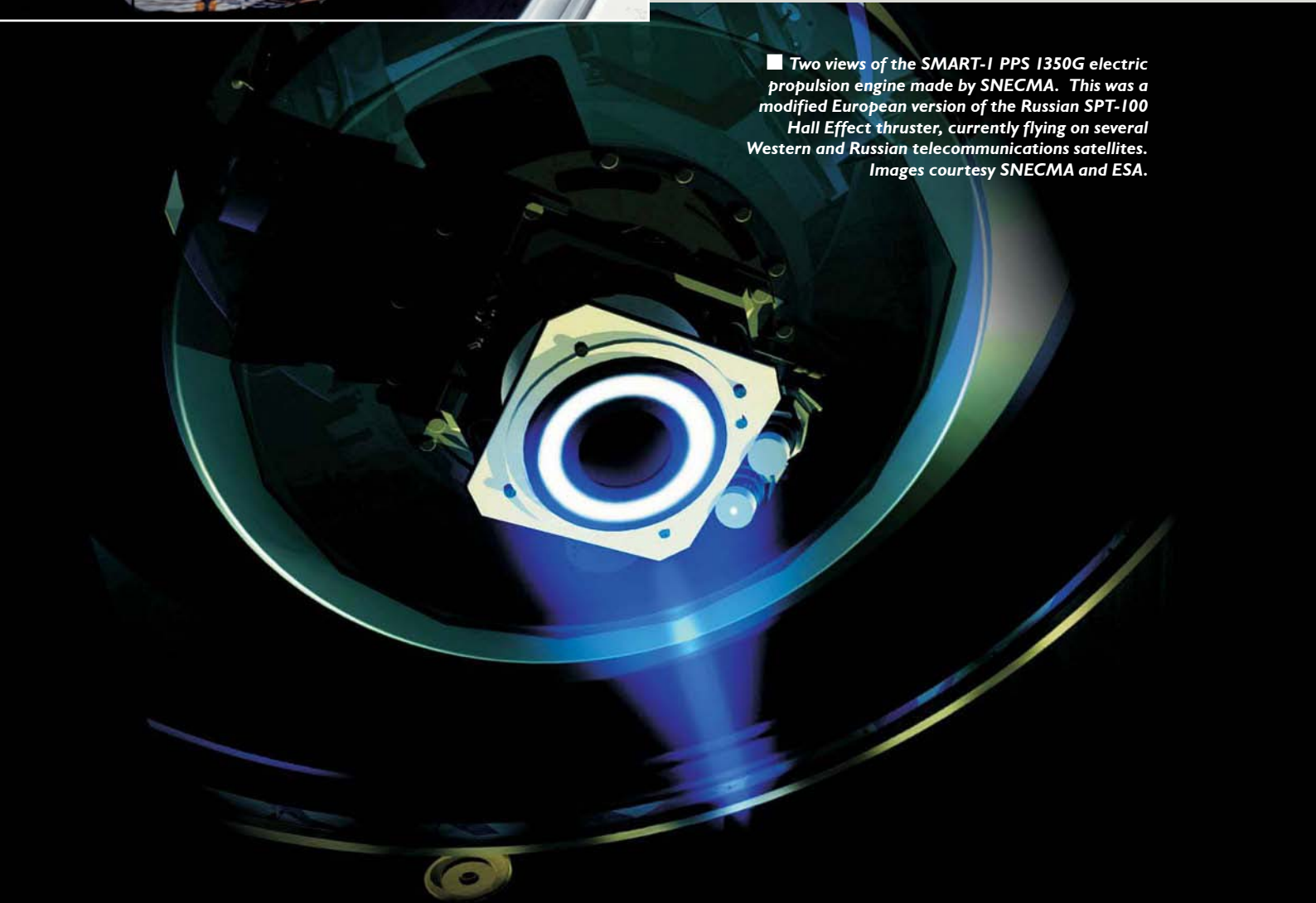



D-CIXS/XSM Demonstration of a Compact Imaging X-ray Spectrometer (5.2 kg, 20 W, including XSM). A 12° x 32° FOV spectral imager in the 0.5-10 keV range based on Swept Charge Device detectors and micro-collimators, measuring X-ray fluorescence from the lunar surface discriminating the solar background by means of the X-ray solar monitor.

AMIE Asteroid-Moon Imaging Experiment (2.2 kg, 9 W). A 5.3° FOV miniaturised camera with a 4-band fixed filter (0.75, 0.9 and 0.95 mm wide-band mineralogical filters and a 0.847 mm narrow-band filter for the Laser-link). The camera was based on high-density 3-D cube-packed Multi-Chip Module electronics.

SIR SMART-1 Infrared Spectrometer (2.3 kg, 4.2 W). A 1 mrad FOV point-spectrometer with 256 channels operating in the 0.9-2.4 mm wavelength range (NIR) for lunar mineralogy. A scan of the Moon took place in February 2004 and other experiments have also been performed.

Laser-link demonstration of a deep-space optical link acquisition (with AMIE), where a laser beam was sent in the direction of the SMART-1 spacecraft by the ESA Optical Ground Station in Tenerife. The aim of the

experiment was to prepare for deep-space laser communication links, by demonstrating the acquisition of the laser-link up to lunar distance and to validate a novel beam arrangement in four sub-apertures for mitigating the effect of atmospheric turbulence on the laser beam.

Results of the Mission: *Flight Trajectory*

The low thrust spiral trajectory flown by SMART-1 was one of the important technology objectives of the mission. The trajectory has been described in several papers and is generally considered to be one of the most complex ever flown. The pre-flight predicted trajectory and the as-flown trajectory (including the first year in lunar orbit) are schematically shown overleaf. The first part of the trajectory consisted of essentially

■ **Above:** The D-CIXS (Demonstration of a Compact Imaging X-ray Spectrometer) instrument used for measuring X-ray fluorescence from the lunar surface, discriminating the solar background by means of an associated X-ray Solar Monitor (XSM). Image courtesy Rutherford Appleton Laboratory.

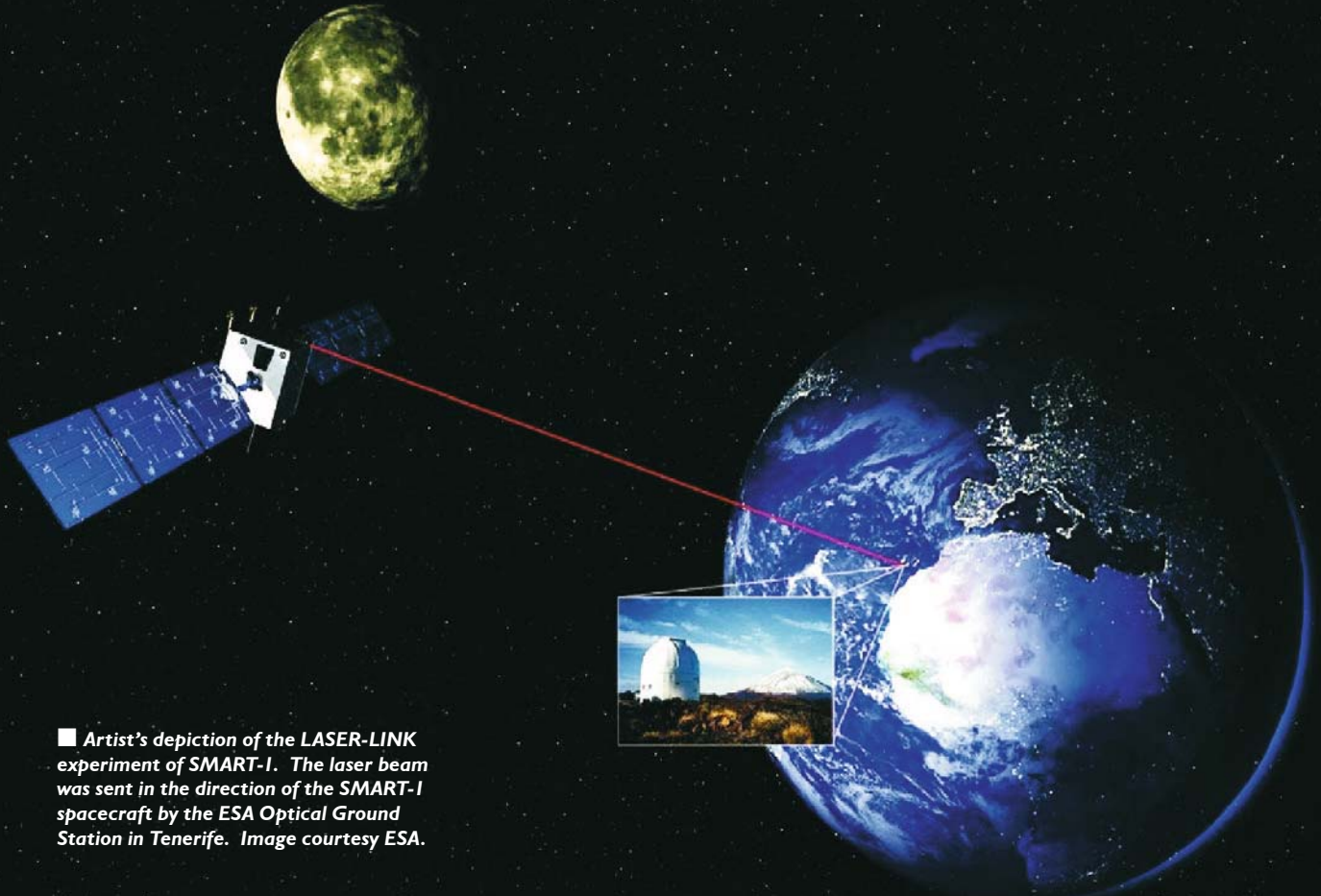

■ Artist's depiction of the LASER-LINK experiment of SMART-1. The laser beam was sent in the direction of the SMART-1 spacecraft by the ESA Optical Ground Station in Tenerife. Image courtesy ESA.

continuous thrusting in order to raise the perigee as quickly as possible above the proton belts. After exiting the proton belts, orbit expansion was obtained by an optimised thrust strategy involving changes in thrust direction and thrust and coast arcs.

The main change in trajectory strategy during the transfer phase was the omission of the two lunar swing-bys which were initially planned. This was done since the swing-bys would have been fairly time consuming, requiring a geometry that could only be achieved with a flight two months longer. Swing-bys were initially considered in order to save fuel, but the actual fuel budget was found to be adequate and thus two months of transfer time could be saved. Instead of swing-bys, another technique was used: a "weak fly-by", outside the sphere of influence of the Moon. These regions, where more than one planetary body affects the flight of a spacecraft, are much more difficult to handle and

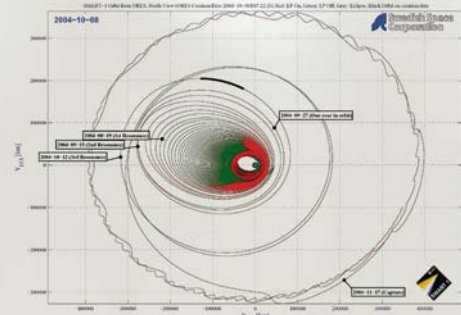
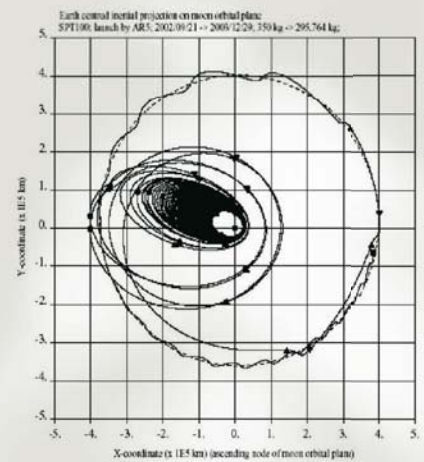

■ Above right: Schematic diagram showing the pre-flight predicted transfer trajectory for SMART-1 from its exit from Earth's radiation belts (perigee at 20,000 km) until capture into its intended lunar orbit. Image courtesy ESA.

■ Right: Schematic diagram showing the as-flown trajectory of SMART-1, including the first year in lunar orbit. The red curves indicate EP thrusting, the green curves are coast arcs. Image courtesy ESA.

enter into the realm of multi-body dynamics. The ESA flight dynamics team at ESOC used newly designed computational techniques to obtain the desired trajectory mainly by controlling the altitude and argument of perigee. The encounters were designed to repeat regularly at each lunar revolution (period of 27.4 days). This was obtained by varying the period of the orbit so that the SMART-1 apogee took place close to the Moon. The SMART-1 orbit was therefore in “resonance” with that of the Moon. At the first encounter the ratio of the periods of the SMART-1 and Moon orbits were 1:5. At the second encounter on 15 September, the ratio was 1:4, at the third one on 12 October, 1:3, and finally the last orbit which lead to the capture on 15 November 2004, the period was half that of the Moon’s. Once in lunar orbit, the EP thruster was used to lower the orbit down to the designated science orbit of 300 km x 3,000 km. The primary mission objective had thereby been successfully completed: the demonstration of EP systems for complex deep space trajectories.

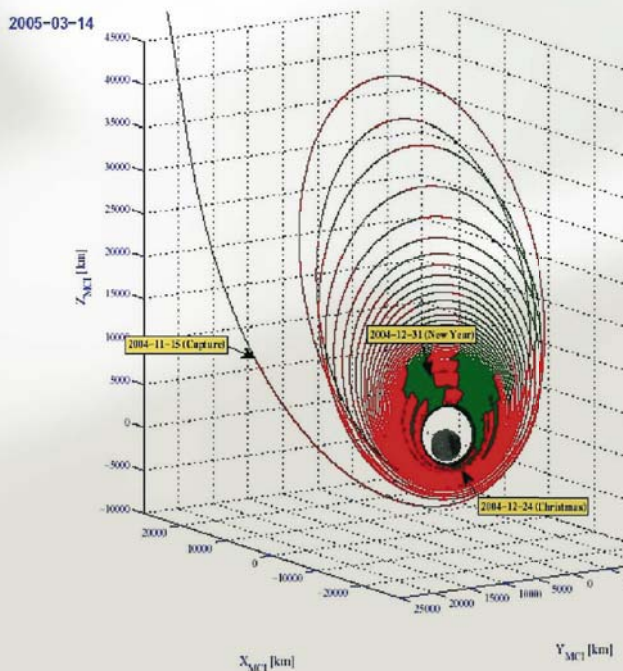

From February 2005 to September 2006, the science mission was performed. To maximize the science return, two re-boosts were performed. The first one was a one-month re-boost in September 2005 in order to optimize the lunar orbit with respect to imaging illumination conditions. A second and final re-boost phase was performed in June/July 2006 to fine-tune the impact date and

location. Lunar impact occurred on 3 September 2006 at 05:42:22 UTC, in an area called the Lake of Excellence located at 34.4° S, 46.2° W).

Results of the Mission: *Radiation Environment*

An important aspect of the first part of the mission was to assess the impact of the long duration in the severe proton radiation environment at altitudes between 2,000 and 10,000 km. A challenging element in all deep-space mission designs is to have sufficient, but not excessive, design margins against solar proton events. For SMART-1, a confidence level of 95% had been used for the planned 2-year mission duration, meaning that the chances of experiencing solar proton events above the predicted dose, was only 5%. In late October 2003, only 6 weeks into the mission, a series of extremely energetic solar storms occurred, which in fact turned out to be the worst ever recorded. Within only 2 months, the radiation exposure was above a 99% confidence level for the entire mission. A large number of hot spots (>3,000) had appeared on the star tracker CCDs, making the autonomous attitude determination increasingly difficult. Using advanced reprogramming of their star tracker, the supplier (DTU) could however successfully restore nominal operation of the Star trackers within a matter of days. The solar arrays experienced an 8% degradation during the transverse of the proton belts. Whilst this degradation was not dramatic, it turned out to be higher than predicted by an a posteriori analysis using SPENVIS (Space Environment Information System). This indicates that the “pumping up” of radiation belts during solar storms is not accurately modelled by state-of-the-art software packages, probably due to lack of empirical data. During the following three years of the mission, the solar activity was fortunately very low. The result was that the end of life solar array power degradation (13%) turned out to be very close to pre-launch predictions.

■ **Above left:** Schematic diagram showing the “braking trajectory” in which the EP thruster was used to lower the orbit of SMART-1 down to the desired lunar science orbit of 300 km x 3,000 km. The red curves indicate EP thrusting, the green curves are coast arcs. Image courtesy ESA.

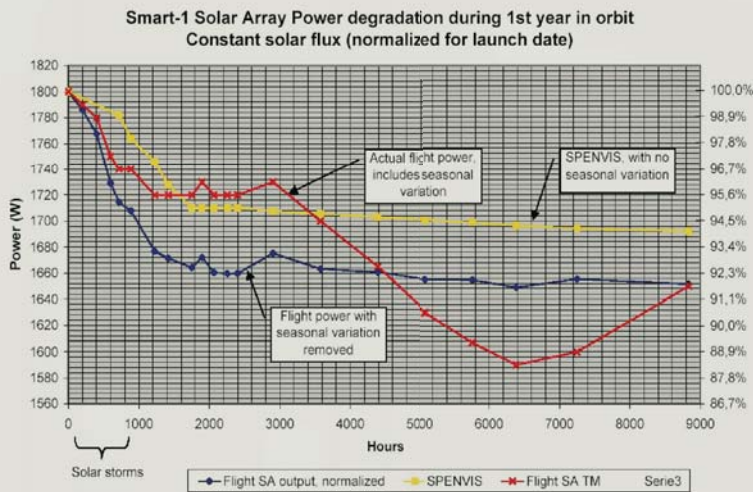

Results of the Mission: Electric Propulsion

In general, the in-flight performance of the SMART-1 EP system showed a very good behaviour. The only exception was a number (38 in total) of proton-induced Optocoupler Single Event Transients (OSET). These caused a false indication of a “flame-out”, resulting in an automatic shut-down of the EP system. The remedy was to implement an on board software patch which automatically detected the OSET event and initiated an autonomous thruster restart. The variation in thrust level during the mission was of the order a few percent. A variation on the floating S/C potential during thruster operation was also identified early in the mission. It was found to be correlated with the solar array angular position. The reason was that the more conductive surface (S/A cell interconnects) shown to the Xenon plasma, the more electrons are absorbed by the S/C and the lower the S/C potential becomes relative to the plasma potential. This electron current is of the order 30 mA. The thruster performance was

■ **Top:** Graph showing the SMART-1 solar array output power (W) during the first year of the mission. The solar arrays experienced an 8% degradation during the transverse of the proton belts. Whilst this degradation was not dramatic, it turned out to be higher than predicted. During the following three years of the mission, solar activity was fortunately very low. The result was that the end of life solar array power degradation (13%) turned out to be very close to pre-launch predictions. Image courtesy ESA.

■ **Above right:** Detection of the laser beam on the AMIE CCD from a distance of 60,000 km during a successful LASER-LINK experiment on 15 February 2004. Image courtesy ESA/Space-X.

determined not to be affected by the S/C potential. It was further established that the radiation belts have no influence on EP performance thanks to the dense artificial plasma generated by the thruster itself.

Results of the Mission: Science and Technology Payload

Since SMART-1 was a technology demonstration mission, the scientific return was naturally not as significant as for other ESA science missions. Below follows some high-lights from the scientific/technology part of the mission.

LASER-LINK

The LASER-LINK experiments were successfully performed up to distances of approximately 100,000 km. In one instance, the laser beam fired from the Tenerife observatory was successfully imaged on the AMIE CCD from a distance of 60,000 km on 15 February 2004.

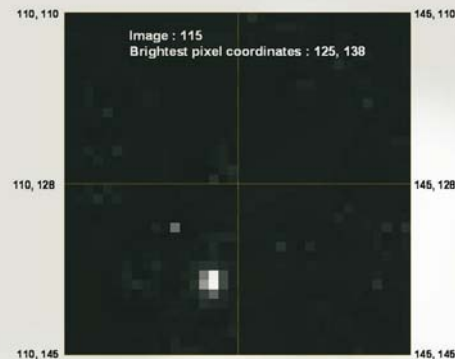

AMIE

On 28 October 2004, the AMIE imager provided the first-ever lunar eclipse imaged from space. During the lunar science phase, AMIE captured some 50,000 high-resolution images of the lunar surface. Scientific analysis of the lunar surface images is on-going and includes high-resolution geology, lunar crust studies, mapping of regions of eternal sun-light and a search for potential water traps around the poles.

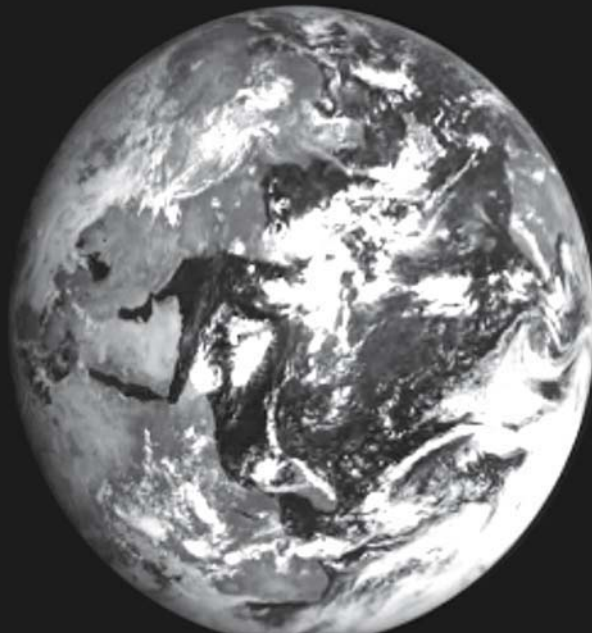
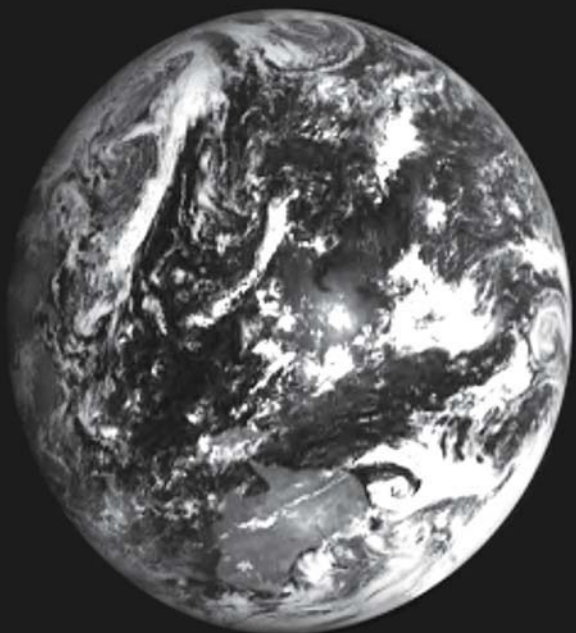

D-CIXS

The X-ray spectrometer (D-CIXS) started taking measurements of the Moon as of the beginning of January 2005. Solar flare events in early January (15th) triggered a high X-ray response level from the lunar surface and D-CIXS detected energy events. SMART-1 was orbiting over Mare Crisium at this time.

The spectral plot below shows counts detected from Facet 1 (blue), Facet 2 (green) and Facet 3 (red) during the early period of the 15 January 2005 solar flare when SMART-1 was orbiting above the Mare Crisium. The data has been partially corrected with initial background removals. The spectra

shows the clear detection of emission from calcium and iron and a merged peak from magnesium, aluminium and silicon visible in Facet 1. Facet 3 is covered by a magnesium filter, and hence does not contain the aluminium and silicon lines visible in Facets 1 and 2.

An upgraded version of D-CIXS will fly on the Chandrayaan mission to the Moon in 2007. While SMART-1 provided a very successful flight qualification of the miniaturized D-CIXS imager, the science return from the instrument

■ **Above:** The first ever lunar eclipse images from space. With the Earth below, the series of SMART-1 AMIE images near the top of the frame shows the Moon entering and leaving the Earth's shadow during the lunar eclipse of 28 October 2004. Images courtesy ESA/Space-X.

■ **Left:** The North Pole of the Moon. During the lunar science phase, SMART-1's AMIE imager captured some 50,000 high-resolution images of the lunar surface. Image courtesy ESA/Space-X.

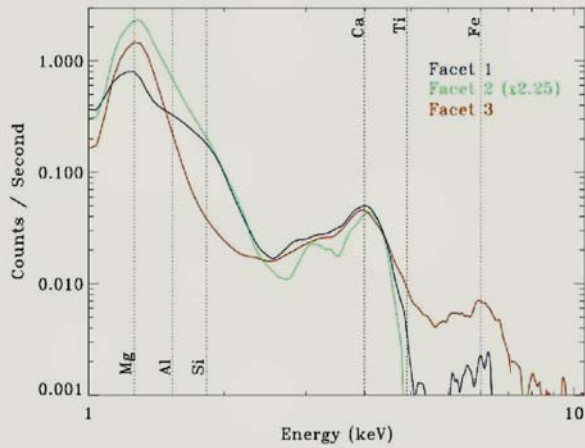

is expected to be higher in the Indian mission due to the much higher solar activity expected then. This will trigger a higher level of solar X-ray emissions, thus creating stronger fluorescent responses from the lunar surface.

The Impact on the Lunar Surface

Towards the end of the SMART-1 mission, a series of orbit control manoeuvres were done to influence the impact date and location such that Earth-based telescopes could observe the impact. Since there was no Xenon remaining, a scheme was devised by which the hydrazine attitude control thrusters were used to provide a total velocity increment of ~ 11.8 m/s. Thanks to this, the perilune could be raised by approximately 90 km, resulting in a 2-week extension of the orbit life, thus providing Earth visibility of the impact site. On 3 September 2006 at 05:42:22 UTC, SMART-1 impacted the Moon in an area called the Lake of Excellence. The impact was observed and confirmed from Earth by both radio, visual and infra-red telescopes.

SMART-1: Paving the Way

SMART-1 was the first lunar mission of the 21st century, paving the way for a number of missions during the coming decade. SMART-1 was used to calibrate the tracking stations which will be used for the upcoming Chang'e and Chandrayaan-1 missions.

■ **Top:** Spectra from SMART-1's X-ray spectrometer, D-CIXS, showing the first detection from space of calcium on the lunar surface. The spectral plot shows counts detected from Facet 1 (blue), Facet 2 (green) and Facet 3 (red) during the early period of the 15 January 2005 solar flare when SMART-1 was orbiting above the Mare Crisium. Image courtesy Rutherford Appleton Laboratory.

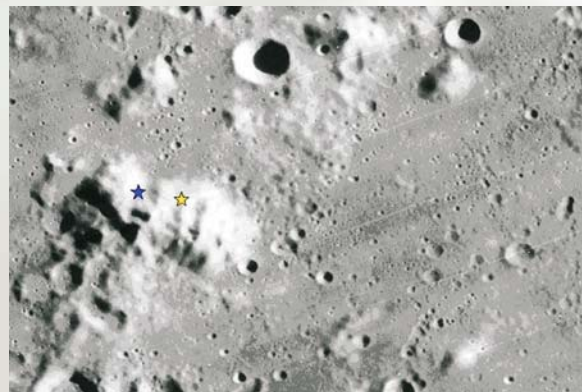
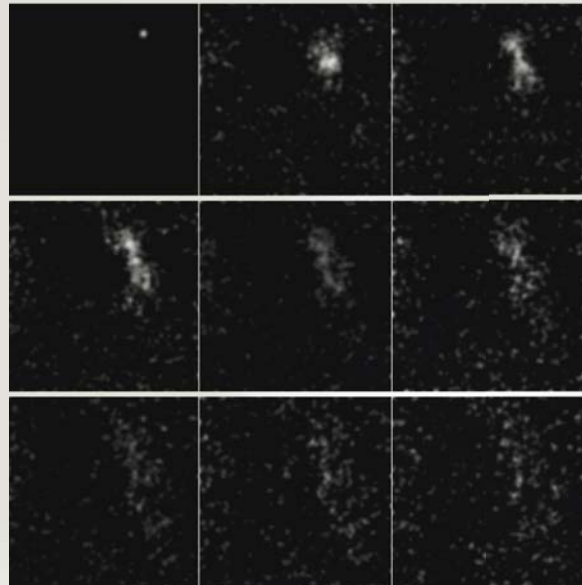
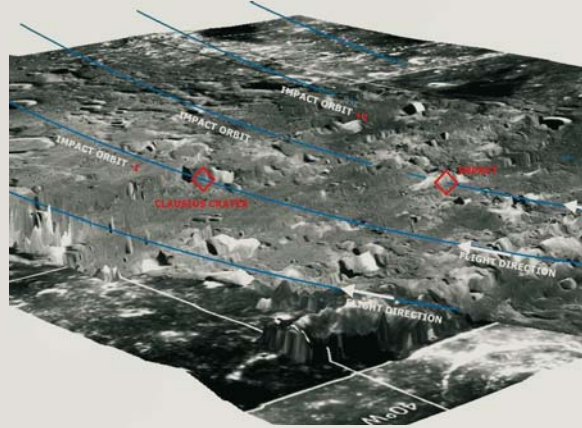
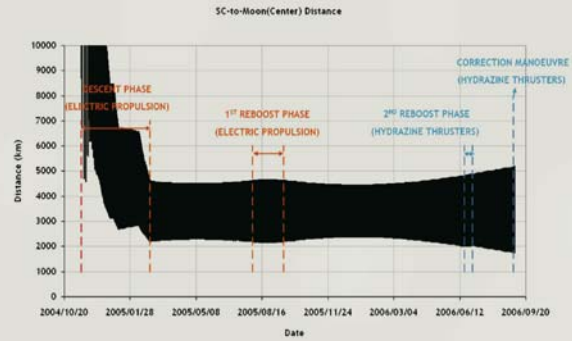

Acknowledgements

I would like to acknowledge the excellent work that was done by all parties involved in the SMART-1 project. In particular I would like to thank my team members at the Swedish Space Corporation for their exceptional dedication throughout the project. I would also like to thank our suppliers for providing excellent equipment and support throughout the mission. This includes in particular SNECMA for the



Peter Rathsman is a space systems engineer who works for the Swedish Space Corporation in Stockholm. He was appointed Project Manager for the SMART-1 mission. Previously, he had been heavily involved in satellite projects such as Freja and Odin, both Swedish projects, but with extensive international participation.

EP system and the Technical University of Denmark for the star tracker system. Special thanks go to the Project and Science Teams at ESTEC, and the Mission Operations Team at ESOC for their excellent trajectory planning and dedicated operational support. For the final preparations and activities in connection with the spectacular lunar impact event, special thanks are due to Nottingham University, the United States Geological Survey (USGS) and all the participating observatories.

Further Reading

SMART-1 home page: <http://sci.esa.int/smart>

Opposite page right hand column - top to bottom:

■ Diagram showing the evolution in the SMART-1 spacecraft's lunar altitude from capture to impact.

Image courtesy European Space Operations Centre (ESOC).

■ A 3-dimensional plot of the impact area, showing the orbits of SMART-1 before and after the planned impact. The spacecraft trajectory (in blue) disappears where the orbital altitude is below the Moon surface.

Image courtesy USGS/University of Nottingham.

■ This sequence showing SMART-1's lunar impact was constructed from infrared images taken by the Canada-France-Hawaii Telescope (CFHT) on 3 September 2006, and shows the flash and the dust cloud that followed the impact. The cloud of ejected material or debris travelled some 80 km in 130 seconds. Image courtesy Canada-France-Hawaii Telescope 2006.

■ A 3-Dimensional view of the SMART-1 impact location. The two possible impact points are marked by the yellow and blue stars, separated by approximately 7 km.

Image courtesy USGS/Mark Rosiek.

Some Lunar Missions: Past, Present and Future

Project	Purpose	Country	Year
Muses-A, Hiten	Lunar Navigation	Japan	1990
Clementine	Multiband imaging, tech dem	USA	1994
Lunar Prospector	Neutron imag science	USA	1997
SMART-1	Technology demonstration multiband imaging, geochemistry	ESA	2004
SELENE	Ambitious science orbiter	Japan	2007
Chang'e	Science orbiter	China	2007
Chandrayaan-1	Science orbiter	India	2008
LRO	Polar orbiter, Search for landing sites	USA	2008
Soft landers		(China, Japan US, Europe)	2010 – 2015 ?
Lunar rover	Analysis of soil samples	China	2012?
Manned lunar missions		USA	2015-18?
Manned lunar missions		China	2020?
Manned lunar bases		USA?	2024?

9 NASA's New Robotic LUNAR PROGRAM...



NASA is planning to resume the human exploration of the Moon. In 2008 the Lunar Reconnaissance Orbiter (pictured here) will be launched to survey the Moon's resources, in particular in the polar regions. As part of that mission the expired rocket stage will be crashed into a site at the south pole where there may be water ice. But is it really there? Here *David Harland* tells the story of NASA's search for water on the Moon.

Seeking WATER on the MOON

ON 14 JANUARY 2004, President George W. Bush issued a policy statement entitled *A Renewed Spirit of Discovery* in which he called upon NASA to begin to plan for a resumption of human missions to the Moon, as a precursor to a mission to Mars. As a first step, and beginning no later than 2008, NASA was instructed to “initiate a series of robotic missions to the Moon to prepare for and support future exploration

activities”. In *The Vision for Space Exploration*, which the agency published on 11 February, the Goddard Space Flight Center was directed to establish a Robotic Lunar Exploration Program.

Between 1969 and 1972 Apollo crews landed at six sites on the Moon to set up instruments and to collect samples. They found that the material on the surface of the Moon is a ‘regolith’ of rocks that are being worn down to ever finer fragments by the ongoing rain of micrometeoroids, and because a side effect is to ‘turn over’ the material to a depth depending on the size of the impact, this process has been named ‘gardening’. One of the most stunning findings from analyses of the lunar material was that although it was rich in a variety of potentially useful minerals, it was devoid of hydrated minerals. However, the range of sites visited by the Apollo crews had been restricted by operational factors. In particular, because the rotation of the Moon is synchronised with the period of its orbit around Earth, it maintains the same hemisphere facing Earth, and not only was it impracticable to land on the ‘far side’ of the Moon, sites in the polar regions were also unreachable. Despite the analyses of the Apollo samples, NASA now has high hopes of finding water at the lunar poles, and if this can be established then it will be a key factor in planning a permanent base.

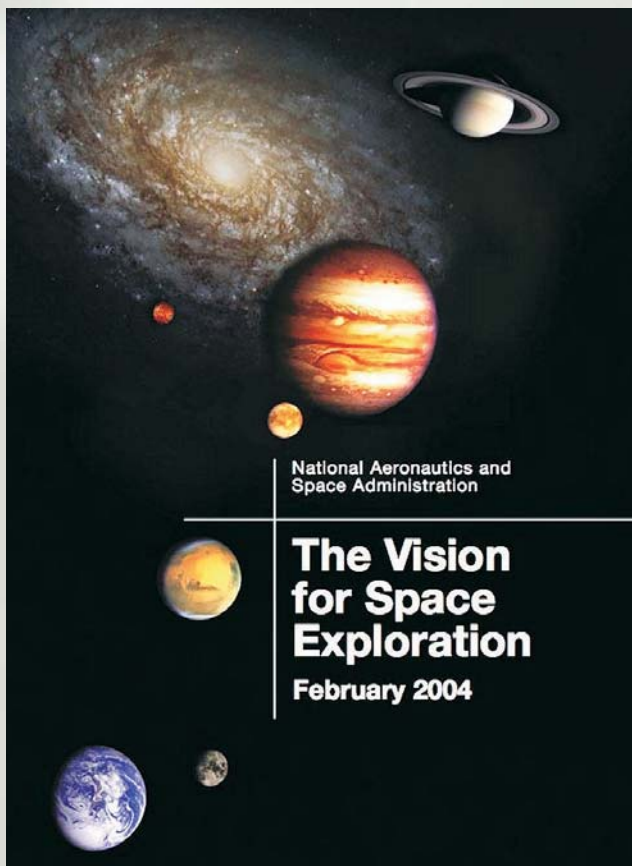

■ **Left:** The cover of *The Vision for Space Exploration*, published on 11 February 2004, in which the Goddard Space Flight Center was directed to establish a Robotic Lunar Exploration Program. Image courtesy NASA.

Clementine

The Clementine spacecraft rose from Vandenberg Air Force Base, California on 25 January 1994 on a refurbished Titan II missile and was put into the desired 'parking orbit' around Earth. On 3 February the solid-propellant motor inserted the spacecraft into a translunar trajectory. On 19 February, Clementine fired its engine to enter into an orbit that was inclined at an angle of 90 degrees relative to the Moon's equator at altitudes ranging between 430 and 2,950 km with its low point at about 30°S. While near perilune the spacecraft undertook laser altimetry and took pictures across the spectrum from the near-infrared to ultraviolet for a multispectral investigation of the composition of the lunar surface, and then at the apolune of its 5-hour orbit this data was downlinked to Earth. In addition, the spacecraft had a 3-axis accelerometer to monitor how its trajectory was perturbed by the lunar mascons. Over the period of a month, as

the Moon rotated on its axis beneath the plane of the vehicle's orbit, the spacecraft was able to inspect the entire range of longitudes. A series of manoeuvres in late March moved the low point to the northern hemisphere in order to complete the coverage. One particularly welcome result was a vertical perspective of each of the polar regions.

Whereas the Earth's rotational axis is tilted at 23.5 degrees to the plane in which the planet orbits the Sun, this plane being called the ecliptic, the rotational axis of the Moon is inclined 1.6 degrees from the ecliptic. Consequently, there might be craters in the lunar polar regions whose floors are never illuminated. However, because the plane in which the Moon orbits Earth is inclined at 5.15 degrees to the ecliptic, when the Moon is south of the ecliptic we can see several degrees beyond its north pole at a time when that is illuminated, and when the Moon is north of the ecliptic we can see beyond its south

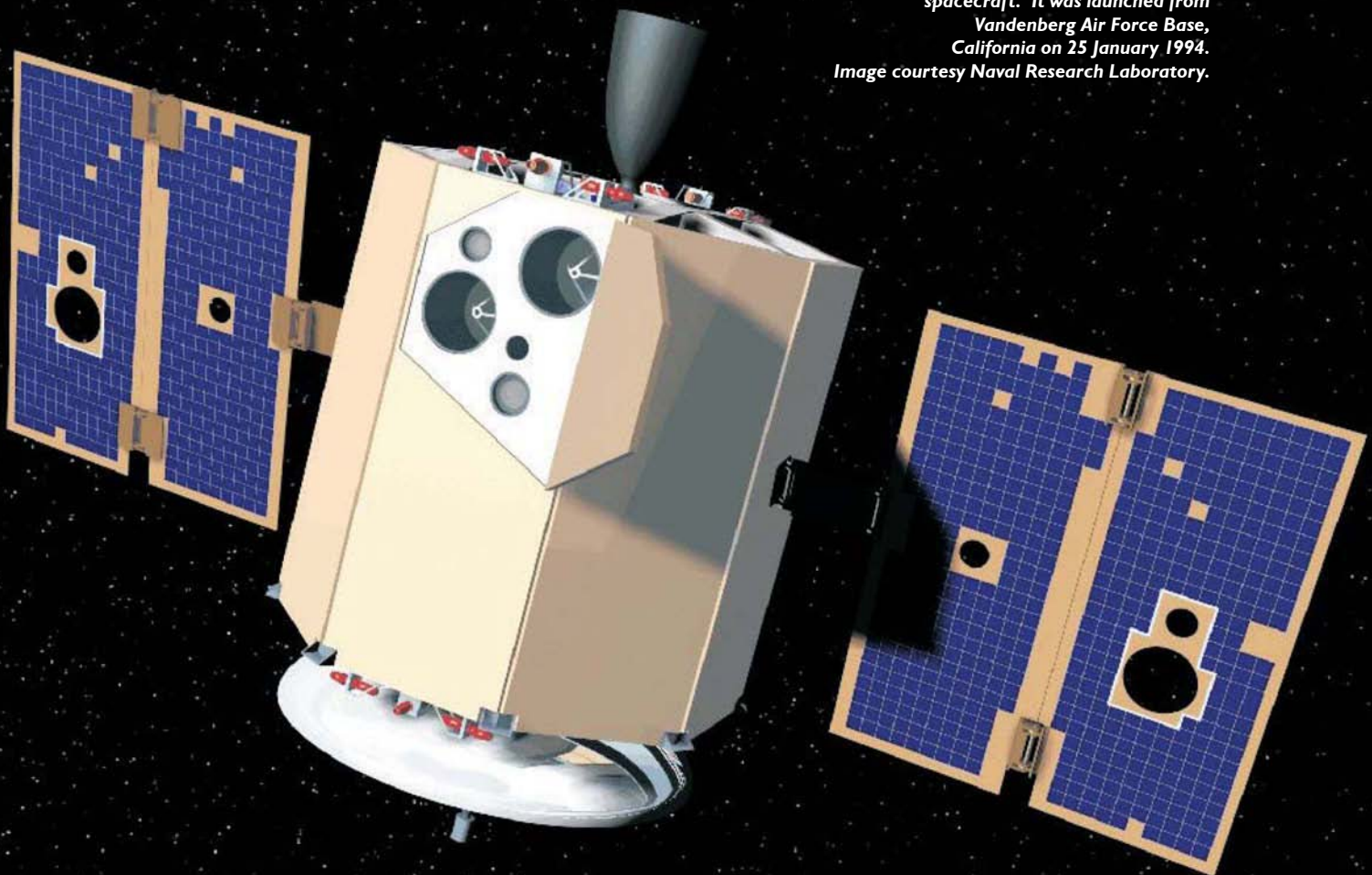

■ An artist's depiction of the Clementine spacecraft. It was launched from Vandenberg Air Force Base, California on 25 January 1994. Image courtesy Naval Research Laboratory.

pole when that is illuminated. In 1961 Kenneth Watson, Bruce Murray and Harrison Brown at the California Institute of Technology in Pasadena had suggested that the floors of permanently shadowed craters might serve as 'cold traps' in which the temperature would hover at about 100K, and in which water ice delivered over the aeons by comets would tend to accumulate.

Clementine's near-polar orbit provided an opportunity to test this idea. Water ice has a unique 'signature' when probed by radio energy. Furthermore, it reflects more efficiently when the angle of incidence of the 'illumination' is near-zero (this is a phenomenon known as coherent backscatter) and, in contrast to rock, ice preserves the polarisation of the wave. When the geometry was suitable in March and April a bistatic experiment was undertaken in which the spacecraft 'beamed' its radio signal into the

shadowed craters at each pole and large antennas of NASA's Deep Space Network monitored the reflection. Although the results in March were inconclusive, those in April were intriguing: two passes over the north pole were unremarkable, as was one pass near the south pole, but on orbit 234, when the 'beam' tracked across the shadowed areas right at the pole, the terrestrial antennas noted both an increase in the strength of the reflection and a greater percentage of the signal preserving the original polarisation. This prompted the team led by P.D. Spudis to report in 1996 the possible detection of water ice making up part of the surface layer near the south pole.

Lunar Prospector

Developed as a low-cost Discovery class mission, Lunar Prospector was intended to undertake remote sensing of the Moon on a global basis

■ An artist's depiction of the Lunar Prospector spacecraft approaching the Moon. Developed as a low-cost Discovery class mission, Lunar Prospector was launched from Cape Canaveral on 6 January 1998. Image courtesy NASA Ames Research Center.

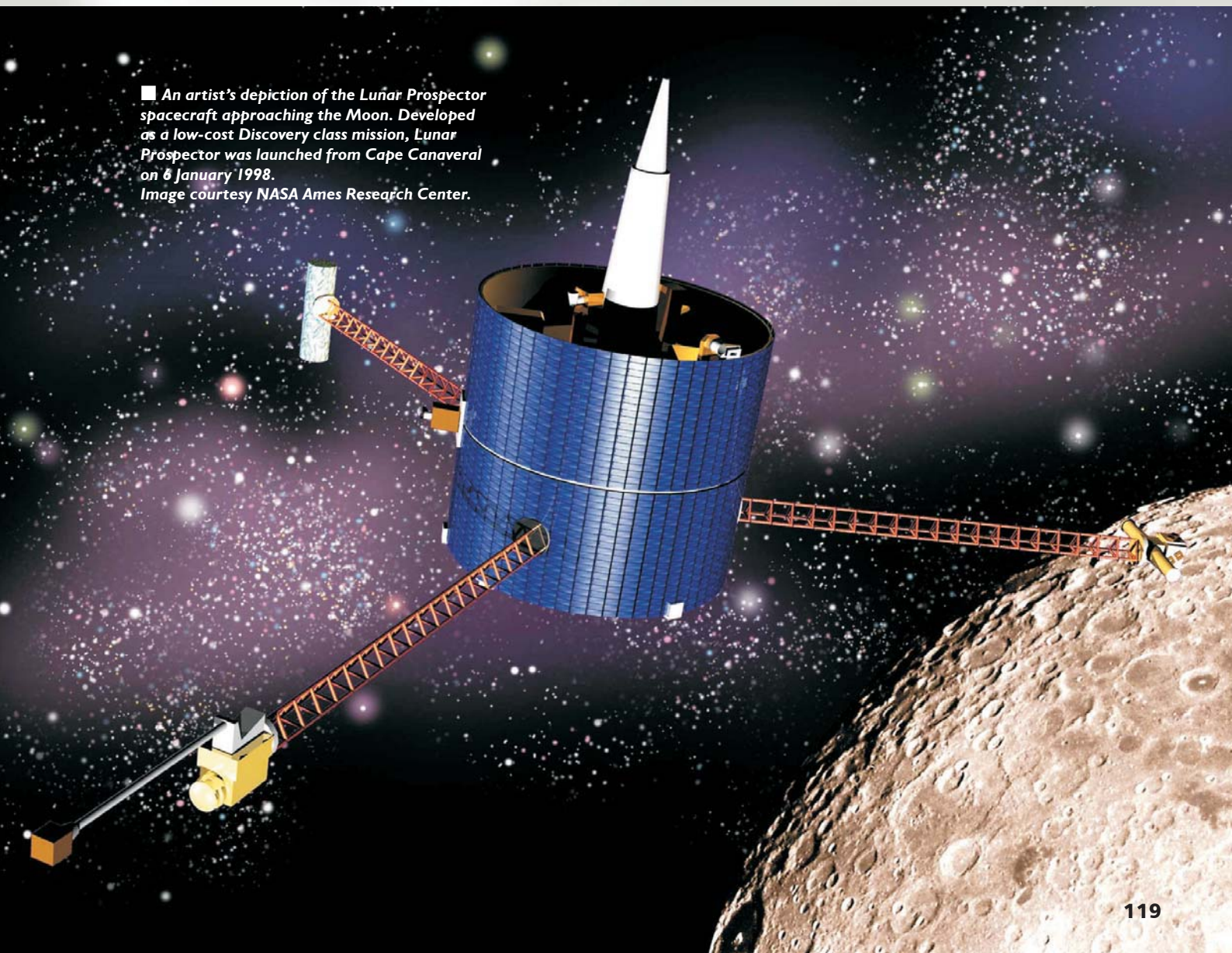

by using a magnetometer and an electron reflectometer to chart the patchy lunar magnetic field, a gamma-ray spectrometer to map the composition of the regolith, an alpha-particle spectrometer to detect outgassing and a neutron spectrometer to sense ice in the polar regions. The spacecraft was dispatched from Cape Canaveral by an Athena 2 launch vehicle on 6 January 1998, entered a highly elliptical lunar polar orbit on 11 January, promptly circularised this at an altitude of 100 km, and began science activities on 16 January.

The first rumour of a discovery was leaked a month later, and on 5 March it was announced that the neutron spectrometer's data suggested the presence of significant water ice at both poles. The preliminary analysis was published in the journal *Science* in September. The instrument did not detect water ice directly; this was inferred from hydrogen, which was itself inferred from remotely sensing neutrons. When a high-energy cosmic-ray particle strikes the nucleus of an atom in the regolith, neutrons are spat out. Most of these neutrons are 'hot', in that they fly off at high speed, but if one subsequently encounters a lightweight nucleus it will yield some of its energy. Each molecule of water contains two hydrogen atoms, the lightest of atoms. The presence of hydrogen could be inferred from the energy spectrum of the neutrons.

■ **Below:** The polar regions of the Moon: north to the left and south to the right. The images were obtained by the Clementine spacecraft. The colour-coded overlays show the epithermal neutron emission measured by the Lunar Prospector spacecraft, with dark blue and purple indicating low counting rates consistent with hydrogen-rich deposits intermixed with desiccated regolith. Clementine images courtesy Naval Research Laboratory, with post-processing by the US Geological Survey. Lunar Prospector images courtesy NASA Ames Research Center, and William Feldman of the Los Alamos National Laboratory.

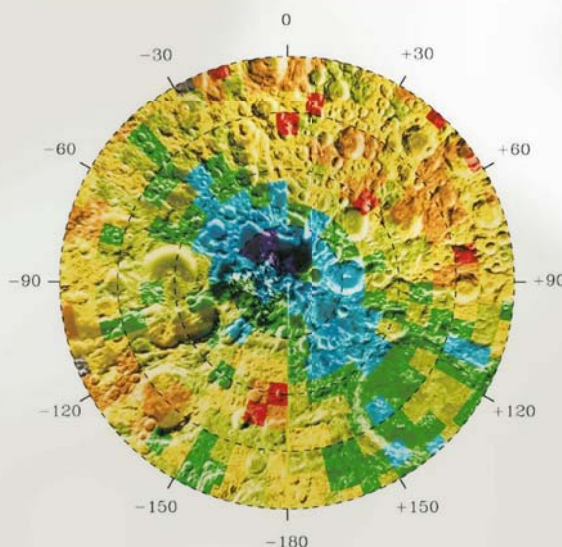
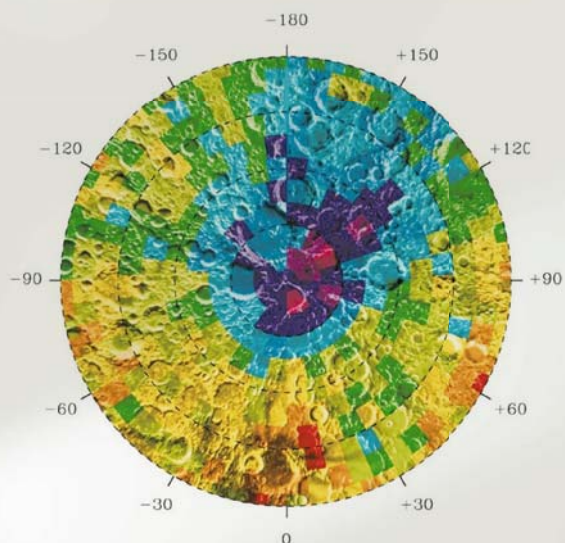
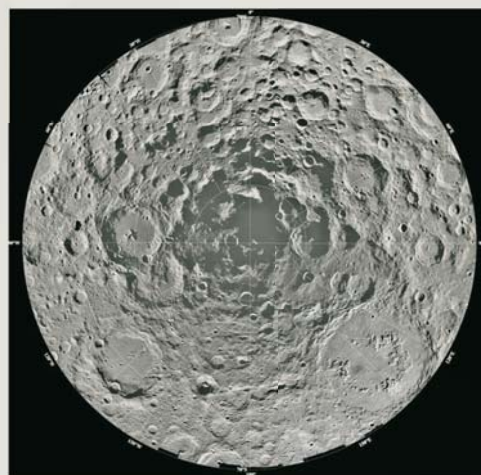
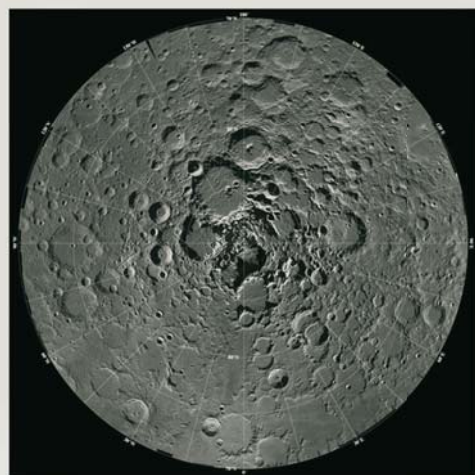



The neutron spectrometer sensed neutrons in three energy categories: thermal, epithermal and fast. A decrease in the epithermal flux was noted close to the permanently shadowed areas at both poles – at the north pole it was 4.6 per cent below the low-latitude average, and at the south pole it was 3.0 per cent below the low-latitude average. Although the 100-km spatial resolution could not precisely identify the sites of hydrogen enrichment, there was a correlation with the suspected cold traps. Data collected through to the end of the mission in 1999 supported the initial findings, and it was concluded that the data was consistent with hydrogen enrichment in the form of ice covered by as much as 40 cm of desiccated regolith. However, because the ice was inferred from the presence of hydrogen, and the solar wind delivers hydrogen to the surface, others argued that the hydrogen was more likely present in this form.

Terrestrial Radar Studies

When conditions are suitable, the beam from a terrestrial radio telescope acting as a radar can provide shallow-angle illumination of some of

the permanently shadowed craters at the lunar poles. Radar can penetrate a loosely packed material such as the lunar regolith to a depth several times that of its wavelength. In principle, a radar is able to 'probe' for the presence of ice deposits. The 1,000-foot-diameter dish of the Arecibo Observatory on the island of Puerto Rico is operated by Cornell University for the US National Astronomy and Ionosphere Center. After the announcement of the Clementine results, Arecibo made a survey at a wavelength of 12.6 cm. The results, reported in 1997, were ambiguous: whereas the strongest reflections were from sites at the south pole that might well be in permanent shadow, strong reflections were also received from places nearby that were not. This prompted the team to explain their results in terms of the roughness of the terrain.

■ **Above:** The 1,000-foot-diameter dish of the Arecibo radio telescope on the island of Puerto Rico is the world's most powerful 'planetary radar'. Image courtesy Arecibo Observatory: National Astronomy and Ionosphere Center, a national facility operated by Cornell University for the National Science Foundation.

After Lunar Prospector charted the distribution of hydrogen in the Moon's polar regions, it was decided to use the Goldstone Solar System Radar in California to locate the cold traps. The 70-m-diameter antenna illuminated the target zones at a wavelength of 3.5 cm, and the echoes were received by two 34-m-diameter antennas located 20 km apart. By comparing the signals from the two receivers using an interferometry technique it was possible to measure the surface elevations to a vertical accuracy of 50 m at horizontal intervals of 150 m, and so produce the first 3-dimensional digital elevation model. In 1999 it was announced that after a computer had calculated how the Sun would illuminate these terrains, it was found that the floors of five large craters in the south polar region were in eternal shadow.

The south pole is located just within the rim of the crater Shackleton, which is some 20 km in diameter, and it was one of the five craters identified by the study. There was a 30-km crater to the west, and a line of three 50-km craters, the middle one of which was Shoemaker. Of course, the radar had not been able to survey their entire interiors because their near rims had blocked the line of sight of the beam, but much of their floors had been 'visible'. These craters constituted the largest potential deposits of water ice at the south pole – and Lunar Prospector had detected a high hydrogen abundance in the crater Shoemaker.

Although a wavelength of 3.5 cm provided high resolution for mapping, it could not penetrate

■ **Below:** The 70-m-diameter antenna of the Goldstone Solar System Radar in California. Image courtesy NASA/JPL-Caltech.



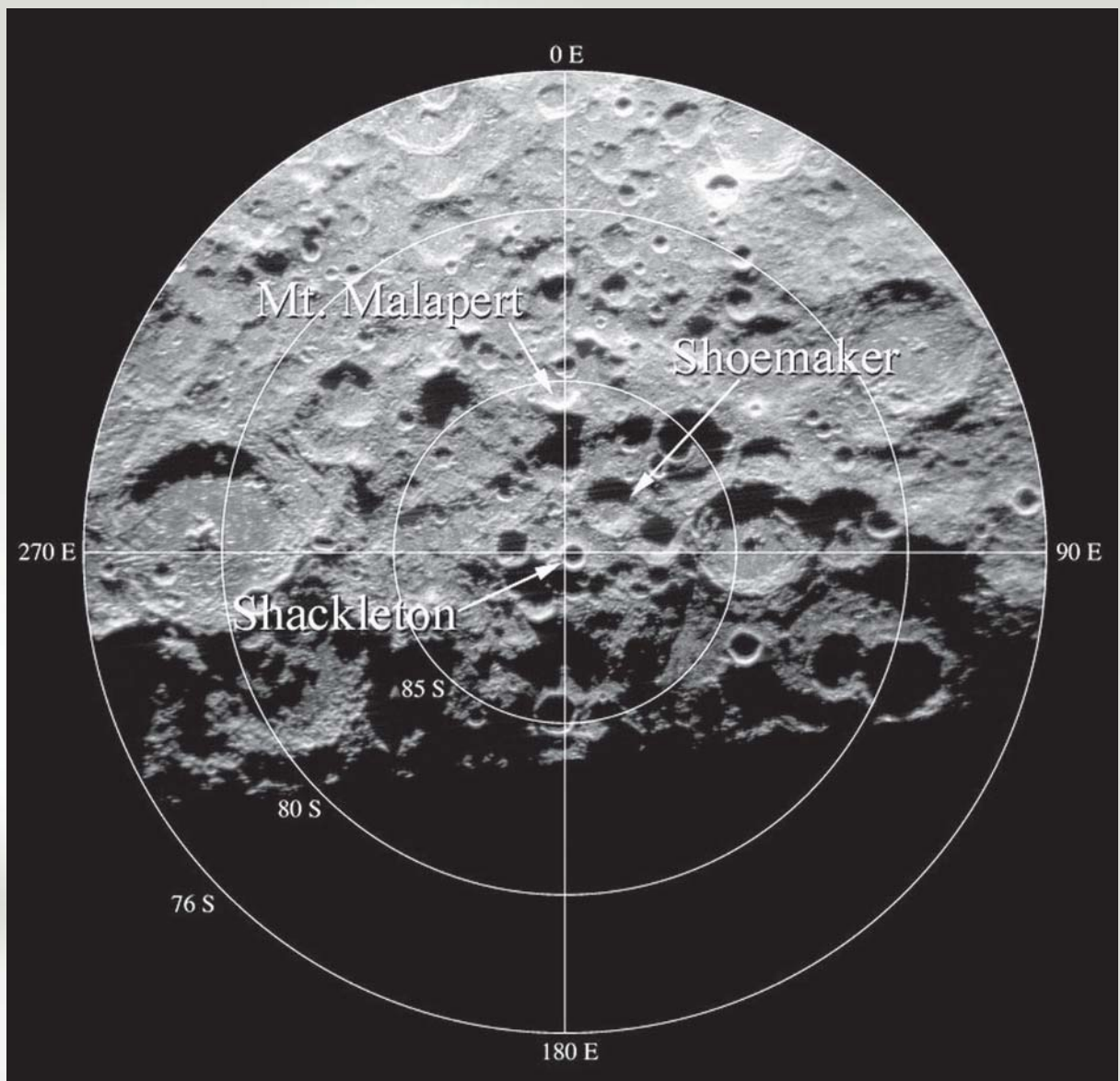

very deeply into the regolith to search for evidence of ice. The Arecibo telescope therefore probed the interesting areas at a wavelength of 70 cm, and the results, published in 2003, were not encouraging. It was not possible to say that there was no ice, but the results imposed strict constraints. In order to explain both the hydrogen detected by Lunar Prospector in the upper half-metre of regolith and the absence of any radar backscatter from a depth of several metres, there could not be solid ice at or near the surface; such ice as might be present at shallow depth must either be in the form of thin layers (i.e. less than the radar wavelength) interbedded with regolith, or as individual grains mixed in with the lithic fragments. Follow-up observations were made at 12.6 cm at the high spatial resolution of 20 m in order to localise specific samples. The results reported in 2006 suggested that thin layers at shallow depth were unlikely.

Meanwhile, D.H. Crider and R.R. Vondrak had modelled the evolution of a cold trap as a function of depth in terms of the 'space weathering' process by which the plasma that was delivered to the lunar surface by the solar wind was gardened into the regolith by micrometeoroids. The results reported in 2001–2003 concluded that the regolith would achieve a steady state of around 4,000 parts per million of water. Of course, the water was not present in the solar wind; it was produced by hydrogen in the solar wind combining with

■ **Above:** An image of the south polar region of the Moon made by the Arecibo Observatory operating as a radar at a wavelength of 70 cm, annotated with features mentioned in the text. Image courtesy Arecibo Observatory: National Astronomy and Ionosphere Center, a national facility operated by Cornell University for the National Science Foundation; and Bruce Campbell of the Center for Earth and Planetary Studies at the Smithsonian Institution.

oxygen drawn from iron oxides in the regolith. Although the solar wind irradiates the entire surface of the Moon, water is stable only in the cold traps of the permanently shadowed areas.

The early idea was that the water arrived in comets that vaporised on impacting, with some of the molecules of water entering the cold traps and remaining, but, surprisingly, the study found that the amount of cometary water was insignificant compared to that from the solar wind. Importantly, this analysis was consistent with the radar data. The model suggested that the thickness of the layer in which the ice was present increased with time, and reached 1.6 m after 1 billion years – although that is not to say that it formed a slab of ice. Although the ice would be diffuse, the fact that it was in a well defined volume close to the surface would make it exploitable once the necessary processing systems were in place. The topographical survey by radar had estimated there to be 5,000 square km in permanent shadow at the south pole, and half as much again in the north polar region, suggesting that there could be a considerable total water resource.

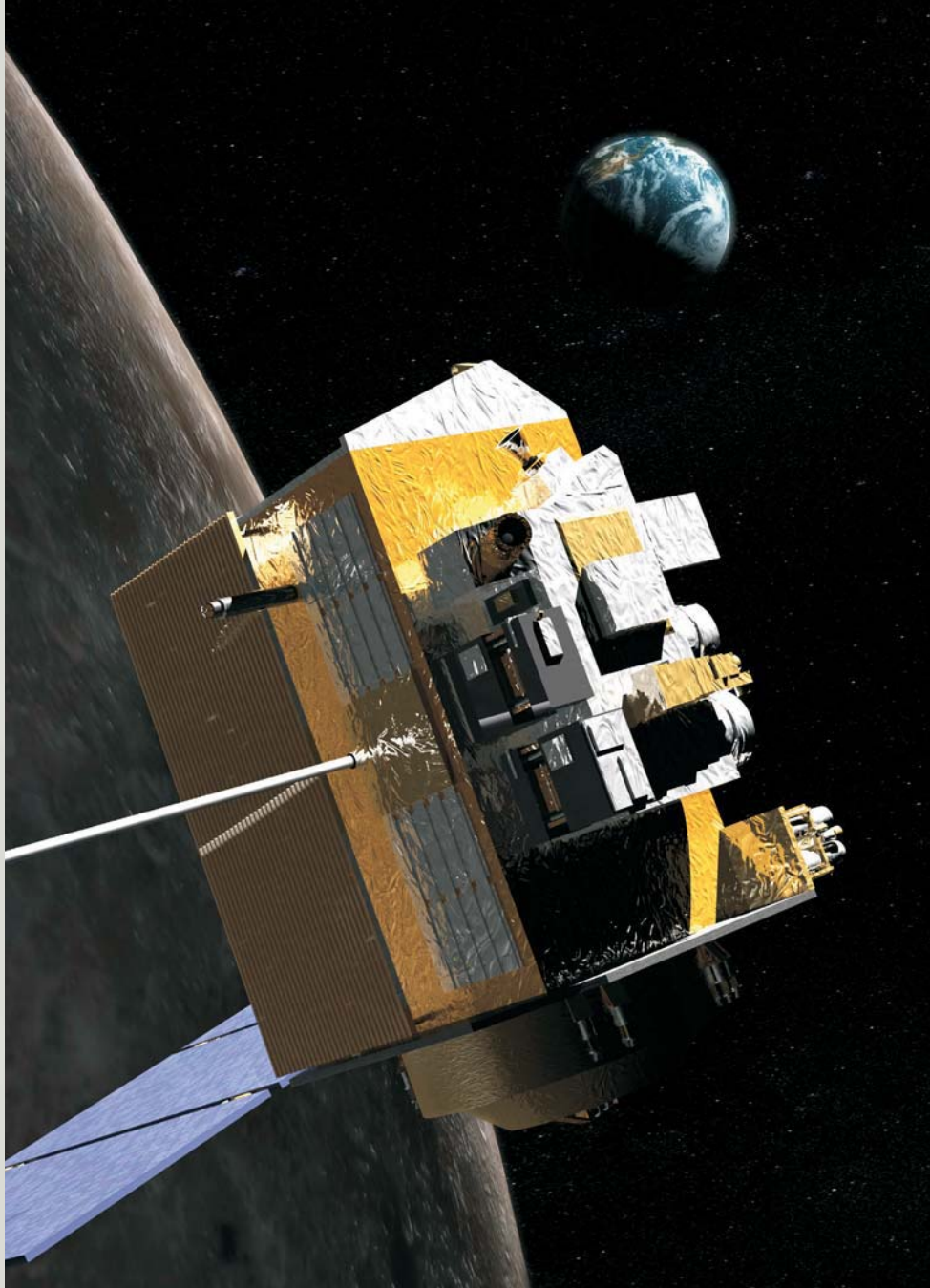

Lunar Reconnaissance Orbiter

The first spacecraft for the Robotic Lunar Exploration Program will be the Lunar Reconnaissance Orbiter (LRO), a 3-axis stabilised platform with a side-mounted solar panel and a boom-mounted high-gain antenna. To maintain its 50-km circular polar orbit it will require to perform frequent manoeuvres

to counter the gravity anomalies discovered in the 1960s known as 'mascons', associated with the 'circular maria'. Its suite of instruments will address the objectives of: (1) creating a global geodetic grid to precisely define the locations of objects in terms of 3-dimensional topography; (2) mapping mineralogical resources; (3) surveying permanently shadowed areas near the poles; (4) seeking confirmation of the presence of water ice in such areas; (5) identifying continuously lit areas near the poles, where a base might subsequently be built; (6) mapping the detailed topography and rock coverage of such areas in order to enable safe landing sites to be selected; and (7) characterising the lunar radiation environment in order to assist in the design of future base facilities.

■ **Above:** An artist's depiction of the Lunar Reconnaissance Orbiter in lunar orbit. Image courtesy NASA Goddard Space Flight Center.

LRO's Suite of Instruments

The Lunar Orbiter Laser Altimeter (LOLA) will yield a global topographic model and geodetic grid on which to locate objects with a spatial resolution of 25 m and a vertical resolution of 10 cm, and will characterise the surface in terms of elevation, slope, roughness and reflectance.

The Lunar Reconnaissance Orbiter Camera (LROC) will utilise a wide-angle system to yield images at a scale of 100 m in seven wavelength bands, and a narrow-angle system to give 0.5-m-scale panchromatic images over a 5-km swath of the ground track. The multispectral imagery will be used to map the mineralogy of the surface on a global basis. In addition, by imaging each polar pass, it will be possible to monitor the lighting conditions throughout a full orbit of the Sun in order to precisely delimit permanently shadowed areas and continuously illuminated terrain. In addition to varying as the Moon turns on its axis monthly and as the Earth–Moon system travels around the Sun, polar illumination also varies over an 18-year precessional cycle. Once the surface topography is accurately known, it will be possible to calculate the permanently shadowed areas taking into account this long-term cycle. By observing sites under the full range of lighting conditions, it should be possible to unambiguously identify metre-scale hazards to landings.

The Lyman Alpha Mapping Project (LAMP) will use starlight and ultraviolet sky-glow as a source of illumination to facilitate optical imaging of areas that are not illuminated by sunlight at a resolution of about 500 m per pixel, and (by an absorption feature at 160 nm) seek direct confirmation of exposed water frost.

The Lunar Exploration Neutron Detector (LEND) will use a set of collimated detectors for epithermal and fast neutrons to map the hydrogen enrichment in the uppermost metre of regolith in the polar areas with a spatial resolution of about 10 km.

The Diviner Lunar Radiometer Experiment (DLRE) will employ a 9-channel infrared radiometer to characterise the surface thermal environment along the ground track with a spatial resolution of 300 m. The data gained under different illuminations will yield a global map of the bulk thermal properties, rock

abundance, and silicate mineralogy (by a spectral emission feature at a wavelength of 8 microns). In addition, it will determine the environmental conditions of the cold traps at the poles.

Mounted on top of the spacecraft, the Cosmic Ray Telescope for the Effects of Radiation (CRATER) will view the zenith in order to measure the flux of galactic cosmic rays. The data will be converted into a tissue-equivalent form in order to assess the threat to humans from this low intensity but continuous source of radiation.

Ground Truth

On 31 July 1999, at the conclusion of its mission, Lunar Prospector was made to impact in a permanently shadowed crater with terrestrial telescopes, including the Hubble Space Telescope, monitoring. It had been calculated that there was a 1-in-10 chance of vaporising sufficient water to produce a detectable plume but nothing was observed, possibly because it hit at too shallow an angle to excavate material from a sufficient depth. On 3 September 2006 (as described by Peter Rathsmann elsewhere in this volume) SMART-1 did likewise, but not in the south polar region.

When NASA decided to switch Lunar Reconnaissance Orbiter from a Delta II to an Atlas V booster in order to relieve mass constraints, it became possible to install a secondary payload. After a brief competition of 19 proposals tightly constrained by mass, budget and development time, NASA selected the Lunar Crater Observation and Sensing Satellite (LCROSS) proposed by the Ames Research Center. This will be integrated into the structure on top of the Centaur stage of the launch vehicle that will hold the primary payload. After the stage has achieved translunar trajectory and released Lunar Reconnaissance Orbiter, the secondary payload will steer the Centaur to fly by the Moon 5 days after launch in order to enter an elliptical orbit of Earth which will return to the vicinity of the Moon 81 days later, whereupon the still-attached LCROSS will refine the trajectory to impact into the 20-km-wide 'hydrogen enriched' crater Shackleton. With 7 hours to go, LCROSS will separate and adjust its speed to trail 15 minutes behind the stage. The high-angle impact of the 2,000-kg stage should excavate a crater 30 m across and 5 m deep, and eject up to

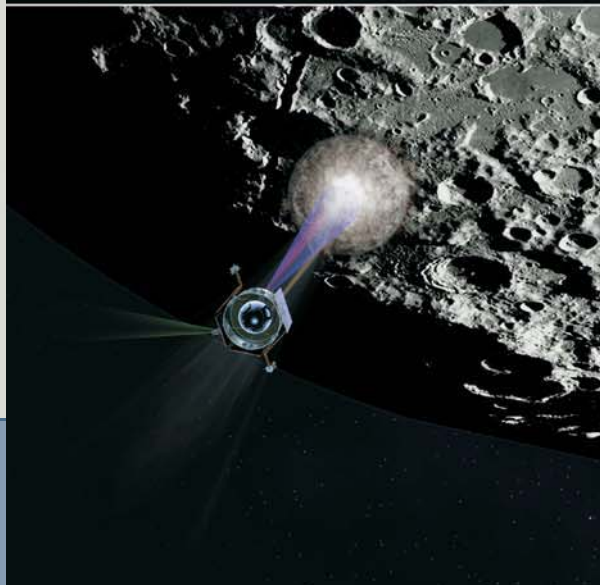
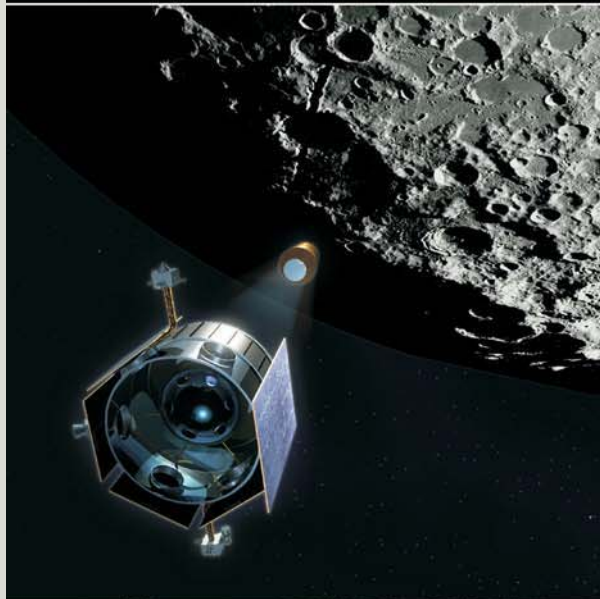

■ **Above:** An artist's depiction of how the impact of the Lunar Reconnaissance Orbiter's rocket stage at the south pole of the Moon will be monitored by the Lunar Crater Observation and Sensing Satellite (LCROSS). Image courtesy NASA Ames Research Center.

1,000 tonnes of material that will cause a plume to rise to an altitude of 60 km. As it observes the impact and passes through the plume, LCROSS will use six instruments to analyse the ejecta for water ice. The 880-kg spacecraft will also impact in Shackleton about 100 m from where the Centaur struck. Both events will be monitored by terrestrial telescopes, and on its next pass over the site Lunar Reconnaissance Orbiter will make follow-up observations. The objective is to provide 'ground truth' for the orbital remote-sensing surveys and, hopefully, provide definitive proof of the presence of water in the polar areas.

The *Exploration Systems Architecture Study* issued by NASA in 2005 urged that if the results from Lunar Reconnaissance Orbiter were sufficiently encouraging, a robotic lander should be sent to Shackleton to drill into the regolith and assay the water reserves.

A Human Outpost

At a press conference to announce the Clementine results in December 1996, team leader P.D. Spudis noted that there was an elevated feature near the south pole that appeared to be in continuous sunlight. Dubbing it the Mountain of Eternal Light, he described it as "the most valuable piece of extraterrestrial real estate", because if a base were to be established there it would both have continuous solar illumination for power and, with the Sun circling low on the horizon, would not be subjected to the thermal extremes of the equatorial zone, where the $\pm 140^{\circ}\text{C}$ diurnal temperature range between lunar noon and midnight would cause severe operational problems. The imagery from the European Space Agency's SMART-1 polar orbiter supports this conclusion. Although the *Exploration Systems Architecture Study* envisaged setting up a human outpost on the rim of Shackleton, in 2006 Paul Lowman of the Goddard Space Flight Center urged that a site in the vicinity of Mt. Malapert "be given systematic study before any decision is made on a landing site". His analysis of imagery from various missions indicated that this peak was illuminated for about 90 per cent of the year. Furthermore, a base on Mt. Malapert would provide better access to the 50-km craters containing the surveyed cold traps.

As for *why* we should establish a base on the Moon, see the next article in this volume...



■ An artist's depiction of a robotic rover collecting samples in the permanently shadowed terrain at the Moon's south pole. Image courtesy NASA.

Further Reading

Vision for Space Exploration:

www.nasa.gov/pdf/55584main_vision_space_exploration-hi-res.pdf

NASA's Exploration Systems Mission Directorate:

<http://www.nasa.gov/exploration/>

Center for Earth and Planetary Studies:

<http://www.nasm.si.edu/ceps/>

Arecibo Observatory:

<http://www.naic.edu/>

Clementine:

<http://www.cmf.nrl.navy.mil/clementine/>

Lunar Prospector:

<http://lunar.arc.nasa.gov/>

Lunar Reconnaissance Orbiter:

<http://lunar.gsfc.nasa.gov/>

Lunar Crater Observation and Sensing Satellite:

<http://lcross.arc.nasa.gov/>

NASA's 2005 Exploration Systems Architecture Study:

http://www.nasa.gov/mission_pages/exploration/news/ESAS_report.html/

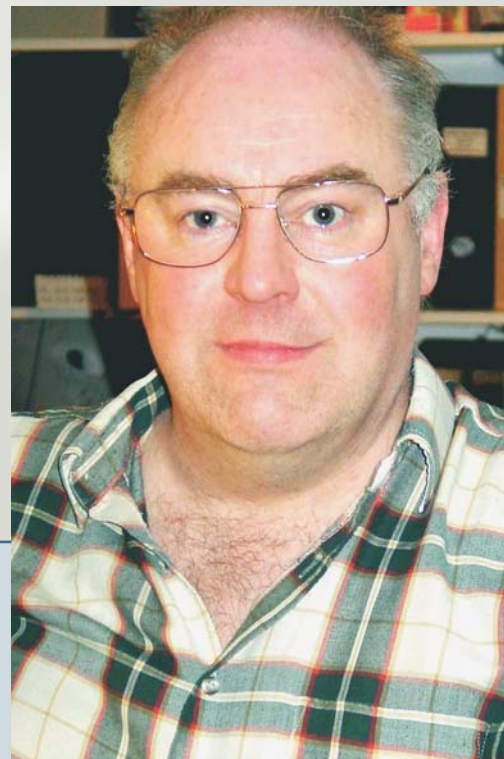

Dr David M. Harland gained his BSc in astronomy in 1977, lectured in computer science, worked in industry and managed academic research. In 1995 he 'retired' to write on space themes.

10

And When We're Back ON THE MOON, What Next?...

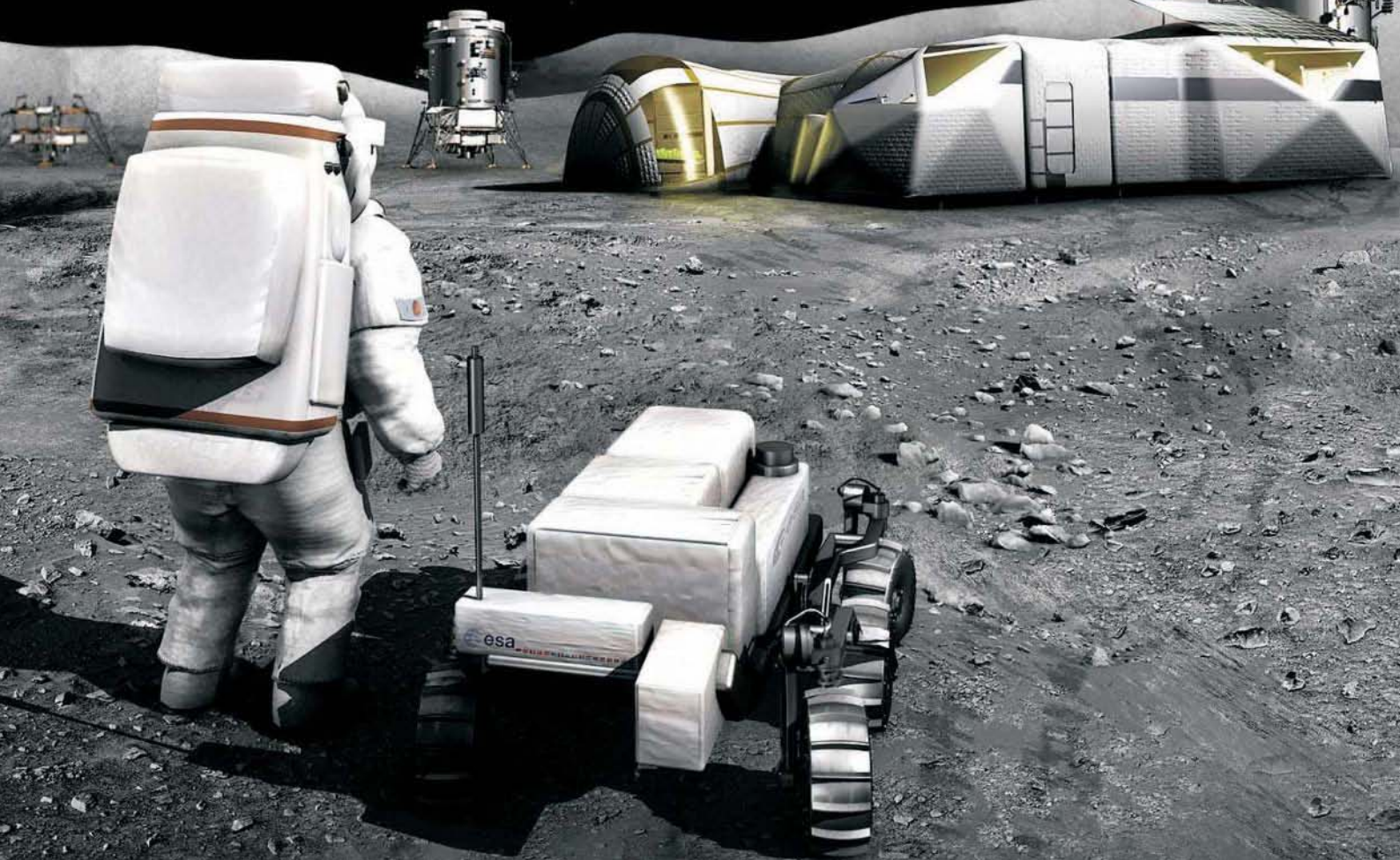

The establishment of a permanent human habitat on the Moon in the coming decades will create a link between our technological expertise and the unlimited resources of space. As *David Schrunk* explains here, the potential of the 'Spacefaring Age' will then be realized, with advances in scientific knowledge, the opening of a great new frontier, and substantial benefits for all humankind.

The Role of a FUTURE MOONBASE

THE PROMISE of the 'Spacefaring Age' – the era of human activities in space – is that it will link the technological expertise of the people of the Earth to the unlimited resources of space. With this linkage established, we shall have access to an abundance of energy and material resources from space; we shall explore the Solar System in person, not just by the use of robotic probes; human settlements will be established on various planets and their moons; and, ultimately, voyages to the stars will be undertaken. Of significance, the present "only one Earth" or "closed Earth" mindset, in which the perceived need is to preserve Earth's environment and halt the depletion of its resources, will be replaced by a much grander "open

space" vision of broad-scale human advancement. This will be based on gaining access to unlimited resources and utilizing them to open a great new frontier – in short to make the Solar System our back yard.

The most expedient means for humankind to realize the full benefits of the Spacefaring Age is to establish a permanent human settlement on the Moon, and that is the aim of current international space exploration efforts. Several lunar orbital missions are scheduled for launch over the next few years, follow-on robotic landers are in the planning stage, and human missions to the lunar south polar region are expected to commence within the next ten to fifteen years.

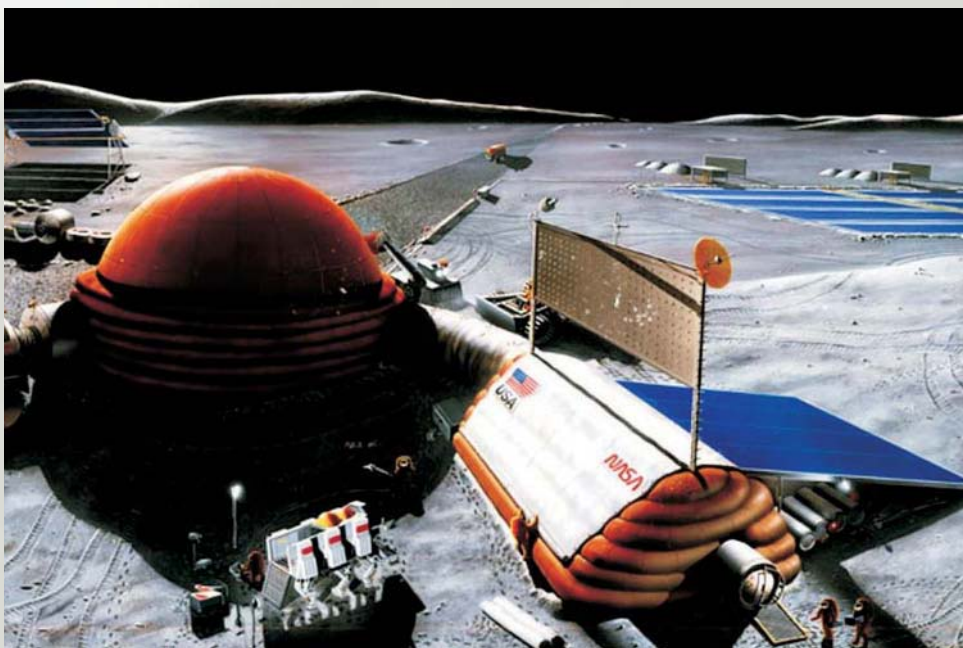

■ **Left:** Artist's concept of a moonbase constructed using inflatable structures, which would be lightweight, compact and less expensive to transport than one constructed of other materials. Being inflatable, there is also minimal assembly. In July 2006, Bigelow Aerospace put an inflatable spacecraft (Genesis I) into orbit as a test of a much larger inflatable module. On the airless surface of the Moon, the air pressure inside pushing outwards makes an inflatable structure quite rigid. Modern synthetic materials are also very strong. Image courtesy NASA.

Lunar Soil Composition

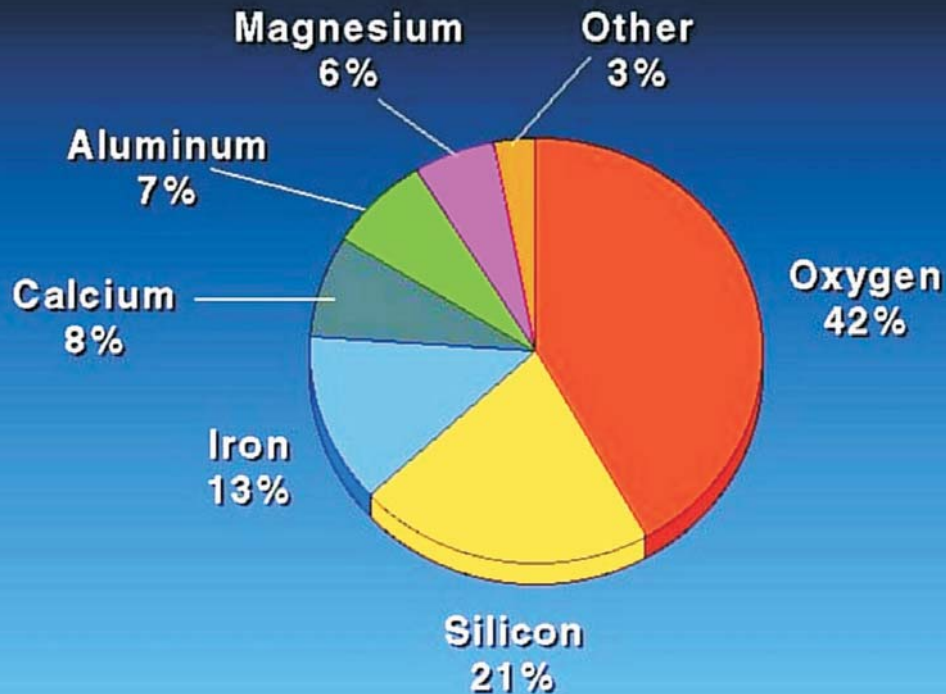

With continued exploration and development efforts, a self-sustaining, permanent human settlement will, predictably, be established on the Moon by the middle of this century.

The question then arises, what comes next? What can be accomplished on the Moon by a permanent human settlement that has technological expertise and access to the resources of space? The following scenario is a prediction, circa 2050, based on the extrapolation of current international plans for the exploration of the Moon and the nominal growth of existing technologies.

The center of human activity on the Moon is an underground city, located within Mons Malapert (formerly Malapert Mountain) in the south polar region, that has been sealed to contain a pressurized atmosphere. It has been developed into a comfortable and safe, self-sufficient habitable enclosure capable of supporting several

thousand people. A closed-cycle regenerative life support system provides all of the essentials for its occupants. The interior has been designed to be esthetically pleasing, with large open spaces (architects will exploit the weak gravity to design spectacular structures), abundant vegetation, lighting that simulates Earth conditions, and viewing access to space.

The lunar city has an industrial / science park where in-situ resource utilization (ISRU) techniques extract elements such as carbon, hydrogen, oxygen, iron, silicon, and aluminum from the lunar regolith ("Moon dirt"). These and other elements are the feedstock for manufacturing processes that produce tools, equipment, and consumables for use on the Moon. Virtually all of the products that are needed for a self-sustaining lunar economy, such as solar cells, computers, and construction equipment, are manufactured on the Moon at the industrial/science park. The only essential imports from the Earth are the people who choose to live and work on the Moon.

A spaceport adjacent to the Moonbase is serviced by an efficient multi-node rocket

■ **Above:** The NASA Apollo missions found that lunar soil is composed of useful elements such as oxygen, silicon, and metals such as iron, calcium, aluminium and magnesium. The relative composition in a typical lunar soil sample is shown in this pie chart. Graphic courtesy University of Wisconsin-Madison.

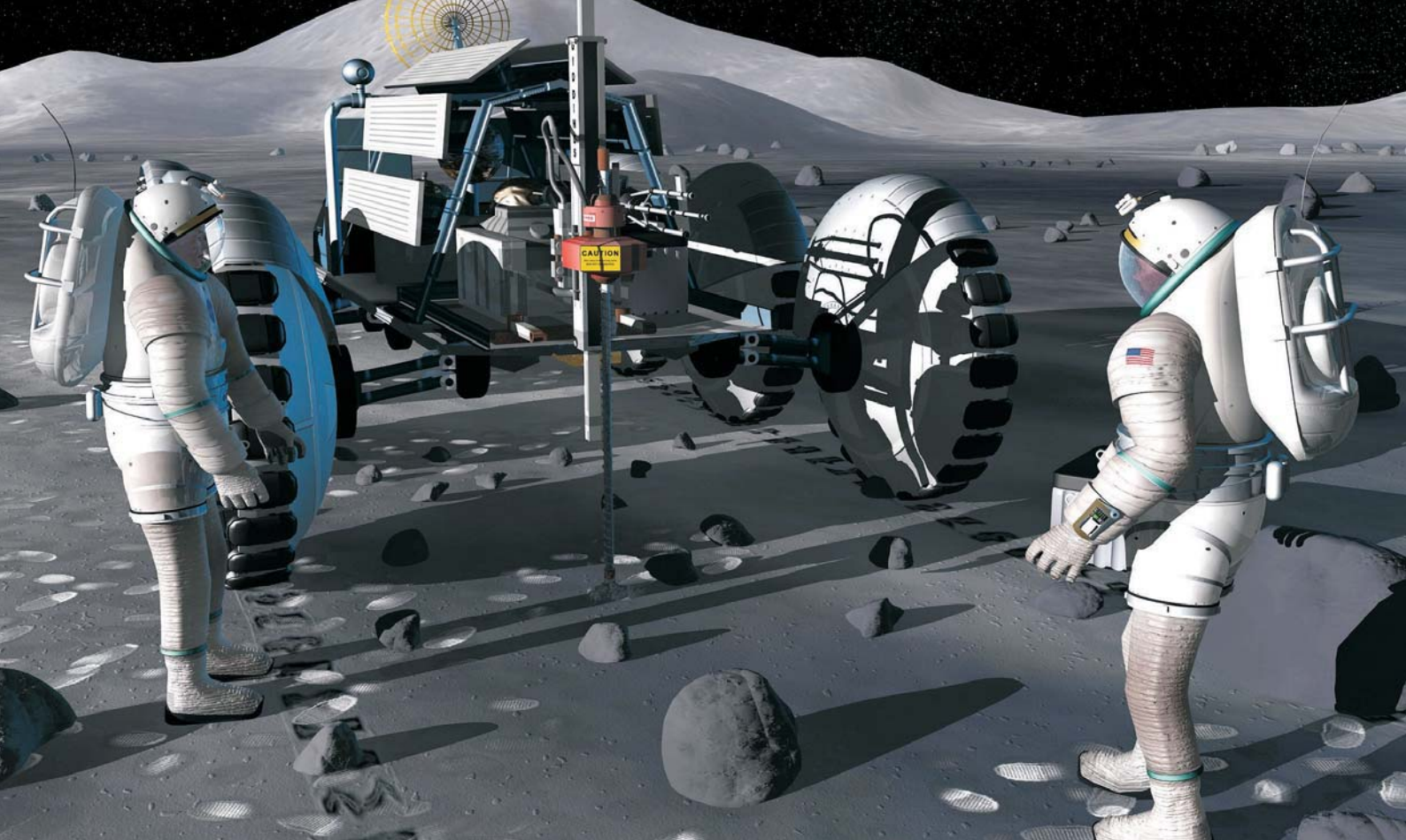

transportation system that operates between the Earth and the Moon. The primary source of fuel for the rockets is hydrogen and oxygen, obtained from ISRU operations and from water ice present in 'cold traps' in the south and north polar regions. (For the purposes of the futuristic scenario presented here, it is assumed that quantities of water ice are present at the bottom of permanently-shadowed depressions in the polar regions.)

Utility infrastructure networks, consisting of an electric grid (powered by lunar-manufactured solar panels), a lunar railroad, a communication network and a pipeline system, have been placed around the Moon in the south polar region. The solar-powered lunar power grid supplies an abundance of electric power for consumption on the Moon, and excess electric power is profitably delivered, via microwave beaming, to energy markets on the Earth. The extension of the utility networks to the equatorial and north polar regions of the Moon led to a demand for the migration of workers from the Earth to the Moon, and the lunar city has been expanded in size so that it can accommodate several thousand more permanent residents. Continued excavations at Mons Malapert and contiguous areas have created large connected underground malls that are several kilometres in length. (As the lunar

city continues to grow, the living spaces on the Moon will eventually measure tens to hundreds of kilometres in length.)

The original two-track rail system has been augmented by a magnetic levitation ("maglev") rail system that provides high-speed transport of humans and cargo on the Moon. Maglev trains are highly efficient because there is no air resistance on the Moon and the only limitation to speed is the comfort of the passengers. A maglev rail line extends from the south pole to the north pole; it has opened up the Moon to global exploration and the founding of additional cities. The rail line also provides access to potential water resources in the north polar region and enables the placement of telescopes and other scientific instruments at the equator and other latitudes.

A lunar economy has come into existence, and is thriving, with involvement by a number of international institutions. Earth governments,

■ **Above:** Two astronauts watch carefully as their drill bores down into the top layers of the lunar surface, in this artist's concept. Using this drill, the astronauts will be able to extract an intact core sample that will be used by Earth-based scientists to learn about the formation of the Moon and Solar System. As the two crewmembers wait for their sample, they use their unpressurized rover as a communication link to relay frequent status reports back to their base. Image courtesy NASA.

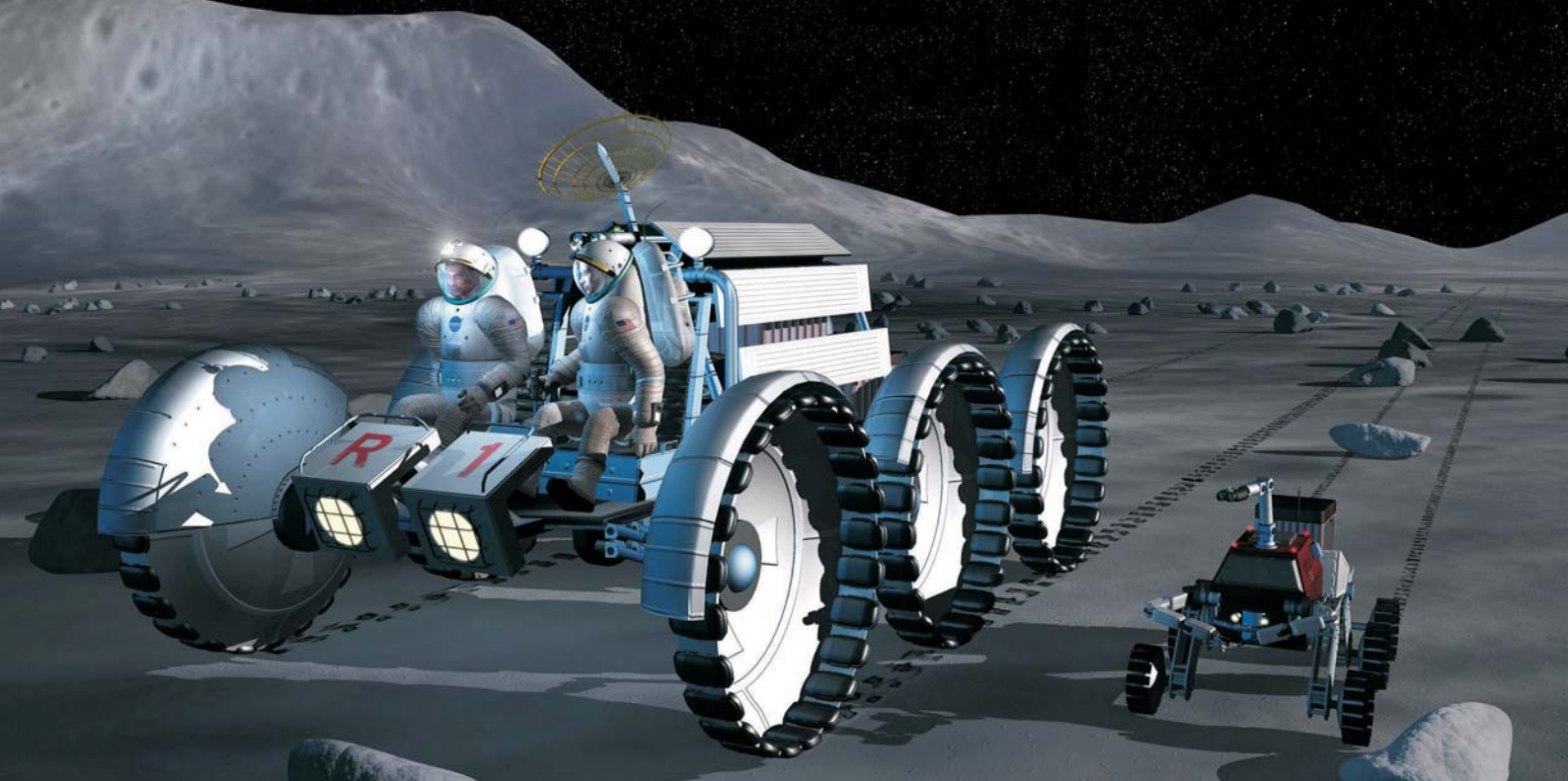

universities, and other institutions are involved in research projects and they purchase power, fuel, communications, and other goods and services from commercial enterprises. An interim lunar governmental authority is in place to define a rule of law for the people and institutions of the Moon. In accordance with United Nations treaties, the lunar government is destined to become a separate, sovereign government.

The advent of a self-sufficient lunar colony and transportation system has led to the development of a robust lunar tourism industry. The Moon is an interesting destination for tourists from the Earth – it is an entirely “new” world whose surface area is as large as the continent of Africa, and there is much to explore, with magnificent scenery. Moving about in the 1/6th gravity is a unique experience, and tourists can participate in human-powered flight in large specially-designed air-excursion spaces. The perspective of space (e.g. of the Earth) as viewed from the lunar surface is spectacular, particularly when there is a special event such as an eclipse of the Sun by the Earth.

To accommodate the demand for tourism and the migration of people to the Moon from

the Earth, the components of a large (e.g. one kilometre in diameter) Earth-Moon Cycluser-hotel were fabricated on the Moon from lunar materials and launched to the Earth-Moon L5 Lagrangian point for final assembly. (This L5 Lagrangian point lies 60° behind the Moon as it orbits the Earth. It is one of five positions in the Earth-Moon system where a small object affected only by gravity can theoretically be stationary relative to the two larger objects – such as a spacecraft with respect to the Earth and Moon.) The Cycluser was then placed in a “figure of eight” orbit that loops around both the Earth and the Moon. It accommodates hundreds of passengers and crew and is shielded, with processed lunar regolith, from the hazards of space.

The advantage of the Cycluser is that it serves as a safe, comfortable, and efficient crew and cargo transfer vehicle between Earth and Moon orbits. When the Cycluser approaches the Earth, a manned spacecraft in low Earth orbit accelerates (e.g. by chemical rockets or space tether) to match the velocity of the Cycluser and the passengers then transfer to the Cycluser for the trip to the Moon. Upon reaching lunar orbital space, they transfer to a lunar lander vehicle that delivers them to a Moonbase. This process is reversed for the people who wish to return from the Moon to the Earth. By this means, large numbers of people are able to transit between the Earth the Moon with relative ease.

■ **Above:** In this artist’s concept, a pair of lunar astronauts embarks on an extra-vehicular science mission onboard an unpressurized rover. Aided by their robotic work assistant travelling at their side, the astronauts will be able to achieve scientific and exploratory objectives never before possible. All equipment will be carried on the two vehicles, thus streamlining mission complexity and allowing the two crewmembers to concentrate all their efforts on the mission at hand. Image courtesy NASA.



■ Artist's concept depicting lunar sample collection by a robotic rover. A lunar industrial / science park will manufacture all of the analytical instruments, robotic devices and other equipment needed for scientific studies of and on the Moon. A diverse range of lunar surface and subsurface structures, e.g. craters, lava tubes, rilles, mountain ranges and mare regions will be extensively explored through an ongoing program of geological exploration. Image courtesy NASA.

Science of and on the Moon

The industrial / science park manufactures all of the analytical instruments, robotic devices, and supplies for the conduct of scientific studies of and on the Moon. Geological surveys of the global surface and subsurface structures of the Moon are underway; craters, lava tubes, rilles, mountain ranges and mare regions are extensively explored through an ongoing international program of geological exploration.

All of the components of telescopes (e.g. mirrors, support structures, detectors, computers) are manufactured and assembled at the industrial park and delivered, via the lunar railroad, to select locations on the Moon to take advantage of ideal astronomical observation conditions. For example, radio telescopes are placed on the far side of the Moon where radio signals from Earth cannot interfere with observations, and infrared telescopes are placed in craters in polar regions where desirable ambient temperatures

■ Artist's concept depicting the setting up of a lunar telescope array. Eventually, telescopes will be placed at regular intervals around the circumference of the Moon at the equator and mid latitudes, and at the poles to facilitate simultaneous and continuous observations. With its ideal observing conditions, the Moon will become the pre-eminent site for astronomical research. Image courtesy NASA.



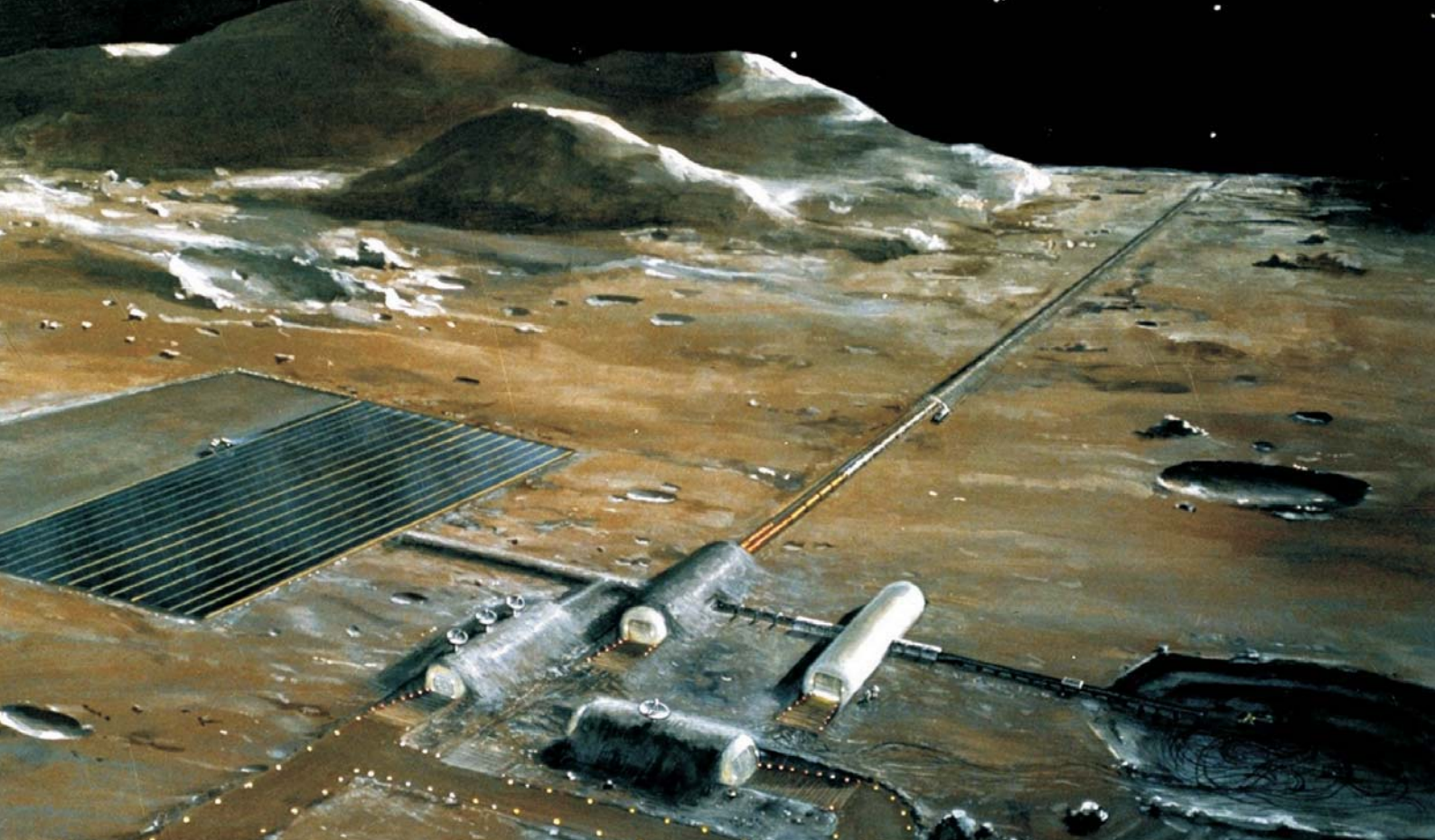

do not exceed 40 to 50 degrees Kelvin. Also, telescopes placed in the polar regions along the axis of rotation of the Moon are able to gather light from the most distant objects in the universe continuously for years or even decades, if necessary, to obtain highly detailed images.

Eventually, telescopes will be placed at regular intervals around the circumference of the Moon at the equator and mid latitudes, and at the poles to facilitate simultaneous and continuous observations – at every wavelength of the electromagnetic spectrum – of any object of interest in the Universe. The Moon will become the pre-eminent site for astronomical observations.

An analytic biohazard laboratory has been built on the Moon to undertake biological experiments that are deemed too risky on Earth. Experiments involving recombinant DNA technologies and bio-hazardous materials, such as bacteria, viruses, and toxins may be performed safely at the facility without the possibility of endangering the environments or

life forms at other locations. The facility also investigates potentially hazardous samples from other regions of the Solar System.

Terawatts (millions of megawatts) of electric power are generated on the Moon by the solar-powered lunar electric power grid. The power levels meet all of the needs of lunar operations and excess energy is exported to other areas in the Solar System, including the Earth. One method for transferring energy from one site to another is to convert the electric energy in the lunar power grid to microwave beams or laser beams. The beamed energy is then reconverted into electric energy at the receiving site. Experiments involving the beaming of gigawatt levels of energy across interplanetary space are underway.

The unique environmental conditions of the Moon (e.g. lack of an atmosphere, temperature extremes) provide opportunities for a host of other areas of scientific investigation such as robotics technology, atomic particle colliders, life support systems, superconductivity, and materials science.

■ **Above:** Artist's concept of a lunar base including a mass driver (the long, straight structure that goes towards the horizon). The mass driver is an electromagnetic launcher that can be used to launch spacecraft from the lunar surface with high acceleration forces on trajectories to any desired location either within the Earth-Moon system (e.g. to the Lagrangian points) or elsewhere in the Solar System. Image courtesy NASA.

The Exploration of Space from the Moon

By 2050, the Moon will have replaced the Earth as the principal base of operations for

the exploration and utilization of space. As compared to the launch of spacecraft from the Earth, approximately twenty times less energy is required for launches from the Moon, and there is no atmosphere on the Moon to block or delay the launches. The industrial base of the Moon produces the hardware that is needed for the exploration of space, such as computers, cameras, rockets, and solar panels, and a vastly increased program of exploration of the Solar System has become possible. To aid in this effort, mass drivers, solar sails, and solar power satellite technologies have been developed for lunar-based space exploration programs, as explained in detail below.

Electromagnetic launchers, termed mass drivers (the same technology that propels the magnetic levitation railroad), have been built on the Moon and are used to launch spacecraft from the lunar surface with high acceleration forces on trajectories to desired locations in the Solar System. Thousands of small spacecraft are thus launched from the Moon at 100 to 1000 g-force accelerations on high velocity fly-by missions to new areas of interest in the Solar System, such as a newly discovered long-period comet.

Larger spacecraft are launched from the Moon to planets and moons where they are maneuvered to desired orbits and surface locations. The ability of mass drivers to operate “in reverse” enables both manned and unmanned spacecraft to de-orbit and land on the Moon without the use of chemical rockets.

Solar sails, which are several square kilometres in size, are emerging as the predominant form of interplanetary transportation in space. They are highly efficient because the source of their energy is sunlight; the sails only need to be positioned in proper alignment with the Sun to produce the thrust that propels them from one part of the Solar System to another. The pressure of sunlight on a sail decreases in proportion to the square of the distance of the sail from the Sun and for this reason solar sails have much greater performance in the inner Solar System (inside the orbit of Mars) than in the outer Solar System.

■ **Below:** On the Moon, astronauts and robots would work together to do important tasks, as depicted in this artist's concept. A self-sustaining permanent human settlement on the Moon will provide a springboard not only for the exploration and exploitation of the Moon, but also for the exploration and development of the Solar System on a grand scale. Image courtesy NASA.

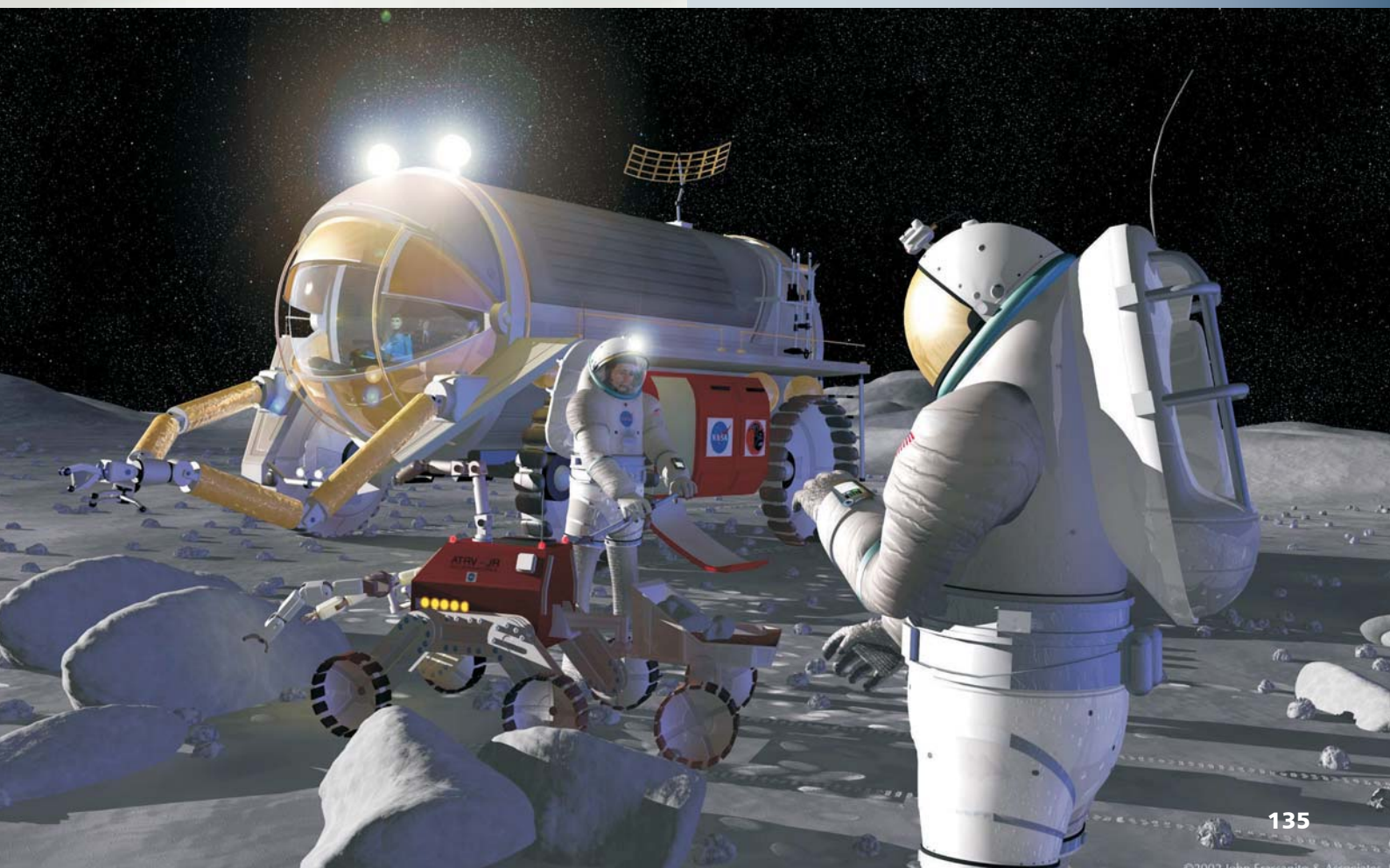

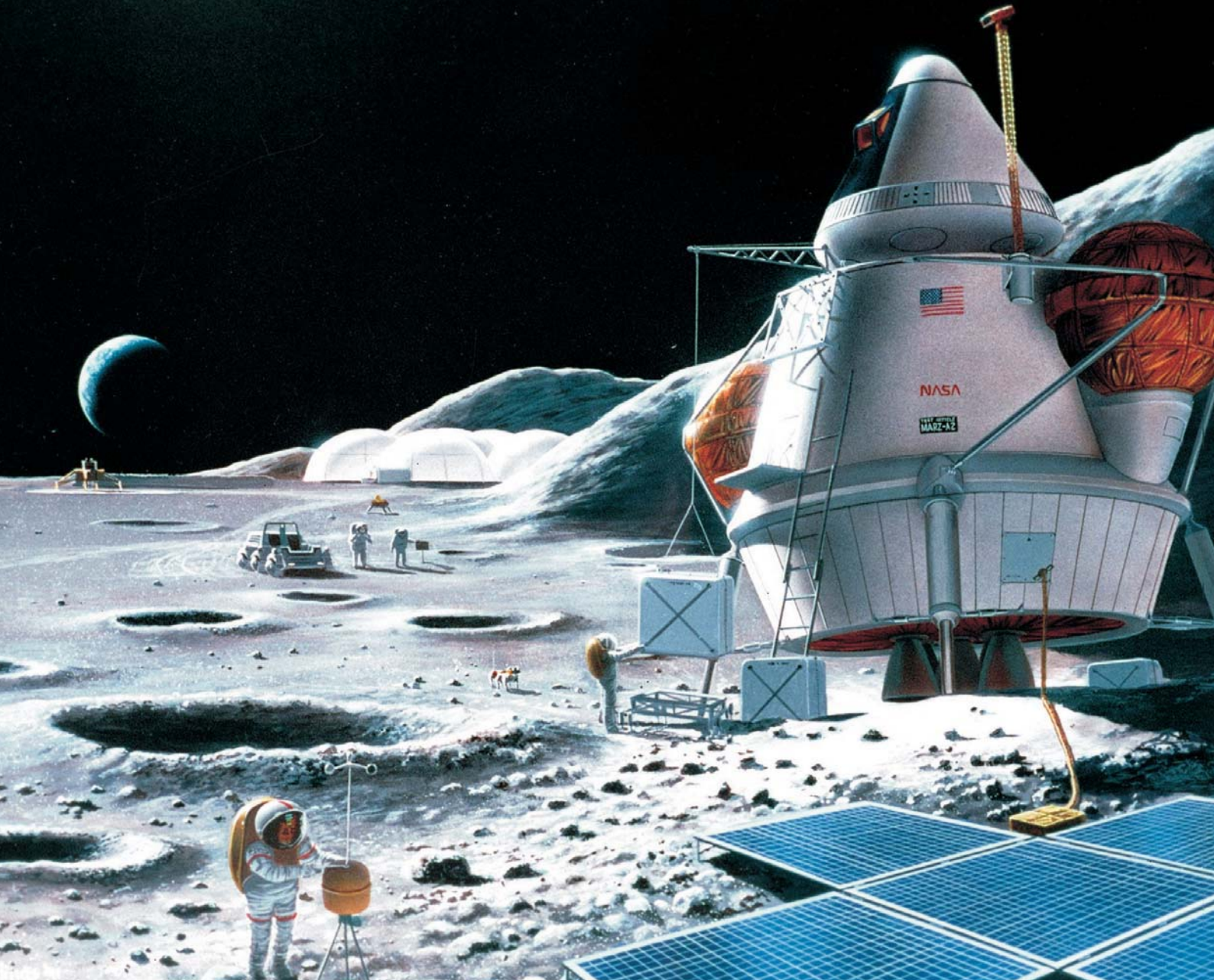

Solar sails are made from very thin (two to four microns) sheets of aluminum. Since aluminum and other construction materials are present on the Moon, all of the components of solar sailing cargo ships are manufactured on the Moon and launched by mass driver into space for final assembly. The fleet of solar sailing ships constitutes a highly efficient and capable interplanetary transportation system. Laser beams that are generated on the Moon are used for augmenting photon propulsion of solar sails on interplanetary missions. Laser

augmented solar sails are the high performance interplanetary transports of the 21st century; they are able to carry 10 kg payloads from the Earth-Moon system to Mars, for example, in less than a month.

Solar power satellites are space-based power supply systems. They are composed of arrays of solar panels that convert sunlight (or photons from other sources such as lasers) into power and then beam that power by microwave (or laser beam) to a distant site such as a receiving station on Earth or Mars; they are able to deliver large amounts of electric power to distant sites at low cost. The lunar industrial base that manufactures the solar panels and other components of the lunar electric grid from lunar regolith resources is used to build the solar panels and other structural components of solar

■ **Above:** Artist's concept demonstrating how the lunar surface will be used to test the hardware and operations that will be utilized in an eventual human mission to Mars. A simulated mission, including the landing of an adapted Mars excursion vehicle (shown here), could test many relevant Mars systems and technologies. Artwork produced for NASA by Pat Rawlings, of SAIC. Technical concepts for NASA's Exploration Office, Johnson Space Center (JSC).

power satellites. The separate components of the solar power satellites are then launched by mass driver from the Moon to their destination in space. They are maneuvered into their final orbit (by aerobraking, tethers, rockets, etc.), and assembled by means of autonomous or teleoperated robotic devices. Large orbiting solar power satellites are able to provide continuous power in the 100-200 megawatt range, for example, for the global exploration and development of planets such as Mars.

The confluence of forces, technologies, and resources that gave rise to the creation of a self-sufficient human settlement on the Moon by the mid-21st century have been combined to enable the exploration and development of the Solar System to begin on a grand scale. Every planet, moon, and major asteroid, comet, and near-Earth object will soon have been subjected to in-

depth analysis by a myriad of satellites, probes and, where possible, by landers and rovers. In particular, Mars will be extensively explored and developed for eventual human settlement.

Based on the experience with the development of the first lunar base, the components of a manned Mars base, including utilities and life-support systems, will be constructed on the Moon and delivered in sections to a pre-selected site on Mars. Aided by solar power and solar sail communication satellites that have been placed in orbit around the planet, robotic devices will

■ **Below:** Artist's concept of a lunar mining facility being used to extract oxygen from the resource-rich volcanic soil of the eastern Mare Serenitatis. The high iron, aluminum, magnesium, and titanium content in the processed tailings could be used as the raw material for a lunar metals production plant. Artwork produced for NASA by Pat Rawlings, (SAIC). Technical concepts for NASA's Exploration Office, Johnson Space Center (JSC).

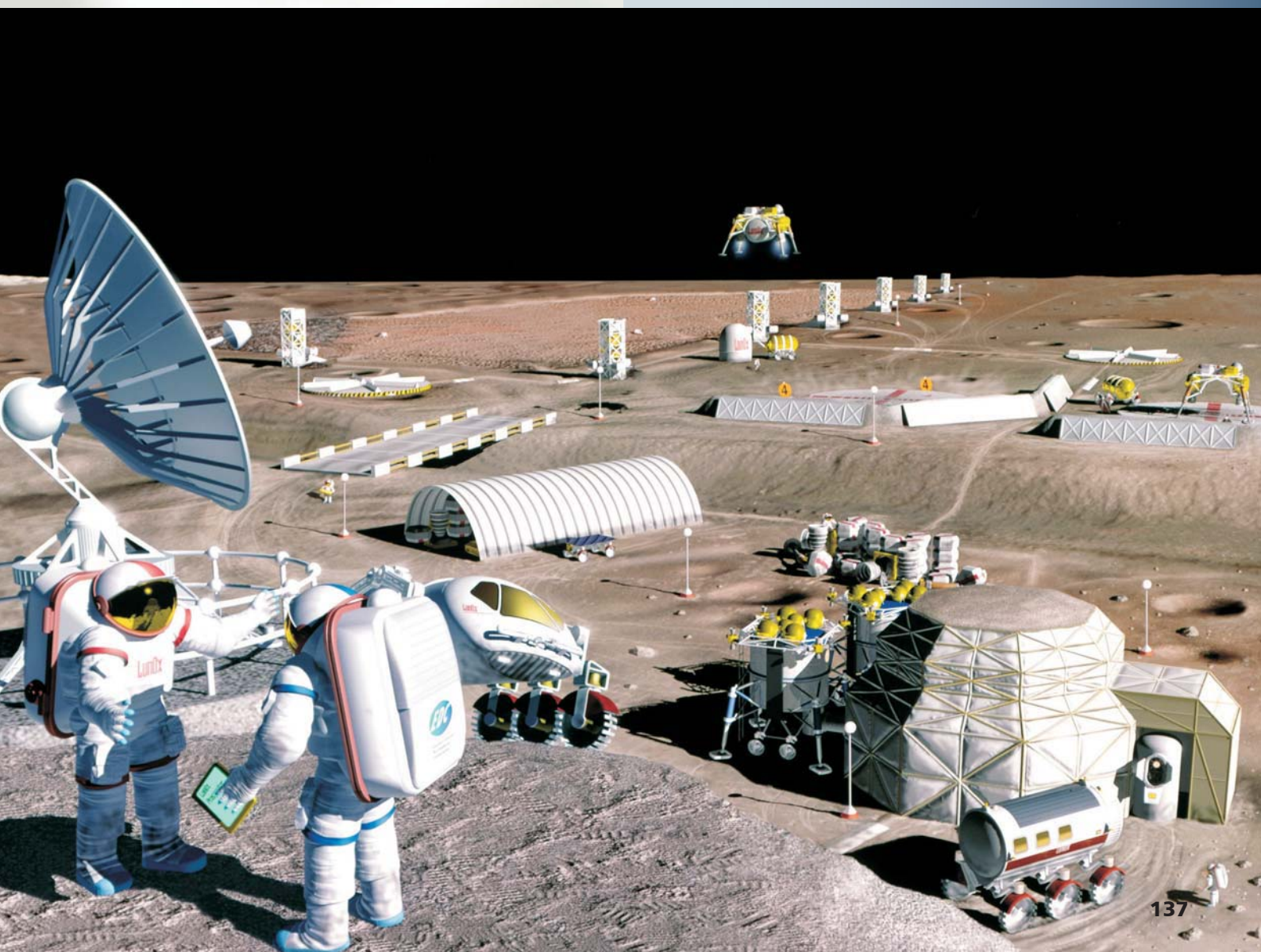

be delivered to assemble a fully functional and habitable surface base. When the first human explorers arrive, they will step out of their lander and proceed to their permanent housing area via the previously constructed Martian railroad. They will have ready access to functioning mining and manufacturing facilities, life support systems, scientific laboratories, and an expanding rail, communications, and electric power network. The global exploration and human settlement of Mars will then commence. Several Earth-Mars Cyler spacecraft, analogous to the Earth-Moon Cyler, will ferry astronauts between Mars and the Earth-Moon planetary system.

As technological expertise with space missions grows, it may be possible to launch the first laser-powered solar sail robotic mission to another star system from the Moon by the end of the 21st century. If the challenges of relativistic speeds (5 to 10 per cent of the speed of light) can be met, scientific data on nearby star systems could be available by the middle of the 22nd century.

Finally, the establishment of permanent human settlements on the Moon will have a profound beneficial impact on the people of the Earth. The industrial capability of the "Planet Moon" will tap into the resources of space and supply the Earth with an abundance of clean energy and material needs. The delivery of terawatts of low-cost, clean solar electrical power to Earth locations from the Moon will satisfy Earth's future energy needs. It will lead to significant advances in living standards on a global scale and, by reducing or eliminating the need to consume fossil and fission fuels, will reduce pollution. Also, excess energy that is not needed for immediate power needs can be used to clean up toxic waste sites, desalinate sea water, and pump potable water to arid regions.

The size and trajectory of all newly-discovered near-Earth objects (NEOs – the asteroids and comets in Earth's vicinity) will be observed by telescopes on the Moon. If trajectory analysis indicates that a large asteroid will collide with the Earth or the Moon, a significant effort will be made to eliminate that threat by altering its orbit. More practically, robotic mining equipment will be delivered from the Moon to the NEO and its bulk mass will be removed and transported, block by block, to the Moon (or to another advantageous location in space

such as the L4 Lagrangian point which lies 60° ahead of the Moon as it orbits the Earth) for resource utilization. The mining process will consume the NEO, thus physically removing it as a threat to the Earth-Moon System. The prevention of a collision between a large NEO and the Earth would justify the total combined investments of all space programs. The mining operation of the NEO will also yield valuable resources not available on the Moon. Water and the lighter-weight elements such as carbon, nitrogen, and phosphorus will be delivered to the Moon, and elements that have higher value on the Earth, such as platinum, nickel, gold, cobalt, and palladium, will be delivered to the Earth (the metals could be shaped into a lifting body, covered with ablative materials, and maneuvered through Earth's atmosphere to a designated landing area). By repeating the above strategy for thousands of NEOs, a steady stream of valuable space resources is delivered to the Earth-Moon system.

If the above vision of the role of future bases on the Moon and the benefits they will bring for all humankind is eventually realized, then resuming human missions to the Moon undoubtedly represents the beginning of a glorious future.



David G. Schrunk is an aerospace engineer and medical doctor. He has published numerous scientific articles related to space exploration and is a co-author of the book, *THE MOON: Resources, Future Development, and Settlement*, published by Springer-Praxis.

11

Probing the Mysteries of our NEAREST STAR...

Bunny spent the day listening to her favourite band The Caterwauls.
Solar activity meant the Human Crew was not so lucky!!!

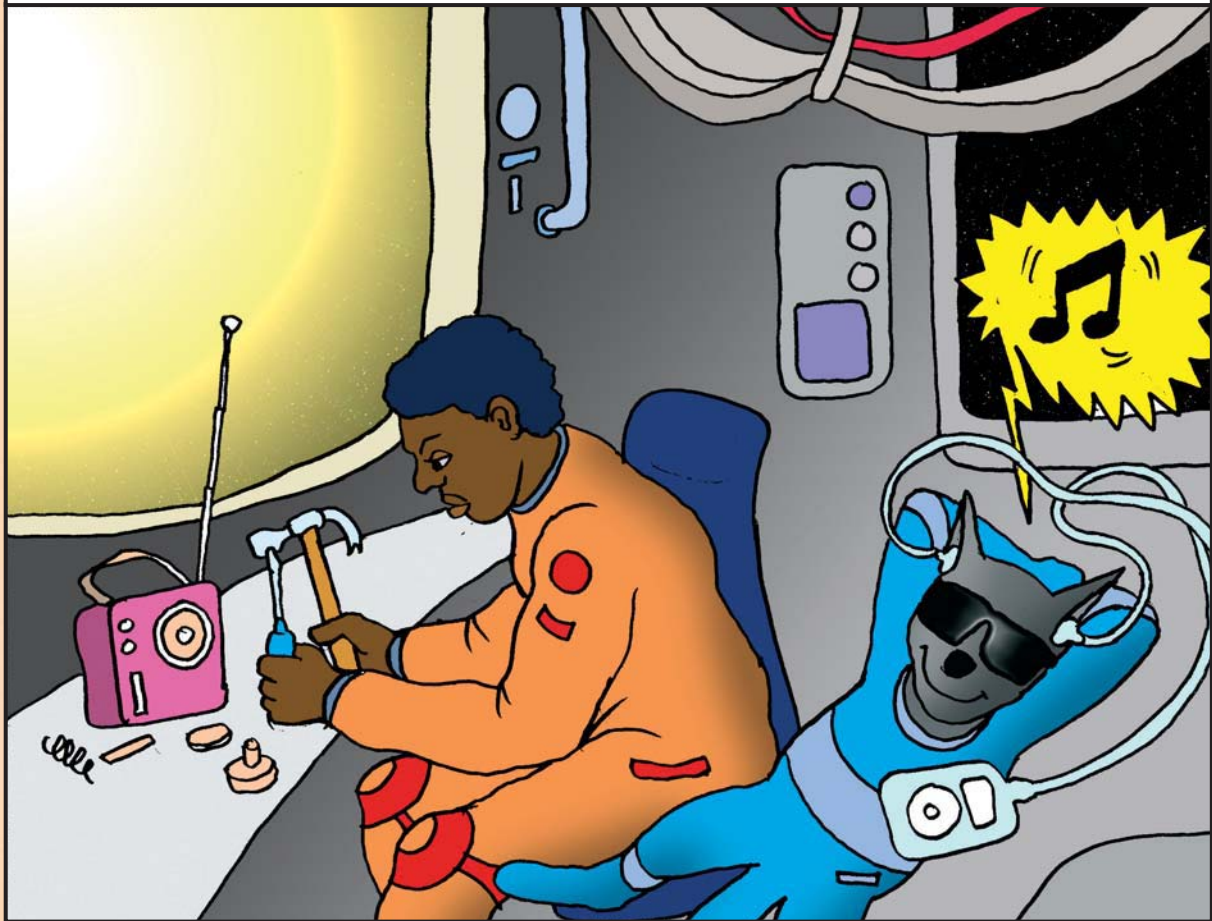

In the last twenty years a succession of increasingly sophisticated spacecraft have been launched to probe the mysteries of our Sun, its extraordinarily powerful magnetic storms and the effects that its violent outbursts have on the Earth. As *Martin Mobberley* explains here, although our knowledge of the Sun and its 11-year cycle of activity has never been greater, many puzzles remain, and we could well be in for the most violent solar maximum ever in 2011.

Studying the Sun from SPACE

LYING AT a safe distance of 150 million kilometres from the Earth, and reassuringly rising and setting every day, one tends to think of our friendly local star as a very predictable and stable body with little variation in its behaviour. However, the Sun follows a roughly 11-year cycle of activity (22 years if one considers its magnetic cycle) and at every solar maximum (the next is predicted to be around 2011) we see its 1.4-million-kilometre diameter disc sporting many large sunspots and producing enormous outbursts. These can bring down national grid power systems on Earth (causing blackouts), interfere with radio communications, damage

orbiting satellites and threaten the safety of astronauts working in space.

Our Violent Sun

The Sun emits a colossal amount of radiation, both as the visible light and heat we can easily appreciate, and at longer and shorter wavelengths right across the electromagnetic spectrum. The solar luminosity (the power emitted in the form of photons) is estimated as 3.83×10^{23} kW. On every square metre of ground at the Earth's equator, with the Sun overhead on a sunny day, an average 1.37 kW of radiation arrives (the so-called Solar Constant). But the Sun emits particles too. The solar wind, which 'blows' outwards from the surface is comprised of a stream of electrically-charged particles (high energy electrons and protons) which are travelling at sufficient speed to move away from, or escape entirely from, the Sun's gravitational field (escape velocity 618 kilometres per second). The solar wind is electrically conductive and so magnetic field lines from the Sun are carried along by the wind. Perhaps the most obvious visual effect of this is the way a comet's gas tail is not only forced away from the

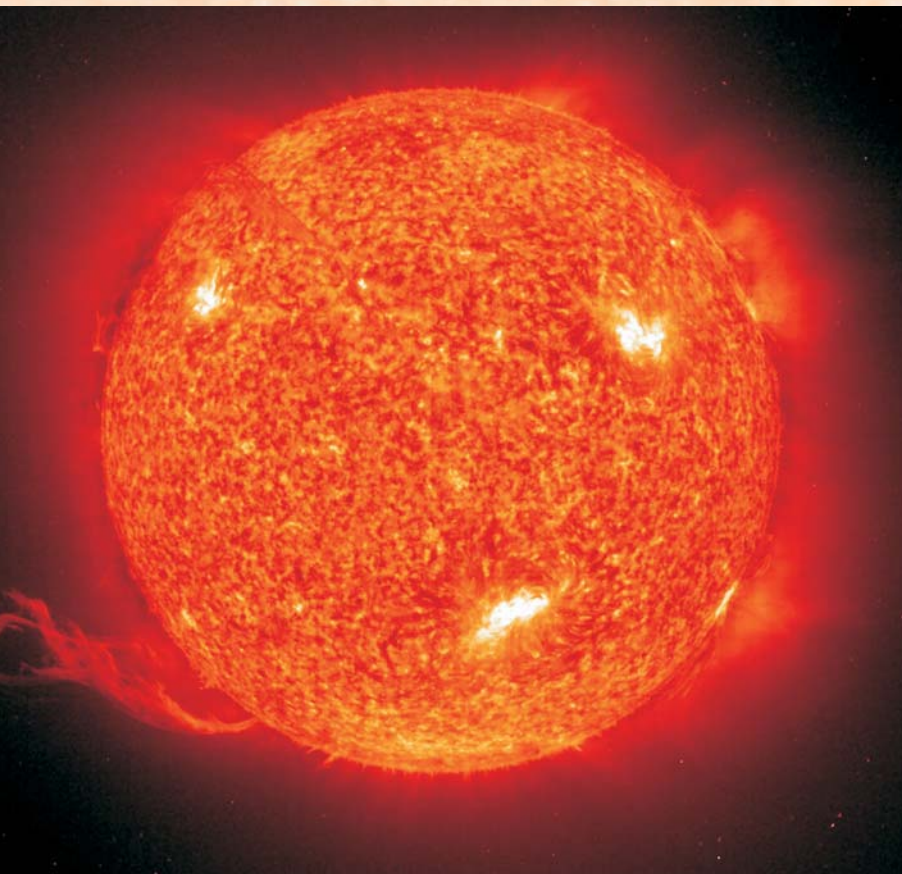

■ **Left:** A SOHO EIT (Extreme ultraviolet Imaging Telescope) image from 14 September 1997 shows a huge eruptive prominence at about 60 to 80 thousand Kelvin in the resonance line of singly ionised helium (30.4 nm in the extreme ultraviolet). Image courtesy SOHO Consortium, ESA, NASA.

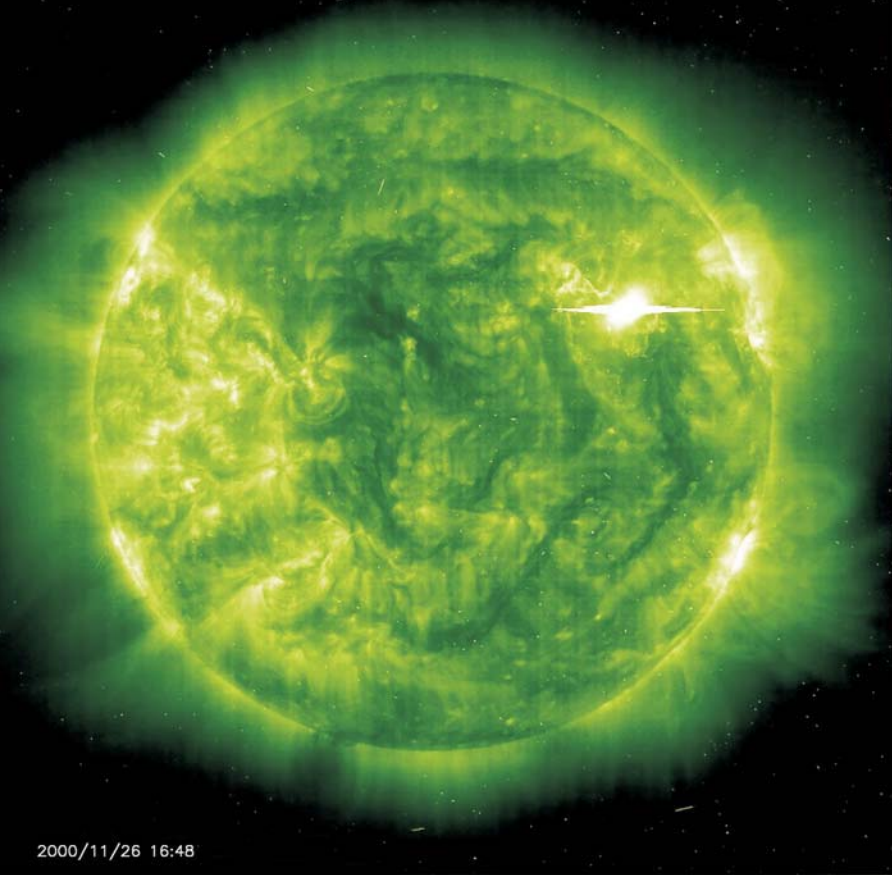

2000/11/26 16:48

circumstances and radiates greatly in the ultra-violet and X-ray regions of the electromagnetic spectrum, producing a solar flare. Even gamma-rays can be emitted in such situations. Rarer 'white light' flares can even be observed in the visible spectrum by amateur astronomers using safe solar filters.

The most dramatic solar events are called Coronal Mass Ejections or CMEs. These events were not observed until the 1970s when orbiting satellite detectors first recorded them. They are the bigger brothers of solar flares and are often associated with them. CMEs resemble enormous bubbles that expand outwards from the surface of the Sun, caused when solar magnetic fields become unstable on a global scale. Billions of tons of solar material can be hurled outwards at speeds of up to 2,000 kilometres per second. This then ploughs into the

Sun by the solar wind, but can corkscrew into intricate patterns and even disconnect when crossing a magnetic boundary in the solar wind. Near to the Earth the solar wind speed varies between 200 kilometres per second and 900 kilometres per second. Even after years of study, from advanced solar satellites the precise manner in which the fastest solar wind speeds are generated is not fully understood.

slower moving solar wind, and, if the CME is heading in our direction, energetic subatomic particles can arrive at the Earth a few days later. The Earth's magnetic field provides protection

Solar flares are violent outbursts occurring on the solar surface which can easily be monitored from the Earth. They are thought to be caused by the rapid release of energy during magnetic reconnection events. The visible solar surface is laced with incredibly powerful changing magnetic fields. When the magnetic field switches to a lower energy state in these regions the excess energy can be dumped into the plasma in and around the magnetic field. The plasma can actually be accelerated to extremely high speeds in these

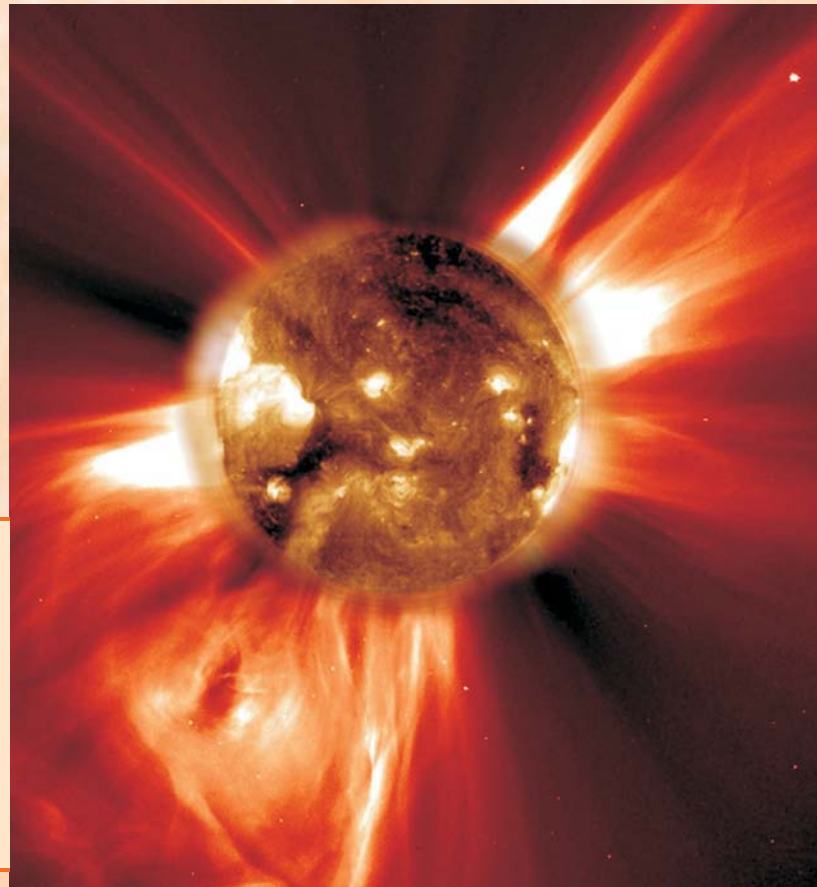

■ **Above:** The intense burst from a solar flare (top right) is captured by the SOHO EIT instrument during the 24–26 November 2000 series of six major solar flares and associated "halo" coronal mass ejections (CMEs). Image courtesy SOHO-EIT Consortium, ESA, NASA.

■ **Right:** In this 2002 SOHO image of a coronal mass ejection (CME) the Sun's face has been replaced by a simultaneous ultraviolet image. The solar environment out to a million kilometres beyond the Sun is shown, but the CME still extends beyond the limit of the frame. Near solar minimum CMEs occur about once per week, but they can occur twice a day at solar maximum. Image courtesy SOHO Consortium, ESA, NASA.

from the constant solar wind which compresses the Earth's magnetosphere forming the so-called 'bow shock' shape on the sunward side and draws it out into the magnetotail on the anti-sunward side. However, a small percentage of electrically-charged particles break through the defences and, if the remnants of a CME hit the Earth's magnetosphere, spectacular aurorae can appear not only around the polar regions but also at lower latitudes, and the resulting electrical currents generated in long power lines can bring down entire national grid systems. Needless to say, orbiting satellites are vulnerable to such electromagnetic onslaughts as are ground-based radio, telephone and TV communications. Studying the solar threat to Earth, its people, power lines and satellites is a major part of the investigation being undertaken by the flotilla of spacecraft now studying the Sun.

The Photosphere and Chromosphere

For hundreds of years the only part of the solar disc that could be studied from the Earth was the photosphere, i.e. the blindingly bright yellow surface which is visible through heavily filtered astronomical telescopes or by safely projecting the solar image onto a piece of white card. However, in the last few decades the Sun has been studied at a variety of ultra-violet, X-ray and gamma-ray wavelengths, by increasingly sophisticated space probes. These have increased our understanding of the processes operating in the nuclear fusion reactor at the Sun's core and in the turbulent electromagnetic environment beyond the visible photosphere.

It is tempting to think of the yellow photosphere as being a solid surface below which the gaseous solar furnace resides. In fact, apart from the central core, we can realistically regard all of the Sun, from the central core to the outer gaseous corona, as being a huge incandescent, unbelievably hot, ball of plasma. The photosphere looks solid simply because it is opaque.

The dense central core is unimaginably hot, at 15 million K, but by the time we reach the visible photosphere the temperature has dropped to 5800 K. The darker central regions of sunspots are the coolest, at about 3800 K, yet, if they were seen in

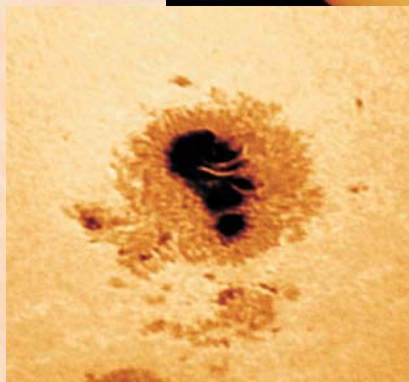

isolation they would shine brighter than any arc lamp. Beyond the photosphere the temperature increases once more; the tenuous corona, seen with the naked eye only at total solar eclipses, has a temperature of between 1

and 2 million degrees, but being so gaseous it has relatively little heat capacity. (Strictly speaking, temperature is a measure of average velocities of the atoms or molecules in a gas). Nevertheless, the ultra-high temperature of the corona is still a puzzle.

If only the photosphere was transparent and astronomers could glimpse the inner machinery of the Sun! In fact, that blindingly bright impenetrable top surface is only a few hundred kilometres thick; the visible surface is, relatively speaking, thinner than the skin on an apple. Nevertheless, it is what Earth-based astronomers see, and it contains the famous 'rice-grain' granulation visible in high resolution images. The sunspots, so well known to all solar observers, are, perhaps surprisingly, regions on the solar surface where intense magnetic fields have actually reduced the energy arriving from the convective layer beneath. That is, the energy

■ **Top:** The visible face of the Sun on 21 June 2004, showing a few sunspots on the yellowish photosphere. Image courtesy Damian Peach.

■ **Inset:** A huge sunspot imaged at high resolution with a modest 80 mm amateur refractor on 19 July 2004. Image courtesy Damian Peach.

is transferred into the magnetic field. Sunspots are therefore considerably cooler and less bright than the rest of the visible solar surface and their darkest parts represent the coolest and most magnetically active areas. Sunspots and the effects they generate are just like bar magnets and iron filings in those early physics lessons at school. They group together in pairs, one spot with a positive polarity and the other with a negative polarity, usually spaced out in an east-west direction. Magnetic arches join the two sunspots, and these solar equivalents of the schoolroom bar magnet's iron-filings manifest themselves as dramatic prominences when the Sun's rotation takes them to the solar limb.

The chromosphere (from the Greek *chromos* meaning colour) lies immediately above the Sun's visible photosphere. It has a depth of some 2,500 kilometres, so it is considerably thicker than the photosphere although still wafer-thin in comparison with the solar diameter. Ultra-high-resolution images at hydrogen-alpha wavelengths show that the outer edge of the chromosphere, when looked at from a shallow angle (i.e. the foreshortened limb view) resembles a spiky mountain range. Indeed, the spiked extensions are actually called spicules. These spicules are short-lived jets of gas (they only live for a matter of five to ten minutes) travelling out from the main body of the chromosphere. They shoot up to more than ten kilometres in height (so the mountain peak analogy is very apt) and then quickly fall back to the average chromosphere surface. In the best images they resemble mountains of iron filings on a sheet of paper with a bar magnet underneath. Indeed, solar physicists think that the spicules may be involved in conveying magnetic fields out from the Sun to heat the next region of the solar atmosphere: the mysterious corona. This field of research is one of the hottest (pun intended) in solar physics, and almost all spacecraft currently studying the Sun have at least one instrument

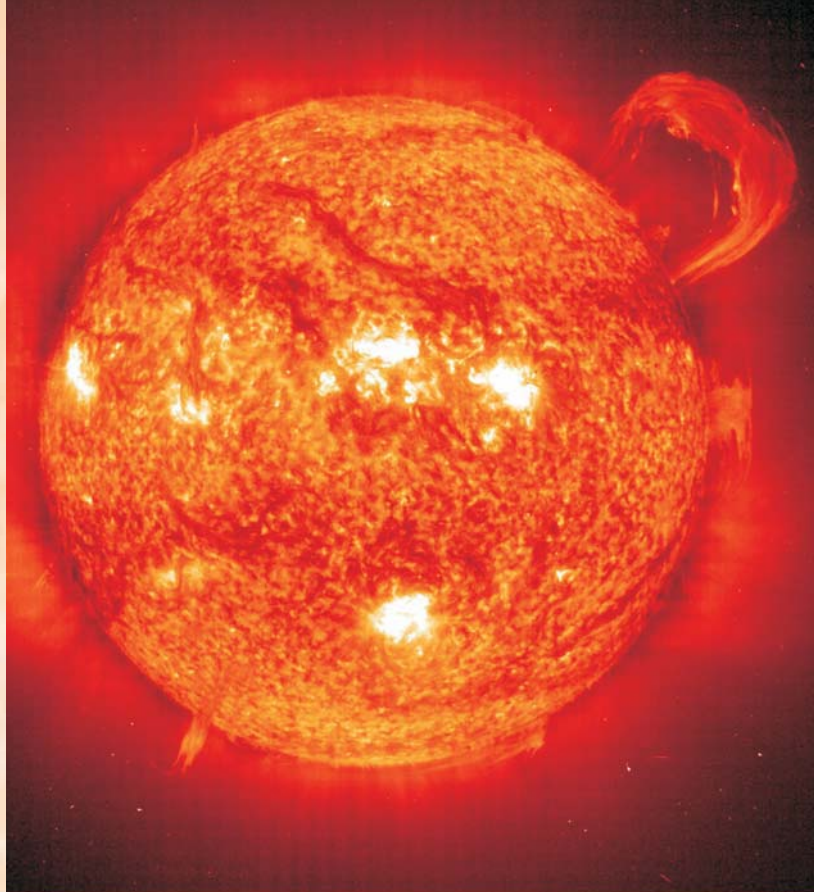

designed to study how heat is conveyed from the cooler chromosphere into the million degree plus solar corona.

The Solar Corona

Unlike the photosphere and the chromosphere, the solar corona is not limited to a thin skin-like surface on top of the seething cauldron of energy we call the Sun. The ghostly corona extends for millions of kilometres into space and is the most awesome sight to behold during the totality phase of a solar eclipse. The corona shines at a total eclipse because it, or rather the free electrons within it, scatter the intense light that is radiated by the photosphere. In fact, the most tenuous extremes of the solar corona spread throughout the Solar System in the form of the solar wind, and astronomers call the point where the solar wind collides with the cooler background of the interstellar medium the heliopause, which is currently estimated to lie at 150 AU from the Sun (1 AU = the Earth-Sun distance of 149.6 million kilometres). Put another way this is 22 billion kilometres, or 21 light-hours out. This is considerably further than the current distances of Voyager 1, Voyager 2 or Pioneer 10 (2007 distances were 102, 82 and 93 AU respectively). Although some astronomers have speculated that Voyager 1 has already reached the termination shock (the inner edge of the boundary) there is

■ **Above right:** Twisted magnetic fields arching from the solar surface can trap ionised gas, suspending it in huge looping structures. These majestic plasma arches are seen as prominences above the solar limb. In September 1999, this dramatic image was recorded by the SOHO EIT instrument in the light emitted by ionised helium. It shows hot plasma escaping into space as a fiery prominence breaks free from magnetic confinement a hundred thousand kilometres above the Sun. Image courtesy SOHO-EIT Consortium, ESA, NASA.



■ An image of the corona surrounding the Sun at the 29 March 2006 total solar eclipse as viewed from Libya. The multiple long coronal streamers seen here are typical of the structure of the corona near solar minimum. Image courtesy Tony Morris.

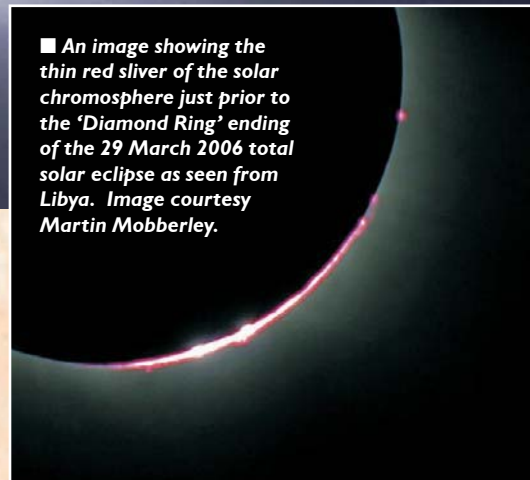

■ An image showing the thin red sliver of the solar chromosphere just prior to the 'Diamond Ring' ending of the 29 March 2006 total solar eclipse as seen from Libya. Image courtesy Martin Mobberley.

considerable disagreement, not least because its solar wind detector ceased functioning in 1990. NASA now believe that Voyager 1 will truly reach the heliopause in 2015.

The inner corona, visible at a total solar eclipse, is only a few million kilometres from the Sun. Its intricate gossamer structure is, once again, tied up with the intense solar magnetic fields. It comes as something of a surprise to learn that the corona has such a very high temperature. This seems at odds with common sense. How can a tenuous region of gas so far from the solar centre have a higher temperature than the actual solar surface? Well, firstly, it is important to re-iterate here that there is a huge difference between the definition of temperature and heat capacity in the physical world. As we saw earlier, the temperature of a gas is determined by its average kinetic energy, which is proportional to the square of the average speed of the particles. Gas at a low temperature will not have the energy to stray far in the immense gravitational pull near the surface of the Sun. So the very fact that we can trace the corona out to great distances tells us that the particles are moving at huge speeds and therefore are, by definition, at a very high temperature. But even bearing this in mind, the million degree plus temperature of the corona is staggering, more

than two orders of magnitude greater than that of the visible photosphere. If there is one mystery that has occupied the minds of the most solar physicists in recent years it is simply why the corona is at such a high temperature.

The Spacecraft

Since 1990 a veritable 'armada' of spacecraft have been launched to study both the Sun and its effect on the Earth's environment. Some of the individual mission objectives have overlapped, competed, or worked in harmony with other spacecraft, but all have added considerably to our knowledge of the Sun. Sadly, there was one disaster. On 4 June 1996, all four Cluster spacecraft were lost on the first flight of Ariane 501, when a software bug slipped through the verification process – software that had been developed for the Ariane 4 had been reused without realising that it would fail due to the greater acceleration of the new vehicle. With the first launch of a new rocket this kind of bug had

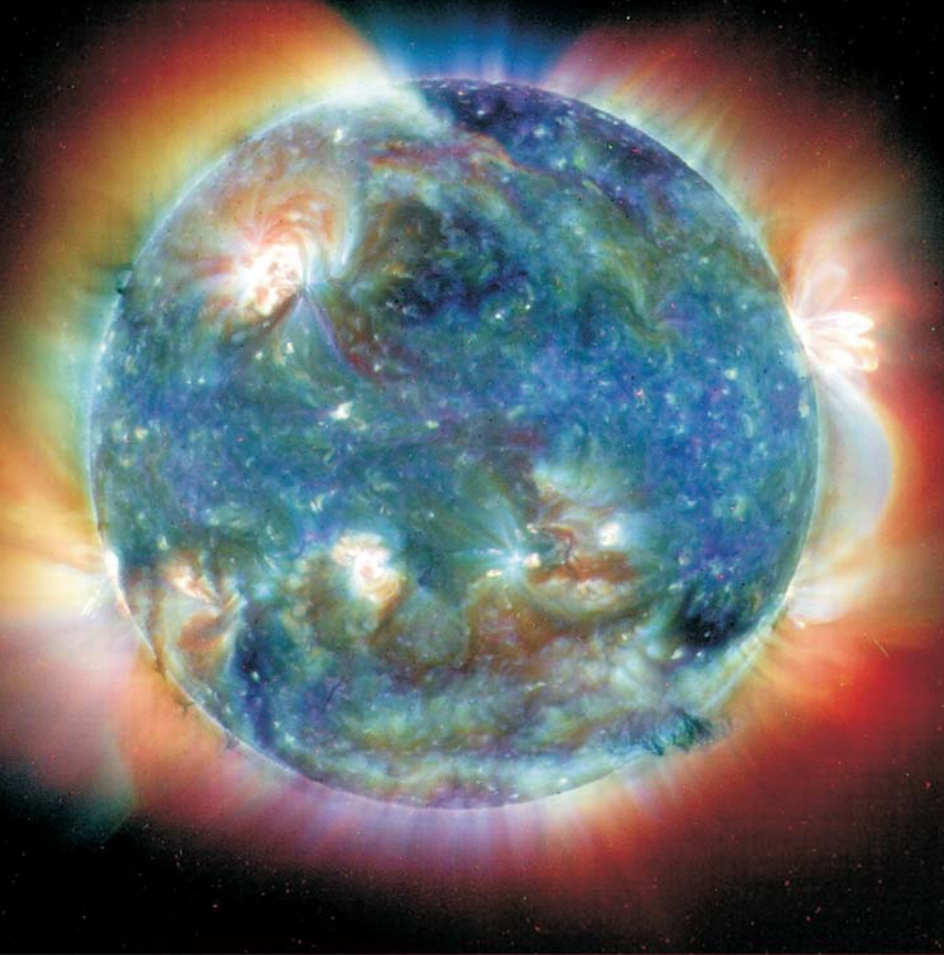

On 24 January 2001, the four Cluster II spacecraft were flying at an altitude of 105,000 kilometres above the Earth, in a tetrahedron formation, with each spacecraft at a distance of about 600 kilometres from the others. Astronomers expected that every spacecraft would show similar readings as they all passed through the 'bow shock', the region where the solar wind interacts with the Earth's magnetic field on the sunward side. However the readings showed major fluctuations in the magnetic and electric fields surrounding each of the spacecraft, as well as considerable differences in the number of solar wind protons that were reflected by the bow shock. This result has been interpreted as the first proof of the bow shock reformation model, postulated by Vladimir Krasnoselskikh in 1985.

always been a small possibility, and even though the risk factor for the Ariane 5 was estimated at only 1.5 per cent it was decided not to carry a commercial satellite, and the maiden launch was provided to Cluster for free in order to cut the costs of that mission. But, as one observer wryly commented later, "there is no such thing as a free launch". Cluster was designed to work in harmony with the highly successful SOHO spacecraft launched 6 months earlier. Its loss was devastating for the scientists involved.

However, four years later, in June and July 2000, four new Cluster II spacecraft were launched by two Soyuz-Fregat launchers from Baikonour Cosmodrome, Kazakhstan. Although the original spacecraft had been lost, the design and expertise had not, and the scientific investment was not wasted. The four spacecraft fly in formation around Earth and relay back groundbreaking information about how the solar wind affects our planet in three dimensions. The project has recently been extended to run until 2009.

Thankfully, no other disasters have befallen major solar spacecraft and, at the time of writing, at least nine other recent spacecraft projects whose prime missions were solar ones, have sent back valuable data. The first solar spacecraft of the 1990s to be launched was called Ulysses, which was dispatched by Shuttle, and took over after the demise of the Solar Maximum Mission (launched in 1980, repaired in 1981 and finally retired in 1989). Ulysses, launched in October 1990, used Jupiter's massive gravitational field to steeply incline its trajectory to the ecliptic (the plane containing the Earth's orbit around the Sun), to enable it to examine the Sun from beneath the south pole (1994) and then above the north pole (1995). This first look was at a period of low solar activity in the 11-year solar cycle, so the process was repeated at solar maximum in 2000 and 2001. Ulysses has returned a huge amount of data from its unique vantage points above and below the ecliptic plane, thanks to using Jupiter as a slingshot; and it is still going strong!

Launched in 1991, one year after Ulysses, the Yohkoh (meaning 'Sunbeam') solar observatory satellite was a co-operative Japanese, American and British venture and observed the energetic phenomena taking place on the Sun, specifically X-ray and gamma-ray solar flares. Three years later, in November 1994, NASA's WIND spacecraft was launched and eventually manoeuvred into a

■ **Above:** This picture is a false-colour composite of three images all made in extreme ultraviolet light by the SOHO EIT instrument. A red coloration represents a temperature of 2 million degrees, green represents 1.5 million, and blue 1 million degrees. This combined image shows bright active regions strewn across the solar disc, which would normally appear as sunspots in visible light images, along with some spectacular plasma loops and a massive prominence at the right hand solar limb. Image courtesy SOHO-EIT Consortium, ESA, NASA

so-called halo orbit at the Lagrange point directly up-Sun of Earth, where the gravitational pull of Sun and Earth are the same (roughly 1.5 million kilometres from Earth). From this vantage point, which is used by many solar spacecraft, the Sun can be studied continuously, without the inconvenience of a standard Earth orbit in which the Earth can obstruct the view of the Sun, and without the consumption of significant amounts of thruster fuel to keep the Sun centred on the imaging detectors. WIND studied the plasma, energetic particle and magnetic field emissions from the Sun and its effect on interplanetary space and the near-Earth environment. It also provided an ecliptic plane viewpoint to enable a 3D perspective when combined with the Ulysses observations from way above and below the Sun's polar regions.

Launched on 2 December 1995, the SOHO (Solar and Heliospheric Observatory) spacecraft is, perhaps, the best-known of the solar monitoring missions, not least amongst astronomers, as its images have enabled the discovery of over 1,000 tiny comets or cometary fragments as they brighten (and indeed evaporate) on flying very close to the Sun. Despite the loss of the sister Cluster mission, when the Ariane 501 launch rocket went out of control, SOHO worked incredibly well as a standalone project for the first 5 years of its life and has now been monitoring the Sun constantly since December 1995 despite a couple of antenna problems in 1998 and 2003. That's pretty good for a spacecraft that was, at one time, only intended to have a two-year lifetime.

Of course, as well as satellites that monitor the Sun itself, it is vital to monitor the effects that violent solar outbursts have here on the Earth. The POLAR satellite launched on 24 February 1996 is responsible for multi-wavelength imaging of the aurora, the entry of plasma into our polar magnetosphere and geomagnetic tail, and the effects on the ionosphere and upper atmosphere. It orbits the Earth in a highly elliptical 17.5-hour orbit inclined at 86 degrees.

Eighteen months after the launch of POLAR, NASA's ACE (Advanced Composition Explorer) spacecraft was successfully placed into its Lagrange vantage point in August 1997. This spacecraft carries out measurements over a wide range of energies and under all solar wind flow conditions during large and small solar events including solar flares. It can provide one hour's warning of the sort of geomagnetic storms that can threaten astronauts in the ISS, disrupt

communications on Earth, overload national power grids, and produce spectacular aurorae.

A mere eight months later, in April 1998, the Transition Region and Coronal Explorer (TRACE) spacecraft was launched on a Pegasus launch rocket carried under the fuselage of a modified Lockheed L-1011 Tristar airliner, which took off from Vandenberg Air Force base. With the SOHO spacecraft still functioning, TRACE would collaborate with that spacecraft in observing the Sun in the build up to the solar maximum of 2000/2001. In particular, TRACE was designed to study the three-dimensional magnetic structures that emerge at sunspots through the Sun's visible photosphere, and examine the mystery of how the transition from the 5800 K photospheric temperature to the 1 - 2 million degree coronal temperatures takes place.

Into the 21st century and there was no relaxing of the quest to understand the Sun. NASA's small explorer mission RHESSI (Reuven Ramaty High Energy Solar Spectroscopic Imager) was launched in February 2002 to study the basic physics underlying particle acceleration and explosive energy release in solar flares.

■ **Below:** In this yellow tinted false colour image, taken on 9 March 2003, the dark shapes visible on the left side of the Sun are coronal holes – low density regions extending above the surface where the solar magnetic field opens freely into interplanetary space. These are known to be the source of the high-speed solar wind, atoms and electrons which flow outward along the open magnetic field lines. Imaged in extreme ultraviolet light by the EIT instrument on board SOHO. Image courtesy SOHO-EIT Consortium, ESA, NASA.

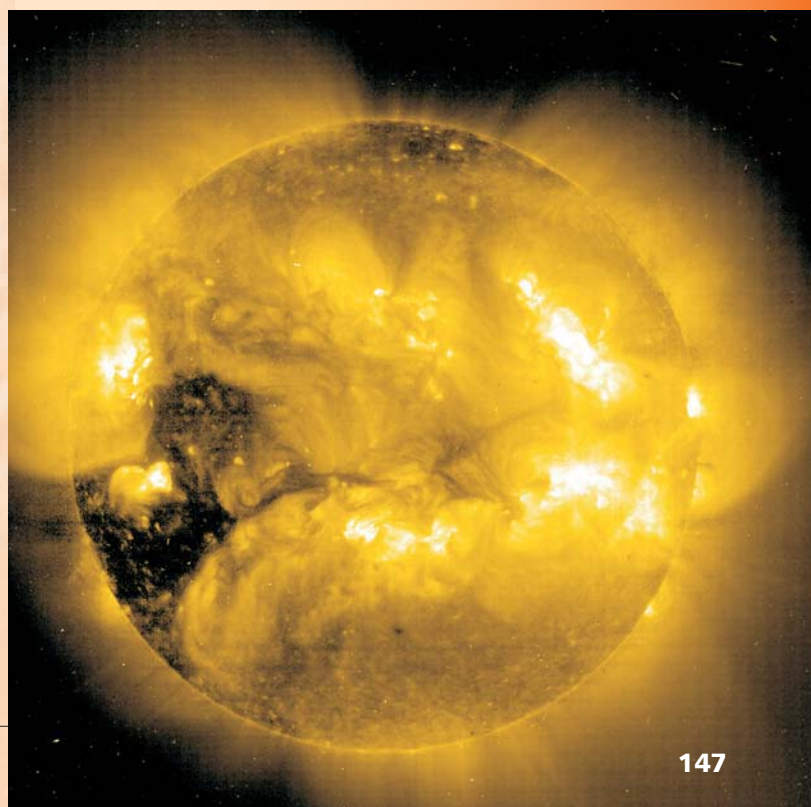

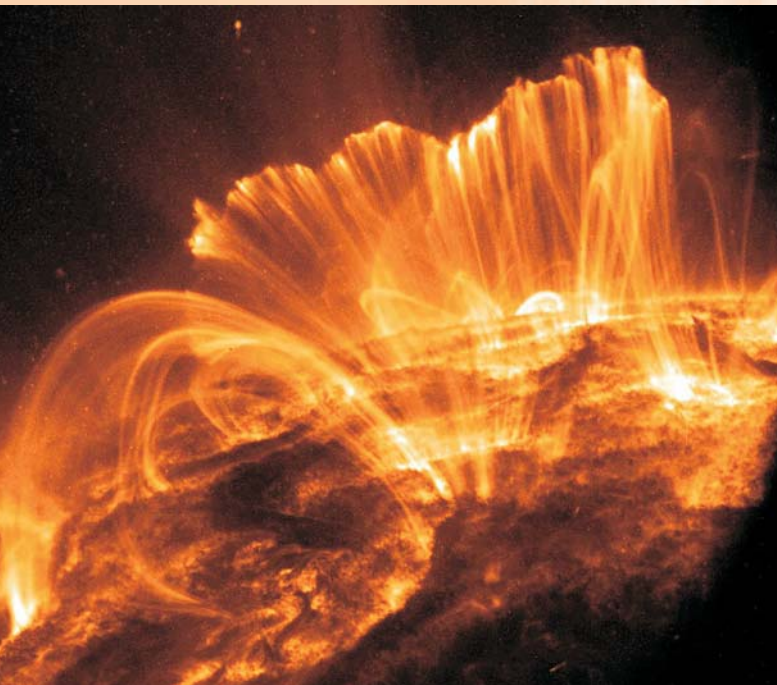
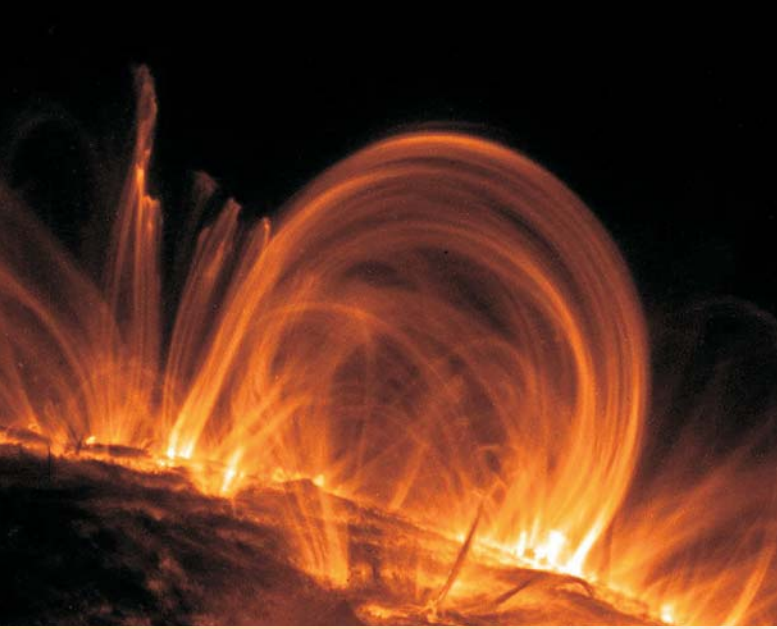

■ **Top:** An extreme ultraviolet light observation of coronal loops imaged by the TRACE satellite. This and other TRACE images indicate that significant heating occurs low in the corona, near the bases of the loops as they emerge from and return to the solar surface. This dramatic image shows clusters of the majestic, hot coronal loops which span 30 or more times the diameter of the Earth. Image courtesy M. Aschwanden et al. (LMSAL), TRACE, NASA.

■ **Above:** This spectacular image in extreme ultraviolet light is a frame from a movie recorded on 9 November 2000 by the TRACE spacecraft. It shows coronal loops towering over an active solar region. The hot plasma contained in arching magnetic fields is cooling and raining back down on the solar surface. The flare material associated with the event hit the Earth's magnetosphere some 30 hours later. Image courtesy TRACE Project, NASA.

■ **Above right:** Artist's impression of the twin STEREO spacecraft observing the Sun. Image courtesy NASA Goddard Space Flight Center and Johns Hopkins University Applied Physics Laboratory.

■ **Opposite page:** The Solar Conveyor Belt is a massive circulating current of hot conducting gas (plasma) within the Sun. It has two branches, north and south, each taking about 40 years to perform one complete circuit. Diagram courtesy David Hathaway, NSSTC and NASA.

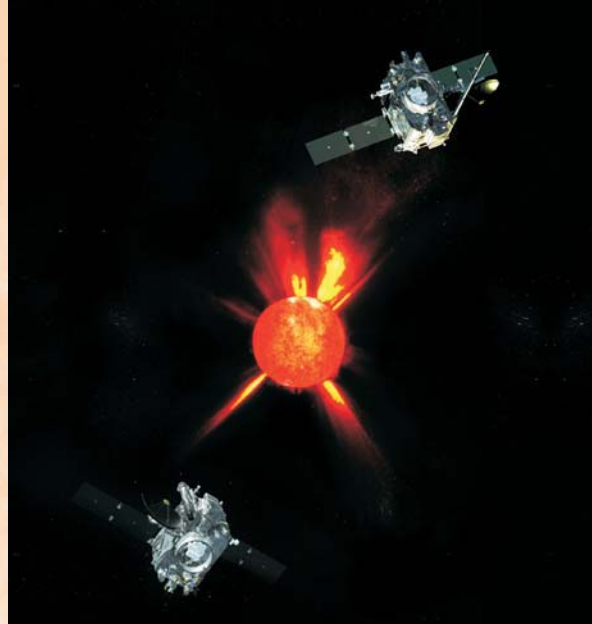

Finally, and comparatively recently, in September and October 2006, two further solar missions were successfully launched: the Japanese Hinode (Solar B) spacecraft and the NASA STEREO spacecraft. Hinode, the successor to the Japanese Yohkoh mission, is using three instruments to understand how energy generated by changes in the magnetic field in the lower photosphere is transmitted to the corona, and also to determine how the energy transfer affects the interplanetary environment. With STEREO (Solar TERrestrial Relations Observatory) the two almost identical spacecraft, one just ahead of the Earth in its orbit, and one just behind, will measure the flow of energy and particles from the Sun to the Earth as well as examining the three-dimensional structure of coronal mass ejections (CMEs). Like ACE, STEREO will provide advanced warning of solar storms that are about to hit the Earth or Earth's magnetosphere.

The 11-Year Cycle and the Solar Conveyor Belt

Although the shape of the solar corona is different at every total eclipse, it does tend to have a distinct generic shape depending on whether the Sun is at the peak of its 11-year activity cycle or at solar minimum. Solar maxima, when the Sun is very active and has the most sunspots on its face, occurred in 1906/7, 1917, 1928, 1937, 1947, 1957/58, 1968/69, 1979/80, 1990/91 and 2000/2001. The period of 11 years is not all that regular; there was a 17-year interval between the solar maxima of 1788 and 1805 and just over 7 years between the maxima of 1829/30 and 1837. However, in the 20th century the most extreme variation was the nine years from 1928 to 1937. Solar minima occur, not surprisingly, about midway between the maxima.

In recent years, the so-called 'Solar Conveyor Belt' hypothesis (a conveyor belt comprised of hot, conducting gas = plasma) has gained popularity through the work of Mausumi Dikpati of the National Center for Atmospheric Research (NCAR) at Boulder, Colorado, USA. In this theory the complex magnetic manifestations called sunspots, once they have decayed, have their old magnetic remnants carried away by this conveyor belt as it sweeps along just beneath the visible solar surface. In fact, this happens in both solar hemispheres. The theory says that these magnetic fields are then carried to the polar regions where they descend to a depth of about 200,000 kilometres, far below the visible surface – in fact, one-third of the way to the centre of the Sun. On their journey at this depth the solar dynamo (for want of a better term) amplifies them and the magnetic forces eventually emerge again at the visible surface as new sunspots. One loop of the conveyor takes between 30 and 50 years to complete, i.e. roughly 3 or 4 solar cycles. The average speed of the conveyor works out at just a few kilometres per hour, but over many decades this crawl builds up to a million kilometre loop.

So, does this theory help us to predict how big the next solar maximum will be? According to Dikpati, and solar physicist David Hathaway of the National Space Science & Technology Center (NSSTC) in Huntsville, Alabama, the conveyor swept up sunspots very rapidly in the 1986 to 1996 period, i.e. almost half a conveyor belt cycle ago. Taking this one step further the magnetic energy from those amplified magnetic storms should re-emerge in the photosphere in the coming years, making the next solar maximum a very violent one – at least if history is anything to

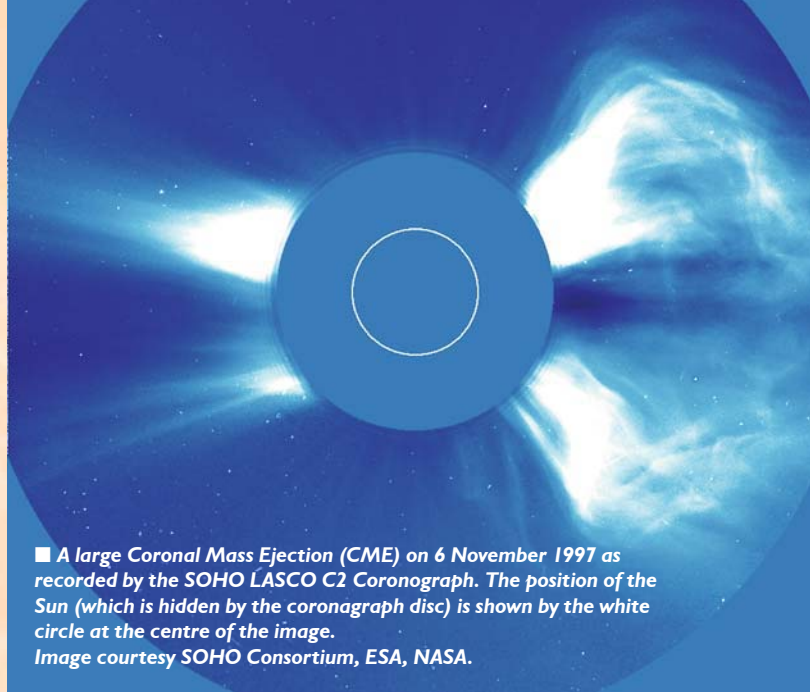
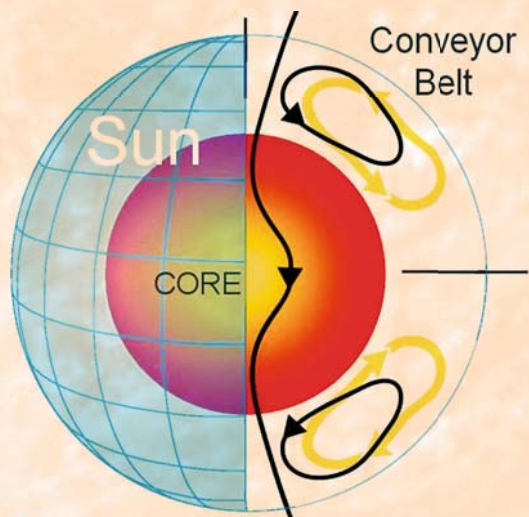

■ A large Coronal Mass Ejection (CME) on 6 November 1997 as recorded by the SOHO LASCO C2 Coronagraph. The position of the Sun (which is hidden by the coronagraph disc) is shown by the white circle at the centre of the image. Image courtesy SOHO Consortium, ESA, NASA.

go by. Dikpati predicts the early years of the next sunspot cycle will be 30 to 50 per cent stronger than the previous one, with a burst in solar activity second only to that seen in 1958, and peaking in 2012. Hathaway predicts an earlier but equally violent solar maximum in 2010/2011 – earlier due to the faster speed of the conveyor.

Only time will tell if the predictions are correct, or if it will be 'back to the drawing board', and a re-examination of all the spacecraft results.



Martin Mobberley is the author of five astronomy books published by Springer, as well as three children's Space Exploration books by 'Top That' publishing. His latest Springer book, just out, is entitled *Total Solar Eclipses and How to Observe Them*. A member of the British Astronomical Association since 1969, Martin served as BAA President from 1997 to 1999 and has his own astronomical observatory in Suffolk, UK.

12

Focusing on the **RED PLANET...**

Calling on her faithful Katnauts Booboo and Ooee, Bunny set out to photograph some Beagles: if she could find one!!

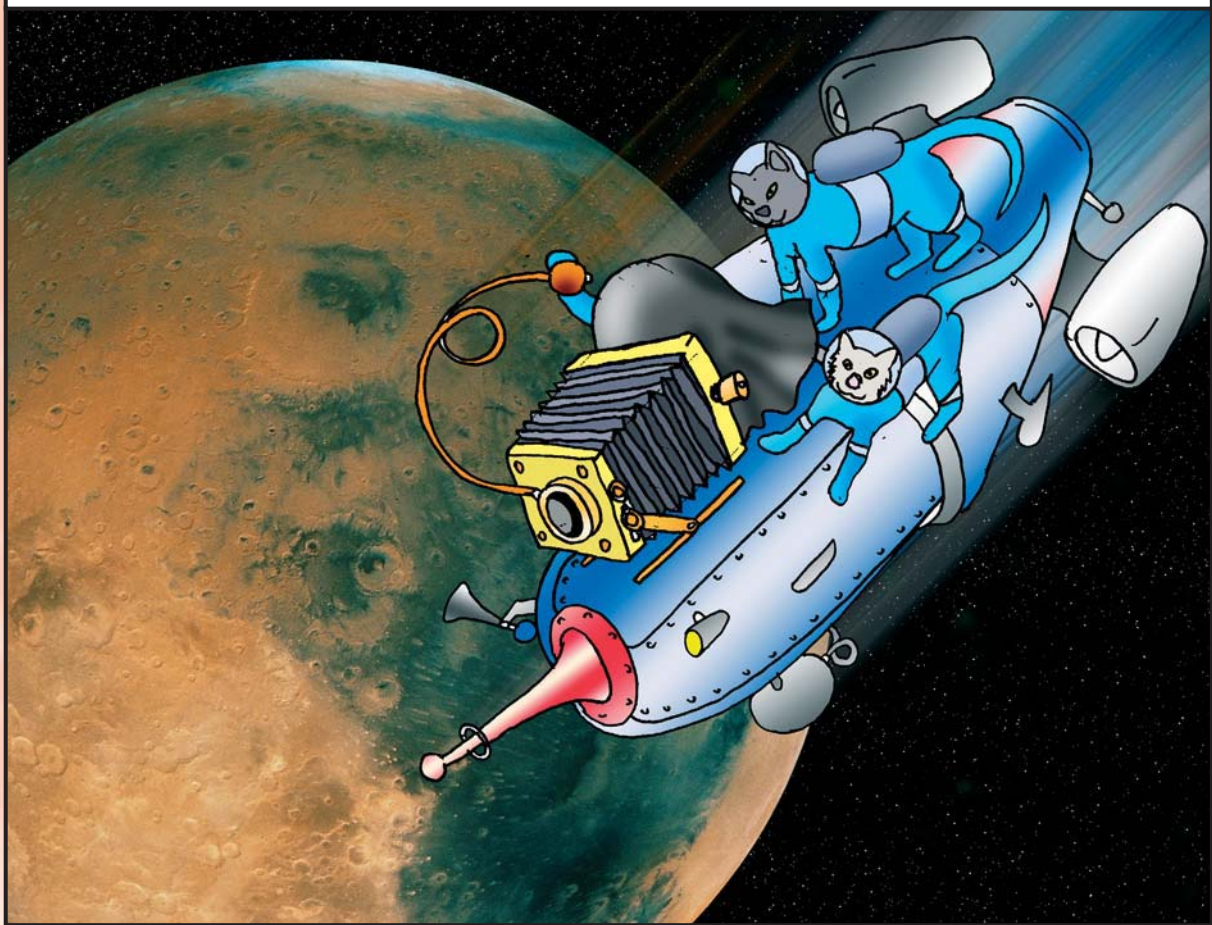

Since March 2006, when Mars Reconnaissance Orbiter (MRO) arrived in orbit around Mars, the Red Planet has been placed firmly under the proverbial microscope and has revealed more of its secrets. With the help of his colleagues *Tom Thorpe*, *Jeff Plaut* and *Diana Blaney*, the project manager for the MRO mission, *James Graf*, describes here the very latest results from all of the Mars missions, both ongoing and recently completed.

MARS

Exploration

UPDATE

THERE HAVE never been so many robotic spacecraft operating at Mars as there are now and the rate of understanding of the planet's geological history is increasing rapidly. The craft carry instruments not only to examine the atmospheric chemistry as well as to study the surface features and composition, but also to peer beneath the surface at the mysteries lurking out of sight.

The two Mars Exploration Rovers (MER) have continued to operate on the surface of Gusev Crater and Meridiani Planum, examining individual rocks in a manner similar to how human geologists would conduct such studies. While this in-depth, intensive investigation of two selected locales was underway, four spacecraft – Mars Express (MEx), Mars Odyssey (ODY), Mars Global Surveyor (MGS) and Mars Reconnaissance Orbiter (MRO) – were orbiting hundreds of kilometres above, applying the local

'ground truth' gleaned from the rovers to the entire planet. This yin and yang of planetary exploration, in situ studies by the rovers complemented by the global investigation of the orbiters, is opening up a new era of discovery for Mars, including a better understanding of the history of water on the planet.

Mars Reconnaissance Orbiter (MRO)

The 'big' new guy on the block at Mars is Mars Reconnaissance Orbiter (MRO), launched on 12 August 2005. Arriving after a seven-month journey from Earth, MRO carries some of the most advanced instruments ever sent to another planet. At a launch mass of 2,180 kg and with solar arrays able to generate 2 kW of power at Mars, MRO is two to three times larger in mass and

physical size than any other orbiter launched in the past twenty years. The baseline science instrument payload for the mission consists

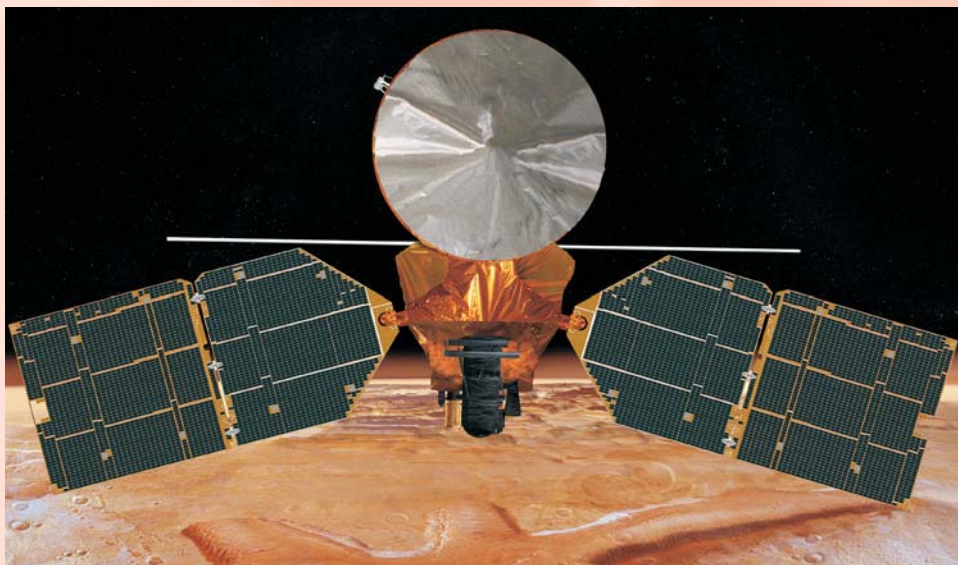

■ **Left:** Artist's impression of the Mars Reconnaissance Orbiter (MRO) spacecraft in orbit above Mars. Image courtesy NASA/JPL-Caltech/Corby Waste.

■ Artist rendering of the MRO spacecraft during the Mars Orbit Insertion (MOI) burn. Image courtesy NASA/JPL-Caltech/Corby Waste.



use by future landers. In addition to conducting detailed global, regional and local science investigations, the payload suite continues to characterize sites for future landers – in particular Phoenix and Mars Science Laboratory. In this characterization role, the observations will both detect potentially hazardous terrain and obstacles in candidate landing sites and identify interesting mineral and geological formations that are attractive targets for a lander to visit.

of a high-resolution imager (HiRISE) capable of resolving 1-metre-scale objects from 300 km altitude; a visible/near-infrared compact reconnaissance imaging spectrometer (CRISM); a climate sounder (MCS) to detect vertical variations of temperature, dust and water vapour in the Martian atmosphere; a subsurface radar sounder (SHARAD) to see if water ice is present at depths greater than one metre; a context camera (CTX) which provides wide area views to provide a context for the high resolution analysis of HiRISE and CRISM; and a wide-angle colour imager (MARCI) to monitor clouds and dust storms. The engineering payload consists of the telecommunications package that provided approach navigation support and now provides a proximity link to the surface assets, and an optical navigation camera that was employed during the approach to the planet to demonstrate a precision entry navigation capability for

The driving design philosophy for the spacecraft and instruments it carries was to provide an improvement over previous orbiters in both the spatial and spectral resolution of the

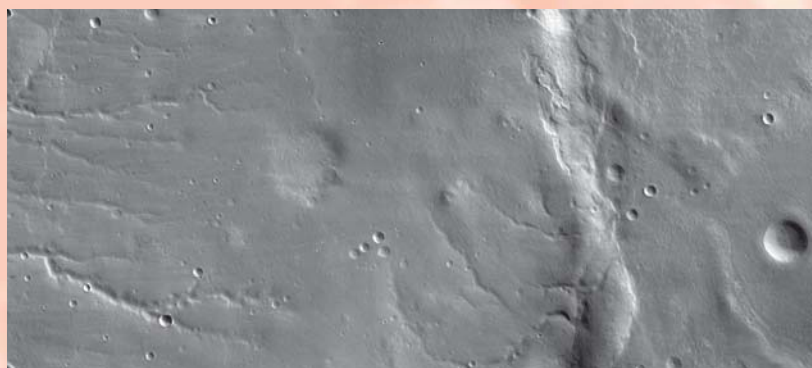

■ **Above right:** The first test image of Mars taken by MRO's HiRISE camera on 24 March 2006, from an altitude of almost 2,500 km. It is a mosaic combining 10 side-by-side exposures and covers an area about 50 km x 24 km of landscape typical of Mars' mid-latitude southern highlands. An old, muted crater lies at the middle of the scene, with sets of channels to the left and right. Superimposed on parts of this terrain is a much younger, layered mantle of debris. Image courtesy NASA/JPL-Caltech/University of Arizona.

■ **Right:** A sample image of a portion of the lower centre of the first test image of Mars taken by the HiRISE camera, shown here at the full resolution of 2.5 metres per pixel. Image courtesy NASA/JPL-Caltech/University of Arizona.

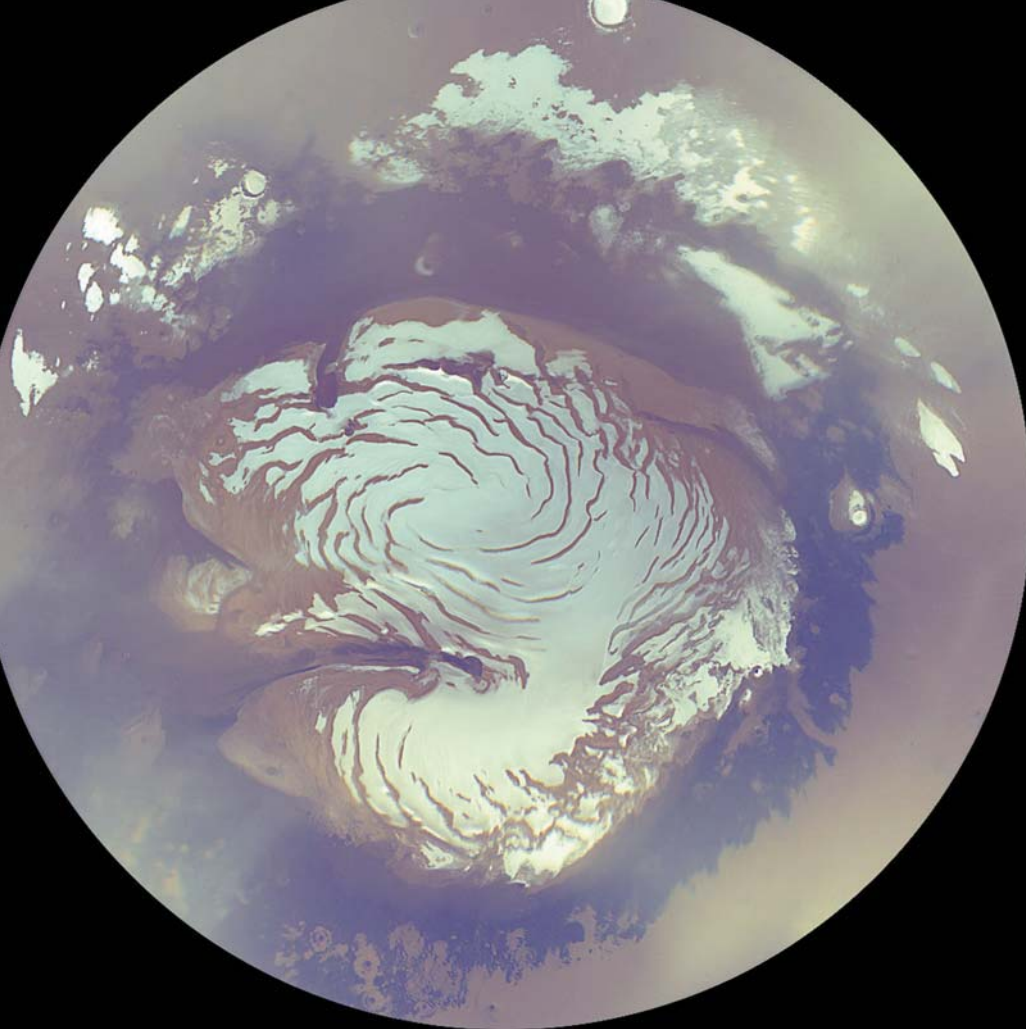

■ **Left:** This image is a mosaic of four polar views of the north polar region, acquired by MRO's wide-angle colour imager (MARCI) at midnight, 6 am, noon, and 6 pm local Martian time. (The south polar region was deep in winter shadow, but the north polar region was illuminated the entire Martian day.) It shows the mostly water ice perennial cap (white area), sitting atop the north polar layered materials (light tan immediately adjacent to the ice), and the dark circumpolar dunes. Image courtesy NASA/JPL/Malin Space Science Systems.

■ **Below:** Mars' north polar region imaged through different filters by MRO's climate sounder (MCS) on 24 March 2006. The visible-and-near-infrared image (left) is bright where surface ice and atmospheric hazes reflect sunlight back to space. The north polar cap is the bright semicircle at upper left. The 12-micron image (centre) indicates that heat is being emitted from both the day side and the night side of the planet. The polar cap is dark in this image because it is very cold. The 15-micron image (right) indicates the temperatures of the atmosphere at an altitude of about 25 km, where there is not much temperature difference even between the night side and the day side of the planet. The polar atmosphere is colder, so it appears darker. Image courtesy NASA/JPL-Caltech.

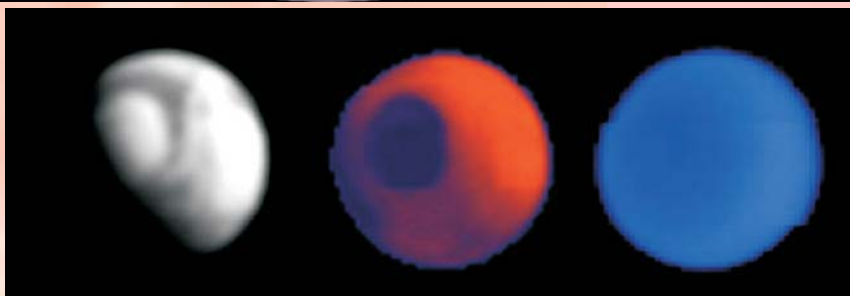

instruments, while at the same time enhancing the spatial coverage of the planet. This required a much more capable telecommunications system than ever previously sent to Mars, including a 3-metre diameter antenna. The result is that the spacecraft is able to transmit from Mars to Earth at the equivalent of today's Earth broadband internet rates.

Upon arrival at Mars on 10 March 2006, the spacecraft performed its Mars Orbit Insertion (MOI) manoeuvre using its six main engines. This put the spacecraft into an initial, highly elliptical capture orbit with a period of 35.5 hours and a periapsis of 426 km. The delta-V required to accomplish this critical manoeuvre was 1000 m/s and the burn duration was approximately 27 minutes. For most of this time, the spacecraft was

visible to the Earth-based Deep Space Network (DSN) radio-tracking stations, but for the final five minutes of the burn the signal was occulted by Mars. The spacecraft remained behind the planet for approximately 30 minutes.

The MRO operations team immediately set out to gain some early engineering images to test many of the science instruments. With the spacecraft still in its highly elliptical capture orbit, and not in the final science orbit, this posed several challenges, the most demanding being to take the images at the same velocity as would be the case if the spacecraft was in its circular science orbit at 300 km altitude. This constraint applied because several of the instruments were designed to operate within a certain velocity range relative to the surface,

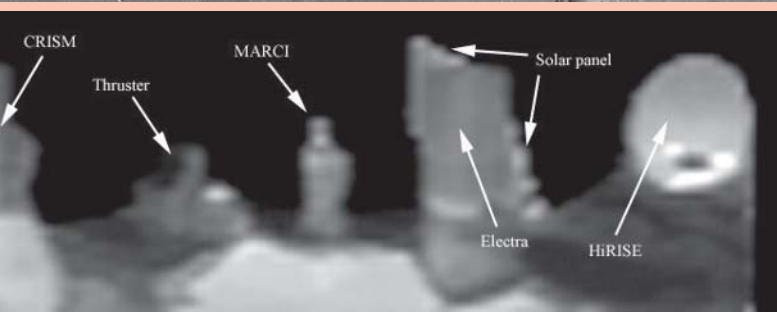
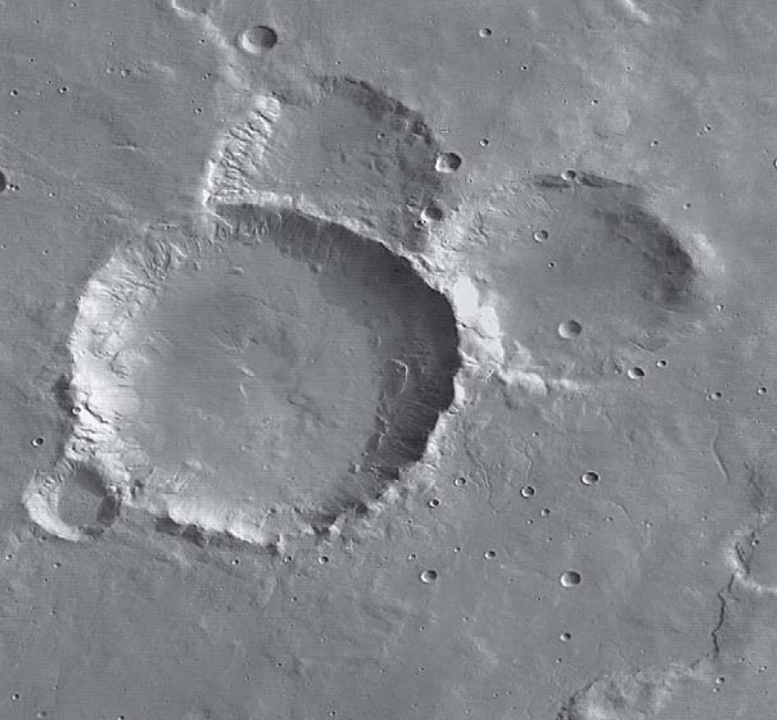

and the capture orbit matched this velocity over only one point. This required the images to be taken from a range of 2,500 to 1,000 km (rather than the science design parameter of 300 km), and at a time of day, at the imaged longitude, of 7:30 am, which made for deep and interesting shadows. Balancing the lighting, velocity, and other constraints, the MRO operations team's plan was flawless and the various science instruments captured images of the poles, of the Martian surface, and a self portrait of the spacecraft nadir deck.

■ **Top:** An enlarged portion of one of the first images acquired by MRO's context camera (CTX) as the spacecraft orbited southward towards the west side of the large Argyre impact basin. The image has a scale of about 90 metres per pixel, which is 14.5 times lower resolution than will be acquired when MRO is in its final mapping orbit. One of the key roles that CTX will play during the MRO mission is acquiring context images for the other science instruments aboard the spacecraft. Image courtesy NASA/JPL/Malin Space Science Systems

■ **Above:** Two weeks after arriving at Mars, MRO captured what may be the first-ever self-portrait from a planetary orbiter. This snapshot of the spacecraft's nadir deck came from the Mars Climate Sounder (MCS). It shows many of the instruments and one of the solar panels. The black-and-white image wasn't taken in wavelengths of light visible to human eyes. The brightness and darkness of the pixels in this image represent heat radiation coming off the objects in view of MCS. Image courtesy NASA/JPL-Caltech.

The next course of business was to slow the spacecraft down in order to achieve the final science orbit and to allow the time-of-day node to rotate about the planet from its 8:30 am ascending equator crossing to the desired 3 pm ascending configuration. This was achieved by 'aerobraking', a technique that uses friction between the spacecraft surfaces and the molecules in the upper Martian atmosphere to reduce the spacecraft's velocity. The use of aerobraking provided MRO an equivalent delta-V capability of nearly 1,184 m/s, and allowed MRO to lighten its overall fuel load (and thus launch mass) by almost 600 kg. Aerobraking was completed in five months with 426 drag passes. During this time, the apoapsis altitude of MRO's orbit was progressively reduced from 44,982 km to 486 km, and the orbital period was reduced from 35.5 hours to 1.91 hours.

The majority of the delta-V benefit was not realized until the last month of aerobraking. Near the end of aerobraking, and as the orbit finally started to approach the science orbit, the operations team began to manoeuvre MRO slightly in order to avoid a collision with one or other of the three known orbiting spacecraft, MEx, MGS, and Odyssey. These manoeuvres were a little like playing a dangerous game of 'dodge ball' from millions of kilometres away. There are other spacecraft orbiting Mars (such as the two Viking orbiters) whose ephemerides are not known, and that made for an exciting time for the entire team. As more and more spacecraft orbit the Red Planet, this issue will grow as a concern for those craft attempting to achieve their final science orbits.

Once in the science orbit, the instruments were turned on for about a week before the spacecraft was configured for solar conjunction, which occurs when the Sun interposes directly between Mars and Earth and disrupts communication. In that one week, 0.31Tb (1 Tb = 1 terabit = one thousand billion (1,000,000,000,000) bits) of raw science data was returned, or roughly the equivalent of four months of Odyssey operations. During the month-long conjunction, two global viewing instruments were left on to start acquiring the data set of seasonal change that is considered critical to understanding Mars. The remaining instruments were turned off during this time due to safety considerations.



■ **Top:** This enlarged portion of a HiRISE image shows a section of the rim of Victoria crater. Five days before this image was taken, the Opportunity rover arrived here after a drive of more than 9 km. It then drove to the position on the rim of the crater where it is seen in this image. Also shown are Duck Bay, the eroded segment of the crater rim where Opportunity first arrived at the crater, and Cape Verde, a sharp promontory to the north. Viewed at the highest resolution, this image shows the rover itself, wheel tracks in the soil behind it, and the rover's shadow, including the shadow of the camera mast. Image courtesy NASA/JPL-Caltech/University of Arizona.

■ **Above:** This HiRISE image shows Victoria crater, an impact crater at Meridiani Planum, near the equator of Mars. The crater is approximately 800 metres in diameter. It has a distinctive scalloped shape to its rim, caused by erosion and downhill movement of crater wall material. Layered sedimentary rocks are exposed along the inner wall of the crater, and boulders that have fallen from the crater wall are visible on the crater floor. The floor of the crater is occupied by a striking field of sand dunes. Image courtesy NASA/JPL-Caltech/University of Arizona.

A special image acquired by the HiRISE camera during the pre-conjunction phase was of the Mars Exploration Rover, Opportunity, which had just reached the rim of Victoria Crater, bringing the yin and yang philosophy of Mars exploration together in one single image. The Opportunity operations team used the aerial view of the crater's terrain to plot their strategy for future excursions. Other landers have been captured by HiRISE, which can resolve 1 metre objects on the surface. It has also captured the bounce marks created by the Opportunity rover during landing, as it rolled into Eagle Crater. To date the expected location of the Mars Polar Lander has been in seasonal night and so no images have been acquired. Beagle 2 locations have been imaged but no lander has been identified.

Mars Express (MEx)

ESA's Mars Express continues to astound scientists with the data returned from its various instruments. Its instrument suite consists of the High Resolution Stereo Camera (HRSC); Energetic Neutral Atoms Analyser (ASPERA); Planetary Fourier Spectrometer (PFS); Visible and Infra Red Mineralogical Mapping Spectrometer (OMEGA); Sub-Surface Sounding Radar Altimeter (MARSIS); Mars Radio Science Experiment (MaRS); and the Ultraviolet and Infrared Atmospheric Spectrometer (SPICAM). With a mass of 1,120 kg at launch on 2 June 2003, the MEx spacecraft avoided the need for aerobraking by injecting directly into a highly elliptical Mars orbit in December 2003.

The MEx orbiter first entered an initial capture orbit 250 km x 150,000 km above Martian surface and inclined about 25 degrees. This orbit was adjusted by four subsequent main engine burnings to a 258 km x 11,560 km near polar (86.3 degree inclination) elliptical orbit with a period of 7.5 hours. After 440 days the apoapsis was lowered to 10,107 km, and the periapsis raised to 298 km with an orbital period of 6.7 hours.

■ **Right:** This image from the High Resolution Stereo Camera (HRSC) on ESA's Mars Express spacecraft shows a perspective view of a possible dust-covered frozen sea near the Martian equator. The image is centred at 5.46° North latitude and 150.30° East longitude. Image courtesy ESA/DLR/FU Berlin (G. Neukum).

The MEx mission objectives were:

- to image the entire surface at high resolution (10 metres/pixel) and selected areas at super resolution (2 metres/pixel);
- to produce a map of the mineral composition of the surface at 100 metre resolution;
- to map the composition of the atmosphere and determine its global circulation;
- to determine the structure of the sub-surface to a depth of a few kilometres;
- to determine the effect of the atmosphere on the surface; and
- to determine the interaction of the atmosphere with the solar wind.

The HRSC camera continues to provide stunning views of surface features, in particular of Mars' northern hemisphere. These have indicated very young ages for both volcanic and glacial processes, ranging from a few million to several hundred thousand years old, respectively. Data from the ASPERA instrument supports the idea that a process known as 'solar wind scavenging' may be responsible for water loss on Mars. The process occurs when the solar wind interacts with a planet's upper atmosphere, allowing for the slow escape of volatile gases and liquid compounds. Data from the PFS instrument support the claim of the presence of methane in the in the Martian atmosphere for the first time. Although this may be volcanic in origin, methane in a planet's atmosphere

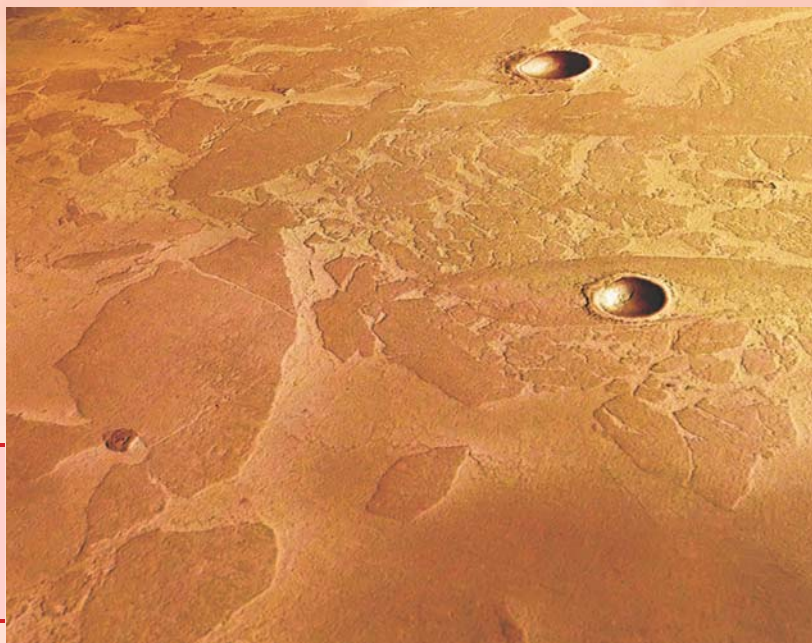

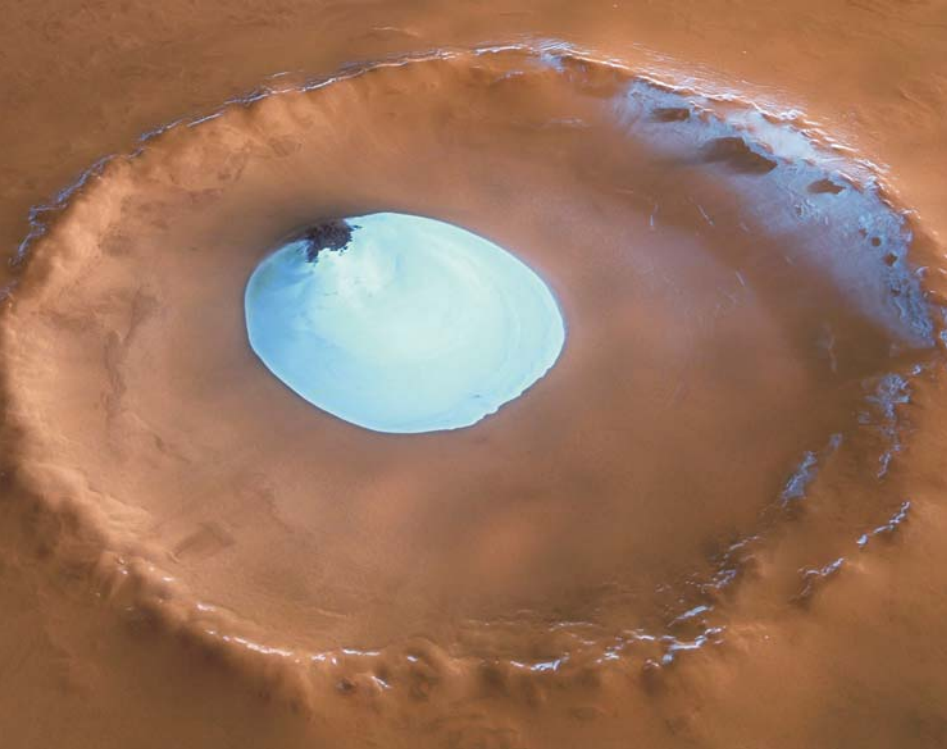

has been identified by scientists as a potential indicator of life due to the fact that methane on Earth is produced by biological activity.

The OMEGA spectrometer has provided detailed maps of water ice, as well as carbon dioxide ice, in Mars' polar regions. It has also revealed the presence of specific surface minerals that indicate the long-term presence of large amounts of liquid water on the planet, and determined that the minerals (alteration products such as phyllosilicates) derive from abundant water in the planet's early history. Other minerals, called post-Noachian products (sulphates), suggest a colder drier planet with only intermittent water on the surface. Results from the Italian-provided MARSIS subsurface sounding radar indicate strong echoes coming from the surface and the subsurface enabling the identification of buried craters and tectonic structures. The MaRS Radio Science Experiment has been used in studies of the planet's surface roughness and has probed the Martian interior by studying the gravity anomalies affecting the orbit. Finally, the SPICAM instrument has provided the first complete vertical profile of carbon dioxide density and temperature, and has discovered the existence of nightglow and aurorae over regions with ancient magnetic signatures.

Mars Global Surveyor (MGS)

MGS, launched in November 1996, continued to operate successfully until the eve of its tenth anniversary, when it went into safe mode and was not heard from again. During its operations

at the planet, MGS's instruments contributed to many amazing discoveries including dramatic evidence that liquid still flows in short bursts down hillside gullies, and the identification of deposits of water-related minerals that led to the selection of the landing site for the Mars Exploration Rover, Opportunity. The orbiter appears to have succumbed to battery failure caused by a complex sequence of events involving the onboard computer memory and ground commands. MGS operated for longer at Mars than any other spacecraft in history, and more than four times longer than

the prime mission originally planned. MRO continues to use its star tracker, which is zenith pointed, to search the heavens periodically in an attempt to identify and track MGS.

With data from its Mars Orbiter Camera, MGS provided a wonderful scientific find immediately before it fell silent. A gully on the wall of an unnamed crater in Terra Sirenum, at 36.6 degrees south, 161.8 degrees west, was initially imaged by the camera on 22 December 2001. It showed nothing noteworthy at the location where a change would later be observed, but a group of nearby gullies exhibited an unusual patch of light-toned material. As part of the routine campaign to re-image gully sites, another image of this location was acquired on 24 April 2005, and this showed a new light-toned deposit in what had been otherwise a nondescript gully. This deposit was imaged again by the camera on 26 August 2005, at a time when the Sun angle and season were the same as in the original December 2001 image, in order to confirm that the light-toned feature was indeed something new, not just a trick of differing lighting conditions.

■ **Above:** This HRSC image shows an unnamed impact crater located on Vastitas Borealis, a broad plain that covers much of Mars's far northern latitudes, at approximately 70.5° North and 103° East. The crater is 35 km across and has a maximum depth of approximately 2 km beneath the crater rim. The circular patch of bright material located at the centre of the crater is residual water ice. The colours are close to natural, but the vertical relief is exaggerated three times. Image courtesy ESA/DLR/FU Berlin (G. Neukum).

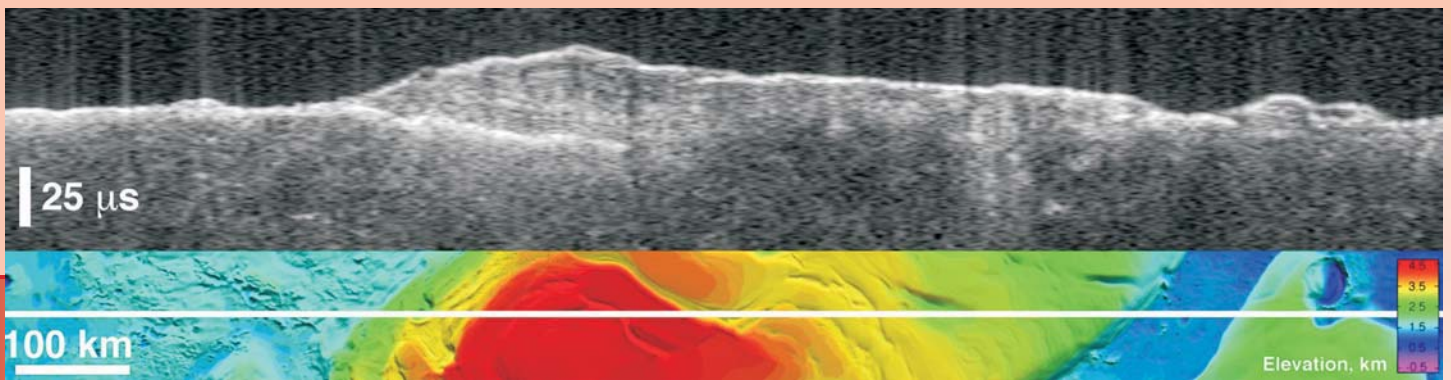

■ **Above:** The upper image of this composite is a 'radargram' from the Italian-provided Mars Advanced Radar for Subsurface and Ionospheric Sounding (MARSIS) on board ESA's Mars Express. The lower image shows the position of the ground track of the spacecraft (indicated by a white line) on a topographic map of the area based on data from the MOLA laser altimeter on board NASA's Mars Global Surveyor. (The total elevation difference shown in the topographic map is about 4 km between the lowest surface (purple) and the highest (red).) The MARSIS radar echo trace (upper image) splits into two traces on the left side of the image, at the point where the ground track crosses from the surrounding plains onto elevated water-ice-rich layered deposits that surround the south pole of the planet. The upper trace is the echo from the surface of the deposits, while the lower trace is interpreted to be the boundary between the lower surface of the deposits and the underlying material. The strength of the lower echo suggests that the intervening material is nearly pure water ice. Near the image centre, the bright lower echo abruptly disappears for unknown reasons. The time delay between the two echoes corresponds to a thickness of 3.5 km of ice. Images courtesy NASA/JPL/ASI/ESA/Univ. of Rome/MOLA Science Team.

(MARIE). On 28 October 2003, during a period of intense solar activity, the MARIE instrument stopped working properly and controllers' efforts to restore the instrument to normal operations were unsuccessful. While MARIE is no longer functioning, THEMIS and GRS continue to collect new data. Odyssey is in the extended phase of its mission, having reached all of its original goals after three years. The goals for the extended mission are as follows:

- to enhance the data sets already acquired, extending their temporal and spatial coverage;
- to enable new types of observations by operating the instruments and spacecraft in innovative ways; and
- to provide operational support for critical phases of future missions, such as communications relay, landing site characterization, and atmospheric monitoring for aerobraking.

The specific scientific objectives of Odyssey's current extended mission are:

- to monitor interannual and secular variations of the Mars climate system and surface processes;

Mars Odyssey (ODY)

Mars Odyssey was launched in 2001 and began orbital science operations at Mars in early 2002. The spacecraft carries three instrument packages: the Thermal Emission Imaging System (THEMIS), the Gamma Ray Spectrometer suite (GRS), and the Martian Radiation Experiment

■ **Right:** These two images from the Mars Orbiter Camera on MGS show that material flowed down through a gully channel on the wall of an unnamed crater in Terra Sirenum between December 2001 and April 2005. After the flow stopped, it left behind evidence – a light-toned deposit. It appears that the material flowed in a fluid-like manner down the approximately 25-degree slope before splaying out into multiple small lobes where the crater wall meets the crater floor. When originally imaged on 22 December 2001 (left), there was nothing noteworthy at the location. Another image was acquired on 24 April 2005. A new light-toned deposit had appeared in what was otherwise a nondescript gully (right). Images courtesy NASA/JPL/Malin Space Science Systems.

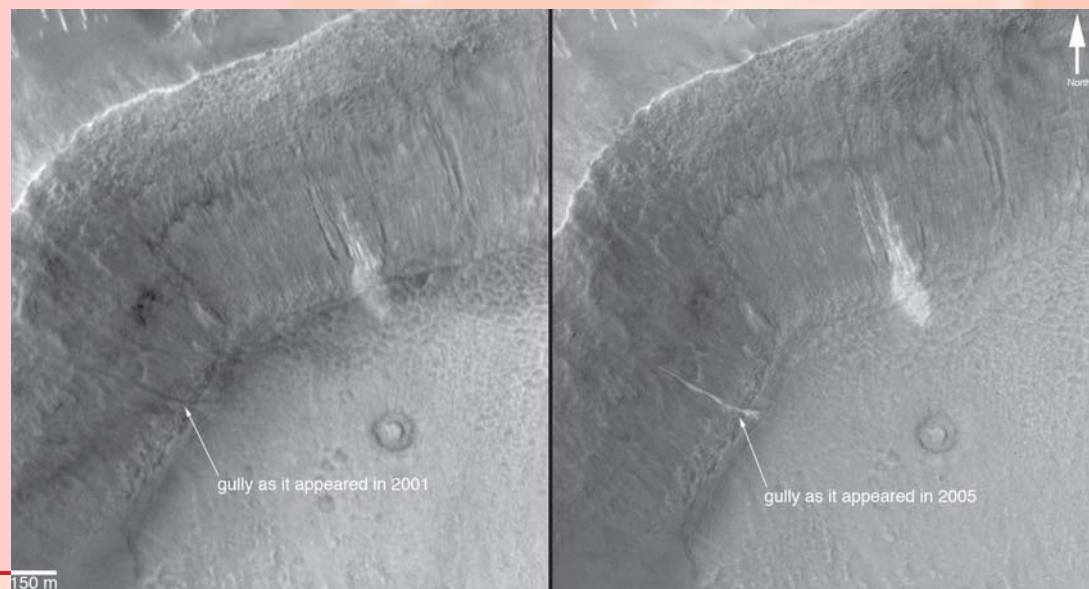

- to improve the resolution of existing elemental maps and generate maps of additional key elements;
- to expand the capability of the THEMIS camera system by implementing off-nadir pointing; and
- to acquire data complementary to those obtained by other spacecraft at Mars, especially MRO.

An additional scientific objective is to acquire and analyze scientific data for landing site selection of future missions.

The THEMIS instrument team recently identified an explanation for the sudden appearance of dark spots on the south polar spring frost layer. Every spring brings violent eruptions as a result of carbon dioxide geyser activity in Mars' south polar ice cap. Jets of carbon dioxide gas erupting from the ice cap as it warms in the spring carry

dark sand and dust high aloft. The dark material falls back to the surface, creating dark patches on the ice cap which have long puzzled scientists. Deducing the eruptions of carbon dioxide gas from under the warming ice cap solves the riddle of the spots. It also reveals that this part of Mars is much more dynamically active than had been expected for any part of the planet.

Odyssey science team members made several major contributions in other ways. The THEMIS team published online, and continues to update and refine, the highest resolution global maps of Mars ever obtained. These include both day and night infrared THEMIS mosaics at 300 metre per pixel resolution. THEMIS also was an active participant in landing site selection activities. When new images from the HiRISE camera on MRO indicated boulder hazards at potential Phoenix landing sites, the THEMIS team collaborated with both Phoenix and MRO team members, using THEMIS infrared data to correlate with HiRISE boulder fields, and identify new safe landing site candidates.

Mars Exploration Rovers (MER)

The Mars Exploration Rover mission is the core of the detailed, local, in-situ measurements or the yin of long-term robotic exploration of the Red Planet. The twin rovers, Spirit and Opportunity, were launched toward Mars on 10 June and 7 July 2003, landed on Mars on 3 January and 24 January 2004, respectively, and they have operated successfully on the surface ever since.

Primary among the mission's scientific goals is to search for and characterize a wide range of rocks and soils that hold clues to past water activity on Mars. The rovers were targeted to sites located on opposite sides of the planet that appeared to have been affected by liquid water in the past: namely Gusev Crater, a possible former lake in a giant impact crater, and Meridiani



■ **Left:** Every spring brings violent eruptions to the south polar ice cap of Mars, according to researchers interpreting new observations by NASA's Mars Odyssey orbiter. In this impression by noted space artist Ron Miller, sand-laden jets shoot into the polar sky. It shows the Martian south polar ice cap as southern spring begins. Image courtesy Arizona State University/Ron Miller.

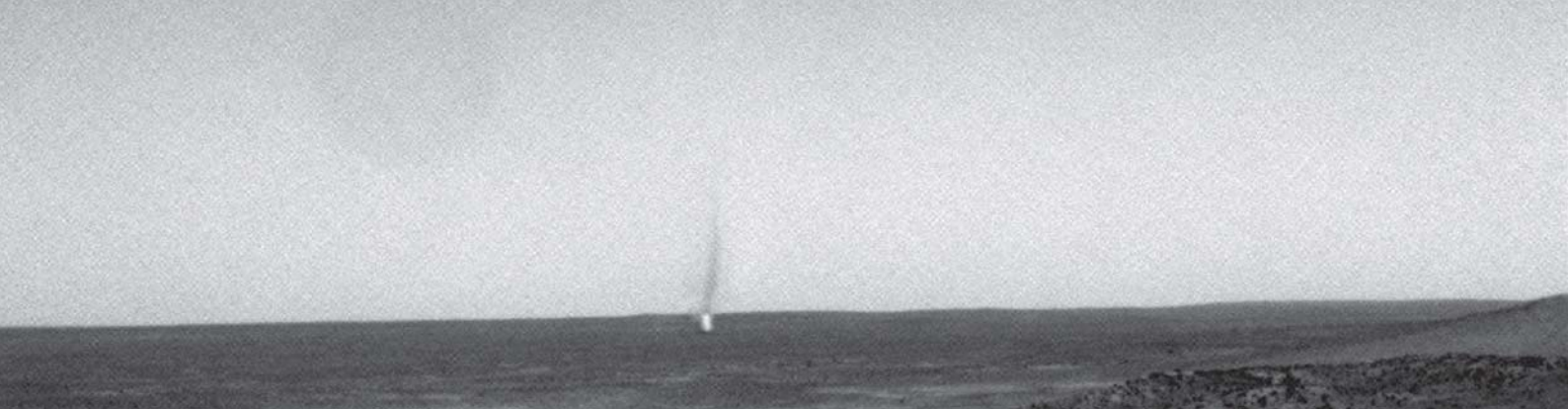

Planum, where hematite mineral deposits suggested that Mars had a wet past.

After the airbag-protected landing craft settled onto the surface and had opened, the rovers rolled out to take panoramic images. These gave scientists the information that they needed to select promising geological sampling targets, and then the rovers drove to those locations to perform on-site scientific investigations.

The primary science instruments carried by the rovers include:

- **Panoramic Camera (Pancam) for determining the mineralogy, texture, and structure of the local terrain;**
- **Miniature Thermal Emission Spectrometer (Mini-TES) for identifying promising rocks and soils for closer examination and for determining the processes that formed Martian rocks. This instrument also looks skyward to provide temperature profiles of the Martian atmosphere;**
- **Mössbauer Spectrometer (MB) for close-up investigations of the mineralogy of iron-bearing rocks and soils;**
- **Alpha Particle X-Ray Spectrometer (APXS) for close-up analysis of the abundances of elements that make up rocks and soils;**
- **Magnets for collecting magnetic dust particles. The Mössbauer Spectrometer and the Alpha Particle X-ray Spectrometer analyze the particles collected and help determine the ratio of magnetic particles to non-magnetic particles. They also analyze the composition of magnetic minerals in airborne dust and rocks that have been ground by the Rock Abrasion Tool;**

- **Microscopic Imager (MI) for obtaining close-up, high-resolution images of rocks and soils; and**
- **Rock Abrasion Tool (RAT) for removing dusty and weathered rock surfaces and exposing fresh material for examination by instruments onboard.**

Before landing, the goal for each rover was to drive up to 40 metres per Martian day (sol), for a total of up to one 1 kilometre. Both goals have been far exceeded! As of Sol 1153 (1 April 2007), Spirit's total odometry was 7,077.10 metres, and as of Sol 1134, Opportunity's total odometry was 10,373.19 metres. Both rovers are still healthy, but Spirit has a crippled front right wheel and to get around some obstacles and make progress over rough terrain using only its remaining five wheels, it sometimes has to reverse for a few metres, pivot around on its front wheel, and then resume its advance.

Moving from place to place, the rovers perform on-site geological investigations. Each rover is the mechanical equivalent of a geologist walking the surface of Mars. The mast-mounted cameras are set 1.5 metres high and provide 360-degree, stereoscopic, human-like views of the terrain. The robotic arm is capable of movement in much the same way as a human arm, with an elbow and wrist, and can place instruments directly up against rock and soil targets of interest. In the mechanical 'fist' of the arm is a microscopic camera that serves the same purpose as a geologist's handheld magnifying lens. The Rock Abrasion Tool serves the purpose of a geologist's rock hammer to expose the insides of rocks.

The Opportunity rover captured an image of a Martian dust devil scouring the surface. Afterwards, the same rover imaged close up one portion of Victoria Crater captured earlier from overhead by the MRO spacecraft.

■ **Above:** On 26 February 2007, the navigation camera aboard NASA's Mars Exploration Rover, Spirit, captured one of the best dust devils seen in its three-plus year mission. The series of navigation camera images were put together to make a dust devil movie and a single frame from this movie is shown here. The dust devil column is clearly defined and is clearly bent in the down wind direction. Image courtesy NASA/JPL-Caltech.



Summing Up

With all the images and data coming back from the currently operational landers and orbiters, Mars is now yielding its secrets at an ever increasing pace. The combination of the local investigations provided by landers coupled with the global view provided by orbiters is proving to be a powerful tool for exploring Mars. The future holds even more opportunities to use this approach with the launch of the Phoenix lander in 2007 and of the Mars Science Laboratory in 2009. As our knowledge of Mars grows, so does our appreciation of this complex and diverse planet. The motto for many of the engineers and scientists still holds true: "Mars rocks!"

Further Reading

MRO home page:

<http://mars.jpl.nasa.gov/mro/>

HiRISE home page:

<http://hirise.lpl.arizona.edu/>

MEx home page:

http://www.esa.int/SPECIALS/Mars_Express/index.html

MGS home page:

<http://mpfwww.jpl.nasa.gov/mgs/>

Malin Space Science Systems home page:

<http://www.msss.com/>

Odyssey home page:

<http://mars.jpl.nasa.gov/odyssey/>

■ **Above:** As part of its investigation of Victoria Crater, the rover Opportunity examined a promontory called Cape St. Mary from the vantage point of Cape Verde, the next promontory counterclockwise around the crater's deeply scalloped rim. This view of Cape St. Mary combines several exposures taken by the rover's panoramic camera into a false-colour mosaic. The upper portion of the crater wall contains a jumble of material tossed outward by the impact that excavated the crater. Below the jumbled material in the upper part of the wall are layers that survive relatively intact from before the crater-causing impact. Near the base of the Cape St. Mary cliff are layers with a pattern called "crossbedding," intersecting with each other at angles, rather than parallel to each other. Large-scale crossbedding can result from material being deposited as wind-blown dunes. Image courtesy NASA/JPL-Caltech/Cornell.



The lead author **James Graf** received a BSE from Princeton University in 1972 and an MS from Colorado State University in 1976. He has been employed at NASA's Jet Propulsion Laboratory in various space-related developments for 33 years, ranging from the development of ion thruster technology and management of the Quick Scatterometer (QuikSCAT) mission to his current role as Project Manager for the Mars Reconnaissance Orbiter mission. He is a recipient of NASA's Outstanding Leadership Medal.

Thomas E. Thorpe is Project Manager for the Mars Global Surveyor mission, **Jeff Plaut** is the 2001 Mars Odyssey Project Scientist, and **Diana Blaney** is the Mars Exploration Rover Deputy Project Scientist. All three work at NASA's Jet Propulsion Laboratory in Pasadena, California.

13

Fire and **WATER...**



If all goes according to plan, in late May 2008 a spacecraft will touch down on the icy northern plains of Mars. Originally built for launch in 2001, the spacecraft was cancelled after the failure of Mars Polar Lander (MPL) in 1999. Now, as *Peter Smith* explains here, not only is a cancelled mission brought back to full flight quality, but the scientific instruments from MPL and the 2001 mission are regenerated. Reborn from its own ashes, the mission is justifiably named Phoenix.

The Phoenix MISSION TO MARS

THE AGE-OLD fascination with planets, the wanderers amidst the stars, has inspired the human imagination from wonder to mythology from fantasy to science. Mars' reddish tint reminded ancient people of blood and war, writers have imagined warrior aliens invading the Earth and scientists spend their careers deciphering its secrets.

Fiction and imagination turned to fact with the advent of the space age in the early 1960s. Telescopic observations had only poorly mapped the planet; the features found by generations of dedicated astronomers are not found on modern maps with the exception of the polar caps.

The first forays to Earth's neighbouring planet revealed a barren, lunar-like surface under a thin, dry atmosphere. Later Mariner 9 and the Viking missions discovered a number of large flood channels indicating that vast amounts of water had at one time carved the landscape in distinctive ways. Ancient lakebeds with hundreds of layers of sediments show that ancient times were very different from present conditions. Inactive volcanoes larger than any on Earth, thousands of impact craters, canyons that dwarf Earth's Grand Canyon, and vast dune fields complete the landscape. The conclusion in 1980 was that Mars had a wet beginning with a thicker atmosphere and has now ceased being a habitable planet.

Mars exploration was re-initiated in 1997 after a 20-year gap with a new generation of

scientists and engineers in an attempt to dig deeper into the mysteries that lingered after the Viking era. Orbiters with sophisticated instrumentation have photographed and measured every physical property from the weather to the heat radiation to the magnetic field. Lasers have accurately positioned the entire surface onto a topographical map that rivals the best available for Earth. Pathfinder and the two rovers (Spirit and Opportunity) have sampled surface materials and established ground truth.



The Phoenix Mission

The basis for the Phoenix mission comes from a discovery made in 2002 by the Gamma Ray Spectrometer (GRS) on the Odyssey orbiter. Energetic cosmic rays bombard and activate the Martian surface; GRS collects the gamma rays and neutrons emitted by the upper metre of surface material. Hydrogen atoms are easily detected since the single proton in its nucleus has the same mass as a cosmic proton, and hydrogen is capable of slowing, or modulating, the energetic radiation more effectively than larger nuclei. It's the difference between bouncing a tennis ball off a backboard or off another tennis ball.

■ **Above:** The Phoenix logo combines the two major themes of the mission: fire and water. The mission not only searches for water, but brings water with it as part of the wet chemistry experiment. Fire, illustrated in the form of the Phoenix bird, is provided by the ovens that heat soil and ice samples. Mars is seen in the background. Image courtesy CSA/I. Tremblay.

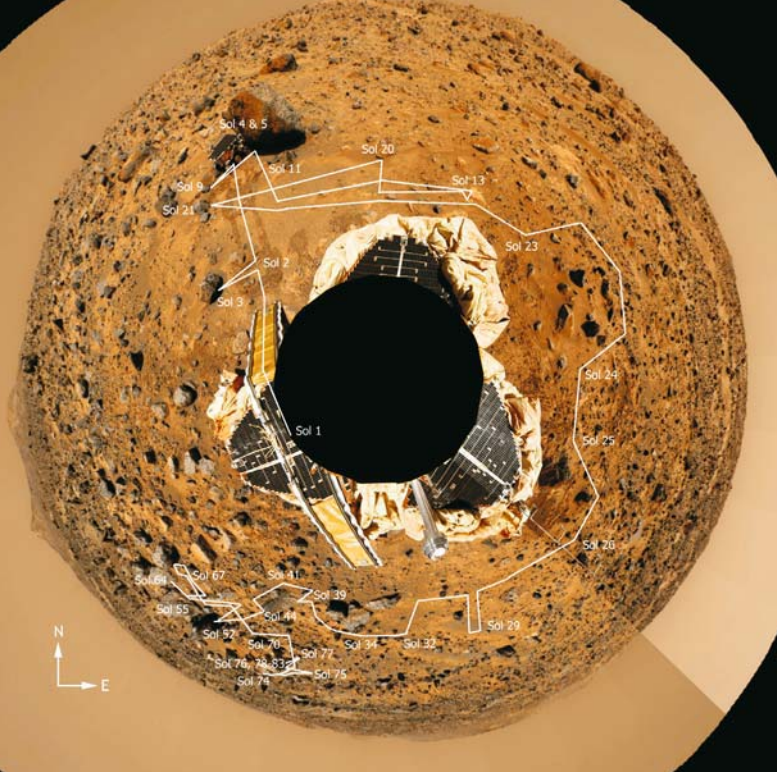

A map of the subsurface hydrogen revealed vast amounts of ice poleward of 60° latitude in both hemispheres. In a landscape similar to the permafrost regions on Earth (25 per cent of the land area on each), the hidden reservoir strongly affects the understanding of how water migrates and influences the geology.

The Martian orbit is variable as is the planet's obliquity, the tilt of the rotation axis to the orbital plane. The orbital dynamics cause dramatic changes in solar insolation on cycles of 50,000-100,000 years. How does this cycle affect the ice?

The spacecraft chosen for this mission has a long history. Originally built by Lockheed Martin (LM) in Denver to launch in 2001, it was cancelled after the failure of Mars Polar Lander (MPL) to land safely in 1999. Several extensive reviews determined the flaws in the system and prescribed a return to flight plan.

Phoenix is named for the mythological bird which dies in flames and is reborn from its own ashes. Not only is a cancelled mission brought back to full flight quality, but the scientific instruments from MPL and the 2001 mission are regenerated. These instruments and the spacecraft are modified for their new mission as explorers of the northern plains.

Phoenix is the first of a series of low cost Scout missions and is led by the author, Peter Smith, the Principal Investigator and a scientist at the University of Arizona. However, the day-to-day management of the program is conducted at the Jet Propulsion Lab (JPL) in Pasadena and the spacecraft is built and tested at Lockheed Martin (LM) in Denver. Instruments are provided by the UA, JPL, Malin Space Science Systems and the Canadian Space Agency. The science team members have been chosen for their expertise in using these instruments and for their knowledge of polar processes.

Science Goals and the Science Instruments

With the discovery of ice in the northern plains, many questions come to mind. These questions have been grouped into three categories for the Phoenix mission. What is the history of the ice in the near surface? If it periodically melts, does it create a habitat for Martian biota? What are the atmospheric properties and the local climate in the polar region?

The history of the ice can be assessed using several indicators quantized by the Phoenix science instruments. Water has tremendous chemical and erosive power as is known from centuries of studying Earth's geological processes. By measuring the abundances of minerals and

■ **Above:** A projection of the Pathfinder images from July 1997 shows the dry, rocky nature of the Martian surface. The path of the Sojourner rover is labeled by sol, or Martian day. An improved version of the camera that took this picture is part of the Phoenix science package. Image courtesy NASA/JPL/UA/IMP.

■ **Right:** A false-colour map of the water content of the upper metre of surface has been displayed using Odyssey GRS data. Note that the polar regions have a high concentration of ice near the surface. The scale changes at 10 per cent to allow details to be seen in the dry equatorial regions. The five successful landing sites are shown: V1 and V2 - Vikings 1 and 2, PF - Pathfinder, M - Opportunity, and G - Spirit. Image courtesy Lunar & Planetary Lab., University of Arizona.

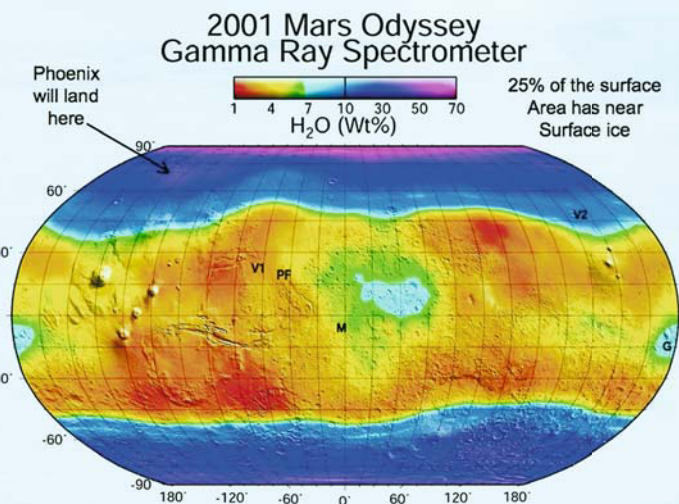



chemicals that are directly created through the action of water on igneous rock, it is possible to assess the long term presence of water in the Martian climate cycles.

For example, in Arizona's desert, basaltic rocks look pristine from above, but if turned over there is an alteration process that is turning the rocky soil to light-toned clay or caliche. This happens because moisture wicks up through the surface and is trapped under the rock making one side wetter than the other. Mars soil may also have clays or limestone or gypsum combined with water of hydration.

Another example is seen in the dry lakes of the Southwest. As the lakes shrink during dry periods pure water evaporates leaving behind the dissolved salts. By studying the salts and their deposition, the composition of the collection basin can be estimated. Are the soils acid or alkaline? Sulphates or limestones? Each pairing allows conclusions to be drawn as to the origin of the deposits. Taken in conjunction with the wealth of information already gathered from Mars, it is hoped to understand the potential of the ice for wetting the soils.

Water is the key ingredient for life. While life can survive in a dormant state for long

periods in a desiccated or cold environment, reproduction and growth require water. Additionally, organic material must be available as complex, long-chain carbon molecules to provide the basis for life as we know it on Earth. Finally, energy sources must power the cells; sunlight is easily available, but chemical transformations can also be utilized. Could life survive in the Martian permafrost?

Just as on Earth, water is transported through the atmosphere. Seasonal variations in the water vapour content of the polar region have been plotted from orbital observations. However, no weather station has ever returned data from a polar location on the surface. The polar caps cool the atmosphere directly above them and the cold, heavy air drops forming a strong wind that is twisted by the Coriolis force of the spinning planet. Cyclonic storms have been observed from space—some of the most dramatic weather on Mars. Little is known of how the soils interact with the wetter storm systems that sweep across these plains. Remember though that the atmosphere is only 1 per cent the surface pressure of the Earth and that water is less abundant by a factor of 10,000.

Studying the History of the Polar Ice

Recent images from the HiRISE instrument on Mars Reconnaissance Orbiter show the morphology of the surface consists of polygons within polygons down to scales of a few metres punctuated by the occasional impact crater. This type of terrain on the Earth is caused by the expansion and contraction of icy soil and is commonly found in polar regions. Because of the near impossibility of missing this sort of terrain due to landing uncertainties, Phoenix has no need of roving capabilities. In any event, the low cost of the mission rules out mobility.

The Phoenix mission is vertical; it digs through soil to ice with the robotic arm and provides samples to the on-deck instruments for processing. The data generated by the instruments are returned in a raw form to the Science Operations Center in Tucson, Arizona, for analysis and interpretation. There is a limit to the number of samples that can be processed so careful selection of sample sites is crucial.

■ **Above left:** Technicians in the Lockheed Martin clean room are working to complete the final assembly and testing of the spacecraft. Notice the solar arrays that open from a stowed position like Chinese fans. Image courtesy Lockheed Martin.

PERMAFROST

Compare to the Earth

- 20%-25% of terrestrial environments
- Different geological eras yield different layers of different age, 20,000 to 3 million yrs
- A selective environment:
 - 1) Long-term freezing
 - 2) Low water activity
 - 3) Back ground ionizing radiation

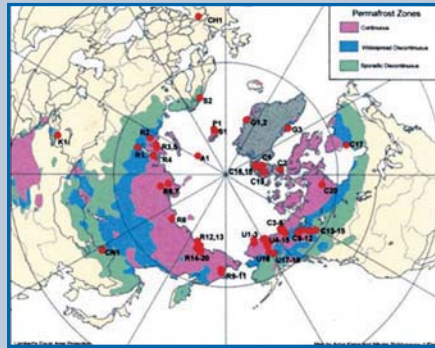

heating circuitry for the eight ovens controls the power to the heaters in order to maintain a constant thermal gradient from ambient to 1000° C. The profile of the power curve versus temperature shows peaks or dips when a phase change is reached. This technique, also used in laboratories, is called Scanning Calorimetry. For instance, ice melting at 0° C or water turning to steam will show a peak whose size depends on the amount of water in the sample.

Other peaks will be encountered for changes in the mineral structures. For instance, at temperatures near 300° C water will be driven from clay minerals, and somewhat higher

temperatures decompose limestone to release carbon dioxide. Crystalline structures can change form at certain temperatures. The exact temperatures of release and the gases evolved are sure indicators of the altered minerals that are being sought.

The additional benefit from the Evolved Gas Analyzer, or mass spectrometer, is the isotopic analysis that is possible. Perhaps the most important measurement is the deuterium-to-hydrogen ratio in the ice versus the atmospheric water vapour. If the two reservoirs are in equilibrium then the D/H ratios will match our calculations. If the ice is from an ancient source and has not interacted with the atmosphere

Water Changes the Soil Mineralogy and Chemistry

TEGA, Thermal and Evolved Gas Analyzer, has three parts. First is the sample acquisition assembly which opens doors to a small hopper that sifts the Martian soil and ice through a 1 mm screen and through a hole to a tiny oven. The oven is sealed to entrain any gases released during heating into a steady stream of nitrogen gas that pushes the evolved gases into a mass spectrometer. This analyzer ionizes and accelerates a portion of the gases into a strong magnetic field sorting ions by mass and by charge then directing them to sensitive detectors. The resulting spectrum indicates the composition and isotopic fractionation of the input gas mixture.

There are several ways to interpret the signatures from TEGA. The

■ **Above:** A map of the permafrost distribution on the Earth; it is similar to Mars. The lower right shows a cross section of the frozen ground that has cracked in a distinctive polygonal pattern. The ice can persist for millions of years and preserves life signatures of creatures long extinct. Image courtesy Ohio University.

■ **Right:** The Phoenix lander labelled to show the location of the instruments. The primary mission consists of digging through the soil to an ice layer and providing a sample of each layer to the instruments on the deck. All analyses are completed on Mars and the data is relayed to Earth via the Mars orbiters. Image courtesy NASA/JPL-Caltech/Corby Waste.

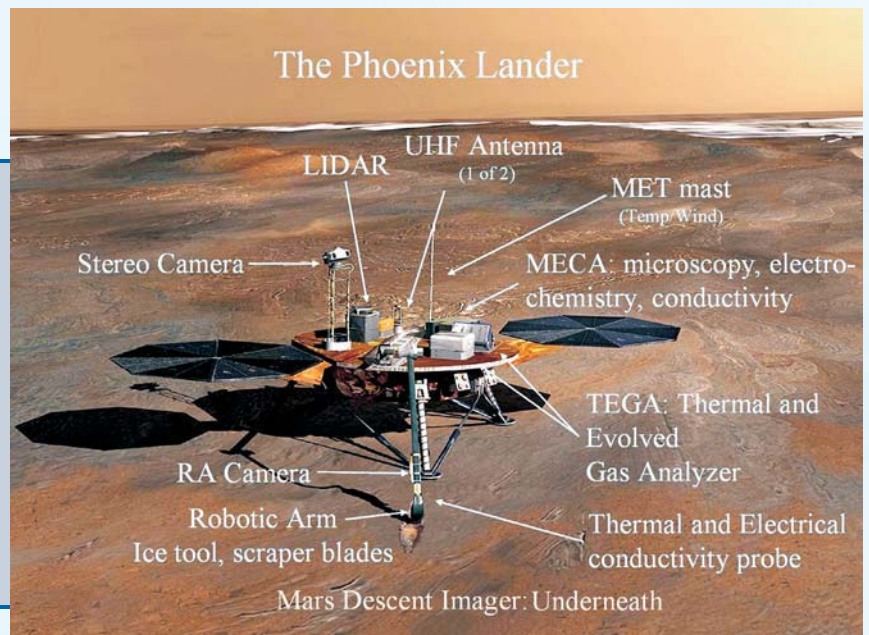



■ *The Phoenix lander as it approaches the Martian surface at about 8 kilometres per hour using 12 thrusters to control its speed. Thrusters have not been used since the Viking days, replaced at the time of Pathfinder by airbags. Image courtesy NASA/JPL-Caltech/Corby Waste.*

then the amount of deuterium in the ice may be completely out of balance with the atmosphere.

A completely different approach to understanding the chemistry of the soils considers the question: what are the soil properties if the ice melts and wets the soil? To answer this question four wet chemistry cells are included in the science payload. Each cell accepts a cubic centimetre of soil and stirs in a small amount of water brought from Earth. Various compounds in the soils can go into solution, particularly salts.

Electrodes that are sensitive to specific ions then measure the electrolytes and produce a complete description of the dissolvable ions in the soil. One wonders if the mixture of salts may approximate that found in Earth's oceans, or perhaps the Great Salt Lake. Is the solution acidic or alkaline? Are there any detectable metals? This type of measurement has never been made on Mars.

If significant salts are found in the soil, one may conclude that water has leached salts from the highland rocks and concentrated them in the polar plains. After all, many deep channels directed their flood waters onto these plains in the distant past, perhaps some signatures of this process still exist.

Grain Shapes and Sizes

Besides the chemical and mineralogical description of the landing site, the appearance as seen through the craft's cameras and microscopes reveals much about the processes at work. Five different cameras transmit a range of views to create a 12-powers-of-ten zoom from descent images to the surface of a grain of sand. As Phoenix lands, the MARDI descent imager takes images during the landing. Combined with panoramic images from the Surface Stereo Imager (SSI) on the spacecraft these form a complete description of the local area. When

digging, there is a focusable camera on the arm that peers into the trench and then documents the samples in the scoop.

Besides the large-scale picture of the terrain, Samples will be delivered to a microscopic station on the deck. The resolution here is 4 microns/pixel, the highest ever achieved on Mars. But once the grains are resolved an atomic force microscope can zoom onto its surface to show the surface abrasions caused by particle-to-particle collisions. Grains shaped in a flood will look rounded, wind-borne grains that form dunes are angular.

The polar weather has been monitored from space since 1997 by Mars Global Surveyor (MGS) and other spacecraft. The Phoenix weather station will track standard weather parameters detecting pressure and temperature regimes that indicate the passage of these weather systems. A powerful LIDAR shoots a laser beam into the sky and detecting reflections that return will characterize the boundary layer from the surface to the cloud bottoms. A description of cloud height versus time of day has never been obtained from Mars.

The SSI panoramic camera has special filters for sighting the Sun and determining the dust and cloud opacity of the atmosphere throughout the day and year. SSI data complement the LIDAR data for the lower atmosphere. Atmospheric models will be constrained from these data and used to predict and understand seasonal trends.

Finally, TEGA can sample the atmosphere directly to measure the composition and isotopic fractionation of the majority gases. Viking also



■ *Above: An image of beach sand taken with the optical microscope in the laboratory. The larger particles are about half a millimeter across. The smallest are 10 microns. By analyzing the colours and shapes, quartz can be distinguished from biotite and feldspar. Image courtesy UA/LPL.*

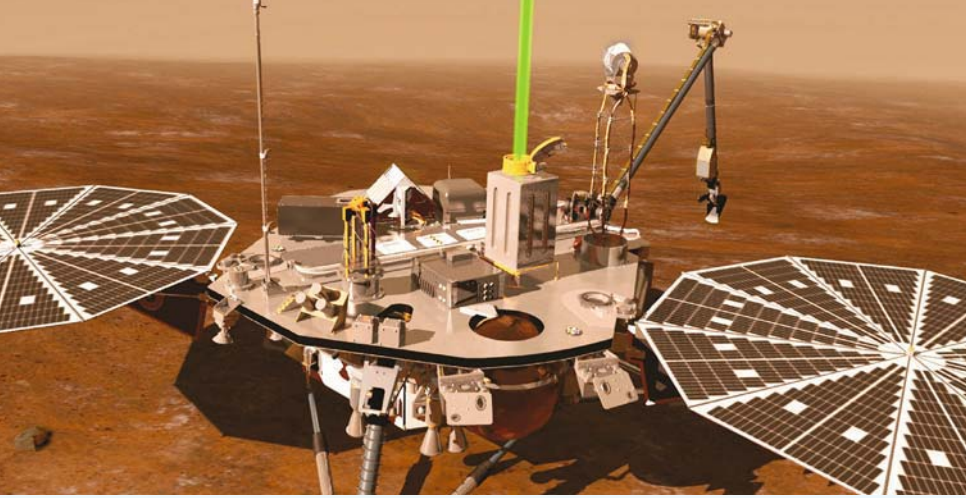

Phoenix lands on Mars in late May 2008 after a launch the previous August. The entry, descent and landing is the most dangerous part of the mission and has been rehearsed and modelled countless times. There is no real-time control from Earth and the atmosphere and surface cannot be completely determined in advance. The team relies on detailed models

made these measurements at lower latitudes, but they have never been verified. The humidity and wind direction determined by a windsock will give us some idea of the horizontal transport of water vapour in the polar regions.

Landing on Mars

The landing region must meet all the criteria for safety and for science interest. The latitude boundaries are 65 to 72° N chosen to maximize the solar energy while maintaining a good communication path to the orbiters. Ice must be known to be near the surface, yet there can only be few hazards such as craters or scarps. The altitude must be below -3.5 km. By the summer of 2006 the science team had chosen an acceptable area called region B.

However, any confidence that the site was safe was shattered in October when Mars Reconnaissance Orbiter's HiRISE telescope returned super high resolution pictures of the proposed area. Patches of large boulders the size of minivans dominate the site and are seen over vast areas. The next few months, while it was still northern summer, were consumed trying to locate a safer landing area.

Using every resource available from the orbiters, an acceptable location has finally been found, in a small valley north of Alba Patera at 69° N. This site has now been well characterized and declared safe. It has been dubbed "Green Valley."

of every phase of the landing to reduce the risk. Even so, this will be the most dangerous period of the mission as we decelerate from 15,000 kilometres per hour to a complete stop in 6.5 minutes. Landing on Mars is never low risk.

After a successful landing, the solar arrays are deployed and the instruments released from their cruise configuration. The spacecraft communicates its status and returns the data saved during descent. The ground crew quickly assesses the health and condition of the spacecraft and its ability to proceed with the science operations. Throughout the cruise and landing the mission control center has been at JPL with support from LM – now it shifts to the University of Arizona for the science operations.

After a short characterization phase that checks the health of the instruments, the robotic arm proceeds to deliver samples to the three analysis stations on the lander deck. The arm is guided by the topographic maps of the digging area provided by the panoramic camera. Commands are sent daily to tell the arm just where to scrape up samples and when the science team agrees, they are dumped into the inlet ports of the TEGA, MECA and optical microscope.

■ **Above:** An artist's drawing of the lander with the LIDAR turned on. The green laser can penetrate 10 km into the atmosphere and a sensitive optical receiver can sense its reflection off cloud and dust layers. Using this instrument, provided by the Canadian Space Agency, the lower atmosphere and its weather patterns can be accurately described. Image courtesy NASA/JPL-Caltech/Corby Waste.

■ **Right:** Four regions (A-D) were examined using orbital data to find safe and scientifically interesting landing sites. In the summer of 2006, region B was the prime choice, but higher resolution images were obtained by the HiRISE instrument on the Mars Reconnaissance Orbiter in October 2007. Those images showed an abundance of minivan-sized boulders – the prime site is now in region D. The colours represent the modelled depth to ice that is shallowest in region D, perhaps about 5 cm on average. Image courtesy NASA/UA/GRS.

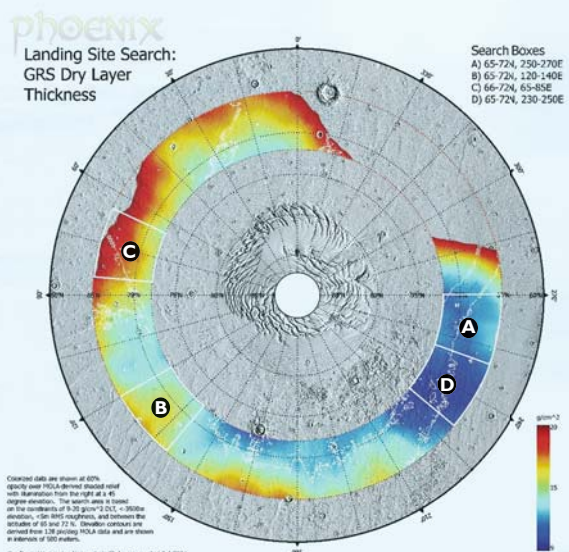

With eight TEGA ovens, four MECA wet chemistry cells and ten microscopic samples, the process takes up to three months.

A day in this process starts at the end of the Mars sol. Data is returned to the operations center in Tucson and the science team evaluates the progress made and compares it to expected results. If everything checks out then the strategic plan sets the stage for the next sol's activities. The scientists determine what measurements or arm movements are required along with the exact timeline. Once approved by the mission manager, the sequence of operations is presented to the sequencing team to be converted into commands that the spacecraft understands and combined with the spacecraft sequences used to maintain a healthy spacecraft and timely communications.

The entire two-shift process takes about 14 hours and must be done on Mars time: one sol = 24h 40m. The 40-minute difference forces the team's schedule to drift around the clock compared to their neighbours and friends. If the mission extends beyond the sample analysis stage, the team will go with a simpler routine: just watching for polar weather changes on Earth time.

Conclusion

As of May 2007, the spacecraft has started the launch process and has been flown in an Air Force C-17 cargo plane from LM in Denver to the Kennedy Space Center in Florida. By mid-July the Phoenix bird will be mated to the three stages of the Delta II rocket and the nine solid rockets will be attached. The launch window opens on 3 August and lasts for about three weeks.

Once on its way, the trip takes 9-10 months and the encounter with Mars will take place in late May 2008. After the three months of the mission, it is expected to continue monitoring weather until the Sun sets for the winter season. Phoenix will be within the arctic circle, so once the Sun disappears below the horizon, there will be insufficient energy to power the spacecraft.

The final demise of the Phoenix will not be in flames to be reborn yet again, but by ice. The carbon dioxide atmosphere actually freezes onto the surface and will encase the spacecraft in dry ice at -126°C . Without heaters, Phoenix will not survive to the next summer. Even so, the mission goals will have been achieved and new chapters written in the Martian textbooks.



■ **Left:** The Phoenix lander is inside the giant box that is ready to be loaded into the C-17 for its first leg on the way to Mars. On 7 May 2007 the spacecraft left the Lockheed Martin facility in Denver for the Kennedy Space Center in Florida. The launch window opens on 3 August and lasts for about three weeks. Image courtesy Arizona Daily Star.

■ **Below:** A mural graces the front of the Science Operations Center at the University of Arizona. Designed and painted by an art class, the mural shows a fiery path through space and time starting from ancient Mars with Earth-like oceans on the left and passing through mythological depictions of Mars ending in the Phoenix landing on modern Mars. This mural is 6.1 m high x 18.3m wide. Image courtesy UA/A. Quiroz.

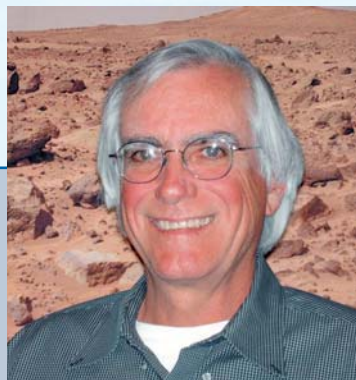

Peter Smith has been a research scientist at the University of Arizona for nearly 30 years. His specialty has been building and operating space instruments on missions to the planets. His camera took the images returned in 1997 from the Mars Pathfinder Mission. Smith is now the Principal Investigator on the Phoenix Mission that will land in the northern polar region in May 2008.

14

Report from the **RINGED PLANET...**

"Where's that cat go??"

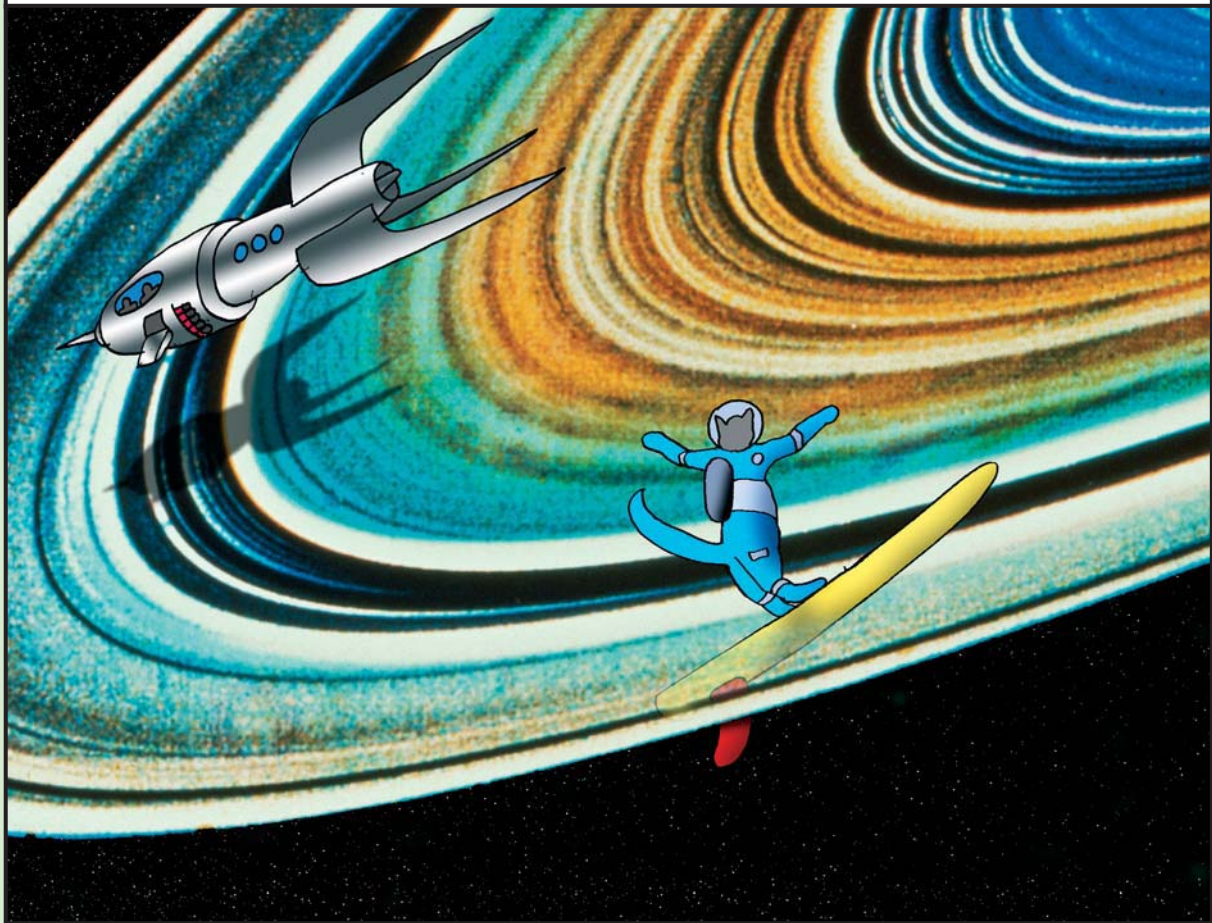

The Voyager flyby missions of the early 1980s posed several intriguing mysteries. Why is the leading hemisphere of the outer moon Iapetus dark? Are there lakes of hydrocarbon below Titan's enshrouding haze? Is the small inner moon Enceladus geologically active? Here *David Harland* gives an update of the Cassini-Huygens mission's investigation of Saturn, its magnetosphere, rings and satellites.

Cassini at SATURN UPDATE

AS CASSINI made its approach to Saturn in early 2004, it monitored the solar wind heading for the planet and radio emission from the planet's auroral activity while the Hubble Space Telescope took imagery of the ultraviolet emission. Large gusts in the solar wind on 17 and 25 January changed both the aurora and the radio emission. As viewed from space, an auroral display is a ring of light around a magnetic pole that is emitted by atoms and molecules that are excited by the electrons that flow in the magnetic field. In the case of Earth the emission is mostly from oxygen atoms and nitrogen molecules, but on Saturn it is from atomic and molecular hydrogen.

On 8 March Cassini began to resolve discrete features in the atmosphere, and on 19–20 March it observed the merger of two storms in the southern hemisphere, each of which was about 1,000 km in diameter. Both were drifting westwards, the more northerly one at twice the rate of the southerly one. When they met, they spun around each other in a counterclockwise manner. The resulting storm was elongated in the north-south direction with bright clouds on either end, but within 2 days it had adopted a more circular shape and the bright clouds were in a circumferential halo. It was only the second time that a merger had been observed on Saturn. In addition, there was a distinctive dark circular

spot right on the south pole. This matched an infrared observation by the Keck Observatory on 4 February showing this location to be warm. In fact, it was the warmest place on the planet. The mystery was not that

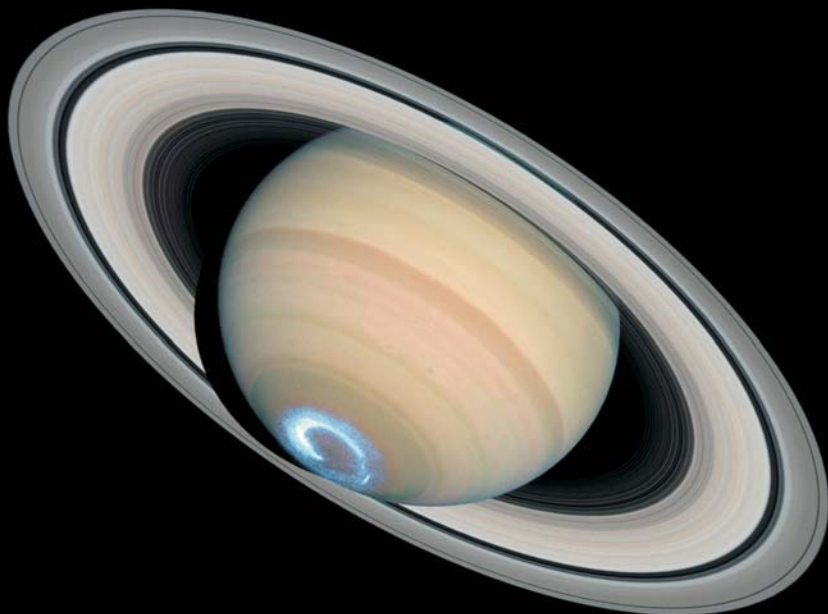

■ **Left:** Seen by the Hubble Space Telescope, Saturn's aurora appears as a ring of glowing gases circling the planet's south polar region. Observations in conjunction with those from the Cassini spacecraft suggest that Saturn's auroral storms are driven mainly by the pressure of the solar wind – a stream of charged particles from the Sun – rather than by the Sun's magnetic field. This image acquired on 28 January 2004 showed a strong brightening in the aurora which corresponded with the recent arrival of a large disturbance in the solar wind. Astronomers combined ultraviolet images of Saturn's southern polar region with visible-light images of the planet and its rings to make this picture. Image courtesy NASA, ESA, J. Clarke (Boston University), and Z. Levay (STScI).

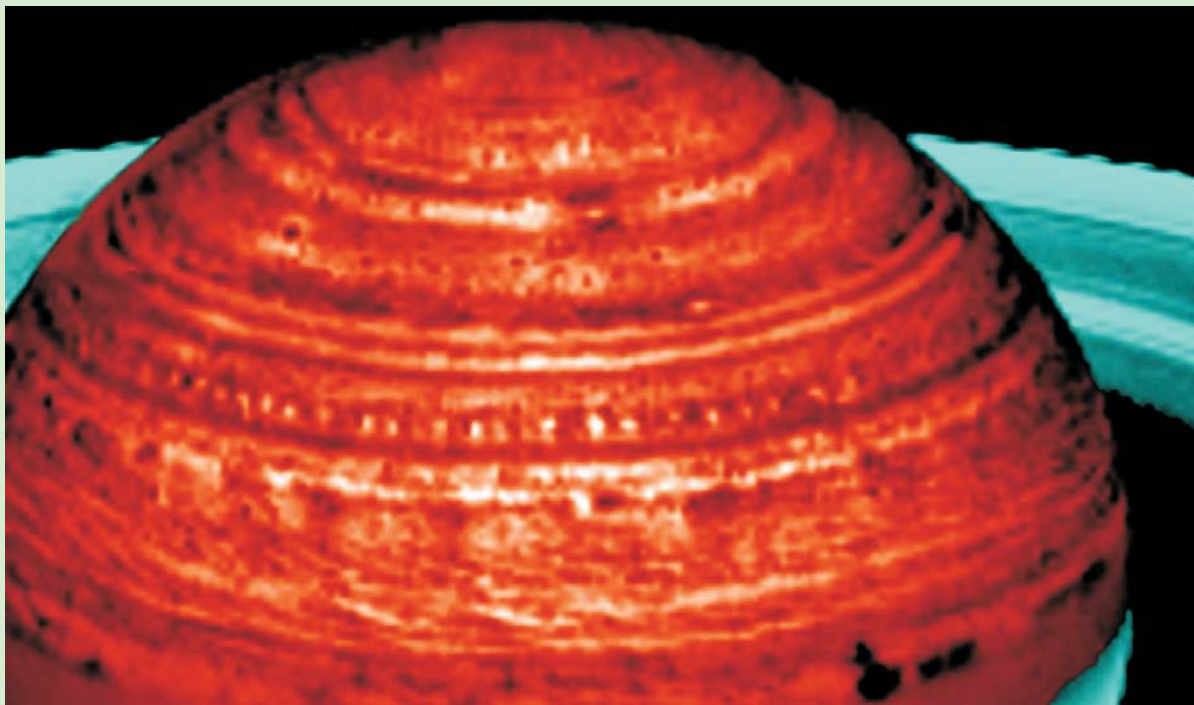

the polar region was warm; it had been in full sunlight for several years, heating the polar vortex – a persistent weather pattern akin to a ‘jet stream’. But both the distinct boundary of the vortex 30 degrees from the pole and the hot spot at its centre were unexpected. If the increased southern temperatures were the result of the seasonal variation in sunlight, they ought to increase smoothly towards the pole, but this was not the case – the temperature increased abruptly near 70°S, and then again right at the pole. If the abrupt change at 70°S was due to a concentration of particles that trapped solar energy in the upper atmosphere, then this would explain why the ‘hot spot’ appeared dark in visible light.

Just why the atmospheres of Jupiter and Saturn have an alternating pattern of east-west winds varying in direction with latitude is disputed. In contrast to Earth, whose weather is driven mainly by sunlight, the gas giants are still in a state of gravitational collapse and therefore have an additional energy source in the form of the heat that leaks from their interiors. The challenge was to understand the role of these interior energy sources in sustaining the strong jet-stream winds of the gas giants. According to

one theory, the circulation was driven by sunlight heating a shallow upper layer of the atmosphere, but by the other theory the winds extended deep into the interior and were driven by the energy that was leaking out. Neither theory could readily account for the maximum wind speed at the equator.

One test was to measure the long-term sensitivity of the winds to variations in sunlight from seasonal and other influences. Studies had shown Jupiter’s winds to be insensitive to seasonal changes, but Saturn was more difficult to monitor because its cloud structure was ‘muted’ visually. In 1980-1981 the Voyager spacecraft were able to resolve sufficient detail to enable the wind speeds to be measured, and revealed that the equatorial jet stream flowed at an astonishingly rapid 1,700 kilometres per hour. The Hubble Space Telescope could track sufficient detail to make further studies, and observations in 1996-2001 found that, notwithstanding the change in season and the location of the shadow cast on the planet by the ring system, the jets far from the equator had not changed – implying they were deeply rooted. However, at just 990 kilometres per hour the equatorial jet stream was much weaker. One suggestion for this apparent change was that the structures viewed by the Hubble Space Telescope were at higher altitudes, where the wind might be slower.

In mid-May 2004 Cassini measured the temperature fields across the southern hemisphere, providing a 3-dimensional chart of the stratospheric winds that confirmed the equatorial winds do indeed decrease rapidly

■ **Above:** In this image taken on 27 April 2006, Saturn’s fascinating meteorology manifests itself in a ‘string of pearls’ formation, extending over 60,000 km. Seen in new images acquired by Cassini’s visual and infrared mapping spectrometer and lit from below by Saturn’s internal thermal glow, the bright ‘pearls’ are actually clearings in Saturn’s deep cloud system. More than two dozen occur at 40 degrees north latitude. Each clearing follows another at a regular spacing of some 3.5 degrees in longitude. The regularity indicates that they may be a manifestation of a large planetary wave. Image courtesy NASA/JPL/University of Arizona.

with increasing altitude above the level of the ammonia cloud layer. Evidently the structures seen by the Hubble Space Telescope were indeed at a higher altitude than those seen by the Voyagers, and that the apparent slowing was due to storms projecting their 'tops' to altitudes at which they were more readily seen from Earth. As for what maintained the energetic jets, Cassini provided a clue. Early on, it found the region near 35°S (i.e. the southern edge of the equatorial jet) to be so active that it was dubbed 'storm alley'. One sequence of images showed a number of dark spots 'emerge' from the upper level outflow of a convective storm and yield their energy to the jet stream, suggesting that this was the mechanism by which the energy that leaked from the interior sustained the horizontal winds of the upper atmosphere.

On the Voyager flybys, sporadic radio emissions from Saturn were inferred to be due to electrostatic discharges in storms in the equatorial region, which was in the shadow of the ring system. Cassini first detected such discharges in July 2003, at a distance of 161 million kilometres. They tended to occur in episodes lasting several hours, in some cases involving hundreds of bursts, often recurring in phase with the planet's rotation then ceasing for long periods. It was not until the range had closed sufficiently to see atmospheric detail that it was possible to seek evidence that the radio bursts were correlated with atmospheric storms. In early August it was noted that there had been a

bigger than average 'white storm' in the southern hemisphere at the time of an intense radio episode in mid-July. When the imaging team saw the storm was back in September, the radio team was alerted and they replied that their instrument was monitoring an episode that was even more intense than that in July. This convective storm was so large and bright that the imaging team named it the 'Dragon Storm'. The fact that over an 18-day interval the largest storm was brightest when the radio emission was strongest, with the storm always in the same position during a burst, indicated that they were the same phenomenon. But instead of the burst being detected when the storm rose over the horizon from Cassini's point of view, and peaking when it was on the meridian facing the spacecraft, the emission started before the storm rose and halted as it crossed the terminator into daylight.

Starting with periapsis on 17 February 2005, Cassini's infrared imaging system began a campaign in which it snapped Saturn at 5 microns to use the heat leaking from the deep interior to illuminate the cloud structures in silhouette. Previously, the deep clouds had been sought by viewing in sunlight, but the view had been obscured by the upper level hazes and clouds. At 5 microns it was possible to map both the day and night sides, and there was a mass of structure. Unlike the hazy global bands of the upper atmosphere, many of the deeper clouds were isolated localised features with a variety of sizes and shapes. Observations of these clouds provided a means of measuring the wind speeds at this deeper level, to make a 3-dimensional chart of the atmospheric circulation. A comparison with the 'high altitude' winds indicated there were substantial wind shears in the equatorial zone. In keeping with the finding that above the ammonia clouds the wind speed decreased with increasing altitude, at this 'low altitude' (estimated to be 30 km beneath the ammonia clouds) the winds

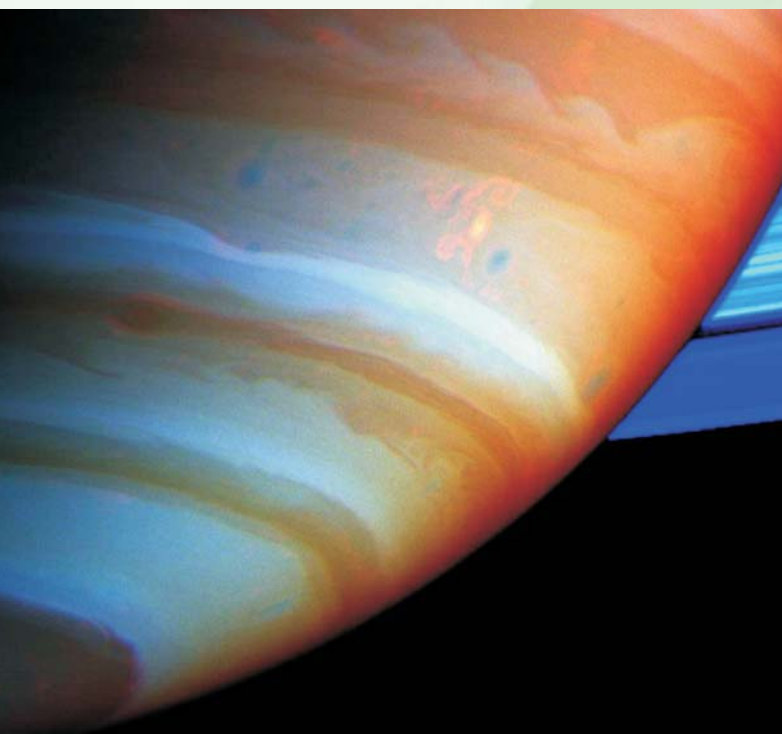

■ **Left:** A false colour composite of Saturn's southern atmosphere made from Cassini images taken in near infrared light through filters that sense different amounts of methane gas. Clouds that are deep in the atmosphere are red, while grey indicates high clouds, and brown indicates clouds at intermediate altitudes. The bright feature just above and to the right of centre is a complex convective storm called the 'Dragon Storm'. It lies in a region referred to as 'Storm Alley' because of the high level of storm activity observed there. The Dragon Storm was a powerful source of radio emissions during July and September of 2004. Scientists have concluded that the Dragon Storm is a giant thunderstorm whose precipitation generates electricity as it does on Earth. Image courtesy NASA/JPL/Space Science Institute.

were 275 kilometres per hour faster. The results of this method of observation were so dramatic that it was decided to make further observations on subsequent periapsis passes.

Iapetus

When Giovanni Domenico Cassini discovered Iapetus in 1671 he inferred from the fact that it was apparent only on one side of its orbit that for some reason the leading hemisphere was dark. When the Voyagers passed through the system in 1980-1981 they confirmed this, but the dark terrain (which was named Cassini Regio) appeared featureless. Two days after entering orbit of Saturn, the Cassini spacecraft turned its cameras to Iapetus at a range of 3 million kilometres and revealed there to be basins on the dark terrain – evidently the relics of a heavy bombardment that occurred early in the moon's history. Imagery on 17 October from a range of 1 million kilometres showed a chain of 'white dots', seemingly mountain peaks rising to heights of 10 to 20 km, contiguous with a dark linear feature. A flyby on 31 December at a range of 123,400 km established this linear feature to be a ridge that spanned Cassini Regio, and further study showed it to run along the equator and extend onto the trailing hemisphere. In fact, Iapetus is not a precise sphere but an ellipsoid, and if the ridge was a compressional structure created by the manner in which the moon's interior shrank early on, then it would form on the circumference with

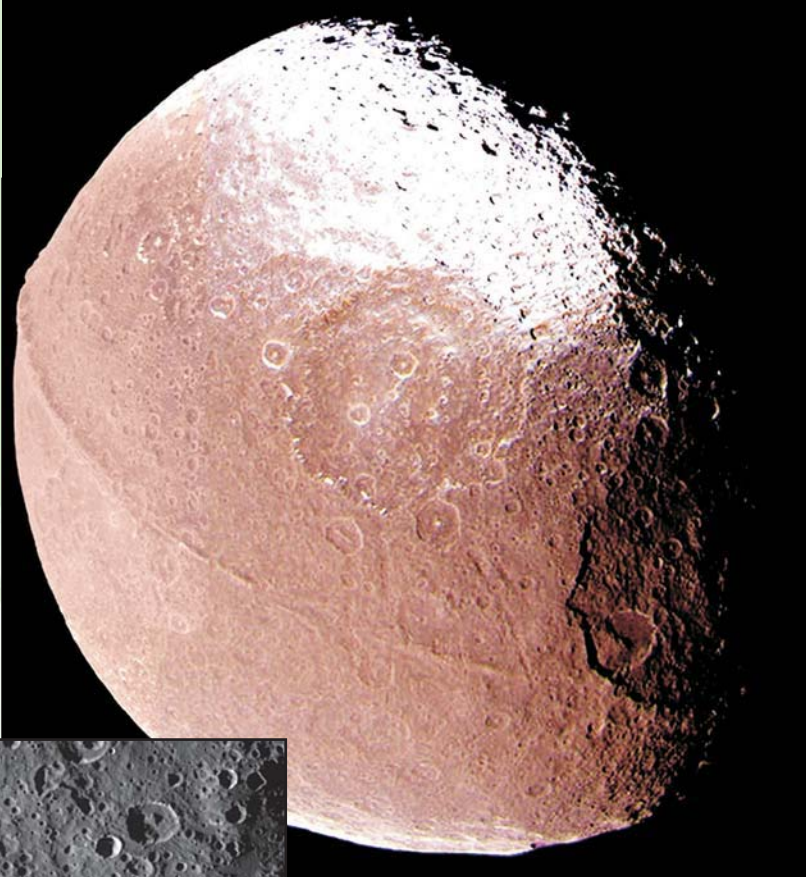

the widest diameter, after which tidal effects would first tip the axis perpendicular to the orbital plane and synchronise the axial rotation with its orbital motion. But what of the dark material on the leading hemisphere?

A recent study by the Arecibo radio-telescope in Puerto Rico operating as a radar at a wavelength of 12.6 centimetres was unable to tell the two hemispheres apart. Although the bright side was known to be primarily water ice, it appeared much less reflective at this wavelength than the icy satellites of Jupiter. If there was ammonia mixed in, it would look like clean ice optically but would not reflect microwaves so well. The fact that Cassini Regio was indistinguishable to radar implied that the dark material was just a thin veneer over the ice. Infrared spectroscopy found the bright terrain to be water ice with a small amount of organic (tholin) material; and Cassini Regio was best modelled as a mix of tholin, a hydrogen cyanide polymer, a small amount of water ice and ferric oxide. A distinctive far-ultraviolet absorption feature for water ice was strong for Phoebe (the outer moon suspected by some as being the source of the dark material on Iapetus) and the bright part of Iapetus, but extremely weak for Cassini Regio; but this did not actually rule out Phoebe as the source of the dark material on Iapetus as the

■ Top: This image from Cassini's narrow angle camera on 31 December 2004 reveals the intriguing surface of Saturn's moon Iapetus. It shows the dark Cassini Regio and the transition zone to a brighter surface at high northern latitudes. Within the transition zone, the surface is stained by roughly north-south trending wispy streaks of dark material. The absence of an atmosphere on Iapetus means that the material was deposited by ballistic placement from impacts occurring elsewhere on Iapetus, or was captured from elsewhere in the Saturn system. Image courtesy NASA/JPL/Space Science Institute.

■ Inset: A spectacular landslide within the dark region known as Cassini Regio is shown in this image of Iapetus obtained with Cassini's narrow angle camera on 31 December 2004, from a distance of about 123,400 km. The landslide material appears to have collapsed from a scarp 15 km high that forms the rim of an ancient 600 km impact basin. Unconsolidated rubble from the landslide extends halfway across a conspicuous, 120-km diameter flat-floored impact crater that lies just inside the basin scarp. Image courtesy NASA/JPL/Space Science Institute.

volatile constituents could have been liberated during emplacement, thereby concentrating the non-ice material. An inspection of Phoebe by Cassini as it entered the Saturnian system showed this to be a captured body that formed in the outer realms of the Solar System. On becoming trapped in the warmer Saturnian environment, it could well have undergone a period of outgassing. Dark streaks on the bright terrain adjacent to Cassini Regio implied the dark material was delivered ballistically, either by being swept up from space or from a source centred on the leading hemisphere. If of exogenic origin, then the material was deposited after the ridge formed, after the moon had adopted its current spin axis and after its rotation had been synchronised – a timescale which may in turn shed light on when Phoebe was captured.

Enceladus

The Voyagers had shown Enceladus to have a sharp line of demarcation between an area that was heavily cratered and a seemingly smooth plain which indicated that the small icy moon had been extensively resurfaced. This impression was reinforced by the early views from Cassini. When it flew by at an altitude of 500 km on 9 March 2005, the magnetometer found that Saturn's magnetic field was 'bent' around the moon by electric currents generated by the interaction of the magnetosphere with neutral atoms of gas, indicating the presence of a tenuous envelope. When neutrals were ionised by magnetospheric plasma, they were 'picked up' by the magnetic field and caused oscillations at frequencies that enabled them to be identified as O^+ , OH^+ and H_2O^+ ions, indicating an envelope of water vapour. With an escape velocity of a mere 212 metres per second, gas would readily leak away if it were not replenished.

The source could be outgassing from the interior through fractures in the crust, geysers or cryovolcanism. It was decided to make the next flyby at 175 km in order to directly sample the envelope. On 14 July Cassini penetrated the electrically conducting envelope, which the magnetometer found to be concentrated at the south pole. Data from other instruments showed that the spacecraft had passed through the fringe of a cloud of water vapour from a localised source in the south polar region. It was evident that water vapour being vented into space was carrying particulates by a process similar to the venting that occurs on an comet. The 'E' ring extends from the orbit of Mimas out to beyond

the orbit of Dione, but is concentrated near the orbit of Enceladus. It was found to be comprised of tiny water-ice grains. Terrestrial studies had established that whereas the material in the 'F' and 'G' rings has a power-law distribution characteristic of debris from impacts, the 'E' ring material is of uniform size.

It had long been suspected that Enceladus was responsible for the 'E' ring, and this was now seen to be the case. But where was the source? Enceladus has such a high albedo that it reflects most of the sunlight, making its surface the coldest in the Saturnian system. The temperature at the subsolar point was expected not to exceed 80K. Even though the south pole was in continual sunlight, the oblique illumination suggested it should be significantly colder, but thermal

■ **Below:** From afar, the anti-Saturn hemisphere of the moon Enceladus exhibits a bizarre mixture of softened craters and complex, fractured terrains. This mosaic of 21 Cassini narrow-angle camera images, acquired on 14 July 2005, is a false-colour view that includes images taken at wavelengths from the ultraviolet to the infrared. In false-colour, many long fractures on Enceladus exhibit a pronounced difference in colour (represented here in blue) from the surrounding terrain. Image courtesy NASA/JPL/Space Science Institute.

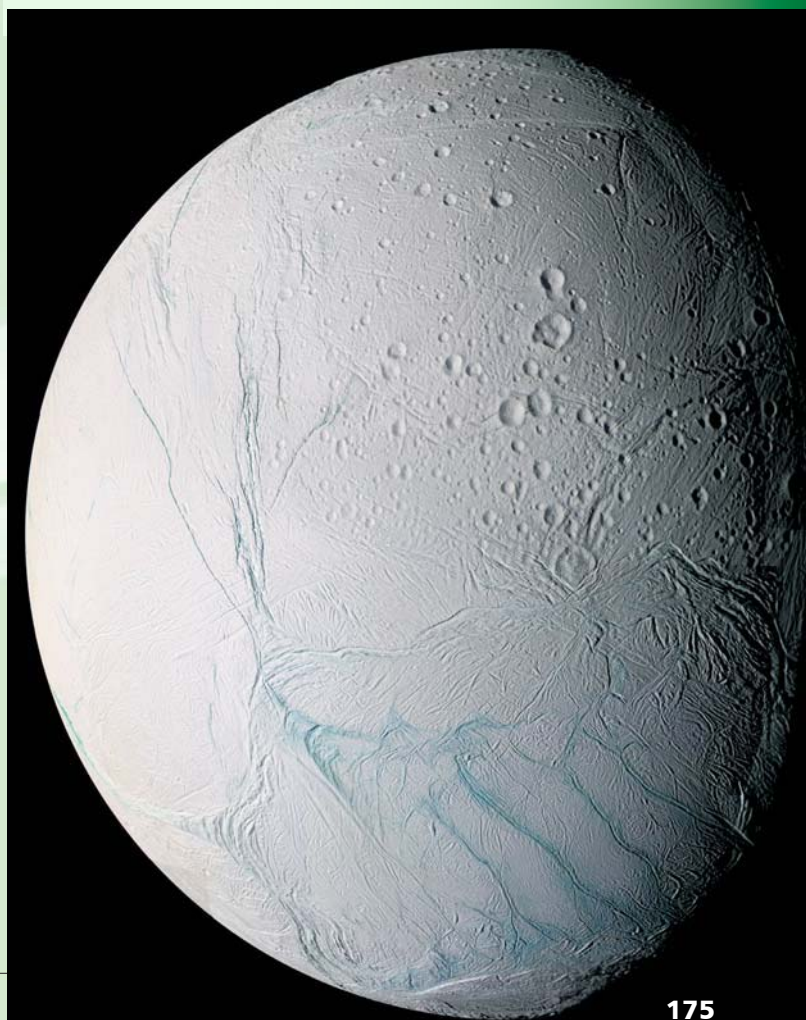

Enceladus Temperature Map

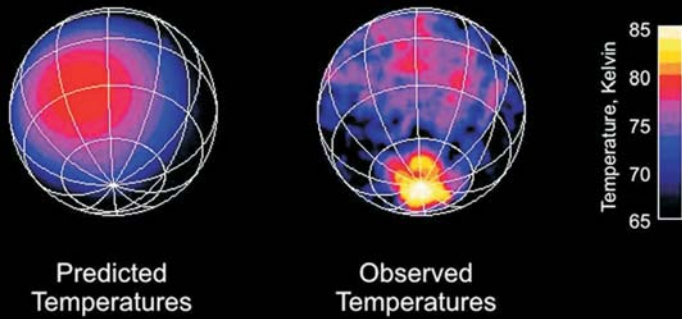

infrared measurements found it to be the warmest place on the moon. The optical imagery showed the south polar region to be bounded by parallel ridges and valleys and to contain a series of arcuate 'tiger stripes' where the temperature rose to 145K, which was astonishingly hot for such a frigid body. When a re-analysis of early long-range imagery of the moon as a crescent showed a glow at its south polar region, it was decided to make further such observations, and on 27 November 2005 a number of geysers were observed issuing material 500 km into space.

It appears there is liquid water at shallow depth beneath the south pole, and the 'tiger stripes', which run in parallel, 40 km apart, for about 140 km, are fractures through which it is able to reach the surface. It has been suggested that this activity is driven by the heat due to the tidal stress resulting from the eccentric orbit. If the ice contained ammonia, this antifreeze would lower the melting point of water ice by 100°C and reduce its density sufficiently for solid-state convection to occur. As a rising diapir neared the surface it would induce characteristic tectonism.

Above: These images from Cassini's composite infrared spectrometer show a dramatic 'warm spot' centred on the south pole of Saturn's moon Enceladus – a sign of internal heat leaking out of the icy moon. It had been expected that the south pole would be very cold, as shown in the left-hand panel. The right-hand panel shows that equatorial temperatures are about 80 K (-193°C), much as expected, but there is a warm spot at the south pole reaching 85 K (-188°C). That is 15°C warmer than expected. (The poles should be colder than the equator because the Sun shines at such an oblique angle there.) Data suggest that small areas of the pole are at even higher temperatures, well over 110 K (-163°C). Image courtesy NASA/JPL/GSFC.

Top right: Images of Saturn's icy moon Enceladus backlit by the Sun show the fountain-like sources of the fine spray of material that extends far above the south polar region. This greatly enhanced and colourised image was taken looking more or less broadside at the so-called 'tiger stripe' fractures observed in earlier Enceladus images. It shows discrete plumes of a variety of apparent sizes above the limb of the moon. It is thought that the jets are geysers erupting from pressurised subsurface reservoirs of liquid water. Image courtesy NASA/JPL/Space Science Institute.

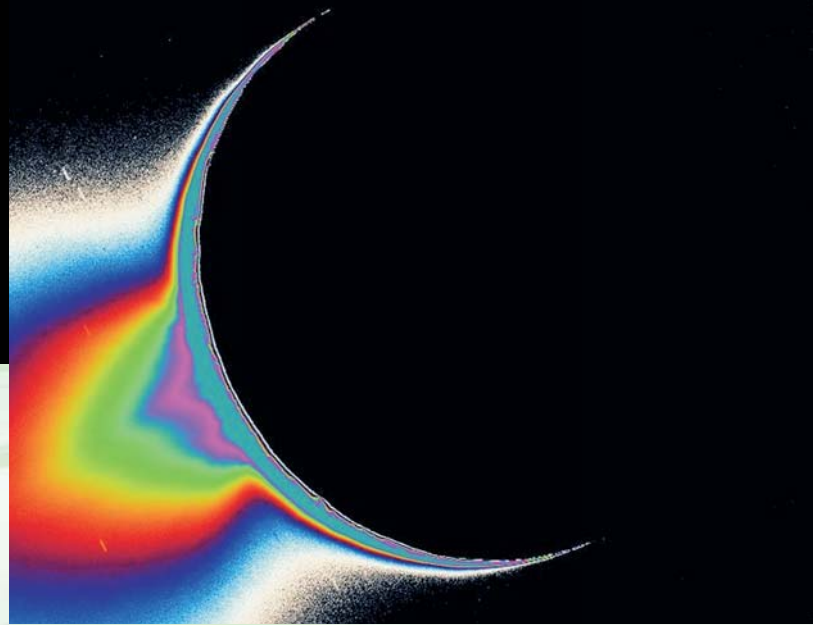

It is clear that although Enceladus has had a long history of activity, this is currently limited to the south polar region. Because a rotating body is more stable if its mass is near its equator, any redistribution of mass within an object will create instability with respect to the axis of rotation. The development of a deeply seated 'hot spot' would therefore induce Enceladus to roll over to position this low-density region on its axis. If diapiric convection is facilitated by the presence of ammonia in the water ice, ammonia ought to be being vented. None was detected, but the fact that nitrogen was present in the cloud over the south pole, and indeed in the 'E' ring, indicated the combination of solar ultraviolet and magnetospheric plasma was rapidly dissociating the ammonia. Other Cassini data showed that the venting varies over a time scale of days. When the spacecraft observed a significant injection of atomic oxygen into the 'E' ring in January 2004, the first hypothesis was that the collision of two yet-to-be-detected moonlets in this vicinity must have released a puff of water ice which had dissociated into its constituent hydrogen and oxygen, but it was now realised that the source must have been an outburst from Enceladus.

The Voyagers noted a periodicity in the rhythm of the radio emission from Saturn, and this was taken to be the rate at which the planet's core was rotating. However, in 1997 the Paris Observatory announced a different radio periodicity. An analysis of Cassini's monitoring between 29 April 2003 and 10 June 2004 showed a periodicity of 10 hours 45 minutes 45 seconds (± 36 seconds), which was about 1 per cent longer than the Voyager time. As it was unreasonable

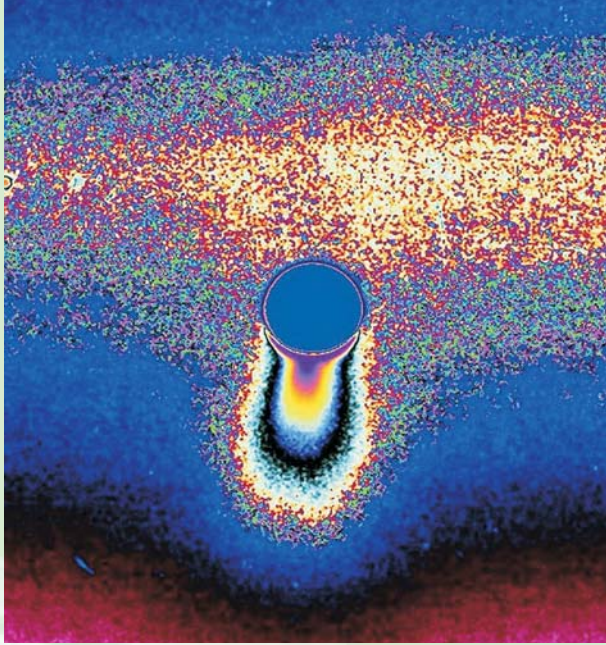

to think the rotation of the planet had slowed, it was suggested that the magnetic field might be similar to that of the Sun, whose rotation varies with latitude, being fastest at the equator, and that the part of the planetary field that controlled the charged particles that issued the radio emission had shifted to a higher latitude. If the magnetic axis of Saturn had been significantly inclined to its rotational axis, it would have been a simple matter to measure the rate at which the magnetic axis was precessing, but at an angle of just 3 degrees such a measurement is difficult. Nevertheless, by the half-way point in Cassini's primary tour the magnetometer had identified a periodicity in the magnetic field itself of 10 hours 47 minutes 6 seconds (± 40 seconds) – even slower than the current radio periodicity. In 2007 it was discovered that the gas emitted by the geysers on Enceladus was being ionised in space, with the charged particles forming a disk close around the planet's equator, and that this imposed such 'drag' on the magnetic field as to make the radio periodicity exceed the planet's rotation; in effect, the radio data had been measuring the rotation of this plasma disk, not the planet. The degree of drag would depend on the amount of material in the plasma disk, which in turn would vary with the activity of Enceladus' geysers.

Rings and Moonlets

Imagery taken on 1 June 2004 included two moonlets about 3 to 4 km in size, between the orbits of Mimas and Enceladus. They were spotted two months later by Sébastien Charnoz, a dynamicist at the University of Paris in France. "I had looked for such objects for weeks while at my office, and it was only on holiday using my laptop that my program detected them; this tells me that I should take more holidays!" The IAU named them Methone and Pallene.

For an hour immediately after Saturn Orbit Insertion on 30 June 2004, while Cassini was north of the ring plane, it observed the rings at unprecedented spatial resolution, viewing the shadowed face of the system. Working inwards, the 'F' ring seemed to be more 'dirt' than ice; the 'A' ring was icy near the outside and dirty towards the inside; the 'B' ring was mainly ice; and the 'C' ring was dirty towards the inside. The most opaque parts of the system – in particular the outer part of the 'A' ring and the entire 'B' ring – were cooler and the translucent parts were warmer. This could be explained in terms of sunlight penetrating the sparsely filled rings to warm the material on the 'far side'.

The gravitational interactions between the rings and the moonlets which orbit in and just beyond the outer part of the ring system transfer angular momentum to the moons, causing them to move out and the rings to sag towards the planet. This implies the rings are a fleeting phenomenon having a lifetime of several hundred million years. However, if there is a collisional cascade at work in which large moons struck by asteroids and comets are broken into smaller moons, and so on, the result is a supply of particles to sustain the ring system beyond the time in which it would otherwise fade. Imagery taken while Cassini was north of the ring plane showed the inner edge of Encke's Division to be scalloped. This was later found to be due to the fact that the moonlet Pan, which is responsible for the 325-kilometre-wide gap, travels in an eccentric orbit. The pattern enabled the mass of the moon to be calculated, which in turn led to a density of 0.5 g/cm^3 . Observations of the perturbations of Atlas gave a similar value. As solid water ice is 0.93 g/cm^3 , this implied that these moonlets were accretions of icy particles. Sightings of 'spikes' and 'wisps' at the outer edge of the Keeler Gap (which is 250 km inside the outer edge of the 'A' ring) led to the discovery of the 7-kilometre-sized moon Daphnis orbiting in the gap. This was only the second moonlet to be

■ **Above left:** The ice jets of Enceladus send particles hundreds of kilometres above the south pole of this spectacularly active moon. Some of the particles escape to form the diffuse 'E' ring around Saturn. This colour-coded image was enhanced to make the extent of the fainter, larger-scale component of the plume easier to see. The bright strip behind and above Enceladus is the 'E' ring, in which this intriguing body resides. The small round object at far left is a background star. The image was taken in visible light with Cassini's narrow-angle camera on 24 March 2006 at a distance of about 1.9 million km from Enceladus. Image courtesy NASA/JPL/Space Science Institute.



Further evidence of gravitational interactions was noted in an image that Cassini took on 29 October 2004, in the form of a faint 'streamer' of material drawn from the inner edge of the 'F' ring towards the shepherding moonlet Prometheus. In fact, this moon not only generates 'knots', 'kinks' and 'clumps' in the ring, but also 'dark channels'. As Prometheus approaches and recedes from the ring during its 14.7-hour elliptical orbit it perturbs ring particles into elliptical

found inside the ring system; the first being Pan. It had a similarly low density.

Monitoring by the spacecraft of stars as they were occulted by the ring system showed that the material in the 'A' ring is concentrated into clumps. This lent support to the theory that the ring material is not simply degrading towards ever finer material, but is also being reaccreted. In fact, imagery taken while Cassini was north of the rings after Saturn Orbit Insertion showed gravitational disturbances in the 'A' ring indicative of the presence of four small embedded moonlets, each of which was calculated to be of the order of 100 metres in size – too small to sweep a clear channel in the rings; their presence was able to be inferred only because their gravitational wakes were superimposed on a particularly smooth section of the ring. If ring material is constantly reaccrting, this will considerably extend the life of the ring system. In total, the ring material is equivalent to an icy moon with a diameter of 200 km – less than half the size of Mimas. The debate about whether the rings are material that did not accrete to create a moon, or the debris of a moon that was shattered, is therefore seen to have been futile, as the system is in an essentially steady state, persisting for billions of years, with different incarnations of moonlets and the rings being present at different times.

orbits, with the result that one orbital period after the encounter there is a dark channel in the interior portion of the ring, and since these disturbances take time to dissipate they form a repeating pattern along the ring.

The irregularly shaped moonlet Epimetheus was found to have a large number of 'softened' craters on a predominantly water-ice surface. Epimetheus is co-orbital with Janus, and on 21 January 2006 they swapped orbits, with Janus taking the low position. They will exchange again in 2010. There is no danger of a collision during such exchanges, as the moonlets approach no closer than 15,000 km. Their low densities suggest they are loosely consolidated accretions, rather than chips off larger bodies. Cassini found that the irregular moon Hyperion, orbiting much further out, has a density of 0.6 g/cm^3 , indicating that it, too, is a loose accretion rather than a solid body. Hyperion is just below the size limit at which internal pressure will crush loosely packed ice and close the pore spaces to form solid ice. It is somewhat larger than Epimetheus and Janus, and smaller than Mimas, which is spherical; however, why there should be a reaccreted object at this location in the Saturnian system is not known. Trojans are a class of objects which occupy the gravitationally stable points 60 degrees leading or trailing a larger body. Tethys was already known to have two such moonlets: Telesto leading and Calypso trailing. Cassini found them to be elongated with cratered but smooth surfaces. Dione was also known to have Helene in its leading Trojan point. Cassini discovered 5-kilometre-sized Polydeuces in the trailing point.

■ **Above:** Saturn's shadow stretches completely across the rings in this view, taken on 19 January 2007. The view is a mosaic of 36 images – that is 12 separate sets of red, green and blue images – taken over the course of about 2.5 hours. This view looks toward the unlit side of the rings from about 40 degrees above the ring plane. The images in this natural-colour view were obtained with Cassini's wide-angle camera at a distance of about 1.23 million km from Saturn. Image courtesy NASA/JPL/Space Science Institute.

Ring 'spokes' comprise dust particles less than about 1 micron in size that collect electrostatic charges in the plasma environment of the rings, then become subject to electric and magnetic forces. In certain conditions, they become negatively charged and are briefly levitated en masse 100 km away from the surface of the rings. When viewed from up-Sun, their shadows are seen projected on the rings, but when observed from down-Sun the forward-scattered sunlight makes them appear bright. The illumination of the ring system changes with Saturn's travel around the Sun, and the presence of the spokes is more likely when the Sun is close to the ring plane. At the time of Cassini's arrival in the Saturnian system the rings were 'open' to the Sun and conditions were unfavourable, but on 5 September 2005 the craft gained its first glimpse of this phenomenon in the shape of several faint narrow radial spokes on the outer part of the shadowed face of the 'B' ring, about to enter the planet's shadow. In the Voyager imagery, the narrow wedge-shaped spokes extended from 10,000 to 20,000 km out across the 'B' ring, but these new spokes were a mere 3,500 km long and 100 km wide. By 2008, however, Cassini's orbit will be steeply inclined to the ring plane, and this will enable it to view the rings almost 'face on', and as spokes become more common it will be well positioned to monitor their motion.

Usually when Cassini passed through Saturn's shadow it was near periapsis, and the occultation lasted only an hour or so, but the occultation on 16 September 2006 occurred while the spacecraft was sampling the 'tail' of the planet's magnetosphere, some 2.2 million kilometres down-Sun, with the result that it spent fully 12

hours in shadow. This offered an opportunity to make a number of intriguing observations of the ring system in silhouette. It was found that there is a tenuous ring associated with Janus and Epimetheus, and another associated with Pallene. In addition, the 'G' ring was revealed to have a very distinct inner edge. Wispy, finger-like projections were evident extending into the 'E' ring from Enceladus, probably ice particles vented by the geysers at the moon's south pole.

Titan

During a flyby of Titan on 26 October 2004 Cassini sampled the outer fringe of this moon's atmosphere. The ratio of the isotopes of nitrogen indicated that 75 per cent of the original nitrogen in the atmosphere may have leaked to space. As water ice is an efficient carrier of primordial noble gases, their absence suggested the nitrogen in the atmosphere derived from the volatilisation of ammonia ice by accretional heat as the moon formed, with the ammonia subsequently having been dissociated by solar ultraviolet. The implication was that the part of the solar nebula from which Titan condensed was cool enough for ammonia ice and methane ice, but too warm for a nitrogen clathrate with trapped primordial noble gases.

On the surface, there was a complex interplay of albedo. There were 'streaks' that were suggestive of the movement of (dark) material across the surface, and the fact that these were consistently aligned with the prevailing 'zonal' circulation implied windblown material. It was initially expected that the particulate 'fall out' from the organic haze would be sticky, but modelling suggested these would harden during

■ This panoramic view of Saturn combines 165 images from Cassini's wide-angle camera taken over nearly three hours on 16 September 2006, while it drifted in the darkness of Saturn's shadow. Cassini detected two new faint rings: one coincident with the shared orbit of the moons Janus and Epimetheus, and another coincident with Pallene's orbit. The narrowly confined 'G' ring is visible outside the bright main rings. Encircling the entire system is the more extended 'E' ring. The icy plumes of Enceladus, whose eruptions replenish the 'E' ring, betray its position in the 'E' ring's left-side edge. Interior to the 'G' ring and above the brighter main rings is the pale dot of Earth, over a billion kilometres distant. Image courtesy NASA/JPL/Space Science Institute.

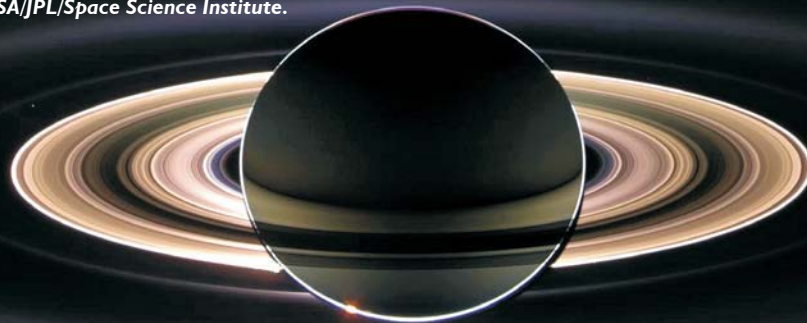

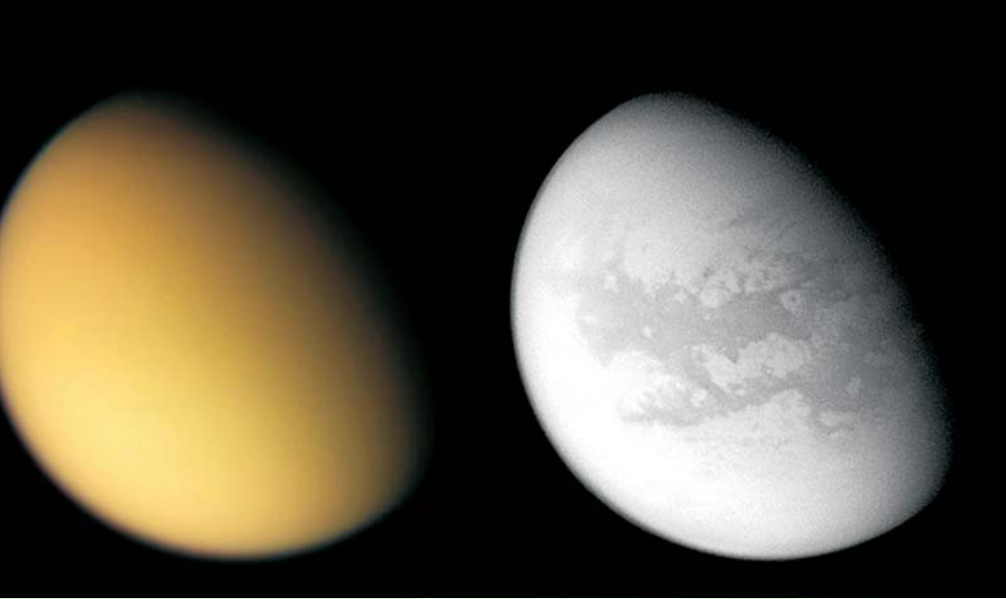

region. A radar study by the Arecibo observatory had shown there to be 'specular' reflections from isolated areas 50 to 100 km across, suggesting the presence of either lakes of hydrocarbons or flat areas such as would be left if lakes had dried out. However, if organic particulates had been blown into low-lying areas to form level plains, it was possible that there were areas that looked just like dry lakes

but which had formed without the involvement of liquid.

their long descent and, being non-sticky, would pile up on the surface like fine dust. It had also been thought that the surface must be stagnant, as the energy of insolation was too weak to drive winds in the lower atmosphere, but then it was realised that Saturn's tidal influence on Titan is 400 times greater than that of our Moon on Earth, and 'atmospheric tides' are dominant at the surface. In Titan's dense atmosphere and low gravity, even a wind averaging 1 kilometre per hour could 'bounce' grains along the surface in a process called saltation.

Cassini released the Huygens probe on 24 December 2004 to trace a ballistic arc leading to entry of Titan's atmosphere on 14 January 2005. It had been expected that the probe would emerge from the base of the optically thick haze at an altitude of 70 km, but this did not happen until 45 km, and the view of the surface remained murky until 30 km. Sampling showed a constant ratio of methane to nitrogen in the stratosphere and upper troposphere, but at about 20 km this ratio began to increase, and at 8 km the methane reached saturation. At about 7 km the wind speed decreased to a mild 1 to 2 metres per second and the direction became variable, implying that the probe had descended into a convective region in which the local winds were disconnected from the zonal jet stream. During the final phase of the descent, the downward-looking infrared spectrometer obtained reflectance spectra to determine the composition of the surface in the vicinity of the landing point, and at an altitude of 700 metres it activated a 20-watt lamp in order to 'fill in' the wavelengths of sunlight that were filtered out during passage through the atmosphere. To the imager, the result resembled a car shining its headlights into fog, suggesting there was a drizzle of liquid methane.

The best views of the surface were provided by the spacecraft's microwave radar, but this was effective only when close to the moon and supplied long narrow swaths of the surface, each of which had an area of approximately 1 per cent of the globe. Statistically, 40 impact craters with diameters larger than 20 km could have been expected in such an area but, to general surprise, none were visible. Because impacts must have occurred, the absence of craters implied that the surface was active. Indeed, not only were there some features with characteristics suggestive of cryovolcanism, the atmosphere contained argon-40, a gas that would be released by such activity. Cassini radar altimetry showed the range of elevation to be confined to 50 metres along one 200-kilometre-long track, indicating a large flat

As hoped, the probe came down over a boundary between the light and dark areas. The imagery appeared to show a network of dark drainage channels on a bright area leading down to a shoreline, with several offshore islands on the dark area. The wind carried the probe out over the dark area for touchdown. The ground-level view showed a solid surface littered with 'rocks'. Since the camera was very close to the ground, the sense of perspective was deceptive: the rocks were not the boulders they appeared; they were actually only a few centimetres in

■ Above: As Cassini approached Titan on 21 August 2005, it captured this natural colour view of the moon's orange, global smog. Images taken with the wide-angle camera using red, green and blue spectral filters were combined to create this colour view. The images were acquired at a distance of about 213,000 km from Titan. Right: This image acquired with Cassini's wide-angle camera on 22 August 2005 using a spectral filter centred on infrared wavelengths at 939 nm, reveals the mid-latitudes on Titan's Saturn-facing side. Features within the region seen here – known informally as the 'H' – now have names such as Tsegih, Atzlan and Quivira. The bright 215-km-wide feature provisionally named Bazaruto Facula is visible right of centre, with a dark, unnamed 80-km-wide crater at its centre. Images courtesy NASA/JPL/Space Science Institute.

size, the nearest being no more than 1 metre away, and they were assuredly not silicate rock but lumps of water ice. The fact that they were rounded and sitting exposed on top of darker finely grained material suggested that they were erosional products that had been washed down the drainage channels onto the plain. The probe impacted the surface at 4.5 metres per second, with a 15-g deceleration over an interval of 40 milliseconds. A penetrometer projecting from the base of the probe had struck a pebble and nudged it aside, then readily penetrated a surface that was neither hard like solid ice, nor readily compressible like a blanket of fluffy aerosols. It was a 'soft' surface, for which plausible candidates were: (1) a solid granular material with little or no cohesion; (2) a 'mud' of ice grains from impact or fluvial erosion wetted by liquid methane; and (3) a 'tar' of finely grained ice and photochemical products. The probe had slipped along the surface for several seconds prior to coming to a halt, tilted at an angle of 10 degrees with its base dug in about 10 centimetres.

The fact that Huygens operated on the surface for over an hour gave a welcome bonus. The measured surface temperature was 93.65 K (± 0.25). The lamp for the spectrometer remained illuminated, and would have provided a source of heat.

In addition, a sample inlet on the base was held at $+90^{\circ}\text{C}$, making Huygens by far the warmest object on the moon. There was a significant increase in the methane fraction several minutes after landing, implying that heat from the probe was boiling volatiles out of the ground. The lens of the downward-looking imager was embedded, but the repeating views of the oblique and side-looking imagers gave hints that the heat from the probe was causing material to splutter across the ground. The implication was that occasional methane rain drained from the elevated terrain onto the low-lying ground, where it rapidly soaked into the porous material, which then served as a reservoir for slow evaporation. The volatiles detected after landing were

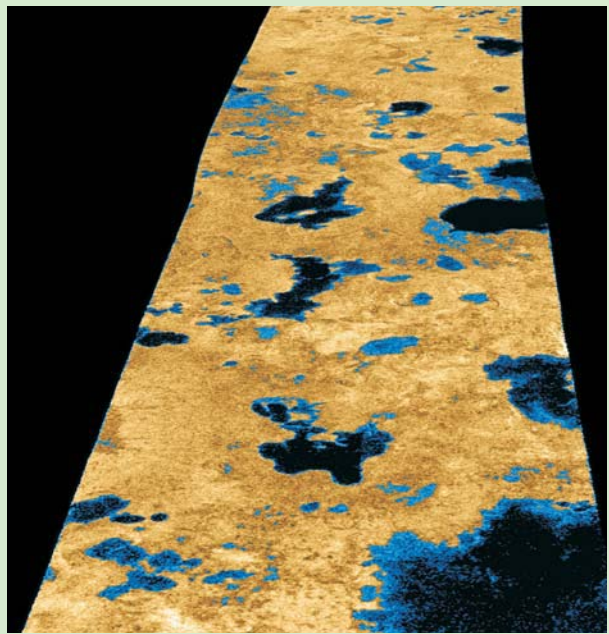

rich in organics that had not been noted during the descent, notably ethane and possibly benzene and cyanogen (both results of methane and nitrogen chemistry) and carbon dioxide, all of which were indicative of a complex chemistry in progress in the surface material.

With the Huygens mission achieved, Cassini resumed its remote-sensing of Titan, in particular the clouds that prevailed near the continuously sunlit south pole and the intriguing 'streaky' clouds that were confined to the southern temperate latitudes. On 28 October 2005 Cassini's radar imaged a field of dark 100-metre-tall dunes. The individual dunes ran for hundreds of kilometres, and the field extended at least 1,000 km along the equatorial zone. Calculations showed that the variable tidal wind caused by Saturn's gravitation was combining with the west-to-east zonal circulation to create surface winds that would yield a sinuous pattern of longitudinal dunes that were aligned with the direction of the prevailing wind flow,

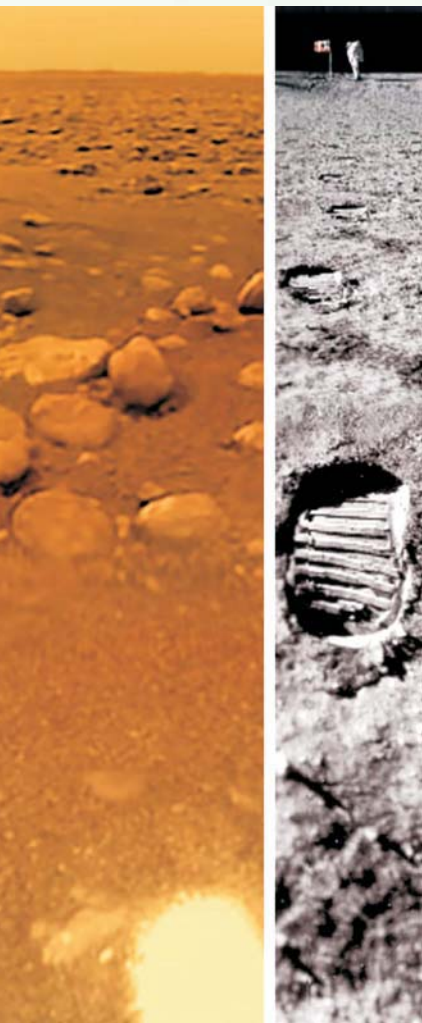

■ **Above:** Radar imaging data acquired during Cassini's flyby of 22 July 2006 provide convincing evidence for large bodies of liquid on the surface of Titan. Intensity in this colourised image is proportional to how much radar brightness is returned. The colours are not a representation of what the human eye would see. The lakes, darker than the surrounding terrain, are emphasized here by tinting regions of low backscatter in blue. Radar-brighter regions are shown in tan. The strip of radar imagery is foreshortened to simulate an oblique view of the highest latitude region, seen from a point to its west. The image is centred near 80 degrees north, 35 degrees west and is about 140 km across. Image courtesy NASA/JPL/USGS.

■ **Left:** This composite shows an image from the descent imager/spectral radiometer (left) taken while the Huygens probe was setting on Titan's surface, alongside a similarly scaled picture taken on the Moon's surface. Objects near the centre of the picture are roughly the size of a man's foot. Objects at the horizon are a fraction of a man's height. The Huygens image was taken on 14 January 2005. Images courtesy ESA/NASA/JPL/University of Arizona.

except near elevated terrain that controlled the local wind direction. This process could transfer material from the mid-latitudes to the equatorial zone. Furthermore, the presence of dunes implied the absence of persistent liquids on the surface in the equatorial zone that would serve as sand traps, a conclusion that seemed to conflict with the idea that Titan was a land of lakes. On 22 July 2006, when Cassini's ground track extended to the northern region that had been in darkness since before the spacecraft's arrival in the Saturnian system, the radar discovered dozens of well-defined dark patches up to 1 kilometre in size, some that were tens of kilometres, and one that was approaching 100 km. These were the darkest radar features yet observed, and dark usually signified either a smooth surface or a radar-absorbent material – and a lake of liquid hydrocarbon would be both. And there were channels leading into or out of some of these patches that had characteristics which were consistent with their having been created by flowing liquid. In 2007 coordinated observations by the optical and radar imaging instruments found a similar dark feature that was so large as to justify being dubbed the 'Black Sea' of Titan.

In its study of the circulation of the upper atmosphere, Cassini had earlier found that at mid-to-high northern latitudes the zonal wind inhibited mixing and created an isolated vortex around the pole. Being in continual darkness, the cold stratosphere in this region was sinking, in the process drawing down and concentrating the organics that were produced in the upper haze. On 23 September 2006 the spacecraft discovered a vast tropospheric cloud spanning the dark north polar region that appeared to be composed of ethane, apparently the result of the concentration of organic haze in the descending north polar vortex. Ethane raining into lakes of methane would dissolve. If the temperature dipped low enough, ethane would undoubtedly fall as snow, and might even build up an ice cap. The localisation of methane and ethane at the winter pole implied a seasonal cycle in which the volatile hydrocarbons migrated from one pole to the other over a Titanian year (which lasts



■ This composite image acquired by Cassini's visual and infrared mapping spectrometer during the 29 December 2006 flyby shows a huge cloud system over the north pole of Titan. The image extends from the north pole down to a latitude of 62 degrees north. Such cloud cover was expected, according to atmospheric circulation models of Titan, but it had never been observed before in such detail. The condensates may be the source of liquids that fill the lakes recently discovered by the radar instrument. Image courtesy NASA/JPL/University of Arizona.

29.5 terrestrial years) and this, in turn, offered an explanation for the current concentration of clouds at the south pole and absence of liquid on the surface at lower latitudes. If the Cassini mission is able to be extended beyond its nominal four years, then it should be possible to monitor the onset of the northern summer, with storms forming in the tropics as the volatiles migrate south, possibly temporarily submerging the now inert Huygens probe on the floor of a lake of rainfall runoff. Between them, the Cassini orbiter and its Huygens probe have certainly lifted the veil on Titan.

Further Reading

Cassini at Saturn: Huygens Results

David M. Harland, Springer-Praxis, 2007

Titan Unveiled

Ralph Lorenz and Jacqueline Mitton, Princeton University Press, 2007

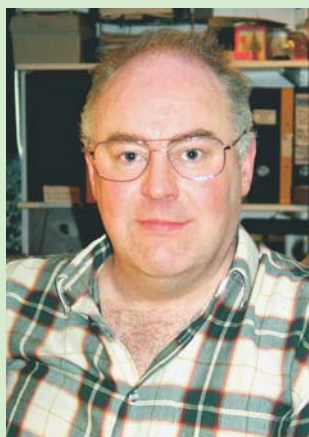

Dr David M. Harland

gained his BSc in astronomy in 1977, lectured in computer science, worked in industry and managed academic research. In 1995 he 'retired' to write on space themes.

THE END



www.springer.com/space www.praxis-publishing.co.uk