

Copyrighted Material

John Hicks

# Building a Roll-Off Roof Observatory

A Complete Guide for Design  
and Construction

Patrick Moore's  
Practical  
Astronomy  
Series

# Patrick Moore's Practical Astronomy Series

---

For other titles published in this series, go to  
[www.springer.com/series/3192](http://www.springer.com/series/3192)



**Building a  
Roll-Off Roof  
Observatory**

**A Complete Guide for Design  
and Construction**

John Hicks

 Springer

John Hicks  
Ontario  
Canada  
jsh@interhop.net

Full-size print copies of the plans are available. Please contact author directly

ISBN: 978-0-387-76603-4 e-ISBN: 978-0-387-76611-9  
DOI: 10.1007/978-0-387-76611-9

Library of Congress Control Number: 2008930762

© 2009 Springer Science+Business Media, LLC

All rights reserved. This work may not be translated or copied in whole or in part without the written permission of the publisher (Springer Science+Business Media, LLC, 233 Spring Street, New York, NY 10013, USA), except for brief excerpts in connection with reviews or scholarly analysis. Use in connection with any form of information storage and retrieval, electronic adaptation, computer software, or by similar or dissimilar methodology now known or hereafter developed is forbidden.

The use in this publication of trade names, trademarks, service marks, and similar terms, even if they are not identified as such, is not to be taken as an expression of opinion as to whether or not they are subject to proprietary rights.

Printed on acid-free paper

9 8 7 6 5 4 3 2 1

springer.com

This book is dedicated to my wife, Lorraine, who has endured my pre-occupation with the design of observatory structures and the countless hours required to produce the drawings and details exhibited in this work. She is also to be credited with her patience in my study of the sun, the many hours I spend at the telescope photographing it, and the never-ending acquisition of expensive scientific equipment to look ever further into the face of our star.



# Preface

*Building a Roll-Off Roof Observatory* has required several years in all to write, redrafting many diagrams and descriptions to arrive at the most practical and universal model illustrated in this book. At various stages, it was delayed for want of more information on existing observatories and at others carried forward again by a rush of newfound techniques. The backbone of observatory performance was always the roll-off mechanism, namely, the perfect caster and caster rail combination. There are a multitude of designs invented to achieve the same result, but only a few good ones, which consumed most of my research effort. Also, all things considered, no one writes a technical book on his own, and at various stages I happily reflect on the people who inspired me to undertake this work.

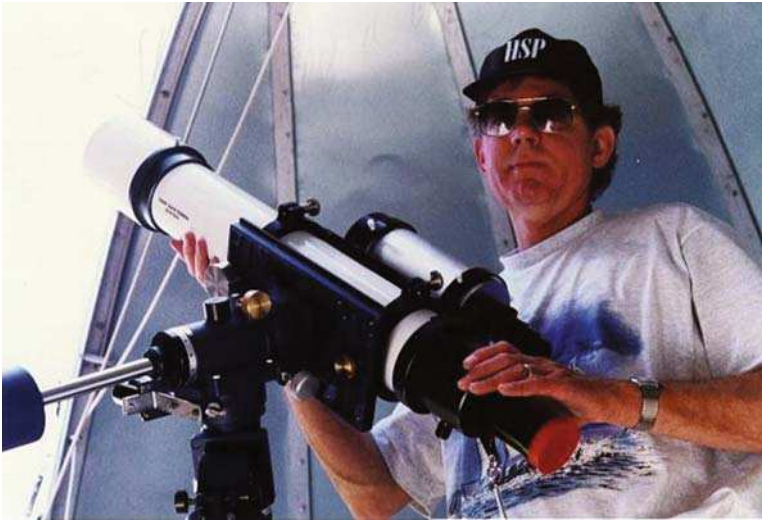
My beginnings in astronomy were unquestionably launched by the Royal Astronomical Society, Toronto Centre, almost 20 years ago, whose extraordinary enthusiasm for astrophotography and observatory building swept me up into a new pursuit. As years went on, attending the annual –Starfest– astronomy convention hosted by the North York Astronomical Association, and the Huronia Star Party Convention in Ontario, Canada, I was an occasional speaker talking about the design of observatories. Various refinements in the construction of these prototypes led to the ultimate design and creation of my own model, which has stood the test of time. My wife, conscripted to help in its construction, was indeed patient and understanding to put up with the countless hours of diagrams produced at the dinner table, and the geometry that was required to design such a structure. As the observatory dome took shape from a skeleton of curved aluminum angle, she was always there to hold a wrench or brace a rib while it was riveted to the curved panels. Many a wrench or rivet gun found its way into the forest, hurled in frustration well into its interior from the lofty dome. It has always been a mystery to me how she endured those hot humid worksessions with the sun’s reflection so strong it burnt our eyelids. She rightly deserves the most respectful acknowledgment for her devotion to a task that was essentially only in “my mind’s eye.– My first observatory was a domed observatory, entirely self-designed. We named it “New Forest Observatory– because of its location in the center of our magnificent pine forest (Figs. P.1 and P.2).



**Fig. P.1** John Hicks beside his observatory within a 20 acre pine forest. (Photo by John Hicks).

The “prototype” turned out so well that in fact it became an extension of the telescope you might say. Inside, on sunny mornings, searching the surface of the Sun with my Daystar hydrogen filter, I felt quite removed from the clamor of the rest of the world, and found real adventure surrounded by the “machinery” of the observatory. Lured by its presence against the forest backdrop, I found it hard to do my usual work, and many a client took second place to an observing run in my beautiful observatory. As time went on with improvements, I felt compelled to share the design with others, so I embarked on selling plans for the structure far and wide. Little did I know that hundreds of plan sets would find their way around the world to places like Iceland, Africa, India, and even Australia. It was a real pleasure to share my inspiration with others just starting on the same journey. My first design for a real customer was a request from Don Trombino in Deltona, Florida, who asked me to design a Roll-Off Roof Observatory for solar astronomy.

Don and I were both avid solar astronomers with special requirements for refractors, especially long-focus refractors, which suited the incredible hydrogen alpha filters produced by Daystar Corporation, then in California. The model in this book closely mirrors that which I designed for



**Fig. P.2** John Hicks inside the dome beside the main instrument – a 102 mm refractor. (Photo by John Hicks) (See *Color Plates*).

Don, which he dedicated as the “Davis Memorial Observatory– in memory of a close friend. We wrote articles together on “Shooting The Sun– and published articles and photos over the years in *Astronomy Magazine* (Figs. P.3 and P.4).

Don passed away in the mid nineties and I must believe his observatory still stands even as an elaborate garden pergola. I say this because he had self-designed an attractive patio under the gantry which held the rolled-off roof. He entertained many prominent guests under this enclosure celebrating his new observatory. Among them was Sir Patrick Moore. The most satisfying aspect of promoting a design is the conversations with clients who seek your help. Many situations arise that one never expects. Take the case of a Manhattan astronomer who had cut a hole in his roof for the observatory.

He called me in desperation with the building inspector and fire marshal at his door. They were demanding to know just what he was up to, perforating a large part of his roof. In a hysterical mood, he passed the telephone over to the fire marshal who inquired of me just what kind of structure the man was adding to his roof. I replied “an observatory of course.– I explained that I was a designer and supplier of plan kits for observatory structures all over the world. The “all over the world part– seemed to appease him somewhat, but he still wanted to know what qualifications I had. He was of course concerned over the draught potential created by the open roof in case of a fire. But I quickly informed him that it had to be sealed with a floor and trap door, in order for it to function properly anyway, as it must remain at ambient air temperature. This precaution seemed to provide him with the confidence he needed, and he left the telephone.

I presume all went well from there on as I was never asked for a set of plans by the fire marshal, or any other Manhattan agency.

I cannot overlook the inspiration which followed, from my good friend Walter Wrightman, endowed with a talent in both craftsmanship and inventiveness. Walter walked into my life after I had completed my first domed observatory, wanting to build one of his own. He was well on





**Fig. P.3** Sir Patrick Moore visits Don Trombino's Observatory in Deltona, Florida. (Courtesy of Jeff Pettitt) (See Color Plates).

into old age, suffered from diabetes, and some disability in walking. Yet bounded by these restrictions he designed and built, by himself, a most unique domed observatory. Walter had no formal education past grade eight, drove a cement truck most of his later working life, and took up the science of astronomy like no one I have ever met. Walter and I spent luncheons and coffee breaks for the next few years discussing ways and means of creating better observatories. We went to star parties far and wide to glean ideas, studied the night sky together, and were both so proud of the two observatories we had created. We became known locally, at least around the Town of Newmarket, Ontario, as the –Observatory Specialists.– We even talked about prefabricating the domes worldwide and traveling to exotic places to site them, all the while meeting the enthusiastic people caught up in a similar rapture. It never happened. Walter eventually died almost blind and unable to move outside the room that imprisoned him. He never stopped talking about observatories nor the various ways to improve the structures. Eventually, his observatory was sold to a friend, who was happy to buy such an exceptional model. I miss his friendship, and his overwhelming devotion to astronomy and the building of observatories.

I cannot help but credit him with being the second most influential person toward the writing of this book. I hope such inspiration spreads over to you, the prospective –inventor– of such a



**Fig. P.4** Don seated in the observatory finishing a solar observation and reading his notes. (Courtesy of Jeff Pettitt) (*See Color Plates*).

structure, for inventor you will be, certainly in the eyes of others who may watch you build it. And remember, before you dedicate its use to just an observatory, it will also serve as a great garden patio enclosure, thanks to my innovative friend, Don Trombino. I credit Don also for most of my inspiration for writing and the idea of launching a book. My only regret is that he is not alive to finally see it. He would have been really proud to see his observatory that he treasured so well, finally in print.



# Contents



<b>Preface</b> .....	vii
<b>1 The Benefits of a Permanent Observatory</b> .....	1
Pros and Cons: The Dome Versus the Roll-Off Roof .....	2
Roll-Off Roof Variations – The Sky is the Limit .....	3
Observatory Kits and Complete Observatory Fabricators .....	9
Other Types of Roll-Off Roof Observatories .....	14
Observing Sheds .....	22
<b>2 Observatory Design Considerations</b> .....	27
Size and Internal Space Required.....	27
Advantages of a Roll-Off Roof Observatory .....	30
Questions to Ask Before You Begin.....	30
Overall Site Requirements.....	32
Zoning – The Surrounding Land Use.....	35
Zoning – The Limitations on Your Own Property .....	37
Ownership Versus Leasing.....	37
Comparison of Roll-Off Roof and Domed Observatories.....	39
The Prestige of Ownership.....	39
<b>3 Options for Foundation Types and Laying out the Observatory ‘Footprint’</b> .....	41
Slab Footing Versus Sono Tube Footings.....	41
Preparing the Site and Orienting the Observatory .....	44
Measuring and Squaring the Building Footprint.....	44

<b>4</b>	<b>Fabricating the Telescope Pier</b> .....	47
	Combining a Concrete Pier Footing with Upper Metal Pier .....	48
	Full Length Concrete Pier .....	52
<b>5</b>	<b>Preparing the Footings and the Observatory Floor</b> .....	57
	The Concrete Slab Floor.....	57
	The Sono-Tube Footings Floor.....	63
	Observatory Floor Framing .....	68
	Combining a Poured Cement Observatory Floor with Sono-Tube Footings Under the Gantry .....	69
	Converting the Gantry Section into an Outdoor Patio .....	69
	Installing the Floor .....	71
<b>6</b>	<b>Framing the Walls</b> .....	75
	Constructing and Erecting the Walls.....	75
	Choosing, Locating, and Installing a Door .....	80
	Installing the Metal Pier Top.....	81
<b>7</b>	<b>Framing the Gantry Section</b> .....	87
<b>8</b>	<b>Fabricating the Track and Base Plate</b> .....	91
	Installing the Track.....	95
	Alternative Track Designs.....	95
	Track Ends and Stops.....	97
<b>9</b>	<b>Framing the Roof</b> .....	99
	The Assembly Process.....	99
	Construction of the Caster Plate.....	99
	Calculating the Rafter Lengths.....	100
	Framing Sequence (Layout of the Rafters on the Caster Plate).....	101
<b>10</b>	<b>Application of Steel Roofing</b> .....	109
	Tools and Equipment (1) .....	110
	Applying the Sheet Steel (see Endnote 1).....	112
<b>11</b>	<b>Exterior and Interior Siding</b> .....	113
	Exterior Siding .....	113
	Gable Vents and Fan Systems .....	114
	Interior Wall Sheathing .....	115
<b>12</b>	<b>Final Luxuries</b> .....	119
	A Winch System for Opening and Closing the Roof .....	119
	Comfort Items.....	120

**Appendix**..... 123  
    Conversion Tables..... 123

**Glossary of Terms** ..... 125

**Tools, Materials & Hardware Checklist** ..... 135  
    Tools ..... 135  
    Nails..... 136  
    Screws..... 136  
    Bolts..... 137  
    Fasteners/Hardware ..... 137  
    Footings/Foundation ..... 137  
    Roofing/Siding ..... 137  
    Track and V-Groove Roller Hardware ..... 137  
    Painting Supplies ..... 138

**Acknowledgements**..... 139  
    Photo Credits ..... 139  
    Products ..... 140  
    Advisors..... 140  
    Disclaimer ..... 140  
    Jobsite Safety Provision ..... 140

**Index**..... 141

## CHAPTER ONE



# The Benefits of a Permanent Observatory

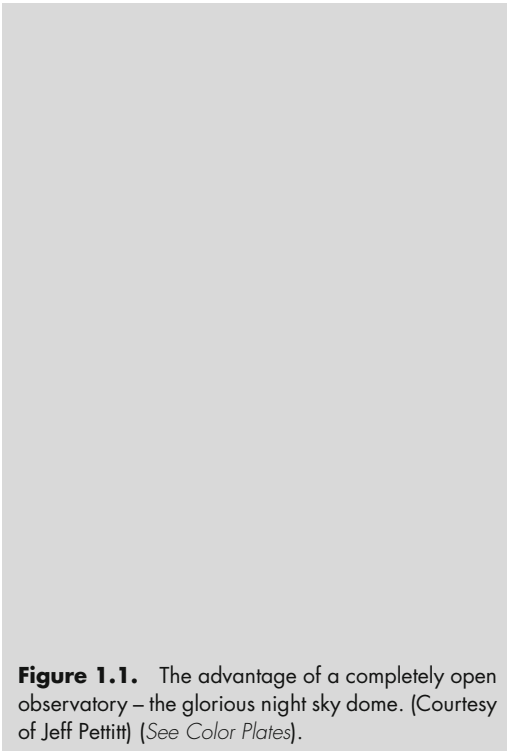
Any astronomer familiar with setting up an equatorial telescope will realize the time required to level, polar align, and prepare an instrument for an observing session. In the case of a non-computerized system, the tasks involved with centering Polaris with its required off-set for the North Celestial Pole is daunting enough night after night. Even with a computer-assisted “scope,” set-up time still involves the usual lugging of equipment out-of-doors from either residence or vehicle (although polar alignment is greatly reduced with computer alignment hardware). Final assembly can still stretch patience with the attachment of battery, dew heaters, and a myriad of wires connecting all the apparatus. Additional to all of this, many observers still have to carry out and assemble an observing table complete with sky charts, red light, lens case, camera and film. After completing this Herculean effort, particularly in northern latitudes, an astronomer usually begins to feel cold and exhausted while a degree of anxiety increases to finally use the instrument. This is often the prelude to damaging equipment or injury through acting too hastily with impatience. Repetition of such set-up experiences eventually discourages most observers who eventually reduce the frequency of their observing sessions, or trade the heavy equipment for lighter instruments with less aperture. The “lightening up” process works opposite to the usual “aperture-fever” affliction that burdens most astronomers with greater diameter lenses and mirrors and their subsequent weight increase. Under normal circumstances, amateur astronomers also find themselves observing out in the wind, in the cold, and eventually using an instrument that is covered with dew. In order to eliminate the majority of these unwanted effects, one really needs a permanent observatory. Simple forms of observatories are available, but almost of them also require a set-up time, offer little weather protection, and are not quite as “portable” as advertised. The primary decision involved with observatory design rests between choosing either a domed-type or a roll-off roof type structure. Both have distinct advantages however, depending on your personal observing needs – including the requirement for an all-sky view, protection from the environment, and degree of privacy. There are other design options for simple observatories such as the “clam shell roof,” the new cylindrical domes, and various types of shelters or housings that roll away to expose the telescope. Although these may be simpler to construct, they most often expose the observer to the elements, and are more difficult to weather-seal when not in use.

## Pros and Cons: The Dome Versus the Roll-Off Roof

Many owners of the roll-off roof type prefer an all-sky view, and are willing to tolerate the residual effects of wind, cold, and less control over light pollution (without the benefit of being able to select specific sky segments as with the dome slot). They also may be interested in hosting large groups, which of course demands the more spacious accommodation offered by the roll-off model. The person demanding a high degree of privacy in his viewing may appreciate the canopy provided by the dome, although the side walls of a roll-off type observatory still afford a reasonable degree of privacy. It is hard to concentrate on solar viewing for example when a host of neighbors watch you set up and enjoy your fumbles. Solitude is important for concentration and speculation. Admittedly, the roll-off roof offers a substantial improvement over just an open observing site, while the domed observatory may further reduce most annoyances, achieving a completely sheltered structure. The crucial decision to make in selecting either is one of sky view. If you want to see the whole sky dome at once, the roll-off is the better choice (Figure 1.1).

In addition, the roll-off roof type quickly cools down to ambient temperature with the entire roof rolled off and the instrument(s) entirely exposed to the open sky. Fast cool down is not as easily attained with a dome-type structure.

However, on the other hand one need only step outside to see the heavens, and concentrate on a portion of it inside. Cost factors and degree of skill enter into the equation also. The roll-off will be simpler to build (wood construction and no curved sections) and less expensive in parts and labor. But in terms of durability, the all-metal dome will outlast it.



**Figure 1.1.** The advantage of a completely open observatory – the glorious night sky dome. (Courtesy of Jeff Petiitt) (See *Color Plates*).







**Figure 1.2.** The author’s domed observatory – portrays its single use, attracting both desirable and undesirable attention. (Photo by John Hicks) (See *Color Plates*).

Identification of the dome as the “symbolic” structure used by astronomers may be an asset to someone who wants to advertise to the community that their hobby is astronomy (Figure 1.2).

On the other hand, one may want to maintain a lower profile in high crime areas, preferring to “hide” the facility as a garden shed. In essence, the choice is dependent on many factors, including site constraints and budget, along with the particular objectives and skills of the observer.

## Roll-Off Roof Variations: The Sky is the Limit

The observatory I designed for Don Trombino in Florida, fulfills both astronomical and landscape functions. With its exquisitely finished interior, and practical outdoor patio under the gantry, this observatory stands out prominently.

The owner, the late Don Trombino, was so proud of his achievement, that he spent almost all his waking hours either inside it or under the patio. He further extended the observatory feature out into the garden with a stone paver walkway leading across the yard terminating with a sundial monument. The floor under the roof gantry was also set in stone pavers and the underside of the gantry “ceiling” covered in a prefab wooden lattice. When not solar observing, Don spent many hours on the patio, examining the results of his photography, or writing. He dedicated the structure “The Davis Memorial Observatory” and symbolized the dedication with various artifacts and historical items placed in the garden and on walls of the structure (Figures 1.3 and 1.4).

Once and a while certain observatories stand out as truly professional structures, finished to the point excellence. Such a model is Mike Hood’s observatory, complete with outside porch under the gantry, featuring a door on the gable end. Mike has put extra effort into tapering the hip roof back from the gable ends, adding a small “cottage look” to his observatory. Very tastefully finished, it has an interior just as spectacular. His structure is long enough to hold a complete control room with desks, cupboards, an air-conditioning unit, and a window. Overall the





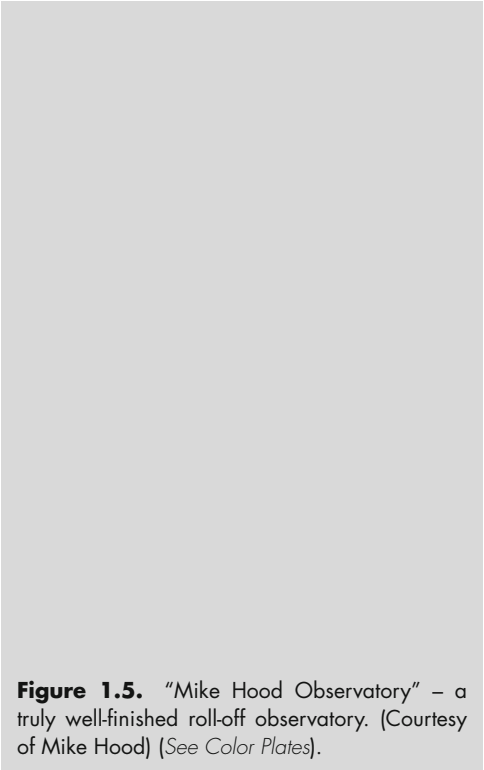
**Figure 1.3.** Close-up “Davis Memorial Observatory” with its patio garden under the gantry. (Photo from the collection of John Hicks) (See *Color Plates*).



**Figure 1.4.** “Davis Memorial Observatory” with walkways, sundial, and landscaping. (Photo from the collection of John Hicks).

control room has the appearance of a high-tech whiteroom, temperature-controlled and very well designed. Apparently the observatory was from an original model by “Backyard Observatories” (Figures 1.5 and 1.6).

Gerald Dyck’s roll-off roof observatory in Massachusetts presents a compact, attractive addition to his yard. The roof line is particularly well-designed with a skirt that extends down



**Figure 1.5.** “Mike Hood Observatory” – a truly well-finished roll-off observatory. (Courtesy of Mike Hood) (See Color Plates).



**Figure 1.6.** Mike Hood’s Control Room complete with desks, cabinets and air conditioning. (Courtesy of Mike Hood) (See Color Plates).



**Figure 1.7.** Gerald Dyck's Compact Observatory, well-protected from the elements. (Courtesy of Gerald Dyck) (See *Color Plates*).

over the walls to keep out insects, and the elements. Note the use of an exhaust fan on the gable (Figure 1.7).

The wall height is also kept lower, presumably due to the roof skirt which replaces a portion of it below the normal soffit level. This allows for more accessible horizon-level viewing as the photo below illustrates. The telescope shown can reach lower elevations than most, swinging even further down than the position shown. The Dyck's prefer to utilize telescopes on tripods rather than on a fixed pier. Although quite suitable for alt-azimuth mounts such as a Dobsonian cradle (shown), their future plans will most certainly involve a fixed pier with an equatorial mount (Figure 1.8).

Although the entry door is lower than a full height door, it is made more accessible by the fact that the observatory is raised off the ground considerably. Such an arrangement allows the operator to step up into the structure rather than stoop to get into it at more normal foundation levels. I used this technique myself on my first observatory which had only 4 ft high walls. The increased height of the floor off the ground also prevents skunks, squirrels, possums and groundhogs from seeking refuge permanently under it. There is little protection from wind or the elements with so high a crawl space underneath. It also allows alterations in wiring underneath or the addition of insulation under the floor. In crawl spaces like this, it is wise to line the ground surface with landscape fabric (two layers minimum), covering the entire area underneath with 4 in. of 3/4" crushed gravel. This treatment prevents weeds, and discourages animals with its sharp edges of gravel. It also has an attractive, clean look underneath which prevents excess moisture, moss etc, from accumulating in the shaded environment (Figure 1.9).

Dave Petherick of Ontario, Canada has built a well-landscaped observatory on a typical suburban lot. He has incorporated a beautiful deck complete with trellis as an integral part of his observatory design. In fact, the deck is an extension of the observatory which allows for a large area for entertaining, barbecuing etc. The trellis appears to be an extension of the gantry which





**Figure 1.8.** Gerald Dyck’s low observatory wall design with Dobsonian telescope inside. (Courtesy of Gerald Dyck) (See Color Plates).



**Figure 1.9.** Gerald Dyck’s Roll-Off Observatory showing open roof with low door. (Courtesy of Gerald Dyck).

transforms it into a “landscape feature” thereby creating a dual function for the observatory – both astronomy and gardening. It also serves to “hide” the true function of the gantry which would lessen the footprint area of the structure, the gantry portion appearing more like a garden trellis. Complete with shutters on “mock windows,” the observatory looks just like any other

well-designed garden shed. This is the look I'm recommending builders aim for. Again, notice the gable fan which can be used prior to an observing session to evacuate hot air from the interior, bringing the observatory and contents closer to ambient temperature. Dave appears to have constructed a corner dark room for his computer, the monitor shown temporarily outside on a table. Overall, a very handsome design, well thought out, and an attractive addition to any rear yard (Figures 1.10–1.12).



**Figure 1.10.** Petherick Roll-Off Observatory showing gantry transformed into trellis. (Courtesy of Dave Petherick) (See *Color Plates*).



**Figure 1.11.** Petherick Roll-Off Observatory showing deck and surrounding landscaping. (Courtesy of Dave Petherick).



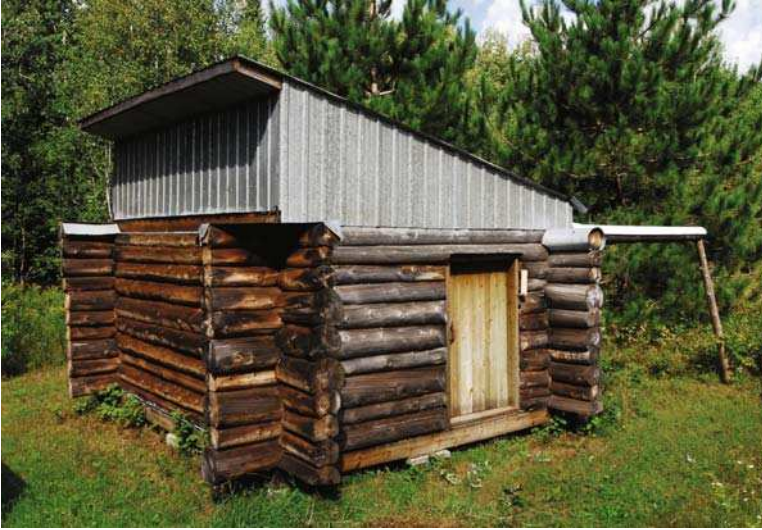
**Figure 1.12.** Inside Petherick Roll-Off Observatory. (Courtesy of Dave Petherick) (See Color Plates).

Of the various types of Roll-Off Roof observatories I have seen, Guy Boily's log frame observatory wins first place for unique structural components. Only the roof appears to be constructed with traditional framing materials, finished in an metal or vinyl ribbed siding. The logs forming the four walls had to be carefully chain-sawed to lap one over the other at the corners, and further grooved along their lengths to fit comfortably together, avoiding the normal "chinking" process to seal off draughts. Looking at the walls from the inside there appears to be no air gaps whatsoever, requiring some precision in fabrication. Bracing the gantry appears to be accomplished by burying poles on an angle resisting the force of the roof being pushed out over rails toward them. The top log, which would be the caster rail nailed to the top plate in our model, is a continuous log pole in Guy Boily's model which simply extends out over the entire run of the gantry (something we cannot do with traditional lumber with its 16 ft maximum length). The castor track appears to be a steel angle fixed to the top log throughout, and the casters running on it fixed to the roof framing. Its refreshing to see the use of unique materials and a departure from the usual "balloon frame" construction (Figures 1.13–1.17).

## Observatory Kits and Complete Observatory Fabricators

For those who do not wish to construct an observatory themselves, or who need it in a kit form, there are suppliers who will manufacture and install complete observatories. Often included in their list of services are options for rolling left or rolling right variations, material lists, step-by-step construction advice, steel pier plans, and even maintenance hints.



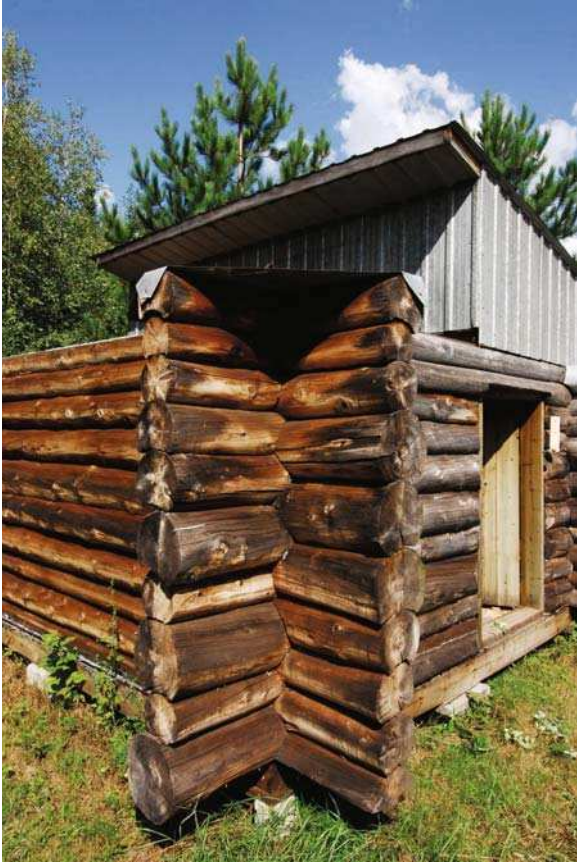


**Figure 1.13.** Log frame observatory with roof in closed position. (Courtesy of Guy Boily) (See Color Plates).



**Figure 1.14.** Log frame observatory with roof in open position. (Courtesy of Guy Boily) (See Color Plates).

Some of the sizes offered range as high as 10 ft  $\times$  14 ft – nearing the size of the model featured in this book. For the more senior astronomer, or one who is not familiar with using hand tools, or understanding diagrams, it is a definite option. These models possess light construction techniques throughout, and sturdy engineering where it counts. Overall the customers seem quite satisfied and proud of their observatories. Although this book is directed toward constructing



**Figure 1.15.** Log frame observatory showing log walls with corner overlap. (Courtesy of Guy Boily).



**Figure 1.16.** Log frame observatory looking inside. (Courtesy of Guy Boily).





**Figure 1.17.** Log frame observatory gantry. (Courtesy of Guy Boily).



**Figure 1.18.** "The Ussher Observatory" – a prefabricated model by "Sky Shed." (Courtesy of Terry Ussher).

an observatory from plans of my own design, I still feel it is fitting to offer options that might otherwise be suitable for those that do not have the resources to build it. And, by coincidence, a close associate of mine has such an observatory which I would like to illustrate. The main attraction with this particular model is the use of garage door track and rollers, which for a small roof load seem to operate satisfactorily. This arrangement omits the requirement to make a track and purchase the V-groove casters outlined in this book. However, for a larger roof section, such as the size that our model requires, I would highly recommend the more sturdy assembly that I have detailed. Overall, the prefabricated structures look like a normal garden shed, and are complete with planked siding, steel roof, door and optional window (Figures 1.18–1.21).



**Figure 1.19.** "The Ussher Observatory" – close – up of structure with roof closed. (Courtesy of Terry Ussher)



**Figure 1.20.** "The Ussher Observatory" – roof interior showing rafters and no collar ties. (Courtesy of Terry Ussher) (See *Color Plates*).



**Figure 1.21.** “The Ussher Observatory” – close-up of garage rollers and track. (Courtesy of Terry Ussher).

## Other Types of Roll-Off Roof Observatories

Some roll-off roof systems are designed to roll off in two halves, in opposing directions which requires two separate gantries and two sets of tracks. This arrangement lessens the roof load on each separate gantry, but requires more workmanship in building and aligning the two gantries. It also introduces the prospect of misalignment of the extra gantry due to settling, wind storms, etc. Several techniques have been used to solve the problems of roof flashing where the two halves come together upon closing. A simple solution to securing the roofs together once shut, is the use of large wood clamps where they meet. An additional clamp would have to be placed at either end of the observatory (Figures 1.22–1.24).

The heart of this ingenious roof system is the four wheel beam assemblies which are made of 3” × 3” steel box tubing. The box tubing was cut open to house two wheels on each length. Each side of the 10 ft roofs held one box tube complete with its two rollers. The wheels run in steel angle just as we are proposing in our design (Figure 1.25).

Tabs welded onto the top of the box tubing allowed attachment to the roof trusses. This design allowed the roof to “hug” the top plate very closely, almost eliminating the usual air gap between roof and walls. An extra bonus of such an arrangement is the ease of keeping the track and rollers clean. Overall, a very efficient design and worthy of copying by those with milling and welding skills (Figure 1.26).

Weather-proofing the rolling roofs usually requires a “Z” type flashing on one half with an angle strip on the other half which the top flange of the “Z” flashing slides over. The design and





**Figure 1.22.** "Rocky Plains Observatory" – a twin roll-off roof observatory showing open roofs. (Courtesy of Bob Luffel) (See *Color Plates*).



**Figure 1.23.** "Rocky Plains Observatory" – showing roofs closed and the gantry braces. (Courtesy of Bob Luffel) (See *Color Plates*).



**Figure 1.24.** Roof Clamps hold the two halves together when the observatory is not in use. (Courtesy of Bob Luffel).



**Figure 1.25.** “Rocky Plains Observatory” roller system – the wheels are V-groove, same as suggested in our plan but Bob has ingeniously enclosed them in a steel box beam – each roof section carries its own two sets of box beams enclosing the wheels. (Courtesy of Bob Luffel) (See *Color Plates*).



**Figure 1.26.** “Rocky Plains Observatory” inside track – illustrating how snugly the roof joists and thus the roof hugs the top of the observatory wall. (Courtesy of Bob Luffel).

braking of these flashings are best left to a roofing or heating contractor, who should be consulted if you wish to go this route (Figures 1.27 and 1.28).

With the increasing use of computers and CCD cameras, it is very advantageous to incorporate a “warm room” into the observatory structure to keep the computer warmer than ambient air in cool seasons. It also serves as a dark room to house the astronomer preferably at a small desk with a comfortable chair. A particularly unique variation in possible designs is placing the observing part of the structure lower than a “warm” room section. This arrangement allows for a smaller roll-off roof portion, which is lighter and shorter than a design which tries to put both uses under one long rolling roof. This is a very effective solution accommodating both uses. The rolling roof rolls off in the opposite direction to the fixed “warm room” roof, and simply “tucks” under the fixed warm room roof gable when closed (Figures 1.29 and 1.30).

Another innovative variation resembles an “A-frame.” When rolled fully apart the two halves create an open-sky viewing area. The telescope rests on a pier in a somewhat “lofty” position well above the level of the observer’s head – a good position for a refracting telescope. Because of its height, the telescope can swing to most areas in the sky being high-up towards the “peak” of the two roof halves.

When finished for the night, the owner simply points the telescope east-west horizontally, pushing the two halves of the structure together, then exits via the undersized door. Notice how the overhang on the north end of the observatory will clear the horizontal tube when in a closed position. The taller (north) half blocks an area of the circumpolar region under Polaris where little observing is done. Each half moves on six casters running on 20 ft wooden rails set 10 ft apart. The owner finds that sometimes it is not necessary to roll both halves apart: one side can remain stationary to block the wind while the other moves to an advantageous position for viewing.



**Figure 1.27.** Z-flashing on open roofs – “Rocky Plains Observatory.” (Courtesy of Bob Luffel).



**Figure 1.28.** Z-flashing on closed roofs – “Rocky Plains Observatory.” (Courtesy of Bob Luffel) (*See Color Plates*).





**Figure 1.29.** “Ballauer Observatory” – illustrating higher warm room section, lower roll-off roof, and attached open storage area. (Courtesy of Jay Ballauer).



**Figure 1.30.** “Ballauer Observatory” – illustrating how roll-off roof tucks under the higher warm room roof above it. Note casters and the large air gap between roof and walls. (Courtesy of Jay Ballauer) (See *Color Plates*).

When closed, this observatory measures only 10 ft × 10 ft, just fulfilling the maximum area size under building code exemption. The observatory eliminates the effort of constructing a roll-off roof track and gantry, although I suspect in a harsh climatic zone, a foot of snow could provide a real nuisance, requiring shoveling the rails and platform clean. Once left for any period of time encrusted snow would create a larger problem (Figures 1.31–1.34).



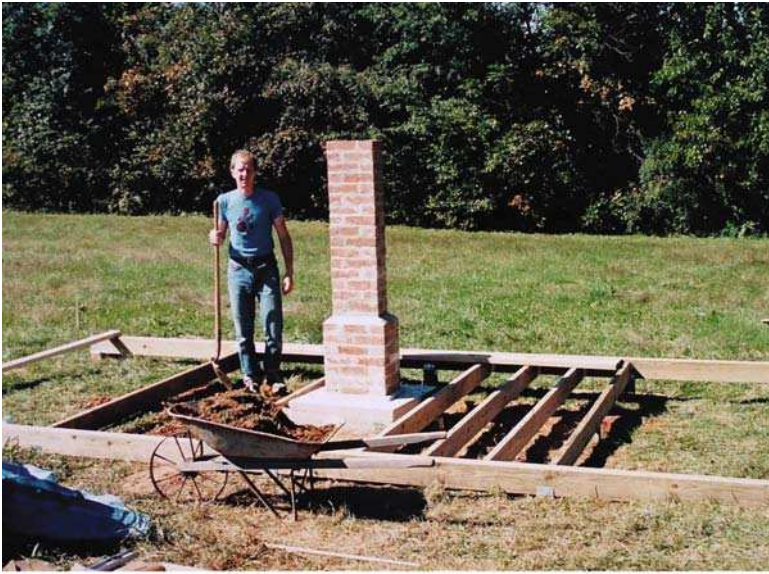


*Closed Roll-Apart Observatory- (During Construction)*

**Figure 1.31.** "A-frame" style observatory built in two rolling halves showing observatory closed. (Courtesy of Greg Mort).



**Figure 1.32.** The owner seated inside the "A"-frame observatory with the two halves open and a cloth screen for wind protection. (Courtesy of Greg Mort) (See Color Plates).



*Observatory floor & pier construction*

**Figure 1.33.** Tall brick pier designed to hold a large refractor just below the roof peak such that it will clear the lower roof half. Note the size of the cement footing just visible under the pier and the stepped nature of the brick column. (Courtesy of Greg Mort).



*partially framed roll-apart observatory-showing casters*

**Figure 1.34.** Sturdy observatory foundation showing the six castors on each side. Also note the simple construction which eliminates fabricating roof trusses. The walls are the trusses. (Courtesy of Greg Mort) (See Color Plates).

## Observing Sheds

One solution to eliminating the roll-off roof and gantry entirely is to construct a normal garden shed in either hip roof or barn roof format, adding a small enclosure to it at the south end. This is constructed large enough to allow full instrument swing and room for the observer. The roof on this addition is simply a normal shed-style roof, hinged to swing upward with appropriate braces to hold it in position vertically. It could also be designed to slide off or lift off much like a cabin hatch on a sailboat. The roof will have to be constructed of light-weight materials if it is a lift-off arrangement. Ideally, the telescope, mount and pier are fixed in place under the “hatch” and polar aligned. This can be accomplished with a suitable pier if there is room for it, or a tripod that rests upon small pedestals under each tripod leg. To assure that polar-alignment is maintained, the small pedestals must be impressed in some way to accept the legs in the same orientation each viewing session. Conversely, a telescope on a tripod could be hefted from the shed portion into the addition and polar-aligned each session, but this defeats the purpose of an “instant” viewing session afforded by a permanent, fixed situation. Its drawbacks include little or no view of Polaris and the northern celestial sphere, plus the difficulty to keep a tripod polar-aligned unless a permanent pier is poured in position. A permanent, fixed pier is the best solution which takes us back to the roll-off roof design (Figure 1.35).

Clam-shell Roof observatories are worth investigating, even though their roof(s) do not roll-off. Built on a low box-type wall, they offer the maximum sky view, almost completely exposing the astronomer to the elements. Most are designed such that the operator must step over the low wall into the structure, which in the dark becomes a hazard for visitors who have to be guided over it. Occasionally, a builder includes a low hinged entry door as in the model shown below. The roof halves are each counterweighted with heavy cement blocks or thick steel plates on arms



**Figure 1.35.** Barn-Shed style Observatory “Big Woodchuck Solar Observatory” showing the roof hatch open ready for observing. (Courtesy of Larry McHenry).





**Figure 1.36.** North York Astronomical Association Observatory at the “Bog” with roofs open showing the small entry door and excavated channel alongside wall for the swing of the counter – weights. (Courtesy of Danny Driscoll and NYAA).

which extend outward from the roof “gables.” These “arms” must be constructed such that they will not hit the ground surface as they rotate when the roof is swung open. The “arms” must also be of sturdy construction to carry the heavy counterweights. Often it will be necessary to dig a channel alongside the observatory walls to allow for the swing of the counterweights, which appears in the picture below with the white roofs (North York Astronomical Association observatory at the “Bog,” designed by Andreas Gada, north-west of Toronto). Notice the supports on this model holding the heavy roof sections once opened, to ease the stress placed upon the hinges. The other model shown with particle board exterior has no such support but is of lighter construction.

The main difficulty in building this type of structure is balancing the roof sections with the counterweights (which can only be done with trial and error procedures), and the construction of the triangular roof sections. For all the trouble in constructing this type of observatory, it does not offer the protection nor convenience of the roll-off roof model. A major complaint with the structure is leakage through the roofs at the seam, or at the junction of roofs with the low walls (Figures 1.36–1.38).

The simplest of designs involves a lightweight, transportable “hut” which assembles in panels with a roof “lid.” The panels are hinged together with upper portions that can be hinged down individually to allow viewing near the horizon. The roof “lid,” sits on top of the vertical side-panels with its own small hinged panel which can be swung open and back to create a “slot” for viewing. Overall the design was very simple yet effective, and easy to put up in 10 min. It was affectionately named the “Clapp-Trapp” after its creator, Douglas Clapp, and found use throughout Ontario with stargazers who wanted a quick, temporary shelter for observing. Large enough to house a single astronomer comfortably, the walls held pouches for accessories which could be reached with a turn of the body inside. Fully erected, each section stood 6 ft high, and 4 ft wide (2 ft × 2 ft sections hinged together). A tarpaulin placed on the ground before assembly kept out moisture, snow, and insects. The entire structure assembled weighed in at 125 lb. Requiring only about three evenings to construct, it could be built from 4-1/2 sheets of 1/4 in. plywood for less than \$200.00. Plans for the model are still available from the author, now known as “The Super Portable Observatory” (Figures 1.39–1.42).



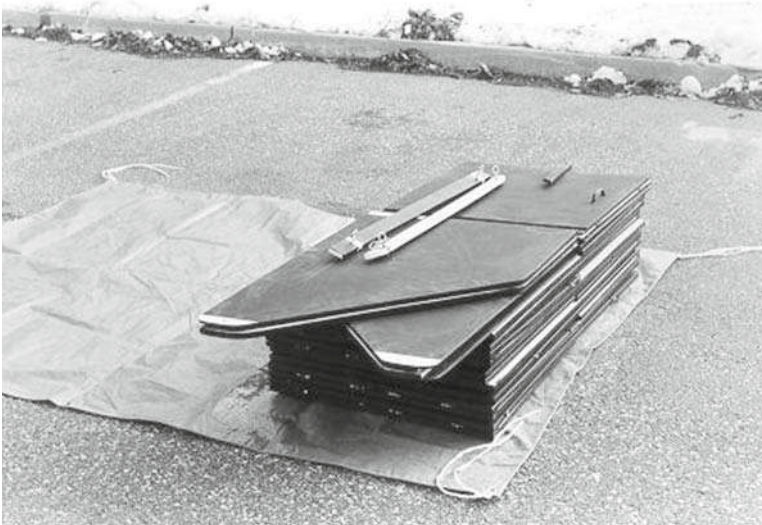
**Figure 1.37.** Paul Smith's Clam shell Observatory closed showing slope on split roofs. (From the collection of John Hicks).



**Figure 1.38.** Paul Smith's (1995) Clam Shell Observatory open showing 10 in. reflector. Note that the north roof half swings only vertical affording an excellent shelf for equipment cases, lenses etc. (From the collection of John Hicks).

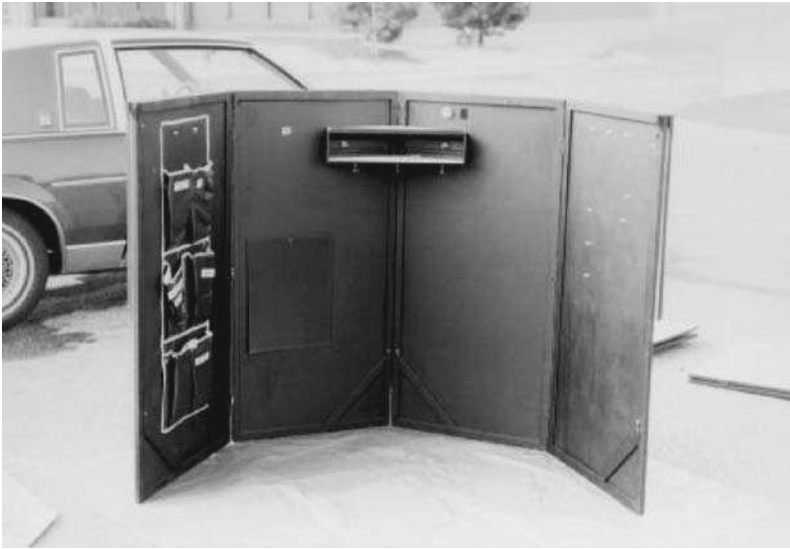


**Figure 1.39.** The first model of the "Clapp Trapp" showing the numbered wall panels, with some wall faces swung down, and the roof in place. The purpose of the wall panels which swung down was to observe objects nearer to the horizon. Not all wall sections had swinging panels in order to maintain stability. Too many panels swinging down would leave the roof unsupported. (Courtesy of Doug Clapp).

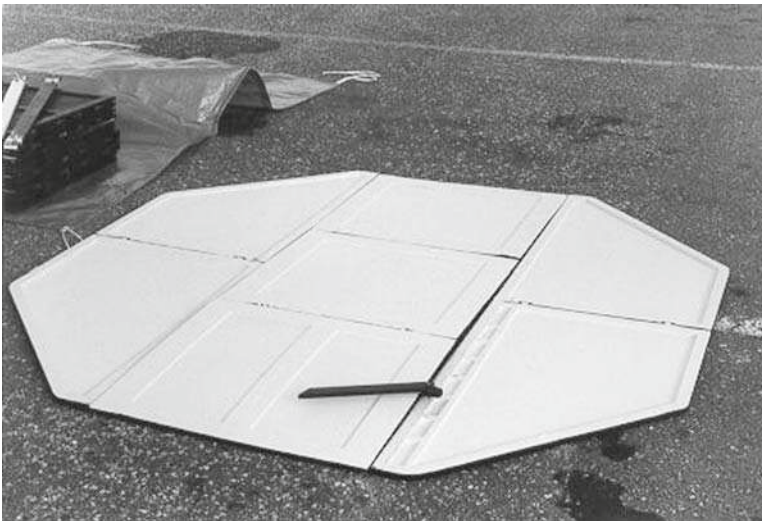


**Figure 1.40.** The "Clapp Trapp" was easily folded up into a 14 inch high stack of folded panels measuring 2 ft x 4 ft and weighed only 125 lb. It fit into most larger vehicle trunks. (Courtesy of Doug Clapp).





**Figure 1.41.** The “Clapp Trapp” walls were hinged in pairs allowing them to be self-supporting during assembly. They hooked together to form an octagonal structure which supported the roof. Note the smart use of “pouches” to hold accessories on the inside walls. (Courtesy of Doug Clapp).



**Figure 1.42.** The “Clapp Trapp” roof assembly showing the folding observing hatch and its “prop stick.” To follow the motion of the stars, the roof is simply lifted off slightly from inside (it weighed only 25 lb), and rotated into the proper position. (Courtesy of Doug Clapp).

## CHAPTER TWO



# Observatory Design Considerations

## Size and Internal Space Required

Several criteria combine to create the minimum size requirements for your observatory. These include the height of the astronomer first and foremost. The focal length of the telescope combined with its type of mounting are primary factors to consider next. The optical configurations of existing and future instruments planned for are equally important whether refractor, Newtonian, or Schmidt Cassegrain models. The walls surrounding the observatory are usually designed to allow the optical axis of the telescope to clear them when it is in the horizontal viewing position. Since this is also the usual storage position, the walls will have to be higher to allow the rolling roof to completely clear it when rolled shut. This is a necessity since the gable ends or roof rafters would strike the telescope on closing. At any rate, seldom does one observe on the horizon, or even a degree or two above it due to light pollution or landscape obstructions, so the need for horizontal viewing is largely unnecessary (Figures 2.1 and 2.2).

The German Equatorial Mount, possibly the most ordinary configuration, is the most demanding to accommodate since its swing and roll-over positions require an extra space tolerance beyond most other mountings. For refractors, a typical allowance between eyepiece and walls might amount to about a meter, – still wide enough to allow for some crouching on the part of the observer. Newtonian reflectors, which place the eyepiece off the optical axis on the telescope tube side need less allowance for the observer viewing objects at the Zenith, since he/she is likely standing for such an observation. *Clearances* as low as one-half meter are suitable in this position, provided the observer is standing and not bent over. In the case of Newtonian-type telescopes, the mount is usually designed to place the eyepiece at eye level, and is dependent upon the height of the observer (Figure 2.3).

Lower-angled Newtonians often need a bent or seated position on the part of the observer, and possibly the accommodation of an observing chair, which will require more clearance.

Refractors on German Equatorials present the observer with the same awkward positions.





**Figure 2.1.** Mid-construction test: Refractor fits under closed roof when rotated completely horizontal. If calculations had been incorrect, the pier or cement base pedestal would have to be shortened. (From the collection of John Hicks).

The difference is largely due to the fact that the observer looks down the optical axis of the refractor which places him/her at the very end of the telescope, really squeezing the observer against the walls or even the floor in certain viewing orientations.

Schmidt-Cassegrain type reflectors, although compact, are often mounted on a fork & wedge assembly which is adjusted to the observer's latitude. This arrangement offsets the instrument from the pier and is usually best arranged so that the offset is to the south (mainly because the majority of deep sky objects locate in the southern sky). This allows more space for the observer to sit or bend down on the north side of the pier, but constricts space on the south side. The zenith position of the telescope usually places the eyepiece within the confines of the forks, (held in a diagonal), and the telescope pointing vertically. Often this position is more easily accessed on the other side of the mount, with the diagonal rotated toward the south wall where space is more limited. Respecting all these criteria when planning will produce a comfortable volume for you to observe within, but neglects the requirement for visitor space.

If your interests include accommodating groups, the above measurements will have to be increased to provide ample space.



**Figure 2.2.** Completed “Davis Memorial Observatory” with refractor at rest position ready for roof closure. (From the collection of John Hicks).



**Figure 2.3.** Don Trombino imaging the Sun with ample wall clearance behind him. With this much Instrumentation, it is essential to have a good working distance. (Courtesy of Jeff Pettitt).

Tables have been created listing instrument type, focal ratio, telescope tube length, mount height, and floor area required. Actual measurements of your instrument on your pier of choice in all its various swing positions is actually required. Nothing substitutes for a well-planned analysis of your present or future instrument. It is always best to err on the design toward oversize because your instrument may change with time. The expenses involved with a slight increase in size are

not excessive if you are self-constructing it. Build your observatory with the prospect of expanding it someday. The requirement for a computer room/warm room is better accommodated now than having to add onto the structure later. The design which involves a higher roofed, permanent warm room with a lower roll-off roof section is the way to go. I would not advise the lengthening of the roll-off roof section as that will increase its weight and load on the track, requiring extra casters and more force to move it on and off.

An alternative arrangement toward establishing a warm room using the model exhibited in this book involves the addition of a lower-roofed extension under the gantry in the north end. With its own permanent roof, insulated wall between, door, and a thermal window between the rooms, it will function as an ideal warm room without disturbing the gantry or compromising the roll-off feature. Although the roof will be low, working on a computer is normally more comfortable in the seated position, so complete standing room clearance is not necessary.

## Advantages of a Roll-Off Roof Observatory

The decision to build a roll-off roof type observatory affords the following benefits:

- (a) the telescope, mount, and drive components are protected from the elements when not in use.
- (b) instrument cool-down time is fast with the entire roof rolled away, and ambient air temperature is reached quickly.
- (c) some equipment in use can be protected from dew if the roof is partially rolled off.
- (d) wind and cold protection is partially afforded from ground level currents with adequate side walls.
- (e) offers a permanent storage area for charts, books, and even equipment.
- (f) offers a permanent electrical connection, covered and water-tight.
- (g) offers a safe lock-up area if wired to a house alarm system.
- (h) increased security through its shed-like appearance, masquerading as a normal out-building (unlike the domed type which portrays a scientific use with its associated expensive instrumentation contained within).
- (i) the option to use it for general storage purposes if the hobby loses its appeal.
- (j) opportunity for work station, greater visitor accommodation and group sessions (Figure 2.4).
- (k) generally easier to accept on a re-sale of the property because it masks as a shed.
- (l) easier to construct than a domed observatory.
- (j) usually less expensive to build than a domed observatory (aluminum domes are high in price).
- (n) no special tools required (except for the welding of track – best contracted out).

## Questions to Ask Before You Begin

1. Do you have sufficient space to build an observatory? (the roll-off roof type requires more space than a domed observatory requiring a roll-off gantry frame).
2. Are you planning an outdoor patio? The roll-off roof observatory can be utilized as an outdoor sitting area if the gantry portion is improved with a sun trellis just under the gantry



**Figure 2.4.** Cramped interior of a domed observatory leaves little space for a work station or room for more than two visitors due to curved walls and central pier. (Photo by John Hicks).

frame. A stone paver patio can be added underneath the gantry thereby disguising the whole observatory as a shed with patio attached.

3. Are you willing to exert the effort to build an observatory?
4. Does your observing program demand an all-sky view?
5. Does your local building code exempt structures less than 100 ft<sup>2</sup> in area from building permit requirements? (if so, it might be to your advantage to limit the observatory dimensions to 10 ft × 10 ft, although the building code may not exempt the extra square footage contributed by the gantry).
6. Do you plan to host large groups of observers or star parties?
7. Will the roll-off roof model house your present or planned instrument? Beware that longer refractors require a large volume to swing through all viewing positions.
8. Can you orient the observatory to fulfil all the necessary sideyard requirements of your local Zoning By-Law? This could also include rear yard set-back, side yard set-back, and lot coverage (the % of the lot covered by buildings). It might also forbid the construction and use of an “accessory building” without a “main use,” meaning that you cannot construct an observatory without a residence being there first, or at least simultaneously).
9. Assuming you have a partially treed lot, can you site the observatory with enough open sky opportunity? Will it require some tree removal? Note that some municipalities have stringent tree by-laws which require an exception to the by-law or a minor variance and a permit to remove. Careless removal could result in a fine.
10. Is the star Polaris accessible in your chosen location? (a necessity for polar-alignment with non-computerized telescopes).
11. Some counties/municipalities define the “permanence” of a structure as the limiting factor in exceptions to the local building code. Placing the structure on footings might qualify as a temporary-type building, whereas pouring a huge concrete (permanent) slab, may not. In all cases, describe your project as a garden shed observatory. Larger observatory structures will require engineering approval and a building permit, whereas a smaller garden shed-style

observatory will generally fall within the exception limits of the building permit requirements. Research the application of your town's building code, find out how your structure can be permitted, and then build it to suit the requirements of the code.

## Overall Site Requirements

### Polaris and the Southern Sky

A prime concern in siting the observatory will be the availability of Polaris and the southern sky. The star Polaris is essential for polar alignment of your instrument on the pier during observatory construction, and in years following for accurate tracking. In addition, since the southern sky has so many interesting objects to explore, its access is almost a prerequisite for siting an observatory. If foliage does block the view to Polaris, it can be selectively pruned for the few times that one does need access, although this may require permission from adjacent owners. It may also take some precision, requiring two people – one at the finder telescope eyepiece, and one distant with a pole saw.

### Access

Considering the tools and materials that are required to build the observatory, access by vehicle is important, particularly when a cement truck is available to pour the slab and telescope pier. The use of a portable gas or tractor-driven cement mixer is quite acceptable but the provision of water, mix, and construction materials will require some slugging from a roadside vehicle to the observatory site. Also, vehicular access becomes a critical factor when planning future star parties, and along with a small parking area, makes the observatory all the more functional. A good road with a good base and sufficient gravel added will make the venture more feasible.

### Electrical Service

The potential to hook up to electrical service is a factor to consider in the siting of an observatory, eliminating the need for an electric generator. In the future it will become increasingly obvious that electrical service is a real asset, providing reliable lighting, steady telescope drive control, heating for a warm-up hut, and possibly security alarm power. Poles carrying service are cheaper than burial of wire but obvious against the sky if observing low on the horizon. In addition, buried cable is very expensive. In some states and northern municipalities burial of wire is mandatory.

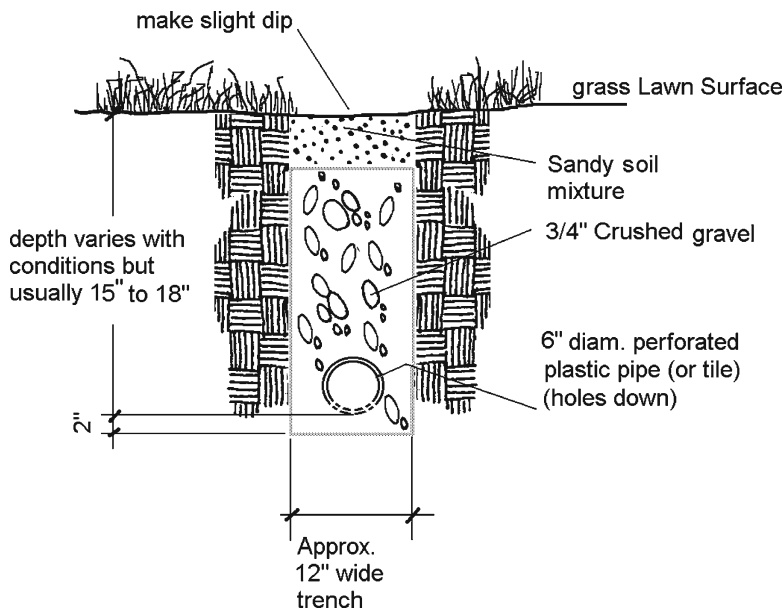
### Elevation and Seeing

Second in importance is the elevation of the proposed site in relationship to the surrounding landscape. Obviously, the higher the chosen site is with respect to land around it, the more available is the southern horizon for viewing. Also, a higher site will tend to reduce air turbulence near the ground, particularly if the observatory is on a knoll or hill top. This is largely because rising, hot air from the surrounding landscape is confined somewhat to lower elevations. Every meter above the surrounding base plane will normally improve seeing.



## Soils and Drainage Suitability for Footings

Several issues confront the observatory builder in addition to maximum sky access, and the technical constraints required for good astronomy – probably the most important is drainage. Make sure your chosen location isn't in a low area, or on a drainage course. Permanent wetness along with freeze-thaw cycles will destroy concrete footings and slabs faster than any other environmental effect. Footings may fracture and slabs will crack or flake with continued wetness and freezing. Even moderate dampness will flake the top surface of a cement floor once frigid weather settles in permanently. If your chosen site is wet and not on a drainage course, attempt to fill it in. Adding a good sandy soil mixture, tamp it firm or compact it by rolling it repeatedly with a heavy turf roller. You can alternatively let it sit over a year for the soil to compact under its own weight before any construction commences. On excavation, a wet sub-soil can be improved with the addition of plenty of 3/4" crushed gravel around and underneath the sono-tube footings or under a cement slab if you choose to go that route. This allows air to circulate and dry out the interstitial spaces between gravel and soil, maintaining a dry column around and under the cement forms. This technique is usually mandatory in the construction trades whenever concrete is poured. If your problem of drainage is severe, you can also install sub-surface perforated tile drains around your proposed observatory site, ushering the water elsewhere. Just make sure it isn't onto your neighbor's property or you could face a violation under the Drainage Act. The tile drains should also be encased in a trench of 3/4" crushed gravel on all sides so that the drain is surrounded, even on top. This will aid in percolation through the "pipe" and also in drying out when flows reduce. Over time this will seed in with a light covering of grass, which will hide its presence and not seriously affect its drainage characteristics (Figure 2.5).



**Figure 2.5.** Installation of tile drains will lower the water table around your site. Carefully directed away to a lower spot on your lot, they will transfer the moisture to a less critical area. (Diagram by John Hicks).

## Ground Surfaces, Turbulence and Light Pollution

Seeing also depends largely on the ground surface composition adjacent to and nearby the observatory. Bare soil, cultivated soil, hard surfaced areas (such as roads, parking lots, and house roofs) all have a deleterious effect on seeing due to heating during the day, and the retention of heat which radiates slowly off into the near-ground air column in the evening hours. Hence, the surrounding ground surfaces and land uses will affect the overall performance of your instrument and the practicality of your chosen observatory site. The asphalt and cement surfaces of roads and parking areas are the prime destroyers of good “seeing.” Second to these are rooftop areas with their rising columns of hot turbulent air (refer to “emitted radiation” Figure 2.6).

In the realm of solar observing a close water surface becomes an asset, and a coniferous forest type cover produces less transpiration than deciduous trees, creating less turbulence. These conditions are well met at the Big Bear Solar Observatory in Big Bear Lake, California. The observatory is actually built on a man-made peninsula out into the lake. The lake water stays cool so convection does not disturb seeing, and the smooth lake surface produces mainly a laminar airflow. The site is located on a mountain tarn surrounded by a heavy coniferous forest (Figure 2.7).

Observatory sites to avoid include the following:

Airport runways (asphalt/cement surface, jet exhaust)

Large parking lots

Highway interchanges and major super highway easements

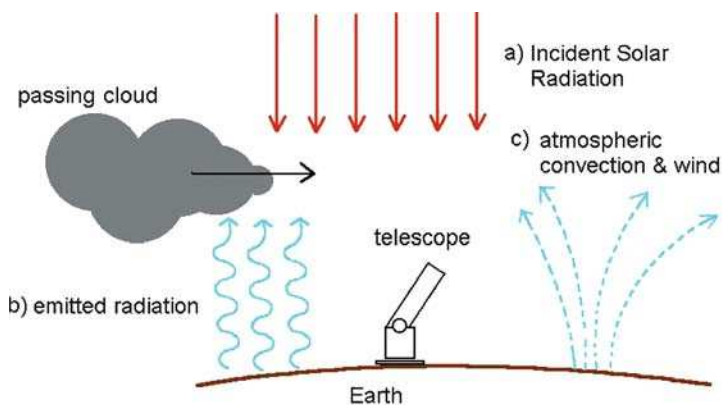
Heat-producing Industrial plants

Pits and Quarries (not yet rehabilitated)

Large roofs in your best line-of-sight

You should give priority to any “window of opportunity” for access to the southern skies. This may mean re-assessing your situation, and moving to another location within a site to utilize the most important segment of the skies.

At this point also, you must address the threat of distant light pollution: existing or potential. A line of trees, a forest edge, or a higher elevation between your site and a source of light pollution can be an asset. Although you may not be able to view right down to the horizon, the aesthetic advantage of a curtain of trees blocking a light source can be an improvement. The time and expense of



Surface heating and the normal balance of incoming and outgoing energy

**Figure 2.6.** Diagram showing the effect of radiation, reflection, re-radiation and convection, on Earth's surface. (Diagram modified from “Nearest Star” by Jay Pasachoff) 1.



**Figure 2.7.** Big Bear Observatory on a man-made peninsula, Big Bear Lake, California, benefits from a laminar flow of air across a lake surface, high altitude, and a surrounding coniferous forest – all the necessary conditions to improve seeing. (Photo by John Hicks).

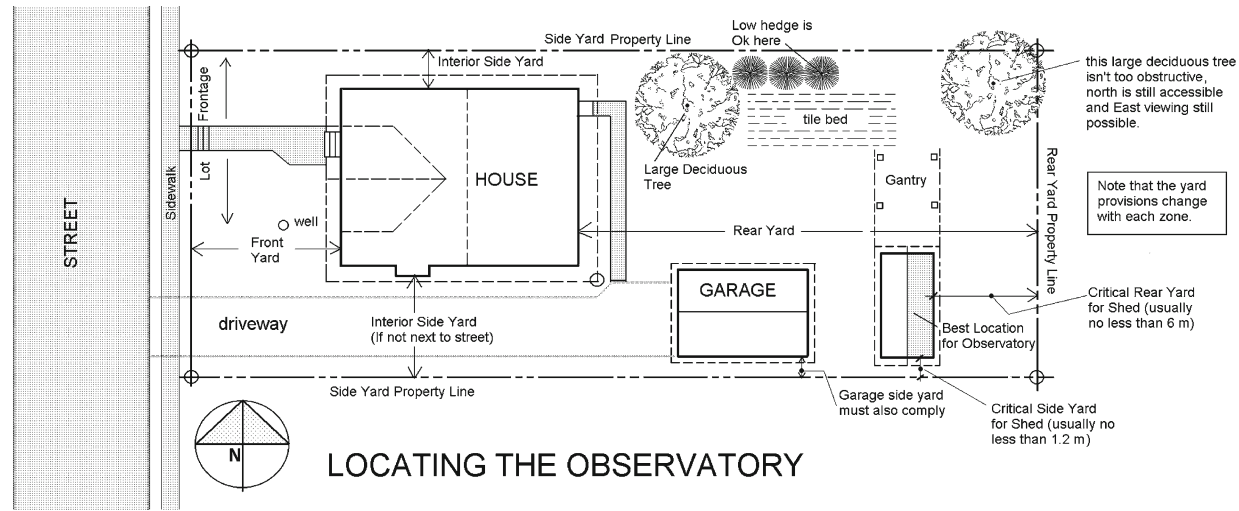
building an observatory will become a major frustration if the viewing isn't near optimum upon completion. Consider the adjacent land zoning designation before you begin to predict the future lighting impact upon your site. Serious thought must be given toward all site requirements in order that your observatory project will be a successful venture (Figure 2.8).

## Zoning: The Surrounding Land Use

The zoning or land-use designation of properties in the immediate area should be of great concern to the observatory builder. Lands zoned for high density housing, particularly apartments and condos, often with flat expansive roofs and asphalt parking surfaces should influence your decision to build. Similarly, industrial or commercial zones on land which may now be vacant, constitute a real threat to your future use of the facility.

In this respect, you must consult the Official Plan (OP), and the Zoning By-law within your County, State, Regional Municipality or Town to ascertain what uses are allowed in each zone designation around your chosen site. Ask the Municipal or Town planner for zoning assistance, and explain the special requirements of your situation. Encourage the planner to predict trends in rezoning that are occurring, because these may have surfaced at public meetings held in the past for development proposals of the future. There may also be some restrictions that can be imposed upon a developer to reduce light pollution, parking area buffering (trees or berming) or no tree cutting etc., when proposals come to a public hearing and conditions are considered to reduce impact on the surrounding properties.

If a proposal is already launched, either before you begin, or while the observatory is under construction, consider appealing any Official Plan change or Zoning Amendment that might restrict your "continued use and enjoyment of the structure." Explain your requirement of reduced lighting to the council or committee during the public hearing.



### LOCATING THE OBSERVATORY

1. Determine North with a Compass
2. Determine the minimum sideyard and rear yard restrictions and measure in from the lot lines (string the bars together)
3. Position the observatory building to take advantage of south, south/west and west viewing opportunities if possible
4. Avoid water wells, water lines, septic beds and septic tanks
5. Have your local service provider from hydro, telephone and gas line companies locate all service lines for you.

**Figure 2.8.** A typical suburban lot complete with garage showing the critical zoning provisions which change for each zone. Note the multitude of factors which direct the observatory location: – side-yard minimums, rear yard minimum, proximity to tile field, well, trees, and the requirement for a northerly alignment. Normally the rolled-off roof should go in a northerly direction. (Diagram by John Hicks).



It is better to attend this in person rather than sending a letter so that you may be able to speak about your project, the investment, and the scientific merit of your project. Your concern may constitute grounds for modification of an application for zone change, a consent, or a minor variance. It may even limit the developer's lighting of certain areas in order to reduce the impact upon you, an adjacent property owner. You have some bargaining power at this point because the developer will "bend" to conditions under the pressure of a refusal from council or the prospect of an appeal from a citizen holding his venture up.

## Zoning: Limitations on Your Own Property

With regard to zoning, attention must be given at this point to the property upon which the observatory is to be built. Most zoning by-laws require a "main use" on the property (such as a dwelling) before an "accessory use" (such as an observatory) can be permitted. The implication of such zoning is that an accessory structure cannot precede a dwelling on the parcel, for reason that it could be used as an (unsatisfactory) residence.

An exemption from the by-law must be sought for the observatory if there is no residence on the parcel, through the mechanism of a minor variance. In this case, it will have to be launched by the owner of the parcel, and usually approved by a Committee of Adjustment.

A public hearing is required, and sufficient reason will have to be given to convince the committee that no improper use of the structure will take place. It is likely that a warm-up hut will be discouraged since it will constitute the very use the by-law is trying to prevent -that of a structure used as a residence.

I was myself trapped in a similar situation, my observatory constructed on a vacant parcel of land – contravening the "accessory use without a main use" statutory. I was forced to launch a rezoning application, relieving me from the by-law. The council questioned the possible use of the building as a domicile (home), and despite a heated argument over the fact that it was actually part of an instrument – and only its protective housing, produced no mercy on their part. The cost was excessive, and the hearing plus the 30 day appeal period put me behind schedule. There were no objections from surrounding neighbors, and although delayed, I eventually had my observatory. Oddly, years later, the rezoning protected me from light pollution from a cellular radio tower because I bluffed my way through the fact that I had a by-law permitting it and could enjoy "protection" under the by-law from light intrusion. I claimed by correspondence to the owners that they were "obstructing the application of the by-law." They didn't realize that "light intrusion" was not a condition of the by-law nor the fact that I was mainly a Solar astronomer! The tower was curtailed short of its designed height and a new one was built further away. I felt pretty well satisfied over my "super-threat" being encumbered unfairly myself years earlier by an unnecessary restriction.

## Ownership Versus Leasing

Ownership of the land is probably the most controversial item to be considered in the siting of an observatory. The merits of private ownership are obvious, but often the magnitude and expense of the project requires leasing. If leasing a portion of a parcel is possible it should be undertaken

only with appreciation of future problems. The maximum lease duration in most areas for a parcel of land is 21 years less a day, without application for consent (formal land severance and deeding). In the case of an observatory, the lease should not be for any less time considering the effort and cost that is required to complete the observatory. In the case of a club leasing a parcel, it should be done after incorporation of the club, since this will save the directors from direct legal suit and allow the club to handle its assets in a legally accepted manner. If leasing is possible, the observatory functions must regard the sanctity of the land-owner, particularly if in residence on the site. Respect for the owner might involve limiting the number of parked cars, noise restrictions, or even access points.

The terms of the lease are critical to the continued use of the facility, and should be drawn up under the guidance of a lawyer who will also search title and discover any easements or encroachments existing on the parcel to be leased or on the remainder. "Squatting" on a parcel temporarily without a lease is to be discouraged, for not only will "squatting" invite ownership problems but also will place the observatory in jeopardy at the whim of the landowner. Due to the expense and effort of construction, siting without a lease or ownership is hazardous. The whole aspect of zoning and siting must be thoroughly investigated before any attempt at purchase or lease is undertaken. The dark sky requirement coupled with unobstructed horizon limits opportunities for sites, and a good Landscape Architect or Site Planner could be well worth contracting to select an optimum site on the land, since he/she will consider other environmental constraints that have not been considered.

## Comparison of Roll-Off Roof and Domed Observatories

Criteria	Roll-Off Roof	Domed
Inside Space/ volume	More space for operator/visitors to move around in a rectangular format	Less horizontal space but more vertical. Often confined to one observer on a rolling ladder if using a long refractor or Newtonian.
Weatherproofing	Roof is easily made weather-proof on whole roof systems, although soffits and gables require extra protection	Dome requires much attention to sealing the gore panels and slot door.
Sky View	Fully open to entire sky dome with roof retracted	Slot has narrow aperture. Dome must be rotated to re-position opening to the various sky segments.
Thermal Equilibrium	Telescope and accessories reach thermal equilibrium quickly with open roof	Takes more time to reach thermal equilibrium. Mixing of ambient air outside the dome with internal air inside the dome produces eddies at the slot opening.
Dew-up	Exposed fully to dew. Every surface inside cools to temp. lower than ambient air temp., and collects dew.	Instruments and surfaces inside rarely collect dew, Dew settles only on Dome outer surface.
Wind Exposure	Very exposed – high winds will affect viewing	Little wind effect other than wind buffeting dome.

Criteria	Roll-Off Roof	Domed
Versatility	More versatile – often will accommodate several instruments on several piers.	Less volume horizontally, but more volume vertically, Limited to one pier – perhaps with dual instruments.
Snow & Ice load	Significant amounts may require removal, as snow load increases stress on castors, track and gantry. If tracks are icy, some danger exists in rolling the roof back.	Snow slides off the dome very easily but it must be broomed off the slot door. Track & castors are safe & protected inside the skirt.
Automation	Not easily accomplished and dangerous if not supervised.	Dome rotation is easily automated, although slot door is more complex to engineer.
Site Suitability	More difficult to site due to size and long rectangular footprint. Requires uniform stability in footings or flexure will occur between gantry and observatory proper.	Since structure is vertical it requires less space and less flexure occurs within a single round footing. Often the only choice in small, narrow lots.
Zoning & By-Law Conformity	May exceed by-law minimum in some states and towns, particularly if gantry is considered part of the structure.	Requires less footprint being round, and can be often exempt under the 100 ft <sup>2</sup> maximum if kept to 10 ft diameter.
Privacy	Less privacy from shoulders up.	Maximum privacy.
Cost	Usually much lower due to all-wood construction (track is the only exception – welding)	Higher fabrication cost due ribs, arches, and dome ring requiring bending in mill. Requirement for all-stainless fixtures, bolts, nuts, washers, etc., is costly.
Difficulty to build	Again, usually within the scope of a home handyman with the average inventory of tools. Only the track needs light welding by a contractor.	Requires much extra skill in cutting and fitting of gore panels to create the Dome. Riveting and tapping is required for bolts, along with metalwork on arches and ribs. Being perfectly round, the walls and precise fit of dome on round track require close attention to tolerances.
Maintenance	Exterior track, and gantry need paint and stain only. If walls are finished in vinyl Board & Batten, they are maintenance-free.	Only the Dome requires paint, usually in 3 year intervals, – a difficult task on a spherical surface. If walls are finished in vinyl Board and Batten they are maintenance free.

## The Prestige of Ownership

Once you have completed the observatory, you will experience a personal pride in owning a structure that signals to others that you are indeed an astronomer. Several spin-offs will occur from such a structure. Local schools and institutions will likely be aware of the fact that you are more serious about astronomy as a hobby if they visit your observatory. Its presence will indicate your involvement and investment in the science of astronomy. It is likely that you will be asked to host viewing sessions for various organizations, including school groups, cubs etc. The press will also become interested since few people embark on such a project. In all, the observatory will increase and improve your public profile.

The observatory is a place where the universe becomes your private domain. It is a place where you can concentrate on the sky and eliminate the distractions of the world around you. It becomes an extension of your telescope, and in fact you will find that it becomes increasingly difficult to distinguish the importance of one over the other.

## **End Note**

1. Golub Leon, Pasachoff Jay M (2001) Nearest Star, The Exciting Science of Our Sun, Harvard University Press



## CHAPTER THREE



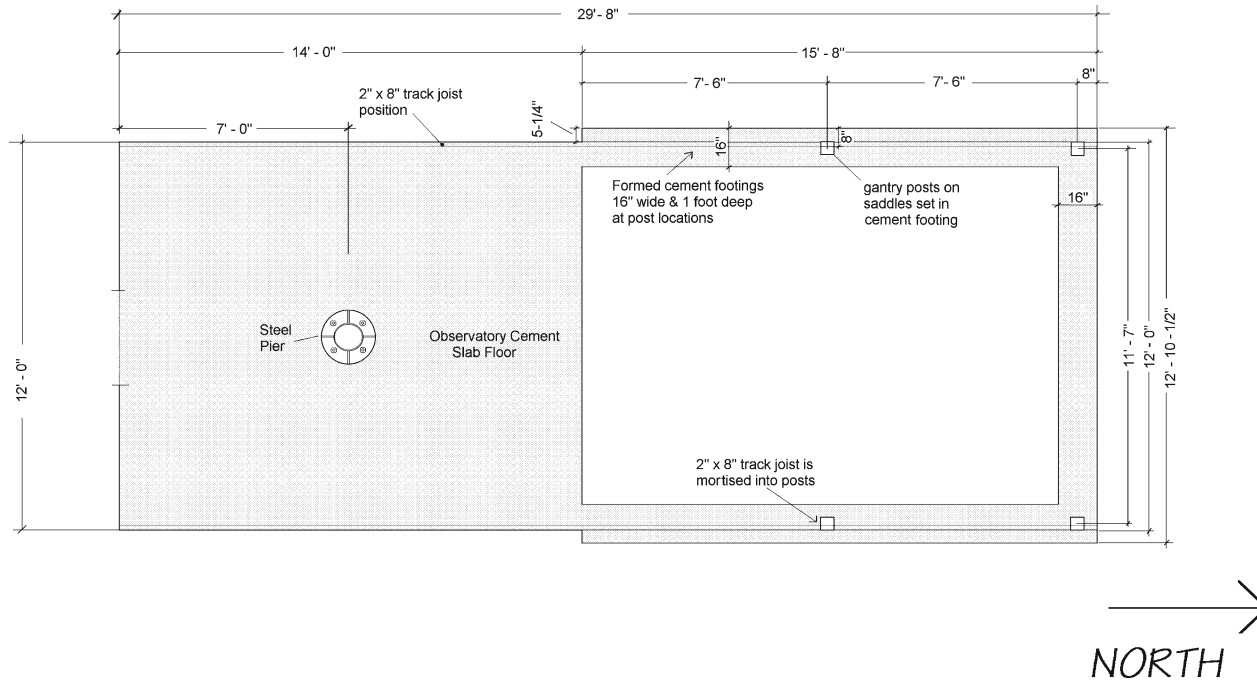
# Options for Foundation Types and Laying out the Observatory “Footprint”

Once you have studied all the previous requirements and are satisfied that you qualify with respect to all of the physical and legal parameters, you are ready to begin construction. Again, I cannot stress enough the importance of building an observatory that you will not outgrow. The observing limitations you experience today will not be what you can tolerate tomorrow. Larger aperture instruments will be within your economic grasp and larger CCD sensors will become commonplace (the CCD sensor driving you to create a warm room for a computer). Both opportunities could make you wish you had constructed an observatory at least as large as the model promoted in this book.

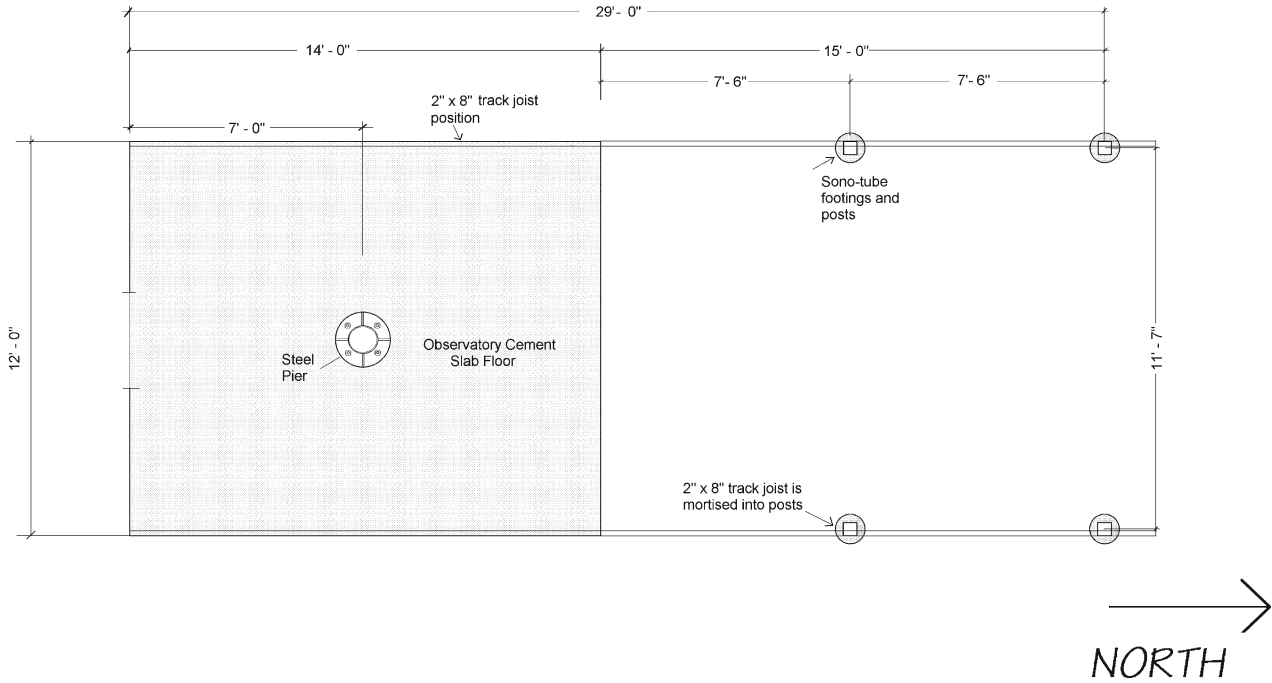
## Slab Footing Versus Sono Tube Footings

A complete poured cement slab under the observatory proper is the easiest to install, providing you have cement truck access, several wheelbarrow assistants, and some careful planning. It will save you the arduous task of excavating at least 16 holes for sono-tube footings and filling them with concrete. In addition, the alignment of the filled tubes is not easy and nor is the setting of the iron saddles in line to hold the floor joists. If you have an inaccessible site, then the sono-tube footings will have to be undertaken. However, most situations will permit a cement truck to fill wheel barrows which can be wheeled to the site. This technique usually becomes economical if one has several assistants to help, since the driver starts adding on a surcharge after an hour's time has passed. This means that you will have to prepare the route to the observatory to make sure the soils will support the continuous parade of heavy wheel barrows. This is usually achieved by laying construction planking down in endless fashion from the truck to the site.

A little bit of preparatory work at this point will save you grief when the cement truck arrives and the clock starts ticking (Figures 3.1 and 3.2).



**Figure 3.1.** Cement Slab Footing with cement footing extending out under the gantry section. (Diagram by John Hicks).



**Figure 3.2.** Cement Slab Footing with Sono-tube piers under the gantry section. (Diagram by John Hicks).

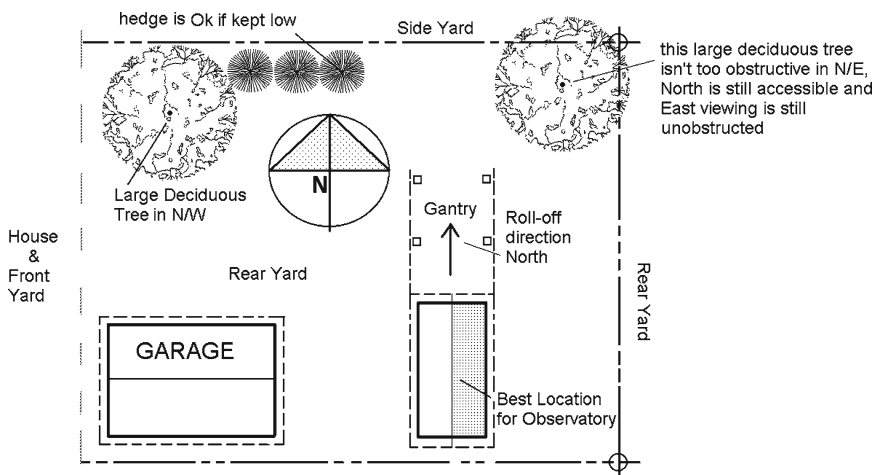
## Preparing the Site and Orienting the Observatory

The first action you should take is to level off the site and smooth it to a good working surface, free of turf, roots, rocks etc. Once this is done, it helps to lay down a shallow depth of cement sand over the whole footing area to keep your boots from getting all gummed up with existing soil. (In all likelihood, once you excavate for footings, wetter soil profiles will be encountered, and the wet, sticky material will get underfoot).

Following your requirement for a southern sky, the gantry section should be oriented in the north and observatory itself in the south. This is not always possible, but usually the preferred arrangement. Rolled-off in the north position, the roof gives good weather protection from the cold north and north-westerly winds, whereas, if located with the observing room on the north side, it would receive the full force of these winds (Figure 3.3).

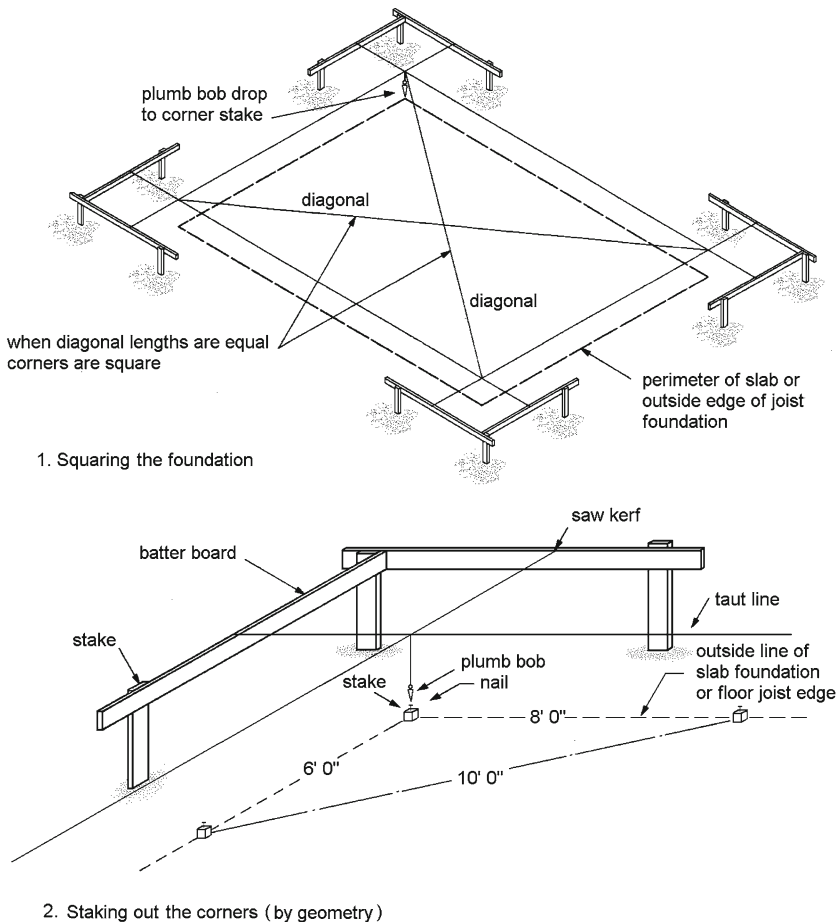
## Measuring and Squaring the Building Footprint

Measure off the length and width of the entire structure and site the entire footprint to comply with your local zoning restrictions. Establish the floor of the observatory itself first. In this design it will be 14 ft long  $\times$  12 ft wide. To assure squareness, measure both diagonals from corner-to-corner. They should be exactly equal if your measurements are true.



**Figure 3.3.** Orientation of the observatory with roof rolled off northward is the best arrangement with no southern obstruction by the roof gable. Normally, except in very southern latitudes Polaris is still high enough above the roof gable to be imaged and allow for polar-aligning the telescope. In this set-up the garage, large trees and rear-yard set-back limit possible locations, but if the garage roof is low enough a fair western view is still possible. The Southern sky is completely accessible which is a priority. (Diagram by John Hicks).

Repeat the length & width measurements, repositioning the stakes at the corners and adjusting all the stakes until the diagonal measure is satisfied. Once this is accomplished, locate the pier position at the center of the two diagonals with a string line and stake it firmly. The gantry posts should next be located measuring outwards from the corners of the observatory and the hypotenuse measured from the end posts until the ends are square with the observatory. Holding a string in line along the forms for the observatory slab, extend it out to the corner of each proposed end post, locate it and measure in to locate the middle posts (note that all these  $5\frac{1}{2}'' \times 5\frac{1}{2}''$  posts are flush in line with the foundation edge which means their centers are offset inward by  $2\frac{3}{4}''$ ). Make sure all the gantry stakes are firmly located at the center of the proposed posts, and drive a nail in at the exact center point in each stake (Figure 3.4).



METHOD OF STAKING OUT & SQUARING SLAB OR SONO-TUBE FOUNDATION

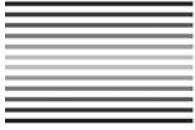
**Figure 3.4.** Foundation Layout – Measuring and Squaring the Observatory footprint. (Diagram modified from Canadian Wood Frame Construction).



**End Note**

1. Canadian Wood Frame Construction, Central Mortgage and Housing Corporation

## CHAPTER FOUR



# Fabricating the Telescope Pier



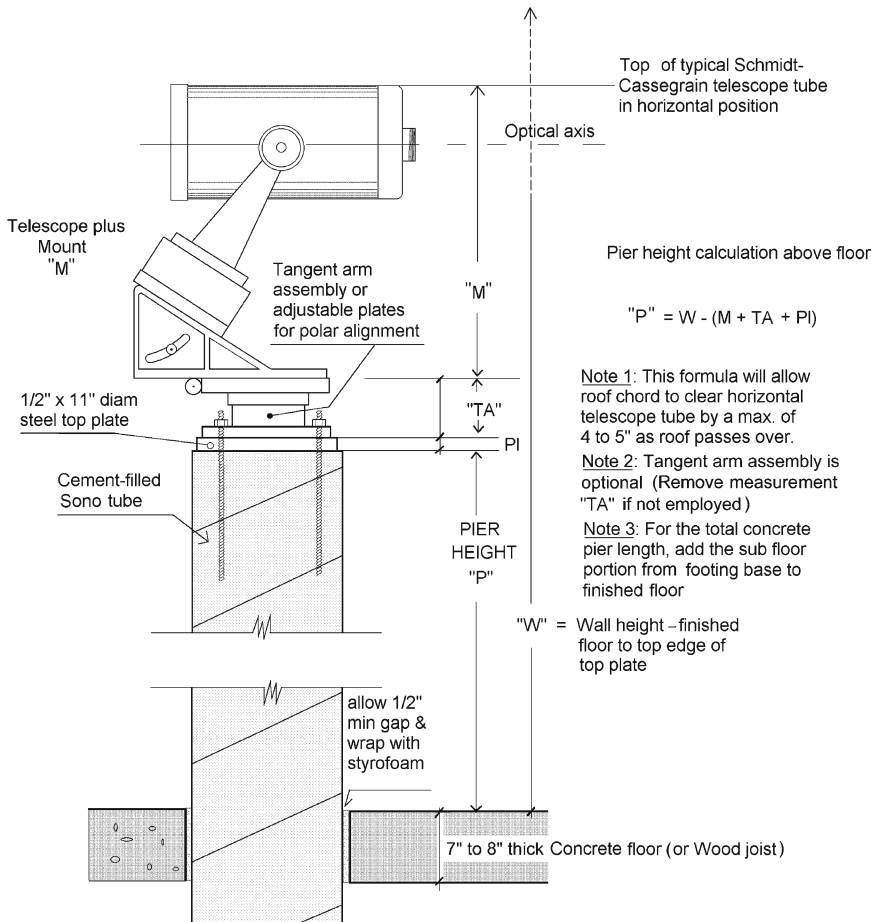
Whether you choose the poured concrete slab or the sono-tube footings construction for your foundation, the pier must be located and poured first in position. At this time it is essential to decide which type of foundation you wish to install for two reasons:

- (a) the electrical wiring to the pier should be installed in plastic pipe under or within the concrete slab if you plan to pour a complete cement floor.
- (b) the height of the concrete portion of the pier (the pier footing) must be pre-calculated to a greater height above the ground in a sono-tube footing and wood joist style observatory (usually about 2 ft high).

The pier must go in first for another reason; – regardless of the footing type, the building wall height relates to the footing and the finished pier top. A poured concrete slab footing positions the finished floor about 8 in. above grade with the concrete pier footing top another 2 in. higher, whereas a sono-tube-plus joist style floor construction will place the pier footing top about 2 ft above grade. Also, in order to pour the concrete pier to a suitable height, *if you choose a totally poured concrete column*, the height of instrument calculation becomes essential now in order that the instrument doesn't get in the way of the rolling roof, opening or closing (Figure 4.1).

In my own case, I used a column of concrete in a sono-tube to about one-half the height of the proposed pier above the floor, completing the rest with the same length of equal diameter thick-walled aluminum pipe. I machined heavy 1½" thick aluminum flanges as caps over each end, recessed to fit into the pipe, and machine-bolted into the tapped flanges through the pipe walls. The flanges were pre-drilled to fit the bolts protruding from the concrete pier base on the bottom end (requiring a template to be made first in heavy card), and to match the bolt circle of the telescope mount on the top end. Also, circles were cut out of the pipe at positions convenient for access to the bolt threads inside in order to put the nuts on and tighten them with a wrench. When completed, I covered the whole length of pier inside with soft broadloom, sewing it all the way down the pier. This gave me "creature comfort" on cold clammy days when I had to straddle the pier or otherwise come in contact with it. The overall fabrication was difficult but worth the effort in appearance and function (Figure 4.2).

## CALCULATING THE HEIGHT OF THE PIER



**Figure 4.1.** Calculating the Pier height above the floor. A typical Schmidt-Cassegrain telescope on a fork mount is shown in horizontal position atop a full length sono-tube concrete pier. The cement-filled sono-tubed pier extends down to the footing. Calculating the height as shown will place the horizontal telescope tube under the bottom roof chord by about 4 to 5 inches. (Diagram by John Hicks).

## Combining a Concrete Pier Footing with Upper Metal Pier

The usual method of pier construction involves an oversize concrete footing with a much less diameter steel or aluminum extension to the telescope. In our design, the pier footing is 16 in. in diameter, preferably poured into a sono-tube form seated in a large excavation. Concrete could



**Figure 4.2.** Typical Aluminum or Steel Pier top showing end-plates: - the top plate with bolts protruding to accept the telescope mount, the bottom plate with pre-drilled holes to fit bolts from cement footing underneath. Note the access-holes sawn into the tube required for tightening up the bolts from inside. Both top and bottom plates were drilled and tapped to take large threaded bolts. The access holes serve another purpose also; - the tube can be filled with sand from this point to dampen any vibration in the pier. (Photo by John Hicks).

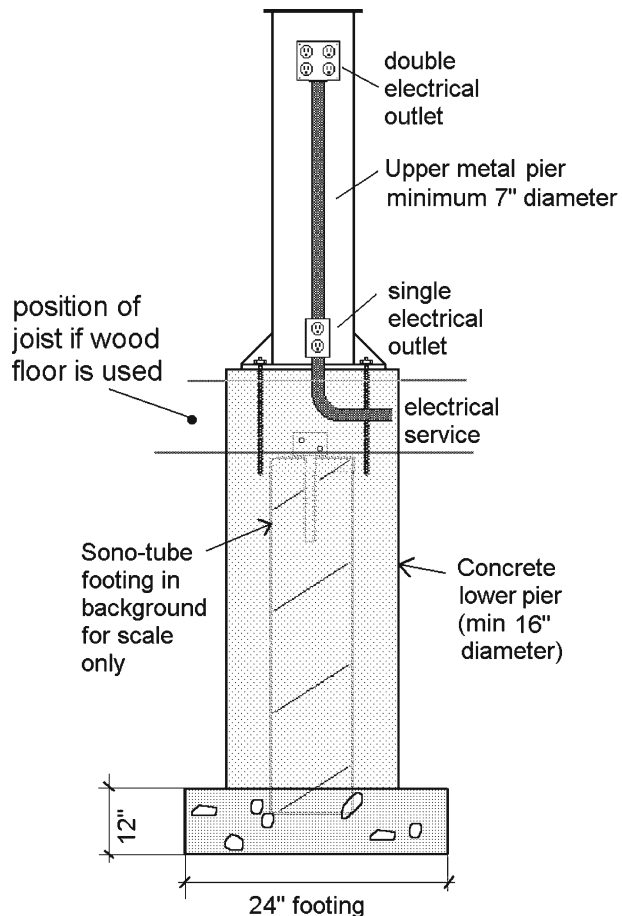
be poured simply into an excavation 16 in. in diameter, but it is always wiser to pour into a form for several reasons, the most important being that you might have to remove it some day. In frost zones, the excavation should go down 4 ft to assure that no frost heave can occur. If it is poured in a sono-tube footing, they are designed to allow for frost expanded soil to slide by the outside walls of the waxed tube and I strongly advise using one. I needed only a single 10" diameter sono-tube in an excavation 4 ft deep with gravel bedding underneath and around it. I also only needed to support a light 100 mm diameter refractor or at most an 8" Schmidt Cassegrain telescope. My soil profile is hard-pan clay, with no moisture. The soil resisted my digging like concrete. In other soil types with more sand or more water, you will need a wider footing with a flat base slab underneath.

Pouring the 24" × 24" × 8" thick base slab is no easy task since the pier hole will have to be widened at its bottom, and some sort of a form made. Creating a perfect 24" × 24" footing is ideal, but simply pouring a flat concrete pad into an enlarged bottom will suffice.

Smooth out the top surface flat to seat the 16" diameter sono-tube footing and let it dry. Insert the 16" diameter sono-tube and fix it into position vertically with a carpenter's level. Add 3/4 crushed gravel around its sides up to soil surface level to hold it in position. Tamp the gravel into place and repeatedly check with a level. Fabricate a 5/8" rebar cage by wiring eight strands of rebar together to form a basket about 12" diameter. This should be in a column long enough to extend the length of the pier but also accommodate the bolts that will hold the steel upper pier portion. Leave enough room above the rebar cage for them. I used coat-hanger wire to fasten the cage together. Heavy duty pliers, a wire cutter, and hacksaw are needed to build the rebar cage.

Note that if you are using a full-length concrete pier make allowance for the length of mounting bolts that fasten the telescope mount to the pier.

Your finished concrete footing should terminate an inch or two above the finished concrete floor in a slab type observatory floor and about 2 ft above grade in a sono-tube and wood joist floor type. In both cases it should terminate above the floor so that you can get at the bolts securing the rest of the metal pier. When pouring the concrete into the sono-tube form, continuously tamp the wet concrete around the rebar cage with a long stick to eliminate air pockets and voids in the cement. In preparation for pouring the pier base, you must also prepare a pier base template



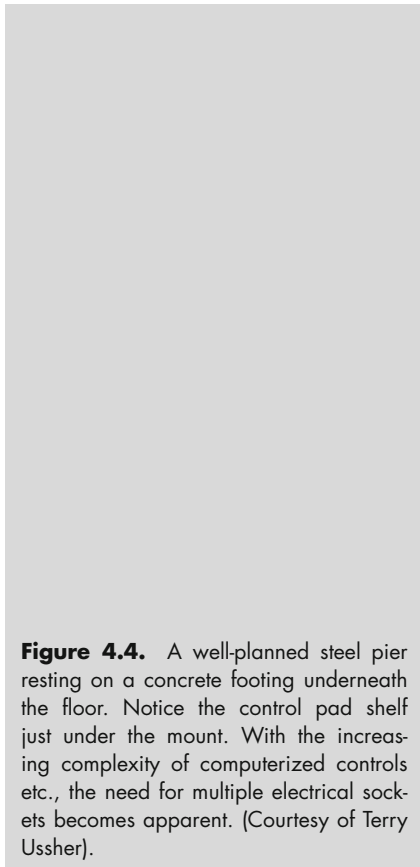
**Figure 4.3.** Detail of finished metal pier top on its concrete foundation showing electrical conduit, electrical outlets, and bolts anchoring the metal top to the concrete footing underneath. Normally the metal pier top should begin about 2 in. above your observatory floor. For comparison, the faint image of a foundation Sono-tube footing is aligned at its exact height illustrating where floor joists would sit in the bracket on the top. From this you can visualize that the steel pier base rests about 2" above the finished floor surface. (Diagram by John Hicks).



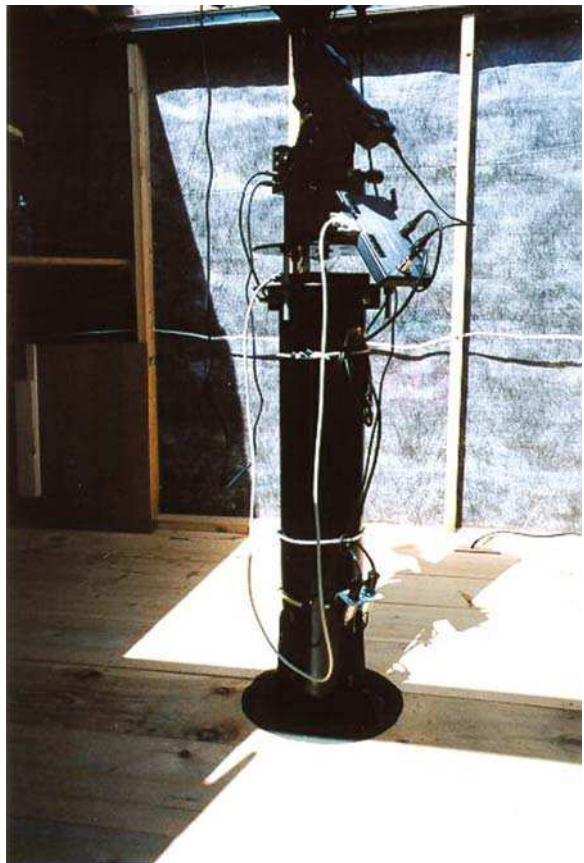
in 3/4" plywood drilled accurately to hold the anchor bolts in place which will hold the metal top section of the pier. This means you will have to design the metal pier portion at least on paper beforehand, and drill a bolt circle in the plywood template to hold the anchor bolts matching the design of your metal pier base. It is safer to proceed this way, rather than attempting to fabricate the entire metal pier portion first, and find the concrete pier footing has a shortfall. The metal pier portion can always be made longer once you measure the height of the finished wall, which will enable you to more accurately locate your telescope height just where you want it to be (Figures 4.3–4.5).

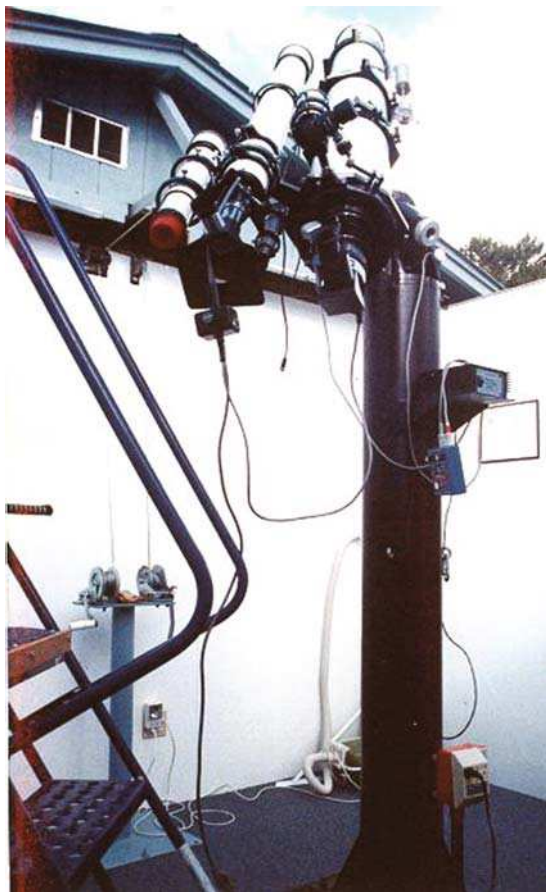
Place nuts on both sides of the plywood template, securing the threaded rods at the correct length to anchor into both the concrete pier below and the metal pier base above. When the pour reaches the top of the sono-tube footing, plunge the threaded-rod-bolt assembly into the concrete, center and level it. Trim off any excess concrete that oozes out from under the template.

This is a very critical step, so perform it carefully. Before pouring concrete, make sure that there is sufficient room between the top of the sono-tube and the inserted rebar cage. Try it with your plywood template before you pour the concrete. Some builders prefer at this point to leave the nuts on the underside of the template also, to act as good "seats" for the metal pier section, the nuts staying flush in the concrete once the plywood template is removed (Figures 4.6 and 4.7).



**Figure 4.4.** A well-planned steel pier resting on a concrete footing underneath the floor. Notice the control pad shelf just under the mount. With the increasing complexity of computerized controls etc., the need for multiple electrical sockets becomes apparent. (Courtesy of Terry Ussher).





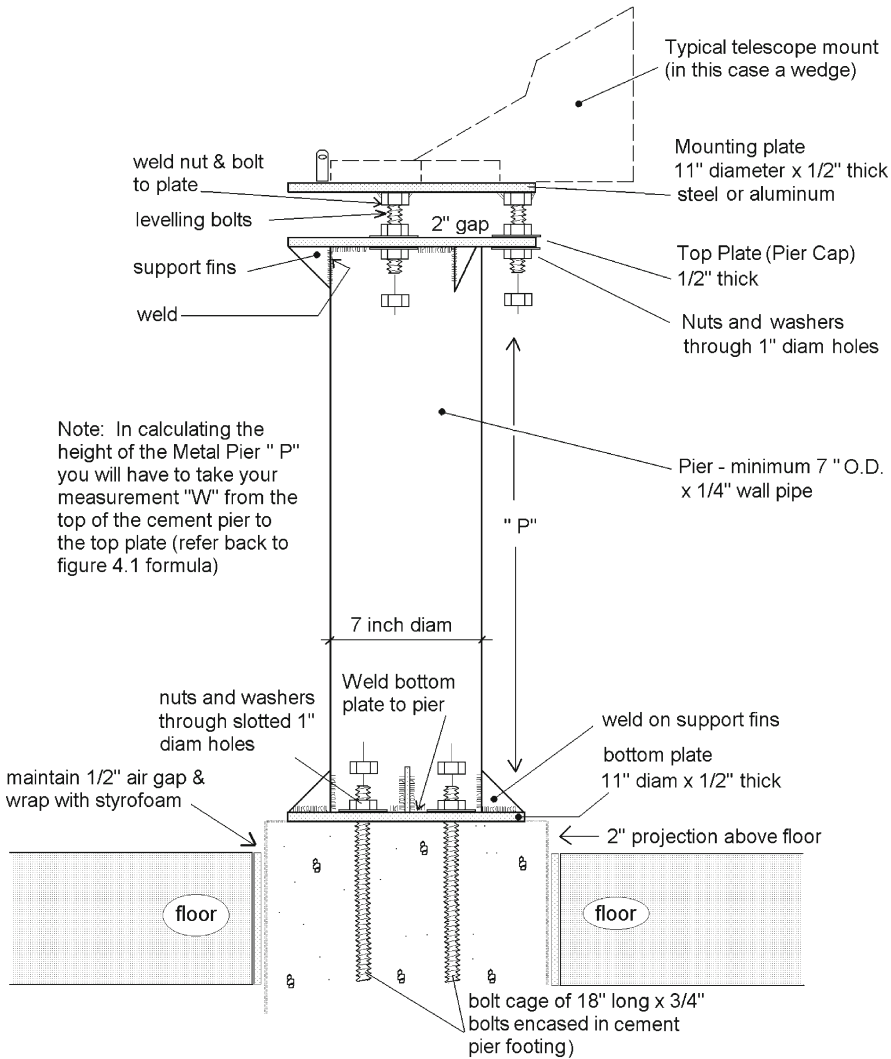
**Figure 4.5.** The stronger the steel pier the better. This pier carries multiple telescopes which add up to a lot of weight. (From the collection of John Hicks).

## Full Length Concrete Pier

In pouring a full-length concrete pier, you will have to pre-calculate the height your telescope and mount require, with the telescope in a horizontal position. With the top plate of the wall (holding the castor track) as maximum height, the sono-tube form length then equals the below floor length to footing, plus above floor calculation. Refer to Figure 4.1 to see the required calculation.

Be aware that when pouring the a high concrete column you will have to brace the sono-tube with stakes and boards to the ground. A pier 5 ft high will start to lean under its own weight and the sono-tube can rupture or split. If a full length concrete pier is poured in place with no metal extension, you will also have to make a pier cap with a bolt circle that matches your mount for the top. In this case, you should use a steel or aluminum cap about 3/4"–1" thick. Trace out the base of your telescope mount and center the holes on paper card stock precisely, then transfer this to metal cap and thread in the bolts leaving an adequate amount to extend into the concrete (mine were 18 in. in the concrete) and projecting from the top of the cap. Secure with nuts above and below (the bottom nuts can stay in the concrete with the cap) (Figure 4.8 - note steel metal plate cap labeled 1a).

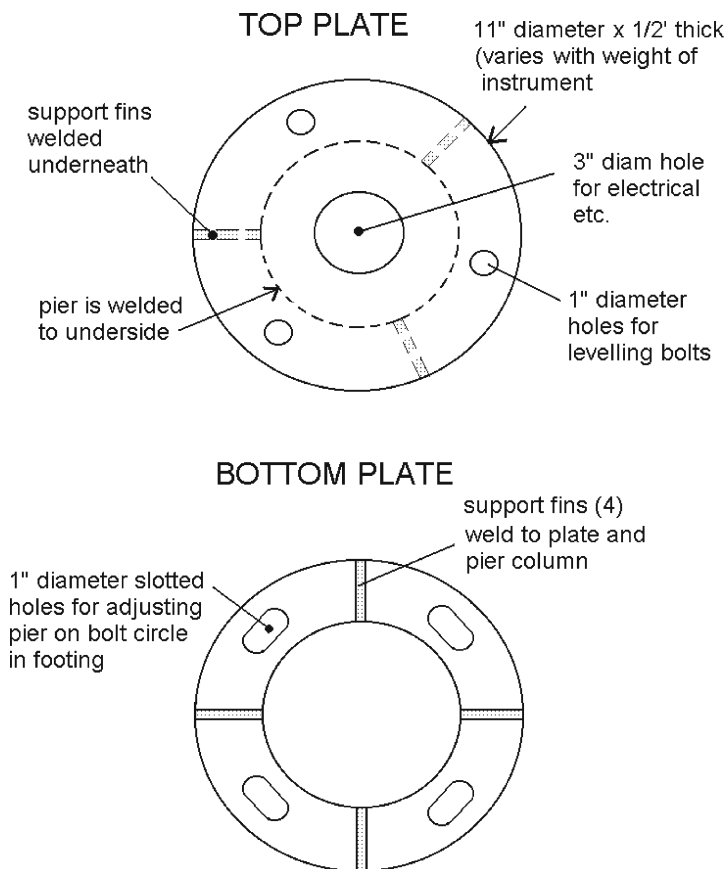
TYPICAL METAL UPPER PIER DESIGN



**Figure 4.6.** Detail showing construction of typical metal pier. Note cement-filled oversize sono tube underneath and the level of finished floor. (Diagram adapted from Astrolmage Database) 1.

If you cannot find a blacksmith or machinist to fabricate a cap for you, check out your local scrap yard. Boiler punch-outs are perfect for this purpose and most are quite thick.

If you find one close to the pier diameter take it home, have it machined smooth to your exact finished concrete pier, and drilled to take the mounting bolts. If your telescope mount has projecting bolts then you will have to drill and tap the pier cap also. I was able to get my pier cap machined by a local machinist and drilled the holes myself on a drill press.



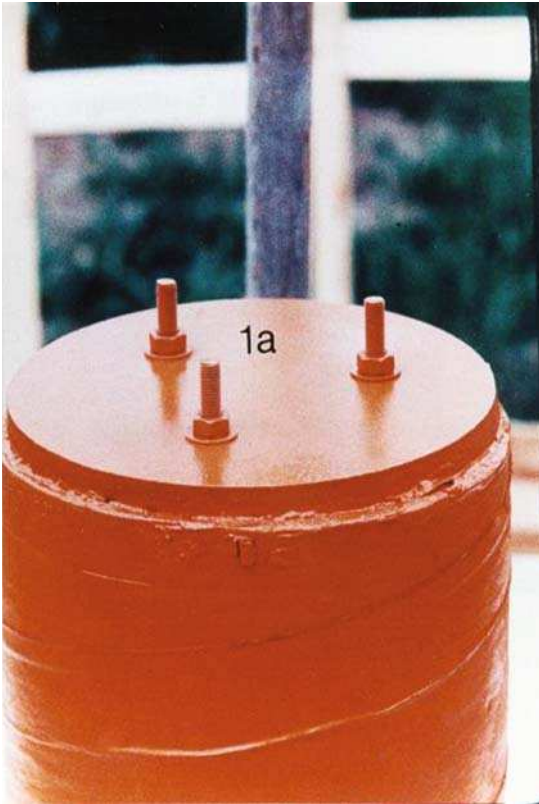
**Figure 4.7.** Detail showing construction of a typical metal pier cap. (Diagram adapted from AstroImage Database).

This cap is pushed onto the top of the finished pour and leveled. Check every fifteen minutes or so as the concrete dries to adjust for level. If you are using a full length concrete-filled pier, you will want several electrical box outlets on the side of the concrete column. Before the concrete pour dries, drill through the sono tube using the junction box bolt holes as a template. Insert Stainless Steel mounting bolts in the box and push them through the sono-tube walls into the wet concrete. Leave these in while the concrete dries. (I prefer to use long S/S round headed  $1/4 \times 20$  bolts, cutting off the heads, and fastening stainless steel nuts to eventually tighten down the box, allowing removal at some later date) (Figure 4.9).

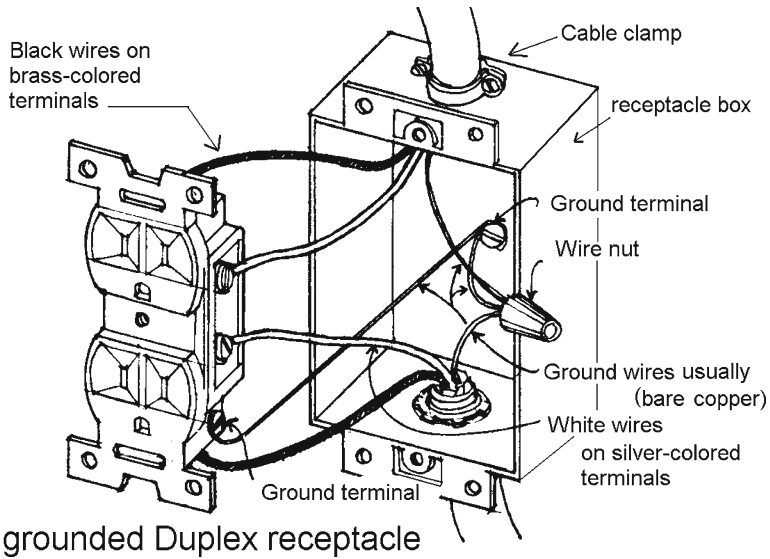
The pier must have no connection to the concrete floor or the wood joist floor to avoid vibrations produced by people walking around in the observatory. If a poured concrete floor is used, wrap a 1" thick collar of Styrofoam around the pier at least a foot high at this stage before pouring any concrete into the forms.

David's astronomy Pages, AstroImage Database, Pier to Mount Engineering Drawing. Web address: <http://www.richweb.fg.co.uk/astro/imagelib/PierDrawing.html>

Ching, Francis D.K & Miller, Dale E. (1983) Home Renovation, Van Nostram Reinhold Company Inc.



**Figure 4.8.** Typical all-cement pier, enclosed in a Sono-tube form, with bolt heads protruding from the steel-plate top cap, ready to accept the telescope mount. (Diagram by John Hicks).



**Figure 4.9.** Wiring a Grounded Duplex Receptacle. (Diagram adapted from Home Renovation)2.





## Preparing the Footings and the Observatory Floor

### The Concrete Slab Floor

#### Preparing the Forms for the Observatory Floor

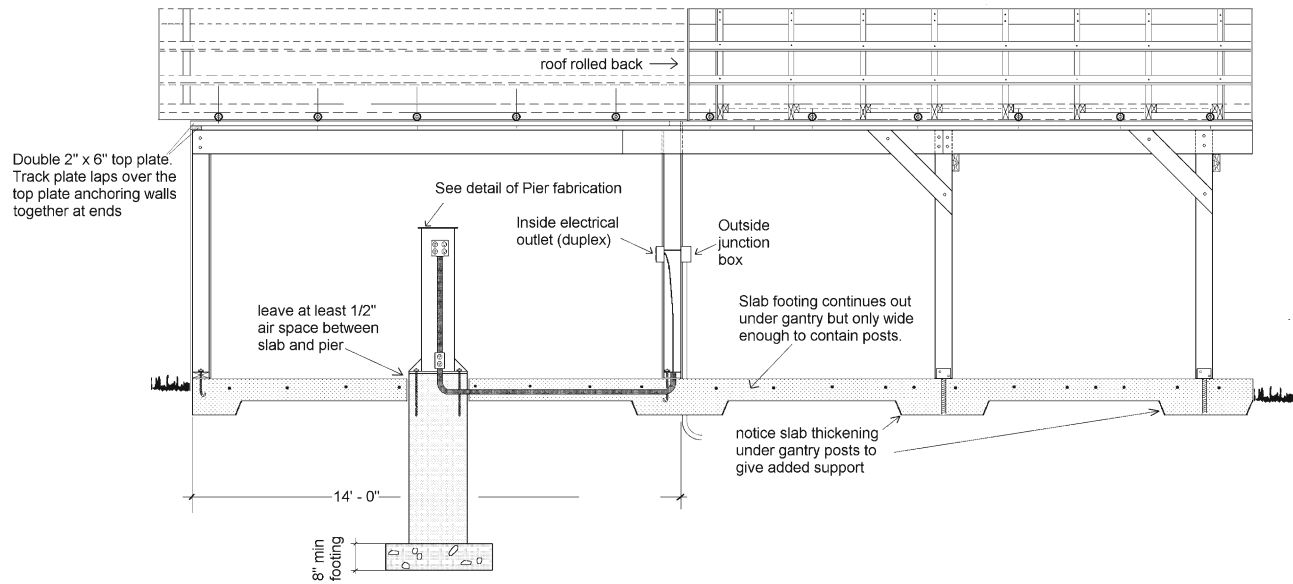
Referring to the following plans, you will notice that the thickness of the concrete slab increases under the walls around the perimeter of the observatory, and under each of the posts supporting the gantry section (Figure 5.1).

The normal floor thickness should be about 7½" thick throughout increasing to 12" under the walls and posts. Prior to pouring any concrete, forms must be firmly in place to retain the concrete and create a finished, clean edge about the perimeter. Since the concrete is heavy, it will attempt to push out any substandard forms you use, so use heavy boards and substantial stakes to hold them in place. I recommend using 2" × 8" boards nailed to 2" × 2" stakes. (The concrete can be cleaned off and the boards used later in framing).

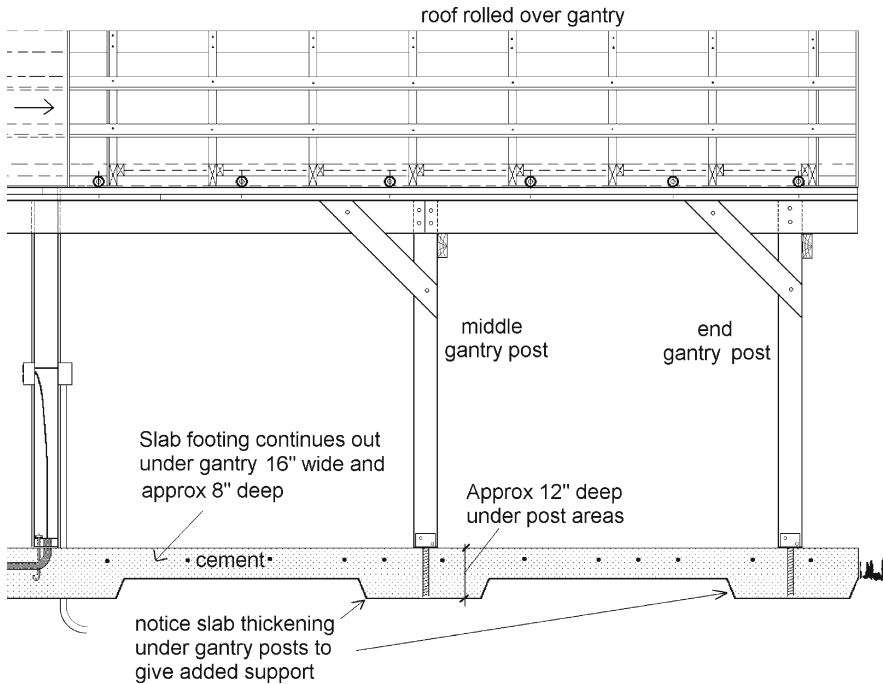
Carefully line the boards on edge along a string line stretched between the corner stakes, nailing them carefully to the stakes. Drive the stakes in every 2 ft securely all around the floor perimeter. Excavate shallow 4"–6" trenches at least a foot wide under the wall sections. This will create a footing ~12" deep × 12" wide to support the walls.

#### Preparing the Forms for the Gantry Section

The gantry footing is offset from the observatory walls to create the proper positioning of the track and frame over the gantry posts (they must be right under the center-line of the track to carry the load of the roll-off roof). Refer back to Figure 3.1. You can see the offset in the gantry footing better in the end view (Figure 5.3).



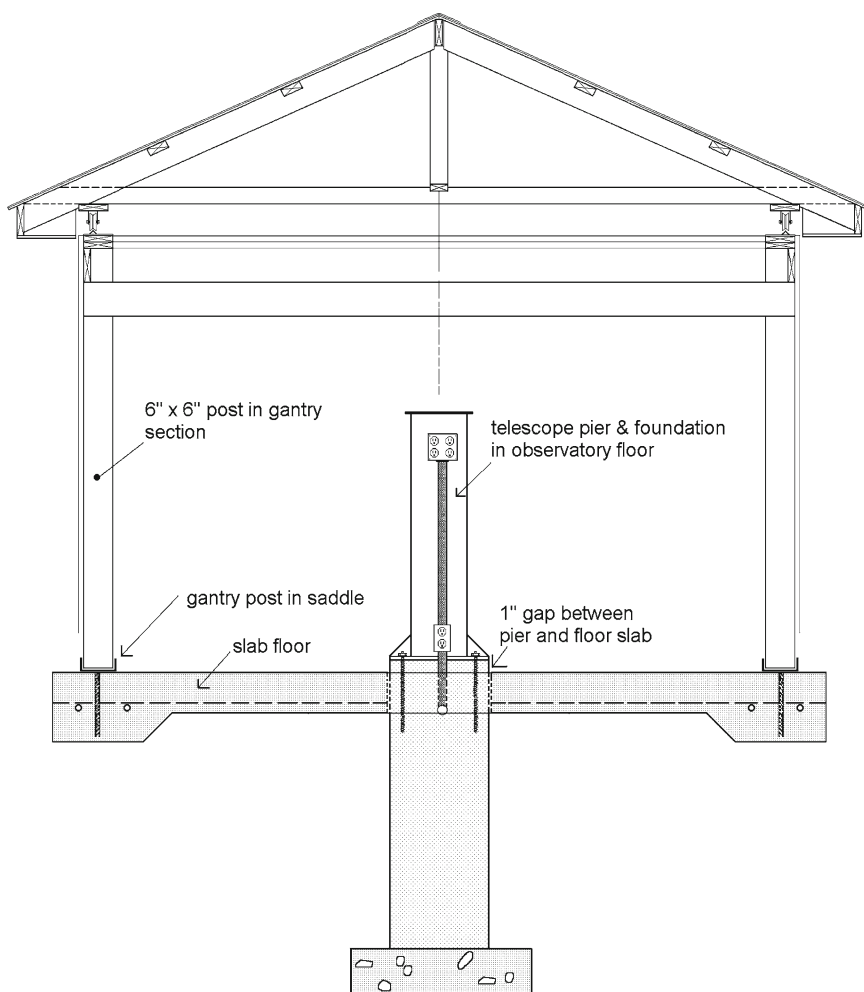
**Figure 5.1.** Elevation view of observatory cement slab floor and gantry slab footing. (Diagram by John Hicks).



**Figure 5.2.** Enlarged view of concrete footing under gantry. (Diagram by John Hicks).

The entire gantry footing should be about 16" wide and 7-1/2" to 8" deep, increasing to a foot deep under the posts, in order to provide enough mass for concealing the rebar reinforcing and support for the roof once it is overhead (Figure 5.2). The need for a completely poured floor extending all the way from observatory section out under the gantry is up to the individual. It requires a great deal more concrete, lots of effort, and is unnecessary. Finally, insert lengths of 5/8" rebar in double rows in the concrete at half-filled stage around the perimeter to prevent cracking and displacement.

Line out the forms for the gantry footing same as you did for the observatory floor, following the measurements on Figure 3.1 the *plan of gantry and concrete footing*. The forms that you used to line out the floor of the observatory will act as guides for locating the outside face of the gantry posts. The track sits on the center line of the beams mortised into the face of these posts. Measure out the distances shown from the observatory slab, and follow the measurements on the plan to locate the post centers and the edges of the footings. Notice that they are offset from the observatory floor edge. The offset places the post in the center of the concrete providing equal bearing all around it. Leaving the center of the gantry section open will allow you to fill this area with a lockstone patio later on, providing a neat concrete edge all around, and an attractive outdoor sitting area.

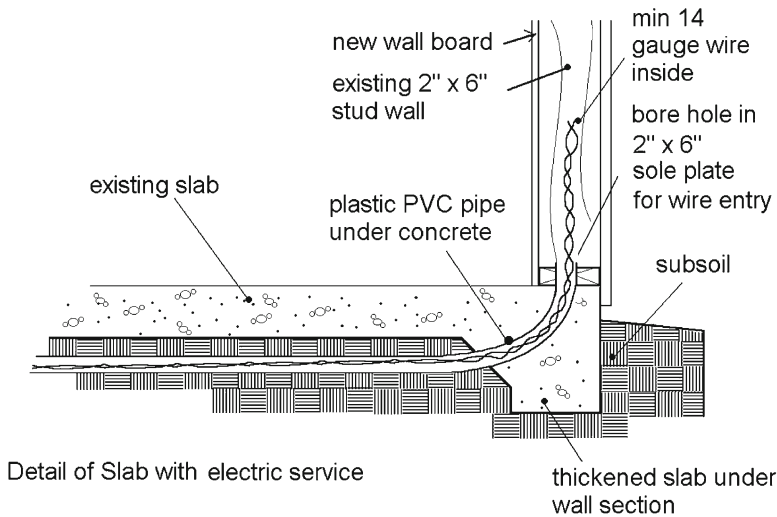


**Figure 5.3.** End elevation of gantry section. (Diagram by John Hicks).

## Electrical Service

In the case of a full concrete floor, before concrete is poured, you must prepare your electrical service lines and computer/telephone feed wires in two adjacent PVC pipes ( $1\frac{1}{2}$ " – 2" I.D. plumbing pipe). These must be long enough to reach from the pier to the wall where you have chosen to locate an electrical outlet. The PVC pipes at the wall will come up through holes drilled in the sole plates (the  $2" \times 6"$  plate under the studs) through the hollow wall framing to a receptacle. It is best to locate a sealed junction box on the outside wall at this point also, so the connecting wires just go through a short section of wall to connect to the underground wire source from your house (Figure 5.4).

Number 14 gauge wire is suitable for the inside portion of the observatory, under the floor in PVC pipes and up the walls, but 8 gauge wire should be used for distances to the house. To get the wires through the PVC pipes, feed light fishing line with a sinker attached first, pulling the



**Figure 5.4.** Detail of electrical service under slab and through wall sole plate. (Diagram by John Hicks).

wires with it. Both ends of each PVC pipe are then fitted with rounded fittings such that the wires will go up the pier on one end, and up the wall cavity on the other end. Measure the PVC pipes carefully, trying them in the footings so you know they will reach from pier to wall. Make sure the wall exit end does so in a mid-stud position by measuring in from a corner. When satisfied, leave about a yard or so of wire projecting at each end and cut off the balance. Wire or rope the ends of the rounded fittings at the pier such that the fittings just emerge about an inch or so above the level of the finished floor, and stake the fittings upright at the wall plate position with the same amount projecting. Coil up the wire at the wall end, wrapping it in plastic. Loop the wire around the pier at the pier end, tying it with a rope to keep it free of the concrete. Make sure both pipes are flat on the ground so that they will remain at the base of the concrete floor, then cover the entire ground with construction grade 6 mil plastic sheeting.

## Pouring the Concrete Floor

Make sure to provide a ramp up onto the form boards to get the wheelbarrows into the center area of the observatory, and nail it to the forms securely well in advance of the cement truck arriving. Also, get the pathway from the truck to the observatory lined out in rough planks, and as level as you can make it. The wheelbarrows full of concrete are so heavy and cumbersome they will sink into your lawn and mire.

Starting at the center area of the floor around the pier, dump the first loads of concrete, working outward in all directions to the outside walls. Try to keep all concrete off the pier and just surrounding the 1/2" Styrofoam sheet wrapped around the pier base.

As dumping proceeds, rake the concrete level out over the floor area. When about 1/2 full, drop in the sheets of 6" x 6" #8 welded wire mesh covering most of the floor area. Avoid placing it near the location of the walls because that is where the anchor bolts (j-bolts) will have to be set. Instead of the wire mesh, you can use 5/8 in. diameter rebar, cut to fit in a radial fashion outward around the pier. It should extend, as above, just short of the anchor bolt areas. Be aware that neither of the



reinforcing materials are bent upward, and lie flat on the bed of concrete, or they will protrude from the finished floor. When the concrete level reaches the batter board height (about 7½"), smooth out the surface with a screed board to flatten out the floor. This is accomplished with a long board stretching right across the width of the floor, resting on its edge upon the tops of the batter boards.

Finish all the floor area as far out as your arm can extend, with a cement trowel, smoothing out the surface flat to make a good seat for the wall sole plates.

## Positioning the J-bolts

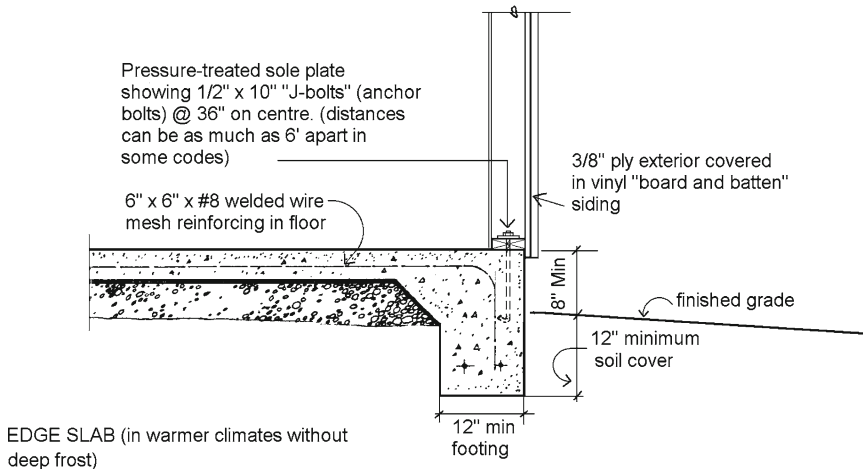
The next step, setting the j-bolts in position before concrete dries, is fairly critical.

The j-bolts holding the building to the slab, and the saddles (or rods) holding the gantry posts must now be pushed into the wet concrete at the appropriate locations.

For the observatory walls with 5½" wide sole plates, the j-bolts should be placed inside the concrete edge 2½" to 3" about every yard. Measure in to locate each j-bolt and push it into the wet concrete with about 2½" thread exposed above it. Keep the concrete off the bolt threads. Do not locate a j-bolt where the door opening is to be located, as the door threshold will be placed directly on the slab (Figure 5.5).

## Positioning the Gantry Posts

The gantry posts can be set in steel saddles for 6" × 6" posts, or they can be pre-drilled to fit over thick rods or re-bar set in the cement footing. If using rods or rebar leave about 4"–6" exposed above the concrete. I prefer steel saddles because they don't weaken the post bases and a post can be removed and re-set easily in the saddle. Pull out the stakes you used to locate the exact position of the posts, and quickly insert the steel saddle or rod, pushing them deep into the concrete



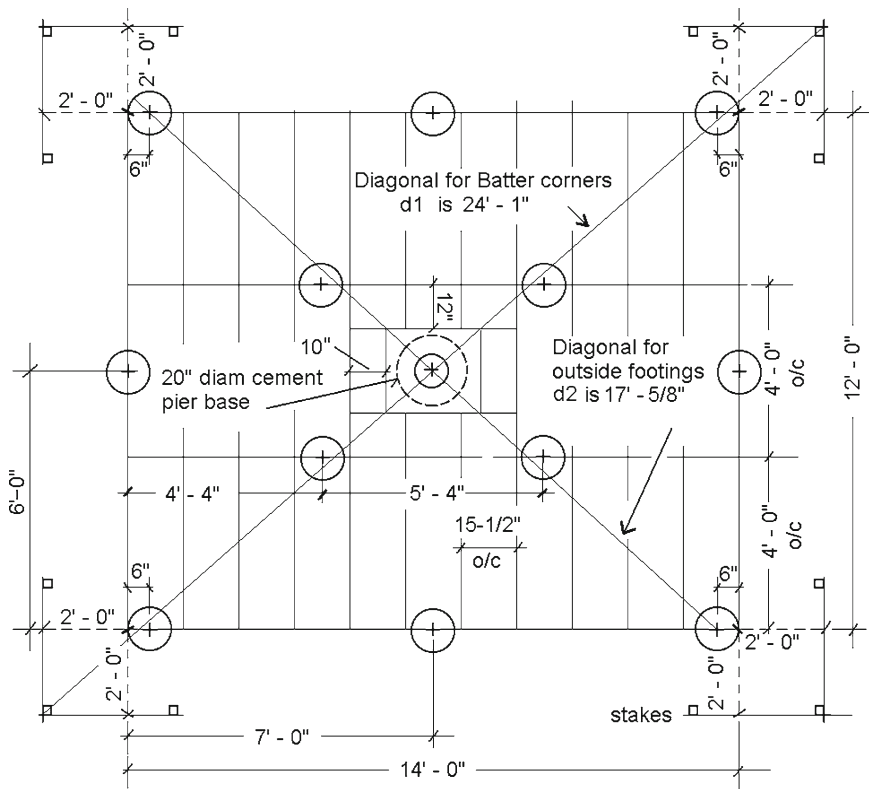
**Figure 5.5.** Detail of floor slab and sole plate with "j-bolts" (Diagram adapted from Home Renovation, see Endnote 2, Chapter 4).

footing. In using steel saddles, you will have to align them relative to each other, accomplished easily with a section of 2" x 6" board, placed flat in them. The saddle should sit about 1" above the finished concrete surface. If hot-dip galvanized (preferred) they can rest right on the concrete surface which lends greater support (less torque on the rod supporting it). The reason for raising the normal metal saddle is to prevent corrosion under the saddle at the concrete interface.

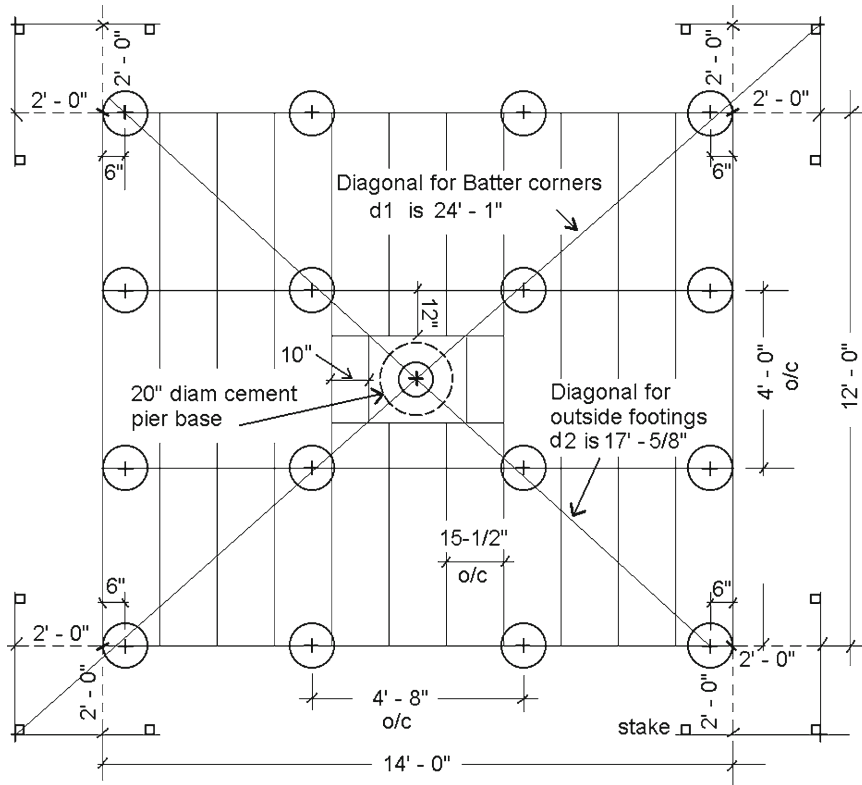
Check the drying concrete, maintaining that the j-bolts, saddles or rods remain perpendicular and in-line. Toward evening, lightly sprinkle the concrete surface with a fine mist of water from a garden hose so that the mixture does not dry too fast and crack. When concrete is hard, strip off the forms and remove the stakes in preparation for framing the walls.

## The Sono-Tube Footings Floor

This footing arrangement requires a total of 16 sono-tube footings (12 for the observatory floor and 4 for the gantry posts). With the 2" x 10" heavy floor joists this footing arrangement will provide all the support you will ever need, even with a crowd in the observatory. If one were to use a smaller size joist such as a 2" x 8", additional footings would be required as shown in the second diagram with 16 footings under the observatory floor (Figures 5.6–5.12).



**Figure 5.6.** Plan view of 12 sono-tube footing arrangement showing joist pattern. (Diagram by John Hicks).



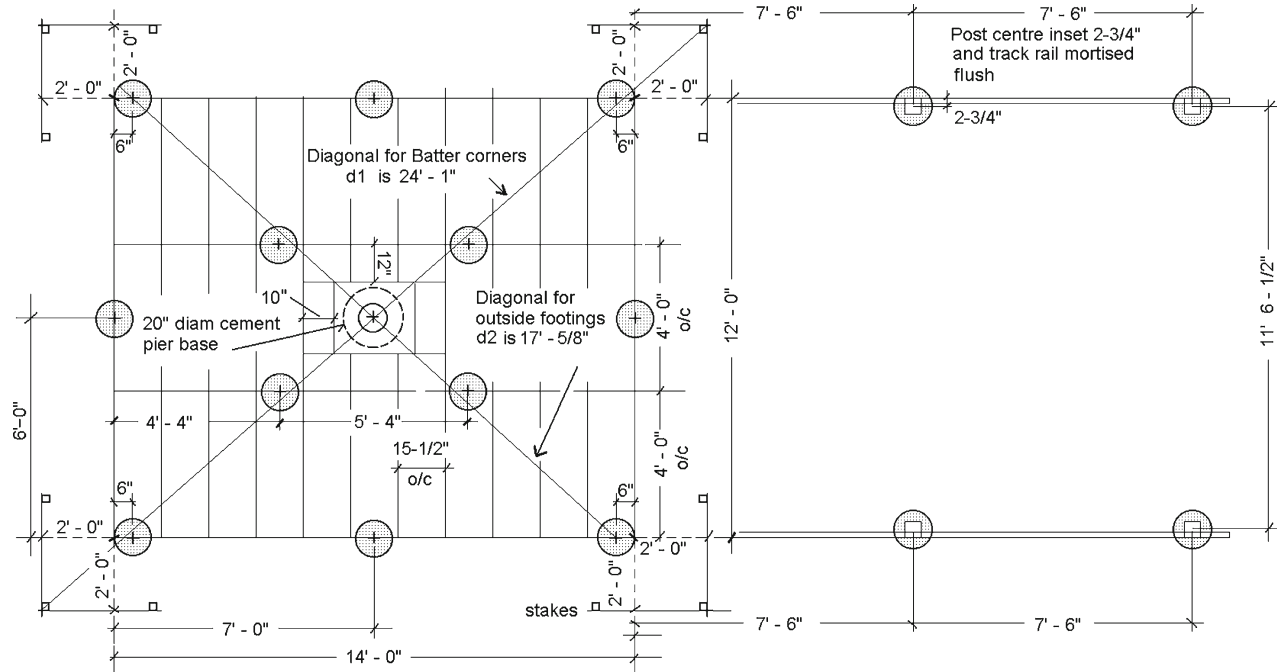
**Figure 5.7.** Elevation of 16 sono-tube footing arrangement showing joist pattern. (Diagram by John Hicks).

The joists forming the sub-floor of the observatory are held in place over the footings with iron saddles set in concrete. These will allow for some adjustment, shimming, etc., in case you make a mistake in squaring the foundation. Construction measurements should always be taken from corner “batter boards” staked at the outside corners. These are offset from the actual corner footings by 2 ft to allow space for digging holes for the sono-tube footings. If you add exactly 2 ft on both ends and sides of the staked floor dimensions you will end up with a rectangle 18 ft × 16 ft measured from the “batter board” corners. Set the batterboards to describe an 18" × 16" rectangle. Measure the diagonals, corner to corner of the “batter boards” to make sure they are equal.

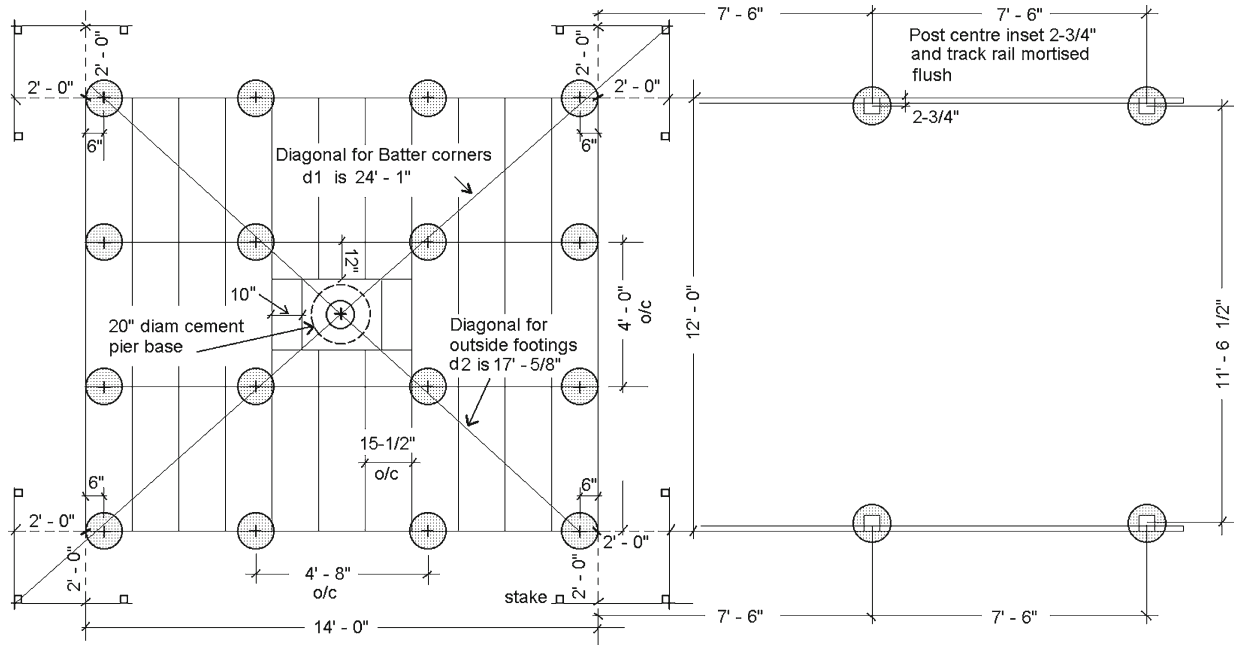
The sono-tube corner footings are measured in 2 ft from batter boards on the sides but 2 ft 6 in. from batter boards on the ends (the 12 ft dimension).

Referring to the diagrams of sono-tube footings, you will notice that the end footings are an additional 6 inches in from the batter boards, – to avoid clashing the joist saddles with the floor joist junctions at the corners. Drive in stakes at the 4 corner footing locations. It will soon be apparent why we use offsets to the actual footing locations: because once the holes are dug, one loses any idea where the exact center of the footing is. In order to square the footings, again the diagonals should be equal. Measure from corner to corner diagonally.

All the floor joist saddles are arranged so as not to clash with cross joists. This also allows for easier nailing at the corners.

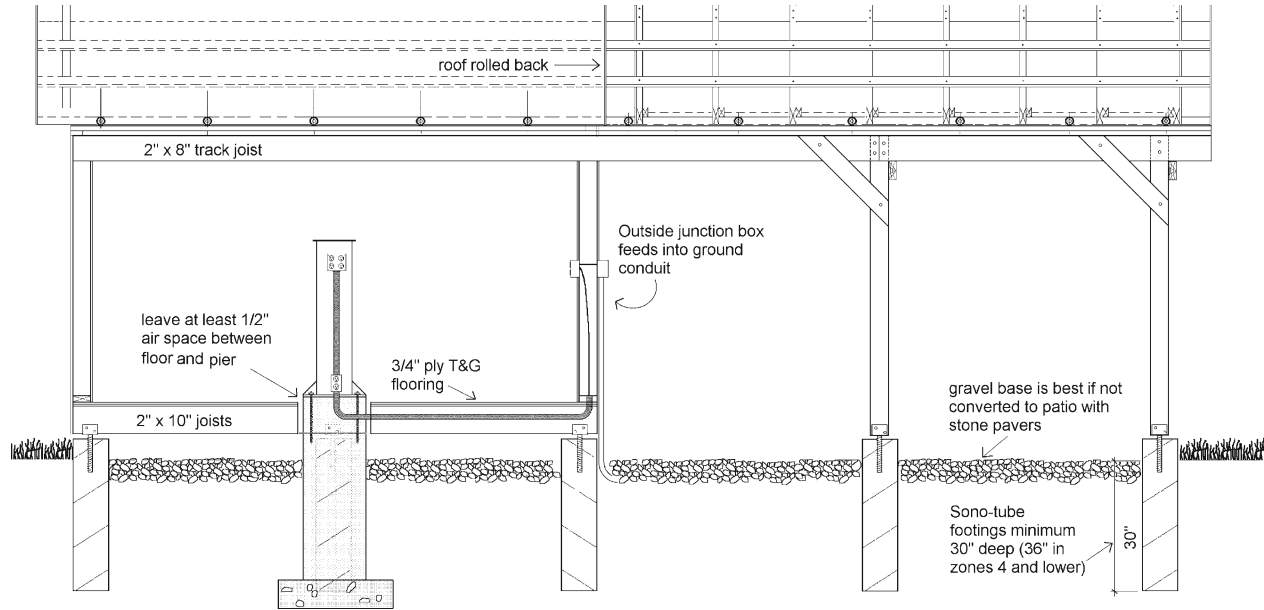


**Figure 5.8.** Plan view of complete sonotube footing arrangement including gantry showing 12-footing observatory foundation. (Diagram by John Hicks).

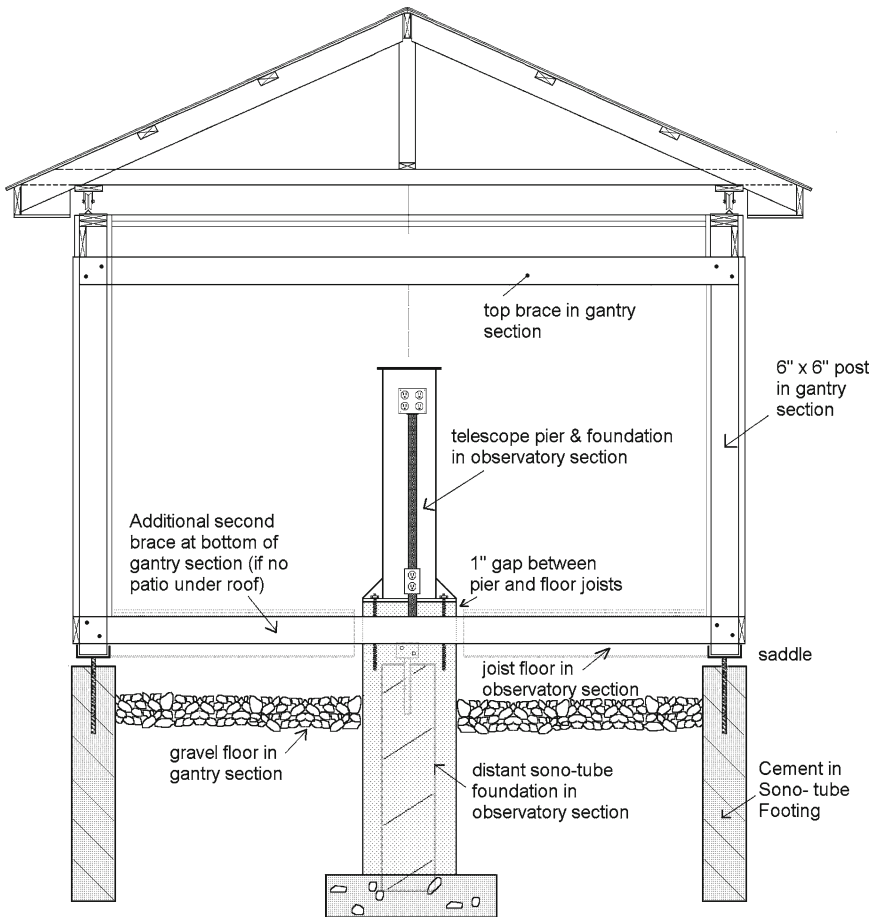


**Figure 5.9.** Plan view of complete sono-tube footing arrangement including gantry showing 16-footing observatory foundation. (Diagram by John Hicks).





**Figure 5.10.** Elevation of sonotube footings arrangement – observatory and gantry. (Diagram by John Hicks).



**Figure 5.11.** End view of gantry with sono-tube footings showing pier in distance. (Diagram by John Hicks).

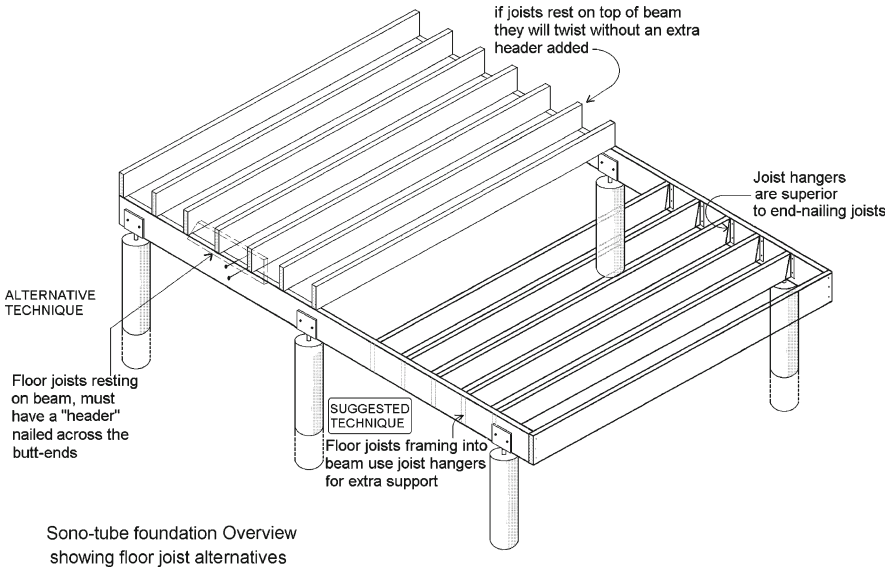
## Observatory Floor Framing

The wood floor framing is constructed of even-spaced joists covered in a layer of 5/8" tongue and groove plywood sub-flooring. Joists are 2" x 10" to hold the weight of a group in a concentrated viewing session to guarantee little or no deflection in the floor.

With 16" spacing, these will easily support a live load of 40 lb/ft<sup>2</sup>.

Normally 2" x 8" joists would suffice in an application as small as this, but a rigid floor is essential for minimum movement. Use 14 ft 2" x 10" beams for the outer framing on both sides with no joints. Position and nail these first in the saddles, verifying the squareness by measuring the diagonals from corner to corner. Use 3–4 in. spiral ardox nails to nail the ends together and to end-nail all the joists (if you do not use joist hangers).

Position the 2" x 10" joists on 16 in. centers and nail with joist hangers (preferred method – stronger and meets newer building codes).



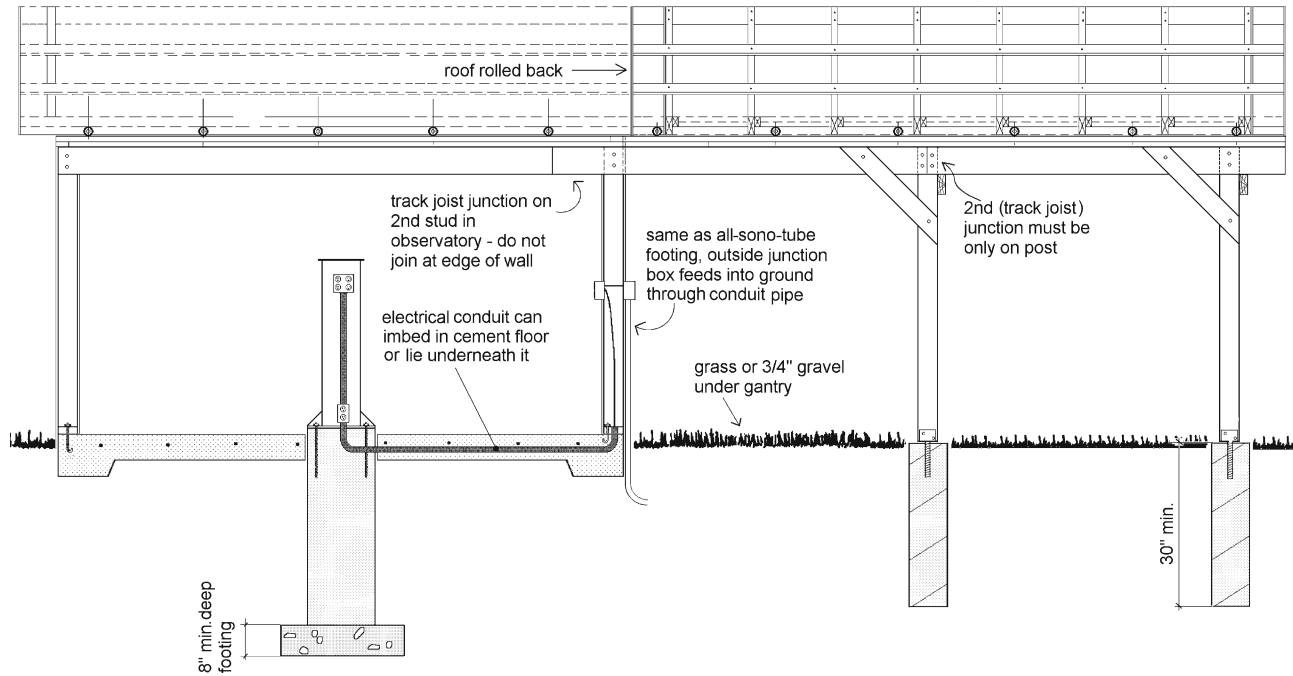
**Figure 5.12.** Overview of typical sono-tube footings with choice of joist placement. (Diagram adapted from Home Renovation – see Endnote 2, Chapter 4).

## Combining a Poured Cement Observatory Floor with Sono-Tube Footings Under the Gantry

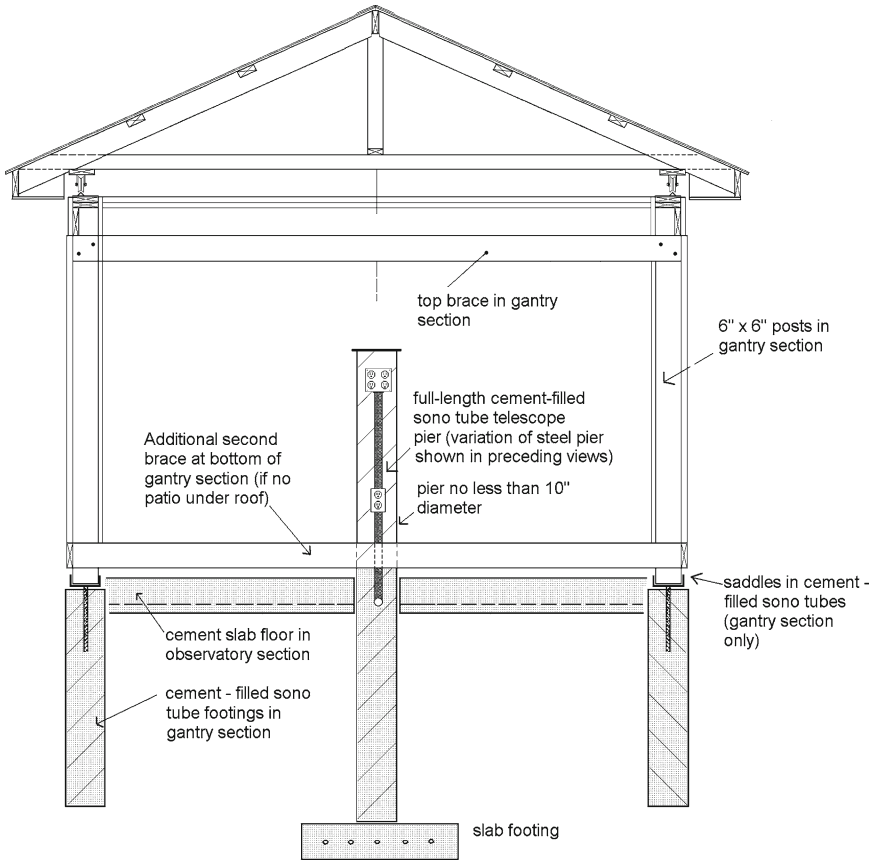
In some locations with no threat of frost and differential soil heaving, a combination of footings could be used to simplify construction. Using a poured concrete slab for the floor and four sono-tube footings for the gantry posts will make the footing task easier, eliminating forms for the gantry section. Such an arrangement introduces a differential foundation support which could allow flexing at the gantry/observatory junction. This is somewhat catastrophic because the track would bend at this point, preventing the roof from rolling off easily or perhaps entirely. In perfect conditions of soil and moisture, and no frost, the combination will work well. Consider this very carefully before you attempt it. Personally, I do not recommend it (Figures 5.13 and 5.14).

## Converting the Gantry Section into an Outdoor Patio

If you follow the route of pouring a solid concrete floor for both observatory and gantry perimeter, a stone paver patio can be installed interior to the gantry strip footings. This is the ideal finishing touch to an otherwise “just functional” observatory. When the roof is rolled off for solar



**Figure 5.13.** Side elevation of combined footings – slab under observatory and sono-tubes under gantry. (Diagram by John Hicks).



**Figure 5.14.** End elevation of combined footings – slab under observatory and sono-tubes under gantry. (Diagram by John Hicks).

observing etc., you can sit in the shade of the roof rolled off over the gantry. Even when the roof is closed, at the correct daylight hour, a sunny or shady nook is still created. The concrete margins, clean and sharp, add an ideal border to the stone paver patio, creating a truly professional touch. If you were to use the sono-tube footings, it can still be done, but with much less effect, since the sono-tubes will interfere with the installation of a “clean” stone paver margin. You will have to cut the stones to fit and make some sort of border in wood or concrete to hold them in. You save all this extra work with a purely poured footing all around (Figure 5.15).

## Installing the Floor

The finished sub floor of the sono-tube footings model should be covered in a layer of outdoor 5/8” tongue and groove plywood. This should preferably be screwed down which allows tightening later as the plywood dries out. Make sure to use at least coated screws or preferably hot-dipped galvanized type deck screws.

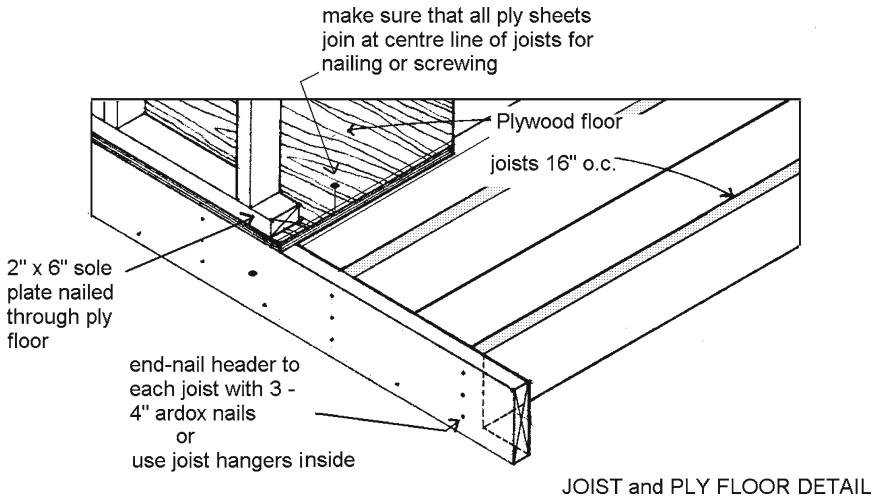




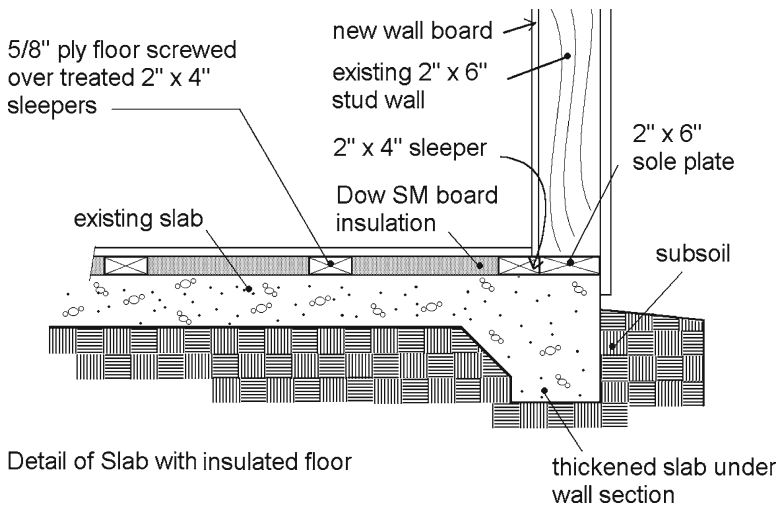
**Figure 5.15.** Photo of “Davis Memorial Observatory” with roof over patio (From the collection of John Hicks).

Cut the ply to fit around the pier base leaving at least  $\frac{1}{2}$ ” gap all around. Do not allow the ply to touch the pier at any point. I wrapped a  $\frac{1}{2}$ ” thick sheet of Styrofoam around my pier to seal the floor from drafts underneath. The styrofoam is cellular enough that it will not transmit vibration even if touching the pier. It serves a double purpose also as an insect barrier and dust barrier as the draft created through the track gap will pull air up through this opening depending on wind velocity. Note that the sole plate is nailed through the ply floor (Figure 5.16).

The finished concrete floor of the poured foundation model can be insulated and covered in ply to create a “warmer” less damp floor to stand on. Installing  $2'' \times 4''$  or  $2'' \times 2''$  battens across the concrete floor in a lattice formation (at about  $2 \text{ ft}^2$ ), cover as above with  $\frac{5}{8}''$  tongue and groove plywood. Filling in the spaces with Dow SM board or similar will aid in your comfort on the cold winter nights (Figure 5.17).



**Figure 5.16.** Detail of floor framing. (Diagram adapted from Home Renovation – see Endnote 2, Chapter 4).



**Figure 5.17.** Detail of concrete slab with insulated floor. (Diagram adapted from Home Renovation – see Endnote 2, Chapter 4).

## CHAPTER SIX



# Framing the Walls



## Constructing and Erecting the Walls

The 4 walls are best constructed on the ground, later to be raised up into position either on the joisted floor or poured cement floor with its j-bolts. Studs should be “end-nailed” through the sole plate (the bottom 2” × 6” plate) at a standard 16” apart on center. This method is much more satisfactory than installing the sole plate first and “toe-nailing” the studs into it while standing. Before installing the studs, depending upon the foundation type, it is essential to complete the following preparatory tasks:

- (a) locate the position of the j-bolts on the sole plate in the case of a poured slab
- (b) mortise the upper section of each of the side wall studs to accommodate the 2” × 8” track joist.

### Locating the Position of the J-Bolts on the Sole Plate

Carefully position the sole plate on the threaded bolt ends projecting from the concrete slab, aligning it with the ends and flush with the sides of the slab. If you set the j-bolts at the same height in the concrete, you can simply hit the sole plate with a hammer impressing the bolt ends into the wood. If there is some difference in height of the j-bolts, carefully mark their position with a magic marker. Drill the holes for the bolts slightly larger than the thread size so the bolts won’t bind in the holes. No matter how carefully you do this it won’t be easy to lift up the whole wall and place it over the bolts without some binding – it pays to be very accurate locating the bolt ends. Make sure to try the drilled sole plate over the j-bolts before you begin nailing the studs to it, and mark the respective sole plate side (East or West). This may seem to be over-cautious, but when you are lifting the weight of the whole side wall, you will be thankful of the knowledge that it has been pre-fitted successfully. Don’t forget to pre-drill the holes for the electrical conduit protruding from the poured concrete foundation also (mark their location at the same time you

mark the j-bolt locations in the sole plate). Wire from these passes up through the interior of the wall to a receptacle. It is a good idea to brace the studs horizontally with small sections of 2" × 6" placed midway between the sole plate and the top plate to add extra strength to the walls – particularly when you raise them up into position. These will also provide an extra support across the walls when you apply interior sheathing. They will have to be staggered up and down on the studs in order that you have a butt to end-nail into.

## Cutting the Mortise for the Track Joist

To support the track and rolling roof the side walls need a 2" × 8" track joist installed flush in a mortise cut at the top of the studs. It is far better to cut the mortise for the track joists now before the studs are attached. Cut the mortise deep enough that the 2" × 8" joist will be flush with the outside surface of the 2" × 6" stud, and also long enough that the joist sits perfectly flush with the top of the stud. Cut the mortise in all the studs before nailing them onto the sole plate.

Do not extend the track joist all the way to the corner nearest the gantry, leave it open for 16" in order that the next section of joist over the gantry fits inside the observatory wall providing an internal support for the outside joist. This is necessary because beginning a new joist section outside the observatory walls introduces a weak junction and a possible flexure point. This means that the track joist mortised into the studs will fall short of the wall length required by 16". It also requires that the corner stud(s) be cut shorter to accommodate it.

To assist in tying the studs all together, you can nail on the 2" × 6" top plate, end-nailing it to the top of the studs thereby securing the whole wall as a rigid unit (see Figures 6.1 and 6.2).

## Raising the Wall Sections and Tying the Frame Together

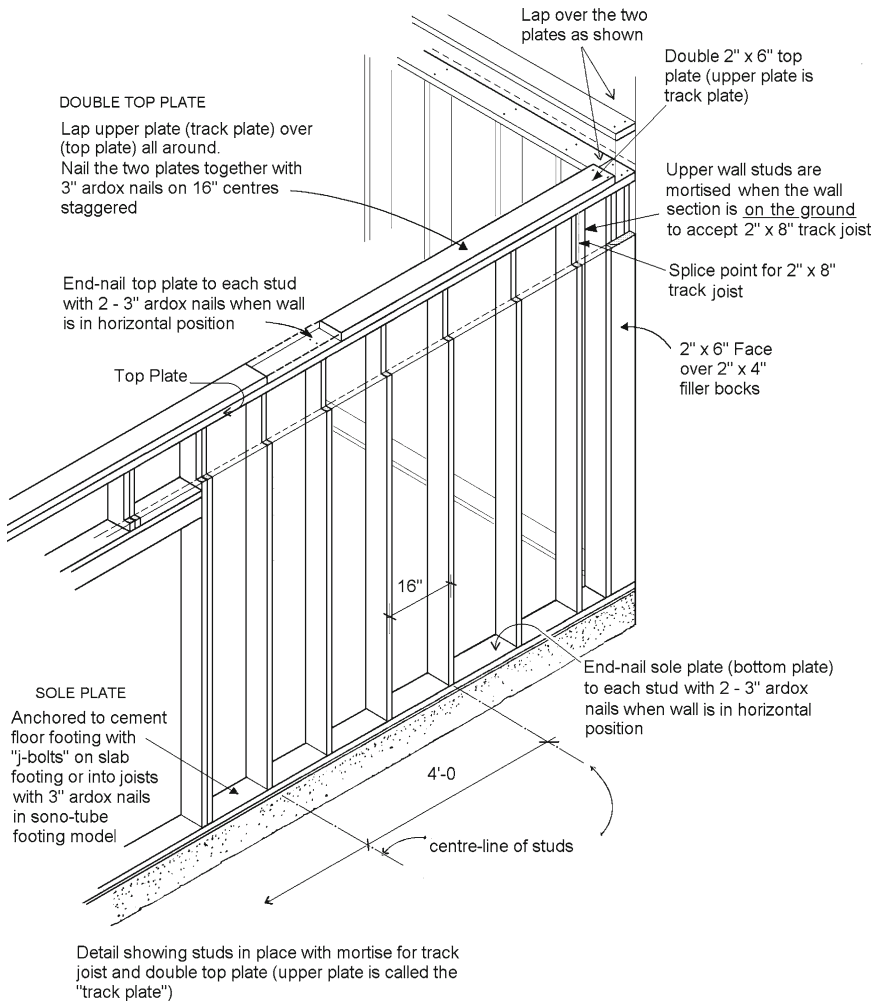
Raising the assembled wall sections is typically a two or three person job, so enlisting friends or astronomy associates is essential. Once a wall is lifted into place it should be temporarily secured with 2" × 4" braces, holding it in position until an adjoining wall is also lifted into place. Square the walls plumb with a carpenter's level and shim if necessary before nailing them together at the corners. Lastly secure the walls to the foundation using j-bolts or nails (Figure 6.3).

Looking at the detail showing the "outside corner assembly," notice how the 2" × 4" filler blocks are placed – the corner stud is followed by filler blocks sandwiched between it and the next 2" × 6" stud nailed together. The innermost 2" × 6" serves as a nailing stud for the interior wall sheathing. This arrangement may look over-structured, but it is a practical assembly method assuring both a rigid support and a means of fastening the exterior and interior sheathing at the corners (Figure 6.4).

The top plate is a double top plate for strength in carrying the roof load. It consists of a lower 2" × 6" plate capping the wall studs and interior track joists, with another 2" × 6" track plate nailed on top. The 2" × 6" top plate nailed directly to the studs caps the wall section completely, sealing off the top of the observatory walls (prevents insects, such as wasps etc., from entering down into the wall sections).

Make sure to lap the second 2" × 6" over all joints in the lower 2" × 6" plate, particularly at the wall junctions where the lap is essential to help hold the walls together.

In the next stage "building and aligning the gantry section" the track joists outside are capped in a double 2" × 6" aligned precisely with the inside 2" × 6" upper plates. The steel track base is lag-bolted directly down onto this, covering the top of the 2" × 6" surface completely. Since the



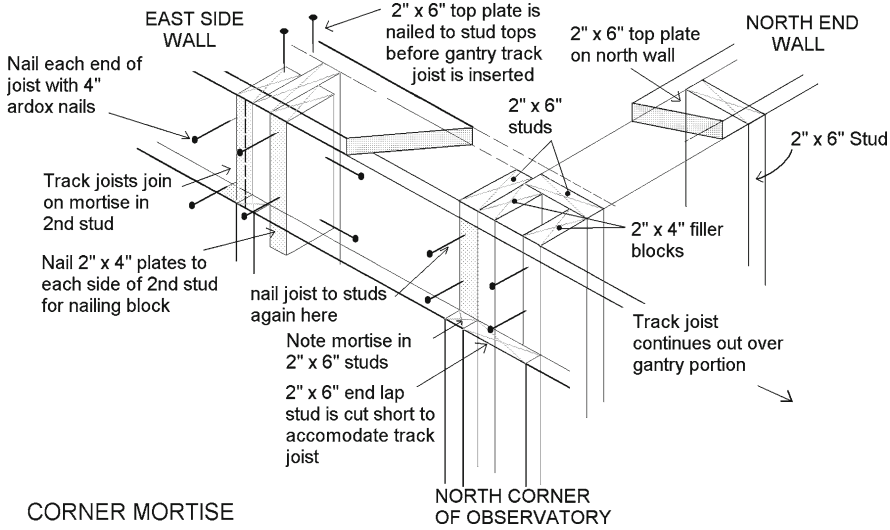
**Figure 6.1.** Detail of wall showing studs, track joist, sole plate, mortise, and top plate(s). (Diagram adapted from Home Renovation – see Endnote 2, Chapter 4).

track joists penetrate into the observatory about 16" the gantry/ observatory connection is well supported from any flexure (Figure 6.5).

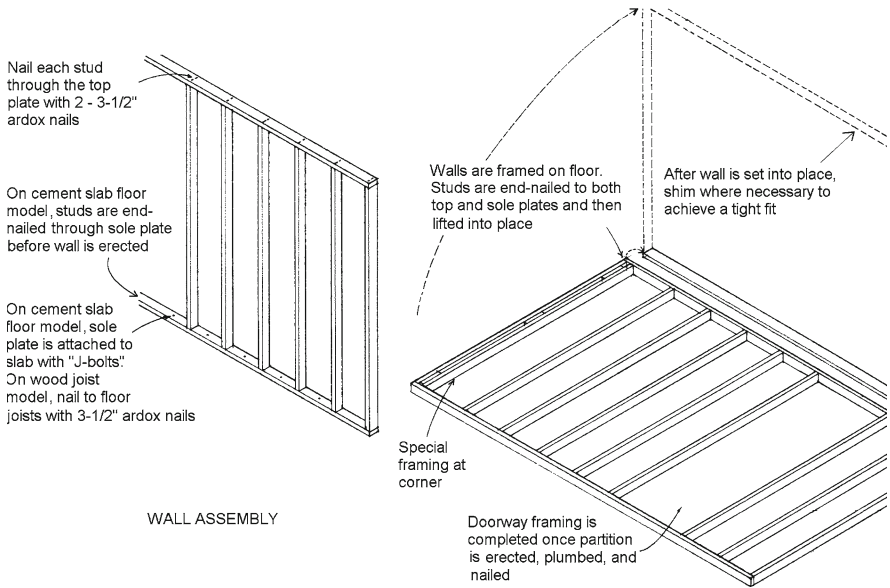
Nail the 2" x 6" plate to the track joist and wall stud ends with 4" ardox nails. Add the second 2" x 6" upper plate with 3½" ardox nails @~16" on center. When nailing on the double 2" x 6" plates make sure they are flush with the outside face of the track joist.



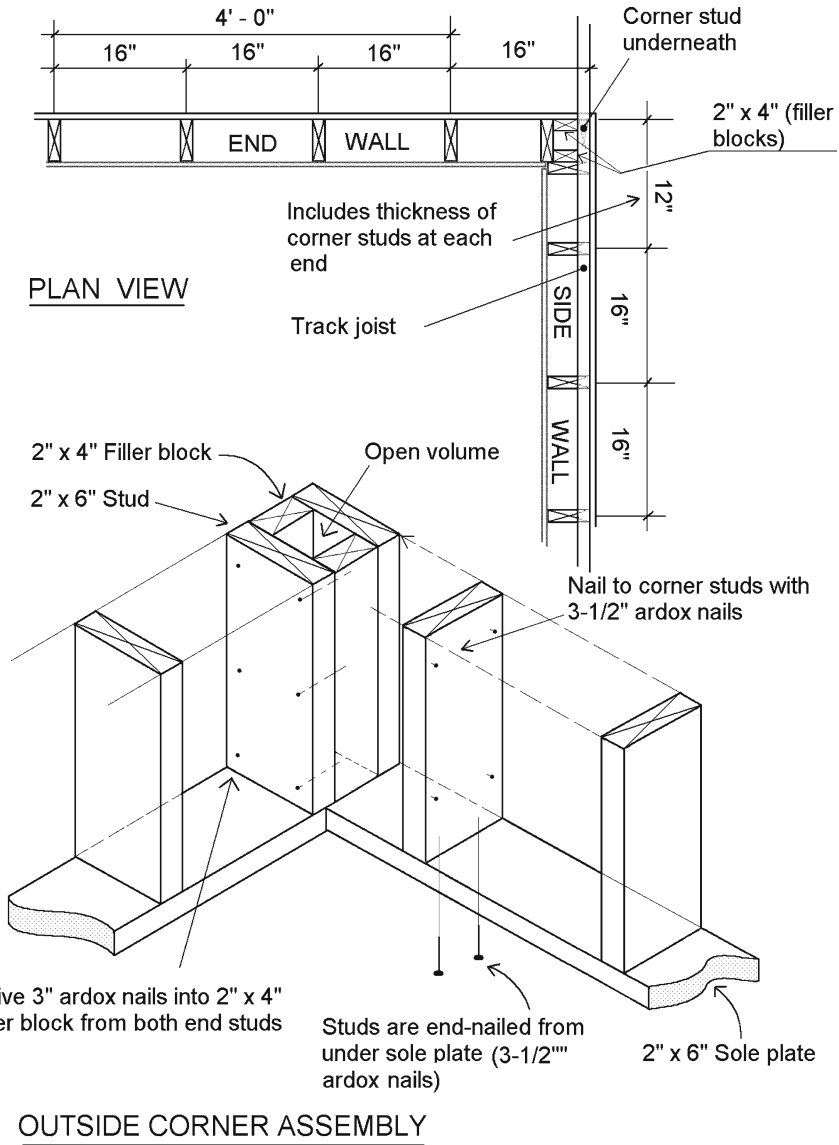
### Building a Roll-Off Roof Observatory



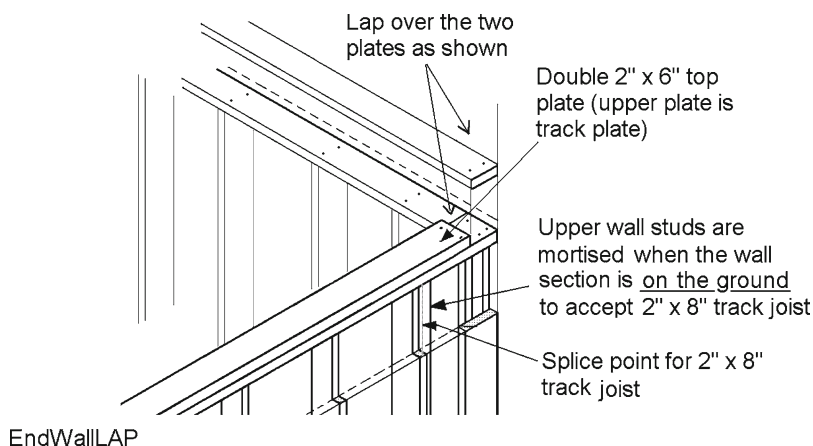
**Figure 6.2.** Detail of corner stud assembly showing mortise left in last two studs for the track joist. (Diagram by John Hicks).



**Figure 6.3.** Method of assembling and erecting the walls. (Diagram adapted from Home Renovation – see Endnote 2, Chapter 4).



**Figure 6.4.** Detail of outside corner assembly showing corner stud arrangement. (Diagram adapted from Home Renovation – see Endnote 2, Chapter 4).



**Figure 6.5.** Detail of double top plate showing end-wall lap technique. (Diagram adapted from Home Renovation – see Endnote 2, Chapter 4).

## Choosing, Locating, and Installing a Door

### Choosing a Door

When framing the walls in our model leave a rough opening in the stud locations sufficient to locate your proposed door style. The dimensions for this opening, called a “rough opening” will be specified in your door literature. Once the walls are erected, you can cut out the sole plate in the rough opening. The door threshold will replace it. If you followed instructions earlier, there will be no j-bolt in this position. I advise you to purchase your door in advance so that you can allow for the exact rough opening you will require. I suggest the purchase of a steel panel door, with no window (for security and light-proofing), and a double lock set (both knob set and dead bolt). Choose the stainless type if your budget allows, as the normal plated sets lose their finish quickly out in the elements. Make sure that the hinges have pressed-in pins (bearings) not the screw-in type which can easily be removed by vandals. A good security technique is to hammer a sturdy nail into the wood frame just above each of the hinges and drill holes in the door edge to seat the nails as the door is swung closed. No matter what a thief does to the hinges (even remove them completely) he cannot pull the door past the nails pinning it.

### Locating the Door

The location for the door is a matter of individual preference, however if you plan to carry items from the observatory interior to the outside “patio” under the gantry, then it pays to place the door in the end wall. Normally this would be the North end wall. Place the door off to one side on

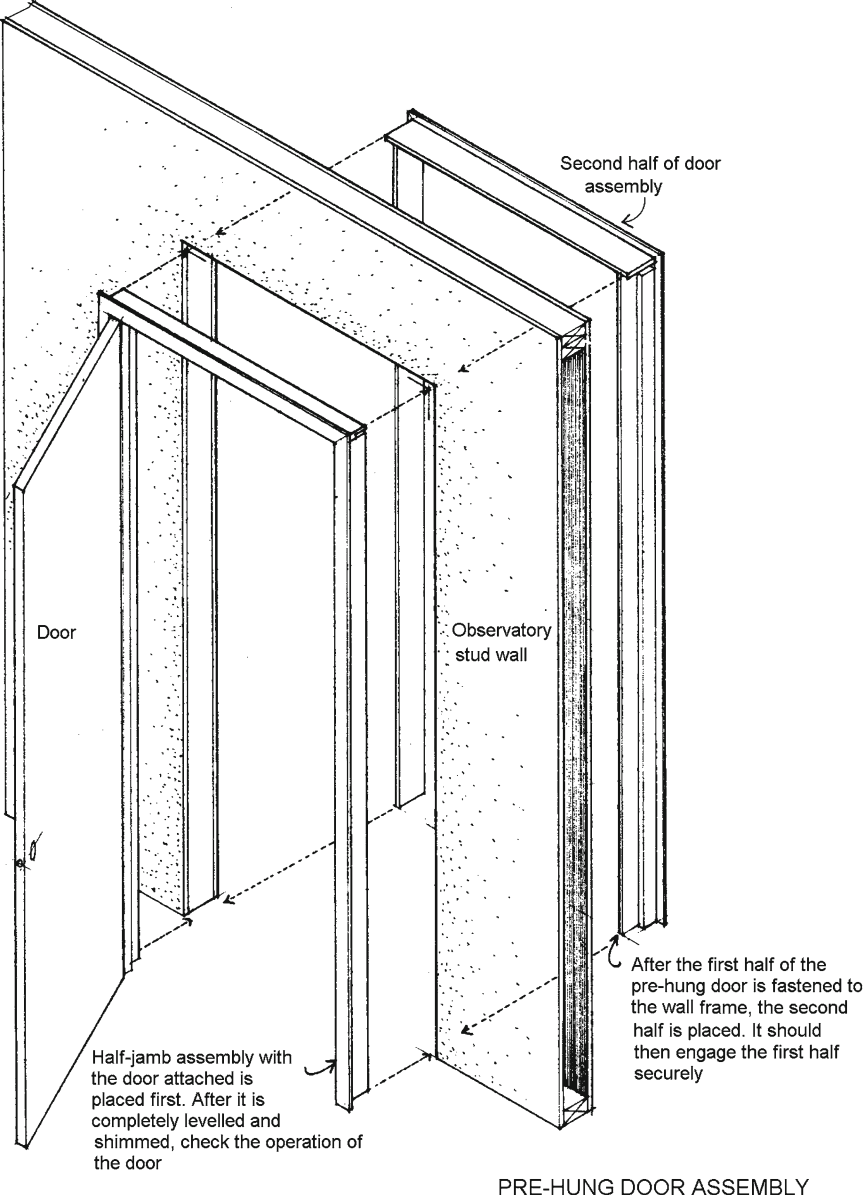
the end, on the North-east end if the door swings inward so that when it is fully open it will lie flat against the east wall. If placed along a side wall, it is best to locate the door again in the North-east corner, again such that when it is swung inward it will lie this time against the North wall. Most of your observation will be in an arc from South-east through South to West, so don't put the door in this segment. Guests entering will either disrupt or block your line of sight and admit light in the wrong place entirely. A good tip is to remove the door after you have installed it, allowing for easier roof construction, adding interior sheathing, adjusting the pier etc. It's a nuisance while you are constructing the roof, particularly if you are climbing down to go outside and retrieve components. Make sure to allow for the door threshold.

The following diagram illustrates the pre-hung door assembly technique after the rough opening has been completed. The pre-hung door will have to be shimmed at various locations (or "blocked") to hold the pre-hung frame tightly. The diagram showing the blocking locations will help you determine where these "blocks" should be installed (Figures 6.6 and 6.7).

Should you wish to construct the door and frame yourself the detail labeled "Self-hung door installation" will guide you in the construction of the jambs, stops, and blocking. The detail labeled "Head jamb, Side Jamb, and Sill" will assist you in understanding the cross-sectional make-up of the door. Finally, "Cylindrical lock and Strike plate installation," along with "Hinge and Knob installation" will complete the assembly. Is a tricky task for a beginner, and again I suggest you purchase a pre-hung door (Figures 6.8–6.11).

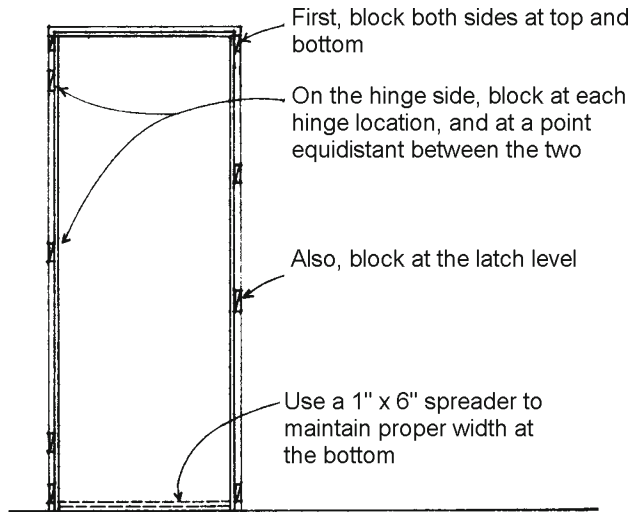
## Installing the Metal Pier Top

Once the door (or at least the rough opening) is placed, the metal pier top section can be bolted down to its concrete base (if that was your chosen option instead of a full cement pier). It is better to wait until the walls are in place, and all top plates fastened before installing the pier top, as it would present an obstacle to positioning the walls, and could be damaged in the process. If you have not fabricated the metal pier top until now, take some measurements at this time to verify your earlier calculations for pier height. Measure the finished wall height from cement pier footing surface to the top surface of the wall plates, adding the estimated track gap which is  $\sim 4\frac{1}{2}$ " if using the 3" diameter V-groove castors suggested. The total height should be  $7" - 4\frac{1}{2}"$  if your total wall height (including top plates) is 7.0 ft. This is your clearance height maximum for a horizontal telescope. Subtracting the height of your telescope optical tube in horizontal position on its own mount from this height will give you an indication of your maximum metal pier height. Allow for some clearance, since the roof joists won't be all exactly at the same level, and there will be days you don't get the telescope tube completely horizontal on closing up (Figure 6.12)!



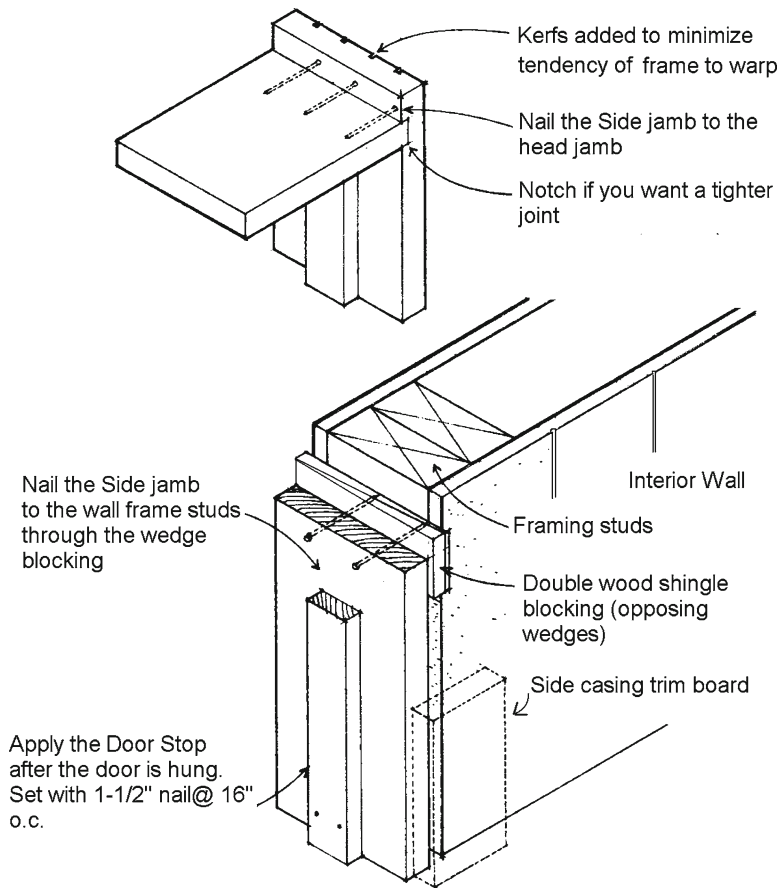
**Figure 6.6.** Detail of pre-hung door assembly. (Diagram adapted from Home Renovation—see Endnote 2, Chapter 4).





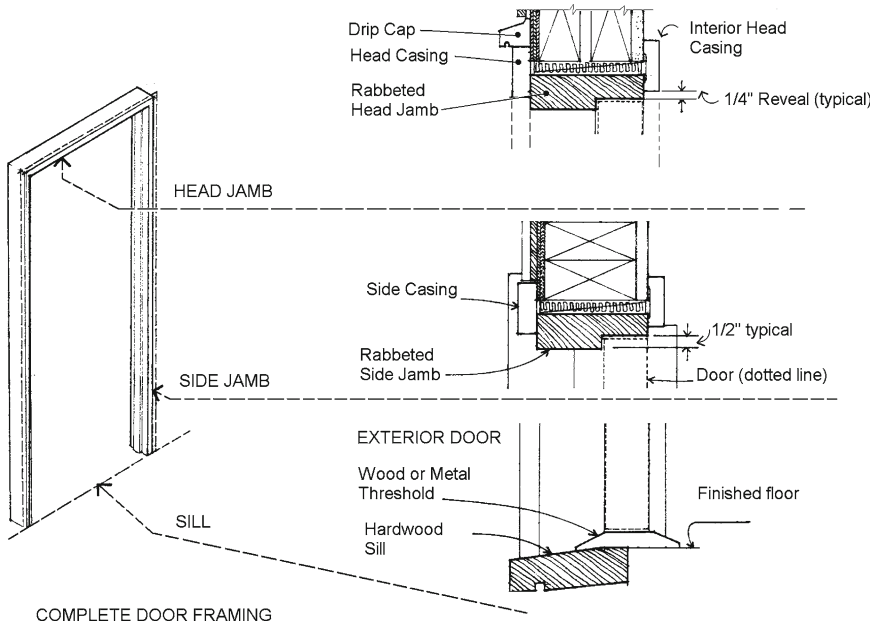
DETAIL OF BLOCKING LOCATIONS

**Figure 6.7.** Detail of blocking locations. (Diagram adapted from Home Renovation – see Endnote 2, Chapter 4).

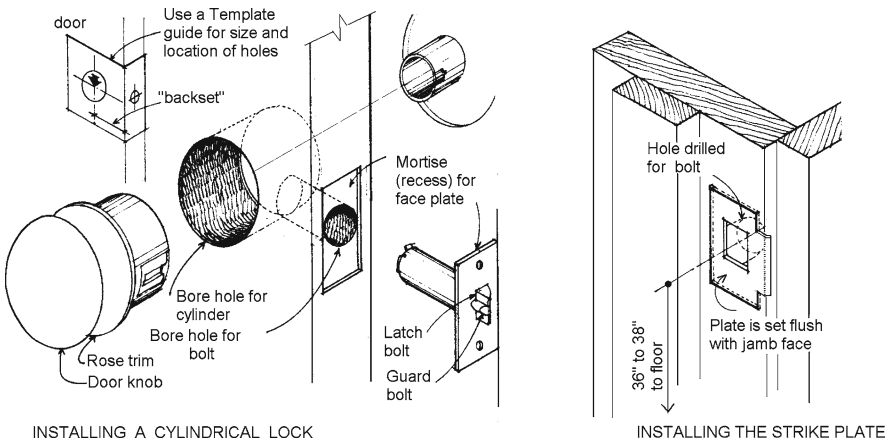


CLOSE-UP OF DOOR FRAME CONSTRUCTION

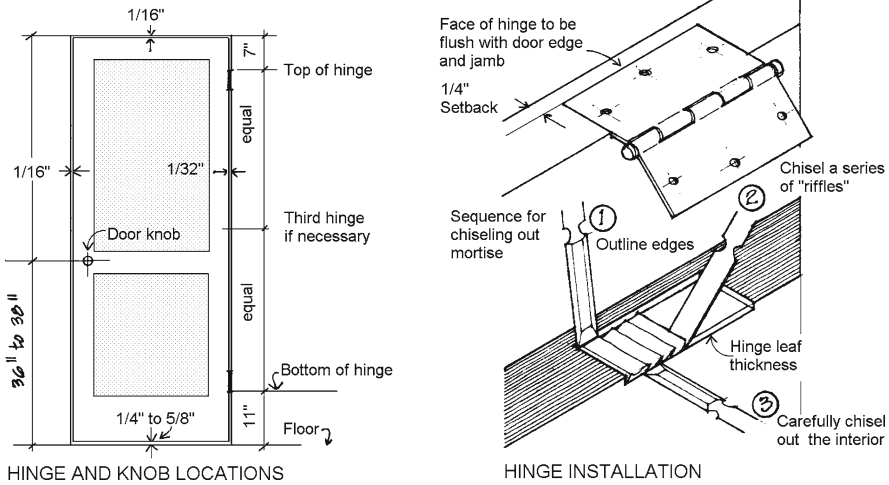
**Figure 6.8.** Close-up Detail of Self-hung doorframe installation. (Diagram adapted from Home Renovation – see Endnote 2, Chapter 4).



**Figure 6.9.** Detail of Head Jam, Side Jam and Threshold construction. (Diagram adapted from Home Renovation – see Endnote 2, Chapter 4).



**Figure 6.10.** Detail of Cylindrical lock and Strike plate installation. (Diagram adapted from Home Renovation-see Endnote 2, Chapter 4).



**Figure 6.11.** Detail of Hinge and Knob installation. (Diagram adapted from Home Renovation – see Endnote 2, Chapter 4).



**Figure 6.12.** Photo – Guidscope on Mount intended for large refractor awaits final construction. At this point the cradle rings justify calculating the horizontal rest position of the final telescope assembly. (From the collection of John Hicks).

## CHAPTER SEVEN



# Framing the Gantry Section



Whether you chose to install a full cement footing as an extension to the observatory floor, or you used sono tube piers, or a combination of the two, at this stage you will find it necessary to locate the gantry post supports precisely in their saddles.

To assure an effortless roll-off, the gantry and its track must be precisely in line with the observatory track section. This requires no deviation in height or angle, maintaining precise parallel supports for the steel castor track installed later. To fabricate such an arrangement requires careful attention to alignment and construction.

The first step involves temporarily placing the 6" × 6" posts in the four saddles now firmly set in concrete, and bracing them with 2" × 4" supports until each post is plumb (perfectly vertical). Use a carpenter's level to plumb the posts, then lightly nail the posts through the saddles just enough to hold them in temporary position.

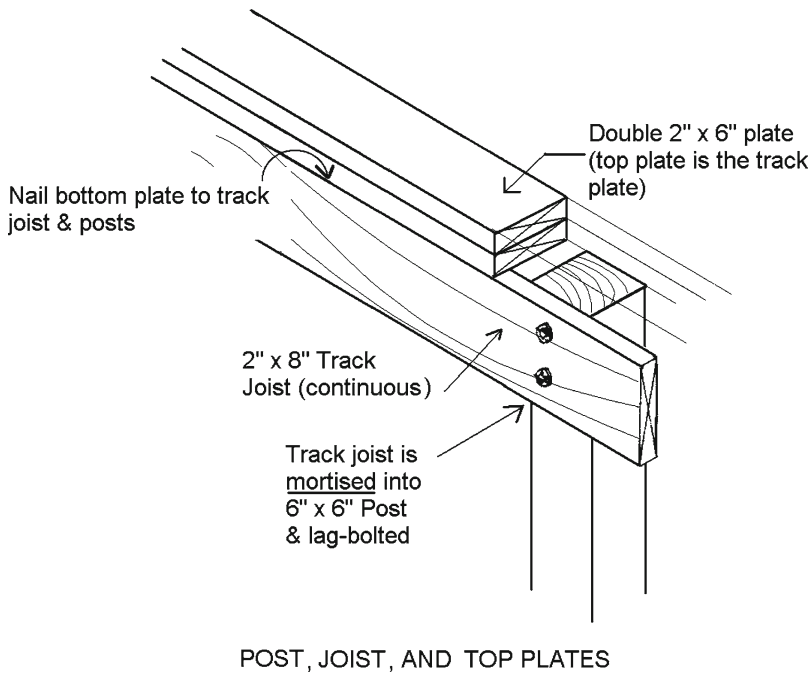
When you are satisfied the framework of posts is square and "true," you can locate the position of the 2" × 8" track joist on the side of each post extending from the observatory proper. An easy way to achieve linearity in the track joist is with the use of a string line pinned to the top of the opposite end of the track joist in the observatory. Standing on a ladder beside the end post of the gantry, sight along the string pulled taut, and mark its intersection with the post. Providing the observatory track joist is perfectly level, you can also use a level on the new track joist to achieve linearity. Number the posts with a magic marker before taking them down, and locate them on your plan, so that each will go in its proper place in the final installation.

Take all the posts down and cut the mortise in them exactly as you did with the observatory studs. Be precise cutting the mortise so that the 2" × 8" track joist will fit flush with the surface of the 6" × 6" post and the 2" × 6" top plates will seat flat on top of post and joist (Figure 7.1).

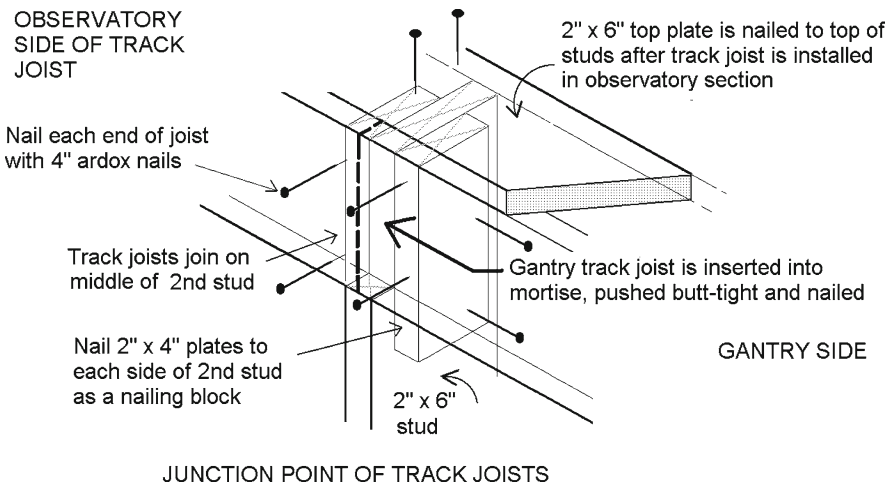
Re-install all the posts in their correct positions, and lag screw them through the saddle holes.

Use 5/16" × 3" long lag screws (don't use longer lag screws as they will meet in the center of the post).

Employ a washer with each lag screw and make sure both lag screws and washers are hot-dipped galvanized for endurance. Pre-drill a 1/4" guide hole for each lag screw (two lag screws are sufficient per post). Brace the posts as before with temporary 2" × 4" lumber. Install the 2" × 8" track joist in the mortised posts, pushing the joist all the way into the observatory wall until it



**Figure 7.1.** Detail – post mortised with track joist capped in double 2" x 6" plates. (Diagram by John Hicks).



**Figure 7.2.** Detail – junction of track joists inside the stud wall showing laminated nailing plates. (Diagram by John Hicks).

butts up against the joist in the stud wall (remember that we left the last stud gap of 16" open for the gantry section of the track joist) (Figure 7.2).

Lag screw the track joist to each post top with 5/16" x 4" hot-dipped galvanized lag screws – 2 per post – set diagonally). Pre-drill all lag screw guide holes with a 1/4" drill. In the observatory

wall section, use two 4" ardox nails per stud, nailed flush so that outside panels will remain flat when nailed over them. Note the nailing plates laminated to each side of the stud where the joists meet mid-way on the stud. Nail the joist into each of these plates using two 4" ardox nails. Make sure to lag screw the nailing plates on to the stud leaving room for the ardox nails to penetrate.

Leave a full 16 ft of track joist extending from the observatory wall to beyond the last post – this will be exactly what is needed to hold the entire roof rolled completely off the observatory.

Finally, nail on the double 2" × 6" top plate in line with the double top plate inside the observatory.

Nail on the first 2" × 6" plate first with 4" ardox nails about 16" apart into the track joist maintaining it flush with the joist's outer surface, and into the tops of the posts. Then nail the upper 2" × 6" plate exactly over this, making sure that no joints are co-incident (maintains rigidity). Use 3½" nails about every 16" (same as the observatory section). This effectively forms a 3½"×5½" beam over the 2" × 8" track joist creating a strong support for the roof once rolled off the walls of the observatory (refer to Figure 7.1).



## CHAPTER EIGHT



# Fabricating the Track and Base Plate

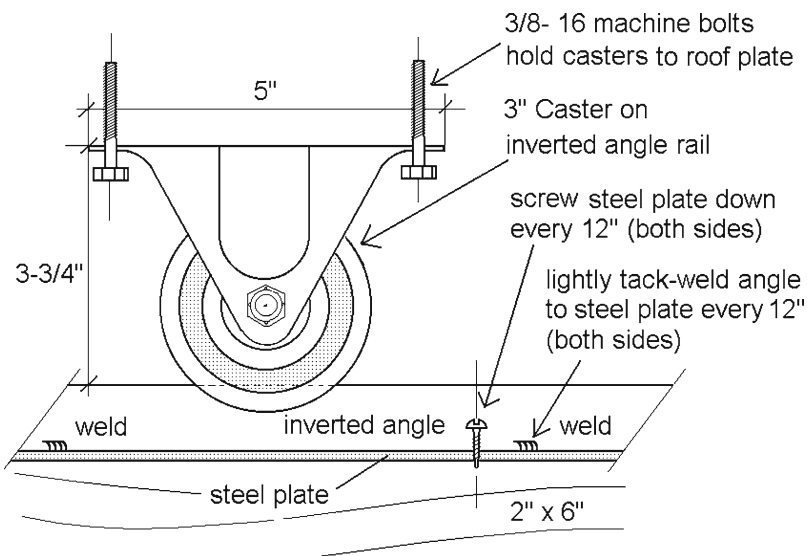
There are a multitude of roll-off mechanisms in use. Some are simple to construct but they usually require more mechanical advantage to operate. Rubber wheeled casters, for example, flatten from prolonged periods of inactivity and hobble along the track base requiring a lot of force to move them. This is made worse by colder temperatures. A winch system consisting of stainless cable, various pulleys and a lot of preliminary “engineering” solves the problem. Success isn’t usually achieved on the first attempt either because of the requirement for very specific locations of the pulleys. On one observatory I designed, the owner had intended to use a “closed-loop” winch system but was forced to resort to a two-winch system, one to winch off the roof, and another to winch it back on. The system worked well although he installed the two winches on pedestals mounted on the floor, which took up needed space within the observatory. Some very southern owners may even find that in order to see Polaris and polar-align their telescopes they may have to extend the gantry further north enabling them to pull the roof a greater distance on the track than it would normally travel. In observatory construction, one always hears suggestions to use golf balls in a channel, either wood or metal, but they will rattle along clumsily as they “gang-up” and roll in a convoy. They inevitably clash, grate together, and produce an unacceptable amount of friction. I have seen examples of golf balls contained by various tubing, either flanked or overhead to lessen the frictional problem, but in the final analysis it’s difficult to prevent them from rubbing together and creating a drag.

Our design uses five V-groove steel casters on each side of the rolling roof. These are typically used to roll on the back of an inverted angle iron rail, rather than on a “flat” leg section of the angle, although both will work. As we shall see later on, if the angle is laid flat with the caster running on a flat side its “leg-up” side will produce unwanted friction. The model I specify is made by Bestway Casters in Toronto, Ontario, with the designation “V-groove Steel Caster  $3\frac{1}{2}'' \times 1\frac{1}{2}''$  Model No. 1303-VG-RB.” The caster has roller bearings and rigid forks. They are rugged casters which will last the lifetime of your observatory. If you are unable to purchase from Bestway, present your dealer with the above specification, which will guarantee an approximate match in strength and endurance (Figures 8.1–8.3).

The track, all of 30 ft long on each side, is fabricated with  $1\frac{1}{2}''$  inverted steel angle, nip-welded to a continuous  $3\frac{1}{2}''$  wide  $\times$   $\frac{3}{16}''$  min thick steel plate. You can make the plate  $5\frac{1}{2}''$  if you prefer

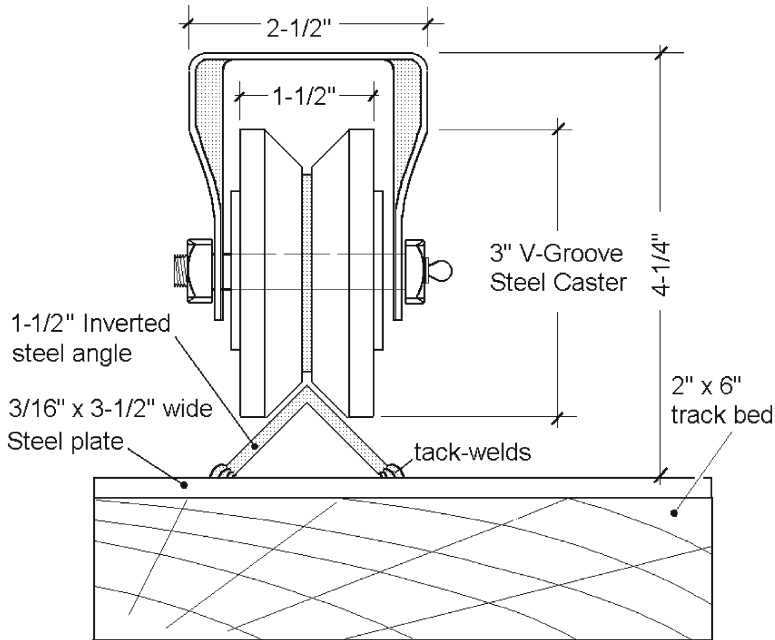


**Figure 8.1.** Photo - V-Groove caster on section of inverted angle resting on double 2" x 6" plate. (Photo by John Hicks).



**Figure 8.2.** Detail – side view V-Groove caster resting on inverted angle track. (Diagram by John Hicks).

but no less in thickness. It is best to make the steel base plate in as long a section as transportation will permit. If you can persuade a metal fabricator to assemble it in 15 ft sections it would be best, although hard to carry without bending, and you should increase the thickness of the plate to  $\frac{1}{4}$ ". Such a length requires a long flat bed truck to transport it and two men to carry it. For self-transport, six 10 ft sections would be next in preference. If your car or van only holds 8 ft lengths



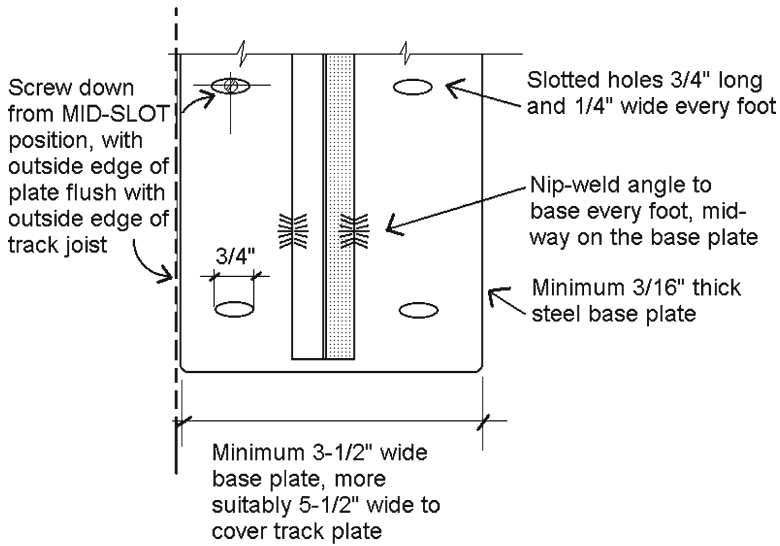
V-groove Cast Steel Caster  
 3-1/2" x 1-1/2" #1303 - VG - RB  
 roller bearings, rigid fork by  
 Bestway Casters

**Figure 8.3.** Detail – end view V-Groove caster resting on inverted angle track. (Diagram by John Hicks).

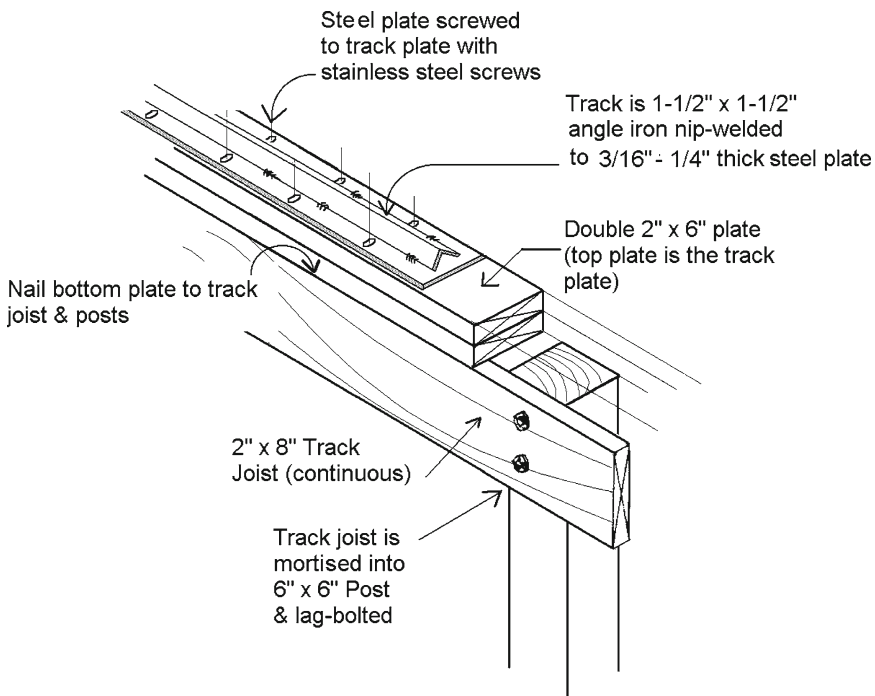
of lumber, then six 8 ft sections plus two 6 ft sections will suffice. Up to four sections on each track introduces 3 joints for the casters to roll over, but if you reverse the sequence of lengths in laying the track, one side relative to the other, there will be no common joint for the casters to run over. This may be a bonus in the long run and a good reason to use three or four lengths of track over two equal ones on each side.

Ask the metal fabricator to make slotted holes on both sides of the steel base plate about every foot, such that adjustments can be made in widening or narrowing the width of the track simply by loosening the hold-down screws and sliding the track to the left or right on the wooden plate underneath (the uppermost 2" x 6"). The slotted holes should accommodate 1/4" wide fasteners and be well-finished so that a 1/4" diameter screw will slide easily in the slot (Figure 8.4a).

The inverted angle is nip-welded to the steel base plate, in its center, about every 12" on both sides of the angle. Intense welding is to be discouraged as it will warp the track and steel plate. Make sure to ask the fabricator to cut off the angle lengths cleanly and squarely, such that when the rails are butted together it's a flush joint – with no gaps in the top rail junction. When the track is finished, spray it twice with a good coat of metal primer and allow it to dry thoroughly. Finally, spray with two coats of Tremclad or similar rust proof coating in the color of your choice. I like to exhibit the mechanical workings to visitors, so I coat the tracks in bright orange. If you want to conceal what they are, spray the tracks in a black or dark blue.



## FABRICATING THE STEEL TRACK BASE PLATE



## POST, TRACK BEAM AND TRACK CONNECTION

**Figure 8.4.** (a) Detail – plan view of track section showing nip-welds and slotted holes. (Diagram by John Hicks) (b) Detail of post with track joist, track plate, with steel track in place. (Diagram by John Hicks).

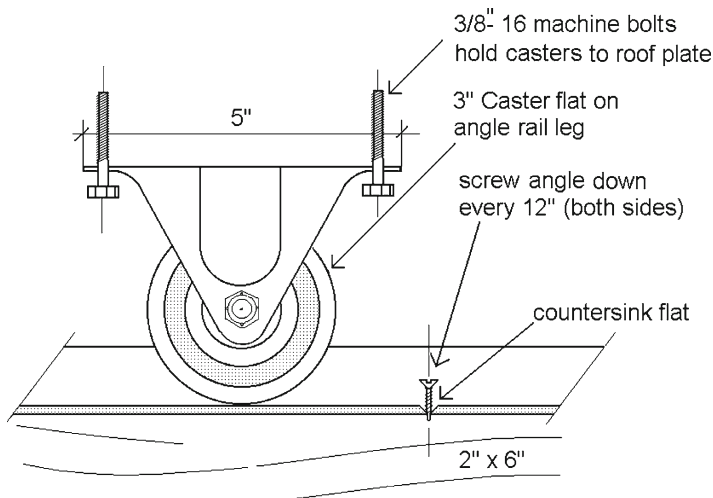
## Installing the Track

Position the tracks on the observatory section first, starting from the southernmost observatory wall. Use zinc-coated  $1\frac{1}{2}$ " long  $\times$   $\frac{1}{4}$ " diameter large Robertson wood screws, but do not screw the tracks down tightly at this time. Initially, the base plates should locate such that their outer edges are flush with the outer face of the  $2" \times 8"$  track joists, and in this position the screws should be mid-way in their slots. This will allow a slight relocation of the track base should it be necessary. The effects of shrinking wood or a foundation movement could produce just enough shift in the track to change the critical distance between tracks. Butt each of the track sections up firmly against each other such that the casters won't encounter any misaligned or rough joints. Make sure that the ends at each joint are square and clean (you may have to file them smooth). Measuring progressively across from the top of the angle on one side to the top of the angle on the other, install the track across the observatory walls out over the gantry making sure the separation is constant (Figure 8.4b).

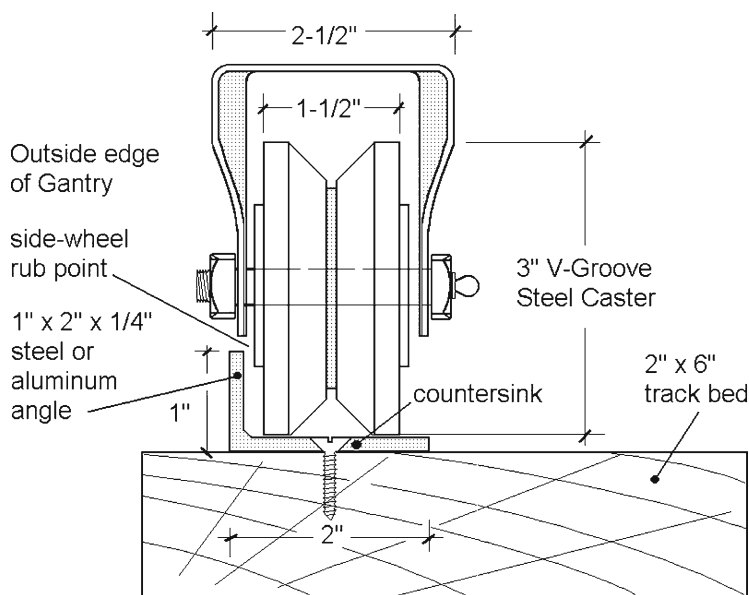
## Alternative Track Designs

### The Flat Track Rail

The inverted angle track could be replaced by a  $1" \times 2" \times \frac{3}{16}"$  thick angle positioned on the  $2" \times 6"$  track bed with its  $1"$  leg up (Figures 8.5 and 8.6).



**Figure 8.5.** Detail –side view V-Groove caster running on flat leg of angle with leg-up. (Diagram by John Hicks).



V-groove Cast Steel Caster  
 3-1/2" x 1-1/2" #1303 - VG - RB  
 roller bearings, rigid fork by  
 Bestway Casters

**Figure 8.6.** Detail – end view V-groove caster running on flat leg of channel with leg-up. (Diagram by John Hicks).

Providing that the screws holding down the angle to the 2" × 6" bed are recessed sufficiently, the casters will roll over the flat leg of the rail with moderate ease, although more “bumpy” than the V-groove-inverted rail set-up. There are two flaws in this arrangement. The 1" leg-up side will rub on the outside face of the caster wheels producing unwanted friction as the wheels contact it, and the recessed flat-head screws will create a rough road-bed. The design offers additional security however, in that the 1" leg-up prevents any jump-off the caster rail, confining the casters within the two track angles. The observatory I designed in Florida utilized this arrangement, but required a winch system to roll the roof off and roll it back into position.

## The Garage Door Track and Roller Alternative

Although designed for a lighter purpose, the garage/barn door type roller & track will support a heavier roof load if it contains enough casters. The problems with the system are two-fold: the track is light and because it “contains” the caster tends to increase the frictional area, and the joints in the track are more difficult to align. Using this type of system will require a sturdy beam on top of the stud walls to support the track because it will now be held vertically on the



inside face of the beam (the track is vertically-oriented). The casters ride in prefabricated carriages bolted to the underside of the roof plate. Since the casters have to “reach” down into the track on the inside of the studs, an extra 4” × 4” beam must also be bolted underside the roof plate (or a double 2” × 6” plate). This type of caster arrangement also has an added advantage: it reduces the air-gap between roof and wall edges because the casters “reach down” into a vertical track fixed to the inside wall edge. This seats the roof joists lower on the wall, dropping the soffit considerably (Figure 8.7).

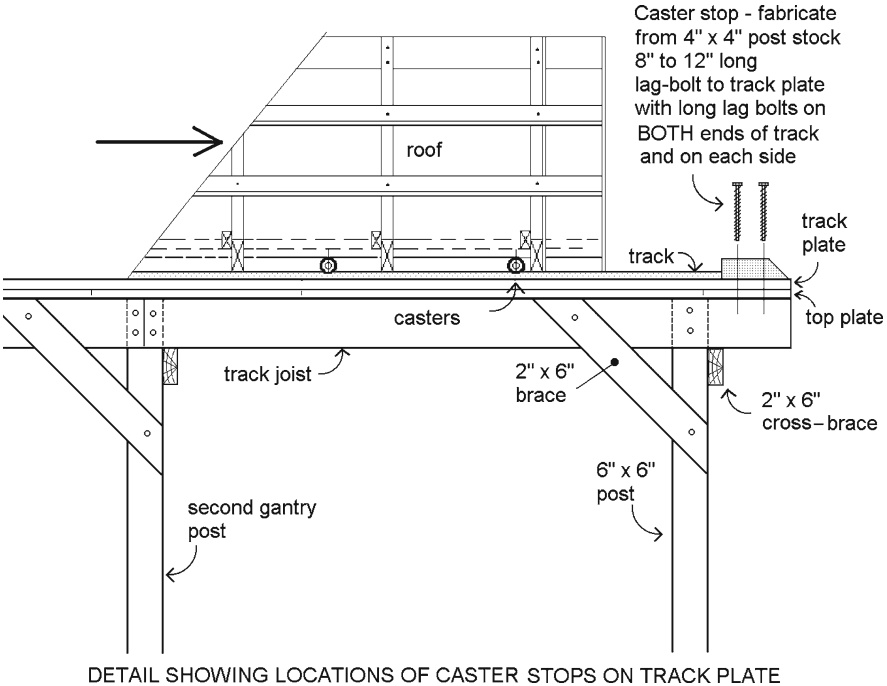
Although there are a number of alternative roller systems, the V-groove caster and inverted angle offers the best strength and ease of movement.

## Track Ends and Stops

Before advancing to the roof fabrication, it is wise to install the Caster stops on the ends of both tracks. The caster wheel stops are simply made from a 12” long block of 4” × 4” pressure-treated timber that has one end cut at 90° and the other at 45° (for design purposes only). It is beneficial to install a 1/4” slab of rubber on the 90° ends of the stops for cushioning, as the heavy roof could do some damage if pushed back too forcefully. The caster stops are pre-drilled for long lag screws which bed down the stops on the track plate-top plate assembly. Put them at the very end of the track – each end, and on both sides. The caster should be placed to allow a 12” overhang on each end of the track at the stop (i.e. when the roof is at rest over the observatory in fully closed position, the roof soffits should extend 12” further on each end) (Figure 8.8).

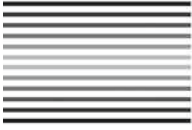


**Figure 8.7.** Photo – Terry Ussher’s “Sky Shed” Observatory showing garage door track and rollers on double plate under roof. (Courtesy of Terry Ussher).



**Figure 8.8.** Detail showing locations of caster stops on track plate. (Diagram by John Hicks).

## CHAPTER NINE



# Framing the Roof



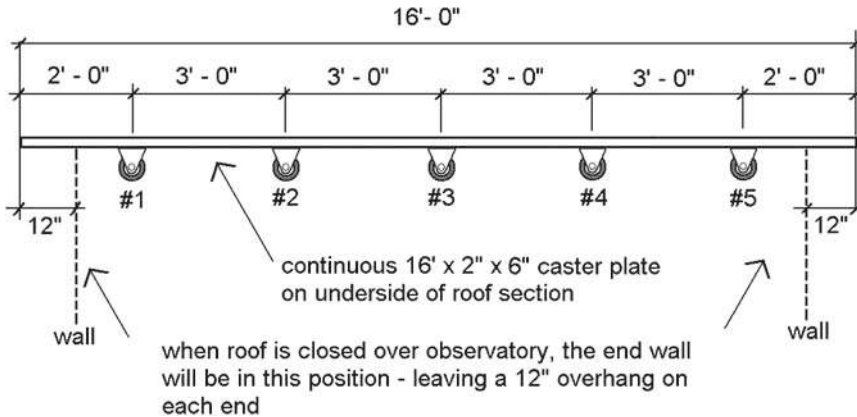
## The Assembly Process

The roof should be framed in place, meaning that the caster plate (the bottom plate of the roof framework) is placed on the track with casters intact, and the roof trusses built upon it. Otherwise, the roof could be constructed on a “bench” of sawhorses and lifted into place. This is an extremely difficult operation without the assistance of a crane, because the walls of the observatory (including foundation) are too high for a crew of people to simply lift the roof over and onto the track. Unless you have an army of helpers enlisted to do the job, a group of people cannot lift so much weight over their heads. If you have crane access (the mobile type) that won’t alter the appearance of your lawn, the saw horse “bench” process is the way to go, saving you the arduous task of climbing up a step ladder each and every time you add a framed truss, and nail it in place. Later, when installing the 15 pound roof felt underlay and the corrugated steel roof panels, the requirement for reaching up into the roof framework becomes necessary. This becomes particularly stressful when applying the roof felt and later the steel roof sheets starting at the ridge board, although you can get nailing access through the openings in the trusses and purlins (the metal roof sheets are normally about 30 in. wide).

## Construction of the Caster Plate

Generally then, it is advisable to construct the caster plate first, bolting on all the casters in exact position. This has the added advantage of being able to “test” the casters on the track, making sure they all roll without binding and lie perfectly in line on the caster plate. Once fabricated, the caster plates can be held together across the span of the gantry or the observatory with 2” × 4” braces. Usually the roof is constructed over the observatory section because the floor is higher than the ground level outside in the gantry section, and it is smoother and easier to work upon. You will drop a myriad of fasteners and parts by accident, easily retrieved on the observatory floor, rather

N.B. Bolt casters down to caster rail first before installing roof trusses on it (much easier than installing them on underside of roof later)



**Figure 9.1.** Detail of caster sequence and alignment on the 2" x 6" caster plate. (Diagram by John Hicks).

than searching for them in gravel or bare soil under the gantry. The following diagram illustrates how to position the casters on the caster plate (Figure 9.1).

Bolt the casters in place right through the caster plate precisely, paying particular attention to the center-line of the V-groove as you place each caster in its position. The brand of caster I recommend does not have slotted holes in the caster base which means you cannot re-adjust their position laterally. You have to get it right the first time. I recommend using a string line fixed just over the groove in the end caster, pulling it tight over each caster installed to check for any misalignment. If you had an extra 16 ft section of track available, that would make a perfect "gauge" for testing their alignment as you proceed.

This is unlikely, however due to the added cost.

## Calculating the Rafter Lengths

Typically, a minimum requirement in roof pitch is 3 in 12 (3 in. vertical rise per 12" of run) for medium snow loads. Our design uses 6 in. rise in 12 in. of run, which is more than sufficient for northern cold climates with heavier snow loads. This works out to a rise of 3 ft over a 6 ft span which is  $\frac{1}{2}$  the roof width. To calculate what length of rafters you will need, think of the vertical rise as the vertical side of a right triangle, and the run as the horizontal side, then calculate the hypotenuse (or rafter length). In our case this becomes  $6' 8\frac{1}{2}"$  (6 ft  $8\frac{1}{2}"$  in.), derived from 3 ft squared plus 6 feet squared = 45, where the square root of 45 is 6.708 ft (or  $6' 8\frac{1}{2}"$ ).

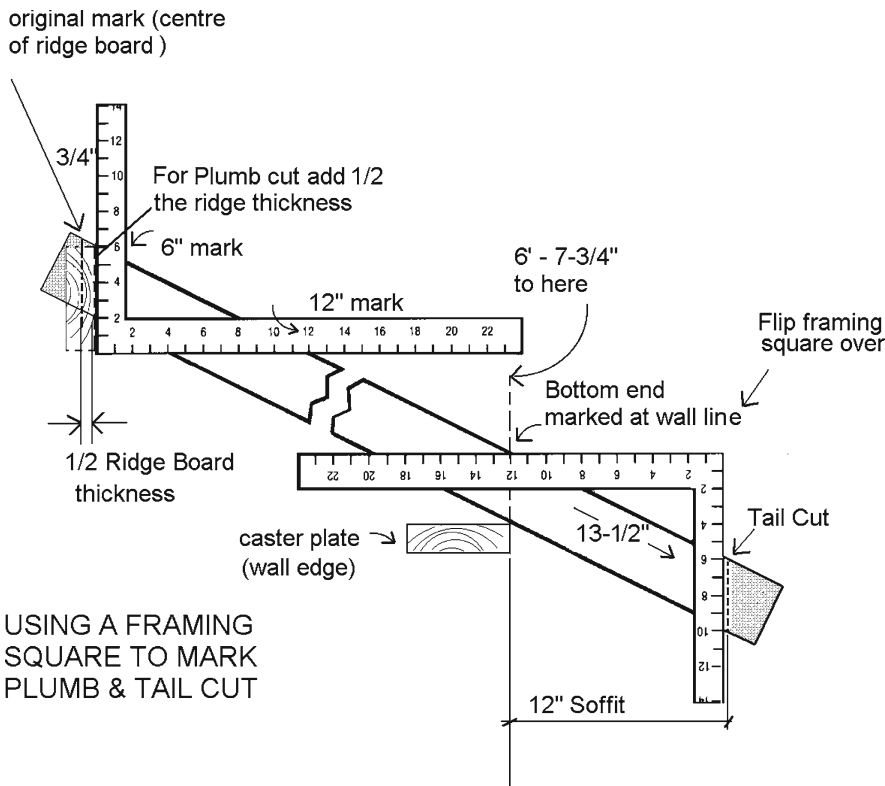
From this length deduct  $\frac{1}{2}$  the ridge board thickness ( $\frac{1}{2}$  of  $1-1\frac{1}{2}" = 3/4"$ ) to arrive at the main rafter length from ridge to the outside face of the observatory wall [i.e.  $6' 8\frac{1}{2}" - 3/4" = 6' 7\frac{3}{4}"$  (6 ft  $7\frac{3}{4}"$  in.)].

Since there is a 12 in. overhang for the soffit, the same right triangle calculation will produce a hypotenuse of  $13\frac{1}{2}"$  i.e. 6 in. squared plus 12 in. squared = 180 in. The square root of 180 is 13.416

in. or  $13\frac{1}{2}$ " (close enough). Adding this to the rafter length above we arrive at ( $6' 7\frac{3}{4}" + 13\frac{1}{2}" = 7' 9\frac{1}{4}"$  total rafter length. One should add an inch at each end to allow for an angled "plumb" and "tail" cut in each rafter. Total length is then  $7' 11\frac{1}{4}"$  (7 ft 11¼ in.). This is convenient because you will be cutting your rafters from 8 ft stock and have very little waste lumber.

## Framing Sequence (Layout of the Rafters on the Caster Plate)

Since there is no "bird's mouth" in the bottom end of the rafter it is not necessary to locate one, making your rafter installation a lot less precise than it could have been. A long "bottom chord" plus "king posts" hold the rafters in place quite rigidly. Mark the "plumb cut" at the top (ridge board contact) and the "tail cut" at the bottom of the rafter with an inverted framing square (flip the square over) and cut the rafter at these points. The top mark is located by positioning the framing square *at the top end of the rafter* (see detail 9.2), aligning the 6 in. mark on the tongue (short leg of the square) and the 12 in. mark on the body *with the top edge of the rafter*. Scribe or mark a line along the tongue of the square, this will be the center of the ridge pole. Then move



**Figure 9.2.** Detail showing method of marking "tail cut" and "plumb cut" on rafter. (Diagram adapted from Creative Homeowner Press) (1).

the square down in the same 6/12 orientation exactly  $\frac{3}{4}$ " (1/2 the thickness of the ridge board). Mark the "Plumb Cut" point here. Measure down the rafter 6 ft  $7\frac{3}{4}$ " to the point where the rafter intersects with the caster plate (the outside edge of the wall below) and scribe a mark there.

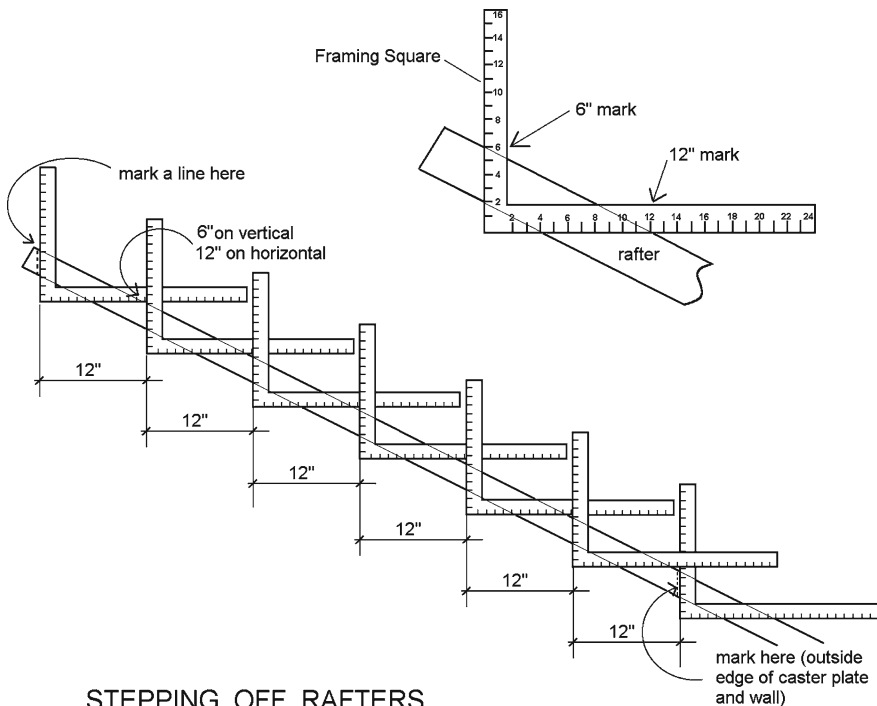
From that point measure  $13\frac{1}{2}$ " (the distance to the end of the overhang) and using the inverted framing square, mark off the "tail cut" (see detail 9.2). Cut the rafter at these marks (plumb cut and tail cut).

You can also measure down the entire rafter from the "plumb cut line" with the framing square alone by "stepping off" 6 increments of 12" by holding the square in the 6/12 orientation on the rafter. The six increments will locate the intersection with the caster plate (the outside edge of the wall below). Mark this point, and then invert the square using the 6/12 orientation, and measure the last 12" (horizontal overhang). Cut the rafter here. (See details in Figures 9.2 and 9.3.)

Cut the mortises in the rafter for the roof purlins at this stage by sawing the  $1\frac{1}{2}$ " depth and chiseling out the  $3\frac{1}{2}$ " width of a  $2" \times 4"$  if you go this route (recommended). Alternatively, framing anchors can be used but the assembly is not as rigid as a mortise joint and the full-length purlins. Refer to the following details..... (Figures 9.4 and 9.5).

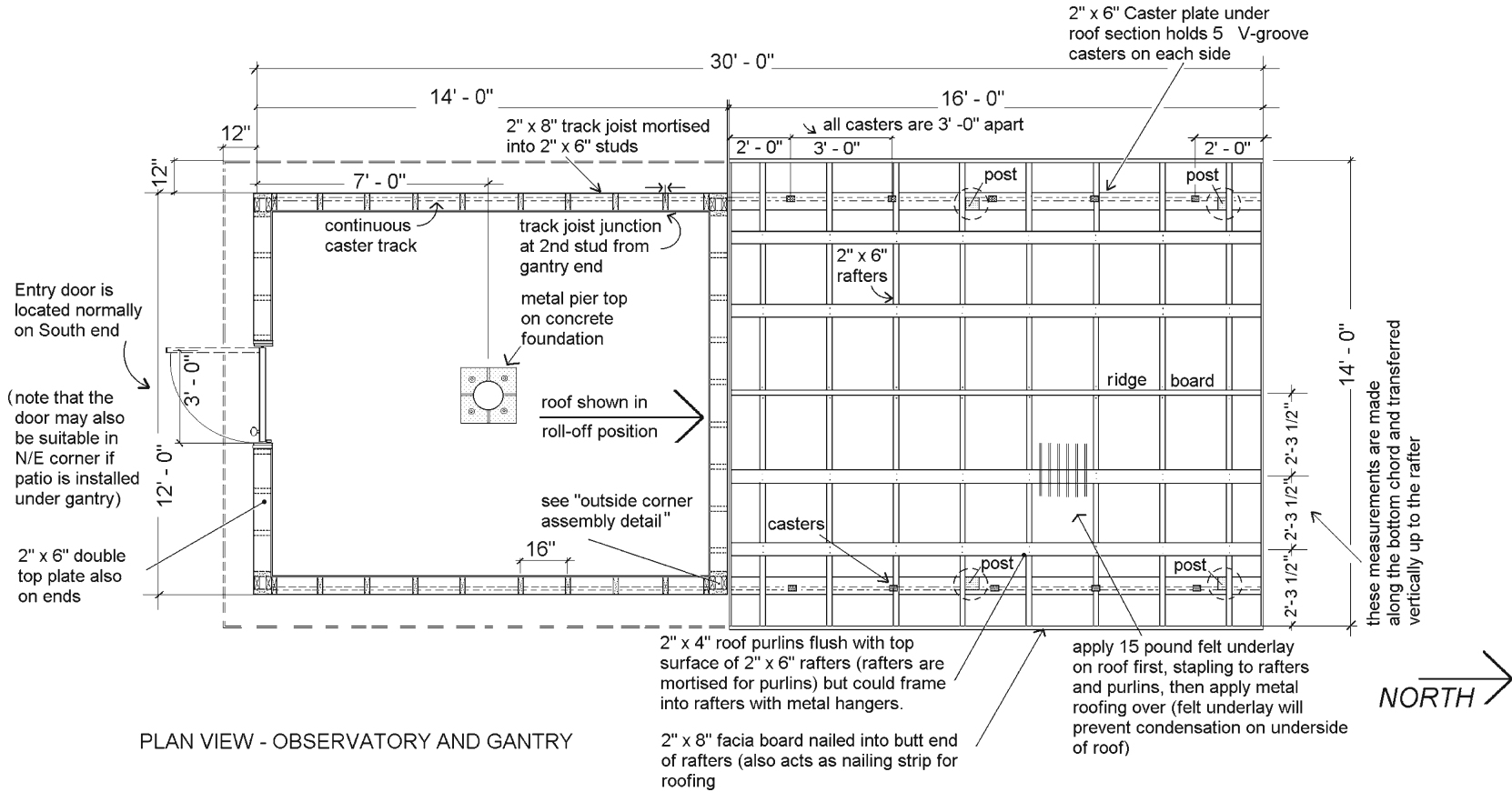
#### STEP 1

Lay out and assemble one roof framing member section first, including the two rafters, a section of ridge board and the bottom chord, cut to the specifications outlined above. Nail it all firmly together. This will be used as a template to make all the eight trusses. Use a short piece of  $2" \times 6"$  plank to duplicate the ridge board thickness and temporarily nail it in place (do not set the nails, but leave heads protruding – you will have to remove them to fit the real ridge board when

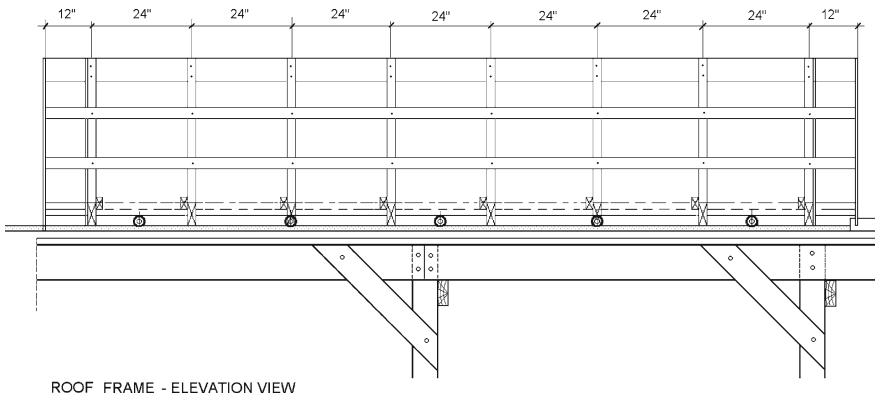


**Figure 9.3.** Detail showing method of "stepping off" 12" horizontal increments from top to bottom of rafter. (Diagram adapted from Creative Homeowner Press – see reference 1).

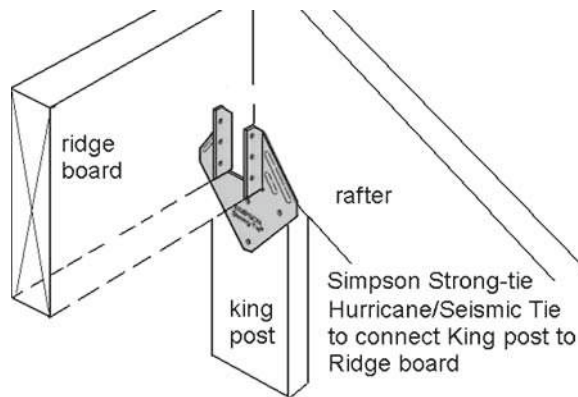




**Figure 9.4.** Plan view detail of entire observatory showing roof section and purlin spacing measured on the slope of the rafter. (Diagram by John Hicks).



**Figure 9.5.** Elevation of entire roof over gantry showing the rafter spacing with purlins. (Diagram by John Hicks).



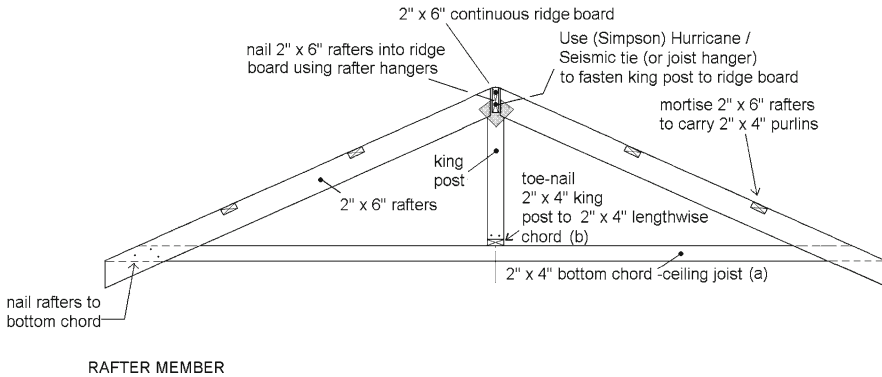
**Figure 9.6.** Detail of “Simpson Hurricane/Seismic-tie” used to connect King Post to Ridge Board. (Diagram by John Hicks).

in place permanently). Attach the 2" × 4" king post supporting the ridge board from the bottom chord. There is a convenient metal tie to fasten these two items together called a Simpson Hurricane/Seismic tie, or you can use a regular joist hanger, nailing the bottom flange of it to the king post flank. Either way it's a lot easier than mortising the king post into the ridge board (Figure 9.6).

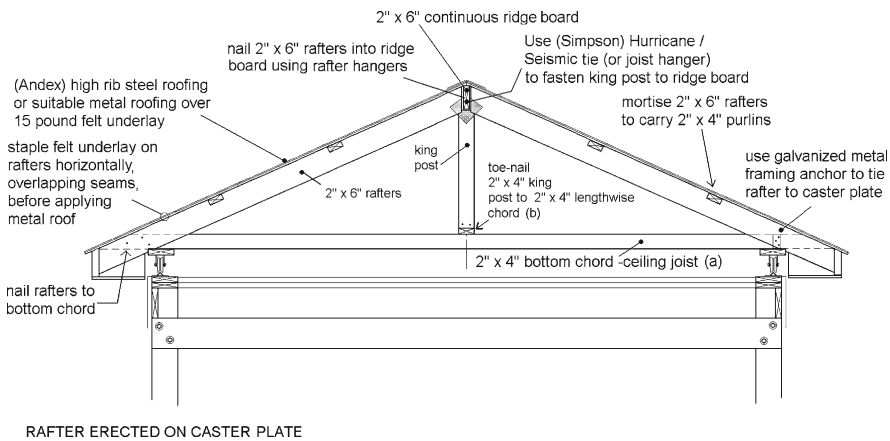
You will also have to temporarily install a short section of 2" × 4" at the bottom for the continuous chord running the length of the roof. Set the template on your caster plate and tie it in temporarily with 2" × 4" struts. Make any adjustments to the length of the rafters at this time, if any (Figure 9.7).

#### STEP 2

Cut the ridge board to length and mark the rafter locations on it every 24" O.C. so you know exactly where to place them. Mark the positions for the rafters also on the caster plate. Make sure to allow for the 1 ft overhang at the gable end when you cut the ridge board.



**Figure 9.7.** Roof framing member detail showing rafters, purlins, ridge board, bottom chord, king post, and continuous chord. (Diagram by John Hicks).



**Figure 9.8.** Detail showing roof framing member in place on caster plate. (Diagram by John Hicks).

**STEP 3**

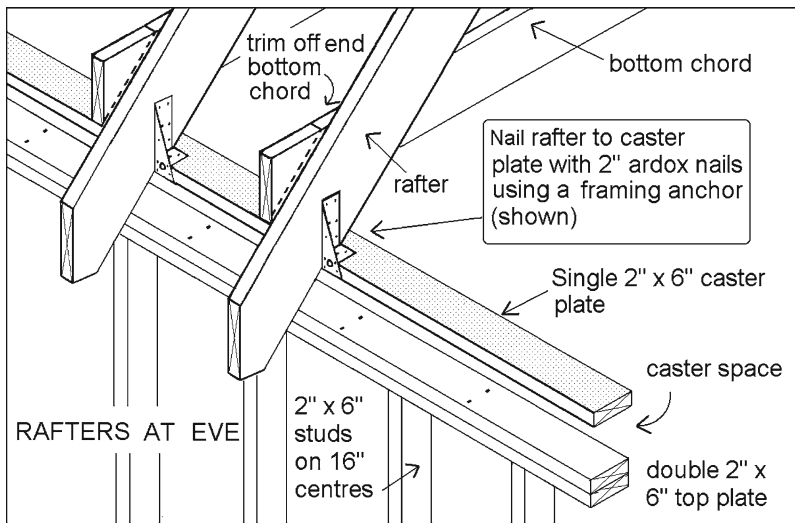
Once you have verified the exact length of the rafters and the bottom chord after placing the “test” rafter frame on the caster plate, take it down and construct 7 more pairs exactly the same length. On the ground make another complete framing member. This time, attach the two rafter members to the ridge board in the position of “gable ends”. Use either the “Hurricane-ties” or joist-hangers to fix the rafters to the ridge board. Following this, tie the two rafters on each frame with their bottom chords (a) and insert their king posts resting on the continuous 2" x 4" chord (b) running lengthwise. At this point you will have constructed the two end gables held together by the ridge board, and the 2" x 4" chord under the king post (see the following diagram) (Figure 9.8).

## STEP 4

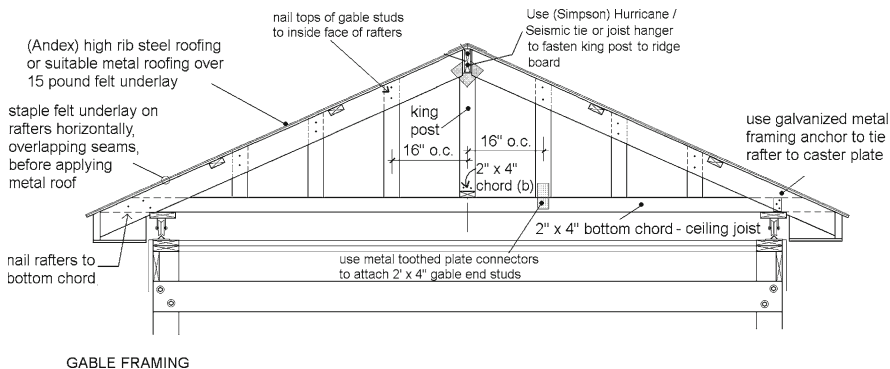
Get some help to lift this assembly up onto the track, and attach temporary braces to the end walls to support the assembly. Braces can be sections of 2" × 6" running up the studs of both end walls, temporarily nailed into both end gable members. Tie each rafter section down to the caster plate with a framing anchor on the open side of the rafter with the bottom chord nailed flush on the other side (Figure 9.9).

Fill in all the remaining rafter frames and frame in the gable ends using a ladder to get access to the roof now in place. Install the 2" × 4" purlins, making sure the frames are plumb (Figure 9.10).

Following the basic erection of the roof framework, the next task should be to fabricate the boxed-in-soffits before the roof sheathing is applied, which is a lot easier done without the roof deck in the way. Cut triangular sections from 2" × 6" which will fit under your rafter overhang.

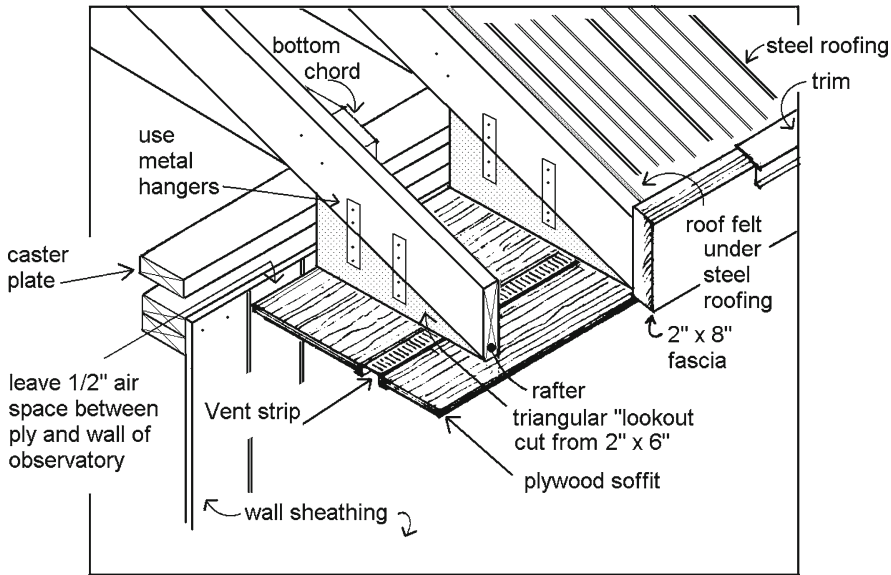


**Figure 9.9.** Detail showing rafter-caster plate connection and use of framing anchors. (Diagram by John Hicks).



GABLE FRAMING

**Figure 9.10.** Detail of gable end showing installation of 2" × 4" gable studs. (Diagram by John Hicks).



BOXING IN THE SOFFIT

**Figure 9.11.** Detail showing method of boxing in the soffit with a "look-out." (Diagram adapted from Home Renovation – see Endnote 2, Chapter 4).

You will find that a triangular section  $6'' \times 12''$  will suffice giving you a hypotenuse of  $13\frac{1}{2}''$  which will run under the rafter. These are called "look-outs". Cut 16 "lookouts" in total for the eight pairs of rafter-members. Glue these under the rafter end, allowing for the  $2'' \times 8''$  fascia board which will nail to the end of the rafter. Also, employ metal hangers to attach them to the joists since glue will only last so long. After the glue has dried cut the plywood soffit strips and allow room for a standard "vent-strip" available at lumber supply centers. Screw these in place after you have nailed on the  $2'' \times 8''$  fascia board across the ends of the rafters. This board will likely need planing to fit the profile of the roof unless you drop it below the roof profile (Figure 9.11).

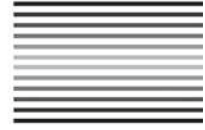
## End Note

1. Barrett James (1993) *The Concise Guide To Building Sheds*, Creative HomeownerPress, A Division of Federal Marketing Corp., Upper Saddle River, New Jersey, USA

## CHAPTER TEN



# Application of Steel Roofing



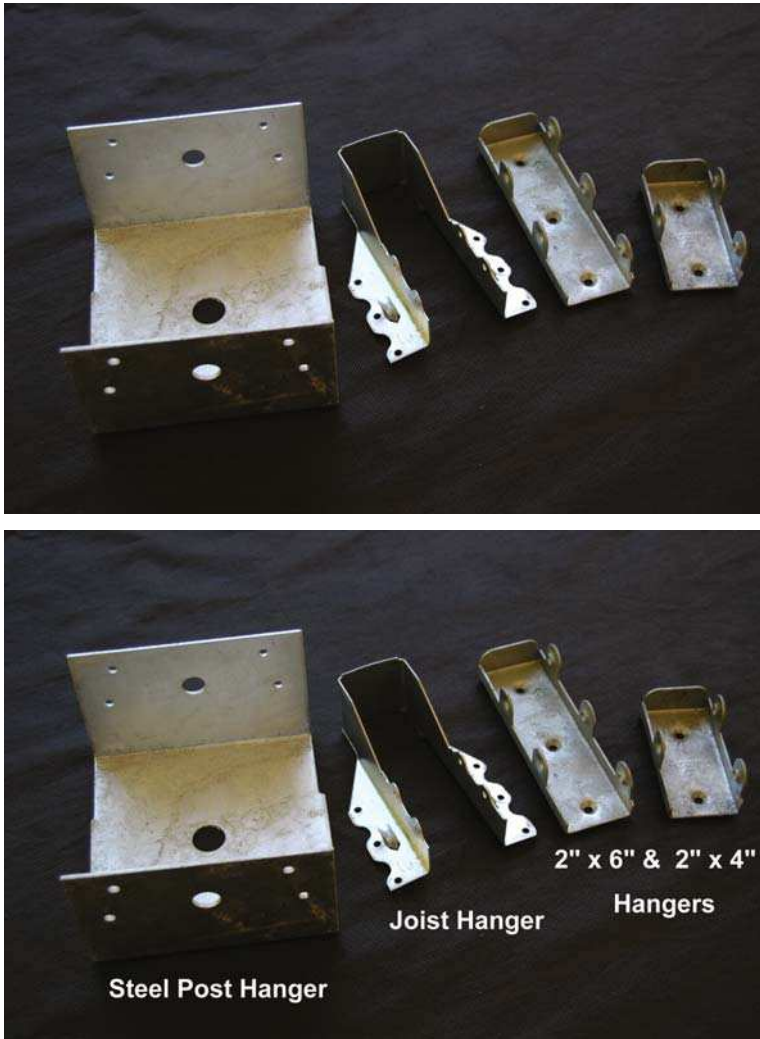
The choice in roofing falls logically to sheet steel roofing manufactured in panels and cut to length for you by the manufacturer. Requiring no roof sheathing for our application (since it does not need to be insulated and can be applied directly on the horizontal purlins), the application of metal roofing directly over the roof frame saves weight, while outlasting shingles and almost all other normal roofing. The diagrams earlier in this book portray a roof frame with only two rows of purlins on each side of the ridge board, as this would be sufficient should you use standard roof sheathing (ply deck) and asphalt shingles.

If you go this route you need to apply 3/8" or 7/16" plywood sheathing first over the entire roof framework, then apply your choice of shingles. This type of roofing will be much heavier than the steel panels, and I would not advise it.

For the application of steel roofing you will need an extra pair of 2" × 4" purlins – one row about 2" from the ridge board, and another row about 2" up from the fascia board. These short 24" sections of 2" × 4" purlins can be installed with prefabricated metal hangers made for 2" × 4" studs. Nailed flush with the top edge of the rafter, they hold the purlins quite rigidly. The top edges and bottom edges of the steel sheets will screw down to these points, there being no other attachment point at top and bottom. The reason I did not specify the prefab metal hangers earlier was for purposes of structural rigidity – the mortised purlins tie the roof together very well, whereas the hanger-type connections can provide some “wobble” on a large, heavy movable roof (Figure 10.1).

Measure your roof surface across from gable to gable and ridge board to eaves, calculating the area required. Steel roofing suppliers will normally supply you with all the fasteners required for the area you dictate to them. These are hardened screws with neoprene washers attached, designed to be driven with a power driver. They will also supply the ridge cap, rake flashing (for along the outside edge of the gables), and eave flashing. You will require all of these components. You will not need the closure strips (or seals) since the roof isn't insulated and you want air-flow through it anyway. Your first action is to measure the distance from the top of the ridge to the eave, and order the exact length of steel roof sheet that fits. The company will supply it cut cleanly. If you have to cut it with a steel cutting saw, it will be messy. I suggest a panel design called “*Century Rib*” which has a repetitive mix of larger and smaller standing “ribs.” The larger “rib” on the outside edge of the sheet overlaps the next larger “rib” on the adjacent panel being applied, helping to hold it while you screw it down (Figures 10.2 and 10.3).



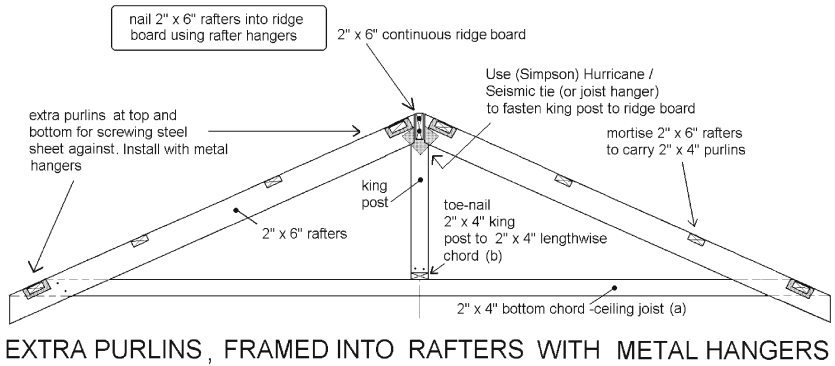


**Figure 10.1.** Photo of various sheet metal hangers for joists, purlins, post saddle. (Photo by John Hicks).

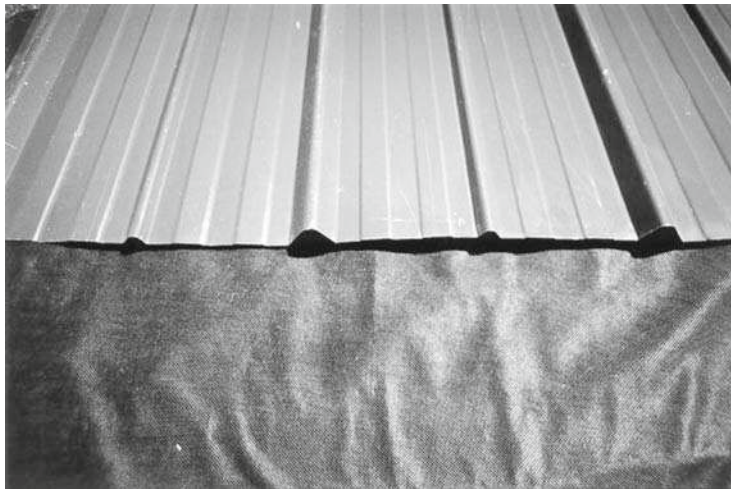
## Tools and Equipment (1)

The following selection of tools would normally be required to install steel panel roofing.

- Electric screw gun
- Hammer
- Electric drill for pre-drilling holes in sheets for fasteners (better than punching)
- Steel cutting disk on a Skill saw
- Shears



**Figure 10.2.** Section of rafter showing required extra purlins for sheet steel attachment at ridge and eaves. (Diagram by John Hicks).



**Figure 10.3.** Photo of a typical steel roof sheet – “Century Rib” design by Andex Metal Products. (Photo by John Hicks).

- Tape measure
- Leather gloves
- Chalk line
- Safety glasses (when cutting steel sheets)
- vice grips
- rope

Always use gloves while handling or working with steel roof sheets as the edges are sharp and produce nasty, deep cuts. When cutting with the Skill saw and metal disk, watch for sparks, and always wear the safety glasses

## Applying the Sheet Steel (see Endnote 1)

### STEP 1 Installing Felt Underlay

The first step involves the nailing down of 15 lb felt underlay horizontally across the roof members. Use galvanized shingle nails and pull the felt underlay tight while applying it rafter-to-rafter. Make sure to provide about a 2" overlap on each row of felt starting from the roof ridge downward over the roof. Do not apply the felt over the ridge board since it will seal off air flow from the interior of the observatory, rising to the ridge cap. Its purpose will be to conduct "hot" observatory air out of roof volume accumulating all day in the sun.

### STEP 2 Install Eave Flashing

Screw on the two Eave flashings first, they will cover a small edge of roof surface and the fascia board (they are pre-bent for this purpose). You must put this on first as you cannot get it under the steel sheets later, once they are screwed down. Do not put on the Gable trim now because it overlaps the top edge of the last steel sheet you install at the edge of the gable.

### STEP 3 Test for Squaring

Check the roof squareness. At the corner where an eave and gable meet, measure 8 ft along the eave and mark. Then measure 6 ft up the gable edge from the eave and make another mark. Measure the distance between the two marks. If you find that it is exactly 10 ft, your roof is square at that particular corner. Checking all the roof corners will verify "squareness."

### STEP 4 Installing Roof sheets

If the roof is not square you can correct this on the overlap joints of the steel roofing, little by little, by taking advantage of the tolerances in the laps. Also at the end gable, the gable flashing (rake) will hide any imperfections as far as "slant". To place the steel sheets up on the roof, put a board against the fascia board and slope it gradually as possible to the ground surface. Clamp a vice grip to the upper edge of the sheet, attach a rope and pull it up onto the roof. Be careful of wind, and prevent the sheet from buckling. Start at the eave furthest from the prevailing wind. Extend the sheet about 1" over the gable edge and 1"-2" over the eave. Do not fasten the open side furthest from the gable edge before starting the second row because the second row sheet must overlap the first. Usually, the overlap occurs on a large standing rib on the edge of the sheet. Leave the required space at the ridge to allow a little ridge ventilation under the ridge cap. The sheets should stop short of the ridge. Drill through both sheets at the edges of sheets such that one roofing screw will penetrate and tie down both. When you arrive at the other gable side, test-fit the last sheet, mark the gable end, and take the sheet down to cut it (allow an extra 1" over the gable end as before)

### STEP 5 Install Ridge Cap

Place the ridge cap on the ridge and make sure its position is even on both sides of the roof. Mark the edges with a chalk line or felt pen. When fastening the ridge cap, drive the screws through the ribs of the roof sheets (not lower on the sheet because the ridge cap metal will pucker between the raised ribs making an unsightly appearance. For a ridge longer than the length of ridge cap supplied, overlap the caps.

### STEP 6 Install Gable Trim

The gable trim is the last to be installed. The best style overlaps the steel roof at the edge of the gable extending down over the fascia board. Make sure you specify the same color for all the flashings, trim, and ridge cap. A color different from the roofing color looks horrible.

Check before you install it because outdoor light can be deceiving on the shiny steel surfaces. Your roof when completed will make you feel very proud of your work as it will appear structurally perfect.

## End Note

1. Canadian Sheet Steel Building Institute, CSSBI, How to Series – Light Gauge Steel Roofing & Siding, Cambridge, Ontario, Canada

## CHAPTER ELEVEN



# Exterior and Interior Siding

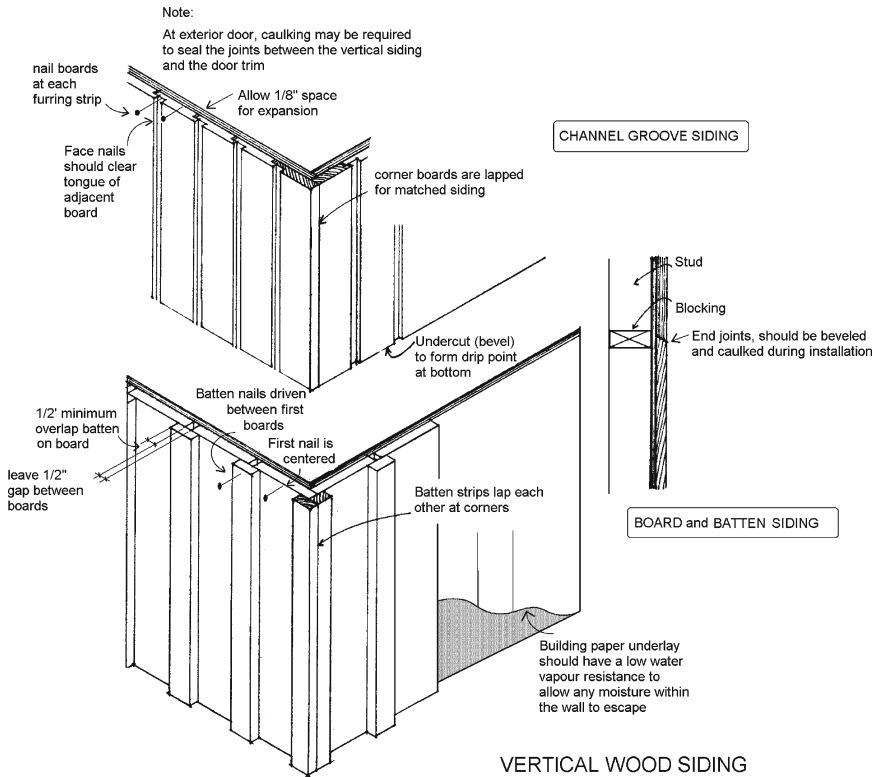
## Exterior Siding

There is a great variety of exterior siding materials available. The normal exterior wall covering, at least the underlay, is usually plywood or waferboard. This can be installed directly over the studs, vertically. If you plan to cover this in a wood-board type siding, several designs are available to you. Most have a 1-inch nominal thickness (actually  $\frac{3}{4}$ " thick) and are usually installed vertically. If you are planning to use wood board siding you will have to install blocking at midspan between the wall studs to nail the boards to, since you would only have the sole plate at the bottom and the double top plates at the top.

Typical patterns which suit observatories are “channel groove siding” and “board-and-batten” style siding. The following detail illustrates the two types and the basic application technique for each (Figure 11.1).

Sometimes local building codes will require sheathing under the board siding i.e. like plywood or waferboard. Hardboard siding (manufactured from compressed wood pulp) is available in a variety of traditional board designs in 4' × 8' panels. These are fairly long-lasting and can mimic the real board texture quite well, complete with a simulated wood grain. My design incorporates vinyl siding because I did not want to have another out-building to stain or paint periodically. I also prefer the vinyl siding because insects such as wasps etc. do not like it, being next to impossible to build nests on. Animal control is also a must in the observatory with sensitive computer cables to chew on etc., and the board siding is easy to climb up on and “squeeze” into the soffit space. Vinyl is too slippery for most squirrels especially if you run a coating of “Armour-all” over the siding periodically.

Vinyl siding comes in a variety of “earthy” colors which match environmental surroundings quite well, fitting into your landscape or rear yard without dominating it. The vinyl “package” comes with trim for doors and corners and is quite easy to apply, usually only nailed on with color-matching nails. It does require an underlay of ply or waferboard, but this doesn't have to be applied seamlessly since the vinyl will cover all defects in application of the underlay.



**Figure 11.1.** Detail illustrating the application technique for Channel Groove siding and Board and Batten Siding. (Diagram adapted from Home Renovation – see Endnote 2, Chapter 4).

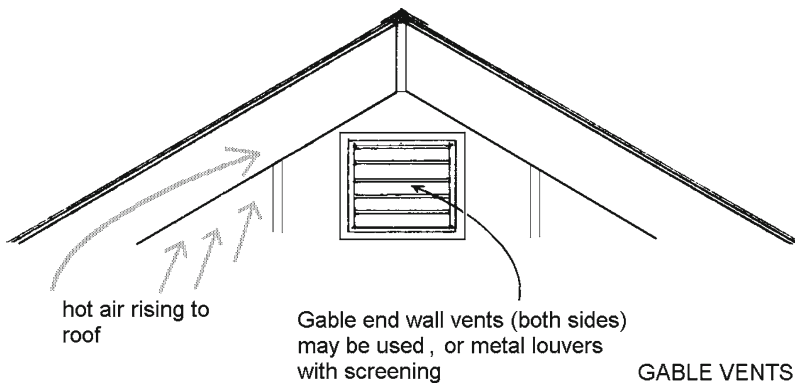
You must consult your local aluminum siding supplier for this material. The great thing about vinyl is that you never need to paint it (Figure 11.2).

## Gable Vents and Fan Systems

It is very advantageous to have an exhaust fan on at least one gable end wall to exhaust the hot air accumulating all day in the closed observatory. So much the better if it is either timed or on a thermostat. This helps your cool-down time for any observing session, night or day. A minimum requirement would be the installation of two air vent grills on both gable wall ends without a fan, as this arrangement allows a passive air flow-through. Most wall fans are designed to fit within studs on a stud wall, and the kits come with full installation instructions. The simplest procedure is to cut exact apertures in the exterior wall board, if wood, and place the fan housing next to a stud. Vents can go almost anywhere on the board or vinyl siding as they are just grills over an opening. Vinyl siding is a little bit harder to cut once applied, so it is best to install the fan first in this case and cut the vinyl to fit around it snugly. A vent application will require some pre-engineered cutting also. You will also have to pre-wire the fans (if you use fans) through the wall



**Figure 11.2.** Photo of vinyl siding application on domed observatory exhibiting its elegant appearance. (Photo by John Hicks).



**Figure 11.3.** Detail of Gable Vent air flow (Diagram adapted from Home Renovation – see Endnote 2, Chapter 4).

stud openings to an electrical box on the inside wall of the observatory, before you install the interior wall sheathing (Figures 11.3–11.5).

## Interior Wall Sheathing

Most observatories I have inspected are painted dull black inside to eliminate any reflected light. Thus, the wall texture really doesn't have to be anything special since it almost vanishes in the night. Standard 3/8' ply sheathing would be quite acceptable, with narrow 1½'x¼' combing strips





**Figure 11.4.** Photo of gable vent on Ussher Observatory. (Courtesy of Terry Ussher).



**Figure 11.5.** Photo of internal fan housing fitted to inside of gable wall. (Courtesy of Jay Ballauer).

nailed over the seams. Since I am a solar observer specialist, I prefer the white glossy walls that you see in the earlier photos of Don Trombino's Observatory (The Davis Memorial Observatory). This effect was achieved by applying pre-coated gloss-white masonite panels directly over the studs. I finished the seams in bands of anodized  $1\frac{1}{2}' \times '$  aluminum strips that I picked up in a local scrapyards. These were screwed down with stainless steel round-head screws with stainless finishing washers under. The effect was truly professional. An extra bonus is that I can remove them for





**Figure 11.6.** Looking down into the interior of my domed observatory at the white masonite panels and the aluminum strips over the seams. Notice how high the pier is in this high-wall observatory. (Photo by John Hicks).

access to wiring etc., without using a pry-bar and mutilating the wall surfaces. Anything you place in the observatory such as a lap-top computer, small tables etc., fit well within this interior wall scheme. It is however, not suitable for the night sky purist whose observations will be mostly in the dark. If you prefer the texture of masonite panels which are hard and quite thin, you can pre-coat the clear finished masonite with a starch wash which will help to bind flat black paint on its surface. For example you could use the same technique that I used with aluminum strips on the seams sprayed flat black. The effect would be the same. Figure 11.6 shows the neat effect created by masonite panel sheathing and aluminum seam strips.

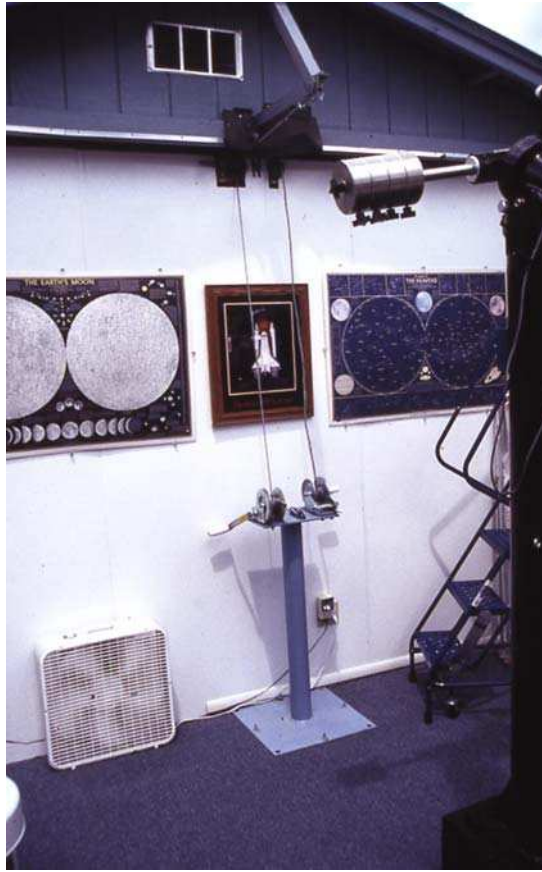


## Final Luxuries

### A Winch System for Opening and Closing the Roof

The following photo illustrates a well-designed winch system for removal and closure of the roll-off roof, placed on the observatory floor against the north wall (Figure 12.1).

The steel cable for such a system has to be strong. The type of cable used for sailboat stays is ideal, usually 1/8"–3/16" diameter. You will need at least 100 ft of stainless steel cable for this mechanism. The “rolling-off” winch cable will attach to the inside of the south-facing roof gable, then north to a pulley on the end cross-member of the gantry. From there it runs back across the gantry south and over a pillow-block on the top plate of the north wall and down the north wall interior to winch installed on the inside wall or on a pedestal on the floor. The “closing-roof” cable will simply exit another winch, running up the north wall interior, over another pillow-block, and attach to the inside of the north-facing roof gable, preferably at its bottom chord for strength. The system requires two winches in order that the wires do not get snagged, and also two pillow blocks so that the wires do not run over each other on the blocks and bind. Cranking the “closing-roof” winch simply winds the cable up, pulling the roof back over the observatory room. Adding a metal extension which equals the soffit width to the *outside face* of the north gable will permit winching the roof via the “closing-roof winch” past the south-facing wall of the observatory. This allows the soffit to overhang the wall as usual. Winding one cable will, of course, cause the other to unwind so a light brake of some kind is necessary, or the wire will uncoil off the winch in a rather unruly manner. It works well, and can be motorized as the following photo illustrates. Battery operated, the 12 v car/boat winch is bolted to the floor with a control box next to it for forward or backward motion of the pulley, which translates into roll-off, or roll-on motion. The system is tricky to engineer, and much “fiddling around” with the tension, pulley locations, is necessary before final satisfaction. Notice that the motorized winch system is bolted right into the cement floor (Figure 12.2).



**Figure 12.1.** A double winch system allows both roll-off and roll-back-on functions to be done within the observatory. (From the collection of John Hicks).

## Comfort Items

Most observatory floors, particularly cement slab type, should be covered in a carpet to prevent lenses and other equipment from breaking when dropped, as they surely will be. It is customary to use household living room carpet, and is usually achieved when the homeowner re-carpets the home and has a quantity of old carpet available. It pays to go to a carpet supplier/installer and ask if he can supply you with a section of used, but acceptable, carpet for your observatory. In my observatory it simply lies on the floor, fitted exactly to the confines of the walls. Being heavy enough not to curl or slide it was never glued or fastened to the cement floor which is rough enough to grip it. Installing carpet over a plywood floor on joists will require stapling or nailing. I went further with carpeting, covering the entire pier and the track/caster gap so that no wind would chill me passing through the gap from the outside. The pier is also covered for warmth, the carpet cut to exactly wrap around it. It takes a while to sew it together along a vertical seam but it



**Figure 12.2.** Motorized winch system operating on a 12 v battery. (Photo from the collection of John Hicks).

is the best way to attach it tightly. This comes in handy when you are viewing at the zenith close-up to the pier, if you are using a refractor on a German equatorial mount which demands that you come close to the pier. Cold cement or steel is not a welcome sensation against your legs when you are observing or tracking celestial objects. The use of carpet also “softens” the “mechanical aspect” of the observatory, and it offers yet another bonus – when you are awaiting an event, or just relaxed from a long observing session you can lie on the floor and take in the glory of the heavens above you (Figure 12.3).

I also find the use of a “rolling ladder” for access to the instrument, and to the roof, to be an advantage. Often I need to re-position a pulley, or to remove an insect nest, and the rolling ladder is handy. It also serves as a great “perched” desk for my lap-top, which easily fits with mouse, mouse pad, and log book on the uppermost platform-stair of the ladder right beside the telescope. I often sit on this platform at the level of the telescope (mine is perched on a very high 7 ft pier) and just watch the sky overhead.

It is on summer days, after viewing the active surface of the Sun, which is the mainstay of my hobby, that I feel so much joy in having an observatory. It is almost a religious experience to lie on the warm carpeted floor and watch the beauty of the summer sky from your own “camera obscura.” It is really a “cloister” of sorts, where you can undertake your study in isolation, where you can concentrate free of the hub-hub in the world around you.

In building this observatory, you will discover a magical sphere of activity from the minute you mark out its “footprint” on the ground to the moment you install carpet on its finished floor. The “magic” begins when you survey the contents of this book, visualizing what your observatory will look like out in your yard, and continues through every hour you spend building this structure. It will not be easy, but rewarding every time you leave it after a day’s work, satisfied with your progress, and dreaming of the day it is finished. I guarantee you will be swept away, on a journey that will build self confidence and satisfaction, developing skills you may never have felt you possessed. For sure, your neighbors’ curiosity will be perked, and his/her respect for your inventiveness will escalate. The Universe lies waiting for you to experience it, don’t waste another day.



**Figure 12.3.** Rug-covered pier offers real “creature warmth” in the “machinery” of the observatory. (Photo by John Hicks).



# Appendix



## Conversion Tables

### (a) Nails

1"	Ardox	2d
1¼"	Ardox	3d
1½"	Ardox	4d
1¾"	Ardox	5d
2"	Ardox	6d
2¼"	Ardox	7d
2½"	Ardox	8d
2¾"	Ardox	9d
3"	Ardox	10d
3¼"	Ardox	12d
3½"	Ardox	16d
4"	Ardox	20d
4½"	Ardox	30d
5"	Ardox	40d
5½"	Ardox	50d
6"	Ardox	60d

Metric equivalents – wood construction

### (b) Board sizes

Imperial	Metric
1" x 2"	20 mm x 38 mm
1" x 3"	20 mm x 63 mm
1" x 4"	20 mm x 90 mm
1" x 6"	20 mm x 150 mm

1" × 8"	20 mm × 180 mm
1" × 10"	20 mm × 240 mm
2" × 2"	38 mm × 38 mm
2" × 4"	38 mm × 90 mm
2" × 6"	38 mm × 150 mm
2" × 8"	38 mm × 180 mm
2" × 10"	38 mm × 240 mm
2" × 12"	38 mm × 275 mm
4" × 4"	90 mm × 90 mm
4" × 6"	90 mm × 150 mm
4" × 8"	90 mm × 180 mm
6" × 6"	150 mm × 150 mm

## Metric equivalents

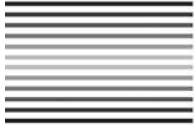
(c) Plywood – (same spec. for wafer-board/ particle board/ masonite)

Imperial	Metric
1/8"	3.00 mm
1/4"	6.00 mm
3/8"	9.50 mm
1/2"	12.00 mm
5/8"	16.00 mm
3/4"	19.00 mm
1"	25.00 mm

## (d) Steel track angle

1½" × 1½"	38 mm × 38 mm (knife edge track as suggested) or
1" × 2"	20 mm × 50 mm (flat track alternative)
To Convert	Multiply by
Sq. m to Sq. yd	1.196
Cu. m to Cu. yd	1.308
Sq. ft to Sq. m	0.09290
Sq. m to Sq. ft	10.76
Ft to cm	30.48
Ft to m	0.3048
m to ft	3.281
m to yd	1.094





# Glossary of Terms



## A

### **Accessory building**

In zoning this refers to a building other than the dwelling on a lot. This would include a detached garage, a tool shed, or any out-building. The reason for this description in the by-law is simply to prevent occupation of the accessory building as a domicile (home), particularly before a home is built on the lot.

### **A-frame**

A type of building or structure that resembles an “A.” Structurally, the frame of the building is in the form of an “A.” In observatory design, it relates to a set of walls that form an “A” when closed.

### **Ambient air (temp)**

Air that is at the same temperature as surrounding air. In the observatory, air that is the same temperature as the outside air. It is essential that the telescope optics be at the same temperature as the outside air.

## B

### **Balloon framing**

A framing method where the wall studs are attached directly to wood foundation members that are bolted to a concrete slab. Both the studs and first-floor joists rest on the foundation. The joists are nailed to these studs.

### **Base plane**

The lowest part of the ground surrounding the observatory.

### **Battens**

Narrow boards used to cover vertical joints in siding or wall-board.

### **Batter Boards**

A temporary board construction forming a right angle to which strings are attached for locating and squaring the corners of the observatory. It is usually offset from the foundation corners by at least 2 ft.

### **Birds’s-Mouth (cut)**

A cutout in a rafter where it crosses the top plate of the wall, to provide a bearing surface for nailing. Due to its “triangular” notch, it requires a wider rafter than a 2” × 4”. It can be eliminated with modern sheet steel “hangers.”

- Blocking** Short sections of wood installed between framing studs, used to provide a nailing surface for boards or panel edges, or simply to reinforce the framing strength of walls.
- Board-and-Batten** A type of board siding which consists of an initial layer of boards nailed with 2½" (8d) nails at 16" on center, leaving a gap between boards of 1/2". The next layer of boards (the battens) are less than 1/4 the width of the initial boards, nailed over the gaps in the initial boards with ¾" (12d) nails. These nails should be driven between and not through the initial boards.
- Boiler "punch-outs"** Slabs of thick circular steel either cut by torch or "punched out" with a large press to make holes for fittings in a boiler. Usually from 1/2" to 1" thick they are perfect for pier caps if not curved. They can be either filed smooth around the edges or spun in a lathe to make a completely round platform. Found in scrap yards.
- Bolt circle** The exact pattern of bolts that are to pass through a pier cap (at the top of the pier) or pier flange (at the bottom of the pier). In this case, the reference is to creating a template in plywood to contain the bolts that anchor the pier into the cement footing underneath it.
- Bottom chord** The long 2" × 4" chord that runs from the caster plate-rafter connection across the roof bottom. Sometimes called the "ceiling joist" if a ceiling is planned for.
- Box tube** A hollow steel beam that is used to contain the V-groove casters in an elaborate split-roof observatory model.
- Bridging** 1" × 2" lumber placed in an "X" pattern between floor joists to keep them from twisting or warping.
- Building code** The regulatory code or system of laws used by cities, towns and municipalities to control and regulate building procedures and practices.
- C**
- "Camera obscura"** A term applied to a camera hidden within a walled structure, usually elevated on a roof. Often hidden in a cupola or hut to survey the town below without being seen.
- Caster plate** The 2" × 6" rail that the casters are bolted to, which each rafter frame is also tied to with a framing anchor. The caster plate runs the full length of the roof under all the rafter frames, and supports the roof framework over the track.
- Caster stops** Wooden blocks bolted to the "track plate" or uppermost 2" × 6" plate of the observatory wall. At the very ends of the track plate, they prevent the casters from moving further off the rack.
- Caster track** The steel inverted angle that runs the length of the track plate, through the entire length of the observatory, upon which the casters ride. Nip-welded to a steel base plate which is screwed down to the track plate, it can be adjusted sideways slightly to allow for slight changes in the width of the track.
- Channel-groove siding** A type of wall siding that presents a grooved appearance created by an overly wide tongue which only partly fits into the adjacent board's channel creating a "groove" at each joint. It should be nailed with 2½" siding nails (8d) at 16" o/c.

- Chinking** The stuffing of “chinks” or spaces in a log-cabin style structure with cement, mud, or plaster. In early days, cattle hair was added to the plaster to increase its adhesive consistency and hold it rigidly in place. “Chinkless” log-cabin construction involves grooving the under side of every log in each tier so that it saddles the log beneath, making a close joint for its entire length. The log observatory in this book was built in this fashion.
- Chord** The bottom or top cleat running across the rafter frame joining the rafters at their tops or at their bottoms. In our case the bottom 2” × 4” cleat is the chord referred to, running from the track plate across to the opposite track plate.
- Clam-shell roof (design)** A type of observatory with hinged roofs that swing out from the center, and are supported by short “legs” on the ground. They are balanced by counterweights exactly so they swing up and out effortlessly. Weather-sealing the roof members at their junction when closed is a major problem.
- Collar Tie** A horizontal cleat placed between rafters to reinforce their strength. Usually applied very near to the ridge board.
- Concrete pier** A full-length pier from footing to pier cap (attachment point for telescope mounts). A cement footing at least 4 ft in ground is poured first. Cement is then poured into a sono-tube form positioned vertically on top of the footing. The use of a full cement pier requires pre-calculation of the height of the telescope in its horizontal, storage position in order that it not interfere with roof closing.
- Counterweights** Cement or iron weights used to counterbalance the weight of the clam-shell observatory roofs as they are swung open. These weights are achieved by trial and error usually by adding sand or water in a container until balance is achieved. At that point the container is weighed on a scale and comparative cement or iron weights are fabricated and bolted to the arms.
- Crawl space** The space under the floor joists in an elevated floor such as in the sono-tube footing type foundation.
- D**
- Diagonal** The line connecting opposite corners of the observatory foundation batter boards or the foundation itself. It is the hypotenuse of the right-angle triangle formed. The two diagonals (hypotenuse) should be exactly the same when measured, assuring squareness of the foundation.
- Drainage Act** A provincial, or state act that regulates the distribution of water over land, in our case from one property to another.
- E**
- Eave** The roof overhang which extends out from the observatory side walls.
- Exhaust Fan** A wall fan that can be built into the gable of the observatory to pull the hot air out of the observatory.
- F**
- Fascia** The finishing board applied over the end of the rafters at the eaves

<b>Filler Blocks</b>	Same as “blocking,” used alongside studs at wall ends to provide a nailing surface, and (also in the case of a corner) to provide extra strength and support.
<b>Flanges</b>	Circular (or square) steel platforms welded or bolted to both upper and lower ends of the steel pier. At the bottom the flange allows bolting of the pier to the concrete pier footing, and at the top to the telescope mount. Usually made of steel plate turned on a lathe.
<b>Footing</b>	The below-ground portion of a foundation, or a poured-concrete base upon which sono-tube concrete piers are set. A widened concrete footing sits beneath the metal pier extending below-ground.
<b>Footprint</b>	The area covered by the building foundation, or first floor.
<b>Framing Square</b>	A steel square used by carpenters and contractors to calculate and lay out rafter lengths and right angle cut-offs.
<b>Frost Heave</b>	The shifting or upheaval of ground due to alternate freeze-thaw cycles, usually attributed to freezing water in the soil.
<b>Frost Line</b>	The maximum depth to which soil freezes in your climatic zone.
<b>G</b>	
<b>Gable</b>	The portion of roof overhanging the end walls of a gable roof structure.
<b>Gable Trim</b>	The metal finishing trim that is applied at the end of a gable (like a fascia board on the eaves portions). It is usually “braked” (bent in a “brake”) to fit your particular gable-end.
<b>Gable Roof</b>	A pitched roof with two sides.
<b>Gantry</b>	The supporting framework for the track and roll-off roof beyond the end-wall of the observatory.
<b>H</b>	
<b>Hatch</b>	Used mostly in sailing jargon, the term refers to a removable, sliding, or swing-out small door. Our reference is to a small swing-open door in the roof of a shed.
<b>Header</b>	A horizontal framing member nailed across the ends of joists, usually to close the ends of joists flush with the outside observatory walls. Also framing over doors and windows.
<b>Head Jamb</b>	The top jamb in door framing, usually rabbeted (stepped channel) to accept the top of the door.
<b>Hip Roof</b>	A pitched roof having four sides.
<b>Hurricane/Seismic Tie</b>	A metal bracket prefabricated to hold the rafters to a ridge board without toe-nailing the rafter to the ridge board. Although specifically made for Hurricane/Seismic-proof roofing construction, it offers a strong tie for a movable roof. Offered by the Simpson Company.
<b>Hypotenuse (Diagonal)</b>	In our layout of the foundation, the diagonal between two opposite corners of either the batter boards or the edges of the footing(s).
<b>I</b>	
<b>Inverted Angle</b>	Right-angle steel track that is welded legs-down with back up to form our caster track.

**J****J-Bolts**

Steel foundation bolts in the shape of a “J” which are sunk into wet concrete and bolted to the sole plates of the wall sections.

**Joists**

Horizontal framing members which support the floors or ceilings.

**Joist-Hanger**

Prefabricated sheet metal hanger which holds a joist against a header or any other horizontal member. Nails are driven through tabs in the hanger which gives the unit exceptional strength – much preferable to butt-nailing or toe-nailing it.

**K****King Post**

A vertical member which supports the ridge board from underneath, stretching from a bottom chord to the ridge board. It is often butted against a long chord running the length of the roof, which sits on the bottom chord running transversely *across* the roof.

**L****Lag Bolts**

Long screw-threaded bolts with a hex-head that are used for supporting heavier loads in wood-framing. More often used in square timber connections such as post and beam structures.

**Laminar Air Flow**

Air that moves horizontally over a surface in a layer, such as over the surface of water.

**Look-Out**

A strut under the eaves of the roof running horizontally from the fascia trim back to the wall where it is usually fastened to a ledger running parallel to the eaves. In our case, the look-out is a triangular section of 2” x 6” lumber cut in a triangle to terminate at its 6” width. Glued and strapped with hangers to the rafter it forms a member upon which the soffit (plywood or aluminum) can be nailed.

**Louvers**

Narrow boards spaced and angled to stop rain etc., from entering, but allowing air to flow through.

**M****Main Use**

In zoning refers to a Dwelling Unit or Home versus an “Accessory Use” such as a shed or outbuilding.

**Mortise**

A recess or cut-out in a board or member designed to receive the end or flank of another member.

**Masonite**

A hardboard of pressed-wood composition used for underlay and sometimes as a finish wall board.

**Metal Pier**

The uppermost section of pier that the mount and telescope is bolted to. Usually large diameter steel or aluminum thick-walled pipe, with flanges welded to top and bottom for attaching telescope mount above, or for attachment to the cement Pier below.

**Minor Variance**

A granted variance to the Zoning Bylaw allowing a slight modification to the by-law (minor). Major deviations to the by-law require a Re-zoning or Zoning Amendment. The process requires an application to the “Committee of Adjustment” or the Town Council who judge its merits. An example would be a reduced side-yard width to accommodate our Roll-Off Observatory. The appellant (owner of the parcel) would have to give good evidence of why he needed the variance. The application has merit if it does not affect the adjoining properties. It is not a question of size, area, length or width, but more of a question of impact on surrounding property.

## N

**Nip-Weld**

A slight weld which involves only a “spot” of welding applied at intervals to avoid warping the metals being joined.

## O

**Official Plan**

The main legal “instrument” the Town, city, state, or municipality has to control development on its land base. It is a broad planning document which describes the intent of the Zoning By-law as it is applied to all land uses, and is implemented by the Zoning By-law. It usually avoids the deeper criteria involved with measurements carried out specifically by the Zoning By-law. The Official Plan can be compared to the “Driver’s Handbook” in the glove compartment of your car, whereas the Zoning By-law is the “Mechanic’s Manual”. An application for Official Plan Amendment may meet the size criteria of the Zoning By-law, but fail to meet the *intent* of the Official Plan which takes precedence over measurements.

## P

**Particle Board**

Particle Board or “Wafer-board” is a compressed wood fiber product manufactured in sheets. It is used largely for underlay on floors, roofs and walls. Since it is affected by water soaking into it, I prefer it only used on vertical walls where a water soaking will simply run off or evaporate quickly. It is not a good nailing surface, but rather only an intermediate layer usually sandwiched between outside boarding and the studs of a wall. I do not advise its use on roofs or floors. Tongue and Groove ply is safest on floors and roofs.

**Perforated Tile**

A plastic ribbed drain tile usually 4” 6” diameter with a series of slits in its underside which allow water to enter it and thus drain it off by gravity.

**Pergola**

An arbor usually covered with vines or flowers trailing over a trellis, or often just a open joist structure which lets sunlight through.

**Pier**

In this book, a pier refers to a telescope foundation- either a concrete form or a steel tube supported by a concrete footing.

**Pillow Block**

Refers to a wide bearing or set of bearings on a steel shaft acting like a broad pulley. It allows flexibility in travel for steel cables.

**Platform Framing**

A framing method that involves building a plywood floor on which the walls are erected (see balloon framing).

**Plumb**

Vertical, or to make vertical.

**Plumb Cut**

A vertical cut made on the top end of a rafter to meet the ridge board at the top of the roof.

**Purlins**

Narrow boards running cross-wise to the roof rafters for support of the roof sheathing or steel sheet roofing. Either mortised into the rafter if it is wide enough or framed into the rafter with metal anchors.

## R

**Rafter**

Framing members used to support the roof.

**Rafter Hanger**

A pre-formed sheet metal support used in lieu of butt-nailing or toe-nailing rafters to either ridge pole or top plate.

<b>Rebar</b>	A ridged iron bar usually 1/2" 5/8" diameter used to reinforce concrete footings. Usually laid within a cement pour about mid-level of the pour.
<b>Reinforced Concrete</b>	Concrete containing either wire (steel) mesh or rebar.
<b>Rebar cage</b>	A basket-like column of rebar tied together with heavy wire which runs the length of a cement pier or foundation.
<b>Receptacle</b>	An electrical outlet box usually containing twin plug outlets. Sometimes called a "duplex."
<b>Ridge Board (Ridge Beam)</b>	The upper-most portion of a roof structure. A beam running the whole length of the roof at the peak with roof rafters nailed into it.
<b>Ridge Cap</b>	A pre-formed metal cap that runs along a steel roof peak. It is constructed to allow air to flow through it ventilating the steel sheets.
<b>Rise/Run</b>	A formula representing the pitch of a roof expressed as a ratio. For instance a rise of 4 in. for every 12 in. run (horizontal) represents a 4-in-12 pitch.
<b>Robertson Screws</b>	Screws with a square recess to fit a square-tipped screwdriver.
<b>Rolling Ladder</b>	A steel ladder in the form of steps on a platform with casters underneath which can be rolled around. It can be fixed in place with a brake on the casters. Enables you to sit on the upper stair (which is a platform) at a convenient height for viewing through a telescope.
<b>Roll-Off Roof</b>	A roof which rolls or slides off a structure revealing an open room.
<b>Roof Felt</b>	An asphalt-saturated material used under shingles or steel roofing for water-proofing. It serves to prevent condensation under a steel roof undergoing rapid cooling.
<b>Roof Framing Member</b>	A complete rafter assembly section rafters, ridge beam, collar ties or chord tied together as a whole.
<b>Roof Pitch</b>	See Rise/Run.
<b>Roof Sheathing</b>	Covering over the rafters in the form of plywood or particle board etc. Sometimes referred to as the "roof deck."
<b>S</b>	
<b>Saddles (Iron Saddles)</b>	Heavy gauge steel brackets pre-formed to fit various size timber posts. Variations in design include flat base with holes to be bolted into set concrete, or with a welded post which is to be imbedded into a wet concrete form.
<b>Side Jam</b>	The vertical member or stop at the sides of a door frame.
<b>Skirt</b>	A portion of roof overhang that extends vertically down the wall. Usually no more than a foot long, it is advantageous for covering and weatherproofing the caster gap, normally an area open to the air.
<b>Slab</b>	In our text, it refers to a full concrete floor in the observatory section or a continuous footing under the gantry section.
<b>Soffits</b>	The portions of the rolling roof overhanging on the sides of the observatory that are sheathed underneath to enclose the rafter framework.



<b>Soil Profile</b>	The <b>στοιλ στρωχτυρε</b> including the soil horizon usually visible in a dug hole. For instance a clay soil profile would indicate a high concentration of clay and clay-based ingredients.
<b>Sole Plate</b>	The lower “plate” or member on a wall section. The joists are usually butt-nailed through this plate when the wall framework is being assembled on the ground. When the wall framework is hoisted up onto the plywood floor deck the sole plate is nailed to the floor underneath. In the case of a cement slab floor it is tied down with J-bolts.
<b>Sono-tube</b>	A rolled fiber tube used for forms in footings. It is spiral-wound and usually waxed so that if the soil heaves from frost, it will slide by the tube without lifting the footing. (hence the necessity of placing the bottom of the sono-tube well below the frost-line where it could be lifted by vertical forces on the bottom).
<b>Span</b>	The distance between vertical supports for horizontal framing members, such as joists or beams. For rafters it is the distance between two opposite walls that support them, or sometimes the span of a building.
<b>Squatting</b>	Residing on land (either in a home or structure) without permission and particularly without legal ownership or a deed.
<b>Studs</b>	The vertical members of a building forming the framework for the walls.
<b>T</b>	
<b>Tail Cut</b>	The bottom vertical cut at the lower end of the rafters where a fascia board is usually nailed.
<b>Tapping</b>	The action of threading a hole for a bolt accomplished with a “tap” (threading tool).
<b>Tarn</b>	A small mountain Lake formed by meltwater.
<b>Template</b>	In our text this refers to a temporary rafter member, or test rafter, temporarily assembled to verify its proper dimensions to fit the “span.”
<b>Thermal Equilibrium</b>	When a telescope has reached the same temperature as the outside surrounding air.
<b>Thermal Window</b>	If installed between “warm room” and observing room this refers to a window that is well-insulated to keep any heat supporting the warm room from leaking into the observatory.
<b>Threshold</b>	The portion of a door or “sill” that lies at its base, usually replacing the sole plate in that gap.
<b>Top Plate</b>	The upper-most part of a wall section, usually a double plate. In the Roll-Off observatory the double top plate carries the track. The top plate of the two is referred to as the “track plate” in our text and diagrams.
<b>Track Gap</b>	The air gap created between the track plate and the caster plate above it. Essentially the total gap formed by the casters plus track.
<b>Track Joist</b>	A joist mortised into the top of the wall studs that runs the full length of the observatory (walls plus gantry). It aids in supporting the weight of the roof both on the observatory section and over the gantry section.

<b>Track Plate</b>	The upper top plate that carries the track rail running the full length of the observatory structure (from walls through gantry). Part of it sits over the track joist underneath.
<b>Trellis</b>	A wooden garden lattice structure. In our case it is installed as a partially-open ceiling on the inside of the gantry joists to clear the rolling roof.
<b>Truss</b>	A reinforced rafter member, pre-manufactured to fit your span. It is held together with a nailing plate to support a specific weight. You could have such a member made up by your local lumber company avoiding the trouble to make your own rafter members.
<b>Turbulence</b>	The effect of rising hot air. Detrimental to viewing with optical aid such as with a telescope.
<b>V</b>	
<b>Variance</b>	(See “minor variance.”)
<b>V-Groove Casters</b>	A type of cast steel roller that is designed to roll on a 90° Knife-edge track such as an angle iron mounted with its back up.
<b>W</b>	
<b>Warm Room</b>	A separate room partitioned off from the regular portion of the observatory for warm, relaxed viewing by means of a digital camera and lead to a computer screen. Most often also a “dark room” to make the monitor screen visible.
<b>White Room</b>	A “clean” room deriving its name and appearance from clean, white walls in a dust-free, uncontaminated environment. Slang for a room with extraordinary cleanliness.
<b>Z</b>	
<b>Zoning</b>	The legal “instrument” through which a state, town, or municipality controls its development, - its purpose is to create “orderly” development through a series of numerical standards for yards, areas, lot sizes etc.
<b>Zoning Amendment</b>	An alteration or change to the Zoning By-law to allow something that is not normally permitted in that zone. It requires an application and review by town or city council who will judge it as appropriate or non-conforming. You want to avoid having to go through this costly, and risky business, if at all possible.
<b>Zoning By-law</b>	A formal document that outlines all the types of zoning categories within a state, town, or municipality. It also contains a list of zoning amendments or exceptions to the zoning by-law.

## **End Note**

1. Glossary adapted from Creative Homeowner Press, see Endnote 1, Chapter 9.



## Tools, Materials & Hardware Checklist

### Tools

- Tape Measure
- 2-ft level
- Line level
- Framing Square
- Combination Square
- Pencil
- Regular Wood Plane & Chamfer Plane
- Plumb Bob
- Staple Gun
- ½” Staples
- Box Cutter
- Caulking Gun
- Long-Handled Shovel
- Rake
- Hoe
- Pick
- Concrete Tamper (you can make this)
- 2-gallon Plastic Bucket
- Wood or Metal Concrete Float
- Wheelbarrow

- Small Sledgehammer
- Mason's Twine
- Chalk and Chalkline
- Handsaw and Keyhole Saw
- Metal Hacksaw
- Circular Saw
- Electric Drill and Bits
- Brace and Bit with Bits (for longer bolt-holes)
- Claw Hammer
- Range of Screwdrivers
- Adjustable (Crescent) Wrench
- Various size Nail Sets
- Wood Chisel
- Short Pry Bar
- Miter box and Backsaw
- 6-foot Stepladder
- Work Gloves
- Safety Goggles
- Dust Mask

## Nails

- 1" Ardox
- 1-1/4" Ardox
- 1-1/2" Ardox
- 2" Ardox
- 2-1/2" Ardox
- 3" Ardox
- 3-1/2" Ardox
- 1" or 1-1/2" Roofing Nails
- 2" or 2-1/2" Siding Nails

## Screws

- Round-Head Wood
- Flat-Head Wood
- Lag Screws

## **Bolts**

- Anchor or “J-Bolt”
- Carriage Bolts
- Machine Bolts

## **Fasteners/Hardware**

- Joist Hangers
- Hurricane/Seismic Hangers
- Header Hangers
- Truss/Rafter Hangers
- Hinges
- Door Latch
- Pre-hung Door
- Door Knob and Deadbolt kit

## **Footings/Foundation**

- ¾” Crushed Gravel
- Concrete mix
- Polyethylene Sheet
- Preformed Sono-tubes
- Wood Shims (Shingles)
- 5/8” T&G Plywood Floor Sheathing

## **Roofing/Siding**

- Plywood roof sheathing (if deemed necessary by building code only)
- Siding Panels/Boards (if not vinyl)
- Wall Sheathing to back up vinyl siding
- 15-lb Roofing Felt
- Vinyl Board and Batten Siding

## **Track and V-Groove Roller Hardware**

- 4 sections each 15’ long – 1-1/2” x 1-1/2” Steel track angle
- 4 sections each 15’ long - 3-1/2” x ¼” Steel Plate
- 10 – V-Groove Casters (Bestway Casters specified)

- 2 X 1000lb Boat Winches with safety-dogs
- 125 feet 1/8" Woven Stainless Steel Cable
- 2 Enclosed Sailboat Pulleys and Eyes
- Eyelet Guides for Stainless Steel Cable
- 2 Pillow Blocks with 1" Diameter Roller Bearings
- 6" long stainless steel pillows with matching shaft size for Pillow Block Roller Bearings

## Painting Supplies

- Wide Brush
- Paint Tray
- Roller
- Spray Gun
- Wood Stain
- Water Repellant
- Orange Metal Spray
- Exterior Paint (If wood siding)
- Rags
- Caulking (tubes)

Tools, Materials & Hardware Checklist adapted from Creative Homeowner Press (see Endnote 1, Chapter 9)



# Acknowledgements

## Photo Credits

Throughout the United States and Canada, I searched for owners of Roll-Off Observatories who had applied their skills to create designs that I would recommend to readers. That search consumed most of my time in the process of writing this book, and proved to be a necessity. A design/build book would be uninteresting without images of actual observatories built mostly by amateurs – people who are not by profession carpenters, builders, or contractors. Their innovative ideas sparked a lot of my enthusiasm for the task that lay ahead of me. Frankly, their creativity opened paths for many new ideas on techniques that I will use in future designs. For their generosity in supplying photos and descriptions, I am most thankful. I know they will feel gratified seeing their particular model exhibited in the book, inspiring others with new construction ideas.

The following observatory owners supplied photos and assistance:

Donald Trombino (1998), Florida, USA

Mike Hood, Georgia, USA

Bob Luffel, Idaho, USA

Jay Ballauer, Texas, USA

Greg Mort, Maryland, USA

Larry McHenry, Pennsylvania, USA

Gerald Dyck, Massachusetts, USA

Jeff Pettitt, Florida, USA

Terry Ussher, Ontario, Canada

Guy Boily, Quebec, Canada

Doug Clapp, Ontario, Canada

Dave Petherick, Ontario, Canada

Paul Smith (1995), Ontario, Canada

Danny Driscoll, Ontario, Canada

Andreas Gada, President, North York Astronomical Association (NYAA),  
Toronto, Ontario <http://www.nyaa-starfest.com>



## Products

Companies and Suppliers that offered brochures and advice on their products include the following:

Andex Metal Products (Ron Scott) Suppliers of Sheet Steel Roofing, Exeter, Ontario  
Layton Roofing (Blake Layton) Keswick, Ontario  
Bestway Casters (Fred and Richard Shouldice), Gormley, Ontario, Canada  
Schell-Ace Building Centre, Sutton, Ontario

## Advisors

John Ecclestone, former Manager Production and Design, University of Toronto Press  
Peter Sibbald Brown, Book Designer, Sutton West, Ont

## Disclaimer

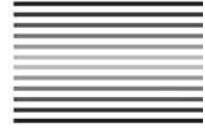
The author has made every effort to ensure that all instructions given in this book are accurate and safe, but cannot accept liability for any injury, damage, or loss to either person or property – whether direct or consequential – resulting from the use of these plans and instructions. The author, however, will be grateful for any information that will assist him in improving the clarity and use of these instructions.

## Jobsite Safety Provision

The author's instructions as written in the book, carried out on the construction site, shall not relieve the owner or General Contractor of its obligations, duties, and responsibilities, including, but not limited to, construction means, methods, sequence, techniques, or procedures, necessary for performing, superintending, and coordinating the work in accordance with the plans, diagrams, and text in the book, and any health or safety procedures required by any regulatory agency. The author has no authority to exercise any control over any construction contractor or its employees in connection with their work or any health or safety programs or procedures. The owner agrees that he or his General Contractor shall be solely responsible for jobsite safety, and warrants that this intent shall be carried out in any contract he has with the General Contractor. The owner also agrees that the Author and the Publisher shall be indemnified by the General Contractor, if any, and shall be made additional insureds under the General Contractor's Policies of General Liability Insurance.<sup>1</sup>



# Index



## A

Accessory building 16, 34, 41  
A-frame 20  
Air gap 19, 101, 125 (also see Track Gap)  
All-sky view 1, 2, 33  
Alt-azimuth mount 6  
Ambient temperature 2, 8, 19  
Andex steel roofing 111  
Angle steel rail 14, 95, 96  
Animal nuisances 5, 7, 119  
Aperture fever 1  
Appeal 40  
Armour-all 119  
Astronomy magazine viii

## B

Backyard observatories 5  
Ballauer Observatory 19  
Ballauer, Jay 19  
Balloon framing 8  
Batten strips 120  
Battens 77  
Batter board 49, 66, 68, 69  
Battery 125  
Bench 103  
Bestway casters 95  
Big Bear Solar Observatory 36  
Big Woodchuck Solar Observatory 23  
Bird's mouth 105  
Blacksmith 58  
Blocking (between studs) 119  
Blocking (door) 85  
Board-and-batten siding 43, 67, 119, 120  
Boiler punch-out 58  
Boily, Guy 10, 11, 12  
Bolt cage 57

Bolt circle 51, 55  
Bottom chord 105, 107, 110  
Box beam *see* box tubing  
Box tubing 14, 17  
Boxed-in soffits 111  
Bracing 8, 110  
Brake 125  
Brick pier 21  
Building code 20, 33, 34  
By-law conformity 43

## C

Cabin hatch 22  
Camera obscura 127  
Carpenter's level 80  
Caster plate 103, 104  
Caster rail 8, 104  
Caster track 8  
Caster wheel stop 102  
Casters 32  
Caulking 120  
CCD Camera 19  
CCD sensor 45  
Ceiling joist *see* Bottom chord  
Celestial sphere 22  
Century rib 113, 115  
Channel groove siding 119, 120  
Chinking 8  
Chord 105, 106, 107  
Clam shell roof 1, 23  
Clapp, Douglas 25  
Clapp-Trap Observatory 25  
Clearances 29  
Cloister 127  
Closed-loop system 95  
Closing-roof-winch 125

Closure strips 113  
 Cloth screen 21  
 Collar tie 14  
 Combing strips 122  
 Committee of Adjustment 40  
 Compass 39  
 Computer 8  
 Computer room 32  
 Conduit 79  
 Coniferous forest 38  
 Construction advice 10  
 Continuous chord 106  
 Control pad 56  
 Corner stud 83  
 Corrugated roof panels 103  
 Countersink 100  
 Counterweights 23  
 Counties 34  
 Cradle rings 89  
 Crane 103  
 Crawl space 7  
 Cushioning 102  
 Cylindrical dome 1  
 Cylindrical lock 85

**D**

Davis Memorial Observatory viii, 4, 31, 77  
 Daystar filter viii  
 Dead bolt 84  
 Deck 7  
 Deflection 73  
 Deltona viii  
 Diagonal 49, 69, 73  
 Dobsonian 6  
 Door framing 82  
 Door Jamb 88  
 Door stops 87  
 Door threshold 67  
 Double lock set 84  
 Double plate *see* Track bed  
 Dow SM board 77  
 Drainage 36  
 Drainage Act 36  
 Drip cap (door) 88  
 Driscoll, Danny 24  
 Duplex receptacle 60, 65  
 Dyck, Gerald 5

**E**

Electric box 59  
 Electrical outlet 65  
 Electrical service 35  
 Elevation 35  
 Emitted radiation 36, 37  
 Encroachment 41  
 End-nailing 80  
 Equatorial mount 6  
 Equatorial telescope 1, 6  
 Eve flashing 113, 116  
 Exceptions 34  
 Exhaust fan 120

**F**

Fascia board 108, 112, 116  
 Felt underlay 103, 115  
 Filler blocks 81, 83  
 Flanges 51  
 Flat bed truck 97  
 Flexing 74, 80, 83  
 Flush joint 99  
 Fork and Wedge 30  
 Framing anchors 105, 110  
 Framing square 105  
 Framing studs (door) 87  
 Freeze-thaw cycle 36  
 Friction 99  
 Frost zone 53

**G**

Gable ends 107, 111  
 Gable fan 8  
 Gable flashing *see* Rake flashing  
 Gable studs 111  
 Gada, Andreas 23  
 Galvanized 67, 77, 83  
 Gantry 3, 32, 61, 63, 64, 65, 73  
 Gantry posts 49, 67, 91  
 Gantry section 61, 73, 76  
 Gantry stakes 50  
 Gantry footings 76  
 Gantry track 82, 93  
 Garage door track 13, 101  
 Garden shed 7, 22  
 Gauge 104  
 Generator 35  
 German equatorial mount  
   29, 126  
 Golf balls 95  
 Golib, Leon 44  
 Gore panels 43  
 Ground-level currents 32  
 Group sessions 32, 33  
 Guide scope 89

**H**

Hardwood siding 119  
 Head casing (door) 88  
 Head jamb (door) 85  
 Header 74, 78  
 Heat pump 5  
 Hicks, John S. ix, 3  
 Hicks, Lorraine Ann v  
 Hinge (door) 85  
 Hinge leaf (door) 89  
 Hood, Mike 5  
 Horizon-level viewing 5  
 Huronia Star Party v  
 Hypotenuse 49, 104

**I**

Insects 5, 81, 119  
 Intense welding 99  
 Interior sheathing 80, 85

## Index

## J

J-bolts 66  
 Joist hanger 74, 78  
 Junction box 62, 65

## K

Kerf *see* Saw kerf  
 King post 105, 106  
 Kit form 9  
 Knob (door) 85

## L

Lag bolt 83  
 Lag screw *see* Lag bolt  
 Laminar air flow 38  
 Laminated 92  
 Landscape Architect 42  
 Landscape fabric 7  
 Landscape feature 7  
 Latch (door) 87  
 Lattice 77  
 Leg-up 95, 99  
 Leveling bolts 57  
 Light pollution 2  
 Light proofing 84  
 Linearity (achieving) 91  
 Lock stone pavers 65  
 Log frame 8  
 Look out 111  
 Lot coverage 34  
 Luffel, Bob 15, 16

## M

Machinist 58  
 Main use 34, 40  
 Manhattan viii  
 Masonite panels 123  
 McHenry, Larry 23  
 Metal framing anchors 111  
 Metal louvers 121  
 Metal pier 85  
 Minor Variance 34  
 Mock windows 7  
 Monitor 8  
 Moore, Sir Patrick viii  
 Mort, Greg 20  
 Mortise 64, 79, 80, 82, 84, 88, 91, 105  
 Motorized winch 127  
 Municipalities 34

## N

Nailing block 82, 93  
 Nailing plates (*see* Nailing block)  
*Nearest Star* 37  
 New Forest Observatory viii  
 Newmarket xi  
 Newtonian telescope 29  
 Nip-weld 96  
 Non-computerized system 1, 34  
 North York Astronomical Society vii  
 NYAA *see* North York Astronomical Society

## O

Observing hatch 27  
 Official plan 40  
 Outdoor patio xii, 3, 33,  
 Outside corner assembly 83

## P

Panels 25  
 Parking 35  
 Pasachoff, Jay 37  
 Passive air circulation 120  
 Patio 77, 85  
 Pedestal 22, 95  
 Perched desk 127  
 Perforated tile 36  
 Perforated tile drain 36  
 Pergola ix  
 Permanence 34  
 Petherick, Dave 7  
 Pettitt, Jeff x, 2  
 Pier 51  
 Pier base template 54  
 Pier cap 55, 59  
 Pier footing 51  
 Pillow block 125  
 Plumb 91  
 Plumb cut 105  
 Ply deck 113  
 Polar axis 1  
 Polar-align 22, 34, 95  
 Polaris 20, 34, 95  
 Poles 8  
 Prefabricated carriages 101  
 Pre-hung door 85  
 Privacy 2  
 Public hearing 40  
 Pulleys 95, 125  
 Purlins 105, 111  
 PVC pipe 65

## R

Rabbet (door) 88  
 Rafter lookout 111, 112  
 Rafters 104  
 Rake flashing 113  
 RASC *see* Royal Astronomical Society  
 Rebar 54, 61, 64  
 Reflector 25  
 Refracting telescope 22, 29  
 Rezoning application 41  
 Ridge board 105, 106, 113  
 Ridge cap 113  
 Riffler 89  
 Riveting and tapping 43  
 Road access 35  
 Robertson screws 99  
 Rocky Plains Observatory 15, 16  
 Roller bearings 97  
 Rolling ladder 127  
 Rolling-off winch 125  
 Roll-over position 29

- Roof chord 52
  - Roof flashing 13
  - Roof framing member 109
  - Roof gable 19, 23, 29, 48
  - Roof joists 86
  - Roof pitch 104
  - Roof truss 15, 22
  - Rough opening 84
  - Royal Astronomical Society vii
  - Rubber-wheeled casters 95
- S**
- Saddle holes 83
  - Saddles 45, 66, 67, 68, 69, 76, 91
  - Saw kerf 49, 87
  - Sawhorse 103
  - Schmidt-Cassegrain telescope 29, 52
  - Scrap yard 58
  - Screed board 66
  - Security 32, 99
  - Septic bed 39
  - Septic tank 39
  - Set-back 34
  - Sheet metal hangers 113
  - Shimming (door) 82, 85
  - Shingle 87
  - Shutters 7
  - Side casing trim (door) 87, 88
  - Side jamb (door) 85
  - Sill (door) 85
  - Simpson Hurricane/Seismic tie 106, 107, 109, 111
  - Skill saw 114
  - Skirt 5
  - Sky dome 2
  - Slab 45, 46, 47, 61, 62, 64, 65, 66
  - Sleepers 78
  - Smith, Paul 24
  - Snow load 20, 104
  - Soffit 102, 125, 111
  - Soil heaving 74
  - Soil profile 53
  - Sole plate 65, 67, 77, 79, 81, 82, 119
  - Sono-tube 45, 47, 57, 59, 68, 69, 72, 73, 74, 75, 76, 91
  - Splice point 81, 84
  - Spreader (door) 87
  - Squatting 41
  - Stainless cable 125
  - Stainless steel 59
  - Starch wash 123
  - Starfest vii
  - Steel base plate 96, 97, 98
  - Steel caster track 91
  - Steel pier 10
  - Steel roofing 113
  - Stepping-off 105, 107
  - Stone pavers 76
  - Strike plate (door) 85
  - String line 91, 104
  - Styrofoam 77
  - Super Portable Observatory 25
- T**
- Tack-weld 96
  - Tail cut 105
  - Tangent arm 52
  - Tarn 38
  - Template (roof framing) 106
  - Template (lock) 88
  - The "Bog" 23
  - Thermal equilibrium 42
  - Thermostat 120
  - Threshold (door) 84
  - Toe-nailing 79
  - Track bed 100
  - Track gap 85
  - Track joist 75, 80, 83, 91, 92, 98
  - Track plate 81
  - Track/ caster gap *see* Track gap
  - Transpiration 36
  - Tree By-law 34
  - Trellis 7
  - Tremclad 99
  - Tripod 5
  - Trombino, Don viii, 3, 31
  - Trusses 106
  - Turbulence 35, 36, 42
  - Two-winch system 95
- U**
- Universe 128
  - Ussher Observatory *see* Ussher, Terry
  - Ussher, Terry 13, 14
- V**
- Vent strip 111, 112
  - Vents 121
  - V-groove steel caster 13, 85, 95
  - Vinyl siding 119
  - Vinyl-ribbed siding 8
  - Visitor accommodation *see* Group sessions
- W**
- Wafer board 119
  - Warm room 19, 32, 41
  - Wedge 57
  - Weeds 7
  - Winch system 95, 125
  - Window 5, 13
  - Wire mesh 66
  - Wood clamps 13
  - Wood grain siding *see* Hardwood siding
  - Wrightman, Walter x
- Z**
- Zenith 29
  - Z-flashing 18
  - Zinc-coated 99
  - Zoning amendment 40
  - Zoning By-law 34
  - Zoning restrictions 48



© 2009 Springer Science+Business Media, LLC

This electronic component package is protected by federal copyright law and international treaty. If you wish to return this book and the electronic component package to Springer Science+Business Media, LLC, do not open the disc envelope or remove it from the book. Springer Science+Business Media, LLC, will not accept any returns if the package has been opened and/or separated from the book. The copyright holder retains title to and ownership of the package. U.S. copyright law prohibits you from making any copy of the entire electronic component package for any reason without the written permission of Springer Science+Business Media, LLC, except that you may download and copy the files from the electronic component package for your own research, teaching, and personal communications use. Commercial use without the written consent of Springer Science+Business Media, LLC, is strictly prohibited. Springer Science+Business Media, LLC, or its designee has the right to audit your computer and electronic components usage to determine whether any unauthorized copies of this package have been made.

Springer Science+Business Media, LLC, or the author(s) makes no warranty or representation, either express or implied, with respect to this electronic component package or book, including their quality, merchantability, or fitness for a particular purpose. In no event will Springer Science+Business Media, LLC, or the author(s) be liable for direct, indirect, special, incidental, or consequential damages arising out of the use or inability to use the electronic component package or book, even if Springer Science+Business Media, LLC, or the author(s) has been advised of the possibility of such damages.