

# **MBA**

**(DISTANCE MODE)**

**DBA 1730**

**SUPPLY CHAIN MANAGEMENT**

**IV SEMESTER  
COURSE MATERIAL**



**Centre for Distance Education**

**Anna University Chennai  
Chennai – 600 025**

**Author**

**Dr.R.Raju**

Assistant Professor  
Department of Industrial Engineering  
Anna University Chennai  
Chennai - 600 025

**Reviewer**

**Mr.Jayanth Jacob**

Senior Lecturer  
Department of Management Studies  
Anna University Chennai  
Chennai - 600 025

**Editorial Board**

**Dr.T.V.Geetha**

Professor  
Department of Computer Science and Engineering  
Anna University Chennai  
Chennai - 600 025

**Dr.H.Peeru Mohamed**

Professor  
Department of Management Studies  
Anna University Chennai  
Chennai - 600 025

**Dr.C. Chellappan**

Professor  
Department of Computer Science and Engineering  
Anna University Chennai  
Chennai - 600 025

**Dr.A.Kannan**

Professor  
Department of Computer Science and Engineering  
Anna University Chennai  
Chennai - 600 025

Copyrights Reserved  
(For Private Circulation only)

Dr. P. MANNAR JAWAHAR, Ph.D., M.E., DMIT, B.Sc.,  
MISTE, MISME, MISNDT, MSAE(USA), FIE, Chartered Engineer

VICE-CHANCELLOR



**ANNA UNIVERSITY CHENNAI**  
Chennai - 600 025, INDIA

September, 2008

## FOREWORD

The prime objective of education is conversion of human being into intellectual capital of a nation. Conventional education system has its own limitations to achieve this objective. Realizing this fact all over the world more and more traditional universities are rapidly transforming themselves from single mode of traditional education to dual mode of both traditional as well as distance education. Distance Education is becoming an accepted and indispensable part of the main stream of the educational system of any nation. Technology has made it possible to provide the best and the most up-to-date education at a reasonable cost and without geographical boundaries.

Anna University Chennai has started the Centre for Distance Education during 2006 with the aim of providing equity access to quality professional education to all the deserving aspirants. The Centre for Distance Education, Anna University Chennai has introduced MBA in General Management, Technology Management, Retail Management, Human Resource Management, Financial Services Management and Health Services Management, MCA with emphasis on Banking Technology, Call Centre Management, E-Learning, Trading and Equity Management, Health Care Management, and M.Sc in Computer Science, Information Technology, Software Engineering and Computer Technology. These programmes have been well received by all the stake holders. Anna University Chennai has absorbed large number of learners from multiple segments for all the programmes introduced. Yes, we have achieved impressive success to celebrate, and that induce us to perform much better, in the days to come.

The course materials play vital role in imparting knowledge, specially in distance education. These materials delivered to you were prepared by experts in the respective areas. Authors have prepared the course materials based on learner centric approach, fine tuned by self instructional mode. I am sure these materials will meet your learning requirements in full by inculcating a new learning culture.

As we move towards more knowledge intensive economy, acquiring and sustaining relevant skills and knowledge is becoming increasingly significant.

On this line Anna University Chennai, shall continue to contribute its best and thereby enable our nation a much more knowledge rich nation.

My hearty congratulations and best wishes to all.

(P. MANNAR JAWAHAR)



## ACKNOWLEDGEMENT

The author has drawn inputs from several sources for the preparation of this course material, to meet the requirements of the syllabus. The author gratefully acknowledges the following sources:

- Sunil chopra & Peter Meindal, (2003), "Supply Chain Management, Strategy, Planning, and Operation, PHI, second edition.
- Jeremy.F.Shapiro, (2002), "Modeling the supply chain", Thomson Asia Pvt. Ltd., Singapore.
- Michael Hugos, (2006), "Essential of Supply Chain Management", Second edition, John Wiley & Sons, Inc.
- James B.Ayers, (2001), "Hand book of supply chain management, St.Luie press, APICS series on Resource management.
- Monczha, Trent and Handfield, (2002), Purchasing and supply chain management, Thomson, South-Western, 2<sup>nd</sup> Edition.
- Sunil Chopra and Peter Meindal, Supply Chain Management, Strategy, Planning, and Operation, Second edition, Prentice-Hall, inc,(2004).
- Jeremy F. Shapiro (2002), "Modeling the supply chain", Duxbury, Thomson learning.
- Ronald H.Ballou (2004), "Business Logistics / Supply Chain Management", Pearson education, 5<sup>th</sup> edition.
- Carlos J.Vidal, et-al (1997), "Strategic Production distribution models: A Critical review with emphasis on global supply chain models," European journal of operational research, 1-18.
- Geoffrion, A.M., and Graves, G.W.(1974), Multi-commodity distribution system design by Benders decomposition, Management science 20/5, 822-844
- Geoffrion.A.M, Graves, G.W, and Lee, S.J(1978), strategic distribution system design: An evolutionary perspective, Inter faces 25, 105-128
- Arntez.B.C.Et.al(1995), 'Global supply chain management at Digital equipement corporation, Interfaces 25/1, 69-93.
- Cohen.M.A,et.al (1991), An integrated plant loading model with economies of scale and scope, European journal of operations research 50,266-279.
- Cole.M.H (1995), Service considerations and the design of strategic distribution system, Ph.D thesis, school of industrial and systems engineering, Georgia institute of Technology, Atlanta, GA.

- Ali Amiri, (2006), Designing a distribution network in a supply chain system: Formulation and efficient solution procedure, European journal of operation research 171-567-576.
- PARK.Y.B (2005), An integrated approach for production and distribution planning in supply chain management, international journal of production research, vol 43, No6 1205-1224.

In spite of at most care taken to prepare the list of references any omission in the list is only accidental and not purposeful.

**DR.R.RAJU**

**Author**

# **DBA 1730 SUPPLY CHAIN MANAGEMENT**

## **UNIT I INTRODUCTION**

Supply Chain – Fundamentals, Importance, Decision Phases, Process View. Supplier- Manufacturer –Customer chain, Drivers of Supply Chain Performance. Structuring Supply chain Drivers. Overview of Supply Chain Models and Modeling Systems.

## **UNIT II STRATEGIC SOURCING**

In-sourcing and out-sourcing –Types of purchasing strategies. Supplier Evaluation, Selection and Measurement. Supplier Quality Management. Creating a world-class supply base. World Wide Sourcing

## **UNIT III SUPPLY CHAIN NETWORK**

Distribution Network Design –Role, Factors Influencing, Options, Value Addition. Modles for Facility Location and Capacity Location. Impact of uncertainty on Network Design. Network Design decisions using Decision trees. Distribution Center Location Models. Supply Chain Network optimization Models.

## **UNIT IV PLANNING DEMAND, INVENTORY AND SUPPLY**

Overview of Demand forecasting in the supply chain. Aggregate planning in the supply chain. Managing Predictable Variability. Managing supply chain cycle inventory. Uncertainty in the supply chain –Safety inventory. Determination of Optimal level of product availability. Coordination in the Supply Chain.

## **UNIT V CURRENT TRENDS**

E-Business –Framework and Role of Supply Chain in e-business and b2b practices. Supply Chain IT Framework internal Supply Chain Management. Fundamentals of transaction management. Supply Chain in IT Practice. Supplier relationship Management. Information Systems development. Packages in Supply Chain –eSRM, eLRM, eSCM. Supply Base Management.

## **REFERENCES**

1. Sunil Chopra and Peter Meindi, Supply Chain Management –Strategy Planning and Operation, Pearson Education, Third Indian Reprint, 2004.
2. Monczka et al., Purchasing and Supply Chain Management, Thomson Learning, Second edition, Second Reprint, 2002.
3. Altekar Rahul V, Supply Chain Management – Concept and cases, Prentice Hall India, 2005.
4. Shapiro Jeremy F, Modeling the Supply Chain, Thomson Learning, Second Reprint, 2002.
5. Ballou Ronald H, Business Logistics and Supply Chain Management, Pearson Education, Second Indian Reprint, 2004.





# CONTENTS

## UNIT I

### INTRODUCTION

1.1	OVERVIEW	1
1.2	FUNDAMENTALS OF SUPPLY CHAIN	1
	1.2.1 Objectives Of Supply Chain	3
	1.2.2 Supply Chain Management	3
1.3	IMPORTANCE OF SUPPLY CHAIN	5
1.4	DECISION PHASE IN A SUPPLY CHAIN	6
1.5	PROCESS VIEW OF A SUPPLY CHAIN	7
	1.5.1 Cycle View	7
	1.5.2 Push /Pull View Of Supply Chain Process	8
1.6	SUPPLIER –MANUFACTURER – CUSTOMER CHAIN	8
1.7	DRIVERS OF SUPPLY CHAIN PERFORMANCE	9
	1.7.1 Production	10
	1.7.2 Inventory	11
	1.7.3 Location	12
	1.7.4 Transportation	12
	1.7.5 Information	12
1.8	STRUCTURING SUPPLY CHAIN DRIVERS	12
1.9	OVERVIEW OF SUPPLY CHAIN MODEL AND MODELING SYSTEM	13
	1.9.1 Models With Transactional IT	14
	1.9.2. Supply Chain Models With Analytical IT	14

## UNIT II

### STRATEGIC SOURCING

2.1	INTRODUCTION	17
2.2	INSOURCING	17

2.3	OUTSOURCING	19
2.3.1	Process of Outsourcing	20
2.3.2	Reasons for Outsourcing	21
2.3.3	Outsourcing Objectives	22
2.3.4	Quality of Service in Outsourcing	22
2.3.5	Impact of Outsourcing	23
2.3.6	Advantage of Outsourcing	23
2.3.7	Disadvantage of Outsourcing	23
2.4	TYPES OF PURCHASE STRATEGIES	23
2.5	THE SUPPLIER EVALUATION AND SELECTION PROCESS	25
2.5.1	Supplier Selection Process	26
2.5.2	Supplier Measurement and Evaluation	27
2.6	SUPPLIER QUALITY MANAGEMENT	29
2.7	CREATING A WORLD – CLASS SUPPLY BASE	31
2.7.1	Supply Base Optimization	31
2.7.2	Supplier Development	32
2.7.3	Barriers to Supplier Development	34
2.7.4	Initial Supplier Selection	35
2.8	WORLDWIDE SOURCING	38
2.8.1	World wide sourcing process	38

### **UNIT III**

#### **SUPPLY CHAIN NETWORK**

3.1	INTRODUCTION	41
3.2	DISTRIBUTION NETWORK DESIGN	41
3.3	THE ROLE OF DISTRIBUTION IN THE SUPPLY CHAIN	42
3.4	FACTORS AFFECTING THE DISTRIBUTION NETWORK	42
3.5	DESIGN OPTIONS FOR A DISTRIBUTION NETWORK	43
3.5.1	Supply Directly To The Customer	43
3.5.2	Distribution Through In Transit To The Customer	44

3.5.3	Supply Through A Distributor With A Carrier Delivery	45
3.5.4	Home Delivery Through A Distributor	45
3.5.5	Customer Pick Up Points	46
3.6	THE VALUE ADDITION IN THE SUPPLY CHAIN	47
3.7	MODEL FOR FACILITY LOCATION AND CAPACITY ALLOCATION	47
3.7.1	Gravity Location Problem	48
3.7.2	Limitations Of Single Facility Location Models	51
3.7.3	Multi Facility Location Models	52
3.7.4	Regional Location Model	53
3.7.5	Location Using Integer Programming Method	55
3.7.6	Demand Allocation To Facilities	56
3.8	IMPACT OF UNCERTAINTY ON NETWORK DESIGN	62
3.9	EVALUATING NETWORK DESIGN DECISIONS USING DECISION TREES	63
3.10	DISTRIBUTION CENTRE LOCATION MODELS	69
3.11	SUPPLY CHAIN NETWORK OPTIMIZATION MODEL	71

## **UNIT IV**

### **PLANNING DEMAND, INVENTORY AND SUPPLY**

4.1	INTRODUCTION	79
4.2	OVERVIEW OF DEMAND FORECASTING IN THE SUPPLY CHAIN	79
4.3	AGGREGATE PLANNING IN THE SUPPLY CHAIN	90
4.3.1	Aggregation Methods	92
4.4	MANAGING PREDICTABLE VARIABILITY	97
4.5	MANAGING SUPPLY CHAIN CYCLE INVENTORY	98
4.6	MANAGING UNCERTAINTY IN THE SUPPLY CHAIN: SAFETY INVENTORY	103
4.7	DETERMINATION OF OPTIMUM LEVEL OF PRODUCT AVAILABILITY	107

4.8	CO-ORDINATION IN THE SUPPLY CHAIN	110
4.8.1	Managerial Levers To Achieve Co-Ordination	111

**UNIT V**  
**CURRENT TRENDS**

5.1	INTRODUCTION	117
5.2	E-BUSINESSES AND ITS ROLE	117
5.3	FRAMEWORK OF E-BUSINESS	118
5.3.1	Impact of E-business on Responsiveness	118
5.3.2	Impact of E-business on efficiency	120
5.4	ROLE OF SUPPLY CHAIN IN B2B PRACTICES	122
5.5	SUPPLY CHAIN IT FRAME WORK	122
5.6	INTERNAL SUPPLY CHAIN MANAGEMENT	124
5.7	SUPPLIER RELATIONSHIP MANAGEMENT	124
5.8	FUNDAMENTALS OF TRANSACTION MANAGEMENT	125
5.9	SUPPLY CHAIN IT IN PRACTICE	126
5.10	INFORMATION SYSTEMS DEVELOPMENT	127
5.10.1	The order management system	128
5.10.2	The warehouse management system	128
5.10.3	The transportation management system	129
5.10.4	Internal information systems	129
5.11	E-SUPPLIER RELATIONSHIP MANAGEMENT(E-SRM)	131
5.12	E-CUSTOMER RELATIONSHIP MANAGEMENT(E-CRM)	132
5.13	E- SCM	135
5.14	SUPPLY BASE MANAGEMENT	136

# UNIT I

## NOTES

### INTRODUCTION

#### LEARNING OBJECTIVE

After reading this chapter you will be able to

- Appreciate what a supply chain is and its importance.
- Understand the different phases in supply chain.
- Identify the drivers of supply chain performance.
- Overview the supply chain models and its systems.

#### 1.1 OVERVIEW

A supply chain may be considered as network of organizations, connected by a series of trading relationships. This network covers the logistics and manufacturing activities from raw materials to the final consumer. Each organization in the chain procures and transforms materials and information into intermediate / final products, and distributes them to customers and consumers. As such every organization has a supply chain and represents one step in the total 'value adding' process. There are three aspects to the supply chain. Upstream—those activities linking organizations to their suppliers. Internal – or primary activities and Down stream those activities linking organizations to their customer. In this chapter let us define what is supply chain and its management.

#### 1.2 FUNDAMENTALS OF SUPPLY CHAIN

The term supply chain refers to the “processes from the initial raw materials to the end user of the finished product linking across supplier-user”, or as the “functions within and outside an industry that enable the value chain to make products and render services to the customer”. Let us try to understand the meaning of the word 'value chain' and distinguish it with 'supply chain'. The supply chain is linking the companies from raw material stage to the ultimate consumption. In the process more than one entity is involved. Where as the 'value chain' refers to the internal operations of a particular company. Operations include purchasing, marketing and operations management. So, value chain is an internal concept and the supply chain consists of both internal and external.

# NOTES

## Here are some definitions of a supply chain

- “A supply chain is the alignment of firms that bring products or services to market.” (Lambert, et al, 1998).
- “A supply chain consists of all stages involved, directly or indirectly, in fulfilling a customer request. The supply chain not only includes the manufacturer and suppliers, but also transporters, warehouses, retailers, and customer themselves...” (Chopra and Meindl, 2003).
- “A supply chain is a network of facilities and distribution options that performs the functions of procurement of materials, transformation of these materials into intermediate and finished products, and the distribution of these finished products to customers”. (Ganeshan, et al, 1995).

Hope you have understood the concept of supply chain. Now, let us consider an example for supply chain to make you understand the concept further.

Consider a customer walking into a departmental store to purchase a toilet soap. The supply chain begins with the customer and his need for a toilet soap. The next stage of this supply chain is the departmental store that the customer visits. The departmental store stocks its shelves using inventory that may have been supplied from a distributor using trucks supplied by a third party. The distributor in turn is stocked by the manufacturer. The manufacturer plant receives raw material from a variety of suppliers who may themselves have been supplied by lower tier suppliers. This supply is illustrated in fig 1.1.

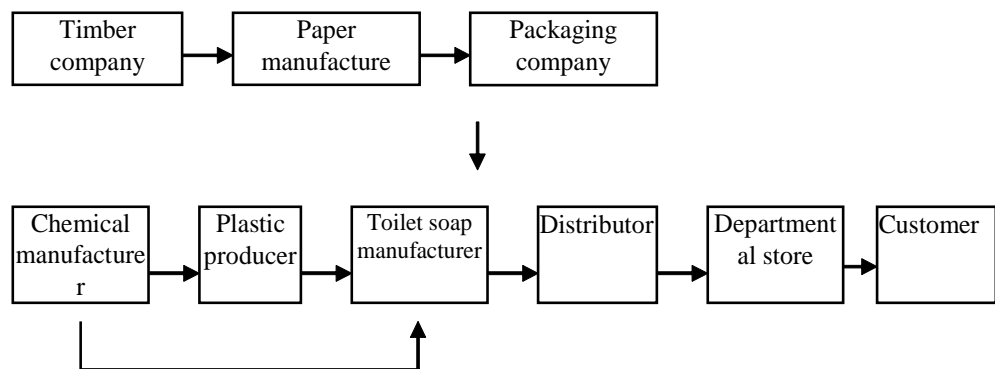

**Figure 1.1 An example of supply chain**

This example illustrates that the customer is an integral part of the supply chain. We can conclude that the primary purpose for the existence of any supply chain is to ensure the satisfaction of the customer need. So, supply chain activities begin with a customer order and end with a satisfied customer. It may appear that in the process, there is only one player involved at each stage. But it is not so. In fact, most supply chains are actually networks, as shown in fig 1.2.

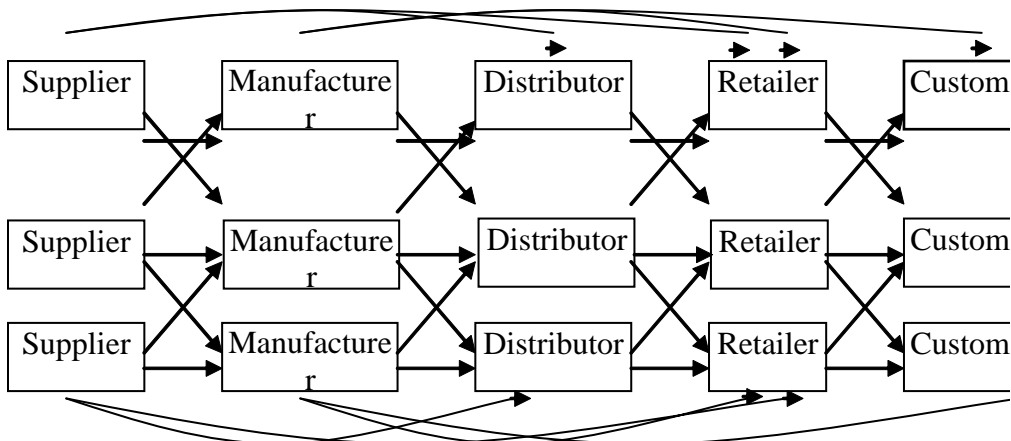

**Figure 1.2 Supply chain stages.(Adapted from Sunil Chopra, 2003)**

From fig 1.2 you can notice the different stages in supply chain. It consists of Customers, Retailers, Distributors, Manufacturers and raw material suppliers. Each stage in fig 1.2 need not be present in a supply chain. The actual design of the supply chain will depend on both the customers' requirements and the roles of the stages involved. In some cases, a manufacturer may fill customer order directly. Similarly some firms may not use the distributors or retailers.

### 1.2.1 Objectives of Supply Chain

The primary objective of any supply chain is to maximize the overall value generated. For most commercial supply chains, value will be strongly correlated with supply chain profitability. Profitability is the total profit to be shared across all supply chain stages. The higher the supply chain profitability, the more successful the supply chain. Next objective is management of the supply chain. Supply chain management involves the management of flows between and among stages in a supply chain to maximize total supply chain profitability. Let us elaborate further what is supply chain management and its evolution in the next section.

### 1.2.2 Supply chain management

The term "supply chain management" was coined in the late 1980's and became very popular in the 1990's. Before that, firms used terms such as "logistic" and "operation management" instead. Some definition of supply chain management are:

- "The systematic, strategic co-ordination of the traditional business function and the tactics across this business function within a particular company and across businesses within the supply chain for the purpose of improving the long term performance of the individual companies and the supply chain as a whole"(mentzer, et.al,2001)

## NOTES

- “Supply chain is the co-ordination of the production, inventory, location, and transportation among the participants in a supply chain to achieve the best mix of responsiveness and efficiency for the market being served.” (Michael Higos, 2006).

Managing a supply chain is more complex and difficult than managing an individual firm. But, the principle of management is used to integrate a firm's own internal function (value management) also apply to managing the entire supply chain. Those firms that successfully integrated their purchasing, operation and distribution functions did improve their performance in the past. The power of supply chain management is its potential to include the customer as a partner in supplying the goods or services provided by a supply chain. Integrating the customer into the management of supply chain has several advantages. First, integration improves the flow of information throughout the supply chain; a second advantage of integrating the customer into the supply chain is that this integrates the product development function (QFD analysis) with the other function in the firm. By focusing on a customer, all members of supply chain see the need and benefits of obtaining and using information about the end customer.

Supply chain management, just-in-time, quick response manufacturing, total quality management, vendor management, agile manufacturing, etc all share the goal of improving customer satisfaction. All this attempt to improve customer service by eliminating waste from the system in all of its forms including wasted time. Supply chain management embraces the other philosophies and extends the scope from one firm to all the firms in a supply chain.

There is a difference between the concept of supply chain management and traditional concept of logistics, logistics typically refers to activities that occur within the organization and supply chain refers to network of organizations that work together and coordinate their actions to deliver a product to market. Also, traditional logistics focusing its attention to activities such as purchasing, distribution, maintenance, and inventory management. In the wider view of supply chain thinking, these additional activities are now seen as part of the work needed to fulfill customer request. Supply chain management views the supply chain and the organization in it as a single entity. Supply chain brings a system approach to understanding and managing the different activities needed to co-ordinate the flow of products and services to best serve the ultimate customer. Effective supply chain management requires simultaneous improvements in both customer service levels and the internal operating efficiencies of the companies in the supply chain. There is a basic pattern to the practice of supply chain management. Companies in any supply chain must make decisions individually and collectively regarding their actions in production, inventory, Location, Transportation and Information. So far, we have discussed the concept of both supply chain and its management. Let us now try to understand the importance of supply chain in the next section.



### 1.3 IMPORTANCE OF SUPPLY CHAIN

Supply chain is about creating value-value for customers and suppliers of the firm, and value for the firm's stakeholders. Value in supply chain is primarily in terms of time and place. Productions and services have no value unless they are supplied to customers when (time) and where (place) they wish to consume them. Good supply chain management views each activity in the supply chain as contributing to the process of adding value. To many firms throughout world, supply chain has become an increasingly important value-adding process for a number of reasons. They are discussed below.

1. **Costs are Significant:** Statistics show that average about 12% of worlds GDP accounts supply chain costs. About 7-9% sales accounts physical distribution costs. Supply chain cost, substantial for most firms, rank second only to the cost of goods sold. Value is added by minimizing these costs and by passing the benefits on to customers and to the firm's shareholders.
2. **Increased expectations of the customers:** Awareness of customers has gone up. Customers expect rapid processing of their requests, quick delivery and also expect a high degree of product availability. Supply chain assures less error rates, lower order processing costs, reduced inventory, minimum cycle time and lowest transportation costs. To meet the increased exceptions of the present day customer, it is essential that every firm should implement supply chain management.
3. **Supply and distributions lines are lengthening with greater complexity.** Today's trend is towards an integrated world economy. Firms are seeking, or have developed, global strategies by designing their products for a world market and producing them wherever the low-cost raw materials, components, and labour can be found, or they simply produce locally and sell internationally. In either case, supply and distribution lines are stretched, as compared with the producer who wishes to manufacture and sell only locally. As this happens, supply chain takes on increased importance with in the firm and can considerably reduce the other costs.
4. **Supply chain is important to strategy:** Firms spend a great deal of time finding ways to differentiate their product offerings from those of their competitors. When management recognizes that supply chain affects a significant portion of a firm's costs and that the result of decisions made about the supply chain processes yields different levels of customer service, it is in a position to use this effectively to penetrate new markets, to increase market share, and to increase profits. That is, good supply chain management can generate sales, not just reduce costs.
5. **Supply Chain adds Significant Customer Value:** Customers become unsatisfied, if the product/service is not delivered to him/her at the time and place he/she wish to consume it. When a firm incurs the cost of moving the product toward the customer or making inventory available in a timely manner, customer value has been created. It is value as surely as that created through the production of a quality product or through a low price. Supply chain controls two (time and place) out of four values creating variables.

## NOTES

6. **Customers increasingly want QUICK customized Response:** Today's customers expect that products and services be delivered at very short time. In addition, improved internet service, quick information systems, and flexible manufacturing systems have led the market place toward customization. Rather than consumers having to accept the 'One size fits all' philosophy in their purchase, suppliers are increasingly offering products that meet individual customer needs.
7. **Supply Chain in Service Industry:** Service sector of industrialized countries is large and growing. The size of this sector alone forces us to use the supply chain concepts to untap the potentials so far not tapped

### 1.4 DECISION PHASE IN A SUPPLY CHAIN

Successful management of supply chain requires many important decisions, such as strategy, planning and operations. They are very important because they affect the flow of information, product and funds in the supply chain. Let us discuss each these decisions.

**Strategy or Design:** Strategy is a grand plan. Supply chain strategy involving decisions how to structure the supply chain over next several years. It decides what the chains configuration will be, how resources will be allocated, and what processes each stage will perform. Strategic decisions made by companies include the location and capacities of production and warehouse facilities, the products to be manufactured or stored at various locations, the modes of transportation to be made available along different shipping legs, and the type of information system to be utilized. A firm must ensure that the supply chain configuration supports its strategic objectives during this decision phase. Supply chain design decisions are made for the long term and are very expensive to alter on short notice. Consequently when companies make these decisions, they must take into account uncertainty in anticipated market conditions over the next few years.

1. **Planning:** The supply chains configuration determined in design phase is fixed for making planning decisions. Companies start the planning phase with a forecast for the coming year of demand in different markets. Planning includes decisions regarding which markets will be supplied from which locations, the sub contracting of manufacturing, the inventory policies to be followed, and the timing and size of marketing promotions. Planning establishes parameters within which a supply chain will function over a specified period of time. In the planning phase, companies must include uncertainty in demand, exchange rates, and competition over this time horizon in their decisions. Given a shorter time horizon and better forecast than the design phase, companies in the planning phase try to incorporate any flexibility built into optimize performance. As a result of the planning phase, companies define a set of operating polices that govern short-term operations.
2. **Operation:** During operation phase (weekly or daily) companies make decisions regarding individual customer orders. At the operational level, supply chain configuration is considered fixed and planning policies are already defined. The goal of supply chain operations is to handle incoming customer orders in the best possible manner. During

this phase, firms allocate inventory or production to individual orders, set a date that an order is to be filled, generate pick lists at a warehouse, allocate an order to a particular shipping mode and shipment, set delivery schedules of trunks and place replenishment orders. Because operational decisions are being made in the short term, there is less uncertainty about demand information. Given the constraints established by the operation phase is to exploit the reduction of uncertainty and optimize performance.

## 1.5 PROCESS VIEW OF A SUPPLY CHAIN

We have seen in section 1.1 that supply chain consists of different stages. There are two different ways to view (Sunil Chopra, 2003) the processes performed in a supply chain. They are : 1. Cycle view, 2. Push / Pull view.

### 1.5.1 Cycle view

Cycle view consists of four process cycles, namely customer order cycle, replenishment cycle, Manufacturing cycle and Procurement cycle. Each cycle occurs at the interface between two successive stages of the supply chain. It is pointed out here that, not every supply chain will have all four cycles clearly separated. A cycle view clearly specifies the role and responsibilities of each member of the supply chain. The detailed process description of a supply chain in the cycle view forces a supply chain design to consider the infrastructure required to support these processes. When we want set up an information systems to support supply chain operations, the cycle view is very useful, as process ownership and objectives are clearly defined in cycle view. We now describe the various supply chain cycles briefly.

**Customer order cycle:** All processes directly involved in receiving and filling the customer orders at the customer / retailer interface consist of customer order cycle. Customer initiates this cycle at a retailer site and the cycle primarily involves filling customer demand. (For more details please see, Sunil chopra, 2003).

**Replenishment Cycle:** The replenishment cycle includes all processes involved in replenishing retailer inventories to meet future demand. It occurs at the retailer / distributor interface. A replenishment cycle may be triggered at a firm when it is running out of stock.

**Manufacturing Cycle:** The manufacturing cycle occurs at the distributor / manufacturer (or retailer, manufacturer) interface and includes all processes involved in replenishing distributor (or retailer) inventory. Based on the customer orders, or by the forecast the replenishment order is placed on the manufacturer. Manufacturing cycle starts immediately after the receipt of the order.

**Procurement Cycle:** The procurement cycle occurs at the manufacturer / supplier interface and includes all processes necessary to ensure that materials are available for manufacturing to occur according to schedule. Suppliers supply the necessary components

## NOTES

that replenish the component inventories. The relationship is quite similar to that between a distributor and manufacturer. While retailer / distributor orders are triggered by uncertain customer demand, component orders can be determined from the manufacturer's production schedule. Precisely the component orders depend on the production schedule. Thus, it is important that suppliers be linked to the manufacturer's production schedule.

### 1.5.2 Push / Pull view of supply chain process

All processes in a supply chain fall into one of two categories depending on the timing of their execution relative to end customer demand. Execution is initiated in response to a customer order in pull process. With push process, execution is initiated in anticipation of customer orders. Therefore, at the time of execution of a pull process, customer demand is known with certainty whereas at the time of execution of a push process, demand is uncertain and must be forecast. Pull process is referred to as reactive processes because they react to customer demand. Push processes are referred to as speculative processes because they respond to speculated (or forecasted) rather than actual demand. The push / pull boundary in a supply chain separates push process from pull process. A push / pull view is useful when considering strategic decisions relating to supply chain design. This view forces a more global consideration of supply chain processes as they relate to a customer order. Such a view may, for instance, result in responsibility for certain processes being passed on to a different stage of the supply chain of making this transfer allows a push process to become a pull process.

### 1.6 SUPPLIER – MANUFACTURER – CUSTOMER CHAIN

Any supply chain consists of three major stages. They are suppliers, manufacturers and customers. In the chain, the supplier is positioned at the front end of the supply chain because it provides supplies for downstream manufacturers. At times suppliers may perform a distribution network analysis to determine the least-cost and best service option. Such studies become more the norm as a firm develops supply chain skills and begins looking at the total organization. A secondary objective of the supplier could be inventory rationalization study, determining the correct A-B-C stratification at the stock keeping unit level, and to set inventory improvement targets. The material flows from the supplier end to manufacture for conversion process. Here, the delivery performance is of paramount importance. Service levels portray the delivery performance. To optimize the transportation cost linear programming techniques may also be used. At the supplier end the supply chain cost of flowing material from supplier to manufacturer has to be optimized.

Manufacturer forms a second stage in this chain. Here conversion of raw material into finished product is taking place. In the manufacturing place, material flow takes place. Before it becomes a finished product it undergoes several operations and movements adding cost. At the completion of the conversion, the products are in the form of finished or semi-finished goods, to be transported through an appropriate channel of distribution.

Products as large as automobiles go by truck directly to a dealer or by railroad carriers to a staging area for delivery to area dealers. Because of large number of smaller items being supplied in a typical chain of delivery and the range in size of retail customers, distributors are often involved. In this discussion we consider distributors and retailers as customers. High-volume consumer products can move directly from manufacturing to a large customer in truckload quantities, but low-volume items must be gathered in bulk at a staging area by a distributor, broken down and packaged into smaller units, and transferred to local customers who are unable to order truckloads or large volumes of the item. A pallet load of paper towels might make sense for some retailers and could be direct-shipped, but a pallet load of particular food seasoning would be a multilayer supply for a small specialty food retailer, the model therefore includes warehouses or distribution centers, where appropriate, for completing the delivery of goods and services.

Finally the product reaches the customer. The customer in the supply chain is some type of retailer or institution that sells and delivers the final product and service to the ultimate consumer, generally through a store or local facility. For food delivery, a grocery store would be an appropriate customer. For automobiles, it would be a local dealership or one of the growing number of large multibrand organizations. For clothing, traditional retail outlets are preferred by the customer. In all cases, the flow of the product or service moves toward the ultimate consumer, who purchases the goods and services for personal reasons. Simply put, the satisfaction of the individual consumer should drive a company to analyze, manage and improve its supply chain continuously. The buying options are currently so large and the loyalties so weak that shifts in consumption patterns can be swift and deadly. Whether the chain is for products or services, the flow may appear to be from left to right, and movement efforts have been conducted in that direction. In reality, however, an analysis of the chain should focus on the finish line (demand), not the starting point (supply). Companies that believe that the primary objective of supply chain improvements is to improve internal efficiency rather than to serve ultimate consumer more effectively are demand to fail in to-days competitive environment.

### **1.7 DRIVERS OF SUPPLY CHAIN PERFORMANCE**

The goal of supply chain management can be defined using Mr. Goldratt's words as, "Increase throughput while simultaneously reducing both inventory and operating expense". In this definition throughput refers to the rate at which sales to the end customer occur. To understand how a company can improve supply chain performance in terms of responsiveness and efficiency, we must examine the five drivers of supply chain performance: Production, Location, inventory, transportation and Information. These drivers not only determine the supply chains performance in terms of responsiveness and efficiency, they also determine whether strategic fit is achieved across the supply chain.

Effective supply chain management calls first for an understanding of each driver and how it operates. Each driver has the ability to directly affect the supply chain and enable

# NOTES

certain capabilities. The next step is to develop an appreciation for the results that can be obtained by mixing different combinations of these drivers.

## 1.7.1 Production

Production refers to the capacity of a supply chain to make and store products. The facilities of production are factories and warehouse the fundamental decision that manager's face when making production decision is how to resolve the trade-off between responsiveness and efficiency. If factories and warehouses are built with a lot of excess capacity, they can be very flexible and respond quickly to wide variations in product demand. Facilities where all or almost all capacity is being used are not capable of responding easily to fluctuations in demand. On the other hand, capacity costs money and excess capacity is idle capacity not in use and not generating revenue. So the more capacity that exists, the less efficient the operation becomes.

Industries can be built to accommodate one of two methods to manufacturing.

1. **Product focus:** An industry that takes a product focus performs the range of operations required to produce a given product line from manufacturing of different product part to assembly of these parts.
2. **Functional focus:** A functional approach concentrates on performing just a few operations such as only making a select group of parts or only doing assembly. These functions can be applied to making many different kinds of product.

A product approach tends to result in developing expertise about a given set of products at the expense of expertise about any particular function. A functional approach results in expertise about particular functions instead of expertise in a given product companies need to decide which approach or what mix of these two approaches will give them the capability and expertise they need to best respond to customer demand. As with factories, warehouse too can be built to accommodate different approaches. There are three main approaches to use in ware housing.

1. **Store keeping units storage:** In the traditional approach, all of a given type of product is stored together. This is an efficient and easy to understand way to store products.
2. **Job lot storage:** In this approach, all the different products related to the needs of a certain type of customer or related to the needs of a particular job are stored together. This allows for an efficient picking and packing operation but usually requires more storage space than the traditional SKU storage approach.
3. **Cross docking:** An approach that was pioneered by wal-mart in its drive to increase efficiencies in its supply chain. In this approach, product is not actually ware housed in the facility. Instead the facility is used to house a process where trucks from suppliers arrive and load large quantities of different products. These large lots are then broken down into smaller lots. Smaller lots of different products are recombined according to the needs of the day and quickly loaded on to outbound trucks that deliver the products to their final destination.

### 1.7.2 Inventory

Through out supply chain, inventory is held in various forms. It is ranging from raw material to finished good via work in progress. Raw material is with the supplier; work-in-progress is with the manufacturer and finally the finished goods with the distributors and retailers. The supply chain performance is very much affected by the value of inventory in the supply chain. As we know, we are interested in improving responsiveness and efficiency; the persons involved in the inventory should try to find trade off between the efficiency and responsiveness. Holding very high inventory carrying cost leading to poor efficiency. Inventory also has a significant impact on the material flow time in a supply chain. The elapsed time between entry and exist of material is known as material flow time. Another important aspect where inventory plays a significant role in supply chain is the 'throughput'. For a supply chain throughput is the rate of sales. It can be inferred that material flow time and throughput are synonymous in a supply chain. Inventory also plays a major role in supply chains ability to improve the firm's competitive strategy. Trading off between keeping more stock or less stock depending upon the situation, the responsiveness or the efficiency or both can be improved for achieving the competitiveness. Sunil chopra, et al (2003) have identified three basic decisions that supply chain managers must make regarding the creation and holding of inventory.

1. **Cycle Inventory:** It is the average amount of inventory that is demanded by the customers between successive shipments. Manufacturers tend to produce more to enjoy economies of scale. Purchasers would like to buy in bulk to avail discounts. Both these actions will lead to holding of excess inventory and the corresponding higher inventory carrying cost.
2. **Safety Inventory:** It is primarily to counter the unexpected demand from the customers if the forecasting has significant error that can also contribute loss of sales due to non availability of required goods or may lead to excess holding of inventory. Safety stocks are held in the firms to meet the unexpected demand. It should be noted here that, if the forecasting is very near to actual demand cycle inventory itself is sufficient. However, in reality it is not so. We need to make provision for holding safety inventory to be responsive in the market.
3. **Seasonal Inventory:** Certain products demand fluctuates from period to period. There will be high demand during certain period and low demand during other periods. Manufacturers may find it difficult to manufacture this varying demand due to capacity related issues. Hence they should determine the constant rate of production that builds inventory during low demand and meet the higher demand from the inventory during the peak periods. It requires careful planning. Otherwise the wrong planning may lead to excess stock during low demand period associated with high inventory carrying cost and less to meet the customer demand. Hence managers must make proper decisions regarding the production rate to meet the seasonal demands.

## NOTES

### 1.7.3 Location

Where to locate the facility is the strategic choice. Managers must make judicious choice between various factors in locating facilities. Location decision affects both responsiveness as well as efficiency of the supply chain. To improve responsiveness the firm may decide to decentralize the activities and if they want to improve efficiency centralization can be made. Several factors like availability of raw material, skilled labour, proximity to customers, climate, government regulations, etc., are analyzed and carefully considered in fixing the location for the facilities. Location decision reflects a company's basic strategy for building and delivering its products to market.

### 1.7.4 Transportation

The cost of transportation constitutes 60-65 percent of the total manufacturing cost of a product. Even though there is no value addition in the transportation activity, the movement of material from one place to other is the most cost. So, it has to be very well planned. Networking of several activities and optimizing the routes shall bring reduction in transportation cost. Efficiency of supply chain is very much affected by this single factor. Managers must make contributing proper decision in choosing the correct and economical mode of transport in moving their materials. Modes like air, ship, rail, road, pipeline and electronic transport should be judiciously selected in improving the responsiveness as well as efficiency.

### 1.7.5 Information

Information has become very vital link in the supply chain. IT tools are available for improving supply chain efficiency by way of effective communication of required information at the right place, at the right time by the right person to the right person. In fact, information is the basis upon which to make decisions regarding the other four supply chain drivers. For coordinating daily activities and also for making forecast and planning, information plays a vital role. Within the individual company the trade-off between responsiveness and efficiency involves weighing the benefits that good information can provide against the cost of acquiring that information. Mainly the information's regarding product supply, customer demand, market forecasts, and production schedules are to be shared effectively by the supply chain participants in order to improve the responsiveness. Thus it can be noticed that good information systems can help a firm improve both its responsiveness and efficiency.

## 1.8 STRUCTURING SUPPLY CHAIN DRIVERS

We come to know the purpose of supply chain strategy is to make compromise between responsiveness and efficiency. This could be achieved by properly managing the supply chain drivers discussed in section 1.6. the combined effect of these five drivers determines the required level of responsiveness and efficiency of the entire supply chain. A



frame work as shown in fig 1.3 provides the structure of the supply chain drives with the supply chain as a whole,

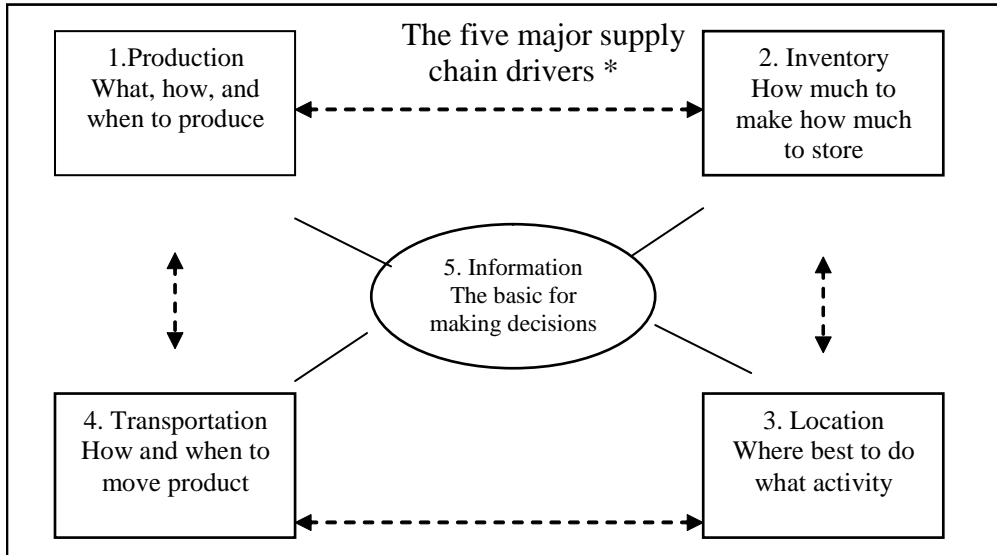

\* Adapted from “Essentials of supply chain management” by Micheal Hugos.

**Figure 1.3 Frame Work of Supply Chain drivers**

the responsiveness versus efficiency trade off that companies make is purely based on the combination of these five supply chain derivers. Combination determines how well the supply chain services its market and how possible it is for the participants in that supply chain.

**1.9 OVER VIEW OF SUPPLY CHAIN MODELS AND MODELING SYSTEMS**

Supply chain models are a pre requisite for successful implementation of supply chain management. Modeling practitioners might develop skill in integrating Transactional IT with Analytical IT for the purpose of integrated supply chain planning. Analytical IT, which involves both descriptive models and optimization models form part of the supply chain models. The construction of optimization model demands descriptive data and models as inputs. Input data and reports must be manageable, by the manager. A good model and a modeling system should expand the consciousness of managers and analyst regarding decision options and methods for improving supply chain design and operation. Also supply chain modeling should incorporate concepts from several management discipline like strategy formulation and theory of the firm, logistics, production and inventory management, management accounting, demand forecasting, marketing science and operation research. The various supply chain models available in the literature are grouped into two categories and are discussed below :

# NOTES

## 1.9.1 Models With Transactional IT

**Enterprise Resource Planning System (ERP):** ERP is only a partial SCM solution. It has its root in MRP (Materials Requirements Planning). The scope of ERP includes product development, capacity planning, and marketing. Common modules for a typical ERP system for manufacturers and distributors are capacity requirements, cost management, financial and Accounting, manufacturing processes, order management, purchasing and inventory, real time planning and scheduling, material bills and routings, human resource management and engineering / product definition. The ERP system manages company's transactional data, on real time basis.

**Material Requirements Planning System:** MRP system develops net requirements for each period. It uses bill of material data (BOM), inventory data and the master production schedule to calculate requirements for materials. Time-phased MRP is accomplished by exploding the Bill of material, adjusting for stock on hand and offsetting the net requirements by the appropriate lead times.

**Distribution Requirements Planning System:** DRP system schedules inbound, inter facility and out bound shipments through the company's logistics network. It takes into account the transportation factors such as vehicle loading and routing, consolidations, model choice channel selection, and carrier selection. Stock on hand, inventory management data and forecasted demand are the input to DRP.

## 1.9.2 Supply Chain Models With Analytical IT

**Production Scheduling Optimization Modeling Systems:** The objectives of this model is to minimize avoidable short term costs while satisfying customer requirements. This model fit the appropriate type of manufacturing. It addresses mainly the operational decisions such as sequencing, change overs and management of work-in-progress inventories.

**Distribution scheduling optimization modeling systems:** Vehicle routing problem and other scheduling problems are addressed through this model. On time delivery is one of the important key elements of competitive advantage. This type of modeling systems help achieve on time delivery of products / service to the customers.

**Production planning optimization modeling systems:** This is a manufacturing model which minimizes manufacturing cost by implementing master production schedule. An allocation resource along with resource level reduces avoidable manufacturing costs. It can also determine WIP, major machine changeovers and make-or-buy decisions.

**Logistics optimization modeling systems:** This model occurs on the assignment of markets to distribution centers. Its main aim is to minimize transportation costs, material-handling costs, warehousing costs, and inventory costs across the network. Ultimately it

helps in preparing master plan for the entire supply chain that meets the full customer demand over the next quarter.

**Tactical optimization modeling system:** This model helps in minimizing the total supply chain cost at the same time maximizes the net revenues. This integrates supply, manufacturing, distribution and inventory plan for the entire supply chain for the next one-year.

**Strategic optimization modeling system:** The goal of this model is to maximize the net revenues on return on investment. This model applied for acquisition of resources for new manufacturing and design of supply chain for a new product.

**Demand forecasting and order management systems:** Forecasting the demand accurately is very important. This is done using this model, which combines data about current orders with historical data to produce requirements for finished products. It deals with the uncertainty in demand.

### Chapter Summary

A supply chain is composed of all the firms involved in the design, production, and delivery of a product to market. Supply chain management is the coordination of production, location, transportation, information and inventory among the participants in a supply chain. The primary objective of good supply chain management is to achieve optimum level of responsiveness coupled with higher efficiency. Proper SCM increase sales of goods and services to the customers.

Supply chain is important because it helps in reducing cost, meets the increased expectation of the customer, solves the complex problems exist in the distribution lines, and helps in meeting the customer requirements quickly. Successful management of supply chain requires decisions such as strategy, planning and operation. Supply chain is viewed as cycle view and push / pull view. Cycle view consists of customer order cycle, replenishment cycle, manufacturing cycle and procurement cycle. With pull process, execution is initiated in response to a customer order. With push process, execution is initiated in anticipation of customer orders.

The goal of supply chain can be achieved by identifying the supply chain drivers. Production, location, inventory, transportation and information are the key drivers of supply chain. Combination of these drivers helps in achieving higher responsiveness and efficiency. Supply chain models and modeling system are two types. Models with transactional IT consist of materials requirements planning system, distribution requirements planning system and enterprise resource planning models. Analytical IT models are production scheduling, distribution scheduling, production planning, logistics, tactical, strategic and demand forecasting optimization models.

## NOTES

### Review Questions

1. Define supply chain.
2. Explain supply chain with an example.
3. Discuss the importance of supply chain.
4. What are the objectives of supply chain?
5. What is supply chain management? Explain.
6. Distinguish between logistics and supply chain.
7. Explain the decision phases in a supply chain.
8. Discuss the process view of a supply chain.
9. Bring out the importance of drivers of supply chain.
10. Discuss the various supply chain drivers.
11. How will you structure a supply chain?
12. Give an overview of supply chain models.

## UNIT II

## NOTES

### STRATEGIC SOURCING

#### LEARNING OBJECTIVES

After reading this chapter you will be able to

- Understand what is insourcing and outsourcing.
- Classify various types of purchasing strategies
- Conduct supplier evaluation
- Appreciate the procedure for selection and measurement of suppliers
- Gain knowledge and understand what is supplier quality management
- Create world class data base on suppliers
- Gain some insight into worldwide sourcing.

#### 2.1 INTRODUCTION

We have seen in detail, the fundamentals of supply chain in the first chapter. We have also defined the supply chain in its perspective. As such supply chain management is the process of designing, planning and implementation change in the structure and performance of the 'total' material flow in order to generate increased value, lower costs, enhance customer service and yield a competitive advantage. To achieve the objective of supply chain management, it is important to implement sourcing technology strategically. Strategic sourcing involves taking decision with regard to insourcing or outsourcing. Various purchasing strategies are used to optimize the purchasing activities. In insourcing, the supplier evaluation is of greater importance in identifying the good supplier source. In this chapter we are going to see the various strategic sources and its implications including supplier evaluations.

#### 2.2 INSOURCING

Insourcing is the opposite of outsourcing.

##### Definition

Insourcing can be defined as the delegation of operations or jobs from production within a business to an internal entity that specializes in that operation.

## NOTES

Insourcing is the utilization of professional from another company employed as a turnkey global extension of a company's work place and workforce, without transferring the project management and decision-making control to an outside provider.

### **What is insourcing?**

When an organization delegates its work to another entity, which is internally yet not a part of the organization, it is termed as insourcing. The internal entity will usually have a specialized team who will be proficiency in providing the required services. Insourcing enables organization to maintain a better control of what they outsource. Insourcing can also be defined as transferring work from one organization to another organization, which is located within the same country. Insourcing can also mean an organization building a new business center or facility which would specialize in a particular activity, usually opt for insourcing in order to cut down the cost of labour and taxes amongst others. The trend towards insourcing has increased since the year 2006. Organizations who have been dissatisfied with outsourcing have moved towards insourcing. Some organization feels that they can have better customer support and better control over the work outsourcing by insourcing their work rather than outsourcing it. U.S and U.K are currently the largest outsourcing in the world. The U.S and U.K outsourcing and insourcing work equally.

### **What is best for your organization?**

If the work involves production, it is ideal for the organization to opt for insourcing, as reduction in transportation costs and exercise a better control over the project.

If the organization has a number of non-core processes, which are taking plenty of time, effort and resources to perform in house, it would be wise to outsource these non-core functions.

### **Salient features**

- Insourcing is also referred to as contracting in.
- Contracting is often defined as the delegation of operations or jobs from production within a business to an internal (but 'stand-alone') entity (such as a sub contractor) that specifies in that operation.
- It is a business decision that is often made to maintain control of certain productions or competencies
- An alternate use of the term implies transferring jobs to within the country where the term is used, either by hiring local sub contractors or building a facility.
- Insourcing is widely used in an area such as production to reduce costs of taxes, labour, transportation, etc.,
- Insourcing is a business model that requires multi-dimensional expertise and adequate know-how of technology, trends and business practices.

- Insourcing offers benefits over outsourcing
  - Greater control over resources because they are direct employees.
  - Better control over intellectual property
  - Higher acceptance of insourcing. Insourcing can work well for companies looking to use offshore resources for long periods of time working on strategic activities such as product engineering and customer facing strategies.

### Advantages

1. Higher degree of control over inputs
2. Increases visibility over the process
3. Economies of scale / Scope uses integration

### Disadvantages

1. Require high volume
2. High investment
3. Dedicated equipment has limited
4. Problem with supply chain

## 2.3 OUTSOURCING

Outsourcing is subcontracting a process, such as product design or manufacturing, to a third-party company. The decision to outsource is often made in the interest of lowering firm costs, redirecting or conserving energy directed at the competencies of a particular business, or to make more efficient use of labour, capital, technology and resources. Outsourcing became part of the business lexicon during the 1980's.

- The strategic use of outside service provides to perform non-revenue generating activities so that an organization may focus on its core competencies. Outsourcing is a business model for leveraging the capability and capacity externally. Outsourcing is a long-term result oriented business in an external service provider for services traditionally performed with in a company. Outsourcing means taking out a specific area of the business and giving it to some one who is an expert and having assumed end-to-end deliveries.
- Outsourcing involves the transfer of the management and / or day-to-day execution of an entire business function to an external service provider. The client organization and the supplier enter into a contractual agreement that defines the transferred services. Under the agreement the supplier acquires the means of production in the form of a transfer of people, assets and other resources from the client. The client agrees to procure the services from the supplier for the term of the contract. Business segments typically outsourced include information technology, human resources, facilities and real estate management, and accounting. Many companies also outsource customer support and call center functions like telemarketing, customer services, market research, manufacturing and engineering.

## NOTES

Outsourcing and offshoring are used interchangeably in public discourse despite important technical differences. Outsourcing involves contracting with a supplier, which may or may not involve some degree of offshoring. Offshoring is the transfer of an organizational function to another country, regardless of whether the work is outsourced or stays within the same corporation.

With increasing globalization of outsourcing companies, the distinction between outsourcing and offshoring will become less clear over time. This is evident in the increasing presence of Indian outsourcing companies in the US and UK. The globalization of outsourcing operating models has resulted in new terms such as nearshoring and rightshoring that reflect the changing mix of locations. This is seen in the opening of offices and operations centers by Indian companies in the US and UK.

Multisourcing refers to large (predominantly IT) outsourcing agreements. Multisourcing is a framework to enable different parts of the client business to be sourced from different suppliers. This requires a governance model that communicates strategy, clearly defines responsibility and has end-to-end integration.

### **2.3.1 Process of outsourcing**

#### **Deciding to outsource**

The decision to outsource is taken at a strategic level and normally requires board approval. Outsourcing is the divestiture of a business function involving the transfer of people and the sale of assets to the supplier. The process begins with the client identifying what is to be outsourced and building a business case to justify the decision. Only once a high-level business case has been established for the scope of services will a search begin to choose an outsourcing partner. A request for proposal (RFP) is issued to the shortlist suppliers requesting a proposal and a price. A competition is held where the client marks and scores the supplier proposals. This may involve a number of face-to-face meetings to clarify the client requirements and the supplier response. The supplier will be qualified out until only a few remain. This is known as down select in the industry. It is normal to go into the due diligence stage with two suppliers to maintain the competition. Following due diligence the supplier submit a “best and final offer” (BAFO) for the client to make the final down select decision to one suppliers to go into competitive negotiations.

#### **Negotiations and Finalization**

The negotiation takes the original RFP, the supplier proposals, BAFO submissions and convert these into the contractual agreement between the client and the supplier. This stage finalizes the documentation and the final pricing structure. At the heart of every outsourcing deal is a contractual agreement that defines how the client and the supplier will work together. This is a legally binding document and is core to the governance of the



relationship. There are three terms become active and a service commencement date when the supplier will take over the services.

### Execution

The transition will begin from the effective date and normally run until four months after service commencement date. This is the process for the staff transfer and take-on of services. The transformation is the execution of a set of projects to implement the Service Level Agreement (SLA), to reduce the Total Cost of Ownership (TCO) or to implement new services. Emphasis is on 'standardization' and 'centralization'. This is the execution of the agreement and lasts for the term of the contract. Near the end of the contract term a decision will be made to terminate or renew the contract. Termination may involve taking back services (insourcing) or the transfer of services to another supplier.

### 2.3.2 Reasons for outsourcing

**Organization that outsource are seeking to realize benefits or address the following issues:**

- **Cost savings:** The lowering of the overall cost of the service to the business. This will involve reducing the scope, defining quality levels, re-pricing, re-negotiation, cost re-structuring. Access to lower cost economies through offshoring called "labor arbitrage" generated by the wage gap between industrialized and developing nations.
- **Cost restructuring:** Operating leverage is a measure that compares fixed costs to variable costs. Outsourcing changes the balance of this ratio by offering a move from fixed to variable cost and also by making variable costs more predictable.
- **Improve quality:** Achieve a step change in quality through contracting out the service with a new service level agreement.
- **Knowledge:** Access to intellectual property and wider experience and knowledge.
- **Contract:** Services will be provided to a legally binding contract with financial penalties and legal redress. This is not the case with internal services.
- **Operational expertise:** Access to operational best practice that would be too difficult or time consuming to develop in-house.
- **Staffing issues:** Access to a larger talent pool and a sustainable source of skills.
- **Capacity management:** an improved method of capacity management of services and technology where the risk in providing the excess capacity is borne by the supplier
- **Catalyst for change:** An organization can use an outsourcing agreement as a catalyst for major step change that cannot be achieved alone. The outsourcer becomes a change agent in the process.
- **Reduce time to market:** The acceleration of the development or production of a product through the additional capability brought by the supplier.

# NOTES

- **Commodification:** The trend of standardizing business processes, IT services and application services enabling businesses to intelligently buy at the right price. Allows a wide range of businesses access to services previously only available to large corporations.
- **Risk Management:** An approach to risk management for some types of risks is to partner with an outsourcer who is better able to provide the mitigation.
- **Time zone:** A sequential task can be done during normal day shift in different time zones – to make it seamlessly available 24X7. Same/similar can be done on a longer term between earth's hemispheres of summer/winter.
- **Customer Pressure:** Customer may see benefits in dealing with your company, but are not happy with the performance of certain elements of the business, which they may not see a solution to except through outsourcing.

### 2.3.3 Outsourcing objectives

- Focus core activity
- Reduced costs
- Improved operational quality
- Achieve high productivity
- De-risk the business

### 2.3.4 Quality of service in outsourcing

Quality of service is measured through a Service Level Agreement (SLA) in the outsourcing contract. In poorly defined contracts there is no measure of quality or SLA defined. Even when an SLA exists it may not be to the same level as previously enjoyed. This may be due to the process of implementing proper objective measurement and reporting which is being done for the first time. It may also be lower quality through design to match the lower price.

There are a number of stakeholders who are affected and there is no single view of quality. The CEO may view the lower quality acceptable to meet the business needs at the right price. The retained management team may view quality as slipping compared to what they previously achieved. The end consumer of the service may also receive a change in service that is within agreed SLAs but is still perceived as inadequate. The supplier may view quality in purely meeting the defined SLAs regardless of perception or ability to do better. Quality in terms of end-user-experience is best measured through customer satisfaction questionnaires, which are professionally designed to capture an unbiased view of quality. Surveys can be one of research. This allows quality to be tracked over time and also for corrective action to be identified and taken. A McKinsey study shows that when processes are outsourced to India, companies not only get the advantage of low cost but also experience improvement and quality.

### 2.3.5 Impact of outsourcing

Offshore outsourcing for the purpose of saving cost can often have a negative influence on the real productivity of a company. Rather than investing in technology to improve productivity, companies gain non-real productivity by hiring fewer people locally and outsourcing work to less productivity facilities offshore that appear to be more productive simply because the workers are paid less. In contrast, increases in real productivity are the result of more productive tools or methods of operating that make it possible for a worker to do more work. Non-real productivity gains are the shifting work to lower paid workers, often without regards to real productivity. The net result of choosing non-real over real productivity gain is that the company falls behind and obsolesces itself overtime rather than making real investments in productivity. From the standpoint of labor within countries on the negative end of outsourcing this may represent a new threat, contributing to rampant worker insecurity, and reflective of the general process of globalization. While the “outsourcing” process may provide benefits to less developed countries or global society as a whole, in some form and to some degree – include rising wages or increasing standards of living – these benefits are not secure. Further, the term outsourcing is also used to describe a process by which an internal department, equipment as well as personal, is sold to a service provider, who may retain the workforce on worse conditions or discharge them in the short term. The affected workers thus often feel they are being “sold down the river”.

### 2.3.6 Advantages

- 1) Greater flexibility suppliers
- 2) Lower investment risk
- 3) Improved cash flow
- 4) Lower potential labour costs shortage

### 2.3.7 Disadvantages

- 1) Possibility of choosing wrong
- 2) Loss of control over process
- 3) Potential for guard banding
- 4) Long lead – times / capacity
- 5) “Hollowing out” of the corporation

## 2.4 TYPES OF PURCHASING STRATEGIES

Corporate strategy addresses the long-term mission of an organization, including long-term survival. Companies follow poor strategies are unable to withstand the market force of competition. A corporate strategy involves more than just survival. It requires a definition of how a company will compete in a changing competitive environment. Therefore, the strategy of an organization must address the long-term objectives of the organization.

## NOTES

Purchasing strategy is one of the most important strategies that organization must develop and maintain. Organization follows different types of purchasing strategies to suit their requirements. Some of the most common and important purchasing strategies are: (i) optimizing the supply base, (ii) Supplier quality management, (iii) Sourcing globally, (iv) Long-term supplier relationship, (v) Supplier involvement right from the initial stage, (vi) Supplier development and (vii) Cost consciousness. Let us discuss briefly each of these strategies.

**Optimizing the supply base:** Right sizing is the term associated with the reduction of number of suppliers. Deming advocates to have fewer suppliers. To reach this goal the supply base should be optimized to avoid risk in the purchasing. Suppliers, who are not capable of achieving world-class performance, either currently or in the near future, may be eliminated from the supply base. This process has to be continued. Optimization requires an analysis of number of suppliers required currently and in the near future for each purchased item.

**Supplier quality management:** Variation in the process is inevitable. Variation may be due to man, material or machine. Quality depends mainly on variation in the process. Companies follow newer techniques like, Statistical Quality Control (SQC), Statistical Process Control (SPC), Process Capability studies, Design of Experiments (DOE), Quality audits, etc to reduce variations in their process. TQM requires reduction of variation and should lead to continuous improvement in the process. TQM emphasizes the need to meet and exceed the expectations of the customer. In order to ensure high quality and to meet the customer's present and future needs, a purchaser must communicate to the supplier any expectations regarding quality. Supplier quality is to be managed through imitations from the purchaser. Purchaser should make arrangements for implementing TQM in the supplier permits.

**Sourcing Globally:** Present day competition is global due to globalization. World has been reduced to a very small entity by the Internet. Searching suppliers globally improves supplier selection process effectiveness. Entire world should be viewed as a potential source for supply. It can be used to access for a new market to gain access to global competitiveness. The major objective of global sourcing is to provide immediate and excellent improvement in cost and quality through commodity research process. It is an opportunity to gain exposure to product and process technology, increase the number of available research satisfies counter trade requirements, and establish a presence in foreign markets. There are several drawbacks in the global sourcing. Different cultures prevailing different countries should be understood. More complex logistics and current fluctuations require measuring all relevant costs before entering into global sourcing.

**Long-term supplier relationships:** Treating suppliers as partners can solve many suppliers' related issues and pave way for good relationships. Identifying few vendors and

developing mutual long lasting relationship is important for better supplier management. It is preferable to have long-term relationship with exceptionally good suppliers. A long-term relationship may include a joint product development relationship with shared development costs and intellectual property.

**Supplier involvement:** Making supplier understand the importance of involvement right from the design stage of product to the final stage is very important for getting highly competitive quality and price for the product. Early involvement should take place through participation on cross-functional product development teams.

**Supplier development:** Developing the supplier to the quality supplier is the prime duty of the customer organization in the TQM environment. There may be a supplier who is willing to participate in improving quality and cost performance, but they may not have adequate technical expertise or sufficient fund to upgrade their facilities. Instead of removing such suppliers from the supply base, organization can extend their help in improving the supplier's position as part of long-term relationship. Buyer-seller consulting teams may be formed to improve the supplier position. The basic motivation and success lead to longer-term benefits to both buyer and seller. This will certainly support the development of world-class suppliers in new areas of product and process technology.

**Cost consciousness:** In supply chain management, the cost of shipment of materials from the supplier unit to the customer unit includes cost of late delivery, poor quality or other forms of non-performance. Cost of transportation includes the above mentioned costs have to be clearly understood by both buyer and seller. Total cost concept has to be implemented and decisions regarding shipment should be made based on this total cost concept. Cost variances from planned results can be analyzed to determine the cause of the variance. Corrective actions can then be taken to prevent future problems. The cost conscious approach will certainly lead to minimum total cost of transportation of the material from the supplier to the customer.

## 2.5 THE SUPPLIER EVALUATION AND SELECTION PROCESS

We are aware that there is no single method available to evaluate and select suppliers. Every organization uses an evaluation procedure suitable to it. However, the overall objective of the supplier evaluation process is to reduce purchase risk and maximize overall value to the purchaser. An organization must select supplier it can do business for a longer period of time. In any case, supplier evaluation is a must to update the supply base in the organization. Changing technology, taste of customer and globalization forces companies to institute a system in the organization to evaluate the supplier on a continuous basis. Formal supplier evaluation can involve a team of experts from a purchaser spending several days at a supplier's work place. This selection address many issues and decisions involved in effectively and efficiently evaluating selecting, and maintaining a supply base. Supplier evaluation begins in anticipation of a future purchase requirement. Throughout the supplier

## NOTES

evaluation and selection process, it is important to understand the requirements that are important to that purchase. They differ widely from item to item, firm to firm or industry to industry. The supplier evaluation and selection process involve the following general steps:

Step 1: Understand the need for supplier selection

Step 2: Identify critical sourcing requirement

Step 3: Determine the appropriate type of sourcing

Step 4: Identify the potential suppliers / sources

Step 5: Select the appropriate method of supplier evaluation and selection

Step 6: Select the supplier.

### 2.5.1 Supplier selection process

Supplier selection is based upon criteria that are vital to a particular process and indicative of future success. The criteria are weighted and some attribute may be more important for one process than another. For example, technical support may be more important for surveillance process than field service and support capabilities and will be weighted accordingly. Each criterion has detailed descriptions that define the requirements that are important to the company.

Quite often, organization use price as the determining factor when considering which supplier to select. While price is an important determining factor; other dimensions such as quality, lead-time and payment terms must not be overlooked. Here is a comprehensive list of criteria that may be used to make the best decisions.

**Quality:** The cost of poor quality extends much further than the carrying cost of safety stock to ensure supply can meet demand. If a component of your product has been outsourced and that part is defective, the customer will associate the poor quality with advertisement. Not only the organizations have to pay to replace or repair them, but it will also affect the perceived quality of the brand, further reducing future sales opportunities.

**Lead-time:** Lead-time is the time between placing an order and delivery of the product. The longer the lead-time, the higher the cycle inventory and safety stock must be to meet demand. This inventory translates to higher costs to maintain these inventories and must be taken into account when evaluating the 'best price' from each supplier.

**Delivery Reliability:** While this may be difficult to evaluate, especially for a new supplier, it is worth investing from past or current customers. For example, a large supplier may place your order on a lower priority when they are busy if you are one of their smaller customers. This means you will receive your order late, which again may mean having to carry extra stock. It is much better to have a reliable delivery at the expense of a longer lead-time as other operational activities may be planned in advance to reduce costs.

**Flexibility:** Since forecasts are almost always wrong, a flexible supplier should be able to quickly respond to changing market needs. For example, what mechanisms exist for a rush delivery? What costs are involved? Will the lead-time be the same as for a regular delivery, or will it be the shorter?

**Transportation Costs:** The transportation costs associated with delivering the product to your location is part of the total purchase cost. In some cases this cost is buried in the products unit cost, while in others it is shown as a separate line item. For local suppliers, it may be possible to arrange a pick up using your own trucks, reducing transportation costs further. Distance and mode of transportation are key drivers that affect transportation costs.

**Pricing terms:** Suppliers typically offer quantity discounts for larger batch sizes, however extra holding costs for inventory should be factored in if the batch size is significantly larger than what your requirements are. Some supplier offer additional discounts for early payment. For example, a two percent discount may be applied if payment is made within 10days. This may be beneficial for your organization depending on what other options it has to utilize its working capital.

**Technological capability:** Although this is more quantitative, the ability of your supplier to provide you with accurate, timely information will help with planning and increase customer service in the event of a stock-out situation. Web-enabled suppliers that track your order status enable you to make adjustments as well as to inform your customers of changes to their order. Using the phone to track down the supplier and wait for an answer may not be good enough for some of your customers who demand instant updates for their order status. Selecting the supplier for the first time requires different set of criteria's than applying criteria's for retaining the existing suppliers. Let us discuss how to select a initial supplier in this section and measuring the performance of the existing supplier will be discussed later in this chapter.

### 2.5.2 Supplier measurement and Evaluation

Initial supplier selection based on seven key criteria's has been discussed in the previous section. In this section let us discuss how to measure the performance of the existing suppliers in the supply base. An organization must have the tools to measure, manage and develop the performance of its supply base. Supplier performance measurement includes the system of collecting and providing information to measure, rate or rank supplier performance on a continuous basis. Central to all measurement systems is the decision about what to measure and how to weight the performance criteria's. There are three categories of performance measures, which are generally followed in evaluating the performance of the existing suppliers. They are discussed below:

## NOTES

**Performance of on-time delivery:** When purchase order is issued to the supplier, the buyer mentions the delivery date (due date) within which the material has to be supplied. In many cases companies fail to supply on or before the delivery date causing inconvenience to the buyer. So, the buyer can track how well a supplier satisfies the quantity and due date performance. The supplier delivery performance could be tracked by reporting material lead-time, quantity supplied, lead-time requirements and due date compliance.

**Quality of material supplied:** Quality measurement is a critical component in the evaluation system. A buyer can compare a supplier's quality against some previously specified performance objectives, track improvement rates, and compare similar supplier. Supplier quality requirements have to be specified in order to measure quality compliance.

**Price:** Price is essentially an important aspect in the performance evaluation of the suppliers. A supplier quotes a price with a validity period. Buyer has to buy the material within the date to avoid price escalation. On request, the supplier may extend the validity period. This is how a buyer-supplier relationship can be maintained with respect to price adjustments to accommodate the inflation. Another way is to compare a supplier's price against other suppliers within the same industry.

Buyer can also use a number of qualitative factors to assess supplier performance. The problem with the qualitative factors is the subjectivity. These factors can be weighted against a 5-point likert's scale to get the overall assessment. Some of the qualitative factors are:

- \* Problem solving ability
- \* Technical capability
- \* Progress reporting method
- \* Responsiveness
- \* Price responsibility
- \* Support to RSS initiatives
- \* Buyer / seller compatibility.

A typical supplier evaluation form with a hypothetical score for each criteria is given in table 2.2.

The score for each sub items can be given on a five-point scale and weightage given for each major factor may be considered for determining the level of each factor. Based on the total score, the performance of the supplier is determined.



**Table 2.2 Supplier Performance measurement scorecard:**

Sl.No	Performance Criteria	Weight	Sub Weight	Score on 5	Tot
1.	On-time delivery	20	20	4	16
2.	Lead time performance	5	5	4	4
3.	Quality	25			17
	A. Discrepancy rate		5	3	3
	B. Reliability		5	3	3
	C. Defects rate		5	3	3
	D. Customer complaints		5	4	4
	E. Warranty claims		5	4	4
4.	Services	25			19
	A. Responsiveness				
	B. Compatibility		5	4	4
	C. Flexibility		5	3	3
	D. Knowledge (technical capability)		5	4	4
	E. After sales service		5	4	4
5.	Financial soundness	5		4	4
6.	Cost	20			15
	A. Cost reduction strategies		4	4	3
	B. Cost of quality		4	4	3
	C. Price trends		4	3	2
	D. Price reasonableness		4	4	3
	E. Supplier savings		4	4	3
	* 5 points scale 1 = poor, 2 = below average, 3 = avg, 4 = above avg, 5 = excellent	100			71
	** $3 = 3/5 * 5 =$ score on 5 point scale/5 weight				

**NOTES****2.6 SUPPLIER QUALITY MANAGEMENT**

In late 80's TQM become very popular. As a part of TQM initiatives supplier quality management was evolved, because supplier quality management was considered as one of the important critical success factors for successful implementation of TQM. Quality was defined as fitness for use (Juran), conformance to specifications (Crosby), conformance to requirements (Deming) and meeting the stated and implied needs of customers. Over a period of time the definition of quality is changed and it is defined now as customer satisfaction by exceeding the expectation of customer. Competition also creates new quality exceptions on the part of users. From these various quality perspectives, we can define what we mean by supplier quality, the ability to consistently meet or exceed current and future customer expectations.

## NOTES

Within supply chains, purchasing means buying supplier capabilities. It is not only the product but also systems and procedures that produces product should be viewed. Companies should take active interest in the quality performance of suppliers. Supplier quality is certainly going to impact the internal process quality. Most firms plan to achieve continuous quality improvements in all aspects of their business. One way to do this is through effective management of supplier quality. Some firms are willing to purchase entire sub-assemblies from suppliers. In that case it is the supplier quality, which is going to decide the final assembly quality of the product. The larger proportion of the final product that suppliers provide, the greater the impact they have on overall product cost and quality.

Buyers play a key role in managing supplier quality. Over a period of time, the role of a purchasing manager is changed dramatically. The first and foremost task of a purchasing manager's job is to clearly communicate the specifications and expectations. This will make the supplier understand what customer wants. If specifications are vague, it will lead to supply of poor quality product. The clear understanding of buyer expectations has two dimensions. The first one is the ability of the buying company to specify its requirements and the other is the buyer's ability to communicate these expectations to the supplier. The ability of a supplier to meet its requirements is partly a function of the buyer clearly communicating the supplier about what the buyer expects.

For a successful supplier quality management, the buyer should be a good customer. He/she should not interface the supplier during production process by giving too many changes in the design and specifications. Buyer also should give reasonable lead-time; treat supplier with respect and dignity and most importantly the buyer should make payments within the reasonable period of time. Buyer should give periodic feedback about supplier performance. Effective supplier feedback is timely and the feedback must be specific and accurate. Many organizations send a corrective action request, a form that demands actions to be taken by a supplier to ensure that a problem does not occur again. A good supplier will treat these corrective action requests seriously. Buyers also required involving with supplier on a daily basis. These actions will surely improve the supplier performance.

Right sizing the supply base is another aspect in supplier quality management. Most companies reduce the number of suppliers. Reducing the size alone does not guarantee good supplier base. Supply base should be optimized. This is the first step toward world-class supplier quality. Measuring supplier performance periodically improves the supplier quality. Measurement provides opportunities to the supplier to improve performance. Through measurement system a buyer can communicate his/her requirements throughout the supply chain. Establishing aggressive performance targets improve supplier rate of improvement. Bench marking can be used as a tool to improve supplier performance through aggressive targets. Offering performance related rewards to the supplier links the supplier improvement. Supplier cost will also substantially reduce, if a proper reward system is established. Suppliers can be rewarded by many ways. Sharing the benefits resulting

from supplier initiated improvements, awarding greater share of volume, provide access to new technology, offer opportunity to involve right from the design stage, Awarding longer-term purchase contracts, listing 'Top 10' and awarding best supplier of the year award and publically recognizing the superior supplier are some of the ways with which suppliers can be awarded. Buyer can certify the supplier through audits. Audit improves consistency in quality. Certification indicates that a supplier's processes and methods are in total control and that incoming material, components usually do not require inspection upon receipt. Purchasers usually rely on cross-functional teams and rigorous audits when performing certification visits. Finally the buyer should take proper care in developing a good supplier. Development activities represent a conscious effort to identify, integrate, and develop key supply chain members. Once a firm fully renationalizes its supply base, improvements will occur primarily through the development of existing supplier capabilities rather than larger scale-supplier switching. Suppliers can be asked to register for ISO 9000 quality system and or subject to the national/international quality awards. These actions will certainly improve supplier quality management in a grand manner.

## **2.7 CREATING A WORLD –CLASS SUPPLY BASE**

The primary objective of supplier management is the continuous development and performance improvement of suppliers. Supplier management involves purchasing, engineering, quality assurance, and suppliers working together to achieve better relationship between buyer and seller. Unless companies are able to improve their supply base upto world-class levels, they will be at the mercy of competitors who can take market share with in short period of time. Therefore it is essential that companies must take effort in improving their supply base to world-class level. Bringing up the level of suppliers to the world-class level is possible through effective supplier development process. Let us discuss in this section how organization manage, develop and improve the performance of suppliers to the level of world-class.

### **2.7.1 Supply Base Optimization**

In section 2.3 under types of strategic sources, we have introduced the concept of optimizing the supply base. This strategy is utmost important in developing a world-class supplier. The process of identifying the proper mix and number of suppliers to maintain is known as the supply base optimization. Effective supplier management and development begins with a determination of the correct number of suppliers an organization should maintain. It involves eliminating suppliers who are not meeting the world-class requirements either currently or in the near future. The trend in the market forced manufacturers to have few vendors. Most purchasers have taken suitable steps to reduce the total number of suppliers with whom they do business. Eliminating the un-qualified vendors from the list is the first step in optimizing the supply base. Subsequent optimization requires the replacement of qualified suppliers with the better performing suppliers. During the optimization phase,

## NOTES

the buyer takes effort in developing the supplier to meet the world-class requirements. Supply-base optimization should result in improvements in costs, quality, delivery and information sharing between buyer and seller. Suppliers in an optimized supply base often develop longer-term relationships with purchasers, which can lead to further joint improvement efforts. Some of the benefits of doing business with world-class suppliers include reduced defects, fewer delivery problems, visibility to leading edge technology, opportunities to develop closer relationships with high performing suppliers, and a lower total production cost.

Maintaining few suppliers may some times pose certain risk. Maintaining large supply base may promote a healthy competition between suppliers, whereas a single or few supplier sources is selected carefully and develop close working relationships, supply risk can actually decrease. Maintaining fewer suppliers will lead to lower supply-Base maintenance costs. If a single supplier receives large quantity order, lower production costs can be attained due to economies of scale. Also, if we want to implement complex purchasing strategies the small supply base is appropriate. Some purchasers fear that a small supply base can become too dependent on a purchaser for its economic survival. Mutual commitment between buyer and seller can solve this dependency problem. Supply disruption is a potential risk when sourcing from a single supplier. This risk can be solved in carefully selecting the supplier who is having multiple capabilities. Enough care should be taken on optimizing the supply base. There are several approaches available for optimizing the supply base. Pareto's 80/20 rule can be applied in choosing the vital few suppliers. Improve or Else' is another approach in which suppliers are given a chance to remain in supply base. Competency stair case approach provides opportunities to the existing suppliers to meet buyer's quality standards.

### 2.7.2 Supplier Development

Supplier development is a critical activity in creating world-class supply base. Supplier development is any activity undertaken by a purchaser to improve a supplier's performances to meet the purchasers supply needs. Supplier assessment rewarding supplier for their performance, creating healthy competition among suppliers, and making them involve in buyer activities are activities performed to develop the supplier. Effective supplier development requires the commitment of financial, capital and Human resources, skilled personnel, information sharing between the purchaser and supplier and measurement of supplier performance. The steps involved in supplier Development are discussed below:

#### Step1

**Identify critical components for development:** In this step the purchaser has to scan all the components that are purchased form outside. If already a world-class supplier is supplying certain components, they need not be considered again. Therefore the components, which require world-class supplier list, has to be prepared before actually

developing the supplier. A corporate level steering committee may be formed for this exercise. They can investigate whether the commodity account for more than 50% of the turnover value and whether the purchaser is willing to develop mutual trust with the supplier. After answering to these questions, the committee can conduct assessment including personnel from finance, marketing, technology, accounting, production and design. Using this process, a company separates low opportunity goods from high opportunity. Finally identifies the components for which supplier has to be developed.

### Step 2

**Identify critical suppliers for development:** Identifying the supplier for development is an important aspect. For the items identified in the previous step, the various suppliers who are presently supplying these components must be listed for selection. The supply base assessment identifies the suppliers within any product group requiring development. Parato's 80/20 analysis can be used to select the vital few supplier performance based on their facilities and suppliers are ranked from worst to best. The suppliers who meet the requirements are selected for development.

### Step 3

**Form steering committee:** The buying company must demonstrate its commitment by forming executive steering committee to oversee the supplier development process. Team members may come from all functions and not just from purchasing. Team members must visit the supplier premises and assist the supplier company to attain the world-class quality. Continuous monitoring through audits improves the supplier quality.

### Step 4

**Collaboration between steering committee and suppliers Top Management team:** Once steering committee is formed at the buyer's premises, they interact with the top management team of the supplier's company. Team identifies the improvement opportunities for improving quality. They use strategic alignment for improving quality. They use strategic alignment, measurement and professionalism to institutionalize the practice at the supplier's premises. Collaborations between the steering committee and the supplier's top management team improves the relationship and trust between them, which will enable continuous improvement throughout the supply chain.

### Step 5

**Identify Areas for improvements:** Steering committee and top management team of supplier company meet periodically and during discussions they identify the critical areas for improvement companies adopting a strategic approach to supply base development are able to identify a wide variety of areas for improvement.

## NOTES

### Step 6

**Identification of critical success factors:** Critical success factors that help in improving the supplier's quality are identified in the areas identified for improvement. Metrics are developed to measure the critical success factors. In this stage two parties come together and analyse for mutual benefits. The critical success factors may include percentage of cost savings shared, percentage of quality improvements, percentage of delivery or cycle time improvement, key performance targets, technology availability, or system implementation targets. The most critical portion is that they contain visible milestones and time horizons for improvement. Both the parties agree to achieve the milestones and are responsible for the success of the quality improvement project.

### Step 7

**Monitoring the progress:** Success of quality improvement project at the suppliers' premises depends upon how it is monitored throughout its execution period. Communication and information sharing should be effective and efficient for proper monitoring of the progress. Based on the progress, modifications, if any is required are being carried out duly updating the information.

The result of all these seven steps is a successful development of a supplier.

### 2.7.3 Barriers to Supplier Development

There are three categories of Barriers in supplier Development. They are: (i) Buyer specific (ii) Supplier specific and (iii) Interface Barriers. Let us discuss each one after the other.

**Buyer specific Barriers:** The following are the Buyer specific Barriers:

- The order quantity of the buying firm does not justify development projects.
- No immediate benefit foreseen to the buying organization
- Un important product purchased does not justify development efforts
- Lack of Top Management commitment at the buying firm.

**(ii) Supplier Specific Barriers: Supplier specific barriers are listed below:**

- Lack of Top management commitment at the supplier's firm.
- Lack of commitment in implementing the improvement efforts by the top management team at supplier's premises.
- Lack of resources at the supplier's premises to support improvement efforts.
- Lack of information to implement improvement projects at suppliers premises
- Lack of consensus on the benefits accrued by the projects to the supplier.
- Lack of skilled personnel at the supplier's premises to tackle improvement projects

**(iii) Interface Barriers:** The interface between buyer and supplier creates certain barriers to implement improvement projects.

- Some of them are listed below:
- Reluctance of suppliers in sharing vital information's of the project
- Confidentiality (Technology related) inhibits sharing information
- Lack of Trust between supplier and buyer
- Prevailing organizational culture at both supplier and buyer organization
- No encouragement and positive reinforcements between supplier and buyer.

#### 2.7.4 Initial Supplier Selection

It is useful when selecting a supplier to have a checklist with which to evaluate the supplier's suitability. How much of the checklist is used and how thoroughly will depend of the buyer's own needs. However, even a brief review using this checklist may help raise points that could otherwise be overlooked and become issues later. Data relating to the following items may be collected in the form of questionnaire to ascertain the suitability of the supplier. Scores can be obtained using Likert's five points scale wherever required and ranking of suppliers can be made after collecting data from the likely suppliers. Let us discuss each factor one by one as follows.

##### Status of Supplier

- How many employees are there in the company?
- Where are your employees based?
- Are any of your employees critical?
- How wide spread is your office? (Head office, Local, National, Regional, Global)
- What is the nature of the office? (Sales, Development, Implementation, Support)
- Have you ever published white paper?
- What is your involvement in industries bodies?
- What is your involvement in public seminars?
- Who is your main competitor?
- What is your position in your industry?
- To whom you have worked with before on similar projects?
- Could you explore work with other parts of your business?
- Give particular of your clients.
- Have you done any work for your competitors?
- Who are your partners and what is the quality and range of your formal partnership?

##### Delivery capability

- Please provide your technical capability.
- What support services you are having?
- What design creative do you have?
- Could you provide evidence of your good quality work?
- Do you have enough resources to execute the work?
- Would you able to deal with the unexpected?
- Do you have customer interface for account management, business consultant and Technology consultant?

# NOTES

## Processes

- Do you have robust, repeatable, measurable, process for creating their deliverables?
- Are you formally certified (e.g ISO 9000)?
- Are project tracking & reporting procedures in place?
- Could you provide evidence of executing earlier projects?
- What methodology you follow in executing projects?
- What is the procedure you follow in project tracking and reporting progress?
- How do you take advantage of economies of scale across projects?
- How do you ensure reuse of technology component?
- What problems escalation procedures exist?
- How willing are you to invest in a long-term relationship?

## Technical status

- Do you have the necessary technical infrastructure to develop the application?
- Can you test in an environment compatible to ours?
- Are the system management tools used in support industry standard?
- Do you use appropriate standard or proprietary tools?
- Will your output be supportable at reasonable cost?
- How productive are you?
- Is your documentation, clean enough for hand-over to other?
- Is your environment secure to the level required by the application and its content?

## Supplier culture

- Could you provide details of your professionals/ domain experts?
- How well will you handle schedule upsets, changes to requirements?
- How honest are you about problems faced & overcome?
- Are you suitably discrete about your other clients?
- Do you feel comfortable with your client?
- Do you communicate openly and freely internally?
- Do you stand by your offerings?
- Are you happy to be technically / financially audited if necessary?
- Do you really understand why you want to do this project, from a business perspective?
- Do you offer sensible & appropriate advice on potential solutions?
- Are you willing to work with other 3<sup>rd</sup> party development environments and ours?
- How innovative you are? Provide evidence.

## Financial / Commercial

- Financial soundness of the supplier
- When does the establishment started?



**NOTES**

- Who is the owner of the company?
- What is the position of cash flow?
- Could you accept payment at the end of the project?
- Is there a clear agreement about the ownership of any deliverables?
- Is an appropriate security agreement in place to protect buyer and supplier’s interests?
- What is the variation in your pricing strategy?
- Is there trade off fixed price against time & materials?
- Do you fix price considering the balance between cost, time & quality?
- Can you supply with in the delivery date?

**Support**

- What will be ours role in extending help?
- Will the solution be created in a way that permits others to support it?
- What is annual fixed coasts?
- What is the cost per call or per hour?
- What is your working hours?
- What are your holidays?
- How long will you take to respond our quarry?
- Do you have call management?
- Are the price escalation procedures clear?

**Note:** Questions may be framed for the above mentioned seven factors and data collected from the potential suppliers. The data can be analyzed and the summary table as given in table 2.1 may be prepared. Based on the final score the supplier may be selected.

**Table 2.1 Supplier evaluations.**

Sl. No	Description	Comment	Score(1-10)	Pass Y/N
1.	Supplier status			
2.	Delivery capability			
3.	Processes			
4.	Technical status			
5.	Supplier culture			
6.	Financial / Commercial			
7.	Support			
Total:				

# NOTES

## 2.8 WORLD WIDE SOURCING

As world market becomes highly competitive, purchasers must identify suppliers who are capable of providing world-class performance at the lowest total cost. Purchasing strategies followed in domestic market may not be suitable to worldwide sourcing. Worldwide sourcing requires a new set of competencies and skill within the logistics management function. International buying is an extension of domestic buying crossing the border of the country. Internet sourcing i.e., world wide sourcing is different from international buying. In international buying increased rules and regulations, currency fluctuations, customs requirements, language and time differences are predominant. Whereas in global sourcing, integration and co-ordination across worldwide business units are the requirements and that differs from international buying. Shortage of basic materials and technical expertise inland forces companies to explore world wide to identify the potential suppliers. When we go globally, we can identify the quality and cost leaders worldwide. While every company will have its own reasons for global sourcing, the four most important reasons are (1) cost/price benefits (2) Superior quality (3) Sophisticated technology and (4) To have access on the only available source. Worldwide sourcing makes domestic competitors to become world class while exporting goods; there may be compulsion to buy some parts from the purchaser country (Foreign country). To satisfy such counter trade requirements, we may resort to worldwide sourcing.

### 2.8.1 World wide sourcing process

International sourcing approach differs from company to company. These section discusses critical elements in world wide sourcing strategy. First step in the strategy requires identifying the global opportunity for sourcing. The step-by-step procedure to be followed in global sourcing is discussed below:

#### Step 1

**Identify items that qualify for worldwide sourcing:** Companies should select items for foreign purchase considering the cost benefit, quality excellence, superior technology, customer responsiveness and product features. Items available from multiple sources are good candidates for selection. The volume should justify to go for global sourcing. Items with high product life cycle are also considered for global sourcing.

#### Step 2

**Gather information about global sourcing:** After identifying items to source world wide, a company must gather and evaluate information about potential suppliers. Internet plays a very important role for gathering information about the potential suppliers. Trade centres conduct exhibitions. These become important source for identifying potential source. Trading companies can be approached for assistance. Most of these companies have a long history of trade and have the expertise to provide sufficient support throughout the world.

International trade experts also can be utilized for getting information about the potential suppliers. Other potential sources include yellow pages for a country, trade journals and sale catalogs.

### Step 3

**Supplier source Evaluation:** Evaluation is key in locating correct supplier globally. Enough care should be taken in evaluating the identified potential suppliers for awarding contract. The foreign suppliers should be subjected to the same standard of evaluation as applicable to domestic suppliers. The aspects like stability of price, inventory holdings, technical and quality capabilities, ability to assist in new designs, quality system established in the company, lead time requirements, extend of relationship that could be established with the company, trust worthiness of the supplier and impact of foreign relation with the domestic suppliers have to be examined and evaluated for selecting the supplier.

### Step 4

**Awarding the contract:** After identifying the qualified supplier globally, the purchaser can obtain the details from the supplier. In case if the foreign source is not competitive, the domestic supplier can be selected alternatively. If foreign supplier is proved to be competitive, then the buyer can establish contact with the foreign supplier and obtain details regarding terms and conditions. After negotiating with the supplier, a formal purchase order detailing the contract can be issued to the supplier. Once order is issued, the supplier can be subjected to performance for continuous improvement.

### Chapter Summary

Chapter - 2 introduces insourcing / outsourcing. Globalization paved the way for outsourcing globally. There are benefits and some drawbacks in out sourcing. Among the beneficiaries, India enjoys prime position in getting outsourcing orders. Methodology followed in outsourcing has been discussed in detail. There after different purchasing strategies were discussed. Strategies like optimizing the supply base, supplier quality, Global sourcing, long-term relationships, supplier involvement and cost consciousness were discussed briefly. Then, the supplier evaluation, selection and measurement were discussed in detail. Evaluating the initial supplier and performance measurement of existing suppliers were also discussed in details. Then, the procedure involved in managing supplier quantity was discussed. The need for creating a world-class supply base was taken up next and discussed. In the same section, how organizations manage, develop and improve the performance of the suppliers were discussed. The key to develop suppliers for world-class quality was discussed through a seven-step procedure. Barriers in developing suppliers were also categorized and given in this section. Finally worldwide sourcing and the procedure involved in it were discussed.

# NOTES

## Review questions

1. What do you mean by core competence?
2. What is insourcing?
3. What is outsourcing?
4. Explain outsourcing procedure.
5. Why should we go for outsourcing?
6. What is supply base optimization?
7. What is global sourcing?
8. Why long-term relationship is required in purchasing strategy development?
9. How will you involve suppliers in purchasing strategy development?
10. Why most organizations develop suppliers? Is suppliers development a long-term trend or st a fad? Explain
11. Explain the procedure involved in developing strategy for purchasing.
12. Discuss different types of strategies for purchasing.
13. Discuss the possible ways that purchasing becomes aware of the need to evaluate and select a supplier.
14. Discuss why purchasers should measure supplier performance on a continuous basis.
15. Explain how will you evaluate and select supplier?
16. Write an essay about supplier quality Management
17. Why is it critical to have a smaller supply base before committing to a supplier management and development programme?
18. What are the most important reasons for pursuing the world wide sourcing today?
19. .Explain the procedure in selecting supplier worldwide.

# UNIT III

## NOTES

### SUPPLY CHAIN NETWORK

#### LEARNING OBJECTIVES

After completing this chapter you will be able to:

- Understand the meaning of distribution network design
- Appreciate role and factors influence network design
- Identify the options available for network distribution
- Understand the meaning and importance of value addition
- Discuss the various models for facility location and its capacity
- Understand the impact of uncertainty on network design
- Identify the network decisions using decision trees
- Develop distribution center location and supply chain network optimization models.

#### 3.1 INTRODUCTION

In the last chapter we have seen the various strategic decisions available for sourcing. Once sources are identified, the optimum distribution design linking various sources minimizes the production and distribution cost in the supply chain. Various approaches and options available for designing distributor location center and other issues concerning network design are taken up in this chapter.

#### 3.2 DISTRIBUTION NETWORK DESIGN

Network design decisions are most important supply chain decisions. When designing supply chain network, we need to consider the various facilities available, transportation options available, inventory portion, and information methods are in use. In this chapter we are going to discuss the design aspect and other important decisions relating to distribution design network. Distribution means moving raw material from supplier end to manufacturing end to customer hand. Various distribution options are available in moving materials. Since the cost of transporting materials accounts major share in the item cost, distribution has to be planned efficiently and at the same time responsiveness also should be ensured.

## NOTES

### 3.3 THE ROLE OF DISTRIBUTION IN THE SUPPLY CHAIN

Without distribution there is no supply chain. It occurs at every stage of the supply chain. The cost of supply chain and customer satisfaction depends on the efficiency of the distribution in the supply chain. Distribution accounts more than 20 percent of the cost of manufacturing. Companies, which followed effective distribution system, succeeded in achieving world-class competitiveness. Distribution should provide higher level of customer responsiveness at a reasonable cost. Companies can directly deal with the customer or can contact through retailers. When they contact directly the customer, the products may move faster. On the other hand distributors who are intermediaries play a much more significant role in distributing the consumer goods. In India, distributors play a major role in distributing consumer goods. So, it is to be justified whether direct selling is profitable through distribution. A poor distribution network can hamper the level of service that customer receive while increasing the cost. An inappropriate network in distribution can affect the profitability negatively. So, it is important to design the distribution network appropriate to the business. Let us discuss the factors, which are influencing the distribution in the next section.

### 3.4 FACTORS AFFECTING THE DISTRIBUTION NETWORK

The performance of the distribution network can be measured by the level of customer service provided and the associated cost of maintaining distribution network. According to Sunil Chopra (2003), the factors responsible for customer services are: Response time, Product variety, product availability, Customer experience, Order visibility and Returnability.

Response time is the time elapsed between order placement and receipt of the same. Customer expect lower response time to become satisfied. Product availability is the ability of the firm to meet customer requirements as and when demand arises. Higher inventory improves the availability but increases the inventory cost. Customer experience leads the customer satisfaction. Good experience leads better satisfaction, whereas bad experience in dealing with retailer / distributors in getting products leading to dissatisfaction. So distributors should ensure good customer experience in getting their products / service. Order visibility is nothing but transparency in dealing with the transactions. Finally the returnability is the ease with which a customer can return unsatisfactory products and the network should be sufficiently geared to handle such cases effectively. Maintaining higher level in one of the dimensions may lead to reduction in the other dimension level. However customer always wants higher level in all these parameters. So there must be a trade off in designing distribution network and provide customer service at the highest level.

Distribution network is also affected by the level of inventories available, method of transportation, facilities available along with the material handling system and the system of communication in the distribution network. We can see that when we try to increase the number of facilities, the inventory also will increase. A distribution network with many

warehouses allows reduction in transportation cost relative to a network with a single warehouse. Total supply chain costs are the sum of inventory, transportation, and facility costs. To reduce the total cost, the cost of maintaining facilities should be minimized. So, in order to maintain good customer service at minimum cost is the objective to designing distribution network.

### 3.5 DESIGN OPTIONS FOR A DISTRIBUTION NETWORK

We have seen that the distribution is the movement of materials from supplier end to manufacturing end and also from manufacturing end to customer end. Under this context, let us try to understand the various options available for us to design efficient distribution network system. We should decide whether we would deliver the product be delivered through a distributor. Based on the above discussions we can have the following distribution choices:

- (i) Supply directly to the customer
- (ii) Distribution through in transit to the customer
- (iii) Supply through a distributor with a carrier delivery
- (iv) Home delivery through a distributor
- (v) Customer pick up points

Let us discuss briefly each of the above options in the succeeding paragraphs.

#### 3.5.1 Supply directly to the customer

In this option, there is a direct contact between the manufacturer and the customer. Recently on line supplier are also uses this option for delivery. Since there is no intermediate storage, material is directly delivered to the customer with less inventory cost. Generally slow moving items are shipped directly to the customers. A simple network using this option is shown in figure 3.1.

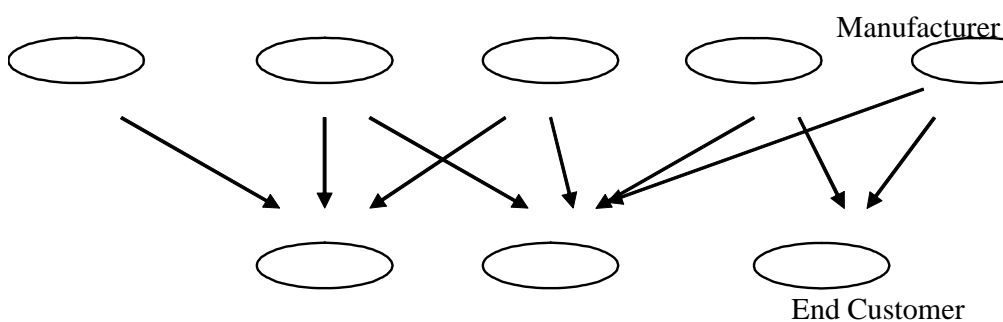

**Figure 3.1 Supply directly to customer.**

If retailer is available between the manufacturer and the customer, they carry no inventory but transmit the information between the manufacturer and the customer. In this

## NOTES

option less inventory is required to be maintained at the manufacturer end. Information regarding customer requirements can be collected from the retailer and aggregated. This option uses the centralization approach in realizing the customer demand. Supply chain cost can be minimized since there is no warehouse cost involved. Handling costs are also minimized. Information in fracture has to be simplified to achieve the full benefits under this option. Manufacturer storage allows a high level of product variety to be made available to the customer. Every product at the manufacturer can be made available to the customer without any limits. This method provides a good customer experience in the form of delivery to the customer location. Order visibility is also achieved in this type of supply chain. It may be difficult to handle supply returns. Handling of returns may be expensive since each order may involve movement from more than one manufacturer. So it is essential to simplify the procedure in handling customer complaints.

### 3.5.2 Distribution through in transit to the customer

Distribution through an intermediate system to the customers is another type of network. In this system an intermediate agency is developed. Customer requirements are collected by the retailers and communicated to the manufacturers. Deliveries in the transit place customers get a single delivery from the transit after merging their requirements. Mostly computer related components or computers themselves are purchased through this system. A customer's requirements may be met from different manufactures and merged/ assembled at the merger hut and then supplied to the customer A typical Net work is shown in figure 3.2

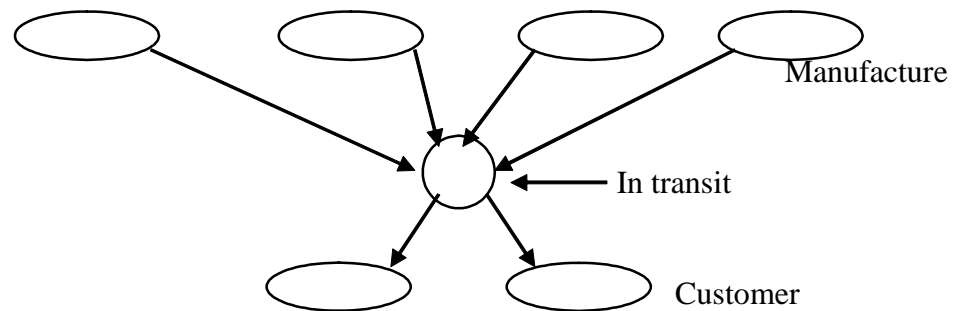

**Figure 3.2 Distribution Through In transit System**

In most cases, transportation costs will be lower, because of the merger that takes place at the merger hut prior to delivery to the customer. The agency that involved in merging has higher facility costs. Receiving costs at the customers end will be lesser because a single delivery is done. For establishing information system, this system requires a very sophisticated communication system. Co-ordination among retailers, manufactures and customers is also required at the higher level. Repose time, product variety and product availability are at optimum in this system. Customer experience is likely to be better than other systems. Since merger is taking place between the supply, order visibility is very



important requirements. Initial setup may be difficult because it requires integration of manufacturer, carrier, and retailer. Tracking itself becomes easier given the merge that occurs at the carrier point. Tracking up to merger may be difficult but it is relatively simpler after the transit point since delivery is single. And also handling returnable will be relatively difficult due to supply from different manufactures. One main advantage of the in transit over the direct supply is the lower transportation cost and improved customer experience. This is best suited low to medium demand. If there are too many manufactures, in transit may be difficult to co-ordinate and implement.

### 3.5.3 Supply through a distributor with a carrier delivery.

Distributors play a key role in the supply chain network. They consolidate the customer's requirements and arrange for delivery. They collect finished goods from the manufactures and stores in their place. The level of inventory at Distributors point is significant because it is the place where in various manufactures products are stored. These distributors are different from transit mergers. Package carriers are used for transporting to the customers. Transportation costs will be somewhat lower for distributor network system because economic mode of transportation can be employed for shipping materials from raw materials storage to the warehouse, which is closer to the customer. Facility costs will be somewhat higher in this system because of a loss of aggregation. Processing and handling costs will also be somewhat higher in distributor network. From a facility cost angle, distributor network is not appropriate for very low-moving items. Information processing cost is competitively less in this system of distribution. Customer service will be better. Product visibility is moderate in the distributor network. Response time is also better in this system. It is suited for medium to fast moving items. A typical network is given in fig 3.3

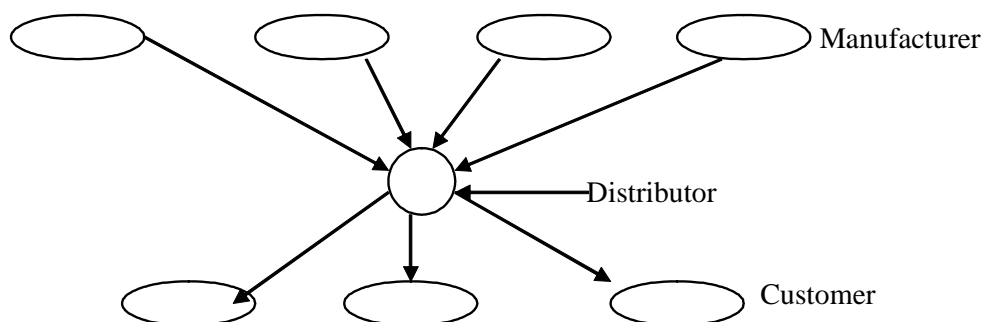

Figure 3.3 Supply through Distributor

### 3.5.4 Home delivery through a distributor

In this option products are delivered to the customer at his / her home. In our day-to-day life, we buy groceries either from a super market or send a list to the retailer for home delivery. Supermarket requires customer's presence where as in the later case, the retailer arranges supply at the doorsteps. This kind of delivering products at the doorsteps through

# NOTES

the distributors / retailers have several advantages over the other distribution networks. The retailers arrange more number of warehouses closer to the customer place for easy delivery and also to reduce the transport action costs. A typical distribution using home delivery is shown in fig 3.4.

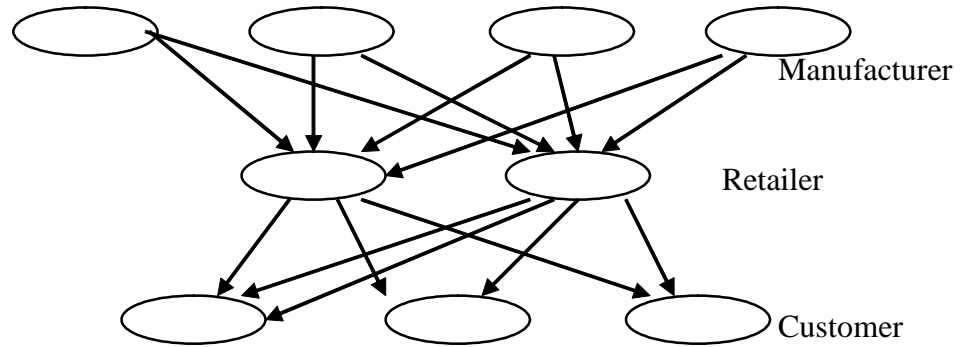
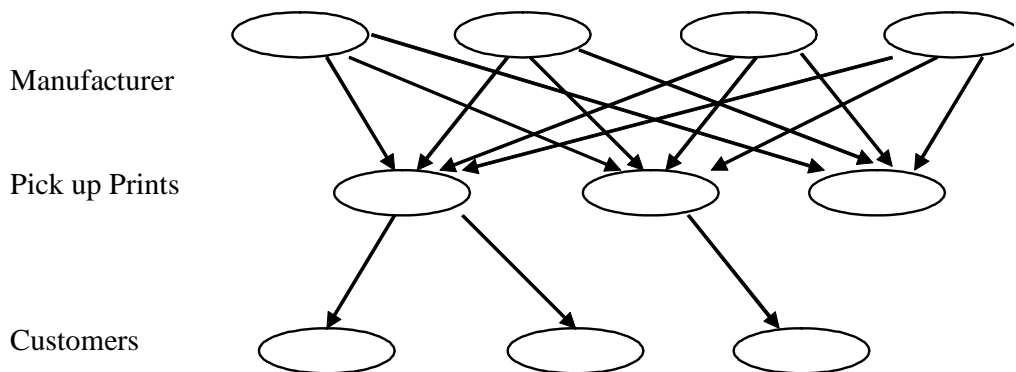

**Fig 3.4 Home delivery network**

Home delivery for water and large amount of rice has proved quiet successful in china. Facility and processing costs are very high in home delivery. Response time will be faster than the use of carriers. Product variety will generally be lower than distributor network systems. Since the material is supplied at the doorsteps, customer experience is good in home delivery network. Order visibility and tracking are comparatively difficult and complex. Returns also will be expensive in this type of network. More laborers are required to be used for home delivery and hence the cost of the network will also increase. Order size and discount systems can be operated to reduce the cost.

### 3.5.5 Customer picks up points

In this approach, products are stored at the manufacturer or distributor / retailer warehouse. Customers can place their orders either online or over phone. They will be intimated about the delivery status and the customers are required to go to the pick up point and collect the material. Pick up points are designed and located several in numbers closer to the targeted customers. A typical network using pickup point is given in fig 3.5.



**Figure 3.5 Pick up points network**

Customer requirements must reach the manufacturer through effective communication systems. Inventory costs will be very low in this approach. Transportation costs is also lesser when comparing to other networks. Trucks utilized for delivering other stores can be utilized for online orders also. Facility costs will be somewhat higher in this case due to establishment of new pick up points. Processing costs will be comparable with the other networks. Increased processing costs are considered as one of the hurdles for successful operation of this network. High level of co-ordination is also required between the manufacturers, pick up points and customer. Comparatively good response time can be achieved in this case. Customer experience can be somewhat lesser in this case and due to this there may be a loss in customers due to the pick up option in this system. Order must be highly visible for a customer to pick up. Returns must be handled effectively at the pick up point to avoid frustration among customers. Since customers can easily bring and return to pick up points, they may not find it difficulty in returning goods, but there must be a system for handling them properly. The main advantage of pickup points is that it can lower the delivery cost. Pick up points must be designed to allow the customer to do the pick up of his/her specific order.

### 3.6 THE VALUE ADDITION IN THE SUPPLY CHAIN

Distributors in the supply chain play an important role. The presence of distributors in the supply chain is inevitable in Indian context even though e-business and web-based business tries to replace distributors in the supply chain. Country like India deal with small lots of \essential items need to have distributors for storing the bulk quantity and distribution to retailers of small lots which the retailers can hold in their premises. Presence of distributors thus improves the performance of the supply chain. The variety of items from different manufacturers have to be stored in a central place and from where goods are distributed to the retailers / customers. Distributors no doubt add value to a supply chain between manufacturer and customers. Following are some of the value additions due to the presence of distributors in the supply chain.

- Reduction in cost of transporting material from supplier to manufacturer.
- Reduction in cost of moving finished goods from manufacturer to customer
- Reduction in inventory cost due to aggregation of requirements.
- Better planning of production by manufacturers due to stable order.
- Distribution can ensure better response time due to closer to customer
- Customer can get product from several manufacturers.

### 3.7 MODEL FOR FACILITY LOCATION AND CAPACITY ALLOCATION

Supply chain network is influenced by inventory strategy, transport strategy and location strategy. Transportation and location are highly correlated. When there is a reduction in material weight, it may be better to locate facilities closer to the supply source. Location decision involves determination of number of facilities, location and size of the facilities

## NOTES

used. The facilities in a supply chain network must be equal to the number that minimizes total logistics costs. Economic factor dominant in locating facilities at the same time locating single facilities is different from locating multifacility. Maximizing profitability and improving responsiveness are the goals of a manager in locating facilities. Locating facilities and thereafter allocating capacity to each facility is the job of a manager. Location decision uses the following information's:

- Location of supply sources and markets
- Identification of potential sites
- Demand forecast for each product
- Facility, labour, and material costs by site
- Transportation costs and its implication
- Selling price of each commodity at each site
- Taxes and tariffs as product is moved between locations
- Expected response time and other service factors

Given this information, either gravity (single facility) or network optimization models (multifacility location problems) may be used to design the network. Let us first take up single facility problems.

### 3.7.1 Gravity Location Problem

Single facility location model uses center of gravity as approach in locating a single plant, terminal, warehouse, or retailer service points. The approach is simple, since transportation cost between the source and the material is only considered as location factor. Here the material is moved from a source point to a demand point. The model is based on minimizing the total cost of transportation that is.

Min TC =  $\sum Q_i C_i d_i$  where;

$Q_i$  = Quantity of material shipped per unit period

$C_i$  = Cost of transporting a unit per unit distance

$d_i$  = Distance between source point and demand point

$T_c$  = Total transportation cost.

Further we define a weightage ( $W_i$ ), which is nothing, but a weight associated with the source facility  $i$ . This is the product of quantum of materials ( $Q_i$ ) moved and the cost per unit distance between the demand point (new facility) and the supply source  $i$  per unit period. The distance ( $d_i$ ) between the source and the demand point is considered as squared Euclidean and is given by:  $(x-a_i)^2 + (y-b_i)^2$ , where:

$x$  =  $x$  .co-ordinate of demand point (new facility)

$y$  =  $y$  .co- ordinate of demand point (new facility)

$a_i$  =  $X$  . co-ordinate of source point

$b_i$  =  $Y$  .co-ordinate of source points

Therefore the sum of weighted squared Euclidean distance is given as:

$$F(x,y) = \sum_{i=1}^m w_i [ (x - a_i)^2 + (y - b_i)^2 ]$$

To minimize f(x,y), equate partial derivatives to zero as given below:

$$\frac{\partial f(x,y)}{\partial x} = 0 \quad \text{and} \quad \frac{\partial f(x,y)}{\partial y} = 0$$

On solving the above equations we get

$$x^* = \frac{\sum_{i=1}^n w_i a_i}{\sum_{i=1}^n w_i} \quad \dots(3.1)$$

$$y^* = \frac{\sum_{i=1}^n w_i b_i}{\sum_{i=1}^n w_i} \quad \dots(3.2)$$

Next, we discuss a typical scenario where gravity models can be used.

Consider, for example, a manufacturer manufactures high quality home appliances. The company has one assembly factory located near 'A' from which it has supplied the entire Tamil Nadu. Demand has grown rapidly and the company has decided to set up another factory to serve its nearby states. The supply chain manager is asked to find a suitable location for the new factory. Three plants located in P, Q and R will supply parts to the new factory, which will serve markets in B, C, D and E. The co-ordinate location, the demand in each market, the required supply from each plant, and the transportation cost from each source or market are given in table 3.1.

Gravity model assume both the market and the supply source can be located as grid points on a plane. All distance are assumed to be squared Euclidean. These models also assume that the transportation cost is linearly related to the quantity shipped. We discuss a gravity model for locating a single facility that receives raw materials from supply sources and ship finished products to markets. The basic input to the model are as follows:

# NOTES

$a_i, b_i$  : Co-ordinate location of either a market or supply source

$C_i$  : Cost of shipping one unit for unit distance between the facility and either market or supply source.

$Q_i$  : Quantity to be shipped between facility and market or supply source.

$$w_i = Q_i \times C_i$$

If  $(x,y)$  is the location selected for the facility, the distance  $d_i$  between the facility at location  $(x,y)$  and the supply source or market is given by:

$$d_i = \sqrt{(x - a_i)^2 + (y - b_i)^2}$$

The total transportation cost (TC) is given by:

$$TC = \sum_{i=1}^n w_i d_i$$

**Table 3.1 Locations of supply sources and markets for home appliances**

Source/ Market	Cost per unit ( $C_i$ )	Quantity ( $Q_i$ )	Coordinates	
			$a_i$	$b_i$
P Source	0.85	450	7	12
Q Source	0.90	250	3	6
R Source	0.80	600	2	8
B Market	1.25	200	6	5
C Market	1.25	150	10	12
D Market	1.25	225	8	3
E Market	1.25	180	9	10

The optimal location is one that minimizes the total transportation cost. The optimal solution is obtained using the equations (3.1) and (3.2).  $w_i$  is the weightage factor which should be computed before using these formulas.  $W_i$  for each source and market is given below:

Source	P	Q	R	B	C	D	E
$C_i$	0.85	0.90	0.80	1.25	1.25	1.25	1.25
$Q_i$	450	250	600	200	150	225	180
$W_i (C_i \times Q_i)$	382.5	225	480	250	187.5	281.25	225

Substituting values in eqn. (3.1) we get  $X^*$  ie X-co ordinate for the new facility.

$$x^* = \frac{382.5 \times 7 + 225 \times 3 + 480 \times 2 + 250 \times 6 + 187.5 \times 10 + 281.25 \times 8 + 225 \times 9}{382.5 + 225 + 480 + 250 + 187.5 + 281.25 + 225}$$

$$x^* = \frac{3677.5 + 675 + 960 + 1500 + 1875 + 2250 + 2025}{2031.25} = 5.89$$

The y Co-ordinate for the new facility is obtained by substituting  $w_i$  and  $b_i$  in eqn (3.2): Thus, we have

$$y^* = \frac{382.5 \times 12 + 225 \times 6 + 480 \times 8 + 250 \times 5 + 187.5 \times 12 + 281.25 \times 3 + 225 \times 10}{2031.25}$$

$$= \frac{4590 + 1350 + 3840 + 1250 + 2250 + 843.75 + 2250}{2031.25}$$

$$= 8.06$$

The optimum solution obtained are  $(x,y) = (5.89,8.06)$ . The manager thus identifies the co-ordinate 5.89 and 8.06 as the location of the factory that minimizes total cost TC. It is noted here that the precise co-ordinates provided by the gravity model may not correspond to a feasible location. The manager should look for desirable sites close to the optimal co-ordinates that have the required infrastructure as well as the appropriated labour force available.

### 3.7.2 Limitations of single facility location models

Any models will exhibit some shortcomings, when applied to real problems. It does not mean that the model is not useful. Let us try to understand some of the limitations of single facility location models.

- Transportation cost is calculated for a single point instead of to individual demand points.
- Single facility location models typically find a location based on variable costs. ie Fixed costs of establishing centres are not considered.

## NOTES

- Total transportation costs usually are assumed to increase proportionately with distance, however most transport costs per unit are composed of fixed component that varies with the distance.
- Straight-line routes are commonly assumed between the facility and other Network prints. This is not true always, since travel is over defined road network, rail system, or through a rectilinear city Location network.

### 3.7.3 Multi facility Location Models

When we want to locate more than one facility, the problem become complex. It is quite common that any logistics will have more than one facility, to be located. Such problems are called multi-facility location problems. A number of location methods have been developed that help in solving multi-facility location problems. Mathematical programming models are employed to get optimum solutions. But they result in long computer running times, huge memory requirements, and a compromised problem definition when applied to practical problems. Multiple-centre of gravity approach can also be used to solve multi-location problems. In this method centre of gravity is found for several clusters. Although this method is optimal if all the ways of assigning points to clusters are evaluated, it becomes computationally impractical for realistic-size problems. Mixed integer linear programming is yet another method to solve the multi-facility location problems. Goal programming, tree search methods and dynamic programming techniques are also used for solving this difficult problem optimally. The most promising among these techniques is mixed integer linear programming approach. In this method, fixed cost is dealt with optimally. Researchers who have applied the integer programming approach have explained solving warehouse location problem as detailed below:

There are several plants, which manufacture products with known production capacities. Customer demand is also known for each product at each of the number of customer zones. Warehouses are used to store and transmit to the needy customers. The warehouse costs are given as fixed costs plus linear variable costs. Transportation costs are considered as linear. Thus, the problem is to determine the location of warehouses and the pattern of transportation flows at minimum distribution cost, subject to plant capacity and warehouse size. The problem can be solved using general integer linear programming computer software packages. These optimization models are often difficult to understand and require technical skills that many managers do not possess. Therefore, researchers recommended to use simulation techniques to solve multifacility location problems. It is a mathematical representation of a logistics system by algebraic and logic statements that can be manipulated with the aid of a computer. Through simulation technique we can get either optimal or near optimal solution to the problems.



**3.7.4 Regional Location Model**

In the supply chain network, location facilities assume greater importance. To locate facilities in the selected sites, optimization models can be used. Before we consider potential sites, at macro level, regions can be first located. Let us discuss how to select a region using a least cost approach with an example. The production, transportation and inventory costs, capacities and demands for five regions are given in table 3.2.

**Table 3.2 Costs and demand data for regions.**

Supply Region	Demand Region					Fixed cost (Rs)	Capacity
	North	South	West	East	South West		
North	60	62	80	100	95	60000	1200
South	80	55	75	70	68	50000	2000
West	70	75	68	80	78	62000	1800
East	80	85	65	40	64	40000	800
South west	100	90	80	90	70	45000	1200
Demand	1500	1000	1800	2000	700		

The above problem can be formulated as integer program and solved using a computer software. However for getting an idea about the initial solution Least cost method is used to solve the problem manually. Here the rate of fixed cost is computed for each region using the following formula and the result is given in table 3.3:

$$\text{Fixed cost rate} = \frac{\text{Fixed cost of north}}{\text{Total customer demand}} = \frac{60000}{7000} = 8.6$$

**Table 3.3 Fixed cost rate**

Region	Fixed cost	Customer Demand	Fixed cost rate
Northern	60000	1500	8.6
Southern	50000	1000	7.1
Western	62000	1800	8.86
Eastern	40000	2000	5.71
South Western	45000	700	6.43
	Total	7000	

These rates can be included into the production and transportation cost and the cost matrix is prepared. The resulting matrix is given in table 3.4.

## NOTES

Table 3.4 Cost and demand data (modified)

Supply Region	Demand Region					Capacity
	North	South	West	East	South West	
Northern	68.6 1500	70.6	88.6	108.6	103.6	3000
Southern	87.1	62.1 1000	82.1	77.1	75.1 700	2000
Western	78.86	83.86	76.86 1800	88.86	86.86	3000
Eastern	85.71	90.71	70.71	45.71 2000	69.71	2000
South western	106.43	96.43	86.43	96.43	74.43	2000
Demand	1500	1000	1800	2000	700	1000

By following the least cost method allocation is made in table 3.3. In this method least cost of production, inventory, transportation and fixed cost rate between supply source and the demand point is identified and allotment to that least cost cell is made by checking the demand and supply position. For example, by scanning all the costs in the matrix, it is seen that the cost value of 45-71 is found to be least, which is a eastern region. The demand of eastern region is 2000 and the capacity of eastern region is also 2000, therefore allotment of 2000 is made in that cell Following the same procedure other allotments are made and the final allotment is given in table 3.5.

Table 3.5 Final Allotments

Supply region	Demand region	Unit Cost	Qty	Cost
Northern	Northern	68.60	1500	102900
Southern	Southern	62.1	1000	62100
Southern	South western	75.1	700	52570
Western	Western	76.86	1800	138348
Eastern	Eastern	45.71	2000	91420
		<b>Total</b>	<b>7000</b>	<b>447338</b>

Based on the above analysis it is seen that except southwestern region, all other regions qualified to supply to their respective regions demands. However the demand of southwestern region can be met from southern region. Total cost involved is minimized to 447338. It is to be noted that the solution obtained is only approximate and it can be

optimized using MODI method. A MODI method is explained in the section 3.6.6 same procedure can be applied here to get the optimal solution.

**3.7.5 Location using integer programming method: The optimization of network requires the following inputs:**

$n$  = Number of potential plant locations (Regions)

$m$  = Number of demand points (Regions)

$D_j$  = Annual demand from demand point  $j$

$K_i$  = Potential capacity of plant  $i$

$f_i$  = Annual fixed cost of plant  $i$  open

$C_{ij}$  = Cost of producing and transporting one unit from plant  $i$  to demand point  $j$  (Cost includes

production, inventory, transportation and Taxes)

The objective is to minimize the total cost of supply chain. Let us define the decision variables:

$y_i = 1$  if plant  $i$  is open, 0 otherwise.

$x_{ij}$  = Quantity moved from plant  $i$  to demand point  $j$ .

The problem is then formulated as the following integer program:

$$Tc \text{ min} = \text{Min} \sum_{i=1}^n f_i y_i + \sum_{i=1}^n \sum_{j=1}^m c_{ij} x_{ij}$$

Subject to

$$\sum_{i=1}^n x_{ij} = D_j \text{ for } j = 1, 2, \dots, m \tag{3.3}$$

$$\sum_{j=1}^m x_{ij} \leq k_i y_i \text{ for } i = 1, 2, \dots, n \tag{3.4}$$

$$y_i \in \{0, 1\} \text{ for } i = 1, 2, \dots, n \tag{3.5}$$

The objective function minimizes the total cost (fixed & variable) of operating the network. The constraint in equation (3.3) shows that the demand at each regional (demand) be satisfied. The constraint in equation (3.4) shows that no plant can supply more than its capacity. The product  $k_i y_i$ , ensure this aspect. The constraint in equation (3.5) enforce that each plant is either open ( $y_i=1$ ) or closed ( $y_i=0$ ). The solution will identify the plants that are to be kept open, their capacity, and the allocation of regional demand to these

## NOTES

plants. The problem can be solved either using a computer or using excel solver (for details, please refer, Sunil Chopra, 2003).

### 3.7.6 Demand allocation to facilities

In the pervious sections we have seen how to select regions for locating facilities using manual and integer programming methods. Once a region is selected, we can locate plants according to the demand in that region. There can be demand from various points and to meet and allocate those demands we must locate plants economically. For this also we can use integer programming. In this section let us discuss how demand is allocated to various sources using Vogel's approximation method.

Let us consider five plants which are manufacturing a product and they have the demand in five cities. The plant capacities, market demand, variable production and transportation cost per unit shipped are given in table 3.6.

**Table 3.6 Capacity, Demand, and Cost data for plants and cities**

Plants	Demand City (Production and Transportation cost per unit)					Capacity
	City 1	City 2	City 3	City 4	City 5	
Plant 1	18	8	10	11	24	1800
Plant 2	15	19	12	6	12	2800
Plant 3	20	20	15	10	8	1200
Plant 4	10	12	6	8	22	2200
Plant 5	12	16	7	5	18	2400
<b>Demand</b>	<b>1800</b>	<b>1200</b>	<b>2400</b>	<b>2000</b>	<b>3000</b>	<b>10400</b>

It can be seen from the table 3.6 that there are five plants and five demand points. Total demand and capacity are same, which is equal to 10400 units. Now let us allocate the demand to each plant based on their capacities and other cost data. Vogel's approximation is used to solve this problem. In VAM method penalty cost method is used. First, every row is examined and least cost cell is selected. Then the penalty cost for not allotting this least cost cell is computed from subtracting this value from the next best cells cost. Same way all the remaining rows are examined and penalty costs are calculated. The same procedure is repeated for column. Finally select the biggest penalty cost from among the penalty costs computed. To avoid that penalty cost, select the cell associated with that biggest penalty cost and allot the cell a quantity comparing the demand and capacity. After allotment repeat the computation of penalty cost for the remaining rows and columns. The computations are given in tables 3.7 through 3.13.

**NOTES**

**Table 3.7 Iteration –1**

Plants	City 1	City 2	City 3	City 4	City 5	Supply	Row Penalty
Plant 1	18	8	10	11	24	1800	$10 - 8 = 2$
Plant 2	15	19	12	6	12	2800	$12 - 12 = 0$
Plant 3	20	20	15	10	8 1200	1200	$10 - 8 = 2$
Plant 4	10	12	6	8	22	2200	$8 - 6 = 2$
Plant 5	12	16	7	5	18	2400	$7 - 5 = 2$
<b>Demand</b>	<b>1800</b>	<b>1200</b>	<b>2400</b>	<b>2000</b>	<b>3000</b>	<b>10400</b>	

Column    ←12-10    ← 12-8    ← 7-6    ← 6-5    ← 12-8  
 Penalty            2            4            1            1            4



Maximum penalty column

**Table 3.8 Iteration 2**

Plants	City 1	City 2	City 3	City 4	City 5	Supply	Row Penalty
Plant 1	18	8	10	11	24	1800	$10 - 8 = 2$
Plant 2	15	19	12	6	12 1800	2800	$12 - 12 = 0$
Plant 4	10	12	6	8	22	2200	$8 - 6 = 2$
Plant 5	12	16	7	5	18	2400	$7 - 5 = 2$
<b>Demand</b>	<b>1800</b>	<b>1200</b>	<b>2400</b>	<b>2000</b>	<b>3000</b>	<b>10400</b>	

Column    ←12-10    ← 12-8    ← 7-6    ← 6-5    ← 18-12  
 Penalty            2            4            1            1            6



Max. Penalty ←

**Table 3.9 Iteration – 3**

Plants	City 1	City 2	City 3	City 4	Supply	Row Penalty
Plant 1	18	8	10	11	1800	$10 - 8 = 2$
Plant 2	15	19	12	6 1000	2800	$12 - 6 = 6$
Plant 4	10	12	6	8	2200	$8 - 6 = 2$
Plant 5	12	16	7	5	2400	$7 - 5 = 2$
<b>Demand</b>	<b>1800</b>	<b>1200</b>	<b>2400</b>	<b>2000</b>	<b>10400</b>	

Max. Pena ←

# NOTES

Column ← 12-10 ← 12-8 ← 7-6 ← 6-5  
 Penalty 2 4 1 1

**Table 3.10 Iteration – 4**

Plants	City 1	City 2	City 3	City 4	Supply	Row Penalty
Plant 1	18	8 1200	10	11	1800	10 – 8 = 2
Plant 4	10	12	6	8	2200	8 – 6 = 2
Plant 5	12	16	7	5	2400	7 – 5 = 2
<b>Demand</b>	<b>1800</b>	<b>1200</b>	<b>2400</b>	<b>1000</b>	<b>6400</b>	

Column ← 12-10 ← 12-8 ← 7-6 ← 8-5  
 Penalty 2 4 1 3  
 ↑ Max. Penalty

**Table 3.11 Iteration – 5**

Plants	City 1	City 3	City 4	Supply	Row Penalty
Plant 1	18	10	11	600	11 – 10 = 1
Plant 4	10	6	8	2200	8 – 6 = 2
Plant 5	12	7	5 1000	2400	7 – 5 = 2
<b>Demand</b>	<b>1800</b>	<b>2400</b>	<b>1000</b>	<b>5200</b>	

Column ← 12-10 ← 7-6 ← 8-5  
 Penalty 2 1 3  
 ↑ Max. Penalty

**NOTES**

**Table 3.12 Iteration – 6**

Plants	City 1	City 3	Supply	Row Penalty
Plant 1	18	10 600	600	18 - 10 = 8
Plant 4	10	6	2200	10 - 6 = 4
Plant 5	12	7	1400	12 - 7 = 5
<b>Demand</b>	<b>1800</b>	<b>2400</b>	<b>4200</b>	

Max. Penalty ←

Column ← 12-10 ← 7-6  
Penalty 2 1

Plants	City 1	City 3	Supply	Row Penalty
Plant 4	10	6	2200	10 - 6 = 4
Plant 5	12	7 1400	1400	12 - 7 = 5
<b>Demand</b>	<b>1800</b>	<b>1800</b>	<b>3600</b>	

Max. Penalty ←

Plants	City 1	City 3	Supply
Plant 4	10 1800	6 400	2200
<b>Demand</b>	<b>1800</b>	<b>400</b>	<b>2200</b>

Column ← 12-10 ← 7-6  
Penalty 2 1

**Table 3.13 Iteration – 7**

**Table 3.14 Iteration – 8**

The final allotments of five cities demands to the plants are given in table 3.15.

**Table 3.15 Allotments**

From	To	Quantity	Rate	Cost(Rs)
Plant 1	City 2	1200	8	9600
Plant 1	City 3	600	10	6000
Plant 2	City 5	1800	12	21600
Plant 2	City 4	1000	6	6000
Plant 3	City 5	1200	8	9600
Plant 4	City 1	1800	10	18000
Plant 4	City 3	400	6	2400
Plant 5	City 4	1000	5	5000
Plant 5	City 3	1400	7	9800
			<b>Total(Rs)</b>	<b>88000</b>

# NOTES

The result obtained using VAM method can be examined using MODI method for optimality. To apply MODI, let us define new variables  $u_i$  and  $v_j$ . There after using the condition  $u_i + v_j = c_{ij}$  the individual values of  $u_i$  and  $v_j$  are determined. Let us apply the MODI to our example problem. The solution table should satisfy the condition of  $m + n - 1$  allotments. We have 5 rows and 5 columns. Therefore there must be  $5 + 5 - 1 = 9$  allotments. We got nine allotments for our example problem. So, there is no problem in applying modi method. Let us first prepare the final table with individual allotments. The solution table is available in table 3.16

**Table 3.16 Solution Table**

$$v_1 = 14 \quad v_2 = 8 \quad v_3 = 10 \quad v_4 = 8 \quad v_5 = 14$$

$u_i \backslash v_j$	Plants	City 1	City 2	City 3	City 4	City 5	Supply
$u_1 = 0$	Plant 1	18	8 <b>1200</b>	10 <b>600</b>	11	24	1800
$u_2 = -2$	Plant 2	15	19	12	6 <b>1000</b>	12 <b>1800</b>	2800
$u_3 = -6$	Plant 3	20	20	15	10	8 <b>1200</b>	1200
$u_4 = -4$	Plant 4	10 <b>1800</b>	12	6 <b>400</b>	8	22	2200
$u_5 = -3$	Plant 5	12	16	7 <b>1400</b>	5 <b>1000</b>	18	2400
	<b>Demand</b>	<b>1800</b>	<b>1200</b>	<b>2400</b>	<b>2000</b>	<b>3000</b>	<b>10400</b>

We know  $u_i + v_j = c_{ij}$  for allotted cells. Let us form equations for all the occupied cells.

$$u_1 + v_2 = 8 - (1)$$

$$u_1 + v_3 = 10 - (2)$$

$$u_2 + v_4 = 6 - (3)$$

$$u_2 + v_5 = 12 - (4)$$

$$u_3 + v_5 = 8 - (5)$$

$$u_4 + v_1 = 10 - (6)$$

$$u_4 + v_3 = 6 - (7)$$

$$u_5 + v_3 = 7 - (8)$$

$$u_5 + v_4 = 5 - (9)$$

There are nine equations and 10 unknown variables. To solve simultaneous equations, we need to have number of equations equal to the

number of unknown variables. Since we have more unknown variables, in

this problem, let us assume that  $u_1 = 0$ ; substituting this value in equation (1)

we get  $v_2 = 8$ , similarly other values are obtained

$$u_1 = 0, \quad v_2 = 8, \quad v_3 = 10, \quad u_4 = -4, \quad u_5 = -3, \quad v_4 = 8, \quad v_1 = 14$$

$$u_2 = -2, \quad v_5 = 14, \quad u_3 = -6$$

For unoccupied cells determine net change value.



NOTES

Cell	$c_{ij} - u_i - v_j$	NC	Cell	$c_{ij} - u_i - v_j$	NC
$u_1v_1$	18-0-14	4	$u_3v_4$	10+6-8	8
$u_1v_4$	11-0-8	3	$u_4v_2$	12+4-8	8
$u_1v_5$	24-0-14	10	$u_4v_4$	8+4-8	4
$u_2v_1$	15+2-14	3	$u_4v_5$	22+4-14	12
$u_2v_2$	19+2-8	13	$u_5v_1$	12+3-14	1
$u_3v_1$	20+6-14	12	$u_5v_2$	16+3-8	11
$u_3v_2$	20+6-8	18	$u_5v_4$	18+3-14	7
$u_3v_3$	15+6-10	11			

**Note:** Since all the NC values are positive, the solution obtained is optimal. Thus the minimum TC for our example problem is Rs. 88,000/-.

The demand allocation problem can also be solved by using a demand allocation model. The model requires the following inputs:

$n$  = Number of plants producing product

$m$  = Number of warehouses or demand points

$D_j$  = Annual demand from  $j$ .

$K_i$  = Capacity of plant  $i$

$C_{ij}$  = Cost of producing and transporting one unit from plant  $i$  to demand point  $j$ .

The objective is to allocate the demand from different demand points to the various plants to minimize the total cost of facilities, and inventory.

Let the decision variable be,

$x_{ij}$  = Quantity transported from plant  $i$  to demand point / warehouse  $j$ .

Formulation of the problem:

$$\text{Minimize } Z = \sum_{i=1}^n \sum_{j=1}^m c_{ij} x_{ij}$$

$$\text{Subject to } \sum_{i=1}^n x_{ij} = D_j \text{ for } j = 1, 2, \dots, m \tag{3.6}$$

$$\sum_{j=1}^m x_{ij} \leq k_i \text{ for } i = 1, 2, \dots, n \tag{3.7}$$

## NOTES

The constraints in equation (3.6) ensure that all market demand is satisfied and the constraints in equation (3.7) ensure that no plant produces more than its capacity.

### 3.8 IMPACT OF UNCERTAINTY ON NETWORK DESIGN

Supply chain design involves long-term decisions. Long-term decisions are strategic in nature. Once decisions are made, alterations/ modifications in the future are very difficult and prove to be costly. The important decisions involved in design of supply chain are number of plants to be established, the size of plants, number of trucks to be purchased or leased and the number of warehouses to be built or leased. All these decisions are long term in nature. Since it is difficult to modify, the decisions must be made very accurately. However, the uncertainty in the demand, fluctuations in market price, an expected swing in the exchange rates and turbulent competitive environment make decision making difficult. These uncertainties causes supply chain design complex. The manufacturing plant should be flexible enough in accommodating the variations in demand and price. The main benefits of this flexibility is that it allows companies to react to fluctuations in demand, exchange rates and local prices by altering production to maximize profits. Hence, it is suggested that when we make network design decisions, we must consider both supply and demand uncertainty and the financial uncertainty.

If enough care is not taken, the impact of uncertainty will make it operational to be vary costly and complex. Financial uncertainty can be taken care if discounted cash flow technique is followed in designing network. Discounted cash flow analyses the present value of future cash flows. This helps in making decision when comparing two or more alternatives proposals. Net present value (NPV) is arrived for comparing the alternatives. NPV is the result of discounted cash flow technique. The present value of future cash flow is found by using a discount factor  $1/1+k$  where  $k$  is the discount rate. Discount factors can also be taken from the ready-made table. Future cash flow is multiplied by the discount factor to get the present value. NPV is computed by subtracting the total present value of future cash flow from the initial investment. Positive NPV indicates a supply chain with the highest financial return. The negative NPV indicates that the supply chain will loose money. Decisions regarding leasing of warehouse or building of warehouse can be taken based on the NPV analysis. Cash flow technique is suitable only when the demand and market price are predictable. In reality demand and prices are uncertain and are likely to fluctuate during the life of any supply chain decisions. For a supply chain exchange rates and inflation are also likely to vary over time. Hence, it is essential to incorporate uncertainties when making network design decisions.

### 3.9 EVALUATING NETWORK DESIGN DECISIONS USING DECISION TREES

When designing a supply chain, a manager is making several decisions. Examples are:

- Whether the firm enter into a long-term agreement for warehousing or get space from the spot market as and when needed?
- What should be the mix of long-term agreement for warehousing or get space from the spot market as and when needed?
- What should be the mix of long-term and spot market be in the portfolio of transportation capacity?
- What should be the capacity of each facility? And what fraction of this capacity should be flexible?

If a manager does not consider uncertainty, he is sure of signing the long-term contract, and avoids flexible capacity, since flexible capacity is more expensive. It may harm the firm in the future due to unutilization of part of the capacity, if the forecast demand does not materialize. At the same time, if the firm has a flexible capacity, they can move it to dedicated capacity only when they are sure of accuracy in their forecast. Thus, it is suggested that managers when they design network, they need to use a methodology that allows them to estimate the uncertainty in their forecast of demand and price and then incorporate this uncertainty in the decision-making process. In this section we describe such a methodology and show that how uncertainty impact on the value of network design decisions.

A decision tree is a graphic tool used to evaluate decisions under uncertainty. The uncertainty in price, demand, exchange rates and inflation are incorporated using DCF technique in the decision tree to solve such problems. The first and foremost thing that is considered in decision tree is the time horizon. The time horizon may be a day, month, a quarter, or any other time period. Normally planning period is used as time period as 'N'. The next step is to identify factors that will affect the value of the decision and are likely to fluctuate over the next 'N' periods. Naturally these factors are: demand, price, exchange rate and inflation. Then we should evaluate the probability of each of these factors fluctuate from one period to the next. The next is to identify a periodic discount rate 'K'. This is considered to account the inherent risk associated with the investment. The decision is now computed using a decision tree, which contains the present and 'N' future periods. Within each period a node must be defined for every possible combination of factor value. Arrows are used to connect the nodes between periods. The probability of transitioning from one node to the other is indicated on the arrow. The decision tree is evaluated starting from nodes in period N and working back to period 'O'. For each node, the decision is optimized taking into account the present and future values of each factor. The analysis is based on Bellman's Principle, which states that for any choice of strategy in a given state, the optimal strategy in the next period is the one that is selected if entire analysis is assumed

## NOTES

to begin in the next period. This principle allows the optimal strategy to be solved in a backward direction starting from the last period. Expected future cash are discounted and brought to the present period value. The value of the node in period 'o' given the value of investment as well as the decisions taken during each time period.

Let us illustrate the above decision tree process using the lease decision facing the manager at a typical logistics center. The decision to be taken by the manager is whether to lease warehouse space for the coming three years and the amount to lease. Let us assume that long-term lease is cheaper than the spot market rate for warehouse space. Also assume that the demand and spot prices vary over the coming three years. It is to be noted that if future demand is high the spot market cost will be high. There are three options before the manager, they are:

Option 1: Use spot market strategy

Option 2: Sign for three years contract and use

Spot market for additional requirements.

Option 3: Sign a flexible contract with a minimum charge that allows variable usage of warehouse space of to a certain limit with additional requirement from the spot market.

Let us see how the manager makes decisions taking uncertainty into account.

Five hundred square feet of warehouse space is required for every five hundred units of demand and the current demand at the logistics is for 50000 units per year. The manager decides to use a multiplicative binomial representation of uncertainty for both demand and price. From one year to next, demand may go by 20 percent with a probability of the two outcomes are unchanged from one year to the next.

The manager can sign a three-year lease at a price of Rs 8 per square foot per year. Warehouse space is currently available on the spot market for Rs10 per square foot per year. From one year to the next, spot prices for warehouse space may go up by 15 percent with probability 0.50 or go down by 15 percent with probability 0.50 according to a binomial process. The probabilities of the two outcomes are unchanged from one year to the next. The manager feels that prices of warehouse space and demand for the products fluctuate independently. Each unit logistics handles results in revenue of Rs 14 and the logistics is committed to handling all demand that arises. The logistics uses a discount rate of  $K=0.10$  for each year and thus constructs a decision tree with  $N=2$ . The guideline for constructing tree is given in fig 3.6. The decision tree is shown in fig 3.7 with each node representing for the problem demand (D) in thousands of units and price (p) in rupees. The probability of each transition is 0.20 because price and demand fluctuate independently.

NOTES

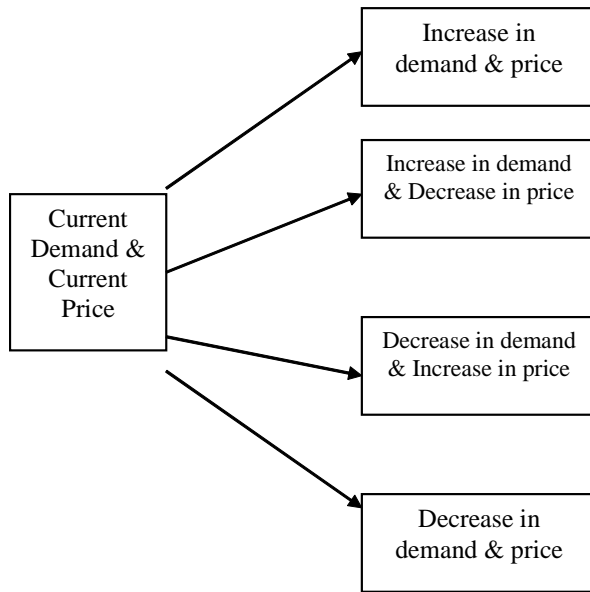

Figure. 3.6 Guidelines for constructing decision tree

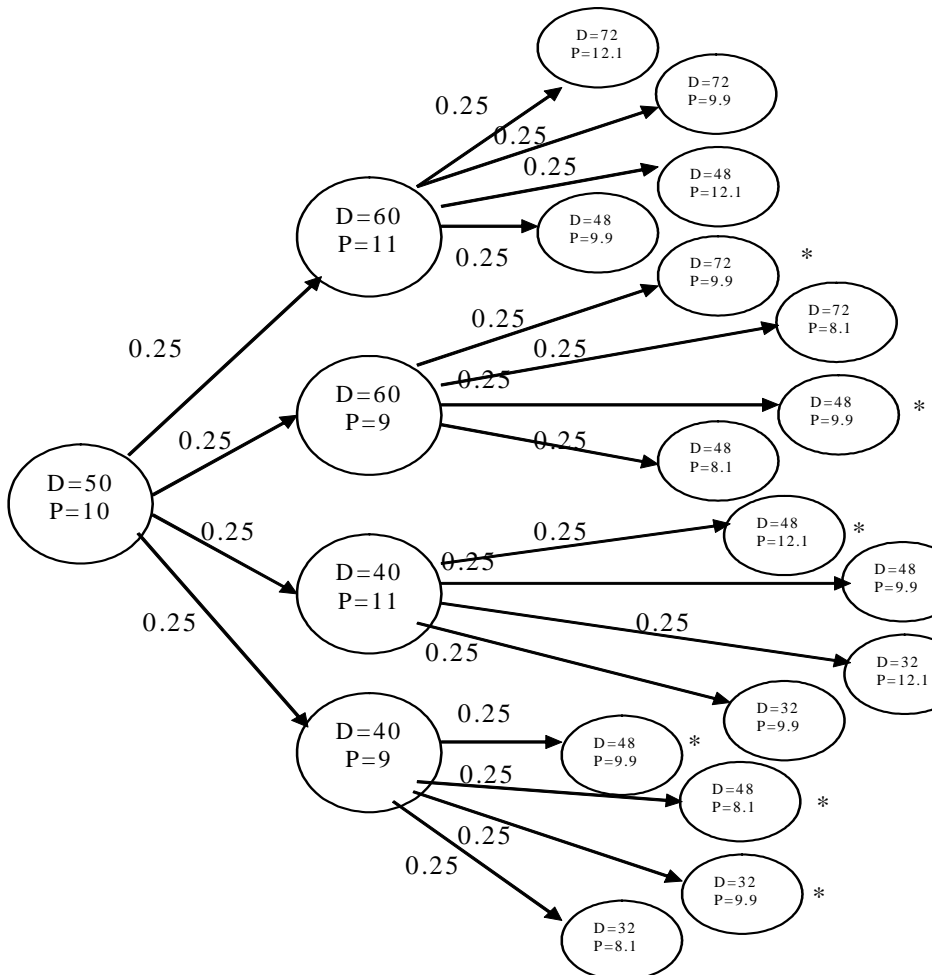

Figure. 3.7 Decision tree for Logistics considering demand and price fluctuations. \* Repetitions – can be ignored.

## NOTES

Let us first analyze the option not signing a lease and obtaining all warehouse space from the spot market. Let us start with period 2 and evaluate the profit for the logistics at each node. At node  $D=72$ ,  $P=Rs.12.1$ , the logistics must satisfy a demand of 72000 and faces a spot price of Rs.121 per square foot for warehouse space in period 2. The cost incurred by the logistics in period 2 at the node  $D=72$ ,  $P=Rs.12.1/-$  is equal to  $72000 \times 12.1 = Rs.871200$ . The revenue at the node  $D=72$  and  $P=12.1$  is  $72000 \times 14 = Rs.1008000$ . Therefore profit at the mode  $D=72$  and  $P=12$  is equal to  $1008000 - 8711200 = Rs.137000/-$ . The profit for the logistics at each of the other nodes in period 2 is evaluated similarly and given in table 3.17.

**Table 3.17 Period 2 calculations for spot market option**

Node	Revenue	Cost	Profit
D=72, P=12.1	$72000 \times 14 = 1008000$	$72000 \times 12.1 = 871200$	137000
D=72, P=9.9	$72000 \times 14 = 1008000$	$72000 \times 9.9 = 712800$	295200
D=48, P=12.1	$48000 \times 14 = 672000$	$48000 \times 12.1 = 580800$	92000
D=48, P=9.9	$48000 \times 14 = 672000$	$48000 \times 9.9 = 475200$	197000
D=72, P=8.1	$72000 \times 14 = 1008000$	$72000 \times 8.1 = 583200$	424800
D=48, P=8.1	$48000 \times 14 = 672000$	$48000 \times 8.1 = 388800$	283200
D=32, P=12.1	$32000 \times 14 = 448000$	$32000 \times 12.1 = 3387200$	60800
D=32, P=9.9	$32000 \times 14 = 448000$	$32000 \times 9.9 = 316800$	131200
D=32, P=8.1	$32000 \times 14 = 448000$	$32000 \times 8.1 = 259200$	188800

Let us now evaluate the expected profit at each node in period 1. Profit at period 1 is equal to the profit during period 1 plus the present value (at the time of period 1) of the expected profit in period 2. The expected profit from period 2 for the node  $D=60$ ,  $P=11$  is equal to  $0.25 [137000 + 295200 + 92000 + 197000] = 180300$  and for the node  $D=60$  and  $P=9$  is equal to  $0.25 [295200 + 424800 + 197000 + 283200] = 3,00,000$  and for the node  $D=40$ ,  $P=11$  is  $= 0.25 [92000 + 197000 + 60800 + 131200] = 120250$  and for the node  $D = 40$ ,  $P = 9$  is  $= 0.25 [197000 + 283200 + 131200 + 188800] = 2,00,050$ . Therefore the present value for the expected profit from period 2 for period 1 are  $180300/1.1 = 163909$ ,  $300000/1.1 = 272727$ ,  $120250/1.1 = 109318$  and  $200050/1.1 = 181864$ . The profit for period 1 is computed and given in table 3.18

**Table 3.18 Profit for period 1.**

Node	Revenue	Cost	Period 1 Profit
D=60, P=11	60000x14=840000	60000x11=660000	180000
D=60, P=9	60000x14=840000	60000x9=540000	300000
D=40, P=11	40000x14=560000	40000x11=440000	120000
D=40, P=11	40000x14=560000	40000x9=360000	200000

**NOTES**

Therefore the expected profit at period 1 is equal to  $0.25 [180000 + 300000 + 120000 + 200000] = 200000$ . The expected present value from period 2 is equal to  $0.25 [163909 + 272727 + 109318 + 181864] = 181955$ . Therefore the total expected profit for period 1 is equal to expected profit from period 1 plus expected present value of profits from period 2, which is equal to  $200000 + 181955 = 381955/-$

Next, let us compute the profit for the period '0'. At period zero the profit is sum of the profit at period zero and the net present value (NPV) of profit expected from period 1. The NPV of period 1 profit =  $381955/1.1 = 347232$ . Profit expected at period zero operation is equal to (D=50, P=10);  $(50000 \times 14 - 50000 \times 10) = \text{Rs. } 200000/-$ .

Therefore the total profit for not signing a lease is equal to  $:200000 + 347232 = 547232$ .

Let us now evaluate the alternative where the lease for 50000 sq. ft. of warehouse space is signed. The evaluation procedure is very similar to the previous case but the outcome in terms of profit changes. For example, at the node D=72, P=12.1, the manager has to obtain 22000 sq. ft. of warehouse space from spot market at Rs. 12.10 per square foot because only 50000 sq. ft has been leased at Rs. 8 per square foot. If demand happens to be less than 50000 units, the logistics still has to pay for the entire 50000 sq. ft leased space. For period 2 the profit at each of the nine nodes are worked out and given in table 3.19

**Table 3.19 Period 2 profit calculations at logistics for lease option**

Node	Leased space	Warehouse space at Spot price (S)	Profit D x 14 – (50000x8+SxP)
D = 72, P = 12.1	50000	22000	341800
D = 72, P = 9.9	50000	22000	390200
D = 48, P = 12.1	50000	0	608000
D = 48, P = 9.9	50000	0	608000
D = 72, P = 8.1	50000	22000	429800
D = 48, P = 8.1	50000	0	608000
D = 32, P = 12.1	50000	0	608000
D = 32, P = 9.9	50000	0	608000
D = 32, P = 8.1	50000	0	608000

**NOTES****The expected profit for period 1 from period 2:**

$$D=60, P=11 = 0.25 [341800+390200+608000+608000] = 487000$$

$$D=60, P=9 = 0.25 [390200+429800+608000+608000] = 509000$$

$$D=40, P=11 = 0.25 [608000+608000+608000+608000] = 608000$$

$$D=40, P=9 = 0.25 [608000+608000+608000+608000] = 608000$$

TOTAL EXPECTED

$$\begin{aligned} \text{PROFIT AT PERIOD 2} &= 0.25 [487000 + 509000 + 608000 + 608000] \\ &= 53000 \end{aligned}$$

$$\begin{aligned} \text{NPV of Total expected profit from period 2} &= 553000/1.1 \\ &= 502727 \end{aligned}$$

**Profit generated at period 1**

Node	Leased space	Space from spot	Profit $D \times 14 - [50000 \times 8 + SP]$
D = 60, P = 11	50000	10000	330000
D = 60, P = 9	50000	10000	350000
D = 40, P = 11	50000	0	440000
D = 40, P = 9	50000	0	440000

$$\begin{aligned} \text{Expected Value} &= 0.25[330000+350000+440000+440000] \\ &= 0.25 \times 1560000 \\ &= 390000 \end{aligned}$$

$$\begin{aligned} \text{Total expected profit for period 1} &= 390000 + 502727 \\ &= 892727 \end{aligned}$$

**Profit generated at period '0'**

$$\text{Demand} = 50000$$

$$\text{Price} = \text{Rs. } 10$$

$$\text{Profit} = 50000 \times 14 - 50000 \times 8 = 300000$$

$$\begin{aligned} \text{Total profit} &= \text{profit at '0' period} + \text{NPV of period 2} \\ &= 300000 + 892727/1.1 \\ &= 300000 + 811570 \end{aligned}$$

$$\text{NPV (lease)} = 1111570$$

It can be seen that the presence of uncertainty in demand and price reduces the value of the lease but does not affect the value of the spot market price option. It is recommended



that the manager can sign the three years lease for 50000 sq. ft. because this option has a higher expected profit.

### 3.10 DISTRIBUTION CENTRE LOCATION MODELS

It is quite common to see manufacturers and retailers joining efforts to efficiently handle the flow of products and to closely coordinate the production and supply chain system. An important strategic issue related to the design and operation of a physical distribution network in a supply chain system is the determination of the best sites for intermediate stocking points or warehouses. The use of warehouses provides a company with flexibility to respond to changes in the market place and can result in significant cost savings due to economies of scale in transportation or shipping costs. Hence it is important to design a distribution network that involves determining simultaneously the best sites of both plants and warehouses and the best strategy for distributing the product from the plants to the warehouses and from the warehouses to the customers.

A common objective in designing such a distribution network is to determine the least cost system design such that the demands of all customers are satisfied without exceeding the capacity of the warehouses and plants. This involves making trade off's inherent among the cost components of the system that include:

1. Costs of opening and operating the plants and warehouse and
2. The inbound and outbound transportation costs.

Let us consider a general model of a distribution center as given in fig 3.8

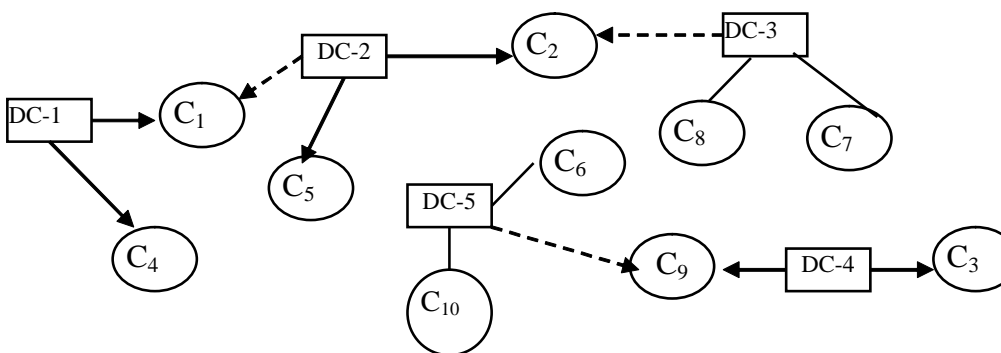

**Figure 3.8 Distribution center location model**

The model presented in fig 3.8 portrays the operation of a simple distribution centre model. This model deals with the allocation of products from the potential distribution centre to the various customers, who serve as the market for those products. The dotted lines shown in the diagram shows that the customer requirements are met from more than one distribution centre i.e. they are all not sole sourced. This is much higher percentage than in the reality. In fact the real life distribution centers would involve more than 20

# NOTES

distribution centers and would serve nearly 300 markets. Out of 300 markets we would expect hardly 5 to 10 markets that are not sole sourced. The main objective of the distribution centre location problem is to minimize the cost associated with both transportation and warehousing (already stated) while maintaining the service level which the customer expects. Mixed integer programming models are used to formulate and solve distribution centre location problems. In the model it is assumed that the demand is fixed and known over the entire planning horizon. The manager's of the sales and marketing division plan right from estimating the sales and provide the requirements to the logistics manager. The logistics manager of the organization ensures that the product reach the customer on time with low cost of distribution. Let us assume that fixed costs as well as variable cost for outbound flows are associated with each distribution behavior. The variables in the model are:

Decision Variable =  $Y_{ij}$  fraction of demand (regarding  $a_i$ ) of customer zone  $i$  delivered from warehouse at site  $j$

$a_i$  = demand per unit of time of customer zone  $i$

$a_{ij}$  = cost of supplying one unit of demand to customer zone  $i$  from warehouse at site  $j$

$V_j^c$  = if a warehouse  $j$  in capacity level  $R$  is located at site  $j$

And  $f_i$  = fixed cost per unit time for opening warehouse with capacity level  $C$  at site  $j$

$M$  = Index set of potential warehouse sites

$N$  = Index set of customer zones

$R$  = Index set of capacity levels available to the potential warehouse

## Objective Function

$$\text{Min : } Z = \sum \sum C_{ij} a_i Y_{ij} + \sum \sum f_j^c \times V_j^c$$

## Subject to

$$\sum Y_{ij} = 1 \quad \forall i \in N \quad \text{-----} \quad (3.8)$$

$$\sum a_i Y_{ij} \leq \sum V_j^c \times b_j^c \quad \text{-----} \quad (3.9)$$

$$\sum V_j^c \leq 1 \quad \forall j \in M \quad \text{-----} \quad (3.10)$$

$$Y_{ij} \geq 0 \quad \forall i \in N \text{ and } j \in M \quad \text{-----} \quad (3.11)$$

$$V_j^c \in (0,1) \quad \forall j \in M \text{ and } C \in R \text{-----} \quad (3.12)$$

This model minimizes total costs made of the costs to serve the demand of customers from the warehouse and the cost associated with opening and operating the warehouses and the plants.

The constraint equation (3.8) ensures that the demands of all customers are satisfied by the open warehouse. Constraint equation (3.9) guarantees that the total customer demands satisfied by an open warehouse do not exceed the capacity of the warehouses. The constraint equation (3.10) ensures the non-negativity restrictions on the corresponding decision variables and finally the constraint equation (3.12) enforces the integrity restriction on the binary variable.

Even though the model explicitly consider just one product or one family of products, it can be easily extended to handle multiple products or family of products by adding an index to the decision variable  $Y_{ij}$  for the different products and modifying the corresponding constraints accordingly.

### 3.11 SUPPLY CHAIN NETWORK OPTIMIZATION MODEL

In the past, researchers concentrated on designing single component of the overall – production – distribution system, such as purchasing, production and scheduling, inventory, warehousing or transportation. To date there exists little work that addresses the integration of such single components in to overall supply chain. Later, researchers concentrated on integrating two sub-systems of a whole supply chain. Some developed models integrating buyer – vendor coordination, production – distribution coordination and inventory distribution co-ordination. The need of the hour is integration of all the constituents of the supply chain. Optimization of the complete supply chain needs to address the following:

- The number, location, capacity and type of manufacturing plants and warehouses to use:
- The set of suppliers to select;
- The transportation channels to use:
- The amount of raw materials and products to produce and ship among suppliers, plants, warehouses and customers: and
- The amount of raw materials, intermediate products and finished goods to hold at various locations in inventory.

Many models have been formulated for the strategic design of supply chains. Among all these models, the mixed integer programming models are popular. The model by Geoffrion and Graves (1974) represents a production – distribution system with several plants with known capacities, distribution centers and a number of customer zones; discrete candidate locations are considered for opening Distribution Centre. Fixed and Variable (Linear) costs for Distribution Centre, Production costs and linear transportation costs are included in the objective function. The constraints considered in the model are capacity at plants, customer demand satisfaction, single sourcing by customer zone, bounds on the throughput at Distribution Centre and linear configuration constraints on binary variables (Logical Constraints), While solving this model, some binary variables are temporarily

## NOTES

fixed by solving a 'master Problem'; then the remaining problem may be addressed as a set of classical transportation problems, one for each commodity. This process is iterative and develops lower and upper bounds on the complete problem; it stops when the difference between the upper bound and the lower bound is less than or equal to a specified value.

Cohen and Moon (1991) present a mixed integer multi commodity model to find inbound raw material flows, assignment of product lines and specification of production volumes, and bound finished product flows in a production – distribution network. Here the location of facilities (Vendors, plants and distribution centers) is given and fixed. They have given an algorithm to solve some production – distribution models piece wise linear concave costs of production. However, the model is very restricted because the plant-loading problem under consideration assumes a fixed facility network configuration, with the Distribution Centre as the final demand points. The model contains binary variables for assigning products to plants and for determining the part of the concave curve of production costs to be applied. By this model, the solution of small problems with 60 binary variables in 49 seconds of CPU time is possible.

Arntzen et al (1995) present a multi – period, multi commodity mixed integer model to optimize a global supply chain. Its objective function includes variable production, inventory and shipping costs; fixed production and production 'style' costs and savings from credit earned for re – exporting products. All the costs considered in the objective function are weighted by a factor  $\alpha$ . The objective function also contains production time and transportation time terms weighted by a factor  $(1 - \alpha)$ . The constraints include customer demand satisfaction, balance of materials, global Bill of materials, throughput capacity at each facility per production style, System configuration constraints and bounds on decision variables. Offset trade and local content, duty drawback and duty relief are the international constraints included in the model.

Cole (1995) developed a Strategic Inventory Location Allocation System (SILAS), In which he presented a multi commodity, multi echelon, single period mixed integer model for optimizing a strategic production – distribution system. The specialty about this model is the consideration of normal demands and stochastic customer service by carrying safety stock, together with warehouse location, customer allocation and channel selection. This model is applicable when safety stock costs are significant. In the model, customer service is considered as the fraction of customer demand satisfied routinely from warehouse stock and by limiting delivery time and distance for serving each customer.

The objective function includes plant fixed and closing costs, plant production and inventory costs, trucking transportation and inventory costs, fixed operating costs and closing costs of depots, variable warehouse costs and total average warehousing inventory costs. The constraints include plant production capacity, logical constraints on channels and warehouses, channels capacity, customer demand satisfaction, single sourcing of

customers by distribution channel and product, limits on the distance and time from a warehouse to serve a customer, maximum on – hand inventory at warehouses, warehouse storage and handling capacities per warehouse type, balance constraints at warehouses, warehouse single sourcing by distribution channel and product, a set of constraints describing demand variances at warehouses, a set of linearized safety stock constraints, and bounds on decision variables.

Let us consider a production and distribution problem to maximize the total net profit in a multi – plant, multi – retailer, multi – item and multi – period logistic environment and propose an optimization model. Model considers plants that produce multi items with a limited capacity over time. For each product type, it is necessary to incur a fixed set-up cost for a lot – for – lot basis, not dependent on the realized volume, which captures the setup cost for the whole plant. It is possible to store excess production at the plant warehouse. There is no storage capacity limit at the plant. The manufactured products are directly delivered to retail outlets. The movement of vehicle incurs a fixed cost related to vehicle depreciation and insurance, cost of capital, order cost and driver wages and a variable transportation cost dependent on transported item, its quantity and traveled path. It is assumed that the firm can change the effect size freely without extra cost. The demand for an item in a period at a retail outlet is expressed as ‘ core demand ‘ and ‘ forecasted demand ’. It is assumed that the demands are given and fixed without variation. The unsatisfied forecasted demand at the retail outlet is considered as stock out. Back ordering is not allowed. The problem is to plan production and distribution so as to maximize the total net profit of a supply chain over a planning horizon.

### The Model

A mixed integer model is developed to solve the above-described problem in an integrated way. In presenting the model, the following notations are used. It is assumed that the size of packing box is the same for all items.

### Indices

$i$  = Plants,  $i \in \{ 1, \dots, I \}$

$j$  = retail outlets,  $j \in \{ 1, \dots, J \}$

$p$  = product items,  $p \in \{ 1, \dots, P \}$

$t$  = time periods,  $t \in \{ 1, \dots, T \}$

### Parameters

$C_{i,p}$  = unit processing cost of item  $P$  at plant  $i$

$S_{i,p}$  = Set up cost for item  $P$  at plant  $i$  ( $C_p = \sum_i C_{i,p} / I$ )

$O_{i,p}$  = unit processing time of item  $P$  at plant  $i$ .

$u_{i,p}$  = set up time for item  $P$  at plant  $i$

$h_{i,p}$  = unit holding cost of item  $P$  per period at plant  $i$  ( $h_p = \sum_i h_{i,p} / I$ )

# NOTES

$L_i$  = available production capacity at plant  $i$  in time in any given period  
 $d_{jp}$  = unit transportation cost of item  $P$  from plant  $i$  to retail outlet  $j$   
 $F$  = fixed cost per vehicle  
 $B$  = vehicle available capacity  
 $D_{jpt}$  = Core Business demand for item  $P$  at retail outlet  $j$  in period  $t$ .  
 $Q_{jpt}$  = forecasted demand for item  $P$  at retail outlet  $j$  in period  $t$ .  
 $R_{jp}$  = unit selling price of item  $P$  at retail outlet  $j$  ( $R_p = \sum_j R_{jp} / J$ )  
 $h_{jp}$  = unit holding cost per period at retail outlet  $j$  for item  $P$   
 $w_j$  = storage capacity at retail outlet  $j$   
 $v_{jp}$  = unit stock out cost of item  $P$  at retail outlet  $j$  ( $V_p = \sum_j V_{jp} / J$ )

## Variables

$X_{iP_t}$  = amount of item  $P$  produced at plant  $i$  in period  $t$ .  
 $Q_{ijP_t}$  = amount of item  $P$  delivered from plant  $i$  to retail outlet  $j$  in period  $t$ .  
 $Y_{iP_t} = \begin{cases} 1 & \text{if plant } i \text{ must be set up for item } P \text{ in period } T \\ 0 & \text{otherwise} \end{cases}$   
 $a_{iP_t}$  = inventory level for item  $P$  at plant  $i$  in period  $t$  ( $A_{pt} = \sum_i a_{iP_t}$ )  
 $a_{jP_t}$  = inventory level for item  $P$  at retail outlet  $j$  in period  $t$   
 $Z_{ijt}$  = Number of vehicles required for delivering from plant  $i$  to retail outlet  $j$  in period  $t$ .

The integrated production and distribution-planning problem may therefore be formulated as:

$$\begin{aligned}
 \text{Max } & \sum_j \sum_P R_j K \sum_t (a_{jP_{t-1}} + \sum_i q_{iP_t} - a_{jP_t}) - \{ \sum_i \sum_P C_{iP} \sum_t X_{iP_t} + \sum_i \sum_P S_{iP} \sum_t Y_{iP_t} + \\
 & \sum_i \sum_P h_{iP} \sum_t a_{iP_t} + \sum_j \sum_P h_{jP} \sum_t a_{jP_t} + \sum_j \sum_P V_{jP} \sum_t (Q_{jP_t} - a_{jP_{t-1}} - \sum_t Q_{ijP_t} + a_{jP_t}) \\
 & + g \sum_i \sum_j \sum_t Z_{ijt} + \sum_i \sum_j \sum_P d_{ijP} \sum_t q_{iP_t} \} \tag{3.13}
 \end{aligned}$$

## Subject to

$$\left( \sum_P O_{iP} X_{iP_t} + \sum_P U_{iP} Y_{iP_t} \right) \leq L_i \quad \forall i, t, \dots \tag{3.14}$$

$$X_{iP_t} \leq M Y_{iP_t} \quad i, P, t \tag{3.15}$$

NOTES

$$a_{ip_t} = a_{ij_p_{t-1}} + X_{ipt} - \sum_j \dot{O}_{q_{ipt}} \quad , p,t,\dots\dots\dots (3.16)$$

$$a_{jp_{t-1}} = \sum_i \dot{O}_{q_{ij_p_t}} - d_{jpt} e'' E_{jpt} \quad j, p,t,\dots\dots\dots (3.17)$$

$$a_{jp_{t-1}} + \sum_i \dot{O}_{q_{ij_p_t}} - a_{jpt} d'' F_{jpt} \quad j, p,t,\dots\dots\dots (3.18)$$

$$\sum_j \dot{O}_{a_{jp_t} d''} w_j \quad j,t,\dots\dots (3.19)$$

$$Z_{jt} e'' \sum_i \dot{O}_{q_{ijpt}} \quad i,j,t,\dots\dots (3.20)$$

$$a_{ip_0} = 0, a_{jp_0} = 0 \quad i,j,p,\dots\dots (3.21)$$

$$x_{jpt} e'' 0, q_{jpt} e'' 0, a_{ipt} e'' 0, a_{jpt} e'' 0, Y_{ipt} \in \{0,1\}, \\ Z_{ijt} e'' 0 \text{ and all are integers } \quad i,j,p,t,\dots\dots (3.22)$$

The objective function (3.13) expresses the total net profit over the time periods computed by subtracting total cost from total revenue. The total revenue is simply the selling income at retail outlets. The total cost includes the cost of production, inventory, stock-out, and distribution. Constraint (3.14) represents the capacity restriction on production at a plant. Constraint (3.15) used to force the binary-set up variables. The parameter M is a sufficiently large positive member. Constraint (3.16) assures the inventory balance in periods at a plant. Constraint (3.17) requires that the core business demand for an item at a retail outlet in any period must be satisfied from its inventory carried forward and (3.18) assures that the actual demand for any item at a retail outlet in any period cannot exceed the forecasted demand in that period. Constraints (3.17) and (3.18) determine the inventory levels of items at retail outlets. Constraint (3.19) represents the restriction on storage capacity at a retail outlet. Constraint (3.20) determines the number of vehicles required for a delivery. Constraint (3.21) expresses the initial inventory levels at both plants and retail outlets. Constraint (3.22) enforces the restrictions of non-negativity, integer, and binary nature on the decision variables.

Optimal production quantities  $X_{ipt}$ , and optimal delivery quantities  $q_{jpt}$  are obtained by solving the model. The model essentially utilizes the production capacities at plants up to the limits to increase revenue, but it reduces production quantity and allows stock-outs at retail outlets when the marginal unit cost of an item exceeds its marginal revenue.

# NOTES

## Chapter Summary

Through Chapter-3, we have understood the meaning of distribution network design. Distribution network design decisions are most important supply chain decisions. Also discussed the role and factors that influence network design. We know, distribution accounts more than 20% of the cost of manufacturing a product. To minimize the production and distribution cost, optimum network design is the need of the hour. There are several factors that are influencing the network design decisions response time, product variety, product availability, customer experience, order visibility and returnability are some of the important factors.

Various design options available for network design are also discussed in detail while designing a network, value addition must be kept in mind. Models for facility location and allocation have been brought out with a suitable example. Designing network under uncertain demand and supply needs special treatment. Decision tree approach in designing the network has been brought out using an example. Finally distribution network model has been designed using mixed integer programming method. Students are advised to read journals to understand the various mathematical models available for distribution.

## Review Questions

1. Bring out the importance of distribution network design.
2. What is the role of distribution in the supply chain.
3. What are the factors affecting the distribution network?
4. List the design options that are available for a distribution network.
5. Discuss the various distribution choices giving suitable examples.
6. Discuss value addition in the supply chain.
7. What information's are used in location decisions?
8. Explain gravity location problem with an example.
9. What are the techniques used for solving multi facility location problems?
10. Discuss location models that are solved using integer-programming method.
11. Explain demand allocation to facilities in location decisions.
12. Explain the impact of uncertainty on network design.
13. How will you evaluate network design using decision trees?
14. Describe the distribution center location models.
15. Design a distribution center location model assuming that fixed costs as well as variable cost for outbound flows are associated with each distribution behaviour.
16. Discuss the supply chain network optimization models.
17. What types of distribution networks are typically best suited for commodity items?



NOTES

18. A speciality chemical company is considering expanding its operations into Bombay where five companies dominate the consumption of speciality chemicals. What sort of distribution network should this company utilize?
19. What differences in the retail environment may justify the fact that the fast moving consumer goods supply chain in India has for more distributors than in the western countries?
20. What are the major financial uncertainties faced by an electronic components manufacturer deciding whether to build plant in Bangalore or Bombay?
21. A large corporation has employed a campus plan layout for its Head quarters. A centralized heating system is to be installed, which will heat each of the four buildings. Considering the cost of installation and the heat losses, it is agreed that the cost for the system is proportional to the square of the Euclidean distance between the heating facility and each building. The buildings to be served by the heating system are located as follows:  
 $P_1 = (20,8)$ ,  $P_2 = (15,10)$ ,  $P_3 = (25,12)$  and  $P_4 = (8,12)$ . The BTU requirements per hour are 15000, 6000, 5000 and 18000 respectively. Find the least-cost location using gravity model for the central heating facility.
22. Let four existing facilities be located at  $P_1 = (4,2)$ ,  $P_2 = (5,0)$ ,  $P_3 = (5,8)$  and  $P_4 = (6,10)$  with  $w_1=2$ ,  $w_2=1$ ,  $w_3=2$  and  $w_4=2$ . Determine the optimum location for a single new facility when cost is proportional to squared Euclidean distance.
23. Consider four plants which are manufacturing a product and they have the demand in four cities. The plant capacities, market demand, variable production and transportation cost per unit shipped are given below.

Plants	Demand City				Capacity
	City 1	City 2	City 3	City 4	
Plant 1	20	10	14	12	2020
Plant 2	18	16	13	8	2600
Plant 3	12	18	16	12	1950
Plant 4	14	10	11	10	1075
Demand	1975	1855	1900	1915	7645

Allocate the demand using:

- (i) Least cost method
- (ii) Vogel's approximation method
- (iii) Check for optimality using MODI method.

# NOTES

## UNIT IV

## NOTES

### PLANNING DEMAND, INVENTORY AND SUPPLY

#### LEARNING OBJECTIVES

After reading this chapter you will be able to:

1. Understand the role of demand forecasting in the supply chain.
2. Assess the aggregate plan for the company to meet the expected demand.
3. Manage the predictable change in demand that can be forecasted.
4. Appreciate the role of cycle inventory in the supply chain.
5. Manage the uncertainty in demand through safety inventory in the supply chain.
6. Determine the optimum level of product availability.
7. Better understand the coordination required in the operation of the supply chain.

#### 4.1 INTRODUCTION

In Chapter-3 we have studied the various design options available for designing network. We have understood the network design using illustrations. Operational part of network design demands, planning the demand using appropriate forecasting techniques, managing inventory to reduce the carrying cost and ensure supply in the supply chain. In this chapter we are going to study the forecasting method using simple examples. After forecasting demand, aggregating the demand for planning is required. This is discussed using various options. The roles of predictability and cycle inventory were also brought out using examples, and illustrations. Finally the coordination required in the effective management of supply chain is discussed in this chapter.

#### 4.2 OVERVIEW OF DEMAND FORECASTING IN THE SUPPLY CHAIN

Decision making in supply chain is based on the forecasts of future demand. Forecasting customer demand is the first step a manager must take in designing the supply chain. Some of the important decisions, which are taken in supply chain, that are based on forecast are: production decisions, marketing decisions, finance decisions and personal decisions.

## NOTES

Scheduling, inventory control, aggregate planning and purchasing are the decisions with regard to production decisions. Sales – force allocation, promotion and new product introductions are marketing decisions. Investment decisions including budgetary planning are concerned with financial decisions. Workforce planning, hiring and firing and layoff are personnel decisions. These decisions utilize forecasts for their enhancement through collaborative forecasting among supply chain partners.

In a collaborative forecasting environment, the error in forecasting demand can be controlled. Demand for the immediate future is more accurate than the long-term period forecast. And also the aggregation across many companies ensures greater accuracy in forecast. All forecasts deal with four major variables. They are supply, demand, product characteristics and competitive environment. The uncertainty in supply makes forecasting more difficult. Markets where there is little historical data and lots of variability are the most difficult when it comes to demand forecasting. Product features forms the characteristics of product. These characteristics influence customer demand. Competitive environment decides the market share. Forecast should take into account the promotions and price wars that will be initiated by competitors.

Companies must be knowledgeable about the factors that are related to the demand forecast. Past demand, lead-time, promotion efforts, economy and price discounts are some of the factors. Before adopting a particular methodology of forecast, companies must understand these factors. There are four basic methods to use when doing forecasting. Most forecasts are done using various combinations of these four methods. According to Chopra and Meindl the four types of forecasting are: qualitative, causal, time series and simulation.

Qualitative methods rely upon a person's subjective opinion or perception about a market. When there is a little historical data, these qualitative methods are working very well. When new products are introduced, virtually there must be no historical data available. In such situations, expert's opinion through brainstorming or Delphi could be obtained. Experts foresee what will happen in the future and give their opinions based on their intuition. They help to some extent to forecast the demand for the future.

Time series methods use historical data. Here the basic expectation is what happened in the past will happen in the future also. These methods will be effective if the demand pattern is stable over a period of time. Mathematical techniques such as moving average and exponential smoothing techniques are generally used to forecast the future demand. Trend and seasonal adjustments are appropriately made during forecasting to get the more accurate results. Software packages are available for all these techniques.

Causal forecasting methods assume that the demand forecast is highly correlated with certain factors in the environment. For instance, demand for commercial loan is often closely correlated to interest rates. When interest rates are expected to be reduced, loan

amount is expected to go up. Similarly price and demand are correlated highly. If prices are lowered, demand can be expected to fall. Companies can thus use causal methods to determine the impact of price promotions on demand.

Simulation methods use combination of causal and time series methods to imitate the behavior of consumers under different circumstances. Using simulation, a firm can combine time series and causal methods to answer such questions as: what will the impact be of a competitor opening a store nearby?

Some companies use only one of these methods to do forecasts. Most companies use combination of these techniques to get their forecasted demand. Studies have shown that combining the results of various methods provide less error in forecasting the demand. Regardless of the forecasting methods used, when doing forecasts and evaluating their results, it is important to keep several things in mind. The short-term forecasts are inherently more accurate than long-term forecasts. This must be kept in mind during forecasting. Most long range, multi-year forecasts are highly speculative. It is to be kept in mind that forecasts are always wrong to a greater extent. There are no perfect forecasts and business need to assign some expected degree of error to every forecast. Therefore while planning for a supply chain, demand has to be forecasted with care and the error in forecasting should be contained for effective supply chain performance.

Let us illustrate the various methods of forecasting using examples:

### Illustration 1: Simple exponential smoothing

Suppose that a demand level of 1200 units was forecasted for the current month. Actual demand for the current month is 1000 units. The value of the smoothing constant is 0.25. the expected value for demand next month is forecasted as below:

$$\text{New forecast } (F_{t+1}) = \hat{\alpha}D_t + (1-\hat{\alpha}) F_t$$

where t = time period

$\hat{\alpha}$  = exponential smoothing constant

$D_t$  = Demand at period t

$F_t$  = Forecast for period t

$(F_{t+1})$  = Forecast for the next period.

Therefore  $F_t = 0.25(1000) + 0.75(1200)$

$$= 250 + 900 = 1150 \text{ units.}$$

Let us extend the number of period and forecast using smoothing technique for further understanding.

# NOTES

## Illustration 2

The following quarterly data represent a demand time series for a product:

Quarter				
	1	2	3	4
Last year	1200	800	1000	1200
This year	1400	900		$F_3 = ?$

We are interested in forecasting the third quarter of this year. Let us assume that  $\alpha = 0.2$  and the previous forecast is determined from the average for the four quarters of last year. Hence  $F_0 = (1200 + 800 + 1000 + 1200)/4 = 1050$ . We begin forecasting the first quarter of this year and continue the computations forward until we reach the third quarter.

$$F_1 = 0.2(1200) + 0.8(1050)$$

(Assume  $D_0 = 1200$  i.e fourth quarter demand of previous year)

Therefore  $F_1 = 1080$

$$F_2 = 0.2(1400) + 0.8(1080) = 1144$$

$$F_3 = 0.2(900) + 0.8(1144) = 1095$$

Summarizing,

Quarter				
	1	2	3	4
Last year	1200	800	1000	1200
This year	1400	900		
Forecast	1080	1144	1095	

The value of  $\alpha$  should be chosen very carefully. The higher the value of  $\alpha$ , the greater is the weight placed on the more recent demand levels. This permits the model to respond more quickly to change in the time series. The lower the  $\alpha$  values, the greater is the weight given to demand history in forecasting future demand and the longer is the time lag in responding to fundamental changes in the demand level. Low values provide very 'stable' forecasts that are not likely to be heavily influenced by randomness in the time series.  $\alpha$  values typically range from 0.01 to 0.30. A good rule to follow when searching for an  $\alpha$  value is to choose one that will allow the forecast to track major changes occurring in the time series and average the random fluctuations.  $\alpha$  should minimize the forecast error.

**Illustration 3****(Trend Correction)**

Let us consider the previous example and forecast the demand for third period correcting the trend. The trend corrected version of the model has a set of equations that can be stated as:

$$S_{t+1} = \hat{\alpha} D_t + (1 - \hat{\alpha})(S_t + T_t)$$

$$T_{t+1} = \hat{\alpha}(S_{t+1} - S_t) + (1 - \hat{\alpha})T_t$$

$$F_{t+1} = S_{t+1} + T_{t+1}$$

where  $F_{t+1}$  = trend – corrected forecast for period t+1

$S_t$  = initial forecast for period t

$T_t$  = trend for period t

$\hat{\alpha}$  = trend smoothing constant.

Let us use the arbitrary starting value of  $S_t = 1050$  (average demand values of previous year) and  $T_t = 0$  (no trend). The smoothing constant  $\hat{\alpha}$  is assumed 0.25 and  $\hat{\alpha}$  remains the previous value of 0.2. Now forecast using the set equations given above.

$$S_1 = 0.2(1200) + 0.8(1050 + 0) = 1080$$

$$T_1 = 0.25(1080 - 1050) + 0.75(0) = 7.5$$

$$F_1 = 1080 + 7.5 = 1087.5 \approx 1088$$

$$S_2 = 0.2(1400) + 0.8(1088) = 1150$$

$$T_2 = 0.25(1150 - 1080) + 0.75(7.5) = 17.5 + 5.63 = 23.13$$

$$F_2 = 1150 + 23.13 = 1173.13 \approx 1173$$

$$S_3 = 0.2(900) + 0.8(1150 + 23.13) = 1118.51119$$

$$T_3 = 0.25(1119 - 1150) + 0.75(23.13) = -7.88 + 17.35 = 9.47$$

$$F_3 = 1119 + 9.47 = 1128.5 \approx 1129$$

From illustration 2, we got  $F_3$  as 1095. When we corrected the trend we got  $F_3$  as 1129. Let us now discuss how to forecast considering level, trend and seasonality using HOLT-WINTER's trend and seasonality method.

**Illustration 4: (HOLT – WINTER'S MODE)**

If the data pattern is stationary, then the moving average and single exponential smoothing methods are appropriate to find out forecast from the past data. When the data is exhibiting trend and level, the trend correction as illustrated above can be used. However, in many cases, Holt-winter's trend and seasonality is found to be more appropriate. In this model level, trend, seasonality and the forecast are expressed as follows:

# NOTES

Level,  $L_t = (\hat{\alpha}D_t/S_{t-s}) + (1-\hat{\alpha})(L_{t-1} + T_{t-1})$

Trend,  $T_t = \hat{\alpha}(L_t - L_{t-1}) + (1-\hat{\alpha})T_{t-1}$

Seasonality,  $S_t = (\hat{\alpha}D_t/L_t) + (1-\hat{\alpha})S_{t-s}$

Forecast  $F_{t+m} = (L_t + T_t * m) S_{(t-s)+m}$

Where  $s$  = the length of seasonality (no of months or quarter)

$L_t$  = the level of the series

$T_t$  = the trend component

$S_t$  = the seasonality component

$F_{t+m}$  = forecast for  $m$  periods ahead.

Initialization is done as follows:

$$L_s = 1/s(D_1 + D_2 + \dots + D_s)$$

$$T_s = 1/s(D_{s+1} - D_1)/s + (D_{s+2} - D_2)/s + \dots + (D_{s+s} - D_s)/s$$

$$S_1 = D_1/L_s, S_2 = D_2/L_s, \dots, S_s = D_s/L_s$$

Table 4.1 contains the calculations for an example situation using Holt-Winter's trend and seasonality method. The data set of Table 4.1 indicates that there is a seasonality in every 4 periods and this seasonal variation is associated with trend.

$$\hat{\alpha} = 0.25, \hat{\alpha} = 0.05, \hat{\alpha} = 0$$

**Table 4.1 Using Holt-winter's model to forecast for the 13<sup>th</sup> period.**

Period $t$	Actual demand $D_t$	Level $L_t$	Trend $T_t$	Seasonal $S_t$	Forecast $F$
1	350			0.927	
2	380			1.007	
3	430			1.1391	
4	350	377.5	9.375	0.927	
5	380	392.64	9.663	0.927	358.63
6	400	401.03	9.599	1.007	372.93
7	500	417.71	9.953	1.391	413.50
8	380	423.23	9.711	0.927	594.88
9	475	452.81	10.705	0.927	401.34
10	510	474.25	10.733	1.007	429.68
11	585	468.88	9.928	1.1391	488.38
12	475	487.21	10.349	0.927	541.53
13					461.24
14					511.46
15					590.35



**Computations**

Initial values: (s=4)

$$L_4 = \frac{1}{4}[(D_1 + D_2 + D_3 + D_4)] = (350 + 380 + 430 + 350)/4 = 377.5$$

$$\begin{aligned} T_4 &= \frac{1}{4}[(D_{4+1} - D_1)/4 + (D_{4+2} - D_2)/4 + (D_{4+3} - D_{3/4}) + (D_{4+4} - D_{4/4})] \\ &= \frac{1}{4} [(380 - 350)/4 + (400 - 380)/4 + (500 - 430)/4 + (380 - 350)/4] \\ &= \frac{1}{4} [7.5 + 5 + 17.5 + 7.5] \\ &= 9.375 \end{aligned}$$

$$S_1 = D_1/L_4 = 350/377.5 = 0.927 ; S_2 = D_2/L_4 = 380/377.5 = 1.007$$

$$S_3 = D_3/L_4 = 430/377.5 = 1.1391 ; S_4 = D_4/L_4 = 350/377.5 = 0.927$$

$$\begin{aligned} L_5 &= (\hat{\alpha} * D_5 / S_{5-4}) + (1 - 0.25)(L_{5-1} + T_{5-1}) \\ &= (0.25 * 380 / 0.927) + 0.75(377.5 + 9.375) \\ &= (102.48) + 290.16 = 392.64 \end{aligned}$$

$$\begin{aligned} T_5 &= \hat{\alpha}(L_5 - L_4) + (1 - \hat{\alpha})T_4 \\ &= 0.05(392.64 - 377.5) + (1 - 0.05)9.375 \\ &= 0.757 + 8.91 = 9.663 \end{aligned}$$

$$\begin{aligned} S_5 &= \tilde{\alpha}(D_5 / L_5) + (1 - \tilde{\alpha})S_{5-4} \\ &= 0(380/392.64) + 1(0.927) \\ &= 0.927 \end{aligned}$$

$$\begin{aligned} F_{4+1} &= (L_4 + T_4 * 1)S_{(4+1)+1} = F_5 \\ &= (377.5 + 9.375 * 1)0.927 \\ &= 358.63 \end{aligned}$$

$$\begin{aligned} L_6 &= (0.25 * 400 / 1.007) + 0.75(392.64 + 9.663) \\ &= 99.305 + 301.723 = 401.03 \end{aligned}$$

$$\begin{aligned} T_6 &= 0.05(401.03 - 392.64) + 0.95(9.663) \\ &= 0.4196 + 9.1799 = 9.599 \end{aligned}$$

$$S_6 = 0 + 1(1.007) = 1.007$$

$$\begin{aligned} L_7 &= (0.25 * 500 / 1.1391) + 0.75(401.03 + 9.599) \\ &= 109.74 + 307.97 = 417.71 \end{aligned}$$

$$\begin{aligned} T_7 &= 0.05(417.71 - 401.03) + 0.95(9.599) \\ &= 0.8341 + 9.119 = 9.953 \end{aligned}$$

$$\begin{aligned} L_8 &= 0.25 * 380 / 0.927 + 0.75(417.71 + 9.953) \\ &= 102.481 + 320.747 = 423.228 \end{aligned}$$

## NOTES

$$T_8 = 0.05(423.23 - 417.71) + 0.95 (9.953)$$

$$= 0.256 + 9.455 = 9.7114$$

$$L_9 = 0.25*475/0.927 + 0.75(423.23 + 9.711)$$

$$= 128.10 + 324.71 = 452.81$$

$$T_9 = 0.05(452.81 - 423.23) + 0.95(9.711)$$

$$= 1.4791 + 9.225 = 10.7046$$

$$L_{10} = (0.25*510/1007) + 0.75 (452.81+10.705)$$

$$= 126.6+347.64 = 474.25$$

$$T_{10} = 0.05(474.25 - 452.81) + 0.95(10.705)$$

$$= 1.0722 + 9.6613 = 10.733$$

$$L_{11} = 0.25*585/1.1391 + 0.75(474.25 + 10.733)$$

$$= 105.14 + 363.74 = 468.88$$

$$T_{11} = 0.05(468.88 - 474.25) + 0.95 (10.733)$$

$$= -0.268 + 10.1964 = 9.928$$

$$L_{12} = 0.25*475/0.927 + 0.75(468.88 + 9.928)$$

$$= 128.10 + 359.11 = 487.21$$

$$T_{12} = 0.05(487.21 - 468.88) + 0.95(9.928)$$

$$= 0.917 + 9.432 = 10.349$$

$$F_{12+2} = L_{12} + T_{12} (2) S_{10(m=2)}$$

$$F_{12+2} = (487.21 + 10.349 * 2) 1.007 = 511.46$$

$$F_{12+3} = (L_{12} + T_{12} (3) S_{11(m=3)})$$

$$= [487.21 + 10.349*3] 1.1391$$

$$= 590.35$$

### Illustration5: Forecast error

We know that forecast contains error. Hence we are interested in finding out the forecast value range within which the actual demand may occur. This requires a statistical forecast. The forecast error is the difference between the actual demand and the forecast value. It is properly expressed statistically as a standard deviation, variance or mean absolute deviation. We are going to see the application of standard deviation in estimating the statistical demand. Let us recall an example illustrated earlier:

Quarter				
	1	2	3	4
Last year	1200	800	1000	1200
This year	1400	900		
Forecast	1080	1144	1095	

Now, let us estimate the standard error of the forecast for the two periods (N=2) for which the forecast has been made and actual demand values are available. Assuming that demand is normally distributed about the forecast, we can develop a 95 percent confidence band around the third quarter forecast.

$$\text{The standard error} = \sqrt{\frac{\sum_t (D_t - F_t)^2}{N-1}}$$

$$= 402$$

The best estimate for the actual demand level (D) for the third quarter with  $Z_{0.95\%} = 1.96$  from a normal distribution table is:

$$\begin{aligned} D &= F_3 \pm Z (S_e) \\ &= 1095 \pm 1.96 (402) \\ &= 1095 \pm 788 \end{aligned}$$

Hence, the 95 percent confidence range for the forecast of actual demand is  $307 < D < 1883$ .

### Illustration6: Decomposition method

Decomposition forecasting is built on the philosophy that a historical sales pattern can be decomposed into four categories: trend, seasonal, cyclical and random. Trend represents long term movement in sales caused by various factors: seasonal variation represents the peaks and valleys in the time series. Cyclical variation is the long term variations in the demand pattern. Random variation is that portion of total sales that is unaccounted for by trend, seasonal or cyclical components. Decomposition method combines all these effects as given below:

$$F = T * S * C * R \text{ Where}$$

F= Demand forecast

## NOTES

S= Seasonal component

C= Cyclical component

T= Trend component

R= Random component or residual.

In practice, the model is often reduced to only trend and seasonal components. This is due to a well specified model has a random component of 1.0(R). Same way the cyclical component is also considered as 1.0(C), because the model is usually updated when new data become available. Trend component may be obtained by least square method. The mathematical expression for a linear trend is  $T = a+bt$ , where t is time, T is the average demand level and 'a' and 'b' are co-efficients to be determined.

These co-efficients are obtained by:

$$a = D_t - bt$$

N = the number of observations

$D_t$  = the actual demand in time period t

D = average demand for Ntime periods

t = average of t over N time periods.

The seasonal component can be found by the following equation:

$$S_t = D_t / T_t \text{ where}$$

$S_t$  = seasonal component in time period t

$T_t$  = trend component from  $T=a+bt$

Finally, the forecast is made for time period t in the future as follows:

$$F_t = (T_t) (S_{t-s}) \text{ where}$$

$F_t$  = the forecasted demand in time period t

s = number of periods in the seasonal cycle.

Let us illustrate this method using the following example: A manufacturer has the demand in the past twelve periods is given in table4.2

**Table 4.2 Sales data for twelve periods**

Period	1	2	3	4	5	6	7
Demand	950	1200	1400	1500	1000	1250	1500
Period	8	9	10	11	12		
Demand	1600	1100	1300	1480	1650		

**NOTES**

By observing the data it is found that 4 period seasonal cycle(s) is available in the data. The trend component, seasonal component and forecast values are given in table 4.3.

**Table 4.3 Forecast values for Decomposition Method**

Time(t)	Sales(D <sub>t</sub> )	D <sub>t</sub> * t	t <sup>2</sup>	Trend(T <sub>t</sub> )	Seasonal S <sub>t</sub>
1	950	950	1	1143.46	0.8308
2	1200	2400	4	1176.92	1.0196
3	1400	4200	9	1210.38	1.1567
4	1500	6000	16	1243.84	1.2059
5	1000	5000	25	1277.30	0.7829
6	1250	7500	36	1310.76	0.9536
7	1500	10500	49	1344.22	1.1159
8	1600	12800	64	1377.68	1.1614
9	1100	9900	81	1411.14	0.7795
10	1300	13000	100	1444.60	0.8999
11	1480	16280	121	1478.06	1.0013
12	1650	19800	144	1511.52	1.0916

SUM 78            15930            108330            650

$\bar{D}_t = 15930/12 = 1327.5$              $t = 78/12 = 6.5$

Computations

$$b + \frac{\sum Dt(t) - N\bar{D}_t\bar{t}}{\sum t^2 - NE^2}$$

$$= \frac{108330 - (12)(1327.5)(6.5)}{650 - 12(6.5)^2}$$

**NOTES**

$$= 4785 / (650-507)$$

$$= 4785 / 143$$

$$= 33.46$$

$$a = \bar{D}_t - bt$$

$$= 1327.5 - 33.46 * 6.5$$

$$= 1327.5 - 217.49 = 1110$$

$$T_1 = 1110 + 33.46 * 1 = 1143.46$$

$$T_2 = 1110 + 33.46 * 2 = 1176.92$$

$$T_3 = 1110 + 33.46 * 3 = 1210.38$$

$$T_4 = 1110 + 33.46 * 4 = 1243.84$$

$$T_5 = 1110 + 33.46 * 5 = 1277.30$$

$$T_6 = 1110 + 33.46 * 6 = 1310.76$$

$$T_7 = 1110 + 33.46 * 7 = 1344.22$$

$$T_8 = 1110 + 33.46 * 8 = 1377.68$$

$$T_9 = 1110 + 33.46 * 9 = 1411.14$$

$$T_{10} = 1110 + 33.46 * 10 = 1444.60$$

$$T_{11} = 1110 + 33.46 * 11 = 1478.06$$

$$T_{12} = 1110 + 33.46 * 12 = 1511.52$$

$$T_{13} = 1110 + 33.46 * 13 = 1544.98$$

$$S_1 = D_4 / T_1 = 950 / 1143.46 = 0.8308 \quad S_2 = 1200 / 1176.92 = 1.0196$$

Similarly  $S_3$  to  $S_{12}$  are computed and entered into the table 4.3.

$$\text{Forecast value of 13}^{\text{th}} \text{ period} = F_{13} = T_{13} * S_{13-4}$$

$$\text{Therefore } F_{13} = 1544.98 * 1.0013$$

$$= 1546.988 \text{ H} \approx 1547.$$

This is how the decomposition method is used to forecast the future demand.

### 4.3 AGGREGATE PLANNING IN THE SUPPLY CHAIN

Once forecasting of demand is done, the next step is to plan for production of the demand. Initially production planning is made at the aggregate level. Aggregation is total demand of the company. A company may produce more than one component. Planning is made to produce all the varieties for a specified time period. Production capacity of a firm may be expressed in plant hours and the total demand is converted into plant hours and it

can be compared with the existing capacity of the plant for making arrangement. Aggregate planning is basically examining the capacity of the plant with the forecasted demand. This planning is at macro level and do not deal with the stock keeping unit (SKU's) levels. Therefore aggregate planning can be defined as the process by which a company determines levels of capacity, production, subcontracting, inventory, stock outs and even pricing over a specified time horizon. The ultimate goal is to maximize the profit.

Traditionally aggregate planning was considered as an internal affair and not considered as a part of supply chain. Aggregate planning, however is an important constituent of supply chain network. Aggregate planning requires input throughout the supply chain and its results have significant impact on supply chain. Good forecasts require collaborative approach. Collaboration with down stream supply chain partners help achieve good forecast. Forecast become input to aggregate planning. So, aggregate planning has an important role in the supply chain. Additionally, many constraints that are considered in aggregate planning come from supply chain partners, particularly upstream supply chain. Without these inputs from both downstream and upstream partners, aggregate planning can not be made successfully. Production plans for a firm decide the demand for suppliers and made the supply constraints for customers. Hence the aggregate planning is considered as foundation for creating plan within as well as outside the enterprise across the supply chain.

The aggregate planning consists of planning the production through various strategies. The strategies include, regular time production, over time production, inventory carrying, sub-contracting, back-ordering and hiring and firing of human resources. A company can have a single strategy or combination of any of the above mentioned policies in arriving their aggregate plan. The operational parameters to be identified in aggregate planning are:

1. Production rate: Quantity completed per unit of time (such as hour, day, week or per month)
2. Work force: Determination of number of workers per unit of capacity needed for production.
3. Over time: Over and above the regular time, the extra hours required per unit of time. Remember over time costs more to the company.
4. Machine capacity: Number of items that can be produced per unit of time.
5. Subcontracting: It is the kind of outsourcing. This may also increase / decrease the manufacturing cost. If technology is not available in the company, there is no other go other than sub-contracting.
6. Backlog: Back ordering is another policy with which the delivery is postponed by supplying later. Company may loose its good will.
7. Inventory: Producing at the constant rate, accumulating inventory during slack period and utilizing during peak period is a common phenomena noticed in the supply chain.

# NOTES

## 4.3.1 Aggregation Methods

The following are the pure strategies that are generally used in planning of production.

1. Varying the inventory levels
2. Varying the workforce size
3. Overtime working
4. Subcontracting
5. Back ordering

By combining two or more of the above strategies we can form a mixed strategy to meet the demand. The various methods used to solve the aggregate planning can be classified as: graphical method, chase method, transportation method, linear programming and simulation methods. Linear programming and transportation methods are discussed in production management course in detail. Students are advised to refer the same. The graphical method and chase method are discussed in this section.

### Graphical method

Graphical method is a very simple and straight forward method in determining the production rate to meet the demand based on the forecast. In this method cumulative demand values and cumulative production capacities are plotted on the same graph. The gap between the demand and production capacity in different periods could be easily read from the graph. This is a very old method and the major limitation in this method is non inclusion of cost.

**Example4.1:** ABC limited has forecasted its demand for eight periods as given below:

Period	1	2	3	4	5	6	7	8
Demand	300	260	450	650	480	320	300	420

- I. Plot the demand as a histogram. Determine the production rate required to meet average demand and plot the average demand on the graph.
- II. Plot the actual cumulative forecast requirements overtime and compare them with the available average forecast requirements. Indicate the excess inventories and backorders on the graph.

### Solution

- (i) The graphical representation of the demand is shown in fig4.1. The average is also shown as dotted line.
- (ii) The cumulative and average forecast are shown in fig4.2. At any period, if the cumulative forecast exceeds the cumulative production, there will be shortage and will be filled through back order. Otherwise, there will be an excess stock will be absorbed by future demands



NOTES

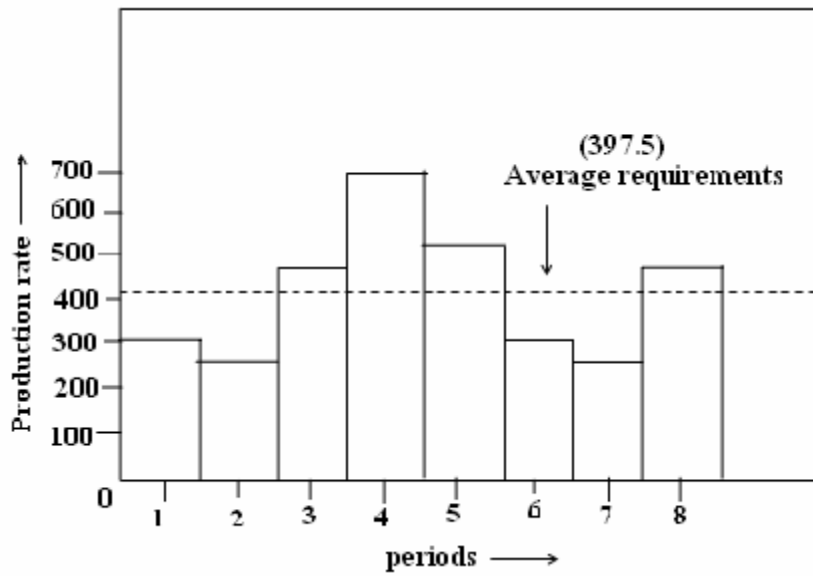
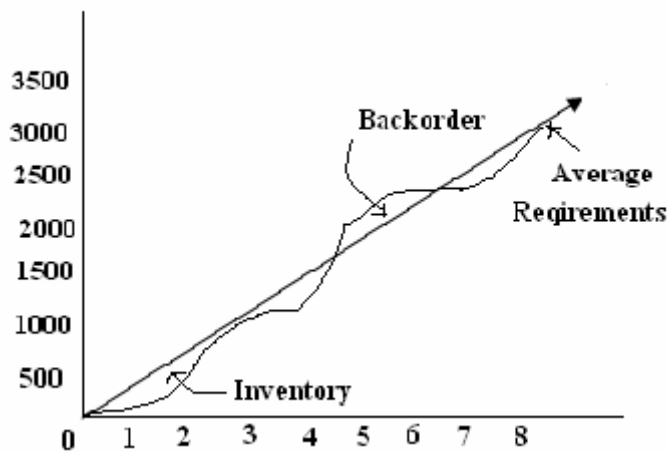

Figure 4.1 Histogram of fore cast and averag requirements



Demand	Cumulative demand
300	300
260	560
450	1010
650	1660
480	2140
320	2460
300	2760
420	3180

Figure 4.2 Cumulative and average forecast

## NOTES

**Example 4.2:** For the example 4.1, (i) Suppose that the firm estimates that it costs Rs.200 per unit to increase the production rate, Rs.250 per unit to decrease the production rate, Rs.50 per unit per period to carry the items on inventory and Rs.125 per unit if subcontracted. Compare the cost incurred, if pure strategies are followed. (ii) Given these costs, evaluate the following mixed strategy.

The firm decides to maintain a constant production rate of 300 units per period and permits 20% over rate when the demand exceeds the production rate. The incremental cost of overtime is Rs.30 per unit. It plans to meet the excess demand by hiring and firing of employees.

### Solution

#### (i) Pure strategies

**Plan 1:** Varying the work force size: In this pure strategy, the work force size will be varied to meet the actual demand. This is done by hiring or firing the employees as the case may be. The computations are shown in table 4.4. The cost of this plan is Rs.1,99,500/-.

**Table 4.4 Cost of varying the work force size**

Period	Demand forecast	Hiring cost	Firing cost	Total cost
1	300	-	-	-
2	260	-	10000	10000
3	450	38000	-	38000
4	650	40000	-	40000
5	480	-	42500	42500
6	320	-	40000	40000
7	300	-	5000	5000
8	420	24000	-	24000
Total				199500

**Plan 2:** Varying the inventory levels: Average demand is planned to produce at constant rate. This may result in excess of units during some periods and shortage during some other periods. The excess unit will be carried for other periods. Shortage is met with future inventory. The cost of the plan is given in table 4.5. The plan incurs a maximum shortage of 150 units during the period 5. Since a certain amount of uncertainty is involved in any forecast, the firm might decide to carry 150 units from the beginning of period 1 to avoid shortages. Adjusted inventories and cost of carrying inventories are shown. The total cost of the plan is Rs.69200/-

**Table 4.5 Varying Inventory Strategy**

Period	Forecast demand	Cumulative demand	Production rate	Cumulative production	Inventory	Adjusted inventory with 150 at the beginning	Cost of carrying inventory
1	300	300	398	398	98	248	12400
2	260	560	398	796	236	386	19300
3	450	1010	398	1194	184	234	11700
4	650	1660	398	1562	-68	82	4100
5	480	2140	398	1990	-150	0	0
6	320	2460	398	2388	-72	78	3900
7	300	2760	398	2786	26	176	8800
8	420	3180	398	3184	4	180	9000
Total							69,200

**NOTES**

**Plan3: Subcontracting:** If the company decides to produce some minimum at its premises and the rest be met with subcontracting, the option has to be examined for cost implications. In our example, we have a plan to subcontract at Rs.125 per unit, with the constant production rate of 260. The cost of such a plan is Rs.1,17,500/- as computed in table4.6.

**Table 4.6 Subcontracting Strategy**

Period	Demand forecast	Production rate	Subcontract units	Cost of subcontracting
1	300	260	40	5000
2	260	260	0	0
3	450	260	190	23750
4	650	260	390	48750
5	480	260	220	27500
6	320	260	60	7500
7	300	260	40	5000
8	420	260	160	20000
<b>Total</b>				<b>1,17,500</b>

The total costs of pure strategies are summarized below. Among the three plans, the plan2 (varying inventory levels) has the least cost.

Plan	Total cost
1	199500
2	69200
3	117500

# NOTES

## (ii) Mixed strategy

For the given problem, the mixed strategy has got the following components.

1. Maintain a constant production rate of 300 per period.
2. Permit 20% overtime when the demand exceeds the production rate. The incremental cost of overtime is Rs.30 per unit.
3. To meet any further demand, choose hiring / firing.

The computation of mixed strategy is given in table4.7.

**Table 4.7 Mixed Strategy Solution**

Period	Demand	Production rate(regular)	OT @ 20%	Hiring	Firing	End inventory	Cost of OT	Cost hiring	Cost firing	Cost inventory	Total cost
1	300	300	0	0	-	0	-	-	-	-	-
2	260	300	0	0	-	40	-	-	-	2000	2000
3	450	300	60	50	-	0	1800	10000	-	-	11800
4	650	300	60	240	-	0	1800	48000	-	-	49800
5	480	300	60	-	170	0	1800	-	42500	-	44300
6	320	300	60	-	120	40	1800	-	30000	2000	33800
7	300	300	0	-	-	40	0	-	-	2000	2000
8	420	300	60	20	-	0	1800	4000	-	-	5800

It can be seen from the table4.7 that the total cost of the plan is Rs.1,49,500/-. During period1 the demand is 300 units and the constant work force available in the company is capable of producing at the rate of 300 units per period. So, for the first period demand and production are the same. For second period the demand is 260 and the balance 40 units is carried as inventory. For the third period demand is 450. To meet this demand constant production of 300 units, inventory 40 units, overtime 60 units and by hiring 50 units, total demand of 450 is met. For the fourth period, 240 more units through hiring is arranged in addition to the existing 50 units through hiring. For the fifth period, we need only 480 units. Therefore out of 290 units, 170 is fired to meet this period demand. Similarly 6<sup>th</sup>, 7<sup>th</sup> and 8<sup>th</sup> period demand are also met.

Summary of the strategies is given below:

Strategy	Total cost(Rs)
Plan-1	1,99,500
Plan-2	69,200
Plan-3	1,17,500
Mixed strategy	1,49,500

From the above it is seen that the total cost for the plan-2 is minimum, which is pure strategy of changing inventory levels. It is recommended to use the varying inventory strategy for the company.

#### 4.4 MANAGING PREDICTABLE VARIABILITY

Customer demand and firms supply, both are vary due to various reasons. The demand of air conditioners will be very high during summer and woolen cloths will be in high demand during winter seasons. Likewise the demand may fluctuate from period to period. The reason for variation in demand and supply may be predictable or unpredictable. Predictable variability is change in demand that can be predicted. If the demand is stable, forecasting future requirement is relatively easy. With predictable variability company can maximize its profitability by responding properly to the variations in demand and supply.

A firm must decide how to handle predictable variability through capacity management, inventory management, subcontracting and using backlogs. Whereas while managing, the variations in demand can be managed using short time price discounts and trade promotions.

Supply of product can be controlled combining production capacity and inventory. Capacity can be managed using any one or more of the following:

1. Flexible work force
2. Seasonal work force
3. Subcontracting
4. Combination of flexible and dedicated capacity
5. Flexible manufacturing
6. Standardization and variety reduction
7. Inventory buildup during off-season.

Out of the seven items listed above, the first five are related to capacity management and the last two items are related to inventory management. Modifying capacity or managing inventory the output of the firm can be controlled. Change in capacity should result in optimizing the profit.

Next, let us discuss the predictable variability in demand. Pricing the product is one of the most important strategies in meeting the demand. Very often pricing decisions are based on revenue earning capacity of the firm. Sometimes it may result in lower profitability. Promotional techniques may also be used to boost sales. It may increase the demand. Changing the demand pattern may change the cost to be incurred in making the product. If pricing and promotion are combined the objective of maximizing profit may be achieved. The precise use of either pricing or promotion or both varies with the situation. This makes it crucial that companies in a supply chain co-ordinate both their forecasting and planning efforts. Only then are profits maximized.

## NOTES

For a supply chain to successfully manage predictable variability, the entire supply chain must work towards one goal of maximizing the profit. Incentives play an important role in this. Working closer with co-coordinated effort to achieve the overall goal. Predictable variability has a great impact on the operations of a company. The management of supply as well as demand provides the best response to predictable variability. It is important for marketing and operations to co-ordinate their efforts and plan for predictable variability together well before the peak demand is required. This coordination allows companies to preempt predictable variability and come up with a response that maximizes profit.

### 4.5 MANAGING SUPPLY CHAIN CYCLE INVENTORY

Inventory is an idle resource but has a useful value. When we purchase / produce a lot which is more than the requirement, inventory accumulates. Let us assume that we need 10 items per day and if our lot size is 50, then at the end of the first day, we will have 40 items on hand. At the end of second day 30 items will be on our hand. This balance stock on hand is referred as inventory. For all computation purposes, we use average inventory. In our example at the end of 5<sup>th</sup> day, we will be left with no stock. It means zero inventory. At beginning of the first day we had 50 numbers. This is the lot size and also maximum inventory that we can have at any point of time. This 50 numbers deplete and finally become zero at the end of the 5<sup>th</sup> day. There should be arrangement for replenishing the stock and it should arrive at the end of the 5<sup>th</sup> day. It means instantaneous recoument of stock. At the beginning of the 6<sup>th</sup> day we will again have 50 units. Recoument is done taking few days. Let us assume that we need atleast two days to recoupe the quantity. These two days is known as lead-time. Lead-time is the time elapsed between initiation of purchase activity and realization of material. This phenomena of inventory is shown as the saw tooth diagram in figure 4.3.

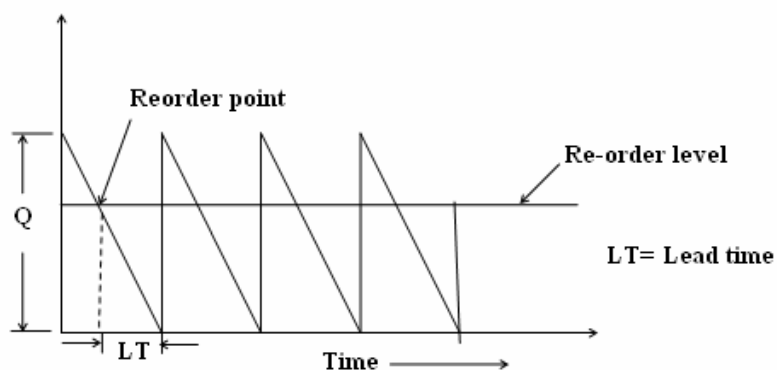

**Figure 4.3 Saw-tooth diagram.**

Maximum inventory under this deterministic situation is  $Q$  and the minimum inventory level is zero. Therefore the average cycle inventory is equal to  $(Q+0)/2 = Q/2$ . This average inventory is used for all computation purposes.

Let us define the following variables:

$D$  = Annual demand

$A$  = Ordering / setup cost in rupees per order

$C$  = cost of item or unit cost in rupees.

$i$  = Inventory carrying cost on average inventory

$H = i * C$  = Holding cost per unit per annum

$Q$  = lot size.

No of orders per annum = Annual demand / lot size =  $D/Q$

Therefore ordering cost / annum =  $(D/Q) * A$

Average inventory value =  $(Q/2) * H$

Annual item value =  $C * D$

Therefore total annual cost =  $CD + (AD/Q) + (QH/2)$

Our objective is to minimize the total cost. i.e. we are interested in a lot size that minimizes the total cost due to inventory. We know, if we purchase / produce a small lot size, we may have to do this more number of times incurring high ordering cost. If our lot size is high enough, then we need to store the inventory and the cost associated with holding the inventory increases. We must strike balance between these two costs .i.e ordering cost and holding cost. The best way to do this is to differentiate the total cost function with respect to the decision variable ( $Q$ ) and equating it to zero.

$$TC = CD + \frac{AD}{Q} + \frac{QH}{2}$$

$$\frac{dTC}{dQ} = 0 - \frac{AD}{Q^2} + \frac{H}{2} = 0$$

$$\frac{H}{2} = \frac{AD}{Q^2}; \quad Q^2 = \frac{2AD}{H}$$

$$\text{Therefore } Q^* = \sqrt{\frac{2AD}{H}};$$

$Q^*$  is the optimal order size

## NOTES

This quantity minimizes the total cost of inventory operation. In our example problem, the daily demand is 10 units and lot size is 50. the variability in demand is already discussed in the previous section and we are not going to include in this section. And also the impact of variability of demand is very small and can be ignored. Whereas the quantity i.e lot size plays an important role in the supply chain. For the lot size 50, let us define other variables.

$$i = 1 \text{ percent} = 0.01$$

$$A = \text{Rs.2 per order}$$

$$C = \text{Rs.5 per unit. Therefore } H = 5 * 0.01 = 0.05$$

Total cost for our present practice is :

$$TC = 5 * 10 * 365 + \frac{365 * 10}{50} * 2 + \frac{50}{2} * 0.05$$

$$= 18250 + 146 + 1.25$$

$$\text{Total cost} = \text{Rs.18397.25.}$$

As can be seen from the above that the procurement / ordering cost per annum is Rs.146 and the carrying cost is just Rs.1.25. it is because our lot size is very small which has resulted in very less inventory to be handled . we need to purchase 73 times in a year incurring at Rs.2/- per purchase, leading to Rs.146 as total purchasing cost per annum. Let us find out what is the economic order quantity. We know,

$$EOQ = Q^* = \sqrt{\frac{2AD}{H}} = \sqrt{\frac{2 * 2 * 365 * 10}{0.05}} = 540.37$$

Instead of buying 50 units at a time, the EOQ recommends to buy 540.37 numbers at a time. Let us first compute the cost implications.

$$TC = 5 * 10 * 365 + \frac{365 * 10}{540.37} * 2 + \frac{540.37}{2} * 0.05$$

$$= 18250 + 13.51 = 18277.02$$

Instead of purchasing 50 units at a time, if we purchase 540.37 units as a lot size, we incur less cost towards inventory management. Rs.18250 is a constant factor. It is known as fixed cost. The variable costs are those which are varied with the decision variables. Purchase cost and inventory carrying costs are affected by the lot size. For a lot size 540(rounded off to integer), the cycle inventory is the average resulting inventory and is given by:  $Q^*/2 = 540/2 = 270$  Number of orders per year =  $D/Q^* = 3650 / 270 = 13.52$



Average flow time =  $Q^* / 2D = 540 / 2 * 3650 = 0.07$  year which is equal to 27 days. Each unit thus spends 27 days, on average, before it is consumed. A few key issues can be discussed from this simple example. The economic lot size is 540.37, if we round it off to 540, the optimality cannot be ensured. Next, by increasing lot size, the increase in total cost is marginal. Number of orders per year (optimal) is 13.52, hereagain either we can have 13 orders or 14 orders in a year. This will also alter the total cost but marginally. It can be seen that if demand increases by a factor 'd', the optimal lot size increases by a factor of "d. The number of orders placed per year should also increase by a factor of "d. Flow time attributed to cycle inventory should decrease by a factor of "d. Any attempt to reduce the lot size will increase the total cost. Instead if an attempt is made and the ordering cost is reduced, this will certainly reduce the lot size as well as the total cost. Let us assume that our ordering cost is reduced from Rs.2 per order to Rs.1 per order. The EOQ for the new ordering cost is

$$\sqrt{\frac{2 * 3650 * 1}{0.05}} = 382$$

which is very less from 540. Studies have shown that to reduce the optimal lot size by a factor of d, the order cost, 'A' must be reduced by a factor of  $d^2$ . To effectively reduce the lot size, we need to understand the source of fixed cost (order cost). Transportation cost is one of sources in the ordering cost. Each item is separately ordered, we need to spend the same transportation cost individually. Efforts may be made to combine the items and transport in a bulk so that transportation cost may be reduced. Aggregating across products, retailers or suppliers in a single order allows for a reduction in lot size for individual products because ordering and transportation costs are now spread across multiple products, retailers or suppliers.

Next let us see how pricing affects the economies of scale. Economic order quantity ensures the minimum total cost in the inventory operations. In the foregoing discussions we have seen reducing lot size is the key to reducing cycle inventory. A key to reducing lot size without increasing costs is to reduce the fixed costs (ordering / setup costs) associated with each lot. This may be achieved by reducing the ordering cost itself or by aggregating lots across multiple products, customers, or suppliers. In this approach, we assumed that the material cost (unit cost) remains constant regardless of the quantity purchased. In reality it is not so. When customer buys more numbers (bulk), the suppliers offer discounts in the unit cost. Many occasions it is found that price discounts prove to be economical than the economic order quantity. When lot sizes increases, the price is reduced to improve the sales volume. Let us analyze the impact of price discounts in the supply chain. Particularly how this price discounts affect the lot sizes, cycle inventories and flow times are discussed in the following paragraph.

## NOTES

By offering discount, the material cost varies with lot size. We need to consider annual material cost, ordering cost and holding costs when making the lot sizing decision. Our objective is to select lot sizes to minimize the total annual cost. Next we should evaluate the optimal lot size in the case of all unit quantity discounts. Let us consider our example, in which the unit cost is varied as follows.

Quantity range	Price
0 – 499	5.00
500 – 999	4.50
e”1000	4.00

We know the economic order size is 540 ( $Q_1^*$ ) for the price Rs.5 / unit. If we check up with the quantity range, the company is offering price of Rs.5 only if the quantity is less than 500. our  $Q^*$  does not fall in this range. Next let us find out the  $Q_2^*$  for the price Rs. 4.50 and  $H= 0.045$

$$Q_2^* = \sqrt{\frac{2 * 2 * 3650}{0.045}}$$

$$= 569.6$$

This quantity is feasible, because the quantity (596.6) falls within the range of quantity offered by the supplier. Since it is feasible, let us find out the total cost:

$$TC = 4.50 * 3650 + \frac{3650}{570} * 2 + \frac{570}{2} * 0.045$$

$$= 16425 + 12.81 + 12.81$$

$$= 16450.6$$

The total cost is reduced from 18277 to 16450 by accepting the quantity discount. Before we conclude, let us examine the total cost implication for the price Rs.4/-. If we want to avail this discount, the minimum lot size should be 1000. if we buy 1000 at a time the total cost is:

$$4 * 3650 + (3650 / 1000) * 2 + (1000 / 2) * 0.04 = 14627.30$$

By availing the discount and increasing the lot size, the total cost is further reduced to Rs.14627.30 from 16450.60. Hence, it is recommended to order 1000 at a time and the number of orders per annum is 3.65. The mean flow time is 50 days. When we ordered 547, the mean flow time was found to be 27 days. If we avail prize discount and order 1000, we need to keep inventory for more number of days. Thus quantity discounts lead to a significant build up of cycle inventory in the supply chain. Though it increases the cycle inventory and flow time, studies have shown that it improved the co-ordination in the supply chain, and also helps in exploiting positively the prize discounts.

**4.6 MANAGING UNCERTAINTY IN THE SUPPLY CHAIN: SAFETY INVENTORY**

In the classical economic order quantity model, we assumed that the demand is constant and the lead time does not vary. In actual practice, it is not so. We know that the demand is forecasted with limited accuracy. It means, the demand forecasting has errors. Therefore, the demand of customer may be increased or decreased. Apart from this, due to various factors, the demand may fluctuate and rarely it is held constant. Therefore, the assumption of constant demand may lead to either shortage or excess inventory. If excess inventory is there, it is not going to affect the availability. It will only increase the cost. However, if shortage occurs, it will lead to lost customer. Another aspect is the uncertainty in lead time. We assume that within the specified time, the quantity is purchased. In reality, this lead time is not constant, leading to shortage of supply. This is explained in the fig4.4.

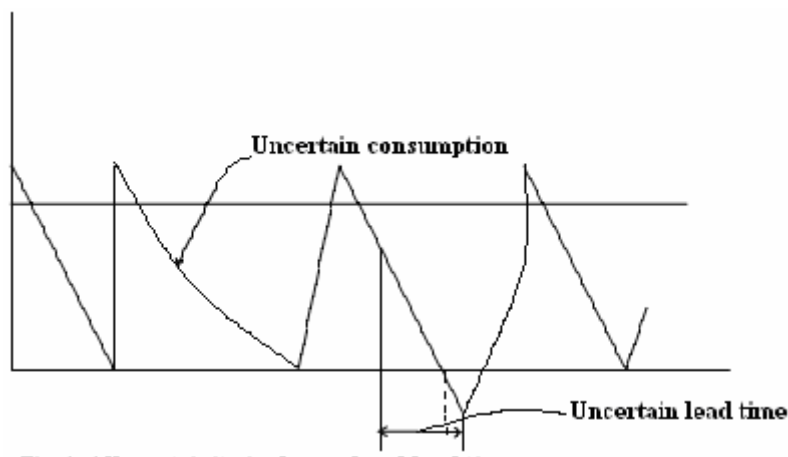

**Figure 4.4 Uncertainty in demand and lead time**

To tide over the crisis created by the uncertainty in demand and lead time we can have sufficient safety stock. This will ensure uniform supply. Managing safety stock ensures availability of product in the supply chain. The fig4.5 portrays the safety stock in the supply.

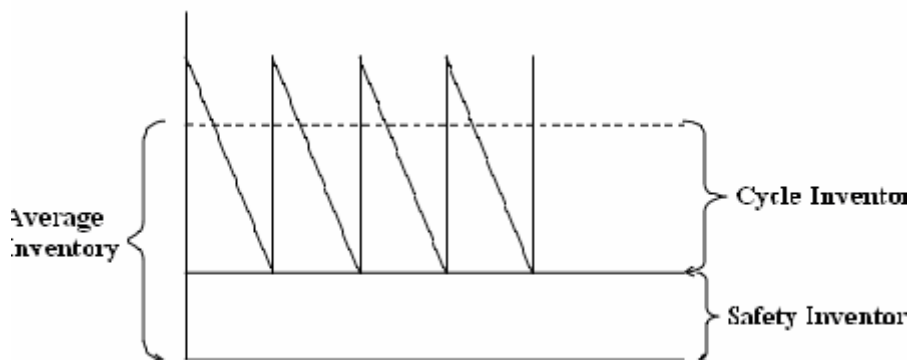

**Figure 4.5 Inventory profile with safety inventory**

## NOTES

The problem here is to determine the optimum size of the safety inventory. This can be done by considering the uncertainty in demand and supply. And also the desired level of product availability should be considered in designing the optimum level of safety stock. If uncertainty in supply or demand increases, the required level of safety stock also increases. It is also affected by the required level of product availability. Demand has two components of uncertainty that is systematic as well as random component. The estimate of random component is a measure of demand uncertainty and is usually estimated as the standard deviation of demand ( $\sigma$ ). Let us assume that the demand is normally distributed with a mean demand 'D'. Lead time ( $L_T$ ) is the time gap between when an order is placed and when it is received. The safety inventory is the average number of items available on hand when a replenishment order arrives. Given the lead time of  $L_T$  weeks and a mean weekly demand of D, the expected demand during lead time =  $DL_T$ . Therefore the safety inventory =  $ROP - DL_T$ .

**Example 4.1:** Assume that weekly demand for a company is normally distributed with a mean of 2750 and a standard deviation of 550. The supplier takes two weeks to fill an order placed by the company. The company currently orders 12000 items when the inventory on hand drops to 6000. Evaluate the safety inventory carried by the company and the average inventory carried by the company. Also evaluate the average time spent by an item at the company.

Solution: Data given:

$$\text{Average demand per week} = D = 2750$$

$$\text{Standard deviation of weekly demand } \sigma = 550$$

$$\text{Average lead-time for replenishment, } L_T = 2 \text{ weeks.}$$

$$\text{Therefore } DL_T = 2750 * 2 = 5500$$

$$\text{Reorder point (ROP)} = 6000$$

$$\text{Average lot size (Q)} = 12,000$$

$$\begin{aligned} \text{Safety inventory} &= \text{ROP} - DL_T \\ &= 6000 - 5500 = 500 \end{aligned}$$

$$\text{Cycle inventory} = Q/2 = 12000/2 = 6000$$

$$\begin{aligned} \text{Therefore average inventory} &= \text{cycle inventory} + \text{safety stock} \\ &= 6000 + 500 = 6500 \end{aligned}$$

$$\begin{aligned} \text{Average flow time} &= \text{Average inventory} / \text{throughput} \\ &= 6500/2750 = 2.36 \text{ weeks} \end{aligned}$$

Next let us discuss the measures of product availability. Product availability reflects firm's ability to fill a customer order out of available inventory. A shortage results if a customer order is not fulfilled. There are several ways to measure product availability. Product fill rate is the probability that product demand is met from the available inventory. For example, a customer wants 100 items, whereas the firm's inventory is only 80 items. This is 80% service level. Order fill rate is the fraction of orders that are filled from available inventory. For example, a firm wanted 3 varieties of products and the company is in a position to supply only two varieties. Two third request is fulfilled in this case. Finally, the cycle service level is the fraction of replenishment cycles that end with all the customer demand being met. The cycle service level is the probability of not having a stock out in a replenishment cycle. Replenishment policies like continuous review and periodic review are important issues in deciding the safety stock.

Given a replenishment policy, we can evaluate the cycle service level, the probability of not stocking out in a replenishment cycle.

Let:

$Q$  = Lot size

ROP = Re-order point

$L_T$  = Lead time in weeks

$D$  = Demand

$\sigma$  = Standard deviation

Cycle service level = probability (demand during lead time of  $L_T$  weeks  $\leq$  ROP)

Assumption: Demand during lead time is normally distributed with a mean of  $D_{LT}$  and a standard deviation of  $\sigma_{LT}$  where:

$D_{LT} = D * L_T$  and  $\sigma_{LT} = \sqrt{L_T} * \sigma$

Safety stock during lead time =  $K * \sigma_{LT}$

Where  $k$  = service level.

**Example4.2:** Weekly demand for a product is normally distributed with a mean of 2400 and a standard deviation of 450. The replenishment time is two weeks. Assume that the demand is independent from one week to the next. Evaluate the cycle service level resulting from a policy of ordering 12000 items when there are 6000 items in inventory.

**Solution:**

Data given:  $Q = 12000$ ,  $ROP = 6000$ ,  $L_T = 2$  weeks  $D = 2000$  / week,  $\sigma = 450$

Demand during lead time =  $2400 * 2 = 4800$

## NOTES

$$\begin{aligned}\text{Standard deviation during lead time} &= \text{“LT} * \sigma \\ &= \text{“2} * 450 \\ &= 636.4\end{aligned}$$

$$\text{Safety stock} = \text{ROP} - D_{\text{LT}} = 6000 - 4800 = 1200$$

$$\text{Safety stock during lead time} = K * \sigma_{\text{LT}}$$

$$\text{Therefore } 2000 = K * 636.4$$

$$\text{Therefore } K = 1200 / 636.4 = 1.8868$$

For  $k = 1.89$  from the normal distribution table, probability value = 0.9706

Therefore the service level = 97.06%

**Example4.3:** Weekly demand for a company is normally distributed with a mean of 2400 items and a standard deviation of 450. The replenishment lead-time is two weeks. Assuming a continuous review replenishment policy, evaluate the safety inventory that the company should carry to achieve a cycle service level of 95 percent.

### Solution:

Data given :  $Q = 12000, SL = 0.95, L = 2, D = 2400 / \text{week}, \sigma = 450.$

We know  $D_{\text{LT}} = 2400 * 2 = 4800$

$$\begin{aligned}\sigma_{\text{LT}} &= \text{“LT} * \sigma \\ &= \text{“2} * 450 = 636.4\end{aligned}$$

$$\begin{aligned}\text{Safety stock} &= K * \sigma_{\text{LT}} \text{ (for } K=0.95, P=1.65) \\ &= 1.65 * 636.4 \\ &= 1050\end{aligned}$$

Therefore, the required level of safety inventory at the 95% cycle service level is 1050.

In the periodic review policies, the inventory levels are reviewed after a fixed period of time  $t$  and an order is placed taking the current level of inventory and the replenishment lot size. Here, the order size may vary between successive orders and the resulting inventory at the time of ordering.

To understand the safety inventory requirement under periodic review process, let us define the following terms:

$D$  = Average demand per period

$\sigma$  = Standard deviation of demand per period

$L_T$  = Average lead time for replenishment

$t$  = Review interval

$SL$  = Desired service level.

The probability (demand during lead time + demand during review interval) = SL

Mean demand during  $t + L_T$  = periods,  $D_{t+L_T} = (t + L_T)D$

Standard deviation of demand during  $(t + L_T)$  periods,  $\sigma_{t+L_T} = \sqrt{t + L_T} * \sigma$

The safety inventory is the excess of  $D_{t+L_T}$  carried over the time interval  $t + L_T$ . the order upto level (OL) and the safety inventory SS are related as follows;

$$OL = D_{t+L_T} + SS$$

**Example4.4:** Weekly demand for a company is normally distributed with a mean of 2400 items and a standard deviation of 450. The replenishment lead time is two weeks and the company has decided to review inventory every 3 weeks. Assuming a periodic review replenishment policy, determine the safety inventory that the company should carry to provide a service level of 95 percent. Evaluate the order upto level (OL) for such a policy.

#### Solution

Data given:  $D = 2400$ ,  $\sigma = 450$ ,  $LT = 2$  weeks,  $t = 3$  weeks.

Demand during the time interval  $t + L_T$  is:

$$\begin{aligned} \text{Mean demand during } t + L_T (D_{t+L_T}) &= (t + L_T) D \\ &= (3+2)2400 = 12000 \end{aligned}$$

$$\begin{aligned} \text{Standard deviation of demand during } t + L_T (\sigma_{t+L_T}) &= \sqrt{t+L_T} * \sigma \\ &= \sqrt{3+2} * 450 \\ &= 1006 \end{aligned}$$

$$\text{Safety stock} = K * \sigma_{t+L_T}$$

For 95%,  $K = 1.65$

$$\text{Therefore } SS = 1.65 * 1006 = 1660$$

$$\text{Order upto level (OL)} = D_{t+L_T} + SS = 12000 + 1660 = 13660$$

#### 4.7 DETERMINATION OF OPTIMUM LEVEL OF PRODUCT AVAILABILITY

The level of product availability is measured using service level (SL) or the order fill rate. This reflects the level of customer satisfaction. In any supply chain, the product availability is an important component. A supply chain can use high level of product availability to attract more customers. This will improve the profitability. However, a large amount of product availability increases the level of inventories. In turn the large inventory increases the cost of inventory. Thus, there should be a balance between the availability and cost to achieve the profitability. Therefore, for maximizing the profit, the product availability has to be optimized.

## NOTES

The factors affecting the optimal level of product availability are cost of overstocking and cost of under stocking. Overstocking leads to excess inventory and thus increases the cost. Under stocking leads to out of stock and leading to lost customer. Therefore, the optimum level of availability is achieved by balancing the cost of over and under stocking. As the cost of overstocking increases, it is optimal to lower the targeted level of product availability.

Let us define the following terms;

Cost of item = Rs C

Price of item = Rs P

Salvage value of unsold item = Rs S

Inventory carrying cost = Rs  $I_c$

Cost of overstocking =  $C_o = C - S$

Cost of under stocking =  $C_u = P - C$

Service level = Probability (Demand  $d \geq 0$ )

$$= \frac{C_u}{C_u + C_o}$$

**Example 4.5:** Demand of a certain product is normally distributed with a mean of 400 and a standard deviation of 80. The cost of each item is Rs.90 and retails for Rs.240. Any unsold items at the end of the season are disposed off Rs.80. Assume that it costs Rs.5 to hold the item in inventory for the season. Determine the number of items that the company should order to maximize expected profit.

### Solution

Salvage value (S) =  $80 - 5 = 75$

Cost of overstocking ( $C_o$ ) =  $90 - 75 = 15$

Cost of under stocking ( $C_u$ ) =  $240 - 90 = 150$

$$\text{Service level} = \frac{C_u}{C_u + C_o} = \frac{150}{150 + 15} = 150/165 = 0.91$$

Safety stock =  $k\sigma = 1.34 * 80 = 107$

For {P=0.91, from normal data k=1.34}

Order size = mean demand + safety stock

$$= 400 + 107$$

$$= 507$$



NOTES

Thus it is optimal for the company to order 507 items even though the expected number of sales is 400. In this case, because the cost of under stocking, management is better off ordering more than the expected value to meet the uncertainty in demand.

**Example4.6:** Demand of a certain product is distributed with certain probability distribution as given below:

Demand	100	150	200	250	300	400	500
Probability	0.21	0.13	0.14	0.12	0.10	0.19	0.11

The cost of each item is Rs.90 and retails for Rs.240. Any unsold items at the end of the season are disposed off Rs.80. Assume that it costs Rs.5 to hold the item in inventory for the season. Determine the optimal order size to maximize the expected profit.

**Solution**

Demand	100	150	200	250	300	400	500
Probability	0.21	0.13	0.14	0.12	0.10	0.19	0.11
Cum. Prob.,	0.21	0.34	0.48	0.60	0.70	0.89	1.00
Range	0-0.21	0.22-0.34	0.35-0.48	0.49-0.60	0.61-0.70	0.71-.89	0.90-1.00

Salvage value =  $S = 80 - 5 = 75$

Cost of overstocking =  $C_o = 90 - 75 = 15$

Cost of under stocking =  $C_u = 240 - 90 = 150$

$$\text{Service level} = \frac{C_u}{C_u + C_o} = \frac{150}{150 + 15} = 0.91$$

From the range of cumulative probability it is seen that the optimal order size for the service level 0.91 is 500.

It is demonstrated that cost of overstocking and under stocking have a direct impact on both the optimal service level and the profitability. A manager may increase supply chain profitability by:

1. Increasing the salvage value of each unit overstocked
2. Decreasing the margin lost from a stock out
3. Using improved forecasting to reduce demand uncertainty
4. Using quick response to reduce lead times and allow multiple orders in a season

## NOTES

5. Using postponement to delay product differentiation
6. Using tailored sourcing with a flexible, short lead time supply source serving as a backup for a low cost, long supply source with long lead times.

### 4.8 CO-ORDINATION IN THE SUPPLY CHAIN

Coordination help ensure that each part of the supply chain takes actions that increase total supply chain profits and avoids that improve its local profits but hurt total profits. Lack of co-ordination leads to a degradation of responsiveness and an increase in cost within a supply chain. Supply chain co-ordination improves if all stages of the chain take action that together increase total supply chain profits. For effective co-ordination, the effect of each stage has on other stages must be taken into account. If conflicting objectives are found in different stages they lead to lack of co-ordination. In each stage, the stage owner tries to maximize their own profit which may lead to lack of co-ordination. Lack of co-ordination may lead to lowering of total supply chain profit. The basic challenge today is to improve the co-ordination inspite of multiple ownership.

When products move from retailer stage to wholesalers it experiences bullwhip effect. Bullwhip effect is the fluctuations in orders increase as they move up the supply chain from retailers to wholesalers. Same thing happens when it moves up to manufacturers and further up as suppliers. The bullwhip effect distorts demand information within the supply chain, with different stages having a very different estimate of what demand looks like. It may be found that the consumption of end product may be stable, whereas lot of variation may be found at raw material stage, making it difficult for supply to match demand. Industry experienced lot of fluctuations in the past. Large fluctuations in price were driven by either shortage or surpluses in capacity. This has lead to panic buying or over ordering depending upon the situation.

Lack of co-ordination results if each stage of the supply chain attempts to optimize locally. Total supply chain profit could have been achieved, if there exist co-ordination. Each stage of supply chain, in trying to optimize its local objective, takes actions that end up hurting the performance of the entire supply chain. Information distortion occurs when there is a lack of co-ordination among the various stages in the supply chain. The bullwhip effect impacts the performance negatively. This affects the relationships between different stages of the supply chain. The bullwhip effect leads to a loss of trust between different stages of the supply chain. The bullwhip effect increase the manufacturing cost in the supply chain. The bullwhip effect increases the inventory cost in the supply chain. The bullwhip effect increases the replenishment lead times in the supply chain. The bullwhip effect increases transportation cost within the supply chain. The bullwhip effect increases labour costs associated with shipping and receiving in the supply chain. The bullwhip effect hurts the level of product availability and results in more stockouts within the supply chain. The bullwhip effect moves a supply chain away from the efficient frontier by increasing cost and

decreasing responsiveness. Thus, the bullwhip effect reduces the profitability of a supply chain by making it more expensive to provide a given level of product availability.

Local optimization by different stages of the supply chain, information delay, distortion in information and variability within the supply chain are the sources for the lack of co-ordination in the supply chain. We should identify the key obstacles and take suitable actions in order to achieve co-ordination. There are five categories of obstacles (Chopra, 2004). They are:

1. Incentive obstacles
2. Information processing obstacles
3. Operational obstacles
4. Behavioural obstacles

Incentive obstacles refer to situations where incentives offered to different stages or participants in a supply chain lead to actions that increase variability and reduce total supply chain profits. Information processing obstacles refer to situations where demand information is distorted as it moves between different stages of the supply chain, leading to increased variability in orders within the supply chain. Lack of information sharing between stages of the supply chain increases the bullwhip effect. If the manufacturer is not aware of the planned promotions, they may mistake it as a permanent increase in demand and place orders with suppliers accordingly. Thus, the lack of information sharing between the retailer and manufacturer may lead to a large fluctuation in manufacturer orders. Operational obstacles are the actions taken in the course of placing and filling orders that lead to an increase in variability. Pricing obstacles are the pricing policies for a product leading to an increase in variability of orders placed. Discounting policy increases the lot size. The resulting large lots magnify the bullwhip effect within the supply chain. Finally the behavioral obstacles are problems in learning within organizations that contribute to the bullwhip effect. It may be due to communication between different stages. Different stages of the supply chain react to the current local situation rather than trying to identify the root causes. A lack of trust between supply chain partners causes them to be opportunistic at the expense of overall supply chain performance.

#### **4.8.1 Managerial Levers to Achieve Co-Ordination**

We have seen the obstacles to co-ordination in the previous section. To overcome these obstacles and also to achieve co-ordination in the supply chain, the following managerial actions can be used to moderate the bullwhip effect

1. Align goals and incentives
2. Improve information accuracy
3. Improve operational performance
4. Design pricing strategies to stabilize orders
5. Build partnership and trust

## NOTES

By aligning the goals and incentives, managers can improve the co-ordination within the supply chain. Aligning individual goals with the company's overall objective of improving profitability improves the co-ordination. Incentives given to sales persons can be made more attractive to reduce the bullwhip effect. Managers can achieve co-ordination by improving the accuracy of information available to different stages in the supply chain. Use of appropriate information sharing system help reduce the bullwhip effect. Implementing collaborative forecasting and planning, the information sharing can be achieved. Also by designing the single stage control of replenishment reduces the bullwhip effect. The bullwhip effect can also be reduced by carefully designing the appropriate product rationing schemes in case of shortages and by improving operational performance. By reducing replenishment lead times managers can decrease the uncertainty of demand during lead time that helps in dampening the bullwhip effect by reducing the uncertainty of demand. The operation improvements like reducing lot size also reduces the bullwhip effect by devising pricing strategies that encourage retailers to order in small lots and reduce forward buying. By doing so, retailers can take full advantage of the discount. Volume based quantity discounts result in smaller lot sizes, thus reducing order variability in the supply chain. Offering the discounts over a rolling time horizon helps reduce the bullwhip effect. The bullwhip effect can also be reduced by eliminating promotions. The elimination of promotions removes forward buying by retailers and results in orders that match customer demand, which ultimately improves co-ordination. To achieve the reduction in bullwhip effect for improving co-ordination, managers must use the levers discussed above with trust and by building strategic partnership within the supply chain. To achieve co-ordination in practice the following steps may be followed

1. Quantify the bullwhip effect
2. Improve co-ordination by getting top management commitment for aligning goals
3. Provide sufficient resources to co-ordination
4. Share information and improve communication
5. Get co-ordination in the entire supply chain
6. Use technology to improve connectivity in the supply chain
7. Share the benefit of co-ordination among all the partners in the supply chain equally.

### Chapter Summary

In this chapter we started with the role of demand forecasting in supply chain. We have understood the role of forecasting for an enterprise and a supply chain. It is established that the forecasting is a key driver of virtually every design and planning decision made in a supply chain. Then we have discussed the role of time series methods and the importance of forecast error in estimating the forecast. Then we have identified the types of decisions that are best solved by aggregate planning. Thereafter we tried to understand the importance of aggregate planning as a supply chain activity. We have used the pure and mixed strategies and solved the aggregate planning problem.

Predictable variability was taken up next and discussed how to manage supply to improve synchronization in the supply chain in the face of predictable variability. To maximize profit how pricing and promotion are mixed in a supply chain also been discussed. Next we have seen how to balance the costs to choose the optimal amount of cycle inventory in the supply chain. We have also seen the impact of quantity discounts on lot size and cycle inventory. Thereafter we tried to understand the role of safety inventory in a supply chain. We have also identified the factors that have also identified the factors that influence the required level of safety inventory. Then we described the different measures of product availability. We have seen how management levers are utilized to lower safety inventory and improve product availability. The impact of overstocking and under stocking have been discussed with an example. Optimal order size including the uncertainties has been determined using an example.

Finally we described the essentials of supply chain co-ordination. In that we discussed the impact of bullwhip effect and actions for reducing the bullwhip effect. We have also identified the causes of the bullwhip effect and various obstacles to achieve co-ordination. Lastly we have given the managerial levers that help achieve coordination in the supply chain.

### Review Questions

1. What is the role of forecasting in the supply chain?
2. How companies can use collaborative forecasting with its suppliers to improve its supply chain?
3. What is importance of aggregate planning?
4. Distinguish between pure and mixed strategies.
5. How does the subcontracting affect the aggregate planning?
6. What are the benefits of flexible work force?
7. How would a firm combine pricing and promotion to change demand patterns?
8. As demand at the enterprise grows, how would you expect the cycle inventory measured in days of inventory to change? Explain.
9. When are quantity discounts justified in a supply chain?
10. What is the role of safety inventory in the supply chain?
11. What is the impact of supply uncertainty on safety inventory?
12. What are the factors that affect the optimal level of product availability?
13. What are the managerial levers to improve supply chain profitability?
14. Describe the supply chain co-ordination and the bullwhip effect on the coordination.
15. What are the causes of the bullwhip effect and also discuss the obstacles to co-ordination in the supply chain.
16. Describe the managerial levers that help achieve co-ordination in the supply chain.

# NOTES

## PROBLEMS

### A. Demand Forecasting

1. A trucking company would like to determine the number of drivers and trucks to be available on a weekly basis. The standard schedule is to send drivers over the pick up and delivery route on Monday and return them to the originating point on Friday. The trucking requirements can be determined from the total volume to be moved for the week; however, they must be known a week in advance for planning purposes. The volume for the last ten weeks is given here:

Week	Volume	Week	Volume
10 weeks ago	20,60,000	5 weeks ago	23,65,000
9 weeks ago	22,50,000	4 weeks ago	27,50,000
8 weeks ago	18,95,000	3 weeks ago	21,20,000
7 weeks ago	15,15,000	2 weeks ago	24,00,000
6 weeks ago	12,92,000	This week	25,10,000

- (i) Using exponential smoothing model, predict the expected volume for the next week for  $\alpha = 0.20$ .
  - (ii) Estimate the forecast error.
  - (iii) Find the range over which the actual volume is likely to vary. (Hint: Compute statistical confidence band. Assume 95% confidence level)
1. For the problem (1) if  $\hat{\alpha} = 0.2$ , what is the trend corrected forecast for the next week?
  2. An electric company has a difficult in predicting the quarterly sales for its room air conditioner due to the substantial seasonality in product sales. Quarterly sales data for the last three years are shown as follows:

Last year		Two years ago		Three years ago	
Quarter	Units	Quarter	Units	Quarter	Units
1	35000	1	30000	1	28000
2	80000	2	72000	2	68000
3	50000	3	45000	3	42000
4	18000	4	16000	4	12000

- i) Determine the best straight line trend using simple regression analysis.
- ii) Determine the seasonal indices for each quarter using the trend line values in your seasonal index computations.
- iii) By means of decomposition, forecast the sales for the next four quarters.

**NOTES**

**B. Inventory Management**

1. An equipment manufacturer purchases lubricants at the rate of Rs 50 per unit from a vendor. The requirement of these lubricants is 2000 per year. What should be the order quantity per order, if the cost per placement of an order is Rs 20 and inventory carrying charge is 20% of the average inventory value?
2. An item is produced at the rate of 100 per day. The demand occurs at the rate of 75 per day. If the setup cost is Rs 125 and holding cost is Rs 0.05 per unit of item per day, find the economic lot size for one run, assuming that shortages are not permitted. Also, find the time of cycle and minimum total cost for one run.

3. Find the optimum order quantity for the following

Annual Demand	=	4000 units
Ordering cost	=	Rs 100
Cost of carrying inventory	=	20% of the unit cost.

Quantity range	Price/Unit (Rs)
Upto 99	20.00
100 – 199	18.00
$\geq 200$	16.00

4. A shop keeper has uniform demand of an item at the rate of 100 per month. He buys from supplier at a cost of Rs 10 per unit and cost of ordering is Rs 18 each time. If the sock holding costs are 20% per year of stock value, how frequently should be replenish his stock? Now suppose the supplier offers a 5% discount on orders between 300 and 999 items, and a 10% discount on orders exceeding or equal to 1000. Can shop keeper reduce his costs by taking advantage of either of these discounts?
5. A firm uses Rs 40,000 worth of a raw material per year. The ordering cost per orders is Rs 120 and the carrying cost is 20% per year of the average inventory. If the company follows the EOQ purchasing policy, calculate the re-order point, the maximum inventory and the average inventory, given that the firm works for 300 days a year, the replenishment time is 12 days and the safety stock is worth Rs 500.
6. A newspaper boy buys paper for Rs 1.50 each and sells them for Rs 2.00 each. He cannot return unsold newspapers. Daily demand has following distribution:

Number sold	22	23	24	25	26	27	28	29	30	31
Probability	0.01	0.03	0.06	0.1	0.2	0.25	0.15	0.1	0.05	0.05

If each day’s demand is independent of the previous day’s demand, how many papers should be ordered each day?

**NOTES****C. Aggregate production planning**

1. A company's marketing manager has estimated the following demand requirement for the forth coming periods:

Period	Forecast	Period	Forecast
1	1600	5	2400
2	1800	6	2500
3	2000	7	2000
4	2100	8	1600

The operations manager is considering the following plans

Plan 1: maintain a stable workforce that is capable of producing 2000 units per period, and meet the demand by overtime at a premium of Rs 25 per unit. Idle time costs are equivalent to Rs 30 per unit. Do not build to inventory.

Plan 2: produce at a steady state of 1800 units per period, and a limited number of backorders during periods when demand exceeds 1800 units. The stock out cost of lost sales is Rs.100 per unit. Inventory costs per period are Rs.20 per unit.

Plan 3: produce at a steady rate equal to minimum requirements of 1600 units and subcontract the additional units at a Rs.75 per unit premium.

Plan 4: vary the workforce level, which is currently capable of producing 1600 units per period. The cost of additional workforce per 100 units is Rs.5000 and the cost of layoffs per 100 units is Rs.7500.

Plan 5: vary inventory levels, but maintain a stable workforce level by maintaining a constant production rate equal to the average requirements. The company can accumulate required inventory before period 1 at no additional cost. The inventory cost per period is Rs.20 per unit. Plot a histogram for the demand and show the average requirements on your graph. Discuss the merits and demerits of these plans. Which plan would you recommend?

2. Refer Seetharaman



# UNIT V

## CURRENT TRENDS

### LEARNING OBJECTIVES

After reading this chapter, you will be able to:

- Understand the scope of e-business and its framework
- Identify the role of supply chain in e-business and in b2b practices.
- Understand the importance of IT in a supply chain
- Appreciate the use of information in the supply chain
- Understand the various applications of supply chain, IT and the process that they enable.
- Know about esrm, ecrm, escm and supply base management.

### 5.1 INTRODUCTION

Planning the demand and inventory management for minimizing the total production cost has been discussed in chapter-4. Production planning and inventory management assumes greater importance in the supply chain activities. After understanding the core activities in the supply chain, we need to concentrate on recent trends available in the supply chain management. This is mainly concentrating on the marketing activities. The Internet plays a very crucial role in marketing products. The efficiency and responsiveness in the supply chain can be drastically improved by e-business. All those e-business activities are discussed in this chapter.

### 5.2 E-BUSINESSES AND ITS ROLE

Today we are living in the age of Internet. Internet is used for several applications. E-business is one such important application. Executing business transactions via Internet is known as E-business. The flow of information, product and funds are the supply chain transitions in the e-business. In e-business we can provide product information to the people in the supply chain and also we can place orders with the suppliers. The placed orders can also be traced easily in e-business. Moreover customer orders can be filled and delivered promptly. Finally the payment from customer can be easily realized. All

## NOTES

these transactions are possible through the Internet. One can wonder whether these transactions are specific to Internet. It is not so. All these transactions were practiced in traditional supply chain process. The only difference in the concept of e-business is the mode of transaction. Here we use Internet for communication purpose. It is very quick, and highly efficient. Product information can reach the target customer instantly, which saves a lot of time and improves the responsiveness. Today companies display their product information over the Internet, so customers are able to identify all options available for a product they want to purchase along with the price of the product. Companies use the Internet for negotiations and auctions to set prices of products and services. Electronic money transfer and credit card usages have made the e-business process very simple. Customers can pay for their purchase over the Internet using their credit cards and the business houses will pay their invoices electronically. However, in the mid 2000, the e-business received severe criticism. The way e-business was executed resulted in failure. But there are cases in which e-business proved to be very successful. Let us discuss the success of e-business in this chapter.

### 5.3 FRAMEWORK OF E-BUSINESS

First we need to develop a framework for determining the impact of E-business on a firm transacting with customers through Internet. The framework should consist of several items (elements). Scores can be attached to each element. The firm can evaluate each item and can assign a score. We have seen in the previous chapters that the two most important aspects in the supply chain are the responsiveness and efficiency. The framework should bring out the level of responsiveness and the efficiency when we use Internet for doing business. Let us first discuss the impact of E-business on responsiveness, and in the subsequent section let us see the impact of E-business on the efficiency of the firm.

#### 5.3.1 Impact Of E-Business On Responsiveness

To preserve the existing revenue and also to enhance the revenue, it is essential to improve the responsiveness. Revenue enhancing opportunities are available to the firm, if it follows the following responsiveness while transacting through Internet.

- Direct sales to customers.
- Anytime access from anywhere.
- Information aggregation and wider product portfolio.
- Customization of products.
- Quicker time to market.
- Flexible pricing, product portfolio and promotions.
- Price discrimination.
- Service discrimination.
- Transfer of fund with efficiency.
- Lower stock outs.
- Automated and convenient process.

**NOTES**

Through direct selling, the manufactures can avoid parting off their revenues with the intermediaries like distributors and retailers. E-business allows the manufactures to interact with the customers and sell their products directly. E-business allows the customers and manufactures to interact at any time online. The geographical location does not matter in E-business. Even if order is filled, still order can be placed by the customer from anywhere at any time on the globe. This improves flexibility and ensures high responsiveness. E-business allows the customer to browse wide variety of products through Internet. This increases the sales and revenue. Effective search tools can be provided to select the appropriate product with less browsing time. E-business allows customers to specify their own requirements. Companies can make products that suit exactly the requirement of individual customers. This process of customization increases customer satisfaction and in turn increases the revenue for the company. Apart from customization, a personalization task, like reminding customers their birthdays and anniversaries enhances the revenue by increased sales. For example reminding the customer on his\her spouse birthday and encouraging him\her to buy a gift enhances customer satisfaction and revenue to the company.

Companies can use E-business to introduce new products much faster than the traditional ways. Information about the new features or even the new product can reach the customer very quickly through E-business. An E-business can easily alter prices by changing one entry in the database linked to its website. This ability permits an E-business to maximize profits by setting prices based on the inventory-on-hand and demand. Airlines for example use different fare structure for different time periods and are able to sell unsold tickets through E-business. This helps the company to fill the seats as well as ensures higher revenues. Companies can change prices at an E-business much more easily than traditional methods. Simultaneously an E-business can easily alter the product portfolio that they are running. Price changes can be made based on the characteristics of individual customers to enhance their own revenues. This discrimination is possible in E-business. Further, in an attempt to keep one's best customers satisfied, highly profitable customers can be offered certain services that are not ordinarily available to other customers. This service discrimination can be effectively handled in E-business.

Payment collection is an important activity in supply chain. E-business allows flexible payment collection at faster rate. By understanding the customer's need accurately at the appropriate time, E-business allows the firm to meet the customer's requirements at lower risk of stock outs. Enough stock can be made available to meet all the requirements of the customers. Hence the customer will never have a no-stock situation. Thus for both the customers and the business people, E-business can increase the ease with which one does business. E-business automates the buying process and helps customer to get the product on their convenience.

## NOTES

### 5.3.2 Impact Of E-Business On Efficiency

In any business transactions, the efficiency depends on the cost of transaction. Once cost is minimized, the efficiency in terms of performance improves. Therefore, cost performance indicates the efficiency of the business. Cost performance depends on the efficiency with which the cost drivers or simply the supply chain drivers are operated in the process. The impact of E-business on efficiency is nothing but the impact on the supply chain drivers. Let us discuss one by one how E-business impacts on each of the supply chain drivers.

**Inventory:** Inventory levels can be lowered by E-business. The supply chain coordination ensures better match between supply and demand. E-business enables companies to reduce inventories by exploiting the time that elapses from the point at which the order arrives to the point at which it must be shipped. Due to geographical aggregation also, E-business requires less inventory. By postponing the introduction of variety until after the customer order is received, an E-business can significantly reduce its inventories.

**Facilities:** E-business allows the companies to lower the facilities costs because the companies need not have distribution or retail outlets in the supply chain. E-business also allows companies to take advantage of customer participation in order placement and decrease processing costs at its facility. Companies can also save call center costs because in E-business customers do all the work when placing an order online.

**Production:** The costs associated with the operation are known as production cost. By centralizing operations, E-business can reduce network facility costs. Operating costs can be lowered by customer participation in selection and order placement. At an E-business, if a reasonable buffer of unfilled order is maintained, the rate of order fulfillment can be made significantly better than the rate at which order arrive, which lowers the peak level for order fulfillment and thus reduces the resource requirements and cost. Furthermore, production and operation costs of a manufacturer can be lowered by using E-business to sell direct to customers because fewer supply chain stages involved as it makes its way to a customer, thereby reducing handling costs.

**Transportation:** In the traditional supply chain, companies have the advantage of having to bear only inbound transportation cost for products, with customers providing transportation from the selling point (like super market) to their homes. In E-business, the companies have to bear inbound transportation cost to its fulfillment centers and then outbound transportation costs from the fulfillment centers to customer places. Outbound delivery costs are high because individual orders must be delivered to each customer's place. Thus, transportation costs are likely to increase in the E-business. However the downloadable products reduce the transportation costs considerably in the E-business.

## NOTES

**Information:** Information sharing is maximized in E-business resulting in lower cost of information. Sharing of demand information throughout supply chain reduces the bullwhip effect and improves co-ordination. Improving co-ordination in turn reduces bullwhip effect. Co-ordination can be improved significantly by E-business. The cost of software can be outweighed by the gain achieved through lowering information cost in E-business.

Having discussed the impact of E-business on both the responsiveness and cost, it is our duty to design a scorecard for assessing whether E-business has created positive impact or negative impact on the firm. Companies can assess using the framework discussed here by assigning score between -2 to +2. -2 being very negative, -1 being negative, 0 being neutral, 1 being positive and 2 being very positive. The summated score can be used to assess whether E-business has created a positive impact or negative impact on the firm. A typical E-business score card is given in table 5.1

**Table 5.1 The E-business score card**

ITEM	SCORE
Direct sales to customers	*
Anytime access from anywhere	*
Information aggregation and wider product portfolio	*
Customization of products	*
Quicker time to market	*
Flexible pricing, product portfolio and promotions	*
Price discrimination	*
Service discrimination	*
Transfer of fund	*
Lower stock outs	*
Automated and convenient process	*
Inventory	*
Facilities	*
Production	*
Information	*
Transportation	*

(\* => ranges from -2 to +2)

Note: -2 = very negative, -1 = negative, 0 = neutral, +1 = positive and +2 = very positive

## NOTES

### 5.4 ROLE OF SUPPLY CHAIN IN B2B PRACTICES

E-business framework discussed in section 5.2 is useful for analyzing all types of E-business opportunities. This framework can be applied to b2b relationship also. B2B is the abbreviation of business to business. In B2B customers can pick up their orders at one of the companies retail outlets. Inventory is stored at the manufacturer or distributor warehouse. Customers place their order online and then come to designated pick up points as needed. In b2b customers pick up their order at the collecting point. The E-business frame work covers a wide variety of factors each listed in the score card ( pl see table 5.1 ), that may or may not be particularly important to customers or sellers in the E-business transaction. With b2b transactions, however, this wide variety of factors can be greatly simplified in to a much smaller list of motivations for pursuing e-business. Adding b2b framework helps business target their e-business efforts. Reduced transactions costs, improved market efficiencies and benefits to supply chain are the three sources from which values are derived in E-business.

Companies should analyze the current strengths and weakness in their supply chain to identify the magnitude in their supply chain to identify the magnitude of the value from b2b business. Significant value can be extracted from each of the three categories only if the current supply chain structure has inefficiencies that can be corrected using the Internet. E-business is likely to reduce transaction costs, if transactions are frequent and small in size, phone and fax are the current mode of transmitting orders and a lot of effort is spent reconciling product and financial flows. B2B E-business can provide significant value by reducing prices. If limited buyer\seller qualification is required, a fragmented market exists with many competing players either on the buy or the sell side and a large number of buyers can be attracted to the online side. The b2b business can provide significant value by improving the matching of supply surplus and unmet demand. In industries where capacity is expensive and mismatches of surplus supply and unmet demand are common. The value of supply chain benefits is likely to be the highest in industries with the following characteristics:

- The bullwhip effect is quite high due to information distortion in the supply chain.
- Low inventory turns and poor product availability are achieved through the supply chain.
- Each stage has lower visibility into either the customer or supplier stage.
- Lower collaboration in the supply chain in terms of promotions and new product information.
- Short product life cycles.

### 5.5 SUPPLY CHAIN IT FRAME WORK

One of the important jobs of a manager is decision making. Decision-making requires information. Information is crucial to performance of a supply chain. Information technology

(IT) consists of the tools used to gain awareness of information, analyze this information, and act on it to improve the performance of the supply chain. We know that, information is one of the most important supply chain drivers. It helps other drivers to perform well. A manager will not know what customers want, how much stock is currently available, and how many products should be produced and shipped. Information makes the supply chain visible. IT comes into play by making managers to gather information and analyze it for taking proper decision. IT serves as the eyes and ears of management in a supply chain. Using IT to capture and analyze information can have a significant impact on a firm's performance. The supply chain scope is made up of information. Information must be accurate, must be accessible in a timely manner, and it must be of the right kind. So, information is crucial to making good supply chain decisions at all levels of the organizations. To understand how this information is utilized by the various segments of IT within the supply chain, it is essential to develop a frame work.

Enterprise software acts as a driver of IT in the supply chain. This software enables process both within and across companies. Enterprise software analyses the data for making decisions. Apart from software, the other parts of IT such as hardware, implementation services, and support are all crucial to making IT effective. The enterprise software shapes the entire industry of IT as other components follow the software. The software provides insights into what the key supply chain process are made of. During late 1990's the enterprise software landscape became increasingly popular. This has led to proliferation of software. The growth of software companies started increasing in multifold. During mid 2000, there was a sudden surge in the software technology. This downturn in technology has led companies to cease operations or merge with existing software companies. The reason for the downfall is attributed to three major groups of supply chain process.

They are as follows

- Customer relationship management.
- Internal supply chain management.
- Supplier relationships management.

Apart from these three processes, the fourth important software building block that provides foundation is the transaction management foundation. Transaction management foundation is necessary for the three-macro process to function and to communicate with each other. The performance of the company depends on the outcome of these three-macro processes. Good supply chain management is a positive sum game where supply chain partners can increase their overall level of profitability by working together. To achieve this, firms must think beyond their enterprise and think in terms of all three-macro process.

The success of supply chain in terms of macro process depends on functional performance of the company, integration with other macro process and strength of the software firm's ecosystem. Functional performance provides capabilities that create a

## NOTES

complete advantage. Advanced functionality may be difficult to use. Hence such functionality is rarely used. Software firms with lower levels of functionality but with high ease of use can, in essence, provide more “usable” functionality to their customers and therefore gain an edge. Integration is no doubt important to a customer for a variety of reasons. Integration produces value. Application that integrates across macro process will be able to provide the benefits of making decisions for the external supply chain. For a customer, a strong ecosystem means a strong network to support both during implementation and down the road.

### 5.6 INTERNAL SUPPLY CHAIN MANAGEMENT

Internal supply chain management includes the operation performed inside the company. It consist of all process involved in planning for and fulfilling a customer order. Strategic planning is the foremost activity in internal supply chain management. In strategic planning resources planning is made. The decisions regarding location choice for facilities including warehouse are taken. Successful software provides capability of analyzing strategic plans under uncertainty. Next under consideration is demand planning. Successful software provides a demand plan accounting for marketing and promotional efforts. Supply planning software provides factory planning and inventory planning capabilities. Once a plan is in place to supply the demand, it must be executed. The order fulfillment should link supply source and means of transportation. Software provides transportation and warehouse applications. Finally, after the product has been delivered to the customer, it eventually must be serviced. Service process focus on setting inventory levels for spare parts as well as scheduling service calls.

Internal supply chain management macro processes discussed above aims to fulfill demand that is generated by customer relation’s management process. The internal supply chain management processes should have strong integration with the supplier relation’s management macro process. Unless adequate numbers of spare parts are not supplied on time, products cannot be manufactured on time. Hence relationship between supplier and internal operations are of utmost importance. Order management must integrate closely with fulfillment and be an input for effective demand planning. Successful internal supply chain management software provides good integration with customer relations and supplier relations. There are many successful software providers like 12 technologies and manugistris, who are able to provide solutions to internal supply chain management problems. This software can be used for successful supply chain management.

### 5.7 SUPPLIER RELATIONSHIP MANAGEMENT

Supplier relationship management includes those process focused on the interaction between the enterprise and suppliers that are upstream in the supply chain. Design collaboration, source, negotiate, buy and supply collaboration are the process involved in supplier relationship management. The goal of design collaboration is to improve the design of products through joint selection of products that have positive supply chain characteristics



such as ease of manufacturability. Engineering change orders are shared between the manufacturer and supplier for eliminating the costly delays. Successful software ensures correct design collaboration. The source identifies the right suppliers. Suppliers are evaluated along several key criteria including lead time, reliability, quality, and price. Contract management is also an important part of sourcing, as many suppliers' contracts have complex details that must be tracked. This software available in the market is helping the companies in analyzing supplier performance and management of contracts.

Negotiations with suppliers assume greater importance. The negotiation process includes design and execution of auctions. The process of negotiations is to get appropriate price and to settle other delivery issues. The buying process executes the actual procurement of material from suppliers. Issuing purchase orders for supply of materials is the main activity in buying process. Software is available to automate the buying process. Once an agreement for supply is established by the way of issuing purchase orders, the supply chain performance can be improved by collaborating on forecasts and inventory levels. The purpose of collaboration is to ensure a common plan across the supply chain. Good software in this area should be able to facilitate collaborative forecasting and planning in a supply chain.

Excellent improvement can be achieved in supply chain performance if supplier relationships management and customer relationship management are well integrated with internal supply chain management. Sourcing, negotiating, buying, and collaborating are primarily plug in to internal supply chain management as the supplier inputs are needed to produce and execute an optional plan. There are different players available in the market in the form of software to meet the demand of firm on supplier relationship management.

## 5.8 FUNDAMENTALS OF TRANSACTION MANAGEMENT

The transaction management foundation is the base for the largest enterprise software players. In early 1990.s there was little attention towards the macro processes we discussed in the previous sections. The focus at that time was on building transaction management and process automation systems that proved to be foundations for future decision support applications. These systems were found useful for simple transaction ad processes as well as the creation of an integrated way to store and view data across the division.

During 1990's, the demand for the transaction management systems have become exceedingly high and it drove the enterprise resource planning players to become the largest enterprise software companies. SAP continued to dominate the market during that time. However, ERP sales slowed. The real value of the transaction management foundation can only be extracted if decision-making within the supply chain is improved. Thus, presently companies focus on improving making the three-macro process. The shift from ERP to CRM, SRM and ISCM is expected to continue for the future also. Such being the case, the transaction management which is the foundation will occupy prominent place in the supply chain.

# NOTES

## 5.9 SUPPLY CHAIN IT IN PRACTICE

A five-step practice of supply chain IT is as follows

### **Step 1: Identify and select appropriate IT system**

Every industry and even companies within an industry can have different key success factors. These factors determine the success of the company. It is the responsibility of the company, to determine the key success factors. A factor, which is critical to a company, need not be critical to other companies. Hence companies should be very careful in identifying the critical success factors and select an IT system that addresses these critical factors.

### **Step 2: Measurement of value**

The success of any system is to be measured incrementally. Sudden improvements or drastic improvements are rare in most of the companies. Hence, it should be measured step by step. Even for implementation of supply chain it can be done in phases in the company. Once its success is ensured in one part of the company, the efforts can be extended to the other parts of the company. This incremental step does not mean that one should not take a big picture perspective but rather that the big picture perspective should be implemented in digestible pieces.

### **Step 3: Alignment**

Management must consider the extent with which an IT system can deal with the firm's critical success factors. Alignment is nothing but matching the need of the sophistication level in the company. The level of sophistication required to achieve its goal must be considered. This is important because any lapse on the less sophisticated side leaves the firm with a competitive weakness, whereas trying to be too sophisticated leads to a higher possibility of the entire system failing.

### **Step 4: Use of IT system**

IT applications are to be carefully judged. It is not the motive to make only decisions using IT tools rather they are developed to support the decision making process. By installing IT, one should not reduce the managerial efforts that will certainly lead to poor decision making in the company. Therefore management must keep its focus on the supply chain because as the competitive and customer landscape changes, there needs to be a corresponding change in the supply chain.

### **Step 5: Future needs**

Companies should think about the future needs when they install IT tools in their organizations. It may be difficult to decide about the IT system with the future in mind than the present. However, it is important that managers must include the future state of business in the decision process. The trends expected in the business should be incorporated in the

IT system to match the future needs of the IT system. The IT system should be flexible enough to make changes in the future, accommodating the changes expected in the business trends. Therefore the key here is to ensure that the software not only fits a company's important, that it will meet the company's future needs.

### 5.10 INFORMATION SYSTEMS DEVELOPMENT

Information system for a company is based on its functionality and internal operations. The purpose of information is to make decisions. The decisions may be operational, tactical and strategic to facilitate the transactions of the business. IT tools have created the opportunity for firms to share information conveniently and inexpensively throughout the supply chain. A typical information system for a company is given in figure 5.1.

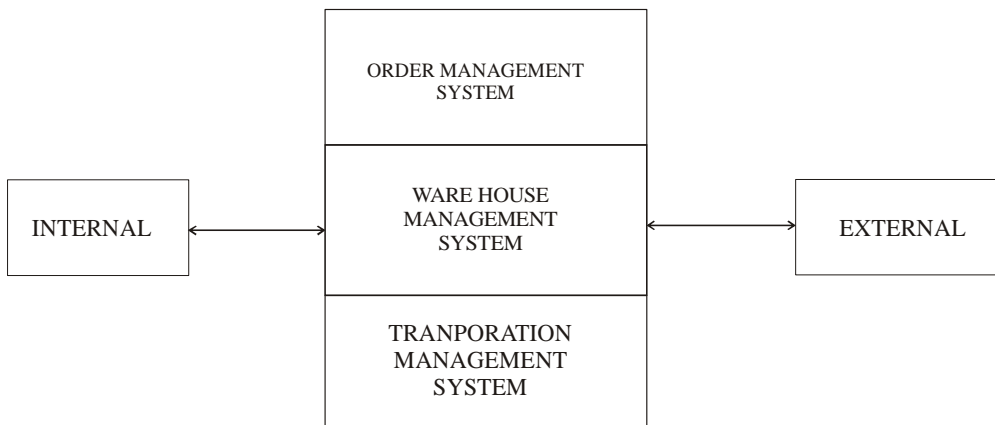

**Figure 5.1 A typical information system.**

The information system should be comprehensive and enable to communicate between functional areas and also between members of the supply chain. To reduce uncertainties, the information about sales, shipments, production schedules, stock availability, order status, and the like with vendors and buyers have to be shared among the partners in the supply chain. Even though the benefits of information sharing across the partners in the supply chain are being recognized, there is likely to be a limit to how much information firms are willing to share with others outside of their control.

Within the information system the major subsystems are:

- I. Order management system,
- II. A warehouse management system and,
- III. A transportation management system.

Let us discuss each of these three sub systems in the subsequent paragraphs.

## NOTES

### 5.10.1 The order management system

The order management subsystem enables the organization to make initial contact with the customer. It is the front end system of the information system. Before making order, this system ensures the availability of product, by communicating with warehouse management. Once product availability is ensured, credit checking may occur whereby the order management system communicates with the company's financial information system to check customer status and verify credit standing. Next invoicing takes place by allocating the product to the customer order and assigning it to a production location duly decrementing the inventory status. If the order management system is to provide order tracking, the transportation management system will be integrated. Similarly company places orders with its suppliers through purchase based order management system concentrating on the company's vendors showing their delivery performance ratings, costs and terms of sale, capabilities, availabilities and financial strength. Vendors are constantly monitored and reports prepared that assist in optimizing vendor selection.

### 5.10.2 The warehouse management system

The warehouse management system is an information subsystem assisting management in product flow through network by storing in the facilities. It is basically a stock level management. It can have order management system or can separately function within the information system itself. The key elements of warehouse management system are: receiving, put away, inventory management, order processing, retrieving of order, and shipment preparation. Receiving is the entry point for information into the warehouse management system. Data about the product are entered into the system using bar code, radio frequency or manual keyboards. Put away is earmarking location for temporary storage of product. Inventory management monitors the stock level at each stocking location in the warehouse. Replenishment of quantities and timing are suggested to purchasing department or directly to vendors through EDI or the statement. Order processing and retrieving is the planning for stock retrieval in the warehouse. Stock retrieval is the most labor intensive and expensive part of warehouse operations. Items will be grouped according to the location where inventory is stored. Depending upon the requirements lots will be formed for order pricing and schedules the order flow through the various areas of the warehouse. Further, warehouse management system subdivides the items within an order-picking area among the order pickers to balance picker workload. Orders for customers located within the same proximity are picked simultaneously to arrive at the shipping dock and truck stall at the same time. Efficient shipment requires proper sequencing it on to the delivery vehicle.

Overall, the warehouse management system aids the management in the effort warehousing operations in the form of labor planning, inventory level planning, space utilization, and picker routing. The warehouse management system shares information with the order management system and transportation management to achieve integrated performance.

### 5.10.3 The transportation management system

We know there are two types of transportation. One is inbound i.e. materials received up to storage point and the other is outbound. The transportation management system consists of shipment consolidation, vehicle routing, mode selection, claims, tracking, bill payment and freight bill auditing. Like warehouse management system, the transportation management system shares information with other information system components. In shipment consolidating small shipments into larger ones, there by unit shipment cost is minimized. In vehicle routing, the efficient routing is designed taking information from order management and warehouse management systems. Efficient vehicle routing minimizes transportation costs. In mode selection

TMS can match shipment size with transport service cost and performance requirements. It is inevitable in transportation that some shipments will be damaged. By retaining such information as shipment content, product value, carrier used, origin and destination, and liability limits, many claims can be processed automatically or with minimal human intervention. The progress of shipment can be tracked by bar coding, radio transmission route, global positioning, etc. tracing information from the TMS can be made available to the shipment's receivers through the internet or other electronic means. The small-shipment carriers such as DHL, Air Bourne Express, Fed Ex and UPS are at the forefront in such information system development, since it is customer satisfaction that they sell. Guaranteed delivery service is often promised, and a sophisticated shipment tracking system helps fulfill the goal.

### 5.10.4 Internal information systems

From sections 5.9.1 to 5.9.3, we have seen the various information systems for a supply chain. In the supply chain, the internal operation of a company is the main activity involving value addition. Therefore, every company must have internal information system for their internal operations. From the view point of internal operation, an information system can be represented schematically, as shown in fig 5.2.

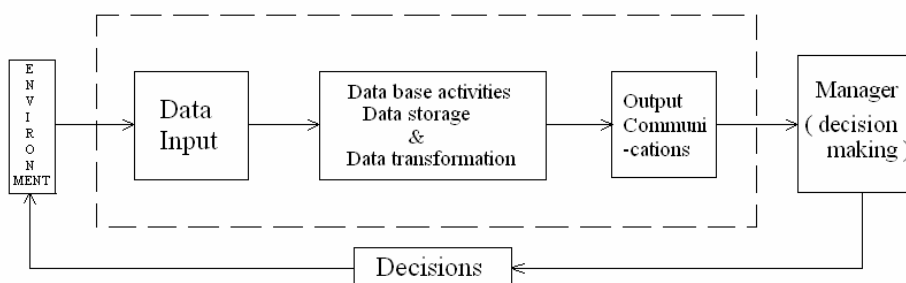

**Figure 5.2 Internal information system**

## NOTES

From the figure it can be noted that the system has three distinctive elements.

They are:

- I. The input,
- II. The database, and
- III. The output.

The input consists of customer data, company records, published information and management data. The first activity is acquiring the data that will assist the decision-making. The computer has brought about new sources of data not previously available and has led to significant improvements in operations. Database activities are nothing but database management. Converting data into information which is useful for making decisions and interfacing the information with decision assisting methods are often considered to be at the heart of an information system.

Management of the database involves selection of database to be stored and retrieved, choice of the methods of analysis to include, and choice of the basic data processing procedures to implement. Data maintenance can be expensive and data retention is based on:

- How critical the information is,
- The rapidity of information retrieval,
- The frequency of data,
- And the effort required for manipulating the data in to the form needed.

Data processing is one of the oldest and most popular features of an information system. Data processing or transactional activities represent relatively simple and straight forward conversion of the data into files, and then to some more useful form.

Data analysis is the most modern and latest use made of information system. The ERP software systems are now adding decision-support modules to improve their capabilities.

The output is generally of several types and transmitted in several forms. The output consists of:

- Performance statistics,
- Inventory status report,
- Exception reports, etc.

The output may in the form of prepared documents such as transportation bills and freight bills. The output may also be the result of data analysis from mathematical and statistical models.

## 5.11 E-SUPPLIER RELATIONSHIP MANAGEMENT (e-SRM)

e-SRM streamlines and make more effective processes between an enterprise and its suppliers just as CRM does. e-SRM leverages EDI technology to streamline the purchasing process, implement comprehensive buying strategies, and evaluate vendor and inventory performance. It not only facilitates the implementation of buying strategies at the company, vendor, and item level, but also provides the ability to carefully assess past performance, and predict future performance with what if analysis tools.

### e-SRM Sub-Module Capabilities Include

- Definition and automation of buying strategy
- Vendor pricing, discounts, and promotions
- Demand analysis
- Velocity (ABC) routings
- *What If* calculations
- Optimum buy quantity suggestions
- On-line buyers guide with suggested order quantity
- Suggested order quantity derivation inquiry
- Manual purchase order entry
- Purchase order maintenance
- Electronic Data Interchange

### Unique Features Include

There are a number of features that help reduce purchasing costs, optimize sourcing decisions, and more effectively manage vendor performance. These include: defining the buying strategy at the company level, vendor level, and item level, and incorporating them into the monthly demand analysis and buying guides. The buyer's guide is the result of a rightly comparison between current stock status and each item's reorder point. It is presented to the buyer in the form of purchase orders ready to be submitted to the vendor.

### e-SRM Helps Wholesale Distributors To Reduce Purchasing Costs

- Take advantage of volume and promotion discounts
- Reduce Premium Freight Charges
- Reduce administrative overhead

### Optimize Sourcing Decisions

- Define and implement tailored buying strategies

# NOTES

## Improve Supplier Relations

- Provide ability to view inventory

## 5.12 E-CUSTOMER RELATIONSHIP MANAGEMENT (e-CRM)

### About e-CRM

Customer Relationship Management (CRM) is a way to identify, acquire, and retain customers - a business' greatest asset. By providing the means to manage and coordinate customer interactions, CRM helps companies maximize the value of every customer interaction and in turn improve corporate performance.

eCRM, or electronic Customer Relationship Management, is an integrated online sales, marketing and service strategy that is used to identify, attract and retain an organization's customers. It describes improved and increased communication between an organization and its clients by creating and enhancing customer interaction through innovative technology.

eCRM software provides profiles and histories of each interaction the organization has with its customers, making it an important tool for all small and medium businesses. eCRM software systems may contain a selection of the following features:

- **Customer management** – Provides access to all customer information including enquiry status and correspondence
- **Knowledge management** – A centralized knowledge base that handles and shares customer information
- **Account management** – Access to customer information and history, allowing sales teams and customer service teams to function efficiently
- **Case management** – Captures enquiries, escalates priority cases and notifies management of unresolved issues
- **Back-end integration** – Blends with other systems such as billing, inventory and logistics through relevant customer contact points such as websites and call centers.
- **Reporting and analysis** – Report generation on customer behavior and business criteria.

### Benefits of eCRM

Implementation of an eCRM system enables an organization to streamline processes and provide sales, marketing and service personnel with better, more complete customer information. The result is that eCRM allows organizations to build more profitable customer relationships and decrease operating costs.



Direct benefits of an eCRM system include:

- **Service level improvements** – Using an integrated database to deliver consistent and improved customer responses
- **Revenue growth** – Decreasing costs by focusing on retaining customers and using interactive service tools to sell additional products
- **Productivity** – Consistent sales and service procedures to create efficient work processes
- **Customer satisfaction** – Automatic customer tracking and detection will ensure enquiries are met and issues are managed. This will improve the customer’s overall experience in dealing with the organization.
- **Automation** - eCRM software helps automate campaigns including:
  - Telemarketing
  - Telesales
  - Direct mail
  - Lead tracking and response
  - Opportunity management
  - Quotes and order configuration

Across every sector and industry, effective CRM is a strategic imperative for corporate growth and survival:

- Sales organizations can shorten the sales cycle and increase key sales-performance metrics such as revenue per sales representative, average order size and revenue per customer.
- Marketing organizations can increase campaign response rates and marketing driven revenue while simultaneously decreasing lead generation and customer acquisition costs.
- Customer service organizations can increase service agent productivity and customer retention while decreasing service costs, response times and request-resolution times.

### Working of eCRM

In today’s world, customers interact with an organization via multiple communication channels—the World Wide Web, call centers, field salespeople, dealers and partner networks. Many organizations also have multiple lines of business that interact with the same customers. (Pl. see Fig 5.3)

eCRM systems enable customers to do business with the organization the way the customer wants - any time, via any channel, in any language or currency—and to make customers feel that they are dealing with a single, unified organization that recognizes them every step of the way.

## NOTES

The eCRM system does this by creating a central repository for customer records and providing a portal on each employee's computer system allowing access to customer information by any member of the organization at any time.

Through this system, eCRM gives you the ability to know more about customers, products and performance results using real time information across your business.

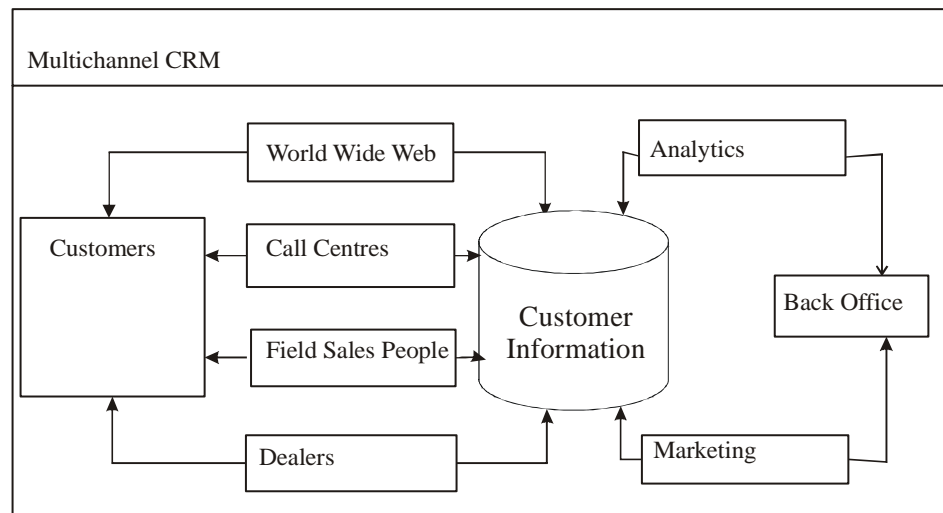

**Figure 5.3 Working of a e-CRM.**

### Application of eCRM system:

When approaching the development and implementation of eCRM there are important considerations to keep in mind:

- **Define customer relationships** – Generate a list of key aspects of your customer relationships and the importance of these relationships to your business.
- **Develop a plan** – Create a broad Relationship Management program that can be customized to smaller customer segments. A suitable software solution will help deliver this goal.
- **Focus on customers** - The focus should be on the customer, not the technology. Any technology should have specific benefits in making customers' lives easier by improving support, lowering their administrative costs, or giving them reasons to shift more business to your company.
- **Save money** – Focus on aspects of your business that can contribute to the bottom line. Whether it is through cutting costs or increasing revenue, every capability you implement should have a direct, measurable impact on the bottom line.
- **Service and support** - By tracking and measuring the dimensions of the relationship, organizations can identify their strengths and weaknesses in the relationship management program and continually fine tune it based on ongoing feedback from customers.

### Suppliers of eCRM software

Once a CRM plan has been developed, with key objectives and goals identified, eCRM deployment can begin. There are two main options available for small and medium size businesses to deploy e-CRM.

### Contact management software

Easy to install CRM software for small organizations which comprise a directory of customer details and allows sales and activity reports to be generated. The following organizations provide this type of eCRM Software

- ACT – [www.act.com](http://www.act.com)
- Act Today – [www.acttoday.com.au](http://www.acttoday.com.au)
- Contact Business Communications – [www.contactsoftware.com](http://www.contactsoftware.com)
- Maximizer – [www.maximizer.com.au](http://www.maximizer.com.au)
- Legrand CRM – [www.legrandsoftware.com.au](http://www.legrandsoftware.com.au)
- Vital Software – [www.vitalsoftware.net](http://www.vitalsoftware.net)

### 5.13 e- SCM

The eSCM-SP provides IT-enabled sourcing service providers a framework to improve their capability to deliver consistently high quality services and aids them in establishing, managing and continually improving relationships with clients. The intent of the eSCM is to present service providers with a set of best practices that help them effectively manage sourcing relationships, and it presents clients with a way to evaluate and compare service provider's capabilities. This intent is achieved by focusing on the critical organizational attributes for organizational management, people, business operations, technology and knowledge management, and their applicability to the sourcing process.

The eSCM Practices cover the entire sourcing life-cycle, including activities leading to the formation of sourcing relationships, service design and deployment (transition) activities, the delivery and enhancements of sourced services and the transitioning of sourced services back to the client or another provider at contract completion.

Supply chain has been viewed as an inflexible series of events that somehow managed to get products out the door. It often involved questionable inventory forecasts, rigid manufacturing plans and hypothetical shipping schedules. The Internet has changed all that. It has transformed this old-fashioned process into something closer to an exact science. An Internet-enabled supply chain helps companies to

- avoid costly disasters
- reduce administrative overhead
- reduce unnecessary inventory (thereby increasing working capital)
- decrease the number of hands that touch goods on their way to the end customer

## NOTES

- eliminate obsolete business processes
- reap cost-cutting and revenue-producing benefits
- speed up production and responsiveness to consumers
- garner higher profit margins on finished goods

Effective integration of an Organizations supply chain can save millions, improve customer service and reduce inventories. The key to getting optimum value out of automating your supply chain is to make sure you have your internal systems working well before you start extending them out over the Internet.

### Few tips to bear in mind while evaluating a e-SCM initiative

- **Get Perspective** -One should envision the business as a whole including its current strategy and where it wants to go. Supply chain strategy is increasingly being integrated with overall corporate strategy.
- **Don't Underestimate Learning Costs** - The cost of training people to use new software should not be underestimated. Sending information around the world takes lesser time than it takes to get into someone's mind!
- **Link to existing architecture** - Supply chain applications must link to existing enterprise resource planning applications. ERP serves as the nerve center of the organization. Ideally, it should be a single point of visibility for inventory and order taking.
- And last but not the least, **Think Global, Start Local !**

### 5.14 SUPPLY BASE MANAGEMENT

Supply-base management techniques relate to selection and maintenance of relationships with suppliers, for a purchasing company. The purchasing company desires to manage its relationships with those other companies that supply the purchasing company with goods. It would be advantageous for the purchasing company to obtain both the best price and the best value from its suppliers. Evaluation of best value can be a complex issue, involving parameters such as product reliability, order scalability, product line flexibility or variety, time from order to delivery and other factors responsive to decisions made by the purchasing company.

The supply-base management techniques use substantial resources at the purchasing company, particularly individuals skilled at locating, evaluating and negotiating with suppliers on a global level. These substantial resources can include, without limitation, substantial effort, allocation of personnel, money, and time, all used to determine which of those suppliers provide best value to the purchasing company and to develop long term, mutually beneficial relationships with them. The supply-base management techniques are best applied when the purchasing company has substantial purchasing requirements, such as if the purchasing company is relatively large or has a relatively large number of suppliers.

The supply-base management techniques often involve a continuing relationship between the purchasing company and its suppliers. Thus, the purchasing company would find it advantageous to apply supply- base management techniques on an ongoing basis, rather than for individual, or sporadic, purchasing needs. Purchasing companies often desire continuous development of their products or product lines, and thus often desire continuous development of the goods supplied to them, including preferred product attributes contributed by suppliers desiring to participate with the purchasing company in its product development.

The supply-base management techniques are advantageous when applied to a relatively larger pool of possible suppliers. Thus, the purchasing company would find it advantageous to apply supply-base management techniques to a set of possible suppliers, where that set is relatively disparate and possibly large in number. This problem is particularly exacerbated when the set of possible suppliers includes companies in other countries or other cultures, or involves the use of unfamiliar languages, standards of measurement, or different supply channels for distribution of goods.

The supply-base management techniques are not readily applicable to suppliers in search of purchasing companies that provide best value to the suppliers. Evaluation of best value to suppliers can be a complex issue, quite different from that evaluation for purchasing companies, and can involve parameters such as payment reliability, order regularity, product line fit with the supplier, requirements for reliability, time allowed for delivery, cost of account management and opportunity for new business.

Accordingly, it would be advantageous to provide a technique for using supply- base management techniques for purchasing companies and other entities such as suppliers and trading partners that (1) lack resources for applying those techniques; (2) desire continuing relationships with their trading partner, but lack resources for evaluating or managing those continuing relationships; (3) lack expertise in the markets in which their best value suppliers or buyers might be found ; (4) seek markets outside their ordinary realm of expertise; and (5) wish to avoid the fragmentation that results when numerous different entities are used to facilitate a transaction.

The supply- base management techniques provide a method and system for an internetworking environment. A set of purchasing companies can leverage their purchasing volumes so as to obtain the benefit of a collaborative process of qualification and negotiation with suppliers to obtain the benefit of continuous best value scoring of suppliers. Each individual purchaser retains the ability to determine which aspects of “best value” are important to it and to base each transaction on those specific aspects. A set of suppliers can obtain access to a new set of buyers, expand business with existing buyers and achieve a level of account management efficiency not otherwise available.

## NOTES

In a preferred embodiment, scoring of both suppliers and purchasers is continuously updated, and is responsive to feedback from third parties who facilitate transactions. This continuous feedback is made available to both suppliers and purchasers when making new sales or purchase commitments. Similarly, in a preferred embodiment, both suppliers and purchasers can make use of an organized set of expertise in evaluating, negotiating, and complying with regulations for transactions that cross borders, cultures, language or other barriers.

The supply- base management provides solutions for a wide variety of problems to obtain substantial advantages and capabilities that are novel and non-obvious. These advantages include offering suppliers and buyers access to a globally integrated platform that presents the parties with pre-qualified best value options. These pre-qualified best value options remove the uncertainty.

### **Chapter summary**

This chapter introduces the role of e-business in a supply chain. E-business is the execution of business transaction over the internet. Firms use E-business to provide information across the supply chain, negotiate prices and contracts, allow customers to place and track orders, allow customers to download orders, and receive payments from customers. The main aim of E-business is to make these payments both more responsive and more efficient. Then we have seen the impact of E-business on supply chain performance. The E-business frame work developed in this chapter can be utilized by the firms to evaluate whether a company is a good candidate for E-business and where they should target their E-business efforts.

Thereafter we emphasized the importance of IT in a supply chain. We have seen that information is essential to make good supply chain decisions because it provides the global scope needed to make optimal decisions. We have also seen that IT tools are important to gather information and analyze it to make the best supply chain decisions. The role of supply chain drivers in using IT is also portrayed in this chapter. Major applications of supply chain IT and the processes that they enable were also understood in this chapter. Also the steps involved in practicing IT, in a supply chain has been discussed. Thereafter we have seen how to develop information system. Then, the various packages available like esrm, escm and ecrm were brought out. Finally, supply base management has been defined and the need for it was also discussed.

- 4) Discuss the impact of E-business on responsiveness?

**Review questions**

- 1) What is E-business?
- 2) Bring out the role of E-business in a supply chain.
- 3) What is the E-business framework?
- 4) Discuss the impact of E-business on responsiveness?
- 5) Discuss how efficiency can be improved using E-business?
- 6) What is the role of supply chain in b2b practices?
- 7) Explain supplier relations management.
- 8) What is internal supply chain management?
- 9) Explain supplier relations management?
- 10) What are fundamentals of transaction management?
- 11) Explain the steps involved in practicing supply chain IT
- 12) Explain the information system development focusing on function of the organization.
- 13) Explain the internal information system.
- 14) Consider a company of your choice and apply E-business frame work and evaluate whether it is a good candidate for E-business.
- 15) Give examples for information systems from Indian industry.

**NOTES**

---

# NOTES