

A NEW MONETARY THEORY

# THE CREATORS OF INSIDE MONEY



D. Gareth Thomas



# The Creators of Inside Money

D. Gareth Thomas

# The Creators of Inside Money

A New Monetary Theory

palgrave  
macmillan

D. Gareth Thomas  
Department of Accounting, Finance  
and Economics  
University of Hertfordshire  
Business School  
Hatfield, UK

ISBN 978-3-319-90256-2      ISBN 978-3-319-90257-9 (eBook)  
<https://doi.org/10.1007/978-3-319-90257-9>

Library of Congress Control Number: 2018942206

© The Editor(s) (if applicable) and The Author(s) 2018

This work is subject to copyright. All rights are solely and exclusively licensed by the Publisher, whether the whole or part of the material is concerned, specifically the rights of translation, reprinting, reuse of illustrations, recitation, broadcasting, reproduction on microfilms or in any other physical way, and transmission or information storage and retrieval, electronic adaptation, computer software, or by similar or dissimilar methodology now known or hereafter developed.

The use of general descriptive names, registered names, trademarks, service marks, etc. in this publication does not imply, even in the absence of a specific statement, that such names are exempt from the relevant protective laws and regulations and therefore free for general use. The publisher, the authors and the editors are safe to assume that the advice and information in this book are believed to be true and accurate at the date of publication. Neither the publisher nor the authors or the editors give a warranty, express or implied, with respect to the material contained herein or for any errors or omissions that may have been made. The publisher remains neutral with regard to jurisdictional claims in published maps and institutional affiliations.

Cover illustration: Lindarks/Getty

Printed on acid-free paper

This Palgrave Macmillan imprint is published by the registered company Springer International Publishing AG part of Springer Nature  
The registered company address is: Gewerbestrasse 11, 6330 Cham, Switzerland

*To Sienna*

## PREFACE

The book develops a new monetary model in the light of the events of 2007/2008 that led to the present Great Recession, representing a long period of puny growth, particularly in the UK, and no sight of recovery into the expansionary state. Historically, financial crises have not been satisfactorily explained by the traditional theory in the form of neoclassical analysis. According to Keen (2011), the reason may well lie with the endemic adoption of a body of theory based either on a barter system of exchange, or with one-commodity used as money, and then used to explain a dynamic, monetary economy.

A monetary economy today uses a non-commodity as money that is intrinsically valueless in the form of a ‘token’ or an ‘electronic’ number on a balance sheet of a bank to facilitate exchange of goods and services produced from the real economy, fiat money. In fact, banks specialise in the activity of producing the means of payment by providing tokens in the form of cash supplied by the Central Bank or by creating ‘inside’ money endogenously in the form of loans as credit to link payer and payee in the process of exchange and production. The bulk of the money supply is the banks’ liabilities (or deposits) generated from income, which is approximately 97% of the flow that finances durable consumption and investment in the UK. The other 3% represents ‘outside’ money that comes from the monetary base, namely the reserves of deposits of commercial banks plus the cash balances. This is initially assumed to be fixed within the analysis by the monetary authorities, but in reality even this is partly endogenous and determined by banks because they decide on the amount of excess

deposits that are kept. In other words, firms produce goods and services over time for sale by combining factors of production in the output process, whereas retail banks create the medium of exchange and loans as credit to finance production and consumption. In today's monetary economy, banks and firms must be treated differently and not as one entity as in conventional analysis.

An analogy would reinforce the theme. Banks are like the intercity trains of the railway infrastructure, unbelievably fast and efficient when transporting travellers to and from their destinations, but disastrous when they come off the rails, causing catastrophes as in the case study of the financial crash in 2007/2008. The objective, therefore, is to construct a monetary model, highlighting the importance of how money is created endogenously as a wheel of circulation and to derive the corresponding loanable supply curve within the new theory.

### **Case Study: The Banking Crisis of 2007–2008**

The financial crisis in 2007/2008 led to the current growth recession, considered by many economists to be the worst slump in economic activity since the Great Depression of the 1930s. The collapse of the USA's housing bubble, which peaked in 2006, caused the value of securities tied to house pricing to plummet, damaging financial institutions globally. The plunging of Lehmann Bros. into bankruptcy, because of a rather clumsy failure of lender of last resort facilities, led both the USA and finance globally, into financial crisis. Thus, economies worldwide slowed as credit tightened and international trade declined. The signal of a crisis in the UK culminated in the fiasco surrounding the Northern Rock Bank, which obtained the majority of its funds from the 'wholesale' sector, which are deposits from other banks in the form of interbank loans to finance their mortgage loans. In some cases, the mortgages were in excess of hundred percent. This Bank became particularly vulnerable when interest rates started to rise with falling house prices, reducing collateral from the increased number of repossessions from subprime households. When these interbank deposits were not renewed because of the growing uncertainty and risk, Northern Rock was hit by a massive removal of funds in the form of cash withdrawals. The Bank had no other option but to

seek help from the Bank of England in its capacity of lender of last resort. Once this became common knowledge, agents began to withdraw their deposits from other institutions. In other words, this triggered runs on other similar banks such as Alliance and Leicester, Bradford and Bingley, simultaneously hit by massive withdrawals, causing a disastrous liquidity crisis. This led to serious negative effects on the endogenous money supply through the creation of loans by the retail banks quite apart from cash withdrawals of deposits.

What was the cause? The number of residential mortgages had soared, fuelled by the growth in house prices between 1996 and 2008, which was growing faster than the consumer prices, so that the real price of housing was rising considerably. The mortgage lenders responded by boosting advances and relaxing the lending criteria. This was aggravated by the banks discovering ways of keeping these risky assets off the balance sheet by the process of ‘securitising’ some of the subprime mortgages and selling them on. They were often mis-sold by exploiting asymmetric information. These assets, however, evidently became increasingly worthless as their market value plummeted and were regarded as ‘toxic’.

The difficulties started to arise when mortgage defaults began to increase in 2007 because of the rising rate of interest, resulting in a crisis and the banks rushed to build up reserves, and consequently, there was an unwillingness to lend. The result was an enlarged holding of deposits at the Bank of England in place of deposits that had previously held within other banks. With some banks so heavily dependent on other banks’ deposits, it became very difficult for them to lend at the previous level. In fact, the shortage of interbank deposits meant a sharp rise in the rate of interest in the market. The use of ‘wholesale funding’ had become widespread between lenders, which represented another avenue besides their own deposit base to fund the creation of loans, especially mortgages. In fact, it was this phenomenon: the high degree of interbank funding that speeded up the process and transmitted a general collapse of liquidity triggered by one bank’s problem, which dramatically increased the level of systematic risk within the banking system.

According to Bain and Howells (2009), what had come into play was the **asymmetric information problem**, whereby if Bank



One has funds available to lend, as in the past, with Two, but in the midst of growing uncertainty and risk, leading to higher interest rates, Bank One interprets the willingness of Two to borrow that it is in trouble and redraws, resulting in deadlock across the system. Bank One accumulates enlarged deposits at the Central Bank, increasing its reserves and reducing the endogenous growth of loans. The worsening situation within the balance sheets of banks meant that there were less excess deposits available to finance the creation of loans. Thus, this means less liquidity to finance durable consumption, investment and the formation of output of goods and services. The impact on the interbank market can be seen by the fact that despite a fall in the bank rate from 5 to 4.5% in October 2008, the one-month LIBOR actually went up, reflecting the shortage of excess funds available to lend and the fear that some banks might default on unsecured debt and become bankrupt. It was this phenomenon of no confidence that caused interbank lending to shrink drastically. So, banks dependence on this market for funds with a high proportion of subprime assets looked increasingly vulnerable as the fear of bankruptcy spread. The end result was a shortage of liquidity for loan creation as credit to finance production and trade.

The impact on the housing and mortgage markets is shown in Fig. 1, where the positive mark-up on the bank rate determines the standard, variable mortgage rate, reflecting the heightening uncertainty and risk. This positive value starts rising in the last quarter of 2007, leading to a staggering 3.5% rise in January 2011 over the bank rate. The outcome is that, the Bank of England is not always able to determine the interest rate for institutions that hold balances at the Central Bank. This means that the official and market-determined rates can be quite different.

Another dimension of the financial crisis was the lack of financial capital measured by the value of assets relative to equity. Losses financed by shareholders' funds reduced capital sufficiency, which means that banks reduce their assets by not renewing loans or reducing its growth of credit. The banks could have attempted to issue new shares but that would have been difficult in a situation where confidence was rapidly disappearing within the banking system. The other way is to reduce dividend

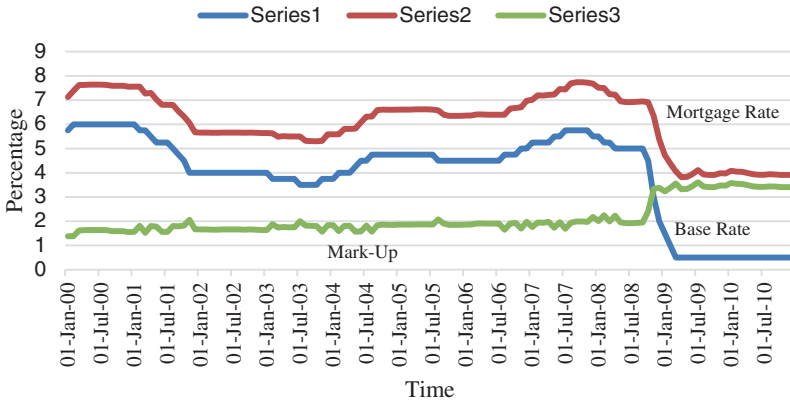

**Fig. 1** Base rate, mortgage rate and mark-up (*Source* Statistical interactive database, Bank of England)

outgoings to shareholders, which is essentially retaining profit in order to restore capital provision, although this policy would stretch over a considerable period because profitability was falling. Furthermore, the regulations influencing the banks' capital sufficiency since 1988 had been the Basel Committee and known as the 'Basel Accords', which have been revised and redefined on numerous occasions, but has been prevalent in making the creation of loans very costly (Bain and Howells 2009). The fundamental criterion involves the employment of 'risk-asset ratios'. The assets of a bank are categorised into five risk-weightings. For instance, currency as a weight of zero whereas at the other extreme, advances as a weighting of one. Generally, the method is to take the market value of assets in each category and multiply it by the risk-weighting, giving a risk-adjusted value for each. These are then summed up to derive the overall value for the bank's risk-adjusted assets. This is compared with the bank's capital base. The Basel Committee set a lower minimum of 8% for the ratio of capital to risk-adjusted assets, although the Central Bank has discretion to set

greater values. The effect of such ratios for banks is to reduce their profitability and possibility of credit expansion.

Normally, the Bank of England provides liquidity to banks through ‘open market operations’, involving the use of repos. Basically, the Bank of England offers funds for a fixed term against eligible collateral such as government bonds, representing short-term lending for such measures as short stay stabilisation. In the summer of 2007, however, conditions ceased to be routine. In response to the liquidity shortage, there were a number of initiatives undertaken between March and April of 2008 to provide liquidity and, therefore, to overcome the deficiency and reinstate trust within the monetary system. For instance, the Special Liquidity Scheme introduced on 21 April, allowing the swap of illiquid, high-quality assets such as mortgages for Treasury bills that could be sold for currency on the money market. This process itself had made £100 billion of funds available to retail banks, but these various measures by the Central Bank to provide financial resources to restore confidence had failed to correct the problem. The end result was the increasing stake of public ownership in number of large banks by way of the process of the state buying up new share issues, so that they could raise additional capital. Furthermore, the Special Liquidity Scheme was extended to include more risky assets in the swap along with the Credit Guarantee Scheme, where Government becomes a guarantor of loans on the interbank market in order to jump-start lending.

As the recession gathered momentum, the scale of bank deficits turned out to be even larger than expected and consequently, banks were loath to raise the growth of loan creation in fear of accumulating further toxic debt, adding to their risk factor. To prevent further catastrophic falls in aggregate demand and supply, quantitative easing was used by the monetary authorities in order to stimulate the economy. This is where the Bank of England credits its own account with money it creates electronically and then buys financial assets with the newly created funds. In January 2009, the Bank of England was given powers by the Treasury to buy up to £50 billion of private sector assets, such as corporate bonds, commercial paper and various viable securitised assets. The aim was directly

to increase the supply of loanable funds. The result, however, was banks' accumulation of the additional currency as part of their reserve ratio because of the climate of increasing defaults within their current loan portfolio.

The difficulty was that the Government was running out of options. Interest rates had been cut to an unprecedented rate of 0.5% by March 2009. The Bank of England, therefore, could no longer target interest rates as the interbank rate was close to zero in the midst of a liquidity trap. These extensive programmes of support for bank lending were happening across the globe, from America to Europe, in an attempt to restore money as a matter of confidence and trust, because liquidity was being restricted further as the recession deepened worldwide.

## THE CONTENT OF CHAPTERS

Therefore, the following chapters analyse and theoretically model the endogenous money supply as loanable funds and the rôle of the retail banks in the process of loan creation outlined in the case study above. This lending is in conjunction with the demand for loanable funds, which determines the rate of interest on borrowing to finance partially consumption and production:

**Chapter 1:** An overview and the need for a financial system

This introductory chapter presents the scope of the book and summarises its main theme, in particular the need to develop a monetary model that goes beyond the traditional theory of a barter system, or one with one-commodity used as money to proxy the 'workings' of a modern-day economy, with credit. The assumption of money neutrality is dropped along with treating the medium of exchange as a 'veil'.

**Chapter 2:** The money supply process

The analysis will involve a tripartite system of agents in the form of depositors (which includes households and firms), retail banks and the monetary authorities in determining the money supply process within the economic system. It is the interaction of these economic actors that

determines the money supply process in the form a monetary multiplier that supports the real economy.

**Chapter 3:** The mechanism behind the money multiplier and the loanable funds model

This section will show how the retail banks can create (or destroy) loans and liabilities in the form of money credit, depending on lending opportunities and interest rates in the prevailing winds of uncertainty and perceived credit risk. This is the main ingredient of the money supply, which retail banks create by using available reserves in the form of using internal profits from interest payments, the selling of financial assets and securities, buying reserves from other banks as well as using reserves held at the Central Bank or borrowing from it. This generates profit in the form of interest payments from the geometric process of credit growth and represents a cumulative (or diminishing) process based on monetary circuitism. This leads to the formation of the new loanable funds model when the demand is married with the supply, so that the equilibrium rate of interest on borrowing can be determined.

**Chapter 4:** The demand for money: another piece of the jigsaw puzzle

This part of the theory examines the desire to hold wealth and assets in the form of money balances by identifying the three motives for holding the medium of exchange in conjunction with saving. This will provide a clear description of the nature and origins of liquidity demand, which goes on to show it can be met by the various institutions providing time deposits, money and credit, exploring to what extent and under which conditions they are complements or substitutes. Once the scissors of supply and demand are applied to the ‘output’ of the banking sector, then the unregulated supply of loanable funds curve will appear as a crucial component of the model, which is the major theme of the next chapter.

**Chapter 5:** The rate of interest and the new monetary theory of loanable funds

The analysis reaches the stage where the new monetary model can be partly built on the endogenous loanable funds supply, which is partially controlled by the commercial banks, and partly with the demand for these funds. This supplements the exogenous assumption that underlies the majority of textbooks underpinning theoretical models such as the IS/LM analysis of macroeconomics. It should be noted, however, that

this is going against the grain because a number of textbooks are no longer making any reference to the LM curve.

#### Chapter 6: The term structure of interest rates

If the banks have some control over the endogenous money supply, then they partly determine the market rates of interest in the borrowing and saving process on various terms through a mark-up on the ‘bank’ rate set by the Central Bank. The link between the rates implies that they could well be formed by the term structure either through the expectations theory or an imperfect configuration of it, with an empirical illustration.

#### Chapter 7: The loanable funds cycle and the variability of the deposit base

The analysis lays the foundation for Minsky’s theory, which exposes the states of the economy it goes through over evolutionary time: expansion and significant progress then downturn in the form of either recession with negative development (or growth recession) or full-blown depression with heightened uncertainty and risk that seems uncontrollable. At some stage, the economy goes into recovery mode from Darwin’s ‘survival of fittest’ account of the intense market competition, travelling back to the expansion stage with fresh consumption and investment opportunities to explore and exploit on account of Schumpeter’s process of creative destruction. This will have significant implications for the variability of the banking sector’s deposit base, which can be modelled within the catastrophe framework to explain abrupt changes in money as loanable funds in relation to the build-up of uncertainty and default risk within the monetary economy.

#### Chapter 8: A catastrophe theory and the loanable funds cycle

The discussion of Minsky’s theory reaches up to the macro-level to expose the full effect of the credit phases and the possibility of the catastrophic moment, triggered by changing perceptions of risk and uncertainty. This leads to the modelling exposition in the form of the catastrophe framework of thought, where a number of multiple equilibrium paths can be taken by the financial sector, driving business (or residential) cycles with either inflationary or deflationary tendencies. This links to the deposit base embodied in the components of the money multiplier, which is driven by the mechanism of credit creation (or extinction) of loans. The variability of the deposit base is largely

dependent on the state of the economy in terms of the cyclical growth of GDP, intertwined with the financial cycle of the multiple equilibria.

**Chapter 9:** Rebuilding the theoretical model of inflation on credit with loanable funds

In this chapter, the core concepts of inflation, disinflation and deflation with expectations that underpin the credit cycle in Chapter 7 are modelled to provide a theoretical link that relates to the growth of loans and, consequently, to the endogenous flow of the money supply. The idea is to add to Friedman's notion *that*

'Inflation is always and everywhere a monetary phenomenon in the sense that it is and can be produced only by a more rapid increase in the quantity of money than output'.

Now put this into reverse, disinflation and deflation are forever and ubiquitously a monetary occurrence in that it can only happen because of an abrupt decrease in the growth of the money supply, which is less than the expected change in production, leading to real, destabilising effects, triggered by endogenous changes to the desires of commercial banks to create money in the economy.

**Chapter 10:** The conclusions with policy recommendations

The book recommendations will be based on analysis of the properties of the new model, which explains the monetary system. This traces the development of catastrophes in the form of repeated financial instability leading to inflation, deflation and unemployment over the course of history, as the capitalist system evolves. The cycle either speeds up or it slows down improvements and progress in our standard of living. This phenomenon is ignored in the traditional neoclassical theory of economics, because of its emphasis on the rôle of barter in exchange. The structure and behaviour of the banking system are regarded there as a 'shroud' over the real economy. The analysis here will show that in recent years, concerning the latest financial crisis, the lender of last resort interventions have staved off part of the deep economic depression, but the current demand management policies have perpetuated the current Great Recession with growing income inequality.

Moreover, Chapters 1–3 build the loanable funds model that determines the borrowing rate of interest, which derives and restores the LM

curve with its ‘twin’, the IS. Chapter 4, the money demand and supply establish the rate of interest on saving and partially explain the accumulation of wealth. Chapter 5 brings the ‘threads’ together under the umbrella of the determination of the rate of interest with its assorted components. This allows the analysis in Chapter 6 to explore the various ‘mark-ups’ embodied within the rate of interest that reflects uncertainty and risk on borrowing and saving. Chapter 7 lays the foundations concerning the determination of the changing deposit base via the hybrid hypothesis based on Minsky’s theory. This flows into the catastrophic framework of Chapter 8 to explain the conditions that give rise to abrupt changes into the three states of economic activity within the economy: expansion, slump and recovery. This chapter reveals the need to rebuild the theory of inflation in nine as this is a key variable in the cycle of loanable funds. The final chapter, therefore, is concerned with the policy implications of the ongoing model.

The content grew out of the need to explain the financial crisis outlined previously that started in 2007 and the resulting never-ending current, growth recession that prevails with no sight yet of recovery into the expansion state. Clearly, one of the major objectives is the modelling of the economic activity of inside money and its endogenous nature that flows from the retail banking sector as part of the monetary system. This process is largely absent from conventional theory and assumed to be exogenous and controlled by the monetary authorities. Therefore, the need to reconstruct traditional theory to include the function of money as part of the evolutionary division of labour in the routine practice of exchange of goods and services as well as its provision as finance in the output process to engage the factors of production.

The analysis formed out of a series of lectures that were developed on an undergraduate module of money, banking and finance for final year students on a number business school degree programmes. In the meantime, the teaching modern econometrics to final year students was based on the theme of the demand for money using American data from the Federal Reserve Bank of St. Louis. It became progressively more obvious that the function of inside money as a source of supply was just as important in the provision of loanable funds to meet the demand as outside money. It became apparent that the traditional approach of the demand and the supply of money determined the rate of interest on savings with Federal debt.



**Acknowledgements** The writer would like to thank David Bywaters, an ex-colleague at the University of Herefordshire for reading and editing the material, although the errors are mine. Also, I would like to acknowledge the help and stimulating conversations with Rex Obeng, another colleague at the University, on the ethos of the analysis. Furthermore, the study has greatly benefited from the comments made by various cohorts of students.

Hatfield, UK

D. Gareth Thomas

## REFERENCES AND FURTHER READING

- Bain, K., & Howells, P. (2009). *Monetary Economics, Policy and Its Theoretical Basis* (2nd ed.). Basingstoke: Palgrave Macmillan.
- Keen, S. (2011). *Debunking Economics: The Naked Emperor Dethroned*. London: Zed Books limited.
- Pilbeam, K. (2010). *Finance and Financial Markets* (3rd ed.). Basingstoke: Palgrave Macmillan (Chap. 17).
- Slooman, J., & Wride, A. (2009). *Economics* (7th ed.). Harlow: Pearson Education Limited (Box 18.3).

# CONTENTS

1	The Need for a Financial System?	1
2	The Money Supply	15
3	The Adjustment Process of the Money Multiplier and the Loanable Funds Model	29
4	The Demand for Money: Another Piece of the Jigsaw Puzzle	43
5	The Rate of Interest and the New Monetary Theory of Loanable Funds	63
6	The Term Structure of Interest Rates	77
7	The Loanable Funds Cycle and the Variability of the Deposit Base	97
8	A Catastrophe Theory of the Endogenous Cycle of Loanable Funds	123

<b>9</b>	<b>Rebuilding the Theoretical Model of Inflation on Credit with Loanable Funds</b>	141
<b>10</b>	<b>The Conclusions and the Policy Recommendations</b>	155
	<b>Index</b>	161

# LIST OF FIGURES

Fig. 1.1	Decline of saving ratio over the period, 2007 Q1–2017 Q1 ( <i>Source</i> Office of National Statistics)	3
Fig. 2.1	Aggregate demand and supply with the labour market	17
Fig. 2.2	IS/LM model with the Pigou effect	18
Fig. 2.3	The monetary base	25
Fig. 2.4	Changes in the monetary base	25
Fig. 2.5	Open market operations	26
Fig. 2.6	Asset purchases by the Bank of England	27
Fig. 3.1	Loanable funds with a rightward shift of the supply function	37
Fig. 3.2	The derivation of the LM curve from the loanable funds market	38
Fig. 3.3	Endogenous Money and Loanable Funds in an Open Economy	41
Fig. 4.1	The average money holding in a current account	48
Fig. 4.2	The optimal number of withdrawals	50
Fig. 4.3	The optimal amount of precautionary balances	52
Fig. 4.4	The allocation of bonds and money	55
Fig. 4.5	The demand for money	56
Fig. 4.6	The determination of the saving rate of interest	59
Fig. 4.7	Gilt yields ( <i>Source</i> UK Debt Management Office)	60
Fig. 5.1	Classical demand and supply of loanable funds	67
Fig. 5.2	The real demand and supply of money	69
Fig. 5.3	Interest rates, loanable funds and reserves	72
Fig. 6.1	The components of nominal rates of interest ( <i>Source</i> Howells and Bain 2008)	78
Fig. 7.1	The firm's short-run output decision with abnormal profit	99
Fig. 7.2	The firm's short-run output decision with normal profit	100

Fig. 7.3	The firm's short-run output decision with losses	101
Fig. 7.4	A plot of M1 money supply in the USA ( <i>Source</i> The Federal Reserve Bank of St. Louis)	108
Fig. 7.5	A plot of the monetary base ( <i>Source</i> The Federal Reserve Bank of St. Louis)	108
Fig. 7.6	A plot of the money multiplier ( <i>Source</i> The Federal Reserve Bank of St. Louis)	109
Fig. 7.7	A plot of excess reserves ( <i>Source</i> The Federal Reserve Bank of St. Louis)	110
Fig. 7.8	The firm's short-run output decision under imperfect competition	115
Fig. 7.9	The equilibrium of the portfolio possibilities and the efficient frontier	119
Fig. 8.1	A catastrophe model of endogenous change in loanable funds	126
Fig. 8.2	Changes in the endogenous growth of the money supply through loanable funds	128
Fig. 8.3	Uniform change from rising to a falling adjustment in loans	130
Fig. 8.4	Catastrophic changes in the endogenous loans	130
Fig. 8.5	Demand and supply of loanable funds	134

## LIST OF TABLES

Table 6.1	Terms to maturity	79
Table 6.2	Stationarity tests over sample period of 1992 M12–2012 M8	92
Table 6.3	Test statistics and choice criteria for selecting the order of the VAR model	92
Table 6.4	Cointegration with restricted intercept and no trend, log ratio test (LR) based on maximal and trace eigenvalues of the stochastic matrix	93
Table 6.5	ML estimation of cointegrating vector with restricted intercept and no trend	94



## CHAPTER 1

---

# The Need for a Financial System?

## 1.1 INTRODUCTION

Money is a characteristic of every transaction since the dawn of civilisation and trade. There have been various commodities and precious metals used as the medium of exchange, but it was the warrior monks (<http://www.bbc.co.uk/news/business-38499883>) that were the forefathers of modern banking and the creation of paper money, which has evolved into a digital format on computer platforms, underpinned by legal tender.<sup>1</sup> It shows the crucial part of money plays in the evolutionary development of the modern economy and that it is the lifeblood of the monetary system. It is a fact that the lion's share of consumption and investment depends not only on saving but on the creation of loanable funds by retail banks. They can create money with loans as a medium of exchange out of themselves (Schumpeter 1934). At the height of the process of creative destruction (Schumpeter 1943), where the new stage of growth by way of new goods and services based on fresh discoveries of new technological advances and innovations, which must be financed by the banking sector (which) and is key part of the division of labour.

In this introductory chapter, the concept to notice is the flow of income through the medium of money from those who have a surplus to those in deficit via the financial system, which embodies markets where agents and financial firms trade financial instruments such as derivatives,

shares and bonds. These financial firms include commercial (or retail) banks, for example, which are institutions that receive agents' creation of real income in the form of interest, profit, rent and wages paid as deposits, who wish partly to save or use as a medium of exchange for their day-to-day transactions. In turn, banks use this deposit base to lend to borrowers through loans, creating new credit as a medium of exchange for households and companies. They create further deposits and saving in the form of 'circular causation': circularism. The point to notice is that they are not financial intermediaries in the traditional sense because they create new money, whereas contributions by policyholders within insurance companies form investment funds in a broad range of securities. The buying of these securities, such as equities, represents the flow of income to the issuers for, say, the running of firms to earn profits from production or in providing services. These activities are effectively transferring saving of excess income in the form of bank deposits from lenders to borrowers.

In the advanced countries like the UK, incomes are high with many individuals and groups of agents who would like to lend. Keynes in the *General Theory of Employment, Interest and Money* (1936) made the assertion that as income grows the difficulty is that the marginal propensity to save has a tendency to rise, whilst the marginal propensity to consume falls. This, however, has not been the experience of the UK economy recently, where the underlying trend of the saving ratio (<http://www.bbc.co.uk/news/business-40454385>) has been in decline along with disposable income, as shown in Fig. 1.1, which means the demand for loanable funds will increase. Historically setting aside this recent fact, this is why developed economies have complex financial systems with **indirect lending** to reduce transaction costs and increase economic growth (Bywaters and Mlodkowski 2012). **Direct lending** is **costly** and **risky**, although unlikely to happen in reality because organised markets reduce this costly search and risk on account of willing **traders** and **financial intermediaries** who provide the avenue for the transfer of funds between borrowers and lenders, pushing the banking sector to one side. The biggest advantage for lenders is that they can sell their financial claims on the borrowers after making loans. In fact, the main activity is the refinancing of loans originally made by others. This is the advantages of organised markets for saving and lending of financial funds.



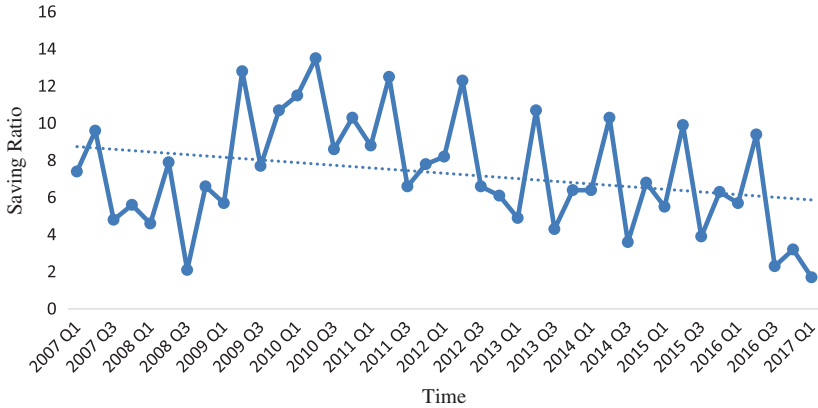

**Fig. 1.1** Decline of saving ratio over the period, 2007 Q1–2017 Q1 (*Source* Office of National Statistics)

## 1.2 SAVING AND LENDING

According to Keynes, agents have conflicting motives and it is the financial system’s function to reconcile these differences. Saving ( $S$ ) is the difference between income ( $Y$ ) and consumption ( $C$ ), which is  $S = Y - C$ , which is a function of income along with the secondary variable, the rate of interest, whereas real investment depends on expectations of future profit. In theory, this saving finances the purchase of capital goods via real investment ( $I$ ), but there is no reason why they should be equilibrium. In fact, in advanced countries incomes are high and exceed real investment, and as a result, there is a financial surplus (or surplus units) available for lending. This is the **net acquisition of financial assets (NAFA)**, expressed in the following form as an identity:

$$(Y - C) - I = \text{NAFA}. \quad (1.1)$$

This is equal to potential lending or the accumulation of ‘hoards’ in the form of liquidity.<sup>2</sup> Initially, saving can be a combination of investment and net acquisition of financial assets, which could be in the form of lending or hoards, that is

$$(Y - C) = S = \text{NAFA} + I. \quad (1.2)$$

In order to induce lenders with a surplus to lend, it is necessary for them to obtain the **maximum return** for the **minimum of risk**, although there is a **chance** that the return may differ from their expectations. It could come in the form of default, reduced income and capital losses as well as inflationary risks. Organised markets reduce these risks in addition to offering **liquidity** to lenders so that they can retrieve their capital funds quickly with certainty. There are, however, considerable advantages for borrowers as well, the discussion below at the outset.

### 1.3 BORROWING

Those who wish to spend over and above their income have **financial deficits** (or deficit units). This means having to reduce the accumulation of past financial assets or incur liabilities (or debts). This could be state institutions, firms and individual households, whose incomes are not large enough to cover their current consumption or capital expenditure. In the case of firms, they borrow funds to buy investment goods and renew circulating capital that will derive future incomes at present value that will not only service the loans, but also repay the principal debts along with earning gross profits.

The motives of the borrowers are to **minimise cost** and to **maximise the period** for which they want to borrow. The advantages are two-fold if a financial system exists. One, it reduces the risk for borrowers to repay at an inconvenient time. Two, it also decreases the danger of loans replaced with higher rates of interest.

### 1.4 LENDING, BORROWING AND WEALTH

A surplus of funds is a flow that can potentially increase the stock of net financial wealth, whereas a deficit flow reduces the size of it. Many individuals jointly hold debts as well as credits. For example, people with mortgages hold bank deposits, which give them the advantage of liquidity to meet unforeseen demand for payments or purchase, like the so-called **precautionary demand for money**. The decisions to acquire financial assets and liabilities depend on the **best mix** for the individual household's circumstances, leading to their **portfolio choice**. This is a mixture of assets and liabilities; given the cost, portfolio equilibrium takes place when the benefits from each are equal at the margin.

## 1.5 FINANCIAL INSTITUTIONS

Financial institutions bring together those who have a surplus with those agents who have a deficit, offering different types of loans for borrowers and a wide range of assets for lenders. It is the financial institutions interacting in markets that make up the financial system. Financial firms operate on a large scale and can reduce risk through diversification with a specialist management. Risk decreases with increasing size. Clearly, holding one asset is likely to produce an ‘unlikely’ outcome compared with a portfolio of assets. These financial intermediaries provide specialists who have the expertise in assessing that risk and the likely return of particular categories of potential borrowers. This is why the study examines portfolio theory in the case of the type of loans made by banks. Assessing whether their projects will be low, medium or high risk with their potential returns, that is small, average or large. If they cannot assess and discriminate between more or less risky projects, then banks, for example, could well result to **credit-rationing** of loans in the market for credit.

Financial firms fall into two categories: the banks (or deposit takers) and the other non-deposit taking institutions. In the case of the latter, a large number of small savers contribute to a managed fund such as Unit Trusts and Pension Funds, where the managers distribute over large holdings of financial assets to reduce the element risk. In the former, the same process resides in the banking sector, although banks provide the medium of exchange mechanism by accepting deposits from the creation of real income, which form loans to borrowers. The study will show that banks have a unique characteristic in that their **liabilities have become the medium of exchange and store of value**. Therefore, an increase in banking activity will lead to an expansion in the money supply, and vice versa. This will be the topic of the **next chapter**, how these financial institutions are able to **create** liquidity and, therefore, are not intermediaries in the financial system.

## 1.6 FINANCIAL MARKETS

There are numerous financial markets trade in financial securities such as bonds and stocks as well as commodities like precious metals and agricultural products. They also include currencies and derivative products where agents interact within spot and future markets, which are subject to movement of prices, interest rates and currency rates creating risk,

although derivative markets exist to manage and exploit the prevalence of risk. Clearly, markets subdivide into categories depending on the type of finance.

For instance, the **money markets** trade in short-run money instruments such as Treasury and commercial bills, interbank loans and certificates of deposit, which have a short maturity of less than three months on issue. The **capital markets** deal with long-term capital, which are company shares with an infinite life. This market includes the trade of government and corporate bonds with maturity periods of 10–25 years.

Nevertheless, there is also a distinction between ‘primary’ and ‘secondary’ markets. The former is concerned with newly issued instruments and traded only once. For example, in the case of company shares, it is the new issue or the underwriting of fresh funds for real investment expenditure. In the case of the latter, they are the trade in existing instruments, and therefore, both link together. Clearly, these financial markets are providing and channelling funds to the real sector of the economy.

The one that is of interest for the analysis, not normally listed in the standard textbooks on finance, is the **depository market** where the commercial banks exist, providing loans and mortgages to firms and households as a medium of exchange. This is the main source of the money supply used in the real economy to finance the process of output and trade. Clearly, the state and health of this market have led to the unhealthy development of loan sharks that prevail on the high street and on the Internet along with peer-to-peer lending by individuals on such platforms like Rate % Setter. This so-called shadow banking sector has grown considerably during the post-2008 era and may have grown much faster than traditional banks.

These institutions and platforms in the shadow industry, however, use the liabilities of the commercial banks for loans as credit as well as keeping a reserve ratio of deposits within their accounts. In fact, as the absolute size of shadow banking gathers momentum, it increases the proportion of retail banks’ deposits being created and used as medium of exchange throughout the economy. In other words, the retail banking system takes on a priestly status in which retail banks have access to Central Bank deposits and cash as reserves relative to deposits, whereas institutions within the shadow banking use commercial bank deposits and cash as their reserves. The thrust towards this hierarchical structure of banking depends on the development and growth of shadow banking as the traditional banks remove themselves from this segment of

the market. It should be noted that there are other sales and consumer finance companies that are closely associated with particular industries such as loans to buy cars and consumer durables, although mainly for household finance. The objective of the study, however, is to explain the rôle of the retail banks which make up the monetary structure within the financial system as well as its link to the cycles of real activity and loanable funds as well as shadow banking.

## 1.7 THE REAL ECONOMY AND THE FINANCIAL SYSTEM

The financial system makes it easier for agents to borrow and to lend money in the midst of asymmetric information, leading to credit risk. The permanent income/life-cycle theories of consumption suggest that lenders can store their monetary wealth for later consumption, whereas borrowers can advance their income for consumption now by borrowing loanable funds from the banking sector. To facilitate this, the function of the monetary system is of paramount importance to the real economy. For instance, without financial institutions as already said, lenders and borrowers would find it difficult to negotiate terms and obtain money without taking considerable risk. With financial intermediation, lenders are more willing to lend and borrowers are more willing to borrow at lower rates of interest because efficient markets will lead to lower transaction costs. For example, if lower interest rates prevail, then real investment increases because the Marginal Efficiency Capital, that is the expected rate of return, would be higher in relation to the marginal cost of funds.

According to Minsky (2008), however, the difficulty arises when modelling the function of the financial system within the economic system because the traditional theory of neoclassical economics treats money as a measure to transform real wages and the relative prices of goods and services into wages and prices denominated in money. It is just a numeraire and has no significant relationship to finance and the financing of economic activity within the real economy and, therefore, earns no income such as interest.

In the traditional approach, for example, the introduction of money comes through the **Quantity Theory of Money** (QTM) via the identity of exchange, which is as follows:

$$MV \equiv PY, \quad \text{or} \quad M = KPY, \quad (1.3)$$

where  $M$  denotes the stock of money and is assumed to be exogenously determined and given from ‘outside’ by the monetary authorities such as the Bank of England;

$V$  refers to the velocity of circulation of the money stock, institutionally determined by the existing integration of production and payment conventions;

$P$  stands for the average price level, determined by the quantity of money;

$Y$  represents Real Gross Domestic Product, a measure of the amount of output of goods and services over a given year, determined by the demand and the supply of labour and the production function; and finally,

$K$  equals  $1/V$ .

This version of QTM, typically, views money as ‘neutral’ in the sense that it does not matter, apart from the determination of the general price level. There is no recognition of the need for money to finance the organisation of inputs and the output process of goods and services in the production function. The institutional arrangement of created money on the ‘inside’ is not important. Labour market adjustments suggest that output is constant at the full-employment position along with the assumption of a fixed velocity. There can only be temporary deviations from this equilibrium. This means that the aggregate supply is vertical in relation to the price, given the full-employment output. Thus, the quantity of money determines the price level through the aggregate demand.

Clearly, if  $V$  (or  $K$ ) initially assumed fixed only, then a change in  $M$  will modify either the price level or the amount of goods and services, resulting in a change in the level of aggregate demand and supply. Since the bulk of the money supply is in the form of bank deposits, the liabilities of banks, then an expansion (or contraction) in their activity will have profound effects on aggregate expenditure and output as well as the price level. This is why it is necessary to study the flow of ‘inside’ money and the act of banks as a liquid store of wealth.

Moreover, **Tobin (1963)** argues, in the real world, the medium of exchange in the form of money is mainly demand deposits (or liabilities) at the commercial (or retail) banks, which is the bulk of finance for business and household expenditure. This involves the ‘creation’ of money as debts entered upon the ‘computers’ of banks as well as the ‘destruction’ of money as when liabilities are repaid. Furthermore, the velocity

of circulation of the money supply in the form of the creation/destruction of loans will depend on the available reserves within the financial system. They come in the shape of reserves held at the Central Bank, the borrowing of excess reserves of deposits from other banks in the money market and the utilisation of internally generated profits from interest payments and charges for transaction services provided to customers. Therefore, in the light of the recent experience of low growth and recession sparked off by the financial crisis of 2007/2008, the monetary authorities have implemented the policy of quantitative easing (QE) in response. This is where the Central Bank creates new ‘outside’ money electronically to buy financial assets like government bonds in the form of Gilts to increase reserves. This has also happened in USA and across Europe.

In the traditional approach, this exogenous increase automatically creates the money supply as a medium of exchange for consumption and investment. The difficulty, however, is that the retail banks have not endogenously created the equivalent amount of ‘inside’ money in the form of loans. In fact, the growth of loans has declined, resulting in a decrease of the velocity of circulation even though reserves have increased. This induces a fall in economic activity, although the process could well reverse itself with inflationary pressures. The complexity of how new, ‘inside’ money is created and destroyed with velocity of circulation on the left-hand side of (1.3) in a monetary economy is a theoretically neglected subject.

Historically, **Keynes (1936)** compounds the issue and draws the attention away from the rôle and supply of money by focusing on the demand for money, where the determinants are the rate of interest on saving and the level of income. Again, the assumption of an exogenous, ‘outside’ money supply is assumed within the theoretical framework. According to **Friedman (1970)**, Keynes stresses the importance of the flow of income that corresponds to autonomous and induced spending of aggregate demand. He argues that the contraction in economic activity in the 1930s, resulting in the depression, was the product of the collapse of demand for investment amplified by the reduction of income and employment by the **multiplier effect** under the assumption that the price level is fixed. Even today, the real economy is inherently unstable because of persistent multipliers that arise not just from changes in investment expenditure, but also from the other autonomous components of aggregate demand along with the variables relating to income,

such as the average rate of income tax and transfers as well as the marginal propensity to import. These multipliers are constantly causing change within the real economy that might well cause breakdowns.

The recent experience of the financial crisis of 2008/2009, however, highlights the Cinderella one, the **money multiplier** on the left-hand side of (1.3), with its economic mechanism of ‘creation’ and ‘destruction’ of ‘inside’ money generating chaotic dynamics that have led to the current Great Recession. Actually, the collapse of investment in the 1930s in the UK and the USA may have been a forerunner of the contraction of the money supply through the money multiplier, leading a cyclical oscillation of bank failure and shrinkage of the deposit base because the public were converting their deposits into cash during that period. In turn, the reduction in the deposit base means less loans available for capital expenditure and consumption. These historical events represent long period of subpar, anaemic growth, not satisfactorily explained by the traditional approach of neoclassical analysis.

According to Keen (2011), why the traditional approach-based neoclassical theory did not predict the financial crisis of 2007/2008 and the aftermath of events lie with the endemic adoption of a body of analysis based on a barter system of exchange with one-commodity used as money to explain the dynamic, monetary economy of today. Indeed, money has evolved from a system of barter to become a medium of exchange based on fiat money and credit currency underpinned by legal tender, and therefore, a creature of law. As suggested above, if households and firms lose confidence in the banking system, they can withdraw their deposits in the form of notes and coins as a medium of exchange for goods and services.

This evolution of the medium of exchange and banking has allowed more trade, production and consumption than would prevail under a barter equilibrium of exchange because the innovation of money produces and buys goods and services more cheaply than do any other asset. Clearly, the total utility gained by exchanging money for goods and services at given range of prices is greater than the utility derived from exchanging goods directly for an equivalent amount of money. Therefore, there is comparative disadvantage from direct exchange of commodities in an economy. Thus, there is a comparative advantage in production and trade when agents adopt money because it has an externality that captures the notion of ‘one for all, all for one’ within the



market, removing the untrustworthiness of direct barter because every transaction has to be revalued individually. In other words, money is used as medium of exchange for all goods and services produced for money. In the alleged words of Smith (1776).

### 1.7.1 *All Money is a Matter of Belief*

When the farm worker harvests the crop of corn at the prevailing price within the market, he or she is paid in money wages as if paid in corn. Money, therefore, reduces the transaction costs of the worker in exchanging corn directly into other goods and services for consumption. The advent of money, with its own evolutionary history, consequently, has transmuted the economy from barter into a monetary system of production and trade. The act of exchange through money provides trustworthy trade, but also means of intertemporal transfer of finance with self-assurance. The existence of money makes it more profitable to create production for exchange. As noted by Smith in 1776, the division of labour evolves out of a capitalist system. This would not occur under a subsistence economy with barter. An essential precondition for the adaptation of the division of labour within the evolutionary process of development is money because it embraces a wider variety of goods and services produced on a large scale for exchange, exploiting increasing returns (Hahn 1981).

Today's monetary system stems from this evolution, where the banking system of the Templars and the Goldsmiths has developed to one where a non-commodity is used as money that is intrinsically valueless in the form of a 'token' or an 'electronic' number on a 'computer' balance sheet of a bank to facilitate exchange of goods and services produced from the real economy. As a matter of fact, banks specialise in the activity of producing the means of payment by providing tokens in the form of cash supplied by the Central Bank or by creating credit money in the form of loans to link payer and payee. In truth, the bulk of the money supply process is the banks' liabilities that come from real income and forms the deposit base, and its growth depends on loan creation or destruction when repaid with interest, which is source of profit. Firms produce goods and services over time for sale by combining factors of production in the output process, whereas banks create 'inside' money as a medium of exchange and a store of value to finance economic activity.

In theory, banks and firms must be treated differently and not as one entity as in conventional analysis.

This study assumes that the policies of retail (or commercial) banks affect the money supply of the economy. The financial market which retail banks operate in is oligopolies and is not perfectly competitive, which is typically what neoclassical economists assume. Something like ‘an efficient markets hypothesis’ might have some contact with reality in a perfectly competitive banking environment, where the norm would be bankruptcy, so savers would keep their money under their mattresses, but in the oligopoly banking world of most economies, commercial bank policies matter and insolvency a rare occurrence as in the case of 2007/2008. An analogy would reinforce the theme. Banks are like the intercity trains of the railway infrastructure, unbelievably fast and efficient when transporting travellers to and from their destinations, but disastrous when they come off the rails as in the case of the financial crash of 2007/2008. The objective, therefore, is to construct a monetary model within the book, emphasising the importance of how money is created or destroyed endogenously, and derive the corresponding, all-important, loanable supply curve within a new monetary theory. This is an integral part of the economic system and ultimately ties the hands of the real economy in the form of aggregate demand and supply. Thus, the analysis represents a new piece in the puzzle, an extension of the existing theory, representing value-added to the traditional analysis. It will be straightforward to visualise and contrast it with the benchmark approach as the course of study progresses. The method will represent critical thinking and the realisation of a more precise formulation of the money supply with various features systematically added in an attempt to derive a fully dynamic model.

At each stage in the development of the theory, there will be the inclusion of graphs and figures with the use of **mathematics** to reinforce the analysis. Mathematics gives a coherence framework and pinpoints where the source of instability as well as modelling the ingenious operations of the banking sector in the depository market. Thus, the application of mathematics leads to a simplified, coherent model that is logical and consistent in explaining the economic mechanism of banks in the creation (or extinction) of credit money as a medium of exchange by way of loans. This is the task of the next chapter, an attempt to develop part of a new monetary model in the light of the events of 2007/2008. To be

more precise, next chapter's analysis will attempt to build the monetary system based on a tripartite structure of agents: the depositors, which are households and firms, the retail banks and the monetary authorities in determining the endogenous money supply process.

See the following link: <https://www.youtube.com/watch?v=2nBPN-MKefA>.

## NOTES

1. For an historical overview of the major innovations of money as well as the future, see Halaburda and Sarvary (2016), although some of the suggested digital currencies such as Amazon Coin are not money, but merchandise credit and a form of discount with the Company.
2. This could well be the form of the precautionary and the speculative demand for money.

## REFERENCES AND FURTHER READING

- Bywaters, D., & Mlodkowski, P. (2012). The Role of Transactions Cost in Economic Growth. *The International Journal of Economic Policy Studies*, 3(7), 54–66.
- Friedman, M. (1970). *The Counter-Revolution in Monetary Theory*. London: The Institute of Economics Affairs.
- Hahn, F. (1981). *Money and Inflation*. Oxford: Bail Blackwell Publisher.
- Keen, S. (2011). *Debunking Economics: The Naked Emperor Dethroned?* London: Zed Books Ltd. Chaps. 13 & 14.
- Keynes, J. M. (1936). *The General Theory of Employment, Interest and Money*. London: Macmillan (Reprint, 2007).
- Minsky, P. H. (2008). *Stabilizing an Unstable Economy*. New York: McGraw-Hill.
- Roubini, N., & Mihm, S. (2010). *Crisis Economics: A Crash Course in the Future of Finance*. London: Penguin Books.
- Schumpeter, J. A. (1934). *The Theory of Economic Development: An Inquiry into Profits, Capital, Credit, Interest, and Business Cycle*. New Brunswick, NJ: Transaction Publishers (Reprint, 1996). Chap. III.
- Schumpeter, J. A. (1943). *Capitalism, Socialism and Democracy*. London: Routledge (Reprint, 1992). Chap. VII.
- Smith, A. (1776). *An Inquiry into the Nature and Causes of the Wealth of Nations*. London: Penguin Classics (Reprint, 1986).
- Tobin, J. (1963). Commercial Banks as Creators of 'Money', No. 159, Cowles Foundations Discussion Papers from Cowles Foundation for Research in

Economics, Yale University in W. L. Smith, & R. L. Teign (Eds.). (1974). *Readings in Money, National Income, and Stabilization Policy* (3rd ed.), 224–229. Homewood, IL: Richard D. Irwin Inc.

Click on the link (<http://www.bbc.co.uk/programmes/p03plzdp>) to download the BBC radio programme on the ‘Economic Rebellion’, which summaries the need for this framework to be included in main-stream economics.



## CHAPTER 2

---

# The Money Supply

## 2.1 INTRODUCTION

In a monetary economy, a simple principle suggested by Clower (1967) directs the thrust of the analysis in this chapter's part of the discussion:

Money buys goods and goods buy money; but goods do not buy goods.  
(p. 5)

Households in the dress of entrepreneurs use money to form firms and purchase the factor endowments of raw materials, capital and labour for the process of production of goods and services to take place and generate income that forms rent, interest, wages and profit. The exchange of these commodities and services in the market at the prevailing twin factors of demand and supply buys money, the medium of exchange in the make-up of bank deposits or cash. All payments and receipts are market-determined revenues and costs within a capitalist economy, which are deposit flows in and out of banks. Taxes and transfer payments for final and intermediate outputs are too, as well as financial instruments as marketable assets within portfolios. They are annuities deriving money income over a fixed period, becoming expenditure in future. These assets and liabilities mean a dated sequence of either cash or bank deposits or a combination of both, representing payments or receipts. Clearly, financial relationships are vital determinants of how the monetary economy functions, and therefore, endogenous money supply should be the natural

starting point for economic theory because it embodies the flow of cash and deposit flows within the economy.

In a monetary economy, goods do not exchange for other ones as in a barter system of trade, which is the essence of the neoclassical approach to economics. According to Minsky (1975), the financial liabilities of banks used as money acquire to control (or ownership) of assets and commodities in the act of exchange within the market. The holder of a bank deposit is directly or indirectly financing exchange of goods and services along with the creation of income flows as wages, sales of products that generate revenue in the market and, therefore, gross profit and rent. In order to reveal the importance of the endogenous money supply process and how its agents are involved, it is necessary to introduce theory with the goal of explaining the rôle of the monetary sector.

## 2.2 THE BEGINNINGS OF A MONETARY ANALYSIS

The analysis assumes a monetary framework that sits between the two extremes of the Classical and the Keynesian Schools of thought, so that the proposed scenario can fasten together the adjustment processes of both price and output with money, which is normally limited to one or the other. In terms of aggregate demand and supply in (a) of Fig. 2.1, there is excess supply between A and B because of a drop in aggregate demand for the reason of austerity.

Prices fall to equilibrate the market, although this will have significant effects in other markets such as the labour one in (b). Remembering that the demand for labour is a derived demand, the appearance of excess supply as a result will trigger a fall in money wages as shown in Fig. 2.1. Therefore, prices will have a tendency to fall with nominal wages.<sup>1</sup> Money wages, although, enter price determination in two ways: first, as a cost and two, as an income.

In the case of one, the lowering of money wages will tend to increase the quantity of production that firms are willing to supply at any price, but in the instance of point two, workers can purchase less. Wage deflation, therefore, can be a struggle for real wages to achieve an equilibrium position if both money wages and prices move in the same direction. If they are the same rate, the market will be stuck at B. Thus, to get to point C, the fall in money wages must be greater than the drop in prices to achieve equilibrium, although still below the full-employment level.

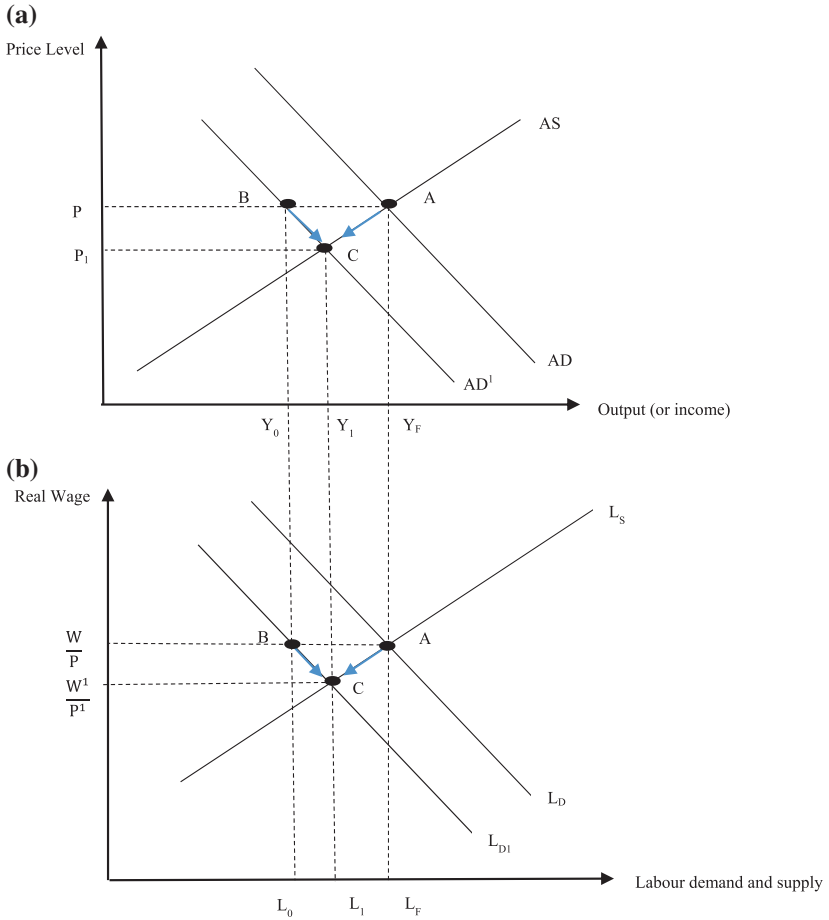

Fig. 2.1 Aggregate demand and supply with the labour market

This is, however, when in the Classical world that the financial Cavalry in the form of the Pigou effect comes to the rescue. In the case of outside money, cash and bank reserves at the Central Bank, in a period of deflation, the real value of these will rise. In addition, government debt in the form of bonds owned by banks and the private sector will experience an increase in wealth and money as these financial assets increase in purchasing power. The effect of a rise in real balances of wealth is to

shift the LM to the right in Fig. 2.2,  $LM^1$ , forcing the cost of borrowing down to  $i_1$ , raising investment and, therefore, shifting aggregate demand back via shifts in the IS curve along with the demand for labour to position A in Fig. 2.1, the full-employment position, assuming no liquidity trap is present.

The picture, however, is more complicated than this, because of the fact that in a monetary economy, the bulk of income (interest, rents, wages and profit) created in the production of goods and services paid is bank deposits on account they represent the medium of exchange and store of value, which is not explained in the textbook. For instance, wages paid for services rendered are bank transfers by firms into bank accounts, representing part of the deposit base,  $D$ , of commercial banks. Thus, the missing component in the Classical set-up just described above is the title rôle of inside money from the commercial banking system underpinning the monetary system. Henceforth, whether the increase in the value of bank reserves,  $RE$ , is present in outside money to be used or is held as a propensity to hoard, affecting the velocity of circulation, depends on the commercial banks unique ability to create inside money from outside money. The reserves of deposits at the Central Bank have

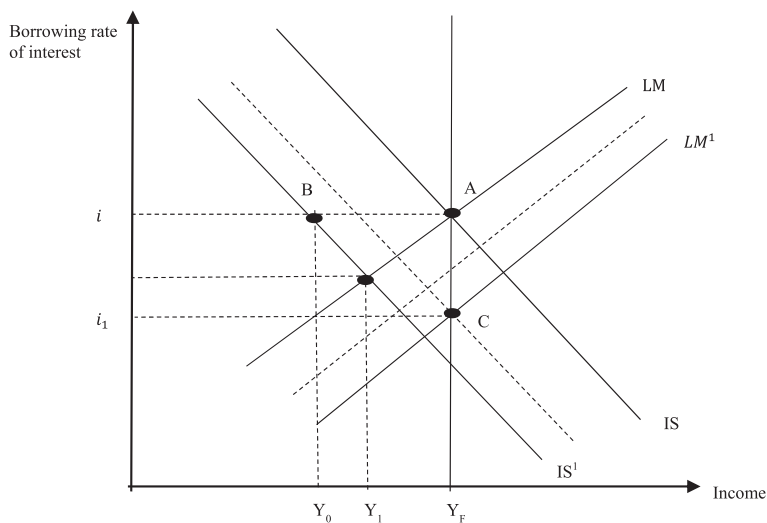

Fig. 2.2 IS/LM model with the Pigou effect



no direct contact with the public unless used by the retail banks (McLeay et al. 2014). Therefore, there is no reason to suppose that the LM curve in Fig. 2.2 will automatically shift to the right, forcing the rate of interest rate down from  $i$  to  $i_1$ . Furthermore, there is no motive for these agents with increasing wealth from the holding of government bonds and rising real money balances to translate this into consumption and investment growth. Thus, no shift of the IS curve outwards. In a period of uncertainty and unemployment, they may well postpone current consumption in favour of a higher propensity to save or hoard and, therefore, may shift inwards.

Nevertheless, for every real gain to holders of money and wealth by way of price falls, there is real loss to debtors on credit assets owned by the banks because the real burden of private debt is rising over the course of time on existing loans. There is an inducement for private agents to decrease their debt in the midst of falling money wages. In other words, the process of declining money wages and prices will be associated with decreases in the amount of nominal, inside money supply because of the falling deposit base,  $D$ , which is a part of the money creation/destruction process. The accumulated effect will be a money-decreasing process. There is a downward pressure on real money balances through  $M$ , and if the reduction is larger than  $P$ , then the fall in aggregate expenditure continues, exacerbating the initial fall in demand for labour in (b) of Fig. 2.1.

Adding to this, however, the Classical process does not take account of the augmenting effect of aggregate supply on the economy because the falling price level will also mean a decreasing rate of profit with expectations of future output on a downward spiral. This will lead to price expectations on consumption–investment goods also falling and will continue in a downward trend. Thus, entrepreneurs in a period of disinflation or deflation with excess supply of labour and capital equipment will postpone the ordering of new investment goods and allow the process of disinvestment through scrapping to take place.

Taking stock, if the growth of money wages, profits and income flows are falling, induced by a decreasing growth of prices, in the form of either disinflation or deflation, then initially there is an upward trend in the real value of money. The quantity of money, however, fixed in nominal terms, will be declining over time as this represents decreasing deposit liabilities. Thus, the deposit base is declining, and therefore, any stimulus from outside money is undone by the inside money effect in the

form of the banks' reduced ability to endogenously create private debt through money creation. It is more than likely that there is destruction of bank deposits because of the increasing real burden of debt on existing and potential borrowers. Clearly, what is required is an additional analysis of the endogenous process of money creation, and consequently, a study into the modelling of the agents and workings of the monetary stem of the financial system, which is the essence of the next section.

### 2.3 MODELLING THE INTERACTION OF AGENTS

In the majority of universities, the second-year module on macroeconomics analysis of an undergraduate programme of economics entails the assumption that the money supply is given (or exogenous) and determined directly by the monetary authorities. The discussion above, however, reveals the necessity to model the interaction of the monetary authorities, the commercial banks and the depositors, which include households and firms (McLeay et al. 2014). This determines the endogenous, inside money supply process within a monetary economy.

There are numerous measures of money supply. Not all of them are widely used, and the exact classification depends on the country of origin.  $M_0$  and  $M_1$  definitions denote narrow money, which includes cash in circulation and other money instruments easily exchanged into notes and coins.  $M_2$  includes  $M_1$ , plus short-term time deposits in retail banks and twenty-four-hour money market assets that are cash equivalent.  $M_3$  adds in  $M_2$  with longer-term time deposits and money market funds greater than twenty-four-hour maturity, representing near cash.  $M_4$  comprises  $M_3$  plus other deposits. The term, broad money, refers to  $M_2$ ,  $M_3$  or  $M_4$ , depending on the country's monetary authority usage. The UK money measure, previously known as  $M_2$ , is the sum of deposits within retail banks and building societies, RD plus cash (notes and coins) held by depositors, CA is that

$$M_2 = \text{Deposits (RD)} + \text{Cash (CA)}. \quad (2.1)$$

A broader measure of the money supply,  $M_4$  which include deposits of wholesale banks, WD plus certificates of deposits, C added to  $M_2$ , that is

$$M_4 = M_2 + \text{WD} + \text{C}. \quad (2.2)$$

So, the difference between  $M_4$  and  $M_2$  is the inclusion of wholesale deposits plus certificates of deposits, where the former is regarded as less

liquid in comparison with the latter, which is more akin to the public holdings of currency and retail deposits. These standard measures of the money supply are mainly inside money: that is, money created by the commercial banks. According to King and Plosser (1984), these inside transaction services are the ‘output’ of the banking sector, responding to changes in the productivity of other sectors within the economy and not the monetary authorities.

Using the simplified notation, the study defines money as cash plus deposits as

$$M = CA + D, \quad (2.3)$$

where  $D = RD + WD + C$ . It is the interaction amongst the depositors, the commercial banks and the Central Bank that determines the money supply in expression (2.3). From the viewpoint of the money supply determination, the variable on which the analysis concentrates as representing the behaviour of depositors is **the cash–deposit ratio** ( $CA^*$ ), that is the ratio between the depositors’ funds of cash to its deposits,  $D$ , expressed as follows:

$$CA^* = \frac{CA}{D}, \quad (2.4)$$

where  $D$  could be represented either by retail or with the added ingredients of wholesale deposits and certificates, if using  $M_4$ .

The behaviour of the banks relates to the **reserve–deposit ratio**. The reserves  $RE$  are assets held by the commercial banks, which consist of notes, coins and deposits held at the Central Bank, in order to meet demands for cash and payments by customers to other banks by means of debit cards and bank transfers.<sup>2</sup> The behaviour of banks manifests itself within this reserve–deposit ratio as

$$r = \frac{RE}{D}, \quad (2.5)$$

The behaviour of the monetary authorities, MA, such as the Bank of England or the Federal Reserve, is summarised by the stock of **high-powered money** or the **monetary base**, MB, which means that

$$MA : MB. \quad (2.6)$$

The monetary base consists of cash in circulation and commercial banks’ deposits at the Central Bank, which is essentially outside money.

The demand for the monetary base (or outside money), which arises from the cash demand by depositors,  $CA$ , and the need to keep reserves deposited at the Central Bank by the banks,  $RE$ :

$$MB^D \equiv CA + RE. \quad (2.7)$$

These reserves are ‘outside’ money partly generated by the monetary authorities in addition to profits of interest payments and transactional charges produced by commercial banks’ economic activity. This monetary base becomes the initial source for the creation of ‘inside’ money. Even the excess reserves of individual banks could well be utilised not only to meet shortfalls in reserves in the form of loans to other banks through the interbank market but also represents another avenue for others to increase their deposit base in order to generate loans. If these idle balances decrease because of the substitution of debt in the form of loans,<sup>3</sup> then the velocity increases.

The monetary authorities can either attempt to control the demand for the monetary base, or the supply, that is

$$\overline{MB}^S = MB^D. \quad (2.8)$$

The interaction of the Bank of England or the Federal Reserve with the depositors’ demand for cash and the banks’ demand for reserves in part determines the equilibrium stock of money. Therefore, it would be sensible for this purpose to express the discussion in terms of the ratios of  $CA^*$  and  $r$  with the money supply,  $M$ . In the case of cash holdings, this can be expressed in terms of the money stock,  $M$  and the cash–deposit ratio,  $CA^*$ . First, multiply and divide  $CA$  by the money stock,  $M$ , to form

$$CA = \frac{CA}{M} \cdot M, \quad (2.9)$$

now substitute the definition of the money supply, that is expression (2.3) into (2.9), gives

$$CA = \left( \frac{CA}{D + CA} \right) \cdot M. \quad (2.10)$$

Divide each variable on the right-hand side by  $D$ , that is the numerator and denominator of the terms in parentheses, to give

$$CA = \left( \frac{\frac{CA}{D}}{\frac{D}{D} + \frac{CA}{D}} \right) \cdot M, \quad (2.11)$$

then substitute in the definition for the cash–deposit ratio,  $CA^*$  which leads to

$$CA = \left( \frac{CA^*}{1 + CA^*} \right) \cdot M. \quad (2.12)$$

The expression above gives the analysis an equation for the cash demand in relation to the cash–deposit ratio and the money stock. It shows that depositors want to hold a fraction  $CA^*/(1 + CA^*)$  of the money supply,  $M$ , in the form of cash. The higher the value of  $CA^*$ , the greater the portion of money held in cash by depositors, and therefore, the lower the share held in the form of deposits.

If the analysis proceeds in the same manner as above to derive an expression for reserves,  $RE$ , in terms of the money supply,  $M$ , and the reserve ratio,  $r$ , then the procedure will yield

$$RE = \left( \frac{r}{1 + CA^*} \right) \cdot M. \quad (2.13)$$

This expression illustrates the portion of the money supply that commercial banks want to hold in the form of reserves. Now substituting expressions (2.12) and (2.13) into (2.7), to derive the total demand for the monetary base in the form of

$$\begin{aligned} MB^D &= \left( \frac{CA^*}{1 + CA^*} \right) \cdot M + \left( \frac{r}{1 + CA^*} \right) \cdot M, \\ \text{or} \\ MB^D &= \left( \frac{CA^* + r}{1 + CA^*} \right) \cdot M. \end{aligned} \quad (2.14)$$

This is the demand for the monetary base,  $MB^D$ , in relation to reserves and cash ratios in addition to the money stock. The monetary authority, where the stock, denoted by  $\overline{MB}$  determines the supply of the monetary base,  $MB^S$ . Equating the supply and the demand for the monetary base allows the formation of the following statement:

$$MB^S = \overline{MB} = MB^D = \left( \frac{CA^* + r}{1 + CA^*} \right) \cdot M. \quad (2.15)$$

How do the monetary authorities **attempt** to control the money supply? If Eq. (2.15) is rearranged to read as

$$M = \left( \frac{1 + CA^*}{CA^* + r} \right) \cdot \overline{MB}, \quad (2.16)$$

which means that changes in  $\overline{MB}$ , under normal circumstances, will lead to adjustments in the money supply,  $M$ , via the **money multiplier** ( $mm$ ),  $(1 + CA^*/CA^* + r)$ . If  $r$  is equal to one, then the whole expression goes to the value of one. It is more likely that  $r$  is less than one, and therefore, the money multiplier is greater than one. It is clear from Eq. (2.16) that the smaller the values of  $CA^*$  and  $r$ , the greater the money multiplier. Thus, the Central Bank could possibly influence the supply of money, for example, by increasing the reserve ratio,  $r$ , which means banks have to hold more deposits as reserves and, therefore, reducing the money multiplier along with the money stock in circulation under routine conditions. Differentiating the money multiplier with respect to  $r$  in expression (2.16) can clearly show this, which is

$$\frac{\partial M}{\partial r} < 0. \quad (2.17)$$

Using the quotient rule<sup>4</sup> to derive the following form:

$$\begin{aligned} \frac{\partial M}{\partial r} &= \frac{(CA^* + r) \cdot 0 - (1 + CA^*) \cdot 1}{(CA^* + r)^2}, \\ &= - \frac{(1 + CA^*)}{(CA^* + r)^2} < 0. \end{aligned} \quad (2.18)$$

Clearly, the expression (2.18) shows that if the banks hold more reserves in relation to deposits, then the money multiplier decreases because of the negative sign. What is the effect of increasing the value of  $CA^*$ ? Using the same procedure as before, except, differentiating with respect to  $CA^*$  using the differentiation rule.

The demand for high-powered money derived from expression (2.15) is shown in Fig. 2.3 by the positively sloped line, which is less than one.

Figure 2.3 reflects the portfolio preferences of the depositors and the commercial banks. On the one hand, depositors desire to divide their portfolio between cash and demand for deposits. On the other, bank preferences are between holding reserves and other assets. Overall, these two agents determine  $CA^*$  and  $r$ , respectively. The equilibrium money stock occurs at the point E, where the demand and supply for

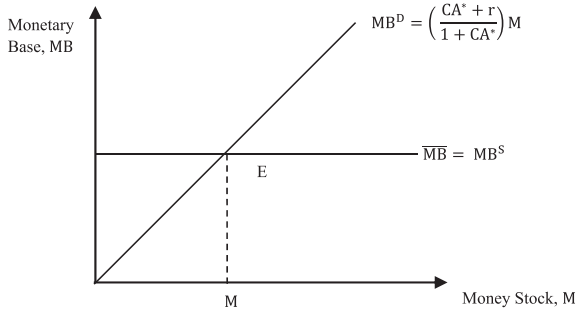

Fig. 2.3 The monetary base

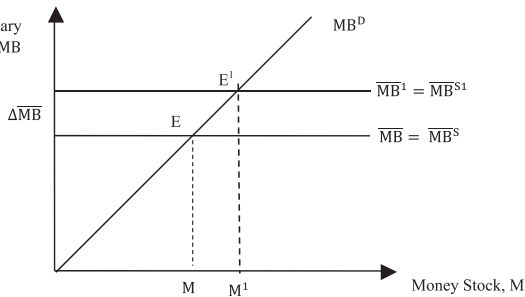
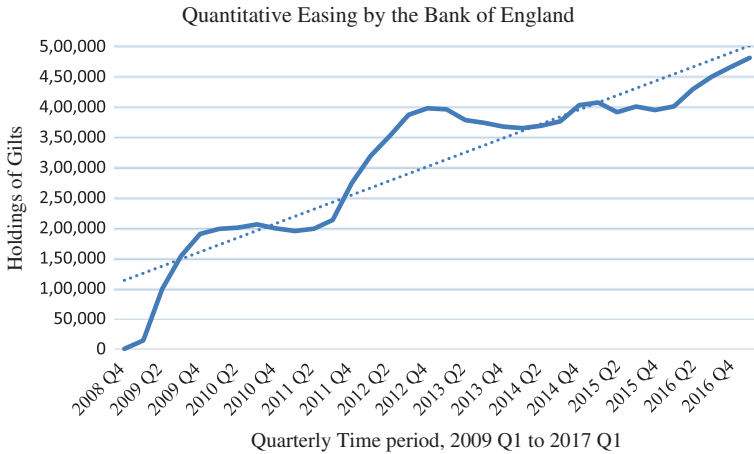

Fig. 2.4 Changes in the monetary base

the monetary base interact. The slope of the  $MB^D$  line reflects the portfolio preferences of the public and the banks, and the  $\overline{MB}$  represents the behaviour of the Central Bank.

What happens if  $\overline{MB}$  changes under routine conditions, as in Fig. 2.4?

An increase in the supply of the monetary base (or high-powered money) shifts the  $\overline{MB}$  curve upwards by  $\Delta\overline{MB}$ , that is outside money. At the initial level of the money stock, the supply exceeds the demand. The money supply shifts to the point  $E^1$ , where the new equilibrium rests. The mechanism by which the Central Bank changes the monetary base is via **open market operations**. For example, the Bank buys, say, £1 million of short-term government securities from private individuals. As shown in Fig. 2.5, the Bank's ownership of government securities rises by £1 million. How does the Bank pay for the bonds? It writes cheques on itself in return for the bonds, and therefore, the sellers receive

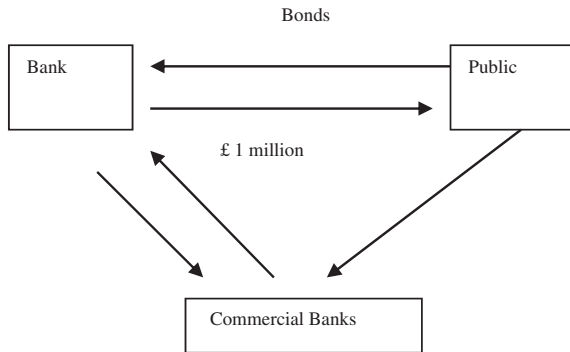

**Fig. 2.5** Open market operations

instructions to pay them £1 million. They take them to the commercial banks and credited as deposits. The commercial banks have accounts at the Central Bank, therefore credited with the money. The commercial banks' reserves of deposits increase by the equivalent amount. The result is that the Central Bank owns more government securities, and the stock of the monetary base increases by the amount of the open market purchase. This enlargement of the monetary base shows up as an increase in commercial banks' deposits or cash. Briefly, the cheques that the Bank writes on itself are payments giving the owners deposits. They can obtain cash in exchange or deposit the cheques at the commercial banks, thus this is creating a bigger monetary base, which potentially, if used, can create loans via the money multiplier mechanism.

If this increased monetary base leads to greater commercial banks' deposits, they could well possibly create credit by making loans to the public via money creation, which are part of the money supply. This is the topic for the next section. Before the discussion ends, however, **a question that needs addressing**, how does quantitative easing (QE) affect this process? It is an unconventional form of open market operations, where the Central Bank electronically creates new, outside money supply in order to buy financial assets such as long-term government bonds in an attempt to increase aggregate demand and stimulate supply within the economy. The application of this unconventional monetary policy in the UK and the US economies remains in place since the





**Fig. 2.6** Asset purchases by the Bank of England

financial crisis 2007/2008. Figure 2.6 shows the outcomes of this policy instrument for the British economy. See the following link ([http://www.youtube.com/watch?v=ohKQP\\_wSO9k](http://www.youtube.com/watch?v=ohKQP_wSO9k)) as well as the BBC's newspaper (<http://www.bbc.co.uk/news/business-15198789>) article and the video from the Bank of England (<https://www.youtube.com/watch?v=J9wRq6C2fgo>). This policy, however, has substantially increased the quantity of outside money, but without significantly increasing the quantity of inside money from the creation of loanable funds by banks on account of the perceived high levels of risk because of the extreme height of uncertainty prevailing within the economy. The situation is not normal. The paradox is the same as in the case of the Pigou effect.

The analysis has reached the stage where it is necessary to bring down the curtain on this part of the study. The need, however, is to give a summary of the main findings before building the next chapter that attempts to explain the mechanism that hides behind the money multiplier formulation and elucidates the supply function of loanable funds.

## 2.4 CONCLUSION/SUMMARY

The simple theoretical model developed in the first part of the chapter shows that an increase in the real value of outside money that follows from the Classical Pigou effect. To be effective, this must translate into the growth of inside money to energise aggregate demand and supply, which means loanable funds must increase within the monetary economy. This requires the interaction of the monetary authorities, the commercial banks and the depositors: households and firms determining the

supply of money in circulation. It cannot be assumed to be a constant term, which is solely, exogenously determined by the monetary authorities. It evolves from the workings of the monetary system as explained by the interaction of agents. In fact, in the next chapter, the objective is to show how the commercial banks can create money endogenously by way of the money multiplier with loans to households and firms, which represents greater generation of liabilities.

## NOTES

1. The price level by definition amounts to money wages divided by labour productivity.
2. Yesterday, my son, Matthew, used his mobile phone to make a payment for goods at Sainsbury's supermarket. Should I buy a number of phones on eBay to increase my holding of money as a medium of exchange?
3. In the case of Northern Rock, and many other small retail banks at the time, before the financial events of 2007/2008, used these interbank funds to not only meet shortfalls in reserves, but also as a way to increase their deposit base and generate additional loans, which became a major source of risk and uncertainty for other banks.
4.  $\frac{\partial Y}{\partial X} = \frac{v \frac{\partial u}{\partial x} - \frac{\partial v}{\partial x}}{v^2}$ .

## REFERENCES AND FURTHER READING

- Clower, R. W. (1967). A Reconsideration of the Microfoundations of Monetary Policy. *Western Economic Journal* (Now *Economic Inquiry*), 6, 1–9. In R. W. Clower (Ed.) (1969), *Monetary Theory: Selecting Readings* (pp. 202–211). London: Penguin Books.
- Howells, P. (1995). The Demand for Endogenous Money. *Journal of Post Keynesian Economics*, 18(1), 89–106.
- Keiding, H. (2016). *Economics of Banking*. London: Palgrave Macmillan.
- King, R. G., & Plosser, C. I. (1984, June). Money, Credit and Prices in a Real Business Cycle. *American Economic Review*, 74, 363–380.
- McLeay, M., Radia, A., & Thomas, R. (2014). Money Creation in the Modern Economy. *Bank of England Quarterly Bulletin*, 54(1), 4–13.
- Minsky, H. P. (1975). *John Maynard Keynes*. New York: Macmillan Press Ltd.
- Wicksell, K. (1936). *Interest and Prices: A Study of the Causes Regulating the Value of Money*. London: Published on behalf of the Royal Economic Society, Macmillan.



## CHAPTER 3

---

# The Adjustment Process of the Money Multiplier and the Loanable Funds Model

### 3.1 INTRODUCTION

In this chapter, the analysis examines, in the first instance, the adjustment process behind the money multiplier formula that leads to the formation of the new loanable funds model of the money supply. The commercial banks create ‘inside money’ in the economy with their loans, generating liabilities via the money multiplier effect, which transmutes into the supply of loanable funds. The second part considers the demand for loanable funds, which leads to a marriage with the supply, so that the equilibrium rate of interest on borrowing can be determined along with the amount of loanable funds. The new loanable funds model is put into the framework of an open economy in order to view what happens within the international sector and to see how the balance of payments influences the money supply by altering the level of reserves as a proxy effect with government borrowing. The discussion considers the money multiplier at the outset, starting with the first round of the mechanism.

### 3.2 THE GEOMETRIC MECHANISM AND THE ROUNDS

Assume that the monetary base has increased,  $\Delta MB$ , by £1 million through open market operations. In the **first round**, the monetary base is at the disposal of the public to hold in the form of either cash or deposits at the commercial banks, which is the initial change in the

money supply, that is  $\Delta M = \Delta MB$ . If individuals hold a fraction in the form of cash, then

$$\Delta CA = \left( \frac{CA^*}{1 + CA^*} \right) \Delta M = \left( \frac{CA^*}{1 + CA^*} \right) \Delta MB. \quad (3.1)$$

The change in bank deposits, therefore, must be the remainder, where

$$\Delta D = \left( \frac{1}{1 + CA^*} \right) \Delta M = \left( \frac{1}{1 + CA^*} \right) \Delta MB. \quad (3.2)$$

The portfolio preference of the banks is to keep a fraction,  $r$ , of its increase as reserves. The reserve ratio is as follows:

$$\Delta RE = r \Delta D. \quad (3.3)$$

By substituting Eq. (3.2) into the expression above gives

$$\Delta RE = r \Delta D = r \left( \frac{1}{1 + CA^*} \right) \Delta MB. \quad (3.4)$$

The remaining fraction  $(1 - r)$  is available to the commercial banks to extend credit by either making loans (LO) or purchase securities, that is

$$\Delta LO = (1 - r) \Delta D = (1 - r) \left( \frac{1}{1 + CA^*} \right) \Delta MB. \quad (3.5)$$

The **second round** starts with individuals receiving loans of  $((1 - r)/(1 + CA^*))\Delta MB$  from banks, which is equal to the  $\Delta M$ . The sum of the second starts with

$$\Delta_2 M = \Delta MB + \left( \frac{1 - r}{1 + CA^*} \right) \Delta MB. \quad (3.6)$$

The individuals hold a fraction of the increased money holdings as cash  $(CA^*/(1 + CA^*))$  and the remaining fraction of  $(1/(1 + CA^*))$  as deposits. The change in deposits is

$$\Delta D = \left( \frac{1}{1 + CA^*} \right) \Delta M = \left( \left( \frac{1}{1 + CA^*} \right) \left( \frac{1 - r}{1 + CA^*} \right) \right) \Delta MB, \quad (3.7)$$

where the  $\Delta M = ((1-r)/(1+CA^*))\Delta MB$ . Once again individuals deposit them back into the banks (not necessarily the same ones) who will hold some of the increase as reserves and extend credit with what is left, which is

$$\begin{aligned}\Delta LO &= (1-r)\Delta D = (1-r)\left(\left(\frac{1}{1+CA^*}\right)\left(\frac{1-r}{1+CA^*}\right)\right)\Delta MB, \\ &= \left(\frac{1-r}{1+CA^*}\right)^2\Delta MB.\end{aligned}\quad (3.8)$$

It is evident that in the **third round**, the expression is as follows:

$$\Delta_3 M = \Delta MB + \left(\frac{1-r}{1+CA^*}\right)\Delta MB + \left(\frac{1-r}{1+CA^*}\right)^2\Delta MB. \quad (3.9)$$

Obviously, this process continues to infinity in the form of a geometric series as

$$\begin{aligned}\Delta M &= \Delta MB + \left(\frac{1-r}{1+CA^*}\right)\Delta MB + \left(\frac{1-r}{1+CA^*}\right)^2\Delta MB \\ &\quad + \left(\frac{1-r}{1+CA^*}\right)^3\Delta MB + \dots\end{aligned}\quad (3.10a)$$

$$\begin{aligned}\left(\frac{1-r}{1+CA^*}\right)\Delta M &= +\left(\frac{1-r}{1+CA^*}\right)\Delta MB + \left(\frac{1-r}{1+CA^*}\right)^2\Delta MB \\ &\quad + \left(\frac{1-r}{1+CA^*}\right)^3\Delta MB + \dots\end{aligned}\quad (3.10b)$$

The subtraction of the two geometric series, (3.10a) and (3.10b), results in

$$\Delta M - \left(\frac{1-r}{1+CA^*}\right)\Delta M = \Delta MB,$$

or

$$\Delta M = \left(\frac{1}{1 - \frac{1-r}{1+CA^*}}\right)\Delta MB. \quad (3.11)$$

Rearranging this expression as

$$\Delta M = \left( \frac{1 + CA^*}{CA^* + r} \right) \Delta MB. \quad (3.12)$$

The analysis discovers that  $(1 + CA^*/CA^* + r)$  is nothing more than the money multiplier, where  $CA^*$  is the portion of cash held by the public in relation to the demand for deposits and  $r = RE/D$  is the reserve ratio. Eq. (3.12) above shows how and by how much the banks could endogenously create credit on the inside when the Central Bank such as the Bank of England increases the monetary base from the outside. Normally, the Central Bank affects the money supply through three methods:

1. Control by open market operations,  $\overline{MB}$ ;
2. The bank rate,  $i_{BR}$ , where this operation emphasises the Central Banks's rôle as lender of last resort; and
3. The alteration of the reserve ratio,  $r$ .

The most frequently used instrument of monetary control is the first one above in conjunction with three. In the case of the second method, for instance, the monetary authorities raise the interest rate via the lender of last resort; this leads to increasing interest paid on saving deposits in the long run. In the short run, larger reserves than necessary are kept by banks, increasing  $r$ , because it is more expensive to run short of them when the cost of borrowing from the Central Bank with collateral to cover the shortage is rising. Thus, an increase in the bank rate under the umbrella of instrument 2 reduces the money multiplier, shifting the supply of loanable funds to the left at a given level of income. In terms of the IS/LM apparatus, the LM curve would shift to the left, indicating that interest rates will rise and output will fall. In brief, an increase in the bank rate is a contractionary monetary policy in the short term. In the long run, however, the efficiency of reserves depends on the ability of retail banks to manipulate the level that is required for a specific deposit base,  $D$ . In the long run, the rate of interest on saving will rise, so that households and firms will transfer a proportion of deposit liabilities into time accounts to earn a rate of return. Therefore, the opportunity of withdrawing from time to current accounts is rising, meaning that agents will be reluctant to withdraw funds from interest-earning

accounts. This means that banks can reduce the level of reserves, decreasing  $r$ . Furthermore, this process will result in reduced  $CA^*$ . The money multiplier recovers in the long run.

Why is the Central Bank's ability to control the money flow rather limited? The reasons for this are transparent from the money multiplier in Eq. (3.12). The analysis so far assumes a constant  $CA^*$ , when it varies from month-to-month and the Bank does not know what its value will be exactly in advance. The public, therefore, varies the ratio of cash to deposits.

Similarly, the reserve ratio,  $r$ , varies, because deposits move between banks and they change the amount of excess reserves they want to hold. They do not automatically re-lend money pushed into the system by the Central Bank. The banks create and control the process of loans. Succinctly, the Central Bank cannot control the money supply exactly because the money multiplier is not constant, nor is it fully predictable because the behaviour of households, firms and retail banks determine its value.

Moreover, the Central Bank cannot simultaneously attempt to control both the interest rate and the supply of money at any given target levels that it may choose. If, on the one hand, the Bank wants to achieve a given interest rate target, it has to supply the amount of outside money that is demanded at that rate. If, on the other hand, it wants to set the money supply at a given level, it has to allow the interest rate to adjust to equate the demand and supply of loanable funds.

### 3.3 THE LOANABLE SUPPLY FUNCTION

The discussion can now rewrite Eq. (3.12) as a loanable supply function that takes into account the behaviour of the banking system and the public over time:

$$\begin{aligned}\Delta LO_t^S &= \Delta M = \left( \frac{1 + CA^*}{CA^* + r} \right) \Delta \overline{MB}, \\ \Delta LO_t^S &= mm \left( i^B, i_{BR}, r, CA^*, \Delta D \right) \overline{MB}.\end{aligned}\tag{3.13}$$

The money multiplier,  $mm$ , is a function of the borrowing rate of interest, the base rate, the required reserves, the cash–deposit ratio and the variability of deposit flows,  $\Delta D$ . Given the stock of the monetary base,

the endogenous supply of loanable funds, for example, increases with the money multiplier,  $mm$ . The multiplier, in turn, increases with the level of market interest rates on borrowing and decreases with the base rate, the required reserves and the cash–deposit ratio. Expression (3.13) refers to a supply function because it describes the behaviour that determines the creation and the destruction of inside money, given  $\overline{MB}$ .

### 3.4 THE LOANABLE DEMAND FUNCTION AND THE EQUILIBRIUM IN THE MARKET

The analysis now combines the endogenous loanable funds supply function in Eq. (3.13) with the loanable demand function in order to derive the market equilibrium. Before combining this function, it is necessary to construct it, representing the demand by agents for loans. Nevertheless, agents such as households with large incomes,  $Y^D$ , and wealth,  $WL$ , find it easier to borrow to finance the consumption of durable goods and services at the going, lending rate of interest. This is consumption over and above day-to-day transactions on non-durable goods and services financed from current income.

Clearly, if the growth of income is falling, saving by agents will drop and borrowing will increase, although not essentially all from the banking sector, which is more than likely to be imposing constraints and rationing credit in the midst of growing uncertainty surrounding the economy as it goes into a downturn or starts suffering from growth recession. Those people restricted to low disposable income will turn to online platforms of loan sharks as well as high street pawnbrokers and door-to-door lending of cash. Thus, those people on meagre disposable income will use more cash as credit restrictions grow with the depth of the recession in economic activity.

In the case of firms, they borrow from the banking sector to cover the variable costs of current and expected output along with the purchase of real capital goods such as plant and machinery as well as commercial buildings. Investment in such assets will provide a stream of revenues (or cash flows) from the provision of services or production of goods for sale that is greater than the running outlays and costs, which essentially reduces to net present value (NPV) in the following mathematical form:

$$NPV = CF_0 + \frac{CF_1}{(1+e)^1} + \frac{CF_2}{(1+e)^2} + \dots + \frac{CF_N}{(1+e)^N} = PK_t^S,$$



which gives

$$NPV = \sum_{t=0}^n \frac{CF_t}{(1+e)^t} = PK_t^S, \quad (3.14)$$

$CF_t$  represents the flows of cash on the accounting balance sheet coming from money revenue after deducting running costs in each period  $t$ , and  $e$  is the internal rate of return that equates the supply price of the capital asset,  $PK_t^S$ , with NPV (or the marginal efficiency of capital). The supply price is the necessary inducement for the capital goods industry to produce extra units, namely the marginal cost of production. Thus, the profit-maximising firm will keep investing in additional units of capital until the marginal revenue product of capital is equal to the marginal cost.

Moreover, the point of the analysis above is to reduce the income capacity of the asset to a measure parallel with the lending rate of interest. This rate of interest enters through the demand-price of the capital asset, which is the present value of the expected net cash flow returns at the current borrowing rate. The demand-price at time  $t$ ,  $PK_t^D$ , given by

$$NPV = \sum_{t=0}^n \frac{CF_t}{(1+i^B)^t} = PK_t^D, \quad (3.15)$$

where  $i^B$  is equal to the relatively long-term rate of interest on borrowing. Therefore, if  $e$  is greater than the cost of loanable funds,  $i^B$ , then the demand for capital expenditure will increase and justify the borrowing of finance from the bank. Alternatively, the firm will keep employing additional units of capital if  $e$  is greater than the market rate of interest,  $i^B$ , which is the marginal cost of borrowing funds.

Moreover, the cash flows that come from the generated revenues in exchange for money will depend on the productivity. The greater the productivity of a capital asset, the higher the value at which  $e$  can be set, without breaching the condition of a positive net present value. Clearly, the lower the real borrowing rate of interest, the more capital projects where productivity generates positive net present values. This leads to the familiar condition that a profit-maximising firm will invest in new capital goods until the internal rate of return is equal to the market rate of interest on borrowing,  $e \geq i^B$ . The return on real assets, in theory, should reflect the yield underlying financial instruments as well.

Summarising the analysis of households and firms decision-making concerning the demand for loanable funds as

$$LO_t^D = \kappa Y^D + \lambda WL - hi^B, \quad (3.16)$$

$LO_t^D$  denotes the demand for loanable funds, which is a function of a positive, real aggregate demand income,  $Y^D$ , as well as wealth represented as  $WL$ . In addition, there is a negative relationship between loanable funds and the cost of borrowing,  $i^B$ , from retail banks to finance the demand for durable consumption by households and capital expenditure by firms. This also includes the day-to-day running of companies to cover variable costs such as wages and material input expenditures.

Assume that the price level is given at the level  $\bar{P} = P_0$  along with the level of real income,  $\bar{Y}^D = Y_0^D$ , and wealth,  $WL/\bar{p} = WL/P_0$ . The equilibrium condition in the loanable funds market is where the real supply,  $LO^S/P_0$ , equals the real demand for loans and credit, that is

$$\frac{LO_t^S}{P_0} = LO^D\left(i^B, Y_0^D, \frac{WL}{P_0}\right). \quad (3.17)$$

Substituting expression (3.13) for  $LO_t^S$  in the loanable funds market equilibrium of (3.17) with the previous assumptions, then the study obtains the following form:

$$mm\left(i^B, i_{BR}, r, CA^*, \Delta D\right) \frac{\overline{MB}}{P_0} = LO^D\left(i^B, Y_0^D, \frac{WL}{P_0}\right). \quad (3.18)$$

Expression (3.18) is the loanable funds market equilibrium in terms of interest rates and the other variables affecting the supply of and demand for loans. The following diagram shows the real loanable demand function ( $LO^D$ ) as a downward-sloping schedule with the cost of borrowing, drawn for a given level of real income and wealth, which is *ceteris paribus*. The real loanable supply function ( $LO^S$ ), given  $P_0$ ,  $i_{BR}$ ,  $r$ ,  $CA^*$  and  $\Delta D$ , is upward-sloping curve for a particular monetary base,  $\overline{MB}$ . The positive slope of the  $LO^S$  curve reflects that, at higher interest rates on borrowing of funds, banks prefer to hold fewer reserves, and consequently, the money multiplier is greater in value, creating more loans and inside money. The factors of  $mm$  in the bracket on the right-hand side of (3.18) will alter the slope, making it either more or less elastic, whereas the  $\overline{MB}$  will lead to a shift. The equilibrium demand and supply

of real loanable funds along with interest rates on the cost of borrowing are jointly determined at point E (Fig. 3.1).

In normal circumstances, an increase in the monetary base,  $\Delta MB$ , outside money could shift the  $LO^{S0}$  curve to the right,  $LO^{S1}$ , enlarging the endogenous, inside money supply by way of the creation of loans, reducing the prevailing interest rate on borrowing, although the money multiplier decreases as a result.

The analysis has reached the stage where it is possible to summarise the exposition within the LM curve, as seen in (a) and (b) of Fig. 3.2. If the demand for loanable funds increases, because the economy is going into a recovery state, that is  $LO^D$  shifts to  $LO^{D1}$ , leading to an upward movement along the  $LO^S$  curve, meaning an expansion in the endogenous money supply on account of an increase in loans made to agents because the rate of interest is rising to  $i_1^B$  from  $i_0^B$  as a result of excess demand. Translating the information from (a) into (b) traces out the LM (liquidity-money) curve, representing the banking sector's activity within the monetary system interacting with firms, households and the Central Bank. The banks are providing financial services and creating money for exchange of aggregate demand and providing finance for production within the IS curve. Furthermore, in the IS/LM model, returning back to the original scenario in Fig. 3.1, the result shifts the LM curve downwards with interest rates on borrowing when the monetary

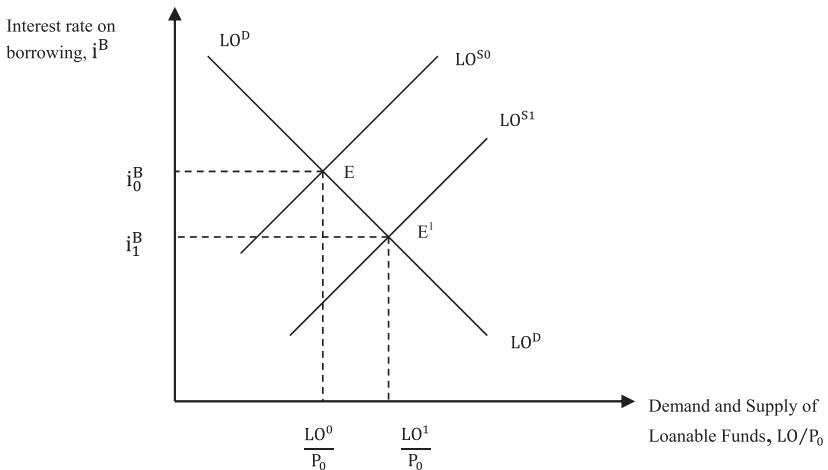
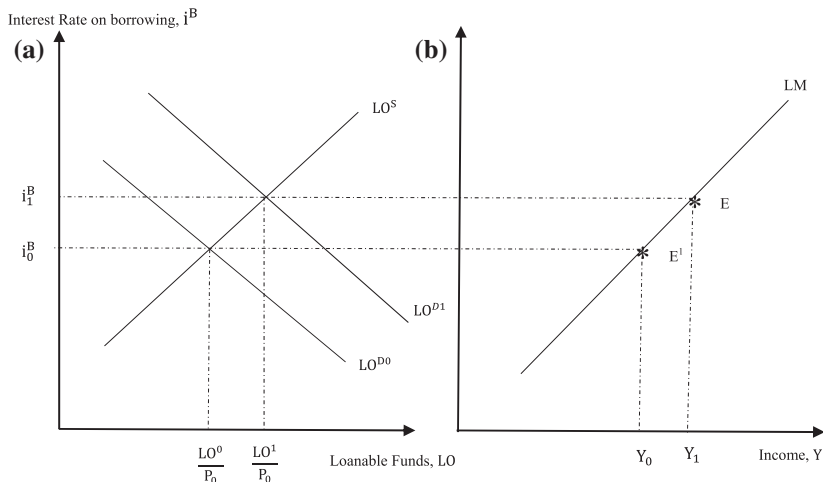

Fig. 3.1 Loanable funds with a rightward shift of the supply function



**Fig. 3.2** The derivation of the LM curve from the loanable funds market

base is increased, given the level of aggregate income and wealth. The final part of the analysis within this chapter is the consideration when the economy is open to the influences of the international sector.

### 3.5 MONEY IN AN OPEN ECONOMY

In the analysis so far, the assumption has been that the money supply and loanable funds are in an essentially closed economy. The UK government in the past has had great difficulty in controlling the money supply, partly because of the influence of the international sector through the proxy level of reserves. The balance of payments on the current and financial account is equal to official financing and that applies to the change in the level of overseas reserves. A balance of payments surplus on the current and financial account brings a rise in the level of the country's reserves, which are a part of the monetary base. It is important to break down a change in the monetary base into the following four components:

1. A change in the monetary base induced by the government borrowing requirement, that is a rise in the money base required to pay for some (or all) of the excess government expenditure over taxes. In real terms, this is denoted by  $\delta(\text{MB}^d/P_0)$ .

2. An adjustment in the level of reserves arising from the balance of payment transactions and in real terms is denoted by  $\delta rs$ .
3. Government action to sterilise the effects of a reserve change by altering the level of the monetary base, where  $\mu$  represents the proportion of reserves offset, then its change for sterilisation purposes is  $\mu\delta rs$ .
4. A change in the Central Bank's loans to the commercial banks and denoted by  $\delta l_b$ .

Therefore, the variation in the monetary base  $\delta\left(\frac{MB^S}{P_0}\right)$  is equal to

$$\begin{aligned}\delta\left(\frac{MB^S}{P_0}\right) &= \delta\left(\frac{MB^D}{P_0}\right) + \delta rs - \mu\delta rs + \delta l_b, \\ &= \delta\left(\frac{MB^D}{P_0}\right) + (1 - \mu)\delta rs + \delta l_b.\end{aligned}\tag{3.19}$$

The change in the monetary base required to pay for the excess of government expenditure over taxes arises from the budget deficit, represented by  $(G - tY)$ . Let a proportion of this deficit be financed by government borrowing money from the Central Bank, then

$$\delta\left(\frac{MB^D}{P_0}\right) = \beta(G - tY).\tag{3.20}$$

Substituting (3.20) into (3.19) gives

$$\delta\left(\frac{MB^S}{P_0}\right) = \beta(G - tY) + (1 - \mu)\delta rs + \delta l_b.\tag{3.21}$$

Assuming a loanable supply expression of the form

$$\frac{LO^S}{P_0} = mm\left(\frac{MB^S}{P_0}\right) + ji^B,\tag{3.22}$$

or

$$\delta\left(\frac{LO^S}{P_0}\right) = mm\delta\left(\frac{MB^S}{P_0}\right) + \delta ji^B.\tag{3.23}$$

By substituting (3.21) into (3.23), this derives the change in the money supply by way of an adjustment of loanable funds for an open economy:

$$\delta \frac{M^s}{P_0} = \delta \left( \frac{LO^S}{P_0} \right) = mm \beta (G - tY) + mm(1 - \mu) \delta rs + mm \delta l_b + \delta j i^B. \quad (3.24)$$

The change in the money supply depends on the budget deficit and real income, a change in foreign exchange reserves, a change in Central Bank loans to the commercial banks and the interest rate, which partly originates from the Central Bank's open market operations.

In Fig. 3.3,  $LO^S$  denotes the supply of loanable funds. This is the endogenous money supply at some desired level of exchange reserves ( $rs^* = \delta rs = 0$ ). On the one hand, a deficit on the balance of payments will lead to a negative change in  $\delta rs$ , which is a fall in the level of reserves. This represents a decline in the money supply, which shifts the loanable supply curve upwards to the left,  $LO_1^S$  ( $\delta rs < 0$ ).

On the other hand, a surplus on the balance of payments results in a rise in the level of reserves and a rightward shift of the loanable supply curve,  $LO_2^S$  ( $\delta rs > 0$ ). Furthermore, the LM curve shifts to the left with a deficit on the balance of payments, whilst a surplus means a shift to the right. There is no longer a single aggregate demand curve, but ultimately a series of curves depending on the change in the level of reserves, as illustrated in diagram. Finally, the degree of instability of aggregate demand depends on the extent to which the Central Bank engages in sterilisation and what is the desired level of reserves the Government has in mind.

### 3.6 CONCLUSION/SUMMARY

This chapter has concerned itself with the money multiplier and the mechanism behind it in creating inside money within the economy. The discussion also observed the influence of the international sector through the effects on the level of reserves. Clearly, the Government and the monetary authorities cannot exogenously determine the money supply because it comes from the endogenously determined loanable funds and the combination of forces from the behaviour of households, firms, banks and international trade in an open economy. The topic for the next chapter is the demand for money, which partly determines the rate of interest on saving within the economy.

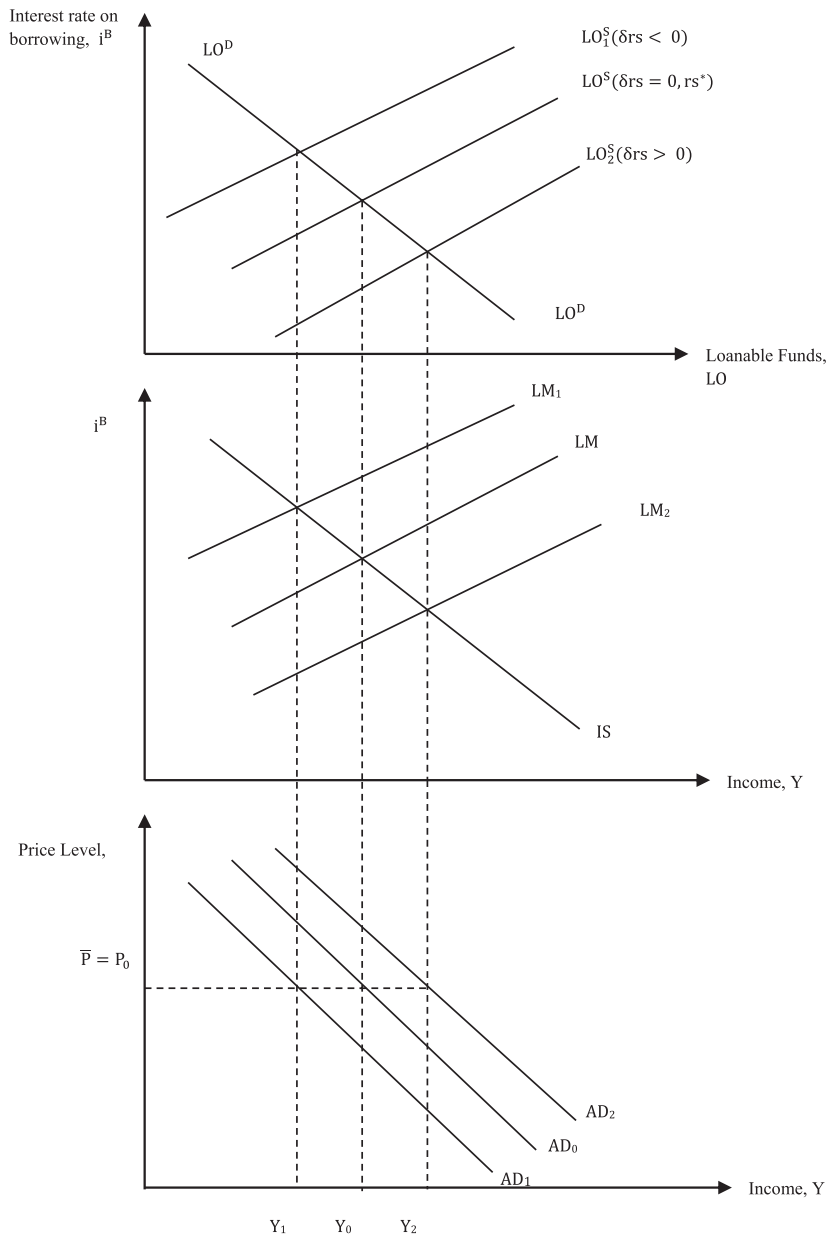

Fig. 3.3 Endogenous Money and Loanable Funds in an Open Economy

### FURTHER READING

- Keynes, J. M. (1972). *Essays in Persuasion: Collected Writings of John Maynard Keynes* (Vol. 9). London: Macmillan, St. Martin's Press, For Royal Economic Society.
- Moore, B. (1979). The Endogenous Money Stock. *Journal of Post-Keynesian Economics*, II(Fall), 49–70.
- Tobin, J. (1963). Commercial Banks as Creators of 'Money'. *Cowles Foundation, Discussion Papers*, No. 159.
- Tobin, J. (1965). Money and Economic Growth. *Econometrica*, 33(October), 671–684.
- Tobin, J. (1970). Money and Income: Post Hoc Ergo Propter Hoc? *Quarterly Journal of Economics*, 84(May), 301–317.





## CHAPTER 4

---

# The Demand for Money: Another Piece of the Jigsaw Puzzle

### 4.1 INTRODUCTION

The analysis in the last chapter has been developing a hybrid version of the Classical loanable funds doctrine, which is the demand for and supply of financial funds from the retail banks in the form of loans, determining the market rate of interest for borrowing. There is, however, another rate of interest on saving deposits within banks, in competition with other wealth-creating assets, such as government bonds or equities.

This suggests that there are two sides to the banking system. In normal times, one side wants to attract customers: getting households and firms, as well as existing ones, to switch proportions of their deposits from current to saving accounts in order for banks to carry fewer reserves at a given level of loans. The incentive for banks is to tie customers into lengthy saving accounts to reduce their liquidity, which means that a slice of liabilities are not available to be used as a medium of exchange for long periods of time without due cost.

On the other side, banks want to lend to households and firms to make profit by creating and supplying loans from their liabilities, generated from factor incomes paid as bank deposits, and therefore, banks are not just intermediaries between saving and borrowing. As a result, there are two prevailing rates of interest within banks:

- (1) the rate of interest (or the rate of return) on saving accounts in competition with other financial investments outside the banking sector;
- (2) the rate of interest on the borrowing (or the rate of cost) of loanable funds by households and firms: the public.

In the case of (1), it is demand for and supply of money in conjunction with saving that determines the average saving rate of interest within the economy. The importance of this aspect of the theory pinpoints that the initial supply of inside money comes from agents in the process of creating real income in the creation and production of goods and services, which includes the banking system. In other words, in the case of households, in return for supplying the factors of production to firms, financial and state institutions, income creation takes place and is paid as wages, rent, interest and profit from accounting cash sheets in the form of bank deposits (or liabilities), the main source of the medium of exchange within a monetary economy. This is the bulk of the money supply, generated from the real sector.

What is more, the demand for money depends on the saving rate within time deposits in competition with other interest-bearing assets such as equities or government bonds, where the prime rate comes from the Central Bank in the form of the Bank rate and used in the mark-up process. Clearly, the determinants of the demand for money are the rate of interest on saving accounts within retail banks in union with other financial instruments as well as the level of income created. This is so-called Keynesian: a new version of the liquidity preference theory.

In the case of (2), the loanable funds doctrine developed in the previous chapter extends this Keynesian approach, where the determination of the borrowing rate of interest is by the demand for and supply of loans and credit created by banks within themselves from liabilities. The destruction of credit and loans takes place when households and firms pay back the principal sums with interest.

More to the point, putting the two theories together, extends the explanation that the interest rate is not just solely saving and investment because the additional explanation of loanable funds adds the ability of the banks to create money as a medium of exchange through the granting of loans. In fact, the total change of credit money over the course of time far exceeds the availability of the level of saving ( $S$ ). Thus, the expression of  $S + \Delta M$ , where the change in the money supply,  $\Delta M$ ,

comes from the creation and destruction of loans,  $\Delta LO$ , as discussed in Chapter 3. The two equilibria interest rates come about, not only by the propensities to save, invest and consume, but also by the creation and destruction of the growth of fiat money in the loans/depository market.

In this chapter, the concern is with the demand for money, which is the desire to hold either cash or depository money generated from real income in relation to other monetary assets. It examines the suggested three motives for holding money. The first one is the transactions motive that takes into account the need for money for regular purchase of everyday goods and services, whereas the precautionary one arises from unforeseen expenditure because of uncertainty. The third motive, the speculative demand for money, arises from uncertainties about the nominal values of bonds as a risky asset that comes from movements in prices on account of changing expectations over interest rates, which acts as a proxy for rates of interest on saving in general. This concept introduces portfolio choice and, therefore, includes real wealth. In other words, the portfolio demand for money is determined by the same elements that effect the demand for bonds. The final part brings in the possible effects of inflation. For an opening introduction to the subject area, click on the following link: <https://www.youtube.com/watch?v=tooU9RnYAPM>.

## 4.2 THE DEMAND FOR MONEY

The starting point of the analysis is the Quantity Theory of Money, which is a very ‘long-standing’ model in the form of cash as a means of exchange. The desire to hold money in the first instance is because it is required for everyday purchases. It is clear in the economy as a whole, the amount purchased must be equal to the value sold. This refers to a mathematical identity that is always true. Let  $M$  equal the stock of money within the economy,  $V$  denotes the average velocity of circulation of money that is the average number of times money circulates over time. Hence,  $MV$  is the total value of money required for purchases over the course of time.

This must equal the worth of goods and services. If  $T$  represents transactions in goods and services over a specified period, and  $P$  is the average price level, then  $PT$  represents the value of goods services produced. Since the value purchased must equal to the worth being sold over a particular interval of time, it follows that

$$MV \equiv PT. \quad (4.1)$$

If  $T$  is considered in terms of real income,  $Y$  and  $V$  now represent the income velocity of circulation, and then the identity takes the form of

$$MV \equiv PY. \quad (4.2)$$

Solving this identity for  $M$ , the transactions demand would be derived,  $M_T$ , with  $\kappa = 1/V$  denoting a constant; the familiar Cambridge expression would be

$$M_T = \frac{1}{V}PY,$$

or

$$M_T = \kappa PY. \quad (4.3)$$

It follows that the transactions demand for real money balances is equal to

$$\frac{M_T}{P} = \kappa Y. \quad (4.4)$$

The empirical evidence supports this theoretical argument to some extent that the demand for money is a desire for real balances. Thus, individuals are concerned with real money holdings, which is the demand for a money stock deflated by the price system. If behaviour is unaffected by changes in the price level, then individual agents are free from money illusion, holding all real variables constant. Real demand for money and behaviour remains unchanged. If they are affected in their behaviour from a change in the price level, then it is said that agents are suffering from money illusion.

### 4.3 THE INVENTORY APPROACH

So far the discussion has focused on real transaction balances depending merely on real income. Such a view, however, assumes that income is in the form of notes and coins, although individual households and firms do hold the bulk of their income flows in current and saving accounts at commercial banks. In most capitalist economies, individual workers receive either weekly or monthly payment of wages by bank transfer, and therefore, expression(4.4) above in the form of cash is not an applicable explanation of the transactions demand for money in a modern, monetary economy of today. Baumol (1952)–Tobin (1956) analysis

developed an inventory approach to the demand for money based on the opportunity cost of interest payments when cash withdrawals are made from interest-bearing accounts (equivalently, bond or share portfolios) for the purchase of day-to-day goods and services. This framework, however, needs to be adapted because the use of cash in exchange is relatively small in today's monetary economy. In fact, contactless payments can replace the tiniest cash transactions.

The analysis, therefore, now concerns itself with the trade-off between the amount of interest individual households and firms may forgo by holding money in current accounts. Suppose that the real monthly income of an individual is  $Y$  and is paid into a current account by bank transfer, where part of the deposit is transferred at the beginning of the period into a saving account or equivalent portfolio of interest-bearing assets such as government bonds or equities, earning an interest  $i\%$  per month.<sup>1</sup> If the household or firm withdraws ( $n$ ) their income over the month at regular intervals, they will withdraw  $Y/n$  each time. If the size of each withdrawal from the saving account denoted by  $W$ , then the discussion can write

$$W = \frac{Y}{n},$$

or

$$Wn = Y. \tag{4.5}$$

If spending is assumed to take place over the period during which the individual is holding money deposits in a current account, subsequently the average is  $(Y/n)/2 = W/2$  or  $Y/2$  ( $n$ ).

If there is only one withdrawal, everything goes into the current account on the first day of the bank transfer, no interest payment from the saving account on that amount. The depository money falls largely smoothly on the first day to £0 at the end of the month. For example, if the income is the form of wages of £1800, then the average balance is  $(£1800 - £0)/2 = £900$ , forgoing interest of  $i * £900$ . This one withdrawal into the current from saving account may reflect the fact that the rate of interest is significantly higher on the former.

If agents are keeping majority of their monetary assets as depository money in a current account, then it becomes impossible to separate money holdings into the three motives. Money held to satisfy one motive is always available for another use. The agent holding unusually

large balances for speculative reasons also has those balances available for unexpected emergencies, so they serve too as precautionary balances. All three motives influence the holding of depository money by the individual. This predicament is because the monetary economy is suffering from disinflation, leading to deflationary tendencies, and therefore, exceptionally low rates of interest on saving accounts (or bonds).

Moreover, if the rate of interest starts to rise, say, because of an expected increase in the rate of inflation on the saving account in comparison with the current one, then the number of withdrawals will start to rise. For example, suppose  $Y$  is equal to £1800, and  $n$ , the number of transactions, equals three, consequently the average amount of money holding in the current account becomes

$$\frac{1800}{2(3)} = 300.$$

Graphically, the average money balance over the course of the month is as follows (Fig. 4.1).

If the individual makes three withdrawals from the saving account, the first transfer of money is  $Y/3$  into the current account at the beginning of the month, resulting in a balance that is run down to zero, at which time another  $Y/3$  is relocated into depository money and spent, and so on. The interest cost of holding money in the current account is the interest rate times the average balance, that is

$$i \frac{W}{2}, \text{ or } \frac{iY}{2n}. \quad (4.6)$$

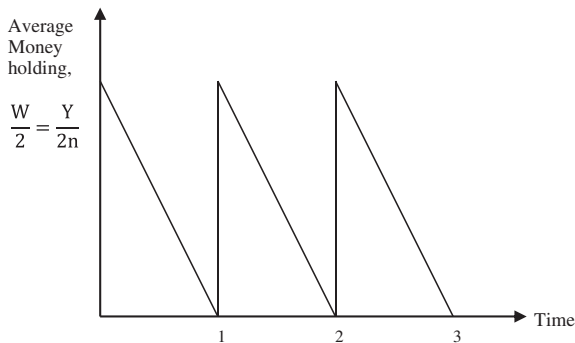

Fig. 4.1 The average money holding in a current account

There is, however, another cost. Each withdrawal involves a transaction cost (or brokerage fee) with the bank, or the cost in terms of the individual's time and inconvenience in managing the money account. If  $c$  denotes the transaction cost, the individual will incur,  $nc$  costs over the month. Hence, the total cost of managing their portfolio is

$$\text{TC} = nc + \frac{iY}{2n}. \quad (4.7)$$

This shows that the transaction cost increases as the number of withdrawals rises, whilst the interest cost decreases. Expression (4.7) emphasises the trade-off faced in managing depository money, suggesting that there is an optimal number of withdrawals the individual household or firm should make to minimise the total cost of holding money to meet transaction requirements for buying goods and services. This can be obtained by minimising Eq. (4.7) with respect to  $n$ . Partially differentiating the expression and setting the result equal to zero, which is

$$\frac{\partial \text{TC}}{\partial n} = c - \left( \frac{iY}{2n^2} \right) = 0. \quad (4.8)$$

The second term, on the right-hand side of the expression, is obtained by way of the quotient rule. This gives the optimal value of  $n$ , denoted by  $n^*$ . Multiplying everything in Eq. (4.8) by  $2n^2$  derives

$$c2n^2 - iY = 0.$$

Taking  $iY$  to the right-hand side of the expression and dividing both sides by  $c2$  give  $n^2 = iY/2c$ , resulting in

$$n^* = \sqrt{\frac{iY}{2C}}, \quad (4.9)$$

The optimal point is the position where the benefit of carrying out another withdrawal is just equal to the cost of moving income to depository money in the current one from the saving one, as shown in Fig. 4.2.

The costs of making a further transaction are captured by the marginal cost curve, MC, with an intercept at the level  $c$ . The financial benefit from making another transaction, represented by the marginal benefit (MB) curve, denotes the **interest saved** by making another withdrawal

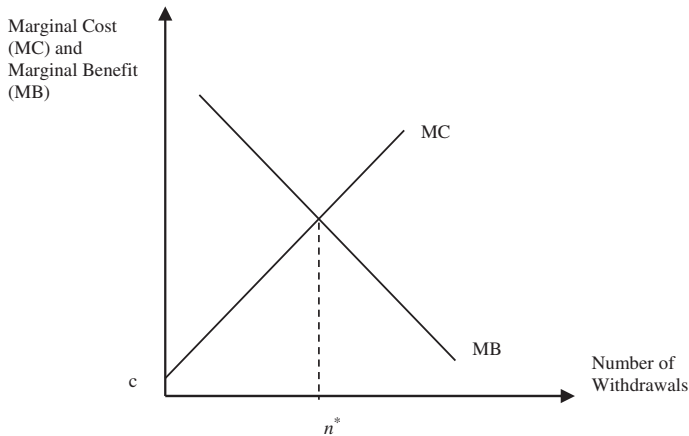

**Fig. 4.2** The optimal number of withdrawals

and having a smaller money balance on average during the month. The more transactions between money and the saving account the individual makes, the lower is the total interest cost. The reduction in interest cost, obtained by making more transactions, decreases rapidly as the number of withdrawals increase, and therefore, the MB curve is downward sloping.

Relating expression (4.4) to the average demand for transaction balances, that is given by  $M_T^*/P = Y/2n^*$ , if expression (4.9) is substituted into this for  $n^*$ ,  $M_T^*/P$ , the optimal transaction balance, is obtained, that is

$$\frac{M_T^*}{P} = \kappa \frac{Y}{2\sqrt{\frac{iY}{2c}}},$$

which can be simplified as

$$\frac{M_T^*}{P} = \kappa \sqrt{\frac{cY}{2i}}. \quad (4.10)$$

The optimal transactions demand for money,  $M_T^*/P$ , is positively related to real income and inversely linked to the rate of interest. Furthermore, the greater the transaction cost, the greater the demand for money.



First, if the MC curve shifts upwards, decreasing the number of withdrawals,  $n$ , as a result the average holdings of money increase. Second, increases in the interest rate shift up the MB curve, and consequently, increasing  $n$  with money holdings reducing. There is, however, a new variable in the disguise of  $\kappa$ , the inverse of the velocity, appears in the adapted theory. It now represents the optimal propensity to hold depository money for day-to-day transactions. In short, with  $\kappa$ , the transactions demand for real money balances relate positively to real income, but inversely linked to the interest rate. So far the analysis has examined the demand for money assuming that the only rationale for holding money is for transaction purposes only. Keynes argued that there were three motives for holding money:

1. Transactions demand;
2. Precautionary purposes; and
3. The speculative demand for money.

The analysis has dealt with the first one in depth, and the investigation will proceed onto the second motive.

#### 4.4 THE PRECAUTIONARY MOTIVE

People tend to withdraw more out of their saving than they actually need for known transactions and keep money in their current account because they are uncertain about the payments and unexpected purchases. The precautionary motive for holding money arises because of an uncertain future. The loss from not having money immediately available is denoted by  $\mathcal{L}q$ . The more money the individual demands, the lesser the risk of incurring the costs of being illiquid. The amount withdrawn for precautionary reasons, however, incurs a loss of interest. The optimal amount depends on balancing the interest costs against the benefits of not being illiquid.

Writing the probability function of the individual being illiquid at some time during the month as  $\rho(M, \sigma)$ . This is dependent on the money balances being held,  $M$ , and the degree of uncertainty,  $\sigma$ , about the net payments over the period. The expected cost is associated with the probability of illiquidity times the cost of being illiquid, which is  $\rho(M, \sigma)q$ . The interest cost linked with holding a cash balance of  $M$  is just  $iM$ . Thus, the expected costs essentially become

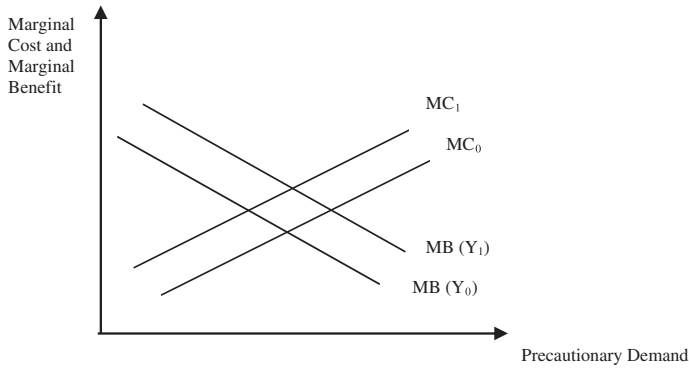

Fig. 4.3 The optimal amount of precautionary balances

$$\text{Expected Cost} = iM + \rho(M, \sigma)q. \quad (4.11)$$

The optimal number of withdrawals for precautionary purposes by an individual occurs when the marginal benefit from the increased liquidity is equal to the marginal cost. Since the marginal cost of the withdrawal once again involves the interest forgone,  $i$ , it is clear that the optimal amount of precautionary balance will be related to the rate of interest, as shown in the Fig. 4.3.

The higher the rate of interest, the greater the marginal cost of the withdrawal, and lowered precautionary demand for money culminates in a shift of the MC curve to the left, from  $MC_0$  to  $MC_1$ . If the marginal benefit of increasing money holding rises from the lower expected costs of illiquidity. An increase in money balances will reduce the probability of illiquidity at decreasing rate. Ultimately, an increase in income (or uncertainty) leads to increased money holdings because it shifts the MB curve upwards, from  $MB(Y_0)$  to  $MB(Y_1)$ .

#### 4.5 THE SPECULATIVE DEMAND FOR MONEY

In the analysis, so far it has not been clear whether money is substitutable with other assets. Once the study moves away from money in isolation and considers it merely as one in a spectrum of assets, then the theory begins to define the demand for money in terms of the outcome of a **portfolio choice**. An individual who has wealth will hold it in

specific assets in the form of a portfolio. An investor would want to hold the asset that provides the higher returns. Given that that return on most assets is uncertain, it is unwise to hold the entire portfolio in **one risky asset**. Uncertainty about the returns on insecure assets leads to a diversified portfolio choice.

A typical risk-averse investor will want to hold some amount of a safe asset as insurance against capital losses on assets whose price changes vacillate unpredictably. The safe asset would be held precisely because it is secure, even though it pays a lower return than the insecure assets. Money is a safe asset in that its nominal value is known with certainty. In a famous article, James Tobin outlines a portfolio choice model that suggests that a money holding is the safe asset in the portfolio of investors.<sup>2</sup> In Tobin's model, the individual holds wealth either in money,  $M$ , or in bonds,  $B$ , or some combinations of the two. Bonds have an interest payment,  $i$ , whilst money has zero interest. A bond in perpetuity has a price,  $p^B$ , equal to the coupon value,  $A$ , divided by the rate of interest, which is  $p^B = A/i$ . Also,  $p^B$  is the purchase price and  $p_e^B$  equal to the expected selling price. The expected selling price is dependent on the expected interest rate, that is  $p_e^B = A/i_e$ . Therefore, the expected capital gain or loss,  $G$ , would be

$$G = \left( \frac{p_e^B - p^B}{p^B} \right) = \frac{\frac{A}{i_e} - \frac{A}{i}}{\frac{A}{i}} = \frac{A}{i_e} \cdot \frac{i}{A} - 1 = \frac{i}{i_e} - 1. \quad (4.12)$$

The total earnings on a bond, denoted by  $E$ , will be the interest rate at the time of purchase plus the capital gain (or less the capital loss) in the form of

$$E = i + G. \quad (4.13)$$

Assuming that the capital gain is dependent on some expected interest rate, which is assumed to be a random variable, normally distributed with a mean,  $\mu$ , and a standard deviation,  $s$ . Thus,  $G \approx N(\mu, s)$ , where ' $s$ ' is used as a measure of risk. Since  $G$  is normally distributed, then so is  $E$  (since  $E$  is a linear function of  $G$ ). The mean and standard deviation of  $E$  are

$$\text{Ex}(E) = i + \text{Ex}(G) = i + \mu,$$

$$\text{Var}(E) = \text{Var}(G) = s^2,$$

so that

$$\text{SD}(E) = s, \quad (4.14)$$

where  $\text{Ex}(\cdot)$  denotes the expected value,  $\text{Var}(\cdot)$  represents the variance and  $\text{SD}(\cdot)$  the standard deviation. If  $B$  also equals the amount of money spent on bonds, the total return, denoted by  $R$ , is

$$R = BE. \quad (4.15)$$

Since  $E$  is a random variable,  $R$  must be one too because  $E$  is normally distributed, then so is  $R$ . The mean and standard deviation of the distribution of  $R$  are

$$\begin{aligned} \text{Ex}(R) &= \mu_R = B\text{Ex}(E) = B(i + \mu), \\ \text{Var}(R) &= s_R^2 = B^2\text{Var}(E) = B^2s^2, \\ s_R &= Bs. \end{aligned} \quad (4.16)$$

From this statement, the analysis obtains

$$B = \left(\frac{1}{s}\right)s_R, \quad (4.17)$$

and from the  $E(R)$  in Eq. (4.16), the study derives

$$\begin{aligned} \mu_R &= B(i + \mu), \\ &= \left[\frac{(i + \mu)}{s}\right]s_R. \end{aligned} \quad (4.18)$$

The information in Eq. (4.18) is graphically drawn on the left-hand side in Fig. 4.4 and Eq. (4.17) on the right. Given a risk of gain (or loss),  $s$ , if all wealth were invested in bonds, then  $B = \bar{W}$ . If both  $\mu$  and  $s$  are determined, along with the interest rate  $i$ , from Eq. (4.18) the slope of the line in the left-hand diagram will be  $(i + \mu)/s$ .

The household is assumed to have a utility function based on returns derived from bond purchases, that is  $U = U(R)$ . The shape of the utility function is the assumption of risk aversion. The individual will maximise their expected utility by moving to the highest possible indifference curve, subject to the budget constraint. Thus, the individual will hold  $B^*$  of his (or her) wealth in the form of bonds. This means that they will

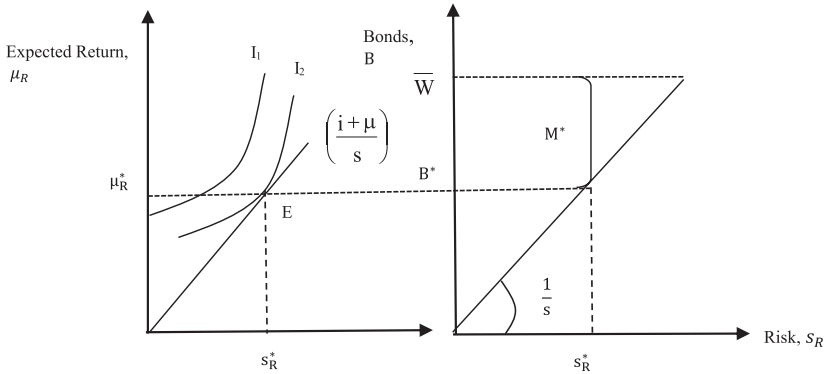

**Fig. 4.4** The allocation of bonds and money

hold  $M^* = \bar{W} - B^*$  of wealth in money. With this particular portfolio, the expected return is  $\mu_R^*$  with a risk of  $s_R^*$ .

The study is now in the position to derive the speculative demand for money balances explicitly. This is shown in the set of diagrams, Fig. 4.5. At interest rate,  $i_1$ , equilibrium is at point  $E_1$ . At the lower interest rate,  $i_2$ , equilibrium is  $E_2$ , where the demand for money rises from  $M_1$  to  $M_2$ . From this, it is possible to derive the speculative demand for money, a downward-sloping curve, showing an inverse relationship between money balances and the various rates of interest.

The conclusion to be drawn is that all the three motives for demanding money pinpoint positive relationship to real income and inversely linked to the rate of interest. The equation that utilises this notion is as follows:

$$\frac{M^d}{P} = \kappa Y - hi, \tag{4.19}$$

where  $\kappa$  and  $h > 0$ . The analysis of the speculative demand for money reveals the importance of the level of wealth. So far, the speculative demand for real money balances is for a given level of real wealth,  $WL/P$ . A rise in real wealth leads to an increase in the demand for speculative balances, and therefore, a greater amount of real money being held. Explicitly bringing in wealth alters the equation above as

$$\frac{M^d}{P} = \kappa Y - hi + n \frac{WL}{P}, \tag{4.20}$$

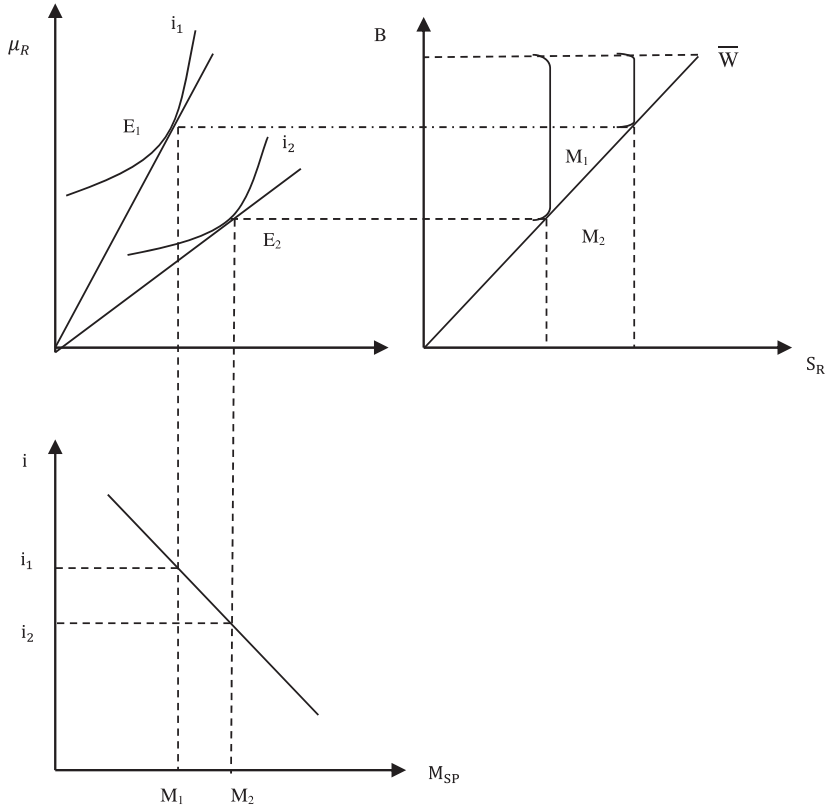

Fig. 4.5 The demand for money

$\kappa$ ,  $h$  and  $n > 0$ . Finally, the consideration of the rate of inflation, which is in the next section overleaf.

#### 4.6 MONEY DEMAND AND THE RATE OF INFLATION

At the beginning of the chapter, the income velocity of circulation of money was

$$V \equiv \frac{PY}{M}. \tag{4.21}$$

In the Cambridge expression,  $\kappa = 1/V$ , which is now been redefined in this lecture as the optimal propensity to hold depository money, the assumption at the beginning is a constant value. Suppose that this velocity of circulation of depository money is not a constant, but rises with the rate of inflation,  $\hat{p}$ . It is reasonable to assume that

$$V = V(\hat{p})V' > 0$$

or

$$\kappa = \kappa(\hat{p})\kappa' < 0. \quad (4.22)$$

The money demand for real money balances becomes

$$\frac{M^d}{P} = \kappa(\hat{p})Y - hi + n\frac{WL}{P}. \quad (4.23)$$

A rise in the rate of inflation lowers  $\kappa$ , thus reducing the demand for real money balances. Hence, rising inflation rate increases the velocity of money income, so that agents either spend it or invest it before the medium of exchange loses its value. With low rate of inflation, the growth of real money demand could well exceed the growth of prices if the economy is growing and, therefore, requires a greater supply of inside money. Does it matter that the income velocity is constant or variable? It does, because a variable income velocity of circulation of depository money will lead to an unstable demand curve for money, which in turn will raise problems for monetary management of the economy. Before all the threads are brought together to derive the equilibrium rate of interest on saving, a major area of work on the demand for money comes under the heading of the monetarists' revival of the Quantity Theory of Money, which is the section below.

#### 4.7 THE MONETARISTS' REVIVAL OF THE QUANTITY THEORY OF MONEY

The monetarists' theory of the demand for money began in 1963 with *A Monetary History of the United States* by Friedman and Schwartz, concluding that money is neutral in the long term, but not in the short run. The investigation relies on informal observation of the fact that as output expands and contracts, this was always supported by the money. Their study of the depression in the 1930s concluded on a fall in the

growth of the money supply was the cause rather than a drop in aggregate demand from investment expenditure ruled by pessimistic, animal spirits, as indicated by Keynes in 1936. The drop in the growth of inside money resulted from a contractionary monetary policy which augmented the upsurge of bank failures, and consequently, the contraction of output and income. The work, however, has been criticised for lacking an empirical foundation and many econometric studies have investigated the link the between money and income.<sup>3</sup>

Moreover, the monetarist theory is also based on the portfolio investment decisions of agents, although it replaces current income,  $\mathcal{Y}$ , with permanent income  $\mathcal{Y}^P$ , which is function of human wealth as well as greater range of assets and not just bonds, such as real estate and share ownership within a portfolio of assets. Thus, the monetarist demand for money depends a greater range of rates of return:

$$\frac{M^d}{P} = f\left(r^m, r^b, r^s, E_t \Delta P_{t+1}, \mathcal{Y}^P, \text{WL}, u\right), \quad (4.24)$$

where  $r^m, r^b, r^s$  are returns on money, bonds and shares,  $E_t \Delta P_{t+1}$  denotes the expected rate of inflation, where  $P_{t+1}$  is the expected price level and the change,  $\Delta$  is the rate of inflation, measured as  $(P_{t+1} - P_t)/P_t$ ,  $E_t$  indicates expectations at time  $t$ ,  $\mathcal{Y}^P$  is a measure of wealth in the form permanent income, WL represents a percentage of the total of non-human wealth such as estate investments, and finally,  $u$  represents all other elements that affect agents' preference for demanding money. This approach incorporates the Keynesian prospective because of the greater variety of assets, including bonds within the demand for money function. This means that adjustments in money holdings should be more stable in the presence of variations in  $I$  along with public's taste,  $u$ .

Nevertheless, since the money demand is stable within the money market, representing saving, and any disruptions to the monetary system within the economy come primarily from the supply side of the loanable funds market. Clearly, variations in the money supply via loanable funds will lead to changes in the borrowing of rates of interest that dictates the tempo of the demand for loanable funds that partly finances durable consumption as well as real investment within the IS curve. Thus, the change in money through loans and credit will alter permanent income,  $\mathcal{Y}^P$ , through wage growth and profit, or change the relative



prices,  $P$ , or both. According to monetarist's view point, 'money talks' in the medium term because of its impact on output and price, but the long-run result is neutrality of money, which is essentially the same as the Classical Quantity Theory of Money with stability. No matter case, whether Keynesian or monetarist point of view, the end product is a negative demand for money.

#### 4.8 THE DETERMINATION OF THE RATE OF INTEREST ON SAVINGS

By combining the demand for money, derived in Fig. 4.5 with the positive supply of money in the form of bank transfers into saving accounts at higher rates of interest, this will reduce the cash and reserve ratios embodied within the money multiplier formula, summarising the money creation mechanism of loanable funds. The depiction of the equilibrium saving rate of interest determination comes about in Fig. 4.6 because of the demand and supply of money.

It shows that if incomes rises, then the demand for money shifts from  $M^d$  to  $M_1^d$ , forcing up the rate of interest on saving balances on account of the excess demand between  $M^*$  and  $M_1$ . Agents, therefore, transfer more, or less to the current accounts, to take advantage of the

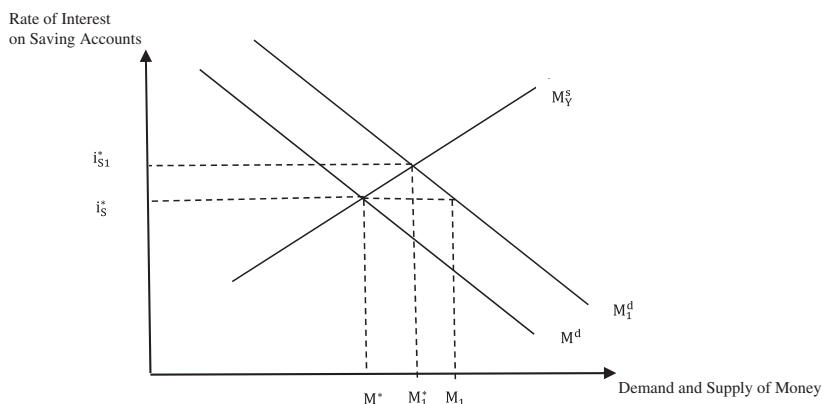

Fig. 4.6 The determination of the saving rate of interest

higher rate of return, from  $i_S^*$  to  $i_{S1}^*$ . This means that banks will have to carry fewer reserves because of the high penalties of withdraw in terms of the opportunity cost on households and firms. Clearly, the opposite effect means excess supply and the reduction in the rate of interest on saving accounts, which has been taking place since the financial crisis of 2007/2008. This means more money held in current accounts, and therefore, banks carry a high reserve ratio, reducing the bank multiplier and the possibility of loan creation.

On examination of the plot of the Gilt yields on five-year government bonds in the Fig. 4.7, acting as a proxy for the rate of interest on saving, reveals a significant decline from the peak at over five per cent in June 2008 to below one in May 2017 on the rate of return. This confirms the theoretical outcomes from the model that evolves from Fig. 4.6 when the opposite effect takes place. Furthermore, an article that comes from the following link, which is an empirical investigation into the determinants of the demand and supply of money, and Federal Government debt, which is a proxy for the rôle of interest-bearing instruments such as bonds that lead to the accumulation of financial wealth over time within the US economy. It is, to some extent, an empirical test of the theoretical model proposed in this chapter, with the 30-year rate of interest on bonds as a Keynesian substitute for the rate of return on saving. It is a response to Hendry's and Ericsson's (1983) comments that empirical assertions should be supported by econometric evidence.

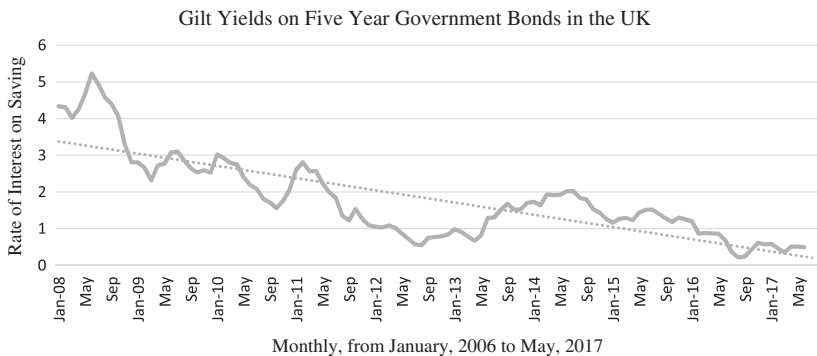

Fig. 4.7 Gilt yields (*Source* UK Debt Management Office)

## 4.9 CONCLUSION/SUMMARY

This chapter has been concerned with analysing the demand for money and its underlying three motives with the supply coming from the creation of real income paid as bank liabilities, which are the main medium of exchange within a monetary economy. The analysis led to the field of portfolio theory, which brought other assets besides money that earn a rate of return and determines the saving rate of interest, which adds to the stock of wealth and a further dimension to the demand for money. In fact, the monetarist prospective extends this further by widening the portfolio range assets that accumulates into wealth. Furthermore, the discussion examined the unstable effects of inflation on the income velocity of circulation concerning depository money. Finally, the analysis explains the low rate of interest on saving when combining the supply and the demand for money as well as the implications for the supply of loanable funds to meet the demand for finance to create economic activity. The implication is that money causes income as well as income produces money.

## NOTES

1. The distinction between current and saving accounts within commercial banks have become blurred because the saving rate of interest is abnormally low, meaning that the merge rate of interest on current accounts may will be greater.
2. Tobin, J. (1958). Liquidity Preferences as Behaviour Towards Risk. *Review of Economic Studies*, February.
3. For further details of the empirical debate see Hendry and Ericsson (1983).

## REFERENCES AND FURTHER READING

- Baumol, W. J. (1952, November). The Transactions Demand for Cash: An Inventory Theoretic Approach. *The Quarterly Journal of Economics*, 66, 546–556.
- Dowd, K. (1990, February). The Value of Time and the Transaction Demand for Money. *Journal of Money, Credit and Banking*, 22, 51–64.
- Goodhart, C. (1989, June). The Conduct of Monetary Policy. *Economic Journal*, 99(396), 293–346.

- Hendry, D. F., & Ericsson, N. R. (1983, October). *Assertion Without Empirical Basis: An Econometric Appraisal of Monetary Trends in the United Kingdom*, Milton Friedman and Anna Schwartz (Bank of England Panel of Academic Consultants, Panel Paper No. 22).
- Laider, D. (1993). *The Demand for Money: Theories, Evidence and Problems*. New York: HarperCollins.
- Tobin, J. (1956, August). The Interest-Elasticity of Transactions Demand for Cash. *The Review of Economic Studies*, 38, 241–247.
- Whalen, E. L. (1996, May). A Rationalization of the Precautionary Demand for Cash. *The Quarterly Journal of Economics*, 80(2), 314–324.



# The Rate of Interest and the New Monetary Theory of Loanable Funds

## 5.1 INTRODUCTION

In this chapter, the analysis attempts to define and determine nominal rates of interest that prevail within the monetary system. Its importance, as already mentioned, is partly determined by the payment made by borrowers to lenders. The analysis draws on three theories to explain the determination of rates of interest on borrowing and saving. The first one is the Classical, loanable funds theory (LFT), that describes the formation of rates of interest through the process of saving, made available as loanable funds to satisfy the demand to finance real investment by way of the banking system. This recognises banks as intermediaries in the process of lending. The second one is a hybrid theory developed in Chapter 4, based on the liquidity preference theory (LPT), which is a product of Keynes' *General Theory of Employment, Interest and Money* (1936). Once again, it explains the rate of interest on saving, although it reveals the source and the supply of bank liabilities as real income generated within the real economy. The third one, a new version based on a mixture of both frameworks to explain the role of the rate of interest on borrowing via loan creation to finance durable consumption and the supply of goods and services. This identifies banks as creators of inside money. This is a new format born out of the analysis developed so far from the analysis of this book. The idea is to start bringing the threads together to knit the model into one in the context of explaining the cost of borrowing from the endogenous money supply within the monetary

system of the economy. In the first instance, the study considers the definition of the rate of interest with the view of examining short-term rates on borrowing and saving. The presentation of the material relies heavily on the book by Howells and Bain (2008), Chapter 9.

## 5.2 DEFINITION AND COMPOSITION OF NOMINAL INTEREST RATES

The study starts with defining nominal rates of interest, paid in money terms with four components embodied within its format:

$$i = ri + E_t \Delta P_{t+1} + l + \sigma_R, \quad (5.1)$$

where  $ri$  is the real short-term rate of interest;  $E_t \Delta P_{t+1}$  denotes the premium on the expected rate of inflation, where  $P_{t+1}$  is the expected price level and the change,  $\Delta$  is the rate of inflation, measured as  $(P_{t+1} - P_t)/P_t$ ,  $E_t$  indicates expectations at time  $t$ ;  $l$  represents the liquidity payment; and lastly,  $\sigma_R$  equals the risk premium within (5.1).

The real rate is the return,  $ri$ , required even when there is no risk and prices are constant, namely the yield for the shortest period over time. The inflationary premium  $E_t \Delta P_{t+1}$  is compensation for any rising prices that reduce the value of saving or the loan during its period. This is the make-up of short-run rates of interest. Clearly, long-term real rates entail the differences in the liquidity payment,  $l$ , as well as the final premium required to compensate for the level of risk,  $\sigma_R$ . The former is particularly relevant when agents have a low preference rate and therefore save a significant portion of their real income. The latter is important for the banking sector because lending is subject to default in the midst of asymmetry of information within the loanable funds market. In this chapter, the investigation concentrates mainly on three of the elements of (5.1),  $ri$ ,  $E_t \Delta P_{t+1}$  and  $\sigma_R$ . The other component, the liquidity premium, is subject to the term structure of interest rates, which will be the theme of the next chapter.

## 5.3 CLASSICAL VERSION OF INTEREST DETERMINATION: LOANABLE FUNDS THEORY (LFT)

According to Snowdon et al. (1996), at the heart of this theory, is Say's law of markets, originally set in the context of a barter economy, where the supply of a good implies the demand for another. This proposition is

assumed to hold within a monetary system, where commodity money as a medium of exchange avoids the transaction costs associated with barter. Thus, if aggregate demand, AD, and supply, AS, are always in equilibrium at the full-employment position within a perfectly competitive system because of flexibility of prices and wages within the product and the labour market, then money is simply the determination of the price level and a ‘veil’ covering the real economy, which is exogenously controlled and fixed in supply by the monetary authorities.

What is more, the supply of goods creates current, real income that can only be consumed or saved, S, although the latter rather than the former can be channelled into finance of real investment, I, another component of AD. The equilibration process between S and I is the flexible adjustment of the rate of interest, where the former represents the supply of loanable funds and the latter denotes the demand. Therefore, the determination of interest rates is an outcome of the interaction between the **decisions to invest and save**. Investment in this speculation is the desire to profit from future output of goods and services, and where the wish to save is the accumulation of wealth for future consumption including the effect of the rate of interest. Hoarding comes to be irrational behaviour because it forgoes the benefits of the rate of interest and the accumulation of the stock of wealth for future consumption. If, for example, savers decide to save more, then this would lead to excess supply of funds, which would cause interest rates to fall to encourage investment and, therefore, bring them back into equilibrium. In particular, there would be no leakage from the circular flow of income because ‘real’ forces of productivity embodied in the technology and innovation of capital goods, such as machinery and industrial buildings, determine what borrowers will pay and what savers will lend.

#### 5.4 THE REAL RATE OF INTEREST IN LFT

By assuming that prices are constant, the nominal and the real rate of interest are the same. The real rate is the required rate to compensate lenders for the postponement of consumption until some future date. The delay of consumption by agents depends on their rate of time preference and the determination by the size of income and wealth. Agents with large incomes will find it easier to postpone consumption for their retirement, whilst those on very low earnings will struggle to cover even the basic requirements of life. In aggregate, however, the higher the income of the society, the greater the level of savings expected.

Moreover, as discussed in Chapter 3, borrowers will purchase capital assets in order to earn positive net present value (PV), which is discounted net profit after subtracting the price of the machine, the running and the borrowing costs. In terms of an expression:

$$PV = \sum_{t=0}^n \frac{R_t}{(1+e)^t} = P_t^S, \quad (5.2)$$

where the  $R_t$  are the balance sheet cash flows of revenue minus the variable running costs for each time period  $t$ , and  $e$  is the required rate of return on the project that equalises the discounted returns with the supply price of capital goods,  $P_t^S$ .

If  $e \geq r_i$ , then the profit from the project is covering the cost of borrowing and matches the risk-free, short-term real rate of interest and the various risk premia, depending on the length of time involved. Thus, the capital outlay will justify the borrowing of funds and undertaking of the project. The determination of cash flows of revenue is essentially by the productivity of the capital equipment. The larger it is, the greater the positive present value from imposition of the value of  $e$ . Figure 5.1 can illustrate this analysis.

On the one hand, the supply curve,  $S$ , is sloping upwards, because a higher the rate of interest attracts a larger number of individuals who will find that it exceeds their rate of time preference. On the other hand, the demand curve,  $D$ , is downward sloping, because a lower interest rate means more capital projects with greater productivity can be undertaken.

If, for example, society's time preferences fall, then the supply curve shifts to the right, indicating that more funds are available for lending,  $S_1$ . The result is excess supply if the number of profitable projects remains unchanged; the interest rate must drop,  $r_{i1}$ , in order to seek out investments that are more profitable and bring the market back into equilibrium. An increase in productivity of capital goods will lead to excess demand as the demand curve shifts outwards to  $D_1$ . This will force the interest rate to  $r_{i2}$ , because of the competition from potential lenders.

## 5.5 THE INTRODUCTION OF THE RATE OF INFLATION

The analysis introduces the element of inflation into the study. Since the Second World War, constant prices are an unrealistic assumption. Suppose that the rate of time preference to sacrifice one hundred pounds



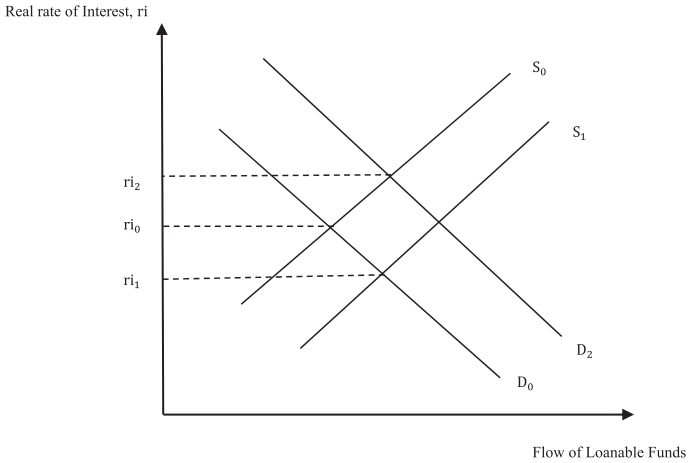

**Fig. 5.1** Classical demand and supply of loanable funds

worth of current consumption is one hundred and four pounds in one year's time. The real rate of interest,  $ri$ , is four percent, that is

$$ri = \frac{104}{100} - 1 = 0.04 = 4\%.$$

In the absence of inflation, then the cash flow of  $R_t$  from revenue would be

$$R_t = 100(1 + ri). \quad (5.3)$$

It is necessary to extend the model and include the rôle of prices, especially the rate of inflation because the nominal rate of interest will become a crucial variable within the analysis at a later stage. Assume that prices are expected to rise by six percent over the period; subsequently, a further adjustment is required to the format of (5.3), which is

$$R_t = 100(1 + ri)(1 + E_t \Delta P_{t+1}). \quad (5.4)$$

where, as already stated at the beginning of the analysis that  $P_t$  is the price level and the change,  $\Delta$  is the rate of inflation;  $E_t$  indicates expectations at time  $t$ , within the cash flow balance sheets of revenue. The nominal interest rate, therefore, must be equal to

$$\begin{aligned} (1 + i) &= (1 + ri)(1 + E_t \Delta P_{t+1}), \\ &= 1 + E_t \Delta P_{t+1} + ri + ri(E_t \Delta P_{t+1}). \end{aligned} \quad (5.5)$$

Expanding the brackets in (5.5) above and solving for  $i$  gives

$$i = ri + E_t \Delta P_{t+1} + ri(E_t \Delta P_{t+1}). \quad (5.6)$$

If the expected inflation is small, then the cross product can be removed in order that

$$i \approx ri + E_t \Delta P_{t+1}, \quad (5.7)$$

this compares with expression (5.1), in the short term.

## 5.6 THE FISHER EFFECT

Rearranging Eq. (5.7) in terms of the real rate of interest

$$ri \approx i - E_t \Delta P_{t+1}, \quad (5.8)$$

this is the difference between the nominal rate and the expected (ex-ante) rate of inflation. This entails the formation of expectations, but if what is expected is realised, then the ex-post expression becomes

$$ri \approx i - \Delta P_t, \quad (5.9)$$

Expression (5.9) above is known as the Fisher equation. The suggestion is that the real rate of interest is stable over the long run since time preference and productivity of capital assets are not subject to short-term fluctuations. Consequently, nominal rate adjustments are a product of the changes in the expected rate of inflation in (5.7). In other words, the nominal rate of interest reflects the stable real rate plus a premium that tracks the expected rate of inflation, which is the Fisher effect (Fisher 1907). The empirical evidence, however, ambiguous and does not refute or prove the Fisher supposition. See the following link: <https://www.youtube.com/watch?v=Qg9cTyEF3VI>.

## 5.7 LIQUIDITY PREFERENCE THEORY (LPT)

Keynes' *General Theory* represented an attack on the traditional model previously outlined. According to him, saving is a function of income in addition to rejecting the notion of full-employment. The interest rate plays a secondary rôle in influencing the decision on how much households save. In some cases, it is rational for one to save in the form of notes and coins and then leave them under the mattress. In fact, for Keynes, the twin forces of the money demand and supply determine interest rates on saving, as shown in Fig. 5.2.

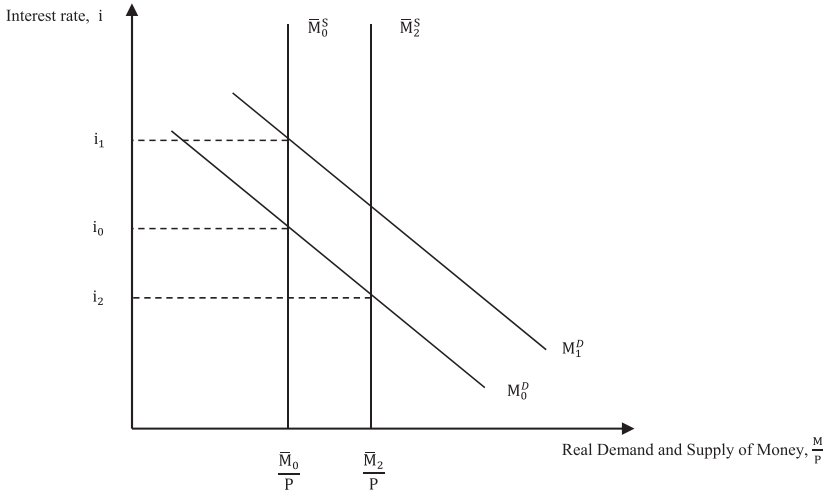

Fig. 5.2 The real demand and supply of money

In his original analysis, Keynes assumes that the supply of outside commodity money is exogenously fixed by the actions of monetary authorities in conjunction with the demand. The demand curve is downward sloping, which reflects the negative slope of opportunity cost and the speculative motive for holding money, where the rate of interest on bonds becomes a proxy for all rates within the economy. Money is in the form of cash that pays no interest and, therefore, represents a liquid asset. Keynes argued that at low rates of interest, agents expect them to rise, causing asset prices on bonds to fall and, therefore, leading to capital losses. In these circumstances, the demand for money is the speculative requirement as a safe asset, thus avoiding risk.<sup>1</sup>

Moreover, at today's rate, the demand for money tomorrow may well increase (or decrease), and therefore, the introduction of expectations and uncertainty means that the demand for money curve may shift and become unstable. An increase in uncertainty will enlarge the demand for money and the curve shifts to  $M_1^D$ , forcing up the interest rate,  $i_1$ . Alternatively, if the exogenous, outside money supply increases to  $M_2^S$ , then the interest rate falls to  $i_2$ . In brief, the point made by Keynes is that leakages from the circular flow of income may cause output and employment to decrease and become chaotic via the Keynesian multiplier effect.

Therefore, the unstable nature of the demand for money could be bringing instability to the real economy.

In Chapter 4, the post-Keynesian versions have been adapted to explain the rate of interest on saving, although the analysis reveals that the initial source of the deposit base is the creation of real income: interest, rent, profit and wages paid as retail bank liabilities (or deposits) as a medium of exchange. This enables for the transact use of households' factors of production: land, labour, capital and entrepreneurship in exchange.

The supply of money into saving by households and firms depends on demand for money as a trade-off between sight (or current) and time (or saving) deposits, where the latter represents the accumulation of additional wealth via the interest rate payments. Once again, the rate of return on interest-bearing assets such as government bonds acts as a proxy for rate of interest on all forms of saving within the economy and is closely linked to the Central Bank's base rate.

Both theories, however, have weaknesses. In the case of the Classical version, the main source of loanable funds is no longer saving, but the loans and credits created via deposits by the banking system. Concerning Keynes' theory and the post-Keynesian versions, they relate to the rate of interest on saving, whereas the former depends on outside money supply being exogenous and controlled by the monetary authorities. The analysis in this study has indicated that they have limited control over the retail banks that essentially create and control the bulk of inside money supply in the form of bank deposits. These characteristics are the focus of the alternative theory as well as determining the borrowing rate of interest and not the rate on saving.

## 5.8 AN ALTERNATIVE THEORY: THE NEW LOANABLE FUNDS THEORY

In the Chapter 3 on the money supply, banks can expand lending by creating deposits with the Central Bank providing the facilities for reserve deposits at the base rate of interest. The analysis so far allows the construction of a theory that describes a monetary structure whereby the Central Bank sets the base interest rate and attempts to affect the activities of the commercial banks indirectly (Fontana 2003). According to Goodhart (2002):

1. The official Bank Rate of the Bank of England partly determines interbank rates on which banks ‘mark-up’ the interest cost of loans with the risk and expected rate of inflation premiums;
2. Given these rates, the private sector agents of the economy determine the quantity of endogenous loans and credit from the banking sector;
3. Retail banks then adjust their relative interest rates on borrowing and balance sheets to meet the demand and supply of loanable funds;
4. Step 3 determines the demand and supply of loanable funds along with the required level of reserves;
5. The Bank of England employs ‘rep’ deals to fulfil the banks’ requirement for reserves;
6. The Central Bank can also partially influence short-term rates of interest through its ability to be lender of last resort, which is the supplier of liquidity in a cash crisis. This reassures depositors that they will always obtain cash and the banks can avert failure. Without this safety net, the banks would have to carry larger amounts of reserves in the event of bank runs, or go bankrupt.

Figure 5.3 exhibits the features outlined in the previous chapters. In (a), the Central Bank sets the official base rate of interest via ‘open market operations’, which is the bank rate (repo rate and the rate it pays on banks’ reserves), that is  $i_{BR}$ , which reflects (or equivalent) to the risk-free real rate of interest in (5.1),  $ri$ , with the added premium of expected inflation,  $E_t \Delta P_{t+1}$ . This means that

$$i_{BR} = ri + E_t \Delta P_{t+1}. \quad (5.10)$$

Under normal conditions, the bank rate establishes the level of interbank rates on which banks determine their loan rates with the risk,  $\sigma_R$ , premium in (5.1), although it can be simply put as a form of a mark-up,  $MU$ , so that

$$i^B = ri + MU, \quad (5.11)$$

where  $MU = E_t \Delta P_{t+1} + \sigma_R$ . In (b), banks supply the quantity of new loans (or money) that is determined by the demand from households and businesses at the loan rate of  $i^B$ . At  $ri + MU$  loans are increasing to meet the demand-determined rate of  $LO_0$  namely as

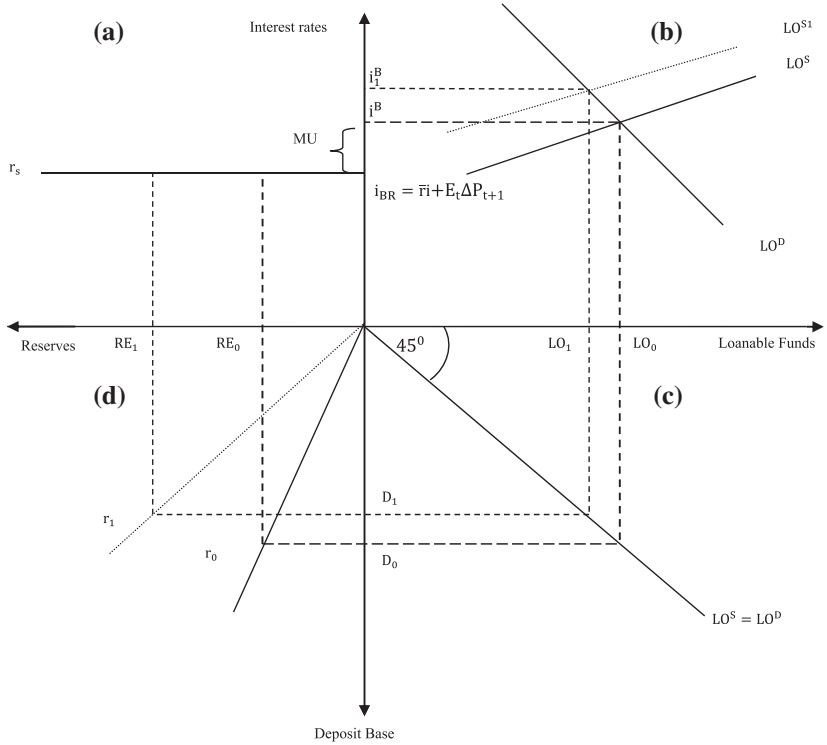

Fig. 5.3 Interest rates, loanable funds and reserves

$$LO^D = LO^S, \tag{5.12}$$

where

$$\frac{LO^D}{P} = f\left(Y, i^B, \frac{WL}{P}\right), \tag{5.13}$$

$$\frac{LO^S}{P} = f\left(mm(i^B, i_{BR}, r, CA^*, \varepsilon) \frac{\overline{MB}}{P}\right). \tag{5.14}$$

The real demand for loanable funds  $LO^D/P$  is drawn as a downward-sloping schedule of  $i^B$ , given  $(P, Y, WL/P)$ , the levels of price, real income and wealth. The real supply of loanable funds  $LO^S/P$ , given  $P, i_{BR}, CA^*$  and  $\varepsilon$ , the price level, the discount rate, the cash–deposit ratio and the variability of deposit flows, is an upward-sloping curve of  $i^B$ , for a particular monetary base,  $\overline{MB}$ . The positive slope of the  $LO^S$  curve reflects the fact that at higher interest rates on borrowing, banks prefer to hold fewer reserves, increasing the value of the money multiplier,  $mm$ , and consequently, the supply of loanable funds increase, that is loans.

Section (C) of Fig. 5.3 represents the banks' balance sheet constraint so that the  $L^D = L^S$  line passes through the origin at  $45^\circ$ , so that at  $i_{BR} + MU$ , the growth of loans is creating deposits at the rate of  $D_0$ , which means

$$L^D = L^S = LO_0 = D_0. \quad (5.15)$$

The  $r$  line in (d) illustrates the demand for reserves, where the angle depends on the reserve ratio, that is

$$r = \frac{RE}{D}. \quad (5.16)$$

In the UK, the reserve ratio is discretionary rather than mandatory; the  $r$  line will rotate with changes in banks' desire for liquidity. Even in a mandatory system, the curve may rotate if the reserves axis represents total reserves in the form of required plus excess.

Finally, in (a), the Central Bank's willingness to allow the expansion of reserves at whatever rate is required by the banking system at  $r_0$ , given developments in (b) to (d), means that

$$r_0 = \frac{RE_0}{D_0}, \quad (5.17)$$

$$r_S = r_D. \quad (5.18)$$

The Central Bank such as the Bank of England attempts to control retail bank credit and money, by managing and varying the amount of reserves available and fixing the interest rate at which commercial banks can acquire them by borrowing. Since 2007/2008, this has been mainly in the form of quantitative easing. The control, however, over the volume of bank loans, let alone the total loans, by this policy instrument is

limited. It sets the environment by which banks seek profits and explore the leverage ratios of firms and households within the monetary economy. Effectively, what the Central Bank controls is the volume of its own liabilities outstanding and the terms under which retail banks can borrow them. The end result is that the Central Bank largely implements guarantees and commitments to exert some control over bank liabilities.

The analysis has reached the stage where it is easy to trace the effect of a financial disturbance that increases asymmetric information in the form of adverse selection and moral hazard problems in credit markets, as in the case of the financial crisis, which started in 2007/2008. The commercial banks are cutting-back on lending by credit-rationing to households and firms, shifting the supply of loanable funds curve to the left from  $LO^S$  to  $LO^{S1}$  with rising interest rates,  $i^B$  to  $i_1^B$  in (b), because of the perceived high level of borrowing risk. With greater asymmetric information during a financial crisis, lenders cannot easily measure credit-worthiness of the borrower. In these circumstances, they charge a higher interest rate to protect themselves against the default risk (in the form of the possibility that the borrower may not pay back the loan) and therefore,  $MU$  goes up in value on reflection.

Moreover, consequently, there is a sharp rise in the **interest rate-spread**. It is more than likely that the ‘base rate’ set by monetary policy will be declining when private agents are facing a rise in the rate of interest on borrowing. In other words, the rise in the interest rate-spread suggests that for any given interest rate set by the monetary authorities for safe assets, the interest rate paid by households and firms rises, from  $(i_{BR} - i^B)$  to  $(i_{BR} - i_1^B)$ , reducing the demand for loans, showing a lower monetary expansion at  $LO_1$  and a reduced deposit base of  $D_1$  in (c).<sup>2</sup> Furthermore, it is probable that the banks will carry more reserves because of the uncertainty and the heightened element of risk, leading to a rotation of the reserve ratio line upwards to the left in (d),  $r_1$  indicating a higher level of reserves held at  $RE_1$  in (a).

The end result is a reduction in the value of the money multiplier because of the increased reserve ratio of the banks with the possibility of an increased cash ratio held by households and firms. This reduces the monetary expansion within the economy. The interest rate-spread has increased significantly over and above the base rate set by the Bank of England. The framework developed here can cope with abnormal as well as normal circumstances that might prevail within the monetary sector of the economy.



## 5.9 CONCLUSION/SUMMARY

The determination of nominal interest rates on saving and borrowing is determined by way of a combination of market forces, as highlighted in the theories discussed in this chapter, in addition to the decisions made by the monetary authorities. This chapter has largely focused on the real interest rates and the influence of inflation as determining elements of nominal ones. This led into the discussion of the theories of loanable funds put forward by the Classical economists, whereas the counter attack came from Keynes's approach embodied in the LPT. It appears that both have weaknesses, which has led to the development of a new version of the loanable funds theory, derived from the analysis embodied in this book.

The topic of the next chapter: "The Term Structure of Interest Rates", adopted to explain further the expectational effect of inflation and the rate of interest. This is added to the risk factors to form the 'mark-up' with the Central Bank rate, which determines the high street market rates of interest that prevail on various terms to maturity of loans within the retail bank sector. This is an important component of the new theory, advanced by the book's analysis.

## NOTES

1. See discussion on the liquidity trap.
2. See preface for case study, on the banking crisis for graphs on interest rate-spreads over the course of time.

## REFERENCES AND FURTHER READING

- Bain, K., & Howells, P. (2008). *The Economics of Money, Banking and Finance, A European Text* (4th ed., Ch. 9). Harlow: Pearson Education Limited.
- Bain, K., & Howells, P. (2009). *Monetary Economics, Policy and Its Theoretical Basis* (2nd ed.). Basingstoke: Palgrave Macmillan.
- Dow, S. C. (1996, May). Why the Banking System Should be Regulated. *The Economic Journal*, 106(436), 698–707.
- Dowd, K. (1996, May). The Case for Financial Laissez-Faire. *The Economic Journal*, 106(436), 679–687.
- Fisher, I. (1907). *The Rate of Interest*. New York: Macmillan.
- Fontana, G. (2003). Post Keynesian Approaches to Endogenous Money: A Time Framework Explanation. *Review of Political Economy*, 15(3), 291–314.

- Goodhart, C. A. E. (1991). Are Central Banks Necessary? In F. Capie & G. E. Wood (Eds.), *Unregulated Banking: Chaos or Order?* London: Macmillan.
- Goodhart, C. A. E. (2002). The Endogeneity of Money. In P. Arestis, M. Desai, & S. Dow (Eds.), *Money, Macroeconomics and Keynes: Essays in Honour of Victoria Chick* (Vol. 1). London: Routledge.
- Keynes, J. M. (1936). *The General Theory of Employment, Interest and Money* (Chaps. 13 and 14). London: Macmillan.
- Llewellyn, D. T. (1990). Money Market Operations of the Bank of England and the Determination of Interest Rates. In T. Bandopadhyay & S. Ghatak (Eds.), *Current Issues in Monetary Economics*. New York: Barnes & Noble.
- Pilbeam, K. (2010). *Finance and Financial Markets* (3rd ed.). Basingstoke: Palgrave Macmillan.
- Snowdon, B., Vane, H., & Wynarczyk, P. (1996). *A Modern Guide to Macroeconomics: An Introduction to Competing Schools of Thought*. Cheltenham: Edward Elgar Publishing Limited.



# The Term Structure of Interest Rates

## 6.1 INTRODUCTION

In the last chapter, the nominal rate of interest,  $i$ , was formed by four elements within expression (5.1), that is the real rate,  $r_i$ , the premium for the expected rate of inflation,  $E_t \Delta P_{t+1}$ , the notion of liquidity,  $l$ , and the risk premium,  $\sigma_R$ . This part of the study concentrates on the two latter components, although there was application of the risk premium in the last chapter, in the main, the former were the centre of attention. Actually, in the developed financial markets, there is a vast range of instruments offering different interest rates and returns. This **structure** arises from the borrowing and lending over various periods of  $n$  (or **terms**) with varying degrees of risk. The premia on risky assets reflect the unwillingness of holders to offer or purchase such assets. The analysis examines whether there is a connection and interplay between the various rates of interest on borrowing and saving. The presentation relies heavily on Howells and Bain (2008) along with Mishkin (2016) for guidance and organisation, the difference is the application.

## 6.2 THE EFFECT OF TERM

Expression (5.1) can be put into a simple diagram as follows.

Figure 6.1 shows that the rate of interest on long-term financial instruments (or loans) that make up saving should be higher because the liquidity and risk premiums positively increase with the term in order

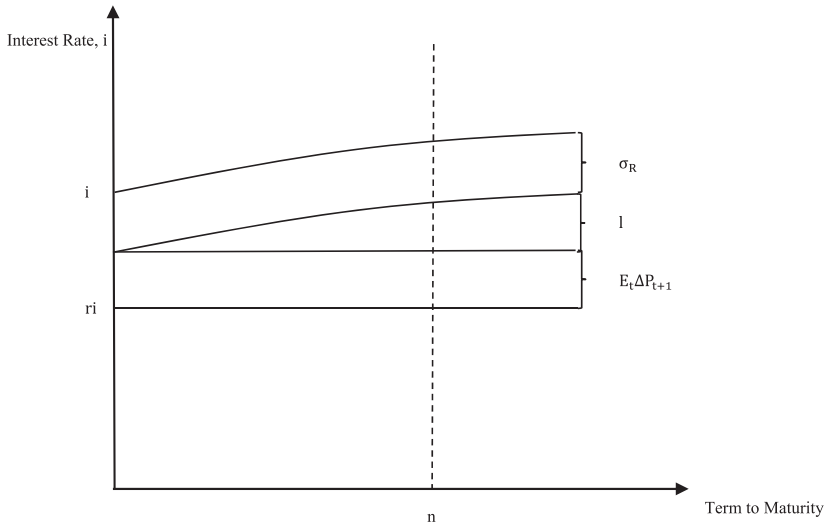

**Fig. 6.1** The components of nominal rates of interest (*Source* Howells and Bain 2008)

to induce lenders away from their preferred position of wanting to lend short term to reduce the element of uncertainty and risk that prevails within the future. Funds tied up in long-term loans and saving could leave the lender financially vulnerable when confronted with unforeseen expenditure. Financial difficulties could well provoke a reverse of rôles, where the lender becomes the borrower, and in extreme circumstances, if unable to meet financial commitments, the lender is declared bankrupt. Short-term lending, therefore, is obviously more appealing and more flexible and less risky for lenders, because they can reinvest their funds in other loans to borrowers or finance their own expenditure.

Borrowers obviously prefer long-term loans to avoid the costs of renegotiations, which entail the probability of higher rate of interest. In parallel, some firms are prepared to pay more for long-term loans to avoid refinancing. The liquidity and risk premiums increase with the term of the loan and the length of the saving period, but at diminishing rate, in order to induce lenders to lend beyond their short-term preferences. This factor is explained by the present value of future incomes, that is the

discount over a time period. Each income is divided by  $(1 + i)^t$ , where  $t$  is the number of periods and  $i$  is the rate of interest, which reduces the present value rapidly. For instance, in 20 years' time, income is heavily discounted and lenders might be unconcerned to lend for either 20 or 25 years. So far, in the discussion, the analysis has revolved around fixed loans, which liquidise at the end of the term. The concern here is about **non-marketable loans** made by the banking sector.

The bulk of lending in large amounts, however, involves borrowers issuing instruments, bought on a primary market by lenders. These instruments are then tradable on a secondary market such as company shares. Buying a long-dated bond, for example, is not the same as making a long-term loan, because this asset can be subject to trade on the bond market. This situation, therefore, leads to a range of interest rates, which mature at a fixed point in time, reduced to present value (PV), which is the price of the bond,  $P^B$ , by the following formula:

$$PV = P^B = \sum_{t=1}^n \frac{c_t}{(1+i)^t} + \frac{M}{(1+i)^n}, \quad (6.1)$$

where  $\sum c_t$  represents the summation of the coupon payments, whereas  $M$  denotes the maturity value.  $(1+i)^t$  discounts each income flow with the indexing  $t$ , denoting the year. The number of years to maturity is represented by  $n$ . The current interest rate is denoted by  $i$ .

Consider two bonds with different terms to maturity: one to mature in one year's time and the other to mature in two years' time. The redemption values are the same, £100, and the coupon payments are £10 each year, which means the analysis is dealing with 10% bonds. Now compare the two market interest rates of 4 and 8%. Table 6.1 shows and summarises the potential outcomes that could well prevail in reality.

**Table 6.1** Terms to maturity

<i>Term (n)</i>	<i>Interest rate (i)</i>	
	<i>i = 0.08</i>	<i>i = 0.04</i>
<i>n = 1</i>	101.85	105.77
<i>n = 2</i>	103.57	111.32

At 8%, the price of the one-year bond sells at £101.85. In the case of the two-year one, the price must be equal to £103.57. The results clearly indicate that with a 4% drop in the interest rate, both present values increase to 105.77 and 111.32. In other words, this means that when interest rate falls, bond prices must rise. The one-year bond rises by 3.85 ( $3.92/101.85 \times (100/1)$ )% compared with the two-year one of 7.49. It follows that if the interest rate rises from 4 to 8, then the price of bonds falls. The example shows the higher volatility of bond prices is greater for long-dated than short-term loans as instruments of saving, and therefore, one should expect a term-related, liquidity premium to be paid for the risk involved. Furthermore, because these bonds are marketable, lenders can recoup their funds by selling in the secondary markets. See the following link (<https://www.youtube.com/watch?v=Q7wOcrbV3eo>) for a summary.

### 6.3 THE EFFECT OF RISK

The risk premium,  $\sigma_R$ , paid on a loan is the apparent risk relative to the typical portfolio multiplied by the market price of the mean risk. The risk premium is triggered by greater volatility, which could take the form of capital gains, as well as capital losses; obviously, risk aversion is triggered by the risk of loss, but risk is unpredictable volatility. The flow of income, for example, from shares in the form of dividends may well be less than expected. This is income risk from the holding of assets, which partly depends on the nature of the business risk of borrowers. Furthermore, financial risk arises from the different forms of financing that the borrowers may choose. Thus,  $\sigma_R$  emanates in many disguises, which tends to dominate the borrowing rate of interest on loanable funds. Although there is scope to reduce these risk factors by diversification between individual, interest-bearing assets, there are still loans that are riskier than others because of the type of borrower and the length of time involved. The contribution of time means the inclusion of the liquidity premium,  $l$ , with its corresponding risk factors. This premium tends to most prevail upon the saving rate of interest, reflecting the length of time to maturity with risk and, therefore, the action of the postponement of current expenditure. Whatever the premium involved, the result means the formation of predictions concerning the future, which affects the current structure of behaviour by borrowers and lenders. The starting point for this is the expectations theory.

## 6.4 THE EXPECTATIONS THEORY

There is generally a systematic relationship between the yields and the term to maturity as when this is plotted, it leads to a smooth curve known as the time-yield amongst homogenous categories of assets. A subset of assets, for example, likely to be government bonds or Treasury bills has a close to zero value of default risk. The major factor of influence over this relationship is the **expectations of future interest rates**, where future changes affect the **current structure**. If the yield curve is stable, then lenders and borrowers are in equilibrium at the current pattern of interest rates, which means that rewards from long-term loans must equal the **average** of the series of short-term loans. This is how the future enters the relationship and the analysis.

Suppose that the long-term rate of interest,  $i_L$ , is for two years and expressed in the form of:

$$\begin{aligned}(1 + i_L)^2 &= (1 + i_L)(1 + i_L), \\ &= 1 + i_L + i_L + i_L^2,\end{aligned}\tag{6.2}$$

which is approximately equal to

$$\approx 1 + 2i_L,$$

if the interest rate is low, then it is possible to ignore the power term. A short-term loan is for one year. Lenders lend for one year at current rate of interest,  $i_{s,t}$ , they then renew at the expected one-year rate,  $i_{s,t+1}$ , by comparing this with what they would have earned by lending at today's rate over a two years' term, that is

$$\begin{aligned}(1 + i_{s,t})(1 + i_{s,t+1}), \\ = 1 + i_{s,t+1} + i_{s,t} + i_{s,t}(i_{s,t+1}),\end{aligned}\tag{6.3}$$

where  $i_{s,t}$  is the short-run rate of interest and  $i_{s,t+1}$  is the expected rate. The cross-products are set equal to zero if the rates are low. At equilibrium, it is possible to set the products of Eqs. (6.2) and (6.3) equal to each other in order to derive the average rate:

$$1 + i_{s,t} + i_{s,t+1} = 1 + 2i_L,\tag{6.4a}$$

$$i_L = \frac{i_{s,t} + i_{s,t+1}}{2}.\tag{6.4b}$$

The result is the long-term rate of interest based on an average, where the future plays a vital rôle via the expectation relating to the course of the short-run rate of interest. For example, the current short-run rate is 6% with the long-term rate prevailing at 8%, at this point lenders will expect 10% at the beginning of the second periods by substituting the values into (6.4b) and solving for  $i_{s,t}$ . In this case, the yield curve will be upward sloping with higher rates on long-dated bonds, because the current yield encourages those willing to lend for longer periods. Conversely, if future short-term rates are expected to fall, then the yield will be downward sloping, indicating that long-term rates will be decreasing over time. This implies that it is necessary to extend (6.4a) to include additional future values to establish the connection with forthcoming rates. Suppose the analysis extends to the third expected period. First, rewrite the right-hand side of (6.4a) as

$$(1 + 2i_L)(1 + i_L), \quad (6.5)$$

which is equal to  $(1 + 3i_L)$ , when multiplying out the brackets and setting the power term to zero. The left-hand side becomes

$$(1 + i_{s,t} + i_{s,t+1})(1 + i_{s,t+2}), \quad (6.6)$$

this derives  $(1 + i_{s,t} + i_{s,t+1} + i_{s,t+2})$  when following the same procedure as before. Equalising the two, resulting expressions, leads to the following expression:

$$i_L = \frac{(i_{s,t} + i_{s,t+1} + i_{s,t+2})}{3}. \quad (6.7)$$

Generalising this format as

$$i_L = \frac{(i_{s,t} + i_{s,t+1} + \cdots + i_{s,t+(n-1)})}{n}. \quad (6.8)$$

The link between the yields (the rates) on various interest-bearing assets, differentiated by their term to maturity, becomes the **term structure of interest rates with expectations**. See the following YouTube: <https://www.youtube.com/watch?v=rmfnjo45E7A>.

These expectations come partially determined by the monetary authorities. Since the Northern Rock fiasco of 2007/2008 and the current growth recession, the authorities have been lowering the base rate of interest to an historical low until recently, with the end result that the yield curve became downward sloping, showing an expectation of



falling short-term rates, which drives down long-term rates. This caused the price of long-term bonds to rise. Now there are concerns that the rate of inflation is on an upward trend, therefore, the policy may go into reverse, generating inflationary expectations, and namely, that interest rates will rise in future to maintain the real rate of return on savings. As a result, the yield curve will become steeper. See Bank of England: <http://www.bankofengland.co.uk/statistics/yieldcurve/index.htm>.

## 6.5 THE SEGMENTED MARKETS THEORY

Based on this hypothesis, the term structure comes by way of different markets that represent separation, which is unlike the expectations speculation. The demand and supply for a particular bond determine the interest rate and the expected return do not influence any other asset. These markets are segmented and do not substitute for one another. This is the opposite of the expectations theory, where bonds of differing maturities are substitutes and influence each other.

The reason for this assumption is based on the investors' preference to invest in one particular level of maturity. This is because they desire to hold for a specific period with a certain return and risk. Some investors have a short-holding period to minimise the interest-risk. This clarifies why the demand for long-term bonds is lower than short-term ones. Hence, the lower prices but higher interest rates. In other words, the rise in interest rates on different yearly bonds cannot affect each other and their maturity. This speculation, however, fails to explain why interest rates on bonds of different maturities have a tendency to move together in the same direction.

## 6.6 THE LIQUIDITY PREMIUM AND THE PREFERRED HABITAT THEORIES

According to Mishkin (2016), in the liquidity premium theory, the term structure expresses the interest rate on a long-term bond as equal to the average of short-term rates of interest expected over the lifetime of the asset, but also includes a positive liquidity premium and reflects the demand and supply circumstances within a particular market. Thus, this approach adapts the expectations model in expression (6.9) by including a liquidity premium,  $l_{n,t}$ , at the  $n$ -period of maturity of the bond at time  $t$  and, therefore, equals the interest rate on long-term bonds,  $i_{L,n,t}$ , that is

$$i_{L,n,t} = \frac{i_{s,t} + i_{s,t+1} + i_{s,t+2} + \cdots + i_{s,t+(n-1)}}{n} + l_{n,t}. \quad (6.9)$$

This recognises that savers must receive a liquidity premium to induce them to hold longer-term bonds in compensation for the interest rate risk, and furthermore, interest-bearing assets of different maturities are imperfect substitutes with the overall preference for short-term lending, even though there is a lower expected return. This scenario links with the **preferred habitat theory**, where savers prefer bonds of a particular maturity, but are willing to consider other bonds if the expected return is higher within  $l_{n,t}$  of expression (6.9).

This theory adapts the expectations hypothesis by suggesting a positive liquidity premium  $l_{n,t}$  that rises with the term to induce investors to buy the various long-term bonds. Following the simple example proposed by Mishkin (2016), the one-year interest rates over the next five years are 5, 6, 7, 8 and 9%. Suppose that the liquidity term premium is equal to 0.5% times to maturity, and therefore, rising with the term. The two-year bond will be

$$\frac{5 + 6}{2} + 1 = 6.5\%,$$

whilst the five-year bond would be

$$\frac{5 + 6 + 7 + 8 + 9}{5} + 2.5 = 9.5\%.$$

The comparison of the expectations hypothesis with the previous two theories will derive yield curves that slope more steeply upwards because of investors' taste for short-term assets. In the language of Keynes, if investors' expectations of short-term interest rates are rising because they are below the 'established norm', so that the average of future rates will become relatively higher than current values with the additional liquidity positive premiums, long-term rates on saving will move substantially above current short-term rates, and the yield curve will become steep and upward sloping, reducing the demand for money and increasing the amount of money held in time deposits as well as in bonds. Furthermore, this in turn, this will be reducing the cash–deposit ratio,  $CA^*$ , increasing the money multiplier and money creation, whereas the reserve–deposit ratio,  $r$ , depends on the borrowing rate of interest,  $i_t^B$ . Equally, if short-term rates are high, then agents will have expectations

of a fall. Long-term rates on saving and bonds will drop below short-term rates because the average of future short-term rates will be below current rates, despite the positive premiums; the yield curve will be downward sloping and the demand for money will rise along with the  $CA^*$ , decreasing the money multiplier and the amount of loans created. For a recap, see the following: <https://www.youtube.com/watch?v=Hl5zOAxBoDw>.

Moreover, the analysis above shows that any empirical studies will expect to find  $n - 1$  cointegrating relationships between a set of  $n$  interest rates with different maturities. Hallet al. (1992) have applied the term structure model to analyse USA data on interest rates and found strong support for the existence of  $n - 1$  cointegrating vectors amongst a set of interest rates. In fact, in the Appendix A of this chapter, a further empirical study examines whether there is a rôle for expectations on Treasury bill yields within the determination of the term structure, and found a strong statistical contribution over time. Furthermore, a statistical study by Pesaran and Wright (1995) applies cointegrating VAR techniques to the UK term structure in the case of London Interbank Offer Rates (LIBORs) at different maturities: one, three, six and twelve months. The empirical results indicate there is one-to-one convergence of these interest rates over the sample and forecast period, after an initial shock within a cointegrating VAR model, with a significant constant. In reality, the bank rate set by the monetary authorities partly determines the various interbank rates on the borrowing and lending of excess reserve deposits amongst the retail banks. They, then, add their mark-up, MU, to determine the high street rates of interest on borrowing that reflects the level of risk and uncertainty perceived in the market for loanable funds. The evidence therefore, might be suggesting that a term structure relationship of interest rates on borrowing might well exist within the loanable funds theory, the topic of the next section.

## 6.7 USING THE TERM STRUCTURE OF INTEREST RATES IN THE NEW LOANABLE FUNDS THEORY

As already mentioned on the previous page, the reserve–deposit ratio,  $r$ , within the money multiplier mechanism, depends on rate of interest, not on saving but on borrowing, which somewhat determines the positive supply in conjunction with the negative effect on the demand of loanable funds. Therefore, the analysis has reached the stage where the theory

of the term structure of interest rates with the risk premium,  $\sigma_R$ , indicated in the introduction, to a degree explains the ‘mark-up’ (MU) element of the borrowing rate included in the alternative theory proposed in Chapter 5. This represents the difference between the market and the Central Bank’s rate of interest on borrowing, namely by taking the format of (6.4b) with the logic of (6.9), so that

$$i_t^B = \frac{i_{BR}^e + i_{BR}}{2} + \sigma_R, \quad (6.10)$$

where  $i_t^B$  denotes the market rate of interest on borrowing by the retail banks, formed by the average of the expected bank rate,  $i_{BR}^e$  as well as the current value of  $i_{BR}$ , plus the credit risk,  $\sigma_R$ , as perceived by the commercial banks in the face of uncertainty that prevails within the economy. The direction of the expected rate of inflation,  $E_t \Delta P_{t+1}$ , within the economy reflects into the expectations surrounding the bank rate. The risk premium added represents that certain borrowers will not be able or not willing to pay off their loans, and therefore, they will default.

Now, if  $\frac{i_{BR}^e}{2} = i_{BR} - \frac{i_{BR}}{2}$ , then (6.10) becomes

$$\begin{aligned} i_t^B &= i_{BR} + \frac{i_{BR}^e}{2} - \frac{i_{BR}}{2} + \sigma_R, \\ &\text{OR} \\ i_t^B &= i_{BR} + \frac{i_{BR}^e - i_{BR}}{2} + \sigma_R, \end{aligned} \quad (6.11)$$

where  $i_{BR}$  is the Central Bank rate set by the monetary authorities in the form of  $ri + E_t \Delta P_{t+1}$  with the term structure effect  $\frac{i_{BR}^e - i_{BR}}{2}$ , plus  $\sigma_R$ . Setting the mark-up, MU, as  $E_t \Delta P_{t+1} + \frac{i_{BR}^e - i_{BR}}{2} + \sigma_R$ , which means (6.11) becomes

$$i_t^B = ri + MU. \quad (6.12)$$

This is the same as the interest rate concept used in the alternative theory of Chapter 5 with the added ingredient of interest rate expectations working through the term structure. It is possible, therefore, for expectations with the Bank rate to fall in a growth recession, set by the monetary authorities, but the retail bank rate on borrowing to rise. This is because the mark-up is rising on account of the credit risk being significantly upwards in the midst of heightened uncertainty on account of increasing number of defaults on loans, causing the loanable supply curve to shift to the left along the demand function, representing a

reduction in the growth of lending by the commercial banks at a greater interest cost.

## 6.8 CONCLUSION/SUMMARY

The term structure arises from the borrowing and lending over various periods with varying degrees of risk *via* the nature of the business, the risk of default or capital loss. The expectations theory argues that predictions of future interest rates alter the current structure, influenced by an average of short-term loans, determining long-term loans. The segmented markets theory, however, claims that the link is non-existent, and the laws of demand and supply within each separate market determine each asset value. In the case of the preferred habitat and liquidity premium theories, they are extending and adapting the expectation speculation. In fact, at the end of the study, the liquidity premium theory is adapted for use in the alternative theory proposed in Chapter 5 to explain the financial difficulties experienced since 2007/2008 to date.

### NOTES

1. Another introductory chapter, see Sollis (2012).
2. Carlson's article (1977) studies the advantages and disadvantages of the Livingston Survey in particular, from the point of view of the CPI.

## APPENDIX A: AN ECONOMETRIC CASE STUDY: DOES THE EXPECTATIONS THEORY EXIST?

### *Overview*

The analysis addresses the expectations theory of the term structure of interest rates. The hypothesis crucially depends on the measurement of expectations and the monetary transmission that exists via short-term rates of interest. The novel idea embodied in the econometric analysis here is the conversion of the Livingston Survey of half-yearly observations into monthly data on the forward-looking rates of interest on the three-month Treasury bill. The empirical results show a clear 'one-to-one' relationship between the six- and three-month rates of interest on Treasury bills within USA by way of the VAR methodology of estimation.

### *Introduction*

Macroeconomics essentially assumes one interest rate, when in fact there are many existing in the practice of finance for many reasons. The term structure of interest rates, however, recognises a common link between them all in the form of expectations of the future, whether long or short, which determines the holding of various financial assets of maturity as well as influencing the determination of aggregate demand and supply within the real economy. The term structure, therefore, is important for Central Bank's policymakers. If these monetary instruments affect short-term rates of interest in the first instance, which leads to the determination of long-term rates of interest, which drives capital and consumption expenditure, then analysing the term structure is crucial for understanding the transmission mechanism of monetary policy (Fender 2012).<sup>1</sup>

Nevertheless, it is also relevant for many households in terms of the portfolio choice of assets. Suppose a family requires expenditure on private school fees in ten years' time and decides to save now. There are a number of options. They could save by investing into a ten-year bond. Alternatively, they could purchase a short-term bill and then take the earnings into another bond each time it matures, until the ten years are up.

Clearly, the important components determining the choice will be the expected return (or cost) and the risk involved, embodied in the term structure. Therefore, the analysis must consider the various theoretical models put forward in the literature to explain the relationship between interest rates on bonds (or bills) of differing maturity, although the hypothesis can applied to other assets as diverse as housing and the mortgage rate.

The foremost theory of the term structure of interest rates is the so-called expectations hypothesis, which focuses on the rôle of expectations of future short-term interest rates in the determination of prices and yields on longer-term bills (or bonds). There a number of ways in which the theory in the literature differs in terms of the length of the bills (or bonds) included in the analysis. The discussion will employ a simple version of the theory and adopt this within the empirical framework using the VAR methodology with its associated tools of analysis.

*Review of the Proposed Theoretical Models*

The expectations hypothesis indicates that there is generally a systematic relationship between the yields and the term to maturity as when plotted, leading to a smooth curve known as the time-yield amongst homogeneous categories of assets. A subset of assets such as government bonds or Treasury bills will have default risk that is close to the value zero. The major factor of influence over this relationship is the expectations of future interest rates, where future changes affect the current structure. If the yield curve is stable, then lenders and borrowers are in equilibrium at the current pattern of interest rates. The rewards from longer-term loan must therefore equal the average of the series of shorter-term advances. This is how the future enters the analysis.

Suppose the choice of loans is either in the form of six- or three-month bond (or bill). This means lenders can lend for six months or on two conservative occasions with a three-month bill. Thus, the long-term is for the six-month period and expressed in the form of

$$i_{L,t} = \frac{i_{s,t} + \hat{i}_{s,t+1}}{2}, \quad (6.13)$$

where  $i_L$  is the long-run interest rate and equal to the average of the current and the expected three-month rate of interest, where the future plays a vital rôle via the expectations relating to the course of the short-run rate of interest. The link between yields (the rates) on various assets differentiated by their term to maturity is essentially the term structure of interest rates. The hypothesis clearly assumes a transmission mechanism for monetary policy.

The opposite theory is that financial assets are separate and there is no link between them, unlike the expectations speculation. This is the so-called segmented hypothesis. The term structure becomes represented by different markets. The demand and supply for a particular bond determine the interest rate and the expected return do not influence any other interest-bearing assets. These markets are segmented and do not act as substitutes one another. This is the reverse of the expectations theory, where bonds (or bills) of differing maturities are substitutes and influence each other.

The reason for the adoption of this assumption is because investors' preference is to invest in one particular level of maturity. This is because they desire to hold for a specific period with a certain return and risk.

Some investors have a short-holding period to minimise the interest-risk. In other words, the rise in interest rates on different bonds cannot affect each other and their maturity.

The bridge between the two extreme theories is the preferred habitat speculation proposed by Hicks (1946), suggesting that the term structure expresses the interest rate on the six-month bond as equal to the average of the three-month rate, as in the case of the expectations model, but plus a risk premium which is determined by demand and supply conditions. According to this theory, bonds (or bills) of different maturities are imperfect substitutes, because savers have preferences for particular periods, that is the preferred habitat. Savers prefer bonds of a particular maturity, but are willing to consider other assets if the somewhat expected return is high. If the preferred habitat is short-term over long-term bonds, investors are only willing to hold long-term bonds if liquidity premiums are paid, which alters (6.13) as follows:

$$i_{L,t} = \frac{(i_{s,t} + \hat{i}_{s,t+1})}{2} + l_{n,t}, \quad (6.14)$$

where  $l_{n,t}$  is the premium term. The theory suggests that the yield curve will normally be upward-sloping even though short-term interest rates are expected to stay static, then long-term rates will be greater than short-run rates because of the constant term being included.

Moreover, which theory is correct could well be a statistical matter, although there is a considerable body of empirical work on the term structure of interest rates. Useful summaries are provided by Shiller (1990) and Cuthbertson and Nitzsche (2004). The key studies in the field of study are Campbell and Shiller (1987) for an application to USA data and Cuthbertson (1996) for the UK economy. The overall assessment of the empirical work on this topic is inconclusive. The major difficulty, however, in testing these theories is the measurement of expectations. The next section of the discussion considers the measurement of the expectations by the Livingston Survey, which becomes a crucial component of the empirical study.

### *Measurement of Expectations*

In June and December of each year, from 1946, the Livingston Survey asks a number of professional economists in academic, business, Government and finance sectors to forecast a number of key variables of



the economy such as the rate on the three-month Treasury bill, although this particular dataset started in 1992. They provide, for example, forecasts for the end of the current month as well as six- and twelve-month-ahead, receiving, on average, fifty replies each time (Cronshore 1997).

Pesando (1975) suggested that the six-month-ahead forecasts were unbiased, whereas the twelve-month forecasts were biased. In fact, Carlson (1977) compared statistical forecasts with the Survey predictions and found that the latter performed better than the former despite a number of problems with the Survey.<sup>2</sup> Given the discussion within the literature, and the results of a statistical experimentation between the two Surveys, the empirical analysis adopted the six-month-ahead, mean statistics.

To create monthly forecast values of the rate of interest on the three-month Treasury bill over the next six months, an econometric model based on Ordinary Least Squares Method of Estimation was constructed from the half-yearly rates, 1992: H2 to 2012: H1. This allowed the empirical analysis to derive the missing, monthly expected values, from the actual average rates. The statistical model used in the process of conversion is as below:

$$\Delta \hat{i}_{s,t+1} = 0.0048516 - 1.2374 \Delta \hat{i}_{s,t} + 1.1879 i_{s,t} + \varepsilon_t, \quad (6.15)$$

(0.0010146) (0.082411) (0.078601)

$$R^2 = 0.8627, \bar{R}^2 = 0.8553, SS = 0.003055, RSS = 0.0003454,$$

$$DW = 1.8082, LL = 176.4373, T = 40.$$

where  $\Delta \hat{i}_{s,t+1} = \hat{i}_{s,t+1} - i_{s,t}$ ,  $\hat{i}_{s,t+1}$  denotes the forecast values of rates of interest on the three-month Treasury bill over the next six months,  $t + 1$ , so that  $\Delta \hat{i}_{s,t}$  represents the change in predicted observations at time  $t$ , and finally,  $i_{s,t}$  equals the actual rates of interest on three-month Treasury bills. The next stage in the analysis is to check the order of integration.

### *Order of Integration*

The data generated above, along with the rates of interest on the six-month Treasury bills,  $i_{L,t}$ , were subject to statistical tests to observe whether the endogenous variables are  $I(1)$  before including them into the cointegrating analysis. The statistical findings using the Dickey–Fuller tests for stationarity are showing in Table 6.2.

**Table 6.2** Stationarity tests over sample period of 1992 M12–2012 M8<sup>a</sup>

<i>Statistics</i>	$\Delta i_{L,t}$	$\Delta i_{s,t}$	$\Delta \hat{i}_{s,t+1}$	$\Delta (i_{s,t} + \hat{i}_{s,t+1})/2$
ADF(1)				-7.4960
ADF(2)			-6.3051	
ADF(6)		-3.4003		
ADF(9)	-3.3295			

<sup>a</sup>Statistics above reject non-stationarity at the 5% level of significance and are absent of auto-correlation

It is clear from Table 6.2 that all the data sets are stationary on first-difference, so that all variables included in the VAR are  $I(0)$ . The next part of the process is to determine the order of the VAR.

### Order of the VAR

In order to determine the lag structure, the empirical study ran an unrestricted VAR of a relatively high order of twelve with all the available data, including an intercept term with the variables of interest. This included a dummy variable,  $D$ , which takes on the values of minus one

**Table 6.3** Test statistics and choice criteria for selecting the order of the VAR model

<i>Order</i>	<i>LL</i>	<i>AIC</i>	<i>SBC</i>
12	2453.6	2401.6	2312.3
11	2452.0	2404.0	2321.6
10	2448.7	2404.7	2329.1
9	2442.8	2402.8	2334.1
8	2437.2	4201.2	2339.4
7	2344.2	2401.2	2346.3
6	2425.3	2397.3	2349.3
5	2423.2	2399.2	2358.0
4	2422.2	2402.2	2367.8
3	2419.7	2403.7	2376.3
2	2416.8	2404.8	2384.2
1	2368.6	2360.6	2346.9
0	1754.3	1750.3	1743.5

Based on 229 observations from 1993 M: 6 to 2012 M: 6. Order of the VAR=12

List of variables included in the unrestricted VAR:

$$i_{L,t}, (i_{s,t} + \hat{i}_{s,t+1})/2$$

List of deterministic or exogenous variables: Constant,  $D$

for 2007 M: 12 and 2008 M: 12, otherwise takes the value of zero elsewhere. The inclusion of the dummy variable captures the effect of the financial crisis that started to ‘bite’ in 2007, leading to observations that can be regarded as outliers in order to identify the long-term relationship. Since interest rates are not trended, the analysis did not include a trend in the VAR.

According to Table 6.3, both statistics, the Akaike Information Criterion (AIC) and Schwarz Bayesian Criterion (SBC), agree that order of VAR should be two for determining whether the cointegrating vector exists, which is the process in the next section of the analysis.

### *Cointegrating Vector with Expectations*

To identify and test the relationships in (6.14) and (6.15), the next stage in development of the modelling process is to determine the number of cointegrating vectors along with a constant term and the dummy variable by examining the sequence of log-likelihood statistics that exposes the rank of the long-run multiplier matrix, as shown in Table 6.4. As expected, the statistics provide support for the existence of one cointegrating vector amongst the variables of interest, presented in Table 6.5. The results and the LR statistics for the testing of two, over-identifying restrictions,  $\chi^2(2) = 1.4100$ , are included. At the 95% critical value,  $\chi^2$

**Table 6.4** Cointegration with restricted intercept and no trend, log ratio test (LR) based on maximal and trace eigenvalues of the stochastic matrix

<i>Null</i>	<i>Alternative</i>	<i>Statistic</i>	<i>95% critical value</i>	<i>90% critical value</i>
LR test based on Maximal Eigenvalue of the Stochastic Matrix				
$r = 0$	$r = 1$	34.9678	15.8700	13.8100
$r \leq 1$	$r = 2$	<b>1.8242</b>	9.1600	7.5300
LR test based on Trace Eigenvalue of the Stochastic Matrix				
$r = 0$	$r \geq 1$	36.7920	20.1800	17.880
$r \leq 1$	$r = 2$	<b>1.8242</b>	9.1600	7.5300

239 observations from 1992 M: 8 to 2012 M: 6. Order of VAR=2

Variables included in the cointegrating vector:  $\hat{i}_{L,t}$ ,  $(\hat{i}_{S,t} + \hat{i}_{S,t+1})/2$ , Constant

Unrestricted deterministic variables included in the VAR: D

List of eigenvalues in descending order: 0.13611, 0.0076035

$r$  equals the number of cointegrating vectors

**Table 6.5** ML estimation of cointegrating vector with restricted intercept and no trend

---

*List of imposed restrictions on cointegrating vector*

---

	Vector one
$\hat{i}_{L,t}$	1.000 (none)
$(i_{s,t} + \hat{i}_{s,t+1})/2$	-1.000 (none)
Constant (Standard errors in brackets)	0.000 (none)
LR Test restrictions $\chi^2(2) = 1.4100$ [0.494],	
DF = Total number of restrictions (3), number of just-identifying restrictions (1),	
LL subject to exactly identifying restrictions = 2524.7,	
LL subject to over-identifying restrictions = 2524.0	

---

239 observations from 1992 M: 8 to 2012 M: 6. Order of VAR = 2  
 Variables included in the cointegrating vector:  $i_{L,t}$ ,  $(i_{s,t} + \hat{i}_{s,t+1})/2$ , Constant  
 Unrestricted deterministic variables included in the VAR: D

with two degrees of freedom, the restrictions are accepted. It should be noted that the constant term with  $(i_{s,t} + \hat{i}_{s,t+1})/2$  does not add any statistical significance to the cointegrating vector.

### *Conclusions/Summary*

Overall, the weight of statistical evidence suggests that the pure expectations theory of the term structure of interest rates does exist and that future values of interest play vital rôle in linking short- and longer-run rates on Treasury bills between three and six months in US economy. This is tentative, empirical evidence, suggesting that monetary policy may have an important function in determining the future direction of financial assets and pending aggregate demand and supply within the product market. This is an essential element of monetary policy and leads to a ripple effect on interest rates over time and within the term structure of interest rates. The transmission mechanism of monetary policy on saving could well exist!

## REFERENCES AND FURTHER READING

- Campbell, J. Y., & Shiller, R. J. (1987). Co-integration and Tests of Present Value Models. *Journal of Political Economy*, 95, 1062–1088.
- Carlson, J. (1977, Winter). A Study of Price Forecasts. *Annals of Economic and Social Measurement*, 6(1), 27–56.
- Cronshore, D. (1997, March/April). The Livingston Survey: Still Useful After all These Years. *Federal Bank of Philadelphia, Business Review*, 2, 1–12.
- Cuthbertson, K. (1996). The Expectations Hypothesis of the Term Structure: The U.K. Interbank Market. *Economic Journal*, 106, 578–592.
- Cuthbertson, K., & Nitzsche, D. (2004). *Quantitative Financial Economics* (2nd ed.). Chichester: Wiley.
- Fender, J. (2012). *Monetary Policy* (Ch. 12). Chichester: Wiley.
- Goodhart, C. A. E. (1989). *Money, Information and Uncertainty* (Ch. 11). London: Macmillan.
- Hall, A. D., Anderson, H. M., & Granger, C. W. J. (1992). A Cointegration Analysis of Treasury Bill Yields. *Review of Economics and Statistics*, 74, 116–126.
- Hicks, J. R. (1946). *Value and Capital* (2nd ed.). Oxford: Clarendon Press.
- Howells, P., & Bain, K. (2008). *The Economics of Money, Banking and Finance: A European Text* (5th ed., Ch. 10). Harlow: Pearson Education Limited.
- Hubbard, R. H. (1997). *Money, the Financial System and the Economy* (2nd ed.). Reading: Addison Wesley.
- Mishkin, F. S. (2016). *The Economics of Money, Banking, and Financial Markets* (11th ed., Ch. 6). Harlow: Pearson Education Limited.
- Mishkin, F. S., & Eakins, S. G. (2016). *Financial Markets and Institutions* (3rd ed., Ch. 5). Reading: Addison Wesley.
- Pesando, J. E. (1975, August). A Note on the Rationality of the Livingston Price Expectations. *Journal of Political Economy*, 83, 849–855.
- Pesaran, B., & Wright, G. (1995). *The Use of Spreads in Forecasting Medium Term U.K. Interest Rates* (Working Paper). University of East London.
- Pilbeam, K. (2010). *Finance and Financial Markets* (2nd ed., Ch. 4). Basingstoke: Palgrave Macmillan.
- Shiller, R. J. (1990). The Term Structure of Interest Rates. In B. M. Friedman & E. H. Hahn (Eds.), *Handbook of Monetary Economics* (Vol. 1). Amsterdam: North-Holland.
- Sollis, R. (2012). *Empirical Finance for Finance and Banking*. Chichester: Wiley.



## The Loanable Funds Cycle and the Variability of the Deposit Base

### 7.1 INTRODUCTION

In Chapter 3, the loanable supply function, expression (3.13), takes into account the behaviour of the banking system and the public as well as the monetary authorities of the monetary system in the form of

$$\begin{aligned}\Delta LO_t^S &= \Delta M = \left( \frac{1 + CA^*}{CA^* + r} \right) \Delta \overline{MB}, \\ &= mm(i^B, i_{BR}, r, CA^*, \Delta D) \overline{MB}.\end{aligned}\tag{7.1}$$

The money multiplier,  $mm$ , is a function of the interest rate on borrowing,  $i^B$ , the base rate,  $i_{BR}$ , the required reserves,  $r$ , the cash–deposit ratio,  $CA^*$ , and the variability of deposit flows,  $\Delta D$ . Given the monetary base,  $\overline{MB}$ , the endogenous supply of money, for example, under normal conditions increases with the money multiplier,  $mm$ . This, in turn, increases with the level of market interest rates and decreases with the base rate, the required reserves and the cash–deposit ratio. It is this behaviour that determines the creation and the destruction of inside money via loans and mortgages, given  $\overline{MB}$ . It does not come from agents' saving and the transfer of existing purchasing power from the postponement of current consumption, so that banks are not regarded as only intermediaries. As seen in previous chapters, the banks have the ability to create the medium of exchange through credit via the monetary deposit base, underpinned by legal tender, the numeraire, representing new purchasing power for households, firms and the Government. This is why

theory must treat them as a separate entity, where the source of the deposit base comes from the creation of real income paid as wages, profits, rent and interest in the form of bank transfers. Thus, the objective of this chapter is to model the variability of the monetary deposit flows,  $\Delta D$ , that underpins the variables within the mm, which is multiplied by the monetary base,  $\overline{MB}$ .

The core analysis adopts Minsky's Financial Instability Hypothesis to model the underlying cash flows of the monetary deposit base,  $\Delta D$ , which underpins the loanable funds system of the banks. Minsky's proposition extends Schumpeter (1934) by including Ponzi finance. Increased credit and debt help to create productive capacity for the economy. Excessive growth of loanable funds will generate an initial boom and expansion, but with an inevitable later slow down, causing a slump and stagnation of economic activity because of the growing element of Ponzi debt with higher risk based the profitability of which relies heavily on the speculative rise of prices on existing assets as well as the production of new goods and services. This situation arises because of the fatigue of investment opportunities and innovation that comes from the law of diminishing marginal returns, lowering the rate of profit. The difficulty, however, is that the credit cycle repeats itself with no rhythm, but with chaotic consequences for the deposit base,  $\Delta D$ , which is the theme below in the next section. This contributes 'value-added' to the theoretical explanation of the events leading up to the financial crisis of 2007–2008 as well as an analysis of the aftermath of the effects, which is largely absent from the traditional, neoclassical approach because there is no rôle for money, credit and private debt there.

## 7.2 THE LOANABLE FUNDS CYCLE

The change in the flow of the deposit base,  $\Delta D$ , of the retail banks that underpins  $r$  and  $CA^*$  in the money multiplier (mm) theory can vary because of the Central Bank's open market operations (or quantitative easing), but also depends on the health of their internal reserves and profits as well as from the behaviour of households, firms and the Government. All these factors essentially depend on the credit cycle of loanable funds that evolves from the economy, which endogenously creates or destroys deposits, contributing to the flow within the base. In fact, it goes through transitory states of **boom**, **expansion**, followed by **crisis**, **deflation**, **stagnation**, but eventually **recovers** to start the cycle again. During each state, there are destabilising processes at work that

will cause disequilibrium of the short period of equilibrium whenever something approaching stability appears. The instability appears from the interaction of the banks with their borrowers that come from households and firms. Thus, it is necessary to define the type of borrowers.

### 7.3 THREE TYPES OF BORROWERS

The following analysis is loosely based on the framework of Minsky (2008), where there are three types of borrowers over the loanable funds cycle: **hedge, speculative and Ponzi**.<sup>1</sup>

**The first set**, the hedge borrowers, can make debt payments on loans, covering the interest and the principal sum payments from their current sources of cash flow income, representing low risk. This definition is clearer by examining the nature of short-run profit generated by individual firms, illustrated in Fig. 7.1, which refers to the standard cost curves of price theory under perfect competition.<sup>2</sup> The average variable cost curve (SAVC) represents labour and material costs that vary with level of production divided by output, whereas the average fixed cost curve (SAFC) of labour and capital services (overheads) do not vary

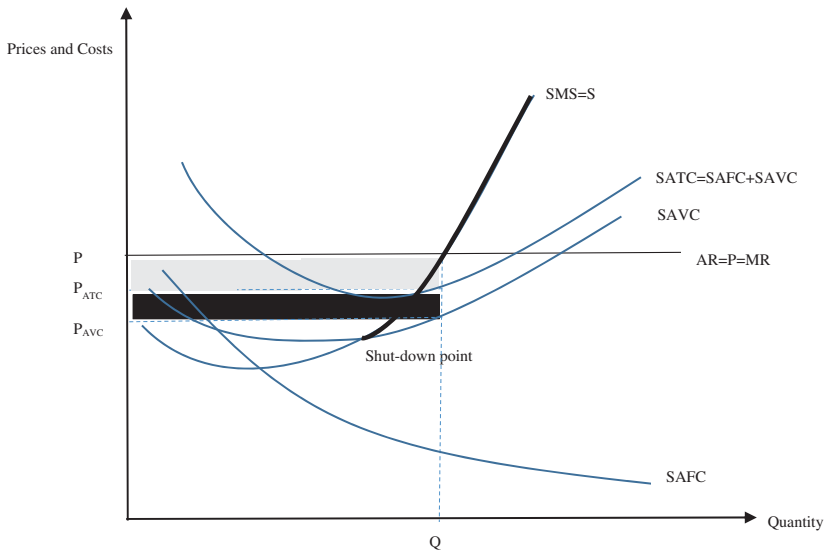

Fig. 7.1 The firm's short-run output decision with abnormal profit



with output, although when they are divided by output they become the average fixed cost curve (SAFC). The summation of these two gives rise to the average total cost curve (SATC). Since fixed factors cannot vary in the short run, the marginal cost (SMC), which is the supply curve of the firm above the (SAVC), is set equal to the marginal revenue (MR) to determine the level of output,  $Q$ , that maximise profits or minimise losses.

Since the price level,  $P = AR = MR$ , is greater than SATC at this output, the firm is making abnormal profit, indicated by the shaded, grey area between  $P$  and  $P_{ATC}$ , covering all costs plus interest payments and contributing to paying off the principal sum of any overhead, bank loan.

**The second one**, the speculative borrowers, can service the debt from their current cash flow of income, which are interest payments, but may require reborrowing of the principal sum of any loan from the banking sector. They represent medium risk.

In Fig. 7.2, the money price,  $P = P_{ATC}$ , received is just enough to cover average total costs, including the fixed costs of interest payments,

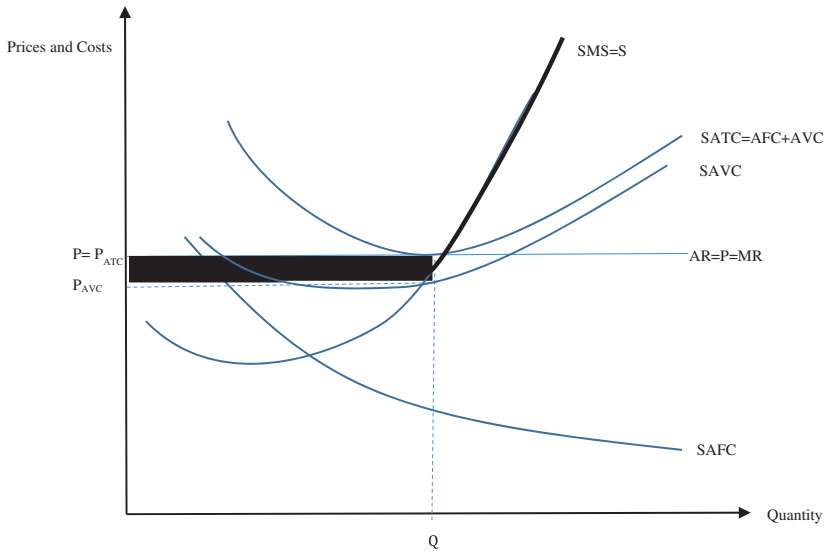

Fig. 7.2 The firm's short-run output decision with normal profit

although probably making little (or no) contribution to reducing the principal sum of any bank loan. Only normal profit exists at the output,  $q$ , represented by the black, shaded area between  $P_{ATC}$  and  $P_{AVC}$ . The firm will only stay in business over the long term if there is an appreciation of the commodity (or asset) price.

**The third set**, the Ponzi borrowers, take out loans on the belief that the value of production (or assets purchased) will appreciate enough in value to refinance their debts, although they are unlikely to make sufficient payments on the interest burdens of their fixed costs or principal sums from their current cash flow of income in the short run. They are high-risk borrowers. The appreciation of output values (or assets) is a necessary condition for the Ponzi borrowers to stay afloat in future and avoid bankruptcy from the accumulation of losses over the long term, as indicated in the shaded area in Fig. 7.3.

At the price of  $P$ , the firm is making some profit over and above the price at  $P_{SAVC}$ , as indicated by the shaded area, contributing to the reduction in the size of losses, shown by the unshaded area. The only way that this agent can survive, in the end, is by being in the period of

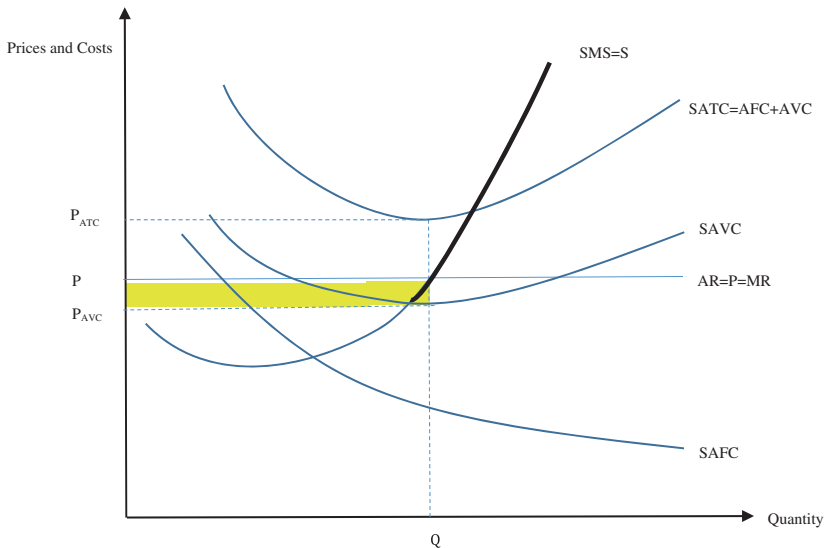

Fig. 7.3 The firm's short-run output decision with losses

expansion and boom, where the relative price is on an upward trend, and therefore, the good or service (or asset) is in the process of appreciation in value and exceeds the interest payments from the cash flows.<sup>3</sup> Thus, the profit margin will grow and the losses will fall. The bank might well allow this and lend at a higher rate of interest, reflecting the greater probability of default and cost if the firm goes bankrupt, although it can take possession of the product and sell on a rising market to recoup the principal sum of the loan with profit. Generally, these agents are significant in pushing up interest rates as anxiety of uncertainty grows.

The difficulty of instability arises, however, when the banking system has been lending to a large number of households and firms on the premise of expanding the deposit base,  $D$ , but relative prices have stopped growing over time with increasing interest payments, reducing profit margins, which means acceleration in default and bankruptcy. In this situation, elements of the conservative hedge borrowers become speculative ones, whereas a proportion of speculative become Ponzi. The end result is that a significant part of the Ponzi family will disappear and default on loans. New firms will enter to asset strip those assets still in the process of growth. Others at the margin must sell assets to finance debt servicing and obtain cash flow. The financial system will stop in the wake of a catastrophic event finally occurring, breaking the camel's back from the weight of default, which means a halt to the growth of the real economy as well.<sup>4</sup> In this chaotic environment, in the aftermath, a large number of speculative borrowers can no longer refinance their debts and some hedge borrowers are unable to find fresh loans even though they are financially sound. Destruction of the deposit base begins.

Clearly, the economy goes through an evolutionary process of boom and bust. The severity of the bust depends on the rate of inflation at the initial point of the catastrophe. If the rate is low at the time of the crisis, then the depth of the slump could have serious implications for the economy. These are deflationary processes leading to negative income effects and write-offs as a significant proportion of households and firms go bankrupt since cash flows will be inadequate to service debts. It is possible that debt servicing will exceed the economy's available cash flows—leading to not only a recession, but also a depression.

According to Minsky, this process of adjustment is self-reinforcing in the absence of the government sector. If government structures are well developed, then the vacuum left by the Keynesian multiplier is naturally

filled by rising government expenditure through automatic stabilisers,  $T$ , in the following form of

$$T = \bar{T} - bY, \quad (7.2)$$

where  $\bar{T}$  represents autonomous transfer payments,  $b$  denotes the average rate of transfer payments times income,  $Y$ . Obviously, as income,  $Y$ , declines within the economy, transfer payments such as unemployment benefits increase. Finance as growing public debt in a slump via budget deficits, perhaps augmented by Central Bank interventions to increase liquidity and offset the destruction of the deposit base of the banking system, may enable the economy can go into recovery and head towards the boom state of equilibrium.<sup>5</sup>

On the other hand, if the rate of inflation is high at the point of the catastrophe, then the collapse of the period of expansion causes consumption and investment to plummet along with economic growth, although rising cash and income flows will allow the repayment of debt incurred during the boom period. The economy will emerge from the crisis more quickly with a lower growth rate, but the high inflation rate means less bankruptcies and no substantial need to increase liquidity. The mechanism of adjustment is self-correcting in avoiding a long period of recession and reverting to the 'road' of recovery and expansion, so that the cycle can repeat itself from ecstasy to panic. In fact, the study has reached stage when the analysis looks at the period of expansion in more detail, which is below.

#### 7.4 INFLATION AND EXPANSION

During a boom period of economic activity, in the midst of money illusion, an environment of optimism and growing monetary profitability looms as nominal interest rates rise with self-fulfilling inflationary expectations of consumer and capital as well as services and commodity prices. If the expected growth of prices is greater than nominal rates of interest, in terms of the Fisher equation, the expected real rate of interest could well be falling and very negative with the value of private debt. In this period of credit inflation, there is an inherent propensity for loan creation without many constraints and, therefore, the flow into the deposit base,  $\Delta D$  will expand rapidly with the banks' profitability via interest payments, causing the cash,  $CA^*$ , and the reserve,  $r$ , ratios to get smaller, meaning that the whole money multiplier (mm) process enlarges

considerably. In other words, this generates substantial growth of internal reserves, which in turn creates even greater availability of credit currency in the form of loans.

As **private debt expands**, the **public one contracts** on account of the enlarging tax revenues and the effect of automatic stabilisers reducing the rate of transfer payments that are required to supplement aggregate income and alleviate the Keynesian multiplier. In fact, if the budget surplus is used to pay off part of the previous accumulation of the public debt by buying back bonds from the public, inducing pressure for a fall in the nominal interest rate. These agents will have more to spend or lend to the commercial banks to create an even larger deposit base,  $D$ . This whole process reduces the values of  $r$  and  $CA^*$  within the mm, escalating the geometric growth of loans for greater consumption and investment expenditure to take place. This is an epoch when new forms of money are created in the process of borrowing and lending by banks to expand liabilities and maximise profits. In fact, financial innovation is a characteristic of a monetary economy in a thriving period with heightened expectations of inflation that are self-fulfilling prophecies. It represents an evolutionary process, whereby the money supply endogenously expands to meet expected growth in aggregate demand and supply. It is not mechanically controlled by the monetary authorities.

## 7.5 SOWING THE SEEDS FOR A CRISIS

This boom leads to a financial structure that is conducive to a crisis because forces of change are always at work. Disequilibrating forces may be weak for long periods over the course of time, although they accumulate and gather strength at short notice, so that prevailing equilibria face disruption. This period of growth in the credit cycle of loanable funds will end when the element of **credit risk rises** with inflationary expectations because of the apparent visibility of the greater weight at the macro-level of investment schemes with rates of return based on speculative and Ponzi agents.

The cycle is now at the end of the spectrum of the law of diminishing marginal returns of capital projects, meaning that loans with uncertain revenues are in excess of the hedge borrowers with investment strategies based on high productivity. The phase has reached the stage when a significant proportion of capital expenditure schemes are destined to collapse and a **Minsky Moment** (or **catastrophe**) takes place, causing new

investment to rapidly tail off with expectations of lower output growth and consumption. The increasing rates of default may entail many company re-organisations with paralysing effects on investment growth. Recently, in the UK, the catalyst was the collapse of the Northern Rock caused by the subprime mortgage investment crisis and its need of help from the Bank of England as lender of last resort. In USA, it was the bankruptcy of Lehman Brothers. This ‘virus’ then swiftly replicates itself through the world economy, through changed expectations.

## 7.6 DEFLATION AND STAGNATION

Banks start to withdraw loans and overdraft facilities,  $\Delta LO_7^S$ , as perceived uncertainty grows because of the **increasing credit risk**,  $\sigma_R$ , of further defaults on payment within the MU, the mark-up within expression (6.13). In addition, they return to more stringent lending practices with credit-rationing, according to risk categories, since the observation on reflection during the boom period with rising inflationary expectations that increases in nominal interest rates, the result is adverse selection of risky projects with high rates of default. The credit market for loans may not clear.

Clearly, at this point in the cycle there will be a contraction in the deposit base with the money supply,  $\Delta M$ , through the money multiplier mechanism of loans and therefore, a fall in aggregate demand of goods and services, depressing the expected growth of prices, if below aggregate supply. The value of assets will drift downwards as anticipated prices fall, triggering disinflation or deflationary expectations with the reduction of loans, inducing gloom and pessimism with the likelihood of the hoarding of liquidity in the form of an increase in  $CA^*$ , representing an increase in the precautionary and the speculative demand for money. There is the possibility of bank runs with the advent of bank failures to meet demand for cash,  $CA$ .

The increasingly harsh lending conditions imposed by banks to reduce their risk of default, especially targeting households on low income and small businesses such as sole traders. This is when pawnbrokers prosper offering loans to agents with items of personal property used as collateral.<sup>6</sup> If they default on loans, their goods could end up on such platforms as eBay for selling, or sold by pawnbrokers. Furthermore, this is a period when there is an upsurge of loan sharks, payday lenders such as Wonga, along with the development of peer-to-peer lending platforms. This partly offsets the shortage of credit created by the banks. There is

a large reduction in the deposit base,  $D$ , at this stage within  $r$  and  $CA^*$ , reducing the mm and the geometric process of lending.

The **history of financial crises** teaches us that these practices are common during a downturn of the credit cycle of loanable funds over the course of time. For example, Christmas reminds us of Dickens's (1843) Ebenezer Scrooge in the *Christmas Carol*, who was a cold-hearted man, who might have been a moneylender, set in Victorian times who despised the festive activities and exploited the poor to accumulate his personal wealth in a downturn.<sup>7</sup> Clearly, what is required to offset the length and severity of a recession is the appearance of the 'Three Ghosts of Christmas' in the disguise of monetary policy, regulation and fiscal stimulus. The same kind of greedy agents appeared in the 1930s depression<sup>8</sup> in a different 'guise', as a result of bank failures and the contraction of the money supply on account of the decline of the deposit base,  $D$ . This causes a rise in the cash,  $CA^*$  and reserve,  $r$  ratios of the mm, leading to a fall in the growth of loans created,  $\Delta LO_t^S$ . In fact, in 1929, the Great Depression in USA caused the banks to withdraw loans from the German nation, and evidently led to the catastrophic collapse of an already struggling economy. In the midst of chaos ignited by the financial crisis, Hitler feeds the growing anger and fear to gather political power and popularity for the Nazis Party.<sup>9</sup>

What is more, if foreseeable prices continue to fall along with the circulating system of money flows in a downturn, triggering further deflationary expectations, then paradoxically, there is an increase in the purchasing power of the money, **the so-called Pigou effect**, but with an increasing real burden of all nominal debt, private and public. The potential increase in expenditure caused by a rise from the price-deflated value of money will be counteracted by a real reduction effect upon both investment and consumption, on account of the increasing burden of servicing debt as expected prices fall unless nominal interest rates decrease enough. This reinforces the projected downhill spiral of aggregate demand and supply via the **Keynesian multiplier** with the increasing probability that agents will be falling behind on their loan payments or 'tightening their belts' to maintain debt expenditures. This occurs as the real rate of interest is rising when debts contracted at earlier periods when money income was growing. Furthermore, the other subset of borrowers will have an incentive to reduce the burden of debt by paying off their loans if they have the financial means.

Clearly, this scenario of liquidation of debts will decrease the deposit currency of banks and destroy part of the deposit base,  $D$ , reducing their ability to create loans as well as decreasing their profitability on account of diminished interest payments, which in turn lowers their internal reserves that contribute to the money-making process. This becomes another channel of destabilisation of the money supply process in the form of indebtedness, amplified by the negative income effect at the macro-level that emanates from the deflationary expectations process in terms of the downward pressure on the growth of money income. This leads to a plunging trend of money wages and profit.

The economy can potentially go into reverse via the money multiplier process, leading to a sudden, severe downturn in economic activity augmented by the Keynesian multiplier, as in the case of the recent Great Recession to date. The system generates its own endogenous shocks through its own internal dynamics of change, which reflects the reduction in the deposit base of banks, increasing  $CA^*$  and  $r$ . This is augmented by the snowballing effect of uncertainty that could lead to an upsurge in the use of cash, reflecting the public's distrust and their perception of increasing risk of holding their money as bank deposits. Furthermore, the increasing credit risk perceived by the banks materialises itself in the accumulation of excess reserves, which are idle funds in terms of banks' ability to generate loans. The velocity of money creation drops. On examination of M1 in the USA over the period from January 2007 to the same month in 2012, which is shown in the plot of monthly data, it exhibits an apparent 60% increase in the flow over this sample of statistics, and therefore, on the face it, an upward movement in growth of money as medium of exchange for consumption and to renew production (Fig. 7.4).

This comes, however, from the significant injection of funds made available to retail banks from the 213.90 percentage increase of the monetary base over the same period, as shown in the plot of data below, and hence, the upward trend generated in M1 comes from the induced growth of outside money by monetary authorities (Fig. 7.5).

If the money supply was exogenously controlled, then this increase in the monetary base would be translated into a multiple rise in the flow of loans created by the retail banks. Clearly, that has not been the case. So, what has gone wrong? In fact, on examination of inside money, the endogenous creation of loans, the money multiplier has been a declining



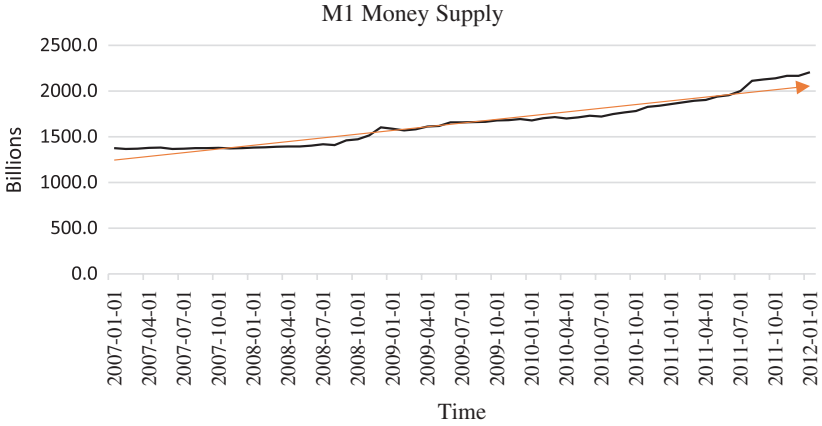

Fig. 7.4 A plot of M1 money supply in the USA (Source The Federal Reserve Bank of St. Louis)

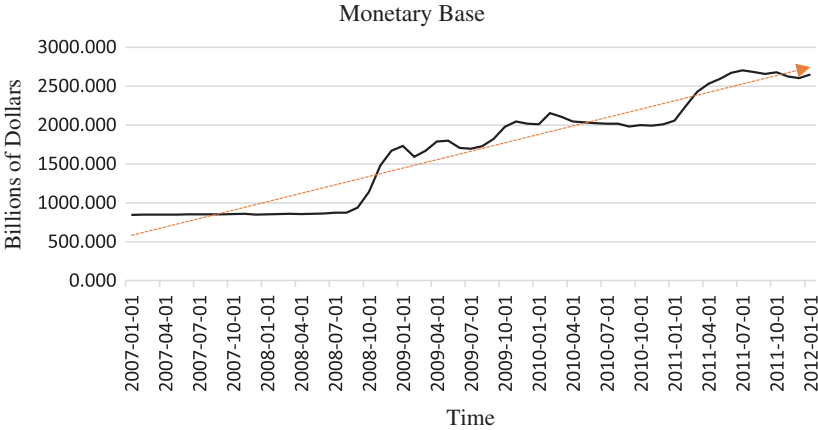
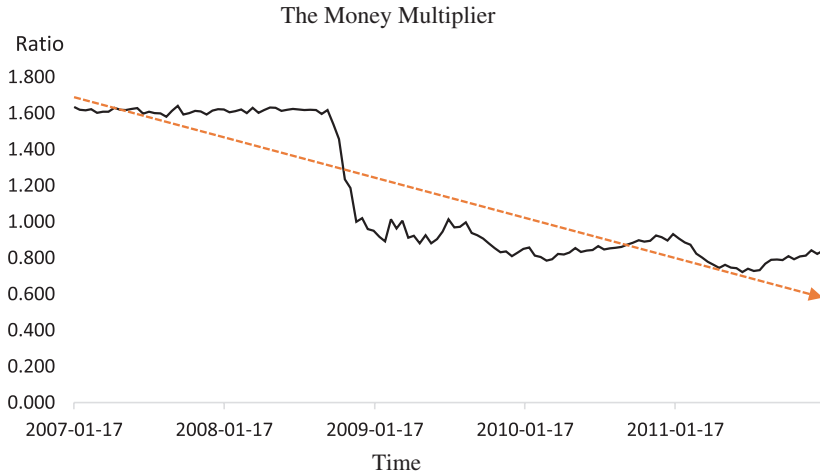

Fig. 7.5 A plot of the monetary base (Source The Federal Reserve Bank of St. Louis)

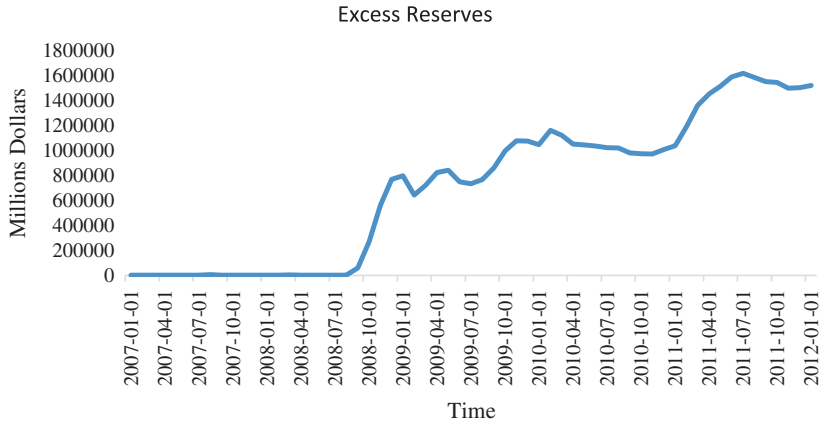

**Fig. 7.6** A plot of the money multiplier (*Source* The Federal Reserve Bank of St. Louis)

function, as shown in the Fig. 7.6. The ratio has declined by 95.78% over the period from January 2007 to the same month in 2012. The critical turning point in reduction is September 2008 (Fig. 7.6).

The source of the problem is the excess reserves accumulated by the banks on account of the growing perceived uncertainty and risk, as shown in Fig. 7.7, which results in the rise of the reserve ratio,  $r$ , embodied in the money multiplier, leading to its substantial fall in the money multiplier, that generates the endogenous growth of loans and the money supply that funds consumption in exchange and finances the aggregate supply.

Wheelock (1992) shows similar conditions arose in the Great Depression in America, where there were again substantial falls in the money supply on account of the reduction in the money multiplier because of the increase in value of the currency ratio,  $CA^*$ , that resulted from the depositors withdrawing substantial amounts of cash, and consequently, the banks suffering a loss of reserves from bank runs. In fact, Federal Reserve Member banks suffered a 22% fall in reserves from 16 September 1931 to 24 February 1932. Obviously, the end result is the reduction in loan creation and credit to finance economic activity, and hence, the reduction in money supply within the economy.



**Fig. 7.7** A plot of excess reserves (*Source* The Federal Reserve Bank of St. Louis)

Undoubtedly, in these recessionary periods, **private debt** is being destroyed rather than created, although **public debt** should be multiplying to fill the ‘void’ on account of the natural expansion of transfer payments with falling tax revenues. This is the opposite of the boom period. The traditional belief in major macro-textbooks is that a budget deficit is expansionary. Whether the budget deficit stabilises aggregate income and the Keynesian multiplier effect depends on the financial arrangements by the monetary authorities. On the one hand, if the monetary authorities print money to pay for the Government’s extra expenditure, then monetary and fiscal policies are stabilising aggregate income and reducing the multiplier effect on the macroeconomy. On the other hand, if the Government obtains the funds by borrowing from the public by selling bonds, then those agents will have less to spend or lend to the retail banks for the purposes of money creation via loans. The effect simply means higher government expenditure at the expense of private spending or lending with the added pressure of rising interest rates as the price of bonds are forced down from the open market operation. The overall consequence could well be negligible or even may result in a negative growth rate on expected output.

## 7.7 RECOVERY AND GROWTH

In future, there must be a point when the after-effects of the debt-deflation process abate on the deposit base with disinvestment by firms grinding to a halt and investment along with consumption growth begins to recover as financial positions are rebuilt during the stagnant recession, which is the phase of activity with no growth. Price competition between firms is intense from the decreasing sales, igniting the instinct to survive by creating new investment opportunities from technological advancement into new products that open up new markets, or the introduction of innovative methods of production and industrial organisation to reduce input costs and raise profit margins (Schumpeter 1943). This represents the process of creative destruction: the replacement of old with new endogenous technology, although the process depends on the fiscal stabilisers alleviating the instability and reversing the Keynesian multiplier.

The liability structures become purged of debt. In this stagnant recession, the conventional rule that prevails is that debt leads to disaster. A mutation takes place. Thus, recovery of the deposit base occurs in the midst of fresh memories of the penalties imposed on debt liability positions during the debt-deflationary period. As the recovery gathers momentum and velocity, success cultivates venture and over time the memory of past catastrophes in terms of speculative and Ponzi loans and the effects on the deposit base are eroded. There will be a modest period of growth recession, where stability becomes destabilising, as the investment by the ‘alpha’ entrepreneurs and the followers of the pack prove successful, representing lending to the hedge borrowers. There is an expansionary flow of monetary deposits into the banking base as well as cash flows into financial balance sheets of households, firms and the Government. Bank deposits and cash flows of financial balance sheets are interwoven. Pack and herd behaviour starts the diffusion process of interwoven expansion at an accelerating rate, feeding into a boom (Thomas 1999).

According to Minsky (1975), the design of new policy instruments suggested by economists and built into the financial infrastructure ensures that the business/financial cycle will not happen again in future. Boom and bust periods are mentally consigned to the ‘dustbin’ of the past. The forecast is a new era of permanent propensity in the ‘Garden of

Eden' by the current generation of economic clairvoyants, re-forced by the media circus. This leads to another **catastrophic moment** at the cusp when economy goes into the state of boom and expansion. This state, once again, will nurture its own forces of destruction through the loan process, as described earlier, sending the economy in the near future to the slump state.

## 7.8 CONCLUSIONS/SUMMARY

Taken as a whole, the loanable funds cycle of a monetary economy endogenously creates speculative bubbles and shocks. In boom times, agents' income flows exceed what is necessary to pay off loans and ignites speculative tendencies, where debts begin to exceed revenues because households, firms, investors and bankers believe that the good times will keep going-on in the face of greater expectations of inflation. In the midst of increasing escalation of asset and commodity values, they start taking greater risks in pursuit of profit with investments of lower earnings because of the law of diminishing marginal returns. This is sowing the seeds for the next financial crisis in the shape of a sudden, major collapse of asset values. This leads to the possibility of bank runs and the need for emergency help from the lender of last resort, the Central Bank, in providing greater reserves, RE within  $r$  via increases in monetary base,  $\Delta\overline{MB}$ . This is after a long period of prosperity with increasing values fuelled by inflationary expectations, leading to increasing speculation using borrowed money. In the aftermath of speculative bubbles and catastrophes, bankers and lenders tighten credit availability, even to consumers, firms and investors who can afford the loans, that is hedge borrowers. As a result, aggregate demand contracts along with expected output and deflationary price expectations become entrenched and self-fulfilling in extreme situations.

The financial process that underlies a monetary economy endogenously converts a stable system into an unstable one with its own movements. Given the credit cycle model of loanable funds developed here, this leads to the variability of the deposit base within the money multiplier of the banking system. It is clear that during the boom period, the money supply curve will be shifting to the right along the demand for loanable funds curve, forcing down the nominal, market rate of interest. Whereas in a recession (or depression) period, then the curve will shift to the left, leaving a higher nominal, market rate of interest prevailing

in the monetary economy. The downward direction of economic activity gathers more momentum from the Keynesian multiplier effect, adding more instability from output and employment. This could well lead to social unrest and greater inequality of income. Both multipliers are a part of the concept of monetary circularism, magnifying instability by igniting the credit and business cycles. The analysis has reached the stage where the theory outlined in this chapter can be modelled using the catastrophe framework to expose the multiequilibria and nonlinearities that lie within, which is the theme of the next instalment.

## NOTES

1. For a micro-analysis of the type of borrowers with regard to the portfolios of loans created and granted by retail banks, then see Appendix B, where the hypothesis developed is based on Modern Portfolio Theory, which encapsulates the concept of diversification to reduce the effect of risk and uncertainty.
2. It is possible to show the results under imperfect competition as in Appendix A. Figure 7.8 exhibits the possibilities.
3. A Ponzi financier does the same by trading in financial assets (or instruments) on a rising market as well as incurring significant debt and servicing costs in the process, which is likely to be greater than the cash flows of the firms, with reliance upon anticipated capital gains being in excess of the interest payments on loans.
4. The catastrophic spark of the financial crisis in 2007/2008 was the rôle of Ponzi borrowers in conjunction with banking system lending on expectations of a rising housing market. The downward spiral of residential prices left the banks with household defaults on loans because of the effect of rising market rates of interest, and possession of assets that were declining in value.
5. Since the financial crisis of 2007/2008, the economy has been in a prolonged period of stagnation and growth recession with no evidence of the economy going into the recovery state of equilibrium. This is because of the present Government imposing austerity measures reversing the natural tendency of automatic stabilizers to boost the economy's income. Keynes declared in 1937, *boom, not the slump, is the right time for austerity at the Treasury*.
6. Watch BBC programme on Life in Debt Valley by clicking on the following link: <https://www.youtube.com/watch?v=gFDJgXPH2LE>.
7. The best film version is the *Muppet Christmas Carol* (1992). See link: [https://www.youtube.com/watch?v=KBthi\\_An5qQ](https://www.youtube.com/watch?v=KBthi_An5qQ).

8. To get a feel of the problems in the depression of the 1930s in the USA, view the link: <https://www.youtube.com/watch?v=THWK-t7WkaWU> as well as watch the film of the *Cinderella Man* (2006). For an interesting view of the causes of the Great Depression in the USA, see Friedman (<https://www.youtube.com/watch?v=ObiIp8TKaLs>). For more on him and his theory, click on the link: [https://en.wikipedia.org/wiki/A\\_Monetary\\_History\\_of\\_the\\_United\\_States,\\_1867%E2%80%931960](https://en.wikipedia.org/wiki/A_Monetary_History_of_the_United_States,_1867%E2%80%931960). In the UK, the trigger was the return to the Gold Standard in 1925 despite Keynes' warnings of deflation, unemployment and labour unrest. In fact, at the height of the depression in 1931, the Snowden's Budget cut unemployment benefits and public sector pay. For some music whilst you study, click on the following YouTube connection ([https://www.youtube.com/results?search\\_query=10cc+wall+street+shuffle+](https://www.youtube.com/results?search_query=10cc+wall+street+shuffle+)).
9. The People's Century, Part 07 (<https://www.youtube.com/watch?v=zq9yh0Pc6N4>) is very good on the problems experienced in the 1930s depression.
10. The former can service the debt by covering the interest payments, but normally requires 'rolling' reborrowing of the principal sum with regard to the original investment. The latter obtain loanable funds on the premise that appreciation of asset values will be sufficient to refinance the loan, but are unlikely to be able to make sufficient payments on the interest or the principal sum in the absence of no expected asset appreciation.
11. The covariance can be calculated as  $\text{Cov}(i_s, i_M) = \sum P_j (i_s - \hat{i}_s) (i_M - \hat{i}_M)$ , which reveals that  $\hat{i}_s$  and  $\hat{i}_M$  are the mean returns that correspond to each state of the economy, and therefore,  $P_j$  is the probability of a particular equilibrium condition prevailing within the economy: boom, slump and recovery.
12. Click the following link: [http://media.pimco-global.com/pdfs/pdf/GCB%20Focus%20May%2009.pdf?WT.cg\\_n=PIMCO-US&WT.ti=GCB%20Focus%20May%2009.pdf](http://media.pimco-global.com/pdfs/pdf/GCB%20Focus%20May%2009.pdf?WT.cg_n=PIMCO-US&WT.ti=GCB%20Focus%20May%2009.pdf).

## APPENDIX A

Assuming that the firm adopts the profit-maximising position, it produces  $Q$ , where  $\text{SMC} = \text{SMR}$  in Fig. 7.8. If the price,  $P$ , is above  $\text{SATC}_1$ , then the firm is making an abnormal profit as shown in the area as indicated. If  $P$  is between  $\text{SATC}_1$  and  $\text{SAVC}_1$ , partly covering fixed costs as well contributing to interest payments on loans, although, overall, the firm is making a loss. If price is below  $\text{SAVC}_1$ , production is zero, and therefore, there is no contribution to fixed costs and interest expenditures.

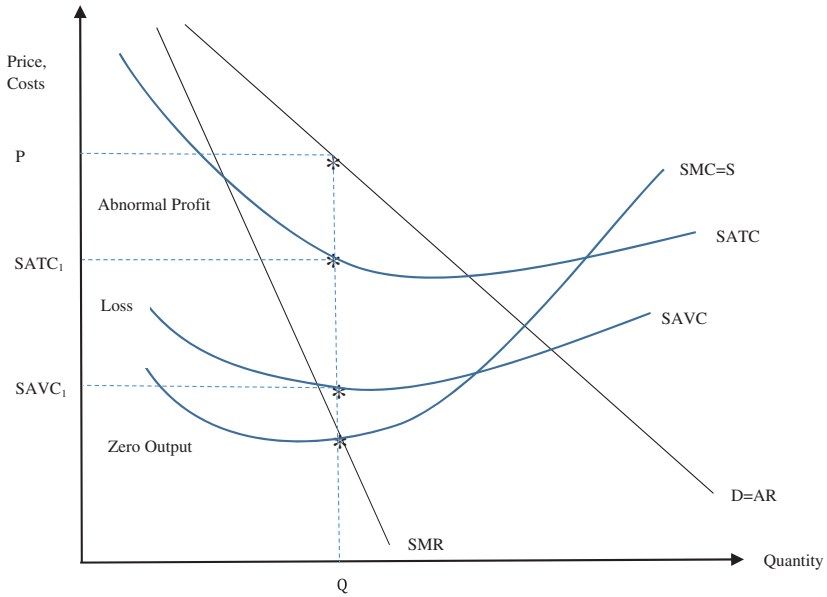

Fig. 7.8 The firm's short-run output decision under imperfect competition

## APPENDIX B: A PORTFOLIO THEORY OF LOANABLE FUNDS: DEFAULT AND RISK

### *Introduction*

The book has partially developed a new model based on the principle that inside money comes from the formation of real income in production, paid as bank transfers, which leads to endogenous loan creation by the banking sector. The money supply is not only outside money, exogenously controlled by the Central Bank with the monetary base via reserves. Thus, the purpose of the analysis within this Appendix is to apply a Modern Portfolio Theory (MPT) framework to the area of loans granted by the retail (or commercial) banks to borrowers in the midst of asymmetric information. The objective is to adapt the MPT as the modelling process in terms of the risk-weighted loans of default embodied in the total number of assets on the balance sheets of the banks. This discussion leads to a hybrid theory of default and risk concerning



loans made by the commercial banks. Before starting the development of the model, a recap of the main features of the MPT would not go amiss by clicking on the following links, 1 ([https://www.youtube.com/watch?v=IPKtI90f\\_sE](https://www.youtube.com/watch?v=IPKtI90f_sE)) and 2 ([https://www.youtube.com/watch?v=zVsCgU26U\\_8](https://www.youtube.com/watch?v=zVsCgU26U_8)).

### *Development of the Theoretical Analysis*

Suppose that a selection of loans, denoted by  $W$ , are perceived to be at risk of default in the midst of asymmetric information that lies within the portfolio of assets on the balance sheets. It is the speculative and Ponzi borrowers of loans that reflect the inclusion and measurement of the high degree of credit risk rate added to the mark-up,  $MU$ , of the rate of interest,  $i$ , outlined in the new theory.<sup>10</sup> This relates to the unsystematic, specific (or idiosyncratic) risk of the individual borrowers, firms or industries in which they operate.

Moreover, this implies the remaining cluster,  $(1 - W)$ , is the market group of loans within the assortment of assets, representing the pure, normal market risk, which depends on the equilibrium states of the macroeconomy and cannot be diversified away unlike specific risk. They represent the hedge borrowers within the economy. It should be noted, however, in abnormal times like the current Great Recession following the events of 2007/2008, the market rate of interest changes its form on account of the mutable market risk within the  $MU$ , the so-called systematic component is altering to reflect the growing insecurity and indecision. In fact, whilst the monetary authorities are reducing the bank rate within the market to stimulate growth and increase the level of confidence, as in the 2007/2008 downturn, the commercial banks are raising market rates on loans as well as restricting the growth of the money supply, reflecting the heightened uncertainty and higher pure market risk within the macroeconomy. This is because of the deteriorating state of the macroeconomy, leading to more likelihood of borrowers defaulting on loans.

Moreover, the combination of the two determinants, the systematic and the unsystematic risk, determines the expected, mean rate of return on a portfolio of loans,  $Ei_p$ , representing interest-earning assets of the banks, which is as follows:

$$Ei_p = Wi_s + (1 - W)i_M, \quad (7.3)$$

where  $i_s$  is the expected mean rate of interest on a subset,  $s = 1, 2, \dots, n$ , of risky loans within the portfolio of interest-earning assets.  $i_m$  is the market, mean rate of interest, which can range from virtually no credit risk being added, nearing the risk-free rate,  $i_{rf}$ , on loans such as Treasury bills to low doses of credit risk costs, depending on the length of time to maturity, determining a ray of values forming the 'pure' market risk within  $W$ .

This analysis implies that a measure of risk would be the standard deviation between the two, that is

$$\sigma_p = \left( W^2 \sigma_s^2 + (1 - W)^2 \sigma_M^2 + 2W(1 - W)\text{Cov}(i_s, i_M) \right)^{\frac{1}{2}}, \quad (7.4)$$

or

$$= \sqrt{W^2 \sigma_s^2 + (1 - W)^2 \sigma_M^2 + 2W(1 - W)\text{Cov}(i_s, i_M)},$$

where  $\sigma_s^2$  and  $\sigma_M^2$  are the variances of the risky and the market loans. The first part of expression (7.4),  $W^2 \sigma_s^2 + (1 - W)^2 \sigma_M^2$ , is the weighted average of the variances of each set of loans, whereas the interesting part is the second portion in the form of  $2W(1 - W)\text{Cov}(i_s, i_M)$ , which contains the covariance,  $\text{Cov}(i_s, i_M)$ , of the returns between the two sets of loans.

The market trade-off between the mean rate of interest on the portfolio and the factor of risk at any point is given by  $\partial \text{E}i_p / \partial \sigma_p$ , which is essentially equal to

$$\frac{\partial \text{E}i_p}{\partial W} \cdot \frac{\partial W}{\partial \sigma_p}, \quad (7.5)$$

this is taking into account the weighting component of risky loans that prevail in the banks' portfolio of assets.

Differentiating  $\text{E}i_p$  of (7.3) with respect to  $W$  gives

$$\frac{\text{E}i_p}{\partial W} = (i_s - i_M). \quad (7.6)$$

Denoting the expression within the square root of (7.4) by  $x$ , the analysis uses the inverse rule of  $\frac{\partial W}{\partial \sigma_p} = \frac{1}{\frac{\partial x}{\partial W} \cdot \frac{\partial \sigma_p}{\partial x}}$ .

In the case of  $\sigma_p = x^{\frac{1}{2}}$ , so that,  $\frac{\partial \sigma_p}{\partial x} = \frac{1}{2}x^{-\frac{1}{2}} = \frac{1}{2 \cdot \sqrt{x}}$ , which is equal to the following format:

$$= \frac{1}{2 \cdot \sqrt{W^2 \sigma_s^2 + (1 - W)^2 \sigma_M^2 + 2W(1 - W)\text{Cov}(i_s, i_M)}}. \quad (7.7)$$

Now multiplying out  $x$  and simplifying before differentiating with regard to  $W$  leads to the following form:

$$\frac{\partial x}{\partial W} = 2W\sigma_s^2 - 2\sigma_M^2 + 2W\sigma_M^2 + 2\text{Cov}(i_s, i_M) - 4W\text{Cov}(i_s, i_M). \quad (7.8)$$

Putting all the threads together, that is (7.6), (7.7) and (7.8) to form expression (7.5) with the inverse rule, which is

$$\frac{\partial E_i_p}{\partial \sigma_p} = \frac{\partial E_i_p}{\partial W} \cdot \frac{\partial W}{\partial \sigma_p} = \frac{\partial E_i_p}{\partial W} \cdot \frac{1}{\frac{\partial x}{\partial W} \cdot \frac{\partial \sigma_p}{\partial x}} = (i_s - i_m) \cdot \frac{1}{(2W\sigma_s^2 - 2\sigma_M^2 + 2W\sigma_M^2 + 2\text{Cov}(i_s, i_M) - 4W\text{Cov}(i_s, i_M)) \cdot \left( \frac{1}{2 \cdot \sqrt{W^2 \sigma_s^2 + (1 - W)^2 \sigma_M^2 + 2W(1 - W)\text{Cov}(i_s, i_M)}} \right)}.$$

This can be rearranged to derive the following expression:

$$= (i_s - i_m) \cdot \frac{2 \cdot \sqrt{W^2 \sigma_s^2 + (1 - W)^2 \sigma_M^2 + 2W(1 - W)\text{Cov}(i_s, i_M)}}{2W\sigma_s^2 - 2\sigma_M^2 + 2W\sigma_M^2 + 2\text{Cov}(i_s, i_M) - 4W\text{Cov}(i_s, i_M)}. \quad (7.9)$$

If the market is in equilibrium at  $M$ , as indicated in Fig. 7.9, then  $W$  can be set to zero, because diversification of risky loans removes an element of unsystematic risk until only the systematic (or market) one prevails, and therefore, the portfolio contains the appropriate proportion (or combination) of  $S$ , and consequently no need to change the weighting. This means at point  $M$ ,  $W = 0$ , which reduces (7.9) to

$$= (i_s - i_m) \cdot \left( \frac{\sigma_M}{\text{Cov}(i_s, i_M) - \sigma_M^2} \right). \quad (7.10)$$

If the market line (ML) is tangential to the efficient frontier, EE, at  $M$ , as shown in Fig. 7.9, where the slope of the ML curve is

$$\frac{i_m - i_{rf}}{\sigma_M}, \quad (7.11)$$

where  $i_{rf}$ , is the risk-free rate of interest and  $\sigma_M$  is the market standard deviation. Equating (7.10) with (7.11) gives  $(i_s - i_m) \cdot \frac{\sigma_M}{\text{Cov}(i_s, i_M) - \sigma_M^2} = \frac{(i_m - i_{rf})}{\sigma_M}$ . Now simplifying for  $i_s$  derives the following expression:

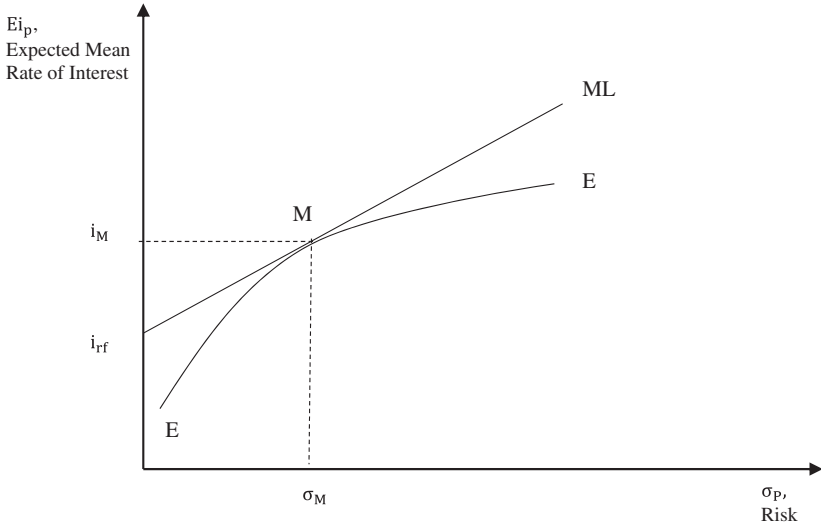

Fig. 7.9 The equilibrium of the portfolio possibilities and the efficient frontier

$$i_s = i_{rf} + (i_M - i_{rf}) \left( \frac{\text{Cov}(i_s, i_M)}{\sigma_M^2} \right),$$

or

$$i_s = i_{rf} + \beta_S(i_M - i_{rf}), \tag{7.12}$$

since  $\beta_S = \left( \frac{\text{Cov}(i_s, i_M)}{\sigma_M^2} \right)$ , it formulates the loan asset subset’s risk relative to the dangers of the whole market portfolio.<sup>11</sup> This is the additional rate of interest over and above  $i_{rf}$  that is required on each asset, whose risk characteristic is compared with the whole market portfolio via the  $\beta$ . In other words, Eq. (7.12) displays the theory how to find the expected mean rate of interest on a risky set of loanable funds,  $i_s$ . Clearly, this depends on the risk-free rate of interest,  $i_{rf}$ , plus a weighted market premium, which depends on the loan set’s risk relative to the market one.

If  $\beta_S = 1$ , then the loan subset has the equivalent risk characteristic as the whole market portfolio and its expected mean rate of interest is the same as the market one. If  $\beta_S < 1$ , then the expected mean rate of interest is less than the whole, which is a ‘hedge’ loan set of assets, and finally, if  $\beta_S > 1$ , then the loans are riskier than the market portfolio and attracts higher mean rate of interest to reflect the greater credit risk on account

of a speculative or Ponzi loan set of assets. If  $\beta = 0$ , then the expected mean rate of return is equal to the risk-free, mean rate,  $i_{rf}$ .

So far, the analysis is at the micro-level with regard to its implications for theory. At the macro-level of aggregation, the risky loans granted by the commercial banks at higher interest rates than the norm represent the ‘speculative’ and ‘Ponzi’ borrowers. If the bubble bursts like in the case of the housing market in 2007/2008, then these borrowers can cause the banking sector to freeze up, providing the initial condition for a slump in economic activity in the form of a recession or depression. There is a Minsky Moment, a sudden catastrophic fall in asset prices that represents a snowball effect of multiplication of the initial, increasing state of risk. Briefly, the risk builds on itself. Clearly, these categories prevail within the mortgage sector as well as borrowers on low incomes to who find it difficult to reach the end of the month and require rolling overdraft facilities. As retail banks withdraw from this segment of the market, they leave the doors open for loan sharks to enter, like Wonga.<sup>12</sup>

Moreover, the end result is an unstable financial environment, caused by the increase in F. Knight uncertainty because the rate of default increases on Ponzi loans, resulting an accumulation of insolvent debt carried by the banking system and the adoption of credit-rationing practices (Stiglitz and Weiss 1981). ‘Speculative’ borrowers find they cannot refinance the principal loans even if they are able to cover the higher interest rate payments. This chain reaction even affects the ‘hedge’ borrowers who are able to cover the interest and principal from their current investment income. If hedge financing dominates the banking sector, then it is more likely to be stable. In the opposite case, with a greater weight of speculative and Ponzi borrowers, then it is likely to be unstable.

### *Conclusion/Summary*

In this Appendix, the focus has been on the determination of the rate of interest on loanable assets, whereby the required rate of interest is made up from the risk-free rate of interest plus the risk premium, which is the difference between the market portfolio of risky loans and the risk-free rate in collaboration with  $\beta$  – coefficient. This measures the risk on a subset of loanable assets if it is included in the portfolio, taking into account the whole market together with its standard deviation. This

framework develops an understanding of the financial crisis with the concepts provided by Minsky, which is centrepiece in the next chapter on catastrophe theory.

## REFERENCES AND FURTHER READING

- Keen, S. (1995). Finance and Economic Breakdown: Modelling Minsky's "Financial Instability Hypothesis". *Journal of Post Keynesian Economics*, 17(4)(Summer), 607–635. The Analysis Includes a Discussion Outlining the Basic Model of Minsky.
- Keen, S. (2011). *Debunking Economics, The Naked Emperor Dethroned?* London: Zed Books. Chap. 13. There Is Also the Same Summary of Minsky's Basic Model in this Book on Pages 326–330, as in the Previous Article.
- Keynes, J. M. (1982). Activities 1931–1939: World Crises and Policies in Britain and America. In D. Moggeridge (Ed.), *The Collected Writings* (Vol. 21). London: Macmillan, Cambridge University Press, St. Martin's Press for the Royal Economic Society.
- Minsky, H. P. (1975). *John Maynard Keynes*. New York: McGraw-Hill Professional.
- Minsky, H. P. (2008). *Stabilizing an Unstable Economy*. New York: McGraw Hill. The First Edition Published in 1986 by Yale University Press.
- Roubini, N., & Mihm, S. (2010). *Crisis Economics: A Crash Course in the Future of Finance*. New York: Penguin Books.
- Schumpeter, J. A. (1943). *Capitalism, Socialism and Democracy*. London: Routledge (Reprint, 1992).
- Thomas, D. G. (1999). *The Diffusion of Output Expectations* (Economics Paper 19, Working Paper Series). Hertfordshire Business School.
- Watt, R. (2011). *The Microeconomics of Risk and Information*. Basingstoke: Palgrave Macmillan.
- Wheelock, D. C. (1992, March/April). Monetary Policy in the Great Depression: What the Fed Did, and Why. *Federal Reserve Bank of St. Louis Review*, 74(2), 3–28.
- Wolfson, M. H. (2002, June). Minsky Theory of Financial Crises in a Global Context. *Journal of Economic Issues*, XXXVI(2), 393–400.



# A Catastrophe Theory of the Endogenous Cycle of Loanable Funds

## 8.1 INTRODUCTION

The purpose of the analysis here is to build on the hybrid model of the loanable cycle developed in Chapter 3, which can be linked to Minsky's financial instability hypothesis outlined in Chapter 7. It is essentially non-linear because of the presence of multiple equilibria and to accommodate the evolutionary process of loanable funds, which depends on the change of the deposit base of banks as well as the degree of risk that prevails within the monetary system, manifesting itself in the scale of risk. The deposit base,  $D_p$  in the aura of uncertainty and risk, underpins the variables of  $CA^*$  and  $r$  that reside in mm alongside  $MB^D = MB^S$ , and, therefore, shape the geometric interdependence of the money multiplier mechanism: in the form of either creation or destruction of electronic (or digital) bank liabilities as a medium of exchange. The behaviour of CA and RE indirectly affects  $D_p$ . If the former variables are rising, then the latter declines, therefore, so does the endogenous money supply from the lapse of digital loans and credit. Thus, the endogenous change of inside money (or loanable funds),  $\Delta LO_p$  is a disequilibrating variable that should belong to a dynamic framework, such as catastrophe theory, to capture the stimulus-response behaviour that leads to financial instability within the economy. The neoclassical methodology of comparative static equilibrium cannot accommodate such a dynamic mechanism. This is why traditional economics has remained in the 'dark-age' as far as explaining the evolutionary process of the monetary system is concerned.

The sole objective here is combined the deposit base with uncertainty and risk to explain the creative as well as destructive power of loanable funds that underlies the evolutionary mechanism.

To capture and focus on this moving target, the analysis calls upon one of the general constructs of dynamic behaviour: catastrophe theory, which provides a framework of thought that is suitable for observing monetary behaviour over the process of evolutionary time. The distinguishing feature of the model is the explanation of catastrophic effects (or Minsky Moments) that come from abrupt changes in the endogenous money supply of loanable funds. The exercise also allows market forces underlying the theory to pursue paths of development for long periods because of over confident agents. Ultimately, however, their coercion could well pilot a sudden, catastrophic shift in behaviour, leading to long periods of underdevelopment because agents lose their confidence. The inertial quality of the monetary system, emphasised by the deposit base of banks and augmented by uncertainty and risk, is unified within the dynamic framework of catastrophe theory. Thus, the loanable funds cycle is modelled as a 'cusp-catastrophe'.

The main reason for entertaining the more radical, novel approach of catastrophe theory, with regard to the cognizance of money and credit, is that research within the orthodox framework is not providing the answers to explain the dynamics of loanable funds that lead to nonlinearities within monetary systems. Most of macroeconomics at present, following the physical sciences of the early twentieth century, is relentlessly linear in its modelling. For this reason, macroeconomics is over-looking nonlinearities in the same way that the physical sciences have done previously. The alternative view is much more complex than the simple, neo-classical one and differs in certain fundamental respects.

Although simple models serve to focus attention on certain variables and relationships, it is perhaps time to entertain a struggle with complexity. It is not, however, merely intricacy that is the difficulty, but the requirement for a clear, definite and fresh approach (Nelson 1981). This will be different from the traditional approach. The evolutionary model proposed may well be relatively primitive compared with the advanced state of neoclassical modelling. The narrative superimposed, therefore, could well be incorrect in many respects, but the analysis illustrates sufficiently the feasibility of applying the framework of the money wheel of economic circulation within the monetary system. From this discussion, the plan is to pursue the integration of the deposit base with uncertainty



and risk into the model of the loanable funds cycle based on the catastrophe supposition, a subset of chaos theory. The next step, within this framework, is to analyse the theory in the light of adjustment mechanisms and inner feedbacks of dynamics.

## 8.2 THE CATASTROPHE THEORY OF THE ENDOGENOUS CYCLE OF LOANABLE FUNDS

The catastrophe speculation is one of the unique methods that attempts to explain sudden shifts in behaviour. The effects are catastrophes in the sense that the underlying sequence of market forces makes the consequences of the discontinuity so unexpected (Zeeman 1977). Keynes (1936) in the *General Theory* highlighted this fact in Chapter Twenty-Two of his book, he writes on p. 316 that ‘.....when disillusion falls upon an over-optimistic and over-bought market, it should fall with sudden and even catastrophic force’.

The catastrophic fluctuations in retail banks’ money supply, that is the creation and destruction of financial funds in the form of loans and credit that finance durable consumption in exchange as well as the creation of goods and services in production, are represented as ‘ups’ and ‘downs’ along the upper and lower sheets of the cusp-catastrophe, as illustrated in Fig. 8.1.

The analysis builds on the format of Zeeman (1977), Plath et al. (1992) and Oliva (1991). The measurement axes of  $\Delta LO_t$ ,  $\Delta D_t$ ,  $\Delta C_t$  construct the three-dimensional Euclidean domain,  $R^3$ , with  $\Delta LO_t$  as the vertical coordinate,  $\Delta D_t$  and  $\Delta C_t$  denoting the horizontal plane. In this model,  $\Delta LO_t$  represents the behavioural variable of interest, whilst  $\Delta D_t$  and  $\Delta C_t$  are the control variables that partly determine the former, which form of a first-order differential of the following:

$$F(\Delta LO_t, \Delta D_t, \Delta C_t) = 0 \quad (8.1)$$

$\Delta LO_t$  is the change in loanable funds (the creation or destruction of loans) with  $\Delta D_t$  representing the change in the deposit base of commercial banks;  $\Delta C_t$  denotes the uncertainty that translates into risk and feeds into  $\sigma_R$  of the mark-up within the market rate of interest charged on borrowing as well as  $CA^*$  and  $r$  of the money multiplier, which partly determines the profits within retail banks. If depositors sense risk over the banking sector, then households and firms will hold more cash, whereas if banks experience accumulative risk through increasing loan

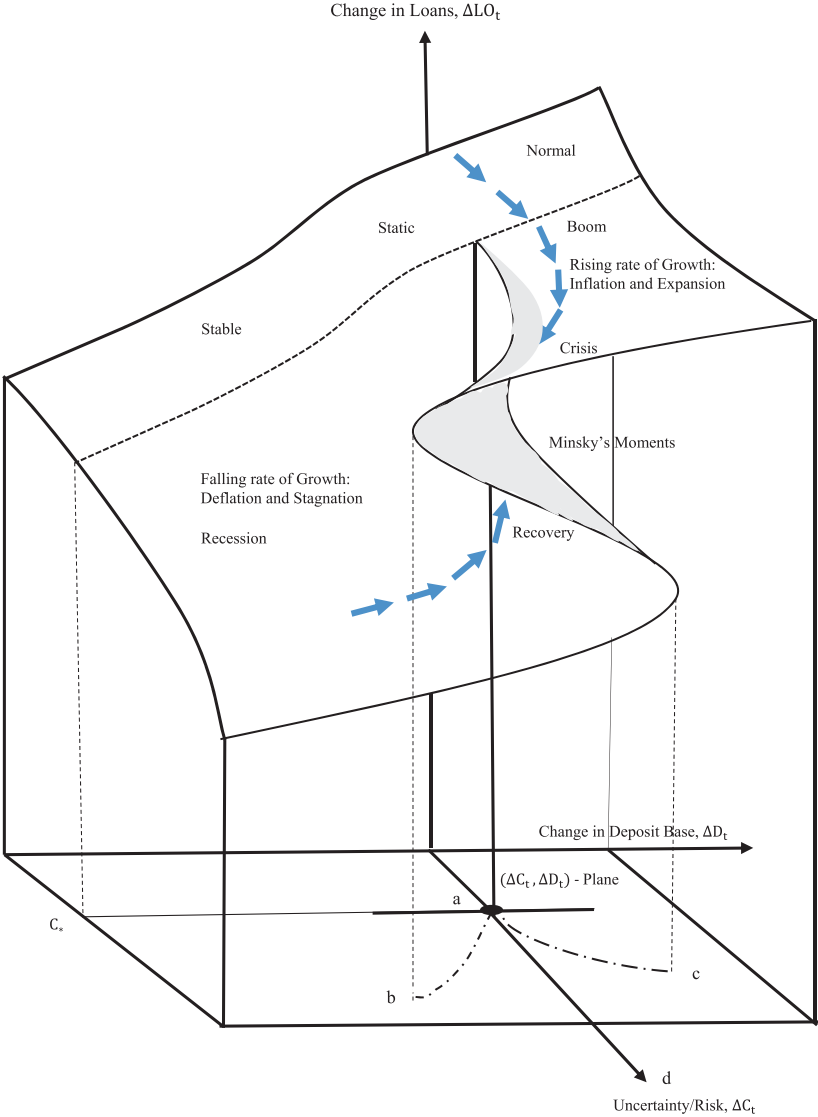

Fig. 8.1 A catastrophe model of endogenous change in loanable funds

defaults, then they build excess reserves in response. Both these factors decrease the money multiplier. It represents the ‘splitting factor’ within the model, dividing the surface into sheets, because the variability of uncertainty through risk increases as its value moves from the origin, (i.e. from the rear to the front), where a point is reached when the plane splits (bifurcates) into two directions.

The cusp-catastrophe is outlined in some detail by the Zeeman’s (1977) book of selected papers, where it is suggested that the response surface, shown in Fig. 8.1, is obtained by setting the change in loanable funds within the following function equal to zero:

$$F = \frac{1}{4}LO_t^4 - \frac{1}{2}(\Delta C_t - C_*)LO_t^2 - \Delta D_t LO_t = 0, \quad (8.2)$$

$$\frac{\partial F}{\partial LO_t} = LO_t^3 - (\Delta C_t - C_*)LO_t - \Delta D_t = 0, \quad (8.3)$$

where  $C_*$  represents the beginning point of the discontinuous feature of the system. Equation (8.3) gives rise to the catastrophe surface, where the folded shape produces the cusp. The bifurcation area of points is derived by projecting the upper and lower fold curves down onto the horizontal plane in  $\Delta C_p$ , which is denoted by line segments ab and ac. This sector provides the particular  $(\Delta C_p, \Delta D_p)$  combinations that motivate abnormal changes in the amount of loans.

In fact, it is the crossing-over the boundary line,  $C_*$ , which introduces unpredictability into the change in loans, which is the growth in the money supply via uncertainty and risk along with the change in the deposit base. A stable path for the rate of growth of money occurs when  $\Delta C_t < C_*$ , depicted by the back portion of the surface. The low degree of uncertainty in the form of risk will mean smooth changes in the  $\Delta D_t$  parameter that lead to monotonic modifications in  $\Delta LO_p$  and therefore, the outcome is a modest oscillation in the amount of loans. Sequentially, the larger the dose of uncertainty and risk, the greater  $\Delta C_t$  is, and hence, the growing insecurity. This leads to the precarious interchange between the deposit base and the change in loans that provokes the division of the surface into two, namely values of  $\Delta C_t > C_*$ . The flows of the change in loans are indicated by arrows are developed further in Fig. 8.2.

Moreover, if the  $\Delta C_t$  variable positions itself over the bifurcation edge, this will cause a significant transposition in the amount of loans,  $\Delta LO_p$ , in conjunction with the deposit base. For example, on the one

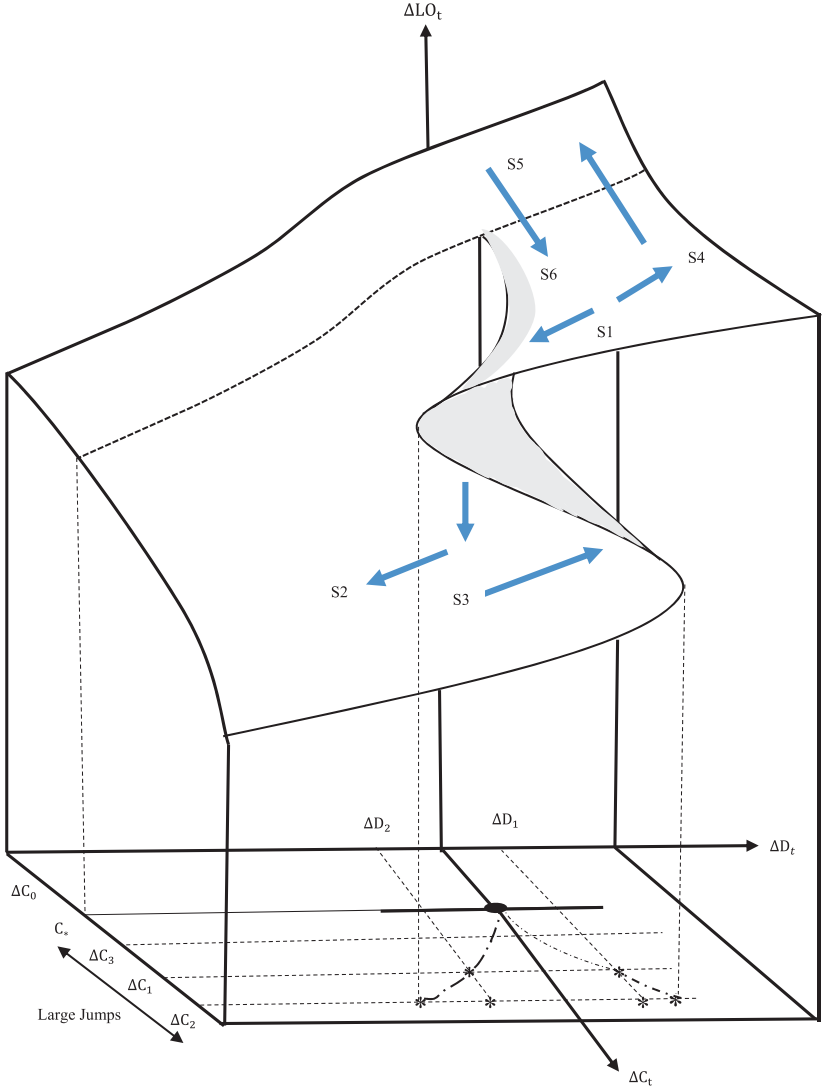

Fig. 8.2 Changes in the endogenous growth of the money supply through loanable funds

hand, if it is supposed that whilst on the upper sheet of the fold in Fig. 8.2,  $C_t$  is at  $\Delta C_1$  and the change in the deposit base falls enough to pass the bifurcation line, from  $S1$  to  $S2$ , then there occurs an abrupt transformation in loans granted by way of a reduction in loan creation. On the other hand, if the change in loans is at  $S3$  such that  $\Delta C_t$  is equal to  $\Delta C_2$ , and the deposit base this time increases from  $S3$  to  $S4$  over the bifurcation border, there will be a striking enlargement in  $\Delta LO_t$ , onto the upper plane moving loan growth over the manifold.

The deduction is that, for some given value of  $\Delta C_p$ , a small shift in the value of  $\Delta D_p$ , the change in the deposit base, could produce a large, discontinuous adjustment in  $\Delta LO_p$ . For other values of  $\Delta C_p$ , however, the same variation in  $\Delta D_t$  can lead to just a moderate change in loans along the surface. It may be observed, then, that fluctuations in  $\Delta D_t$  could produce catastrophic jumps in  $\Delta LO_t$ , as in the case of  $\Delta C_t = \Delta C_2$  in Fig. 8.2. At  $\Delta C_3$ , however, a lower reading of risk that comes from uncertainty, the same alternation in  $\Delta D_t$  leads only to small fluctuations in  $\Delta LO_t$ . Clearly, the behaviour of  $\Delta LO_t$  is partially attributed to  $\Delta C_t$  as a splitting factor, the uncertainty content, measured by risk, increasing instability. The arrows in Fig. 8.1 show that as uncertainty escalates the change in loans becomes insecure, demonstrating this increase of precariousness. This shows how the variation in loans' sensitivity depends on the initial conditions of the variables.

To reiterate,  $\Delta C_t = C_*$ , if then there will be a smooth monotonic change in  $\Delta LO_t$ , which follows a uniform change from rising to a falling alteration in loans, or vice versa, shown from A to B in Fig. 8.3 overleaf. Contrariwise, if the value of  $\Delta C_t$  is greater than  $C_*$ , for example,  $\Delta C_1$  in Fig. 8.2, then the asymmetric behaviour can mean that a large proportion of uncertainty, translated into risk, may lead to a movement from  $S5$  to  $S6$ , out of the monotonic area at the back of the diagram, meaning a fall in the change of loans from A down towards B in Fig. 8.4 overleaf. The change in loans remains high until it reaches B, then it 'fall off' the plane and heads towards the attractor surface of  $B_1$ . What is more, the larger the distance, as in the case of  $\Delta C_1$  or  $\Delta C_2$  in Fig. 8.2, the sharper the catastrophic descent in the adjustment of loans because of the high degree of uncertainty and risk, leading to pessimistic intentions to lend.

This is comparable with a 'collapse' situation, Minsky Moment, as opposed to a smooth movement downwards in the growth of money as the banks destroy part of the deposit base within itself by not renewing

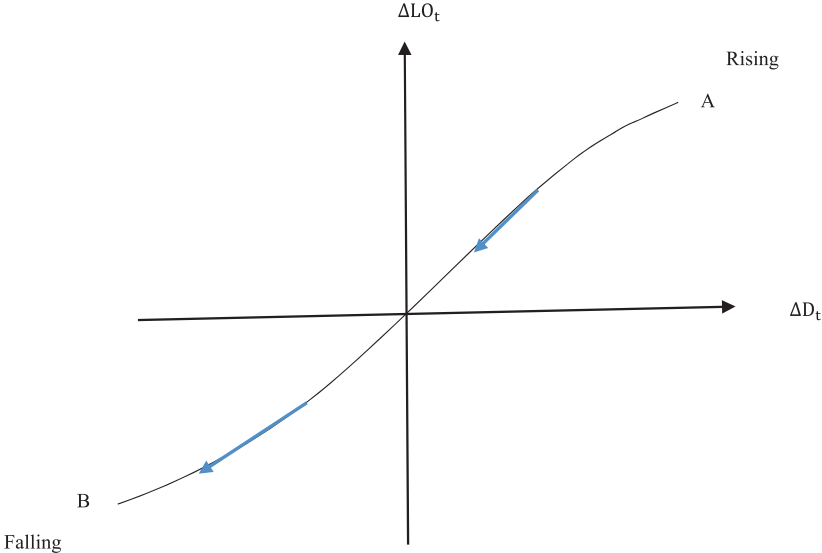

Fig. 8.3 Uniform change from rising to a falling adjustment in loans

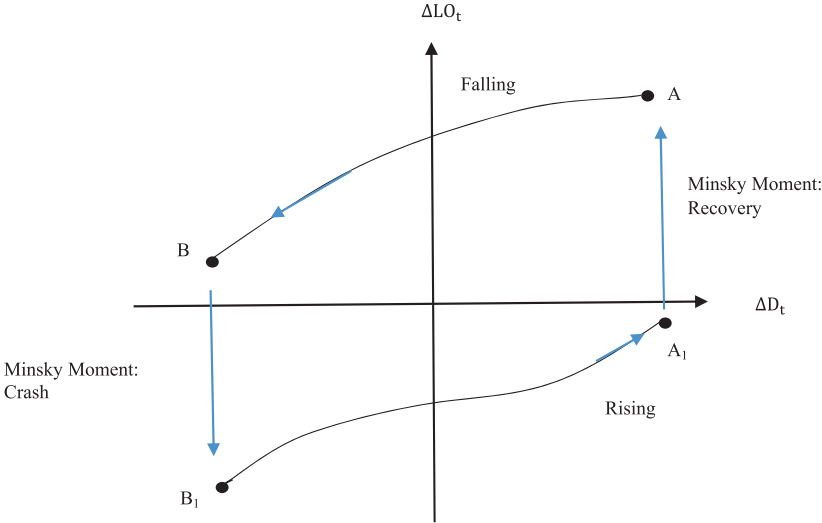

Fig. 8.4 Catastrophic changes in the endogenous loans

or failing to grant new loans along with pressure on agents to pay off credit to reduce the real burden of debt. On the other side of the coin, as confidence swells with the deposit base, there is a movement from  $B_1$  towards  $A_1$ , but the change in loans remain low until it reaches the boundary point  $A_1$ , where the Minsky Moment will be a jump up to a rising money growth rate as the banks create depositary loans out of itself again. Unfortunately, reaching  $A_1$  could be subject to delay by the instincts of 'pack' behaviour and that bankers are ruled by bounded rationality, meaning that these are the major determinants of the rate of growth of the money supply through loan creation in the midst of uncertainty and risk in a slump period.

Given the fact that some loan decisions are irreversible, this augments the pattern of behaviour because there are plenty costs and clauses to prevent early payment and reduction in the current debt burden. This prevents the fall in the debt-to-income ratio. Whereas credit ratings that are associated with credit-rationing of the supply of loanable funds in the downturn period, both physically constrain agents from deviating from their present path of equilibrium and, consequently, delay the recovery process. These factors are the basic source of long-term regularity in agents' behaviour before catastrophes take place. Nevertheless, the never-ending forces of change, induced by the market mechanism, will produce an abrupt shift in behaviour and the return to the so-called norm once the recovery path is in full swing and the crisis gives way to tranquillity as the economy transposes from Schumpeter's creative destruction process. This arises from the collective mass of individual actions of agents moving in a particular direction, imposing mutation on the macro-system.

The study has reached the stage that requires investigation of the flows describing the feedback mechanisms: the flow lines Figs. 8.1 and 8.2. Assuming a positive change in loans means a rising adjustment in the deposit base as the normal state of the market. If, however, the presence of uncertainty (or risk) is high, then it is unlikely that the change in the deposit base will remain constant. There will be a response mechanism to the change in the deposit base via investment and consumption, which in turn induces the change in the rate of growth of money via loans.

The analysis immediately prompts the question, why is the possibility of an abrupt change from a rising rate of loans to one that is plunging for no explicit reason? Behind the feedback mechanism, for example,

growth of real investment that is positive with a high degree of change on the deposit base, which is dependent on expected real income (or output). Embodied in this process of growth is the element of diminishing marginal productivity of capital, which translates into the exhaustion of investment opportunities within the production process. The law of diminishing marginal utility in exchange, exhausting consumption possibilities reinforces this process as well. The high growth rate will mean increased exploitation of capital equipment and consumption goods in production and exchange, and eventually, the marginal product as well as utility will weaken, especially because of the conflict between existing and recent additions (Keynes 1936). Additionally, the surviving capital structures will be subject to the depreciation law, which succours the law of diminishing marginal returns, since they have no independent means of maintenance (Foster 1989; Georgescu-Roegen 1976). The repercussion is the inherent tendency for the marginal efficiency of capital, and, in particular, the expected output (or real income) to modulate and, therefore, change the deposit base as technologies and industries mature on account of the law of diminishing marginal utility setting in at the macro-level. In other words, successful investment leads to consumption, and therefore, through the laws of diminishing marginal productivity of capital in production and utility in exchange, means it contains its own seeds of extinction (Schumpeter 1943). The real problem here is that more output, from new investment, can only be sold at lower prices; often, unexpectedly, at a loss, not a profit.

This factor, however, will be insignificant in the short run, because production of new capital along with consumption goods and services will only be a very modest slice of the existing stock. Clearly, this component will become doubly important as time wears on, and the prominent growth persists. It is when these limits to growth in expected output (or real income) seriously threaten future profits based on imperfect information that the high risks and costs of trying new technologies appear to be clearly justified. It is in this way that new technological systems gradually crystallise and restore confidence to investment decision-makers. This crucially depends on whether the banks are willing to create loans from the eventual change in deposit base,  $\Delta D_p$ , which converts into a lower  $CA^*$  and  $r$  in the money multiplier mechanism.

Moreover, the tendency for the marginal efficiency of capital to dwindle with increased investment comes with mounting marginal costs of the capital goods industry, which, in itself, fuels a rise in the supply price.



It is the pressure to produce additional, large, costly units, like industrial buildings and specialised machinery, which induces the fall in the expected rate of profit of the user firms. Additionally, there is the tendency for the law of diminishing marginal utility of consumption to set in at some stage in the product development process, leading to falling prices in the market for exchange. These links are instrumental in the progression of change in abating high growth of investment.

In this *milieu*, it is common practice, however, for agents to scorn information about the imminent trend because there exists a natural reluctance to change established habits. There is, therefore, the urge for agents to formulate reckless expectations and for bankers to make irresponsible loans to speculative and Ponzi borrowers based on risky investment projects. The corollary is speculative investment that has a low likelihood of success, so increasing the aura of uncertainty: a herd externality of thinking occurs, a herd mentality. The critical point is that agents are choosing not to evaluate relevant information, but, preferably, to ‘blank’ it out (Simon 1979). Consequently, management within mature industries with low prospects for growth, but with experience of earning large cash surpluses from previously profitable investment, will be most tempted to misinvest and take out speculative (or Ponzi) loans from the banking system.

A protracted cycle of expenditure on capital and consumption shifts the demand for loanable funds to  $LO^D_0$  in Fig. 8.5 and induces an upsurge in the expected real rate of interest to  $r_{i_0}$  on loanable funds, which is equal to

$$r_{i_0} = i_0^B - MU, \quad (8.4)$$

where  $i_0^B$  is the borrowing rate, fixed by the retail banks,  $MU$  is their mark-up and embodies,  $E_t \Delta P_{t+1}$ , the expected rate of inflation. At the pinnacle, this rate in the short run will be significantly higher than anticipated in the long term. Furthermore, it is likely that the expected inflation has expedited during this boom cycle, particularly in the sphere of capital goods. If inflationary expectations are operative in reducing the expected real rate, then nominal values must rise by much more with the credit risk.

Nevertheless, deteriorating investment opportunities in terms of the expected profit will influence current information and reach a critical level that will produce a sudden reaction by bankers to reduce anticipated loans and credit because of rising default risk. The response

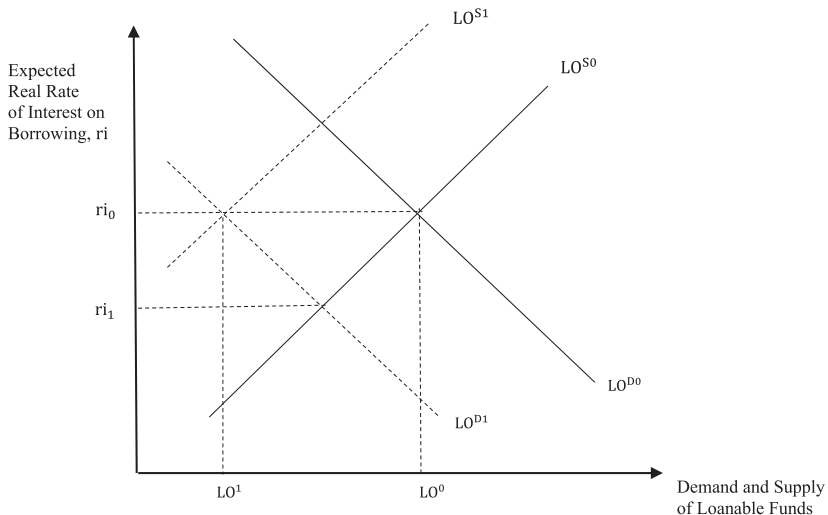

Fig. 8.5 Demand and supply of loanable funds

represents a cumulative effect of all the information, in the sense that the last straw placed on the camel’s back will cause a sudden catastrophic collapse of the animal (Peters 1991).

The end result is the postponement of investment intentions and the demand for loanable funds at  $r_{i0}$  reduces, shifting inwards towards  $LO^{D1}$ , brought about by the ‘last straw’ in terms of the high nominal rates of interest leading to a financial crisis in many firms and households. Hence, the revaluation by bankers of their loans made will shift the supply curve of loanable funds to the left,  $LO^{S1}$ . The money multiplier magnifies this unforeseen, reflexive action, although becoming smaller because of the dwindling deposit base ( $D_t$ ) within the cash,  $CA^*$  and reserve,  $r$  ratios. This will induce by-product effects from the growing demand constraint, arising from the Keynesian multiplier in transit with the downward propensity of loans, portrayed in Fig. 8.5.

The cycle of events is responsible for a furious, dynamic drop that causes the behaviour of bankers to follow the surface area in Fig. 8.1. Thus, the arrows on the upper sheet come forward with a brisk turn to the left. Therefore, with loans remaining constant,  $C_t$  increases in Fig. 8.2, causing a movement from  $S5$  to  $S6$  along the dashed line at  $\Delta D_1$ . What has happened is that  $C_t$  has increased beyond  $C_*$  so there

is bimodality. Although the change in loans is positively high, and everything seems fine in the ‘Garden of Eden’, there is a prominent degree of uncertainty and risk coaxing the instability. This increasingly high level of apprehension in the economy, which is a *malaise* that prevails before the crash descends in the growth rate of money through the process of loans, yet to be recognised.

At this point in the cycle, before the financial collapse, the uncertainty and risk emanate from the rising, expected real rate of interest on borrowing that leads to a greater supply of loanable funds available to the speculative and Ponzi borrowers. This naturally, adversely selects, in the midst of moral hazard, those speculative, risky projects with a low probability of success in terms of expected profit: the ‘lemons’ (Akerloff 1970). The malefactor is the declining MEC that comes from the long period of relatively high growth of investment and consumption with a high rate of inflation. In other words, the high borrowing rate perniciously picks those projects of the speculative and Ponzi borrowers that have a paltry chance of earning a successful prospective yield, because of the high degree of risk of default attached to them (Stiglitz and Weiss 1981, 1986). This ‘boomerang effect’ leads to catastrophic cycles within the monetary economy on account of the adverse selection of speculative and Ponzi borrowers.

Moreover, the massive uncertainty and risk lead to some banks postponing long-term loans for investment and consumption plans to lessen the losses from default. This decreases the excess demand and inflationary pressure, which may even lead to excess supply and a deflationary process with negative income effects. Hence, the arrow at  $S1$  in Fig. 8.2 represents a significant decrease in the deposit base that flows from the falling growth rate of loans, because informed bankers’ expectations are tumbling because of an increased awareness that the economy is going into downturn. Thus, the change in the deposit base falls rapidly and leads to the growth rate of money dropping off the edge from  $S1$  to  $S2$ . To put it another way, this means a mammoth dive in the deposit base occurs, perpetuated by the continued decrease in aggregate demand and supply imposed by the money multiplier effect,  $mm$ , reinforcing the expenditure constraints. The deterioration in consumer and entrepreneurial aplomb means that expectations become self-fulfilling. The combination of these factors takes the change in loans over the bifurcation line and, then, plunges off the ledge onto the lower attractor plane. The higher the proportion of speculative investment financed by loanable

funds to speculative and Ponzi borrowers before the downswing, the more deep-seated the recession becomes with deflationary processes and debt restructuring.

The crumbling rate of growth of money, although it may still be positive, with deflationary tendencies provoke the schematic scrapping of the existing capital stock to service and pay off outstanding debts, and if severe, the bankruptcy of previously efficient firms. The hedge borrowers become speculative debtors whereas the latter turn into Ponzi as the rules of selection by market forces have changed so abruptly. There ensues a period of painful restructuring of debt and loanable funds made available from banks.

There comes a period, however, when seeds for recovery of the economy are planted to accommodate the coming wave of new technologies. This, in turn, flows from the deliberate research and development activity into radical innovations in response to the downturn in economic activity. As a result, this provides a potential platform for the growth of loanable funds and the expansion of the deposit base, which means that the money multiplier grows rapidly to finance expected output into new segments of the market. All this means a big jump in the growth of money via loans to aid recovery. This may well be presumptuous in that the initial innovations out of recession, made by the talented entrepreneurs, must turn out to be productive: then, the less able ones will follow suit by adapting and cloning the ideas of the innovators. The bankers, consequently, perceive that the risk of default is subsiding and back the less gifted with loans. A gush of comparable innovations then follows, which quickly recedes. These surges are a natural characteristic part of the creative, destructive process within the capitalist economy augmented by a monetary system of loanable funds.

The wave of innovations reveals itself as information that the plummeting trend in the change of the deposit base is flattening out arises, because expected output is upwards. The doors are now open for new satisficing firms (Cyert and March 1963), representing a fresh supply of hedge borrowers, to undertake profitable investments with bank loans in innovative forms of production and products that will lead to the expectation of a higher deposit base, ensuring a greater money multiplier with profitability within the MEC. Although the market is depressed, with process undervalued resulting in losses in the short run for speculative and Ponzi borrowers, these losses are offset by greater gains in the long run from the growing proportion of hedge borrowers, as the change in

the deposit base is upwards along with money growth by means of the money multiplier. Accordingly, the arrows on the lower attractor plane go back and bend to the left as shown in Fig. 8.1. This cusp archetype exhibits a discontinuous change in reverse, as in case of S3 in Fig. 8.2, where the monetary economy is gradually recovering with small increases in the growth of money through loans,  $\Delta LO_t$ .

This growing optimism from hedge borrowers for loanable funds and the deposit base evolves out of the conceivable prospective yields that could arise from the new technologies and, therefore, from the potential upward shift in the MEC out of the doldrums of growth recession. This new-found confidence, that stems from the upward direction of the deposit base with future output, steers the economy to the edge of the bifurcation boundary, where there is a discontinuous effect in the direction of loanable funds: upwards. Money growth, therefore, could leap up in an unanticipated, dramatic fashion to the position of S4 in Fig. 8.2. Additionally, if in the process, uncertainty reduces (which is more than likely in this atmosphere), then the economy's change in loans moves back into the stable area of predictability and poise. What the analysis is showing is that market forces over the course of real time will be endogenously producing change, and thus, it is unlikely that the economic system will settle down to any stable equilibrium.

The missing piece of the jigsaw, however, is the public sector with its automatic fiscal stabilisers that can speed-up the process of adjustment and recovery, sending the economy back to the upper surface of monetary growth and expansion. This could be a dampening process, reinforcing the recession if the Government of the day sees the picture of austerity, then the natural recovery process is essentially postponed within the economy, because it is sucking out income, decreasing aggregate demand and supply as well as reducing the deposit base, and therefore, augmenting the money multiplier reduction along with the Keynesian one.

### 8.3 THE CONCLUSIONS TO BE DRAWN

The general characteristic of the proposed model of loanable funds is the cycle of growth, boom, crisis, recession and recovery, with protracted periods when the active forces of the market move only gradually, but these then alter abruptly, without much warning, to change the rules of selection. What underlies the hypothesis is the money multiplier

underpinned by the deposit base that links to loan growth, the marginal efficiency of capital, the expected change in output as well as technology through the micro-evolutionary processes within the macroeconomy.

The theory also suggests that, even without exogenous shocks, there is a natural tendency for monetary behaviour to oscillate for no apparent reason: the financial system produces its own endogenous, disruptive forces of change, the 'boomerang effect'. This occurs because of the key rôle played by the change in loans to various borrowers, in conjunction with the limited ability to process information possessed by bankers, entrepreneurs and households. The bounded rationality framework is essentially shaped by recent history, making the economic machine short-sighted and characterised by high 'holistic effects', self-fulfilling expectations, irreversibility of loanable funds and feedback mechanisms that generate a 'vicious' cycle of monetary activity. Finally, the analysis reveals the importance of inflation and expectations as vital variables in the study of nonlinear dynamics of the monetary system, and therefore, it is necessary to construct an inflationary model with money as the wheel of circulation as centre stage.

#### REFERENCES AND FURTHER READING

- Akerloff, G. (1970). The Market for Lemons: Qualitative Uncertainty and the Market Mechanism. *Quarterly Journal of Economics*, 84, 488–500.
- Cyert, R. M., & March, J. G. (1963). *A Behavioral Theory of the Firm*. Englewood Cliffs: Prentice-Hall.
- Foster, J. (1989). *Evolutionary Macroeconomics*. London: Unwin Hyman.
- Georgescu-Roegen, N. (1971). *The Entropy Law and the Economic Process*. Cambridge: Harvard University Press.
- Keynes, J. M. (1936). *The General Theory of Employment, Interest and Money*. London: Macmillan.
- Nelson, R. A. (1981, September). Research on Productivity Growth and Productivity Differences: Dead Ends and New Departures. *Journal of Economic Literature*, 19(3), 1029–1064.
- Oliva, T. A. (1991, May). Information and Profitability Estimates: Modelling the Firm's Decision to Adopt a New Technology. *Management Science*, 37(5), 607–623.
- Peters, E. E. (1991). *Chaos and Order in the Capital Markets: A New View of Cycles, Prices and Market Volatility*. New York: Wiley.
- Plath, A. D., Krueger, T. M., & Jolly, S. A. (1992). Dynamical Systems Model of Capital Asset Pricing. *Mid-Atlantic Journal of Business*, 28, 253–283.

- Schumpeter, J. A. (1943). *Capitalism, Socialism and Democracy*. New York: Harper & Row.
- Simon, H. (1979). Statistical Behaviour Under Uncertainty. *American Economic Review*, 59(4), 204–224.
- Stiglitz, J. & Weiss, A. (1981). Credit-Rationing in Markets with Imperfect Information. *American Economic Review*, 71, 393–410.
- Stiglitz, J., & Weiss, A. (1986). Credit-Rationing and Collateral. In J. Edwards et al. (Eds.), *Recent Developments in Corporate Finance*. Cambridge: Cambridge Press.
- Zeeman, E. C. (1977). *Catastrophe Theory: Selected Papers, 1972–1977*. Reading, MA: Addison-Wesley.



# Rebuilding the Theoretical Model of Inflation on Credit with Loanable Funds

## 9.1 INTRODUCTION

This chapter presents a theoretical model of inflation based on loanable funds, derived from aggregate demand and aggregate supply, which gives centrepiece to loanable funds with expectations of output and price growth in the monetary cycle of self-fulfilling dynamics derived in the catastrophe model. Despite long periods when there have been substantial changes in monetary policy, in particular, the ‘monetarist experiment’ of 1979–1984 as well as the subsequent and gradual adoption of interest targeting, there has been a failure to control the generation mechanism of loans, and therefore, the money supply growth.

On coming to power in 1979, the Thatcher administration tried to tackle both inflation and the budget deficit, underpinned by Monetarism. The belief of Monetarism was that in order to control inflation, it was necessary to regulate the money supply generated by government debt. This proved difficult because the theory did not take into account the endogenous nature of the money supply via loan creation. It assumed exogenous control by the monetary authorities. The resulting attempt to reduce the fiscal accumulation of debt was extremely deflationary. Taxes rose, government expenditure fell, and borrowing costs soared. These measures did eventually reduce inflationary growth at the cost of falling aggregate demand and lower economic growth, leading to a full-scale recession in 1980 in terms of mass-unemployment, associated with social problems that sparked off riots in inner cities in 1981.



Despite these measures, the growth of the money supply remained stubbornly high because of the high borrowing rate of interest encouraging the growth of the money multiplier and the creation of loans. In other words, the theory assumed that the government deficit and outside money are the all-important components, when, in fact, it is the creation of inside money by retail banks that matters.

The recent stain on UK monetary history is the financial crisis of 2007/2008 sparking off the stagnation of economic activity, followed by a growth recession that seems never-ending. In the current climate, there has been the taking up of various ad hoc responses to the growth recession, in the aftermath of the financial crisis in 2007, especially the policy of ‘quantitative easing’, which has been adopted globally. Successive rounds of this monetary instrument by various governments since 2008 have caused enlargement of outside money in the form of increased banking reserves within MB, but this has failed to enhance the endogenous creation of inside, loanable funds by the banking system to finance recovery of aggregate demand and supply. Thus, it is necessary to include the element of money that is endogenously determined by the retail banks through the process of loans within the theoretical framework that determines the rate of inflation. This adds further legitimacy for a fresh examination of the theoretical causality. The key contribution of this chapter is to restore the money market mechanism as a core part of the analysis, although in the form of representing the contribution of loanable funds that come from the commercial banks. This part of the framework is often left out in the traditional approach because its determination is assumed, erroneously, to be by the monetary authorities and, then, to be exogenous to the model. The next section provides a summary review of recent theoretical debates that will help to set the scene for the current examination, followed by the deviation of a model of inflation based on aggregate demand and supply, which restores ‘money as loans’ along with expectations of output and inflation.

## 9.2 THE THEORIES OF INFLATION

The determination of inflation can be analysed in the ‘Classical’ or the ‘Keynesian’ versions of the expectations augmented Phillips curve. The theoretical debates of the Phillips curve can be analysed as special cases of the following equation:

$$\Delta P_t = \alpha E_t \Delta P_{t+1} + \beta \Delta P_{t-1} + \gamma z_t + \varepsilon_t, \quad (9.1)$$

where  $P_t$  is the price level and the change;  $\Delta$ , is the rate of inflation;  $E_t$  indicates expectations at time,  $t$ ; and  $\varepsilon$  is a residual term, which may be serially correlated (e.g. a moving-average process as in Taylor's model). What really differentiates theoretical studies is how  $z$  is defined. It could be about an 'output gap' as in the new Keynesian Phillips curve case or about real money growth in a Quantity Theory of Money (QTM) context. Typical measures of  $z$  include the deviations of the actual unemployment rate from the natural rate (as in the Friedman (1968) and Phelps (1968) type models), or the variation of the firm's actual price from its optimal one (as in Rotemberg's 1982 model), or a measure of the expected real marginal cost (as in Galí and Gertler 1999; Sbordone 2002).

If the emphasis is on money in the form of loans and rational expectations, then  $\alpha$  should take the value of unity, and  $z_t$  should include some measure of money. If expectations formation is adaptive or the price adjustment mechanism is sticky, which means bounded rationality,  $\beta$  should be statistically significant and positive. If the emphasis is on Phillips curve aspects, then  $z_t$  may include output, employment or other variables. For the conventional QTM and thus neutrality of money to hold, it should be expected that  $\alpha = 1$ , whilst  $\beta$  is statistically insignificant and  $\gamma$  is statistically significant on monetary variables.

There are conflicting empirical results here. For example, Bården et al. (2005) re-examined the data employed in two studies (Galí et al. 2001; Batini et al. 2000) and found that the statistical results were rather weak, which might be a symptom of the omission of a key variable from the Classical and new Keynesian Phillips curve framework of analysis: loanable funds. The implication is the exclusion of the LM curve, or the banking sector, leaving only the 'IS curve' in the specification of the aggregate demand side of the economy (Arestis 2011). In fact, many researchers in this field proceed without introducing money and loans directly into the study. For example, Kerr and King (1996) discuss how one can manipulate an IS curve to study the limits on interest rate rules. Clarida et al. (1999) carry out their analysis of monetary policy without specifying a function of demand and supply of loanable funds. The absence of the depositary market from the specification of the aggregate demand and supply sides can lead to the omission of potential financial portfolio adjustments on inflation and income by firms and households.

Empirical studies for the US economy (for instance, Bywaters and Thomas 2011 along with Hoover, Demiralp and Perez 2009) are relevant. The econometric study by Bywaters and Thomas (2011), over the period 1960–2007 for the US economy, shows that there is a statistically significant link between the rate of inflation, real money balances, income and interest rates on saving. Empirically, potential output and related estimates of the output gap were unsuited to capture the aggregate demand and supply shocks that create inflationary pressures.<sup>1</sup> Therefore, the present study brings back money in the form of loanable funds and production growth together with expectations, in order to explain inflation, disinflation or deflation. The assumption is that economic agents respond to real and not nominal values, and therefore there is an absence of systematic money illusion.<sup>2</sup> Instead, the theoretical model incorporates forward-looking **price** and **output** expectations into the model. This theoretical analysis provides guidance on the qualitative relationship between inflation and potential determinants, although the quantitative strength and especially the rich dynamics of the relationship is a practical matter of econometric estimation. The next part formally introduces the theoretical model.

### 9.3 THE PROPOSED THEORETICAL MODEL OF INFLATION WITH LOANABLE FUNDS

From the discussion in the previous chapter, one of the key variables in the loanable funds cycle of the catastrophe model is the expectations of output, and therefore, this could be the theoretical starting point for the analysis to replicate the effects of the crucial factor in the process of change between states: the rate of inflation (or deflation). To some extent, adopting certain elements of the derivation of the aggregate supply function by Dornbusch and Fischer (1987), suppose the expected output within the macroeconomy takes the form of

$$Y^E = aY + (1 - a)Y^F, \quad (9.2)$$

where  $Y$  is current income (or output) and  $Y^F$  is the full-employment level of capacity, which determines the firms' expectations. The coefficient, ' $a$ ', comes from the simple production function where output is proportional to the labour input from labour demand ( $L^D$ ), measured by the hours worked, that is

$$Y = aL^D. \quad (9.3)$$

Therefore, 'a' is the input coefficient of labour productivity, in the form of  $Y/L^D$ . At the macro-level of aggregation, it tends to move cyclically over time. In fact, there is a tendency for it to fall before the beginning of a tough in economic activity, whereas it improves at the start of recovery. During the recession period, however, firms have a propensity to hoard key workers with implication that employment varies less than output, and as a result, productivity falls. Hence, there is a clear discrepancy between current employment and production. Existing output may be low, but employment remains high because companies believe that the decline in constrained demand is only short-lived. Firms will lay off or dismiss workers only if they believe the decline in demand will last sometime. They will pay overtime to existing labour force or use variable workers on zero-hour contracts, as this is the cheaper option, unless output is exceptionally low.

During the recovery stage because firms have hoarded part of the workforce, employment increases less, and therefore, productivity rises. This reinforces the fact that firms base their hiring and firing on expectations about future production. In other words, firms will employ more workers and incur the cost of increasing employment on fixed-hour contracts only if there is a high probability that output will be growing for a long period. Therefore, employment may lag output.

What is more, at the macro-level, capital utilisation also fluctuates over the loanable funds cycle, becoming somewhat unemployed and underutilised during recessions, although the opposite during booms because of the use of shift work. Thus, the capital utilisation with the labour ratio will be much higher during boom periods, inversely within recessions.<sup>3</sup>

The analysis above indicates that the level of employment ( $L^D$ ) is a function of the positive impact of expected real income ( $Y^E$ ), with a tendency to hoard skilled labour, which adds to the traditional, negative influence of the real wage ( $W/P$ ), which is the money wage ( $W$ ) paid as bank deposits, divided by the general price level ( $P$ ), that is

$$L^D = L^D \left( Y^E, \frac{W}{P} \right). \quad (9.4)$$

+   -

The rate of unemployment is defined as

$$U = \frac{\bar{L}^S - L^D}{\bar{L}^S}, \quad (9.5)$$

where  $\bar{L}^S$  equals the constrained labour supply, where,  $L^D$ , denotes the labour demanded. The difference between the two is the rate of unemployment. The theory that lies behind the Phillips curve implies a reaction of money wages to this rate of unemployment in the following format:

$$W_t - W_{t-1} = -W_{t-1}\varepsilon U,$$

or, rewriting the equation as

$$W_t = W_{t-1}(1 - \varepsilon U), \quad (9.6)$$

where  $\varepsilon$  measures the responsiveness of wages to the unemployment rate. This indicates that a proportionate change in unemployment will lead to an adjustment in wages. For instance, if unemployment is a positive trend, then (real) wages will fall.

The next step in developing the theory is to connect firms' prices to their costs of production, which, in the main, are labour, and therefore,  $c = f(W_t)$  where  $C$  denotes costs and  $W_t$  are the money wages. Thus, costs are a function of money wages. As already noted within the analysis above, each unit of labour produces 'a' quantities of output, and hence, the cost per unit is  $W_t/a$ .

Firms set prices as a mark-up,  $C$ , over and above labour costs that includes the cost of loanable funds per unit to purchase the factors of production with an allowance for the firms' margin of profit. If the bulk of industry is oligopolistic competition in nature, then the mark-up will include an element of abnormal profit. The formation of these elements into price becomes

$$P_t = \frac{(1 + C)W_t}{a}. \quad (9.7)$$

Now including the material prices,  $P^M$ , then (9.7) changes to

$$P_t = \frac{(1 + C)W_t}{a} + \phi P^M, \quad (9.8)$$

where  $\phi$  represents the material requirement per unit of output, and consequently,  $\phi P^M$  is the element of unit costs that comes from raw material or semi-manufactured inputs. Any increase in the price of materials will increase the price level at a given  $W_t$  and  $C$ . Thus, the analysis puts (9.8) in terms of the real price of materials, denoted by  $P^{RM}$  and given by

$$P^{RM} = \frac{P^M}{P_t}. \quad (9.9)$$

Substituting (9.9) into (9.8) gives

$$P_t = \frac{(1 + C)W_t}{a} + \phi P^{RM} \cdot P_t,$$

or

$$P_t = \frac{(1 + C)}{(1 - \phi P^{RM})} \frac{W_t}{a}, \quad 1 > -\phi P^{RM}. \quad (9.10)$$

This shows that for a given wage rate, the cost of loanable funds per unit of output, the profit margin and the labour productivity, any increase in the real price of inputs will add to the price level because it raises costs of production.

Now substituting (9.6) into (9.10) to obtain the link between the rate of unemployment and the price level:

$$P_t = \frac{(1 + C)}{(1 - \phi P^{RM})a} W_{t-1} (1 - \varepsilon U),$$

or

$$P_t = \frac{(1 + C)}{(1 - \phi P^{RM})a} W_{t-1} \left( 1 - \varepsilon \left( \frac{\bar{L}S - L^D}{\bar{L}S} \right) \right), \quad (9.11)$$

with the use of expression (9.5). Now assuming  $P_{t-1} = \frac{(1+C)}{(1-\phi P^{RM})a} W_{t-1}$ , then the equation reduces to

$$P_t = P_{t-1} \left( 1 + \varepsilon \left( \frac{L^D - \bar{L}S}{\bar{L}S} \right) \right), \quad (9.12)$$

Furthermore, the level of output is obviously proportional to employment, and therefore, it is possible to substitute  $L^D$  and  $\bar{L}S$  in the expression above with  $Y^D$  and  $\bar{Y}^S$ , which is aggregate demand income and the constrained level of output. This transforms Eq. (9.12) into

$$P_t = P_{t-1} \left( 1 + \varepsilon \left( \frac{Y^D - \bar{Y}^S}{\bar{Y}^S} \right) \right), \quad (9.13)$$

Finally, putting  $\lambda = \varepsilon/\bar{Y}^S$ , where  $\bar{Y}^S$  is the level of output that would occur if the entire labour supply were used, that is

$$P_t = P_{t-1} \left( 1 + \lambda \left( Y^D - \bar{Y}^S \right) \right). \quad (9.14)$$

This expression implies that a change in real income (or output) will alter expectations, which will lead to more labour being demanded, reducing the rate of unemployment, but forcing up wages and, consequently, pushing up costs and prices. This suggests that rearranging (9.14) has the growth rate of prices over time in the form of

$$\hat{P}_t = \lambda \left( Y_t^D - \bar{Y}_t^S \right), \quad (9.15)$$

where  $\hat{P}_t = (P_t - P_{t-1})/P_{t-1}$ . Therefore, the acceleration of the rate of inflation, or deceleration, that is disinflation or deflation, comes about from changes in either  $Y_t^D$  or  $\bar{Y}_t^S$ , or costs, such as the borrowing rate of interest on loanable funds per unit of production embodied in  $P_{t-1}$ , that lies within the rate of growth of prices on the left-hand side of (9.15).

The next stage in the development of the theory is to model the rôle of aggregate demand income ( $Y_t^D$ ) by formatting its determinants. The analysis casts aggregate demand in the usual Keynesian way as autonomous expenditure with the real, borrowing rate of interest in the form of<sup>4</sup>

$$Y_t^D = \alpha(\bar{A} - bri_t), \quad (9.16)$$

where  $\bar{A}$  represents autonomous expenditure,  $\alpha$  is the multiplier, and  $ri$  equals the real rate of interest on borrowing and credit from the banking sector. In fact, it is the Fisher effect that leads to investment and consumption expenditure being determined by the 'real' and not the nominal interest rate,  $i_t^B$ , in the form of  $ri_t = i_t^B - (E_t \Delta P_{t+1} + C_R)$ . The real borrowing rate of interest, therefore, is equal to the nominal interest,  $i_t^B$

minus the expected rate of inflation,  $E_t \Delta P_{t+1}$ , with the credit risk premium,  $C_R$ , which allows (9.16) to be rewritten as

$$Y_t^D = \alpha (\bar{A} - bi_t^B + b(E_t \Delta P_{t+1} + C_R)). \quad (9.17)$$

In this format, the product market equilibrium depends on both the nominal interest rate and the expected inflation rate. Given the nominal rate of interest, an upward movement in the expected rate of inflation increases aggregate demand income,  $Y_t^D$  because this induces a fall in the real rate of borrowing and, therefore, raises the rate of capital and consumption expenditure.

Nevertheless, the realisation of this effective aggregate demand crucially depends on the banking sector, which is the depositary market for loanable funds ( $LO_t$ ), through the demand and supply equilibrium condition of  $LO_t^e/P_t = LO_t^D/P_t = LO_t^S/P_t$ , where

$$LO_t^D/P_t = \kappa Y_t^D - hi_t^B, \quad (9.18a)$$

and

$$LO_t^S/P_t = mm \left( \frac{MB^S}{P} \right) + \phi i_t^B. \quad (9.18b)$$

As a reminder,  $mm$  is the money multiplier, which is a function of  $mm(i^B, i_{BR}, CA^*, r, \Delta D)$  and  $\left( \frac{MB^S}{P} \right)$  is the supply of the monetary base. Rearranging these Eqs. (9.18a) and (9.18b), in terms of the nominal, borrowing rate of interest, then

$$i_t^B = \frac{1}{(h + \phi)} \left( \kappa Y_t^D - mm \left( \frac{MB^S}{P} \right) \right). \quad (9.19)$$

Substituting (9.19) into (9.17) gives

$$Y_t^D = \alpha \left( \bar{A} - \frac{b}{h + \phi} \left( \kappa Y_t^D - mm \left( \frac{MB^S}{P} \right) \right) + b(E_t \Delta P_{t+1} + C_R) \right),$$

or,

$$Y_t^D = \gamma \left( \bar{A} + \frac{b}{h + \phi} mm \left( \frac{MB^S}{P} \right) + b(E_t \Delta P_{t+1} + C_R) \right), \quad (9.20)$$



where  $\gamma = \frac{\alpha}{1+(\alpha bk/h+\phi)}$ .

This is the aggregate demand function showing that the level of output comes from autonomous components, the behaviour of agents embodied in the money multiplier multiplied by the monetary base (or 'outside' money) to generate 'inside' loanable money with the expected rate of inflation and the risk premium. Any increase in any of these three elements will raise the level of aggregate demand.

Now substituting (9.20) into (9.15) gives

$$\hat{P}_t = \lambda\gamma\bar{A} + \lambda\gamma\frac{b}{h+\phi}\text{mm}\left(\frac{\text{MB}^S}{P}\right) + \lambda\gamma b(\Delta E_t\Delta P_{t+1} + C_R) - \lambda\Delta\bar{Y}_t^S,$$

or

$$\hat{P}_t = B_1\bar{A} + B_2\text{mm}\left(\frac{\text{MB}^S}{P}\right) + B_3(\Delta E_t\Delta P_{t+1} + C_R) - B_4\bar{Y}_t^S, \quad (9.21)$$

where  $B_1 = \lambda\gamma$ ,  $B_2 = \lambda\gamma\frac{b}{h+\phi}$ ,  $B_3 = \lambda\gamma b$  and  $B_4 = \lambda$ . This is derived from the equilibrium in the goods and loanable markets, although it is, in this form, a dynamic process of the rate of growth of prices.

What is more, in this system of aggregate demand and supply, the expectations of future output run through the former rather than the latter, whilst the New Keynesian School incorporates these expectations as a determinant of aggregate demand. The mechanism, therefore, is likely to run through the process of autonomous shifts in aggregate demand. These factors are so-called autonomous and, consequently, fixed by definition, but they do, however, frequently change as a result from structural variations in household expenditure, gross capital formation, net exports and fiscal policy, or from monetary policy effects on real borrowing rates of interest and wealth effects. They ignite adjustments in output expectations that drive forces of alteration towards the economy's equilibrium. Therefore, the term of  $\bar{A}$  in expression (9.21) is then replaced by the expectations of future output,  $Y_t^e$ , adding to the growth of prices in the form of

$$\hat{P}_t = B_1Y_t^e + B_2\text{mm}\left(\frac{\text{MB}^S}{P}\right) + B_3(\Delta E_t\Delta P_{t+1} + C_R) - B_4\bar{Y}_t^S. \quad (9.22)$$

Equation (9.22) is the theoretical expression that outlines the determinants of the rate of inflation (or deflation) over the loanable funds cycle, as derived from the deviations of aggregate demand and supply in the economy. The determinants are the expectations of future output, the growth of inside money in the form of bank credit and loans created by banks within themselves by the money multiplier with the supply of outside money, the adjustment in price expectations with the risk premium and the output with its determining factors in embodied.

## 9.4 CONCLUSIONS/SUMMARY

This theoretical model of inflation outlined in this chapter with the loanable funds theory embodied in the analysis to explain the adjustment in the growth of prices through the medium of deviations in aggregate demand and supply. Both components have elements of the money supply via loan creation, which represents borrowing to finance expenditure and production of goods and services, although supply comes with other cost factors that arise from wage growth and the outlay on material inputs. The growth of wages is partially determined by the rate of unemployment, expectations and output whereas the cost of borrowing on the supply side forms part of the mark-up process that somewhat determines the relative growth of prices.

Clearly, this inflationary process underpins the loanable funds cycle within the catastrophe theory outlined in Chapter 8. In fact, the cycle of loans is a sequence of inflation, disinflation and deflation along with shrink inflation within the various states of expansion, contraction and recovery that arise from the money wheel of economic activity.

## NOTES

1. For an overview of the possible methods, see Kuttner (1994) along with McMorro and Roeger (2001).
2. For a general overview of Classical economics in this area, see Hoover (1988) as well as Sheffrin (1996). For many key articles, see Lucas and Sargent (1981) along with Lucas (1981).
3. Clearly, the fluctuations in the employment of labour goes together with capital because it can be shown *via* the Cobb-Douglas function,  $Y = K^a L^{1-a}$ , that the output per worker  $Y/L$ , is equal to  $(K/L)^a$ , which means labour productivity depends on capital utilisation with its augmented technology embodied.
4. For the derivation of Eq. (9.16), see Appendix.

## APPENDIX

Keynes incorporates the keyword of ‘money’ in his title of the *General Theory* (1936) to highlight its importance in the creation of Gross Domestic Income (GDP) in nominal terms. In contrast, the Classical belief assumes that money is merely a ‘curtain’ hiding the real economy. Money’s only undertaking for Classical economists was the determination of the absolute price level, but it had no function as far as relative prices or the formation of the national output and employment were concerned, behind the curtain. Indeed, for Keynes, money had major rôle in the determination of the rate of interest, which is a determining factor of investment within national income, although the analysis here extends it to consumption as well. It is an irony that many expositions of Keynesian theory concerning fiscal policy neglect the crucial function of the monetary system (Peacock and Shaw 1976).

Moreover, the introduction of the monetary system into the following income identity,  $Y$ , by means of consumption,  $C$ , and investment,  $I$ , partly dependent on the real of interest,  $ri$ , which is equal to  $i_t^B - (E_t\Delta_{t+1} + C_R$ , where  $i_t^B$  denotes the borrowing rate of interest minus the expectations of inflation,  $E_t\Delta_{t+1}$ , and the credit premium,  $C_R$ , which is somewhat determined by the demand and supply of loanable funds from the banking sector:

$$Y_t^D = C + I + G + X - M, \quad (9.23)$$

where consumption, therefore, is equal to the expression of

$$C = \bar{C} + cY^d - \lambda ri, \quad (9.24)$$

$\bar{C}$  is autonomous consumption,  $c$ , the marginal propensity to consume (MPC) and  $Y^d$ , denoting disposable income in the form of

$$Y^d = Y - t \cdot Y + T, \quad (9.25)$$

the average tax rate,  $t$ , and  $T$  denotes transfer incomes, which is determined by

$$T = \bar{T} - \eta Y, \quad (9.26)$$

where  $\bar{T}$  denotes autonomous transfer payments along with a negative  $\eta$ , representing the average rate of credit transfer. The value on  $ri$  measures the negative relationship between the real rate of interest and the borrowing of loanable funds to finance, in the main, consumption of

durable goods, in part, determined by the interest-elasticity coefficient,  $\lambda$ . Investment expenditure is as follows:

$$I = \bar{I} - \beta r i + \Omega Y, \quad (9.27)$$

$\bar{I}$  measures fixed capital formation expenditure along with investment demand relating to the negative,  $\beta$ , on the real rate of interest, but with a positive  $\Omega$ , the accelerator coefficient on income because of the magnifying process of the Keynesian multiplier with the indirect effects of expectations on consumer demand. In the case of government expenditure and exports, the assumption they are exogenous to the model that is

$$G = \bar{G} \text{ in addition to } X = \bar{X} \quad (9.28)$$

Finally, with regard to the negative rôle of imports, the function, which includes income,  $Y$  is as follows:

$$M = \bar{M} + mY, \quad (9.29)$$

where  $\bar{M}$  is autonomous expenditure on imports with  $m$ , the marginal propensity to import out of income,  $Y$ .

Substituting (9.24)–(9.29) into (9.23) and simplifying derive the expression of

$$Y_t^D = \alpha(\bar{A} - b r i), \quad (9.30)$$

where  $\alpha = 1/1 - c(1 - (t + b)) - \Omega + m$ , is the multiplier,  $\bar{A} = (\bar{C} + c\bar{T} + \bar{I} + \bar{G} + \bar{X} - \bar{M})$ , which denotes the autonomous components, and finally,  $b = (\beta + \lambda)$ , captures the sensitivity coefficients that relate to the real rate of interest with respect to investment and consumption that allows for the entrance of the loanable funds market into the analysis and to provide its crucial input into decision-making process within the circular of income, output and employment.

## REFERENCES AND FURTHER READING

- Arestis, P. (2011). *New Consensus Macroeconomics: A Critical Appraisal*. In E. Hein & E. Stockhammer (Eds.), *A Modern Guide to Keynesian Macroeconomics and Economic Policies*. Cheltenham: Edward Elgar Publishing.
- Bårdsen, G., Eitrheim, Ø., Jansen, E. S., & Nymo, R. (2005). *The Econometrics of Macroeconomic Modelling*. Oxford: Oxford University Press.
- Batini, N., Jackson, B., & Nickell, S. (2000). *Inflation Dynamics and the Labour Share in the U.K. (Discussion Paper 2)*. External MPC Unit, Bank of England.

- Bywaters, D. S., & Thomas, D. G. (2011). Real Money Demand and Supply Meets Federal Debt. *Applied Economics Letters*, 18(12), 1189–1193.
- Clarida, R., Galí, J., & Gertler, M. (1999). The Science of Monetary Policy: A New Keynesian Perspective. *Journal of Economic Literature*, 37(4), 1661–1707.
- Dornbusch, R., & Fischer, S. (1987). *Macroeconomics* (4th ed.). Singapore: McGraw-Hill Book Co.
- Friedman, M. (1968). The Role of Monetary Policy. *American Economic Review*, LVIII (March), 1–17.
- Galí, J., & Gertler, M. (1999). Inflation Dynamics: A Structural Econometric Analysis. *Journal of Monetary Economics*, 44(2), 195–222.
- Galí, J., Gertler, M., & López-Salido, D. (2001). European Inflation Dynamics. *European Economic Review*, 45(7), 1237–1270.
- Hoover, K. D. (1988). *The New Classical Macroeconomics: A Sceptical Inquiry*. Oxford: Blackwell.
- Hoover, K. D., Demiralp, S. & Perez, S. J. (2009). Empirical Identification of the Vector Autoregression: The Causes and Effects of U.S. M2. In Castle, J. and Shephard, N. (Eds.), *The Methodology and Practice of Econometrics: A Festschrift in Honour of David F. Hendry*. Oxford: Oxford University Press.
- Kerr, W., & King, R. G. (1996). Limits on Interest Rules in the IS Model. *Federal Reserve Bank of Richmond, Economic Quarterly*, 82, 47–56.
- Keynes, J. M. (1936). *The General Theory of Employment, Interest and Money*. London: Macmillan and Co., Limited.
- Kuttner, K. N. (1994, July). Estimating Potential Output as a Latent Variable. *Journal of Business and Economic Statistics*, 12(3), 361–368.
- Lucas, R. E., Jr. (1981). *Studies in Business Cycle Theory*. Oxford: Blackwell.
- Lucas, R. E., Jr., & Sargent, T. J. (Eds.). (1981). *Rational Expectations and Econometric Practice*. London: Allen and Unwin.
- McMorrow, K., & Roeger, W. (2001, April). Potential Output: Measurement Methods, “New” Economy Influences and Scenarios for 2001–2010—Comparison of the EU-15 and the US. *European Economy, Economic Papers*, 150, 1–142.
- Peacock, A., & Shaw, G. K. (1976). *The Economic Theory of Fiscal Policy* (Revised Edition). London: George Allen and Unwin, Ltd.
- Pelphs, E. S. (1968). Money-Wage Dynamics and Labor-Market Equilibrium. *Journal of Political Economy*, 76, 678–711.
- Rotemberg, J. J. (1982, December). Sticky Prices in the United States. *Journal of Political Economy*, 90(6), 1187–1211.
- Sbordone, A. (2002). Prices and Unit Labour Costs: A New Test of Price Stickiness. *Journal of Monetary Economics*, 49(2), 235–456.
- Sheffrin, S. M. (1996). *Rational Expectations* (2nd ed.). Cambridge: Cambridge University Press.



## CHAPTER 10

---

# The Conclusions and the Policy Recommendations

### 10.1 INTRODUCTION

The retail banking sector working through the monetary system of the economy is the heart of the private debt creation and the medium of exchange of goods and services. Almost all economic agents receive and use either bank deposits or cash as money in return for generating real income by supplying the factors of production, although the major component is the former rather than the latter. Money creation takes place as bankers make loans to consumers, but mainly firms. Destruction takes place when borrowers pay back the principal sums with interest as profit to banks. Therefore, in the majority of cases, bankers create money based on expectations of producers' profits, whereas its destruction is on the realisation of actual profits. This is 'circularism' of monetary behaviour within the real economy. Thus, a stable monetary system is a result of profit flows that allow firms to borrow and fulfil their financial commitments. If the corporate sector of the economy is healthy, then it is more than likely that consumers are in the same mode.

### 10.2 STABILITY OF AN ASYMMETRICAL ECONOMY

Moreover, there will always be instability because of the presence of Keynesian and money multipliers igniting either business or financial cycles, which are difficult to predict, but there are natural fiscal and monetary devices of stabilisation to alleviate the reduction in income

and profit, if left alone to work on their own. In other words, Central Bank interventions to refinance financial institutions and provide reserves of outside money for rapid expansion of credit *via* the creation of loans from the money multiplier mechanism plus the fiscal stabilisation of profit by the natural growth of government deficit, means that crises and growth recessions (or depressions) get ‘reseeded’ into recovery. Clearly, during the period of recovery and in the expansion stage of significant growth, there is a natural cycle for the government deficit to reduce and go into surplus as transfer payments fall and tax receipts explore with inflation. Furthermore, the inflationary process will erode the real value of private as well as public debt that needs to be paid back over the course of time.

Nevertheless, a period of deflation (or exceptionally low inflation) within the growth recession stage will have the opposite effect, leading to an accumulation of real private debt as profit margins and wages falls in on account of negative income effects. Its realisation should quickly come to a halt when public debt naturally goes up as transfer payments rise with falling employment, income and tax receipts, to stimulate the recovery state. The combination of fiscal stimulus and the refinancing by monetary policy as lender of last resort to deal with the shortest of liquidity and creditworthiness of industrial and financial institutions will stabilise income and forestall the downward spiral by Keynesian and money multiplier effects into depression.

Moreover, since the financial events of 2007/2008, the downsizing by the Government in an attempt to reverse and transpose the natural, fiscal tendencies to reduce the size of public debt has led to the persistent growth recession with no sight of the recovery stage. In fact, this has increased the vulnerability and instability of the economy from deflation and disinflation propensities because of the low growth of income in the shape of profits and wages, even though monetary policy interventions have increased bank reserves and reduced solvency of financial institutions. Normally, the inherent course of fiscal policy is to prevent the collapse of profit growth through the expansion of income and reversing the decline. Historically, the presence of the current, growth recession has been the longest and deepest on record for the UK because the Government has been trying to reverse the genetic stance of fiscal policy. This has led to increasing turbulence with the advent of the growth recession, which has been re-enforced by the inappropriate, discretionary fiscal policy counteracting the natural tendencies within the economy.

As a result, over this period, there has been a downward trend in interest rates, fluctuations of sterling on the foreign currency markets, and a significant decline in the growth of consumption and investment along with the public sector. The Central Bank has been increasing liquidity of outside money, but the velocity of inside money has been decreasing, compounded by the money multiplier effect. The loanable and money markets have become characteristically unstable since the financial crisis because of uncertainty surrounding the rapid decline in growth of government expenditure, consumption and investment, augmented by the negative multipliers. What should be happening is positive fiscal policy, stabilising the economy with the Central Bank's lender of last resort, offsetting the harmful multipliers.

In the case of the UK Government, the present discretionary fiscal policy is an attempt to reduce public debt when deflation (or disinflation) is taking place. This process, in fact, increases the real value of debt burden. Therefore, to reduce debt, it is necessary to get the economy into the recovery state with significant growth, which means that positive fiscal policy reinforces monetary interventions to contain the financial crisis and prevent the onslaught of depression. There is a need for both sides of the economy, monetary and fiscal policies to work together simultaneously to halt and turn around the cumulative debt-deflation process prevent the collapse of asset values and restore profit levels.

Moreover, in a modern, monetary economy, where borrowing and lending of loanable funds is an indispensable component in determining the growth of consumption and investment, an increase in loanable funds, because of a financial innovation by retail banks, will boost expenditure. This raises the demand-price for outputs of consumption and investment goods as well as services, although a lowering of the borrowing costs of finance for production in addition to reducing the supply price of capital goods. This means a general increase in cash flow on balance sheets within the economy.

In the opposite case, rising interest rates encourage Ponzi-like financing activity, and accordingly, because of increasing interest payments based on earlier borrowing, will surpass income earned by assets at some stage. This guarantees a financial crisis and rollover borrowing, adding to the accumulation of private debt. If economic activity becomes, if essentially financed by short-term debt, representing refinancing of maturing debt, then the demand curve for debt shifts to the right and becomes less elastic. Furthermore, if the supply of loanable funds is becoming



more elastic, short-run rates of borrowing will escalate rapidly, which may even cause demand to increase again, leading to further surges in borrowing costs. The rise in short-term interest rates produces higher long-term interest rates, which lowers the value (or price) of capital goods. This situation will increase costs of production, lowering liquidity, profitability and increasing solvency of firms and financial institutions. A breakdown occurs when a significant proportion of speculative and Ponzi debtors do not obtain rollover finance of maturing debt, and banks enforce bankruptcy and reduce growth of loanable funds even to hedge borrowers because of the growing uncertainty and risk of default. The lender of last resort must intervene and fiscal stimulus should kick-in if the reduction in income and employment is not to lead to a catastrophic event.

### 10.3 THE POSSIBILITY OF MORE STABILISERS

What is more, there is the possibility of adding to the lender of last resort by introducing a monetary rule based on the growth of outside money in the disguise of the monetary base (or high-powered money) in the hope it will enhance the growth of inside money by way of loan creation by the retail banks before any significant increase in uncertainty and risk takes hold, heading towards the ‘cusp’ that leads to a catastrophe into the depths of recession and depression. This will remove the uncertainty of response by the monetary authorities and the problem of time lags associated with discretionary policy. The formation of the monetary rule of regulation could well be in the form of

$$\frac{\Delta MB}{MB} = \overline{MB} + \lambda(U - \overline{U}), \quad (10.1)$$

where  $\Delta MB/MB$  is the growth of outside money (or the monetary base, MB) at an annual percentage rate,  $U$  is the actual rate of unemployment, and the  $\overline{U}$  would be regarded as the believed natural rate of unemployment prevailing in the labour market. Now putting numbers to the formation of (10.1), that is

$$\frac{\Delta MB}{MB} = 4 + 2(U - 5.0). \quad (10.2)$$

No matter what happens in (10.2), the monetary base will keep growing at four percent. In addition, the monetary base growth rate increases by

two percent for every one percent unemployment in excess of, say, five percent. Consequently, if unemployment rises above five percent, then monetary growth of outside money automatically increases. Conversely, if unemployment dropped below five percent, monetary growth of outside money lowers to below four.

In addition to this process of monetary policy, to make the recovery process swift, however, transfer payments should relate to employment and output. Furthermore, Government should expand its involvement into education and research to enhance resource creation with employment. This development is public investment into capital formation and employment that embody new technology that comes about from research and development. This comes from an educated and trained labour force that manifests itself from public capital spending. Thus, the Government should invest more into education and research at all levels as part of resource creation and development to support the rapid transition to the expansion stage and ensure a catastrophic jump in output and employment from private investment into new technology and consumption of new products. The difficulty, however, is that much of intellectual infrastructure of the economy has been deteriorating in the UK, reaching down as far as basic facilities of scholarship such as public libraries, which are closing down from the lack of public investment.

This implies that private and public investment goes hand-in-hand in resource creation. In fact, there are other components of government expenditure that are required to support private enterprise, which are the necessary goods and services of health provision, transport facilities and law enforcement. These are the foundations that underpin the infrastructure of the economy and should be targeted as resource creation to renew and develop by way of public investment to ensure economic progress by way of the free market.

#### 10.4 THE CONCLUSION

The overall conclusion is that, for an immediate recovery from a state of recession of economic activity, it is necessary to have fiscal stimulus and stabilisation as well as monetary instruments working together. In addition, the more automatic and flexible the response from policy instruments, the quicker the adjustment back to equilibrium state of expansion without time lags because of the reduction of uncertainty and the build-up of risk. Furthermore, this formation of policy takes away

the arbitrary power of small groups of politicians subject to no control by the electorate for a period of five years, although ruled by short-term pressures of partisan politics with thoughts and philosophies that have no scientific substance. They govern by unempirical truths, which manifest itself into the imposition of irrational behaviour on the rational, free market system. The economy stagnates and drifts backward from growth recession into complete stagnation, and even with the possibility of depression. In fact, the requirement is the natural movements between states of expansion, recession and recovery so that creativity, destruction of outmoded techniques and products can take place, renewing economic development and advancement of the economy over the evolutionary process of time.

# INDEX

## A

adverse selection, 74, 105, 135  
aggregate demand, 8, 9, 12, 16–18,  
26, 27, 36, 37, 40, 58, 65, 88,  
94, 104–106, 112, 135, 137,  
141–144, 148–151  
aggregate supply, 8, 19, 105, 109,  
141, 144  
animal spirits, 58  
asymmetric information, 7, 74, 115,  
116  
attractor surface, 129  
austerity, 16, 113, 137  
automatic stabilizers, 113  
average, 5, 8, 10, 44, 45, 47, 48, 50,  
51, 81–87, 89–91, 99, 100, 103,  
117, 143, 152

## B

Bain, K., 64, 77, 78  
bank credit, 73, 151  
bank deposits, 2, 4, 6, 8, 15, 18, 20,  
30, 43, 44, 70, 107, 111, 145,  
155

bank rate, 32, 44, 71, 85, 86, 116  
bank runs, 71, 105, 109, 112  
barter, 10, 11, 16, 64, 65  
base rate, 33, 34, 70, 71, 74, 82, 97  
Baumol, W., 46  
bifurcates, 127  
bifurcation area, 127  
bifurcation edge, 127  
bonds, 2, 5, 6, 9, 17, 19, 25, 26,  
43–45, 47, 48, 53–55, 58, 60,  
69, 70, 79–85, 88–90, 104, 110  
boom, 98, 102–105, 110–114, 133,  
137, 145  
borrowers, 2, 4, 5, 7, 20, 63, 65, 66,  
78–81, 86, 89, 99–102, 104,  
106, 111–113, 115, 116, 120,  
133, 135–138, 155, 158  
bounded rationality, 131, 138, 143  
budget surplus, 104

## C

capital markets, 6  
cash, 6, 10, 11, 15–17, 20–24, 26, 29,  
30, 32–35, 44–47, 51, 59, 66,

- 67, 69, 71, 74, 98–103, 105–107, 109, 111, 113, 125, 133, 134, 155, 157
- cash–deposit ratio, 21–23, 33, 34, 73, 84, 97
- catastrophe(s), 102–104, 111–113, 125–127, 131, 141, 144, 158
- catastrophe theory, 121, 123–125, 151
- catastrophic, 102, 106, 113, 120, 124, 125, 129, 130, 134, 135, 158, 159
- catastrophic moment, 112
- Central Bank, 6, 9, 11, 17, 18, 21, 22, 24–26, 32, 33, 39, 40, 44, 70, 71, 73–75, 86, 88, 98, 103, 112, 115, 156, 157
- circularism, 2, 63, 155
- Classical, 16–19, 27, 43, 59, 63, 64, 67, 70, 75, 142, 143, 151, 152
- cointegrating, 85, 91, 93, 94
- commercial banks, 6, 18, 20–24, 26–30, 39, 40, 46, 61, 70, 73, 74, 86, 87, 104, 116, 120, 125, 142
- constrained demand, 145
- consumption, 1, 3, 4, 7, 9–11, 19, 34, 36, 58, 63, 65, 67, 88, 97, 103–107, 109, 111, 125, 131–133, 135, 148, 149, 152, 153, 157, 159
- cost curves, 99
- costs, 2, 7, 11, 15, 34–36, 49, 51, 52, 65, 66, 78, 99–101, 111, 113, 114, 117, 131, 132, 141, 146–148, 157, 158
- creation, 1, 2, 5, 8–10, 12, 16, 22, 27, 34, 44, 45, 61, 70, 97, 98, 123, 125, 142, 152
- creation of loans, 37, 107, 142, 156
- creative, 124, 136
- creative destruction, 1, 111, 131
- creativity, 160
- creators, 63
- credit, 2, 5–7, 10–13, 19, 26, 30–32, 34, 36, 44, 58, 71, 74, 86, 97, 98, 103–105, 107, 109, 112, 113, 116, 117, 119, 120, 123–125, 131, 133, 148, 149, 152, 156
- credit cycle, 98, 104, 106, 112
- credit rationing, 5, 34, 74, 105, 120, 131
- crisis, 9, 10, 27, 60, 71, 74, 75, 93, 98, 102–106, 112, 113, 121, 131, 134, 137, 142, 157
- cuspid, 112, 127, 137, 158
- cuspid-catastrophe, 124, 125, 127
- cycles, 7, 113, 135, 155
- D**
- debt-deflation process, 111, 157
- debt servicing, 102
- Debt Valley, 113
- deflation, 16, 17, 19, 98, 105, 114, 144, 148, 151, 156, 157
- deflationary, 48, 102, 105–107, 111, 112, 135, 136, 141
- demand for money, 9, 40, 44–47, 50–52, 55, 57–59, 61, 69, 70, 84, 85
- deposit base, 2, 10, 11, 18, 19, 22, 28, 32, 70, 74, 97, 98, 102–107, 111, 112, 123–125, 127, 129, 131, 132, 134–138
- deposit liabilities, 19, 32
- depositors, 13, 20–24, 27, 71, 109, 125
- depository market, 6, 12, 45
- depository money, 45, 47–49, 51, 57, 61
- depression, 9, 57, 102, 106, 109, 112, 114, 120, 156–158, 160

destruction, 8–11, 19, 20, 34, 44,  
45, 97, 102, 103, 112, 123–125,  
136, 155, 160

diminishing marginal productivity of  
capital, 132

diminishing marginal utility, 132, 133

direct lending, 2

discretionary policy, 158

disinflation, 19, 48, 105, 144, 148,  
151, 156, 157

division of labour, 1, 11

## E

education and research, 159

electronic, 11, 123

employment, 2, 8, 9, 16, 18, 63, 65,  
68, 69, 113, 143–145, 148, 152,  
153, 156, 158, 159

endogenous, 20, 34, 37, 41, 63, 71,  
91, 97, 107, 109, 111, 115, 123,  
125, 126, 128, 130, 138, 141,  
142

endogenous money supply, 13, 15, 16,  
37, 40, 63, 123, 124

evolutionary process, 11, 102, 104,  
123, 160

excess reserves, 9, 22, 33, 107, 109,  
110, 127

exogenous, 9, 20, 69, 70, 92, 138,  
141, 142, 153

expansion, 5, 8, 37, 73, 74, 98, 102,  
103, 110–112, 136, 137, 151,  
156, 159, 160

expectations, 3, 4, 19, 45, 58, 64,  
67–69, 81–90, 93, 104–107, 112,  
113, 133, 135, 138, 141–145,  
148, 150–153, 155

expectations theory, 80, 81, 83, 87,  
89, 94

expected rate of inflation, 58, 64, 68,  
71, 77, 86, 133, 149, 150

## F

factors of production, 11, 44, 70, 146,  
155

financial deficits, 4

financial instruments, 1, 15, 35, 44, 77

financial intermediaries, 2, 5

financial liabilities, 16

fiscal policy, 150, 152, 156, 157

fiscal stabilisation, 156

fiscal stimulus, 106, 156, 158, 159

Fisher effect, 68, 148

Fisher equation, 68, 103

Fisher, I., 68

Friedman, M., 9, 57, 114, 143

future output, 19, 65, 137, 150, 151

## G

Goldsmiths, 11

government deficit, 142, 156

government expenditure, 38, 39, 103,  
110, 141, 153, 157, 159

gross domestic income, 152

growth recession, 34, 82, 86, 111,  
113, 137, 142, 156, 160

## H

health provision, 159

hedge, 99, 102, 104, 111, 112, 116,  
119, 120, 136, 137, 158

high-powered money, 21, 24, 25, 158

Howells, P., 64, 77, 78

## I

income effects, 102, 135, 156

indirect lending, 2

inflation, 4, 9, 45, 57, 61, 66–68, 71,  
75, 103, 104, 112, 133, 135,  
138, 141–144, 149, 151, 152,  
156

inflationary expectations, 83, 103–105, 112, 133  
inflationary premium, 64  
infrastructure, 12, 111, 159  
inside money, 18–21, 27, 29, 34, 36, 37, 40, 44, 57, 58, 63, 70, 97, 107, 115, 123, 142, 151, 157, 158  
instability, 12, 40, 70, 99, 102, 111, 113, 123, 129, 135, 155, 156  
instruments, 6, 20, 60, 77, 79, 80, 111, 113, 159  
intellectual infrastructure, 159  
interest-elasticity coefficient, 153  
interest rate on borrowing, 37, 97  
inventory approach, 46, 47  
investment, 1–4, 6, 7, 9, 10, 18, 19, 34, 44, 58, 63, 65, 98, 103–106, 111, 114, 120, 131–135, 148, 152, 153, 157, 159

## K

Keen, S., 10  
Keynesian, 16, 44, 58–60, 70, 137, 142, 143, 148, 150, 152, 155, 156  
Keynesian multiplier, 69, 102, 104, 106, 107, 110, 111, 113, 134, 153  
Keynes, J.M., 2, 3, 9, 51, 58, 63, 68–70, 75, 84, 113, 114, 125, 132, 152

## L

labour supply, 146, 148  
law enforcement, 159  
law of diminishing marginal returns, 98, 104, 112, 132  
legal tender, 1, 10, 97  
Lehman Brothers, 105

lemons, 135  
lender of last resort, 32, 71, 105, 112  
lenders, 2, 4, 5, 7, 63, 65, 66, 74, 78–82, 89, 112  
liquidity, 3–5, 18, 37, 43, 52, 61, 71, 73, 75, 77, 78, 84, 90, 103, 105, 156–158  
liquidity payment, 64  
Liquidity Preference Theory, 44, 63, 68, 75  
liquidity premium, 64, 80, 83, 84, 87  
loanable cycle, 123  
loanable funds, 1, 2, 7, 27, 29, 32–38, 40, 43, 44, 58, 59, 61, 63–65, 67, 70–75, 80, 85, 98, 104, 106, 112, 114, 115, 119, 123–125, 127, 131, 133–138, 141–144, 146–149, 152, 153, 157, 158  
loanable funds cycle, 98, 99, 112, 124, 125, 144, 145, 151  
Loanable Funds Theory, 63, 64, 70, 75, 85  
loanable supply curve, 12, 40, 86  
loanable supply function, 33, 36, 97  
loan creation, 11, 60, 63, 103, 109, 115, 129, 131, 141, 151, 158  
loans, 1, 2, 4–7, 9–12, 19, 22, 26, 28–30, 33, 34, 36, 37, 39, 40, 43–45, 58, 70, 71, 73–75, 77–81, 85–87, 89, 97, 99, 101, 102, 104–107, 109–120, 123, 125, 127, 129–138, 141–143, 151, 155  
loan sharks, 6, 34, 105, 120  
long term interest rates, 158

## M

marginal efficiency of capital, 35, 132, 138  
marginal propensity to consume, 2, 152

- market rate of interest for borrowing, 43
- mark-up, 44, 71, 75, 85, 86, 105, 116, 125, 133, 146, 151
- medium of exchange, 1, 2, 5, 6, 8–12, 15, 18, 28, 43, 44, 57, 61, 65, 70, 97, 107, 123, 155
- Minsky Moment, 104, 120, 131
- Minsky, P.H., 7, 99
- Minsky's Financial Instability Hypothesis, 98, 123
- Mishkin, F.S., 77, 83, 84
- monetarism, 141
- monetarist theory, 58
- monetary authorities, 8, 9, 13, 20–23, 27, 28, 32, 40, 65, 69, 70, 74, 75, 82, 85, 86, 97, 104, 107, 110, 116, 142, 158
- monetary base, 21–23, 25, 26, 29, 32, 33, 36–39, 73, 97, 98, 107, 108, 112, 115, 149, 150, 158
- monetary circularism, 113
- monetary cycle, 141
- monetary economy, 9, 10, 15, 16, 18, 20, 27, 44, 46–48, 61, 74, 104, 112, 113, 135, 137, 157
- monetary instruments, 88, 159
- monetary policy, 26, 32, 58, 74, 88, 89, 94, 106, 141, 143, 150, 156, 159
- monetary rule, 158
- monetary system, 1, 7, 11, 13, 18, 28, 37, 58, 63, 65, 97, 123, 124, 136, 138, 152, 155
- money, 1, 2, 6–13, 15–17, 19–26, 28, 30, 33, 35, 37–39, 41, 44–61, 63–65, 69, 71, 73, 84, 98, 100, 104, 106, 107, 110, 112, 124, 127–129, 131, 135–138, 142–145, 150–152, 155, 157
- money creation, 19, 20, 26, 59, 84, 107, 110, 155
- money demand, 56–58, 68
- money illusion, 46, 103, 144
- money multiplier, 10, 24, 27–29, 32–34, 36, 37, 40, 59, 73, 74, 84, 85, 97, 98, 103, 107, 109, 112, 125, 127, 134–137, 142, 149–151, 156, 157
- money multiplier mechanism, 26, 85, 105, 123, 132, 156
- money supply, 5, 6, 8–12, 19–26, 29, 30, 32, 33, 37, 38, 40, 44, 58, 63, 70, 104–109, 112, 115, 116, 125, 127, 131, 141, 142, 151
- money wages, 11, 16, 19, 28, 107, 146
- moral hazard, 74, 135
- multiple equilibria, 123
- multiplier(s), 9, 10, 34, 60, 93, 110, 113, 148, 153, 155, 157
- N**
- natural cycle, 156
- natural rate, 143, 158
- neoclassical, 7, 10, 12, 16, 98
- Net Acquisition of Financial Assets, 3
- net present value, 34, 35, 66
- nominal rate of interest, 67, 68, 77, 149
- non-commodity, 11
- nonlinearity(ies), 113, 123, 138
- Northern Rock, 28, 82, 105
- numeraire, 7, 97
- O**
- oligopolistic competition, 146
- open economy, 29, 38, 40
- open market operations, 25, 26, 29, 32, 40, 71, 98
- opportunity cost, 47, 60, 69



outside money, 17–19, 21, 22, 25–27,  
33, 37, 69, 70, 107, 115, 142,  
151, 156–159  
own endogenous shocks, 107

**P**

payday lenders, 105  
peer-to-peer lending platforms, 105  
perfectly competitive system, 65  
permanent income, 7, 58  
Phillips curve, 142, 143, 146  
Pigou effect, 17, 18, 27, 106  
Ponzi, 98, 99, 101, 102, 104, 111,  
113, 116, 120, 133, 135, 136,  
157, 158  
portfolio theory, 5, 61, 113, 115  
precautionary balances, 48  
precautionary demand, 4, 52  
precautionary demand for money, 4, 52  
precautionary motive, 51  
precautionary purposes, 51, 52  
preferred habitat, 83, 87, 90  
preferred habitat theory, 84  
premium, 64, 68, 71, 77, 80, 84, 91,  
119, 152  
present value, 4, 35, 66, 78, 79  
price of materials, 147  
private debt, 19, 20, 98, 103, 104,  
110, 156, 157  
private debt creation, 155  
productivity, 21, 28, 35, 65, 66, 68,  
104, 145, 147  
profit, 2, 3, 11, 15, 16, 18, 19, 35, 43,  
44, 58, 65, 66, 70, 98–102, 107,  
111, 112, 114, 132, 133, 135,  
146, 155–157  
profitability, 98, 103, 107, 136, 158  
profit margin, 102, 147  
public debt, 103, 104, 110, 156, 157  
public investment, 159  
public sector, 114, 137, 157

**Q**

quantitative easing, 9, 26, 73, 98, 142  
quantity theory of money, 7, 45, 57, 143

**R**

rate of inflation, 48, 56–58, 64, 66–  
68, 83, 102, 103, 135, 142–144,  
148, 151  
rate of interest, 3, 19, 29, 33–35,  
37, 44, 47, 48, 50, 52, 53, 55,  
59–61, 63–66, 69–71, 74, 75,  
77–82, 84–86, 89, 91, 102, 112,  
116–120, 125, 142, 148, 149,  
152  
rate of interest on saving, 9, 32, 40,  
43, 44, 57, 59–61, 63, 70  
real borrowing rate of interest, 35, 148  
real rate, 64, 65, 68, 77, 83, 133, 149  
real rate of interest, 65–68, 71, 103,  
106, 133, 135, 148, 152, 153  
real short-term rate of interest, 64  
recession, 9, 10, 34, 102, 103, 106,  
107, 112, 116, 120, 136, 137,  
141, 145, 158–160  
recovery, 37, 103, 111, 113, 114,  
131, 136, 137, 142, 145, 151,  
156, 157, 159, 160  
required reserves, 33, 34, 97  
reserve–deposit ratio, 21, 84, 85  
reserve ratio, 6, 23, 24, 30, 32, 33,  
60, 73, 74, 109  
reserves, 6, 9, 17, 18, 21–24, 26,  
28–33, 36, 38–40, 43, 60, 71–74,  
98, 104, 107, 109, 112, 115,  
142, 156  
resource creation, 159  
retail-banking sector, 155  
risk, 2, 4–7, 27, 28, 51, 53–55, 61,  
64, 66, 69, 71, 74, 75, 77, 78,  
80, 81, 83–90, 98–101, 104,  
105, 107, 109, 113, 115–120,

- 123–125, 127, 129, 131, 133,  
135, 136, 158, 159
- risk premium, 64, 77, 80, 86, 90, 120,  
149–151
- S**
- saving, 1–3, 32, 34, 43–51, 58–61,  
63, 64, 68, 70, 75, 77, 78, 80,  
84, 85, 94, 97, 144
- Say's law of markets, 64
- scholarship, 159
- Schumpeter, J.A., 1, 98, 111, 131, 132
- segmented markets theory, 83, 87
- self-fulfilling dynamics, 141
- shadow-banking, 6, 7
- short term interest rates, 84, 90
- Smith, A., 11
- sowing the seeds, 104, 112
- speculative, 48, 55, 69, 98–100, 102,  
104, 111, 112, 116, 120, 133,  
135, 136, 158
- speculative demand, 55
- speculative demand for money, 13, 45,  
51, 52, 55, 105
- splitting factor, 127, 129
- stabilisation, 155, 159
- stagnant recession, 111
- stagnation, 98, 105, 113, 142, 160
- store of value, 5, 11, 18
- structure, 6, 7, 70, 77, 80, 81, 87, 89,  
92, 104
- supply of money, 9, 24, 28, 33, 44,  
59, 60, 69, 70, 97
- T**
- Templars, 11
- term, 6, 20, 25, 26, 28, 32, 35, 49,  
57, 59, 64, 66, 68, 71, 77–85,  
87–94, 101, 131, 133, 135, 143,  
150, 157, 158, 160
- term structure, 64, 75, 82, 83, 85–90,  
94
- time lags, 158, 159
- Tobin, J., 8, 46, 53, 61
- token, 11
- transaction cost, 49
- transactions balances, 46
- transactions demand, 46, 50, 51
- transfer incomes, 152
- transfer payments, 15, 103, 104, 110,  
152, 156, 159
- transport facilities, 159
- tripartite structure, 13
- U**
- uncertainty, 19, 27, 28, 34, 45,  
51–53, 69, 74, 78, 85, 86, 102,  
105, 107, 109, 113, 116, 120,  
123–125, 127, 129, 131, 133,  
135, 137, 157–159
- unemployment, 19, 103, 114, 141,  
146–148, 151, 158, 159
- unemployment rate, 143, 146
- V**
- VAR, 85, 87, 88, 92–94
- variability of deposit flows, 33, 73, 97
- velocity, 8, 9, 18, 22, 45, 46, 51, 56,  
57, 61, 107, 111, 157
- W**
- wealth, 4, 7, 8, 17, 19, 34, 36, 38, 43,  
45, 52–55, 58, 60, 61, 65, 70,  
73, 106, 150